

**CAMERON COUNTY  
REGIONAL WATER AND WASTEWATER  
PLANNING STUDY**

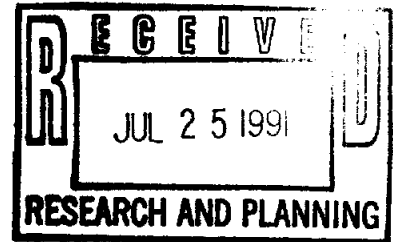

**Presented to:**

**Cameron County Water Development Board**

**and**

**Texas Water Development Board**

**July, 1991**

**Water Resources Planning Group:**

**Donald G. Rauschuber and Associates, Inc.  
Michael Sullivan and Associates, Inc.  
Horizon Environmental Services, Inc.  
Wallace Winkler & Rice, Inc.**

**CAMERON COUNTY WATER DEVELOPMENT BOARD**

**BOARD OF DIRECTORS**

**JUDGE TONY GARZA, CO-CHAIRMAN**

**MR. WILLIAM D. TOWERS, CO-CHAIRMAN**

## **ACKNOWLEDGEMENTS**

We gratefully acknowledge the support of the funding agencies, the Public Utilities Board, Brownsville, Texas, the Cameron County Water Development Board, Brownsville, Texas, and the Texas Water Development Board, Austin, Texas.

Special recognition is extended to Judge Tony Garza, Co-Chairman and Mr. William D. Towers, Co-Chairman of the Cameron County Water Development Board, and Mr. James Fries and Mr. John Miloy, Texas Water Development Board, who were instrumental in planning, awarding and supervising this Project.

Numerous individuals in the public and private sectors were involved in this Project in many capacities. We extend our thanks to them. Particularly, Mr. John Bruciak, P.E., Acting Director of Engineering, Public Utilities Board, and Mr. Alfonso Garcia, Director of Planning, Cameron County, provided their expertise and experience in the performance of this study.

We owe a special thanks to Mr. Raymond Rodriguez, Cameron County Health Department, and Mr. Jack Brown, P.E. Cameron County Engineer for their direction and continual support of the Project.

**CAMERON COUNTY WATER AND WASTEWATER MANAGEMENT PLAN  
TABLE OF CONTENTS**

<b>SECTION</b>	<b>Page</b>
<b>PHASE - I</b>	
1.0 INTRODUCTION	1-1
1.1 Authorization	1-1
1.2 Goals/Objective and Scope	1-1
1.3 Sub-areas	1-3
<u>Sub-area B (Brownsville ETJ)</u>	1-3
<u>Sub-area H (Harlingen ETJ)</u>	1-3
<u>Sub-area E (Eastern Cameron County)</u>	1-3
<u>Sub-area W (Western Cameron County)</u>	1-3
2.0 EXISTING CONDITIONS	2-1
2.1 Current Population Estimates	2-1
<u>Texas Water Development Board (TWDB) Data</u>	2-1
<u>Texas Education Agency (TEA) Data</u>	2-2
<u>Lower Rio Grande Development Council (RGVDC) Data</u>	2-2
<u>Texas A&amp;M University (TAMU) Data</u>	2-2
<u>University of Texas (UT) Data</u>	2-2
<u>PUB Data (R. W. Beck, 1988)</u>	2-3
2.1.1 Cameron County	2-3
2.1.2 Incorporated/Urban Areas	2-4
2.1.3 Rural Areas and Colonias	2-4
<u>Methodology</u>	2-4
<u>Results</u>	2-5
<u>Sub-area B (Brownsville ETJ)</u>	2-5
<u>Sub-area W (Western Cameron County)</u>	2-5
<u>Sub-area E (Eastern Cameron County)</u>	2-9
<u>Sub-area H (Harlingen ETJ)</u>	2-9
2.2 Water Service Area, Historical Use, Supply and Rights, and Facilities	2-10
2.2.1 Service Areas	2-10
2.2.1.1 Certificate of Convenience Necessity Areas	2-10
2.2.1.2 Extraterritorial Jurisdiction	2-11
2.2.1.3 Physical Service Areas	2-11
2.2.2 Historical Water Use	2-14
2.2.2.1 Cameron County	2-14
2.2.2.2 Incorporated/Urban Areas	2-14
2.2.2.3 Rural Areas and Colonias	2-18

**CAMERON COUNTY WATER AND WASTEWATER MANAGEMENT PLAN  
TABLE OF CONTENTS**

<b>SECTION</b>	<b>Page</b>
2.3.2.6 City of Los Fresnos	2-39
2.3.2.7 City of La Feria	2-39
2.3.2.8 Palm Valley Estates Utility District	2-39
2.3.2.9 Valley Municipal Utility District No. 2	2-40
2.3.2.10 City of Rio Hondo	2-40
2.3.3 Wastewater Disposal in Colonias	2-40
<b>3.0 PROJECTED CONDITIONS</b>	<b>3-1</b>
<b>3.1 Population Projections</b>	<b>3-1</b>
<u>Texas Water Development Board (TWDB) Future Population Estimates</u>	3-1
<u>Lower Rio Grande Valley Development Council (LRGVDC) Future Population Estimates</u>	3-2
<u>Texas A&amp;M University (TAMU) Future Population Estimates</u>	3-2
<u>R. W. Beck Future Population Estimates</u>	3-2
3.1.1. Cameron County	3-2
3.1.2. Incorporated/Urban Areas	3-4
3.1.3. Rural Areas and Colonias	3-4
<u>Colonia Projections</u>	3-9
<u>Methodology</u>	3-9
<u>Results</u>	3-9
<u>Sub-area B (Brownsville ETJ)</u>	3-13
<u>Sub-area W (Western Cameron County)</u>	3-13
<u>Sub-area E (Eastern Cameron County)</u>	3-13
<u>Sub-area H (Harlingen ETJ)</u>	3-13
<b>3.2 Projected Water Demands</b>	<b>3-13</b>
<u>Water Use By Type</u>	3-13
<u>Texas Water Development Board (TWDB) Projections</u>	3-16
3.2.1. Cameron County	3-17
3.2.2. Incorporated/Urban Areas	3-17
3.2.3. Rural Areas and Colonias	3-17
<b>3.3 Projected Wastewater Quantities</b>	<b>3-22</b>
3.3.1. Cameron County	3-22
3.3.2. Incorporated/Urban Areas	3-22
3.3.3. Rural Areas and Colonias	3-28
<b>PHASE II</b>	
<b>4.0 FUTURE WATER SUPPLY, TREATMENT AND DISTRIBUTION OPTIONS</b>	<b>4-1</b>
<b>4.1 Identification of Potential Supply Options</b>	<b>4-1</b>

**CAMERON COUNTY WATER AND WASTEWATER MANAGEMENT PLAN  
TABLE OF CONTENTS**

<b>SECTION</b>	<b>Page</b>
Extended Aeration	5-22
Oxidation Ditches	5-22
Contact Stabilization Systems	5-22
Completely Mixed System	5-25
5.1.4 Connection to an Existing Regional System	5-25
5.1.4.1 Available Existing Systems	5-25
<u>Existing and Future Treatment Available Capacities</u>	5-25
<u>Treatment Levels and Discharge Methods</u>	5-28
5.2 Colonia-Specific Disposal Options	5-28
5.2.1 Preliminary Wastewater Options Selection Flow Diagram	5-28
5.2.1.1 Matrix Description	5-28
5.2.1.2 Matrix Application	5-30
5.2.1.3 Classification Modification as a Result of Engineering Judgement	5-33
5.3 Waste Load Evaluation of Primary Disposal Options	5-34
5.3.1 Introduction	5-34
5.3.1.1 Water Quality Segments	5-34
<u>Arroyo Colorado Segment 2201-Tidal</u>	5-34
<u>Segment 2202 - Above Tidal</u>	5-34
5.3.1.2 Water Quality Standards	5-36
5.3.1.3 Wastewater Discharges	5-37
5.3.1.4 Water Quality Conditions	5-38
5.3.1.5 Classification and Rank	5-38
5.3.2 QUAL-TX Surface Water Quality Model Simulations	5-38
5.3.2.1 Impact Analysis Overview	5-38
5.3.2.2 Existing Wasteload Evaluation	5-39
5.3.2.3 Brownsville Ship Channel and Rio Grande Model Development	5-39
<u>Brownsville Ship Channel - Segment 2494</u>	5-39
<u>Rio Grande Tidal - Segment 2301</u>	5-40
5.3.2.4 Model Application	5-40
5.3.2.5 Simulation Results	5-41
5.4 Detailed Cost Analysis of Primary Disposal Options	5-45
<u>Sub-area B (Brownsville ETJ)</u>	5-50
<u>Sub-area H (Harlingen ETJ)</u>	5-55
<u>Sub-area W (Western Cameron County)</u>	5-56

**CAMERON COUNTY WATER AND WASTEWATER MANAGEMENT PLAN  
TABLE OF CONTENTS**

<b>SECTION</b>	<b>Page</b>
7.3.2 Hydrological Elements	7-10
7.3.3 Climatic Elements	7-13
7.3.4 Biological Elements	7-13
7.3.4.1 Vegetation	7-13
<u>Mid-Valley Riparian Woodland</u>	7-15
<u>Sabal Palm Forest</u>	7-15
<u>Clay Loma/Wild Tidal Flats</u>	7-16
<u>Mid-Delta Thorn Forest</u>	7-16
<u>Coastal Brushland Potholes</u>	7-16
7.3.4.2 Wildlife	7-16
7.3.4.3 Aquatic, Estuarine, and Marine Ecology	7-17
Lower Laguna Madre	7-17
Lower Arroyo Colorado	7-19
Rio Grande Estuary	7-21
Riverine Environments	7-21
7.3.4.4 Wetland and Unique Areas	7-21
Estuarine Wetlands	7-23
Palustrine Wetlands	7-23
<u>Southmost Ranch</u>	7-24
<u>Laguna Atascosa National Wildlife Refuge</u>	7-24
<u>Texas Sabal Palm Sanctuary</u>	7-25
7.3.4.5 Threatened and Endangered Species	7-25
7.3.4.6 Archaeological/Cultural Resources	7-25
7.3.4.7 Land-Use and Socioeconomic Conditions	7-30
7.3 Alternative Analysis	7-33
7.4 Potential Environmental Impacts	7-33
<b>8.0 INSTITUTIONAL AND LEGAL ISSUES</b>	<b>8-1</b>
8.1 Regulatory Overview	8-1
8.2 Federal Regulatory Considerations	8-1
<u>Clean Water Act</u>	8-1
<u>USCE Section 404 Permit</u>	8-1
<u>EPA-NPDES Permit</u>	8-5
<u>USFWS Section 7 Consultation for Threatened and Endangered Species</u>	8-5
<u>National Historic Preservation Act</u>	8-5
8.3 State Regulatory Considerations	8-6
<u>Texas Antiquities Code</u>	8-6
<u>TWC-State Water Quality Permit</u>	8-6
<u>TWC-State Water Rights Permit</u>	8-6

## LIST OF TABLES

Table	Title	Page
2-1	Cameron County Current Population Estimates	2-3
2-2	Estimated Housing Units & Population in Colonias	2-6
2-3	Historical Water Use By Supply Entity 1980-1987	2-16
2-4	Water Rights Summary (Cameron, Hidalgo and Starr Counties)	2-26
2-5	Municipal Water Rights by Appropriator in Cameron County	2-27
2-6	Summary of Water Supply and Facilities Located within Cameron County	2-30
2-7	Water Supply Entities Serving Colonias in Cameron County	2-36
2-8	Municipal and Industrial Discharge in Cameron County	2-38
3-1	Population Projections for Municipalities in Cameron County 1990-2020	3-6
3-2	Population Projections for Municipalities in Cameron County	3-7
3-3	Population Projections for Colonias by Sub-Areas	3-10
3-4	Total Population Projections for Colonias by Sub-Areas	3-12
3-5	Projected Water Requirements for Cameron County by Type of Use With Water Conservation	3-14
3-6	Projected Water Requirements for Cameron County by Type of Use Without Water Conservation	3-15
3-7	Projected Municipal Water Demands Average Per Capita Use Series 1990-2020	3-18
3-8	Projected Municipal Water Demands High Per Capita Use Series 1990-2020	3-19
3-9	Projected Municipal Water Demands 1990-2020	3-20
3-10	Water Demand Projections for Colonias by Sub-Areas	3-23
3-11	Total Water Demand Projections for Colonias by Sub-Areas	3-25
3-12	Projected Wastewater Treatment Requirements for Cameron County	3-26
3-13	Projected Wastewater Treatment Capacity Requirements	3-27
3-14	Wastewater Projections for Colonias by Sub-Areas	3-29
3-15	Total Wastewater Projections for Colonias by Sub-Areas	3-31
4-1	Transmission Main Estimating Price	4-13
4-2	Unit Prices for Estimating Water Distribution Costs for Rural Systems	4-14
4-3	Unit Prices for Estimating Water Distribution Costs for Urban Systems	4-14
4-4	Cities and Water Supply Corporation Serving Cameron County	4-16
4-5	Brownsville Sub Area B Populations and Water Service	4-19



## LIST OF TABLES

<b>Table</b>	<b>Title</b>	<b>Page</b>
7-4	Limits of Tolerance of Texas Seagrasses	7-20
7-5	Fish Populations of the Rio Grande	7-22
7-6	Rare, Threatened, and Endangered Species of Potential Occurrence and Known Natural Communities in Cameron County	7-26
7-7	Land Use by SCS Classification	7-31
7-8	Labor Force, Total Employment and Unemployment of the Study Area	7-32
7-9	Employment By Industry in Cameron County	7-32
7-10	Personal Income By Industry Source in The Study Area	7-34
8-1	Synopsis of Environmental Regulatory Programs	8-2
10-1	Wastewater Collection, Treatment and Disposal Options	10-2

## LIST OF FIGURES

Figure	Title	Page
1-1	Cameron County Study Area and Facility Planning Sub-areas	1-4
2-1	Certificate of Convenience and Necessity Map of Cameron County	2-12
2-2	Cameron County Study Area and Facility Planning Sub-areas	2-13
2-3	Service Area Map of Providers in Cameron County	2-15
2-4	Cameron County Non-Agricultural Water Use and Use Per Connection	2-17
2-5	Range of Use Per Connection in Cameron County	2-19
3-1	Cameron County Population Projections	3-3
3-2	City of Brownsville Population Projections	3-5
3-3	Cameron County Rural (Unincorporated and Colonias Area Population Projection	3-8
3-4	Cameron County Rural and Colonia Projections of Municipal Water Demand High Per Capita Water Use Series	3-21
4-1	Capital Cost Membrane Softening and Low Pressure RO	4-7
4-2	Operating Cost Membrane Softening and Low Pressure RO	4-8
4-3	Water Decision Matrix	4-12
4-4	Site Map of Hacienda Gardens	4-20
4-5	Site Map of Cameron Park	4-21
4-6	Area Map of Colonia W (14W), T2 Unknown (6W), Q Unknown (13W), R Unknown (15W), S (17W) and X Unknown (16W)	4-26
4-7	Site Map of W (14W)	4-27
4-8	Site Map of T2 Unknown (6W)	4-28
4-9	Site Map of Q Unknown (13W), R Unknown (15W) and S(17W)	4-29
4-10	Site Map of X Unknown (16W)	4-30
5-1	Two Compartment Septic Tank	5-3
5-2	Soil Absorption Bed	5-4
5-3	Soil Absorption Trench	5-5
5-4	Evapotranspiration Bed	5-6
5-5	Flow Diagram for Selecting Proper Subsurface Disposal Methods	5-8
5-6	Rock Media Trickling Filter	5-18
5-7	Biooxidation Tower	5-19
5-8	Conventional Activated Sludge System	5-21

## LIST OF FIGURES

Figure	Title	Page
5-36	Area Map of Olmito, San Pedro/Carmen Barrera, and Villa Cavazos (2B, 4B, and 11B)	5-70
5-37	Site Map of San Pedro/Carmen Barrera (4B)	5-71
5-38	Site Map of Villa Cavazos (11B)	5-72
5-39	Area Map of Cameron Park, Hacienda Gardens and Villa Nueva (1B, 7B, and 8B)	5-73
5-40	Site Map of Hacienda Gardens (7B)	5-74
5-41	Site Map of Villa Nueva (8B)	5-75
5-42	Area Map of Alabama/Arkansas (La Palma), Villa Pancho, Pleasant Meadows, Los Cuates, Coronado Heights, Unknown, Valle Escondido, Unnamed C, 511 Crossroads, Unknown, Valle Hermosa & 21 (6B, 9B, 10B, 13B, 15B, 16B, 18B, 19B, 22B, 24B, 25B, & 28B)	5-76
5-43	Site Map of Alabama/ Arkansas (La Palma) (6B)	5-77
5-44	Site Map of Villa Pancho (9B)	5-78
5-45	Site Map of Pleasant Meadows, Unknown, and 21 (10B, 24B and 28B)	5-79
5-46	Site Map of Los Cuates and Coronado Heights (13B and 15B)	5-80
5-47	Site Map of Unknown, Valle Escondido and Valle Hermosa (16B, 18B and 25B)	5-81
5-48	Site Map of Unnamed C (19B)	5-82
5-49	Site Map of 511 Crossroads (22B)	5-83
5-50	Facilities Map of Sub-Area H	5-84
5-51	Area Map of Las Palmas (1H)	5-85
5-52	Site Map of Las Palmas (1H)	5-86
5-53	Area Map of La Tina Ranch, Lasana and Laguna Escondido Heights (3H, 4H and 7H)	5-87
5-54	Site Map of La Tina Ranch (3H)	5-88
5-55	Site Map of Lasana (4H)	5-89
5-56	Site Map of Laguna Escondido Heights (7H)	5-90
5-57	Area Map of Lago Subdivision, and Rice Tracts (2H and 5H)	5-91
5-58	Site Map of Lago Subdivision (2H)	5-92
5-59	Site Map of Rice Tracts (5H)	5-93
5-60	Area Map of Rice Tracts and Leal Subdivision (5H and 6H)	5-94
5-61	Site Map of Leal Subdivision (6H)	5-95
5-62	Facilities Map of Sub-Area W	5-96

## LIST OF FIGURES

<b>Figure</b>	<b>Title</b>	<b>Page</b>
5-90	Site Map of Lozano (2E)	5-124
5-91	Site Map of La Tina Ranch (3E)	5-125
5-92	Site Map of Las Yescas (7E)	5-126
5-93	Area Map of Del Mar Heights, Orason Acres/Chula Vista/Shoemaker, and Unknown (Del Mar II) (5E, 6E, and 10E)	5-127
5-94	Site Map of Del Mar Heights and Unknown (Del Mar II) (5E and 10E)	5-128
5-95	Site Map of Orason Acres/Chula Vista/Shoemaker (6E)	5-129
5-96	Area Map of Glenwood Acres Subdivision (9E)	5-130
5-97	Site Map of Glenwood Acres Subdivision (9E)	5-131
5-98	Area Map of Los Cuates (11E)	5-132
5-99	Site Map of Los Cuates (11E)	5-133

## 1.0 INTRODUCTION

### 1.1 Authorization

In November 1989, the Public Utilities Board of Brownsville (PUB) and the Commissioners Court of Cameron County (jointly recognized as the Cameron County Water Development Board) received a planning grant from the Texas Water Development Board (TWDB) to prepare a Water and Wastewater Plan for an area that includes the incorporated boundaries of Brownsville, its extraterritorial jurisdiction (ETJ), the PUB's service area and all unincorporated areas of Cameron County. Funding for this plan was provided by the TWDB (75%) and the PUB (25%). As political subdivisions of the state both the PUB and the County have the authority to plan, develop and operate water and wastewater systems with their respective jurisdictional boundaries.

### 1.2 Goal, Objectives and Scope

The study area, as previously described, includes the incorporated boundaries of Brownsville, its ETJ and all unincorporated areas of Cameron County. There have been several recent water and wastewater plans developed for the study area. For instance the City of Brownsville has recently completed Water (R. W. Beck 1988) and Wastewater Plans (Bovay 1986) for the incorporated boundaries of Brownsville and is currently implementing many of the recommendations of those plans. These plans provided valuable insight to the long range goals and plans of Brownsville and served as a basis for the development of this plan. The availability of these plans coupled with their acceptance by the PUB allowed this study to focus on the unincorporated areas of Cameron County for the planning of additional water and wastewater facilities, compensated with the level of planning performed by the PUB. In addition to water and wastewater planning, this study presents an environmental assessment, wasteload evaluations, water conservation planning and a review of financial programs for the entire study area. Obviously a plan of this complexity cannot be developed without consideration of all influencing factors throughout the entire region including, population dynamics and existing and planned water and wastewater facilities. This effort has two basic planning areas; 1) the County as a whole including all incorporated areas, (and corresponding influencing factors) hereafter referred to as the Study Area; and 2) the problematic unincorporated areas of the county, hereafter referred to as the Facility Planning Area.

A brief review of the unique nature of residential development along the Texas-Mexico border allows the Facility Planning Area to be more delineated. Numerous studies over the past several years have documented the water and wastewater problems (and subsequent health problems) in the "squatter like" unincorporated communities located in rural areas along the Texas-Mexico border. These communities referred to as "colonias" vary in size, population and housing quality. Colonias have been identified on area of rural land ranging from 5 acres and to 1,300 acres (Holtz 1989) in size in Cameron County. Other

colonia characteristics such as housing or road quality also span a wide range of conditions. However, rural communities do have common characteristics which identify the community as a colonia. Colonia characteristics defined in other studies, include location outside of the corporate limits of a municipality or district providing water and sewer, with some substandard housing, and no current service by a sewer collection line (TCB, 1987). By the nature of this definition, colonias can be identified as the area within the County with the highest need for the planning and development of water and wastewater facilities. Based on this need, the Facilities Planning Area was further delineated to represent the "colonias" in Cameron County.

To summarize the above discussion, the Study Area includes the County as a whole including both unincorporated and incorporated areas (and corresponding demands for water and wastewater supplies and facilities); the Facility Planning Area, in contrast, includes the colonias of Cameron County and any improvements necessary to provide service to these areas.

The goal of this plan is to provide a technically, economically and environmentally feasible method of providing water and wastewater service to the residents within the Facility Planning Area and to evaluate water supply options and wasteload impacts (to receiving streams) for the entire Study Area. The following objectives have been identified (per TWDB's Request for Proposal) as components necessary to achieve this goal.

1. Define service area water and wastewater needs;
2. Identify alternative measures to satisfy these needs;
3. Provide an environmental assessment,
4. Identify institutional arrangements,
5. Develop cost estimates, and
6. Provide an implementation schedule

In order to accomplish these objectives a scope of work was developed that includes three phases. Phase I, the Planning Phase, includes a summary of existing and projected conditions for the entire county including incorporated areas and colonias (Sections 2.0 and 3.0). Phase II, the Engineering Phase, includes water supply and wasteload evaluation information for the entire county, and engineering and cost information for water and wastewater facilities in the Facility Planning Area (i.e. colonias). (Sections 4.0 and 5.0). Phase III, the Support Data and Recommendations Phase, includes a Water Conservation and Drought Contingency Plan for the entire county (Section 6.0); a Preliminary Environmental Assessment that identifies significant environmental features throughout the county (Section 7.0); a review of Institutional and Legal Issues associated with development of water and wastewater facilities (Section 8.0); a review of Financing Programs available for such facilities (Section 9.0);

and finally recommendations to satisfy the water and wastewater needs in Cameron County (Section 10.0).

### 1.3 Sub-areas

As described above this plan has two primary areas of concern; the Study Area and the Facility Planning Area. The study areas was divided into 4 separate Facility Planningsub-areas (see Figure 1-1) based on geographic location and jurisdictional boundaries. Sub-area divisions enhanced data collection and analysis activities, and was based on potential types and suppliers of water and wastewater service within the county. The sub-areas used in this study are as follows:

#### Sub-area B (Brownsville ETJ)

This sub-area essentially follows the boundaries of Brownsville's ETJ to the north, east and west, and is bounded on the south by the Rio Grande.

#### Sub-area H (Harlingen ETJ)

Sub-area H includes the area encompassed by the ETJ's of Harlingen, San Bentio, Rio Hondo, Combes and Primera. The ETJ's of each of these municipalities are contiguous and create an area within which Sub-Area H is enveloped.

#### Sub-area E (Eastern Cameron County)

Sub-area E covers the eastern portion of Cameron County on the south from the Rio Grande up to western portion of Brownsville's ETJ to U.S. Highway 77 to the boundaries of Sub-area H up to the Arroyo Colorado to the Cameron/Willacy County line.

#### Sub-area W (Western Cameron County)

Sub-area W encompasses the remainder of the county. The boundary for sub-area W extends from the Rio Grande and follows Brownsville's ETJ to U.S. Highway 77, then extends westward around Sub-Area H up to the Arroyo Colorado, then to the Cameron/Willacy County line.

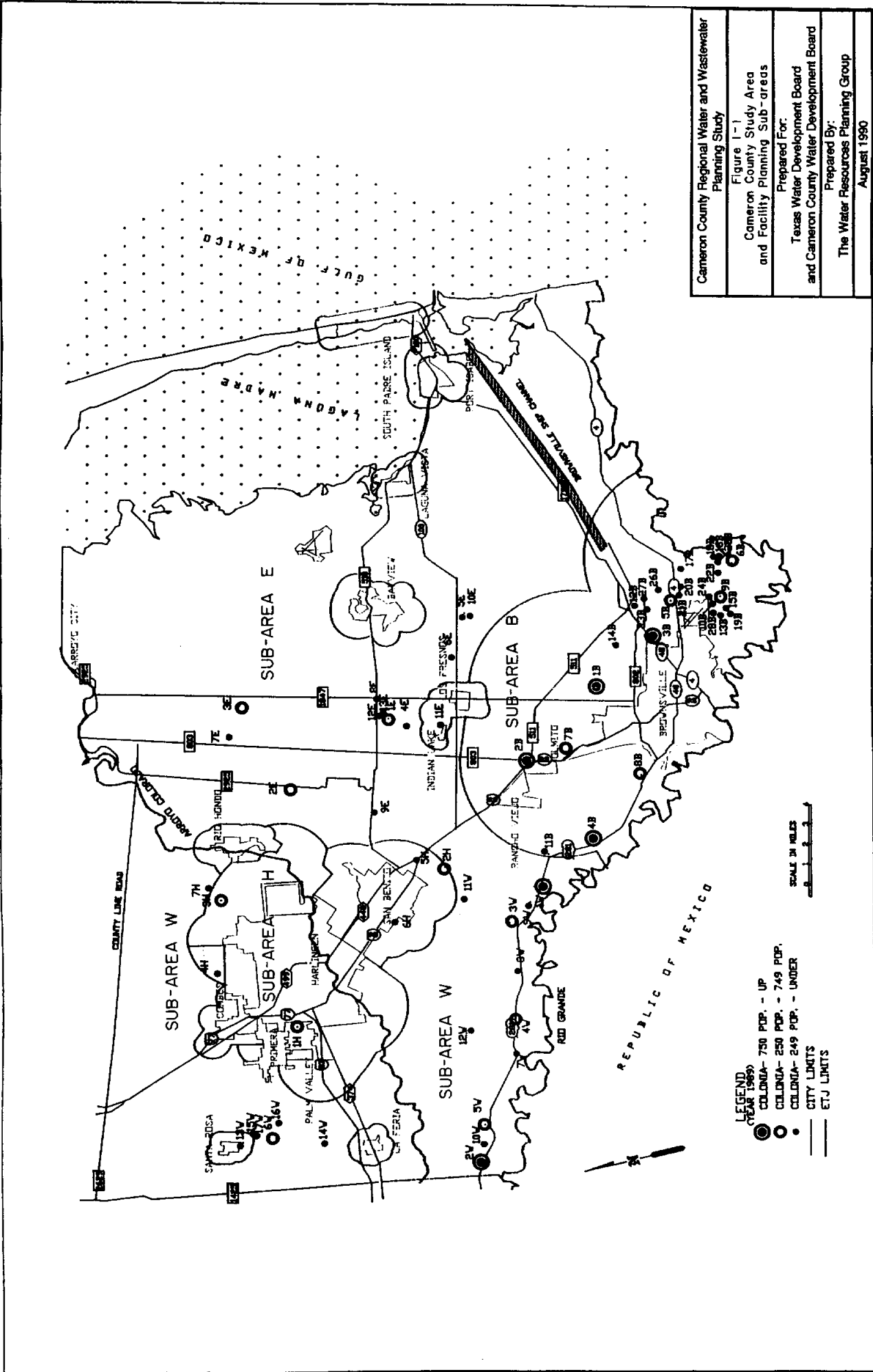

Cameron County Regional Water and Wastewater Planning Study  
 Figure 1-1  
 Cameron County Study Area and Facility Planning Sub-areas  
 Prepared For:  
 Texas Water Development Board and Cameron County Water Development Board  
 Prepared By:  
 The Water Resources Planning Group  
 August 1969

LEGEND  
 (YEAR 1969)  
 ● COLONIA - 750 POP. - UP  
 ○ COLONIA - 250 POP. - 749 POP.  
 ○ COLONIA - 249 POP. - UNDER  
 — CITY LIMITS  
 — ETJ LIMITS

SCALE IN MILES  
 0 1 2 3



## 2.0 EXISTING CONDITIONS

A comprehensive inventory and analysis of existing population and water and wastewater data in Cameron County is integral to the development of this plan. These data provide the basis for determining current and future water and wastewater needs in the cities and unincorporated areas of Cameron County. This section provides information on historical and current population and water and wastewater data in both the urban and rural areas of Cameron County.

### 2.1 Current Population Estimates

The TWDB Water Uses and Projections Section routinely prepares and updates population estimates for all parts of the State of Texas. Other state and regional entities, such as the Texas Department of Commerce (TDOC) and Lower Rio Grande Development Council (LRGVDC) also prepare independent population estimates. However, there currently does not exist a single designated agency or political entity charged with generation of "official" population estimates for use in all state or local planning efforts. Under the terms of the TWDB Planning Grant award, TWDB estimates of current populations and water demand are to be used unless compelling arguments can demonstrate that TWDB estimates are not representative or that other estimates more adequately depict existing conditions or future growth.

Population estimates for incorporated and unincorporated areas of Cameron County from several sources are compared and contrasted in this section. The following data sources were used to develop existing population estimates:

Texas Water Development Board, Water Data Collection, Studies, and Planning Division, Projections of Population and Municipal Water Demands (Average and High Per Capita Use Series), October 1989;

Texas Water Development Board, A Reconnaissance Level Study of Water Supply and Wastewater Needs of the Colonias of the Lower Rio Grande Valley, January 1987;

Lower Rio Grande Development Council - Estimates of Population for Cameron, Hidalgo and Willacy Counties, October 1988;

Texas Education Agency - Cameron County School Enrollment Data (1984-1988), 1988;

Texas A&M University - Estimates of the Total Population of Counties in Texas By Age, Sex and Race/Ethnicity for July 1, 1987; and

University of Texas at Austin Department of Geography - Third World Texas: Colonias in Lower Rio Grande Valley, August 1989.

#### Texas Water Development Board Data

TWDB current population estimates are based on data collected by the U. S. Census Bureau. Information provided by the Census Bureau reflects their best estimates population changes between official census counts based on local fertility, mortality, immigration and emigration rates (including undocumented

aliens). U. S. Census Bureau figures are upgraded every biannually. TWDB demographers adjust, if necessary, U. S. Census Bureau current population estimates to reflect anomalies observed in local water use patterns, either quantity or spacial distribution, which could indicate higher or lower populations.

In 1986, the TWDB funded a reconnaissance level study (TCB, 1987) aimed specifically at identification and quantification of colonia populations and water and wastewater needs of the Lower Rio Grande Valley. TWDB population estimates were verified and supplemented through site surveys which identified specific colonias, the number of housing units per colonia, the area and development density of each colonia and, where possible, the number of occupants per housing unit. The following presents a brief description of population and socio-economic data sources used in this study.

#### Texas Education Agency (TEA) Data

TEA maintains records of public school enrollment for all school districts in Texas. TEA data are reported by school within each independent school district and county, and are further broken down according to ethnicity (White, Hispanic, Black, Asian and American Indian). As local fertility and mortality rates do not vary remarkably from year to year (exclusive of catastrophic changes), school enrollment data are often the first indicator of changes in local populations resulting from immigration or emigration. TEA data for the period 1984-1988 were examined for indications of population changes that may not be included in recent census or vital statistics records.

#### Lower Rio Grande Development Council (LRGVDC) Data

LRGVDC starts with TWDB/U.S. Census Bureau data for current population estimates for urban and rural areas of Cameron County and updates those estimates annually to reflect local vital statistics records. In addition, the LRGVDC attempts to estimate local net immigration rates through independent local surveys.

#### Texas A&M University (TAMU) Data

The TAMU Department of Rural Sociology prepares projections of population for Texas counties by age, sex and race/ethnicity. Much of the current population data used by TAMU is supplied by local councils of government and development agencies.

#### University of Texas (UT) Data

The University of Texas Department of Geography (under funding from UT's LBJ School of Public Affairs) conducted a study (August 1989) to determine the extent and demographic/socioeconomic characteristics of colonias in the Lower Rio Grande Valley. The report provides an overview of data from existing sources, the results of surveys of 2 colonias, and an analysis of the utility of remote sensing as a

method to estimate colonia location and population. This report provides valuable insight with respect to household size within the colonias and the geographic distribution of colonias.

PUB Data ( R. W. Beck, 1988)

R.W. Beck and Associates prepared a Water Master Plan for the PUB in 1988. This Plan considered present and future growth in population, water usage, and the ability of the PUB's system to meet these demands. The plan specifically addressed the need for new raw water supply, treatment and distribution facilities.

Table 2-1 is a compilation of published Cameron County population estimates from the agencies described above.

Table 2-1  
Cameron County Current Population Estimates

	TWDB (1985) <sup>a/</sup>	LRGVDC (1987) <sup>b/</sup>	TAMU (1987) <sup>c/</sup>	Census (1986) <sup>d/</sup>
Brownsville	99,527	105,077		102,110
Harlingen	54,053	53,830		54,980
La Feria	4,288	4,321		4,470
Los Fresnos	2,760			2,780
Port Isabel	4,393	4,659		4,440
Rio Hondo	2,063			2,110
San Benito	21,436	22,239		21,670
Santa Rosa	2,206			2,240
Combes	2,009			2,080
Primera	1,728			1,740
Rural Areas	55,324	69,149		
Total County	249,787	259,272	259,409	257,300

- <sup>a/</sup> U.S. Census Bureau data updated to 1985.
- <sup>b/</sup> U.S. Census Bureau data updated to 1987 using Cameron County Vital Statistics.
- <sup>c/</sup> Produced for TDOC.
- <sup>d/</sup> U.S. Census Bureau data updated to 1986.

2.1.1 Cameron County

The four sources used shown in Table 2.1 to estimate the current population of Cameron County are based on 1980 U.S. Census data projected through various methods to the present. All four sources reflect nearly the same total Cameron County current population. The most recent estimates (1987) are supplied by the LRGVDC; however, TWDB (1985) estimates provide a clearer breakdown of how the population is split between large and small cities within the county and rural unincorporated areas.

To test the assertion that Cameron County experienced a recent (1985 to present) increase in undocumented alien immigration resulting from Latin American political instability, school enrollment statistics were examined to identify and quantify possible increases. While all of the Cameron County Independent School Districts have shown a study increase in Hispanic enrollment (2% to 3% per yr), none

exhibited the dramatic increase that would be associated with a major change in immigration rate that could be considered out-of-line with the general estimated rates of population growth for the county as a whole.

### 2.1.2 Incorporated/Urban Areas

Seventy percent of Cameron County's residents live in one of its three major cities; Brownsville, Harlingen or San Benito. Seventy-eight percent of Cameron County residents live in incorporated cities or subdivisions of greater than 1,000 persons. Brownsville alone accounts for 40% of Cameron County's current population, while Harlingen accounts for 22% and San Benito accounts for 9%.

### 2.1.3 Rural Areas and Colonias

Estimates of population in the rural unincorporated areas of Cameron County range from 22% to 27% of the county total population. Approximately forty-one percent of this total is concentrated in a number of colonias. Colonias in the Lower Rio Grande Valley have been studied and defined in a number of different ways by various public and private entities. Colonia definitions typically have some common characteristics which are best summarized by Holz and Davies (1989) as an organized cluster of generally substandard houses, constructed on small lots, in the rural landscape along the Rio Grande border between Texas and Mexico. For the purposes of this study a somewhat more specific definition developed in the Texas Water Development Board (TWDB) 1987 report "A Reconnaissance Level Study of Water Supply and Wastewater Disposal Needs of the Colonias of the Lower Rio Grande Valley" (here after referred to as 1987 Reconnaissance Level Study) was utilized. This report identified a colonia as a residential development with three common characteristics.

1. The subdivision is located outside of the corporate limits of any city or town, or outside the limits of a utility district providing water and sewer service;
2. The residential community includes at least some substandard housing; and
3. The subdivision is not currently served by a sewer collection line.

### Methodology

A three step approach was used to estimate housing units and populations within the colonias in Cameron County.

The initial step required identifying and locating the colonias within the County. The list of colonias and working maps developed for the TWDB, in the 1987 Reconnaissance Level Study used as the primary data base for colonia identification. These colonias were then located and mapped on 1989 aerial photography (scale 1:40,000) and U. S. Geological Survey (USGS) topographic maps (scale 1:20,000). This database was then reviewed with local officials based on the criteria noted above and additions and deletions made as necessary.

The second step was designed to provide an estimate of housing units within each of the colonias and to verify the areal boundaries identified on the aerial photography. In order to estimate the number of housing units, a windshield survey of each colonia was conducted in November, 1989. During this survey two surveyors counted housing units in each of the colonias and gathered general information on housing conditions, utilities and densities as available. In addition information mapped on the aerial photography was ground verified. This estimate of housing units provided the basis for estimating and projecting population within each of the colonias.

The third step in the process required applying an average household size to the estimated number of housing units to develop estimates of population within each of the colonias. Recent data collected by Cameron County officials for Texas Department of Commerce grants and by researchers at the University of Texas indicate household size within colonias in Cameron County range from 4.67 to 4.99 person per household. A household size of 4.9 person per household was applied to each of the housing units to estimate population in each of the colonias.

### Results

Estimates of November, 1989 housing units and population within each of the colonias in Cameron County are presented in Table 2-2. The results of the colonia survey indicate the number of housing units in colonias increased from 3,761 to 4,629 between 1986 and 1989, an estimated increase of approximately 7.0% annually. A total of 65 colonias were identified within Cameron County. As expected, colonias in Cameron County tend to concentrate around major urban areas and roadways.

Sub-area B (Brownsville ETJ) - Sub-area B has 28 of the 65 colonias located within its boundaries, and over half (53%) of total colonia population in Cameron County. This area experienced an increase of almost 36% in housing units between 1986 and 1989. This increase (considerably higher than the county-wide increase in units of 24%) is primarily attributable to significant growth in the county's largest colonias - Cameron Park and Olmito. These two colonias experienced a 50% (253-unit increase) and 32% (89-unit increase) increase, respectively, between 1986 and 1989. Other colonias in the Brownsville ETJ experiencing significant growth during this period include the San Pedro/Carmen/Barrera Gardens Colonia (85%, 69-unit increase) and the Alabama/Arkansas Colonia (110%, 55-unit increase). The Brownsville ETJ with an estimated 12,039 people residing in colonias has, by far, the highest concentration of the colonia population in Cameron County.

Sub-area W (Western Cameron County) - Sub-area W, with 17 of the 65 colonias and 26% of the estimated total 1989 population, is the second most populated (with respect to colonias) area of the county. Colonias in the unincorporated west sub-area tend to be located along or near major transportation routes, such as, the Military Highway (U.S. Highway 281) and State Highway 506, which

TABLE 2-2  
ESTIMATED HOUSING UNITS & POPULATION IN COLONIAS  
Cameron County  
(1986 & 1989)

*actually 1988 figures*

Colonia No.	Colonia Name	Nov. 1986 Units	Nov. 1989 Units	% Change Units	1986 Pop. a/	1989 Est. Pop. b/
1B	Cameron Park	500	753	50.60%	2250	3,690
2B	Olmite	274	363	32.48%	1233	1,779
3B	Stuart Subd.	200	202	1.00%	900	990
4B	San Pedro/Carmen/Barrera Gd	80	149	86.25%	360	730
5B	King Subd.	130	130	0.00%	585	637
6B	Alabama/Arkansas (La Coma)	50	105	110.00%	225	515
7B	Hacienda Gardesn	-	97	-	-	475
8B	Villa Nueva	83	82	-1.20%	374	402
9B	Villa Pancho	62	62	0.00%	279	304
10B	Pleasant Meadows	50	60	20.00%	225	294
11B	Villa Cavazos	50	41	-18.00%	225	201
12B	Barrio Subd.	40	40	0.00%	180	196
13B	Las Cuates	38	39	2.63%	171	191
14B	Saldivar	30	31	3.33%	135	152
15B	Coronado	29	31	6.90%	131	152
16B	Unknown	25	29	16.00%	113	142
17B	Saldivar (II)	25	28	12.00%	113	137
18B	Valle Escondido	15	28	86.67%	68	137
19B	Unnamed C	15	27	80.00%	68	132
20B	Unnamed D (Keller's Corner)	25	25	0.00%	113	123
21B	Texas 4	-	25	-	-	123
22B	511 Crossroads	-	25	-	0	123
23B	Illinois Heights	20	21	5.00%	90	103
24B	Unknown (Brownsville Airport)	15	20	33.33%	68	98
25B	Valle Hermosa	20	13	-35.00%	90	64
26B	Unknown	12	12	0.00%	54	59
27B	Unnamed B (HWY 802)	10	10	0.00%	45	49
28B	21	10	9	-1000%	45	44
Total Brownsville ETJ Sub-Area		1,808	2,457	35.90%	8,136	12,039

TABLE 2 -2  
ESTIMATED HOUSING UNITS & POPULATION IN COLONIAS  
Cameron County  
(1986 & 1989)  
(Continued)

Colonia No.	Colonia Name	Nov. 1986 Units	Nov. 1989 Units	% Change Units	1986 Pop. a/	1989 Est. Pop. b/
1W	Encantada**	304	263	-13.49%	1368	1289
2W	Santa Maria	239	237	-0.84%	1076	1161
3W	La Paloma ***	119	138	15.97%	536	676
4W	Los Indios	80	112	40.00%	360	549
5W	Bluetown	91	93	2.20%	410	456
6W	T2 Unknown Subd.	69	69	0.00%	311	338
7W	El Venadito	46	46	0.00%	207	225
8W	Carricitos-Londrum	45	44	-2.22%	203	216
9W	El Calaboz	36	37	2.78%	162	181
10W	Iglesia Antigua	32	33	3.13%	144	162
11W	Palmer	30	33	10.00%	135	162
12W	Unknown (mitfa 2)	26	27	3.85%	117	132
13W	Q Unknown Subd. (Santa Rosa)	27	27	0.00%	122	132
14W	W	22	22	0.00%	99	108
15W	R Unknown Subd. (S.Santa Rosa)	12	22	83.33%	54	108
16W	X Unknown Subd. (Santa Feria)	12	13	8.33%	54	64
17W	S	11	13	18.18%	50	64
<b>Total Unincorporated West</b>		<b>1,201</b>	<b>1,229</b>	<b>2.33%</b>	<b>5,405</b>	<b>6,022</b>

Colonia No.	Colonia Name	Nov. 1986 Units	Nov. 1989 Units	% Change Units	1986 Pop. a/	1989 Est. Pop. b/
1E	La Coma Del Norte	130	139	6.92%	585	681
2E	Lozano	120	109	-9.17%	540	534
3E	La Tina Ranch	50	106	112.00%	225	519
4E	Laureles	7	61	771.43%	32	299
5E	Del Mar Heights	47	50	6.38%	212	245
6E	Orason Acres/Chula Vista/Shoemaker	30	48	60.00%	135	235
7E	Las Yescas	40	45	12.50%	180	221
8E	Unknown	35	42	20.00%	158	206
9E	Glenwood Acres Sub	25	35	40.00%	113	172
10E	Unknown (Del Mar II)	20	30	50.00%	90	147
11E	Los Cuates	18	27	50.00%	81	132
12E	25	12	12	0.00%	54	59
13E	Cisneros (Limon)	10	10	0.00%	45	49
<b>Total Unincorporated East</b>		<b>544</b>	<b>714</b>	<b>31.25%</b>	<b>2,448</b>	<b>3,499</b>

**TABLE 2 -2**  
**ESTIMATED HOUSING UNITS & POPULATION IN COLONIAS**  
**Cameron County**  
**(1986 & 1989)**  
**(Continued)**

Colonia No.	Colonia Name	Nov. 1986 Units	Nov. 1989 Units	% Change Units	1986 Pop. a/	1989 Est. Pop. b/
1H	Las Palmas	-	127	-	-	622
2H	Lago Sub	81	80	-1.23%	365	392
3H	26	60	58	-3.33%	270	284
4H	Lasana	30	28	-6.67%	135	137
5H	Rice Tracts	26	27	3.85%	117	132
6H	Leal Sub (Metes & Bounds)		25	-	-	123
7H	Laguna Escondido Hgts.	11	11	0.00%	50	54
Total Harlingen ETJ Sub-Area		208	229	10.10%	936	1,122
TOTAL COUNTY-WIDE		3,761	4,629	23.08%	16,925	22,682

a/ TCB, 1987

b/ TWDB, 1989

\* Percent change for Population is not applicable due to change in Household size (4.5 in 1986 to 4.9 in 1989)

\*\* Includes colonias identified as Montalvo, El Ranchito, and Escamillas in TWDB's 1987 Reconnaissance Level Study

\*\*\* Include colonia identified as Polo Arrizmendia/Padilla identified in TWDB's 1987 Reconnaissance Level Study



passes through Santa Rosa and La Feria. In contrast to the Brownsville ETJ, this area had virtually no growth in housing units during the period 1986 to 1989. Only two colonias in this area experienced any notable growth during this period - Los Indios (40%, 32-unit increase) and a small unnamed colonia located just south of the City of Santa Rosa (83%, 10-unit increase). One area, Encantada, experienced a very notable decrease (24%, 72-unit decrease) during the same period. It is doubtful such a decrease actually occurred, and the decrease may very likely be a result of survey error between the 1986 and 1989 surveys. The Encantada colonia, for the purposes of this study, is made up of four colonias identified in the 1987 Reconnaissance Level Study (i.e., Encantada, Montalvo, El Ranchito, and Escamilla's). This grouping of colonias is due to the lack of clear delineation between colonia boundaries. In order to assure the count was accurate, the 1989 survey was conducted twice, with similar results both times. Again, the lack of clear boundaries from the 1987 study made exact duplication of that effort near impossible, and it is therefore difficult to determine, in this case, if the decrease was real or a result of survey error.

Sub - Area E (Eastern Cameron County) - Sub-area E has 13 colonias and approximately 15% of the colonia population within its boundaries. In contrast to the unincorporated west, this area experienced a considerable increase in housing units of 31% (from 544 to 714) between 1986 and 1989. Colonias experiencing the highest rate of growth during this period include the La Tina Ranch Colonia (112%, 56-unit increase) and the Orason Acres/Chula Vista/Shoemaker Colonia (60%, 18-unit increase). The colonia with the most notable change in number of housing units is the Laureles Colonia. An increase from 7 to 61 housing units was noted during this three (3) year period. It is doubtful such a dramatic increase actually occurred. The change is more likely a result of survey error and/or different areal boundaries in each of the surveys. It is not surprising this sub-area, with influences from Brownsville and tourism with Winter Texans, and South Padre Island experienced this high rate of growth.

Sub-area H (Harlingen ETJ) - Sub-area H, with only seven colonias and approximately 5% of the colonia population, is the least dynamic of any of the sub-areas. Colonias in this area experienced virtually no growth between 1986 and 1989. Table 2-2 notes only a small increase in housing units (24 units) during this period.

In summary, most of the colonias are located in Sub-area B, followed by Sub-area W, Sub-area E, and Sub-area H. The Brownsville ETJ and the Unincorporated East were the only two sub-areas experiencing any significant growth, probably a result of prevailing economic factors (i.e., Brownsville, Port of Brownsville, tourism, fisheries, etc.). In contrast, colonias in the Unincorporated West and Harlingen ETJ experienced little or no growth during this same period.

Of the 65 colonias identified in this study, 36 increased in total number of housing units between 1986 and 1989, with the remainder of the colonias remaining steady or experiencing a minimal decrease in population.

Typically, colonias experiencing significant growth had several common characteristics including:

1. A higher percentage of substandard housing than the colonias not experiencing growth;
2. Typically, road conditions were of significantly lower quality than colonias not experiencing growth;
3. Colonias experiencing the most significant growth were typically located with Brownsville's ETJ.
4. Densities of the areas that experienced growth was far higher than those that remained static.

## 2.2 Water Service Areas, Historical Use, Supply and Rights, and Facilities

An inventory of a variety of components (as they relate to water use, supply and service) is necessary to evaluate existing water supply service in Cameron County. Factors that influence water supply and service are addressed in this section including service areas (jurisdictional and physical) historical water use trends, existing water supplies and, rights, and water treatment and distribution facilities.

### 2.2.1 Service Areas

Water supply service areas are most often defined by jurisdictional and physical boundaries. These service areas do not always follow the same boundaries, i.e., physical service area does not always cover the entire area of the jurisdictional boundaries or vice versa. The following sections provide a brief description of the areas of Certificates of Convenience and Necessity (CCN), ETJ and physical service within Cameron County.

#### 2.2.1.1 Certificate of Convenience and Necessity Areas

Since 1976, the State of Texas has issued to certain utilities CCN for providing utility services to designated areas. These certificates, when awarded, give the utility certain rights and responsibilities within the respective area. These rights and responsibilities include the right to provide service to any current or future customers within the CCN and the responsibility to provide a reasonably priced supply of potable water within the service area. Political subdivisions with CCN's in Cameron County include the PUB, the City of Harlingen, City of La Feria, Military Highway Water Supply Corporation, City of San Benito, Cameron County Freshwater Supply District No. 1, City of Los Fresnos, Olmito Water Supply Corporation, Valley Municipal Utility District No. 2, East Rio Hondo Water Supply Corporation, El Jardin Water Supply Corporation, the City of Port Isabel, and Arroyo City Water Supply Corporation. Several of these entities have overlapping CCN's, when such an overlap occurs, either entity is eligible to provide service to the

area of dual certification. The Texas Water Commission (TWC) is the agency responsible for administering CCN's for water and wastewater. Figure 2-1 reflects the certified areas of Cameron County.

#### 2.2.1.2 Extraterritorial Jurisdiction

Extraterritorial jurisdiction represents the jurisdictional boundary beyond a municipalities incorporated area within which the municipality has certain powers including annexation, subdivision control, and approval of political subdivision creation. These areas normally allow municipalities to extend subdivision authority and control beyond the city limits a distance that is relative to the size of the city. Smaller cities have an ETJ area of one half (1/2) mile, with increments of one (1) mile, two (2) miles, and five (5) miles, with the latter allowed for cities of 100,000 population or more.

The ETJ represents an area within which a city may exercise its annexation power. Through annexation, the municipalities bring additional areas into their zoning, taxing, and ETJ jurisdiction. The State Municipal Annexation Act requires that those annexing must develop a service plan providing for the extension of municipal services to the area within prescribed time limits.

Municipalities, under State-enabling legislation, are authorized to impose certain requirements on subdivision development within their corporate limits and ETJ. Other powers granted to the Texas municipalities require approval of the creation of any political subdivision having as one of its purposes the supplying of water or sewer services for domestic or commercial purposes. These powers enable the cities to manage growth within their ETJ and provide an institutional mechanism for ensuring uncontrolled growth does not occur.

Special legislation was enacted in 1987, in the 71<sup>st</sup> Texas Legislature, in an attempt at colonia development control, which authorized a five (5) mile ETJ area in certain border counties for all cities with a population of 5,000 or more. In Cameron County, no city appears to have acknowledged a five (5) mile ETJ other than Brownsville, and Brownsville is rapidly approaching the population level of 100,000 where that limit would have been authorized without the special legislation.

For the purposes of this report, Brownsville, is shown to have an ETJ area of five (5) miles, with the other cities ETJ as the limits shown on the local maps or reported by local city employees. The ETJ areas for Cameron County are shown as Exhibit Figure 2-2.

#### 2.2.1.3 Physical Service Areas

The actual area of service often varies significantly from the jurisdictional boundaries associated with the CCN. Physical service areas most often are associated with the incorporated boundaries of a municipality

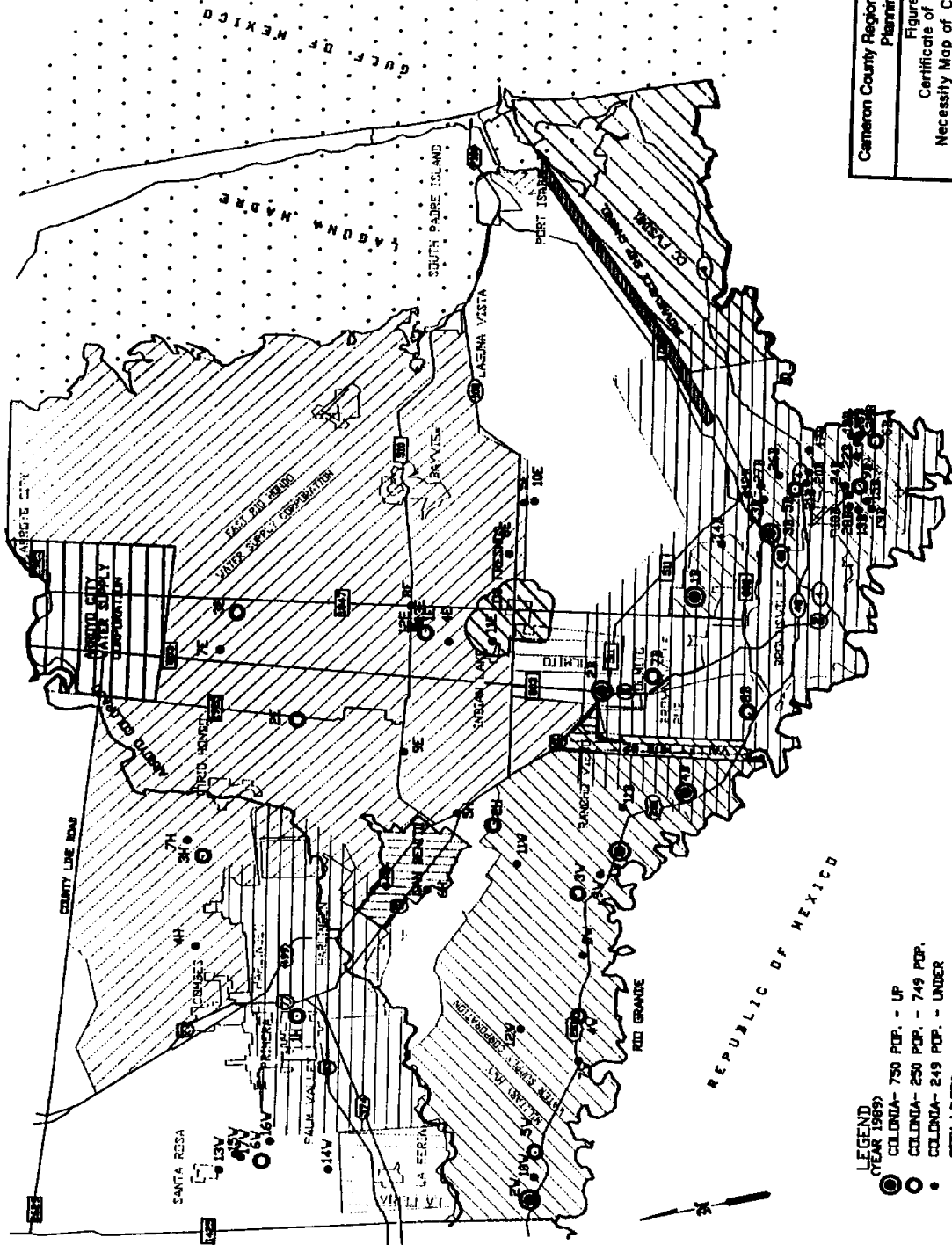

Cameron County Regional Water and Wastewater Planning Study  
 Figure 2-1  
 Certificate of Convenience and Necessity Map of Cameron County  
 Prepared For:  
 Texas Water Development Board and Cameron County Water Development Board  
 Prepared By:  
 The Water Resources Planning Group  
 August 1980

LEGEND  
 (YEAR 1985)  
 ● COLONIA- 750 POP. - UP  
 ○ COLONIA- 250 POP. - 749 POP.  
 ○ COLONIA- 249 POP. - UNDER  
 - - - CITY LIMITS  
 // CCN AREAS



Cameron County Regional Water and Wastewater Planning Study  
 Figure 2-2  
 Cameron County Study Area and Facility Planning Sub-areas  
 Prepared For:  
 Texas Water Development Board  
 and Cameron County Water Development Board  
 Prepared By:  
 The Water Resources Planning Group  
 August 1990

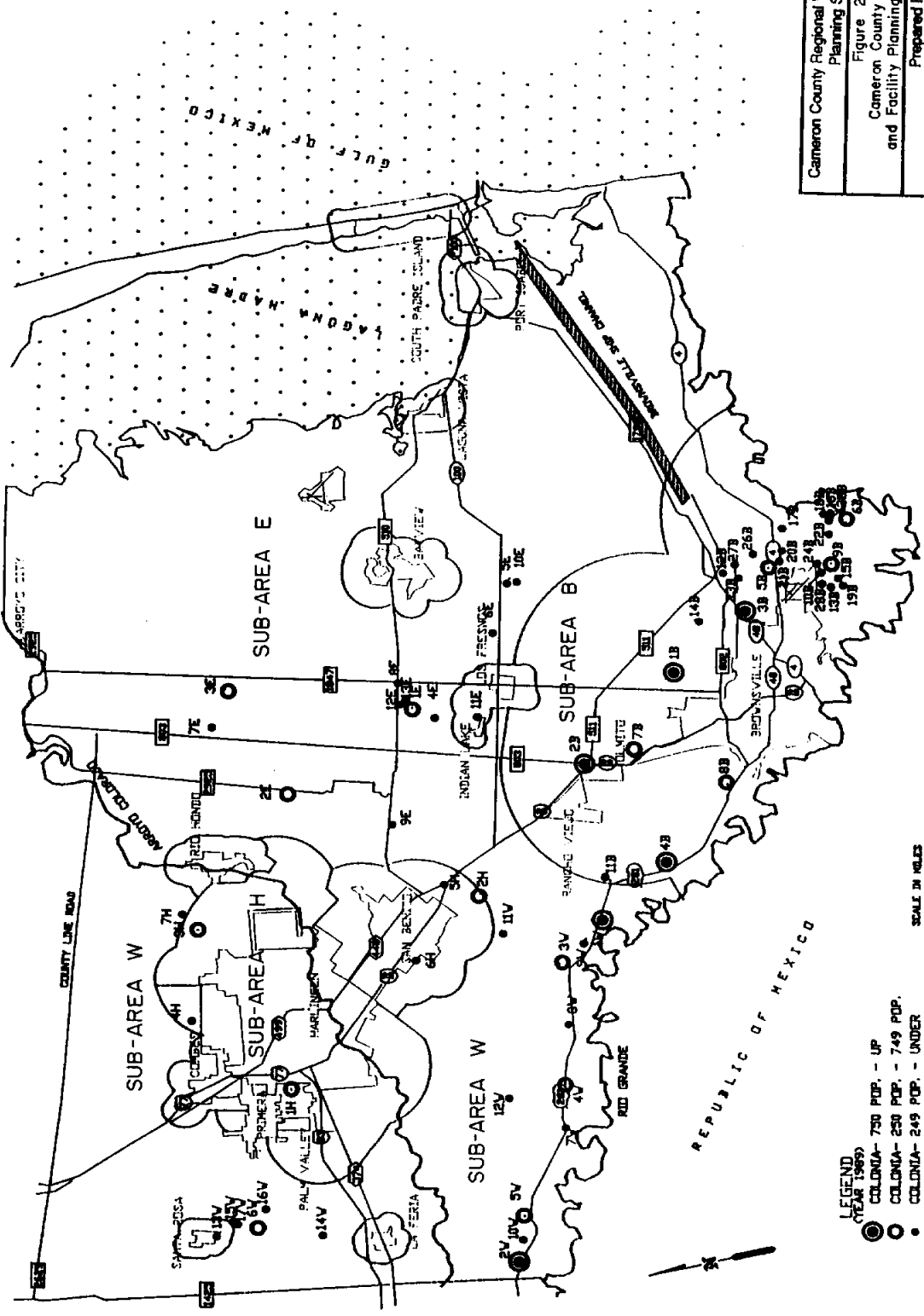

LEGEND  
 (YEAR 1980)  
 ● COLONIA- 750 POP. - UP  
 ○ COLONIA- 250 POP. - 749 POP.  
 ● COLONIA- 249 POP. - UNDER  
 --- CITY LIMITS  
 --- ETJ LIMITS

SCALE IN MILES  
 0 1 2 3

(within the areas taxed of the municipality). The physical service areas of the water supply entities in Cameron County are presented in Figure 2-3.

### 2.2.2 Historical Water Use

Municipal water use is a function of population and per capita use plus water supplied to industrial and commercial users. Domestic water use includes several uses not directly associated with sanitation including, lawn watering, automobile washing and swimming pool maintenance. A decrease in water use during wet periods and an increase during droughts typically occurs due to this variety of uses of municipal water. Industrial and commercial use also typically experience a slight increase in water use during drought periods. This section provides a review of water use and per capita use rates during the period of 1980-1987. Historical water use for the major suppliers of treated water for this same period is presented in Table 2-3.

#### 2.2.2.1 Cameron County

Cameron County's total non-agricultural water use has remained relatively steady, at approximately 50,000 acre-feet per year (AF/yr) or 44.6 million gallons per day (MGD), since 1985 (Figure 2-4). During this same period, Cameron County experienced slight reduction in the rate of per capita use which would account for a stable rate of consumption in the face of an increasing population. At least part of the per capita water demand reduction can be attributed to higher than normal rainfalls since 1983 (110% of average annual precipitation in 1983; 159% in 1984; 129% in 1985; 109% in 1986 and 113% in 1987).

#### 2.2.2.2 Incorporated/Urban Areas

The City of Brownsville supplied approximately 55 to 59% of the treated municipal water to the urban areas of Cameron County between the year 1980-1987. Other major suppliers to urban areas include the City of Harlingen (22% of 1987 total of urban water use), the City of San Benito (6% of same) and the Cameron County Freshwater Supply District No. 1 (7% of same). Municipal water is also supplied to urban areas of Cameron County by the Cities of La Feria and Los Fresnos.

The City of Brownsville experienced a steady increase in municipal water use from 22,525 AF/yr (20.1 MGD) in 1980 to 28,368 AF/yr (25.3 MGD) in 1987. Relatively constant per capita water use rates and wetter than normal conditions during this period indicate this increase is primarily due to a rapidly increasing population. A detailed description of the City of Brownsville's historic water use patterns is presented in the Public Utilities Board of Brownsville's 1988 Water Master Plan (R. W. Beck 1988).

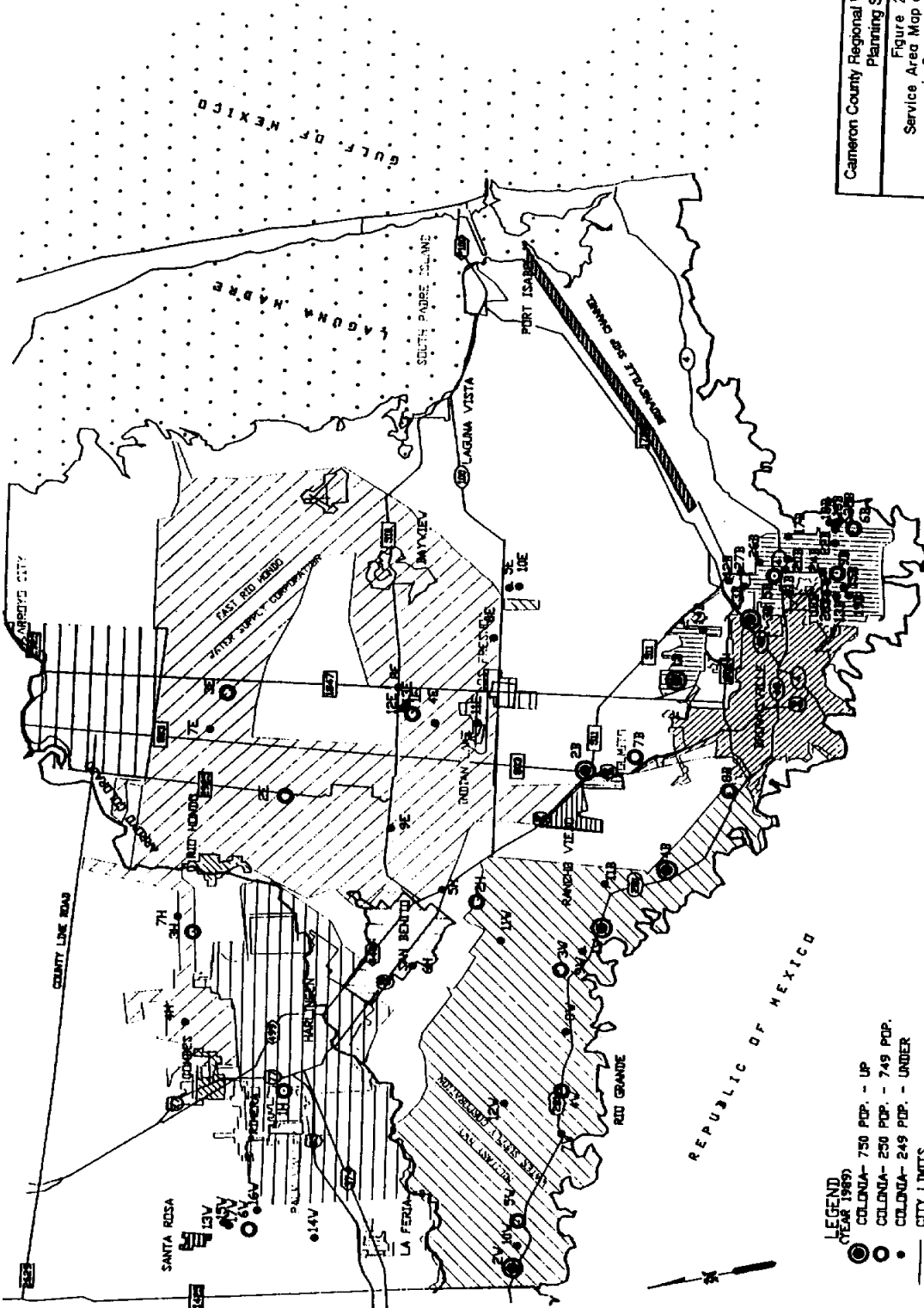

LEGEND  
 (YEAR 1989)  
 ● COLONIA - 750 POP. - UP  
 ○ COLONIA - 250 POP. - 749 POP.  
 ● COLONIA - 249 POP. - UNDER  
 --- CITY LIMITS  
 ▨ EXISTING WATER INFRASTRUCTURE SERVICE AREAS

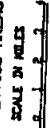

Cameron County Regional Water and Wastewater Planning Study  
 Figure 2-3  
 Service Area Map of Providers in Cameron County  
 Prepared For:  
 Texas Water Development Board  
 and Cameron County Water Development Board  
 Prepared By:  
 The Water Resources Planning Group  
 August 1990

Table 2-3  
Historical Water Use by Supply Entity  
1980 - 1987  
(AF/yr)

Supply Entity	No. of Conn. (1987)	1980		1981		1982		1983	
		No.	% of Total	No.	% of Total	No.	% of Total	No.	% of Total
Brownsville	21,854	22,525	54.92%	20,060	56.42%	26,091	55.22%	22,789	55.65%
Harlingen	16,150	11,144	27.17%	8,243	23.18%	12,250	25.93%	9,159	22.37%
San Benito	4,856	2,984	7.28%	2,899	8.15%	3,250	6.88%	3,419	8.35%
El Jardin WSC	1,600	702	1.71%	605	1.70%	835	1.77%	708	1.73%
CCFWSO# 1	3,166	2,204	5.37%	2,392	6.73%	3,060	6.48%	3,252	7.94%
La Feria	1,694	508	1.24%	551	1.55%	607	1.28%	583	1.42%
Los Fresnos	753	444	1.08%	377	1.06%	532	1.13%	433	1.06%
Olmite WSC	685	162	0.40%	173	0.49%	324	0.69%	294	0.72%
Palm Valley Est. U.D.	414	227	0.55%	182	0.51%	232	0.49%	214	0.52%
Combes	420	111	0.27%	75	0.21%	68	0.14%	100	0.24%
<b>Total</b>	<b>51,592</b>	<b>41,011</b>	<b>100.00%</b>	<b>35,557</b>	<b>100.00%</b>	<b>47,249</b>	<b>100.00%</b>	<b>40,951</b>	<b>100.00%</b>

Supply Entity	No. of Conn. (1987)	1984		1985		1986		1987	
		No.	% of Total	No.	% of Total	No.	% of Total	No.	% of Total
Brownsville	21,854	23,285	52.26%	26,644	54.69%	26,256	53.71%	28,368	59.01%
Harlingen	16,150	11,245	25.24%	11,142	22.87%	11,745	24.03%	10,819	22.50%
San Benito	4,856	4,078	9.15%	4,961	10.18%	4,625	9.46%	3,048	6.34%
El Jardin WSC	1,600	754	1.69%	776	1.59%	862	1.76%	779	1.62%
CCFWSO# 1	3,166	3,704	8.31%	3,269	6.71%	3,650	7.47%	3,363	7.00%
La Feria	1,694	621	1.39%	597	1.23%	600	1.23%	600	1.25%
Los Fresnos	753	349	0.78%	553	1.14%	503	1.03%	494	1.03%
Olmite WSC	685	181	0.41%	441	0.91%	271	0.55%	240	0.50%
Palm Valley Est. U.D.	414	235	0.53%	231	0.47%	250	0.51%	241	0.50%
Combes	420	106	0.24%	107	0.22%	120	0.25%	125	0.26%
<b>Total</b>	<b>51,592</b>	<b>44,558</b>	<b>100.00%</b>	<b>48,721</b>	<b>100.00%</b>	<b>48,882</b>	<b>100.00%</b>	<b>48,077</b>	<b>100.00%</b>

Source: TWDB Records



Figure 2-4  
 Cameron County Non-Agricultural  
 Water Use and Use Per Connection  
 (1980-1987)

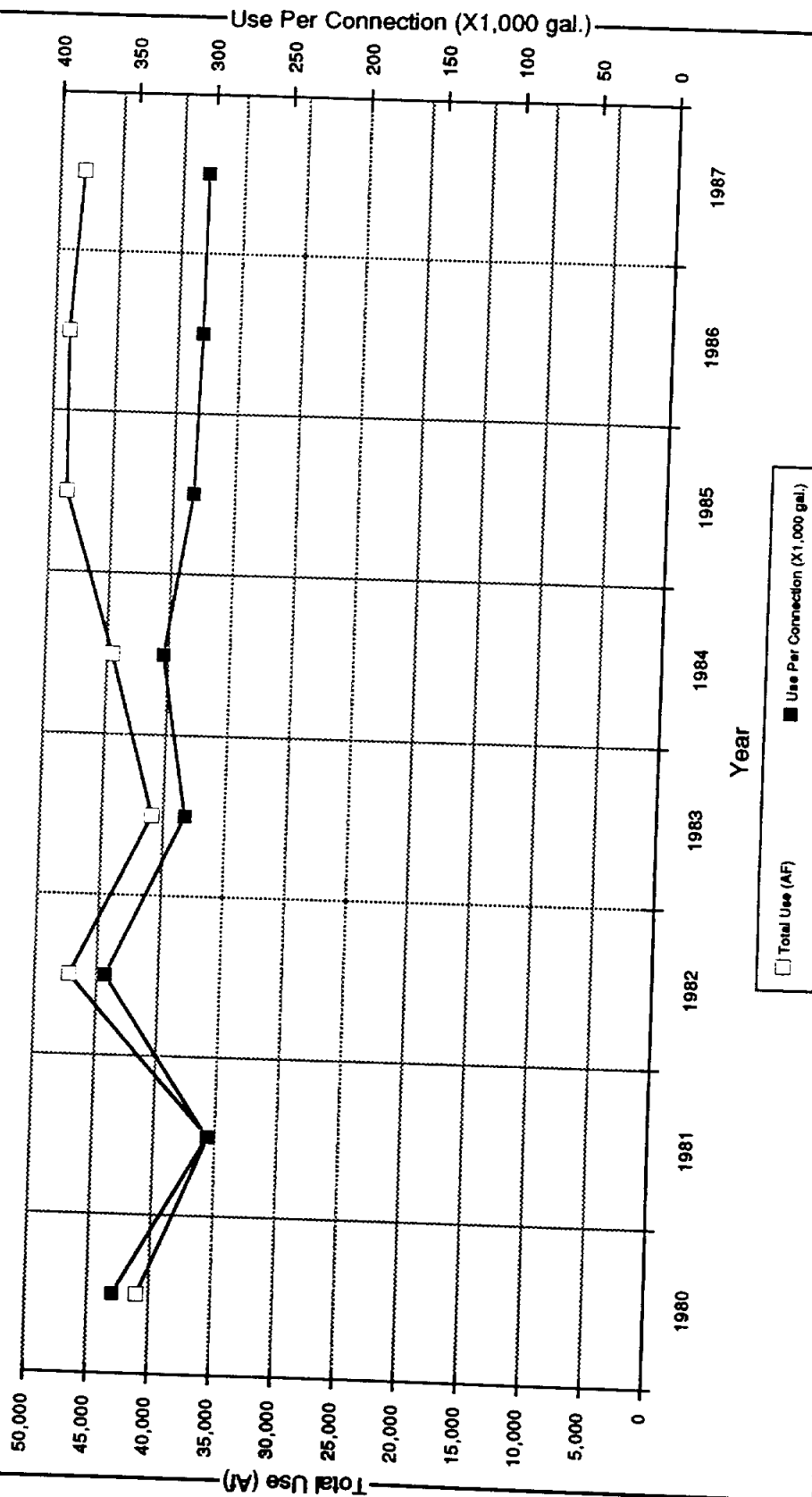

Source: TWDB Records

In contrast to Brownsville the City of Harlingen experienced a slight decrease in municipal water use (11,144 AF/yr in 1980 to 10,819 AF/yr in 1987). This is primarily attributable to a slight decrease in use per connection during this period (Figure 2-5).

The City of San Benito's total water use and use per connection has increased steadily during the first half of the 1980's, but experienced a sharp decline after 1985 (2,984 AF/yr in 1980 to 4,961 AF/yr in 1985 to 3,048 AF/yr in 1987). This decrease is primarily due to a reduction in per capita use rates due to the wet conditions during this period.

Cameron County Freshwater Supply District No. 1 experienced an increase of approximately 52% (2,204 AF/yr in 1980 to 3,363 AF/yr in 1987). This increase is a result of increasing population in the Port Isabel, Laguna Vista area and increasing tourism on South Padre Island and increasing per capita use rates during this period.

The remainder of the entities supplying water to urban areas (Cities of Los Fresnos, Combes, Primera, and La Feria) each supplied less than 1,000 AF/yr of treated water during this period.

#### 2.2.2.3 Rural Areas and Colonias

The rural areas and colonias of Cameron County are served by a number of water supply districts and corporations including El Jardin Water Supply Corporation, Military Highway Water Supply Corporation, East Rio Hondo Water Supply Corporation, Olmito Water Supply Corporation, Valley MUD Nos. 1 & 2, Arroyo City Water Supply Corporation, and the Palm Valley Estates Utility District.

#### Per Capita Water Use

This historical water use data in conjunction with average household size provides a basis for determining per capita water use rates for the colonias of Cameron County. A graph (Figure 2-5) of use per connection data by water suppliers for the period of 1980 to 1987 provides insight as to trends in per capita use in Cameron County. Two facts are obvious from this graph:

1. Except for the Olmito Water Supply Corporation, there does not appear to be evidence of a mass immigration of residents reflected in dramatic increases in per connection water use in either the cities or rural areas of Cameron County.
2. Small cities and water supply corporation (WSC) serving rural populations exhibit much less water use per connection than the larger cities. This, however, is expected for three reasons: 1) the larger cities serve industrial and commercial customers which often have large water demands; 2) larger cities required fire protection that is not required in rural areas; 3) landscape and lawn watering is more prevalent in urban areas; and 4) there generally is more inexpensive water available for use which results in less judicious use of the resource.

Figure 2-5  
 Range of Use Per Connection in Cameron County  
 1980-1987

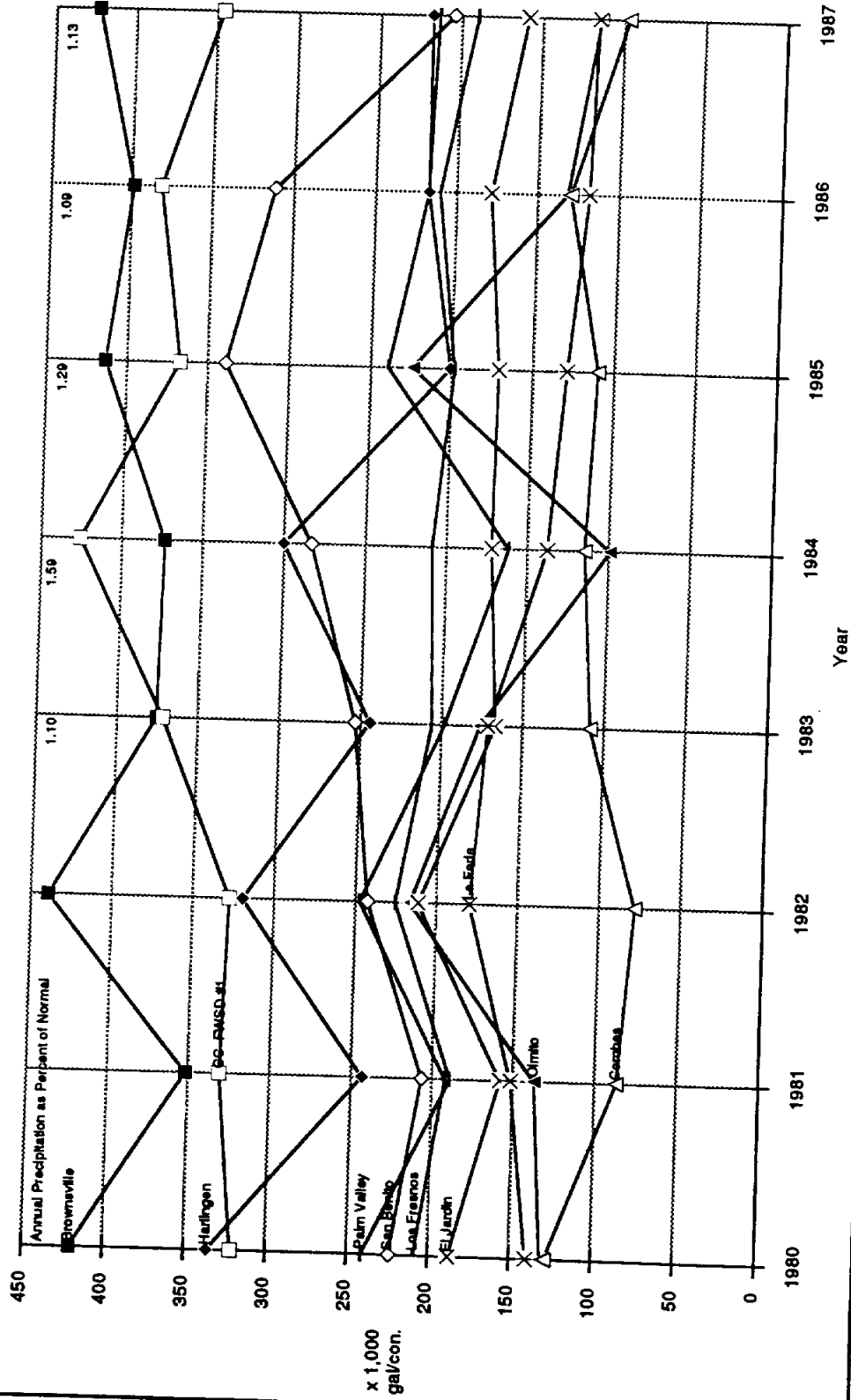

Source: TWDB Records

The information provided in this section coupled with national, state and water use trends provide the rationale for a water design rate of 125 gcpd which will be used throughout the remainder of this plan.

### 2.2.3 Water Supply and Rights

#### 2.2.3.1 Surface Water Supply

Water supply for Cameron County users is derived almost solely from the Rio Grande Basin. The two primary water storage reservoirs that provide water to Cameron County users are International Falcon and Amistad Reservoirs. Two additional water control structures, Retamal and Anzalduas Dams, are located downstream from Falcon Dam.

International Amistad Reservoir is a multipurpose reservoir constructed under the 1944 Water Treaty between the United States and Mexico. This reservoir, completed in 1968, has a controlled storage capacity of 5.66 million acre-feet, of which 3.0 million acre-feet are assigned for conservation storage and 2.11 million acre-feet are allocated to flood control. The United States is assigned 56.2 percent of the conservation storage.

International Falcon Reservoir was completed in 1953 and was the first major reservoir constructed under the 1944 treaty between the United States and Mexico. This reservoir has a total capacity of approximately 3.98 million acre-feet, of which 2.67 million acre-feet are allocated to conservation storage and 1.3 million acre-feet to flood control. Under the 1944 Treaty, the United States is allocated 58.6 percent of the conservation storage.

The Anzalduas Dam was put into operation in 1960 as a joint effort of the United States and Mexico. Over 80 percent of the United States' share of floodwaters below Falcon Dam are diverted to the United States Interior Floodway above Anzalduas Dam, which is located at River Mile 170.3, approximately 3.5 miles south of the City of Mission. This facility also provides for the diversion of water into Mexico's Anzalduas Irrigation Canal. Anzalduas Dam and Reservoir is located upstream of 95 percent of all United States diverters and, therefore, serves as a streamflow measuring point for the division of waters between Mexico and the United States based on the 1944 Treaty.

Retamal Dam is located in Hidalgo County approximately 16 miles southeast of the City of McAllen and 8 miles southwest of the City of Weslaco. The dam presently serves a two-fold purpose: (1) it enables Mexico to divert to its Interior Retamal Floodway its share of Rio Grande floodwaters; and (2) it limits flood flows in the Rio Grande channel downstream to 20,000 cfs. Retamal Dam is 33 feet high and contains three radial gates. The central gate, 82 feet wide by 24 feet high, is automatically controlled and has a maximum flow rate capacity of 20,000 cfs (IBWC 1981). The two side radial gates are controlled manually and have a combined flow capacity of 10,000 cfs.

Surface waters of the Rio Grande are allocated and governed by two interstate compacts, two international treaties and one United States judicial water case:

Rio Grande Compact; Texas, New Mexico and Colorado

Pecos River Compact; Texas and New Mexico

1906 Treaty; United States and Mexico

1944 Treaty; United States and Mexico

1971 Valley Water Case

#### Rio Grande Compact

The Rio Grande Compact became effective in 1939 and included the portion of the Rio Grande Basin in Texas above Fort Quitman in Hudspeth County. The Compact allocated the uncommitted waters of the Rio Grande and provided schedules of required deliveries of water from Colorado to New Mexico and for delivery by New Mexico to Elephant Butte Reservoir and thence to Texas. Provisions allow for annual accrued credits and/or debits. For Colorado, no annual debit nor accrued debit is to exceed 100,000 acre-feet, unless caused by holdover storage of water in reservoirs constructed after 1937 in the Rio Grande Basin above Lobatos, Colorado. The accrued debit for New Mexico is not to exceed 200,000 acre-feet unless held over in reservoirs constructed after 1929 in the Rio Grande Basin above San Marcial, New Mexico. Other provisions of the Compact include the right of the Compact Commission to authorize releases of water being held in storage in New Mexico and Colorado based on accrued debits.

#### Pecos River Compact

The Pecos River Compact between Texas and New Mexico became effective in 1949. It covers the entire drainage area of the Pecos River above its confluence with the Rio Grande. The Compact provided an allocation of water to Texas that varies with streamflow and other conditions in New Mexico. It also provided for a cooperation program for salvage of water from consumption by phreatophytes and for a program to alleviate high salinity conditions. Basically, the Compact provides that New Mexico will not deplete, by man's activities, the flow of the Pecos River at the New Mexico-Texas state line below the amount that Texas received in 1947. The Compact provides for the beneficial consumptive use of unappropriated floodwater on a 50-50 basis between New Mexico and Texas.

#### Treaties of 1906 and 1944

Two treaties between the United States and Mexico, one in 1906 and another in 1944, contain basic provisions regarding development and use of Rio Grande waters. The earlier treaty provided for delivery to Mexico by the United States of 60,000 acre-feet of water annually in the El Paso-Juarez Valley

upstream from Fort Quitman, Texas. If shortages occur in the United States, delivery to Mexico is reduced in the same proportion as deliveries to the United States.

The 1944 Treaty between the United States and Mexico, administered by the IBWC, contains provisions relating to the Rio Grande between Fort Quitman and the Gulf of Mexico. It provides for an allocation of water between the two countries and for joint construction of as many as three major storage reservoirs on the main stream for water supply and flood control. Development of hydroelectric power generation at reservoirs is also permitted. The treaty allocates water between the United States and Mexico as follows:

To Mexico

- A. All the waters reaching the main channel of the Rio Grande from the San Juan and Alamo Rivers, including the return flow from the lands irrigated from the latter two rivers;
- B. One-half of the flow in the main channel of the Rio Grande below the lowest major international storage dam, so far as said flow is not specifically allotted under the treaty to either of the two countries;
- C. Two-thirds of the flow reaching the main channel of the Rio Grande from the Conchos, San Diego, and San Rodrigo, Escondido and Salado Rivers and the Las Vacas Arroyo, subject to the provisions of paragraph B, above;
- D. One-half of all other flows not otherwise allotted occurring in the main channel of the Rio Grande, including the contributions from all the unmeasured tributaries, which are those not named herein, between Fort Quitman and the lowest major international storage dam.

To The United States

- A. All the waters reaching the main channel of the Rio Grande from the Pecos and Devils Rivers, Goodenough Spring, and Alamito, Terlingua, San Felipe and Pinto Creeks;
- B. One-half of the flow in the main channel of the Rio Grande below the lowest major international storage dam, so far as said flow is not specifically allotted under the Treaty to either of the two countries;
- C. One-third of the flow reaching the main channel of the Rio Grande from the Conchos, San Diego, San Rodrigo, Escondido, and Salado Rivers and the Las Vacas Arroyo, provided that this third shall not be less, as an average amount in cycles of five consecutive years, than 350,000 acre-feet annually. The United States shall not acquire any right by the use of the waters of the tributaries named in this section, in excess of the said 350,000 acre-

feet annually, except the right to use one-third of the flow reaching the Rio Grande from said tributaries, although such one-third may be in excess of that amount; and

- D. One-half of all other flows not otherwise allotted by the treaty occurring the main channel of the Rio Grande, including the contributions from all the unmeasured tributaries, which are those not named in the treaty, between Fort Quitman and the lowest major international storage dam.

#### Valley Water Case of 1971

The International Boundary and Water Commission operates Amistad and Falcon Reservoirs as a system for flood control purposes. The United States' share of conservation storage in the projects is administered by the Texas Water Commission under provisions compliant with the decision of the 1971 Lower Rio Grande Valley Water Case. According to the judgement rendered in this case, water was allocated for 742,808.6 acres of irrigation use below Falcon Dam. Of this amount, 641, 221 acres were assigned Class A irrigation rights, and the remaining acres were awarded Class B irrigation rights. The Texas Watermaster is responsible for allocating the amount of water which can be diverted by each Class A and Class B irrigator and for supervising all use of water.

Under current Texas Water Commission rules and regulations, allocated of water in the Lower Rio Grande Valley are based upon the Lower Rio Grande Valley Water Case. Surface water diversions from tributaries in the Middle Rio Grande are based on appropriative water rights recognized by the Texas Water Commission. The current rules provide a reserve of 225,000 acre-feet of storage in Amistad and Falcon Reservoirs for domestic, municipal and industrial uses and an operating reserve which is to fluctuate between 380,000 acre-feet and 275,000 acre-feet of water, depending on the monthly levels of the Amistad-Falcon Reservoir system. The operating reserve is calculated monthly by multiplying the percentage to total United States conservation storage in the system times the maximum operating reserve of 380,000 acre-feet. The calculated reserve cannot be less than 275,000 acre-feet. The operating reserve is necessary to provide for (1) loss of water by seepage, evaporation, and conveyance, (2) emergency requirements and (3) adjustments of amounts in storage as may be necessary by finalization of provisional computations by the IBWC.

The Texas Water Commission rules also provide procedures for water allocations to municipal/domestic, industrial, agricultural and other user accounts. Such allocations are based on water in the unable storage of Falcon and Amistad Reservoirs, as reported by the IBWC on the last Saturday of each month, less dead storage. To determine the amount of water to be allocated to various accounts, the TWC makes the following computations:

- A. From the amount of water in usable storage, 225,000 acre-feet are deducted to re-establish the reserve for municipal, domestic and industrial uses;
- B. From the remaining storage, the total end-of-month account balances for all Lower and Middle Rio Grande irrigation and mining allottees are dedicated; and
- C. From the remaining storage, the operating reserve is deducted.

After the above computations are made, the remaining storage, if any, is allocated to the irrigation and mining accounts. The allotment for irrigation and mining uses is divided into Class A and Class B water rights. Class A rights (allottees) receive 1.7 times as much water as that allotted to Class B allottees. An allottee cannot accumulate in storage more than 1.41 times its annual authorized right, and, if an allottee does not use water for two consecutive years, its account is reduced to zero. Also the rules specify that an allottee is charged for water requested and released as follows:

- A. A diverter shall be charged with the actual amount diverted, without being penalized, if the total diversion is within plus or minus 10% of the amount requested;
- B. A diverted shall be charged with 90% of the certification amount if the total diversion is less than 90% of the amount requested; and
- C. If the quantity of water diverted is more than 110% of the amount requested, the diverter will be charged with the actual amount of water diverted.

#### 2.2.3.2 Surface Water Rights

The development of Texas Law relating to water rights in the Rio Grande Valley has been strongly influenced by the Valley's history. Texas adopted many of the old customs and laws of the Spanish Civil Law System as a natural consequence of Spanish and later Mexican sovereignty over what is now all of Texas. Water rights appurtenant to lands granted by the Sovereign before 1840 are evaluated under the Spanish Civil Law as modified by the Congress of the Republic of Texas in 1937. Between January 20, 1840, and March 19, 1889, the common law of England governed the character of rights pertaining to land by the Republic of Texas, and later by the State. Since 1889 the Texas Legislature has enacted many laws relating to Texas rivers and streams and the use of their public waters.

The Water Act of 1889 declared the unappropriated water of every river, including the Rio Grande, to be the property of the public and subject to appropriation for irrigation. In 1895 the permitted use was broadened to include "the construction of water works for cities and towns". As population grew and frequent droughts caused shortages, additional laws were passed. Since 1889, however, most of the new statutes have incorporated language which has preserved the riparian right of a landowner abutting



the bed of a stream to utilize the benefit of water flowing past his land. The riparian right has been consistently defended and upheld by Texas courts.

The invention of large, efficient irrigation pumps and the development of large irrigation areas led to the need for additional legislation, and in 1913 the Legislature rewrote the irrigation laws and created the State Board of Water Engineers for the purpose of administering water appropriations throughout the entire State. Under the 1913 Statute, a record of all existing appropriations was to be filed with the Board, and these declarations came to be known as "certified filings". All appropriations subsequent to 1913 were to be made by applying to the Board for "permits" to appropriate water. The name of the Board of Water Engineers was changed in 1962 to the Texas Water Rights Commission, and in 1987 to the Texas Water Commission.

Currently, water rights in the Lower Rio Grande Valley, which includes the Rio Grande Basin of Cameron County, are administered by the Texas Water Commission under provisions compliant with the decision of the Thirteenth Court of Civil Appeals in (State of Texas et al., v. Hidalgo Water Control and Improvement District No. 18 et al.) 443 S. W. 2d 728, as approved the Supreme Court of Texas in 1969. The milestone case is commonly referred to as the "Lower Rio Grande Valley Water Case" (see Section 2.2.3.1).

The Rio Grande is primary water supply source in Cameron, Hidalgo and Starr Counties. The major portion of the water (consumptive uses only) in each of these counties (63%, 91% and 97% for Cameron, Hidalgo and Starr Counties, respectively) has been designated for use (per Texas Water Rights) as irrigation supply. Municipal water rights in each of these counties account for a much smaller percentage (7.7%, 8.3% and 2.6% of total water use in Cameron, Hidalgo and Starr County, respectively) of total water rights in each county. The only other consumptive use of any significance in these counties is industrial accounting for approximately 30% of the total water rights in the three county area virtually all of which is in Cameron County. A summary of water rights by type of use for Cameron, Hidalgo and Starr counties is presently in Table 2-4.

In Cameron County over 93,000 acre-feet of water per year are classified under municipal water rights. Major appropriators of water rights in Cameron County include the Harlingen Irrigation District (26% of total), City of Brownsville (15% of total) and the Cameron County Irrigation District No. 2 (13.5% of total). Municipal water rights appropriator in Cameron County are presented in Table 2-5.

#### 2.2.3.3 Ground Water

##### Gulf Coast Aquifer

The availability and quality of ground water in Cameron County for the most part is limited. The County is mostly underlain by the Gulf Coast aquifer.

Table 2-4  
Water Rights Summary  
Cameron, Hidalgo and Starr Counties

County	Industrial		Irrigation		Municipal		Recreation*	Hydroelectric*	Total AF/yr	% of Total Cons. Use
	AF/yr	% of Total by Use	AF/yr	% of Total by Use	AF/yr	% of Total by Use				
Cameron	355,655	29.35%	782,896	62.95%	93,410	7.71%	10,300	0	1,222,261	100.00%
Hidalgo	5,317	0.44%	1,097,501	91.26%	99,749	8.29%	1,000	0	1,203,567	100.00%
Starr	0	0.00%	51,296	97.44%	1,346	2.56%	0	1,200,000	52,642	100.00%
<b>Total</b>	<b>360,972</b>	<b>29.79%</b>	<b>1,911,693</b>	<b>251.65%</b>	<b>194,505</b>	<b>18.56%</b>	<b>11,300</b>	<b>1,200,000</b>	<b>2,478,470</b>	<b>2,467,170</b>

\* Nonconsumptive Use

Source: Texas Water Commission 1990

**Table 2-5  
Municipal Water Rights by Appropriator in Cameron County**

Appropriator	Stream	Amt. AF/yr	% of Total
Harlingen I. D. et al	Rio Grande	24,975	26.72%
City of Brownsville	Rio Grande	24,155	25.84%
Cameron Co. I. D. 2 et al	Rio Grande	12,658	13.54%
Brownsville I. D. Dist.	Rio Grande	8,000	8.56%
Cameron Co. FWSD 1	Rio Grande	6,457	6.91%
La Feria I. D. Cameron 3	Rio Grande	5,300	5.67%
Brownsville N. D.	Rio Grande	2,500	2.67%
City of Edinburg	Rio Grande	1,598	1.71%
Ricardo Ortiz et al	Rio Grande	1,495	1.60%
Querencia L&C Co.	NE Drain-CC10	1,225	1.31%
City of Los Fresnos	Rio Grande	850	0.91%
La Joya WSC	Rio Grande	750	0.80%
Town of Primera	Rio Grande	400	0.43%
Olmito WSC	Rio Grande	339	0.36%
Bayview I.D. # 17	Rio Grande	300	0.32%
Valley HUD 2	Rio Grande	300	0.32%
U. S. Imm. & Nat.	Rio Grande	268	0.29%
City of Edinburg	Rio Grande	250	0.27%
Cameron Co WID # 16 et al	Rio Grande	240	0.26%
City of Edinburg et al	Rio Grande	226	0.24%
Cameron Co. FWSD #1	Rio Grande	180	0.19%
Santa Maria ID CC.4	Rio Grande	160	0.17%
City of Harlingen	Rio Grande	131	0.14%
City of Edinburg	Rio Grande	110	0.12%
Union WSC	Rio Grande	100	0.11%
North Alamo WSC	Rio Grande	94	0.10%
Union WSC	Rio Grande	76	0.08%
East Rio Hondo WSC	Rio Grande	70	0.07%
Sunnydew WSC	Rio Grande	50	0.05%
Bayview ID# 11	Resaca Cuates	45	0.05%
East Rio Hondo WSC	Rio Grande	40	0.04%
Boca Chica WSC	Rio Grande	20	0.02%
Dionicio R. Esparza	Rio Grande	19	0.02%
Pan American University	Laguna Madre	13	0.01%
Military HWSC	Rio Grande	10	0.01%
Frank Green et al	Rio Grande	60	0.06%
<b>TOTAL MUNICIPAL</b>		<b>93,464</b>	<b>100.00%</b>

Source: Texas Water Commission 1990

The Gulf Coast Aquifer (TWDB, 1968) covers most of the coastal plain of Texas from the Lower Rio Grande Valley northeastward into Louisiana, extending about 100 miles inland from the Gulf. The aquifer consists of alternating clay, silt, sand, and gravel beds belonging to the Catahoula, Oakville, Lagarto, Goliad, Willis, Lissie, and Beaumont Formation, which collectively form a regional, hydrologically connected unit.

The aquifer is recharged by precipitation on the surface and seepage from streams crossing the outcrop area. The rate of natural recharge is estimated to be sufficient to sustain the present level of pumpage from the aquifer. In some areas where the ground water is essentially undeveloped, substantial volumes of potential recharge are rejected. Probably the principal factor restricting maximum development of this resource is the limited capability of the aquifer to transmit water from areas of recharge to areas of pumpage.

Maximum thickness of the aquifer in Cameron County, where it contains fresh to slightly saline water, ranges up to 500 feet, with a net sand thickness of 30 to 40 percent. Yields of large-capacity wells range up to 2,000 gpm, but most wells average 500 gpm. Water quality ranges from fresh to slightly saline, with salinity increasing rapidly downdip (TDWR, 1984).

The ground water generally becomes more saline in the southern part of the aquifer, and in some areas highly saline water overlies the fresh water and also underlies the aquifer at a relatively shallow depth. In the Lower Rio Grande Valley, ground water pumped from the aquifer for irrigation and municipal use contains between 1,000 and 1,500 mg/l of dissolved solids in most areas (TWDB, 1968).

#### Lower Rio Grande Valley Aquifer

Along and adjacent to the Rio Grande in Cameron County, fresh to saline ground water is produced from alluvial deposits of Pleistocene and Recent (Quaternary) age. Recent alluvial deposits lie at the surface throughout the study area and over most of Cameron County. These fluvial and deltaic sediments are underlain by several thousand feet of very similar but older Quaternary and Tertiary deposits. Regionally, the erratic horizontal and vertical intergradations of beds allow this entire system to interact. Locally, however, individual sand beds or lenses are effectively separated. There is a wide range in water quality within the system, and extreme quality variations occur within very short distances both horizontally and vertically. Within most of the study area, water of usable quality that has been found occurs within the upper 300 feet (91m) of the section. This system of interbedded clay, silt, sand, and gravel has been designated as the Lower Rio Grande Valley aquifer (TDWR, 1983). Regionally, this aquifer is equivalent to the Gulf Coast aquifer (TDWR, 1977) described above.

In 1972, the PUB requested the Texas Department of Water Resources (formerly known as the Texas Water Development Board) to conduct an inventory and evaluation of water-supply possibilities. This

included a determination of the availability and quality of ground water supplies in the vicinity of Brownsville and an evaluation of the PUB's existing well field.

The TDWR study indicated that large amounts of ground water are contained in the Lower Rio Grande Valley aquifer with the Brownsville area. However, the TDWR study indicates useful production of much of this water is impractical because of severe limitations in the yields of wells completed in the shallow and middle zones of the aquifer.

The TDWR projects that significant amounts of ground water are stored in the upper 225 feet of the aquifer, with a major portion in the Brownsville area. This ground water is typically of variable quality with dissolved solids concentrations in excess of 20,000 mg/L in the shallow zone (0 to 75 feet deep) and concentrations of less than 3,000 mg/L in the deep zone (150 to 225 feet). Approximately 350,000 acre-feet of fresh to slightly saline ground water was estimated by the Texas Department of Water Resources (TDWR, 1983) to be in storage in the deep zone of the Lower Rio Grande Valley Aquifer. Problems associated with the use of this ground water include the sensitive and complex nature of the aquifer (i.e. recharge, movement and discharge) and variable water quality. Despite these problems, use of this ground water is quite possible. As noted in 1983 TDWR report "the high transmissibility of the sands and gravels within this zone should allow the development of a large part of this water for irrigation use, and with proper treatment, possibly including desalination in some area for municipal and industrial supplies as well."

#### 2.2.4 Water Facilities

The Texas Department of Health routinely performs sanitary surveys of water supply systems in Texas. These surveys require an inventory and review of existing facilities. A review of these surveys indicates Cameron County has a total of 20 water supply corporations and utility districts. Table 2-6 provides a summary of service area, raw water pumping capacity, and treatment and storage facilities as for each of these water supply entities. This section provide a brief overview of the pumping treatment and storage facilities provided by the major water supply entities in Cameron County.

##### 2.2.4.1 Public Utilities Board of Brownsville

The PUB provides water service within the area of the incorporated boundaries of the city and the various other locations throughout the Brownsville ETJ.

The PUB has raw water pumping facilities on the Rio Grande with a capacity of approximately 66.5 MGD raw water is treated at one of the PUB's two 20 MGD plants and stored in on-site storage facilities with having a total capacity of 6.5 MGD of elevated and 6.75 MGD of ground storage. The City of Brownsville's average daily use in 1989 was approximately 18 MGD, leaving an excess capacity of about 22 MGD. A detailed

Table 2-6  
Summary of Water Supply Facilities  
Located within Cameron County

Entity	Service Area	Current No. of Connections	SUPPLY		FACILITIES		
			Source	Raw Water** Pump. Cap. (mgd)	Treatment		Storage
					Capacity (mgd)	Average Daily Use (mgd)	Elevated/ Ground
① PUB Plant No. 1 Plant No. 2	Brownsville, N D  El Jardin WSC	22861	Rio Grande	66.528	40.59	17.681	elevated 6.5 ground 6.75
				31.25	20.231 <i>B</i>	9.625	elevated 4.0 ground 2.75
				35.26	20.272 <i>J</i>	8.056	elevated 2.5 ground 4.0
② City of Harlingen Water Board  Plant No. 1 Plant No. 2	City of Harlingen City of Combes Primera Palm Valley MUD Military Hwy. WSC	14750	Rio Grande	51.98	19.96	9.871	elevated 3.65 ground 9.5
				24.12	7.862 <i>b</i>	3.96	elevated 3.25 ground 2.50
				27.86	12.096 <i>b</i>	6.229	elevated 0.4 ground 7.0
③ Cameron Co. FWSD No. 1  Plant No. 1 (Port Isabel) Plant No. 2 (Laguna Vista)	Port Isabel Laguna Vista Padre Island	2840	Rio Grande	21.456	11.589 <i>B</i>	3.213	elevated 1.625 ground 2.568
				10.66	5.14 <i>14</i>	1.063	elevated 0.9 ground 2.27
				10.8	6.526 <i>3</i>	2.15	elevated 0.73 ground 1.73
④ East Rio Hondo WSC	North-east of Harlingen adjacent to San Benito, Rio Hondo, Olmito, Los Fresnos	2587	Rio Grande River	4.03	1.63 <i>12</i>	0.709	ground 0.45 mg elevated 0.70 mg
El Jardin WSC	North-east area of Brownsville	1704	City of Brownsville Rio Grande			0.67	
⑤ City of La Feria	La Feria	1600	Rio Grande	4.032	1.01 <i>11</i>	0.64	elevated 0.25 ground 0.6
⑥ Valley MUD # 2	Rancho Viejo	891	Rio Grande	2.3	1.05 <i>10</i>	0.379	elevated 0.3 ground 0.3
⑦ City of Los Fresnos	Los Fresnos	754	Cameron Co. WID	1.37	0.999 <i>9</i>	0.356	elevated 0.3 ground 0.12
⑧ Olmito	Olmito	769	Cameron Co. WID # 6	0.245	0.122 <i>8</i>	1 MGD	elevated 0.25
Valley MUD # 1	Country Club and adjacent subdivision	618	City of Brownsville			0.22	
⑨ City of Rio Hondo	Rio Hondo	517	San Benito Irrig. Dist.	1.58	0.809 <i>7</i>	0.261	elevated 0.154 ground 0.165
⑩ Arroyo City WSC	Arroyo City	459	San Benito Irrig. Dist.	1.15	0.497 <i>6</i>	0.134	elevated 0.05 ground 0.05
⑪ Palm Valley Estates UD	Municipality	449	Harlingen Water Board			0.264	
Plant No. 1 Plant No. 2				10.66	5.14 <i>5</i>	1.063	elevated 0.8 ground 2.27
				10.8	6.526 <i>4</i>	2.15	elevated 0.73 ground 1.73

Table 2-6  
Summary of Water Supply Facilities  
Located within Cameron County

(continued)

Entity	Service Area	Current No. of Meters	SUPPLY		FACILITIES		
			Source	Raw Water Pump. Cap. (mgd)	Treatment		Storage
					Capacity (mgd)	Average Daily Use (mgd)	Elevated/ Ground
Brownsville ND	Brownsville ND	181	Brownsville PUB	3.02	2	0.363	elevated 1.5 ground 1.008
Cameron Co /NCID	Santa Rosa	510	Rio Grande	1.15	0.504	0.179	ground 0.5
Town of Combes	Combes Township	468	City of Harlingen Rio Grande			0.121	elevated 0.05
Town of Indian Lake	Town of Indian Lake	355	East River Hondo WSC City of Los Fresnos			0.03	
Military Hwy. WSC			City of Harlingen				elevated 1.5 ground 3.1
City of Primera	City of Primera	654				0.160	elevated 0.3
City of San Benito	San Benito	4783	Rio Grande	11.9	11.502	3.797	elevated 1.25 ground 1.518

Source: Texas Department of Health Sanitary Surveys 1989 and local records.

description of the PUB's water treatment and distribution system can be found in the City of Brownsville 1988 Water Master Plan by R. W. Beck.

#### 2.2.4.2 City of Harlingen Water Board

The City of Harlingen Water Board provides water service to the City of Harlingen and sells water to the Cities of Combes, Primera, Palm Valley MUD, and Military Highway WSC. Harlingen Water Board receives raw water (via the Harlingen Irrigation District) from pumping facilities on the Rio Grande with a pumping capacity of approximately 52 MGD. This system operates two water treatment plants with capacities of 7.8 and 12 MGD, respectively, for a total treatment capacity of approximately 20 MGD. Storage facilities include 3.65 MG of elevated and 9.5 million gallons (MG) of ground storage. Daily water use averaged approximately 9.8 MGD in 1989, resulting in an excess treatment capacity of 10 MGD.

#### 2.2.4.3 City of San Benito

The City of San Benito provides water service to most of the city, excluding a small area on the southern side of city which is served by the Military Highway WSC. Raw water (via the San Benito Irrigation District) is pumped to the City's 11.5 MGD treatment plant via a 11.9 MGD pumping facility located on the Rio Grande. Storage facilities include 1.25 MG of elevated and 1.5 MG of ground storage. In 1989, water use in San Benito average approximately 3.8 MGD, leaving an excess treatment capacity of approximately 7.7 MGD.

#### 2.2.4.4 Military Highway Water Supply Corporation

The Military Highway WSC purchases treated water from a number of supply entities in Cameron and Hidalgo Counties including the Cities of Alamo and Weslaco in Hidalgo County and the PUB, East Rio Hondo WSC, and City of Harlingen in Cameron County. Approximately 75% (.95 MGD) of the purchased water is supplied to Cameron County, where the MHWSC operates a system of pump stations, elevated and ground storage facilities, and a distribution system. Currently, the Military Highway WSC has no raw water treatment facilities.

#### 2.2.4.5 Cameron County Fresh Water Supply District No. 1

The Cameron County Fresh Water Supply District No. 1 obtains raw water from the Rio Grande through a pump station with a capacity of 21.5 MGD. This system operates two surface water treatment plants, a 5.2 MGD plant at Port Isabel and a 6.5 MGD plant at Laguna Vista. The system contains four elevated storage tanks with a total capacity of 1.375 MGD. Additionally, 4 MG of ground storage capacity is provided. This system has approximately, 2824 meters and treats an average of approximately 3.2 MGD and serves the Cities of South Padre Island, Port Isabel, and Laguna Vista.

#### 2.2.4.6 East Rio Hondo Water Supply Corporation



The East Rio Hondo WSC purchases raw water from the San Benito Irrigation District. This water supplier has a current treatment capacity of approximately 1.63 MGD. East Rio Hondo WSC serves approximately 2,500 meters and has an average daily usage of 0.70 MGD. This system on elevated storage capacity of 0.70 MG, and a ground storage capacity of 0.45 MG. East Rio Hondo WSC has distribution mains throughout the rural area in the northeastern portion of Cameron County.

#### 2.2.4.7 El Jardin Water Supply Corporation

The El Jardin WSC purchases treated water directly from the PUB through several direct metered connections. The El Jardin WSC has approximately 1,704 metered customers in their service area. This WSC has a distribution system throughout their service area serving primarily rural customers. An average daily use of 0.67 MGD was recorded for the El Jardin WSC in 1989. The system has no ground or elevated storage and relies on pressure of the PUB system. The system has recently upgraded some mains and has plans to upgrade other water mains as funds are available.

#### 2.2.4.8 City of La Feria

The City of La Feria receives raw water from the La Feria Irrigation District. La Feria treats this raw water in a 1.0 MGD treatment plant which is scheduled to be enlarged in 1990 or 1991. The La Feria distribution system is principally limited to the city limits of La Feria and has approximately 1,600 meters. La Feria has elevated storage in the amount of 0.25 MG and total ground storage of 0.6 MG. The average daily production is approximately 0.6 MGD.

#### 2.2.4.9 Valley Municipal Utility District No. 2

Valley Municipal Utility District No. 2 (Rancho Viejo) diverts water directly from the Rio Grande and provides raw water which is treated to serve the Rancho Viejo development. This development contains approximately 891 meters which is served by a centralized distribution system. The treatment plant capacity is approximately 1.0 MGD with an average daily consumption of approximately 0.38 MGD. The system includes elevated a ground storage tanks of 0.3 MG capacity each.

#### 2.2.4.10 City of Los Fresnos

The City of Los Fresnos receives water from the Cameron County Water and Improvement District # 6. Los Fresnos has a 1.0 MGD water treatment plant which treats water to serve approximately 754 metered customers. The system contains 0.3 MG of elevated storage capacity and approximately 0.12 MG in ground storage capacity. The average day consumption is approximately 0.36 MGD. The City of Los Fresnos sells water to the City of Indian Lake.

#### 2.2.4.11 Olmito Water Supply Corporation

The Olmito WSC receives raw water from the Cameron County Water and Improvement District # 6 and treats the water in a 1.0 MGD plant. The Olmito WSC's distribution system principally serves the developed area of Olmito along U. S. Highway 77. The system has approximately 775, metered customers and has two elevated storage tanks with a total capacity of 0.1 MG approximately of storage. Average day's production is approximately 0.3 MG.

#### 2.2.4.12 City of Primera

The City of Primera purchases water from the Harlingen Water Board to serve their approximate 637 metered customers. The Primera system has approximately 0.3 MG in elevated storage capacity. The average day's consumption is approximately 0.18 MG.

#### 2.2.4.13 Valley Municipal Utility District No 1

The Valley Municipal Utility District No 1 purchases treated water directly from the PUB and is connected directly for system pressure. The Valley Municipal Utility District No. 1 has no pumping or storage facilities and serves their 618 customers directly off of the PUB system. The system uses approximately 0.225 MGD.

#### 2.2.4.14 City of Rio Hondo

The City of Rio Hondo receives raw water from the San Benito Irrigation District. It treats raw water in their 0.80 MGD water treatment plant. They serve approximately 517 meters and has elevated storage of approximately 0.15 MG and ground storage capacity of approximately 0.165 MG. The system has an average day production of 0.261 MG. The distribution system is limited to the incorporated area of the City of Hondo.

#### 2.2.4.15 Arroyo City Water Supply Corporation

The Arroyo City WSC receives raw water from the San Benito Irrigation District. This system has treatment plant capacity of approximately 0.50 MGD and serves approximately 459 metered customers, principally in the rural area of northeastern Cameron County. The system has 50,000 gallons of ground storage and an average day's production of 0.134 MG. The distribution system serves the area in and around Arroyo City.

#### 2.2.4.16 Palm Valley Estates Utility District

Palm Valley Estates Utility District purchases raw water from the Harlingen Water Board and directly serves their 445 metered customers. The system has no pumping or storage facilities and uses approximately 0.206 MGD. The distribution system serves the developed area of the district.

#### 2.2.4.17 Brownsville Navigation District

The Brownsville Navigation District operates a water system within the district to serve its industrial and commercial customers. This district with approximately 181 metered accounts, purchases treated water from the PUB, and operates a 1.5 MG elevated storage system. The district's water treatment plants are currently inactive.

#### 2.2.5 Water Service in Colonias

Several of the previously mentioned entities provide treated water to the colonias in Cameron County. Typically, water is supplied by water supply corporations, such as, the Olmito WSC, Military Highway WSC, El Jardin WSC and the East Rio Hondo WSC. Distribution is typically through relatively small lines (2- inch to 4 inch in diameter). The major portion (59 of 65) of the colonias in Cameron County have some type of water service provided by one of these entities. The remaining six (6) are currently on individual wells. Table 2-7 provides a list of water supply entities serving each of the colonias in Cameron County.

### 2.3 Wastewater Service Area and Facilities

#### 2.3.1 Service Areas

The areas of ETJ and CCN are the same for water and wastewater. However, no water supply corporation provide any wastewater service in Cameron County, and all other utilities generally provide wastewater service to a smaller area than severed by water. Physical service area for wastewater are illustrated in Figure 2-4.

#### 2.3.2 Permitted Facilities

All municipal and industrial wastewater treatment plants (WWTP's) and disposal systems in Texas must obtain a Texas Wastewater Discharge Permit from the TWC and a National Pollutant Discharge Elimination System (NPDES) Permit from the United States Environmental Protection Agency (EPA). In addition, each discharger must provide monthly "Self-Reports" to the TWC indicates the amounts of wastewater treated and effluent concentrations of specific pollutants identified in individual permits. These data are used to determine the existing use and excess treatment capacity, if any, of each discharger and compliance of that discharge with specified permits limits. Data retrieved from the TWC Self-Reporting S

Table 2-7  
Water Supply Entities  
Serving Colonias In Cameron County

Sub-area	Colonia	Served by Central System	Sub-area	Colonia	Served by Central System	Sub-area	Colonia	Served by Central System	Sub-area	Colonia	Served by Central System
1B	Cameron Park 1	PUB*	1H	Las Palmas	ERH-WSC	1W	Encantada	MH-WSC			MH-WSC
2B	Olmite	O-WSC	2H	Lego Subd.	ERH-WSC	2W	Santa Maria	MH-WSC			MH-WSC
3B	Stuart Subd.	EJ-WSC	3H	26	ERH-WSC	3W	La Paloma	MH-WSC			MH-WSC
4B	San Pedro/Cameron/Barrera Gd.	MH-WSC	4H	Lasana	ERH-WSC	4W	Los Indios	MH-WSC			MH-WSC
5B	King Subd.	EJ-WSC	5H	Rice Tracts	ERH-WSC	5W	Bluetown	MH-WSC			MH-WSC
6B	Alabama/Arkansas (LaCome)	EJ-WSC	6H	Leal Subd. (Metas & Bounde)	ERH-WSC	6W	2 Unknown Subd.	-			-
7B	Hacienda Gardens	PUB*	7H	Laguna Escondido Heights	ERH-WSC	7W	El Venedito	MH-WSC			MH-WSC
8B	Villa Nueva	MH-WSC				8W	Carricitos-Londrum	MH-WSC			MH-WSC
9B	Villa Pancho	EJ-WSC	1E	La Coma Del Norte	ERH-WSC	9W	El Calaboz	MH-WSC			MH-WSC
10B	Pleasant Meadows	EJ-WSC	2E	Lozano	ERH-WSC	10W	Iglesia Antigua	MH-WSC			MH-WSC
11B	Villa Cevazos	MH-WSC	3E	La Tina Ranch	ERH-WSC	11W	Palmer	MH-WSC			MH-WSC
12B	Barrio Subd.	EJ-WSC	4E	Laureles	ERH-WSC	12W	Unknown (mitia 2)	MH-WSC			MH-WSC
13B	Las Cuatas	EJ-WSC	5E	Del Mar Heights	ERH-WSC	13W	Q Unknown Subd. (Santa Rosa)	-			-
14B	Saldivar	EJ-WSC	6E	Oraon Ac/Chula Vst/Shoemaker	ERH-WSC	14W	W	-			-
15B	Coronado	EJ-WSC	7E	Las Yucas	ERH-WSC	15W	R Unknown Subd. (S. Santa Rosa)	-			-
16B	Unknown	EJ-WSC	9E	Unknown	ERH-WSC	16W	X Unknown Subd. (Santa Feria)	-			-
17B	Saldivar (II)	EJ-WSC	9E	Glenwood Acres Subd.	ERH-WSC	17W	S	-			-
18B	Valle Escondido	EJ-WSC	10E	Unknown (Del Mar II)	MH-WSC						
19B	Unnamed C	EJ-WSC	11E	Los Cuates	ERH-WSC						
20B	Unnamed D (Keller's Corner)	EJ-WSC	12E	25	ERH-WSC						
21B	Texas 4	EJ-WSC	13E	Cieneros (Limon)	ERH-WSC						
22B	511 Crossroads	EJ-WSC									
23B	Illinois Heights	EJ-WSC									
24B	Unknown (Brownville Airport)	EJ-WSC									
25B	Valle Hermosa	EJ-WSC									
26B	Unknown	EJ-WSC									
27B	Unnamed B (Hwy 802)	EJ-WSC									
28B		EJ-WSC									

ystem Data Bank for all permitted municipal and industrial wastewater discharges in Cameron County are shown in Table 2-8.

Currently there are 27 permitted municipal and two industrial discharges in Cameron County, releasing a combined maximum of 37.4 MGD of treated effluent to various receiving streams and water courses of Cameron County. The Brownsville Ship Channel (TWC Designated Segment No. 2494) has the largest permitted waste load at 15.4 MGD followed, in descending order, by the Arroyo Colorado above tidal influence (Segment 2202) with 14.1 MGD, the tidally influenced portion of the Rio Grande (Segment 2301) with 7,187 MGD, the Laguna Madre (Segment 2491) with 3.0 MGD, the tidally influenced portion of the Arroyo Colorado (Segment 2201) with 2.9 MGD, the Rio Grande above tidal influence (Segment 2302) with 0.25 MGD, and South Bay (Segment 2493) with 0.02 MGD.

#### 2.3.2.1 Public Utilities Board of Brownsville

By far the largest single municipal wastewater discharger in Cameron County is the PUB, with two facilities and a combined permitted wastewater treatment capacity of 17.8 MGD. The new PUB North Robindale Plant, which discharges to the Brownsville Ship Channel, is permitted at 10 MGD; however, examination of TWC 1988 Self-Reporting Data indicates that the maximum month average daily flow to the plant is only 3.4 MGD (35% of permitted capacity), which leaves a current excess capacity in that plant of 6.4 MGD. The older PUB Southside Plant discharges to the tidally influenced portion of the Rio Grande below Brownsville. The permitted capacity of the Southside Plant is 7.8 MGD, and the 1988 maximum month average day flows to the plant were 6.34 MGD (81% of permitted capacity), which leaves little room for future expansion.

#### 2.3.2.2 City of Harlingen

The City of Harlingen Water Board operates a wastewater collection system within the incorporated limits of the City of Harlingen. This entity operates two wastewater treatment plants.

The eastern most plant is rated a 3.5 MGD. The plant located between Highway 77 and Highway 448 in the southern portion of the City, is rated at 3.1 MGD. Both facilities are currently operating at approximately 80% of capacity. These plants are adjacent and discharge into the Arroyo Colorado.

Currently the county is administering Housing and Urban Development (HUD) funds to service a few outlying developments that are being added to the City of Harlingen system.

#### 2.3.2.3 City of San Benito

The City of San Benito operates a wastewater collection and treatment system that serves the developed area within the City of San Benito. The sewage treatment plant is located north of the city adjacent to

**Table 2-8**  
Municipal and Industrial Dischargers In Cameron County  
Permitted Capacities, 1988 Maximum Month Use and Available Capacities

Seg. No.	Municipal Discharges		Permitted						Wastewater Discharge Date				
	Permit No.	Permit Holder	Annual Avg. Flow (MGD)	Dly. Avg. BOD (mg/L)	Dly. Avg. NHS (mg/L)	Avg. Flow (MGD)	Dly. Avg. BOD (mg/L)	Dly. Avg. NHS (mg/L)	Max. Month Useage	Avg. Flow (MGD Avail.)	Avg. Flow (% Used)	Max. Month Capacity	Avg. Flow (% Avail.)
2201	10972-002	Palm Valley Est.	0.280	20.0						0.280	0.00	100.00	100.00
2201	10475-002	Rio Hondo	0.150	30.0					0.150	0.00	100.00	100.00	
2202	10490-003	Herrlingen No.2	3.500	20.0		2.780	28.00		0.720	78.43	20.67	19.03	
2202	10490-002	Herrlingen No.1	3.100	20.0		2.610	14.00		0.590	80.97	19.03	7.41	
2202	10479-002	San Benito	2.180	30.0		2.000	60.00		0.180	92.69	7.41	-130.80	
2202	10687-001	La Feria	0.500	30.0		1.164	35.00		-0.664	230.80	-130.80	95.84	
2202	11628-001	Winter Garden Pk.	0.110	20.0		0.005	8.00		0.106	4.36	100.00	100.00	
2202	11659-001	Herrlingen Cons. ISD	0.008	20.0					0.008	0.00	17.51		
2301	10397-003	PUB - S. Side Plant	7.800	20.0		6.434	9.00		1.366	82.49	17.51		
2301	12823-001	Playa Del Rio	0.070	20.0		Not Constructed							
2302	10862-001	Valley MUD 001	0.130	20.0					0.130	0.00	100.00	100.00	
2302	11348-002	Valley MUD 002	0.115	20.0					0.115	0.00	100.00	100.00	
2491	10767-001	CC FWSD #1 Isl. Bl.	1.500	10.0	15.0	1.717	6.30		-0.217	114.47	-14.47	50.53	
2491	11389-001	CCFWSD #1 Andy B	0.750	10.0	15.0	0.371	3.70		0.370	49.47	50.53	32.48	
2491	10330-001	Santa Rosa WCID	0.390	20.0		0.283	6.00		0.127	67.54	32.48	-1.25	
2491	12321-001	U.S. Dept. Justice	0.080	20.0		0.061	2.00		-0.001	101.25	-1.25	94.83	
2491	12617-001	Fig. Tree RV Park	0.024	20.0		0.001	8.00		0.023	5.17	94.83	100.00	
2493	12741-001	Berryman Builders	0.020	20.0					0.020	0.00	100.00	100.00	
2494	11803-001	PUB - N. Robinsdale	5.000	20.0		3.408	5.00		1.594	88.12	31.88	31.13	
2494	10350-001	CC FWSD #1 Pl. Is.	1.500	10.0	15.0	1.033	7.10		0.487	88.87	31.13	93.90	
2494	10332-005	Brownville ND	1.000	20.0		0.061	9.00		0.939	6.10	93.90	96.61	
2494	10332-001	Brownville ND	0.980	20.0		0.043	8.00		0.937	4.39	96.61	52.03	
2494	10590-001	Los Fresnos	0.590	20.0		0.283	4.25		0.307	47.97	52.03	100.00	
2494	11348-001	Valley Mud 002	0.400	20.0					0.400	0.00	100.00	100.00	
2494	13041-001	St. Francis of Assis	0.350	20.0		0.030	12.50		0.350	0.00	100.00	90.91	
2494	12580-001	Las Palmas STP	0.330	20.0					0.300	9.09	90.91	100.00	
2494	10397-004	PUB Rio Del Sol	0.040	20.0					0.040	0.00	100.00	100.00	
			<b>30.875</b>						<b>8.633</b>				
<b>Industrial Discharges</b>													
2202	01256-001	CP&L La Palma	1.200			1.210	14.00		-0.010	100.83	-0.83	39.20	
2494	02617-001	Brownville ND	0.250	42.0		0.152	14.00		0.098	60.80	39.20	0.088	
			<b>1.450</b>						<b>0.088</b>				

Segment Identification  
 2201 Arroyo Colorado Tidal  
 2202 Arroyo Colorado Above Tidal  
 2301 Rio Grande Tidal  
 2302 Rio Grande Below Falcon Reservoir  
 2491 Laguna Madre  
 2493 South Bay  
 2494 Brownville Ship Channel

Arroyo Colorado and across the arroyo from the eastern most City of Harlingen's wastewater treatment plant. The San Benito plant rated at 2.16 MGD day is currently operating at 98% of capacity.

#### 2.3.2.4 Cameron County Freshwater Supply District No. 1

The Cameron County Fresh Water Supply District No. 1 operates three wastewater systems, one on South Padre Island, one in Port Isabel, and one in Laguna Vista.

South Padre Island has a conventional system installed in the built up portion of the island. There is a 0.70 MGD plant near the northern end of the development near Andy Bowie Park. A 1.5 million gallon per day plant is located near the southern end of the island at Isla Blanca Park. The Isla Blanca Plant is 15% hydraulically overloaded, however, permitted maximum discharge concentration limits for BOD<sub>5</sub> and NH<sub>3</sub>-N are not being exceeded. The Andy Bowie Plant is currently operating at 49% capacity.

The development area of Port Isabel is serviced by a wastewater collection system. The Port Isabel wastewater treatment plant has a capacity of 1.5 MGD. The plant is currently operating at approximately 69% of capacity.

Laguna Vista is served by a collection system that has a lift station that pumps to the Port Isabel wastewater treatment plant.

#### 2.3.2.5 Brownsville Navigation District

The Brownsville Navigation District operates wastewater collection and treatment systems within the district. Three plants are utilized, the main plant being a 1.0 MGD plant located in the central part of the district. Additionally, there is a 0.25 MGD facility operated at the fishing harbor and a 0.1 MGD facility operated at the Marathon Manufacturing Plant.

#### 2.3.2.6 City of Los Fresnos

The City of Los Fresnos has a wastewater collection system in the development area of the city with a 0.59 MGD treatment plant on the south side of the city. This plant is currently operating at 48% capacity.

#### 2.3.2.7 City of La Feria

The City of La Feria has a wastewater collection system in the developed portions of the city. Wastewater is treated at a 0.50 MGD facility plant on the southern side of the city, which is currently operating at capacity. This wastewater plant was enlarged two years ago.

#### 2.3.2.8 Palm Valley Estates Utility District

The Palm Valley Estates Utility District operates a collection system for approximately 440 customers and has a treatment plant with a capacity of 0.28 MGD.

#### 2.3.2.9 Valley Municipal Utility District No. 2

The Rancho Viejo area developed portion is served by a wastewater system operated by the Valley Municipal Utility District No 2. The treatment plant has a rated capacity of 0.115 MGD capacity.

#### 2.3.2.10 City of Rio Hondo

The City of Rio Hondo has a wastewater collection system that serves most of its developed areas. The wastewater treatment plant is rated at 0.15 MGD.

#### 2.3.3. Wastewater Disposal in Colonias

A colonia, as partially, defined previously in this report, is a residential development that is outside the boundaries of a municipality or district and is not currently served by an organized sewer collection system line. Virtually all of the colonias in Cameron County use private on-site septic or latrine system for wastewater disposal. Visual inspection during the windshield survey of the colonias indicate indoor plumbing was available in most of the colonias, but in those colonias where outdoor privies were used, they tended to dominate. Densities and soil conditions, as well as, discussions with local health officials, indicate most of the county is unsuitable for this type of wastewater disposal and environmental health problems may occur as a result. The remainder of this report will focus on developing methods to solve these problems.



### 3.0 PROJECTED CONDITIONS

The previous section provides the basis for projecting population and water and wastewater needs for the urban and rural areas of Cameron County through the year 2020. Projected water and wastewater needs are a function of future populations and per capita use rates. This section provides an overview of projected populations and water and wastewater needs in Cameron County in five (5) year increments for the years 1990 through 2020.

#### 3.1 Population Projections

Under the terms of the TWDB Planning Grant award, TWDB population projections and water demand projections are to be used unless compelling arguments can demonstrate that TWDB estimates are not representative or that other estimates more adequately depict future conditions. The following data sources were reviewed and contrasted to develop future population and water demand projections used in this planning effort:

Texas Water Development Board, Water Data Collection, Studies, and Planning Division, Projections of Population and Municipal Water Demands (Average and High Per Capita Use Series), October 1989;

Lower Rio Grande Development Council - Population Projections for Selected Rural Unincorporated Communities in Cameron, Hidalgo and Willacy Counties (1980-2005), 1988

Texas A&M University - Projections of the Population of Texas and Counties in Texas By Age, Sex and Race/Ethnicity for 1990-2025, December 1988; and

R. W. Beck and Associates, Inc. - Brownsville Public Utilities Board - 1988 Wastewater Master Plan, 1988.

#### Texas Water Development Board (TWDB) Future Population Estimates

The TWDB uses the Cohort Survival Method With a Migration Component to construct two future population estimate scenarios for each county, major incorporated areas within each county (population > 1,000) and rural areas (includes colonias and incorporated townships > 1,000 persons). A "Low Population Series" reflects a minimum expected populations based on historical fertility and mortality trends and average net migration, estimated over the period 1950-70; a "High Series" uses the same fertility and mortality rates, but assumes the maximum net migration observed over the period 1970-80. Weighing factors based on 1980-88 rates, which reflect most recent trends, are used to adjust the 1950-70 and 1970-80 migration factors. When plotted, these two series present an envelop within which the actual future populations of a county or city are most likely to occur. Periodic adjustments are made to TWDB estimates to reflect updated information from the U.S. Census Bureau.

### Lower Rio Grande Valley Development Council (LRGVDC) Future Population Estimates

LRGVDC future population estimates were constructed using four commonly accepted estimating techniques. Those techniques are: (1) Arithmetic Change, (2) Exponential Rate of Change, (3) Cohort Component Method, and (4) Cohort Component Method Increased by Mean Population Growth Rates. Arithmetic and Exponential Change Method coefficients were computed for different base periods (1970-80, 1980-85, 1986-87 and 1987-88) and predicted populations compared with county vital statistics data. In addition, a Cohort Component Method Increased by the Median Population Growth Rate was tested. Cohort Component and Cohort Component Increased by Mean/Median Population Growth Rate Methods were calibrated for the 1980-87 period. The Cohort Component Increased by Mean and Median Population Growth Rates were selected as most representative of historical measured population dynamics for the LRGVDC estimates (LRGVDC, 1988).

### Texas A&M University (TAMU) Future Population Estimates

TAMU population estimates, prepared for the TDOC, assume three population projection scenarios based on different rates of net migration. All three scenarios assume the same set of mortality and fertility factors. Net migration patterns from 1970-80 were altered relative to general population trends of the 1980s to construct the three scenarios. One scenario assumes zero net migration; a second scenario assumes a continuation of trends in the age, sex and race/ethnicity net migration rates of the 70s; and the third scenario assumes a 50% of the 1970-1980 net migration rate through the year 2025 (TAMU, 1988).

### R. W. Beck Future Population Estimates

R. W. Beck, and Assoc. analyzed City of Brownsville population trends of the last 30 years and observed an annual average growth rate of 3.3% per yr. R. W. Beck extended this growth rate was through the year 2010 and represents the basis for recommendations to the PUB contained in their 1988 Wastewater Master Plan.

#### 3.1.1 Cameron County

County-wide population projections through the year 2020 developed by the TWDB and LRGVDC are in reasonably close agreement (Figure 3-1). The LRGVDC Mean and Mean Series estimates are both slightly higher than TWDB estimates (LRGVDC highest estimates are approximately 23% higher than the lowest TWDB estimates). However, comparing the LRGVDC and TWDB High Series shows only a 15% difference. Given the volatile rates of net migration within Rio Grande Valley Counties, this represents a reasonable correlation. In planning for future water supplies, the most conservative population estimates, that can be justified through application of rigorous forecasting techniques, generally offer the most reasonable numbers.

Figure 3-1  
Cameron County Population Projections

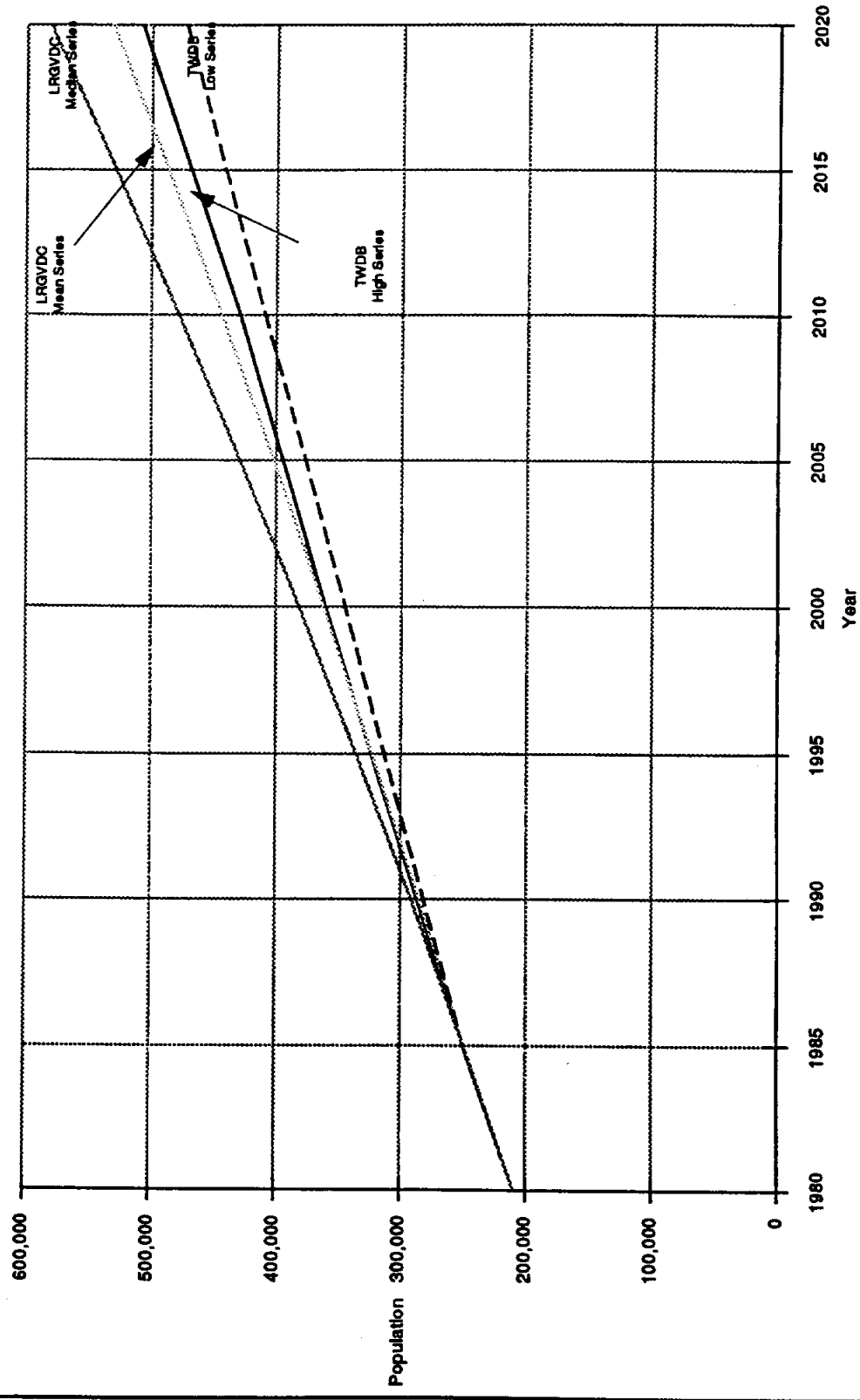

Source: TWDB Records & LRGVDC

### 3.1.2 Incorporated/Urban Areas

Examination of TWDB and LRGVDC population estimates for cities within Cameron County shows a general consensus between the two agencies. The City PUB estimates of future populations, generated by R. W. Beck and Assoc.(extrapolated from 2010 to 2020) are considerably higher than estimated by either the TWDB or LRGVDC (Figure 3-2). The R. W. Beck estimates assume a constant 3.3% annual future population increase not supported by LRGVDC vital statistics data for the period 1980-87, which shows a decreasing annual growth rate from 4.34% in 1980-81 to 1.78% in 1986-87 (R. W. Beck, 1988). This decreasing rate of annual growth is reflected in both the TWDB and LRGVDC estimated. A summary of population projections for municipalities in Cameron County is presented in Table 3-1.

TWDB and LRGVDC population projections for the Cities of Harlingen, San Benito, Los Fresnos, Rio Hondo, Primera, and La Feria are very similar to the Brownsville projected growth patterns. In most instances, LRGVDC Median Series estimates are slightly higher than TWDB High Series estimates and form a more conservative basis for future water supply and wastewater planning. TWDB and LRGVDC projected populations for the Cities of Port Isabel, Santa Rosa, and Combes differ by slightly higher margins. With the exception of Combes, the LRGVDC estimates are higher than TWDB estimates and serve as reasonable estimates. However, the populations of these cities (1980 U.S. Census populations of 3,769; 1,888; and 1,447, respectively) represent a small fraction of the aggregate population of Cameron County. The TWDB High Series (Table 3-2) will be used throughout the remainder of this report for projecting water and wastewater needs.

### 3.1.3 Rural Areas and Colonias

Population projections for rural and unincorporated areas of Cameron County, which include municipalities with a population of less than 1,000 persons and colonias, generated by the TWDB and LRGVDC differ noticeably (Figure 3-3). The LRGVDC estimates a Median Series population of 125,669 persons by the year 2020 while the TWDB High Series estimate is only 76,765 (36% less). Examination of the data indicates that the LRGVDC estimates assume a continuation of Cameron County rural population trends of the 1980-87 model calibration period while TWDB estimates assume a considerable slowing of growth. LRGVDC (1988) reported annual changes in rural community growth rates show the same decline as were shown for Brownsville and other major cities in the county (a decreasing annual growth rate from 4.35% in 1980-81 to 1.79% in 1986-87 with a mean annual rate decrease of 3.08%). The LRGVDC reported vital statistics data do not, however, suggest the drastic growth rate reduction suggested by the TWDB curves.

Figure 3-2  
City of Brownsville Population Projections

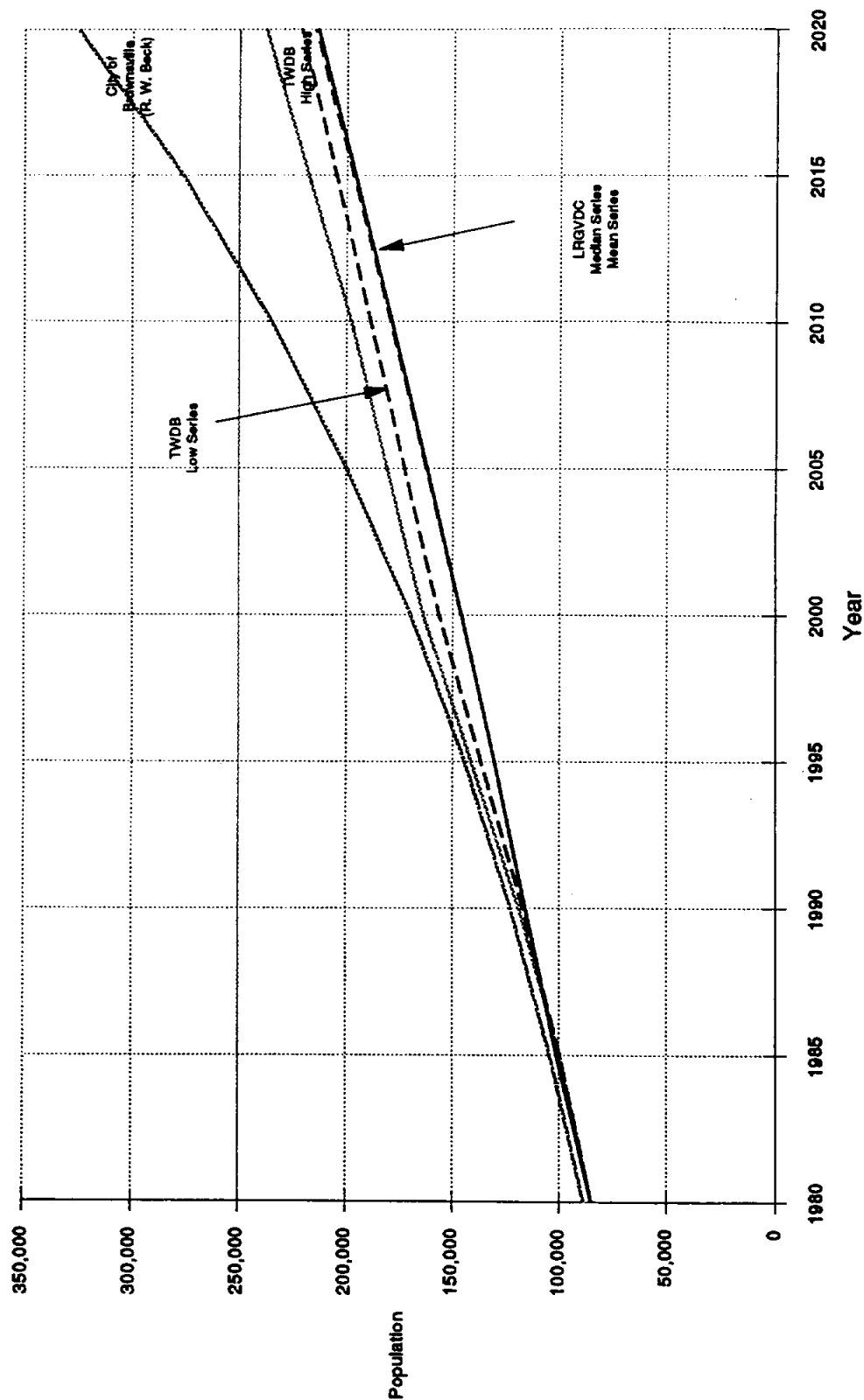

Source: TWDB Records, R. W. Beck  
& LRGVDC

Table 3-1  
Population Projections for Municipalities in Cameron County 1990-2020

City	TWDB													
	Low Series					High Series								
	1990	1995	2000	2005	2010	2015	2020	1990	1995	2000	2005	2010	2015	2020
Brownsville	115,553	134,714	153,874	169,634	185,394	201,454	217,513	119,454	141,583	163,712	180,664	197,616	217,576	237,536
Harlingen	59,859	65,379	70,898	78,164	85,429	92,829	100,229	61,880	68,656	75,431	83,246	91,061	100,259	109,456
La Feria	4,866	5,344	5,821	6,418	7,014	7,622	8,229	5,031	5,613	6,194	6,836	7,477	8,232	8,987
Los Fresnos	3,225	3,745	4,264	4,702	5,139	5,584	6,028	3,334	3,936	4,537	5,008	5,478	6,031	6,583
Port Isabel	4,700	5,061	5,422	5,978	6,533	7,099	7,665	4,859	5,314	5,769	6,367	6,964	7,668	8,371
Rio Hondo	2,310	2,578	2,845	3,136	3,427	3,724	4,020	2,389	2,708	3,027	3,340	3,653	4,022	4,391
San Benito	23,450	25,525	27,600	30,428	33,256	36,137	39,018	24,242	26,804	29,365	32,407	35,449	39,030	42,610
Santa Rosa	2,466	2,736	3,005	3,313	3,621	3,935	4,248	2,550	2,874	3,198	3,529	3,860	4,250	4,640
Combes	2,337	2,653	2,968	3,273	3,577	3,886	4,195	2,416	2,787	3,158	3,486	3,813	4,198	4,582
Primera	1,955	2,219	2,483	2,737	2,991	3,250	3,509	2,006	2,021	2,642	2,642	3,189	3,189	3,833
Unincorporated	74,163	77,664	81,164	86,381	91,597	95,667	99,737	76,661	81,505	86,349	91,990	97,630	103,271	108,911
County Total	294,984	327,614	360,344	394,161	427,978	461,185	494,391	304,837	344,110	383,382	419,786	456,190	498,045	539,900

City	LRGVDC													
	Median					Mean								
	1990	1995	2000	2005	2010	2015	2020	1990	1995	2000	2005	2010	2015	2020
Brownsville	115,457	130,412	145,897	161,917	178,504	195,675	213,450	115,696	130,898	146,635	162,925	179,787	197,242	215,310
Harlingen	59,217	66,951	74,937	83,244	93,822	100,732	109,894	59,269	67,057	75,119	83,464	92,102	101,044	110,301
La Feria	4,706	5,277	6,068	6,481	7,314	7,770	8,450	4,757	5,382	6,029	6,698	7,391	8,108	8,851
Los Fresnos	3,035	3,494	3,969	4,461	4,970	5,497	6,042	2,969	3,359	3,763	4,181	4,614	5,062	5,525
Port Isabel	5,122	5,787	6,476	7,189	7,928	8,692	9,483	5,130	5,808	6,501	7,223	7,971	8,744	9,545
Rio Hondo	2,335	2,688	2,995	3,432	3,823	4,228	4,648	2,284	2,584	2,895	3,216	3,549	3,893	4,250
San Benito	24,215	27,151	30,191	33,338	36,595	39,967	43,457	24,486	27,703	31,034	34,481	38,050	41,744	45,568
Santa Rosa	2,627	3,024	3,435	3,860	4,301	4,757	5,229	2,569	2,907	3,166	3,619	3,993	4,380	4,781
Combes	2,014	2,318	2,633	2,960	3,292	3,647	4,009	1,970	2,229	2,497	2,774	3,061	3,358	3,666
Primera	1,926	2,218	2,518	2,831	3,154	3,438	3,835	1,884	2,132	2,392	2,653	2,928	3,212	3,506
Unincorporated	63,130	72,674	82,554	92,381	103,367	114,325	125,669	61,748	69,862	78,261	86,954	95,954	105,270	114,913
County Total	291,965	335,989	381,667	428,944	477,886	528,549	580,992	285,476	322,986	361,815	402,008	443,615	486,684	531,267

**Table 3-2**  
**Population Projections for Municipalities in Cameron County**  
**1990-2020**  
**Plan Development Projections \***

City	1990	1995	2000	2005	2010	2015	2020
Brownsville	119,454	141,583	163,712	180,664	197,616	217,576	237,536
Harlingen	61,180	68,306	75,431	83,246	91,061	100,259	109,456
La Feria	5,031	5,613	6,194	6,836	7,477	8,232	8,987
Los Fresnos	3,334	3,936	4,537	5,008	5,478	6,031	6,583
Port Isabel	4,859	5,314	5,769	6,367	6,964	7,668	8,371
Rio Hondo	2,389	2,708	3,027	3,340	3,653	4,022	4,391
San Benito	24,242	26,804	29,365	32,407	35,449	39,030	42,610
Santa Rosa	2,550	2,874	3,198	3,529	3,860	4,250	4,640
Combes	2,416	2,787	3,158	3,486	3,813	4,198	4,582
Primeria	2,021	2,332	2,642	2,916	3,189	3,511	3,833
Unincorporated	76,661	81,505	86,349	91,990	97,630	103,271	108,911
County Total	304,837	344,110	383,382	419,786	456,190	498,045	539,900

\*Projections used in the remainder of this study

Figure 3-3  
Cameron County Rural (Unincorporated)  
and Colonias Area Population Projections

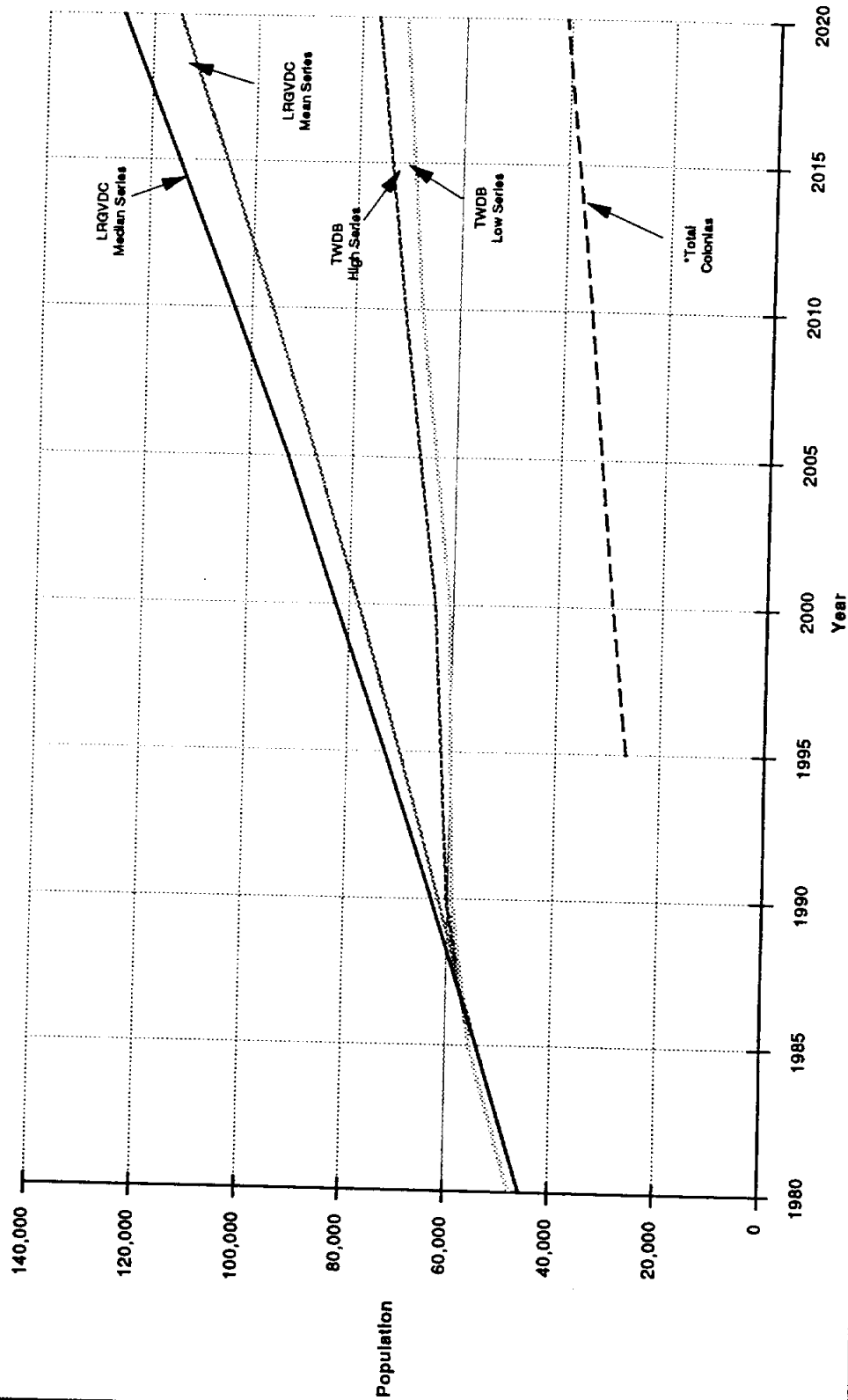

Source: TWDB Records, LRGVDC  
\* As computed by this study



## Colonia Projections

### **Methodology**

In 1987, the TWDB projected population through the year 2020 for the colonias in Cameron County (TWDB, 1987). These projections were based on 1986 estimates of housing units and population, and TWDB growth rates for the entire county. In order to more accurately predict areas of growth within the county, the population projections have been revised and updated based on new and more detailed estimates and growth rate information.

These projections were developed in a four-step approach, designed to provide as accurate projection of population as possible in relation to geographic location. Population was projected in five-year increments for the years 1990-2020. A summary of the four step approach follows:

1. Population estimates were updated to 1989;
2. The County was divided into four sub-areas and corresponding annual growth rates (per TWDB) were determined;
3. Density (Housing Units per Acre) was set a maximum of 6.0 units per acre to determine a maximum population for each colonia.
4. Each colonia was individually analyzed in relationship to geographical factors that may affect growth (i.e., distance to municipalities, major employment areas, etc.) and corresponding growth rates were applied to each colonia.

The data gathered in the four steps served as the basis for projecting population through the year 2020. The 1989 population was used as the base figure to which varying growth rates (per TWDB) were applied (as determined in Steps 2 and 4) and population (by colonia) was subsequently projected (in five-year increments) for the years 1990-2020. Finally, the maximum capacity (as determined in Step 3) was used to determine the year in which any given colonia would reach maximum density and growth would cease.

### Results

Population projections for the colonias for the years 1990-2020 are presented in Table 3-3. Housing units in the colonias are projected to increase from an estimated 4,629 units in 1990 to approximately 8,343 in the year 2020, an 80% increase over the 30-year planning horizon. Population in the colonias is expected to increase by approximately 18,200 persons to approximately 41,000 during the same time frame. The most rapid growth within the existing colonias is expected to occur in the next 5 years followed by decreasing growth rates through the year 2020.

Table 3-4 presents projected population by the sub-areas previously identified. The sub-areas (identified in detail in Section 1.0) are: 1) Sub-Area B (Brownsville ETJ); 2) Sub-Area W (Western Cameron County); 3) Sub-Area E (Eastern Cameron County); and 4) Sub-Area H (Harlingen ETJ).

Table 3-3  
Population Projections For Colonias by Sub-Areas

Colonia No.	Colonia Name	Colonia Area (Ac)	YEAR					
			1995	2000	2005	2010	2015	2020
1B	Cameron Park 1	360	4,378	5,068	5,587	6,105	6,714	7,327
2B	Olmito	387	2,110	2,443	2,693	2,943	3,237	3,532
3B	Stuart Subd.	50	1,174	1,360	1,499	1,638	1,801	1,960
4B	San Pedro/Carmen/Barrera Gd	63	866	1,003	1,106	1,208	1,329	1,450
5B	King Subd.	62	756	875	965	1,054	1,159	1,265
6B	Alabama/Arkansas (La Coma)	242	610	707	779	851	936	1,022
7B	Hacienda Gardens	51	564	653	720	786	865	944
8B	Villa Nueva	64	477	552	608	665	731	798
9B	Villa Pancho	74	360	417	460	503	553	603
10B	Pleasant Meadows	41	349	404	445	486	535	584
11B	Villa Cavazos	35	238	276	304	332	366	399
12B	Barrio Subd.	18	233	269	297	324	357	389
13B	Las Cuates	45	227	262	289	316	348	379
14B	Saldivar	44	180	209	230	251	276	302
15B	Coronado	56	180	209	230	251	276	302
16B	Unknown	30	169	195	215	235	259	282
17B	Saldivar (II)	33	163	188	208	227	250	272
18B	Valle Escondido	38	163	188	208	227	250	272
19B	Unnamed C	24	157	182	200	219	241	263
20B	Unnamed D (Keller's Corner)	22	145	168	185	203	223	243
21B	Texas 4	33	145	168	185	203	223	243
22B	511 Crossroads	29	145	168	185	203	223	243
23B	Illinois Heights	25	122	141	156	170	187	204
24B	Unknown (Brownsville Airport)	21	116	135	148	162	178	195
25B	Valle Hermosa	19	76	87	96	105	116	126
26B	Unknown	38	70	81	89	97	107	117
27B	Unnamed B (HWY 802)	22	58	67	74	81	89	97
28B	21	9	52	61	67	73	80	88
TOTALS		1,935	14,283	16,536	18,228	19,918	21,909	23,901

Colonia No.	Colonia Name	Colonia Area (Ac)	YEAR					
			1995	2000	2005	2010	2015	2020
1E	La Coma Del Norte	100	700	719	758	797	832	868
2E	Lozano	50	549	564	594	625	652	680
3E	La Tina Ranch	59	534	548	578	608	634	662
4E	Laureles	58	307	315	333	350	365	381
5E	Del Mar Heights	206	290	334	389	403	443	483
6E	Orason Ac/Chula Vista/Shoe.	211	278	321	354	387	425	464
7E	Las Yecas	16	227	233	245	258	269	281
8E	Unknown	16	212	217	229	241	251	262
9E	Glenwood Acres Sub.	32	176	181	191	201	209	218
10E	Unknown (Del Mar II)	62	174	201	221	242	266	290
11E	Los Cuates	22	156	180	199	218	239	261
12E	25	32	60	62	65	69	72	75
13E	Cisneros (Limon)	9	50	52	55	57	60	62
TOTALS		873	3,713	3,927	4,191	4,456	4,717	4,987

**Table 3-3**  
**Population Projections For Colonias by Sub-Areas**  
(continued)

Colonia No.	Colonia Name	Colonia Area (Ac)	YEAR					
			1995	2000	2005	2010	2015	2020
1H	Las Palmas	78	692	763	841	919	1,010	1,103
2H	Lago Subd.	41	436	480	530	579	637	695
3H	26	41	316	348	384	420	461	504
4H	Lasana	25	153	168	185	203	223	243
5H	Rice Tracts	32	147	162	179	195	215	234
6H	Leal Subd. (Metes & Bounds)	24	136	150	166	181	199	217
7H	Laguna Escondido Heights	16	60	66	73	80	88	95
TOTALS		257	1,940	2,137	2,358	2,577	2,833	3,091

Colonia No.	Colonia Name	Colonia Area (AC)	YEAR					
			1995	2000	2005	2010	2015	2020
1W	Encantada	215	1,325	1,360	1,434	1,508	1,574	1,641
2W	Santa Maria	80	1,378	1,595	1,758	1,922	2,113	2,306
3W	La Paloma	71	695	714	752	791	826	861
4W	Los Indios	100	564	579	611	642	670	699
5W	Bluetown	59	468	481	507	533	557	580
6W	T2 Unknown Subd.	45	348	357	376	396	413	431
7W	El Venadito	41	232	238	251	264	275	287
8W	Carricitos-Londrum	116	222	228	240	252	263	275
9W	El Calaboz	23	215	249	275	300	330	360
10W	Iglesia Antigua	10	168	171	180	189	198	206
11W	Palmer	32	179	197	217	237	261	285
12W	Unknown (mitla 2)	32	136	140	147	155	162	169
13W	Q Unknown Subd. (Santa Rosa)	16	150	167	184	201	221	241
14W	W	48	111	114	120	126	132	137
15W	R Unknown Subd. (S.Santa Rosa)	25	122	136	150	164	180	196
16W	X Unknown Subd. (Santa Feria)	16	72	80	89	97	106	116
17W	S	25	72	80	89	97	106	116
TOTALS		954	6,455	6,886	7,380	7,874	8,387	8,906

Table 3-13  
Projected Wastewater Treatment Capacity Requirement  
1990-2020

Entity	Existing Capacity (gpd)	Exceeded a/	Capacity (gpd)							
			1990	1995	2000	2005	2010	2015	2020	
Brownsville	12,800,000	1995	11,858,000	14,114,600	16,371,200	18,066,400	19,761,600	21,757,600	23,753,600	
Harlingen	9,850,000	2015	6,142,700	6,842,900	7,543,100	8,324,600	9,106,100	10,025,900	10,945,600	
San Benito	2,160,000	1990	2,406,400	2,671,500	2,936,500	3,240,700	3,544,900	3,903,000	4,261,000	
Los Fresnos	590,000	2014	330,900	392,300	453,700	500,800	547,800	603,100	658,300	
Rio Hondo	150,000	1990	237,100	269,900	302,700	334,000	365,300	402,200	439,100	
La Feria	500,000	1990	499,400	559,400	619,400	683,600	747,700	823,200	898,700	
Port Isabel	1,500,000	2020	482,300	529,600	576,900	636,700	696,400	766,800	837,100	
Santa Rosa	390,000	2011	253,100	286,500	319,800	352,900	386,000	425,000	464,000	

a/ Year that wastewater treatment requirements are expected to exceed available capacity.

Sub-area B (Brownsville ETJ) - This sub-area, with 28 of the 65 colonias, is projected to have approximately 58% of the colonia population (23,901 persons) in Cameron County by the year 2020. The two largest colonias in the County-Cameron Park and Olmito are projected to account for approximately 25% of the county's colonia residents by the year 2020.

Sub-area W (Western Cameron County) - This sub-area with 17 of the 65 colonias is projected to have approximately 22% of the colonias population (8,906 persons) by the year 2020. The colonias in this area are expected to have the highest population by the year 2020 include Santa Maria (2,306 persons), Encantada (1,641 persons) and La Paloma (861 persons).

Sub-area E (Eastern Cameron County) - Sub-Area 3E, with 13 colonias, is projected to have approximately 12% of the colonia population by the year 2020. Colonia in Sub-area E projected to experience significant growth include La Coma Del Norte (868 persons) Lozano (680 persons) and La Tina Ranch (662 persons).

Sub-area H (Harlingen ETJ) - This sub-area, with only 7 colonias, is projected to account for only 7.5% of the colonia population in the County by the year 2020. Las Palmas (1,103 persons) and the Lago Subdivision (695 persons) are expected to be the largest colonias in this sub-area by the year 2020.

In short, the Sub-area B (Brownsville ETJ), is expected to have the highest number of colonia residents by the year 2020, followed by the Unincorporated West, Unincorporated East, and the Harlingen ETJ. Population of the colonias in Cameron County are graphed with projected total rural area population in Figure 3-3.

### 3.2 Projected Water Demands

#### Water Use By Type

Projected water requirements for Cameron County are separated into a number of consumptive use categories including municipal, manufacturing, steam electric, irrigation, mining and livestock. Currently irrigation accounts for approximately 84% of the total use in Cameron County. Approximately 15% of water in Cameron County is currently used for municipal uses. All other categories each account for less than 1% of the total water use in the county. Projected water use is expected to reach a high of 416,014 acre feet per year (High Series Without Conservation) by the year 2020. Approximately 24% and 73% of this total is expected to be used for municipal and irrigation purposes respectively. Tables 3-5 and 3-6 (Projected Water Requirements for Cameron County by Type; with and without conservation, respectively) indicate an increase in municipal water use and decrease in irrigation is projected through the year 2020. All other uses are expected to remain relatively constant. The remainder of this section focuses on municipal water use in Cameron County for the years 1990-2020.

Table 3-5  
Projected Water Requirements for Cameron County  
By Type of Use With Water Conservation

Use	TWDB Low Series (Acre-Feet/Year)													
	1990	% of Total	1995	% of Total	2000	% of Total	2005	% of Total	2010	% of Total	2015	% of Total	2020	% of Total
Municipal	53,511	14.87%	58,115	15.94%	62,718	16.97%	66,713	18.13%	70,708	19.29%	75,177	20.60%	79,645	21.93%
Manufacturing	1,759	0.49%	1,927	0.53%	2,095	0.57%	2,220	0.60%	2,345	0.64%	2,491	0.68%	2,637	0.73%
Steam Electric	1,600	0.44%	1,600	0.44%	1,600	0.43%	2,300	0.62%	3,000	0.82%	3,000	0.82%	3,000	0.83%
Irrigation	302,008	83.94%	302,008	82.82%	302,008	81.74%	295,720	80.36%	289,432	78.96%	283,137	77.60%	276,842	76.23%
Mining	6	0.00%	9	0.00%	11	0.00%	10	0.00%	8	0.00%	5	0.00%	1	0.00%
Livestock	905	0.25%	976	0.27%	1,047	0.28%	1,047	0.28%	1,047	0.29%	1,047	0.29%	1,047	0.29%
Total	359,789	100.00%	364,634	100.00%	369,479	100.00%	368,010	100.00%	366,540	100.00%	364,856	100.00%	363,172	100.00%

Use	TWDB High Series (Acre-Feet/Year)													
	1990	% of Total	1995	% of Total	2000	% of Total	2005	% of Total	2010	% of Total	2015	% of Total	2020	% of Total
Municipal	55,316	14.28%	61,024	15.69%	66,731	17.09%	71,050	18.10%	75,368	19.10%	81,173	20.41%	86,977	21.71%
Manufacturing	1,803	0.47%	2,041	0.52%	2,278	0.58%	2,517	0.64%	2,756	0.70%	3,091	0.78%	3,426	0.86%
Steam Electric	1,600	0.41%	1,600	0.41%	1,600	0.41%	2,300	0.59%	3,000	0.76%	3,000	0.75%	3,000	0.75%
Irrigation	327,800	84.61%	323,293	83.12%	318,786	81.65%	315,642	80.41%	312,498	79.18%	309,354	77.79%	306,210	76.43%
Mining	6	0.00%	9	0.00%	11	0.00%	10	0.00%	8	0.00%	6	0.00%	4	0.00%
Livestock	905	0.23%	976	0.25%	1,047	0.27%	1,047	0.27%	1,047	0.27%	1,047	0.26%	1,047	0.26%
Total	387,430	100.00%	388,942	100.00%	390,453	100.00%	392,565	100.00%	394,677	100.00%	397,671	100.00%	400,664	100.00%

Source: TWDB, 1989

**Table 3-6**  
**Projected Water Requirements for Cameron County**  
**By Type of Use Without Water Conservation**

Use	TWDB Low Series (Acre-Feet/Year)													
	1990	% of Total	1995	% of Total	2000	% of Total	2005	% of Total	2010	% of Total	2015	% of Total	2020	% of Total
Municipal	54,884	15.20%	61,345	16.68%	67,806	18.10%	74,308	19.78%	80,810	21.46%	87,255	23.15%	93,700	24.84%
Manufacturing	1,759	0.49%	1,927	0.52%	2,095	0.56%	2,220	0.59%	2,345	0.62%	2,491	0.66%	2,637	0.70%
Steam Electric	1,600	0.44%	1,600	0.43%	1,600	0.43%	2,300	0.61%	3,000	0.80%	3,000	0.80%	3,000	0.80%
Irrigation	302,008	83.62%	302,008	82.10%	302,008	80.63%	295,720	78.73%	289,432	76.85%	283,137	75.12%	276,842	73.39%
Mining	6	0.00%	9	0.00%	11	0.00%	10	0.00%	8	0.00%	5	0.00%	1	0.00%
Livestock	905	0.25%	976	0.27%	1,047	0.28%	1,047	0.28%	1,047	0.28%	1,047	0.28%	1,047	0.28%
<b>Total</b>	<b>361,162</b>	<b>100.00%</b>	<b>367,865</b>	<b>100.00%</b>	<b>374,567</b>	<b>100.00%</b>	<b>375,605</b>	<b>100.00%</b>	<b>376,642</b>	<b>100.00%</b>	<b>376,935</b>	<b>100.00%</b>	<b>377,227</b>	<b>100.00%</b>

Use	TWDB High Series (Acre-Feet/Year)													
	1990	% of Total	1995	% of Total	2000	% of Total	2005	% of Total	2010	% of Total	2015	% of Total	2020	% of Total
Municipal	56,736	14.59%	64,439	16.42%	72,141	18.22%	79,140	19.75%	86,138	21.25%	94,233	22.94%	102,327	24.60%
Manufacturing	1,803	0.46%	2,041	0.52%	2,278	0.58%	2,517	0.63%	2,756	0.68%	3,091	0.75%	3,426	0.82%
Steam Electric	1,600	0.41%	1,600	0.41%	1,600	0.40%	2,300	0.57%	3,000	0.74%	3,000	0.73%	3,000	0.72%
Irrigation	327,800	84.30%	323,293	82.40%	318,786	80.53%	315,642	78.78%	312,498	77.07%	309,354	75.32%	306,210	73.61%
Mining	6	0.00%	9	0.00%	11	0.00%	10	0.00%	8	0.00%	6	0.00%	4	0.00%
Livestock	905	0.23%	976	0.25%	1,047	0.26%	1,047	0.26%	1,047	0.26%	1,047	0.25%	1,047	0.25%
<b>Total</b>	<b>388,850</b>	<b>100.00%</b>	<b>392,357</b>	<b>100.00%</b>	<b>395,863</b>	<b>100.00%</b>	<b>400,655</b>	<b>100.00%</b>	<b>405,447</b>	<b>100.00%</b>	<b>410,731</b>	<b>100.00%</b>	<b>416,014</b>	<b>100.00%</b>

Source: TWDB, 1989

Extrapolation of population projections to raw water demands is accomplished through application of per capita use rate factors. Per capita water use rates vary remarkably throughout Texas and show wide variations within counties. Major cities, such as Brownsville, Harlingen and San Benito, account for substantial industrial and commercial users in their respective per capita water use factors while smaller cities and rural area water use rates reflect purely residential consumption. In addition, water conservation practices play an important role in the development of local per capita water use rates.

Three sources of data were used to develop future raw water demands for incorporated and unincorporated areas of Cameron County.

Texas Water Development Board - Water Data Collection, Studies, and Planning Division - Projections of Population and Municipal Water Demands (Average and High Per Capita Use Series) , October 1989;

Texas Water Development Board - Survey of Ground and Surface Water Use (1980-1987); and

Lower Rio Grande Development Council - Estimates of Population for Cameron, Hidalgo and Willacy Counties, October 1988.

#### Texas Water Development Board (TWDB) Projections

TWDB projections of future water use are developed from population estimates and historical patterns of water use specific to the region or political subdivision. For each estimated future population series (High and Low), the TWDB develops an Average Water Demand Series based on average historical per capita water use rates and a High Water Demand Series based on the highest (drought condition) use year. In addition, the TWDB develops water conservation use estimates based on implementation of a rigorous water conservation programs. Those estimates assume a non-linear demand reduction increasing from 2% in 1990, to 7.5% in 2000, and 12.5% in 2010. The conservation water use reduction remains constant from 2010 through 2020. Thus, there are eight possible future TWDB water demand scenarios:

- Low Population Series  
Average Per Capita Use Series
  - Without Water Conservation
  - With Water Conservation
- Low Population Series  
High Per Capita Use Series
  - Without Water Conservation
  - With Water Conservation
- High Population Series  
Average Per Capita Use Series
  - Without Water Conservation
  - With Water Conservation



- High Population Series  
High Per Capita Use Series  
Without Water Conservation  
With Water Conservation

TWDB rural and urban per capita water use factors are developed using municipal and WSC reported data, which includes monthly and annual purchased, and/or self-supplied surface and ground water, quantities including the source of purchase water, number of wells, and number of connections (TWDB, 1989a).

### 3.2.1 Cameron County

TWDB High Per Capita Uses Series, which represents potential demand under drought conditions, and LRGVDC future Cameron County water supply demand estimates are in relatively close agreement. Depending on the population growth and conservation scenario selected, the 2020 total municipal water supply demand for the county ranges from approximately 92,000 AF/yr to over 122,000 AF/yr. Average Per Capita Use Series estimates are somewhat less and range from about 80,000 AF/yr to over 110,000 AF/yr.

### 3.2.2 Incorporated/Urban Areas

Estimates of future water supply needs of the City of Brownsville range from a high of 59,600 AF/yr predicted the TWDB High Per Capita Use High Population Growth, without Conservation Series, to a low of 40,639 AF/yr predicted by the TWDB Average Per Capita Use Low Population Growth, with Conservation Series. The R. W. Beck High Series water demand estimate, extrapolated from 2010 to 2020, is approximately 59,000 AF/yr.

Projected year 2020 water supply demands of the City of Harlingen range from nearly 16,000 AF/yr to 25,500 AF/yr depending on the per capita use, population growth rate and conservation scenario selected. San Benito's future water supply requirements range from 5,400 AF/yr to 9,350 AF/yr. Future water supply demands for other cities of Cameron County are shown in Tables 3-7 and 3-8 (Average and High Per Capita Use Series, respectively). Table 3-9 shows projected water requirements that will be used throughout the remainder of this study.

### 3.2.3 Rural Areas and Colonias

Predicted 2020 water supply requirements of rural areas of Cameron County, including colonias, vary significantly depending on population estimates, per capita use factors and conservation scenario used. The LRGVDC projects the highest rural county needs at nearly 15,600 AF/yr while the TWDB average per capita use low population estimate with water conservation scenario projects the lowest demand at 8,700 AF/yr (Figure 3-4). Rural Cameron County and colonias in particular are currently under served by existing

Table 3-7  
Projected Municipal Water Demands  
Average Per Capita Use Series 1990 - 2020

City	TWDB Low Series (Acre-Feet/Year)										TWDB Low Series (Acre-Feet/Year)									
	Without Water Conservation										With Water Conservation									
	1990	1995	2000	2005	2010	2015	2020	1990	1995	2000	2005	2010	2015	2020						
Brownsville	24,982	29,124	33,265	36,673	40,080	43,552	47,023	24,357	27,564	30,771	32,921	35,070	37,520	39,970						
Harlingen	10,996	12,010	13,024	14,359	15,694	17,053	18,412	10,721	11,384	12,047	12,890	13,732	14,692	15,651						
La Feria	649	713	776	856	935	1,016	1,097	632	675	718	768	818	875	932						
Los Fresnos	531	617	702	774	846	920	993	518	584	649	695	740	792	844						
Port Isabel	1,906	2,053	2,199	2,424	2,649	2,879	3,108	1,858	1,946	2,034	2,176	2,318	2,480	2,642						
Rio Hondo	528	589	650	717	783	851	919	515	558	601	643	685	733	781						
San Benito	3,756	4,089	4,421	4,874	5,327	5,789	6,250	3,662	3,876	4,089	4,375	4,661	4,987	5,312						
Santa Rosa	304	337	370	408	446	485	523	296	319	342	366	390	418	445						
Combes	288	327	366	404	441	479	517	281	310	338	362	386	413	439						
Primera	311	353	395	436	476	517	558	303	334	365	391	416	445	474						
Unincorporated	10,633	11,136	11,638	12,386	13,133	13,717	14,300	10,368	10,566	10,764	11,128	11,492	11,824	12,155						
County Total	54,884	61,345	67,806	74,308	80,810	87,255	93,700	53,511	58,115	62,718	66,713	70,708	75,177	79,645						

City	TWDB High Series (Acre-Feet/Year)										TWDB High Series (Acre-Feet/Year)									
	Without Water Conservation										With Water Conservation									
	1990	1995	2000	2005	2010	2015	2020	1990	1995	2000	2005	2010	2015	2020						
Brownsville	25,825	30,609	35,392	39,058	42,723	47,038	51,353	25,179	28,959	32,738	35,060	37,382	40,516	43,650						
Harlingen	11,368	12,613	13,857	15,293	16,728	18,418	20,107	11,083	11,951	12,818	13,728	14,637	15,864	17,091						
La Feria	671	749	826	912	997	1,098	1,198	654	709	764	818	872	945	1,018						
Los Fresnos	549	648	747	825	902	993	1,084	535	613	691	740	789	855	921						
Port Isabel	1,970	2,155	2,339	2,582	2,824	3,109	3,394	1,921	2,043	2,164	2,318	2,471	2,678	2,885						
Rio Hondo	546	619	692	764	835	919	1,003	532	586	640	685	730	792	853						
San Benito	3,883	4,294	4,704	5,191	5,678	6,252	6,825	3,786	4,069	4,351	4,660	4,968	5,385	5,802						
Santa Rosa	314	354	394	435	476	524	572	306	335	364	390	416	451	486						
Combes	298	344	389	430	470	518	565	290	325	360	386	411	446	480						
Primera	321	371	420	464	507	559	610	313	351	389	417	444	481	518						
Unincorporated	10,991	11,686	12,381	13,190	13,998	14,807	15,616	10,717	11,085	11,452	11,850	12,248	12,761	13,273						
County Total	56,736	64,439	72,141	79,140	86,138	94,233	102,327	55,316	61,024	66,731	71,050	75,368	81,173	86,977						

Table 3-8  
Projected Municipal Water Demands  
High Per Capita Use Series 1990 - 2020

City	TWDB Low Series (Acre-Feet/Year)										TWDB Low Series (Acre-Feet/Year)									
	Without Water Conservation										With Water Conservation									
	1990	1995	2000	2005	2010	2015	2020	1990	1995	2000	2005	2010	2015	2020						
Brownsville	28,994	33,801	38,608	42,563	46,518	50,548	54,577	28,269	31,992	35,714	38,209	40,703	43,547	46,390						
Harlingen	13,947	15,233	16,519	18,212	19,904	21,628	23,352	13,598	14,439	15,280	16,348	17,416	18,633	19,849						
La Feria	796	874	952	1,050	1,147	1,247	1,346	776	829	881	943	1,004	1,074	1,144						
Los Fresnos	643	747	850	938	1,025	1,114	1,202	627	707	786	842	897	960	1,022						
Port Isabel	2,611	2,812	3,012	3,321	3,629	3,944	4,258	2,546	2,666	2,786	2,981	3,176	3,398	3,619						
Rio Hondo	723	807	891	982	1,073	1,166	1,258	705	765	824	882	939	1,005	1,070						
San Benito	5,146	5,602	6,057	6,678	7,298	7,930	8,562	5,017	5,310	5,602	5,994	6,386	6,832	7,278						
Santa Rosa	345	383	421	464	507	551	595	337	363	389	417	444	475	506						
Combes	394	448	501	553	604	656	708	385	424	463	496	528	565	602						
Primera	440	508	576	636	695	765	835	415	458	500	535	570	610	650						
Unincorporated	12,212	12,789	13,365	14,224	15,082	15,752	16,422	11,906	12,134	12,362	12,780	13,197	13,578	13,959						
County Total	66,237	73,977	81,717	89,578	97,439	105,242	113,045	64,581	70,084	75,587	80,424	85,260	90,675	96,089						

City	TWDB High Series (Acre-Feet/Year)										TWDB High Series (Acre-Feet/Year)									
	Without Water Conservation										With Water Conservation									
	1990	1995	2000	2005	2010	2015	2020	1990	1995	2000	2005	2010	2015	2020						
Brownsville	29,972	35,525	41,077	45,331	49,584	54,593	59,601	29,223	33,610	37,996	40,691	43,386	47,024	50,661						
Harlingen	14,417	15,996	17,575	19,396	21,216	23,359	25,502	14,057	15,157	16,257	17,411	18,564	20,271	21,977						
La Feria	823	918	1,013	1,118	1,223	1,347	1,470	802	870	937	1,004	1,070	1,160	1,249						
Los Fresnos	665	785	805	999	1,092	1,203	1,313	648	743	837	897	956	1,036	1,116						
Port Isabel	2,699	2,952	3,205	3,537	3,889	4,260	4,650	2,632	2,798	2,964	3,175	3,385	3,669	3,953						
Rio Hondo	748	848	948	1,046	1,144	1,260	1,375	729	803	877	939	1,001	1,085	1,168						
San Benito	5,320	5,882	6,444	7,112	7,779	8,565	9,351	5,187	5,574	5,961	6,384	6,807	7,378	7,948						
Santa Rosa	357	403	448	494	540	595	650	348	381	414	444	473	513	552						
Combes	408	471	533	589	644	709	773	398	446	493	528	563	610	657						
Primera	440	508	576	636	695	765	835	429	481	533	571	608	659	710						
Unincorporated	12,623	13,421	14,218	15,147	16,075	17,005	17,934	12,307	12,730	13,152	13,609	14,066	14,655	15,244						
County Total	68,472	77,707	86,942	95,402	103,861	113,658	123,454	66,760	73,591	80,421	85,650	90,879	97,907	104,935						

Table 3-9  
 Projected Municipal Water Demands  
 1990-2020  
 Plan Development Projections \*  
 (Acre-Foot/Year)

City	1990	1995	2000	2005	2010	2015	2020
Brownsville	29,223	33,610	37,996	40,691	43,386	47,024	50,661
Harlingen	14,057	15,157	16,257	17,411	18,564	20,121	21,677
La Feria	802	870	937	1,004	1,070	1,160	1,249
Los Fresnos	648	743	837	897	956	1,036	1,116
Port Isabel	2,632	2,798	2,964	3,175	3,385	3,669	3,953
Rio Hondo	729	803	877	939	1,001	1,085	1,168
San Benito	5,187	5,574	5,961	6,384	6,807	7,378	7,948
Santa Rosa	348	381	414	444	473	513	552
Combes	398	446	493	528	563	610	657
Primera	429	481	533	571	608	659	710
Unincorporated	12,307	12,730	13,152	13,609	14,066	14,655	15,244
County Total	66,760	73,591	80,421	85,650	90,879	97,907	104,935

\* Projections used in the remainder of this study

**Figure 3-4**  
**Cameron County Rural and Colonia Projections of Municipal Water Demands**  
**High Per Capita Water Use Series**

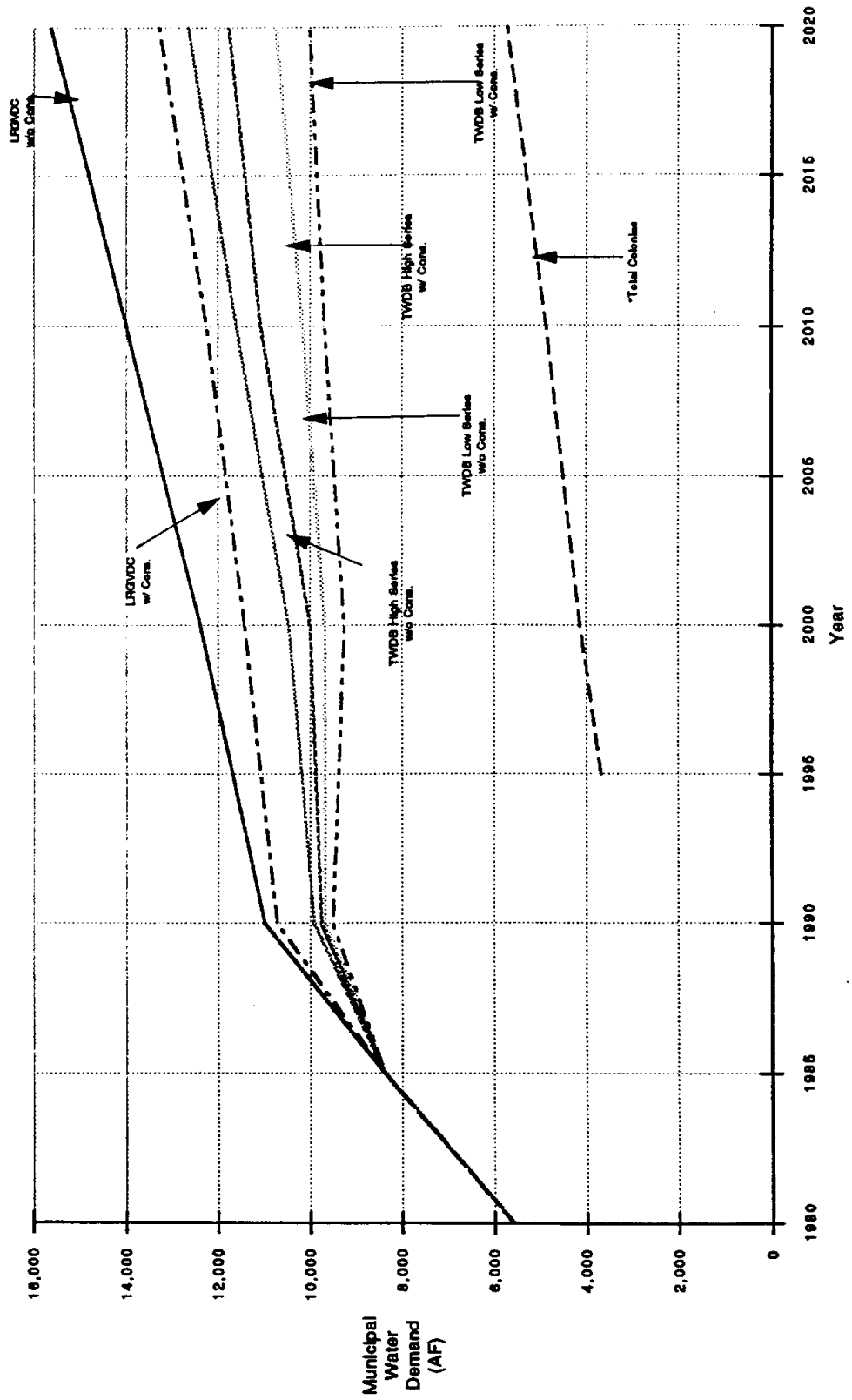

Source: TWDB Records, the LRGVDC

water supplies. Service is currently not available to a large number of residents or is supplies from an out of residence source, which severely limits availability and use.

Water demand in the colonias identified in this report are projected to be approximately 37% of the total water demand for the rural areas of Cameron County. Water demand projections in the colonias are directly related to the population projections discussed earlier. Therefore it is not unexpected to find that over 58% of the total projected year 2020 water demand of over 5 MGD occurs within Sub-area B. Sub-area B is followed in projected demand by Sub-area W (22% of total projected demands), sub-area E (12% of same), and Sub-area H (8% of same). Total water demand for all of the colonias in Cameron County is expected to increase from 3.2 MGD in 1990 to approximately 5.1 MGD in the year 2020. Projected water demand for the colonias in Cameron County is presented in Tables 3-10 and 3-11.

### 3.3 Projected Wastewater Quantities

Wastewater quantities are directly related to water use with wastewater quantities typically ranging from 50 to 75% of water use. Table 3-12 identifies projected wastewater quantities for the urban and rural areas of Cameron County.

#### 3.3.1 Cameron County

Currently, Cameron County residents, commercial users and industries generate a total of 29.2 MGD of wastewater. The projected Cameron County total for the year 2020 is 52.7 MGD or approximately an 80% increase over present levels.

#### 3.3.2 Incorporated/Urban Areas

Table 3-13 provides a synopsis of existing capacities and projected wastewater quantities for various municipalities through the year 2020. The City of Brownsville is expected to double its required treatment capacity between 1990 and 2020. Currently, Brownsville has 12.8 MGD of treatment capacity (7.8 MGD at the Southside Plant and 5.0 MGD at the Robinsdale Plant). However, an additional 5.0 MGD of capacity is planned for the Robinsdale Plant, which will provide a total of 17.8 MGD to the city. Even with this additional capacity, it appears that Brownsville's wastewater generation will exceed existing treatment capacities before the year 2000.

The City of Harlingen's current rate of wastewater generation, 6.4 MGD, already stretches its existing treatment capacity of 6.6 MGD. By the year 2020, Harlingen will need to construct at least 5.0 MGD of additional treatment capacity to accommodate the City's projected growth.

In 1990, San Benito's projected wastewater flows will exceed existing treatment capacities by 0.3 MGD. San Benito will require a total of 4.2 MGD to carry projected loads through the year 2020.

Table 3-10  
Water Demand Projections For Colonias by Sub-Areas  
Average Daily (Gallons per Day)

Colonia No.	Colonia Name	YEAR					
		1995	2000	2005	2010	2015	2020
1B	Cameron Park 1	547,250	633,500	698,375	763,125	839,250	915,875
2B	Olmito	263,750	305,375	336,625	367,875	404,625	441,500
3B	Stuart Subd.	146,750	170,000	187,375	204,750	225,125	245,000
4B	San Pedro/Carmen/Barrera Gd	108,250	125,375	138,250	151,000	166,125	181,250
5B	King Subd.	94,500	109,375	120,625	131,750	144,875	158,125
6B	Alabama/Arkansas (La Coma)	76,250	88,375	97,375	106,375	117,000	127,750
7B	Hacienda Gardens	70,500	81,625	90,000	98,250	108,125	118,000
8B	Villa Nueva	59,625	69,000	76,000	83,125	91,375	99,750
9B	Villa Pancho	45,000	52,125	57,500	62,875	69,125	75,375
10B	Pleasant Meadows	43,625	50,500	55,625	60,750	66,875	73,000
11B	Villa Cavazos	29,750	34,500	38,000	41,500	45,750	49,875
12B	Barrio Subd.	29,125	33,625	37,125	40,500	44,625	48,625
13B	Las Cuates	28,375	32,750	36,125	39,500	43,500	47,375
14B	Saldivar	22,500	26,125	28,750	31,375	34,500	37,750
15B	Coronado	22,500	26,125	28,750	31,375	34,500	37,750
16B	Unknown	21,125	24,375	26,875	29,375	32,375	35,250
17B	Saldivar (II)	20,375	23,500	26,000	28,375	31,250	34,000
18B	Valle Escondido	20,375	23,500	26,000	28,375	31,250	34,000
19B	Unnamed C	19,625	22,750	25,000	27,375	30,125	32,875
20B	Unnamed D (Keller's Corner)	18,125	21,000	23,125	25,375	27,875	30,375
21B	Texas 4	18,125	21,000	23,125	25,375	27,875	30,375
22B	511 Crossroads	18,125	21,000	23,125	25,375	27,875	30,375
23B	Illinois Heights	15,250	17,625	19,500	21,250	23,375	25,500
24B	Unknown (Brownsville Airport)	14,500	16,875	18,500	20,250	22,250	24,375
25B	Valle Hermosa	9,500	10,875	12,000	13,125	14,500	15,750
26B	Unknown	8,750	10,125	11,125	12,125	13,375	14,625
27B	Unnamed B (HWY 802)	7,250	8,375	9,250	10,125	11,125	12,125
28B	21	6,500	7,625	8,375	9,125	10,000	11,000
TOTALS		1,785,375	2,067,000	2,278,500	2,489,750	2,738,625	2,987,625

Colonia No.	Colonia Name	YEAR					
		1995	2000	2005	2010	2015	2020
1E	La Coma Del Norte	87,500	89,875	94,750	99,625	104,000	108,500
2E	Lozano	68,625	70,500	74,250	78,125	81,500	85,000
3E	La Tina Ranch	66,750	68,500	72,250	76,000	79,250	82,750
4E	Laureles	38,375	39,375	41,625	43,750	45,625	47,625
5E	Del Mar Heights	36,250	41,750	46,125	50,375	55,375	60,375
6E	Orason Ac/Chula Vista/Shoe.	34,750	40,125	44,250	48,375	53,125	58,000
7E	Las Yescas	28,375	29,125	30,625	32,250	33,625	35,125
8E	Unknown	26,500	27,125	28,625	30,125	31,375	32,750
9E	Glenwood Acres Sub.	22,000	22,625	23,875	25,125	26,125	27,250
10E	Unknown (Del Mar II)	21,750	25,125	27,625	30,250	33,250	36,250
11E	Los Cuates	19,500	22,500	24,875	27,250	29,875	32,625
12E	25	7,500	7,750	8,125	8,625	9,000	9,375
13E	Cisneros (Limon)	6,250	6,500	6,875	7,125	7,500	7,750
TOTALS		464,125	490,875	523,875	557,000	589,625	623,375

Table 3-10  
 Water Demand Projections For Colonias by Sub-Areas  
 Average Daily (Gallons per Day)

(continued)

Colonia No.	Colonia Name	YEAR					
		1995	2000	2005	2010	2015	2020
1H	Las Palmas	86,500	95,375	105,125	114,875	126,250	137,875
2H	Lago Subd.	54,500	60,000	66,250	72,375	79,625	86,875
3H	26	39,500	43,500	48,000	52,500	57,625	63,000
4H	Lasana	19,125	21,000	23,125	25,375	27,875	30,375
5H	Rice Tracts	18,375	20,250	22,375	24,375	26,875	29,250
6H	Leal Subd. (Metes & Bounds)	17,000	18,750	20,750	22,625	24,875	27,125
7H	Laguna Escondido Heights	750	8,250	9,125	10,000	11,000	11,875
TOTALS		235,750	267,125	294,750	322,125	354,125	386,375

Colonia No.	Colonia Name	YEAR					
		1995	2000	2005	2010	2015	2020
1W	Encantada	165,625	170,000	179,250	188,500	196,750	205,125
2W	Santa Maria	172,250	199,375	219,750	240,250	264,125	288,250
3W	La Paloma	86,875	89,250	94,000	98,875	103,250	107,625
4W	Los Indios	70,500	72,375	76,375	80,250	83,750	87,375
5W	Bluetown	58,500	60,125	63,375	66,625	69,625	72,500
6W	T2 Unknown Subd.	43,500	44,625	47,000	49,500	51,625	53,875
7W	El Venadito	29,000	29,750	31,375	33,000	34,375	35,875
8W	Carmitos-Londrum	27,750	28,500	30,000	31,500	32,875	34,375
9W	El Calaboz	26,875	31,125	34,375	37,500	41,250	45,000
10W	Iglesia Antigua	20,750	21,375	22,500	23,625	24,750	25,750
11W	Palmer	22,375	24,625	27,125	29,625	32,625	35,625
12W	Unknown (mitta 2)	17,000	17,500	18,375	19,375	20,250	21,125
13W	Q Unknown Subd. (Santa Rosa)	18,750	20,875	23,000	25,125	27,625	30,125
14W	W	13,875	14,250	15,000	15,750	16,500	17,125
15W	R Unknown Subd. (S.Santa Rosa)	15,250	17,000	18,750	20,500	22,500	24,500
16W	X Unknown Subd. (Santa Feria)	9,000	10,000	11,125	12,125	13,250	14,500
17W	S	9,000	10,000	11,125	12,125	13,250	14,500
TOTALS		806,875	860,750	922,500	984,250	1,048,375	1,113,250



**Table 3-11**  
**Total Water Demand Projections for Colonias by Sub-Areas**  
**Average Daily (Gallons/Day)**

Name	1995	% of Total	2000	% of Total	2005	% of Total	2010	% of Total	2015	% of Total	2020	% of Total
Sub-Area B	1,785,375	54.23%	2,067,000	56.08%	2,278,500	56.68%	2,489,750	57.19%	2,738,625	57.89%	2,987,625	58.46%
Sub-Area E	464,125	14.10%	490,875	13.32%	523,875	13.03%	557,000	12.80%	599,625	12.46%	623,375	12.20%
Sub-Area H	235,750	7.16%	267,125	7.25%	294,750	7.33%	322,125	7.40%	354,125	7.49%	386,375	7.56%
Sub-Area W	806,875	24.51%	860,750	23.35%	922,500	22.95%	984,250	22.61%	1,048,375	22.16%	1,113,250	21.78%
<b>TOTALS</b>	<b>3,292,125</b>	<b>100.00%</b>	<b>3,685,750</b>	<b>100.00%</b>	<b>4,019,625</b>	<b>100.00%</b>	<b>4,353,125</b>	<b>100.00%</b>	<b>4,730,750</b>	<b>100.00%</b>	<b>5,110,625</b>	<b>100.00%</b>

Sub-Area B Brownsville ETJ  
 Sub-Area E Eastern Cameron County  
 Sub-Area H Harlingen ETJ  
 Sub-Area W Western Cameron County

**Table 3-12  
Projected Wastewater Treatment Requirements of Cameron County (1990-2020)  
(Millions of Gallons Per Day)**

Area	1990	1995	2000	2005	2010	2015	2020
Cameron Co.	29.2	33.1	37.1	40.7	44.4	48.6	52.7
Brownsville	13.3	15.8	18.3	20.2	22.1	24.4	26.6
Harlingen	6.4	7.1	7.8	8.6	9.5	10.4	11.4
San Benito	2.4	2.6	2.9	3.2	3.5	3.8	4.2
La Feria	0.4	0.4	0.5	0.5	0.5	0.6	0.7
Los Fresnos	0.3	0.3	0.4	0.4	0.5	0.5	0.6
Port Isabel	1.2	1.3	1.4	1.6	1.7	1.9	2.1
Rio Hondo	0.3	0.4	0.4	0.5	0.5	0.6	0.6
Santa Rosa	0.2	0.2	0.2	0.2	0.2	0.3	0.3
Combes	0.2	0.2	0.2	0.3	0.3	0.3	0.3
Primera	0.2	0.2	0.3	0.3	0.3	0.3	0.4
Unincorporated	4.4	4.5	4.7	4.9	5.2	5.4	5.6

Los Fresnos does not appear to need additional wastewater treatment capacity within the planning period unless services is extended to unincorporated areas outside its current ETJ. Currently Los Fresnos uses approximately half of its 0.59 MGD constructed capacity.

Rio Hondo's wastewater generation will exceed existing treatment capacity in 1995 Rio Hondo will need an additional 0.20 to 0.22 MGD of treatment capacity to carry it through the planning horizon without extension of service to outlying unincorporated areas.

The City of Primera is expected to double its current generation of nearly 0.20 MGD within the planning horizon. The source of that additional capacity could come from self supplies or provided through connections to Harlingen, Combes or Palm Valley.

La Feria has sufficient wastewater treatment capacity through the year 2000. Beyond that, the City will need to develop an additional 0.20 MGD of wastewater treatment capacity to accommodate growth within its current ETJ.

Cameron County Fresh Water Supply District No. 1 supplies wastewater treatment to the Cities of Port Isabel, South Padre and Laguna Vista. The Port Isabel Plant currently has sufficient capacity to serve the city through approximately the year 2003. South Padre, however, is experiencing an uneven distribution of flow which results in severe overloading of the Isla Blanca Facility and under-utilization of the Andy

**Table 3-4  
 Total Population Projections for Colonias by Sub-Areas**

Name	1995	% of Total	2000	% of Total	2005	% of Total	2010	% of Total	2015	% of Total	2020	% of Total
Sub-Area B	14,283	54.12%	16,536	56.06%	18,228	56.68%	19,918	57.19%	21,909	57.89%	23,901	58.46%
Sub-Area E	3,713	14.07%	3,927	13.32%	4,191	13.03%	4,456	12.80%	4,717	12.46%	4,987	12.20%
Sub-Area H	1,940	7.35%	2,137	7.25%	2,358	7.33%	2,577	7.40%	2,833	7.49%	3,091	7.56%
Sub-Area W	6,455	24.46%	6,886	23.95%	7,380	22.95%	7,874	22.61%	8,387	22.15%	8,906	21.78%
<b>TOTALS</b>	<b>26,391</b>	<b>100.00%</b>	<b>29,486</b>	<b>100.00%</b>	<b>32,157</b>	<b>100.00%</b>	<b>34,825</b>	<b>100.00%</b>	<b>37,848</b>	<b>100.00%</b>	<b>40,895</b>	<b>100.00%</b>

Sub-Area B Brownsville ETJ  
 Sub-Area E Eastern Cameron County  
 Sub-Area H Harlingen ETJ  
 Sub-Area W Western Cameron County

Bowie Plant. Corrective measures are currently underway to solve this problem. In addition, Cameron County Fresh Water Supply District No. 1 is contemplating construction of a new facility at Laguna Vista. In general, the Laguna Madre portion of Cameron County is well served and should not be short of service through the planning horizon.

Santa Rosa is not expected to use all of its constructed wastewater treatment capacity through the year 2020 and would provide a possible treatment option to surrounding areas not currently served.

Combes will require an additional 0.10 MGD between the years 2000 and 2020.

### 3.3.3 Rural Areas and Colonias

The TWDB projects an increase of approximately 27% (4.4 to 5.6 MGD) in wastewater quantities in the rural areas of Cameron County between the years 1990 through 2020. Approximately 73% of the 2020 flow is expected to occur in the colonias identified in this report. Again wastewater, like water, is a direct function of population and per capita use, thus it is not surprising to find the unincorporated areas of the Brownsville sub-area with the highest projected quantity of wastewater (2.39 MGD in 2020), followed by the unincorporated west (.89 MGD in 2020), unincorporated east (.49 MGD in 2020) and the unincorporated areas in the Harlingen sub-area (.30 MGD in 2020). Projected wastewater quantities for each of the colonias are presented in Tables 3-14 and 3-15. These figures, coupled with projected water demand provide the basis for developing the remainder of this plan.

Table 3-14  
**Wastewater Projections For Colonias by Sub-Areas**  
**Average Daily Flow (Gallons/Day)**

Colonia No.	Colonia Name	YEAR					
		1995	2000	2005	2010	2015	2020
1B	Cameron Park 1	437,800	506,800	558,700	610,500	671,400	732,700
2B	Olmito	211,000	244,300	269,300	294,300	323,700	353,200
3B	Stuart Subd.	117,400	136,000	149,900	163,800	180,100	196,000
4B	San Pedro/Carmen/Barrera Gd	86,600	100,300	110,600	120,800	132,900	145,000
5B	King Subd.	75,600	87,500	96,500	105,400	115,900	126,500
6B	Alabama/Arkansas (La Coma)	61,000	70,700	77,900	85,100	93,600	102,200
7B	Hacienda Gardens	56,400	65,300	72,000	78,600	86,500	94,400
8B	Villa Nueva	47,700	55,200	60,800	66,500	73,100	79,800
9B	Villa Pancho	36,000	41,700	46,000	50,300	55,300	60,300
10B	Pleasant Meadows	34,900	40,400	44,500	48,600	53,500	58,400
11B	Villa Cavazos	23,800	27,600	30,400	33,200	36,600	39,900
12B	Barrio Subd.	23,300	26,900	29,700	32,400	35,700	38,900
13B	Las Cuates	22,700	26,200	28,900	31,600	34,800	37,900
14B	Saldivar	18,000	20,900	23,000	25,100	27,600	30,200
15B	Coronado	18,000	20,900	23,000	25,100	27,600	30,200
16B	Unknown	16,900	19,500	21,500	23,500	25,900	28,200
17B	Saldivar (II)	16,300	18,800	20,800	22,700	25,000	27,200
18B	Valle Escondido	16,300	18,800	20,800	22,700	25,000	27,200
19B	Unnamed C	15,700	18,200	20,000	21,900	24,100	26,300
20B	Unnamed D (Keller's Corner)	14,500	16,800	18,500	20,300	22,300	24,300
21B	Texas 4	14,500	16,800	18,500	20,300	22,300	24,300
22B	511 Crossroads	14,500	16,800	18,500	20,300	22,300	24,300
23B	Illinois Heights	12,200	14,100	15,600	17,000	18,700	20,400
24B	Unknown (Brownsville Airport)	11,600	13,500	14,800	16,200	17,800	19,500
25B	Valle Hermosa	7,600	8,700	9,600	10,500	11,600	12,600
26B	Unknown	7,000	8,100	8,900	9,700	10,700	11,700
27B	Unnamed B (HWY 802)	5,800	6,700	7,400	8,100	8,900	9,700
28B	21	5,200	6,100	6,700	7,300	8,000	8,800
<b>TOTALS</b>		<b>1,428,300</b>	<b>1,853,600</b>	<b>1,822,800</b>	<b>1,991,800</b>	<b>2,190,900</b>	<b>2,390,100</b>

Colonia No.	Colonia Name	YEAR					
		1995	2000	2005	2010	2015	2020
1E	La Coma Del Norte	70,000	71,900	75,800	79,700	83,200	86,800
2E	Lozano	54,900	56,400	59,400	62,500	65,200	68,000
3E	La Tina Ranch	53,400	54,800	57,800	60,800	63,400	66,200
4E	Laureles	30,700	31,500	33,300	35,000	36,500	38,100
5E	Del Mar Heights	29,000	33,400	36,900	40,300	44,300	48,300
6E	Orason Ac/Chula Vista/Shoe.	27,800	32,100	35,400	38,700	42,500	46,400
7E	Las Yescas	22,700	23,300	24,500	25,800	26,900	28,100
8E	Unknown	21,200	2,170	22,900	24,100	25,100	26,200
9E	Glenwood Acres Sub.	17,600	18,100	19,100	20,100	20,900	21,800
10E	Unknown (Del Mar II)	17,400	20,100	22,100	24,200	26,600	29,000
11E	Los Cuates	15,600	18,000	19,900	21,800	23,900	26,100
12E	25	6,000	6,200	6,500	6,900	7,200	7,500
13E	Cisneros (Limon)	5,000	5,200	5,500	5,700	6,000	6,200
<b>TOTALS</b>		<b>371,300</b>	<b>373,170</b>	<b>419,100</b>	<b>445,600</b>	<b>471,700</b>	<b>498,700</b>

Table 3-14  
**Wastewater Projections For Colonias by Sub-Areas**  
**Average Daily Flow (Gallons/Day)**

(continued)

Colonia No.	Colonia Name	YEAR					
		1995	2000	2005	2010	2015	2020
1H	Las Palmas	69,200	76,300	84,100	91,900	101,000	110,300
2H	Lago Subd.	43,600	48,000	53,000	57,900	63,700	69,500
3H	26	31,600	34,800	38,400	42,000	46,100	50,400
4H	Lasana	15,300	16,800	18,500	20,300	22,300	24,300
5H	Rice Tracts	14,700	16,200	17,900	19,500	21,500	23,400
6H	Leal Subd. (Metes & Bounds)	13,600	15,000	16,600	18,100	19,900	21,700
7H	Laguna Escondido Heights	6,000	6,600	7,300	8,000	8,800	9,500
<b>TOTALS</b>		<b>194,000</b>	<b>213,700</b>	<b>235,800</b>	<b>257,700</b>	<b>283,300</b>	<b>309,100</b>

Colonia No.	Colonia Name	YEAR					
		1995	2000	2005	2010	2015	2020
1W	Encantada	137,800	159,500	175,800	192,200	211,300	230,600
2W	Santa Maria	132,500	136,000	143,400	150,800	157,400	164,100
3W	La Paloma	69,500	71,400	75,200	79,100	82,600	86,100
4W	Los Indios	56,400	57,900	61,100	64,200	67,000	69,900
5W	Bluetown	46,800	48,100	50,700	53,300	55,700	58,000
6W	T2 Unknown Subd.	34,800	35,700	37,600	39,600	41,300	43,100
7W	El Venadito	23,200	24,900	27,500	30,000	33,000	36,000
8W	Carricitos-Londrum	22,200	23,800	25,100	26,400	27,500	28,700
9W	El Calaboz	21,500	22,800	24,000	25,200	26,300	28,500
10W	Iglesia Antigua	17,900	19,700	21,700	23,700	26,100	27,500
11W	Palmer	16,600	17,100	18,400	20,100	22,100	24,100
12W	Unknown (mitla 2)	15,000	16,700	18,000	18,900	19,800	20,600
13W	Q Unknown Subd. (Santa Rosa)	13,600	14,000	15,000	16,400	18,000	19,600
14W	W	12,200	13,600	14,700	15,500	16,200	16,900
15W	R Unknown Subd. (S.Santa Rosa)	11,100	11,400	12,000	12,600	13,200	13,700
16W	X Unknown Subd. (Santa Feria)	7,200	8,000	8,900	9,700	10,600	11,600
17W	S	7,200	8,000	8,900	9,700	10,600	11,600
<b>TOTALS</b>		<b>645,500</b>	<b>688,600</b>	<b>738,000</b>	<b>787,400</b>	<b>838,700</b>	<b>890,600</b>

**Table 3-15**  
**Total Wastewater Projections for Colonias by Sub-Areas**  
**Average Daily (Gallons/Day)**

Name	1995	% of Total	2000	% of Total	2005	% of Total	2010	% of Total	2015	% of Total	2020	% of Total
Sub-Area B	1,428,300	54.12%	1,653,600	56.45%	1,822,800	56.68%	1,991,800	57.19%	2,190,900	57.89%	2,390,100	58.46%
Sub-Area E	371,300	14.07%	373,170	12.74%	419,100	13.03%	445,600	12.80%	471,700	12.46%	498,700	12.20%
Sub-Area H	194,000	7.35%	213,700	7.30%	235,800	7.33%	257,700	7.40%	283,300	7.49%	309,100	7.56%
Sub-Area W	645,500	24.46%	688,600	23.51%	738,000	22.95%	787,400	22.61%	838,700	22.16%	890,600	21.78%
<b>TOTALS</b>	<b>2,639,100</b>	<b>100.00%</b>	<b>2,929,070</b>	<b>100.00%</b>	<b>3,235,700</b>	<b>100.00%</b>	<b>3,482,500</b>	<b>100.00%</b>	<b>3,784,600</b>	<b>100.00%</b>	<b>4,088,500</b>	<b>100.00%</b>

Sub-Area B Brownville ETJ  
 Sub-Area E Eastern Cameron County  
 Sub-Area H Harlingen ETJ  
 Sub-Area W Western Cameron County

## **4.0 FUTURE WATER SUPPLY, TREATMENT AND DISTRIBUTION OPTIONS**

### **4.1 Identification of Potential Water Supply Options**

A shortage of adequate water supplies to meet the future domestic, municipal and industrial water needs of Cameron County will occur, if existing water supplies are not augmented or developed. The TWDB (1990) projects that by the year 2040 municipal water requirements will double those currently being experienced in the study area.

In order to solve future water supply problems, it will be necessary to increase the available supplies and/or reduce demand by increasing water use efficiency through water conservation. Techniques to increase supplies include development of new sources, recycling and reuse of some existing supplies and increased efficiency in water use and distribution.

Therefore, potential water supply alternatives for the study area (Cameron County) can be grouped into two categories: (1) those sources which are capable of increasing the firm annual water supplies; and (2) those which can augment existing supplies during times of drought. For the study area, these two categories include the following specific projects and programs:

- Rio Grande Valley Water Conservation Project;
- Development of Ground Water Resources;
- Desalinization;
- Purchase and Reallocation of Existing Agricultural Rights;
- Importation from Other River Basins;
- Reduction in Water Conveyance and Distribution Losses;
- Wastewater Reuse; and
- Water Conservation.

Each of these water supply alternatives are discussed in the following subsections.

#### **4.1.1 Rio Grande Valley Water Conservation Project**

The Rio Grande Valley Water Conservation Project (RGVWC Project) is a major water development effort being sponsored by the Rio Grande Valley Municipal Water Authority (RGVMWA) and the PUB. This project is currently being considered by the TWC for permitting and water appropriation.

The proposed RGVWC Project is comprised of two principal elements which, either individually or in combination, can be operated to effectively increase the available water supply in the Lower Rio Grande Valley. The first element involves the use of the United States' share of the existing conservation storage in Anzalduas Reservoir. This will not require any structural changes or modifications to the existing Anzalduas Dam. Operation of Anzalduas Reservoir began in 1960 as a joint effort of the United States and Mexico for flood control and water supply purposes. Over 80 percent of the United States' share of floodwater below Falcon Dam is diverted to the United States Interior Floodway by Anzalduas Dam. This



facility also provides for the diversion of water from the Rio Grande into Mexico's Anzalduas Irrigation Canal. Anzalduas Dam is located upstream of 95 percent of all United States diverters and, therefore, serves as a streamflow measuring point for the division of waters between the two countries. Anzalduas Reservoir has a total storage capacity of approximately 15,003 acre-feet of water. The ownership of this storage is divided between the United States and Mexico. The International Boundary and Water Commission (IBWC) has indicated that the United States has 4,214 acre-feet of conservation storage capacity in Anzalduas Reservoir, which may be available for use to Valley sponsors. It is proposed that the United States storage capacity be used as a reregulation and water conservation facility.

The second element of the RGVWC Project involves the construction of the proposed Brownsville Weir and Reservoir on the mainstream of the Rio Grande just downstream of Brownsville, Texas. This reservoir will provide for both the impoundment and reregulation of flows in the Lower Rio Grande. Like Anzalduas Reservoir, its entire pool will be contained within the existing banks of the Rio Grande. At its maximum pool elevations, the Brownsville Weir will impound approximately 6,000 acre-feet of water with a surface area of about 600 acres.

Either of the Project elements can be implemented without the other, but maximum water conservation can only be accomplished by developing both facilities. In concept, the Anzalduas and Brownsville pools will be operated as a system with International Falcon Reservoir and International Amistad Reservoir.

The proposed RGVWC Project would significantly improve the "mechanical efficiency" of the existing water delivery system operation and can conserve substantial quantities of water (Rauschuber, 1989).

This would be accomplished by:

- Re-regulating and controlling water released from Falcon Reservoir;
- Decreasing the travel time from control point to diverter, thereby decreasing the potential for unforecasted demand and pumpage reductions;
- Supplying diverter demands from "local" storage reservoirs; and,
- Capturing and conserving surface runoff and other river gains below Falcon Dam.

It is projected that if both Project elements were in place, an additional 205,000 acre-feet of water could be developed annually from the Rio Grande (Rauschuber, 1989). If this project is constructed, the PUB will receive at least 40 percent of its dependable supply. The remaining dependable supply will be available for use by the participating members of the RGVWMA, which includes political subdivisions in Cameron County.

The current projected cost of the RGVWC Project is \$30 million. If only 50% of the Project's firm annual yield could be permitted and used by water suppliers in the Lower Rio Grande Valley, the cost of raw water

developed to yield 10,800 acre-feet per year (9.64 MGD), at an annual cost to the PUB of \$1.38 million. This results in a cost of \$0.39 per 1,000 gallons, assuming no additional conveyance or treatment cost.

#### 4.1.3 Desalinization

The conversion of brackish and saline water to potable water can produce additional fresh water to meet future demands in Cameron County. Desalting is currently being utilized to a limited extent in Texas to produce fresh water, primarily for industrial boiler feedwater and for municipal purposes. Desalinization of water is not a new process or idea. Urban development in coastal areas with little available fresh water have increased the demand for affordable desalinization technologies for public water supplies. Additionally, the need for "ultra pure" water for industrial and medical use spawned development of improved water treatment facilities. The demand from power plants, computer chip manufactures, and the food and drink industry furthered the development of membrane technologies that have been adapted for public water treatment.

Membranes are available that can be used for the entire treatment range. Currently, membrane elements are specifically manufactured for standard pressure (400 psi) and low pressure (250 psi) treatment. Generally, low pressure technology is applied to brackish waters with a TDS less than 3,500 mg/L. Some systems use high pressure (300-1,000 psi) applicators to treat water having a TDS of 7,000 mg/L or greater, including seawater.

Membrane softening technology operates at 50 to 150 psi and provides a significant reduction in hardness, with a moderate reduction in TDS. It is applicable to waters with a TDS of 2,000 mg/L or lower. Ultrafiltration (UF) membranes have been used to treat organic constituents in water. Ultrafiltration is a macromolecular separation process which has proven to be effective for the removal of precursors associated with trihalomethane forming potential (THMFP), color and total organic carbon (TOC). Nanofiltration (NF) and ultrafiltration (UF) techniques provides a technology for use in designing facilities that can meet the ever changing drinking water regulations and standards. These processes are among the better available technologies for achieving both present and future water quality treatment goals.

In newer systems and applications, engineers and manufacturers are working together to improve production capabilities for available site specific water resources. Membrane selection is evaluated in consonance with membrane characteristics, operating pressures, volumes of water rejected, and waste disposal considerations to optimize the design and afford the best treatment possible. Included in the objectives may be organic contaminant and/or precursor removal, color reduction, softening or lowering of TDS.

Membrane technology treatment has been applied on shallow ground waters having high color intensity similar to surface waters. These shallow supplies may also have high THMFP, and serious considerations must be given to removal of these precursors and other organic contaminants. Studies on surface and shallow resources have documented that UF membranes will reduce the color and other organic constituents to acceptable standards. These membranes have a higher porosity (flux) than standard RO or softening membranes and operate between 50 to 100 psi pressures depending on optimized conditions for a given UF membrane and a specific water resource. Use of UF treatment for these higher organic resources looks very promising. With the increased concerns for trace organics under the Safe Drinking Water Act (SDWA) amendments, membranes are also being evaluated to improve potable water quality.

The cost of these processes is considered to be high, since they are energy intensive. RO is often considered after all other treatment possibilities have been exhausted. The fact that operating cost for the original seawater RO units was at least five times greater than standard pressure brackish water systems (400 psi) probably led to the conclusion that membrane technology was not cost-effective. However, by tailoring membranes to the specific water treatment needs, design and operating cost can be greatly reduced.

The capital and O&M costs for treating brackish water with membrane softening and low pressure RO are shown in Figures 4-1 and 4-2 respectively. Treating ground water developed from the Gulf Coast aquifer or the Lower Rio Grande Valley aquifer that has a TDS concentration of 3,000 mg/L could be accomplished using low pressure RO. A plant to treat 10,000 acre-feet of water per year (8.9 mgd) would cost approximately \$8.72 million dollars (see Figure 4-1). This results in a capital cost of \$0.16 per 1,000 gallons. O&M cost for this scenario will be about \$0.65 per 1,000 gallons at the plant (see Figure 4-2), excluding transmission and brine disposal costs. Therefore, the total projected cost (capital and O&M) of this example is \$0.91 per 1,000 gallons.

By contrast, the PUB reported (R. W. Beck 1988) that the cost of treating brackish water (ground or surface) ranges from approximately \$2,500 to 4,000 per MG (\$2.50 to \$4.00 per 1,000 gallons respectively). The PUB's cost projections did not include conveyance, transmission or brine disposal.

#### 4.1.4 Purchase and Reallocation of Existing Agricultural Rights

As a result of the 1971 Lower Rio Grande Valley Water Case, irrigators and municipalities were assigned specific water allocations to be administered by the TWC. Irrigators were allotted 2.5 acre-feet of water per acre per year, with a lower priority of use than that allotted to municipalities. The irrigation districts that were a party to the suit were given Class A rights. Of the 742,808.6 acres of irrigation use provided for by this suit, 641,221 acres were assigned Class A irrigation rights; the remainder are Class B. As of July 29,

Figure 4- 1  
Capital Cost  
Membrane Softening and Low Pressure RO

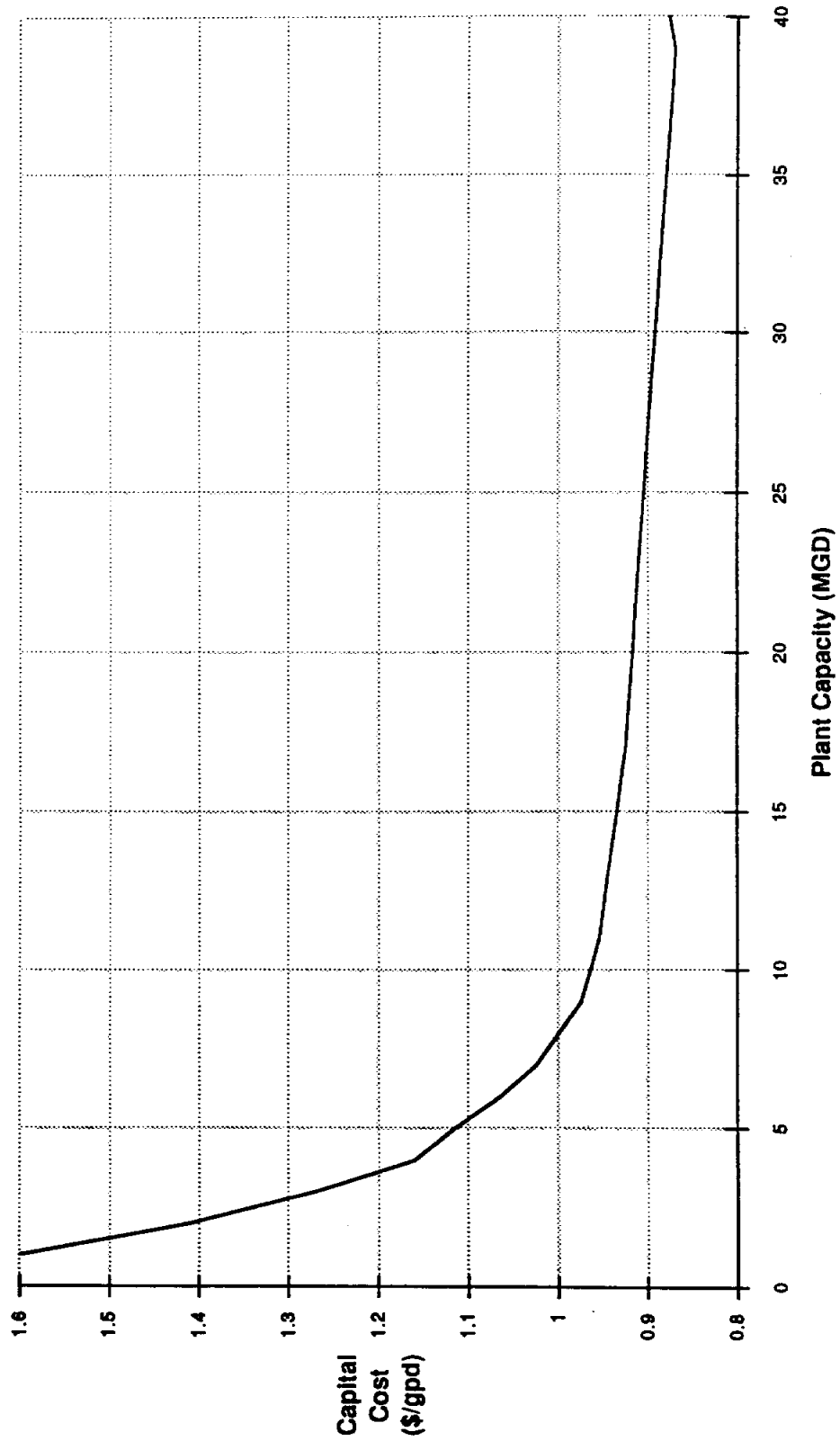
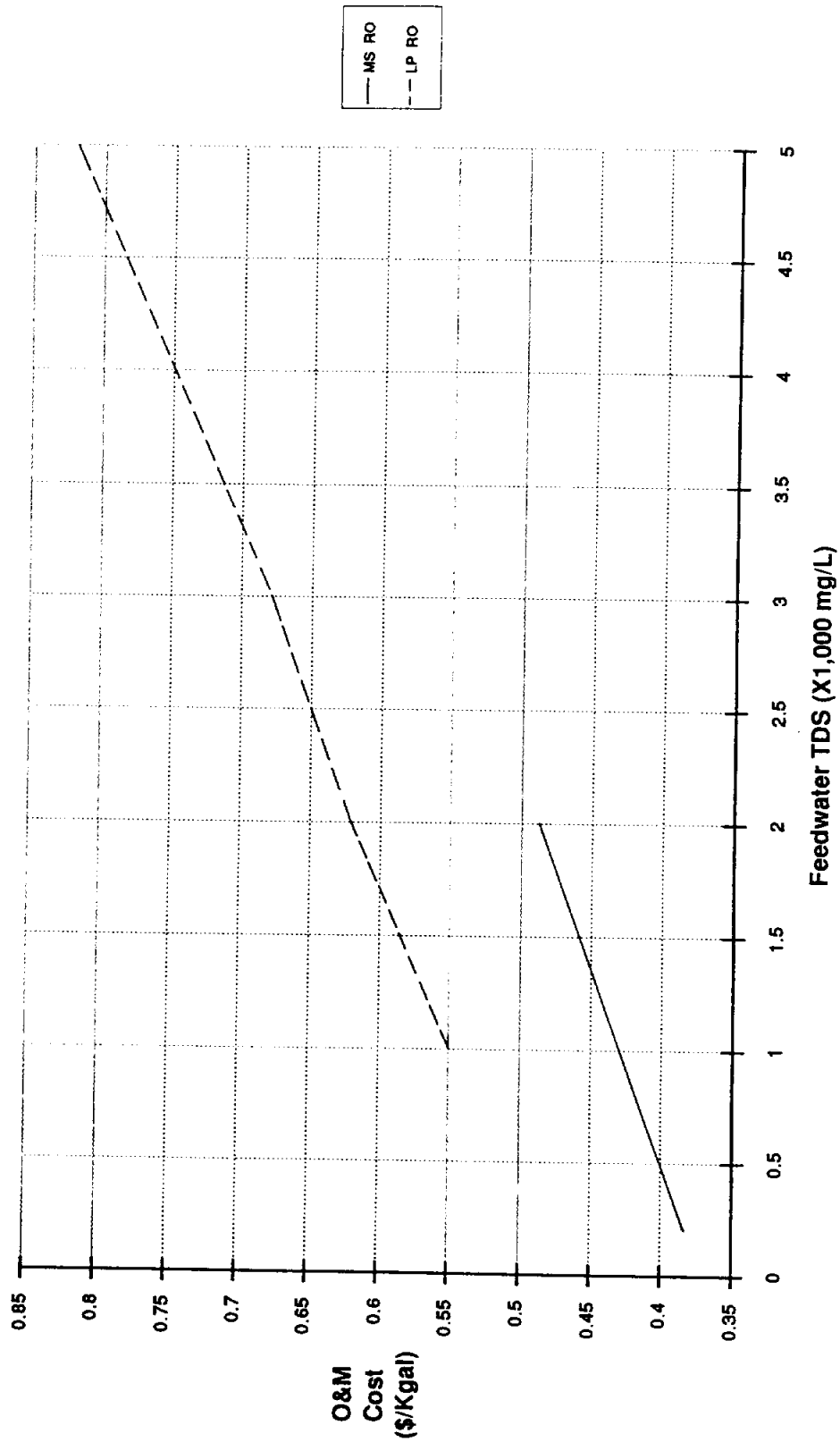

Figure 4-2  
Operating Cost  
Membrane Softening and Low Pressure RO



1986, authorized rights assigned to municipal and domestic use amounted to 174,245 acre-feet, 9 percent of the total amount of water used in the Lower Rio Grande Valley.

Recent population growth in the Valley has resulted in increasing pressure to provide additional municipal water supplies. However, given the Texas Water Commission's (TWC) current method of managing water in the Lower Rio Grande Basin, there is no additional surface water available for allocation to municipal users. In fact, the amount of water already allocated for certain uses may exceed the firm annual yield of the system, as it is presently operated and configured. Because irrigation techniques can be made more efficient and water losses through seepage can be reduced, one solution would be to reallocate this water savings from agricultural to municipal use. Under a program administered by the TWC a market system for reallocating water rights has been established. This system provides for the reallocation of 2.5 acre-feet of agricultural water rights to be converted to 1.25 acre-feet of municipal rights, with a higher priority of use.

Presently, there are many adjudicated water rights holder in the Rio Grande who are not utilizing their full annual allotment of water from the Rio Grande (R. W. Beck, 1988). Entities in Cameron County, such as the PUB and other political subdivisions, could purchased or contracted for these water rights.

The cost of purchasing existing water rights is difficult to project due to market conditions, (available and seniority of rights). The PUB (R. W. Beck, 1988) purchased approximately 2,000 acre-feet of water rights during the 1984-1985 period, for \$1.1 million. This resulted in a cost of \$550 per acre-foot. Assuming an annual inflation rate of 4 to 5 percent per year, this results in a current rate of about \$700 per acre-foot or \$2.14 per 1,000 gallons. However, since an entity who purchases water rights uses this water every year, the true cost amortized over time is only a fraction of this amount. For example, if 10,000 acre-feet of existing and available water rights were purchased at \$700 per acre-foot, the annual amortized cost would be \$0.21 to 1,000 gallons in the river (based on 8.5% annual interest rate for 25 years). This analysis, of course, assumes that water rights are available for purchase.

#### 4.1.5 Importation From Other River Basins

Alternative sources of surface water for municipal and industrial purposes include Lake Texana in the Lavaca River Basin and potential reservoirs in the Guadalupe and San Antonio River Basins. Construction and operating costs of water conveyance and storage systems are extremely high, and would require a state and, possibly, federal effort to implement. Therefore, water importation is not considered feasible herein for implementation on a "local" basis.

#### 4.1.6 Reduction in Water Conveyance and Distribution Losses

An alternative mechanism to more efficiently utilize the existing surface water resources of the Rio Grande would be to eliminate or minimize current conveyance and distribution losses. For example, canal losses

in open channel, delivery systems municipal and irrigation can range, as high as, 45% (R. W. Beck, 1988) Canal losses for irrigation systems of between 25% and 35% are not uncommon in the Rio Grande Valley.

Political subdivisions in California have undertaken an aggressive program to assist agricultural entities in implementing structural implements, such as concrete lining earthen channels, replacing open canals with closed conduit systems, and improving irrigation practices. In these cases, political subdivisions and other municipal water purveyors pay for the improvements in exchange for the water "saved".

A similar type program could be implemented in the Lower Rio Grande Valley. On the average, approximately 850,000 acre-feet per year is used by Valley irrigators. If 25% of this water could be saved through improvements to irrigation conveyance systems, this would yield an additional 212,500 acre-feet of water per year for municipal, industrial and other uses.

Similarly, treated water losses in municipal and other public/private water distribution systems are reported (TDH, R. W. Beck 1988) to be as high as 25%. Acceptable water distribution losses (TWC, TDH) should be in the 10% to 15% range.

Performing a cost evaluation for this water saving alternatives is beyond the scope of this study. However, it is recommended that these alternatives be investigated further by local and state entities, since a significant amount of water can be developed.

#### 4.1.7 Wastewater Reuse

The reuse of grey water or treated effluent has significant potential for extending water supplies to the users of Cameron County. Currently, municipal entities alone in Cameron County collectively discharge about 32,700 acre-feet per year. This is projected to increase to 59,020 acre-feet per year by 2020, within the county. There are no known entities within Cameron County that are extensively reusing treated wastewater effluent.

The opportunities for reuse are extensive. Even with modest conventional reuse practices of 12.5% (state-wide average), another 4,088 acre-feet of water could be made available for use today within Cameron County. Wastewater reuse, without going through the water rights process, is permitted as long as the use is the same as that specified in the water right. The wastewater once discharged into a public water course cannot be sold, traded or converted to another use without going through the permitting process. However, the possibility of trading or selling wastewater to adjacent irrigation districts should not be excluded. The main applications are to municipal parks, golf courses and cropland where the crop is harvested. Direct consumption of reused water is prohibited, as is its use on crops that are directly consumed by humans. There are also some industrial uses for treated wastewater.

#### 4.1.8 Water Conservation

The more efficient use of water is essential, if Cameron County residents are to have adequate, clean and affordable water in the future. The total dependable annual yield (municipal water rights) of surface water resources in Cameron County is 93,410 acre-feet. The potential benefit of water conservation, in the municipal and domestic sector alone, is significant. With a targeted savings goal of only 15 percent by the year 2020, 14,000 acre-feet per year could be realized.

Municipal (residential, commercial, domestic, and institutional) water use in Texas currently averages 165 gallons per person per day (TWDB, 1990). However, a significant portion of this water is lost or wasted. On a statewide basis, utilities generally cannot account for 15 to 20 percent of the water it treats and distributes. It is estimated that one-half of this loss is from leaks in distribution systems.

Many times, municipal water customers waste water. Seasonal hot-weather peak water use averages about 1.0 to 2.0 times based winter usage rates. The TWDB (1990) estimates that about one-half of the water used for landscape irrigation during hot weather periods is wasted.

Inside a home with indoor plumbing, about three-quarters of all water use occurs in the bathroom. In office buildings, schools and public buildings, toilet flushing is a major water use. There are toilets available on the market that use only 25% to 50% of water per flush for toilets commonly in use today.

A proposed water conservation plan for the CCWDB and other water purveyors in Cameron County is presented in Section 6.0 of this report. If this plan were followed, very achievable savings in water use could be realized. Implementation of the water savings techniques shown in the proposed plan would have the effect of reducing per capita water use. Projected effects of these programs are reductions in municipal per capita water demands of 2.5% in immediate demands, 7.5% by 2000, 12.5 percent by 2010 and 15 percent by 2020. The cost of implementing and maintaining an effective water conservation plan is small compared to potential savings. Each gallon of water saved through conservation is one less gallon of water that has to be developed, pumped, treated, distributed, and retreated.

#### 4.2 Matrix Evaluation of Potential Water Distribution System Options

This section evaluates the infrastructure necessary to provide treated water distribution systems for colonias not currently served. To assist in sorting out the various options of water service, a decision matrix was developed (Figure 4-3). The matrix starts with existing conditions and determines future demands.



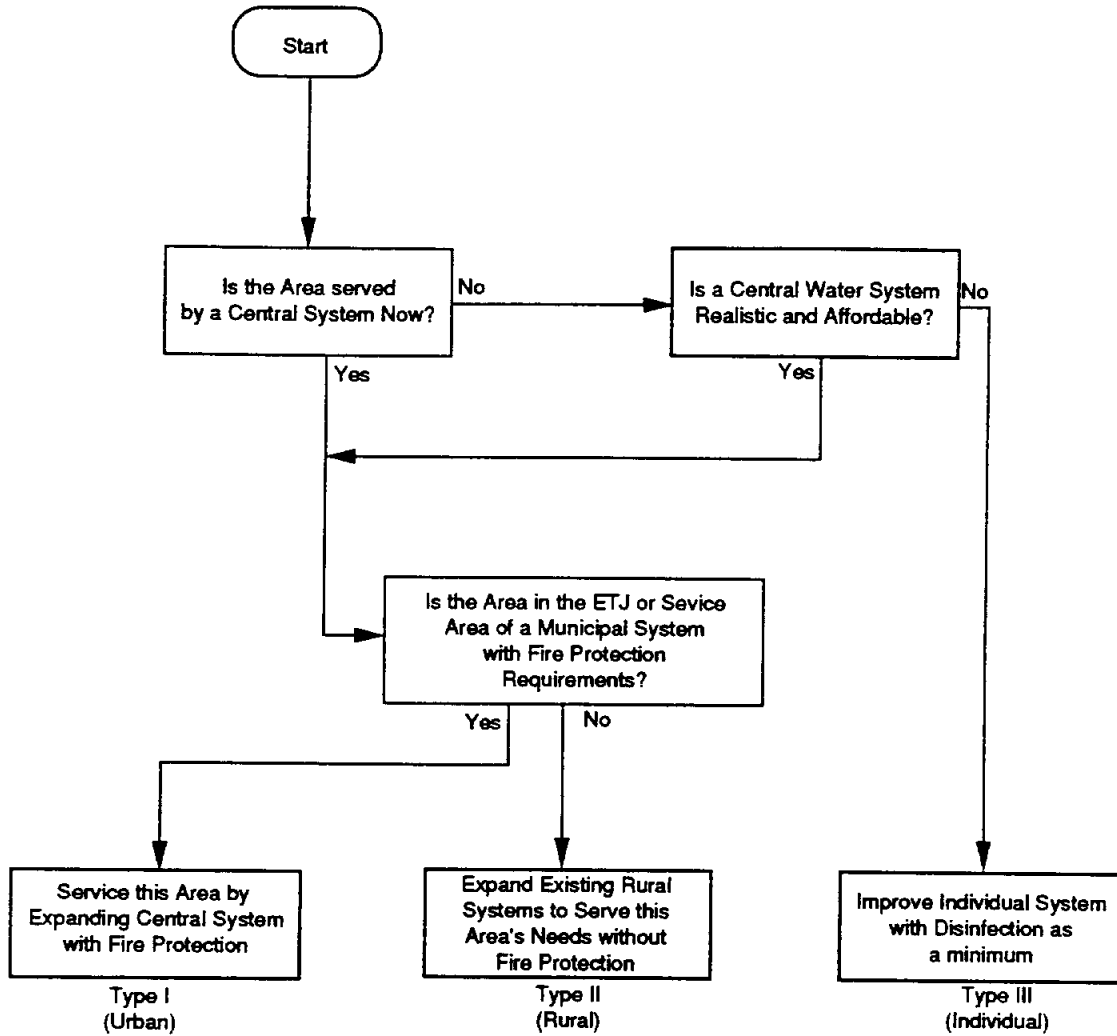

Figure 4-3  
WATER DECISION MATRIX

4.2.1 Preliminary Design Data

All systems in Cameron County primarily use directly or indirectly, water from the Rio Grande. In all cases, this water is treated by conventional methods. The Texas Health Department criteria for such systems include the following:

- a) total storage capacity of 200 gallons per connection
- b) pressure maintenance facilities of 100 gallons per connection of elevated storage or pressure tank storage of 20 gallons per connection
- c) raw water pumping, transfer pumping and treatment plant capacity of 0.6 gpm per connection
- d) service pump capacity of 2 gpm per connection and able to meet peak demand
- e) minimum pressure of 35 psi with 1.5 gpm used per connection

Treatment plants, planning facilities, and transmission lines are normally designed to serve the needs of the "maximum" day. Fluctuation in elevated storage tanks normally absorb the "peak hour demands" and the distribution system is sized to deliver "peak hour demands". In urban areas, fire flows are considered in designing facilities.

Cost estimates for transmission mains were derived from an analysis of recent bid tabulations from the PUB. Contingency allowances and engineering cost were added to the bid prices to develop estimated totals. The unit prices for costing transmission mains used in this study are shown in Table 4-1, cost estimates for elevated storage facilities and pump stations were derived on an individual basis.

**Table 4-1  
 Transmission Main Estimating Price**

<u>Item</u>	<u>Price</u>
16" Main	\$ 40 plf
16" Valve	\$2,000 Ea
16" Bore & encasement	\$ 200 plf
12" Main	\$ 25 plf
12" Valve	\$1,000 Ea
12" Bore & encasement	\$ 150 plf

Distribution systems were analyzed in two categories; rural and urban. Pipe and facility sizes, capacities, and cost vary widely between these two categories.

Rural distribution systems provide service to widely dispersed areas and customers. The number of customers per mile of pipe can be small. Fire protection is usually minimal. As a result, these systems often have large amounts of small diameter (less than 6") pipe. These systems provide for only a little fire

protection capability. Unexpected growth in a small area can easily overload a rural system. The systems were normally designed to meet the minimum state criteria and standards. Generally only minimal provisions for growth are allowed in the initial system design and construction.

Estimating prices for rural water system were developed after consultation with Farmers Home Administration personnel. The estimating prices for rural distribution systems are shown in Table 4-2.

**Table 4-2**  
**Unit Prices for Estimating**  
**Water Distribution Costs for Rural Systems**

<u>Item</u>	<u>Price</u>
10" Main	\$ 8.50 plf
10" Valve	\$600.00 Ea
8" Main	\$ 7.25 plf
8" Valve	\$400.00
6" Main	\$6.00 plf
6" Valve	\$300.00 Ea
4" Main	\$ 4.50 plf
4" Valve	\$200.00 Ea
Service Correction	\$250.00 ea

Urban distribution systems are sized to meet fire flow requirements (600 gpm to 3,000 gpm minimum). These flows result in looped mains, with the minimum main sizes of 6-inch diameter. Major and secondary transmission mains larger than 6-inch diameter pipe are frequently used. Cost for urban distribution mains were derived from recent PUB bid tabulations and are shown in Table 4-3.

**Table 4-3**  
**Unit Prices for Estimating Water**  
**Distribution Costs for Urban Systems**

<u>Item</u>	<u>Price</u>
10" Main	\$ 20.00 plf
10" Valve	\$750.00 Ea
8" Main	\$ 17.00 plf
8" Valve	\$500.00
6" Main	\$13.50 plf
6" Valve	\$400.00 Ea
Fire Hydrant Assembly	\$1,500.00 Ea
Services Correction	\$350.00 Ea
Tie In	\$500.00 ea

For rural and urban systems, the 1990 populations and water demands for the various colonias were tabulated and compared to year 2020 projections. For areas with existing service, the increase in supply

needed by the water purveyor to that colonia was evaluated. Peaking factors were applied to treatment and delivery systems to determine average day conditions for design and estimating purposes.

#### 4.2.2 Colonia Water Suppliers

Table 4-4 lists the major water suppliers to the colonias in Cameron County. Also, shown on this table are current and projected population and water demands for the 65 colonias located in the study area.

All but seven colonias in Cameron County are on a centralized water supply and distribution. As described below, the sewer system without water service are recommendations connected to existing water suppliers. Therefore, no new water supply options for the colonias were evaluated in this project.

##### 4.2.2.1 Sub-area B (Brownsville Area ETJ)

Table 4-5 presents current and projected populations and water systems design data for colonias in Sub-Area B. The Brownsville Sub-Area has only one colonia that reports no water service; Hacienda Gardens (7B). Hacienda Gardens is located immediately adjacent to Resaca Rancho Viejo and could use either shallow ground water, if treated. However, the PUB has water mains in this area, therefore, it is recommended that the PUB provide water service to this colonia.

Figure 4-4 presents a proposal water distribution system for Hacienda Gardens to satisfy year 2020 demands. This proposed system includes fire protection and other appurtenances that are required by the PUB. The projected cost of the water distribution improvement for Hacienda Gardens is \$330,000.

Cameron Park, the largest colonia in Cameron County, is served water by both the PUB and the Military Highway WSC. Due to the dense, urban nature of this colonia, and its proximity to Brownsville, it is recommended that the PUB serve as the sole provider of water service to entire Cameron Park colonia. This will also enhance PUB's ability to provide sewer service to this colonia.

Figure 4-5 illustrates a proposed water distribution system layout for that part of Cameron Park not currently served by PUB. The projected cost of these improvements is \$ 2,970,000.

The south-east side of the Brownsville Sub-area is served by El Jardin WSC. This large rural area contains twenty-two (22) colonias. While the growth of urban development will eventually develop problems for this rural water system, El Jardin is the obvious provider of service in this area in the future.

Along U.S. Highway 281, in a rural setting, three (3) colonias are served by the Military Highway WSC, This area should continue to be served by the Military Highway WSC.

TABLE 4-4  
 CITIES AND WATER SUPPLY CORPORATIONS SERVING CAMERON COUNTY

BROWNSVILLE WATER SUPPLY CORPORATION											
Colonia	Served by Central System	1990 Population	1990 Avg Daily Demand (GPD)	1990 Max Daily Demand (GPD)	2020 Population	2020 Avg Daily Demand	2020 Max Daily Demand	1990/2020 Average	1990/2020 Maximum		
1B Cameron Park 1	B-PUB*	3,690	461,250	1,153,125	7,327	91,587	2,289,688	454,625	1,136,563		
7B Hacienda Gardens	B-PUB*	475	59,375	148,438	944	118,000	295,000	58,625	145,562		
2		4,165	520,625	1,301,563	8,271	209,587	2,584,688	519,250	1,283,125		
OLMITO WATER SUPPLY CORPORATION											
Colonia	Served by Central System	1990 Population	1990 Avg Daily Demand (GPD)	1990 Max Daily Demand (GPD)	2020 Population	2020 Avg Daily Demand	2020 Max Daily Demand	1990/2020 Average	1990/2020 Maximum		
2B Olmito	O-WSC	1,178	147,375	368,438	3,532	44,150	1,103,750	294,125	735,312		
1		1,178	147,375	368,438	3,532	44,150	1,103,750	294,125	735,312		
CAMERON COUNTY WCID (SANTA ROSA)											
Colonia	Served by Central System	1990 Population	1990 Avg Daily Demand (GPD)	1990 Max Daily Demand (GPD)	2020 Population	2020 Avg Daily Demand	2020 Max Daily Demand	1990/2020 Average	1990/2020 Maximum		
6W T2 Unknown Subd.	SANTA ROSA*	338	42,250	105,625	431	53,875	134,688	11,625	29,063		
13W Q Unknown Subd. (Santa Rosa)	SANTA ROSA*	132	16,500	41,250	241	30,125	75,313	13,625	34,063		
14W W	SANTA ROSA*	108	13,500	33,750	137	17,125	42,813	3,625	9,063		
15W R Unknown Subd. (S. Santa Rosa)	SANTA ROSA*	108	13,500	33,750	196	24,500	61,250	11,000	27,500		
18W X Unknown Subd. (Santa Feria)	SANTA ROSA*	64	8,000	20,000	116	14,500	36,250	6,500	16,250		
17W S	SANTA ROSA*	64	8,000	20,000	116	14,500	36,250	6,500	16,250		
8		814	101,750	254,375	1,237	154,625	366,584	52,875	132,189		
HARLINGEN WATER BOARD											
Colonia	Served by Central System	1990 Population	1990 Avg Daily Demand (GPD)	1990 Max Daily Demand (GPD)	2020 Population	2020 Avg Daily Demand	2020 Max Daily Demand	1990/2020 Average	1990/2020 Maximum		
1H Las Palmas	HARLINGEN	622	77,750	194,375	1,103	137,875	344,688	60,125	150,313		
1		622	77,750	194,375	1,103	137,875	344,688	60,125	150,313		

TABLE 4-4 (continued)  
 CITIES AND WATER SUPPLY CORPORATIONS SERVING CAMERON COUNTY

EL JARDIN WATER SUPPLY CORPORATION											
Colonia	Served by Central System	1990 Population	1990 Avg Daily Demand (GPD)	1990 Max Daily Demand (GPD)	2020 Population	2020 Avg Daily Demand	2020 Max Daily Demand	1990/2020 Average	1990/2020 Maximum		
3B											
5B	Stuart Subd.	990	123,750	309,375	1,960	245,000	612,500	121,250	303,125		
5B	King Subd.	637	78,625	199,063	1,265	158,125	395,313	78,500	196,250		
6B	Alabama/Arkansas (La Coma)	515	64,375	160,938	1,022	127,750	318,375	63,375	158,437		
9B	Villa Pancho	304	38,000	95,000	603	75,375	188,438	37,375	93,438		
10B	Pleasant Meadows	294	36,750	91,875	584	73,000	182,500	36,250	90,625		
12B	Berio Subd.	196	24,500	61,250	389	48,625	121,563	24,125	60,313		
13B	Las Cuatras	191	23,875	59,696	379	47,375	118,438	23,500	58,750		
14B	Saldivar	152	19,000	47,500	302	37,750	94,375	18,750	46,875		
16B	Coronado	152	19,000	47,500	302	37,750	94,375	18,750	46,875		
16B	Unknown	142	17,750	44,375	282	35,250	88,125	17,500	43,750		
17B	Saldivar (II)	137	17,125	42,813	272	34,000	85,000	16,875	42,187		
18B	Valle Escondido	137	17,125	42,813	272	32,875	85,000	16,875	42,187		
19B	Unnamed C	132	16,500	41,250	263	30,375	82,188	16,375	40,938		
20B	Unnamed D (Keller's Corner)	123	15,375	38,438	243	30,375	75,938	15,000	37,500		
21B	Texas 4	123	15,375	38,438	243	30,375	75,938	15,000	37,500		
22B	511 Crossroads	123	15,375	38,438	243	30,375	75,938	15,000	37,500		
23B	Illhole Heights	103	12,875	32,188	204	24,375	63,750	12,625	31,562		
24B	Unknown (Brownsville Airport)	96	12,250	30,625	195	15,750	60,938	12,125	30,313		
25B	Valle Hermosa	64	8,000	20,000	126	14,625	38,375	7,750	19,375		
26B	Unknown	59	7,375	18,438	117	12,125	36,563	7,250	18,125		
27B	Unnamed B (Highway 802)	49	6,125	15,313	97	11,000	30,313	6,000	15,000		
28B	21	44	5,500	13,750	88	11,875	27,500	5,500	13,750		
	22	4,785	595,625	1,489,368	9,451	1,159,250	2,953,443	585,750	1,484,375		

TABLE 4-4 (continued)  
 CITIES AND WATER SUPPLY CORPORATIONS SERVING CAMERON COUNTY

EAST RIO HONDO WATER SUPPLY CORPORATION									
Colonia	Served by Central System	1990 Population	1990 Avg Daily Demand (GPD)	1990 Max Daily Demand (GPD)	2020 Population	2020 Avg Daily Demand	2020 Max Daily Demand	1990/2020 Average	1990/2020 Maximum
1E La Coma Del Norte	ERH-WSC	681	85,125	212,813	868	108,500	271,250	23,375	58,437
2E Lozano	ERH-WSC	534	66,750	166,875	680	85,000	212,500	18,250	45,625
3E La Tina Ranch	ERH-WSC	519	64,875	162,188	662	82,750	206,875	17,875	44,687
4E Laureles	ERH-WSC	299	37,375	93,438	381	47,625	119,063	10,250	25,625
5E Del Mar Heights	ERH-WSC	245	30,625	76,563	438	60,375	150,938	29,750	74,375
6E Orason Ac/Chula Vista/Shoemaker	ERH-WSC	235	29,375	73,438	464	58,000	145,000	28,625	71,562
7E Las Yescas	ERH-WSC	221	27,625	69,063	281	35,125	87,813	7,500	18,750
8E Unknown	ERH-WSC	206	25,750	64,375	262	32,750	81,875	7,000	17,500
9E Glenwood Acres Subd.	ERH-WSC	172	21,500	53,750	218	27,250	68,125	5,750	14,375
11E Los Cuates	ERH-WSC	132	16,500	41,250	261	32,625	81,563	16,125	40,313
12E 25	ERH-WSC	59	7,375	18,438	75	9,375	23,438	2,000	5,000
13E Clareros (Limon)	ERH-WSC	48	6,125	15,313	62	7,750	19,375	1,625	4,062
3H 26	ERH-WSC	284	35,500	88,750	504	63,000	157,500	27,500	68,750
4H Lasena	ERH-WSC	137	17,125	42,813	243	30,375	75,938	13,250	33,125
7H Laguna Escondito Heights	ERH-WSC	54	6,750	16,875	95	11,875	29,688	5,125	12,813
15		3,827	473,375	1,185,942	5,484	692,375	1,730,841	214,000	534,998
MILITARY HIGHWAY WATER SUPPLY CORPORATION									
Colonia	Served by Central System	1990 Population	1990 Avg Daily Demand (GPD)	1990 Max Daily Demand (GPD)	2020 Population	2020 Avg Daily Demand	2020 Max Daily Demand	1990/2020 Average	1990/2020 Maximum
4B San Pedro/Carmen/Barrera Gd.	MH-WSC	730	91,250	228,125	1,450	181,250	453,125	90,000	225,000
8B Villa Nueva	MH-WSC	405	50,625	126,563	788	99,750	249,375	49,125	122,812
11B Villa Covazos	MH-WSC	201	25,125	62,813	389	49,875	124,688	24,750	61,875
10E Unknown (Del Mar II)	MH-WSC	147	18,375	45,938	290	36,250	90,625	17,875	44,687
2H Lago Subd.	MH-WSC	392	49,000	122,500	695	86,875	217,188	37,875	94,688
5H Rice Tracts	MH-WSC	132	16,500	41,250	234	28,250	73,125	12,750	31,875
6H Leal Subd. (Mates & Bounds)	MH-WSC	123	15,375	38,438	217	27,125	67,813	11,750	29,375
1W Encantada	MH-WSC	1,288	161,125	402,813	1,641	205,125	512,813	44,000	110,000
2W Santa Maria	MH-WSC	1,161	145,125	362,813	2,306	288,250	720,625	143,125	357,812
3W La Paloma	MH-WSC	676	84,500	211,250	861	107,625	269,063	23,125	57,813
4W Los Indios	MH-WSC	549	68,625	171,563	699	87,375	218,438	18,750	46,875
5W Bluetown	MH-WSC	456	57,000	142,500	580	72,500	181,250	15,500	38,750
7W El Venadito	MH-WSC	225	28,125	70,313	287	35,875	89,688	7,750	19,375
8W Carricitos-Londrum	MH-WSC	216	27,000	67,500	275	34,375	85,938	7,375	18,438
9W El Galaboz	MH-WSC	181	23,875	59,688	360	45,000	112,500	21,125	52,812
10W Iglesia Antigua	MH-WSC	162	20,250	50,625	206	25,750	64,375	5,500	13,750
11W Palmer	MH-WSC	162	20,250	50,625	265	35,625	89,063	15,375	38,438
12W Unknown (mita 2)	MH-WSC	132	16,500	41,250	169	21,125	72,813	4,625	11,563
18		7,349	887,325	2,298,567	11,752	1,498,000	3,892,505	550,375	1,385,838

\* Projected Service

TABLE 4-5  
 Brownsville Sub Area B  
 Populations and Water Service

	Colonia	Served by Central System	1980 Population	1990 Avg Daily Demand (GPD)	1990 Max Daily Demand (GPD)	2020 Population	2020 Avg Daily Demand	2020 Max Daily Demand	1990/2020 Average	1990/2020 Maximum
1B	Cameron Park 1	B-PUB	3,690	461,250	1,153,125	7,327	91,567	2,289,688	454,625	1,136,563
2B	Olimto	O-WSC	1,178	147,375	368,438	3,532	441,500	1,103,750	294,125	735,312
3B	Stuart Subd.	EJ-WSC	990	123,750	309,375	1,960	245,000	612,500	121,250	303,125
4B	San Pedro/Carmen/Barrera Gd.	MH-WSC	730	91,250	228,125	1,450	181,250	453,125	90,000	225,000
5B	King Subd.	EJ-WSC	637	79,625	199,063	1,265	158,125	395,313	78,500	196,250
6B	Alabama/Arkansas (La Come)	EJ-WSC	515	64,375	160,838	1,022	127,750	319,375	63,375	158,437
7B	Hacienda Gardens	B-PUB	475	59,375	126,563	788	99,750	249,375	49,125	122,812
8B	Villa Nueva	MH-WSC	405	50,625	126,563	788	99,750	249,375	49,125	122,812
9B	Villa Pancho	EJ-WSC	304	38,000	95,000	603	75,375	188,438	37,375	93,438
10B	Pleasant Meadows	EJ-WSC	294	36,750	91,875	584	73,000	182,500	36,250	90,625
11B	Villa Cavazos	MH-WSC	201	25,125	62,813	389	49,875	124,688	24,750	61,875
12B	Barrio Subd.	EJ-WSC	196	24,500	61,250	389	48,625	121,563	24,125	60,313
13B	Las Cuates	EJ-WSC	181	23,875	59,688	379	47,375	118,438	23,500	58,750
14B	Saldívar	EJ-WSC	152	19,000	47,500	302	37,750	94,375	18,750	46,875
15B	Coronado	EJ-WSC	152	19,000	47,500	302	37,750	94,375	18,750	46,875
16B	Unknown	EJ-WSC	142	17,750	44,375	282	35,250	88,125	17,500	43,750
17B	Saldívar (II)	EJ-WSC	137	17,125	42,813	272	34,000	85,000	16,875	42,187
18B	Valle Escondido	EJ-WSC	137	17,125	42,813	272	32,875	85,000	16,875	42,187
19B	Unnamed C	EJ-WSC	132	16,500	41,250	263	30,375	82,188	16,375	40,938
20B	Unnamed D (Keller's Corner)	EJ-WSC	123	15,375	38,438	243	30,375	75,938	15,000	37,500
21B	Texas 4	EJ-WSC	123	15,375	38,438	243	30,375	75,938	15,000	37,500
22B	511 Crossroads	EJ-WSC	123	15,375	38,438	243	25,500	75,938	15,000	37,500
23B	Illinois Heights	EJ-WSC	103	12,875	32,188	204	24,375	63,750	12,625	31,562
24B	Unknown (Brownsville Airport)	EJ-WSC	98	12,250	30,625	195	15,750	60,938	12,125	30,313
25B	Valle Hermosa	EJ-WSC	64	8,000	20,000	126	14,625	39,375	7,750	19,375
26B	Unknown	EJ-WSC	59	7,375	18,438	117	12,125	36,563	7,250	18,125
27B	Unnamed B (Highway 802)	EJ-WSC	49	6,125	15,313	97	11,000	30,313	6,000	15,000
28B	21	EJ-WSC	44	5,500	13,750	88	11,875	27,500	5,500	13,750



**LEGEND**

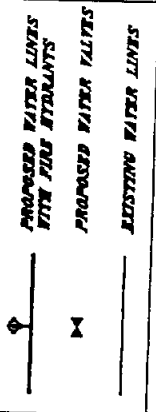

WATER DISTRIBUTION Quantities Estimate & Quantity	
Item	Quantity
8" C-900 PVC	1708 LF.
8" C-900 PVC	5078 LF.
10" C-900 PVC	1433 LF.
FIRE HYDRANT ASSEMBLIES	14 EA.
8" GATE VALVES	3 EA.
8" GATE VALVES	8 EA.
10" GATE VALVES	3 EA.
BORNE SERVICES	1 EA.
TOTAL COST	180 EA. \$336,000

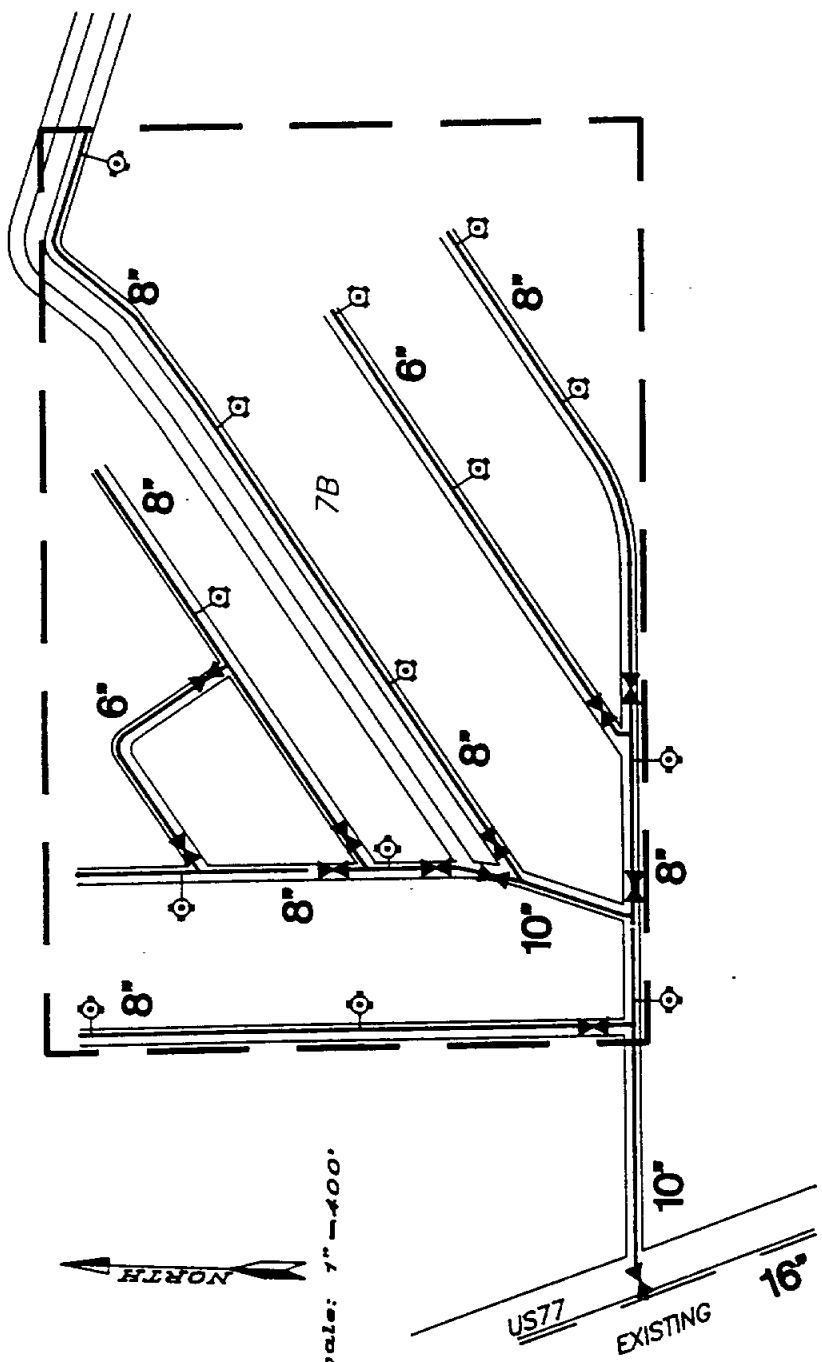

Colonia Designation	Colonia Name	Area (Ac)	2020 Population	2020 Population Density (Cap./Ac)	2020 Units	2020 Unit Density (Units/Ac)
7B	Hacienda Gardens	51	944	18.51	193	3.78

Cameron County Regional Water and Wastewater Planning Study

Figure 4-4  
Site Map of Hacienda Gardens

Prepared For:  
Texas Water Development Board  
and Cameron County Water Development Board

Prepared By:  
The Water Resources Planning Group

August 1990

**MATCH LINE**

Colonia Designation	Colonia Name	Area (Ac)	2020 Population	2020 Population Density (Cap./Ac)	2020 Units	2020 Unit Density (Units/Ac)
1B	Cameron Park	360	7,327	20.35	1,495	4.15

Scale: 1" = 600'

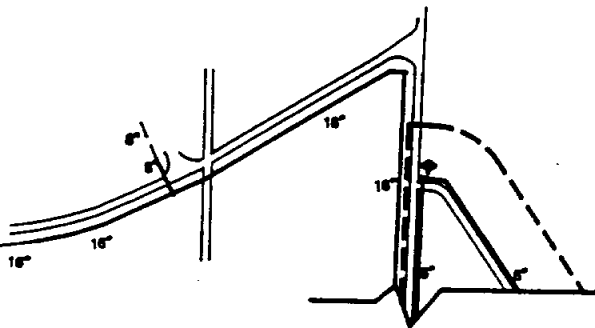
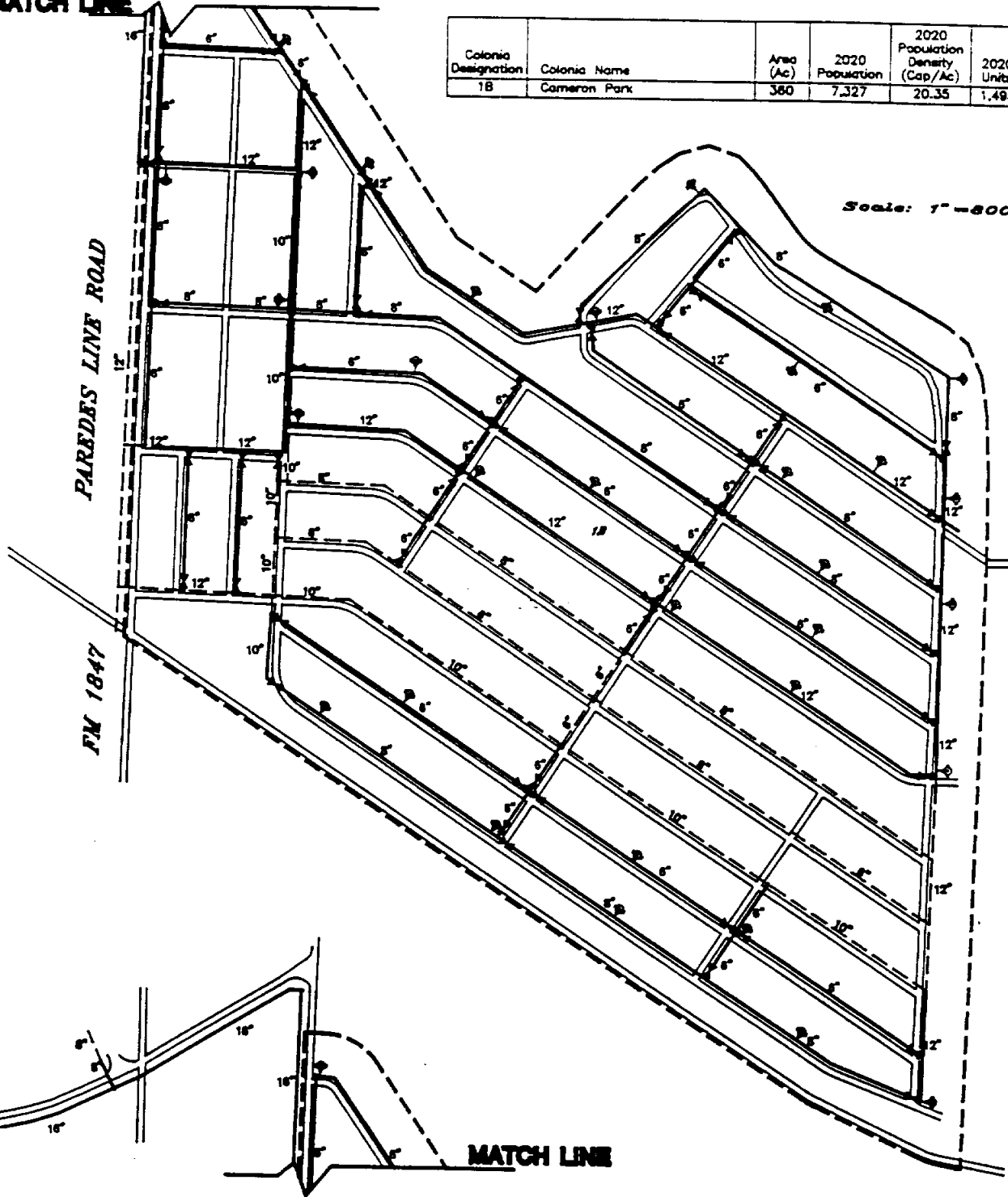

WATER DISTRIBUTION	
Item	Quantity
6" C-800 PVC	21,216 L.F.
8" C-800 PVC	11,884 L.F.
10" C-800 PVC	1,793 L.F.
12" C-800 PVC	11,888 L.F.
16" RCP	1,888 L.F.
FIRE HYDRANT ASSEMBLIES	33 EA.
6" GATE VALVES	42 EA.
8" GATE VALVES	19 EA.
10" GATE VALVES	8 EA.
12" GATE VALVES	8 EA.
	\$2,970,000

LEGEND	
	PROPOSED WATER LINES WITH FIRE HYDRANTS
	PROPOSED WATER VALVES
	EXISTING WATER LINES

Cameron County Regional Water and Wastewater Planning Study

**Figure 4-5**  
Site Map of Cameron Park

Prepared For:  
Texas Water Development Board  
and Cameron County Water Development Board

Prepared By:  
The Water Resources Planning Group

August 1990

#### 4.2.2.2 Sub-area H (Harlingen Area ETJ)

Table 4-6 presents current and future water system demand for the colonias in Sub-Area H. In the Harlingen Sub-Area, the largest colonia, Las Palmas (1H), is currently served by the City of Harlingen. Three colonias south of San Benito are served by the Military Highway WSC. These colonias are near urban areas and may require additional service in the future. For now, the recommended provider of service is the Military Highway WSC. No improvements were planned in this project for these colonias, since the Military Highway WSC would not provide detail information on the existing systems.

Near the northern edge of the Harlingen ETJ are three colonias. These are served by the East Rio Hondo WSC, which should continue to provide future water service. The existing water distribution systems for these colonias are sufficient to supply their projected year 2020 needs. These water purveyors should continue to provide water to their respective colonias in the future.

#### 4.2.2.3 Sub-area E (Eastern Cameron County)

Table 4-7 lists current and projected population and water system data for colonias in Sub-Area E. The Eastern Sub-Area, rural in nature, has thirteen (13) colonias, which all have central water systems. All the colonias in this planning area are served by the East Rio Hondo WSC, except for Unknown Colonia (Del Mar II) which is served by the Military Highway WSC.

#### 4.2.2.4 Sub-area W (Western Cameron County)

Table 4-8 shows current and projected population and water system data for colonias in Sub-Area W (Western Cameron County). The western sub-area of Cameron County has seventeen (17) colonias in a rural setting divided into two distinct groups. One group is located at various points along U.S. Highway 281 (Military Highway). This group contains eleven (11) colonias and all are served by the Military Highway WSC, which is the recommended provider of water service in the future. This WSC would not provided system data for these colonias, therefore no proposed improvements were made.

The second group of six (6) colonias, W (14W), T2 Unknown (6W), Q Unknown (13W), R Unknown (15W), X Unknown (16W), and S (17W), are located between the Cities of La Feria and Santa Rosa. These colonias are on small lots with septic tanks and shallow wells. No central system serves this area. Most of these colonias are closer to the City of Santa Rosa than to the City of La Feria. For this reason, it is recommended that a central system be extended from the Santa Rosa WCID to serve this area (see Figures 4-6 through 4-10). The total cost for the water system improvements for all six colonias combined is \$ 1.9 million (see Figure 4-6).

TABLE 4-6  
 Harlingen Sub Area H  
 Populations and Water Service

	Colonia	Served by Central System	1990 Population	1990 Avg Daily Demand (GPD)	1990 Max Daily Demand (GPD)	2020 Population	2020 Avg Daily Demand	2020 Max Daily Demand	1990/2020 Average	1990/2020 Maximum
1H	Las Palmas	HARLINGEN	622	77,750	194,375	1,109	137,875	344,688	60,125	150,313
2H	Lago Subd.	MH-WSC	392	49,000	122,500	695	86,875	217,188	37,875	94,688
3H	26	ERH-WSC	284	35,500	88,750	504	63,000	157,500	27,500	68,750
4H	Lasana	ERH-WSC	137	17,125	42,813	243	30,375	75,938	13,250	33,125
5H	Rice Tracts	MH-WSC	132	16,500	41,250	234	28,250	73,125	12,750	31,875
6H	Leal Subd. (metes & Bounds)	MH-WSC	123	15,375	38,438	217	27,125	67,813	11,750	28,375
7H	Laguna Escondido Heights	ERH WSC	54	6,750	16,875	95	11,875	29,688	5,125	12,813

TABLE 4-7  
 East Cameron County Sub Area E  
 Populations and Water Service

	Colonia	Served by Central System	1990 Population	1980 Avg Daily Demand (GPD)	1980 Max Daily Demand (GPD)	2020 Population	2020 Avg Daily Demand	2020 Max Daily Demand	1990/2020 Average	1990/2020 Maximum
1E	La Coma del Norte	ERH-WSC	681	85,125	212,813	868	108,500	271,250	23,375	58,437
2E	Lozano	ERH-WSC	534	66,750	166,875	680	85,000	212,500	18,250	45,625
3E	La Tina Ranch	ERH-WSC	518	64,875	162,188	662	82,750	206,875	17,875	44,687
4E	Laureles	ERH-WSC	299	37,375	93,438	381	47,625	119,063	10,250	25,625
5E	Del Mar Heights	ERH-WSC	245	30,625	76,563	438	60,375	150,838	29,750	74,375
6E	Oreason Ac/Chula Vst/Shoemaker	ERH-WSC	235	29,375	73,438	464	58,000	145,000	28,625	71,562
7E	Las Yucas	ERH-WSC	221	27,625	69,063	281	35,125	87,813	7,500	18,750
8E	Unknown	ERH-WSC	208	25,750	64,375	262	32,750	81,875	7,000	17,500
9E	Glenwood Acres Subd.	ERH-WSC	172	21,500	53,750	218	27,250	68,125	5,750	14,375
10E	Unknown (Del Mar II)	MH-WSC	147	18,375	45,938	290	36,250	90,625	17,875	44,687
11E	Los Cuates	ERH-WSC	132	16,500	41,250	261	32,625	81,563	16,125	40,313
12E	25	ERH-WSC	59	7,375	18,438	75	9,375	23,438	2,000	5,000
13E	Claneros (Limon)	ERH-WSC	49	6,125	15,313	62	7,750	19,375	1,625	4,062

TABLE 4-8  
 West Cameron County Sub Area W  
 Populations and Water Service

	Colonia	Served by Central System	1990 Population	1990 Avg Daily Demand (GPD)	1990 Max Daily Demand (GPD)	2020 Population	2020 Avg Daily Demand	2020 Max Daily Demand	1990/2020 Average	1990/2020 Maximum
1W	Encantada	MH-WSC	1,289	161,125	402,813	1,641	205,125	512,813	44,000	110,000
2W	Santa Maria	MH-WSC	1,181	145,125	362,813	2,306	288,250	720,625	143,125	357,812
3W	La Paloma	MH-WSC	678	84,500	211,250	861	107,625	269,063	23,125	57,813
4W	Los Indios	MH-WSC	549	68,625	171,563	698	87,375	218,438	18,750	46,875
5W	Bluetown	MH-WSC	456	57,000	142,500	580	72,500	181,250	15,500	38,750
6W	2 Unknown Subd.	SANTA ROSA	338	42,250	105,625	431	53,875	134,888	11,625	29,063
7W	El Venadito	MH-WSC	225	26,125	70,313	287	35,875	89,688	7,750	19,375
8W	Carricitos-Landrum	MH-WSC	216	27,000	67,500	275	34,375	85,938	7,375	18,438
9W	El Calaboz	MH-WSC	191	23,875	59,888	360	45,000	112,500	21,125	52,812
10W	Iglesia Antigua	MH-WSC	162	20,250	50,625	206	25,750	64,375	5,500	13,750
11W	Palmer	MH-WSC	162	20,250	50,625	285	35,625	89,063	15,375	38,438
12W	Unknown (Milia 2)	MH-WSC	132	16,500	41,250	169	21,125	52,813	4,625	11,563
13W	Q Unknown Subd. (Santa Rosa)	SANTA ROSA	132	16,500	41,250	241	30,125	75,313	13,625	34,063
14W	W	SANTA ROSA	106	13,500	33,750	137	17,125	42,813	3,625	9,063
15W	R Unknown Subd. (S. Santa Rosa)	SANTA ROSA	106	13,500	33,750	196	24,500	61,250	11,000	27,500
16W	X Unknown Subd. (Santa Feria)	SANTA ROSA	64	8,000	20,000	116	14,500	36,250	6,500	16,250
17W	S	SANTA ROSA	64	8,000	20,000	116	14,500	36,250	6,500	16,250

**ADDITIONAL PUMPING  
PIPING & TREATMENT**

SANTA ROSA



Scale: 1" = 3800'

**ELEV. STORAGE  
100000 GAL**

North Rabb Road

Kansas City Road

Dukes Highway

LA FERIA  
16W

Q  
13W

R  
15W

S  
17W

T2  
6W

W  
14W

LEGEND	
	PROPOSED WATER LINES WITH FIRE HYDRANTS
	PROPOSED WATER VALVES
	PROPOSED ELEVATED STORAGE

WATER DISTRIBUTION Quantities Estimate #/	
Item	Quantity
4" WATER LINE	12,500 L.F.
6" WATER LINE	27,080 L.F.
8" WATER LINE	14,340 L.F.
FIRE HYDRANT ASSEMBLIES	13 EA.
4" GATE VALVES	18 EA.
6" GATE VALVES	2 EA.
8" GATE VALVES	3 EA.
SERVICES	250 EA.
BORES	10 EA.
PAVEMENT REPLACEMENT	3000 L.F.
0.5 MGID WTP ADDITION	1 EA.
100,000 GAL. ELEV. STOR.	1 EA.
PUMPING FACILITIES	1 EA.
TELEMETRY	1 EA.
<b>TOTAL COST</b>	<b>\$1,800,000</b>

1425

**Cameron County Regional Water and Wastewater  
Planning Study**

Figure 4-6  
Area Map of Colonia W (14W), T2 Unknown (6W), Q  
Unknown (13W), R Unknown (15W), S (17W), and X  
Unknown (16W)

Prepared For:  
Texas Water Development Board  
and Cameron County Water Development Board

Prepared By:  
The Water Resources Planning Group

August 1990

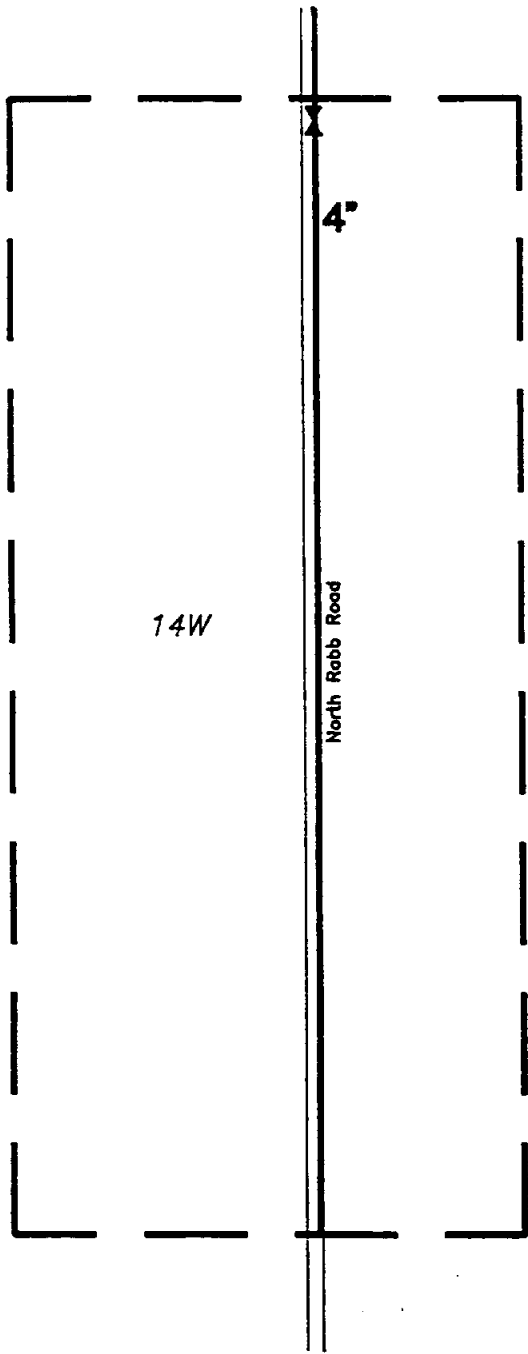

Scale: 1" = 400'

LEGEND	
	PROPOSED WATER LINES WITH FIRE HYDRANTS
	PROPOSED WATER VALVES
	EXISTING WATER LINES

Colonia Designation	Colonia Name	Area (Ac)	2020 Population	2020 Population Density (Pop./Ac)	2020 Units	2020 Unit Density (Units/Ac)
14W	W	48	137	2.85	28	0.58

Cameron County Regional Water and Wastewater Planning Study

Figure 4-7  
Site Map of W (14W)

Prepared For:  
Texas Water Development Board  
and Cameron County Water Development Board

Prepared By:  
The Water Resources Planning Group  
August 1990



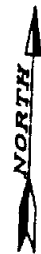
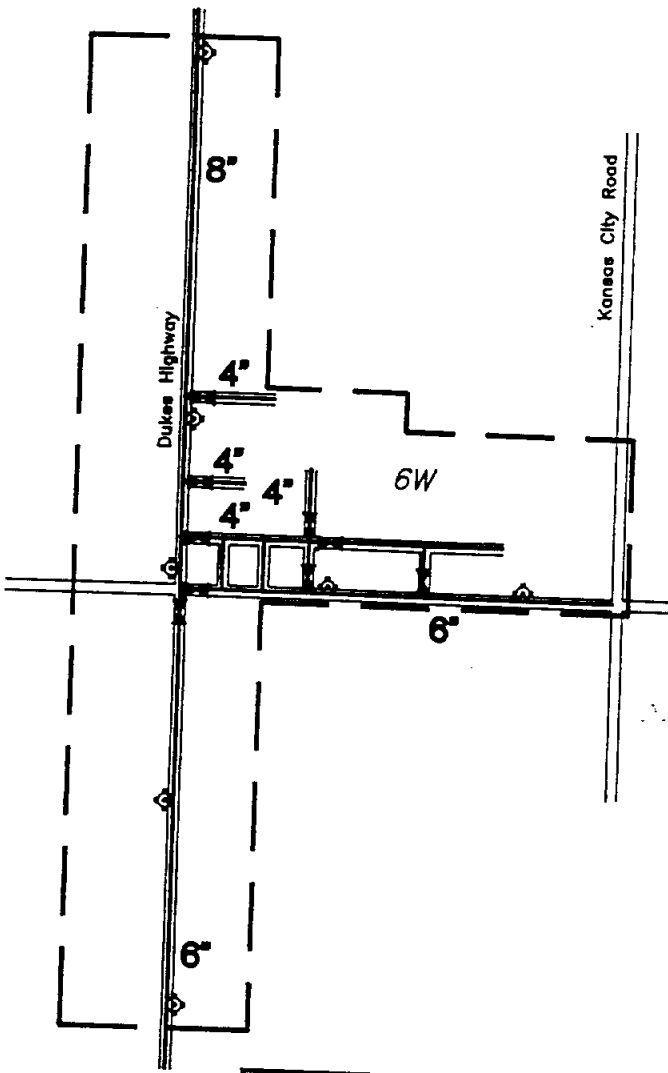

Scale: 1" = 800'

LEGEND	
	PROPOSED WATER LINES WITH FIRE HYDRANTS
	PROPOSED WATER VALVES
	EXISTING WATER LINES

Colonia Designation	Colonia Name	Area (Ac)	2020 Population	2020 Population Density (Cap/Ac)	2020 Units	2020 Unit Density (Units/Ac)
6W	T 2 Unknown Subdivision	45	431	9.58	88	1.96

**Cameron County Regional Water and Wastewater Planning Study**

---

**Figure 4-8  
Site Map of T2 Unknown (6W)**

---

Prepared For:  
**Texas Water Development Board  
and Cameron County Water Development Board**

---

Prepared By:  
**The Water Resources Planning Group**

---

August 1990

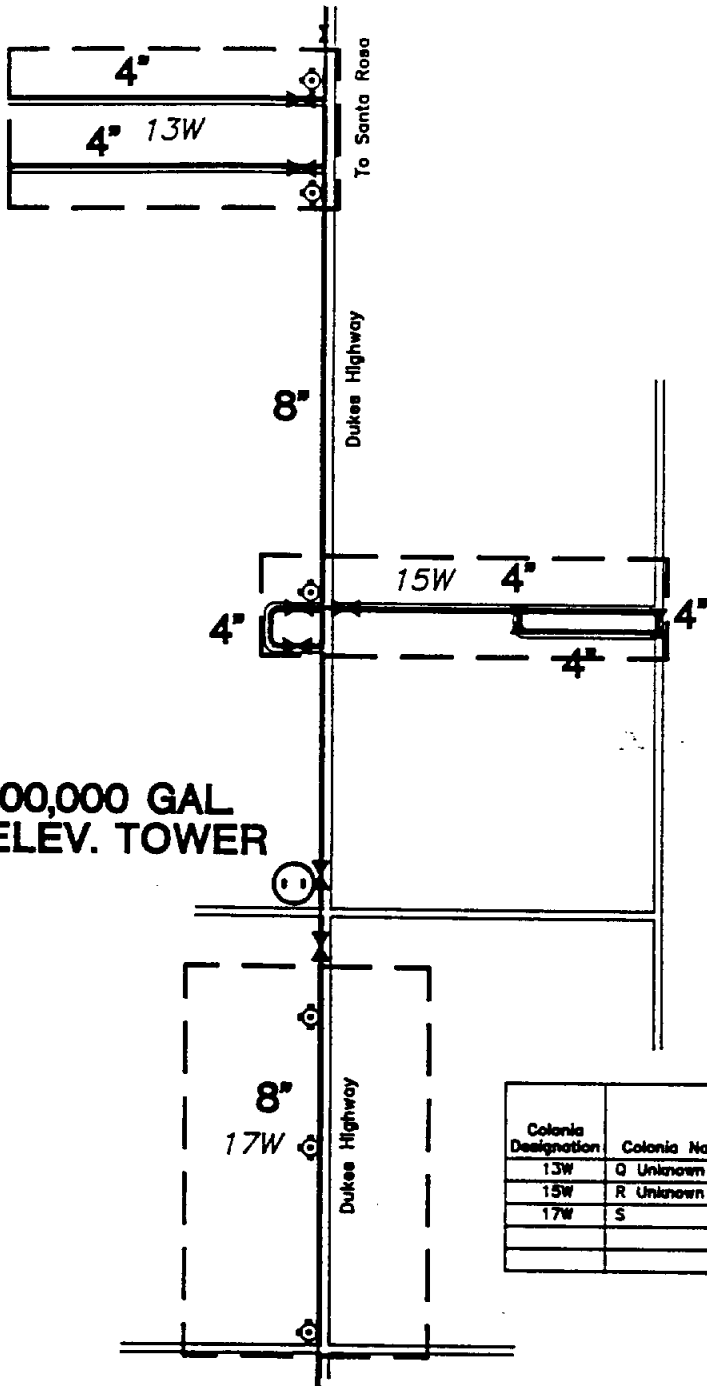

Scale: 1" = 800'

LEGEND	
	PROPOSED WATER LINES WITH FIRE HYDRANTS
	PROPOSED WATER VALVES
	EXISTING WATER LINES

100,000 GAL  
ELEV. TOWER

Colonia Designation	Colonia Name	Area (Ac)	2020 Population	2020 Population Density (Pop/Ac)	2020 Units	2020 Unit Density (Units/Ac)
13W	O Unknown Subd. (Santa Rosa)	16	241	15.06	49	3.06
15W	R Unknown Subd. (Santa Rosa)	25	196	7.84	40	1.60
17W	S	25	116	4.64	24	0.96

<b>Cameron County Regional Water and Wastewater Planning Study</b>
<b>Figure 4-9 Site Map of Unknown (13W), R Unknown (15W) and S (17W)</b>
<b>Prepared For: Texas Water Development Board and Cameron County Water Development Board</b>
<b>Prepared By: The Water Resources Planning Group</b>
<b>August 1990</b>

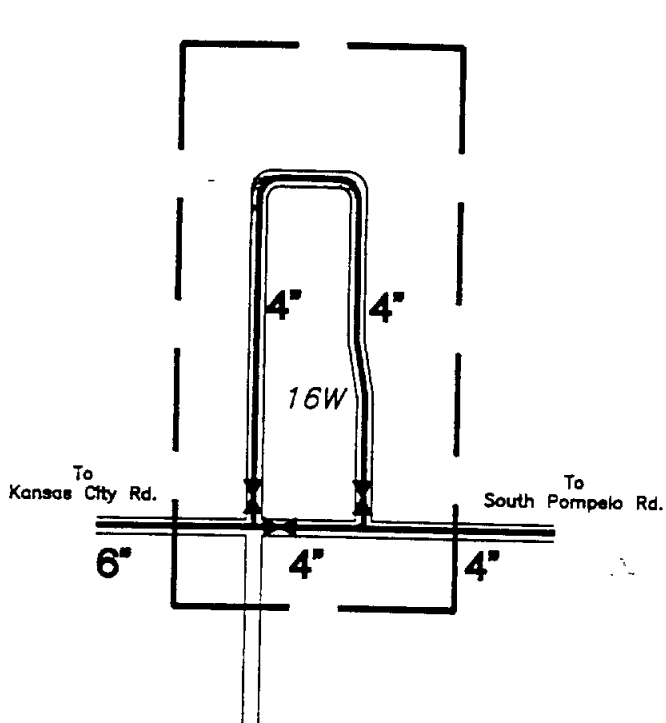

Scale: 1" = 400'

LEGEND	
	PROPOSED WATER LINES WITH FIRE HYDRANTS
	PROPOSED WATER VALVES
	EXISTING WATER LINES

Colonia Designation	Colonia Name	Area (Ac)	2020 Population	2020 Population Density (Cap/Ac)	2020 Units	2020 Unit Density (Units/Ac)
16W	X Unknown Subd. (La Feria)	16	116	7.25	24	1.50

Cameron County Regional Water and Wastewater Planning Study
Figure 4-10 Site Map of X Unknown (16W)
Prepared For: Texas Water Development Board and Cameron County Water Development Board
Prepared By: The Water Resources Planning Group
August 1990

## 5.0 FUTURE WASTEWATER COLLECTION, TREATMENT AND DISPOSAL OPTIONS

### 5.1 Identification of Potential Disposal Options

#### 5.1.1 On-Site Treatment and Disposal

On-site wastewater treatment and disposal is currently practiced in virtually all of the colonias of Cameron County. The level of sophistication of this treatment is generally governed by economics and need. The most common form of on-site wastewater disposal is the individual septic system with a conventional drainfield or trench system.

Personnel in the Texas Department of Health (TDH) District Office estimate that 15 percent of all septic systems in Cameron County are not operating properly and that many more are either providing only marginal treatment or are on the verge of failure. The consensus among Cameron County governmental and regulatory officials is that all septic systems will eventually fail and that, from a public health viewpoint, they should be avoided.

Pit privies and latrines are used in only a few of the poorest colonias, such as Cameron Park. TDH personnel estimate that virtually none of the systems are operating properly and that the potential public health hazard is significant.

##### 5.1.1.1 Available on-site Treatment Options

Texas Water Development Board publications list numerous on-site wastewater treatment and disposal techniques that may be theoretically applicable to the colonias of Cameron County; all are considered either "non-conventional" or "innovative technologies."

The non-conventional treatment options include:

- On-site individual septic tank systems with
  - drainfields
  - dosing mounds
  - evapotranspiration beds
  - aerobic treatment systems with
    - subsurface disposal or
    - irrigation disposal
- Land treatment systems with
  - slow rate irrigation or
  - rapid infiltration
- Total containment (evaporation) ponds

The innovative treatment options include:

- On-site individual septic tank systems with  
artificial marsh or  
sand filter
- Overland flow treatment.

#### Pit Privies/Latrines

Properly constructed and operated, pit privies or latrines can be a viable treatment option where in-house plumbing is not available or affordable. Proper construction requires an impervious super-structure and adequate site grading to prevent stormwater from entering the pit. The pit must be constructed of an impervious material to prevent leaching and contamination of ground water. The pit must be periodically pumped out and the waste disposed of in an acceptable facility. Unfortunately, the majority of latrines in Cameron County are improperly constructed and are not properly maintained. Most do not have impervious lining and few are regularly pumped.

#### Individual Septic Systems

Individual on-site septic systems are a well established method for treatment and disposal of domestic wastewater. The typical septic tank (Figure 5-1) is sized to accommodate the expected volumes and strengths of the waste stream. Septic tanks are generally divided into two or three sequential treatment chambers.

Septic tank drainfields are designed in a number of formats. The costs associated with the various types of drainfields vary markedly. Choice of drainfield type is driven by cost/availability of land, soil suitability and depth to ground water. Conventional absorption beds (Figure 5-2) and absorption trenches (Figure 5-3) are the least expensive and easiest to construct. However, when soil conditions and/or land constraints warrant, it may be necessary to use evapotranspiration beds or dosing mounds (Figure 5-4) to achieve satisfactory disposal. Where soil conditions are especially restrictive to soils loading, intermittent sand filters may be required before discharge to the absorption bed.

#### 5.1.1.2 TWC/TDH Design Criteria

Sections 301.11 - 301.15 of the Texas Water Code contain construction standards for on-site sewerage facilities (effective January 1990). At the state level, responsibility for management and control of on-site sewerage system practices is shared by the TWC and TDH. Section 301.11(f) (4) addresses residential lot sizing.

in the river would be approximately \$0.10 per 1,000 gallons (including capital and O&M costs). In addition, existing raw water diversion and conveyance facilities could be used, thereby, making this project more attractive than other raw water development projects.

The TWDB, in their (1990) "Water For Texas: Today and Tomorrow Plan", recommended that this reservoir be built. The TWDB's Plan states:

"In the lower basin, a channel dam (Site A) on the Rio Grande below Brownsville needs to be developed and would provide water to the immediate area. It has been estimated that the project could provide 27,697 million gallons per year, barely meeting projected additional needs of about 27,375 million gallons per year by the year 2040."

#### 4.1.2 Development of Ground Water Resources

Development of ground water in Cameron County can be derived from the Gulf Coast aquifer and the Lower Rio Grande Valley aquifer.

##### 4.1.2.1 Gulf Coast Aquifer

The Gulf Coast aquifer consists of complexly interbedded sand, gravel, silt, and clay. Maximum thickness of the aquifer in Cameron County, where it contains fresh to slightly saline water, is 500 feet, with a net sand thickness of 30 to 40 percent (TWDB, 1977). Yields of large-capacity wells range up to 2,000 gpm, but most wells average 500 gpm.

Water residing in the Gulf Coast aquifer generally contains a total dissolved solids (TDS) concentration of between 3,000 to 10,000 mg/L (TWC, 1989). There are isolated areas in the western part of the county that contain between 1,000 to 3,000 mg/L TDS, with a few isolated pockets with reported TDS concentrations of less than 1,000 mg/L. The TWC also reports that the water quality of the Gulf Coast aquifer exceeds primary and secondary drinking water standards for sulfate and chloride (TWC, 1989), and that the aquifer throughout Cameron County has suspected pollution resulting for pesticide activities.

In 1977 the TWDB reported that approximately 11.4 thousand acre-feet of ground water were withdrawn annually on a sustained basis from the Gulf Coast aquifer in Cameron, Starr and Hidalgo Counties. The TWDB reports that pumpage in excess of this amount could result in significant land subsidence, due to decline in asterian pressure and saline-water encroachment within the basin.

##### 4.1.2.2 Lower Rio Grande Valley Aquifer

The Lower Rio Grande Valley aquifer is situated in Cameron County along the Rio Grande. In a narrow band, adjacent to the Rio Grande, the aquifer extends from the surface to 400 or 500 feet (TDWR, 1983).

Recharge of water to the Lower Rio Grande Valley aquifer is derived from rainfall on the outcrop and from seepage of surface waters where the Rio Grande and other streams (mostly resacas or meander scars) cross the outcrop of sediments with relatively high permeability. In the immediate vicinity of the City of Brownsville, the shallow water-producing zone, which is less than 75 feet in depth, contains extremely poor quality water (TDS content measured in excess of 30,000 mg/L). This indicates that in this immediate area direct downward percolation of precipitation is not the prime source of recharge to the major producing zone, which contains better quality water between depths of 150 and 225 feet (46 and 69 m). Surface-water flow records for the Rio Grande indicate that there are significant water losses, especially during drought conditions, between Brownsville and the upstream measuring stations (TWDB, 1983). Water-level data indicate that the Rio Grande is losing water from a point near the City of Landrum to the west edge of the City of Brownsville. It seems probable that these streamflow losses are the source of much of the recharge to the major producing zone (deep zone) of the Lower Rio Grande Valley aquifer within the study area (TDWR, 1983). Ground water is located in the upper 225 feet (69 m) of the Lower Rio Grande Valley aquifer within the immediate vicinity of Brownsville. The aquifer consists of three producing zones, which can generally be differentiated both by water-producing characteristics (transmissibility, net sand thickness, particle sizes, etc.) and chemical quality of the produced water. These zones include a shallow zone (0 to 75 feet deep) and a middle zone (75 to 150 feet) which produce only limited amounts of ground water, often of poor quality. The quality of water produced from the shallow zone is especially poor over much of the area; two wells produce water with dissolved-solids concentrations in excess of 20,000 mg/L. The deep zone (150 to 225 feet) is capable of producing large amounts of water, and over much of the study area the produced water contains dissolved-solids concentrations of less than 3,000 mg/L.

Although the availability of ground water from the deep zone in the Brownsville area is restricted by water-quality problems, at least 350,000 acre-feet of water is estimated to be in storage in the deep zone of the Lower Rio Grande Valley aquifer within the study area. The high transmissibility of the sands and gravels within this zone should allow the development of a large part of this water for irrigation use, and with proper treatment, possibly including desalination, for municipal and industrial supplies as well. The TWDB (1983) reports that any significant increase in ground-water withdrawals could result in increased recharge of surface water into the aquifer, both directly from the Rio Grande and the numerous resacas, and from the several municipal and irrigation district lakes or holding basins.

The PUB has constructed a test and production well in the middle or deep zone of the Lower Rio Grande Valley aquifer. Production data for the well were not available from the PUB at publication of this report. However, R. W. Beck (1988) reports that water from the PUB's production well ranges in TDS concentration from 800 to 1,200 mg/L. R. W. Beck also projects that a well field in this aquifer could be

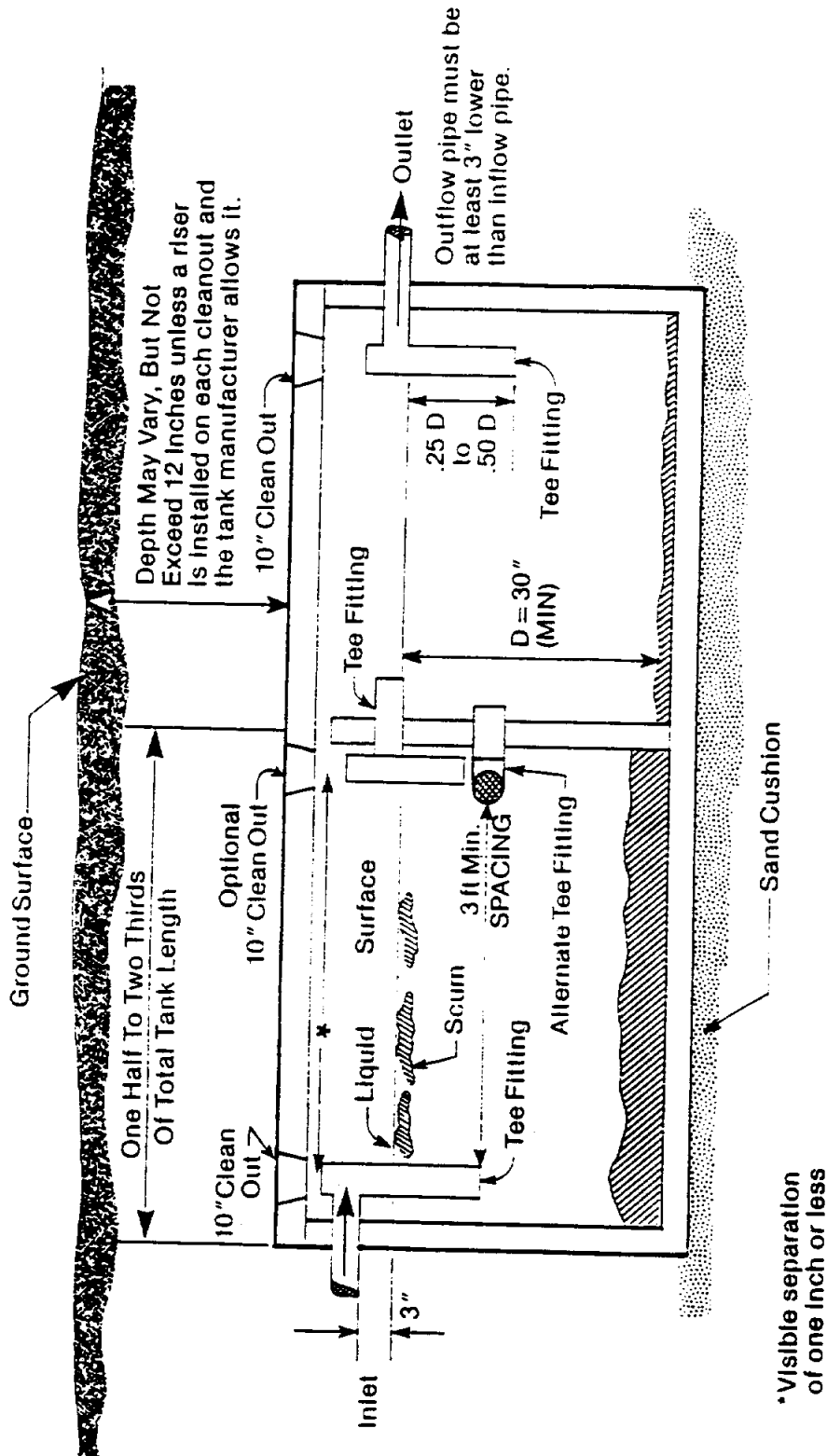

\*Visible separation of one inch or less

Not intended to serve as an engineered design for construction purposes

Figure 5-1  
 Two Compartment Septic Tank



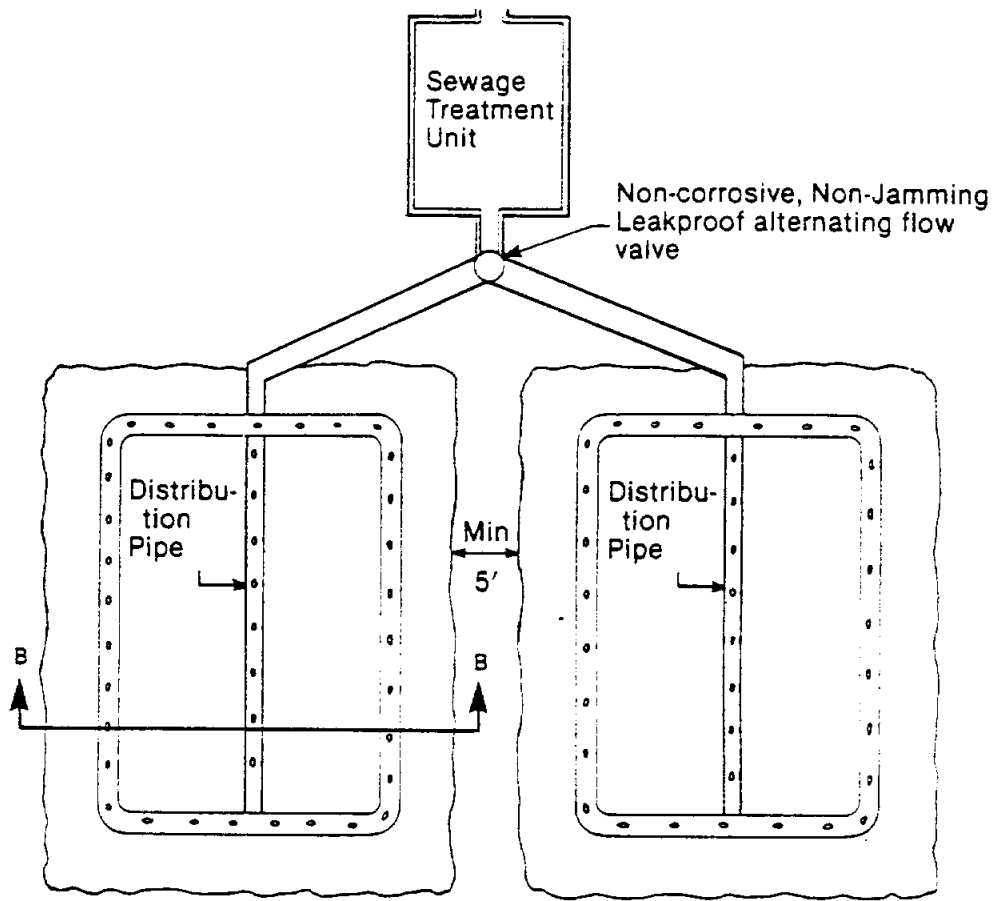

Plan View Of Dual Bed System

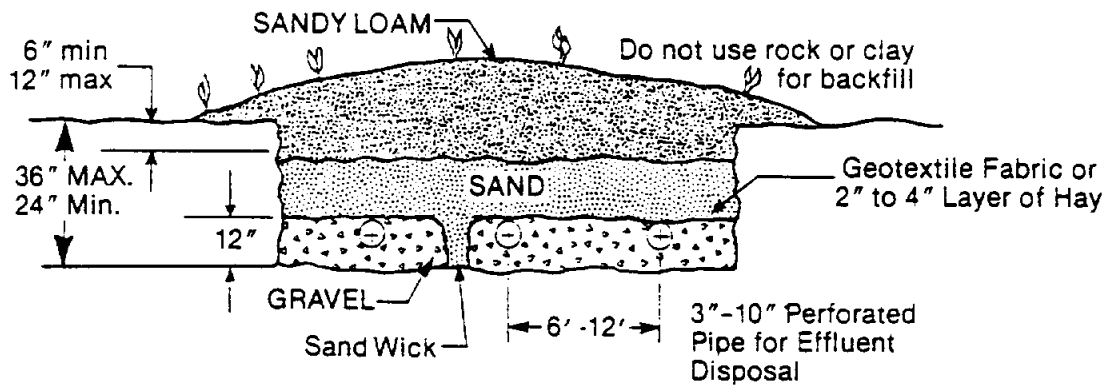

Section B-B

*Not intended to serve as an engineered design for construction purposes.*

Figure 5-2  
 Soil Absorption Bed

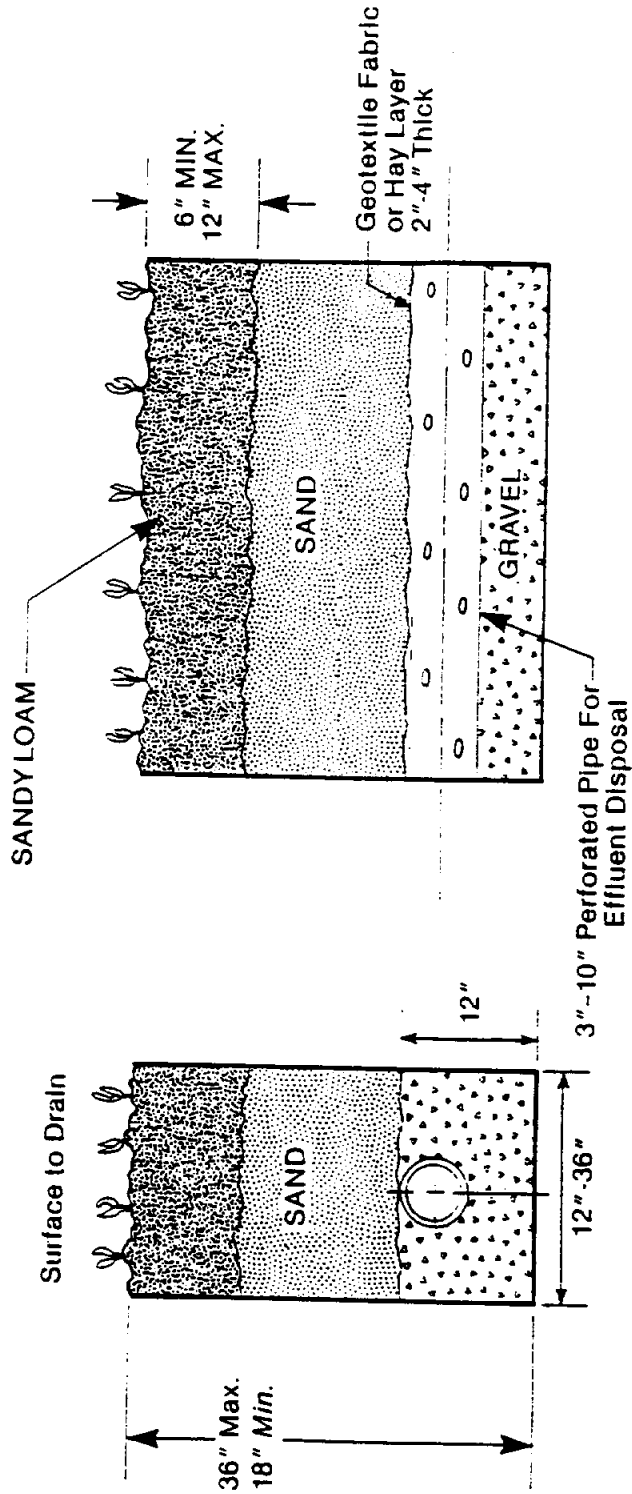

*Not intended to serve as an engineered design for construction purposes.*

**Figure 5-3**  
**Soil Absorption Trench**

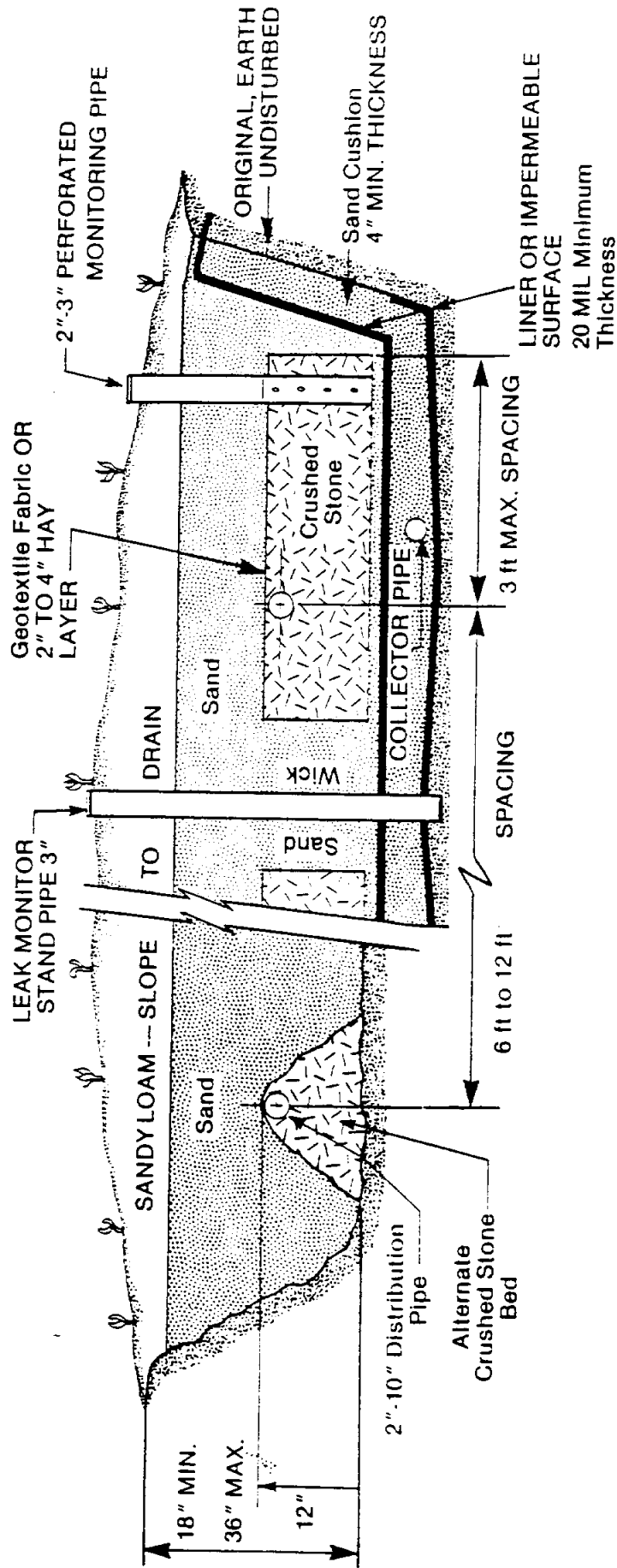

Figure 5-4  
 Evapotranspiration Bed

Sub-part (B) states:

Subdivisions of single family residences platted or designed after January 1, 1988, and served by a public water supply but utilizing individual subsurface methods for sewage disposal, shall provide for individual lots having surface areas of at least one-half acre, or shall have a site-specific design by a registered professional engineer or registered professional sanitarian and approved by the department or its designee. In no instance, shall the area available for such system be less than two times the design area.

Sub-part (D) further states:

The construction or installation of on-site sewerage facility on a lot or tract that is smaller than the size required in subparagraphs (B) and (C) of this paragraph shall not be allowed. However, on such smaller lots or tracts, designed or recorded with a county in its official plat record, deed, or tax records prior to January 1, 1988, an on-site sewerage facility may be permitted to be constructed and licensed to operate if it meets the following criteria. It must be demonstrated through a thorough investigation by a registered professional engineer, a registered professional sanitarian (either having demonstrated expertise in on-site sewerage system design) or by a designated representative of the licensing authority that an on-site sewerage facility on one of these lots can be operated without causing a threat or harm to an existing or proposed water supply system or to the public health, or creating the threat of pollution or nuisance conditions. Regardless of lot size utilized for an on-site sewerage facility, all other requirements contained in these sections still apply.

Conventional engineering practice generally recognizes lot sizes less than one-half acre as unsuitable for on-site septic systems regardless of drainfield design. In addition, these criteria were developed based on state-wide average household population and water use rates, both of which vary from the norm in colonias located in the Lower Rio Grande Valley.

The TDH has developed a flow sheet for selection of proper subsurface disposal methods (Figure 5-5) and criteria for soil absorption of sewage effluent (Table 5-1).

Section 301.13(c)(1) states:

(1) **General Considerations.** The effluent discharge from a septic tank or aerobic plant requires further handling to render it safe from a public health standpoint. A well-designed subsurface soil absorption system will allow these liquids to seep into the ground without creating a health hazard or nuisance. After the prospective builder has selected a suitable area and is assured that safe distances from wells, lakes, etc. can be maintained, the builder must determine, with the assistance of an experienced soils scientist, registered professional engineer or registered professional sanitarian whether soil formation in the selected area will allow a soil absorption system to work. When conventional soil absorption systems are used, there shall be no interference from ground water. The ground water table must be situated at least four feet below the bottom of the soil absorption system [emphasis added]. In the coastal areas of Texas, fresh or salt water may occur at depths less than four feet. The design standards for conventional soil absorption systems set forth in this publication are based on the premise that impervious strata are at depths greater than four feet below the bottom of the absorption trench. Conventional soil absorption systems shall not be used if either impervious strata or ground water exists at depths less than four feet from the trench or bed bottom, unless a detailed site evaluation is made and a design by a registered professional engineer or registered professional sanitarian is accepted by the local regulatory authority. [emphasis added]

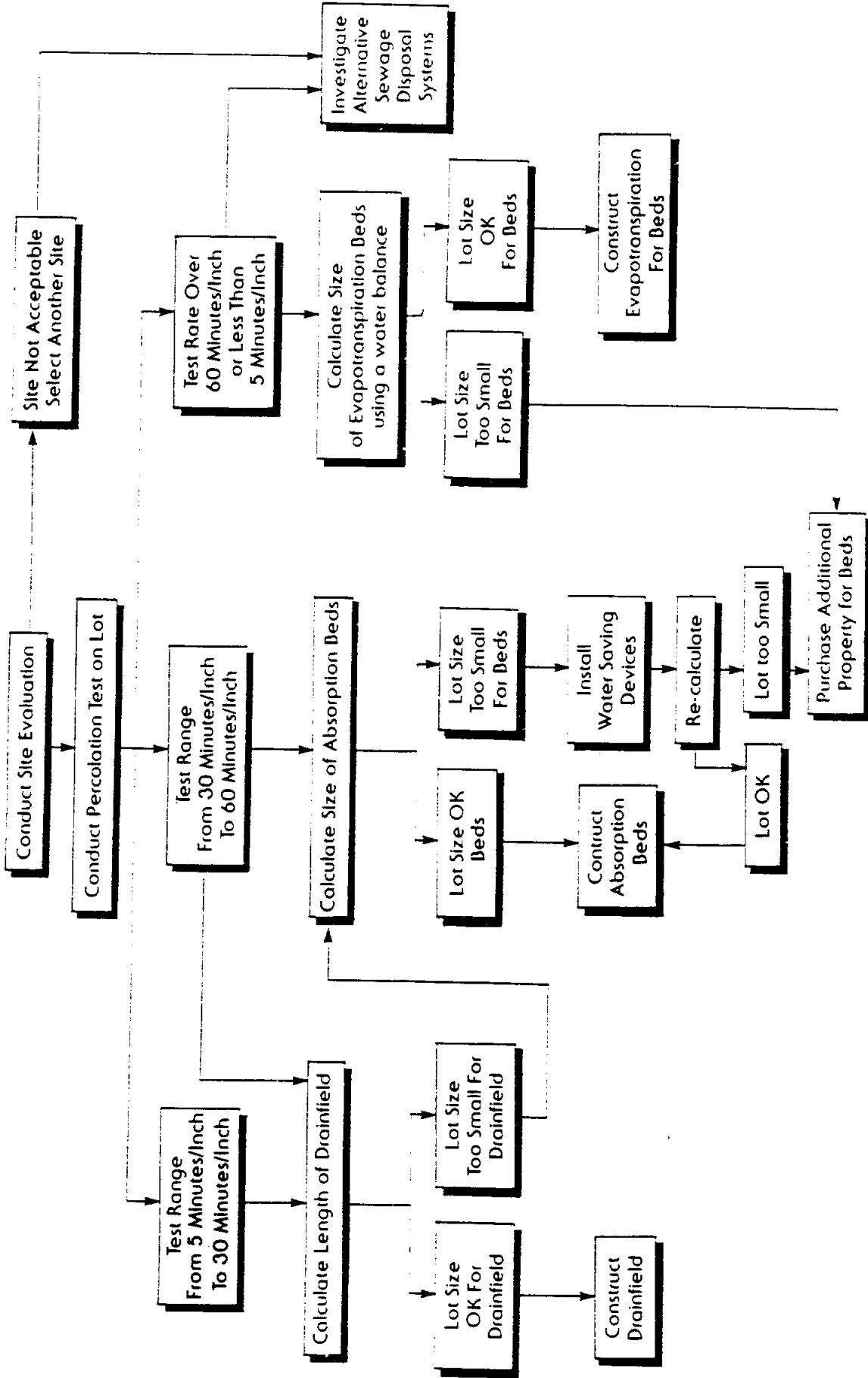

Figure 5-5  
 Flow Diagram for Selecting Proper Subsurface Disposal Methods

Table 5-1  
 Criteria for Soil Absorption of Sewage Effluent

Classification

Site Characteristic	Suitable	Provisionally Suitable (1)	Not Suitable
Topography	Slopes 0-15%	Slopes 15-30%	Slopes greater than 30% Complex slopes.
Subsoil Texture	Sandy soils Loamy soils	Clayey soils with low shrink-swell potential.	Clayey soils with high shrink-swell potential.
Subsoil Structure		Angular or subangular blocky.	Platy structure. Weathered rock. Massive clayey soils.
Soil Depth	Weathered rock or consolidated bedrock greater than 48 inches below the bottom of disposal system.	Weathered bedrock or consolidated rock from 36 to 48 inches below the bottom of disposal system.	Weathered rock or consolidated bedrock less than 36 inches below the bottom of disposal system.
Restrictive Layer	None within 36 inches of the ground surface.		Restrictive horizon within 36 inches of the ground surface or below the trench bottom.
Soil Drainage	No drainage mottles within 36 inches of the bottom of disposal system.		Drainage mottles (chroma 2 or less) within 36 inches of the bottom of disposal system.
Flooding			Areas subject to a possible flood. Depressional areas without adequate drainage.
Percolation	Greater than or equal to 5 min/inch but less than or equal to 60 min/inch.		Less than or equal to 5 min/inch or greater than 60 min/inch. Unselective fill materials.

(1) Soil may be reclassified from unsuitable to provisionally suitable under certain conditions using acceptable site or system modification.

### 5.1.1.3 Application Limitations

The Cameron County colonia household population count of 4.9 persons per household is approximately 70 percent higher than the 2.7 - 2.9 persons per household observed throughout most of Texas. Historical per capita water use rates, however, are less than statewide averages; due principally to the lack of supply and appropriate distribution facilities. As a result of greater supply availability, per capita use rates are expected to increase dramatically and eventually approach statewide averages. The PUB water use rates have shown a marked increase in areas where city services have been improved (John Bruciak, personal communication).

The TWC/TDH design criteria recommends a minimum one-half acre lot size as appropriate for septic systems. This is based on the 2.7 - 2.9 persons per household assumption. With the higher household population densities of Cameron County colonias, an equivalent minimum lot size would be approximately 0.85 acres. Therefore, a minimum lot size of at least one-half acre was adopted as a rigid rule to assess on-site septic systems as a viable alternative for each colonia.

Table 5-2 identifies the dominate soil type and depth to the seasonal high water table of each colonia. Using soil type, degree and kind of limitation for septic tank absorption fields, permeability and depth to seasonal high water table, the suitability of absorption trenches as an appropriate method of on-site septic system effluent disposal was assessed. Inspection of Table 5-2 shows that none of the colonias of Cameron County have soil and/or water table conditions appropriate for use of conventional trench-type septic system absorption beds. Therefore, only engineered on-site disposal systems, such as evapotranspiration beds or dosing mounds, was considered.

### 5.1.2 Grouped (Cluster) Systems

#### 5.1.2.1 Available Grouped System Technologies

Most grouped (cluster) wastewater disposal systems use a type of septic tank treatment and drainfield system designed to accommodate two or more dwellings. Texas Water Code exempts systems which treat less than 5,000 gpd from the formal permitting process. Thus, grouped or cluster systems are typically limited to 10 dwellings/system (5,000 gal/day)/(50 gpd/4.9 persons/dwelling).

Cluster systems suffer some of the limitations of on-site septic systems, avoid some of the problems of on-site systems, and create a new set of operation and maintenance difficulties. Cluster systems marginally reduce land requirements for the septic tank and drainfield because the required distances between individual on-site system drainfields is eliminated and they can use alternative disposal methods such as evapotranspiration beds or low pressure dosing mounds more efficiently. A wastewater collection system must be constructed and maintained in conjunction with a cluster system. The responsibility of operation

Table 5-2  
 Soils Summary and On-site  
 Absorption System Suitability for  
 Each Colonia

Colonia PUB Designation	Colonia	Soils Designation	Degree and Kind of Limitation for Septic Tank Absorption Fields	Permeability (in/hr)	Depth to Seasonal High Water Table (in)	Suitable for Absorption Trench On-Site Disposal (Y/N)
1B	Cameron Park	Laredo Silty Clay Loam (0-1% Slopes)	Moderate: Percs Slowly	0.06 - 0.20	36 - 120	N
		Laredo Silty Clay Loam (1-3% Slopes)	Moderate: Percs Slowly	0.06 - 0.20	36 - 120	N
		Olmito Silty Clay	Severe: Percs Slowly	0.06 - 0.20	36 - 120	N
2B	Olmito	Harlingen Clay	Severe: Percs Slowly	0.06	60 - 120	N
		Chargo Silty Clay	Severe: Percs Slowly	0.06 - 0.20	24 - 36	N
		Benito Clay	Severe: Percs Slowly; Wet	< 0.06	60 - 120	N
3B	Stuart Subdivision	Benito Clay	Severe: Percs Slowly; Wet	< 0.06	60 - 120	N
		Olmito Silty Clay	Severe: Percs Slowly	0.06 - 0.20	36 - 120	N
		Laredo Silty Clay Loam (0-1% Slopes)	Moderate: Percs Slowly	0.06 - 0.20	36 - 120	N
4B	San Pedro/Cameron/Barrera Gd	Tiocoano Clay	Severe: Floods; Percs Slowly	< 0.06	> 74	Y
		Laredo-Urban Land Complex	Severe: Percs Slowly; Wet	< 0.06	36 - 120	N
		Benito Clay	Severe: Percs Slowly; Wet	< 0.06	60 - 120	N
5B	King Subdivision	Benito-Urban Land Complex	Moderate: Percs Slowly	0.63 - 2.0	60 - 120	N
		Laredo-Urban Land Complex	Moderate: Percs Slowly	0.63 - 2.0	60 - 120	N
		Laredo Silty Clay Loam (0-1% Slopes)	Moderate: Percs Slowly	0.06 - 0.20	36 - 120	N
6B	Alabama/Arkansas (la Coma)	Laredo Silty Clay Loam (0-1% Slopes)	Moderate: Percs Slowly	0.06 - 0.20	36 - 120	N
		Olmito Silty Clay	Severe: Percs Slowly	0.06 - 0.20	36 - 120	N
		Olmito-Urban Land Complex	Severe: Percs Slowly	0.06 - 0.20	36 - 120	N
7B	Hacienda Gardens	Laredo-Urban Land Complex	Severe: Percs Slowly	0.06 - 0.20	60 - 120	N
		Rio Grande Silty Loam	Severe: Floods	0.63 - 2.0	> 63	N
		Benito Clay	Severe: Percs Slowly; Wet	< 0.06	60 - 120	N
8B	Villa Nueva	Olmito Silty Clay	Severe: Percs Slowly	0.06 - 0.20	60 - 120	N
		Laredo Silty Clay Loam (0-1% Slopes)	Moderate: Percs Slowly	0.06 - 0.20	36 - 120	N
		Laredo Silty Clay Loam (1-3% Slopes)	Moderate: Percs Slowly	0.06 - 0.20	36 - 120	N
9B	Villa Pancho	Rio Grande Silty Loam	Severe: Floods	0.63 - 2.0	> 63	N
		Laredo Silty Clay Loam (0-1% Slopes)	Moderate: Percs Slowly	0.06 - 0.20	36 - 120	N
		Olmito Silty Clay	Severe: Percs Slowly	0.06 - 0.20	36 - 120	N
10B	Pleasant Meadows	Benito Clay	Severe: Percs Slowly; Wet	< 0.06	60 - 120	N
		Olmito Silty Clay	Severe: Percs Slowly	0.06 - 0.20	60 - 120	N
		Cameron Silty Clay	Slight	0.20 - 0.63	60 - 120	N
11B	Villa Cavazos	Chargo Silty Clay	Severe: Percs Slowly	0.06 - 0.20	24 - 36	N
		Benito Clay	Severe: Percs Slowly; Wet	< 0.06	60 - 120	N
		Olmito Silty Clay	Severe: Percs Slowly	0.06 - 0.20	36 - 120	N
11B	Villa Cavazos	Laredo Silty Clay Loam (0-1% Slopes)	Moderate: Percs Slowly	0.06 - 0.20	36 - 120	N
		Olmito Silty Clay	Severe: Percs Slowly	0.06 - 0.20	36 - 120	N
		Laredo Silty Clay Loam (0-1% Slopes)	Severe: Percs Slowly	0.06 - 0.20	36 - 120	N



Soils Summary (Sub-Area B) continued

Colonia PUB Designation	Colonia	Soils Designation	Degree and Kind of Limitation for Septic Tank Absorption Fields	Permeability (in/hr)	Depth to Seasonal High Water Table (in)	Suitable for Absorption Trench On-Site Disposal (Y/N)
12B	Barrio Subdivision	Laredo-Urban Land Complex				
13B	Las Cuates	Lomaita Clay Laredo Silty Clay Loam (0-1% Slopes) Laredo Silty Clay Loam (0-1% Slopes)	Severe: Percs Slowly Moderate: Percs Slowly Moderate: Percs Slowly Severe: Percs Slowly	0.06 0.06 - 0.20 0.06 - 0.20	60 - 120 48 - 120 36 - 120	N N N
14B	Saldivar	Olmito Silty Clay Haringen Clay Benito Clay	Severe: Percs Slowly Severe: Percs Slowly; Wet Severe: Percs Slowly	0.06 < 0.06	60 - 120 60 - 120	N N
15B	Coronado	Olmito Silty Clay	Severe: Percs Slowly	0.06 - 0.20	36 - 120	N
16B	Unknown	Laredo-Olmite Complex Laredo Silty Clay Loam (0-1% Slopes) Benito Clay	Severe: Percs Slowly Moderate: Percs Slowly Severe: Percs Slowly; Wet Severe: Floods; Percs Slowly	0.06 - 0.20 0.06 - 0.20 < 0.06 0.06 - 0.20	60 - 120 60 - 120 36 - 120 > 50	N N N N
17B	Saldivar (II)	Matamoros Silty Clay Lomaita Clay Olmito Silty Clay	Severe: Percs Slowly Severe: Percs Slowly Moderate: Percs Slowly	0.06 0.06 - 0.20 0.06 - 0.20	48 - 120 36 - 120 36 - 120	N N N
18B	Valle Escondido	Haringen Clay	Severe: Percs Slowly	0.06	60 - 120	N
19B	Unnamed C	Benito Clay	Severe: Percs Slowly; Wet	< 0.06	60 - 120	N
20B	Unnamed D (Keller's Corner)	Olmito Silty Clay Laredo Silty Clay Loam (0-1% Slopes) Olmito Silty Clay	Severe: Percs Slowly Moderate: Percs Slowly Moderate: Percs Slowly	0.06 - 0.20 0.06 - 0.20 0.06 - 0.20	36 - 120 36 - 120 36 - 120	N N N
21B	Texas 4	Benito Clay Laredo Silty Clay Loam (0-1% Slopes) Laredo Silty Clay Loam (0-1% Slopes)	Severe: Percs Slowly; Wet Moderate: Percs Slowly Moderate: Percs Slowly	< 0.06 0.06 - 0.20 0.06 - 0.20	60 - 120 36 - 120 36 - 120	N N N
22B	511 Crossroads	Olmito Silty Clay Laredo-Urban Land Complex Laredo Silty Clay Loam (0-1% Slopes) Laredo Silty Clay Loam (Saline)	Severe: Percs Slowly Moderate: Percs Slowly Moderate: Percs Slowly Severe: Percs Slowly	0.06 - 0.20 0.06 - 0.20 0.63 - 2.0 0.06 - 0.20	36 - 120 36 - 120 60 - 120 24 - 36	N N N N
23B	Illinois Heights	Chargo Silty Clay Olmito Silty Clay Laredo Silty Clay Loam (Saline) Lomaita Clay	Severe: Percs Slowly Moderate: Percs Slowly Moderate: Percs Slowly Severe: Percs Slowly	0.06 - 0.20 0.63 - 2.0 0.06 0.06 - 0.20	36 - 120 60 - 120 48 - 120 36 - 120	N N N N
24B	Unknown (Brownsville Airport)	Laredo Silty Clay Loam (0-1% Slopes) Olmito Silty Clay	Moderate: Percs Slowly Severe: Percs Slowly	0.06 - 0.20 0.06 - 0.20	36 - 120 36 - 120	N N
25B	Valle Hermosa	Benito Clay	Moderate: Percs Slowly	0.06 - 0.20	36 - 120	N
26B	Unknown	Benito Clay Laredo Silty Clay Loam (0-1% Slopes) Laredo Silty Clay Loam (1-3% Slopes)	Severe: Percs Slowly; Wet Moderate: Percs Slowly Moderate: Percs Slowly	< 0.06 0.06 - 0.20 0.06 - 0.20	60 - 120 36 - 120 36 - 120	N N N
27B	Unnamed B (Hwy 802)	Olmito Silty Clay Olmito Silty Clay	Severe: Percs Slowly Moderate: Percs Slowly	0.06 - 0.20 0.06 - 0.20	36 - 120 36 - 120	N N
28B	21	Laredo Silty Clay Loam (0-1% Slopes) Laredo Silty Clay Loam (0-1% Slopes) Cameron Silty Clay Olmito Silty Clay	Moderate: Percs Slowly Moderate: Percs Slowly Slight Severe: Percs Slowly	0.06 - 0.20 0.20 - 0.63 0.06 - 0.20	36 - 120 0 - 23 36 - 120	N N N N

Soils Summary (Sub-Area W)

Colonia PUB Designation	Colonia	Soils Designation	Degree and Kind of Limitation for Septic Tank Absorption Fields	Permeability (in/hr)	Depth to Seasonal High Water Table (in)	Suitable for Absorption Trench On-Site Disposal (Y/N)
1W	Encantada	Laredo Silty Clay Loam (0-1% Slopes) Laredo Silty Clay Loam (1-3% Slopes) Laredo-Reynosa Complex (0-1% Slopes) Laredo-Reynosa Complex (1-3% Slopes) Rio Grande Silty Loam	Moderate: Percs Slowly Moderate: Percs Slowly Moderate: Percs Slowly Severe: Floods Severe: Floods; Percs Slowly	0.06 - 0.20 0.06 - 0.20 0.63 - 2.0 0.63 - 2.0 < 0.06	36 - 120 36 - 120 60 - 120 60 - 120 > 63	N N N N N
2W	Santa Maria	Tiicano Clay Laredo Silty Clay Loam (0-1% Slopes)	Moderate: Percs Slowly	0.06 - 0.20	60 - 120	N
3W	La Paloma	Laredo-Urban Land Complex Olmuito Silty Clay	Severe: Percs Slowly	0.06 - 0.20	60 - 120	N
4W	Los Indios	Laredo Silty Clay Loam (0-1% Slopes) Rio Grande Silty Loam	Moderate: Percs Slowly Severe: Floods	0.06 - 0.20 0.63 - 2.0	36 - 120 > 63	N N
5W	Bluetown	Laredo-Urban Land Complex Laredo Silty Clay Loam (0-1% Slopes)	Moderate: Percs Slowly	0.06 - 0.20	60 - 120	N
6W	T2 Unknown Subdivision	Laredo-Reynosa Complex (0-1% Slopes) Benito Clay	Moderate: Percs Slowly Severe: Percs Slowly; Wet	0.63 - 2.0 < 0.06	60 - 120 60 - 120	N N
7W	El Venadito	Raymondville Clay Loam Olmuito Silty Clay	Severe: Percs Slowly	0.20 - 0.63	60 - 120	N
8W	Carricitos-Landrum	Laredo Silty Clay Loam (0-1% Slopes) Laredo Silty Clay Loam (0-1% Slopes) Olmuito Silty Clay	Moderate: Percs Slowly Moderate: Percs Slowly Severe: Percs Slowly	0.06 - 0.20 0.06 - 0.20 0.06 - 0.20	60 - 120 36 - 120 36 - 120	N N N
9W	El Calaboz	Rio Grande Silty Loam	Severe: Floods	0.06 - 0.20	60 - 120	N
10W	Iglesia Antigua	Laredo Silty Clay Loam (0-1% Slopes)	Moderate: Percs Slowly	0.06 - 0.20	36 - 120	N
11W	Palmer	Olmuito Silty Clay Laredo Silty Clay Loam (0-1% Slopes)	Moderate: Percs Slowly Severe: Percs Slowly	0.06 - 0.20 0.06 - 0.20	60 - 120 36 - 120	N N
12W	Unknown (Mita 2)	Benito Clay	Severe: Percs Slowly; Wet	< 0.06	60 - 120	N
13W	Q Unknown (Santa Rosa)	Laredo Silty Clay Loam (0-1% Slopes) Tiicano Clay	Moderate: Percs Slowly Severe: Floods; Percs Slowly	0.06 - 0.20 < 0.06	36 - 120 60 - 120	N N
14W	W	Raymondville Clay Loam (Salline) Raymondville Clay Loam Raymondville Clay Loam Recombe Sandy Clay Loam Willacy Fine Sandy Loam (0-1% Slopes) Hidalgo Sandy Clay Loam Hidalgo Fine Sandy Loam (0-1% Slopes)	Severe: Percs Slowly Severe: Percs Slowly Severe: Percs Slowly Severe: Floods Slight Slight Slight	0.06 - 0.20 0.20 - 0.63 0.20 - 0.63 0.63 - 2.0 2.0 - 6.3 0.63 - 0.20 0.63 - 2.0	60 - 120 60 - 120 60 - 120 60 - 120 > 74 60 - 120 > 15	N N N N Y N N
15W	R Unknown (Santa Rosa)	Mercedee Clay (0-1% Slopes)	Severe: Percs Slowly	< 0.60	60 - 120	N
16W	X Unknown (La Feria)	Raymondville Clay Loam	Severe: Percs Slowly	0.20 - 0.63	60 - 120	N
17W	El Venadito	Raymondville Clay Loam Hidalgo Sandy Clay Loam Benito Clay Raymondville Clay Loam	Severe: Percs Slowly Severe: Percs Slowly Slight Severe: Percs Slowly; Wet	0.20 - 0.63 0.63 - 0.20 < 0.06 0.20 - 0.63	60 - 120 60 - 120 60 - 120 60 - 120	N N N N

Soils Summary (Sub-Area H)

Colonia PUB Designation	Colonia	Soils Designation	Degree and Kind of Limitation for Septic Tank Absorption Fields	Permeability (in/hr)	Depth to Seasonal High Water Table (in)	Suitable for Absorption Trench On-Site Disposal (Y/N)
1H	Las Palmas	Hidalgo-Urban Land Complex Hidalgo Sandy Clay Loam Raymondville Clay Loam Raymondville-Urban Land Complex Racombes Soils and Urban Land Racombes Sandy Clay Loam Willacy Fine Sandy Loam (0-1% Slopes)	Slight Severe: Percs Slowly  Severe: Floods Slight	0.63 - 0.20 0.20 - 0.63  0.63 - 2.0 2.0 - 6.3	60 - 120 60 - 120 60 - 120 36 - 72 60 - 120 60 - 120 > 74	N N N N N N Y
2H	Lago Subdivision	Chiargo Silty Clay Laredo Silty Clay Loam (0-1% Slopes) Tocano Clay	Severe: Percs Slowly Moderate: Percs Slowly Severe: Floods; Percs Slowly	0.06 - 0.20 0.06 - 0.20 < 0.06	24 - 36 60 - 120 > 74	N N Y
3H	26	Racombes Sandy Clay Loam Willacy Fine Sandy Loam (0-1% Slopes) Hidalgo Fine Sandy Loam (0-1% Slopes)	Severe: Floods Slight Slight	0.63 - 2.0 2.0 - 6.3 0.63 - 2.0	60 - 120 > 74 60 - 120	N Y N
4H	Lasana	Raymondville Clay Loam Racombes Sandy Clay Loam	Severe: Percs Slowly	0.20 - 0.63	60 - 120	N
5H	Rice Tracts	Rio Clay Loam Tocano Clay	Severe: Floods Severe: Floods; Percs Slowly Severe: Floods; Percs Slowly	0.63 - 2.0 0.63 - 2.0 < 0.06	60 - 120 36 - 72 > 74	N N Y
6H	Leal Subd. (Metes & Bounds)	Laredo Silty Clay Loam (0-1% Slopes) Harlingen Clay	Moderate: Percs Slowly	0.06 - 0.20	60 - 120	N
7H	Laguna Escondido Heights	Omito Silty Clay Raymondville Clay Loam	Severe: Percs Slowly Severe: Percs Slowly	0.06 0.06 - 0.20	60 - 120 60 - 120	N N

Soils Summary (Sub-Area E)

Colonia PUB Designation	Colonia	Soils Designation	Degree and Kind of Limitation for Septic Tank Absorption Fields	Permeability (in/hr)	Depth to Seasonal High Water Table (in)	Suitable for Absorption Trench On-Site Disposal (Y/N)
1E	La Coma Del Norte	Berito Clay Harlingen Clay Laredo-Olmito Complex	Severe: Percs Slowly; Wet Severe: Percs Slowly Severe: Percs Slowly	< 0.06 0.06 0.06 - 0.20	60 - 120 60 - 120 60 - 120	N N N
2E	Lozano	Raymondville Clay Loam Lyford Sandy Clay Loam	Severe: Percs Slowly Moderate: Percs Slowly; Wet	0.20 - 0.63 0.63 - 2.0	60 - 120 36 - 72	N N
3E	Latina Ranch	Lyford Sandy Clay Loam William Soil Defina Fine Sandy Loam Lozano Fine Sandy Loam Willacy Fine Sandy Loam	Moderate: Percs Slowly; Wet Severe: Percs Slowly Severe: Percs Slowly Severe: Percs Slowly Severe: Percs Slowly	0.63 - 2.0 0.63 - 2.0 2.0 - 6.3 2.0 - 6.3 2.0 - 6.3	36 - 72 36 - 72 60 - 72 36 - 72 > 74	N N N N Y
4E	Laureles	Harlingen Clay	Severe: Percs Slowly	0.06	60 - 120	N
5E	Del Mar Heights	Lomalta Clay	Severe: Percs Slowly	0.06	48 - 120	N
6E	Orason Ac/Chula Vista/Shoe.	Selita Silty Clay Loam Chargo Silty Clay Lomalta Clay	Severe: Floods; Wet Severe: Percs Slowly Severe: Percs Slowly	0.20 - 0.63 0.06 - 0.20 0.06	20 - 48 24 - 36 48 - 120	N N N
7E	Las Yescas	Harlingen Clay (Saline)	Severe: Shrink-Swell	0.06	60 - 120	N
8E	Unknown	Lozano Fine Sandy Loam Berito Clay	Severe: Percs Slowly Severe: Percs Slowly; Wet	2.0 - 6.3 0.06	36 - 72 60 - 120	N N
9E	Glenwood Acres Subd.	Olmito Silty Clay	Severe: Percs Slowly	0.06 - 0.20	60 - 120	N
10E	Unknown (Del Mar II)	Berito Clay Lomalta Clay	Severe: Percs Slowly; Wet Severe: Percs Slowly	0.06 0.06	60 - 120 48 - 120	N N
11E	Los Cuates	Selita Silty Clay Loam Laredo Silty Clay Loam (0-1% Slopes) Laredo Silty Clay Loam (1-3% Slopes) Tiocano Clay	Severe: Floods; Wet Moderate: Percs Slowly Moderate: Percs Slowly Severe: Floods; Percs Slowly	0.20 - 0.63 0.06 - 0.20 0.06 - 0.20 < 0.06	20 - 48 60 - 120 60 - 120 > 74	N N N Y
12E	25	Laredo-Olmito Complex	Severe: Percs Slowly	0.06 - 0.20	60 - 120	N
13E	Cisneros (Limon)	Berito Clay Berito Clay	Severe: Percs Slowly; Wet Severe: Percs Slowly; Wet	0.06 0.06	60 - 120 60 - 120	N N

and maintenance of such systems is often difficult to assign and, as a result, the operational efficiency of such systems is generally less than theoretically attainable. In addition, cluster systems suffer from the same disposal system limitations as individual on-site septic systems. If soil and water table conditions are non-conducive to trench or drainfield absorption systems, then costly engineered systems may be required.

### 5.1.3 Regional/Centralized Collection and Treatment

#### 5.1.3.1 Available Regional System Technologies

Regional or centralized collection and treatment of wastewater is most applicable where population densities are relatively high, on-site or cluster systems are infeasible, or significant environmental constraints require higher levels of treatment. The number of centralized treatment options available is large, ranging from simple pond systems to advanced activated sludge systems. Selection within this group is driven by the quantities of wastewater produced and the levels of treatment necessary to maintain State Water Quality Standards, protect sensitive environments or maintain designated receiving stream uses.

#### Pond Systems

The U.S. EPA has published Process Design Manual - Wastewater Treatment Facilities for Sewered Small Communities as part of the agency's Technology Transfer Program. Portions of the following sections describing regional/centralized systems have been excerpted from that document.

#### Stabilization Lagoons

Stabilization lagoons are typically earthen basins that rely on exposure to the sun and air to aid in waste decomposition. They rely on natural biological, chemical and physical processes for waste treatment. These processes, which may take place simultaneously, include sedimentation, digestion, oxidation, microbial synthesis, photosynthesis, endogenous respiration, gas exchange, aeration, evaporation and seepage.

Because of increasingly stringent effluent quality requirements, utilization of lagoons has become limited. Lagoon problems generally fall into three areas:

- unsatisfactory effluent quality,
- odors or other environmentally unsatisfactory characteristics and
- water loss.

The major advantages of lagoons are:

- wide variations in organic and/or hydraulic loadings are possible while maintaining consistent effluent quality; and
- only minimal maintenance and operational control is necessary.

The major disadvantages of lagoons are:

- relatively large land areas are required;
- localized odor problems can occur when they become anoxic; and
- effluent can contain significant levels of BOD and suspended solids resulting from algal and bacterial cell washout.

### Aerated Lagoons

Aerated lagoons differ from stabilization lagoons in that mechanical devices serve as the principal source of dissolved oxygen. Aerated lagoons offer many of the advantages of stabilization lagoons, but require less land area and are better at control of odors. They do, however, require installation of mechanical aerators which are both an expense and an extra maintenance requirement.

### Facultative Lagoons

Facultative lagoons are medium depth ponds with an aerobic zone overlying an anaerobic zone. Facultative bacteria (bacterial strains that can operate with or without dissolved oxygen) perform waste decomposition. Most wastewater treatment lagoons in the U.S. are facultative lagoons. They offer the advantage of less required area than stabilization lagoons but do not require mechanical aerators.

### Fixed Film Systems

#### Trickling Filters

A trickling filter contains a stationary medium providing surface area and void space. The zoogeal film develops on the surfaces and the void space allows air and wastewater to pass through the medium and come in contact with the microorganisms in the film. The organisms utilize the oxygen and material in the wastewater for their metabolism.

Many variations of trickling filter systems have been developed and used successfully (Figures 5-6 and 5-7). In the past, the trickling filter has been considered ideal for plants serving populations of 2,500 to 10,000 persons.

Historically, trickling filters have been popular for use in small plants, because they are seasonal and have the ability to recover from shock loads and to perform well with a minimum of skilled technical supervision.

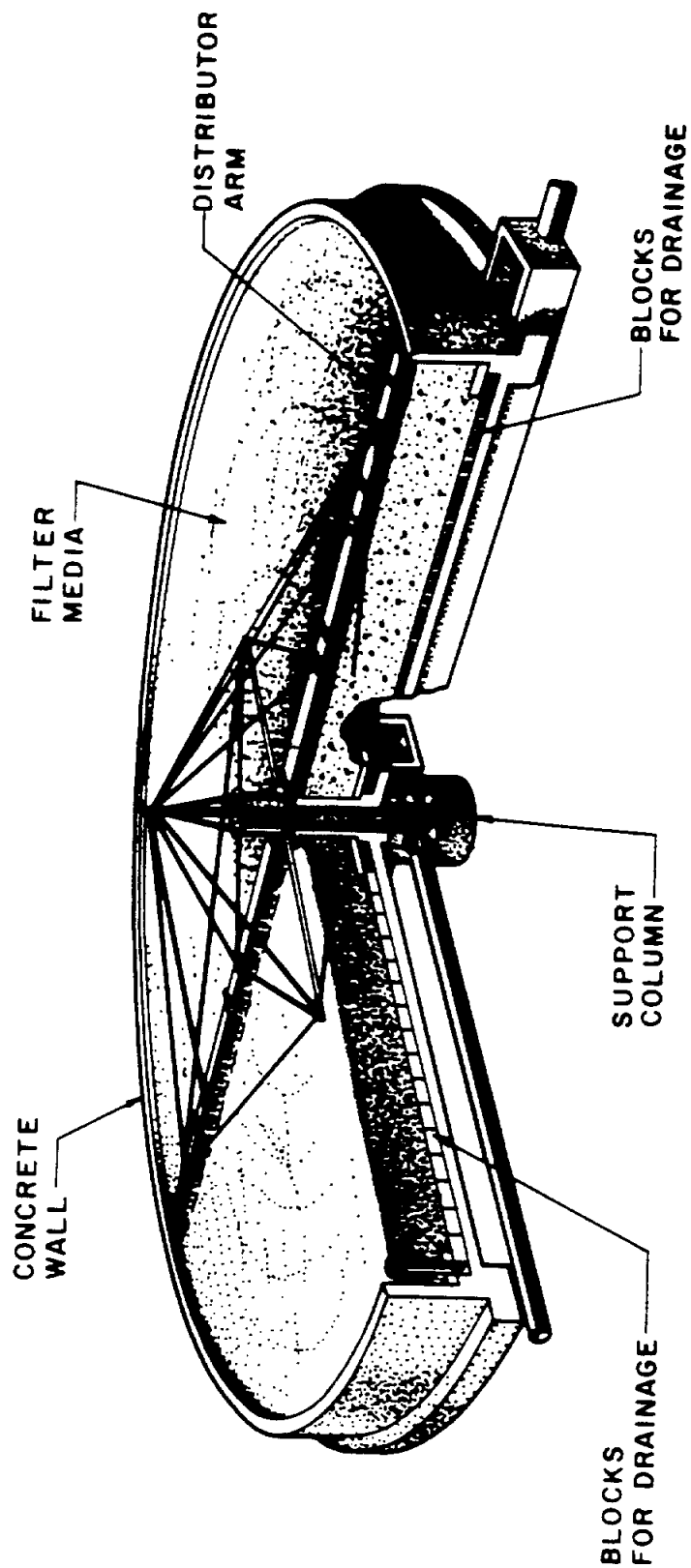

Figure 5-6  
Rock Media Trickling Filter

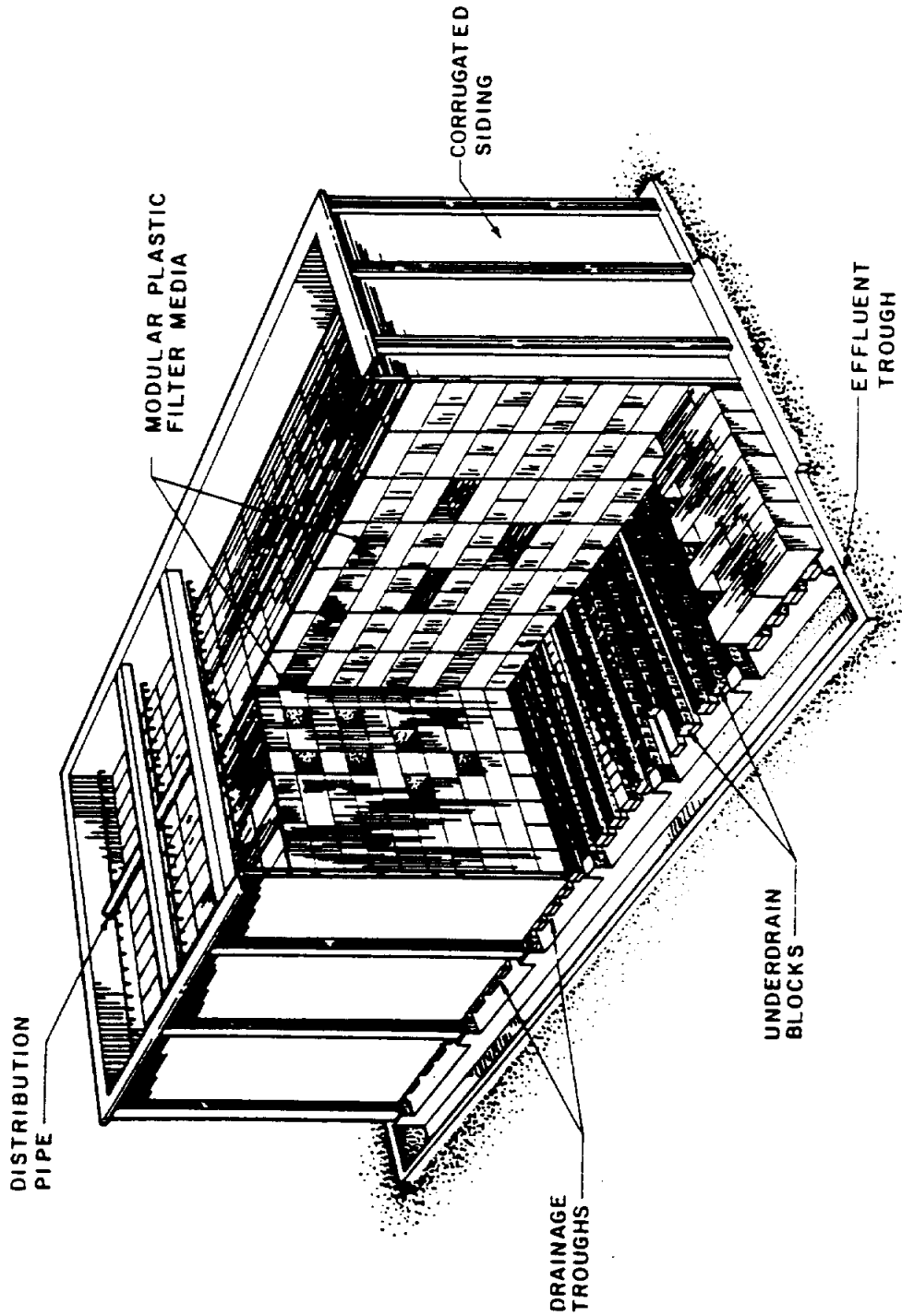

Figure 5-7  
Biooxidation Tower



### Rotating Biological Contractors

Rotating biological contractors (RBC) are gaining popularity worldwide. They have been used in plants that serve populations of 12,000 to 100,000 persons, treating both domestic and industrial wastes. The process has been developed in package plants for flows between 10,000 and 120,000 gpd. It has also been found suitable for plants up to 0.5 MGD and may be used for larger plants.

Basically, the process consists of a series of plastic disks mounted on a horizontal shaft and placed in a tank with a contoured bottom. The disks rotate slowly in the wastewater, with about 40 percent of the surface area submerged. During the rotation, the disks pick up a thin layer of wastewater, which flows over the disk surface and absorbs oxygen from the air. The fixed biomass film on the disk surface removes both dissolved oxygen and organic material from the wastewater. As the biomass becomes submerged in the wastewater, additional organic material is removed.

The rotation disk process is similar to the trickling filter process, because both use fixed growth reactors. Some of the advantages of trickling filters also apply to the rotating disk process. These advantages include economics, simple operation and maintenance, suitability for step and stage construction, resistance to organic and hydraulic shock loads, and low process control requirements.

### Activated Sludge Processes

Activated sludge has become the most versatile biological process available to the designer of wastewater treatment plants. The activated sludge process, designed for large communities and some pre-engineered (package) plants in small communities, has been successfully employed for decades.

"Activated sludge" describes a continuous flow, biological treatment system characterized by a suspension of aerobic micro-organisms. These micro-organisms are maintained in a relatively homogeneous state by the mixing and turbulence induced in conjunction with the aeration process. These conditions are in contrast to those in processes characterized by fixed growths of micro-organisms attached to solid surfaces, such as trickling filters.

Basically, the activated sludge process uses micro-organisms in suspension to oxidize soluble and colloidal organics in the presence of molecular oxygen. During the oxidation process, a portion of the organic material is synthesized into new cells. A part of the synthesized cells then undergoes auto-oxidation (self-oxidation, or endogenous respiration) in the aeration tank. Oxygen is required to support the synthesis and auto-oxidation reactions. To operate the process on a continuous basis, the solids generated must be separated in a clarifier; the major portion is recycled to the aeration tank and the excess sludge is withdrawn from the clarifier underflow for additional handling and disposal. The two basic units in an activated sludge system are the aerator and the clarifier. In a conventional system (Figure 5-8), the

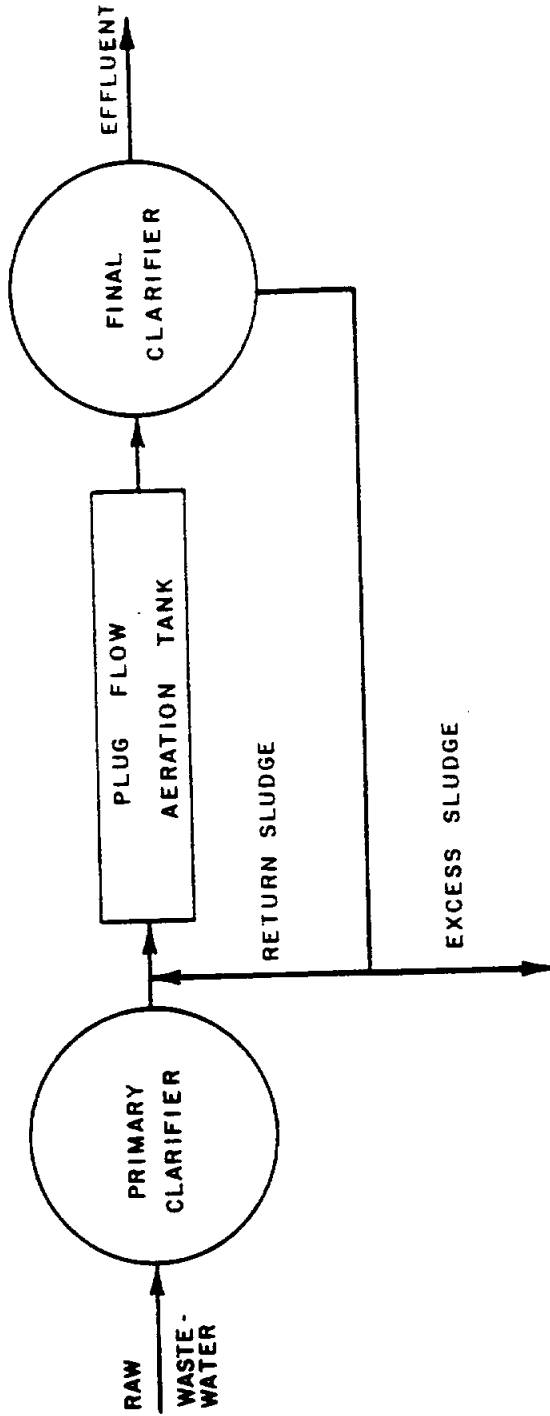

Figure 5-8  
Conventional Activated Sludge System

primary effluent and the return sludge enter one end of a rectangular tank and move turbulently through the aerated chamber in a substantially plug-type flow. They are then discharged as a treated mixture at the other end.

The (essentially) completely mixed activated sludge systems commonly used to treat wastewater from small communities are:

- Extended Aeration (low loading rate)
- Oxidation Ditch (low loading rate)
- Contact Stabilization (high loading rate)
- Completely Mixed (high loading rate).

#### Extended Aeration

Extended Aeration Systems (Figure 5-9) operate in the endogenous respiration phase of the bacterial growth cycle, which occurs when the BOD loading is so low that organisms are starved and undergo partial auto-oxidation. Because of the oxidation of more volatile solids during the long sludge retention time, the waste sludge production is relatively low. The hydraulic retention time in the aeration basin is about 24 hr.

#### Oxidation Ditches

Oxidation ditches (Figure 5-10) were originally developed in the Netherlands for the extended aeration process in small towns. It consists of a continuous channel, usually in the form of an oval "racetrack" or ring with an aeration rotor (or rotors) revolving on a horizontal shaft. This system supplies oxygen by intense surface agitation and also circulates the liquid around the channel. It is considered to be a low rate system with a completely mixed flow.

For an oxidation ditch to function satisfactorily, the velocity gradients and DO's in all parts of the ditch should be relatively constant. To maintain a relatively uniform DO, the velocity in the channels should ensure that the travel time between aerators is no more than 3 to 4 minutes.

#### Contact Stabilization System

Contact stabilization systems (Figure 5-11) are adapted to wastewaters that have an appreciable amount of BOD in the form of suspended and colloidal solids. The highly adsorptive properties of activated sludge are used to physically adsorb the suspended and colloidal solids in a short contact period. Primary settling may be omitted, but an equalization unit may be necessary for reliable performance. The raw wastewater is contacted with aerated sludge in a contact basin and completely mixed and aerated. Suspended, colloidal, and some dissolved organics, are adsorbed on the activated sludge in an average hydraulic

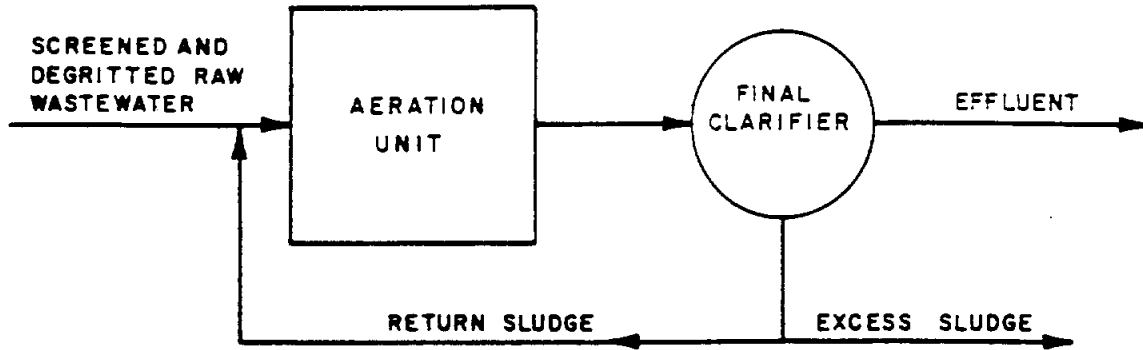

Figure 5-9  
Extended Aeration Activated Sludge System

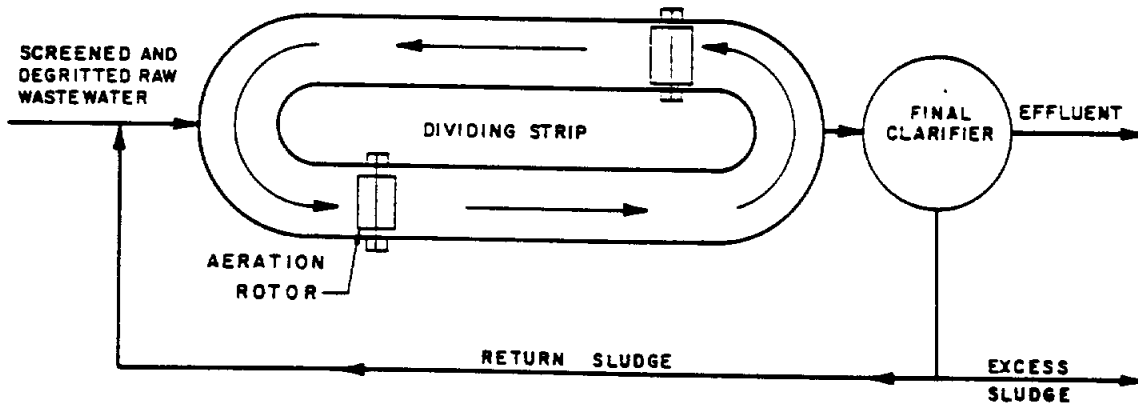

Figure 5-10  
Oxidation Ditch Activated Sludge System

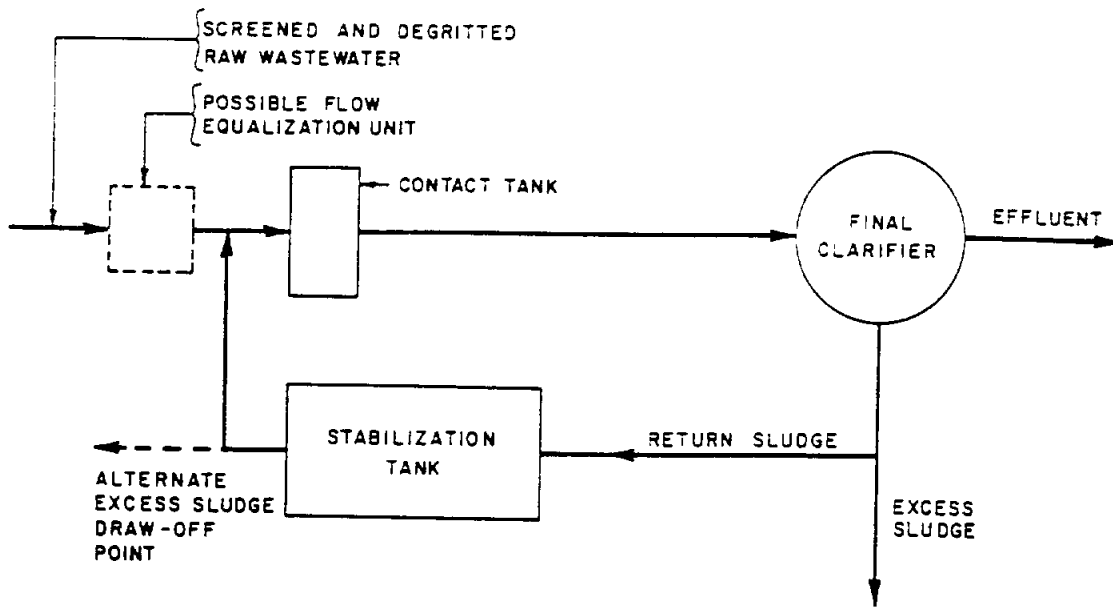

Figure 5-11  
Contact-Stabilization Activated Sludge System

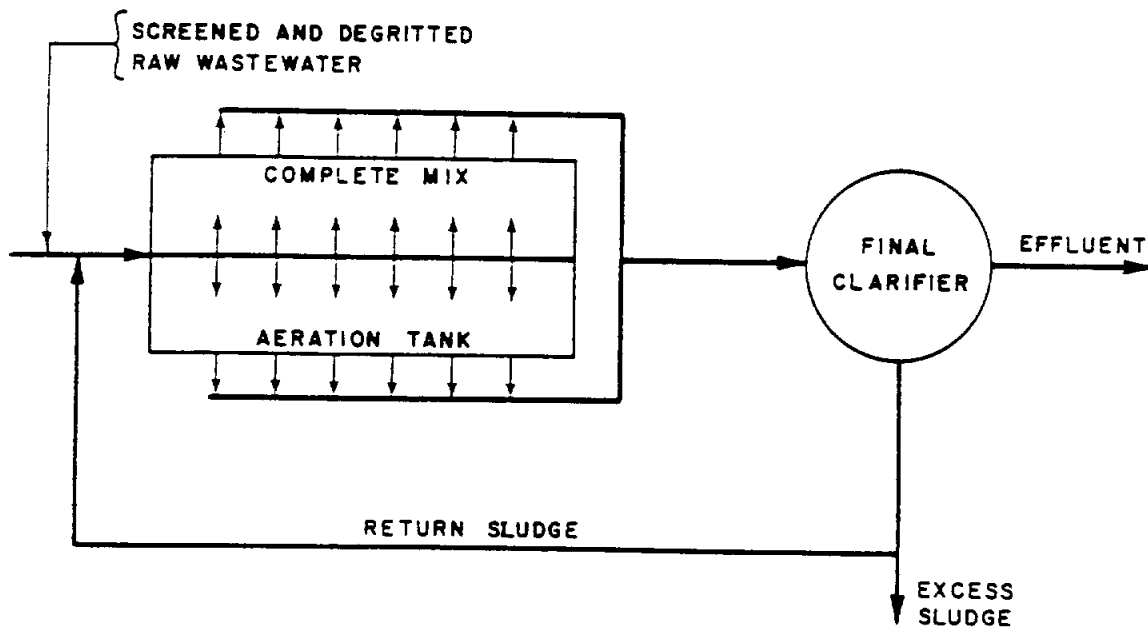

Figure 5-12  
Completely Mixed Activated Sludge System

retention time of 20 to 40 minutes. The sludge is then settled and returned to a stabilization (reaeration) basin with a retention time of 4 to 8 hr, based on the sludge flow. For very small or package plants, the retention time in the stabilization basin has been increased to 24 hr with good results. The adsorbed organics undergo oxidation and are synthesized into microbial cells in the stabilization basin. This process can handle shock organic and toxic loads better than a conventional process, because of the buffering capacity of the sludge reaeration tank, which is isolated from the mainstream of flow. Generally, the total aeration basin volume (contact plus stabilization basins) is only about 50 percent of that required in the conventional system.

#### Completely Mixed System

In a high-rate completely mixed system (Figure 5-12), as in low-rate completely mixed systems, all portions of the aeration basin are essentially homogeneous, resulting in a uniform oxygen demand throughout the aeration tank. This condition can be accomplished fairly simply in a symmetrical (square or circular) basin with a single mechanical aerator or by diffused aeration. The raw wastewater and return sludge enter at a point (e.g., under a mechanical aerator) where they are quickly dispersed throughout the basin. In rectangular basins with mechanical aerators or diffused air, the incoming waste and return sludges are distributed along one side of the basin and the mixed liquor is withdrawn from the opposite side.

All parts of the basin receive the same organic load, and all organisms are fed uniformly. This allows higher loadings, resulting in a more stable system. It also allows shock and toxic loads to be handled without the detrimental effect on microorganisms that occurs in plug flow systems. However, the high-rate completely mixed system is slightly less efficient than plug flow, oxidation ditch or contact stabilization systems.

#### 5.1.4 Connection to an Existing Regional System

##### 5.1.4.1 Available Existing Systems

#### Existing and Future Available Treatment Capacities

There are numerous existing wastewater treatment facilities operating in Cameron County. Some of these have excess capacity that could be used to serve one or more nearby colonia. Others could be expanded to provide colonia service. Table 5-3 shows all currently permitted wastewater treatment facilities in Cameron County. Table 5-4 shows when the projected wastewater growth within each of the service areas will reach the existing treatment capacity, necessitating construction of additional capacity. Only the Cities of Los Fresnos and Santa Rosa appear to have sufficient capacity to serve their own projected demand through the 2020 planning horizon. Even with the current expansion to the North Side Plant, the PUB will require additional capacity by 1998. Harlingen has recently permitted an additional 3.25 MGD facility that will provide adequate capacity through 2010. And San Benito's flows currently exceed existing

Table 5-3  
 Municipal and Industrial Dischargers in Cameron County  
 Permitted Capacities, 1988 Maximum Month and Available Capacities

Seg. No.	Municipal Discharge		Wastewater Discharge Data									
	Permit No.	Permit Holder	Annual Avg. Flow (MGD)	Dily. Avg. BOD (mg/L)	Dily. Avg. NH3 (mg/L)	Avg. Flow (MGD)	Dily. Avg. BOD (mg/L)	Dily. Avg. NH3 (mg/L)	Max. Month Usage	Avg. Flow (MGD Avail.)	Avg. Flow (% Used)	Max. Month Capacity
2201	10972-002	Palm Valley Est.	0.280	20.0						0.280	0.00	100.00
2201	10475-002	Rio Honda	0.150	30.0					0.150	0.00	100.00	
2202	10490-003	Harlingen No.2	3.500	20.0		2.760	28.00		0.720	79.43	20.57	
2202	10490-002	Harlingen No.1	3.100	20.0		2.510	14.00		0.590	80.97	19.03	
2202	10473-002	San Benito	2.180	30.0		2.000	60.00		0.160	92.59	7.41	
2202	10987-001	La Feria	0.500	30.0		1.154	35.00		-0.654	230.80	-130.80	
2202	11628-001	Winter Garden Pk.	0.110	20.0		0.005	8.00		0.106	4.36	95.64	
2202	11959-001	Harlingen Cons. ISD	0.008	20.0					0.008	0.00	100.00	
2301	10397-003	PUB - S. Side Plant	7.800	20.0		6.434	8.00		1.366	82.49	17.51	
2301	12923-001	Playa Del Rio	0.070	20.0		Not Constructed						
2302	10952-001	Valley MUD 001	0.130	20.0					0.130	0.00	100.00	
2302	11348-002	Valley MUD 002	0.115	20.0					0.115	0.00	100.00	
2401	10757-001	CC FWSD #1 Isl. Bl.	1.500	10.0	15.0	1.717	6.30		-0.217	114.47	-14.47	
2491	11383-001	CCFWSD #1 Andy B	0.750	10.0	15.0	0.371	3.70		0.379	49.47	50.63	
2491	10330-001	Santa Rosa WCID	0.390	20.0		0.263	5.00		0.127	67.54	32.46	
2491	12321-001	U.S. Dept. Justice	0.080	20.0		0.081	2.00		-0.001	101.25	-1.25	
2491	12517-001	Fig Tree RV Park	0.024	20.0		0.001	8.00		0.023	6.17	94.83	
2493	12741-001	Berrymen Builders	0.020	20.0					0.020	0.00	100.00	
2494	11803-001	PUB - N. Robinsdale	5.000	20.0					1.594	68.12	31.88	
2494	10350-001	CC FWSD #1 Pt. Is.	1.500	10.0	15.0	1.033	7.10		0.487	68.87	31.13	
2494	10332-005	Brownsville ND	1.000	20.0		0.061	9.00		0.939	6.10	93.90	
2494	10332-001	Brownsville ND	0.880	20.0		0.043	8.00		0.937	4.39	95.61	
2494	10590-001	Los Fresnos	0.590	20.0		0.263	4.25		0.307	47.97	52.03	
2494	11348-001	Valley Mud 002	0.400	20.0					0.400	0.00	100.00	
2494	13041-001	St. Francis of Assis	0.350	20.0					0.350	0.00	100.00	
2494	12580-001	Las Palmas STP	0.330	20.0		0.030	12.50		0.300	9.09	90.91	
2494	10397-004	PUB Rio Del Sol	0.040	20.0					0.040	0.00	100.00	
			30.875						8.633			
<b>Industrial Discharges</b>												
2202	01258-001	CP&L La Palma	1.200			1.210			-0.010	100.83	-0.83	
2494	02817-001	Brownsville ND	0.250	42.0		0.152	14.00		0.098	60.80	39.20	
			1.450						0.088			

**Segment Identification**  
 2201 Arroyo Colorado Tidal  
 2202 Arroyo Colorado Above Tidal  
 2301 Rio Grande Tidal  
 2302 Rio Grande Below Falcon Reservoir  
 2491 Laguna Madre  
 2493 South Bay  
 2494 Brownsville Ship Channel

Table 5-4  
 Projected Wastewater Treatment Capacity Requirement  
 1990-2020

Entity	Permitted Capacity (gpd)	Exceeded a/	Capacity (gpd)							
			1990	1995	2000	2005	2010	2015	2020	
Brownsville	12,800,000	1995	11,858,000	14,114,600	16,371,200	18,066,400	19,761,600	21,757,600	23,753,600	
Harlingen	9,850,000	2015	6,142,700	6,842,900	7,543,100	8,324,600	9,106,100	10,025,900	10,945,600	
San Benito	2,160,000	1990	2,406,400	2,671,500	2,936,500	3,240,700	3,544,900	3,903,000	4,261,000	
Los Fresnos	590,000	2014	330,900	392,300	453,700	500,800	547,800	603,100	658,300	
Rio Hondo	150,000	1990	237,100	269,900	302,700	334,000	365,300	402,200	439,100	
La Feria	500,000	1990	499,400	559,400	619,400	683,600	747,700	823,200	898,700	
Port Isabel	1,500,000	2020	482,300	529,600	576,900	636,700	696,400	766,800	837,100	
Santa Rosa	390,000	2011	253,100	286,500	319,800	352,900	386,000	425,000	464,000	

a/ Year that wastewater treatment requirements are expected to exceed available capacity.



treatment capacity. The remainder of the county's permitted facilities will reach capacity by the late 1990's. Therefore, if any of the existing systems (with the exception of Los Fresnos and Santa Rosa) are to serve any colonias, additional capacity will have to be designed into future plant expansions or new plant construction.

### Treatment Levels and Discharge Methods

All of the currently permitted wastewater treatment systems in Cameron County, with the exception of Port Isabel and South Padre Island, discharge either directly to the Arroyo Colorado or to water courses tributary to the Arroyo Colorado, Brownsville Ship Channel or Rio Grande. The discharge limits (i.e., required levels of treatment) of each permit is set by the TWC and reflects treatment levels necessary to maintain the health, integrity and designated uses of the receiving stream.

Within Cameron County, most wastewater treatment facilities have limits of 20/20 (i.e., 20 mg/L BOD<sub>5</sub> and 20 mg/L TSS). The exceptions are those held by the three Cameron County Freshwater Supply District No.1 plants, which all discharge to the Laguna Madre, and the recently permitted City of Harlingen Plant (10490-004) all of which treat to a 10/15 level. This may change as a result of future TWC Wasteload Evaluations of each of the three segments.

## 5.2 Colonia - Specific Disposal Options

### 5.2.1 Preliminary Wastewater Options Selection Flow Diagram

The reconnaissance level study of the Water Supply and Wastewater Disposal Needs of the Colonias of the Lower Rio Grande Valley produced for the TWDB by Turner Collie & Braden, Inc. (TC&B, 1987) contained a flow diagram for selection of candidate treatment alternatives for each colonia. That TC&B matrix has been modified slightly and used in this study.

#### 5.2.1.1 Matrix Description

Preliminary identification of each Cameron County colonia by Class was accomplished through application of the flow diagram shown in Figure 5-13. The classes assigned to each colonia are described as follows:

- **Class I** - If a colonia is within two miles of an existing regional wastewater treatment system or within the ETJ of an incorporated city with a treatment facility, then service can be provided to the colonia(s) by:
  - (1) extending or expanding the existing collection system or
  - (2) development of new components of the system specifically to serve the colonia(s).

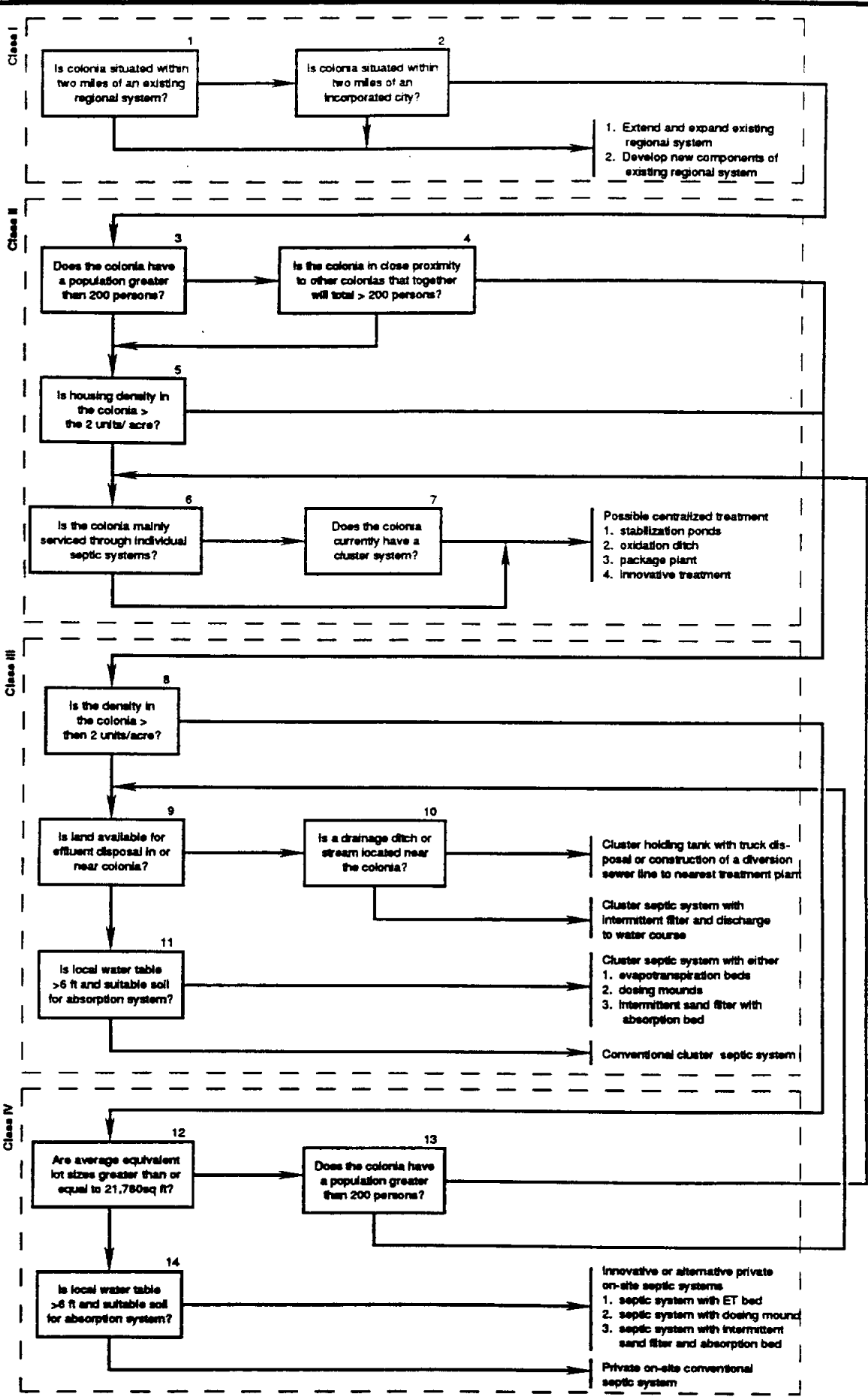

Figure 5-13  
Treatment Option Flow Diagram

- **Class II** - If a colonia, or closely grouped system of colonias, have an aggregate population greater than 200 persons **and** a housing density greater than two units per acre then the colonia(s) are candidate(s) for a centralized treatment system.
- **Class III** - If a colonia has less than 200 persons and a housing density greater than 2 units per acre **or** more than 200 persons and a housing density less than or equal to two units per acre, then the colonia **may** be a candidate for a cluster septic system (depending on other limitations).
- **Class IV** - If a colonia has less than 200 persons **and** a housing density less than or equal to two units per acre, then the colonia **may** be a candidate for on-site septic system disposal (depending on other limitations).

Each of these classifications is also restricted by sound engineering judgement and by design criteria associated with each technology.

#### 5.2.1.2 Matrix Application

Each of the 65 colonias in Cameron County was assigned a classification according to the preliminary wastewater options selection flow diagram (Table 5-5). As would be expected, all of the colonias of Sub-areas B and H are considered as Class I because the sub-area boundaries were defined to correspond to the ETJ of Brownsville (Sub-area B) or the aggregate ETJs of Harlingen, San Benito, Rio Hondo, Combes, Primera and Palm Valley (Sub-area H). Thus, the preliminary option for all colonias of these two sub-areas is to install wastewater collection systems and transport, generally through force mains, the wastes to one of the existing organized systems for disposal. This option is, perhaps, more final in Sub-area B than in Sub-area H, as the PUB has expressed both a willingness and desire to eventually serve all subdivisions within their ETJ.

Within Sub-area H, the Cities of Harlingen and San Benito are the two logical sources of wastewater treatment and disposal for the colonia wastes. Both cities have an organized wastewater collection and treatment system that can accommodate colonia wastes as a minor component of their total treatment load; additional year 2020 loads to Harlingen would be approximately 190,000 gpd and the San Benito load would be approximately 110,000 gpd.

In Sub-area W the only available source of regional treatment (i. e., designated Class I) is Santa Rosa. The total additional year 2020 load to the plant, from colonias, would be approximately 100,000 gpd.

Table 5-5  
 Colonia Classification

Class I						Class II						
Col. Desig.	Colonia Name	2020 Pop.	2020 Unit Density (1/Ac)	2020 WW Gen. (MGD)	Potential Connection to Existing POTW	Col. Desig.	Colonia Name	2020 Pop.	2020 Unit Density (1/Ac)	2020 WW Gen. (MGD)		
1B	Cameron Park	7,327	4.15	0.73	Brownsville	2W	Santa Maria	2,306	5.89	0.231		
2B	Olmite	3,532	1.86	0.35	Brownsville	3W	La Paloma	861	2.48	0.086		
3B	Stuart Subdivision	1,960	8.02	0.20	Brownsville	5W	Bluetown	580	2.00	0.058		
4B	San Pedro/Carmen	1,450	4.07	0.15	Brownsville	9W	El Calaboz	260	3.17	0.026		
5B	King Subdivision	1,265	4.16	0.13	Brownsville	10W	Iglesia Antigua	206	4.20	0.021		
6B	Alabama/Arkansas	1,022	0.86	0.10	Brownsville	TOTAL Subarea W		4,213		0.421		
7B	Hacienda Gardens	944	3.78	0.09	Brownsville	2E	Lozano	680	2.78	0.007		
8B	Villa Nueva	798	2.55	0.08	Brownsville	3E	La Tina Ranch	662	2.29	0.007		
9B	Villa Pancho	603	1.66	0.06	Brownsville	7E	Las Yescas	281	3.56	0.003		
10B	Pleasant Meadows	584	2.90	0.06	Brownsville	8E	Unknown	262	3.31	0.003		
11B	Villa Cavazos	399	2.31	0.04	Brownsville	TOTAL Subarea E		1,885		0.019		
12B	Barrio Subdivision	389	4.39	0.04	Brownsville	TOTAL CLASS II				6,098		0.440
13B	Las Cuates	379	1.71	0.04	Brownsville							
14B	Saldivar	302	1.41	0.03	Brownsville							
15B	Coronado	302	1.11	0.03	Brownsville							
16B	Unknown	282	1.93	0.03	Brownsville							
17B	Saldivar (II)	272	1.70	0.03	Brownsville							
18B	Villa Escondido	272	1.47	0.03	Brownsville							
19B	Unnamed C	263	2.25	0.03	Brownsville							
20B	Unnamed D (Keller's)	243	2.27	0.02	Brownsville							
21B	Texas 4	243	1.52	0.02	Brownsville							
22B	511 Crossroads	243	1.72	0.02	Brownsville							
23B	Illinois Heights	204	1.68	0.02	Brownsville							
24B	Unkn. (Bmsvile Air.)	195	1.90	0.02	Brownsville							
25B	Villa Hermosa c/	126	1.37	0.01	Brownsville							
26B	Unknown c/	117	0.63	0.01	Brownsville							
27B	Unknown B (Hwy 802)	97	1.91	0.01	Brownsville							
28B	21	88	2.00	0.01	Brownsville							
TOTAL Subarea B		23,901		2.39								
1H	Las Palmas	1,103	2.88	0.11	Harlingen							
2H	Lago Subdivision	695	3.46	0.07	San Benito							
3H	26	504	2.51	0.05	Harlingen							
4H	Lasana	217	2.00	0.02	Harlingen							
5H	Rice Tracts b/	234	1.50	0.02	San Benito							
6H	Leal Subdivision b/	217	1.83	0.02	San Benito							
7H	Lag Escond. Hghts. c/	95	1.10	0.01	Harlingen							
TOTAL Subarea H		3,065		0.31								
6W	T2 Unknown Sub. b/	431	1.96	0.04	Santa Rosa							
13W	Santa Rosa	241	3.06	0.02	Santa Rosa							
15W	South Santa Rosa b/	196	1.60	0.02	Santa Rosa							
17W	S b/	116	0.96	0.01	Santa Rosa							
TOTAL Subarea W		984		0.10								
6E	Las Yescas b/	464	0.45	0.05	Los Fresnos							
11E	Los Cuates	261	2.41	0.03	Los Fresnos							
TOTAL Subarea E		725		0.07								
TOTAL CLASS I		28,675		2.87								

Table 5-5  
 Colonia Classification (Continued)

Class III					Class IV				
Col. Desig.	Colonia Name	2020 Pop.	2020 Unit Density (1/Ac)	2020 WW Gen. (MGD)	Col. Desig.	Colonia Name	2020 Pop.	2020 Unit Density (1/Ac)	2020 WW Gen. (MGD)
1W	Encantada	1,641	1.56	0.164	12W	Unknown	169	1.06	0.0169
4W	Los Indios	699	1.43	0.070	14W	W	137	0.58	0.0137
7W	El Venadito	287	1.44	0.029	16W	X Unknown	116	1.5	0.0116
8W	Carricitos-Landrum	275	0.48	0.028	TOTAL Sub-area W		422		0.0422
11W	Palmer	285	1.81	0.029	12E	25	75	0.47	0.0075
TOTAL Subarea W		3,187		0.319	13E	62	144	1.44	0.0144
1E	La Coma Del Norte	868	1.77	0.087	TOTAL Sub-area W		219		0.0219
4E	Laureles	381	1.34	0.038	TOTAL CLASS IV		641		0.0641
5E	Del Mar Heights	483	0.48	0.048					
9E	Glenwood Acres	218	1.41	0.022					
10E	Unknown (Del Mar II)	290	0.95	0.029					
TOTAL Subarea E		2,240		0.224					
TOTAL CLASS III		5,427		0.543					

Based on the matrix analysis, Los Fresnos provides the only entity capable of providing service to the colonias of Sub-area E. If Los Fresnos accepts the wastes from all colonias within two miles of their system, it will increase the load to their plant by 110,000 gpd.

Because their populations and housing densities are relatively high, Class II colonias are considered candidates for conventional organized collection and treatment systems. Depending on the magnitude of the waste stream and receiving stream treatment level requirements, candidate treatment systems range from simple ponds (facultative or aerated lagoons) to activated sludge processes (constructed on-site or skid mounted package plants) or trickling filters. More often than not, receiving stream requirements drive the economics and ultimate option selection.

Within Subarea-W there are eight colonias which ostensibly qualify as Class II: Encantada (1W), Santa Maria (2W), La Paloma (3W), Los Indios (4W), Bluetown (5W) and Palmer (11W). The total projected year 2020 flow from those colonias totals 663,000 gpd. Two colonias located far apart on Highway 281, Encantada and Santa Maria, account for nearly 60% of the projected flow. All of the colonias along US Hwy. 281 west of Brownsville are served by Military Highway WSC, which has expressed the desire and intent to eventually provide wastewater service to the majority of their colonia water customers. A facilities engineering report produced by J. W. Fontain for Military Highway WSC in the mid 1980s analyzes the collection and treatment options for most of the US Hwy. 281 colonias within their service area.

Sub-area E has six colonias that qualify as Class II: La Coma Del Norte (1E), Lozano (2E), La Tina Ranch (3E), Las Yescas (7E), Unknown (8E) and Glenwood Acres (9E). Except for La Coma Del Norte and one other (8E), the six colonias are widely spread throughout the sub-area. The total wastewater flow of these colonias is projected at 297,000 gpd.

Only three colonias each in Sub-areas E: Del Mar Heights (5E), Del Mar II (10E) and Cisneros (13E) and Sub-areas W: Carricitos - Londrum (8W), Mitla 2 (12W) and Unknown (16W) are considered Class III. Barring other limitations, such as poor soils or overriding environmental concerns, these colonias are considered prime candidates for cluster type wastewater treatment and disposal systems. As a result of the flow chart analysis, only one colonia, Colonia 25 (12E) is considered Class IV.

#### 5.2.1.3 Classification Modification as a Result of Engineering Judgement

Examination of the colonia location maps for each sub-area shows natural colonia groupings that warrant further examination. Near the City of Santa Rosa, in Sub-area W, are five tightly clustered colonias: T2 Unknown (6W), Santa Rosa (13W), South Santa Rosa (15W), Colonia S (17W) and X-Unknown (16W). All but X-Unknown lie within two miles of the City of Santa Rosa, which currently has treatment facilities; these four are, thus, classified as Class I. Colonia X-Unknown has a 2020 projected population of only 116

persons; however, lot sizes are relatively small and this makes on-site septic systems unattractive. However, X-Unknown is very close to Colonia Santa Rosa. Therefore, it is recommended that all five colonias be sewerred and their wastes sent to the City of Santa Rosa by force main for treatment and disposal.

Near the intersection of Ranch Roads 1847 and 510 in Sub-area E are also five clustered colonias: La Coma Del Norte (1E), Laureles (4E), Unknown (8E), Colonia 25 (12E), and Cisneros/Limon (13E). La Coma Del Norte has an estimated 2020 population of 868 persons and a projected 87,000 gpd of wastewater production. Coupled with the other four colonias, the total projected population in this area will reach 1,648, with approximately 164,800 gpd of wastewater. This makes these four colonias, as a group, attractive for a grouped conventional treatment alternative; whereas, taken individually, each would be less attractive.

One possible development scenario for colonias 1E, 4E, 8E, 12E and 13E would be to construct a treatment facility near the intersection of Ranch Roads 1847 and 510. Treated effluent would be discharged to an unnamed drainage channel, thence to the Resaca de Los Fresnos.

Table 5-6 shows the recommended primary treatment option for each colonia based on the matrix evaluation and application of engineering judgement.

### 5.3 Waste Load Evaluation of Primary Disposal Options

#### 5.3.1 Introduction

##### 5.3.1.1 Water Quality Segments

##### Arroyo Colorado Segment 2201 - Tidal Segment 2202 - Above Tidal

The Arroyo Colorado is located in the Nueces-Rio Grande Coastal Basin in the Lower Rio Grande Valley. The Arroyo Colorado Above Tidal (the portion of the Arroyo Colorado that is above the tidal influence) flows from south of Mission 62.9 miles eastward to 100 yards downstream of Cemetery Road south of Port Harlingen. The Arroyo Colorado Tidal continues from this point 26.2 miles to the confluence with the Laguna Madre. The Arroyo Colorado serves communities in Cameron, Hidalgo and Willacy counties as a conveyance for flood waters and for municipal, industrial and agricultural treated wastewaters. The Arroyo also serves as an inland waterway for commercial boat traffic, wildlife habitat, and a recreational boating and fishing.

Many studies have been performed for the Arroyo Colorado, including:

- August 1976, an Intensive Survey was conducted by the Texas Department of Water Resources for the tidal portion of the stream. Results of the survey (TDWR, 1984) indicated that the stream has low assimilative capacity during low flow conditions. Nutrient and oxygen-demanding material loading from municipal discharges were determined to be responsible for eutrophic conditions.
- March 1981, a priority pollutant survey was conducted by the TDWR from McAllen to Arroyo City (TDWR, 1984). Twenty-two priority pollutants were detected during the survey, seventeen in significant quantities.
- December 1982 to March 1984, a bacteriological water quality survey was conducted by the TDWR downstream of Harlingen (TWC, 1986). Fecal coliform bacteria were found to be significantly elevated in the area, and elevated levels were attributable to municipal dischargers, septic discharges and nonpoint agricultural sources. Nutrient enhancement was determined to be a significant factor in the fecal coliform regrowth potential.
- August 1982, water quality data consisting of flow, field, laboratory, time-of-travel, cross-sectional, fecal coliform and tidal stage data by the TDWR from Mission to the Laguna Madre (TDWR, 1983). Low flows and high temperatures prevailed throughout the survey.
- August 1983, water quality data also consisting of flow, field, laboratory, time-of-travel, cross-sectional, fecal coliform and tidal stage data were again collected by the TDWR from Mission to the Laguna Madre (TDWR, 1985). The survey took place under low flow and high temperature conditions.

A draft Waste Load Evaluation (WLE) is available for the Arroyo Colorado (TDWR, 1985) for use in this study. Waste load projections were made for the year 2000 for dischargers to the stream using a calibrated, verified QUAL-TX dissolved oxygen model. The model was calibrated using data collected during the August 1983 water quality survey. The model verification was made using data collected during the August 1982 water quality survey. At the time the WLE was drafted, a total of 29 dischargers had been permitted. Of these, 4 were "No Discharge" permits, 2 permits were for utility or cooling water returns, with the remaining 23 projected to discharge a total of 35.2 MGD by 2000. A projection model was created for low flow, high temperature conditions, and using this model, alternative effluent sets were run for dischargers to the Arroyo Colorado. Effluent limits recommended in the WLE as necessary to maintain the 4 mg/L dissolved oxygen standard were, in general, at secondary treatment level with the exception of McAllen, Mission, and Pharr. These were recommended to discharge at advanced secondary treatment with nitrification.



Since the WLE was drafted, the projection model set-up has not been altered by the TWC except for the effluent limitations modeled. The projection model has been obtained and may be utilized in order to evaluate projected impacts of alternate dischargers to the system. The most recent update of waste load dischargers to the system includes permitted and projected dischargers as of April, 1990.

The seven-day two-year low flow (7Q2) for Segment 2202 is 6.0 ft<sup>3</sup>/sec. Since the Arroyo's effluent and irrigation return was dominant during the dry summer season, the 7Q2 of the tidal portion of the river (Segment 2201) is driven by the quantities of return flows from Segment 2202.

### 5.3.1.2 Water Quality Standards

Pursuant to The Texas Water Code §26.023 and The Federal Water Pollution Control Act §303, rules on required water quality standards and numerical criteria have been developed for both segments. The rules concerning Texas Surface Water Quality Standards are contained in 31 TAC §§333.11-333.21 and in the most current TWC publication of the Texas Surface Water Quality Standards.

For Segments 2201 and 2202 of the Arroyo Colorado the designated uses are: contact recreation, high quality aquatic habitat, and public water supply. The numerical criteria developed for the Arroyo Colorado are intended to ensure water quality consistent with these designated uses. The water quality criteria for both segments are shown in Table 5-6.

**Table 5-6  
 Water Quality Criteria of Segments 2201 and 2202**

Parameter	Segment 2201	Segment 2202
Dissolved oxygen	Not less than 4 mg/L (24-hr min.) (3.0 mg/l min.)	Not less than 4 mg/L (24-hr min.) (3.0 mg/l min.)
pH (range)	6.5 to 9.0	6.5 to 9.0
Temperature	Not to exceed 95°F	Not to exceed 95°F
Chloride (annual average)	No criteria	Not to exceed 1,200 mg/L
Sulfate (annual average)	No criteria	Not to exceed 1,000 mg/L
Total dissolved solids (annual average)	No criteria	Not to exceed 4,000 mg/L
Fecal coliform (30-day geometric mean)	Not to exceed 200/100 mL	Not to exceed 200/100 mL

For Segment 2494 of the Brownsville Ship Channel the designated uses are noncontact recreation and exceptional quality aquatic habitat. The designated uses for Segment 2301 of the Rio Grande are contact

recreation and exceptional quality aquatic habitat. The water quality criteria for both segments are shown in Table 5-7.

**Table 5-7  
 Water Quality Criteria of Segments 2301 and 2494**

Parameter	Segment 2301	Segment 2494
Dissolved oxygen	Not less than 5 mg/L (24-hr avg.) (4.0 mg/l min.)	Not less than 5 mg/L (24-hr avg.) (4.0 mg/l min.)
pH (range)	6.5 to 9.0	6.5 to 9.0
Temperature	Not to exceed 95°F	Not to exceed 95°F
Chloride (annual average)	No criteria	No criteria
Sulfate (annual average)	No criteria	No criteria
Total dissolved solids (annual average)	No criteria	No criteria
Fecal coliform (30-day geometric mean)	Not to exceed 200/100 mL	Not to exceed 200/100 mL

The proposed Texas Water Quality Standards condition permit issuance on nonimpairment of designated uses. Therefore, not only must the numerical criteria of each segment be maintained, but all designated uses must also be maintained. Deviation from these rules can only be accomplished through implementation of a Use Attainability Study conducted under the guidance of the U.S. Environmental Protection Agency.

Determination of criteria attainment is made from samples collected one foot below the water surface (or one third of the water depth if the depth is less than 1.5 feet) if the stream exhibits a vertically mixed water column. If the stream is vertically stratified, a depth integrated sample is required. Sampling is required four or more times a year. Exceptions to these numerical criteria apply whenever the flow is less than 7Q2.

### 5.3.1.3 Wastewater Discharges

Approved, pending and projected permits for wastewater discharge affecting Segments 2201, 2202, 2301 and 2494 were shown in Table 5-3. Existing loadings are based on monthly self-reporting data. Permitted loadings are based on the 30-day (or annual) average value in the permit. Ammonia nitrogen loading is based on an assumed effluent concentration of 15 mg/L NH<sub>3</sub>-N for those domestic discharges that do not have a permitted NH<sub>3</sub>-N limitation or that did not self-report NH<sub>3</sub>-N.

#### 5.3.1.4 Water Quality Conditions

Data stored in the Texas Natural Resources Information Service (TNRIS) Stream Monitoring Network (SMN) data base include that collected by TWC at four monitoring stations within Segment 2201, 13 stations within Segment 2202 and only one station in Segment 2301. No data was available for the Brownsville Ship Channel (Segment 2494).

#### 5.3.1.5 Classification and Rank

Classification and Rank are taken from The State of Texas Water Quality Inventory (1988) prepared by TWC. Segment 2201 is classified as effluent limited and is not ranked in the State's top 40 segments with respect to total BOD load. No current water quality problems exist and a formal use attainability study verified current uses and standards. This segment experiences periods of super saturation and pronounced DO fluctuations resulting from a high algal population. Advanced waste treatment (AWT) is required to maintain Texas Water Quality Standards.

Segment 2202 is classified as water quality limited, which means that no standard effluent limits apply to the entire segment and that new and renewal permit applications are reviewed on an individual and cumulative impact basis. The segment ranks 22nd in the State's ranking of the highest loaded streams. There have been no recorded water quality standard violations over the last four years. However, the elevated levels of total nitrogen and total phosphorus signify potential problems of high algal populations. A minimum of AWT is required to maintain the Segment's designated uses and water quality criteria.

Segment 2301 is classified as effluent limited and is not ranked in the State's top 40 segments with respect to total BOD load. The segment has only one recorded instance of depressed DOs. Segment 2301 occasionally experiences high DOs because of substantial algal populations.

Segment 2494 is classified as effluent limited and is not ranked in the State's top 40 segments with respect to total BOD load. The segment has no known or potential water quality problems.

### 5.3.2 QUAL-TX Surface Water Quality Model Simulations

#### 5.3.2.1 Impact Analysis Overview

Water quality simulations using the QUAL-TX Model can serve two separate functions: (1) for existing or proposed facilities, the model can be used to predict the DO concentrations downstream of the treatment plant outfall under existing or proposed conditions; and (2) where minimum receiving streamwater quality criteria have been established, the model can be used to analyze any number of proposed facility location and treatment level scenarios.

The scope of this modeling analysis included simulation of the main stem of the Arroyo Colorado (Segments 2301 and 2302), Brownsville Ship Channel (Segment 2494) and Rio Grande (Segment 2301) under a variety of proposed wastewater treatment plant locations, each at different flows and treatment levels. The goal of this QUAL-TX Model application was to provide information on treatment plant locations and treatment levels necessary to maintain DO levels downstream of the outfall(s) above minimum standards.

#### 5.3.2.2 Existing Wasteload Evaluation

The Water Quality Assessment Unit of the Texas Water Commission performed a waste load evaluation (WLE) for the Arroyo Colorado (Segments 2301 and 2302) in 1985. The TWC study focused on existing permitted facilities or facilities with pending permits applications. In addition, the TWC study did not consider development scenarios beyond the proposed maximum lifetime capacities of existing facilities.

As part of 1985 WLE, the TWC calibrated and validated the QUAL-TX Water Quality Simulation Model for Segments 2301 and 2302 and the major tributaries using measured data collected during August, 1983 and August 1982, respectively. The segmentation developed for the TWC's WLE formed a basis for the segmentations used in this study. Examination of the calibration and validation simulation output demonstrated a reasonable fit with the empirical data.

#### 5.3.2.3 Brownsville Ship Channel and Rio Grande Model Development

##### QUAL-TX Simulation Alternatives

##### Brownsville Ship Channel - Segment 2494

The Brownsville Ship Channel (BSC) is TWC designated Segment 2494. The Brownsville Ship Channel is a dead-end channel which extends 14.8 miles from the Turning Basin northeast of Brownsville to the Laguna Madre, with the main channel continuing another 3.1 miles to the Gulf of Mexico. The main source of flow in the BSC is the tidal waters from the Gulf of Mexico. The BSC is predominantly utilized for the transport of commercial cargo, the transit of fishing and shrimping boats, as well as a conveyance for industrial and municipal effluents. A dissolved oxygen criterion of 5 mg/L has been established for the Brownsville Ship Channel by the TWC. The major tributary to the system, San Martin Lake, transports treated sewage effluents, industrial cooling water and agricultural runoff from various ditches and canals north and west of the lake to the BSC.

An intensive survey was conducted for the BSC by the TDWR during the period of June 14-17, 1982 from the turning basin to Marker 2 in the Gulf of Mexico. The survey took place under conditions of normal flows and moderately high temperatures. A fish kill was observed during the survey, but was not attributed

to point source discharges to the system. During the survey, field, laboratory, bacterial and benthic macroinvertebrate data were collected from water samples. Pesticide and metals data were also collected from water and sediment samples.

#### Rio Grande Tidal - Segment 2301

Rio Grande Tidal is located in the Lower Rio Grande Valley and provides a boundary between the United States and Mexico. Rio Grande Tidal flows 50 miles from the Brownsville Irrigation District No. 1 weir approximately 8 miles downstream of the International Bridge in Brownsville to the Gulf of Mexico. The stream has been designated for use by the TWC as an exceptional quality aquatic habitat and for noncontact recreation. Dissolved oxygen criterion assigned to protect these uses is 5 mg/L (24-hr avg.).

No intensive stream surveys are available for this segment of the Rio Grande. One TWC SMN station is located in the segment at SH-4 near Boca Chica (mile 8.1). In order to formulate a dissolved oxygen model for this stream, many assumptions were made. These assumptions were based mainly on the calibrated models for the Arroyo Colorado and the Brownsville Ship Channel. First, a schematic was created for the stream. Next, cross-section data from mile 28.1 to the headwater of Rio Grande Tidal were utilized to approximate stream channel dimensions during low-flow conditions. Using the TWC Methodology for advective hydraulic coefficients in tidal reaches, these cross-section data were used to estimate coefficients. For non-tidal reaches, "typical" values for hydraulic coefficients were assumed from the Arroyo Colorado model.

The headwater flow for Rio Grande Tidal was calculated from daily flow data measured at USGS Station No. 08475000 for a period of record from January 1, 1957 to December 21, 1988. A 7Q2 year low flow value of 26.56 cfs was calculated in this manner. The quality at the headwater was assumed to equal the average quality from the most downstream SMN station in Segment 2302 (upstream of Segment 2301). Initial conditions were assumed based on the quality at the headwater and the average quality at mile 8.1. A critical temperature of 31.1 degrees Centigrade was calculated by averaging all measured values within Segment 2301 for the months of July, August and September and adding one standard deviation. The dissolved oxygen (80 percent of saturation) at this temperature is 5.9 mg/L.

#### 5.3.2.4 Model Application

QUAL-TX was applied to all affected existing wastewater treatment plants in Cameron County and all proposed new WWTPs to serve the colonias, with projected 2020 wastewater loads. If the existing discharges with projected loads and current treatment levels resulted in violation(s) of the established minimum DO criteria for that segment, successively more restrictive treatment levels were applied until DO standards were maintained. For new discharges, future treatment levels were established through

successive application of typical effluent characteristics for the various treatment methods, starting with ponds and progressing through secondary treatment, to advanced treatment, and to advanced treatment with nitrification. The treatment type commensurate with the least restrictive treatment level that maintained minimum DO standards was selected as the recommended treatment.

#### 5.3.2.5 Simulation Results

The PUB's future wastewater treatment scenarios will be relatively unaffected by extending service to all colonias within the PUB service area. By the year 2020 the total wastewater contribution of all colonias in Sub-area B is expected to be 2,390,000 gpd or approximately 9 percent of the total 23,753,600 gpd expected from the remainder of the PUB service area. Current PUB strategy has all new wastewater sent to the Robindale Plant. Assuming that the Robindale Plant is expanded from its currently permitted 10 MGD to 18 MGD as a result of growth, the impacts to the Brownsville Ship Channel are predicted to be negligible (Figure 5-14).

The average DO criteria of the channel is 5.0 mg/L. As a result of wastewater discharges by the PUB and others, the current 7Q2 condition DO in the upper ship channel starts out at about 4.3 mg/L and steadily increases to about 5.4 mg/L near the confluence with the Laguna Madre. The predicted 4.3 mg/L is an apparent violation of criteria. With the discharged increased to 18 MGD at current treatment levels (20/20) there is almost no impact on DO levels. Indeed, increasing treatment to 10/15 has a negligible impact on DO levels. Thus, the recommendation is that future expansions of the Robindale Plant be permitted at 20/20, as the increased cost of higher treatment levels is not warranted.

The Cities of Harlingen and San Benito both discharge to the Arroyo Colorado. Harlingen has two plants permitted at 20/20 and one at 10/15/3; San Benito has a single plant permitted at 30/90. With increased flows and current treatment levels, there will be a violation of minimum 4.0 mg/L (24-hr avg.) DO criteria set for the Arroyo (Figure 5-15). The minimum predicted 7Q2 DO level is 3.7 mg/L. Increasing the treatment level of all dischargers to 10/15 results in a reattainment of standards. Thus, future expansions to the Harlingen and San Benito facilities should be at a 10/15 treatment level.

In Sub-area W, the recommendation is to direct the wastewater from colonias 6W, 13W, 15W, 16W and 17W to the City of Santa Rosa for treatment and disposal. The City discharges to an unnamed drainage canal thence to the North Floodway at a 30/90 treatment level. Simulation of existing conditions (Santa Rosa is permitted maximum flows and treatment levels) shows a severe DO sag in the drainage ditch and a predicted violation of the minimum 7Q2 condition DO criteria of 3.0 mg/L (Figure 5-16). With future predicted flows of the colonias and City, the sag is exacerbated. A treatment level of 10/3 is require to maintain minimum DO standards in the receiving drainage ditch. Thus, future expansions to the Santa Rosa treatment plant will have to include advanced secondary treatment with nitrification.

Figure 5-14  
 Dissolved Oxygen Profiles  
 Brownsville Ship Channel

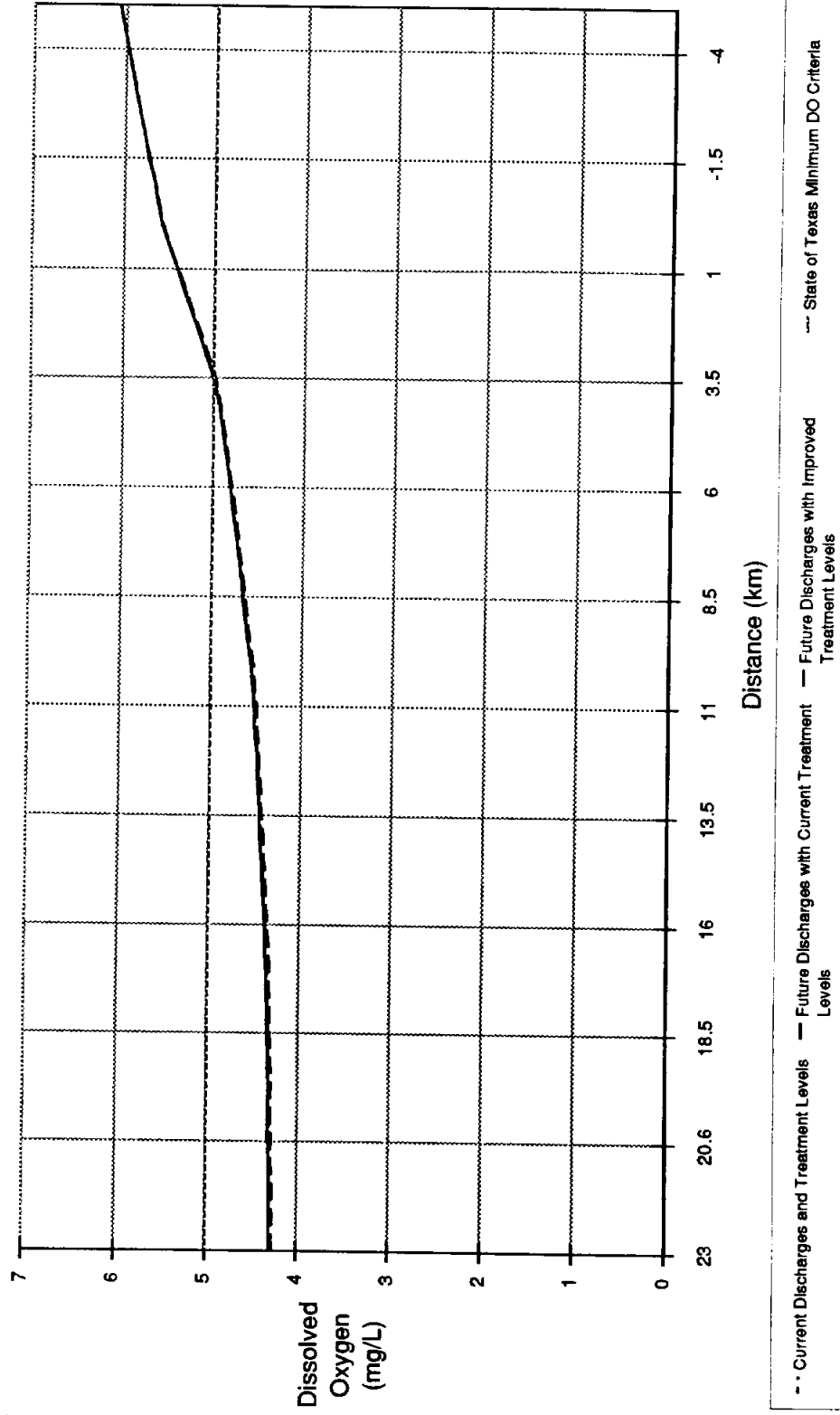

Figure 5-15  
 Dissolved Oxygen Profiles  
 Arroyo Colorado - Harlingen to Tidal

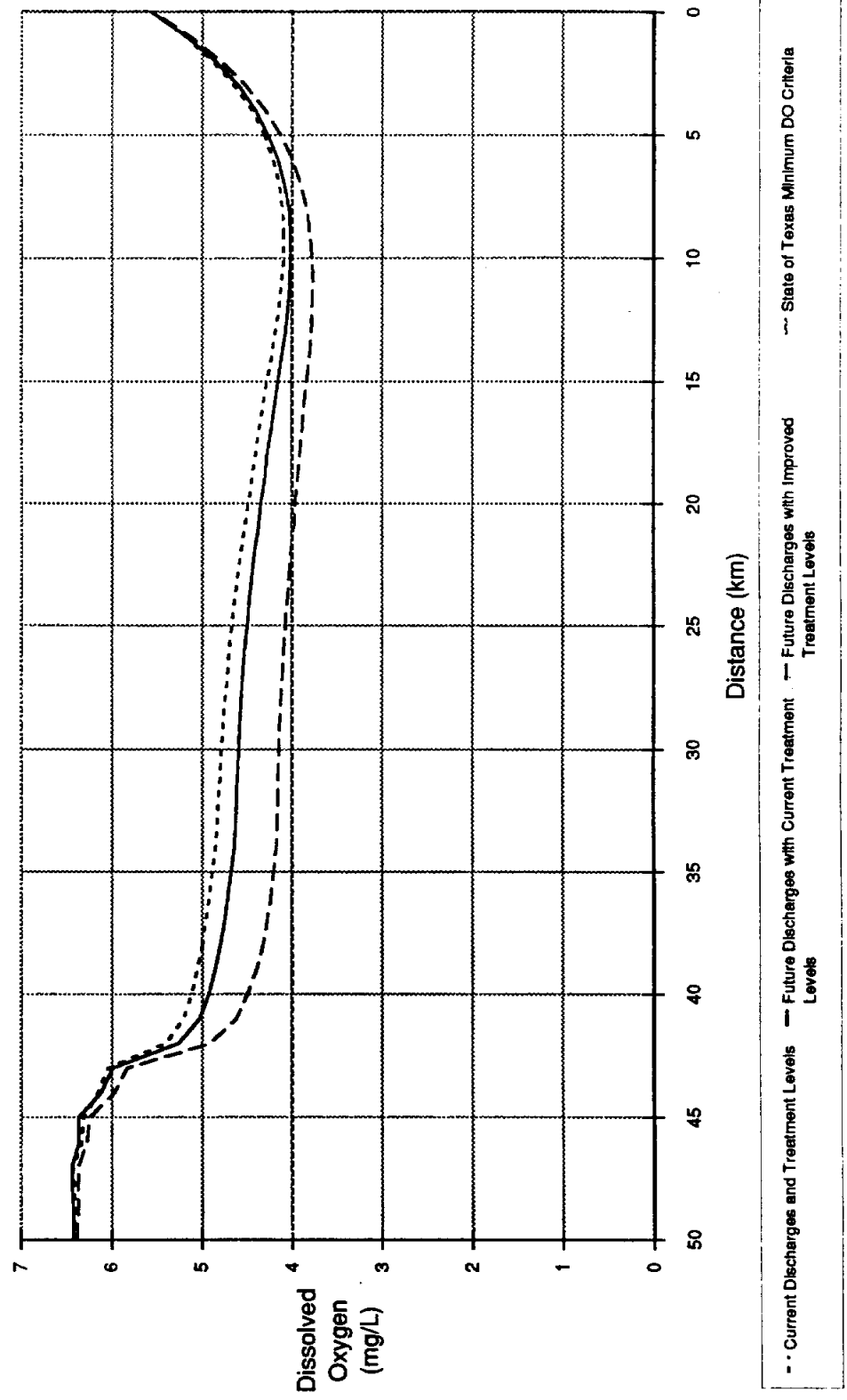
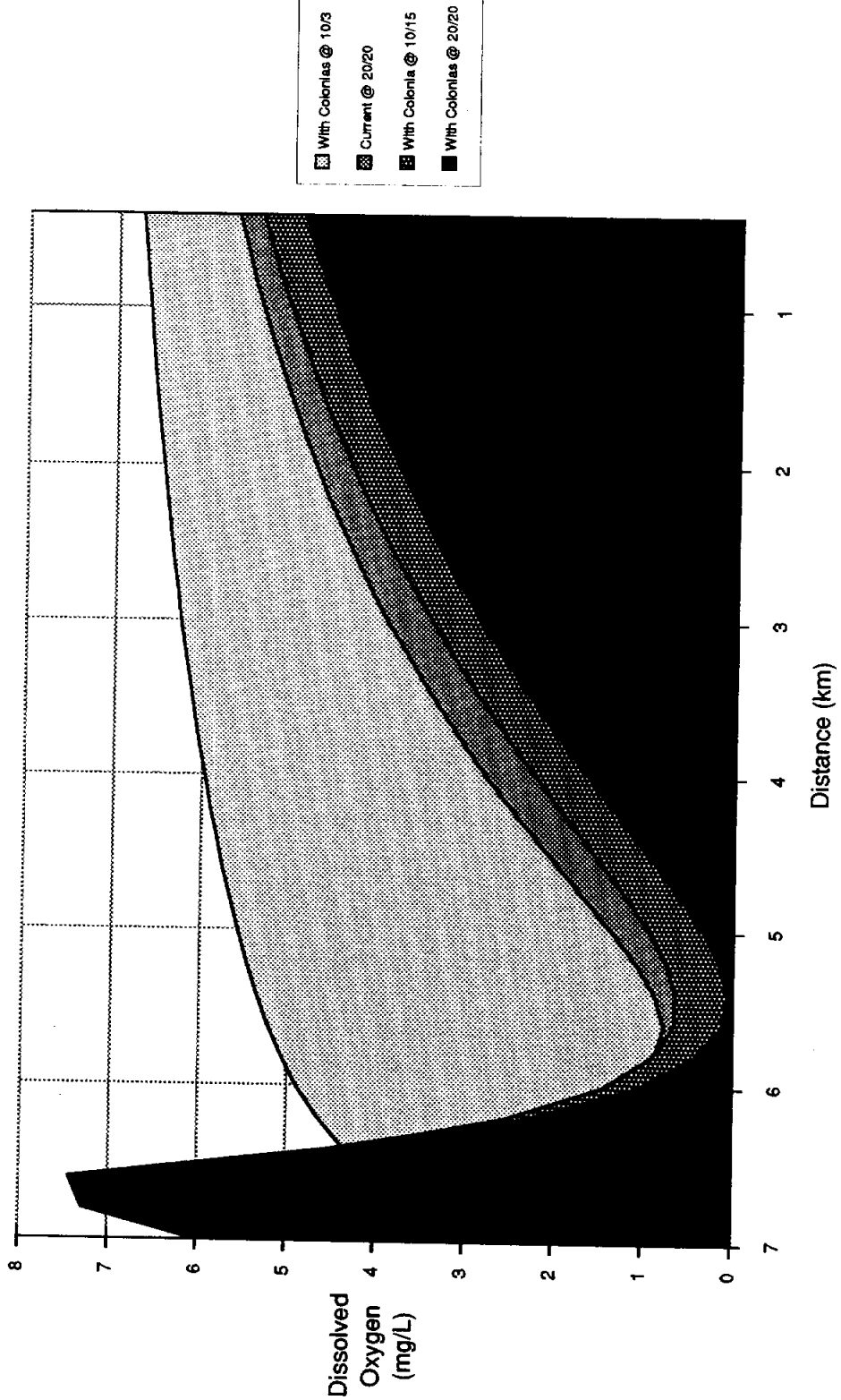



Figure 5-16  
Dissolved Oxygen Profile for The City of Santa Rosa  
Without and With Colonias 6W, 13W, 15W, 16W AND 17W



In addition to higher levels of treatment, the City of Santa Rosa will have to upgrade its existing treatment plant approximately 10 years earlier than predicted without acceptance of the colonia wastes (Figure 5-17).

At flows less than 200,000 gpd, a 30/90 effluent quality will generally maintain the 3.0 mg/L minimum DO standard applied to most of the drainage ditches of Cameron County. The colonias along U.S. Highway 281 west of Brownsville, where Military Highway WSC intends to supply wastewater service through construction of a number of facultative lagoon treatment plants, are all projected to produce discharges of less than 200,000 gpd.

In Sub-area E, the recommendation is to direct the wastewater from colonias 4E, 8E, 12E and 13E to colonia La Coma Del Norte (1E) for treatment. Disposal would be to an unknown drainage canal, thence to Resaca de Los Fresnos. At a total combined discharge of 167,800 gpd, a 30/90 treatment level will maintain a 4.0 mg/L DO level in the drainage canal (Figure 5-18).

Colonias 2E (Lozano), 3E (La Tina Ranch) and 7E (Las Yescas) are also recommended to construct individual wastewater treatment facilities. Both plants would discharge to unnamed drainage canals, thence to resaca de Los Fresnos. And both facilities would maintain receiving stream DO standards at a 30/90 treatment level (Figures 5-19 and 5-20).

#### 5.4 Detailed Cost Analysis of Primary Disposal Options

Detailed cost evaluations have been performed for each of the sixty-five colonias. Development of costs was based on preliminary screening of wastewater collection/treatment alternatives and preparation of a schematic collection/treatment system based on the recommended alternative. Where on-site disposal is recommended, a mounded pressure-dose disposal system was assumed. The mounded pressure-dose system was used because it provides a means of disposal in areas where soil conditions and/or groundwater levels are not conducive to standard absorption systems. In areas where conventional collection systems were recommended, depth constraints (i.e., maximum allowable sewer depths) were used to determine when lift stations and force mains would be required. In general, when the depth of a gravity line approached 18 feet, a lift station was recommended. The terrain and geometry of each colonia determined the length of the proposed force main. Where possible, lift stations discharge into gravity lines immediately adjacent to the lift station. In most instances, however, a nominal length of force main was required to deliver the wastewater to another part of the colonia that could be drained by gravity. Texas Department of Health/Texas Water Commission criteria were used in sizing all wastewater related items.

Figure 5-17  
City of Santa Rosa Available Wastewater Treatment Capacity  
With and Without Additional Colonia Loads

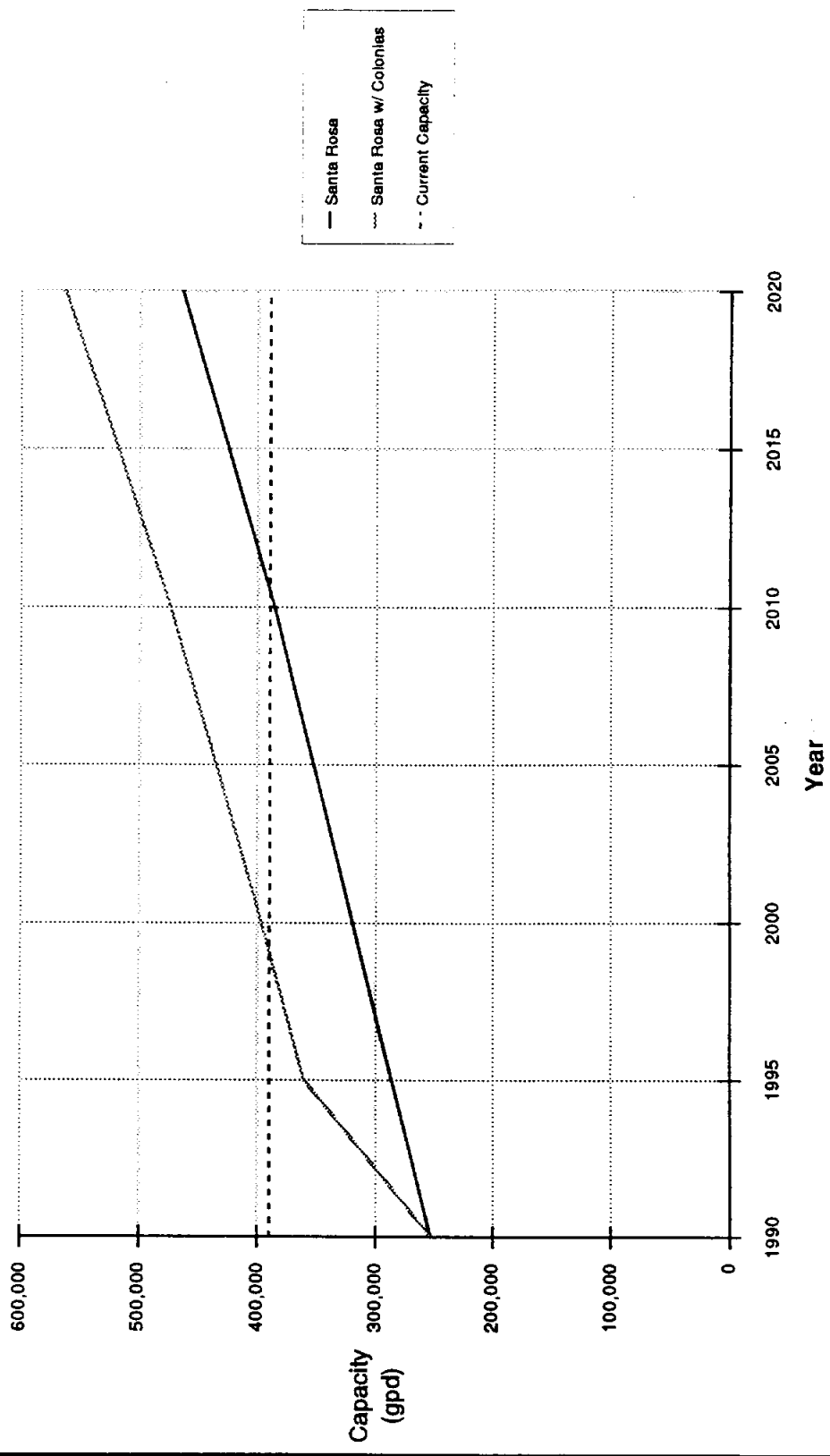

Figure 5-18  
Dissolved Oxygen Profile for Colonias 1E, 4E, 6E, 12E and 13E  
Discharging a Total of 167,800 gpd at a 30/90 Treatment Level

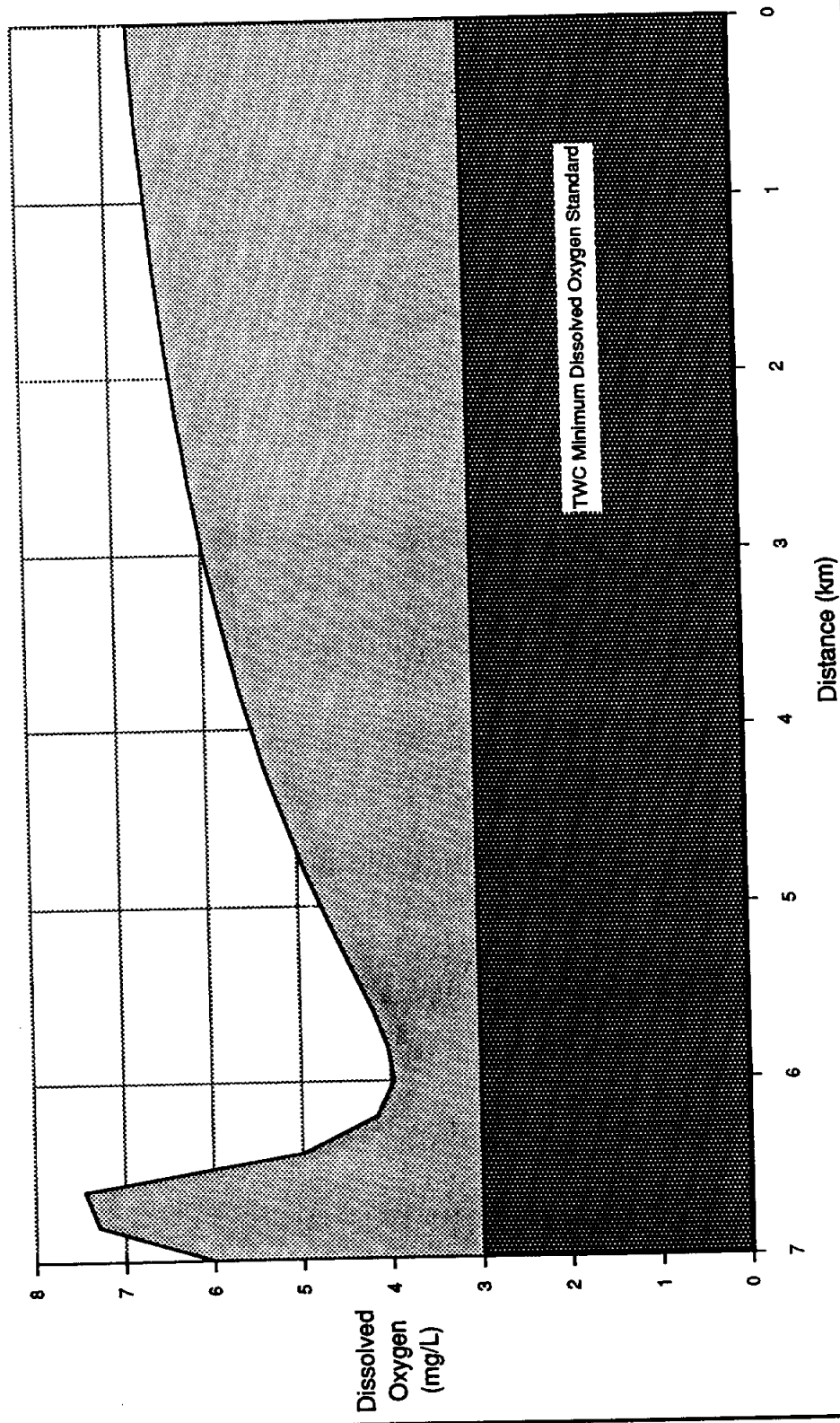

Figure 5-19  
Dissolved Oxygen Profile for Colonia 2E Discharging a  
Total of 68,000 gpd at a 30/90 Treatment Level

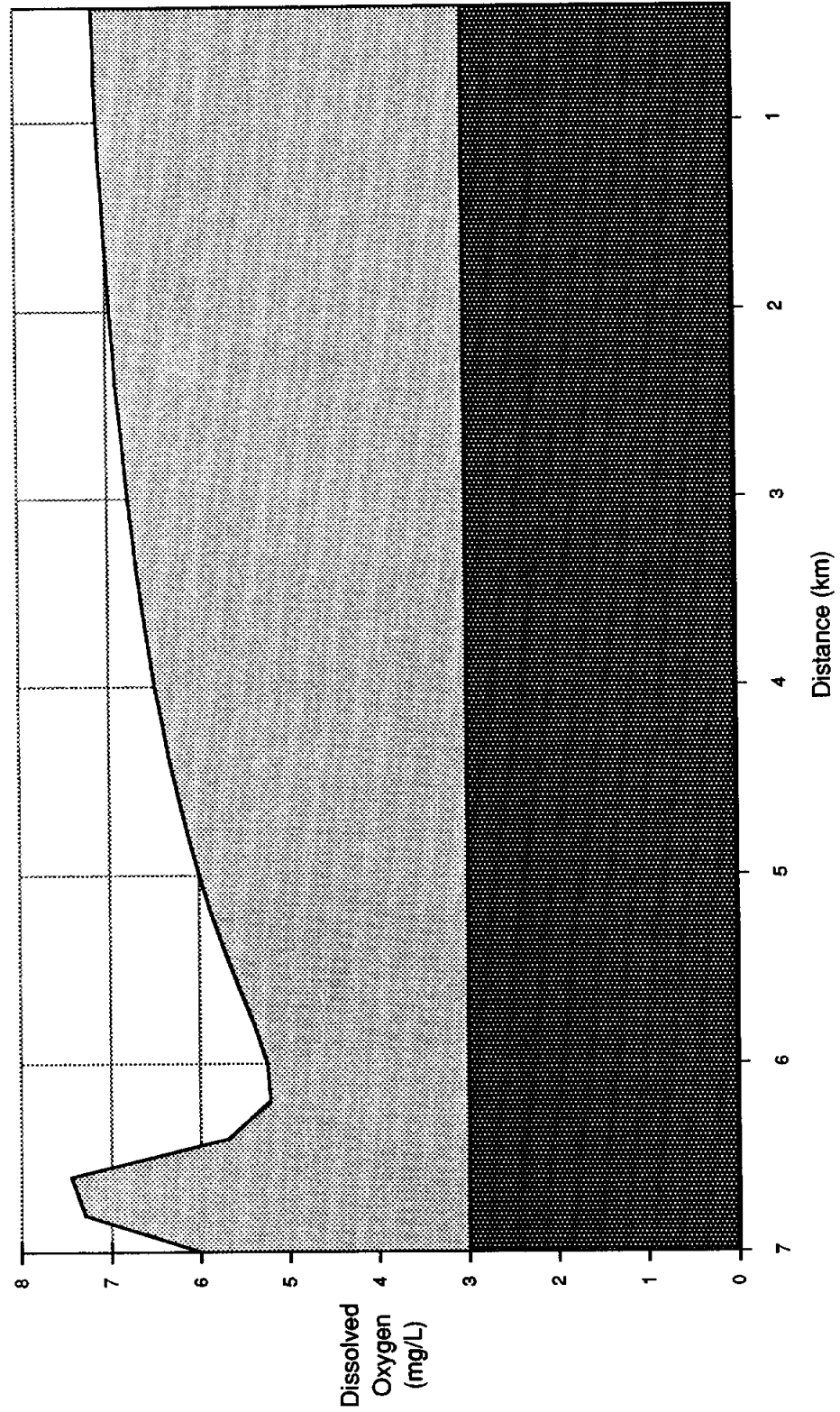
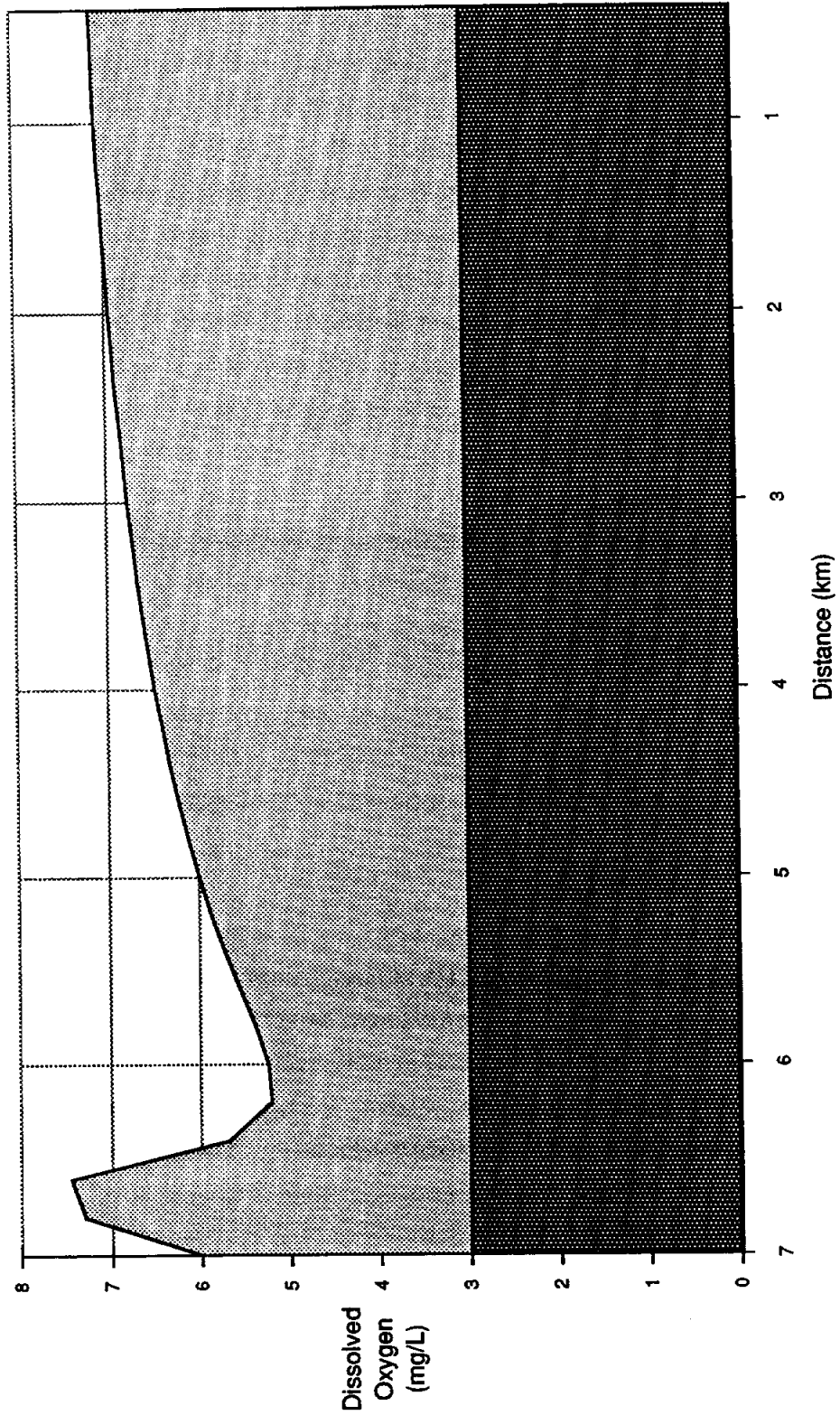

Figure 5-20  
Dissolved Oxygen Profile for Colonia 3E Discharging a  
Total of 66,000 gpd at a 30/90 Treatment Level



On-site disposal cost estimates were based on \$5,000 per unit cost for design and installation of a typical mounded pressure-dose system. Costs for conventional wastewater collection systems were developed after examining the bid tabulation for the PUB's 'Brownsville Wastewater Collection and Conveyance System Improvements', Contract Number 003, dated December 16, 1989. Fourteen contractors responded to the request for bids. Contract Number 003 included a variety of gravity collection system improvements, along with several lift station and force main improvements. Costs for gravity and pressure components were evaluated separately. For the gravity component (e.g., pipe, manholes, cleanouts, etc.) an average of the seven lowest bidders was used. For the pressure component (e.g., lift station structures, pumps, force mains, etc.) an average of the middle six bidders was used. Table 5-8 (for convenience of the reader, the remainder of the tables and figures follow the last page of text in this section) summarizes the gravity and force main system costs utilized for each item identified in the recommended system schematic. Costs associated with lift station construction were developed using horsepower ratings as the determining cost factor. In developing lift station costs, total friction losses within the recommended system were approximated and an estimated total required motor brake horsepower calculated. Conventional wastewater treatment plant costs, as a function of size and required level of treatment, were obtained from the curves of Figure 5-21. Figure 5-22 summarizes lift station costs used for this cost analysis. Pond-type treatment plant costs were based on construction of a prototypical facultative pond system using an average cost of \$2.07/gpd. Detailed costs associated with construction of the recommended treatment facilities are presented in their appropriate sections below.

#### Sub-area B (Brownsville ETJ)

Twenty-eight colonias have been identified within the Brownsville ETJ (Sub-area B). None of these colonias are located within the City of Brownsville corporate boundary. Wastewater collection and treatment options were minimized for these colonias early in the evaluation process. Figure 5-23 (see map pocket at end of report) shows the colonias located within Sub-area B and major components of the recommended wastewater improvements. Figures 5-24 through 5-49 provide a detailed view of the recommended improvements and provide system schematics for individual colonias, along with estimated construction costs of recommended sewer collection system improvements.

In order to provide efficient wastewater service to the Sub-area B colonias, a series of grouped collection systems that would ultimately discharge to existing or proposed PUB wastewater collection facilities was established. The PUB currently operates two wastewater treatment plants. The majority of future colonia flows will be directed to the Robindale Sewage Treatment Plant (North Plant). The remainder of future colonia flows will be directed to the South Side Sewage Treatment Plant (South Plant). A brief summary of

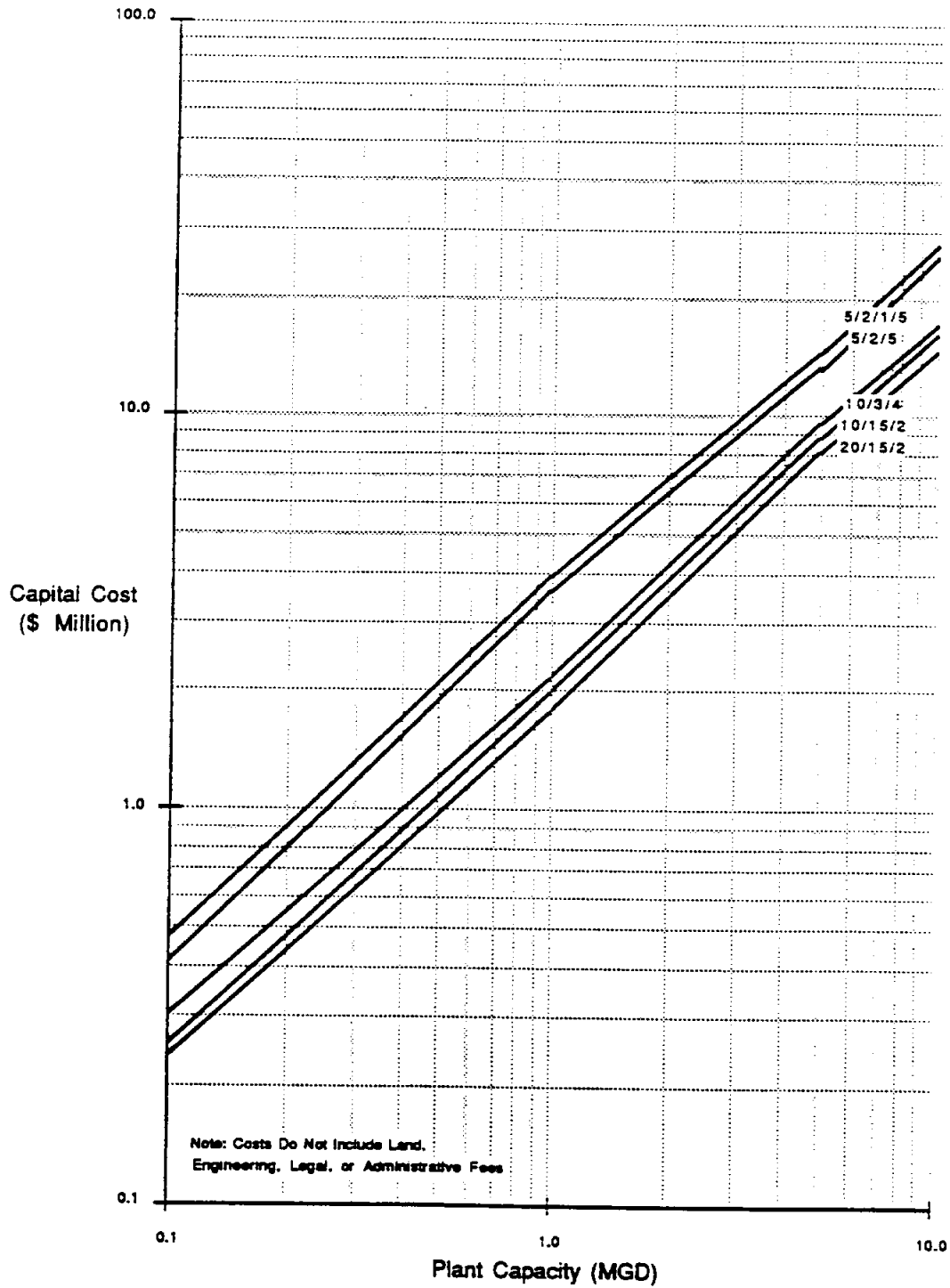

**Figure 5-21**  
**Capital Cost of Treatment Capacity for**  
**Different Levels of Treatment**



Figure 5-22  
\$/hp Middle 6 Bids  
PUB Contract 003

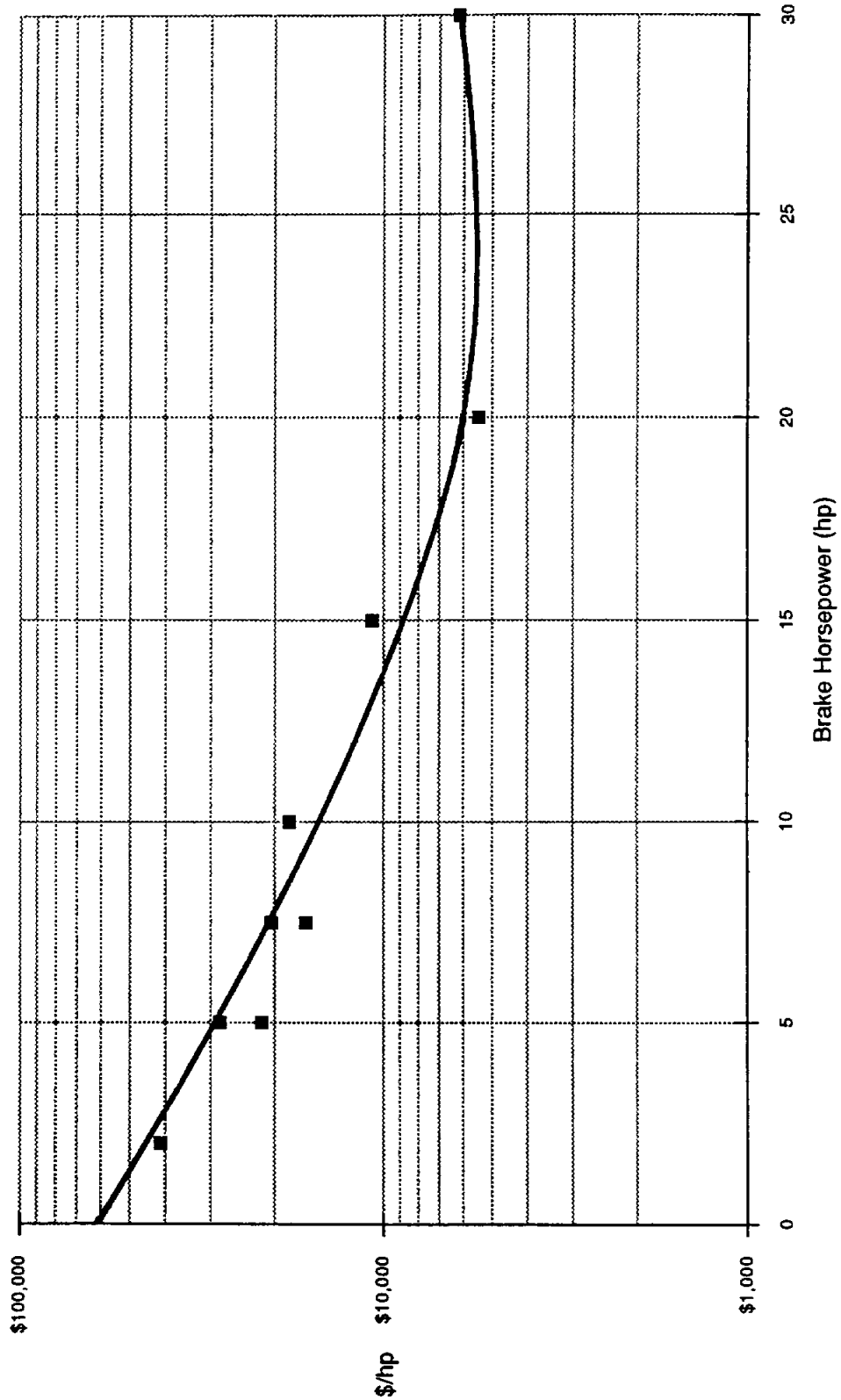

the colonias which will flow to the north plant will be presented first with a description of south plant flows to follow.

Six groups of colonias (sixteen individual colonias) will ultimately discharge to the north treatment plant. The proposed improvements for Cameron Park (1B) include a gravity collection system consisting of 8-inch through 18-inch lines and two internal lift stations (LS-1B2 rated at 590 gpm and LS-1B3 rated at 370 gpm). Flows from Cameron Park ultimately discharge into the PUB's Cameron Park Lift Station located at the southwest corner of the colonia adjacent to Paredes Line Road. Recommended improvements for Olmito (2B) include a gravity collection system and two lift stations. Lift station LS-2B1 is rated at 803 gpm and discharges through a 10-inch force main to a manhole within Olmito. Flow continues by gravity to a 900 gpm lift station (LS-2B2) located at the south end of Olmito. A 10-inch force main connects Olmito to the PUB's Hacienda Gardens Lift Station located at the southwest corner of Hacienda Gardens (7B). The internal gravity collection system for Hacienda Gardens also discharges into the Hacienda Gardens Lift Station.

The most westerly colonias, Villa Cavazos (11B), San Pedro (4B) and Villa Nueva (8B) combine to form a group collection system which discharges to the PUB's Military Highway-North Lift Station and Force Main located on the west end of Villa Nueva. The recommended improvements for Villa Cavazos consist of a gravity collection system discharging into a 120 gpm lift station (LS-11B). Lift station LS-11B discharges through a 6-inch force main to San Pedro. Flows from Villa Nueva enter the San Pedro system and flow by gravity to one of two San Pedro lift stations (LS-4B1). Lift station LS-4B1 is rated at 300 gpm and discharges through a 6-inch force main to lift station LS-4B2. Lift station LS-4B2 is rated at 520 gpm and discharges through a 10-inch force main to Villa Nueva. The combined flows from Villa Cavazos and San Pedro enter Villa Nueva from the west and are carried via the Villa Nueva gravity collection system to the PUB's Military Highway -North Lift Station and Force Main.

Due to the slope of the area surrounding Saldivar (14W), a gravity collection system that flows to the south to lift station LS-14B (rated at 90 gpm) is proposed. Lift station LS-14B discharges through a 3-inch force main to the north to tie into the PUB's Morrison Road Gravity Main. Recommended improvements for the Stuart Subdivision (3B) include a gravity collection system and a lift station (LS-3B) rated at 530 gpm. Lift station LS-3B would discharge through a 6-inch force main to the PUB's Central Avenue Lift Station and Force Main.

The three remaining group collection systems combine to discharge to the King Subdivision (5B) lift station (LS-5B). The proposed improvements for Barrio Subdivision (12B), Illinois Heights (23B), and Unnamed B Hwy 802 (27B) consist of individual gravity collection systems discharging to respective lift stations and force mains. The Barrio Subdivision Lift Station (LS-12B) is rated at 120 gpm and discharges

through a 4-inch force main to Unnamed B Hwy 802. The Illinois Heights lift station (LS-23B) is rated at 61 gpm and discharges through a 3-inch force main to Unnamed B Hwy 802. The Unnamed B Hwy 802 lift station (LS-27B) is rated at 210 gpm and discharges through a 6-inch force main to lift station LS-21B located at Keller's Corner. Proposed improvements for Unknown Colonia (26B) and Saldivar II (17B) include gravity collection systems, lift stations and force mains. Lift station LS-26B, associated with the Unknown Colonia (26B) is rated at 35 gpm and discharges through a 2-inch force main to the proposed Boca Chica Lift Station. The proposed Saldivar II gravity collection system discharges to lift station LS-17B and then via a 3-inch force main to the proposed Boca Chica Lift Station. The Boca Chica Lift Station is rated at 400 gpm and discharges through a 4-inch force main to lift station LS-21B, at Keller's Corner. Recommended improvements for Unnamed D Keller's Corner (20B) consist of a gravity collection system that connects directly to Texas 4 Subdivision (21B). The proposed Texas 4 gravity system flows to the north to lift station LS-21B. Lift station LS-21B is rated at 500 gpm and discharges into a proposed gravity line in Boca Chica Highway, which flows west to the west end of the King Subdivision (5B). The proposed King Subdivision gravity collection system flows west to lift station LS-5B (rated at 900 gpm). Lift station LS-5B discharges through a 10-inch force main to the PUB's Central Avenue Lift Station and Force Main, which in turn flows to the north plant.

The remaining Sub-area B colonias will ultimately discharge to the South Side Sewage Treatment Plant. Beginning in the southeast corner of the study area, Unknown Colonia 16B will discharge by gravity to Valle Escondido, which in turn will discharge by gravity to Valle Hermosa. A proposed lift station (LS-25B) located on the southwest side of Valle Hermosa is rated at 205 gpm and discharges through a 6-inch force main to the Alabama/Arkansas (6B) gravity collection system. Alabama/Arkansas is large enough to require two lift stations. Lift station LS-6B1, rated at 110 gpm, is situated in the southeast corner of the colonia and discharges via a 4-inch force main to a manhole located in Southmost Road. Lift station LS-6B2, rated at 495 gpm, is located in the southwest corner of the colonia and discharges through an 8-inch force main along Southmost Road to the PUB's Dakota/Southmost Road Lift Station and Force Main. The remaining colonia to discharge to the Dakota/Southmost Road Lift Station is the Unnamed C Colonia (19B), which flows by gravity to the PUB lift station.

The remaining eight colonias ultimately converge at the PUB's Dakota Avenue/FM-511 Lift Station and Force Main. The proposed Villa Pancho (9B) gravity system flows to lift station LS-9B (rated at 180 gpm) and then via a 4-inch force main to lift station LS-22B (rated at 250 gpm). The 511 Crossroads (22B) improvements consist of a gravity collection system discharging to LS-22B. Lift station LS-22B discharges to a 6-inch force main to the west end of the Unknown Brownsville Airport Colonia (24B). Flows from the Unknown Brownsville Airport Colonia flow by gravity and connect directly to the Pleasant Meadows (10B) gravity system. The proposed Pleasant Meadows gravity system will flow directly to the

PUB's Dakota Avenue/FM-511 Lift Station. The Los Cuates (13B) improvements will consist of a gravity collection system that connects directly to the Coronado (15B) gravity collection system. Los Cuates and Coronado discharge into lift station LS-15B, located adjacent to the north side of Coronado. It discharges through a 6-inch force main to the PUB's Dakota/FM-511 Lift Station. Finally, the Colonia 21 (28B) improvements consist of a gravity collection system that connects directly to the Dakota/FM-511 Lift Station.

A lift station cost summary for Sub-area B is supplied in Table 5-9. And a cost comparison of sewer systems and on-site disposal is presented in Table 5-10. Without exception, it is less expensive to provide sewer service to all of the colonias in Sub-area B than to construct mounded pressure-dose on-site septic systems.

#### Sub-area H (Harlingen ETJ)

Seven colonias have been identified within Sub-area H. Because of their proximity to organized wastewater collection systems, it is recommended that all but one of the Sub-area H colonias be connected to the Harlingen and San Benito collection/treatment system. The remaining Sub-area H colonia, Laguna Escondido Heights (7H), is recommended for on-site disposal. Figure 5-50 (see map pocket at end of report) illustrates the colonias located within Sub-area H and major components of the recommended wastewater improvements. Figures 5-51 through 5-61 provide detailed system schematics for the recommended improvements for individual colonias, along with estimated construction costs for the recommended sewer collection system improvements.

The recommended wastewater improvements for Las Palmas (1H) include a gravity collection system and a 310 gpm lift station (LS-1H) discharging through a 6-inch force main to the Harlingen collection system in the vicinity of the Fred Adams Subdivision. Lago Subdivision (2H) and Rice Tracts (5H) comprise a grouped collection system. The recommended Lago Subdivision collection system consists of a gravity collection system discharging to a 75 gpm lift station (LS-4H) at the north end of Lago Subdivision. The Lago Subdivision lift station would discharge through a 6-inch force main to the most southerly point of the proposed Rice Tracts collection system. The Rice Tracts gravity system has been sized to accommodate the flows from Lago Subdivision. The Rice Tracts gravity collection system would discharge to a 345 gpm lift station (LS-5H) near the intersection of US 77/83 and Rice Tract Road. It is from this point that the combined flows from Lago Subdivision and the Rice Tracts would be incorporated into the San Benito wastewater collection system.

Two Sub-area H colonias are located near the Harlingen Industrial Airpark. It is recommended that these two colonias be connected to the Harlingen collection system in the vicinity of the Industrial Airpark. Lasana (4H) and Colonia 26 (3H) each have recommended a gravity collection system discharging to

individual lift stations. The Lasana lift station (LS-4H) is rated at 75 gpm and would discharge through a 4-inch force main east to a point located northwest of the Industrial Airpark on Highway 107. The Colonia 26 lift station (LS-3H) is rated at 150 gpm and would discharge through a 6-inch force main to the same location as the Lasana force main. A 225 gpm lift station (the Airport Lift Station) is proposed to receive flows from Lasana and Colonia 26 and convey these flows to a point adjacent to the Industrial Airpark, where the Harlingen collection system will intercept their combined flows.

A lift station cost summary for Sub-area H is supplied in Table 5-11. And a cost comparison of sewer systems and on-site disposal is presented in Table 5-12. With the exception of Las Palmas (1H), it would be marginally less expensive to construct on-site septic systems than to provide sewer service. The control and additional levels of treatment offered by the cities of Harlingen and San Benito, however, overshadow the small savings that could be derived from on-site systems.

#### Sub-area W (Western Cameron County)

Seventeen colonias have been identified within Sub-area W. Figure 5-62 (see map pocket at end of report) illustrates the colonias located within Sub-area W and major components of the recommended wastewater improvements. Figures 5-63 through 5-83 provide detailed system schematics for recommended improvements for the individual colonias, along with estimated construction costs for the recommended sewer collection system improvements. Four categories of collection/treatment alternatives are represented within Sub-area W. Five colonias have on-site disposal recommended; four colonias are recommended for individual collection/treatment systems; four colonias are recommended for a grouped collection/treatment system; and four colonias are recommended for connection to an existing collection/treatment system.

Due to their low projected 2020 unit densities and the lack of any existing organized collection and treatment system in their vicinity, it is recommended that El Venadito (7W), Carricitos-Landrum (8W), W (14W), and X Unknown Subdivision (16W) have on-site disposal systems. Individual collection/treatment systems are recommended for La Paloma (3W), Los Indios (4W), Bluetown (5W), and Palmer (11W). The grouped systems consist of El Calaboz (9W) and Encantada (1W) as a group and Iglesias Antigua (10W) and Santa Maria (2W) as a group. Due to their proximity to the City of Santa Rosa, it is recommended that T2 Unknown Subdivision (6W), Q Unknown Subdivision (13W), R Unknown Subdivision (15W) and Colonia S (17W) connect to the City of Santa Rosa collection/treatment system.

The recommended collection/treatment system for La Paloma consists of a gravity collection system discharging to a 250 gpm lift station (LS-3W) adjacent to a proposed 86,100 gpd pond treatment system (STP-3W). The proposed Los Indios collection/treatment system consists of a gravity collection system discharging to a 205 gpm lift station (LS-4W) adjacent to a 69,900 gpd pond treatment system (STP-4W).

The proposed Bluetown collection/treatment system consists of a gravity collection system terminating at a 170 gpm lift station (LS-5W) adjacent to a 58,000 gpd pond treatment system (STP-5W). The Palmer collection/treatment system consists of a gravity collection system discharging to a 85 gpm lift station (LS-11W) adjacent to a 28,500 gpd pond treatment system (STP-11W).

The grouped collection/treatment alternative for El Calaboz and Encantada consists of a gravity collection system in El Calaboz terminating in a 115 gpm lift station (LS-9W) at the west end of El Calaboz. The proposed El Calaboz lift station discharges through a 4-inch force main to the east end of Encantada to be received by the Encantada gravity collection system. An internal lift station (LS-1W1), rated at 425 gpm, collects flows from both ends of Encantada and lifts the flows to an adjacent manhole. From this point, the remainder of the collection system flows by gravity to the north along Rice Tract Road to a second Encantada lift station (LS-1W2). LS-1W2 (560 gpm) discharges into a 200,100 gpd pond treatment system (STP-1W) tentatively located north of Encantada and west of Rice Tract Road.

The grouped collection system for Santa Maria (2W) and Iglesia Antigua (10W) consists of a gravity system in Iglesia Antigua which connects directly to the west end of the Santa Maria gravity system. The Santa Maria gravity collection system flows to the northwest corner of Santa Maria, discharging into a 670 gpm lift station (LS-2W), thence discharging into the proposed 251,200 gpd pond treatment system (STP-2W).

T2 Unknown Subdivision (6W), Q Unknown Subdivision (13W), R Unknown Subdivision (15W) and Colonia S (17W) comprise a grouped collection system that flows from one to the other and ultimately to the City of Santa Rosa. The proposed gravity collection system for the most southerly member of this grouped collection system, T2 Unknown Subdivision, will flow to the north along Dukes Highway to Colonia S (17W). The gravity collection system for Colonia S will be sized to accommodate flows from T2 Subdivision and will discharge into a 170 gpm lift station (LS-17W) located on the northern end of Colonia S. LS-17W will discharge through a 6-inch force main to the southern extent of the R Unknown Subdivision gravity collection system. The R Unknown collection system continues by gravity to Q Unknown Subdivision. The collection system within Q Unknown Subdivision will be sized to accommodate flows from the preceding three colonias. All flows will continue by gravity to a 300 gpm lift station (LS-13W) located at the north end of Q Unknown Subdivision. From there, the combined flows from 6W, 17W, 15W, and 13W will be discharged through a 6-inch force main to the City of Santa Rosa wastewater collection system for ultimate treatment at the City of Santa Rosa Sewage Treatment Plant.

Lift station and sewage treatment plant cost summaries for Sub-area W are presented in Tables 5-13 and 5-14. A cost comparison for sewer systems versus on-site disposal costs is presented in Table 5-15.

#### Sub-area E (Eastern Cameron County)

Thirteen colonias have been identified within Sub-area E. Figure 5-84 (see map pocket at end of report) illustrates the colonias located within Sub-area E and major components of the recommended wastewater improvements. Figures 5-85 through 5-99 provide detailed system schematics for the recommended improvements for individual colonias, along with estimated construction costs for the recommended sewer collection system improvements.

Four categories of wastewater collection/treatment alternatives are represented in Sub-area E. Four colonias have on-site systems treatment recommended; three colonias have individual collection/treatment systems recommended; five colonias have a grouped collection/treatment system recommended; and one colonia is recommended for connection to an existing wastewater treatment facility. Due to their remote location, with respect to existing organized collection systems, and relatively low projected unit densities in the year 2020, Del Mar Heights (5E), Orason Acres (6E), Unknown Del Mar II (10W) and Glenwood Acres Subdivision (9E) are recommended for on-site disposal systems. Colonia specific wastewater treatment facilities are recommended for Lozano (2E), La Tina Ranch (3E) and Las Yescas (7E). A grouped wastewater treatment facility is recommended for La Coma del Norte (1E), Laureles (4E), an Unknown Colonia (8E), Colonia 25 (12E) and Cisneros (13E). A conventional collection system is recommended for Los Cuates (11E), with ultimate treatment being provided by the City of Los Fresnos.

The recommended improvements for Lozano (2E) consist of a gravity collection system discharging to a 200 gpm lift station (LS-2E) discharging directly to a 68,000 gpd pond treatment system. The La Tina Ranch (3E) improvements consist of a gravity collection system discharging to a 195 gpm lift station, which in turn discharges to a 66,200 gpd pond treatment system. The remaining colonia specific collection/treatment system, Las Yescas (7E), consists of a gravity collection system which discharges to a 85 gpm lift station, thence to a 28,100 gpd pond treatment system.

The grouped collection/treatment system consists of connecting four remote colonia collection systems to the La Coma del Norte gravity collection system. The Laureles gravity collection system connects to the La Coma del Norte gravity system via a 205 gpm lift station (LS-4W) and 4-inch force main located on the north end of Laureles. An Unknown Colonia (8E) connects to La Coma del Norte via a 78 gpm lift station and 3-inch force main. Colonia 25 (12E) and Cisneros (13E) connect by gravity to the La Coma del Norte system. The combined wastewater flows terminate at the northwest corner of La Coma del Norte at a 480 gpm lift station (LS-1E), which ultimately discharges through an 8-inch force main to a proposed 164,800 gpd pond treatment system located west of La Coma del Norte.

The recommended improvements for Los Cuates include construction of a gravity collection system flowing to the south to an 80 gpm lift station (LS-11E) located at the south end of Los Cuates. A 4-inch

force main would discharge from LS-11E along the Old Alice Road to Highway 106. From this intersection, the 4-inch force main would continue east to the Los Fresnos vicinity where the Los Cuates wastewater flows would be received by the City of Los Fresnos' collection system for ultimate treatment at the existing City of Los Fresnos sewage treatment works.

Lift station and wastewater treatment plant cost summaries are presented in Tables 5-16 and 5-17. A cost comparison for sewer systems versus on-site disposal costs is presented in Table 5-18.



Table 5-8  
 Gravity and Force Main System Costs

Item	Estimated Cost a/
6" Service Connection	\$ 500.00/EA
8" SDR-35 PVC Sanitary Sewer	\$ 20.00/LF
10" SDR-35 PVC Sanitary Sewer	\$ 26.00/LF
12" SDR-35 PVC Sanitary Sewer	\$ 38.00/LF
15" SDR-35 PVC Sanitary Sewer	\$ 50.00/LF
18" SDR-35 PVC Sanitary Sewer	\$ 65.00/LF
Clean Out	\$ 300.00/EA
Manhole	\$ 1,745.00/EA
4" PVC Force Main	\$ 8.00/LF
6" PVC Force Main	\$ 11.00/LF
8" PVC Force Main	\$ 14.00/LF
10" PVC Force Main	\$ 17.00/LF
12" PVC Force Main	\$ 19.00/LF

a/ Based on average of seven lowest bidders for 'Brownsville Wastewater Collection & Conveyance System Improvements' Contract Number 003, 12/89.

Table 5-9  
 Proposed Lift Stations  
 Sub-Area B Colonias

Lift Station Designation	Flow Rate (gpm)	Estimated Brake Horsepower	Estimated Cost (\$) a/
LS-1B1	By PUB	-	-
LS-1B2	590	2.00	\$90,000
LS-1B3	370	5.00	\$150,000
LS-2B1	830	8.00	\$200,000
LS-2B2	900	12.50	\$237,500
LS-3B	530	6.00	\$150,000
LS-4B1	300	3.00	\$117,000
LS-4B2	520	8.50	\$68,000
LS-5B	900	15.00	\$127,500
LS-6B1	110	1.00	\$52,000
LS-6B2	495	11.50	\$143,750
Hacienda Gardens	By PUB	-	-
Military Hwy.	By PUB	-	-
LS-9B	180	2.50	\$100,000
Dakota Avenue	By PUB	-	-
11B	120	4.00	\$140,000
12B	120	2.00	\$90,000
14B	90	1.00	\$52,000
15B	205	2.00	\$90,000
17B	85	1.50	\$75,000
Southmost Road	By PUB	-	-
LS-21B	500	4.00	\$140,000
LS-22B	250	3.00	\$117,000
LS-23B	61	1.00	\$52,000
LS-25B	205	2.00	\$90,000
LS-26B	35	2.00	\$90,000
LS-27B	210	4.00	\$140,000
Boca Chica LS	400	4.00	\$140,000

a/ From Figure 5-22

Table 5-11  
 Proposed Lift Stations  
 Sub-Area H Colonias

Lift Station Designation	Flow Rate (gpm)	Estimated Brake Horsepower	Estimated Cost (\$) a/
LS-1H	310	7.00	\$150,000
LS-2H	205	4.50	\$144,000
LS-3H	150	21.00	\$126,000
LS-4H	75	7.00	\$154,000
Airport LS	225	3.50	\$136,500
LS-5H	345	4.00	\$140,000
LS-6H	65	1.50	\$72,000
LS-7H	30	1.00	\$52,000

a/ From Figure 5-22

Table 5-12  
 Cost Comparison for Sewered System vs On-Site Wastewater Disposal  
 Cameron County Sub-Area H Colonias (HAKLINGEN ETC)

Colonia Identification Number	2020 Population	2020 Units	2020 Unit Density (Units/Acre)	2020 Discharge (GPD)	WWTP Cost a/ (\$)	Sewer Cost b/ (\$)	Total Sewered Cost c/ (\$)	On-Site Cost d/ (\$)
A	B	C	D	E	F	G	H	I
1H	1103	225	2.88	110,300	\$0	\$860,267	\$860,267	\$1,125,000
2H,5H	929	190	2.60	92,900	\$0	\$1,042,819	\$1,042,819	\$950,000
3H	504	103	2.51	50,400	\$0	\$824,870	\$824,870	\$515,000
4H	243	50	2.00	24,300	\$0	\$477,516	\$477,516	\$250,000
6H	217	44	1.83	21,700	\$0	\$285,079	\$285,079	\$220,000
7H	95	19	1.19	9,500	\$0	\$164,744	\$164,744	\$95,000

a/ Includes construction cost, engineering, land acquisition, administrative fees, permitting fees, and contingencies.  
 b/ Cost based on preliminary design schematics. See pertinent section of report for detailed schematics and associated costs.  
 c/ F+G  
 d/ Based on mounded pressure-dose system at \$5,000/unit

3,125,000

Table 5-13  
Proposed Lift Stations  
Sub-Area W Colonias

Lift Station Designation	Flow Rate (gpm)	Estimated Brake Horsepower	Estimated Cost (\$) a/
LS-1W1	425	3.50	\$136,500
LS-1W2	560	5.50	\$148,500
LS-2W	670	5.50	\$148,500
LS-3W	250	2.50	\$100,000
LS-4W	205	2.00	\$90,000
LS-5W	170	1.50	\$72,000
LS-9W	115	2.50	\$100,000
LS-11W	85	1.00	\$52,000
LS-13W	300	2.50	\$100,000
LS-17W	170	2.50	\$100,000

a/ From Figure 5-22

Table 5-14  
 Estimated Cost of Wastewater Treatment Plants  
 Cameron County Sub-Area W Colonias (Western Cameron County)

Function	Treatment Plants						
	STP-1W	STP-2W	STP-3W	STP-4W	STP-5W	STP-11W	
1. Construction Cost a/	\$414,207	\$519,984	\$178,227	\$144,639	\$120,060	\$58,995	
2. Engineering b/	\$20,710	\$25,999	\$8,911	\$7,232	\$6,003	\$2,950	
3. Land Acquisition c/	\$20,000	\$20,000	\$20,000	\$20,000	\$20,000	\$20,000	
4. Surveying/staking d/	\$12,426	\$15,600	\$5,347	\$4,339	\$3,602	\$1,770	
5. Legal and Administrative fees e/	\$10,355	\$13,000	\$4,456	\$3,616	\$3,002	\$1,475	
6. Permitting and fees f/	\$8,284	\$10,400	\$3,565	\$2,893	\$2,401	\$1,180	
7. Contingencies g/	\$62,131	\$77,998	\$26,734	\$21,696	\$18,009	\$8,849	
<b>TOTAL</b>	<b>\$548,114</b>	<b>\$682,980</b>	<b>\$247,239</b>	<b>\$204,415</b>	<b>\$173,077</b>	<b>\$95,219</b>	

a/ All costs assume 1990 dollars (0% inflation)

b/ Based on 5% of construction cost

c/ Based on current estimated cost of \$5,000/acre

d/ Based on 3% of construction cost

e/ Based on 2.5% of construction cost

f/ Based on 2% of construction cost

g/ Based on 15% of construction cost

Table 5-15  
 Cost Comparison for Sewered System vs On-Site Wastewater Disposal  
 Cameron County Sub-Area W Colonias (Western Cameron County)

Colonia Identification Number	2020 Population	2020 Units	2020 Unit Density (Units/Acre)	2020 Discharge (GPD)	WWTP Cost a/ (\$)	Sewer Cost b/ (\$)	Total Sewered Cost c/ (\$)	On-Site Cost d/ (\$)
A	B	C	D	E	F	G	H	I
1W, 9W	2,001	408	1.71	200,100	\$548,114	\$1,592,178	\$2,140,292	\$2,040,000
2W, 10W	2,512	513	5.70	251,200	\$682,980	\$1,039,757	\$1,722,737	\$2,565,000
3W	861	176	2.48	86,100	\$247,239	\$760,094	\$1,007,333	\$880,000
4W	699	143	1.43	69,900	\$204,484	\$674,211	\$878,695	\$715,000
5W	580	118	2.00	58,000	\$173,077	\$367,166	\$540,243	\$590,000
6W, 17W, 15W, 13W	984	201	1.81	98,400	\$95,746 to Santa Rosa	\$1,042,403	\$1,042,403	\$1,005,000
7W	287	59	1.44	28,700	\$95,746	\$267,162	\$362,908	\$295,000
8W	275	56	0.48	27,500	\$92,579	\$428,510	\$521,089	\$280,000
11W	285	58	1.81	28,500	\$95,219	\$314,769	\$409,988	\$290,000
12W	169	34	1.06	16,900	\$64,603	\$196,855	\$261,458	\$170,000
14W	137	28	0.58	13,700	\$56,158	\$149,463	\$205,621	\$140,000
16W	116	24	1.50	11,600	\$50,615	\$141,000	\$191,615	\$120,000
								9,090,000

a/ Includes construction cost, engineering, land acquisition, administrative fees, permitting fees, and contingencies.  
 b/ Cost based on preliminary design schematics. See pertinent section of report for detailed schematics and associated costs.  
 c/ F+G  
 d/ Based on mounded pressure-dose system at \$5,000/unit

Table 5-16  
Proposed Lift Stations  
Sub-Area E Colonias

Lift Station Designation	Flow Rate (gpm)	Estimated Brake Horsepower	Estimated Cost (\$) a/
LS-1E	480	5.00	\$150,000
LS-2E	200	3.50	\$126,000
LS-3E	195	3.00	\$114,000
LS-4E	120	1.50	\$72,000
LS-7E	85	1.50	\$82,500
LS-8E	78	6.50	\$162,500
LS-11E	80	2.50	\$100,000

a/ From Figure 5-22



Table 5-17  
 Estimated Cost of Wastewater Treatment Plants  
 Cameron County Sub-Area E Colonias

Function	Treatment Plants			
	STP-1E	STP-2E	STP-3E	STP-7E
1. Construction Cost a/	\$414,207	\$519,984	\$178,227	\$58,167
2. Engineering b/	\$20,710	\$25,999	\$8,911	\$2,908
3. Land Acquisition c/	\$20,000	\$20,000	\$20,000	\$20,000
4. Surveying/staking d/	\$12,426	\$15,600	\$5,347	\$1,745
5. Legal and Administrative fees e/	\$10,355	\$13,000	\$4,456	\$1,454
6. Permitting and fees f/	\$8,284	\$10,400	\$3,565	\$1,163
7. Contingencies g/	\$62,131	\$77,998	\$26,734	\$8,725
<b>TOTAL</b>	<b>\$548,114</b>	<b>\$682,980</b>	<b>\$247,239</b>	<b>\$94,163</b>

- a/ All costs assume 1990 dollars (0% inflation)
- b/ Based on 5% of construction cost
- c/ Based on current estimated cost of \$5,000/acre
- d/ Based on 3% of construction cost
- e/ Based on 2.5% of construction cost
- f/ Based on 2% of construction cost
- g/ Based on 15% of construction cost

Table 5-18  
 Cost Comparison for Sewered System vs On-Site Wastewater Disposal  
 Cameron County Sub-Area E Colonias (Eastern Cameron County)

Colonia Identification Number	2020 Population	2020 Units	2020 Unit Density (Units/Acre)	2020 Discharge (GPD)	WWTP Cost a/ (\$)	Sewer Cost b/ (\$)	Total Sewered Cost c/ (\$)	On-Site Cost d/ (\$)
A	B	C	D	E	F	G	H	I
1E,4E,8E,12E,13E	1,648	336	1.56	164,800	\$454,948	\$1,580,332	\$2,035,280	\$1,680,000
2E	680	139	2.78	68,000	\$199,469	\$566,019	\$765,488	\$695,000
3E	662	135	2.29	66,200	\$194,718	\$585,266	\$779,984	\$675,000
5E,10E	268	158	0.59	26,800	\$90,732	\$2,073,556	\$2,164,288	\$790,000
6E	211	95	0.45	21,100	\$75,688	\$750,817	\$826,505	\$475,000
7E	281	57	3.56	28,100	\$94,163	\$261,333	\$355,496	\$285,000
9E	218	45	1.41	21,800	\$77,536	\$265,995	\$343,531	\$225,000
11E	261	53	2.41	26,100	To Los Fresnos	\$439,666	\$439,666	\$265,000

a/ Includes construction cost, engineering, land acquisition, administrative fees, permitting fees, and contingencies.

b/ Cost based on preliminary design schematics. See pertinent section of report for detailed schematics and associated costs.

c/ F+G

d/ Based on mounded pressure-dose system at \$5,000/unit

5,090,000

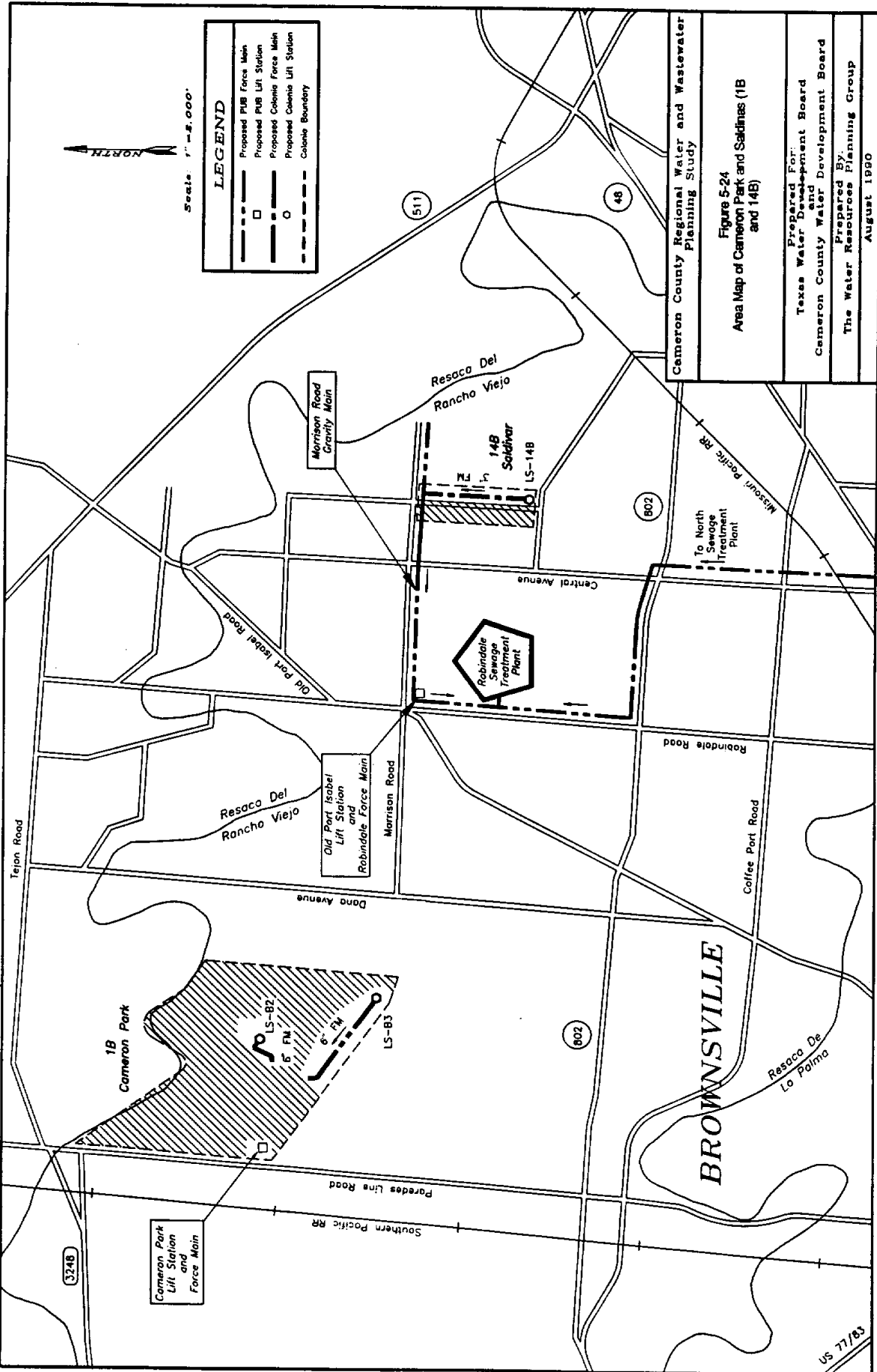

Scale: 1" = 5,000'

**LEGEND**

- Proposed PWB Force Main
- Proposed PWB Lift Station
- Proposed Coloma Force Main
- Proposed Coloma Lift Station
- Coloma Boundary

Cameron County Regional Water and Wastewater Planning Study

Figure 5-24  
Area Map of Cameron Park and Saldinas (1B and 14B)

Prepared For:  
Texas Water Development Board  
Cameron County Water Development Board  
Prepared By:  
The Water Resources Planning Group  
August 1990

US 71/83

Cameron County Regional Water and Wastewater Planning Study

Figure 5-25  
Site Map for Cameron Park (1B)

Prepared For:  
Texas Water Development Board  
and Cameron County Water Development Board

Prepared By:  
The Water Resources Planning Group  
August 1990

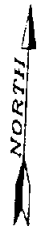
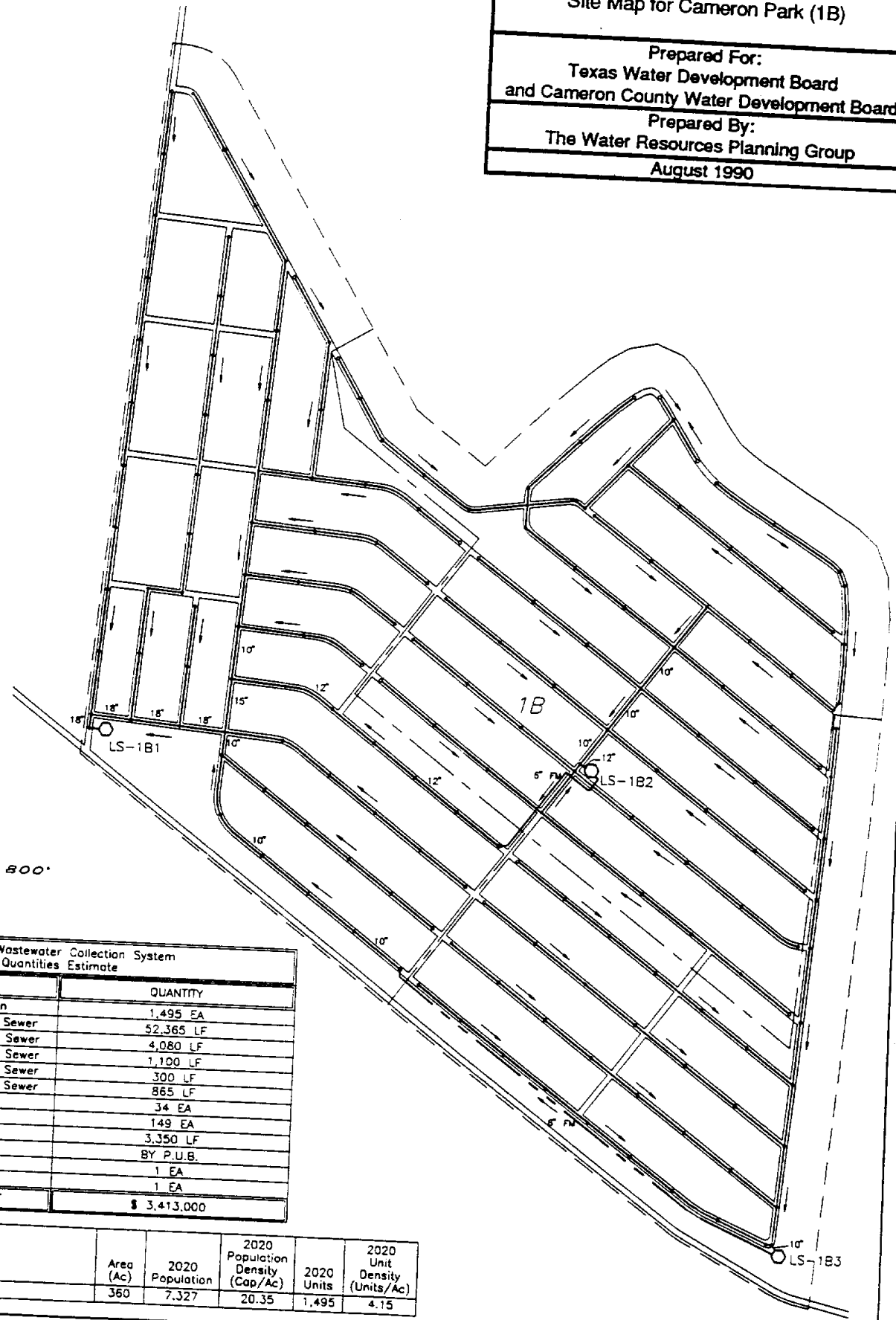

Scale: 1" = 800'

Internal Wastewater Collection System  
Quantities Estimate

ITEM	QUANTITY
6" Service Connection	1,495 EA
8" SDR-35 PVC Sanitary Sewer	52,365 LF
10" SDR-35 PVC Sanitary Sewer	4,080 LF
12" SDR-35 PVC Sanitary Sewer	1,100 LF
15" SDR-35 PVC Sanitary Sewer	300 LF
18" SDR-35 PVC Sanitary Sewer	865 LF
Clean Out	34 EA
Manhole	149 EA
6" PVC Force Main	3,350 LF
LS-1B1	BY P.U.B.
LS-1B2 590 GPM	1 EA
LS-1B3 370 GPM	1 EA
<b>TOTAL ESTIMATED COST</b>	<b>\$ 3,413,000</b>

Colonia Designation	Colonia Name	Area (Ac)	2020 Population	2020 Population Density (Cap/Ac)	2020 Units	2020 Unit Density (Units/Ac)
1B	Cameron Park	360	7,327	20.35	1,495	4.15

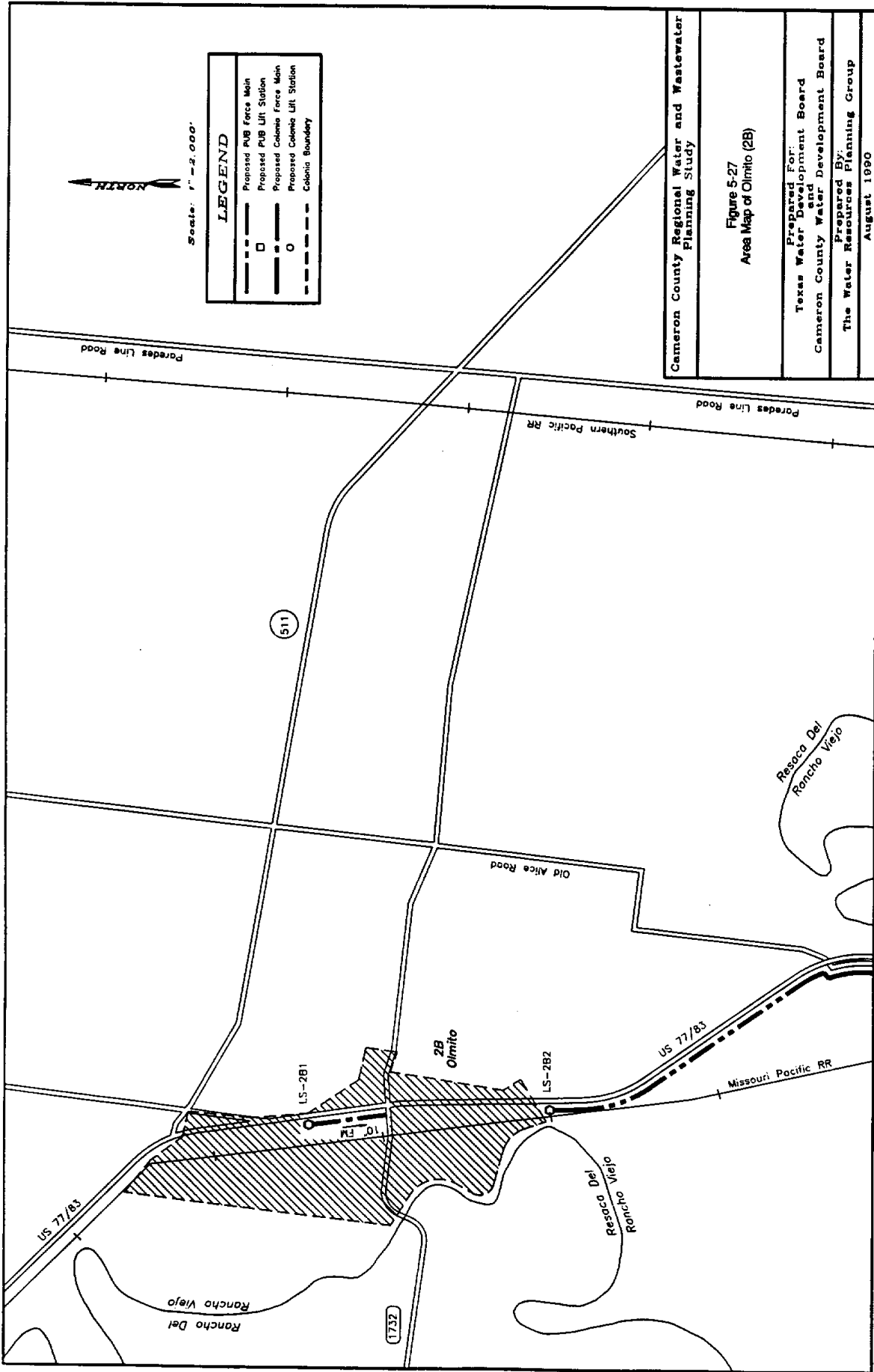

Cameron County Regional Water and Wastewater Planning Study

Figure 5-27  
Area Map of Olmito (2B)

Prepared For:  
Texas Water Development Board  
Cameron County Water Development Board

Prepared By:  
The Water Resources Planning Group

August 1990

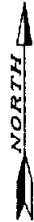

Scale: 1" = 1,000'

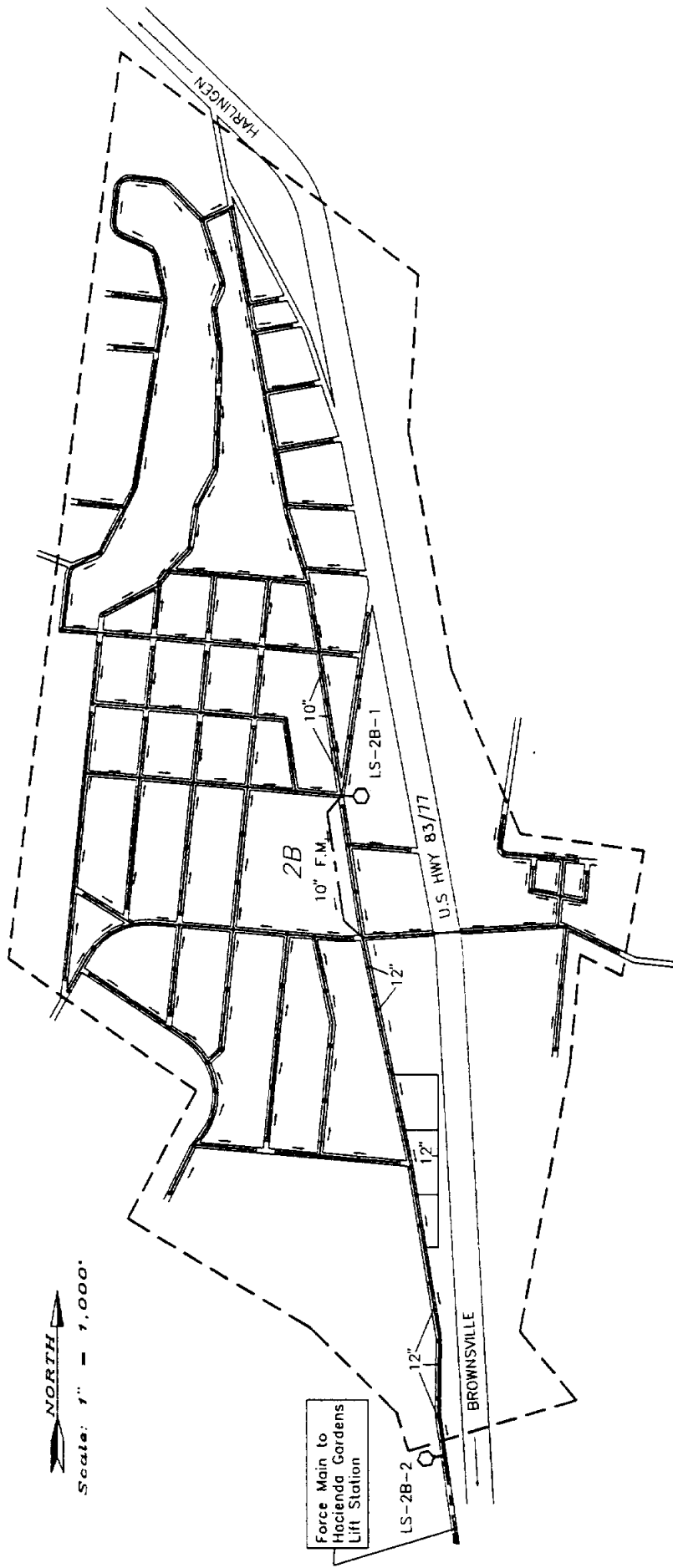

Colonia Designation	Colonia Name	Area (Ac)	2020 Population	2020 Population Density (Pop./Ac)	2020 Units	2020 Unit Density (Units/Ac)
2B	Olmito	387	6,532	9.13	721	1.86

Internal Wastewater Collection System Quantities Estimate		QUANTITY
6" Service Connection		721 EA
8" SDR-35 PVC Sanitary Sewer		42,910 LF
10" SDR-35 PVC Sanitary Sewer		900 LF
12" SDR-35 PVC Sanitary Sewer		2,850 LF
15" SDR-35 PVC Sanitary Sewer		N/A
18" SDR-35 PVC Sanitary Sewer		N/A
Clean Out		46 EA
Manhole		108 EA
4" PVC Force Main		N/A
6" PVC Force Main		N/A
8" PVC Force Main		N/A
10" PVC Force Main		10,900 LF
12" PVC Force Main		N/A
LS-2B1	830 GPM (8.0 HP)	1 EA
LS-2B2	900 GPM (12.5HP)	1 EA
TOTAL ESTIMATED COST		\$ 2,877,866

Cameron County Regional Water and Wastewater Planning Study

Figure 5-28  
Site Map of Olmito (2B)

Prepared For:  
Texas Water Development Board  
and Cameron County Water Development Board

Prepared By:  
The Water Resources Planning Group

August 1990

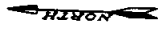

Scale: 1" = 2,000'

**LEGEND**

- Proposed PUB Force Main
- Proposed PUB Lift Station
- Proposed Colonia Force Main
- Proposed Colonia Lift Station
- Colonia Boundary

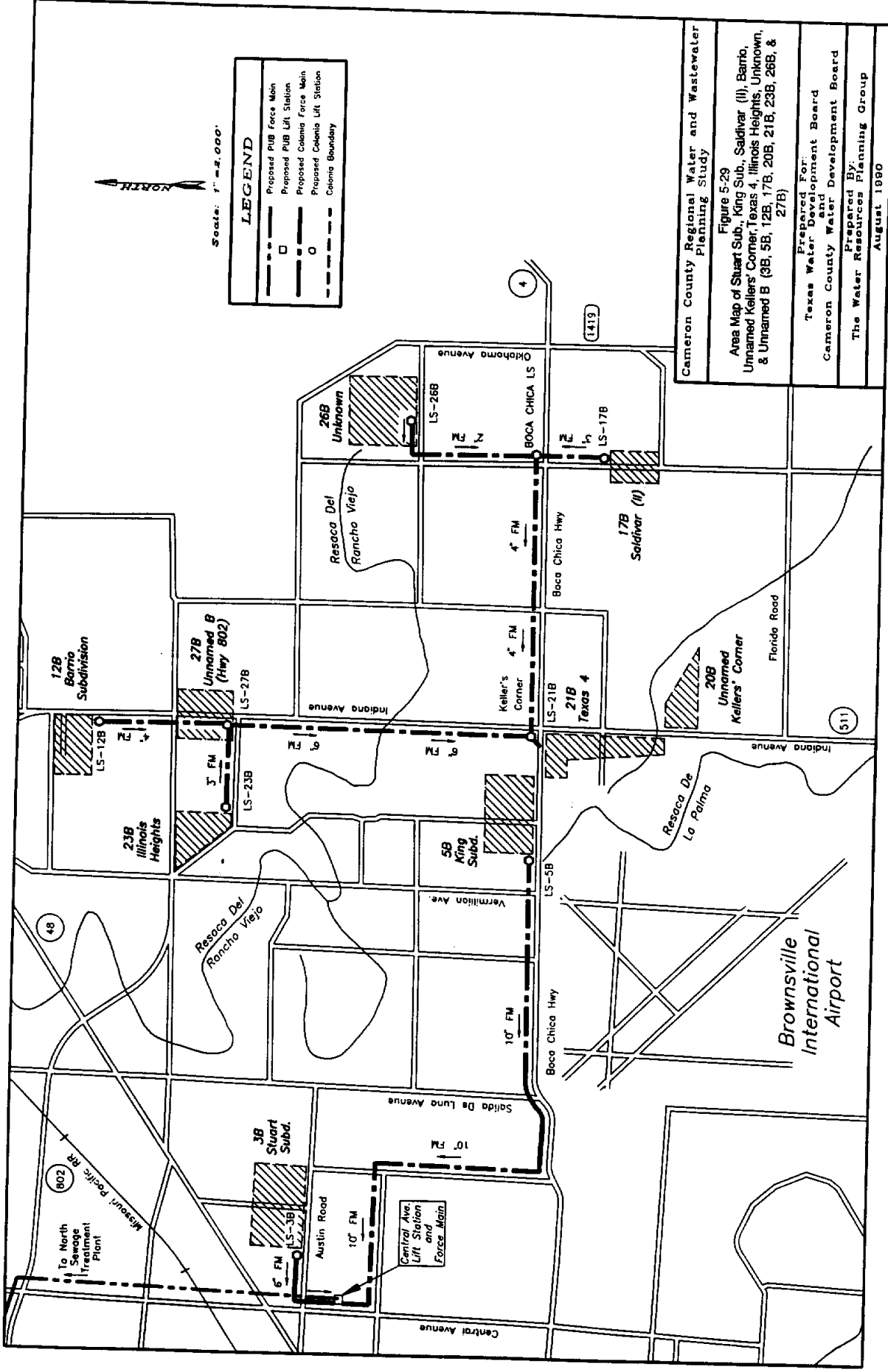

Cameron County Regional Water and Wastewater Planning Study

Figure 5-29  
 Area Map of Stuart Sub., King Sub., Soldivar (II), Barrio, Unnamed Kellers' Corner, Texas 4, Illinois Heights, Unknown, & Unnamed B (3B, 5B, 12B, 17B, 20B, 21B, 23B, 26B, & 27B)

Prepared For:  
 Texas Water Development Board  
 Cameron County Water Development Board

Prepared By:  
 The Water Resources Planning Group

August 1990

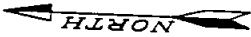

Scale: 1" = 400'

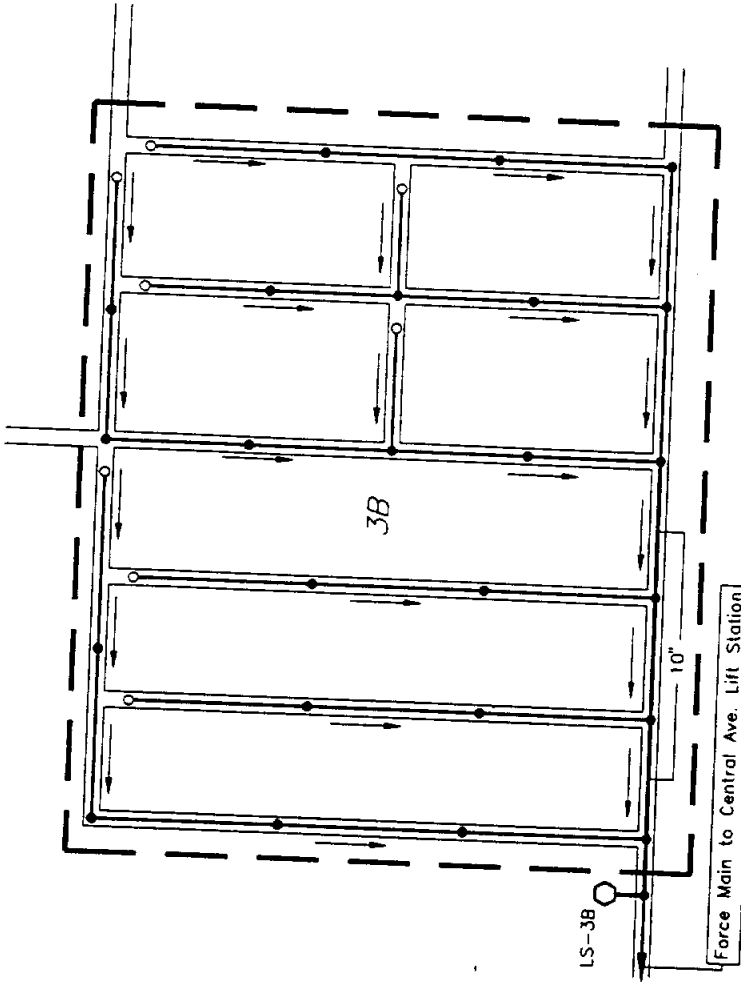

Colonia Designation	Colonia Name	Area (Ac)	2020 Population	2020 Population Density (Cap/Ac)	2020 Units	2020 Unit Density (Units/Ac)
3B	Stuart Subdivision	50	1,960	39.20	401	8.02

Internal Wastewater Collection System Quantities Estimate	
ITEM	QUANTITY
6" Service Connection	401 EA
8" SDR-35 PVC Sanitary Sewer	9,250 LF
10" SDR-35 PVC Sanitary Sewer	800 LF
12" SDR-35 PVC Sanitary Sewer	N/A
15" SDR-35 PVC Sanitary Sewer	N/A
18" SDR-35 PVC Sanitary Sewer	N/A
Clean Out	8 EA
Manhole	24 EA
4" PVC Force Main	N/A
6" PVC Force Main	N/A
8" PVC Force Main	2,000 LF
10" PVC Force Main	N/A
12" PVC Force Main	N/A
LS-3B 530 GPM (6 HP)	1 EA
<b>TOTAL ESTIMATED COST</b>	<b>\$ 831,300</b>

Cameron County Regional Water and Wastewater Planning Study

Figure 5-30  
Site Map of Stuart Subdivision (3B)

Prepared For:  
Texas Water Development Board  
and Cameron County Water Development Board

Prepared By:  
The Water Resources Planning Group  
August 1990



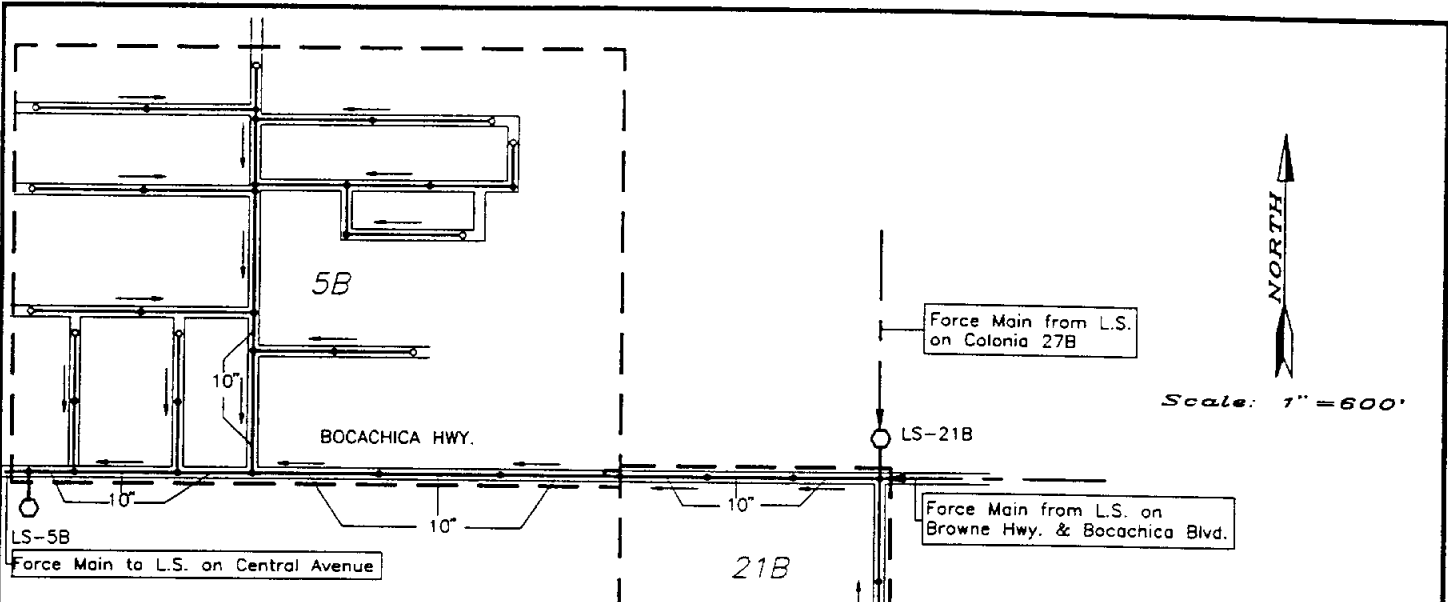

Colonia Designation	Colonia Name	Area (Ac)	2020 Population	2020 Population Density (Cap/Ac)	2020 Units	2020 Unit Density (Units/Ac)
5B	King Subdivision	62	1,285	24.40	258	4.18
20B	Unnamed D (Keller's Corner)	22	243	11.05	50	2.27
21B	Texas 4	33	243	7.38	50	1.20

5B

Internal Wastewater Collection System Quantities Estimate	
ITEM	QUANTITY
6" Service Connection	258 EA
8" SDR-35 PVC Sanitary Sewer	5,320 LF
10" SDR-35 PVC Sanitary Sewer	2,400 LF
12" SDR-35 PVC Sanitary Sewer	N/A
15" SDR-35 PVC Sanitary Sewer	N/A
18" SDR-35 PVC Sanitary Sewer	N/A
Clean Out	10 EA
Manhole	23 EA
4" PVC Force Main	N/A
6" PVC Force Main	N/A
8" PVC Force Main	N/A
10" PVC Force Main	N/A
12" PVC Force Main	14,500 LF
LS-5B 900 GPM (13 HP)	1 EA
<b>TOTAL ESTIMATED COST</b>	<b>\$ 1,010,305</b>

20B

Internal Wastewater Collection System Quantities Estimate	
ITEM	QUANTITY
6" Service Connection	50 EA
8" SDR-35 PVC Sanitary Sewer	3,400 LF
10" SDR-35 PVC Sanitary Sewer	N/A
12" SDR-35 PVC Sanitary Sewer	N/A
15" SDR-35 PVC Sanitary Sewer	N/A
18" SDR-35 PVC Sanitary Sewer	N/A
Clean Out	4 EA
Manhole	9 EA
4" PVC Force Main	N/A
6" PVC Force Main	N/A
8" PVC Force Main	N/A
10" PVC Force Main	N/A
12" PVC Force Main	N/A
<b>TOTAL ESTIMATED COST</b>	<b>\$ 91,392</b>

21B

Internal Wastewater Collection System Quantities Estimate	
ITEM	QUANTITY
6" Service Connection	50 EA
8" SDR-35 PVC Sanitary Sewer	2,800 LF
10" SDR-35 PVC Sanitary Sewer	2,400 LF
12" SDR-35 PVC Sanitary Sewer	N/A
15" SDR-35 PVC Sanitary Sewer	N/A
18" SDR-35 PVC Sanitary Sewer	N/A
Clean Out	1 EA
Manhole	11 EA
4" PVC Force Main	N/A
6" PVC Force Main	N/A
8" PVC Force Main	N/A
10" PVC Force Main	N/A
12" PVC Force Main	N/A
LS-21B 500 GPM (4 HP)	1 EA
<b>TOTAL ESTIMATED COST</b>	<b>401,974</b>

**Cameron County Regional Water and Wastewater Planning Study**

---

**Figure 5-31  
Site Map of King Subdivision (5B)**

---

**Prepared For:  
Texas Water Development Board  
and Cameron County Water Development Board**

---

**Prepared By:  
The Water Resources Planning Group**

---

**August 1990**

Colonia Designation 12B	Colonia Name Barrio Subdivision	Area (Ac) 1B	2020 Population 389	2020 Population Density (Pop/Ac) 21.61	2020 Units 79	2020 Unit Density (Units/Ac) 4.39
----------------------------	------------------------------------	-----------------	------------------------	---	------------------	--------------------------------------

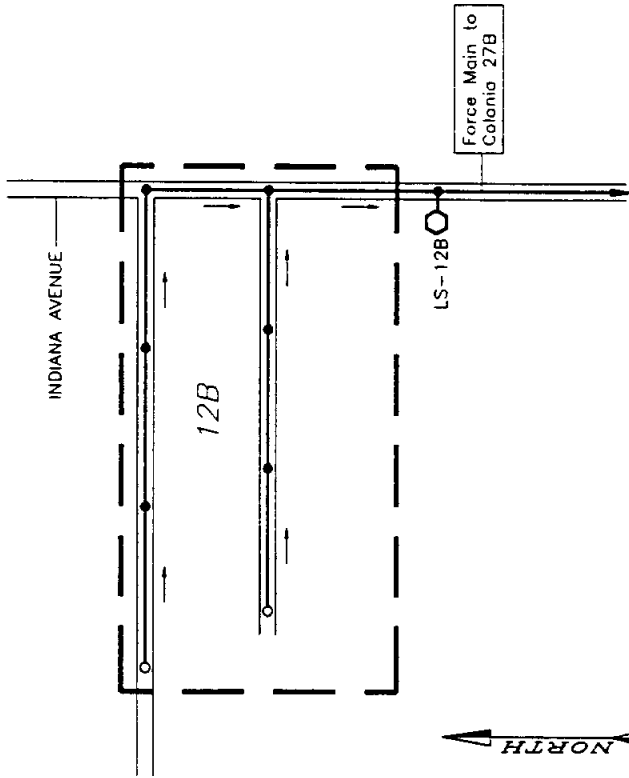

NORTH

Scale: 1" = 400'

Internal Wastewater Collection System Quantities Estimate	
ITEM	QUANTITY
6" Service Connection	79 EA
8" SDR-35 PVC Sanitary Sewer	2,450 LF
10" SDR-35 PVC Sanitary Sewer	N/A
12" SDR-35 PVC Sanitary Sewer	N/A
15" SDR-35 PVC Sanitary Sewer	N/A
18" SDR-35 PVC Sanitary Sewer	N/A
Clean Out	2 EA
Manhole	7 EA
4" PVC Force Main	2,200 LF
6" PVC Force Main	N/A
8" PVC Force Main	N/A
10" PVC Force Main	N/A
12" PVC Force Main	N/A
LS-12B 120 GPM (2 HP)	1 EA
<b>TOTAL ESTIMATED COST</b>	<b>\$ 276,291</b>

Cameron County Regional Water and Wastewater Planning Study

Figure 5-32  
Site of Barrio Subdivision (12B)

Prepared For:  
Texas Water Development Board  
and Cameron County Water Development Board

Prepared By:  
The Water Resources Planning Group  
August 1990

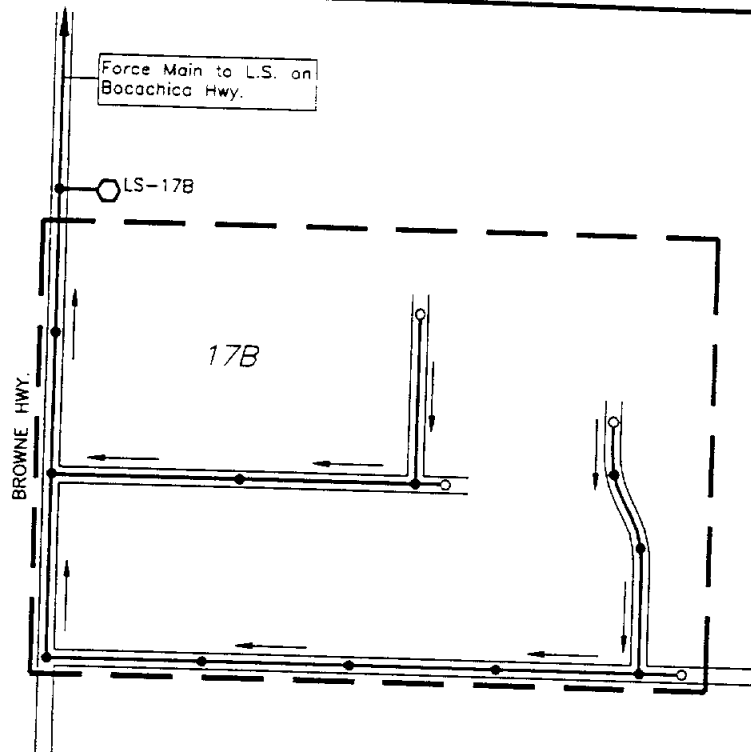

NORTH  
↑  
Scale: 1" = 400'

Colonia Designation	Colonia Name	Area (Ac)	2020 Population	2020 Population Density (Cap/Ac)	2020 Units	2020 Unit Density (Units/Ac)
17B	Saldivar (II)	33	272	8.24	56	1.70

Internal Wastewater Collection System Quantities Estimate	
ITEM	QUANTITY
6" Service Connection	56 EA
8" SDR-35 PVC Sanitary Sewer	3,980 LF
10" SDR-35 PVC Sanitary Sewer	N/A
12" SDR-35 PVC Sanitary Sewer	N/A
15" SDR-35 PVC Sanitary Sewer	N/A
18" SDR-35 PVC Sanitary Sewer	N/A
Clean Out	4 EA
Manhole	12 EA
3" PVC Force Main	1,500 LF
6" PVC Force Main	N/A
8" PVC Force Main	N/A
10" PVC Force Main	N/A
12" PVC Force Main	N/A
LS-17B 85 GPM (1.5 HP)	1 EA
<b>TOTAL ESTIMATED COST</b>	<b>\$ 282,672</b>

<b>Cameron County Regional Water and Wastewater Planning Study</b>
<b>Figure 5-33 Site Map of Saldivar (II) (17B)</b>
<b>Prepared For: Texas Water Development Board and Cameron County Water Development Board</b>
<b>Prepared By: The Water Resources Planning Group</b>
<b>August 1990</b>

VERMILION AVE.

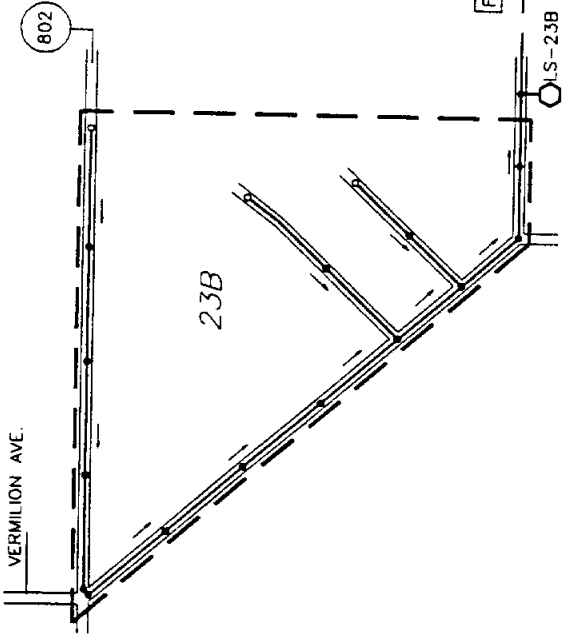

INDIANA AVENUE

802

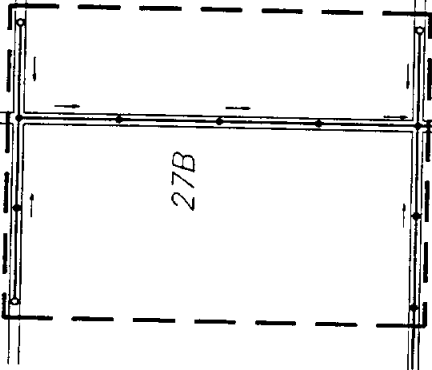

Force Main to L.S. on Keller's Corner (21B); Intersection of Bacachica Hwy & Indiana Ave.

LS-27B

LS-23B

23B

27B

Scale: 1" = 600'

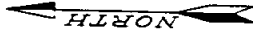

Colonia Designation	Colonia Name	Area (Ac)	2020 Population	2020 Population Density (Cap/Ac)	2020 Unit Density (Units/Ac)
23B	Illinois Heights	25	204	8.16	42
27B	Unnamed B (HWY 802)	22	97	4.41	20
					0.91

23B

Internal Wastewater Collection System Quantities Estimate	
ITEM	QUANTITY
6" Service Connection	42 EA
8" SDR-35 PVC Sanitary Sewer	4,800 LF
Clean Out	3 EA
Manhole	15 EA
3' PVC Force Main	1,500 LF
LS-23B 61 GPM (1 HP)	1 EA
TOTAL ESTIMATED COST	\$ 271,212

27B

Internal Wastewater Collection System Quantities Estimate	
ITEM	QUANTITY
6" Service Connection	20 EA
8" SDR-35 PVC Sanitary Sewer	3,050 LF
Clean Out	3 EA
Manhole	9 EA
6" PVC Force Main	7,000 LF
LS-27B 210 GPM (4 HP)	1 EA
TOTAL ESTIMATED COST	\$ 402,841

Cameron County Regional Water and Wastewater Planning Study  
 Figure 5-34  
 Site Map of Illinois Heights and Unnamed B (23B and 27B)  
 Prepared For:  
 Texas Water Development Board  
 and Cameron County Water Development Board  
 Prepared By:  
 The Water Resources Planning Group  
 August 1990

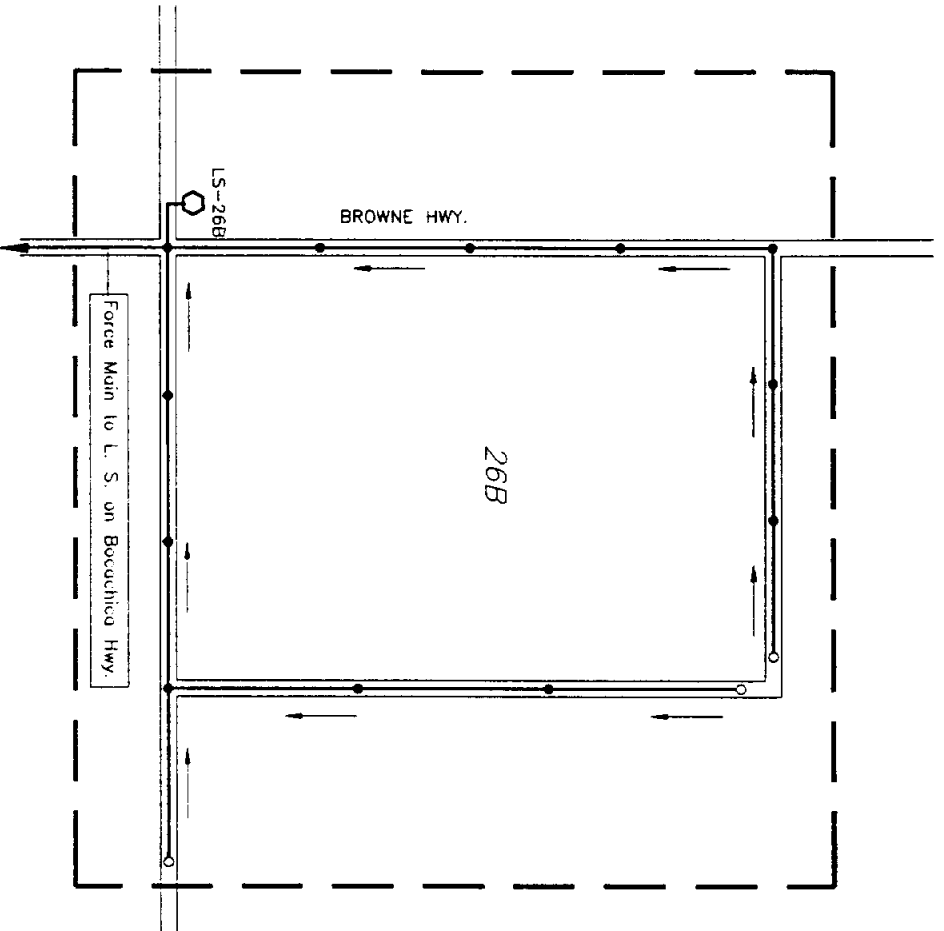

Scale: 1" = 400'

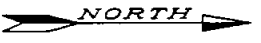

Colonia Designation	Colonia Name	Area (Ac)	2020 Population	2020 Population Density (Pop/Ac)	2020 Units	2020 Unit Density (Units/Ac)
26B	Unknown	38	117	3.08	24	0.63

Internal Wastewater Collection System Quantities Estimate	
ITEM	QUANTITY
6" Service Connection	24 EA
8" SDR-35 PVC Sanitary Sewer	4,730 LF
10" SDR-35 PVC Sanitary Sewer	N/A
12" SDR-35 PVC Sanitary Sewer	N/A
15" SDR-35 PVC Sanitary Sewer	N/A
18" SDR-35 PVC Sanitary Sewer	N/A
Clean Out	3 EA
Manhole	12 EA
2" PVC Force Main	3,500 LF
6" PVC Force Main	N/A
8" PVC Force Main	N/A
10" PVC Force Main	N/A
12" PVC Force Main	N/A
LS-26B 35 GPM (2 HP)	1 EA
<b>TOTAL ESTIMATED COST</b>	<b>\$ 316,660</b>

<p><b>Cameron County Regional Water and Wastewater Planning Study</b></p> <p><b>Figure 5-35</b> <b>Site Map of Unknown (26B)</b></p> <p>Prepared For: Texas Water Development Board and Cameron County Water Development Board</p> <p>Prepared By: The Water Resources Planning Group</p> <p>August 1990</p>
--

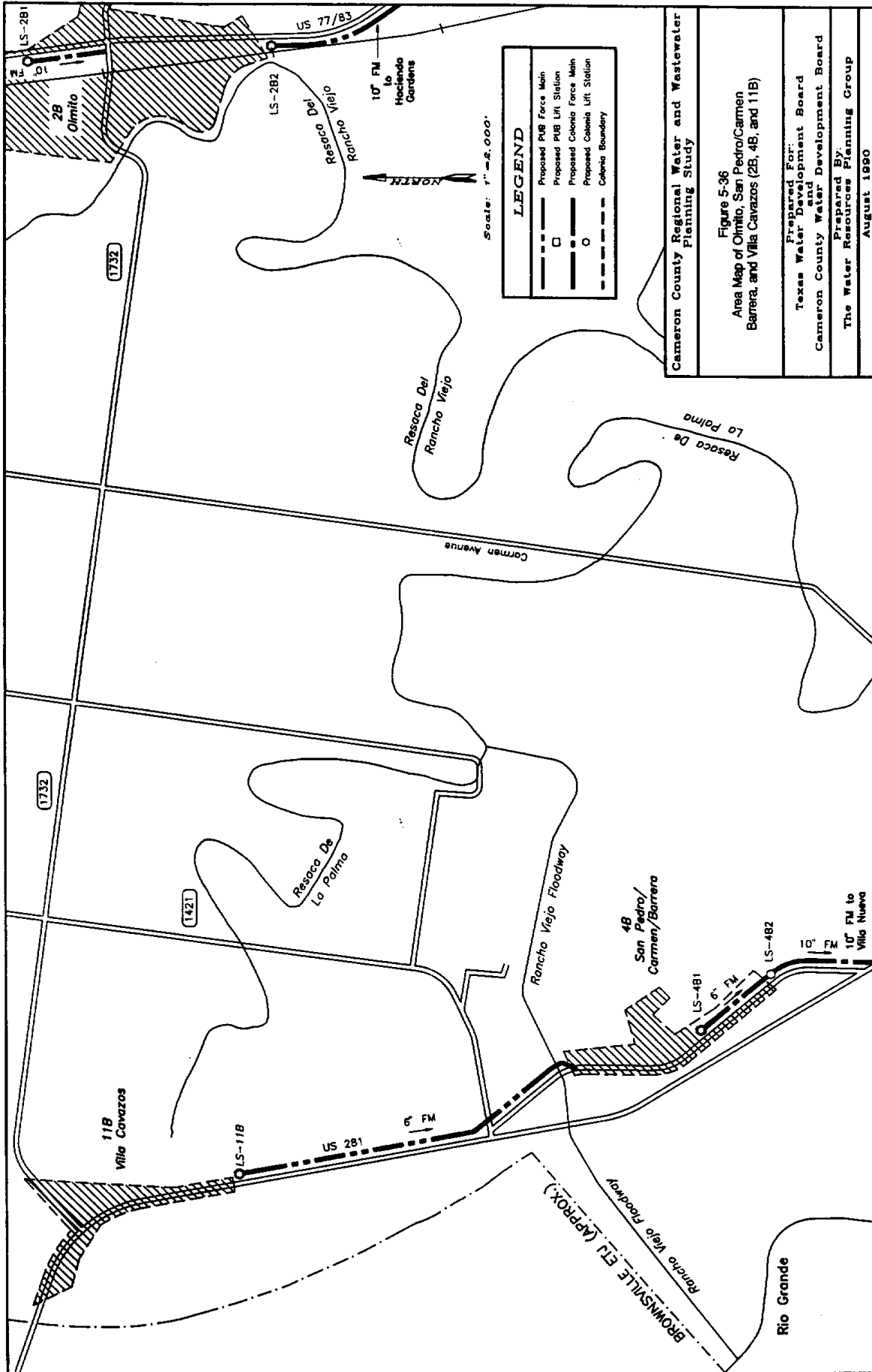

**Figure 5-36**  
**Area Map of Olmito, San Pedro/Carmen, Barrera, and Villa Cavazos (2B, 4B, and 11B)**  
 Cameron County Regional Water and Wastewater Planning Study

Prepared For:  
 Texas Water Development Board  
 and  
 Cameron County Water Development Board

Prepared By:  
 The Water Resources Planning Group  
 August 1990

Force Main from Colonia Villa Cavazos (11B)

Colonia Designation	Colonia Name	Area (Ac)	2020 Population	2020 Population Density (Cap/Ac)	2020 Units	2020 Unit Density (Units/Ac)
4B	San Pedro/Carmen/Barrera Gd.	63	1,450	23.02	296	4.70

Internal Wastewater Collection System Quantities Estimate	
ITEM	QUANTITY
6" Service Connection	296 EA
8" SDR-35 PVC Sanitary Sewer	8,950 LF
10" SDR-35 PVC Sanitary Sewer	350 LF
12" SDR-35 PVC Sanitary Sewer	N/A
15" SDR-35 PVC Sanitary Sewer	N/A
18" SDR-35 PVC Sanitary Sewer	N/A
Clean Out	6 EA
Manhole	28 EA
4" PVC Force Main	100 LF
5" PVC Force Main	N/A
8" PVC Force Main	N/A
10" PVC Force Main	16,000 LF
12" PVC Force Main	N/A
LS-4B1 300 GPM (3.0HP)	1 EA
LS-4B2 520 GPM (8.5HP)	1 EA
<b>TOTAL ESTIMATED COST</b>	<b>\$ 1,112,964</b>

4B

LS-4B1

U.S. HWY 281

LS-4B2

Force Main to Colonia Villa Nueva (8B)



Scale: 1" = 1,000'

Cameron County Regional Water and Wastewater Planning Study

Figure 5-37  
Site Map of San Pedro/Carmen Barrera (4B)

Prepared For:  
Texas Water Development Board  
and Cameron County Water Development Board

Prepared By:  
The Water Resources Planning Group

August 1990



Scale: 1" = 600'

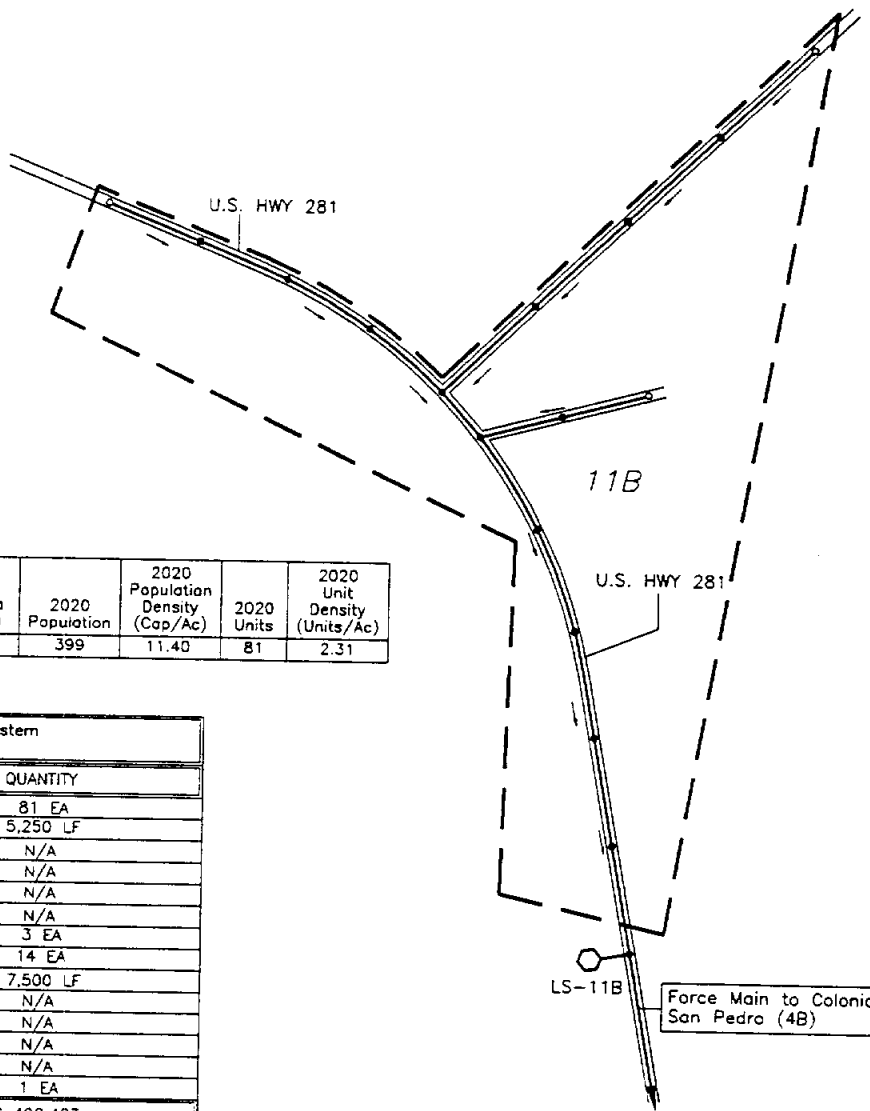

Colonia Designation	Colonia Name	Area (Ac)	2020 Population	2020 Population Density (Cap/Ac)	2020 Units	2020 Unit Density (Units/Ac)
11B	Villa Cavazos	35	399	11.40	81	2.31

Internal Wastewater Collection System Quantities Estimate	
ITEM	QUANTITY
6" Service Connection	81 EA
8" SDR-35 PVC Sanitary Sewer	5,250 LF
10" SDR-35 PVC Sanitary Sewer	N/A
12" SDR-35 PVC Sanitary Sewer	N/A
15" SDR-35 PVC Sanitary Sewer	N/A
18" SDR-35 PVC Sanitary Sewer	N/A
Clean Out	3 EA
Manhole	14 EA
4" PVC Force Main	7,500 LF
6" PVC Force Main	N/A
8" PVC Force Main	N/A
10" PVC Force Main	N/A
12" PVC Force Main	N/A
LS-11B 120 GPM (4 HP)	1 EA
<b>TOTAL ESTIMATED COST</b>	<b>\$ 490,423</b>

<b>Cameron County Regional Water and Wastewater Planning Study</b>
<b>Figure 5-38 Site Map of Villa Cavazos (11B)</b>
<b>Prepared For: Texas Water Development Board and Cameron County Water Development Board</b>
<b>Prepared By: The Water Resources Planning Group</b>
<b>August 1990</b>



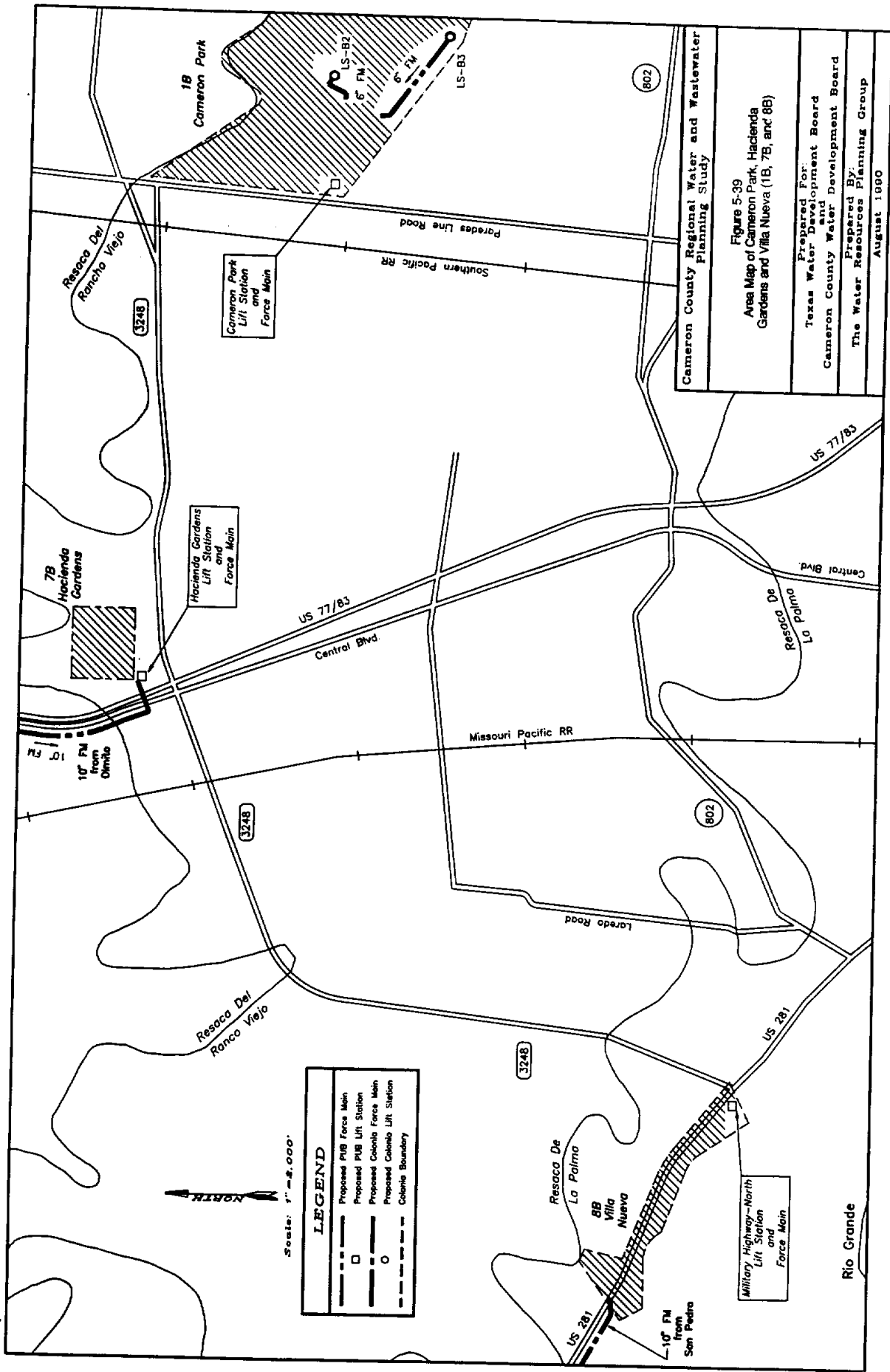

Scale: 1" = 5,000'

NORTH

**LEGEND**

- Proposed PUB Force Main
- Proposed PUB Lift Station
- Proposed Colonia Force Main
- Proposed Colonia Lift Station
- Colonia Boundary

**Figure 5-39**  
**Area Map of Cameron Park, Hacienda Gardens and Villa Nueva (1B, 7B, and 8B)**

Prepared For:  
 Texas Water Development Board  
 Cameron County Water Development Board

Prepared By:  
 The Water Resources Planning Group  
 August 1990

Cameron County Regional Water and Wastewater Planning Study

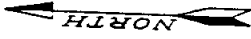

Scale: 1" = 400'

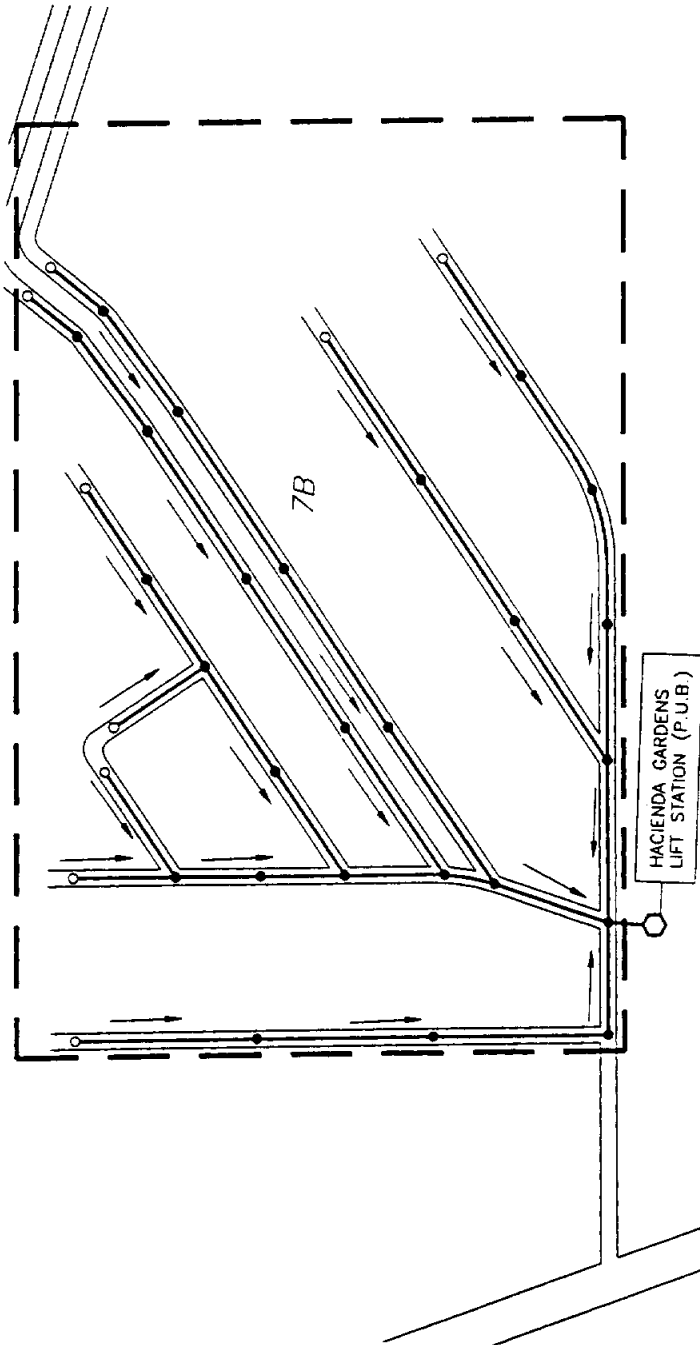

Colonia Designation	Colonia Name	Area (Ac)	2020 Population	2020 Population Density (Cap/Ac)	2020 Units	2020 Unit Density (Units/Ac)
7B	Hacienda Gardens	51	944	18.51	193	3.78

Internal Wastewater Collection System Quantities Estimate	
ITEM	QUANTITY
6" Service Connection	193 EA
8" SDR-35 PVC Sanitary Sewer	10,000 LF
10" SDR-35 PVC Sanitary Sewer	N/A
12" SDR-35 PVC Sanitary Sewer	N/A
15" SDR-35 PVC Sanitary Sewer	N/A
18" SDR-35 PVC Sanitary Sewer	N/A
Clean Out	9 EA
Manhole	26 EA
4" PVC Force Main	N/A
6" PVC Force Main	N/A
8" PVC Force Main	N/A
10" PVC Force Main	N/A
12" PVC Force Main	N/A
L.S. HACIENDA GARDENS	BY P.U.B.
TOTAL ESTIMATED COST	\$ 455,694

Cameron County Regional Water and Wastewater Planning Study

Figure 5-40  
Site Map of Hacienda Gardens (7B)

Prepared For:  
Texas Water Development Board  
and Cameron County Water Development Board

Prepared By:  
The Water Resources Planning Group  
August 1990

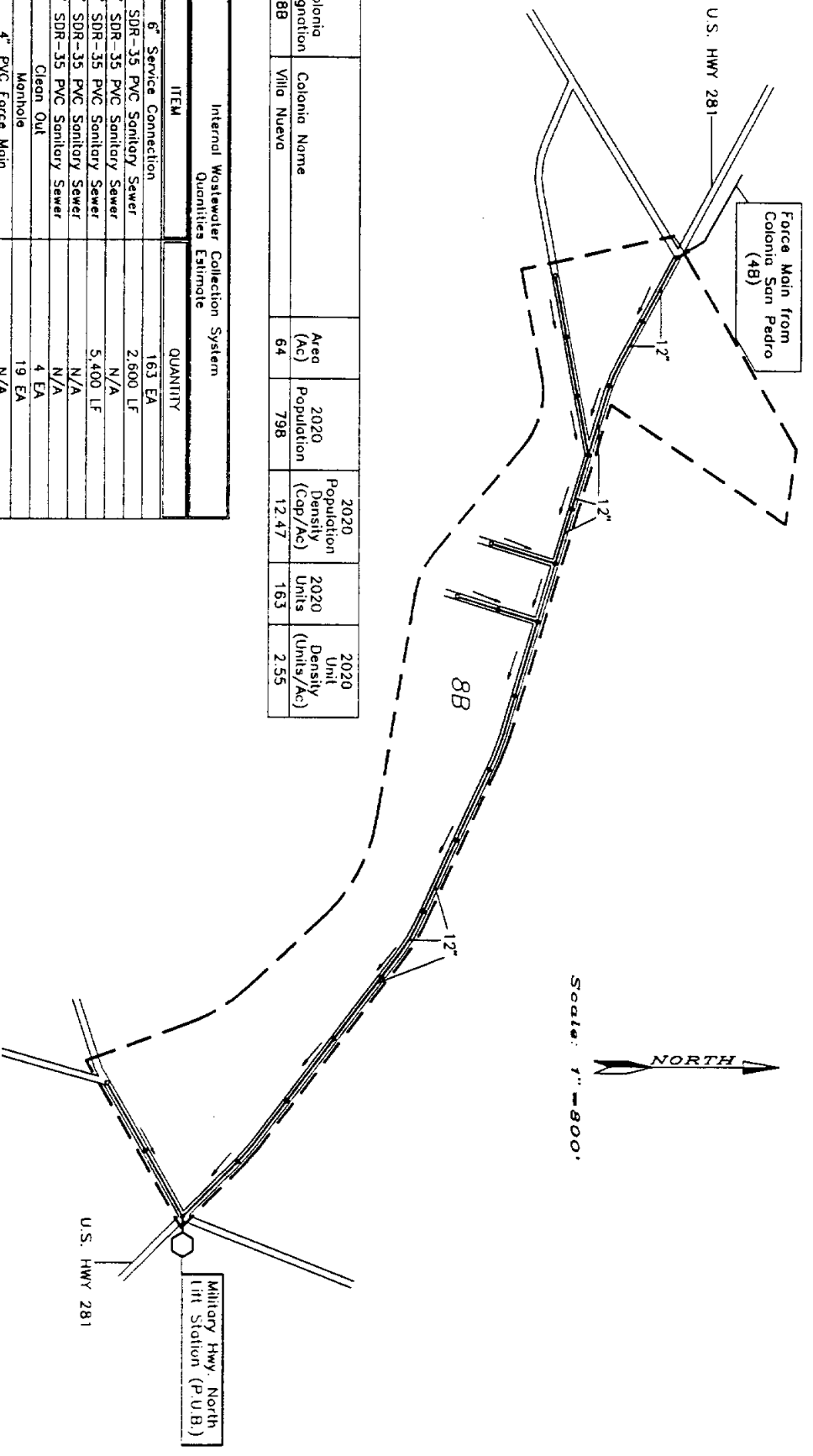

Colonia Designation	Colonia Name	Area (Ac)	2020 Population	2020 Population Density (Cap/Ac)	2020 Units	2020 Unit Density (Units/Ac)
8B	Villa Nueva	64	798	12.47	163	2.55

ITEM	QUANTITY
6" Service Connection	163 EA
8" SDR-35 PVC Sanitary Sewer	2,600 LF
10" SDR-35 PVC Sanitary Sewer	N/A
12" SDR-35 PVC Sanitary Sewer	5,400 LF
15" SDR-35 PVC Sanitary Sewer	N/A
18" SDR-35 PVC Sanitary Sewer	N/A
Clean Out	4 EA
Manhole	19 EA
4" PVC Force Main	N/A
6" PVC Force Main	N/A
8" PVC Force Main	N/A
10" PVC Force Main	N/A
12" PVC Force Main	N/A
MILITARY HWY. L.S.	BY P.U.B.
<b>TOTAL ESTIMATED COST</b>	<b>\$ 493,366</b>

**Cameron County Regional Water and Wastewater Planning Study**

Figure 5-41  
Site Map of Villa Nueva (8B)

Prepared For:  
Texas Water Development Board  
and Cameron County Water Development Board

Prepared By:  
The Water Resources Planning Group

August 1990

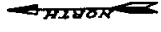

Scale: 1" = 2,000'

**LEGEND**

- Proposed PUB Force Main
- Proposed PUB Lift Station
- Proposed Colonia Force Main
- Proposed Colonia Lift Station
- Colonia Boundary

**Cameron County Regional Water and Wastewater Planning Study**

Figure 5-42

Area Map of Alabama/Arkansas (La Palma), Villa Pancho, Pleasant Meadows, Los Cuales, Coronado Heights, Unknown, Valle Escondido, Unnamed C, 511 Crossroads, Unknown, Valle Hermosa & 21 (8B, 9B, 10B, 13B, 15B, 16B, 18B, 19B, 22B, 24B, 25B, & 28B)

Prepared For:  
Texas Water Development Board  
Cameron County Water Development Board  
Prepared By:  
The Water Resources Planning Group  
August 1990

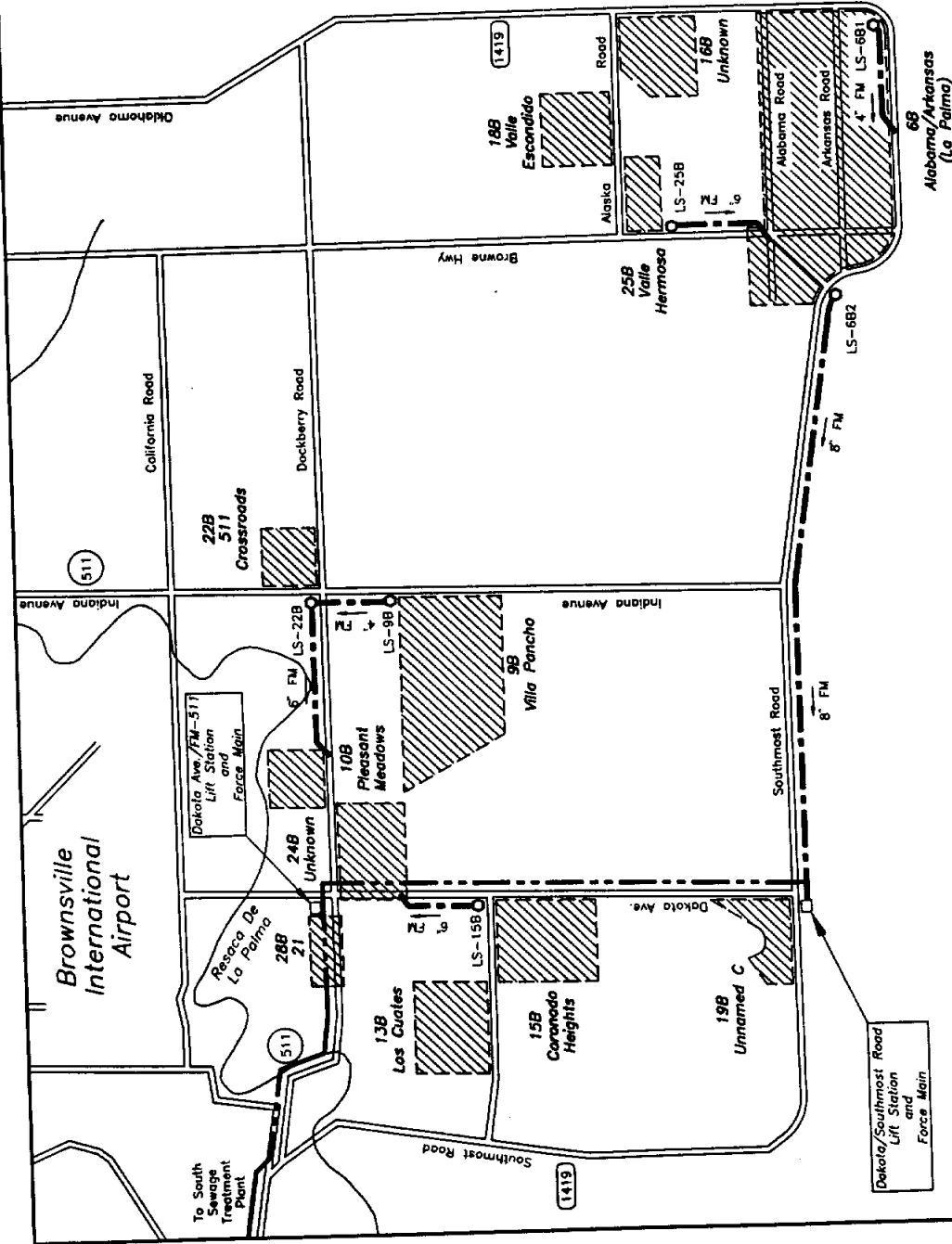

68  
Alabama/Arkansas  
(La Palma)

Dakota/Southmost Road  
Lift Station  
and  
Force Main

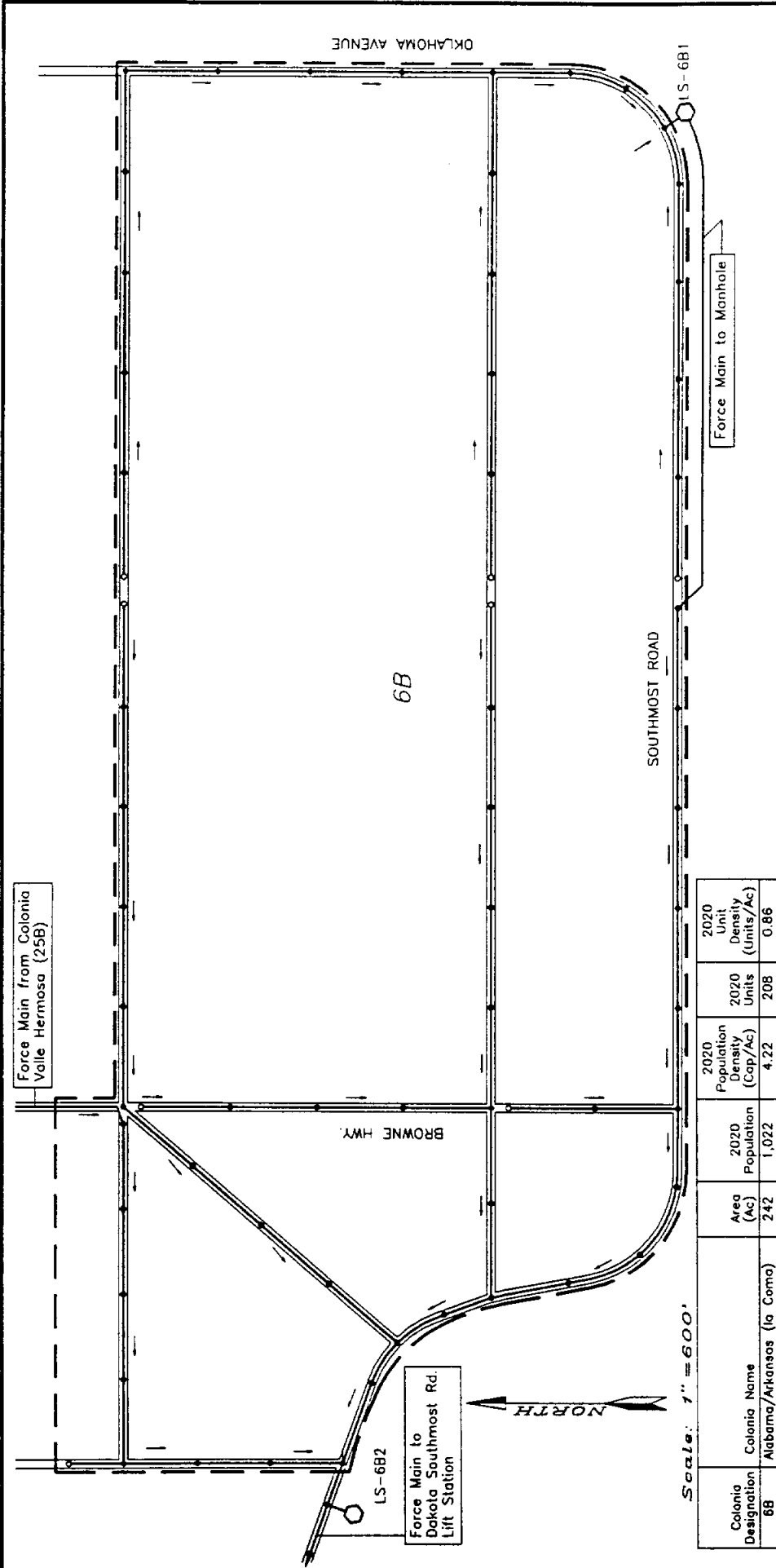

Colonia Designation	Colonia Name	Area (Ac)	2020 Population	2020 Population Density (Cap/Ac)	2020 Units	2020 Unit Density (Units/Ac)
6B	Alabama/Arkansas (La Coma)	242	1,022	4.22	208	0.86

Internal Wastewater Collection System Quantities Estimate	
ITEM	QUANTITY
6" Service Connection	208 EA
8" SDR-35 PVC Sanitary Sewer	22,200 LF
10" SDR-35 PVC Sanitary Sewer	N/A
12" SDR-35 PVC Sanitary Sewer	N/A
15" SDR-35 PVC Sanitary Sewer	N/A
18" SDR-35 PVC Sanitary Sewer	N/A
Clean Out	8 EA
Manhole	59 EA
4" PVC Force Main	2,100 LF
6" PVC Force Main	10,000 LF
8" PVC Force Main	N/A
10" PVC Force Main	N/A
12" PVC Force Main	N/A
LS-6B1 110 GPM (1 HP)	1 EA
LS-6B2 495 GPM (11.5HP)	1 EA
<b>TOTAL ESTIMATED COST</b>	<b>\$ 1,290,635</b>

**Cameron County Regional Water and Wastewater Planning Study**

**Figure 5-43**  
**Site Map of Alabama/ Arkansas (La Palma) (6B)**

**Prepared For:**  
**Texas Water Development Board**  
**and Cameron County Water Development Board**

**Prepared By:**  
**The Water Resources Planning Group**  
**August 1990**

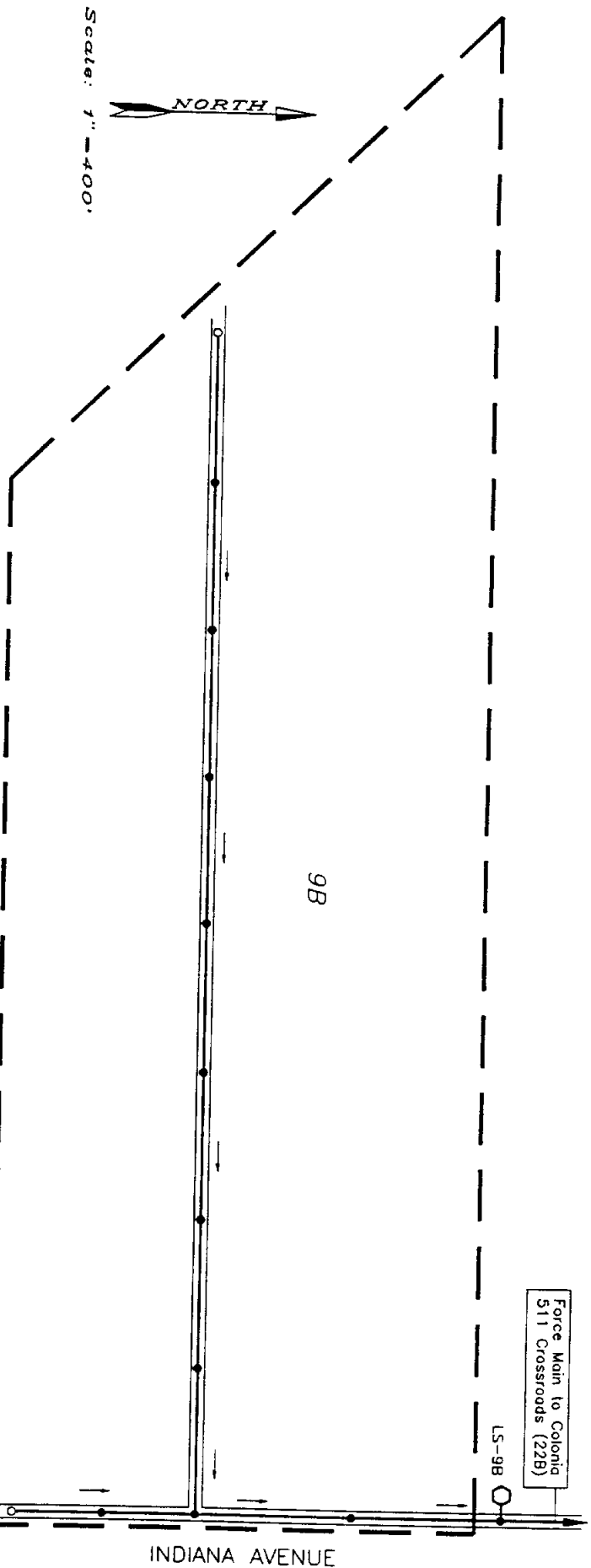

Colonia Designation	Colonia Name	Area (Ac)	2020 Population	2020 Population Density (Cap/Ac)	2020 Units	2020 Unit Density (Units/Ac)
9B	Villa Pancho	74	603	8.15	123	1.66

Internal Wastewater Collection System		QUANTITY
ITEM		
6" Service Connection		123 EA
8" SDR-35 PVC Sanitary Sewer		4,200 LF
10" SDR-35 PVC Sanitary Sewer		N/A
12" SDR-35 PVC Sanitary Sewer		N/A
15" SDR-35 PVC Sanitary Sewer		N/A
18" SDR-35 PVC Sanitary Sewer		N/A
Clean Out		2 EA
Manhole		11 EA
4" PVC Force Main		1,400 LF
6" PVC Force Main		N/A
8" PVC Force Main		N/A
10" PVC Force Main		N/A
12" PVC Force Main		N/A
LS-9B	180 GPM(2.5 HP)	1 EA
TOTAL ESTIMATED COST		\$ 276,495

Cameron County Regional Water and Wastewater Planning Study  
 Figure 5-44  
 Site Map of Villa Pancho (9B)  
 Prepared For:  
 Texas Water Development Board  
 and Cameron County Water Development Board  
 Prepared By:  
 The Water Resources Planning Group  
 August 1990

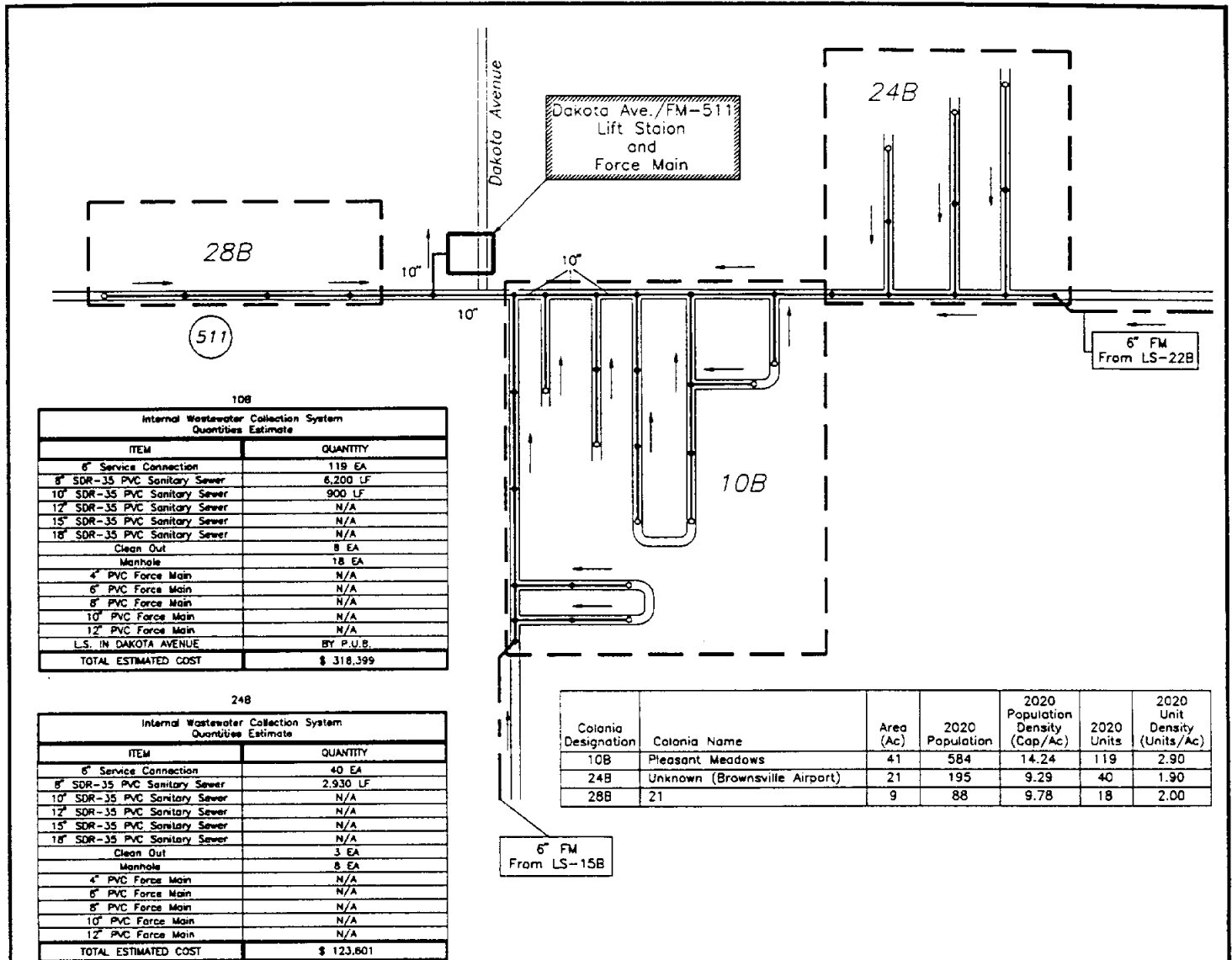

Dakota Ave./FM-511  
Lift Station  
and  
Force Main

28B  
511

24B

6" FM  
From LS-22B

10B

6" FM  
From LS-15B

**10B**

Internal Wastewater Collection System  
Quantities Estimate

ITEM	QUANTITY
6" Service Connection	119 EA
8" SDR-35 PVC Sanitary Sewer	6,200 LF
10" SDR-35 PVC Sanitary Sewer	900 LF
12" SDR-35 PVC Sanitary Sewer	N/A
15" SDR-35 PVC Sanitary Sewer	N/A
18" SDR-35 PVC Sanitary Sewer	N/A
Clean Out	8 EA
Manhole	18 EA
4" PVC Force Main	N/A
6" PVC Force Main	N/A
8" PVC Force Main	N/A
10" PVC Force Main	N/A
12" PVC Force Main	N/A
L.S. IN DAKOTA AVENUE	BY P.U.B.
<b>TOTAL ESTIMATED COST</b>	<b>\$ 318,399</b>

**24B**

Internal Wastewater Collection System  
Quantities Estimate

ITEM	QUANTITY
6" Service Connection	40 EA
8" SDR-35 PVC Sanitary Sewer	2,930 LF
10" SDR-35 PVC Sanitary Sewer	N/A
12" SDR-35 PVC Sanitary Sewer	N/A
15" SDR-35 PVC Sanitary Sewer	N/A
18" SDR-35 PVC Sanitary Sewer	N/A
Clean Out	3 EA
Manhole	8 EA
4" PVC Force Main	N/A
6" PVC Force Main	N/A
8" PVC Force Main	N/A
10" PVC Force Main	N/A
12" PVC Force Main	N/A
<b>TOTAL ESTIMATED COST</b>	<b>\$ 123,601</b>

**28B**

Internal Wastewater Collection System  
Quantities Estimate

ITEM	QUANTITY
6" Service Connection	18 EA
8" SDR-35 PVC Sanitary Sewer	1,200 LF
10" SDR-35 PVC Sanitary Sewer	N/A
12" SDR-35 PVC Sanitary Sewer	N/A
15" SDR-35 PVC Sanitary Sewer	N/A
18" SDR-35 PVC Sanitary Sewer	N/A
Clean Out	1 EA
Manhole	4 EA
4" PVC Force Main	N/A
6" PVC Force Main	N/A
8" PVC Force Main	N/A
10" PVC Force Main	N/A
12" PVC Force Main	N/A
<b>TOTAL ESTIMATED COST</b>	<b>\$ 53,271</b>

Colonia Designation	Colonia Name	Area (Ac)	2020 Population	2020 Population Density (Cap/Ac)	2020 Units	2020 Unit Density (Units/Ac)
10B	Pleasant Meadows	41	584	14.24	119	2.90
24B	Unknown (Brownsville Airport)	21	195	9.29	40	1.90
28B	21	9	88	9.78	18	2.00

**Cameron County Regional Water and Wastewater  
Planning Study**

**Figure 5-45  
Site Map of Pleasant Meadows, Unknown,  
and 21 (10B, 24B and 28B)**

**Prepared For:  
Texas Water Development Board  
and Cameron County Water Development Board**

**Prepared By:  
The Water Resources Planning Group**

**August 1990**

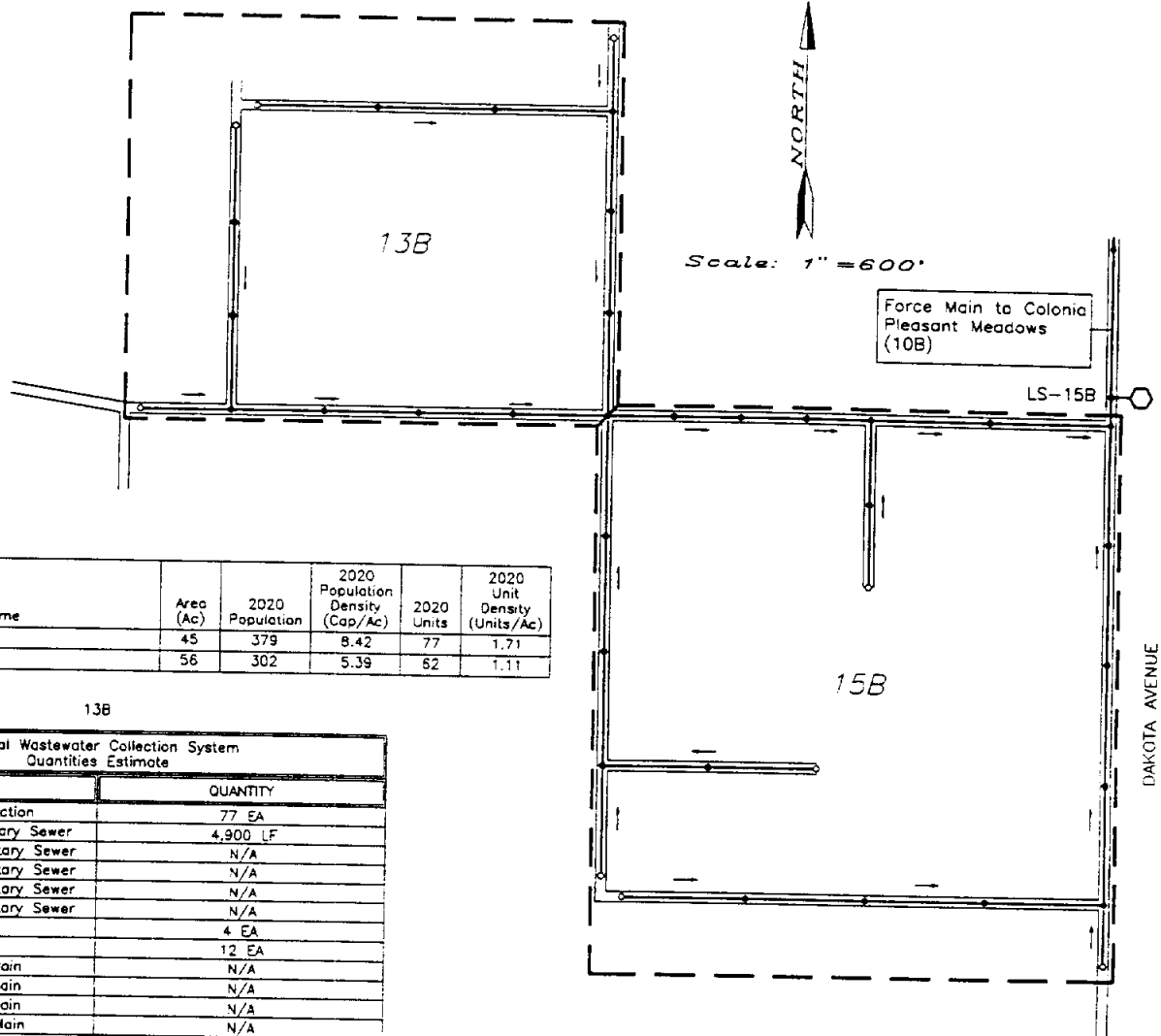

Colonia Designation	Colonia Name	Area (Ac)	2020 Population	2020 Population Density (Cap/Ac)	2020 Units	2020 Unit Density (Units/Ac)
13B	Los Cuates	45	379	8.42	77	1.71
15B	Coronado	56	302	5.39	62	1.11

13B

Internal Wastewater Collection System Quantities Estimate	
ITEM	QUANTITY
6" Service Connection	77 EA
8" SDR-35 PVC Sanitary Sewer	4,900 LF
10" SDR-35 PVC Sanitary Sewer	N/A
12" SDR-35 PVC Sanitary Sewer	N/A
15" SDR-35 PVC Sanitary Sewer	N/A
18" SDR-35 PVC Sanitary Sewer	N/A
Clean Out	4 EA
Manhole	12 EA
4" PVC Force Main	N/A
6" PVC Force Main	N/A
8" PVC Force Main	N/A
10" PVC Force Main	N/A
12" PVC Force Main	N/A
<b>TOTAL ESTIMATED COST</b>	<b>\$ 209,802</b>

15B

Internal Wastewater Collection System Quantities Estimate	
ITEM	QUANTITY
6" Service Connection	62 EA
8" SDR-35 PVC Sanitary Sewer	7,600 LF
10" SDR-35 PVC Sanitary Sewer	N/A
12" SDR-35 PVC Sanitary Sewer	N/A
15" SDR-35 PVC Sanitary Sewer	N/A
18" SDR-35 PVC Sanitary Sewer	N/A
Clean Out	5 EA
Manhole	19 EA
4" PVC Force Main	N/A
6" PVC Force Main	1,500 LF
8" PVC Force Main	N/A
10" PVC Force Main	N/A
12" PVC Force Main	N/A
LS-15B 205 GPM (2 HP)	1 EA
<b>TOTAL ESTIMATED COST</b>	<b>\$ 428,695</b>

**Cameron County Regional Water and Wastewater Planning Study**

**Figure 5-46  
Site Map of Los Cuates and Coronado Heights (13B and 15B)**

**Prepared For:  
Texas Water Development Board  
and Cameron County Water Development Board**

**Prepared By:  
The Water Resources Planning Group**

**August 1990**



Colonia Designation	Colonia Name	Area (Ac)	2020 Population	2020 Population Density (Pop./Ac)	2020 Unit Density (Units/Ac)
16B	Unknown	30	282	9.40	58
18B	Valle Escondido	38	272	7.16	56
25B	Valle Hermosa	19	126	6.63	26
					1.37

16B		
Internal Wastewater Collection System		
ITEM	QUANTITY	ESTIMATED COST
6" Service Connection	58 EA	
8" SDR-35 PVC Sanitary Sewer	2,150 LF	
Clean Out	1 EA	
Manhole	6 EA	
<b>TOTAL ESTIMATED COST</b>		<b>\$ 109,464</b>

18B		
Internal Wastewater Collection System		
ITEM	QUANTITY	ESTIMATED COST
6" Service Connection	56 EA	
8" SDR-35 PVC Sanitary Sewer	6,850 LF	
Clean Out	5 EA	
Manhole	18 EA	
<b>TOTAL ESTIMATED COST</b>		<b>\$ 261,736</b>

25B		
Internal Wastewater Collection System		
ITEM	QUANTITY	ESTIMATED COST
6" Service Connection	28 EA	
8" SDR-35 PVC Sanitary Sewer	3,900 LF	
10" SDR-35 PVC Sanitary Sewer	N/A	
12" SDR-35 PVC Sanitary Sewer	N/A	
15" SDR-35 PVC Sanitary Sewer	N/A	
18" SDR-35 PVC Sanitary Sewer	N/A	
Clean Out	3 EA	
Manhole	10 EA	
4" PVC Force Main	N/A	
6" PVC Force Main	2,000 LF	
8" PVC Force Main	N/A	
10" PVC Force Main	N/A	
12" PVC Force Main	N/A	
LS-25B 200 GPM (3 HP)	1 EA	
<b>TOTAL ESTIMATED COST</b>		<b>\$ 292,736</b>

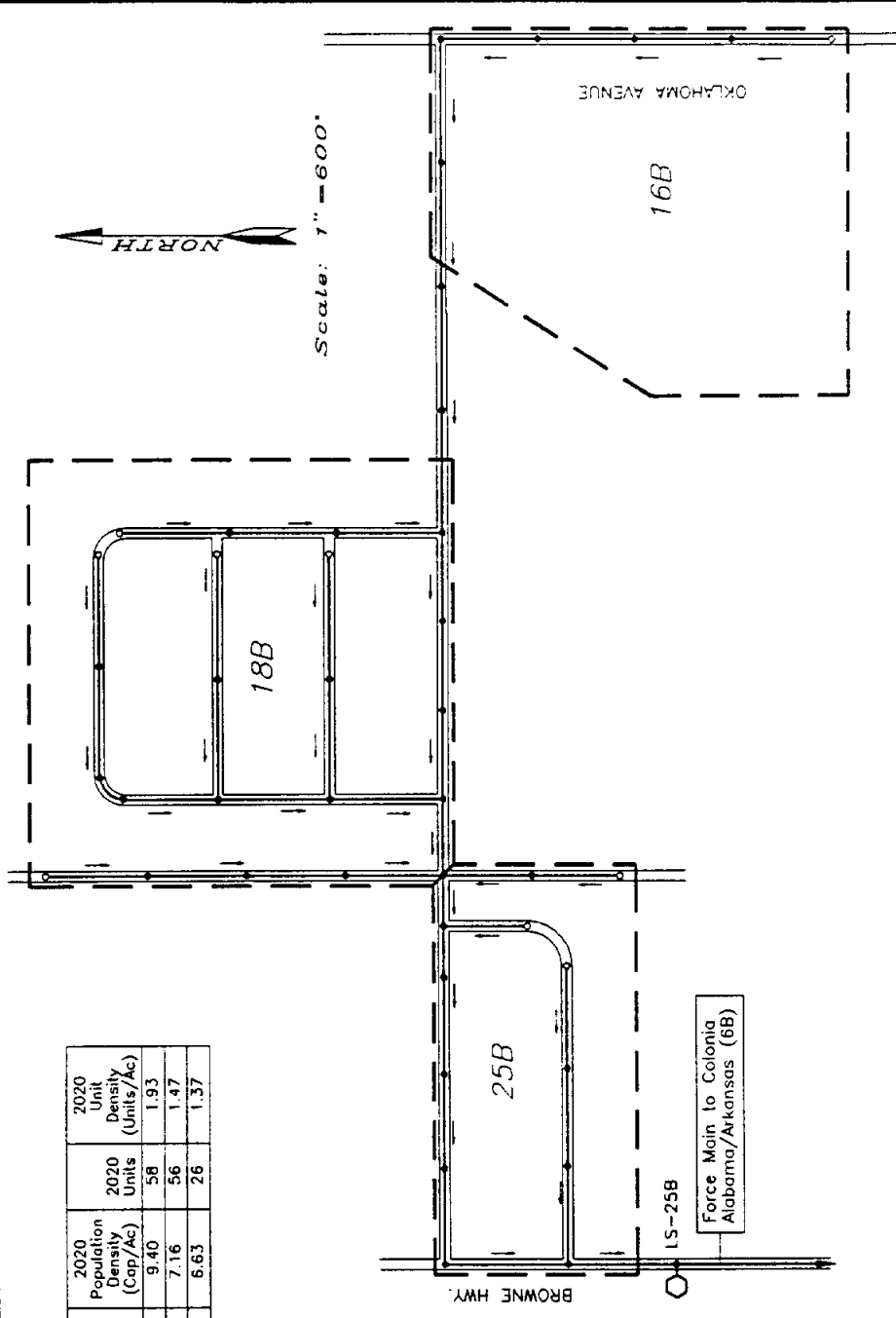

**Cameron County Regional Water and Wastewater Planning Study**

**Figure 5-47**

**Site Map of Unknown, Valle Escondido and Valle Hermosa (16B, 18B and 25B)**

Prepared For:  
Texas Water Development Board  
and Cameron County Water Development Board

Prepared By:  
The Water Resources Planning Group

August 1990

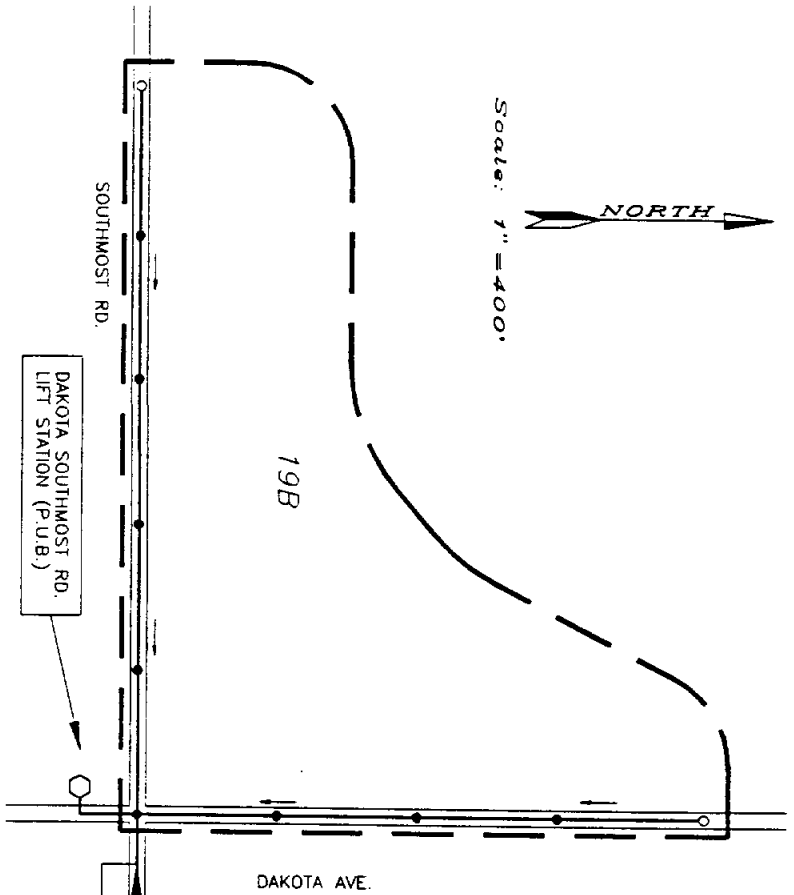

Colonia Designation 19B	Colonia Name Unnamed C	Area (Ac) 24	2020 Population 263	2020 Population Density (Pop/Ac) 10.96	2020 Units 54	2020 Unit Density (Units/Ac) 2.25
----------------------------	---------------------------	-----------------	------------------------	---	------------------	--------------------------------------

Internal Wastewater Collection System Quantities Estimate	
ITEM	QUANTITY
6" Service Connection	54 EA
8" SDR-35 PVC Sanitary Sewer	2,800 LF
10" SDR-35 PVC Sanitary Sewer	N/A
12" SDR-35 PVC Sanitary Sewer	N/A
15" SDR-35 PVC Sanitary Sewer	N/A
18" SDR-35 PVC Sanitary Sewer	N/A
Clean Out	2 EA
Manhole	8 EA
4" PVC Force Main	N/A
6" PVC Force Main	N/A
8" PVC Force Main	N/A
10" PVC Force Main	N/A
12" PVC Force Main	N/A
L.S. IN SOUTHMOST RD	BY P.U.B.
TOTAL ESTIMATED COST	\$ 129,023

Cameron County Regional Water and Wastewater Planning Study  
 Figure 5-48  
 Site Map of Unnamed C (19B)

Prepared For:  
 Texas Water Development Board  
 and Cameron County Water Development Board  
 Prepared By:  
 The Water Resources Planning Group  
 August 1990

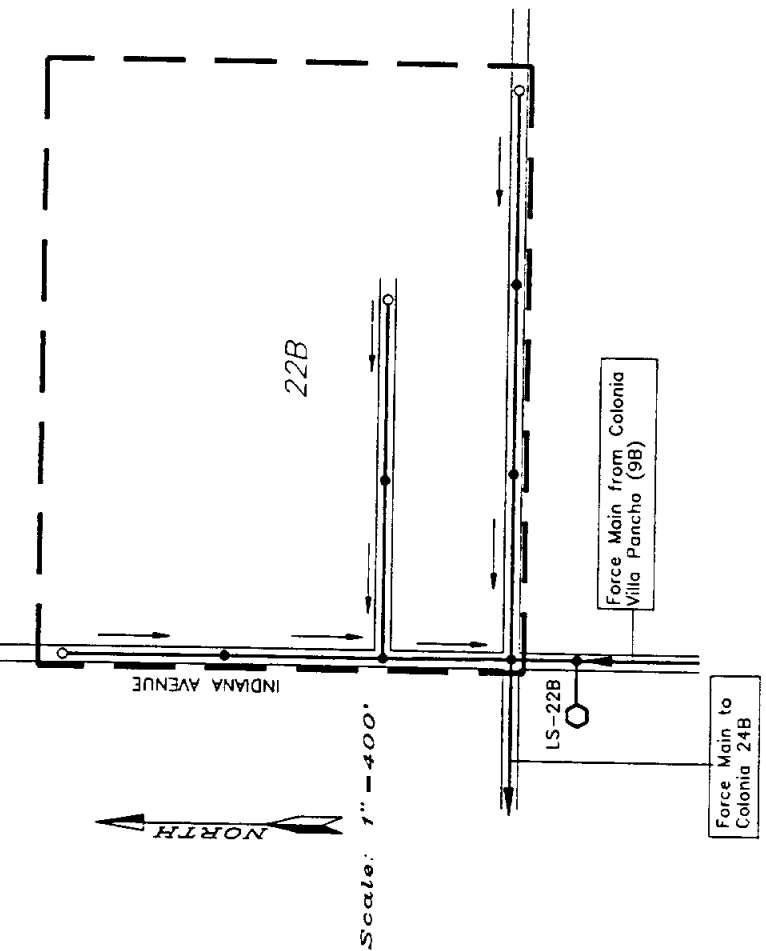

Colonia Designation	Colonia Name	2020 Population	2020 Population Density (Cap/Ac)	2020 Unit Density (Units/Ac)
22B	511 Crossroads	243	8.38	1.72
		29		50

Internal Wastewater Collection System Quantities Estimate	
ITEM	QUANTITY
6" Service Connection	50 EA
8" SDR-35 PVC Sanitary Sewer	3,000 LF
10" SDR-35 PVC Sanitary Sewer	N/A
12" SDR-35 PVC Sanitary Sewer	N/A
15" SDR-35 PVC Sanitary Sewer	N/A
18" SDR-35 PVC Sanitary Sewer	N/A
Clean Out	N/A
Manhole	3 EA
4" PVC Force Main	7 EA
6" PVC Force Main	N/A
8" PVC Force Main	3,500 LF
10" PVC Force Main	N/A
12" PVC Force Main	N/A
LS-22B 250 GPM (3 HP)	1 EA
TOTAL ESTIMATED COST	\$ 335,406

**Cameron County Regional Water and Wastewater Planning Study**

**Figure 5-49**  
**Site Map of 511 Crossroads (22B)**

**Prepared For:**  
Texas Water Development Board  
and Cameron County Water Development Board

**Prepared By:**  
The Water Resources Planning Group

**August 1990**

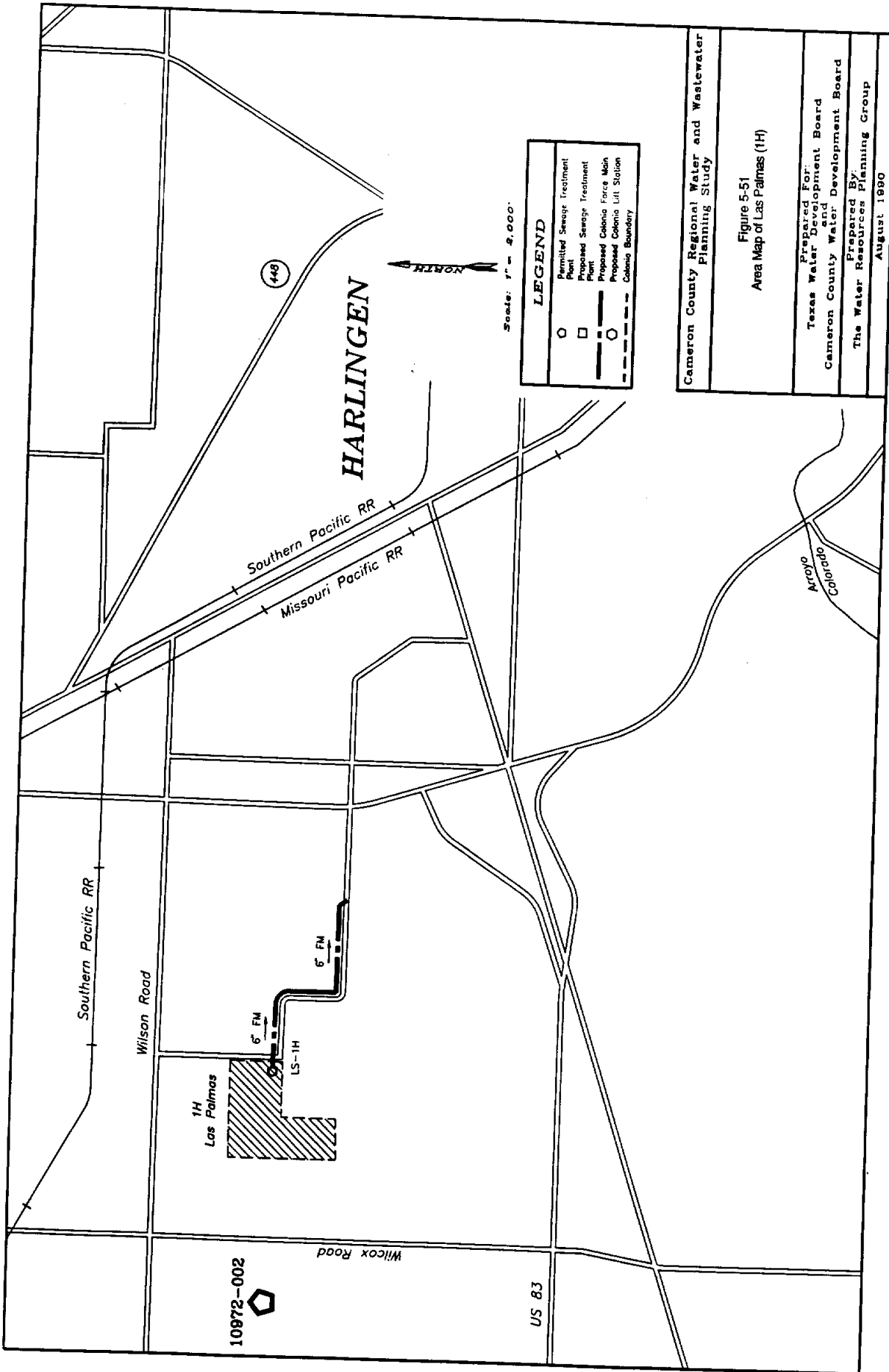

# HARLINGEN

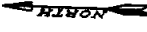

Scale: 1" = 2,000'

LEGEND	
○	Permitted Sewage Treatment Plant
□	Proposed Sewage Treatment Plant
—○—	Proposed Colonia Force Main
○	Proposed Colonia Lift Station
- - -	Colonia Boundary

Cameron County Regional Water and Wastewater Planning Study

Figure 5-51  
Area Map of Las Palmas (1H)

Prepared For:  
Texas Water Development Board  
Cameron County Water Development Board

Prepared By:  
The Water Resources Planning Group  
August 1990

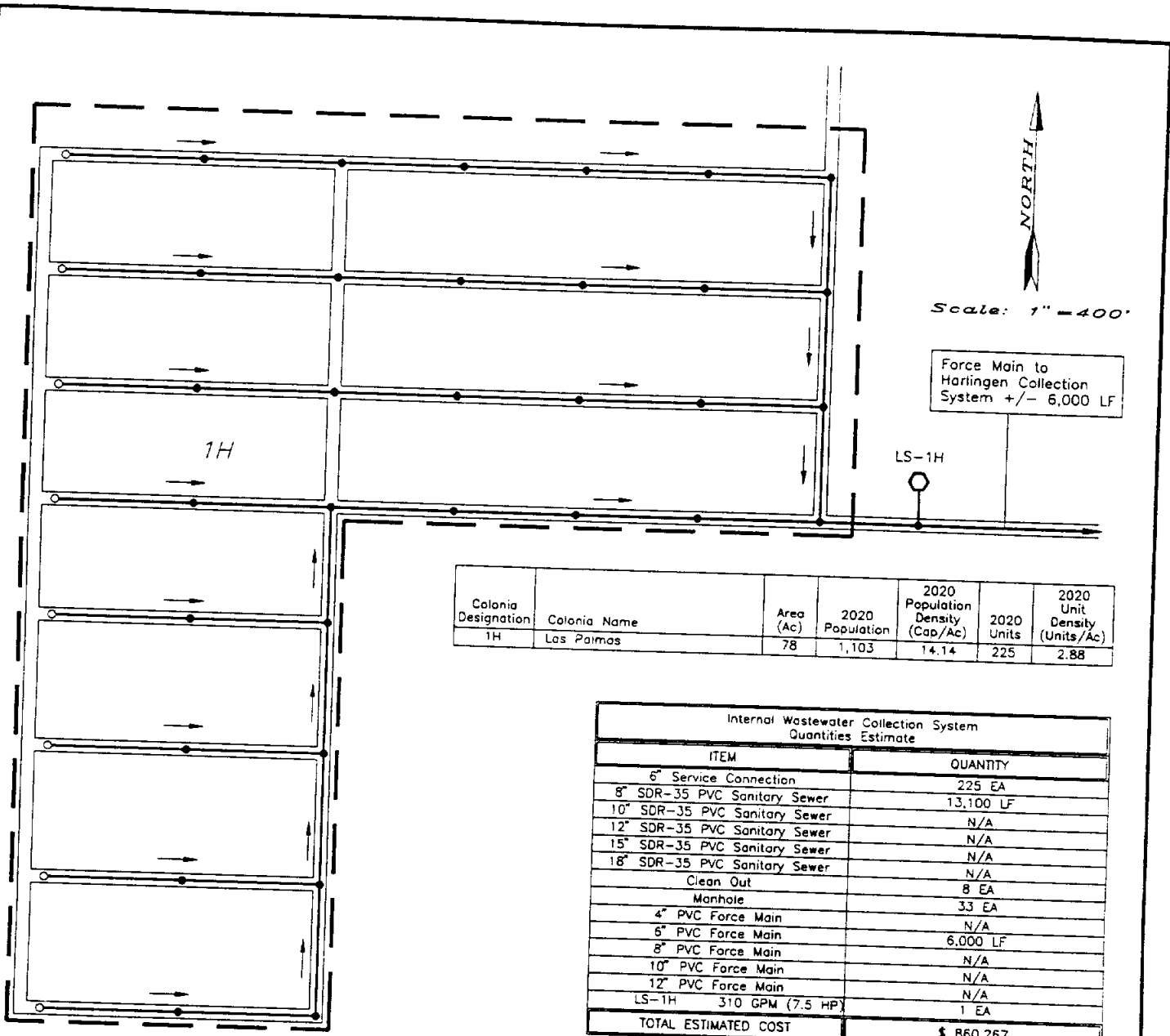

Colonia Designation	Colonia Name	Area (Ac)	2020 Population	2020 Population Density (Cap/Ac)	2020 Units	2020 Unit Density (Units/Ac)
1H	Las Palmas	78	1,103	14.14	225	2.88

Internal Wastewater Collection System Quantities Estimate	
ITEM	QUANTITY
6" Service Connection	225 EA
8" SDR-35 PVC Sanitary Sewer	13,100 LF
10" SDR-35 PVC Sanitary Sewer	N/A
12" SDR-35 PVC Sanitary Sewer	N/A
15" SDR-35 PVC Sanitary Sewer	N/A
18" SDR-35 PVC Sanitary Sewer	N/A
Clean Out	8 EA
Manhole	33 EA
4" PVC Force Main	N/A
6" PVC Force Main	6,000 LF
8" PVC Force Main	N/A
10" PVC Force Main	N/A
12" PVC Force Main	N/A
LS-1H 310 GPM (7.5 HP)	1 EA
<b>TOTAL ESTIMATED COST</b>	<b>\$ 860,267</b>

**Cameron County Regional Water and Wastewater Planning Study**  
**Figure 5-52**  
**Site Map of Las Palmas (1H)**  
 Prepared For:  
 Texas Water Development Board  
 and Cameron County Water Development Board  
 Prepared By:  
 The Water Resources Planning Group  
 August 1990

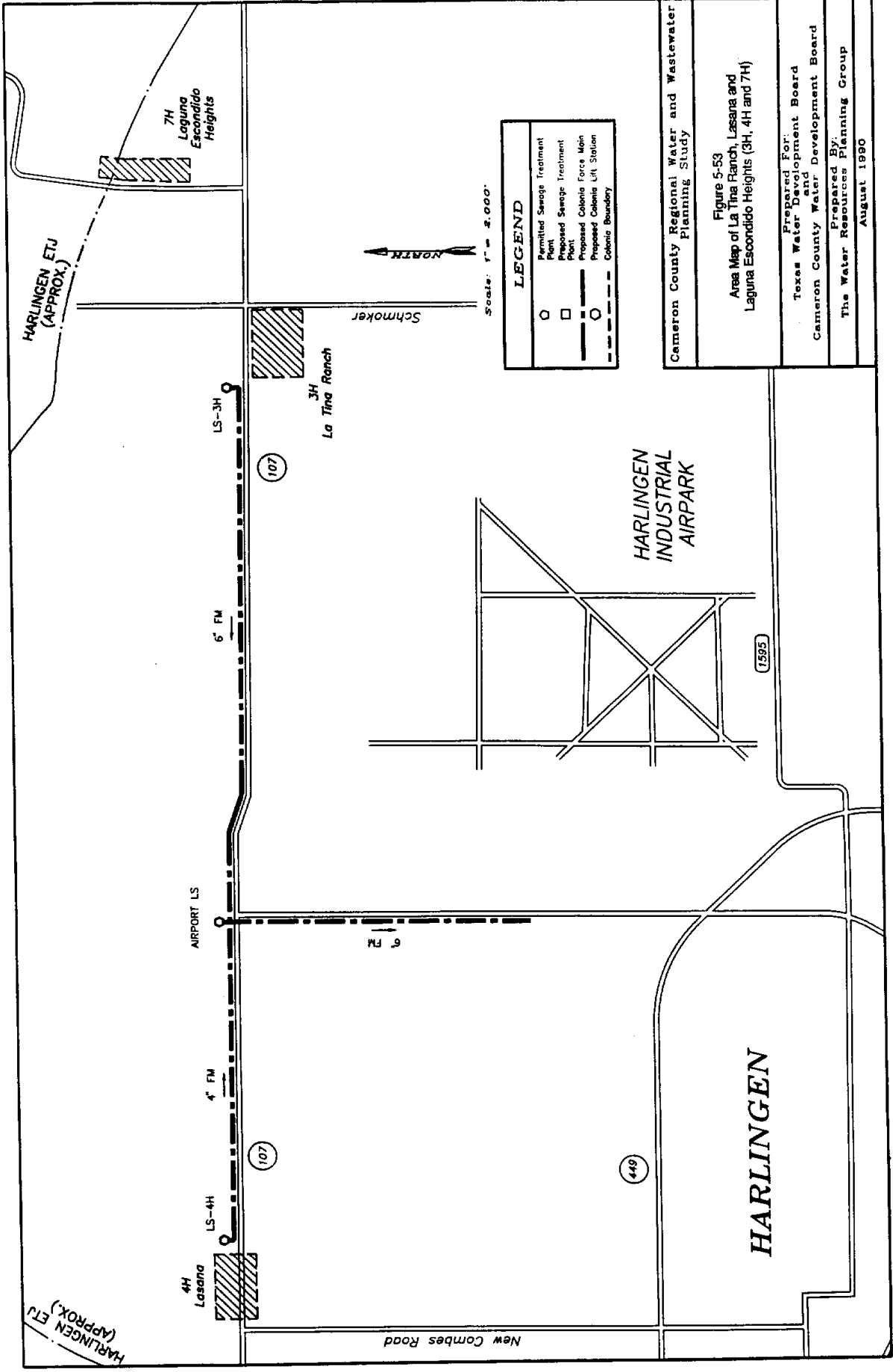

Scale: 1" = 3,000'

NORTH

LEGEND	
○	Permitted Sewage Treatment Plant
□	Proposed Sewage Treatment Plant
—	Proposed Colonia Force Main
○	Proposed Colonia Lift Station
- - -	Colonia Boundary

Cameron County Regional Water and Wastewater Planning Study

Figure 5-53  
 Area Map of La Tina Ranch, Lasana and Laguna Escobedo Heights (3H, 4H and 7H)

Prepared For:  
 Texas Water Development Board  
 Cameron County Water Development Board

Prepared By:  
 The Water Resources Planning Group  
 August 1990

HARLINGEN ETJ (APPROX.)

7H  
Laguna  
Escobedo  
Heights

LS-3H

3H  
La Tina Ranch

(107)

6' FM

HARLINGEN  
INDUSTRIAL  
AIRPARK

(1595)

AIRPORT LS

6' FM

4' FM

(107)

LS-4H

4H  
Lasana

(449)

HARLINGEN

New Combes Road

HARLINGEN ETJ (APPROX.)

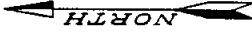

Scale: 1" = 400'

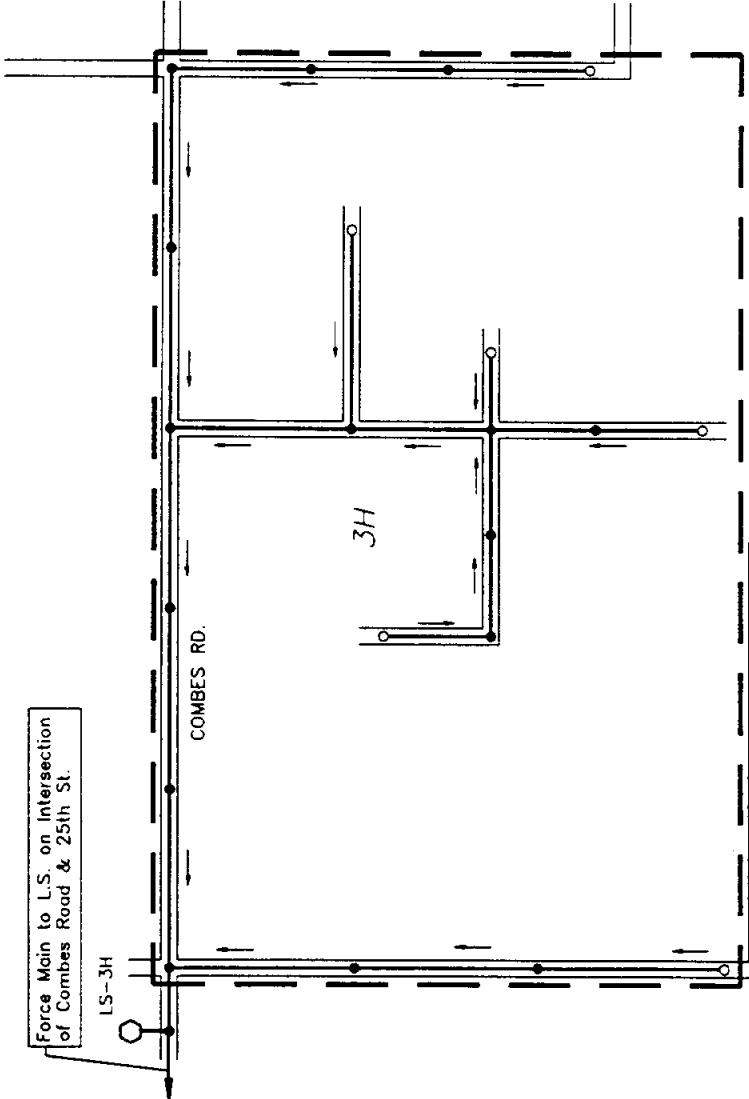

Colonia Designation	Colonia Name	Area (Ac)	2020 Population	2020 Population Density (Cap/Ac)	2020 Units	2020 Unit Density (Units/Ac)
3H	26	41	504	12.29	103	2.51

Internal Wastewater Collection System Quantities Estimate	
ITEM	QUANTITY
6" Service Connection	103 EA
8" SDR-35 PVC Sanitary Sewer	6,250 LF
10" SDR-35 PVC Sanitary Sewer	N/A
12" SDR-35 PVC Sanitary Sewer	N/A
15" SDR-35 PVC Sanitary Sewer	N/A
18" SDR-35 PVC Sanitary Sewer	N/A
Clean Out	6 EA
Manhole	16 EA
4" PVC Force Main	26,500 LF
6" PVC Force Main	N/A
8" PVC Force Main	N/A
10" PVC Force Main	N/A
12" PVC Force Main	N/A
LS-3H 150 GPM(21 HP)	1 EA
TOTAL ESTIMATED COST	\$ 824,870

**Cameron County Regional Water and Wastewater Planning Study**

**Figure 5-54**  
**Site Map of La Tina Ranch (3H)**

**Prepared For:**  
**Texas Water Development Board**  
**and Cameron County Water Development Board**

**Prepared By:**  
**The Water Resources Planning Group**  
**August 1990**

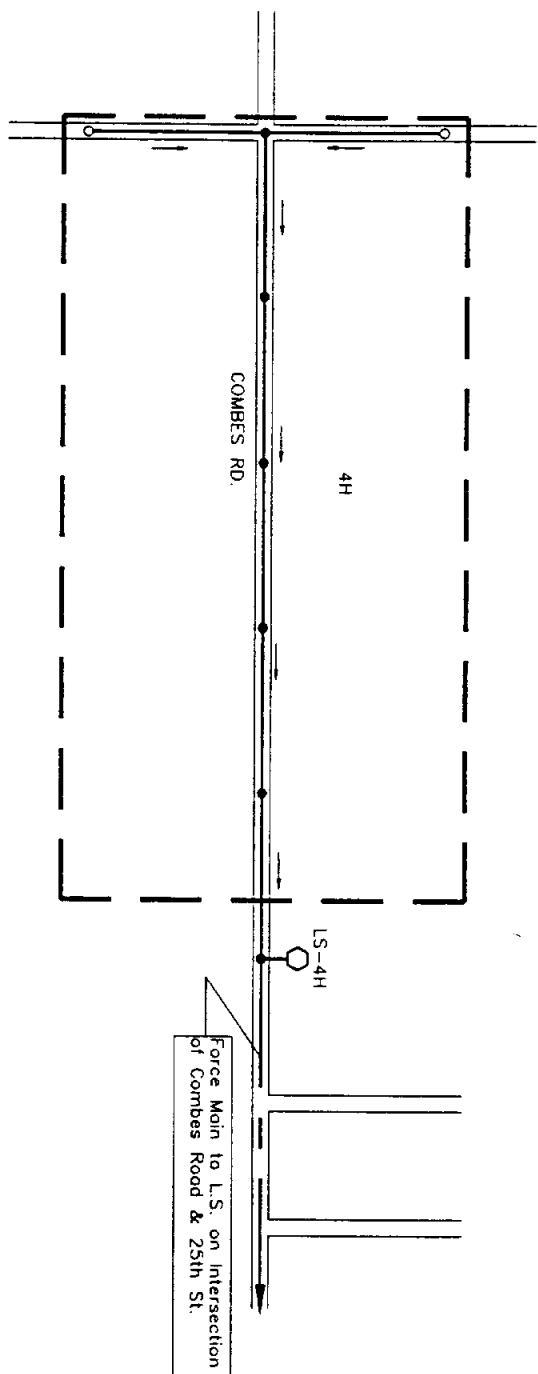

Scale: 1" = 400'



Colonia Designation	Colonia Name	Area (Ac)	2020 Population	2020 Population Density (Cap/Ac)	2020 Units	2020 Unit Density (Units/Ac)
4H	Lasana	25	243	9.72	50	2.00

Internal Wastewater Collection System Quantities Estimate		QUANTITY
6" Service Connection		50 EA
8" SDR-35 PVC Sanitary Sewer		2,550 LF
10" SDR-35 PVC Sanitary Sewer		N/A
12" SDR-35 PVC Sanitary Sewer		N/A
15" SDR-35 PVC Sanitary Sewer		N/A
18" SDR-35 PVC Sanitary Sewer		N/A
Clean Out		2 EA
Manhole		6 EA
4" PVC Force Main		15,000 LF
6" PVC Force Main		N/A
8" PVC Force Main		N/A
10" PVC Force Main		N/A
12" PVC Force Main		N/A
LS-4H	75 GPM (7 HP)	1 EA
TOTAL ESTIMATED COST		\$ 477,516

**Cameron County Regional Water and Wastewater Planning Study**

Figure 5-55  
Site Map of Lasana (4H)

Prepared For:  
Texas Water Development Board  
and Cameron County Water Development Board

Prepared By:  
The Water Resources Planning Group

August 1990



Internal Wastewater Collection System Quantities Estimate	
ITEM	QUANTITY
6" Service Connection	19 EA
8" SDR-35 PVC Sanitary Sewer	2,300 LF
10" SDR-35 PVC Sanitary Sewer	N/A
12" SDR-35 PVC Sanitary Sewer	N/A
15" SDR-35 PVC Sanitary Sewer	N/A
18" SDR-35 PVC Sanitary Sewer	N/A
Clean Out	2 EA
Manhole	6 EA
2" PVC Force Main	1,000 LF
6" PVC Force Main	N/A
8" PVC Force Main	N/A
10" PVC Force Main	N/A
12" PVC Force Main	N/A
LS-7H 30 GPM (1.0 HP)	1 EA
<b>TOTAL ESTIMATED COST</b>	<b>\$ 164,744</b>

Colonia Designation	Colonia Name	Area (Ac)	2020 Population	2020 Population Density (Cap/Ac)	2020 Units	2020 Unit Density (Units/Ac)
7H	Laguna Escondida Heights	16	95	5.94	19	1.19

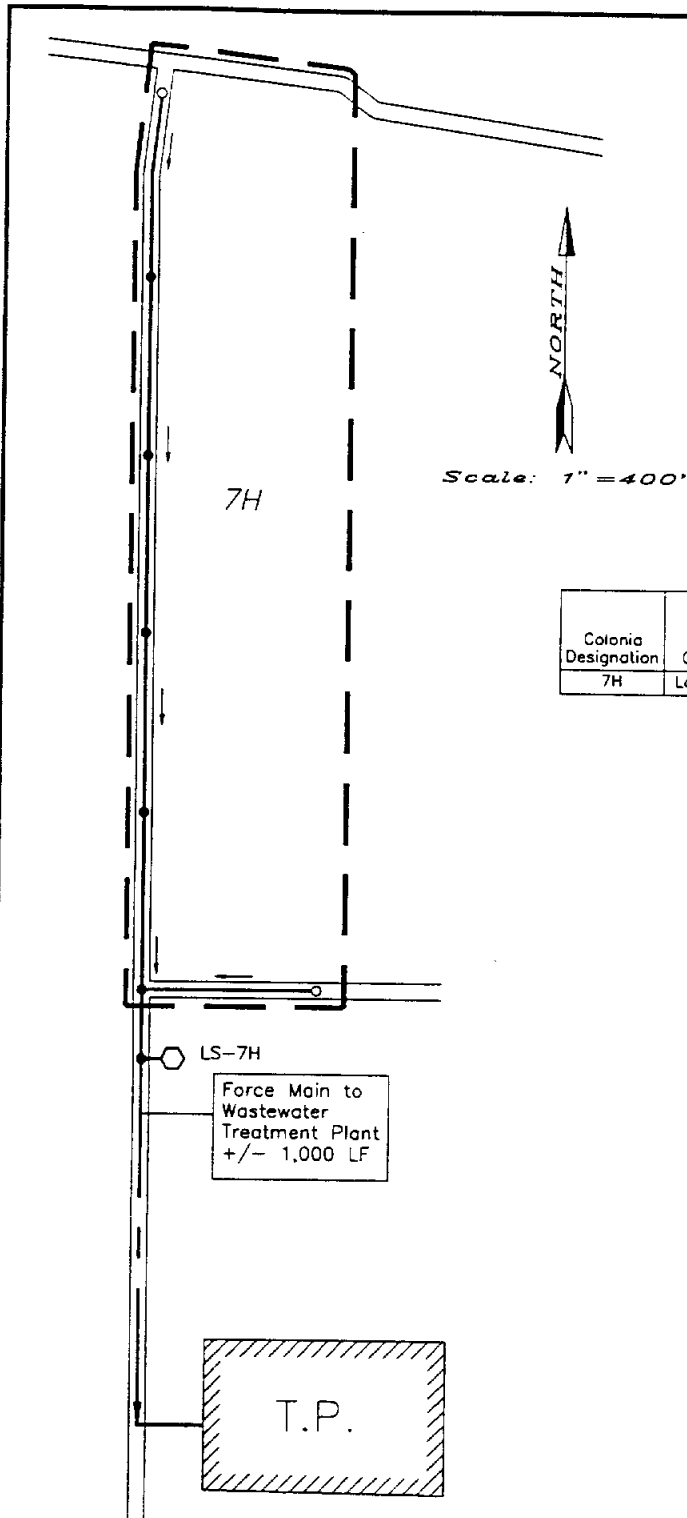

<b>Cameron County Regional Water and Wastewater Planning Study</b>
<b>Figure 5-56 Site Map of Laguna Escondida Heights (7H)</b>
<b>Prepared For: Texas Water Development Board and Cameron County Water Development Board</b>
<b>Prepared By: The Water Resources Planning Group</b>
<b>August 1990</b>

2925

SAN BENITO

Iowa Gardens Road



Scale: 1" = 5,000'

LEGEND	
○	Permitted Sewage Treatment Plant
□	Proposed Sewage Treatment Plant
○	Proposed Colonic Force Main
○	Proposed Colonic Lift Station
---	Colonia Boundary

Cameron County Regional Water and Wastewater Planning Study

Figure 5-57  
Area Map of Lago Subdivision, and Rice Tracts (2H and 5H)

Prepared For:  
Texas Water Development Board  
Cameron County Water Development Board

Prepared By:  
The Water Resources Planning Group  
August 1990

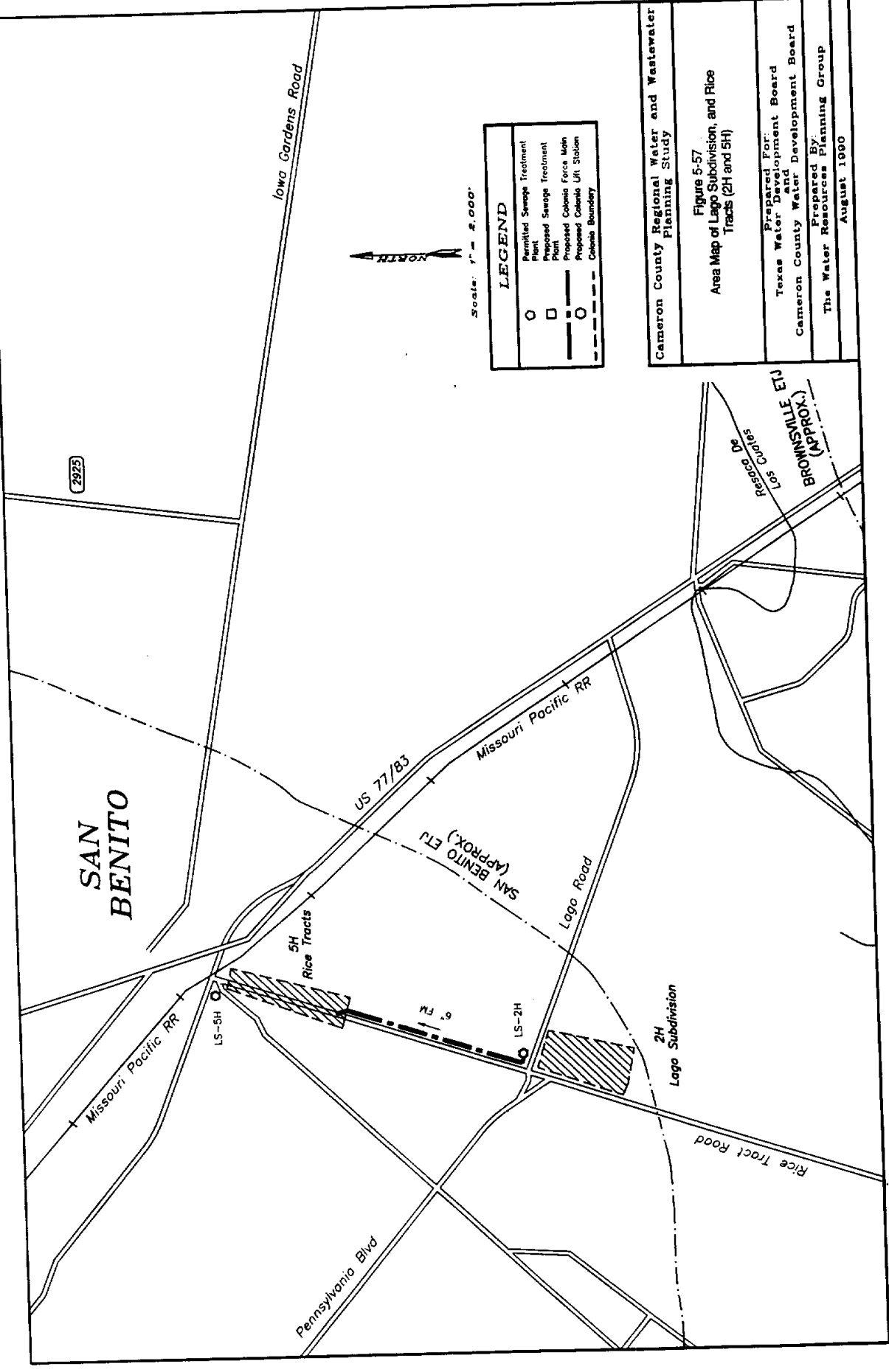

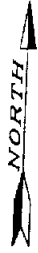

Scale: 1" = 400'

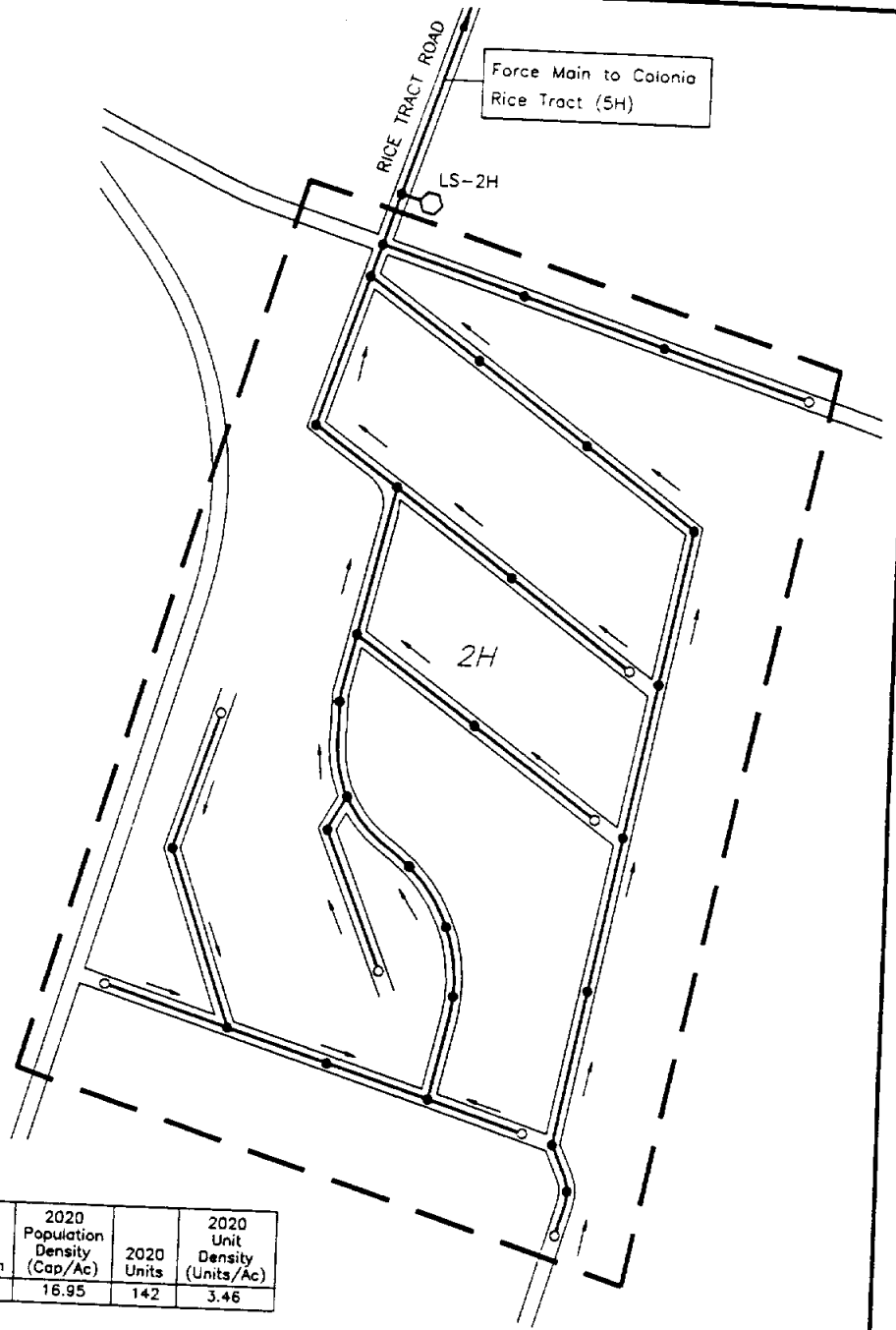

Colonia Designation	Colonia Name	Area (Ac)	2020 Population	2020 Population Density (Cap/Ac)	2020 Units	2020 Unit Density (Units/Ac)
2H	Lago Subdivision	41	695	16.95	142	3.46

Internal Wastewater Collection System Quantities Estimate	
ITEM	QUANTITY
6" Service Connection	124 EA
8" SDR-35 PVC Sanitary Sewer	8,815 LF
10" SDR-35 PVC Sanitary Sewer	N/A
12" SDR-35 PVC Sanitary Sewer	N/A
15" SDR-35 PVC Sanitary Sewer	N/A
18" SDR-35 PVC Sanitary Sewer	N/A
Clean Out	8 EA
Manhole	28 EA
4" PVC Force Main	N/A
6" PVC Force Main	10,000 LF
8" PVC Force Main	N/A
10" PVC Force Main	N/A
12" PVC Force Main	N/A
LS-2H 205 GPM (4.5 HP)	1 EA
<b>TOTAL ESTIMATED COST</b>	<b>\$ 718,859</b>

**Cameron County Regional Water and Wastewater Planning Study**

**Figure 5-58  
Site Map of Lago Subdivision (2H)**

**Prepared For:  
Texas Water Development Board  
and Cameron County Water Development Board**

**Prepared By:  
The Water Resources Planning Group**

**August 1990**

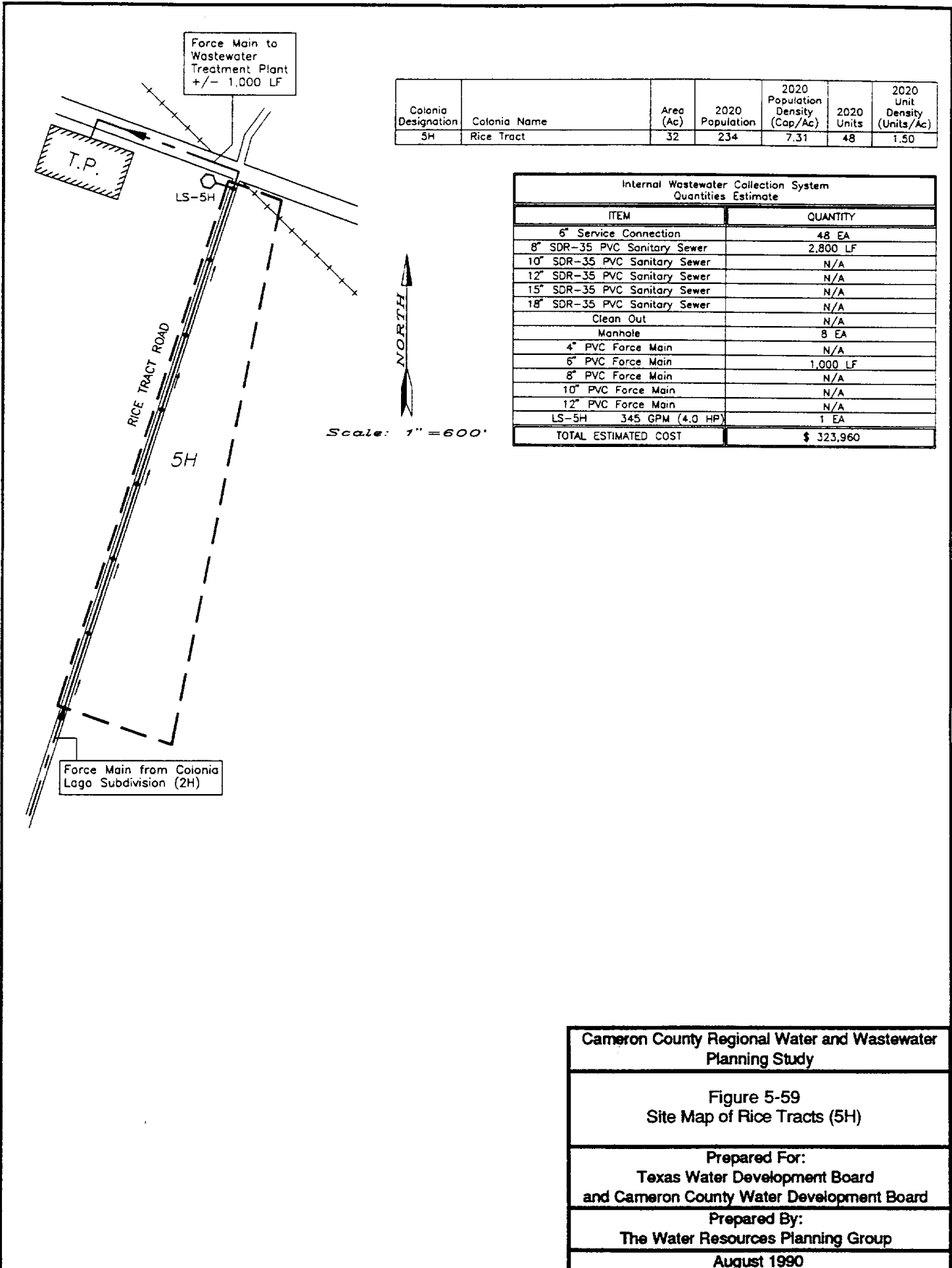

Force Main to Wastewater Treatment Plant +/- 1,000 LF

T.P.

LS-5H

RICE TRACT ROAD

5H

Force Main from Colonia Lago Subdivision (2H)

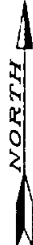

Scale: 1" = 600'

Colonia Designation	Colonia Name	Area (Ac)	2020 Population	2020 Population Density (Cap/Ac)	2020 Units	2020 Unit Density (Units/Ac)
5H	Rice Tract	32	234	7.31	48	1.50

Internal Wastewater Collection System Quantities Estimate	
ITEM	QUANTITY
6" Service Connection	48 EA
8" SDR-35 PVC Sanitary Sewer	2,800 LF
10" SDR-35 PVC Sanitary Sewer	N/A
12" SDR-35 PVC Sanitary Sewer	N/A
15" SDR-35 PVC Sanitary Sewer	N/A
18" SDR-35 PVC Sanitary Sewer	N/A
Clean Out	N/A
Manhole	8 EA
4" PVC Force Main	N/A
6" PVC Force Main	1,000 LF
8" PVC Force Main	N/A
10" PVC Force Main	N/A
12" PVC Force Main	N/A
LS-5H 345 GPM (4.0 HP)	1 EA
<b>TOTAL ESTIMATED COST</b>	<b>\$ 323,960</b>

**Cameron County Regional Water and Wastewater Planning Study**

---

**Figure 5-59  
Site Map of Rice Tracts (5H)**

---

**Prepared For:  
Texas Water Development Board  
and Cameron County Water Development Board**

---

**Prepared By:  
The Water Resources Planning Group**

---

**August 1990**

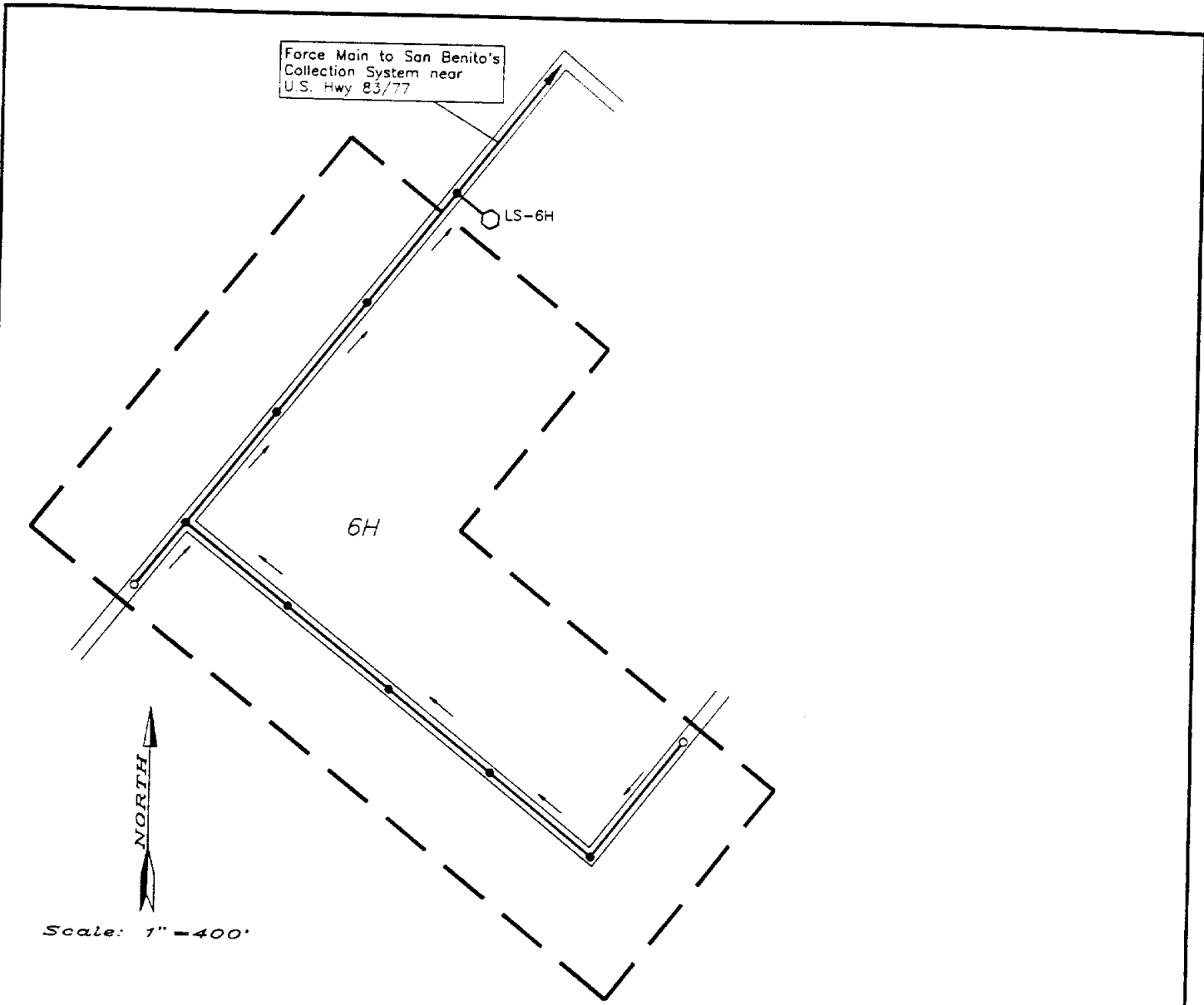

Colonia Designation	Colonia Name	Area (Ac)	2020 Population	2020 Population Density (Cap/Ac)	2020 Units	2020 Unit Density (Units/Ac)
6H	Leal Subdivision	24	217	9.04	44	1.83

Internal Wastewater Collection System Quantities Estimate	
ITEM	QUANTITY
6" Service Connection	44 EA
8" SDR-35 PVC Sanitary Sewer	2,150 LF
10" SDR-35 PVC Sanitary Sewer	N/A
12" SDR-35 PVC Sanitary Sewer	N/A
15" SDR-35 PVC Sanitary Sewer	N/A
18" SDR-35 PVC Sanitary Sewer	N/A
Clean Out	2 EA
Manhole	8 EA
4" PVC Force Main	8,000 LF
6" PVC Force Main	N/A
8" PVC Force Main	N/A
10" PVC Force Main	N/A
12" PVC Force Main	N/A
LS-6H 65 GPM (1.5HP)	1 EA
<b>TOTAL ESTIMATED COST</b>	<b>\$ 285,079</b>

**Cameron County Regional Water and Wastewater Planning Study**

---

Figure 5-61  
Site Map of Leal Subdivision (6H)

---

Prepared For:  
Texas Water Development Board  
and Cameron County Water Development Board

---

Prepared By:  
The Water Resources Planning Group

---

August 1990

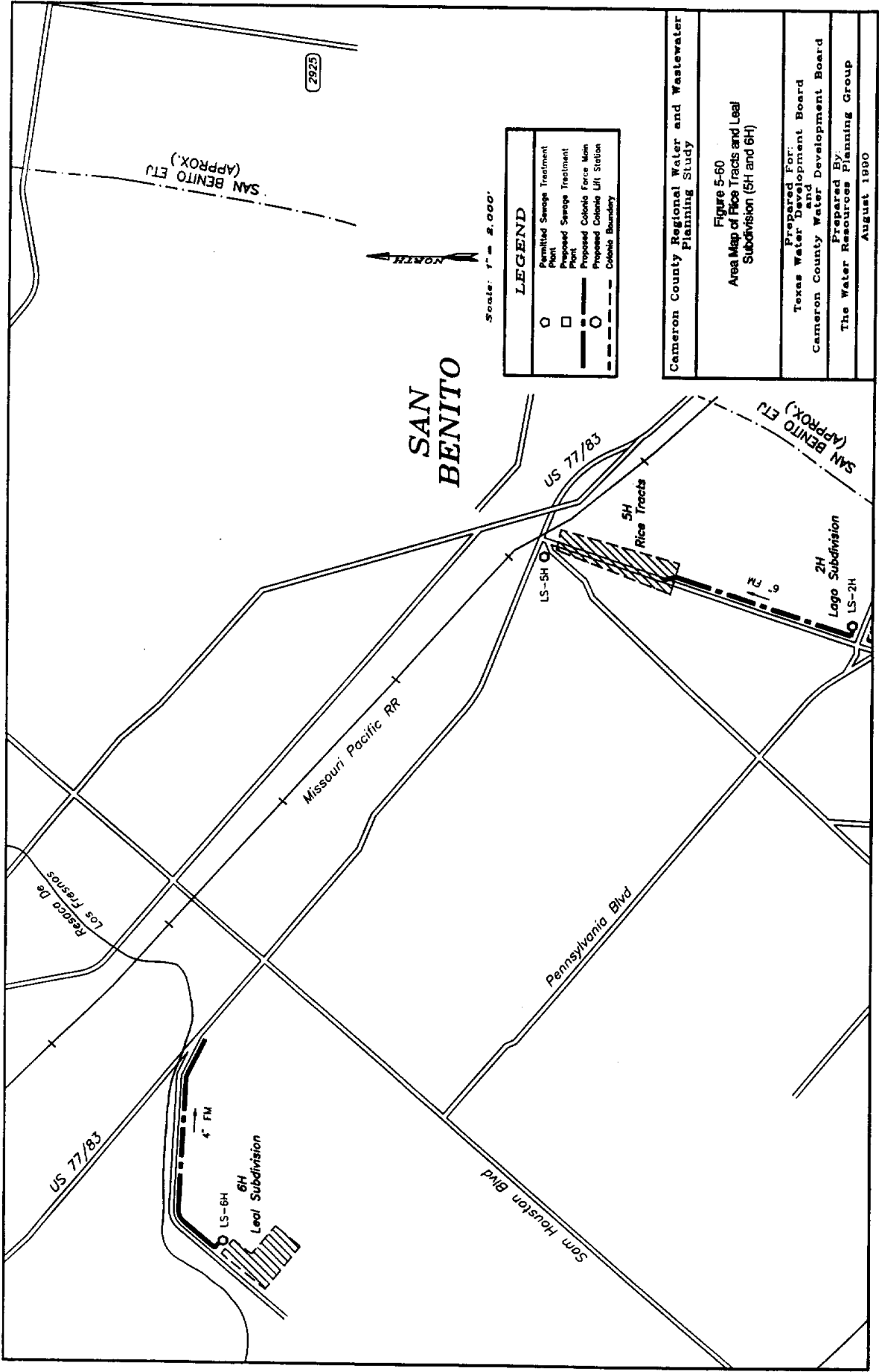

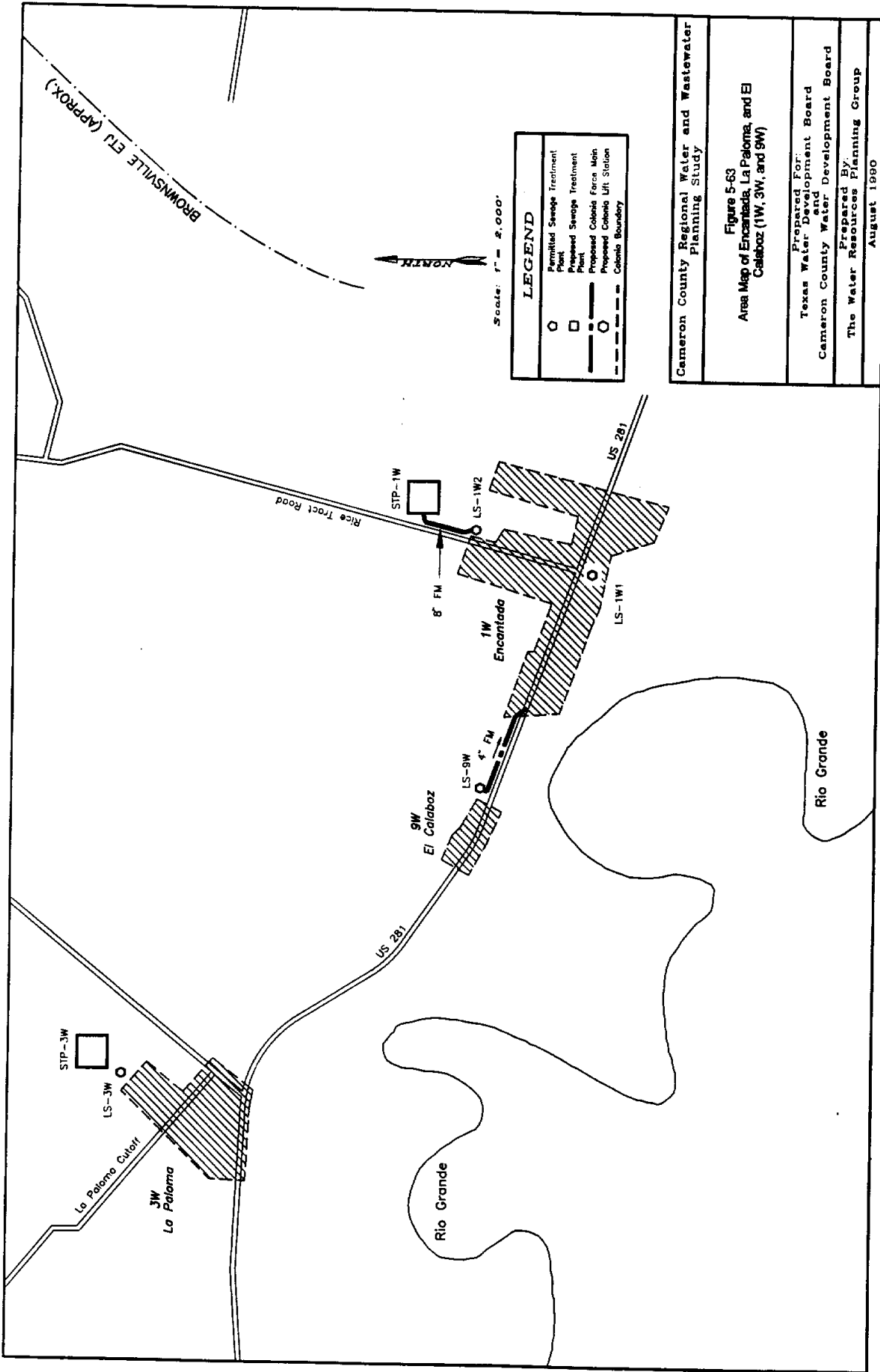

Cameron County Regional Water and Wastewater Planning Study

**Figure 5-63**  
**Area Map of Encantada, La Paloma, and El Calaboz (1W, 3W, and 9W)**

Prepared For:  
 Texas Water Development Board  
 Cameron County Water Development Board

Prepared By:  
 The Water Resources Planning Group

August 1990

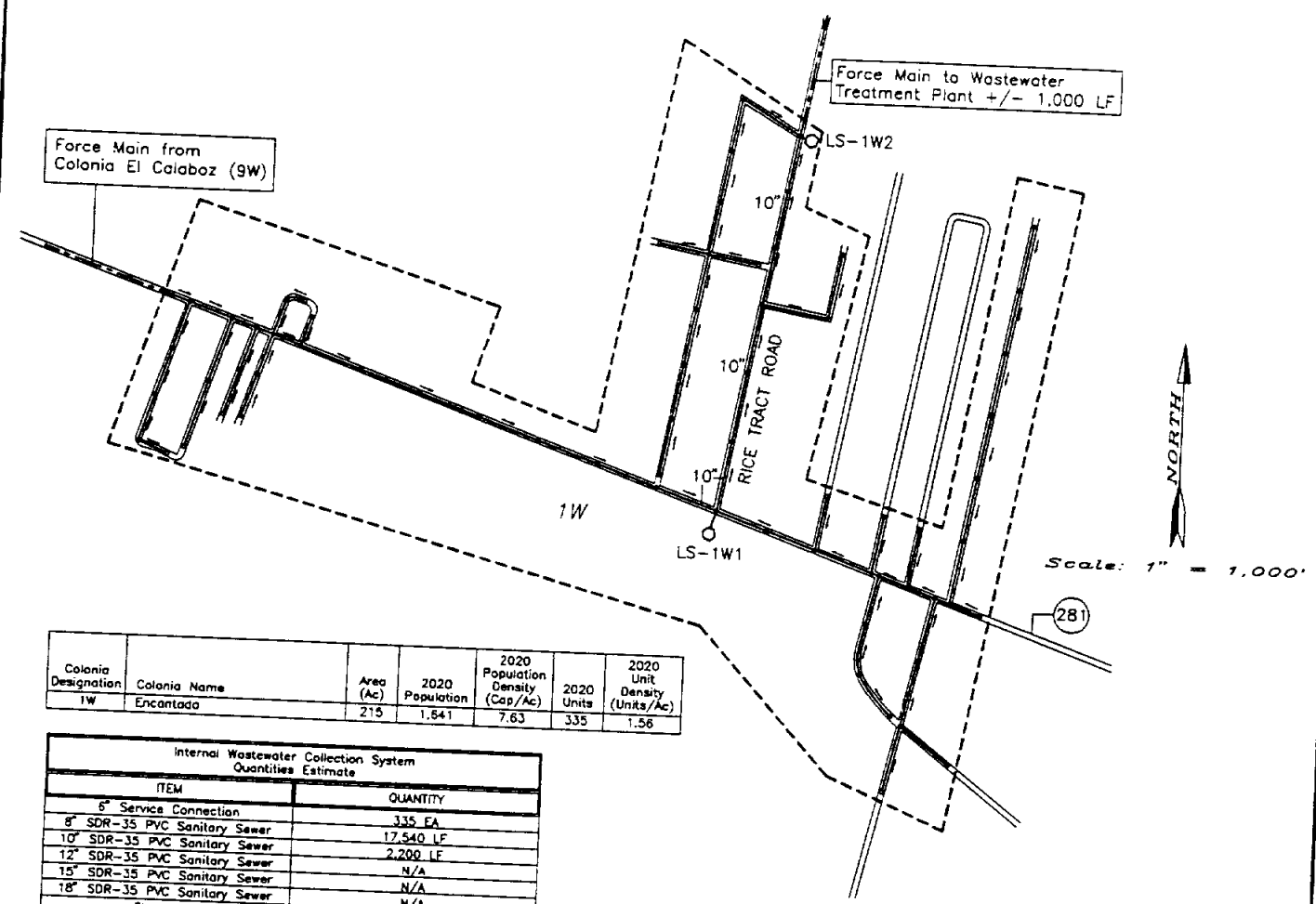

Colonia Designation	Colonia Name	Area (Ac)	2020 Population	2020 Population Density (Cap/Ac)	2020 Units	2020 Unit Density (Units/Ac)
1W	Encantada	215	1,841	7.63	335	1.56

Internal Wastewater Collection System Quantities Estimate	
ITEM	QUANTITY
6" Service Connection	335 EA
8" SDR-35 PVC Sanitary Sewer	17,540 LF
10" SDR-35 PVC Sanitary Sewer	2,200 LF
12" SDR-35 PVC Sanitary Sewer	N/A
15" SDR-35 PVC Sanitary Sewer	N/A
18" SDR-35 PVC Sanitary Sewer	N/A
Clean Out	18 EA
Manhole	50 EA
4" PVC Force Main	N/A
6" PVC Force Main	150 LF
8" PVC Force Main	1,000 LF
10" PVC Force Main	N/A
12" PVC Force Main	N/A
LS-1W1 425 GPM (3.5 HP)	1 EA
LS-1W2 580 GPM (5.5 HP)	1 EA
<b>TOTAL ESTIMATED COST</b>	<b>\$ 1,269,600</b>

**Cameron County Regional Water and Wastewater Planning Study**

**Figure 5-64  
Site Map of Encantada (1W)**

Prepared For:  
**Texas Water Development Board  
and Cameron County Water Development Board**

Prepared By:  
**The Water Resources Planning Group**

**August 1990**



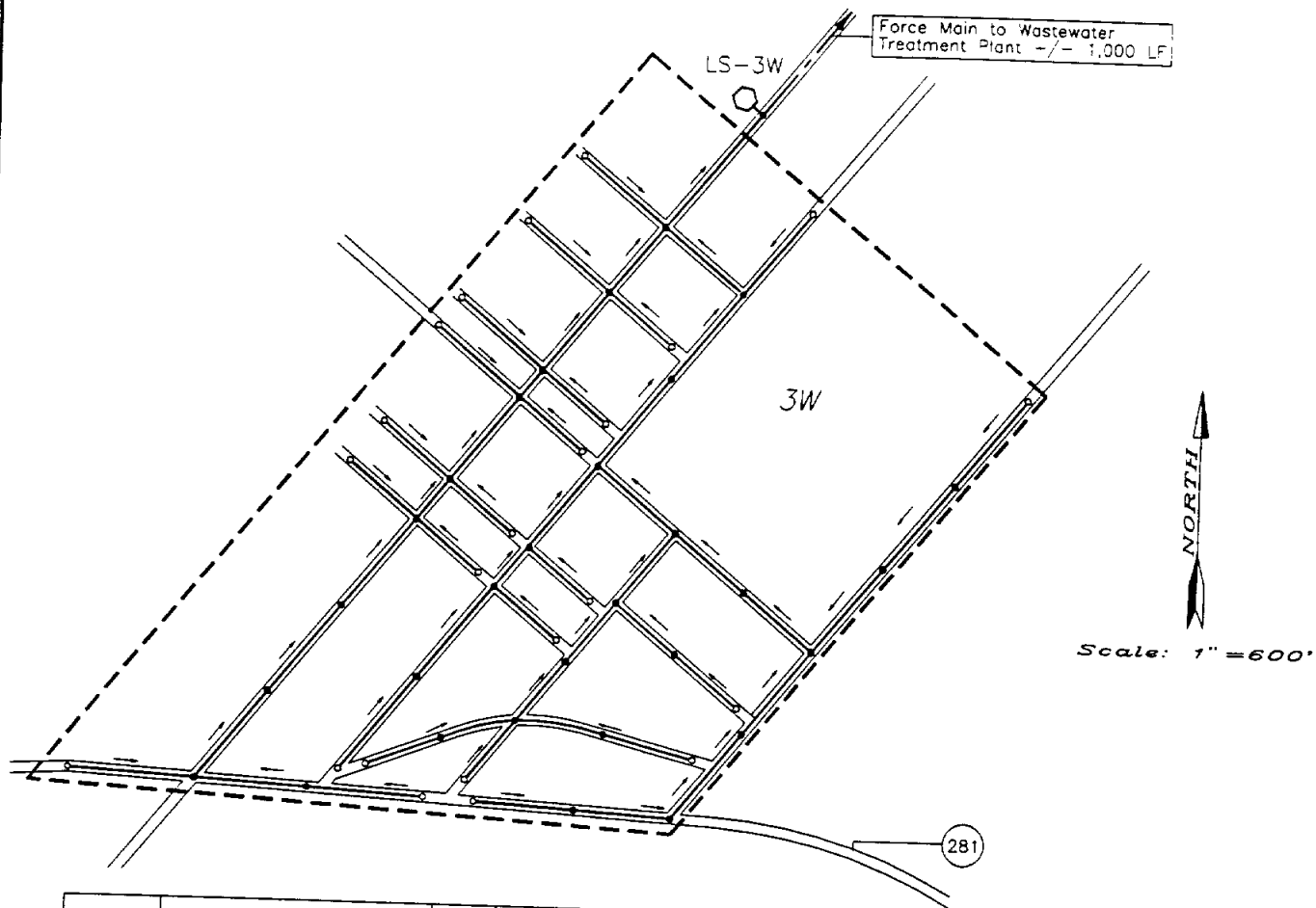

Colonia Designation	Colonia Name	Area (Ac)	2020 Population	2020 Population Density (Cap/Ac)	2020 Units	2020 Unit Density (Units/Ac)
3W	La Paloma	71	861	12.13	176	2.48

Internal Wastewater Collection System Quantities Estimate	
ITEM	QUANTITY
6" Service Connection	176 EA
8" SDR-35 PVC Sanitary Sewer	15,650 LF
10" SDR-35 PVC Sanitary Sewer	N/A
12" SDR-35 PVC Sanitary Sewer	N/A
15" SDR-35 PVC Sanitary Sewer	N/A
18" SDR-35 PVC Sanitary Sewer	N/A
Clean Out	23 EA
Manhole	32 EA
4" PVC Force Main	N/A
6" PVC Force Main	1,000 LF
8" PVC Force Main	N/A
10" PVC Force Main	N/A
12" PVC Force Main	N/A
LS-3W 250 GPM (2.5HP)	1 EA
<b>TOTAL ESTIMATED COST</b>	<b>\$ 760,094</b>

<b>Cameron County Regional Water and Wastewater Planning Study</b>
<b>Figure 5-65 Site Map of La Paloma (3W)</b>
<b>Prepared For: Texas Water Development Board and Cameron County Water Development Board</b>
<b>Prepared By: The Water Resources Planning Group</b>
<b>August 1990</b>

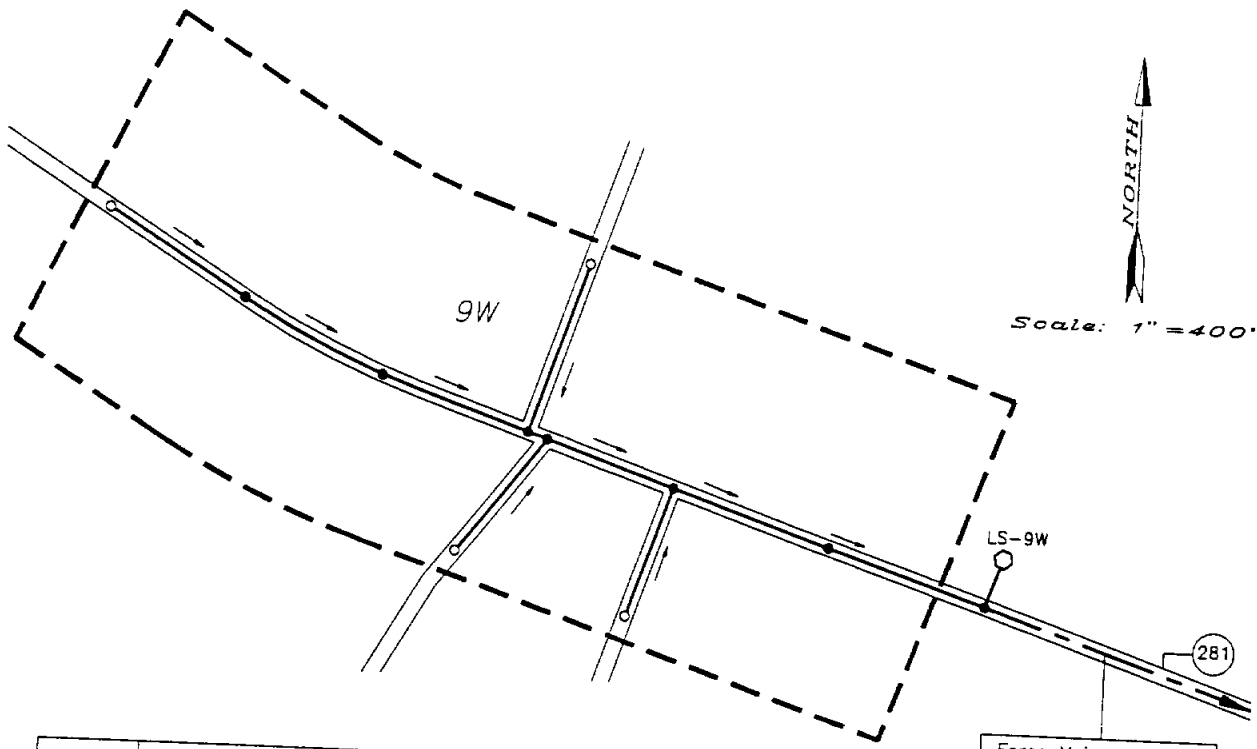

Colonia Designation	Colonia Name	Area (Ac)	2020 Population	2020 Population Density (Cap/Ac)	2020 Units	2020 Unit Density (Units/Ac)
9W	El Calaboz	23	360	16.65	73	3.17

Internal Wastewater Collection System Quantities Estimate	
ITEM	QUANTITY
6" Service Connection	73 EA
8" SDR-35 PVC Sanitary Sewer	3,100 LF
10" SDR-35 PVC Sanitary Sewer	N/A
12" SDR-35 PVC Sanitary Sewer	N/A
15" SDR-35 PVC Sanitary Sewer	N/A
18" SDR-35 PVC Sanitary Sewer	N/A
Clean Out	4 EA
Manhole	7 EA
4" PVC Force Main	4,000 LF
6" PVC Force Main	N/A
8" PVC Force Main	N/A
10" PVC Force Main	N/A
12" PVC Force Main	N/A
LS-9W 115 GPM (2.5HP)	1 EA
<b>TOTAL ESTIMATED COST</b>	<b>\$ 322,578</b>

**Cameron County Regional Water and Wastewater Planning Study**

**Figure 5-66  
Site Map of El Calaboz (9W)**

Prepared For:  
**Texas Water Development Board  
and Cameron County Water Development Board**

Prepared By:  
**The Water Resources Planning Group**

August 1990

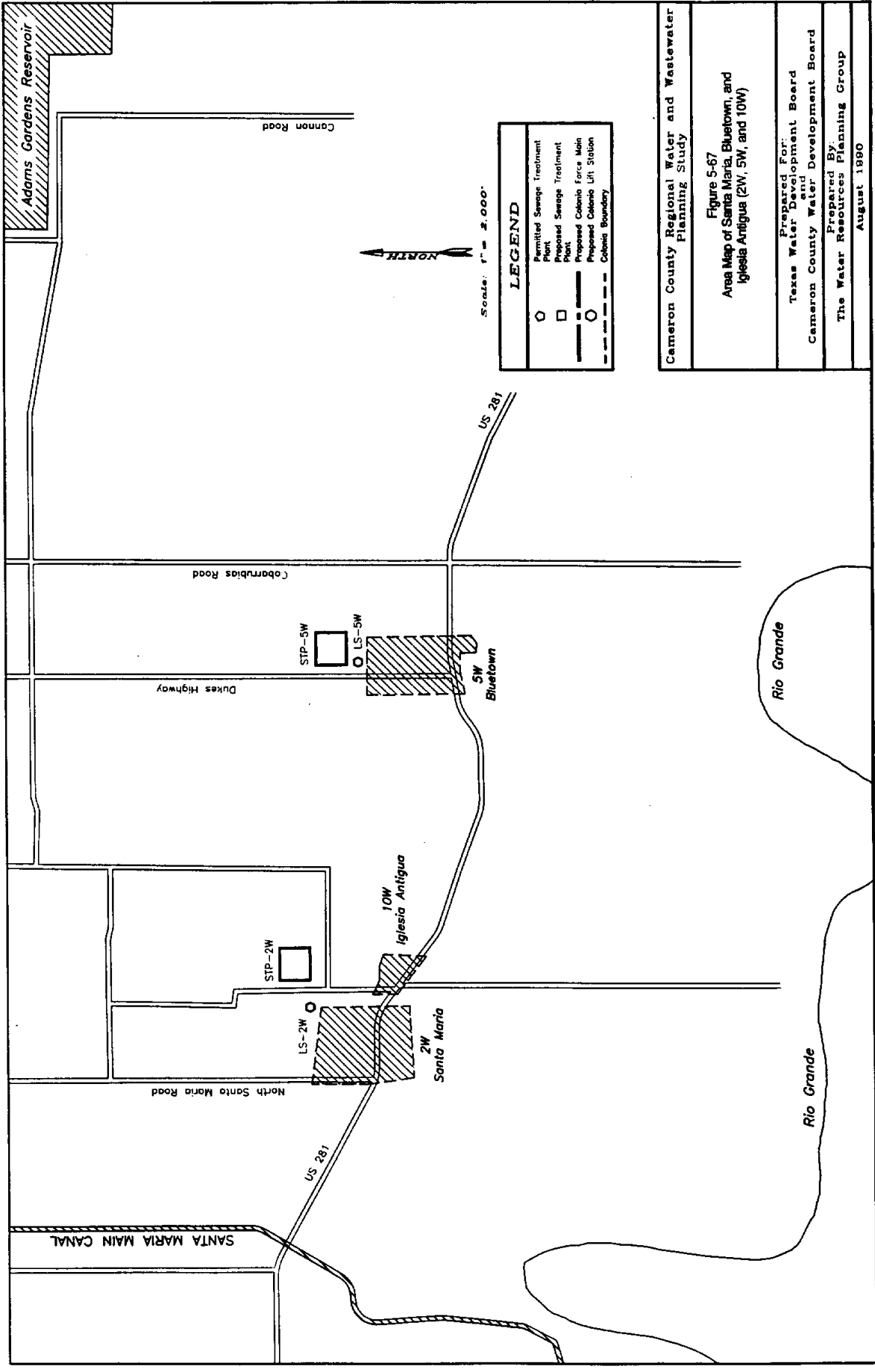

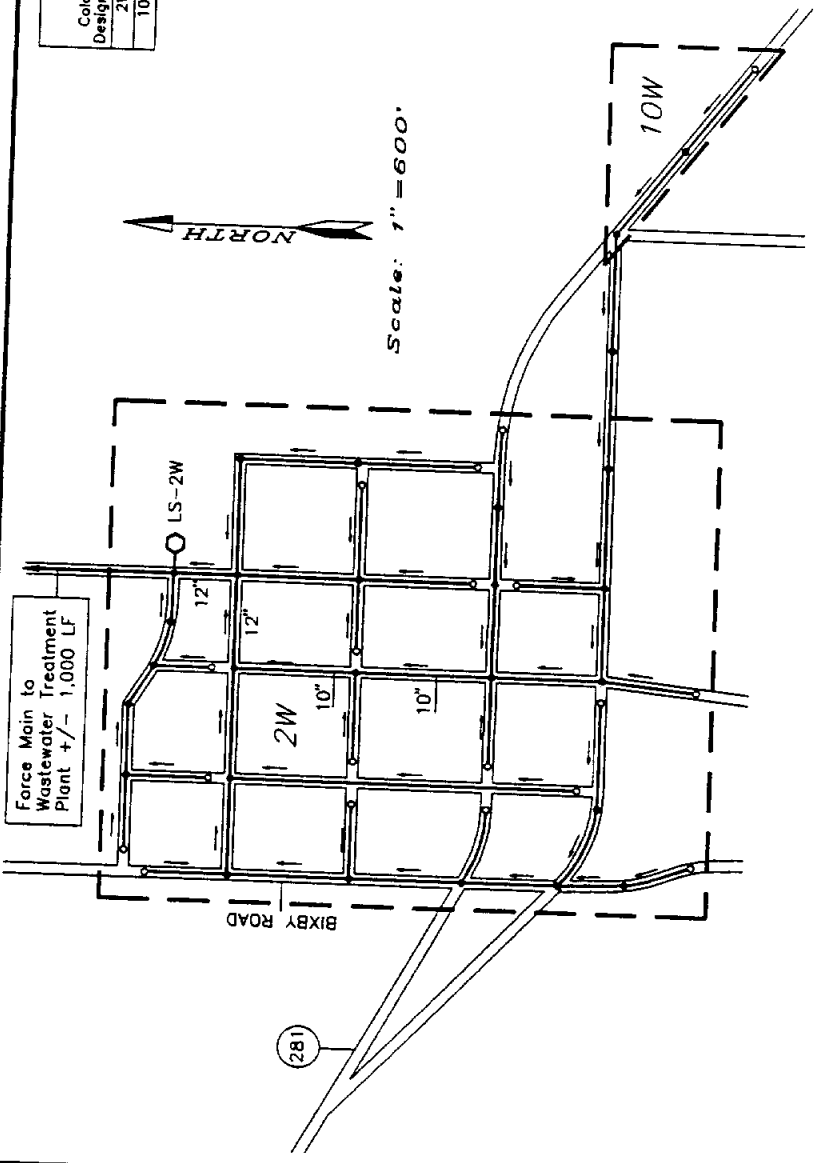

Colonia Designation	Colonia Name	Area (Ac)	2020 Population	2020 Population Density (Cap./Ac)	2020 Units	2020 Unit Density (Units/Ac)
2W	Santa Maria	80	2,306	28.83	471	5.89
10W	Iglesia Antigua	10	206	20.60	42	4.20

2W

ITEM	QUANTITY
6" Service Connection	471 EA
8" SDR-35 PVC Sanitary Sewer	11,250 LF
10" SDR-35 PVC Sanitary Sewer	800 LF
12" SDR-35 PVC Sanitary Sewer	950 LF
15" SDR-35 PVC Sanitary Sewer	N/A
18" SDR-35 PVC Sanitary Sewer	N/A
Clean Out	N/A
Manhole	18 EA
4" PVC Force Main	26 EA
6" PVC Force Main	N/A
8" PVC Force Main	N/A
10" PVC Force Main	N/A
12" PVC Force Main	1,000 LF
LS-2W	870 GPM (5.5 HP)
LS-2W	1 EA
TOTAL ESTIMATED COST	\$ 970,279

10W

ITEM	QUANTITY
6" Service Connection	42 EA
8" SDR-35 PVC Sanitary Sewer	1,300 LF
10" SDR-35 PVC Sanitary Sewer	N/A
12" SDR-35 PVC Sanitary Sewer	N/A
15" SDR-35 PVC Sanitary Sewer	N/A
18" SDR-35 PVC Sanitary Sewer	N/A
Clean Out	1 EA
Manhole	3 EA
4" PVC Force Main	N/A
6" PVC Force Main	N/A
8" PVC Force Main	N/A
10" PVC Force Main	N/A
12" PVC Force Main	N/A
TOTAL ESTIMATED COST	\$ 69,478

**Cameron County Regional Water and Wastewater Planning Study**

**Figure 5-68**

**Site Map of Santa Maria and Iglesia Antigua (2W and 10W)**

Prepared For:  
Texas Water Development Board  
and Cameron County Water Development Board

Prepared By:  
The Water Resources Planning Group

August 1990

Colonia Designation	Colonia Name	Area (Ac)	2020 Population	2020 Population Density (Pop/Ac)	2020 Units	2020 Unit Density (Units/Ac)
5W	Bluetown	59	580	9.83	118	2.00

Internal Wastewater Collection System		QUANTITY
ITEM		
6" Service Connection		118 EA
8" SDR-35 PVC Sanitary Sewer		5,500 LF
10" SDR-35 PVC Sanitary Sewer		N/A
12" SDR-35 PVC Sanitary Sewer		N/A
15" SDR-35 PVC Sanitary Sewer		N/A
18" SDR-35 PVC Sanitary Sewer		N/A
Clean Out		4 EA
Manhole		14 EA
4" PVC Force Main		N/A
6" PVC Force Main		1,000 LF
8" PVC Force Main		N/A
10" PVC Force Main		N/A
12" PVC Force Main		N/A
LS-5W 170 GPM (1.5HP)		1 EA
<b>TOTAL ESTIMATED COST</b>		<b>\$ 367,166</b>

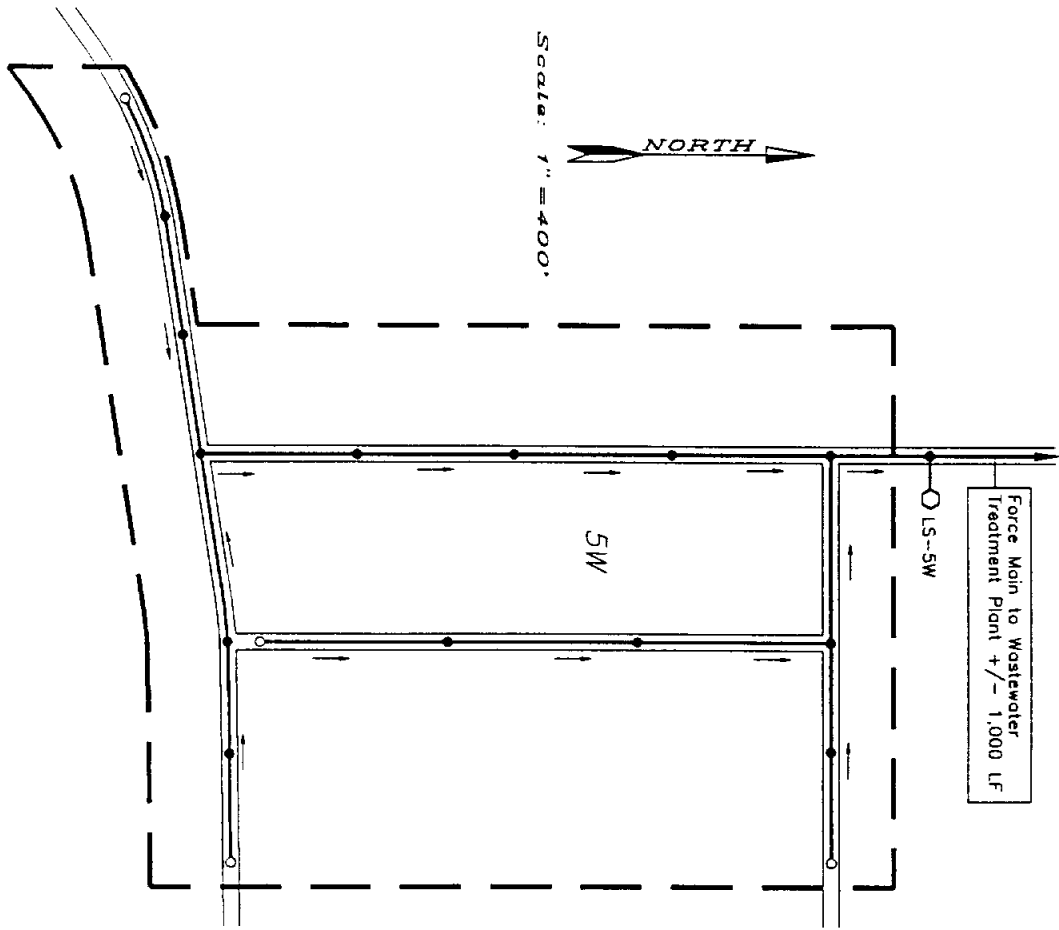

**Cameron County Regional Water and Wastewater Planning Study**

Figure 5-69  
Site Map of Bluetown (5W)

Prepared For:  
Texas Water Development Board  
and Cameron County Water Development Board

Prepared By:  
The Water Resources Planning Group

August 1990

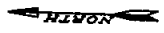
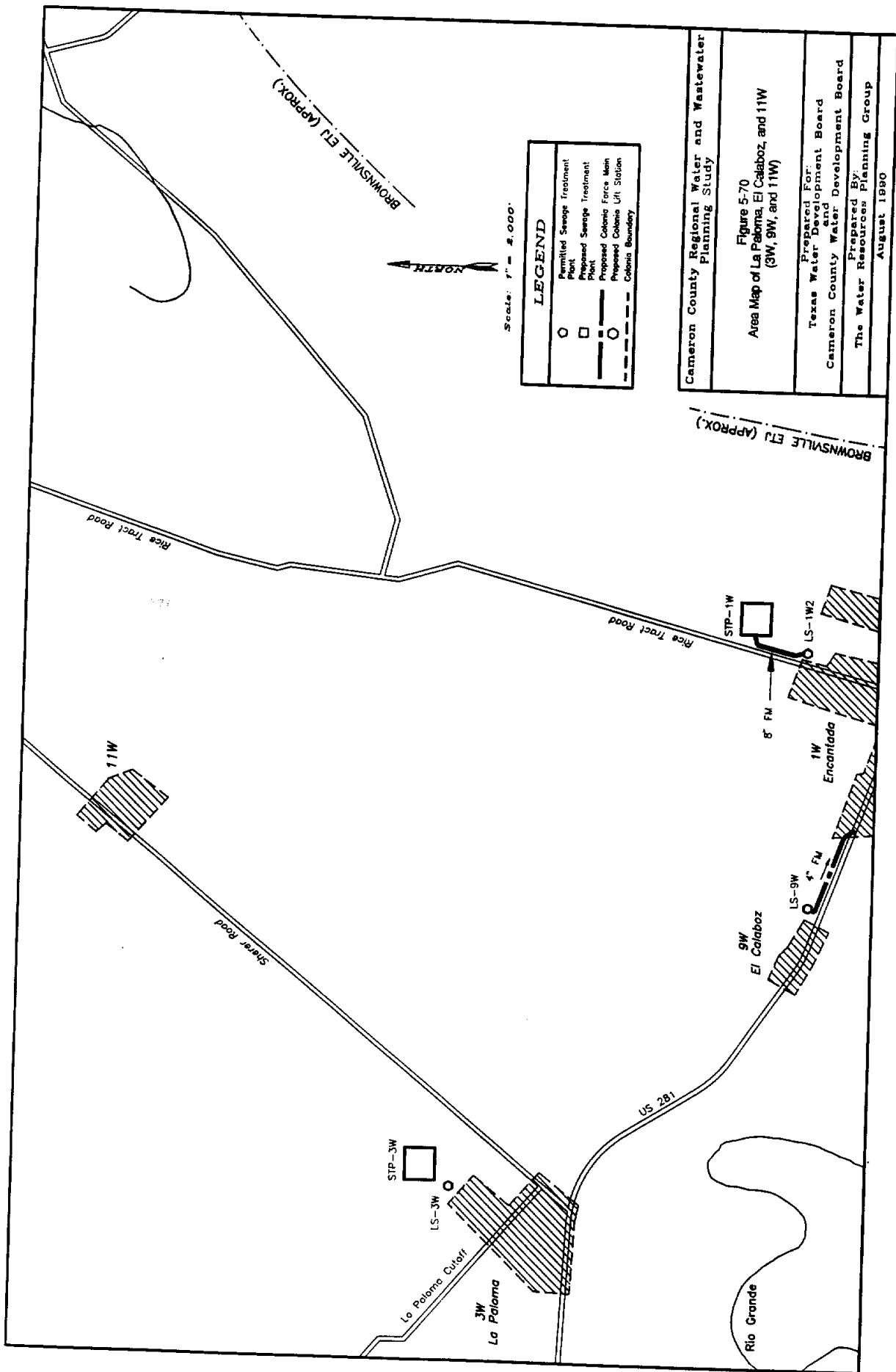

Scale: 1" = 4,000'

LEGEND	
	Proposed Sewage Treatment Plant
	Permitted Sewage Treatment Plant
	Proposed Cobito Force Main
	Proposed Cobito Lift Station
	Colonia Boundary

Cameron County Regional Water and Wastewater Planning Study

Figure 5-70  
Area Map of La Paloma, El Calaboz, and 11W  
(3W, 9W, and 11W)

Prepared For:  
Texas Water Development Board  
Cameron County Water Development Board

Prepared By:  
The Water Resources Planning Group

August 1990

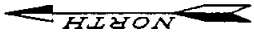

Scale: 1" = 400'

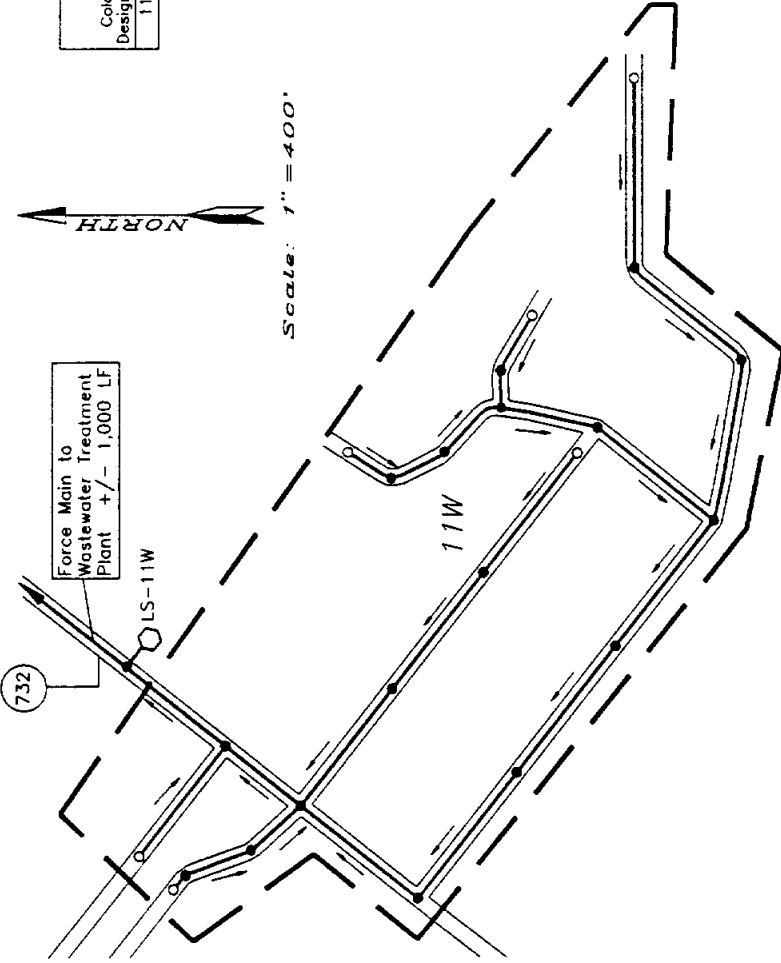

Colonia Designation	Colonia Name	Area (Ac)	2020 Population	2020 Population Density (Cap/Ac)	2020 Unit Density (Units/Ac)
11W	Palmer	32	285	8.91	1.81

Internal Wastewater Collection System Quantities Estimate		QUANTITY
6" Service Connection		58 EA
8" SDR-35 PVC Sanitary Sewer		5,775 LF
10" SDR-35 PVC Sanitary Sewer		N/A
12" SDR-35 PVC Sanitary Sewer		N/A
15" SDR-35 PVC Sanitary Sewer		N/A
18" SDR-35 PVC Sanitary Sewer		N/A
Clean Out		7 EA
Manhole		18 EA
4" PVC Force Main		1,000 LF
6" PVC Force Main		N/A
8" PVC Force Main		N/A
10" PVC Force Main		N/A
12" PVC Force Main		N/A
LS-11W 85 GPM (1.0 HP)		1 EA
TOTAL ESTIMATED COST		\$ 314,769

Cameron County Regional Water and Wastewater Planning Study

Figure 5-71  
Site Map of 11W

Prepared For:

Texas Water Development Board  
and Cameron County Water Development Board

Prepared By:

The Water Resources Planning Group

August 1990

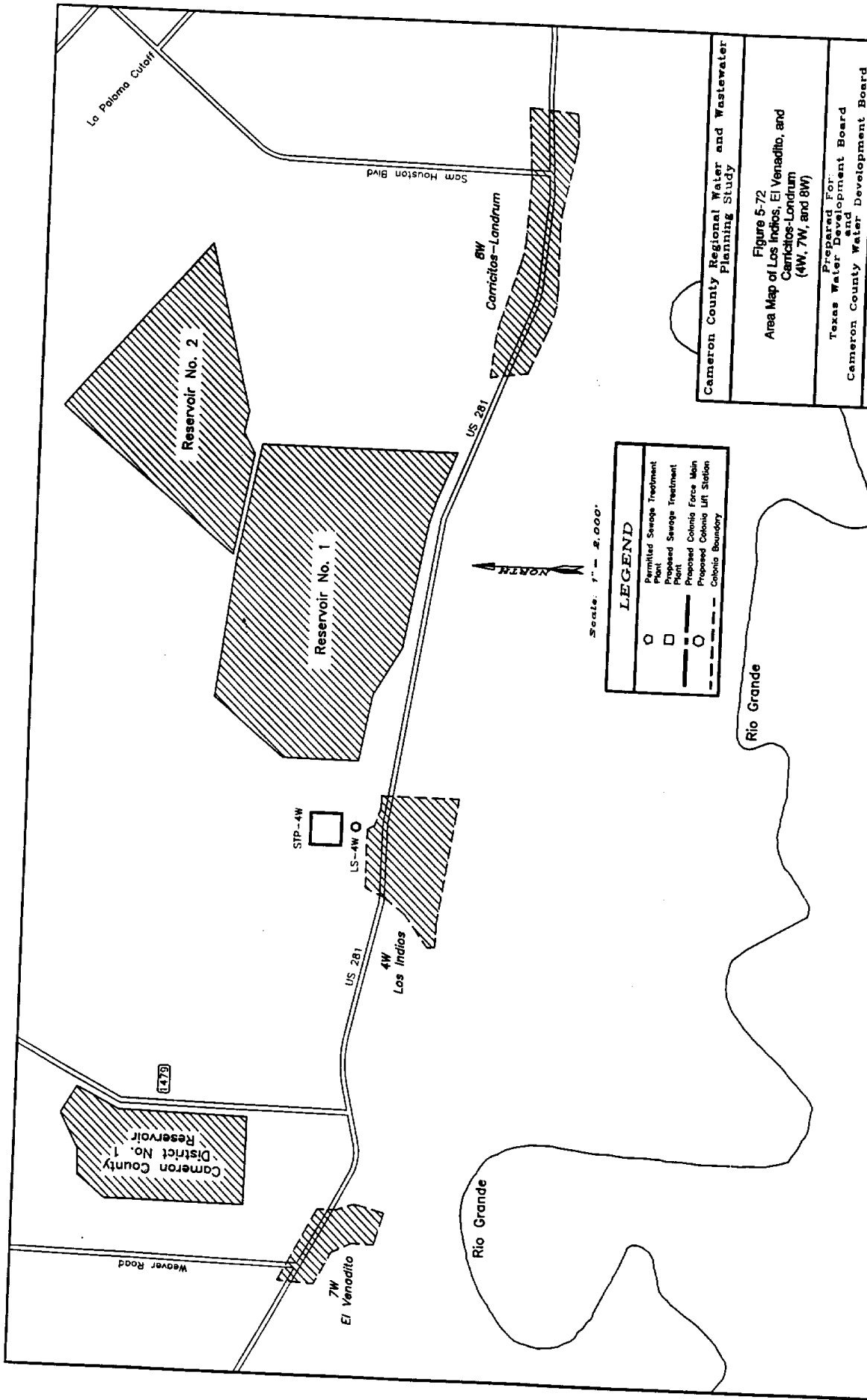

Scale: 1" = 2,000'

**LEGEND**

○	Permitted Sewage Treatment Plant
□	Proposed Sewage Treatment Plant
○	Permitted Colonic Force Main
○	Proposed Colonic Lift Station
- - -	Colonia Boundary

Cameron County Regional Water and Wastewater Planning Study

Figure 5-72  
 Area Map of Los Indios, El Venadito, and Carricitos-Londrum (4W, 7W, and 8W)

Prepared For:  
 Texas Water Development Board  
 Cameron County Water Development Board

Prepared By:  
 The Water Resources Planning Group  
 August 1990



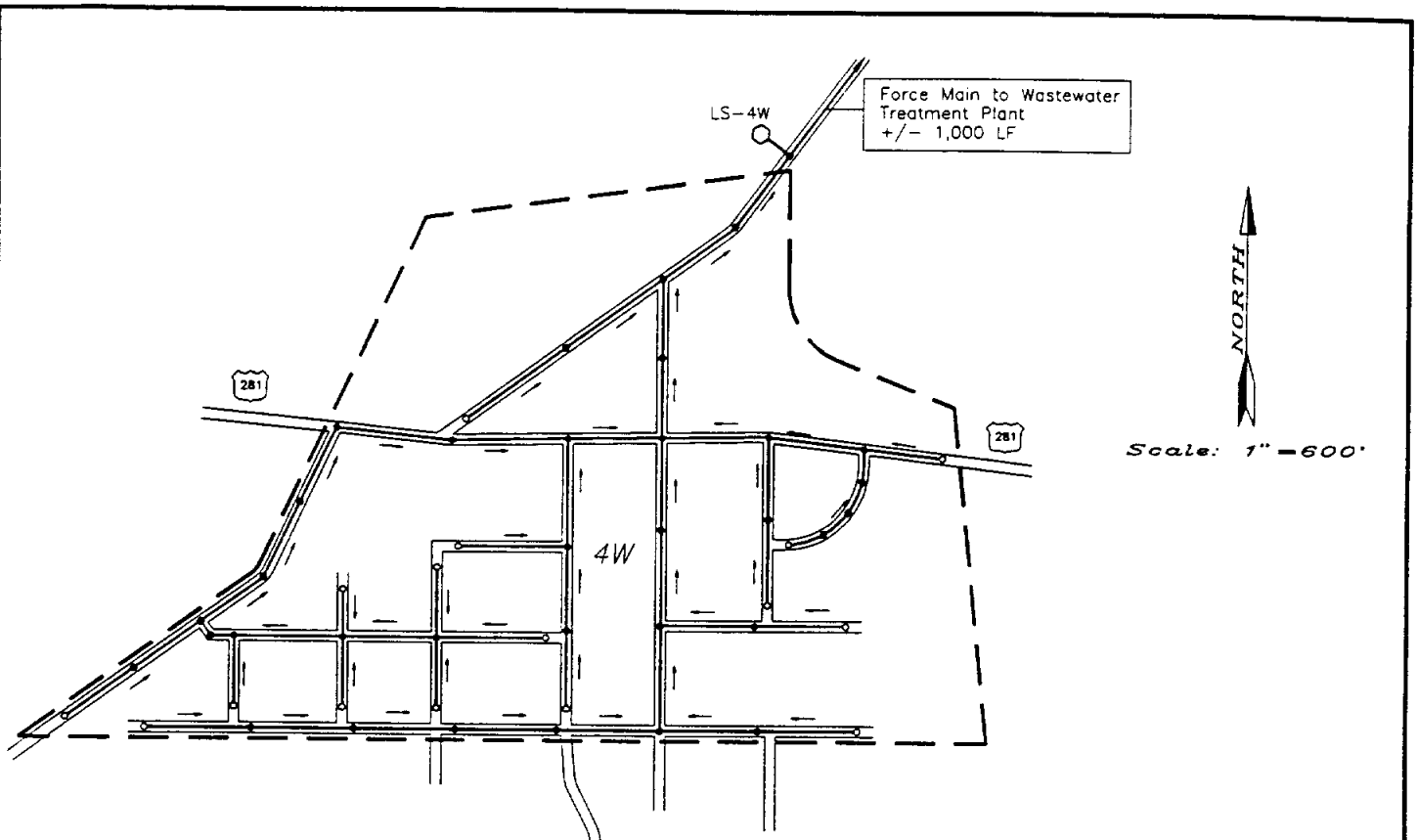

Colonia Designation	Colonia Name	Area (Ac)	2020 Population	2020 Population Density (Cap/Ac)	2020 Units	2020 Unit Density (Units/Ac)
4W	Los Indios	100	699	6.99	143	1.43

Internal Wastewater Collection System Quantities Estimate	
ITEM	QUANTITY
6" Service Connection	143 EA
8" SDR-35 PVC Sanitary Sewer	13,850 LF
10" SDR-35 PVC Sanitary Sewer	N/A
12" SDR-35 PVC Sanitary Sewer	N/A
15" SDR-35 PVC Sanitary Sewer	N/A
18" SDR-35 PVC Sanitary Sewer	N/A
Clean Out	16 EA
Manhole	34 EA
4" PVC Force Main	N/A
6" PVC Force Main	1,000 LF
8" PVC Force Main	N/A
10" PVC Force Main	N/A
12" PVC Force Main	N/A
LS-4W 205 GPM (2.0HP)	1 EA
<b>TOTAL ESTIMATED COST</b>	<b>\$ 674,211</b>

Cameron County Regional Water and Wastewater Planning Study

Figure 5-73  
Site Map of Los Indios (4W)

Prepared For:  
Texas Water Development Board  
and Cameron County Water Development Board

Prepared By:  
The Water Resources Planning Group

August 1990

NORTH  
Scale: 1" = 600'

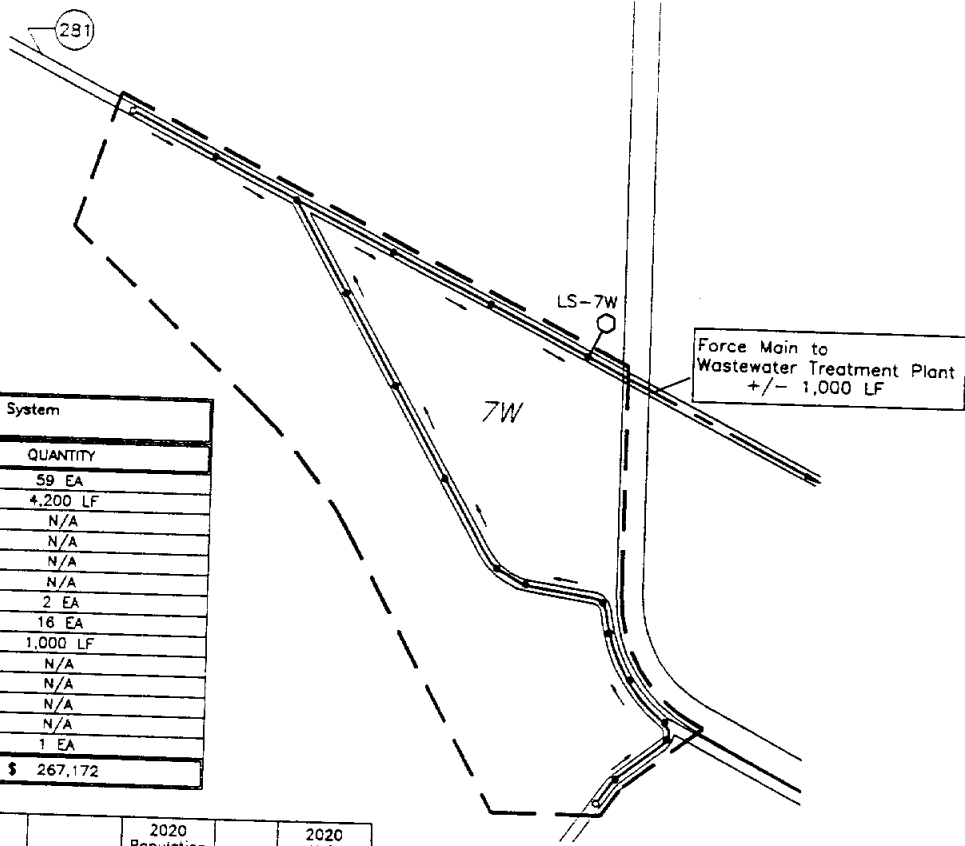

Internal Wastewater Collection System Quantities Estimate	
ITEM	QUANTITY
6" Service Connection	59 EA
8" SDR-35 PVC Sanitary Sewer	4,200 LF
10" SDR-35 PVC Sanitary Sewer	N/A
12" SDR-35 PVC Sanitary Sewer	N/A
15" SDR-35 PVC Sanitary Sewer	N/A
18" SDR-35 PVC Sanitary Sewer	N/A
Clean Out	2 EA
Manhole	16 EA
4" PVC Force Main	1,000 LF
6" PVC Force Main	N/A
8" PVC Force Main	N/A
10" PVC Force Main	N/A
12" PVC Force Main	N/A
LS-7W 90 GPM (1.0 HP)	1 EA
<b>TOTAL ESTIMATED COST</b>	<b>\$ 267,172</b>

Colonia Designation	Colonia Name	Area (Ac)	2020 Population	2020 Population Density (Cap./Ac)	2020 Units	2020 Unit Density (Units/Ac)
7W	El Venadito	41	287	7.00	59	1.44

<b>Cameron County Regional Water and Wastewater Planning Study</b>
<b>Figure 5-74 Site Map of El Venadito (7W)</b>
<b>Prepared For: Texas Water Development Board and Cameron County Water Development Board</b>
<b>Prepared By: The Water Resources Planning Group</b>
<b>August 1990</b>

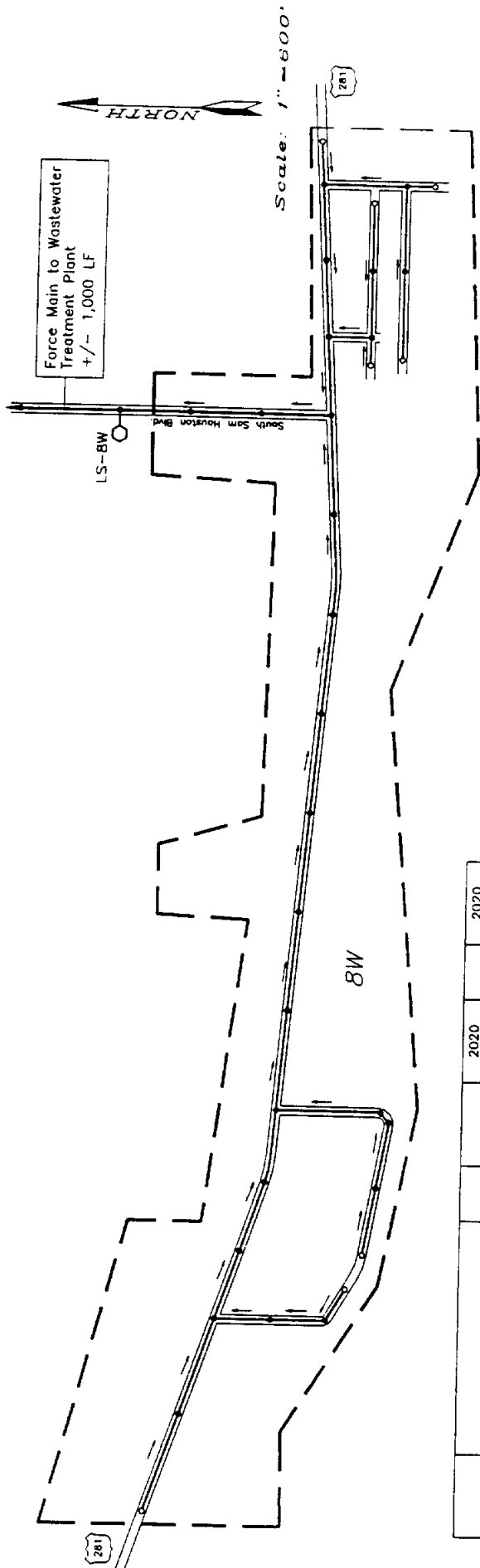

Colonia Designation	Colonia Name	Area (Ac)	2020 Population	2020 Population Density (Cap/Ac)	2020 Units	2020 Unit Density (Units/Ac)
BE	Carricitos-Londrum	1.16	275	2.37	56	0.48

Internal Wastewater Collection System Quantities Estimate	
ITEM	QUANTITY
6" Service Connection	56 EA
8" SDR-35 PVC Sanitary Sewer	9,325 LF
10" SDR-35 PVC Sanitary Sewer	N/A
12" SDR-35 PVC Sanitary Sewer	N/A
15" SDR-35 PVC Sanitary Sewer	N/A
18" SDR-35 PVC Sanitary Sewer	N/A
Clean Out	8 EA
Manhole	27 EA
4" PVC Force Main	1,000 LF
6" PVC Force Main	N/A
8" PVC Force Main	N/A
10" PVC Force Main	N/A
12" PVC Force Main	N/A
LS-8W 85 GPM (1.0HP)	1 EA
<b>TOTAL ESTIMATED COST</b>	<b>\$ 428,510</b>

**Cameron County Regional Water and Wastewater Planning Study**

**Figure 5-75**

**Site Map of Carricitos-Londrum (8W)**

Prepared For:  
Texas Water Development Board  
and Cameron County Water Development Board

Prepared By:  
The Water Resources Planning Group

August 1990

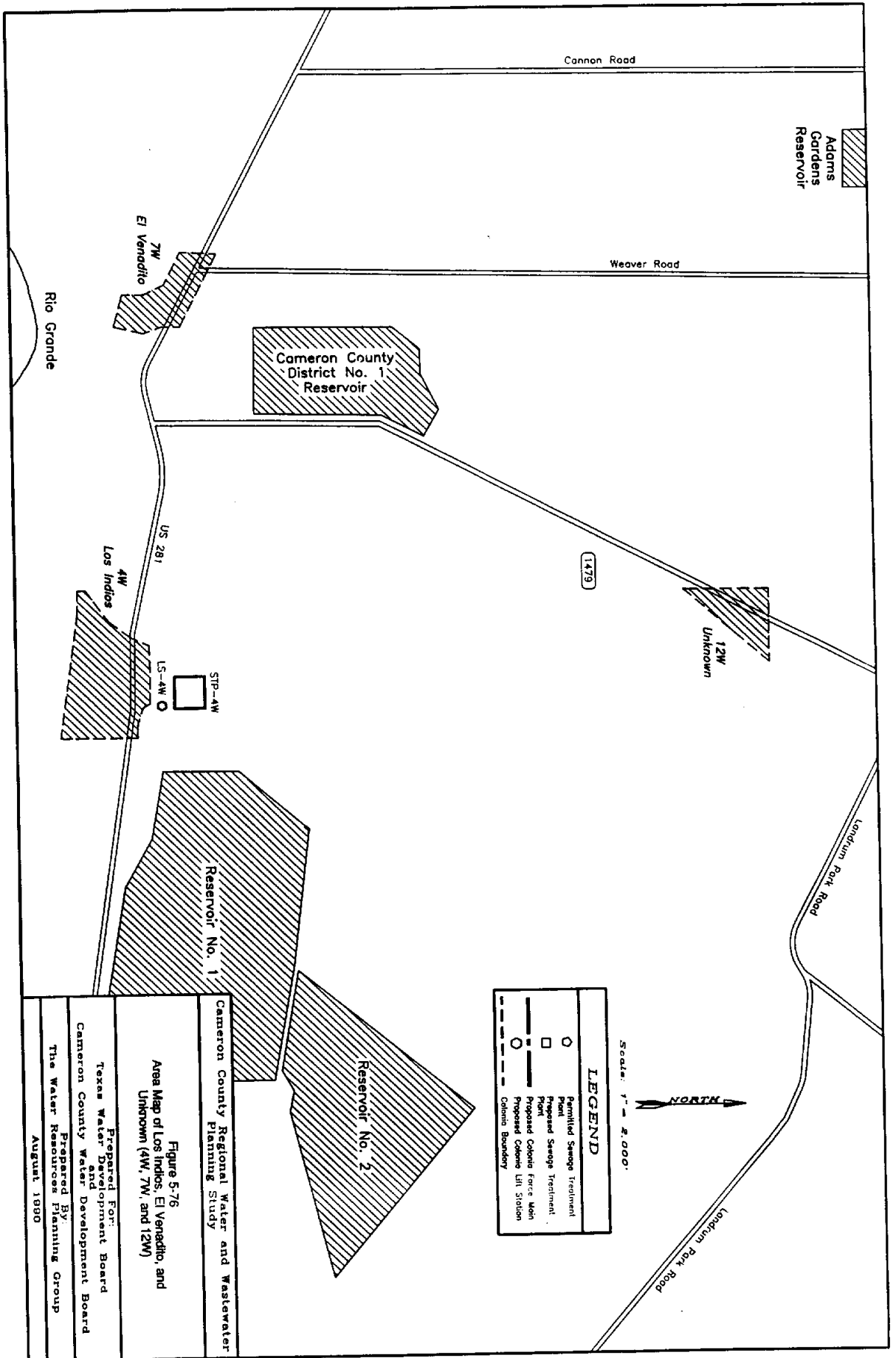

**LEGEND**

○	Proposed Sewage Treatment Plant
□	Proposed Sewage Treatment Plant
—	Proposed Colonia Force Main
○	Proposed Colonia Lift Station
- - -	Cameron Boundary
- - -	Colonia Boundary

Scale: 1" = 2,000'



**Cameron County Regional Water and Wastewater Planning Study**

**Figure 5-76**  
**Area Map of Los Indios, El Venadito, and Unknown (4W, 7W, and 12W)**

Prepared For:  
 Texas Water Development Board  
 Cameron County Water Development Board

Prepared By:  
 The Water Resources Planning Group  
 August 1980

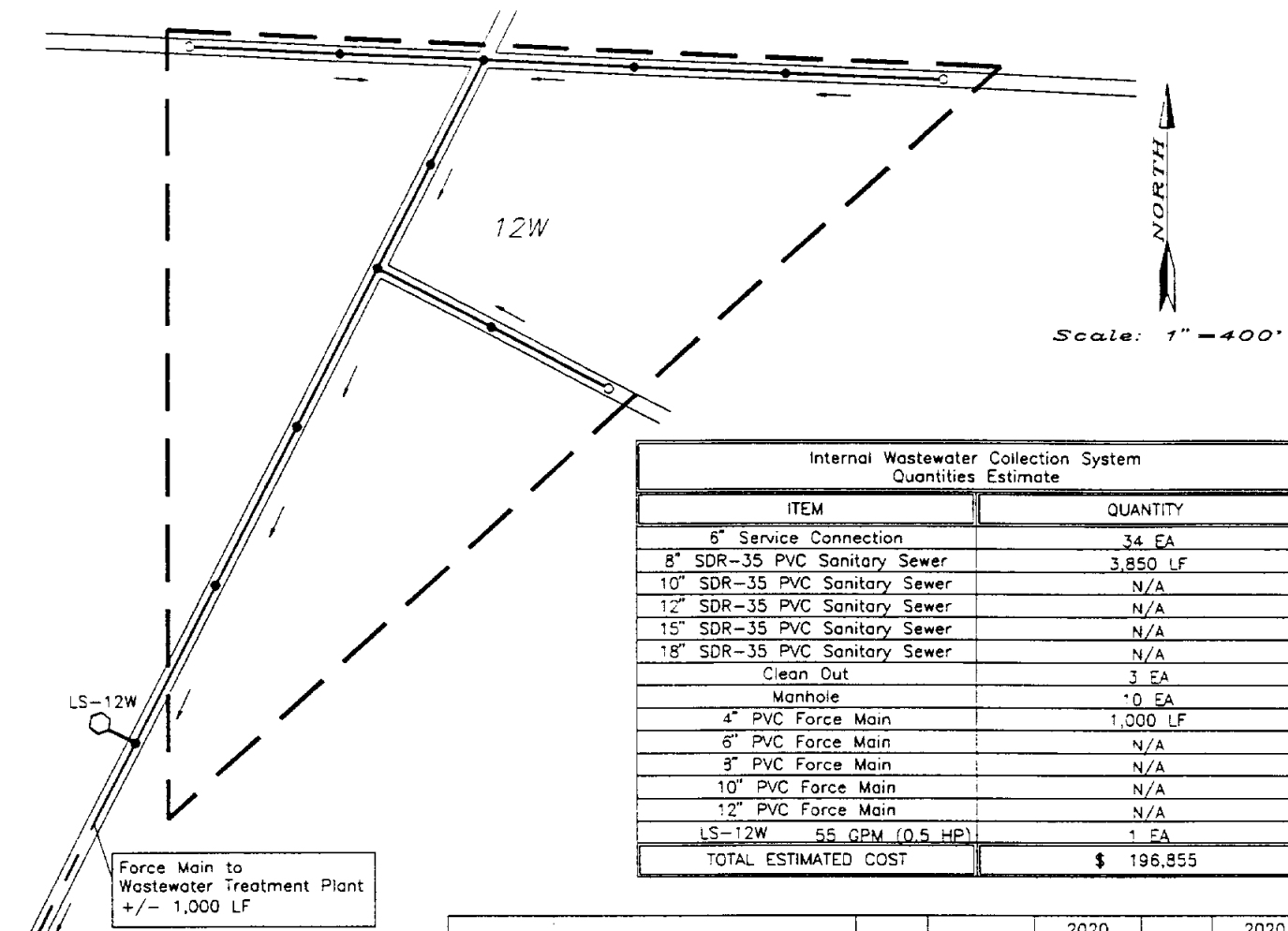

Internal Wastewater Collection System Quantities Estimate	
ITEM	QUANTITY
5" Service Connection	34 EA
8" SDR-35 PVC Sanitary Sewer	3,850 LF
10" SDR-35 PVC Sanitary Sewer	N/A
12" SDR-35 PVC Sanitary Sewer	N/A
15" SDR-35 PVC Sanitary Sewer	N/A
18" SDR-35 PVC Sanitary Sewer	N/A
Clean Out	3 EA
Manhole	10 EA
4" PVC Force Main	1,000 LF
6" PVC Force Main	N/A
8" PVC Force Main	N/A
10" PVC Force Main	N/A
12" PVC Force Main	N/A
LS-12W 55 GPM (0.5 HP)	1 EA
<b>TOTAL ESTIMATED COST</b>	<b>\$ 196,855</b>

Colonia Designation	Colonia Name	Area (Ac)	2020 Population	2020 Population Density (Pop/Ac)	2020 Units	2020 Unit Density (Units/Ac)
12W	Unknown (Mitla 2)	32	169	5.28	34	1.06

<b>Cameron County Regional Water and Wastewater Planning Study</b>
<b>Figure 5-77 Site Map of Unknown (12W)</b>
<b>Prepared For: Texas Water Development Board and Cameron County Water Development Board</b>
<b>Prepared By: The Water Resources Planning Group</b>
<b>August 1990</b>

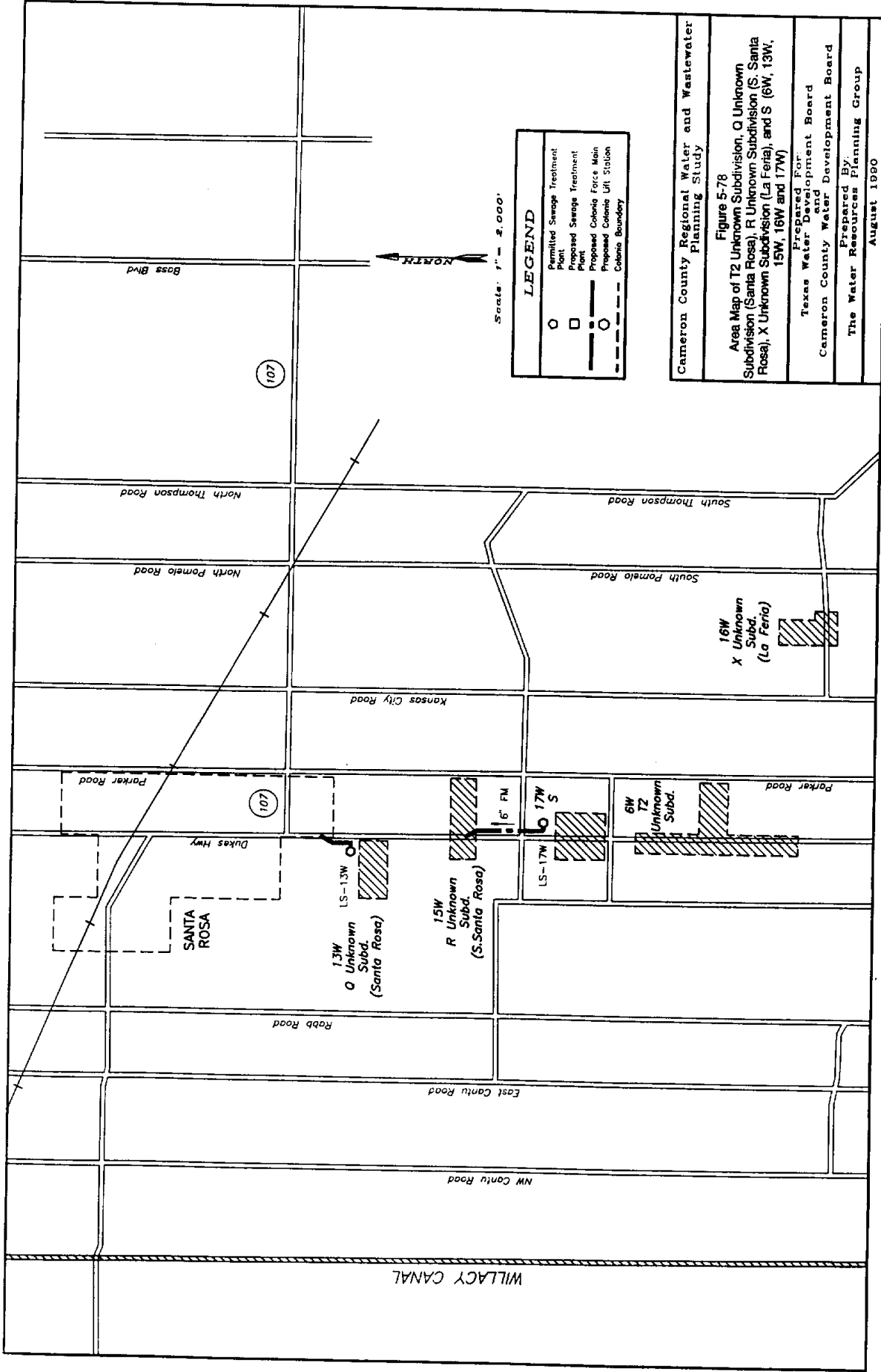

Scale: 1" = 2,000'

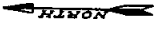

LEGEND	
	Permitted Sewage Treatment Plant
	Proposed Sewage Treatment Plant
	Proposed Colonia Force Main
	Proposed Colonia Lift Station
	Colonia Boundary

Cameron County Regional Water and Wastewater Planning Study

Figure 5-78

Area Map of T2 Unknown Subdivision, Q Unknown Subdivision (Santa Rosa), R Unknown Subdivision (S. Santa Rosa), X Unknown Subdivision (La Feria), and S (6W, 13W, 15W, 16W and 17W)

Prepared For  
Texas Water Development Board

Cameron County Water Development Board

Prepared By  
The Water Resources Planning Group

August 1990

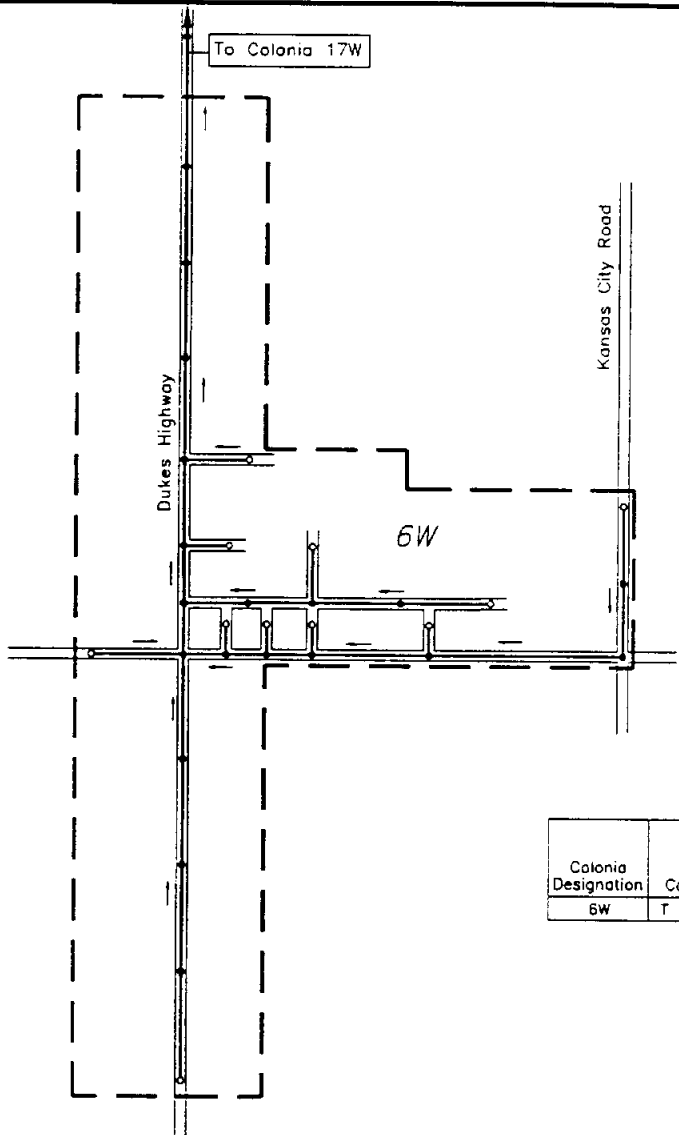

Internal Wastewater Collection System Quantities Estimate	
ITEM	QUANTITY
6" Service Connection	88 EA
8" SDR-35 PVC Sanitary Sewer	7,400 LF
10" SDR-35 PVC Sanitary Sewer	N/A
12" SDR-35 PVC Sanitary Sewer	N/A
15" SDR-35 PVC Sanitary Sewer	N/A
18" SDR-35 PVC Sanitary Sewer	N/A
Clean Out	11 EA
Manhole	20 EA
4" PVC Force Main	N/A
6" PVC Force Main	N/A
8" PVC Force Main	N/A
10" PVC Force Main	N/A
12" PVC Force Main	N/A
<b>TOTAL ESTIMATED COST</b>	<b>\$ 304,440</b>

Colonia Designation	Colonia Name	Area (Ac)	2020 Population	2020 Population Density (Cap/Ac)	2020 Units	2020 Unit Density (Units/Ac)
6W	T 2 Unknown Subdivision	45	431	9.58	88	1.96

**Cameron County Regional Water and Wastewater Planning Study**

**Figure 5-79  
Site Map of T2 Unknown Subdivision (6W)**

**Prepared For:  
Texas Water Development Board  
and Cameron County Water Development Board**

**Prepared By:  
The Water Resources Planning Group**

**August 1990**

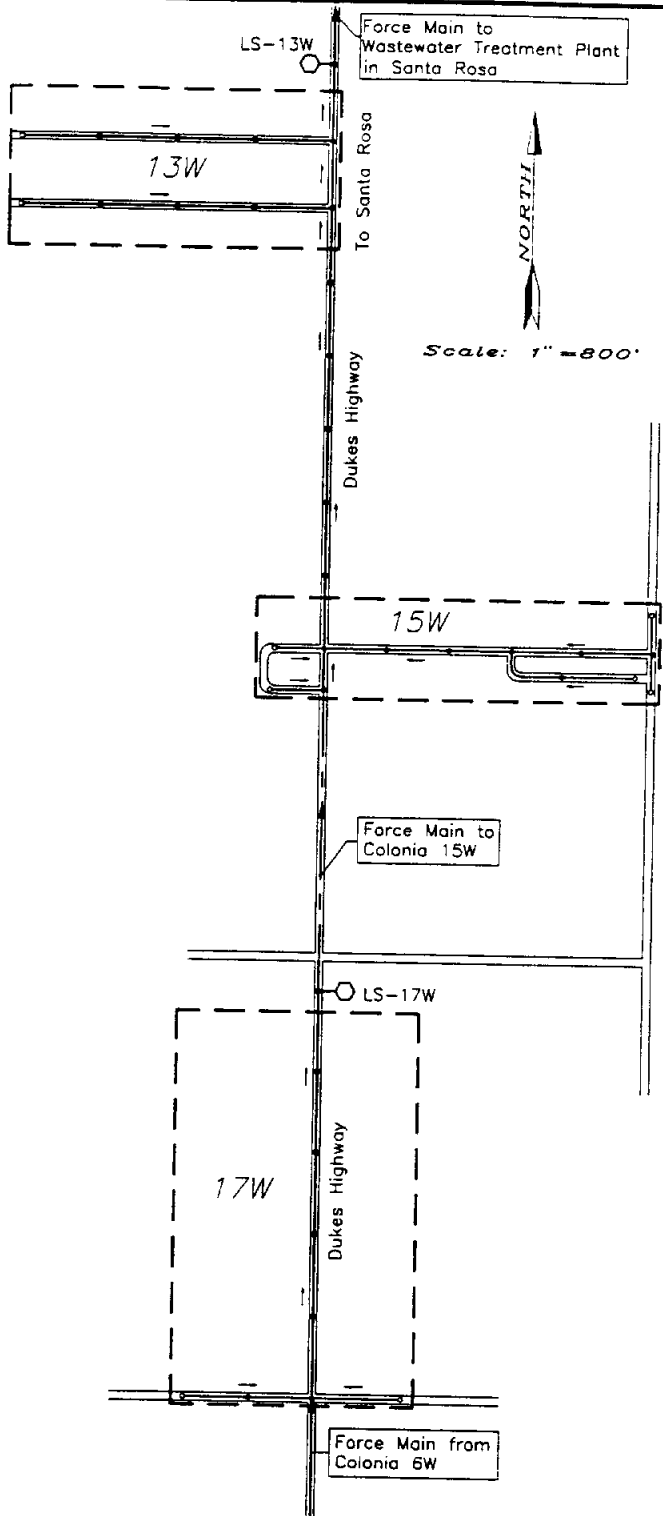

Colonia Designation	Colonia Name	Area (Ac)	2020 Population	2020 Population Density (Pop./Ac)	2020 Units	2020 Unit Density (Units/Ac)
13W	Q Unknown Subd. (Santa Rosa)	16	241	15.06	49	3.06
15W	R Unknown Subd. (Santa Rosa)	25	196	7.84	40	1.60
17W	S	25	116	4.64	24	0.96

13W

Internal Wastewater Collection System Quantities Estimate	
ITEM	QUANTITY
6" Service Connection	49 EA
8" SDR-35 PVC Sanitary Sewer	4,100 LF
10" SDR-35 PVC Sanitary Sewer	N/A
12" SDR-35 PVC Sanitary Sewer	N/A
15" SDR-35 PVC Sanitary Sewer	N/A
18" SDR-35 PVC Sanitary Sewer	N/A
Clean Out	2 EA
Manhole	11 EA
4" PVC Force Main	N/A
6" PVC Force Main	N/A
8" PVC Force Main	N/A
10" PVC Force Main	1,500 LF
12" PVC Force Main	N/A
15" PVC Force Main	N/A
18" PVC Force Main	N/A
LS-13W 300 GPM (2.5 HP)	1 EA
<b>TOTAL ESTIMATED COST</b>	<b>\$ 327,048</b>

15W

Internal Wastewater Collection System Quantities Estimate	
ITEM	QUANTITY
6" Service Connection	40 EA
8" SDR-35 PVC Sanitary Sewer	3,700 LF
10" SDR-35 PVC Sanitary Sewer	N/A
12" SDR-35 PVC Sanitary Sewer	N/A
15" SDR-35 PVC Sanitary Sewer	N/A
18" SDR-35 PVC Sanitary Sewer	N/A
Clean Out	5 EA
Manhole	11 EA
4" PVC Force Main	N/A
6" PVC Force Main	N/A
8" PVC Force Main	N/A
10" PVC Force Main	N/A
12" PVC Force Main	N/A
<b>TOTAL ESTIMATED COST</b>	<b>\$ 151,685</b>

17W

Internal Wastewater Collection System Quantities Estimate	
ITEM	QUANTITY
6" Service Connection	24 EA
8" SDR-35 PVC Sanitary Sewer	3,000 LF
10" SDR-35 PVC Sanitary Sewer	N/A
12" SDR-35 PVC Sanitary Sewer	N/A
15" SDR-35 PVC Sanitary Sewer	N/A
18" SDR-35 PVC Sanitary Sewer	N/A
Clean Out	2 EA
Manhole	7 EA
4" PVC Force Main	1,400 LF
6" PVC Force Main	N/A
8" PVC Force Main	N/A
10" PVC Force Main	N/A
12" PVC Force Main	N/A
LS-17W 170 GPM (2.5 HP)	1 EA
<b>TOTAL ESTIMATED COST</b>	<b>\$ 259,230</b>

**Cameron County Regional Water and Wastewater Planning Study**

**Figure 5-80**  
Site Map of Q Unknown Sub.(Santa Rosa), R Unknown Sub. (S. Santa Rosa), & S (13W, 15W, & 17W)

**Prepared For:**  
**Texas Water Development Board**  
**and Cameron County Water Development Board**

**Prepared By:**  
**The Water Resources Planning Group**  
**August 1990**



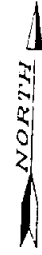
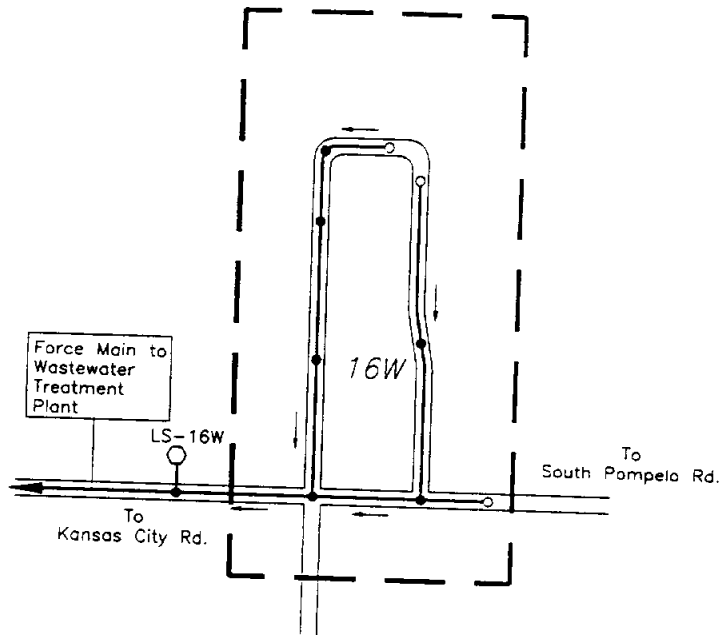

Scale: 1" = 400'

Colonia Designation	Colonia Name	Area (Ac)	2020 Population	2020 Population Density (Cap/Ac)	2020 Units	2020 Unit Density (Units/Ac)
16W	X Unknown Subd. (La Feria)	16	116	7.25	24	1.50

Internal Wastewater Collection System Quantities Estimate	
ITEM	QUANTITY
6" Service Connection	24 EA
8" SDR-35 PVC Sanitary Sewer	2,250 LF
10" SDR-35 PVC Sanitary Sewer	N/A
12" SDR-35 PVC Sanitary Sewer	N/A
15" SDR-35 PVC Sanitary Sewer	N/A
18" SDR-35 PVC Sanitary Sewer	N/A
Clean Out	3 EA
Manhole	7 EA
4" PVC Force Main	1,000 LF
6" PVC Force Main	N/A
8" PVC Force Main	N/A
10" PVC Force Main	N/A
12" PVC Force Main	N/A
LS-16W 35 GPM (0.5 HP)	1 EA
<b>TOTAL ESTIMATED COST</b>	<b>\$ 141,000</b>

Cameron County Regional Water and Wastewater Planning Study

Figure 5-81  
Site Map of X Unknown Subdivision (La Feria) (16W)

Prepared For:  
Texas Water Development Board  
and Cameron County Water Development Board

Prepared By:  
The Water Resources Planning Group

August 1990

Force Main to Wastewater Treatment Plant  
 +/- 1,000 LF

LS-14W

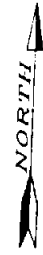

Scale: 1" = 400'

Colonia Designation	Colonia Name	Area (Ac)	2020 Population	2020 Population Density (Cap/Ac)	2020 Units	2020 Unit Density (Units/Ac)
14W	W	48	137	2.85	28	0.58

14W

North Rabb Road

Internal Wastewater Collection System Quantities Estimate	
ITEM	QUANTITY
6" Service Connection	28 EA
8" SDR-35 PVC Sanitary Sewer	2,500 LF
10" SDR-35 PVC Sanitary Sewer	N/A
12" SDR-35 PVC Sanitary Sewer	N/A
15" SDR-35 PVC Sanitary Sewer	N/A
18" SDR-35 PVC Sanitary Sewer	N/A
Clean Out	1 EA
Manhole	7 EA
4" PVC Force Main	1,000 LF
6" PVC Force Main	N/A
8" PVC Force Main	N/A
10" PVC Force Main	N/A
12" PVC Force Main	N/A
LS-14W 45 GPM (0.5 HP)	1 EA
<b>TOTAL ESTIMATED COST</b>	<b>\$ 149,463</b>

**Cameron County Regional Water and Wastewater Planning Study**

**Figure 5-83  
 Site Map of W (14W)**

**Prepared For:  
 Texas Water Development Board  
 and Cameron County Water Development Board**

**Prepared By:  
 The Water Resources Planning Group**

**August 1990**

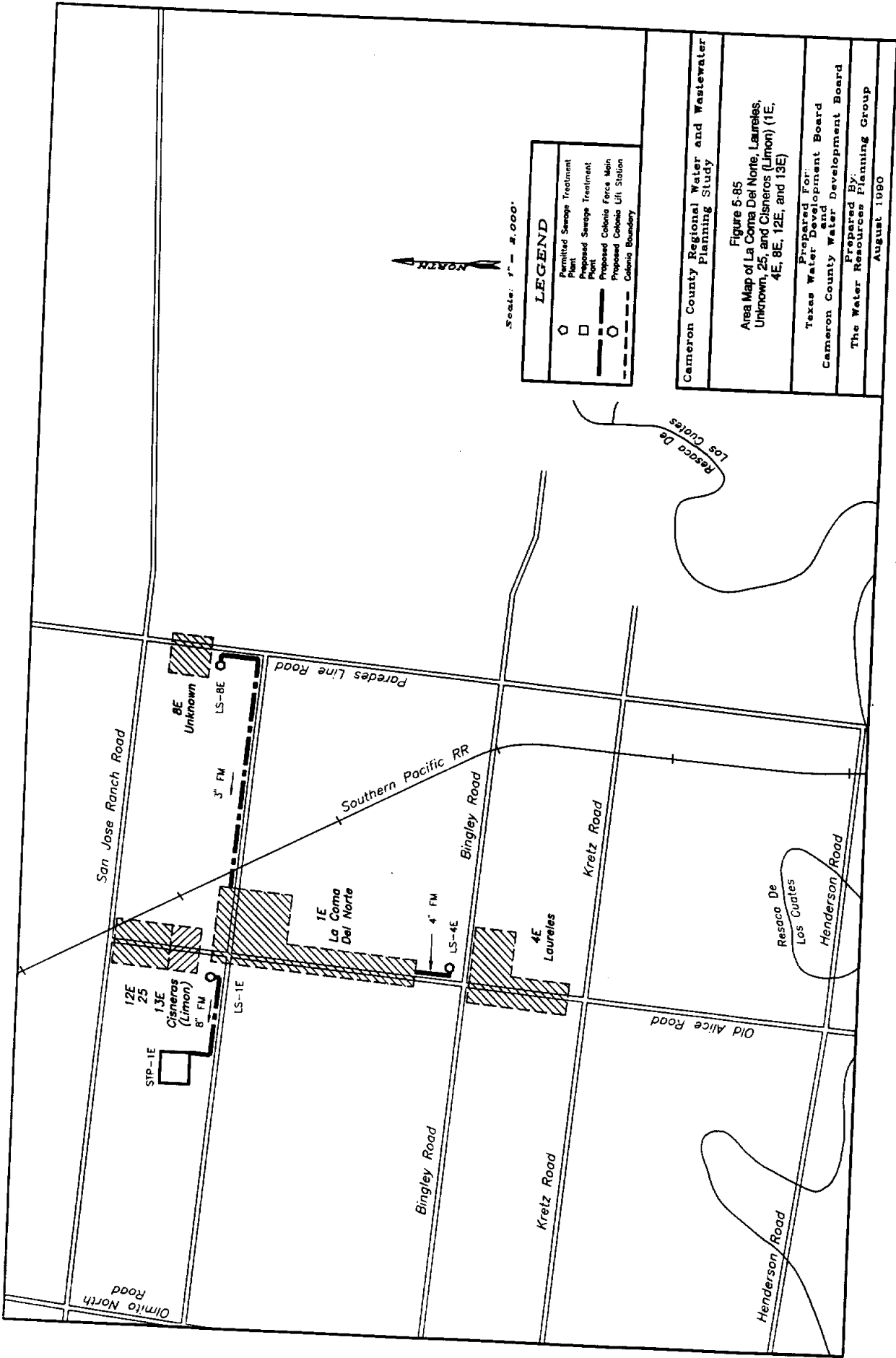

Scale: 1" = 2,000'

**LEGEND**

○	Permitted Sewage Treatment Plant
□	Proposed Sewage Treatment Plant
—○—	Proposed Colonia Force Main
—○—	Proposed Colonia Lift Station
- - -	Colonia Boundary

Cameron County Regional Water and Wastewater Planning Study

Figure 5-85  
 Area Map of La Coma Del Norte, Laureles, Unknown, 25, and Cisneros (Limon) (1E, 4E, 8E, 12E, and 13E)

Prepared For:  
 Texas Water Development Board  
 Cameron County Water Development Board

Prepared By:  
 The Water Resources Planning Group  
 August 1990

Colonia Designation	Colonia Name	Area (Ac)	2020 Population	2020 Population Density (Pop./Ac)	2020 Units	2020 Unit Density (Units/Ac)
1E	La Coma Del Norte	100	888	8.88	177	1.77
12E	25	32	75	2.34	15	0.47
13E	Cisneros (Limon)	9	62	8.89	13	1.44

1E

Internal Wastewater Collection System Quantities Estimate	
ITEM	QUANTITY
6" Service Connection	177 EA
8" SDR-35 PVC Sanitary Sewer	10,200 LF
10" SDR-35 PVC Sanitary Sewer	400 LF
12" SDR-35 PVC Sanitary Sewer	N/A
15" SDR-35 PVC Sanitary Sewer	N/A
18" SDR-35 PVC Sanitary Sewer	N/A
Clean Out	6 EA
Manhole	28 EA
4" PVC Force Main	N/A
6" PVC Force Main	N/A
8" PVC Force Main	2,000 LF
10" PVC Force Main	N/A
12" PVC Force Main	N/A
LS-1E 480 GPM (S.OHP)	1 EA
<b>TOTAL ESTIMATED COST</b>	<b>\$ 698,375</b>

12E

Internal Wastewater Collection System Quantities Estimate	
ITEM	QUANTITY
6" Service Connection	15 EA
8" SDR-35 PVC Sanitary Sewer	900 LF
10" SDR-35 PVC Sanitary Sewer	N/A
12" SDR-35 PVC Sanitary Sewer	N/A
15" SDR-35 PVC Sanitary Sewer	N/A
18" SDR-35 PVC Sanitary Sewer	N/A
Clean Out	3 EA
Manhole	5 EA
4" PVC Force Main	N/A
6" PVC Force Main	N/A
8" PVC Force Main	N/A
10" PVC Force Main	N/A
12" PVC Force Main	N/A
<b>TOTAL ESTIMATED COST</b>	<b>\$ 46,453</b>

13E

Internal Wastewater Collection System Quantities Estimate	
ITEM	QUANTITY
6" Service Connection	13 EA
8" SDR-35 PVC Sanitary Sewer	800 LF
10" SDR-35 PVC Sanitary Sewer	N/A
12" SDR-35 PVC Sanitary Sewer	N/A
15" SDR-35 PVC Sanitary Sewer	N/A
18" SDR-35 PVC Sanitary Sewer	N/A
Clean Out	N/A
Manhole	2 EA
4" PVC Force Main	N/A
6" PVC Force Main	N/A
8" PVC Force Main	N/A
10" PVC Force Main	N/A
12" PVC Force Main	N/A
<b>TOTAL ESTIMATED COST</b>	<b>\$ 29,082</b>

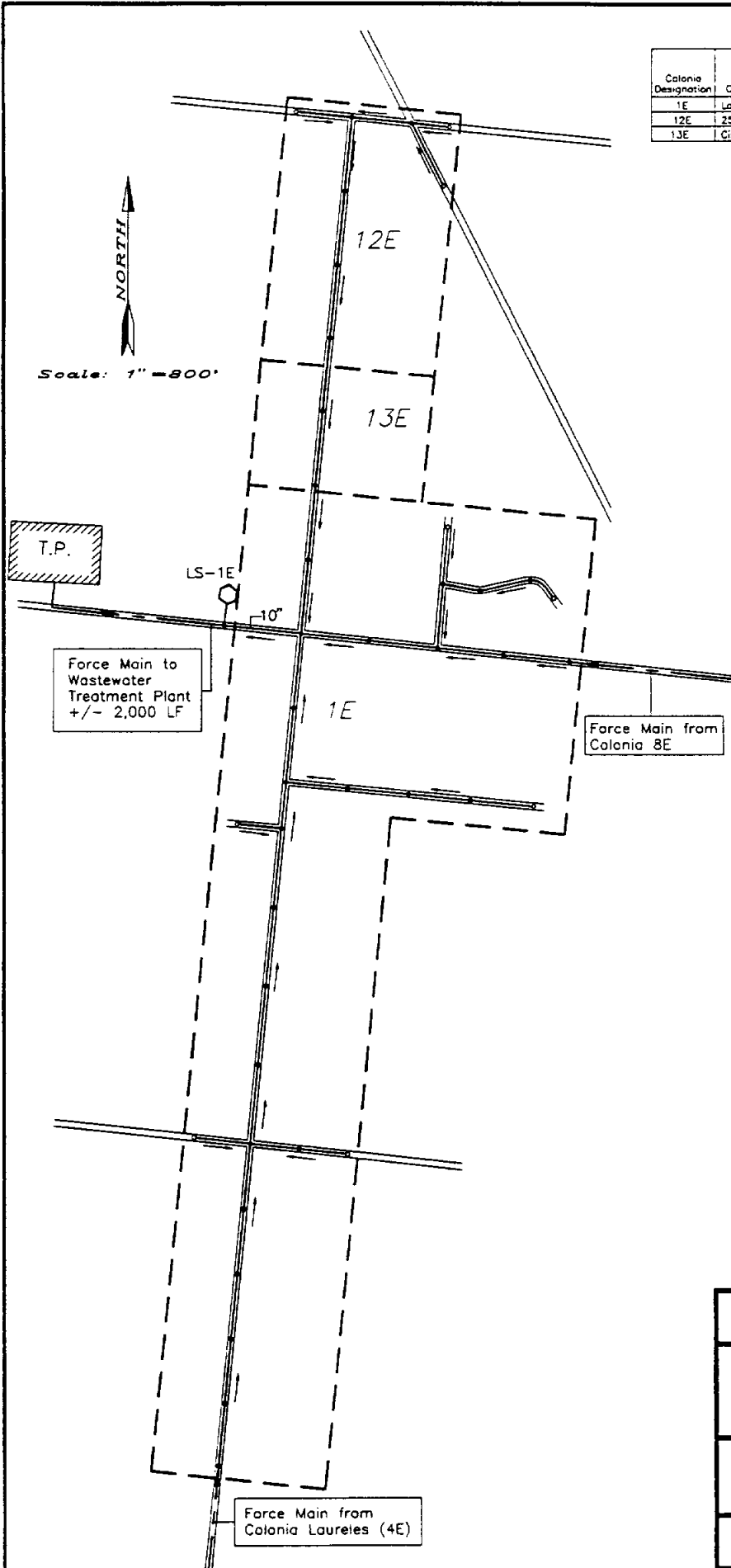

**Cameron County Regional Water and Wastewater Planning Study**

**Figure 5-86  
Site Map of La Coma Del Norte, 25, and  
Cisneros (Limon) (1E, 12E, and 13E)**

**Prepared For:  
Texas Water Development Board  
and Cameron County Water Development Board**

**Prepared By:  
The Water Resources Planning Group**

**August 1990**

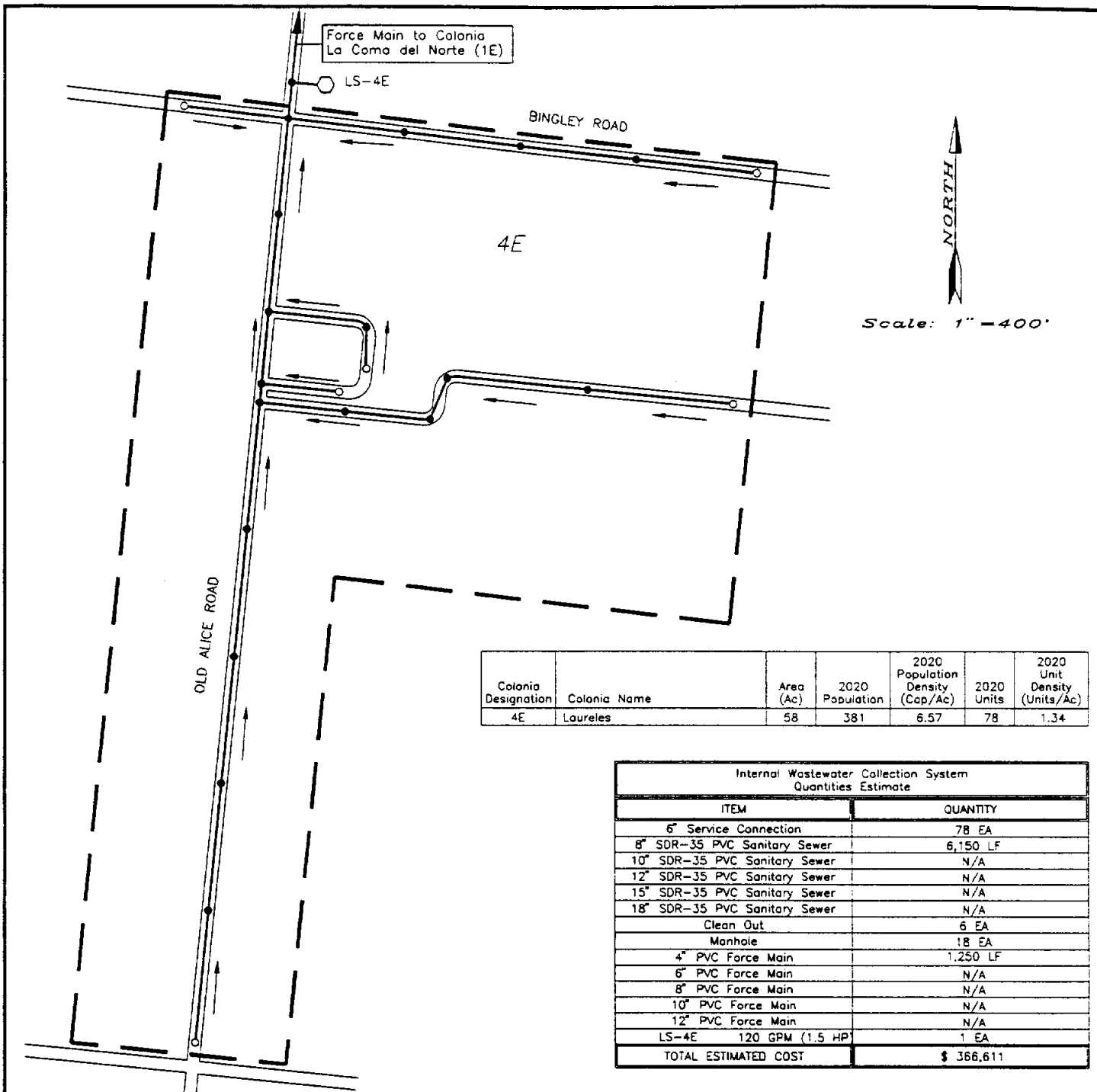

Force Main to Colonia  
La Coma del Norte (1E)

LS-4E

BINGLEY ROAD

4E

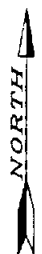

Scale: 1" = 400'

OLD ALICE ROAD

Colonia Designation	Colonia Name	Area (Ac)	2020 Population	2020 Population Density (Cap/Ac)	2020 Units	2020 Unit Density (Units/Ac)
4E	Laureles	58	381	6.57	78	1.34

Internal Wastewater Collection System Quantities Estimate	
ITEM	QUANTITY
6" Service Connection	78 EA
8" SDR-35 PVC Sanitary Sewer	6,150 LF
10" SDR-35 PVC Sanitary Sewer	N/A
12" SDR-35 PVC Sanitary Sewer	N/A
15" SDR-35 PVC Sanitary Sewer	N/A
18" SDR-35 PVC Sanitary Sewer	N/A
Clean Out	6 EA
Manhole	18 EA
4" PVC Force Main	1,250 LF
6" PVC Force Main	N/A
8" PVC Force Main	N/A
10" PVC Force Main	N/A
12" PVC Force Main	N/A
LS-4E 120 GPM (1.5 HP)	1 EA
<b>TOTAL ESTIMATED COST</b>	<b>\$ 366,611</b>

**Cameron County Regional Water and Wastewater  
Planning Study**

**Figure 5-87  
Site Map of Laureles (4E)**

**Prepared For:  
Texas Water Development Board  
and Cameron County Water Development Board**

**Prepared By:  
The Water Resources Planning Group**

**August 1990**

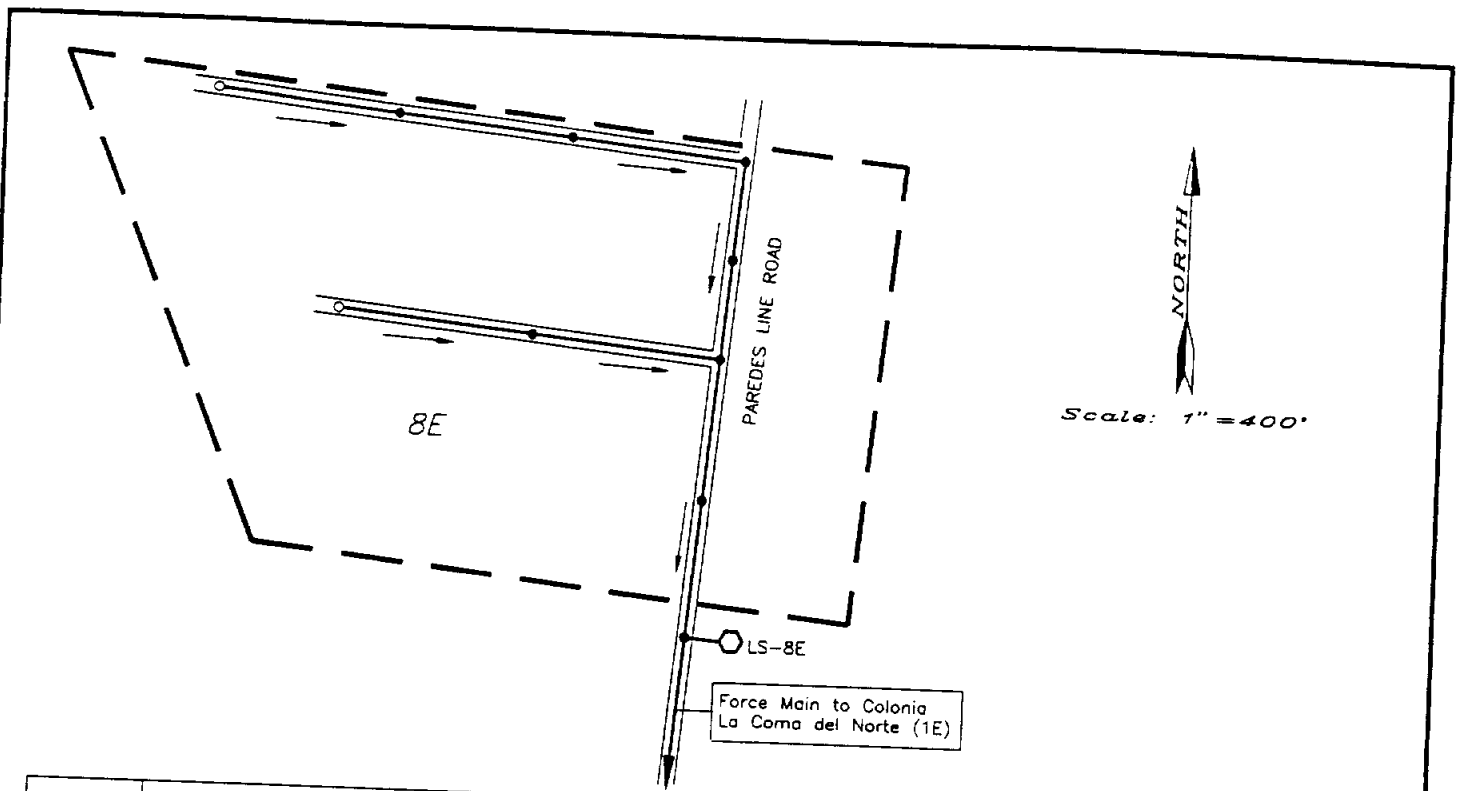

Colonia Designation	Colonia Name	Area (Ac)	2020 Population	2020 Population Density (Cap/Ac)	2020 Units	2020 Unit Density (Units/Ac)
8E	Unknown	16	262	16.38	53	3.31

Internal Wastewater Collection System Quantities Estimate	
ITEM	QUANTITY
6" Service Connection	53 EA
8" SDR-35 PVC Sanitary Sewer	2,850 LF
10" SDR-35 PVC Sanitary Sewer	N/A
12" SDR-35 PVC Sanitary Sewer	N/A
15" SDR-35 PVC Sanitary Sewer	N/A
18" SDR-35 PVC Sanitary Sewer	N/A
Clean Out	2 EA
Manhole	8 EA
3" PVC Force Main	12,000 LF
6" PVC Force Main	N/A
8" PVC Force Main	N/A
10" PVC Force Main	N/A
12" PVC Force Main	N/A
LS-8E 78 GPM (6.5 HP)	1 EA
<b>TOTAL ESTIMATED COST</b>	<b>\$ 439,811</b>

<b>Cameron County Regional Water and Wastewater Planning Study</b>
<b>Figure 5-88 Site Map of Unknown (8E)</b>
<b>Prepared For: Texas Water Development Board and Cameron County Water Development Board</b>
<b>Prepared By: The Water Resources Planning Group</b>
<b>August 1990</b>

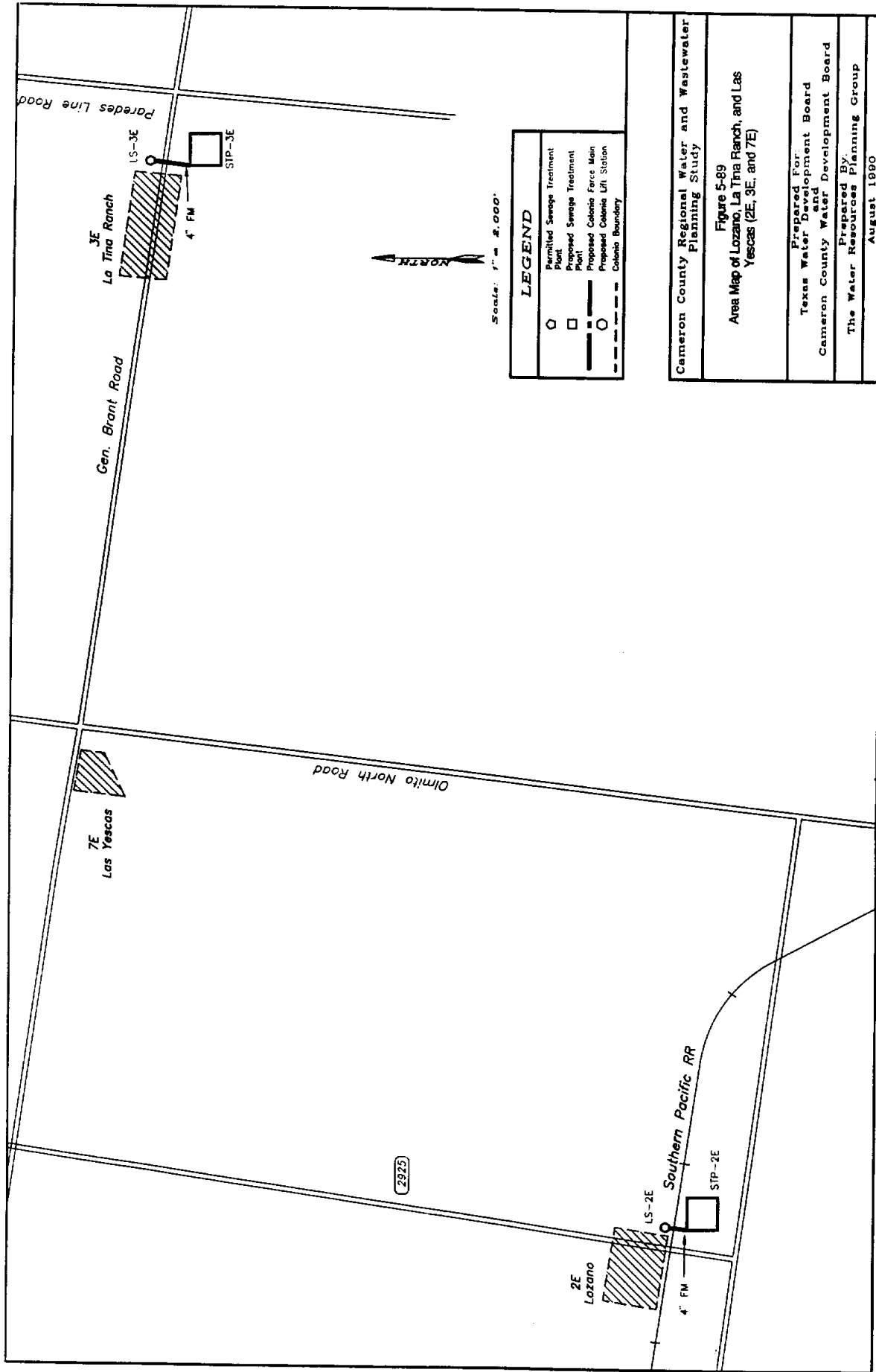

Scale: 1" = 2,000'

**LEGEND**

○	Permitted Sewage Treatment Plant
□	Proposed Sewage Treatment Plant
—	Proposed Colonia Force Main
○	Proposed Colonia Lift Station
- - -	Colonia Boundary

Cameron County Regional Water and Wastewater Planning Study

Figure 5-89  
Area Map of Lozano, La Tina Ranch, and Las Yescas (2E, 3E, and 7E)

Prepared For:  
Texas Water Development Board  
Cameron County Water Development Board

Prepared By:  
The Water Resources Planning Group  
August 1990

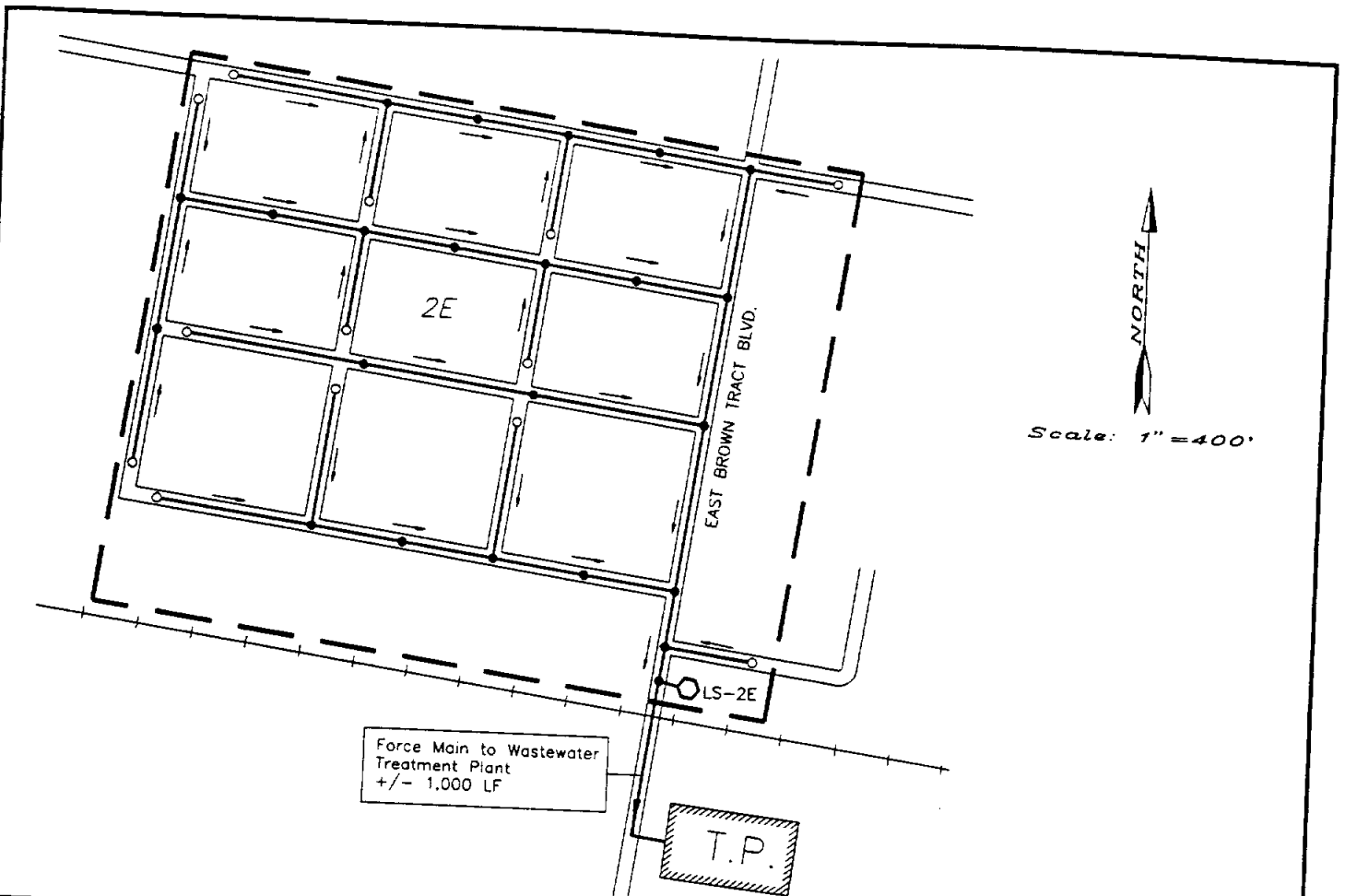

Colonia Designation	Colonia Name	Area (Ac)	2020 Population	2020 Population Density (Cap/Ac)	2020 Units	2020 Unit Density (Units/Ac)
2E	Lozano		680	13.60	139	2.78

Internal Wastewater Collection System Quantities Estimate	
ITEM	QUANTITY
6" Service Connection	139 EA
8" SDR-35 PVC Sanitary Sewer	9,000 LF
10" SDR-35 PVC Sanitary Sewer	N/A
12" SDR-35 PVC Sanitary Sewer	N/A
15" SDR-35 PVC Sanitary Sewer	N/A
18" SDR-35 PVC Sanitary Sewer	N/A
Clean Out	12 EA
Manhole	23 EA
4" PVC Force Main	1,000 LF
6" PVC Force Main	N/A
8" PVC Force Main	N/A
10" PVC Force Main	N/A
12" PVC Force Main	N/A
LS-2E 200 GPM (3.5HP)	1 EA
<b>TOTAL ESTIMATED COST</b>	<b>\$ 566,019</b>

**Cameron County Regional Water and Wastewater Planning Study**

**Figure 5-90  
Site Map of Lozano (2E)**

**Prepared For:  
Texas Water Development Board  
and Cameron County Water Development Board**

**Prepared By:  
The Water Resources Planning Group**

**August 1990**



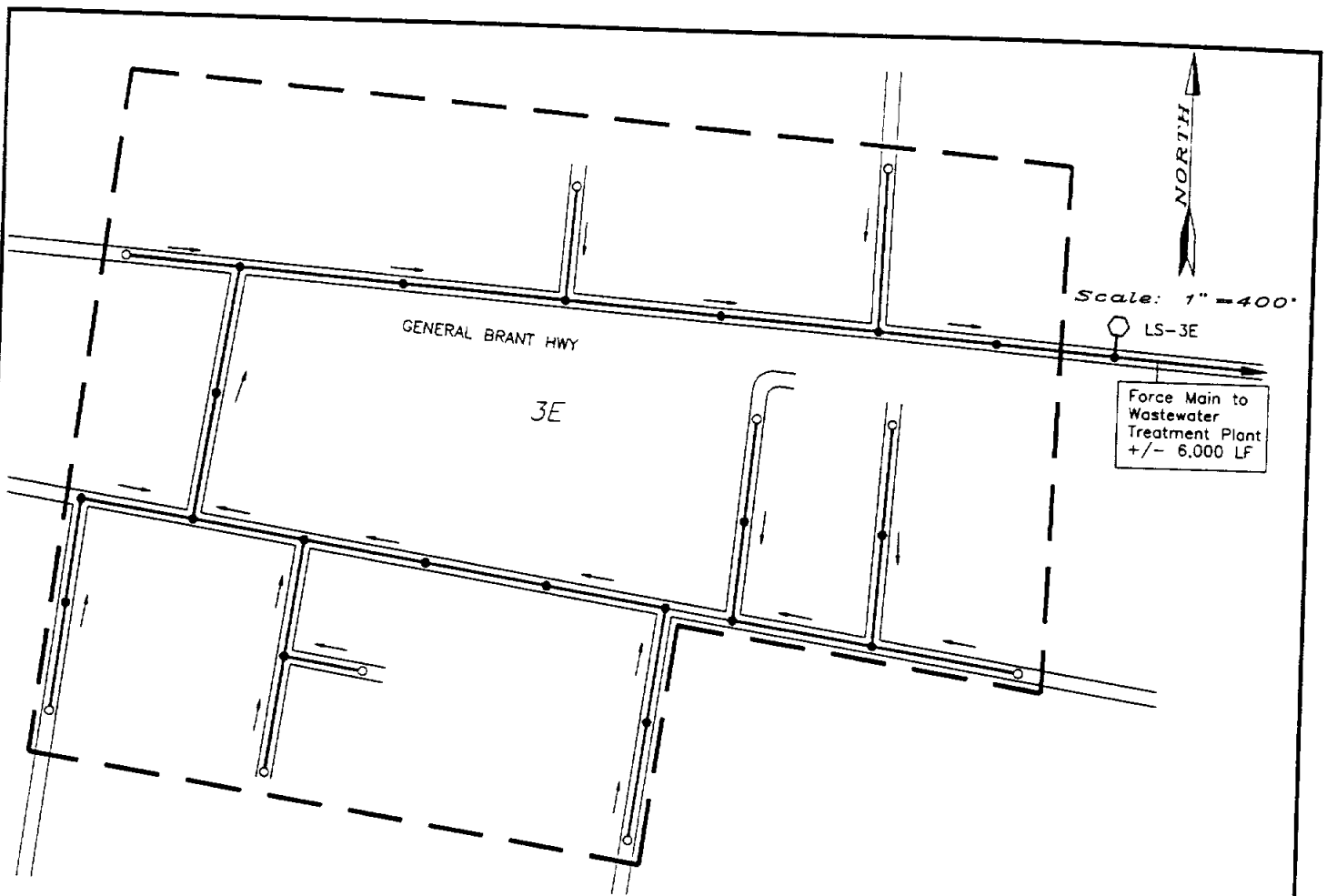

Colonia Designation	Colonia Name	Area (Ac)	2020 Population	2020 Population Density (Cap/Ac)	2020 Units	2020 Unit Density (Units/Ac)
3E	La Tina Ranch	59	662	11.22	135	2.29

Internal Wastewater Collection System Quantities Estimate	
ITEM	QUANTITY
6" Service Connection	135 EA
8" SDR-35 PVC Sanitary Sewer	8,670 LF
10" SDR-35 PVC Sanitary Sewer	N/A
12" SDR-35 PVC Sanitary Sewer	N/A
15" SDR-35 PVC Sanitary Sewer	N/A
18" SDR-35 PVC Sanitary Sewer	N/A
Clean Out	10 EA
Manhole	21 EA
4" PVC Force Main	6,000 LF
6" PVC Force Main	N/A
8" PVC Force Main	N/A
10" PVC Force Main	N/A
12" PVC Force Main	N/A
LS-3E 195 GPM (3.0 HP)	1 EA
<b>TOTAL ESTIMATED COST</b>	<b>\$ 585,266</b>

<b>Cameron County Regional Water and Wastewater Planning Study</b>
<b>Figure 5-91 Site Map of La Tina Ranch (3E)</b>
<b>Prepared For: Texas Water Development Board and Cameron County Water Development Board</b>
<b>Prepared By: The Water Resources Planning Group</b>
<b>August 1990</b>

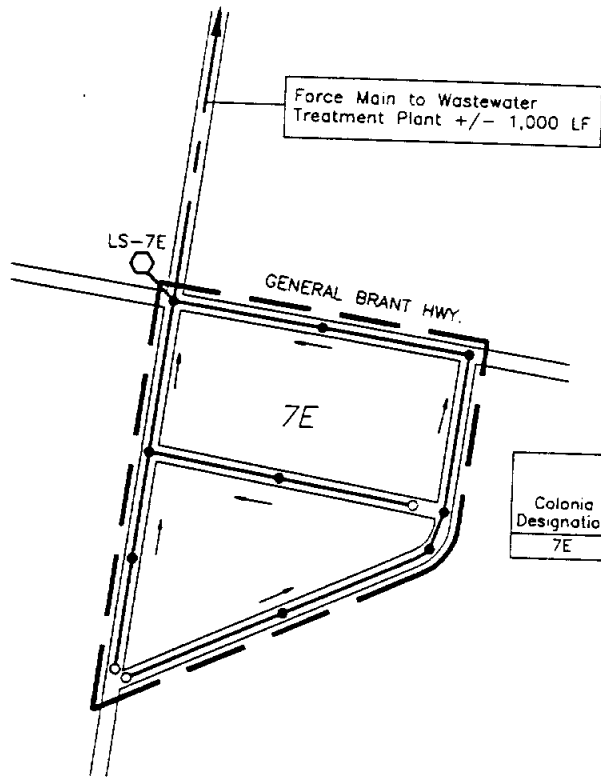

Scale: 1" = 400'

Colonia Designation	Colonia Name	Area (Ac)	2020 Population	2020 Population Density (Cap/Ac)	2020 Units	2020 Unit Density (Units/Ac)
7E	Las Yescas	16	281	17.56	57	3.56

Internal Wastewater Collection System Quantities Estimate	
ITEM	QUANTITY
6" Service Connection	57 EA
8" SDR-35 PVC Sanitary Sewer	3,200 LF
10" SDR-35 PVC Sanitary Sewer	N/A
12" SDR-35 PVC Sanitary Sewer	N/A
15" SDR-35 PVC Sanitary Sewer	N/A
18" SDR-35 PVC Sanitary Sewer	N/A
Clean Out	3 EA
Manhole	9 EA
3" PVC Force Main	1,000 LF
6" PVC Force Main	N/A
8" PVC Force Main	N/A
10" PVC Force Main	N/A
12" PVC Force Main	N/A
LS-7E 85 GPM (1.5 HP)	1 EA
<b>TOTAL ESTIMATED COST</b>	<b>\$ 261,333</b>

**Cameron County Regional Water and Wastewater Planning Study**

**Figure 5-92  
Site Map of Las Yescas (7E)**

**Prepared For:  
Texas Water Development Board  
and Cameron County Water Development Board**

**Prepared By:  
The Water Resources Planning Group**

**August 1990**

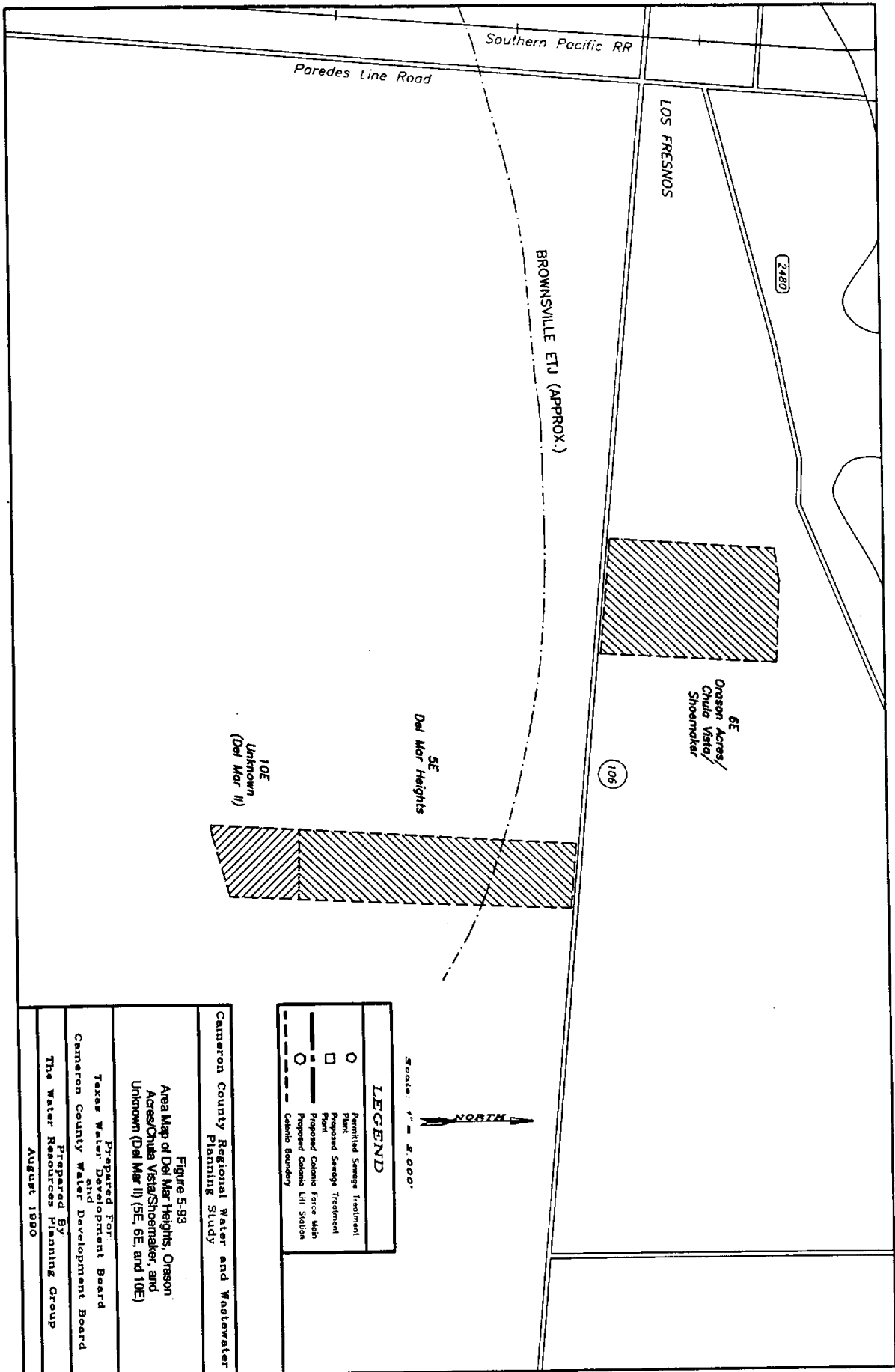

Scale: 1" = 5,000'

**LEGEND**

○	Permitted Sewage Treatment Plant
□	Proposed Sewage Treatment Plant
—	Proposed Colonia Force Main
○	Proposed Colonia Lift Station
- - -	County Boundary

Cameron County Regional Water and Wastewater Planning Study

Figure 5-93  
 Area Map of Del Mar Heights, Orson Acres/Chula Vista/Shoemaker, and Unknown (Del Mar II) (5E, 6E, and 10E)

Prepared For:  
 Texas Water Development Board  
 Cameron County Water Development Board

Prepared By:  
 The Water Resources Planning Group  
 August 1990

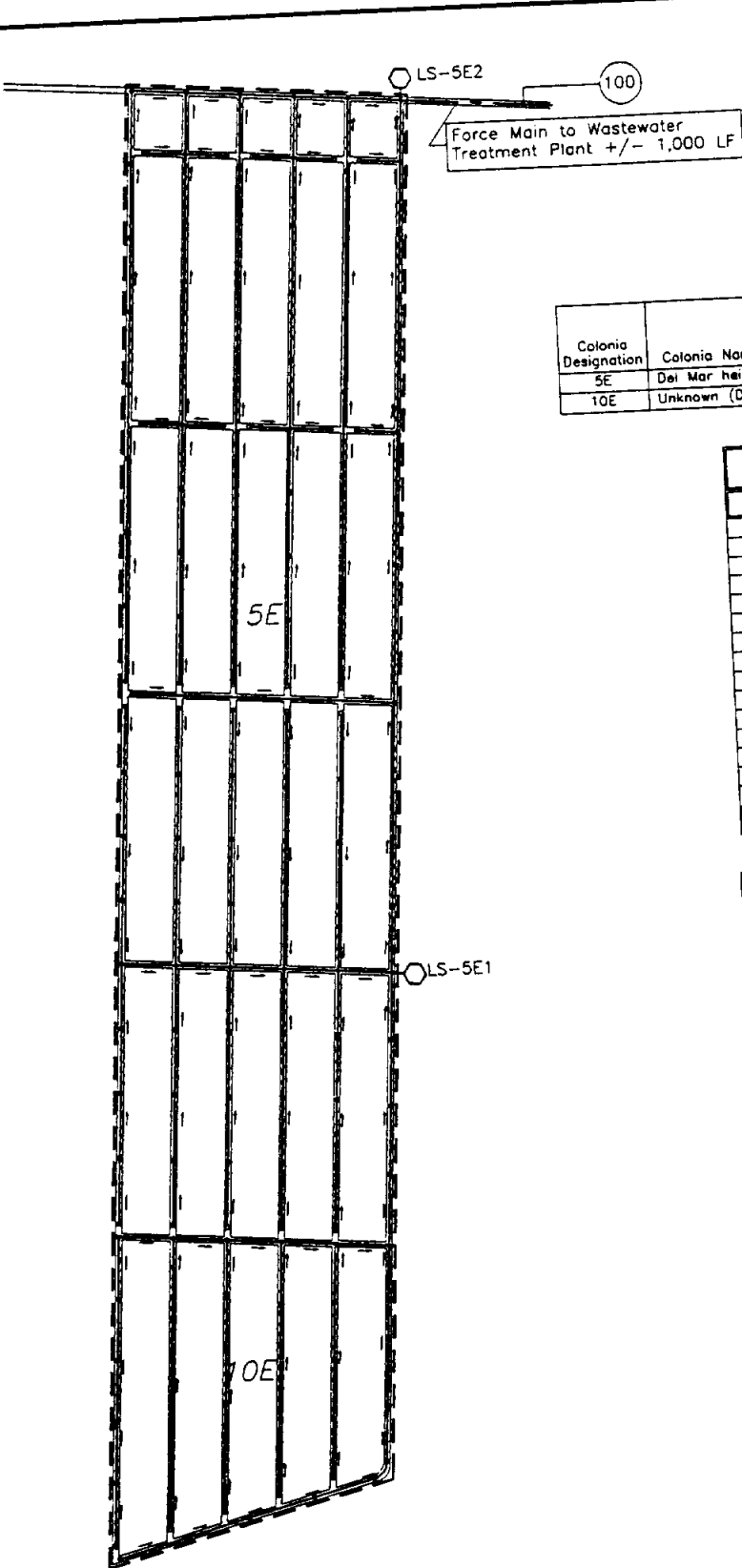

Colonia Designation	Colonia Name	Area (Ac)	2020 Population	2020 Population Density (Cap/Ac)	2020 Units	2020 Unit Density (Units/Ac)
5E	Del Mar heights	206	483	2.34	99	0.48
10E	Unknown (Del Mar II)	62	290	4.68	59	0.95

5E

Internal Wastewater Collection System Quantities Estimate	
ITEM	QUANTITY
6" Service Connection	99 EA
8" SDR-35 PVC Sanitary Sewer	43,650 LF
10" SDR-35 PVC Sanitary Sewer	N/A
12" SDR-35 PVC Sanitary Sewer	N/A
15" SDR-35 PVC Sanitary Sewer	N/A
18" SDR-35 PVC Sanitary Sewer	N/A
Clean Out	26 EA
Manhole	97 EA
4" PVC Force Main	150 LF
6" PVC Force Main	1,000 LF
8" PVC Force Main	N/A
10" PVC Force Main	N/A
12" PVC Force Main	N/A
LS-5E1 115 GPM (1.0 HP)	1 EA
LS-5E2 230 GPM (2.0 HP)	1 EA
<b>TOTAL ESTIMATED COST</b>	<b>\$ 1,658,105</b>

10E

Internal Wastewater Collection System Quantities Estimate	
ITEM	QUANTITY
6" Service Connection	59 EA
8" SDR-35 PVC Sanitary Sewer	11,350 LF
10" SDR-35 PVC Sanitary Sewer	N/A
12" SDR-35 PVC Sanitary Sewer	N/A
15" SDR-35 PVC Sanitary Sewer	N/A
18" SDR-35 PVC Sanitary Sewer	N/A
Clean Out	6 EA
Manhole	32 EA
4" PVC Force Main	N/A
6" PVC Force Main	N/A
8" PVC Force Main	N/A
10" PVC Force Main	N/A
12" PVC Force Main	N/A
<b>TOTAL ESTIMATED COST</b>	<b>\$ 415,451</b>

**Cameron County Regional Water and Wastewater Planning Study**

Figure 5-94  
 Site Map of Del Mar Heights and Unknown (Del Mar II) (5E and 10E)

Prepared For:  
 Texas Water Development Board  
 and Cameron County Water Development Board

Prepared By:  
 The Water Resources Planning Group

August 1990

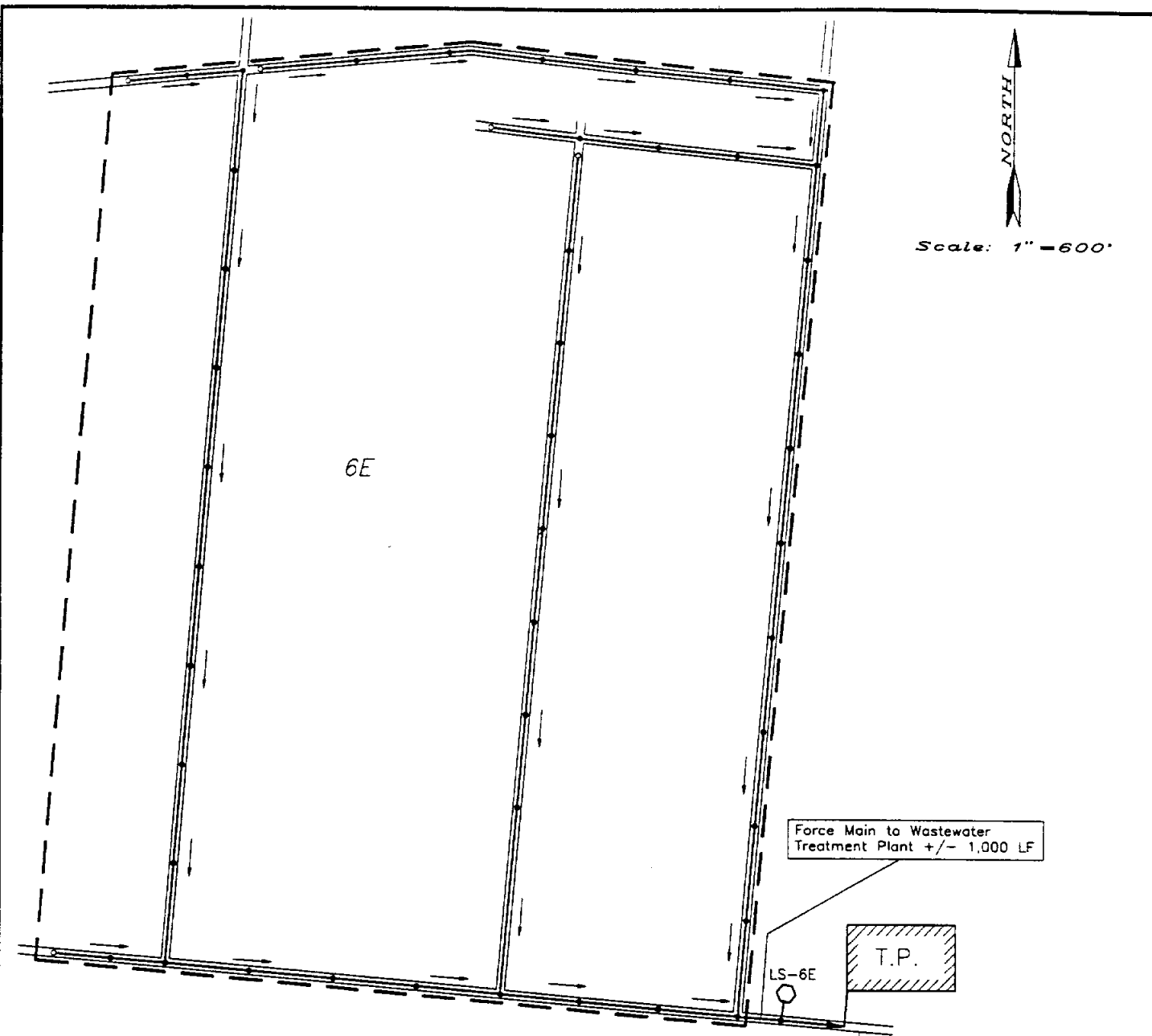

Colonia Designation	Colonia Name	Area (Ac)	2020 Population	2020 Population Density (Cap/Ac)	2020 Units	2020 Unit Density (Units/Ac)
6E	Orason/ChulaVista/Shoemaker	211	464	2.20	95	0.45

Internal Wastewater Collection System Quantities Estimate	
ITEM	QUANTITY
6" Service Connection	95 EA
8" SDR-35 PVC Sanitary Sewer	17,110 LF
10" SDR-35 PVC Sanitary Sewer	N/A
12" SDR-35 PVC Sanitary Sewer	N/A
15" SDR-35 PVC Sanitary Sewer	N/A
18" SDR-35 PVC Sanitary Sewer	N/A
Clean Out	5 EA
Manhole	45 EA
4" PVC Force Main	1,000 LF
6" PVC Force Main	N/A
8" PVC Force Main	N/A
10" PVC Force Main	N/A
12" PVC Force Main	N/A
LS-6E 140 GPM (1.7HP)	1 EA
<b>TOTAL ESTIMATED COST</b>	<b>\$ 750,817</b>

**Cameron County Regional Water and Wastewater Planning Study**  
**Figure 5-95**  
**Site Map of Orason Acres/Chula Vista/Shoemaker (6E)**  
**Prepared For:**  
**Texas Water Development Board**  
**and Cameron County Water Development Board**  
**Prepared By:**  
**The Water Resources Planning Group**  
**August 1990**

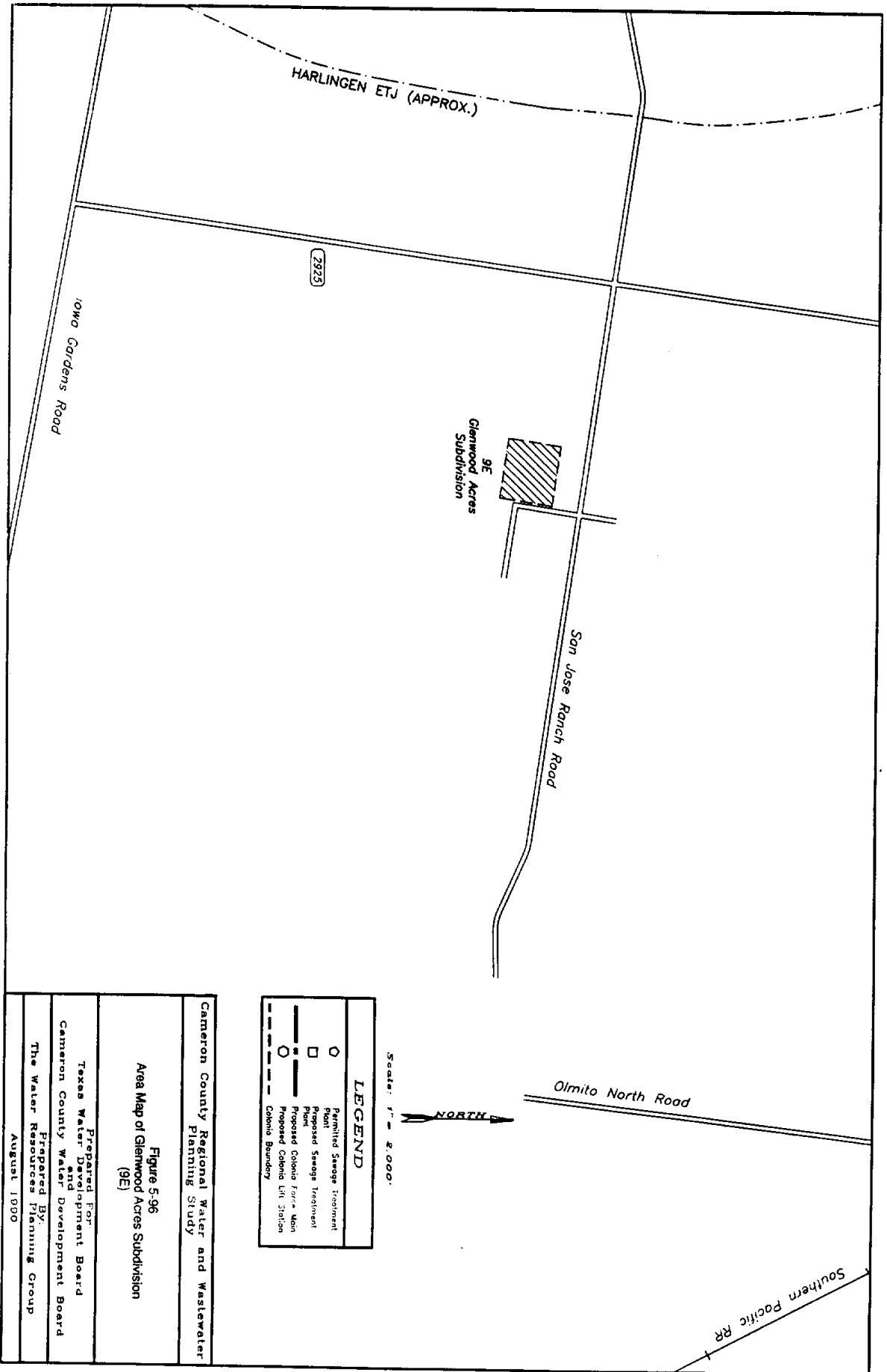

Scale: 1" = 2,000'

**LEGEND**

○	Permitted Sewage Treatment Plant
□	Proposed Sewage Treatment Plant
—	Proposed Colonia Fortuna
○	Proposed Colonia Life Station
- - -	Colonia Boundary

Cameron County Regional Water and Wastewater Planning Study

**Figure 5-96**  
Area Map of Glenwood Acres Subdivision (9E)

Prepared For  
Texas Water Development Board  
Cameron County Water Development Board

Prepared By  
The Water Resources Planning Group  
August 1990

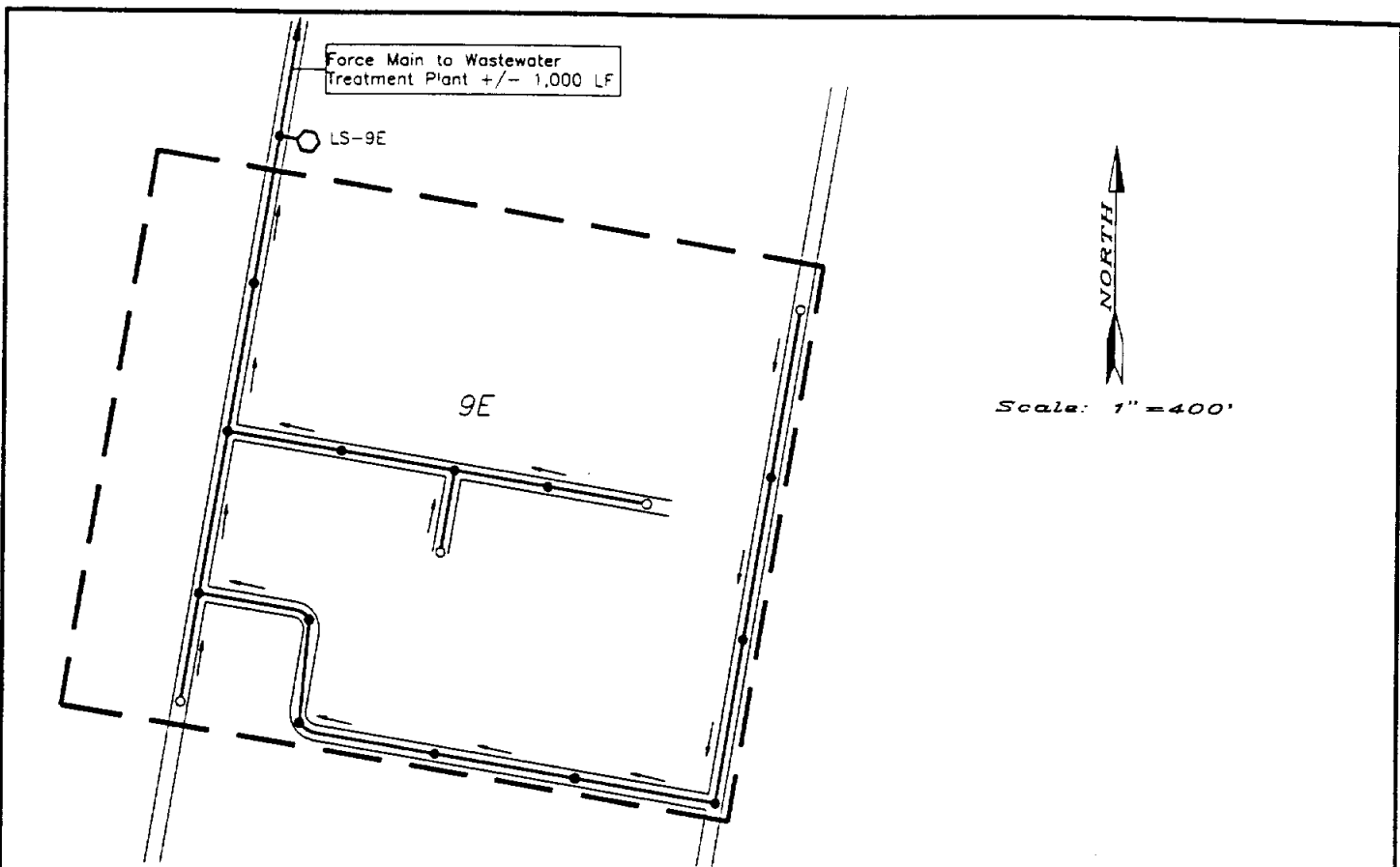

Colonia Designation	Colonia Name	Area (Ac)	2020 Population	2020 Population Density (Cap/Ac)	2020 Units	2020 Unit Density (Units/Ac)
9E	Glenwood Acres Subdivision	32	218	6.81	45	1.41

Internal Wastewater Collection System Quantities Estimate	
ITEM	QUANTITY
6" Service Connection	45 EA
8" SDR-35 PVC Sanitary Sewer	4,750 LF
10" SDR-35 PVC Sanitary Sewer	N/A
12" SDR-35 PVC Sanitary Sewer	N/A
15" SDR-35 PVC Sanitary Sewer	N/A
18" SDR-35 PVC Sanitary Sewer	N/A
Clean Out	4 EA
Manhole	14 EA
3" PVC Main Force	1,000 LF
6" PVC Force Main	N/A
8" PVC Force Main	N/A
10" PVC Force Main	N/A
12" PVC Force Main	N/A
LS-9E 65 GPM (1.0 HP)	1 EA
<b>TOTAL ESTIMATED COST</b>	<b>\$ 265,995</b>

**Cameron County Regional Water and Wastewater Planning Study**

**Figure 5-97**  
**Site Map of Glenwood Acres Subdivision (9E)**

**Prepared For:**  
**Texas Water Development Board**  
**and Cameron County Water Development Board**

**Prepared By:**  
**The Water Resources Planning Group**

**August 1990**

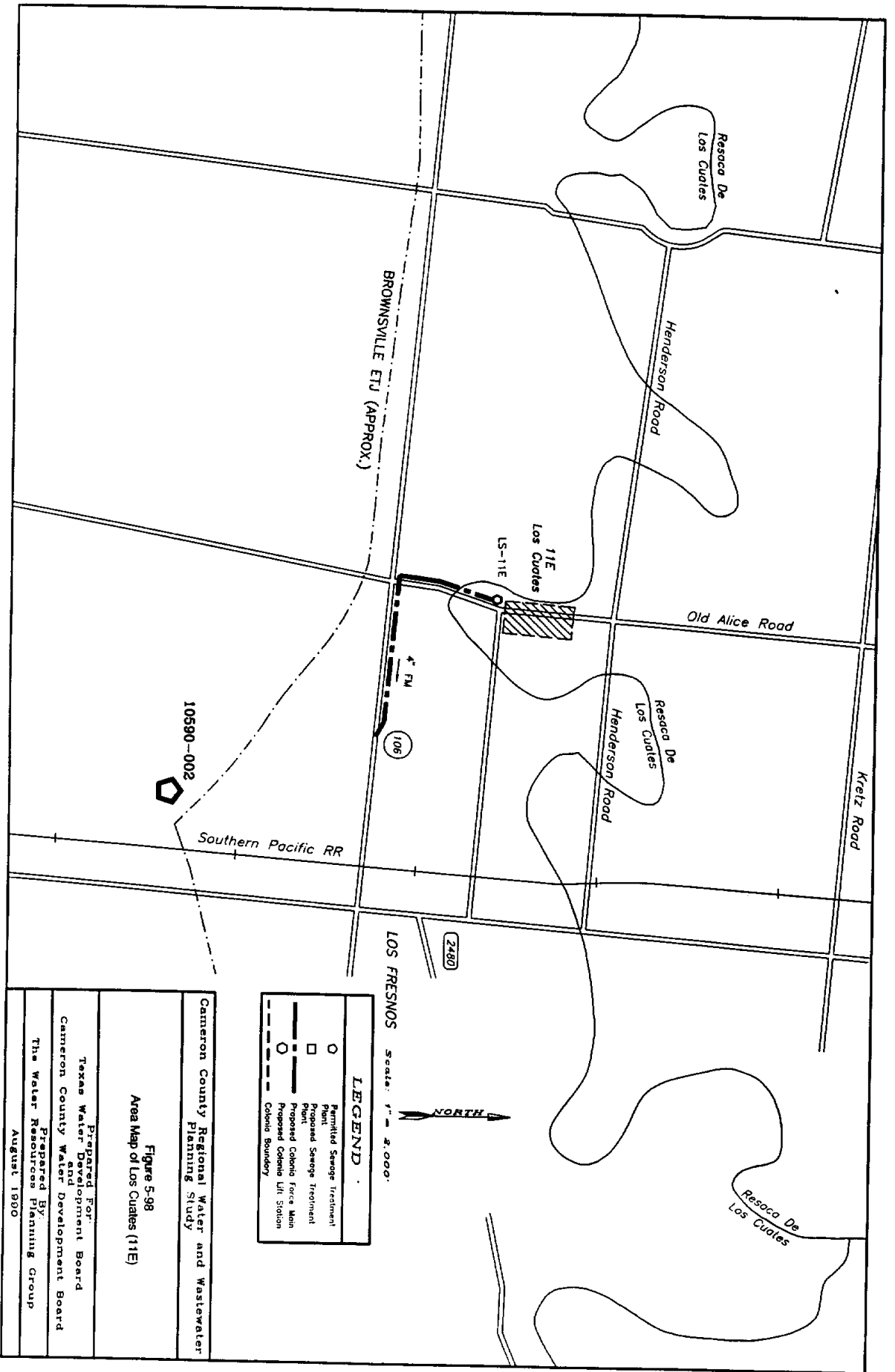
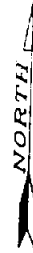

Figure 5-98  
Area Map of Los Cuates (11E)

Gamernon County Regional Water and Wastewater Planning Study
Prepared For: Texas Water Development Board Cameron County Water Development Board
Prepared By: The Water Resources Planning Group
August 1980





Scale: 1" = 400'

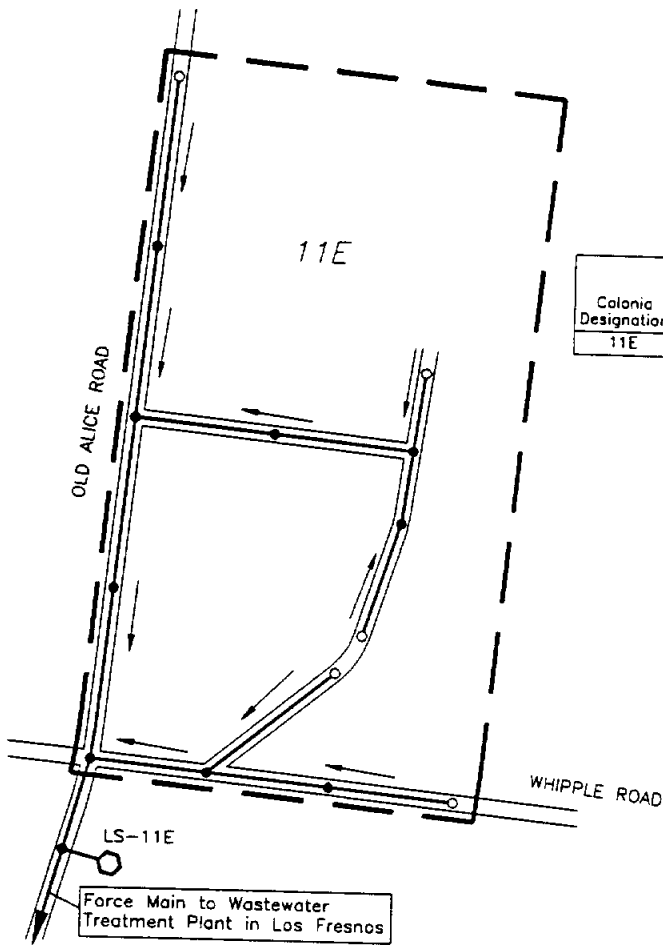

Colonia Designation	Colonia Name	Area (Ac)	2020 Population	2020 Population Density (Cap/Ac)	2020 Units	2020 Unit Density (Units/Ac)
11E	Los Cuates	22	261	11.86	53	2.41

Internal Wastewater Collection System Quantities Estimate	
ITEM	QUANTITY
6" Service Connection	53 EA
8" SDR-35 PVC Sanitary Sewer	3,750 LF
10" SDR-35 PVC Sanitary Sewer	N/A
12" SDR-35 PVC Sanitary Sewer	N/A
15" SDR-35 PVC Sanitary Sewer	N/A
18" SDR-35 PVC Sanitary Sewer	N/A
Clean Out	5 EA
Manhole	10 EA
4" PVC Force Main	14,000 LF
6" PVC Force Main	N/A
8" PVC Force Main	N/A
10" PVC Force Main	N/A
12" PVC Force Main	N/A
LS-11E 80 GPM (2.5 HP)	1 EA
<b>TOTAL ESTIMATED COST</b>	<b>\$ 439,666</b>

**Cameron County Regional Water and Wastewater Planning Study**

**Figure 5-99  
Site Map of Los Cuates (11E)**

**Prepared For:  
Texas Water Development Board  
and Cameron County Water Development Board**

**Prepared By:  
The Water Resources Planning Group**

**August 1990**

## **6.0 WATER CONSERVATION AND DROUGHT MANAGEMENT PLAN**

### **6.1 Introduction**

#### **6.1.1 Planning Area and Project**

The service area of this study is the unincorporated areas of Cameron County. And the incorporated area with the City of Brownsville; however, the majority of the unincorporated area population is grouped into relatively small communities. With the exception of the City of Brownsville, many of these communities are either not served or underserved by a centralized water supply system and virtually none are served by a centralized wastewater collection and treatment system. Therefore, many of the conventional water conservation measures normally applied in urban or other rural areas are not directly applicable except within Brownsville.

An objective of the study was to determine the availability and adequacy of current and future treated water supplies and wastewater options available to rural customers of Cameron County, as well as, wastewater collection and treatment options when water becomes more available, the impetus to conserve generally weakens and wasteful consumption increases. Thus it is imperative that a comprehensive water conservation program be adopted from the beginning and rigorously enforced to minimized capital and operation and maintenance costs for both water and wastewater services.

#### **6.1.2 Need for and Goals of Program**

The Texas Water Development Board has promulgated Financial Assistance Rules which require water conservation planning for any entity receiving financial assistance from the TWDB. These planning requirements are designed to encourage cost-effective regional water supply and wastewater treatment facility development. On November 5th, 1985, Texas voters approved an amendment to the Texas Constitution that provided for the implementation of HB 2. Previous to this study, the CCWB has not developed a comprehensive plan for water conservation or drought contingency management of available supplies. This document provides specific guidelines for developing a water conservation and drought management program that will meet the regulatory requirements of the TWDB for the CCWB Planning Area.

Since the early 1960s, per capita water use in the state has increased approximately four gallons per capita per decade. More important, per capita water use during droughts is typically about one third greater than during periods of average precipitation. Thus, the goals of the program are to reduce overall water usage through water conservation practices and to provide for a reduction in water usage during times of shortage.

Water use in the residential and commercial sectors involves day-to-day activities of all citizens of the state, and includes drinking, bathing, cooking, toilet flushing, fire protection, lawn watering, swimming pools, laundry, dishwashing, car washing and sanitation. In addition, rural areas, served by the CCWB member WSCs, carry the additional demands of supporting small-scale private livestock production and the, often not-so-small, family garden. The objective of a conservation program is to reduce the quantity of water required for each of these activities, where practical, through implementation of efficient water use practices. The drought contingency program provides procedures for both voluntary and mandatory actions placed in effect to temporarily reduce usage demand during a water shortage crisis. Drought contingency procedures include water conservation and prohibition of certain uses. Both are tools that CCWB member WSC managers and officials will have available to them in order to effectively operate in all situations.

The water conservation plan outlined herein has the overall objective of reducing water consumption in the CCWB service area. Implementation of this plan will also reduce the amount of wastewater needing treatment and disposal. Although the impetus for this report is regional planning for water supply needs, it focuses on measures that specifically reduce the amount of water used and, ultimately, on the amount of wastewater produced. Such measures will have the effect of extending the time until additional water and wastewater treatment capacity must be provided.

Various cities throughout the country have adopted water conservation techniques and technologies depending upon the severity of their water supply situation. In particular, California has taken significant steps to reduce water consumption, and here in Texas, Austin has an aggressive water conservation program. Drawing on the experiences of some of these cities, some assumptions about the feasibility, cost and effectiveness of specific measures can be made. For the purpose of reducing the quantities of water required, two of the measures outlined below deserve particular attention: adopting vigorous plumbing codes for new construction and retrofitting.

According to figures developed in Section 3.0, between 1990 and 2020, the population of the study area is expected to at least double. Under drought conditions, when consumption is typically at its highest, and without implementation of water conservation measures, a doubling of the population would increase demand from its current 5,200 AF/yr to over 13,500 AF/yr (TDWR, 1989). With such high rates of growth, it is evident that the greatest savings in water usage can be realized by adopting stringent plumbing codes for new construction. Nationwide it is being realized that the marginal cost of supplying new water sources and water and wastewater treatment facilities is so high, that new plumbing codes that reduce water usage by 25-30 percent are the most economical solution. However, because water use in rural areas are less weighted toward domestic functions, lesser reductions on the order of 10-15% can be expected.

Existing facilities can also be retrofitted in order to reduce water consumption. Although this may involve some capital outlay, all of the measures are cost-effective, and various schemes have been devised to recover the costs. For instance, a plan for San Antonio assumes that a 2 percent increase in water and wastewater rates for 5 years would raise enough money to cover a \$100 rebate for each customer retrofitting a toilet to flush on 1.5 gallons (resulting in an overall savings on the customer's water and wastewater bill). An aggressive retrofit program can result in water savings of 15-25 percent per residence. With market penetration typically running at 20-50 percent, this would result in an overall water consumption savings of around 5 percent. In its water conservation program, the City of Austin estimates a 6.7 percent savings within 5 years. This program consists of substituting low-flow shower heads, installing toilet dams and checking for leaks. The benefit/cost ratio is estimated at more than ten, with an average savings to the customer of \$52/year from reductions in water, wastewater and electricity.

In Figure 6-1, drought condition water demands through the year 2020 for the entire CCWB service area is shown without implementation of water conservation measures. Also shown are the flows that would result from the adoption of the two measures outlined above. Overall savings in wastewater flows by 2020 are approximately 15% or approximately 2,000 AF/yr. This estimate is based on the following assumptions:

- adoption of a code that would reduce water consumption in all new construction from the current rural area statewide average of 140-160 gcd to 125 gcd;
- this code would be phased in during the 1990s and early 2000s ( a net water savings of 2% by 1995; 5% by 2000; 7-1/2% by 2005; 10% by 2010; and 12-1/2% by 2015 and 15% by 2020);
- existing uses could be reduced by 5 percent through retrofitting and other conservation measures.

These savings in water demand can be related directly to savings in water supply procurement, treatment and distributions costs as well as wastewater disposal costs. By reducing average daily demand and peak 2 hour demands by as much as 15% percent, water treatment and distribution system requirements will be commensurably reduced by 15% percent. Operation and maintenance costs to the water system infrastructure will be lower because of lower chemical requirements, reduced pumping requirements, and appropriate pump station and line sizing. Design of urban water treatment and distribution systems are influenced more by fire protection requirements than average daily per capita water usage. Rural fire protection demands are less stringent; the Fire Protection Bureau requires a minimum flow rate of 500 gpm. Thus, the impacts of water conservation are not diminished by fire protection requirements.

The drought contingency program includes those measures that can cause the CCWB to significantly reduce water use on a temporary basis. These measures involve voluntary reductions, restrictions and/or elimination of certain types of water use and water rationing. Because the onset of an emergency condition is often rapid, it is important that the CCWB be prepared in advance. Further, the citizen or customer

must know that certain measures not used in the water conservation program may be necessary if a drought or other emergency condition occurs.

## 6.2 Long-term Water Conservation

### 6.2.1 Plan Elements

Nine principal water conservation methods are delineated as part of the proposed water conservation plan.

#### Education and Information

The CCWB will promote water conservation by informing water users about ways to save water inside of homes and other buildings, in landscaping and lawn maintenance, and in recreational uses. Information will be distributed to water users as follows:

#### Initial Year:

- The initial year shall include the distribution of educational materials outlined in the Maintenance Program section.
- Distribution of a fact sheet explaining the newly-adopted Water Conservation Program and the elements of the Drought Contingency Plan. The initial fact sheet shall be included with the first distribution of educational material.
- In addition to activities scheduled in the Maintenance Program, an outline of the program and its benefits shall be distributed either through the mail or as a door-to-door hand-out.

#### Maintenance Program:

- Distribution of educational materials will be made semi-annually, timed to correspond with peak summer demand periods. Such material will incorporate information available from the American Water Works Association (AWWA), Texas Water Development Board (TWDB) and other similar associations in order to expand the scope of this project. A wide range of materials may be obtained from:

Texas Water Development Board  
P.O. Box 13231, Capitol Station  
Austin, Texas 78711-3231

- New customers will be provided with a similar package of information as that developed for the initial year, namely, educational material, a fact sheet explaining both the Water Conservation Pro-

gram and the elements of the Drought Contingency Plan, and a copy of "Water Saving Methods that can be Practiced by the Individual Water User."

### Plumbing Codes

Each of the CCWB member WSCs currently adhere to and enforce independent plumbing code for their respective service areas. These Codes have been in effect for several years. During the 1990s a more stringent unified CCWB Plumbing Code, modeled after the Massachusetts Code, will be adopted for all new construction and remodelled structures. The most significant components under consideration are:

- showers used for other than safety reasons shall be equipped with approved flow control devices to limit total flow to a maximum of 3 gallons per minute (gpm);
- toilets shall use a maximum of 1.6 gallons per flush;
- urinals shall use a maximum of 1.5 gallons per flush.

### Retrofit Program

The CCWB will make available, through its education and information programs, pertinent information for the purchase and installation of plumbing fixtures, lawn watering equipment and appliances. The advertising program will inform existing users of the advantages of installing water saving devices. The CCWB will contact local plumbing and hardware stores and encourage them to stock water conserving fixtures, including retrofit devices.

In addition, the CCWB will embark upon an aggressive retrofit program. Several alternatives are summarized in Table 6-1. Market penetration is based on the experience of other cities offering such programs. Savings are calculated on the basis of 4.9 persons per household for year 2020, a total of 26,651 residences in the Facility Planning Area.

The least cost alternative is to deliver two packages/house containing two flow restrictors, a plastic restrictor for a shower head, a toilet bag and two dye tablets. Based on past experience, the toilet bags are the most acceptable to customers and could be expected to realize savings of 4.8 gpd in participating households. A more acceptable and more permanent option is to provide customers with low-flow shower heads and toilet dams. Because of the greater costs associated with providing these items, vouchers would be included in the water bill to be exchanged at convenient locations for each water supply system. It is assumed that most of the equipment claimed through this mechanism would be installed. Another more fool-proof system, used extensively in the City of Austin, involves the installation of low-flow shower heads and toilet dams at no charge to the customer. In Austin, market penetration has exceeded 50 percent and in participating household has resulted in water savings of around 15 percent of household

usage. A fourth option is to provide rebates of \$100 to customers who replace their toilets with those that use on 1.5 gallons per flush.

**Table 6-1  
 Expected Savings Through Implementation  
 of a Water Use Retrofit Program**

Action	Cost Per House <sup>a/</sup>	Savings Per House <sup>b/</sup>	Penetration <sup>c/</sup>	Total Savings <sup>d/</sup>	Total Cost <sup>e/</sup>	Cost Per gpd <sup>f/</sup>
Distribution of Water Savings Kits <sup>g/</sup>	\$0.50	28.9 gpd	50%	120,643 gpd	\$2,087	\$0.017
Vouchers for Shower Heads and Toilet Dams <sup>h/</sup>	\$4.00	55.7 gpd	20%	93,000 gpd	\$6,679	\$0.072
Installation of Shower Heads and Toilet Dams <sup>i/</sup>	\$10.00	56.7 gpd	50%	236,694 gpd	\$41,745	\$0.176
Refund for Replacing Toilets <sup>j/</sup>	\$100.00	66.7 gpd	10%	55,694 gpd	\$83,490	\$1.499

- <sup>a/</sup> Assumes one bathroom per single-family residence.
- <sup>b/</sup> Based on 125 gpd and 4.90 persons per residence.
- <sup>c/</sup> Percentage of residences participating fully in the program.
- <sup>d/</sup> Based on current 8,349 residences in CCWDB Colonia Study Area.
- <sup>e/</sup> Total Program implementation cost.
- <sup>f/</sup> Cost per gpd saved.
- <sup>g/</sup> Assumes free distribution to all services area residences @ one kit per residence.
- <sup>h/</sup> Assumes participant retrieval of kits @ one kit per residence.
- <sup>i/</sup> Assumes installation by private contractors.
- <sup>j/</sup> Assumes \$100 per toilet.

**Water Rate Structure**

The PUB uses a uniform rate structure for all residential users. That is to say that consumers pay the same unit rate for water regardless of usage. The PUB, however, charges for only 80% of the first 10,000 gal per month; thus, effectively operating as an inclining block rate system.

**Universal Metering**

All water users, including utility and public facilities are currently metered. Also, master meters are installed and periodically calibrated at all existing water sources. All new construction, including multi-family dwellings, are separately metered. The program of universal metering will continue, and is made part of the Water Conservation Plan.

The CCWB, through their computer billing system, currently monitors water consumption and inspects meters that vary from previously established norms. In addition, the CCWB could operate under the following meter maintenance and replacement programs:

<u>Meter Type</u>	<u>Test and Replacement Period</u>
Master meter	Annually
Larger than 1 inch	Annually
1-inch and less	Every 5 years

Through a successful meter maintenance program, coupled with computerized billing and leak detection programs, the CCWB will be able to maintain water delivery rates, from production to consumer, in the 85 percentile range.

#### Water Conservation Landscaping

In order to reduce the demands placed on the water system by landscape, livestock and garden watering, the CCWB, through its information and education program, will encourage customers and local landscaping companies to utilize water saving practices during installation of landscaping, gardens and stock watering facilities for residential and commercial institutions. The following methods will be promoted by the education and information program:

- Encourage subdivisions to require drought-resistant grasses and plants that require less water.
- Initiate a program to encourage the adoption of xeriscaping.
- Encourage landscape architects to use drought-resistant plants and grasses; and efficient irrigation systems.
- Encourage licensed irrigation contractors to use drip irrigation systems, when possible, and to design all irrigation systems with conservation features such as sprinklers that emit large drops rather than a fine mist and a sprinkler layout that accommodates prevailing wind patterns.
- Encourage commercial establishments to use drip irrigation for landscape watering, when practical, and to install only ornamental fountains that use minimal quantities of water, including recycling features.
- Encourage local nurseries to offer adapted, drought-resistant plants and grasses and efficient watering devices.

#### Leak Detection and Repair

The CCWB and its member WSCs will utilize modern leak detection techniques, including listening devices, in locating and reducing leaks. Through their respective billing program, each WSC will identify excessive usage and take steps to determine whether it is a result of leakage. Once located, all leaks will be immediately repaired. A continuous leak detection and repair program is vital to the WSC's profitability. The CCWB is confident that the program more than pays for itself.



### Recycle and Reuse

The CCWB does not own or operate any conventional wastewater treatment facilities. Nearly all CCWB customers utilize some sort of on-site wastewater treatment and disposal method. However, the CCWB will make available to its customers, information on on-site reuse of non-sewage wastewater.

### 6.3 Implementation/Enforcement

The staff of the CCWB will administer the Water Conservation Program. They will oversee the execution and implementation of all elements of the program and supervise the keeping of adequate records for program verification.

The plan will be enforced through the adoption of the Water Conservation Plan by each of the CCWB member or water supplier in the following manner:

- Water service taps will not be provided to customers unless they have met the plan requirements;
- The proposed block rate structure should encourage retrofitting of old plumbing fixtures that use large quantities of water; and
- The building inspector will not certify new construction that fails to meet plan requirements.

The CCWB member WSCs will adopt the final approved plan and commit to maintain the program for the duration of the CCWB's financial obligation to the State of Texas.

### Annual Reporting

In addition to the above outlined responsibilities, the CCWB staff will submit an annual report to the Texas Water Development Board on the Water Conservation Plan. The report will include the following:

- Information that has been issued to the public.
- Public response to the plan.
- The effectiveness of the water conservation plan in reducing water consumption, as demonstrated by production and sales records.
- Implementation progress and status of the plan.

### Contracts with Other Political Subdivisions

The CCWB will, as part of a contract for sale of water to any other political subdivision, require that entity to adopt applicable provisions of the CCWB's water conservation or already have a TWDB-approved plan in effect. These provisions will be through contractual agreement prior to the sale of water to the political subdivision.

## 6.4 Drought Management Plan

### 6.4.1 Cameron County Drought Management Authority

Nearly all public and private water supplies in Cameron County are derived, either directly or indirectly, from the Rio Grande. Those waters are regulated jointly by the United States and Mexico. The Texas Water Master, in consortium with the International Boundary and Water Commission regulates the operation of Amistad, Falcon, and Anzalduas Reservoirs as a hydrologic system to supply normal and drought condition flows to Mexico and the Lower Valley. Cameron County will adopt, and follow to the extent practicable and legally enforceable, the procedures of the Water Master and the IBWC with regards to water supply operations during hydrologic droughts.

On a local basis and where enforceable, the County will require cities to adopt drought contingency ordinances in accordance with the provisions of the drought contingency plan presented herein for the CCWDB.

### 6.4.2 Drought and/or Emergency Trigger Conditions

The County will adopt the following set of "triggers" or threshold conditions to indicate the various stages of increasing drought severity and water shortage conditions:

1. The County will recognize that a mild drought (water demand is approaching the safe capacity of the system) is in progress when the Texas Water Master (Texas Water Commission) determines that the operating reserve in Falcon and Amistad Reservoirs is at 25% capacity.
2. The County will recognize that a moderate drought (reservoir reserves are still high enough to provide an adequate supply, but the reserves are low enough to disrupt some beneficial activities) is in progress when the Texas Water Master determines that the operating reservoir in Falcon and Amistad Reservoirs is zero.
3. The County will recognize that a severe drought (reservoir reserves are low enough that there is a real possibility that the supply situation may become critical if the drought or emergency continues) is in progress when the Texas Water Master determines that the irrigation reserve in Falcon and Amistad Reservoirs is less than 50 percent of assigned capacity.
4. The County will recognize that the system is in emergency operation modes if one or more of its customer's major pumps or transmission lines in the raw water supply system fail, significantly impairing the capability to deliver water to contracting cities.

### 6.4.3 Drought and/or Emergency Measures

The County will incorporate the following measures and encourage water use by affected cities, depending on the degree of efficient severity of the drought and other system emergency conditions.

### Mild Condition Measures

1. Cities will be asked to activate an information center to answer inquiries from citizens and other customers regarding water shortage conditions and required conservation measures. The Authority will discuss the drought condition potential and its impact on the water supply situation in the news media.
2. The County will continue to advise the cities of the reservoir reserves on a monthly basis.
3. The County will request the cities to implement a voluntary daily lawn watering schedule through the media.

### Moderate Condition Measures

1. The County will inform the cities by mail and telephone that the drought has reached the moderate trigger level. This information will be given at seven-day intervals until the drought trigger condition changes.
2. The County will request that contracting cities implement mandatory lawn irrigation schedules.
3. The County will request that the contracting cities prohibit other non-essential uses such as car washing, filling of swimming pools, etc.

### Severe Drought Condition and/or System Emergency Mode

1. The County will immediately inform the cities, by telephone and mail, about the serious water supply situation. Similar action will be taken in the event of a major system failure. The news media will also be informed. Situation reports will be issued to the contracting cities and news media daily.
2. The County will request that the cities prohibit all outdoor water use.

#### 6.4.4 Drought Termination Notification

Termination of the drought/emergency condition and corresponding measures will take place when the trigger condition that initiated the drought/emergency situation no longer exists. The County will inform the member cities and the media of the end of the drought trigger or emergency condition in the same manner as they were previously informed.

## **7.0 PRELIMINARY ENVIRONMENTAL ASSESSMENT**

The purpose of this section is to provide preliminary environmental support for the development of the Cameron County Regional Water and Wastewater Plan. This section is designed to accomplish two primary goals: 1) Provide a preliminary baseline assessment of environmental and cultural features that, under Federal, State, and local regulations may become of concern in the development of regional water supply, treatment and distribution, and wastewater treatment and collection facilities; and, 2) Identify potential effects and/or constraints to the development of such facilities. This section generally follows guidelines for environmental assessments as described by TWDB for state funding programs. This assessment is general and is designed to provide data for preliminary evaluation of alternative water and wastewater options. Site specific detail for a complete Environmental Assessment or Environmental Information Document will require further study. Significant environmental constraints within Cameron County are presented on the Environmental Constraints Map (USGS Quad base map) in the map report accompany this plan.

### **7.1 Purpose and Need for Project**

The purpose and need for this project is described in detail in Sections 1.0, 2.0 and 3.0 of this report.

### **7.2 Project Description**

The proposed project has been previously defined throughout this study. Details of proposed water and wastewater facilities to serve the colonias of Cameron County can be found in Sections 4.0 and 5.0 of this report.

### **7.3 Baseline Conditions**

#### **7.3.1 Geological Elements and Soils**

Cameron County is located on the nearly level coastal plain of Texas. The county gradually dips to the East toward the Gulf of Mexico at typically less than a one percent (1%) slope. Generally, the topographic features of Cameron County consists of tidal flats, resacas, backswamps, barrier islands, levees, point bars, clay dunes, depressing areas, and deltaic features of the Rio Grande. Elevations throughout the county range from sea level to approximately 70 feet MSL near Santa Maria (Williams et al., 1977).

Two (2) geologic formations are exposed in Cameron County. The Beaumont formation and the younger Holocene sediments (Williams et al., 1977). The older Beaumont formation, which is of Pleistocene age, and the Holocene sediments at the surface are separated by a contact point

which occurs as a low scarp in the area of Sweeney and Cross Lakes and, west of Harlingen, by the Arroyo Colorado which flows along the contact (Williams et al., 1977).

The older exposed Pleistocene system that outcrops along the Gulf of Mexico coastal plain is the Houston group (Sellards et al., 1981). The Houston group sediments are unconsolidated, alluvial, deltaic, and brackish-water or lagoonal deposits (Sellards et al., 1981). The Houston group is divided into two (2) formations, the Lissie sand, and the Beaumont clay (Sellards et al., 1981). The former of which is not exposed in Cameron County (BEG, 1976).

The Beaumont clay formation is present mainly in the North-western part of the county. It is 400 to 900 feet thick, about 75% to 80% sand with considerable gravel and some limestone originally deposited as caliche (Sellards et al., 1981). The Beaumont formation was largely deposited by rivers by way of natural levees and deltas systems and to a lesser extend by marine and lagoonal processes (Sellards et al., 1981). In extensive areas along the Gulf of Mexico coast the Beaumont clay formation is overlain unconformably by recent stream deposits and wind-blown beach sands (Sellards et al., 1981).

The recent Holocene sediments dominate the southern and eastern part of Cameron County. These sediments are characterized by three (3) distinct deposits: wind-blown, barrier island, and alluvial.

The wind-blown deposits are primarily found along the extreme mainland coast of Cameron County. These sediments are generally characterized as clay dunes, active dunes and dune complexes on the mainland, and stabilized sand dune deposits (BEG, 1976).

The barrier island deposits exist as part of Padre Island and to a small extend Brazos Island. These sediments are generally characterized as sand, silt and clay, mostly sand, well sorted, fine grained, with interfingers of silt and clay in the landward direction. These island deposits also include a beach ridge, spit, tidal channel, tidal delta, washover fan, and sand dune deposits (BEG, 1976).

The third and most extensive Holocene sediments in Cameron County are the alluvial or flood plain deposits. These sediments overlay greater than fifty percent (50%) of the county. These were transported by the Rio Grande and its associated streams, resacas and arroyos. These alluvial deposits in the lower River Grande are composed of a wide variety of sediments characterized as clay, silt, mainly quartz sand, dark gray to dark brown; and includes sedimentary rocks from the Cretaceous and Tertiary and a wide variety of igneous and sedimentary rocks from the Trans-Pecos of Texas, Mexico and New Mexico (BEG, 1976).

## Soil

The following paragraphs will present the general soil associations and descriptions of Cameron County (Williams, et al., 1977) as mapped by the Soil Conservation Service. These general descriptions will include soil properties that are pertinent to the proposed activity, such as landscape position, slopes, permeability and texture. A more specific quantitative listing of the engineering properties for Cameron County soils and how they relate to individual colonias within the study area are presented in Table 7-1.

The Sejita-Lomalta-Barrada soil association occupies level areas of saline, loamy and clayey soils at or near sea level and broad areas of barren clay that are inundated by high tides and heavy rains. This association occupies about 23% of the county and is generally poorly drained and very poorly drained clays and silty clay loams. Much of this association has a water table depth of 1 to 5 feet throughout the year.

The Laredo-Lomalta soil association occupies gently sloping to level areas and is well-drained to poorly drained silty clay loams and clays. This association is mainly adjacent to Laguna Atascosa National Wildlife Refuge. This association occupies about 4% of the county and a seasonal high water table exists at about 2 to 6 feet. The soils of this association occupy the slightly depressed areas and adjacent sloping areas slightly greater in elevation (1-5 feet).

The Willamar association soils are described as nearly level, somewhat poorly drained fine sandy loams and sandy clay loams. These soils comprise about 4% of Cameron County. These soils are somewhat poorly drained and have very slow permeability. A seasonal high water table exists at about 36 to 72 inches and these soils are saline.

The soils of the Laredo-Olmito association are characterized as nearly level to gently sloping, well-drained and moderately well-drained silty clayloams and silty clays. These soils generally follow the pattern of the old resacas on a low terrace of the Rio Grande. This association comprises about 19% of the county.

The Rio-Grande-Matamoros association can be described as nearly level to gently sloping, well-drained and moderately well-drained silt loams and silty clays. These soils occupy a narrow band adjacent to the Rio-Grande and the nearly level slack water areas associated with it. This association occupies about 4% of the county. These soils are geologically very young (Holocene age).

Table 7-1  
Soils Summary and On-site  
Absorption System Suitability for  
Each Colonia

Colonia PUB Designation	Colonia	Soils Designation	Degree and Kind of Limitation for Septic Tank Absorption Fields	Permeability (in/hr)	Depth to Seasonal High Water Table (in)	Suitable for Absorption Trench On-Site Disposal (Y/N)
1B	Cameron Park	Laredo Silty Clay Loam (0-1% Slopes)	Moderate; Percs Slowly	0.06 - 0.20	36 - 120	N
		Laredo Silty Clay Loam (1-3% Slopes)	Moderate; Percs Slowly	0.06 - 0.20	36 - 120	N
		Omito Silty Clay	Severe; Percs Slowly	0.06 - 0.20	60 - 120	N
		Harlingen Clay	Severe; Percs Slowly	0.06	60 - 120	N
2B	Omito	Chargo Silty Clay	Severe; Percs Slowly	0.06 - 0.20	24 - 36	N
		Benito Clay	Severe; Percs Slowly; Wet	< 0.06	60 - 120	N
		Omito Silty Clay	Severe; Percs Slowly; Wet	< 0.06	60 - 120	N
		Laredo Silty Clay Loam (0-1% Slopes)	Moderate; Percs Slowly	0.06 - 0.20	36 - 120	N
3B	Stuart Subdivision	Tiocano Clay	Severe; Floods; Percs Slowly	< 0.06	> 74	Y
		Laredo-Urban Land Complex	Severe; Percs Slowly	< 0.06	36 - 120	N
		Benito Clay	Severe; Percs Slowly; Wet	< 0.06	60 - 120	N
		Benito-Urban Land Complex	Severe; Percs Slowly; Wet	< 0.06	60 - 120	N
4B	San Pedro/Cameron/Barrera Gd	Laredo-Urban Land Complex	Moderate; Percs Slowly	0.63 - 2.0	60 - 120	N
		Laredo Silty Clay Loam (0-1% Slopes)	Moderate; Percs Slowly	0.06 - 0.20	60 - 120	N
		Laredo Silty Clay Loam (0-1% Slopes)	Moderate; Percs Slowly	0.06 - 0.20	36 - 120	N
		Laredo Silty Clay Loam (0-1% Slopes)	Moderate; Percs Slowly	0.06 - 0.20	36 - 120	N
5B	King Subdivision	Omito Silty Clay	Severe; Percs Slowly	0.06 - 0.20	36 - 120	N
		Omito Silty Clay	Severe; Percs Slowly	0.06 - 0.20	36 - 120	N
		Omito-Urban Land Complex	Severe; Percs Slowly	0.06 - 0.20	60 - 120	N
		Laredo-Urban Land Complex	Severe; Percs Slowly	0.06 - 0.20	60 - 120	N
6B	Alabama/Arkansas (la Coma)	Rio Grande Silty Loam	Severe; Floods	0.63 - 2.0	> 63	N
		Benito Clay	Severe; Percs Slowly; Wet	< 0.06	60 - 120	N
		Omito Silty Clay	Severe; Percs Slowly	0.06 - 0.20	36 - 120	N
		Laredo Silty Clay Loam (0-1% Slopes)	Moderate; Percs Slowly	0.06 - 0.20	36 - 120	N
7B	Hacienda Gardens	Omito Silty Clay	Severe; Percs Slowly	0.06 - 0.20	36 - 120	N
		Laredo Silty Clay Loam (0-1% Slopes)	Moderate; Percs Slowly	0.06 - 0.20	36 - 120	N
		Laredo Silty Clay Loam (1-3% Slopes)	Moderate; Percs Slowly	0.06 - 0.20	36 - 120	N
		Laredo Silty Clay Loam (0-1% Slopes)	Moderate; Percs Slowly	0.06 - 0.20	36 - 120	N
8B	Villa Nueva	Rio Grande Silty Loam	Severe; Floods	0.63 - 2.0	> 63	N
		Laredo Silty Clay Loam (0-1% Slopes)	Moderate; Percs Slowly	0.06 - 0.20	36 - 120	N
		Omito Silty Clay	Severe; Percs Slowly	0.06 - 0.20	36 - 120	N
		Benito Clay	Severe; Percs Slowly; Wet	0.06 - 0.20	36 - 120	N
9B	Villa Pancho	Omito Silty Clay	Severe; Percs Slowly	< 0.06	60 - 120	N
		Omito Silty Clay	Severe; Percs Slowly	0.06 - 0.20	60 - 120	N
		Cameron Silty Clay	Slight	0.20 - 0.63	60 - 120	N
		Chargo Silty Clay	Severe; Percs Slowly	0.06 - 0.20	24 - 36	N
10B	Pleasant Meadows	Benito Clay	Severe; Percs Slowly; Wet	< 0.06	60 - 120	N
		Omito Silty Clay	Severe; Percs Slowly	0.06 - 0.20	36 - 120	N
		Omito Silty Clay	Moderate; Percs Slowly	0.06 - 0.20	36 - 120	N
		Laredo Silty Clay Loam (0-1% Slopes)	Severe; Percs Slowly	0.06 - 0.20	36 - 120	N
11B	Villa Cavazos	Omito Silty Clay	Severe; Percs Slowly	0.06 - 0.20	36 - 120	N
		Omito Silty Clay	Severe; Percs Slowly	0.06 - 0.20	36 - 120	N

Soils Summary (Sub-Area B) continued

Colonia PUB Designation	Colonia	Soils Designation	Degree and Kind of Limitation for Septic Tank Absorption Fields	Permeability (In/hr)	Depth to Seasonal High Water Table (In)	Suitable for Absorption Trench On-Site Disposal (Y/N)
12B	Barrío Subdivision	Laredo-Urban Land Complex Lomelta Clay Laredo Silty Clay Loam (0-1% Slopes) Laredo Silty Clay Loam (0-1% Slopes) Olmito Silty Clay	Severe: Percs Slowly Moderate: Percs Slowly Moderate: Percs Slowly Severe: Percs Slowly Severe: Percs Slowly; Wet	0.06 0.06 - 0.20 0.06 - 0.20 0.06 - 0.20	60 - 120 48 - 120 36 - 120 36 - 120 60 - 120	N N N N N
13B	Las Cuatas	Haringen Clay	Severe: Percs Slowly	0.06	60 - 120	N
14B	Saldivar	Benito Clay	Severe: Percs Slowly; Wet	< 0.06	60 - 120	N
15B	Coronado	Olmito Silty Clay	Severe: Percs Slowly	0.06 - 0.20	36 - 120	N
16B	Unknown	Laredo-Olmito Complex Laredo Silty Clay Loam (0-1% Slopes) Benito Clay Matamoros Silty Clay	Severe: Percs Slowly Moderate: Percs Slowly Severe: Percs Slowly; Wet Severe: Floods; Percs Slowly	0.06 - 0.20 0.06 - 0.20 0.06 - 0.20 0.06 - 0.20	60 - 120 36 - 120 60 - 120 > 50	N N N N
17B	Saldivar (II)	Lomelta Clay Olmito Silty Clay Laredo Silty Clay Loam (0-1% Slopes) Haringen Clay	Severe: Percs Slowly Severe: Percs Slowly Moderate: Percs Slowly Severe: Percs Slowly	0.06 0.06 - 0.20 0.06 - 0.20 0.06	48 - 120 36 - 120 36 - 120 60 - 120	N N N N
18B	Valle Escondido	Haringen Clay	Severe: Percs Slowly	0.06	60 - 120	N
18B	Unnamed C	Benito Clay	Severe: Percs Slowly; Wet	< 0.06	60 - 120	N
20B	Unnamed D (Keller's Corner)	Olmito Silty Clay Laredo Silty Clay Loam (0-1% Slopes) Olmito Silty Clay Benito Clay	Severe: Percs Slowly Moderate: Percs Slowly Severe: Percs Slowly Severe: Percs Slowly	0.06 - 0.20 0.06 - 0.20 0.06 - 0.20 0.06 - 0.20	36 - 120 36 - 120 36 - 120 60 - 120	N N N N
21B	Texas 4	Laredo Silty Clay Loam (0-1% Slopes) Laredo Silty Clay Loam (0-1% Slopes) Olmito Silty Clay	Moderate: Percs Slowly Moderate: Percs Slowly Severe: Percs Slowly	0.06 - 0.20 0.06 - 0.20 0.06 - 0.20	36 - 120 36 - 120 60 - 120	N N N
22B	511 Crossroads	Laredo-Urban Land Complex Laredo Silty Clay Loam (0-1% Slopes) Laredo Silty Clay Loam (Saline)	Moderate: Percs Slowly Moderate: Percs Slowly Severe: Percs Slowly	0.06 - 0.20 0.63 - 2.0 0.06 - 0.20	36 - 120 60 - 120 24 - 96	N N N
23B	Illinola Heights	Chargo Silty Clay Olmito Silty Clay Laredo Silty Clay Loam (Saline) Lomelta Clay	Severe: Percs Slowly Moderate: Percs Slowly Severe: Percs Slowly Severe: Percs Slowly	0.06 - 0.20 0.06 - 0.20 0.63 - 2.0 0.06	36 - 120 60 - 120 48 - 120 36 - 120	N N N N
24B	Unknown (Brownsville Airport)	Laredo Silty Clay Loam (0-1% Slopes) Olmito Silty Clay	Moderate: Percs Slowly Severe: Percs Slowly	0.06 - 0.20 0.06 - 0.20	36 - 120 36 - 120	N N
25B	Valle Hermosa	Benito Clay	Moderate: Percs Slowly	< 0.06	60 - 120	N
26B	Unknown	Laredo Silty Clay Loam (0-1% Slopes) Laredo Silty Clay Loam (1-3% Slopes) Olmito Silty Clay	Moderate: Percs Slowly Moderate: Percs Slowly Severe: Percs Slowly	0.06 - 0.20 0.06 - 0.20 0.06 - 0.20	36 - 120 36 - 120 36 - 120	N N N
27B	Unnamed B (Hwy 802)	Olmito Silty Clay Laredo Silty Clay Loam (0-1% Slopes) Laredo Silty Clay Loam (0-1% Slopes)	Severe: Percs Slowly Moderate: Percs Slowly Moderate: Percs Slowly	0.06 - 0.20 0.06 - 0.20 0.06 - 0.20	36 - 120 36 - 120 36 - 120	N N N
28B	21	Laredo Silty Clay Loam (0-1% Slopes) Cameron Silty Clay Olmito Silty Clay	Moderate: Percs Slowly Slight Severe: Percs Slowly	0.06 - 0.20 0.20 - 0.63 0.06 - 0.20	36 - 120 0 - 23 36 - 120	N N N



Soils Summary (Sub-Area W)

Colonia PUB Designation	Colonia	Soils Designation	Degree and Kind of Limitation for Septic Tank Absorption Fields	Permeability (in/hr)	Depth to Seasonal High Water Table (in)	Suitable for Absorption Trench On-Site Disposal (Y/N)
1W	Encantada	Laredo Silty Clay Loam (0-1% Slopes)	Moderate; Percs Slowly	0.06 - 0.20	36 - 120	N
		Laredo Silty Clay Loam (1-3% Slopes)	Moderate; Percs Slowly	0.06 - 0.20	36 - 120	N
		Laredo-Reynosa Complex (0-1% Slopes)	Moderate; Percs Slowly	0.63 - 2.0	60 - 120	N
		Laredo-Reynosa Complex (1-3% Slopes)	Moderate; Percs Slowly	0.63 - 2.0	60 - 120	N
		Rio Grande Silty Loam	Severe; Floods	0.63 - 2.0	> 63	N
		Tocano Clay	Moderate; Percs Slowly	< 0.06	60 - 120	N
2W	Santa Maria	Laredo Silty Clay Loam (0-1% Slopes)	Moderate; Percs Slowly	0.06 - 0.20	36 - 120	N
		Laredo-Urban Land Complex				
3W	La Paloma	Olmito Silty Clay	Severe; Percs Slowly	0.06 - 0.20	60 - 120	N
		Laredo Silty Clay Loam (0-1% Slopes)	Moderate; Percs Slowly	0.06 - 0.20	36 - 120	N
4W	Los Indios	Rio Grande Silty Loam	Severe; Floods	0.63 - 2.0	> 63	N
		Laredo-Urban Land Complex				
5W	Bluetown	Laredo Silty Clay Loam (0-1% Slopes)	Moderate; Percs Slowly	0.06 - 0.20	60 - 120	N
		Laredo Silty Clay Loam (0-1% Slopes)	Moderate; Percs Slowly	0.06 - 0.20	36 - 120	N
6W	T2 Unknown Subdivision	Laredo-Reynosa Complex (0-1% Slopes)	Moderate; Percs Slowly	0.06 - 0.20	36 - 120	N
		Benito Clay	Severe; Percs Slowly; Wet	0.63 - 2.0	60 - 120	N
7W	El Venadito	Raymondville Clay Loam	Severe; Percs Slowly	< 0.06	60 - 120	N
		Olmito Silty Clay	Severe; Percs Slowly	0.20 - 0.63	60 - 120	N
8W	Carricitos-Landrum	Laredo Silty Clay Loam (0-1% Slopes)	Severe; Percs Slowly	0.06 - 0.20	60 - 120	N
		Laredo Silty Clay Loam (0-1% Slopes)	Moderate; Percs Slowly	0.06 - 0.20	36 - 120	N
9W	El Calaboz	Olmito Silty Clay	Moderate; Percs Slowly	0.06 - 0.20	36 - 120	N
		Rio Grande Silty Loam	Severe; Floods	0.63 - 2.0	60 - 120	N
10W	Iglesia Antigua	Laredo Silty Clay Loam (0-1% Slopes)	Moderate; Percs Slowly	0.06 - 0.20	36 - 120	N
		Olmito Silty Clay	Severe; Percs Slowly	0.06 - 0.20	60 - 120	N
11W	Palmer	Laredo Silty Clay Loam (0-1% Slopes)	Moderate; Percs Slowly	0.06 - 0.20	36 - 120	N
		Benito Clay	Severe; Percs Slowly; Wet	< 0.06	60 - 120	N
12W	Unknown (Milla 2)	Laredo Silty Clay Loam (0-1% Slopes)	Moderate; Percs Slowly	0.06 - 0.20	36 - 120	N
		Benito Clay	Severe; Percs Slowly	0.06 - 0.20	60 - 120	N
13W	O Unknown (Santa Rosa)	Tocano Clay	Severe; Floods; Percs Slowly	0.06 - 0.20	36 - 120	N
		Raymondville Clay Loam (Saline)	Severe; Percs Slowly	< 0.06	60 - 120	N
14W	W	Raymondville Clay Loam	Severe; Percs Slowly	0.06 - 0.20	60 - 120	N
		Raymondville Clay Loam	Severe; Percs Slowly	0.20 - 0.63	60 - 120	N
15W	R Unknown (Santa Rosa)	Racombes Sandy Clay Loam	Severe; Percs Slowly	0.20 - 0.63	60 - 120	N
		Willacy Fine Sandy Loam (0-1% Slopes)	Severe; Floods	0.63 - 2.0	60 - 120	N
16W	X Unknown (La Feria)	Hidalgo Sandy Clay Loam	Slight	2.0 - 6.3	> 74	Y
		Hidalgo Fine Sandy Loam (0-1% Slopes)	Slight	0.63 - 2.0	60 - 120	N
17W	El Venadito	Mercedes Clay (0-1% Slopes)	Slight	0.63 - 2.0	> 15	N
		Raymondville Clay Loam	Severe; Percs Slowly	< 0.60	60 - 120	N
		Raymondville Clay Loam	Severe; Percs Slowly	0.20 - 0.63	60 - 120	N
		Raymondville Clay Loam	Severe; Percs Slowly	0.20 - 0.63	60 - 120	N
		Hidalgo Sandy Clay Loam	Slight	0.63 - 0.20	60 - 120	N
		Benito Clay	Severe; Percs Slowly; Wet	< 0.06	60 - 120	N
		Raymondville Clay Loam	Severe; Percs Slowly	0.20 - 0.63	60 - 120	N

Soils Summary (Sub-Area H)

Colonia PUB Designation	Colonia	Soils Designation	Degree and Kind of Limitation for Septic Tank Absorption Fields	Permeability (in/hr)	Depth to Seasonal High Water Table (in)	Suitable for Absorption Trench On-Site Disposal (Y/N)
1H	Las Palmas	Hidalgo-Urban Land Complex Hidalgo Sandy Clay Loam Raymondville Clay Loam Raymondville-Urban Land Complex Racombes Soils and Urban Land Racombes Sandy Clay Loam Willacy Fine Sandy Loam (0-1% Slopes)	Slight Severe: Percs Slowly  Severe: Floods Slight	0.63 - 0.20 0.20 - 0.63  0.63 - 2.0 2.0 - 6.3	60 - 120 60 - 120 36 - 72 60 - 120 60 - 120 > 74	N N N N N N Y
2H	Lago Subdivision	Chargo Silty Clay Laredo Silty Clay Loam (0-1% Slopes) Tiocono Clay	Severe: Percs Slowly Moderate: Percs Slowly Severe: Floods; Percs Slowly	0.06 - 0.20 0.06 - 0.20 < 0.06	24 - 36 60 - 120 > 74	N N Y
3H	26	Racombes Sandy Clay Loam Willacy Fine Sandy Loam (0-1% Slopes) Hidalgo Fine Sandy Loam (0-1% Slopes) Raymondville Clay Loam	Severe: Floods Slight Slight Severe: Percs Slowly	0.63 - 2.0 2.0 - 6.3 0.63 - 2.0 0.20 - 0.63	60 - 120 > 74 60 - 120 60 - 120	N Y N N
4H	Lasana	Racombes Sandy Clay Loam Rio Clay Loam Tiocono Clay	Severe: Floods Severe: Floods; Percs Slowly Severe: Floods; Percs Slowly	0.63 - 2.0 0.63 - 2.0 < 0.06	60 - 120 36 - 72 > 74	N N Y
5H	Rice Tracts	Laredo Silty Clay Loam (0-1% Slopes) Harrington Clay	Moderate: Percs Slowly Severe: Percs Slowly	0.06 - 0.20 0.06	60 - 120 60 - 120	N N
6H	Leal Subd. (Meas & Bounded)	Olmillo Silty Clay	Severe: Percs Slowly	0.06 - 0.20	60 - 120	N
7H	Laguna Escondido Heights	Raymondville Clay Loam	Severe: Percs Slowly	0.20 - 0.63	60 - 120	N

Soils Summary (Sub-Area E)

Colonia PUB Designation	Colonia	Soils Designation	Degree and Kind of Limitation for Septic Tank Absorption Fields	Permeability (in/hr)	Depth to Seasonal High Water Table (in)	Suitable for Absorption Trench On-Site Disposal (Y/N)
1E	La Coma Del Norte	Benito Clay	Severe: Percs Slowly; Wet	< 0.06	60 - 120	N
2E	Lozano	Harlingen Clay Laredo-Olmito Complex Raymondville Clay Loam Lyford Sandy Clay Loam	Severe: Percs Slowly Severe: Percs Slowly Severe: Percs Slowly	0.06 0.06 - 0.20 0.20 - 0.63	60 - 120 60 - 120 60 - 120	N N N
3E	Laina Ranch	Lyford Sandy Clay Loam Willamar Soils Delina Fine Sandy Loam Lozano Fine Sandy Loam Willacy Fine Sandy Loam	Moderate: Percs Slowly; Wet Moderate: Percs Slowly; Wet Severe: Percs Slowly Severe: Percs Slowly Severe: Percs Slowly	0.63 - 2.0 0.63 - 2.0 2.0 - 6.3 2.0 - 6.3 2.0 - 6.3	36 - 72 36 - 72 60 - 72 60 - 72 36 - 72	N N N N N
4E	Laureles	Harlingen Clay	Slight	2.0 - 6.3	> 74	Y
5E	Del Mar Heights	Harlingen Clay	Severe: Percs Slowly	0.06	60 - 120	N
6E	Orason Ac/Chula Vista/Shoe	Lomaita Clay Selita Silty Clay Loam Chargo Silty Clay Lomaita Clay	Severe: Percs Slowly Severe: Floods; Wet Severe: Percs Slowly Severe: Percs Slowly	0.06 0.20 - 0.63 0.06 - 0.20 0.06	48 - 120 20 - 48 24 - 36 48 - 120	N N N N
7E	Las Yescas	Harlingen Clay (Saline)	Severe: Shrink-Swell	0.06	60 - 120	N
8E	Unknown	Lozano Fine Sandy Loam Benito Clay	Severe: Percs Slowly	2.0 - 6.3	36 - 72	N
9E	Glenwood Acres Subd.	Olmito Silty Clay	Severe: Percs Slowly; Wet	0.06	60 - 120	N
10E	Unknown (Del Mar II)	Benito Clay	Severe: Percs Slowly	0.06 - 0.20	60 - 120	N
11E	Los Cuates	Lomaita Clay Selita Silty Clay Loam Laredo Silty Clay Loam (0-1% Slopes) Laredo Silty Clay Loam (1-3% Slopes) Tiocono Clay	Severe: Percs Slowly Severe: Floods; Wet Moderate: Percs Slowly Moderate: Percs Slowly Severe: Floods; Percs Slowly	0.06 0.20 - 0.63 0.06 - 0.20 0.06 - 0.20 < 0.06	48 - 120 20 - 48 60 - 120 60 - 120 > 74	N N N N Y
12E	25	Laredo-Olmito Complex	Severe: Percs Slowly	0.06 - 0.20	60 - 120	N
13E	Cienecos (Limon)	Benito Clay Benito Clay	Severe: Percs Slowly; Wet Severe: Percs Slowly; Wet	0.06 0.06	60 - 120 60 - 120	N N

The Willacy-Racombes association soils are nearly level to gently sloping, well-drained fine sandy loams and sandy clay loams. This association makes up about 7% of the county. About 10% to 15% of this association is affected by a seasonal high water table and slight to moderate salinity.

The Lyford-Raymondville-Lozano soil association can be described as nearly level, well-drained and moderately well-drained sandy clay loams, clay loams, and fine sandy loams. This association occupies about 4% of the county. A seasonal high water table is at a depth of 2 to 6 feet in about 40% to 50% of the acreage in the association. Approximately 30% of this association is affected by moderate to severe salinity.

The Hidalgo-Raymondville association can be described as nearly level to gently sloping, well-drained and moderately well-drained sandy clay loams and clay loams. This association makes up about 4% of the county. A seasonal high water table is in 15% to 20% of this association.

The Willacy-Raymondville soil association is described as nearly level to gently sloping, well-drained and moderately well-drained fine sandy loams and clay loams. This soil association comprises about 4% of the county. Approximately 10% of this association is irrigated and less than 5% is affected by a seasonal high water table.

The Raymondville association soils are described as nearly level, moderately well-drained clay loams. These soils occupy small irregularly shaped areas of nearly level plains that are broken by slight rises. The Raymondville association makes up about 4% of Cameron County. Much of this association lacks adequate surface drainage and a seasonal high water table exists at 2 to 10 feet in irrigated areas.

The Harlingen-Benito association soils can be described as level to nearly level, moderately well-drained to poorly drained. These soils make up about 8% of the county. This association occupies broad areas of slightly depressed areas that lack adequate surface drainage and are flooded for several days after heavy rains. Generally this association has a water table below 5 feet.

The Harlingen association soils are described as level and nearly level, and nearly level, moderately well-drained clays that occupy broad plains broken by slight depressing drainages. This association makes up about 7% of the county. The water table in the association is generally below 5 feet.

The Mercedes association soils occupy broad plains that are level to gently sloping. The soils are moderately well-drained clays that make up about 5% of the county. The water table generally is at a depth below 5 feet.

The Mustang-Coastal dune association is best described as nearly level to steep, poorly drained fine sands and sand dunes. These soils are found in a narrow band along the Gulf of Mexico coast. This soil association consists of active to partially stabilized windblown sands that are up to 30 feet above sea level.

### 7.3.2 Hydrological Elements

Cameron County is located in the West Gulf Coast section of the Coastal Plain Physiographic province. The major portion of the county is gently rolling to flat, gradually sloping toward the coast and the Rio Grande. The county is crossed by many sinuous resacas, abandoned former courses of the Rio Grande and its tributaries. Other major waterways in the county include the Arroyo Colorado, Resaca de Rancho Viejo and Resaca de los Cuates. All of these waterways eventually empty into the Laguna Madre or any of several lakes on bays along the Laguna Madre.

Cameron County abuts eight TWC Designated Water Quality Segments.

These segments are:

- Segment 2201: Arroyo Colorado Tidal - from the confluence with the Laguna Madre to a point 100 meters (110 yards) downstream of Cemetery Road south of Port Harlingen.
- Segment 2202: Arroyo Colorado Above Tidal - from a point 100 meters (110 yards) downstream of Cemetery Road south of Port Harlingen to FM 2062 in Hidalgo County. Segment 2202 is Water Quality Limited.
- Segment 2301: Rio Grande Tidal - from the confluence with the Gulf of Mexico to a point 10.8 kilometers (6.7 miles) downstream of the International Bridge in Cameron County.
- Segment 2302: Rio Grande Below Falcon Reservoir - from a point 10.8 kilometers (6.7 Miles) downstream of the International Bridge in Cameron County to Falcon Dam in Starr County.
- Segment 2491: Laguna Madre
- Segment 2493: South Bay
- Segment 2494: Brownsville Ship Channel
- Segment 2501: Gulf of Mexico

The designated uses and water quality criteria of each Cameron County segment are shown in Table 7-2. All segments are classified by the TWC and EPA as "effluent limited" which indicates that the water quality of the segment is not currently considered to be severely degraded, designated segment uses are not threatened, and the assimilative capacity of the segment is relatively high. With the exception of the Brownsville Ship Channel, all segments are considered

Table 7-2

**Designated Uses and Water Quality Criteria of  
Cameron County Segments**

Segment	Segment Name	Uses	Criteria
2201	Arroyo Colorado Tidal	Contact Recreation High Qual Aq. Life.	D.O. <sup>a/</sup> 40. mg/L pH 6.5-9.0 fecal coli. <sup>b/</sup> 200/100 ml Temp. 95°
2202	Arroyo Colorado Above Tidal	Contact Recreation Intermediate Aq. Habitat	Cl- <sup>c/</sup> 1,200 mg/L SO4= <sup>c/</sup> 1,000 mg/L TDS <sup>c/</sup> 4,000 mg/L D.O. <sup>a/</sup> 4.0 mg/L pH 6.5-9.0 fecal coli. <sup>b/</sup> 200/100 ml Temp. 95°
2301	Rio Grande Tidal	Contact Recreation Excep. Qual Aq. Life	D.O. <sup>a/</sup> 5.0 mg/L pH 6.5-9.0 fecal coli. <sup>b/</sup> 200/100 ml Temp. 95°
2302	Rio Grande Below Falcon R.	Contact Recreation High Qual. Aq. Life Public Water Supply	Cl- <sup>a/</sup> 270 mg/L SO4= <sup>a/</sup> 350 mg/L TDS <sup>a/</sup> 880 mg/L D.O. <sup>a/</sup> 5.0 mg/L pH 6.5-9.0 fecal coli. <sup>b/</sup> 200/100 ml Temp. 95°
2491	Laguna Madre	Contact Recreation Excep. Qual Aq. Life	D.O. <sup>a/</sup> 5.0 mg/L pH 6.5-9.0 fecal coli. <sup>b/</sup> 14/100 ml Temp. 95°
2493	South Bay	Contact Recreation Excep. Qual Aq. Life	D.O. <sup>a/</sup> 5.0 mg/L pH 6.5-9.0 fecal coli. <sup>b/</sup> 14100 ml Temp. 95°
2491	Brownsville Ship Channel	Non-contact Recreation Excep. Qual Aq. Life	D.O. <sup>a/</sup> 5.0 mg/L pH 6.5-9.0 fecal coli. <sup>b/</sup> 2,000/100 m Temp. 95°
2501	Gulf of Mexico	Contact Recreation Excep. Qual Aq. Life	D.O. <sup>a/</sup> 5.0 mg/L pH 6.5-9.0 fecal coli. <sup>b/</sup> 14/100 ml Temp. 95°

<sup>a/</sup> Mean over 24-hour period

<sup>b/</sup> Thirty-day geometric mean not to exceed.

<sup>c/</sup> Annual average not to exceed

Source: TWC, 1990

suitable for contact recreation. The tidal portion of the Rio Grande, Laguna Madre, South Bay, Brownsville Ship Channel, and the Gulf of Mexico are all considered to possess habitats and conditions suitable for "Exceptional Quality Aquatic Life" and, as such, have an average dissolved oxygen (D.O.) criteria of 5.0 mg/L. The tidally influenced portion of the Arroyo Colorado and the Rio Grande Above Tidal are considered to be indicative of a "High Quality Aquatic Life" habitat and also have a 5.0 mg/L minimum D.O. criteria. Because the Arroyo Colorado Above Tidal receives the wastes from a large number of municipal and industrial dischargers as well as significant quantities of irrigation return flow, water quality and habitat are considered to support only "Moderate Quality Aquatic Life." As a result the D.O. criteria for the Arroyo Colorado Above Tidal is only 4.0 mg/L.

The Texas Water Commission, Texas Parks and Wildlife Department, U.S. Geological Survey, and International Boundary Water Commission routinely sample portions of the Rio Grande, Arroyo Colorado, Laguna Madre and Gulf of Mexico. In addition, several studies have been performed by State and local Universities. The Lower Rio Grande Valley Development Council (LRGVDC) commissioned a number of special studies in support of the areawide water quality management planning process conducted under Section 208 of the Federal Water Pollution Control Act of 1972 (LRGVDC 1977-78). Most of this data is contained in the Texas Natural Resource Information Service's (TNRIS) statewide monitoring data base (SMN).

In August 1976, an Intensive Survey was conducted by the TDWR for the tidal portion of the Arroyo Colorado. Results of the survey indicate that the stream has a low assimilative capacity during low-flow conditions. Nutrient and oxygen-demanding material loading from municipal dischargers were determined to be responsible for eutrophic conditions.

A draft Waste Load Evaluation (WLE) is available for the Arroyo Colorado (TDWR, 1985). Waste load projection were made for existing dischargers for the year 2000 and dissolved oxygen conditions simulated using a calibrated and verified version of the QUAL-TX water quality model. Effluent limits recommended in the WLE in order to maintain the 4.0 mg/L D.O. standard were, in general, at secondary treatment.

Waste load evaluations are not currently available for the Brownsville Ship Channel or the Rio Grande. The QUAL-TX Model will be applied to these segments as a part of this planning study. Treatment levels necessary to maintain designated uses and minimum water quality standards will be determined for each existing and proposed discharge under future conditions.

### 7.3.3 Climatic Elements

The Cameron County climate is subtropical in nature and is characterized by dry, mild winters and hot humid summers. The general weather patterns in Cameron County vary from the tropical maritime air masses during the warmer months to the continental or polar air masses during the colder months.

The prevailing winds are southeasterly to south-southeasterly for a majority of the year and north-northwesterly during December (Orton et al., 1977).

The fact that Cameron County borders the Gulf of Mexico and progresses westward, weather conditions vary somewhat from east to west. Temperature are moderated by the Gulf of Mexico; consequently, freezing temperatures are less frequent and precipitation increases as the proximity to the Gulf of Mexico decreases.

The following climatic data was recorded in Harlingen, Texas from 1931-1969 (Orton, 1977). A summary of climatic data is presented on Table 7-3. The average annual rainfall is about 26 inches, most of which occurs in September due to heavy rains attributed to tropical depressions, tropical storms or hurricanes. Another annual period of peak precipitation occurs in May and June which recorded 3.18 and 2.49 inches of rain, respectively, during the survey period (Orton, 1977). Conversely, March typically yields the least rainfall with 0.95 inches (Orton, 1977).

Infrequently, snow or sleet does fall in January; however, amounts are typically too slight to be accurately measured. Temperatures of 32°F or below do occur; however, not on an annual basis and the county enjoys a 341-day warm season (Orton, 1977). The average daily maximum temperature for Cameron County from 1931-1969 varied from 70.9 (°F) in January to 96.7 (°F) in August. Historically, severe freezes have caused considerable damage to the vegetable and citrus crops and were documented in 1949, 1951, 1962 (Orton, 1977), 1983 and 1989.

Typically the free-water evaporation exceeds precipitation by 32 to 36 inches annually, the higher value being toward the coast (Orton, 1977).

### 7.3.4 Biological Elements

#### 7.3.4.1 Vegetation

Cameron County is located within an area that is bisected by the Gulf Prairie and Marsh Vegetation Area and South Texas Plains Vegetational Area described by Gould (1975). The study area is level to gently sloping and bisected by the Arroyo Colorado, and several other small tributaries flowing into the Laguna Madre, and bordered by the Rio Grande which flows into the open Gulf of



Table 7-3  
 Summary of Climatic Data For  
 Cameron County, Texas Recorded at  
 Harlingen, Texas from 1931-1969

<u>Month</u>	<u>Average Daily Maximum (°F)</u>	<u>Average Monthly Lowest Temperature (°F)</u>	<u>Precipitation (Inches)</u>
January	70.9	31.4	1.43
February	74.5	34.8	1.22
March	79.0	39.4	0.95
April	85.9	49.4	1.47
May	90.0	58.5	3.18
June	93.7	66.2	2.49
July	96.0	69.5	1.71
August	96.7	68.9	3.04
September	92.3	62.1	4.80
October	87.1	51.4	2.56
November	78.9	39.9	1.43
December	73.0	34.0	1.57
<b>Year</b>	<b>84.8</b>	<b>-----</b>	<b>25.85</b>

\* Source USDA; Cameron County Soil Survey

Mexico. Elevations in Cameron County range from sea level to approximately 70 feet in the western portions of the county.

Gould (1975) describes distinct differences in climax plant communities throughout the area of Cameron County located within the South Texas Plains Vegetational Area. Grasses characteristic of the sandy loam soils include seacoast bluestem, species of *Setaria*, longspike silver bluestem, big sandbur, and tanglehead. Clays and clay loams are characterized by longspike silver bluestem, Arizona cottontop, buffalo grass, and curly mesquite. The lower elevation saline areas are characterized by gulf cordgrass, seashore saltgrass, and switchgrass (Gould, 1975).

The Gulf Prairie and Marsh, as described by Gould, is typically separated into two major divisions: the Coastal Prairie - a nearly-level, slowly-drained plain less than 150 feet in elevation; and Coastal Marsh - the low west marsh area located immediately adjacent to the coast.

Gulf Prairie climax vegetation is primarily comprised of tall bunch grasses, including big bluestem, seacoast bluestem, Indiangrass, eastern gamagrass, and several species of *Panicum*, among others. The marsh areas typically support salt-tolerant species such as *Carex*, *Cyperus*, *Juncus*, *Scripus*, and several species of cordgrass, including *Spartina* and marsh millet.

Biotic communities within the Rio Grande Valley have recently been further divided into 11 distinct areas within the Tamaulipan Biotic Province (as described by Blair, 1950). Five of these communities, located within the study area, are described below (per USFWS Biological Report 88(36); November, 1988):

**Mid-Valley Riparian Woodland** - This is essentially a bottomland hardwood site, with stands of cedar elm, Berlandier ash (*Fraxinus berlandieriana*), and sugar hackberry (*Celtis laevigata*) mixed with mesquite/granjeno. The result is a dense, tall, canopied forest and greater availability of water and wildlife foods. This habitat is preferred by many rare birds; orioles (*Icterus spp.*), chachalacas (*Ortalis vetula*), and green jays (*Cyanocorax yncas*) may reach their greatest density in this habitat. Resacas in this habitat provide aquatic ecosystems that protect a unique group of Tamaulipan biota.

**Sabal Palm Forest** - The 149-ha (367 acre) USFWS tract in this community is known as "Boscaje de la Palma" and is located in the southmost bend of the Rio Grande near Brownsville. Remnant stands of Mexican palmettos (*Sabal mexicana*) - locally called sabal palm - found in a 1,418-ha (3,500-acre) area represent a remnant of a former 16,200-ha (40,000-acre) community. Palms were so prevalent that early Spanish explorers called the Rio Grande "Rio de las Palmas" (Crosswhite, 1980). These stands are best described as palm-dominated, brush tracts with

Mexican palmettos, tepeguaje (*Leucaena pulverulenta*), anacua, and Texas ebony as major woody associated. Characteristic fauna include ocelot, jaguarundi, lesser yellow bat (*Lasiurus ega*), hooded oriole (*Icterus cucullatus*), speckled racer (*Drymobius margaritiferus*), and northern cat-eyed snake (*Leptoderia septentrionalis*).

Clay Loma/Wild Tidal Flats - Three different communities form a "miniature ecosystem" of wooded islands in tidal flats that are periodically inundated by water from South Bay and the Gulf of Mexico. Lomas are formed from wind-blown silt or clay particles, originally deposited in tidal flats by periodic flooding from the Rio Grande. When flats are dry and barren, prevailing winds deposit particles on dunes, which are normally covered with woody vegetation. Dunes may grow to 9m (30 ft) above surrounding tidal flats. Rains and flooding can erode outer edges of the lomas. When wind or storm tides retreat, loma building begins again. Characteristic vegetation includes fiddlewood (*Citharexylum brachyanthum*) and Texas ebony on the lomas; borrichia (*Borrichia frutescens*) and salicornia (*Salicornia spp.*) on the flats; and black mangrove (*Avicennia nitida*) on South Bay. Representative vertebrates are the Texas tortoise (*Gopherus berlandieri*), long-billed curlews (*Numenius americanus*), and a unique hypersaline-tolerant population of oysters (*Ostrea equestris*).

Mid-Delta Thom Forest - This community contains a mesquite and granjeno association mixed with Texas ebony, anacua, and brazil (*Condalia hookeri*) and was once an extensive thicket that covered most of the Rio Grande delta. There is <5% of the original acreage left, mostly in fence rows, highway rights-of-way, canals, and ditch banks. Remnant tracts are small (normally <40 ha [ $<100$  acres]) and scattered. Shrubs in this habitat form a tight interwoven canopy of 4-6m (15-20 ft). The mid-delta thom forest was used historically for nesting by white-winged doves.

Coastal Brushland Potholes - The southern edge of the Coastal Brushland Pothole biotic community extends into Cameron County. Here, the Gulf's influence creates a stable, saline microclimate which differs from that of other inland wetlands. In this area, moving sand dunes cover vegetation, subsequently uncover it and often leave depressions. When these depressions hold water, they provide excellent habitat for water fowl and the brushy perimeter may be utilized by ocelot and jagurundi.

#### 7.3.4.2 Wildlife

Cameron County, located in extreme southeastern Texas, lies within the Matamorán District of the Tamaulipan Biotic Province described by Blair (1950). The vertebrate fauna of the Tamaulipan Province is represented by a mixture of species (including a considerable element of Neotropical species) from the Texan, Kansan, Austroriparian, and Chihuahuan provinces (Blair, 1950). The

major wildlife habitats in the Tamaulipan Province are synonymous with the vegetative types discussed previously.

Approximately 700 species of vertebrates have been identified in the Matamorán District of the Lower Rio Grande Valley, a number of which are not found elsewhere in the U.S. (USFWS, 1988). The wide range of habitat types provides the study area with a diverse array of vertebrate fauna that includes subtropical, southwestern desert, prairie, coastal marshlands, eastern forest, and marine species.

#### 7.3.4.3 Aquatic, Estuarine, and Marine Ecology

The study area is characterized by a wide range of aquatic, estuarine, and marine ecosystems. Significant habitat include the hypersaline marine environment found in the Lower Laguna Madre; the Lower Arroyo Colorado and Rio Grande Estuaries; and the Riverine habitats of the Arroyo Colorado and the Rio Grande. A detailed discussion of each of these habitats was developed in a report completed in March 1989 for the Rio Grande Municipal Water Authority and the Public Utilities Board of Brownsville "Environmental Inventory and Issues Report Rio Grande Valley Water Conservation Project". The following section is a reprint from this report.

##### Lower Laguna Madre

High temperature and high evaporation, combined with a low annual rainfall, favor the production of hypersaline waters. There is an almost total lack of freshwater inflow into the lower Laguna Madre, except for drainage water from the Arroyo Colorado. As a consequence, the number of species that inhabit the area is severely limited. However, the number of individual members of each species is very high and the Laguna has a disproportionately high level of productivity, as compared with other Texas bays. The limited number of species results in a simplified food chain, in which benthic plants assume a more important role than phytoplankton. Most of the animals probably obtain primary nutrients via an abbreviated detrital food chain, which results in a more efficient transfer of carbon to higher trophic levels. This efficient recycling of detrital constituents depends upon the retention of detritus within the Laguna, associated with low tidal flushing (Pulich 1980).

The lower Laguna Madre supports five species of seagrasses. Each is adapted to specific ecological conditions, of which salinity, temperature and light are the most significant. The physical requirements and limitations of each species is shown in Table 7-4. In general, shoal grass is the most abundant of the five species. It can withstand the greatest salinity fluctuations, particularly hypersalinity. While manatee grass and turtle grass prefer the areas around inlets and passes,

shoal grass is widespread in more restricted areas where other grasses do not grow. It is considered the most desirable species of seagrass to maintain in the Laguna Madre because it provides spawning areas for fish and food for waterfowl (Espey Huston, 1981).

Seagrass ecosystems are recognized as some of the most productive in the world. While direct grazing on their leaves is not common, grazing on the epiphytic organisms they support does occur. Decaying leaves settle in the sediment and are later consumed as detritus. They also aid in the maintenance of an active sulphur cycle and the leaves slow water currents near the sediment surface. Together with the root and rhizome systems, which bind the sediment, they inhibit erosion, enabling rapid recovery of the ecosystem following severe storms. In general, there is a positive correlation between sediment stability and invertebrate diversity (Espey Huston, 1981).

The zooplankton include rotifers, cladocerans, copepods, coelentrates, ctenophores and larvae of molluscs and crustaceans. The calanoid copepod *Acartia tonsa* tends to dominate the zooplankton in inshore areas as a result of its tolerance of wide variations in temperature and salinity. In brackish water it is replaced by freshwater copepods, cladocerans and rotifers. Benthic species that are important components of the food chain include the polychaete *Nereis pelagica occidentalis*, the amphipod *Elasmapus* sp., the pistol shrimp *Crangon heterochaelis* and the blue crab *Callinectes sapidus* (Espey Huston, 1981).

Nekton species of the lower Laguna Madre resemble those found in other Texas bays. In a 1962 study, 77 species of fish were reported. Of these 5 percent were restricted to the brackish waters of the Arroyo Colorado. Numerous species, including redfish, white shrimp, bay anchovies and spotted seatrout utilize this brackish area as both a nursery and foraging ground. The distribution of juvenile shrimp is salinity dependent. Brown shrimp prefer salinities of 10-30 ppt, and are most abundant when salinities are above 20 ppt. White shrimp prefer lower salinity and are largely restricted to the brackish Arroyo Colorado and other channels. In general, nekton in the Laguna Madre exhibit three different reproductive cycles. Many species are estuarine dependent, with adults spawning in the Gulf of Mexico and young organisms being carried into the bay to mature.

The most important sport and commercial species in the inshore areas are the red drum, spotted seatrout and black drum. The Laguna Madre is the preferred habitat for the black drum, which feeds mainly on bivalves concentrated in the seagrass beds. Red drum and spotted seatrout each made up approximately 40 percent of the commercial catch in the lower Laguna Madre in the mid 1970s. Both feed on a variety of crustaceans and to some extent on small fish. Seatrout are tolerant of warm temperatures and high salinity. In one study (Shew *et al* 1981) a positive

correlation between salinity and seatrout size was found. Other commercial species of lesser importance to this area include oysters, finfish, sheepshead, flounder and Atlantic croaker.

The extensive mud flats along the Laguna Madre are the chief feeding ground for shore birds and some wading birds. Geese, pintails and other waterfowl use them as nesting areas. They are an important contributor to the food chain of many marine organisms, used by crab, shrimp and other organisms when inundated. The normal tide of 5 inches covers part of the flats and three or four times a year, winter wind tides inundate all or most of the area.

Of the approximately 650 bird species in the U.S., 380 occur along the Texas coastal zone. Many, such as the Louisiana heron and the reddish egret, depend heavily on the estuarine community, whereas the terns are also part of the beach and marine community. The Laguna Madre provides the wintering ground for 78 percent of the world's redhead ducks, which feed primarily on shoal grass (Shew *et al* 1981).

#### Lower Arroyo Colorado

The Arroyo Colorado is one of the major arteries in the Rio Grande Valley drainage system and receives much of the municipal, agricultural and industrial waste of the area. Small ox-bow lakes indicate that at one time it was an arm of the Rio Grande, branching from the river at a point below the city of Mission. The Arroyo Colorado is a deep channel cut through the Beaumont delta plain, and has a small delta at its mouth. In the late 1940s, the lower 25 miles was dredged to a depth of 14 feet to accommodate barge traffic to the Port of Harlingen. During this process some curves in the original river bed were by-passed, leaving shallow ox-bow areas. For the first 7 miles inland, the old bed was by-passed completely; a new channel runs almost due east to the Gulf Intracoastal Waterway, approximately 21 miles north of Port Isabel. It serves as a floodway, an inland waterway and as a recreational area for boating and fishing (Bryan 1971).

The lower Arroyo Colorado is one of the very few brackish water areas in the Lower Laguna Madre and provides a nursery ground for marine species of the area. Typically, the salinity pattern shows a gradation from lower to higher saline water both with increasing depth and with distance downstream. From surface to bottom it can vary by as much as 29.4 ppt. However, this pattern can be severely disrupted during major storm activity. For instance, following Hurricane Beulah salinity levels in the entire Arroyo Colorado approached that of freshwater. There is also an inverse correlation between salinity and dissolved oxygen. In general, tides are highest in fall and spring and lowest during winter and summer. In 1969 the tide level at mile 8 fluctuated 18 inches. Tides are also greatly influenced by prevailing winds (Bryan 1971).

Table 7-4  
 Limits of Tolerance of Texas Seagrasses

	Optimum salinity (ppt)	Limits of salinity (ppt)	Optimum temperature
<i>Thalassia testudinum</i> (turtle grass)	37.0	to 60	18-32°C growth 29°C max prod.
<i>Syringodium filiformis</i> (manatee grass)	<36.0	to 40	23-25°C flowers 26°C fruits
<i>Halodule wrightii</i> (shoal grass)	35 to 44	to <72	
<i>Halophila Engelmannii</i> (halophila)	37.0	23 to 50	
<i>Ruppia maritima</i> (widgeon grass)	<25.0	0 to 40/60 >30.0 no flowering	15-20°C germ. 20-25°C growth

Espey, Huston and Associates, Inc. *Final Environmental Report: Proposed Deepwater Channel and Multipurpose Terminal Construction and Operation near Brownsville, Texas*, Volume 6, appendix H, I and J, 1981.

A study performed by C.E. Bryan at the University of Texas in 1971 showed that the most numerous economically important species were juvenile menhaden (*Brevoortia* sp.), redfish (*Sciaenops ocellata*) and white shrimp (*Penaeus setiferus*). Brown shrimp (*Penaeus aztecus*) and the blue crab (*Callinectes sapidus*) were found in the area to a lesser degree. The spotted sea trout (*Cynoscion nebulosus*) was the most abundant adult species taken. Less abundant fish, concentrated in the lower 12 miles, were redfish, black drum (*Pogonias cromis*), sheephead (*Archosargus probatocephalus*) and southern flounder (*Paralichthys lethostigma*). Between October, 1965 and August, 1966 water flow into the Arroyo Colorado at Mercedes, Texas averaged 92 cubic feet per second, with a peak flow of 943 cfs and a minimum flow of 24 cfs. During the 1967 flood following Hurricane Beulah, the flow reached an estimated 55,400 cfs (Bryan 1971).

Fish kills are common in the Arroyo Colorado. During the sampling period of the Bryan study, eight kills were investigated. Most of the mortalities occurred between June and September, and were associated with high salinity and dissolved oxygen levels close to zero. DDT sampling revealed that the Arroyo Colorado had the highest level of any area sampled on the Texas coast. Dieldrin and Endrin were also found in many of the samples. This could explain the decline in numbers of spotted sea trout observed during the 1960s. By 1970 there was a tenfold increase in the number of juvenile spotted sea trout in the lower Laguna Madre as compared with the previous year, and this was attributed to reduced pesticide levels in the Arroyo Colorado. Tarpon, which were numerous in the early 1950s, have also disappeared (Bryan 1971).

## Rio Grande Estuary

In 1969 the Texas Parks and Wildlife Department conducted a study in the tidal water section of the Rio Grande. During this study period dissolved oxygen levels ranged from 0.3 to 12.2 mg/L. It was higher during winter months and generally higher at the surface than at the bottom. Salinity also showed a gradation from surface to bottom; at the mouth of the river a freshwater override was evident in surface samples. At river mile 12 some bottom water contained traces of salinity, but all surface samples reflected river flow and registered zero.

Marine species appeared to use the river as a nursery or feeding ground, but not as a spawning area. The most important commercial invertebrate found in the tidal Rio Grande was the white shrimp (*Penaeus setiferus*). Brown shrimp (*P. azetecus*) were much less frequent. A few blue crabs (*Callinectes sapidus*) were present at most stations, but did not appear to use the area as a nursery ground. The most important marine fish was the Atlantic croaker, which used the entire area as a nursery. Adult spotted sea trout, redfish, black drum and snook were important commercial and sportsfish found near the mouth of the river (Breuer 1970).

## Riverine Environments

An inventory of fish caught downstream from Falcon dam in the Rio Grande in 1954 is shown in Table 7-5 (Trevino 1955). Trevino's study extended from the mouth of the river to the Pecos. The river water was generally muddy, with no significant amounts of aquatic vegetation. The distribution of species indicates that, at that time, brackish water forms are replaced by freshwater species just east of Brownsville.

In addition to fish, two species of shrimp were reported in the freshwater stretches of the river within the study area. *Macrobrachium acanthurus* and *M. ohione* were reported as far upstream as the Hidalgo/Starr County line.

### 7.3.4.4 Wetlands and Unique Areas

Wetlands are defined as those areas which are saturated or inundated by ground or surface water at a frequency sufficient to support, and under normal circumstances, do support prevalence of vegetation typically adapted to saturated conditions. Wetlands are usually a transition area between aquatic and terrestrial environments. A description of significant wetland habitat from the Environmental Inventory and Issues Report follows :



Table 7-5  
Fish Populations of the Rio Grande

Species	Distribution
<i>Lepisosteus spatula</i>	Starr County, including Falcon Lake
<i>L. osseus</i>	Locally abundant, prefer moderately moving water
<i>Dorosoma petenense</i>	Found at every station
<i>D. cepedianum</i>	Found at every station
<i>Astyanax fasciatus</i>	The most widespread and common fish collected
<i>Carpiodes carpio</i>	Numerous everywhere in moderate currents
<i>Hybopsis aestivalis</i>	Caught throughout study area
<i>Notropis jemezianus</i>	One of the most prevalent species taken
<i>N. braytoni</i>	Caught upstream of Roma
<i>N. lutrensis</i>	West of Cameron County one of the most common fish
<i>N. buchanaui</i>	Upstream of western Hidalgo County in fast moving water
<i>Hybognathus placita</i>	Common throughout
<i>Ictalurus lupus</i>	Spotty distribution; found at Roma
<i>I. furcatus</i>	Found in Cameron and Starr counties
<i>Cyprinodon variegatus</i>	Common in side pools and shallow water
<i>Gambusia affinis</i>	Common throughout study area
<i>Mollienisia formosa</i>	Not numerous, but widespread
<i>M. latipinna</i>	Caught at one station below Hidalgo
<i>Mugil cephalus</i>	Abundant in Cameron County, less common upstream
<i>Menidia beryllina</i>	Common throughout close to shore
<i>Micropterus salmoides</i>	Immature samples found near Roma
<i>Lepomis macrochirus</i>	Hidalgo and Starr counties
<i>Aplodinotus grunniens</i>	Found throughout area, but not at every station
<i>Chichlasoma cyanoguttatum</i>	Most common upstream from Hidalgo
<i>G. dormitator</i>	Few specimens throughout area, most caught 9 miles east of Brownsville

Trevino, D.B. *The Ichthyofauna of the Lower Rio Grande River, from the Mouth of the Pecos to the Gulf of Mexico*. Masters thesis, University of Texas at Austin, 1955.

## Estuarine Wetlands

Cattail/bullrush marshes occur primarily in the lower reaches of the Rio Grande, between 2 and 12 miles from the mouth in water up to 2 feet deep. They also grow in the floodplain immediately upstream from Anzalduas Dam. The last 2.5 miles of the river supports a community of cordgrass. *Spartina alterniflora* is the dominant species, growing in a narrow band 2 to 8 feet from the river (Ramirez 1986).

Black mangrove (*Avicennia germinans*) thickets are found in isolated patches, at the mouth of the Rio Grande. A small distributary channel funnels river water into a thicket immediately behind the fore dunes. These mangroves are the largest in the state, attaining a height of 12 feet. Of the estimated 7400 acres of mangroves in the state, 1200 acres occur in Cameron County. These thickets are very productive, providing shelter, nesting sites and food for wildlife (Espey Huston, 1981).

Mud flats near the mouth of the Rio Grande may support algal mat growth after extensive rains or storm tide inundation. Such algal mats contribute to the lagoon system by fixing nitrogen (Shew *et al* 1981).

At the edge of lagoons and tidal bodies, and extending into salt water a few inches deep, grows a community of succulent halophytes, known as Batis-Salicornia-Suaeda. It is composed chiefly of *Batis maritima*, *Salicornia perennis*, *S. Bigelovii*, *Suaeda conferta* and *S. linearis* in varying relative abundance. *S. tampicensis* and *Cakile lanceolata geniculata* have also been found in Cameron and Willacy counties (Johnston 1955).

The Laguna Atascosa National Wildlife Refuge is an important estuarine wildlife habitat. To its north, the outflow regions of the Cayo Atascoas, the North Floodway and the Arroyo Colorado provide additional nursery areas for marine life. This area represents a logical extension of the conditions that led to the formation of the Refuge, and the Lower Rio Grande Valley Development Council designated it as one of six unique ecological areas within the region. It is considered essential habitat for large waterfowl and for fish, shrimp and crabs. It is an important source of fresh-water and nutrients for the Laguna Madre (Corps of Engineers 1980).

## Palustrine Wetlands

Resacas are often dry during summer months, but have a varied flora when filled. Spikesedge and mud plantain are often surrounded by dock and flat sedges. A succession of plant communities grows in and around the swales and ponds. In saline areas, succulent halophytes give way to the borrichia community, followed by cordgrass and finally brush. In cultivated areas only

succulent halophytes are present. At lower salinity, ponds in agricultural areas may contain bull-rushes, cattails, smart weeds, water-lilies, arrowheads, spikerushes and water hyacinth, which occasionally congests a freshwater pond, preventing the growth of other species. Aquatic vegetation, such as arrowheads, widgeon grass and burheads is common in man-made tanks and stock ponds (Corps of Engineers 1980).

The Lower Rio Grande Valley is very distinctive in terrain, vegetation, and climate; thus, it has a number of unique ecological areas. The following is a description of these unique areas (as described in the USFWS Biological Report 88(36) November 1988) in Cameron County.

#### Southmost Ranch

Southmost Ranch, located southeast of Brownsville, Texas, on the Rio Grande supports part of the remaining native Mexican palmetto community in the United States. Rio Grande thorn woodland also is present on the ranch. Southmost Ranch was ranked number 42 of the Top 100 Nationally Significant Fish and Wildlife Areas (USFWS, 1983). Within the 259-ha (640-acre) ranch, 6-ha (15 acres) are dominated by Mexican palmetto, 61-ha (150 acres) have mesquite and acacia with some palmetto, and the remainder is cultivated fields and pastures (USFWS, 1979). A variety of wildlife, including many peripheral species, exists in the Mexican palmetto forest community. Rare wildlife includes; the Mexican white-lipped frog (*Leptodactylus labialis*); Texas indigo snake; speckled racer; white-tipped dove (*Leptotila verreauxi*), tropical kingbird (*Tyrannus melancholicus*); white-collared seedeater (*Sporophila torqueola*); lesser yellow bat; and Mexican spiny pocket mouse (*Liomys irroratus*). The ocelot and jaguarundi may be present. Agricultural development and recreational use are primary threats to this area (USFWS, 1979).

#### Laguna Atascosa National Wildlife Refuge

Laguna Atascosa National Wildlife Refuge (NWR), the southernmost waterfowl refuge in the Central Flyway, was established in 1946. It contains 19,680-ha (48,597 acres) and is the largest refuge in the Lower Rio Grande Valley. About 65,000 ducks winter on the refuge (USFWS, 1986). Laguna Atascosa NWR contains coastal prairies, salt flats, and low vegetated ridges supporting thick, thorny shrubs (Fleetwood, 1973). Habitat types of the refuge include: 9,720-ha (24,000 acres) of wetlands; 5,670-ha (14,000 acres) of coastal prairie; 3,280-ha (8,100 acres) of brushland; 405-ha (1,000 acres) of croplands; and 607-ha (1,500 acres) of grasslands and savannah (USFWS, 1986). The refuge fauna includes 354 bird and 31 mammal species. Ocelot and jaguarundi recently have been sighted in the vicinity of Laguna Atascosa (S. Labuda, personal communication). In a 1980-81 survey of the area, 8 species of amphibians and 23 species of reptiles were collected (Scott, 1982). Because of drought conditions during this

period, 95% of the American alligators (*Alligator mississippiensis*) in the Lower Rio Grande Valley were concentrated on the refuge (Scott, 1982).

#### Texas Sabal Palm Sanctuary

The National Audubon Society's Texas Sabal Palm Sanctuary, purchased in 1971, is south of Brownsville along the Rio Grande. The sanctuary preserves part of one of the largest remaining stands of the native Mexican Palmetto. In 1940, the palm grove was >40-ha (>100 acres). By 1971, only about 13-ha (32 acres) remained. Currently, the sanctuary has a total of 70-ha (172 acres), including 49-ha (120 acres) of old fields that are being revegetated, and an 8-ha (20 acre) resaca (Miller, 1985a). Many birds use the area (Land, 1983; Miller, 1985a); for example, plain chachalaca, common ground dove (*Columbina passerina*), golden-fronted woodpecker (*Centurus aurifrons*), common pauraque (*Nyctidromus albicollis*), green jay, great kiskadee, Altamira orioles, and reseat spoonbills (*Ajaia ajaja*). Nearly 400 plant species have been identified in the palm grove.

#### 7.3.4.5 Threatened and Endangered Species

The Lower Rio Grande Valley has a wide array of habitat types and a corresponding diversity of species including subtropical species, species of the southwestern desert, and prairie, coastal marshlands, eastern forest, and estuarine and marine environments. This significant diversity in habitat, coupled with the fact that the Lower Rio Grande Valley is the northernmost limit for several subtropical species, has resulted in a significant number of species that are recognized as threatened or endangered by the Federal and State governments. Table 7-6 identifies the threatened, endangered, and rare fauna and flora which are known to occur or are highly likely to occur in the study area.

#### 7.3.4.6 Archaeological/Cultural Resources

Lying at the extreme southern tip of Texas, Cameron County contains a rich and unique selection of cultural resource sites. Numerous prehistoric and historic sites are found within the county. As of 1985, 96 prehistoric sites had been officially recorded in the county. Since then this number has increased substantially. Additionally, the official number does not reflect nearly a hundred sites recorded in the 1930s by A. E. Anderson. At least one of the Cameron County prehistoric sites, the Garcia Pasture site, is listed on the National Register of Historic Places (NRHP). Dozens of historic sites have been recorded or reported from Cameron County. These sites include 13 listed on the NRHP. Historic sites include both standing structures such as the Charles Stillman House, the Southern Pacific Railroad Passenger Depot, and the Port Isabel Lighthouse,

Table 7-6  
Rare, Threatened, and Endangered Species of Potential Occurrence and Known  
Natural Communities in Cameron County

COMMON NAME	SCIENTIFIC NAME	STATUS			
		FWS 1	TPWD 2	TNHP 3	TOES 4
<b>AMPHIBIANS</b>					
Sheep-Frog	<i>Hypopachus variolosus</i>		T	G5S2	T
White-lipped Frog	<i>Leptodactylus fragilis</i>		E	G4S1	E
Mexican Treefrog	<i>Smilisca baudini</i>		T		T
Mexican Burrowing Toad	<i>Rhinophrynus dorsalis</i>		T	G5S2	T
Giant Toad	<i>Bufo marinus</i>				WL
Black-Spotted Newt	<i>Notophthalmus meridionalis</i>	C2	E	G1S1	E
Rio Grande Lesser Siren	<i>Siren intermedia Texana</i>	C2	E	G5T2S2	E
Rio Grande chirping frog	<i>Synthopopus cystignathoides</i>			G5S3	WL
<b>REPTILES</b>					
American Alligator	<i>Alligator mississippiensis</i>	T/SA			WL
Speckled Racer	<i>Drymobius margaritiferus</i>		E	G5S1	WL
Texas Horned Lizard	<i>Phrynosoma cornutum</i>	C2	T		T
Reticulate Collared Lizard	<i>Crotaphytus reticulatus</i>	C2	T	G3S2	T
Northern Cat-eyed Snake	<i>Leptoderia septentrionalis</i>		E	G5T5S2	T
Black-Striped Snake	<i>Coniophanes imperialis</i>		T	G3S2	WL
Texas Indigo Snake	<i>Drymarchon corais erebennus</i>		T		WL
Texas Scarlet Snake	<i>Cemophora coccinea linei</i>		T	G5T2S2	WL
Mexican Milk Snake	<i>Lampropeltis triangulum</i>				WL
Texas Tortoise	<i>Gopherus berlandieri</i>		T	G4S3	T
Green Sea Turtle	<i>Chelonia mydas</i>	T	T	G3S2	T
Hawksbill Sea Turtle	<i>Eretmochelys imbricata</i>	E	E	G3S1	E
Loggerhead Sea Turtle	<i>Caretta caretta</i>	T	E	G3S2	T
Kemp's Ridley Sea Turtle	<i>Lepidochelys kempii</i>	E	E	G1S1	E
Leatherback Sea Turtle	<i>Demochelys coriacea</i>	E	E	G3S1	E
<b>MAMMALS</b> (excluding Cetaceans)					
Southern Yellow Bat	<i>Lesiurus ega</i>		T	G5S1	WL
Coues' Rice Rat	<i>Oryzomys couesi</i>		T	G5S2	T
Ocelot	<i>Felis pardalis</i>	E	E	G2S1	E
Jaguarundi	<i>Felis yagouaroundi</i>	E	E	G4S1	E
Cougar	<i>Felis concolor</i>			G4S2	
Jaguar	<i>Felis onca</i>	E	E	G3S4	E
Coati	<i>Nasua nasua</i>		E	G5S2	WL
Black Bear	<i>Ursus americanus</i>		E	G5S3	T
<b>BIRDS</b>					
Brown Pelican	<i>Pelecanus occidentalis</i>	E	E	G5S1	E
Reddish Egret	<i>Egretta rufescens</i>	C2	T	G4S2	T
Whitefaced Ibis	<i>Plegadis chihi</i>	C2	T	G4S2	T
Roseate Spoonbill	<i>Ajaia ajaja</i>			G5S4	
Wood Stork	<i>Mycteria americana</i>		T		T
Fulvous Whistling Duck	<i>Dendrocygna bicolor</i>				T
Least Grebe	<i>Tachybaptus dominicus</i>			G5S3	

CAMERON COUNTY REGIONAL PLANNING STUDY  
PRELIMINARY ENVIRONMENTAL ASSESSMENT

Masked Duck	<i>Oxyura dominica</i>			G5S4	WL
Osprey	<i>Pandion haliaetus</i>			G5S3	
American Swallow-tailed Kite	<i>Elanoides forficatus</i>		T	G5S2	T
Bald Eagle	<i>Haliaeetus leucocephalus</i>	E	E	G3S2	E
Common Black-hawk	<i>Buteogallus anthracinus</i>		T	G5S2	T
Northern Gray Hawk	<i>Buteo nitidus</i>		T	G5S1	T
White-tailed Hawk	<i>Buteo albicaudatus</i>		T	G5S2	T
Zone-tailed Hawk	<i>Buteo albonotatus</i>		T	G5S3	T
Golden Eagle	<i>Aquila chrysaetos</i>				WL
Merlin	<i>Falco columbarius</i>				T
Aplomado falcon	<i>Falco femoralis</i>	E	E	G4S1	E
American Peregrine Falcon	<i>Falco peregrinus anatum</i>	E	E	G3T2S1	E
Arctic Peregrine Falcon	<i>Falco peregrinus tundrius</i>	T	T	G3T1S1	T
Piping Plover	<i>Charadrius melodus</i>	T	T	G2S2	T
Northern Jacana	<i>Jacana spinosa</i>			G5S3	T
Coastal Least Tern	<i>Sterna antillarum antillarum</i>				T
Interior Least Tern	<i>Sterna antillarum athalassos</i>	E	E	G4T2S2	E
Sooty Tern	<i>Sterna fuscata</i>		T	G5S2	WL
Black Skimmer	<i>Rhyncops niger</i>				T
Red-billed Pigeon	<i>Columba flavorostris</i>			G5S4	T
Ferruginous pygmy-owl	<i>Glaucidium brasilianum</i>		T		WL
Ringed Kingfisher	<i>Ceryle torquata</i>			G5S2	WL
Northern beardless-tyrannulet	<i>Camptostoma imberbe</i>		T	G5S3	WL
Rose-throated becard	<i>Pachyrhamphus aglaiae</i>		T	G4G5S2	WL
Brown Jay	<i>Psittorhynchus morio</i>			G5S2	WL
Black-capped Vireo	<i>Vireo atricapillus</i>	E	E		T
Tropical Parula	<i>Parula pitiayumi</i>		T	G5S3	T
Golden-cheeked Warbler	<i>Dendroica chrysoparia</i>	E	E	G2S2	E
Botter's sparrow	<i>Aimophila botterii</i>	C2	T	G4S3	T
<b>FISH</b>					
Blackfin Goby	<i>Gobionellus atripinnus</i>		E	G3S1	
Phantom shiner	<i>Notropis orca</i>		E	G2	E
River Goby	<i>Awaous tajasica</i>		T		WL
Opossum Pipe Fish	<i>Oostethus brachyurus</i>		T		
<b>PLANTS</b>					
Montezuma Bald Cypress	<i>Taxodium mucronatum</i>			G4S1	E
Runyon's Water Willow	<i>Justicia runyonii</i>	C2		G2S2	
Texas Palmetto	<i>Sabal mexicana</i>			G2S1	T
Adelia Vesyl	<i>Adelia vaseyi</i>			G2S2	
Texas Stonecrop	<i>Lenophyllum texanum</i>			G3S3	
Lila de los Llanos	<i>Anthericum chandleri</i>	C1		G2S2	
Plains Gumweed	<i>Grindelia oolepis</i>			G2S2	WL
Texas Ayenia	<i>Ayenia limitaris</i>			G2S1	
South Texas Ragweed	<i>Ambrosia cheiranthifolia</i>	C1		G1S1	
Gregg Wild Buckwheat	<i>Eriogonum greggii</i>			G2S1	
Runyon's Huaco	<i>Polianthes runyonii</i>	C2		G2S2	
Wherry Mimosa	<i>Mimosa wherryana</i>			G3S3	
Mission Fiddleweed	<i>Citharexylum spathulatum</i>			G2S2	

CAMERON COUNTY REGIONAL PLANNING STUDY  
PRELIMINARY ENVIRONMENTAL ASSESSMENT

Rio Grande Ballon Vine	<i>Cardiospermum dissectum</i>			G2S2	
Johnston's Frankenia	<i>Frankenia johnstonii</i>	E	E	G2S2	
Shurbleaf Bladderpod	<i>Lesquerella thamnophila</i>	C2		G1S1	
Prostrate Milkweed	<i>Asclepias prostrata</i>	C2		G1S1	
Terrey's Tetramerium	<i>Tetramerium platystegium</i>			G3S3	
Ashy Dogweed	<i>Dyssodia tephroleuca</i>	E	E		
<b>NATURAL COMMUNITIES</b>					
Texas Palmetto Series				G2S1	
Texas Ebony - Snake-eye Series				G2S2	
Texas Ebony - Anacua Series				G2S1	
Sugarberry-Elm Series				G4S4	
Blackbrush Series				G5S5	

1

U.S. Fish and Wildlife service (1989a) E- Endangered; T-Threatened; T/SA - Threatened due to similarity of appearance. Because of the similarity of appearance of the Texas American Alligator hides and parts to the hides and parts of other protected crocodilians, it is necessary to restrict commercial activities involving alligator specimens taken in Texas to ensure the conservation of other alligator populations, as well as other crocodilians that are threatened or endangered. USFWS, 12 October 1983. Fed. Reg. 48 (198):46332-46337. C1-Candidate, category 1. USFS has substantial information on biological vulnerability threats to support proposing to list as endangered or threatened. Data are being gathered on habitat needs and for critical designations. C2-Candidate, category 2. Information indicates that proposing to list as endangered or threatened is possibly appropriate substantial data on biological vulnerability and threats are not currently known to support the immediate preparation of rules. Further biological research field study will be necessary to ascertain the status and/or taxonomic validity of the taxa in Category 2. C3-Former candidate, rejected because more common, widespread, or adequately protected.

2

Texas Parks and Wildlife Department, Endangered/Threatened Species Data File (TPWD, 1988 a,b,c). E-Endangered; T-Threatened.

3

Texas Natural Heritage Program, Special Species and Natural Community Status. G1-Critically imperiled globally, extremely rare, 5 or fewer occurrences. G2-Imperiled globally, very rare, 6 to 20 occurrences. G3-Very rare and local throughout range or found locally in restricted range, 21 to 100 occurrences. G4-Apparently secure globally. G5-Demonstrably secure globally S1-5 state ranking of the same categories as those listed globally.

4

Texas Organization for Endangered Species; Endangered, Threatened and watch lists of Plants and Vertebrates of Texas (March, 1987 - plants and January, 1988 - vertebrates). E-State endangered species - any species which is in danger of extinction in Texas or in addition to its federal status. T-State threatened species - any species which is likely to become a state endangered species within the foreseeable future. WL-TOES Watch List - any species which at present has either low population or restricted range in Texas and is not declining or being restricted in its range but requires attention to insure that the species does not become endangered or threatened. (State or Federal)

structural groups associated with archaeological deposits such as Fort Brown and the Old Brunlay Plantation, and historic archaeological sites without structures such as the Palo Alto Battlefield and the Resaca de la Palma Battlefield.

Archaeological sites in the Cameron County area fall into four general chronological periods. The earliest period, the Paleoindian, dates to the very late Pleistocene and early Holocene. Cultures of this period are often associated with now-extinct genera of Pleistocene mammals, including larger species such as mammoth, mastodon, camel, and horse. The subsequent Archaic period represents a long and diverse occupation of the region, with potential shifts in subsistence, settlement, technology, and population dynamics. The final prehistoric stage, the Late Prehistoric, is marked by the introduction of pottery and the bow and arrow. In extreme South Texas, the Mexican influence is dramatic during this period. Most of the known prehistoric sites in Cameron County date to this period. The final period, the Historic, begins with the arrival of the Europeans. Aboriginal sites from this period are marked by the presence of historic artifacts. The earliest European settlement of the area dates to the Spanish period although little remains of that era. Settlement began in earnest after Mexico won its independence from Spain.

A long list of archaeological studies have been completed in the Cameron County area, beginning with the work of A. E. Anderson in the 1920s and 1930s. An engineer and amateur archaeologist, he recorded more than 400 sites in southern Texas and northeastern Mexico. E. B. Sayles used Anderson's data to define the Brownsville archaeological complex which represents the Late Prehistoric Mexican-influenced cultures of the area. Early professional studies were conducted in the general area by T. N. Campbell of the University of Texas as well as Richard MacNeish, then of the Peabody Museum at Yale. In more recent years, major studies have been conducted by T. R. Hester, E. R. Prewitt and R. J. Mallouf. The 1977 study by Mallouf, Baskin and Killen was a predictive model survey which still stands as some of the better work in the area. Recent geomorphic/geoarchaeological studies by Michael Collins have helped to clarify the stratigraphy of archaeological sites in the area.

The density of recorded cultural resource sites in the Cameron County is unusually high and the expected density of unrecorded sites is enormous. Because of the uniqueness of both the Mexican-influenced prehistoric cultural sites and the early historic sites, many either associated with the Mexican or early Texas occupation as well as the Mexican Water itself, an unusually high proportion of sites can be expected to be significant. Some of these sites will be eligible for the NRHP or worthy of formal designation as State Archaeological Landmarks. Any projects undertaken by political subdivisions of the state or with Federal funds or permitting should involve



archaeological studies as part of the planning process since location of significant sites may act as a constraint on timing or location of projects.

#### 7.3.4.7 Land-Use and Socioeconomic Conditions

A three step approach has been used in assessing social and economic conditions in Cameron County, as they pertain to this plan. A broad overview of county-wide land use is followed by analysis of the basic socioeconomic structure of Cameron. The analysis includes summaries of recent demographic, employment and industrial data. Lastly, a focus upon the colonias will underscore the need for the Regional Plan in Cameron County.

Cameron County land use revolves around agriculture. Slightly over 50% of the land is utilized for cropland (irrigated and dryland), pasture/hayland and orchard land. Rangeland comprises another 15% of the land use base. Coastal, riverine and drainage features influence a significant portion of the county. Over 17% of the county possesses surface water and another 3% is occupied by wetlands. Table 7-7 presents a breakdown of land use by soil conservation service classifications. [Of the less significant land uses, barren land occupies 8%, urban/built-up land 4% and recreation land 1% (SCS 1980)].

Of the 259,409 residents of Cameron County approximately 52% are female (July 1987). Ethnically, the population is largely hispanic. Seventy-nine percent (79%) of the people are of spanish decent and only .3% are black. The two major cities are Brownsville and Harlingen. Brownsville, the largest in the Lower Rio Grande Valley, supports a population of over 102,000. Harlingen, the third largest in the Lower Rio Grande Valley, has a population of nearly 55,000 people (1986 U. S. Dept. of Commerce, Bureau of the Census).

In 1989 Cameron County possessed a labor force of approximately 104,095 people. Unemployment for 1989 was nearly 12% (see Table 7-8 for labor and employment figures in the study area from 1985-1989). The largest sources of employment include trade, service and local government sectors (see Table 7-9 for employment by industry in the study area from 1985-1989).

Private industry produces 75% of all non-farm income in Cameron County. Services, retail trade and manufacturing make up the bulk of this 75%. The remaining 25% of non-farm income stems from government sources (see Table 7-10 for personal income by industry source in the study area from 1982 through 1987).

The target communities for water and wastewater improvements in Cameron County are the colonias. These colonias range in size from 15 to over 700 households which have an average of

4.81 occupants. Surveys conducted for Texas Department of Commerce grants indicate annual per capita income in the households surveyed ranges from a high of greater than \$14,300.00 to a low of less than \$3,000.00. A 1987 survey of the colonias in the Lower Rio Grande Valley by the Texas Department of Human Services indicates that 98.8% of the colonias population is Hispanic, with an average household income of \$6,932. This data coupled with the 47% unemployment rate reported in this study reveal the service economic depression in the colonias.

**Table 7-7  
 Land Use By SCS Classification**

Land Use Category	Cameron Acreage	% of Total
Urban and Built up Land		
Urban	28638.31	3.86%
Other	30.66	0.00%
Agricultural Land	79337.94	10.70%
Cropland	292837.52	39.48%
Cropland (Irrigated)	5549.82	0.75%
Pasture and Hay Land	3020.20	0.41%
Pasture and Hay Land (Irrigated)	10149.12	1.37%
TOTAL AGRICULTURE	390,894.66	52.71%
Rangeland		
Open	78617.39	10.60%
Bushy	19163.75	2.58%
Water	128,182.52	17.28%
Wetlands	23655.74	3.19%
Barren Land	51726.80	6.97%
	11237.62	1.51%
Recreation Land	7573.51	1.02%
Other Land	2039.02	0.27%
<b>TOTAL</b>	<b>741759.92</b>	

Source: Soil Conservation Service 1980

In 1989 Cameron County possessed a labor force of approximately 104,095 people. Unemployment for 1989 was nearly 12% (see Table 7-8 for labor and employment figures in the study area from 1985-1989). The largest sources of employment include trade, service and local government sectors (see Table 7-9 for employment by industry in the study area from 1985-1989).

**Table 7-8**  
**Labor Force, Total Employment and**  
**Unemployment of the Study Area**  
**\*1985-1989**

	Cameron County	% Change
<b>Labor</b>		
1985	92,468	
1986	94,727	2.44%
1987	95,788	1.12%
1988	98,828	3.17%
1989	104,095	5.33%
<b>Total Employment</b>		
1985	79,092	
1986	79,759	0.84%
1987	82,050	2.87%
1988	85,725	4.48%
1989	91,866	7.16%
<b>Unemployment Rate</b>		
1985	14.5	
1986	15.8	+8.96%
1987	14.3	-9.49%
1988	13.3	-6.99%
1989	11.7	-12.03%

Source: Texas Employment Commission 1989

**Table 7-9**  
**Employment by Industry**  
**In Cameron County**  
**1985 - 1989**

Sector	1985	1986	1987	1988	1989
Agriculture	1806	1740	1757	1929	1974
Mining	81	76	44	42	14
Construction	3193	3037	9588	9610	2035
Manufacturing	9694	9209	9588	9610	10419
Transportation	3424	3236	2926	2950	2918
Communications and Utilities					
Trade	18276	17992	17466	17716	19213
Finance, Insurance, and Real Estate	3438	3350	3422	3501	3550
Service and other	11362	11787	12372	13711	16260
State Government	1875	2011	1939	2051	2014
Local Government	11254	12136	12891	13266	13975
<b>TOTAL</b>	<b>64403</b>	<b>64574</b>	<b>64735</b>	<b>66833</b>	<b>72372</b>

Source: Texas Employment Commission 1989

Private industry produces 75% of all non-farm income in Cameron County. Services, retail trade and manufacturing make up the bulk of this 75%. The remaining 25% of non-farm income stems from government sources (see Table 7-10 for personal income by industry source in the study area from 1982 through 1987).

The target communities for water and wastewater improvements in Cameron County are the colonias. These colonias range in size from 15 to over 700 households which have an average of 4.81 occupants. Surveys conducted for Texas Department of Commerce grants indicate annual per capita income in the households surveyed ranges from a high of greater than \$14,300.00 to a low of less than \$3,000.00. A 1987 survey of the colonias in the Lower Rio Grande Valley by the Texas Department of Human Services indicates that 98.8% of the colonias population is Hispanic, with an average household income of \$6,932. This data coupled with the 47% unemployment rate reported in this study reveal the service economic depression in the colonias.

### 7.3 Alternatives Analysis

The TWDB's Environmental Assessment guidelines require evaluation of alternative engineering methods and siting of facilities and subsequent evaluation of these alternatives with respect to environmental constraints. A preliminary set of alternatives was evaluated during this study. Sites and treatment methods with the most significant environmental constraints were avoided (for example, wetlands and wildlife management areas for sites; and on-site disposal in areas of poor soil conditions for treatment methods) to the highest degree possible. A detailed alternative analysis will be conducted in more specific documents (i.e. site specific Environmental Assessment or Environmental Information Documents) as necessary for specific state and federal programs.

### 7.4 Potential Environmental Impacts

Environmental constraints, if not avoided, can often become environmental impacts. During the preliminary design phase of this study environmental constraints were identified and avoided to the greatest extent possible. Potential impacts that could occur in Cameron County, if proper design does not occur, include, among others, impacts to threatened and endangered species, wetlands and cultural resources. At this preliminary level of evaluation none of the proposed water and wastewater plans were noted to have any significant environmental impacts. Again, a more detailed Environmental Assessment for any specific site will be necessary to further evaluate potential environmental impacts.

**Table 7-10**  
**Personal Income by Industry Source**  
**in the Study Area (thousands of dollars)**  
**1982-1987**

	1982	1987
<b>Nonfarm</b>	<b>1,043,681</b>	<b>1,233,031</b>
<b>Private</b>	<b>851,567</b>	<b>925,601</b>
<b>Manufacturing</b>	<b>171,604</b>	<b>158,976</b>
<b>Mining</b>	<b>12,276</b>	<b>3,774</b>
<b>Construction</b>	<b>85,651</b>	<b>70,882</b>
<b>Wholesale/Trade</b>	<b>75,805</b>	<b>55,975</b>
<b>Retail Trade</b>	<b>165,561</b>	<b>170,338</b>
<b>Finance, Insurance</b>	<b>51,646</b>	<b>68,183</b>
<b>and Real Estate</b>		
<b>Transportation,</b>		
<b>Communication</b>	<b>75,995</b>	<b>79,485</b>
<b>and Utilities</b>		
<b>Services</b>	<b>194,006</b>	<b>281,067</b>
<b>Ag. Services,</b>		
<b>Forestry Fisheries</b>	<b>19,023</b>	<b>36,921</b>
<b>and other</b>		
<b>Government</b>	<b>192,114</b>	<b>307,430</b>
<b>Federal Civilian</b>	<b>27,169</b>	<b>33,939</b>
<b>Federal Military</b>	<b>6,600</b>	<b>6,962</b>
<b>State and Local</b>	<b>158,345</b>	<b>266,529</b>
<b>Total</b>	<b>2,087,362</b>	<b>2,466,062</b>

Source: U. S. Department of Commerce 1987

## 8.0 INSTITUTIONAL AND LEGAL ISSUES

### 8.1 Regulatory Overview

Federal, State and local regulations will affect the development of water supply treatment and distribution facilities, and wastewater treatment and collection facilities within Cameron County. This section reviews Federal regulations, including U.S. Fish and Wildlife Service (FWS) Section 7 consultation for threatened and endangered species; U. S. Army Corps of Engineers (USCE) 404 permits for stream crossing and/or dredge and fill operations; the Environmental Protection Agency (EPA) - National Pollutant Discharge Elimination Systems (NPDES) permit for wastewater discharges; and the National Historic Preservation Act for cultural resources. State environmental regulations expected to be of concern include the Texas Antiquities Code, which applies to all action taken by political subdivisions of the State of Texas, and the Texas Water Commission (TWC) Water Quality Permit for wastewater discharges and appropriation of surface water rights. Local environmental regulations expected to be of particular concern include Cameron County's septic tank and local permitting, etc. Table 8-1 provides a synopsis of environmental considerations which may be of concern in the development of water supply facilities.

### 8.2 Federal Regulatory Considerations

#### Clean Water Act

The Clean Water Act (CWA) prohibits the discharge of pollutants from any discernible point source into the waters of the U.S., with the exceptions of those discharges that are permitted in compliance with the CWA. Permits authorized under the CWA that may be of concern in this plan include Section 404 permits for dredge and fill as issued by the USCE and the NPDES for the discharge of water as issued by the EPA.

#### USCE Section 404 Permit

Section 404 of the CWA, as administered by the USCE, regulates the placement of dredged (excavated) or fill material in "Waters of the U.S." Waters of the U.S. are broadly defined in Section 404 as any body of surface water (such as oceans, bays, rivers), all surface tributary streams with a defined channel (including intermittent waterways), any in-stream impoundments (i.e., lakes and ponds), many off-channel impoundments, and wetlands. "Dredged or fill material" has also been given rather broad meaning to include almost any material or object used for construction such as dirt, rocks, concrete, piles, pipes, etc. In regards to construction of a water intake structure or pipeline where a crossing or direct involvement with a surface tributary stream, impoundment, or wetland may be required, placement of the pipeline itself (regardless of construction material) and

Table 8-1  
 Synopsis of Environmental Regulatory Programs

Program	Considerations
<p><u>Federal</u></p> <p>Section 7 of the Endangered Species Act of 1973, as amended</p>	<ol style="list-style-type: none"> <li>1) Format Section 7 consultation with FWS and USCE and the applicant may be of USCE permit or any other Federal Permit.</li> <li>2) It will be the responsibility of the applicant to prove whether or not Federally-listed species occur in the project.</li> <li>3) If formal Section 7 consultation is required, schedule delays up to 90 days can be expected.</li> </ol>
<p>Corps of Engineers 404 Permit Requirement</p>	<ol style="list-style-type: none"> <li>1) A permit is required for pipeline crossing of surface water tributaries and waterways</li> <li>2) A "general permit" exists which significantly reduces the time and paperwork for pipeline construction authorizations.</li> <li>3) Should have information on potential impacts to cultural resources and threatened or endangered species prior to involvement of Corps.</li> </ol>
<p>EPA - NPDES Discharge Permit</p>	<ol style="list-style-type: none"> <li>1) Establishes criteria for treatment and discharge of wastewater, including pollutant limitations, prohibitions, and monitoring and reporting criteria.</li> <li>2) Administered by Texas Historic Commission and State Historic Preservation Officer.</li> <li>3) Generally requires archaeological survey of affected areas, and, occasionally, testing of more important sites; in some cases, indirect impact areas must be considered.</li> <li>4) Sites which are determined to be eligible for the National Register of historic Places may need preservation and/or mitigation.</li> </ol>

**Table 8-1**  
**Synopsis of Environmental Regulatory Programs**  
 (continued)

Program	Considerations
<p><b>State</b></p> <p>Texas Antiquities Code</p>	<p>1) Applies to actions taken by political subdivisions of the State of Texas.</p> <p>2) Administered by Texas Antiquities Committee.</p> <p>3) Generally requires archaeological survey of area of primary impact, and, occasionally, testing of potentially important sites.</p>
<p>TWC - State Water Quality Permit</p>	<p>1) Parallel program to NPDES permit.</p> <p>2) Designed to maintain ambient stream standards.</p> <p>3) Administered by Texas Water Commission.</p>
<p>TWC - State Water Rights Permit</p>	<p>1) Texas Water Law requires that a permit be acquired to divert, use or store State waters.</p> <p>2) Typical components of water rights application include a water conservation plan, an Environmental Assessment (or, possibly, an Environmental Impact Statement) and detailed engineering information.</p>



any trench backfill material within the area or jurisdiction is subject to permit requirements under 404 regulations.

The USCE Galveston District, has 404 regulatory responsibility for Cameron County, maintains a "general permit" for most pipeline construction projects. A general permit is a pre-authorized permit for a specifically identified activity which is conducted under certain specified conditions. General permits are issued on either a nationwide or regional basis. The purpose of general permits is to provide paperwork and time expenditure relief for permitting actions which are determined to be routine and resulting in little or no impacts to waters of the U.S.

With regard to water and wastewater storage and transmission facilities, crossing of surface tributaries with water lines will be necessary and, therefore, legally subject to permitting requirements under federal law. As pipeline construction activities are considered minor works with minimal impacts to waters of the U.S. by the USCE Galveston District (hence the general permit), the USCE does not spend much effort trying to enforce and specifically permit all pipeline construction projects. Even though the legal requirement for permitting exists, the USCE generally takes the position that as long as pipelines are constructed according to the conditions of the general permit (basically, return of natural contours and no permanent obstruction of water-courses); that no impacts occur to cultural resources or threatened or endangered species for which other federal regulations exist; and that no one (agency or individual) objects and complains about the activity, the activity is authorized under the general permit without formal notification and paperwork.

Under 404 regulations a general permit may be suspended for any given project and a full individual permit required if impacts to cultural resources, threatened or endangered species, or other factors of the public health and welfare are potentially to occur. An individual permit action can require from a minimum of three months to a year or longer to complete, and may also require public hearings and an Environmental Impact Statement. It should be noted that any of the service options which do or have a high probability of resulting in significant impacts to cultural resources or federally listed threatened or endangered species stand a high probability of not being authorized under a general permit.

### EPA-NPDES Permit

All point source discharges of wastewater into the waters of the U.S. are regulated under the CWA and require a NPDES permit. The NPDES permit establishes the criteria for treatment and discharge of the wastewater including pollutant limitations, prohibitions, and monitoring and reporting criteria. The treatment and discharge conditions described in the NPDES permit (in conjunction with the TWC - State Water Quality Permit) are typically designed to maintain ambient stream standards (as defined by the TWC) and require wasteload evaluation of all the cumulative impacts of all point sources discharged into receiving streams. Detailed evaluation of stream standards and existing wasteloads is required to determine the conditions of the NPDES permit.

### USFWS Section 7 Consultation for Threatened and Endangered Species

It is possible that formal Section 7 consultation between the FWS, USCE, and the County will be required before issuance of a USCE permit because of perceived direct and indirect impacts to Federally-listed Threatened and Endangered Species. Additionally, environmental groups may petition the FWS and the USCE to initiate Section 7 consultation if it is not initiated by the applicant (local project sponsor). It is the responsibility of the applicant to prove whether or not Federally-listed threatened or endangered species occur on the project area. If Section 7 consultation is required, considerable schedule delays (60-90 days minimum) will be inevitable during the period in which FWS conducts biological assessments and forms its "biological opinions".

### National Historic Preservation Act

Protection of cultural resource sites may be invoked through application for a Section 404 or Section 10 permit from the USCE should structures or lines be located in waters of the United States. Should the USCE become involved, it may request the opinion of the State Historic Preservation Officer (SHPO) concerning the effect of the project on cultural resources. Because of the high potential for cultural resources in the general area, it is certainly possible that the SHPO would, like the Texas Antiquities Committee (TAC), require an archaeological survey, site evaluation, and protection and/or mitigation measures for important sites located during the initial survey. In such cases, where both the TAC and the SHPO have jurisdiction, one agency will operate as the lead agency.

Cultural resources studies may be coordinated through the TWDB, where TWDB funds are utilized, or coordinated directly through the TAC.

### 8.3 State Regulatory Considerations

#### Texas Antiquities Code

Cameron County and all municipalities, water districts, etc. in the county are considered to be political subdivisions of the state under the provisions of the Texas Antiquities Code, and, therefore, must consider the effects of its actions upon possible archaeological sites. Under the code, all archaeological sites, either historic or prehistoric, and significant historic structures on lands belonging to or controlled by political subdivisions of the state are automatically considered to be State Archaeological Landmarks (SALs) and may be eligible for protection. Construction projects by the district will require a Texas Antiquities Permit and coordination with the TAC. In practice, this often necessitates an archaeological and historical survey or previously unsurveyed areas prior to any potentially destructive action. Sites recorded during this survey must be evaluated; those which are of significant historical or scientific value will be formally designated for SAL status and measures of protection or mitigation of adverse impact negotiated between the political subdivision and the TAC.

#### TWC-State Water Quality Permit

The TWC-State Water Quality Permit is the State of Texas' EPA-NPDES parallel program for wastewater discharges. Like the NPDES permit, the State Permit is designed to maintain stream standards. The permit is administered by the Wastewater Permits Section of the TWC. Any new discharges or change in quantity and/or quality of discharge will likely require both a NPDES and State Water Quality Discharge Permit.

#### TWC-State Water Rights Permit

The development of this plan requires a thorough analysis of the water demand and supply and use of existing water. Expected water supply shortage may require one or more of the following actions related to water rights: 1) reallocation of existing agricultural rights and/or 2) development of a surface water supply source and, thus, the need for a water (storage, diversions, and/or use) rights permit as issued by the TWC.

Anyone who desires to appropriate water must make an application in writing to the Texas Water Commission. The TWC, as a regulatory agency with broad discretionary powers, is charged with the administration of rights to the surface water resources of the State. The TWC consists of three members appointed by the Governor for six-year terms, with the consent of the Senate. The Chairman is designated by the Governor.

The Rules, Regulations, and Modes of Procedure of the Texas Water Commission prescribed the procedures for applying for a water permit. The TWC will consider an application for approval if the application is in proper form, complies with statutory provisions, contemplates and authorized use of water, does not impair existing water rights or vested riparian rights, and is not detrimental to the public welfare and environment.

After approval of an application, the TWC issues a permit giving the applicant the right to take and use water only to the extend stated. Permits may be "regular," "seasonal," "temporary," or "contract" in nature. A "regular" permit is permanent in nature and does not limit the appropriator to the taking of water during a particular season or between certain dates. A "seasonal" permit is also permanent in nature, but the taking of water is limited to certain months or days during the year. A "temporary" permit is granted for a period of time not exceeding three years and does not vest in the holder any permanent right to the use of water. A "contract" permit is granted for a stated duration and governs the use of water to be obtained from the storage facilities owned by another person or entity. A "contract" permit requires a written consent agreement or "contract" with the owner of the facility.

The TWC may also grant permits for the impoundment and storage of water with the use of the impounded water to be determined at a later date by the TWC.

Once the right to the use of water has been perfected by (1) issuance of a permit from the TWC and (2) subsequent beneficial use of the water by the permittee, the water authorized to be appropriated under the terms of the particular permit is not subject to further appropriation until the permit is cancelled. Formal cancellation of unused permits and certified filings is possible by administrative action initiated by the TWC or by judicial proceedings to adjudicate water rights between claimants (TWDB, 1977).

## 9.0 REVIEW OF FINANCING PROGRAMS

### 9.1. Bond Market

Construction of public works projects, like those described in Sections 4.0 and 5.0 of this report, is frequently financed by the selling of bonds. Entities such as cities, river authorities and other political subdivision can issue bonds and use the proceeds to construct capital improvement projects. The bonds are repaid, with interest, from taxes and/or fees collected in the service area. Because bonds issued by public entities are for the purpose of providing services, they are classified under federal law as "tax exempt," and the interest paid to bond holders does not have to be declared as ordinary income. Consequently, these bond holders are willing to lend their financial resources to public entities at a lower rate of interest than the going market rate.

#### 9.1.1 Texas Water Development Fund and Water Assistance Fund

In 1985 constitutional amendments were approved by Texas voters, authorizing the issuance of \$980 million of general obligation bonds to fund water development projects. An additional \$250 million was approved to establish the Water Bond Insurance Program which guarantees bonds issued by local governments. This was in addition to \$600 million previously authorized for the Water Development Fund and \$40 million appropriated for the Water Assistance Fund, which includes the Water Loan Assistance Fund. These loan funds are administered by the Texas Water Development Board (TWDB).

The Water Development Fund is used to provide loans to political subdivisions for the construction of water supply, wastewater treatment, flood control, regional water and wastewater facilities, and other related projects. Historically, the Water Development Fund was reserved for use by "hardship" political entities, who were unable to sell bonds at reasonable rates on the open market. The passage in 1985 of House Bill 2 resulted in an expansion of this program to include the use of the funds to provide loans for the construction of regional facilities. The TWDB is also authorized to purchase an interest in local/regional water supply or wastewater treatment projects in order to provide future excess capacity. The acquisition and/or construction of any one of the following engineering projects may be eligible for consideration under the Water Loan Assistance Program, Water Development Program, Water, Wastewater and Storage Facilities Acquisition Program, Water Quality Enhancement Program or Flood Control Program, as appropriate:

- conservation and development of surface or subsurface water resources, including the acquisition, modification or construction of dams, reservoirs and underground storage, or the the acquisition or purchase of rights in underground water and the drilling of wells;
- development of saline or brackish water, including desalination facilities;

- transportation facilities used to transport water to treatment facilities, storage or wholesale purchasers (retail distribution systems are not included);
- water treatment, including filtration and water and wastewater treatment plants;
- treatment works including those used in the storage, treatment, recycling and reclamation of waste, or which are necessary to recycle or reuse water at the most economical cost;
- structural and nonstructural flood control and drainage facilities.

Cities, special purpose districts, nonprofit water supply corporations and regional entities can apply to the TWDB for loan funds. In accordance with House Bill 2, the Board will continue to encourage local political entities to implement regional water supply and wastewater treatment facilities, consistent with the Texas Water Plan and the State Water Quality Management Plan. The bonds are issued as State of Texas General Obligation Bonds and, because they are guaranteed by the state, provide funding at generally a lower rate of interest than bonds sold on the open market. The interest rate is intended to reflect the true interest cost to the state, including issuance costs. The bonds are retired by the TWDB from funds collected from each loan.

Priority for the funds is given to regional projects which, by definition, serve more than one city, district, or other political entity. Individual cities and special purpose districts must be classified as "hardship cases" in order to be eligible. Small cities that do not have a credit rating and would have difficulty obtaining loans are typical applicants. Even though these cities would have difficulty obtaining funds on the open market, they must also be able to demonstrate to the TWDB that the funds will be repaid.

#### Water, Wastewater and Storage Facilities Acquisition Program

As a result of comprehensive water legislation in 1985, the TWDB was authorized to issue up to \$400 million in State of Texas General Obligation Bonds in order to purchase an undivided interest in water, sewer and flood protection projects insuring that optimum project development can be achieved. The TWDB's share could be as high as 50 percent. However, because of the State's poor financial condition there has not been a source of revenue available to the TWDB to repay debt service on this obligation. As a result, implementation of the program has been slow.

The program allows for projects to be designed to meet the future needs of a community, even if current demand is insufficient to provide the necessary revenues to retire the debt load associated with a larger project. Through the State Participation Program, a local entity could plan a larger project than necessary, with phasing of elements to the maximum extent possible, and solicit financial assistance from the TWDB. The TWDB would pay up to 50 percent of the project

costs and hold its share until some future date, at which time the local entity would be required to buy the Board's share. The local entity must enter into a binding agreement obligating it to begin paying debt service on the Board's original share, plus interest and financing costs, within a period of 8-12 years following project completion.

### 9.1.2 State Revolving Loan Fund

#### 9.1.2.1 Overview

The Texas State Water Pollution Control Revolving Fund (SRF) is administered by the TWDB and provides a source of low interest loan money for the construction of wastewater treatment facilities. The 1987 Clean Water Acts Amendments replaces the federal construction grants program and provides federal funds, at zero interest, which must be match by the state. State funds are provided from the sale of Texas Water Quality Enhancement bonds. By providing up to one dollar of state funds for each dollar of federal funds, the TWDB has been able to increase the availability of the funds, while making the loan money available at an interest rate of 5 to 6 percent.

Successful applicants must issue bonds, which are purchased by the TWDB. The applicant then redeems the bonds with revenues from taxes or user fees. As the loans are repaid and the bonds retired, the federal funds can be used again for subsequent loans with new bond money. In this manner, the federal government has provided a perpetual fund to sustain an ongoing program for water quality improvements.

#### 9.1.2.2 Eligibility

Any public entity having the authority to treat sewage and is designated as (or has applied for designation as) a waste treatment management agency is eligible to apply for these funds. This includes cities, towns, special purpose districts, river authorities or other public bodies. Eligible projects include:

- construction of secondary and advanced treatment works;
- alternatives to secondary and advanced treatment works;
- construction of interceptor sewers;
- repairs to existing collection systems to reduce inflow/infiltration;
- construction of reserve capacity;
- rehabilitation or replacement of collection systems necessary to overall project integrity; and
- new collection systems to complement existing or planned treatment capacity.

### 9.1.2.3 Conditions for a SRF Loan

The following conditions must be met in order to be eligible for a SRF loan:

- have the project on the TWDB's priority project list;
- develop or have in effect a water conservation plan;
- have an eligible project;
- demonstrate that a dedicated source of funds exists for loan repayment;
- use best practice treatment technology;
- have a cost effective project;
- consider alternative waste management techniques and innovative alternative waste treatment processes;
- show that I/I is not excessive or include I/I reduction as a part of the project;
- consider the project's recreational and open space potential;
- be consistent with area wide 208 and 303e water quality management plans;
- implement a user fee system and demonstrate financial and managerial capability;
- for projects over \$10 million, apply "Value Engineering;"
- obtain an environmental determination in compliance with the National Environmental Policy Act;
- comply with the Davis-Bacon Act in setting wage rates for labor used during construction; and
- consider the development of a capital financing plan.

### 9.1.2.4 Applying for a SRF Loan

It is advisable for an entity seeking to apply for a SRF loan to schedule a preplanning meeting with the TWDB staff. A representative of the entity's governing body and its engineering consultant should be present in order to obtain information about the eligibility of the project and the preparation of the application. When the facilities plans and environmental documents have been filed, a preapplication meeting with the TWDB staff should be scheduled.

The TWDB's annual schedule for processing an application is as follows:

- On or before April 1: A priority rating report is solicited by the TWDB Executive Administrator from all entities wishing to be included in the forthcoming year's intended use plan. The following information is required:
  - description and condition of existing facilities;



- description of present wastewater problems and future needs;
  - analysis of the planning area to include current and projected population, wastewater sources, influent and effluent characteristics and uses of receiving bodies of water;
  - status of the required wastewater permit for the project;
  - description of the means proposed to correct present problems and meet future demand;
  - estimated total cost; and
  - estimated project schedule.
- On or before July 1: The priority report is due at TWDB. Late applications will be added and considered with the appropriate population class list, in order of the date of submission, if all of the funds are not allocated.
  - By July 1: Project rating reports filed by applicants are used by TWDB staff to prepare a preliminary intended use plan.
  - After July 1: A public hearing is held on the intended use plan. By this date, the applicant must have filed a certified copy of a resolution of its governing body estimating total project costs and committing to file an application for an SRF loan on or before March 15 of the following year. Failure to do this will mean that the project will not be included in the intended use plan.
  - September: The intended use plan is presented to the Board for approval at a regularly scheduled meeting after federal appropriations have been made and funding levels established.
  - October: Board sets funding limits and determines which projects will be funded in each category. If projects cost less than estimated, remaining funds become available to those lower on the list. Those costing more can obtain additional funds from the water quality enhancement fund at higher interest rates.
  - March 15: Loan applications are due. This consists of an SRF engineering plan, environmental documents, water conservation plan and general, legal and fiscal data. Upon approval of the loan, contract documents are prepared and submitted to TWDB for review and approval. Following approval, the applicant then hires engineering contractors, using an open bidding system. The applicant should print the bonds and await notification of a closing date from TWDB staff. Upon closure of the loan, the cost for preparation of the required reports and contract documents used in the application can be reimbursed from the loan proceeds.

Because the rules specify that a new Intended Use Plan and priority funding list must be developed each year, an unsuccessful applicant must begin the process anew to secure funding in the following year.

### 9.1.3 State Participation Program

#### 9.1.3.1 Program Description

The Community Development Block Grant (CDBG) program was created by United States Congress in 1974 and is administered by the U.S. Department of Housing and Urban Development (HUD). Cities exceeding 50,000 population and counties larger than 200,000 are funded through the entitlement program; smaller entities are included in the non-entitlement category. Since 1981 the responsibility for administering the non-entitlement portion of the CDBG program has been transferred to the Texas to the Department of Commerce's Finance Division.

#### 9.1.3.2 Programs

The Community Development Fund contains about two-thirds of the total funding. Public works projects funded under the program include water/sewer improvement, street/drainage improvements, community centers and handicapped accessibility projects.

Texas Capital Fund is part of a program designed for the express purpose of creating new permanent jobs, primarily for low or moderate income persons. It is part of the Texas Community Development Program and encourages business development and expansion.

The Emergency/Urgent Need fund was established to respond to natural disasters and urgent situations that pose a threat to public health and safety. To qualify under the first category, the Governor must declare a state of emergency. The second category would be more applicable to water and sewer projects. The urgent need must have arisen within the last 18 months and must be based on satisfactory documentation completed or certified by the Texas Department of Health's Regional Director of Environmental and Consumer Health Protection.

The Special Impact Fund, funded under the Texas Community Development Program, provides funding to assist in infrastructure development in severely distressed unincorporated areas of counties. Water, sewer, street and drainage are the only eligible projects, which have to compete for funding in an annual statewide competition.

The Planning/Capacity Building Fund is designed to help communities to become more involved in community and economic development projects. It is also awarded as a result of a statewide

competition and focuses on planning activities that may be addressed with Texas Community Development Program funds and other similar resources.

## 9.2 Economically Distressed Areas Program (EDAP)

The Economically Distressed Areas Program (EDAP) is a recent financial assistance program designed to provide financial assistance for water and wastewater facilities in economically distressed areas. An economically distressed area is defined by the TWDB as an area in which water supply or sewer services are inadequate to meet minimal needs of residential users and in which financial resources are inadequate to meet these needs.

The general goal of the EDAP is to encourage and provide grant assistance to political subdivisions to serve economically distressed areas and further the orderly development of regional water and wastewater facilities. To ensure this goal, is EDAP monies may be used to fund for the entire range of activities related to the development of such facilities, including preliminary planning to determine the feasibility of a project:

- engineering, architectural, environmental, legal, title, fiscal, or economic studies;
- surveys, designs, plans, working drawings, specifications, procedures;
- any condemnation or other legal proceedings; and
- erection, building, acquisition, alteration, remodeling, improvement, or extension of a project, or the inspection or supervision of any of the foregoing items.

### 9.2.1 Applicability and Eligibility

Counties eligible for this program must either meet income (average per capita income of 25% below state average) and unemployment rate (average rate of 25% above state average) or be adjacent to an international border. Cameron County has been identified as an affected county by the TWDB.

### 9.2.2 Funding Mechanisms, Requirements and Repayment

The amount and form of financial assistance and repayment is typically based upon need and customer ability to pay. Need is first and foremost determined by the presence of serious and unacceptable health hazard to residents. Repayment is typically a function of ability to pay and other available source of funding available to the subdivision. The TWDB has developed a model that calculates the ability to pay based on the rates, fees, and charges that the average customer to be served by the project will be able to pay based on a comparison of what other families of similar income pay for comparable services. In short, the amount and form of financial assistance

and repayment is unique for each political subdivision and facility engineering data must be evaluated by the TWDB to determine the terms associated with the financial assistance.

### Facility Engineering

Facility engineering is made up of the two phases of studies and tasks that are performed to determine the engineering feasibility of water and wastewater facilities and to obtain plans and specification for constructing the facilities for an economically distressed area. The two phase of facility engineering are described below:

Facility Engineering Phase I - The studies, tasks, and reports that are performed to determine the most cost-effective alternative to meet water and wastewater facilities needs, determine the feasibility of the proposed alternative, and prepare an application for board financial assistance to construct the alternative. The requirements of Phase I are shown in Table 9-1.

Facility Engineering Phase II - The tasks that yield design reports, construction drawings, technical specifications, instructions, and other contract conditions and forms needed to construct water or wastewater facility.

The TWDB may through funds available through the research and planning fund, provide up to 75% of the cost of facility engineering.

## 10.0 RECOMMENDATIONS

### 10.1 Recommendations for Water Supply Options - Cameron County.

- Pursue the implementation of the Rio Grande Valley Water Conservation Project.
- Implement area-wide water conservation programs.
- Initiate area/regional treated wastewater reuse/recycling programs.
- Investigate programs to eliminate/decrease irrigation water losses with water savings being used to meet future municipal , industrial and domestic water demands.
- Continue to research the use of using low cost RO membrane technology to treat ground water supplies.
- Secure (purchase) irrigation water rights to convert to municipal rights as opportunities prevail.
- Continue prudent development of the Lower Rio Grande Valley aquifer for direct use or blending with existing supply.

### 10.2 Recommendations for Water Supply Options - Colonias.

- The PUB should provide water service to Hacienda Gardens (No. 7B), including a centralized water distribution system. The estimated cost for these improvements is \$330,000.
- The PUB should provide water service to the portion of Cameron Park currently served by the Military Highway WSC. The estimated cost of these improvements is \$2,970,000.
- A centralized water distribution system, should be constructed in the following colonias, with treated water supply being furnished by Santa Rosa (Cameron County WCID):
  - 6W -T2 Unknown Subdivision,
  - 13W -Q Unknown Subdivision (Santa Rosa),
  - 14W - W,
  - 15W- R Unknown Subdivision (S. Santa Rosa),
  - 16W-X Unknown Subdivision (Santa Rosa),
  - 17W- S.
- All raw and treated water purveyors who are currently serving colonias should continued to do so in the future, except for the Military Highway WSC's service to part of Cameron Park.

### 10.3 Recommendations for Wastewater Options - Colonias.(Table 10-1)

### 10.4 Implementation Schedule

- The PUB of Brownsville should immediately prepare an application to the TWDB for Phase I Engineering funds for Cameron Park under the Economically Distressed Areas Program (EDAP). Cameron Park is on the TWDB list of identified priority colonias.
- The PUB of Brownsville should begin screening the remainder of colonias within the PUB service area and begin preparation of EDAP funding application(s) for other areas of significant need.

TABLE 10-1  
Wastewater Collection, Treatment And Disposal Options  
for The Colonias of Cameron County, Texas

Desig.	Colonia Name	Year 2020			Sewered (Y/N)	Recommended Treatment Method	Recommended Disposal Method	Total Cost
		Pop.	Unit Density (1/Ac)	WW Gen. (MGD)				
1B	Cameron Park	7,327	4.15	0.73	Y	Wastewater Treatment Plant		
2B	Olmillo	3,532	1.86	0.35	Y	Wastewater Treatment Plant	\$3,413,000	
3B	Stuart Subdivision	1,960	8.02	0.20	Y	Wastewater Treatment Plant		
4B	San Pedro Carmen	1,450	4.07	0.15	Y	Wastewater Treatment Plant	\$3,605,000	
8B	Villa Nueva	798	2.55	0.08	Y	Wastewater Treatment Plant		
11B	Villa Cavazos	399	2.31	0.04	Y	Wastewater Treatment Plant	\$2,005,000	
5B	King Subdivision	1,265	4.16	0.13	Y	Group Together		
12B	Barrio Subdivision	389	1.39	0.04	Y	Group Together	\$2,700,000	
17B	Saldívar (I)	272	1.70	0.03	Y	Group Together		
20B	Unnamed D (Keller's)	243	2.27	0.02	Y	Group Together		
21B	Texas 4	243	1.52	0.02	Y	Group Together		
23B	Illinois Heights	204	1.68	0.02	Y	Group Together		
26B	Unknown	117	0.63	0.01	Y	Group Together		
27B	Unknown B (Hwy 802)	97	1.91	0.01	Y	Group Together		
6B	Alabama/Arkansas	1,022	0.86	0.10	Y	Group Together	\$2,775,000	
16B	Unknown	282	1.93	0.03	Y	Group Together		
18B	Villa Escondido	272	1.47	0.03	Y	Group Together		
25B	Villa Hermosa	126	1.37	0.01	Y	Group Together		
7B	Hacienda Gardens	944	3.78	0.09	Y	Wastewater Treatment Plant		
9B	Villa Pancho	603	1.66	0.06	Y	Wastewater Treatment Plant	\$1,860,000	
10B	Pleasant Meadows	584	2.90	0.06	Y	Wastewater Treatment Plant	\$965,000	
13B	Los Cuates	379	1.71	0.04	Y	Group Together		
15B	Coronado	302	1.11	0.03	Y	Group Together		
22B	511 Crossroads	243	1.72	0.02	Y	Group Together		
24B	Unkn. (Bimaville Air.)	195	1.90	0.02	Y	Group Together		
28B	21	88	2.00	0.01	Y	Group Together		
14B	Saldívar	302	1.41	0.03	Y	Wastewater Treatment Plant	\$2,445,000	
19B	Unnamed C	263	2.25	0.03	Y	Wastewater Treatment Plant	\$310,000	
						South Sewage Treatment Plant	\$270,000	

CAMERON COUNTY REGIONAL PLANNING STUDY  
RECOMMENDATIONS AND IMPLEMENTATION SCHEDULE

Wastewater Collection, Treatment And Disposal Options  
for The Colonias of Cameron County, Texas

Desig.	Colonia Name	Year 2020			Sewered (Y/N)	Recommended Treatment Method	Recommended Disposal Method	Total Cost
		Pop.	Unit Density (1/Ac)	WW Gen. (MGD)				
1W	Encantada	1,641	1.56	0.16	Y	Group Together	Own Treatment Plant	\$2,140,292
9W	El Calaboz	260	3.17	0.03	Y	Group Together	Own Treatment Plant	\$1,722,737
2W	Santa Maria	2,306	5.89	0.23	Y	Individual Collection / Treatment System	Own Treatment Plant	\$1,007,333
10W	Iglesia Antigua	206	4.20	0.02	Y	Individual Collection / Treatment System	Own treatment plant	\$878,695
3W	La Paloma	861	2.48	0.09	Y	Individual Collection / Treatment System	Own Treatment Plant	\$540,243
4W	Los Indios	699	1.43	0.07	Y	Group Together to Santa Rosa	Santa Rosa's Collection System	\$1,042,403
5W	Bluetown	580	2.00	0.06	Y	On-Site System	Mounded Pressure -dose System	\$295,000
6W	T2 Unknown Subd.	431	1.96	0.04	Y	On-Site System	Mounded Pressure -dose System	\$280,000
13W	Q Unknown Subd.	241	3.06	0.02	Y	Individual Collection / Treatment System	Own Treatment Plant	\$409,988
15W	R Unknown Subd.	196	1.60	0.02	Y	On-Site System	Mounded Pressure -dose System	\$170,000
17W	S	116	0.96	0.01	Y	On-Site System	Mounded Pressure -dose System	\$140,000
7W	El Venadito	287	1.44	0.29	N	On-Site System	Mounded Pressure -dose System	\$120,000
8W	Carricitos-Londrum	275	0.48	0.03	N	On-Site System	Mounded Pressure -dose System	\$295,000
11W	Palmer	285	1.81	0.03	Y	Individual Collection / Treatment System	Own Treatment Plant	\$409,988
12W	Unknown (Milita 2)	169	1.06	0.17	N	On-Site System	Mounded Pressure -dose System	\$170,000
14W	W	137	0.58	0.14	N	On-Site System	Mounded Pressure -dose System	\$140,000
16W	X Unknown Subd.	116	1.50	0.01	N	On-Site System	Mounded Pressure -dose System	\$120,000
1E	La Coma del Norte	868	1.77	0.09	Y	Group Together	Own Treatment Plant	\$2,035,280
4E	Laureles	381	1.34	0.04	Y	Individual Collection / Treatment System	Own Treatment Plant	\$765,488
8E	Unknown	262	3.31	0.00	Y	Individual Collection / Treatment System	Own Treatment Plant	\$779,984
12E	25	75	0.47	0.01	Y	On-Site System	Mounded Pressure -dose System	\$790,000
13E	Cisneros	144	1.44	0.01	Y	On-Site System	Mounded Pressure -dose System	\$475,000
2E	Lozano	680	2.78	0.01	Y	Individual Collection / Treatment System	Own Treatment Plant	\$355,496
3E	La Tina Ranch	662	2.29	0.01	Y	Individual Collection / Treatment System	Mounded Pressure -dose System	\$225,000
5E	Del Mar Heights	483	0.48	0.05	N	On-Site System	Mounded Pressure -dose System	\$439,666
10E	Unknown (Del Mar II)	290	0.95	0.03	N	On-Site System	To Los Fresnos' Collection System	\$860,267
6E	Orason/Chula Vista	464	0.45	0.05	N	Individual Collection / Treatment System	Harlingen Collection System	\$1,042,819
7E	Las Yeacas	281	3.56	0.00	Y	On-Site System	Harlingen Collection System	\$824,870
9E	Glenwood Acres Subd.	218	1.41	0.02	N	On-Site System	Harlingen Collection System	\$477,516
11E	Los Cuates	261	2.41	0.03	Y	Individual Collection System	Mounded Pressure -dose System	\$285,079
1H	Las Palmas	1,103	2.88	0.11	Y	Individual Collection System	Mounded Pressure -dose System	\$95,000
2H	Lago Subd.	695	3.46	0.07	Y	Group Together	San Benito Collection System	\$1,042,819
5H	Rice Tracts	234	1.50	0.02	Y	Individual Collection System	San Benito Collection System	\$824,870
3H	26	504	2.51	0.05	Y	Individual Collection System	Harlingen Collection System	\$477,516
4H	Lasana	217	2.00	0.02	Y	Individual Collection System	Harlingen Collection System	\$285,079
6H	Leal Subd.	217	1.83	0.02	Y	Individual Collection System	Mounded Pressure -dose System	\$95,000
7H	Leguna Escondido	95	1.10	0.01	N	On-Site System	Mounded Pressure -dose System	\$95,000

CAMERON COUNTY REGIONAL PLANNING STUDY  
RECOMMENDATIONS AND IMPLEMENTATION SCHEDULE

- The CCWDB should begin preparation of a screening mechanism to rate the colonias of Cameron County on severity of need.
- The CCWDB should begin preparation of applications for Phase I Engineering funding from the TWDB for the most severely distressed colonias.



11.0 REFERENCES

- Audrey's data on ethnicity, gender in Cameron County
- Blair, W. F. 1950. The Biotic Province of Texas. Texas Journal of Science 2:93-117.
- Bowles, William F. Intensive Survey of the Brownsville Ship Channel (Segment 2494), Report IS-55. Texas Department of Water Resources. Austin, Texas (August, 1983).
- Bowles, William F., Jr. Bacteriological Water Quality of the Arroyo Colorado (Segment 2201), Report LP86-05. Texas Water Commission, Austin, Texas (July, 1986).
- Bureau of Economic Geology, 1976, Geologic Atlas of Texas; The University of Texas at Austin.
- Cameron County Program Development and Management Department. 1986 Cameron County Colonia Re-Development Study
- Davis, Jack R. Intensive Survey of the Arroyo Colorado Segment 2201, Report IS-61. Texas Department of Water Resources. Austin, Texas (May, 1984).
- Davis, Jack R. Intensive Survey of the Arroyo Colorado Segment 2201, Report IS-69. Texas Department of Water Resources. Austin, Texas (January, 1985).
- Davis, Jack R. Intensive Survey of the Arroyo Colorado Segment 2201. Report IS-49. Texas Department of Water Resources. Austin, Texas (April, 1983).
- Gould, F. W. 1975. Texas Plants: A Checklist and Ecological Summary. Texas A&M University Press. College Station, Texas.
- Holz, Robert K. and Shane Davies. August 1989. Third World Texas: Colonias in the Lower Rio Grande Valley. A Report Submitted to The Policy Research Center. The LBJ School of Public Affairs. The University of Texas at Austin.
- Low Energy Membrane Nanofiltration for Removal of Color, Organics, and Hardness from Drinking Water Supplies, B. M. Watson et al, Kuwait Symposium on Management and Technology of Water Resources in Arid Zones, 1987
- Lower Rio Grande Development Council. 1988. Population Projections for Selected Rural Unincorporated Communities in Cameron, Hidalgo and Willacy Counties (1980-2005).
- Membrane Softening - The Concept and Application to Municipal Water Supply, William J. Conlon, P.E., et al, 4th World Congress on Desalination and Water Use, 1989, Kuwait
- Orton, R. B., 1977. National Weather Service, Cameron County Soil Survey, U.S.D.A. Soil Conservation Service.
- R. W. Beck and Associates, Inc. 1988. Brownsville Public Utilities Board - 1988 Wastewater Master Plan.
- Rauschuber, D. G. and M.P. Sullivan. March 1989. Environmental Inventory and Issues Report, Rio Grande Valley Water Conservation Project. Prepared for Rio Grande Valley Municipal Water Authority and Public Utilities Board of Brownsville.
- Rauschuber, D. G. and R. J. Brandes. April 1989. Technical Report - Operations Study Rio Grande Valley Water Conservation Project. report No. 03-02. Prepared for Rio Grande Valley Municipal Water Authority and Public Utilities Board of Brownsville. 5 Vols. Austin, Texas.
- SCS data on Cameron County
- Sellards, E. H., Akins, W. S., Plummer, F. B., 1981. The Geology of Texas: Bureau of Economic Geology.

- Skillem, Frank F. 1988. Texas Water Law Volume I. Sterling Press Incorporated, San Antonio, Texas.
- Texas A&M University. 1987. Estimates of the Total Population of Counties in Texas By Age, Sex and Race/Ethnicity for July 1, 1987.
- \_\_\_\_\_. 1988. Projections of the Population of Texas and Counties in Texas By Age, Sex and Race/Ethnicity for 1990-2025, December 1988.
- \_\_\_\_\_. 1988. Estimates of Population for Cameron, Hidalgo and Willacy Counties.
- Texas Board of Water Engineers. May 1960. Bulletin 6008-Water Levels in Observation Wells in Cameron, Hidalgo, and Starr Counties Texas 1950-1959. Austin, Texas.
- Texas Department of Commerce. November 1988. Estimates of the Total Population of Counties in Texas by Age, Sex, and Race/Ethnicity for July 1, 1987. Prepared by the Department of Rural Sociology, Texas Agricultural Experiment Station, Texas A&M University.
- Texas Department of Health. 1988. Rules & Regulations For Public Water Systems.
- Texas Department of Health. Construction Standards For On-Site Sewerage Facilities. January 1, 1990.
- Texas Department of Health. November 1977. Construction Standards For Private Sewage Facilities.
- Texas Department of Human Services. June 1988. The Colonias Fact Book.
- Texas Department of Water Resources. July 1979. Report 236-Stratigraphic and Hydrogeologic Framework Of Part Of The Coastal Plain of Texas. Austin, Texas.
- Texas Department of Water Resources. September 1983. Report 279-Occurrence and Quality of Ground Water in the Vicinity of Brownsville, Texas.
- Texas Department of Water Resources. Waste Load Evaluation For The Arroyo Colorado In The Nueces-Rio Grande Coastal Basin. Austin, Texas (draft, May 13, 1985).
- Texas Department of Water Resources. Water For Texas. 2 Vols. Austin, Texas. November 1984.
- Texas Education Agency. 1988. Cameron County School Enrollment Data (1984-1988).
- Texas Employment Commission 1985-1989. Annual Average Labor Force Estimates for Texas Counties. Austin, Texas.
- Texas Natural Heritage Program. 1989. Sensitive Species and Natural Communities within Cameron County, Texas.
- Texas Water Commission. 1989. Rules, Regulations and Design Criteria For Sewerage Systems.
- Texas Water Commission. Methodology. Compiled by the Modeling Unit of the Water Quality Standards and Evaluation Section, Austin, Texas.
- Texas Water Commission. The State of Texas Water Quality Inventory, 9th Edition, Report LP88-04. Austin, Texas (April, 1988).
- Texas Water Development Board. A Summary Of The Preliminary Plan For Proposed Water Resources Development in the Rio Grande Basin. Austin, Texas. August 1966.
- Texas Water Development Board. Continuing Water Resources Planning and Development for Texas - Draft. 2 Vols. Austin, Texas. May 1977.
- Texas Water Development Board. The Texas Water Plan. Austin, Texas. November 1968.

- Texas Water Development Board. Water For Texas: Today and Tomorrow - Draft. Austin, Texas. July 1990.
- Twidwell, Steve R. Intensive Surface Water Monitoring Survey for Segment 2201, Report IMS-72. Texas Department of Water Resources. Austin, Texas (reprinted March, 1984).
- U. S. Department of Commerce, Bureau of the Census. 1986. Population estimates, 1984 and per capita income, 1983. Series P-26.
- U. S. Department of Commerce. 1987. Local Area Personal Income 1982-1987
- U. S. Department of Interior. Bureau of Reclamation. September 1956. Availability of Ground Water In The Gulf Coast Region Of Texas - Open File Report. Austin, Texas.
- U. S. Environmental Protection Agency. On-Site Wastewater Treatment and Disposal Systems. Design Manual. October 1980.
- U. S. Environmental Protection Agency. Wastewater Treatment Facilities For Sewered Small Communities. EPA-625/1-77-009. Process Design Manual. October 1977.
- U. S. Soil Conservation 1980. Land Use By Type For Cameron County.
- U. S. Soil Conservation Service, Soil Survey for Cameron County, Texas.
- Use of Membrane Technology in Florida, Glenn M. Dykes, P.E., Administrator, Water Supply Section, Florida Department of Environmental Regulation, and William J. Conlon, P.E., Vice-President, Stone and Webster Water Technology Services
- Williams, D., Thompson, C.M., Jacobs, J.L., 1977. Cameron County Soil Survey: U.S.D.A., Soil Conservation Service.

August 29, 1991

Dr. Tommy Knowles, Director of Planning  
Texas Water Development Board  
P.O. Box 13231 Capitol Station  
Austin, Texas 78711-3231

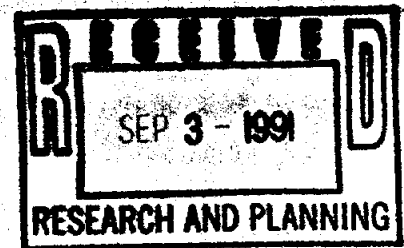

Re: Response to Letter of July 31, 1991 to  
The Honorable Antonio Garza, Jr., Cameron County Judge  
Review Comments to TWDB Contract No. 9-483-733  
Cameron County Regional Water and Wastewater Planning Study

Dear Dr. Knowles:

The following responses are presented pursuant to your supplemental comments.

**Response to Comment 5.**

We concur with staff's comment that "...certain on-site systems have been shown to operate effectively under conditions such as exist in Cameron County". As such, recommendations for the use of on-site technologies were made in the original draft of the study. Table 10-1 summarizes recommended wastewater disposal methods for the colonias evaluated. On-site technologies were recommended for nine of the colonias. At the level which this study was performed, it was not possible to make lot-by-lot determinations for the suitability of on-site technologies. Based on more intensive site analyses for specific areas, on-site technologies may be found to be appropriate and the preferred method of disposal.

**Response to Comment 8.**

The attached Figures A-1 and A-2 summarize, in chart form, data contained in the 1987 Turner Collie & Braden/Texas Water Development Board (TCB/TWDB) study entitled "A Reconnaissance Level Study of Water Supply and Wastewater Disposal Needs of the Colonias of the Lower Rio Grande Valley". Appendix A-4 of the TCB/TWDB study identified estimated capital and operating and maintenance costs for providing wastewater treatment to 39 individual colonias in Cameron County. The 39 colonias fell into Classifications 1, 2, and 3, as defined in the TCB/TWDB study. The wastewater treatment methods evaluated included a generic oxidation pond system and a generic activated sludge treatment system. Figure A-1 summarizes estimated total capital costs based on projected average daily wastewater flows for each of the 39 colonias. Figure A-2 summarizes estimated annual operating and maintenance costs for the treatment systems evaluated. Data contained in the TCB/TWDB study was utilized to form the basis of our recommendations. The TCB/TWDB data presented the most comprehensive database from which to develop our recommendations. In all flow categories, oxidation pond systems were found to be the most cost-effective method of providing the levels of treatment anticipated for the projected wastewater flows for the colonias which these systems were recommended.

Subsequent to submittal of the the Draft Cameron County study, we have been involved in attempting to summarize unit cost estimates for various other treatment technologies, including constructed wetlands. At the time the Draft Cameron County study was submitted, the Texas Water Commission had not adopted final rules concerning design of constructed wetlands. Data on construction costs and operations and maintenance costs for constructed wetlands in Texas is limited due to the minimal number of systems in operation. In an effort to develop a basic understanding of the costs associated with constructed wetlands, we contacted Mr. Andrew Cueto, P.E. (a) of the Texas Water Commission. Mr. Cueto was very helpful in providing us with cost information which he had collected during his work on developing design criteria for constructed wetlands. A summary of the information which was made available to us is presented in the attached Tables A-1 through A-6.

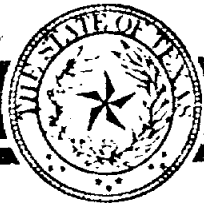

# TEXAS WATER DEVELOPMENT BOARD

Charles W. Jenness, *Chairman*  
Thomas M. Dunning, *Member*  
Né Fernandez, *Member*

Craig Pedersen,  
*Executive Administrator*

Wesley E. Pittman, *Executive Director*  
William B. Madden, *Member*

July 31, 1991

The Honorable Antonio Garza, Jr.  
Cameron County Judge  
904 E. Harrison  
Brownsville, Texas 78540

Dear Judge Garza:

Re: TWDB Contract No. 9-483-733: Cameron County Regional Water and Wastewater Planning Study

The Texas Water Development Board has received Michael P. Sullivan's letter of July 26, 1991, responding to comments on subject study contained in our letter of November 7, 1990. We have reviewed Mr. Sullivan's responses, and find that all review comments have been adequately addressed except for comments 5, 8, and 11. These numbers refer to Water Development Board comments, which are consistently numbered in both our original letter and Mr. Sullivan's July 26, 1991 letter.

We would appreciate your reconsidering the responses to these three items, and making some adjustments which should allow the local perspective to be maintained, while adequately addressing contract requirements. Bold type shows our original comment, with additional comments/responses in regular type below.

5. Page 5-1 contains the statement that "The consensus among Cameron county governmental and regulatory officials is that all septic systems will eventually fail and that, from a public health viewpoint, they should be avoided." The Board's staff believes that the statement lacks accuracy and that the logic that septic systems should be avoided because they eventually fail is defective. According to Texas Department of Health estimates, as many as 4,000,000 Texans rely on on-site systems for sewage treatment and disposal, and most of these individuals are being adequately serviced by on-site systems. Septic systems and other on-site systems which meet the present day standards are viable alternatives and, in many cases, offer the most cost-effective means of handling the wastewater. Accordingly, the Board's staff recommends that the applicability of the sentence be reconsidered and modified appropriately.

July 31, 1991

Page Two

There certainly was no intention on the part of the Board's staff to minimize or trivialize the viewpoint of local officials who are very close to the situation. We concur that most conventional on-site septic systems are not appropriate for the Cameron County area. However, as numerous studies have shown, mound systems, pressure-dosed systems, and other nonconventional on-site systems operate very effectively with a high ground water table, such as exists in Cameron County. We note that in Mr. Sullivan's analysis of alternative systems, a pressure-dosed mound system was included as an alternative. Accordingly, while certainly acknowledging the preference of local officials for centralized wastewater treatment, and concurring that conventional on-site systems are not generally applicable in Cameron County, we believe this section should at least note that certain on-site systems have been shown to operate effectively under conditions such as exist in Cameron County.

8. The draft report does not appear to provide an actual cost effectiveness analysis of alternatives. Instead, tables 5-10, 5-12, 5-15, and 5-18 only present initial capital costs of two alternatives for each colonia. An acceptable cost comparison would need to include operation and maintenance costs, salvage values, and other costs factors presented in terms of present worth values (or equivalent annual costs) and to detail any overriding social and environmental costs. It also appears that the costs for conventional sewers in the tables do not include the costs of house laterals. The cost for on-site systems needs to be revised because it appears to assume that every single system would have to be replaced. This assumption is probably not valid considering that only about 15 percent of the systems are having problems according to the estimate given on page 5-1 of the report. Without a complete cost-effectiveness analysis of alternatives, the recommendations in table 10-1 can only be considered unsubstantiated.

A cost effective analysis, which is required by our contract with Cameron County, requires the comparison of both construction, operating, and maintenance costs to determine a recommended system, rather than assuming a recommended system, and then calculating the cost. While we certainly do not expect individual alternatives to be prepared for each possibility within Cameron County, it seems appropriate to compare at least two different treatment technologies, for example, facultative lagoons and an alternative treatment system such as artificial wetlands, or rock reed filters. Please review this particular section, and see if it can be revised so as to actually show comparative costs between at least two different treatment systems. Use of a standard per lot cost for the on-site alternative seems reasonable.

11. Several water supply alternatives are proposed, but a recommendation is not given, and the names of users who might need additional supplies were not provided.

Although we concur that a detailed analysis of the adequacy of water supplies in Cameron County is beyond the scope of the study, a planning recommendation that a particular unincorporated area receive water from a water supplier which may not have capacity to supply this water seems inconsistent, even in a study of limited specificity, such as this one. We suggest that you simply check with the proposed suppliers, and include a statement as to the ability of that supplier to meet the demands of the recommended option.

July 31, 1991

Page Three

We appreciate the response to our comments, and those of the Texas Water Commission. While we certainly do not wish to burden you with details that are unnecessary and redundant, we believe that these three remaining items should be addressed prior to acceptance of the planning report for Cameron County if it is to be consistent with the body of engineering knowledge that is available today, our contract with Cameron County, and if it is to be useful to the County for future planning purposes.

If you have questions, or wish to discuss it further, please let us know.

Sincerely,

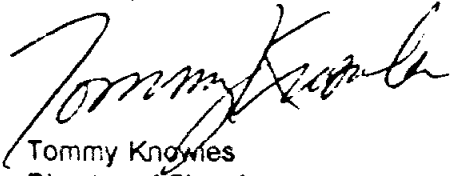
A handwritten signature in black ink, appearing to read "Tommy Knowles". The signature is written in a cursive, flowing style.

Tommy Knowles  
Director of Planning

cc: Mr. Michael P. Sullivan, P.E.

July 31, 1991

Brittin GBB 7-31-91  
Bond 47  
Knowles JKB/VA

The Honorable Antonio Garza, Jr.  
Cameron County Judge  
904 E. Harrison  
Brownsville, Texas 78540

Dear Judge Garza:

Re: TWDB Contract No. 9-483-733: Cameron County Regional Water and Wastewater  
Planning Study

The Texas Water Development Board has received Michael P. Sullivan's letter of July 26, 1991, responding to comments on subject study contained in our letter of November 7, 1990. We have reviewed Mr. Sullivan's responses, and find that all review comments have been adequately addressed except for comments 5., 8., and 11. These numbers refer to Water Development Board comments, which are consistently numbered in both our original letter and Mr. Sullivan's July 26, 1991 letter.

We would appreciate your reconsidering the responses to these three items, and making some adjustments which should allow the local perspective to be maintained, while adequately addressing contract requirements. Bold type shows our original comment, with additional comments/responses in regular type below.

5. Page 5-1 contains the statement that "The consensus among Cameron county governmental and regulatory officials is that all septic systems will eventually fail and that, from a public health viewpoint, they should be avoided." The Board's staff believes that the statement lacks accuracy and that the logic that septic systems should be avoided because they eventually fail is defective. According to Texas Department of Health estimates, as many as 4,000,000 Texans rely on on-site systems for sewage treatment and disposal, and most of these individuals are being adequately serviced by on-site systems. Septic systems and other on-site systems which meet the present day standards are viable alternatives and, in many cases, offer the most cost-effective means of handling the wastewater. Accordingly, the Board's staff recommends that the applicability of the sentence be reconsidered and modified appropriately.



There certainly was no intention on the part of the Board's staff to minimize or trivialize the viewpoint of local officials who are very close to the situation. We concur that most conventional on-site septic systems are not appropriate for the Cameron County area. However, as numerous studies have shown, mound systems, pressure-dosed systems, and other nonconventional on-site systems operate very effectively with a high ground water table, such as exists in Cameron County. We note that in Mr. Sullivan's analysis of alternative systems, a pressure-dosed mound system was included as an alternative. Accordingly, while certainly acknowledging the preference of local officials for centralized wastewater treatment, and concurring that conventional on-site systems are not generally applicable in Cameron County, we believe this section should at least note that certain on-site systems have been shown to operate effectively under conditions such as exist in Cameron County.

8. **The draft report does not appear to provide an actual cost effectiveness analysis of alternatives. Instead, tables 5-10, 5-12, 5-15, and 5-18 only present initial capital costs of two alternatives for each colonia. An acceptable cost comparison would need to include operation and maintenance costs, salvage values, and other costs factors presented in terms of present worth values (or equivalent annual costs) and to detail any overriding social and environmental costs. It also appears that the costs for conventional sewers in the tables do not include the costs of house laterals. The cost for on-site systems needs to be revised because it appears to assume that every single system would have to be replaced. This assumption is probably not valid considering that only about 15 percent of the systems are having problems according to the estimate given on page 5-1 of the report. Without a complete cost-effectiveness analysis of alternatives, the recommendations in table 10-1 can only be considered unsubstantiated.**

A cost effective analysis, which is required by our contract with Cameron County, requires the comparison of both construction, operating, and maintenance costs to determine a recommended system, rather than assuming a recommended system, and then calculating the cost. While we certainly do not expect individual alternatives to be prepared for each possibility within Cameron County, it seems appropriate to compare at least two different treatment technologies, for example, facultative lagoons and an alternative treatment system such as artificial wetlands, or rock reed filters. Please review this particular section, and see if it can be revised so as to actually show comparative costs between at least two different treatment systems. Use of a standard per lot cost for the on-site alternative seems reasonable.

11. **Several water supply alternatives are proposed, but a recommendation is not given, and the names of users who might need additional supplies were not provided.**

Although we concur that a detailed analysis of the adequacy of water supplies in Cameron County is beyond the scope of the study, a planning recommendation that a particular unincorporated area receive water from a water supplier which may not have capacity to supply this water seems inconsistent, even in a study of limited specificity, such as this one. We suggest that you simply check with the proposed suppliers, and include a statement as to the ability of that supplier to meet the demands of the recommended option.

July 31, 1991  
Page Three

We appreciate the response to our comments, and those of the Texas Water Commission. While we certainly do not wish to burden you with details that are unnecessary and redundant, we believe that these three remaining items should be addressed prior to acceptance of the planning report for Cameron County if it is to be consistent with the body of engineering knowledge that is available today, our contract with Cameron County, and if it is to be useful to the County for future planning purposes.

If you have questions, or wish to discuss it further, please let us know.

Sincerely,

Tommy Knowles  
Director of Planning

cc: Mr. Michael P. Sullivan, P.E.



July, 26, 1991

Dr. Tommy Knowles, Director of Planning  
Texas Water Development Board  
P.O. Box 13231 Capitol Station  
Austin, Texas 78711-3231

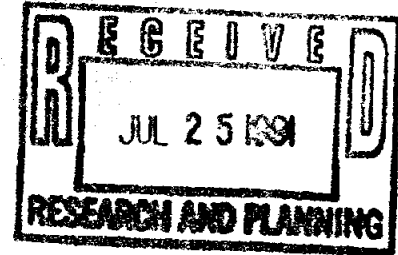

Re: Response to Letter of November 7, 1990  
Review Comments to TWDB Contract No. 9-483-733  
Cameron County Regional Water and Wastewater Planning Study

Dear Mr. Knowles:

This letter shall serve as a formal response to the comments contained in your November 7, 1990 letter regarding the Review of Draft Final Report for TWDB Contract No. 9-483-733, Cameron County Regional Water and Wastewater Planning Study (the Study). In order to insure a continuity between the original staff comments and our responses, the comments are presented in *bold italics* with the response following. The comments are presented in the order in which they occur in your letter.

#### Texas Water Development Board Comments

1. *The final report needs to be amended to fully satisfy the scope of work detailed in TWDB Contract No. 9-483-733.*

With the incorporation of these responses to comments we hope that the scope of work will be satisfactorily addressed. Where we concurred with staff comments, changes have been incorporated into the report text. Where we do not concur, explanation is supplied in this letter.

2. *Population and water demand projections utilized in the report are adequate for planning purposes.*

No response required.

3. *The wastewater flow projections of chapter 3 are based on 100 gallons per capita per day. This rate is significantly higher than what is expected for a bedroom type community such as a colonia. EPA studies into domestic water uses indicate that middle income residents typically generate 60 to 80 gpcd of sewage. This historical range does not account for reductions available through a good water conservation program. Data available to the TWDB's Water Uses and Projections section indicate that total water consumption in the rural areas of Cameron County are in the range on 90 gallons per capita per day. The sewage would be expected to be 90% or less of that. Since alternative identification is so dependant on flow rates, the report should reconsider the appropriateness of the 100 gpcd in light of existing rates and water conservation options. A 10% to 20% change in the flows may change the alternatives, and economic rankings.*

The use of 100 gpcd for wastewater design flows is consistent with accepted engineering practice and State design criteria for wastewater collection and treatment systems. The recently constructed 390,000 gpd wastewater treatment facility in Santa Rosa (funded through the Texas Department of Commerce) was designed based on a design flow of 100 gpcd. Information which we have obtained through the review of sanitary surveys of water purveyors in the Lower Rio Grande area (performed by the

Texas Department of Health) indicate a wide range of water use patterns. Current sanitary survey results are summarized below:

Summary of Sanitary Surveys for Typical Rural Areas of  
the Lower Rio Grande Valley

System Name	Population Served	Average Daily Usage (gpd)	Average Daily Per Capita Usage (gpcd)
City of Lyford	1,900	225,000	118
Port Mansfield PUD	734	75,000	102
Sunny Dew WSC	306	36,000	118
City of Raymondville	9,348	1,545,000	165
Santa Rosa WCID	238,000	1,889	126
Sebastian WSC	1,565	116,000	74

Using these figures, the average daily per capita water usage is estimated to be approximately 117 gallons. Table 3-1 of the Study lists TWDB population projections (low series and high series) for municipalities in Cameron County through 2020. Table 3-8 lists projected municipal water demands for the high per capita TWDB water use series with and without water conservation. Development of projected populations and water use for the Study was based on TWDB high series population projections and TWDB high water use series with water conservation. Combining the population and projected water use figures found in Tables 3-2 and 3-9, average daily water use projections for 'unincorporated' areas are estimated to be 143 gpcd for planning year 1990 and 125 gpcd for planning year 2020. Thus, for the purposes of the Study, we feel that the use of 100 gpcd is appropriate.

- Page 5-10 of the report states that 'per capita (water) use rates are expected to increase dramatically and eventually approach statewide averages,' and according to John Bruclak of Brownsville's' PUB, 'water use rates have shown a marked increase in areas where city services have been improved.' First, the Board staff expects water use to approach the county or regional average rather than the statewide average, and further, the report should also recognize that the 10-year regional trend for South Texas is a decreasing consumption rate. Secondly, because the Board lacks data on the long-term water use changes in colonias after adequate water and wastewater services are provided, the contractor should quantify in the report the increases that John Bruclak reports as having occurred after the PUB has provided city services to a colonia.*

Prior to commencement of the study, discussions were held with Mr. James T. Fries (then Contract Administrator for TWDB). The wide disparity of water use rates in the Lower Rio Grande Valley were discussed and all agreed that a water use rate of 125 gpcd and a wastewater generation rate of 100 gpcd were appropriate for the county-wide planning level study.

The anecdotal reference to water use rates attributed to Mr. Bruclak is an opinion based on his personal and professional experience in the area and will remain as it was originally stated without further clarification. The water use projections used throughout the Study are based on TWDB high population series/high water use series estimates with water conservation.

- Page 5-1 contains the statement that 'The consensus among Cameron County governmental and regulatory officials is that all septic systems will eventually fail and that, from a public health viewpoint, they should be avoided.' The Board's*

*staff believes that the statement lacks accuracy and that the logic that septic systems should be avoided because they eventually fail is defective. According to Texas Department of Health estimates, as many as 4,000,000 Texans rely on on-site systems for sewage treatment and disposal, and most of these individuals are being adequately serviced by on-site systems. Septic systems and other on-site systems which meet the present day standards are viable alternatives and, in many cases, offer the most cost-effective means of handling the wastewater. Accordingly, the Board's staff recommends that the applicability of the sentence be reconsidered and modified appropriately.*

Although the comment summarizes the feelings of numerous individuals in County and local government, the comment may be more directly attributed to Mr. Ray Rodriguez, R.S, Chief Sanitarian for the Cameron County Environmental Health Department. The comment is based on Mr. Rodriguez' extensive personal and professional experience in the County and should not be minimized or trivialized by Board's staff. County health officials rarely have problems with systems which are properly designed and constructed. The problem is that most of the on-site systems in Cameron County are improperly constructed and if not failing now, are destined to fail prematurely, when compared to properly constructed and maintained systems. The reasons for this include: less than adequate lot size; improper use and maintenance of the systems; dwelling densities typically far in excess of 2 units per acre; and inadequate drainage. Environmental Assessments and Wastewater Assessments, performed by the Texas Department of Health in Cameron County and Willacy County, support the observation that on-site wastewater disposal systems are inappropriate under conditions common to colonias in the Lower Rio Grande Valley.

6. *Table 5-4 incorrectly lists the City of Harlingen's wastewater treatment capacity at 3.6 mgd because the capacity of plant number 1 was excluded. The table identifies five (5) mgd capacity for the Brownsville PUB as existing even though construction has not yet started. Therefore, the table should be corrected.*

We concur with the comment. A corrected version of the table has been included in the final report.

7. *The study does not appear to consider innovative and non-conventional alternatives for the colonias, which is a prerequisite for the Board to fund the construction of wastewater treatment facilities. If the regional report is to be used in conjunction with requests for financial assistance for colonia facilities, innovative and non-conventional alternatives need to be presented and assessed in the report.*

The Study is not intended as an Economically Distressed Areas Program Phase I Facility Engineering Plan. The Study is intended to serve as a long-term regional planning tool. Funds for construction of wastewater treatment facilities are not being sought as part of the Study. Specific studies meeting the requirements of the various State and Federal grant/loan assistance programs will be developed if and when funds are requested under those programs.

8. *The draft report does not appear to provide an actual cost effectiveness analysis of alternatives. Instead, tables 5-10, 5-12, 5-15, and 5-18 only present initial capital costs of two alternatives for each colonia. An acceptable cost comparison would need to include operation and maintenance costs, salvage values, and other costs factors presented in terms of present worth values (or equivalent annual costs) and to detail any overriding social and environmental costs. It also appears that the costs for conventional sewers in the tables do not include the costs of house laterals. The cost for on-site systems needs to be revised because it appears to assume that every single system would have to be replaced. This assumption is probably not valid considering that only about 15 percent of the systems are having problems according to the estimate given on page 5-1 of the report. Without a complete cost-effectiveness analysis of*

*alternatives, the recommendations in table 10-1 can only be considered unsubstantiated.*

Based on consultations with local engineers, past engineering experience within the Water Resources Planning Group, and review of existing planning reports for the Lower Rio Grande Valley, it was determined that proposed wastewater treatment plant facilities would consist solely of facultative lagoons (where new facilities were required and projected wastewater flows were less than 300,000 gallons per day). Many systems of this variety exist in the vicinity. Under normal conditions, these plants are the least expensive to design, construct, operate, and maintain. Evaluation of more energy consumptive, high operations and maintenance cost systems, was considered unnecessary and redundant based on available information for the area.

The costs for house laterals have previously been included in the cost estimates for sanitary sewers under the item for 6-inch house connection.

It is difficult to provide an exact percentage for the number of on-site systems that are having problems in the colonias of Cameron County. Based on site visits to the colonias performed as part of this project, it was determined that a 'worst case' scenario would be appropriate for estimating projected costs for providing on-site systems. Conditions within the majority of colonias are unsuitable for proper construction, operation, and maintenance of on-site systems. Typical lot sizes for colonias which are located in platted subdivisions are typically less than 1/5-acre. The on-site disposal systems are typically overloaded. Grey water is discharged to the ground surface in order to reduce overall wastewater flows to the subsurface disposal system. Colonias which do not lie within a platted subdivision typically display similar housing densities. In order to insure that an artificially low value for providing adequate on-site systems was not presented in the Study, an average cost for providing a generic on-site system was applied to all dwellings. In approaching the issue in this manner, the costs associated with various on-site treatment technologies have been normalized, since it would be impossible at the level of this study to determine how many and which lots would be possible candidates of evapotranspiration systems, mound systems, absorption systems, pressure-dose systems, etc.

9. *Although the water conservation recommendations made in Section 10 of the report are satisfactory, the specific comments for the water conservation portions of the study for individual tasks are as follows:*

*Task I.C.*

1. *On page 3-16, the discussion at the top of the page implies that per capita water use figures for larger cities include industrial use, but TWDB per capita water use figures do not include industrial use. The inclusion of industrial use figures should be clarified, and if industrial use figures were included, they should be presented separately.*

The statement presented in the Study is accurate since large cities typically calculate per capita water usage based on total plant output, which includes sale to industrial customers. Texas Water Development Board per capita water use estimates do not include an industrial component. No connection was made in the referenced section of the report to the inclusion of industrial flows in TWDB water use projections.

2. *Many of the tables in this section do not include units of water. For example, Table 3-7 on page 3-18 reports per capita water use but does not give the units. The correct units should be added to the tables.*

We concur with this comment and have provided revised tables which include all appropriate units.

3. *The statement that 'The TWDB estimates that about one-half of the water used for landscape irrigations during hot weather periods is wasted' in the third paragraph on page 4-11 should be modified to read that 'as much as on-half' rather than 'about one-half'.*

Page 4-11 has been revised to reflect this comment.

Task II, B.&E.

1. *The method used to incorporate water conservation into the wastewater projections is unclear. On page 3-22, Section 3.3 implies that a S/W ratio method was used, but when the S/W ratio was calculated based on water use from Table 3-11 and wastewater from Table 3-15, the resulting S/W ratio was 79. This is higher than the range quoted in Section 3.3. The figures should be checked, and the correct figure should be listed, and if necessary, the basis for the calculations should be explained.*

The range given for typical S/W ratios on page 3-22 of the report is one generally accepted by the engineering community and was intended to serve merely as a background for further discussions. Water use projections for unincorporated areas developed in the Study range from 143 gpcd in 1990 to 125 gpcd in 2020 and include water conservation practices. Wastewater generation projections are based on State design criteria (100 gpcd). The S/W ratio based on these values ranges from 0.70 to 0.80. The corresponding numbers in the final report have been corrected.

2. *As previously stated under Task I.C., several of the tables do not state units of water use.*

The referenced tables have been revised to indicate appropriate units.

Task IV

1. *The water conservation plan is excellent. The drought contingency portion of the plan is satisfactory, but individual utility plans would need to be activated if the drought contingency portions were to be implemented. The Board's staff understands that implementation is beyond the scope of the study.*

No response required.

2. *On page 6-6, the Water Rate Structure Section states that the PUB uses a "flat rate." According to American Water Works Association definitions, this rate should be called a "uniform rate."*

Your comment is noted and the term has been revised.

3. *The annual reporting requirement described on page 6-8 is not a requirement of the Regional Planning grant program, but such a report would be very useful to the TWDB staff and would be much appreciated.*

The referenced section does not state that the report is required. Submittal of the report is intended to be voluntary and for informational purposes only.

10. *The water supply portion of the study should be strengthened by an evaluation of the supply adequacy of the various water suppliers in the county.*

Numerous municipalities and water supply corporations supply water in the Lower Rio Grande Valley through an intricate and convoluted system of supply agreements, contracts, and other instruments. Tracking the adequacy of existing supplies, future options, and agreements is virtually impossible and beyond the scope of this study. The overall supplies in the Lower Rio Grande Valley are agreed to be generally inadequate to meet future demands; however, identification of specific sources with specific suppliers is beyond the scope of this study.

11. *Several water supply alternatives are proposed, but a recommendation is not given, and the names of users who might need additional supplies were not provided.*

The scope of the Study focused on the needs of the unincorporated areas of Cameron County. No effort was made to assess the future supply adequacy of incorporated municipalities and water supply corporations.

12. *A detailed analysis was done for the colonias in terms of who would supply which colonia. However, no analysis was presented as to whether the proposed suppliers have adequate water supplies to meet the additional needs or what additional supplies would need to be developed.*

Again, this is beyond the scope of the Study.

#### Texas Water Commission Comments

1. *Regarding population projections, the draft plan utilizes the TWDB High Series population projections to develop water and wastewater needs. The Lower Rio Grande Valley Development Council (LRGVDC) has developed population projections for the Texas Water Commission (report dated August 1989) which have recently been certified as updates to the State Water Quality Management Plan. The TWDB's and LRGVDC's population figures differ quite substantially for the Brownsville area in the year 2010. The Board's population is 197,616 in the year 2010, and the LRGVDC's projections for the year 2010 are 178,504 (median) or 179,787 (mean). This difference in population projections should be resolved, particularly if Brownsville applies for funding that requires consistency with the Water Quality Management Plan. The Board's and LRGVDC's total population figures for the rural (or unincorporated areas) are very similar.*

Use of TWDB population and water use projections is consistent with the scope of work and contract requirements of this project.

2. *LRGVDC's population figures in Table 3-1 on page 3-6 should be updated to reflect the LRGVDC's most recent August 1989 population report.*

This section of the Study has been revised to reflect staff's comment.

3. *Page 5-36, Second Paragraph*

*The seven-day two-year low flow (7Q2) for Segment 2202 is 6.0 ft/s.*

This section of the Study has been revised to reflect staff's comment.



4. **Page 5-36, Table 5-6**

*Dissolved oxygen criteria should read not less than 4.0 mg/l 24-hour average, 3.0 mg/l minimum.*

This section of the Study has been revised to reflect staff's comment.

5. **Page 5-37, Table 5-7**

*Dissolved oxygen criteria should read not less than 5.0 mg/l 24-hour average, 4.0 mg/l minimum.*

This section of the Study has been revised to reflect staff's comment.

6. **Page 5-37, Second Paragraph**

*The last statement is very poorly worded. It gives the impression that the normal standards do not apply when the flow equals or is greater than the 7Q2 flow. It should more clearly state that exceptions to numerical criteria apply when the flow is less than 7Q2.*

This section of the Study has been revised to reflect staff's comment.

7. **Page 5-38, Second Paragraph**

*There is no formal ranking of segments at this time by TWC in the 305(b) report. All references to segment ranking should be deleted on page 5-38. In addition, the report should clarify that advance treatment is not required for discharges to Segment 2201.*

This section of the Study has been revised to reflect staff's comment.

8. **Page 5-38, Third Paragraph**

*The statement... "no standard effluent limits apply to the entire segment and that new and renewal permit applications are reviewed on an individual and cumulative impact basis" applies to effluent-limited segments as well. Specific dissolved oxygen criteria have not been assigned to each individual tributary within segments based on observed uses. The criterion for these streams will be evaluated as a result of a Texas Water Commission Receiving Water Assessment, which is conducted in response to individual permit actions in unclassified waters. The report should state that, at such time, advanced treatment may be required of dischargers.*

This section of the Study has been revised to reflect staff's comment.

9. **Page 5-40, First Paragraph**

*The 5.0 mg/l criterion is 24-hour average.*

This section of the Study has been revised to reflect staff's comment.

10. **Page 5-41, Second Paragraph**

*The average DO criterion of the channel is 5.0 mg/l.*

This section of the Study has been revised to reflect staff's comment.

11. *Page 5-41, Second Paragraph*

*Tributary impacts were not addressed. Refer to Comment 8 above from page 5-38 on tributary impacts. Higher treatment requirements are probable for the PUB plant.*

This section of the Study has been revised to reflect staff's comment.

12. *Page 5-41, Third Paragraph*

*The 10/15 permit should read 10/15/3 or 10/3, because the Harlingen plant permit has a nitrification requirement. The report should also state that the 4.0 mg/l DO criteria is a 24-hour average.*

This section of the Study has been revised to reflect staff's comment.

13. *Page 5-45*

*The 20/90 effluent quality should read 30/90.*

This section of the Study has been revised to reflect staff's comment.

14. *Page 7-10, Last Paragraph*

*Segment 2022 should be listed as Water Quality Limited.*

This section of the Study has been revised to reflect staff's comment.

15. *Page 7-11, Table 7-2*

*The table should state that uses for Segment 2202 include Intermediate Aquatic Habitat, and the DO criterion should include the a/ superscript. Further, the table shows that the uses for Segment 2302 include Public Water Supply.*

This section of the Study has been revised to reflect staff's comment.

16. *Page 7-12, First Paragraph*

*The reference to minimum dissolved oxygen criteria should be changed to average D.O. criteria.*

This section of the Study has been revised to reflect staff's comment.

The Water Resources Planning Group wishes to thank the Board and Commission staff members for their thoughtful comments and observations regarding the draft study. Please contact our office if you or your staff have questions regarding our responses to their comments.

Sincerely,

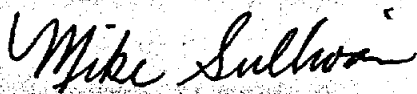

Michael P. Sullivan, Ph.D., P.E.  
President  
Michael Sullivan and Associates, Inc.

Cameron County Regional  
Water And Wastewater  
Planning Study  
Contract No. 9-483-733

The following maps are not attached to this report. They are located in the official file and may be copied upon request.

Map No. 1 – Facilities Map of Sub-Area E  
Figure 5-84

Map No. 2 Facilities Map of Sub-Area H  
Figure 5-50

Please contact Research and Planning  
Fund Grants Management Division at (512)  
463-7926 for copies.

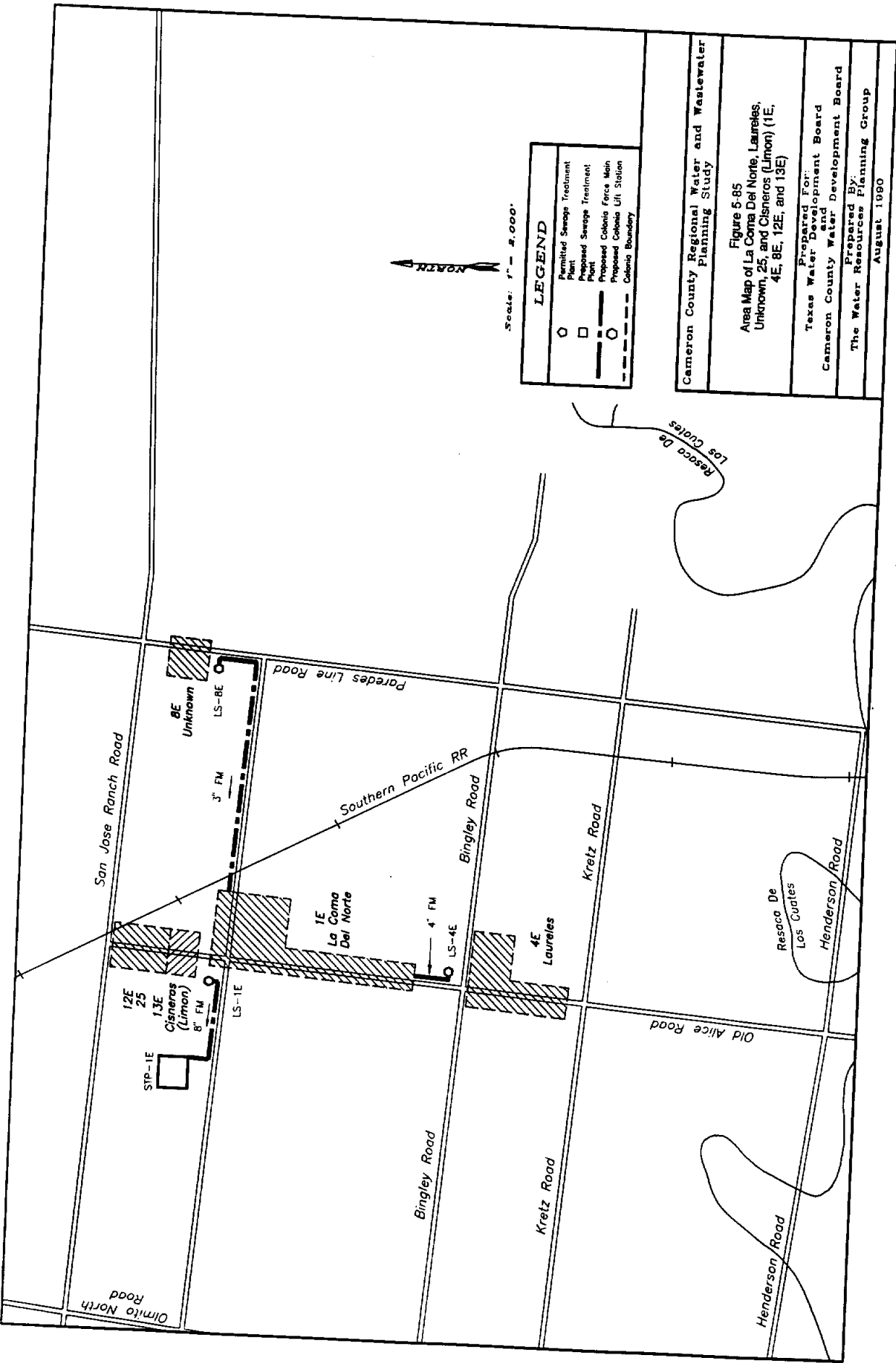

Olmite North

San Jose Ranch Road

12E  
25  
13E  
Cisneros  
(Limon)  
8" FM

STP-1E

8E  
Unknown

LS-8E

3" FM

Paredes Line Road

1E  
La Coma  
Del Norte

4" FM

LS-4E

4E  
Laureles

Southern Pacific RR

Bingley Road

Kretz Road

Bingley Road

Kretz Road

Old Alice Road

Henderson Road

Resaca De  
Los Cuates

Henderson Road

Resaca De  
Los Cuates

Colonia Designation	Colonia Name	Area (Ac)	2020 Population	2020 Population Density (Pop./Ac)	2020 Units	2020 Unit Density (Units/Ac)
1E	La Coma Del Norte	100	888	8.88	177	1.77
12E	25	32	75	2.34	15	0.47
13E	Cisneros (Limon)	9	62	8.89	13	1.44

1E

Internal Wastewater Collection System Quantities Estimate	
ITEM	QUANTITY
6" Service Connection	177 EA
8" SDR-35 PVC Sanitary Sewer	10,200 LF
10" SDR-35 PVC Sanitary Sewer	400 LF
12" SDR-35 PVC Sanitary Sewer	N/A
15" SDR-35 PVC Sanitary Sewer	N/A
18" SDR-35 PVC Sanitary Sewer	N/A
Clean Out	6 EA
Manhole	28 EA
4" PVC Force Main	N/A
6" PVC Force Main	N/A
8" PVC Force Main	2,000 LF
10" PVC Force Main	N/A
12" PVC Force Main	N/A
LS-1E 480 GPM (S.OHP)	1 EA
<b>TOTAL ESTIMATED COST</b>	<b>\$ 698,375</b>

12E

Internal Wastewater Collection System Quantities Estimate	
ITEM	QUANTITY
6" Service Connection	15 EA
8" SDR-35 PVC Sanitary Sewer	900 LF
10" SDR-35 PVC Sanitary Sewer	N/A
12" SDR-35 PVC Sanitary Sewer	N/A
15" SDR-35 PVC Sanitary Sewer	N/A
18" SDR-35 PVC Sanitary Sewer	N/A
Clean Out	3 EA
Manhole	5 EA
4" PVC Force Main	N/A
6" PVC Force Main	N/A
8" PVC Force Main	N/A
10" PVC Force Main	N/A
12" PVC Force Main	N/A
<b>TOTAL ESTIMATED COST</b>	<b>\$ 46,453</b>

13E

Internal Wastewater Collection System Quantities Estimate	
ITEM	QUANTITY
6" Service Connection	13 EA
8" SDR-35 PVC Sanitary Sewer	800 LF
10" SDR-35 PVC Sanitary Sewer	N/A
12" SDR-35 PVC Sanitary Sewer	N/A
15" SDR-35 PVC Sanitary Sewer	N/A
18" SDR-35 PVC Sanitary Sewer	N/A
Clean Out	N/A
Manhole	2 EA
4" PVC Force Main	N/A
6" PVC Force Main	N/A
8" PVC Force Main	N/A
10" PVC Force Main	N/A
12" PVC Force Main	N/A
<b>TOTAL ESTIMATED COST</b>	<b>\$ 29,082</b>

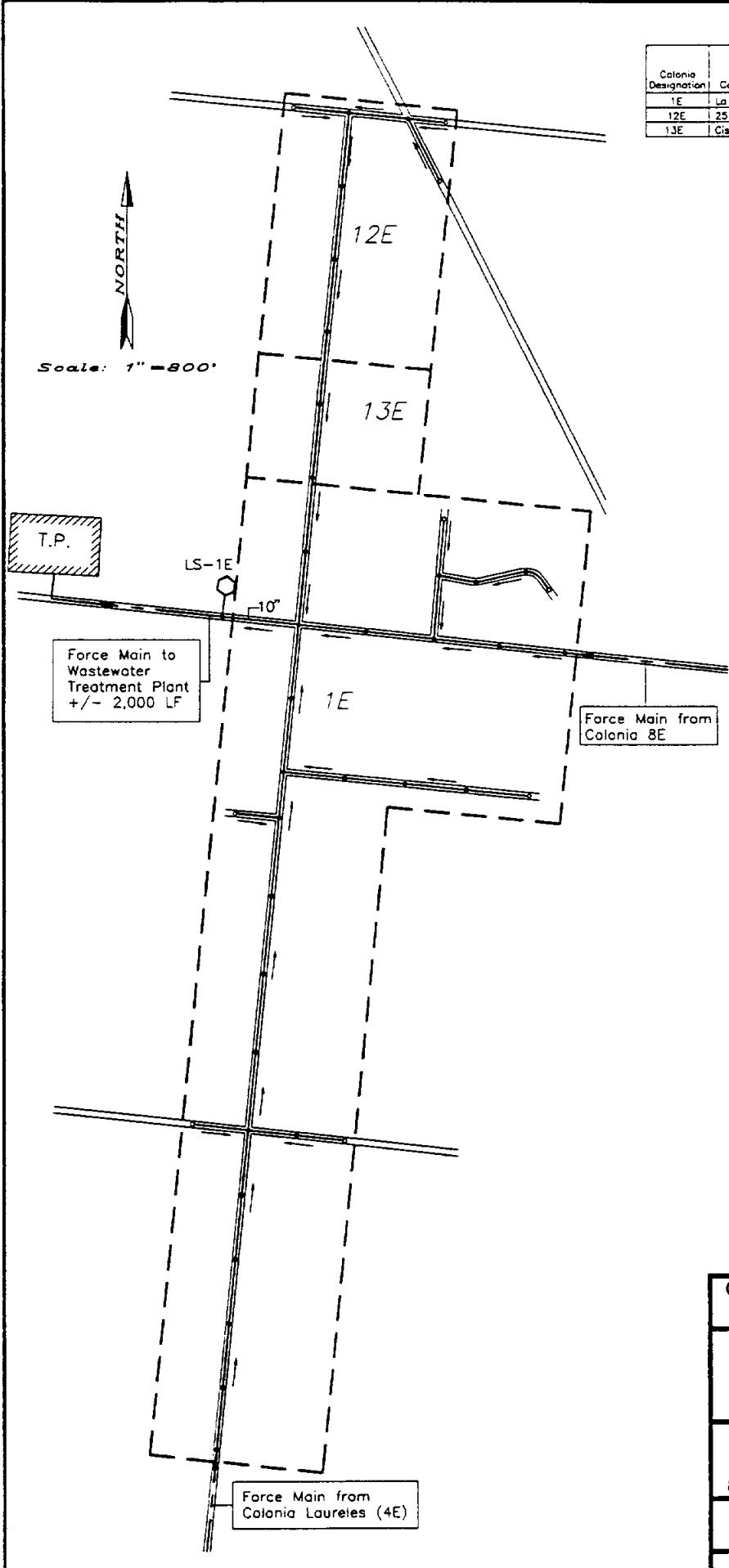

**Cameron County Regional Water and Wastewater Planning Study**

**Figure 5-86**  
**Site Map of La Coma Del Norte, 25, and Cisneros (Limon) (1E, 12E, and 13E)**

**Prepared For:**  
**Texas Water Development Board**  
**and Cameron County Water Development Board**

**Prepared By:**  
**The Water Resources Planning Group**

**August 1990**

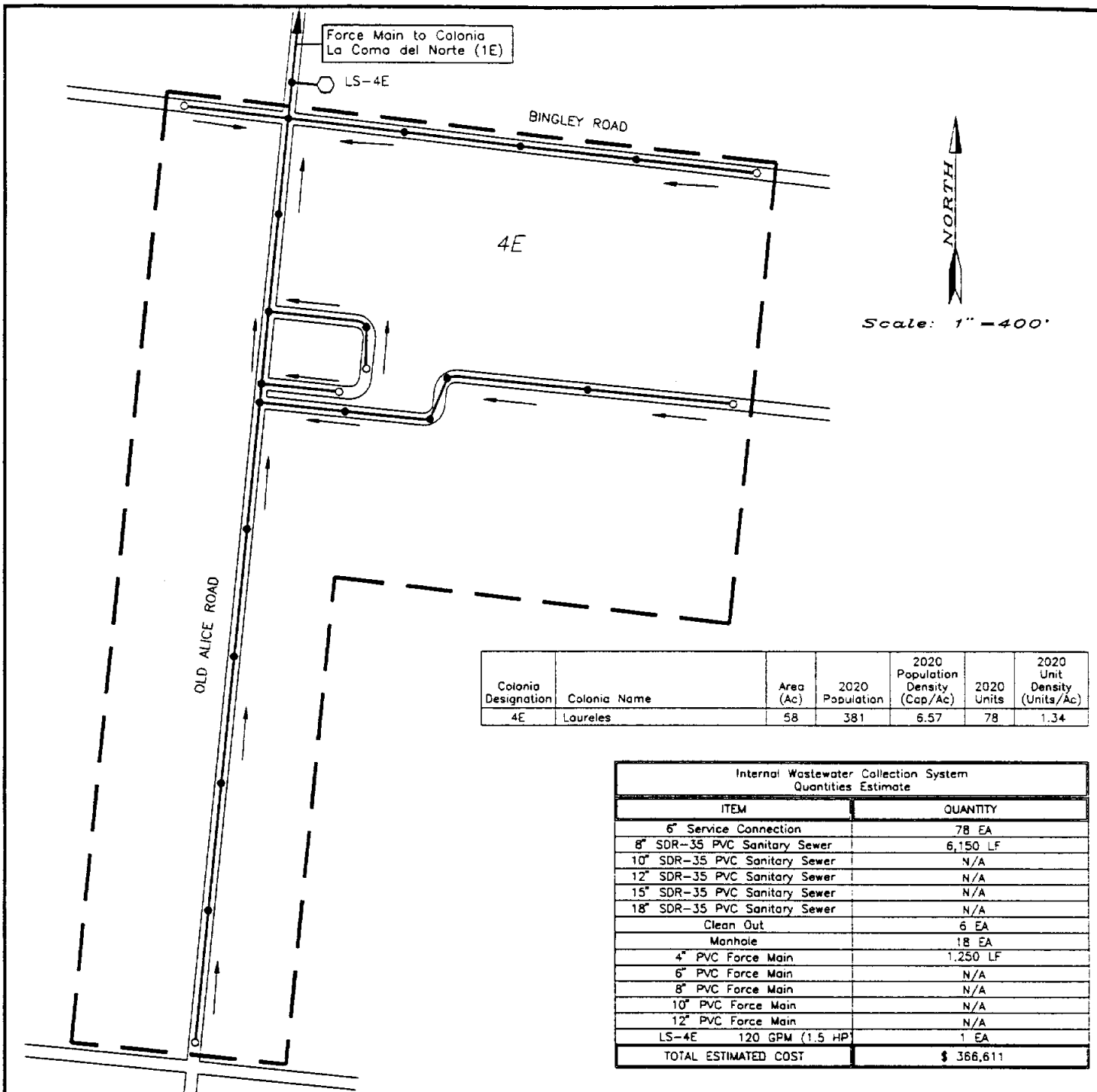

Force Main to Colonia  
La Coma del Norte (1E)

LS-4E

BINGLEY ROAD

4E

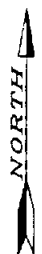

Scale: 1" = 400'

OLD ALICE ROAD

Colonia Designation	Colonia Name	Area (Ac)	2020 Population	2020 Population Density (Cap/Ac)	2020 Units	2020 Unit Density (Units/Ac)
4E	Laureles	58	381	6.57	78	1.34

Internal Wastewater Collection System Quantities Estimate	
ITEM	QUANTITY
6" Service Connection	78 EA
8" SDR-35 PVC Sanitary Sewer	6,150 LF
10" SDR-35 PVC Sanitary Sewer	N/A
12" SDR-35 PVC Sanitary Sewer	N/A
15" SDR-35 PVC Sanitary Sewer	N/A
18" SDR-35 PVC Sanitary Sewer	N/A
Clean Out	6 EA
Manhole	18 EA
4" PVC Force Main	1,250 LF
6" PVC Force Main	N/A
8" PVC Force Main	N/A
10" PVC Force Main	N/A
12" PVC Force Main	N/A
LS-4E 120 GPM (1.5 HP)	1 EA
<b>TOTAL ESTIMATED COST</b>	<b>\$ 366,611</b>

**Cameron County Regional Water and Wastewater Planning Study**

**Figure 5-87  
Site Map of Laureles (4E)**

**Prepared For:  
Texas Water Development Board  
and Cameron County Water Development Board**

**Prepared By:  
The Water Resources Planning Group**

**August 1990**

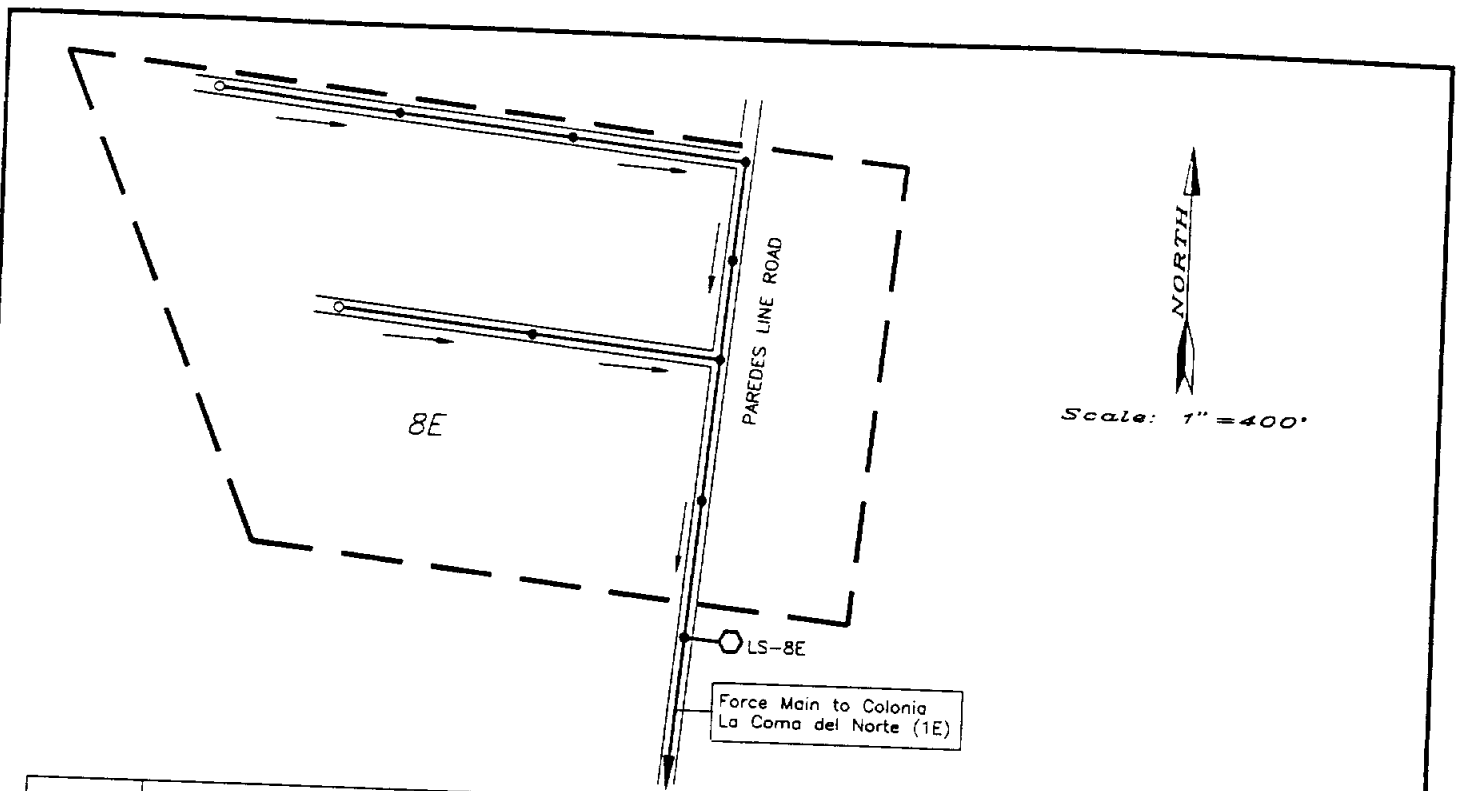

Colonia Designation	Colonia Name	Area (Ac)	2020 Population	2020 Population Density (Cap/Ac)	2020 Units	2020 Unit Density (Units/Ac)
8E	Unknown	16	262	16.38	53	3.31

Internal Wastewater Collection System Quantities Estimate	
ITEM	QUANTITY
6" Service Connection	53 EA
8" SDR-35 PVC Sanitary Sewer	2,850 LF
10" SDR-35 PVC Sanitary Sewer	N/A
12" SDR-35 PVC Sanitary Sewer	N/A
15" SDR-35 PVC Sanitary Sewer	N/A
18" SDR-35 PVC Sanitary Sewer	N/A
Clean Out	2 EA
Manhole	8 EA
3" PVC Force Main	12,000 LF
6" PVC Force Main	N/A
8" PVC Force Main	N/A
10" PVC Force Main	N/A
12" PVC Force Main	N/A
LS-8E 78 GPM (6.5 HP)	1 EA
<b>TOTAL ESTIMATED COST</b>	<b>\$ 439,811</b>

<b>Cameron County Regional Water and Wastewater Planning Study</b>
<b>Figure 5-88 Site Map of Unknown (8E)</b>
<b>Prepared For: Texas Water Development Board and Cameron County Water Development Board</b>
<b>Prepared By: The Water Resources Planning Group</b>
<b>August 1990</b>

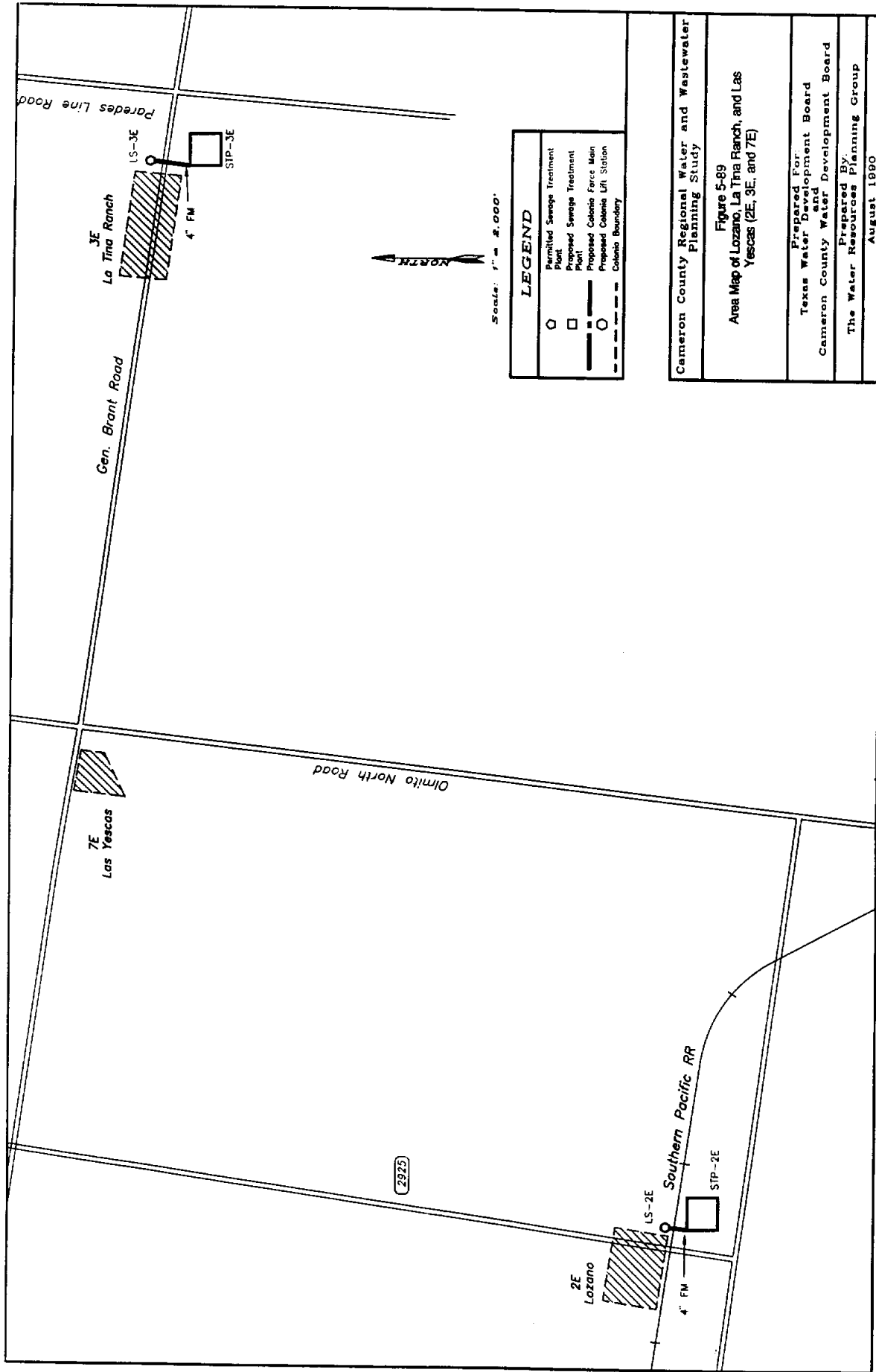

Scale: 1" = 2,000'

**LEGEND**

○	Permitted Sewage Treatment Plant
□	Proposed Sewage Treatment Plant
—	Proposed Colonia Force Main
○	Proposed Colonia Lift Station
- - -	Colonia Boundary

Cameron County Regional Water and Wastewater Planning Study

Figure 5-89  
Area Map of Lozano, La Tina Ranch, and Las Yescas (2E, 3E, and 7E)

Prepared For:  
Texas Water Development Board  
Cameron County Water Development Board

Prepared By:  
The Water Resources Planning Group  
August 1990



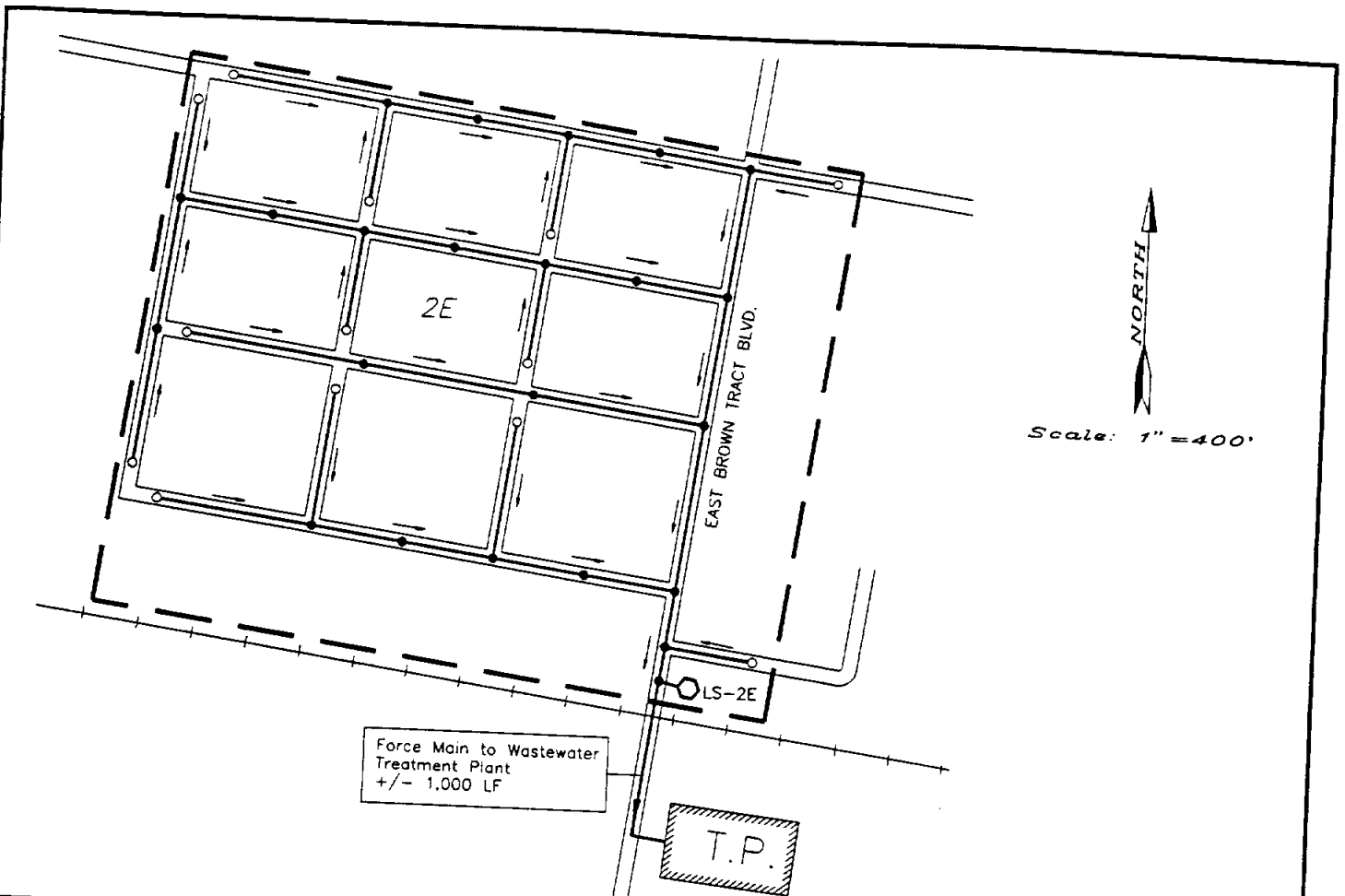

Colonia Designation	Colonia Name	Area (Ac)	2020 Population	2020 Population Density (Cap/Ac)	2020 Units	2020 Unit Density (Units/Ac)
2E	Lozano		680	13.60	139	2.78

Internal Wastewater Collection System Quantities Estimate	
ITEM	QUANTITY
6" Service Connection	139 EA
8" SDR-35 PVC Sanitary Sewer	9,000 LF
10" SDR-35 PVC Sanitary Sewer	N/A
12" SDR-35 PVC Sanitary Sewer	N/A
15" SDR-35 PVC Sanitary Sewer	N/A
18" SDR-35 PVC Sanitary Sewer	N/A
Clean Out	12 EA
Manhole	23 EA
4" PVC Force Main	1,000 LF
6" PVC Force Main	N/A
8" PVC Force Main	N/A
10" PVC Force Main	N/A
12" PVC Force Main	N/A
LS-2E 200 GPM (3.5HP)	1 EA
<b>TOTAL ESTIMATED COST</b>	<b>\$ 566,019</b>

Cameron County Regional Water and Wastewater  
Planning Study

Figure 5-90  
Site Map of Lozano (2E)

Prepared For:  
Texas Water Development Board  
and Cameron County Water Development Board

Prepared By:  
The Water Resources Planning Group

August 1990

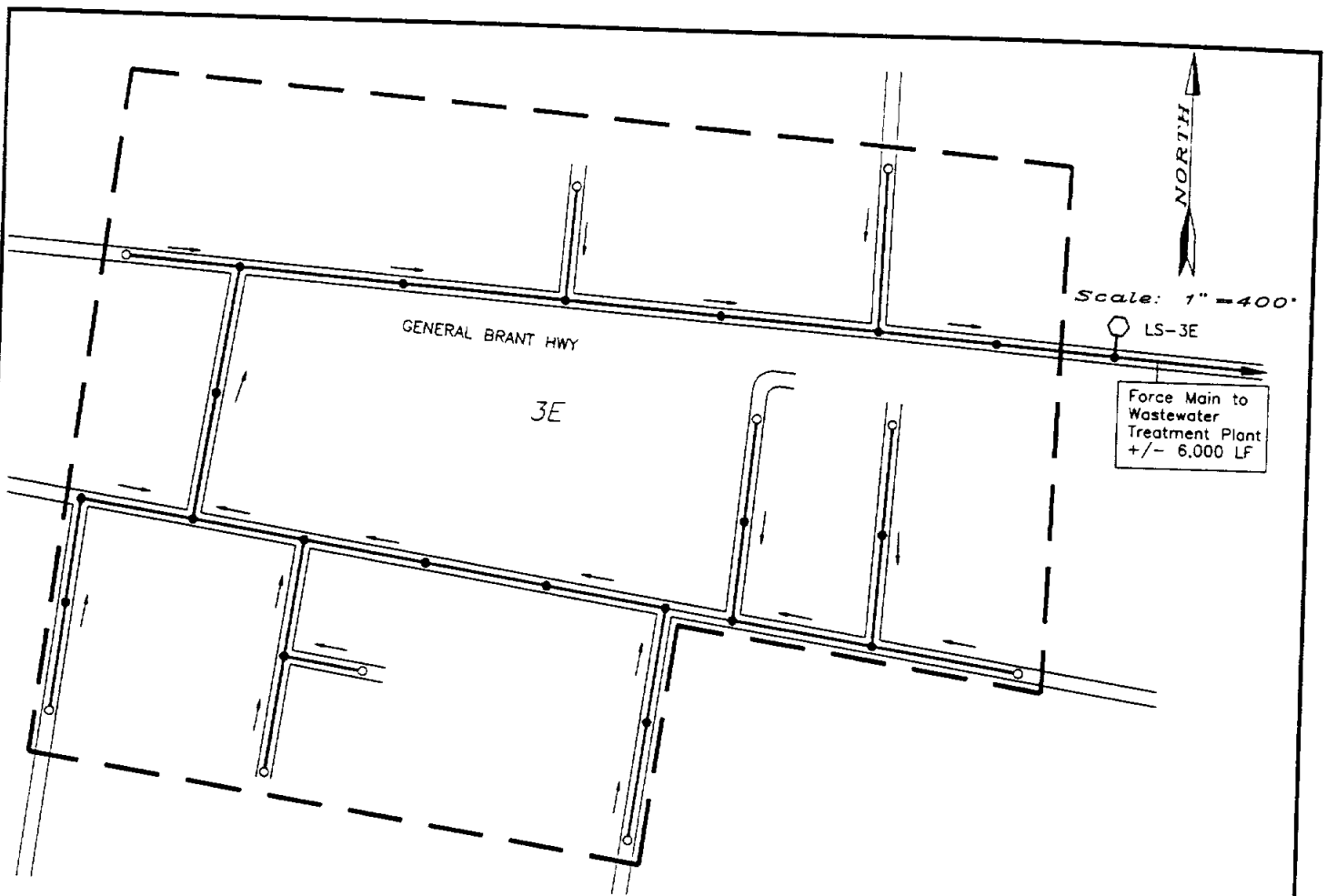

Colonia Designation	Colonia Name	Area (Ac)	2020 Population	2020 Population Density (Cap/Ac)	2020 Units	2020 Unit Density (Units/Ac)
3E	La Tina Ranch	59	662	11.22	135	2.29

Internal Wastewater Collection System Quantities Estimate	
ITEM	QUANTITY
6" Service Connection	135 EA
8" SDR-35 PVC Sanitary Sewer	8,670 LF
10" SDR-35 PVC Sanitary Sewer	N/A
12" SDR-35 PVC Sanitary Sewer	N/A
15" SDR-35 PVC Sanitary Sewer	N/A
18" SDR-35 PVC Sanitary Sewer	N/A
Clean Out	10 EA
Manhole	21 EA
4" PVC Force Main	6,000 LF
6" PVC Force Main	N/A
8" PVC Force Main	N/A
10" PVC Force Main	N/A
12" PVC Force Main	N/A
LS-3E 195 GPM (3.0 HP)	1 EA
<b>TOTAL ESTIMATED COST</b>	<b>\$ 585,266</b>

<b>Cameron County Regional Water and Wastewater Planning Study</b>
<b>Figure 5-91 Site Map of La Tina Ranch (3E)</b>
<b>Prepared For: Texas Water Development Board and Cameron County Water Development Board</b>
<b>Prepared By: The Water Resources Planning Group</b>
<b>August 1990</b>

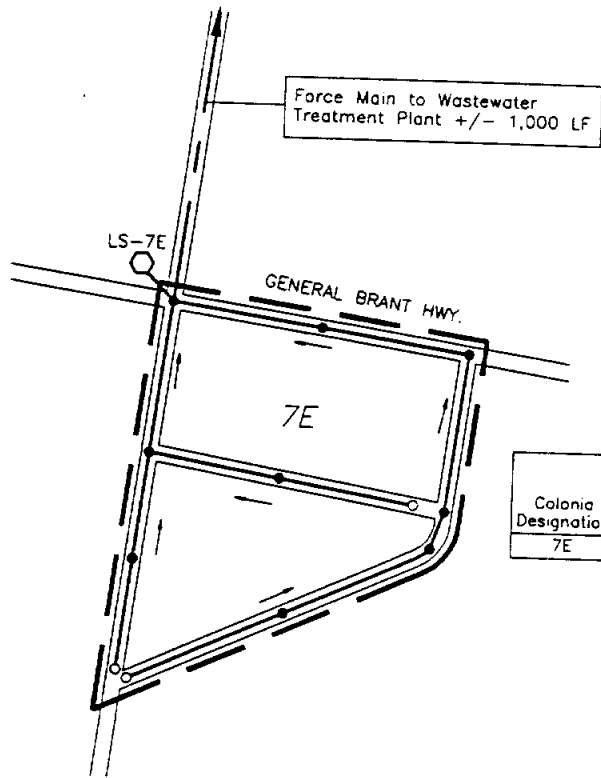

Scale: 1" = 400'

Colonia Designation	Colonia Name	Area (Ac)	2020 Population	2020 Population Density (Cap/Ac)	2020 Units	2020 Unit Density (Units/Ac)
7E	Las Yescas	16	281	17.56	57	3.56

Internal Wastewater Collection System Quantities Estimate	
ITEM	QUANTITY
6" Service Connection	57 EA
8" SDR-35 PVC Sanitary Sewer	3,200 LF
10" SDR-35 PVC Sanitary Sewer	N/A
12" SDR-35 PVC Sanitary Sewer	N/A
15" SDR-35 PVC Sanitary Sewer	N/A
18" SDR-35 PVC Sanitary Sewer	N/A
Clean Out	3 EA
Manhole	9 EA
3" PVC Force Main	1,000 LF
6" PVC Force Main	N/A
8" PVC Force Main	N/A
10" PVC Force Main	N/A
12" PVC Force Main	N/A
LS-7E 85 GPM (1.5 HP)	1 EA
<b>TOTAL ESTIMATED COST</b>	<b>\$ 261,333</b>

**Cameron County Regional Water and Wastewater Planning Study**

**Figure 5-92  
Site Map of Las Yescas (7E)**

**Prepared For:  
Texas Water Development Board  
and Cameron County Water Development Board**

**Prepared By:  
The Water Resources Planning Group**

**August 1990**

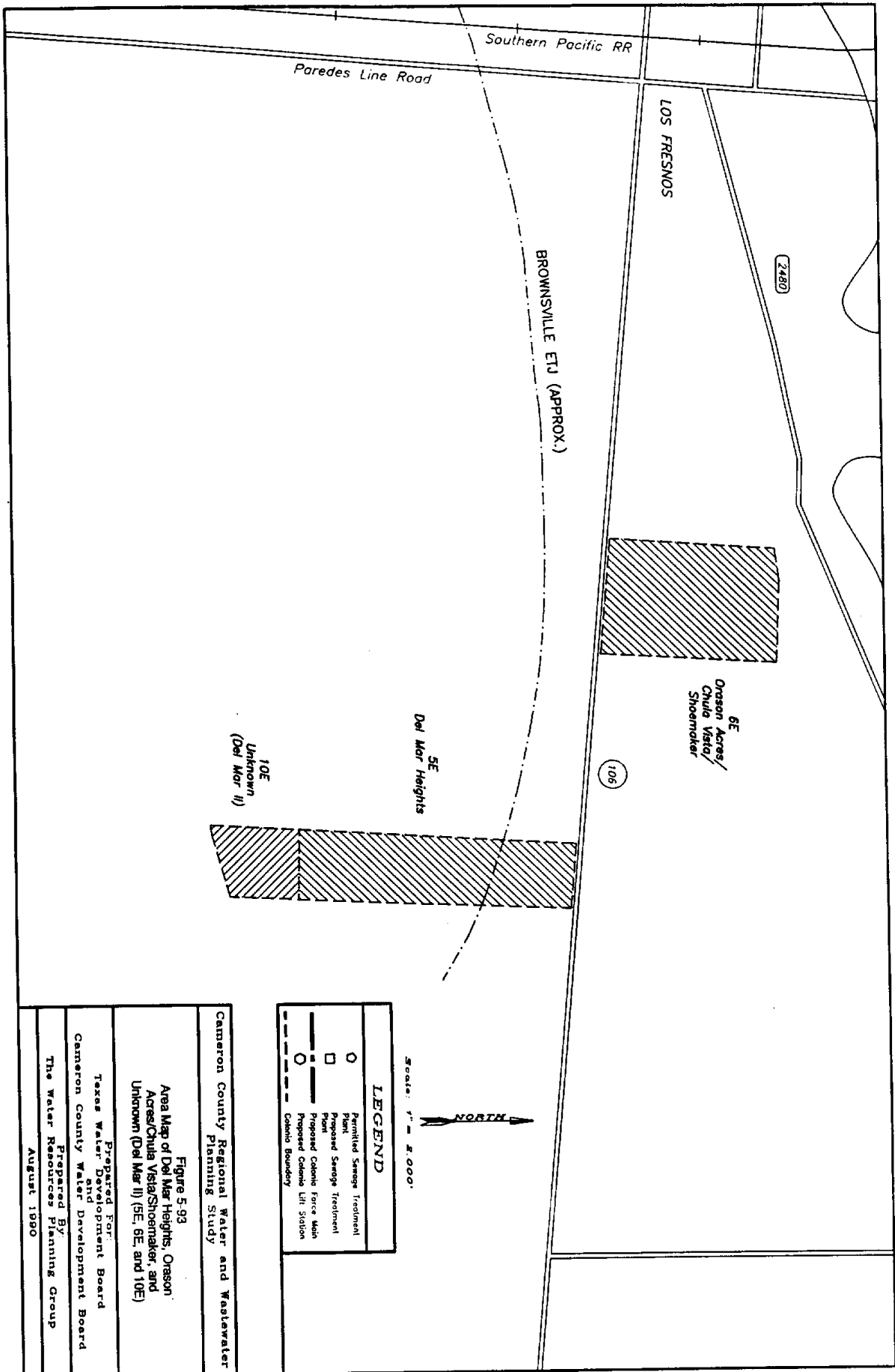

**Cameron County Regional Water and Wastewater Planning Study**

**Figure 5-93**  
 Area Map of Del Mar Heights, Orson Acres/Chula Vista/Shoemaker, and Unknown (Del Mar II) (5E, 6E, and 10E)

Prepared For:  
 Texas Water Development Board  
 Cameron County Water Development Board

Prepared By:  
 The Water Resources Planning Group

August 1990

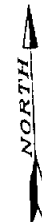
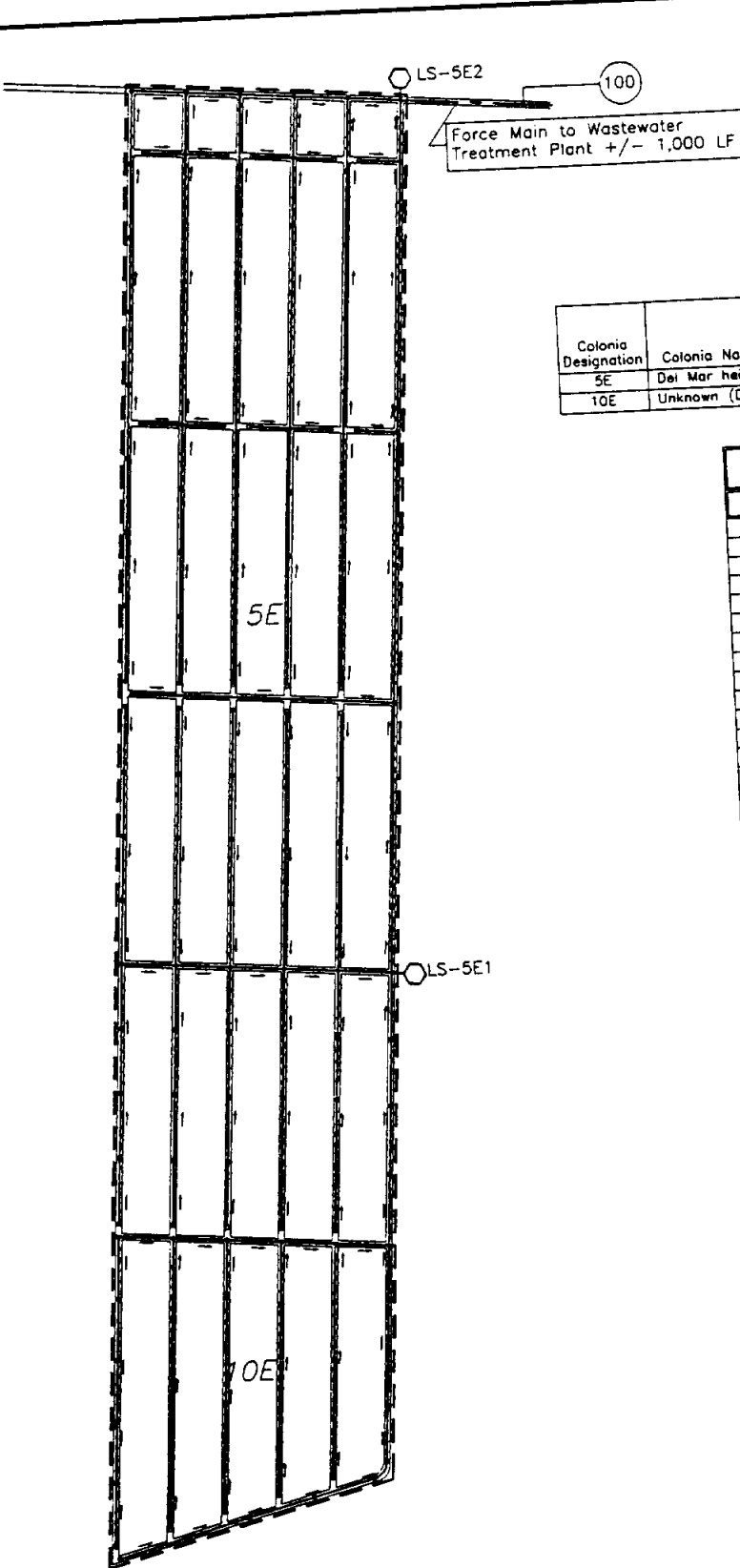

Scale: 1" = 1,000'

Colonia Designation	Colonia Name	Area (Ac)	2020 Population	2020 Population Density (Cap/Ac)	2020 Units	2020 Unit Density (Units/Ac)
5E	Del Mar heights	206	483	2.34	99	0.48
10E	Unknown (Del Mar II)	62	290	4.68	59	0.95

5E

Internal Wastewater Collection System Quantities Estimate	
ITEM	QUANTITY
6" Service Connection	99 EA
8" SDR-35 PVC Sanitary Sewer	43,650 LF
10" SDR-35 PVC Sanitary Sewer	N/A
12" SDR-35 PVC Sanitary Sewer	N/A
15" SDR-35 PVC Sanitary Sewer	N/A
18" SDR-35 PVC Sanitary Sewer	N/A
Clean Out	26 EA
Manhole	97 EA
4" PVC Force Main	150 LF
6" PVC Force Main	1,000 LF
8" PVC Force Main	N/A
10" PVC Force Main	N/A
12" PVC Force Main	N/A
LS-5E1 115 GPM (1.0 HP)	1 EA
LS-5E2 230 GPM (2.0 HP)	1 EA
<b>TOTAL ESTIMATED COST</b>	<b>\$ 1,658,105</b>

10E

Internal Wastewater Collection System Quantities Estimate	
ITEM	QUANTITY
6" Service Connection	59 EA
8" SDR-35 PVC Sanitary Sewer	11,350 LF
10" SDR-35 PVC Sanitary Sewer	N/A
12" SDR-35 PVC Sanitary Sewer	N/A
15" SDR-35 PVC Sanitary Sewer	N/A
18" SDR-35 PVC Sanitary Sewer	N/A
Clean Out	6 EA
Manhole	32 EA
4" PVC Force Main	N/A
6" PVC Force Main	N/A
8" PVC Force Main	N/A
10" PVC Force Main	N/A
12" PVC Force Main	N/A
<b>TOTAL ESTIMATED COST</b>	<b>\$ 415,451</b>

Cameron County Regional Water and Wastewater Planning Study

Figure 5-94  
Site Map of Del Mar Heights and Unknown (Del Mar II) (5E and 10E)

Prepared For:  
Texas Water Development Board  
and Cameron County Water Development Board

Prepared By:  
The Water Resources Planning Group

August 1990

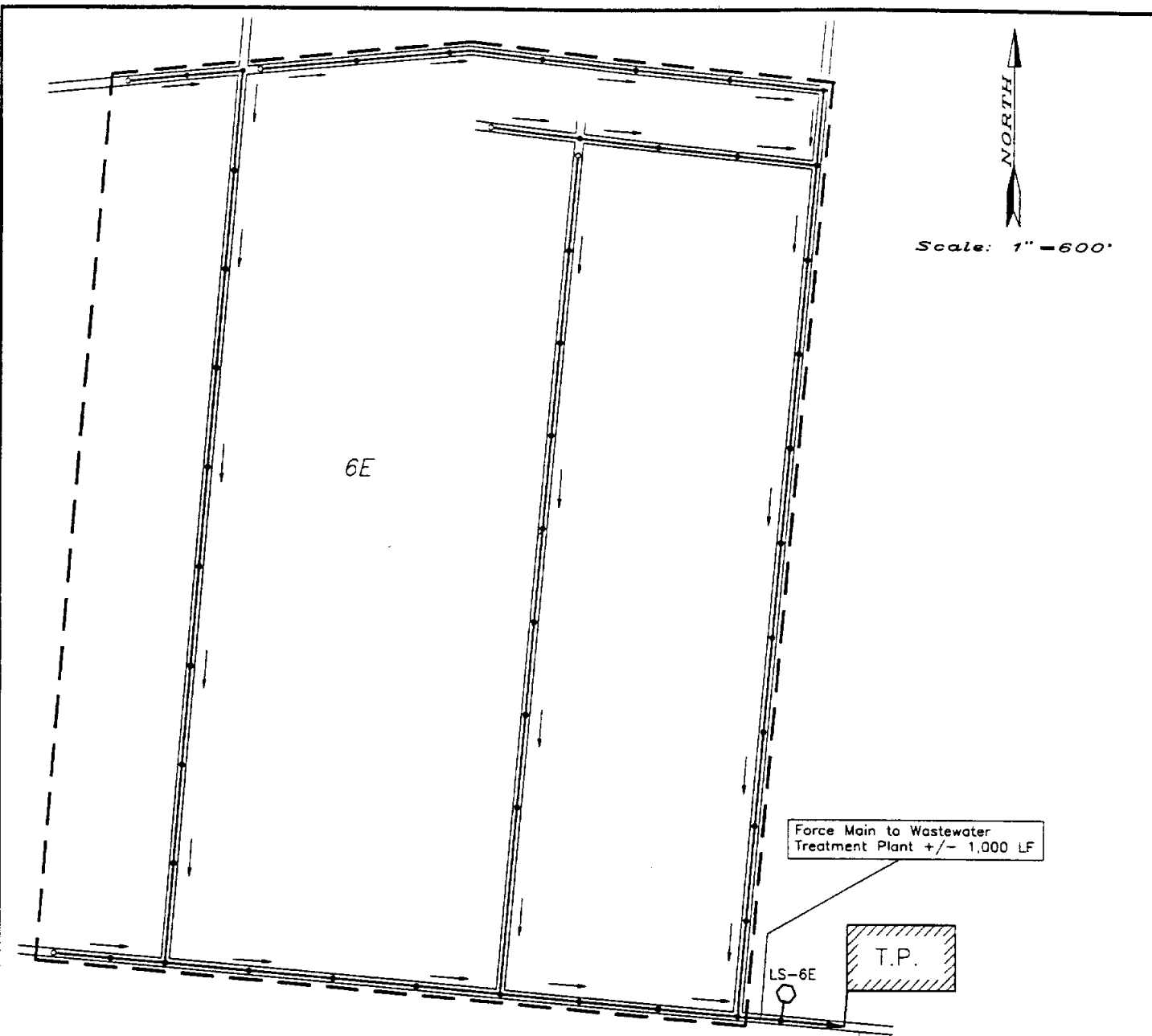

Colonia Designation	Colonia Name	Area (Ac)	2020 Population	2020 Population Density (Cap/Ac)	2020 Units	2020 Unit Density (Units/Ac)
6E	Orason/ChulaVista/Shoemaker	211	464	2.20	95	0.45

Internal Wastewater Collection System Quantities Estimate	
ITEM	QUANTITY
6" Service Connection	95 EA
8" SDR-35 PVC Sanitary Sewer	17,110 LF
10" SDR-35 PVC Sanitary Sewer	N/A
12" SDR-35 PVC Sanitary Sewer	N/A
15" SDR-35 PVC Sanitary Sewer	N/A
18" SDR-35 PVC Sanitary Sewer	N/A
Clean Out	5 EA
Manhole	45 EA
4" PVC Force Main	1,000 LF
6" PVC Force Main	N/A
8" PVC Force Main	N/A
10" PVC Force Main	N/A
12" PVC Force Main	N/A
LS-6E 140 GPM (1.7HP)	1 EA
<b>TOTAL ESTIMATED COST</b>	<b>\$ 750,817</b>

**Cameron County Regional Water and Wastewater Planning Study**  
**Figure 5-95**  
**Site Map of Orason Acres/Chula Vista/Shoemaker (6E)**  
**Prepared For:**  
**Texas Water Development Board**  
**and Cameron County Water Development Board**  
**Prepared By:**  
**The Water Resources Planning Group**  
**August 1990**

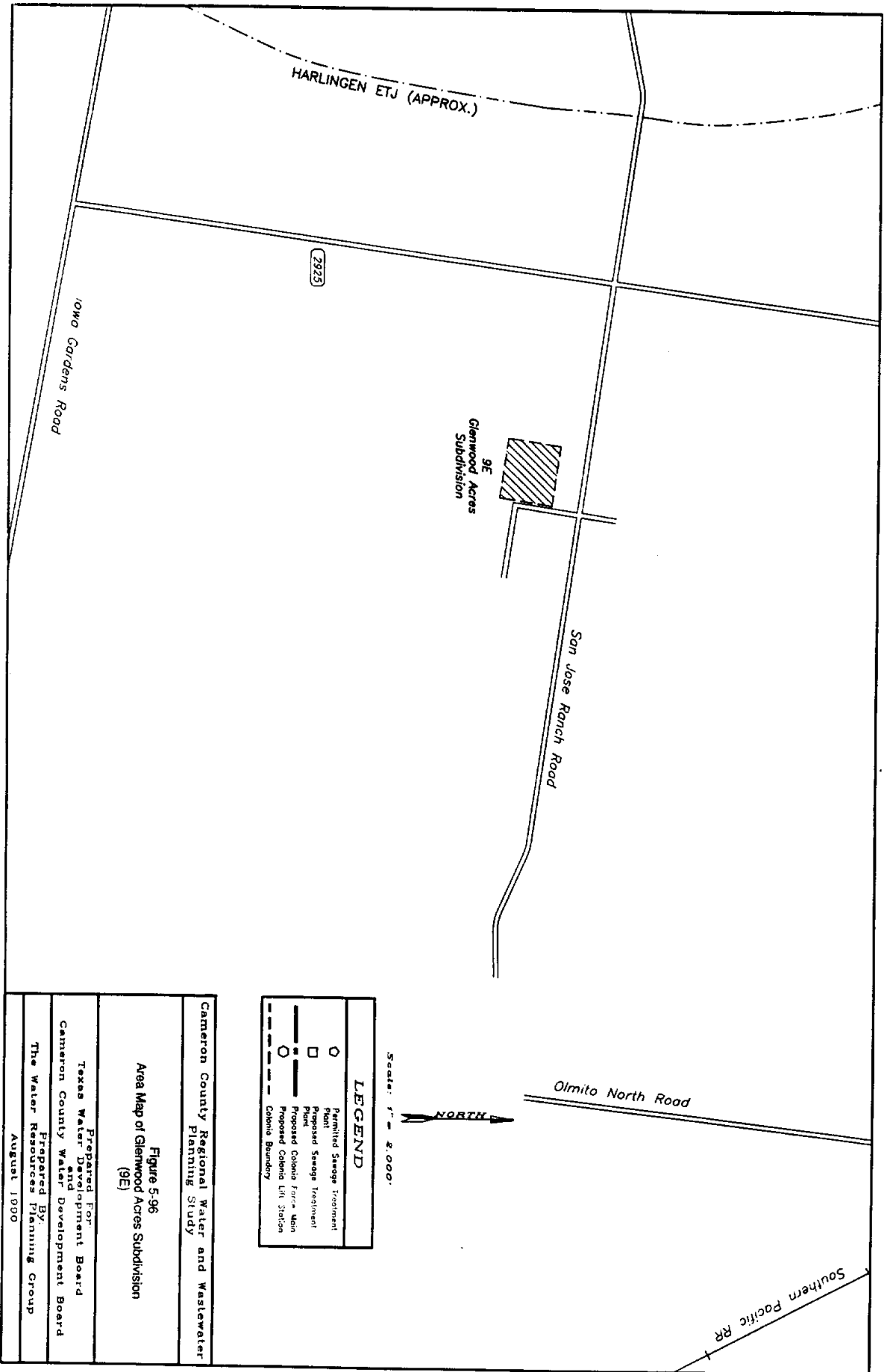

HARLINGEN ETJ (APPROX.)

2923

Iowa Gardens Road

9E  
Glenwood Acres  
Subdivision

San Jose Ranch Road

Olmito North Road

Southern Pacific RR

Scale: 1" = 2,000'

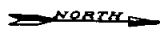

LEGEND	
○	Permitted Sewage Treatment Plant
□	Proposed Sewage Treatment Plant
—	Proposed Colonia Fortuna
○	Proposed Colonia Lift Station
- - -	Colonia Boundary

Cameron County Regional Water and Wastewater Planning Study

Figure 5-96  
Area Map of Glenwood Acres Subdivision (9E)

Prepared For  
Texas Water Development Board  
Cameron County Water Development Board  
Prepared By  
The Water Resources Planning Group  
August 1990

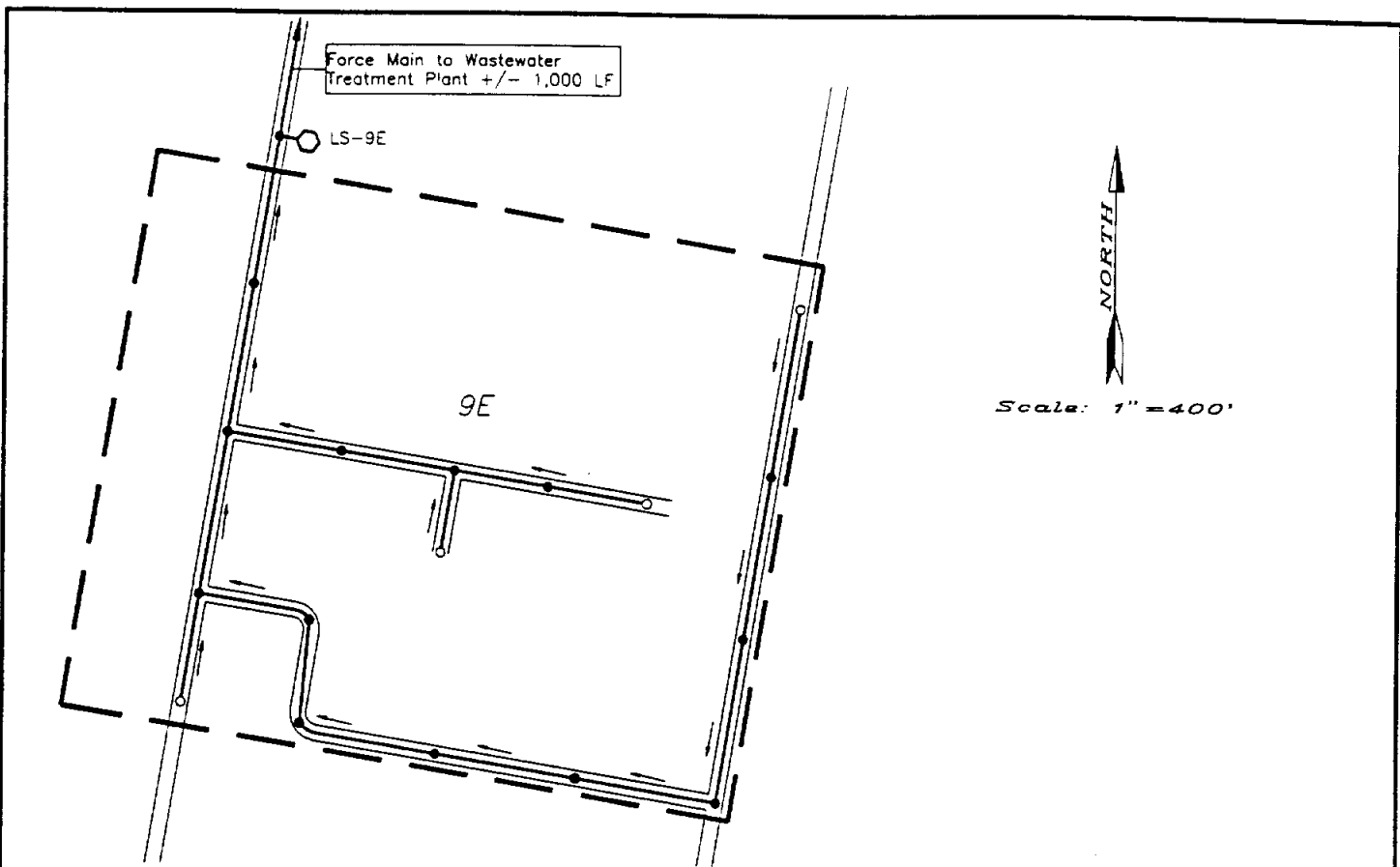

Colonia Designation	Colonia Name	Area (Ac)	2020 Population	2020 Population Density (Cap/Ac)	2020 Units	2020 Unit Density (Units/Ac)
9E	Glenwood Acres Subdivision	32	218	6.81	45	1.41

Internal Wastewater Collection System Quantities Estimate	
ITEM	QUANTITY
6" Service Connection	45 EA
8" SDR-35 PVC Sanitary Sewer	4,750 LF
10" SDR-35 PVC Sanitary Sewer	N/A
12" SDR-35 PVC Sanitary Sewer	N/A
15" SDR-35 PVC Sanitary Sewer	N/A
18" SDR-35 PVC Sanitary Sewer	N/A
Clean Out	4 EA
Manhole	14 EA
3" PVC Main Force	1,000 LF
6" PVC Force Main	N/A
8" PVC Force Main	N/A
10" PVC Force Main	N/A
12" PVC Force Main	N/A
LS-9E 65 GPM (1.0 HP)	1 EA
<b>TOTAL ESTIMATED COST</b>	<b>\$ 265,995</b>

**Cameron County Regional Water and Wastewater Planning Study**

**Figure 5-97**  
**Site Map of Glenwood Acres Subdivision (9E)**

**Prepared For:**  
**Texas Water Development Board**  
**and Cameron County Water Development Board**

**Prepared By:**  
**The Water Resources Planning Group**

**August 1990**



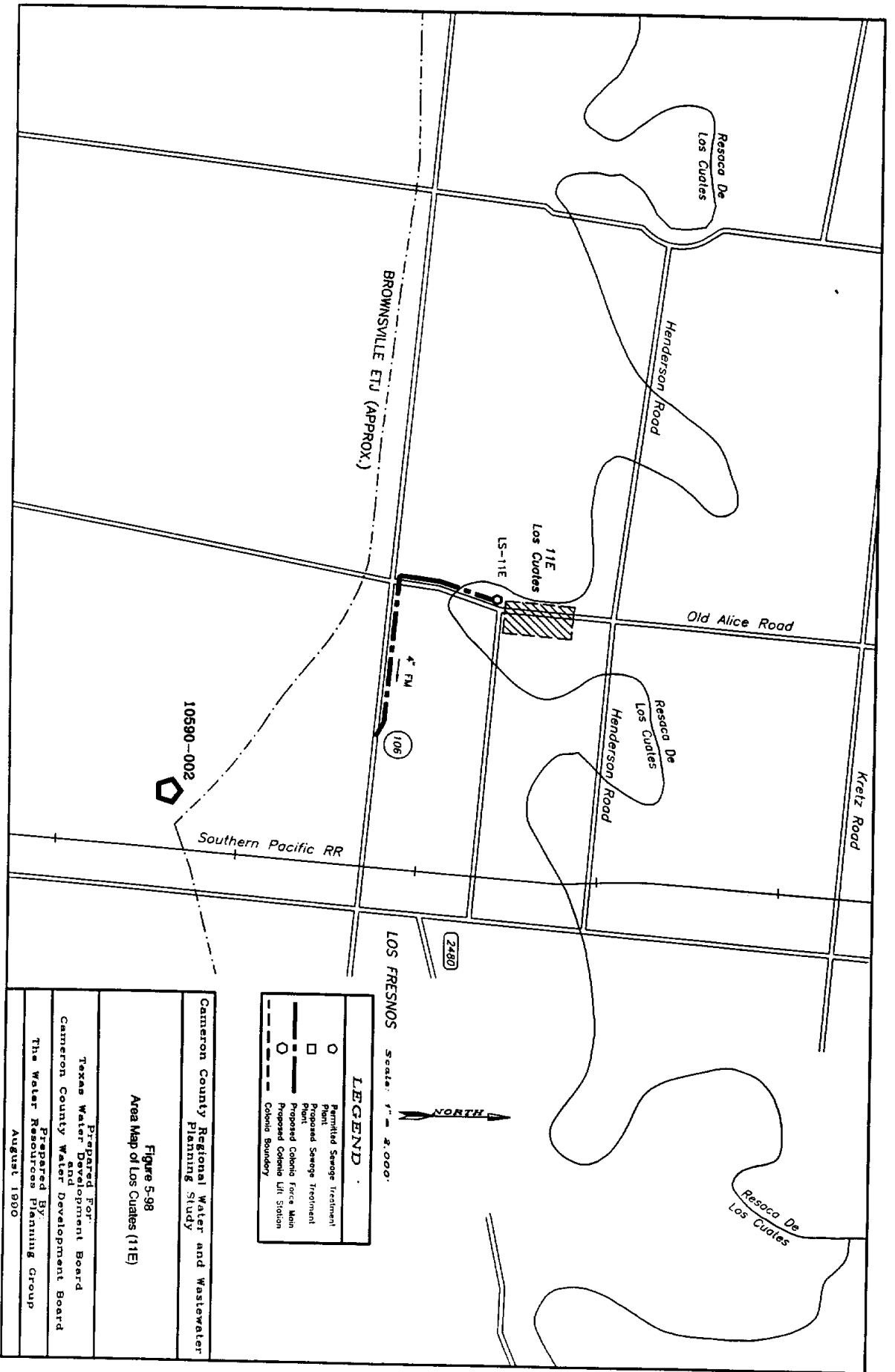

**LEGEND**

	Permitted Sewage Treatment Plant
	Proposed Sewage Treatment Plant
	Proposed Colima Force Main
	Proposed Colima Lift Station
	Colima Boundary

LOS FRESNOS Scale: 1" = 2,000'



Gamernon County Regional Water and Wastewater Planning Study

Figure 5-98  
Area Map of Los Cuates (11E)

Prepared For:  
Texas Water Development Board  
Cameron County Water Development Board

Prepared By:  
The Water Resources Planning Group  
August 1980

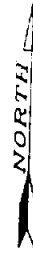

Scale: 1" = 400'

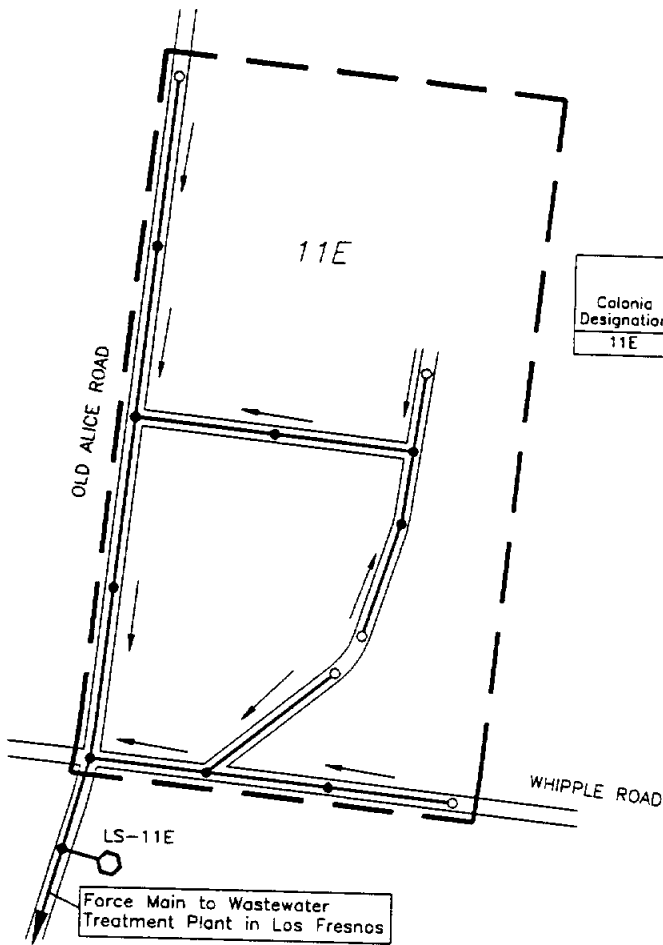

Colonia Designation	Colonia Name	Area (Ac)	2020 Population	2020 Population Density (Cap/Ac)	2020 Units	2020 Unit Density (Units/Ac)
11E	Los Cuates	22	261	11.86	53	2.41

Internal Wastewater Collection System Quantities Estimate	
ITEM	QUANTITY
6" Service Connection	53 EA
8" SDR-35 PVC Sanitary Sewer	3,750 LF
10" SDR-35 PVC Sanitary Sewer	N/A
12" SDR-35 PVC Sanitary Sewer	N/A
15" SDR-35 PVC Sanitary Sewer	N/A
18" SDR-35 PVC Sanitary Sewer	N/A
Clean Out	5 EA
Manhole	10 EA
4" PVC Force Main	14,000 LF
6" PVC Force Main	N/A
8" PVC Force Main	N/A
10" PVC Force Main	N/A
12" PVC Force Main	N/A
LS-11E 80 GPM (2.5 HP)	1 EA
<b>TOTAL ESTIMATED COST</b>	<b>\$ 439,666</b>

<b>Cameron County Regional Water and Wastewater Planning Study</b>
<b>Figure 5-99 Site Map of Los Cuates (11E)</b>
<b>Prepared For: Texas Water Development Board and Cameron County Water Development Board</b>
<b>Prepared By: The Water Resources Planning Group</b>
<b>August 1990</b>

## **6.0 WATER CONSERVATION AND DROUGHT MANAGEMENT PLAN**

### **6.1 Introduction**

#### **6.1.1 Planning Area and Project**

The service area of this study is the unincorporated areas of Cameron County. And the incorporated area with the City of Brownsville; however, the majority of the unincorporated area population is grouped into relatively small communities. With the exception of the City of Brownsville, many of these communities are either not served or underserved by a centralized water supply system and virtually none are served by a centralized wastewater collection and treatment system. Therefore, many of the conventional water conservation measures normally applied in urban or other rural areas are not directly applicable except within Brownsville.

An objective of the study was to determine the availability and adequacy of current and future treated water supplies and wastewater options available to rural customers of Cameron County, as well as, wastewater collection and treatment options when water becomes more available, the impetus to conserve generally weakens and wasteful consumption increases. Thus it is imperative that a comprehensive water conservation program be adopted from the beginning and rigorously enforced to minimized capital and operation and maintenance costs for both water and wastewater services.

#### **6.1.2 Need for and Goals of Program**

The Texas Water Development Board has promulgated Financial Assistance Rules which require water conservation planning for any entity receiving financial assistance from the TWDB. These planning requirements are designed to encourage cost-effective regional water supply and wastewater treatment facility development. On November 5th, 1985, Texas voters approved an amendment to the Texas Constitution that provided for the implementation of HB 2. Previous to this study, the CCWB has not developed a comprehensive plan for water conservation or drought contingency management of available supplies. This document provides specific guidelines for developing a water conservation and drought management program that will meet the regulatory requirements of the TWDB for the CCWB Planning Area.

Since the early 1960s, per capita water use in the state has increased approximately four gallons per capita per decade. More important, per capita water use during droughts is typically about one third greater than during periods of average precipitation. Thus, the goals of the program are to reduce overall water usage through water conservation practices and to provide for a reduction in water usage during times of shortage.

Water use in the residential and commercial sectors involves day-to-day activities of all citizens of the state, and includes drinking, bathing, cooking, toilet flushing, fire protection, lawn watering, swimming pools, laundry, dishwashing, car washing and sanitation. In addition, rural areas, served by the CCWB member WSCs, carry the additional demands of supporting small-scale private livestock production and the, often not-so-small, family garden. The objective of a conservation program is to reduce the quantity of water required for each of these activities, where practical, through implementation of efficient water use practices. The drought contingency program provides procedures for both voluntary and mandatory actions placed in effect to temporarily reduce usage demand during a water shortage crisis. Drought contingency procedures include water conservation and prohibition of certain uses. Both are tools that CCWB member WSC managers and officials will have available to them in order to effectively operate in all situations.

The water conservation plan outlined herein has the overall objective of reducing water consumption in the CCWB service area. Implementation of this plan will also reduce the amount of wastewater needing treatment and disposal. Although the impetus for this report is regional planning for water supply needs, it focuses on measures that specifically reduce the amount of water used and, ultimately, on the amount of wastewater produced. Such measures will have the effect of extending the time until additional water and wastewater treatment capacity must be provided.

Various cities throughout the country have adopted water conservation techniques and technologies depending upon the severity of their water supply situation. In particular, California has taken significant steps to reduce water consumption, and here in Texas, Austin has an aggressive water conservation program. Drawing on the experiences of some of these cities, some assumptions about the feasibility, cost and effectiveness of specific measures can be made. For the purpose of reducing the quantities of water required, two of the measures outlined below deserve particular attention: adopting vigorous plumbing codes for new construction and retrofitting.

According to figures developed in Section 3.0, between 1990 and 2020, the population of the study area is expected to at least double. Under drought conditions, when consumption is typically at its highest, and without implementation of water conservation measures, a doubling of the population would increase demand from its current 5,200 AF/yr to over 13,500 AF/yr (TDWR, 1989). With such high rates of growth, it is evident that the greatest savings in water usage can be realized by adopting stringent plumbing codes for new construction. Nationwide it is being realized that the marginal cost of supplying new water sources and water and wastewater treatment facilities is so high, that new plumbing codes that reduce water usage by 25-30 percent are the most economical solution. However, because water use in rural areas are less weighted toward domestic functions, lesser reductions on the order of 10-15% can be expected.

Existing facilities can also be retrofitted in order to reduce water consumption. Although this may involve some capital outlay, all of the measures are cost-effective, and various schemes have been devised to recover the costs. For instance, a plan for San Antonio assumes that a 2 percent increase in water and wastewater rates for 5 years would raise enough money to cover a \$100 rebate for each customer retrofitting a toilet to flush on 1.5 gallons (resulting in an overall savings on the customer's water and wastewater bill). An aggressive retrofit program can result in water savings of 15-25 percent per residence. With market penetration typically running at 20-50 percent, this would result in an overall water consumption savings of around 5 percent. In its water conservation program, the City of Austin estimates a 6.7 percent savings within 5 years. This program consists of substituting low-flow shower heads, installing toilet dams and checking for leaks. The benefit/cost ratio is estimated at more than ten, with an average savings to the customer of \$52/year from reductions in water, wastewater and electricity.

In Figure 6-1, drought condition water demands through the year 2020 for the entire CCWB service area is shown without implementation of water conservation measures. Also shown are the flows that would result from the adoption of the two measures outlined above. Overall savings in wastewater flows by 2020 are approximately 15% or approximately 2,000 AF/yr. This estimate is based on the following assumptions:

- adoption of a code that would reduce water consumption in all new construction from the current rural area statewide average of 140-160 gcd to 125 gcd;
- this code would be phased in during the 1990s and early 2000s ( a net water savings of 2% by 1995; 5% by 2000; 7-1/2% by 2005; 10% by 2010; and 12-1/2% by 2015 and 15% by 2020);
- existing uses could be reduced by 5 percent through retrofitting and other conservation measures.

These savings in water demand can be related directly to savings in water supply procurement, treatment and distributions costs as well as wastewater disposal costs. By reducing average daily demand and peak 2 hour demands by as much as 15% percent, water treatment and distribution system requirements will be commensurably reduced by 15% percent. Operation and maintenance costs to the water system infrastructure will be lower because of lower chemical requirements, reduced pumping requirements, and appropriate pump station and line sizing. Design of urban water treatment and distribution systems are influenced more by fire protection requirements than average daily per capita water usage. Rural fire protection demands are less stringent; the Fire Protection Bureau requires a minimum flow rate of 500 gpm. Thus, the impacts of water conservation are not diminished by fire protection requirements.

The drought contingency program includes those measures that can cause the CCWB to significantly reduce water use on a temporary basis. These measures involve voluntary reductions, restrictions and/or elimination of certain types of water use and water rationing. Because the onset of an emergency condition is often rapid, it is important that the CCWB be prepared in advance. Further, the citizen or customer

must know that certain measures not used in the water conservation program may be necessary if a drought or other emergency condition occurs.

## 6.2 Long-term Water Conservation

### 6.2.1 Plan Elements

Nine principal water conservation methods are delineated as part of the proposed water conservation plan.

#### Education and Information

The CCWB will promote water conservation by informing water users about ways to save water inside of homes and other buildings, in landscaping and lawn maintenance, and in recreational uses. Information will be distributed to water users as follows:

#### Initial Year:

- The initial year shall include the distribution of educational materials outlined in the Maintenance Program section.
- Distribution of a fact sheet explaining the newly-adopted Water Conservation Program and the elements of the Drought Contingency Plan. The initial fact sheet shall be included with the first distribution of educational material.
- In addition to activities scheduled in the Maintenance Program, an outline of the program and its benefits shall be distributed either through the mail or as a door-to-door hand-out.

#### Maintenance Program:

- Distribution of educational materials will be made semi-annually, timed to correspond with peak summer demand periods. Such material will incorporate information available from the American Water Works Association (AWWA), Texas Water Development Board (TWDB) and other similar associations in order to expand the scope of this project. A wide range of materials may be obtained from:

Texas Water Development Board  
P.O. Box 13231, Capitol Station  
Austin, Texas 78711-3231

- New customers will be provided with a similar package of information as that developed for the initial year, namely, educational material, a fact sheet explaining both the Water Conservation Pro-

gram and the elements of the Drought Contingency Plan, and a copy of "Water Saving Methods that can be Practiced by the Individual Water User."

### Plumbing Codes

Each of the CCWB member WSCs currently adhere to and enforce independent plumbing code for their respective service areas. These Codes have been in effect for several years. During the 1990s a more stringent unified CCWB Plumbing Code, modeled after the Massachusetts Code, will be adopted for all new construction and remodelled structures. The most significant components under consideration are:

- showers used for other than safety reasons shall be equipped with approved flow control devices to limit total flow to a maximum of 3 gallons per minute (gpm);
- toilets shall use a maximum of 1.6 gallons per flush;
- urinals shall use a maximum of 1.5 gallons per flush.

### Retrofit Program

The CCWB will make available, through its education and information programs, pertinent information for the purchase and installation of plumbing fixtures, lawn watering equipment and appliances. The advertising program will inform existing users of the advantages of installing water saving devices. The CCWB will contact local plumbing and hardware stores and encourage them to stock water conserving fixtures, including retrofit devices.

In addition, the CCWB will embark upon an aggressive retrofit program. Several alternatives are summarized in Table 6-1. Market penetration is based on the experience of other cities offering such programs. Savings are calculated on the basis of 4.9 persons per household for year 2020, a total of 26,651 residences in the Facility Planning Area.

The least cost alternative is to deliver two packages/house containing two flow restrictors, a plastic restrictor for a shower head, a toilet bag and two dye tablets. Based on past experience, the toilet bags are the most acceptable to customers and could be expected to realize savings of 4.8 gpd in participating households. A more acceptable and more permanent option is to provide customers with low-flow shower heads and toilet dams. Because of the greater costs associated with providing these items, vouchers would be included in the water bill to be exchanged at convenient locations for each water supply system. It is assumed that most of the equipment claimed through this mechanism would be installed. Another more fool-proof system, used extensively in the City of Austin, involves the installation of low-flow shower heads and toilet dams at no charge to the customer. In Austin, market penetration has exceeded 50 percent and in participating household has resulted in water savings of around 15 percent of household

usage. A fourth option is to provide rebates of \$100 to customers who replace their toilets with those that use on 1.5 gallons per flush.

**Table 6-1  
 Expected Savings Through Implementation  
 of a Water Use Retrofit Program**

Action	Cost Per House <sup>a/</sup>	Savings Per House <sup>b/</sup>	Penetration <sup>c/</sup>	Total Savings <sup>d/</sup>	Total Cost <sup>e/</sup>	Cost Per gpd <sup>f/</sup>
Distribution of Water Savings Kits <sup>g/</sup>	\$ .50	28.9 gpd	50%	120,643 gpd	\$2,087	\$0.017
Vouchers for Shower Heads and Toilet Dams <sup>h/</sup>	\$4.00	55.7 gpd	20%	93,000 gpd	\$6,679	\$0.072
Installation of Shower Heads and Toilet Dams <sup>i/</sup>	\$10.00	56.7 gpd	50%	236,694 gpd	\$41,745	\$0.176
Refund for Replacing Toilets <sup>j/</sup>	\$100.00	66.7 gpd	10%	55,694 gpd	\$83,490	\$1.499

- <sup>a/</sup> Assumes one bathroom per single-family residence.
- <sup>b/</sup> Based on 125 gpd and 4.90 persons per residence.
- <sup>c/</sup> Percentage of residences participating fully in the program.
- <sup>d/</sup> Based on current 8,349 residences in CCWDB Colonia Study Area.
- <sup>e/</sup> Total Program implementation cost.
- <sup>f/</sup> Cost per gpd saved.
- <sup>g/</sup> Assumes free distribution to all services area residences @ one kit per residence.
- <sup>h/</sup> Assumes participant retrieval of kits @ one kit per residence.
- <sup>i/</sup> Assumes installation by private contractors.
- <sup>j/</sup> Assumes \$100 per toilet.

**Water Rate Structure**

The PUB uses a uniform rate structure for all residential users. That is to say that consumers pay the same unit rate for water regardless of usage. The PUB, however, charges for only 80% of the first 10,000 gal per month; thus, effectively operating as an inclining block rate system.

**Universal Metering**

All water users, including utility and public facilities are currently metered. Also, master meters are installed and periodically calibrated at all existing water sources. All new construction, including multi-family dwellings, are separately metered. The program of universal metering will continue, and is made part of the Water Conservation Plan.



The CCWB, through their computer billing system, currently monitors water consumption and inspects meters that vary from previously established norms. In addition, the CCWB could operate under the following meter maintenance and replacement programs:

<u>Meter Type</u>	<u>Test and Replacement Period</u>
Master meter	Annually
Larger than 1 inch	Annually
1-inch and less	Every 5 years

Through a successful meter maintenance program, coupled with computerized billing and leak detection programs, the CCWB will be able to maintain water delivery rates, from production to consumer, in the 85 percentile range.

#### Water Conservation Landscaping

In order to reduce the demands placed on the water system by landscape, livestock and garden watering, the CCWB, through its information and education program, will encourage customers and local landscaping companies to utilize water saving practices during installation of landscaping, gardens and stock watering facilities for residential and commercial institutions. The following methods will be promoted by the education and information program:

- Encourage subdivisions to require drought-resistant grasses and plants that require less water.
- Initiate a program to encourage the adoption of xeriscaping.
- Encourage landscape architects to use drought-resistant plants and grasses; and efficient irrigation systems.
- Encourage licensed irrigation contractors to use drip irrigation systems, when possible, and to design all irrigation systems with conservation features such as sprinklers that emit large drops rather than a fine mist and a sprinkler layout that accommodates prevailing wind patterns.
- Encourage commercial establishments to use drip irrigation for landscape watering, when practical, and to install only ornamental fountains that use minimal quantities of water, including recycling features.
- Encourage local nurseries to offer adapted, drought-resistant plants and grasses and efficient watering devices.

#### Leak Detection and Repair

The CCWB and its member WSCs will utilize modern leak detection techniques, including listening devices, in locating and reducing leaks. Through their respective billing program, each WSC will identify excessive usage and take steps to determine whether it is a result of leakage. Once located, all leaks will be immediately repaired. A continuous leak detection and repair program is vital to the WSC's profitability. The CCWB is confident that the program more than pays for itself.

### Recycle and Reuse

The CCWB does not own or operate any conventional wastewater treatment facilities. Nearly all CCWB customers utilize some sort of on-site wastewater treatment and disposal method. However, the CCWB will make available to its customers, information on on-site reuse of non-sewage wastewater.

### 6.3 Implementation/Enforcement

The staff of the CCWB will administer the Water Conservation Program. They will oversee the execution and implementation of all elements of the program and supervise the keeping of adequate records for program verification.

The plan will be enforced through the adoption of the Water Conservation Plan by each of the CCWB member or water supplier in the following manner:

- Water service taps will not be provided to customers unless they have met the plan requirements;
- The proposed block rate structure should encourage retrofitting of old plumbing fixtures that use large quantities of water; and
- The building inspector will not certify new construction that fails to meet plan requirements.

The CCWB member WSCs will adopt the final approved plan and commit to maintain the program for the duration of the CCWB's financial obligation to the State of Texas.

### Annual Reporting

In addition to the above outlined responsibilities, the CCWB staff will submit an annual report to the Texas Water Development Board on the Water Conservation Plan. The report will include the following:

- Information that has been issued to the public.
- Public response to the plan.
- The effectiveness of the water conservation plan in reducing water consumption, as demonstrated by production and sales records.
- Implementation progress and status of the plan.

### Contracts with Other Political Subdivisions

The CCWB will, as part of a contract for sale of water to any other political subdivision, require that entity to adopt applicable provisions of the CCWB's water conservation or already have a TWDB-approved plan in effect. These provisions will be through contractual agreement prior to the sale of water to the political subdivision.

## 6.4 Drought Management Plan

### 6.4.1 Cameron County Drought Management Authority

Nearly all public and private water supplies in Cameron County are derived, either directly or indirectly, from the Rio Grande. Those waters are regulated jointly by the United States and Mexico. The Texas Water Master, in consortium with the International Boundary and Water Commission regulates the operation of Amistad, Falcon, and Anzalduas Reservoirs as a hydrologic system to supply normal and drought condition flows to Mexico and the Lower Valley. Cameron County will adopt, and follow to the extent practicable and legally enforceable, the procedures of the Water Master and the IBWC with regards to water supply operations during hydrologic droughts.

On a local basis and where enforceable, the County will require cities to adopt drought contingency ordinances in accordance with the provisions of the drought contingency plan presented herein for the CCWDB.

### 6.4.2 Drought and/or Emergency Trigger Conditions

The County will adopt the following set of "triggers" or threshold conditions to indicate the various stages of increasing drought severity and water shortage conditions:

1. The County will recognize that a mild drought (water demand is approaching the safe capacity of the system) is in progress when the Texas Water Master (Texas Water Commission) determines that the operating reserve in Falcon and Amistad Reservoirs is at 25% capacity.
2. The County will recognize that a moderate drought (reservoir reserves are still high enough to provide an adequate supply, but the reserves are low enough to disrupt some beneficial activities) is in progress when the Texas Water Master determines that the operating reservoir in Falcon and Amistad Reservoirs is zero.
3. The County will recognize that a severe drought (reservoir reserves are low enough that there is a real possibility that the supply situation may become critical if the drought or emergency continues) is in progress when the Texas Water Master determines that the irrigation reserve in Falcon and Amistad Reservoirs is less than 50 percent of assigned capacity.
4. The County will recognize that the system is in emergency operation modes if one or more of its customer's major pumps or transmission lines in the raw water supply system fail, significantly impairing the capability to deliver water to contracting cities.

### 6.4.3 Drought and/or Emergency Measures

The County will incorporate the following measures and encourage water use by affected cities, depending on the degree of efficient severity of the drought and other system emergency conditions.

### Mild Condition Measures

1. Cities will be asked to activate an information center to answer inquiries from citizens and other customers regarding water shortage conditions and required conservation measures. The Authority will discuss the drought condition potential and its impact on the water supply situation in the news media.
2. The County will continue to advise the cities of the reservoir reserves on a monthly basis.
3. The County will request the cities to implement a voluntary daily lawn watering schedule through the media.

### Moderate Condition Measures

1. The County will inform the cities by mail and telephone that the drought has reached the moderate trigger level. This information will be given at seven-day intervals until the drought trigger condition changes.
2. The County will request that contracting cities implement mandatory lawn irrigation schedules.
3. The County will request that the contracting cities prohibit other non-essential uses such as car washing, filling of swimming pools, etc.

### Severe Drought Condition and/or System Emergency Mode

1. The County will immediately inform the cities, by telephone and mail, about the serious water supply situation. Similar action will be taken in the event of a major system failure. The news media will also be informed. Situation reports will be issued to the contracting cities and news media daily.
2. The County will request that the cities prohibit all outdoor water use.

#### 6.4.4 Drought Termination Notification

Termination of the drought/emergency condition and corresponding measures will take place when the trigger condition that initiated the drought/emergency situation no longer exists. The County will inform the member cities and the media of the end of the drought trigger or emergency condition in the same manner as they were previously informed.

## **7.0 PRELIMINARY ENVIRONMENTAL ASSESSMENT**

The purpose of this section is to provide preliminary environmental support for the development of the Cameron County Regional Water and Wastewater Plan. This section is designed to accomplish two primary goals: 1) Provide a preliminary baseline assessment of environmental and cultural features that, under Federal, State, and local regulations may become of concern in the development of regional water supply, treatment and distribution, and wastewater treatment and collection facilities; and, 2) Identify potential effects and/or constraints to the development of such facilities. This section generally follows guidelines for environmental assessments as described by TWDB for state funding programs. This assessment is general and is designed to provide data for preliminary evaluation of alternative water and wastewater options. Site specific detail for a complete Environmental Assessment or Environmental Information Document will require further study. Significant environmental constraints within Cameron County are presented on the Environmental Constraints Map (USGS Quad base map) in the map report accompany this plan.

### **7.1 Purpose and Need for Project**

The purpose and need for this project is described in detail in Sections 1.0, 2.0 and 3.0 of this report.

### **7.2 Project Description**

The proposed project has been previously defined throughout this study. Details of proposed water and wastewater facilities to serve the colonias of Cameron County can be found in Sections 4.0 and 5.0 of this report.

### **7.3 Baseline Conditions**

#### **7.3.1 Geological Elements and Soils**

Cameron County is located on the nearly level coastal plain of Texas. The county gradually dips to the East toward the Gulf of Mexico at typically less than a one percent (1%) slope. Generally, the topographic features of Cameron County consists of tidal flats, resacas, backswamps, barrier islands, levees, point bars, clay dunes, depressing areas, and deltaic features of the Rio Grande. Elevations throughout the county range from sea level to approximately 70 feet MSL near Santa Maria (Williams et al., 1977).

Two (2) geologic formations are exposed in Cameron County. The Beaumont formation and the younger Holocene sediments (Williams et al., 1977). The older Beaumont formation, which is of Pleistocene age, and the Holocene sediments at the surface are separated by a contact point

which occurs as a low scarp in the area of Sweeney and Cross Lakes and, west of Harlingen, by the Arroyo Colorado which flows along the contact (Williams et al., 1977).

The older exposed Pleistocene system that outcrops along the Gulf of Mexico coastal plain is the Houston group (Sellards et al., 1981). The Houston group sediments are unconsolidated, alluvial, deltaic, and brackish-water or lagoonal deposits (Sellards et al., 1981). The Houston group is divided into two (2) formations, the Lissie sand, and the Beaumont clay (Sellards et al., 1981). The former of which is not exposed in Cameron County (BEG, 1976).

The Beaumont clay formation is present mainly in the North-western part of the county. It is 400 to 900 feet thick, about 75% to 80% sand with considerable gravel and some limestone originally deposited as caliche (Sellards et al., 1981). The Beaumont formation was largely deposited by rivers by way of natural levees and deltas systems and to a lesser extend by marine and lagoonal processes (Sellards et al., 1981). In extensive areas along the Gulf of Mexico coast the Beaumont clay formation is overlain unconformably by recent stream deposits and wind-blown beach sands (Sellards et al., 1981).

The recent Holocene sediments dominate the southern and eastern part of Cameron County. These sediments are characterized by three (3) distinct deposits: wind-blown, barrier island, and alluvial.

The wind-blown deposits are primarily found along the extreme mainland coast of Cameron County. These sediments are generally characterized as clay dunes, active dunes and dune complexes on the mainland, and stabilized sand dune deposits (BEG, 1976).

The barrier island deposits exist as part of Padre Island and to a small extend Brazos Island. These sediments are generally characterized as sand, silt and clay, mostly sand, well sorted, fine grained, with interfingers of silt and clay in the landward direction. These island deposits also include a beach ridge, spit, tidal channel, tidal delta, washover fan, and sand dune deposits (BEG, 1976).

The third and most extensive Holocene sediments in Cameron County are the alluvial or flood plain deposits. These sediments overlay greater than fifty percent (50%) of the county. These were transported by the Rio Grande and its associated streams, resacas and arroyos. These alluvial deposits in the lower River Grande are composed of a wide variety of sediments characterized as clay, silt, mainly quartz sand, dark gray to dark brown; and includes sedimentary rocks from the Cretaceous and Tertiary and a wide variety of igneous and sedimentary rocks from the Trans-Pecos of Texas, Mexico and New Mexico (BEG, 1976).

## Soil

The following paragraphs will present the general soil associations and descriptions of Cameron County (Williams, et al., 1977) as mapped by the Soil Conservation Service. These general descriptions will include soil properties that are pertinent to the proposed activity, such as landscape position, slopes, permeability and texture. A more specific quantitative listing of the engineering properties for Cameron County soils and how they relate to individual colonias within the study area are presented in Table 7-1.

The Sejita-Lomalta-Barrada soil association occupies level areas of saline, loamy and clayey soils at or near sea level and broad areas of barren clay that are inundated by high tides and heavy rains. This association occupies about 23% of the county and is generally poorly drained and very poorly drained clays and silty clay loams. Much of this association has a water table depth of 1 to 5 feet throughout the year.

The Laredo-Lomalta soil association occupies gently sloping to level areas and is well-drained to poorly drained silty clay loams and clays. This association is mainly adjacent to Laguna Atascosa National Wildlife Refuge. This association occupies about 4% of the county and a seasonal high water table exists at about 2 to 6 feet. The soils of this association occupy the slightly depressed areas and adjacent sloping areas slightly greater in elevation (1-5 feet).

The Willamar association soils are described as nearly level, somewhat poorly drained fine sandy loams and sandy clay loams. These soils comprise about 4% of Cameron County. These soils are somewhat poorly drained and have very slow permeability. A seasonal high water table exists at about 36 to 72 inches and these soils are saline.

The soils of the Laredo-Olmito association are characterized as nearly level to gently sloping, well-drained and moderately well-drained silty clayloams and silty clays. These soils generally follow the pattern of the old resacas on a low terrace of the Rio Grande. This association comprises about 19% of the county.

The Rio-Grande-Matamoros association can be described as nearly level to gently sloping, well-drained and moderately well-drained silt loams and silty clays. These soils occupy a narrow band adjacent to the Rio-Grande and the nearly level slack water areas associated with it. This association occupies about 4% of the county. These soils are geologically very young (Holocene age).

Table 7-1  
Soils Summary and On-site  
Absorption System Suitability for  
Each Colonia

Colonia PUB Designation	Colonia	Soils Designation	Degree and Kind of Limitation for Septic Tank Absorption Fields	Permeability (in/hr)	Depth to Seasonal High Water Table (in)	Suitable for Absorption Trench On-Site Disposal (Y/N)
1B	Cameron Park	Laredo Silty Clay Loam (0-1% Slopes)	Moderate; Percs Slowly	0.06 - 0.20	36 - 120	N
		Laredo Silty Clay Loam (1-3% Slopes)	Moderate; Percs Slowly	0.06 - 0.20	36 - 120	N
		Omito Silty Clay	Severe; Percs Slowly	0.06 - 0.20	60 - 120	N
		Harlingen Clay	Severe; Percs Slowly	0.06	60 - 120	N
2B	Omito	Chargo Silty Clay	Severe; Percs Slowly	0.06 - 0.20	24 - 36	N
		Benito Clay	Severe; Percs Slowly; Wet	< 0.06	60 - 120	N
		Omito Silty Clay	Severe; Percs Slowly; Wet	< 0.06	60 - 120	N
		Laredo Silty Clay Loam (0-1% Slopes)	Moderate; Percs Slowly	0.06 - 0.20	36 - 120	N
3B	Stuart Subdivision	Tiocano Clay	Severe; Floods; Percs Slowly	< 0.06	> 74	Y
		Laredo-Urban Land Complex	Severe; Percs Slowly	< 0.06	36 - 120	N
		Benito Clay	Severe; Percs Slowly; Wet	< 0.06	60 - 120	N
		Benito-Urban Land Complex	Severe; Percs Slowly; Wet	< 0.06	60 - 120	N
4B	San Pedro/Cameron/Barrera Gd	Laredo Silty Clay Loam (0-1% Slopes)	Moderate; Percs Slowly	0.63 - 2.0	60 - 120	N
		Laredo Silty Clay Loam (0-1% Slopes)	Moderate; Percs Slowly	0.06 - 0.20	36 - 120	N
		Laredo Silty Clay Loam (0-1% Slopes)	Moderate; Percs Slowly	0.06 - 0.20	36 - 120	N
		Omito Silty Clay	Severe; Percs Slowly	0.06 - 0.20	36 - 120	N
5B	King Subdivision	Omito Silty Clay	Severe; Percs Slowly	0.06 - 0.20	36 - 120	N
		Omito-Urban Land Complex	Severe; Percs Slowly	0.06 - 0.20	60 - 120	N
		Laredo-Urban Land Complex	Severe; Percs Slowly	0.06 - 0.20	60 - 120	N
		Rio Grande Silty Loam	Severe; Floods	0.63 - 2.0	> 63	N
6B	Alabama/Arkansas (la Coma)	Benito Clay	Severe; Percs Slowly; Wet	< 0.06	60 - 120	N
		Omito Silty Clay	Severe; Percs Slowly	0.06 - 0.20	36 - 120	N
		Laredo Silty Clay Loam (0-1% Slopes)	Moderate; Percs Slowly	0.06 - 0.20	36 - 120	N
		Omito Silty Clay	Severe; Percs Slowly	0.06 - 0.20	36 - 120	N
7B	Hacienda Gardens	Laredo Silty Clay Loam (0-1% Slopes)	Moderate; Percs Slowly	0.06 - 0.20	36 - 120	N
		Laredo Silty Clay Loam (1-3% Slopes)	Moderate; Percs Slowly	0.06 - 0.20	36 - 120	N
		Rio Grande Silty Loam	Severe; Floods	0.63 - 2.0	> 63	N
		Laredo Silty Clay Loam (0-1% Slopes)	Moderate; Percs Slowly	0.06 - 0.20	36 - 120	N
8B	Villa Nueva	Omito Silty Clay	Severe; Percs Slowly	0.06 - 0.20	36 - 120	N
		Benito Clay	Moderate; Percs Slowly	0.06 - 0.20	36 - 120	N
		Omito Silty Clay	Severe; Percs Slowly	0.06 - 0.20	60 - 120	N
		Benito Clay	Severe; Percs Slowly; Wet	< 0.06	60 - 120	N
9B	Villa Pancho	Omito Silty Clay	Severe; Percs Slowly	0.06 - 0.20	60 - 120	N
		Cameron Silty Clay	Slight	0.20 - 0.63	60 - 120	N
		Chargo Silty Clay	Severe; Percs Slowly	0.06 - 0.20	24 - 36	N
		Benito Clay	Severe; Percs Slowly; Wet	< 0.06	60 - 120	N
10B	Pleasant Meadows	Omito Silty Clay	Severe; Percs Slowly	0.06 - 0.20	36 - 120	N
		Omito Silty Clay	Severe; Percs Slowly	0.06 - 0.20	36 - 120	N
		Laredo Silty Clay Loam (0-1% Slopes)	Moderate; Percs Slowly	0.06 - 0.20	36 - 120	N
		Omito Silty Clay	Severe; Percs Slowly	0.06 - 0.20	36 - 120	N
11B	Villa Cavazos	Laredo Silty Clay Loam (0-1% Slopes)	Moderate; Percs Slowly	0.06 - 0.20	36 - 120	N
		Omito Silty Clay	Severe; Percs Slowly	0.06 - 0.20	36 - 120	N



Soils Summary (Sub-Area B) continued

Colonia PUB Designation	Colonia	Soils Designation	Degree and Kind of Limitation for Septic Tank Absorption Fields	Permeability (In/hr)	Depth to Seasonal High Water Table (In)	Suitable for Absorption Trench On-Site Disposal (Y/N)
12B	Barrío Subdivision	Laredo-Urban Land Complex Lomelta Clay Laredo Silty Clay Loam (0-1% Slopes) Laredo Silty Clay Loam (0-1% Slopes) Olmito Silty Clay	Severe: Percs Slowly Moderate: Percs Slowly Moderate: Percs Slowly Severe: Percs Slowly	0.06 0.06 - 0.20 0.06 - 0.20 0.06 - 0.20	60 - 120 48 - 120 36 - 120 36 - 120	N N N N
13B	Las Cuatas	Olmito Silty Clay Haringen Clay	Severe: Percs Slowly Severe: Percs Slowly; Wet	0.06 < 0.06	60 - 120 60 - 120	N N
14B	Saldivar	Benito Clay Olmito Silty Clay	Severe: Percs Slowly Severe: Percs Slowly	0.06 - 0.20 0.06 - 0.20	36 - 120 60 - 120	N N
15B	Coronado	Laredo-Olmito Complex Laredo Silty Clay Loam (0-1% Slopes)	Severe: Percs Slowly Moderate: Percs Slowly	0.06 - 0.20 0.06 - 0.20	36 - 120 60 - 120	N N
16B	Unknown	Benito Clay Matamoros Silty Clay	Severe: Percs Slowly; Wet Severe: Floods; Percs Slowly	< 0.06 0.06 - 0.20	60 - 120 > 50	N N
17B	Saldivar (II)	Lomelta Clay Olmito Silty Clay Laredo Silty Clay Loam (0-1% Slopes) Haringen Clay	Severe: Percs Slowly Severe: Percs Slowly Moderate: Percs Slowly Severe: Percs Slowly	0.06 0.06 - 0.20 0.06 - 0.20 0.06	48 - 120 36 - 120 36 - 120 60 - 120	N N N N
18B	Valle Escondido	Benito Clay	Severe: Percs Slowly; Wet	< 0.06	60 - 120	N
18B	Unnamed C	Olmito Silty Clay Laredo Silty Clay Loam (0-1% Slopes)	Severe: Percs Slowly Moderate: Percs Slowly	0.06 - 0.20 0.06 - 0.20	36 - 120 36 - 120	N N
20B	Unnamed D (Keller's Corner)	Olmito Silty Clay Benito Clay	Severe: Percs Slowly Severe: Percs Slowly; Wet	0.06 - 0.20 < 0.06	36 - 120 60 - 120	N N
21B	Texas 4	Laredo Silty Clay Loam (0-1% Slopes) Laredo Silty Clay Loam (0-1% Slopes) Olmito Silty Clay	Moderate: Percs Slowly Moderate: Percs Slowly Severe: Percs Slowly	0.06 - 0.20 0.06 - 0.20 0.06 - 0.20	36 - 120 36 - 120 60 - 120	N N N
22B	511 Crossroads	Laredo-Urban Land Complex Laredo Silty Clay Loam (0-1% Slopes) Laredo Silty Clay Loam (Saline)	Moderate: Percs Slowly Moderate: Percs Slowly Severe: Percs Slowly	0.06 - 0.20 0.63 - 2.0 0.06 - 0.20	36 - 120 60 - 120 24 - 96	N N N
23B	Illinola Heights	Chargo Silty Clay Olmito Silty Clay Laredo Silty Clay Loam (Saline) Lomelta Clay	Severe: Percs Slowly Moderate: Percs Slowly Severe: Percs Slowly Severe: Percs Slowly	0.06 - 0.20 0.63 - 2.0 0.06 0.06 - 0.20	36 - 120 60 - 120 48 - 120 36 - 120	N N N N
24B	Unknown (Brownsville Airport)	Laredo Silty Clay Loam (0-1% Slopes) Olmito Silty Clay	Moderate: Percs Slowly Severe: Percs Slowly	0.06 - 0.20 0.06 - 0.20	36 - 120 36 - 120	N N
25B	Valle Hermosa	Benito Clay	Severe: Percs Slowly; Wet	< 0.06	60 - 120	N
26B	Unknown	Laredo Silty Clay Loam (0-1% Slopes) Laredo Silty Clay Loam (1-3% Slopes) Olmito Silty Clay	Moderate: Percs Slowly Moderate: Percs Slowly Severe: Percs Slowly	0.06 - 0.20 0.06 - 0.20 0.06 - 0.20	36 - 120 36 - 120 36 - 120	N N N
27B	Unnamed B (Hwy 802)	Olmito Silty Clay Laredo Silty Clay Loam (0-1% Slopes) Laredo Silty Clay Loam (0-1% Slopes)	Severe: Percs Slowly Moderate: Percs Slowly Moderate: Percs Slowly	0.06 - 0.20 0.06 - 0.20 0.20 - 0.63	36 - 120 36 - 120 0 - 23	N N N
28B	21	Cameron Silty Clay Olmito Silty Clay	Moderate: Percs Slowly Slight Severe: Percs Slowly	0.06 - 0.20 0.06 - 0.20	36 - 120	N N N

Soils Summary (Sub-Area W)

Colonia PUB Designation	Colonia	Soils Designation	Degree and Kind of Limitation for Septic Tank Absorption Fields	Permeability (in/hr)	Depth to Seasonal High Water Table (in)	Suitable for Absorption Trench On-Site Disposal (Y/N)						
1W	Encantada	Laredo Silty Clay Loam (0-1% Slopes)	Moderate; Percs Slowly	0.06 - 0.20	36 - 120	N						
		Laredo Silty Clay Loam (1-3% Slopes)	Moderate; Percs Slowly	0.06 - 0.20	36 - 120	N						
		Laredo-Reynosa Complex (0-1% Slopes)	Moderate; Percs Slowly	0.63 - 2.0	60 - 120	N						
		Laredo-Reynosa Complex (1-3% Slopes)	Moderate; Percs Slowly	0.63 - 2.0	60 - 120	N						
		Rio Grande Silty Loam	Severe; Floods	0.63 - 2.0	> 63	N						
		Tocano Clay	Severe; Floods; Percs Slowly	< 0.06	60 - 120	N						
		Laredo Silty Clay Loam (0-1% Slopes)	Moderate; Percs Slowly	0.06 - 0.20	36 - 120	N						
		Laredo-Urban Land Complex	Severe; Percs Slowly	0.06 - 0.20	60 - 120	N						
		Olmito Silty Clay	Moderate; Percs Slowly	0.06 - 0.20	36 - 120	N						
		Rio Grande Silty Loam	Severe; Floods	0.63 - 2.0	> 63	N						
		2W	Santa Maria	Laredo Silty Clay Loam (0-1% Slopes)	Moderate; Percs Slowly	0.06 - 0.20	60 - 120	N				
				Laredo Silty Clay Loam (0-1% Slopes)	Moderate; Percs Slowly	0.06 - 0.20	36 - 120	N				
Laredo Silty Clay Loam (0-1% Slopes)	Moderate; Percs Slowly			0.06 - 0.20	60 - 120	N						
Laredo-Reynosa Complex (0-1% Slopes)	Moderate; Percs Slowly; Wet			< 0.06	60 - 120	N						
Benito Clay	Severe; Percs Slowly			0.20 - 0.63	60 - 120	N						
Raymondville Clay Loam	Severe; Percs Slowly			0.06 - 0.20	60 - 120	N						
Olmito Silty Clay	Moderate; Percs Slowly			0.06 - 0.20	60 - 120	N						
Laredo Silty Clay Loam (0-1% Slopes)	Moderate; Percs Slowly			0.06 - 0.20	36 - 120	N						
Laredo Silty Clay Loam (0-1% Slopes)	Moderate; Percs Slowly			0.06 - 0.20	36 - 120	N						
Olmito Silty Clay	Severe; Percs Slowly; Wet			< 0.06	60 - 120	N						
Benito Clay	Moderate; Percs Slowly			0.06 - 0.20	36 - 120	N						
3W	La Paloma			Laredo Silty Clay Loam (0-1% Slopes)	Severe; Floods; Percs Slowly	0.06 - 0.20	60 - 120	N				
		Raymondville Clay Loam	Severe; Percs Slowly	< 0.06	60 - 120	N						
		Tocano Clay	Severe; Percs Slowly	0.06 - 0.20	60 - 120	N						
		Raymondville Clay Loam (Saline)	Severe; Percs Slowly	0.06 - 0.20	60 - 120	N						
		Raymondville Clay Loam	Severe; Percs Slowly	0.20 - 0.63	60 - 120	N						
		Racombes Sandy Clay Loam	Severe; Percs Slowly	0.20 - 0.63	60 - 120	N						
		Willacy Fine Sandy Loam (0-1% Slopes)	Severe; Floods	0.63 - 2.0	60 - 120	N						
		Hidalgo Sandy Clay Loam	Slight	2.0 - 6.3	> 74	Y						
		Hidalgo Fine Sandy Loam (0-1% Slopes)	Slight	0.63 - 2.0	60 - 120	N						
		Mercedes Clay (0-1% Slopes)	Slight	0.63 - 2.0	> 15	N						
		Raymondville Clay Loam	Severe; Percs Slowly	< 0.60	60 - 120	N						
		4W	Los Indios	Raymondville Clay Loam	Severe; Percs Slowly	0.20 - 0.63	60 - 120	N				
Raymondville Clay Loam	Severe; Percs Slowly			0.20 - 0.63	60 - 120	N						
Hidalgo Sandy Clay Loam	Slight			0.63 - 0.20	60 - 120	N						
Benito Clay	Severe; Percs Slowly; Wet			< 0.06	60 - 120	N						
Raymondville Clay Loam	Severe; Percs Slowly			0.20 - 0.63	60 - 120	N						
5W	Bluetown			Raymondville Clay Loam	Severe; Percs Slowly	0.20 - 0.63	60 - 120	N				
				Benito Clay	Severe; Percs Slowly; Wet	< 0.06	60 - 120	N				
				Raymondville Clay Loam	Severe; Percs Slowly	0.20 - 0.63	60 - 120	N				
				6W	T2 Unknown Subdivision	Raymondville Clay Loam	Severe; Percs Slowly	0.20 - 0.63	60 - 120	N		
						Benito Clay	Severe; Percs Slowly; Wet	< 0.06	60 - 120	N		
						Raymondville Clay Loam	Severe; Percs Slowly	0.20 - 0.63	60 - 120	N		
						7W	El Venadito	Raymondville Clay Loam	Severe; Percs Slowly	0.20 - 0.63	60 - 120	N
		Benito Clay	Severe; Percs Slowly; Wet					< 0.06	60 - 120	N		
		Raymondville Clay Loam	Severe; Percs Slowly					0.20 - 0.63	60 - 120	N		
		8W	Carricitos-Landrum					Raymondville Clay Loam	Severe; Percs Slowly	0.20 - 0.63	60 - 120	N
								Benito Clay	Severe; Percs Slowly; Wet	< 0.06	60 - 120	N
								Raymondville Clay Loam	Severe; Percs Slowly	0.20 - 0.63	60 - 120	N
9W	El Calaboz							Raymondville Clay Loam	Severe; Percs Slowly	0.20 - 0.63	60 - 120	N
								Benito Clay	Severe; Percs Slowly; Wet	< 0.06	60 - 120	N
								Raymondville Clay Loam	Severe; Percs Slowly	0.20 - 0.63	60 - 120	N
				10W	Iglesia Antigua Palmer			Raymondville Clay Loam	Severe; Percs Slowly	0.20 - 0.63	60 - 120	N
								Benito Clay	Severe; Percs Slowly; Wet	< 0.06	60 - 120	N
								Raymondville Clay Loam	Severe; Percs Slowly	0.20 - 0.63	60 - 120	N
						11W	Unknown (Milla 2)	Raymondville Clay Loam	Severe; Percs Slowly	0.20 - 0.63	60 - 120	N
								Benito Clay	Severe; Percs Slowly; Wet	< 0.06	60 - 120	N
								Raymondville Clay Loam	Severe; Percs Slowly	0.20 - 0.63	60 - 120	N
		12W	O Unknown (Santa Rosa)					Raymondville Clay Loam	Severe; Percs Slowly	0.20 - 0.63	60 - 120	N
								Benito Clay	Severe; Percs Slowly; Wet	< 0.06	60 - 120	N
								Raymondville Clay Loam	Severe; Percs Slowly	0.20 - 0.63	60 - 120	N
13W	W							Raymondville Clay Loam	Severe; Percs Slowly	0.20 - 0.63	60 - 120	N
								Benito Clay	Severe; Percs Slowly; Wet	< 0.06	60 - 120	N
								Raymondville Clay Loam	Severe; Percs Slowly	0.20 - 0.63	60 - 120	N
				14W	Unknown (Santa Rosa)			Raymondville Clay Loam	Severe; Percs Slowly	0.20 - 0.63	60 - 120	N
								Benito Clay	Severe; Percs Slowly; Wet	< 0.06	60 - 120	N
								Raymondville Clay Loam	Severe; Percs Slowly	0.20 - 0.63	60 - 120	N
						15W	X Unknown (La Feria)	Raymondville Clay Loam	Severe; Percs Slowly	0.20 - 0.63	60 - 120	N
								Benito Clay	Severe; Percs Slowly; Wet	< 0.06	60 - 120	N
								Raymondville Clay Loam	Severe; Percs Slowly	0.20 - 0.63	60 - 120	N
		16W	El Venadito					Raymondville Clay Loam	Severe; Percs Slowly	0.20 - 0.63	60 - 120	N
								Benito Clay	Severe; Percs Slowly; Wet	< 0.06	60 - 120	N
								Raymondville Clay Loam	Severe; Percs Slowly	0.20 - 0.63	60 - 120	N

Soils Summary (Sub-Area H)

Colonia PUB Designation	Colonia	Soils Designation	Degree and Kind of Limitation for Septic Tank Absorption Fields	Permeability (in/hr)	Depth to Seasonal High Water Table (in)	Suitable for Absorption Trench On-Site Disposal (Y/N)
1H	Las Palmas	Hidalgo-Urban Land Complex Hidalgo Sandy Clay Loam Raymondville Clay Loam Raymondville-Urban Land Complex Racombes Soils and Urban Land Racombes Sandy Clay Loam Willacy Fine Sandy Loam (0-1% Slopes)	Slight Severe: Percs Slowly  Severe: Floods Slight	0.63 - 0.20 0.20 - 0.63  0.63 - 2.0 2.0 - 6.3	60 - 120 60 - 120 36 - 72 60 - 120 60 - 120 > 74	N N N N N N Y
2H	Lago Subdivision	Chargo Silty Clay Laredo Silty Clay Loam (0-1% Slopes) Tiocono Clay	Severe: Percs Slowly Moderate: Percs Slowly Severe: Floods; Percs Slowly	0.06 - 0.20 0.06 - 0.20 < 0.06	24 - 36 60 - 120 > 74	N N Y
3H	26	Racombes Sandy Clay Loam Willacy Fine Sandy Loam (0-1% Slopes) Hidalgo Fine Sandy Loam (0-1% Slopes) Raymondville Clay Loam	Severe: Floods Slight Slight Severe: Percs Slowly	0.63 - 2.0 2.0 - 6.3 0.63 - 2.0 0.20 - 0.63	60 - 120 > 74 60 - 120 60 - 120	N Y N N
4H	Lasana	Racombes Sandy Clay Loam Rio Clay Loam Tiocono Clay	Severe: Floods Severe: Floods; Percs Slowly Severe: Floods; Percs Slowly	0.63 - 2.0 0.63 - 2.0 < 0.06	60 - 120 36 - 72 > 74	N N Y
5H	Rice Tracts	Laredo Silty Clay Loam (0-1% Slopes) Harrington Clay	Moderate: Percs Slowly Severe: Percs Slowly	0.06 - 0.20 0.06	60 - 120 60 - 120	N N
6H	Leal Subd. (Meas & Bounded)	Olmillo Silty Clay	Severe: Percs Slowly	0.06 - 0.20	60 - 120	N
7H	Laguna Escondido Heights	Raymondville Clay Loam	Severe: Percs Slowly	0.20 - 0.63	60 - 120	N

Soils Summary (Sub-Area E)

Colonia PUB Designation	Colonia	Soils Designation	Degree and Kind of Limitation for Septic Tank Absorption Fields	Permeability (in/hr)	Depth to Seasonal High Water Table (in)	Suitable for Absorption Trench On-Site Disposal (Y/N)
1E	La Coma Del Norte	Benito Clay	Severe; Percs Slowly; Wet	< 0.06	60 - 120	N
2E	Lozano	Harlingen Clay Laredo-Olmito Complex Raymondville Clay Loam Lyford Sandy Clay Loam Lyford Sandy Clay Loam	Severe; Percs Slowly Severe; Percs Slowly Severe; Percs Slowly Moderate; Percs Slowly; Wet Moderate; Percs Slowly; Wet	0.06 0.06 - 0.20 0.20 - 0.63 0.63 - 2.0	60 - 120 60 - 120 60 - 120 36 - 72	N N N N
3E	Laina Ranch	Willamar Soils Delina Fine Sandy Loam Lozano Fine Sandy Loam Willacy Fine Sandy Loam	Severe; Percs Slowly Severe; Percs Slowly Severe; Percs Slowly Slight	0.63 - 2.0 2.0 - 6.3 2.0 - 6.3 2.0 - 6.3	36 - 72 36 - 72 60 - 72 36 - 72 > 74	N N N N Y
4E	Laureles	Harlingen Clay	Severe; Percs Slowly	0.06	60 - 120	N
5E	Del Mar Heights	Lomaita Clay	Severe; Percs Slowly	0.06	48 - 120	N
6E	Orason Ac/Chula Vista/Shoe	Selita Silty Clay Loam Chargo Silty Clay Lomaita Clay	Severe; Floods; Wet Severe; Percs Slowly Severe; Percs Slowly	0.20 - 0.63 0.06 - 0.20 0.06	20 - 48 24 - 36 48 - 120	N N N
7E	Las Yescas	Harlingen Clay (Saline)	Severe; Shrink-Swell	0.06	60 - 120	N
8E	Unknown	Lozano Fine Sandy Loam Benito Clay	Severe; Percs Slowly	2.0 - 6.3	36 - 72	N
9E	Glenwood Acres Subd.	Olmito Silty Clay	Severe; Percs Slowly; Wet	0.06	60 - 120	N
10E	Unknown (Del Mar II)	Benito Clay	Severe; Percs Slowly; Wet	0.06	60 - 120	N
11E	Los Cuates	Lomaita Clay Selita Silty Clay Loam Laredo Silty Clay Loam (0-1% Slopes) Laredo Silty Clay Loam (1-3% Slopes) Tiocono Clay	Severe; Percs Slowly Severe; Floods; Wet Moderate; Percs Slowly Moderate; Percs Slowly Severe; Floods; Percs Slowly	0.06 0.20 - 0.63 0.06 - 0.20 0.06 - 0.20 < 0.06	48 - 120 20 - 48 60 - 120 60 - 120 > 74	N N N N Y
12E	25	Laredo-Olmito Complex	Severe; Percs Slowly	0.06 - 0.20	60 - 120	N
13E	Cienecos (Limon)	Benito Clay Benito Clay	Severe; Percs Slowly; Wet Severe; Percs Slowly; Wet	0.06 0.06	60 - 120 60 - 120	N N

The Willacy-Racombes association soils are nearly level to gently sloping, well-drained fine sandy loams and sandy clay loams. This association makes up about 7% of the county. About 10% to 15% of this association is affected by a seasonal high water table and slight to moderate salinity.

The Lyford-Raymondville-Lozano soil association can be described as nearly level, well-drained and moderately well-drained sandy clay loams, clay loams, and fine sandy loams. This association occupies about 4% of the county. A seasonal high water table is at a depth of 2 to 6 feet in about 40% to 50% of the acreage in the association. Approximately 30% of this association is affected by moderate to severe salinity.

The Hidalgo-Raymondville association can be described as nearly level to gently sloping, well-drained and moderately well-drained sandy clay loams and clay loams. This association makes up about 4% of the county. A seasonal high water table is in 15% to 20% of this association.

The Willacy-Raymondville soil association is described as nearly level to gently sloping, well-drained and moderately well-drained fine sandy loams and clay loams. This soil association comprises about 4% of the county. Approximately 10% of this association is irrigated and less than 5% is affected by a seasonal high water table.

The Raymondville association soils are described as nearly level, moderately well-drained clay loams. These soils occupy small irregularly shaped areas of nearly level plains that are broken by slight rises. The Raymondville association makes up about 4% of Cameron County. Much of this association lacks adequate surface drainage and a seasonal high water table exists at 2 to 10 feet in irrigated areas.

The Harlingen-Benito association soils can be described as level to nearly level, moderately well-drained to poorly drained. These soils make up about 8% of the county. This association occupies broad areas of slightly depressed areas that lack adequate surface drainage and are flooded for several days after heavy rains. Generally this association has a water table below 5 feet.

The Harlingen association soils are described as level and nearly level, and nearly level, moderately well-drained clays that occupy broad plains broken by slight depressing drainages. This association makes up about 7% of the county. The water table in the association is generally below 5 feet.

The Mercedes association soils occupy broad plains that are level to gently sloping. The soils are moderately well-drained clays that make up about 5% of the county. The water table generally is at a depth below 5 feet.

The Mustang-Coastal dune association is best described as nearly level to steep, poorly drained fine sands and sand dunes. These soils are found in a narrow band along the Gulf of Mexico coast. This soil association consists of active to partially stabilized windblown sands that are up to 30 feet above sea level.

### 7.3.2 Hydrological Elements

Cameron County is located in the West Gulf Coast section of the Coastal Plain Physiographic province. The major portion of the county is gently rolling to flat, gradually sloping toward the coast and the Rio Grande. The county is crossed by many sinuous resacas, abandoned former courses of the Rio Grande and its tributaries. Other major waterways in the county include the Arroyo Colorado, Resaca de Rancho Viejo and Resaca de los Cuates. All of these waterways eventually empty into the Laguna Madre or any of several lakes on bays along the Laguna Madre.

Cameron County abuts eight TWC Designated Water Quality Segments.

These segments are:

- Segment 2201: Arroyo Colorado Tidal - from the confluence with the Laguna Madre to a point 100 meters (110 yards) downstream of Cemetery Road south of Port Harlingen.
- Segment 2202: Arroyo Colorado Above Tidal - from a point 100 meters (110 yards) downstream of Cemetery Road south of Port Harlingen to FM 2062 in Hidalgo County. Segment 2202 is Water Quality Limited.
- Segment 2301: Rio Grande Tidal - from the confluence with the Gulf of Mexico to a point 10.8 kilometers (6.7 miles) downstream of the International Bridge in Cameron County.
- Segment 2302: Rio Grande Below Falcon Reservoir - from a point 10.8 kilometers (6.7 Miles) downstream of the International Bridge in Cameron County to Falcon Dam in Starr County.
- Segment 2491: Laguna Madre
- Segment 2493: South Bay
- Segment 2494: Brownsville Ship Channel
- Segment 2501: Gulf of Mexico

The designated uses and water quality criteria of each Cameron County segment are shown in Table 7-2. All segments are classified by the TWC and EPA as "effluent limited" which indicates that the water quality of the segment is not currently considered to be severely degraded, designated segment uses are not threatened, and the assimilative capacity of the segment is relatively high. With the exception of the Brownsville Ship Channel, all segments are considered

Table 7-2

**Designated Uses and Water Quality Criteria of  
Cameron County Segments**

Segment	Segment Name	Uses	Criteria
2201	Arroyo Colorado Tidal	Contact Recreation High Qual Aq. Life.	D.O. <sup>a/</sup> 40. mg/L pH 6.5-9.0 fecal coli. <sup>b/</sup> 200/100 ml Temp. 95°
2202	Arroyo Colorado Above Tidal	Contact Recreation Intermediate Aq. Habitat	Cl- <sup>c/</sup> 1,200 mg/L SO4= <sup>c/</sup> 1,000 mg/L TDS <sup>c/</sup> 4,000 mg/L D.O. <sup>a/</sup> 4.0 mg/L pH 6.5-9.0 fecal coli. <sup>b/</sup> 200/100 ml Temp. 95°
2301	Rio Grande Tidal	Contact Recreation Excep. Qual Aq. Life	D.O. <sup>a/</sup> 5.0 mg/L pH 6.5-9.0 fecal coli. <sup>b/</sup> 200/100 ml Temp. 95°
2302	Rio Grande Below Falcon R.	Contact Recreation High Qual. Aq. Life Public Water Supply	Cl- <sup>a/</sup> 270 mg/L SO4= <sup>a/</sup> 350 mg/L TDS <sup>a/</sup> 880 mg/L D.O. <sup>a/</sup> 5.0 mg/L pH 6.5-9.0 fecal coli. <sup>b/</sup> 200/100 ml Temp. 95°
2491	Laguna Madre	Contact Recreation Excep. Qual Aq. Life	D.O. <sup>a/</sup> 5.0 mg/L pH 6.5-9.0 fecal coli. <sup>b/</sup> 14/100 ml Temp. 95°
2493	South Bay	Contact Recreation Excep. Qual Aq. Life	D.O. <sup>a/</sup> 5.0 mg/L pH 6.5-9.0 fecal coli. <sup>b/</sup> 14100 ml Temp. 95°
2491	Brownsville Ship Channel	Non-contact Recreation Excep. Qual Aq. Life	D.O. <sup>a/</sup> 5.0 mg/L pH 6.5-9.0 fecal coli. <sup>b/</sup> 2,000/100 m Temp. 95°
2501	Gulf of Mexico	Contact Recreation Excep. Qual Aq. Life	D.O. <sup>a/</sup> 5.0 mg/L pH 6.5-9.0 fecal coli. <sup>b/</sup> 14/100 ml Temp. 95°

<sup>a/</sup> Mean over 24-hour period

<sup>b/</sup> Thirty-day geometric mean not to exceed.

<sup>c/</sup> Annual average not to exceed

Source: TWC, 1990

suitable for contact recreation. The tidal portion of the Rio Grande, Laguna Madre, South Bay, Brownsville Ship Channel, and the Gulf of Mexico are all considered to possess habitats and conditions suitable for "Exceptional Quality Aquatic Life" and, as such, have an average dissolved oxygen (D.O.) criteria of 5.0 mg/L. The tidally influenced portion of the Arroyo Colorado and the Rio Grande Above Tidal are considered to be indicative of a "High Quality Aquatic Life" habitat and also have a 5.0 mg/L minimum D.O. criteria. Because the Arroyo Colorado Above Tidal receives the wastes from a large number of municipal and industrial dischargers as well as significant quantities of irrigation return flow, water quality and habitat are considered to support only "Moderate Quality Aquatic Life." As a result the D.O. criteria for the Arroyo Colorado Above Tidal is only 4.0 mg/L.

The Texas Water Commission, Texas Parks and Wildlife Department, U.S. Geological Survey, and International Boundary Water Commission routinely sample portions of the Rio Grande, Arroyo Colorado, Laguna Madre and Gulf of Mexico. In addition, several studies have been performed by State and local Universities. The Lower Rio Grande Valley Development Council (LRGVDC) commissioned a number of special studies in support of the areawide water quality management planning process conducted under Section 208 of the Federal Water Pollution Control Act of 1972 (LRGVDC 1977-78). Most of this data is contained in the Texas Natural Resource Information Service's (TNRIS) statewide monitoring data base (SMN).

In August 1976, an Intensive Survey was conducted by the TDWR for the tidal portion of the Arroyo Colorado. Results of the survey indicate that the stream has a low assimilative capacity during low-flow conditions. Nutrient and oxygen-demanding material loading from municipal dischargers were determined to be responsible for eutrophic conditions.

A draft Waste Load Evaluation (WLE) is available for the Arroyo Colorado (TDWR, 1985). Waste load projection were made for existing dischargers for the year 2000 and dissolved oxygen conditions simulated using a calibrated and verified version of the QUAL-TX water quality model. Effluent limits recommended in the WLE in order to maintain the 4.0 mg/L D.O. standard were, in general, at secondary treatment.

Waste load evaluations are not currently available for the Brownsville Ship Channel or the Rio Grande. The QUAL-TX Model will be applied to these segments as a part of this planning study. Treatment levels necessary to maintain designated uses and minimum water quality standards will be determined for each existing and proposed discharge under future conditions.



### 7.3.3 Climatic Elements

The Cameron County climate is subtropical in nature and is characterized by dry, mild winters and hot humid summers. The general weather patterns in Cameron County vary from the tropical maritime air masses during the warmer months to the continental or polar air masses during the colder months.

The prevailing winds are southeasterly to south-southeasterly for a majority of the year and north-northwesterly during December (Orton et al., 1977).

The fact that Cameron County borders the Gulf of Mexico and progresses westward, weather conditions vary somewhat from east to west. Temperature are moderated by the Gulf of Mexico; consequently, freezing temperatures are less frequent and precipitation increases as the proximity to the Gulf of Mexico decreases.

The following climatic data was recorded in Harlingen, Texas from 1931-1969 (Orton, 1977). A summary of climatic data is presented on Table 7-3. The average annual rainfall is about 26 inches, most of which occurs in September due to heavy rains attributed to tropical depressions, tropical storms or hurricanes. Another annual period of peak precipitation occurs in May and June which recorded 3.18 and 2.49 inches of rain, respectively, during the survey period (Orton, 1977). Conversely, March typically yields the least rainfall with 0.95 inches (Orton, 1977).

Infrequently, snow or sleet does fall in January; however, amounts are typically too slight to be accurately measured. Temperatures of 32°F or below do occur; however, not on an annual basis and the county enjoys a 341-day warm season (Orton, 1977). The average daily maximum temperature for Cameron County from 1931-1969 varied from 70.9 (°F) in January to 96.7 (°F) in August. Historically, severe freezes have caused considerable damage to the vegetable and citrus crops and were documented in 1949, 1951, 1962 (Orton, 1977), 1983 and 1989.

Typically the free-water evaporation exceeds precipitation by 32 to 36 inches annually, the higher value being toward the coast (Orton, 1977).

### 7.3.4 Biological Elements

#### 7.3.4.1 Vegetation

Cameron County is located within an area that is bisected by the Gulf Prairie and Marsh Vegetation Area and South Texas Plains Vegetational Area described by Gould (1975). The study area is level to gently sloping and bisected by the Arroyo Colorado, and several other small tributaries flowing into the Laguna Madre, and bordered by the Rio Grande which flows into the open Gulf of

Table 7-3  
 Summary of Climatic Data For  
 Cameron County, Texas Recorded at  
 Harlingen, Texas from 1931-1969

<u>Month</u>	<u>Average Daily Maximum (°F)</u>	<u>Average Monthly Lowest Temperature (°F)</u>	<u>Precipitation (Inches)</u>
January	70.9	31.4	1.43
February	74.5	34.8	1.22
March	79.0	39.4	0.95
April	85.9	49.4	1.47
May	90.0	58.5	3.18
June	93.7	66.2	2.49
July	96.0	69.5	1.71
August	96.7	68.9	3.04
September	92.3	62.1	4.80
October	87.1	51.4	2.56
November	78.9	39.9	1.43
December	73.0	34.0	1.57
<b>Year</b>	<b>84.8</b>	<b>-----</b>	<b>25.85</b>

\* Source USDA; Cameron County Soil Survey

Mexico. Elevations in Cameron County range from sea level to approximately 70 feet in the western portions of the county.

Gould (1975) describes distinct differences in climax plant communities throughout the area of Cameron County located within the South Texas Plains Vegetational Area. Grasses characteristic of the sandy loam soils include seacoast bluestem, species of *Setaria*, longspike silver bluestem, big sandbur, and tanglehead. Clays and clay loams are characterized by longspike silver bluestem, Arizona cottontop, buffalo grass, and curly mesquite. The lower elevation saline areas are characterized by gulf cordgrass, seashore saltgrass, and switchgrass (Gould, 1975).

The Gulf Prairie and Marsh, as described by Gould, is typically separated into two major divisions: the Coastal Prairie - a nearly-level, slowly-drained plain less than 150 feet in elevation; and Coastal Marsh - the low west marsh area located immediately adjacent to the coast.

Gulf Prairie climax vegetation is primarily comprised of tall bunch grasses, including big bluestem, seacoast bluestem, Indiangrass, eastern gamagrass, and several species of *Panicum*, among others. The marsh areas typically support salt-tolerant species such as *Carex*, *Cyperus*, *Juncus*, *Scripus*, and several species of cordgrass, including *Spartina* and marsh millet.

Biotic communities within the Rio Grande Valley have recently been further divided into 11 distinct areas within the Tamaulipan Biotic Province (as described by Blair, 1950). Five of these communities, located within the study area, are described below (per USFWS Biological Report 88(36); November, 1988):

**Mid-Valley Riparian Woodland** - This is essentially a bottomland hardwood site, with stands of cedar elm, Berlandier ash (*Fraxinus berlandieriana*), and sugar hackberry (*Celtis laevigata*) mixed with mesquite/granjeno. The result is a dense, tall, canopied forest and greater availability of water and wildlife foods. This habitat is preferred by many rare birds; orioles (*Icterus spp.*), chachalacas (*Ortalis vetula*), and green jays (*Cyanocorax yncas*) may reach their greatest density in this habitat. Resacas in this habitat provide aquatic ecosystems that protect a unique group of Tamaulipan biota.

**Sabal Palm Forest** - The 149-ha (367 acre) USFWS tract in this community is known as "Boscaje de la Palma" and is located in the southmost bend of the Rio Grande near Brownsville. Remnant stands of Mexican palmettos (*Sabal mexicana*) - locally called sabal palm - found in a 1,418-ha (3,500-acre) area represent a remnant of a former 16,200-ha (40,000-acre) community. Palms were so prevalent that early Spanish explorers called the Rio Grande "Rio de las Palmas" (Crosswhite, 1980). These stands are best described as palm-dominated, brush tracts with

Mexican palmettos, tepeguaje (*Leucaena pulverulenta*), anacua, and Texas ebony as major woody associated. Characteristic fauna include ocelot, jaguarundi, lesser yellow bat (*Lasiurus ega*), hooded oriole (*Icterus cucullatus*), speckled racer (*Drymobius margaritiferus*), and northern cat-eyed snake (*Leptoderia septentrionalis*).

Clay Loma/Wild Tidal Flats - Three different communities form a "miniature ecosystem" of wooded islands in tidal flats that are periodically inundated by water from South Bay and the Gulf of Mexico. Lomas are formed from wind-blown silt or clay particles, originally deposited in tidal flats by periodic flooding from the Rio Grande. When flats are dry and barren, prevailing winds deposit particles on dunes, which are normally covered with woody vegetation. Dunes may grow to 9m (30 ft) above surrounding tidal flats. Rains and flooding can erode outer edges of the lomas. When wind or storm tides retreat, loma building begins again. Characteristic vegetation includes fiddlewood (*Citharexylum brachyanthum*) and Texas ebony on the lomas; borrichia (*Borrichia frutescens*) and salicornia (*Salicornia spp.*) on the flats; and black mangrove (*Avicennia nitida*) on South Bay. Representative vertebrates are the Texas tortoise (*Gopherus berlandieri*), long-billed curlews (*Numenius americanus*), and a unique hypersaline-tolerant population of oysters (*Ostera equestris*).

Mid-Delta Thom Forest - This community contains a mesquite and granjeno association mixed with Texas ebony, anacua, and brazil (*Condalia hookeri*) and was once an extensive thicket that covered most of the Rio Grande delta. There is <5% of the original acreage left, mostly in fence rows, highway rights-of-way, canals, and ditch banks. Remnant tracts are small (normally <40 ha [ $<100$  acres]) and scattered. Shrubs in this habitat form a tight interwoven canopy of 4-6m (15-20 ft). The mid-delta thom forest was used historically for nesting by white-winged doves.

Coastal Brushland Potholes - The southern edge of the Coastal Brushland Pothole biotic community extends into Cameron County. Here, the Gulf's influence creates a stable, saline microclimate which differs from that of other inland wetlands. In this area, moving sand dunes cover vegetation, subsequently uncover it and often leave depressions. When these depressions hold water, they provide excellent habitat for water fowl and the brushy perimeter may be utilized by ocelot and jagurundi.

#### 7.3.4.2 Wildlife

Cameron County, located in extreme southeastern Texas, lies within the Matamorán District of the Tamaulipan Biotic Province described by Blair (1950). The vertebrate fauna of the Tamaulipan Province is represented by a mixture of species (including a considerable element of Neotropical species) from the Texan, Kansan, Austroriparian, and Chihuahuan provinces (Blair, 1950). The

major wildlife habitats in the Tamaulipan Province are synonymous with the vegetative types discussed previously.

Approximately 700 species of vertebrates have been identified in the Matamoran District of the Lower Rio Grande Valley, a number of which are not found elsewhere in the U.S. (USFWS, 1988). The wide range of habitat types provides the study area with a diverse array of vertebrate fauna that includes subtropical, southwestern desert, prairie, coastal marshlands, eastern forest, and marine species.

#### 7.3.4.3 Aquatic, Estuarine, and Marine Ecology

The study area is characterized by a wide range of aquatic, estuarine, and marine ecosystems. Significant habitat include the hypersaline marine environment found in the Lower Laguna Madre; the Lower Arroyo Colorado and Rio Grande Estuaries; and the Riverine habitats of the Arroyo Colorado and the Rio Grande. A detailed discussion of each of these habitats was developed in a report completed in March 1989 for the Rio Grande Municipal Water Authority and the Public Utilities Board of Brownsville "Environmental Inventory and Issues Report Rio Grande Valley Water Conservation Project". The following section is a reprint from this report.

##### Lower Laguna Madre

High temperature and high evaporation, combined with a low annual rainfall, favor the production of hypersaline waters. There is an almost total lack of freshwater inflow into the lower Laguna Madre, except for drainage water from the Arroyo Colorado. As a consequence, the number of species that inhabit the area is severely limited. However, the number of individual members of each species is very high and the Laguna has a disproportionately high level of productivity, as compared with other Texas bays. The limited number of species results in a simplified food chain, in which benthic plants assume a more important role than phytoplankton. Most of the animals probably obtain primary nutrients via an abbreviated detrital food chain, which results in a more efficient transfer of carbon to higher trophic levels. This efficient recycling of detrital constituents depends upon the retention of detritus within the Laguna, associated with low tidal flushing (Pulich 1980).

The lower Laguna Madre supports five species of seagrasses. Each is adapted to specific ecological conditions, of which salinity, temperature and light are the most significant. The physical requirements and limitations of each species is shown in Table 7-4. In general, shoal grass is the most abundant of the five species. It can withstand the greatest salinity fluctuations, particularly hypersalinity. While manatee grass and turtle grass prefer the areas around inlets and passes,

shoal grass is widespread in more restricted areas where other grasses do not grow. It is considered the most desirable species of seagrass to maintain in the Laguna Madre because it provides spawning areas for fish and food for waterfowl (Espey Huston, 1981).

Seagrass ecosystems are recognized as some of the most productive in the world. While direct grazing on their leaves is not common, grazing on the epiphytic organisms they support does occur. Decaying leaves settle in the sediment and are later consumed as detritus. They also aid in the maintenance of an active sulphur cycle and the leaves slow water currents near the sediment surface. Together with the root and rhizome systems, which bind the sediment, they inhibit erosion, enabling rapid recovery of the ecosystem following severe storms. In general, there is a positive correlation between sediment stability and invertebrate diversity (Espey Huston, 1981).

The zooplankton include rotifers, cladocerans, copepods, coelentrates, ctenophores and larvae of molluscs and crustaceans. The calanoid copepod *Acartia tonsa* tends to dominate the zooplankton in inshore areas as a result of its tolerance of wide variations in temperature and salinity. In brackish water it is replaced by freshwater copepods, cladocerans and rotifers. Benthic species that are important components of the food chain include the polychaete *Nereis pelagica occidentalis*, the amphipod *Elasmapus* sp., the pistol shrimp *Crangon heterochaelis* and the blue crab *Callinectes sapidus* (Espey Huston, 1981).

Nekton species of the lower Laguna Madre resemble those found in other Texas bays. In a 1962 study, 77 species of fish were reported. Of these 5 percent were restricted to the brackish waters of the Arroyo Colorado. Numerous species, including redfish, white shrimp, bay anchovies and spotted seatrout utilize this brackish area as both a nursery and foraging ground. The distribution of juvenile shrimp is salinity dependent. Brown shrimp prefer salinities of 10-30 ppt, and are most abundant when salinities are above 20 ppt. White shrimp prefer lower salinity and are largely restricted to the brackish Arroyo Colorado and other channels. In general, nekton in the Laguna Madre exhibit three different reproductive cycles. Many species are estuarine dependent, with adults spawning in the Gulf of Mexico and young organisms being carried into the bay to mature.

The most important sport and commercial species in the inshore areas are the red drum, spotted seatrout and black drum. The Laguna Madre is the preferred habitat for the black drum, which feeds mainly on bivalves concentrated in the seagrass beds. Red drum and spotted seatrout each made up approximately 40 percent of the commercial catch in the lower Laguna Madre in the mid 1970s. Both feed on a variety of crustaceans and to some extent on small fish. Seatrout are tolerant of warm temperatures and high salinity. In one study (Shew *et al* 1981) a positive

correlation between salinity and seatrout size was found. Other commercial species of lesser importance to this area include oysters, finfish, sheepshead, flounder and Atlantic croaker.

The extensive mud flats along the Laguna Madre are the chief feeding ground for shore birds and some wading birds. Geese, pintails and other waterfowl use them as nesting areas. They are an important contributor to the food chain of many marine organisms, used by crab, shrimp and other organisms when inundated. The normal tide of 5 inches covers part of the flats and three or four times a year, winter wind tides inundate all or most of the area.

Of the approximately 650 bird species in the U.S., 380 occur along the Texas coastal zone. Many, such as the Louisiana heron and the reddish egret, depend heavily on the estuarine community, whereas the terns are also part of the beach and marine community. The Laguna Madre provides the wintering ground for 78 percent of the world's redhead ducks, which feed primarily on shoal grass (Shew *et al* 1981).

#### Lower Arroyo Colorado

The Arroyo Colorado is one of the major arteries in the Rio Grande Valley drainage system and receives much of the municipal, agricultural and industrial waste of the area. Small ox-bow lakes indicate that at one time it was an arm of the Rio Grande, branching from the river at a point below the city of Mission. The Arroyo Colorado is a deep channel cut through the Beaumont delta plain, and has a small delta at its mouth. In the late 1940s, the lower 25 miles was dredged to a depth of 14 feet to accommodate barge traffic to the Port of Harlingen. During this process some curves in the original river bed were by-passed, leaving shallow ox-bow areas. For the first 7 miles inland, the old bed was by-passed completely; a new channel runs almost due east to the Gulf Intracoastal Waterway, approximately 21 miles north of Port Isabel. It serves as a floodway, an inland waterway and as a recreational area for boating and fishing (Bryan 1971).

The lower Arroyo Colorado is one of the very few brackish water areas in the Lower Laguna Madre and provides a nursery ground for marine species of the area. Typically, the salinity pattern shows a gradation from lower to higher saline water both with increasing depth and with distance downstream. From surface to bottom it can vary by as much as 29.4 ppt. However, this pattern can be severely disrupted during major storm activity. For instance, following Hurricane Beulah salinity levels in the entire Arroyo Colorado approached that of freshwater. There is also an inverse correlation between salinity and dissolved oxygen. In general, tides are highest in fall and spring and lowest during winter and summer. In 1969 the tide level at mile 8 fluctuated 18 inches. Tides are also greatly influenced by prevailing winds (Bryan 1971).

Table 7-4  
 Limits of Tolerance of Texas Seagrasses

	Optimum salinity (ppt)	Limits of salinity (ppt)	Optimum temperature
<i>Thalassia testudinum</i> (turtle grass)	37.0	to 60	18-32°C growth 29°C max prod.
<i>Syringodium filiformis</i> (manatee grass)	<36.0	to 40	23-25°C flowers 26°C fruits
<i>Halodule wrightii</i> (shoal grass)	35 to 44	to <72	
<i>Halophila Engelmannii</i> (halophila)	37.0	23 to 50	
<i>Ruppia maritima</i> (widgeon grass)	<25.0	0 to 40/60 >30.0 no flowering	15-20°C germ. 20-25°C growth

Espey, Huston and Associates, Inc. *Final Environmental Report: Proposed Deepwater Channel and Multipurpose Terminal Construction and Operation near Brownsville, Texas*, Volume 6, appendix H, I and J, 1981.

A study performed by C.E. Bryan at the University of Texas in 1971 showed that the most numerous economically important species were juvenile menhaden (*Brevoortia* sp.), redfish (*Sciaenops ocellata*) and white shrimp (*Penaeus setiferus*). Brown shrimp (*Penaeus aztecus*) and the blue crab (*Callinectes sapidus*) were found in the area to a lesser degree. The spotted sea trout (*Cynoscion nebulosus*) was the most abundant adult species taken. Less abundant fish, concentrated in the lower 12 miles, were redfish, black drum (*Pogonias cromis*), sheephead (*Archosargus probatocephalus*) and southern flounder (*Paralichthys lethostigma*). Between October, 1965 and August, 1966 water flow into the Arroyo Colorado at Mercedes, Texas averaged 92 cubic feet per second, with a peak flow of 943 cfs and a minimum flow of 24 cfs. During the 1967 flood following Hurricane Beulah, the flow reached an estimated 55,400 cfs (Bryan 1971).

Fish kills are common in the Arroyo Colorado. During the sampling period of the Bryan study, eight kills were investigated. Most of the mortalities occurred between June and September, and were associated with high salinity and dissolved oxygen levels close to zero. DDT sampling revealed that the Arroyo Colorado had the highest level of any area sampled on the Texas coast. Dieldrin and Endrin were also found in many of the samples. This could explain the decline in numbers of spotted sea trout observed during the 1960s. By 1970 there was a tenfold increase in the number of juvenile spotted sea trout in the lower Laguna Madre as compared with the previous year, and this was attributed to reduced pesticide levels in the Arroyo Colorado. Tarpon, which were numerous in the early 1950s, have also disappeared (Bryan 1971).



## Rio Grande Estuary

In 1969 the Texas Parks and Wildlife Department conducted a study in the tidal water section of the Rio Grande. During this study period dissolved oxygen levels ranged from 0.3 to 12.2 mg/L. It was higher during winter months and generally higher at the surface than at the bottom. Salinity also showed a gradation from surface to bottom; at the mouth of the river a freshwater override was evident in surface samples. At river mile 12 some bottom water contained traces of salinity, but all surface samples reflected river flow and registered zero.

Marine species appeared to use the river as a nursery or feeding ground, but not as a spawning area. The most important commercial invertebrate found in the tidal Rio Grande was the white shrimp (*Penaeus setiferus*). Brown shrimp (*P. azetecus*) were much less frequent. A few blue crabs (*Callinectes sapidus*) were present at most stations, but did not appear to use the area as a nursery ground. The most important marine fish was the Atlantic croaker, which used the entire area as a nursery. Adult spotted sea trout, redfish, black drum and snook were important commercial and sportsfish found near the mouth of the river (Breuer 1970).

## Riverine Environments

An inventory of fish caught downstream from Falcon dam in the Rio Grande in 1954 is shown in Table 7-5 (Trevino 1955). Trevino's study extended from the mouth of the river to the Pecos. The river water was generally muddy, with no significant amounts of aquatic vegetation. The distribution of species indicates that, at that time, brackish water forms are replaced by freshwater species just east of Brownsville.

In addition to fish, two species of shrimp were reported in the freshwater stretches of the river within the study area. *Macrobrachium acanthurus* and *M. ohione* were reported as far upstream as the Hidalgo/Starr County line.

### 7.3.4.4 Wetlands and Unique Areas

Wetlands are defined as those areas which are saturated or inundated by ground or surface water at a frequency sufficient to support, and under normal circumstances, do support prevalence of vegetation typically adapted to saturated conditions. Wetlands are usually a transition area between aquatic and terrestrial environments. A description of significant wetland habitat from the Environmental Inventory and Issues Report follows :

Table 7-5  
Fish Populations of the Rio Grande

Species	Distribution
<i>Lepisosteus spatula</i>	Starr County, including Falcon Lake
<i>L. osseus</i>	Locally abundant, prefer moderately moving water
<i>Dorosoma petenense</i>	Found at every station
<i>D. cepedianum</i>	Found at every station
<i>Astyanax fasciatus</i>	The most widespread and common fish collected
<i>Carpiodes carpio</i>	Numerous everywhere in moderate currents
<i>Hybopsis aestivalis</i>	Caught throughout study area
<i>Notropis jemezianus</i>	One of the most prevalent species taken
<i>N. braytoni</i>	Caught upstream of Roma
<i>N. lutrensis</i>	West of Cameron County one of the most common fish
<i>N. buchanaui</i>	Upstream of western Hidalgo County in fast moving water
<i>Hybognathus placita</i>	Common throughout
<i>Ictalurus lupus</i>	Spotty distribution; found at Roma
<i>I. furcatus</i>	Found in Cameron and Starr counties
<i>Cyprinodon variegatus</i>	Common in side pools and shallow water
<i>Gambusia affinis</i>	Common throughout study area
<i>Mollienisia formosa</i>	Not numerous, but widespread
<i>M. latipinna</i>	Caught at one station below Hidalgo
<i>Mugil cephalus</i>	Abundant in Cameron County, less common upstream
<i>Menidia beryllina</i>	Common throughout close to shore
<i>Micropterus salmoides</i>	Immature samples found near Roma
<i>Lepomis macrochirus</i>	Hidalgo and Starr counties
<i>Aplodinotus grunniens</i>	Found throughout area, but not at every station
<i>Chichlasoma cyanoguttatum</i>	Most common upstream from Hidalgo
<i>G. dormitator</i>	Few specimens throughout area, most caught 9 miles east of Brownsville

Trevino, D.B. *The Ichthyofauna of the Lower Rio Grande River, from the Mouth of the Pecos to the Gulf of Mexico*. Masters thesis, University of Texas at Austin, 1955.

## Estuarine Wetlands

Cattail/bullrush marshes occur primarily in the lower reaches of the Rio Grande, between 2 and 12 miles from the mouth in water up to 2 feet deep. They also grow in the floodplain immediately upstream from Anzalduas Dam. The last 2.5 miles of the river supports a community of cordgrass. *Spartina alterniflora* is the dominant species, growing in a narrow band 2 to 8 feet from the river (Ramirez 1986).

Black mangrove (*Avicennia germinans*) thickets are found in isolated patches, at the mouth of the Rio Grande. A small distributary channel funnels river water into a thicket immediately behind the fore dunes. These mangroves are the largest in the state, attaining a height of 12 feet. Of the estimated 7400 acres of mangroves in the state, 1200 acres occur in Cameron County. These thickets are very productive, providing shelter, nesting sites and food for wildlife (Espey Huston, 1981).

Mud flats near the mouth of the Rio Grande may support algal mat growth after extensive rains or storm tide inundation. Such algal mats contribute to the lagoon system by fixing nitrogen (Shew *et al* 1981).

At the edge of lagoons and tidal bodies, and extending into salt water a few inches deep, grows a community of succulent halophytes, known as Batis-Salicornia-Suaeda. It is composed chiefly of *Batis maritima*, *Salicornia perennis*, *S. Bigelovii*, *Suaeda conferta* and *S. linearis* in varying relative abundance. *S. tampicensis* and *Cakile lanceolata geniculata* have also been found in Cameron and Willacy counties (Johnston 1955).

The Laguna Atascosa National Wildlife Refuge is an important estuarine wildlife habitat. To its north, the outflow regions of the Cayo Atascoas, the North Floodway and the Arroyo Colorado provide additional nursery areas for marine life. This area represents a logical extension of the conditions that led to the formation of the Refuge, and the Lower Rio Grande Valley Development Council designated it as one of six unique ecological areas within the region. It is considered essential habitat for large waterfowl and for fish, shrimp and crabs. It is an important source of fresh-water and nutrients for the Laguna Madre (Corps of Engineers 1980).

## Palustrine Wetlands

Resacas are often dry during summer months, but have a varied flora when filled. Spikesedge and mud plantain are often surrounded by dock and flat sedges. A succession of plant communities grows in and around the swales and ponds. In saline areas, succulent halophytes give way to the borrichia community, followed by cordgrass and finally brush. In cultivated areas only

succulent halophytes are present. At lower salinity, ponds in agricultural areas may contain bull-rushes, cattails, smart weeds, water-lilies, arrowheads, spikerushes and water hyacinth, which occasionally congests a freshwater pond, preventing the growth of other species. Aquatic vegetation, such as arrowheads, widgeon grass and burheads is common in man-made tanks and stock ponds (Corps of Engineers 1980).

The Lower Rio Grande Valley is very distinctive in terrain, vegetation, and climate; thus, it has a number of unique ecological areas. The following is a description of these unique areas (as described in the USFWS Biological Report 88(36) November 1988) in Cameron County.

#### Southmost Ranch

Southmost Ranch, located southeast of Brownsville, Texas, on the Rio Grande supports part of the remaining native Mexican palmetto community in the United States. Rio Grande thorn woodland also is present on the ranch. Southmost Ranch was ranked number 42 of the Top 100 Nationally Significant Fish and Wildlife Areas (USFWS, 1983). Within the 259-ha (640-acre) ranch, 6-ha (15 acres) are dominated by Mexican palmetto, 61-ha (150 acres) have mesquite and acacia with some palmetto, and the remainder is cultivated fields and pastures (USFWS, 1979). A variety of wildlife, including many peripheral species, exists in the Mexican palmetto forest community. Rare wildlife includes; the Mexican white-lipped frog (*Leptodactylus labialis*); Texas indigo snake; speckled racer; white-tipped dove (*Leptotila verreauxi*), tropical kingbird (*Tyrannus melancholicus*); white-collared seedeater (*Sporophila torqueola*); lesser yellow bat; and Mexican spiny pocket mouse (*Liomys irroratus*). The ocelot and jaguarundi may be present. Agricultural development and recreational use are primary threats to this area (USFWS, 1979).

#### Laguna Atascosa National Wildlife Refuge

Laguna Atascosa National Wildlife Refuge (NWR), the southernmost waterfowl refuge in the Central Flyway, was established in 1946. It contains 19,680-ha (48,597 acres) and is the largest refuge in the Lower Rio Grande Valley. About 65,000 ducks winter on the refuge (USFWS, 1986). Laguna Atascosa NWR contains coastal prairies, salt flats, and low vegetated ridges supporting thick, thorny shrubs (Fleetwood, 1973). Habitat types of the refuge include: 9,720-ha (24,000 acres) of wetlands; 5,670-ha (14,000 acres) of coastal prairie; 3,280-ha (8,100 acres) of brushland; 405-ha (1,000 acres) of croplands; and 607-ha (1,500 acres) of grasslands and savannah (USFWS, 1986). The refuge fauna includes 354 bird and 31 mammal species. Ocelot and jaguarundi recently have been sighted in the vicinity of Laguna Atascosa (S. Labuda, personal communication). In a 1980-81 survey of the area, 8 species of amphibians and 23 species of reptiles were collected (Scott, 1982). Because of drought conditions during this

period, 95% of the American alligators (*Alligator mississippiensis*) in the Lower Rio Grande Valley were concentrated on the refuge (Scott, 1982).

#### Texas Sabal Palm Sanctuary

The National Audubon Society's Texas Sabal Palm Sanctuary, purchased in 1971, is south of Brownsville along the Rio Grande. The sanctuary preserves part of one of the largest remaining stands of the native Mexican Palmetto. In 1940, the palm grove was >40-ha (>100 acres). By 1971, only about 13-ha (32 acres) remained. Currently, the sanctuary has a total of 70-ha (172 acres), including 49-ha (120 acres) of old fields that are being revegetated, and an 8-ha (20 acre) resaca (Miller, 1985a). Many birds use the area (Land, 1983; Miller, 1985a); for example, plain chachalaca, common ground dove (*Columbina passerina*), golden-fronted woodpecker (*Centurus aurifrons*), common pauraque (*Nyctidromus albicollis*), green jay, great kiskadee, Altamira orioles, and roseate spoonbills (*Ajaia ajaja*). Nearly 400 plant species have been identified in the palm grove.

#### 7.3.4.5 Threatened and Endangered Species

The Lower Rio Grande Valley has a wide array of habitat types and a corresponding diversity of species including subtropical species, species of the southwestern desert, and prairie, coastal marshlands, eastern forest, and estuarine and marine environments. This significant diversity in habitat, coupled with the fact that the Lower Rio Grande Valley is the northernmost limit for several subtropical species, has resulted in a significant number of species that are recognized as threatened or endangered by the Federal and State governments. Table 7-6 identifies the threatened, endangered, and rare fauna and flora which are known to occur or are highly likely to occur in the study area.

#### 7.3.4.6 Archaeological/Cultural Resources

Lying at the extreme southern tip of Texas, Cameron County contains a rich and unique selection of cultural resource sites. Numerous prehistoric and historic sites are found within the county. As of 1985, 96 prehistoric sites had been officially recorded in the county. Since then this number has increased substantially. Additionally, the official number does not reflect nearly a hundred sites recorded in the 1930s by A. E. Anderson. At least one of the Cameron County prehistoric sites, the Garcia Pasture site, is listed on the National Register of Historic Places (NRHP). Dozens of historic sites have been recorded or reported from Cameron County. These sites include 13 listed on the NRHP. Historic sites include both standing structures such as the Charles Stillman House, the Southern Pacific Railroad Passenger Depot, and the Port Isabel Lighthouse,

Table 7-6  
Rare, Threatened, and Endangered Species of Potential Occurrence and Known  
Natural Communities in Cameron County

COMMON NAME	SCIENTIFIC NAME	STATUS			
		FWS 1	TPWD 2	TNHP 3	TOES 4
<b>AMPHIBIANS</b>					
Sheep-Frog	<i>Hypopachus variolosus</i>		T	G5S2	T
White-lipped Frog	<i>Leptodactylus fragilis</i>		E	G4S1	E
Mexican Treefrog	<i>Smilisca baudini</i>		T		T
Mexican Burrowing Toad	<i>Rhinophrynus dorsalis</i>		T	G5S2	T
Giant Toad	<i>Bufo marinus</i>				WL
Black-Spotted Newt	<i>Notophthalmus meridionalis</i>	C2	E	G1S1	E
Rio Grande Lesser Siren	<i>Siren intermedia Texana</i>	C2	E	G5T2S2	E
Rio Grande chirping frog	<i>Synthopopus cystignathoides</i>			G5S3	WL
<b>REPTILES</b>					
American Alligator	<i>Alligator mississippiensis</i>	T/SA			WL
Speckled Racer	<i>Drymobius margaritiferus</i>		E	G5S1	WL
Texas Horned Lizard	<i>Phrynosoma cornutum</i>	C2	T		T
Reticulate Collared Lizard	<i>Crotaphytus reticulatus</i>	C2	T	G3S2	T
Northern Cat-eyed Snake	<i>Leptoderia septentrionalis</i>		E	G5T5S2	T
Black-Striped Snake	<i>Coniophanes imperialis</i>		T	G3S2	WL
Texas Indigo Snake	<i>Drymarchon corais erebennus</i>		T		WL
Texas Scarlet Snake	<i>Cemophora coccinea linei</i>		T	G5T2S2	WL
Mexican Milk Snake	<i>Lampropeltis triangulum</i>				WL
Texas Tortoise	<i>Gopherus berlandieri</i>		T	G4S3	T
Green Sea Turtle	<i>Chelonia mydas</i>	T	T	G3S2	T
Hawksbill Sea Turtle	<i>Eretmochelys imbricata</i>	E	E	G3S1	E
Loggerhead Sea Turtle	<i>Caretta caretta</i>	T	E	G3S2	T
Kemp's Ridley Sea Turtle	<i>Lepidochelys kempfi</i>	E	E	G1S1	E
Leatherback Sea Turtle	<i>Demochelys coriacea</i>	E	E	G3S1	E
<b>MAMMALS</b> (excluding Cetaceans)					
Southern Yellow Bat	<i>Lesiurus ega</i>		T	G5S1	WL
Coues' Rice Rat	<i>Oryzomys couesi</i>		T	G5S2	T
Ocelot	<i>Felis pardalis</i>	E	E	G2S1	E
Jaguarundi	<i>Felis yagouaroundi</i>	E	E	G4S1	E
Cougar	<i>Felis concolor</i>			G4S2	
Jaguar	<i>Felis onca</i>	E	E	G3S4	E
Coati	<i>Nasua nasua</i>		E	G5S2	WL
Black Bear	<i>Ursus americanus</i>		E	G5S3	T
<b>BIRDS</b>					
Brown Pelican	<i>Pelecanus occidentalis</i>	E	E	G5S1	E
Reddish Egret	<i>Egretta rufescens</i>	C2	T	G4S2	T
Whitefaced Ibis	<i>Plegadis chihi</i>	C2	T	G4S2	T
Roseate Spoonbill	<i>Ajaia ajaja</i>			G5S4	
Wood Stork	<i>Mycteria americana</i>		T		T
Fulvous Whistling Duck	<i>Dendrocygna bicolor</i>				T
Least Grebe	<i>Tachybaptus dominicus</i>			G5S3	

CAMERON COUNTY REGIONAL PLANNING STUDY  
PRELIMINARY ENVIRONMENTAL ASSESSMENT

Masked Duck	<i>Oxyura dominica</i>			G5S4	WL
Osprey	<i>Pandion haliaetus</i>			G5S3	
American Swallow-tailed Kite	<i>Elanoides forficatus</i>		T	G5S2	T
Bald Eagle	<i>Haliaeetus leucocephalus</i>	E	E	G3S2	E
Common Black-hawk	<i>Buteogallus anthracinus</i>		T	G5S2	T
Northern Gray Hawk	<i>Buteo nitidus</i>		T	G5S1	T
White-tailed Hawk	<i>Buteo albicaudatus</i>		T	G5S2	T
Zone-tailed Hawk	<i>Buteo albonotatus</i>		T	G5S3	T
Golden Eagle	<i>Aquila chrysaetos</i>				WL
Merlin	<i>Falco columbarius</i>				T
Aplomado falcon	<i>Falco femoralis</i>	E	E	G4S1	E
American Peregrine Falcon	<i>Falco peregrinus anatum</i>	E	E	G3T2S1	E
Arctic Peregrine Falcon	<i>Falco peregrinus tundrius</i>	T	T	G3T1S1	T
Piping Plover	<i>Charadrius melodus</i>	T	T	G2S2	T
Northern Jacana	<i>Jacana spinosa</i>			G5S3	T
Coastal Least Tern	<i>Sterna antillarum antillarum</i>				T
Interior Least Tern	<i>Sterna antillarum athalassos</i>	E	E	G4T2S2	E
Sooty Tern	<i>Sterna fuscata</i>		T	G5S2	WL
Black Skimmer	<i>Rhyncops niger</i>				T
Red-billed Pigeon	<i>Columba flavorostris</i>			G5S4	T
Ferruginous pygmy-owl	<i>Glaucidium brasilianum</i>		T		WL
Ringed Kingfisher	<i>Ceryle torquata</i>			G5S2	WL
Northern beardless-tyrannulet	<i>Campostoma imberbe</i>		T	G5S3	WL
Rose-throated becard	<i>Pachyrhamphus aglaiae</i>		T	G4G5S2	WL
Brown Jay	<i>Psaltriparus morio</i>			G5S2	WL
Black-capped Vireo	<i>Vireo atricapillus</i>	E	E		T
Tropical Parula	<i>Parula pitiayumi</i>		T	G5S3	T
Golden-cheeked Warbler	<i>Dendroica chrysoparia</i>	E	E	G2S2	E
Botter's sparrow	<i>Aimophila botterii</i>	C2	T	G4S3	T
<b>FISH</b>					
Blackfin Goby	<i>Gobionellus atripinnus</i>		E	G3S1	
Phantom shiner	<i>Notropis orca</i>		E	G2	E
River Goby	<i>Awaous tajasica</i>		T		WL
Opossum Pipe Fish	<i>Oostethus brachyurus</i>		T		
<b>PLANTS</b>					
Montezuma Bald Cypress	<i>Taxodium mucronatum</i>			G4S1	E
Runyon's Water Willow	<i>Justicia runyonii</i>	C2		G2S2	
Texas Palmetto	<i>Sabal mexicana</i>			G2S1	T
Adelia Vesyl	<i>Adelia vaseyi</i>			G2S2	
Texas Stonecrop	<i>Lenophyllum texanum</i>			G3S3	
Lila de los Llanos	<i>Anthericum chandleri</i>	C1		G2S2	
Plains Gumweed	<i>Grindelia oolepis</i>			G2S2	WL
Texas Ayenia	<i>Ayenia limitaris</i>			G2S1	
South Texas Ragweed	<i>Ambrosia cheiranthifolia</i>	C1		G1S1	
Gregg Wild Buckwheat	<i>Eriogonum greggii</i>			G2S1	
Runyon's Huaco	<i>Polianthes runyonii</i>	C2		G2S2	
Wherry Mimosa	<i>Mimosa wherryana</i>			G3S3	
Mission Fiddleweed	<i>Citharexylum spathulatum</i>			G2S2	

CAMERON COUNTY REGIONAL PLANNING STUDY  
PRELIMINARY ENVIRONMENTAL ASSESSMENT

Rio Grande Ballon Vine	<i>Cardiospermum dissectum</i>			G2S2	
Johnston's Frankenia	<i>Frankenia johnstonii</i>	E	E	G2S2	
Shurbleaf Bladderpod	<i>Lesquerella thamnophila</i>	C2		G1S1	
Prostrate Milkweed	<i>Asclepias prostrata</i>	C2		G1S1	
Terrey's Tetramerium	<i>Tetramerium platystegium</i>			G3S3	
Ashy Dogweed	<i>Dyssodia tephroleuca</i>	E	E		
<b>NATURAL COMMUNITIES</b>					
Texas Palmetto Series				G2S1	
Texas Ebony - Snake-eye Series				G2S2	
Texas Ebony - Anacua Series				G2S1	
Sugarberry-Elm Series				G4S4	
Blackbrush Series				G5S5	

1

U.S. Fish and Wildlife service (1989a) E- Endangered; T-Threatened; T/SA - Threatened due to similarity of appearance. Because of the similarity of appearance of the Texas American Alligator hides and parts to the hides and parts of other protected crocodilians, it is necessary to restrict commercial activities involving alligator specimens taken in Texas to ensure the conservation of other alligator populations, as well as other crocodilians that are threatened or endangered. USFWS, 12 October 1983. Fed. Reg. 48 (198):46332-46337. C1-Candidate, category 1. USFS has substantial information on biological vulnerability threats to support proposing to list as endangered or threatened. Data are being gathered on habitat needs and for critical designations. C2-Candidate, category 2. Information indicates that proposing to list as endangered or threatened is possibly appropriate substantial data on biological vulnerability and threats are not currently known to support the immediate preparation of rules. Further biological research field study will be necessary to ascertain the status and/or taxonomic validity of the taxa in Category 2. C3-Former candidate, rejected because more common, widespread, or adequately protected.

2

Texas Parks and Wildlife Department, Endangered/Threatened Species Data File (TPWD, 1988 a,b,c). E-Endangered; T-Threatened.

3

Texas Natural Heritage Program, Special Species and Natural Community Status. G1-Critically imperiled globally, extremely rare, 5 or fewer occurrences. G2-Imperiled globally, very rare, 6 to 20 occurrences. G3-Very rare and local throughout range or found locally in restricted range, 21 to 100 occurrences. G4-Apparently secure globally. G5-Demonstrably secure globally S1-5 state ranking of the same categories as those listed globally.

4

Texas Organization for Endangered Species; Endangered, Threatened and watch lists of Plants and Vertebrates of Texas (March, 1987 - plants and January, 1988 - vertebrates). E-State endangered species - any species which is in danger of extinction in Texas or in addition to its federal status. T-State threatened species - any species which is likely to become a state endangered species within the foreseeable future. WL-TOES Watch List - any species which at present has either low population or restricted range in Texas and is not declining or being restricted in its range but requires attention to insure that the species does not become endangered or threatened. (State or Federal)



structural groups associated with archaeological deposits such as Fort Brown and the Old Brunlay Plantation, and historic archaeological sites without structures such as the Palo Alto Battlefield and the Resaca de la Palma Battlefield.

Archaeological sites in the Cameron County area fall into four general chronological periods. The earliest period, the Paleoindian, dates to the very late Pleistocene and early Holocene. Cultures of this period are often associated with now-extinct genera of Pleistocene mammals, including larger species such as mammoth, mastodon, camel, and horse. The subsequent Archaic period represents a long and diverse occupation of the region, with potential shifts in subsistence, settlement, technology, and population dynamics. The final prehistoric stage, the Late Prehistoric, is marked by the introduction of pottery and the bow and arrow. In extreme South Texas, the Mexican influence is dramatic during this period. Most of the known prehistoric sites in Cameron County date to this period. The final period, the Historic, begins with the arrival of the Europeans. Aboriginal sites from this period are marked by the presence of historic artifacts. The earliest European settlement of the area dates to the Spanish period although little remains of that era. Settlement began in earnest after Mexico won its independence from Spain.

A long list of archaeological studies have been completed in the Cameron County area, beginning with the work of A. E. Anderson in the 1920s and 1930s. An engineer and amateur archaeologist, he recorded more than 400 sites in southern Texas and northeastern Mexico. E. B. Sayles used Anderson's data to define the Brownsville archaeological complex which represents the Late Prehistoric Mexican-influenced cultures of the area. Early professional studies were conducted in the general area by T. N. Campbell of the University of Texas as well as Richard MacNeish, then of the Peabody Museum at Yale. In more recent years, major studies have been conducted by T. R. Hester, E. R. Prewitt and R. J. Mallouf. The 1977 study by Mallouf, Baskin and Killen was a predictive model survey which still stands as some of the better work in the area. Recent geomorphic/geoarchaeological studies by Michael Collins have helped to clarify the stratigraphy of archaeological sites in the area.

The density of recorded cultural resource sites in the Cameron County is unusually high and the expected density of unrecorded sites is enormous. Because of the uniqueness of both the Mexican-influenced prehistoric cultural sites and the early historic sites, many either associated with the Mexican or early Texas occupation as well as the Mexican Water itself, an unusually high proportion of sites can be expected to be significant. Some of these sites will be eligible for the NRHP or worthy of formal designation as State Archaeological Landmarks. Any projects undertaken by political subdivisions of the state or with Federal funds or permitting should involve

archaeological studies as part of the planning process since location of significant sites may act as a constraint on timing or location of projects.

#### 7.3.4.7 Land-Use and Socioeconomic Conditions

A three step approach has been used in assessing social and economic conditions in Cameron County, as they pertain to this plan. A broad overview of county-wide land use is followed by analysis of the basic socioeconomic structure of Cameron. The analysis includes summaries of recent demographic, employment and industrial data. Lastly, a focus upon the colonias will underscore the need for the Regional Plan in Cameron County.

Cameron County land use revolves around agriculture. Slightly over 50% of the land is utilized for cropland (irrigated and dryland), pasture/hayland and orchard land. Rangeland comprises another 15% of the land use base. Coastal, riverine and drainage features influence a significant portion of the county. Over 17% of the county possesses surface water and another 3% is occupied by wetlands. Table 7-7 presents a breakdown of land use by soil conservation service classifications. [Of the less significant land uses, barren land occupies 8%, urban/built-up land 4% and recreation land 1% (SCS 1980)].

Of the 259,409 residents of Cameron County approximately 52% are female (July 1987). Ethnically, the population is largely hispanic. Seventy-nine percent (79%) of the people are of spanish decent and only .3% are black. The two major cities are Brownsville and Harlingen. Brownsville, the largest in the Lower Rio Grande Valley, supports a population of over 102,000. Harlingen, the third largest in the Lower Rio Grande Valley, has a population of nearly 55,000 people (1986 U. S. Dept. of Commerce, Bureau of the Census).

In 1989 Cameron County possessed a labor force of approximately 104,095 people. Unemployment for 1989 was nearly 12% (see Table 7-8 for labor and employment figures in the study area from 1985-1989). The largest sources of employment include trade, service and local government sectors (see Table 7-9 for employment by industry in the study area from 1985-1989).

Private industry produces 75% of all non-farm income in Cameron County. Services, retail trade and manufacturing make up the bulk of this 75%. The remaining 25% of non-farm income stems from government sources (see Table 7-10 for personal income by industry source in the study area from 1982 through 1987).

The target communities for water and wastewater improvements in Cameron County are the colonias. These colonias range in size from 15 to over 700 households which have an average of

4.81 occupants. Surveys conducted for Texas Department of Commerce grants indicate annual per capita income in the households surveyed ranges from a high of greater than \$14,300.00 to a low of less than \$3,000.00. A 1987 survey of the colonias in the Lower Rio Grande Valley by the Texas Department of Human Services indicates that 98.8% of the colonias population is Hispanic, with an average household income of \$6,932. This data coupled with the 47% unemployment rate reported in this study reveal the service economic depression in the colonias.

**Table 7-7  
 Land Use By SCS Classification**

Land Use Category	Cameron Acreage	% of Total
Urban and Built up Land		
Urban	28638.31	3.86%
Other	30.66	0.00%
Agricultural Land	79337.94	10.70%
Cropland	292837.52	39.48%
Cropland (Irrigated)	5549.82	0.75%
Pasture and Hay Land	3020.20	0.41%
Pasture and Hay Land (Irrigated)	10149.12	1.37%
TOTAL AGRICULTURE	390,894.66	52.71%
Rangeland		
Open	78617.39	10.60%
Bushy	19163.75	2.58%
Water	128,182.52	17.28%
Wetlands	23655.74	3.19%
Barren Land	51726.80	6.97%
	11237.62	1.51%
Recreation Land	7573.51	1.02%
Other Land	2039.02	0.27%
<b>TOTAL</b>	<b>741759.92</b>	

Source: Soil Conservation Service 1980

In 1989 Cameron County possessed a labor force of approximately 104,095 people. Unemployment for 1989 was nearly 12% (see Table 7-8 for labor and employment figures in the study area from 1985-1989). The largest sources of employment include trade, service and local government sectors (see Table 7-9 for employment by industry in the study area from 1985-1989).

**Table 7-8**  
**Labor Force, Total Employment and**  
**Unemployment of the Study Area**  
**\*1985-1989**

	Cameron County	% Change
<b>Labor</b>		
1985	92,468	
1986	94,727	2.44%
1987	95,788	1.12%
1988	98,828	3.17%
1989	104,095	5.33%
<b>Total Employment</b>		
1985	79,092	
1986	79,759	0.84%
1987	82,050	2.87%
1988	85,725	4.48%
1989	91,866	7.16%
<b>Unemployment Rate</b>		
1985	14.5	
1986	15.8	+8.96%
1987	14.3	-9.49%
1988	13.3	-6.99%
1989	11.7	-12.03%

Source: Texas Employment Commission 1989

**Table 7-9**  
**Employment by Industry**  
**In Cameron County**  
**1985 - 1989**

Sector	1985	1986	1987	1988	1989
Agriculture	1806	1740	1757	1929	1974
Mining	81	76	44	42	14
Construction	3193	3037	9588	9610	2035
Manufacturing	9694	9209	9588	9610	10419
Transportation	3424	3236	2926	2950	2918
Communications and Utilities					
Trade	18276	17992	17466	17716	19213
Finance, Insurance, and Real Estate	3438	3350	3422	3501	3550
Service and other	11362	11787	12372	13711	16260
State Government	1875	2011	1939	2051	2014
Local Government	11254	12136	12891	13266	13975
<b>TOTAL</b>	<b>64403</b>	<b>64574</b>	<b>64735</b>	<b>66833</b>	<b>72372</b>

Source: Texas Employment Commission 1989

Private industry produces 75% of all non-farm income in Cameron County. Services, retail trade and manufacturing make up the bulk of this 75%. The remaining 25% of non-farm income stems from government sources (see Table 7-10 for personal income by industry source in the study area from 1982 through 1987).

The target communities for water and wastewater improvements in Cameron County are the colonias. These colonias range in size from 15 to over 700 households which have an average of 4.81 occupants. Surveys conducted for Texas Department of Commerce grants indicate annual per capita income in the households surveyed ranges from a high of greater than \$14,300.00 to a low of less than \$3,000.00. A 1987 survey of the colonias in the Lower Rio Grande Valley by the Texas Department of Human Services indicates that 98.8% of the colonias population is Hispanic, with an average household income of \$6,932. This data coupled with the 47% unemployment rate reported in this study reveal the service economic depression in the colonias.

### 7.3 Alternatives Analysis

The TWDB's Environmental Assessment guidelines require evaluation of alternative engineering methods and siting of facilities and subsequent evaluation of these alternatives with respect to environmental constraints. A preliminary set of alternatives was evaluated during this study. Sites and treatment methods with the most significant environmental constraints were avoided (for example, wetlands and wildlife management areas for sites; and on-site disposal in areas of poor soil conditions for treatment methods) to the highest degree possible. A detailed alternative analysis will be conducted in more specific documents (i.e. site specific Environmental Assessment or Environmental Information Documents) as necessary for specific state and federal programs.

### 7.4 Potential Environmental Impacts

Environmental constraints, if not avoided, can often become environmental impacts. During the preliminary design phase of this study environmental constraints were identified and avoided to the greatest extent possible. Potential impacts that could occur in Cameron County, if proper design does not occur, include, among others, impacts to threatened and endangered species, wetlands and cultural resources. At this preliminary level of evaluation none of the proposed water and wastewater plans were noted to have any significant environmental impacts. Again, a more detailed Environmental Assessment for any specific site will be necessary to further evaluate potential environmental impacts.

**Table 7-10**  
**Personal Income by Industry Source**  
**in the Study Area (thousands of dollars)**  
**1982-1987**

	1982	1987
<b>Nonfarm</b>	<b>1,043,681</b>	<b>1,233,031</b>
<b>Private</b>	<b>851,567</b>	<b>925,601</b>
<b>Manufacturing</b>	<b>171,604</b>	<b>158,976</b>
<b>Mining</b>	<b>12,276</b>	<b>3,774</b>
<b>Construction</b>	<b>85,651</b>	<b>70,882</b>
<b>Wholesale/Trade</b>	<b>75,805</b>	<b>55,975</b>
<b>Retail Trade</b>	<b>165,561</b>	<b>170,338</b>
<b>Finance, Insurance</b>	<b>51,646</b>	<b>68,183</b>
<b>and Real Estate</b>		
<b>Transportation,</b>		
<b>Communication</b>	<b>75,995</b>	<b>79,485</b>
<b>and Utilities</b>		
<b>Services</b>	<b>194,006</b>	<b>281,067</b>
<b>Ag. Services,</b>		
<b>Forestry Fisheries</b>	<b>19,023</b>	<b>36,921</b>
<b>and other</b>		
<b>Government</b>	<b>192,114</b>	<b>307,430</b>
<b>Federal Civilian</b>	<b>27,169</b>	<b>33,939</b>
<b>Federal Military</b>	<b>6,600</b>	<b>6,962</b>
<b>State and Local</b>	<b>158,345</b>	<b>266,529</b>
<b>Total</b>	<b>2,087,362</b>	<b>2,466,062</b>

Source: U. S. Department of Commerce 1987

## 8.0 INSTITUTIONAL AND LEGAL ISSUES

### 8.1 Regulatory Overview

Federal, State and local regulations will affect the development of water supply treatment and distribution facilities, and wastewater treatment and collection facilities within Cameron County. This section reviews Federal regulations, including U.S. Fish and Wildlife Service (FWS) Section 7 consultation for threatened and endangered species; U. S. Army Corps of Engineers (USCE) 404 permits for stream crossing and/or dredge and fill operations; the Environmental Protection Agency (EPA) - National Pollutant Discharge Elimination Systems (NPDES) permit for wastewater discharges; and the National Historic Preservation Act for cultural resources. State environmental regulations expected to be of concern include the Texas Antiquities Code, which applies to all action taken by political subdivisions of the State of Texas, and the Texas Water Commission (TWC) Water Quality Permit for wastewater discharges and appropriation of surface water rights. Local environmental regulations expected to be of particular concern include Cameron County's septic tank and local permitting, etc. Table 8-1 provides a synopsis of environmental considerations which may be of concern in the development of water supply facilities.

### 8.2 Federal Regulatory Considerations

#### Clean Water Act

The Clean Water Act (CWA) prohibits the discharge of pollutants from any discernible point source into the waters of the U.S., with the exceptions of those discharges that are permitted in compliance with the CWA. Permits authorized under the CWA that may be of concern in this plan include Section 404 permits for dredge and fill as issued by the USCE and the NPDES for the discharge of water as issued by the EPA.

#### USCE Section 404 Permit

Section 404 of the CWA, as administered by the USCE, regulates the placement of dredged (excavated) or fill material in "Waters of the U.S." Waters of the U.S. are broadly defined in Section 404 as any body of surface water (such as oceans, bays, rivers), all surface tributary streams with a defined channel (including intermittent waterways), any in-stream impoundments (i.e., lakes and ponds), many off-channel impoundments, and wetlands. "Dredged or fill material" has also been given rather broad meaning to include almost any material or object used for construction such as dirt, rocks, concrete, piles, pipes, etc. In regards to construction of a water intake structure or pipeline where a crossing or direct involvement with a surface tributary stream, impoundment, or wetland may be required, placement of the pipeline itself (regardless of construction material) and

Table 8-1  
 Synopsis of Environmental Regulatory Programs

Program	Considerations
<p><u>Federal</u></p> <p>Section 7 of the Endangered Species Act of 1973, as amended</p>	<ol style="list-style-type: none"> <li>1) Format Section 7 consultation with FWS and USCE and the applicant may be of USCE permit or any other Federal Permit.</li> <li>2) It will be the responsibility of the applicant to prove whether or not Federally-listed species occur in the project.</li> <li>3) If formal Section 7 consultation is required, schedule delays up to 90 days can be expected.</li> </ol>
<p>Corps of Engineers 404 Permit Requirement</p>	<ol style="list-style-type: none"> <li>1) A permit is required for pipeline crossing of surface water tributaries and waterways</li> <li>2) A "general permit" exists which significantly reduces the time and paperwork for pipeline construction authorizations.</li> <li>3) Should have information on potential impacts to cultural resources and threatened or endangered species prior to involvement of Corps.</li> </ol>
<p>EPA - NPDES Discharge Permit</p>	<ol style="list-style-type: none"> <li>1) Establishes criteria for treatment and discharge of wastewater, including pollutant limitations, prohibitions, and monitoring and reporting criteria.</li> <li>2) Administered by Texas Historic Commission and State Historic Preservation Officer.</li> <li>3) Generally requires archaeological survey of affected areas, and, occasionally, testing of more important sites; in some cases, indirect impact areas must be considered.</li> <li>4) Sites which are determined to be eligible for the National Register of historic Places may need preservation and/or mitigation.</li> </ol>



**Table 8-1**  
**Synopsis of Environmental Regulatory Programs**  
 (continued)

Program	Considerations
<p><b>State</b>                      Texas Antiquities Code</p>	<p>1) Applies to actions taken by political subdivisions of the State of Texas.                      2) Administered by Texas Antiquities Committee.                      3) Generally requires archaeological survey of area of primary impact, and, occasionally, testing of potentially important sites.</p>
<p><b>TWC - State Water Quality Permit</b></p>	<p>1) Parallel program to NPDES permit.                      2) Designed to maintain ambient stream standards.                      3) Administered by Texas Water Commission.</p>
<p><b>TWC - State Water Rights Permit</b></p>	<p>1) Texas Water Law requires that a permit be acquired to divert, use or store State waters.                      2) Typical components of water rights application include a water conservation plan, an Environmental Assessment (or, possibly, an Environmental Impact Statement) and detailed engineering information.</p>

any trench backfill material within the area or jurisdiction is subject to permit requirements under 404 regulations.

The USCE Galveston District, has 404 regulatory responsibility for Cameron County, maintains a "general permit" for most pipeline construction projects. A general permit is a pre-authorized permit for a specifically identified activity which is conducted under certain specified conditions. General permits are issued on either a nationwide or regional basis. The purpose of general permits is to provide paperwork and time expenditure relief for permitting actions which are determined to be routine and resulting in little or no impacts to waters of the U.S.

With regard to water and wastewater storage and transmission facilities, crossing of surface tributaries with water lines will be necessary and, therefore, legally subject to permitting requirements under federal law. As pipeline construction activities are considered minor works with minimal impacts to waters of the U.S. by the USCE Galveston District (hence the general permit), the USCE does not spend much effort trying to enforce and specifically permit all pipeline construction projects. Even though the legal requirement for permitting exists, the USCE generally takes the position that as long as pipelines are constructed according to the conditions of the general permit (basically, return of natural contours and no permanent obstruction of water-courses); that no impacts occur to cultural resources or threatened or endangered species for which other federal regulations exist; and that no one (agency or individual) objects and complains about the activity, the activity is authorized under the general permit without formal notification and paperwork.

Under 404 regulations a general permit may be suspended for any given project and a full individual permit required if impacts to cultural resources, threatened or endangered species, or other factors of the public health and welfare are potentially to occur. An individual permit action can require from a minimum of three months to a year or longer to complete, and may also require public hearings and an Environmental Impact Statement. It should be noted that any of the service options which do or have a high probability of resulting in significant impacts to cultural resources or federally listed threatened or endangered species stand a high probability of not being authorized under a general permit.

### EPA-NPDES Permit

All point source discharges of wastewater into the waters of the U.S. are regulated under the CWA and require a NPDES permit. The NPDES permit establishes the criteria for treatment and discharge of the wastewater including pollutant limitations, prohibitions, and monitoring and reporting criteria. The treatment and discharge conditions described in the NPDES permit (in conjunction with the TWC - State Water Quality Permit) are typically designed to maintain ambient stream standards (as defined by the TWC) and require wasteload evaluation of all the cumulative impacts of all point sources discharged into receiving streams. Detailed evaluation of stream standards and existing wasteloads is required to determine the conditions of the NPDES permit.

### USFWS Section 7 Consultation for Threatened and Endangered Species

It is possible that formal Section 7 consultation between the FWS, USCE, and the County will be required before issuance of a USCE permit because of perceived direct and indirect impacts to Federally-listed Threatened and Endangered Species. Additionally, environmental groups may petition the FWS and the USCE to initiate Section 7 consultation if it is not initiated by the applicant (local project sponsor). It is the responsibility of the applicant to prove whether or not Federally-listed threatened or endangered species occur on the project area. If Section 7 consultation is required, considerable schedule delays (60-90 days minimum) will be inevitable during the period in which FWS conducts biological assessments and forms its "biological opinions".

### National Historic Preservation Act

Protection of cultural resource sites may be invoked through application for a Section 404 or Section 10 permit from the USCE should structures or lines be located in waters of the United States. Should the USCE become involved, it may request the opinion of the State Historic Preservation Officer (SHPO) concerning the effect of the project on cultural resources. Because of the high potential for cultural resources in the general area, it is certainly possible that the SHPO would, like the Texas Antiquities Committee (TAC), require an archaeological survey, site evaluation, and protection and/or mitigation measures for important sites located during the initial survey. In such cases, where both the TAC and the SHPO have jurisdiction, one agency will operate as the lead agency.

Cultural resources studies may be coordinated through the TWDB, where TWDB funds are utilized, or coordinated directly through the TAC.

### 8.3 State Regulatory Considerations

#### Texas Antiquities Code

Cameron County and all municipalities, water districts, etc. in the county are considered to be political subdivisions of the state under the provisions of the Texas Antiquities Code, and, therefore, must consider the effects of its actions upon possible archaeological sites. Under the code, all archaeological sites, either historic or prehistoric, and significant historic structures on lands belonging to or controlled by political subdivisions of the state are automatically considered to be State Archaeological Landmarks (SALs) and may be eligible for protection. Construction projects by the district will require a Texas Antiquities Permit and coordination with the TAC. In practice, this often necessitates an archaeological and historical survey or previously unsurveyed areas prior to any potentially destructive action. Sites recorded during this survey must be evaluated; those which are of significant historical or scientific value will be formally designated for SAL status and measures of protection or mitigation of adverse impact negotiated between the political subdivision and the TAC.

#### TWC-State Water Quality Permit

The TWC-State Water Quality Permit is the State of Texas' EPA-NPDES parallel program for wastewater discharges. Like the NPDES permit, the State Permit is designed to maintain stream standards. The permit is administered by the Wastewater Permits Section of the TWC. Any new discharges or change in quantity and/or quality of discharge will likely require both a NPDES and State Water Quality Discharge Permit.

#### TWC-State Water Rights Permit

The development of this plan requires a thorough analysis of the water demand and supply and use of existing water. Expected water supply shortage may require one or more of the following actions related to water rights: 1) reallocation of existing agricultural rights and/or 2) development of a surface water supply source and, thus, the need for a water (storage, diversions, and/or use) rights permit as issued by the TWC.

Anyone who desires to appropriate water must make an application in writing to the Texas Water Commission. The TWC, as a regulatory agency with broad discretionary powers, is charged with the administration of rights to the surface water resources of the State. The TWC consists of three members appointed by the Governor for six-year terms, with the consent of the Senate. The Chairman is designated by the Governor.

The Rules, Regulations, and Modes of Procedure of the Texas Water Commission prescribed the procedures for applying for a water permit. The TWC will consider an application for approval if the application is in proper form, complies with statutory provisions, contemplates and authorized use of water, does not impair existing water rights or vested riparian rights, and is not detrimental to the public welfare and environment.

After approval of an application, the TWC issues a permit giving the applicant the right to take and use water only to the extend stated. Permits may be "regular," "seasonal," "temporary," or "contract" in nature. A "regular" permit is permanent in nature and does not limit the appropriator to the taking of water during a particular season or between certain dates. A "seasonal" permit is also permanent in nature, but the taking of water is limited to certain months or days during the year. A "temporary" permit is granted for a period of time not exceeding three years and does not vest in the holder any permanent right to the use of water. A "contract" permit is granted for a stated duration and governs the use of water to be obtained from the storage facilities owned by another person or entity. A "contract" permit requires a written consent agreement or "contract" with the owner of the facility.

The TWC may also grant permits for the impoundment and storage of water with the use of the impounded water to be determined at a later date by the TWC.

Once the right to the use of water has been perfected by (1) issuance of a permit from the TWC and (2) subsequent beneficial use of the water by the permittee, the water authorized to be appropriated under the terms of the particular permit is not subject to further appropriation until the permit is cancelled. Formal cancellation of unused permits and certified filings is possible by administrative action initiated by the TWC or by judicial proceedings to adjudicate water rights between claimants (TWDB, 1977).

## 9.0 REVIEW OF FINANCING PROGRAMS

### 9.1. Bond Market

Construction of public works projects, like those described in Sections 4.0 and 5.0 of this report, is frequently financed by the selling of bonds. Entities such as cities, river authorities and other political subdivision can issue bonds and use the proceeds to construct capital improvement projects. The bonds are repaid, with interest, from taxes and/or fees collected in the service area. Because bonds issued by public entities are for the purpose of providing services, they are classified under federal law as "tax exempt," and the interest paid to bond holders does not have to be declared as ordinary income. Consequently, these bond holders are willing to lend their financial resources to public entities at a lower rate of interest than the going market rate.

#### 9.1.1 Texas Water Development Fund and Water Assistance Fund

In 1985 constitutional amendments were approved by Texas voters, authorizing the issuance of \$980 million of general obligation bonds to fund water development projects. An additional \$250 million was approved to establish the Water Bond Insurance Program which guarantees bonds issued by local governments. This was in addition to \$600 million previously authorized for the Water Development Fund and \$40 million appropriated for the Water Assistance Fund, which includes the Water Loan Assistance Fund. These loan funds are administered by the Texas Water Development Board (TWDB).

The Water Development Fund is used to provide loans to political subdivisions for the construction of water supply, wastewater treatment, flood control, regional water and wastewater facilities, and other related projects. Historically, the Water Development Fund was reserved for use by "hardship" political entities, who were unable to sell bonds at reasonable rates on the open market. The passage in 1985 of House Bill 2 resulted in an expansion of this program to include the use of the funds to provide loans for the construction of regional facilities. The TWDB is also authorized to purchase an interest in local/regional water supply or wastewater treatment projects in order to provide future excess capacity. The acquisition and/or construction of any one of the following engineering projects may be eligible for consideration under the Water Loan Assistance Program, Water Development Program, Water, Wastewater and Storage Facilities Acquisition Program, Water Quality Enhancement Program or Flood Control Program, as appropriate:

- conservation and development of surface or subsurface water resources, including the acquisition, modification or construction of dams, reservoirs and underground storage, or the the acquisition or purchase of rights in underground water and the drilling of wells;
- development of saline or brackish water, including desalination facilities;

- transportation facilities used to transport water to treatment facilities, storage or wholesale purchasers (retail distribution systems are not included);
- water treatment, including filtration and water and wastewater treatment plants;
- treatment works including those used in the storage, treatment, recycling and reclamation of waste, or which are necessary to recycle or reuse water at the most economical cost;
- structural and nonstructural flood control and drainage facilities.

Cities, special purpose districts, nonprofit water supply corporations and regional entities can apply to the TWDB for loan funds. In accordance with House Bill 2, the Board will continue to encourage local political entities to implement regional water supply and wastewater treatment facilities, consistent with the Texas Water Plan and the State Water Quality Management Plan. The bonds are issued as State of Texas General Obligation Bonds and, because they are guaranteed by the state, provide funding at generally a lower rate of interest than bonds sold on the open market. The interest rate is intended to reflect the true interest cost to the state, including issuance costs. The bonds are retired by the TWDB from funds collected from each loan.

Priority for the funds is given to regional projects which, by definition, serve more than one city, district, or other political entity. Individual cities and special purpose districts must be classified as "hardship cases" in order to be eligible. Small cities that do not have a credit rating and would have difficulty obtaining loans are typical applicants. Even though these cities would have difficulty obtaining funds on the open market, they must also be able to demonstrate to the TWDB that the funds will be repaid.

#### Water, Wastewater and Storage Facilities Acquisition Program

As a result of comprehensive water legislation in 1985, the TWDB was authorized to issue up to \$400 million in State of Texas General Obligation Bonds in order to purchase an undivided interest in water, sewer and flood protection projects insuring that optimum project development can be achieved. The TWDB's share could be as high as 50 percent. However, because of the State's poor financial condition there has not been a source of revenue available to the TWDB to repay debt service on this obligation. As a result, implementation of the program has been slow.

The program allows for projects to be designed to meet the future needs of a community, even if current demand is insufficient to provide the necessary revenues to retire the debt load associated with a larger project. Through the State Participation Program, a local entity could plan a larger project than necessary, with phasing of elements to the maximum extent possible, and solicit financial assistance from the TWDB. The TWDB would pay up to 50 percent of the project

costs and hold its share until some future date, at which time the local entity would be required to buy the Board's share. The local entity must enter into a binding agreement obligating it to begin paying debt service on the Board's original share, plus interest and financing costs, within a period of 8-12 years following project completion.

### 9.1.2 State Revolving Loan Fund

#### 9.1.2.1 Overview

The Texas State Water Pollution Control Revolving Fund (SRF) is administered by the TWDB and provides a source of low interest loan money for the construction of wastewater treatment facilities. The 1987 Clean Water Acts Amendments replaces the federal construction grants program and provides federal funds, at zero interest, which must be match by the state. State funds are provided from the sale of Texas Water Quality Enhancement bonds. By providing up to one dollar of state funds for each dollar of federal funds, the TWDB has been able to increase the availability of the funds, while making the loan money available at an interest rate of 5 to 6 percent.

Successful applicants must issue bonds, which are purchased by the TWDB. The applicant then redeems the bonds with revenues from taxes or user fees. As the loans are repaid and the bonds retired, the federal funds can be used again for subsequent loans with new bond money. In this manner, the federal government has provided a perpetual fund to sustain an ongoing program for water quality improvements.

#### 9.1.2.2 Eligibility

Any public entity having the authority to treat sewage and is designated as (or has applied for designation as) a waste treatment management agency is eligible to apply for these funds. This includes cities, towns, special purpose districts, river authorities or other public bodies. Eligible projects include:

- construction of secondary and advanced treatment works;
- alternatives to secondary and advanced treatment works;
- construction of interceptor sewers;
- repairs to existing collection systems to reduce inflow/infiltration;
- construction of reserve capacity;
- rehabilitation or replacement of collection systems necessary to overall project integrity; and
- new collection systems to complement existing or planned treatment capacity.



### 9.1.2.3 Conditions for a SRF Loan

The following conditions must be met in order to be eligible for a SRF loan:

- have the project on the TWDB's priority project list;
- develop or have in effect a water conservation plan;
- have an eligible project;
- demonstrate that a dedicated source of funds exists for loan repayment;
- use best practice treatment technology;
- have a cost effective project;
- consider alternative waste management techniques and innovative alternative waste treatment processes;
- show that I/I is not excessive or include I/I reduction as a part of the project;
- consider the project's recreational and open space potential;
- be consistent with area wide 208 and 303e water quality management plans;
- implement a user fee system and demonstrate financial and managerial capability;
- for projects over \$10 million, apply "Value Engineering;"
- obtain an environmental determination in compliance with the National Environmental Policy Act;
- comply with the Davis-Bacon Act in setting wage rates for labor used during construction; and
- consider the development of a capital financing plan.

### 9.1.2.4 Applying for a SRF Loan

It is advisable for an entity seeking to apply for a SRF loan to schedule a preplanning meeting with the TWDB staff. A representative of the entity's governing body and its engineering consultant should be present in order to obtain information about the eligibility of the project and the preparation of the application. When the facilities plans and environmental documents have been filed, a preapplication meeting with the TWDB staff should be scheduled.

The TWDB's annual schedule for processing an application is as follows:

- On or before April 1: A priority rating report is solicited by the TWDB Executive Administrator from all entities wishing to be included in the forthcoming year's intended use plan. The following information is required:
  - description and condition of existing facilities;

- description of present wastewater problems and future needs;
  - analysis of the planning area to include current and projected population, wastewater sources, influent and effluent characteristics and uses of receiving bodies of water;
  - status of the required wastewater permit for the project;
  - description of the means proposed to correct present problems and meet future demand;
  - estimated total cost; and
  - estimated project schedule.
- On or before July 1: The priority report is due at TWDB. Late applications will be added and considered with the appropriate population class list, in order of the date of submission, if all of the funds are not allocated.
  - By July 1: Project rating reports filed by applicants are used by TWDB staff to prepare a preliminary intended use plan.
  - After July 1: A public hearing is held on the intended use plan. By this date, the applicant must have filed a certified copy of a resolution of its governing body estimating total project costs and committing to file an application for an SRF loan on or before March 15 of the following year. Failure to do this will mean that the project will not be included in the intended use plan.
  - September: The intended use plan is presented to the Board for approval at a regularly scheduled meeting after federal appropriations have been made and funding levels established.
  - October: Board sets funding limits and determines which projects will be funded in each category. If projects cost less than estimated, remaining funds become available to those lower on the list. Those costing more can obtain additional funds from the water quality enhancement fund at higher interest rates.
  - March 15: Loan applications are due. This consists of an SRF engineering plan, environmental documents, water conservation plan and general, legal and fiscal data. Upon approval of the loan, contract documents are prepared and submitted to TWDB for review and approval. Following approval, the applicant then hires engineering contractors, using an open bidding system. The applicant should print the bonds and await notification of a closing date from TWDB staff. Upon closure of the loan, the cost for preparation of the required reports and contract documents used in the application can be reimbursed from the loan proceeds.

Because the rules specify that a new Intended Use Plan and priority funding list must be developed each year, an unsuccessful applicant must begin the process anew to secure funding in the following year.

### 9.1.3 State Participation Program

#### 9.1.3.1 Program Description

The Community Development Block Grant (CDBG) program was created by United States Congress in 1974 and is administered by the U.S. Department of Housing and Urban Development (HUD). Cities exceeding 50,000 population and counties larger than 200,000 are funded through the entitlement program; smaller entities are included in the non-entitlement category. Since 1981 the responsibility for administering the non-entitlement portion of the CDBG program has been transferred to the Texas to the Department of Commerce's Finance Division.

#### 9.1.3.2 Programs

The Community Development Fund contains about two-thirds of the total funding. Public works projects funded under the program include water/sewer improvement, street/drainage improvements, community centers and handicapped accessibility projects.

Texas Capital Fund is part of a program designed for the express purpose of creating new permanent jobs, primarily for low or moderate income persons. It is part of the Texas Community Development Program and encourages business development and expansion.

The Emergency/Urgent Need fund was established to respond to natural disasters and urgent situations that pose a threat to public health and safety. To qualify under the first category, the Governor must declare a state of emergency. The second category would be more applicable to water and sewer projects. The urgent need must have arisen within the last 18 months and must be based on satisfactory documentation completed or certified by the Texas Department of Health's Regional Director of Environmental and Consumer Health Protection.

The Special Impact Fund, funded under the Texas Community Development Program, provides funding to assist in infrastructure development in severely distressed unincorporated areas of counties. Water, sewer, street and drainage are the only eligible projects, which have to compete for funding in an annual statewide competition.

The Planning/Capacity Building Fund is designed to help communities to become more involved in community and economic development projects. It is also awarded as a result of a statewide

competition and focuses on planning activities that may be addressed with Texas Community Development Program funds and other similar resources.

## 9.2 Economically Distressed Areas Program (EDAP)

The Economically Distressed Areas Program (EDAP) is a recent financial assistance program designed to provide financial assistance for water and wastewater facilities in economically distressed areas. An economically distressed area is defined by the TWDB as an area in which water supply or sewer services are inadequate to meet minimal needs of residential users and in which financial resources are inadequate to meet these needs.

The general goal of the EDAP is to encourage and provide grant assistance to political subdivisions to serve economically distressed areas and further the orderly development of regional water and wastewater facilities. To ensure this goal, is EDAP monies may be used to fund for the entire range of activities related to the development of such facilities, including preliminary planning to determine the feasibility of a project:

- engineering, architectural, environmental, legal, title, fiscal, or economic studies;
- surveys, designs, plans, working drawings, specifications, procedures;
- any condemnation or other legal proceedings; and
- erection, building, acquisition, alteration, remodeling, improvement, or extension of a project, or the inspection or supervision of any of the foregoing items.

### 9.2.1 Applicability and Eligibility

Counties eligible for this program must either meet income (average per capita income of 25% below state average) and unemployment rate (average rate of 25% above state average) or be adjacent to an international border. Cameron County has been identified as an affected county by the TWDB.

### 9.2.2 Funding Mechanisms, Requirements and Repayment

The amount and form of financial assistance and repayment is typically based upon need and customer ability to pay. Need is first and foremost determined by the presence of serious and unacceptable health hazard to residents. Repayment is typically a function of ability to pay and other available source of funding available to the subdivision. The TWDB has developed a model that calculates the ability to pay based on the rates, fees, and charges that the average customer to be served by the project will be able to pay based on a comparison of what other families of similar income pay for comparable services. In short, the amount and form of financial assistance

and repayment is unique for each political subdivision and facility engineering data must be evaluated by the TWDB to determine the terms associated with the financial assistance.

### Facility Engineering

Facility engineering is made up of the two phases of studies and tasks that are performed to determine the engineering feasibility of water and wastewater facilities and to obtain plans and specification for constructing the facilities for an economically distressed area. The two phase of facility engineering are described below:

Facility Engineering Phase I - The studies, tasks, and reports that are performed to determine the most cost-effective alternative to meet water and wastewater facilities needs, determine the feasibility of the proposed alternative, and prepare an application for board financial assistance to construct the alternative. The requirements of Phase I are shown in Table 9-1.

Facility Engineering Phase II - The tasks that yield design reports, construction drawings, technical specifications, instructions, and other contract conditions and forms needed to construct water or wastewater facility.

The TWDB may through funds available through the research and planning fund, provide up to 75% of the cost of facility engineering.

## 10.0 RECOMMENDATIONS

### 10.1 Recommendations for Water Supply Options - Cameron County.

- Pursue the implementation of the Rio Grande Valley Water Conservation Project.
- Implement area-wide water conservation programs.
- Initiate area/regional treated wastewater reuse/recycling programs.
- Investigate programs to eliminate/decrease irrigation water losses with water savings being used to meet future municipal , industrial and domestic water demands.
- Continue to research the use of using low cost RO membrane technology to treat ground water supplies.
- Secure (purchase) irrigation water rights to convert to municipal rights as opportunities prevail.
- Continue prudent development of the Lower Rio Grande Valley aquifer for direct use or blending with existing supply.

### 10.2 Recommendations for Water Supply Options - Colonias.

- The PUB should provide water service to Hacienda Gardens (No. 7B), including a centralized water distribution system. The estimated cost for these improvements is \$330,000.
- The PUB should provide water service to the portion of Cameron Park currently served by the Military Highway WSC. The estimated cost of these improvements is \$2,970,000.
- A centralized water distribution system, should be constructed in the following colonias, with treated water supply being furnished by Santa Rosa (Cameron County WCID):
  - 6W -T2 Unknown Subdivision,
  - 13W -Q Unknown Subdivision (Santa Rosa),
  - 14W - W,
  - 15W- R Unknown Subdivision (S. Santa Rosa),
  - 16W-X Unknown Subdivision (Santa Rosa),
  - 17W- S.
- All raw and treated water purveyors who are currently serving colonias should continued to do so in the future, except for the Military Highway WSC's service to part of Cameron Park.

### 10.3 Recommendations for Wastewater Options - Colonias.(Table 10-1)

### 10.4 Implementation Schedule

- The PUB of Brownsville should immediately prepare an application to the TWDB for Phase I Engineering funds for Cameron Park under the Economically Distressed Areas Program (EDAP). Cameron Park is on the TWDB list of identified priority colonias.
- The PUB of Brownsville should begin screening the remainder of colonias within the PUB service area and begin preparation of EDAP funding application(s) for other areas of significant need.

TABLE 10-1  
Wastewater Collection, Treatment And Disposal Options  
for The Colonias of Cameron County, Texas

Desig.	Colonia Name	Year 2020			Sewered (Y/N)	Recommended Treatment Method	Recommended Disposal Method	Total Cost
		Pop.	Unit Density (1/Ac)	WW Gen. (MGD)				
1B	Cameron Park	7,327	4.15	0.73	Y	Wastewater Treatment Plant		
2B	Olmillo	3,532	1.86	0.35	Y	Wastewater Treatment Plant	\$3,413,000	
3B	Stuart Subdivision	1,960	8.02	0.20	Y	Wastewater Treatment Plant		
4B	San Pedro Carmen	1,450	4.07	0.15	Y	Wastewater Treatment Plant	\$3,605,000	
8B	Villa Nueva	798	2.55	0.08	Y	Wastewater Treatment Plant		
11B	Villa Cavazos	399	2.31	0.04	Y	Wastewater Treatment Plant	\$2,005,000	
5B	King Subdivision	1,265	4.16	0.13	Y	Group Together		
12B	Barrio Subdivision	389	1.39	0.04	Y	Group Together	\$2,700,000	
17B	Saldívar (I)	272	1.70	0.03	Y	Group Together		
20B	Unnamed D (Keller's)	243	2.27	0.02	Y	Group Together		
21B	Texas 4	243	1.52	0.02	Y	Group Together		
23B	Illinois Heights	204	1.68	0.02	Y	Group Together		
26B	Unknown	117	0.63	0.01	Y	Group Together		
27B	Unknown B (Hwy 802)	97	1.91	0.01	Y	Group Together		
6B	Alabama/Arkansas	1,022	0.86	0.10	Y	Group Together	\$2,775,000	
16B	Unknown	282	1.93	0.03	Y	Group Together		
18B	Villa Escondido	272	1.47	0.03	Y	Group Together		
25B	Villa Hermosa	126	1.37	0.01	Y	Group Together		
7B	Hacienda Gardens	944	3.78	0.09	Y	Wastewater Treatment Plant		
9B	Villa Pancho	603	1.66	0.06	Y	Wastewater Treatment Plant	\$1,860,000	
10B	Pleasant Meadows	584	2.90	0.06	Y	Wastewater Treatment Plant	\$965,000	
13B	Los Cuates	379	1.71	0.04	Y	Group Together		
15B	Coronado	302	1.11	0.03	Y	Group Together		
22B	511 Crossroads	243	1.72	0.02	Y	Group Together		
24B	Unkn. (Bimaville Air.)	195	1.90	0.02	Y	Group Together		
28B	21	88	2.00	0.01	Y	Group Together		
14B	Saldívar	302	1.41	0.03	Y	Wastewater Treatment Plant	\$2,445,000	
19B	Unnamed C	263	2.25	0.03	Y	Wastewater Treatment Plant	\$310,000	
						South Sewage Treatment Plant	\$270,000	

CAMERON COUNTY REGIONAL PLANNING STUDY  
RECOMMENDATIONS AND IMPLEMENTATION SCHEDULE

Wastewater Collection, Treatment And Disposal Options  
for The Colonias of Cameron County, Texas

Desig.	Colonia Name	Year 2020			Sewered (Y/N)	Recommended Treatment Method	Recommended Disposal Method	Total Cost
		Pop.	Unit Density (1/Ac)	WW Gen. (MGD)				
1W	Encantada	1,641	1.56	0.16	Y	Group Together	Own Treatment Plant	\$2,140,292
9W	El Calaboz	260	3.17	0.03	Y	Group Together	Own Treatment Plant	\$1,722,737
2W	Santa Maria	2,306	5.89	0.23	Y	Individual Collection / Treatment System	Own Treatment Plant	\$1,007,333
10W	Iglesia Antigua	206	4.20	0.02	Y	Individual Collection / Treatment System	Own treatment plant	\$878,695
3W	La Paloma	861	2.48	0.09	Y	Individual Collection / Treatment System	Own Treatment Plant	\$540,243
4W	Los Indios	699	1.43	0.07	Y	Group Together to Santa Rosa	Santa Rosa's Collection System	\$1,042,403
5W	Bluetown	580	2.00	0.06	Y	On-Site System	Mounded Pressure -dose System	\$295,000
6W	T2 Unknown Subd.	431	1.96	0.04	Y	On-Site System	Mounded Pressure -dose System	\$280,000
13W	Q Unknown Subd.	241	3.06	0.02	Y	Individual Collection / Treatment System	Own Treatment Plant	\$409,988
15W	R Unknown Subd.	196	1.60	0.02	Y	On-Site System	Mounded Pressure -dose System	\$170,000
17W	S	116	0.96	0.01	Y	On-Site System	Mounded Pressure -dose System	\$140,000
7W	El Venadito	287	1.44	0.29	N	On-Site System	Mounded Pressure -dose System	\$120,000
8W	Carricitos-Londrum	275	0.48	0.03	N	Group Together	Own Treatment Plant	\$2,035,280
11W	Palmer	285	1.81	0.03	Y	Individual Collection / Treatment System	Own Treatment Plant	\$765,488
12W	Unknown (Milita 2)	169	1.06	0.17	N	On-Site System	Own Treatment Plant	\$779,984
14W	W	137	0.58	0.14	N	Group Together	Own Treatment Plant	\$790,000
16W	X Unknown Subd.	116	1.50	0.01	N	Individual Collection / Treatment System	Mounded Pressure -dose System	\$475,000
1E	La Coma del Norte	868	1.77	0.09	Y	On-Site System	Own Treatment Plant	\$355,496
4E	Laureles	381	1.34	0.04	N	On-Site System	Mounded Pressure -dose System	\$225,000
8E	Unknown	262	3.31	0.00	N	Individual Collection / Treatment System	To Los Fresnos' Collection System	\$439,666
12E	25	75	0.47	0.01	N	Individual Collection / Treatment System	Harlingen Collection System	\$860,267
13E	Cisneros	144	1.44	0.01	Y	Group Together	San Benito Collection System	\$1,042,819
2E	Lozano	680	2.78	0.01	Y	Individual Collection / Treatment System	San Benito Collection System	\$824,870
3E	La Tina Ranch	662	2.29	0.01	Y	Individual Collection / Treatment System	Harlingen Collection System	\$477,516
5E	Del Mar Heights	483	0.48	0.05	N	On-Site System	Harlingen Collection System	\$285,079
10E	Unknown (Del Mar II)	290	0.95	0.03	N	On-Site System	Mounded Pressure -dose System	\$95,000
6E	Orason/Chula Vista	464	0.45	0.05	N	Individual Collection / Treatment System	Own Treatment Plant	\$355,496
7E	Las Yeacas	281	3.56	0.00	Y	On-Site System	Mounded Pressure -dose System	\$225,000
9E	Glenwood Acres Subd.	218	1.41	0.02	N	Individual Collection System	To Los Fresnos' Collection System	\$439,666
11E	Los Cuates	261	2.41	0.03	Y	Individual Collection System	Harlingen Collection System	\$860,267
1H	Las Palmas	1,103	2.88	0.11	Y	Group Together	San Benito Collection System	\$1,042,819
2H	Lago Subd.	695	3.46	0.07	Y	Individual Collection System	San Benito Collection System	\$824,870
5H	Rice Tracts	234	1.50	0.02	Y	Individual Collection System	Harlingen Collection System	\$477,516
3H	26	504	2.51	0.05	Y	Individual Collection System	Harlingen Collection System	\$285,079
4H	Lasana	217	2.00	0.02	Y	On-Site System	Mounded Pressure -dose System	\$95,000
6H	Leal Subd.	217	1.83	0.02	Y	On-Site System	Mounded Pressure -dose System	\$95,000
7H	Leguna Escondido	95	1.10	0.01	N	On-Site System	Mounded Pressure -dose System	\$95,000



CAMERON COUNTY REGIONAL PLANNING STUDY  
RECOMMENDATIONS AND IMPLEMENTATION SCHEDULE

- The CCWDB should begin preparation of a screening mechanism to rate the colonias of Cameron County on severity of need.
- The CCWDB should begin preparation of applications for Phase I Engineering funding from the TWDB for the most severely distressed colonias.

11.0 REFERENCES

- Audrey's data on ethnicity, gender in Cameron County
- Blair, W. F. 1950. The Biotic Province of Texas. Texas Journal of Science 2:93-117.
- Bowles, William F. Intensive Survey of the Brownsville Ship Channel (Segment 2494), Report IS-55. Texas Department of Water Resources. Austin, Texas (August, 1983).
- Bowles, William F., Jr. Bacteriological Water Quality of the Arroyo Colorado (Segment 2201), Report LP86-05. Texas Water Commission, Austin, Texas (July, 1986).
- Bureau of Economic Geology, 1976, Geologic Atlas of Texas; The University of Texas at Austin.
- Cameron County Program Development and Management Department. 1986 Cameron County Colonia Re-Development Study
- Davis, Jack R. Intensive Survey of the Arroyo Colorado Segment 2201, Report IS-61. Texas Department of Water Resources. Austin, Texas (May, 1984).
- Davis, Jack R. Intensive Survey of the Arroyo Colorado Segment 2201, Report IS-69. Texas Department of Water Resources. Austin, Texas (January, 1985).
- Davis, Jack R. Intensive Survey of the Arroyo Colorado Segment 2201. Report IS-49. Texas Department of Water Resources. Austin, Texas (April, 1983).
- Gould, F. W. 1975. Texas Plants: A Checklist and Ecological Summary. Texas A&M University Press. College Station, Texas.
- Holz, Robert K. and Shane Davies. August 1989. Third World Texas: Colonias in the Lower Rio Grande Valley. A Report Submitted to The Policy Research Center. The LBJ School of Public Affairs. The University of Texas at Austin.
- Low Energy Membrane Nanofiltration for Removal of Color, Organics, and Hardness from Drinking Water Supplies, B. M. Watson et al, Kuwait Symposium on Management and Technology of Water Resources in Arid Zones, 1987
- Lower Rio Grande Development Council. 1988. Population Projections for Selected Rural Unincorporated Communities in Cameron, Hidalgo and Willacy Counties (1980-2005).
- Membrane Softening - The Concept and Application to Municipal Water Supply, William J. Conlon, P.E., et al, 4th World Congress on Desalination and Water Use, 1989, Kuwait
- Orton, R. B., 1977. National Weather Service, Cameron County Soil Survey, U.S.D.A. Soil Conservation Service.
- R. W. Beck and Associates, Inc. 1988. Brownsville Public Utilities Board - 1988 Wastewater Master Plan.
- Rauschuber, D. G. and M.P. Sullivan. March 1989. Environmental Inventory and Issues Report, Rio Grande Valley Water Conservation Project. Prepared for Rio Grande Valley Municipal Water Authority and Public Utilities Board of Brownsville.
- Rauschuber, D. G. and R. J. Brandes. April 1989. Technical Report - Operations Study Rio Grande Valley Water Conservation Project. report No. 03-02. Prepared for Rio Grande Valley Municipal Water Authority and Public Utilities Board of Brownsville. 5 Vols. Austin, Texas.
- SCS data on Cameron County
- Sellards, E. H., Akins, W. S., Plummer, F. B., 1981. The Geology of Texas: Bureau of Economic Geology.

- Skillem, Frank F. 1988. Texas Water Law Volume I. Sterling Press Incorporated, San Antonio, Texas.
- Texas A&M University. 1987. Estimates of the Total Population of Counties in Texas By Age, Sex and Race/Ethnicity for July 1, 1987.
- \_\_\_\_\_. 1988. Projections of the Population of Texas and Counties in Texas By Age, Sex and Race/Ethnicity for 1990-2025, December 1988.
- \_\_\_\_\_. 1988. Estimates of Population for Cameron, Hidalgo and Willacy Counties.
- Texas Board of Water Engineers. May 1960. Bulletin 6008-Water Levels in Observation Wells in Cameron, Hidalgo, and Starr Counties Texas 1950-1959. Austin, Texas.
- Texas Department of Commerce. November 1988. Estimates of the Total Population of Counties in Texas by Age, Sex, and Race/Ethnicity for July 1, 1987. Prepared by the Department of Rural Sociology, Texas Agricultural Experiment Station, Texas A&M University.
- Texas Department of Health. 1988. Rules & Regulations For Public Water Systems.
- Texas Department of Health. Construction Standards For On-Site Sewerage Facilities. January 1, 1990.
- Texas Department of Health. November 1977. Construction Standards For Private Sewage Facilities.
- Texas Department of Human Services. June 1988. The Colonias Fact Book.
- Texas Department of Water Resources. July 1979. Report 236-Stratigraphic and Hydrogeologic Framework Of Part Of The Coastal Plain of Texas. Austin, Texas.
- Texas Department of Water Resources. September 1983. Report 279-Occurrence and Quality of Ground Water in the Vicinity of Brownsville, Texas.
- Texas Department of Water Resources. Waste Load Evaluation For The Arroyo Colorado In The Nueces-Rio Grande Coastal Basin. Austin, Texas (draft, May 13, 1985).
- Texas Department of Water Resources. Water For Texas. 2 Vols. Austin, Texas. November 1984.
- Texas Education Agency. 1988. Cameron County School Enrollment Data (1984-1988).
- Texas Employment Commission 1985-1989. Annual Average Labor Force Estimates for Texas Counties. Austin, Texas.
- Texas Natural Heritage Program. 1989. Sensitive Species and Natural Communities within Cameron County, Texas.
- Texas Water Commission. 1989. Rules, Regulations and Design Criteria For Sewerage Systems.
- Texas Water Commission. Methodology. Compiled by the Modeling Unit of the Water Quality Standards and Evaluation Section, Austin, Texas.
- Texas Water Commission. The State of Texas Water Quality Inventory, 9th Edition, Report LP88-04. Austin, Texas (April, 1988).
- Texas Water Development Board. A Summary Of The Preliminary Plan For Proposed Water Resources Development in the Rio Grande Basin. Austin, Texas. August 1966.
- Texas Water Development Board. Continuing Water Resources Planning and Development for Texas - Draft. 2 Vols. Austin, Texas. May 1977.
- Texas Water Development Board. The Texas Water Plan. Austin, Texas. November 1968.

- Texas Water Development Board. Water For Texas: Today and Tomorrow - Draft. Austin, Texas. July 1990.
- Twidwell, Steve R. Intensive Surface Water Monitoring Survey for Segment 2201, Report IMS-72. Texas Department of Water Resources. Austin, Texas (reprinted March, 1984).
- U. S. Department of Commerce, Bureau of the Census. 1986. Population estimates, 1984 and per capita income, 1983. Series P-26.
- U. S. Department of Commerce. 1987. Local Area Personal Income 1982-1987
- U. S. Department of Interior. Bureau of Reclamation. September 1956. Availability of Ground Water In The Gulf Coast Region Of Texas - Open File Report. Austin, Texas.
- U. S. Environmental Protection Agency. On-Site Wastewater Treatment and Disposal Systems. Design Manual. October 1980.
- U. S. Environmental Protection Agency. Wastewater Treatment Facilities For Sewered Small Communities. EPA-625/1-77-009. Process Design Manual. October 1977.
- U. S. Soil Conservation 1980. Land Use By Type For Cameron County.
- U. S. Soil Conservation Service, Soil Survey for Cameron County, Texas.
- Use of Membrane Technology in Florida, Glenn M. Dykes, P.E., Administrator, Water Supply Section, Florida Department of Environmental Regulation, and William J. Conlon, P.E., Vice-President, Stone and Webster Water Technology Services
- Williams, D., Thompson, C.M., Jacobs, J.L., 1977. Cameron County Soil Survey: U.S.D.A., Soil Conservation Service.

August 29, 1991

Dr. Tommy Knowles, Director of Planning  
Texas Water Development Board  
P.O. Box 13231 Capitol Station  
Austin, Texas 78711-3231

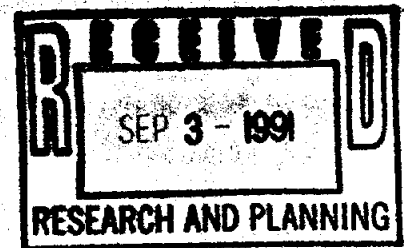

Re: Response to Letter of July 31, 1991 to  
The Honorable Antonio Garza, Jr., Cameron County Judge  
Review Comments to TWDB Contract No. 9-483-733  
Cameron County Regional Water and Wastewater Planning Study

Dear Dr. Knowles:

The following responses are presented pursuant to your supplemental comments.

**Response to Comment 5.**

We concur with staff's comment that "...certain on-site systems have been shown to operate effectively under conditions such as exist in Cameron County". As such, recommendations for the use of on-site technologies were made in the original draft of the study. Table 10-1 summarizes recommended wastewater disposal methods for the colonias evaluated. On-site technologies were recommended for nine of the colonias. At the level which this study was performed, it was not possible to make lot-by-lot determinations for the suitability of on-site technologies. Based on more intensive site analyses for specific areas, on-site technologies may be found to be appropriate and the preferred method of disposal.

**Response to Comment 8.**

The attached Figures A-1 and A-2 summarize, in chart form, data contained in the 1987 Turner Collie & Braden/Texas Water Development Board (TCB/TWDB) study entitled "A Reconnaissance Level Study of Water Supply and Wastewater Disposal Needs of the Colonias of the Lower Rio Grande Valley". Appendix A-4 of the TCB/TWDB study identified estimated capital and operating and maintenance costs for providing wastewater treatment to 39 individual colonias in Cameron County. The 39 colonias fell into Classifications 1, 2, and 3, as defined in the TCB/TWDB study. The wastewater treatment methods evaluated included a generic oxidation pond system and a generic activated sludge treatment system. Figure A-1 summarizes estimated total capital costs based on projected average daily wastewater flows for each of the 39 colonias. Figure A-2 summarizes estimated annual operating and maintenance costs for the treatment systems evaluated. Data contained in the TCB/TWDB study was utilized to form the basis of our recommendations. The TCB/TWDB data presented the most comprehensive database from which to develop our recommendations. In all flow categories, oxidation pond systems were found to be the most cost-effective method of providing the levels of treatment anticipated for the projected wastewater flows for the colonias which these systems were recommended.

Subsequent to submittal of the Draft Cameron County study, we have been involved in attempting to summarize unit cost estimates for various other treatment technologies, including constructed wetlands. At the time the Draft Cameron County study was submitted, the Texas Water Commission had not adopted final rules concerning design of constructed wetlands. Data on construction costs and operations and maintenance costs for constructed wetlands in Texas is limited due to the minimal number of systems in operation. In an effort to develop a basic understanding of the costs associated with constructed wetlands, we contacted Mr. Andrew Cueto, P.E. (a) of the Texas Water Commission. Mr. Cueto was very helpful in providing us with cost information which he had collected during his work on developing design criteria for constructed wetlands. A summary of the information which was made available to us is presented in the attached Tables A-1 through A-6.

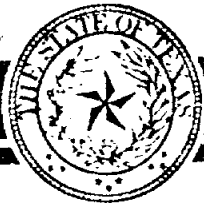

# TEXAS WATER DEVELOPMENT BOARD

Charles W. Jenness, *Chairman*  
Thomas M. Dunning, *Member*  
Néé Fernandez, *Member*

Craig Pedersen,  
*Executive Administrator*

Wesley E. Pittman, *Executive Director*  
William B. Madden, *Member*

July 31, 1991

The Honorable Antonio Garza, Jr.  
Cameron County Judge  
904 E. Harrison  
Brownsville, Texas 78540

Dear Judge Garza:

Re: TWDB Contract No. 9 483-733: Cameron County Regional Water and Wastewater Planning Study

The Texas Water Development Board has received Michael P. Sullivan's letter of July 26, 1991, responding to comments on subject study contained in our letter of November 7, 1990. We have reviewed Mr. Sullivan's responses, and find that all review comments have been adequately addressed except for comments 5, 8, and 11. These numbers refer to Water Development Board comments, which are consistently numbered in both our original letter and Mr. Sullivan's July 26, 1991 letter.

We would appreciate your reconsidering the responses to these three items, and making some adjustments which should allow the local perspective to be maintained, while adequately addressing contract requirements. Bold type shows our original comment, with additional comments/responses in regular type below.

- Page 5-1 contains the statement that **"The consensus among Cameron county governmental and regulatory officials is that all septic systems will eventually fail and that, from a public health viewpoint, they should be avoided."** The Board's staff believes that the statement lacks accuracy and that the logic that septic systems should be avoided because they eventually fail is defective. According to Texas Department of Health estimates, as many as 4,000,000 Texans rely on on-site systems for sewage treatment and disposal, and most of these individuals are being adequately serviced by on-site systems. Septic systems and other on-site systems which meet the present day standards are viable alternatives and, in many cases, offer the most cost-effective means of handling the wastewater. Accordingly, the Board's staff recommends that the applicability of the sentence be reconsidered and modified appropriately.



July 31, 1991

Page Two

There certainly was no intention on the part of the Board's staff to minimize or trivialize the viewpoint of local officials who are very close to the situation. We concur that most conventional on-site septic systems are not appropriate for the Cameron County area. However, as numerous studies have shown, mound systems, pressure-dosed systems, and other nonconventional on-site systems operate very effectively with a high ground water table, such as exists in Cameron County. We note that in Mr. Sullivan's analysis of alternative systems, a pressure-dosed mound system was included as an alternative. Accordingly, while certainly acknowledging the preference of local officials for centralized wastewater treatment, and concurring that conventional on-site systems are not generally applicable in Cameron County, we believe this section should at least note that certain on-site systems have been shown to operate effectively under conditions such as exist in Cameron County.

8. The draft report does not appear to provide an actual cost effectiveness analysis of alternatives. Instead, tables 5-10, 5-12, 5-15, and 5-18 only present initial capital costs of two alternatives for each colonia. An acceptable cost comparison would need to include operation and maintenance costs, salvage values, and other costs factors presented in terms of present worth values (or equivalent annual costs) and to detail any overriding social and environmental costs. It also appears that the costs for conventional sewers in the tables do not include the costs of house laterals. The cost for on-site systems needs to be revised because it appears to assume that every single system would have to be replaced. This assumption is probably not valid considering that only about 15 percent of the systems are having problems according to the estimate given on page 5-1 of the report. Without a complete cost-effectiveness analysis of alternatives, the recommendations in table 10-1 can only be considered unsubstantiated.

A cost effective analysis, which is required by our contract with Cameron County, requires the comparison of both construction, operating, and maintenance costs to determine a recommended system, rather than assuming a recommended system, and then calculating the cost. While we certainly do not expect individual alternatives to be prepared for each possibility within Cameron County, it seems appropriate to compare at least two different treatment technologies, for example, facultative lagoons and an alternative treatment system such as artificial wetlands, or rock reed filters. Please review this particular section, and see if it can be revised so as to actually show comparative costs between at least two different treatment systems. Use of a standard per lot cost for the on-site alternative seems reasonable.

11. Several water supply alternatives are proposed, but a recommendation is not given, and the names of users who might need additional supplies were not provided.

Although we concur that a detailed analysis of the adequacy of water supplies in Cameron County is beyond the scope of the study, a planning recommendation that a particular unincorporated area receive water from a water supplier which may not have capacity to supply this water seems inconsistent, even in a study of limited specificity, such as this one. We suggest that you simply check with the proposed suppliers, and include a statement as to the ability of that supplier to meet the demands of the recommended option.

July 31, 1991

Page Three

We appreciate the response to our comments, and those of the Texas Water Commission. While we certainly do not wish to burden you with details that are unnecessary and redundant, we believe that these three remaining items should be addressed prior to acceptance of the planning report for Cameron County if it is to be consistent with the body of engineering knowledge that is available today, our contract with Cameron County, and if it is to be useful to the County for future planning purposes.

If you have questions, or wish to discuss it further, please let us know.

Sincerely,

A handwritten signature in black ink, appearing to read "Tommy Knowles". The signature is written in a cursive, flowing style.

Tommy Knowles  
Director of Planning

cc: Mr. Michael P. Sullivan, P.E.



July 31, 1991

Brittin GBB 7-31-91  
Bond (7)  
Knowles JKB/VA

The Honorable Antonio Garza, Jr.  
Cameron County Judge  
904 E. Harrison  
Brownsville, Texas 78540

Dear Judge Garza:

Re: TWDB Contract No. 9-483-733: Cameron County Regional Water and Wastewater  
Planning Study

The Texas Water Development Board has received Michael P. Sullivan's letter of July 26, 1991, responding to comments on subject study contained in our letter of November 7, 1990. We have reviewed Mr. Sullivan's responses, and find that all review comments have been adequately addressed except for comments 5., 8., and 11. These numbers refer to Water Development Board comments, which are consistently numbered in both our original letter and Mr. Sullivan's July 26, 1991 letter.

We would appreciate your reconsidering the responses to these three items, and making some adjustments which should allow the local perspective to be maintained, while adequately addressing contract requirements. Bold type shows our original comment, with additional comments/responses in regular type below.

5. Page 5-1 contains the statement that "The consensus among Cameron county governmental and regulatory officials is that all septic systems will eventually fail and that, from a public health viewpoint, they should be avoided." The Board's staff believes that the statement lacks accuracy and that the logic that septic systems should be avoided because they eventually fail is defective. According to Texas Department of Health estimates, as many as 4,000,000 Texans rely on on-site systems for sewage treatment and disposal, and most of these individuals are being adequately serviced by on-site systems. Septic systems and other on-site systems which meet the present day standards are viable alternatives and, in many cases, offer the most cost-effective means of handling the wastewater. Accordingly, the Board's staff recommends that the applicability of the sentence be reconsidered and modified appropriately.

There certainly was no intention on the part of the Board's staff to minimize or trivialize the viewpoint of local officials who are very close to the situation. We concur that most conventional on-site septic systems are not appropriate for the Cameron County area. However, as numerous studies have shown, mound systems, pressure-dosed systems, and other nonconventional on-site systems operate very effectively with a high ground water table, such as exists in Cameron County. We note that in Mr. Sullivan's analysis of alternative systems, a pressure-dosed mound system was included as an alternative. Accordingly, while certainly acknowledging the preference of local officials for centralized wastewater treatment, and concurring that conventional on-site systems are not generally applicable in Cameron County, we believe this section should at least note that certain on-site systems have been shown to operate effectively under conditions such as exist in Cameron County.

8. **The draft report does not appear to provide an actual cost effectiveness analysis of alternatives. Instead, tables 5-10, 5-12, 5-15, and 5-18 only present initial capital costs of two alternatives for each colonia. An acceptable cost comparison would need to include operation and maintenance costs, salvage values, and other costs factors presented in terms of present worth values (or equivalent annual costs) and to detail any overriding social and environmental costs. It also appears that the costs for conventional sewers in the tables do not include the costs of house laterals. The cost for on-site systems needs to be revised because it appears to assume that every single system would have to be replaced. This assumption is probably not valid considering that only about 15 percent of the systems are having problems according to the estimate given on page 5-1 of the report. Without a complete cost-effectiveness analysis of alternatives, the recommendations in table 10-1 can only be considered unsubstantiated.**

A cost effective analysis, which is required by our contract with Cameron County, requires the comparison of both construction, operating, and maintenance costs to determine a recommended system, rather than assuming a recommended system, and then calculating the cost. While we certainly do not expect individual alternatives to be prepared for each possibility within Cameron County, it seems appropriate to compare at least two different treatment technologies, for example, facultative lagoons and an alternative treatment system such as artificial wetlands, or rock reed filters. Please review this particular section, and see if it can be revised so as to actually show comparative costs between at least two different treatment systems. Use of a standard per lot cost for the on-site alternative seems reasonable.

11. **Several water supply alternatives are proposed, but a recommendation is not given, and the names of users who might need additional supplies were not provided.**

Although we concur that a detailed analysis of the adequacy of water supplies in Cameron County is beyond the scope of the study, a planning recommendation that a particular unincorporated area receive water from a water supplier which may not have capacity to supply this water seems inconsistent, even in a study of limited specificity, such as this one. We suggest that you simply check with the proposed suppliers, and include a statement as to the ability of that supplier to meet the demands of the recommended option.

July 31, 1991  
Page Three

We appreciate the response to our comments, and those of the Texas Water Commission. While we certainly do not wish to burden you with details that are unnecessary and redundant, we believe that these three remaining items should be addressed prior to acceptance of the planning report for Cameron County if it is to be consistent with the body of engineering knowledge that is available today, our contract with Cameron County, and if it is to be useful to the County for future planning purposes.

If you have questions, or wish to discuss it further, please let us know.

Sincerely,

Tommy Knowles  
Director of Planning

cc: Mr. Michael P. Sullivan, P.E.



July, 26, 1991

Dr. Tommy Knowles, Director of Planning  
Texas Water Development Board  
P.O. Box 13231 Capitol Station  
Austin, Texas 78711-3231

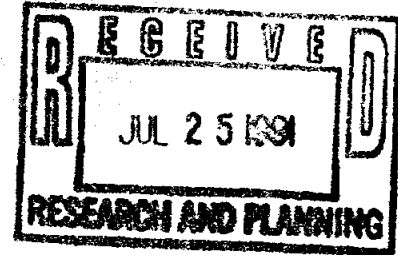

Re: Response to Letter of November 7, 1990  
Review Comments to TWDB Contract No. 9-483-733  
Cameron County Regional Water and Wastewater Planning Study

Dear Mr. Knowles:

This letter shall serve as a formal response to the comments contained in your November 7, 1990 letter regarding the Review of Draft Final Report for TWDB Contract No. 9-483-733, Cameron County Regional Water and Wastewater Planning Study (the Study). In order to insure a continuity between the original staff comments and our responses, the comments are presented in *bold italics* with the response following. The comments are presented in the order in which they occur in your letter.

#### Texas Water Development Board Comments

1. *The final report needs to be amended to fully satisfy the scope of work detailed in TWDB Contract No. 9-483-733.*

With the incorporation of these responses to comments we hope that the scope of work will be satisfactorily addressed. Where we concurred with staff comments, changes have been incorporated into the report text. Where we do not concur, explanation is supplied in this letter.

2. *Population and water demand projections utilized in the report are adequate for planning purposes.*

No response required.

3. *The wastewater flow projections of chapter 3 are based on 100 gallons per capita per day. This rate is significantly higher than what is expected for a bedroom type community such as a colonia. EPA studies into domestic water uses indicate that middle income residents typically generate 60 to 80 gpcd of sewage. This historical range does not account for reductions available through a good water conservation program. Data available to the TWDB's Water Uses and Projections section indicate that total water consumption in the rural areas of Cameron County are in the range on 90 gallons per capita per day. The sewage would be expected to be 90% or less of that. Since alternative identification is so dependant on flow rates, the report should reconsider the appropriateness of the 100 gpcd in light of existing rates and water conservation options. A 10% to 20% change in the flows may change the alternatives, and economic rankings.*

The use of 100 gpcd for wastewater design flows is consistent with accepted engineering practice and State design criteria for wastewater collection and treatment systems. The recently constructed 390,000 gpd wastewater treatment facility in Santa Rosa (funded through the Texas Department of Commerce) was designed based on a design flow of 100 gpcd. Information which we have obtained through the review of sanitary surveys of water purveyors in the Lower Rio Grande area (performed by the

Texas Department of Health) indicate a wide range of water use patterns. Current sanitary survey results are summarized below:

**Summary of Sanitary Surveys for Typical Rural Areas of  
the Lower Rio Grande Valley**

System Name	Population Served	Average Daily Usage (gpd)	Average Daily Per Capita Usage (gpcd)
City of Lyford	1,900	225,000	118
Port Mansfield PUD	734	75,000	102
Sunny Dew WSC	306	36,000	118
City of Raymondville	9,348	1,545,000	165
Santa Rosa WCID	238,000	1,889	126
Sebastian WSC	1,565	116,000	74

Using these figures, the average daily per capita water usage is estimated to be approximately 117 gallons. Table 3-1 of the Study lists TWDB population projections (low series and high series) for municipalities in Cameron County through 2020. Table 3-8 lists projected municipal water demands for the high per capita TWDB water use series with and without water conservation. Development of projected populations and water use for the Study was based on TWDB high series population projections and TWDB high water use series with water conservation. Combining the population and projected water use figures found in Tables 3-2 and 3-9, average daily water use projections for 'unincorporated' areas are estimated to be 143 gpcd for planning year 1990 and 125 gpcd for planning year 2020. Thus, for the purposes of the Study, we feel that the use of 100 gpcd is appropriate.

- 4. Page 5-10 of the report states that 'per capita (water) use rates are expected to increase dramatically and eventually approach statewide averages,' and according to John Bruclak of Brownsville's' PUB, 'water use rates have shown a marked increase in areas where city services have been improved.' First, the Board staff expects water use to approach the county or regional average rather than the statewide average, and further, the report should also recognize that the 10-year regional trend for South Texas is a decreasing consumption rate. Secondly, because the Board lacks data on the long-term water use changes in colonias after adequate water and wastewater services are provided, the contractor should quantify in the report the increases that John Bruclak reports as having occurred after the PUB has provided city services to a colonia.***

Prior to commencement of the study, discussions were held with Mr. James T. Fries (then Contract Administrator for TWDB). The wide disparity of water use rates in the Lower Rio Grande Valley were discussed and all agreed that a water use rate of 125 gpcd and a wastewater generation rate of 100 gpcd were appropriate for the county-wide planning level study.

The anecdotal reference to water use rates attributed to Mr. Bruclak is an opinion based on his personal and professional experience in the area and will remain as it was originally stated without further clarification. The water use projections used throughout the Study are based on TWDB high population series/high water use series estimates with water conservation.

- 5. Page 5-1 contains the statement that 'The consensus among Cameron County governmental and regulatory officials is that all septic systems will eventually fail and that, from a public health viewpoint, they should be avoided.' The Board's***

*staff believes that the statement lacks accuracy and that the logic that septic systems should be avoided because they eventually fail is defective. According to Texas Department of Health estimates, as many as 4,000,000 Texans rely on on-site systems for sewage treatment and disposal, and most of these individuals are being adequately serviced by on-site systems. Septic systems and other on-site systems which meet the present day standards are viable alternatives and, in many cases, offer the most cost-effective means of handling the wastewater. Accordingly, the Board's staff recommends that the applicability of the sentence be reconsidered and modified appropriately.*

Although the comment summarizes the feelings of numerous individuals in County and local government, the comment may be more directly attributed to Mr. Ray Rodriguez, R.S, Chief Sanitarian for the Cameron County Environmental Health Department. The comment is based on Mr. Rodriguez' extensive personal and professional experience in the County and should not be minimized or trivialized by Board's staff. County health officials rarely have problems with systems which are properly designed and constructed. The problem is that most of the on-site systems in Cameron County are improperly constructed and if not failing now, are destined to fail prematurely, when compared to properly constructed and maintained systems. The reasons for this include: less than adequate lot size; improper use and maintenance of the systems; dwelling densities typically far in excess of 2 units per acre; and inadequate drainage. Environmental Assessments and Wastewater Assessments, performed by the Texas Department of Health in Cameron County and Willacy County, support the observation that on-site wastewater disposal systems are inappropriate under conditions common to colonias in the Lower Rio Grande Valley.

6. *Table 5-4 incorrectly lists the City of Harlingen's wastewater treatment capacity at 3.6 mgd because the capacity of plant number 1 was excluded. The table identifies five (5) mgd capacity for the Brownsville PUB as existing even though construction has not yet started. Therefore, the table should be corrected.*

We concur with the comment. A corrected version of the table has been included in the final report.

7. *The study does not appear to consider innovative and non-conventional alternatives for the colonias, which is a prerequisite for the Board to fund the construction of wastewater treatment facilities. If the regional report is to be used in conjunction with requests for financial assistance for colonia facilities, innovative and non-conventional alternatives need to be presented and assessed in the report.*

The Study is not intended as an Economically Distressed Areas Program Phase I Facility Engineering Plan. The Study is intended to serve as a long-term regional planning tool. Funds for construction of wastewater treatment facilities are not being sought as part of the Study. Specific studies meeting the requirements of the various State and Federal grant/loan assistance programs will be developed if and when funds are requested under those programs.

8. *The draft report does not appear to provide an actual cost effectiveness analysis of alternatives. Instead, tables 5-10, 5-12, 5-15, and 5-18 only present initial capital costs of two alternatives for each colonia. An acceptable cost comparison would need to include operation and maintenance costs, salvage values, and other costs factors presented in terms of present worth values (or equivalent annual costs) and to detail any overriding social and environmental costs. It also appears that the costs for conventional sewers in the tables do not include the costs of house laterals. The cost for on-site systems needs to be revised because it appears to assume that every single system would have to be replaced. This assumption is probably not valid considering that only about 15 percent of the systems are having problems according to the estimate given on page 5-1 of the report. Without a complete cost-effectiveness analysis of*

*alternatives, the recommendations in table 10-1 can only be considered unsubstantiated.*

Based on consultations with local engineers, past engineering experience within the Water Resources Planning Group, and review of existing planning reports for the Lower Rio Grande Valley, it was determined that proposed wastewater treatment plant facilities would consist solely of facultative lagoons (where new facilities were required and projected wastewater flows were less than 300,000 gallons per day). Many systems of this variety exist in the vicinity. Under normal conditions, these plants are the least expensive to design, construct, operate, and maintain. Evaluation of more energy consumptive, high operations and maintenance cost systems, was considered unnecessary and redundant based on available information for the area.

The costs for house laterals have previously been included in the cost estimates for sanitary sewers under the item for 6-inch house connection.

It is difficult to provide an exact percentage for the number of on-site systems that are having problems in the colonias of Cameron County. Based on site visits to the colonias performed as part of this project, it was determined that a 'worst case' scenario would be appropriate for estimating projected costs for providing on-site systems. Conditions within the majority of colonias are unsuitable for proper construction, operation, and maintenance of on-site systems. Typical lot sizes for colonias which are located in platted subdivisions are typically less than 1/5-acre. The on-site disposal systems are typically overloaded. Grey water is discharged to the ground surface in order to reduce overall wastewater flows to the subsurface disposal system. Colonias which do not lie within a platted subdivision typically display similar housing densities. In order to insure that an artificially low value for providing adequate on-site systems was not presented in the Study, an average cost for providing a generic on-site system was applied to all dwellings. In approaching the issue in this manner, the costs associated with various on-site treatment technologies have been normalized, since it would be impossible at the level of this study to determine how many and which lots would be possible candidates of evapotranspiration systems, mound systems, absorption systems, pressure-dose systems, etc.

9. *Although the water conservation recommendations made in Section 10 of the report are satisfactory, the specific comments for the water conservation portions of the study for individual tasks are as follows:*

*Task I.C.*

1. *On page 3-16, the discussion at the top of the page implies that per capita water use figures for larger cities include industrial use, but TWDB per capita water use figures do not include industrial use. The inclusion of industrial use figures should be clarified, and if industrial use figures were included, they should be presented separately.*

The statement presented in the Study is accurate since large cities typically calculate per capita water usage based on total plant output, which includes sale to industrial customers. Texas Water Development Board per capita water use estimates do not include an industrial component. No connection was made in the referenced section of the report to the inclusion of industrial flows in TWDB water use projections.

2. *Many of the tables in this section do not include units of water. For example, Table 3-7 on page 3-18 reports per capita water use but does not give the units. The correct units should be added to the tables.*

We concur with this comment and have provided revised tables which include all appropriate units.

3. *The statement that 'The TWDB estimates that about one-half of the water used for landscape irrigations during hot weather periods is wasted' in the third paragraph on page 4-11 should be modified to read that 'as much as on-half' rather than 'about one-half'.*

Page 4-11 has been revised to reflect this comment.

Task II, B.&E.

1. *The method used to incorporate water conservation into the wastewater projections is unclear. On page 3-22, Section 3.3 implies that a S/W ratio method was used, but when the S/W ratio was calculated based on water use from Table 3-11 and wastewater from Table 3-15, the resulting S/W ratio was 79. This is higher than the range quoted in Section 3.3. The figures should be checked, and the correct figure should be listed, and if necessary, the basis for the calculations should be explained.*

The range given for typical S/W ratios on page 3-22 of the report is one generally accepted by the engineering community and was intended to serve merely as a background for further discussions. Water use projections for unincorporated areas developed in the Study range from 143 gpcd in 1990 to 125 gpcd in 2020 and include water conservation practices. Wastewater generation projections are based on State design criteria (100 gpcd). The S/W ratio based on these values ranges from 0.70 to 0.80. The corresponding numbers in the final report have been corrected.

2. *As previously stated under Task I.C., several of the tables do not state units of water use.*

The referenced tables have been revised to indicate appropriate units.

Task IV

1. *The water conservation plan is excellent. The drought contingency portion of the plan is satisfactory, but individual utility plans would need to be activated if the drought contingency portions were to be implemented. The Board's staff understands that implementation is beyond the scope of the study.*

No response required.

2. *On page 6-6, the Water Rate Structure Section states that the PUB uses a "flat rate." According to American Water Works Association definitions, this rate should be called a "uniform rate."*

Your comment is noted and the term has been revised.

3. *The annual reporting requirement described on page 6-8 is not a requirement of the Regional Planning grant program, but such a report would be very useful to the TWDB staff and would be much appreciated.*

The referenced section does not state that the report is required. Submittal of the report is intended to be voluntary and for informational purposes only.



10. *The water supply portion of the study should be strengthened by an evaluation of the supply adequacy of the various water suppliers in the county.*

Numerous municipalities and water supply corporations supply water in the Lower Rio Grande Valley through an intricate and convoluted system of supply agreements, contracts, and other instruments. Tracking the adequacy of existing supplies, future options, and agreements is virtually impossible and beyond the scope of this study. The overall supplies in the Lower Rio Grande Valley are agreed to be generally inadequate to meet future demands; however, identification of specific sources with specific suppliers is beyond the scope of this study.

11. *Several water supply alternatives are proposed, but a recommendation is not given, and the names of users who might need additional supplies were not provided.*

The scope of the Study focused on the needs of the unincorporated areas of Cameron County. No effort was made to assess the future supply adequacy of incorporated municipalities and water supply corporations.

12. *A detailed analysis was done for the colonias in terms of who would supply which colonia. However, no analysis was presented as to whether the proposed suppliers have adequate water supplies to meet the additional needs or what additional supplies would need to be developed.*

Again, this is beyond the scope of the Study.

#### Texas Water Commission Comments

1. *Regarding population projections, the draft plan utilizes the TWDB High Series population projections to develop water and wastewater needs. The Lower Rio Grande Valley Development Council (LRGVDC) has developed population projections for the Texas Water Commission (report dated August 1989) which have recently been certified as updates to the State Water Quality Management Plan. The TWDB's and LRGVDC's population figures differ quite substantially for the Brownsville area in the year 2010. The Board's population is 197,616 in the year 2010, and the LRGVDC's projections for the year 2010 are 178,504 (median) or 179,787 (mean). This difference in population projections should be resolved, particularly if Brownsville applies for funding that requires consistency with the Water Quality Management Plan. The Board's and LRGVDC's total population figures for the rural (or unincorporated areas) are very similar.*

Use of TWDB population and water use projections is consistent with the scope of work and contract requirements of this project.

2. *LRGVDC's population figures in Table 3-1 on page 3-6 should be updated to reflect the LRGVDC's most recent August 1989 population report.*

This section of the Study has been revised to reflect staff's comment.

3. *Page 5-36, Second Paragraph*

*The seven-day two-year low flow (7Q2) for Segment 2202 is 6.0 ft/s.*

This section of the Study has been revised to reflect staff's comment.

4. **Page 5-36, Table 5-6**

*Dissolved oxygen criteria should read not less than 4.0 mg/l 24-hour average, 3.0 mg/l minimum.*

This section of the Study has been revised to reflect staff's comment.

5. **Page 5-37, Table 5-7**

*Dissolved oxygen criteria should read not less than 5.0 mg/l 24-hour average, 4.0 mg/l minimum.*

This section of the Study has been revised to reflect staff's comment.

6. **Page 5-37, Second Paragraph**

*The last statement is very poorly worded. It gives the impression that the normal standards do not apply when the flow equals or is greater than the 7Q2 flow. It should more clearly state that exceptions to numerical criteria apply when the flow is less than 7Q2.*

This section of the Study has been revised to reflect staff's comment.

7. **Page 5-38, Second Paragraph**

*There is no formal ranking of segments at this time by TWC in the 305(b) report. All references to segment ranking should be deleted on page 5-38. In addition, the report should clarify that advance treatment is not required for discharges to Segment 2201.*

This section of the Study has been revised to reflect staff's comment.

8. **Page 5-38, Third Paragraph**

*The statement... "no standard effluent limits apply to the entire segment and that new and renewal permit applications are reviewed on an individual and cumulative impact basis" applies to effluent-limited segments as well. Specific dissolved oxygen criteria have not been assigned to each individual tributary within segments based on observed uses. The criterion for these streams will be evaluated as a result of a Texas Water Commission Receiving Water Assessment, which is conducted in response to individual permit actions in unclassified waters. The report should state that, at such time, advanced treatment may be required of dischargers.*

This section of the Study has been revised to reflect staff's comment.

9. **Page 5-40, First Paragraph**

*The 5.0 mg/l criterion is 24-hour average.*

This section of the Study has been revised to reflect staff's comment.

10. **Page 5-41, Second Paragraph**

*The average DO criterion of the channel is 5.0 mg/l.*

This section of the Study has been revised to reflect staff's comment.

**11. Page 5-41, Second Paragraph**

*Tributary impacts were not addressed. Refer to Comment 8 above from page 5-38 on tributary impacts. Higher treatment requirements are probable for the PUB plant.*

This section of the Study has been revised to reflect staff's comment.

**12. Page 5-41, Third Paragraph**

*The 10/15 permit should read 10/15/3 or 10/3, because the Harlingen plant permit has a nitrification requirement. The report should also state that the 4.0 mg/l DO criteria is a 24-hour average.*

This section of the Study has been revised to reflect staff's comment.

**13. Page 5-45**

*The 20/90 effluent quality should read 30/90.*

This section of the Study has been revised to reflect staff's comment.

**14. Page 7-10, Last Paragraph**

*Segment 2022 should be listed as Water Quality Limited.*

This section of the Study has been revised to reflect staff's comment.

**15. Page 7-11, Table 7-2**

*The table should state that uses for Segment 2202 include Intermediate Aquatic Habitat, and the DO criterion should include the a/ superscript. Further, the table shows that the uses for Segment 2302 include Public Water Supply.*

This section of the Study has been revised to reflect staff's comment.

**16. Page 7-12, First Paragraph**

*The reference to minimum dissolved oxygen criteria should be changed to average D.O. criteria.*

This section of the Study has been revised to reflect staff's comment.

The Water Resources Planning Group wishes to thank the Board and Commission staff members for their thoughtful comments and observations regarding the draft study. Please contact our office if you or your staff have questions regarding our responses to their comments.

Sincerely,

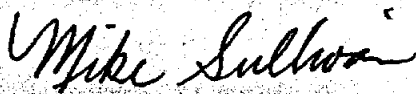

Michael P. Sullivan, Ph.D., P.E.  
President  
Michael Sullivan and Associates, Inc.

Cameron County Regional  
Water And Wastewater  
Planning Study  
Contract No. 9-483-733

The following maps are not attached to this report. They are located in the official file and may be copied upon request.

Map No. 1 – Facilities Map of Sub-Area E  
Figure 5-84

Map No. 2 Facilities Map of Sub-Area H  
Figure 5-50

Please contact Research and Planning  
Fund Grants Management Division at (512)  
463-7926 for copies.