

**CREATION OF THE GREENS BAYOU REGIONAL DETENTION
AND WETLANDS MITIGATION BANK FACILITY**

**FISCAL YEAR 1994 INTERIM REPORT
FOR THE WATER RESEARCH STUDY
(CONTRACT NO. 94-483-054)**

**Prepared For:
THE TEXAS WATER DEVELOPMENT BOARD**

**Prepared By:
THE HARRIS COUNTY FLOOD CONTROL DISTRICT**

MARCH 1995

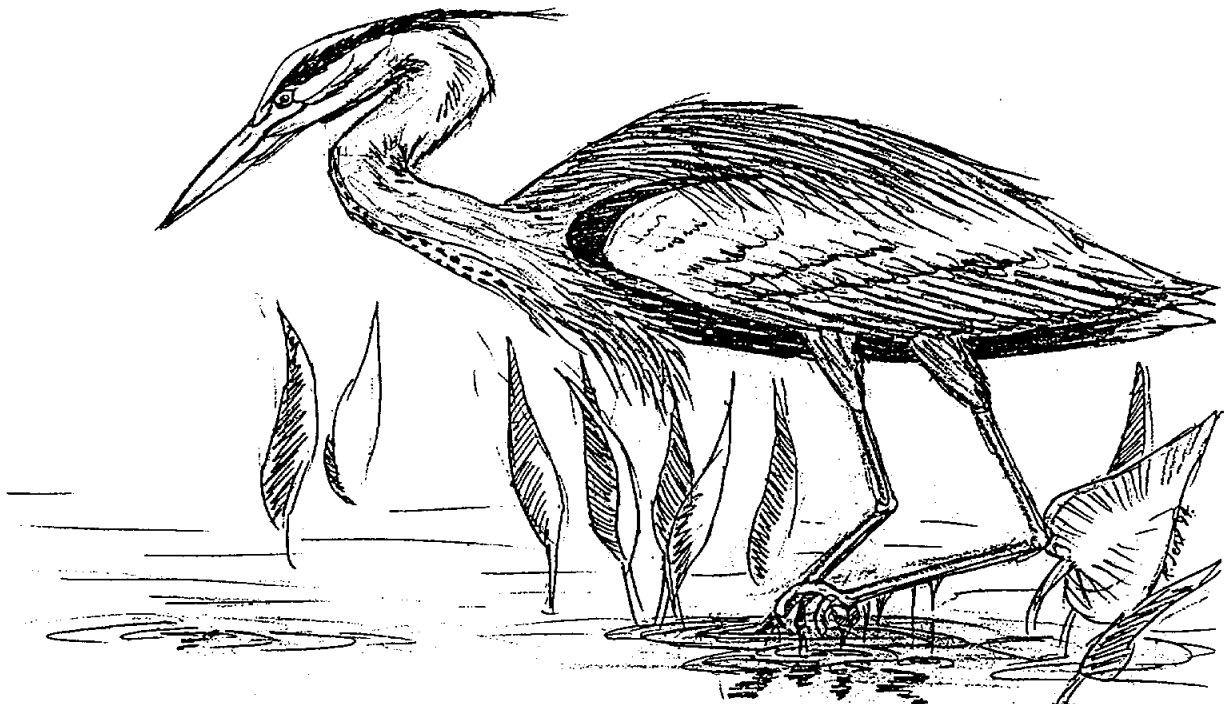



HARRIS COUNTY FLOOD CONTROL DISTRICT

Arthur L. Storey, Jr., P. E.
Executive Director

March 29, 1995

Mr. Craig D. Pedersen
Executive Administrator
Texas Water Development Board
P. O. Box 13231
1700 N. Congress Ave.
Austin, Texas 78711-3231

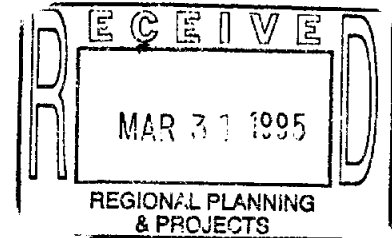

RE: Greens Bayou Regional Detention and Wetlands Mitigation
Bank Water Research Study (Contract No. 94-483-054)
Harris County Flood Control Unit P500-03-00

Dear Mr. Pedersen:

The Flood Control District is pleased to submit the proposed Greens Bayou Regional Detention and Wetlands Mitigation Bank facility interim report prepared under a water research study for the Texas Water Development Board. Significant progress has been achieved in resolving several key issues necessary to create a wetlands mitigation bank. These issues are discussed in further detail in the attached report, and we hope you will find them as interesting as we have.

Should this interim report prove to be satisfactory to the Texas Water Development Board, the Flood Control District would like to respectfully request the additional \$100,000.00 in grant assistance be approved. If this is acceptable, please let us know what our next steps should be to proceed.

The District would like to take this opportunity to thank the Texas Water Development Board for their support in helping to bring to fruition this innovative and multi-beneficial project. Should you need any additional information, I can be reached at (713) 684-4067.

Sincerely,

A handwritten signature in cursive script that reads "Colleen R. O'Brien".

Colleen R. O'Brien, P.E.
Project Manager
Watershed Management Dept.

CRO:ep
Attachment: Report

cc: Arthur L. Storey, Jr.
E. C. Kobs

95CRO046.DOC

TABLE OF CONTENTS

- I. INTRODUCTION
- II. PROJECT DESCRIPTION
- III. HISTORY
- IV. SCOPE OF SERVICES
- V. DISCUSSION
 - A. Hydraulics and Hydrology
 - B. Data Gathering and Assessments
 - 1. Existing Wetlands Delineation
 - 2. Avian/Wildlife Survey
 - 3. Soil Survey
 - 4. Vegetation Survey
 - 5. Topographic Survey
 - 6. Water Budget
 - C. Conceptual Design
 - 1. Conceptual Plan
 - 2. Baseline Evaluation
 - 3. Quantification Methodology
 - 4. Memorandum of Agreement
 - D. Preliminary Engineering
- VI. SUMMARY

APPENDICES

APPENDIX A - THE SCOPE OF SERVICES TASK STATUS

APPENDIX B - REVISED SCHEDULE

APPENDIX C - CORRESPONDENCE AND AGREEMENTS BETWEEN HCFCD AND TWDB

TABLE OF EXHIBITS

- A. Location Map of the Project
- B. Major Sub-Watersheds in the Greens Bayou Watershed
- C. Layout Map, Proposed Lower Greens Bayou Detention System
- D. Site Layout, Basin P500-03-00
- E. Typical Cross Section, Basin P500-03-00
- F. Proposed Diversion Structure, Basin P500-03-00
Elevation and Plan Views
- G. Proposed Diversion Structure, Basin P500-03-00
Cross Sections
- H. Proposed Diversion Structure, Basin P500-03-00
Block Dimensions and Spacing
- I. Proposed Connector Structure, Basin P500-03-00
- J. Proposed Discharge Structure, Basin P500-03-00
- K. HEC-1 Subarea Map, Greens Bayou Watershed
- L. Subarea Map, Lower Greens Bayou Project Area,
Current Conditions
- M. Subarea Map, Lower Greens Bayou Project Area,
Proposed Conditions
- N. HEC-1 Routing Reaches, Greens Bayou Watershed,
Ditch P138-00-00 to Ship Channel
- O. Greens Bayou Mitigation Bank, Wetland Delineation Map
- P. Greens Bayou Mitigation Bank, Soil Index Map
- Q. Greens Bayou Mitigation Bank, Vegetation Index Map
- R. Greens Bayou Mitigation Bank, Topography Map
- S. Greens Bayou Mitigation Bank, Subdivision Acreage
- T. Garners Bayou Mitigation Bank, Detention Site Map
- U. Subdivision A Conceptual Plan

I. INTRODUCTION

On March 17, 1994, the Texas Water Development Board approved an unsolicited water research grant for \$100,000.00 to the Harris County Flood Control District. This grant is to assist in funding the preliminary investigations necessary to create the Greens Bayou Regional Detention and Wetlands Mitigation Bank. The Flood Control District has prepared this interim report to present the findings of the investigations to date.

For simplification, this report has been written to emphasize those services for which the Texas Water Development Board will be providing funds. A summary of the status of each task has been included in the appendix for the Texas Water Development Board's use. The District has also included in this report discussion on additional topics when it seemed appropriate to provide a clearer picture of the proposed project.

This project offers the opportunity to achieve multiple benefits of social and environmental significance. To date, feedback from the community and public agencies has been positive and supportive with a strong desire to see this innovative and environmentally enhanced project succeed. Not only is this site intended to provide a large area of high quality wetlands to be preserved in perpetuity, but water quality and flood protection are two other key issues associated with implementation of the project.

II. PROJECT DESCRIPTION

The Greens Bayou Regional Detention and Wetland Mitigation Bank Facility consists of approximately 1450 acres of undeveloped vacant land located in northeast Harris County, immediately south of Beltway 8 and east of the confluence of Greens and Garners Bayous (see Exhibit A). The site contains a diverse mixture of pine/hardwood forests and open grassy prairies interspersed with wetlands that exist in a system of relict meander scars and large depressions.

The Harris County Flood Control District (HCFCD) is developing a 1450-acre detention basin and wetlands mitigation bank in the Greens/Garners watersheds that will be the first public mitigation bank of its magnitude in the Galveston District of the Corps of Engineers. The concept of Mitigation Banking has been endorsed by the U.S. Environmental Protection Agency and the Clinton Administration as a means of compliance with the Section 10/404 permitting requirements of the Clean Water Act for achieving a "no net loss of wetlands." The responsibility of regulating wetlands mitigation banks has been given to the Corps of Engineers. The Corps procedure requires comprehensive planning and involves a high level of oversight from multiple state and federal agencies.

EXHIBIT A

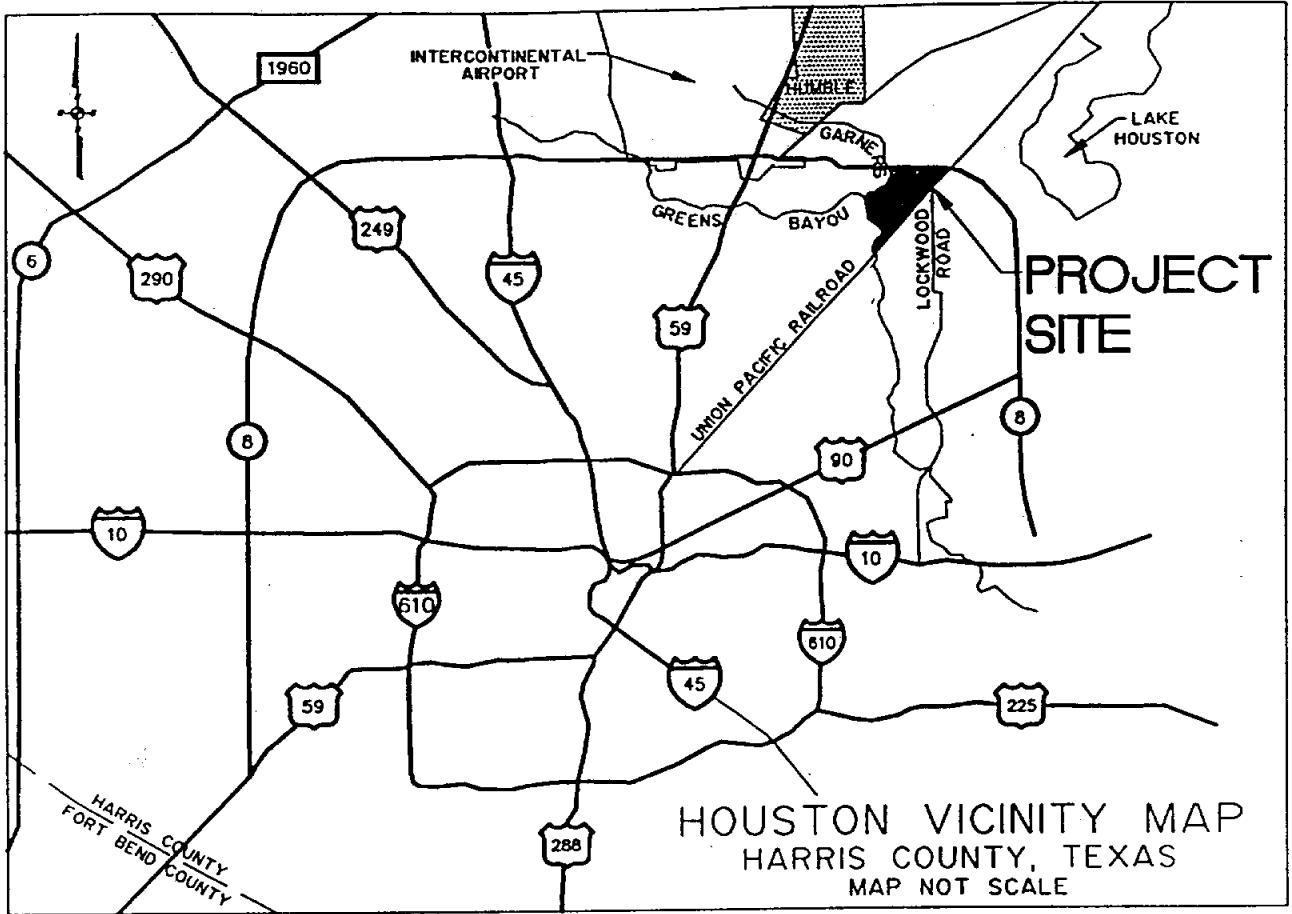

Wetlands mitigation banking is defined as advanced compensation by creation, restoration, enhancement or in some cases preservation of a wetland or other aquatic habitats and their functional values. The Corps acknowledged advantages to mitigation banking over small piecemeal mitigation sites.

The goal of this long term mitigation bank project is to create a large contiguous area of protected wetland habitats by enhancing selected existing wetlands and by creating new wetlands from upland areas. This goal will be accomplished by carefully planning wetland construction and development to make use of natural topography, soils, vegetation, and available hydrology to create a passively functioning wetland system that will be successful for many years.

These wetlands will be designed with the toxicant removal function as an additional objective. Specific wetland plant species with a documented high water purification function will be planted into the proposed wetland system. In order to maximize the aesthetic potential of this wetland creation, special attention will be made to the selection of those species that have high ornamental and flowering qualities.

To further enhance the public benefit of this project, the wetland site topography is proposed to be recontoured to create a series of swales and islands. These created islands will allow for maximum diversity in wildlife habitats and also the ability to introduce aesthetically pleasing hardwood trees whose form and food production will add another biological strata to the wetlands system.

The proximity of TxDOT's Beltway 8 to the Flood Control District's proposed wetlands site provides a unique opportunity to enhance water quality through a natural purification system which would require minimal maintenance. The project could become a model for mitigating pollution of runoff water from roadways. This District is proposing to reroute part of Beltway 8's drainage onto the property for filtration. Not only is the rerouting of a portion of Beltway 8's drainage onto the Flood Control District's property a key factor in conveying pollutants away from Greens Bayou, but also the modified hydrology will be beneficial in creating and sustaining the wetlands system which is intended to filter the polluted drainage. The quality of the water returning to the bayou drainage system will be improved and the actual quantity of runoff reaching the main stem drainage will be reduced due to infiltration and resultant groundwater recharge, as well as evapotranspiration occurring within the wetland.

Further flood protection is proposed for this project in the form of a 200-acre detention basin proposed onsite. The basin is to be designed to capture the peak flows coming off of Greens and Garners Bayou during extreme storm events to provide some relief to the flood prone area along the lower reaches of Greens Bayou.

The preservation of wetlands, flood protection, and the removal of pollutants from runoff provides obvious environmental benefits. The high quality wildlife habitat that the open area of the detention pond and large wetland areas will provide is another direct benefit that this wetland creation project will have for the environment. The high visibility of the project location will offer an excellent opportunity for interpretation of wetlands and their functions for the motoring public. Motorists traveling the Beltway 8 bridge high over the Union Pacific Railroad will experience exciting views of a wetland system full of the color of flowering wetland plants, and the extensive bird and other wildlife that will be attracted to the project.

III. HISTORY

The master drainage plan of HCFCD identified the Greens Bayou watershed as a geographical region requiring large sites to act as regional detention basins. To this end, the HCFCD acquired a 234-acre site for \$497,000 located at the confluence of Greens Bayou and Garners Bayou for the purpose of excavated detention. A Phase One Environmental Assessment identified 30% of the site as jurisdictional wetlands. Excavation would have required permitting from the Corps of Engineers under Section 404 of the Clean Water Act and mitigation of wetlands.

As the HCFCD began to examine options for minimizing and avoiding such impacts, as required by law, it became aware of a contiguous FDIC tract of 1,231 acres. This tract demonstrated physical characteristics that would allow reconfiguration of the proposed detention basin to an upland. In addition to allowing an opportunity for avoiding and minimizing impact, the site could provide opportunities for future wetlands mitigation that the HCFCD was certain to need.

Concurrent with these activities, the Corps of Engineers, responding to national concerns, published preliminary Interagency Guidelines for the Development and Use of Mitigation Banks. Defining wetlands mitigation banking as "advanced compensation by creation, restoration, enhancement or in some cases preservation of a wetland or other aquatic habitats and their functional values," the Corps acknowledged advantages to mitigation banking over small piecemeal mitigation sites. In June 1993, final guidelines were published.

Anticipating these events, Harris County Commissioners Court approved the concept of the HCFCD's participation in wetlands mitigation banking. The purpose of banking would be to provide wetlands mitigation opportunities to HCFCD and to offset the costs by selling bank credits to others, including the private sector. To date, wetlands mitigation costs to the HCFCD for other flood management projects not related to this bank have been in excess of \$2,000,000.

In April 1993, a meeting was held between the Mitigation Bank Review Team (MBRT), made up of seven state and federal agencies, and HCFCO. These seven agencies include the U.S. Army Corps of Engineers, U.S. Environmental Protection Agency, U.S. Fish and Wildlife, Texas Parks and Wildlife, Texas General Land Office, Texas Natural Resource Conservation Commission and the National Marine Fisheries Services. The seven agencies serve at the request of the Corps of Engineers. Each agency has the option of not participating, in which case the Corps has the authority to proceed. Since the Greens Bayou site is not tidally influenced, the National Marine Fisheries Services is not interested in participating in this proposed wetlands bank. The remaining six agencies are active participants.

In this April 1993 meeting, the HCFCO presented this site to the MBRT and requested preliminary approval to create a wetlands mitigation bank. Each member of the MBRT brought the proposal back to their respective agencies for review. Following that meeting, a visit was made to the site; and, subsequently, preliminary approval was given by the Corps to proceed with the bank, the largest and probably the first, ever to be approved in the Galveston District. An important milestone had been reached.

The next step was acquisition of the 1,231-acre site which was completed in September 1993, for a cost of \$2,783,000. This opened the way for further evaluation of the site in preparation for entering into a Memorandum of Agreement with the MBRT for development and operation of the bank. Comprehensive baseline studies for vegetation, wildlife, soil characteristics and hydrology are needed.

The Flood Control District applied to the Texas Water Development Board (TWDB) for a water research grant to assist with funding of several services necessary to create the Greens Bayou Regional Detention and Wetlands Mitigation Project. This grant was approved on March 17, 1994 and the Harris County Commissioners Court entered into agreement with the TWDB on August 16, 1994.

Significant progress has been made on several key issues, and much of this information has been summarized within this interim report.

IV. SCOPE OF SERVICES

The Flood Control District identified the services which were believed to be necessary to create and maintain the 1450-acre Greens Bayou Regional Detention and Wetland Mitigation Bank Facility proposed to be located at the southeast quadrant of the Garners Bayou and Greens Bayou confluence. The following is a description of those particular services that the TWDB Water Research Grant assisted in funding.

A. Hydraulics and Hydrology for the Preliminary Environmental and Engineering Design

1. Data Collection and Project Coordination:

Collect and review available data concerning the site including property boundary maps, proposed layouts and grading plans, existing HEC-1 and HEC-2 models of the Greens Bayou Watershed, previous engineering studies, aerial photographs, and topographic maps. Meet with HCFCF as necessary to discuss the results of the data collection effort and to plan the completion of the analysis.

2. Water Budget:

Meet with environmental consultant and with HCFCF representatives as needed to discuss the water supply requirements of the wetlands banking area. Supply preliminary information required to plan wetlands design and define the concept of the wetlands area.

3. HEC-1 and HEC-2 Computer Model Update:

Perform appropriate hydrologic analyses to determine the available sources of water supply for these wetlands areas and incorporate this information into the HEC-1 and HEC-2 models.

4. Alternative Detention Design:

Update the Greens Bayou HEC-1 and HEC-2 computer models to reflect current conditions and estimate peak flow rates and water surface elevations. Review various detention alternatives to determine the maximum benefit design for flood protection.

5. Letter Report:

Prepare a letter report summarizing the recommended methods of water supply for the wetlands area.

B. Data Gathering and Assessments for Preliminary Environmental Assessment and Conceptual Design

1. Soil Data and Report:

Provide comprehensive soil taxonomy, soil map and permeabilities for project area, test borings and monitoring of groundwater depths, and compile a detailed soil analysis report.

2. Biological and Habitat Assessment and Report:

Determine and recommend methodology for wetland creation and/or enhancement including minimum success criteria, provide onsite biological and habitat assessment, and prepare assessment report including maps and recommendations.

3. Water Budget and Report:

Review and analyze hydrology characteristics for water budget provided by other consultants and apply to wetland design, determine secondary water source for enhancement, and prepare a wetland hydrology and water budget report.

C. Conceptual Design Phase Services For Preliminary Environmental Assessment and Conceptual Design

1. Establish Baseline

Establish baseline functions and values for wetland mitigation bank. Compile data and evaluate wetland characteristics (soil, topography, biological and water budget) to establish baseline functions and values.

2. Methodology and Conceptual Plans:

Establish methodology for wetland creation/enhancement using minimum success criteria, categorize creation/enhancement areas for maximum banking credits, and prepare conceptual plan for wetland creation/enhancement to be reviewed and approved by the Flood Control District.

3. Site Master Plans:

Prepare a Site Master Plan which includes the conceptual plan for wetland creation/enhancement and preliminary layouts of the seven subdivisions of the proposed bank which are to be reviewed and approved by the Flood Control District.

4. Minimum Success Criteria, Memorandum of Agreement, and the Land Use Agreement:

Determine minimum success criteria for wetland creation/enhancement and prepare necessary documents to obtain a Memorandum of Agreement between the HCFCD and the Corps of Engineers. This is to include the required land use agreements.

D. Preliminary Engineering Design

1. Project Coordination

Provide project coordination and attend meetings with HCFCO, COE, MBRT, and other relevant agencies to discuss the requirements of the wetlands banking design and the associated detention facilities.

2. Alternative Water Sources:

Investigate alternative water sources to feed wetlands creation and enhancement.

3. Construction Phasing and Cost Estimates:

Establish a conceptual construction phasing sequence and prepare preliminary cost estimates for the creation of each wetlands subdivision.

V. DISCUSSION

Significant progress has been made in researching, investigating, and creating the data and techniques necessary to establish the Greens Bayou Regional Detention Basin and Wetlands Mitigation Bank (HCFCD Unit P500-03-00). A portion of this information is included herein. This report has been written to emphasize those services which the Texas Water Development Board (TWDB) helped to fund. Other key issues are also discussed to provide a clear picture of what is being proposed for the project.

This discussion section is being broken into four sections for clarity. These sections include: Hydraulics and Hydrology; Data Gathering and Assessments; Conceptual Design; and Preliminary Engineering. Although some of the information provided is in a completed format, portions of the data are still being reviewed. It was decided that this information should be included in its interim state to provide the TWDB with an idea of where this project is headed.

A. Hydraulics and Hydrology

One of the long-term goals of the proposed Greens Bayou Regional Detention and Wetlands mitigation project is to increase wetland productivity by augmenting existing hydrologic regimes. A large (approximately 200 acre) stormwater detention pond will be constructed for storage of excess flood waters. State-of-the-art stormwater management techniques will be implemented to maintain or augment existing water regimes.

Water management structures such as culverts, weirs, or open channel hydrologic conveyances would be used to increase the duration of inundation and soil saturation in marginal wetland areas. Open water connections to adjacent water bodies would improve water and material exchange throughout the contiguous wetlands. Soil excavation might also be required and desirable to restore altered surficial drainage patterns or prolong saturation periods. These types of hydrologic improvements should increase wetland plant productivity, provide increased edge habitat, and benefit wildlife.

At this conceptual stage of project development, detailed design features for site-specific conditions cannot be determined. Following preliminary approval from the appropriate regulatory agencies, the hydrologic design will be more fully developed. In addition to the completed vegetation studies, topographic and hydrologic surveys were conducted to establish existing drainage patterns and determine the needed hydrologic improvements. Following construction, continuous monitoring of established water regimes will identify and necessary hydrologic adjustments that need to be made. Agency participation will be encouraged throughout the phases of project development from predesign to post-construction monitoring. Comprehensive engineering studies, biological assessments, and agency coordination will ensure the successful development and implementation of the proposed hydrologic improvements.

Along with analyzing the hydrology necessary to sustain wetlands growth, a detailed investigation of the proposed detention facility is required to provide maximum flood protection to the Greens Bayou Watershed as an additional benefit of this project.

The Flood Control District contracted with Dodson & Associates, Inc. to maximize the effectiveness of two regional detention facilities located in lower Greens Bayou. Their objective was to provide a design for a 1500-acre levee detention facility (P500-01-00) and the 200-acre detention facility proposed at Garners Bayou (P500-03-00), to work in tandem with each other, to reduce peak flow rates in the lower flood prone regions of Greens Bayou. The following is a summary of their preliminary results:

SECTION 1: INTRODUCTION

1. INTRODUCTION

1.1 Purpose of This Report

This report describes the results of a hydrologic and hydraulic analysis of a proposed regional detention system for the lower Greens Bayou watershed. This analysis is intended to assess the effectiveness of the proposed detention system in reducing downstream peak flow rates along Greens Bayou.

1.2 Report Preview

Section 1 (this section) provides a brief overview of the report, including a description of the proposed regional drainage system and a summary of conclusions regarding its projected effectiveness. Section 2 provides a detailed description of each of the major components in the regional detention system. Section 3 describes the methods and data used in hydrologic analyses of the Greens Bayou watershed and provides a summary of the results obtained. Section 4 presents a summary of hydraulic analyses of Greens Bayou and Garners Bayou, including tabulations of computed 10-year and 100-year water surface elevations.

1.3 Description of the Greens Bayou Watershed

The watershed of Greens Bayou covers a total area of approximately 209 square miles. As indicated on Exhibit 1, the Greens Bayou watershed covers a significant portion of north-central Harris County. Exhibit 2 illustrates the extents of the watersheds of the two major Greens Bayou tributaries, Halls Bayou (HCFCD Ditch P118-00-00) and Garners Bayou (HCFCD Ditch P130-00-0).

1.4 Recent Flooding in the Lower Greens Bayou Watershed

The most recent rainfall events causing widespread flooding in the lower Greens Bayou watershed occurred on May 17-18, 1989, June 25-27, 1989, and March 4, 1992. Each of these storm events was characterized by heavy rainfall and subsequent flooding of homes, especially in areas downstream of the confluence of Greens Bayou with Halls Bayou. The May and June, 1989 storm events were the most severe rainfall events on record for the Greens Bayou watershed, while the March 1992 event was preceded by unusually heavy and persistent winter rainfall.

1.5 Brief Description of the Proposed Regional Detention System

In an effort to reduce flooding in the lower Greens Bayou watershed, the Harris County Flood Control District proposes to implement a regional detention system as illustrated on Exhibit 3. The proposed system composed of the following major components.

- **Basin P500-01-00:** This on-stream regional detention facility will be located between Greens Bayou tributaries P121-00-00 and P127-00-00.
- **Basin P500-03-00:** This off-stream regional detention basin will be located east of the confluence of Greens Bayou with Garners Bayou.
- **Flood Plain Storage Reclamation Structure:** This sheet-pile structure will be located in the channel of Greens Bayou a short distance upstream of the Forest Acres subdivision.

SECTION 1: INTRODUCTION

- **HCFCW Wetlands Bank:** This area of enhanced and man-made wetlands will retard runoff from an area bounded by Garners Bayou on the west, Beltway 8 to the north, and the Missouri Pacific Railroad to the south and east.

1.6 Objectives of the Lower Greens Bayou Regional Detention System

The major objectives of the proposed regional drainage system are as follows:

1. to reduce peak flow rates downstream of the Garners Bayou confluence to levels which existed prior to the completion of recent roadway construction along Beltway 8, improvements to tributary channels P121-00-00 and P127-00-00, and improvements to the channel of Greens Bayou between Ditch P121-00-00 and Garners Bayou;
2. to provide for the development of 200 acres of new development within the Williams Gully sub-watershed of the Garners Bayou watershed without increasing downstream peak flow rates or water surface elevations above pre-project levels.

1.7 Conditions Analyzed for This Study

A number of different watershed conditions have been analyzed in connection with this study. These conditions are as follows:

- **Pre-Project Conditions:** Conditions which existed prior to the completion of Beltway 8 and improvements to Ditch P121-00-00, P127-00-00, and Greens Bayou.
- **Current Conditions:** Conditions existing subsequent to the completion of Beltway 8 and improvements to Ditch P121-00-00, P127-00-00, and Greens Bayou.
- **Phase I Detention:** Current conditions plus the proposed flood plain storage reclamation structure upstream of the Forest Acres development.
- **Phase II Detention:** Phase I Detention plus the first phase of construction on Basin P500-01-00. For this condition, a flood containment berm recommended for Basin P500-01-00 is only partially constructed.
- **Full Detention:** All detention facilities and measures fully implemented, including Basin P500-01-00, Basin P500-03-00, the flood plain storage reclamation structure, and the HCFCW wetlands bank, plus 200 acres of new development in the Garners Bayou watershed.

1.8 Summary of Conclusions

The results of the analysis indicate that the proposed regional detention plan will be effective in reducing 10-year and 100-year peak flow rates to pre-project levels. In the case of the 10-year storm, a few flow rates between U.S. Highway 90 and Ditch P107-00-00 remain slightly higher than pre-project levels. For the 100-year storm event, all computed peak flow rates downstream of the Garners Bayou-Greens Bayou confluence are less than corresponding pre-project values. Water surface profile computations indicate that 10-year water surface elevations may remain 0.01 foot to 0.02 foot above pre-project levels in limited areas, but that 100-year water surface elevations will be lower than pre-project values at all points downstream of Garners Bayou.

SECTION 2: PRIMARY DETENTION SYSTEM COMPONENTS

2. PRIMARY DETENTION SYSTEM COMPONENTS

2.1 *Regional Detention Basin P500-01-00*

2.1.1 **Location and General Description of Basin P500-01-00**

The proposed Basin P500-01-00 is an on-stream facility located between the confluences of Ditch P121-00-00 and Ditch P127-00-00 with Greens Bayou. The site is illustrated on Exhibit 4. Basin P500-01-00 covers a total of approximately 1,540 acres of land. As indicated on Exhibit 5, natural ground on the P500-01-00 site slopes downward from west to east. Therefore, a low berm will be constructed along the southern and eastern sides of the property in order to contain flood waters within the detention site. For the first phase of construction on Basin P500-01-00, this berm will extend northward only as far as Garrett Road. Later, the berm will be extended to tie into high ground on the south side of Ditch P127-00-00. The location of the berm relative to the channel of Greens Bayou may be seen on Exhibit 6, which illustrates a typical cross-section of the P500-01-00 facility. Flood storage is to be created on the P500-01-00 site through impoundment. No major excavation work will be completed for the purpose of creating storage volume.

Flood waters will be discharged from the basin via two 25' x 25' box culverts and a 700-foot concrete overflow spillway. These structures are illustrated on Exhibits 7 and 8. Provisions are made in the design of the spillway to increase the crest elevation for all or part of the spillway length.

2.1.2 **Alternative Configurations Considered for Basin P500-01-00**

A number of alternative configurations were considered during the development of the recommended design for Basin P500-01-00. These configurations were considered in connection with efforts to maximize the effectiveness of the detention basin. These included the following:

- Expand the size of the basin by acquiring adjacent upstream property, thereby increasing the potential storage volume by increasing both the basin surface area and the depth of ponding.
- Construct an excavated diversion-type detention facility in the southern portion of Basin P500-01-00 to work in conjunction with the impoundment created by the proposed levee and discharge structure.
- Construct levees along Greens Bayou upstream of the P500-01-00 site to contain increased flood levels and allow greater ponding elevations within Basin P500-01-00.
- Improve the channel of Greens Bayou to a bottom width of 100 feet, thereby reducing the slope of the water surface profile through Basin P500-01-00 and allowing greater ponding depths in the southern portion of the basin without exceeding pre-project water surface elevations in upstream areas.

Cost considerations have made it impossible to include any of these alternatives in the recommended plan for Basin P500-01-00. However, each of them could be implemented in the future either singly or in combination with one or more other alternatives.

SECTION 2: PRIMARY DETENTION SYSTEM COMPONENTS

2.2 Flood Plain Storage Reclamation Structure

2.2.1 Location and Description of the Structure

This facility consists of a steel sheet-pile structure to be constructed in the channel of Greens Bayou at stream station 973+00. As indicated on Exhibit 9, proposed widths of openings in the sheet piling range from 24 feet to 144 feet. Concrete slope paving and rip-rap will protect the Greens Bayou channel upstream and downstream of the structure. Exhibit 10 provides a plan view of the installation.

2.2.2 Purpose of the Flood Plain Storage Reclamation Structure

A large proportion of the land in the vicinity of the confluence of Greens Bayou and Garners Bayou is low-lying and prone to flooding. When inundated during major storm events, this area provides a large amount of flood plain storage. The Greens Bayou channel improvements completed in the 1980's reduced 100-year flood levels in this area and thus eliminated significant amounts of flood plain storage. In order to reclaim a portion of this flood plain storage, the proposed steel sheet-pile structure will be placed in the channel of Greens Bayou at approximately stream station 973+00. The structure will retard the progress of flood flows passing down Greens Bayou and increase flood elevations to levels between those corresponding to pre-project and current conditions. The accompanying increase in flood storage volume will serve to attenuate peak flow rates and alleviate flooding in downstream areas.

2.3 Regional Detention Basin P500-03-00

2.3.1 General Description of Basin P500-03-00

The proposed site of Basin P500-03-00 lies immediately east of the confluence of Greens Bayou and Garners Bayou. As indicated on Exhibit 11, the detention basin, which covers approximately 185 acres, is to be located in the western portion of a larger tract of land which covers a total area of about 1,460 acres. Exhibit 12 provides general topographic data on the detention site. Exhibit 13 illustrates a typical cross-section of the facility. As indicated on these exhibits, Basin P500-03-00 is approximately 5,500 feet long and has a maximum width of about 1,800 feet. The basin will be surrounded by a low levee with side slopes of 4 horizontal to 1 vertical (4:1) and a top width of 20 feet. The proposed internal side slope of the basin is also 4:1. Maintenance "shelves" 10-12 feet in width are provided on the interior slopes of the basin to provide access for maintenance vehicles and to improve slope stability and erosion resistance. The basin will be excavated to a depth of about 18-20 feet. Pilot channels with bottom widths of 20 feet and side slopes of 4 horizontal to 1 vertical will drain the bottom of the basin.

2.3.2 Proposed Storm Water Diversion Structures

Flood waters will be diverted into Basin P500-03-00 from Garners Bayou. Flow into the basin will be regulated by 3' x 3' x 24' box culverts. Energy dissipation requirements related to potential differences between external flood levels and internal basin water surface elevations will be satisfied using baffled chute spillways. Exhibits 14 through 16 illustrate the proposed configuration of the diversion structures. These exhibits show a 12-foot wide baffled chute with three 3' x 3' x 24' box culverts. Chute and baffle block dimensions are designed for a flow capacity of 25 cfs per foot of chute width. This structure provides a diversion capacity of 12 ft x 25 cfs/ft = 300 cfs. This constitutes 10% of the required total diversion capacity of 3,000 cfs. Therefore, 10 of these structures are required in order to provide the total diversion

SECTION 2: PRIMARY DETENTION SYSTEM COMPONENTS

requirement. With three box culverts per structure, each culvert carries a maximum 100-year diversion flow of 100 cfs.

2.3.3 Requirements for Connector Structures

Two pipeline easements cross the proposed site of Basin P500-03-00. These easements effectively divide the basin into three parts. In order to minimize the differences in water surface elevations in each of the three parts, sufficient cross-drainage capacity must be provided. This may be accomplished by either of the following means:

1. provide culverts to carry flow under the pipelines;
2. adjust the pipelines downward in the immediate vicinity of the basin's pilot channel, thereby leaving unobstructed trapezoidal openings between the parts of the basin;
3. adjust the pipelines downward over the entire width of the basin and excavating away the material between the parts of the basin, thereby forming a single-segment basin.

For culvert connectors, it is recommended that the culverts have sufficient capacity to carry the proposed total diversion flow of 3,000 cfs at a head loss of 1.0 foot or less. This would require five 10' x 10' box culverts as indicated on Exhibit 17. The length of the culverts would vary from about 120 feet to about 180 feet. Adjusting the pipelines in the immediate vicinity of the pipelines would eliminate structural requirements beyond the possible need for slope protection on the slopes of the trapezoidal openings between the parts of the basin. Finally, adjusting the pipelines downward over the entire width of the basin would, in addition to completely eliminating all structural requirements, significantly increase the available detention storage volume within the basin.

2.3.4 Discharge Structure Requirements

The proposed discharge structure for Basin P500-03-00 consists of two 10' x 10' box culverts. As indicated on Exhibit 18, a flap gate will be required at the downstream end of each culvert to prevent backflows of storm water from Greens Bayou into the detention basin. Directly above the culverts is a depressed overflow section with a bottom elevation of 55.5 feet. The purpose of this section is to allow rapid equalization of water levels inside and outside Basin P500-03-00 under conditions in which overtopping of the perimeter levee is possible. While such conditions are not anticipated in connection with storm events up to and including a 100-year frequency, provision of the overflow section is recommended as a safety measure which will protect the integrity and stability of the levee.

2.3.5 Alternative Configurations Considered for Basin P500-03-00

A number of alternative configurations were considered during the development of the recommended design for Basin P500-03-00. These configurations were considered in connection with efforts to maximize the effectiveness of the detention basin. These included berming only a portion of the basin, allowing a portion of the basin to act as flood plain storage only, and operating the basin as a multiple-level facility with a different water surface elevation in each segment of the facility. In addition, a number of diversion structures were investigated, including a straight drop (weir) overflow, drop inlet spillways, culvert spillways, and chute spillways. However, the recommended basin configuration yields the maximum effectiveness with respect to reductions in downstream peak flow rates.

SECTION 2: PRIMARY DETENTION SYSTEM COMPONENTS

2.4 Harris County Flood Control District Wetlands Bank

2.4.1 Description of the Wetlands Bank Site

The site of the proposed Harris County Flood Control District wetlands bank is illustrated on Exhibit 11. The total area on which wetlands will be created or enhanced is approximately 1,000 acres. Wetlands creation and/or enhancement projects will be completed on the site in order to mitigate damage to wetlands associated with construction projects in Harris County. Wetlands areas will be created or enhanced through the construction of berms and other water-control facilities and modifications to existing topography to cause ponding of water at optimum depths for wetlands establishment. Plantings of wetlands vegetation will be used to accelerate the establishment of new wetlands areas. In order to utilize the beneficial aspects of wetlands with respect to water quality, it has been proposed that storm runoff from the Beltway 8 system be directed through the wetlands bank. This measure will also help to ensure that a sufficient supply of water is available for creating and maintaining high-quality wetlands.

2.4.2 Effects of the Wetlands Bank on Local Hydrology

The proposed wetlands bank will have a pronounced impact on the rate and timing of storm runoff from areas draining through the site. The construction of berms and other water-control devices within the wetlands banking area will store storm water on the site and retard the progress of flows toward Garners and Greens Bayous. This will have the effect of reducing peak runoff rates from the wetlands bank and from those portions of Beltway 8 which are proposed to drain into the bank. In addition, peak flow rates from the wetlands banking site will occur significantly later in time with respect to peak flow rates from surrounding areas.

SECTION 3: HYDROLOGIC ANALYSIS OF THE GREENS BAYOU WATERSHED

3. HYDROLOGIC ANALYSIS OF THE GREENS BAYOU WATERSHED

3.1 Method of Analysis

Hydrologic analyses of the Greens Bayou watershed are completed using the HEC-1 computer program developed by the Hydrologic Engineering Center of the U.S. Army Corps of Engineers. The HEC-1 provides the means for computing, routing, and combining runoff hydrographs from multiple sub-areas within a watershed. For this study, the effectiveness of the proposed regional detention system is evaluated by comparing the results of various HEC-1 models which represent past, current, and future conditions within the Greens Bayou watershed.

The base HEC-1 modeling data used in this study was provided by the Harris County Flood Control District. The analytical methods primarily used in the base models of the Greens Bayou watershed include the Clark unit hydrograph method for computing runoff hydrographs and the Modified Puls method for routing hydrographs from point to point within the watershed. Clark unit hydrograph parameters are computed using the Harris County Standard Hydrologic Methodology. Storage-discharge data for the Modified Puls method are developed using HEC-2 computer models of Greens Bayou and major tributaries. Rainfall data used for 10-year and 100-year storm events was developed in the 1980's for the Harris County Flood Hazard Study. Infiltration losses are calculated using the exponential loss function with the percent impervious cover for urbanized areas assumed to average 35%.

3.2 Alternative Ponding Adjustment Methodology

The Harris County Standard Hydrologic Methodology provides a method for adjusting the Clark storage coefficient (R) to account for the rice farming or other land practices which retard storm runoff from reaching a major watercourse. The Harris County methodology relates the percentage of the total drainage area involved in rice farming or similar land practices to the a factor which used to adjust the storage coefficient. For this study, however, the ponding adjustment methodology described in the *Dickinson Bayou Watershed Regional Drainage Plan Drainage Criteria Manual* dated August 1992. The methodology developed for the Dickinson Bayou study is based on the same source material (U.S. Soil Conservation Service Technical Release No. 55, *Urban Hydrology for Small Watersheds*, January 1975) utilized in developing the Harris County adjustment method. However, the method developed for the Dickinson Bayou study allows for a more precise evaluation of the effects of ponding.

3.3 Description of HEC-1 Models Used in This Analysis

- A total of 10 HEC-1 models are used in this analysis. These models represent two storm events (10-year and 100-year) and five watershed conditions. The watershed conditions analyzed are as follows:
- **Pre-Project Conditions:** Conditions which existed prior to the completion of Beltway 8 and improvements to Ditch P121-00-00, P127-00-00, and Greens Bayou.
- **Current Conditions:** Conditions existing subsequent to the completion of Beltway 8 and improvements to Ditch P121-00-00, P127-00-00, and Greens Bayou.
- **Phase I Detention:** Current conditions plus the proposed flood plain storage reclamation structure upstream of the Forest Acres development.

SECTION 3: HYDROLOGIC ANALYSIS OF THE GREENS BAYOU WATERSHED

- **Phase II Detention:** Phase I Detention plus the first phase of construction on Basin P500-01-00. For this condition, a flood containment berm recommended for Basin P500-01-00 is only partially constructed.
- **Full Detention:** All detention facilities and measures fully implemented, including Basin P500-01-00, Basin P500-03-00, the flood plain storage reclamation structure, and the HCFCD wetlands bank, plus 200 acres of new development in the Garners Bayou watershed.

Exhibit 19 illustrates the boundaries of the Greens Bayou watershed and the boundaries of each sub-area included in the HEC-1 computer models. Differences between the various watershed conditions analyzed for this study are reflected in the HEC-1 models by modifying the hydrologic parameters of sub-areas affected by urban development or detention measures and by revising Modified Puls storage routing data for affected routing reaches. The impacts of past or future changes in the lower Greens Bayou watershed may be determined by comparing the results obtained using the various HEC-1 computer models.

3.4 Hydrologic Parameters for Sub-Watersheds in the Project Area

The changes examined in this study with respect to urban development and proposed detention measures affect a total of 13 sub-areas included in the base HEC-1 models provided by the Harris County Flood Control District. One of these, sub-area P100N, is divided for purposes of this analysis into two separate sub-areas designated P100N1 and P100N2. Another, sub-area P13002AB, represents a combination of sub-areas P13002A and P13002B with corrections in the overall drainage boundary of the two sub-watersheds.

The following tables provide a summary of the hydrologic parameters used for each of the affected sub-areas. Table 1 presents hydrologic parameters for pre-project conditions. These conditions existed prior to the construction of Beltway through the project area, the completion of channel improvements to Ditch P121-00-00 and Ditch P127-00-00, and the completion of improvements to Greens Bayou between Ditch P121-00-00 and Garners Bayou.

Sub-Area	A (sq.mi.)	L (mi.)	Lca (mi.)	S (ft/mi)	So (ft/mi)	UD (%)	CI (%)	CC (%)	P (%)	TC (hr.)	R ₁₀ (hr.)	R ₁₀₀ (hr.)
P133B	2.45	3.25	1.43	10.50	5	29.00	0	41	0	0.98	11.12	11.12
P100K	3.34	3.11	1.16	2.80	16	0.00	0	52	0	1.67	9.56	9.56
P130E	1.24	2.23	0.94	4.70	10	51.80	100	70	0	0.48	4.48	4.48
P130F	1.35	2.15	0.88	6.50	10	0.00	100	80	0	0.45	5.98	5.98
P13002AB	3.08	3.23	1.59	4.28	8	12.10	100	100	0	1.01	8.92	8.92
P130G	2.25	3.69	1.74	7.52	10	8.60	0	60	0	1.49	7.45	7.45
P100L	4.69	4.00	1.37	3.93	10	2.60	67.4	100	0	1.17	10.73	10.73
P127A	1.58	3.32	1.58	2.81	10	16.10	74.9	100	0	1.49	10.25	10.25
P100M	2.21	3.33	1.84	8.41	10	3.40	0	100	0	1.51	6.48	6.48
P121A	1.32	2.77	1.77	3.01	10	2.30	41.8	100	0	2.05	8.04	8.04
P100N1	1.46	2.97	1.92	3.59	10	20.80	0	80	0	2.4	8.49	8.49
P100N2	3.04	4.19	2.14	6.91	10	26.00	0	80	0	1.88	7.59	7.59
P107A	1.98	4.42	1.95	4.04	10	12.40	61.7	100	0	1.69	10.95	10.95
P107B	4.28	5.05	2.64	5.73	10	22.2	0	50	0	2.62	17.62	17.62

SECTION 3: HYDROLOGIC ANALYSIS OF THE GREENS BAYOU WATERSHED

Table 2 summarizes the parameters used for current conditions, which are defined as those conditions existing subsequent to the construction of Beltway through the project area, the completion of channel improvements to Ditch P121-00-00 and Ditch P127-00-00, and the completion of improvements to Greens Bayou between Ditch P121-00-00 and Garners Bayou. Differences between pre-project and current conditions sub-area parameters are attributable to these improvement projects.

Sub-Area	A sq. mi.	L (mi.)	Lca (mi.)	S (ft/mi)	So (ft/mi)	UD (%)	CI (%)	CC (%)	P (%)	TC (hr.)	R ₁₀ (hr.)	R ₁₀₀ (hr.)
P133B	2.40	3.25	1.46	10.50	5	29.7	0	41	0	1.00	10.91	10.91
P100K	3.17	3.11	1.2	2.80	16	0	0	52	0	1.73	9.50	9.50
P130E	1.17	2.23	0.8	4.70	10	55	100	70	0	0.40	4.36	4.36
P130F	1.35	2.15	0.88	6.50	10	0	100	80	0	0.45	5.98	5.98
P13002AB	3.08	3.23	1.59	4.28	8	12.1	100	100	0	1.01	8.92	8.92
P130G	2.62	3.69	1.97	7.52	10	13.1	46.5	60	0	1.34	7.60	7.60
P100L	4.69	4.00	1.37	3.80	10	2.6	100	100	0	0.95	11.09	11.09
P127A	4.57	5.17	2.57	2.64	10	8.4	100	100	0	2.21	14.21	14.21
P100M	2.21	3.33	1.84	8.41	10	3.4	24	100	0	1.35	6.64	6.64
P121A	3.71	4.65	2.82	3.38	10	7.2	100	100	0	2.15	11.81	11.81
P100N1	1.46	2.97	1.92	3.59	10	20.8	0	80	0	2.40	8.49	8.49
P100N2	2.39	3.96	2.04	7.44	10	33	0	80	0	1.70	5.84	5.84
P107A	---	---	---	---	---	---	---	---	---	---	---	---
P107B	4.64	5.05	2.75	5.73	10	24.6	0	50	0	2.72	16.16	16.16

Table 3 presents a listing of sub-area parameters for conditions which reflect the complete implementation of the proposed lower Greens Bayou regional detention system. Only sub-areas P130G, P100L, and P127A are changed with respect to current conditions. Changes made to the parameters for these sub-areas are directly related to the construction of Basin P500-03-00 and the Harris County Flood Control District wetlands bank. For example, areas within the perimeter of Basin P500-03-00 are subtracted from the drainage areas of the three sub-watersheds, and a portion of the wetlands bank currently draining to Ditch P127-00-00 is assumed to be diverted to Garners Bayou in order to keep as much water within the wetlands bank as possible.

SECTION 3: HYDROLOGIC ANALYSIS OF THE GREENS BAYOU WATERSHED

Table 3: Sub-Area Parameters for Full Implementation of Regional Detention Plan

Sub-Area	A (sq.mi.)	L (mi.)	Lca (mi.)	S (ft/mi)	So (ft/mi)	UD (%)	CI (%)	CC (%)	P (%)	TC (hr.)	R ₁₀ (hr.)	R ₁₀₀ (hr.)
P133B	2.40	3.25	1.46	10.50	5	29.7	0	41	0	1.00	10.91	10.91
P100K	3.17	3.11	1.2	2.80	16	0	0	52	0	1.73	9.50	9.50
P130E	1.17	2.23	0.8	4.70	10	55	100	70	0	0.40	4.36	4.36
P130F	1.35	2.15	0.88	6.50	10	0	100	80	0	0.45	5.98	5.98
P13002AB	3.08	3.23	1.59	4.28	8	22.2	100	100	0	0.98	7.39	7.39
P130G	2.53	3.69	1.97	7.52	10	13.6	46.5	60	11	1.34	8.47	8.22
P100L	5.39	4.00	1.37	3.80	10	2.3	100	100	31	0.95	16.05	14.66
P127A	3.67	5.17	2.20	2.64	10	10.5	100	100	0	1.86	14.56	14.56
P100M	2.21	3.33	1.84	8.41	10	3.4	24	100	0	1.35	6.64	6.64
P121A	3.71	4.65	2.82	3.38	10	7.2	100	100	0	2.15	11.81	11.81
P100N1	1.46	2.97	1.92	3.59	10	20.8	0	80	0	2.40	8.49	8.49
P100N2	2.39	3.96	2.04	7.44	10	33	0	80	0	1.70	5.84	5.84
P107A	---	---	---	---	---	---	---	---	---	---	---	---
P107B	4.64	5.05	2.75	5.73	10	24.6	0	50	0	2.72	16.16	16.16

Exhibits 20-22 illustrate the data developed for these sub-areas for pre-project, current, and proposed conditions, respectively. The particular parameters illustrated on these exhibits include the length, length to centroid, and area. In addition, the boundaries of existing urbanized areas are indicated.

3.5 Storage Routing Data for Greens Bayou Below Ditch P138-00-00

Exhibit 23 illustrates the extents of the twelve routing reaches for which storage-discharge are re-defined for each condition analyzed in this study. Table 4 presents a summary of the storage routing data developed for each routing reach and watershed condition. Routing volumes are computed using HEC-2 models of Greens Bayou which reflect each of the watershed conditions analyzed for this study. The number of routing steps used for each reach is determined by using HEC-2 results to compute the average travel time through the reach and dividing by the HEC-1 computation interval of 15 minutes (0.25 hour).

SECTION 3: HYDROLOGIC ANALYSIS OF THE GREENS BAYOU WATERSHED

Table 4: Storage Routing Data for Routing Reaches 1 Through 6										
Reach #1: Station 15+00 to Station 202+41										No. of
Flow Rate (cfs)	4500	9000	13500	18000	22500	27500	32500	37500	42500	Steps
Pre-Project	1651	1710	1825	1934	2059	2242	2385	2524	2665	6
Current	1651	1710	1825	1934	2059	2242	2385	2524	2665	6
Phase 1 Detention	1651	1710	1825	1934	2059	2242	2385	2524	2665	6
Phase 2 Detention	1651	1710	1825	1934	2059	2242	2385	2524	2665	6
Full Detention	1651	1710	1825	1934	2059	2242	2385	2524	2665	6
Reach #2: Station 202+41 to Station 402+75										No. of
Flow Rate (cfs)	4500	9000	13500	18000	22500	27500	32500	37500	42500	Steps
Pre-Project	870	1259	1735	2161	2582	3083	3622	4196	4811	5
Current	870	1259	1735	2161	2582	3083	3622	4196	4811	5
Phase 1 Detention	870	1259	1735	2161	2582	3083	3622	4196	4811	5
Phase 2 Detention	870	1259	1735	2161	2582	3083	3622	4196	4811	5
Full Detention	870	1259	1735	2161	2582	3083	3622	4196	4811	5
Reach #3: Station 402+75 to Station 454+46										No. of
Flow Rate (cfs)	4400	8800	13200	17600	22000	27000	32000	37000	42000	Steps
Pre-Project	242	448	663	864	1061	1277	1486	1697	1913	2
Current	242	448	663	864	1061	1277	1486	1697	1913	2
Phase 1 Detention	242	448	663	864	1061	1277	1486	1697	1913	2
Phase 2 Detention	242	448	663	864	1061	1277	1486	1697	1913	2
Full Detention	242	448	663	864	1061	1277	1486	1697	1913	2
Reach #4: Station 454+46 to Station 585+21										No. of
Flow Rate (cfs)	4400	8800	13200	17600	22000	27000	32000	37000	42000	Steps
Pre-Project	561	1126	1802	2446	3141	4037	5224	6581	8247	4
Current	561	1126	1802	2446	3141	4037	5224	6581	8247	4
Phase 1 Detention	561	1126	1802	2446	3141	4037	5224	6581	8247	4
Phase 2 Detention	561	1126	1802	2446	3141	4037	5224	6581	8247	4
Full Detention	561	1126	1802	2446	3141	4037	5224	6581	8247	4
Reach #5: Station 585+21 to Station 638+60										No. of
Flow Rate (cfs)	4300	8600	12900	17200	21500	26500	31500	36500	41500	Steps
Pre-Project	342	658	901	1116	1322	1575	1877	2181	2502	3
Current	342	658	901	1116	1322	1575	1877	2181	2502	3
Phase 1 Detention	342	658	901	1116	1322	1575	1877	2181	2502	3
Phase 2 Detention	342	658	901	1116	1322	1575	1877	2181	2502	3
Full Detention	342	658	901	1116	1322	1575	1877	2181	2502	3
Reach #6: Station 638+60 to Station 732+00										No. of
Flow Rate (cfs)	3400	6800	10200	13600	17000	20500	24000	27500	31000	Steps
Pre-Project	333	697	1080	1526	2059	2806	3540	4175	4790	4
Current	333	697	1079	1526	2058	2806	3539	4173	4788	4
Phase 1 Detention	333	697	1079	1526	2058	2806	3539	4173	4788	4
Phase 2 Detention	337	702	1084	1531	2064	2812	3545	4180	4796	4
Full Detention	337	702	1084	1531	2064	2812	3545	4180	4796	4

Table 5 presents storage routing data for routing reaches between Ditch P121-00-00 and Ditch P138-00-00. Reaches 7 and 8 fall within the proposed Basin P500-01-00. Storage data for reach #9 has been adjusted to account for the presence of the proposed perimeter berm around Basin P500-03-00.

SECTION 3: HYDROLOGIC ANALYSIS OF THE GREENS BAYOU WATERSHED

Table 5: Storage Routing Data for Routing Reaches 7 Through 12										
Reach #7: Station 732+00 to Station 798+38										No. of Steps
Flow Rate (cfs)	3300	6600	9900	13200	16500	20000	23500	27000	30500	
Pre-Project	198	313	425	529	634	773	969	1192	1467	2
Current	179	282	385	483	582	698	851	1039	1250	2
Phase 1 Detention	179	282	385	483	582	698	851	1039	1250	2
Phase 2 Detention	181	291	414	553	730	993	1182	1349	1545	2
Full Detention	181	291	414	553	730	1070	1407	1710	2177	2
Reach #8: Station 798+38 to Station 861+00										No. of Steps
Flow Rate (cfs)	3300	6600	9900	13200	16500	20000	23500	27000	30500	
Pre-Project	150	261	368	472	609	858	1150	1457	1931	2
Current	113	201	288	373	462	593	790	1032	1282	2
Phase 1 Detention	113	201	288	373	462	593	790	1032	1282	2
Phase 2 Detention	114	205	303	415	585	871	1100	1302	1538	2
Full Detention	114	205	303	415	585	945	1299	1601	1998	2
Reach #9: Station 861+00 to Station 1004+07										No. of Steps
Flow Rate (cfs)	3200	6400	9600	12800	16000	19500	23000	26500	30000	
Pre-Project	294	493	676	955	1415	2108	3121	4156	5522	4
Current	283	455	608	751	919	1248	1711	2386	3460	3
Phase 1 Detention	307	474	632	793	1037	1422	2061	2837	3542	3
Phase 2 Detention	307	475	636	804	1080	1501	2195	2910	3683	3
Full Detention	307	475	636	803	1031	1339	1840	2719	3581	3
Reach #10: Station 1004+07 to Station 1116+22										No. of Steps
Flow Rate (cfs)	2300	4600	6900	9200	11500	14000	16500	19000	21500	
Pre-Project	206	361	498	1113	2119	3292	4332	5053	5734	5
Current	178	304	420	569	1059	1884	2865	3966	4921	4
Phase 1 Detention	194	323	452	733	1380	2383	3700	4580	5013	4
Phase 2 Detention	194	323	452	729	1404	2450	3782	4540	5042	4
Full Detention	194	323	452	731	1407	2494	3918	5205	5919	4
Reach #11: Station 1116+22 to Station 1222+88										No. of Steps
Flow Rate (cfs)	2300	4600	6900	9200	11500	14000	16500	19000	21500	
Pre-Project	172	284	396	807	1265	1778	2305	3198	3769	3
Current	171	278	378	738	1193	1664	2175	3093	3688	3
Phase 1 Detention	171	280	383	772	1212	1697	2242	3148	3696	3
Phase 2 Detention	171	280	383	771	1214	1702	2250	3144	3698	3
Full Detention	171	280	383	771	1214	1706	2265	3215	3791	3
Reach #12: Station 1222+88 to Station 1321+51										No. of Steps
Flow Rate (cfs)	2200	4400	6600	8800	11000	13500	16000	18500	21000	
Pre-Project	189	302	398	539	891	1425	2212	3285	4130	3
Current	189	300	395	535	887	1418	2202	3278	4125	3
Phase 1 Detention	189	301	396	537	888	1420	2207	3282	4126	3
Phase 2 Detention	189	301	396	537	888	1420	2208	3281	4126	3
Full Detention	189	301	396	537	888	1421	2209	3287	4131	3

3.6 Elevation-Storage-Discharge Data for Basin P500-01-00

Table 6 summarizes the relationship between water surface elevation, storage volume, and discharge for Basin P500-01-00. The storage volumes for the basin are set equal to the total volume computed for routing reaches 7 and 8 (see Table 5). Water surface elevations and discharge values are obtained from the multi-profile HEC-2 models used to generate the storage routing data presented in Table 4 and Table 5.

SECTION 3: HYDROLOGIC ANALYSIS OF THE GREENS BAYOU WATERSHED

Table 6: Elevation-Storage-Discharge Data for Basin P500-01-00						
Detention Phase	Discharge (cfs)	Reach 7 Volume (ac.-ft.)	Reach 8 Volume (ac.-ft.)	Total Volume (ac.-ft.)	WSEL @ Sta. 733+20 (feet)	WSEL @ Sta. 861+00 (feet)
1	3300	179	113	292	20.50	27.79
	6600	282	201	483	24.75	31.75
	9900	385	288	673	28.36	34.83
	13200	483	373	856	31.28	37.41
	16500	582	462	1044	33.93	39.67
	20000	698	593	1291	36.65	41.82
	23500	851	790	1641	38.82	43.60
	27000	1039	1032	2071	40.43	45.06
	30500	1250	1282	2532	41.87	46.36
2	3300	181	114	295	20.66	27.80
	6600	291	205	496	25.25	31.81
	9900	414	303	717	29.54	35.09
	13200	553	415	968	33.59	38.12
	16500	730	585	1315	37.73	41.14
	20000	993	871	1864	40.59	43.53
	23500	1182	1100	2282	41.87	44.96
	27000	1349	1302	2651	42.75	46.10
	30500	1545	1538	3083	43.52	47.10
Full	3300	181	114	295	20.66	27.80
	6600	291	205	496	25.25	31.81
	9900	414	303	717	29.54	35.09
	13200	553	415	968	33.59	38.12
	16500	730	585	1315	37.73	41.14
	20000	1070	945	2015	41.23	43.88
	23500	1407	1299	2706	43.29	45.78
	27000	1710	1601	3311	44.34	46.96
	30500	2177	1998	4175	45.19	47.92

3.7 Diversion Data for Basin P500-03-00

Table 7 provides a summary of the HEC-1 diversion data used to represent Basin P500-03-00. This data was developed using rating curves developed at the upstream end of the box culvert diversion structures and at Garners Bayou cross-section 4382. HEC-2 computer models of the diversion structure and Garners Bayou were used to develop these rating curves. Exhibit 24 illustrates the rating curves for the diversion structure and Garners Bayou. The Garners Bayou flow rates in the table represent various percentages of the 10-year as well as the 50-year and 100-year peak flow rates from the HEC-2 model currently recognized by FEMA. These flow rates were used to compute the Garners Bayou water surface elevations given in the second column of the table. The diversion structure rating curve was then used to determine the diversion capacity corresponding to the Garners Bayou water surface elevation. The total flow rates in the final column of the table are equal to the sum of the Garners Bayou flow rate and the diversion capacity corresponding to each Garners Bayou water surface elevation.

SECTION 3: HYDROLOGIC ANALYSIS OF THE GREENS BAYOU WATERSHED

Table 7: Diversion Data for Basin P500-03-00

Garners Flow Rate (cfs)	Garners WSEL (cfs)	Diversion Capacity (cfs)	Total Flow Rate (cfs)
0	34.50	0	0
667	42.02	0	670
1334	45.40	0	1330
2001	47.85	0	2000
2050	48.00	0	2050
2668	49.81	660	3330
3335	51.39	1440	4780
4002	52.49	1920	5920
5336	53.97	2480	7820
6670	55.00	2840	9510
8790	56.30	3230	12020
10000	56.90	3380	13380

In both the 10-year and 100-year full detention conditions HEC-1 models of the Greens Bayou watershed, it is assumed that the diversion structure will operate without tailwater interference until the water surface elevation in Basin P500-03-00 submerges the tailwater supported by the proposed baffled chute spillway. This will occur at an elevation of approximately 52.0 feet. The total storage capacity of the basin at that elevation is about 2,349 acre-feet. HEC-1 results indicate that the basin water surface elevation will reach 52.0 feet only for the 100-year storm event.

At basin water surface elevations greater than 52.0 feet, the capacity of the diversion structure is reduced by tailwater submergence. Because it is difficult to fully account for the effects of this tailwater submergence when using the simple diversion capabilities available in the HEC-1 program, external computations are used to estimate the amount of flood water which would be diverted into Basin P500-03-00 after the basin water surface reaches 52.0 feet during the 100-year design storm event. The results of these computations indicate that approximately 417 acre-feet of water would be diverted into the basin under high tailwater conditions. This would put the maximum 100-year flood storage volume at $2,349 + 417 = 2,766$ acre-feet. Subtracting the anticipated storm runoff resulting from rainfall directly over the basin (assuming an SCS curve number of 80 yields 155 acre-feet for the 185-acre basin) yields a net available diversion volume of 2,611 acre-feet for the 100-year storm event.

3.8 Description of HEC-1 Models Used in the Analysis

A total of ten (10) HEC-1 computer models are used in this analysis to represent the five different watershed conditions and two storm events (10-year and 100-year) being studied. The following descriptions of the models provide a basic overview of the HEC-1 modeling work completed in connection with this study.

- **PRE10.IH1 & PRE100.IH1:** These models represent pre-project conditions within the Greens Bayou watershed.
- **CUR10.IH1 & CUR100.IH1:** Current Greens Bayou watershed conditions are reflected in these models.
- **PHS1-10.IH1 & PHS1-100.IH1:** These models are the same as the current conditions models, with the exception that storage routing data are modified in order to account for the proposed flood plain storage reclamation structure at Greens Bayou station 973+00.

SECTION 3: HYDROLOGIC ANALYSIS OF THE GREENS BAYOU WATERSHED

- **PHS2-10.IH1 & PHS2-100.IH1:** These models reflect both the flood plain storage reclamation structure at stream station 973+00 and the existence of Basin P500-01-00 with the flood containment berm extending only to Garrett Road.
- **FULL-10.IH1 & FULL-100.IH1:** In these models, Basin 500-01-00, Basin P500-03-00, the flood plain storage reclamation structure, and the Harris County Flood Control District wetlands bank are all assumed to be fully implemented.

3.9 Summary of Results for the 10-year Storm Event

Table 8 provides a summary of computed 10-year peak flow rates at a number of analysis points along Greens Bayou. As indicated, current conditions flow rates are significantly higher than corresponding pre-project values at a number of locations along Greens Bayou. However, the proposed detention measures are effective in reducing 10-year peak flow rates to values which, for the most part, are less than pre-project rates. Only in the area between U.S. Highway 90 and Ditch P107-00-00 are full detention conditions flow rates higher than pre-corresponding project values.

Table 8: Computed 10-Year Peak Flow Rates for Given Locations and Watershed Conditions					
Location	Pre-Project	Current	Phase 1 Detention	Phase 2 Detention	Full Detention
Below Ditch P138-00-00	12769	12770	12770	12770	12770
At U.S. Highway 59	13052	13057	13056	13056	13054
Above Ditch P133-00-00	13027	13066	13055	13053	13049
Below Ditch P133-00-00	13620	13667	13652	13649	13643
Above Gamers Bayou (P130-00-00)	13210	13518	13349	13305	13267
Gamers Bayou Above P130-02-00	4699				4685
Gamers Bayou Below P130-02-00	6440				6424
Gamers Bayou at Mouth	6253				6270/4247
Below Gamers Bayou (P130-00-00)	17329	18272	17930	17849	16225
Above Ditch P127-00-00	17462	18601	18244	18155	16567
Below Ditch P127-00-00	17571	18974	18611	18517	16844
Below Ditch P126-00-00	17675	19196	18822	18678	16982
Above Ditch P125-00-00	17754	19338	18957	18762	17061
Below Ditch P125-00-00	18041	19722	19330	19089	17379
Below Ditch P121-00-00	18112	20042	19639	19363	17656
Above Halls Bayou (P118-00-00)	18190	20134	19711	19408	17787
Below Halls Bayou (P118-00-00)	23264	25534	24984	24393	23254
At U.S. Highway 90	23620	25892	25338	24772	23639
Above Ditch P110-00-00	23676	25978	25435	24893	23743
Below Ditch P110-00-00	23743	26045	25502	24962	23812
Below Ditch P109-00-00	23795	26097	25554	25016	23865
Above Ditch P107-00-00	23815	26118	25576	25040	23888
Below Ditch P107-00-00	24372	26454	25912	25384	24237
At Interstate Highway 10	24505	26592	26052	25535	24390
At Houston Ship Channel	24687	26774	26236	25722	24578

Exhibit 25 illustrates computed 10-year runoff hydrographs for Gamers Bayou and Greens Bayou at the confluence of those two streams. The exhibit effectively illustrates the impact of the proposed diversion into Basin P500-03-00 on combined hydrographs at the mouth of Gamers Bayou.

SECTION 3: HYDROLOGIC ANALYSIS OF THE GREENS BAYOU WATERSHED

3.10 Summary of Results for the 100-year Storm Event

Table 9 provides a summary of computed 100-year peak flow rates along Greens Bayou. As indicated in the table, current conditions peak flow rates are higher than corresponding pre-project conditions values at all points downstream of the Garners Bayou confluence. However, the results of the 100-year HEC-1 analysis indicate full implementation of the proposed regional detention plan will bring peak flow rates down to and even slightly below pre-project levels.

Table 9: Computed 100-Year Peak Flow Rates for Given Locations and Watershed Conditions

Location	Pre-Project	Current	Phase 1 Detention	Phase 2 Detention	Full Detention
Below Ditch P138-00-00	16807	16809	16809	16809	16809
At U.S. Highway 59	16813	16815	16814	16814	16812
Above Ditch P133-00-00	16835	16836	16833	16835	16824
Below Ditch P133-00-00	17581	17592	17561	17559	17546
Above Garners Bayou (P130-00-00)	17802	17645	17646	17682	17463
Garners Bayou Above P130-02-00	7137				7108
Garners Bayou Below P130-02-00	9581				9660
Garners Bayou At Mouth	9723				9861/6967
Below Garners Bayou (P130-00-00)	24400	24647	23795	23734	22869
Above Ditch P127-00-00	24424	25040	24188	24138	22846
Below Ditch P127-00-00	24566	25622	24746	24690	23187
Below Ditch P126-00-00	24664	25876	24994	24939	23137
Above Ditch P125-00-00	24730	26044	25161	25105	23091
Below Ditch P125-00-00	25087	26574	25686	25624	23394
Below Ditch P121-00-00	25172	27038	26150	26079	23673
Above Halls Bayou (P118-00-00)	25288	27257	26359	26259	23668
Below Halls Bayou (P118-00-00)	31548	35210	34230	33918	31171
At U.S. Highway 90	31754	35674	34686	34312	31595
Above Ditch P110-00-00	31792	35583	34641	34207	31648
Below Ditch P110-00-00	31869	35675	34732	34295	31742
Below Ditch P109-00-00	31929	35747	34804	34365	31815
Above Ditch P107-00-00	31965	35778	34838	34395	31852
Below Ditch P107-00-00	32644	36256	35317	34846	32341
At Interstate Highway 10	32781	36373	35441	34959	32489
At Houston Ship Channel	33025	36624	35694	35198	32750

Exhibit 26 illustrate computed 100-year runoff hydrographs at the confluence of Greens Bayou and Garners Bayou. This exhibit reveals a discontinuity in the "after-diversion" hydrograph for Garners Bayou. This discontinuity is the result of difficulties in defining a HEC-1 diversion relationship which adequately accounts for tailwater submergence. The hydrograph shown on Exhibit 26 illustrates the best fit possible considering the limitations of the HEC-1 diversion option. A better estimate of the actual "after-diversion" hydrograph is shown as a dashed line on Exhibit 26. This estimate is based on manual computations of diversions into Basin P500-03-00 under high tailwater conditions.

4. HYDRAULIC ANALYSES OF GREENS AND GARNERS BAYOUS

4.1 Method of Analysis

The HEC-2 computer program developed at the U.S. Army Corps of Engineers Hydrologic Engineering Center is used for all hydraulic analyses of Greens and Garners Bayous associated with this study. The base HEC-2 data used for all analyses was provided by the Harris County Flood Control District. Modifications have been made to the data as necessary to correct errors and discrepancies and to make the HEC-2 modeling data as accurate as possible with respect to the various conditions analyzed.

4.2 Brief Description of Hydraulic Conditions Along Greens Bayou

Greens Bayou runs from west to east across the north-central portion of Harris County. At its confluence with Garners Bayou, the channel of Greens Bayou turns southward, emptying into the Houston Ship Channel 19 stream miles from the point where Garners Bayou enters from the northeast. Much of Greens Bayou has been channelized, especially in the portion of the watershed upstream of the Garners Bayou confluence. A channel improvement project completed by the Harris County Flood Control District in the mid-1980's involved cleaning out the channel from Ditch P121-00-00 upstream to the Missouri-Pacific Railroad and widening the channel to a bottom width of 60 feet from the Missouri-Pacific Railroad to Garners Bayou.

4.3 Brief Description of Hydraulic Conditions Along Garners Bayou

Garners Bayou is, along with Halls Bayou, one of the two major tributaries to Greens Bayou. Draining a total watershed area of approximately 32 square miles, Garners Bayou has, as does Greens Bayou, a largely improved channel. Past improvements have extended downstream as far as Beltway 8. The channel downstream of Beltway 8, however, is entirely unimproved. Currently, the channel upstream of Beltway 8 is for the most part improved, uniform, and in good hydraulic condition. Downstream of Beltway 8, the channel is unimproved and partially obstructed by vegetation.

4.4 Description of HEC-2 Models Used in This Analysis

A total of twelve (12) HEC-2 models are used in this analysis. Ten of these are models of Greens Bayou. Five are multi-profile (10-year and 100-year) models representing pre-project, current, phase 1 detention, phase 2 detention, and full detention conditions within the Greens Bayou watershed. The other five are corresponding storage-discharge models used to compute Modified Puls routing data for use in HEC-1 models of the watershed. The HEC-2 models used in this analysis represent that portion of Greens Bayou extending from the Houston Ship Channel upstream to stream station 1321+51, which is near the confluence of Greens Bayou and Ditch P138-00-00. The following brief descriptions of the HEC-2 models provide an overview of the conditions represented in each.

- **P10OPRE.IH2 & P10OPRSQ.IH2 (Pre-Project):** These models represent pre-project conditions along Greens Bayou. The improvements to Greens Bayou completed in the mid-1980's are not included.
- **P10OCUR.IH2 & P10OCUSQ.IH2 (Current):** These HEC-2 models represent current conditions along Greens Bayou. Improvements to the channel of Greens Bayou between the Missouri Pacific Railroad and Garners Bayou are modeled using the Channel

SECTION 4: HYDRAULIC ANALYSIS OF GREENS AND GARNERS BAYOUS

Improvement Option of the HEC-2 computer program. The clean-out of the Greens Bayou channel from the Missouri Pacific Railroad downstream to Ditch P121-00-00 is reflected through a reduction in the Manning roughness coefficient to 0.035.

- **P10OPHS1.IH2 & P10OP1SQ.IH2** (Phase 1): These models are the same as the current conditions models, with the exception that the proposed sheet pile flood plain storage reclamation structure is included at cross-section 97300.
- **P10OPHS2.IH2 & P10OP2SQ.IH2** (Phase 2): In these models, the first phase of Basin P500-01-00 is included by modeling the proposed discharge structure at cross-section 73320. The Special Bridge Method is used to represent the discharge structure. The existence of the proposed flood water containment berm is reflected on GR records and through the use of X3 encroachments. The flood plain storage reclamation structure proposed to be located at stream station 973+00 is also included in these models.
- **P10OFULL.IH2 & P10OFLSQ.IH2** (Full Detention): The full detention models reflect the extension of the Basin P500-01-00 flood containment berm northward to Ditch P121-00-00 and an adjustment in the crest of the discharge structure overflow weir. . The flood plain storage reclamation structure proposed to be located at stream station 973+00 is also included in these models. In addition, the presence of Basin P500-03-00 is reflected through the use of NH records and high Manning roughness coefficients ($n=99$) to eliminate ineffective flow areas attributable to the proposed P500-03-00 perimeter berm. Losses in storage volume due to the presence of the perimeter berm are computed external from HEC-2, and the storage volumes computed using computer model P10OFLSQ.IH2 are adjusted manually to account for the loss. The presence of the proposed wetlands bank is accounted for by increasing Manning roughness coefficients to 0.20 to reflect berms and heavy vegetation.

The remaining two models represent Garners Bayou for pre-project and full detention conditions. The file names assigned to these models are P130PRE.IH2 and P130DET.IH2, respectively. Only these two conditions are represented in modeling efforts for Garners Bayou because only minor changes in peak flow rates in the lower reaches of Garners Bayou are associated with current, phase 1 detention, and phase 2 detention conditions. Only the full detention condition, which involves the construction of Basin P500-03-00 within the flood plain of Garners Bayou and increased urban development in the Williams Gully watershed, represents a significant potential with respect to impacts on Garners Bayou flood levels. The full detention conditions model reflects the presence of Basin P500-03-00 in the left overbank area of the channel and accounts for changes in flow rates at the proposed diversion point, which coincides closely with cross-section 4382. The Garners Bayou HEC-2 models developed for this study represent that portion of Garners Bayou between Greens Bayou and the confluence of Garners Bayou and Williams Gully.

4.5 Summary of HEC-2 Modeling Results for Greens Bayou

Tables 10 and 11 present a summary of HEC-2 modeling results for 10-year and 100-year storm events along Greens Bayou. Exhibits 27 and 28 illustrate corresponding computed water surface profiles. HEC-2 modeling results for the 10-year storm event indicate that each phase of the proposed regional detention plan plays a significant role in reducing flood levels downstream of Basin P500-01-00. With full implementation of the detention plan, computed 10-year water surface elevations are at or below corresponding pre-project values with the exception of only three of the locations included in Table 10: U.S. Highway 90, the Southern Pacific Railroad, and Greenriver Drive. Proposed water surface elevations at these locations are 0.01 foot to 0.02 foot higher than pre-project conditions values.

SECTION 4: HYDRAULIC ANALYSIS OF GREENS AND GARNERS BAYOUS

Table 10: Computed 10-Year Water Surface Elevations in Greens Bayou for Given Condition						
Location	HEC-2 Cross-Station	Computed Water Surface Elevations (feet)				
		Pre-Project	Current	Phase 1 Detention	Phase 2 Detention	Full Detention
Port Terminal Railroad	16098	8.29	9.05	8.84	8.63	8.26
Missouri Pacific Railroad	16704	8.81	9.56	9.36	9.15	8.77
Market Street	17707	9.15	9.88	9.68	9.48	9.11
Interstate Highway 10	20399	10.24	10.96	10.77	10.58	10.21
Normandy Drive	25978	13.16	13.88	13.70	13.51	13.12
Wallisville Road	43337	22.95	23.99	23.73	23.48	22.91
FM 526	45446	23.87	24.95	24.68	24.42	23.83
South Lake Houston Parkway	45726	23.94	25.03	24.76	24.50	23.91
U.S. Highway 90	58451	31.17	32.39	32.11	31.82	31.18
Southern Pacific Railroad	58532	31.24	32.46	32.18	31.89	31.25
Greenriver Drive	63892	32.24	33.63	33.31	32.98	32.26
Tidwell Road	69594	34.25	35.66	35.34	35.03	34.20
Upstream of P500-01-00	86100	43.50	41.45	41.22	42.95	42.04
North Lake Houston Parkway	87493	44.84	42.55	42.33	43.70	42.80
Missouri Pacific Railroad	90794	49.00	45.50	45.30	46.05	45.14
Upstream of Restrictor	97310	52.87	50.42	51.82	51.93	51.04
At P500-03-00	100307	54.28	51.97	53.01	53.09	52.17
Southern Pacific Railroad	118643	60.50	60.47	60.48	60.48	60.46
Homestead Road	120750	61.97	61.96	61.96	61.96	61.95
U.S. Highway 59	122332	63.27	63.27	63.27	63.27	63.26

For the 100-year storm, proposed conditions water surface elevations are at or below corresponding pre-project elevations at all locations included in Table 11. This confirms that the proposed detention plan is effective in reducing downstream peak flow rates and flood levels.

SECTION 4: HYDRAULIC ANALYSIS OF GREENS AND GARNERS BAYOUS

Table 11: Computed 100-Year Water Surface Elevations in Greens Bayou for Given Condition

Location	HEC-2 Cross-Station	Computed Water Surface Elevations (feet)				
		Pre-Project	Current	Phase 1 Detention	Phase 2 Detention	Full Detention
Port Terminal Railroad	16098	10.49	11.19	11.02	10.92	10.44
Missouri Pacific Railroad	16704	11.08	11.83	11.64	11.54	11.02
Market Street	17707	11.40	12.15	11.96	11.86	11.34
Interstate Highway 10	20399	12.59	13.41	13.20	13.09	12.52
Normandy Drive	25978	15.65	16.55	16.33	16.21	15.58
Wallisville Road	43337	26.73	28.16	27.81	27.62	26.62
FM 526	45446	27.73	29.21	28.84	28.66	27.63
South Lake Houston Parkway	45726	28.00	29.41	29.06	28.89	27.91
U.S. Highway 90	58451	35.12	36.44	36.13	35.98	35.06
Southern Pacific Railroad	58532	35.19	36.47	36.20	36.05	35.13
Greenriver Drive	63892	36.46	37.76	37.48	37.33	36.40
Tidwell Road	69594	38.55	39.76	39.44	39.32	38.31
Upstream of P500-01-00	86100	46.72	44.75	44.42	45.55	45.69
North Lake Houston Parkway	87493	48.14	45.72	45.39	46.32	46.36
Missouri Pacific Railroad	90794	52.20	48.88	48.50	49.03	48.79
Upstream of Restrictor	97310	55.63	53.60	55.37	55.35	54.55
At Basin P500-03-00	100307	56.49	55.08	56.12	56.11	55.61
Southern Pacific Railroad	118643	63.04	62.98	63.02	63.02	62.99
Homestead Road	120750	64.72	64.67	64.70	64.70	64.68
U.S. Highway 59	122332	66.52	66.49	66.51	66.51	66.49

4.6 Summary of HEC-2 Modeling Results for Garners Bayou

One of the major concerns associated with the provision of storage volume in Basin P500-03-00 for 200 acres of new development in the Williams Gully watershed is the potential for increases in flood levels along Garners Bayou between the Williams Gully confluence and the P500-03-00 diversion structure. However, the results of the HEC-2 analysis indicate that proposed conditions water surface elevations are lower than pre-project values at all points downstream of Williams Gully. Exhibit 29 illustrates computed 10-year and 100-year water surface profiles for pre-project and full detention conditions along Garners Bayou. Table 12 presents a summary of computed water surface elevations in the lower reaches of Garners Bayou.

SECTION 4: HYDRAULIC ANALYSIS OF GREENS AND GARNERS BAYOUS

Table 12: Computed Water Surface Elevations in Garners Bayou						
HEC-2 Cross- Section	Computed Water Surface Elevations (feet)					
	Pre-Project 10-Year	Full Detention 10-Year	Difference	Pre-Project 100-Year	Full Detention 100-Year	Difference
158	51.32	49.43	-1.89	52.53	52.37	-0.16
2481	53.26	51.55	-1.71	54.49	54.29	-0.20
4382	54.25	52.83	-1.42	55.49	55.20	-0.29
5222	54.69	53.58	-1.11	55.84	55.64	-0.20
6600	55.63	55.41	-0.22	56.67	56.59	-0.08
6659	55.72	55.57	-0.15	56.66	56.58	-0.08
6709	55.72	55.57	-0.15	56.66	56.58	-0.08
6814	55.74	55.59	-0.15	56.69	56.62	-0.07
6919	55.75	55.60	-0.15	56.69	56.62	-0.07
6969	55.75	55.60	-0.15	56.69	56.62	-0.07
7063	55.79	55.64	-0.15	56.77	56.70	-0.07
8192	55.92	55.78	-0.14	56.93	56.88	-0.05
9670	56.31	56.20	-0.11	57.46	57.43	-0.03
11835	57.05	56.98	-0.07	58.25	58.24	-0.01
12785	57.41	57.35	-0.06	58.73	58.72	-0.01

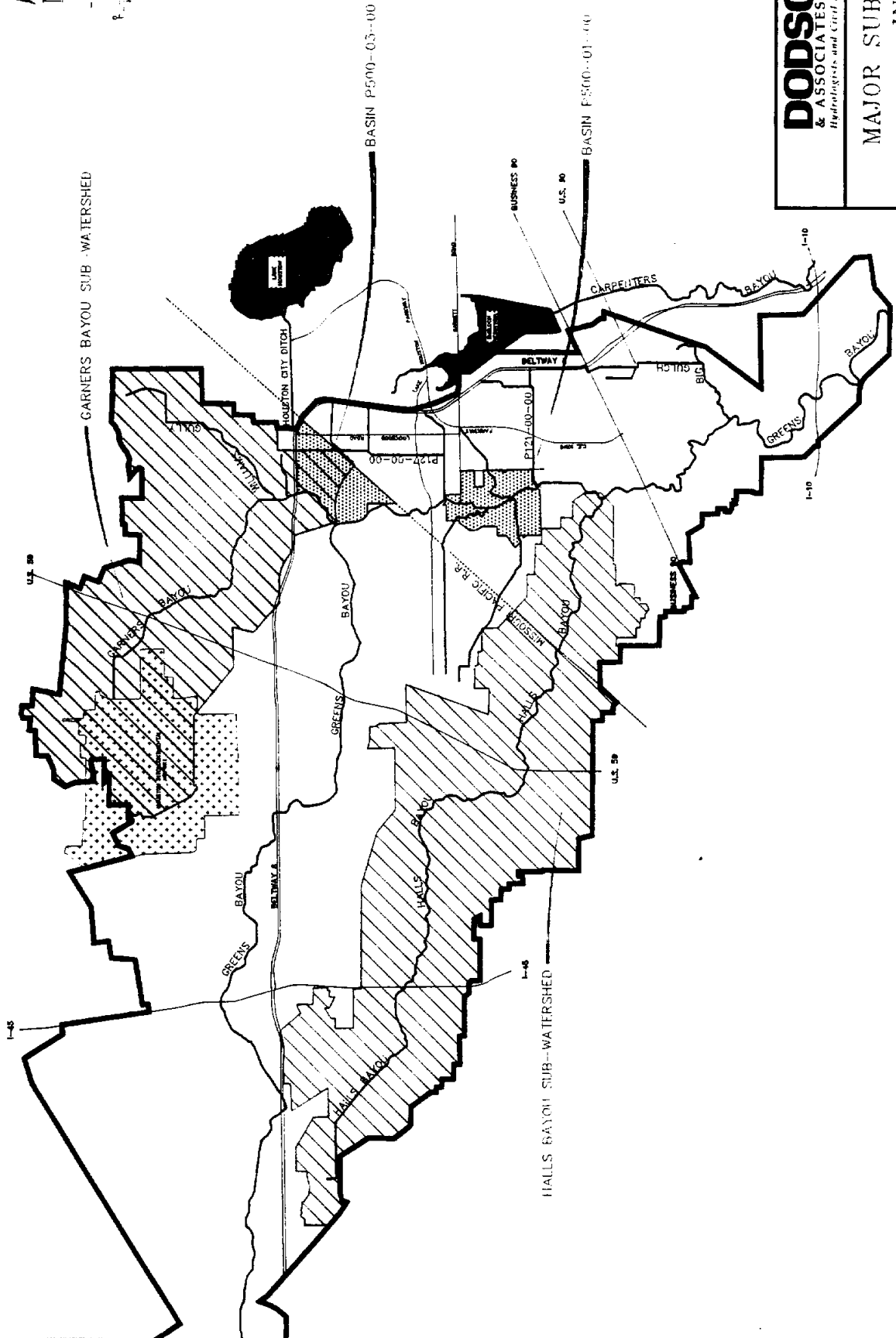
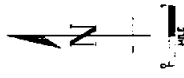

DODSON
 & ASSOCIATES, INC.
 Hydrologists and Civil Engineers

MAJOR SUB-WATERSHEDS
 IN THE
 GREENS BAYOU WATERSHED

02-30

DATE FEB. '95

NO.

2

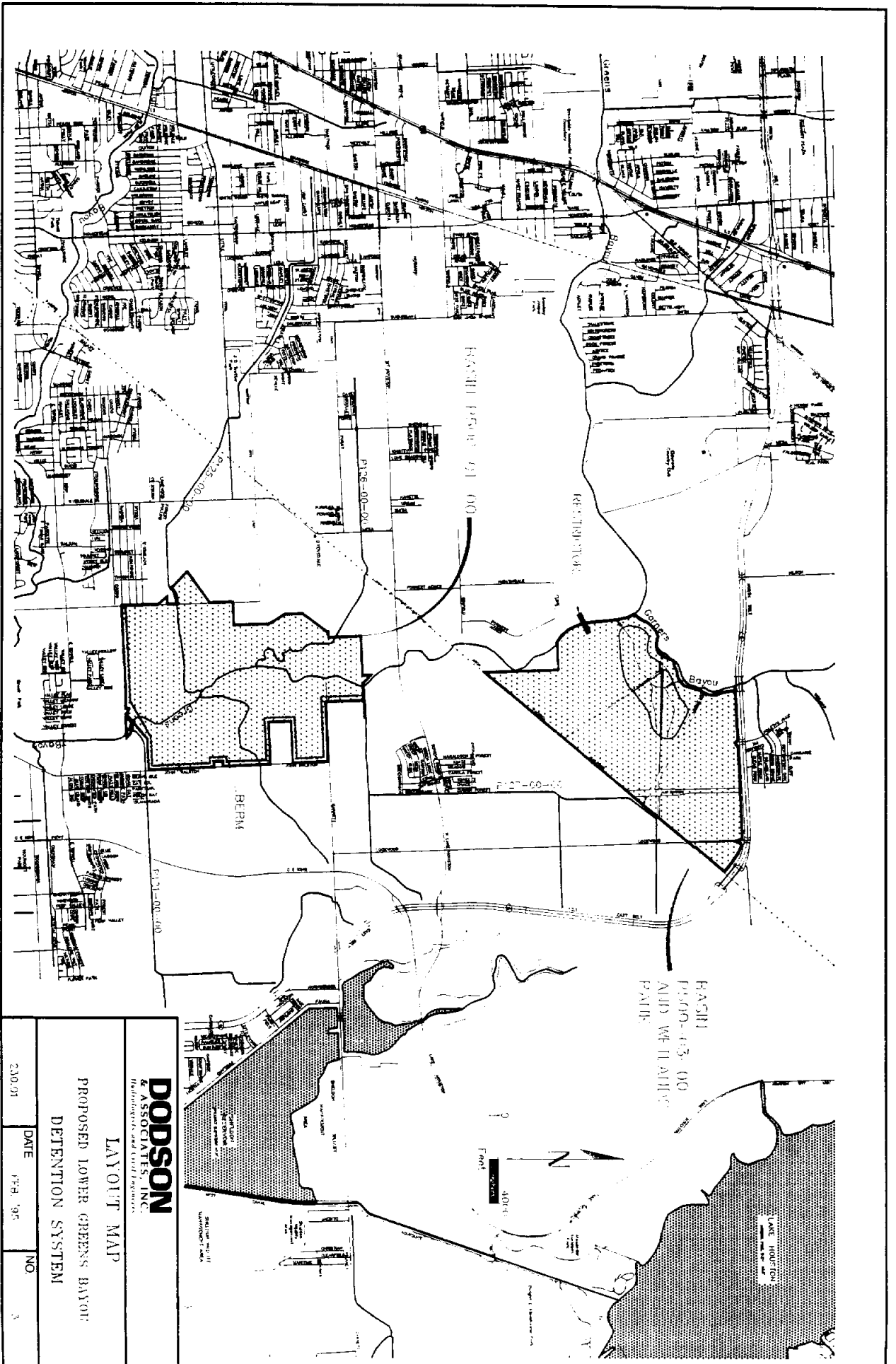

DODSON
E ASSOCIATES, INC.
Houston and Fort Worth, Texas

LAYOUT MAP
PROPOSED LOWER GREENS BAYOU
DETENTION SYSTEM

230/01	DATE	FEB '95	NO.	3
--------	------	---------	-----	---

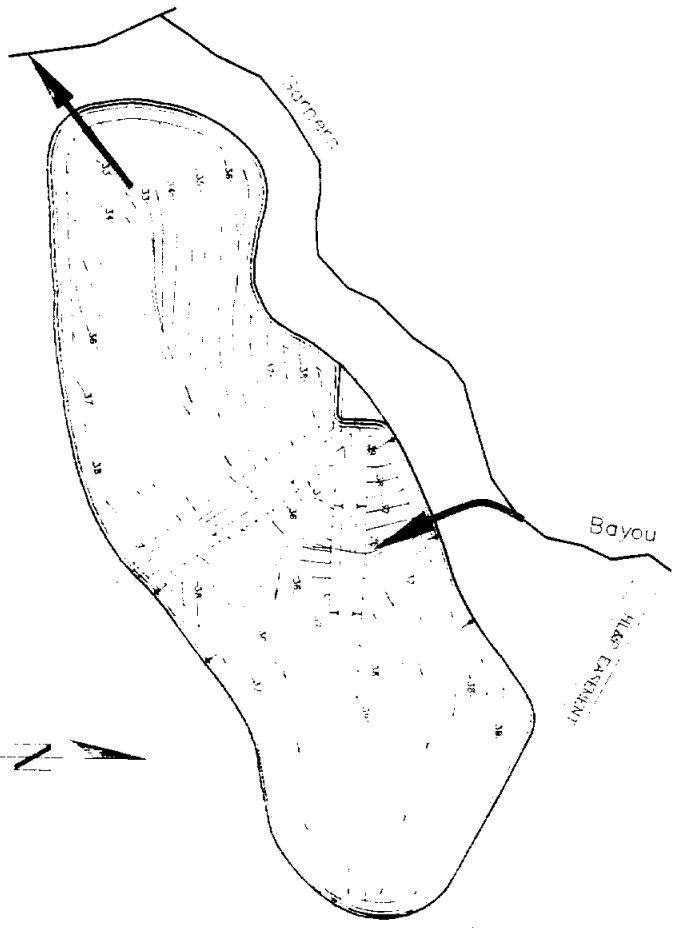
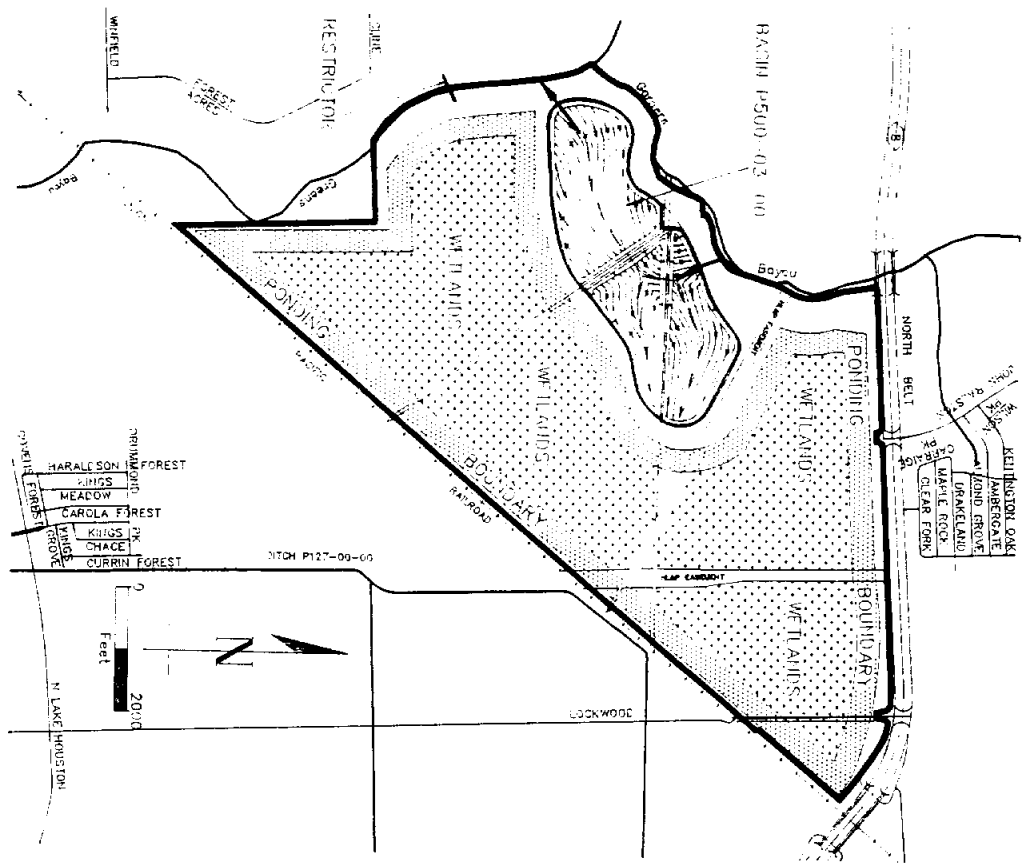

DODSON & ASSOCIATES, INC. <small>Wetland Consultants and Surveyors</small>		
SITE LAYOUT BASIN P500-03-00		
NO.	DATE	230.01
11	11/14/96	

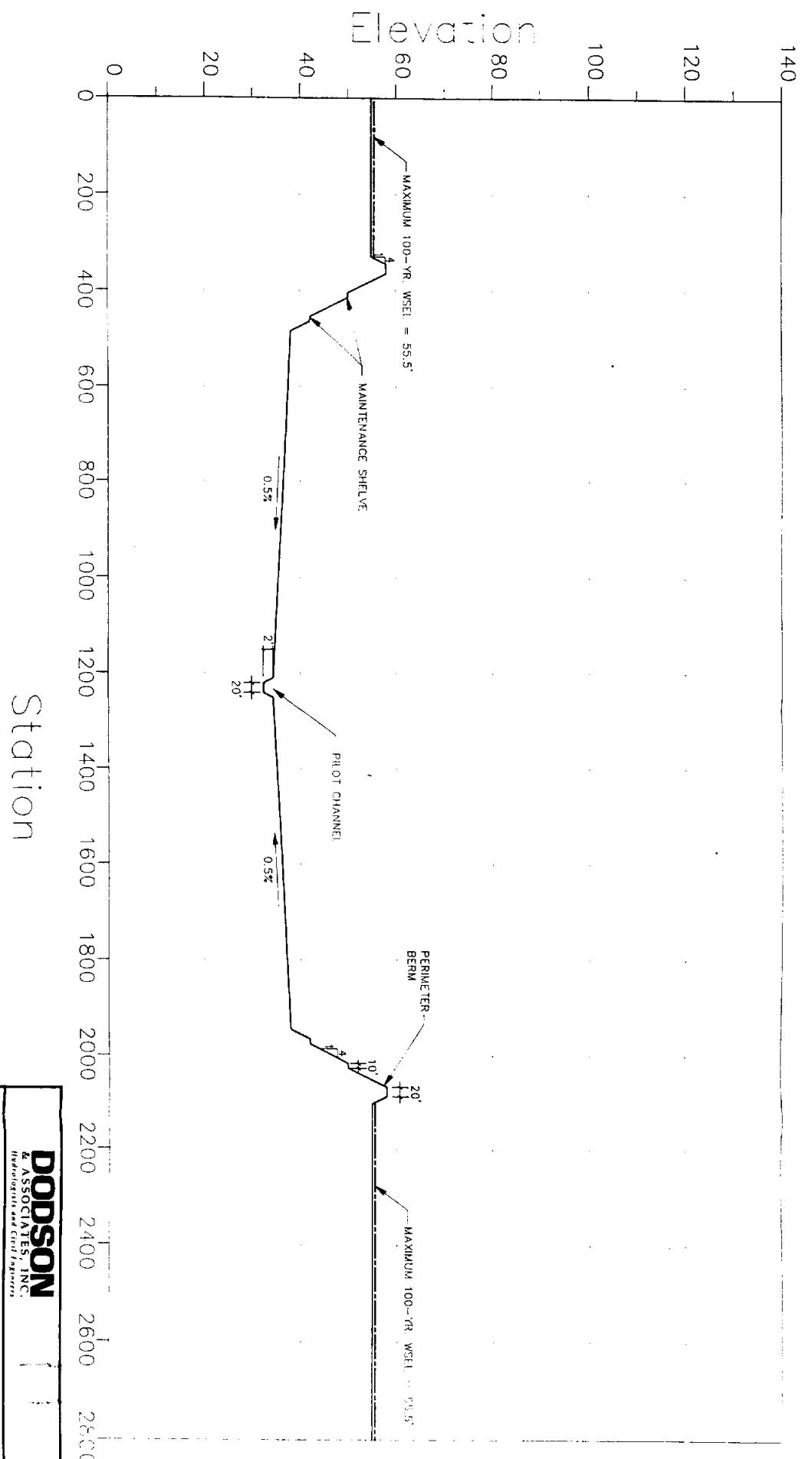

DODSON & ASSOCIATES, INC. <i>Hydrologists and Civil Engineers</i>		
TYPICAL CROSS-SECTION BASIN P500-03-00		
0230	DATE FEB. '95	NO. 13

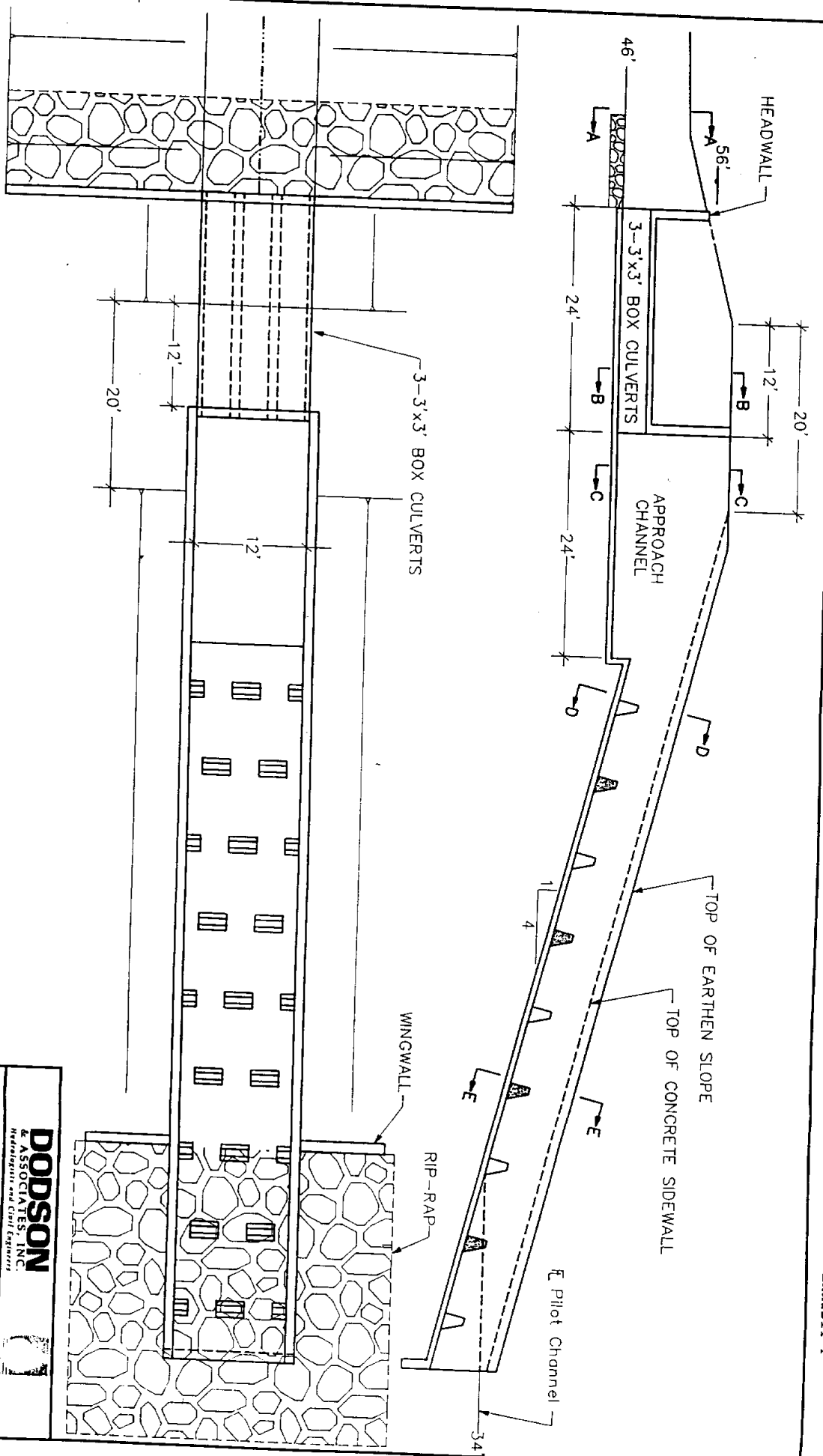

Scale: 1"=10'

DODDSON & ASSOCIATES, INC. <small>Hydrologists and Civil Engineers</small>		
PROPOSED DIVERSION STRUCTURE		
BASIN P500-03-00		
ELEVATION & PLAN VIEW		
230.01	DATE	NO.
FEB. '95		14

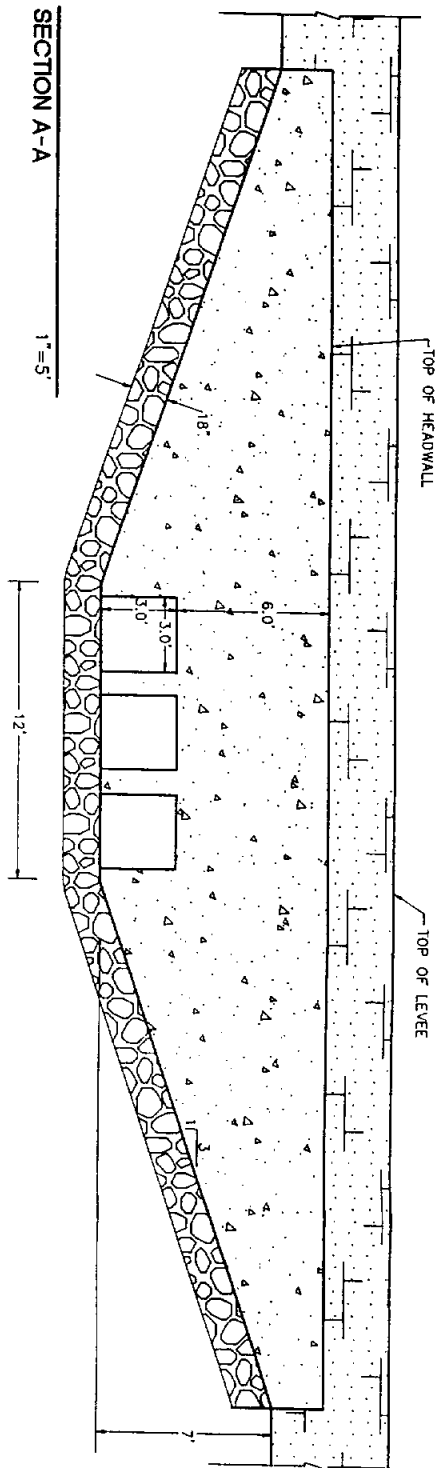

SECTION A-A

1"=5'

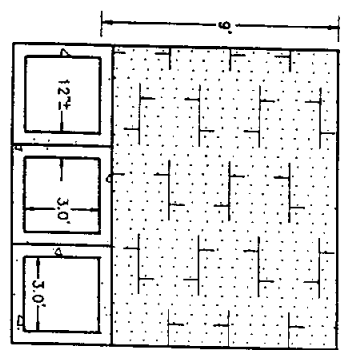

SECTION B-B

1"=5'

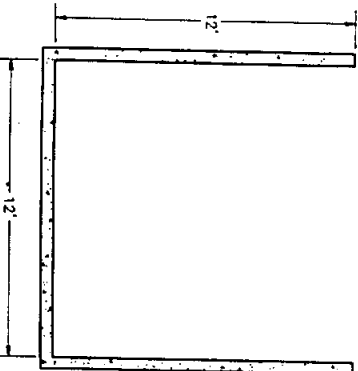

SECTION C-C

1"=5'

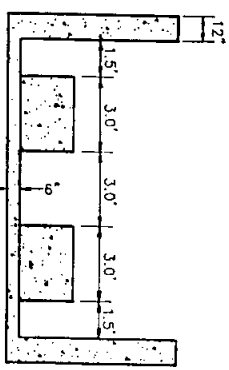

SECTION D-D

1"=5'

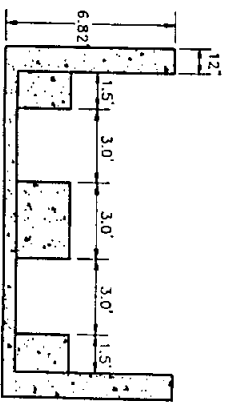

SECTION E-E

1"=5'

DODDSON & ASSOCIATES, INC. <i>Hydrologists and Civil Engineers</i>		
PROPOSED DIVERSION STRUCTURE BASIN P500-03-00 CROSS SECTIONS		
230.01	DATE FEB. '95	NO. 15

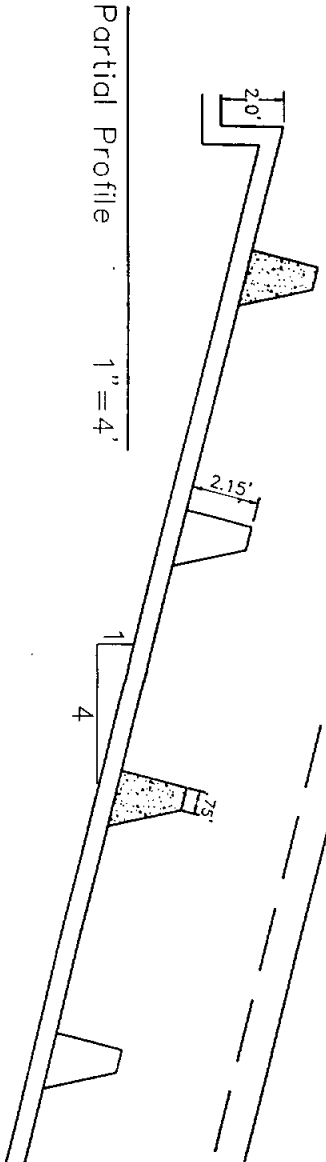
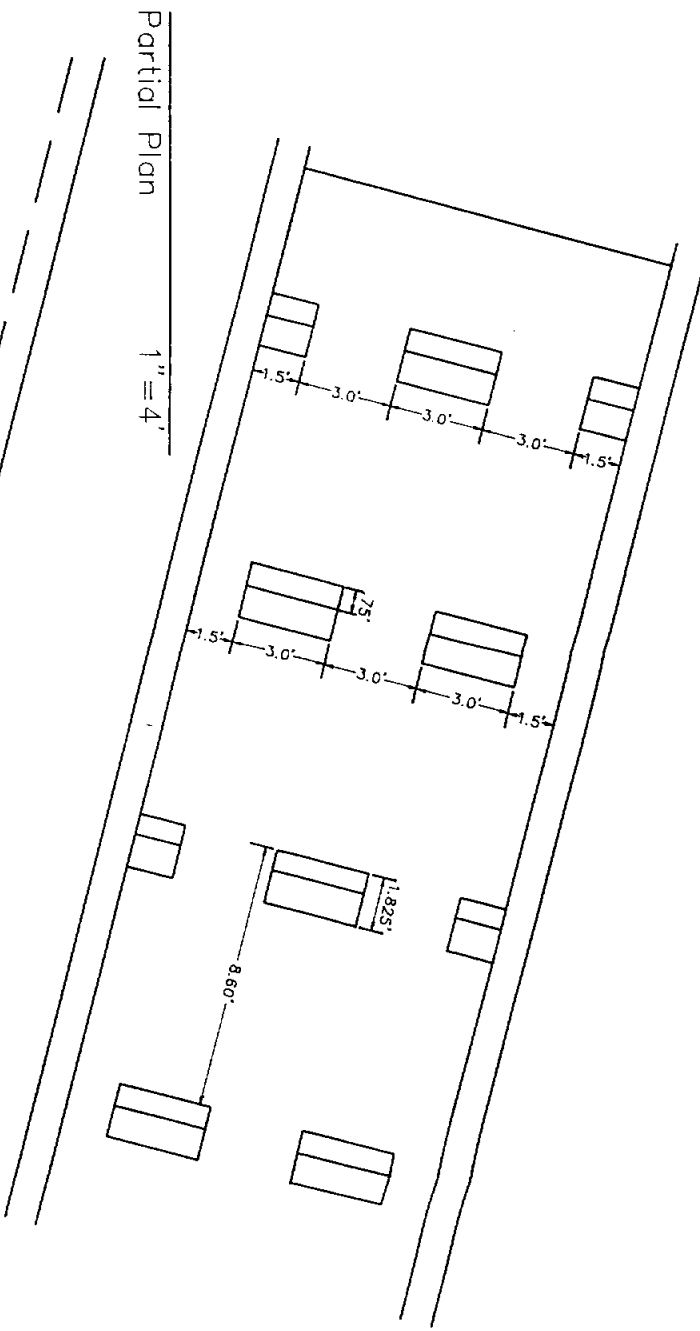

DODDSON & ASSOCIATES, INC. <i>Hydrologists and Civil Engineers</i>			
PROPOSED DIVERSION STRUCTURE			
BASIN P500-03-00			
BLOCK DIMENSIONS & SPACING			
230.01	DATE	FEB. '95	NO
			16

LONGITUDINAL SECTION 1"=40'

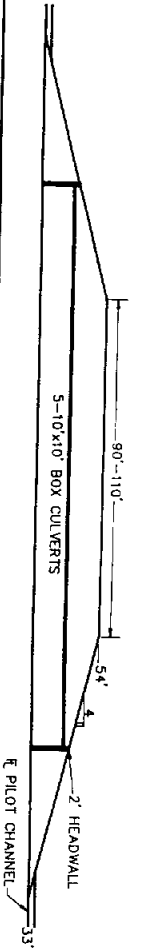

PLAN VIEW 1"=40'

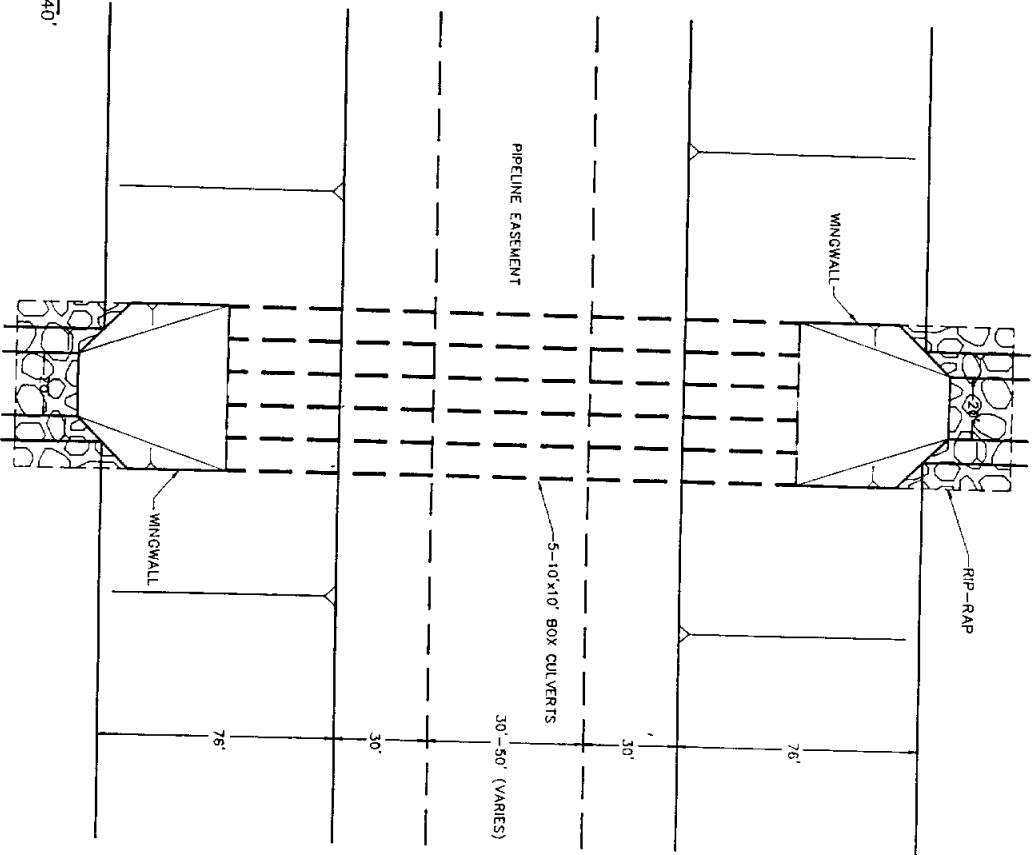

<p>DODDSON & ASSOCIATES, INC. Hydrologists and Civil Engineers</p>		
<p>PROPOSED CONNECTOR STRUCTURE BASIN P500-03-00</p>		
DATE	NO.	17
FEB. '95		
230.0'		

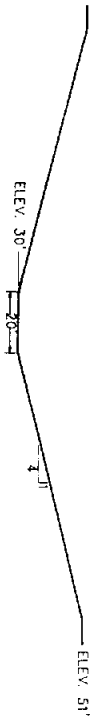
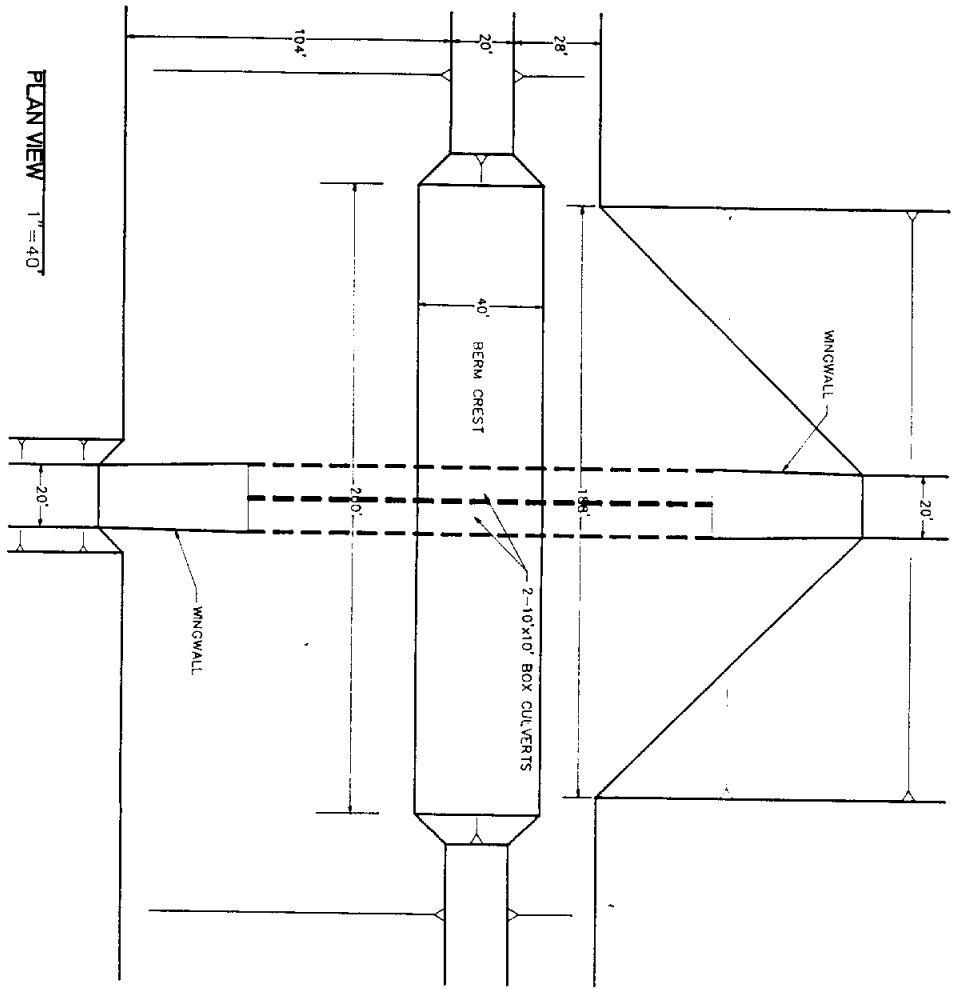
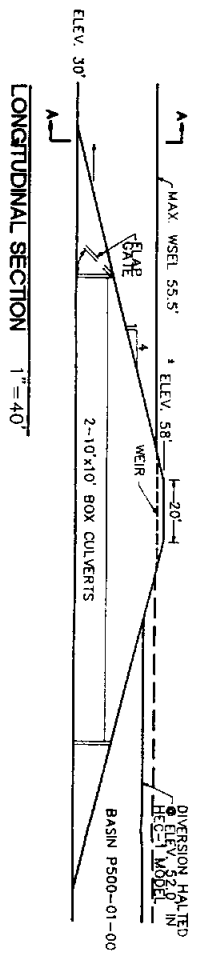

DODDSON & ASSOCIATES, INC. <i>Hydrologists and Civil Engineers</i>		
PROPOSED DISCHARGE STRUCTURE		
BASIN P500-03-00		
230.01	DATE FEB. '95	NO. 18

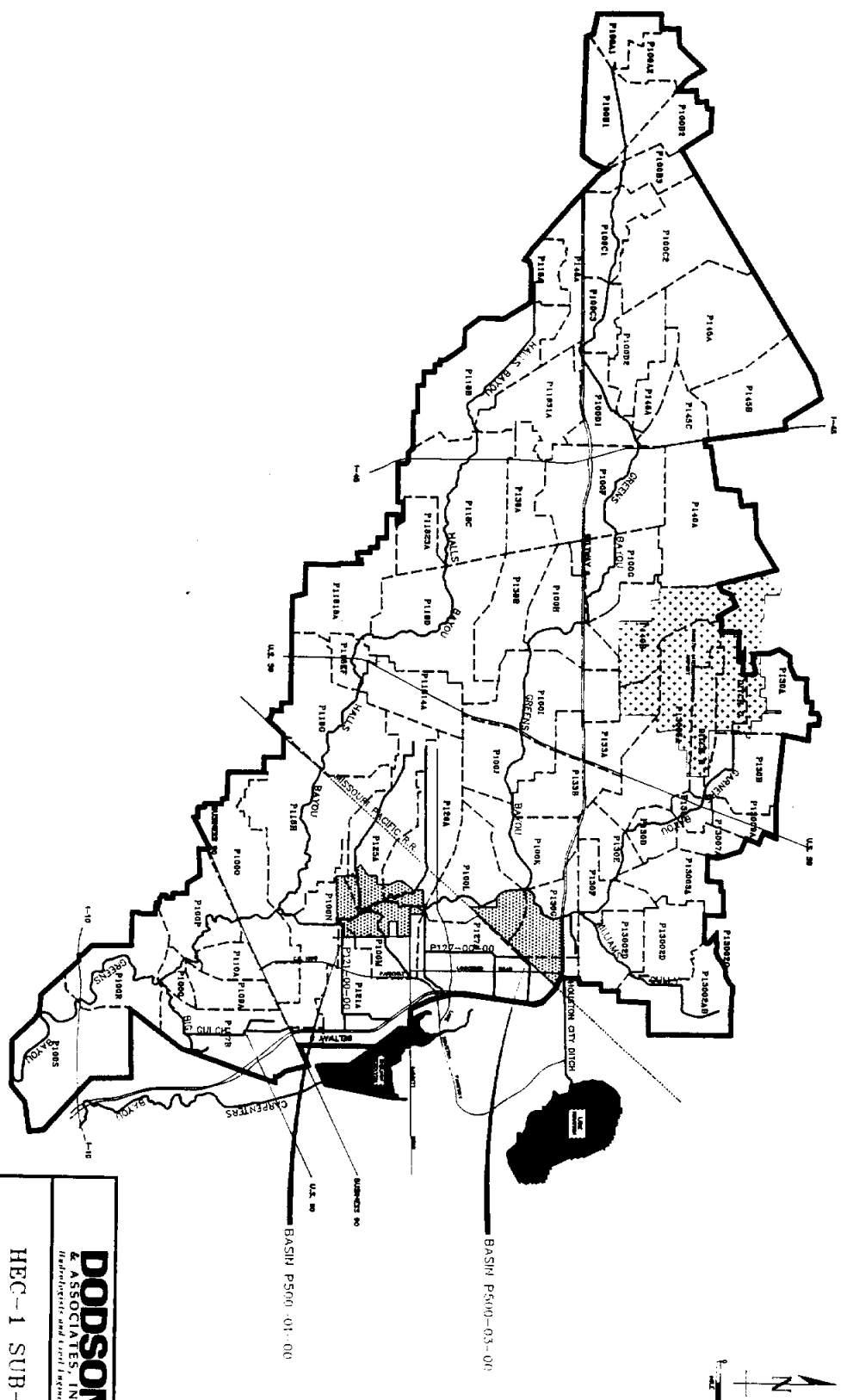

<p>DODDSON & ASSOCIATES, INC. <i>Hydrologists and Civil Engineers</i></p>		
<p>HEC-1 SUB-AREA MAP GREENS BAYOU WATERSHED</p>		
<p>0230</p>	<p>DATE FEB. '95</p>	<p>NO 19</p>

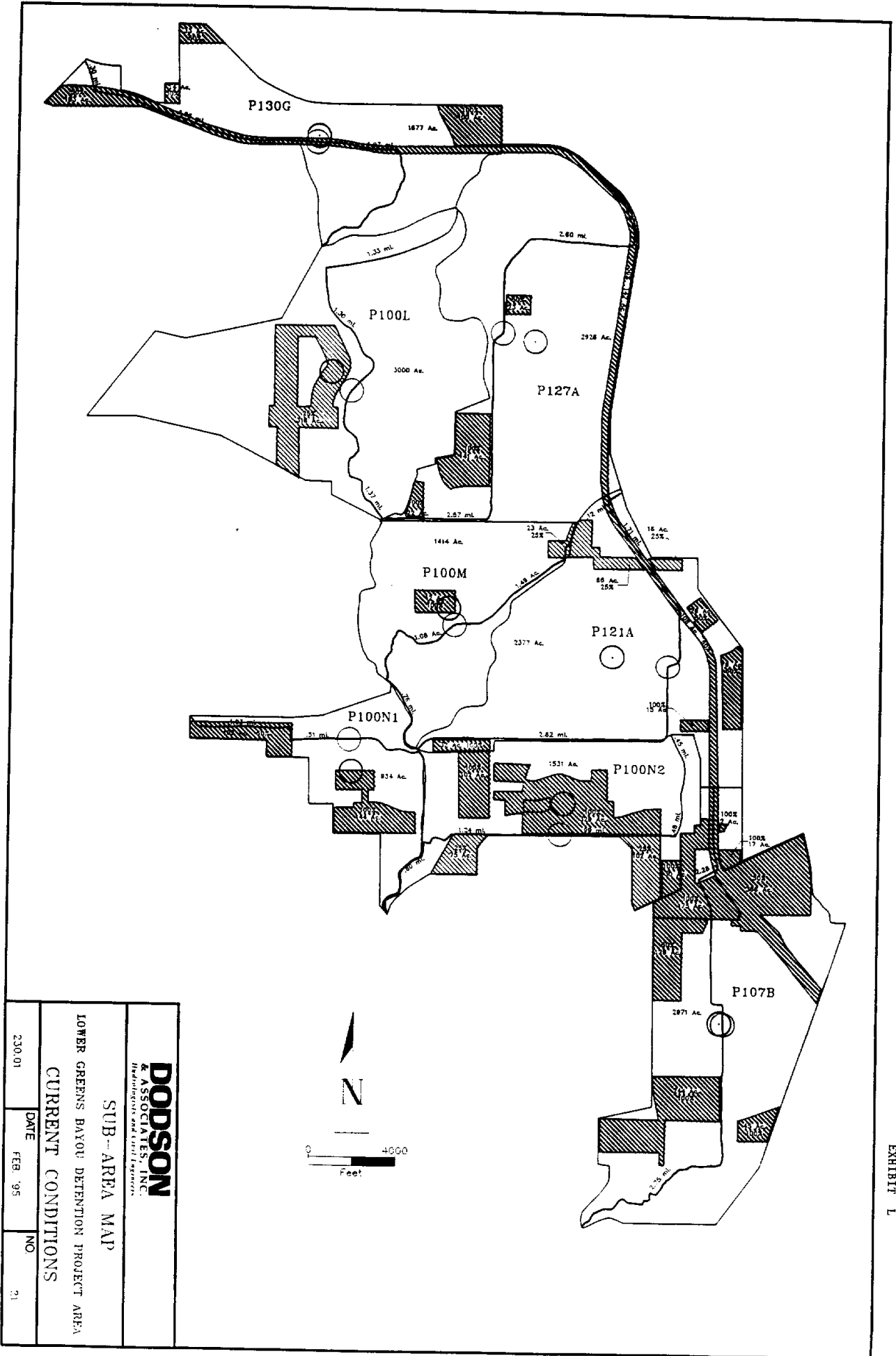

DODSON & ASSOCIATES, INC. <i>Hydrologist and Land Engineers</i>		
SUB-AREA MAP		
LOWER GREENS BAYOU DETENTION PROJECT AREA		
CURRENT CONDITIONS		
NO	DATE	230.01
21	FEB '95	

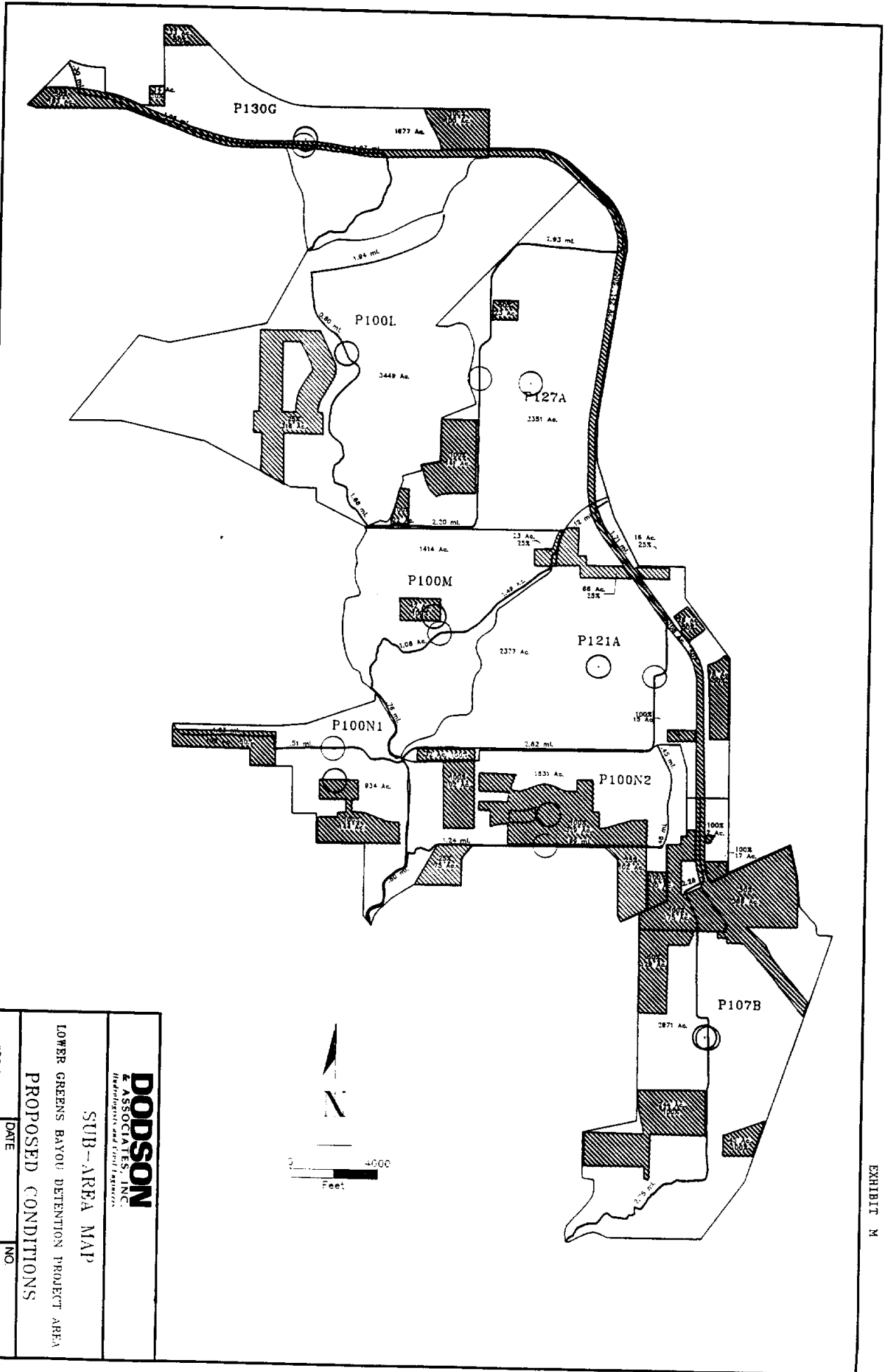

<p>DODDSON & ASSOCIATES, INC. Hydrologists and Civil Engineers</p>		
<p>SUB-AREA MAP</p>		
<p>LOWER GREENS BAYOU DETENTION PROJECT AREA</p>		
<p>PROPOSED CONDITIONS</p>		
<p>230.01</p>	<p>DATE</p>	<p>FEB '95</p>
	<p>NO</p>	<p>22</p>

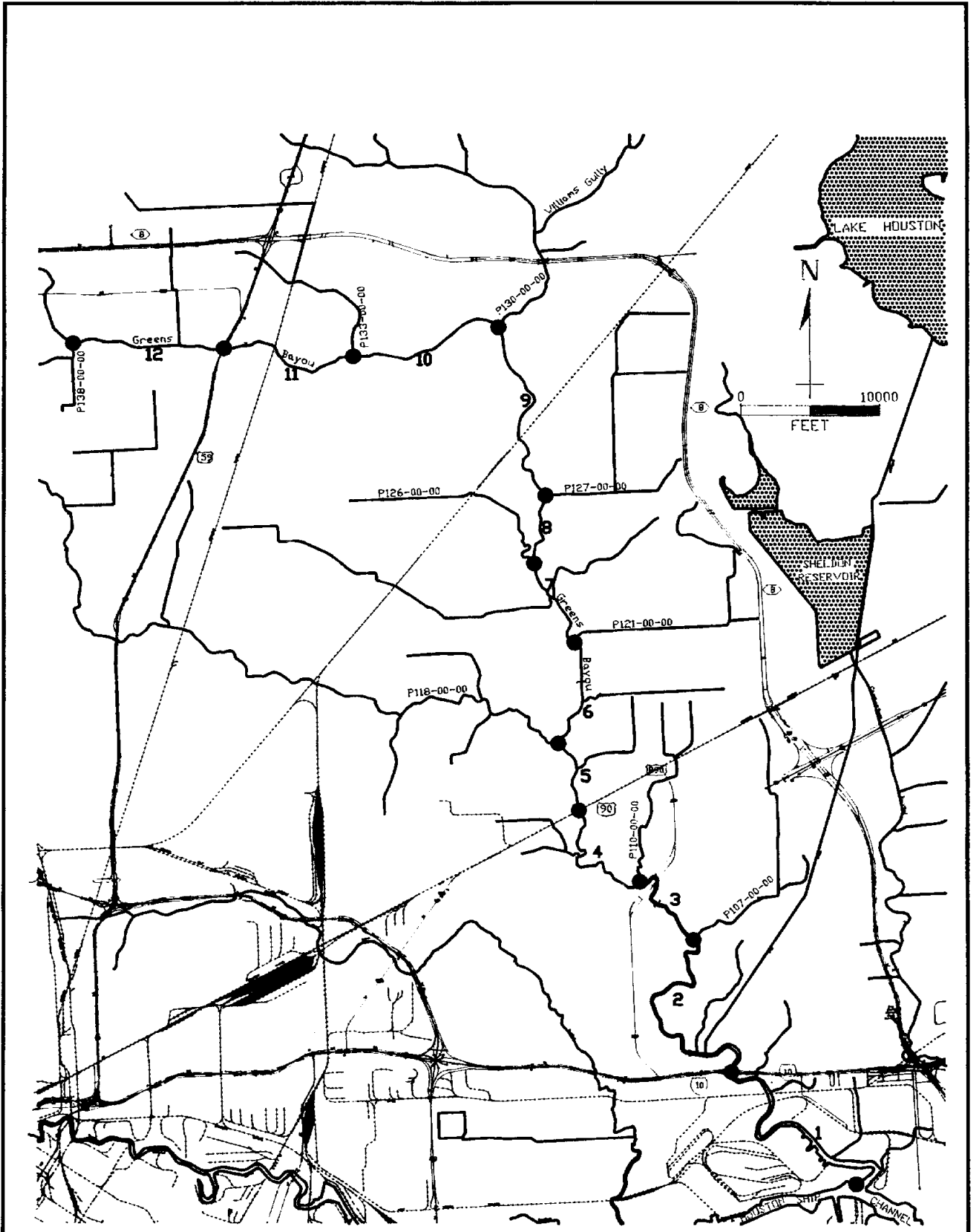

<p>HEC-1 ROUTING REACHES GREENS BAYOU WATERSHED</p>		<p>DODSON & ASSOCIATES, INC. <i>Hydrologists and Civil Engineers</i></p>	
<p>DITCH P138-00-00 TO SHIP CHANNEL</p>		<p>JOB 230.01</p>	<p>DATE FEB. '95</p>
		<p>NO. 23</p>	

B. Data Gathering and Assessments

In order to accurately evaluate the extensive physical, chemical, and biological changes that would occur as the bank develops and matures, it was necessary to gather data about characteristics of the site from both current and historical perspectives.

The data gathering process evolved over an approximate two-year period, beginning with the initial wetland analysis and delineation, continuing through the most recent surveys of the property. As a result, the site was surveyed and mapped in substantial detail for wetland patterns and types, vegetation diversity and coverage, soil patterns and types, and wildlife diversity and abundance, including avian species as well as certain mammals and reptiles.

The data gathered during these surveys provided baseline information that has been fundamental for evaluating present wetland functions and values, habitat diversity, and enhancement potential. By evaluating the site at these baseline levels, conceptual design for future gains in functions and values have been optimized, and detailed historical records have been created.

The scope of this data gathering and assessment was to perform and evaluate surveys and models of the proposed Greens Bayou Regional Detention and Wetlands Mitigation Bank. The specific tasks were as follows:

- Existing Wetlands Delineation - Determine the existing jurisdictional wetlands onsite based on soil, hydrology, and vegetative characteristics.
- Avian/Wildlife Service - Observe, document, and evaluate avian species that reside, breed, or migrate at the project site. Perform additional observations of mammals, reptiles, and amphibians and document the findings.
- Soil Survey - Perform comprehensive on-site testing, evaluation, and taxonomic referencing of soil conditions through the project site, and prepare a soil survey map of delineated trends.
- Vegetation Survey - Perform on-site surveys and historical reviews of vegetation composition throughout the project site, evaluate and identify typical plant associations and trends, and prepare a vegetation survey map of delineated patterns.
- Topographic Survey - Perform an aerial survey to determine existing topographic conditions. This information is to be used to determine existing hydrology patterns and to evaluate design alternatives to create and enhance wetlands on-site.

- Water Budget - Perform the SWRRBWQ Model (Simulator for Water Resources in Rural Basins - Water Quality) for the site to evaluate surface hydrology, runoff potential, and ponding tendencies that can be utilized in wetland designs.

1. Existing Wetlands Delineation

The long term goal of the mitigation bank project is to create wetland habitats by enhancing the existing lower quality wetlands, preserving existing pristine wetland areas, and creating new wetlands from existing uplands.

Since the creation of the mitigation bank will ultimately result in the conversion of many upland areas to wetland habitats, a baseline record of the site's current features is required in order to evaluate and monitor the changes and enhancements to habitat quality that will result from the conversion of the site to a dominantly wetland environment. Therefore, careful consideration must be given to the conditions that currently exist on the property; that is, the biological, geological, and hydrological features of the site that exist prior to commencement of project construction and development.

The project site presents a diverse blend of habitats consisting of dominantly mixed hardwood and pine forests that occupy approximately 75-80% of the property. The remainder of the site contains largely open grass prairies, the majority of which are found in two large sections on the east and north-central portions of the site.

Interspersed throughout the bank site are approximately 382 acres of wetlands that exist primarily in a network of relict stream meander scars that form the majority of topographic lows on the site. Several large prominent depressions lie within this system to form the more pristine wetland habitats on the site.

A previous Wetland Assessment study was performed for the mitigation bank property in March 1993 by W. K. Berg & Associates, Inc. for HCFCD. Some of the information presented in the report has been used as reference data for portions of this Baseline Ecological Assessment.

GREENS BAYOU MITIGATION BANK FIGURE 1 - PROJECT P500-03-00

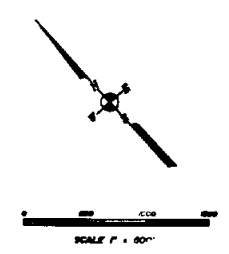
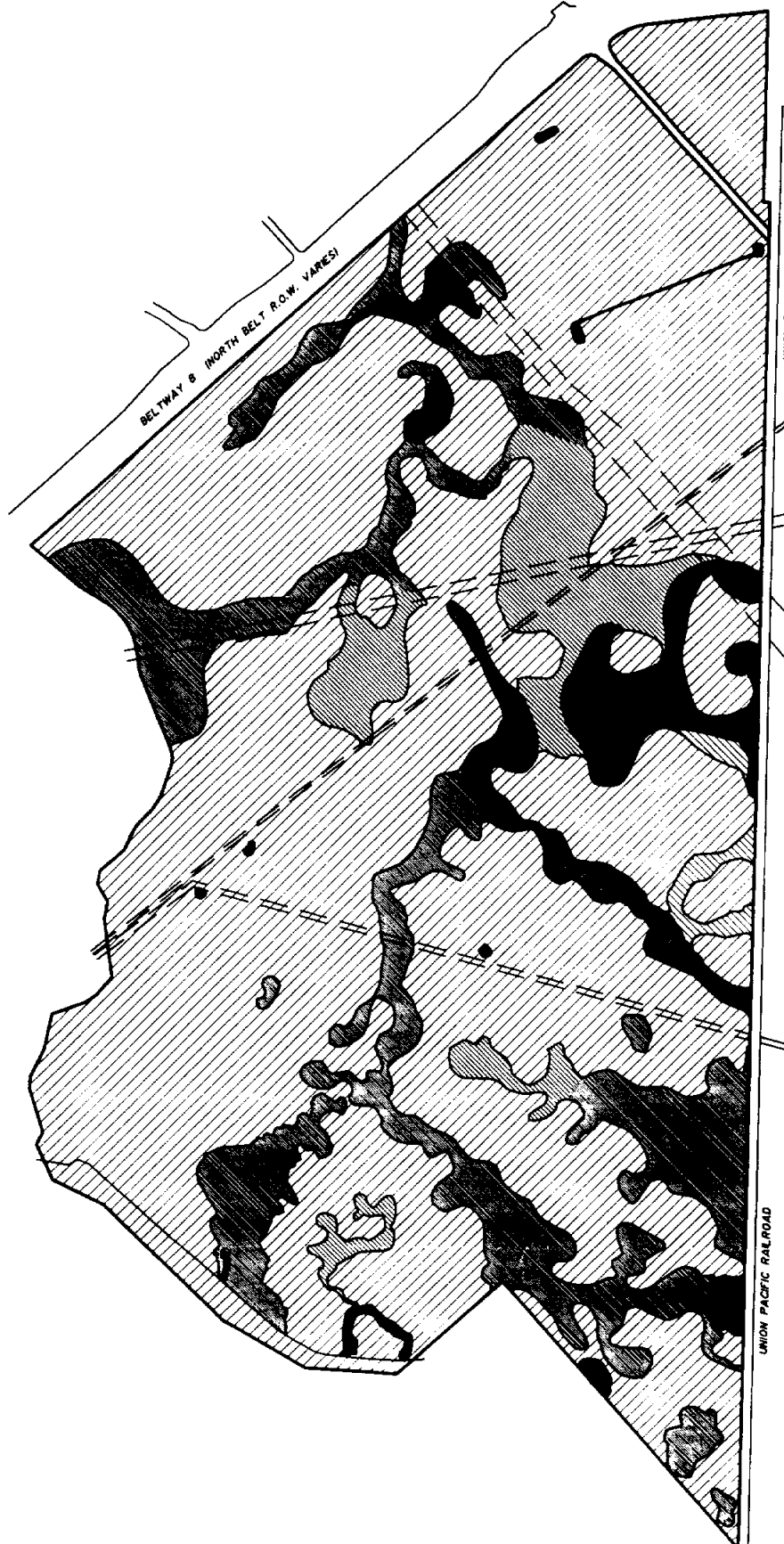

LEGEND	ACREAGE
PERMANENT WETLANDS	0.00
PERMANENT WETLANDS	0.00
PERMANENT WETLANDS - DEGRADED	0.00
PERMANENT WETLANDS - PERMANENTLY DEGRADED	0.00
COMPLEX WETLANDS	74.00
USE TO 40% WETLAND COVERAGE OF AVERAGE WETLAND DEPRECIATION PATTERNS	0.00
USE TO 20% WETLAND COVERAGE OF AVERAGE WETLAND DEPRECIATION PATTERNS	0.00
UPLAND AREAS	0.00
UPLAND DEWETLAND AREAS	0.00
TOTAL APPROXIMATE ACREAGE OF SUBJECT TRACT UNDER TOTAL APPROXIMATE ACREAGE OF WETLANDS TOTAL APPROXIMATE UPLAND ACREAGE (FWS)	74.00

GREENS BAYOU MITIGATION BANK
FIGURE 1 - PROJECT P-500-03-00
WETLAND DELINEATION MAP
HARRIS COUNTY, TEXAS

REVISIONS:

REV. 1 1982 BY C. H. ANDREWS
REV. 2 1983 BY C. H. ANDREWS
REV. 3 1984 BY C. H. ANDREWS
REV. 4 1984 BY C. H. ANDREWS
REV. 5 1984 BY C. H. ANDREWS

W.K. BERG & ASSOCIATES, INC.
ENVIRONMENTAL ENGINEERING, SCIENCE
& LAND USE CONSULTANTS
14811 ST. MART'S LANE, SUITE 863
HOUSTON, TEXAS 77079 PHONE (713) 660-0888

0 11311878

BIRD SURVEY
GARNERS BAYOU MITIGATION SITE

HARRIS COUNTY, TEXAS

Conducted for
W. K. BERG & ASSOCIATES
Houston, Texas

by
John L. Tveten, Ph.D.
and
Gloria A. Tveten

January/February 1994

TABLE OF CONTENTS

	<u>Page</u>
SUMMARY.....	1
OBJECTIVES.....	2
CONCLUSIONS.....	3
SITE DESCRIPTION.....	5
SEASONAL INFLUENCES.....	5
Spring and Fall.....	6
Winter.....	7
Summer.....	7
SURVEY METHODS.....	8
MAJOR HABITATS.....	9
Deciduous Woodland.....	9
Pine Woodland.....	10
Thickets and Brushy Edges.....	10
Grassy Fields and Corridors.....	11
Ponds and Bayous.....	11
WETLAND POTENTIAL.....	12
SUGGESTED PLANTINGS FOR BIRDS.....	13
Wetland Plants.....	13
Upland Plants.....	13
Birdhouses.....	14
APPENDIX	
Bird Checklist.....	5 pages
Daily Survey Routes.....	5 pages
Potential Nesting Birds.....	3 pages
Bibliography.....	1 page

SUMMARY

The Garners Bayou Mitigation Site contains a number of different ecological habitats and plant communities and harbors a corresponding diversity of bird species. Seventy-four (74) species were recorded in five visits to the site during the months of January/February 1994. The species identified were those to be expected for the region during the winter season.

Construction of additional wetlands on the site in question would be expected to increase the use by various waterfowl. Several species of ducks could be attracted to the ponds in winter; herons, rails and gallinules, and other marsh birds would probably inhabit the vegetated margins of the ponds.

A checklist of the birds observed during the winter season and their numbers is appended to this report. Also included is a list of potential nesting birds based on their known breeding ranges and the habitat presently available.

OBJECTIVES

1. To conduct a census of the bird species utilizing the Garners Bayou Mitigation Site during January/February 1994.
2. To determine the bird species and their numbers in each of the different habitat types on the Garners Bayou tract.
3. To construct a list of potential nesting species based on habitats currently available.
4. To predict the effect on bird populations of increasing the number and size of ponds and other wetland habitats.
5. To suggest appropriate cover and food plants to attract birds to the various upland and wetland habitats.

CONCLUSIONS

1. Diversity of ecological habitats on the Garners Bayou Mitigation Site is high, with an attendant diversity of bird species .
2. Seventy-four (74) species of birds were observed on the tract during January/February 1994. A list of these species and their daily numbers is appended to this report.
3. No extremely rare or unusual birds were detected. Most species to be expected in the area were observed in normal numbers.
4. The majority of the upland song birds were present in the small mixed feeding flocks that range widely through the deciduous and pine woodlands. This is the normal behavior for these birds during the winter months.
5. Several hawks, owls, and pileated woodpeckers were observed, indicating a rather productive woodland habitat with adequate food reserves.
6. Only a few ducks and other waterfowl were observed, primarily in water-filled ditches and along Greens and Garners bayous. Many of the small ponds on the tract are too heavily wooded to attract most waterfowl species.
7. Increasing the number and size of ponds and other wetland habitats could be expected to increase the number of water birds. These wetlands would provide wintering grounds for ducks as well as feeding areas and potential nest sites for herons and other wading birds, rails and gallinules, and such marsh dwellers as red-winged blackbirds, common yellowthroats, and marsh wrens.
8. Selected grasses and other native plants could be planted around wetland areas to provide cover and food, thereby increasing bird populations. Similarly, planting of fruiting trees in upland areas would attract additional birds, particularly during migration.

A list of potential nesting birds was constructed based on the known ranges of these birds within the region and the habitats presently available on the Garners Bayou tract. It is unlikely, however, that all of these species are present during the breeding season. While some birds are year-round residents of Harris County, many others spend only the winter or summer months. Still others pass through eastern Texas during their spring and fall migrations. Another census should be conducted in early summer to determine the current status of nesting species.

SITE DESCRIPTION

The Garners Bayou Mitigation Site is located within the northeastern corner of Beltway 8 that circles Houston, Texas. That beltway serves as the northern boundary of the site, while the Beaumont, Sour Lake, and Western Railway track borders the property on the east. Garners Bayou and Greens Bayou downstream from its junction with Garners Bayou provide the western boundary. Lockwood Road cuts across the northeastern corner of the tract; several power-line and pipeline corridors transect the remainder of the property.

Much of the site is presently a mixed hardwood/pine woodland, with pines predominating in the northwestern portion. Although some large timber remains, the tract has been logged extensively. Open, marshy areas occur at lower elevations, and several ponds and oxbows provide permanent water. The utility corridors; the northeastern corner bordered by Beltway 8, Lockwood Road, and the railroad track; and the mowed bank of Greens Bayou offer open, grassy areas attractive to many species of birds. Brushy woodland borders, particularly along the railroad track, harbor wintering sparrows and other species that prefer thicket habitats.

This vegetational diversity provides habitats for a wide range of bird species. Most of the expected winter birds were encountered during the period of this survey.

SEASONAL INFLUENCES

Some birds are permanent residents of the region and doubtless remain year-round on or near the tract in question. Many others, however, occur only during certain seasons of the year. Some are breeding summer residents, departing for the American tropics in the fall and returning again in spring. Their places are taken in winter by other species that move southward from more northern latitudes. In addition to these nesting and wintering populations, there are many other birds that appear only during the spring and fall migrations as they move from the North to the American tropics and back again.

Birds migrate with the seasons to ensure adequate food supplies, not in response to cold weather, although the latter factor is of secondary importance. Thus most of the flycatchers, warblers, thrushes, orioles, buntings, tanagers, grosbeaks, and other avian families that feed largely on insects and fruits spend our winter months in Central and South America. These "neotropical migrants" are replaced in Texas during that season by numerous sparrows, finches, blackbirds, and others that subsist primarily on seeds and the occasional insects and berries still available.

Species diversity reaches its maximum during spring and fall migrations when numerous long-distance migrants cross eastern Texas, mixing with both summer and winter residents. These migrations are particularly difficult to survey, however, for they are highly dependent on local weather. Birds moving northward across the Gulf of Mexico in spring congregate along the Texas coast in enormous numbers when they have battled strong headwinds or rain produced by an advancing weather system. Upon reaching land, they then drop into the nearest shelter to rest and feed, filling the trees and bushes. Flying through clear skies or with a following wind, on the other hand, migrants may continue far inland before stopping. Thus on warm, clear spring days, only small numbers of arriving migrants will be seen in coastal counties.

A Birder's Checklist of the Upper Texas Coast lists more than 400 species for the six-county area centered around Houston. With the exception of those species that seldom stray from salt water, virtually any of those 400 birds might occur on the survey site over a period of several years. The creation of a year-round checklist would thus be a long-term project.

Winter

Wintering and nesting population are easier to assess and are probably of greater importance in terms of avian survival. They are essentially independent of weather, more limited in scope, and less likely to change dramatically from year to year. There is always the possibility, however, that previously undetected birds might be present in a given year, particularly as habitat changes occur.

The authors of this survey, conducted in January/February 1994, found seventy-four (74) bird species on the Garners Bayou Mitigation Site. A few species would undoubtedly be added by further surveys, but most of the expected birds were encountered. The attached list should provide good baseline data for evaluation of the tract as a wintering ground for local bird populations.

Summer

A list of potential nesting birds is also appended to this report. It was constructed from area checklists of breeding birds and the habitats presently available on the mitigation site. Some of those species (*) were also encountered on the winter survey and are likely to be year-round residents. Others will not arrive until spring. It must be noted that this is a hypothetical list, based on the experience of the authors. In order to have good baseline data on breeding birds, we suggest conducting another population survey during the nesting season, perhaps in early June.

SURVEY METHODS

The attached bird checklist was compiled by the two authors during five visits to the Garners Bayou site. These occurred on January 10, 12, and 31 and on February 3 and 6, 1994. As far as possible, sunny days with little wind were selected, although some rain was encountered. Temperatures varied from near freezing to 70 degrees, with dramatic fluctuations from day to day. During favorable winter weather, the small woodland birds are likely to be more active and vocal and large raptors are more likely to be on the wing. Bird counts thus tend to be higher on clear, still days.

Schematic maps appended to this report show the route taken on each census day. Bird numbers can thus be traced to particular sections of the tract or to particular habitats. Some species were recorded only once during the census period; many others were present in good numbers every day. The daily numbers for each species are shown on the checklist.

Utility corridors, woodland trails, the railroad track, and Lockwood Road provided access to various segments of the site, and all sections were covered on one or more days. The authors moved slowly along these routes and through the woods, observing the birds with 10x40 Zeiss and 8x36 Bausch and Lomb binoculars. Several species were also identified and counted by hearing their characteristic songs and calls.

Tape recordings of an eastern screech-owl were used to attract many of the birds and entice them from dense cover. Such recordings are particularly effective with sparrows, wrens, and many of the small woodland birds that travel in mixed, wideranging feeding flocks. The "mobbing" of owls by other birds is a well-documented behavior. In addition, the vocal squeaks and chips routinely used by birders lured many secretive birds into closer range.

MAJOR HABITATS

It is possible to make some general statements about bird populations in specific habitats; however, many of the species roam widely through the surrounding area and may occur in several ecological niches. They may also be present in a particular tract one day and absent the next. This is especially true during the winter season, when birds must range widely in search of food. Resident species are much more stable during the

breeding season, when they establish and defend specific territories and can be found there day after day.

The most abundant inhabitants of the deciduous and mixed woodlands were small songbirds that congregate in mixed flocks to troop through the trees in search of food. Such cooperative behavior apparently allows the flock to investigate more territory in search of new resources and to avoid covering niches already explored by other individuals. Periodic use of screech-owl tape recordings lured these flocks into range, sometimes within a few feet of the observers.

Most abundant and vocal of the mixed-flock birds were Carolina chickadees and ruby-crowned kinglets. With them were smaller numbers of tufted titmice, golden-crowned kinglets, blue-gray gnatcatchers, solitary vireos, orange-crowned warblers, yellowrumped warblers, pine warblers, eastern phoebes, and an occasional hermit thrush, downy woodpecker, and yellow-bellied sapsucker. A single brown creeper was discovered with one flock.

Also present, but less inclined to congregate with others, were numerous blue jays, northern cardinals, and brown thrashers. American robins and cedar waxwings were observed feeding on the abundant fruits of yaupon and American holly, while American goldfinches and a pine siskin fed among flowering red maples. At least one pair of red-bellied woodpeckers and a pair of pileated woodpeckers appear to be resident in the woodlands, and two different pairs of red-shouldered hawks were sighted on one occasion. The presence of the latter raptors suggests a fairly stable and productive environment.

Pine Woodland

Small pines predominate in some sections of the woodland tracts, particularly in the northwestern corner of the site. In general, these tend to be less productive for birds than the deciduous or mixed woodlands. Several of the small, mixed songbird flocks were located among the pines, however, and chickadees were particularly common.

A number of pine warblers were found in the wooded areas during the survey, and some of these are likely to remain as breeding residents. This species, as its name suggests, is strongly tied to a pine-forest habitat, particularly during the nesting season. It is thus a species that would decline if the pines were cleared for wetland creation. Most of the other avian species prefer bottomland hardwoods as nesting sites and would be affected to a lesser extent.

Thickets and Brushy Edges

Several bird species prefer the dense cover of shrubby thickets overgrown with vines and briar tangles to the relatively open woodlands with reduced understory vegetation. Such habitats are present along the edges of the woodlands, where they border the utility corridors and bayous, and along the railroad track. Particularly common in this environment were several species of native sparrows, dark-eyed juncos, gray catbirds, Carolina and house wrens and northern cardinals. and will move northward in the spring. Other birds, however, will nest preferentially in such thicket habitats during the summer months. To maintain maximum avian diversity, it is important to preserve, and perhaps even create, shrubby thickets along boundaries between woodlands and open, grassy areas.

Grassy Fields and Corridors

Several bird species prefer open, grassy habitats to more wooded environments. These are provided on the Garners Bayou site by the long-grass field east of Lockwood Road, the southern portion of the tract along the west side of Lockwood Road, and the utility corridors that transect the property.

Red-tailed hawks, turkey vultures, and black vultures were seen regularly hunting over the open areas and perching on the powerline towers or in trees along the woodland edges. Great blue herons and great egrets were also seen in the wet portions of the clearings and in water-filled ditches. Mourning doves, feral rock doves, killdeer, American crows, American pipits, Savannah sparrows, red-winged blackbirds, common grackles, and brown-headed cowbirds made up the bulk of birds encountered in the grassland tracts.

The field east of Lockwood Road, in the northeastern corner of the site, provides a unique habitat. Although it did not harbor many bird species, it contained the majority of the sedge wrens and swamp sparrows, species that prefer wet, marshy grasslands and thickets. Both are winter residents and will not be present during the breeding season. A very large flock of eastern meadowlarks was also discovered foraging in the field.

Ponds and Bayous

Only a few waterfowl were encountered during the survey. Doublecrested cormorants and lesser scaup were present on Greens Bayou, and a pair of buffleheads flushed from Garners Bayou near its junction with Greens Bayou. A pair of wood ducks occupied a woodland pond along the railroad track, and another wood duck and a green-winged teal were discovered in a water-filled ditch along the track. A single flock of snow geese flew overhead on one day of the survey but did not land.

Most of the ponds on the property are too heavily wooded to provide favorable habitats for any waterfowl except wood ducks. In addition, the fast-flowing bayous provide little food or cover. Thus, it appears unlikely that the Garners Bayou site would presently attract significant numbers of waterfowl.

It should be noted, however, that smaller songbirds were present in considerable numbers in the long grasses and shrubs around the ponds and ditches. These included eastern phoebes, swamp sparrows, common yellowthroats, and yellow-rumped warblers. The plumegrass wetland near the southern end of the site also harbored a single marsh wren that responded to taped owl calls.

WETLAND POTENTIAL

Increasing the extent of the wetland areas on the Garners Bayou Mitigation Site has the potential for creating habitat for both wintering waterfowl and nesting water and marsh birds. Ducks, gallinules, grebes, and herons would all be attracted to more open water, providing it contains sufficient plant and animal life to sustain the bird populations. In addition, several species of songbirds would be expected to forage and nest along the edges of such environments.

It would be desirable, from an avian standpoint, to stock ponds with small fish and other aquatic life and to provide water plants for both cover and food. The edge cover would also prove important in attracting marshland birds. Several suggestions are offered in the section below. These changes could be effected without severely altering the productivity of the adjacent deciduous woodlands.

SUGGESTED PLANTINGS FOR BIRDS

Wetland Plants

In order to attract significant numbers of birds, it will be important to provide appropriate food and cover plants in any wetlands improved or constructed on the Garners Bayou site. Ones proven to be popular waterfowl food include pondweeds (*Potamogeton* sp.), sedges (*Carex* sp.), and members of the

knotweed/smartweed Ocomplex (*Polygonum sp.*).

Several grasses planted around the edges of these wetlands would likewise serve both waterfowl and smaller perching birds. Among the best wildlife foods are the panicums (*Panicum sp.*), paspalums (*Paspalum sp.*), and bristlegasses (*Setaria sp.*).

Southern wax-myrtle (*Myrica cerifera*) now grows in several of the open, marshy areas, and this species would provide good cover along the fringes of the wetlands. Its fruits are eaten by wintering warblers and other birds.

Upland Plants

Many of the birds were observed feeding on the fruits of yaupon (*Ilex vomitoria*) and American holly (*Ilex opaca*) present in substantial numbers in the deciduous and mixed woodlands. The planting of additional fruiting trees and shrubs in the open woodlands and around new or existing wetlands would greatly increase available food for birds. Red mulberry (*Morus rubra*) is favored by a wide variety of songbirds, and its fruiting season corresponds with the spring migration along the Texas coast. Its use is highly recommended. American beautyberry (*Callicarpa americana*) is an attractive woodland shrub whose fruits are used extensively by fall and winter birds.

Open, sunlit areas would benefit from plantings of the various amaranths, or pigweed species, (*Amaranthus sp.*) and some of the sunflowers. Common sunflower (*Helianthus annuus*) and swamp sunflower (*Helianthus angustifolius*) grow vigorously in Harris County and provide abundant seeds for birds and other wildlife.

Birdhouses

The Garners Bayou site lies along the southern edge of the normal nesting range of the eastern bluebird, a species that has been aided greatly in recent years by the construction of bluebird nest boxes. These beautiful and highly beneficial birds prefer nest sites in open areas near scattered trees; thus, the woodland edge along Greens Bayou and the margins of other wooded tracts would provide excellent locations for a "bluebird trail."

Larger nest boxes in wetland areas might also serve breeding wood ducks, and smaller boxes would accommodate such songbirds as Carolina chickadees and tufted titmice. Regular maintenance and cleaning of the birdhouses would be required, but a scout troop or youth group might adopt such a project in the future if the Garners Bayou site is opened to the public.

The construction of additional wetland areas, combined with wellplanned plantings of appropriate food plants and with nesting sites would, in the opinion of the authors, increase dramatically the potential of the Garners Bayou Mitigation Site for birds and other wildlife.

BIRD CHECKLIST

GARNERS BAYOU MITIGATION SITE

January 10, 1994 - February 6, 1994

John & Gloria Tveten

<u>Bird Species</u>	<u>Date and Numbers</u>				
	<u>1/10</u>	<u>1/12</u>	<u>1/31</u>	<u>2/3</u>	<u>2/6</u>
Double-crested Cormorant <i>Phalacrocorax auritus</i>	4		1		
Great Blue Heron <i>Ardea herodias</i>	2	3	2	4	1
Great Egret <i>Casmerodius albus</i>		1	1		2
Snow Goose <i>Chen caerulescens</i>	40				
Wood Duck <i>Aix sponsa</i>				2	1
Green-winged Teal <i>Anas crecca</i>					1
Lesser Scaup <i>Aythya affinis</i>			7		
Bufflehead <i>Bucephala albeola</i>			2		
Black Vulture <i>Coragyps atratus</i>	2		8	6	
Turkey Vulture <i>Cathartes aura</i>	30	21	40	14	3
Coopers Hawk <i>Accipiter cooperii</i>				1	
Red-shouldered Hawk <i>Buteo lineatus</i>	1	1	4	2	2
Red-tailed Hawk <i>Buteo jamaicensis</i>	1	2	3	3	1

2 - Bird Checklist

	<u>1/10</u>	<u>1/12</u>	<u>1/31</u>	<u>2/3</u>	<u>2/6</u>
American Kestrel <i>Falco sparverius</i>		2		1	1
Northern Bobwhite <i>Colinus virginianus</i>					2
Killdeer <i>Charadrius vociferus</i>		3			4
Spotted Sandpiper <i>Actitis macularia</i>			1		
Ring-billed Gull <i>Larus delawarensis</i>	1	6			
Rock Dove <i>Columba livia</i>		2		16	30
Mourning Dove <i>Zenaida macroura</i>		3	2		2
Great Horned Owl <i>Bubo virginianus</i>					1
Barred Owl <i>Strix varia</i>		1			
Belted Kingfisher <i>Ceryle alcyon</i>			1		
Red-bellied Woodpecker <i>Melanerpes carolinus</i>	1	2	2	3	2
Yellow-bellied Sapsucker <i>Sphyrapicus varius</i>		2	6	4	3
Downy Woodpecker <i>Picoides pubescens</i>	1		3	2	2
Northern Flicker <i>Colaptes auratus</i>	1		1		1
Pileated woodpecker <i>Dryocopus pileatus</i>	1		2	2	
Eastern Phoebe <i>Sayornis phoebe</i>	4	3	8	9	5

3 - Bird Checklist

	<u>1/10</u>	<u>1/12</u>	<u>1/31</u>	<u>2/3</u>	<u>2/6</u>
Blue Jay <i>Cyanocitta cristata</i>	30	23	35	6	5
American Crow <i>Corvus brachyrhynchos</i>	40	23	30	45	25
Carolina Chickadee <i>Parus carolinensis</i>	20	20	37	25	15
Tufted Titmouse <i>Parus bicolor</i>		3	16	10	4
Brown Creeper <i>Certhia americana</i>			1		
Carolina Wren <i>Thryothorus ludovicianus</i>	1	5	5	5	1
House Wren <i>Troglodytes aedon</i>	2	3	3	10	2
Sedge wren <i>Cistothorus platensis</i>		1		9	6
Marsh Wren <i>Cistothorus palustris</i>	1				
Golden-crowned Kinglet <i>Regulus satrapa</i>		5	12		
Ruby-crowned Kinglet <i>Regulus calendula</i>	6	32	75	50	30
Blue-gray Gnatcatcher <i>Poliopitila caerulea</i>		6	10	2	1
Hermit Thrush <i>Catharus guttatus</i>		2	4	3	2
American Robin <i>Turdus migratorius</i>	5	24	25	6	250
Gray Catbird <i>Dumetella carolinensis</i>		1	1	1	
Northern Mockingbird <i>Mimus polyglottos</i>	3	4	4	8	10

4 - Bird Checklist

	<u>1/10</u>	<u>1/12</u>	<u>1/31</u>	<u>2/3</u>	<u>2/6</u>
Brown Thrasher <i>Toxostoma rufum</i>	1	1	7	2	2
American Pipit <i>Anthus rubescens</i>				27	
Cedar Waxwing <i>Bombycilla cedrorum</i>					4
Loggerhead Shrike <i>Lanius ludovicianus</i>				2	1
European Starling <i>Sturnus vulgaris</i>			1	31	14
White-eyed Vireo <i>Vireo griseus</i>			1		
Solitary Vireo <i>vireo solitarius</i>		2	4		
Orange-crowned Warbler <i>Vermivora celata</i>	8	10	55	9	4
Yellow-rumped Warbler <i>Dendroica coronata</i>	15	10	17	25	20
Pine Warbler <i>Dendroica pinus</i>		5	2	10	
Common Yellowthroat <i>Geothlypis trichas</i>	1			3	
Northern Cardinal <i>Cardinalis cardinalis</i>	25	12	33	55	50
Chipping Sparrow <i>Spizella passerina</i>			20	2	8
Field Sparrow <i>Spizella pusilla</i>				1	
Vesper Sparrow <i>Pooecetes gramineus</i>				2	
Savannah Sparrow <i>Passerculus sandwichensis</i>		6	30	25	30

5 - Bird Checklist

	<u>1/10</u>	<u>1/12</u>	<u>1/31</u>	<u>2/3</u>	<u>2/6</u>
Song Sparrow <i>Melospiza melodia</i>			2	4	3
Lincoln's Sparrow <i>Melospiza lincolnii</i>		2	3	2	
Swamp Sparrow <i>Melospiza georgiana</i>		5		60	6
White-throated Sparrow <i>Zonotrichia albicollis</i>	3		30	40	20
White-crowned Sparrow <i>Zonotrichia leucophrys</i>			2		
Harris' Sparrow <i>Zonotrichia querula</i>			1		
Dark-eyed Junco <i>Junco hyemalis</i>				4	
Red-winged Blackbird <i>Agelaius phoeniceus</i>			20		15
Eastern Meadowlark <i>Sturnella magna</i>			2		200
Common Grackle <i>Quiscalus quiscula</i>			35		
Brown-headed Cowbird <i>Molothrus ater</i>				4	
Pine Siskin <i>Carduelis pinus</i>			1		
American Goldfinch <i>Carduelis tristis</i>			6	30	25

74 Species

POTENTIAL NESTING BIRDS

GARNERS BAYOU MITIGATION SITE

John & Gloria Tveten

The following list contains potential nesting birds based on known breeding ranges and the habitats presently available on the Garners Bayou tract. Several other species breed within the county, but conditions do not presently appear suitable for nesting on the tract under consideration. For example, no evidence of previous nesting by colonial herons was observed. If larger pond areas with scattered trees and shrubs are subsequently developed, this potential would increase.

* Species observed during winter census in January-February 1994

- Green Heron, *Butorides virescens*
- Yellow-crowned Night-Heron, *Nyctanassa violacea*
- * Wood Duck, *Aix sponsa*
- Mottled Duck, *Anas fulvigula*
- * Black Vulture, *Coragyps atratus*
- * Turkey Vulture, *Cathartes aura*
- * Red-shouldered Hawk, *Buteo lineatus*
- * Northern Bobwhite, *Colinus virginianus*
- King Rail, *Rallus elegans*
- Common Moorhen, *Gallinula chloropus*
- * Killdeer, *Charadrius vociferus*
- Black-necked Stilt, *Himantopus mexicanus*
- * Mourning Dove, *Zenaida macroura*
- Inca Dove, *Columbina inca*
- Yellow-billed Cuckoo, *Coccyzus americanus*
- Barn Owl, *Iyto alba*
- Eastern Screech-Owl, *Otus asio*
- * Great Horned Owl, *Bubo virginianus*
- * Barred Owl, *Strix varia*
- Common Nighthawk, *Chordeiles minor*
- * Belted Kingfisher, *Ceryle alcyon*
- Red-headed Woodpecker, *Melanerpes erythrocephalus*
- * Red-bellied Woodpecker, *Melanerpes carolinus*

2 - Potential Nesting Birds

- *Downy Woodpecker, *Picoides pubescens*
- *Northern Flicker, *Colaptes auratus*
- *Pileated Woodpecker, *Dryocopus pileatus*
- Eastern Wood-Pewee, *Contopus virens*
- Acadian Flycatcher, *Empidonax virens*
- Great Crested Flycatcher, *Myiarchus crinitus*
- Eastern Kingbird, *Tyrannus tyrannus*
- Scissor-tailed Flycatcher, *Tyrannus forficatus*
- *Blue Jay, *Cyanocitta cristata*
- *American Crow, *Corvus brachyrhynchos*
- *Carolina Chickadee, *Parus carolinensis*
- *Tufted Titmouse, *Parus bicolor*
- *Carolina Wren, *Thryothorus ludovicianus*
- *Marsh Wren, *Cistothorus palustris*
- *Blue-gray Gnatcatcher, *Poliophtila caerulea* Eastern Bluebird, *Sialia sialis*
- *Northern Mockingbird, *Mimus polyglottos*
- *Brown Thrasher, *Toxostoma rufum*
- *Loggerhead Shrike, *Lanius ludovicianus*
- *European Starling, *Sturnus vulgaris*
- *White-eyed Vireo, *Vireo griseus*
- *Pine Warbler, *Dendroica pinus*
- Prothonotary Warbler, *Protonotaria citrea*
- Swainson's Warbler, *Limnithlypis swainsonii*
- Kentucky Warbler, *Oporornis formosus*
- *Common Yellowthroat, *Geothlypis trichas*
- Hooded Warbler, *Wilsonia citrina*
- Yellow-breasted Chat, *Icteria virens*
- Summer Tanager, *Piranga rubra*
- *Northern Cardinal, *Cardinalis cardinalis*
- Blue Grosbeak, *Guiraca caerulea*
- Indigo Bunting, *Passerina cyanea*
- Painted Bunting, *Passerina ciris*
- Dickcissel, *Spiza americana*
- *Red-winged Blackbird, *Agelaius phoeniceus*
- *Eastern Meadowlark, *Sturnella magna*
- *Common Grackle, *Quiscalus guiscula*
- *Brown-headed Cowbird, *Molothrus ater*
- Orchard Oriole, *Icterus spurius*

BIBLIOGRAPHY

- Dauphin, David T., A. Noel Pettingell, and Edward R. Rozenburg. 1989. *A birder's checklist of the upper Texas coast*. 7th ed. Houston: Outdoor Nature Club.
- Hatch, Stephan L., Kancheepuram N. Gandhi, and Larry E. Brown. 1990. *Checklist of the vascular plants of Texas*. College Station: Texas A&M Univ.
- Lane, James A. and John L. Tveten, 1984. *A birder's guide to the Texas coast*. Denver: L&P Press.
- Martin, Alexander C., Herbert S. Zim, and Arnold L. Nelson. 1961. *American Wildlife & Plants: A guide to wildlife food habits*. New York: Dover.
- National Geographic Society. 1987. *Field guide to the birds of North America*. 2nd ed. Washington, D.C.
- Oberholser, Harry C. 1974. *The bird life of Texas*. 2 vols. Edited by Edgar B. Kincaid, Jr. Austin: Univ. of Texas Press.
- Robison, B.C., photos by John L. Tveten. 1990. *Birds of Nouston*. Houston: Rice Univ. Press.
- Tveten, John L. 1993. *The birds of Texas*. Fredericksburg, Texas: Shearer Publishing.

SURVEY ROUTES

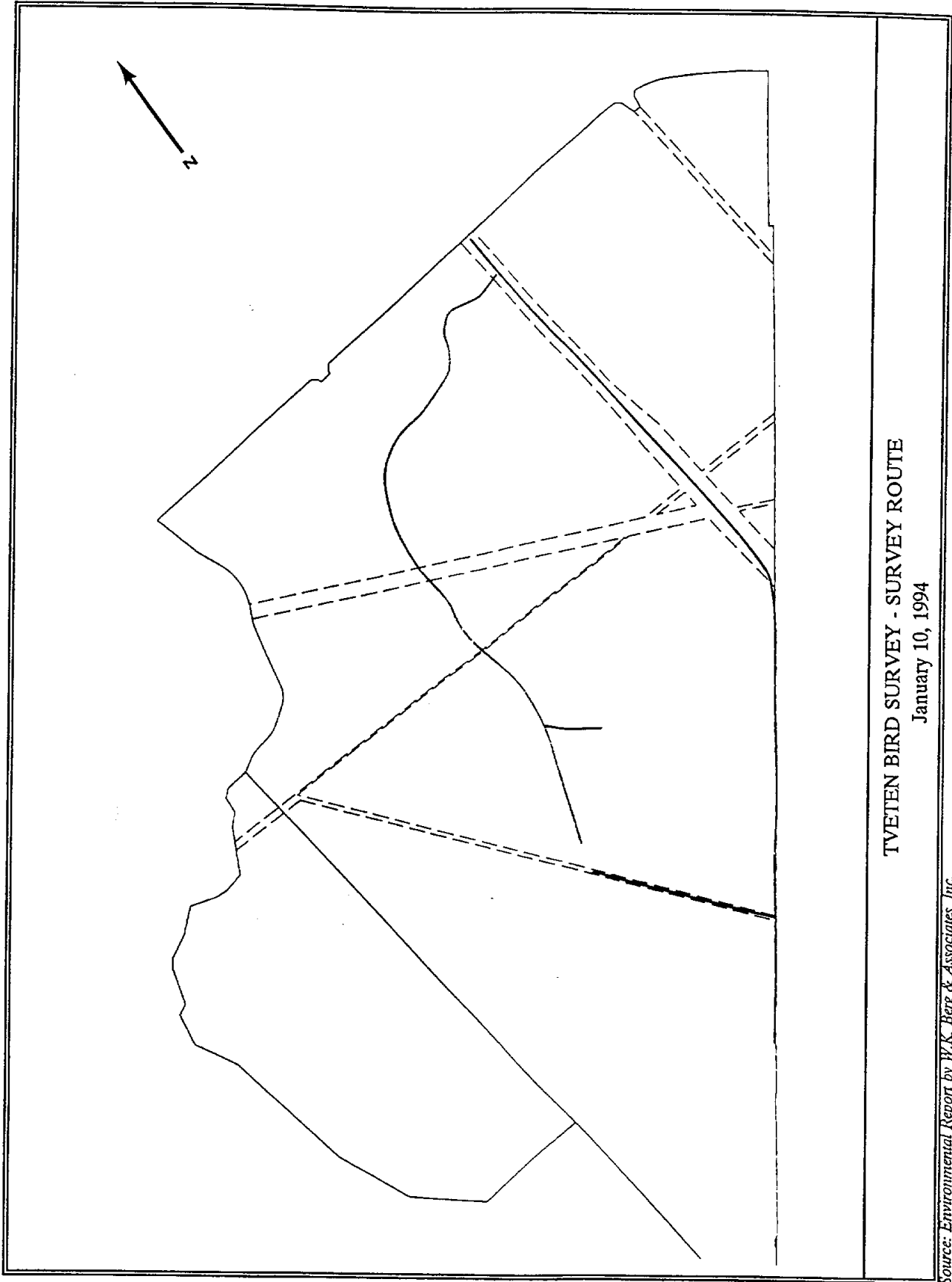

TVEIEN BIRD SURVEY - SURVEY ROUTE

January 10, 1994

Source: Environmental Report by W.K. Berg & Associates, Inc.

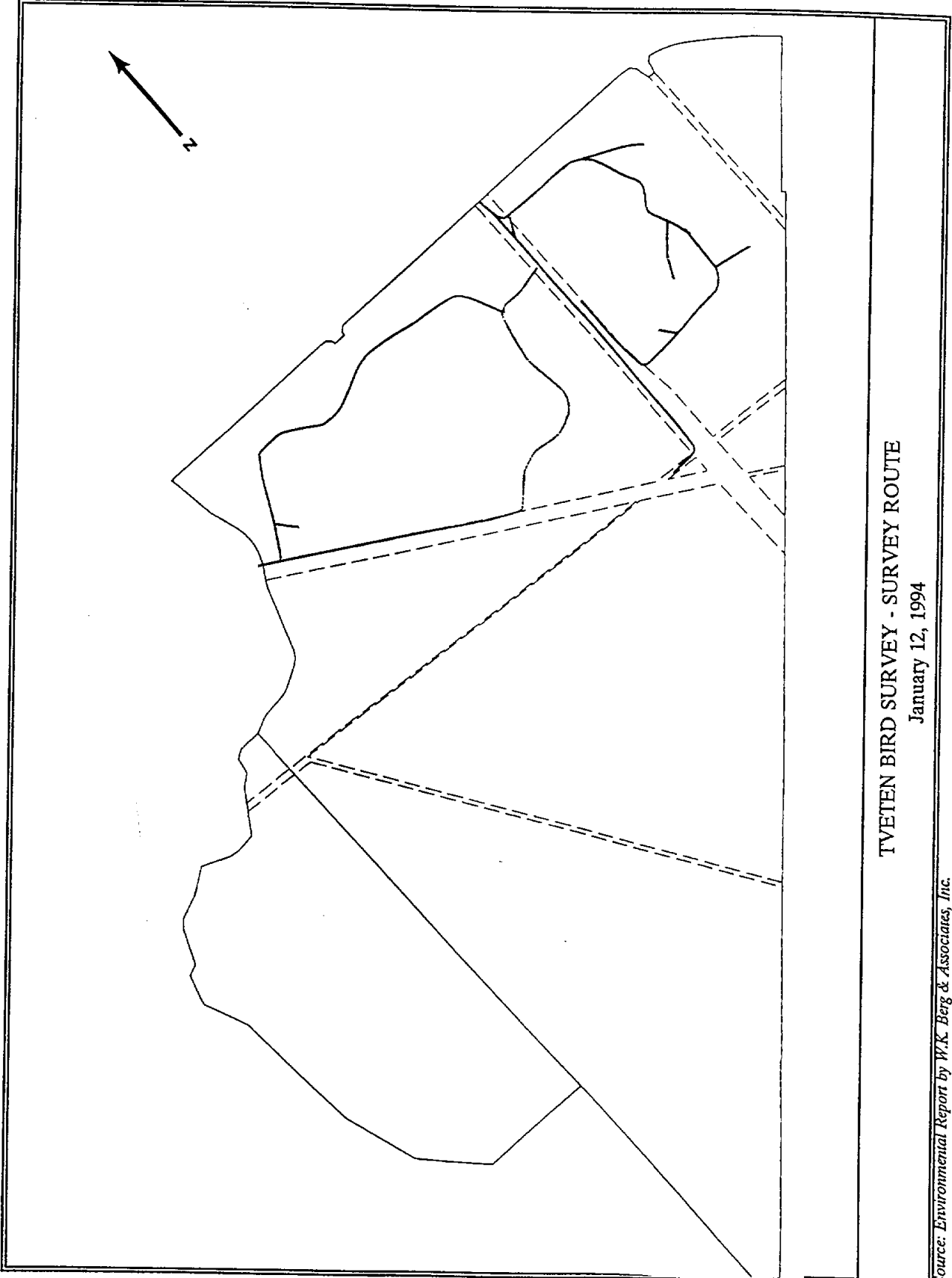

TVETEN BIRD SURVEY - SURVEY ROUTE
January 12, 1994

Source: Environmental Report by W.K. Berg & Associates, Inc.

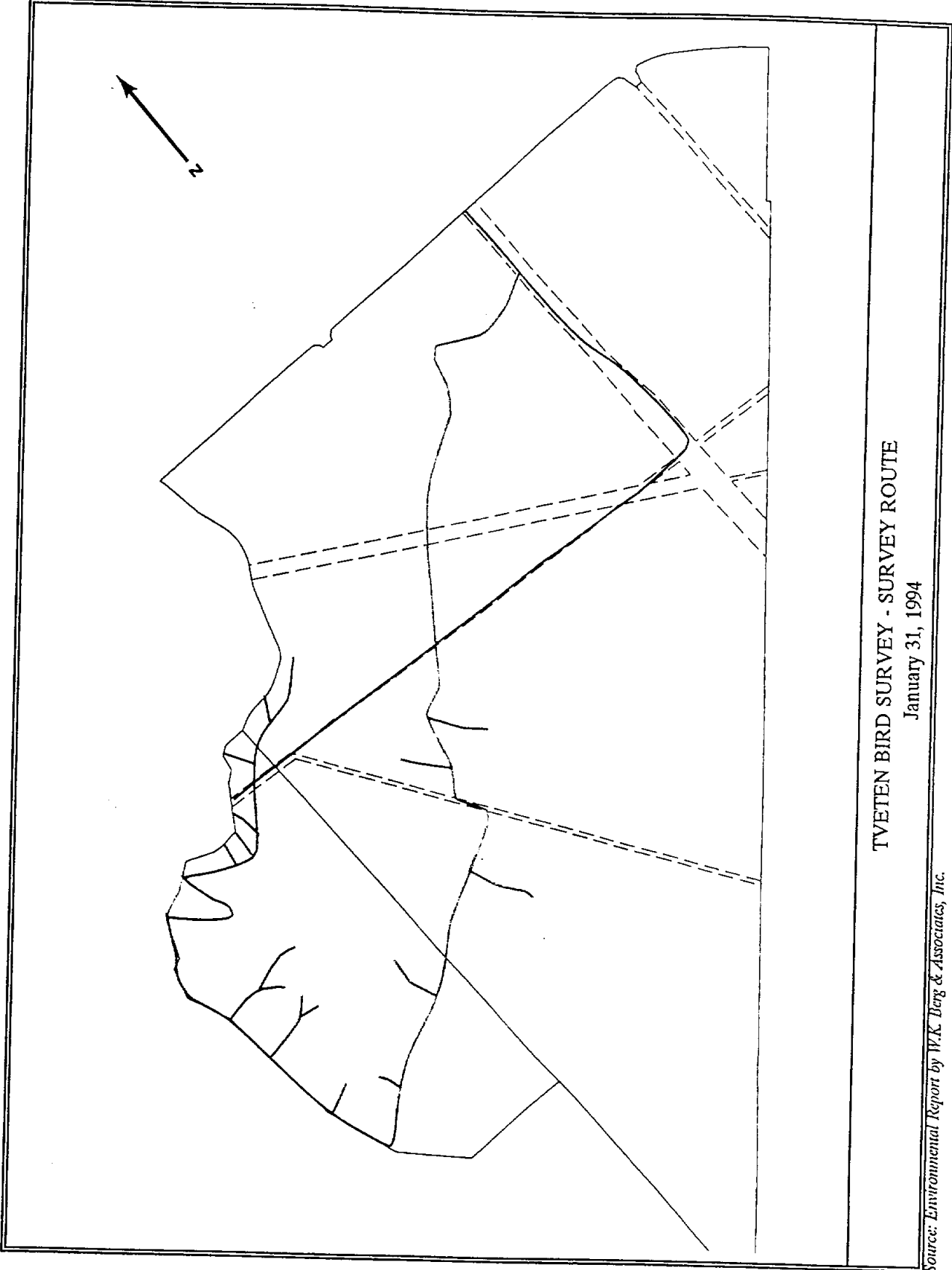

TVETEN BIRD SURVEY - SURVEY ROUTE

January 31, 1994

Source: Environmental Report by W.K. Berg & Associates, Inc.

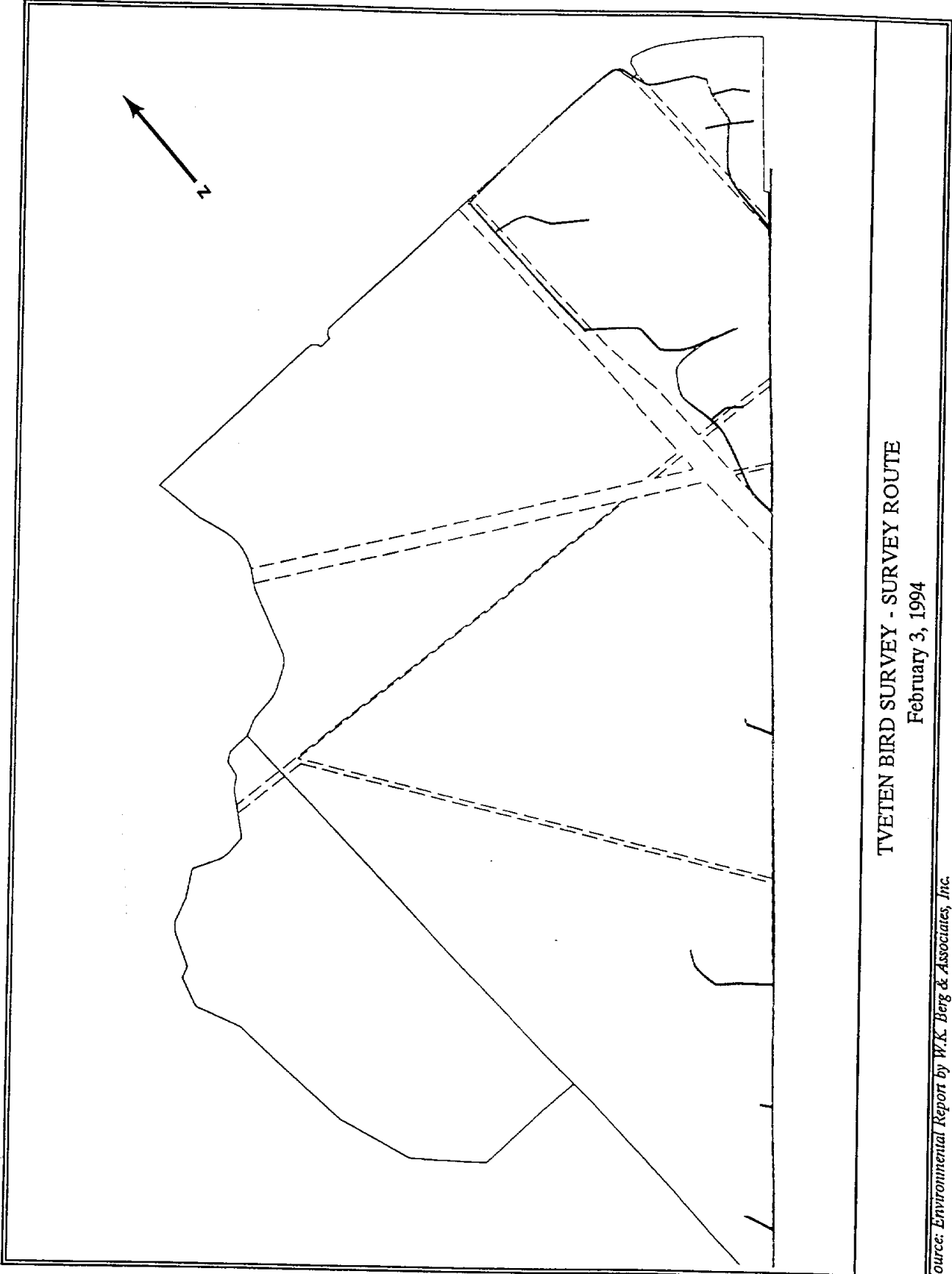

TVETEN BIRD SURVEY - SURVEY ROUTE

February 3, 1994

Source: Environmental Report by W.K. Berg & Associates, Inc.

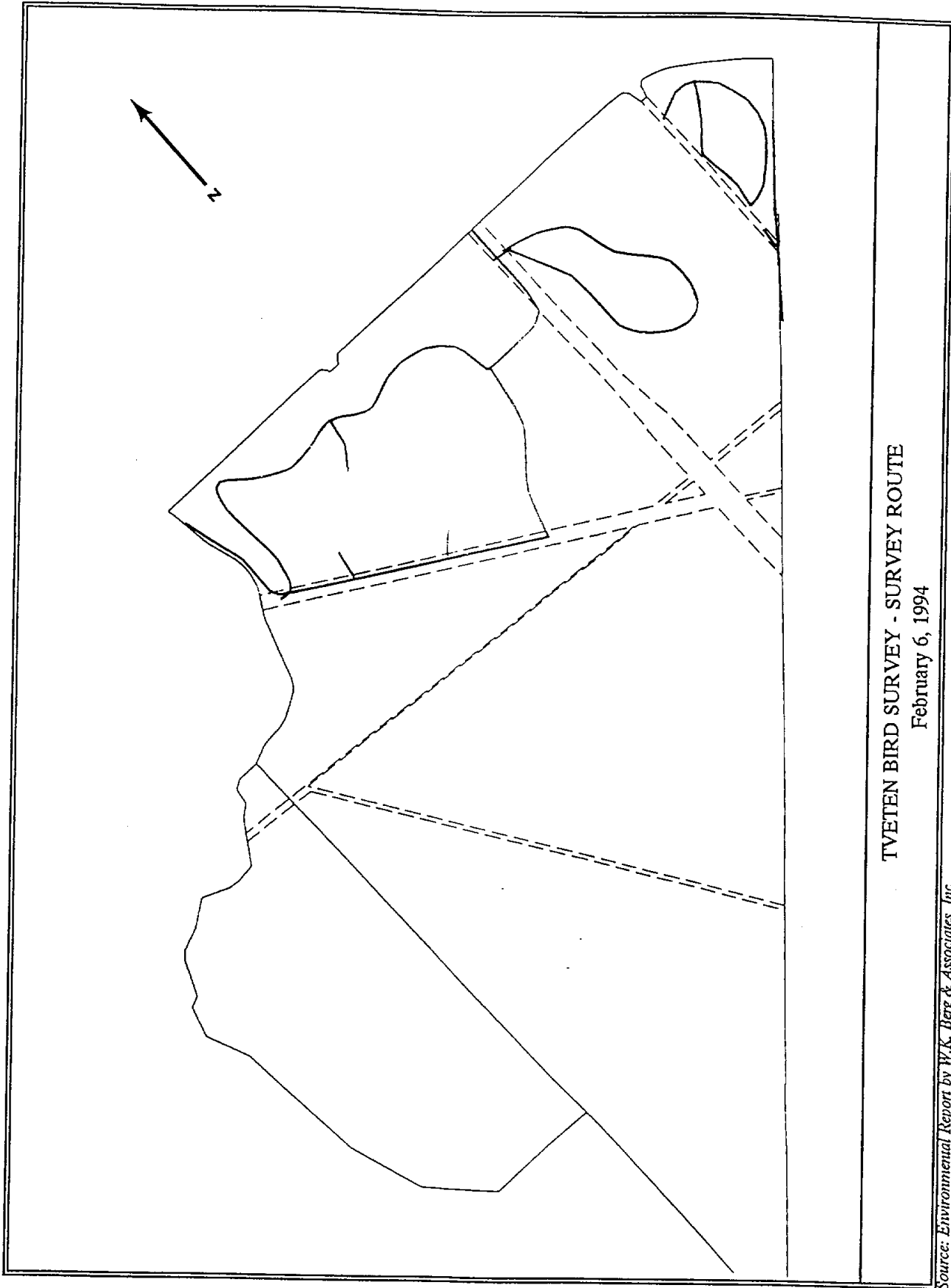

TVETEN BIRD SURVEY - SURVEY ROUTE
February 6, 1994

Source: Environmental Report by W.K. Berg & Associates, Inc.

**BREEDING BIRD SURVEY
GARNERS BAYOU MITIGATION SITE**

**With Supplemental Lists of:
Mammals
Reptiles and Amphibians
Butterflies**

HARRIS COUNTY, TEXAS

Conducted for
W. K. BERG & ASSOCIATES
Houston, Texas

by
John L. Tveten, Ph.D.
and
Gloria A. Tveten

June 15-23, 1994

TABLE OF CONTENTS

	<u>Page</u>
SUMMARY.....	1
OBJECTIVES.....	2
CONCLUSIONS.....	3
PREVIOUS SURVEY.....	5
SITE DESCRIPTION.....	5
SEASONAL INFLUENCES.....	6
SURVEY METHODS.....	7
ASSESSMENT OF BREEDING STATUS.....	8
MAJOR HABITATS.....	9
Deciduous Woodland.....	9
Pine Woodland.....	10
Thickets and Brushy Edges.....	10
Grassy Fields and Corridors.....	11
Ponds and Bayous.....	11
WETLAND POTENTIAL.....	11
SUPPLEMENTAL SURVEYS.....	12
Mammals.....	12
Reptiles and Amphibians.....	13
Butterflies.....	13
APPENDIX	
Bird Checklist.....	4 pages
Mammal Checklist.....	1 page
Reptile and Amphibian Checklist.....	1 page
Butterfly Checklist.....	2 pages
Daily Survey Routes.....	5 pages
Bibliography.....	1 page

SUMMARY

The Garners Bayou Mitigation Site contains a number of different ecological habitats and plant communities and harbors a corresponding diversity of bird species. Seventy-four (74) species of wintering birds were recorded during a previous survey conducted in January/February 1994. Fifty-one (51) species were observed during the present survey from June 15 through June 23, 1994. With a few exceptions, as noted in the text, these can be considered to be breeding on the tract in question.

There is a high concentration of woodland birds, the most abundant being northern cardinal, Carolina wren, white-eyed vireo, Carolina chickadee, and tufted titmouse. In addition, a number of neotropical migrants were detected. The latter are birds that spend the winter in the American tropics and return to North America to breed. Some of these are declining rapidly throughout the eastern United States due to habitat loss at both ends of their migration routes. A checklist of the birds observed and their numbers on five different days is appended to this report along with schematic maps of the routes traversed each day.

In addition, supplemental checklists of observed mammals (14 species), reptiles and amphibians (20 species), and butterflies (44 species) are attached. The abundance and diversity of these animals further illustrates the variety of microhabitats present on the Garners Bayou Site.

OBJECTIVES

1. To conduct a census of the bird species utilizing the Garners Bayou Mitigation Site at the peak of the breeding season, June 1994.
2. To determine the species and their relative numbers in each of the different habitat types on the Garners Bayou tract.
3. To determine, as much as possible, whether the birds present are nesting on the tract or simply utilizing it as a feeding area.
4. To predict the effect on bird populations of increasing the number and size of ponds and other wetland habitats.
5. To compile, during the course of the breeding bird survey, supplementary lists of the mammals, reptiles and amphibians, and butterflies encountered on the Garners Bayou property.

CONCLUSIONS

1. Diversity of ecological habitats on the Garners Bayou Mitigation Site is high, with an attendant diversity of bird species. These findings agree with a prior bird survey conducted in January/February 1994.
2. Fifty-one (51) species of birds were observed on the tract from June 15 through June 23, 1994. As expected, this total is somewhat lower than that of the earlier survey (74 species), when a number of northern birds had moved southward for the winter.
3. Most of the species appear to be nesting on or near the Garners Bayou Site as evidenced by the presence of nests, fledgling young, or singing territorial males.
4. A number of long-legged wading birds--herons, egrets, and ibis--were observed each day; however, with the exception of the solitary green heron, no evidence was found of a nesting colony. The herons and egrets appear to fly in from the Lake Houston or Sheldon Reservoir areas to the east to forage in the marshy ponds along power-line and pipeline clearings and in the water-filled ditches or bayous.
5. No extremely rare or unusual birds were detected; however, several species reach the southern edge of their breeding range in Harris County and are more typical of the river-bottom forests and piney woods of East Texas.
6. At least two pairs of red-shouldered hawks and two pairs of pileated woodpeckers occupy territories within the survey tract. Combined with other large species, including barred owl and American crow, they indicate a productive woodland habitat with substantial food reserves.
7. No ducks, grebes, gallinules, cormorants, anhingas, or other waterfowl were observed. Many of the small ponds on the tract are too heavily wooded to attract such waterfowl species. Although marshy, ephemeral ponds exist along the power-line clearings, they lack sufficient permanence and cover for

nesting.

8. Increasing the number and size of ponds and other wetland habitats could be expected to increase the number of water birds. These wetlands would provide wintering grounds for ducks as well as feeding areas and potential nest sites for herons and other wading birds; rails and gallinules; and such marsh dwellers as red-winged blackbirds, common yellowthroats, and marsh wrens. Selective planting in and around such wetlands would greatly increase their carrying capacity for wildlife.
9. Fourteen (14) mammal species were encountered on the survey tract. Several deer were seen on each visit. No attempt was made to census the nocturnal bats, nor were live traps used to sample the rodent population. Closer observation of the latter two orders would undoubtedly add several species to the list.
10. Twenty (20) species of reptiles and amphibians were seen or heard, including four turtles, three lizards, five snakes, and eight toads and frogs. Most of the lizards and snakes were found by turning over fallen logs and debris; some frogs were identified by their characteristic calls.
11. Forty-four (44) butterfly species were seen on the Garners Bayou tract, many of them in substantial numbers. The authors, who have recently completed a book on the butterflies of Houston and Southeast Texas, consider this to be a very high total for so brief a time span. It is indicative of the variety of microhabitats and larval food plants available to insect populations.

PREVIOUS SURVEY

The authors of this breeding bird survey conducted a similar bird census on the Garners Bayou Mitigation Site during January and February 1994. A report was produced and submitted to W.K. Berg & Associates.

The purpose of the prior survey was to determine the species and numbers of birds using the site during the winter season. Seventy-four (74) species were observed, and a list was included in the subsequent report.

The present study covered the same areas during the peak of the breeding season, June 1994. As expected, there were significant differences in the bird populations.

SITE DESCRIPTION

The Garners Bayou Mitigation Site is located within the northeastern corner of Beltway 8 that circles Houston, Texas. That beltway serves as the northern boundary of the site, while the Beaumont, Sour Lake, and Western Railway track borders the property on the east. Garners Bayou and Greens Bayou downstream from its junction with Garners Bayou provide the western boundary. Lockwood Road cuts

across the northeastern corner of the tract; several power-line and pipeline corridors transect the remainder of the property.

Much of the site is presently a mixed hardwood/pine woodland, with pines predominating in the northwestern portion. Although some large timber remains, the tract has been logged extensively. Open, marshy areas occur at lower elevations, and several ponds and oxbows provide permanent water. The utility corridors; the northeastern corner bordered by Beltway 8, Lockwood Road, and the railroad track; and the mowed bank of Greens Bayou offer open, grassy areas attractive as feeding areas to some species of birds. Brushy woodland borders, particularly along the railroad track, harbor other species that prefer thicket habitats.

This vegetational diversity provides habitats for a wide range of bird species. Most of the expected nesting birds were encountered during the period of this survey.

SEASONAL INFLUENCES

Some birds are permanent residents of the region and remain year-round on or near the tract in question. Many others, however, occur only during specific seasons of the year. Some are breeding summer residents, departing for the American tropics in the fall and returning again in spring. Their places are taken in winter by other species that move southward from more northern latitudes. In addition to those nesting and wintering populations, there are many other birds that appear only during their spring and fall migrations as they move from the North to the tropics and back again.

Birds migrate with the seasons to ensure adequate food supplies, not in response to cold weather, although the latter factor is of secondary importance. Thus, most of the flycatchers, warblers, thrushes, orioles, buntings, tanagers, grosbeaks, and other avian families that feed largely on insects and fruits spend our winter months in Central and South America. These "neotropical migrants" are replaced in Texas during that season by numerous sparrows, finches, blackbirds, and others that subsist primarily on seeds and the occasional insects and berries still available.

Species diversity reaches its maximum during spring and fall migrations, when numerous long-distance migrants cross eastern Texas, mixing with both summer and winter residents. These migrations are particularly difficult to survey, however, for they are highly dependent on local weather. More significant are the numbers of birds that utilize a particular area during the winter months and during the breeding season, when populations are more stable.

The current breeding bird survey identified fifty-one (51) species on the Garners Bayou Site. This was less than the winter total, an expected result. Many of the waterfowl, hawks, sparrows, and finches present during the winter months have moved northward to nest. A number of new species have likewise returned from the tropics to breed in our area, but they do not equal the winter residents in diversity or number. Breeding birds, in general, occupy and defend larger individual territories than do foraging winter flocks that wander more widely.

SURVEY METHODS

The attached bird checklist was compiled by the two authors during five visits to the Garners Bayou Site. These occurred on June 15, 17, 20, 22, and 23, 1994. The weather was hot and humid, with afternoon temperatures rising well into the 90s. The days were generally sunny, but with some late-afternoon thundershowers.

Because birds are least active during the midday heat, each survey was begun at dawn, when territorial males began singing. However, some activity continued throughout the day, and highly territorial birds were easily located by their repeated vocalizations. Many were lured into view with the vocal squeaks and chips routinely used by birders. Tape recordings of the calls of an eastern screech-owl were used extensively during the winter census to attract small flocks of woodland birds. These proved less effective during the breeding season, when birds are defending their own territories and are less inclined to "mob" owls in mixed, wide-ranging flocks. Utility corridors, woodland trails, the railroad track, and Lockwood Road provided access to various segments of the site, and all sections were covered on one or more days. The authors moved slowly along these routes and through the woods, observing the birds with 10X40 Zeiss and 8X36 Bausch and Lomb binoculars. Many of the most vocal species were best identified and counted by hearing their characteristic songs and calls.

Schematic maps appended to this report show the route taken on each census day. Bird numbers can thus be traced to particular sections of the tract or to particular habitats. Some species were recorded only once during the census period; many others were present in good numbers every day. The daily numbers for each species are shown on the checklist.

ASSESSMENT OF BREEDING STATUS

Most of the birds encountered can be assumed to be nesting on the census tract. The presence of nests or fledgling young verified the status of several species, while highly vocal, defensive birds revealed the number and extent of individual breeding territories. Such territorial behavior is commonly used to

indicate status as a breeding species.

It appears that a few species listed do not presently breed within the confines of the Garners Bayou tract. Chief among these are the colonial wading birds, the herons, egrets, and ibis. No evidence was found for nesting activity in spite of their abundance along the rights-of-way and wet ditches. Most observed in flight were flying toward the southeast, apparently moving between the census site and Sheldon Lake State Park and Wildlife Management Area, a rich wetland little more than three miles away. A visit to that park did, indeed, reveal large flocks of wading birds, which move out to the surrounding fields and roadsides to feed each day. The exception was a green heron, a more solitary bird, that was discovered nesting near the oxbow lake on the southern border of the Garners Bayou Site.

No breeding of black or turkey vultures was verified, but these silent birds are very secretive around their well-hidden nests. Certainly such breeding is possible, and numerous vultures use the tall trees and power-line towers as roosting sites.

Fledgling barn swallows were located along Lockwood Drive, and a flock of swallows was seen hawking insects over the open field to the east and along the railroad track. These birds apparently nest in a colony beneath the Beltway 8 overpass at the northeast corner of the tract. Similarly, purple martins seen overhead presumably came from the residential subdivision north of the Beltway.

MAJOR HABITATS

It is possible to make some general statements about bird populations in specific habitats, although some species roam widely through the surrounding area and may occur in several ecological niches. Most breeding birds have habitat preferences, where they establish and defend clearly defined territories, and they can be found there day after day.

Deciduous Woodland

The most abundant inhabitants of the deciduous and mixed woodlands proved to be northern cardinals, Carolina wrens, white-eyed vireos, Carolina chickadees, and tufted titmice. Along some portions of the woodland trails, these birds could be found every 50 to 100 yards. The authors were seldom out of range of one singing male before hearing another ahead. Blue jays and American crows were also prominent members of the woodland avifauna.

At the southern end of the tract, red-eyed vireos replaced some of the white-eyed vireos so abundant in the northern end. Here, too, the oxbows with tall trees and a palmetto understory provided sites for hooded, prothonotary, and Swainson's warblers and an Acadian flycatcher. These are birds more typical

of the Big Thicket habitats of East Texas.

At least two pairs of red-shouldered hawks inhabit Garners Bayou, as do two pairs of pileated woodpeckers. Red-bellied woodpeckers and downy woodpeckers were most frequent in the dead trees at the edge of the forest along the railroad track.

Pine Woodland

Small pines predominate in some sections of the woodland tracts, particularly in the northwestern corner of the site. In general, these proved to be less productive for birds than the deciduous or mixed woodlands, but they did harbor some of the same small songbirds, particularly chickadees and titmice. In addition, this is the preferred habitat for the pine warbler, and that species was located at several locations in stands of pines.

Thickets and Brushy Edges

Several bird species prefer the dense cover of shrubby thickets overgrown with vines and briar tangles to the relatively open woodlands with reduced understory vegetation. Such habitats are present along the edges of the woodlands, where they border the utility corridors and bayous, and along the railroad track. During the winter season, this was the habitat for native sparrows, juncos, catbirds, and house wrens. Now, during the breeding season, it also harbored nesting cardinals, Carolina wrens, painted buntings, and a blue grosbeak. Male buntings sang repeatedly from exposed perches along the woodland fringes.

Grassy Fields and Corridors

Several herons, egrets, and ibis were seen regularly in the utility corridors that transect the property and along the open roadsides and bayou banks. Cattle egrets were particularly abundant, feeding with the cattle in the open corridors. As noted, however, no evidence was found for nesting of these colonial wading birds.

Mourning doves, killdeer, American crows, northern mockingbirds, and common grackles also frequented these open areas. The field east of Lockwood Road in the northeastern corner of the site harbored numbers of sedge wrens and sparrows during the winter census. Now, however, it was the site of very little bird activity.

Ponds and Bayous

None of the ducks and cormorants found during the winter was located in this breeding bird survey. Most of the ponds on the property are too heavily wooded to provide favorable habitats for waterfowl. Common yellowthroats and other small songbirds were seen around the fringes of some ponds, and a

prothonotary warbler was nesting on the deep oxbow at the southern end of the tract, a niche that also produced a green heron.

WETLAND POTENTIAL

As noted in the previous January/February 1994 report, increasing the extent of the wetland areas on the Garners Bayou Mitigation Site has the potential for creating habitat for both wintering waterfowl and nesting water and marsh birds. These changes could be effected without severely altering the productivity of the adjacent deciduous woodlands. Combining wetlands creation with selected planting could further enhance the site for a wide variety of wildlife. Several potential plants were mentioned previously.

SUPPLEMENTAL SURVEYS

During the course of the breeding bird survey, the authors also compiled checklists of observed mammals, reptiles and amphibians, and butterflies. These lists further illustrate the diversity of the site and its enormous wildlife potential.

Mammals

Evidence of fourteen (14) different mammal species was obtained during the five days of the survey. Most of the listings stem from sightings of live animals; a few come from identification of tracks or animal skulls. The list is appended to this report.

Two or more white-tailed deer were seen each day, ranging from a large six-point buck to a small, spotted fawn. Abandoned hunting blinds throughout the property still stand as a tribute to the thriving deer population.

No attempt was made to observe nocturnal or crepuscular bat species, and the authors did not employ live traps to sample the rodent population. The latter is probably rich and diverse, and several more mice could be added to the list by trapping in various habitats.

Reptiles and Amphibians

Twenty (20) species of reptiles and amphibians were observed on the census site. These included four turtles, three lizards, five snakes, and eight toads and frogs. The complete list is attached.

Most of the lizards and snakes were found by turning over logs and other debris; some of the frogs were identified by their characteristic songs.

Several other snake species should occur in the area and would probably be found by a more diligent search of fallen and rotting logs. The search for such reptiles was regarded as secondary to the documentation of breeding birds during this survey.

Butterflies

Insects, spiders, and other invertebrates abound on the Garners Bayou Site. Cicadas; dragonflies and damselflies; lubber and other short-horned and long-horned grasshoppers; tiger beetles; and a variety of flies, bees, and wasps can be found throughout the tract. At least two large nests of southern yellowjackets were discovered, each housing thousands of wasps. The larvae of fall webworms were particularly prevalent, especially on sweet-gum and button-bush.

Because the authors have recently completed a book on the butterflies of Houston and Southeast Texas, they were able to identify the various species without capturing specimens in the field. Forty-four (44) different butterflies were found, some in large numbers. This represents a surprising diversity for so small an area and so limited a time span. More species could undoubtedly be added to the list, particularly in the early spring and late fall. Some butterflies appear only in spring; other more southern species wander gradually northward to populate Harris County late in the year.

Although adult butterflies sip nectar from a wide variety of flowering plants, their larvae are far more selective in their choice of foods. Many are confined to a single family or genus of plants; some, to a single species. The caterpillars of the satyrs, for example, feed on grasses, as do many of the skippers. Sulphurs utilize legumes; monarchs and queens, milkweeds; and gulf fritillary larvae consume nothing but passion-vines. For the most part, adult butterflies seldom wander far from their larval food plants.

The presence of so many butterfly species thus reflects the wide variety of microhabitats and vegetative types on the Garners Bayou Mitigation Site. It is another indication of a healthy biological diversity.

BIRD CHECKLIST

GARNERS BAYOU MITIGATION SITE

June 15-23, 1994

John & Gloria Tveten

<u>Bird Species</u>	<u>Date and Numbers</u>				
	<u>6/15</u>	<u>6/17</u>	<u>6/20</u>	<u>6/22</u>	<u>6/23</u>
Great Blue Heron <i>Ardea herodias</i>	5	2	3	2	1
Great Egret <i>Casmerodius albus</i>	3	2	9	2	4
Snowy Egret <i>Egretta thula</i>	1	2	1	1	2
Little Blue Heron <i>Egretta caerulea</i>	1	1	13	4	6
Cattle Egret <i>Bubulcus ibis</i>	10	60	90	40	75
Green Heron <i>Butorides virescens</i>	1		1		
Yellow-crowned Night-Heron <i>Nyctanassa violacea</i>			2	1	
White Ibis <i>Eudocimus albus</i>		2	4		3
Black Vulture <i>Coragyps atratus</i>	3	2	17	9	6
Turkey Vulture <i>Cathartes aura</i>	2	4	5	2	1
Red-shouldered Hawk <i>Buteo lineatus</i>	3	2	1		
Killdeer <i>Charadrius vociferus</i>		1	2		
Mourning Dove <i>Zenaida macroura</i>		1	8		5

2 - Bird Checklist

				Tveten	
	<u>6/15</u>	<u>6/17</u>	<u>6/20</u>	<u>6/22</u>	<u>6/23</u>
Yellow-billed Cuckoo	4	3	3	2	1
<i>Coccyzus americanus</i>					
Barred Owl				1	
<i>Strix varia</i>					
Common Nighthawk				1	
<i>Chordeiles minor</i>					
Ruby-throated Hummingbird				1	
<i>Archilochus colubris</i>					
Red-headed Woodpecker			1		
<i>Melanerpes erythrocephalus</i>					
Red-bellied Woodpecker	2		4	2	1
<i>Melanerpes carolinus</i>					
Downy Woodpecker			3		
<i>Picoides pubescens</i>					
Pileated Woodpecker	3	2	2	2	
<i>Dryocopus pileatus</i>					
Eastern Wood-Pewee			2		
<i>Contopus virens</i>					
Acadian Flycatcher	1				
<i>Empidonax virescens</i>					
Scissor-tailed Flycatcher		1	2		1
<i>Tyrannus forficatus</i>					
Purple Martin			3		7
<i>Progne subis</i>					
Barn Swallow		10		3	42
<i>Hirundo rustica</i>					
Blue Jay	30	20	18	9	4
<i>Cyanocitta cristata</i>					
American Crow	15	18	23	20	17
<i>Corvus brachyrhynchos</i>					
Carolina Chickadee	45	25	37	16	5
<i>Parus carolinensis</i>					

3 - Bird Checklist

				Tveten	
	<u>6/15</u>	<u>6/17</u>	<u>6/20</u>	<u>6/22</u>	<u>6/23</u>
Tufted Titmouse	30	15	22	9	2
<i>Parus bicolor</i>					
Carolina Wren	25	16	9	11	1
<i>Thryothorus ludovicianus</i>					
Eastern Bluebird			2		
<i>Sialia sialis</i>					
Northern Mockingbird		2	2		1
<i>Mimus polyglottos</i>					
Loggerhead Shrike		1			1
<i>Lanius ludovicianus</i>					
European Starling	2		2		
<i>Sturnus vulgaris</i>					
White-eyed Vireo	50	22	20	17	2
<i>Vireo griseus</i>					
Yellow-throated Vireo			1		
<i>Vireo flavifrons</i>					
Red-eyed Vireo	7	3	4		
<i>Vireo olivaceus</i>					
Pine Warbler	1	2		2	
<i>Dendroica pinus</i>					
Prothonotary Warbler	1				
<i>Protonotaria citrea</i>					
Swainson's Warbler	1				
<i>Limnithlypis swainsonii</i>					
Common Yellowthroat			2		1
<i>Geothlypis trichas</i>					
Hooded Warbler	6	1			
<i>Wilsonia citrina</i>					
Northern Cardinal	60	34	50	30	12
<i>Cardinalis cardinalis</i>					
Blue Grosbeak				1	
<i>Guiraca caerulea</i>					

4 - Bird Checklist

				Tveten	
	<u>6/15</u>	<u>6/17</u>	<u>6/20</u>	<u>6/22</u>	<u>6/23</u>
Painted Bunting	1	4		1	2
<i>Passerina ciris</i>					
Red-winged Blackbird			1		2
<i>Agelaius phoeniceus</i>					
Eastern Meadowlark		1			1
<i>Sturnella magna</i>					
Common Grackle	4		25	7	56
<i>Quiscalus quiscula</i>					
Brown-headed Cowbird			1		2
<i>Molothrus ater</i>					
Orchard Oriole		2			
<i>Icterus spurius</i>					

51 Species

MAMMAL CHECKLIST
GARNERS BAYOU MITIGATION SITE
June 15-23, 1994
John & Gloria Tveten

MARSUPIALS

Virginia Opossum

Marsupicarnivora

Didelphis virginiana
virginiana

SHREWS & MOLES

Least Shrew

Soricomorpha

Cryptotis parva parva

EDENTATES

Nine-banded Armadillo

Edentata

Dasyus novemcinctus
mexicanus

LAGOMORPHS

Eastern Cottontail

Swamp Rabbit

Lagomorpha

Sylvilagus floridanus
alacer

Sylvilagus aquaticus
aquaticus

RODENTS

Fox Squirrel

Marsh Rice Rat

Hispid Cotton Rat

Eastern Woodrat

Nutria

Rodentia

Sciurus niger ludovicianus

Oryzomys palustris texensis

Sigmodon hispidus texianus

Neotoma floridana rubida

Myocastor coypus
bonariensis

CARNIVORES

Coyote

Raccoon

Striped Skunk

Carnivora

Canis latrans frustror

Procyon lotor fuscipes

Mephitis mephitis mesomelas

UNGULATES

White-tailed Deer

Artiodactyla

Odocoileus virginianus
mcilhennyi

REPTILE & AMPHIBIAN CHECKLIST

GARNERS BAYOU MITIGATION SITE

June 15-23, 1994
John & Gloria Tveten

TURTLES

Mississippi Mud Turtle

Ornate Box Turtle

Red-eared Slider

Midland Smooth Softshell

Testudines

Kinosternon subrubrum
hippocrepis

Terrapene ornata ornata

Trachemys scripta elegans

Apalone mutica mutica

LIZARDS

Green Anole

Ground Skink

Five-lined Skink

Squamata: Lacertilia

Anolis carolinensis

Scincella lateralis

Eumeces fasciatus

SNAKES

Broad-banded Water Snake

Texas Rat Snake

Speckled Kingsnake

Southern Copperhead

Western Cottonmouth

Squamata: Serpentes

Nerodia fasciata confluens

Elaphe obsoleta
lindheimerii

Lampropeltis getula
holbrooki

Agkistrodon contortrix
contortrix

Agkistrodon piscivorus
leucostoma

TOADS & FROGS

Gulf Coast Toad

Cricket Frog

Green Treefrog

Squirrel Treefrog

Gray Treefrog

Upland Chorus Frog

Bullfrog

Southern Leopard Frog

Anura

Bufo valliceps valliceps

Acris crepitans

Hyla cinerea

Hyla squirella

Hyla versicolor or *Hyla*
chrysoscelis

Pseudacris triseriata
feriarum

Rana catesbeiana

Rana utricularia

BUTTERFLY CHECKLIST

GARNERS BAYOU MITIGATION SITE

June 15-23, 1994

John & Gloria Tveten

SWALLOWTAILS

Pipe-vine Swallowtail
Giant Swallowtail
Tiger Swallowtail
Spicebush Swallowtail
Palamedes Swallowtail

WHITES and SULPHURS

Checkered White
Orange Sulphur
Dog Face
Cloudless Sulphur
Little Sulphur

GOSSAMER-WINGED BUTTERFLIES

Red-banded Hairstreak
Gray Hairstreak
Western Pygmy Blue

SNOUT BUTTERFLIES

Snout Butterfly

LONGWINGS

Gulf Fritillary

NYMPHALIDS

Variiegated Fritillary
Texan Crescent
Phaon Crescent
Pearl Crescent
Question Mark
Red Admiral
American Painted Lady

Papilionidae

Battus philenor
Papilio cresphontes
Papilio glaucus
Papilio troilus
Papilio palamedes

Pieridae

Pontia protodice
Colias eurytheme
Colias cesonia
Phoebis sennae
Eurema lisa

Lycanidae

Calycopis cecrops/isobea
Strymon melinus
Brephidium exile

Libytheidae

Libytheana bachmanii

Heliconiidae

Agraulis vanillae

Nymphalidae

Euptoieta claudia
Anthanassa texana
Phyciodes phaon
Phyciodes tharos
Polygonia interrogationis
Vanessa atalanta
Vanessa virginiensis

Painted Lady
Buckeye

Red-spotted Purple
Hackberry Emperor
Tawny Emperor

SATYRS

Gemmed Satyr
Carolina Satyr
Little Wood Satyr

MILKWEED BUTTERFLIES

Monarch
Queen

SKIPPERS

Silver-spotted Skipper
Northern Cloudywing
Horace's Duskywing
Funereal Duskywing
Common Checkered Skipper
Tropical Checkered Skipper
Neamathla Skipper
Clouded Skipper
Least Skipper
Southern Skipperling
Fiery Skipper
Dun Skipper

Vanessa cardui
Junonia coenia

Limenitis arthemis astyanax
Asterocampa celtis
Asterocampa clyton

Satyridae

Cyllopsis gemma
Hermeuptychia sosybius
Megisto cymela

Danaidae

Danaus plexippus
Danaus gilippus

Hesperiidae

Epargyreus clarus
Thorybes pylades
Erynnis horatius
Erynnis funeralis
Pyrgus communis
Pyrgus oileus
Nastra neamathla
Lerema accius
Ancyloxypha numitor
Copaeodes minimus
Hylephila phyleus
Euphyes vestris

BIBLIOGRAPHY

- Dauphin, David T., A. Noel Pettingell, and Edward R. Rozenburg. 1989. *A birder's checklist of the upper Texas coast*. 7th ed. Houston: Outdoor Nature Club.
- Conant, Roger, and Joseph T. Collins. 1991. *A field guide to reptiles and amphibians: eastern and central North America*. 3rd ed. Boston: Houghton Mifflin.
- Elliott, Lang. 1992. *The calls of frogs and toads: eastern and central North America* (tape recording). Ithica, New York: NatureSound Studio.
- Hatch, Stephan L., Kancheepuram N. Gandhi, and Larry E. Brown. 1990. *Checklist of the vascular plants of Texas*. College Station: Texas A&M Univ.
- Lane, James A. and John L. Tveten. 1984. *A birder's guide to the Texas coast*. Denver: L&P Press.
- Martin, Alexander C., Herbert S. Zim, and Arnold L. Nelson. 1961. *American wildlife & plants: A guide to wildlife food habits*. New York: Dover.
- National Geographic Society. 1987. *Field guide to the birds of North America*. 2nd ed. Washington, D.C.
- Oberholser, Harry C. 1974. *The bird life of Texas*. 2 vols. Edited by Edgar B. Kincaid, Jr. Austin: Univ. of Texas Press.
- Opler, Paul A. 1992. *A field guide to eastern butterflies*. Boston: Houghton Mifflin.
- Robison, B.C., photos by John L. Tveten. 1990. *Birds of Houston*. Houston: Rice Univ. Press.
- Schmidly, David J., photos by John L. Tveten. 1983. *Texas mammals east of the Balcones fault zone*. College Station: Texas A&M Univ. Press.
- Taft, Stan, and Charles Kowaleski. 1993. *Birds of Sheldon Lake State Park/Wildlife Management Area and vicinity: A field checklist*. Austin: Texas Parks and Wildlife Department.
- Tveten, John L. 1993. *The birds of Texas*. Fredericksburg, Texas: Shearer Publishing.
- Tveten, John & Gloria. 1993. *Wildflowers of Houston*. Houston: Rice Univ. Press.
- Tveten, John & Gloria. In press. *Butterflies of Houston and Southeast Texas*. Houston: Rice Univ. Press.

SURVEY ROUTES

SURVEY ROUTE

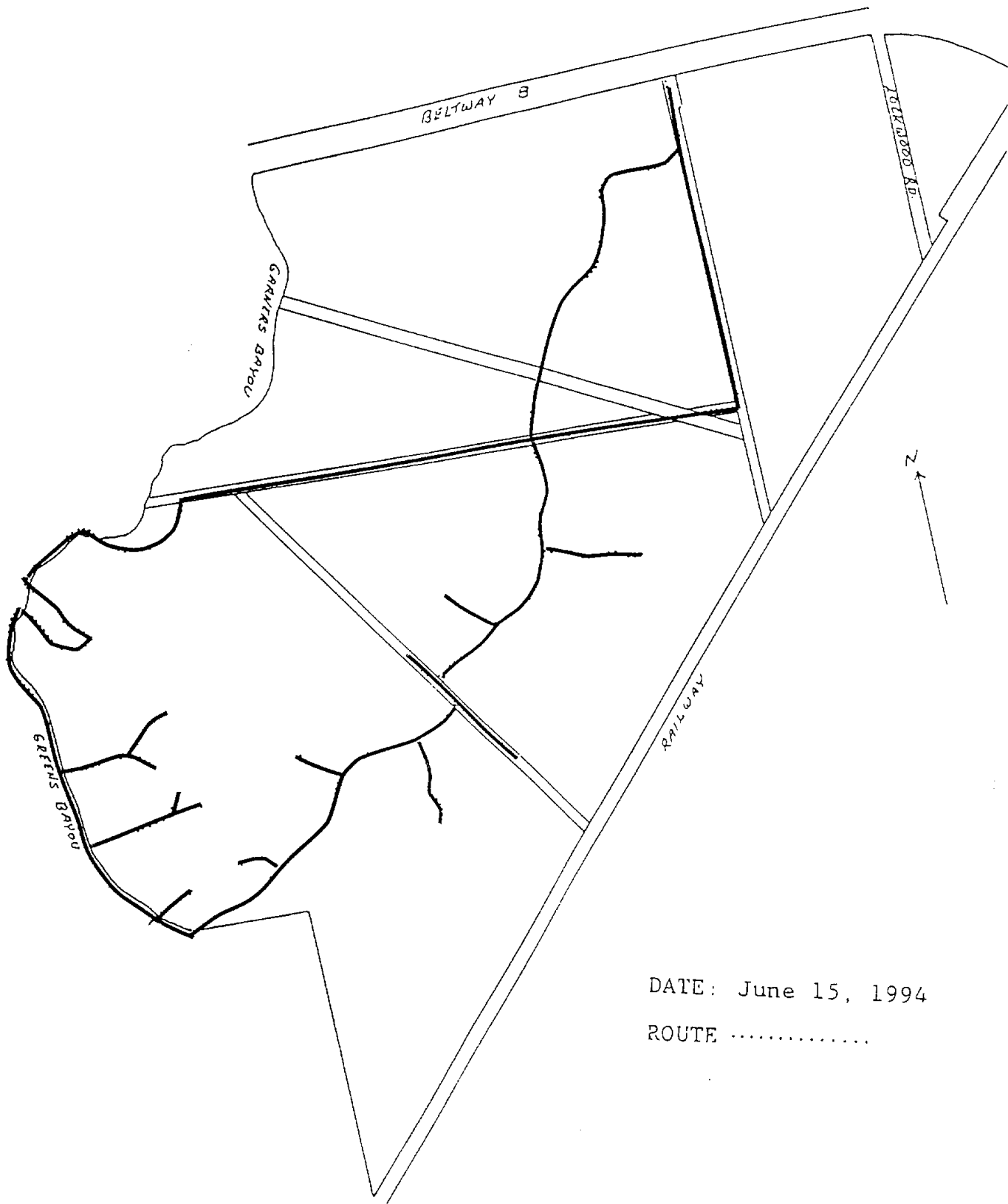

DATE: June 15, 1994

ROUTE

SURVEY ROUTE

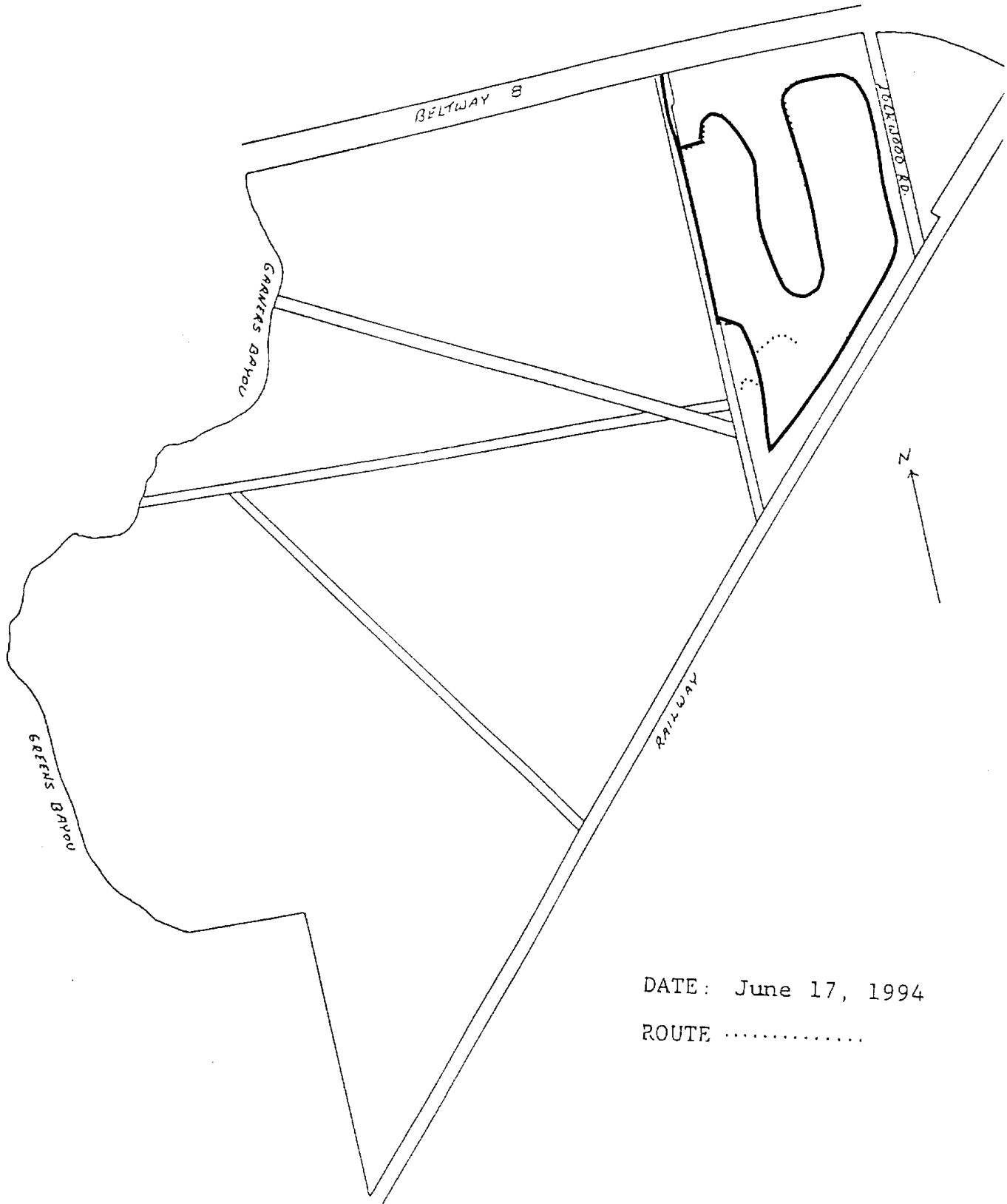

DATE: June 17, 1994

ROUTE

SURVEY ROUTE

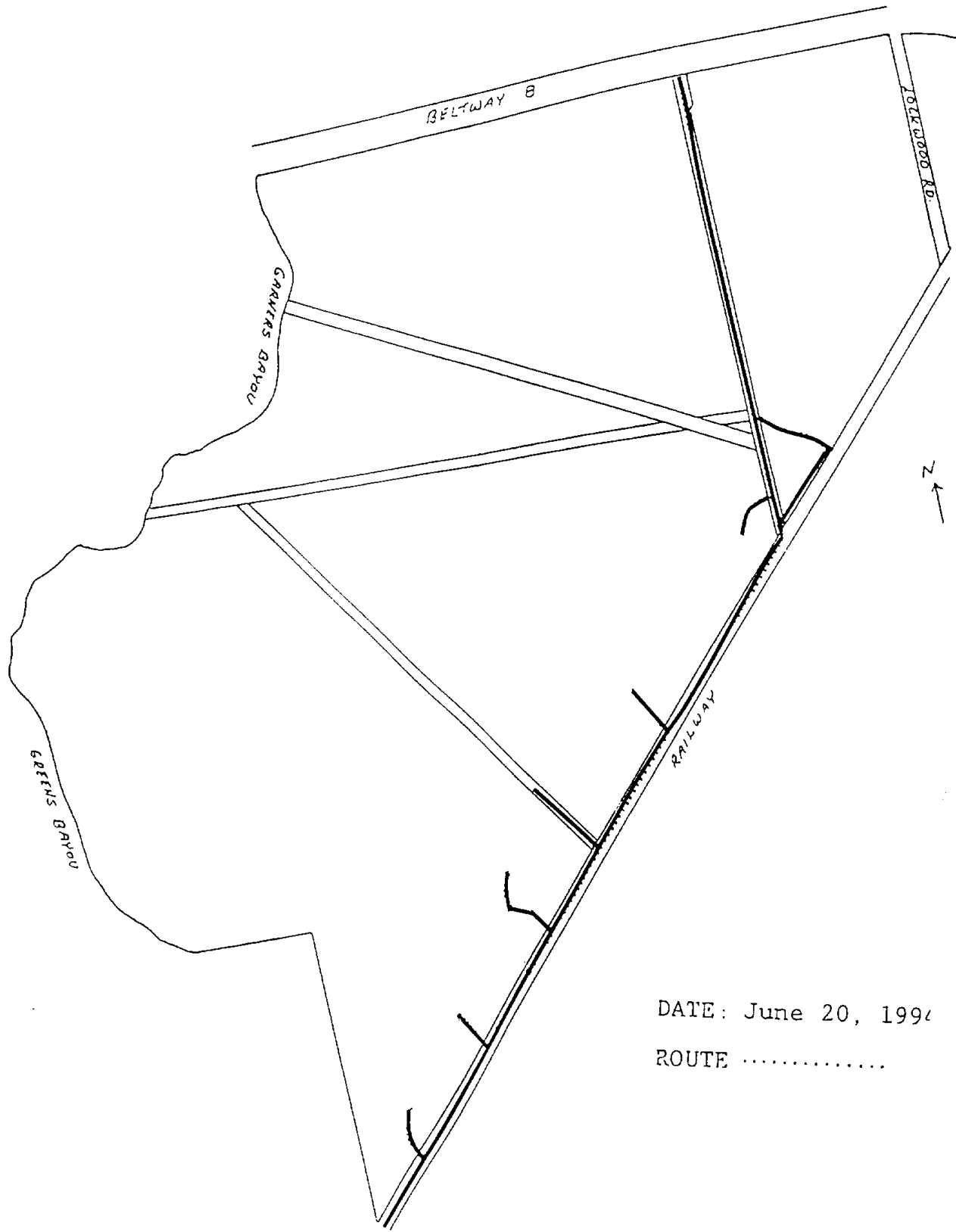

DATE: June 20, 1994

ROUTE

SURVEY ROUTE

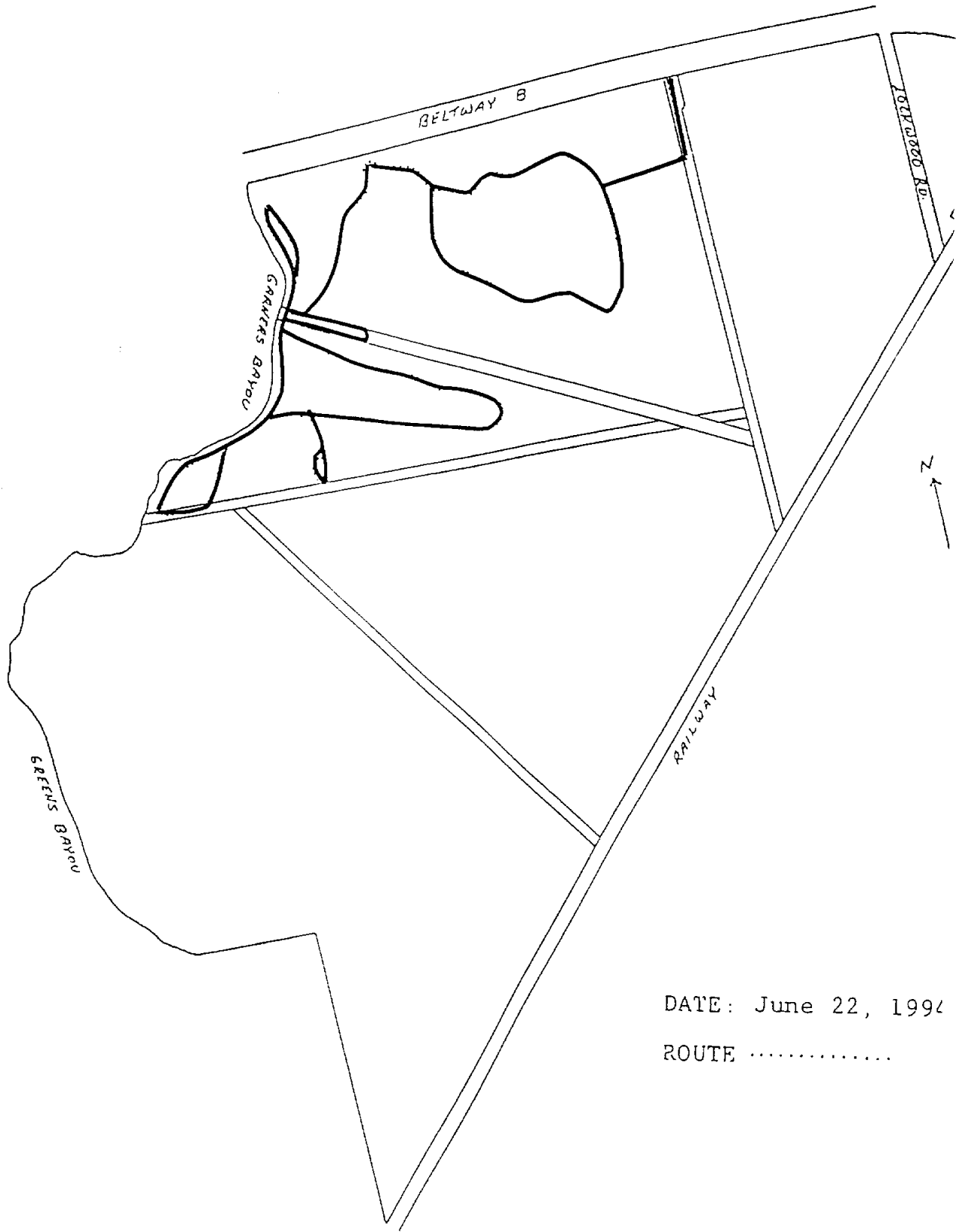

DATE: June 22, 1994

ROUTE

SURVEY ROUTE

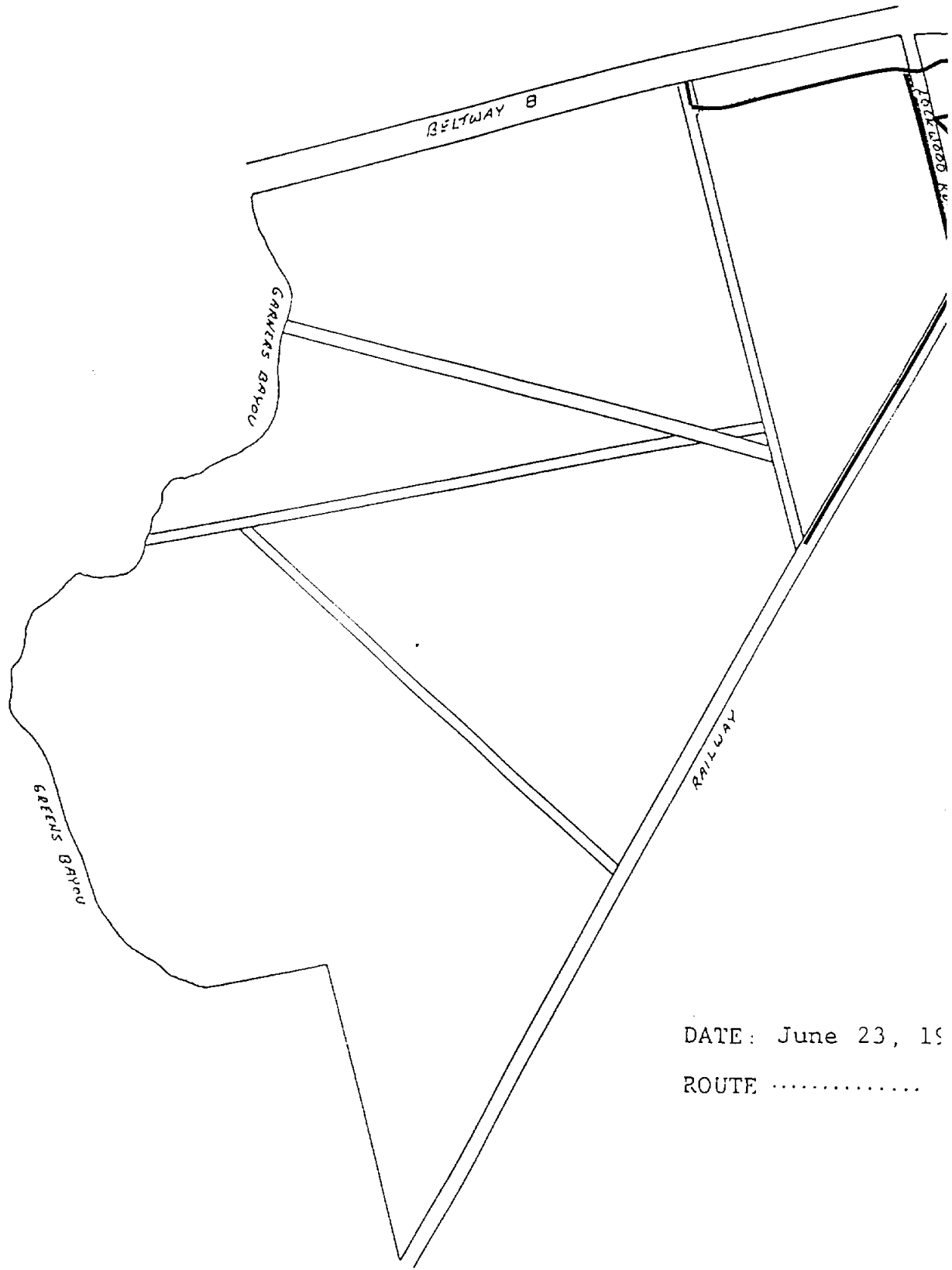

DATE: June 23, 19

ROUTE

2. Soil Survey

The subject property appears to lie on the Beaumont Geologic formation, laid down between 30,000 and 100,000 years ago by rivers crossing a delta shaped plain. Examinations of a soil profile along Greens Bayou to a depth of 15-20 feet indicated that the depositional features of soils and subsurface horizons are characteristic of historical Brazos River sediment patterns. The relatively "flat" nature of the delta plain across which low gradient river activity has taken place over time has resulted in the low energy deposition of thick clay layers which form the foundation for the majority of soils in the area. Sand deposits are also characteristic of this type of river activity, and were found to be present in the soil horizons of several areas. These features characterize the broader geographic area in which the property lies, and are consistent with the geology found along this portion of the Gulf Coast and Harris County.

Riverine elements such as elongate channel scars and levees are found along meander ridges within the broader flood basins across a large area. Wetlands are most likely to occur in these channel scars which are generally more depressional than the surrounding landscape. However, wetlands may also appear in the overflow zones of these channels and, depending on the topographical features, can extend into flats or other areas which are less easily defined. The subject property was found to contain an intricate pattern of slightly depressional wetland flats, with transitions to the more pronounced wet areas which have formed in the channel scars.

Complex and detailed on-site soil surveys were conducted over a two month period by Dr. John S. Jacob, Certified Professional Soil Scientist, Texas A&M University and personnel from W. K. Berg & Associates. Dr. Richard Griffin, Certified Professional Soil Scientist, Prairie View A&M University, was also present and assisted on one specific interpretive site visit. The purpose of the soil surveys was 1) to evaluate and document the hydric or (non-hydric) soil characteristics on the site; and 2) to accurately describe and map any jurisdictional wetland areas.

Hydric soils on the subject property were found to occur in intricate patterns with considerable interfingerings into upland areas, thus forming complex areas of wetland soil features. Hydric boundaries were often gradational through the overflow zones of pronounced wet areas and into the subtle elevation

transitions between flats. Due to the complexity of the soil boundaries on the site, a conservative approach was taken which defined areas as hydric if marginal characteristics were present.

Topographic inversion has resulted from subsidence of the clayey flood basin deposits. Therefore, the present day meander ridges form convex highs on the landscape, commonly two to five feet higher than the surrounding landscape. It was in the more prominent channel scars along these highs where the well-defined hydric soils were found to exist. This was especially true of a distinct elongated ridge located approximately in the center of the site and oriented north-south. These soils had prominent features of long-term saturation and reduction, indicating well-developed hydric conditions over a long period of time. Other distinct hydric features were noted in the more pronounced depressions and potholes which were characteristic of the terrain.

The soils of the site consist of extensive clayey lower layers extending to the near surface in the flatter areas, with loam and sand present in complex patterns. The high shrink-swell tendencies of these clayey soils have created an intricate pattern of microdepressions and pimple mounds throughout the majority of the site, resulting in the formation of scattered small depressions and restricted water movement. The soils are poorly drained with slow permeability and high water capacity.

The following is the summary report submitted by W. K. Berg & Associates, reflecting the onsite soil conditions. This information will be critical to creating and sustaining wetland growth.

Soil Survey of Garner's Bayou Tract - Harris County Flood Control

John S. Jacob, Ph.D.
Certified Professional Soil Scientist

March 19, 1994

Field work on this property was carried out in January and February, 1994. In addition, observations from the 1993 Berg and Assoc. wetland survey were used. Soils were described according to Soil Survey Staff (1993). The soils were commonly described to about 36 inches, with some occasional deep borings to 80 inches. Additional information with respect to underlying sediments was obtained from cutbanks along Garner's and Green's Bayous.

This survey at best represents an approximation of the true soil distribution on the site. Soils exist as a continuum on the landscape. Soil boundaries are drawn to approximate changes in soil bodies; some changes may be abrupt, others are much more gradual. The lines on the map do not convey this information. In addition, some areas were too complex to map individually. For example, two complex wetland/upland units were established on the southern side of the property. Other areas varied in a random manner between a few dominant soil types. These areas were mapped as undifferentiated units.

All soil surveys contain some degree of error. Quantification of that error was not a part of this survey. Random transects and statistical treatment of data did not constitute the scope of work for this contract. Some idea, however, of soil variability and range of properties were obtained from the observations made.

Only a few of the units conformed to the map units described in Soil Survey Staff (1976). Taxonomic names (Soil Survey Staff, 1992) were used where a suitable match with the 1976 survey was unavailable. Although individual soil taxa are used as names for the map units, it should be recognized that the named taxa represents only the central concept, and that in reality a range of soil types are represented in each map unit. The typifying pedon described for each unit is somewhat fictitious in that it represents an amalgamation of the most common properties.

All of the soils were described from hand-auger borings, and in some cases from a 15" pit dug with a spade. Information on structure, and thus permeability, is therefore inferential.

Permeabilities (saturated hydraulic conductivity) were estimated primarily from texture and secondarily from structure. Conductivity classes (Table 1) are taken from Soil Survey Staff (1993). Surface horizons were assumed to be in the low bulk density range.

No measurements were taken, in-situ or in the lab. Structure is extremely important for the determination of permeability, but it cannot be quantitatively described from borings. Because of this deficiency, and because permeability is one of the most spatially-variable soil properties, these numbers should be taken as order-of-magnitude estimates only. On a gross scale, the hydrologically salient features of this tract are the sandy ridge of Boy soils and the clayey Lake Charles/Aquert soils on the east and west sides of the property.

Table 1. Saturated Hydraulic Conductivity Classes

Class	Ksat (um/s)
Very High	≥ 100
High	10-100
Moderately High	1-10
Moderately Low	0.1-1
Low	0.01-0.1
Very Low	≤ 0.01

MAP UNIT DESCRIPTIONS

#1. Ochraqualfs (AQ)

Except for the complex units on the southern side of the property, this unit represents wetlands with hydric soils and hydrophytic vegetation. Most of the wetlands on this site appear to be relict fluvial channel scars, probably associated with the paleo San Jacinto River. The area is mapped as the Beaumont Geologic Formation (BEG), but I believe it may be a Deweyville-aged terrace. Surprisingly, the wetland soils varied little whether in narrow channel scars or on broader flats. Only a few spots had significantly different soils, but these were not extensive enough to warrant a separate unit given the intended use of this survey.

TYPIFYING PEDON

Ag horizon: 0-20 inches 10YR 5/2 loam, with common distinct and prominent Fe pore coats; pH 5-6.

Btg horizons: 20 to 60+ inches 10YR 5/2 clay loam, with Fe pore coats in the upper part. Common sand and silt coats on ped faces. pH ranges from 6 to 7.

Hydrology: Wetness varies in this unit. Some areas, notably the deepest and most prominent channel scars, stay wet most if not all year. Other areas have a much reduced hydro-period, but still remain ponded several weeks to months each year. In several instances, the soil was moist or even dry beneath 5-10 inches of standing water on the surface. Deeper water tables were also frequently observed, however. The sand and silt coats are strong indicators of preferred flow regimes in these soils.

Range in Characteristics:

Ag horizon: most commonly loam, but also fine sandy loam, sandy clay loam, and clay loam. Color values of 4 to 6 and chromas of 1 to 2.

Btg horizons: most commonly clay loam, less commonly sandy clay loam, clay, and loam. Color values of 4 to 6 and chromas of 1 to 2.

The control section is fine-loamy, probably averaging about 30-38% clay. Most common taxa are Ochraqualfs and Glossaqualfs.

Inclusions: Occasional pimple mounds, elevated 1-2 feet above the surrounding surface, with Aldine-like and occasionally Boy-like soils (probably less than 5%). Similar soils with fine-textured (>35% clay) subsoils.

Parent Materials: Deep borings to 80+ inches occasionally reveal interstratified loamy and sandy deposits. In all cases, the deep sands were saturated.

Vegetation: *Acer rubrum*, *Sabal minor*, *Quercus phellos*, *Ulmus spp*, *Juncus spp*, *Panicum haemotomum*, *Quercus nigra*, *Chasmanthium spp*, *Sapium sebiferum*, *Rhyncospora spp*. *Taxodium* and *Cephalanthus* were observed in the most prominent channel scars only.

Permeability:

Ag Moderately high
Bg Moderately low
Hydrologic Soil Group: D

Aquic Hapludalfs - Edna Variant Soils (ED) (Wood Oats Flats)

This unit represents low wet flats with soils that have some redoximorphic features but not enough to classify as hydric.

TYPIFYING PEDON

A horizon: 0-11 inches, 10YR 4/2 fine sandy loam; some beached zones; occasional Fe pore coats; pH 5-6.5.

Btg horizons: 11-40 inches, 10YR 4/2 clay loam or sandy clay loam; occasional Fe pore coats; common Fe masses; common bleached sand coats on macrovoids (ped faces); carbonates commonly below about 30 inches; pH 6-8.

Hydrology: Surface commonly ponded with water in late winter, less commonly in spring. No information on deep water table. The sand and silt coats on macrovoids are strong indicators of preferred flow regimes in these soils.

Range in Characteristics:

A horizon: Less commonly silt loam and loam; colors of 10YR 5/2, 4/2, 3/2, 3/3, 5/3, and 6/2,

Btg horizons: occasionally sandy clay loam, rarely clay; colors of 10YR 4/2, 4/1, 5/2, 5/3, 6/2, 6/3.

Inclusions: Occasional to common small areas of Ochraqualfs (less than about 15%). Common inclusions of Aldine-like soils (less than about 5-10%).

Parent materials: Interstratified loams, sands, and clays.

Vegetation: *Quercus nigra*, *Pinus taeda*, *Ilex vomitoria*, *Chasmanthium spp.*, *Sabal minor*, *Ulmus spp.*, *Liquidambar*, *Quercus phellos*, *Celtis spp.*, *Sapium sebiferum*, *Quercus stellata*.

Permeability

A High
Btg Moderately low
Hydrologic Soil Group: D

Boy - Grossarenic Paleudalfs (BO)

Deep sandy soils on convex surfaces.

TYPIFYING PEDON

A horizon: 0-10 inches, 10YR 4/2 loamy fine sand.

E horizons: 10-60 inches, 10YR 6/3 loamy fine sand.

Btg horizon: 60 to 80 inches, 10YR 6/2 clay loam with common prominent Fe masses; common sand-coated macrovoids.

Hydrology: Very rapidly draining soils. Rarely ponded, almost never flooded. Water frequently stands on Btg horizon (perched water table).

Range in Characteristics:

A horizon: less commonly fine sandy loam, colors of 10YR 4/2, 4/3, 4/4, 5/3, 5/4.

E horizons: occasionally fine sandy loam, colors of 10YR 6/3, 6/4, and 7/3. Common Fe/Mn nodules just above Btg horizon.

Btg horizon: highly variable texture: clay loam, fine sandy loam, sandy clay loam, loam, and clay.

Inclusions: Aldine-like soils commonly on margins of delineations.

Parent materials: Stratified sands and loams.

Vegetation: *Quercus falcata*, *Ilex vomitoria*, *Ilex Opaca*, *Quercus nigra*, *Pinus Taeda*.

Permeability

A&E High to Very High
Btg Moderately low
Hydrologic Soil Group: B

Aldine variant (AL)

Moderately deep sandy soils on convex to flat surfaces.

TYPIFYING PEDON

A horizon: 0-6 inches, 10YR 3/2 fine sandy loam;

E horizon: 6-20 inches, 10YR 6/3 fine sandy loam.

Btg horizons: 20-40 inches, 10YR 5/2 clay loam, common prominent Fe pore coats and few ped coats. Prominent sand coats on macrovoids.

Hydrology: Rarely ponded or flooded. Frequently saturated on top of Btg horizon. The sand and silt coats on macrovoids are strong indicators of preferred flow regimes in these soils.

Range in Characteristics:

A horizon: Colors of 10YR 3/2, 4/2, and 5/3.

E horizon: Colors of 10YR 6/3, 7/3, 5/2, and 6/2.

Btg horizon: less commonly clay, colors of 5Y 5/1, 10YR 6/2, 5/2, and 6/1.
Occasionally carbonate nodules below 30".

Inclusions: Common inclusions of Boy and Aquic Hapludalfs.

Parent materials: Stratified loams, sands, and clays.

Vegetation: *Pinus taeda*, *Quercus stellata*, *Quercus falcata*, *Ilex vomitoria*, *Sabal minor*, *Quercus nigra*, *Quercus phellos* (-), *Chasmanthium spp*, *Liquidambar*.

Permeability

A&E Moderately high
Btg Moderately low
Hydrologic Soil Group: C

Lake Charles Clay (LC)

Clayey soils with high-shrink-swell capacity.

TYPIFYING PEDON

A horizon: 0-20 inches, 10YR 3/1 clay; pH 8.0

Bss horizons: 20-60 inches, 10YR 3/1 clay; common slickensides from 20-50 inches, grading to 10YR 4/2 with depth.

Hydrology: Occasionally to frequently ponded in microlows. Ground water dynamics not well understood.

Range in Characteristics:

A horizon: colors of 10YR 2/1 and 3/1; occasional redox pore coats.

Bss horizon: colors of 10YR 3/1, 4/2, 4/1.

Inclusions: Common inclusions of Bernard and Addicks-like soils

Parent materials: Dense clays, few sand bodies.

Vegetation: Wooded areas *Pinus taeda*; *Bacchus haematofolium*, *Carex cherokeensis*, *Spartina spartinae*, *Andropogon glomeratus*.

Permeability

A Moderately low to low
Bssg Low to very low
Hydrologic Soil Group D

Note: permeability in Vertisols is extremely variable.

Aquert (AV)

Depressional clayey soils with high shrink-swell potential.

TYPIFYING PEDON

Ag horizon: 0-10 inches 5Y 4/1 clay; common Fe pore and ped coats. pH 5-6.

Bssg horizon: 10-40 inches, 10YR 5/2 clay; common faint Fe pore coats.

Hydrology: frequently ponded. Groundwater situation unclear.

Range in Characteristics:

Ag horizon: less commonly clay loam, colors of 5Y 4/1, 10YR 4/1 and 5/2.

Bgss horizon: colors of 5Y 4/1 and 6/1, 10YR 4/2, 5/2, 6/2.

Inclusions: Lake Charles Clay, Addicks, Bernard.

Parent materials: Dense clays, few sand bodies.

Vegetation: *Quercus phellos*, *Quercus falcata* (var. *pagodafolia?*), *Quercus nigra*, *Pinus taeda*, *Sapium sebiferum*, sedges and rushes.

Permeability

Ag Moderately low to low
Bssg Low to very low
Hydrologic soil group D

Addicks/Bernard, undifferentiated (AB)

This unit represents soils with generally fine-textured subsoils and dark surface horizons. The Addicks-like soils are sometimes coarser in the subsoil and usually always in the surface soil versus the Bernard-like soils. The Addicks-like soils are considerably finer in the subsoil than what is described in Soil Survey Staff (1976), but apparently fit the norm of what has actually been mapped in the county as Addicks. These two soils grade into each other on the landscape and it was not possible to differentiate them in the field under the present scope of work.

TYPIFYING PEDON

Addicks-like soil

A horizon: 0-10 inches, 10YR 3/2 loam; pH 7-8.

Bw horizons: 10-30 inches, 10YR 4/2 clay loam; pH 7-8.

Bk horizon: 30-50 inches, 10YR 4/2 clay loam; few carbonate nodules; pH 7.5-8.

Hydrology: rarely flooded, infrequently ponded.

Range in Characteristics:

A horizon: less commonly sandy clay loam, colors of 10YR 3/2, 3/0, 3/3

Bw horizon: colors of 20YR 4/1, 4/1, 3/2, 6/2.

Bk horizon: colors of 10YR 6/2 and 4/2; infrequently clay.

Permeability:

A Moderately high

B Moderately low

Hydrologic Soil Group D

Bernard

A horizon: 0-20 inches, 10YR 3/2 clay loam; ; pH 7-8.

Bt_{kg} horizons: 20-50 inches, 10YR 4/2 clay loam; carbonates commonly below about 30 inches; pH 7-8.

Hydrology: rarely flooded, infrequently ponded.

Range in Characteristics:

A horizon: colors of 10YR 3/2 and 3/1.

B_{kg} horizons: less commonly clay; colors of 10YR 4/1, 4/2, 5/2, 6/2. Depth to carbonates ranges from 6-34 inches.

Inclusions:

Common inclusions of Lake Charles Clay and Edna-like soils, particularly on pimple-mounds. Some pimple mounds may have Aldine-like soils.

Parent materials: Stratified clays and loams. Fine textured materials generally to at least 60-80 inches.

Vegetation: *Pinus taeda*, *Quercus nigra*, *Quercus phellos* (minor), *Sapinum sebiferum*, *Chasmanthium sp.*, *Ilex vomitoria*.

Permeability

A Moderately high to moderately low

B Moderately low

Hydrologic Soil Group D

Edna-Aqualf complex (EA)

This unit is a complex mix of intermixed depressions, flats, and pimple mounds. The soil pattern is too complex to delineate at the mapping scale of this project. Flat and mounded soils are dominantly Edna-like, with some pimple mounds more like Aldine-like soils and occasionally Boy soils, and depressional soils are similar to the soils described for the Aqualf unit. Most depressions are interconnected, and range in width

from 10 to 50 feet. Mounds are irregular in shape range up to 50 feet across. Depressional coverage averaged about 20%, but in a few cases ranged to 70% coverage. These are ocular estimates only; no transects were carried out to quantify this estimate. Edna-like soils constituted the majority of the unit, probably 60% coverage.

Hydrology: I estimate the depressions in this unit are not quite as wet as the *Acer-Q. Phellos-Sabal* depressions to the east, but still wet enough to qualify as jurisdictional wetlands.

Range in Characteristics: Ranges similar to individual units described above.

Inclusions: Most large depressions that could be easily identified on aerial photography were delineated separately. Some mappable depressions included in this unit.

Parent materials: Stratified loams, sands, and clays.

Vegetation:

Mounds

Pinus taeda, Quercus stellata, Ilex vomitoria, Muhlenbergia sp., Tridens strictus.

Edna flats

Muhlenbergia sp., Spartina spartinae, Ilex vomitoria, Schizocharium scoparium, Quercus stellata, Ulmus sp.

Aqualf depressions

Panicum ridgillum, Juncus spp., Andropogon virginicus, Rhynchospora spp., Eleocharis spp., Panicum virgatum.

Permeability As above for individual units.

Aqualf-Edna (AE)

This unit is similar to the Edna-Aqualf unit except that the depressions make up a larger percentage of the soil cover. Depressions average about 50% of the cover, with a few spots averaging less than 20% and a few averaging about 80%. Again, no transects were run to confirm these numbers. Edna soils averaged about 30-40%, and Aldine and Boy soils about 10-20%.

Hydrology: as above for each component of the complex.

Range in Characteristics: Ranges similar to individual units described above.

Inclusions: Most large depressions that could be easily identified on aerial photography were delineated separately. Some mappable depressions included in this unit.

Parent materials: Stratified loams, sands, and clays.

Vegetation: as above for each named component.

Permeability as above.

GREENS BAYOU MITIGATION BANK

FIGURE 7 - PROJECT P500-03-00

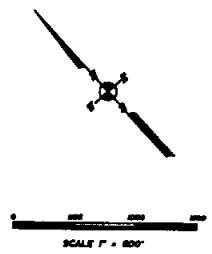
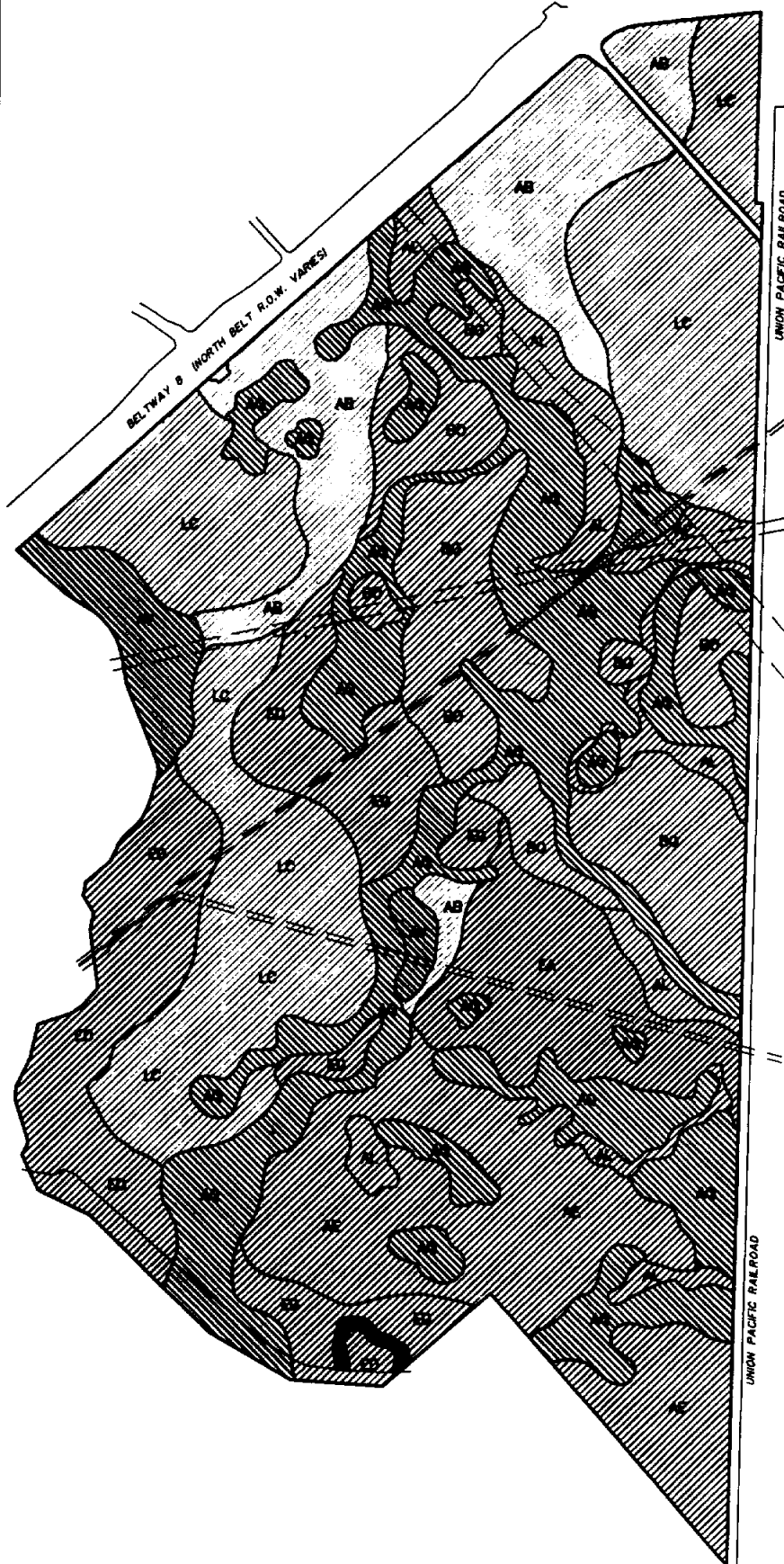

MAP UNIT	TYPING PEDON
AB - Oxisol	A horizon 0-20 inches, 85% 5/2 clay, with reddish-brown and prominent Fe pore coats at 2-6. Dry horizon 20-30 inches, 85% 5/2 clay, with Fe pore coats in the upper 10 inches, and all depth on soil faces at 10 inches from 2 to 7.
EB - Arid Entisol (Cm Yellow)	A horizon 0-6 inches, 85% 4/2 clay, with some reddish-brown pore coats at 2-6. Dry horizon 6-10 inches, 85% 4/2 clay, with some reddish-brown pore coats at 2-6. Dry horizon 10-20 inches, 85% 4/2 clay, with some reddish-brown pore coats at 2-6.
SB - Dry Entisol (Cm Yellow)	A horizon 0-6 inches, 85% 4/2 clay, with some reddish-brown pore coats at 2-6. Dry horizon 6-10 inches, 85% 4/2 clay, with some reddish-brown pore coats at 2-6. Dry horizon 10-20 inches, 85% 4/2 clay, with some reddish-brown pore coats at 2-6.
LB - Arid Entisol	A horizon 0-6 inches, 85% 5/2 clay, with some reddish-brown pore coats at 2-6. Dry horizon 6-10 inches, 85% 5/2 clay, with some reddish-brown pore coats at 2-6. Dry horizon 10-20 inches, 85% 5/2 clay, with some reddish-brown pore coats at 2-6.
LC - Latic Oxisol (Cm Yellow)	A horizon 0-20 inches, 85% 5/2 clay, with some reddish-brown pore coats at 2-6. Dry horizon 20-30 inches, 85% 5/2 clay, with some reddish-brown pore coats at 2-6. Dry horizon 30-40 inches, 85% 5/2 clay, with some reddish-brown pore coats at 2-6.
LF - Arid Entisol	A horizon 0-6 inches, 85% 4/2 clay, with some reddish-brown pore coats at 2-6. Dry horizon 6-10 inches, 85% 4/2 clay, with some reddish-brown pore coats at 2-6. Dry horizon 10-20 inches, 85% 4/2 clay, with some reddish-brown pore coats at 2-6.
AS - Arid Entisol (Cm Yellow)	A horizon 0-6 inches, 85% 5/2 clay, with some reddish-brown pore coats at 2-6. Dry horizon 6-10 inches, 85% 5/2 clay, with some reddish-brown pore coats at 2-6. Dry horizon 10-20 inches, 85% 5/2 clay, with some reddish-brown pore coats at 2-6.
EA - Arid Entisol (Cm Yellow)	A horizon 0-6 inches, 85% 5/2 clay, with some reddish-brown pore coats at 2-6. Dry horizon 6-10 inches, 85% 5/2 clay, with some reddish-brown pore coats at 2-6. Dry horizon 10-20 inches, 85% 5/2 clay, with some reddish-brown pore coats at 2-6.
AL - Arid Entisol	A horizon 0-6 inches, 85% 5/2 clay, with some reddish-brown pore coats at 2-6. Dry horizon 6-10 inches, 85% 5/2 clay, with some reddish-brown pore coats at 2-6. Dry horizon 10-20 inches, 85% 5/2 clay, with some reddish-brown pore coats at 2-6.
Water	

GREENS BAYOU MITIGATION BANK
 FIGURE 7 - PROJECT P-500-03-00
 SOILS INDEX MAP
 HARRIS COUNTY, TEXAS

REVISIONS:

March 20, 1994	by C. H. Andrews
April 5, 1994	by C. H. Andrews
April 8, 1994	by C. H. Andrews

W.K. BERG & ASSOCIATES, INC.
 ENVIRONMENTAL ENGINEERING, SCIENCE
 & LAND USE CONSULTANTS
 14811 ST. MARY'S LANE, SUITE 803
 HOUSTON, TEXAS 77079 PHONE (713) 596-0886

VEGETATION SURVEY

GREENS BAYOU MITIGATION BANK

INTRODUCTION

The following report is a general description of the vegetation composition currently identified on the Green's Bayou Mitigation Bank Site. This analysis of vegetation is part of a more comprehensive biological assessment of the subject property that includes soils, wildlife, and hydrology studies that are necessary to evaluate habitat potential and wetland functions and values.

This study was undertaken to establish baseline data that will serve two primary purposes. First, an historical record will be established that will provide a benchmark for future evaluations of species composition and distribution that will evolve as a result of wetland creation and growth during the mitigation bank project.

Second, the data has been used to aid in the conceptual design of wetland creation and enhancement areas within the bank site. The composite of surveys (vegetation, soils, wildlife, etc.) provide the basis for many planning, design, and construction decisions, such as pine removal, construction techniques, and hydrological design among others.

The following report, therefore, is a general description of the current vegetation composition identified on the subject site. In analyzing the vegetation patterns on this relatively large tract, it became evident that a trend-based analysis would be appropriate. While species mix varied across the site, certain trends were identified wherein one or two species remained dominant throughout. By grouping similar areas, based on the dominant trends, vegetation "associations" were identified and mapped for the entire mitigation bank site.

OBJECTIVES

1. To survey and evaluate current vegetation communities on the subject site with respect to species composition, pattern, vertical and horizontal stratification, and topographic position.
2. To compile information from the survey into a baseline record.
3. To aid in the determination of creation, enhancement and laize faire areas for the conceptual design of the mitigation bank development plan.
4. To construct a detailed map displaying relative patterns of vegetation associations determined from the survey.

SITE DESCRIPTION

The Garners Bayou Mitigation Site is located within the northeastern corner of Beltway 8 that circles Houston, Texas. The beltway serves as the northern boundary of the site, while a Union Pacific Railroad track borders the property on the east. Garners Bayou and Greens Bayou provide the western boundary. Lockwood Road transects the northeastern corner of the tract; several power-line and pipeline corridors transect the remainder of the property.

Much of the site is presently a mixed hardwood/pine woodland, with pines predominating in the north and west portions. Although some large timber remains, the tract has been logged extensively. Open, marshy areas occur at lower elevations, and several ponds and oxbows provide permanent water. The utility corridors at the northeastern corner bordered by Beltway 8, Lockwood Road, the railroad track, and the mowed bank of Greens Bayou offer open, grassy areas. Brushy woodland borders exist in the majority of open areas, especially along the railroad track and pipeline easements.

SITE HISTORY

According to local sources and historic aerial photographs, the subject site was used for the commercial harvesting of pine lumber in the mid to late 1980s. The logging activity appears to have been performed harshly and abruptly. Evidence of the resulting disturbance can be seen in the change of vegetation composition, historic aerial photographs, and the alteration of natural topography done by the building of roads. Subsequent to the period of heavy site disturbance, areas varying in secondary successional stages or seral stages have been created, where the expected natural vegetation composition differs from that of nearby undisturbed areas.

Site reconnaissance indicates that much of the subject site was once dominated by hardwood and grassland that generally followed a relict meander scar wetland system and adjacent prairies. For the most part, pines were found to exist only in the topographic highs, as evidenced by the contrasting ages of older pine growth compared to the overall growth of hardwoods.

Prior to logging activities, the property was not used for any consumptive purposes. The age of the hardwoods, remaining pines, understory, regrowth, and surrounding forest suggest that the area may have been used as agriculture land prior to the turn of the century.

Currently the property is being leased for cattle grazing. Hunting rights were leased routinely until approximately two years ago, around 1992 to 1993.

The vegetation composition as it occurs today helps provide the habitat for whitetail deer, feral hogs, annelids, crayfish, rabbits, snakes and other reptiles, armadillos, grey squirrels, and numerous species of birds.

METHODOLOGY

This vegetation survey was conducted by using a combination of office and field evaluation techniques. Analyses of historic black and white aerial photographs, infra-red photographs, wetland determination data forms, and soil surveys were performed in-office to identify general vegetation trends on the site.

Before the field survey, a review of the wetland determination data forms was performed. This review provided a baseline of species expected to be encountered. These forms only identify vegetation by the presence of facultative (FAC), facultative wet (FACW), and obligate (OBL) indicators. Therefore, a general map was made using this information. Once the review was complete, the general map was compared to infra-red, historical aerial photographs, and site photographs taken from the wetland determination project.

It was found that the vegetation trends generally follow the soils depicted in the Soils of Harris County Soil Survey (SCS 1976) in the areas where the soils are relatively undisturbed. However, a more detailed soil survey, which was conducted independently, shows a more intricate pattern which better correlates with the vegetation configuration illustrated in the map located in the appendices of this report.

The vegetation trends were then field truthed for the entire site using pace transects, general range site observations, and additional evaluations of overall species composition. A site survey was conducted in which several pace transects of each assessment area were performed to verify the conclusions made in the office review. The transects were performed by taking two paces and noting the species at the tip of the toe at the end of the second pace. This method gave an approximate dominance value to the species identified on the site. Vegetation associations were then identified and mapped for the project site.

INFLUENCES

The current vegetation composition has been influenced most greatly by logging activities. The predominance of this activity is evident in historic aerial photographs and in the contrasting ages of pines compared to hardwoods on site and in surrounding areas. The logging opened up the canopy, thereby allowing pine and hardwood seedlings to establish. Pines are much faster growing than hardwoods and, once established, create an understory microenvironment in which few other plants can thrive. It is possible that at one time this area was dominated by hardwoods and grasslands, since the area covered by old meander scars seen in aerial photographs is extensive.

Other dominant influences include hydrology and soil composition. Precipitation, available soil water, soil drainage capability or class, infiltration rate, percolation rate, water holding capacity, and evaporation rate of bare soil are among the primary factors that must be considered. The interaction of soils and hydrology determines vegetation composition; that

is, the proportion of these two parameters determines the compatible species inhabiting a particular area. Species able to tolerate water-logged soil with an acidic pH will differ considerably in growth form and function of vital processes from those that can tolerate aerated soil with a more basic pH.

VEGETATION ASSOCIATIONS

PINUS ASSOCIATION (Pine)

Dominated by Pinus taeda (Loblolly Pine) interspersed with few Quercus nigra (Water Oak), Myrica cerifera (Wax Myrtle) and Ilex vomitoria (Yaupon) mostly on the edges, yet occasionally becoming dense where Pinus taeda (Loblolly Pine) is slightly sparse. Grass cover varies in dominance. The main herbaceous species occurring are Andropogon virginicus (Broomsedge Bluestem), Muhlenbergia capillaris (Long Awn Muhly) and Spartina spartinae (Gulf Cordgrass) also along the edges. Deep within the association Chasmanthium sessiliflorum (Long Leaf Spikegrass) can be found among a solid ground cover of Pinus taeda (Loblolly Pine) leaf litter.

QUERCUS ASSOCIATION (Oak)

The characteristic species of this association are Quercus nigra (Water Oak), Quercus falcata (Red Oak), Quercus phellos (Willow Oak) and Quercus stellata (Post Oak). Dominance of each species varies with soil type, age and severity of past disturbance, topography and photoperiod allowed by surrounding canopy. This association is additionally characterized by the scattered presence of Myrica cerifera (Wax Myrtle), Ulmus alata (Winged Elm), Chasmanthium sessiliflorum (Long Leaf Spikegrass), Sabal minor (Palmetto), Sapium sebiferum (Chinese Tallow-Tree), and Liquidambar styraciflua (Sweet Gum).

PINUS-QUERCUS ASSOCIATION (Pine-Oak)

Predominantly Pinus taeda (Loblolly Pine) with the secondary species being a mix of Quercus nigra (Water Oak), Quercus falcata (Red Oak), and Quercus stellata (Post Oak) varying in density by soil type and time and severity of past disturbance. The understory is dominated by shrub species. This shrub layer is characterized by Ilex vomitoria (Yaupon) and Myrica cerifera (Wax Myrtle) occurring more densely along cleared edges. Herbaceous cover is interspersed and consists mainly of Carex cherokeensis (Cherokee Sedge), Eleocharis montevidensis (Sand Spikerush), Chasmanthium sessiliflorum (Long Leaf Spikegrass), and Andropogon virginicus (Broomsedge Bluestem).

ACER-QUERCUS ASSOCIATION (Maple-Oak)

Varying in dominance with soil type and time of disturbance, this association is characterized by the presence of Acer rubrum (Red Maple) and Quercus phellos (Willow Oak) with Sabal minor (Palmetto) miscellaneously occurring.

TAXODIUM ASSOCIATION (Bald Cypress)

Dominant canopy is Taxodium sp. (Bald Cypress) with few Sabal minor (Palmetto) along the edges of the ponding area.

ERIANTHUS ASSOCIATION (Plumegrass)

Erianthus strictus (Plumegrass) is the dominant species with scattered Sabal minor (Palmetto) and Pinus taeda (Loblolly Pine).

MUHLENBERGIA ASSOCIATION (Long Awn Muhly)

This area has an almost equally distributed canopy cover of Muhlenbergia capillaris (Long Awn Muhly), Spartina spartinae (Gulf Cordgrass), Carex cherokeensis (Cherokee Sedge), Crataegus sp. (Hawthorne), Baccharis halimifolia (Willow Baccharis) and interspersed with saplings of Pinus taeda (Loblolly Pine).

MUHLENBERGIA-ANDROPOGON ASSOCIATION (Muhly-Bluestem)

This grassland is occupied most dominantly by Muhlenbergia capillaris (Long Awn Muhly), Andropogon virginicus (Broomsedge Bluestem) and Andropogon glomeratus (Bushy Bluestem). Patches of Myrica cerifera (Wax Myrtle), Schizachyrium scoparium (Little Bluestem), and Panicum virgatum (Switchgrass) are dispersed throughout the area.

TRIDENS-ELEOCHRIS ASSOCIATION (Tridens-Spikerush)

This association is characterized by a dominant cover of Tridens strictus (Long Spike Tridens) in the higher topographic locations and Eleocharis montevidensis (Sand Spikerush) in the depressions caused by the shrink/swell characteristics of the soil. Secondary species include Andropogon virginicus (Broomsedge Bluestem), Muhlenbergia capillaris (Long Awn Muhly), Crataegus sp. (Hawthorne), and Sapium sebiferum (Chinese Tallow-Tree).

ANDROPOGON-CAREX-PANICUM ASSOCIATION (Bluestem-Carex-Panicgrass)

Ground cover is dominated by Andropogon glomeratus (Bushy Bluestem), Carex cherokeensis (Cherokee Sedge), and Panicum rigidulum (Red Top Panic Grass). This area is beginning to show signs of invasion by Pinus taeda (Loblolly Pine) saplings.

WETLAND POTENTIAL

A significant portion of the Greens Bayou Mitigation Site has been delineated as wetland. The majority of these wetland areas are dominated by Quercus phellos (Willow Oak), Sabal minor (Palmetto), Acer rubrum (Maple), and Liquidambar (Sweetgum). There are also two very distinct wetland areas, one of which is dominated by Taxodium spp. (Bald Cypress) and the other is dominated by Erianthus strictus (Plumegrass). The presence of these plant species suggest that the increase of wetland areas would be successfully "planted" by natural means. Although the wetland areas are currently present and functioning, it is undetermined what effect the past logging activity may have had on their value.

However, to help ensure unneeded competition, the pines that currently grow in low lying areas and areas designated as creation plots should be permanently removed. Pines can use up to 600 gallons of water per day, transpiring and intercepting more water than hardwoods or grass/grasslike species. The transformation of a pine forest to a hardwood forest will result in an estimated 4 inch increase in the water budget in the first year following the metamorphosis. To change a pine forest to a grassland will result in an estimated 8 inch increase in the water budget in the first year following the transformation.

Once the creation process begins and soil saturation levels increase in duration, the pines will become stressed. When this occurs, the induced conditions are favorable for Pine Bark Beetle infestation. The beetle is a very prolific menace and would spread rapidly if established. Even if the beetle does not establish itself, it is unlikely that the pines will survive the new soil conditions created. When the pines die, and eventually fall, they will add to the nutrient cycle. It is possible to overload the system beyond its current capacity. However, the eutrophication process will develop slowly over time and should not be accelerated. The fallen pines could also "clog" a system, preventing it from functioning properly. The encroachment of Pinus taeda (Loblolly Pine), therefore, would alter the hydrology. Therefore the removal of pine trees would enhance the abilities of the wetland areas to function.

In addition to the prime resource areas, there are four distinctly different grasslands. Beginning in the northeast corner of the property, on the east side of Lockwood Road is a grassland dominated by Muhlenbergia capillaris (Long Awn Muhly), Andropogon glomeratus (Bushy Bluestem) and Andropogon virginicus (Broomsedge Bluestem). On the west side of Lockwood Road is an area dominated by Eleocharis spp. (Eleocharis) and Tridens strictus (Long Spike Tridens). In the northwest portion of the property is a grassland dominated by Muhlenbergia capillaris (Long Awn Muhly). The southwest segment of the property shows a grassland dominated by Andropogon glomeratus (Bushy Bluestem), Carex cherokeensis (Cherokee Sedge), and Panicum rigidulum (Red Top Panic Grass). All of these grassland areas are greatly utilized by wildlife.

The greatest percentage of the site is dominated by a mix of pine and hardwood, with the observed dominant species varying with soil and hydrology conditions. The perceived age

of the pine population indicates that their occurrence and relatively recent spreading is a direct result of the logging activity done in the late 1980s.

The potential for creating and enhancing wetland areas in this site is high if the proper steps are taken. The wetland areas, currently identified as covering thirty percent of the site, are rich with diversity and function. Since the site currently contains many species of hydrophytic vegetation, it is probable that if given the appropriate hydrogeomorphic conditions, the remaining areas to be created would be "naturally" planted with these species.

GREENS BAYOU MITIGATION BANK FIGURE 6 - PROJECT P500-03-00

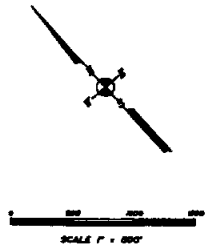
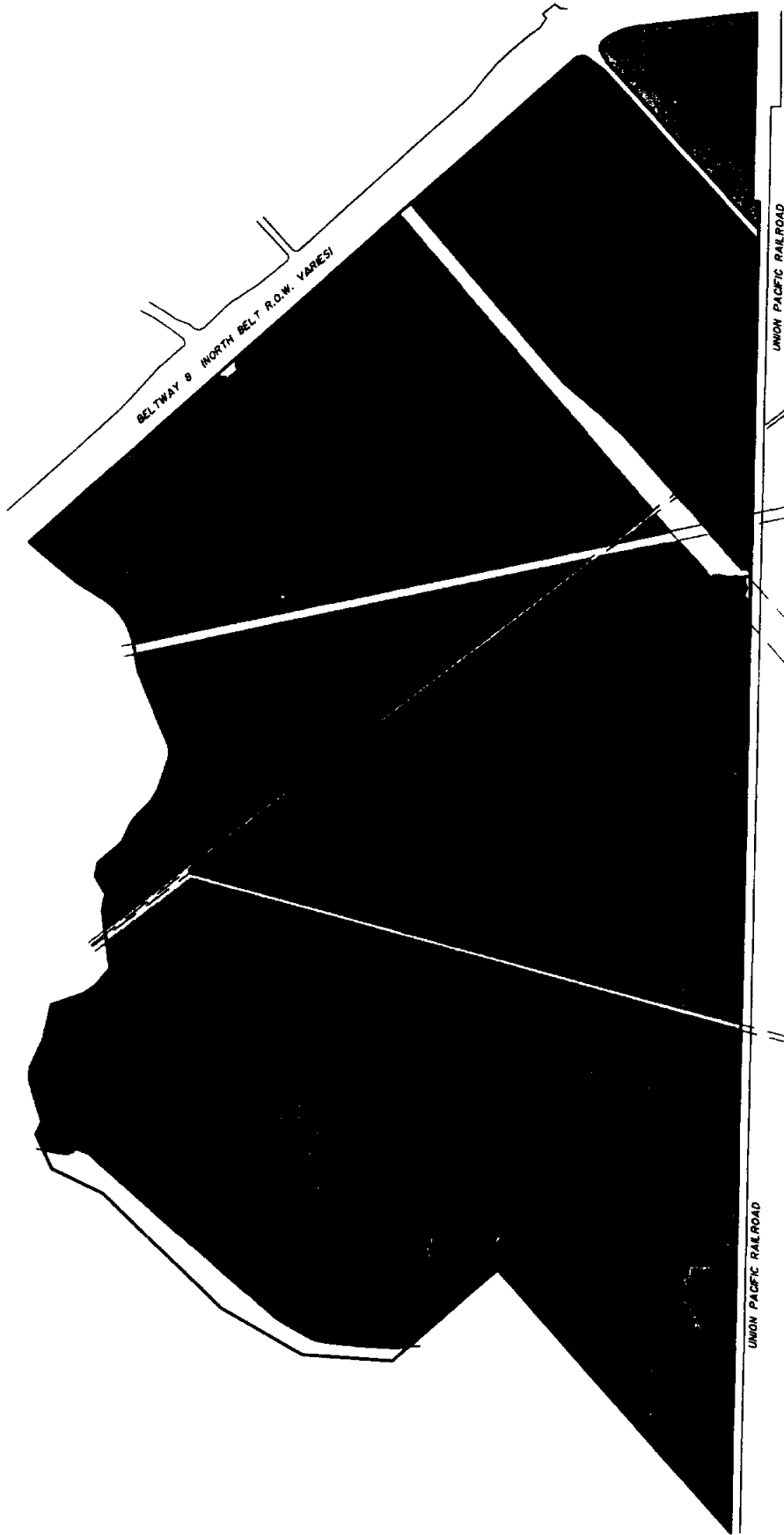

VEGETATION INDEX	
	FORE PINE
	FORE-OPENED FORE-PINE
	TAMARAC SWAMP
	BURMOSA PINE
	WATER-SEEPING
	WATER-SEEPING-FOREPINE
	ASH-OPENED BAYOU PINE
	SHRUBBY PINE SWAMP
	WATER-SEEPING-FOREPINE
	WATER-SEEPING
	WATER

GREENS BAYOU MITIGATION BANK
FIGURE 6 - PROJECT P-500-03-00
VEGETATION INDEX MAP
HARRIS COUNTY, TEXAS

REVISIONS:
Jan. 10, 1994 by C. H. Andrews
Jan. 28, 1994 by C. H. Andrews
Jan. 28, 1994 by C. H. Andrews
March 15, 1994 by C. H. Andrews
March 22, 1994 by C. H. Andrews
Aug. 6, 1994 by C. H. Andrews

W.K. BERG & ASSOCIATES, INC.
ENVIRONMENTAL ENGINEERING, SCIENCE
& LAND USE CONSULTANTS
14811 ST. MART'S LANE, SUITE 263
HOUSTON, TEXAS 77079 PHONE (713) 688-0888

5. Topographic Survey

The topography of the site is described as a complex of upland flats in a somewhat convoluted orientation with broad, subtle changes in elevation. This results in very complex areas of intricate depression patterns, with the more pronounced channel scars being the generally dominate low areas. Historical one foot and current five foot topographical maps from the U. S. Department of the Interior Geological Survey (USGS) were reviewed in order to evaluate the site's elevation changes and to establish probable flow patterns related to hydrology. In addition, Federal Emergency Management Agency (FEMA) maps were reviewed to establish flood plain boundaries on the site.

The most prominent feature of the landscape is a slight ridge which runs in a generally north-south direction just east of the center line of the property and curves northeast toward Beltway 8 and the HL&P power line easement. The majority of pristine wetlands on the site are located immediately east of this ridge in a series of large irregular depressions and meander channel scars. Continuing east, the terrain forms a large, broad prairie flat on the northeast portion of the tract.

West of the ridge, the topography runs gently downgrade toward Garners and Greens Bayous with very subtle drops in elevation. The different elevational levels occur as narrow bands in some areas, then spread to broad open flats which generally dominate the terrain. The random, non-linear depressions of varying sizes and concentrations that exist on these flats have created surface formations which characterize the majority of complex wetland areas found on the site.

GARNERS BAYOU MITIGATION BANK

FIGURE 4 - PROJECT P500-03-00

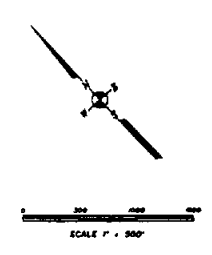
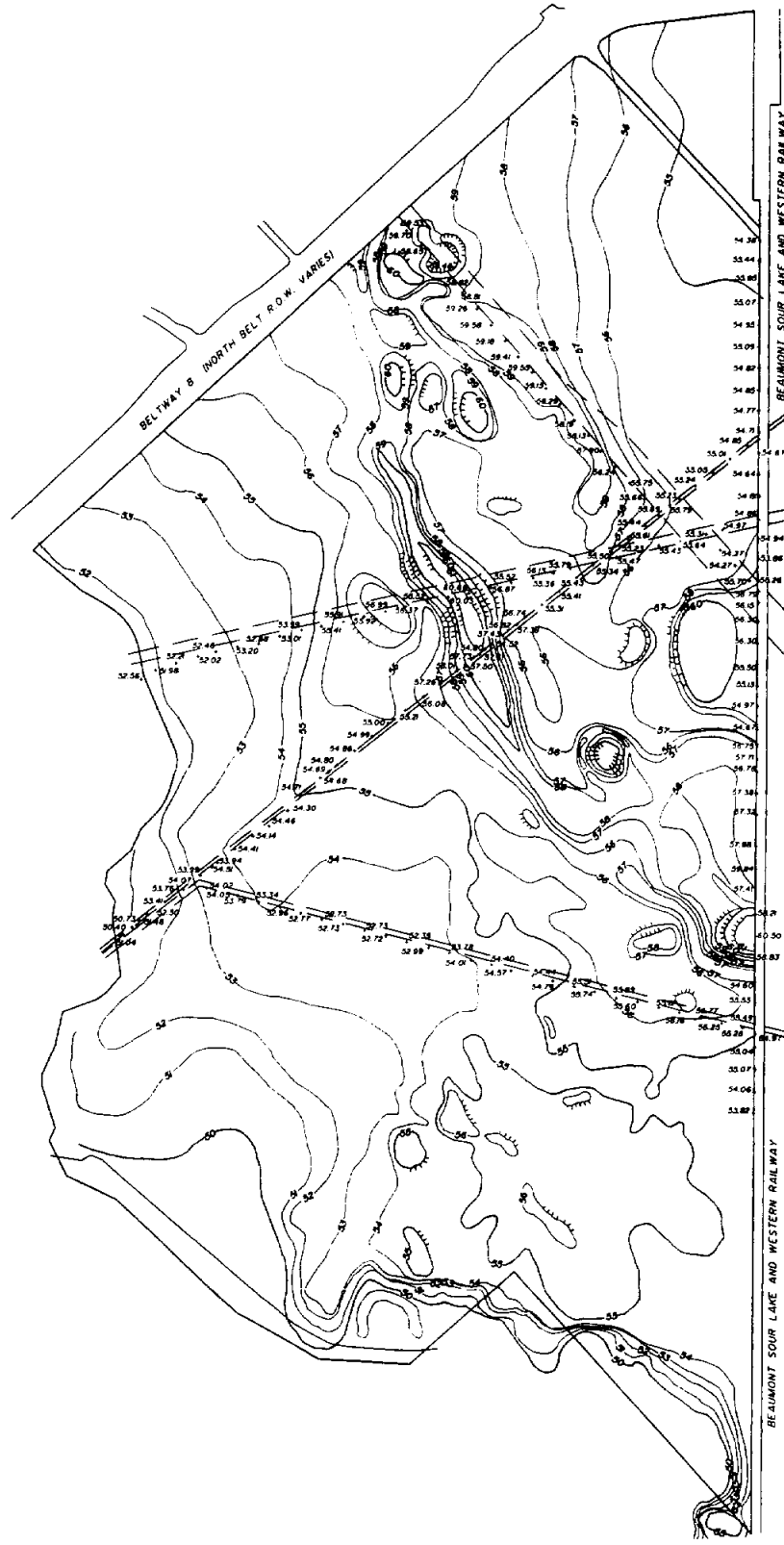

GARNERS BAYOU MITIGATION BANK
 FIGURE 4 - PROJECT P500-03-00
 TOPOGRAPHIC CONTOUR MAP
 HARRIS COUNTY, TEXAS

REVISIONS	
REV. 6, 1993 BY C. AUGUST	
REV. 10, 1993 BY C. AUGUST	
REV. 12, 1994 BY C. AUGUST	
REV. 25, 1994 BY C. AUGUST	

W.K. BERG & ASSOCIATES, INC.
 ENVIRONMENTAL & LAND USE CONSULTANTS
 14811 ST. MARY'S LANE, SUITE 203
 HOUSTON, TEXAS 77079 PHONE (713) 689-0908

6. Water Budget

The hydrology of the subject property is largely affected by a combination of historical natural features, topography, soil compositions, rainfall, periodic flooding, and manmade barriers. The pristine wetland areas appear to be major collection points that would not be dry except under extreme conditions. The deeper channel scar depressions also demonstrate the ability to retain water for extended periods and are probably wet under most circumstances. The predominance of clayey soils, which have low permeabilities and poor drainage, enhance the retention time of waters that occupy significant surface areas on the property. The relatively flat nature of the terrain generally does not provide adequate slope for runoff and, therefore, the residence time of rain and periodic flood waters is high within the complex "up and down" areas which occur in some of the flats.

The historical natural flow patterns, especially those along channel scar meanders, have been interrupted by the construction of an elevated railway and utility easements. These manmade barriers have been in place for many years and have served to restrict flow patterns and create ponding areas adjacent to the actual installations or along spoil banks. The resulting soil saturation has produced hydric conditions and wetland development. The most pronounced areas of restrictions are located along the railroad right-of-way, between the north/south oriented utility easement and the meander ridge.

The property showed very little evidence of high velocity water flow, indicating that drainage of the property is slow to moderately slow. There were few visible signs of debris or driftlines in high water areas which would be indicative of high flow rates. Obviously, flow rates would be expected to increase during periodic floods and the subsequent receding of water. However, since the majority of the site lies on the outer edge of the flood plain of the nearby bayous, the primary driver of hydrological activity is considered to be rainfall and its collection and movement on the property. Soil saturation and ponding were prevalent during site investigations and were attributed to recent heavy rains.

The upland portions of the site, which occupy the majority of acreage, contain sufficient topographical features and drainage mechanisms to prevent extended periods of water retention. During periods of above normal precipitation these areas may, from time to time, show signs of moderate soil saturation or some

standing water. However, the necessary conditions do not exist for wetlands to develop and these portions of the property remain characteristically upland in their features. Overall hydrological patterns on the subject property indicate that high velocity water flow is generally not present except under extreme conditions (e.g., floods). Under normal circumstances the highest flow rates appear to be along the prominent channel scar meanders, as would be expected, which move through the site in an "S" shaped system and provide the primary drivers of hydrological activity.

WATER BUDGET ANALYSIS SWRRBWQ MODEL

The Greens Bayou Mitigation Bank site was evaluated using the Simulator for Water Resources in Rural Basins - Water Quality (SWRRBWQ) model to simulate surface hydrology behavior on the property and wetland ponding tendencies for created wetlands. The simulations were performed using historical precipitation, temperature, soil, and evaporation data for the immediate area, as well as topographic and vegetation information compiled from direct site evaluations.

Since the bank site is isolated from surrounding watersheds by roads and railway installations, the primary source of water for wetland development is considered to be rainfall. Occasional floods from the adjacent Greens and Garners Bayous will supply high volume, short duration hydrologic events that will inundate significant portions of the site. However, these events are not considered to be consistent sources of water and should be seen only as supplements to precipitation.

A ten year interval was simulated in the model to evaluate the site under the 3-4 year wet and dry cycles that are characteristic of the Gulf Coast area. This wet/dry cycle can be directly correlated to spatial water expansion and drawdown that occurs in palustrine wetland systems such as those that will be created in the mitigation bank.

SIMULATION RESULTS

Subdivision A, which will be the first wetland creation area in the bank, was chosen for the pond budget evaluation. Because it is somewhat isolated from the other subdivisions and is located topographically "high" in the watershed, a positive pond budget analysis in this subdivision would suggest that rainfall driven wetlands would have significant chances of success. This would be true not only for the higher position areas, but for those downslope as well.

Subdivision A slopes gently and uniformly from north to south, with a total elevation drop of approximately five feet. The simulation was set up to assume that the southern end of the subdivision would be bermed on all sides, thereby creating an approximate 100 acre reservoir in the southern half of the site with a potential nominal water depth of 1.5 feet. The average slope through the reservoir area would be approximately 0.13 ft/100 ft.

Based on the results of the pond budget simulation, it was found that a shallow pond, or wetland depression, could be successfully constructed relatively high in the watershed of the bank site, and could be hydrologically sustained by precipitation. Under average conditions, the surface area of the pond would cover approximately 50-55 acres, leaving additional expansion capacity of 45-50 acres. Since this geographical area is subject to high intensity, short duration rainfall events that produce rapid runoff conditions, the additional capacity

would be utilized, thereby creating periodic inundation of fringe areas in the upslope portion of the pond. Post-event water recession and drawdown would be correspondingly rapid; however, saturated soil conditions would be expected to exist for some time after.

It was also found that under extremely dry conditions, the pond would reduce in size to approximately 18-20 acres. There was no indication in the simulation that a completely dry pond condition would occur. During extended wet conditions of above average rainfall years, the pond would expand to approximately 75 acres.

The surface hydrology model indicates that, during moderate to wet years, as much as 30-40% of available precipitation may leave the site by surface and subsurface flows on an annual cumulative basis, after allowances for deep soil percolation and evapotranspiration. During wetter periods, as much as 50% losses may be expected during single events of 2± inches. Dry periods showed little or no losses, as would be expected.

HYDROLOGY ENHANCEMENTS

Given the results of the surface hydrology and pond budget models, the goal of a successful wetland design would be to capture and retain the precipitation normally lost through surface and subsurface runoff during larger rain events. In Subdivision A, this can be accomplished by making use of the natural topographic slope with a low berm constructed at the downslope end. This will create a reservoir to capture surface runoff during average conditions and provide sufficient capacity to capture peak flow events as well.

Complete hydrological enhancement of the site would also include design parameters for capturing subsurface flows to induce longer periods of soil saturation and greater ponding tendencies. This goal could be accomplished by placing an impermeable barrier perpendicular to flows in the upper few feet of the soil strata. The installation of this feature should take place at the same downslope end of the subdivision as the berm, thereby creating a full cross sectional barrier to potential off site flows.

Once the structural modifications to the site are complete, the wetland site can be flooded to induce soil saturation and ponding. This activity is recommended to accelerate wetland development and to prevent a long initial filling period that may result, especially if construction is completed during a dry cycle.

Rainfall Data for Greens Bayou

AVERAGE ANNUAL RAINFALL
on a
MONTHLY BASIS

Water Year	Month												Total
	OCT	NOV	DEC	JAN	FEB	MAR	APR	MAY	JUN	JUL	AUG	SEP	
1971	8.67	1.75	.60	.22	2.37	1.00	2.40	3.17	.30	3.10	5.18	7.92	36.68
1972	1.45	1.55	7.12	3.10	1.13	6.30	2.20	7.86	1.15	3.69	2.78	6.84	45.17
1973	3.44	5.76	1.33	3.94	3.68	3.12	7.40	2.04	12.43	4.95	3.80	7.14	59.03
1974	8.76	1.23	2.54	7.68	.54	3.82	1.68	5.59	.30	2.51	7.06	5.32	47.03
1975	4.67	8.25	3.36	1.39	2.05	2.51	4.46	5.87	3.03	5.35	4.39	.81	46.14
1976	4.96	2.04	3.16	1.25	.28	1.29	6.60	3.45	4.57	5.05	1.90	11.35	45.90
1977	5.41	3.01	5.78	2.18	1.56	1.64	4.37	.76	4.81	1.77	2.74	3.62	37.65
1978	.57	3.29	2.39	7.31	3.01	1.36	.45	2.28	6.63	2.64	2.25	5.56	37.74
1979	.11	6.98	2.50	5.62	4.32	3.00	7.92	4.43	1.65	8.27	3.14	9.44	57.38
1980	2.51	1.50	3.21	5.00	2.22	5.36	1.55	4.65	1.74	1.40	1.55	5.39	36.08
1981	4.48	2.05	1.28	2.49	2.44	1.48	2.76	8.46	10.25	6.26	8.89	1.41	52.25
1982	6.31	5.19	1.56	2.10	1.59	1.36	2.69	8.47	1.55	2.32	1.78	0.69	35.61
1983	6.49	8.57	3.80	1.82	4.48	4.00	0.21	7.90	4.45	4.83	10.22	6.05	62.82
1984	1.04	3.29	2.08	2.75	3.27	1.64	0.46	2.07	1.42	3.61	2.88	2.39	26.90
AVG	4.20	3.89	2.91	3.35	2.35	2.71	3.23	4.78	3.88	3.98	4.18	5.28	44.74

Data taken from "Hydrologic Data for Urban Studies". Data recorded at gage 08076000, located on U.S. Highway 59 at Greens Bayou.

Water Year	Average Rainfall over Greens Bayou Drainage Basin above U.S. Highway 75 (inches)	Average Rainfall over Greens Bayou Drainage Basin above U.S. Highway 59 (inches)
1969	39.0	---
1970	43.6	---
1971	36.2	---
1972	45.2	36.7
1973	59.0	45.2
1974	48.7	59.0
1975	46.1	47.0
1976	45.9	46.1
1977	36.6	46.0
1978	37.0	37.6
1979	57.7	37.7
1980	35.9	57.4
1981	56.0	36.1
1982	36.0	52.2
1983	65.6	35.6
1984	33.2	62.8
		26.9

C. Conceptual Design Phase Services:

The contents of this section include a generalized fashion the geomorphic characteristics of the existing wetland hydrology the proposed hydrologic improvements, and proposed planting scheme for the Greens Bayou Wetlands Mitigation Bank. Although the discussions herein are directed at the proposed mitigation standards, the nature of the discussion must be limited to a conceptual discussion. The final design is dependent upon the constructive input and approval of the interagency Mitigation Bank Review Team (MBRT).

Several key issues required resolution prior to proceeding with the creation of the mitigation bank. Of these issues the following are discussed in further detail in this section:

- Conceptual Plans - Prepare conceptual plans for the various subdivisions in the project.
- Baseline - Perform the Wetland Evaluation Technique for the project subdivisions within the bank in order to model and evaluate the wetland functions and values that currently exist within the site.
- Quantification Methodology - Establish a methodology to quantify the value of functions and values of a wetland.
- Memorandum of Agreement (MOA) and Land Use Agreement - Prepare the MOA and land use agreement necessary to obtain MBRT approval for the creation of a wetlands mitigation bank.

1. Conceptual Plans

It was determined that the site consists of several distinct ecological divisions, distinguishable by vegetation associations within the site. These vegetation associations in turn reflect differing ecological functions for wildlife diversity and abundance, flood flow alteration, and the other functions and values generally associated with wetland systems. The site was therefore divided into areas with generally similar ecological characteristics and planned banking activities so that individual site development plans could be designed for each division by identifying appropriate functional parameters and objectives (see Exhibit S).

Areas within the site were evaluated based on their existing conditions and potential design. Various portions of the site were identified as locations to create, enhance, or preserve wetlands (see Exhibit T). Although this layout is preliminary, it gives a general conceptual plan to pursue.

Subdivision A was selected as the first subdivision for wetlands creation as it was expected to provide the quickest success. A conceptual plan was developed and preliminarily approved by the MBRT for the creation of a palustrine emergent wetland. Wetlands creation was to be achieved through enhanced hydroperiod, grading, contouring and structural improvements and vegetation management.

Subdivision A is one division within the site that is based on differing vegetation patterns, topographical features, soil types, and hydrologic characteristics. Subdivision A differs quite dramatically from the other subdivisions in that it is as a relatively flat, native grass upland with little or no forested evergreen or hardwood cover, except for its northwest portion. This upland grass prairie is further divided by the existence of a cleared, one hundred and twenty foot electric transmission easement along its western boundary. It is, by far, the most logical subdivision of the project.

Additionally, it appears to represent the subdivision with the greatest immediate potential for producing and demonstrating wetland conversion values. When complete, the area is designed to attract migrating and resident waterfowl, create habitat for aquatic lifeforms and other wetland dependent species, provide functional sediment and toxicant removal, and provide flood flow alteration. It clearly represents the

GREENS BAYOU MITIGATION BANK

FIGURE 8 - PROJECT P500-03-00

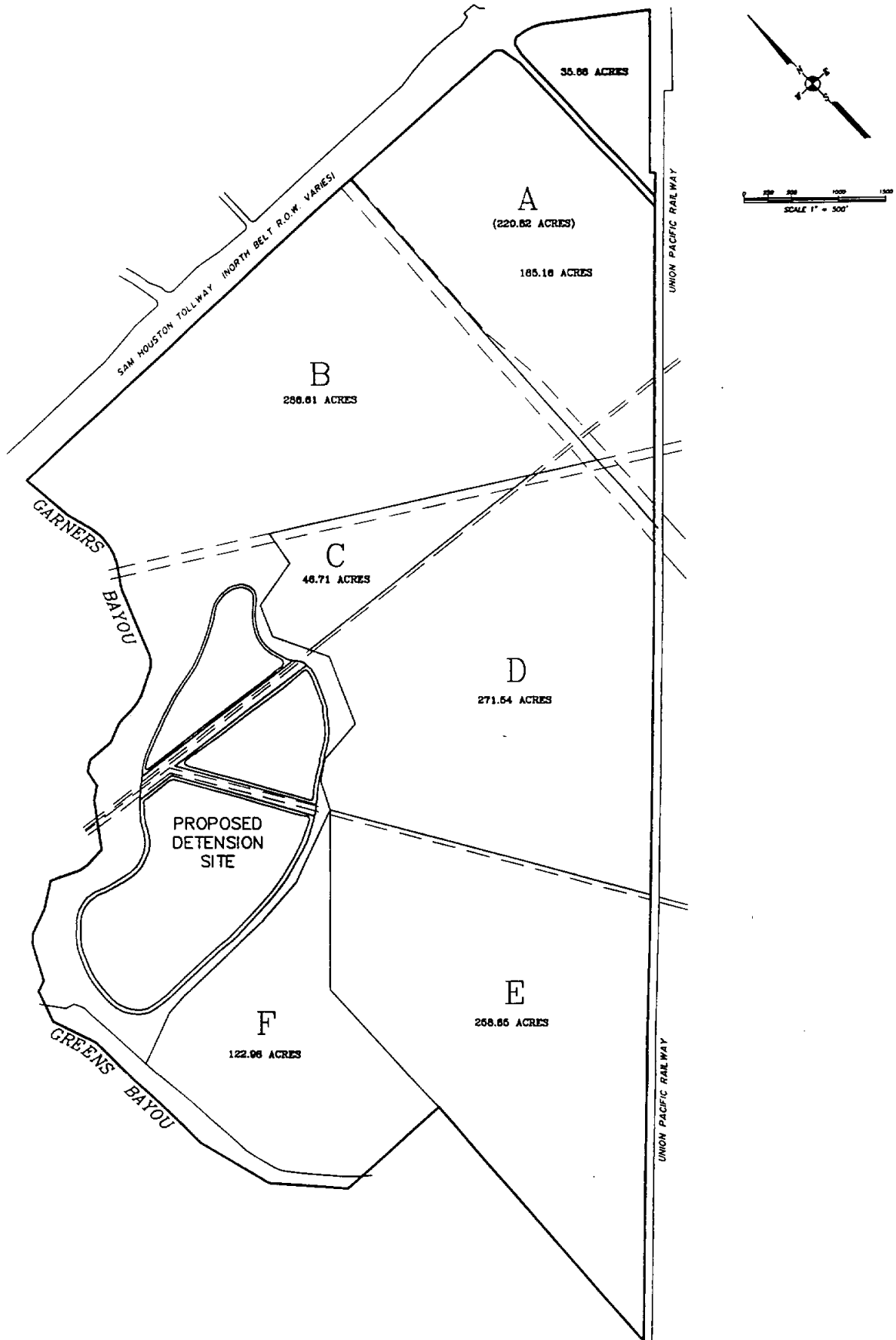

GREENS BAYOU MITIGATION BANK,
 PROJECT P-500-03-00
 FIGURE 8 - SUBDIVISION ACREAGE
 HARRIS COUNTY, TEXAS

REVISIONS:
Feb. 21, 1993 by C. H. Andrews

W.K. BERG & ASSOCIATES, INC.
 ENVIRONMENTAL ENGINEERING, SCIENCE
 & LAND USE CONSULTANTS
 14811 ST. MARY'S LANE, SUITE 263
 HOUSTON, TEXAS 77079 PHONE (713) 689-0888

GARNERS BAYOU MITIGATION BANK

FIGURE 2 - PROJECT P500-03-00

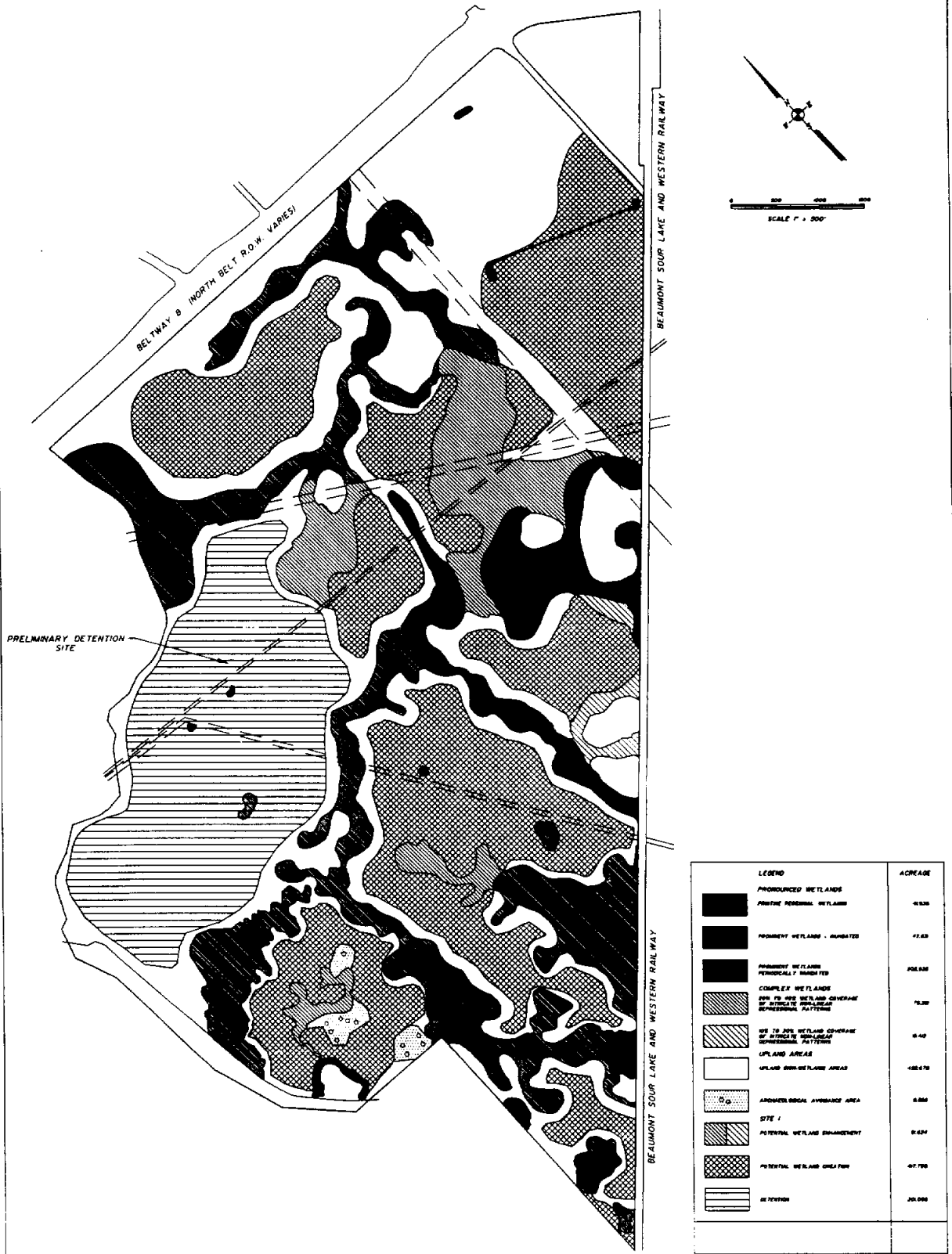

PRELIMINARY DETENTION SITE

LEGEND	ACREAGE
PROFOUND WETLANDS	
POTENTIAL WETLANDS	45.50
POTENTIAL WETLANDS - AUGMENTED	11.63
POTENTIAL WETLANDS - PERMANENT / TRANSFERRED	104.50
COMPLEX WETLANDS	75.30
USE TO 20% WETLAND COVERAGE BY INTRODUCING HETEROGENEOUS PATTERNS	0.40
UPLAND AREAS	148.70
UPLAND BROWNE PLAINS AREAS	0.00
ARCHAEOLOGICAL AVOIDANCE AREA	0.00
SITE 1	0.00
POTENTIAL WETLAND ENHANCEMENT	0.00
POTENTIAL WETLAND CREATION	07.70
DETENTION	20.00

GARNERS BAYOU MITIGATION BANK
 FIGURE 2 - PROJECT P500-03-00
 DETENTION SITE MAP
 HARRIS COUNTY, TEXAS

REVISIONS
Nov. 4, 1993 by C. Andrews
Nov. 6, 1993 by C. Andrews
Jan. 28, 1994 by C. Andrews
March 23, 1994 by C. Andrews

W.K. BERG & ASSOCIATES, INC.
 ENVIRONMENTAL & LAND USE CONSULTANTS
 14811 ST. MARY'S LANE, SUITE 203
 HOUSTON, TEXAS 77079 PHONE (713) 688-0890

logical choice within the entire Garners Bayou Mitigation Site for the Flood Control District to demonstrate and verify the success of the mitigation bank concept.

Since the success of any wetland is dependent on its available hydrology regime, Subdivision A is designed to make optimal use of existing water sources using passive collection systems to create a seasonally to semipermanent flooded hydroperiod in an upland area that currently has moderate to high surface runoff and water yield. Two water sources are available for the site. The primary source will be precipitation capture and retention; the secondary source will be potential stormwater runoff diverted from surrounding roadways along the northern boundary of the site.

Water collection will be accomplished using two primary methods. To capture precipitation runoff that would otherwise leave the site, a berm will be constructed along the east, south, and west boundaries which lie at the topographic downslope position of the Subdivision. (See Exhibit U) Stormwater runoff from roadways will be conveyed to the site by constructing generally linear channels that will provide necessary gradient and flow rates to deliver maximum available water to the wetland area with minimal infiltration in the upland soils on the northern portion.

At the upland/wetland transition linear water delivery will be desynchronized by a network of shallow swaled conveyances interspersed with varying bottom contours. This design provides uniform water distribution throughout the site for maximum coverage, at the same time reducing velocity-induced erosion forces and increasing sediment/toxicant retention for waters brought in from off site.

The hydrology of Subdivision A is designed to optimize natural hydroperiod cycles characteristic of this geographic region. More specifically, this cycle is identified as the period between late October and late May of most years when peak annual rainfall occurs in conjunction with low evapotranspiration rates and high soil saturation. Ponding and soil saturation tendencies are high during this period, creating optimal conditions for wetland plant growth. Natural draw down periods will occur between June and October during offpeak rainfall months with higher temperatures.

The existing natural site characteristics and natural features of Subdivision A provide the basis for the site design and grading plan to accomplish successful wetland construction. From the principal of "following the lead of nature," the site grading plan was derived and incorporated into the design.

The existing site gently slopes (0-1%) from the northwest corner of the site (elevation 60') to the southeast corner (elevation 54'). Approximately 15% of the site, in the northwest corner, is forested and tapers from dense woodland to new emerging, widely scattered saplings progressing to the southwest. The saplings give way to a mildly sloping native upland grass prairie which comprises approximately 85% of the Subdivision.

Subdivision A is further divided into two areas which are separated by Lockwood Street. The boundaries of the subdivision are Beltway 8 on the north, the remainder of the Mitigation Bank property to the west (separated by the power line easement), and the elevated railroad track to the southeast. The boundaries create a triangular shaped property which is isolated from surrounding property influences of largely man-made improvements.

Improvements to the property to enhance the natural existing features will be performed according to a grading plan, carried out as follows:

The east, south and west boundaries of the site will contain a levee type berm constructed to 59' ASL so that existing primary surface drainage from the site will be retained. An overflow weir structure will be constructed on the southern end of the western berm to create both overflow and diversion mechanisms for water during high input periods. Since water depths are expected to vary with climatic conditions, freeboard is inherent to this design and will enhance the floodflow alteration functions for the area.

The surface of the prairie/forest fringe will be cut to approximately 12 inches below natural grade to allow the created wetland to intersperse with forested areas, creating irregularly shaped upland/wetland boundaries that increase fringe habitat and diverse cover types preferred by some emergent plant species, wildlife, and wading birds.

The existing surface of the construction site will be excavated as necessary and the soil stockpiled in upland areas. This "seedbed" material will be retained for its organic and seedstock value, then will be spread over the site when the finished elevations are established. Spreading will allow a shallow organic-rich cover to be placed over the clayey Lake Charles soil surface, thereby enhancing preferred vegetation succession.

Convex landscape positions (island habitat) and depressions will be created from soil movement on the site. The size and shape of both islands and depressions will be subject to minor modification which will result from the "cut and fill" volumetric calculations at the time of final engineered drawings. Levee berm material will be obtained from surface soils.

Detailed evaluations of the entire mitigation site and surrounding properties have indicated that a large diversity of wetland plants inhabit the area surrounding Subdivision A. The vegetation management plan for the site is designed to make use of expected natural seed transport and plant succession that will develop wetland vegetation classes consistent with adjacent and nearby sites.

Based on the planned hydrology regime, emergent species such as Sedges (*Carex* spp.), Flatsedges (*Cyperus* spp.), Rushes (*Juncus* spp.), and Spikerushes (*Eleocharis* spp.) are expected to develop quickly in drawdown zones, eventually covering most of the site.

After final grading elevations have been achieved, selected species will be planted above the normal high water level to enhance plant strata and encourage additional wildlife diversity. Candidate species such as Pecan (*Carya* spp.), Hackberry (*Celtis* spp.), Panic grasses (*Panicum* spp.), and Paspalums (*Paspalum* spp.) will be used in this application. Water Oaks (*Quercus nigra*) and Willow Oaks (*Quercus phellos*) are also expected to inhabit these areas through natural seed transport from dense populations of these species in surrounding areas.

Invasive species, such as Chinese Tallows (*Sapium sebiferum*), are also expected to generate on the site. However, through regular inspection and maintenance procedures, these species will be removed and controlled as necessary to ensure that more desirable species have maximum opportunity to flourish.

GARNERS BAYOU MITIGATION BANK SECTION A - CONCEPTUAL PLAN

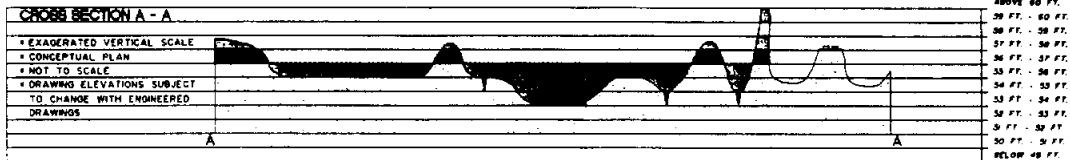
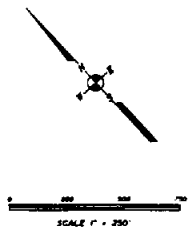
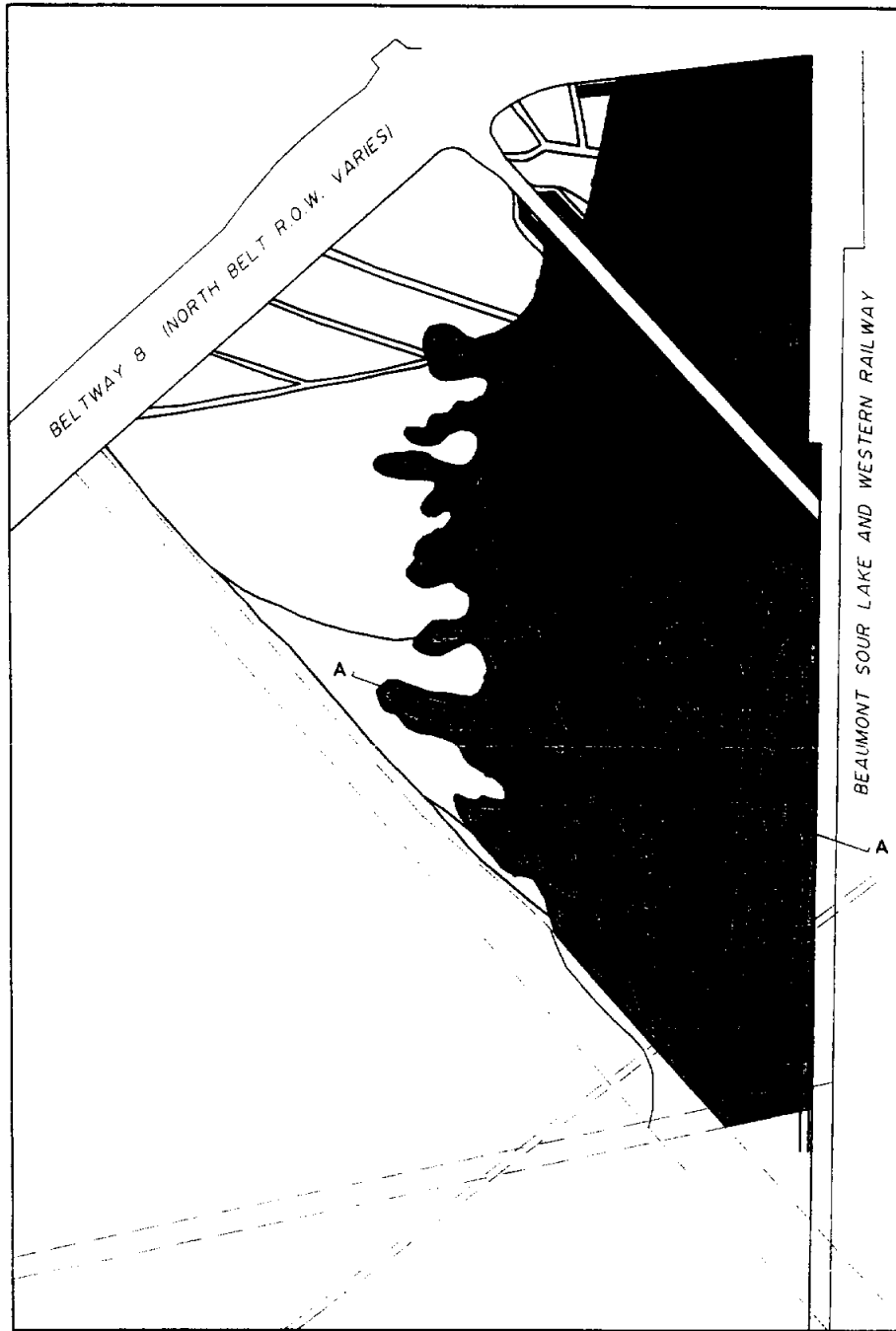

GARNERS BAYOU MITIGATION BANK
PROJECT P-600-03-00
SECTION A - CONCEPTUAL PLAN
HARRIS COUNTY, TEXAS

REVISIONS:	
March 7, 1991 by C. Andrews	
March 9, 1991 by C. Andrews	
March 8, 1994 by C. Andrews	

W.K. BERG & ASSOCIATES, INC.
ENVIRONMENTAL & LAND USE CONSULTANTS
14811 ST. MARY'S LANE, SUITE 203
HOUSTON, TEXAS 77079 PHONE (713) 589-0898

2. Baseline Evaluation:

Establishing the value of existing wetlands functions and values is critical to operating a mitigation bank. After extensive research, it was determined that the Wetland Evaluation Technique Volume 2 (WET) would be the appropriate technique for this site. This technique was approved for usage on this property by the Mitigation Banking Review Team on November 29, 1993.

The Wetland Evaluation Technique (WET), which has been used extensively to evaluate wetlands, identifies and assesses priority functions of wetlands and their interactions with each other. Since WET was developed as a general assessment method for wetlands on a national scale; that is, it is not region-specific, wetland functions that may be characteristic of one geographical area may not be characteristic of another. Therefore, it is possible for certain wetland functions to have conflicting interactions with others. For example, WET evaluates both groundwater recharge and groundwater discharge effectiveness, even though it is highly unlikely that these two functions would co-exist in a given wetland.

However, when used and evaluated properly, WET can identify and measure, to a great extent, the higher valued functions of a given wetland as they relate to the ecological setting in which the wetland exists. This capability is especially useful for predicting the functions and values that will develop in a properly designed and constructed wetland as well.

Using information gathered from detailed baseline evaluations, including WET, surface hydrology modeling, vegetation surveys, avian surveys, soil surveys, and topographic contour mapping and modeling, Subdivision A is designed to produce the priority functions and values generated by the WET evaluation for this area.

Subdivision A was evaluated for its current wetland functions and values using the 1987 version of WET Volume 2 Methodology. This methodology was interpreted and adapted to generate applicable baseline functions and values for current site conditions, and to identify the priority functions and/or values to be incorporated into the goals of the project.

Based on the total assessment of the site, a palustrine emergent class wetland has been designed, resulting in the following priority functions and values expected to increase in effectiveness over the life of the project: 1) Floodflow Alteration, 2) Sediment Stabilization, 3) Sediment/Toxicant Retention, 4) Wildlife Diversity/Abundance, and 5) Uniqueness-Heritage.

Field data and other raw input are maintained as permanent records of the sponsor and are available for MBRT review. The summary results of the Wetland Evaluation Technique model for Subdivision A are identified below.

Summary of Evaluation Results for Subdivision A

	<u>Social Significance</u>	<u>Effective- ness</u>	<u>Oppor- tunity</u>
Groundwater Recharge	L	L	*
Groundwater Discharge	L	L	*
Floodflow Alteration	M	M	H
Sediment Stabilization	M	H	*
Sediment/Toxicant Retention	M	L	L
Nutrient Removal/Transform	M	L	L
Production Export	*	M	*
Wildlife Diversity/Abundance	M	*	*
Wildlife D/A Breeding	*	L	*
Wildlife D/A Migration	*	L	*
Wildlife D/A Wintering	*	M	*
Aquatic Diversity/Abundance	L	L	*
Uniqueness/Heritage	M	*	*
Recreation	L	*	*

NOTE: "H"=High, "M"=Moderate, "L"=Low, "U"=Uncertain, and "*"s identify conditions where WET does not evaluate functions and values.

The following information is the detailed baseline evaluation for Subdivision A utilizing the WET evaluation technique. Although baseline evaluations have been preliminarily performed on all the subdivisions, only Subdivision A is included herein to keep the report from becoming too cumbersome.

AA INFORMATION

Page 1

Site: GREENS BAYOU BANK

AA: SUBDIVISION A

Prepared by Berg-Oliver Associates, Inc.

Printed 02/09/95

Description:

Approximately 220.82 acres located in the northeast portion of the bank site, bounded by Beltway 8 on the north, the Union Pacific Railroad on the east-southeast, and an HL&P easement on the west. The far east part of the subdivision is transected by Lockwood Road.

This AA represents present conditions.

EVALUATION SUMMARY

Site: GREENS BAYOU BANK

AA: SUBDIVISION A

Prepared by Berg-Oliver Associates, Inc.

Printed 02/09/95

Function	Social Significance	Effectiveness	Opportunity
Ground Water Recharge	Low *	Low	-
Ground Water Discharge	Low *	Low	-
Floodflow Alteration	Moderate	Moderate	High
Sediment Stabilization	Moderate	High	-
Sediment/Toxicant Retention	Moderate	Low	Low
Nutrient Removal/Transformation	Moderate	Low	Low
Production Export	-	Moderate	-
Wildlife Diversity/Abundance	Moderate	-	-
Breeding	-	Low	-
Migration	-	Low	-
Wintering	-	Moderate	-
Aquatic Diversity/Abundance	Low *	Low *	-
Uniqueness/Heritage	Moderate	-	-
Recreation	Low	-	-

Harvested Waterfowl Groups

	Value
Wood Duck - Migrating	Low
Wood Duck - Wintering	Low
Scaup (Greater and Lesser) - Migrating	Low
Scaup (Greater and Lesser) - Wintering	Low
Bufflehead - Migrating	High
Bufflehead - Wintering	High
Inland Geese - Migrating	Low
Inland Geese - Wintering	Low

Wetland-Dependent Bird Species

	Value
Egret, Great - All Year	Low
Egret, Snowy - All Year	Low
Heron, Great Blue - All Year	Moderate
Heron, Green - All Year	Low
Heron, Little Blue - All Year	Low
Ibis, White - All Year	Low
Kingfisher, Belted - All Year	Low
Sandpiper, Spotted - All Year	Low
Sparrow, Swamp - All Year	Low
Warbler, Prothonotary - Nesting	Low
Warbler, Swainson's - Nesting	Low
Yellowthroat - All Year	Moderate
Heron, Yellow-crowned Night - All Year	Low

(Note: An (*) represents an alternative value)

Analysis Graph: Summary

Site: GREENS BAYOU BANK

AA: SUBDIVISION A

Prepared by Berg-Oliver Associates, Inc.

Printed 02/09/95

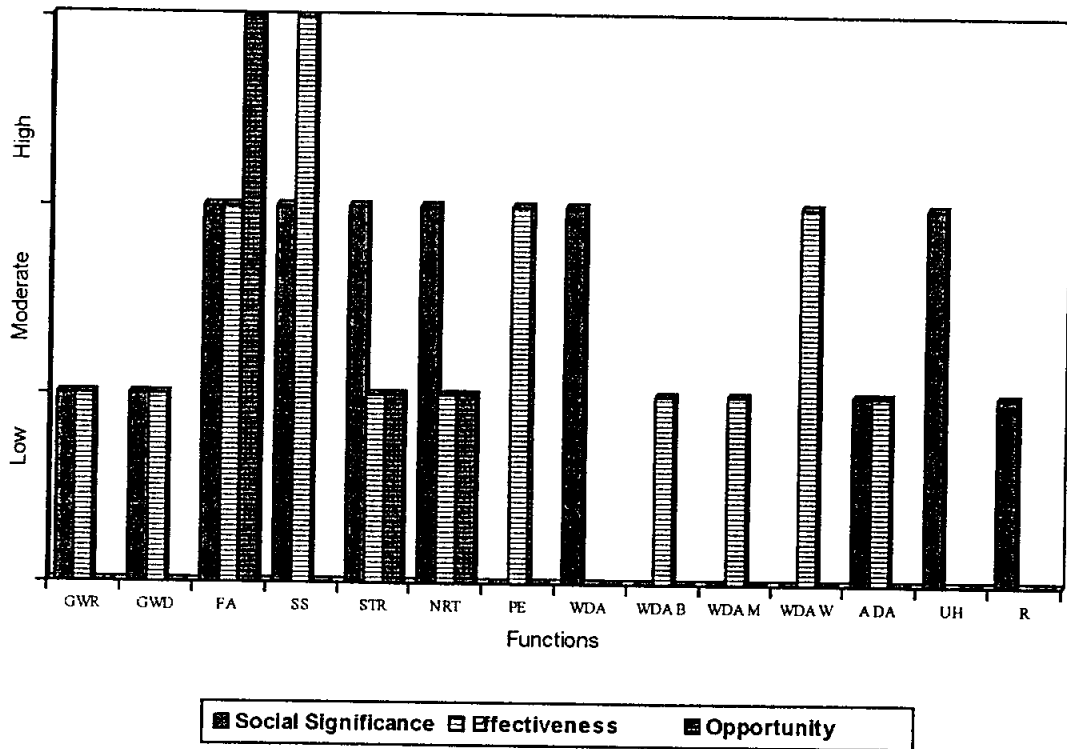

Social Significance Analysis Level 2

Site: GREENS BAYOU BANK

AA: SUBDIVISION A

Prepared by Berg-Oliver Associates, Inc.

Printed 02/09/95

Function	Value	Comment
Ground Water Recharge	Low	<i>ALTERNATIVE VALUE USED Groundwater recharge is known to be of low social significance and function to this part of the Gulf Coast area. (WET Value = Moderate)</i>
Ground Water Discharge	Low	<i>ALTERNATIVE VALUE USED Groundwater discharge is known to be of low social significance and function to this part of the Gulf Coast area. (WET Value = Moderate)</i>
Floodflow Alteration	Moderate	
Sediment Stabilization	Moderate	
Sediment/Toxicant Retention	Moderate	
Nutrient Removal/Transformation	Moderate	
Wildlife Diversity/Abundance	Moderate	
Aquatic Diversity/Abundance	Low	<i>ALTERNATIVE VALUE USED Aquatic diversity and abundance is considered to be of moderate significance to the service area of this site. The types of wetlands systems identified in this service area are predominantly palustrine systems with little or no aquatic habitat (aquatic emphasis in WET 2.0 focuses on fish species). Therefore, the Social Significance of this function for the AA is considered low. (WET Value = Moderate)</i>
Uniqueness/Heritage	Moderate	
Recreation	Low	

Answer Set Detail: Social Significance

Page 1

Site: GREENS BAYOU BANK

AA: SUBDIVISION A

Prepared by Berg-Oliver Associates, Inc.

Printed 02/09/95

Red Flags

1. Federal or State endangered, threatened, or candidate species use the AA: NO
2. The AA is part of an area owned by an organized conservation group or public agency: NO
The assessment for this AA was performed prior to its purchase by HCFCD for the creation of a mitigation bank. Ownership by HCFCD for this purpose constitutes an activity that increases the social significance for the site. However, since this evaluation determines baseline values prior to improvements, this question was answered "No."
3. The AA is included in a statewide listing of historical or archaeological sites: NO
4. The AA has ecological or geological features considered by scientists to be unusual or rare for wetlands in the region: NO
5. The AA represents most or all of the wetland system in this locality: NO
6. Substantial public or private expenditures have been made to create, restore, protect, or ecologically manage the AA/IA: NO
See "Comment" in Question 2.

On-Site Wetland Social Significance

7. In the AA or in contiguous wetlands there are biological communities that are stressed by saline springs or abnormally high salinities: NO
8. Point sources of pollution or other features of social or economic value exist within or adjacent to the AA that might be inundated by flooding of the AA: NO

Off-Site Wetland Social Significance

9. Features of social or economic value exist within the 100 year floodplain of the area specified, or a dam for flood control has been proposed within 5 miles upstream or downstream: NO
10. The following are present within the area specified: harbors, channels, stormwater detention ponds, or reservoirs that are dredged or cleaned regularly -OR- artificial recharge pits -OR- fish spawning areas that are known to be sensitive to siltation -OR- commercial shellfish beds -OR- areas known to be in violation of Section 401 of the Clean Water Act water quality standards due to suspended solid or toxicant levels: NO
11. There are bodies of water within the area specified that have been targeted by government agencies as "priority areas" for construction of wastewater treatment facilities or other water quality improvement projects: NO

Answer Set Detail: Social Significance

Page 2

Site: GREENS BAYOU BANK

AA: SUBDIVISION A

Prepared by Berg-Oliver Associates, Inc.

Printed 02/09/95

12. There is surface water within the AA or the area specified that is a major source of drinking water: NO
13. In the area specified bodies of water are known to be especially nutrient-sensitive or subject to regular blooms of algae, aquatic fungi, or oxygen-related fish kills -OR- bodies of water are known to be in violation of Section 401 water quality standards due to nutrient levels: NO
14. There are swimming/bathing areas that are used frequently in the area specified: NO
15. A threatened or endangered species that is wetland-dependent regularly inhabits the area specified: NO
16. In the area specified there are either sites designated by the USEPA as Sole Source Aquifers or Class II (Special) Ground Waters -OR- wells that serve at least 2,500 people -OR- actively used wells with yields that are greater than yields shown for this region -OR- wells that are within a major alluvial valley and have yields exceeding 2,500 gallons per minute: NO
17. Well yields in the area specified surpass the criteria in Question 16 or the AA empties into an area where fish or wildlife use has been critically limited by excessively low water flow or low water level during dry years: NO
18. For any of Questions 9 through 17 that were answered "Yes", either the AA is the only AA in the watershed of the closest service area -OR- the AA is closer to the service area, where the service identified in the question is delivered, than any other AA in the watershed of the closest downstream service area: INAPPROPRIATE
19. The AA/IA acts as a buffer to features of social or economic value that are situated in erosion-prone or wave-vulnerable areas: NO
20. The AA/IA supports at least one fish species that is on USFWS National Species of Special Emphasis List and is rare or declining in the region -OR- the AA/IA has a State or Federal special designation relating to its recognized fishery value -OR- there is commercial fishing or shellfishing within the AA/IA: NO
21. The AA/IA supports at least one fish species that is on USFWS National Species of Special Emphasis List and is rare or declining in the region -OR- the AA/IA has a State or Federal special designation relating to its recognized fishery value -OR- a fee is charged at the AA/IA for consumptive (hunting) or nonconsumptive (observation) use of wildlife: NO
22. The AA is in a waterfowl use region of major concern as defined by the FWS or it has received a priority rating in state waterfowl concept plans: INAPPROPRIATE
23. This AA/IA supports plant or animal species with exceptionally narrow habitat requirements or of extremely limited occurrence in this region: NO
24. The AA/IA is the closest wetland to any nature center, school, camp, college, or similar educational facility and is within 2,000 feet of public road where parking is allowed: NO
25. The AA/IA is part of and essential to an ongoing, long-term environmental research or monitoring program: NO

Answer Set Detail: Social Significance

Page 3

Site: GREENS BAYOU BANK

AA: SUBDIVISION A

Prepared by Berg-Oliver Associates, Inc.

Printed 02/09/96

26. The AA and its watershed is a "pristine" natural area, in the sense of having no lasting, direct or indirect, human alteration: NO
The AA has been impacted by cattle grazing, some agriculture, timber harvesting, and construction of roads and railways.
27. The AA/IA is used regularly for recreation or consumptive activities for which opportunities are otherwise locally deficient as recognized by a local or state recreational plan: NO
28. The AA/IA is a major public access point to a recreational waterway: NO
29. The AA is located in an urban area: YES
This question could be answered "No" since it specifically addresses wetland significance to an urban area. However, since the AA is part of a large contiguous area of mixed wetland/upland habitats, it was determined to be significant to the surrounding area. Therefore, this question was answered "Yes."
30. The AA is located in a state that is losing wetlands at a rate greater than or equal to the national annual average of .45% per year: NO
The validity of data in Table 2, pages 36-37 of WET 2.0 may be questionable, according to the USFWS, and in many cases is based on small data sets. Until more accurate information is available to warrant a "Yes" answer, the loss rate is not assumed to be above 0.42%/year.
31. The AA's wetland acreage is greater than the annual percentage loss rate of wetlands for the state: NO

Social Significance Level II

1. The wetland's class is the rarest or next-to-rarest wetland class in the context region by number or acreage: NO
2. The wetland's subclass is the rarest or next-to-rarest wetland subclass in the context region by number or acreage: NO
3. The wetland's hydroperiod is the rarest or next-to-rarest wetland hydroperiod in the context region by number or acreage: NO
4. This wetland possesses more than 80% of all the wetland hydroperiods or subclasses that are present in this context region: NO

Effectiveness Analysis Level 3

Site: GREENS BAYOU BANK

AA: SUBDIVISION A

Prepared by Berg-Oliver Associates, Inc.

Printed 02/09/95

Function	Value	Comment
Ground Water Recharge	Low	
Ground Water Discharge	Low	
Floodflow Alteration	Moderate	
Sediment Stabilization	High	
Sediment/Toxicant Retention	Low	
Nutrient Removal/Transformation	Low	
Production Export	Moderate	
Wildlife Diversity/Abundance (Breeding)	Low	
Wildlife Diversity/Abundance (Migration)	Low	
Wildlife Diversity/Abundance (Wintering)	Moderate	
Aquatic Diversity/Abundance	Low	<i>ALTERNATIVE VALUE USED Since the AA is an existing upland, the potential for Aquatic Diversity/Abundance effectiveness does not exist. (WET Value = Moderate)</i>

Opportunity Analysis Level 3

Site: GREENS BAYOU BANK

AA: SUBDIVISION A

Prepared by Berg-Oliver Associates, Inc.

Printed 02/09/95

Function	Value	Comment
Floodflow Alteration	High	
Sediment/Toxicant Retention	Low	
Nutrient Removal/Transformation	Low	

Answer Set Detail: Effectiveness and Opportunity

Page 1

Site: GREENS BAYOU BANK

AA: SUBDIVISION A

Prepared by Berg-Oliver Associates, Inc.

Printed 02/09/95

Climate

- 1.1. The AA is located in one of the precipitation deficit regions or local data indicates that on-site evaporation exceeds precipitation on an annual basis.

Average: Yes

- 1.2. The region is located in an intense storm region or the rainfall erosivity factor for the region is greater than 300 and if the AA is tidal, the tidal range is less than 3 feet.

Average: Yes

- 1.3. The entire AA freezes over for more than 1 month during most winters.

Average: No

Acreage

- 2.1. The surface area of the AA/IA and any accessible wetlands within 1 mile of the AA/IA is:

Less than 5 acres.

Seasons: Average

No portion of this AA is accessible. However, a "No" answer to all parameters defined in this question would cause a default condition in which the "accessible" AA would be identified as being between 5 and 40 acres. Therefore, the most appropriate selection for this question is 2.1.1, "Less than 5 acres".

- 2.2. The forested area within the AA/IA and up to 1 mile away is:

Greater than 40 acres.

Seasons: Average

Complex, cluster, oasis

- 3.1. There are other wetlands within 1 mile of the AA.

Average: Yes

- 3.2. The acreage of emergent or scrub-shrub/forested wetland classes is greater than the criteria acreage shown for the corresponding type in the "cluster" columns of Table 2 within 1,000 yards of the AA's center.

Average: Yes

- 3.3. The acreage of emergent or scrub-shrub/forested wetland classes is less than the criteria acreage shown for the corresponding type in the "oasis" columns of Table 2 within 1,000 yards of the AA's center.

Average: No

Answer Set Detail: Effectiveness and Opportunity

Page 2

Site: GREENS BAYOU BANK

AA: SUBDIVISION A

Prepared by Berg-Oliver Associates, Inc.

Printed 02/09/95

Location and size

4.1. The AA is within 5 miles of tidal waters, the Great Lakes, or a river of at least 100 miles length.

Average: No

4.2. The watershed of the AA is:

Between 1-100 square miles.

Seasons: Average

Assessment area/watershed ratio

5.1. The percentage of the AA watershed acreage which the AA comprises is:

Between 5% and 20% (or between 10% and 15% if the region is dry).

Seasons: Wet

5.2. Upslope AA's comprise more than 5% of the total acreage of this AA's watershed or more than 3% if the region is dry.

Wet: No

Local topography

6.1. The AA is a playa -OR- the drop in elevation from the downslope end of the AA to a point 2 miles downslope is greater than the rise in elevation from the upslope end of the AA to a point 2 miles upslope -OR- the AA is located within 2 miles of a topographic divide that separates two major watersheds and is not at the toe of a slope of greater than 20%.

Average: No

6.2. Soil maps, geologic maps, or field inspection indicate that a geologic fault is present within the AA -OR- that within the AA's watershed the permeability of the soils decreases in a downslope direction toward the AA -OR- the AA is at the base of a relatively steep regional slope.

Average: No

Gradient

7. The AA/IA does not have a channel or the annual floodplain is wider than the channel -OR- the channel gradient of the AA/IA is less than the corresponding gradient value.

Average: Inappropriate

Answer Set Detail: Effectiveness and Opportunity

Page 3

Site: GREENS BAYOU BANK

AA: SUBDIVISION A

Prepared by Berg-Oliver Associates, Inc.

Printed 02/09/95

Inlets, outlets

8. Surface water enters and/or exits the AA through an:

Inlet with intermittent flow.

Seasons: Average

Outlet with intermittent flow.

Seasons: Average

Constriction

- 9.1. Channel flow is present and the width of the AA/IA's outlet at annual high water is less than one-third the average width of the AA/IA perpendicular to flow -OR- channel flow is present and the cross-sectional area of the AA/IA's outlet(s) is less than the cross-sectional area of the inlet(s) -OR- channel flow is not present and the total width of the AA/IA's outlet(s) is less than one-tenth the average width of the AA/IA.

Wet: No

- 9.2. Sheetflow from a contiguous body of water inundates wetlands in the AA/IA at least once a year and subsequently exits the wetland through a constricted outlet or does not exit the AA/IA wetland at all.

Wet: No

- 9.3. Outflow from the AA/IA originates mostly from precipitation or snowmelt occurring within the AA/IA.

Wet: Yes

Wetland system

10. The wetland system which covers the greatest area in the AA/IA is:

No Answer Specified

Seasons: Average

Fringe wetland or island

11. The AA/IA is part of a fringe wetland or an island -OR- the AA/IA is comprised of all or most of a fringe wetland or an island.

Average: No

Wet: No

Dry: No

Vegetation class/subclass (primary)

12. The primary vegetation class/subclasses are:

Scrub-shrub and broad-leaved deciduous.

Seasons: Average, Wet, Dry

In current condition, this AA is not a wetland and, therefore, cannot exactly be classified using the

Answer Set Detail: Effectiveness and Opportunity

Page 4

Site: GREENS BAYOU BANK

AA: SUBDIVISION A

Prepared by Berg-Oliver Associates, Inc.

Printed 02/09/95

Cowardin system employed by WET. However, the vegetation class has been selected to allow more accurate evaluations by the methodology.

Vegetation class/subclass (secondary)

13. The secondary vegetation class/subclasses are:

Forested and dead.

Seasons: Average, Wet, Dry

Islands

- 14.1 The AA/IA is an island or it contains part, or all of an island that is at least 25 sq ft in size -AND- at least 50 ft from the shoreline.

Average: No

Wet: No

Dry: No

- 14.2 The AA/IA is an island or it contains part, or all of an island that is at least 2 acres in size, separated from the mainland by water at least 30 in. deep -AND- at least 2 miles offshore if the wetland system is marine or 0.5 mile offshore if the wetland is not marine.

Average: No

Wet: No

Dry: No

Vegetation/water interspersation

- 15.1 The horizontal pattern of erect vegetation in Zone B consists of:

Relatively few, continuous areas supporting vegetation with little or no interspersation with channels, pools, or flats.

Seasons: Average

- 15.2 In that portion of the AA/IA having measurable flow in channel situations, vegetation in Zone B consists mainly of persistent emergent -OR- under average flow conditions, water enters the AA/IA in a channel and then spreads out over a wide area.

Average: Inappropriate

Vegetation class interspersation

16. The horizontal pattern of vegetation classes in the AA/IA consists of:

Relatively homogeneous areas supporting a single vegetation class with little or no interspersation between these homogeneous areas.

Seasons: Average, Wet, Dry

Answer Set Detail: Effectiveness and Opportunity

Site: GREENS BAYOU BANK

AA: SUBDIVISION A

Prepared by Berg-Oliver Associates, Inc.

Page 5

Printed 02/09/95

Vegetation form richness

17. The AA/IA is 1-10 acres and supports at least three vegetation classes or four vegetation subclasses -OR- is 10-100 acres and supports at least three vegetation classes or six vegetation subclasses -OR- is 100 or more acres and has four or more vegetation classes or at least eight vegetation subclasses.

Average: No

Shape of upland/wetland edge

18. The boundary between the upland and the AA/IA is irregular.

Average: No

No wetland/upland boundary exists in this AA since the site is currently upland.

Fetch/exposure

- 19.1 Adjacent vegetation or topographic relief is sufficient to shelter at least 1 acre of open water in Zones B or C from wind -OR- open water fetch is less than 100 feet.

Average: **Inappropriate**

Since neither option (a) or (b) can be applied in this AA, "Inappropriate" has been selected as the most applicable answer.

- 19.1 Vegetation or topographic relief adjacent to the AA/IA is insufficient to shelter at least 1 acre of open water in Zone B or Zone C from wind and fetch is greater than 2 miles -OR- vegetation at the deepwater edge of Zone B is exposed to waves taller than 1 foot.

Average: No

- 19.2 The AA/IA, or a portion thereof, is an island, delta, bar, or peninsula that intercepts waves and thereby protects other nearby shores.

Average: No

- 19.3 Woody vegetation within the AA/IA shelters adjacent and otherwise unsheltered uplands from wind.

Average: Yes

Vegatative canopy

- 20.1 There is sufficient vegetative canopy or topographic relief in and around the AA to shade at least 80% of Zone B at midday.

Average: **Inappropriate**

- 20.2 There is a balanced interspersion of shaded and unshaded area in the input zone, Zone A, and Zone B.

Answer Set Detail: Effectiveness and Opportunity

Site: GREENS BAYOU BANK

Page 6

AA: SUBDIVISION A

Prepared by Berg-Oliver Associates, Inc.

Printed 02/09/95

Average: Inappropriate

Land cover of the watershed

21. The majority of the AA's watershed land cover is:

Forest and scrub-shrub.

Seasons: Average

Flow, gradient, deposition

22.1 The AA/IA contains a channel -OR- has an outlet and an inlet -OR- is tidal -OR- has seasonal flow as suggested by gage data, scour lines, sediment deposition on vegetation, etc

Average: No

22.1 The channel is at least mildly sinuous with a meander ratio exceeding 1.2.

Average: Inappropriate

22.2 The AA/IA includes, or is part of, an actively accreting delta.

Average: No

22.3 Aerial photos or other sources of information indicate long-term erosion of the AA/IA.

Average: No

Ditches/canals/channelization/levees

23. Functioning ditches, canals, levees, or similar artificial features cause surface water to leave the AA/IA at a faster rate than it would if these features were not present.

Average: Yes

Drainage ditches along the east and south boundaries facilitate faster water removal from the site than would normally be possible.

Soils

24.1 Analysis indicates that the soil types present in the AA/IA contain more than 4,000 mg/kg of amorphous extractable aluminum in the upper 8 inches.

Average: No

24.2 Soil maps or a site visit indicate the dominance of alluvial, alfisol, ferric, clay or other primarily fine mineral soils in the AA/IA -AND- the soils of this region normally have elevated concentrations of aluminum or iron, or analysis indicates there is less than 20% organic matter by weight in the upper 3 inches of sediment.

Average: Inappropriate

Answer Set Detail: Effectiveness and Opportunity

Page 7

Site: GREENS BAYOU BANK

AA: SUBDIVISION A

Prepared by Berg-Oliver Associates, Inc.

Printed 02/09/95

24.3 Soil surveys indicate that soils in the AA/IA have exceptionally slow infiltration rates due to the presence of impeding layers or very shallow depth to unfractured bedrock.

Average: Yes

24.4 Soil surveys indicate that soils in the watershed have mostly slow infiltration rates or these soils are impermeable due to fine texture, impeding layers, high water table, shallow depth to unfractured bedrock, or frozen condition during the usual time of greatest flooding.

Average: Yes

24.5 The AA/IA is in a karst (limestone) region.

Average: No

Sediment sources

25.1 There are sediment sources that contribute inorganic sediment to the AA.

Average: No

25.2 The primary source of sediment entering the AA is:

Neither overland runoff or channel flow.

Seasons: Average

25.3 Significantly elevated levels of suspended solids in a major portion of the AA is the result of: erosion within the AA caused by drastic fluctuation in water levels due to artificial manipulation or urban runoff -OR- slopes immediately adjacent to the AA being steeper than 10% and unstable -OR- boating activity causing frequent wakes that impinge on the deepwater fringes of the AA -OR- tributaries immediately upstream of the AA having been channelized.

Average: No

Nutrient sources

26.1 There is evidence of high nutrient concentration in the AA, or any of the following sources contribute nutrients to the AA: sewage outfalls, phosphate mines, tile drains, canals or other nutrient-rich sources -OR- areas containing any of the following: feedlots, active pastureland, landfills, septic fields, fertilized soils, or soils tilled, burned, or cleared within the last 2 years -OR- areas where the acreage of the AA divided by the number of houses with septic systems within the input zone is less than eight -OR- areas where the acreage of the AA divided by the number of people living within the input zone is less than 25.

Average: No

26.2 Overland sheetflow is the primary source of the nutrients entering the AA.

Average: Inappropriate

26.3 Channel flow is the primary source of the nutrients entering the AA.

Average: Inappropriate

Answer Set Detail: Effectiveness and Opportunity

Page 8

Site: GREENS BAYOU BANK

AA: SUBDIVISION A

Prepared by Berg-Oliver Associates, Inc.

Printed 02/09/95

Contaminant sources

27.1 There is evidence of waterborn contaminants -OR- there is a source that contributes waterborn contaminants to the AA.

Average: No

27.2 Sheetflow is the primary source of the waterborn contaminants in the AA.

Average: Inappropriate

27.3 Channel flow is the primary source of the waterborn contaminants in the AA.

Average: Inappropriate

Direct alteration

28. Most of the AA/IA has been tilled, filled, or excavated at least once in the past 3 years -OR- an outlet has recently been added to the AA/IA where none previously existed or an inlet has recently been blocked off and an outlet is still present.

Average: No

Wetland/upland edge

29.1 The boundary between the wetland and upland support adequate understory vegetation to serve as cover for vertebrates using the wetland.

Average: No

29.2 Slopes in most of the input zone are less than 5%.

Average: Yes

Disturbance

30. The AA/IA, or areas adjacent and visible to the AA/IA, are visited by people on foot, boat, or off-road vehicle at least three times daily -AND- surface water in the AA/IA is mostly less than 3 feet deep and less than 1,000 feet from the usual places of human activity or greater than 3 feet deep and less than 600 feet from the usual places of human activity.

Average: Yes

Wet: Yes

Dry: Yes

The intent of this question is to determine if the level of human activity is enough to effect the type and abundance of wildlife inhabiting the AA. The adjacency of this AA to Beltway 8 and Lockwood Road is believed to have some bearing on this function, although the magnitude cannot necessarily be quantified at this time. Therefore, a conservative approach was taken for this question, thereby generating a "Yes"

Answer Set Detail: Effectiveness and Opportunity

Page 9

Site: GREENS BAYOU BANK

AA: SUBDIVISION A

Prepared by Berg-Ollver Associates, Inc.

Printed 02/09/95

answer.

Water/vegetation proportions

31.1 Zones A and B combined are greater than Zone C.

Average: No

Wet: No

Dry: No

There is no Zone C for this AA.

31.2 Zone B is at least 10% of the AA.

Average: No

Wet: No

Dry: No

31.3 Zone B is larger than Zone A.

Average: No

Wet: No

Dry: No

31.4 The area of submerged vegetation in Zone B is larger than the unvegetated area of Zones B and C.

Average: Inappropriate

Wet: Inappropriate

Dry: Inappropriate

31.5 The area of Zone A is at least 10% of the area of Zones B and C.

Average: No

Wet: No

Dry: No

31.6 The percentage of Zone B and C together dominated by emergent vegetation is:

No Answer Specified

Seasons: Average, Wet, Dry

Hydroperiod (spatially dominant)

32. The dominant flooding regime of the AA/IA is:

Saturated (no standing water) nontidal.

Seasons: Average

Answer Set Detail: Effectiveness and Opportunity

Page 10

Site: GREENS BAYOU BANK

AA: SUBDIVISION A

Prepared by Berg-Olliver Associates, Inc.

Printed 02/09/95

Most permanent hydroperiod

33. The hydroperiod that best describes the portion of the AA, or the contiguous deepwater, that is inundated or saturated for the longest part of the year and comprises at least 1 acre or 10% of the AA is:

Saturated (no standing water) nontidal.

Seasons: Average

Water level control

- 34.1 The AA/IA's existence is dependent on upstream or downstream artificial control structures built within the last 20 years.

Average: No

- 34.2 The AA/IA is located less than 2 miles downslope from a large impoundment -OR- the AA/IA's water table is influenced by another type of upstream impoundment.

Average: No

- 34.3 Any part of the AA/IA is flooded due to permanent or temporary ponding created by a dam or dike -OR- the AA/IA is actively managed for stormwater or floodwater detention.

Average: No

- 34.3 Flooding in the AA/IA is a result of beaver activity.

Average: Inappropriate

Flooding extent and duration

- 35.1 Flooding causes surface water to expand to more than 3 times its extent under average conditions for more than 25 days during an average year -OR- the relationship between extent and duration lies above the curve in Figure 27 (WET 2.0).

Average: No

- 35.2 Base flow typically fills less than 60% of the channel volume -OR- surface water is absent 5 days after a mean monthly 25-hr storm and the watershed is larger than 10 square miles -OR- the ratio of the high flow that is reached or exceeded 10% of the year, versus the typical low flow that is exceeded 90% of the year, is greater than 1.5.

Average: Inappropriate

Vegatated width

- 36.1 The average width of the area dominated by emergent, scrub/shrub, or forest vegetation in Zones A and/or Zone B is:

Answer Set Detail: Effectiveness and Opportunity

Page 11

Site: GREENS BAYOU BANK

AA: SUBDIVISION A

Prepared by Berg-Oliver Associates, Inc.

Printed 02/09/95

Less than 20 feet.

Seasons: Average, Wet, Dry

- 36.2 The average width of the area in Zone B that supports emergent vegetation and where depth seldom exceeds 50% plant height is:

Less than 20 feet.

Seasons: Average, Wet, Dry

Open water width

37. An area of open water in the AA/IA is mostly devoid of aquatic bed vegetation -AND- exceeds a depth of 2 feet -AND- has a width greater than 6 feet -AND- has a length of at least 1,000 feet or an area which serves to connect two large bodies of water.

Average: No

Type combinations

38. The AA/IA is predominantly:

No Answer Specified

Seasons: Average

Special habitat features

39. The AA/IA is less than 100 acres and two or more of the features listed below are present in the AA/IA or buffer zone at some time during the year -OR- the AA/IA is more than 100 acres and three or more of the features listed below are present. THIS LIST INCLUDES: (a) standing snags with cavities larger than 2 in. (b) trees with diameter exceeding 10 in. (c) plants bearing fleshy fruit (d) mast-bearing hardwoods (e) cone-bearing trees or shrubs (f) tilled land with waste grains (g) evergreen tree stands with over 80% canopy closure (h) native prairie (i) exposed bars.

Average: No

Bottom water temperature

40. The average daily minimum summer water temperature at the deepest part of the AA/IA is usually:

Between 50 and 69 degrees F.

Seasons: Average

Velocity (spacially dominant)

41. During peak, annual flow the velocity throughout most of the AA/IA is:

Between 0.3 ft/sec. and 1.5 ft/sec.

Seasons: Wet

Answer Set Detail: Effectiveness and Opportunity

Page 12

Site: GREENS BAYOU BANK

AA: SUBDIVISION A

Prepared by Berg-Oliver Associates, Inc.

Printed 02/09/96

Velocity (secondary)

42.1 The following velocity categories reflect seasonal flows that occur in at least 1 acre or 10% of the AA/IA:

Less than 1 ft/sec.

Seasons: Average, Wet, Dry

42.2 The following velocity categories reflect seasonal flows that occur in other AA/IA's within 1 mile of the AA/IA and are accessible to fish for at least 20 days a year:

Less than 1 ft/sec.

Seasons: Average, Wet, Dry

Other AA/IA's are not accessible from this AA. The majority of wetlands within one mile of AA are inaccessible.

Water depth (spatially dominant)

43. The depth category which covers the greatest portion of the AA/IA is:

Less than 1 in.

Seasons: Average, Wet, Dry

Water depth (secondary)

44. The following depth categories cover at least 1 acre or 10% of the AA/IA or other AA/IA's within 1 mile that are accessible to fish from this AA/IA during at least 20 days of the year:

No Answer Specified

Seasons: Average, Wet, Dry

Substrate type (spatially dominant)

45. The surface substrate (upper 3 in.) in the AA/IA is predominantly:

Mineral soil or mud.

Seasons: Average

Physical habitat interspersion

46. Within Zones B and C are substrate types, velocity and depth categories distributed:

Uniformly with similar substrate types, velocities and depth throughout the AA/IA.

Seasons: Average, Wet, Dry

pH

47. The pH of water in the AA/IA is:

Below 6.0 (generally acidic).

Seasons: Average

Answer Set Detail: Effectiveness and Opportunity

Page 13

Site: GREENS BAYOU BANK

AA: SUBDIVISION A

Prepared by Berg-Oliver Associates, Inc.

Printed 02/09/95

Salinity and conductivity

48. The AA/IA's salinity/halinity -OR- conductivity is:

Less than 0.5 ppt (Salinity/Halinity) -OR- less than 800 (Conductivity).

Seasons: Average, Wet, Dry

Aquatic habitat features

49.1 The AA includes, or is included in, a permanently flooded stream reach comprised of 20-80% pools, backwaters, or similar slow-water areas.

Average: No

Wet: No

Dry: No

49.1 The AA includes, or is included in a stream reach with cobble-gravel substrate and riffles spaced at intervals of five to seven times the average stream width.

Average: No

Wet: No

Dry: No

49.2 The AA has fish cover available for at least 20 days annually in at least 20% of Zone B -OR- has fish cover available in other AA's that are within 1 mile and accessible to fish from this AA.

Average: No

Wet: No

Dry: No

49.3 Carp are prevalent in the AA.

Average: No

Wet: No

Dry: No

Plants: waterfowl value

50. A plant or combination of plants listed in Table 5 comprises more than 10% or 1 acre of the AA/IA.

Average: Yes

Wet: Yes

Dry: Yes

Answer Set Detail: Effectiveness and Opportunity

Page 14

Site: GREENS BAYOU BANK

AA: SUBDIVISION A

Prepared by Berg-Oliver Associates, Inc.

Printed 02/09/95

Plant productivity

51. The net annual aboveground productivity of any species, or group of species, that predominates in more than 10% of the AA/IA is:

Less than 500 grams per meter squared per year.

Seasons: Average

Freshwater invertebrate density

52. Representative field sampling of the AA/IA's benthic and epiphytic macroinvertebrates indicate that during the growing season there are:

Between 25 and 500 individuals per square foot.

Seasons: Average

Tidal flat invertebrate density/biomass

53. Representative field sampling of the AA/IA indicates that the relationship between density and biomass of macroscopic annelids, molluscs, or crustaceans is:

Neither in the "H" or the "L" portion of the graphs in Figure 29.

Seasons: Average

Ground water measurements

54. Given two wells drilled next to each other, one to the depth of the water table and the other to the base of the organic layer, the ground water level in the deeper well is below the ground water level in the shallow well.

Average: Yes

Wet: Yes

Dry: Yes

Suspended solids

55. Most runoff or surface water entering the AA/IA has a concentration of suspended solids:

Almost always below 25 mg/l -OR- a Secchi disc reading consistently greater than 8 m.

Seasons: Average

Dissolved solids or alkalinity

- 56.1 Alkalinity is less than 20 mg/l.

Average: Inappropriate

- 56.2 The morphedaphic index is less than 7 -OR- greater than 35.

Answer Set Detail: Effectiveness and Opportunity

Page 15

Site: GREENS BAYOU BANK

AA: SUBDIVISION A

Prepared by Berg-Oliver Associates, Inc.

Printed 02/09/95

Average: Inappropriate

Eutrophic condition

- 57.1 During the growing season for a period of at least 1 day, within the AA the wetland system is palustrine or lacustrine and total phosphorus is less than 0.01 mg/l -OR- inorganic nitrogen is less than 0.05 mg/l -OR- a Secchi disc is visible at greater than 8m -OR- the wetland system is palustrine or lacustrine and chlorophyll is less than 0.001 mg/l -OR- the wetland system is estuarine and the relationship between chlorophyll and light intensity at the sediment interface is in the "L" region of the graph -OR- the wetland system is not marine or estuarine and the relationship between phosphorous loading rate and flushing capacity is in the "L" region of the graph.

Average: No

- 57.2 During the growing season for a period of at least 1 day, within the AA the wetland system is palustrine or lacustrine and total phosphorus is greater than 0.025 mg/l -OR- inorganic nitrogen is greater than 0.30 mg/l -OR- a Secchi disc is not visible at greater than 1 m -OR- the wetland system is palustrine or lacustrine and chlorophyll is greater than 0.020 mg/l -OR- the wetland system is estuarine and the relationship between chlorophyll and light intensity at the sediment interference is in the H region of the graph -OR- the wetland system is not marine or estuarine and the relationship between phosphorus loading rate and flushing capacity is in the H region of the graph.

Average: No

Coliform

58. The AA/IA is classified by the state as unsuitable for swimming or shellfish harvesting based on bacterial counts or other health hazards.

Average:

Water quality anomalies

- 59.1 Water samples from the AA/IA exhibit elevated levels of magnesium, chloride, bicarbonate, alkalinity, hardness, specific conductance, halinity, total dissolved solids, and possibly silica when compared to water samples collected in the rest of the AA/IA or other nearby AA/IA's.

Average: No

- 59.2 Water samples from the AA/IA exhibit reduced, and sometimes seasonally variable, levels of total dissolved solids, halinity, and alkalinity or hardness with increased prevalence of sulfates or bicarbonates of calcium or magnesium when compared to water samples collect in the rest of the AA/IA or other nearby AA's.

Average: No

Answer Set Detail: Effectiveness and Opportunity

Page 16

Site: GREENS BAYOU BANK

AA: SUBDIVISION A

Prepared by Berg-Oliver Associates, Inc.

Printed 02/09/95

Water temperature anomalies

60. Springs are present within the AA/IA -OR- there are localized, atypical thermal conditions which might suggest substantial ground water input.

Average: No

Dissolved Oxygen

61. Dissolved oxygen is known to be limiting, at least annually, to fish that could otherwise use this AA/IA.

Average: Inappropriate

Underlying strata

62. Geologic maps indicate that any part of the AA is underlain by at least 10 feet of predominantly porous materials or well-fractured rock.

Average: No

Discharge differential

- 63.1 Inlet hydrographs exhibit higher flood peaks than outlet hydrographs.

Average: No

- 63.2 Surface water inflows exceed simultaneously measured surface water outflows after accounting for losses due to evapotranspiration.

Average: No

Total suspended solids (TSS) differential

64. Levels of total suspended inorganic solids, measured at the AA's inlet are greater than those measured simultaneously at the outlet -OR- the detention time is at least 3 days in summer and 15 days in winter.

Wet: Inappropriate

3. Quantification Methodology

Using the function and value approach, a method for calculating bank credits was eventually developed and approved by the MBRT. This method is based on emphasizing the functions and values identified in WET as important to the local region, weighting them for priority, and producing a Quality Point Score that could be multiplied by acreage to determine credit deposits into the bank.

This method can be replicated over time to assess increases in functions and values as the site matures and generates more potential credits. This method also makes it possible to evaluate offsite impact areas for their debit values in the bank.

The following is a detailed discussion of the quantification methodology which will be used to establish a value of a wetlands based on its functions and values. This methodology is intended to be utilized not only on the mitigation banking site, but also for those debit sites which propose to utilize the Greens Bayou Mitigation Bank to mitigate their impacts to wetlands.

GREEN'S BAYOU MITIGATION BANK
CREDIT DETERMINATIONS USING WET VERSION 2.0

The successful operation of the Green's Bayou Mitigation Bank is dependent upon a manageable method of determining the number of credits that are available in the bank at any given time, and a comparable method of evaluating debit site wetlands for their exchange values in the bank. This document discusses the need for such a method, the rationale of method development, and the method itself.

NEED FOR METHODOLOGY

Prior to the establishment of the Green's Bayou Bank, wetland comparisons and compensations for losses have generally been applied on an acre-for-acre basis, resulting in the now familiar mitigation ratios of 2:1, 5:1, and so on. Using the safety-in-numbers approach, the primary goal of these ratios has been to ensure that no net loss of wetland functions and values occurs from permitted activities. This method of compensation does not address wetland "quality", per se, and few assurances can be made that the results of acre-for-acre ratios would prevent net losses of functions and values.

The general consensus among the regulatory agencies and those who are involved in wetland issues is that acre-for-acre compensation (exchange) is not a realistic approach, since an acre of one wetland may not "equal" an acre of another. That being the case, a method by which wetlands can be evaluated on the basis of quality is highly desirable for determining compensation.

The quality of a wetland can be defined by the ecological functions it performs and the values that it adds to the overall environment in which it exists. If a method of evaluating and comparing these functions and values can be developed, proportional exchanges can be made between banked wetlands and debit site wetlands. The net result will be an exchange of wetland quality.

Using the quality assessment approach, the need for mitigation ratios, as in acre-for-acre compensation, should not be necessary. Since a mitigation bank, by definition, must contain functioning wetlands before any exchanges can be made, there will not be the net loss of functions and values that many times occur in conventional mitigation practices where the time between wetland impacts and a functioning mitigation site may be lengthy. Therefore, a quantification methodology must not only establish a

means for assessing wetland quality, it must also establish a means for determining appropriate exchanges.

Quality comparisons between wetlands do not automatically translate to proportional exchanges. However, if separate wetlands are evaluated using the same criteria, the resulting quality ratings provide a foundation for applying quantification factors that can be used to calculate exchange rates as well as banked credits. The task then becomes to develop a method of quantification whereby wetlands can be compared, scored, and proportionally exchanged.

METHOD DEVELOPMENT AND RATIONALE

The Wetland Evaluation Technique Version 2.0 (WET) , which has been used for the Green's Bayou Bank, evaluates wetland functions and values in terms of social significance, effectiveness, and opportunity and assigns "qualitative probability ratings" (called "probability ratings" or "ratings") for each function or value under one or more of these categories. Social significance and effectiveness ratings are the applicable evaluations derived from WET for credit calculation purposes since they assess the current conditions on a site at any given point in time. The opportunity rating merely represents the potential for a function or value to occur in a wetland and is not a good current indicator of whether or not the function or value actually occurs. Therefore, the opportunity ratings have not been utilized in the methodology.

While the probability ratings of Low, Moderate, or High generated by WET reflect the probability of a function or value to provide social significance or effectiveness, they do not provide an order of magnitude for comparing the importance of one function or value to another. However, by prioritizing functions and values based on their regional or local importance, and weighting them accordingly, an order of magnitude can be established.

The authors of WET state in their explanatory and rationale statements that "The authors recognize the desirability of regionalizing WET..." and they emphasize that professional judgements and knowledge by local experts and regulatory agencies are highly desirable for effective regional adaptations of the methodology. Prioritizations of functions and values for regional interpretations can substantially enhance the quality and confidence level of a wetland evaluation derived from WET.

For example, in some areas of the country a wetland's ability to recharge groundwater may be very significant while in other areas, such as the local Gulf Coast, this function may not be as important. A local adaptation of WET, therefore, might de-

emphasize this particular function. In contrast, floodflow alteration in a local WET application might receive a much higher importance ranking than it would in other areas where flooding is not a problem.

Since WET was developed to evaluate the major functions and values of wetlands for broad applications (i.e. nationwide) prioritizations of functions and values can fine tune WET for local or regional use. Once the functions and values have been ranked for priority, wetlands can be evaluated for their abilities to provide those functions and values in terms of social significance and effectiveness for the local area. In essence, the quality of a particular wetland can be determined.

Table 1 illustrates the regional prioritization of the functions and values for the Greens Bayou Mitigation Bank service area that are evaluated in the Social Significance and Effectiveness categories of WET Version 2.0. Under these WET evaluation categories the functions and values have been divided into three (3) priority rating groups -- High, Moderate, Low -- based on their regional importance, as discussed previously. Those that have a High rating have been weighted by assigning a value of 3; those with a Moderate rating, a 2; and those with a Low rating, a 1.

SOCIAL SIGNIFICANCE			EFFECTIVENESS		
HIGH 3	MOD 2	LOW 1	HIGH 3	MOD 2	LOW 1
WDA	UH	REC	WDAB	NRT	GWR
STR	NRT	GWR	WDAW	PE	GWD
FFA	ADA	GWD	WDAM	ADA	
SS			STR		
			FFA		
			SS		
Wildlife Diversity Abundance (WDA)			Uniqueness/Heritage (UH)		
Breeding (WDAB)			Nutrient Removal/Transport (NRT)		
Wintering (WDAW)			Aquatic Diversity/Abundance (ADA)		
Migration (WDAM)			Recreation (REC)		
Sediment/Toxicant Retention (STR)			Groundwater Recharge (GWR)		
Flood Flow Alteration (FFA)			Groundwater Discharge (GWD)		
Sediment Stabilization (SS)					

Table 1. Regional Prioritization of WET Functions and Values with Weighting. Greens Bayou Mitigation Bank Service Area.

Likewise, the WET probability ratings of High, Moderate, or Low for each function or value have been assigned values of 3, 2, and 1, respectively.

When comparing wetlands certain restrictions must be applied to the types of systems being evaluated. For example, it would not be reasonable to compare marine systems with palustrine systems since their physical, chemical, and biological functions are too broadly separated. However, it would be reasonable to compare

marine with marine, palustrine with palustrine, and so on. WET is very effective for evaluating and comparing wetlands within the same systems classification.

The Green's Bayou Mitigation Bank, by definition of its market area, excludes wetlands that would be classified as marine or estuarine systems. Since the geographical area to be served by the bank is limited to Harris County, non-Section 10 limits, the types of systems that will be involved in bank exchanges are predominantly palustrine. Therefore, for this bank project service area, a method of comparative evaluation with regional function and value priorities for palustrine systems is necessary.

CREDIT DETERMINATION METHODOLOGY

The method for converting a WET evaluation for palustrine systems in the Green's Bayou Mitigation Bank is outlined in the following section. There are two primary development criteria that were considered for this methodology.

First, the method should be easily applied and understood by all the principals involved in the development, monitoring, accounting, and auditing of the bank. An intricate system would increase the probability of error in usage of the methodology and, subsequently, increase the probability of misunderstanding.

Second, the method should not distort the function and value probability ratings generated by a WET evaluation. We acknowledge that the authors of WET have stated that "it is inappropriate to assign numerical values to probability ratings, multiply these values by acreage figures, and use the values to derive an overall probability rating for a wetland." This methodology is intended to generate a Quality Points Score (QPS) that may be converted to available credits in the bank or exchange rates of mitigation into the bank. An overall probability rating for an evaluated wetland is not the goal of this quantification methodology.

The Social Significance and Effectiveness ratings for the nine (9) functions and two (2) values that are evaluated by WET have been used for this quantification. In most cases, each of the functions or values are evaluated by WET for both categories, resulting in a total of twenty one (21) ratings.

The score for any given function or value is derived by multiplying its priority value by its probability rating value. For example, a function or value with a Moderate priority rating (value, 2) that has a WET probability rating of Low (value, 1), would score a total of 2 points. This is benchmarked against the

maximum possible score, which would be Moderate priority rating (2) x High probability rating (3), or a total of six (6) points.

This procedure is repeated for each function or value under each of the two evaluation categories (Social Significance and Effectiveness). The total number of points scored (actual) compared to the total number of points available (maximum) results in a percentage that becomes the Quality Points Score (QPS) for the functions and values of the wetland.

Tables 2 and 3 illustrate the score determinations for a sample upland or low quality wetland assessment area (a potential wetland creation/enhancement area) that has been evaluated by the WET methodology. The Regional Priority Rating column reflects the prioritized functions and values (From Table 1) while the WET Rating column represents typical probability ratings derived from a WET evaluation of the area.

SOCIAL SIGNIFICANCE EVALUATION				
FUNCTION VALUE	REGIONAL PRIORITY RATING	SAMPLE WET RATING	SAMPLE SCORE	MAX POSSIBLE SCORE
WDA	3	2 (M)	6	9
STR	3	2 (M)	6	9
FFA	3	2 (M)	6	9
SS	3	2 (M)	6	9
UH	2	3 (H)	6	6
NRT	2	2 (M)	4	6
ADA	2	2 (M)	4	6
REC	1	2 (M)	2	3
GWR	1	2 (M)	2	3
GWD	1	2 (M)	2	3
TOTAL SOCIAL SIGNIFICANCE SCORE			44	63

Table 2. Social Significance Score Determination

EFFECTIVENESS EVALUATION				
FUNCTION VALUE	REGIONAL PRIORITY RATING	SAMPLE WET RATING	SAMPLE SCORE	MAX POSSIBLE SCORE
WDAB	3	1 (L)	3	9
WDAW	3	1 (L)	3	9
WDAM	3	1 (L)	3	9
STR	3	1 (L)	3	9
FFA	3	2 (M)	6	9
SS	3	1 (L)	3	9
NRT	2	1 (L)	2	6
PE	2	1 (L)	2	6
ADA	2	2 (M)	4	6
GWR	1	1 (L)	1	3
GWD	1	1 (L)	1	3
TOTAL EFFECTIVENESS SCORE			31	78

Table 3. Effectiveness Score Determination

The QPS is then determined by adding the scores for both categories and comparing the total to the combined Max Scores for both categories, which is 141 (63+78). This comparison results in a percentage that becomes the QPS for the assessment area (See Table 4.)

	SAMPLE SCORE	MAX POSS SCORE	QPS
SOCIAL SIGNIFICANCE	44	63	
EFFECTIVENESS	31	78	
ASSESSMENT AREA	75	141	0.532

Table 4. Assessment Area QPS Calculation

This QPS may then be applied to the number of acres in the assessment area to determine Function/Value Units (units). Acreage is used in the quantification to determine the total number of units to be deposited as credits into the bank. For example, if the assessment area evaluated in Tables 2, 3, and 4 above contained 100 acres, the unit calculation would be as follows:

$$\text{UNITS} = 100 \text{ acres} \times 0.532 = 53.2$$

By using the above calculation method, mitigation bank credits can be determined at any given point in time, thereby providing a method for quantifying the gains (or losses) in functions and values that may occur over the useful life of the bank. For example, if positive creation or enhancement activities of the bank sponsor for the above assessment area resulted in increased wetland functions and values that yielded a new QPS of 0.732 at some point in the future, the unit calculation would be as follows:

$$\text{UNITS} = 100 \text{ acres} \times 0.732 = 73.2$$

(Net Gain = 20 Units)

It is also apparent in this methodology that a wetland bank can also experience a net loss in units if the QPS decreases. Therefore, there is an obvious financial incentive for the bank sponsor to create well-managed high quality wetlands to keep sellable credits at optimum levels while the bank is in service.

METHOD APPLICATION

Since credits are first deposited in a mitigation bank when a wetland assessment area achieves Minimum Success Criteria (MSC), this is obviously the critical point at which WET evaluations should be performed and credits calculated for deposit into the bank. However, it must be acknowledged that some assessment

areas may contain wetland functions and values prior to creation or enhancement activities. In these cases, it would be inappropriate to obtain future credits for the functions or values that were already in existence.

A mitigation bank, by its nature, would be comprised dominantly of upland (non-wetland) acreage prior to its development. However, within the designated bank area there may be some wetlands already in existence. These areas could vary greatly from low quality wetlands to pristine areas marked for preservation. Therefore, in addition to performing WET credit calculations at MSC, it becomes necessary to assess the functions and values at some representative point prior to any creation or enhancement activities.

This point, called the "Baseline" in this methodology, determines the units in the assessment area prior to bank development. The difference between the units at MSC and the units at Baseline determines the bank credits available for deposit and, ultimately, exchange. By calculating credits in this manner, prior existing wetland functions and values are not "sold", resulting in a net loss. Only those credits which were actually created by the bank sponsor are available for sale. The following basic calculation illustrates this concept:

$$\text{UNITS @ MSC} - \text{UNITS @ BASELINE} = \text{AVAILABLE BANK CREDITS}$$

Additionally, it should be pointed out that in large or diverse assessment areas, such as those in the Greens Bayou Bank, there may be pristine wetlands (preservation areas) in existence at Baseline. Since these types of wetlands generally have higher functions and values scores, an "averaging down" effect would result from their inclusion in the unit evaluation for the entire assessment area. To compensate for this, Baseline unit calculations for preservation acreage should be evaluated separately using this methodology. The number of units from this evaluation can then be combined with the calculated units for the remaining acreage to determine Baseline credits for the entire assessment area. Using the above basic calculation as a foundation for the methodology, the actual bank credit calculations may be developed. Table 5 illustrates the calculation to be used for determining the credits in the bank at any given time.

MITIGATION BANK CREDITS (C)

$$C = C_p + U_{aa}$$

Where:

C_p = Credits for Preservation, Pristine Wetlands

U_{aa} = Units for Remaining Assessment Area

Table 5. Mitigation Bank Credit Calculation

The component C_p (Preservation Credits) of the credit calculation is determined by the formula shown in Table 6. By evaluating preservation wetlands separately, as called for in this methodology, a Quality Point Score (Shown as QPS_p) will be generated for the preservation area. In addition, since only partial credit can be received for preservation, a Preservation Ratio (PR) must be applied to the calculated units to reflect the fractional portion of the units that can be deposited as credits in the bank. For the Green's Bayou Mitigation Bank, the Preservation Ratio has been established as 20% (PR=0.2) due to the high quality of the preservation sites.

PRESERVATION CREDITS (C_p)

$$C_p = QPS_p (A_p) (PR)$$

Where: QPS_p = QPS of Preservation Wetland
 A_p = Area of Preservation Wetlands, acres
 PR = Preservation Ratio

Table 6. Preservation Credit Calculation

The remaining component, U_{aa} (Assessment Area Units), is calculated in a two step process which calls for first determining the Baseline Units (U_b) shown in Table 7. These units, which are considered pre-existing, remain constant throughout the life of the bank and are therefore subtracted from the total units in the assessment area, as shown in Table 8.

BASELINE FUNCTION/VALUE UNITS (U_b)

$$U_b = QPS_b (A_e)$$

Where: QPS_b = QPS of Existing Wetlands @ Baseline
 A_e = Area of Existing Wetlands, acres

Table 7. Baseline Unit Calculation

ASSESSMENT AREA UNITS (U_{aa})

$$U_{aa} = QPS (A_{aa}) - U_b$$

Where: QPS = QPS of Assessment Area
 A_{aa} = Total acreage (A_t) of Assessment Area minus Preservation Acreage (A_p)

Table 8. Assessment Area Unit Calculation

Table 9 on the following page illustrates a sample credit calculation for an assessment area that is comprised of upland acreage, or a pure wetland creation site. Following that, Table 10 illustrates a sample credit calculation for a more complex assessment area that contains a mixture of upland, wetland, and preservation acreages which could produce a combination of creation and enhancement. The quantities or values used in these

two calculations are not derived from any specific areas in the Greens Bayou Bank, rather they are representative "numbers" that might be generated by this methodology for sites within the service area of this bank.

For illustration purposes, the available bank credits are assumed to be calculated at MSC, as shown in the sample calculations. However, this calculation may be performed at any time during the useful life of a bank to quantitatively monitor any gains or losses in credits.

SAMPLE CREDIT CALCULATIONS

<u>SAMPLE WETLAND</u>		<u>Calculations</u>
<u>Upland Conversion</u>		
At	200 acres	$A_{aa} = 200 - 0 = 0$
Ap	0 acres	
Ae	0 acres	$C_p = 0 (0) (0.2) = 0$
QPS _b *	0.53	
QPS	0.74	$U_b = 0.53(0) = 0$
		$U_{aa} = 0.72(200) - 0 = 144$
		$C = 0 + 144 = 144$

Table 9. Sample Credit Calculation of Upland Assessment Area (Wetland Creation)

*NOTE: Even though there may be no existing wetland acreage in a pure upland conversion, a site may possess some of the functions and values attributed to wetlands, such as flood flow alteration, wildlife diversity, or uniqueness/heritage. These will generally be reflected in the WET Social Significance ratings, thus generating a QPS_b.

<u>SAMPLE WETLAND</u>		<u>Calculations</u>
<u>Mixed Area</u>		
At	300 acres	$A_{aa} = 300 - 6 = 294$
Ap	6 acres	
Ae	54 acres	$C_p = 0.89(6) (0.2) = 1.07$
QPS _p	0.89	
QPS _b	0.56	$U_b = 0.56(54) = 30.24$
QPS	0.74	$U_{aa} = 0.74(294) - 30.24 = 187.32$
		$C = 1.07 + 187.32 = 188.39$

Table 10. Sample Credit Calculation of Mixed Assessment Area (Wetland Creation/Enhancement)

DEBIT/CREDIT EXCHANGES

Once available bank credits have been determined, as shown in Tables 9 or 10, they can be deposited in the bank. Permitted wetland impacts from off site debit locations may then be debited against the balance.

To determine applicable debits, the off site debit wetlands should be evaluated using both WET Version 2.0 and the regionally prioritized quantification method that was used for credit calculations in the bank. By doing so, proportional exchanges based on wetland quality can be achieved. The basic calculation for debits/credits is as follows:

$$\text{AVAILABLE BANK CREDITS} - \text{DEBIT SITE UNITS} = \text{AVAILABLE CREDIT BALANCE}$$

Table 11 illustrates a sample debit/credit calculation based on a typical off site debtor wetland, and available bank credits as determined in Table 10.

SAMPLE DEBIT SITE WETLAND		DEBIT/CREDIT CALCULATION	
Size:	9 acres	Available Bank Credits	188.39
QPS	0.65	Debits	-5.85
Debits	5.85 (9 x 0.65)	Available Credit Balance	182.54

Table 11. Sample Credit/Debit Calculation

4. Memorandum of Agreement

Before a wetlands mitigation bank can be created, a formal agreement, referred to as the Memorandum of Agreement (MOA) must be approved by the applicant and seven state and federal agencies which comprise the Mitigation Banking Review Team (MBRT). The Flood Control District has been steadily working towards entering into this agreement. Currently, the District has what is believed to be the final draft, in to the agencies of the MBRT for signature.

The Galveston District of the Corps of Engineers, along with the resource agencies, developed and published guidelines for mitigation banking. However, since a MOA, under these guidelines, has not yet been executed for any prior bank, there is no precedent to follow. Therefore, the Harris County Flood Control District found it necessary to interpret the guidelines into the first working document for an MOA.

During the drafting of this document, five significant issues, lacking definition under the guidelines, immediately emerged: 1) protection of wetlands in perpetuity, 2) minimum success criteria, 3) quantification of the habitat evaluation methodology (WET) which, unfortunately, rendered qualitative results but not quantitative, 4) preservation credits, and 5) definition of geographic region for which projects could be mitigated.

After significant research, investigate, analysis, and debate, the District believes a resolution has been found to adequately address these issues for the Greens Bayou Wetlands Mitigation Bank. The results are summarized as follows:

Protection of Wetlands

Meetings were held with the County Attorney to discuss options for permanent protection of the wetlands. The requirement of the guidelines is to achieve "no net loss" of wetlands. The County Attorney has drafted a document for placement of a conservation easement on each subdivision at the time minimum success criteria is achieved. This conservation easement is for "establishment of a wetlands mitigation bank only." Maintenance and preservation responsibility stay with the landowner (HCFCD) until such time that the tract is transferred to a third party. Transfer must be approved by the MBRT and HCFCD.

Minimum Success Criteria

After considerable negotiations, minimum success criteria has been defined and approved as a percent of vegetative coverage and increased hydroperiod to be achieved on each individual subdivision defined in detail on each site development plan approved by the MBRT.

Quantification of WET

Since this issue had not been defined in the guidelines, it became necessary for the HCFCF to solve the problem. While earlier mitigation plans approved by the Corps based replacement of wetlands on an acreage ratio, new thinking called for replacement of wetland *functions and values* rather than acres. This strategy assures a more equitable replacement from an ecological viewpoint as well as incentive for creation of higher quality wetlands.

Eventually, the MBRT approved a formula for converting WET ratings and weighting functions and values to arrive at a score that could be multiplied by acres. This formula can be replicated so that future increases in functions and values on enhanced and created wetlands can be assessed for determining credits to be deposited in the bank. The formula also makes it possible to use WET in evaluating the impacted project site to assess replacement credits using the mitigation bank. The weighting is based on placing emphasis on those functions and values identified in the WET methodology which are considered more important to the local region.

Preservation Credits

Guidelines of the MOA referenced allowing minimal credits for preservation of wetlands, but they did not define a formula. Therefore, it again became necessary for the HCFCF to work through this problem. The MBRT had issued warnings at every meeting that preservation did not fulfill the intent of "no net loss," and credits would be carefully scrutinized. Seeking a solution that would be acceptable to both the MBRT and to HCFCF, a proposal for receiving credits for 20% of wetlands determined by the delineation to be pristine and that would not be altered by bank design was presented to the MBRT and approved.

Geographic Region

The Guidelines state:

Mitigation banks should be located in the same geographic area as wetland project sites, i.e., within the same watershed, regime, hydrological sub-basin, or as specified in the specific bank MOA.

Recognizing that mitigation banking offers higher quality compensation for wetland habitat losses, the case was made to the MBRT that allowing mitigation from outside the watershed of a specific bank would result in greater ecological opportunity for quality mitigation. The MBRT approved the concept that mitigation will be allowed for projects within all of Harris County excepting Section 10 waterway limits as defined in the Rivers and Harbors Act. These limits correspond to salt water intrusion on waterways that would result in saline influenced wetlands.

The following is a copy of the final draft of the Memorandum of Agreement for the Greens Bayou Wetlands Mitigation Bank. It is currently being reviewed by the participating state and federal agencies. (National Marine Fisheries Services is not participating in this MOA as the project does not experience saline intrusion.) Until this document is approved by all appropriate parties it should be considered preliminary, but is included herein for informational purposes.

**MEMORANDUM OF AGREEMENT
FOR THE GREENS BAYOU WETLAND
MITIGATION BANK IN HARRIS COUNTY**

PRELIMINARY

THIS AGREEMENT is made, entered into, and executed by and between the Harris County Flood Control District, a body corporate and politic under the laws of the State of Texas, hereinafter called "HCFCD" and the members of the Mitigation Bank Review Team ("MBRT"), consisting of the United States Army Corps of Engineers District Galveston (COE), the United States Environmental Protection Agency, Region 6 (EPA), the United States Fish and Wildlife Service (FWS), National Marine Fisheries Service (NMFS), Texas Parks and Wildlife Department (TPWD), Texas General Land Office (GLO), and the Texas Natural Resources Conservation Commission (TNRCC).

PURPOSE

This Memorandum of Agreement (MOA) for the proposed Greens Bayou Wetlands Mitigation Bank has been developed to serve as a mechanism to allow necessary public and private projects to take place, in keeping with relevant legal requirements and environmental concerns. This mitigation bank will provide a means for the Harris County Flood Control District (HCFCD) and other entities or mitigation bank debtors to meet this essential need for compliance with regulations of the Clean Water Act as administered by the U.S. Army Corps of Engineers program. This mitigation bank is to provide compensatory mitigation in advance of unavoidable impacts to wetlands. The general location of this bank is shown on Exhibit A.

The MOA has been developed in accordance with the Interagency Guidelines for the Development and Use of Mitigation Banks published by the U.S. Army Corps of Engineers Galveston District (Guidelines), dated June 1993, which establishes terms and conditions for a Mitigation Bank in Harris County.

I. LEGAL AUTHORITY - The Greens Bayou Wetlands Mitigation Bank shall comply with existing Federal and State statutes, regulations, and policies, including the following:

- Clean Water Act (33 USC 1251 et seq.)
- Executive Order 11990 (Protection of Wetlands)
- Executive Order 11988, Floodplain Management
- Final Rule for Regulatory Program of the Corps of Engineers (33 CFR 320-330)
- Memorandum of Agreement Between Environmental Protection Agency and Department of Army concerning Determination of Mitigation under the Clean Water Act, Section 404(b)(1) Guidelines
- Fish and Wildlife Service Mitigation Policy

Texas Parks and Wildlife Department Mitigation Policy
Texas General Land Office Mitigation Policy
Texas Coastal Management Program
Rivers and Harbors Act of 1899 (33 USC 403 et seq.)
National Env. Policy Act (42 USC 4321 et seq.)
Texas Civil Statutes Article 5421u, as amended
Council on Environmental Quality Regulations for the
implementation of NEPA 40 CFR Parts 1500-1508
Fish and Wildlife Coordination Act (16 USC 661 et seq.)
National Historic Preservation Act as amended through 1992
(16 U.S.C. 470)
Endangered Species Act (16 USC 1531 et seq.)

Pursuant to Section 404 of Clean Water Act will apply for the necessary Corps permits to address the construction of the wetlands on the site. Although the sole purpose of the project covered under this Memorandum of Agreement is to create and enhance wetlands, the implementation and construction of the design strategy may require minimal impacts to existing wetlands in order to retain the necessary hydrology. These impacts will be sequenced to be avoided when possible and minimized when unavoidable.

Although the Interagency Guidelines recommends submittal of the proposed construction plans and design specifications as a part of the MOA, the large size of this project area makes it impractical to submit this detailed information at this time. This information, along with the descriptions of current conditions (baseline), will be submitted prior to the construction of each section. This site is to be subdivided into several sections. Construction will occur by HCFCD sequentially. Before construction of each section, the MBRT will review and approve design plans and assess the wetlands impacted by the construction of that section. Upon MBRT approval, a permit application will be filed with the Corps to address any wetland impacts necessary for the creation and enhancement of wetlands in that section.

In addition to the above, HCFCD will be required to comply with all relevant local, state, and federal laws in the construction of the mitigation bank.

II. CRITERIA FOR USE

Conceptual review and concurrence for the proposed use of the wetlands mitigation bank has been sought by HCFCD from the regulatory and resource agencies since the inception of this project. This process requires HCFCD to demonstrate that a wetlands bank site is likely to function according to a site development plan approved by the MBRT.

In compliance with the Interagency Guidelines, specific criteria are established herein for utilization of this Greens Bayou tract as a wetlands mitigation bank. The criteria for use includes the following:

- A. Use of the wetland bank to mitigate for project-related wetland impacts will require the Debtor to demonstrate that the activity causing a wetland impact has gone through the sequencing process of avoidance and minimization including demonstrating mitigation banking is preferable to traditional mitigation measures, and that it requires a Section 10 or Section 404 permit.
- B. Use of mitigation bank credits will not be permitted to offset impacts from any non-permitted Section 10 or Section 404 activity.
- C. Past mitigation work performed as compensation requirements for previously permitted work will not be accepted as bank credit.
- D. This mitigation bank may be used to mitigate for impacts to wetlands resulting from multiple public or private projects within Harris County excluding any impacts to riparian corridors under saline influence and all brackish and saline wetlands. The Section 10 limits of major bayou corridors roughly correspond to mixosaline intrusion (5 ppt). (See Exhibit B for approximate geographic limits.)
- E. Wetlands functions and values of all debit sites proposing to use this mitigation bank are to be determined according to the same assessment methodology used in determining the bank credits. In utilizing this mitigation bank, the methodology intended to assess credits and debits for wetland functions and values is a Quantification Methodology using the Wetland Evaluation Technique 2.0 (WET 2.0) as published by the U. S. Army Corps of Engineers Waterways Experiment Station, October 1987 (see Section IV for further definition).
- F. Bank credits cannot be established until minimum success criteria (MSC) has been achieved (see Section III for further definition). Once MSC has been achieved for a specific subdivision, credits will be assessed, in accordance with the Quantification Methodology WET 2.0 (see Section IV for further definition), for increased functions and values. Once these credits are approved by the U. S. Army Corps of Engineers, they are to be deposited into the bank for use.

III. MINIMUM SUCCESS CRITERIA

Minimum Success Criteria (MSC) is generally defined for the following wetland categories anticipated in the Greens Bayou Mitigation Bank:

- A. Palustrine Emergent Persistent and Non-Persistent¹ Wetlands
 - 1. Achieve a minimum of 70% coverage of desirable facultative (FAC)² or wetter plant species in Zone A³.
 - 2. Achieve a minimum of 70% coverage of desirable facultative wet (FACW)² or obligate (OBL)² species in Zone B.
 - 3. Achieve a wetland hydroperiod of seasonally flooded¹.
- B. Palustrine Scrub-Shrub Broad-leaved Deciduous¹ Wetlands
 - 1. Achieve a minimum of 70% coverage of desirable facultative (FAC)² or wetter species.
 - 2. Achieve a wetland hydroperiod of saturated¹.
- C. Palustrine Forested Broad-leaved Deciduous¹ Wetlands
 - 1. Achieve a minimum 70% canopy of desirable facultative (FAC)² or wetter species.
 - 2. Achieve a wetland hydroperiod of seasonally flooded¹.

Definitions of Wetland Zones are included on Exhibit C.

HCFCF will identify priority vegetation species and desired hydroperiod, and HCFCF will design construction plans specifically to achieve MSC for each individual subdivision. The types of wetlands to be created in each

¹Cowardin et.al. (1979/*). USFWS Wetland Classification System.

²Porter B. Reed, Jr. (May 1988). USFWS National List of Plants Species That Occur in Wetlands: South Plains (Region 6).

³Adamus, P.R., Clarain, E.J., Smith, R.D., and Young, R.E. 1987.

Wetland Evaluation Technique (WET); Volume II: Methodology. USAE Waterways Experiment Station, Vicksburg, Miss.

individual subdivision will be specified, and their designs will be based on hydrology models, WET evaluations, vegetation surveys, avian surveys, soil surveys, grading, and contouring. Their detailed plans will be included in the Site Development Plan for each subdivision. All site development plans are to be approved by the MBRT prior to beginning construction.

IV. ASSESSMENT METHODOLOGY

Based on extensive research and data gathering, the MBRT and HCFCD determined that the appropriate quantification assessment methodology for the Greens Bayou Mitigation Bank would be based on a quantified version of WET 2.0. This methodology has been designed to emphasize wetland functions and values which are of significance to the local geographic region. Since the geographical area to be served by this bank is limited to non-tidal areas of Harris County, the types of systems that will be involved in the bank exchanges are predominantly palustrine. Therefore, for this bank project, a method of comparative evaluation, with regional function and value priorities for palustrine systems has been established. A detailed discussion of the quantification methodology is attached as Exhibit D. All wetlands bank credits and development site debits are to be assessed utilizing this same methodology.

V. CREDITS

Development for preservation, enhancement, and creation of wetlands by HCFCD will occur in phases, in defined subdivisions of the site, and for future tracts which may be added to the bank, according to individual site development plans approved by the MBRT prior to construction.

The criteria for establishing the credits value are as follows:

- A. **Preservation Credit** - In accordance with the Guidelines, published June 1993, it is agreed that only minimal credits will be assigned to preservation of wetlands. Therefore, delineated high quality, hard to replicate wetlands, as verified by the COE biologists and so identified in the site plan for each individual subdivision, are to be given credit at a value of 20% of their total wetland functions and values as quantified by the Quantification Methodology utilizing WET 2.0 (see Exhibit D for a sample calculation). Preservation credits within a specific section of the mitigation bank will be deposited in the bank at the time the site development plans for that section are approved by the MBRT.

- B. Enhancement or Creation Credit - Enhancement credits and creation credits will also be established by the Quantification Methodology utilizing WET 2.0. At the time of an initial site assessment, this quantification methodology will be performed by HCFCD to establish current wetland functions and values (baseline value). Subsequent site assessment will also utilize the same methodology for evaluation. The value at the time of the subsequent assessment, minus the baseline value will establish the number of credits to be deposited in the bank (see Exhibit D for a sample calculation).

Enhancement and creation credits will be deposited in the bank as soon as development of each subdivision of the mitigation bank site has been completed and minimum success criteria, as defined in the site development plan and in Section III, have been met and approved by the Corps of Engineers.

Each site will continue to be periodically evaluated by HCFCD to establish credit value as described in VIII(B). These evaluations, as approved by the Corps of Engineers, will be utilized to adjust the number of credits deposited in the bank until maximum credits are achieved or until the site is closed for banking use.

VI. WITHDRAWAL

As previously stated, losses in wetland functions and values on the Debtor's development site will be measured by the same assessment methodology used in determining bank credits. Use of credits will be to offset unavoidable impacts to jurisdictional wetlands assessed by the Debtor's Section 10 and or Section 404 permit, including Individual Permits, General Permits, and Nationwide Permits. The number of credits required for mitigating such impacts will be established and stated in the conditions of each Section 10 or Section 404 permit issued by the Corps of Engineers to the Debtor. The permit will provide documentation for withdrawal activity.

VII. RECORD KEEPING

The HCFCD will establish and maintain a current ledger of credits and debits. An official map of the bank showing the status of wetland creation and maturing will be a part of the permanent record.

- A. Credits withdrawn will be recorded in the ledger by:
1. applicant's name
 2. COE permit number and/or identification number
 3. credits withdrawn (debit)
 4. date of transaction

- B. The HCFCD will provide the COE an official copy of each debit and credit transaction after it has occurred.
- C. The HCFCD will provide annual statements documenting the status of the account to the MBRT until all credits have been withdrawn and the bank is closed.

VIII. MONITORING OF THE WETLANDS MITIGATION BANK

Monitoring the growth of the wetlands which would include consistent maintenance in each subdivision is critical to achieving a successful site, and to properly assess the increased functions and values credits to be deposited in the bank. To meet these objectives, the following minimum criteria are established herein:

- A. Within one year after development is complete for enhancement or creation of a defined subdivision, the WET 2.0 Assessment will be run again by HCFCD exclusively on that defined subdivision to assess credits for increased functions and values. Once minimum success criteria have been achieved, credits assessed for increased functions and values and approved by the Corps of Engineers will be deposited in the bank. Adjustments to the maintenance program will be made by HCFCD after this annual assessment.
- B. For the first six years, HCFCD will run the WET 2.0 Assessment bi-annually and every five years for the subsequent fifteen years on each of those subdivisions for which development has been completed for enhancement and creation. Additionally, assessments may be performed by HCFCD at its discretion. The methodology will be run by HCFCD to further assess changes in functions and values resulting in corresponding increases or decreases of credits in the bank, which must be approved by the Corps of Engineers, until maximum functions and values are achieved, or until maximum credits have been withdrawn from the tract. Credits will continue to be accrued until the maximum possible score is achieved as defined in the quantification methodology (see Exhibit D).
- C. In addition to periodic running of the assessment methodology, HCFCD will monitor wetlands on at least a bi-monthly basis through on-site inspections of developed subdivisions to observe changes in hydrology, soils and vegetation for the first year. Thereafter, until the bank is closed, on-site inspections by HCFCD staff will be conducted quarterly. The MBRT may conduct on-site inspections at will.

- D. HCFCFCD will provide an annual Progress Report to the MBRT until all credits are withdrawn from the bank. Upon completion of construction of each individual subdivision of the bank, record drawings with photographic coverage will be submitted by HCFCFCD along with the subsequent annual progress report.
- E. Monitoring of the bank will continue by HCFCFCD until all credits have been withdrawn as provided for in Section VI. At that point, the MBRT will meet and review the operation of the bank, and a final report will be written by HCFCFCD summarizing the successes and failures of the bank.
- F. Maintenance of the wetlands and mitigation bank will consist primarily of controlling noxious and undesirable plants. HCFCFCD is obligated to provide reasonable corrective measures of deficiencies resulting in a loss of function and values below minimum success criteria. Specific maintenance plans and anticipated corrective measures will be defined in the MBRT approved submittal of construction plans and design specifications for each individual subdivision.

IX. OWNERSHIP

The Greens Bayou Wetlands Mitigation Bank site is owned in fee simple by HCFCFCD which has full financial responsibility for operation, maintenance and preservation of the integrity of the wetlands. The HCFCFCD retains these responsibilities until such time as they can be transferred to another party. (See Section XI for the criteria to transfer responsibility.)

X. DEDICATION

At the time of establishing the minimum success criteria for each individual subdivision, and prior to depositing credits into the bank, a conservation easement will be placed on the subdivision by HCFCFCD to protect the wetland functions and values from other conflicting uses. This conservation easement will be dedicated to the public for creation of a wetlands mitigation bank only, in accordance with the Memorandum of Agreement. This dedication is intended to prohibit conflicting land usage. Exhibit E shows the typical conservation easement proposed to be utilized. This conservation easement is to be filed in the public records of Harris County, Texas.

By retaining fee simple ownership of the tract, HCFCFCD retains responsibility for maintenance, operation, and preservation of the wetland functions and values, until such time as this responsibility can be transferred to another party (see Section XI).

XI. TRANSFER

In the event the HCFCD wishes to sell, lease, or transfer maintenance, operation, and preservation responsibility of the wetlands site to another party after all credits are withdrawn, this third party will be required to fulfill all commitments set forth in the MOA, including land use restrictions. The HCFCD and the MBRT have approval authority over designation of the party to whom the bank may be transferred.

XII. GENERAL CONDITIONS

- A. This instrument and the attached exhibits may be reviewed by all signatories to the agreement within two years of establishing the wetlands bank.
- B. This agreement may be amended as agreed by all signatories.
- C. A signatory may terminate its participation in this MOA upon written notice to all other signatories.
- D. No party hereto shall make, in whole or in part, any assignment of this Agreement or any obligation hereunder without the prior consent of the other parties.
- E. This instrument contains the entire agreement between the parties relating to the rights herein granted and the obligations herein assumed. Any modifications concerning this instrument shall be of no force or effect, excepting a subsequent modification in writing signed by all parties hereto.

EXECUTED in duplicate originals on this ____ day of _____, 1995.

APPROVED AS TO FORM:

MIKE DRISCOLL, County Attorney

HARRIS COUNTY FLOOD CONTROL
DISTRICT

Paul Taparauskas
Assistant County Attorney
Harris County, Texas

BY _____
Arthur L. Storey, Jr.
Executive Director

BY _____
Robert Eckels, County Judge

James P. King, Colonel, U. S. Army
Commanding Officer
U. S. Army Corps of Engineers, Southwestern Division

Russell F. Rhoades
Director, Environmental Services Division
U. S. Environmental Protection Agency, Region 6

David L. Hankla
Field Supervisor
U. S. Fish and Wildlife Service

Andrew Sansom
Executive Director
Texas Parks and Wildlife Department

Garry Mauro
Commissioner
Texas General Land Office

Dan Pearson
Executive Director
Texas Natural Resources Conservation Commission

EXHIBIT A

VICINITY MAP FOR THE
GREENS BAYOU WETLANDS MITIGATION BANK

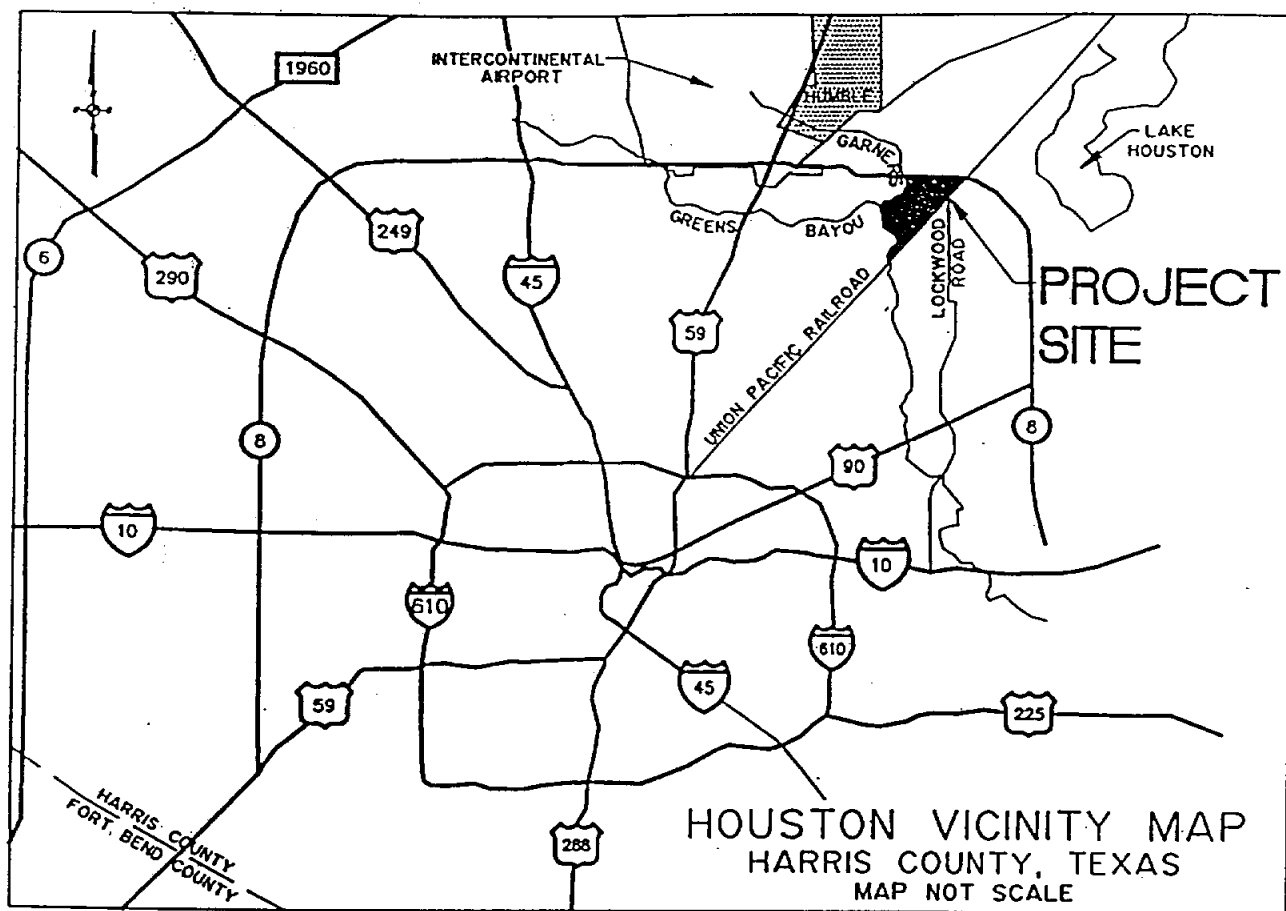

**GEOGRAPHIC AREA OF USE
GREENS BAYOU MITIGATION BANK**

**AREA EXCLUDED FROM UTILIZATION -
RIPARIAN CORRIDORS UNDER
SALINE INFLUENCE AND ALL
BRACKISH AND SALINE WETLANDS
(CORRESPONDS TO SECTION 10 LIMITS
APPROXIMATING MIXOSALINE INTRUSION)**

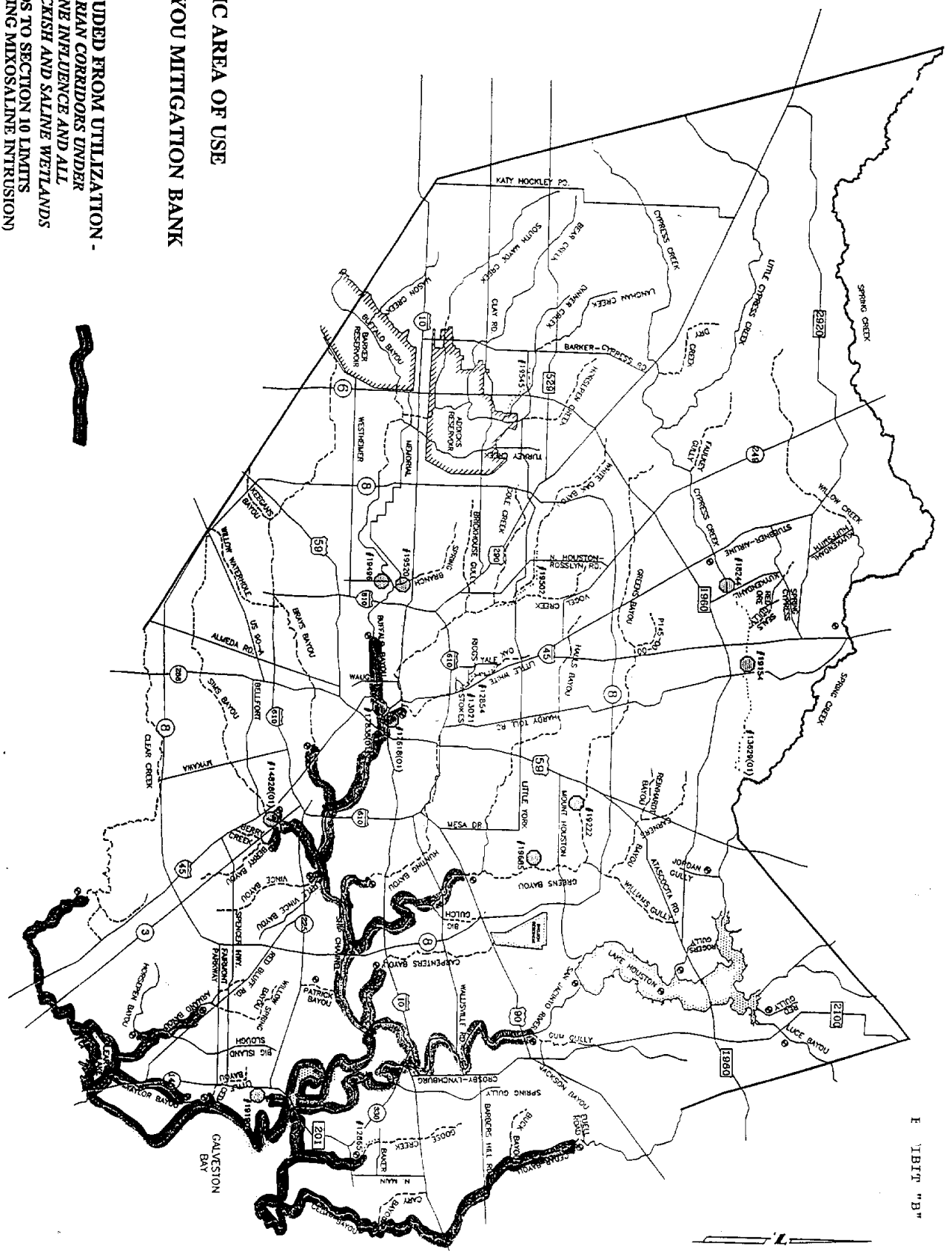

SECTION 10 LIMITS (MAVAGRELL WATERWAYS) WERE DETERMINED FROM THE CORP OF ENGINEERS, GALVESTON DISTRICT

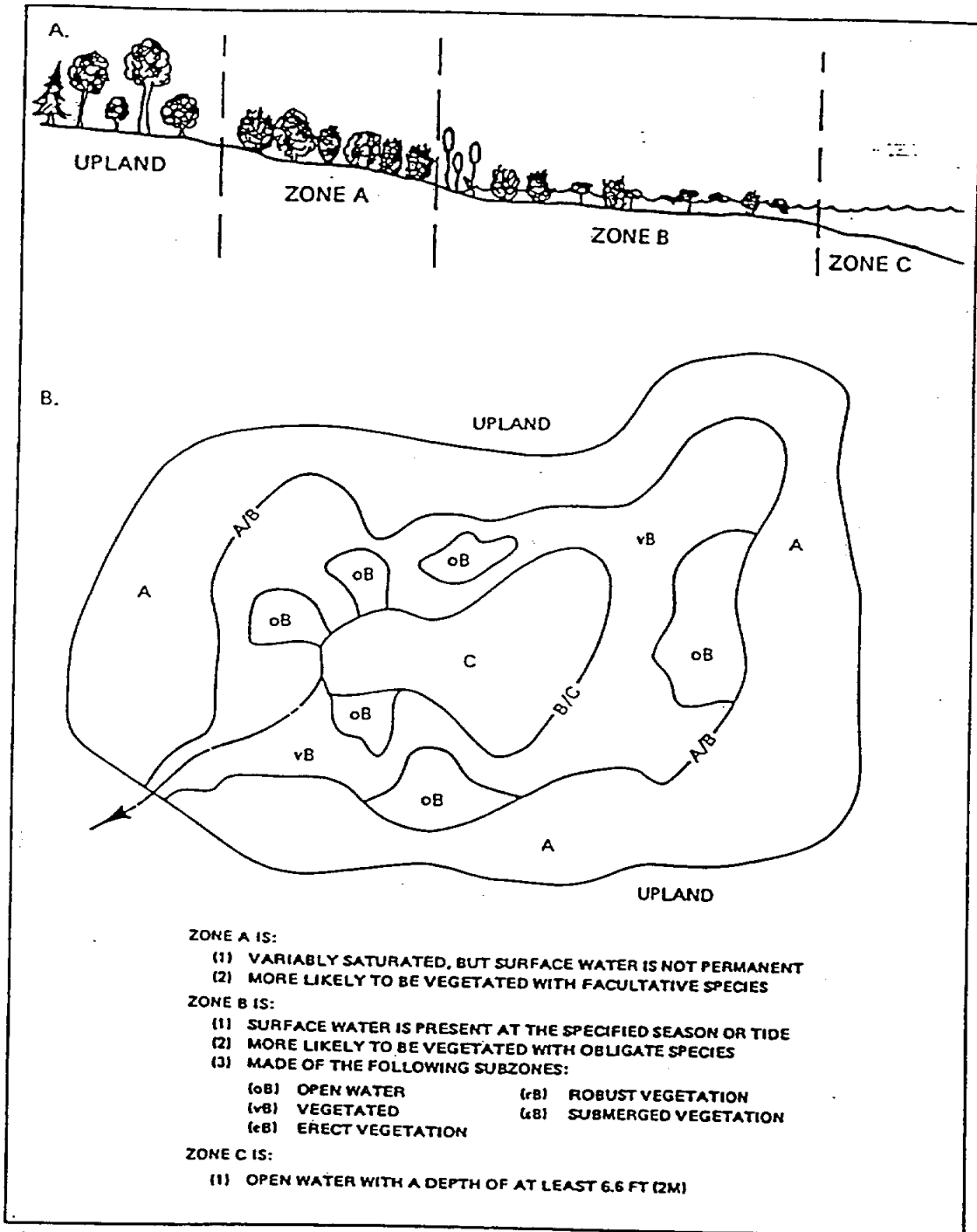

The above figure is reproduced from the Wetland Evaluation Technique (WET); Volume II Methodology by Adamus, P.R., Clarain, E.J., Smith, R.D., and Young, R.E., U.S. Army Corps of Engineers Waterways Experiment Station.

Figure 15. Wetland zones

EXHIBIT D

GREEN'S BAYOU MITIGATION BANK CREDIT DETERMINATIONS USING WET VERSION 2.0

The successful operation of the Green's Bayou Mitigation Bank is dependent upon a manageable method of determining the number of credits that are available in the bank at any given time, and a comparable method of evaluating debit site wetlands for their exchange values in the bank. This document discusses the need for such a method, the rationale of method development, and the method itself.

NEED FOR METHODOLOGY

Prior to the establishment of the Green's Bayou Bank, wetland comparisons and compensations for losses have generally been applied on an acre-for-acre basis, resulting in the now familiar mitigation ratios of 2:1, 5:1, and so on. Using the safety-in-numbers approach, the primary goal of these ratios has been to ensure that no net loss of wetland functions and values occurs from permitted activities. This method of compensation does not address wetland "quality", per se, and few assurances can be made that the results of acre-for-acre ratios would prevent net losses of functions and values.

The general consensus among the regulatory agencies and those who are involved in wetland issues is that acre-for-acre compensation (exchange) is not a realistic approach, since an acre of one wetland may not "equal" an acre of another. That being the case, a method by which wetlands can be evaluated on the basis of quality is highly desirable for determining compensation.

The quality of a wetland can be defined by the ecological functions it performs and the values that it adds to the overall environment in which it exists. If a method of evaluating and comparing these functions and values can be developed, proportional exchanges can be made between banked wetlands and debit site wetlands. The net result will be an exchange of wetland quality.

Using the quality assessment approach, the need for mitigation ratios, as in acre-for-acre compensation, should not be necessary. Since a mitigation bank, by definition, must contain functioning wetlands before any exchanges can be made, there will not be the net loss of functions and values that many times occur in conventional mitigation practices where the time between wetland impacts and a functioning mitigation site may be lengthy. Therefore, a quantification methodology must not only establish a

means for assessing wetland quality, it must also establish a means for determining appropriate exchanges.

Quality comparisons between wetlands do not automatically translate to proportional exchanges. However, if separate wetlands are evaluated using the same criteria, the resulting quality ratings provide a foundation for applying quantification factors that can be used to calculate exchange rates as well as banked credits. The task then becomes to develop a method of quantification whereby wetlands can be compared, scored, and proportionally exchanged.

METHOD DEVELOPMENT AND RATIONALE

The Wetland Evaluation Technique Version 2.0 (WET) , which has been used for the Green's Bayou Bank, evaluates wetland functions and values in terms of social significance, effectiveness, and opportunity and assigns "qualitative probability ratings" (called "probability ratings" or "ratings") for each function or value under one or more of these categories. Social significance and effectiveness ratings are the applicable evaluations derived from WET for credit calculation purposes since they assess the current conditions on a site at any given point in time. The opportunity rating merely represents the potential for a function or value to occur in a wetland and is not a good current indicator of whether or not the function or value actually occurs. Therefore, the opportunity ratings have not been utilized in the methodology.

While the probability ratings of Low, Moderate, or High generated by WET reflect the probability of a function or value to provide social significance or effectiveness, they do not provide an order of magnitude for comparing the importance of one function or value to another. However, by prioritizing functions and values based on their regional or local importance, and weighting them accordingly, an order of magnitude can be established.

The authors of WET state in their explanatory and rationale statements that "The authors recognize the desirability of regionalizing WET..." and they emphasize that professional judgements and knowledge by local experts and regulatory agencies are highly desirable for effective regional adaptations of the methodology. Prioritizations of functions and values for regional interpretations can substantially enhance the quality and confidence level of a wetland evaluation derived from WET.

For example, in some areas of the country a wetland's ability to recharge groundwater may be very significant while in other areas, such as the local Gulf Coast, this function may not be as important. A local adaptation of WET, therefore, might de-

emphasize this particular function. In contrast, floodflow alteration in a local WET application might receive a much higher importance ranking than it would in other areas where flooding is not a problem.

Since WET was developed to evaluate the major functions and values of wetlands for broad applications (i.e. nationwide) prioritizations of functions and values can fine tune WET for local or regional use. Once the functions and values have been ranked for priority, wetlands can be evaluated for their abilities to provide those functions and values in terms of social significance and effectiveness for the local area. In essence, the quality of a particular wetland can be determined.

Table 1 illustrates the regional prioritization of the functions and values for the Greens Bayou Mitigation Bank service area that are evaluated in the Social Significance and Effectiveness categories of WET Version 2.0. Under these WET evaluation categories the functions and values have been divided into three (3) priority rating groups -- High, Moderate, Low -- based on their regional importance, as discussed previously. Those that have a High rating have been weighted by assigning a value of 3; those with a Moderate rating, a 2; and those with a Low rating, a 1.

SOCIAL SIGNIFICANCE			EFFECTIVENESS				
HIGH	3	MOD 2	LOW 1	HIGH	3	MOD 2	LOW 1
WDA		UH	REC	WDAB		NRT	GWR
STR		NRT	GWR	WDAW		PE	GWD
FFA		ADA	GWD	WDAM		ADA	
SS				STR			
				FFA			
				SS			
Wildlife Diversity Abundance (WDA)			Uniqueness/Heritage (UH)				
Breeding (WDAB)			Nutrient Removal/Transport (NRT)				
Wintering (WDAW)			Aquatic Diversity/Abundance (ADA)				
Migration (WDAM)			Recreation (REC)				
Sediment/Toxicant Retention (STR)			Groundwater Recharge (GWR)				
Flood Flow Alteration (FFA)			Groundwater Discharge (GWD)				
Sediment Stabilization (SS)							

Table 1. Regional Prioritization of WET Functions and Values with Weighting. Greens Bayou Mitigation Bank Service Area.

Likewise, the WET probability ratings of High, Moderate, or Low for each function or value have been assigned values of 3, 2, and 1, respectively.

When comparing wetlands certain restrictions must be applied to the types of systems being evaluated. For example, it would not be reasonable to compare marine systems with palustrine systems since their physical, chemical, and biological functions are too broadly separated. However, it would be reasonable to compare

marine with marine, palustrine with palustrine, and so on. WET is very effective for evaluating and comparing wetlands within the same systems classification.

The Green's Bayou Mitigation Bank, by definition of its market area, excludes wetlands that would be classified as marine or estuarine systems. Since the geographical area to be served by the bank is limited to Harris County, non-Section 10 limits, the types of systems that will be involved in bank exchanges are predominantly palustrine. Therefore, for this bank project service area, a method of comparative evaluation with regional function and value priorities for palustrine systems is necessary.

CREDIT DETERMINATION METHODOLOGY

The method for converting a WET evaluation for palustrine systems in the Green's Bayou Mitigation Bank is outlined in the following section. There are two primary development criteria that were considered for this methodology.

First, the method should be easily applied and understood by all the principals involved in the development, monitoring, accounting, and auditing of the bank. An intricate system would increase the probability of error in usage of the methodology and, subsequently, increase the probability of misunderstanding.

Second, the method should not distort the function and value probability ratings generated by a WET evaluation. We acknowledge that the authors of WET have stated that "it is inappropriate to assign numerical values to probability ratings, multiply these values by acreage figures, and use the values to derive an overall probability rating for a wetland." This methodology is intended to generate a Quality Points Score (QPS) that may be converted to available credits in the bank or exchange rates of mitigation into the bank. An overall probability rating for an evaluated wetland is not the goal of this quantification methodology.

The Social Significance and Effectiveness ratings for the nine (9) functions and two (2) values that are evaluated by WET have been used for this quantification. In most cases, each of the functions or values are evaluated by WET for both categories, resulting in a total of twenty one (21) ratings.

The score for any given function or value is derived by multiplying its priority value by its probability rating value. For example, a function or value with a Moderate priority rating (value, 2) that has a WET probability rating of Low (value, 1), would score a total of 2 points. This is benchmarked against the

maximum possible score, which would be Moderate priority rating (2) x High probability rating (3), or a total of six (6) points.

This procedure is repeated for each function or value under each of the two evaluation categories (Social Significance and Effectiveness). The total number of points scored (actual) compared to the total number of points available (maximum) results in a percentage that becomes the Quality Points Score (QPS) for the functions and values of the wetland.

Tables 2 and 3 illustrate the score determinations for a sample upland or low quality wetland assessment area (a potential wetland creation/enhancement area) that has been evaluated by the WET methodology. The Regional Priority Rating column reflects the prioritized functions and values (From Table 1) while the WET Rating column represents typical probability ratings derived from a WET evaluation of the area.

SOCIAL SIGNIFICANCE EVALUATION				
FUNCTION VALUE	REGIONAL PRIORITY RATING	SAMPLE WET RATING	SAMPLE SCORE	MAX POSSIBLE SCORE
WDA	3	2 (M)	6	9
STR	3	2 (M)	6	9
FFA	3	2 (M)	6	9
SS	3	2 (M)	6	9
UH	2	3 (H)	6	6
NRT	2	2 (M)	4	6
ADA	2	2 (M)	4	6
REC	1	2 (M)	2	3
GWR	1	2 (M)	2	3
GWD	1	2 (M)	2	3
TOTAL SOCIAL SIGNIFICANCE SCORE			44	63

Table 2. Social Significance Score Determination

EFFECTIVENESS EVALUATION				
FUNCTION VALUE	REGIONAL PRIORITY RATING	SAMPLE WET RATING	SAMPLE SCORE	MAX POSSIBLE SCORE
WDAB	3	1 (L)	3	9
WDAW	3	1 (L)	3	9
WDAM	3	1 (L)	3	9
STR	3	1 (L)	3	9
FFA	3	2 (M)	6	9
SS	3	1 (L)	3	9
NRT	2	1 (L)	2	6
PE	2	1 (L)	2	6
ADA	2	2 (M)	4	6
GWR	1	1 (L)	1	3
GWD	1	1 (L)	1	3
TOTAL EFFECTIVENESS SCORE			31	78

Table 3. Effectiveness Score Determination

The QPS is then determined by adding the scores for both categories and comparing the total to the combined Max Scores for both categories, which is 141 (63+78). This comparison results in a percentage that becomes the QPS for the assessment area (See Table 4.)

	SAMPLE SCORE	MAX POSS SCORE	QPS - PERCENT
SOCIAL SIGNIFICANCE	44	63	
EFFECTIVENESS	31	78	
ASSESSMENT AREA	75	141	0.532

Table 4. Assessment Area QPS Calculation

This QPS may then be applied to the number of acres in the assessment area to determine Function/Value Units (units). Acreage is used in the quantification to determine the total number of units to be deposited as credits into the bank. For example, if the assessment area evaluated in Tables 2, 3, and 4 above contained 100 acres, the unit calculation would be as follows:

$$\text{UNITS} = 100 \text{ acres} \times 0.532 = 53.2$$

By using the above calculation method, mitigation bank credits can be determined at any given point in time, thereby providing a method for quantifying the gains (or losses) in functions and values that may occur over the useful life of the bank. For example, if positive creation or enhancement activities of the bank sponsor for the above assessment area resulted in increased wetland functions and values that yielded a new QPS of 0.732 at some point in the future, the unit calculation would be as follows:

$$\text{UNITS} = 100 \text{ acres} \times 0.732 = 73.2$$

(Net Gain = 20 Units)

It is also apparent in this methodology that a wetland bank can also experience a net loss in units if the QPS decreases. Therefore, there is an obvious financial incentive for the bank sponsor to create well-managed high quality wetlands to keep sellable credits at optimum levels while the bank is in service.

METHOD APPLICATION

Since credits are first deposited in a mitigation bank when a wetland assessment area achieves Minimum Success Criteria (MSC), this is obviously the critical point at which WET evaluations should be performed and credits calculated for deposit into the bank. However, it must be acknowledged that some assessment

areas may contain wetland functions and values prior to creation or enhancement activities. In these cases, it would be inappropriate to obtain future credits for the functions or values that were already in existence.

A mitigation bank, by its nature, would be comprised dominantly of upland (non-wetland) acreage prior to its development. However, within the designated bank area there may be some wetlands already in existence. These areas could vary greatly from low quality wetlands to pristine areas marked for preservation. Therefore, in addition to performing WET credit calculations at MSC, it becomes necessary to assess the functions and values at some representative point prior to any creation or enhancement activities.

This point, called the "Baseline" in this methodology, determines the units in the assessment area prior to bank development. The difference between the units at MSC and the units at Baseline determines the bank credits available for deposit and, ultimately, exchange. By calculating credits in this manner, prior existing wetland functions and values are not "sold", resulting in a net loss. Only those credits which were actually created by the bank sponsor are available for sale. The following basic calculation illustrates this concept:

$$\text{UNITS @ MSC} - \text{UNITS @ BASELINE} = \text{AVAILABLE BANK CREDITS}$$

Additionally, it should be pointed out that in large or diverse assessment areas, such as those in the Greens Bayou Bank, there may be pristine wetlands (preservation areas) in existence at Baseline. Since these types of wetlands generally have higher functions and values scores, an "averaging down" effect would result from their inclusion in the unit evaluation for the entire assessment area. To compensate for this, Baseline unit calculations for preservation acreage should be evaluated separately using this methodology. The number of units from this evaluation can then be combined with the calculated units for the remaining acreage to determine Baseline credits for the entire assessment area. Using the above basic calculation as a foundation for the methodology, the actual bank credit calculations may be developed. Table 5 illustrates the calculation to be used for determining the credits in the bank at any given time.

MITIGATION BANK CREDITS (C)

$$C = C_p + U_{aa}$$

Where: C_p = Credits for Preservation, Pristine Wetlands
 U_{aa} = Units for Remaining Assessment Area

Table 5. Mitigation Bank Credit Calculation

The component C_p (Preservation Credits) of the credit calculation is determined by the formula shown in Table 6. By evaluating preservation wetlands separately, as called for in this methodology, a Quality Point Score (Shown as QPS_p) will be generated for the preservation area. In addition, since only partial credit can be received for preservation, a Preservation Ratio (PR) must be applied to the calculated units to reflect the fractional portion of the units that can be deposited as credits in the bank. For the Green's Bayou Mitigation Bank, the Preservation Ratio has been established as 20% (PR=0.2) due to the high quality of the preservation sites.

PRESERVATION CREDITS (C_p)

$$C_p = QPS_p (A_p) (PR)$$

Where: QPS_p = QPS of Preservation Wetland
 A_p = Area of Preservation Wetlands, acres
 PR = Preservation Ratio

Table 6. Preservation Credit Calculation

The remaining component, U_{aa} (Assessment Area Units), is calculated in a two step process which calls for first determining the Baseline Units (U_b) shown in Table 7. These units, which are considered pre-existing, remain constant throughout the life of the bank and are therefore subtracted from the total units in the assessment area, as shown in Table 8.

BASELINE FUNCTION/VALUE UNITS (U_b)

$$U_b = QPS_b (A_e)$$

Where: QPS_b = QPS of Existing Wetlands @ Baseline
 A_e = Area of Existing Wetlands, acres

Table 7. Baseline Unit Calculation

ASSESSMENT AREA UNITS (U_{aa})

$$U_{aa} = QPS (A_{aa}) - U_b$$

Where: QPS = QPS of Assessment Area
 A_{aa} = Total acreage (A_t) of Assessment Area minus Preservation Acreage (A_p)

Table 8. Assessment Area Unit Calculation

Table 9 on the following page illustrates a sample credit calculation for an assessment area that is comprised of upland acreage, or a pure wetland creation site. Following that, Table 10 illustrates a sample credit calculation for a more complex assessment area that contains a mixture of upland, wetland, and preservation acreages which could produce a combination of creation and enhancement. The quantities or values used in these

two calculations are not derived from any specific areas in the Greens Bayou Bank, rather they are representative "numbers" that might be generated by this methodology for sites within the service area of this bank.

For illustration purposes, the available bank credits are assumed to be calculated at MSC, as shown in the sample calculations. However, this calculation may be performed at any time during the useful life of a bank to quantitatively monitor any gains or losses in credits.

SAMPLE CREDIT CALCULATIONS

<u>SAMPLE WETLAND</u>		<u>Calculations</u>
<u>Upland Conversion</u>		
At	200 acres	$A_{aa} = 200 - 0 = 0$
Ap	0 acres	
Ae	0 acres	$C_p = 0 (0) (0.2) = 0$
QPSb*	0.53	
QPS	0.74	$U_b = 0.53(0) = 0$
		$U_{aa} = 0.72(200) - 0 = 144$
		$C = 0 + 144 = 144$

Table 9. Sample Credit Calculation of Upland Assessment Area (Wetland Creation)

*NOTE: Even though there may be no existing wetland acreage in a pure upland conversion, a site may possess some of the functions and values attributed to wetlands, such as flood flow alteration, wildlife diversity, or uniqueness/heritage. These will generally be reflected in the WET Social Significance ratings, thus generating a QPSb.

<u>SAMPLE WETLAND</u>		<u>Calculations</u>
<u>Mixed Area</u>		
At	300 acres	$A_{aa} = 300 - 6 = 294$
Ap	6 acres	
Ae	54 acres	$C_p = 0.89(6) (0.2) = 1.07$
QPSp	0.89	
QPSb	0.56	$U_b = 0.56(54) = 30.24$
QPS	0.74	$U_{aa} = 0.74(294) - 30.24 = 187.32$
		$C = 1.07 + 187.32 = 188.39$

Table 10. Sample Credit Calculation of Mixed Assessment Area (Wetland Creation/Enhancement)

DEBIT/CREDIT EXCHANGES

Once available bank credits have been determined, as shown in Tables 9 or 10, they can be deposited in the bank. Permitted wetland impacts from off site debit locations may then be debited against the balance.

To determine applicable debits, the off site debit wetlands should be evaluated using both WET Version 2.0 and the regionally prioritized quantification method that was used for credit calculations in the bank. By doing so, proportional exchanges based on wetland quality can be achieved. The basic calculation for debits/credits is as follows:

$$\text{AVAILABLE BANK CREDITS} - \text{DEBIT SITE UNITS} = \text{AVAILABLE CREDIT BALANCE}$$

Table 11 illustrates a sample debit/credit calculation based on a typical off site debtor wetland, and available bank credits as determined in Table 10.

SAMPLE DEBIT SITE WETLAND		DEBIT/CREDIT CALCULATION	
Size:	9 acres	Available Bank Credits	188.39
QPS	0.65	Debits	-5.85
Debits	5.85 (9 x 0.65)	Available Credit Balance	182.54

Table 11. Sample Credit/Debit Calculation

EXHIBIT "E"

PRELIMINARY

CONSERVATION EASEMENT

**THE STATE OF TEXAS §
 §
COUNTY OF HARRIS §**

KNOW ALL MEN BY THESE PRESENTS:

This instrument is executed by the Harris County Flood Control District (the "District") on the date below written for the purpose of establishing a Conservation Easement upon, over and across those certain lands more particularly described below, subject to those certain limitations and restrictions herein contained.

WHEREAS, the District is a political subdivision of the State of Texas, established under Article XVI, Section 59, of the Texas Constitution as a conservation and reclamation district; and

WHEREAS, the boundaries of the District as a conservation and reclamation district are located within a county having a population in excess of 2.1 million people; and

WHEREAS, the District, as a political subdivision of the State of Texas, is authorized, pursuant to the provisions of Tex. Rev. Civ. Stat. Ann. art. 5421u, (Vernon 1993), to take all necessary and reasonable actions to comply with certain federal requirements for the establishment and maintenance of a mitigation bank (as that term is defined therein) including, but not limited to: 1.) acquiring any land necessary for a mitigation bank; 2.) adopting and enforcing permanent land use and control measures upon such land consistent with federal requirements; and 3.) contracting for the use or operation of the mitigation banks or any part thereof by an operator (as that term is defined therein); and

WHEREAS, the District pursuant to its desire to establish a mitigation bank, and by the authority vested in it by the above referenced statute, has acquired by purchase the fee simple estate in and to those certain lands more particularly described by metes and bounds in that certain Exhibit "A" which is attached hereto and made a part hereof for descriptive purposes; and

WHEREAS, pursuant to its authority to comply with federal requirements in the form of legislation, rules or guidelines necessary for an eligible program of mitigation banking, the District, together with certain other state and federal agencies and/or authorities named and

described therein, has joined in the execution of that certain Memorandum of Agreement dated _____, 199____, (the "MOA"), which MOA is based upon and is required by those certain Interagency Guidelines, dated June 1993 and prepared by the U.S. Army Corps of Engineers and certain other state and federal agencies more particularly described in such Interagency Guidelines; and

WHEREAS, the District is obligated under the terms of the MOA executed by it in conformity with the above referenced Interagency Guidelines to adopt and enforce permanent land use control measures on land owned by it in a mitigation bank consistent with those federal requirements expressed in the above referenced Interagency Guidelines and is further authorized to adopt and enforce such permanent land use and control measures under the terms of the above referenced statute; and

WHEREAS, it has been determined by the District that the establishment of a mitigation bank is a proper and authorized use of those lands described in Exhibit "A" and that the use of such land for such purposes would benefit and serve the interest of the District in performing and discharging its statutory duties under the laws of Texas; and

WHEREAS, it has been further determined by the District that a Conservation Easement of the nature and type provided for hereinbelow would be the most advantageous means whereby the permanent land use and control measures contemplated by the above referenced Interagency Guidelines, and which the District is obligated to impose under the terms of the MOA, may be accomplished.

NOW, THEREFORE, the District, for and in consideration of the benefits that would be provided by the establishment of a mitigation bank, and pursuant to the authority conferred upon it by TEX. REV. CIV. STAT. ANN. art. 5421u, §6.02(a)(2) (Vernon 1993) does hereby create a conservation easement (the Easement) over, across and upon that certain parcel of land containing _____ acres more or less described in Exhibit "A" (the Easement Area). No use will be made of the Easement Area that is not consistent with or is not otherwise permitted by this Easement. As used in connection with those certain itemized limitations Nos. "1" through "12", only, which limitations are set forth more particularly

below, certain words and/or phrases shall have only those certain, specific meanings ascribed to them. The meanings ascribed to such terms and/or phrases, hereinbelow, shall be applied to such terms and/or phrases when used in the context of the itemized limitations, Nos. "1" through "12", and in no other context. The meanings to be ascribed to such terms and/or phrases as they appear or may be used in the context of other provisions of this instrument shall be only as therein indicated. The words and/or phrases and their meanings, as used in item Nos. "1" through "12" are as follows:

A.) "Interagency Guidelines" shall mean that document, and that document only, that is entitled "INTERAGENCY GUIDELINES FOR THE DEVELOPMENT AND USE OF MITIGATION BANKS IN THE GALVESTON DISTRICT, CORPS OF ENGINEERS, dated June 1993 and which was prepared jointly by the U.S. ARMY CORPS OF ENGINEERS together with certain other state and federal agencies or governmental authorities more particularly described therein;

B.) "Memorandum of Agreement" shall mean those certain written documents specifically identified, entitled or referred to as "Memorandum of Agreement" which have been prepared with the assistance of a Mitigation Bank Review Team (MBRT), as that term is defined in the Interagency Guidelines (as that term is defined in item "A", above), and which document has been prepared in conformity with and pursuant to such Interagency Guidelines. Notwithstanding anything contained herein to the contrary, the term "Memorandum of Agreement" shall mean only those valid and subsisting Memorandum of Agreements, as that term is defined herein, which have been properly executed by such parties as may be required under the terms of the Interagency Guidelines (including the "Mitigation Bank Operator", as that entity is defined in the such Interagency Guidelines) and which specifically covers and includes all or part of the Easement Area;

C.) "Mitigation Bank" shall mean only those mitigation banks which have been approved or authorized pursuant to a Memorandum of Agreement (as that term is defined in item "B", above), which specifically covers or embraces all or part of the Easement Area. Notwithstanding anything contained herein to the contrary, should the Easement be used in

conjunction with one or more other conservation easements created by the District covering lands owned by the District other than the Easement Area, for the purpose of establishing a Mitigation Bank, the Easement hereby created by the District, and the use which may be made of the Easement Area, shall not be otherwise limited or impaired, nor shall such Easement or the use that may be made of the Easement Area, be limited or impaired by the failure of such other lands to be embraced by or remain part of a mitigation bank;

The limitations which the Easement is subject to, and which shall govern all uses made of the Easement Area, are as follows, to wit:

1.) except as otherwise provided for herein, no use shall be made of the Easement Area which is not otherwise necessary, incidental or appurtenant to the establishment of a Mitigation Bank upon the Easement Area. Without in anywise limiting the effect of the foregoing provision, the establishment or use of a "Buffer Zone", as that term is defined in TEX. REV. CIV. STAT. ANN. art. 5421u, §6.01 (1993) shall be permitted (but shall not be required) so long as the establishment and use of such Buffer Zone is necessary, incidental or appurtenant to the establishment of a Mitigation Bank;

2.) no use shall be made of the Easement Area by the District as the owner of the fee simple estate therein nor will the District take any action that shall otherwise substantially conflict with or impair the use herein permitted to be made of the Easement Area as such use may have been limited herein. Any transfer, assignment or conveyance, in whole or in part, of any interest in the Easement Area, or part thereof, including any conveyance of the fee simple estate therein, shall be subject to the Easement created hereby. Without in anywise limiting the effect of the foregoing provision, nothing herein shall be construed as prohibiting the District as the owner of the fee simple estate therein from making any use of the Easement Area or exercising any right thereto not otherwise inconsistent with the Easement, including, by way of description and not by way of limitation, the right, from time to time, and at any time, to make additional conservation easements or dedications for the purpose of conserving, maintaining or protecting wetlands located on the Easement Area which may have been preserved, enhanced, restored or created, whether directly or indirectly, through the agency of

a mitigation bank established on the Easement Area, so long as any such easement or dedication is made subject to the terms of any Memorandum of Agreement that may be applicable to the Easement Area at such time;

3.) to the extent that they do not conflict with the terms and provisions of any Memorandum of Agreement or the Interagency Guidelines, the District may from time to time, and at any time, promulgate and adopt such reasonable rules and regulations consistent with its rule making authority under law as may be necessary or that otherwise serve to promote or to implement the objects and purposes of this Easement, or which serve to promote the interests of the District as a reclamation and conservation district, including (by way of description and not by way of limitation) rules and regulations requiring the execution by those persons seeking access to the Easement Area of "right of entry agreements", or other similar written agreements, establishing reasonable restrictions as to manner and time of such access;

4.) this Conservation Easement, shall be subject to all state and federal laws, rules and regulations, and to the extent applicable, any and all municipal or local laws, rules, ordinances, or land use regulations adopted by any governmental authority having jurisdiction over the Easement Area;

5.) any use made of the Easement Area shall be accomplished in a manner that is consistent with good conservation and land management practices and no activity shall be permitted on the Easement Area that does not comply with or which does not conform to the terms and provisions of a Memorandum of Agreement. The use that shall be made of the Easement Area shall not include the introduction or implantation of any species of flora or fauna not native to the Easement Area that has, or may tend to have, the effect of disrupting the existing ecosystem, or that otherwise alters those wetland habitats that may have been preserved, enhanced, restored or created through the agency of a mitigation bank. All uses permitted to be made of the Easement Area under the terms of the Easement shall be done at the sole risk, cost and expense of the party making use of such Easement Area and shall be done in a manner as will not unreasonably interfere with access to the Easement Area;

6.) notwithstanding anything contained herein to the contrary, any entity designated as the Mitigation Bank Operator in a Memorandum of Agreement shall have such right as may be provided under law, including that provided under (TEX. REV. CIV. STAT. ANN. art. 5421u, § 6.02(10) (Vernon 1993) to contract for the use or operation of a Mitigation Bank, or any part thereof, by another party, so long as such party otherwise qualifies as a Mitigation Bank Operator under a Memorandum of Agreement or the approval or the authorization of such contract for the use or operation of a Mitigation Bank has been obtained from all necessary state and federal agencies or other governmental authorities;

7.) except as otherwise specifically provided in this instrument, or when otherwise necessary to establish a Mitigation Bank, no draining, filling, or clearing shall be permitted in the Easement Area at any time; there shall be no removal, destruction, cutting, trimming, mowing, alteration, or spraying with biocides of any vegetation in the Easement Area or any change in the natural habitat in the Easement Area; and no motor vehicles or construction of improvements shall be permitted on the Easement Area, except as shall be necessary, incident and/or appurtenant to the establishment of a Mitigation Bank or as shall be necessary in connection with the continuing operation, maintenance and preservation of a Mitigation Bank being established hereunder;

8.) notwithstanding any other provision of this instrument to the contrary, such pedestrian pathways and rest areas (including benches) may be constructed and maintained throughout the Easement Area as may be permitted under the terms of any Memorandum of Agreement, Interagency Guidelines, or any federal or state law, rule or regulation. The District, as owner of the land shall have no obligation to remedy any damage to the Easement Area, including the wetlands located in the Easement Area, when damage is caused in the future by forces beyond the landowner's control, such as fire, flood, storm, or the unauthorized act of a third party;

9.) the Corps of Engineers of the United States Army, the United States Fish and Wildlife Service, United States Environmental Protection Agency, National Marine Fisheries Service, the General Land Office of the State of Texas, the Texas Natural Resource

Conservation Commission and the State of Texas Department of Parks and Wildlife and any and all other state or federal agencies which may compose a Mitigation Bank Review Team named in any Interagency Guidelines, may inspect the Easement Area from time to time, may enter the premises at all reasonable times to conduct studies and monitor the use of the Easement Area, and together with the District, shall have the right to enforce the provisions of the Easement in law and in equity, against all persons who violate the terms of the instrument. No other person shall have a third-party right of enforcement of the terms of the Easement;

10.) the District shall have the right to use the subsurface of the Easement Area so long as such use does not substantially or materially interfere with the Easement and the use of the Easement Area by those other parties authorized to use the same under the terms of this instrument;

11.) except as herein limited, the grant of the Easement made herein shall include all such rights of ingress, egress and regress as shall be necessary to enjoy and to exercise such other rights to use the Easement Area as shall be conferred by such Easement. All persons entering upon the Easement Area under this grant shall confine themselves to the uses and purposes contemplated herein, and no trespassing or other uses shall be permitted by any user of the Easement, its employees, agents or contractors;

12.) this Easement is perpetual. Its provisions shall be covenants running with the land;

Notwithstanding any other provision of this instrument to the contrary, the itemized limitations Nos. "1" through "12", recited above shall prevail over any other provision of this instrument in the event of a conflict.

Whenever there is a reference in this instrument to a federal or state statute or regulation, the reference shall include all successor statutes and regulations. Whenever a regulatory agency is named in this instrument, the reference shall include any federal or state agency that succeeds to the authority of the named agency to enforce federal and/or state laws and regulations concerning wetlands.

Each and every provision contained in this instrument is, and shall be construed as, a separate and independent provision. If any provision of this instrument should be held to be invalid or unenforceable, the validity and enforceability of the remaining provisions of this instrument to another person or circumstance shall not be affected thereby.

Notwithstanding anything contained herein to the contrary, if at any time, and from time to time, the Easement Area is divided into two or more parcels by conveyance of ownership or by lease, all such parts shall enjoy the benefit of the Easement with respect to the Easement Area in the event of conflict.

Whenever herein the singular number is used, the same shall include the plural, and words of any gender shall include each other gender.

Notwithstanding anything contained herein to the contrary, it is recognized that because of events or circumstances not foreseen or anticipated by the District at the present time, it may be necessary for the District to amend or revise the Easement on occasion. Accordingly, the District may, from time to time, and at anytime, amend or otherwise revise the Easement and, pursuant to such right, may execute and record in the appropriate public records written instruments amending and revising the same. However, the right of the District to amend or revise the Easement shall not be exercised unless the revision or amendment is in furtherance of the purpose and object of the Easement and unless the amendment or revision is made subject to the terms and provisions of any applicable Memorandum of Agreement that may be in effect at the time of the amendment or revision.

Failure or delay to insist by the District, or any other party having a right of enforcement herein, upon strict performance of any one or more covenants, terms or conditions of this instrument or by law, shall not be deemed a waiver of any right to the District, or any other party having the right of enforcement herein, to insist on strict performance hereof, or a waiver of any of its rights or remedies. The consent to or approval of the District of any act shall not be deemed to waive or render unnecessary consent to or approval of any subsequent similar act.

IN TESTIMONY OF WHICH this instrument has been executed on behalf of the Harris County Flood Control District by County Judge Jon Lindsay, pursuant to an Order of Commissioners Court so authorizing, on this the _____ day of _____, A.D., 199____.

APPROVED AS TO FORM:

HARRIS COUNTY FLOOD CONTROL DISTRICT

By: 
JAMES C. JONES

By: _____
JON LINDSAY, County Judge
Harris County, Texas

STATE OF TEXAS

COUNTY OF HARRIS

This instrument was acknowledged before me on _____
by Jon Lindsay, County Judge of Harris County and the presiding officer of the Commissioners Court of Harris County, Texas on behalf of the Commissioners Court of Harris County, Texas, as the governing body of the Harris County Flood Control District.

NOTARY PUBLIC in and for
the STATE OF TEXAS

D. Preliminary Engineering

In order to properly design the Greens Bayou Regional Detention and Wetland Mitigation Bank facility, a thorough investigation of the sites' existing conditions is necessary. R. G. Miller & Associates has been hired by the Harris County Flood Control District to coordinate with all appropriate agencies and provide information concerning all issues which might effect the future design of the project. These issues include existing pipelines, HL&P easements, the inactive Municipal Utility District's onsite, archeological sites, drilling rights, the cattle lease, and site access.

A complete understanding of the site's design constraints is critical to provide a successful project. The investigations are still being performed, but a summary of the findings to date has been attached for informational purposes.

**GREENS/GARNERS BAYOU
WETLAND MITIGATION BANK
AND REGIONAL DETENTION FACILITY**

I. INTRODUCTION

Purpose and Scope

The purpose of this report is to present results of field surveys, research, utility and pipeline investigations, as well as various engineering and environmental issues that will affect any future development of the 1455.45 acre tract of land adjacent to Sam Houston Tollway (Beltway 8) in Northeast Houston. Topics concerning both existing conditions and future recommendations will be discussed thoroughly in this report.

The Scope of this report includes the following objectives:

- Existing Conditions:** Outline the findings of the various investigations performed during the preliminary phase.
- Easements Information:** Outline the recommendations relative to easement access along with a lists of contacts, procedures and requirements. Provide additional information on type of facilities within easements and probing and staking process.
- Base Map:** Prepare a base map suitable for use as an overall layout sheet. Provide preliminary information concerning easements with ownership, Municipal Utility Districts, archeological sites, limits of existing wetlands, and various other existing information.

II. DESCRIPTION OF EXISTING CONDITIONS

The information contained herein has been gathered through review of maps and drawings and discussions with representatives from various entities referred to in this report.

Location and Description of Tract

The subject tract of land ("the subject tract") is owned by the Harris County Flood Control District ("HCFCD"). It is comprised of approximately 1455.45 acres situated in the Victor Blanco Five League Grant, N. Brady Survey and Jacob Karcher Survey in eastern Harris County, Texas. The tract is bounded by Sam Houston Tollway (or Beltway 8) ("the Tollway") to the north and by Union Pacific Railroad to the east and south. On the northwest, the tract is bounded by Garners Bayou. On the southwest, the tract is bounded by Greens Bayou. Accessibility to the subject tract is possible by the Tollway and Lockwood Road, which runs north and south to the property (see Exhibits A).

The site primarily consists of moderate to heavily wooded areas, with some areas considered to be existing wetlands.

Roadway and Railway

As stated earlier, the subject property is bounded by the Tollway (Beltway 8) and Union Pacific Railroad with Lockwood Road intersecting the property.

The existing paving conditions of Sam Houston Tollway are as follows:

- right-of-way with variable width.
- only the left and right frontage roads exists with the main lanes to be constructed in the future.
- bridge exists to pass over existing Union Pacific Railroad.
- work road that U-turns under the bridge exists at the intersection of the Sam Houston Tollway and the Union Pacific Railroad.

The existing paving conditions of Lockwood Drive are as follows:

- 80 feet wide right-of-way.
- pavement section consists of asphalt and open ditch section.

The existing conditions of the Union Pacific Railroad are as follows:

- 100 feet wide right-of-way from southwest, along the subject project's property line until the intersection of Lockwood Drive.
- right-of-way becomes 150 feet to the northeast of Lockwood Drive.

Storm Drainage System

The subject tract is entirely within a drainage area that drains into Greens-Garners Bayou. The Tollroad contains a series of inlet systems and drainage sub-areas. A trunkline along the Tollroad outfalls to the west into Garners Bayou and to the east into a series of HCFCFCD tributaries (P127-00-00 and P127-01-00) that eventually outfalls to Greens Bayou. Therefore, the existing storm sewer system of the Tollroad is not a water source to feed wetlands creation and enhancement unless modifications are done to the existing storm sewer system.

Pipelines

United Texas Transmission Co., 10' Right-of-Way Easement dated October 20, 1981 from Armco, Inc. to United Texas Transmission Company, recorded under Harris County Clerk's File No. H-226875 and Film Code No. 200-90-2096 of the Official Public Records of Real Property of Harris County, Texas.

Humble Oil and Refining Co., 30' Pipeline Easement dated January 17, 1964 from N. C. Ginther, et al., to Humble Oil & Refining Company, recorded in Volume 5388, Page 260 of the Deed Records of Harris County, Texas as defined and located by that certain instrument dated March 20, 1964, executed by Humble Oil & Refining Company and recorded in Volume 5457, Page 96 of the Deed Records of Harris County, Texas.

Texas Eastern Transmission Corp., 30' Pipeline Easement dated April 12, 1956 from Alexander Deussen, et al., to Texas Eastern Transmission Corporation, recorded in Volume 3166, Page 53 of the Deed Records of Harris County, Texas; Pipeline Right-of-Way from Texas National Bank of Commerce of Houston, Administrator to Texas Eastern Transmission Corporation, dated October 23, 1964, recorded in Volume 5749, Page 161 of the Deed Records of Harris County, Texas; Agreement modifying and locating the easements granted above dated August 21, 1967, between Lucile D. McRae, et al, and Texas Eastern Transmission Corporation recorded in Volume 8317, Page 159 of the Deed Records of Harris County, Texas.

Magnolia Petroleum Co. (Mobil), Over and Through Easement dated May 28, 1941 from East Texas Oil Company to Magnolia Petroleum Company, recorded in Volume 1215, Page 260 of the Deed Records of Harris County, Texas.

Sinclair Pipeline Co. (Arco), 50' Pipeline Easement dated March 28, 1957 from Alexander Deussen to Sinclair Pipe Line Company, recorded in Volume 3336, Page 593 of the Deed Records of Harris County, Texas, as corrected by Pipeline Easement dated August 22, 1957 from Alexander Deussen to Sinclair Pipe Line Company recorded in Volume 3389, Page 298 of the Deed Records of Harris County, Texas; Pipeline Easement dated September 9, 1964 from Texas National Bank of Commerce of Houston, Administrator to Sinclair Pipe Line Company, recorded in Volume 5678, Page 22 of the Deed Records of Harris County, Texas.

Explorer Pipeline Co., 20' Easement dated October 9, 1970 from Armco Steel Corporation to Explorer Pipeline Company, recorded under Harris County Clerk's file No. D-208332 and in Volume 8199, Page 82 of the Deed Records of Harris County, Texas.

Houston Pipeline Co., 5' Easement recorded under Harris County Clerk's File No. L-316316 of the Official Public Records of Real Property of Harris County, Texas.

Houston Pipeline Co., 5' Easement recorded under Harris County Clerk's File No. L-316317 of the Official Public Records of Real Property of Harris County, Texas.

Houston Pipeline Co., 30' Easement recorded under Harris County Clerk's File No. L-316317 of the Official Public Records of Real Property of Harris County, Texas.

Houston, Lighting & Power Co.

Houston Lighting & Power Co., Centerline of 3' x 40' guy wire Easement recorded under Harris County Clerk's File No. L-283219 of the Official Public Records of Real Property of Harris County, Texas.

Houston Lighting & Power Co., Right-of-Way Agreement dated March 25, 1964 from N. C. Ginther, et al., to Houston Lighting & Power Company, recorded in Volume 5782, Page 353 of the Deed Records of Harris County, Texas; Right-of-Way Agreement dated December 14, 1964 from Texas National Bank of Commerce of Houston, Administrator, to Houston Lighting & Power Company, recorded in Volume 5782, Page 365 of the Deed Records of Harris County, Texas, (150' easement).

Houston Lighting & Power Co., Right-of-Way Deed dated January 31, 1927 from East Texas Oil Company to Houston Lighting & Power Company recorded in Volume 655, Page 481 of the Deed Records of Harris County, Texas; Right-of-Way Deed dated January 31, 1927 from East Texas Oil Company to Houston Lighting & Power Company recorded in Volume 655, Page 512 of the Deed Records of Harris County, Texas, 80' easement (unrecorded) (includes 22' HL&P Co. easement).

Houston Lighting & Power Co., 100' Easement dated August 27, 1980 from Armco, Inc. to Houston Lighting & Power Company, recorded under Harris County Clerk's File No. G-697764 and Film Code No. 167-98-1129 of the Official Public Records of Real Property of Harris County, Texas.

Houston Lighting & Power Co., 187' Easement dated May 23, 1947 from East Texas Oil Company to Houston Lighting & Power Company, recorded in Volume 1608, Page 430 of the Deed Records of Harris County, Texas (includes 22' HL&P Co. Easement).

Houston Lighting & Power Co., Right-of-Way Agreement dated July 21, 1971 from Armco Steel Corporation to Houston Lighting & Power Company, recorded under Harris County Clerk's File No. D-430090 and Film Code No. 134-37-2254, et seq., of the Official Public Records of Real Property of Harris County, Texas (45' x 25' Easement).

Houston Lighting & Power Co., Easement Agreement dated May 27, 1975 from Armco Steel Corporation to Houston Lighting & Power Company, recorded under Harris County Clerk's File No. E-481518 and Film Code No. 123-12-0442 of the Official Public Records of Real Property of Harris County, Texas, centerline of pipeline easement (width undefined).

Miscellaneous Utilities

Southwestern Bell Telephone Co., 10' Recorded under Harris County Clerk's File No. J-754173 of the Official Public Records of Real Property of Harris County, Texas.

Entex Gas Company, 28' easement shown on Entex maps 0192776 (5-22-91) and F1950782 (3-29-93).

III. CONTACTS, REQUIREMENTS AND LIMITATIONS OF EXISTING EASEMENTS

A. United Texas Transmission Company Easement - currently known as Mid-Con (UTT) Texas Pipeline Company. Contact Mr. Paul Folse at (713) 963-3176 to update the project's progress and to inform them of any proposed improvements.

B. Humble Oil and Refining Co. Easement - pipeline is owned by:

Texas Gas Corporation
1301 McKinney, Suite 700
Houston, Texas 77010
Tel. No. (713) 951-3450

C. Texas Eastern Transmission Corp. Easement - the pipeline is a liquid petroleum pipeline. Contact:

Mr. Rodney Burke
Texas Eastern Products Pipeline Company
P. O. Box 2521
Houston, Texas 77252-2521
Tel No. (713) 759-3636

File Reference: 350-10-332
R/W 32 - Harris County, Texas

D. Magnolia Petroleum Co. (Mobil) Over and Through Easement - Mobil Pipe Line Company owns and operates two (2) 8-3/8" O.D. high pressure pipelines. One line is in crude oil service, the other in refined products. Contact:

Mr. Thomas E. Lucas
Right-of-Way Representative
Mobil Oil Corporation
P. O. Box 670129
Houston, Texas 77267-0129
Tel. No. (713) 591-3715

Contact construction office for depths and staking when ready at (713) 591-3294.

- E. Sinclair Pipeline Co. Easement - ARCO Pipe Line Company owns and operates a 20" welded steel, crude oil pipeline. For a more definitive location and depth of this pipeline, please contact Mr. Dan Smith at 1-800-336-7032 (Access Code 306575).
- F. Explorer Pipeline Co. Easement - A 28" pipeline is buried to a minimum depth of 36 inches and transports refined petroleum products such as gasoline, jet fuel and No. 2 fuel oil. This 28" pipeline is the only pipeline that Explorer owns and operates on subject tract and Explorer has no other easements or pipelines on subject tract that have been abandoned.

Contact for accurate line locating, staking and depth probing is:

Mr. DeWayne Powell
Houston Area Supervisor
15003 Moore Road
Route 25
Houston, Texas 77049
Tel. No. (713) 452-4361

Forward a set of detailed plans for W. M. Bank to Craig Hilgendorf. Upon receipt of plans, Explorer's specific requirements will be determined.

- G. Houston Pipeline Co. Easement - No response to date has arrived from Houston Pipeline Company.
- H. Houston Lighting & Power Easement - Start of construction is not allowed until HL&P underground facilities have been located and staked. To stake underground facilities, call the UCC at (713) 223-4567 or 1-800-669-8344 at least 48 hours prior to starting excavation.

I. Southwestern Bell Telephone Co. Easement - The following are procedures necessary when there is a proposed project crossing any Southwestern Bell Telephone Co. easements:

- Forward preliminary set of plans to Southwestern Bell Telephone Company coordinator. Coordinator will provide SWBT conduit plans and profile drawings.
- Call 1-800-669-8344 at least 48 hours in advance of sending field crew for the base line survey. (Be specific on the project location.)
- SWBT will mark its existing facilities with orange paint and flags.
- Your field party can survey the buried cable location using SWBT's orange marks on the ground.
- Plot the exact location of SWBT facility on plan profile sheets.
- Send final prints to appropriate SWBT Company coordinator to identify and resolve possible conflicts with your proposed facilities.
- Project accomplished with minimum of delays.

J. Entex - 6" I.P. Stl. crosses under N. Belt and enters property approximately 28' east of east side of HL & P Co. 100' R.O.W. It runs south of north property line approximately 62' then turns west changing to a 4" HPL for approximately 80' until it ends, (shown on Entex maps 0192776 (5-22-91) and F1950782 (3-29-93)).

The following are procedures necessary when there is a proposed project crossing any Entex easements:

1. After you have added our facilities to your preliminary plans and have completed your design work, send us two (2) sets of those plans. Please show main lines only without service lines, fittings, or valves. Projects requiring new right-of-way should also submit two (2) sets of R.O.W. plans.

Address to:

Entex
ATTN: Non-Revenue
Engineering Department
P.O. Box 2628s
Houston, TX 77252-2628

Please include the following note on your plans:

CAUTION: UNDERGROUND GAS FACILITIES

Location of Entex main lines (to include Unit Gas Transmission, and/or Industrial Gas Supply Corporation where applicable) are shown in an approximate location only. Services lines are usually not shown. The contractor shall contact the Utility Coordinating Committee at 223-4567 or 1-800-245-4545 a minimum of 48 hours prior to construction to have main and service lines field located. The contractor shall determine the exact location before commencing work and agree to be fully responsible for any damages caused by his failure to exactly locate and preserve these underground facilities.

2. One set will be sent to our drafting department for checking to ensure that our gas lines are properly shown. Any facilities that were inadvertently left out or improperly shown will be marked in red on the plans. Any lines marked in green will signify facilities shown correctly.
3. The plans will be sent to our field engineering department to obtain elevations of our facilities where necessary. Design bench mark, temporary bench mark, and horizontal control information is required to complete this phase. Please provide control information on a computer disk in ASC II format (text file) if available.
4. We will then transfer all information on the second set of plans and call you to come pick them up. We retain the first set of plans for our information.
5. Where conflicts are anticipated between the proposed project and our facilities, it is beneficial to both parties involved if the conflicts can be resolved during the preliminary planning stage.
6. After all design work is completed, you have made any necessary changes, and added our lines to the profile (where elevations were taken) you should make an appointment to have the plans signed.

IV. MUNICIPAL UTILITY DISTRICT

Since the subject tract did not benefited previously from municipal water and sewer service, three (3) existing Municipal Utility Districts (MUDS) were formed to serve the subject tract. They are as follows:

Beltway 8 MUD No. 1

Beltway 8 MUD No. 2

Beltway 8 MUD No. 3.

Within each district, there are five (5) Director's Lots, which would total to fifteen (15) lots in all. Included are copies of the first page of the Special Warranty Deeds showing the owners of the director's lots in the subject tract (see Appendix B).

According to a memorandum dated June 25, 1993 (see Appendix B), HCFCD may request that the existing MUDS within the subject tract be dissolved if it is determined that their existence causes some interference with the planned uses of the property. Also indicated in the said memorandum, these MUDS are "financially dormant." In Appendix B please find copies of Texas Natural Resource Conservation Commission (TNRCC) rules and procedures for the dissolution of districts. If these guidelines are followed dissolution of the MUD can occur over a period of approximately two months. Also, the fee for filing an application for the dissolution of a water district is one hundred dollars (\$100) per district plus the cost of each required notice.

According to a memorandum dated July 19, 1993 (see Appendix B), at least one lot owner had conveyed his interest to Collecting Bank in 1992.

Directors' Lots - The following is a list of owners of the directors' lots within the subject tract taken from the copies of the Special Warranty Deeds in Appendix B:

1. Dale McLeod
16422 Herlen Circle
Spring, Texas 77379
2. Larry Fabian
4028 Branard
Houston, Texas 77027
3. Russell Torian, Jr.
11419 Sunny Creek Drive
Houston, Texas 77066
4. Suzanne B. Martens
13714 Vickston Lane
Houston, Texas 77014
5. Kathleen M. Phillips
5430 Oriole
Houston, Texas 77017
6. Herman Frank Haude
2727 Spring Stuebner
Spring, Texas 77389
7. William M. Clifton, III
16150 Golden Sands Drive
Houston, Texas 77095
8. Vivian Charlene Summerlin
4939 Saxon
Houston, Texas 77092
9. Mark W. Adam
15815 Whipple Tree
Houston, Texas 77070
10. Douglas Gwin
13630 Taylor Crest
Houston, Texas 77079
11. Daniel Earl Kolkhorst
14007 Baltrusol
Houston, Texas 77095
12. Mervyn Barrow
11822 Inga Lane
Houston, Texas 77064
13. Stephen L. Woodring
10215 Autumn Harvest Drive
Houston, Texas 77064
14. Katherine Shone
6444 Ella Lee Lane #4
Houston, Texas 77027

Recommendations

Letters need to be sent to the Director's Lot owner for the purpose of acquiring contact. The owners may not realize that they still have ownership of the lots.

VI. SUMMARY

The concept of wetlands mitigation banking is increasingly being acknowledged as the best mechanism available to address the necessary impacts of construction in jurisdictional wetlands. The cost effectiveness, coupled with the accepted fact that large scale wetlands creation projects achieve a greater habitat value, make the wetlands mitigation banking alternative the best choice for all concerned.

With the approaching signing of the Memorandum of Agreement, a new milestone will have been reached. Design and development of the bank will become the focus as the site is transformed into wetlands that will provide much more than just mitigation opportunities. Successful creation of the wetlands will also create quality wildlife habitat, open space and recreational opportunities, a stormwater cleansing system, flood protection as well as a prime example for future wetlands mitigation banks.

APPENDIX A

TASK STATUS

The following notes the status of each task funded by the TWDB's first \$100,000 provided by the approved Water Research Grant.

<u>SERVICE PROVIDED WITH ORIGINAL ESTIMATED BUDGET</u>	<u>PERCENT COMPLETE</u>
I. HYDRAULICS AND HYDROLOGY FOR THE PRELIMINARY ENVIRONMENTAL AND ENGINEERING DESIGN (\$18,000)	
A. Data Collection and Project Coordination	80%
B. Water Budget	70%
C. HEC-1 and HEC-2 Computer Model Update	100%
D. Alternative Detention Design	80%
E. Letter Report	80%
II. DATA GATHERING AND ASSESSMENTS FOR PRELIMINARY ENVIRONMENTAL ASSESSMENTS AND CONCEPTUAL DESIGN (\$20,000)	
A. Soil Data and Report	100%
B. Biological and Habitat Assessment and Report	100%
C. Water Budget and Report	70%
III. CONCEPTUAL DESIGN PHASE SERVICES FOR PRELIMINARY ENVIRONMENTAL ASSESSMENT AND CONCEPTUAL DESIGN (\$35,000 OF TOTAL \$65,000 BUDGET WAS AUTHORIZED FOR THIS PHASE*)	
A. Establish Baseline	90%
B. Methodology and Conceptual Plans	60%
C. Site Master Plans	10%
D. MSC, MOA, Land Use Agreements	70%

*The remainder of these services are to be provided in the second phase of these projects if the additional \$100,000 grant is approved.

APPENDIX A

TASK STATUS (CONT'D)

IV.	PRELIMINARY ENGINEERING DESIGN (\$27,000)	
A.	Project Coordination	50%
B.	Alternative Water Sources	70%
C.	Construction Phasing and Cost Estimates	20%

REV. 2/27/95

REV. 2/27/95
 SCHEDULE OF SERVICES
 ANTICIPATED TO BE FUNDED BY THE
 TEXAS WATER DEVELOPMENT BOARD

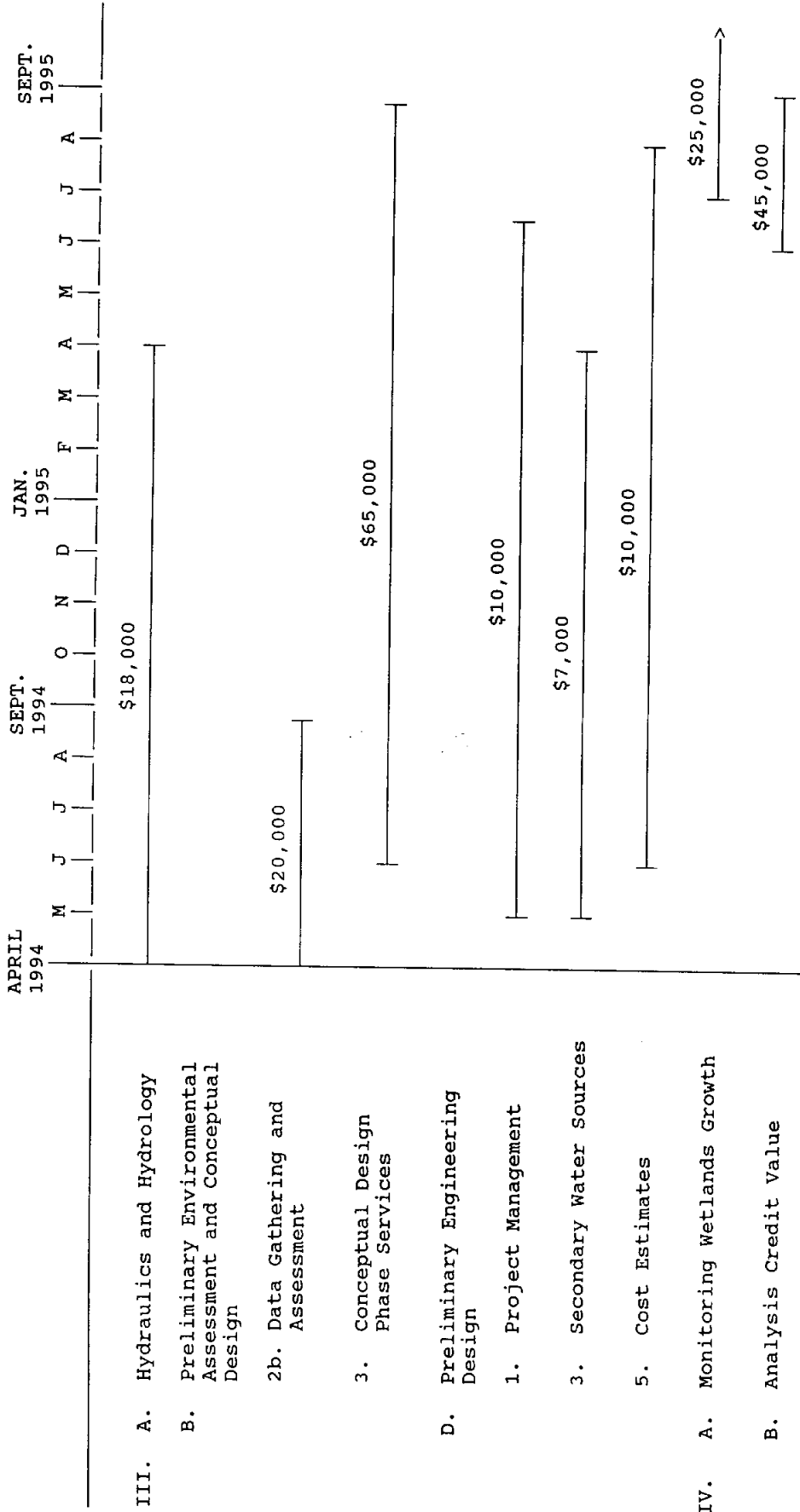

PLEASE NOTE THIS SCHEDULE IS TENTATIVE AND IS BEING EXPEDITED WHEN POSSIBLE.

APPENDIX C

**CORRESPONDENCE BETWEEN
THE HARRIS COUNTY FLOOD CONTROL DISTRICT
AND THE
TEXAS WATER DEVELOPMENT BOARD**

CRO



TEXAS WATER DEVELOPMENT BOARD

Charles W. Jenness, *Chairman*
William B. Madden, *Member*
Diane E. Umstead, *Member*

Craig D. Pedersen,
Executive Administrator

Wesley E. Pittman, *Vice Chairman*
Noe Fernandez, *Member*
Elaine M. Barrón, M.D., *Member*

March 18, 1994

Mr. Arthur L. Storey, Jr.
Executive Director
Harris County Flood Control District
9900 Northwest Freeway
Houston, Texas 77092

Dear Mr. Storey:

Re: Texas Water Development Board's Consideration of an Unsolicited Water Research Grant Application

I am pleased to inform you that the Texas Water Development Board (Board), at its March 17, 1994 meeting, approved negotiation and execution of a water research grant contract with the Harris County Flood Control District in an amount not to exceed \$100,000. This grant approval is contingent upon the following condition:

- 1) The District will obtain review and approval of the project scope of work and budget from the District's Mitigation Bank Review Team.

The Board's staff looks forward to working with you on this project. Mr. Gordon Thorn, the Board's designated Contract Manager for this project, will be in contact with you concerning the execution of a contract to cover the study. Please contact Mr. Thorn at (512) 463-7979 if you have any questions.

Sincerely,



Craig D. Pedersen
Executive Administrator

- cc: The Honorable Rodney Ellis
The Honorable Don Henderson
The Honorable Carl Parker
The Honorable Jerry Patterson
The Honorable Dan Shelley
The Honorable John Whitmire

866460
L

Our Mission

Exercise leadership in the conservation and responsible development of water resources for the benefit of the citizens, economy, and environment of Texas.



HARRIS COUNTY FLOOD CONTROL DISTRICT

Arthur L. Storey, Jr., P. E.
Executive Director

March 9, 1994

Ms. Carolyn Brittin
Section Chief
Regional Planning & Projects
Texas Water Development Board
Room 448C
1700 North Congress Avenue
Austin, Texas 78701

Re: Water Research Application

Dear Ms. Brittin:

Attached is a Water Research Application for a grant request in the amount of \$200,000, for assistance in funding a wetlands mitigation bank in Harris County.

Thank you for your assistance. If you have any questions, please call me at 713/684-4000.

Sincerely,

A handwritten signature in black ink that reads "John M. Koros" with a stylized flourish at the end.

John M. Koros
Manager
Environmental Services

JMK:AF:af

cc: E. C. Kobs
Colleen O'Brien
Bill Lenhart

TEXAS WATER DEVELOPMENT BOARD
WATER RESEARCH
APPLICATION

Applicant's Legal Name and Address:

Harris County Flood Control District
9900 Northwest Freeway, Suite 212
Houston, Texas 77092

Applicant's Executive Director:

Arthur L. Storey, Jr., P.E.

1. Is this application in response to a published Request for Proposals (RFP)?

No.

2. What research topics will the project include?

- A. Wetlands Creation
- B. Credit Assessment Methodology
- C. Water Quality Enhancement and Assessment
- D. Alternative Flood Protection Through Regional Detention and Flood Attenuation by Created Wetlands.

3. Brief description of research proposal.

Through the development of the first public wetlands mitigation bank in Texas, this project will:

- A. Demonstrate the viability of the concept of mitigation banking as a more cost effective and meaningful method of mitigating wetland impacts effectively fulfilling the spirit of the law in achieving no net loss of the nation's wetland resources.
- B. Devise and achieve approval of a more accurate methodology for calculating the value of impacted and created wetlands for the purpose of mitigation banking.
- C. Develop baseline of water quality entering the created wetlands and quantify the enhanced water quality of the affluent passing through them.
- D. Access the hydrological interaction of an excavated detention basin and contiguous wetland system and the resultant flood attenuation.

4. Site(s) of proposed project:

Specific site of the mitigation bank is contiguous and north of the confluence of Greens and Garners Bayous. The project is designed to mitigate impacts to a variety of wetland type throughout Harris County, a total of 1740 square miles.

5. Attachments:

- A. See attached resumes of principals, potential subcontractors, and principal investigators (including names, addresses and phone numbers) and a summary of pertinent experience of proposing organization.
- B. See Attached Schedule of Services
- C. See Attached Scope of Services and Task Budget

6. Describe the plans for:

A. Implementing research results:

Once the research is complete, the results will become a part of the memorandum of agreement with the EPA et al for implementation of this precedent setting public mitigation bank in Harris County, Texas. This will result in an adoption of the improved methodology for wetlands creation, habitat assessment for all subsequent mitigation banks in the region, and better utilization of created wetlands for water quality enhancement. The results will be published in all relevant professional journals as being adopted by the interagency team responsible for approval of all wetland mitigation banks in the Galveston District of the Corps of Engineers.

In addition, the results of the research will be implemented by the significant construction expenditures made by HCFCD to implement the research influenced construction design.

B. Identification and involvement of potential users:

Potential users include all public and private entities in Texas whose activities will have potential impacts on jurisdictional wetlands. These include the TWDB with the Trans Texas Pipeline, the TxDOT, Metro, Harris County, the City of Houston and other political subdivisions.

7. Total Project Cost: \$4,708,801

The amounts and source of the local matching funds and services, and the total amount requested from the research and planning fund:

Local Cash	\$ <u>4,708,801</u>
Local In-kind Services	\$ <u>N/A</u>
Total Requested from TWDB	\$ <u>200,000</u>

8. Why is this research needed?

Through this research, significantly improved methodologies will result for (a) the creation of wetlands in specific habitat types, (b) for assessing the value of both impacted and created wetlands involved in the 404 mitigation process whose regulation has huge financial impact on the ability of both public and private entities to accomplish projects for the public good, (c) interactive design for combinative regional detention and wetlands creation, and (d) utilization of wetlands for enhancing runoff water quality.

9. Does the proposed research project duplicate previously completed or on-going research?

No.

10. If you are a corporation organized under the Texas Business Corporation Act, Article 1.01 et seq., attach proof that the corporation is not delinquent in a tax owed the State under the Tax Code, Chapter 171.

Not applicable.

11. Are you or any of your immediately family employed by the Texas Water Development Board?

No.

12. What products (reports, plans, or other products) will the Board receive, as a result of this research project?

Final project report, credit for funding research in all professional journals publishing results, replicable methodologies for establishing, assessing, and use for mitigation banking of created, restored and enhanced wetlands.

13. What are suggested monitoring procedures?

There will be extensive monitoring and public review of this project at frequent intervals.

Concerning a Steering Committee to oversee the grant contract, this requirement is fulfilled by the authority of the Mitigation Banking Review Team and Harris County Commissioners Court, the governing body of HCFCD.

Concerning a Technical Advisory Committee to review the project during implementation, this requirement is fulfilled, once again, through the MBRT and through the Special Area Management Plan Committee for wetlands in Harris County. This ad hoc committee is made up of members of the private and public sectors and has been an active committee concerned with this mitigation bank since 1992. (See attached letter to Commissioners Court dated July 30, 1992.)

Concerning public comment and review, this requirement is fulfilled in at least two ways:

The Harris County Flood Control Task Force is an advisory committee, established by Commissioners Court, made up of a broad spectrum of community groups, specifically including those focused on environmental matters, that meets periodically to review and comment on HCFCD projects and public interests. This committee was appointed to serve as another link between Commissioners Court and the public.

HCFCD holds regular, open public meetings for the purpose of updating projects on a watershed by watershed basis that offers frequent opportunities for comment and review by the general public. Since their inception, these meetings have been well attended by between 50 and 100 persons each month.

In conclusion, the process for developing a wetlands mitigation bank approved by the Corps of Engineers incorporates a built-in stringent review by state and federal agencies throughout the endeavor. As a public agency, HCFCD adheres to a policy of openness and inclusiveness.

In addition, monthly and quarterly progress reports will be made to the TWDB.

SCOPE OF SERVICES

The Flood Control District has identified the following services which are believed to be necessary to create and maintain the 1450-acre Garner's Bayou Wetland Mitigation Bank and Detention Facility proposed to be located at the southeast quadrant of the Garners Bayou and Greens Bayou confluence.

Please note that all costs shown within parentheses have already been expended by the Harris County Flood Control District (HCFCFCD), and are not eligible for grant consideration. These costs are being provided for informational purposes only.

<u>Service</u>	<u>Anticipated Funder</u>	
	<u>TWDB</u>	<u>HCFCFCD</u>
I. <u>Land Acquisition:</u>		
A. Tarquin Tract (224 Ac.)		(\$497,050)
B. FDIC Tract (1232 Ac.)		(\$2,783,292)
II. <u>Preliminary Site Investigations:</u>		
A. Cultural Resource Investigation		(\$30,331)
1. Secure a Texas Antiquities Permit from the Texas Antiquities Committee for the detention site tract survey.		
2. Determine, by reference to the State of Texas archeological site files at the Texas Archeological Research Laboratory at the University of Texas at Austin, if there are any previously recorded archeological sites within the project area.		
3. Conduct brief historical and geological background data studies of the proposed project region.		
4. Locate through field survey any previously unrecorded archeological features or sites in the project area.		

Service

Anticipated Funder

TWDB

HCFC

5. Prepare a report of investigations for the site for review by the TAC and HCFC;

B. Phase I Environmental Assessment

(\$24,060)

1. Review site maps and data consisting of an in-office review of a Land Title Survey map prepared by G. P. Surveyors, Inc. of Houston, Texas; a USGS 7.5 minute Topographic Quadrangle map; and a Regional Oil and Gas Survey map published by Tobin Research, Inc. of San Antonio, Texas and an SCS 1984 map of Principal Active Faults in the Houston area.
2. Review regulatory agency site listings to determine the proximity of documented regulatory sites to the tract being investigated.
3. Evaluate the impact of the regulatory agency site listings which may store, transport, generate, or dispose waste material within a one (1) mile radius of the site.
4. Review the regional survey data from the Texas Railroad Commission to determine if current or past oil and gas exploration or production activities had taken place on the subject property and evaluated the potential impact.
5. Review of historical aerial photography is to be made to investigate surface anomalies indicative of possible fill areas, oil and gas exploration activities and industrial development. Photographic coverage is to be obtained from local aerial survey firms.
6. Review of a fifty (50) year chain of Title is to be conducted to investigate the previous ownership of the subject property. This title search was prepared by AmeriTitle Abstract and Research, Inc. of

Service

Anticipated Funder

TWDB

HCFCF

Houston, Texas to determine if any previous title holders of the property were determined to be engaged in a business or activity which would possibly contribute to contamination of the site.

7. Conduct site reconnaissance with multiple site visits and surveys including comprehensive walking observations and a general overview of adjacent tracts.
8. Prepare a report of the investigation results for the site for review by HCFCF and all appropriate agencies.

C. Wetlands Analysis and Delineation

(\$14,035)

1. Review geologic and soil conditions for the site including review of the Soil Conservation Survey soil maps.
2. Review the FEMA flood plain maps.
3. Interpretation of historical and current aerial photography.
4. Perform site reconnaissance to test and evaluate hydric soil conditions.
5. Perform site reconnaissance to identify vegetation indicators.
6. Perform site reconnaissance to identify and evaluate topographical and hydrological characteristics.
7. Prepare a report of the investigation results for the site for review by HCFCF and the Corps of Engineers.

D. Threatened or Endangered Species Investigation

(\$2,005)

1. Conduct a survey of the listed federally protected and endangered species to determine if any of the species may inhabit the subject tract.

Service	Anticipated Funder	
	TWDB	HCFCF

2. Prepare a report of the investigation results for the site for review by HCFCF and any other appropriate agency.

III. Preliminary Environmental and Engineering Design

A. Hydraulics and Hydrology \$18,000 (\$57,640)

1. Collect and review available data concerning the site including property boundary maps, proposed layouts and grading plans, existing HEC-1 and HEC-2 models of the Greens Bayou Watershed, previous engineering studies, aerial photographs, and topographic maps. Meet with HCFCF as necessary to discuss the results of the data collection effort and to plan the completion of the analysis.

2. Meet with environmental consultant and with HCFCF representatives as needed to discuss the water supply requirements of the wetlands banking area. Supply preliminary information required to plan wetlands design and define the concept of the wetlands area.

3. Perform appropriate hydrologic analyses to determine the available sources of water supply for these wetlands areas and incorporate this information into the HEC-1 and HEC-2 models.

4. Update the Greens Bayou HEC-1 and HEC-2 computer models to reflect current conditions and estimate peak flow rates and water surface elevations. Review various detention alternatives to determine the maximum benefit design for flood protection.

5. Prepare a letter report summarizing the recommended methods of water supply for the wetlands area.

prelim. water budget

50%

100%

35%

50%

<u>Service</u>	<u>Anticipated Funder</u>	
	<u>TWDB</u>	<u>HCFCF</u>
B. Preliminary Environmental Assessment and Conceptual Design		
1. Preliminary Design and Data Gathering		(\$11,588)
Attend preliminary design meetings with HCFCF and MBRT to determine appropriate project assessment methodology and preliminary phase services.		
2. Preliminary Phase Services		
a. Project Management		(\$10,000)
1) Attend meetings with HCFCF, Corps of Engineers, Mitigation Banking Review Team (MBRT), other relevant agencies and other consultants, and prepare required presentations material.		
2) Coordinate with surveyor to correlate and verify topographic data and pipeline survey data with existing wetlands and flag wetland boundary adjacent to detention basin.		
3) Prepare terrain and contour maps and models using survey and aerial data.		
b. Data Gathering and Assessments	\$20,000	(\$55,000)
1) Provide comprehensive soil taxonomy, soil map and permeabilities for project area, test borings and monitoring of groundwater depths, and compile a detailed soil analysis report.		

Service

Anticipated Funder

TWDB

HCFC

2) Determine and recommend methodology for wetland creation and/or enhancement including minimum success criteria, provide onsite biological and habitat assessment, and prepare assessment report including maps and recommendations.

3) Review and analyze hydrology characteristics for water budget provided by other consultants and apply to wetland design, determine secondary water source for enhancement, and prepare a wetland hydrology and water budget report.

3. Conceptual Design Phase Services

\$65,000

a. Establish baseline functions and values for wetland mitigation bank. Compile data and evaluate wetland characteristics (soil, topography, biological and water budget) to establish baseline functions and values.

b. Establish methodology for wetland creation/enhancement using minimum success criteria, categorize creation/enhancement areas for maximum banking credits, and prepare conceptual plan for wetland creation/enhancement to be reviewed and approved by the Flood Control District.

c. Prepare a Site Master Plan which includes the conceptual plan for wetland creation/enhancement and preliminary layouts of the seven subdivisions of the proposed bank which are to be reviewed and approved by the Flood Control District.

Service

Anticipated Funder

TWDB

HCFCF

- d. Determine minimum success criteria for wetland creation/enhancement and prepare necessary documents to obtain a Memorandum of Agreement between the HCFCF and the Corps of Engineers. This is to include the required land use agreements.

C. Surveying Support

- 1. Flag and delineate key existing wetland boundaries. \$6,000

- 2. Perform aerial photography of approximately 1600 acres with 22 control panel points at critical locations. Planimetric features are to be visible on the photography and sufficient elevation information is to be captured to provide one (1) foot contours at a scale of 1"=500'. \$39,300

- 3. Prepare metes and bounds descriptions of the seven subdivisions of the site for exhibits to the required Land Use Agreement between HCFCF and the Corps of Engineers, as a condition of the Memorandum of Agreement for the creation of the Garners Bayou Wetlands Mitigation Bank. \$10,600

- 4. Locate and flag the required test plots within each wetlands subdivision. Assume 20 plots will be required. These test plots are to be used to monitor wetlands creation/enhancement to establish and increase credits in the wetlands mitigation bank. \$40,000

D. Preliminary Engineering Design

\$87,500

- 1. Provide project coordination and attend meetings with HCFCF, COE, MBRT, and other relevant agencies to discuss the requirements of the wetlands banking design and the associated detention facilities. \$10,000

- 2. Develop conceptual grading plans, for each wetlands subdivision within the site, in accordance with preliminary

Service

Anticipated Funder

TWDB

HCFC

wetlands mitigation requirements and HCFC design criteria. Include typical plan view and cross section exhibits.

3. Investigate alternative water sources to feed wetlands creation and enhancement. \$7,000
4. Coordinate with appropriate agencies for their design considerations including the pipeline companies, Harris County Toll Road Authority, TxDOT, etc., and incorporate their criteria into the preliminary design.
5. Review access criteria for the various pipeline easements, and to the required test plots within each wetlands subdivision. Establish preliminary locations for possible bridges, culvert crossings, and walkways.
6. Establish a conceptual construction phasing sequence and prepare preliminary cost estimates for the creation of each wetlands subdivision. \$10,000
7. Prepare a preliminary engineering report summarizing all findings and recommendations.

IV. Design Phase Services:

A. Mitigation Plans \$105,000

1. Preparation of mitigation plan and notes for each of the wetlands subdivisions proposed within the site.
2. Coordinate with appropriate agencies including Texas Parks & Wildlife, U.S. Fish & Wildlife; U.S. Corps of Engineers; Environmental Protection Agency; and the Texas General Land Office.

<u>Service</u>	<u>Anticipated Funder</u>	
	<u>TWDB</u>	<u>HCFCF</u>
B. Engineering Plans:		\$223,000
1. Preparation of engineering construction plans and specifications for each wetlands subdivision.		
2. Preparation of plans to comply with EPA's NPDES criteria.		
3. Provide geotechnical investigation information as required to support engineering design.		
4. Incorporate preservation of the archeological sites into the design plans.		
C. Permit Submittals and Approvals:		\$25,200
1. Submit mitigation and engineering plans to all necessary agencies for proper permitting.		
2. Meet with these permitting agencies and address their concerns as necessary to obtain permits.		
V. <u>Construction Phase Services:</u>		\$102,200
A. Preparation of the construction package for each wetlands subdivision.		
B. Attend and assist the HCFCF in the prebid and the preconstruction conferences. Prepare and submit to the District written addenda which may be necessary.		
C. Review shop and working drawings furnished by contractors for compliance with design concepts and specifications and with the information given in the contract documents.		
D. Make periodic visits to become familiar with the progress and quality of the work and to determine if the work is proceeding in accordance with the contract documents. After each visit, the Engineer shall prepare and submit to the HCFCF a written report of his observations.		

<u>Service</u>	<u>Anticipated Funder</u>	
	<u>TWDB</u>	<u>HCFCF</u>
E. Consult with and advise the HCFCF during construction. Review change in contracts as requested by the HCFCF.		
F. Participate in company with the HCFCF, in a final inspection of the Project.		
G. Prepare and deliver to the HCFCF a set of reproducible record drawings showing as-built conditions based on field surveys and those changes made during the construction period based on changes in contract and information supplied by the HCFCF.		
VI. <u>Miscellaneous Services:</u>		\$585,000
A. Wetlands Growth: Periodically reassess the site test plots to evaluate the gains in function and values and coordinate with the U.S. Corps of Engineers to establish credits in the Wetlands Mitigation Bank.	\$25,000	
B. Perform detailed economic analysis to establish the value of the wetland mitigation banking credits.	\$45,000	
C. Provide site security as needed to maintain integrity of the site.		
D. Provide maintenance services as needed over the next 10 years.		
	<u>TWDB</u>	<u>HCFCF</u>
GRAND TOTAL	\$200,000	(\$3,485,001) \$1,223,800*

*Please note that these estimated costs for the creation of the Garners Bayou Wetlands Mitigation Bank do not include construction cost as there is not enough information to estimate it at this time.

94CRO012.DOC

SCHEDULE OF SERVICES
 ANTICIPATED TO BE FUNDED BY THE
 TEXAS WATER DEVELOPMENT BOARD

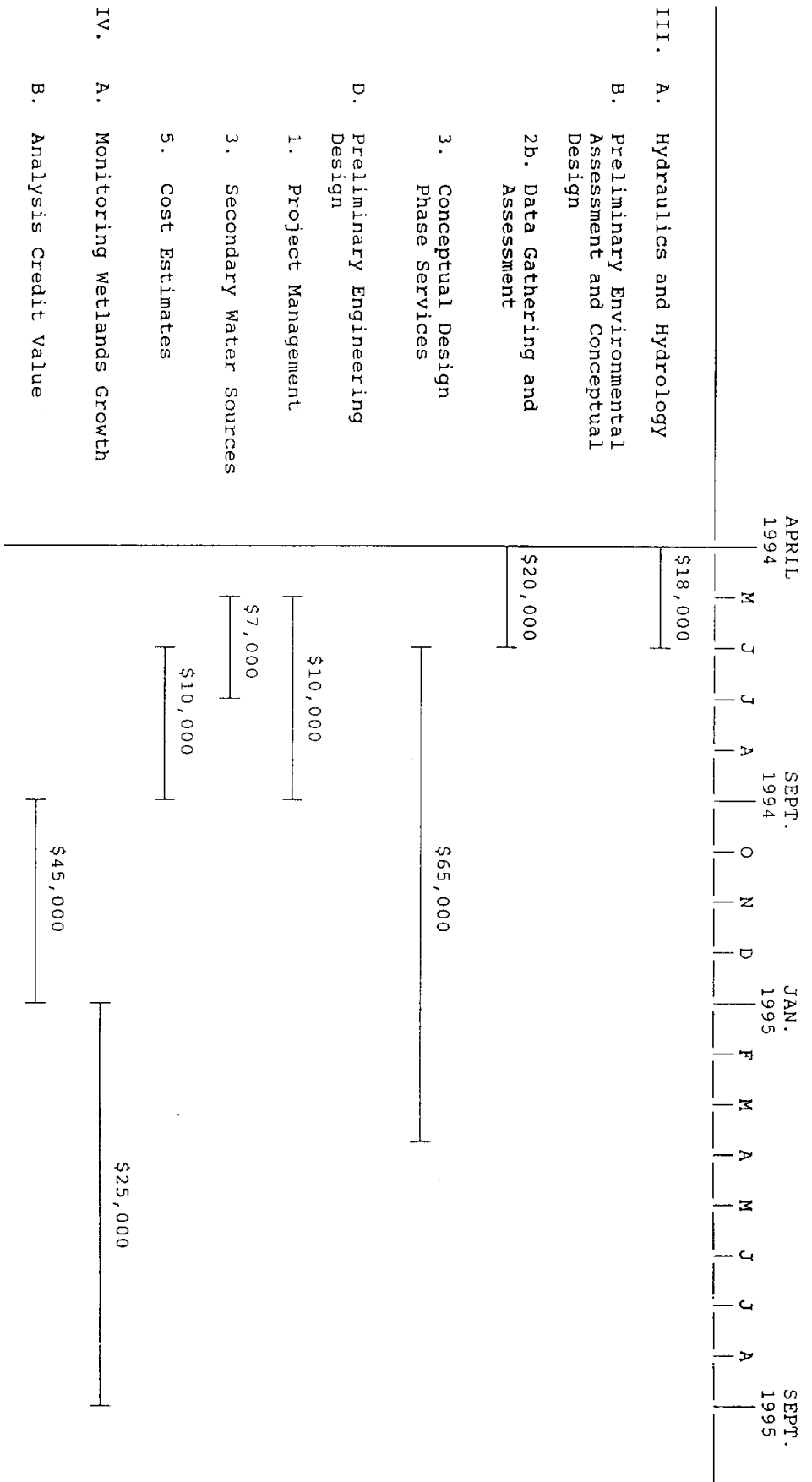

PLEASE NOTE THIS SCHEDULE IS TENTATIVE AND IS BEING EXPEDITED WHEN POSSIBLE.



HARRIS COUNTY FLOOD CONTROL DISTRICT

Arthur L. Storey, Jr., P.E.
Executive Director

August 29, 1994

CERTIFIED MAIL #9112969
RETURN RECEIPT REQUESTED

Mr. Craig D. Pedersen
Executive Administrator
Texas Water Development Board
1700 N. Congress Avenue
Austin, Texas 78711-3231

Attention: Regional Planning and Projects Section

Reference: Agreement for a Water Resources Grant with
the Texas Water Development Board in Connection
with the Creation of a Wetlands Mitigation Bank

Gentlemen:

Please find enclosed two (2) fully executed originals of the above referenced agreement between the Texas Water Development Board and the Harris County Flood Control District. This agreement is being transmitted for your use and files.

Should you require any additional information, please contact this office.

Sincerely,

A handwritten signature in cursive script that reads "Catherine A. Elliott".

Catherine A. Elliott
Engineering Contracts

'cr
Enclosure: Agreement (2)

cc: Contract File

94CAE155.DOC



HARRIS COUNTY FLOOD CONTROL DISTRICT

Arthur L. Storey, Jr., P. E.
Executive Director

August 11, 1994

Commissioners Court
Administration Building
Houston, Texas 77002

Reference: Authorization to Execute an Agreement for a Water Resource Grant with the Texas Water Development Board in connection with the creation of a Wetlands Mitigation Bank.
Harris County Flood Control Unit P500-03-00
Key Map Pages 376-X,Y and 416 A,B,C,F
Harris County Precinct 4

Dear Court Members:

It is recommended that County Judge Jon Lindsay be authorized to execute the attached Agreement for a Water Resource Grant with the Texas Water Development Board.

The purpose of this agreement is to allow the District to be reimbursed for a portion (\$100,000.00) of the funds spent during the initial phase of creating a Wetlands Mitigation Bank. The project is located on Key Map Pages 376-X,Y and 416-A,B,C,F.

Commissioners Court approved the application for this grant on December 7, 1993. The Agreement has been reviewed by the County Attorney and is ready for signature.

No funds are required by the District.

Sincerely,

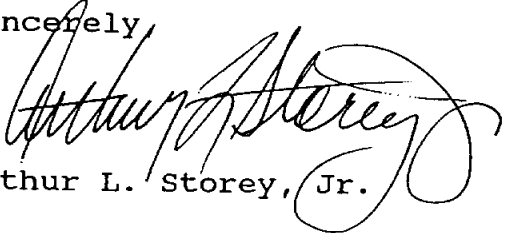
Arthur L. Storey, Jr.

ALS:CAE:cr
Attachment: Agreements

cc: County Auditor

PRESENTED TO
Commissioners Court

Date AUG 16 1994

Recorded Vol. _____ Page _____

Approved
EJ

94CAE145.DOC

If for any reason the District is unable to complete the work program called for under the terms of this Contract on or before September 30, 1994 and is unable to deliver the FY94 Interim Report on or before September 30, 1994, the District and the Board hereby agree to consider negotiating an extension of the Contract period; however, the Board will not be liable for more than \$100,000 for the entire Contract. The Board must, however, be notified in writing ten (10) working days prior to the date for completion of the work program or thirty (30) days prior to the date for submittal of the FY94 Interim Report that the District will be requesting renegotiation.

III. PROGRESS MONITORING PROCEDURES

A progress report, including results to date, will be provided to the Board on a quarterly basis throughout the project. Special interim reports on special topics and (or) results will be provided as appropriate.

IV. COMPENSATION AND REIMBURSEMENT

The Board, for and in consideration of the obligations and responsibilities undertaken by the District, hereby agrees to compensate and reimburse the District, in a total amount not to exceed \$100,000, upon the submission of invoices and a State of Texas Purchase Voucher representing all costs incurred and paid by the District pursuant to performance of this Contract. However, the Board will not reimburse the District for indirect costs associated with this project.

A. Reimbursement to the District shall be made in accordance with Attachment B, the approved task and expense budgets, with the Board contributing 2.1 percent or not to exceed \$100,000 of the total project cost, in the form of cash.

At the discretion of the Board and upon written memorandum to the contract file, budget flexibility within expense categories shall be allowed to the extent that the resulting total by any one category does not exceed one hundred ten percent (110%) of the original budgeted



HARRIS COUNTY FLOOD CONTROL DISTRICT

Arthur L. Storey, Jr., P. E.
Executive Director

August 11, 1994

Commissioners Court
Administration Building
Houston, Texas 77002

Reference: Authorization to Execute an Agreement for a
Water Resource Grant with the Texas Water
Development Board in connection with the
creation of a Wetlands Mitigation Bank.
Harris County Flood Control Unit P500-03-00
Key Map Pages 376-X,Y and 416 A,B,C,F
Harris County Precinct 4

Dear Court Members:

It is recommended that County Judge Jon Lindsay be
authorized to execute the attached Agreement for a Water
Resource Grant with the Texas Water Development Board.

The purpose of this agreement is to allow the District to be
reimbursed for a portion (\$100,000.00) of the funds spent
during the initial phase of creating a Wetlands Mitigation
Bank. The project is located on Key Map Pages 376-X,Y and
416-A,B,C,F.

Commissioners Court approved the application for this grant
on December 7, 1993. The Agreement has been reviewed by the
County Attorney and is ready for signature.

No funds are required by the District.

Sincerely,

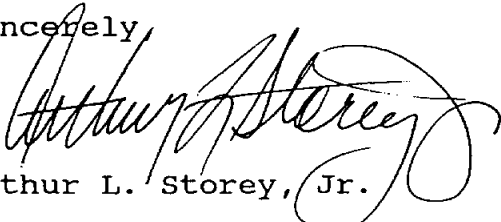
Arthur L. Storey, Jr.

ALS:CAE:cr
Attachment: Agreements

cc: County Auditor

PRESENTED TO
Commissioners Court

Date AUG 16 1994

Recorded Vol. _____ Page _____

Approved
E
J

94CAE145.DOC

TWDB Contract No.

STATE OF TEXAS
COUNTY OF TRAVIS

Texas Water Development Board
and
Harris County Flood Control District

WHEREAS, Harris County Flood Control District, Houston, Texas, hereinafter termed the District, applied to the Texas Water Development Board, Austin, Texas, hereinafter termed the Board, for a water research grant to develop a wetlands mitigation banking study;

WHEREAS, the District is the entity who will act as administrator of the Board's research grant and will be responsible for the execution of this Contract;

WHEREAS, the Mitigation Banking Review Team is comprised of the U.S. Army Corps of Engineers, the U.S. Environmental Protection Agency, the U.S. Fish and Wildlife Service, the National Marine Fisheries Service, the Texas Parks and Wildlife Department, the Texas General Land Office, and the Texas Natural Resource Conservation Commission, hereinafter termed the MBRT;

WHEREAS, the District has agreed to obtain review and approval of the scope of work and budget from the MBRT for those services which are proposed to be reimbursed by the Texas Water Development Board;;

WHEREAS, the District has agreed that the study will be coordinated, monitored, and reviewed by the MBRT, the Harris County Commissioners Court, the Harris County Flood Control Task Force, and the Special Area Management Plan Committee for Wetlands in Harris County;

WHEREAS, on March 17, 1994, the Board approved the District's application for financial assistance in funding the FY94 portion of the research;

NOW, THEREFORE, the Board and the District, for the mutual consideration stated, agree and understand as follows:

WITNESSETH:

I. PROJECT DESCRIPTION AND SERVICES TO BE PERFORMED BY THE DISTRICT

As a joint and cooperative undertaking with the Board, the District will conduct the research project as set forth in Attachment A, the approved research proposal submitted by the District, which is made a permanent part of this contract, except that Board compensation and reimbursement under this contract shall be limited to those tasks listed in Attachment B, the Task Budget.

Services and activities provided under this contract shall be in strict accordance with requirements of the Texas Water Code, Chapter 15; associated rules of 31 Texas Administrative Code, Chapter 355, Sections 355.1-355.11; Attachment A; Attachment B; and with the following procedures and project descriptions:

1. Scope of Work, as described in Attachment A, subject to the review and approval of the MBRT, and with Board compensation and reimbursement under this contract limited to those tasks listed in Attachment B, the Task Budget.
2. Interim Report - The District will submit two (2) copies of a FY94 Interim Report and a camera ready copy of all multicolor figures to the Board for review and comment after completion of those tasks listed in Attachment B, the Task Budget.

II. PROJECT SCHEDULE AND REPORTS

The term of this Contract shall begin and the District shall begin performing its obligations hereunder on March 17, 1994. The District shall complete the work program stated in Article I, above, no later than September 30, 1994, unless such date is extended as provided below, at which time the District shall deliver two (2) copies of the FY94 Interim Report and a camera ready copy of all multicolor figures. Deadlines may be extended only in writing by the Board. Delivery of an acceptable FY94 Interim Report and a camera ready copy of all multicolor figures prior to September 30, 1994, shall constitute completion of the terms of the Contract.

If for any reason the District is unable to complete the work program called for under the terms of this Contract on or before September 30, 1994 and is unable to deliver the FY94 Interim Report on or before September 30, 1994, the District and the Board hereby agree to consider negotiating an extension of the Contract period; however, the Board will not be liable for more than \$100,000 for the entire Contract. The Board must, however, be notified in writing ten (10) working days prior to the date for completion of the work program or thirty (30) days prior to the date for submittal of the FY94 Interim Report that the District will be requesting renegotiation.

III. PROGRESS MONITORING PROCEDURES

A progress report, including results to date, will be provided to the Board on a quarterly basis throughout the project. Special interim reports on special topics and (or) results will be provided as appropriate.

IV. COMPENSATION AND REIMBURSEMENT

The Board, for and in consideration of the obligations and responsibilities undertaken by the District, hereby agrees to compensate and reimburse the District, in a total amount not to exceed \$100,000, upon the submission of invoices and a State of Texas Purchase Voucher representing all costs incurred and paid by the District pursuant to performance of this Contract. However, the Board will not reimburse the District for indirect costs associated with this project.

A. Reimbursement to the District shall be made in accordance with Attachment B, the approved task and expense budgets, with the Board contributing 2.1 percent or not to exceed \$100,000 of the total project cost, in the form of cash.

At the discretion of the Board and upon written memorandum to the contract file, budget flexibility within expense categories shall be allowed to the extent that the resulting total by any one category does not exceed one hundred ten percent (110%) of the original budgeted

amount. Larger deviations shall require formal contract amendment.

Quarterly invoices, State of Texas Purchase Vouchers, and evidence of subcontract charges for work performed shall be submitted for reimbursement. Vouchers and invoices shall be supported by sufficient detail to substantiate billings by the District, said detail to include the following:

- (1) For direct expenses incurred by the District for its expenses and for outside consulting services—copies of invoices to the District showing the tasks that were performed; the percent and cost of each task completed; and the total dollar amount due to the consultant.
- (2) For travel and subsistence expenses, including such expenses for subcontractors—names, date, work location, time period at work location, itemization of subsistence expenses of each employee, limited, however, to travel expense authorized for state employees by General Appropriations Act, Tex. Law Regular Session, 1993, Ch. 1051, Art. IV, Sec. 13 and 14., at V-44 or as amended or superseded;
- (3) Other transportation costs—copies of invoices covering tickets for transportation or, if not available, names, dates, and points of travel of individuals.

The District is fully responsible for paying all charges, including those by subcontractors prior to submitting a bill to the Board. The Board will, in turn, reimburse the District for the Board's share of the payment. Acceptable evidence of the District payment must accompany the District's request for Board reimbursement. A copy of the District's check to the subcontractors shall constitute acceptable evidence of payment.

B. The Board shall reimburse the District only upon receipt of an invoice, and a State of Texas Purchase Voucher; provided, however, the Board shall only pay up to 90 percent of the

Board's share of each invoice pending the District's performance, completion of the FY94 Interim Report, and acceptance and approval of said report by the Board. At the time of said performance, completion, and acceptance of the report by the Board, the Board shall pay the remaining 10 percent to the District.

The Board shall reimburse the District only upon receipt of an invoice, a State of Texas Purchase Voucher, evidence of the District payment of subcontractor charges, and delivery of an acceptable FY94 Interim Report.

C. The District and the subcontractors shall maintain satisfactory financial accounting documents and records, including invoices and receipts, and shall make them available for examination and audit by the Board. Accounting by the District and the subcontractors shall be in a manner consistent with generally accepted accounting principles.

V. PUBLICATION AND SUBCONTRACTING

The Board shall have unlimited rights to technical or other data resulting directly from the performance of services to the Board under this Contract.

It is agreed that the research materials developed by the District pursuant to this contract shall become the joint property of the District and the Board. The District and the Board shall have the right to establish joint copyrights to the material. Provided, however, that copyrighting will in no way limit the Board's access to or right to request and receive data and information obtained or developed pursuant to this contract. Any research materials subject to a copyright and produced by the District or the Board pursuant to this contract may be printed by the District or the Board at its own cost and distributed by either at its discretion. The District or the Board may otherwise utilize such material provided under this contract as it deems necessary and appropriate, including the right to publish and distribute the materials or any parts thereof under its own name, provided that any copyright is appropriately noted on the printed materials, and the District and the Board's

joint participation in the study is prominently disclosed.

The District agrees to acknowledge the Board in any news releases or other publications relating to the work performed under this contract.

No reimbursement shall be made for any work subcontracted by the District without prior written acceptance by the Executive Administrator of the Board for such subcontract. Each subcontract shall include a detailed budget estimate with specific cost details for each item of the work to be performed by the subcontractor and for each category of reimbursable expenses. Each subcontract shall conform to the terms of this contract and include provisions which require subcontractor compliance with Board rules. The District must also adhere to any requirements in state law pertaining to the procurement of professional services.

VI. AMENDMENT, TERMINATION, AND STOP ORDERS

The Board's approval of a \$100,000 grant to the District will be rescinded on August 18, 1994, if this contract has not been signed by the District.

This Contract may be altered or amended only by mutual written consent and may be terminated by the Board at any time by written notice to the District. Upon receipt of such notice, the District shall, unless the notice directs otherwise, immediately discontinue charging any additional amounts to the Board for work in connection with the performance of this contract. The District shall submit a statement showing in detail the work performed under this contract to the date of termination. The Board shall then pay the District promptly that portion of the prescribed fee for work actually performed under this contract, less all payments that have been previously made. Thereupon, copies of all completed work accomplished under this contract shall be delivered to the Board.

The Board may issue a Stop Work Order to the District at any time. Upon receipt of such order, the District is to discontinue charging any additional amounts to the Board for work under

this contract. If the Board does not issue a Restart Order within 60 days after receipt by the District of the Stop Work Order, the District shall regard this contract terminated in accordance with the foregoing provisions.

VII. NO DEBT AGAINST THE STATE

This Contract and Agreement shall not be construed as creating any debt by or on behalf of the State of Texas and the Texas Water Development Board, and all obligations of the State of Texas are subject to the availability of funds. To the extent the performance of this contract transcends the biennium in which this contract is entered into, this contract is specifically contingent upon the continued authority of the Board and appropriations therefor.

VIII. LICENSES, PERMITS, AND INSURANCE

For the purpose of this contract, the District will be considered an independent contractor and therefore solely responsible for liability resulting from negligent acts or omissions. The District shall obtain all insurance deemed necessary, in the judgment of the District, to protect themselves, the Board, and employees and officials of the Board from liability arising out of the Contract. The District shall indemnify and hold the Board and the State of Texas harmless, to the extent that the District may do so in accordance with State Law, from any and all losses, damages, liability, or claims therefore, on account of personal injury, death, or property damage of any nature whatsoever caused by the District, arising out of the activities under this Contract.

The District shall be solely and entirely responsible for procuring all appropriate licenses and permits which may be required by any competent authority for the District to perform the subject work.

IX. SEVERANCE PROVISION

Should any one or more provisions of this contract be held to be null, void, voidable, or for any reason whatsoever, of no force and effect, such provision(s) shall be construed as severable from the remainder of this contract and shall not affect the validity of all other provisions of this contract which shall remain of full force and effect.

X. CORRESPONDENCE

All correspondence between the parties shall be made to the following addresses:

For the Board:
Craig D. Pedersen
Executive Administrator
Texas Water Development Board
P. O. Box 13231, Capitol Station
Austin, Texas 78711-3231

Attn: Regional Planning and Projects
Section

For the District:
Mr. Arthur Storey, Jr., P.E.
Executive Director
Harris County Flood Control District
9900 Northwest Freeway, Suite 212
Houston, Texas 77092

Attn: Colleen Raye O'Brien, P.E.
Project Manager

IN WITNESS WHEREOF the parties hereto cause this Contract and Agreement to be duly executed in triplicate.

TEXAS WATER DEVELOPMENT BOARD

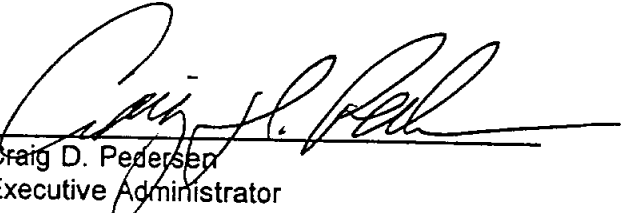
By: 
Craig D. Pedersen
Executive Administrator

Date: 8/4/94

HARRIS COUNTY FLOOD CONTROL DISTRICT

By: 
Jon Lindsay
County Judge

Date: August 16, 1994

APPROVED AS TO FORM:
Mike Driscoll
County Attorney

By: 
Paul Taparaukas
Assistant County Attorney

Date: 8-16/94

ORDER AUTHORIZING EXECUTION OF AGREEMENT BETWEEN THE
HARRIS COUNTY FLOOD CONTROL DISTRICT AND
THE TEXAS WATER DEVELOPMENT BOARD

THE STATE OF TEXAS §
 §
COUNTY OF HARRIS §

On this the 16th day of August, 1994,
the Commissioners Court of Harris County, Texas, sitting as
the governing body of the Harris County Flood Control
District, upon the motion of Commissioner Evercole,
seconded by Commissioner Fonteno, duly put and
carried,

IT IS ORDERED that County Judge Jon Lindsay be, and he
is hereby, authorized to execute for and on behalf of the
Harris County Flood Control District an Agreement between
the Harris County Flood Control District and the Texas Water
Development Board for a water resource grant in connection
with the creation of a wetlands mitigation bank, said
Agreement being incorporated herein by reference for all
purposes as though fully set forth verbatim herein.

94CAE145

PRESENTED TO
Commissioners Court
Date AUG 16 1994
Recorded Vol. _____ Page _____

ATTACHMENT A

UNSOLICITED APPLICATION

TO

TEXAS WATER DEVELOPMENT BOARD

AUSTIN, TEXAS

FOR

WATER RESEARCH PLANNING GRANT

FOR

A WETLANDS MITIGATION BANKING STUDY

BY

HARRIS COUNTY FLOOD CONTROL DISTRICT

HOUSTON, TEXAS

March 17, 1994

TEXAS WATER DEVELOPMENT BOARD
WATER RESEARCH
APPLICATION

Applicant's Legal Name and Address:

Harris County Flood Control District
9900 Northwest Freeway, Suite 212
Houston, Texas 77092

Applicant's Executive Director:

Arthur L. Storey, Jr., P.E.

1. Is this application in response to a published Request for Proposals (RFP)?

No.

2. What research topics will the project include?

- A. Wetlands Creation
- B. Credit Assessment Methodology
- C. Water Quality Enhancement and Assessment
- D. Alternative Flood Protection Through Regional Detention and Flood Attenuation by Created Wetlands.

3. Brief description of research proposal.

Through the development of the first public wetlands mitigation bank in Texas, this project will:

- A. Demonstrate the viability of the concept of mitigation banking as a more cost effective and meaningful method of mitigating wetland impacts effectively fulfilling the spirit of the law in achieving no net loss of the nation's wetland resources.
- B. Devise and achieve approval of a more accurate methodology for calculating the value of impacted and created wetlands for the purpose of mitigation banking.
- C. Develop baseline of water quality entering the created wetlands and quantify the enhanced water quality of the affluent passing through them.
- D. Access the hydrological interaction of an excavated detention basin and contiguous wetlands.

7. Total Project Cost: \$4,708,801

The amounts and source of the local matching funds and services, and the total amount requested from the research and planning fund:

Local Cash \$ 4,708,801
 Local In-kind Services \$ N/A
 Total Requested from TWDB \$ 200,000

8. Why is this research needed?

Through this research, significantly improved methodologies will result for (a) the creation of wetlands in specific habitat types, (b) for assessing the value of both impacted and created wetlands involved in the 404 mitigation process whose regulation has huge financial impact on the ability of both public and private entities to accomplish projects for the public good, (c) interactive design for combinative regional detention and wetlands creation, and (d) utilization of wetlands for enhancing runoff water quality.

9. Does the proposed research project duplicate previously completed or on-going research?

No.

10. If you are a corporation organized under the Texas Business Corporation Act, Article 1.01 et seq., attach proof that the corporation is not delinquent in a tax owed the State under the Tax Code, Chapter 171.

Not applicable.

11. Are you or any of your immediately family employed by the Texas Water Development Board?

No.

12. What products (reports, plans, or other products) will the Board receive, as a result of this research project?

Final project report, credit for funding research in all professional journals publishing results, replicable methodologies for establishing, assessing, and use for mitigation banking of created, restored and enhanced wetlands.

SCOPE OF SERVICES

The Flood Control District has identified the following services which are believed to be necessary to create and maintain the 1450-acre Garner's Bayou Wetland Mitigation Bank and Detention Facility proposed to be located at the southeast quadrant of the Garners Bayou and Greens Bayou confluence.

Please note that all costs shown within parentheses have already been expended by the Harris County Flood Control District (HCFCF), and are not eligible for grant consideration. These costs are being provided for informational purposes only.

<u>Service</u>	<u>Anticipated Funder</u>	
	<u>TWDB</u>	<u>HCFCF</u>
I. <u>Land Acquisition:</u>		
A. Tarquin Tract (224 Ac.)		(\$497,050)
B. PDIC Tract (1232 Ac.)		(\$2,783,292)
II. <u>Preliminary Site Investigations:</u>		
A. Cultural Resource Investigation		(\$30,331)
1. Secure a Texas Antiquities Permit from the Texas Antiquities Committee for the detention site tract survey.		
2. Determine, by reference to the State of Texas archeological site files at the Texas Archeological Research Laboratory at the University of Texas at Austin, if there are any previously recorded archeological sites within the project area.		
3. Conduct brief historical and geological background data studies of the proposed project region.		
4. Locate through field survey any previously unrecorded archeological features or sites in the project area.		

ServiceAnticipated FunderTWDBHCPCD

Houston, Texas to determine if any previous title holders of the property were determined to be engaged in a business or activity which would possibly contribute to contamination of the site.

7. Conduct site reconnaissance with multiple site visits and surveys including comprehensive walking observations and a general overview of adjacent tracts.
8. Prepare a report of the investigation results for the site for review by HCPCD and all appropriate agencies.

C. Wetlands Analysis and Delineation

(\$14,035)

1. Review geologic and soil conditions for the site including review of the Soil Conservation Survey soil maps.
2. Review the FEMA flood plain maps.
3. Interpretation of historical and current aerial photography.
4. Perform site reconnaissance to test and evaluate hydric soil conditions.
5. Perform site reconnaissance to identify vegetation indicators.
6. Perform site reconnaissance to identify and evaluate topographical and hydrological characteristics.
7. Prepare a report of the investigation results for the site for review by HCPCD and the Corps of Engineers.

D. Threatened or Endangered Species Investigation

(\$2,005)

1. Conduct a survey of the listed federally protected and endangered species to determine if any of the species may inhabit the subject tract.

<u>Service</u>	<u>Anticipated Funder</u>	
	<u>TWDB</u>	<u>HCFCD</u>
B. Preliminary Environmental Assessment and Conceptual Design		
1. Preliminary Design and Data Gathering		(\$11,588)
Attend preliminary design meetings with HCFCD and MBRT to determine appropriate project assessment methodology and preliminary phase services.		
2. Preliminary Phase Services		
a. Project Management		(\$10,000)
1) Attend meetings with HCFCD, Corps of Engineers, Mitigation Banking Review Team (MBRT), other relevant agencies and other consultants, and prepare required presentations material.		
2) Coordinate with surveyor to correlate and verify topographic data and pipeline survey data with existing wetlands and flag wetland boundary adjacent to detention basin.		
3) Prepare terrain and contour maps and models using survey and aerial data.		
b. Data Gathering and Assessments	\$20,000	(\$55,000)
1) Provide comprehensive soil taxonomy, soil map and permeabilities for project area, test borings and monitoring of groundwater depths, and compile a detailed soil analysis report.		

Service

Anticipated Funder

TWDB

HCPCD

d. Determine minimum success criteria for wetland creation/enhancement and prepare necessary documents to obtain a Memorandum of Agreement between the HCPCD and the Corps of Engineers. This is to include the required land use agreements.

C. Surveying Support

1. Flag and delineate key existing wetland boundaries. \$6,000

2. Perform aerial photography of approximately 1600 acres with 22 control panel points at critical locations. Planimetric features are to be visible on the photography and sufficient elevation information is to be captured to provide one (1) foot contours at a scale of 1"=500'. \$39,300

3. Prepare metes and bounds descriptions of the seven subdivisions of the site for exhibits to the required Land Use Agreement between HCPCD and the Corps of Engineers, as a condition of the Memorandum of Agreement for the creation of the Garners Bayou Wetlands Mitigation Bank. \$10,600

4. Locate and flag the required test plots within each wetlands subdivision. Assume 20 plots will be required. These test plots are to be used to monitor wetlands creation/enhancement to establish and increase credits in the wetlands mitigation bank. \$40,000

D. Preliminary Engineering Design \$87,500

1. Provide project coordination and attend meetings with HCPCD, COE, MBRT, and other relevant agencies to discuss the requirements of the wetlands banking design and the associated detention facilities. \$10,000

2. Develop conceptual grading plans, for each wetlands subdivision within the

Post-It™ brand fax transmittal memo 7671 # of pages 2

To	ADRYN BRITTON
From	COLLEEN D'BIEN
Co.	HCFC
Dept.	Board
Phone	684-4050
Fax	684-4140
Fax #	512-463-9893

<u>Service</u>	<u>Anticipated Funder</u>	
	<u>TWDB</u>	<u>HCPCD</u>
B. Engineering Plans:		\$223,000
1. Preparation of engineering construction plans and specifications for each wetlands subdivision.		
2. Preparation of plans to comply with EPA's NPDES criteria.		
3. Provide geotechnical investigation information as required to support engineering design.		
4. Incorporate preservation of the archeological sites into the design plans.		
C. Permit Submittals and Approvals:		\$25,200
1. Submit mitigation and engineering plans to all necessary agencies for proper permitting.		
2. Meet with these permitting agencies and address their concerns as necessary to obtain permits.		
V. <u>Construction Phase Services:</u>		\$102,200
A. Preparation of the construction package for each wetlands subdivision.		
B. Attend and assist the HCPCD in the prebid and the preconstruction conferences. Prepare and submit to the District written addenda which may be necessary.		
C. Review shop and working drawings furnished by contractors for compliance with design concepts and specifications and with the information given in the contract documents.		
D. Make periodic visits to become familiar with the progress and quality of the work and to determine if the work is proceeding in accordance with the contract documents. After each visit, the Engineer shall prepare and submit to the HCPCD a written report of his observations.		

SCHEDULE OF SERVICES
ANTICIPATED TO BE FUNDED BY THE
TEXAS WATER DEVELOPMENT BOARD

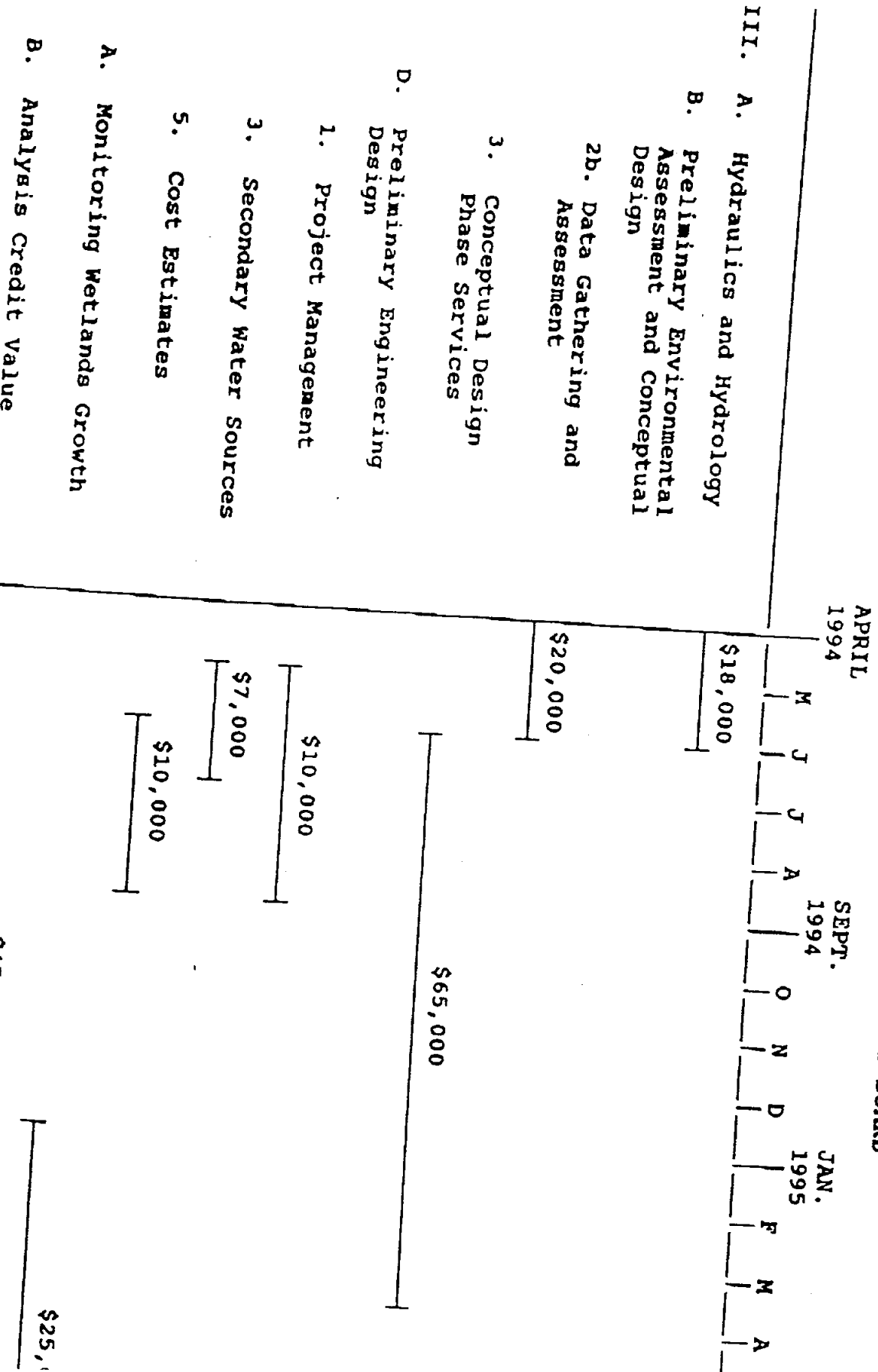

PLEASE NOTE THIS SCHEDULE IS TENTATIVE AND IS BEING EXPEDITED WHEN POSSIBLE.

W040013300C

ATTACHMENT B
TASK & EXPENSE BUDGETS

TASK BUDGET

<u>Task No.</u>	<u>Description</u>	<u>Budget Amount</u>
1.	Hydraulics and Hydrology	\$18,000.00
2.	Preliminary Environmental Assessment and Conceptual Design	
	A. Data Gathering and Assessment	20,000.00
	B. Conceptual Design Phase Services	35,000.00
3.	Preliminary Engineering and Design	
	A. Project Management	10,000.00
	B. Secondary Water Sources	7,000.00
	C. Cost Estimates	<u>10,000.00</u>
	TOTAL	\$100,000.00



HARRIS COUNTY FLOOD CONTROL DISTRICT

bcc: Makela
Kobs
Talbott
Parker
O'Brien
Unit File

Arthur L. Storey, Jr., P. E.
Executive Director

September 28, 1994

Ms. Charmaine Salone
Texas Water Development Board
P. O. Box 13231
Austin, Texas 78711-3231

RE: Request for a Time Extension on the Agreement
Between TWDB and HCFCFCD for the Proposed
Greens Bayou Wetlands Mitigation Bank
Harris County Flood Control Unit P500-03-00, KM 376

Dear Ms. Salone:

The Flood Control District is writing to request an extension to complete the services proposed in our contract with the Texas Water Development Board on the proposed Greens Bayou Wetlands Mitigation Bank. The District shall complete the work program stated in Article 1 of the agreement, and shall deliver the Interim Report by March 30, 1994.

We appreciate your assistance on this matter. If we can provide additional information, please let us know.

Sincerely,

A handwritten signature in cursive script that reads "Colleen R. O'Brien".

Colleen R. O'Brien, P.E.
Project Manager
Watershed Management Dept.

CRO:cr

cc: Elliott
Koros

94CRO177.DOC



TEXAS WATER DEVELOPMENT BOARD

Charles W. Jenness, *Chairman*
William B. Madden, *Member*
Diane E. Umstead, *Member*

Craig D. Pedersen
Executive Administrator

Wesley E. Pittman, *Vice-Chairman*
Noe Fernandez, *Member*
Elaine M. Barrón, M.D., *Member*

October 12, 1994

Ms. Colleen R. O'Brien, P.E.
Project Manager
Harris County Flood Control District
9900 Northwest Freeway, Suite 220
Houston, Texas 77092

Re: Time Extension for Texas Water Development Board (Board) Water Research Study with the Harris County Flood Control District, Contract Number 94-483-054

Dear Ms. O'Brien:

This letter is in response to your September 28, 1994 fax requesting a time extension for the above referenced contract. This letter will represent a contract amendment that will change the due date for the completion of the project from September 30, 1994 to May 30, 1995. I have added an additional two months to your requested date in order to insure adequate review time for the final report. All other terms of the contract will remain unchanged.

Please indicate your concurrence with these revised dates by signing below, retaining a copy for your files and returning the letter to the attention of the Regional Planning and Projects Section at the address shown below. If you have any questions concerning the contract amendment, please contact Mr. Gordon Thorn, the Board's designated Contract Manager for this project, at (512) 463-7979.

Sincerely,

Tommy Knowles
Deputy Executive Administrator
for Planning

109388

HARRIS COUNTY FLOOD CONTROL DISTRICT

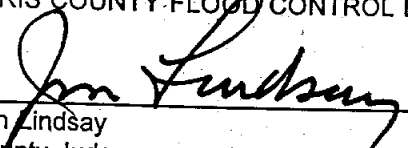
By: 
Jon Lindsay
County Judge

Date: November 1, 1994

51 OCT 24 PM 2:40

APPROVED AS TO FORM:
Mike Driscoll, County Attorney

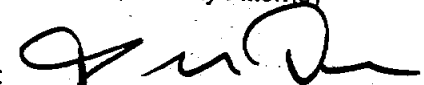
By: 
Paul Taparuskas
Assistant County Attorney

Date: 10-27-94

Our Mission

Exercise leadership in the conservation and responsible development of water resources for the benefit of the citizens, economy, and environment of Texas.

P.O. Box 13231 • 1700 N. Congress Avenue • Austin, Texas 78711-3231
Telephone (512) 463-7847 • Telefax (512) 475-2053 • 1-800- RELAY TX (for the hearing impaired)

♻️ Printed on Recycled Paper ♻️

ORDER AUTHORIZING EXECUTION OF AMENDMENT TO AGREEMENT BETWEEN THE
HARRIS COUNTY FLOOD CONTROL DISTRICT AND
TEXAS WATER DEVELOPMENT BOARD

THE STATE OF TEXAS §
 §
COUNTY OF HARRIS §

On this the 1st day of November, 1994, the
Commissioners Court of Harris County, Texas, sitting as the
governing body of the Harris County Flood Control District, upon
the motion of Commissioner Santeno, seconded by
Commissioner Lo, duly put and carried,

IT IS ORDERED that County Judge Jon Lindsay be, and he is
hereby, authorized to execute for and on behalf of the Harris
County Flood Control District an Amendment to Agreement between
the Harris County Flood Control District and Texas Water
Development Board for a water research study involving the Greens
Bayou Wetlands Mitigation Bank to extend the contract time due to
unavoidable time delays, said Agreement being incorporated herein
by reference for all purposes as though fully set forth verbatim
herein.

94CAE188.DOC

PRESENTED TO
Commissioners Court
Date NOV 01 1994
Recorded Vol. _____ Page _____



HARRIS COUNTY FLOOD CONTROL DISTRICT

Arthur L. Storey, Jr., P.E.
Executive Director

October 27, 1994

Commissioners Court
Administration Building
Houston, Texas 77002

Reference: Authorization to Execute an Amendment to Agreement for a Water Research Grant with the Texas Water Development Board in connection with the creation of the Greens Bayou Wetlands Mitigation Bank.

Harris County Flood Control Unit P500-03-00
Key Map Pages 376-X,Y and 416-A,B,C,F
Harris County Precinct 4

Dear Court Members:

It is recommended that County Judge Jon Lindsay be authorized to execute the attached Amendment to Agreement for a Water Research Grant with the Texas Water Development Board.

The purpose of this Amendment to Agreement is to extend the contract time to allow the District to complete the Water Research Study covered by the Grant. The project is located on Key Map Pages 376-X,Y and 416-A,B,C,F.

The Amendment to Agreement has been reviewed by the County Attorney and is ready for signature.

Sincerely,

A handwritten signature in cursive script, appearing to read "Arthur L. Storey, Jr.", is written over a horizontal line.

Arthur L. Storey, Jr.

ALS:CAE:cr

Attachment: Amendment to Agreement Date NOV 01 1994

cc: County Auditor

Recorded Vol. _____ Page _____

PRESENTED TO
Commissioners Court

Approved
J Lee

94CAE188.DOC