

development & building process

The *Downtown 2010 Plan* introduces a new, innovative approach to Downtown development. This Plan creates an easy four-step approach to building in Downtown.

STEP 1. DISTRICTS MAP - locate your property and the Downtown district it's in. (Color Coded)
.....

STEP 2. DISTRICT USES MATRIX - identify which uses are permitted, regulated or prohibited in your district. (Color Coded)
.....

STEP 3. BUILDING TYPES - identify the building types authorized for your district. (Color Coded)
.....

STEP 4. BUILDING STANDARDS - apply the building standards applicable to your project.

Once you have gone through these four steps, you are ready to begin the **expedited** site development plan approval process.

The *Districts Map* shall be used to guide Downtown development. The *Districts Map* identifies and locates five (5) distinct Downtown districts, each with unique land uses and development characteristics. The *District Map* is color-coded to correspond to the *District Uses Matrix and Building Types chart*. By using this color-coding system, you are able to conveniently follow steps 1, 2, and 3.

The *Districts Map* strategically locates and concentrates complementary land uses within each district. The title designated for each district (Housing, Arts & Entertainment, Government, Financial & Hospitality, Warehouse, Mixed-Use) is intended to be descriptive of the primary function(s) of each district. Other compatible uses are envisioned and encouraged. *The District Uses Matrix* clearly spells out permitted, regulated and prohibited uses in each district. Regulated uses must go through the Environmental Planning Commission (EPC) process, which includes neighborhood notification.

The color-coded *Building Types* chart outlines the types of buildings to be built in each Downtown district. It is intended to provide predictability on how Downtown will develop as far as types, layout and scale of buildings. A key component of the *Downtown Plan* is to build quality urban pedestrian-friendly buildings that will stand the test of time and the multiple uses of buildings over time.

The *Building Standards* consolidates the more than 70 current standards and guidelines required for Downtown development into 21 simple building standards. The new standards are intended to be far more user-friendly and to remove much of the subjectivity in the prior standards/guidelines. Each standard is graphically illustrated and reduced to the most basic form.

.....

The Site Development Plan Approval Process has been streamlined to accommodate Downtown development. For quality Downtown projects, approval will be “short on the process and long on the results.”

.....

The Downtown Development and Building Process is adopted to ensure that building development is predictable and real estate values are stable. This process puts the pedestrian first in all new projects and ensures that developments are compatible with each other and with the existing urban fabric. The Building Types and Building Standards set forth in this Plan are mandatory, however, the Planning Director, and/or the Director’s designee, may approve minor changes or deviations from the Building Types and/or Building Standards pursuant to regulations and procedures to be adopted by the City.

.....

- Notes:*
- a) *The Downtown Districts Map represents the Downtown Core. Surrounding neighborhoods boundaries are amended to correspond with the Downtown Core.*

 - b) *The Building Types and Building Standards are adopted to facilitate and encourage Downtown developments. Adherence to the types and standards within each district are required to obtain a building permit.*

step one

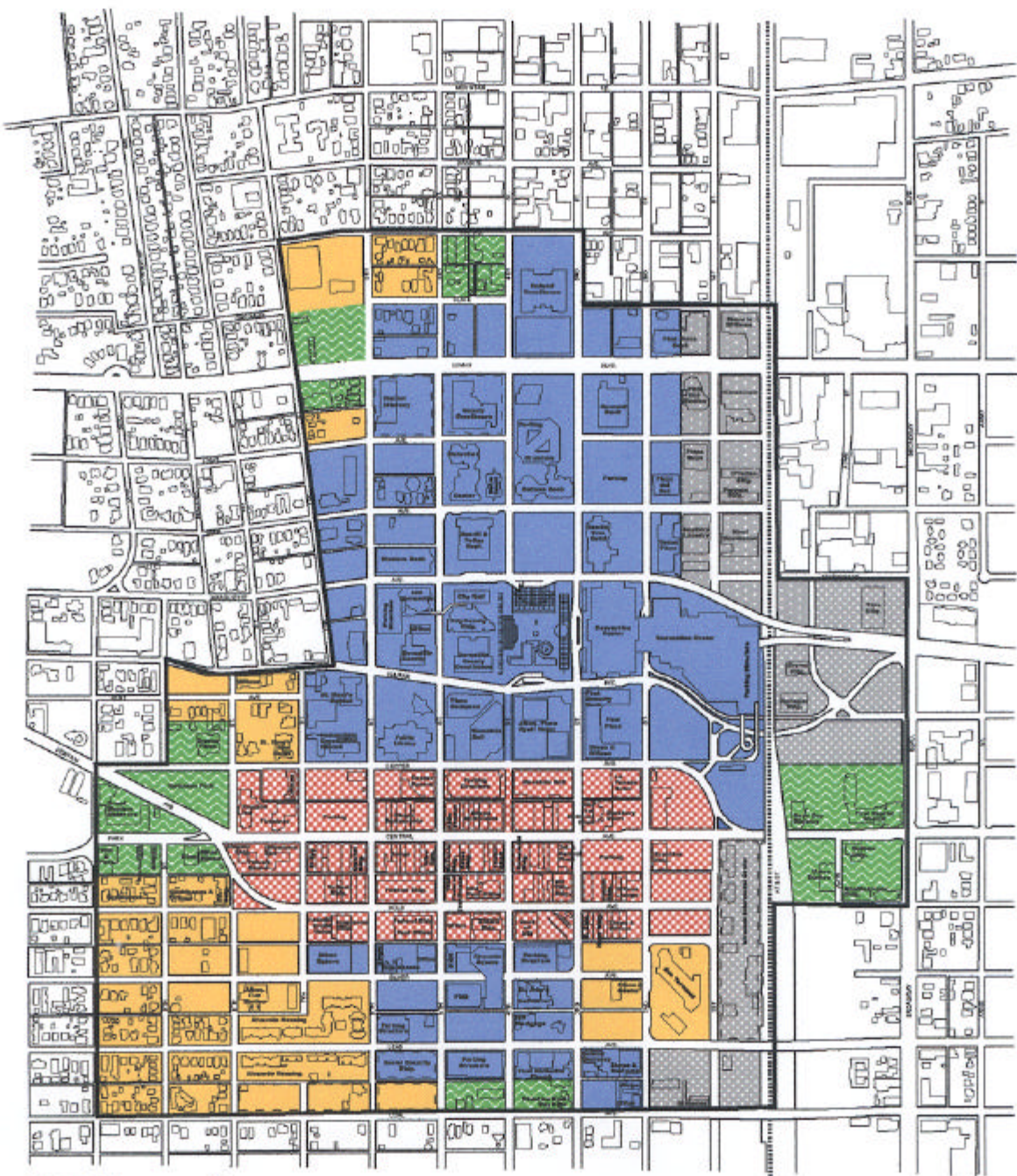

- Housing Focus**
- Warehouse Focus**
- Arts & Entertainment Focus**
- Government/Financial/Hospitality Focus**
- Mixed-Use Corridor**
- Downtown Core**

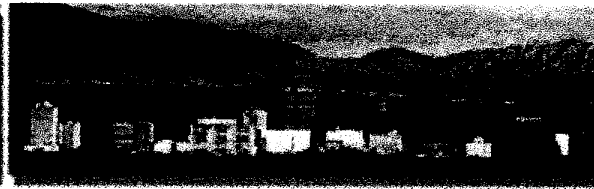

Following is a general description of each of the Downtown districts and the uses envisioned in each district:

Housing District

Residential development is allowed and encouraged in all districts of Downtown. Residential is the primary use within the Housing District. The Housing District should be medium to high density with a range of housing types: 3-4 story townhouses, 4-6 story urban apartments, housing above retail or office, housing integrated into mixed use office structures, loft apartments converted from older mercantile buildings. Other neighborhood serving retail and ancillary office activity are allowed to provide diversity but must be compatible with the residential focus of this district.

Arts and Entertainment District

The Arts & Entertainment District is the primary center for arts, entertainment, cultural, and specialty retail shopping experiences. The Arts & Entertainment District will serve as Downtown's Main Street and host a variety of activities and experiences. The ground floor of all buildings will have exciting street level arts, entertainment and retail presence in this district. Compatible office, hotel institutional, commercial and residential uses are encouraged above the street level. The street level design of buildings should be visually interesting and reinforce the image of a premier urban shopping district and entertainment district. The street level environment will be active, visually exciting and accommodating to the pedestrian. The Arts & Entertainment District is a logical location for a new arena, multi-plex theater, restaurants, clubs, and assorted visual and performing arts venues. It is the logical location for community festivals and celebrations.

Government/Financial/Hospitality District

Downtown will maintain its position as the government, financial, and hospitality center of the metropolitan region. Downtown is the seat of government for the City of Albuquerque, Bernalillo County, and regional Federal Government facilities. These and other State departments and agencies will be located Downtown. It is also the center of the federal, state and local judicial complex. Concentrate new government and private office development in this District. Locate high and medium density office development in the district. Convention and hospitality facilities are strongly encouraged to locate in this district as well. Street level retail is required in the district to provide services and street level vitality.

Warehouse District

The Warehouse District is a lasting remembrance of Downtown's early commercial district along the railroad. Therefore, it is important to protect its historic character by preserving the existing stock of older buildings, while promoting compatible infill development. Within the Warehouse District the reuse and rehabilitation of existing older commercial buildings is strongly encouraged. A broad range and diverse mix of uses are allowed and encouraged in the Warehouse District. These uses include: commercial, office, retail, residential, transportation and sports facilities. Types of development envisioned for this district include mixed use buildings which combine

residents with workplaces, small office blocks, outdoor sports facilities, and product showrooms. The Warehouse District offers several logical locations of an outdoor ballpark. It is an ideal location for live/work artist studios and “funky” off-beat retail and restaurant venues.

Mixed Use Corridors District

Mixed use developments are allowed and strongly encouraged for all of Downtown. No predominant or primary uses are prescribed for the Mixed Use Corridors District. This district is located on the transit corridors through Downtown (Lomas Blvd.-Central Avenue-Fourth Street). Compatible office, institutional, residential, retail, commercial, educational and other uses are encouraged along this district. These developments should be concentrated and of a density to encourage transit use along these principal corridors.

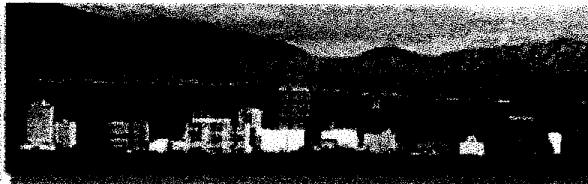

step two

The Downtown Core is zoned SU-3 Special Center, with uses allowed in the R-3 and C-2 zones of the Comprehensive City Zoning Code as further governed by this Sector Development Plan. All uses are encouraged in the Downtown, however the principal uses are: residential, arts, entertainment, office, cultural, hospitality, and specialty retail. *The Plan* strongly encourages a mixture of compatible land uses (office/residential, retail/office, arts/entertainment). Residential development is allowed and encouraged throughout all districts of Downtown.

All types of land uses are encouraged Downtown, however certain uses are not appropriate in some districts. To assure that uses most conducive to achieving *The Plan's* objectives are developed in the appropriate districts, it is important to permit, prohibit, or regulate uses by district. There are no parking requirements in the SU-3 Special Center Zone.

The SU-3 zone creates a clear and defined (hard) boundary between the Downtown Core and surrounding neighborhoods. The Plan and zoning intent is to protect, retain and enhance the integrity of neighborhoods surrounding the Downtown Core. Commercial and office intrusion into the surrounding neighborhoods is strongly discouraged.

Following is a general color-coded District/Use Matrix to guide in determining if a use is appropriate in a District:

	HOUSING ¹	GOVERNMENT FINANCIAL/ HOSPITALITY	WAREHOUSE	MIXED USE	ARTS & ENTERTAINMENT
RESIDENTIAL²					
Ground Floor	P	R	P	P	R
Above Ground Floor	P	P	P	P	P
RETAIL/SERVICES	R ³	P	P	P	P
OFFICE/INSTITUTIONAL	R ⁴	P	P	P	P
WAREHOUSE/WHOLESALE	R	R	P	R	X
MANUFACTURING	X	X	R ⁵	X	X

P = Permitted

R = Review Required

X = Prohibited

1. Housing district area between Central Avenue and Lomas Boulevard is restricted to residential development only to buffer the Downtown Neighborhood Association (DNA). The remaining housing district areas are controlled by the Uses Matrix.
2. Home occupations are allowed as regulated by the R-1 zone.
3. The purpose of *The Plan* is to encourage neighborhood serving retail.
4. The purpose of *The Plan* is to allow ancillary office activity in the Housing District.
5. The purpose of *The Plan* is to allow manufacturing as regulated by the M-1 zone.

Additional Notes:

- Emergency Shelters proposed in the Downtown Core shall be Review Required.
- Any arena or any sports stadium, whether indoor or outdoor, shall be Review Required.
- Proposed developments in areas of the Downtown Core covered by a historic overlay zone shall be reviewed and approved by the Landmarks and Urban Conservation Commission.

Prohibited Uses

Some uses are clearly prohibited or regulated in all Downtown districts. Following is a list of those uses:

- Drive-in/drive-through facilities are not allowed, except that unenclosed outdoor seating is permitted. Existing drive-in/drive-through uses shall be legal, non-conforming uses.
- Adult amusement establishments, adult bookstores, adult photo studios, and adult theaters are allowed in all Downtown districts, except the Housing District, provided:
 - a) the use is located at least 1,000 feet from any other adult amusement establishment, adult bookstore, adult photo studio, or adult theater, and
 - b) the use is located at least 500 feet from the nearest residential zone (surrounding neighborhoods), surrounding sector plan boundaries, or from any church, pre-elementary, elementary, middle or secondary school.
- Commercial surface parking lots are not allowed. Existing commercial surface parking lots shall be legal, non-conforming uses and must meet the landscaping, lighting, buffering and paving requirements identified in the building standards section of *The Plan*.
- Alcoholic drink sales for consumption off-premises are allowed, provided however:
 - a) there shall be no dispensing (sales) of any miniatures;
 - b) there shall be no dispensing (sales) of any fortified wines by volume of alcohol no more than twelve percent; and
 - c) there shall be no dispensing (sales) of any alcoholic beverages in broken packages (singles).

Existing establishments engaged in the sale of alcoholic drink sales for consumption off-premises shall be required to meet the above restrictions within ninety (90) days of The Plan adoption.
 - d) Alcoholic drink sales within 500 feet of the boundary of a residential zone in an adjacent neighborhood or within 500 feet of the boundary of any adjacent sector development plan shall be Review Required, except this provision shall not apply to a full service grocery store.
- Jails or correctional institutions are not allowed, but temporary detention facilities shall be allowed to accommodate police investigative activities and related activities.
- Off-premise free-standing signs are not permitted.
- Existing uses within the Housing district area between Central Avenue and Lomas Boulevard that are inconsistent with the District/Use Matrix are nonconforming and the City's nonconformance regulations shall apply.

DOWNTOWN 2010

step three building types

	Housing	Government Financial	Warehouse	Mixed Use	Arts Entertainment
TYPE 'A'					
TYPE 'B'					
TYPE 'C'					
TYPE 'D'					
TYPE 'E'					
TYPE 'F'					
TYPE 'G'					
TYPE 'M'					
TYPE 'N'					
TYPE 'O'					
TYPE 'P'					
TYPE 'Q'					

**URBAN
REGULATIONS**

PLACEMENT:

- 1. Lot Width: 50' minimum

PARKING:

- 1. Rear yard garages
- 2. Access: through alley

HEIGHT AND PROFILE:

- 1. Height: 2 stories maximum

EXAMPLES:

- 1. Residential and Professional Office; Studio Apartments; Guest Cottages

Sample Block Plan



Bird's Eye View

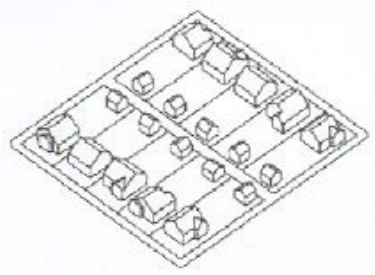

A - SINGLE UNIT

TYPE DESCRIPTION

Free Standing, single unit housing with rear yard garages and studio apartment.

Examples



**URBAN
REGULATIONS**

PLACEMENT:

- 1. Lot Width: 50' minimum

PARKING:

- 1. Rear yard garages
- 2. Access: through alley

HEIGHT AND PROFILE:

- 1. Height: 2 stories maximum

EXAMPLES:

- 1. Residential and Professional Office; Studio Apartments; Guest Cottages; Workshops above Garages

Sample Block Plan



Bird's Eye View

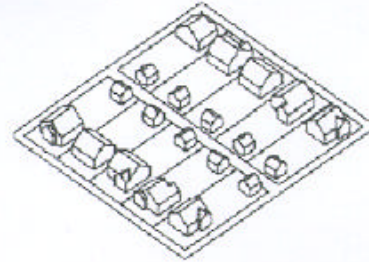

B - DUPLEX

TYPE DESCRIPTION

Free Standing, duplex unit housing with rear yard garages and studio apartments.

Examples



**URBAN
REGULATIONS**

PLACEMENT:

- 1. Lot Width: 20-50'

PARKING:

- 1. Rear yard garages
- 2. Access: through alley

HEIGHT AND PROFILE:

- 1. Height: 3 stories maximum

EXAMPLES:

- 1. Residential and Professional Office; Studio Apartments; Guest Cottages; Workshops above Garages

Sample Block Plan



Bird's Eye View

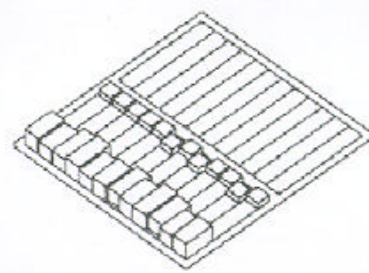

C - TOWNHOUSES

TYPE DESCRIPTION

“Zero” lot line townhouses with rear yard garages and studio apartments.

Examples



**URBAN
REGULATIONS**

PLACEMENT:

- 1. Lot Width: 65'-75'

PARKING:

- 1. Half-level underground and surface
- 2. Access: through alley

HEIGHT AND PROFILE:

- 1. Height: 3 stories maximum with setback beginning at second story

EXAMPLES:

- 1. Residential flats over two-story Townhouses

Sample Block Plan

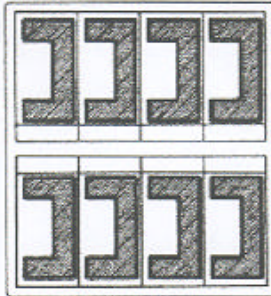

Bird's Eye View

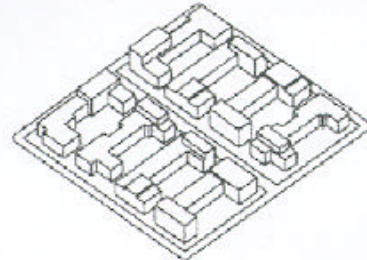

D - SIDEYARD

TYPE DESCRIPTION

Flats above two-story townhouses facing sideyard courts.

Examples



**URBAN
REGULATIONS**

PLACEMENT:

- 1. Lot Width: 100' minimum

PARKING:

- 1. Half-level underground
- 2. Access: through alley

HEIGHT AND PROFILE:

- 1. Height: 2 stories maximum with setback beginning at second story

EXAMPLES:

- 1. Residential flats over two-story townhouses

Sample Block Plan

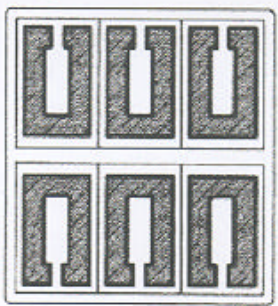

Bird's Eye View

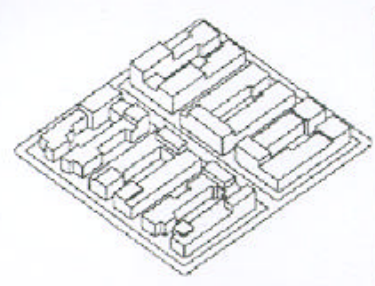

E - COURTYARD

TYPE DESCRIPTION

Flats above two-story townhouses facing interior courts.

Examples



**URBAN
REGULATIONS**

PLACEMENT:
1. Lot Width: 300'

PARKING:
1. Half-level underground for residential flats and garages on grade for townhouses
2. Access: through alley

HEIGHT AND PROFILE:
1. Height: 4 stories maximum with setback beginning at third story

EXAMPLES:
1. Two-story residential flats over two-story townhouses

Sample Block Plan

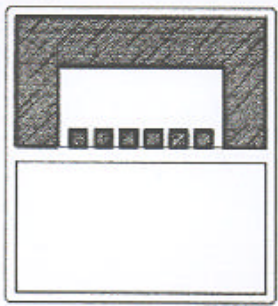

Bird's Eye View

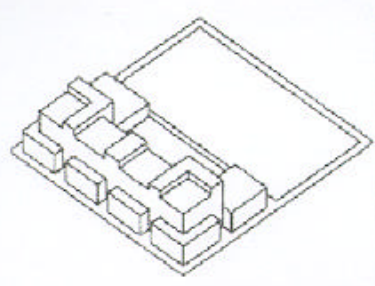

F - TERRACE

TYPE DESCRIPTION

Two-story flats over two-story townhouses over partially submerged parking garages.

Example



URBAN

REGULATIONS

PLACEMENT:

1. Lot Width: 300'
2. Lot Depth: 142' maximum

PARKING:

1. Half-level underground garage podium
2. Access: through alley

HEIGHT AND PROFILE:

1. Height: 8 stories maximum at corners and 4 stories maximum at mid-block, both cases setback begins at third story

EXAMPLES:

1. Commercial or Retail on principal street frontage with double-loaded residential apartments above

Sample Block Plan

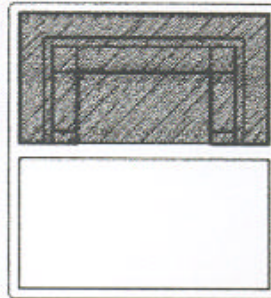

Bird's Eye View

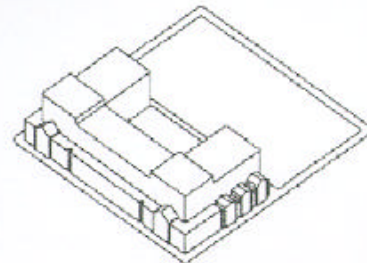

G - MIDRISE PODIUM

TYPE DESCRIPTION

Apartments on double-loaded corridors over storefront lofts over partially submerged parking garage..

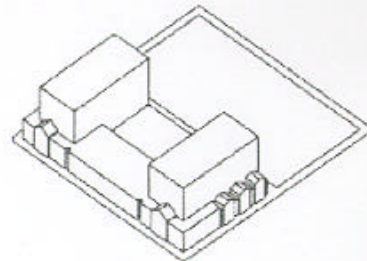

G - MIDRISE PODIUM

Example



URBAN REGULATIONS

WRAPPER BUILDING:

PLACEMENT:

1. Lot Width: 300'
2. Street Frontage: 90% minimum articulated at 25', 50', or 75' increments
3. Lot Depth: 142' to alley at mid-block
4. Building Depth: 20' minimum, 40' preferred
5. Recessed corners shall not exceed 10% of street frontage

PARKING:

1. Types: Interior surface lot, interior garage, or "park-once" garage
2. Access: through alley

HEIGHT AND PROFILE:

1. Street Frontage Height: 3 stories at block centers and 5 stories at street corners
2. Setback: 0'

EXAMPLES:

1. Commercial or Retail on street frontage with mixed-use housing or office lofts above

INTERIOR BUILDING:

HEIGHT AND PROFILE:

1. Height: No restrictions
2. Setback: 20' minimum with 40' preferred

EXAMPLES:

1. Parking; Cinema; "Big-Box" Retail; Office; Hotel; Residential

Sample Block Plan

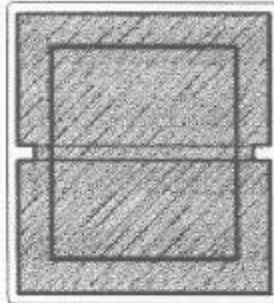

TYPE DESCRIPTION

Large floor plate structure surrounded by low-scale "wrapper" or "liner" buildings at street frontage located on a full block.

Bird's Eye View

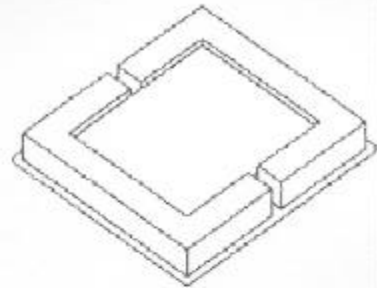

M-1 FULL BLOCK LOW-RISE

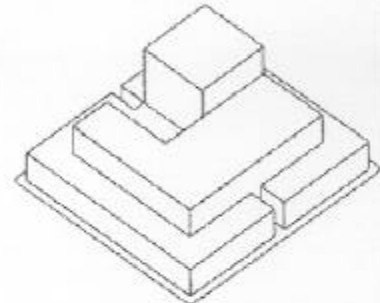

M-2 FULL BLOCK MID-RISE (FRANCISCAN HOTEL TYPE)

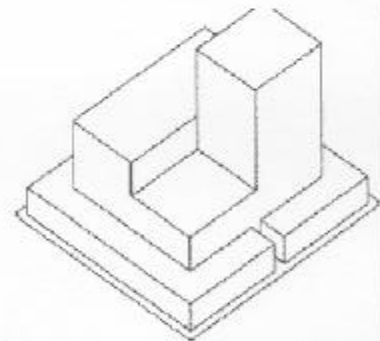

M-3 FULL BLOCK HIGH-RISE (HYATT HOTEL TYPE)

Example



**URBAN
REGULATIONS**

WRAPPER BUILDING:

PLACEMENT:

1. Lot Width: 300'
2. Street Frontage: 90% minimum articulated at 25', 50', or 75' increments
3. Lot Depth: 142' to alley at mid-block
4. Building Depth: 20' minimum, 40' preferred
5. Recessed corners shall not exceed 10% of street frontage

PARKING:

1. Types: Interior surface lot, interior garage, or "park-once" garage
2. Access: through alley

HEIGHT AND PROFILE:

1. Street Frontage Height: 3 stories at block centers and 5 stories at street corners
2. Setback: 0'

EXAMPLES:

1. Commercial or Retail on street frontage with mixed-use housing or office lofts above

INTERIOR BUILDING:

HEIGHT AND PROFILE:

1. Height: No restrictions
2. Setback: 20' minimum with 40' preferred

EXAMPLES:

1. Parking; Cinema; "Big-Box" Retail; Office; Hotel; Residential

Sample Block Plan



TYPE DESCRIPTION

Large floor plate structure surrounded by low-scale "wrapper" or "liner" buildings at street frontage located on a half-block.

Bird's Eye View

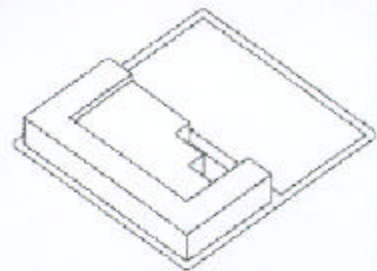

N-1 1/2 BLOCK LOW-RISE

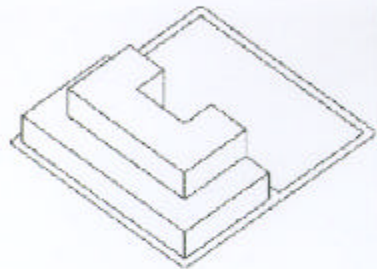

N-2 1/2 BLOCK MID-RISE

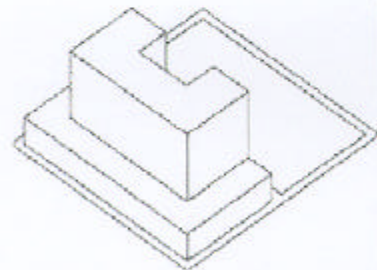

N-3 1/2 BLOCK HIGH-RISE

Example



URBAN REGULATIONS

WRAPPER BUILDING:

PLACEMENT:

1. Lot Width: 150'
2. Street Frontage: 90% minimum articulated at 25', 50', or 75' increments
3. Lot Depth: 142' to alley at mid-block
4. Building Depth: 20' minimum, 40' preferred
5. Recessed corners shall not exceed 10% of street frontage

PARKING:

1. Types: Interior surface lot, interior garage, or "park-once" garage
2. Access: through alley

HEIGHT AND PROFILE:

1. Street Frontage Height: 3 stories at block centers and 5 stories at street corners
2. Setback: 0'

EXAMPLES:

1. Commercial or Retail on street frontage with mixed-use housing or office lofts above

INTERIORS BUILDING:

HEIGHT AND PROFILE:

1. Height: No restrictions
2. Setback: 20' minimum with 40' preferred

EXAMPLES:

1. Parking; Cinema; "Big-Box" Retail; Office; Hotel; Residential

SAMPLE BLOCK

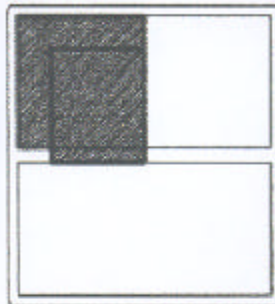

TYPE DESCRIPTION

Large floor plate structure surrounded by low-scale "wrapper" or "liner" buildings at street frontage located on a quarter-block.

Bird's Eye View

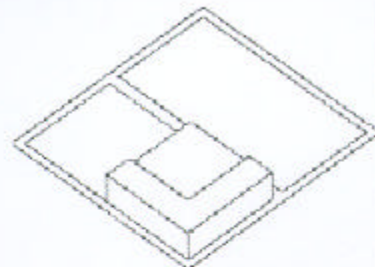

O-1 1/4 BLOCK LOW-RISE

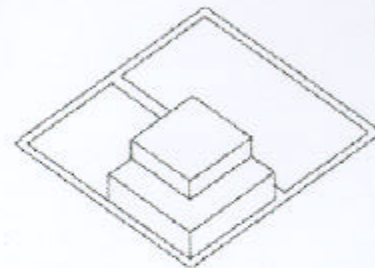

O-2 1/4 BLOCK MID-RISE

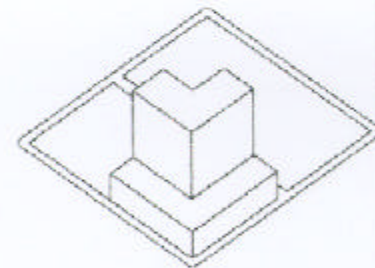

O-3 1/4 BLOCK HIGH-RISE (LA POSADA HOTEL TYPE)

Example



**URBAN
REGULATIONS**

PLACEMENT:

1. Lot Width: 25', 50', or 75'
2. Street Frontage: 90% minimum
3. Lot Depth: 142' maximum

PARKING:

1. Convenience and service parking alley also required at "Park-Once" garages
2. Access: through alley

HEIGHT AND PROFILE:

1. Street Frontage Height: 3 stories maximum and 5 stories 20' from street frontage
2. Setback: 0', 20' at 3rd Level and up

EXAMPLES:

1. Commercial and Retail on street frontage with mixed-use housing or office lofts above

Sample Block Plan

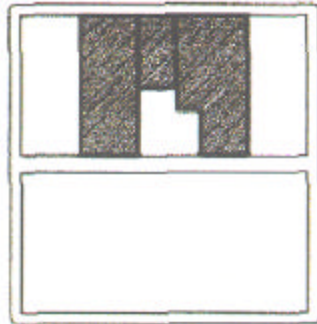

TYPE DESCRIPTION

Infill buildings located on mid-blocks.

Bird's Eye View

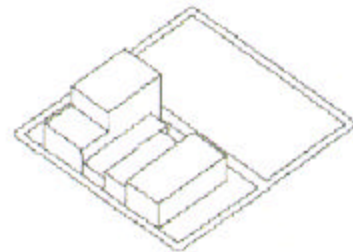

**P - MID-BLOCK
(CENTRAL AVENUE TYPE)**

Examples



**URBAN
REGULATIONS**

PLACEMENT:

1. Lot Width: 50', 75' or 100'
2. Street Frontage: 90% minimum
3. Lot Depth: 142' maximum

PARKING:

1. Convenience and service parking at alley
2. Access: through alley

HEIGHT AND PROFILE:

1. Street Frontage Height: 5 stories maximum
2. Setback: 0'

EXAMPLES:

1. Commercial or Retail on street frontage with mixed-use housing or office lofts above

Sample Block Plan

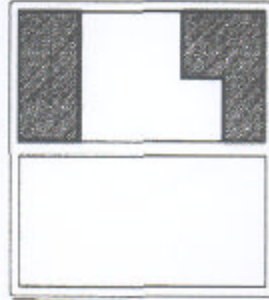

TYPE DESCRIPTION

Infill buildings located on street corner lots.

Bird's Eye View

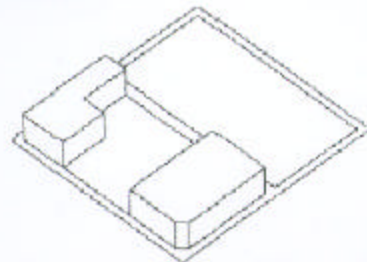

Q -1 END BLOCK LOW-RISE
(WOOLWORTH TYPE)

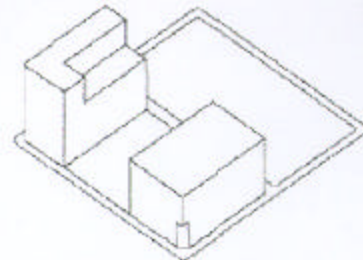

Q -2 END BLOCK MID-RISE
(SUNSHINE BUILDING TYPE)

Examples





The Downtown should serve as Albuquerque's urban main street experience. Street level designs of buildings should be visually interesting and reinforce the image of downtown as a premier urban district. All buildings shall have street level windows, window boxes, entrances, and architectural details.

- A. Building and Street Relationships
 - Standard 1: Access
 - Standard 2: Building Entrances

- B. Pedestrian Orientation and Parking
 - Standard 1: Blank Walls
 - Standard 2: Architectural Details
 - Standard 3: Sidewalks
 - Standard 4: Street Trees
 - Standard 5: Surface Parking
 - Standard 6: Parking Garages
 - Standard 7: Combined Blocks

- C. Plazas and Courtyards
 - Standard 1: Street-Level Orientation
 - Standard 2: Security and Lighting

- D. Building Facades
 - Standard 1: Open Building Frontage
 - Standard 2: Setbacks
 - Standard 3: Building Alignment on Central Avenue
 - Standard 4: Corner Buildings
 - Standard 5: Texture and Pattern on Building Facades on Central Avenue

- E. Lighting and Signage
 - Standard 1: Exterior Lighting Plan
 - Standard 2: Neon Lighting for Buildings on Central Avenue
 - Standard 3: Safety and Visibility
 - Standard 4: Marquee

- F. Historic Preservation
 - Standard 1: Preserving Facades

INTENT

Provide unobstructed access from sidewalks to buildings used by the general public.

Example 1 *Commercial Not Permitted*



Example 2



Residential

Example 3

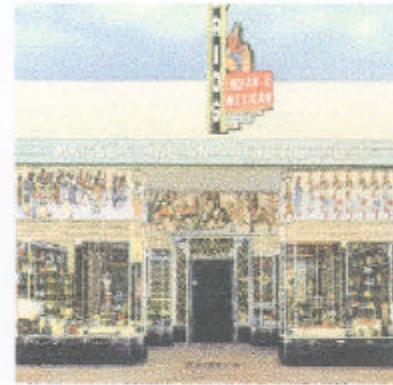

Commercial

STANDARD

Public Access to commercial and governmental buildings shall be provided at sidewalk grade. The primary floor of , and access to, residential structures may be elevated.

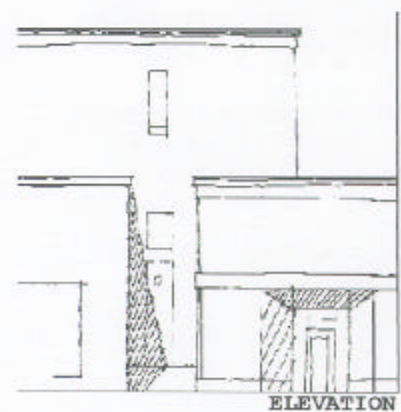
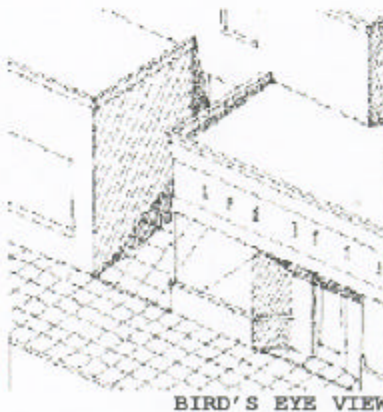
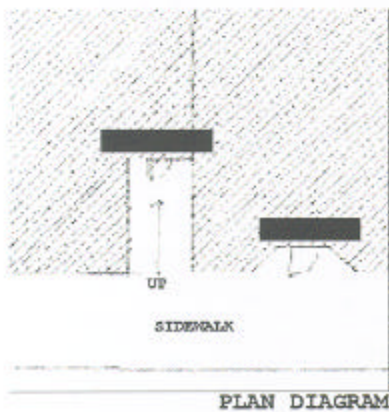

INTENT

Provide safe and easy passage from the public realm into individual buildings.

Example 1

Not Permitted



Example 2



Example 3



STANDARD

The front doors of all buildings shall be visible from the street. If located more than 10 feet from the front building line, their location must be reinforced with additional graphics, lighting, marquees or canopies.

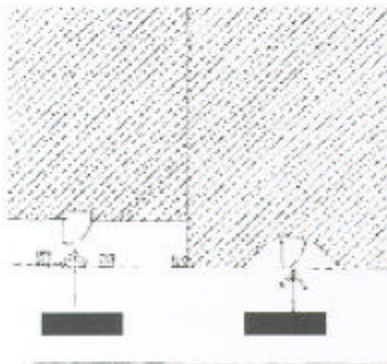

PLAN DIAGRAM

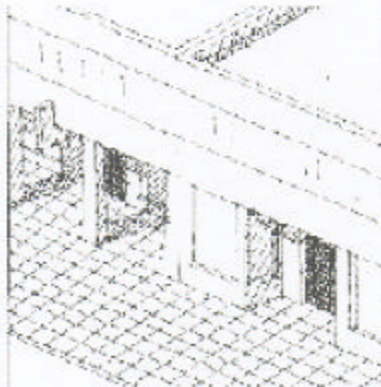

BIRD'S EYE VIEW

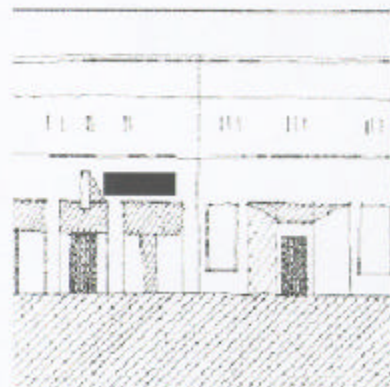

ELEVATION

INTENT

Provide interest for the pedestrian at the ground level of buildings by limiting unembellished solid walls.

Example 1

Not Permitted



Example 2



Example 3



STANDARD

Blank walls in excess of 25% or 10 continuous feet of the frontage of the property shall not be used at the street level. Blank walls must contain architectural relief such as expressive details, blind windows, murals, etc.

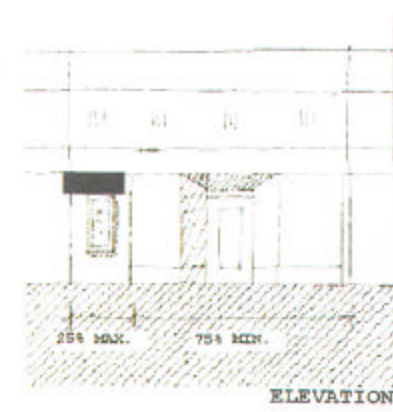
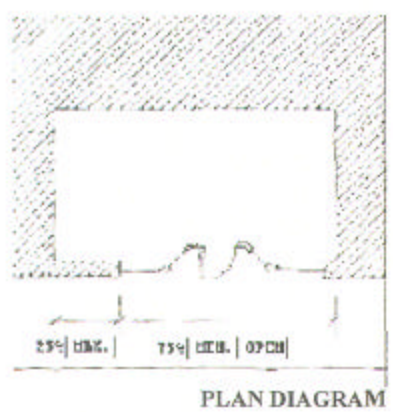

INTENT

Provide interest for the pedestrian at the ground level of buildings through detailing at close view.

Example 1

Not Permitted



Example 2



Example 3



STANDARD

All buildings shall provide scale-defining architectural elements or details at the first two floor levels minimum, such as windows, spandrels, awnings, porticos, pediments, cornices, pilasters, columns and balconies.

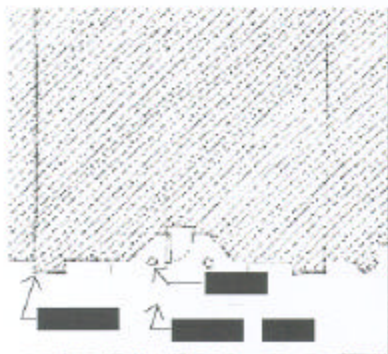

PLAN DIAGRAM

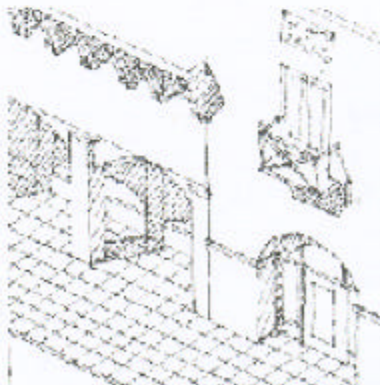

BIRD'S EYE VIEW

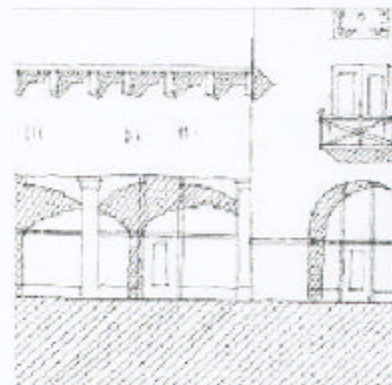

ELEVATION

INTENT

Allow sufficient room for pedestrian passage and additional use of sidewalk such as cafe tables.

Example 1

Not Permitted



Example 2



Example 3



STANDARD

Width of sidewalks shall be maximized within the available right-of-way. A minimum of 48" of the sidewalk must be clear of any obstruction for the entire length of the property.

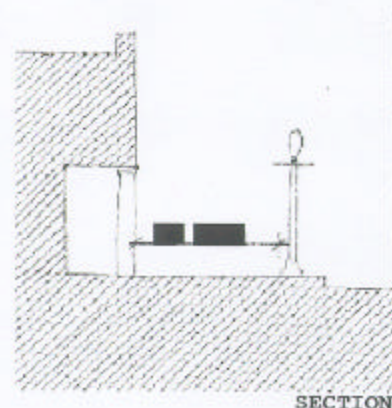
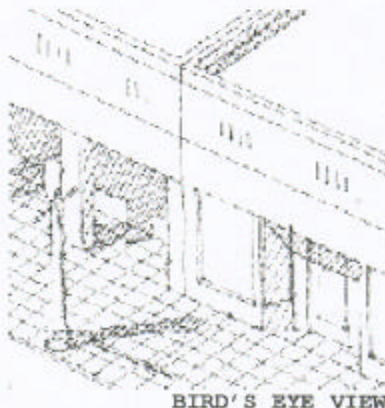

INTENT

Create shaded sidewalks and vertical landscape throughout the downtown.

Example 1

Not Permitted



Example 2



Example 3



STANDARD

Street trees must be provided to the extent that the sidewalk width permits. Selection shall be from the approved list of Downtown street trees and shall be consistent with the established landscape palette.

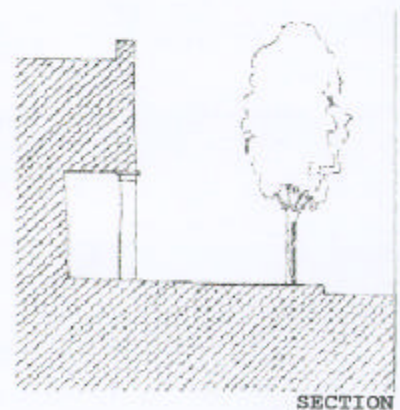
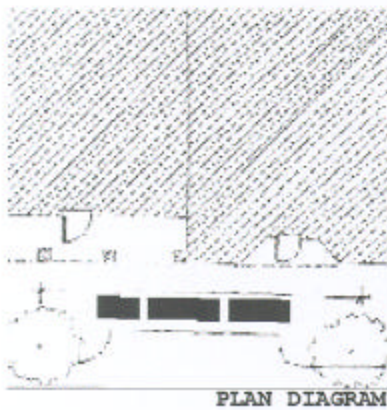

INTENT

Streets and sidewalks lined with buildings rather than parking lots.

Example 1

Not Permitted



Example 2



Example 3



STANDARD

- A. On Central Avenue (between 1st Street and 8th Street) surface parking must be located behind buildings.
- B. Elsewhere in the Downtown, surface parking can not be between the building and the front property line. Parking between the building and the side lot line must be screened from the street by a solid fence or wall at a minimum height of 48".
- C. Shared parking is strongly encouraged.
- D. There is no minimum requirement for parking downtown.
- E. At least 15% of the ground area of parking lots (including driveways) shall be devoted to landscaping along the street right-of-way.

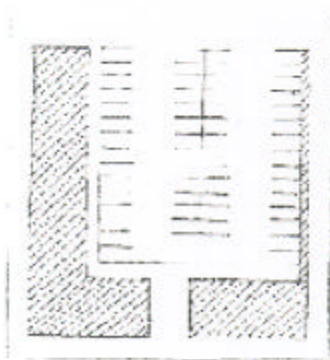

PLAN DIAGRAM

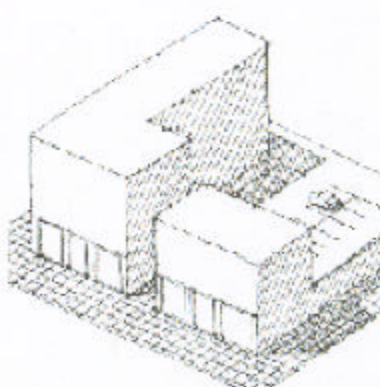

BIRD'S EYE VIEW

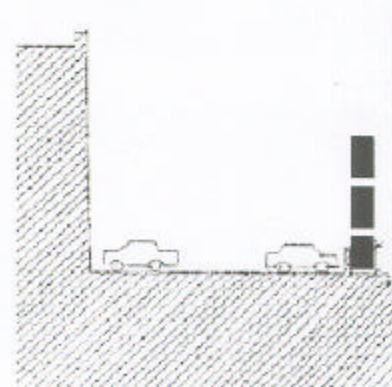

SECTION

INTENT

Parking garages that contribute to pedestrian life through ground level use, scale and detail.

Example 1

Not Permitted



Example 2



Example 3



STANDARD

Parking garages must have a minimum of 50% of their sidewalk frontage along the street (excluding the ingress and egress) designed as retail, commercial or office space. The entire first floor, floor to ceiling height, shall be designed to accommodate future retail, commercial or office uses. There is no minimum depth required for retail, commercial or office uses. Interim uses could include news stands, flower shops, ATM's, display windows, telephone booths, payment boxes, etc.

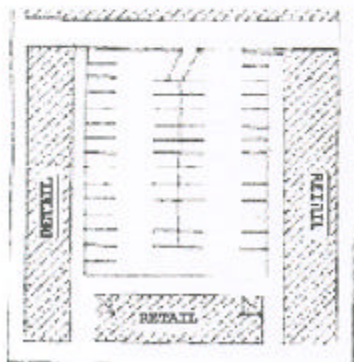

PLAN DIAGRAM

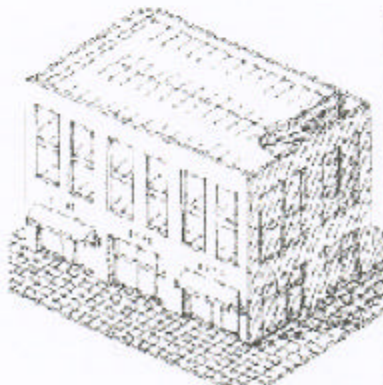

BIRD'S EYE VIEW

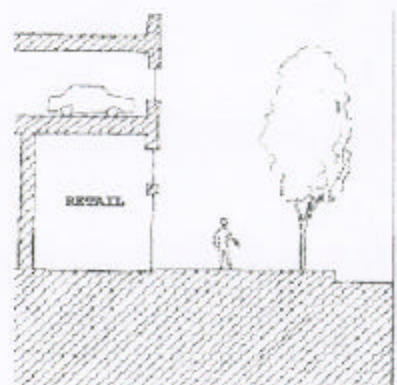

SECTION

INTENT

To keep the traditional Downtown grid of streets and alleys intact, for maximum pedestrian choice and activity.

Example 1

Not Permitted

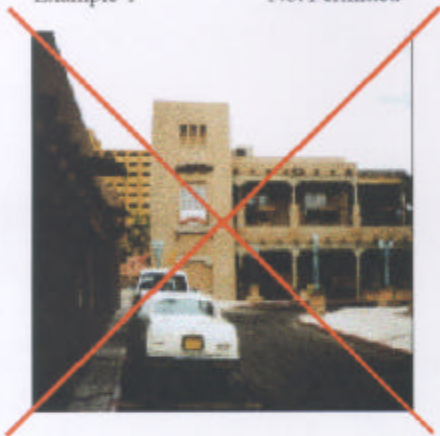

Example 2



Example 3



STANDARD

If the traditional street grid is broken for development, pedestrian connections shall be established to replace those vacated. These connections shall be a continuation of the existing grid and allow for service access.

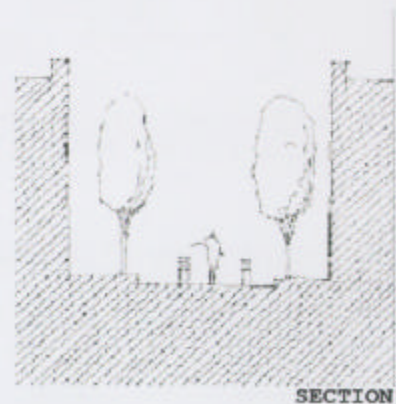
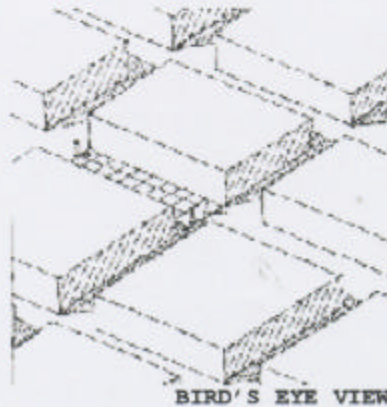

INTENT

To make a seamless connection between the sidewalks at the street and courtyards and plazas towards the interior of the block.

Example 1

Not Permitted



Example 2



Example 3



STANDARD

Plazas designed to be accessible to the public shall be constructed at sidewalk grade. Access to these plazas shall be highly visible, well developed and connected to the street system or to other planned or developed public spaces.

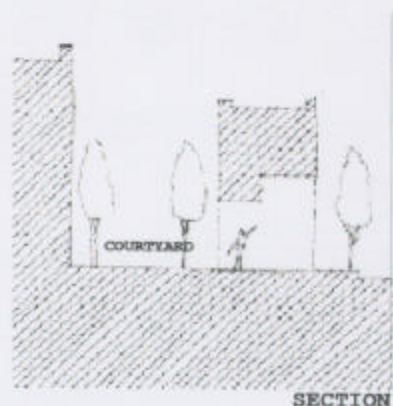
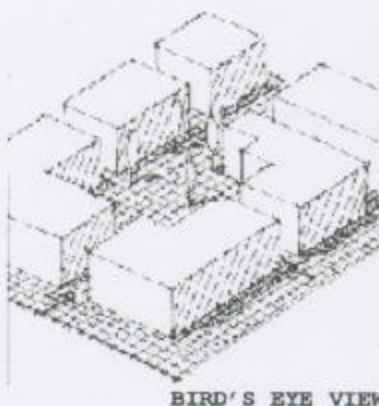
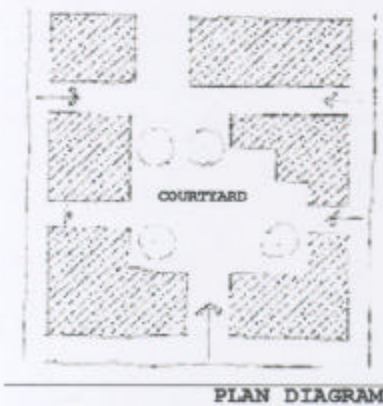

INTENT

Provide a safe and welcoming connection between the sidewalks at the street and courtyards and plazas toward the interior of the block.

Example 1

Not Permitted



Example 2



Example 3



STANDARD

Plaza and courtyard spaces, shall provide pedestrian connections to streets and other planned or developed plazas and courtyards. These connections shall be safe secure through the use of adequate pedestrian lighting. This lighting should accent the ground plane and the building facades.

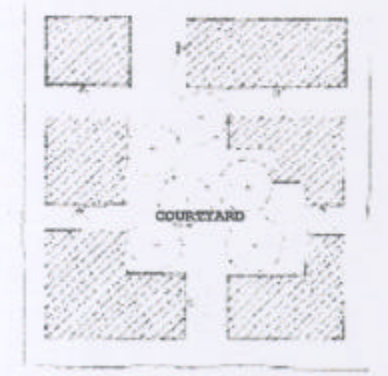

PLAN DIAGRAM

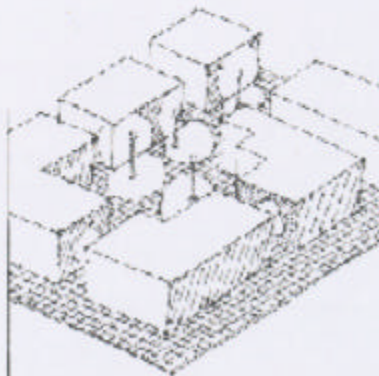

BIRD'S EYE VIEW

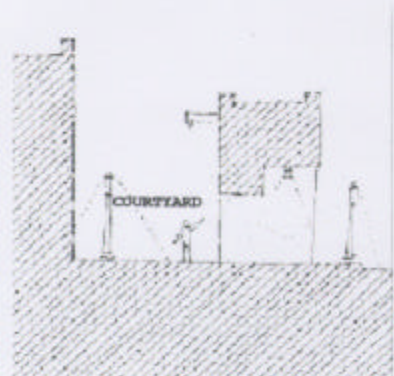

SECTION

INTENT

To visually extend the pedestrian's realm and provide interest along the sidewalk, as well as allowing people inside opportunity to observe the passing street scene.

Example 1

Not Permitted



Example 2



Example 3



STANDARD

A minimum of 75% of commercial building frontage on the first floor level shall be transparent.

"Open Frontage" includes window display areas, or other transparent material.

"Transparent" is defined as the material that permits easy viewing into the building from the sidewalk. The material shall be transparent from a minimum distance of 3 feet. Reflective glass shall not be used at the first floor level.

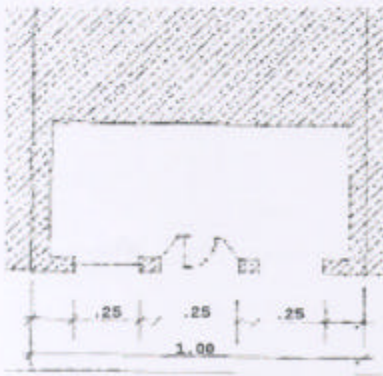

PLAN DIAGRAM

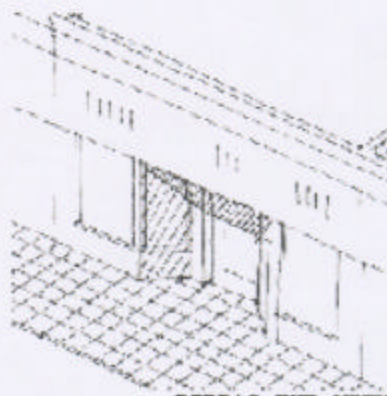

BIRD'S EYE VIEW

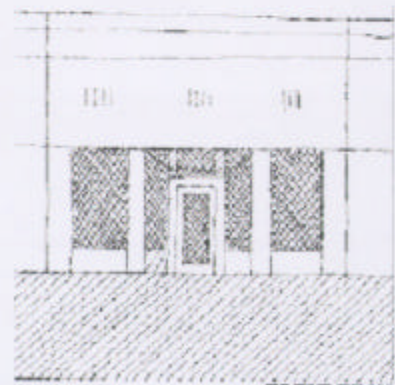

ELEVATION

INTENT

The creation of a continuous street wall without significant breaks that defines the public space of the street.

Example 1

Not Permitted



Example 2



Example 3



STANDARD

The street facade of buildings may be setback a maximum of 15 feet from the front lot line, except those buildings facing Central Avenue between Eight Street and First Street, which shall meet Standard 3. In general, it is preferred to keep the street facade built to the property line, in alignment with adjacent buildings.

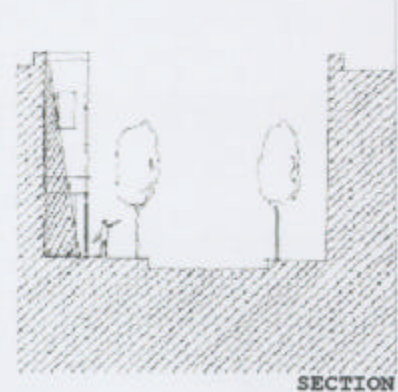
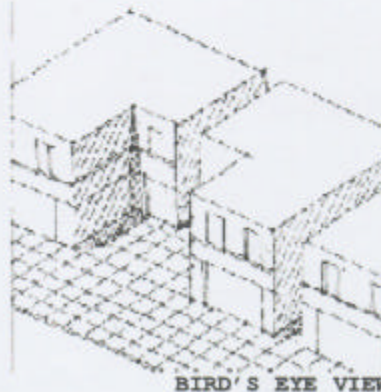
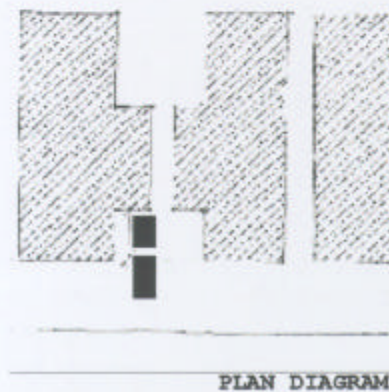

INTENT

The establishment of a continuous street wall, with variety provided in building width and height.

Example 1

Not Permitted



Example 2



Example 3



STANDARD

For buildings on Central Avenue between 8th and the railroad tracks: A minimum of one facade element shall align horizontally with adjacent buildings. Facade elements include, but are not limited to, roof tops, cornices, signs, storefront windows, windows above the first floor and awnings. Awnings are encouraged on the north side of Central Avenue. There should be a balance between variety and harmony of building facades. Maintain the similarity in the building width. New or larger buildings on parcels wider than 40' (maximum 100') shall incorporate architectural elements which reflect the width of adjacent buildings. Successful methods for achieving this include, but are not limited to, window pattern and detail placement.

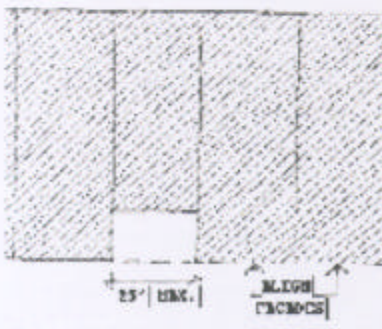

PLAN DIAGRAM

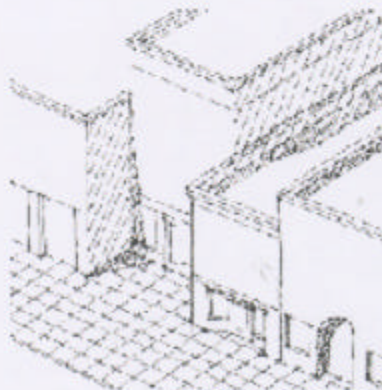

BIRD'S EYE VIEW



ELEVATION

INTENT

Corner buildings shall relate to the activities of the intersection and encourage activity through their design.

Example 1

Not Permitted



Example 2



Example 3



STANDARD

Appropriate design of the corner shall include one of the following successful patterns:

- 1 Opening the space at ground level for people to walk around the corner with the building mass above redefining the corner
- 2 A recessed entry at the corner such as the familiar angled wall with an entry door.
- 3 A corner window with an important view into the building



PLAN DIAGRAM



BIRD'S EYE VIEW

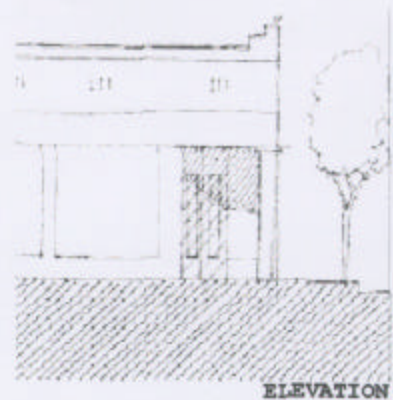

ELEVATION

INTENT

Create pedestrian interest by using materials that relate to the traditional context of Downtown.

Example 1

Not Permitted



Example 2



Example 3



STANDARD

For buildings on Central Avenue between 8th Street and the railroad tracks: Building facades shall incorporate patterned and textured elements that add visual interest to the surface. These elements should be based on materials and patterns that relate to the traditions of Downtown buildings.

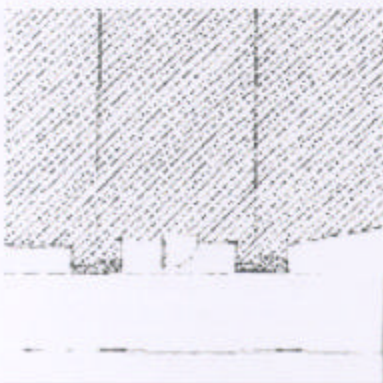

PLAN DIAGRAM

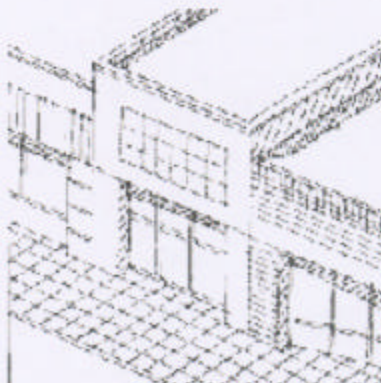

BIRD'S EYE VIEW

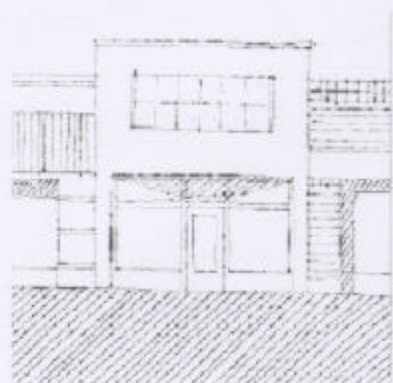

ELEVATION

INTENT

Provide a safe and appealing nighttime environment for the Downtown.

Example 1

Not Permitted



Example 2



Example 3



STANDARD

The design for a proposed facade must consider the appearance of the building in the evening and develop an exterior lighting plan that includes display window lighting, building lighting, and pedestrian-scaled lighting for both buildings and pedestrian areas within the site. Lighting shall be warm in color, with control of glare for the pedestrian.

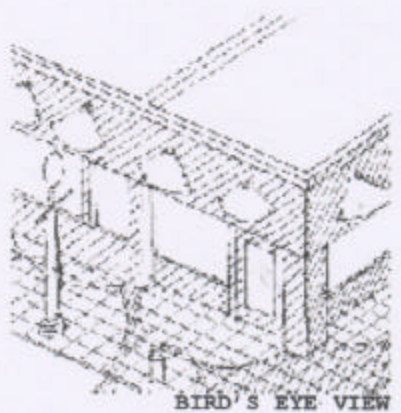
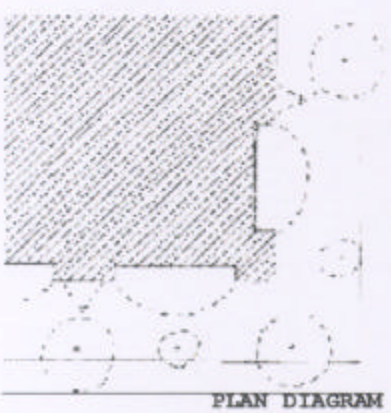

INTENT

Provide an exciting nighttime environment for the Downtown.

Example 1



Not Permitted

Example 2



Example 3



STANDARD

For buildings on Central Avenue between 8th Street and the railroad tracks: the use of neon and fiber optic lighting should be considered since it can contribute to the tradition of strong decorative lighting on Central Avenue. Signage on marquees, blade signs, sign bands, outline of significant architectural details, and in window are all encouraged.

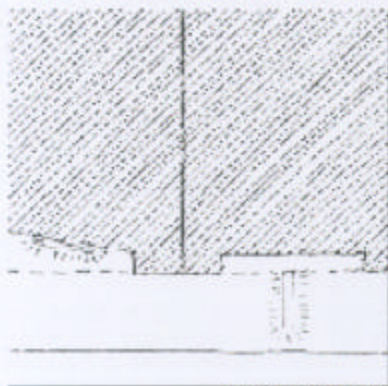

PLAN DIAGRAM

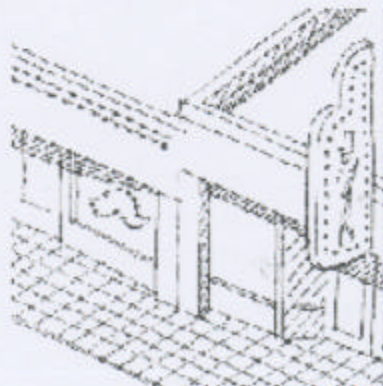

BIRD'S EYE VIEW

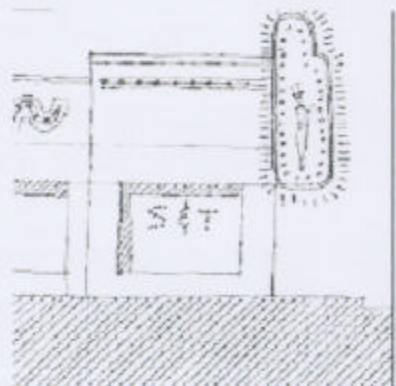

ELEVATION

INTENT

Provide sufficient lighting for safe pedestrian passage in Downtown.

Example 1

Not Permitted



Example 2



Example 3



STANDARD

Adequate lighting must be provided for safety and visibility at night. Project plans must include illumination levels and color rendition of exterior building lighting adjacent to sidewalks.

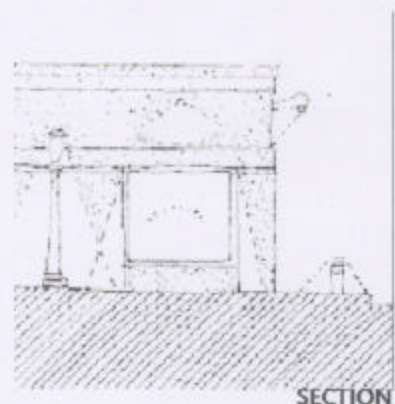
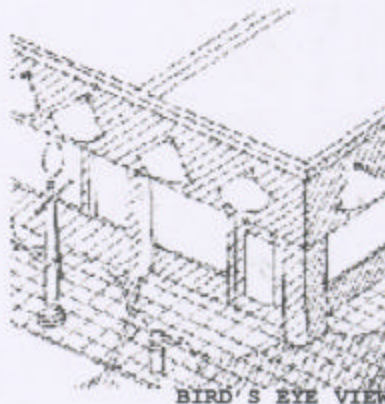
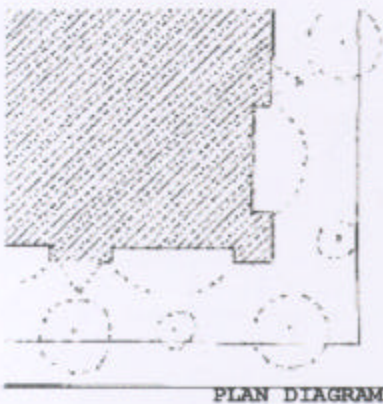

INTENT

Create identity for individual stores and buildings through projecting signs.

Example 1

Not Permitted



Example 2



Example 3



STANDARD

Signs may project into the right of way a maximum of half the adjacent sidewalk width, and the bottom of the sign shall be a minimum of 12 feet above the sidewalk, except along Central Avenue from the railroad tracks to the 8th Street where the sign may project three-quarters of the sidewalk width.

(In addition to these standards, all zoning code regulations regarding signage will apply).

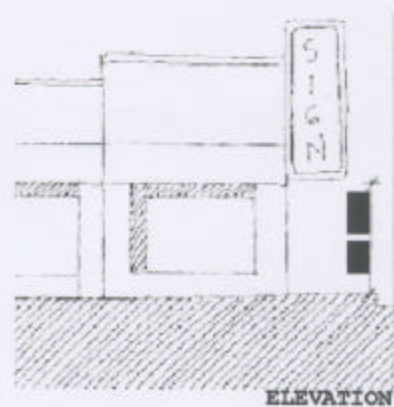
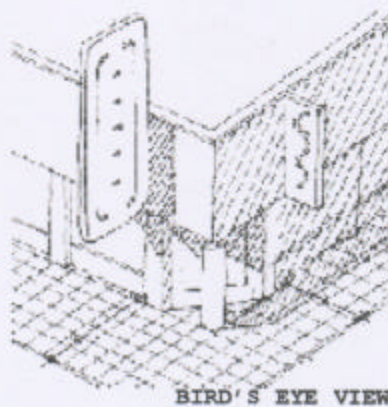
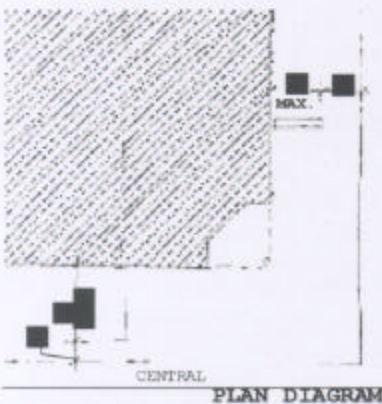

INTENT

Maintain the existing fabric of historic building facades.

Example 1

Not Permitted

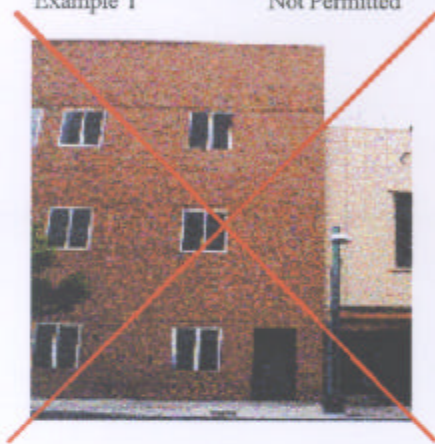

Example 2



Example 3



STANDARD

Buildings shall incorporate elements of the original facade into the renovation scheme:

1. Do not cover existing original facade details by covering them with panels, signs, or by painting them out:
2. Do not alter the shape of existing original openings. If a window must be blocked, maintain its original shape.
3. Restore, where possible, the original facade by removing later additions of materials.

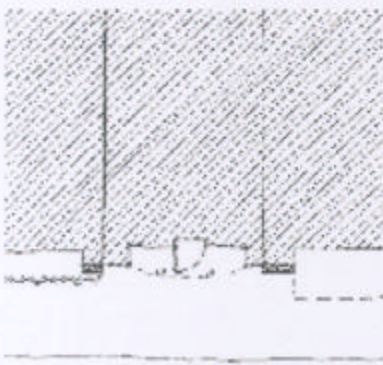

PLAN DIAGRAM

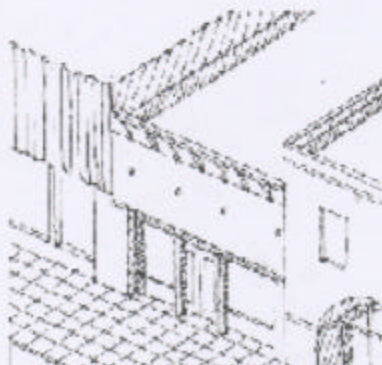

BIRD'S EYE VIEW

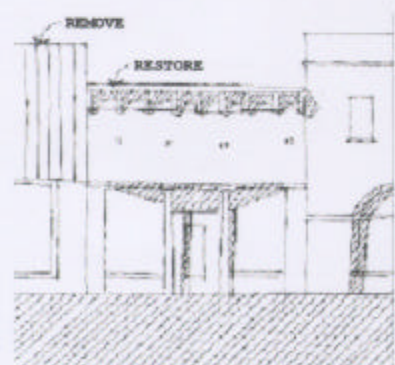

ELEVATION



approval process

By adhering to the District's Plan and Uses, and the Building Types and Standards, as well as preparing complete project documents, a proposed Downtown development will be reviewed and approved within 21 - 24 working days. Following is a chart which outlines the process to obtain a building permit. It is mandatory that applicants present and discuss their project, in its entirety, with the appropriate departments at a Pre-Application meeting. It is also critical for the applicant to understand if their proposed project is a permitted, review required, or prohibited use prior to starting the approval process. Permitted uses will go through either a renovation or a new construction process. "Review Required" uses must go through the Environmental Planning Commission (EPC) process and make a case as to why and how the proposed use fits into the Downtown Plan. The applicant for the proposed use must demonstrate that the use will be compatible with surrounding uses in the district and that it would not be injurious to surrounding properties, adjacent neighborhoods or the community. The EPC may approve or disapprove the proposed use. The EPC's decision is appealable to the City Council in accordance with Section 14-16-4-4 of the Zoning Code.

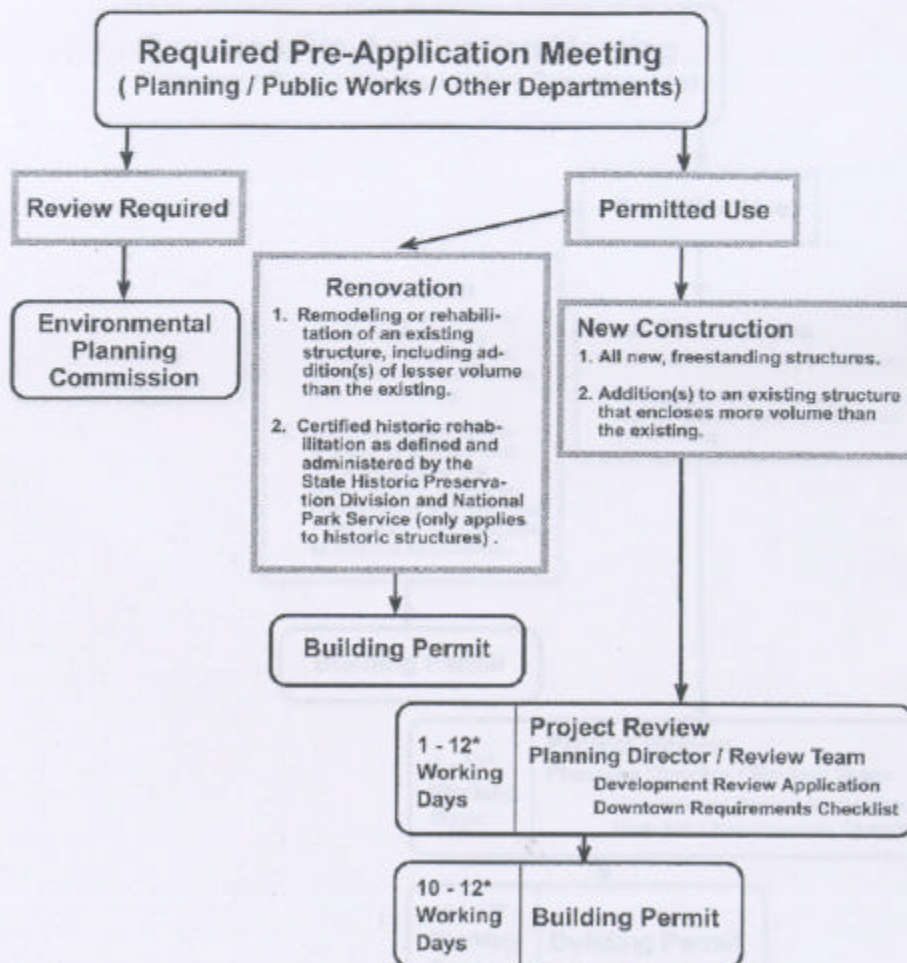

* Estimated Review Process Time = Actual City review time in working days.