

### 8.5.3 Ammonium Phosphate

#### 8.5.3.1 General<sup>1</sup>

Ammonium phosphate ( $\text{NH}_4\text{H}_2\text{PO}_4$ ) is produced by reacting phosphoric acid ( $\text{H}_3\text{PO}_4$ ) with anhydrous ammonia ( $\text{NH}_3$ ). Ammoniated superphosphates are produced by adding normal superphosphate or triple superphosphate to the mixture. The production of liquid ammonium phosphate and ammoniated superphosphates in fertilizer mixing plants is considered a separate process. Both solid and liquid ammonium phosphate fertilizers are produced in the U. S. This discussion covers only the granulation of phosphoric acid with anhydrous ammonia to produce granular fertilizer. Total ammonium phosphate production in the U. S. in 1992 was estimated to be 7.7 million megagrams (Mg) (8.5 million tons).<sup>2</sup>

#### 8.5.3.2 Process Description<sup>1</sup>

Two basic mixer designs are used by ammoniation-granulation plants: the pugmill ammoniator and the rotary drum ammoniator. Approximately 95 percent of ammoniation-granulation plants in the U. S. use a rotary drum mixer developed and patented by the Tennessee Valley Authority (TVA). The basic rotary drum ammoniator-granulator consists of a slightly inclined open-end rotary cylinder with retaining rings at each end, and a scraper or cutter mounted inside the drum shell. A rolling bed of recycled solids is maintained in the unit.

Ammonia-rich offgases pass through a wet scrubber before exhausting to the atmosphere. Primary scrubbers use raw materials mixed with acids (such as scrubbing liquor), and secondary scrubbers use gypsum pond water.

In the TVA process, phosphoric acid is mixed in an acid surge tank with 93 percent sulfuric acid ( $\text{H}_2\text{SO}_4$ ), which is used for product analysis control, and with recycled acid from wet scrubbers. (A schematic diagram of the ammonium phosphate process flow diagram is shown in Figure 8.5.3-1.) Mixed acids are then partially neutralized with liquid or gaseous anhydrous ammonia in a brick-lined acid reactor. All of the phosphoric acid and approximately 70 percent of the ammonia are introduced into this vessel. A slurry of ammonium phosphate and 22 percent water are produced and sent through steam-traced lines to the ammoniator-granulator. Slurry from the reactor is distributed on the bed; the remaining ammonia (approximately 30 percent) is sparged underneath. Granulation, by agglomeration and by coating particulate with slurry, takes place in the rotating drum and is completed in the dryer. Ammonia-rich offgases pass through a wet scrubber before exhausting to the atmosphere. Primary scrubbers use raw materials mixed with acid (such as scrubbing liquor), and secondary scrubbers use pond water.

Moist ammonium phosphate granules are transferred to a rotary concurrent dryer and then to a cooler. Before being exhausted to the atmosphere, these offgases pass through cyclones and wet scrubbers. Cooled granules pass to a double-deck screen, in which oversize and undersize particles are separated from product particles. The product ranges in granule size from 1 to 4 millimeters. The oversized granules are crushed, mixed with the undersized, and recycled back to the ammoniator-granulator.

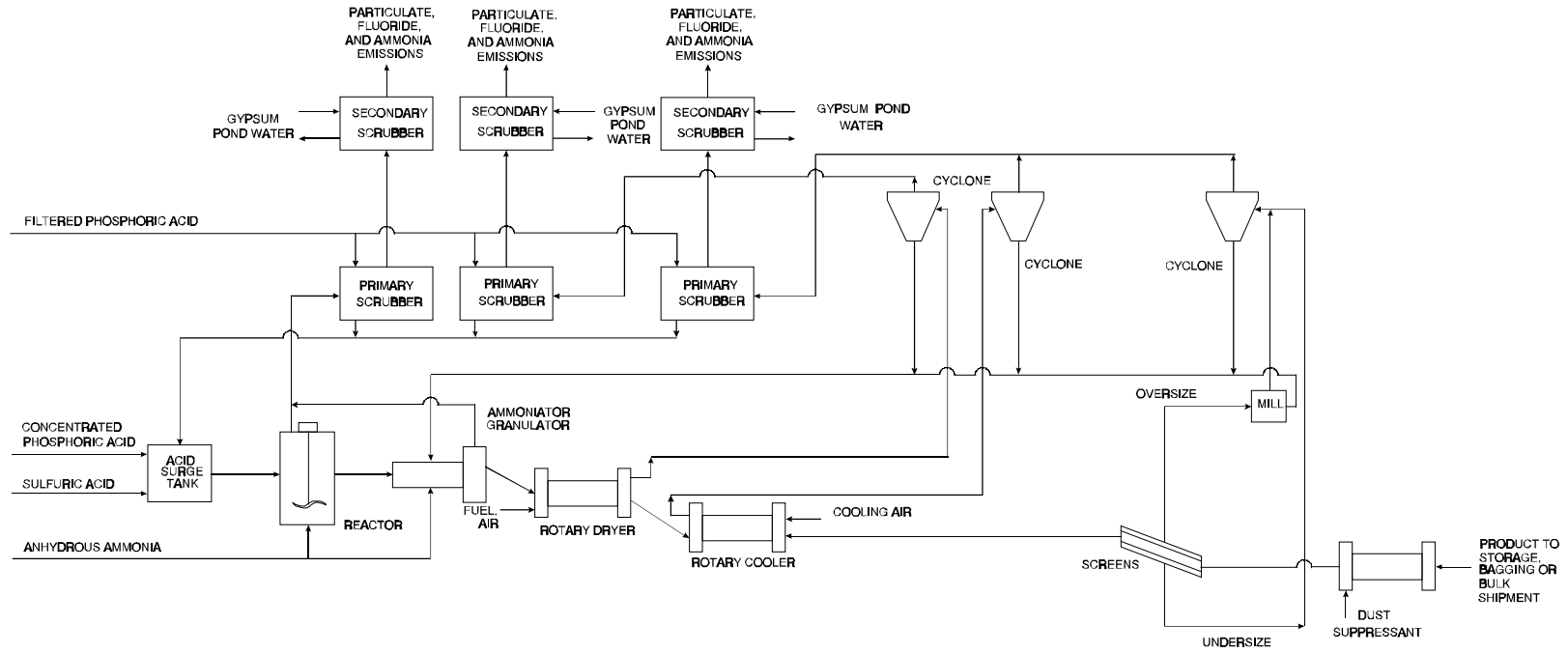

Figure 8.5.3-1. Ammonium phosphate process flow diagram.

### 8.5.3.3 Emissions And Controls<sup>1</sup>

Sources of air emissions from the production of ammonium phosphate fertilizers include the reactor, the ammoniator-granulator, the dryer and cooler, product sizing and material transfer, and the gypsum pond. The reactor and ammoniator-granulator produce emissions of gaseous ammonia, gaseous fluorides such as hydrogen fluoride (HF) and silicon tetrafluoride (SiF<sub>4</sub>), and particulate ammonium phosphates. These 2 exhaust streams are generally combined and passed through primary and secondary scrubbers.

Exhaust gases from the dryer and cooler also contain ammonia, fluorides, and particulates and these streams are commonly combined and passed through cyclones and primary and secondary scrubbers. Particulate emissions and low levels of ammonia and fluorides from product sizing and material transfer operations are controlled the same way.

Emissions factors for ammonium phosphate production are summarized in Table 8.5.3-1. Units are expressed in terms of kilograms per megagram (kg/Mg) and pounds per ton (lb/ton) of product. These emission factors are averaged based on recent source test data from controlled phosphate fertilizer plants in Tampa, Florida.

Table 8.5.3-1 (Metric And English Units). AVERAGE CONTROLLED EMISSION FACTORS FOR THE PRODUCTION OF AMMONIUM PHOSPHATES<sup>a</sup>

EMISSION FACTOR RATING: E (except as noted)

Emission Point	Fluoride as F		Particulate		Ammonia		SO <sub>2</sub>	
	kg/Mg Of Product	lb/ton Of Product	kg/Mg Of Product	lb/ton Of Product	kg/Mg Of Product	lb/ton Of Product	kg/Mg Of Product	lb/ton Of Product
Reactor/ ammoniator - granulator	0.02	0.05	0.76	1.52	ND	ND	NA	NA
Dryer/cooler	0.02	0.04	0.75	1.50	NA	NA	NA	NA
Product sizing and material transfer <sup>b</sup>	0.001	0.002	0.03	0.06	NA	NA	NA	NA
Total plant emissions	0.02 <sup>c</sup>	0.04 <sup>c</sup>	0.34 <sup>d</sup>	0.68 <sup>d</sup>	0.07	0.14	0.04 <sup>e</sup>	0.08 <sup>e</sup>

<sup>a</sup> Reference 1, pp. 80-83, 173. ND = no data. NA = not applicable.

<sup>b</sup> Represents only 1 sample.

<sup>c</sup> References 7-8,10-11,13-15. EMISSION FACTOR RATING: A. EPA has promulgated a fluoride emission guideline of 0.03 kg/Mg (0.06 lb/ton) P<sub>2</sub>O<sub>5</sub> input.

<sup>d</sup> References 7-9,10,13-15. EMISSION FACTOR RATING: A.

<sup>e</sup> Based on limited data from only one plant, Reference 9.

Exhaust streams from the reactor and ammoniator-granulator pass through a primary scrubber, in which phosphoric acid is used to recover ammonia and particulate. Exhaust gases from the dryer,

cooler, and screen first go to cyclones for particulate recovery, and then to primary scrubbers. Materials collected in the cyclone and primary scrubbers are returned to the process. The exhaust is sent to secondary scrubbers, where recycled gypsum pond water is used as a scrubbing liquid to control fluoride emissions. The scrubber effluent is returned to the gypsum pond.

Primary scrubbing equipment commonly includes venturi and cyclonic spray towers. Impingement scrubbers and spray-crossflow packed bed scrubbers are used as secondary controls. Primary scrubbers generally use phosphoric acid of 20 to 30 percent as scrubbing liquor, principally to recover ammonia. Secondary scrubbers generally use gypsum and pond water for fluoride control.

Throughout the industry, however, there are many combinations and variations. Some plants use reactor-feed concentration phosphoric acid (40 percent phosphorous pentoxide [ $P_2O_5$ ]) in both primary and secondary scrubbers, and some use phosphoric acid near the dilute end of the 20 to 30 percent  $P_2O_5$  range in only a single scrubber. Existing plants are equipped with ammonia recovery scrubbers on the reactor, ammoniator-granulator and dryer, and particulate controls on the dryer and cooler. Additional scrubbers for fluoride removal exist, but they are not typical. Only 15 to 20 percent of installations contacted in an EPA survey were equipped with spray-crossflow packed bed scrubbers or their equivalent for fluoride removal.

Emission control efficiencies for ammonium phosphate plant control equipment are reported as 94 to 99 percent for ammonium, 75 to 99.8 percent for particulates, and 74 to 94 percent for fluorides.

#### References For Section 8.5.3

1. J. M. Nyers, *et al.*, *Source Assessment: Phosphate Fertilizer Industry*, EPA-600/2-79-019c, U. S. Environmental Protection Agency, Cincinnati, OH, May 1979.
2. North American Fertilizer Capacity Data, Tennessee Valley Authority, Muscle Shoals, AL, December 1991.
3. *Compliance Source Test Report: Texasgulf Inc., Granular Triple Super Phosphate Plant*, Aurora, NC, May 1987.
4. *Compliance Source Test Report: Texasgulf Inc., Diammonium Phosphate Plant No.2*, Aurora, NC, August 1989.
5. *Compliance Source Test Report: Texasgulf Inc., Diammonium Phosphate Plant #2*, Aurora, NC, December 1991.
6. *Compliance Source Test Report: Texasgulf, Inc., Diammonium Phosphate #1*, Aurora, NC, September 1990.
7. *Compliance Source Test Report: Texasgulf Inc., Ammonium Phosphate Plant #2*, Aurora, NC, November 1990.
8. *Compliance Source Test Report: Texasgulf Inc., Diammonium Phosphate Plant #2*, Aurora, NC, November 1991.
9. *Compliance Source Test Report: IMC Fertilizer, Inc., #1 DAP Plant*, Western Polk County, FL, October 1991.

10. *Compliance Source Test Report: IMC Fertilizer, Inc., #2 DAP Plant, Western Polk County, FL, June 1991.*
11. *Compliance Source Test Report: IMC Fertilizer, Inc., Western Polk County, FL, April 1991.*