

# METHODS FOR MEASURING AND MONITORING FORESTRY CARBON PROJECTS IN CALIFORNIA



Arnold Schwarzenegger  
*Governor*

*Prepared For:*

**California Energy Commission**  
Public Interest Energy Research Program

*Prepared By:*

**Winrock International**

**PIER FINAL PROJECT REPORT**

April 2004

500-04-072F

**Prepared By:**

Winrock International  
Arlington, Virginia

Sandra Brown  
David Shoch  
Tim Pearson  
Matt Delaney

Contract No. 100-98-001

**Prepared For:**

California Energy Commission

Guido Franco,  
**Contract Manager**

Kelly Birkinshaw,  
**Program Manager**  
**Energy-Related Environmental Research**

Terry Surles,  
**PIER Program Director**

Robert L. Therkelsen,  
**Executive Director**



**DISCLAIMER**

This report was prepared as a result of work sponsored by the California Energy Commission (Energy Commission). It does not necessarily represent the views of the Energy Commission, its employees, or the State of California. The Energy Commission, the State of California, its employees, contractors, and subcontractors make no warranty, express or implied, and assume no legal liability for the information in this report; nor does any party represent that the use of this information will not infringe upon privately owned rights. This report has not been approved or disapproved by the Energy Commission, nor has the Energy Commission passed upon the accuracy or adequacy of this information in this report.

The submitted manuscript has been authored by Winrock International to The Regents of the University of California/California Institute for Energy and Environment. Accordingly, The Regents retain a non-exclusive, royalty free license to publish or reproduce the published form of this contribution, or allow others to do so, for CIEE's purposes.

Please cite this report as follows:

Brown, S., D. Shoch, T. Pearson, and M. Delaney. 2004. *Methods for Measuring and Monitoring Forestry Carbon Projects in California*. Winrock International, for the California Energy Commission, PIER Energy-Related Environmental Research. 500-04-072F.

## Preface

The Public Interest Energy Research (PIER) Program supports public interest energy research and development that will help improve the quality of life in California by bringing environmentally safe, affordable, and reliable energy services and products to the marketplace.

The PIER Program, managed by the California Energy Commission (Energy Commission), annually awards up to \$62 million to conduct the most promising public interest energy research by partnering with Research, Development, and Demonstration (RD&D) organizations, including individuals, businesses, utilities, and public or private research institutions.

PIER funding efforts are focused on the following RD&D program areas:

- Buildings End-Use Energy Efficiency
- Energy-Related Environmental Research
- Energy Systems Integration
- Environmentally Preferred Advanced Generation
- Industrial/ Agricultural/Water End-Use Energy Efficiency
- Renewable Energy Technologies

What follows is the final report for the Measurement, Classification, and Quantification of Carbon Market Opportunities in the U.S.: California Component project, contract number 100-98-001, conducted by Winrock International. The report is entitled *Methods for Measuring and Monitoring Forestry Carbon Projects in California*. This project contributes to the PIER program objectives of improving the environmental and public health costs/risks of California's electricity.

For more information on the PIER Program, please visit the Energy Commission's Web site [www.energy.ca.gov/pier](http://www.energy.ca.gov/pier), or contact the Energy Commission at 916-654-5200.

# Table of Contents

Preface.....	ii
Abstract .....	vi
Executive Summary .....	1
1.0 Introduction.....	3
2.0 Monitoring Design.....	4
2.1. Boundaries .....	4
2.2. Stratification of Land Area.....	5
2.3. Selection of Carbon Pools to Measure and Monitor.....	5
2.4. Monitoring Frequency.....	7
3.0 Sampling Plots.....	7
3.1. Type and Number of Sampling Plots.....	7
3.1.1. Plot Type.....	7
3.1.2. Number of Plots .....	8
3.2. Sampling Procedure .....	12
3.2.1. Plot Layout.....	12
3.2.2. Size and Shape of Sample Plots.....	12
3.3. Establishing Sampling Plots .....	14
4.0 Measurement of Live Biomass .....	15
4.1. Measurement of Trees in Sample Plots.....	16
4.2. Calculating the State and Change in Live Tree Biomass .....	16
4.2.1. Calculating changes in aboveground tree carbon stocks from allometric regression equations .....	18
4.2.2. Ingrowth and mortality accounting .....	20
4.3. Non-tree Biomass.....	21
4.4. Belowground Biomass.....	22
4.4.1. Calculating biomass increment in roots.....	22
5.0 Measuring Other Biomass Pools.....	22
5.1. Lying Dead Wood .....	22
5.1.1. Calculating the biomass density of dead wood.....	25
5.2. Standing Dead Wood .....	26
5.3. Litter and Duff.....	27
5.4. Soil Organic Carbon.....	28
6.0 Estimating Net Change in the System.....	29
6.1. Activities on Non-Forested Lands.....	30

6.2. Activities on Forested Lands .....	33
7.0 Quality Assurance and Quality Control .....	36
7.1. QA/QC for Field Measurements .....	37
7.2. QA/QC for Sample Preparation and Laboratory Measurements.....	37
7.3. QA/QC for Data Entry.....	38
7.4. QA/QC for Data Archiving.....	38
8.0 References .....	39

## List of Figures

Figure 1. Illustration of the relationship between the magnitude of the reliable minimum estimate (RME) between Time 1 and Time 2 sampling periods and the 95% confidence interval (the solid and dashed bars) around the mean carbon stock (shaded circle). The confidence interval is a function of the standard error. The larger the sample size, the smaller the standard error, and the smaller the 95% confidence interval. Thus, RME1 is smaller than RME2, because it is based on fewer samples. ....	10
Figure 2. Percent difference in means reported as a function of sampling intensity (with 95% confidence). The example shown here is for a hypothetical soil-sampling plan. ....	11
Figure 3. An example of how the percent absolute change in mean (with 95% confidence) carbon for afforestation activities varies in relation to the sampling interval and sample size (n), assuming constant coefficient of variation (30%), constant rate of soil carbon accumulation of 0.5 tons of carbon per hectare per year ( $t\ C\ ha^{-1}\ yr^{-1}$ ), and initial soil carbon 50 t/ha. ....	11
Figure 4. Schematic diagram of nested, fixed area circular sample plots. Saplings could be measured in the smallest circular plot (about 1 m radius), trees between 5 and 50 cm diameter at breast height (dbh) could be measured in the medium circular plot (about 10- to 14-m radius, depending on stem density), trees above 50 cm dbh could be measured in the largest circular plot (about 20 m radius), and understory and fine litter could be measured in the four small plots located in each quadrant of the sample area. The radius and diameter limits for each circular plot would be a function of local conditions and expected size of the trees through time. ....	13
Figure 5. Measurement locations for diameter at breast height for irregular and normally shaped trees .....	16
Figure 6. The three nested plots at Time 1 and Time 2. The stars indicate the position of trees. At Time 2, black stars indicate trees that remained in the same size class as at Time 1. Grey stars indicate trees that have grown into the next class and white stars are trees that have exceeded the measurement minimum for the first time. ....	18

Figure 7. An illustration of the methods of calculating aboveground biomass increment for permanent plots and temporary plots. AGB = aboveground biomass of live trees; AGB of a minimum-sized tree is set arbitrarily to 4 units (based on Clark et al. 2001). ..... 21

Figure 8. Criteria to determine if a piece of coarse dead wood should be measured during sampling..... 24

Figure 9. Relationship between litter/duff depth and carbon biomass from mixed pine forests in Blodgett Forest Research Station..... 28

Figure 10. Calculating net carbon change for a hypothetical system ..... 32

Figure 11. Carbon stocks associated with (top) complete harvest of forest, followed by 50-year even-aged management and (bottom) limited selective harvest on a similar cutting cycle of a similar forest ..... 33

Figure 12. Carbon stocks associated with complete harvest of a mature forest followed by a 120-year rotation even-aged forest management. The carbon benefits of preservation are represented by the difference between the baseline and the new long-term average C. .... 34

Figure 13. Carbon stocks associated with complete harvesting of a mature forest followed by development. The carbon benefits of preservation are represented by the difference between the baseline and the new long-term average C..... 35

Figure 14. Average carbon stocks through time in hypothetical forest management activities. A rotation of 60 years is represented in (a) and a rotation of 50 years in (b). In this example, additional carbon sequestration occurs with a 10-year rotation extension. Carbon continues to accumulate through time in both scenarios, due to the slow turnover of long-term products and dead wood. .... 35

## List of Tables

Table 1. A decision matrix to illustrate the selection of pools to measure and monitor in forestry projects..... 6

Table 2. Example of nested plot delineation for a hypothetical differentiating cohort..... 13

Table 3. Effect of plot area on inter-plot variability and range of values (min/max) ..... 14

Table 4. Biomass quantities for a hypothetical plot of trees..... 19

Table 5. Dead wood densities measured by Winrock during fieldwork in 2003/4 ..... 24

Table 6. Decomposition rate constants and half-lives for down dead wood by forest type ..... 26

Table 7. Proportions of biomass in tree vegetation components (from Jenkins et al. 2003). Values given are percentage of total aboveground biomass. .... 27

## Abstract

California's forest management activities offer an opportunity to sequester atmospheric carbon that constitutes a portion of the State's greenhouse gas (GHG) contribution. However, to evaluate the efficacy and cost-effectiveness of various forest management activities—as well as to support carbon trading ventures that may arise in the future—it is necessary to develop reliable, accepted carbon measuring and monitoring protocols. The project described in *Methods for Measuring and Monitoring Forestry Carbon Projects in California* sought to develop protocols for measuring and monitoring carbon emissions or removals from three forestry activities: afforestation, forest management, and forest preservation. The report presents California-specific guidelines for measuring, monitoring, and estimating changes in carbon stocks in forest-based projects. Guidance is presented for developing a measuring plan, for physically measuring all applicable carbon pools, and using the results from measurements to obtain estimates of carbon stocks. The focus of these guidelines is on field measurements designed to produce accurate net changes in carbon stocks to known levels of precision. Using the guidelines, California's decision makers will be able to evaluate forest management activities for the sequestration of carbon more easily, and California will benefit from better-targeted, more cost-efficient carbon sequestration.



## Executive Summary

California's forest management activities offer an opportunity to sequester atmospheric carbon that constitutes a portion of the State's greenhouse gas (GHG) contribution. However, to evaluate the efficacy and cost-effectiveness of various forest management activities—as well as to support carbon trading ventures that may arise in the future—it is necessary to develop reliable, accepted carbon measuring and monitoring protocols.

### Objectives

This project described in *Methods for Measuring and Monitoring Forestry Carbon Projects in California* sought to develop guidelines for measuring and monitoring carbon emissions or removals from three forestry activities: afforestation, forest management, and forest preservation.

### Outcomes

The project identified various aspects of measurement and monitoring procedures that should be followed, as well as calculations that can be used to estimate carbon stocks from forest management activities. The report presents guidelines for developing a measuring plan, for physically measuring all applicable carbon pools, and for using the results from measurements to obtain estimates of carbon stocks.

Forestry activities mainly affect the exchange of carbon dioxide between the land and atmosphere. Techniques and methods for measuring and monitoring terrestrial carbon pools that are based on commonly accepted principles of forest inventory, soil sampling, and ecological surveys are well established and are presented in this report. Experience has shown that the following steps are needed in any protocol to produce credible and transparent estimates of net changes in carbon stocks:

- Designing a monitoring plan, including delineation of boundaries, stratification of project area, type and number of sample plots, selection of pools, and frequency of monitoring
- Sampling procedures for field data collection for estimating the carbon stocks in forest components; main pools included are:
  - Trees (above and belowground)
  - Dead wood (standing and downed)
  - Non-tree vegetation
  - Litter and duff
  - Soil organic carbon
- Methods of estimating the carbon stocks and techniques to analyse the results
- Methods for estimating the net change in carbon stocks
- Development of a quality assurance and quality control plan

The report details the implementation of each step. The guidelines focus on field measurements designed to produce accurate net changes in carbon stocks to known levels of precision.

### **Conclusions, Recommendations, and Benefits to California**

A suggested target for the accuracy and precision for forest carbon accounting is to obtain an estimate that is within 10% of the true value, with 95% confidence that the estimate lies within these bounds.

Using these guidelines, it should be possible to design and implement a sampling protocol for estimating the carbon benefits from forestry projects in California. These guidelines will be useful for developing the protocols for California's GHG registry.

## 1.0 Introduction

This report provides protocols for measuring and monitoring carbon emissions or removals from forestry activities. The forestry activities fall into three main groups: (1) afforestation, (2) forest management, and (3) forest preservation. *Afforestation* can include activities such as restoring forests on former rangeland, increasing the stocking of trees in degraded forests (those with canopy crown cover less than 10%–20% but capable of higher density), agroforestry, and restoration of riparian zones. Changes in *forest management* can include lengthening rotation times, converting to group selection, widening buffers around the riparian zone, and variable retention. *Forest preservation* typically includes preserving forests that are under pressure to be harvested or converted to an alternative use.

The most accurate way to estimate the state and change in carbon stocks for an activity is to use direct measurement. *Direct measurement* involves developing and implementing a sampling and estimation approach that is appropriate and efficient for the land area being measured. Implementing the measurement approach involves many steps that are described in detail in this report.

Forestry activities mainly affect the exchange of carbon dioxide (CO<sub>2</sub>) between the land and atmosphere. Techniques and methods for measuring and monitoring terrestrial carbon pools that are based on commonly accepted principles of forest inventory, soil sampling, and ecological surveys are well established and will be elaborated on further in the following sections.

Most forestry activities designed to increase carbon stocks have few non-CO<sub>2</sub> greenhouse gas (GHG) emissions associated with them. Exceptions include: use of fertilizer to enhance tree growth (possible increase in nitrous oxide (N<sub>2</sub>O) emissions), use of nitrogen-fixing trees (possible increase in N<sub>2</sub>O emissions), changes in forest management (possible increase in N<sub>2</sub>O emissions and a reduction in methane (CH<sub>4</sub>) sequestration), and biomass burning for instance in site preparation (possible increase in N<sub>2</sub>O and CH<sub>4</sub> emissions). It is likely that these are for the most part insignificant in the forest sector, and practical and cost-efficient methods for measuring these non-CO<sub>2</sub> greenhouse gases in this sector are less well developed than methods for estimating CO<sub>2</sub>. Methods for these gases will not be provided.

For forestry activities, it is not always necessary to measure all pools (Brown et al. 2000) – selective or partial accounting systems may be appropriate, as long as all pools for which emissions are likely to increase as a result of the activity (i.e., loss in carbon or emission) are included. The selection of which pools to measure and monitor depends on several factors, including expected rate of change, magnitude and direction of the change, availability and accuracy of methods to quantify change, and cost to measure. All carbon pools that are expected to decrease (i.e., a carbon source) should be measured and monitored. Pools that are expected to increase by a small amount may not need to be estimated if costs are high, relative to the magnitude of the increase.

This section focuses on ecosystem carbon only, and includes only the carbon pools existing on the land (e.g., live and dead above- and belowground biomass and soil); it does not include detailed methods for wood products. The experience gained from the many forest-based

carbon sequestration activities in various stages of implementation both in the United States and internationally has shown that the following features are needed in any measuring and monitoring protocol that will produce credible and transparent estimates of net changes in carbon stocks:

- Design of a monitoring plan that includes delineation of the project's boundary, baseline development, stratification of the project area, type and number of sample plots, selection of carbon pools, and monitoring frequency
- Sampling procedures for the carbon stocks
- Methods of estimating the carbon stocks and techniques to analyse the results
- Methods for estimating the net change in carbon stocks
- Development of a quality assurance and quality control plan

The effort (and thus the cost) required to perform direct measurement is usually higher than using look-up or default tables or models. However, the uncertainty of the estimates based on default data should be considerably lower than estimates based on a well-designed monitoring plan. If the guidance in this document is followed, a reporter can develop an accurate estimate of carbon stocks and changes in carbon stocks with known, quantified precision. A suggested target for forest carbon accounting is to obtain an estimate that is within plus/minus 10% of the true value, with 95% confidence that the estimate lies within these bounds (or a 1 in 20 chance the true value lies outside the bounds) – a target that can be achieved at a modest cost.

## **2.0 Monitoring Design**

### **2.1. Boundaries**

Forestry and land-use change activities can vary in size (from tens of hectares to up to hundreds of thousands of hectares) and can be confined to a single geographic area or to several. The area may be one contiguous block of land having a single owner or many small blocks of land spread over a wide area having a large number of small or a few large landowners. The spatial boundaries of the land need to be clearly defined to facilitate accurate measuring, monitoring, accounting, and verification. Boundaries need to be properly documented (mapped and described) from the start and should preferably not be subject to any changes through the duration of the activity.

The spatial boundaries can be in the form of permanent boundary markers (e.g., fences), clearly defined topographic descriptions (e.g., rivers/creeks, mountain ridges), or preferably spatially explicit located boundaries identified with a Global Positioning System (or *GPS*). Ground-based surveys that delineate property boundaries are an accurate means of documenting land boundaries. Larger areas across the landscape can be defined through specific boundary descriptions using *GPS*-based coordinates on topographic maps or through other suitable means.

## **2.2. Stratification of Land Area**

Once the land area has been delineated, it is useful to collect basic background information such as land-use history, maps of soil, vegetation, and topography. The land for the project can be geo-referenced and mapped onto a base map. A geographic information system (GIS) would be useful for such an activity. Such maps can then be used to stratify the area into more or less homogeneous units that increase the efficiency of sampling, and thus reduce cost.

Useful tools for defining strata include ground-truthed maps from satellite imagery, aerial photographs, and maps of vegetation, soil or topography. Many of these products are available as GIS data layers (e.g., State Soil Geographic (STATSGO) soil maps, United States Geological Survey Digital Elevation Model, 1992 National Land Cover map) that can be overlain in a GIS to identify possible strata. The key to useful stratification is to ensure that measurements are more alike within each stratum than in the sample frame as a whole. A geographic information system can automatically determine stratum size and the size of exclusions or buffer zones.

The spatial distribution of the land area does not influence site stratification – one large contiguous block of land or many small parcels are considered the population of interest and are stratified in the same manner. Stratification decreases the costs of monitoring, because it is expected to diminish the sampling effort necessary, while maintaining the same level of confidence, because there is less variation in carbon stocks in each stratum than there is in the whole area. The stratification should be carried out using criteria that are directly related to the variables to be measured and monitored (e.g., the carbon pools in trees for afforestation). For afforestation, the strata may be defined on the basis of variables such as the tree species (if several), age class (as generated by delay in practical planting schedules), initial vegetation (e.g., completely cleared versus cleared with patches or scattered trees), and site conditions (such as soil type, elevation, and slope).

Site visits to the project area and nearby areas with vegetation that will be the target of the activity will aid in the stratification of the area. Field assessments and measurements of key variables such as general soil type, topography, and nearby existing vegetation all greatly aid in the stratification of the area and contribute to a cost-efficient monitoring plan.

Sampling plots assigned to areas under management should be allocated among delineated strata: e.g., (1) unharvested matrix, (2) harvest sites (i.e., clear-cuts or group selections), and (3) harvest edges. Plots should be designated so that plot centers are located at least one radius distance within the strata boundaries.

## **2.3. Selection of Carbon Pools to Measure and Monitor**

The selection of which carbon pools to measure and monitor depends on several factors, including: type of activity, expected rate of change, magnitude and direction of the change, availability and accuracy of methods to quantify change, and cost to measure. All pools that are expected to decrease as a result of activities must be measured and monitored. Pools that are expected to increase by a small amount, relative to the overall rate of change, need not be measured and monitored. For example, understory herbaceous vegetation in the case of afforestation is rarely a significant factor in the ecosystem carbon budget. The decision matrix

shown in Table 1 presents the main carbon pools for forests and examples of which ones should, should possibly, or should not be measured for each forest activity type.

**Table 1. A decision matrix to illustrate the selection of pools to measure and monitor in forestry projects**

Activity type	Carbon pools to be measured and monitored					
	Living biomass			Dead Organic Matter		Soil
	Aboveground: trees	Aboveground: non-tree	Below-ground	Forest floor	Dead wood	
Afforestation	Y1	M2	Y3	M4	M5	Y6
Forest management	Y1	N	Y3	M4	Y5	N
Forest preservation	Y1	M2	Y3	M4	M5	N

Source: Modified from Brown et al. 2000.

**Notes:** The letters refer to the need for measuring and monitoring the carbon pools: Y= Yes (the change in this pool is likely to be large and should be measured), N = No (the change is likely small to none, and thus it is not necessary to measure this pool), and M = Maybe (the change in this pool may need to be measured, depending upon the forest type and/or management intensity of the project).

The numbers refer to different methods for measuring and monitoring the carbon pools:

- 1 = See methods of carbon stock measurement for aboveground biomass of trees (Sections 4.1 and 4.2)
- 2 = See methods described for aboveground biomass of non-trees vegetation (Section 4.3)
- 3 = See methods for measuring/ estimating the carbon stock in belowground biomass (Section 4.4).
- 4 = See methods for measuring the carbon stock in the forest floor (Section 5.3)
- 5 = See methods for measuring dead wood (Section 5.1 and 5.2).
- 6 = See methods for measuring the carbon pool in soils (Section 5.4).

Clearly, it makes sense to measure and monitor the carbon pool in live trees and their roots for all activity types. Aboveground, non-tree biomass may need to be measured if it represents a significant component of the selected area, such as where shrubs are present in large numbers; it may not need to be measured if the understory is dominated by herbaceous material, as this is likely to account for very small changes over the duration of the activity. It is recommended that the forest floor be measured in most activity types, especially where the forest is likely to be dominated by conifers, as this can be a significant component of the total carbon pool. Dead wood is composed of standing dead trees and downed dead wood. For changes in management for timber, dead wood must be measured, because often this pool is affected as a result of an activity. Soil organic carbon is likely to change significantly for afforestation activities if the land on which the activity is to take place has been under cultivation for a decade or more. However, changes in forest management or even forest preservation (from harvesting to preservation) are likely to produce very small changes in soil carbon (or none at all), and the cost to measure this pool could exceed the value of the carbon.

## **2.4. Monitoring Frequency**

The frequency of monitoring is related to the rate and magnitude of change – the smaller the expected change, the greater the potential that frequent monitoring will not detect a significant change. That is, frequency of monitoring should be determined by the magnitude of expected change – less frequent monitoring is applicable if only small changes are expected.

The frequency of monitoring should take into consideration the carbon dynamics of the activity and costs involved. Given the dynamics of forest processes, they are generally measured over periods of five-year intervals (e.g., the U.S. National Forest Inventory). For carbon pools that respond more slowly, such as soil, even longer periods (e.g., 15 to 20 years) could be used. It is recommended that the frequency of measuring and monitoring should be defined in accordance with the expected rate of change of the carbon stock.

Monitoring only the changes in the monitoring plots' carbon stocks does not necessarily provide information that the project is achieving the same changes in carbon stocks across the whole area and that the activity is accomplishing what it set out to do. Repeated visits to the carbon monitoring plots will only show that the carbon in those plots (which were randomly located and represent the population) is accumulating carbon with known accuracy and precision. To give confidence that the overall activity is performing as well as the plots, it is also suggested that, through time, periodic checks are made over larger areas to ensure that the overall area is performing the same way as the plots. This confirmation can be accomplished through field checking, using indicators of carbon stock changes such as tree height for afforestation activities. Thus, entities could produce such indicators that can readily be field checked across the area. High-resolution, remote-sensing imagery could also be used to field check across wide areas.

## **3.0 Sampling Plots**

### **3.1. Type and Number of Sampling Plots**

#### **3.1.1. Plot Type**

For forestry activities, permanent or temporary sampling plots can be used for sampling over time to estimate changes in the relevant carbon pools. Both methods have advantages and disadvantages.

Permanent sample plots are generally regarded as statistically more efficient in estimating changes in forest carbon stocks than temporary plots, because there is high covariance between observations at successive sampling events (Avery and Burkhardt 1983). Moreover, permanent plots permit efficient verification, if needed, at relatively low cost: a verifying organization can find and measure permanent plots at random to verify, in quantitative terms, the change in carbon stocks. Disadvantages of permanent plots are that their location could be known and they could be treated differently (e.g., fertilizing or irrigating to enhance the carbon stocks) and that they could be destroyed or lost by disturbances over the measurement interval.

The advantages of temporary plots is that they may be established more cost-efficiently to estimate the carbon stocks of the relevant pools, their location changes at each sampling interval

and so could not be treated differently to enhance carbon stocks, and they would not be lost by disturbances. The main disadvantage of temporary plots is related to the precision in estimating the change in forest carbon stocks. Because individual trees are not tracked (see Clark et al. 2001 for further discussion), the covariance term is non-existent, and it will be more difficult to attain the targeted precision level without measuring a greater number of plots. Thus, any time advantage gained by using temporary forest plots over permanent ones may be lost by the need to install more temporary plots to achieve the targeted precision.

If permanent sample plots are used, marking or mapping the trees to measure the growth of individuals at each time interval is essential, so that the growth of survivors, mortality, and ingrowth of new trees can be tracked. Changes in carbon stocks for each tree are then estimated and summed per plot. When that activity is completed, statistical analyses on net carbon accumulation per plot—including ingrowth and losses due to mortality, can be performed. The U.S. Forest Service relatively recently modified its Forest Inventory and Analysis (FIA) plots to be permanent, fixed-radius plots, rather than the variable radius plots used before. Because the permanent plots also track mortality, they can be used to track the major changes in dead wood (both lying and standing) after this component's initial inventory.

### **3.1.2. Number of Plots**

The level of precision required for a carbon inventory has a direct effect on inventory costs and needs to be carefully chosen by those who will implement the inventory. As mentioned above, from past experience with forest carbon measurement of projects (e.g., Brown 2002), a reasonable estimate of the net change in carbon stocks that can be achieved at a reasonable cost is to within 10% of the true value of the mean at the 95% confidence level.

Once the level of precision has been determined, sample sizes must be determined for each stratum in the project area. Each carbon pool may have a different variance (i.e., amount of variation around the mean); however, experience has shown that focusing on the variance of the tree component captures most of the total variance. Although the variance in other pools may be high, these pools often are a small contribution to the net change in carbon stocks or can actually decrease the total variance when the net change in all pools is estimated. For example, understory in forests can be quite variable, but it is generally a very small component of the net change; whereas, dead wood, though highly variable, often reduces the *overall* variability of the net change in carbon.

The sample size for monitoring in each stratum needs to be calculated on the basis of the estimated variance of the carbon stock in each stratum and the proportional area of the stratum. Typically, to estimate the number of plots needed for monitoring at a given confidence level, it is necessary to first obtain an estimate of the expected variance of the carbon stock in trees in each stratum. This estimate can be made either from existing data of the type of activity to be implemented (e.g., a forest inventory in an area representative of the proposed activity) or by making measurements on an existing proxy area representing the proposed activity. For example, if the activity is to afforest rangeland and the activity will last for 20 years, then a measure of the carbon stocks in the trees of about 10–15 plots of an existing 20-year forest would suffice. The sample size might not be sufficient to achieve the desired precision level (i.e.,



+/- 10% of the mean) for the smallest anticipated carbon stock change, usually at the first monitoring event, but, as the mean increases over time, so should the precision improve. If the targeted precision is required for each reporting event, then it is likely that the number of plots needed for the early stages may be higher than of latter stages. For activities related to changes in forest management or preservation, the number of plots estimated to be needed at the outset most likely would produce the same level of precision over time. If the project area comprises more than one stratum, then this procedure needs to be repeated for each one. Such measurements will provide estimates of the variance in each stratum and the total number of plots per stratum can be estimated using standard statistical methods.

Sampling plots cannot always be relocated or reoccupied for a variety of reasons (e.g., plot markers are overgrown or are removed by people, plots are burned or records are lost), so it is prudent to increase the number of plots beyond the minimum in the initial sampling design. By increasing the number of plots to some percentage over the calculated minimum number of samples, there is a cushion that helps to meet the minimum precision requirements even though there are missing plots in subsequent inventories. It is recommended that the minimum sample size be increased by 10% to 12%, to allow for plots that cannot be relocated.

Projects that include progressive plantings over time should include an open-ended monitoring framework that can accommodate the progressive addition of plantings to the area over time. This goal can be accomplished by predicting the eventual size of the area at year X, and progressively assigning distinct stand-age cohorts to separate strata within the overall, growing population. It is anticipated that a full contingent of permanent sample plots are to be installed by year X. No more than two or three age classes should be combined into one cohort class.

When sampling forests using temporary plots, or when sampling for soil, the statistical concept of paired samples cannot be employed reliably, and the covariance term is non-existent. Thus, the changes in mean carbon between two temporally separated sample pools are best quantified by comparing means, via the Reliable Minimum Estimate (RME) approach (Dawkins 1957) or by directly calculating the difference between the means and associated confidence limits (Sokal and Rohlf 1995). The objective is not to establish that the two means are significantly different, but rather to estimate with 95% confidence the minimum change in mean carbon that has taken place from one monitoring event to the next. For the RME approach (Figure 1), the monitoring results from plots are pooled to derive a mean for the sample population at "Time 2" then the 95% confidence interval (CI) is subtracted to establish a minimum estimate of the population mean. Change in carbon is calculated by subtracting the maximum estimate of the population mean at "Time 1" (mean at Time 1 plus 95% CI) from the minimum mean estimate at Time 2. The resulting difference represents, with 95% confidence, the minimum change in mean carbon from Time 1 to Time (Figure 1).

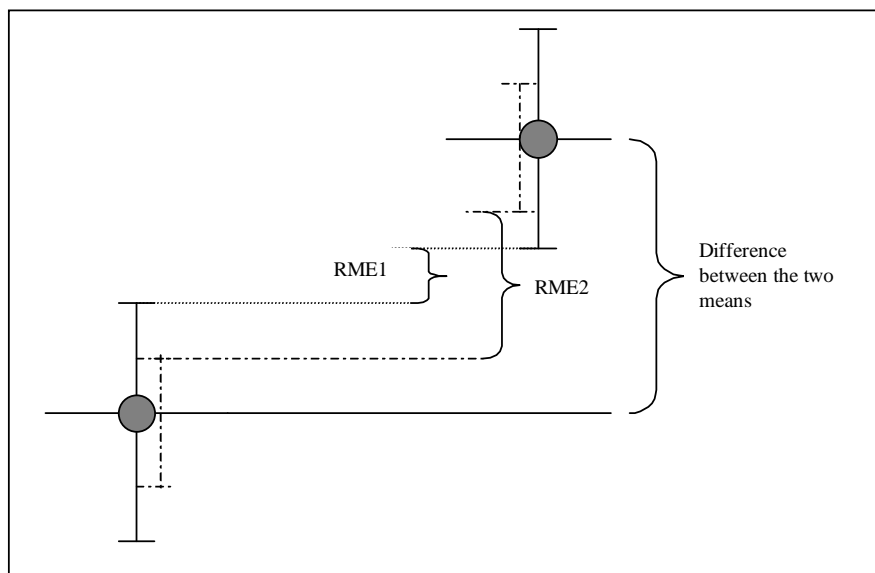
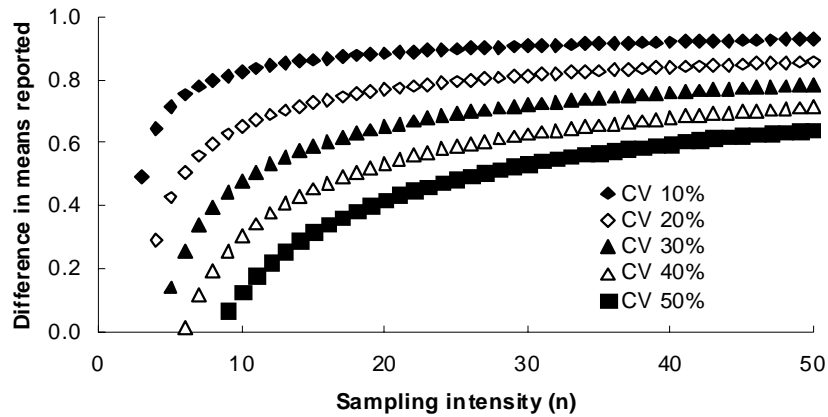

**Figure 1. Illustration of the relationship between the magnitude of the reliable minimum estimate (RME) between Time 1 and Time 2 sampling periods and the 95% confidence interval (the solid and dashed bars) around the mean carbon stock (shaded circle). The confidence interval is a function of the standard error. The larger the sample size, the smaller the standard error, and the smaller the 95% confidence interval. Thus, RME1 is smaller than RME2, because it is based on fewer samples.**

This approach assumes normality, and carbon stock values are usually normally distributed. In cases where a data set is shown to be non-normally distributed – for example, where a number of extreme values positively skew the data, data can be transformed (e.g., by converting values to logarithms), or alternatively the non-normally distributed data set can be divided *a posteriori* into normally distributed subsets (i.e., post stratification). Otherwise, a non-parametric test (e.g., Kruskal-Wallis), using the median to represent central tendency, may be applied to quantify differences between sample means.

How much of the change in the mean carbon stock can be estimated reliably will depend on the resolution permitted by the monitoring framework. Sampling intensity (i.e., number of samples) and frequency must be taken into consideration when attempting to resolve changes in carbon over time. Resolution in quantifying the minimum change between two means with a given level of confidence can be expressed as the percent of the absolute difference between the means. A targeted resolution (e.g., 80% of the absolute difference between the means), or alternatively, a targeted magnitude of change in carbon (not to exceed the absolute difference between the mean estimates), can be achieved by adjusting sampling intensity, sampling frequency, or a combination of both.

Increasing sampling intensity serves to reduce standard error around mean estimates separated in time, and better distinguish change that takes place (Figure 2). As high levels of variability in carbon among sample units often exist (often ~ 30% coefficient of variation (CV) or higher), high sampling intensity is consequently required to discern change.



**Figure 2. Percent difference in means reported as a function of sampling intensity (with 95% confidence). The example shown here is for a hypothetical soil-sampling plan.**

The resolution of change detection also depends on the magnitude of the change itself, and as this is time dependent, it is appropriate to consider frequency of sampling. Increasing the interval between sampling events should increase the magnitude of the change that takes place, which, where variance around the means is constant, increases the percentage and magnitude of the change resolved (Figure 3). This consideration is important – particularly in soil sampling or slowly growing forests – in that small changes expected with short sampling intervals may be undetectable, even with high sampling intensity.

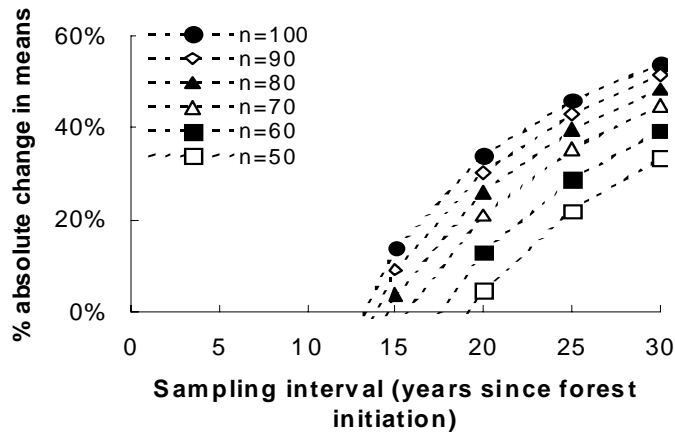

**Figure 3. An example of how the percent absolute change in mean (with 95% confidence) carbon for afforestation activities varies in relation to the sampling interval and sample size (n), assuming constant coefficient of variation (30%), constant rate of soil carbon accumulation of 0.5 tons of carbon per hectare per year ( $t\ C\ ha^{-1}\ yr^{-1}$ ), and initial soil carbon 50 t/ha.**

Required sample size (for a targeted % absolute difference between the means or targeted magnitude of change) is thus a function of: (1) inherent variability (which can be mitigated for via stratification or reduced by composite sampling), (2) magnitude of change expected (thus, sampling interval and assumed rate of C accumulation), and (3) desired confidence level.

## **3.2. Sampling Procedure**

### **3.2.1. Plot Layout**

Permanent plot locations can be selected either randomly or systematically. If little is known about the population being sampled, random selection of sample units is generally safer than systematic selection; however, the area and type of activity can influence which selection method should be used. If plot values are distributed irregularly in a random pattern, then both approaches are equally precise. If some parts of the strata have higher carbon content than others, systematic selection will usually result in greater precision than random selection.

For some areas, it may not be possible to pre-stratify, because from superficial characteristics, the site appears to be homogeneous. However, it is possible that after the first monitoring event, for example, the change in carbon stocks is highly variable and that on further analysis the measurements can be grouped into like classes (i.e., the site can be post-stratified).

### **3.2.2. Size and Shape of Sample Plots**

The size and shape of the sample plots is a trade-off between accuracy, precision, and time (and thus, cost) of measurement. Experience has shown that sample plots containing smaller sub-units of various shapes and sizes, depending on the variables to be measured, are cost efficient. For instance, trees are measured in the entire sample plot; whereas, non-tree vegetation, litter and soil data are generally collected in a smaller subplot.

Nested plots for recording discrete size classes of stems and/or select forest components are a practical design for sample plots and are better suited to stands with a wide range of tree diameters or to stands with changing diameters and stem densities that take place over time than are fixed-area plots (Figure 4). Optimum area for nested plots can be anticipated by predicting changes in stem density and mean stem diameter over time, or by direct measurements of proxy stands of known age. Thus, for an even-aged, aggrading stand, it is anticipated that tree measurements will be focused on the small plot early on, and measurement activity will slowly shift to the medium and large plots over time as the trees grow. Where proxy measurements are available for a range of age classes and plot sizes, the sample size calculation should be based on the nested plot with the highest variation, usually the smallest, to ensure that the precision target is met throughout the life of the project.

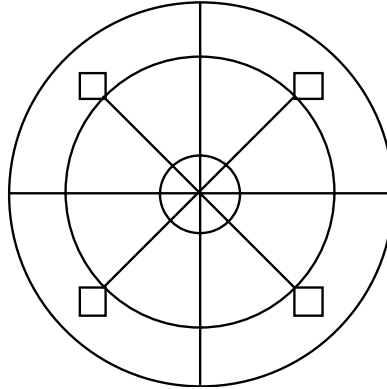

**Figure 4. Schematic diagram of nested, fixed area circular sample plots. Saplings could be measured in the smallest circular plot (about 1 m radius), trees between 5 and 50 cm diameter at breast height (dbh) could be measured in the medium circular plot (about 10- to 14-m radius, depending on stem density), trees above 50 cm dbh could be measured in the largest circular plot (about 20 m radius), and understory and fine litter could be measured in the four small plots located in each quadrant of the sample area. The radius and diameter limits for each circular plot would be a function of local conditions and expected size of the trees through time.**

**Table 2. Example of nested plot delineation for a hypothetical differentiating cohort**

Stand age [years]	Mean dbh (cm)	Mean stand density (stems/hectare)	Plot radius (m) to encompass 12 stems	Suggested plot dbh coverage	Suggested plot radius to encompass $\geq 12$ stems
10	8	1500	5.0	0 to 15 cm	6 m
20	16	1000	6.2		
30	22	600	8.0	16 to 29 cm	10 m
40	27	400	9.8		
50	30	350	10.4	30 cm +	13 m
60	33	300	11.3		
70	35	270	11.9		
80	36	250	12.4		
90	37	240	12.6		
100	38	235	12.7		

Nested plots are composed of several full, circular plots (typically 2 to 4, depending upon the structure of forest), and each of the nested circles should be viewed separately. When trees attain the minimum size for one of the nested circles, they are measured and included, and when they exceed the maximum size, measurement of that tree in that nest stops and begins in the next larger nest. If ingrowth into a new nest occurs between censuses, the growth up to the

maximum size is included with the smaller nest, and growth in excess of this size is accounted in the larger nest.

Plots are extrapolated to full hectare area to produce carbon stock estimates. Plots are extrapolated through the use of expansion factors, which in turn are calculated from the proportion of a hectare that is occupied by a given plot. As an example, if a series of nested circles measuring 4 m, 14 m, and 20 m in radius were used, their areas are equal to 50 m<sup>2</sup>, 616 m<sup>2</sup> and 1,257 m<sup>2</sup> respectively. In this case, the expansion factors for converting the plot data to a hectare basis are 198.9 for the smallest, 16.2 for the intermediate, and 8.0 for the largest nested circular plot.

Time and effort spent in field measurement depends both on sample size (number of plots) and plot area. Although increasing sample size increases precision, increasing plot area decreases variability between samples, roughly following the relationship derived by Freese (1962) (see Table 3),

$$CV_2^2 = CV_1^2 * \sqrt{(P_1 / P_2)}$$

where “CV” is the coefficient of variation and “P” is plot area. Thus, by increasing plot area, variation between plots is reduced, which allows for a smaller sample size while targeting the same precision level. For example, pilot studies could provide an estimate of the CV and plot area (e. g., from FIA plots), then a CV could be selected to achieve the desired precision and cost considerations. Substitution of these values into the above equation will provide an estimate of the plot area needed for optimum sampling.

**Table 3. Effect of plot area on inter-plot variability and range of values (min/max)**

Statistics	0.04-ha plot	1-ha plot
n=	75	3
Mean (t C/ha)	209	209
Variance	22754	5870
Standard Deviation	151	77
Standard Error	17	44
C.V. (%)	72	37
95% Confidence Interval	34	176
Minimum	48	155
Maximum	799	297

### 3.3. Establishing Sampling Plots

For each site, sample plot center/s can be located using the maps and polygons indicating strata type (e.g., forest management activity, compartment), then the Arc View software extension “random.avx” can be used to select points at random from within the area of interest.

For a stratified systematic sampling design, a grid, with the vertical and horizontal lines spaced in such a way as to produce the desired number of intersections, can be overlaid on a map of the

area of interest. The grid features numbers along each axis. The grid will be placed with a random start over the map—to ensure this, the transparency is designed to be bigger than the map itself, so that the transparency and grid are not lined up with the map edges.

All calculations made for a plot are based on a horizontal projection of the area. This means that when dealing with areas on slopes, an additional measurement must be made. On occasion, the selected location for a sample plot might fall in an area of mixed slopes. One portion of the plot might be on level ground, but another portion might fall on a hillside. In this situation, it is better to establish the plot center in an area that is either on a slope or on level ground. The potential for error is too high to have a portion on sloping land and the other portion on level ground. If more than 50% of the sample plot falls on a slope > 10%, the plot center should be moved, so that the entire plot is located on the slope. If more than 50% of the sample plot is located on level ground, but the rest of the area is on a hillside (slope > 10%) the plot center should be moved, so that the entire plot falls on level ground.

If the sample plot is located on a slope that is > 10%, the slope should be measured. It is preferable to record the slope and calculate the true horizontal area after returning from the field. This strategy could produce an error in measurement (e.g., a large tree could be missed), but the error is likely random, and our experience has shown the error in making this adjustment in the field could be higher, especially over the life of the project. True horizontal radius is calculated using the formula:

$$L = L_s * \cos S$$

Where  $L$  is the true horizontal plot radius,  $L_s$  is the standard radius measured in the field along the slope,  $S$  is the slope in degrees, and  $\cos$  is the cosine of the angle.

If permanent plots are used, the plot centers should be permanently marked (e.g., using rebar with PVC pipe) and given unique numbered designation (e.g., engraved aluminum tags) to facilitate easy relocation and identification. Once established in the field, each plot should have its coordinates recorded using a GPS. In cases where there is concern that plots will receive differential treatment from land managers, care should be taken to ensure that plot markers are not prominently displayed.

#### **4.0 Measurement of Live Biomass**

The carbon stocks of trees are estimated through a field inventory in which all the trees in the sample plots above a minimum diameter (a function of the forest structure—a minimum of 5–10 cm is commonly used) are measured. Biomass and carbon stock are estimated from diameter at breast height (dbh) or a combination of dbh and total height using locally relevant allometric equations. Empirical data confirm that highly significant biomass regression equations can be developed with dbh as the single independent variable (Schroeder et al. 1997). As well, measuring tree height can be time consuming and will increase the expense of any monitoring program. An alternative is to develop a local equation between dbh and height, and then use a model for biomass that is based on dbh and predicted height (Brown et al. 1989).

#### 4.1. Measurement of Trees in Sample Plots

Within plots, all trees should be measured at dbh (1.37 m above ground), unless buttressed or with defects at dbh (Figure 5). All trees should be tagged with the placement of an aluminum numbered tag and nail at least 3 cm above or below breast height. Alternatives to tags are to paint the trees (although paint can wear off) or to map the trees in detail.

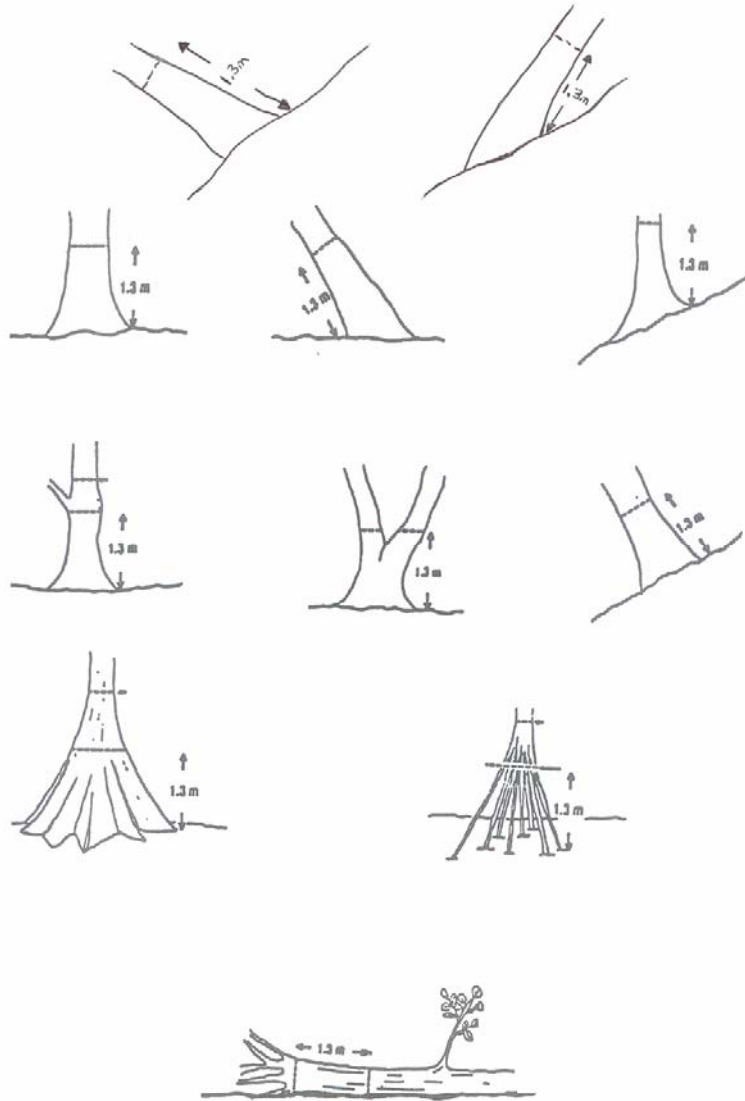

Figure 5. Measurement locations for diameter at breast height for irregular and normally shaped trees

#### 4.2. Calculating the State and Change in Live Tree Biomass

Allometric equations for estimating aboveground biomass (kg per tree) from measurements of dbh for common California species are listed below; the  $r^2$  for all the equations were 0.98 to 0.99



(from Jenkins et al. 2003). Additional equations and the associated species can be found in Jenkins et al. (2003):

**Coastal Redwood / Giant Sequoia / Incense Cedar:**

$$\text{Biomass (kg)} = \text{Exp} (-2.0336 + 2.2592 \times \ln \text{dbh}) \quad \text{max dbh} = 250 \text{ cm}$$

**Douglas Fir:**

$$\text{Biomass (kg)} = \text{Exp} (-2.2304 + 2.4435 \times \ln \text{dbh}) \quad \text{max dbh} = 210 \text{ cm}$$

**Pine species:**

$$\text{Biomass (kg)} = \text{Exp} (-2.5356 + 2.4349 \times \ln \text{dbh}) \quad \text{max dbh} = 180 \text{ cm}$$

**True Fir species:**

$$\text{Biomass (kg)} = \text{Exp} (-2.5384 + 2.4814 \times \ln \text{dbh}) \quad \text{max dbh} = 230 \text{ cm}$$

**Oak species:**

$$\text{Biomass (kg)} = \text{Exp} (-2.0127 + 2.4342 \times \ln \text{dbh}) \quad \text{max dbh} = 73 \text{ cm}$$

**Tanoak:**

$$\text{Biomass (kg)} = \text{Exp} (-2.4800 + 2.4835 \times \ln \text{dbh}) \quad \text{max dbh} = 56 \text{ cm}$$

An alternative approach for estimating biomass of forests is to base it on the volume of the commercial component of the tree. The volume of the commercial component is estimated using standard techniques in forestry. This method is commonly used with temporary plots. The estimated volume then needs to be converted to total aboveground biomass, including the other tree components, such as branches, twigs, and leaves. This volume-based method is based on factors developed at the stand level, for closed canopy forests, and cannot be used for estimating biomass of individual trees. Equations relating growing stock volume (GSV) and biomass are listed below. Additional equations and the associated species can be found in Smith et al. (2003), which can be accessed at:

[www.treearch.fs.fed.us/pubs/viewpub.jsp?index=5179](http://www.treearch.fs.fed.us/pubs/viewpub.jsp?index=5179).

**Coastal Redwood / Giant Sequoia / Incense Cedar:**

$$\text{Biomass (kg)} = 3738.2 \times (0.0122 + (1 - e^{-(\text{vol}/6752.8)})) \quad \text{max vol} = 1,691 \text{ m}^3/\text{ha}$$

**Douglas Fir:**

$$\text{Biomass (kg)} = 1719.4 \times (0.0164 + (1 - e^{-(\text{vol}/2155.5)})) \quad \text{max vol} = 1,096 \text{ m}^3/\text{ha}$$

**Fir and Spruce species:**

$$\text{Biomass (kg)} = 741.8 \times (0.0107 + (1 - e^{-(\text{vol}/776.3)})) \quad \text{max vol} = 1,020 \text{ m}^3/\text{ha}$$

**Other conifer species:**

$$\text{Biomass (kg)} = 1127 \times (0.0368 + (1 - e^{-(\text{vol}/1536.5)})) \quad \text{max vol} = 687 \text{ m}^3/\text{ha}$$

**Hardwood species:**

$$\text{Biomass (kg)} = 1244.62 \times (1 - e^{-(\text{vol}/1142.2)}) \quad \text{max vol} = 639 \text{ m}^3/\text{ha}$$

#### 4.2.1. Calculating changes in aboveground tree carbon stocks from allometric regression equations

This section illustrates how to calculate aboveground tree biomass carbon and its change using a nested plot design and using allometric regression equations. As a hypothetical example, a single sample plot will be examined.

The plot consists of three nested subplots:

1. A 5-m radius for trees measuring 2.5 to < 10 cm dbh
2. A 14-m radius for trees  $\geq 10$  to < 50 cm dbh
3. A 20-m radius for trees  $\geq 50$  cm dbh

Figure 6 and Table 4 show measurements over two time periods. Note the following: at Time 2, ingrowth of trees too small to be measured at Time 1 (trees 101 and 102 in the small nest and 103 in the intermediate nest) and outgrowth from one plot size and ingrowth into the next size when the max/min thresholds are passed (trees 004, 005 small to intermediate, tree 009 intermediate to large).

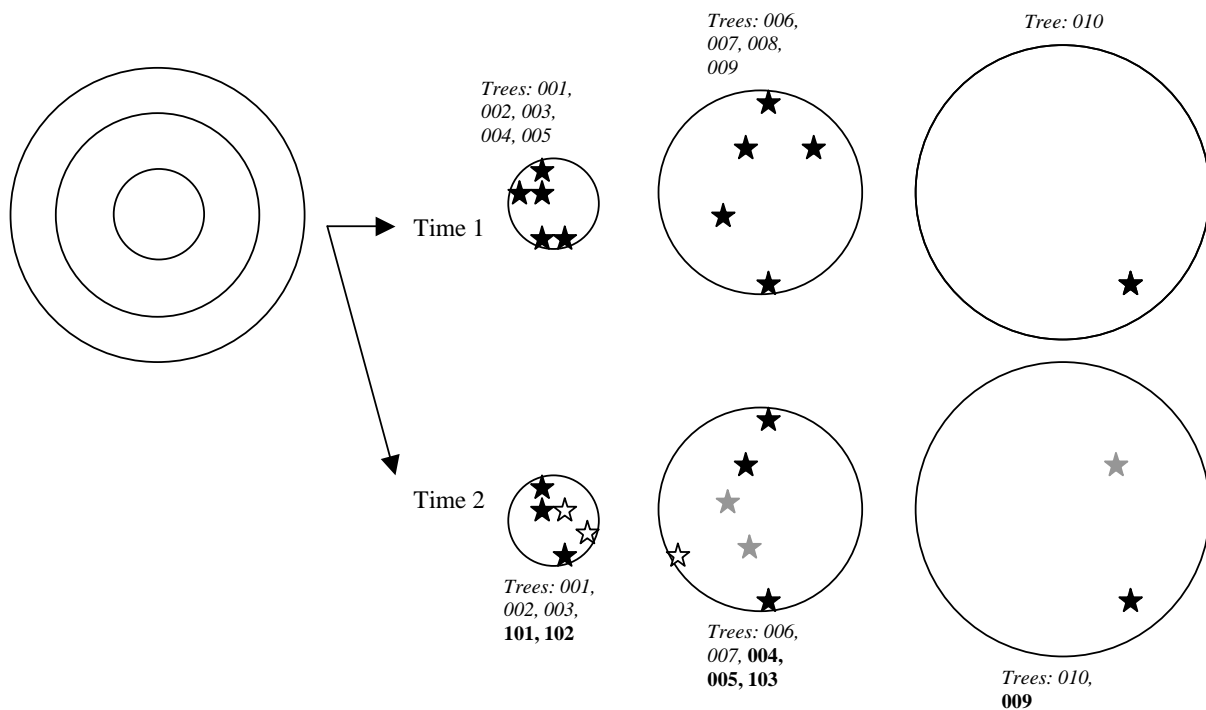

**Figure 6.** The three nested plots at Time 1 and Time 2. The stars indicate the position of trees. At Time 2, black stars indicate trees that remained in the same size class as at Time 1. Grey stars indicate trees that have grown into the next class and white stars are trees that have exceeded the measurement minimum for the first time.

**Table 4. Biomass quantities for a hypothetical plot of trees**

Time 1				Time 2			
Tag	Nest	dbh (cm)	Biomass (kg)	Tag	Nest	dbh (cm)	Biomass (kg)
001	Small	2.6	1.37	001	Small	3.1	2.10
002	Small	5.3	7.74	002	Small	5.8	9.64
003	Small	6.1	10.90	003	Small	6.8	14.20
004	Small	6.2	11.34	004	Intermediate	10	36.32
005	Small	8.1	21.74	005	Intermediate	12.1	57.76
006	Intermediate	10.2	38.11	006	Intermediate	10.9	44.79
007	Intermediate	12.3	60.11	007	Intermediate	13.3	72.71
008	Intermediate	38.6	972.67	008	DEAD	DEAD	972.67
009	Intermediate	48.2	1670.20	009	Large	51	1916.30
010	Large	57.0	2512.15	010	Large	58	2620.79
				101	Small	2.5	1.24
				102	Small	2.8	1.64
				103	Intermediate	10.3	39.03

The Biomass Increment in each subplot =

( $\Sigma$  increments of trees remaining in subplot size class) +

( $\Sigma$  increments for outgrowth trees [=  $\Sigma$  (max biomass for size class - biomass at time 1)]) +

( $\Sigma$  increments for ingrowth trees [=  $\Sigma$  (biomass at time 2 - min biomass for size class)])

Using the values from Table 4, changes in aboveground biomass are calculated as follows:

$$\begin{aligned}
 \text{Small subplot} &= [(2.1-1.37) + (9.64-7.74) + (14.20-10.9)] + \\
 & [(36.32-11.74) + (36.32-21.74)] + [(1.24-1.24) + (1.64-1.24)] \\
 &= (0.73 + 1.90 + 3.30) + (24.97 + 14.57) + (0 + 0.39) = 45.87 \text{ kg}
 \end{aligned}$$

$$\begin{aligned}
 \text{Intermediate subplot} &= [(44.79-38.11) + (72.71-60.11)] + [(1826.12-1670.20)] + [(36.32-36.32) + \\
 & (57.76-36.32) + (39.03-36.32)] \\
 &= (6.68 + 12.60) + (155.92) + (0 + 21.44 + 2.71) = 199.35 \text{ kg}
 \end{aligned}$$

$$\begin{aligned}
 \text{Large subplot} &= ((2620.79-2512.15)) + ((-)) + ((1916.30-1826.12)) \\
 &= (108.64) + (-) + (90.18) = 198.82 \text{ kg}
 \end{aligned}$$

Biomass =  $\Sigma$  biomass in each subplot x expansion factor for that subplot (see Section 3.2.2 to determine how to calculate the expansion factor for a particular subplot)

*Small subplot*             $45.87 \times 127.32 = 5840.50 \text{ kg/ha}$

*Intermediate subplot*     $199.35 \times 16.24 = 3237.44 \text{ kg/ha}$

*Large subplot*             $198.82 \times 7.96 = 1582.13 \text{ kg/ha}$

Sum of biomass =  $10660.07 \text{ kg/ha} = 10.7 \text{ t/ha}$  for the time interval

#### **4.2.2.      Ingrowth and mortality accounting**

An important consideration when calculating biomass increment is the accounting of ingrowth and mortality. Not understanding where, when, and how to include these components can lead to erroneous estimates of changes in aboveground carbon stocks. The approach taken depends on whether permanent or temporary plots are being used. For permanent plots, the method is based on tracking individual surviving trees; whereas, for temporary plots, the measurement is of the pool of biomass at Time 1 and Time 2. For permanent plots, there is no requirement to track tree mortality, but there must be a measure of trees growing into the plots (i.e., exceeding the minimum measurement size only at Time 2). Dead trees are assumed to enter the dead wood pool, where it decomposes and results in carbon emissions.

Figure 7 shows a hypothetical example of the same trees being measured with the temporary plot and the permanent plot method. The increment for ingrowth trees is the biomass of the new tree at Time 2, minus the minimum biomass required for a tree to be measured.

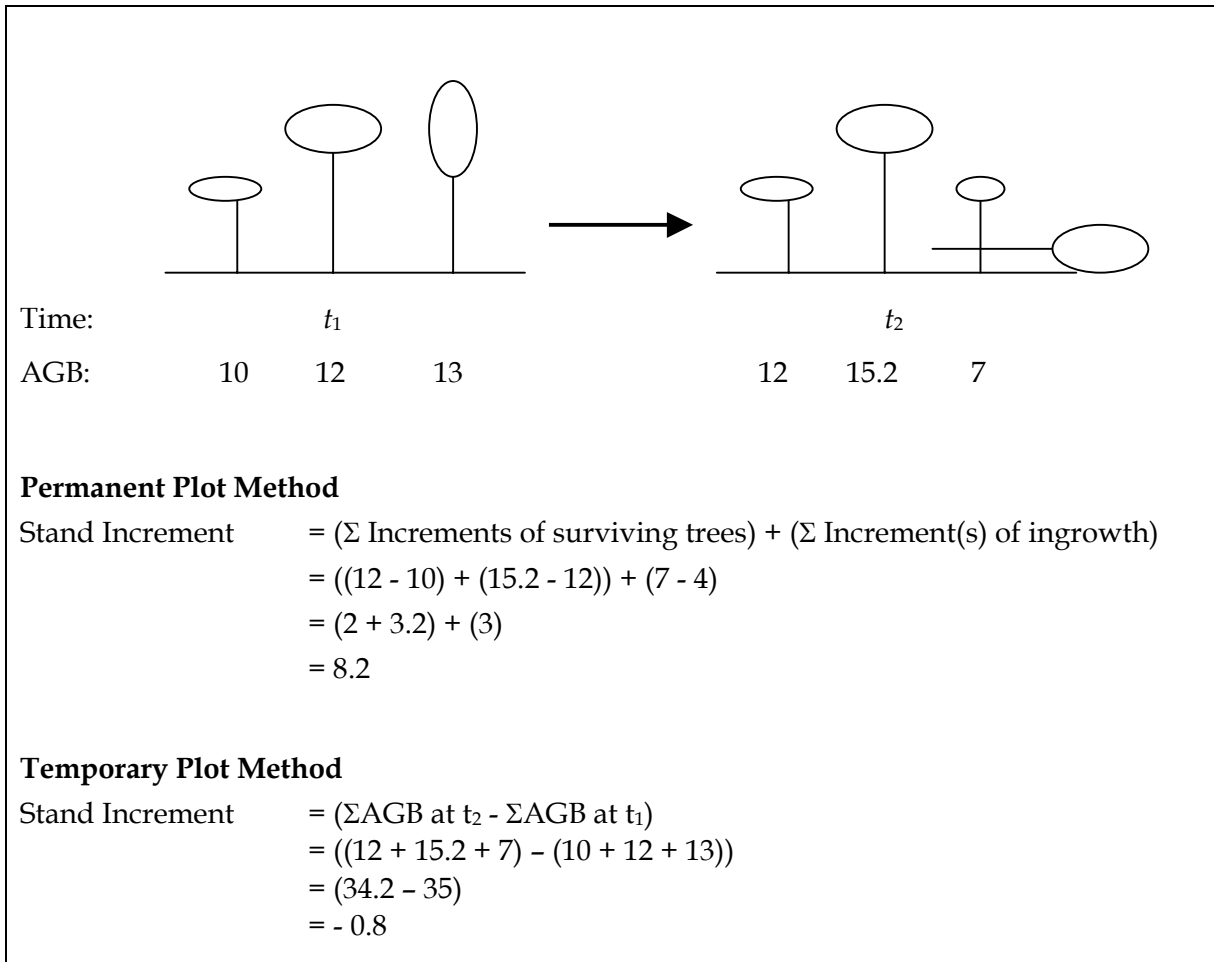

**Figure 7. An illustration of the methods of calculating aboveground biomass increment for permanent plots and temporary plots. AGB = aboveground biomass of live trees; AGB of a minimum-sized tree is set arbitrarily to 4 units (based on Clark et al. 2001).**

It is clear that the two methods give widely different results. Although in this example the temporary plot gives a negative increment, it could just as readily give a larger positive increment than the permanent plots.

### 4.3. Non-tree Biomass

Herbaceous plants in forest understory can be measured by simple harvesting techniques in small subplots (2–4 per plot are recommended) within each sample plot. A small frame (either circular or square), usually encompassing about 0.25 m<sup>2</sup> is used. The material inside the frame is cut to ground level, pooled by plot, and weighed. Well-mixed subsamples are then oven-dried to determine dry-to-wet mass ratios. These ratios are then used to convert the entire sample to oven-dry mass.

For shrubs and other large non-tree vegetation it may be practical to measure their biomass by simple destructive harvesting techniques. A small subplot (dependent on the size of the

vegetation) is established and all the shrub vegetation is harvested and weighed. An alternative approach, if the shrubs are large and common, is to develop local shrub biomass regression equations based on variables such as crown area and height or diameter at base of plant or some other relevant variable (e.g., number of stems in multi-stemmed shrubs). The equations would then be based on regressions of biomass of the shrub versus some logical combination of the independent variables.

#### **4.4. Belowground Biomass**

The measurement of aboveground biomass is relatively established and simple. Belowground biomass, however, can only be measured with time-consuming methods. Thus, it may be more efficient and effective to apply a regression model to estimate belowground biomass. A review of the literature suggests that the model for temperate forests by Cairns et al. (1997) could be used that estimates belowground biomass from knowledge of biomass aboveground only:

$$\text{BBD} = \exp(-0.7747 + 0.8836 \times \ln \text{ABD})$$

Where BBD = belowground biomass density in tons per hectare (t/ha)  
and ABD = aboveground biomass density (t/ha)

$$r^2 = 0.84$$

Applying this equation allows an accurate assessment of belowground biomass. This is a practical and cost-effective method of determining biomass of roots.

##### **4.4.1. Calculating biomass increment in roots**

For the calculation of increment, the exact usage of these equations is important. For tagged trees in permanent plots, it is not possible to simply calculate the total aboveground biomass at Time 1 and Time 2, apply the equations, and then divide by the number of years. This approach cannot account for ingrowth or dead trees. Instead, belowground biomass increments can be calculated using the following method:

1. Calculate aboveground biomass at Time 1.
2. Calculate biomass accumulation aboveground between Time 1 and Time 2, and add to Time 1 to gain biomass at Time 2.
3. Apply the appropriate belowground equation to estimate belowground biomass at each time interval.
4. (Time 2 belowground - Time 1 belowground) / number of years = annual accumulation of biomass belowground.

#### **5.0 Measuring Other Biomass Pools**

##### **5.1. Lying Dead Wood**

Lying dead wood can be measured by complete inventory in one of the nested plot circles or by the line-intersect method outlined by Brown (1974) and Harmon and Sexton (1996). Experience shows that if the line is long enough (at least 100 m), the line-intersect is a time-efficient method.

Two lines (rope or some other appropriate material) 50 m in length are established that intersect at right angles through the plot center. Along the length of the lines, the diameter at the intersection point of any coarse (> 10 cm diameter) dead wood that intersects the line is measured. For smaller-stature forests, coarse wood could be > 5 cm diameter; the method will be the same. Calipers work better for measuring the diameter rather than a tape. There are several criteria that should be observed when deciding if a piece of dead wood should be measured. A piece should only be measured if: (a) more than 50% of the log is aboveground, and (b) the sampling line crosses through at least 50% of the diameter of the piece (Figure 8). If the log is hollow at the intersection point, this should be noted in the data recording system (either electronic or notebook) and the total diameter measured; the hollow portion in the volume estimates is deleted.

Each measured piece is assigned to one of three density states: sound, intermediate, or rotten. A simple and practical method for determining the density class a piece of dead wood is to strike each piece with a saw. If the saw does not sink into the piece (bounces off), it is classified as sound. If it sinks partly into the piece, and there has been some wood loss, it is classified as intermediate. And, if it sticks into the piece, there is more extensive wood loss, and the piece is crumbly, it is classified as rotten.

For each density class separately, the volume is calculated as follows:

$$\text{Volume (m}^3\text{/ha)} = \pi^2 \times [(d_1^2 + d_2^2 \dots \dots d_n^2)/8L]$$

where  $d_1, d_2$  etc = diameters of intersecting pieces of dead wood and  $L$  = length of the line.

Representative dead wood samples of the three density classes, representing the range of species present, should be collected for density (dry weight per green volume) determination. Using a chainsaw or a handsaw, a complete disc from the selected piece of dead wood is cut. The average diameter and thickness of the disc is measured to estimate volume. Volume can also be estimated by the water displacement method. The fresh weight of the disc does not have to be recorded. The disc should be placed in a sample bag; oven dried (80°C/176°F) to a constant weight. Density is calculated by the following formula:

$$\text{Density} = \text{mass (g)} / \text{volume (cm}^3\text{)}$$

Where:

*mass* = the mass of the oven-dried sample

*volume* =  $\pi \times (\text{average diameter}/2)^2 \times \text{average width of sample}$

Examples of densities for dead wood measured in California are given in Table 5.

**Table 5. Dead wood densities measured by Winrock during fieldwork in 2003/4**

	<b>Sierran Mixed Conifer Forest</b>	<b>Coastal Redwood Forest</b>
<i>Sound</i>	0.50 g/cm <sup>3</sup>	0.34 g/cm <sup>3</sup>
<i>Intermediate</i>	0.32	0.25
<i>Rotten</i>	0.17	0.16

**Side View of Dead Wood**

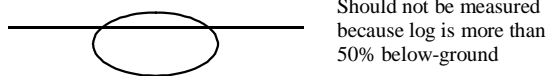

**Top View of Log and Sampling Line**

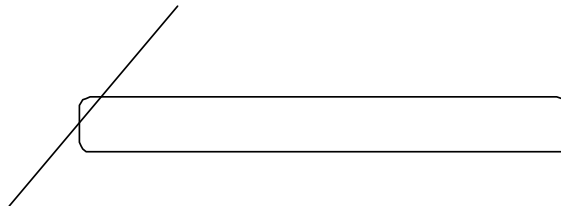

Should not be measured because sampling line does not cross 50% of the dead wood diameter

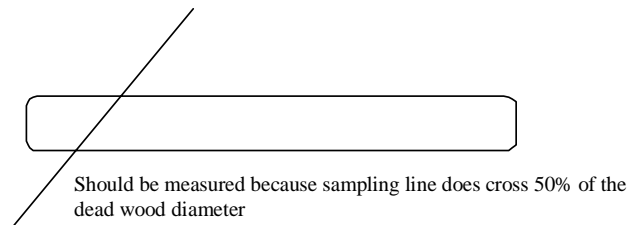

Should be measured because sampling line does cross 50% of the dead wood diameter

**Figure 8. Criteria to determine if a piece of coarse dead wood should be measured during sampling**



### 5.1.1. Calculating the biomass density of dead wood

In the following example, dead wood is sampled along 100 m of line (line-intersect method) to determine biomass density. Diameters and density classes are recorded and subsamples collected to determine density in each of the three density classes (sound, intermediate, and rotten). The following numbers represent the hypothetical results:

13.8 cm	sound
10.7 cm	sound
18.2 cm	sound
10.2 cm	intermediate
11.9 cm	intermediate
56.0 cm	rotten

Densities of subsamples:	Sound:	0.43 t/m <sup>3</sup>
	Intermediate:	0.34 t/m <sup>3</sup>
	Rotten:	0.19 t/m <sup>3</sup>

$$\begin{aligned}\text{Volume of sound wood:} & \quad \pi^2 \times [d_1^2 + d_2^2 + \dots + d_n^2 / 8L] \\ & \quad \pi^2 \times [13.8^2 + 10.7^2 + 18.2^2 / 800] \\ & \quad 7.85 \text{ m}^3/\text{ha}\end{aligned}$$

$$\begin{aligned}\text{Volume of intermediate wood:} & \quad \pi^2 \times [10.2^2 + 11.9^2 / 800] \\ & \quad 3.03 \text{ m}^3/\text{ha}\end{aligned}$$

$$\begin{aligned}\text{Volume of rotten wood:} & \quad \pi^2 \times [56.0^2 / 800] \\ & \quad 38.7 \text{ m}^3/\text{ha}\end{aligned}$$

$$\text{Biomass density} = (7.85 \times 0.43) + (3.03 \times 0.34) + (38.7 \times 0.19) = 11.8 \text{ t/ha}$$

An alternative approach for estimating the biomass of dead wood can be used where the age and species of pieces of dead wood (e.g., known to be slash from a previous timber harvest activity) area known. In this approach, the current density can be calculated from the

decomposition rate specified in Table 6. These estimated densities can then used with the volume estimates, as shown above.

**Table 6. Decomposition rate constants and half-lives for down dead wood by forest type**

Forest Type	Decomposition Rate <sup>a</sup>	Half Life
	<i>Year<sup>-1</sup></i>	<i>Years</i>
Douglas-fir	0.022	31.5
Spruce-fir	0.028	24.8
Hemlock-spruce	0.031	22.4
Lodgepole pine	0.041	16.9
Hardwoods	0.082	8.5
Ponderosa pine	0.017	40.8
Redwoods	0.014	49.5

<sup>a</sup>From Turner et al. 1993

## 5.2. Standing Dead Wood

Within the same plots delineated for live trees, standing dead trees can also be measured. The following measurements need to be made for the dead trees: dbh, relative state of dead tree, and a decomposition state of the dead tree. Relative states for standing dead tree are defined as follows:

1. Tree with branches and twigs and resembles a live tree (except for leaves)
2. Tree with no twigs but with persistent small and large branches
3. Tree with large branches only
4. Bole only, no branches

For state 1, biomass is estimated from dbh using the same function as for live trees, but subtracting out the biomass of leaves (about 2%–3% of aboveground biomass for hardwoods, 5%–6% for softwoods). Where only a bole is remaining (class 4), volume is estimated using dbh and height measurements and an estimate of the top diameter. Volume is then estimated as the volume of a truncated cone, and converted to dry biomass using an appropriate dead wood density class (sound or intermediate).

For classes 2 and 3, estimates of the proportion of the tree that is missing need to be made. The principle of conservatism should be applied. Table 7 provides an estimate of the proportion of biomass in the stem, branches, and foliage for living hardwoods and softwoods in the United States, which could be used to deduct the portion of aboveground biomass that is missing.

**Table 7. Proportions of biomass in tree vegetation components (from Jenkins et al. 2003). Values given are percentage of total aboveground biomass.**

	<i>dbh (cm)</i>									
	10	20	30	40	50	60	70	80	90	100
	%									
<i>Hardwood Stem</i>	54	68	74	77	79	80	81	82	82	83
<i>Branches</i>	43	29	24	21	19	18	17	16	16	15
<i>Foliage</i>	3	2	2	2	2	2	2	2	2	2
<i>Softwood Stem</i>	68	74	77	78	78	79	79	79	80	80
<i>Branches</i>	23	19	17	16	16	16	15	15	15	15
<i>Foliage</i>	8	6	6	6	6	6	6	5	5	5

### 5.3. Litter and Duff

*Litter* is defined as dead surface plant material that is still recognizable and is not decomposed to the point that identification is impossible to define – includes dead leaves, twigs, dead grasses, small branches (less than the minimum diameter used to define coarse woody debris – normally 10 cm). The *duff* layer is the organic material layer between the uppermost soil mineral horizon and the litter layer. The duff layer is defined as decomposing organic material, decomposed to the point at which there is no identifiable organic materials (such as pine straw, leaves, twigs, or fruits). Both of these layers will be combined as one pool and sampled together using small subplots.

A square sample frame 30 cm x 30 cm is sufficient for sampling. Four samples, one located in each of the four N, E, S, and W quadrants of the plot are selected. At each location, all litter and duff that falls inside the frame is collected. The duff layer may have to be collected using garden clippers or a knife. In cases where sample bulk is excessive, the fresh weight of the total sample should be recorded in the field, and a subsample of manageable size (approximately 80–100 g), taken for moisture content determination, from which the total dry mass can be calculated. Litter should be sampled at the identical time of year at each census to eliminate seasonal effects.

In some Californian forests, the litter and duff layer can be relatively deep. In these cases, the *depth* of litter and duff can be measured in the field and related to biomass with a previously developed function (see Figure 9, an example from Blodgett Forest Research Station). To produce a function, measurements are taken of depth (usually at each corner of the frame after the material has been removed), and mass and subsamples are collected to determine dry mass.

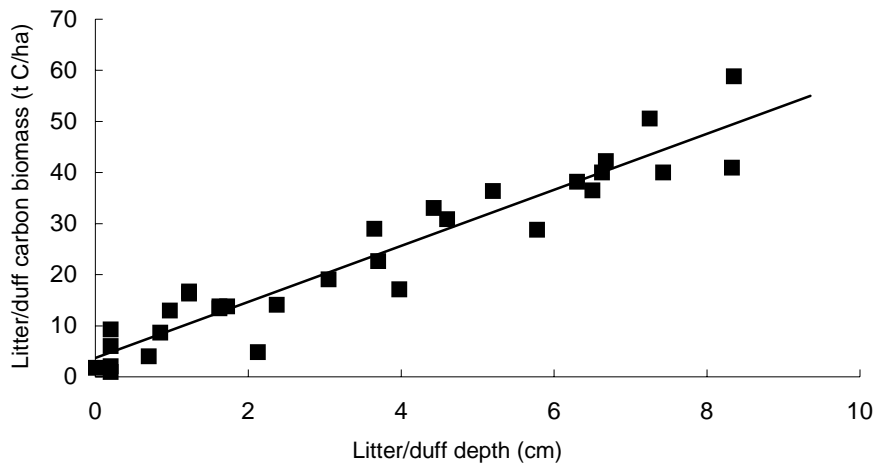

**Figure 9. Relationship between litter/duff depth and carbon biomass from mixed pine forests in Blodgett Forest Research Station**

#### 5.4. Soil Organic Carbon

To obtain an accurate inventory of organic carbon stocks in the mineral soil or organic soil, three types of variables must be measured: (1) soil depth, (2) soil bulk density (calculated from the oven-dry weight of soil from a known volume of sampled material), and (3) the concentrations of organic carbon within the sample. For monitoring changes in soil carbon over time, measuring the changes on the same *equivalent* mass of soil is preferred. Sampling to a fixed depth (equal volumes) can result in underestimation of carbon gains via afforestation, because as the bulk density generally decreases over time, the same sampled volume contains less of the original soil mass equivalent. However, for practical reasons it is generally more convenient to sample to the same fixed depth. Rates of carbon accrual derived in this way should therefore be considered *conservative* estimates of soil carbon accretion.

Coring tools to sample the soil to varying depths are commercially available, and simple soil corers have been found to work in many soils. Shallow soil pits (to 30 cm or so) also work well and have been shown to be a cost-efficient method.

Composite sampling is an effective means to reduce inter-sample variability. This sampling is done by aggregating a pre-determined number of samples (usually 4 samples) from each collection site in the field, from which one sample is derived for analysis. The resulting *composite* sample captures more of the range of inter-microsite variability in soil carbon. It is recommended that if soil sampling is to be done, then a sample can be collected from the subplots used to sample the litter and duff (see Section 5.3). Using the core sampler method, mineral soil samples are collected from within the area of the sampling frame. When taking cores for measurements of bulk density, care should be taken to avoid any loss of soil from the cores; if any material is lost, the sample needs to be taken again.

The excavation method involves digging a small pit, wide enough to collect the soil to the depth desired. A hand shovel can be used to collect material to the desired depth, making sure that sufficient volume of soil from the sides of the pit is collected approximately equal to the volume of a soil corer. It is important that material is collected from the entire depth to avoid biasing the sample. Uniform rings can be used to sample sides of the pit for bulk density, making sure not to compress the soil

Soil chemical concentrations are generally measured on air-dried soils; whereas, bulk density measurements must be made on soil that is oven-dried at 105°C (221°F). It is recommended to take separate sets of cores for the bulk density and carbon determination, because the sample preparation for each differs somewhat. In addition, fewer cores may be needed to accurately estimate bulk density, because it is generally less variable than soil chemical properties. We recommend that four samples for soil carbon and two samples for bulk density be collected to produce composite samples. If however, the soil appears to be different at the four sample points (e.g., in color or texture), then four samples should be collected for bulk density and composited.

Soil samples can be sent to a professional lab for analysis. Commercial laboratories exist throughout the country and routinely analyze plant and soil samples for a variety of measures using standard techniques. It is recommended that the selected laboratory be checked to make sure that they follow the commonly accepted standard procedures both with respect to sample preparation (e.g., sieving), drying temperatures, and method for carbon analysis.

For bulk density determination, the samples must be dried in an oven at 105°C (221°F) for a minimum of 48 hours. If the soil contains coarse rocky fragments, the coarse fragments must be retained and weighed, and their weights recorded. For soil carbon determination, the material is sieved through a 2-mm sieve and the material is then thoroughly mixed. The dry combustion method using a controlled-temperature furnace (e.g., a LECO CHN-2000 or equivalent) is the recommended method for determining total carbon in the soil (Nelson and Sommers 1996).

The bulk density and carbon concentration data are used to compute amounts of carbon per unit area of forest as follows:

$$C (t / ha) = [(soil\ bulk\ density, (g / cm^3) \times soil\ depth (cm) \times C)] \times 100$$

In this equation, the C must be expressed as a decimal fraction (e.g., 2.2% C is expressed as 0.022 in the equation).

## **6.0 Estimating Net Change in the System**

The type of forest management activity influences how each of the carbon stock components are integrated into an estimate of the net change in carbon stock at each monitoring interval.

Potential activities can be grouped into two main classes: (1) tree planting on existing non-forested lands (afforestation), and (2) activities implemented on existing forested land (forest management and forest preservation). These two main classes of activities influence how measurements and estimations are integrated to arrive at an estimate of the net change in total carbon stocks in the time interval.

## 6.1. Activities on Non-Forested Lands

All activities on non-forested lands typically begin on land that initially has very low carbon stocks in vegetation (generally less than a couple of tons/ha) and variable amounts in the soil. In each of these cases a sampling regime would be implemented that monitors each of the carbon stock components indicated in Table 1. These methods have already been discussed in Sections 4 and 5. The task is then how to combine all the estimates of the carbon stock for each component to arrive at an estimate of the net change in total carbon.

Using permanent plots, the carbon stock for living and standing dead trees, down dead wood, and belowground biomass of individual plots can be monitored through time; therefore, the change in carbon stocks can be estimated directly at the plot level. In this case, the change in carbon stocks for the different components should be summed within plots to give a per-plot carbon stock change in t C/ha. The plot-level results are then averaged to give mean and 95% confidence intervals. The mean change in carbon stocks per unit area is then multiplied by the area of the activity to produce an estimate of the total change in carbon. If stratification is used, this approach is repeated for each stratum and then all strata are added together to estimate the total. This total is then converted to t CO<sub>2</sub> equivalent by multiplying by 3.67 (the atomic mass ratio between carbon and carbon dioxide).

Soil, forest floor, and non-tree vegetation are calculated separately as the statistics, number of sampling plots, and even the sampling interval may be different than for the other components. The results from these measurements are analyzed to produce an estimate of the mean and the 95% confidence interval. This estimate is then added to create a system level mean and 95% confidence interval. The total confidence interval is calculated as follows:

$$\text{Total 95\% CI} = \sqrt{([95\% \text{CI}_{\text{veg}}]^2 + [95\% \text{CI}_{\text{soil}}]^2 + [95\% \text{CI}_{\text{forest floor}}]^2 + [95\% \text{CI}_{\text{non-tree vegetation}}]^2)}$$

Where  $[95\% \text{CI}_{\text{veg}}]$  = 95% confidence interval for vegetation,  $[95\% \text{CI}_{\text{soil}}]$  = 95% confidence interval for soil, and so on.

If part of the forest area is eventually harvested, the sampling plots would theoretically monitor the change in live and dead biomass. However, they would not monitor the amount going into wood products. The reason wood products need to be considered is that the decrease in live biomass from harvesting does not mean that the equivalent amount of carbon went into the atmosphere – some of it could go into long-lived wood products. Thus to correctly estimate the effects of harvesting on the net change in carbon stocks, the amount of wood biomass going into long-term wood products is needed (but not discussed here).

An example of the integration of all the components from permanent plots is given in Figure 10. In this case, the initial carbon stock in vegetation and soil on the land is assumed to remain constant throughout the estimation period. The baseline only has to be subtracted one time; at subsequent reporting intervals, the gross increment is the net increment. In the case where the land area had already been abandoned and is undergoing succession or had been planted to perennial vegetation, then it is likely that carbon would be sequestered even without the activity, albeit at slower rates. In this situation, the carbon accumulating on the project lands would need to be factored out of the amount of carbon sequestered by the activity. The amount

that would be sequestered without the activity (the baseline) could be estimated by locally calibrated models or by measurements in a nearby proxy area where the activities are not implemented. In this case, a baseline value must be subtracted from the stocks at each measuring interval. To maintain the high degree of precision in the estimated net change in carbon stocks (the difference between the change in carbon stocks of the activity and the proxy area) means that the precision in the proxy area's measurements must be similar to those of the activity area. This implies a larger measurement and monitoring effort, and is thus more costly to implement. It may make more sense to design and implement activities on lands not already abandoned.

Ideally, the baseline will also have a 95% CI, in which case the confidence interval after the subtraction of means will equal:

$$\text{Total 95\% CI} = \sqrt{([\text{95\% CI carbon stocks}]^2 + [\text{95\% CI baseline}]^2)}$$

This hypothetical example is an afforestation activity on 500 ha of former cropland. The baseline for carbon stocks in the absence of the project is continued coverage by cropland with an average carbon stock in vegetation of 0.9 t C/ha. The following table reports the change in carbon stock between years 1 and 10.

Plot Number	Change in carbon stocks (t C/ha)			Sum (t C/ha)
	Living biomass		Dead Organic Matter	
	Aboveground: Trees	Belowground	Standing Dead Wood	
Plot 1	12.1	2.4	0.1	14.6
Plot 2	11.5	2.3	0.0	13.8
....	...	...	...	...
....	...	...	...	...
Plot 31	12.6	2.5	0.1	15.1
Plot 32	10.9	2.2	0.1	13.2

	Mean	13.9
	95% CI	2.4
	+ Non-tree Vegetation	1.8
	<i>N-T V 95% CI</i>	0.1
	+ Down Dead Wood	3.8
	<i>DDW 95% CI</i>	0.1
	+ Forest Floor	0.2
	<i>F.F. 95% CI</i>	0.1
	+ Soil	0.5
	<i>Soil 95% CI</i>	0.1
	- Stock at previous monitoring event	0.9
	<i>Previous 95% CI</i>	0.1
	<b>NET change in carbon stock</b>	<b>19.3</b>
	<b>95% CI</b>	<b>2.4</b>

Net change in stocks over area:  $19.3 \text{ t C/ha} \times 3.67 \text{ t CO}_2\text{eq/ha} / \text{t C/ha} \times 500 \text{ ha}$   
 $\pm$  the 95 % CI:  $2.4 \text{ t C/ha} \times 3.67 \text{ t CO}_2\text{eq/ha} / \text{t C/ha} \times 500 \text{ ha}$   
 Therefore, the net change is:  $35,416 \pm 4,419 \text{ t CO}_2 \text{ eq. over 10 years}$

**Figure 10. Calculating net carbon change for a hypothetical system**



## 6.2. Activities on Forested Lands

Forest management involves alternating periods of harvest and regrowth, and as such, carbon stocks in forest biomass vary over time (Figure 11). In addition, changes in management practices can result in increased carbon storage through a variety of strategies, such as: changing the timing or intensity of harvest, reducing damage to the residual stand through more efficient logging practices, changing the configuration and relative size of harvest blocks, or by changing the magnitude of harvest.

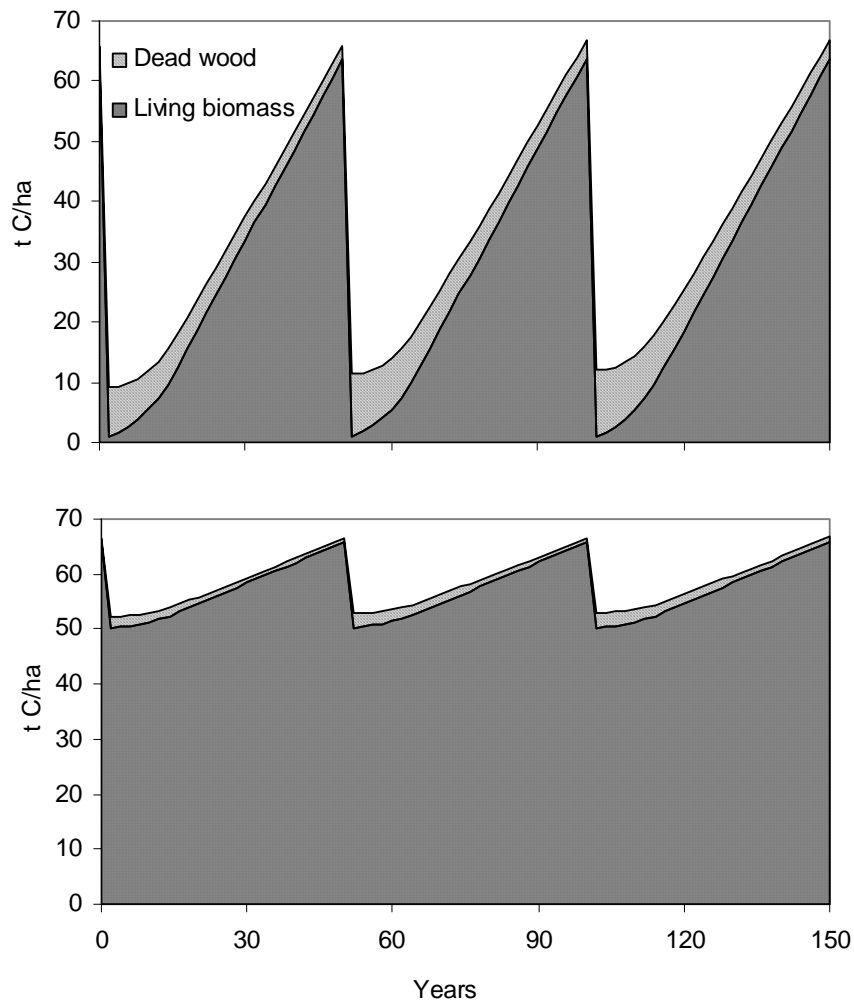
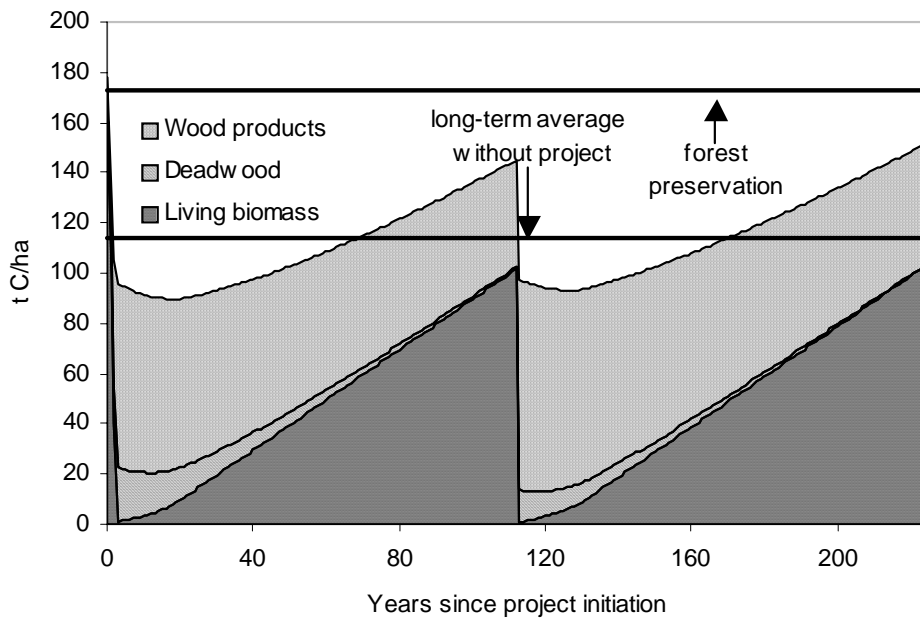

**Figure 11. Carbon stocks associated with (top) complete harvest of forest, followed by 50-year even-aged management and (bottom) limited selective harvest on a similar cutting cycle of a similar forest**

The approach of defining *long-term average* per unit area carbon storage (Figures 12 and 13) offers a simplified point of reference for determining the relative benefits of these dynamic projects. Although a long-term average is often thought of as occurring in a stand, it actually

represents the likely case of a whole sustainably managed forest landscape where parcels that represent the whole range of age classes exist.

The baseline/reference cases vary with the type of project. In a *forest preservation* project, the baseline case is the long-term average carbon storage for the forest management regime the project area would have otherwise been subject to in the absence of the intervention (Figures 12 and 13). The with-project case is represented by a preserved forest with stable carbon stocks (e.g., mature forest) or one with increasing carbon stocks, if it was not at maturity at the date the activity commenced. In an *alternative forest management* project, the baseline and with-project cases are represented by contrasting long-term averages in carbon stocks resulting from different management regimes (Figure 14).



**Figure 12. Carbon stocks associated with complete harvest of a mature forest followed by a 120-year rotation even-aged forest management. The carbon benefits of preservation are represented by the difference between the baseline and the new long-term average C.**

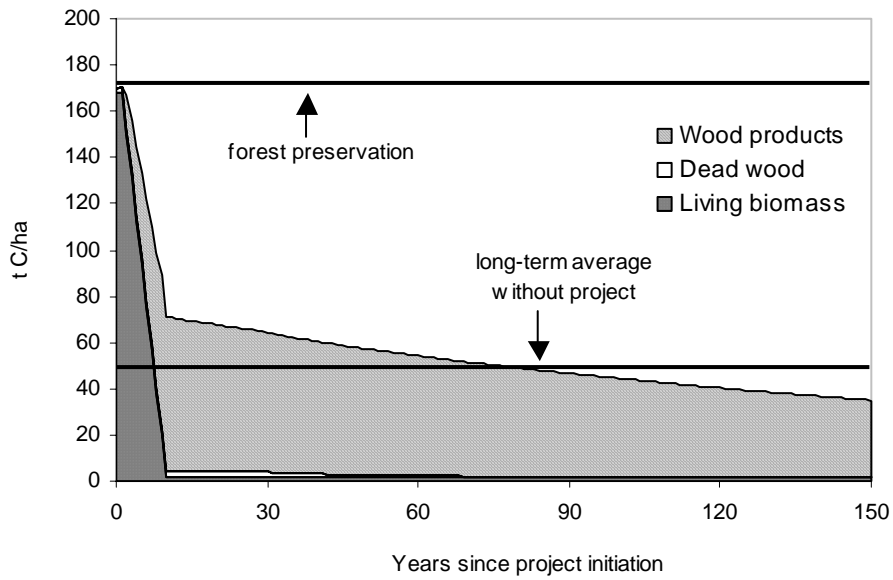

**Figure 13. Carbon stocks associated with complete harvesting of a mature forest followed by development. The carbon benefits of preservation are represented by the difference between the baseline and the new long-term average C.**

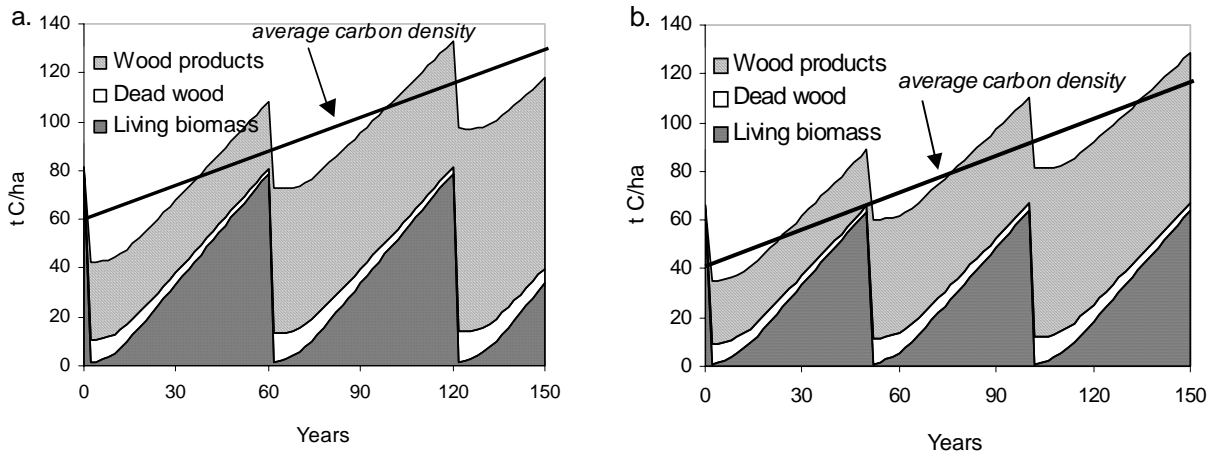

**Figure 14. Average carbon stocks through time in hypothetical forest management activities. A rotation of 60 years is represented in (a) and a rotation of 50 years in (b). In this example, additional carbon sequestration occurs with a 10-year rotation extension. Carbon continues to accumulate through time in both scenarios, due to the slow turnover of long-term products and dead wood.**

Initially, it is important to consider what carbon pools are important in forest management activities. Clearly live vegetation and dead wood and wood products are central. The amount of dead wood that accumulates through time is a function of rate of natural mortality, the amount of slash left behind after harvest, the periodicity of harvest, and the rate of decomposition. Although methods were given for estimating root biomass, it is not clear how this pool responds to harvest. If it is assumed that the roots left behind decompose at the same rate as new ones grow during reforestation of the area, then the carbon in roots could be ignored. However, if the roots decompose at a slower rate after harvest than they grow during reforestation, then roots are a potential carbon sink. Very little work has been done on the fate of roots, particularly coarse roots, after harvest and during reforestation. As soil organic matter is defined as the material passing through a 2-mm sieve, it is possible that the role of coarse roots (most of the belowground biomass is in coarse roots [Cairns et al. 1997]) has been generally left out of forest carbon budgets.

Measurement of soil organic carbon is, at best, marginally beneficial in forest management activities. Soil carbon may be reduced slightly, immediately following harvest (Laiho et al. 2002, Carter et al. 2002); however, any losses will be regained as the succeeding forest regrows with accompanying soil organic matter inputs (Carter et al. 2002). Relative difference in post-harvest effects on soil carbon between varying harvest intensities are slight and often undetectable (Carter et al. 2002). Because differences in soil carbon resulting from changes in management are seldom discernible or long-lived, the significant additional effort of soil sampling on projects on forested lands is not recommended.

To monitor the changes in carbon stocks, the simplest approach is to install sample plots and monitor the changes, as described above. As shown in Figure 11, there will be periods of carbon accumulation and periods of carbon loss, resulting in positive and negative changes in carbon stocks. With a well-designed sampling regime, remeasurements will reveal shifts of pre-harvest living biomass to the dead wood pool (i.e., logging slash and collateral mortality), and subsequent decomposition over time, as well as regrowth, resulting after harvest. The main difference in sampling and integrating measurements from plots in existing forests – either where the activity is preservation or change in management – is that the baseline case is more complex, because it includes all the carbon pools important in forests, which have to be measured to the same accuracy and precision as the activity. However, mean total carbon stocks and 95% confidence intervals are calculated in the same way as for activities on non-forested lands.

## **7.0 Quality Assurance and Quality Control**

Implementation of measuring and monitoring changes in carbon stocks to provide carbon credits should require provisions for quality assurance (QA) and quality control (QC) to be implemented via a QA/QC plan. Such plans provide confidence to all stakeholders that the reported carbon credits are reliable and meet minimum measurement standards. The plan should become part of project documentation and cover procedures for: (1) collecting reliable field measurements; (2) verifying laboratory procedures; (3) verifying data entry and analysis techniques and; (4) data maintenance and archiving. To ensure that these procedures are carried out in a repeatable manner, a set of Standard Operating Procedures (SOPs) should be prepared for each step.

### **7.1. QA/QC for Field Measurements**

Collecting reliable field measurements is an important step in the quality assurance plan. Those responsible for the carbon measurement work should be fully trained in all aspects of the field data collection and data analyses, and standard operating procedures should be followed rigidly to ensure accurate measurement and remeasurement. The SOPs should be detailed enough so that any new person sent to the field should be able to accurately repeat the previous measurements. For example, the SOPs should cover all aspects of the field measurements, including such steps as where to measure the dbh of a tree (e.g., see Figure 5 above), how to classify dead wood, and how to clearly delineate the litter from the mineral soil. The detailed methods presented above are appropriate for creating SOPs for the field phase of the QA/QC plan.

Field crews should receive extensive training and should be fully cognizant of all procedures, and the importance of collecting data as accurately as possible. A check of the field crews should be conducted to identify errors in field techniques, to verify measurement processes and to correct any identified problems before they are applied.

A second type of field check should be used to quantify measurement errors. To implement this type of check, a complete remeasurement of a number of plots by people other than the original field crews is performed at the end of the fieldwork. About 10%–20% of the plots should be remeasured this way. Field data collected at this stage can be compared with the original data. Any errors found should be corrected and recorded. Any errors discovered could be expressed as a percentage of all plots that have been rechecked to provide an estimate of the measurement error.

### **7.2. QA/QC for Sample Preparation and Laboratory Measurements**

Standard operating procedures should also be created and rigorously followed for sample preparation and analyses. In many instances, it is likely that commercial laboratories will be used, and if so, it is important that their procedures follow accepted standards. For example, soil bulk density samples should be dried at 105°C (221°F) in a drying oven to constant weight. By definition, soil organic carbon is that which passes through a 2-mm sieve, thus it is important that the lab follow this step. The well-mixed sample should not be oven-dried for the carbon analysis, but only air-dried; however, the carbon concentration does need to be expressed on an oven dry basis at 105°C (221°F).

For quality control, all combustion instruments for measuring carbon should be calibrated using commercially available certified carbon standards. For example, blanks and samples of known carbon concentration should be analyzed in each batch/run. Similarly, all balances for measuring dry weights should be calibrated against known weights periodically. Where possible, 10%–20% of soils samples could be reanalyzed/reweighed to produce an error estimate. Similar procedures should be applied to plant material such as litter or understory.

### **7.3. QA/QC for Data Entry**

Field data are either collected directly onto electronic media or on field sheets. If entered electronically in the field, then the field data entry step is not needed; however, errors in field data entry can occur and efforts should be made to check this step. If collected on field sheets, the accurate entry of data into the data analyses worksheets is important. To check for data entry errors, it is suggested that another independent person should enter data from about 10%–15% of the field sheets into the data analysis software. These two data sets can then be compared to check for errors. Any errors detected should be corrected in the master file. The data analysis software could be developed so that it has checks built into it to highlight potential errors in data entry. For example, such checks could include tests to check that the diameter limits for a given nested plot (if used) is within the limits set by the field work.

Common sense should be used when reviewing the results of the data analysis, to make sure that they fit within the realm of reality. Errors can be reduced if the entered data are reviewed using expert judgment and, if necessary, through comparison with independent data. All personnel involved in measuring and analyzing data should communicate closely to resolve any apparent anomalies before final analysis of the monitoring data can be completed.

### **7.4. QA/QC for Data Archiving**

Because of the relatively long-term nature of forestry activities, data archiving (maintenance and storage) will be an important component of a project. Copies of all data analyses, and models; the final estimate of the amount of carbon sequestered; any GIS products; and a copy of the measuring and monitoring reports should all be stored in a dedicated and safe place.

Given the time frame over which projects may take place and the pace of production of updated versions of software and new hardware for storing data, the electronic copies of the data and reports should be updated periodically or converted to a format that could be accessed by any future software application.

## 8.0 References

- Avery, T. E., and H. E. Burkhart (eds.). 1983. *Forest Measurements*, 3rd edition. New York: McGraw-Hill.
- Brown, J. K. 1974. *Handbook for inventorying downed woody material*. General Technical Report INT-16. Ogden, Utah: USDA Forest Service Intermountain Forest and Range Experiment Station.
- Brown, S. 2002. Measuring carbon in forests: Current status and future challenges. *Environmental Pollution* 116:363–372.
- Brown, S. 1997. *Estimating Biomass and Biomass Change of Tropical Forests: A Primer*. UN FAO Forestry Paper 134, Rome. 55 pp.
- Brown, S., A. J. R. Gillespie, and A. E. Lugo. 1989. Biomass estimation methods for tropical forests with applications to forest inventory data. *Forest Science* 35:881–902.
- Brown, S. L., and P. E. Schroeder. 1999. Spatial patterns of aboveground production and mortality of woody biomass for eastern US forests. *Ecological Applications* 9:968–980. (errata: Brown, S. L., Schroeder, P. E. 2000. *Ecological Applications* 10:937).
- Brown, S., O. Masera, and J. Sathaye. 2000. Project-based activities. In R. Watson, I. Noble, B. Bolin, N. H. Ravindranath, D. J. Verardo, and D. J. Dokken (eds.). *Land use, land-use change, and forestry; Special Report to the Intergovernmental Panel on Climate Change*, Cambridge University Press, Ch. 5, 283–338.
- Cairns, M. A., S. Brown, E. H. Helmer, and G. A. Baumgardner. 1997. Root biomass allocation in the world's upland forests. *Oecologia* 111:1–11.
- Carter, M. C., T. J. Dean, M. Zhou, M. J. Messina, and Z. Wang. 2002. Short-term changes in soil C, N, and biota following harvesting and regeneration of loblolly pine (*Pinus taeda* L.). *Forest Ecology and Management* 164:67–88.
- Clark, D. A., S. Brown, D. W. Kicklighter, J. Q. Chambers, J. R. Thomlinson, and Jian Ni. 2001. Measuring net primary production in forests: Concepts and field methods. *Ecological Applications* 11:356–370.
- Dawkins, H. C. 1957. Some results of stratified random sampling of tropical high forest. Seventh British Commonwealth Forestry Conf. 7 (iii) 1–12.
- Freese, F. 1962. *Elementary Forest Sampling*. USDA Handbook 232. Washington, D.C.: Government Printing Office. 91 pp.
- Harmon, M. E. and J. Sexton. 1996. Guidelines for measurements of woody detritus in forest ecosystems. U. S. LTER Publication No. 20.
- Jenkins, J. C., D. C. Chojnacky, L. S. Heath, and R. A. Birdsey. 2003. National-scale biomass estimation for United States tree species. *Forest Science* 49:12–35.
- Laiho, R., F. Sanchez, A. Tiarks, P. M. Dougherty, and C. C. Trettin. 2002. Impacts of intensive forestry on early rotation trends in site carbon pools in the southeastern US. *Forest Ecology and Management* 174:177–189.

- Lindquist, J. L., and M. N. Palley. 1963. Empirical yield tables for young-growth redwood. California Agricultural Experiment Station Bulletin 796, Berkeley, California. 47 pp.
- MacDicken, K. G. 1997. *A Guide to Monitoring Carbon Storage in Forestry and Agroforestry Projects*. Winrock International, Arlington, Virginia. 87 pp. Available at [www.winrock.org/what/ecosystem.cfm](http://www.winrock.org/what/ecosystem.cfm)
- Nelson, D. W., and L. E. Sommers. 1996. Total carbon, organic carbon, and organic matter. p. 961-1010. *In*: D. L. Sparks et al. (eds.) *Methods of soil analysis. Part 3. Chemical methods*. Soil Science Society of America, Madison, Wisconsin.
- Schroeder, P., S. Brown, J. Mo, R. Birdsey, and C. Cieszewski. 1997. Biomass estimation for temperate broadleaf forests of the United States using inventory data. *Forest Science* 43:424-434.
- Smith, J. E., L. S. Heath, and J. C. Jenkins. 2003. *Forest volume-to-biomass models and estimates of mass for live and standing dead trees of U.S. forests*. USDA-FS General Technical Report NE-298.
- Sokal, R. R., and F. J. Rohlf. 1995. *Biometry: The principles and practice of statistics in biological research*. 3rd ed. New York: W. H. Freeman and Co. 887 pp. ISBN: 0-7167-2411-1.
- Turner, D. P., J. J. Lee, G. J. Koerper, and J. R. Barker. 1993. *The forest sector carbon budget of the United States: Carbon pools and flux under alternative policy options*. Corvallis, Oregon: U.S. Environmental Protection Agency. 202 pp.
- USDA Forest Service. 2002. *FIA Field Methods for Phase 3 Measurements. Soil measurements and sampling*. Available on-line at <http://fia.fs.fed.us/library.htm#Manuals>