



University of California
 Environmental Restoration Project, MS M992
 Los Alamos, New Mexico 87545
 505-667-0808/FAX 505-665-4747



U. S. Department of Energy
 Los Alamos Area Office, MS A316
 Environmental Restoration Program
 Los Alamos, New Mexico 87544
 505-667-7203/FAX 505-665-4504

911 59166

Date: June 8, 1998
 Refer to: EM/ER:98-183

Mr. Benito Garcia
 NMED-HRMB
 P.O. Box 26110
 Santa Fe, NM 87502

**SUBJECT: SP FOR INSTALLING BMP FOR PRSs AT TA-49 (FORMER
 OU 1144, FU 5)**

Dear Mr. Garcia:

Enclosed for your information and review is the Stabilization Plan (SP) for Installing Best Management Practices (BMP) at Potential Release Sites 49-001(b, c, d, and g). As discussed with your staff at the May 28, 1998, meeting in Santa Fe, the field activities specified in the SP are designed to reduce high moisture conditions present directly below the asphalt pad. Additionally, we have enclosed responses to the specific questions your staff asked during the May 28, 1998, meeting about the data presented for this site.

A phased approach is planned to address these PRSs. First, silt fences and hay bales will be installed to control runoff while a diversion channel is being constructed upgradient to control run-on. The removal of the asphalt pad and regrading of the asphalt pad area of the site will be the second phase of field activities.

Your staff has indicated verbally that these field activities may be considered by the New Mexico Environment Department (NMED) to be an interim measure (IM). Please notify us if any planned activity is considered by your office to be an IM.

If you have any questions or require additional information, please contact Warren Neff at (505) 665-9259 or Joe Mose at (505) 667-5808.

Sincerely,

Julie A. Canepa, Program Manager
 LANL/ER Project

Sincerely,

Theodore J. Taylor, Program Manager
 DOE/LAO

JC/TT/WN/rfr

- Enclosure: (1) SP for Installing BMP for PRSs at TA-49
 (2) Responses to Additional Issues
 (3) Data for TA-49

Received by ER-RPF
 SEP 25 1998
 MA

Mr. Benito Garcia
EM/ER:98-183

-2-

June 8, 1998

Cy (w/ enc.):

J. Mose, LAAO, MS A316
W. Neff, CST-7, MS E525
D. Neleigh, EPA, R.6, 6PD-N
C. Rodriguez, CIO/ER, MS M992
T. Taylor, LAAO, MS A316
T. Trujillo, AL-ERD, MS A906
J. White, ESH-19, MS K498
S. Dinwiddie, NMED-HRMB
M. Leavitt, NMED-GWQB
J. Parker, NMED-OB
G. Saums, NMED-SWQB
S. Yanicak, NMED-AIP, MS J993
RPF, MS M707

Cy (w/o enc.):

T. Baca, EM, MS J591
A. Dorries, TSA-4, MS M992
D. McInroy, EM/ER, MS M992
J. Plum, LAAO, MS A316
G. Rael, AL-ERD, MS A906
T. Longo, DOE-HQ, EM-453
J. Vozella, LAAO, MS A316
EM/ER File, MS M992

CONTENTS

FIGURES _____ **III**

TABLES _____ **IV**

1.0 RATIONALE AND OBJECTIVE _____ **1**

2.0 SITE DESCRIPTION DATA _____ **1**

2.1 General Site Description _____ 1

2.2 Tests at Areas 2, 2A, and 2B _____ 4

2.3 Moisture Conditions at Area 2 _____ 7

3.0 SITE CHARACTERIZATION DATA _____ **10**

3.1 Approach to RFI Site Characterization at MDA AB _____ 10

3.2 Site Characterization at Areas 2, 2A, and 2B _____ 11

 3.2.1 Surface Soils and Vegetation _____ 11

 3.2.2 Subsurface Sampling _____ 14

 3.2.3 Moisture Conditions and Water Sampling _____ 15

 3.2.4 Surface Water Assessment _____ 20

3.3 Summary of Constituents _____ 21

4.0 JUSTIFICATION FOR IMPLEMENTING BMPS _____ **21**

5.0 PROPOSED BMPS _____ **22**

5.1 Site Preparation Activities _____ 23

 5.1.1 Internal Reviews, Permits, and Approvals _____ 23

 5.1.1.1 ER Peer Review _____ 23

 5.1.1.2 ESH-ID Review _____ 24

 5.1.1.3 DOE Review _____ 26

 5.1.1.4 Readiness Review _____ 26

 5.1.2 RFI Sampling _____ 26

 5.1.3 Borings to Competent Tuff _____ 26

 5.1.4 Power Line Relocation _____ 27

 5.1.5 Borehole Plugging and Abandonment _____ 29

 5.1.6 Site Clearing and Fence Removal _____ 29

 5.1.7 Laydown, Stockpile, Parking, and Waste Storage Areas _____ 29

 5.1.8 Baseline Borehole Measurements _____ 29

5.2 Surface Water Run-on Diversion Channel _____ 30

5.3 Asphalt Pad Removal and Fill Excavation _____ 30

5.4 Surface Soil Screening and Release of Site Runoff _____ 33

5.5 Site Regrading and Drainage Improvements _____ 33

5.6 Cover Revegetation _____ 34

6.0 SITE RESTORATION, CLEANUP, AND MONITORING _____ **34**

Contents

7.0 SITE INSPECTION AND MAINTENANCE	35
8.0 ALTERNATIVES TO THE PROPOSED BMPS	35
8.1 No-Action Alternative	35
8.2 Implement Some of the BMPs	35
8.3 Implement Modified Versions of the BMPs	36
8.4 Implement Additional Activities	36
8.5 Future Site Activities and Final Corrective Measures	37
9.0 QUALITY ASSURANCE	37
REFERENCES	39
ATTACHMENT 1 EVALUATION OF POTENTIAL SURFACE WATER CONCERNS	A-1
ATTACHMENT 2 STORM WATER POLLUTION PREVENTION PLAN	B-1
ATTACHMENT 3 MONITORING WELL AND BOREHOLE ABANDONMENT PLAN	C-1
ATTACHMENT 4 DIVERSION CHANNEL CONSTRUCTION, ASPHALT PAD REMOVAL, AND SITE REGRADING PLAN AND DESIGN	D-1
ATTACHMENT 5 SCHEDULE	E-1

FIGURES

Figure 1-1	Map of TA-49	2
Figure 2-1	General configuration of test shaft and equipment at Areas 2, 2A, and 2B before detonation	4
Figure 2-2	General configuration of test shaft and equipment at Areas 2, 2A, and 2B after detonation	5
Figure 2-3	Test shafts at Areas 2, 2A, and 2B	6
Figure 2-4	Locations of constituent releases at Areas 2, 2A, and 2B	8
Figure 2-5	Surface contamination incident involving Shafts 2-L and 2-M at Area 2 in MDA AB	9
Figure 3-1	PRs at Areas 2, 2A, and 2B	12
Figure 3-2	Existing sampling hole locations at Area 2	13
Figure 3-3	Subsurface moisture profiles at Area 2	16
Figure 3-4	Conceptual hydrology of Areas 2 and 2A	17
Figure 3-5	Contemporary aerial photograph of vicinity of Areas 2, 2A, and 2B	18
Figure 3-6	Locations of ponding at Areas 2, 2A, and 2B	19
Figure 5-1	Locations of site run-on and runoff controls	28
Figure 5-2	Schematic cross-section of surface water run-on diversion channel	31
Figure 5-3	Illustration of asphalt pad and fill excavation methodology	32

1.0 RATIONALE AND OBJECTIVE

This stabilization plan proposes implementing best management practices (BMPs) for a portion of Material Disposal Area (MDA) AB located in Technical Area (TA) 49. MDA AB consists of Areas 1, 2, 2A, 2B, 3, and 4 (Figure 1-1). The specific area of concern for this plan includes contiguous Areas 2, 2A, and 2B, which have been identified by Los Alamos National Laboratory (the Laboratory) as Potential Release Sites (PRSs) 49-001(b, c, and d), respectively. Historically, the site is the location of underground nuclear safety and related tests performed during 1960 and 1961. In 1961, the entire surface of Area 2 [PRS 49-001(b)] was covered with fill and an asphalt pad after it was determined in late 1960 that plutonium contamination resulting from an accidental release was present in the surface soils. It was subsequently determined that moisture was accumulating between the asphalt and the tuff surface, that there was a potential for surface water to pond at the site, and that standing water was periodically present in a monitoring well that extended through the site to far below the area of experimentation. These moisture issues have raised concern as to the potential for deep subsurface migration of contaminants.

The objective of this stabilization plan is to reduce the potential for subsurface contaminant migration along water pathways by

- constructing a run-on diversion channel upgradient of the site,
- removing the asphalt pad, and
- regrading the site to eliminate surface water ponding.

This plan describes the site and its history, the proposed stabilization measures, and the schedule and cost to complete those measures.

Following this introduction, an overview of the site history is presented in Section 2.0. Section 3.0 summarizes the available Resource Conservation and Recovery Act (RCRA) facility investigation (RFI) site characterization data, moisture conditions, and other site information; identifies the constituents of potential concern; and provides the rationale for the proposed action. Section 4.0 presents the justification for implementing the stabilization plan. Section 5.0 provides an overview of the proposed stabilization plan. Section 6.0 presents information on-site restoration, cleanup, and monitoring, and Section 7.0 presents information on long-term maintenance. Section 8.0 presents a discussion of alternatives to the proposed BMPs. Section 9.0 presents project management and performance measure information, including project schedule, cost, and quality assurance (QA). References and attachments are at the back of the document; the attachments include detailed design information and plans that will support the activity.

2.0 SITE DESCRIPTION DATA

2.1 General Site Description

TA-49, the Frijoles Mesa Site, occupies approximately 1280 acres along the southwestern boundary of the Laboratory. It is bounded by Bandelier National Monument to the south and west (State Road 4), TA-15 to the north (the edge of Water Canyon), TA-39 to the east, and TA-16 and TA-37 to the north and west. The PRSs addressed in this plan are located on the mesa top at an elevation of approximately 7140 feet. These sites are approximately 1650 feet from an ephemeral stream at the bottom of Water Canyon. The distance to the nearest mesa edge, above a tributary to Water Canyon, is approximately 700 feet. The layout of MDA AB in TA-49 is shown in Figure 1-

1. Much of the information presented in this section was taken from the Operable Unit (OU) 11-44 RFI work plan (LANL 1992, 7670).

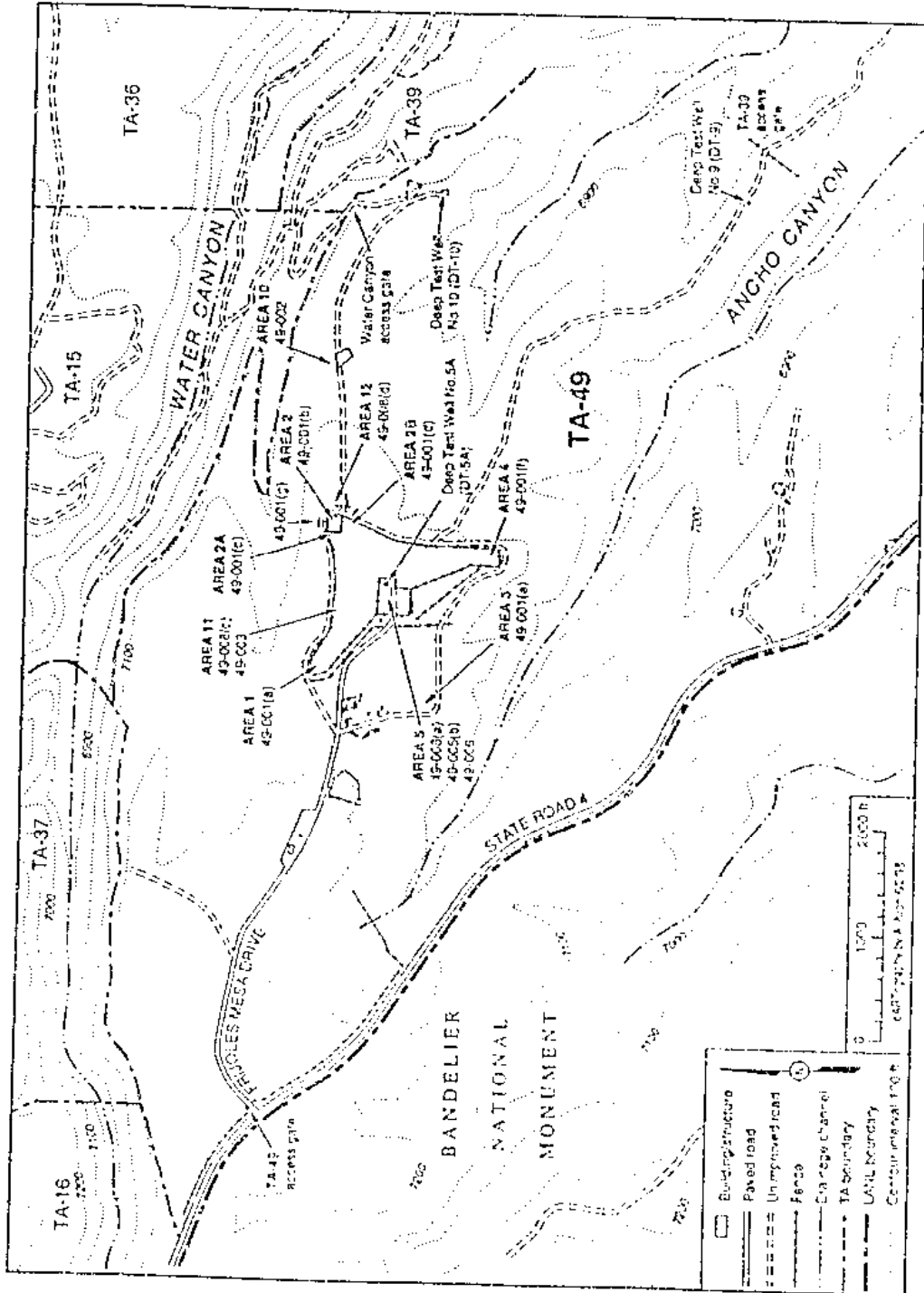

Figure 1-1. Map of TA-49.

TA-49 has been used since the mid-1940s as a buffer zone for firing sites in adjacent TA-15 and TA-39. A period of intense experimental activity took place at TA-49 from late 1959 through mid-1961, during which significant amounts of plutonium, uranium, lead, and beryllium were used in nuclear safety and related experiments in underground shafts. These activities were responsible for almost all of the radioactive and hazardous materials currently present at TA-49.

Between January 1960 and August 1961, 41 underground nuclear safety tests involving high explosives (HE) and special nuclear materials (SNM) were conducted in Areas 1, 2, 3, and 4 at TA-49. The purpose of the tests was to determine if an accidental detonation of the HE in a nuclear weapon would be capable of triggering a nuclear explosion. Of these tests, 37 involved either plutonium or plutonium and uranium-235, and 4 involved only uranium-235. Mockup experiments used in test design incorporated small amounts of depleted uranium (uranium-238) as a radioactive tracer; larger amounts of depleted uranium were also used in the actual safety tests. The area selected for these tests had previously been studied extensively by the Laboratory and the US Geological Survey to determine its suitability. The location was selected because it exhibited geologic characteristics that ensured containment of the experiments and hydrologic characteristics that were thought to preclude the contamination of ground water. The four test areas lie approximately 1200 feet above the main aquifer, and deep core holes drilled at each of the test areas demonstrated that the underlying tuff had very low moisture content and no perched ground water.

The nuclear safety tests were conducted in 3- or 6-foot-diameter shafts at depths ranging from 31 to 108 feet. The general configuration (before detonation) of the test shafts, filter boxes, and equipment used in Areas 2, 2A, and 2B is shown in Figure 2-1. In a typical nuclear safety test, the test apparatus was placed at the bottom of the shaft, instrument cables leading to the surface were installed, and the shaft was backfilled with sand or crushed tuff to contain the explosion. The downhole test assembly was encased in a steel container with substantial amounts of lead shielding. After detonation, completion of measurements, and radiochemical sample collection, the cables were severed, and the shaft was topped off with clean sand or crushed tuff to compensate for the settlement that had occurred during the shot. Most holes containing SNM were capped with concrete. In most cases, the steel filter boxes (when used) also were filled with concrete and left in place. To minimize radiation exposure from a portable neutron source used in some tests, large, portable concrete radiation shields were used. Short-lived activation products, which by now have decayed to undetectable levels, resulted from the operation of the neutron source. Occasional monitoring with field instrumentation has confirmed that the concrete shields remaining at TA-49 have no detectable surface contamination. Approximately ten of the shields still remain at TA-49, of which three are visible in the vicinity of Area 2. The shields were generally placed over the shafts to supplement the concrete caps. Because they cover potentially contaminated soil, there are no plans to disturb either the shields or the associated concrete caps. They do not interfere with the planned BMPs and are not expected to interfere with final corrective measures for the site.

During the test, the experimental apparatus was placed at the bottom of the shaft and oriented to drive gases and particulates generated by detonation of the HE into a collector tube in a short horizontal side drift. The collector tube connected with a 3-inch-diameter pipe in a separately drilled vertical borehole that led to a filter box at the ground surface where samples of radioactive particulates were collected. Excess gas and particulates were directed through piping on the ground surface into vertical shafts called gas expansion holes.

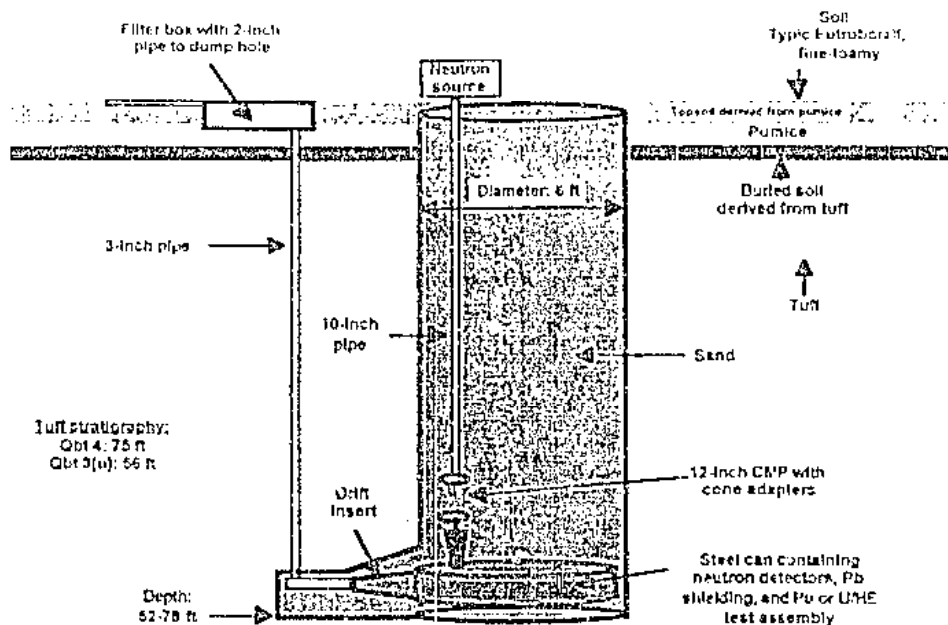

Figure 2-1. General configuration of test shaft and equipment at Areas 2, 2A, and 2B before detonation.

The configuration (after detonation) of the test shafts and equipment used in Areas 2, 2A, and 2B is shown in Figure 2-2. Contaminated surface piping was disposed of in specially drilled *pipe dump* holes. No effort was made to recover any of the downhole test equipment, and residual materials dispersed by detonation of the HE remain at the bottom of the shafts and in the surrounding tuff. It must be assumed that radioactive contamination also remains in the filter boxes, gas expansion holes, and pipe dump holes. It is stated in the OU 1144 RFI work plan (LANL 1992, 7670, p. 7-19) that available information may not account for all of the auxiliary holes. Minor contamination from the oxidation of lead bricks temporarily placed around the experimental shafts may also be present on the original ground surface. A summary of the principal constituents remaining underground at MDA AB is presented in Table 2-1.

2.2 Tests at Areas 2, 2A, and 2B

The activities described in this stabilization plan address conditions at Areas 2, 2A, and 2B. The locations of the test shafts and information on the use of each shaft in these areas are shown on Figure 2-3. Detailed descriptions of the shafts and experiments can be found in the OU 1144 RFI work plan (LANL 1992, 7670, Chapter 7).

The subsurface tests at Areas 2, 2A, and 2B were conducted within the depth range of 52 to 78 feet. The confinement provided by the tuff and sand backfill appears to have successfully contained the explosions and confined most of the test assembly materials to within a predicted maximum radius of 10 to 15 feet from the point of detonation at the bottoms of the shafts. Exceptions included the planned release of test materials into the ground-surface filter boxes described in Section 2.1. To avoid drilling into tuff contaminated by previous shots, the shafts

were located on 25-foot centers. This spacing was found to be adequate and provided a verification of the original design concept.

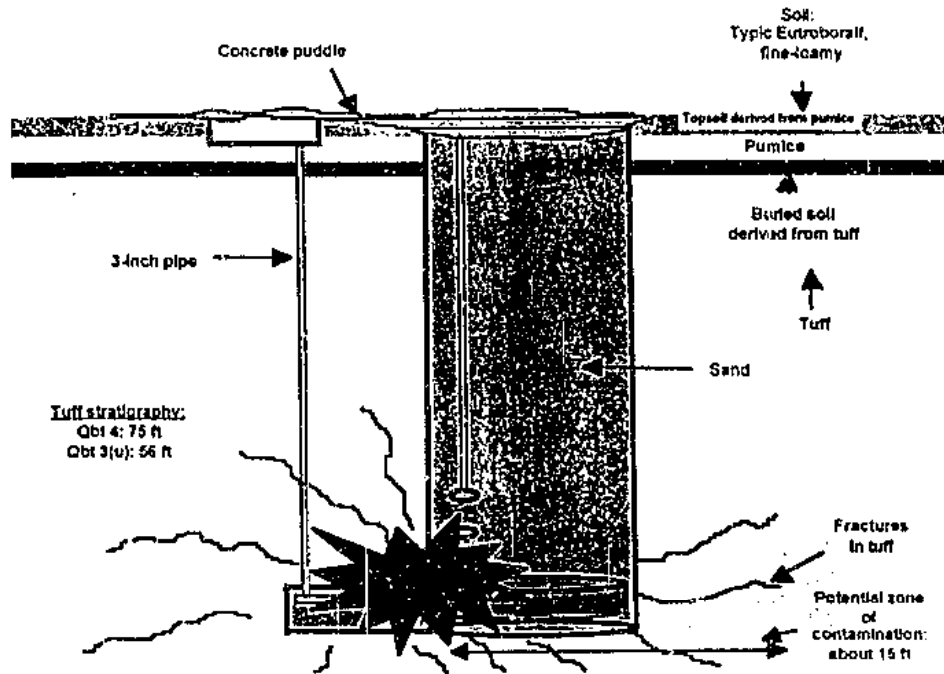

Figure 2-2. General configuration of test shaft and equipment at Areas 2, 2A, and 2B after detonation.

TABLE 2-1
INVENTORIES OF MAJOR CONSTITUENTS^a REMAINING
UNDERGROUND AT MDA AB

PRS Number	MDA Area	Plutonium	Uranium-235	Uranium-238	Beryllium	Lead
49-001(a)	1	1	0	62	N/A ^b	N/A
49-001(b,c,d)	2, 2A, 2B	22	64	78	N/A	N/A
49-001(e)	3	0	<1	<1	N/A	N/A
49-001(f)	4	17	29	29	N/A	N/A
Totals		40	93	169	11	90,000

a. Concentrations are in kg.

b. *N/A = not available

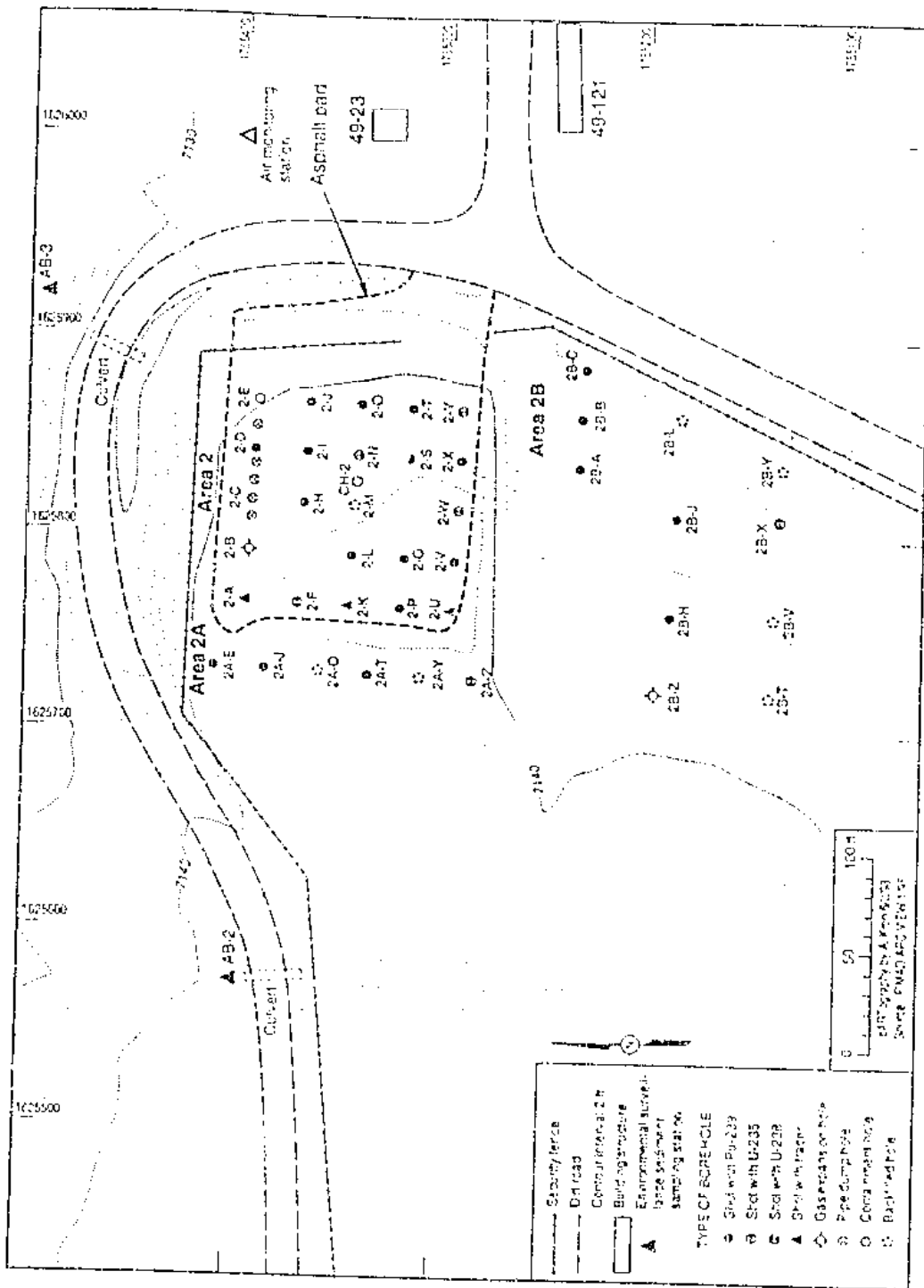

Figure 2.3. Test shafts at Areas 2, 2A, and 2B.

Three accidental releases in Area 2 and one in Area 2B resulted in contamination of the ground surface. Three of these releases were small and affected only the local area around the shaft and filter box. The remaining release caused more widespread contamination and resulted in the closing and capping of Area 2. The test program continued at adjacent locations to the west and

south; the locations were designated Areas 2A and 2B. The smaller releases were generally associated with problems that occurred because of unexpected back pressure when opening the filter box to retrieve the filter for analysis. The first release occurred at Shaft 2-H in January 1960 and was corrected by covering the surface soils around the shaft with 300 cubic feet of concrete. The second release occurred at Shaft 2-S in March 1960 and was again corrected by covering the surface soils with concrete. The third and most extensive release occurred in Shaft 2-M in November 1960 and was detected in December 1960, as described in more detail below. The contamination was addressed by backfilling Shaft 2-M with contaminated surface soil and equipment, covering Area 2 with 2 to 3 feet of fill material, and capping the fill with 4 to 6 inches of asphalt. The fourth and final release was small. It occurred at Shaft 2B-H in March 1961 and was corrected by covering a 30- by 40-foot area with concrete. The locations of these constituent releases are shown in Figure 2-4.

The third and most significant contamination incident occurred in Shaft 2-M in November 1960. An illustration of the conditions that led to this incident is shown in Figure 2-5. Tests were completed in neighboring Shaft 2-L in April 1960, and the succeeding test shaft (2-M) was bored 25 feet to the east of Shaft 2-L in October. In November, a drift toward the southwest was constructed in Shaft 2-M. This drift was mistakenly oriented toward the southeast-trending drift from Hole 2-L, making the ends of the two drifts only about 6 to 7 feet apart. This separation was apparently small enough that the drift from Shaft 2-M encountered radioactive contamination in the tuff resulting from the test detonation in Shaft 2-L. The contamination remained undetected for about one month. In late December, alpha contamination in excess of 100,000 cpm was noted in the as yet empty Shaft 2-M. Monitoring indicated that surface contamination was as high as 800,000 cpm (LANL 1992, 7670, p. 7-27). Surface soil and equipment contaminated by this incident were placed in the unused Shaft 2-M, and the rest of the shaft was backfilled with sand. All remaining open shafts at Area 2 were also filled with sand. In January 1961, Area 2 was covered with a fill material, and in September 1961, it was capped with asphalt pavement and closed. The fill cap and asphalt pad extended approximately 12.5 feet beyond the outermost shafts to form a 125-foot by 125-foot surface. It is almost certain that the accidental release at Shaft 2-M is the source of most or all of the above-background levels of radionuclides now observed in surface soils around the Area 2 pad and at short distances down the natural drainage toward Water Canyon.

In March 1975, it was found that the subsurface had subsided, causing the asphalt pad over the backfilled Shaft 2-M to collapse. It is suspected that the hole in the asphalt formed in the fall of 1974. The opening was about 6 feet long by 3 feet wide and 3 to 4 feet deep in the asphalt and underlying fill. In September 1976, the collapsed opening over Shaft 2-M was filled with crushed rock and clay, and the entire pad was repaved with another 2 inches of asphalt (Purtymun and Ahlquist 1986, 14722).

2.3 Moisture Conditions at Area 2

During the initial site characterization in 1959, a deep core hole was drilled at each of the four areas (1, 2, 3, and 4) at MDA AB and cased with 2-inch galvanized pipe. The purpose of these holes was to determine whether the tuff was dry and to confirm the lack of perched water beneath the candidate test locations. No perched water was found at any of the test areas. The core hole at Area 2 (CH-2) is located approximately 10 feet from where the cave-in around Shaft 2-M occurred (Figure 2-4) and is still available for monitoring. Many of the following details on the

drilling of CH-2 were obtained during an April 1998 conversation between Jack Nyhan representing the Laboratory Asphalt Pad Team and Bill Purtymun, one of the original technical investigators at the site (Nyhan 1998, 57911).

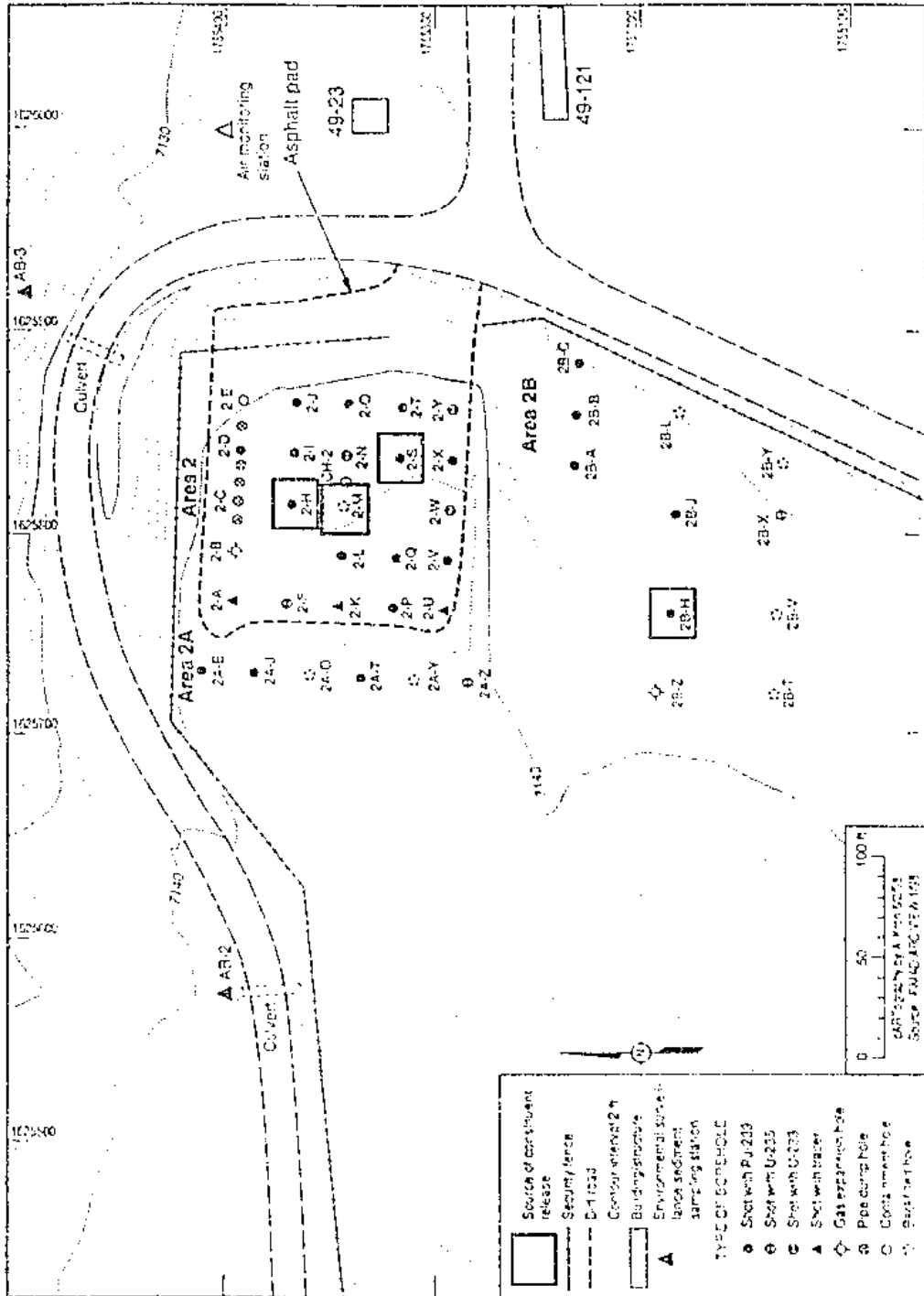

Figure 2-4 Locations of constituent releases at Areas 2, 2A, and 2B.

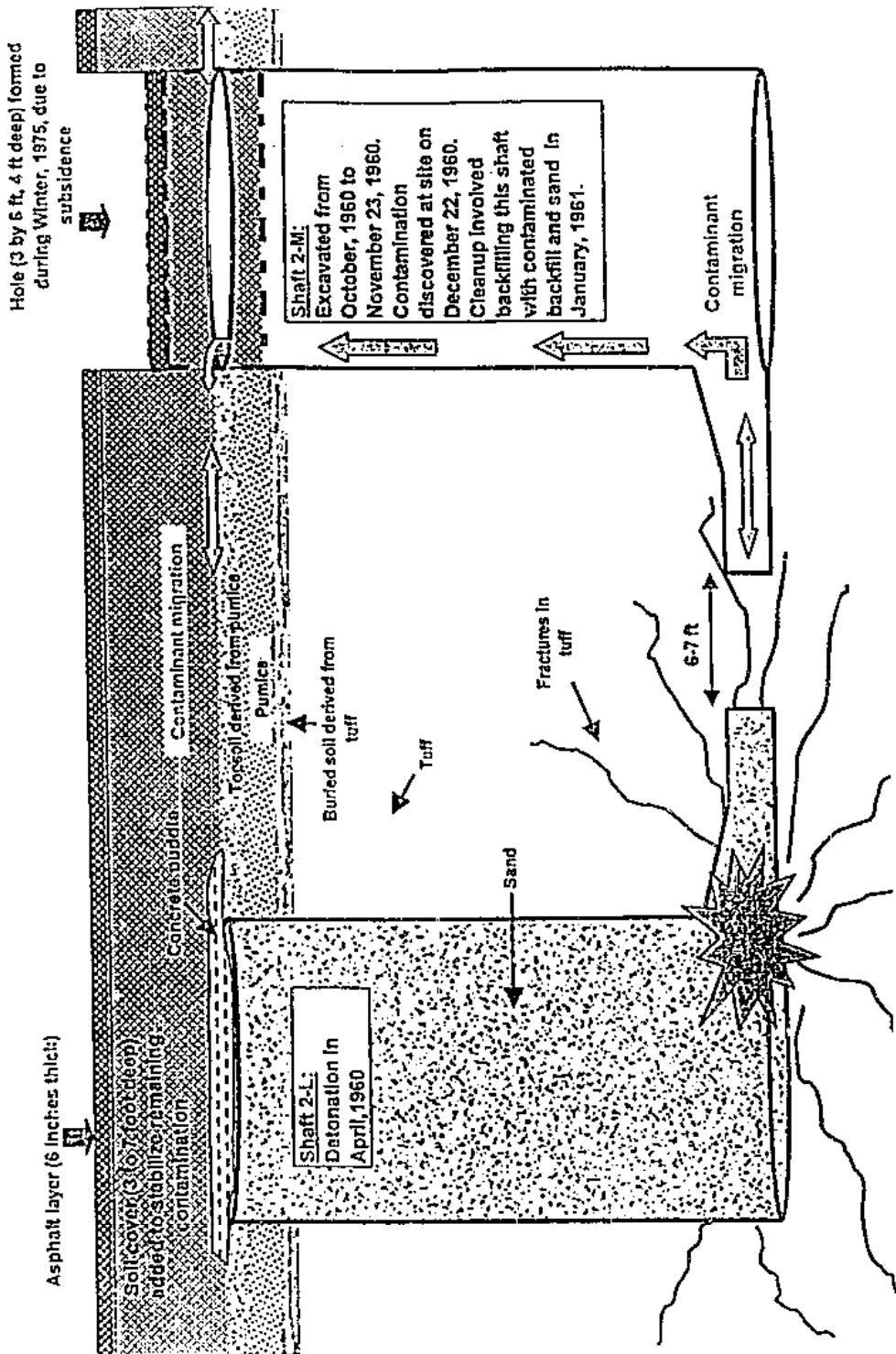

Figure 2.5. Surface contamination incident involving Shafts 2-L and 2-M at Area 2 in MDA AB.

49-001(b, c, d, and g) - 1998

CH-2 was originally drilled with air to a depth of 501 feet below ground surface (bgs). An attempt was made to fill the core hole with water to facilitate geophysical logging, but it could not be filled past the 150-foot-depth level, probably because of a high permeability zone near the bottom of the hole. Because of this, only the lower 350 feet of the hole could be logged. United States Geological Survey personnel directed the drilling contractor to attempt to seal the hole to reduce the drainage rate, so the rest of the hole could be logged. The contractor put into the hole drilling mud (sodium saturated bentonite), peanut shells, cotton seed hulls, and a small amount of geologic material that came out of the bottom of the hole, but the effort was unsuccessful in sealing the hole. The driller completed the hole with 2-inch galvanized steel pipe, with a 20-foot length of slotted pipe in the bottom. The casing was not grouted in place, and the condition of the surface seal is not known. When the fill material and asphalt pad were added to Area 2, an extension pipe was welded to the top of the casing of CH-2 to maintain access. Currently, only about 10 feet of slotted section is available as a result of backfilling with sediment.

An unknown volume of water drained from CH-2 during the initial logging attempts. Following logging, the water level in CH-2 gradually declined from 146 feet bgs in December 1959 to no standing water in June 1960 (LANL 1992, 7670, p. 7-28). After the asphalt pad was installed, the casing for CH-2 was extended through the fill to the top of the pad. Inspection of CH-2 after the 1974 cave-in revealed that there was about 50 feet of standing water in the core hole (about 10 gallons of water). Snowmelt that collected throughout the winter may have drained into CH-2 from Shaft 2-M and moved down the annular space between the fill and the casing to the bottom of the hole. Unfiltered samples of the water bailed from CH-2 in October 1977 and August 1978 contained 1.7 to 3.1 pCi/l of plutonium-239. These concentrations are above background but far below the Department of Energy (DOE) guidance of 100,000 pCi/l for controlled areas (Purtymun and Stoker 1987, 6688). Contaminated backfill in Shaft 2-M was considered a possible source of these radionuclides.

Approximately annual checks of CH-2 between 1980 and 1987 showed no standing water. However, in May 1991, cracks were noted in the Area 2 asphalt pad and vegetation several feet tall was observed to be growing through the cracks. An inspection of CH-2 indicated the presence of about 100 feet of standing water. This finding triggered an investigation of moisture conditions under the asphalt pad; the investigation was conducted as part of the RFI site characterization for OU 1144. Subsequent measurements indicated that CH-2 was dry by the fall of 1993, that about 25 feet of standing water was present in the spring of 1997, and that the hole was again dry in the spring of 1998. The source of the standing water in CH-2 is not well understood. The results of the RFI are summarized in Section 3.0. A summary of the occurrence of standing water in CH-2 and a discussion of the possible sources of that water are presented in the OU 1144 RFI work plan (LANL 1992, 7670, p. 7-30).

3.0 SITE CHARACTERIZATION DATA

3.1 Approach to RFI Site Characterization at MDA AB

For purposes of RCRA site characterization, the four test areas at MDA AB have been divided into the following seven PRSs:

- PRS 49-001(a), shaft area under Area 1
- PRS 49-001(b), shaft area under Area 2
- PRS 49-001(c), shaft area under Area 2A

- PRS 49-001(d), shaft area under Area 2B
- PRS 49-001(e), shaft area under Area 3
- PRS 49-001 (f), shaft area under Area 4
- PRS 49-001(g), surface soil contamination associated with Areas 1, 2, 2A, 2B, 3, and 4

These PRSs are listed as solid waste management units (SWMUs) in the Hazardous and Solid Waste Amendments Module of the Laboratory's RCRA Part B operating permit. The locations of these SWMUs are defined in the SWMU Report (LANL 1990, 07513), as clarified by the Environmental Protection Agency (EPA) approved OU 1144 RFI work plan (LANL 1992, 7670). The definitions of those SWMUs are taken from Page 7-2 of that work plan.

The PRSs of concern in this stabilization plan are 49-001 (b, c, d, and g) (Figure 3-1). PRSs 49-001 (b, c, and d) include the contaminants left beneath the original ground surface at the time of the nuclear safety tests. Because of their similar history and close proximity (they are contiguous), these three PRSs will be treated as a single unit when implementing this stabilization plan. PRS 49-001(g) includes the soil contamination on or above the original ground surface within and adjacent to Areas 2, 2A, and 2B. PRS 49-001(g) thus includes any residual contamination on the original ground surface at the time the nuclear safety tests were performed, any contamination in the soil fill placed over Area 2, any contamination in the asphalt pad placed over Area 2, and any contamination that may have migrated from Areas 2, 2A, and 2B into adjacent land. For example, contaminant migration may have occurred from Areas 2, 2A, and 2B into downslope drainages toward Water Canyon (LANL 1992, 7670, p. 7-27).

The RFI site characterization at MDA AB adopted a streamlined approach wherein a final remedy involving stabilizing the subsurface constituents in place was envisioned. For the subsurface PRSs, only those data were to be collected that defined the consequences of leaving the residual test materials in place and provided information needed to effect an appropriate in situ stabilization (LANL 1992, 7670, p. 2-1). The types, locations, and quantities of constituents for these PRSs (Table 2-1) were considered by the work plan authors to have been adequately identified from process knowledge because extreme care was given to the disposition of the SNM used in the tests. For the surface contamination in PRS 49-001(g), in situ stabilization was not envisioned at all locations, and extensive sampling was planned to determine both the nature and extent of contamination to evaluate appropriate actions.

3.2 Site Characterization at Areas 2, 2A, and 2B

Field efforts to better characterize surface and subsurface contamination at Areas 2, 2A, and 2B were initiated after standing water was found in CH-2 during 1975. Special studies not associated with the RFI work plan were performed before 1993. Site characterization under the work plan began in the spring of 1993.

3.2.1 Surface Soils and Vegetation

In 1975, an annual sediment sampling program was initiated at TA-49 as part of the Laboratory's routine environmental surveillance program. Two of these stations (Stations A-2 and A-3) are located near Area 2, as shown on Figure 3-2. These stations were later designated as AB-2 and AB-3, respectively, and are identified under their current designations on the figure. Analytical results from this sampling program are available in Laboratory memoranda from 1975 to 1986, in annual Environmental Surveillance Group reports since 1987, and in the work plan. Data from 1983 and 1984 (LANL 1992, 7670, p. 4-48) are considered representative and indicated that

Station A-2 was typical of other stations at TA-49. However, Station A-3 had the highest concentrations of plutonium of any of the 11 stations at TA-49 (0.012 to 0.086 pCi/g of plutonium-238 and 0.536 to 3.10 pCi/g of plutonium-239/240). However, the results vary considerably from year to year, and the 1990 sampling data at Station A-3 are similar to those of the other stations (LANL 1992, 7670, Tables D-2 through D-4). Station A-2 is located in a channel that collects surface runoff from upgradient of Areas 2, 2A, and 2B, and Station A-3 is located in a channel that collects surface runoff from Areas 2 and 2A.

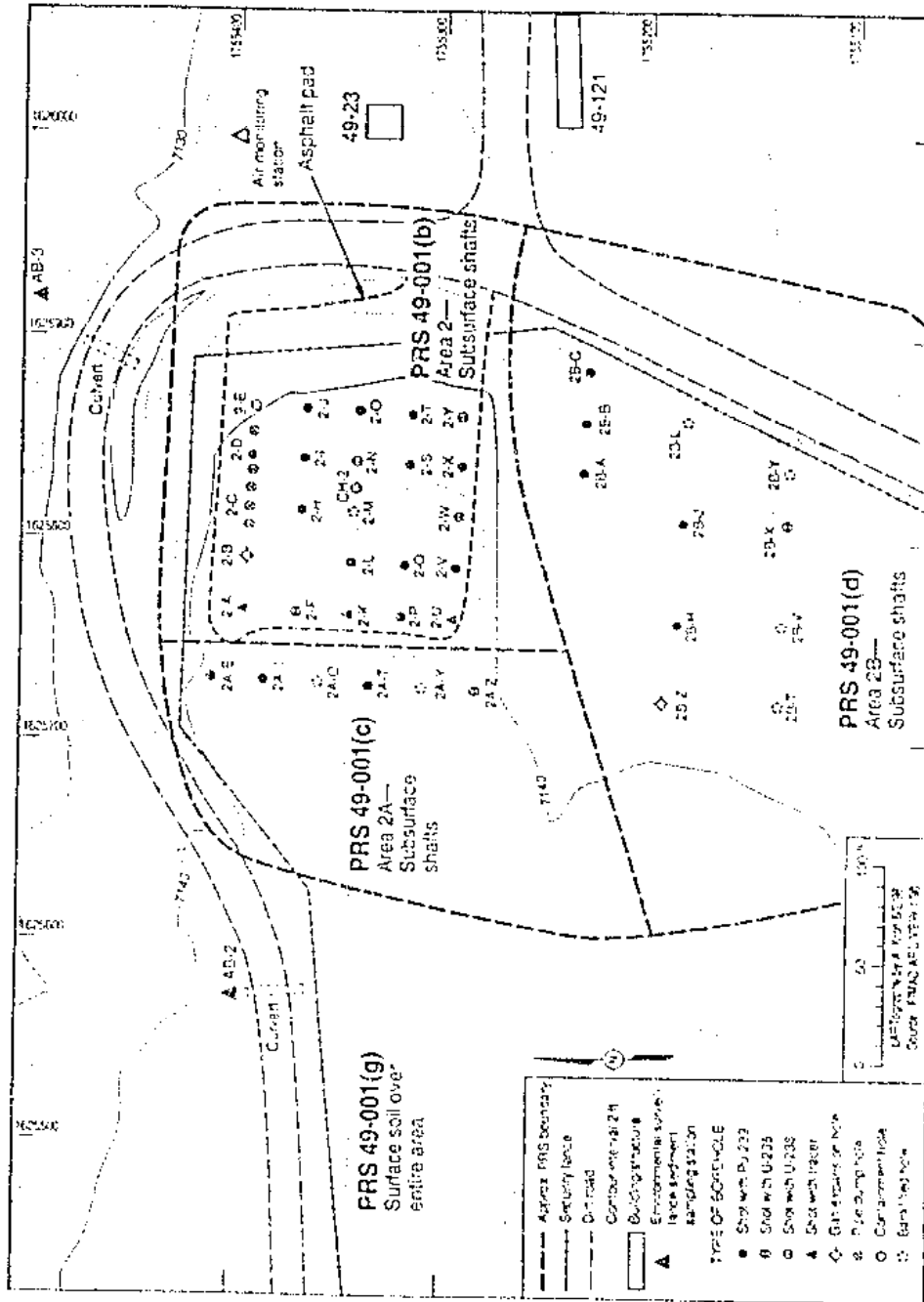

Figure 3-1. PRS at Areas 2, 2A, and 2B.

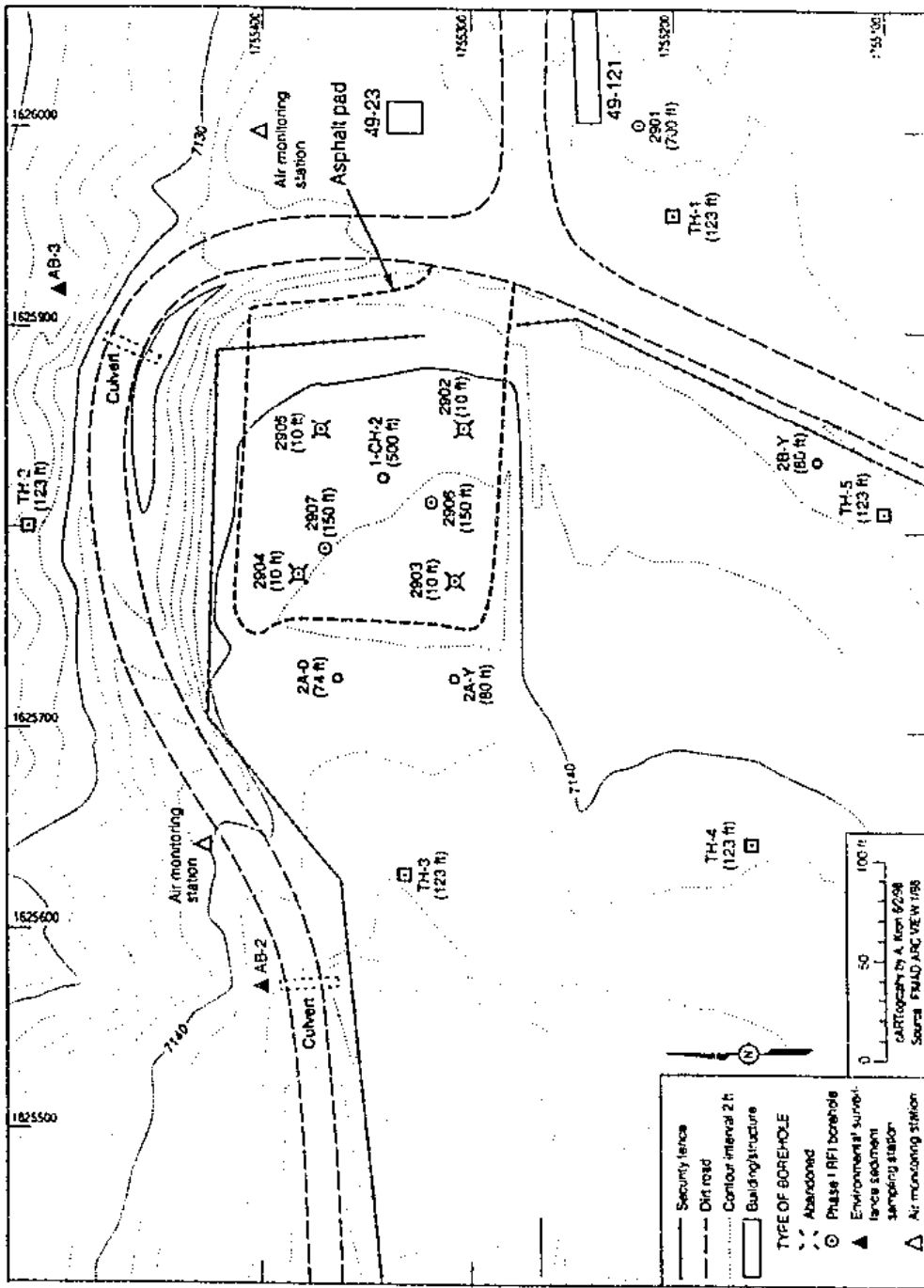

Figure 3-2. Existing sampling hole locations at Area 2.

Several studies of the surface soils and vegetation were conducted in 1987. During the A411 survey (Soholt 1990, 7510), about 40 soil and 45 vegetation samples were collected around Areas 2, 2A, and 2B. Analytical results and sample locations are summarized in the OU 1144 RFI work plan (LANL 1992, 7670, p. 7-37). The study indicated that concentrations of constituents in Area 2B and in the portion of Area 2A farthest from the asphalt pad were at or slightly above

regional background levels. However, at several sampling locations immediately adjacent to the asphalt pad, plutonium and americium levels well above background were observed. Elevated radionuclide levels were particularly notable at the northeast corner of the pad, where the level of americium-241 in one soil sample was 53 pCi/g (LANL 1992, 7670, p. 7-39).

In a second 1987 study, about 20 soil samples and 20 vegetation samples were collected around Area 2 (Fresquez 1991, 14822). Of the soil samples analyzed, one sample from the northeast corner of Area 2 showed elevated levels of gross alpha activity (80 pCi/g), and a nearby sample showed elevated plutonium-239 activity (1660 pCi/g). Replicate analyses for the first sample gave values of 41 pCi/g and 1.7 pCi/g of gross alpha activity, indicating a highly discontinuous distribution of surface contaminants. A PHOSWICH survey over the same area showed readings about twice the background level. Positive readings were also measured along the drainage channel leading to a culvert under the road on the northeast side of Area 2 (Figure 3-1). The highest concentration of beryllium (44 ppm) was found in a sample collected in the same drainage about 50 feet from the pad and was well above the regional background level of about 1.7 ppm. A sample from the same location exhibited the highest concentration of plutonium-239/240 found in vegetation (24 pCi/g). These samples indicated that contaminants may have migrated downgradient of the site. Elevated levels of other potential contaminants from Area 2 were also detected in the soil and vegetation samples; however, mean concentrations were typically much lower than the peak values, again indicating the highly localized nature of the constituent distributions.

During another special study in March 1991, 10 samples of pocket gopher soil diggings along the perimeter of the Area 2 pad were collected and analyzed (Fresquez 1991, 14822). The location of the gopher diggings is shown in Figure 3-2. As observed in the 1987 study, elevated radioactivity was detected in soil samples from the northeast corner of the asphalt pad. Gopher digging samples contained 135 pCi/g of gross alpha, 38 pCi/g of americium-241, 24 pCi/g of plutonium-238, and 43 pCi/g of plutonium-239/240. Gopher diggings at the same location were resampled in April 1991, and elevated gross alpha activity (1200 pCi/g) was again found. Additional analyses indicated no volatile organic compounds (VOCs), semivolatile organic compounds (SVOCs), polychlorinated biphenyls (PCBs), or toxicity characteristic leaching procedure (TCLP) metal levels above EPA guidelines (LANL 1992, 7670, p. 7-37).

In summary, the most elevated radionuclide levels in surface soils at Areas 2, 2A, and 2B are in the northeast corner of Area 2 and appear to be associated with the excavation of contaminated soil from beneath the asphalt pad by gophers. Because of the extensive previous sampling of surface soils and vegetation, the RFI sampling activities focused on subsurface sampling beneath the asphalt pad.

3.2.2 Subsurface Sampling

The only pre-RFI sampling of the soils beneath the asphalt pad was conducted in September 1987 when a power pole was installed 2 feet northeast of Shaft 2-T in the southeast part of the site (Romero 1987, 57904). Four soil samples were collected to a depth of 5 feet and were analyzed for gross alpha and gross beta radioactivity. An average of 44 pCi/g alpha was found, and gross beta was below detection limit. Similar samples were taken away from the asphalt pad at the location of a second power pole 27 feet north of Shaft 2B-Z, where both gross alpha and gross beta were found to be below the detection limits of 25 pCi/g.

In 1994, subsurface sampling of fill materials, soils, and tuff was performed beneath the asphalt pad in Area 2 as part of the Phase I RFI. Four 10-ft core holes (49-2902 through 49-2905) were drilled through the asphalt pad and sampled for gross radiation levels, isotopic plutonium, total uranium, metals, and moisture content. Two 150-ft core holes (49-2906 and 49-2907) were also drilled through the asphalt and sampled. The locations of these core holes are shown in Figure 3-2. The 10-foot holes were drilled with hollow stem augers, and the two 150-foot core holes were odex (air rotary) drilled with tight-fitting steel casings that leave no annular space and therefore do not provide a pathway for contaminant migration. The 150-foot holes also have a 10- to 20-foot-long grouted surface casing that extends from the asphalt surface into the tuff. Detailed results of this investigation are discussed in the TA-49 subsurface RFI status report now being prepared. The shallow core holes penetrated the fill and underlying native soil but did not reach the depth of the test shots. The deep core holes penetrated beyond the depths of the test shots but were specifically located between test shafts to avoid encountering the elevated levels of contamination known to be present in the fractured tuff around the shots.

The only elevated radioactivity found in initial analysis of samples from the RFI core holes occurred in the northeast corner of the pad in shallow core hole 49-2905. In the 3- to 3.5-foot sampling interval of that hole, 291 pCi/g of plutonium-239, 5.1 pCi/g of plutonium-238, and 59 pCi/g of americium-241 were detected. The single elevated sample was taken from the soil beneath the fill materials. Accurate analytical results for total uranium were not obtained in any of the Phase I core hole samples because of poor recovery in the analytical laboratory, and the archived core has been resampled and analyzed for isotopic uranium to replace the lost data. All samples were found to have uranium concentrations of less than 1 pCi/g.

In addition to the aforementioned core holes, a 700-ft-deep core hole (49-2901) was drilled approximately 100 feet east of Area 2B in late 1993 as part of the Phase I RFI (Figure 3-2). This hole was odex (air rotary) drilled in the same manner as the two 150-foot holes. The casing originally installed in the 700-foot hole has since been pulled, and the hole is currently being used for moisture monitoring; however, a 20-foot-deep grouted surface casing remains in place. This hole was located east of the nuclear safety test areas to obtain uncontaminated samples for additional measurements and tests. No perched water and no elevated contaminant levels were found in this core hole. The lack of contamination in either the 150-foot or the 700-foot RFI core holes indicates that any lateral migration of the subsurface contaminants is minor. Vertical migration of the subsurface contaminants has not yet been checked and is the objective of slant drilling beneath the shafts planned for the Phase II RFI site characterization (LANL 1992, 7670, p. 7-68).

3.2.3 Moisture Conditions and Water Sampling

Information on the moisture content of the fill, soil, and tuff beneath the Area 2 asphalt pad was obtained from the RFI core holes and found to be clearly elevated above moisture levels in adjacent holes away from the pad (Figure 3-2). Moisture data from cores taken from 150-ft core hole 49-2907 are presented in Figure 3-3. The depth profiles in that figure show moisture content increasing to near saturation (50% to 60% by volume) immediately above the competent tuff. This trend is representative of conditions in the other deep RFI core hole at the site (49-2906). For comparison, a moisture profile for TH-4 is shown on the same figure. TH-4 is one of five test holes drilled around the site for monitoring moisture conditions in the soil and tuff. Each hole is 123 feet deep and is completed with an ungrouted, sealed PVC casing. In addition to the TH

holes, three similarly completed moisture monitoring holes have been installed in unused shafts 2A-0, 2A-Y, and 2B-Y. TH-4 is located west of Area 2B (Figure 3-2).

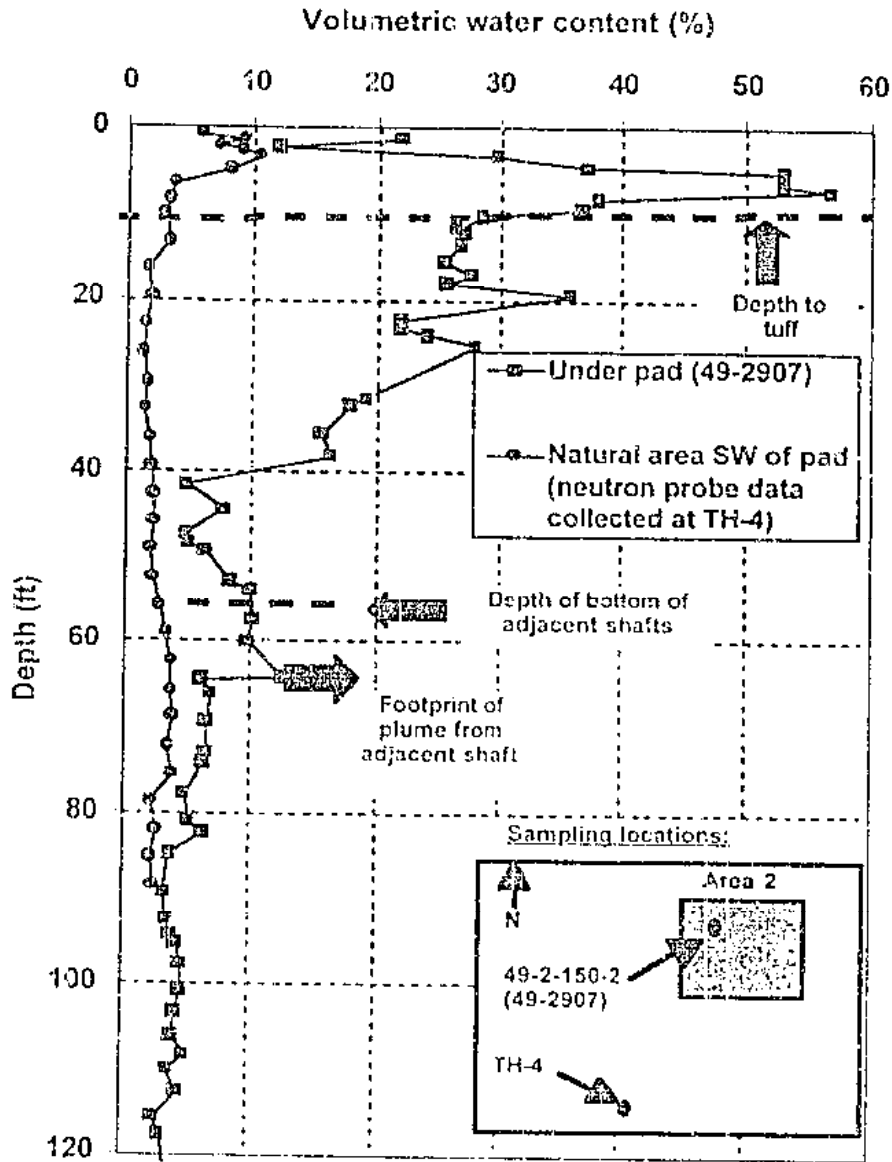

Figure 3-3. Subsurface moisture profiles at Area 2.

The TH-4 data were collected by the Environmental Science Group in March 1996 using neutron probe techniques. The moisture profile in TH-4 is typical for mesa-top test holes at the Laboratory and is similar to the moisture profiles measured in test holes in well-drained areas at TA-49 before the nuclear safety tests began (LANL 1992, 7670, p. 4-16). In TH-4, the moisture content

builds to a maximum of about 10% near the ground surface, and then decreases to a relatively stable 2% to 4% in the underlying tuff. By comparison, the moisture beneath the asphalt pad drops to about 29% at the soil-tuff interface and does not approach natural conditions until a depth of about 70 feet is reached. It is interesting to note the small spike in the data where the moisture beneath the pad increases from about 5% to over 10% in the depth interval of 50 to 65 feet. No stratigraphic changes have been identified in this interval that account for this anomaly. This depth interval roughly corresponds to the depths of the adjacent test shafts and may reflect the influence of excess water seeping from the bottom of the shafts.

The dramatic difference in moisture content between the soils and tuff beneath the asphalt pad and those that are not beneath the pad is thought to be caused primarily by reduced evapotranspiration caused by the asphalt pad. In addition, runoff from direct precipitation on the asphalt is concentrated at the edges of the pad and in cracks in the asphalt and enters the underlying soils through gravity flow and capillary forces. The lack of plant growth on the pad and the minimal effects of evaporation along the cracks and edges of the pad contribute significantly to a buildup of water in the underlying soil. Virtually all of the moisture that percolates into the fill beneath the asphalt remains there until it seeps down toward the underlying contaminants. The periodic appearance of standing water in CH-2 (Section 2.3) results in part from the high moisture content of the fill and tuff, which has little remaining storage capacity to absorb excess moisture that periodically enters the site through direct precipitation, surface run-on, and subsurface interflow. An illustration of the conceptual hydrology of Areas 2 and 2A is shown in Figure 3-4.

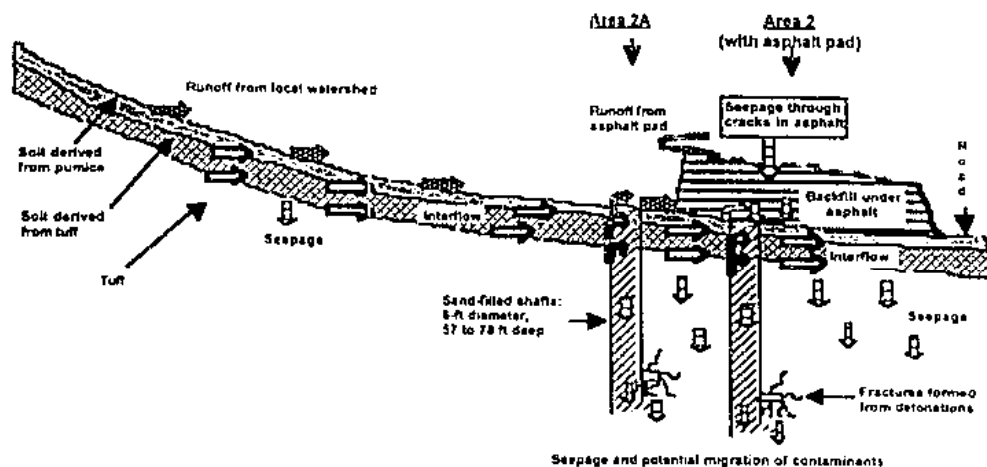

Figure 3-4. Conceptual hydrology of Areas 2 and 2A.

Moisture conditions at the site are made worse by excess surface water run-on and by low spots at the site where storm water can pond and infiltrate to areas of contamination. The site is located downslope from the former test control area (Area 5, Figure 2-1), downslope from an abandoned septic system and leachfield in Area 11, and also downslope from the former MDA AB access road, which passed through the control area. The concentration of traffic between the site and

Area 5 at the time the tests were conducted created rutted dirt roads that can still be seen today, these roads channel surface runoff directly toward Areas 2, 2A, and 2B (Figure 3-5).

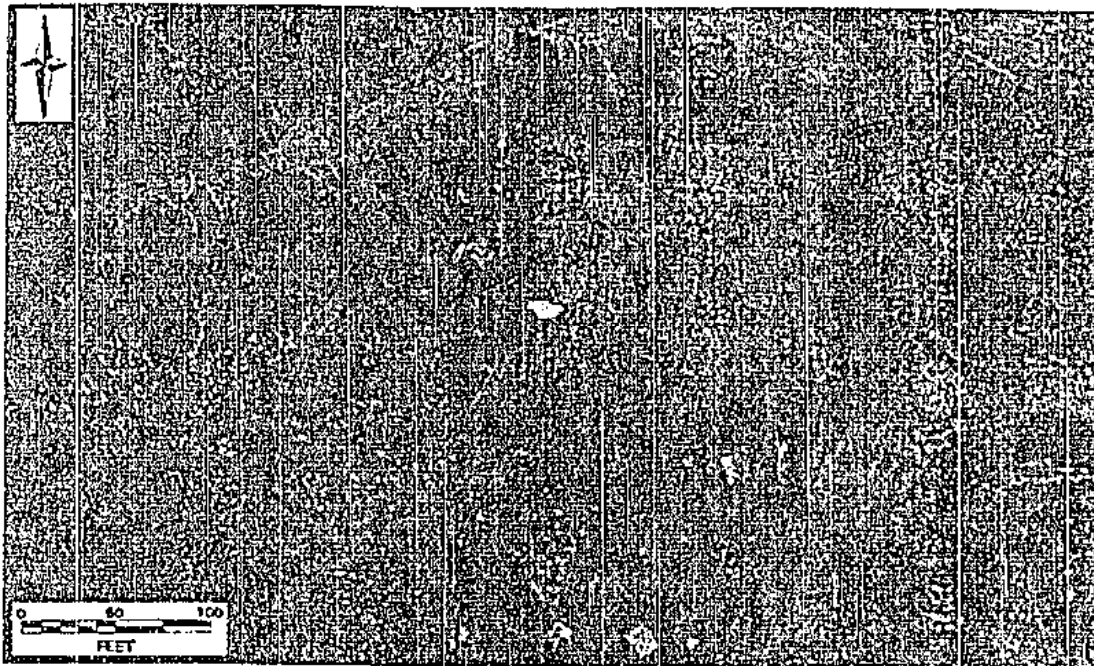

Figure 3-5. Contemporary aerial photograph of vicinity of Areas 2, 2A, and 2B.

In addition, some of the storm water that percolates into the soil has the potential of flowing laterally downslope toward the site as interflow at the soil-tuff interface. This interflow pathway has been shown to be important in a recent field study site at the Laboratory; the site is located on an adjacent mesa on a slope vegetated with ponderosa pine (Wilcox and Breshears 1997, 57578; Wilcox et al. 1997, 57577). As shown in Figure 3-4, the subsurface interflow might directly enter and drain down the sand-filled test shafts, and surface run-on can pond in the low spots, seep into the ground, and enter the shafts along with the interflow.

Low spots where water can pond at the site are present to the northeast of Area 2 (between Area 2 and the site perimeter road), between Areas 2 and 2A, and between Areas 2 and 2B. The locations of these low spots and arrows indicating the directions of surface flow are shown in Figure 3-6. The low spot between Areas 2 and 2A is caused by water backing up against the elevated fill beneath the asphalt pad. The other two low spots are primarily a result of blocking natural drainage patterns by the gravel road that runs around the east and north sides of the site. As previously mentioned, some of the water that collects in these areas comes from upslope storm water run-on, but some also comes from concentrated run off from the asphalt pad.

Water samples have periodically been taken from CH-2 since standing water was found in that hole in 1975. As previously mentioned, low levels of radionuclides were subsequently found in CH-2 water. Unfiltered samples of water bailed from CH-2 in October 1977 and August 1978 contained 1.7 to 3.1 pCi/L of plutonium-239. Contaminated backfill in Shaft 2-M was considered a possible source of these radionuclides. Subsequent water samples taken in 1979 and 1980 were

found to contain from 0.1 to 5.5 pCi/L of plutonium (LANL 1992, 7670, p. 7-30). The results of a more comprehensive analysis from a sample taken in 1991 are shown in Table 3-1.

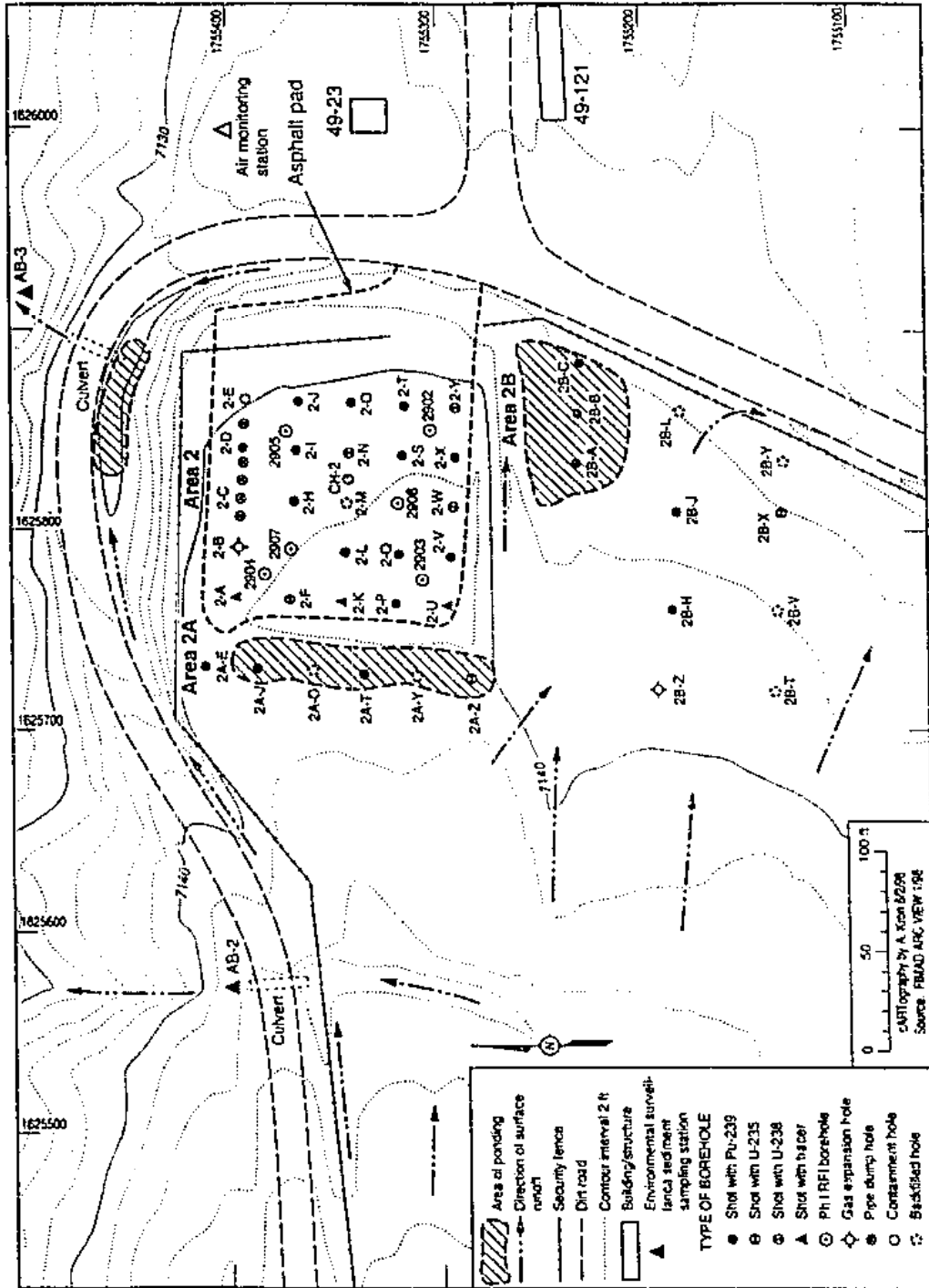

Figure 3-6. Locations of ponding at Areas 2, 2A, and 2B.

TABLE 3-1
ANALYTICAL RESULTS OF 1991 WATER SAMPLE FROM CH 2^{a,b}

Analysis	Result	Uncertainty	Units
Barium	28	3	µg/l
Calcium	8.2	0.8	mg/l
Chlorine	1.1	0.1	mg/l
Cyanide	0.01	0.01	mg/l
Potassium	7.2	0.7	mg/l
Magnesium	1.0	0.1	mg/l
Sodium	33	3	mg/l
Nitrate	0.37	0.04	mg/l
Phosphate	0.26	0.05	mg/l
Sulfate	17	2	mg/l
Conductivity	147	7	µmhos/cm
Dissolved solids	22	2	g/l
pH	9.5	0.1	—
Radionuclides			
Uranium	21	2	µg/l
Plutonium-239/240 (unfiltered)	0.19	0.12	pCi/l
Plutonium-239/240 (filtered)	1.1	0.2	pCi/g
Gross beta	6.2	0.7	pCi/l
Tritium	(below 300 pCi/LSC detection limit)		

a. (LANL 1992, 7670, p.7-34)

b. RCRA-regulated metals were not detected above action levels (TCLP procedure) for characterization as a RCRA waste. VOCs, SVOCs, and PCBs were not detected.

3.2.4 Surface Water Assessment

There are no perennial surface water courses at TA-49. However, ephemeral flow occurs in drainages in response to snowmelt and rain storms. An evaluation of surface water erosion concerns was made using Environmental Restoration (ER) Project Administrative Procedure 4.5, R0, "Evaluation and Notification of Potential Surface Water Concerns at Environmental Restoration Sites." The results of the assessment are provided in Attachment 1.

The only PRSs around Areas 2, 2A, and 2B that scored at or above the level requiring action (a score of 38) were PRS 49-001(g), the site-wide surface contamination PRS (with a score of 57), and PRS 49-003, an unrelated abandoned septic system and leachfield in Area 11 upgradient from the site (with a score of 64.8). These two PRSs received higher scores because runoff terminates in a tributary to Water Canyon and (for PRS 49-003 alone) runoff has caused visible erosion. Surface water erosion concerns related to the upgradient PRS are addressed by the

surface water run-on diversion channel (Section 5.2). Surface water erosion concerns related to the surface contamination in PRS 49-001(g) downgradient are addressed by the storm water pollution prevention (SWPP) plan given in Attachment 2.

3.3 Summary of Constituents

The shafts in Areas 2, 2A, and 2B were used for subsurface nuclear safety and related experiments and contain significant quantities of isotopic plutonium, isotopic uranium, beryllium, and lead, as shown in Table 2-1. In addition, approximately 0.15 kg of americium-241, from the decay of plutonium-241, is expected to be present in the shafts at MDA AB (LANL 1992, 7670, p. 7-4). Tritium was also used in some of the tests and may be locally present in small quantities. The HE used in the tests is thought to have been consumed with high efficiency in the detonations; any residuals remain underground and are negligible in quantity and potential hazard compared with the radionuclide and metal contamination known to be present (LANL 1992, 7670, p. 7-18). There is no basis for expecting HE to be present in the asphalt pad, fill materials, or surface soils that will be disturbed during the stabilization activities. HE is present on or near the ground surface at other Laboratory firing sites because the test devices were detonated on or near the ground surface. At TA-49 the explosive devices were assembled elsewhere and brought to the site as modular units for installation into the downhole test packages, and the test packages were detonated underground at depths sufficient to prevent surface release. Because the current activities will not disturb the subsurface test locations, the near surface filter boxes, or the puddled concrete caps over the shafts and filter boxes, no sampling for HE is required. Samples of surface soils showed no concentrations of VOCs, SVOCs, PCBs, or TCLP metals above EPA guidelines. The surface soils were therefore found to contain no RCRA constituents.

4.0 JUSTIFICATION FOR IMPLEMENTING BMPS

The increased moisture conditions at Areas 2, 2A, and 2B are a potential cause for concern, particularly because standing water is periodically observed in CH-2. For contaminants buried underground in competent geologic media, dissolution and transport by moving soil water is the only significant means of mobilization. During the site selection process for the nuclear safety tests, particular attention was paid by the Laboratory and US Geological Survey personnel to the hydrologic conditions at the candidate test sites. According to the OJ 14 RFI work plan (LANL 1992, 7670, p. 3-7), "Frijoles Mesa emerged as a leading candidate site, and the choice was confirmed after an extensive hydrogeologic study demonstrated that the lack of perched aquifers, lack of recharge waters, and great depth to the main aquifer (about 1200 ft at the main experimental area) made the potential for ground water contamination negligible (Weir and Purtymun 1962, 11890)." A deep core hole was drilled at each candidate test area (500-foot-deep CH-2 was the core hole at Area 2) to confirm the low moisture content of the tuff and the lack of perched water.

The subsequent finding of nearly saturated moisture conditions in the soil beneath the asphalt pad at Area 2 and the periodic presence of standing water in CH-2 clearly conflicts with the low moisture conditions sought in the original hydrogeologic siting criteria. The standing water in CH-2 indicates that moisture periodically enters the core hole at a faster rate than it can drain. The high soil-moisture content and adverse site run-on and ponding conditions also indicate the presence of excessive moisture at the site.

Injection well studies at TA-50, described in the OU 1144 RFI work plan (LANL 1992, 7670, p. 4-29), were performed to evaluate the movement of moisture in moderately welded Bandelier Tuff. At 50% to 100% of saturation, gravity is the dominant force driving the movement of moisture. At lower moisture contents, fluid movement is controlled by capillary forces and molecular diffusion and is considerably slower.

The permeability to water in unsaturated materials increases dramatically as moisture content increases, with a concurrent increase in the velocity of water movement. The hydraulic conductivity of saturated Bandelier Tuff can be from 2 to over 5 orders of magnitude higher than for the unsaturated tuff, indicating that flow velocities can increase by factors of 100 to 100,000 as the tuff becomes wetted (LANL 1992, 7670, p. 4-31). The original concept that a 1200-foot buffer zone between the residual test contaminants and the main ground water aquifer provided adequate isolation is challenged when an essentially continuous source of moisture is located at the ground surface immediately above the test shafts. This conclusion is consistent with the original finding in the siting studies that because the natural moisture content of the tuffs was 5% or less, the main ground water aquifer would be protected from contamination (LANL 1992, 7670, p. 4-17).

Quantitative modeling and risk assessment for conditions at the site will be needed to understand long-term risks and to define actions that may be needed to achieve a final remedy that will successfully isolate subsurface contaminants over the long term. However, current moisture conditions represent an obvious threat to contaminant isolation. Because immediate and obvious actions can be taken to reduce the amount of moisture entering the site, the actions described in Sections 5.0 through 9.0 are being proposed.

Because of the magnitude of the source constituents at Areas 2, 2A, and 2B, this stabilization plan has been prepared to describe near-term activities that will reduce the amount of moisture entering the site and thereby reduce the migration potential of the subsurface contaminants.

5.0 PROPOSED BMP'S

There are four aspects to the moisture accumulations at Areas 2, 2A, and 2B:

- the presence of the asphalt pad traps moisture in the subsurface by limiting evapotranspiration;
- the asphalt pad concentrates runoff into cracks and areas adjacent to the pads;
- poor drainage around the asphalt pad results in ponding and enhanced infiltration of water; and
- surface run-on and potential interflow from upgradient areas can contribute additional water to these areas.

The BMPs described in this plan directly address excess moisture accumulation and may be summarized as follows:

- remove the asphalt pad to eliminate the moisture buildup that presently occurs beneath it;
- construct a diversion channel upgradient of the site to divert surface run-on from the site;
- regrade the fill materials and soils to eliminate ponding and improve drainage at the site, bringing in additional fill materials as needed;
- cover the regraded site with a layer of crushed tuff;
- cover the regraded site with topsoil armored with gravel to resist erosion and revegetate the site with shallow-rooted grasses; and

- monitor the site to determine the effectiveness of the BMPs.

Because these activities may change drainage paths, creating new discharge points and potentially increasing runoff flows in some areas, issues of surface soil and sediment contamination dispersal in some existing surface contaminated areas are also addressed. Thus, the following additional component has been added to the BMPs:

- locate and remove, or stabilize, surface contaminants in affected areas downgradient of the site.

An overview of the nature and purpose of each of these activities is presented in the following paragraphs, beginning with a description of the initial site preparation activities necessary for accomplishing all BMP activities. This plan is consistent with *stabilization in place* as the presumptive remedy and is, therefore, consistent with the basic premise of the EPA-approved OU 1144 RFI work plan (LANL 1992, 7670, Section 7.4.1). However, attention has been given to ensuring that the actions taken under these BMPs will not preclude any foreseeable final remedy or investigation that might be necessary to support that remedy. Detailed design information is presented in the attachments to this plan. Additional sampling of the fill materials underlying the asphalt pad will be performed before excavation as part of the RFI Phase I activities. This sampling is summarized below and described more fully in the 1998 RFI sampling and analysis plan (SAP) for Areas 2, 2A, and 2B at MDA AB [Environmental Restoration Project, in preparation (a)]. This plan is intended to achieve the described actions by the end of Fiscal Year (FY) 1998 (September 30, 1998). Thus, the sequence of events and the schedules presented are optimized for that purpose.

5.1 Site Preparation Activities

The site preparation activities include performing the necessary reviews, obtaining the necessary permits and approvals, and performing the preparatory field activities that initiate all BMP activities.

5.1.1 Internal Reviews, Permits, and Approvals

The BMP activities described in this plan are subject to the internal reviews, permits, and approvals required by the Laboratory and DOE for any field project. The principal internal reviews are the Laboratory ER peer review, the ESH-ID review, the DOE review, and the Laboratory ER readiness review.

5.1.1.1 ER Peer Review

The ER peer review is a relatively new process established in January 1998 to increase the breadth of internal reviews and help ensure that all major issues associated with a project have been anticipated. Both this stabilization plan and the supporting RFI SAP passed through the peer review process and were improved by the peer panel's recommendations. The peer review for the SAP was conducted on February 3, 1998. Verbal recommendations and meeting notes were provided to the TA-49 Asphalt Pad Team for clarifying the description of site conditions that prompted the sampling and for providing a statistical basis for the numbers and locations of samples to be taken. The SAP was subsequently modified in accordance with the peer panel's recommendations. Peer reviews for the stabilization plan were conducted on March 2, 1998, and April 8, 1998. Verbal and written recommendations were provided for ensuring that the BMP activities were appropriately justified, for ensuring that any adverse impacts of the activities were

identified and adequately mitigated, and for conducting additional modeling and evaluation efforts in parallel. The peer panel's recommendations have been incorporated into this draft plan.

5.1.1.2 ESH-ID Review

The ESH-ID review provides a comprehensive checklist for review and approval of field projects by Laboratory organizations outside the ER Project. Information on a project is provided on the ESH-ID checklist, which is then circulated among the appropriate Laboratory organizations for review. The process triggers initiation of all key internal and external permitting and approval processes required for a project, including site surveys for cultural and biological resources, National Environmental Policy Act (NEPA) documentation, health and safety issues, National Emission Standards for Hazardous Air Pollutants (NESHAP) air quality monitoring, storm water management, excavation permits, waste management, regulatory issues, and DOE review and approval. Specifically, the ESH-ID process includes reviews by the following Laboratory organizations outside EM/ER: ESH-3, general safety issues; ESH-19, PCB and RCRA issues; ESH-12, radiological engineering issues; ESH-17, air quality issues; ESH-20, archaeological and historical resources review; ESH-18, water quality issues; ESH-5, ER and decontamination and decommissioning issues; CIC-4, communications facilities issues (telephone lines and network systems); ESH-20, NEPA issues; CST-13, radioactive liquid waste issues; ESH-6, criticality issues; and ESH-20, biological issues (threatened and endangered species).

The ESH-ID checklist was submitted by the TA-49 Asphalt Pad Team on January 28, 1998, to initiate the ESH-ID process. Feedback from the review process began to be received on February 2, 1998, and most of the project's needs have been identified and are addressed in this stabilization plan. Summaries of the status of the key project issues are presented below

Archaeological, Historical, and Biological Resources Review, ESH-20. Archaeological sites were found to the east, southeast, and southwest of Areas 2, 2A, and 2B, but none were found within those areas. Layout, parking, storage, and other lands needed to support the BMP activities will be located to avoid the archaeological sites. A threatened and endangered species survey near the project area was completed on May 8, 1998. There are no threatened and endangered species issues associated with the project.

General Safety Review, ESH-3. Health and safety issues associated with BMP activities are documented in site-specific health and safety plans [Environmental Restoration Project, in preparation (b); Environmental Restoration Project 1998, 57912]. Two site-specific health and safety plans (SSHASPs) have been prepared to support the stabilization activities. The first addresses construction of the surface water diversion channel (Section 5.2), and the second addresses removal of the asphalt pad and regrading of the site (Sections 5.3 through 5.6). Because the planned BMP activities will affect only the asphalt pad and fill materials and not the radionuclides and heavy metals remaining at greater depths, the health and safety issues are expected to be adequately addressed by routine use of personal protective equipment (PPE), radiological monitoring, and decontamination.

Air Quality Review, ESH-17. An air quality monitoring station is currently operating at a location northeast of the site, as shown in Figure 3-2. Because the levels of contamination in the fill, asphalt, and surrounding soils are expected to be low, no additional air quality monitoring at the site has been required by ESH-17. However, as a BMP, an air quality monitor will be installed during construction at a location northwest of the site (Figure 3-2). This location was selected by

ESH-17 because it will help to determine whether any radionuclides from Areas 2, 2A, or 2B are being carried toward the PHERMEX Facility across Water Canyon in TA-15.

Water Quality Review, ESH-18. Storm water management during construction is addressed in the SWPP plan presented as Attachment 2 to this stabilization plan. Storm water issues addressed in the SWPP plan include the diversion of surface water run-on from the site during construction activities and installation of a silt fence to control sedimentation from surface water runoff. The site activities that will be protected by these measures include removal of the asphalt pad, excavation of the old fill beneath the asphalt pad, and regrading of the site to eliminate ponding. The run-on diversion channel installed under the SWPP plan will be left in place to provide long-term surface water diversion from the site after construction activities are completed. A spill prevention, control, and countermeasures implementation plan supporting the SWPP and other BMP activities has also been prepared (Environmental Restoration Project 1998, 57586).

Waste Management Review, EM/ER. Waste management issues for the project address both sampling- and construction-derived waste streams. Waste streams from the RFI sampling activities include PPE, decontamination fluids, and residual sample materials that exceed screening action levels. Residual sample materials that do not exceed action levels will be put back into the sample holes. Waste streams from the BMP construction activities include PPE, decontamination fluids, asphalt, removed vegetation, and wood, metal, concrete, and PVC objects from removed power poles, borehole casing, and fence posts. Under current plans, the asphalt pad will be disposed of off site, and the underlying fill material will remain on site and be used in surface regrading. The Waste Characterization Strategy form prepared for this project addresses both sampling and construction activities (Environmental Restoration Project 1998, 57587).

Regulatory Review, EM/ER. Regulatory issues were also addressed in the review process. Although the stabilization activities at TA-49 Areas 2, 2A, and 2B are being performed BMPs to improve moisture conditions at the site and, therefore, do not require regulatory approval, the ESH-ID process is also used to determine whether other aspects of the BMP activities, such as surface water diversions or affected NEPA issues, may require such approval. Because surface water runoff from the site will be channeled through existing culverts and into the same drainages that are currently carrying site runoff, the work falls under the Laboratory's existing National Pollutant Discharge Elimination System (NPDES) general permit, and no additional discharge permitting is required. Although no changes in the conditions of those drainages are expected as a result of the project, they will be further stabilized to minimize erosion as a BMP. As previously mentioned, no NEPA issues have been identified for the project. Additional internal Laboratory permits required for the project include an excavation permit and a radiation work permit. These will be obtained as part of the readiness review process described in Section 5.1.1.4.

Presentations describing the planned activities are being made to the New Mexico Environment Department (NMED). These presentations are intended to help ensure that the regulatory personnel agree that the planned activities are appropriate and consistent with the ultimate goals for stabilizing the residual subsurface test constituents. An overview of the RFI sampling plan was presented to NMED on February 6, 1998, an overview of the site history, moisture issues, and planned stabilization activities was presented on April 7, 1998, and an overview of surface and near-surface constituent data collected at the site was presented on May 28, 1998. Additional

meetings are planned to further discuss the results of the RFI sampling and additional details on the stabilization activities.

5.1.1.3 DOE Review

The DOE review of this stabilization plan was conducted in two parts. The first was an overall review of the technical aspects of the proposed activities, and the second was a review of the environmental consequences of those activities. DOE's technical comments, approval of the plan, and authorization of field work at the site were transmitted to the ER Project Office in a memorandum dated May 11, 1998 (DOE 1998, 59034). This plan has been modified in response to those comments. DOE's environmental review, performed pursuant to the requirements of (NEPA, was completed on May 13, 1998 (DOE 1998, 58033). No significant environmental consequences were identified, and the project was determined to be covered by the categorical exclusion for small-scale, short-term cleanup actions under RCRA, the Atomic Energy Act, or other authorities (10 CFR 1021, Appendix B 6.1).

5.1.1.4 Readiness Review

Following resolution of all ER peer review recommendations and ESH-ID issues and after obtaining Laboratory, ER Project, and DOE approvals for the work, readiness reviews are conducted with Laboratory EES-13 project manager to ensure that all necessary approvals have been obtained and that field activities are ready to begin. The readiness review for the RFI sampling activities was held on February 19, 1998, and those activities are currently under way. The readiness review for constructing the diversion channel was held on June 2, 1998, and the readiness review for removing the asphalt pad and regrading the site is expected to be held in July 1998.

5.1.2 RFI Sampling

Additional Phase I RFI sampling will be conducted in PRSs 49-001 (b, c, d, and g) to provide information needed to plan the field work and prepare final BMP designs. Principal objectives and the methods for RFI sampling are summarized in Table 5-1.

Land survey personnel placed markers above the centers of each of the shafts to indicate the locations for the subsequent hand-auger borings. Land survey personnel also determined the locations of subsurface anomalies indicated by geophysical survey techniques. A FIDLER radiation survey was conducted in conjunction with the geophysical survey, and radiation measurements were made on the same grid locations as the geophysical survey. Locations with elevated levels of radiation were specially marked. Maps will be prepared showing the results of the geophysical and radiation surveys. A more detailed discussion of the RFI sampling activities is presented in the RFI SAP [Environmental Restoration Project, in preparation (a)]. The results of the RFI surveys and sampling will be documented in an RFI status report.

5.1.3 Borings to Competent Tuff

A series of approximately 20 borings was performed around the upgradient perimeter of Areas 2, 2A, and 2B as part of the RFI activities to determine the depth to competent tuff and to identify any significant irregularities in the elevation of the tuff surface. This information will be used in determining the extent to which interflow may be concentrated by buried channels on the tuff surface and will be used to help determine the importance of interflow as a source of moisture in these areas. The presence of excessive moisture in the cuttings was noted in the field log, and a

preliminary subsurface contour map of the soil-tuff interface will be produced. The borings were 3 to 4 feet deep and were performed using a hand auger. The approximate locations of the borings are shown on Figure 5-1.

**TABLE 5-1
PRINCIPAL OBJECTIVES AND METHODS OF THE RFI SAMPLING**

OBJECTIVE	METHOD
Perform a radiological survey over PRSs 49-001(b,c,and d) to identify and document any surface contamination	Use a FIDLER instrument over a predetermined grid
Perform a radiological survey over PRS 49-001(g) to identify and document any surface contamination	Use a FIDLER instrument on a predetermined spacing within the downgradient drainage areas affected by site runoff
Perform land surveys and geophysical surveys over PRSs 49-001(b,c,and d) to confirm the shaft locations and identify other subsurface hazards that may be present	Perform the land surveys using standard surveying methods, perform the geophysical surveys over a predetermined grid using electromagnetic and magnetic techniques
Confirm the location and elevation of the tops of the shafts in PRSs 49-001(b,c,and d) to support fill excavation	Install hand-auger borings at each shaft location from the ground surface to the top of the puddled concrete cap
Characterize the asphalt pad in PRS 49-001(b) for waste disposal	Sample the asphalt for RCRA metals, plutonium, uranium, americium, PCBs, VOCs, SVOCs, and tritium. Swipe asphalt and sample soil directly beneath asphalt for tritium
Characterize the fill materials beneath the asphalt pad for worker health and safety during excavation and to clarify disposal or reuse issues	Field screen all cuttings from the hand borings, send selected samples representative of the range of contamination will be sent off-site for radiometric analysis, collect extra samples in the northeast corner of the asphalt pad where the highest contaminant levels have been found
Determine the physical characteristics of the fill materials beneath the asphalt pad to facilitate handling during excavation	Collect and send, selected samples representative of the fill composition, off-site for texture and moisture analyses

5.1.4 Power Line Relocation

An existing power line that runs between Areas 2 and 2B will be relocated outside the area that is likely to be influenced by the BMP work. The location of this line is shown in Figure 5-1. The line will be relocated by Johnson Controls in coordination with the TA-49 Asphalt Pad Team and the TA-49 facility manager. Subsurface soils excavated during the relocation and the buried parts of

the power poles will be sampled for disposal in accordance with the project's waste characterization strategy (Environmental Restoration Project 1998, 57587).

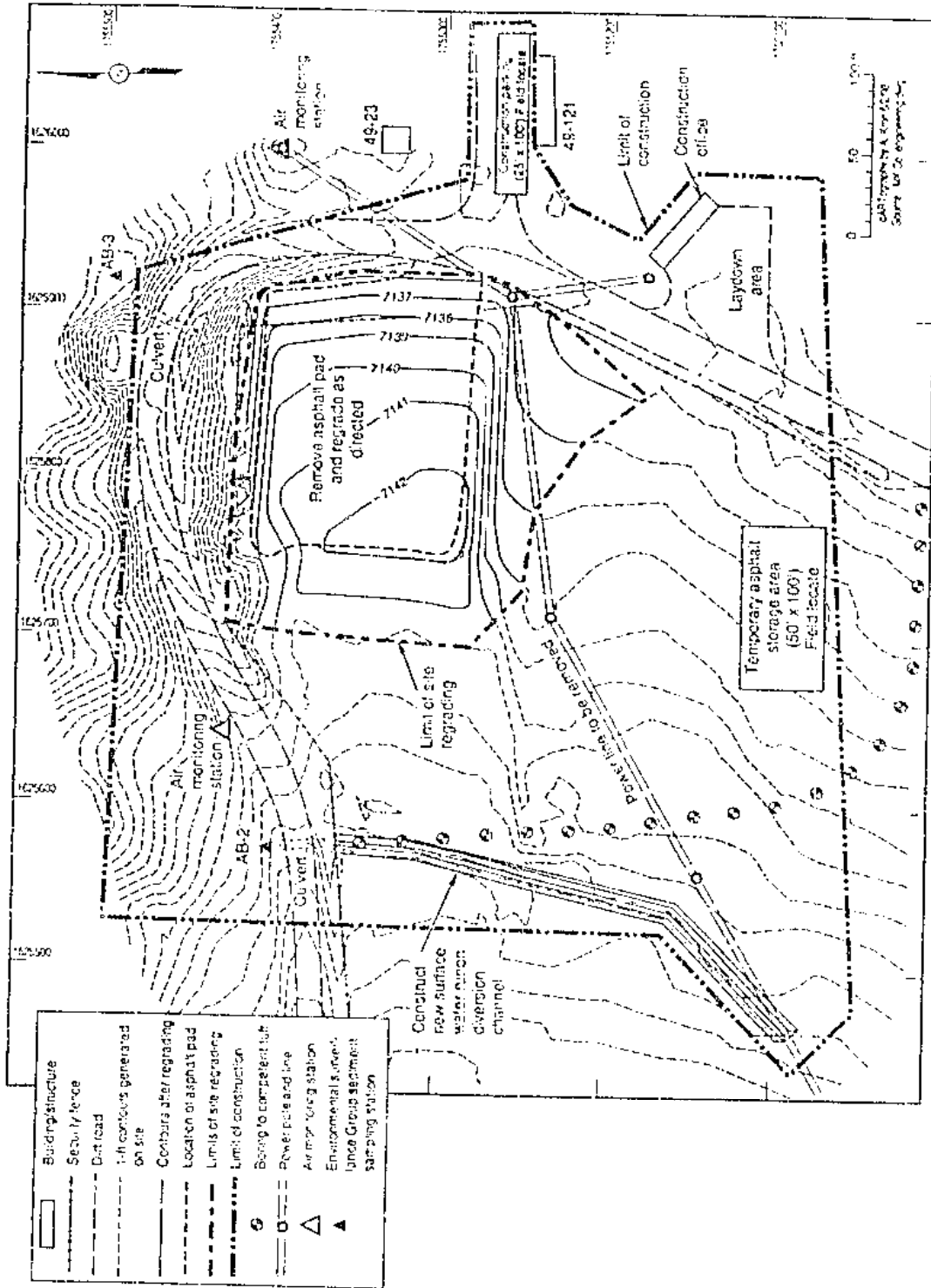

Figure 5-1. Locations of site runoff and runoff controls.

5.1.5 Borehole Plugging and Abandonment

CH 2 will be plugged and abandoned as part of the stabilization activities because of its inadequate annular seal, the standing water that has been found in the hole, and the possibility that the hole may provide a pathway for contaminant migration. The core hole will be plugged and abandoned as described in the monitoring well and borehole abandonment plan presented in Attachment 3. The four 10-foot RFI holes on the asphalt pad (holes 49-2902 through 49-2905) have already been plugged and abandoned. The two 150-foot RFI holes on the asphalt pad (holes 49-2906 and 49-2907) have adequate annular seals, as described in Section 3.2.2. They will be retained during the stabilization activities and will be used as moisture monitoring points to help evaluate the effectiveness of those activities. The remaining moisture monitoring holes previously installed in Areas 2, 2A, and 2B will be retained for future monitoring use. The five TH holes and the 700-foot RFI hole 49-2901 are in low moisture content media outside of contaminated zones and therefore cannot serve as pathways for contaminant migration. The three moisture monitoring holes 2A-O, 2A-Y, and 2B-Y are in unused, sand-filled shafts where vertical permeability is already elevated and settlement of the sand would have closed any annular space that may have existed. The locations of these holes are shown in Figure 3-2.

5.1.6 Site Clearing and Fence Removal

The site will be cleared of surface vegetation before construction activities. This clearing will be performed over the minimum required area by trimming the plants at or above the existing soil level to avoid subsurface disturbance. Scrap metal, glass, and other inorganic debris will also be collected and segregated. Concrete and other materials forming caps over the test shafts will be left undisturbed. The existing site fence will be removed, where needed, to facilitate construction. Organic and inorganic waste materials will be disposed of in accordance with the waste characterization strategy (Environmental Restoration Project 1998, 57587).

5.1.7 Laydown, Stockpile, Parking, and Waste Storage Areas

Areas free of cultural and other resource conflicts will be identified for material laydown and stockpiling, vehicle parking, and waste asphalt storage areas. The laydown areas will be used for temporary storage of construction supplies and equipment, material processing, and material assembly. The stockpile areas will be used for storing crushed tuff, revegetation topsoil, seed, and other materials to be used in regrading the site. The parking areas will be used for construction equipment, personal and government vehicles, and trailer offices. Waste storage areas will be used primarily for waste asphalt, which is expected to be temporarily stockpiled or stored in roll-off bins. Other wastes, including PPE and decontamination fluids, will be temporarily stored in drums before disposal. Additional information on waste storage is presented in the waste characterization strategy (Environmental Restoration Project 1998, 57587). The size of these areas will be minimized to reduce environmental damage. It is anticipated that most of these activities will be conducted in areas already disturbed by past activities along the road leading east from the site toward Area 10 (Figure 2-1).

5.1.8 Baseline Borehole Measurements

The moisture content of the soil and tuff will be measured in the boreholes at the site at the time that construction is initiated. If standing water is present in CH 2, the water level will be measured and filtered, and unfiltered water samples will be taken. Those samples will be analyzed for isotopic uranium, plutonium, americium, total RCRA metals, and HE. The results of these

measurements will be compared with those of the postconstruction monitoring described in Section 6.0 to help determine the effectiveness of the BMPs.

5.2 Surface Water Run-on Diversion Channel

A surface water run-on diversion channel has been designed to divert surface water that currently flows onto the site. This channel will be used to protect the site from storm water during construction and will be left in place after construction is completed to provide longer-term protection of the site until final corrective measures are implemented. For this reason, the channel will be designed for larger runoff events than a diversion channel designed to be effective only for a short period during construction. Completion of these stabilization activities and implementation of a final corrective measure is currently scheduled for FY 2001. Diversion of subsurface interflow was not included in this plan because its significance as a source of moisture for Areas 2, 2A, and 2B is not currently known. An evaluation of the relative significance of interflow is currently under way, and the results will be incorporated into the ongoing RFI/corrective measures study (CMS) studies at MDA AB. Surface run-on and runoff controls during construction are further discussed in the SWPP plan presented in Attachment 2.

The diversion channel will extend across the western, upgradient side of Areas 2, 2A, and 2B, as shown in Figure 5-1. It has been designed to intercept all upgradient surface run-on entering the site. Surface storm water flow running down the mesa south of the end of the channel drains to the southeast and will not enter the site. The channel will drain to the north by gravity flow into an existing culvert.

A cross section of the channel is shown in Figure 5-2. The channel and associated berm will be about 20 feet wide. The channel will be about 2 feet deep, and the berm will be about 2 feet high. The construction zone for this activity is expected to be about 50 feet wide. The berm will be constructed of soil removed from the channel. The facility will be constructed by earth-moving equipment with minimal effort and without formal engineering design. Construction activities will be controlled directly by a field engineer, using land survey information to control grades. The channel and berm will be compacted after excavation to promote stability, but no other materials or lining will be used. Maintenance requirements for this structure are expected to be minimal and are discussed in Section 7.0. The channel and berm are located in uncontaminated areas away from the nuclear safety test sites. Although no monitoring of diverted run-on volumes is currently planned, the water discharged from the channel will be periodically sampled at the culvert by ESH-18 personnel in conformance with the Laboratory's NPDES general permit. Additional discussion of this sampling activity is presented in Section 5.4 of this plan. Drainage of local runoff water from the site east of the diversion channel is discussed in Section 5.5. Design information for the diversion channel is presented in Attachment 4.

5.3 Asphalt Pad Removal and Fill Excavation

The asphalt pad will be removed sequentially in squares with dimensions of about 20 feet by 20 feet. Working from the adjacent asphalt surface, asphalt in the first 20- by 20-foot square will be removed in the southwest corner of the site, probably by backhoe. The surface of the underlying fill material will be scarified and reworked to promote drying, but drying of the fill material will be primarily incidental to regrading and will not be a major objective of the construction activity. The fill is expected to be excavated only at the edges of the pad as needed to promote drainage when regrading. The clay content of the old fill material was found in the recent RFIs to be relatively

high. It is important to reduce the moisture content of the existing fill to minimize the occurrence of shrinkage fracturing before the fill is covered with crushed tuff and topsoil, as described in Section 5.5.

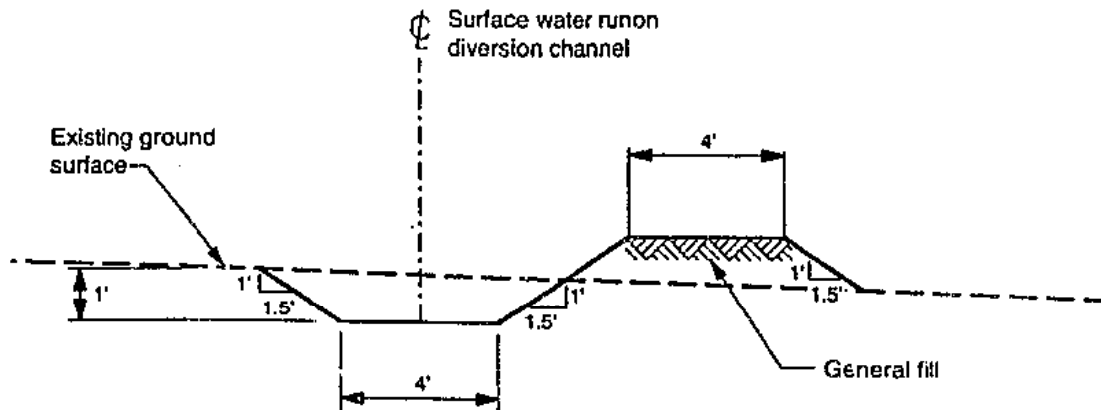

Figure 5-2. Schematic cross-section of surface water run-on diversion channel.

After the asphalt is removed, additional fill is expected to be needed to raise the center of the pad area to promote drainage from the site. The regrading will be performed by earth-moving equipment; no formal engineering design will be used. Construction activities will be controlled directly by a field engineer, following the general guidance provided by the asphalt pad removal and regrading plan; land survey information will be used to control grades.

As the asphalt is removed, the underlying surface of fill materials will be field screened with a FIDLER instrument for radioactive contamination before it is further disturbed. Additional field screening will be performed on newly exposed surfaces at approximately 6-inch-depth intervals, as existing fill material is relocated during the regrading process. Although the fill materials are not expected to be radioactively contaminated, any materials found to exceed the action levels for worker health and safety described in the SSHASP [Environmental Restoration Project, in preparation (b)] will be removed and drummed for shipment to an appropriate disposal facility, in accordance with the waste characterization strategy (Environmental Restoration Project 1998, 57587).

Care will be taken during excavation not to damage the casings of boreholes that will be retained on the site (Section 5.1.5). Excavation of fill material beneath the asphalt will stop when at least 1 foot of fill remains above the original soil surface, as defined by the depths of the puddled concrete shaft caps determined during RFI sampling. An illustration of the methodology that will be used to remove the asphalt pad is shown in Figure 5-3.

Excavation by squares has several advantages over uniform site stripping. It permits most of the work to be performed from a clean, hard asphalt surface. This can be highly advantageous if the underlying fill materials are wet. It allows efficient use of personnel because while excavation is proceeding in one square, the radiological survey can be performed in the previously excavated square. Finally, it provides for progressive worker training by starting in the least likely contaminated (southwest) corner of the pad and working toward the most likely contaminated (northeast) corner of the pad.

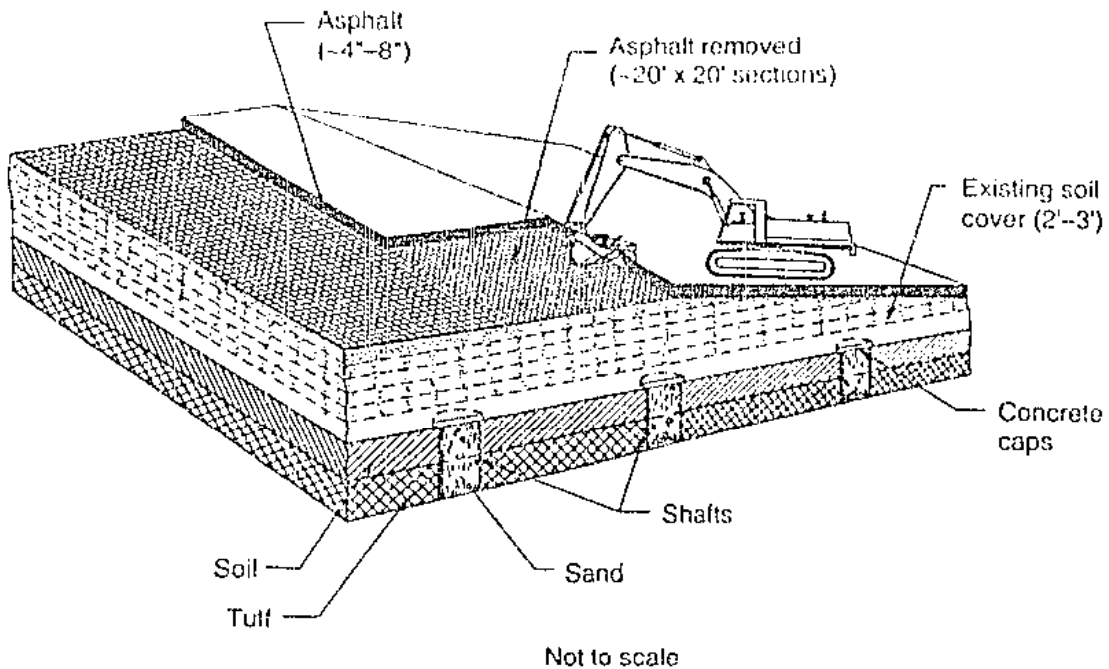

Figure 5-3. Illustration of asphalt pad and fill excavation methodology.

As the final lifts of old fill are excavated, a comprehensive FIDLER survey of the exposed surface will be performed to document radionuclide concentrations on that surface for future site investigations. Although hot spots will be removed from that surface as needed for worker safety, the surface does not have to be free of contamination, and the final survey will not be considered confirmatory sampling. Rows of survey grade markers will be placed on the final surface of the old fill materials to allow them to be identified during future site excavation activities. Design information on the asphalt pad removal and fill excavation is presented in Attachment 4.

Although analysis of the asphalt samples collected during the RFI (Section 5.1.2) is expected to provide sufficient characterization for disposal, additional screening of the asphalt for radioactive contamination will be conducted during removal, as described above. Asphalt found to be clean is planned to be trucked to an asphalt recycling plant. Contaminated asphalt will be stored in roll-off bins for crushing and disposal. Asphalt found to be only radioactively contaminated is planned to be sent to TA-54, Area G, for disposal. Although not expected, asphalt found to be contaminated by other than low levels of radioactivity will be disposed of as indicated in the waste characterization strategy for this stabilization plan (Environmental Restoration Project 1998, 57587). Asphalt, wood, vegetation, and other organic matter will not be disposed of at the site because if the final corrective measure at the site involves an engineered cover, the amount of organic matter beneath the cover should be minimized to avoid gas generation.

The hot spots in the fill that would be of concern for worker safety are expected to be few in number, highly isolated, and small in volume. These materials will be isolated in drums or other suitable containers and disposed of off site in accordance with the waste characterization strategy for this stabilization plan (Environmental Restoration Project 1998, 57587). Other radiologically contaminated inorganic materials from the site, such as metal fencing or concrete on fence posts,

will also be disposed of in accordance with that plan. Previous sampling of the fill materials has indicated that they contain no RCRA wastes (Section 3.2.1).

5.4 Surface Soil Screening and Release of Site Runoff

Surface soils in the vicinity of Areas 2, 2A, and 2B will be screened for radiological contamination in a FIDLER survey as one of the RFI sampling activities described in Section 5.1.2 and in the RFI SAP [Environmental Restoration Project, in preparation (a)]. The objective of this screening will be for purposes of worker health and safety and not for waste characterization or closure. A final remedy for PRS 49-001(g) will be addressed as part of the CMS process for MDA AB. As previously mentioned, surface soil contamination at MDA AB is included in PRS 49-001(g) and has been found in drainage channels downgradient of Areas 2, 2A, and 2B. The field survey will focus on those parts of PRS 49-001(g) that will be affected by runoff from the site, discharges from the surface water diversion channel, and the project support areas discussed in Section 5.1.8. Soils that are found to be above action levels identified in the SSHASP [Environmental Restoration Project, in preparation (b)] will be removed and drummed for disposal in accordance with the waste characterization strategy for this plan (Environmental Restoration Project 1998, 57587).

Periodic sampling of site runoff will be performed by ESH-18 in accordance with the Laboratory's NPDES general permit. Because runoff from upgradient of the site as well as runoff from the site itself originates in identified PRSs, that runoff must be monitored for contaminants. If state water quality standards are found to be routinely exceeded, a site-specific NPDES permit may be required. During the BMP implementation, existing release points will be used rather than creating new ones. Three release points for the site will be used: one at the southeast corner, one at the northeast corner, and one at the northwest corner of the site. Surface water runoff from the site and the upgradient drainage channel will be directed into downgradient areas that are currently receiving runoff from the site. The drainage channels receiving site runoff water will be inspected during the BMP activities, and if remedial stabilization efforts are found to be required, mitigating measures will be taken that could include installation of flow dissipaters, check dams, or sediment traps before completion of the BMP activities. Release of runoff water down the same channels that are currently receiving runoff will minimize the potential for mobilizing downgradient contaminants.

5.5 Site Regrading and Drainage Improvements

Some of the old fill materials beneath the asphalt pad will be used when regrading Areas 2, 2A, and 2B to improve surface water drainage and eliminate ponding. However, because the old fill materials are only about 2 to 3 feet thick and at least 1 foot of fill will be left in place as a buffer against the contaminated soils beneath, little of the old fill will be available for this use. It is expected that only the old fill materials near the edge of the asphalt pad will be used for regrading purposes and that much of the regrading will of necessity be performed with new fill materials (probably predominantly crushed tuff) brought in from off site. Although the volume of material needed from off site is not precisely known, crushed tuff is relatively abundant at the Laboratory, and no difficulty in obtaining this material is anticipated. During regrading, the moisture content of the old fill materials is expected to be reduced by natural solar evaporation.

During regrading, the fill materials will be compacted to reduce pore volume and subsequent moisture storage capacity. The final surface contour in Areas 2, 2A, and 2B will allow surface

water to flow downslope to the edges of the site without ponding. Surface runoff from on site is not expected to go west as far as the diversion channel because of the elevation differences involved. Rather, site surface runoff is expected to go to the south, north, and east toward the perimeter access road. Runoff will be channeled into ditches beside the road and conveyed to culverts at the northeast and southeast corners of the site. These ditches will be graded to keep water from ponding before reaching the culverts. The road cycling MDA AB may be temporarily closed if modifications are required to the existing culverts or if new culverts must be installed. Design information for the regrading activities is presented in Attachment 4.

5.6 Cover Revegetation

An approximately 6-inch-thick layer of crushed tuff will be placed over the entire regraded surface when the final contours are approached. The final surface will consist of an approximately 6-inch layer of uncompacted topsoil to provide a rooting medium for vegetation. It is recognized that a 6-inch layer of topsoil is not thick enough to provide an optimal environment for plant growth; however, it is considered sufficient for purposes of temporary site stabilization. Positive deterrents to gopher burrowing at the site will also be emplaced. These may include a wire mesh placed over the topsoil to exclude gophers from areas where burrowing is likely to reach the depths of the original contaminated surface soils. The elements of the deterrent system, such as the required wire gauge, mesh size, and extent of coverage, will be determined in consultation with rodent control specialists. In addition to deterring gopher burrowing, a wire mesh would also have the advantages of helping to control erosion and providing a reference surface for visually inspecting the extent of erosion. The topsoil will be seeded with shallow-rooting grasses, and gravel will be spread over the topsoil for erosion protection. Revegetation of the regraded area with shallow-rooting grasses is expected to increase moisture removal from the site, increase erosion resistance, and provide competition for plants whose roots could penetrate to the depth of contaminated soils and bring radionuclides to the surface. Only those parts of Areas 2, 2A, and 2B where ponding is potentially problematic will be regraded, and only those parts of Areas 2, 2A, and 2B that are regraded or otherwise significantly disturbed by the construction activities will be revegetated. The area expected to be regraded and revegetated is shown in Figure 5-1.

6.0 SITE RESTORATION, CLEANUP, AND MONITORING

The existing site fencing and MDA AB perimeter road will be restored at the conclusion of the BMPs. Areas that were disturbed by construction activities will be cleaned of trash and construction materials and revegetated. These include the area of the diversion channel and the site laydown, stockpile, parking, and waste storage areas.

The existing boreholes (Figure 3-2) at the site will be used for monitoring subsurface moisture conditions to help determine the effectiveness of the BMP activities described in this plan. Neutron probes will be used to determine moisture profiles for each borehole. If standing water is present in a borehole, the depth to water will be measured, and a water sample will be collected for analysis. The water will be analyzed for isotopic uranium, plutonium, americium, and RCRA metals. Monitoring will be performed on a quarterly basis for the first two years following completion of the BMP activities. At that time, a decision will be made whether to reduce the monitoring frequency to annual or semiannual, depending on the results of the first two years of quarterly sampling.

7.0 SITE INSPECTION AND MAINTENANCE

Minor periodic maintenance of the BMP installation at Areas 2, 2A, and 2B is expected to be required. During each quarterly monitoring round (Section 6.0), the site will be inspected for sedimentation of the diversion channel, erosion of the regraded surface, deep-rooted plants growing on the site, gopher burrows, and evidence of ponding. Any stabilization measures installed in downgradient runoff channels would also be inspected at that time. The site condition will be documented and used to determine the need for maintenance. Maintenance will be performed on an as-needed basis. Excessive accumulations of sediment will be mechanically removed from the diversion channel and placed on the berm beside the channel. Grade markers or a wire mesh that will protrude from the surface if erosion occurs will be placed on the final regraded topsoil surface to facilitate visual inspection of the extent of erosion. Excessive erosion or gullying of the regraded surface will be corrected by placement of additional topsoil, crushed tuff, and gravel, as needed. Deep-rooted plants found growing on the site will be physically removed, and any soil disruption will be repaired. Gophers found on site will be removed, and the effects of their burrows will be repaired. Low-lying areas that may develop because of settlement of the regraded fill will be filled in with soil or crushed tuff.

8.0 ALTERNATIVES TO THE PROPOSED BMPS

Alternatives to the proposed BMPs include no action, implementing some but not all of the proposed BMPs, implementing modified versions of the proposed BMPs, and implementing additional activities. Each of these alternatives is briefly addressed in the following paragraphs.

8.1 No-Action Alternative

The no-action alternative would leave the site in its current condition, without affecting the adverse moisture conditions. Because of the magnitude of the underground source term at the site (Table 2-1), this alternative is not acceptable.

8.2 Implement Some of the BMPs

The proposed BMPs consist of three major activities: constructing a diversion channel and berm to intercept surface run-on; removing the asphalt pad; and regrading the site to improve surface runoff and eliminate ponding. Any one of these three activities could potentially be implemented independently; however, they are closely interrelated and implementing any one of them would leave other significant problem areas uncorrected. The diversion channel and berm are probably the most easily isolated of the three activities. Construction of the channel and berm would divert off-site run-on from Areas 2, 2A, and 2B but would not address the significant issues of moisture buildup under the asphalt pad and the on-site ponding of runoff from direct precipitation. Independently removing the asphalt pad and excavating the fill would improve moisture conditions under the pad but would not address off-site run-on and would not improve drainage conditions. Regrading the site without removing the asphalt pad or constructing a surface water diversion would allow moisture to continue to accumulate under the pad and would not provide for the diversion of runoff away from the site. These three major activities are proposed for concurrent implementation in this stabilization plan because

- each of these activities addresses a different and important water management issue at the site,
- each is interrelated with the others.

- concurrent implementation provides cost savings.
- implementation of the three activities can be budgeted in FY 1998.
- and the planned implementation is consistent with the final remedy of in-place stabilization that has been identified for the site.

8.3 Implement Modified Versions of the BMPs

Variations of the BMP activities proposed in this plan may consist of alternative design components, alternative activity elements, or alternative activity outcomes. There are many alternatives to the design components of the planned BMPs. These include alternative diversion channel capacity, alternative asphalt removal procedures, and alternative revegetation schemes. These and many other variations in the basic design of the major BMP activities were considered by the TA-49 Asphalt Pad Team, and the proposed designs represent the best judgment of that team.

8.4 Implement Additional Activities

The Asphalt Pad Team considered whether other BMP activities should be implemented as part of this plan, e.g., whether a more permanent cover should be constructed instead of the simple layer of tuff that is currently planned. The team believes that the current temporary regrading concepts will be adequate if a more permanent cover can be designed and installed within a few years. The team believes that the final cover design should be supported by

- a comprehensive risk assessment of the site;
- an analysis of cumulative releases from Laboratory MDAs planned for in situ stabilization;
- completion of the ER MDA core document, which will provide a process by which final MDA corrective measures are determined;
- an evaluation of the extent to which the cover design should be a demonstration of technology transferable to other MDAs;
- completion of the CMS process; and
- approval of the final corrective measures by NMED.

Because many of these supporting elements are not currently available, the team believes that design of a more permanent cover for Areas 2, 2A, and 2B at this time would be premature. To expedite corrective action at Laboratory MDAs, the team recommends that work on a comprehensive risk assessment of the site, an analysis of cumulative releases, and preparation of the MDA core document should proceed concurrently with implementation of this stabilization plan. However, those additional activities are beyond the scope of this plan.

The Asphalt Pad Team also recognizes that alternative BMP activities may be required if the geological, hydrological, waste property, material property, and other characteristics of the site affecting the proposed BMP activities are found to be significantly different from what is expected. Uncertain site characteristics that would impact the present design, schedule, and cost estimates include the finding of significantly higher than expected concentrations and volumes of radionuclides in the fill materials beneath the asphalt pad and finding that the asphalt is a different type of waste than expected. In each of these cases, the potential for unexpected problems has been identified, steps have been taken to obtain advance information through early borings and sampling, and alternative approaches have been considered and are available. Unexpectedly high concentrations and volumes of radionuclides in the fill would have the principal effects of slowing work progress and possibly requiring more of the fill materials to be sent to TA-54, Area G, for disposal. Also, as previously mentioned, alternative disposal facilities have been identified

if the asphalt is determined to be other than clean or contaminated by low-levels of radioactivity. Unexpected, extremely low probability events or conditions can also occur and would be handled on a case-by-case basis.

8.5 Future Site Activities and Final Corrective Measures

The BMPs proposed in this plan have been designed to be compatible with a number of alternatives for final in-place site stabilization. These alternatives include construction of an engineered cover (currently considered a possible element of the final remedy), chemical stabilization, grouting, in situ vitrification, in situ physical barriers, and in situ dry barriers. With run-on controlled by the diversion channel and site runoff enhanced by regrading, each candidate final remedy would only need to address the final issues of diverting potential subsurface interflow and controlling infiltration from direct precipitation.

This plan includes monitoring of site moisture conditions to help measure the performance of the BMPs. These results will be transferable and useful in designing BMPs and corrective measures for other MDAs at the Laboratory.

Because of the magnitude of the source term at Areas 2, 2A, and 2B, this site is expected to retain high priority for final stabilization and remain an example for streamlining the CMS/corrective measures implementation (CMI) process for other MDAs at the Laboratory.

9.0 QUALITY ASSURANCE

The sampling and analysis components of this project will be performed in accordance with the QA requirements of the Laboratory Quality Program Plan for Environmental Restoration Activities (LANL 1991, 7651) and the Laboratory generic CIA project plan for RCRA facility investigations (LANL 1991, 31294). QA requirements will also be incorporated into the specifications for the construction aspects of this project.

REFERENCES

The ER ID numbers accompanying the following references will facilitate their retrieval from the ER Project's Records Processing Facility (RPF). The RPF is located in Room 109 of the Pueblo Complex. Contact Yvonne Archuleta at 665-5359.

DOE (US Department of Energy), May 13, 1998. "NEPA Review, LAN-98-072, TA-49 Remedial Action," letter from Dean Triebel (DOE LAAO), Accession No. 6978, Los Alamos, New Mexico. (DOE 1998, ER ID 58033)

DOE (US Department of Energy), May 11, 1998. "Stabilization Plan for TA-49," DOE memorandum to J. Canepa from T. Taylor, Los Alamos, New Mexico. (DOE 1998, ER ID 58034)

Environmental Restoration Project, in preparation. "RCRA Facility Investigation Site Screening Plan for Worker Health and Safety, Areas 2, 2A, 2B, Material Disposal Area AB, Technical Area 49," Los Alamos National Laboratory, Los Alamos, New Mexico. [Environmental Restoration Project, in preparation(a)]

Environmental Restoration Project, in preparation. "LANL ER Project Site-Specific Health and Safety Plan (SSHASP), Best Management Practices/Stabilization (BMP/S) at Material Disposal Area (MDA) AB, Areas 2, 2A and 2B - PRSs 49-001(b, c, d and g)," SSHASP No. 204, Los Alamos National Laboratory, Los Alamos, New Mexico. [Environmental Restoration Project, in preparation(b)]

Environmental Restoration Project, March 1998. "Spill Prevention, Control, and Countermeasures Implementation Plan, PRSs 49-001 (b, c, d, and g), Technical Area 49," Los Alamos National Laboratory, Los Alamos, New Mexico. (Environmental Restoration Project 1998, ER ID 57586)

Environmental Restoration Project, March 6, 1998. "Waste Characterization Strategy Form, MDA Focus Area, TA-49, RFI Sampling, BMP Activities, and Asphalt Pad Removal, Material Disposal Area AB - Areas 2, 2A, and 2B," Los Alamos National Laboratory, Los Alamos, New Mexico. (Environmental Restoration Project 1998, ER ID 57587)

Environmental Restoration Project, May 26, 1998. "LANL ER Project Site-Specific Health and Safety Plan (SSHASP), Construction of the Surface Water Run-on Diversion Channel and Related Features," SSHASP No. 206, Los Alamos National Laboratory, Los Alamos, New Mexico. (Environmental Restoration Project 1998, ER ID 57912)

Fresquez, P., June 5, 1991. "Sampling Activities at TA-49 (Area 2)," Los Alamos National Laboratory memorandum HSE-8:91-956 to G. Eller, Los Alamos, New Mexico. (Fresquez 1991, ER ID 14822)

LANL (Los Alamos National Laboratory), November 1990. "Solid Waste Management Units Report," Volume III, Los Alamos National Laboratory Report LA-UR-90-3400, prepared by International Technology Corporation under Contract 9-XS8-0062R-1, Los Alamos, New Mexico. (LANL 1990, ER ID 07513)

LANL (Los Alamos National Laboratory), May 20, 1991. "Generic Quality Assurance Project Plan for RCRA Facility Investigations for the Los Alamos National Laboratory Environmental Restoration Program," Los Alamos National Laboratory Document LANL-ER-QAPJP, R0, Los Alamos, New Mexico. (LANL 1991, ER ID 31294)

LANL (Los Alamos National Laboratory), June 1991. "Los Alamos National Laboratory Quality Program Plan for Environmental Restoration Activities," Rev. 0, Los Alamos National Laboratory report LA-UR-91-1844, Los Alamos, New Mexico. (LANL 1991, ER ID 7651)

LANL (Los Alamos National Laboratory), May 1992. "RFI Work Plan for Operable Unit 1144," Los Alamos National Laboratory report LA-UR-92-900, Los Alamos, New Mexico. (LANL 1992, ER ID 7670)

References

- Nyhan, J., April 6, 1998. "Vital Information on CH-2," Los Alamos National Laboratory memorandum to Charlie Wilson, Los Alamos, New Mexico. (Nyhan 1998, ER ID 57911)
- Purtymun, W. D. and A. J. Ahlquist, 1986. "Geologic and Hydrogeologic Evaluation of Technical Area 49," Environmental Surveillance Group report HSW-8-86-1183, Los Alamos National Laboratory, Los Alamos, New Mexico. (Purtymun and Ahlquist 1986, ER ID 14722)
- Purtymun, W. D. and A. K. Stoker, November 1987. "Environmental Status of Technical Area 49, Los Alamos, New Mexico," Los Alamos National Laboratory report LA-11135-MS, Los Alamos, New Mexico. (Purtymun and Stoker 1987, ER ID 6688)
- Romero, R., September 14, 1987. "Power Pole at TA-49 Area 2 Asphalt Pad," Los Alamos National Laboratory memorandum HSE8-87-1014 to Thomas Gunderson, Los Alamos, New Mexico. (Romero 1987, ER ID 57904)
- Soholt, L. F. (Comp.) 1990. "Environmental Surveillance of Low-Level Radioactive-Waste-Management Areas at Los Alamos During 1987," Los Alamos National Laboratory report LA-UR-90-3283, Los Alamos, New Mexico. (Soholt 1990, ER ID 7510)
- Weir, J. E., Jr. and W. D. Purtymun 1962. "Geology and Hydrology of Technical Area 49, Frijoles Mesa, Los Alamos County, New Mexico," US Geological Survey Administrative Release, Albuquerque, New Mexico. (Weir and Purtymun 1962, ER ID 11890)
- Wilcox, B. and D. Breshears, 1997. "Interflow in Semiarid Environments: An Overlooked Process in Risk Assessment," *Human and Ecological Risk Assessment* **3** (2), 187-203. (Wilcox and Breshears 1997, ER ID 57578)
- Wilcox, B., B. Newman, D. Brandes, D. Davenport, and K. Reid, October 1997. "Runoff from a Semiarid Ponderosa Pine Hillslope in New Mexico," *Water Resources Research* **33** (10), 2310-2314. (Wilcox et al. 1997, ER ID 57577)

**EVALUATION AND NOTIFICATION OF POTENTIAL SURFACE WATER CONCERNS
AT ENVIRONMENTAL RESTORATION SITES**

Environmental Restoration Project Administrative Procedure (AP) 4.5 provides an evaluation of potential release sites (PRSs) for surface water concerns. The process used for the evaluation incorporates site knowledge and surface soil sample results in a constituent assessment (Part A) and information on the potential for erosion of contaminants from the site in a surface water site assessment (Part B). The process results in a determination of the need for mitigating actions at a site and notification of New Mexico Environment Department, as appropriate (Part C).

The attachment contains the AP 4.5 Part A and B forms for PRSs affecting or affected by planned stabilization activities at Technical Area 49 Material Disposal Area AB, Areas 2, 2A, and 2B.

**Los Alamos National Laboratory
Environmental Restoration Program
CONSTITUENT ASSESSMENT**

LANL-ER-AP-4.5
Part A

SITE INFORMATION

1. PRS Number: 49-001(b) 2. Date (M/D/Y): 03/20/98 Time (am/pm): 9:45:00 AM
 3. ER Point of Contact: Dwain Farley 4. FMU/Responsible Party Contact: Ed Hoth
 5. HSWA Yes 6. Site Ranking System (SRS) # 26

7. Description of the historical operations of this PRS:

Per the TA-49 RFI work plan, PRS 49-001(b) is Area 2 of Material Disposal Area AB. Area 2 was one of six experimental areas at TA-49 where underground hydronuclear and related experiments were performed from late 1959 to mid 1961. The experiments were conducted in backfilled shafts that varied from 31 to 142 feet in depth. The experiments involved HE dispersal of significant quantities of U-235 and Pu-239 as well as lead, beryllium, and U-238 at the bottom of the shafts.

8. Description of the current operations of this PRS (if any):

None. Site is covered with asphalt.

PRS STATUS

9. Action/Status to Date (check all that apply)

<input type="checkbox"/> None	Date Completed or Anticipated	
<input type="checkbox"/> Field Investigation <input checked="" type="checkbox"/> Phase I <input type="checkbox"/> Phase II	_____	
<input type="checkbox"/> Interim Measures <input type="checkbox"/> IM <input type="checkbox"/> BMP	IM: _____	
	BMPs: _____	
<input type="checkbox"/> VCA <input type="checkbox"/> VCM	_____	
<input type="checkbox"/> Other <input type="checkbox"/> Monitoring <input type="checkbox"/> CMS	_____	
<input type="checkbox"/> Report Status <input checked="" type="checkbox"/> SAP <input type="checkbox"/> RFI Report	SAP: _____	RFI RPTs: _____
SAP INFO: _____	_____	_____
<input type="checkbox"/> NFA/DOU If checked, supply HH NFA criteria number and date: _____	_____	_____

SAMPLE INFORMATION

- Yes No 10. Have surface/sediment (depth less than 12 inches) samples been collected that reflect current site conditions?
 If yes: 1) Attach data
 2) Include analyte name, value, units, location ID, sample ID, SAL, depth, and media (soil, tuff, etc.)
 3) Please attach existing map, showing where samples were taken, if available.
- Yes No 11. Have surface water samples been collected that reflect current site conditions?
 If yes: 1) Attach data
 2) Include analyte name, value, units, location ID, filtered/non-filtered, & flow data, if available.
 3) Please attach existing map, showing where samples were taken, if available.
- Yes No 12. Are data pending?
 If yes: 1) List date data are anticipated: _____
 2) Provide list of COPCs identified in RFI Work Plan as an attachment.

Dwain Farley

 13. Signature of ER Representative

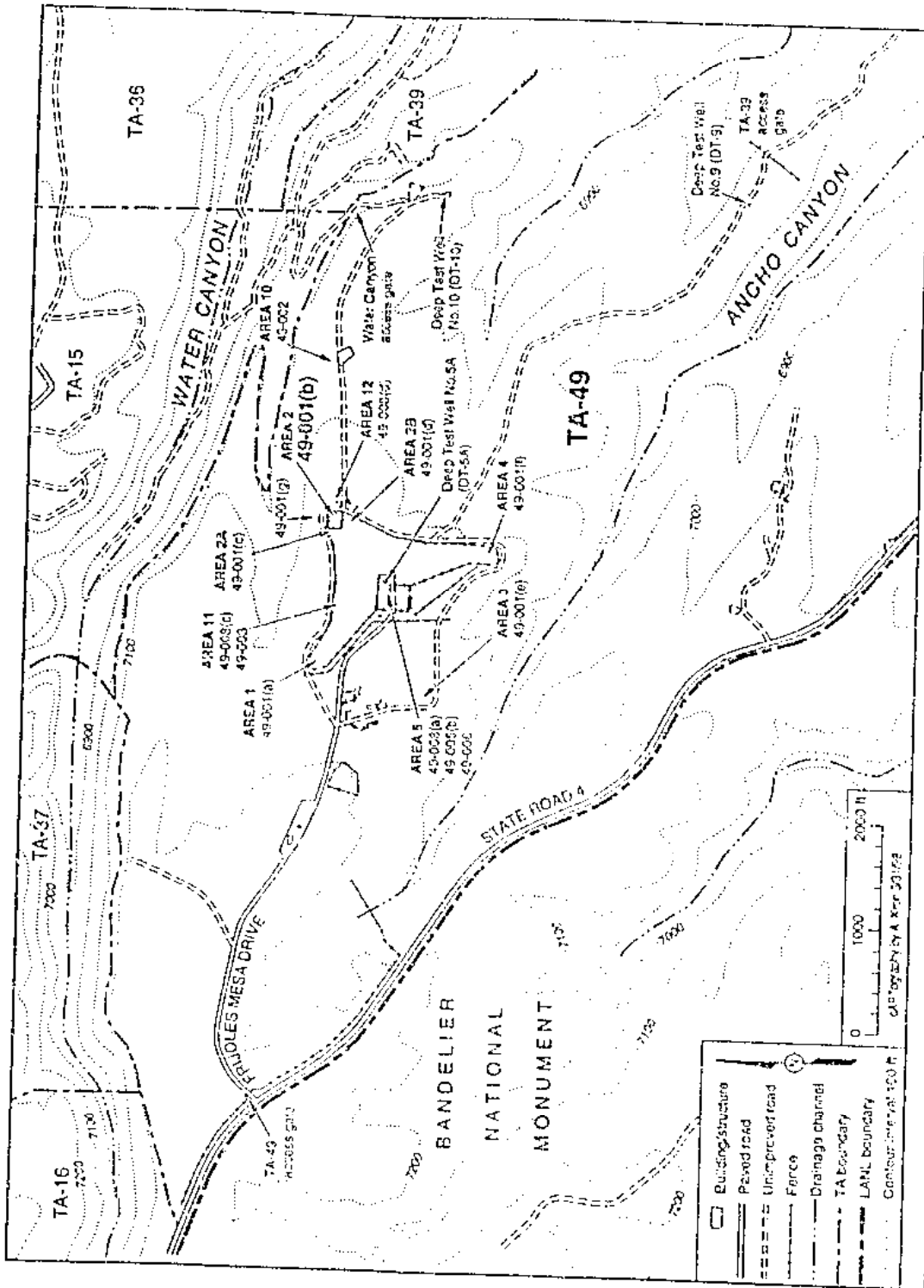

Figure 1. Location of PRS 49-001(b).

Los Alamos National Laboratory

AP 4.5 Surface Water Assessment Erosion Matrix for PRS 49-001(b)

Los Alamos National Laboratory
 Environment, Safety and Health Division
 ESH-18 Water Quality and Hydrology Group

CRITERIA EVALUATED	Value	Erosion/Sediment Transport Potential			Calculated Score
		Low	Medium	High	
		0.1	0.5	1.0	
Site Setting (43)					
On mesa top	1	Defined based on topographic setting			1.0
Within bench of canyon	4				
Within the canyon floodplain but not watercourse	13				
Within bottom of canyon channel in watercourse	17				
Estimated % ground and canopy cover	13	>75%	25-75%	<25%	1.3
Slope	13	0-10%	10-30%	>30%	1.3
Surface Water Factors-Run-off (46)					
Visible evidence of runoff discharging? (Yes/No)	5	If no, score of 0 for runoff section. If yes, score 5 and proceed with section.			5.0
Where does runoff terminate?	19	Other	Bench Setting	Drainage/Wetland	19.0
Has runoff caused visible erosion? (Yes/No)	22	Sheet	Rill	Gully	0.0
If no, score as 0. If yes, calculate as appropriate.					
Surface Water Factors-Run-on (11)					
Structures adversely affecting run-on (Yes/No)	7*	If yes, score as 7. If no, score as 0.			0.0
Current operations adversely impacting (Yes/No)	4	If yes, score as 4. If no, score as 0.			0.0
Natural drainages onto site (Yes/No)	7*	If yes, score as 7. If no, score as 0.			7.0
*Select either structures or natural drainages.					
MAX. POSSIBLE EROSION MATRIX SCORE:	100	Total Score			34.6**

** Indicates BMPs in place. Erosion potential without BMPs may be greater.

AP 4.5 Surface Water Assessment

Los Alamos National Laboratory
**SURFACE WATER
 SITE ASSESSMENT**

LANL-ER-AP-4 5
 Part B: page 2 of 4

SITE INFORMATION



1a) PRS Number 1b) Structure Number 1c) FMU Number
 2. Date/Time (MM/DD/Y H:M am/pm)

SITE SETTING (check all that apply)

3. On mesa top (a). In the canyon floor, but not in an established channel (c).
 Within a bench of a canyon (b). Within established channel in the canyon floor (d).

Explanation: Mesa top area mostly covered with asphalt pad

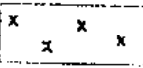
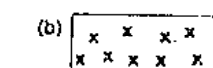
4. Estimated ground and/or canopy cover at site: (deciduous leaves, pine needles, rocks, vegetation, trees, structures, asphalt, etc.)

(illustration) (a)  (b)  (c) 

Estimated % of ground/canopy cover: 0% to 25% 25% to 75% 75% to 100%

Explanation: Covered with asphalt (surrounding area heavily vegetated).

5. Steepest slope at the area impacted:

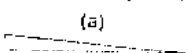
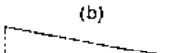
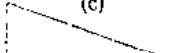
(a)  (b)  (c) 

Less than 10% 10% to 30% 30% and greater

Explanation: Relatively flat until surface water discharges into culvert below road onto PRS 49-001(g).

RUNOFF FACTORS

Y/N

6. Is there visible evidence of runoff discharging from site? If yes, answer a) - c) below:
 6a) Is runoff channelized? If yes, describe: Man-made channel. Natural channel.

Explanation: Run-off to north is conveyed along roadway ditch into culvert. Run-off to east, infiltrates or ponds in southeast corner of site near road intersection and onto access road near gate.

RUNOFF FACTORS, CONT'D

6b) Where does evidence of runoff terminate?

- Drainage or wetland (name)
- Within bench of canyon setting (name)
- Other (i.e., retention pond, meadow, mesa top)

Explanation: Culvert discharges into well defined drainage channel which is eventually reaches a tributary of Water Canyon.

Y/N

- 6c) Has runoff caused visible erosion at the site? If yes, explain below: Sheet Rill Gully

Explanation: None observed, drainage swale from run-on, however. Sediment traps have formed in some locations.

RUN-ON FACTORS

Please rate the potential for storm water to run on to this site: (Check EITHER #7 or #9)

7. Are structures (i.e., buildings, roof drains, parking lots, storm drains) creating run-on to the site?

Explanation:

8. Are current operations (i.e., fire hydrants, NPDES outfalls) adversely impacting run-on to the site?

Explanation:

9. Are natural drainage patterns directing stormwater onto site?

Explanation: Sources from west of site are providing sheet flow run-on.

ASSESSMENT FINDING:

10. Based on the above criteria and the assessment of this site, does soil erosion potential exist? (REFER TO EROSION POTENTIAL MATRIX.)

Steve Vecnis

11. Signature of Water Quality/Hydrology Representative

SV Initials of independent reviewer.

Check here when information is entered in database:

This page is for ESH-18 notes, recommendations, and photos.

Y / N

12. a) Is there visible trash/debris on the site?

b) Is there visible trash/debris in a watercourse?

Description of existing BMPs:

Asphalt cover over PRSs.

Are BMPs being properly maintained? If no, describe in "Other Internal Notes."

Are BMPs effectively keeping sediment in place and reducing erosion potential?

OTHER INTERNAL NOTES:

Los Alamos National Laboratory
Environmental Restoration Program
CONSTITUENT ASSESSMENT

LANL-ER-AP-4.5
Part A

SITE INFORMATION

1. PRS Number: 49-001(c) 2. Date (M/D/Y): 03/20/98 Time (am/pm): 1:20:00 PM
3. ER Point of Contact: Dwain Farley 4. FMU/Responsible Party Contact: Ed Hoth
5. HSWA Yes 6. Site Ranking System (SRS) # 29

7. Description of the historical operations of this PRS:

Per the TA-49 RFI work plan, PRS 49-001(c) is Area 2A of Material Disposal Area AB. Area 2A was one of six experimental areas at TA-49 where underground hydronuclear and related experiments were performed from late 1959 to mid 1961. The experiments were conducted in backfilled shafts that varied from 31 to 142 feet in depth. The experiments involved HE dispersal of significant quantities of U-235 and Pu-239 as well as lead, beryllium, and U-238 at the bottom of the shafts.

8. Description of the current operations of this PRS (if any):

None.

PRS STATUS

9. Action/Status to Date (check all that apply)

<input type="checkbox"/> None	Date Completed or Anticipated
<input type="checkbox"/> Field Investigation <input checked="" type="checkbox"/> Phase I <input type="checkbox"/> Phase II	[]
<input type="checkbox"/> Interim Measures <input type="checkbox"/> IM <input type="checkbox"/> BMP	IM: []
<input type="checkbox"/> VCA <input type="checkbox"/> VCM	BMPs: []
<input type="checkbox"/> Other <input type="checkbox"/> Monitoring <input type="checkbox"/> CMS	[]
<input type="checkbox"/> Report Status <input checked="" type="checkbox"/> SAP <input checked="" type="checkbox"/> RFI Report SAP: [] RFI RPTs: []	[]
SAP INFO: []	[]
<input type="checkbox"/> NFA/DOU If checked, supply HH NFA criteria number and date: [] []	

SAMPLE INFORMATION

- Yes No 10. Have surface/sediment (depth less than 12 inches) samples been collected that reflect current site conditions?
If yes: 1) Attach data
 2) Include analyte name, value, units, location ID, sample ID, SAL, depth, and media (soil, tuff, etc.)
 3) Please attach existing map, showing where samples were taken, if available.
- Yes No 11. Have surface water samples been collected that reflect current site conditions?
If yes: 1) Attach data
 2) Include analyte name, value, units, location ID, filtered/non-filtered, & flow data, if available.
 3) Please attach existing map, showing where samples were taken, if available.
- Yes No 12. Are data pending?
If yes: 1) List date data are anticipated:
 2) Provide list of COPCs identified in RFI Work Plan as an attachment.

Dwain Farley

13. Signature of ER Representative

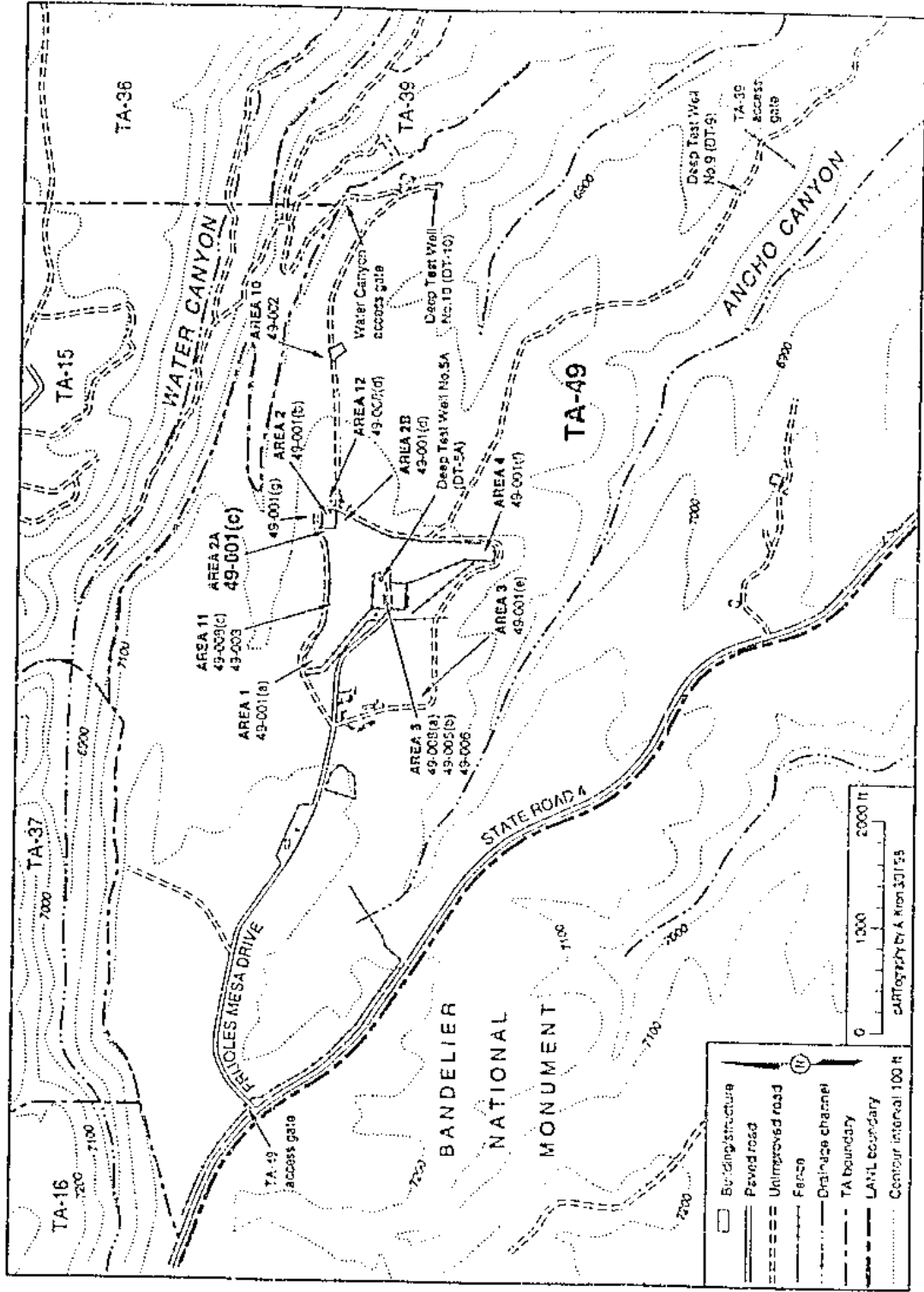

Figure 2. Location of PRS 49-001(c).

Los Alamos National Laboratory

Environment, Safety and Health Division
 ESH-18 Water Quality and Hydrology Group

**AP 4.5 Surface Water Assessment
 Erosion Matrix for PRS 49-001(c)**

CRITERIA EVALUATED	Value	Erosion/Sediment Transport Potential			Calculated Score
		Low	Medium	High	
Site Setting (43)		0.1	0.5	1.0	
On mesa top	1	Defined based on topographic setting			1.0
Within bench of canyon	4				
Within the canyon floodplain but not watercourse	13				
Within bottom of canyon channel in watercourse	17				
Estimated % ground and canopy cover	13	>75%	25-75%	<25%	1.3
Slope	13	0-10%	10-30%	>30%	1.3
Surface Water Factors-Run-off (46)					
Visible evidence of runoff discharging? (Yes/No)	5	If no, score of 0 for runoff section. If yes, score 5 and proceed with section.			5.0
Where does runoff terminate?	19	Other	Bench Setting	Drainage/Wetland	1.9
Has runoff caused visible erosion? (Yes/No)	22	Sheet	Rill	Gully	0.0
		If no, score as 0. If yes, calculate as appropriate.			
Surface Water Factors-Run-on (11)					
Structures adversely affecting run-on (Yes/No)	7*	If yes, score as 7. If no, score as 0.			0.0
Current operations adversely impacting (Yes/No)	4	If yes, score as 4. If no, score as 0.			0.0
Natural drainages onto site (Yes/No)	7*	If yes, score as 7. If no, score as 0.			7.0
*Select either structures or natural drainages.					
MAX. POSSIBLE EROSION MATRIX SCORE:	100	Total Score			17.5

Los Alamos National Laboratory
**SURFACE WATER
 SITE ASSESSMENT**

LANL-ER-AP-45
 Part B, page 2 of 4

SITE INFORMATION



1a) PRS Number 1b) Structure Number 1c) FMU Number
 2. Date/Time (M/D/Y H:M am/pm)

SITE SETTING (check all that apply)

3. On mesa top (a). In the canyon floor, but not in an established channel (c).
 Within a bench of a canyon (b). Within established channel in the canyon floor (d).

Explanation: Mesa top area west of asphalt pad (Area 2A).

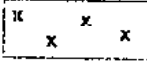
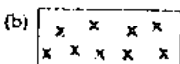
4. Estimated ground and/or canopy cover at site: (deciduous leaves, pine needles, rocks, vegetation, trees, structures, asphalt, etc.)

(illustration) (a)  (b)  (c) 

Estimated % of ground/canopy cover: 0% to 25% 25% to 75% 75% to 100%

Explanation: Area heavily vegetated slightly upslope from the asphalt pad.

5. Steepest slope at the area impacted:

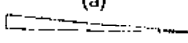
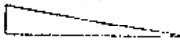
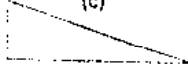
(a)  (b)  (c) 
 Less than 10% 10% to 30% 30% and greater

Explanation: Relatively flat area just west of asphalt pad.

RUNOFF FACTORS

Y / N

6. Is there visible evidence of runoff discharging from site? (if yes, answer a) - c) below:

- 6a) Is runoff channelized? If yes, describe: Man-made channel. Natural channel.

Explanation: Run-off to north is conveyed along roadway ditch into culvert. Run-off to east, infiltrates or ponds in southeast corner of site near road intersection (49-001(d))

RUNOFF FACTORS, CONT'D

6b) Where does evidence of runoff terminate?

- Drainage or wetland (name)
- Within bench of canyon setting (name)
- Other (i.e., retention pond, meadow, mesa top)

Explanation: If runoff reaches culvert, it discharges into well defined drainage channel which is designated as 49-001(g).

Y / N

- 6c) Has runoff caused visible erosion at the site? If yes, explain below: Sheet Rill Gully

Explanation: None observed.

RUN-ON FACTORS

Please rate the potential for storm water to run on to this site: (Check EITHER #7 or #9)

7. Are structures (i.e., buildings, roof drains, parking lots, storm drains) creating run-on to the site?

Explanation:

8. Are current operations (i.e., fire hydrants, NPDES outfalls) adversely impacting run-on to the site?

Explanation:

9. Are natural drainage patterns directing stormwater onto site?

Explanation: Sources from west of site are providing sheet flow run-on.

ASSESSMENT FINDING:

10. Based on the above criteria and the assessment of this site, does soil erosion potential exist? (REFER TO EROSION POTENTIAL MATRIX.)

Steve Veenis

11. Signature of Water Quality/Hydrology Representative

SV Initials of independent reviewer.

Check here when information is entered in database:

49-001(c) page 3 of 4

This page is for ESH-18 notes, recommendations, and photos.

Y / N

12. a) (Y) (N) Is there visible trash/debris on the site?

b) (Y) (N) Is there visible trash/debris in a watercourse?

Description of existing BMPs:

[Empty box for description of existing BMPs]

(Y) (N) Are BMPs being properly maintained? If no, describe in "Other Internal Notes."

(Y) (N) Are BMPs effectively keeping sediment in place and reducing erosion potential?

OTHER INTERNAL NOTES:

[Empty box for other internal notes]

**Los Alamos National Laboratory
Environmental Restoration Program
CONSTITUENT ASSESSMENT**

LANL-ER-AP-4.5
Part A

SITE INFORMATION

1. PRS Number: 49-001(d) 2. Date (M/D/Y): 03/20/98 Time (am/pm): 1:40:00 PM
 3. ER Point of Contact Dwain Farley 4. FMU/Responsible Party Contact Ed Holth
 5. HSWA Yes 6. Site Ranking System (SRS) # 29

7. Description of the historical operations of this PRS:

Per the TA-49 RFI work plan, PRS 49-001(d) is Area 2B of Material Disposal Area AB. Area 2B was one of six experimental areas at TA-49 where underground hydronuclear and related experiments were performed from late 1959 to mid 1961. The experiments were conducted in backfilled shafts that varied from 31 to 142 feet in depth. The experiments involved HE dispersal of significant quantities of U-235 and Pu-239 as well as lead, beryllium, and U-238 at the bottom of the shafts.

8. Description of the current operations of this PRS (if any):

None.

PRS STATUS

9. Action/Status to Date (check all that apply)

<input type="checkbox"/> None	Date Completed or Anticipated
<input type="checkbox"/> Field Investigation <input checked="" type="checkbox"/> Phase I <input type="checkbox"/> Phase II	<input type="text"/>
<input type="checkbox"/> Interim Measures <input type="checkbox"/> IM <input type="checkbox"/> BMP	IM: <input type="text"/>
	BMPs: <input type="text"/>
<input type="checkbox"/> VCA <input type="checkbox"/> VCM	<input type="text"/>
<input type="checkbox"/> Other <input type="checkbox"/> Monitoring <input type="checkbox"/> CMS	<input type="text"/>
<input type="checkbox"/> Report Status <input checked="" type="checkbox"/> SAP <input checked="" type="checkbox"/> RFI Report SAP: <input type="text"/> RFI RPTs: <input type="text"/>	<input type="text"/>
SAP INFO: <input type="text"/>	<input type="text"/>
<input type="checkbox"/> NFA/DOU If checked, supply HH NFA criteria number and date: <input type="text"/> <input type="text"/>	

SAMPLE INFORMATION

- Yes No 10. Have surface/sediment (depth less than 12 inches) samples been collected that reflect current site conditions?
 If yes: 1) Attach data
 2) Include analyte name, value, units, location ID, sample ID, SAL, depth, and media (soil, tuff, etc.)
 3) Please attach existing map, showing where samples were taken, if available.
- Yes No 11. Have surface water samples been collected that reflect current site conditions?
 If yes: 1) Attach data
 2) Include analyte name, value, units, location ID, filtered/non-filtered, & flow data, if available.
 3) Please attach existing map, showing where samples were taken, if available.
- Yes No 12. Are data pending?
 If yes: 1) List date data are anticipated:
 2) Provide list of COPCs identified in RFI Work Plan as an attachment.

Dwain Farley
 13. Signature of ER Representative

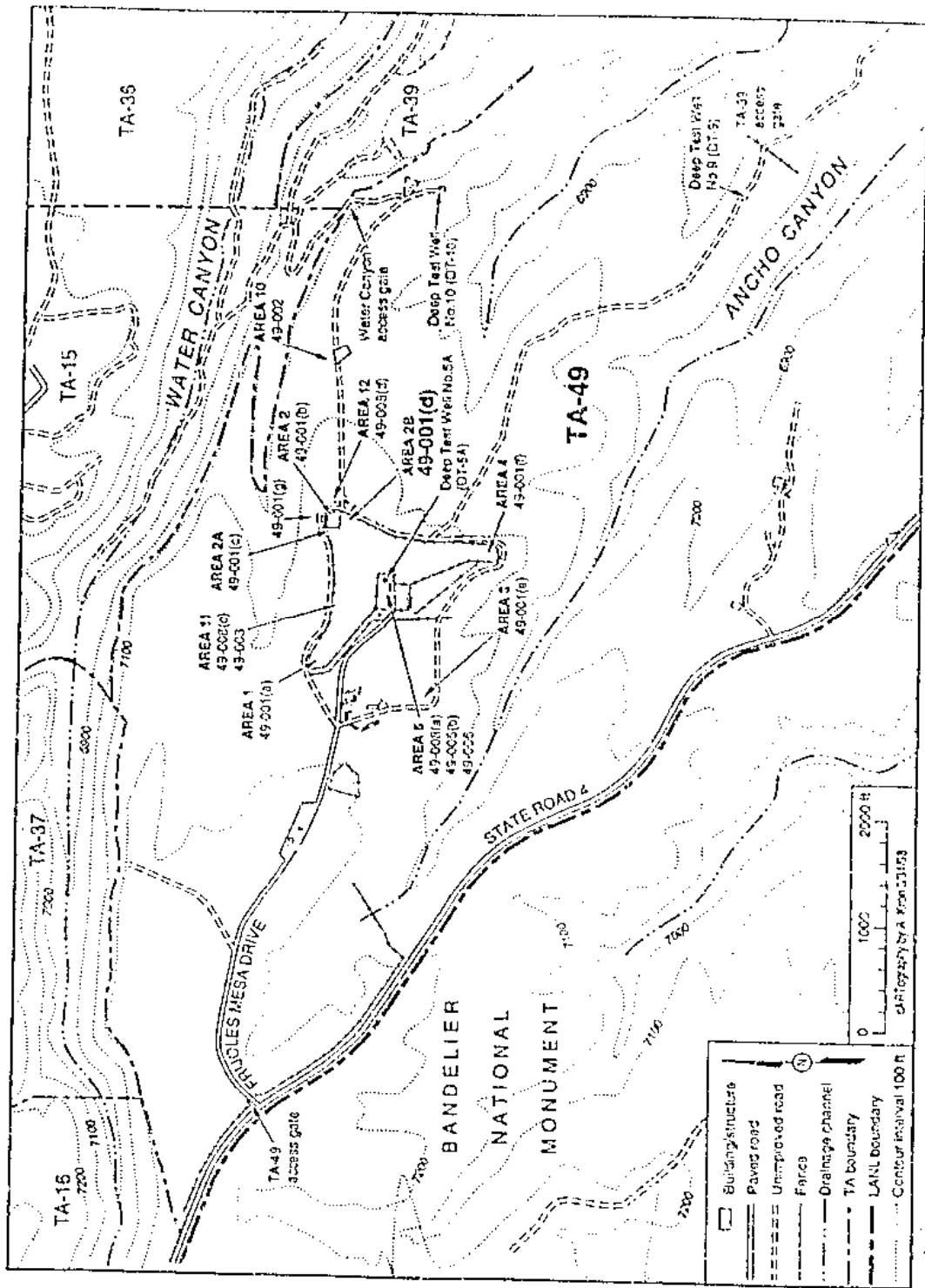

Figure 3. Location of PRS 49-001(d).

Los Alamos National Laboratory

Environment, Safety and Health Division
 ESH-13 Water Quality and Hydrology Group

AP 4.5 Surface Water Assessment Erosion Matrix for PRS 49-001(d)

CRITERIA EVALUATED	Value	Erosion/Sediment Transport Potential			Calculated Score
		Low	Medium	High	
		0.1	0.5	1.0	
Site Setting (43)					
On mesa top	1	Defined based on topographic setting			1.0
Within bench of canyon	4				
Within the canyon floodplain but not watercourse	13				
Within bottom of canyon channel in watercourse	17				
Estimated % ground and canopy cover	13	>75%	25-75%	<25%	1.3
Slope	13	0-10%	10-30%	>30%	1.3
Surface Water Factors-Run-off (46)					
Visible evidence of runoff discharging? (Yes/No)	5	If no, score of 0 for runoff section. If yes, score 5 and proceed with section.			5.0
Where does runoff terminate?	19	Other	Bench Setting	Drainage/Wetland	1.9
Has runoff caused visible erosion? (Yes/No)	22	Sheet	Rill	Gully	0.0
		If no, score as 0. If yes, calculate as appropriate.			
Surface Water Factors-Run-on (11)					
Structures adversely affecting run-on (Yes/No)	7*	If yes, score as 7. If no, score as 0.			0.0
Current operations adversely impacting (Yes/No)	4	If yes, score as 4. If no, score as 0.			0.0
Natural drainages onto site (Yes/No)	7*	If yes, score as 7. If no, score as 0.			7.0
<i>*Select either structures or natural drainages.</i>					
MAX. POSSIBLE EROSION MATRIX SCORE:	100	Total Score			17.5

Los Alamos National Laboratory
**SURFACE WATER
 SITE ASSESSMENT**

LANL-ER-AP-4.5
 Part B page 2 of 4

SITE INFORMATION



1a) PRS Number 1b) Structure Number 1c) FMU Number
 2. Date/Time (M/D/Y H:M am/pm)

SITE SETTING (check all that apply)

3. On mesa top (a). In the canyon floor, but not in an established channel (c).
 Within a bench of a canyon (b). Within established channel in the canyon floor (d).

Explanation: Mesa top source, south of asphalt covered pad (Area 2B).

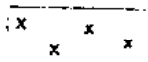
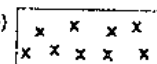
4. Estimated ground and/or canopy cover at site: (deciduous leaves, pine needles, rocks, vegetation, trees, structures, asphalt, etc.)

(illustration) (a)  (b)  (c) 

Estimated % of ground/canopy cover: 0% to 25% 25% to 75% 75% to 100%

Explanation: Heavy vegetation, ground saturated from upslope sheet flow run-on.

5. Steepest slope at the area impacted:

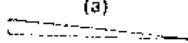
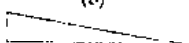
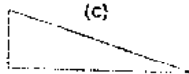
(a)  (b)  (c) 

Less than 10% 10% to 30% 30% and greater

Explanation: Gentle slope from west to east.

RUNOFF FACTORS

Y / N

6. Is there visible evidence of runoff discharging from site? If yes, answer a) - c) below:

- 6a) Is runoff channelized? If yes, describe: Man-made channel Natural channel

Explanation: Sheet flow to east to access road

RUNOFF FACTORS, CONT'D

6b) Where does evidence of runoff terminate?

 Drainage or wetland (name) Within bench of canyon setting (name) Other (i.e., retention pond, meadow, mesa top)

Explanation: Sheet flow stops at roadway.

Y / N

 6c) Has runoff caused visible erosion at the site? If yes, explain below: Sheet Rill Gully

Explanation: Heavy vegetation throughout site.

RUN-ON FACTORS

Please rate the potential for storm water to run on to this site: (Check EITHER #7 or #9)

 7. Are structures (i.e., buildings, roof drains, parking lots, storm drains) creating run-on to the site?

Explanation:

 8. Are current operations (i.e., fire hydrants, NPDES outfalls) adversely impacting run-on to the site?

Explanation:

 9. Are natural drainage patterns directing stormwater onto site?

Explanation: From the west. Sheet flow run-on.

ASSESSMENT FINDING:

 10. Based on the above criteria and the assessment of this site, does soil erosion potential exist? (REFER TO EROSION POTENTIAL MATRIX.)

Steve Veenis

11. Signature of Water Quality/Hydrology Representative

 Initials of independent reviewer.Check here when information is entered in database:

This page is for ESH-18 notes, recommendations, and photos.

Y / N

12. a) Is there visible trash/debris on the site?

b) Is there visible trash/debris in a watercourse?

Description of existing BMPs:

Are BMPs being properly maintained? If no, describe in "Other Internal Notes."

Are BMPs effectively keeping sediment in place and reducing erosion potential?

OTHER INTERNAL NOTES:

Los Alamos National Laboratory
Environmental Restoration Program
CONSTITUENT ASSESSMENT

LANL-ER-AP-4.5
Part A

SITE INFORMATION

1. PRS Number: 49-001(g) 2. Date (M/D/Y): 03/20/98 Time (am/pm): 1:45:00 PM
 3. ER Point of Contact: Dwain Farley 4. FMU/Responsible Party Contact: Ed Hoth
 5. HSWA: Yes 6. Site Ranking System (SRS) #: 39

7. Description of the historical operations of this PRS:

Per the TA-49 RFI work plan, PRS 49-001(g) is contaminated surface soil at Material Disposal Area AB. MDA AB has six experimental areas at TA-49 where underground hydronuclear and related experiments were performed from late 1959 to mid 1961. The experiments were conducted in backfilled shafts that varied from 31 to 142 feet in depth. The experiments involved HE dispersal of significant quantities of U-235 and Pu-239 as well as lead, beryllium, and U-238 at the bottom of the shafts. Some surface releases of contamination resulted in designation of PRS 49-001(g)

8. Description of the current operations of this PRS (if any):

None.

PRS STATUS

9. Action/Status to Date (check all that apply)

<input type="checkbox"/> None	Date Completed or Anticipated
<input type="checkbox"/> Field Investigation <input checked="" type="checkbox"/> Phase I <input type="checkbox"/> Phase II	<input type="text"/>
<input type="checkbox"/> Interim Measures <input type="checkbox"/> IM <input type="checkbox"/> BMP	IM: <input type="text"/>
	BMPs: <input type="text"/>
<input type="checkbox"/> VCA <input type="checkbox"/> VCM	<input type="text"/>
<input type="checkbox"/> Other <input type="checkbox"/> Monitoring <input type="checkbox"/> CMS	<input type="text"/>
<input type="checkbox"/> Report Status <input checked="" type="checkbox"/> SAP <input checked="" type="checkbox"/> RFI Report	SAP: <input type="text"/> RFI RPTs: <input type="text"/>
SAP INFO: <input type="text"/>	<input type="text"/>
<input type="checkbox"/> NFA/DOU If checked, supply HH NFA criteria number and date:	<input type="text"/> <input type="text"/>

SAMPLE INFORMATION

- Yes No 10. Have surface/sediment (depth less than 12 inches) samples been collected that reflect current site conditions?
 If yes: 1) Attach data
 2) Include analyte name, value, units, location ID, sample ID, SAL, depth, and media (soil, tuff, etc.)
 3) Please attach existing map, showing where samples were taken, if available.
- Yes No 11. Have surface water samples been collected that reflect current site conditions?
 If yes: 1) Attach data
 2) Include analyte name, value, units, location ID, filtered/non-filtered, & flow data, if available.
 3) Please attach existing map, showing where samples were taken, if available.
- Yes No 12. Are data pending?
 If yes: 1) List date data are anticipated:
 2) Provide list of COPCs identified in RFI Work Plan as an attachment.

Dwain Farley
 13. Signature of ER Representative

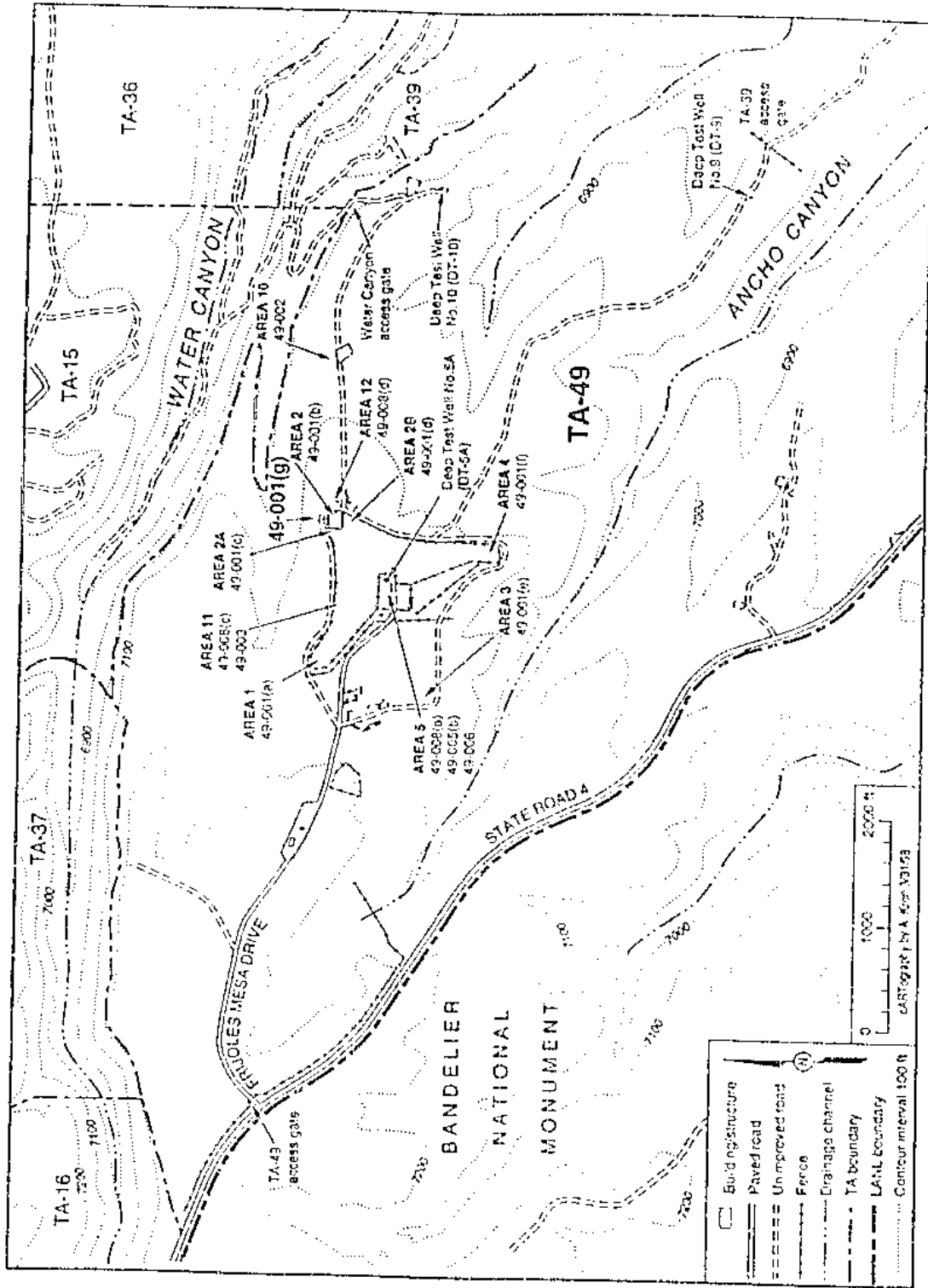

Figure 4. Location of PRS 49-001(g).

Los Alamos National Laboratory
AP 4.5 Surface Water Assessment
Erosion Matrix for PRS 49-001(g)

Environment, Safety and Health Division
ESH-18 Water Quality and Hydrology Group

CRITERIA EVALUATED	Value	Erosion/Sediment Transport Potential			Calculated Score
		Low	Medium	High	
Site Setting (43)		0.1	0.5	1.0	
On mesa top	1	Defined based on topographic setting			
Within bench of canyon	4				13.0
Within the canyon floodplain but not watercourse	13				
Within bottom of canyon channel in watercourse	17				
Estimated % ground and canopy cover	13	>75%	25-75%	<25%	6.5
Slope	13	0-10%	10-30%	>30%	6.5
Surface Water Factors-Run-off (46)					
Visible evidence of runoff discharging? (Yes/No)	5	If no, score of 0 for runoff section. If yes, score 5 and proceed with section.			5.0
Where does runoff terminate?	19	Other	Bench Setting	Drainage/Wetland	19.0
Has runoff caused visible erosion? (Yes/No)	22	Sheet	Rill	Gully	2.2
		If no, score as 0. If yes, calculate as appropriate.			
Surface Water Factors-Run-on (11)					
Structures adversely affecting run-on (Yes/No)	7*	If yes, score as 7. If no, score as 0.			7.0
Current operations adversely impacting (Yes/No)	4	If yes, score as 4. If no, score as 0.			0.0
Natural drainages onto site (Yes/No)	7*	If yes, score as 7. If no, score as 0.			0.0
*Select either structures or natural drainages.					
MAX. POSSIBLE EROSION MATRIX SCORE:	100	Total Score			59.2

Los Alamos National Laboratory
**SURFACE WATER
 SITE ASSESSMENT**

LANL-ER-AP-4.5
 Part B: page 2 of 4

SITE INFORMATION



1a) PRS Number 1b) Structure Number 1c) FMU Number
 2. Date/Time (M/D/Y H:M am/pm)

SITE SETTING (check all that apply)

3. On mesa top (a). In the canyon floor, but not in an established channel (c).
 Within a bench of a canyon (b). Within established channel in the canyon floor (d).

Explanation: Drainage swale and adjacent banks discharge directly towards tributary of Water Canyon.

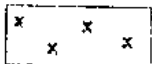
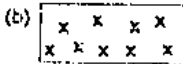
4. Estimated ground and/or canopy cover at site: (deciduous leaves, pine needles, rocks, vegetation, trees, structures, asphalt, etc.)

(illustration) (a)  (b)  (c) 

Estimated % of ground/canopy cover: 0% to 25% 25% to 75% 75% to 100%

Explanation: Mixed vegetation and exposed tuff within channel.

5. Steepest slope at the area impacted:

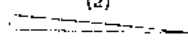
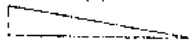
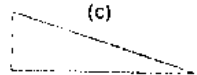
(a)  (b)  (c) 

Less than 10% 10% to 30% 30% and greater

Explanation: Moderate to steep slope from south to north.

RUNOFF FACTORS

YIN

6. Is there visible evidence of runoff discharging from site? If yes, answer a) - c) below:
 6a) Is runoff channelized? If yes, describe: Man-made channel. Natural channel

Explanation: Swale dissipates +/- 100 feet above canyon rim.

This page is for ESH-18 notes, recommendations, and photos.

Y / N

12. a) Is there visible trash/debris on the site?

b) Is there visible trash/debris in a watercourse?

Description of existing BMPs:

--

Are BMPs being properly maintained? If no, describe in "Other Internal Notes."

Are BMPs effectively keeping sediment in place and reducing erosion potential?

OTHER INTERNAL NOTES:

Flow dissipation and/or sediment/erosion controls needed.

Los Alamos National Laboratory
Environmental Restoration Program
CONSTITUENT ASSESSMENT

LANL-ER-AP-4.5
Part A

SITE INFORMATION

1. PRS Number: 49-003 2. Date (M/D/Y): 03/20/98 Time (am/pm): 1:50:00 PM
3. ER Point of Contact Dwain Farley 4. FMU/Responsible Party Contact Ed Hoth
5. HSWA Yes 6. Site Ranking System (SRS) # 38

7. Description of the historical operations of this PRS:

Per the TA-49 RFI work plan, PRS 49-003 is a leachfield located in Area 11 within the Radiochemistry and Small-Scale Shot Area. Significant laboratory used of Area 11 was limited to activities related to the hydronuclear program at TA-49 from 1959 to 1961. Area 11 activities consisted of limited radiochemistry operations and small-scale containment experiments involving HE detonations in shallow (12 feet deep) shafts. PRS 49-003 includes a subsurface leachfield and associated piping connected to building TA-49-15, which contained hoods and sinks for performing radiochemical operations.

8. Description of the current operations of this PRS (if any):

TA-49-15 was decontaminated and demolished in 1971, although the leachfield and piping were left in place. No activities are currently conducted at PRS 49-003.

PRS STATUS

9. Action/Status to Date (check all that apply)

<input type="checkbox"/> None	Date Completed or Anticipated
<input type="checkbox"/> Field Investigation <input checked="" type="checkbox"/> Phase I <input type="checkbox"/> Phase II	<input type="text"/>
<input type="checkbox"/> Interim Measures <input type="checkbox"/> IM <input type="checkbox"/> BMP	IM: <input type="text"/>
<input type="checkbox"/> VCA <input type="checkbox"/> VCM	BMPs: <input type="text"/>
<input type="checkbox"/> Other <input type="checkbox"/> Monitoring <input type="checkbox"/> CMS	<input type="text"/>
<input type="checkbox"/> Report Status <input checked="" type="checkbox"/> SAP <input checked="" type="checkbox"/> RFI Report	SAP: <input type="text"/> RFI RPTs: <u>08/25/97</u>
SAP INFO: <input type="text"/>	<input type="text"/>
<input type="checkbox"/> NFA/DOU If checked, supply HH NFA criteria number and date:	<input type="text"/> <u>5</u> <input type="text"/> <u>08/25/97</u>

SAMPLE INFORMATION

- Yes No 10. Have surface/sediment (depth less than 12 inches) samples been collected that reflect current site conditions?
If yes: 1) Attach data
2) Include analyte name, value, units, location ID, sample ID, SAL, depth, and media (soil, tuff, etc.)
3) Please attach existing map, showing where samples were taken, if available.
- Yes No 11. Have surface water samples been collected that reflect current site conditions?
If yes: 1) Attach data
2) Include analyte name, value, units, location ID, filtered/non-filtered, & flow data, if available.
3) Please attach existing map, showing where samples were taken, if available.
- Yes No 12. Are data pending?
If yes: 1) List date data are anticipated:
2) Provide list of COPCs identified in RFI Work Plan as an attachment.

Dwain Farley
13. Signature of ER Representative

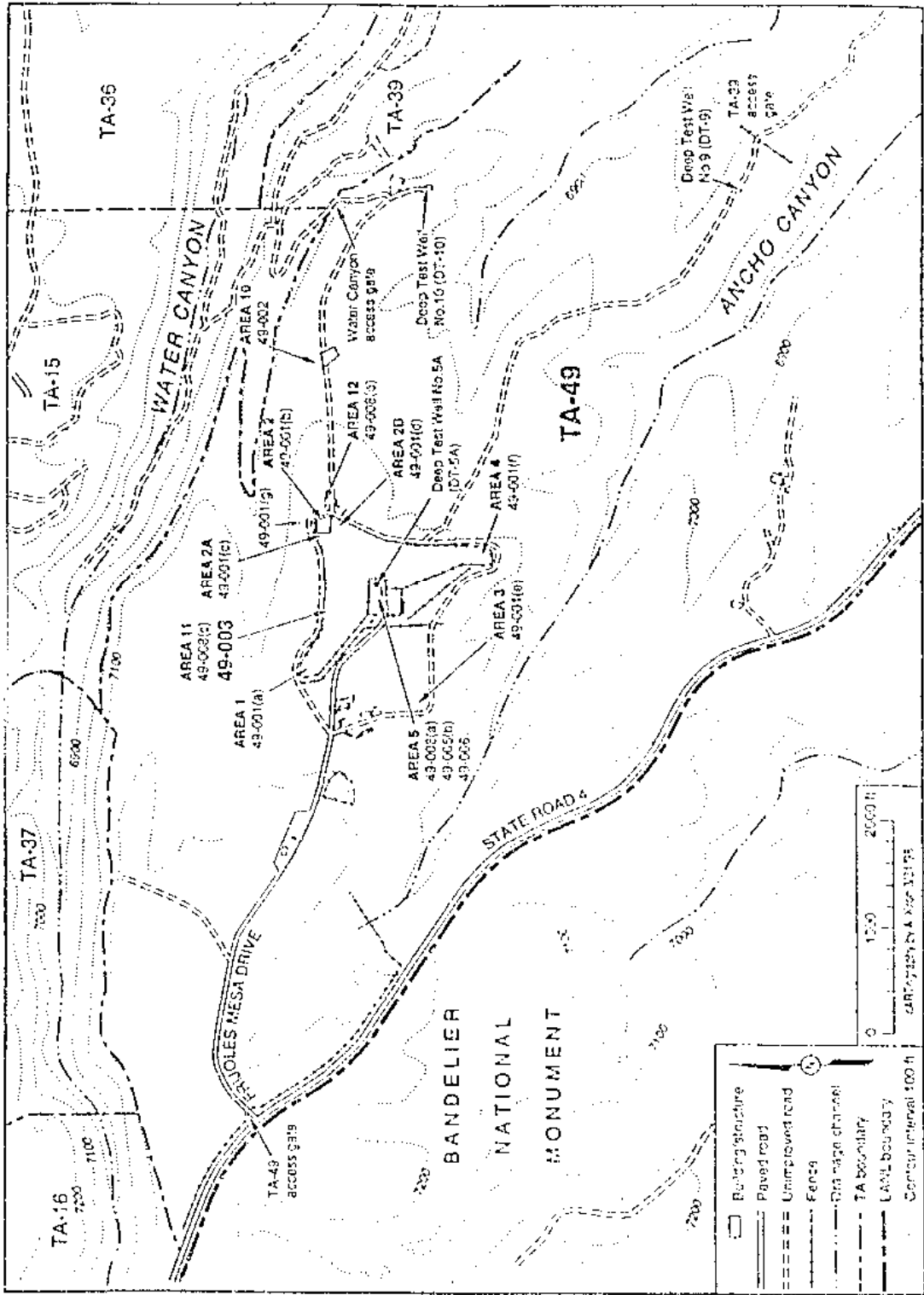

Figure 5. Location of PPS 49-003.

Los Alamos National Laboratory

Environment, Safety and Health Division
 ESH-18 Water Quality and Hydrology Group

AP 4.5 Surface Water Assessment Erosion Matrix for PRS 49-003

CRITERIA EVALUATED	Value	Erosion/Sediment Transport Potential			Calculated Score
		Low	Medium	High	
Site Setting (43)					
On mesa top	1	Defined based on topographic setting			4.0
Within bench of canyon	4				
Within the canyon floodplain but not watercourse	13				
Within bottom of canyon channel in watercourse	17				
Estimated % ground and canopy cover	13	>75%	25-75%	<25%	1.3
Slope	13	0-10%	10-30%	>30%	6.5
Surface Water Factors-Run-off (46)					
Visible evidence of runoff discharging? (Yes/No)	5	if no, score of 0 for runoff section. if yes, score 5 and proceed with section.			5.0
Where does runoff terminate?	19	Other	Bench Setting	Drainage/Wetland	19.0
Has runoff caused visible erosion? (Yes/No)	22	Sheet	Rill	Gully	22.0
if no, score as 0. If yes, calculate as appropriate.					
Surface Water Factors-Run-on (11)					
Structures adversely affecting run-on (Yes/No)	7*	If yes, score as 7. If no, score as 0.			7.0
Current operations adversely impacting (Yes/No)	4	If yes, score as 4. If no, score as 0.			0.0
Natural drainages onto site (Yes/No)	7*	If yes, score as 7. If no, score as 0.			0
*Select either structures or natural drainages.					
MAX. POSSIBLE EROSION MATRIX SCORE:	100	Total Score			64.8

Los Alamos National Laboratory
**SURFACE WATER
 SITE ASSESSMENT**

LANL-ER-AP-4.5
 Part B: page 2 of 4

SITE INFORMATION



1a) PRS Number 1b) Structure Number 1c) FMU Number
 2. Date/Time (MD/Y H:M am/pm)

SITE SETTING (check all that apply)

3. On mesa top (a). In the canyon floor, but not in an established channel (c).
 Within a bench of a canyon (b). Within established channel in the canyon floor (d).

Explanation: Located on mesa top with discharges onto bench slope below roadway.

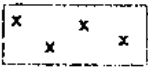
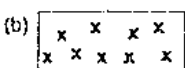

4. Estimated ground and/or canopy cover at site: (deciduous leaves, pine needles, rocks, vegetation, trees, structures, asphalt, etc.)

(illustration) (a)  (b)  (c) 

Estimated % of ground/canopy cover: 0% to 25% 25% to 75% 75% to 100%

Explanation: Grasses, pinon pine trees, pine needles, rocks.

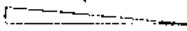
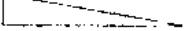
5. Steepest slope at the area impacted:

(a)  (b)  (c) 

Less than 10% 10% to 30% 30% and greater

Explanation: Gently sloped toward tributary of Water Canyon on northside of roadway.

RUNOFF FACTORS

Y/N

6. Is there visible evidence of runoff discharging from site? If yes, answer a) - c) below:
 6a) Is runoff channelized? If yes, describe: Man-made channel. Natural channel.

Explanation: Vegetated swale collects run-off and directs into a 24-inch culvert below access road. Drainage channel formed from culvert discharges directly into tributary of Water Canyon.

RUNOFF FACTORS, CONT'D

6b) Where does evidence of runoff terminate?

- Drainage or wetland (name)
- Within bench of canyon setting (name)
- Other (i.e., retention pond, meadow, mesa top)

Explanation: Channel discharges toward tributary of Water Canyon.

Y/N

- 6c) Has runoff caused visible erosion at the site? If yes, explain below: Sheet Rill Gully

Explanation: Gully formed from culvert discharges.

RUN-ON FACTORS

Please rate the potential for storm water to run on to this site: (Check EITHER #7 or #9)

7. Are structures (i.e., buildings, roof drains, parking lots, storm drains) creating run-on to the site?

Explanation: Culvert 24 inches.

8. Are current operations (i.e., fire hydrants, NPDIS outfalls) adversely impacting run-on to the site?

Explanation:

9. Are natural drainage patterns directing stormwater onto site?

Explanation: Vegetated swale from south of roadway

ASSESSMENT FINDING:

10. Based on the above criteria and the assessment of this site, does soil erosion potential exist? (REFER TO EROSION POTENTIAL MATRIX.)

Steve Veenis

11. Signature of Water Quality/Hydrology Representative

 Initials of independent reviewer.Check here when information is entered in database:

This page is for ESH-18 notes, recommendations, and photos.

Y / N

12. a) Is there visible trash/debris on the site?

b) Is there visible trash/debris in a watercourse?

Description of existing BMPs:

Are BMPs being properly maintained? If no, describe in "Other Internal Notes"

Are BMPs effectively keeping sediment in place and reducing erosion potential?

OTHER INTERNAL NOTES:

ATTACHMENT 2
STORM WATER POLLUTION PREVENTION PLAN

11/15/2011 10:00 AM

STORM WATER POLLUTION

PREVENTION PLAN



**TECHNICAL AREA 49
MATERIAL DISPOSAL AREA AB**

LOS ALAMOS NATIONAL LABORATORY

a requirement of the

NPDES GENERAL PERMIT

prepared by
ERM/Golder Los Alamos Project Team
2237 Trinity Drive, Bldg. 2
Los Alamos, NM 87544

Rev. 2, April 1998

1
2
3
4
5
6
7
8
9
10
11
12
13
14
15
16
17
18
19
20
21
22
23
24
25
26
27
28
29
30
31
32
33
34
35
36
37
38
39
40
41
42
43
44
45
46
47
48
49
50
51
52
53
54
55
56
57
58
59
60
61
62
63
64
65
66
67
68
69
70
71
72
73
74
75
76
77
78
79
80
81
82
83
84
85
86
87
88
89
90
91
92
93
94
95
96
97
98
99
100

**STORM WATER POLLUTION PREVENTION PLAN ,
TECHNICAL AREA 49, MATERIAL DISPOSAL AREA AB
LOS ALAMOS NATIONAL LABORATORY**

PREFACE

This storm water pollution prevention (SWPP) plan was developed in accordance with the provisions of the Clean Water Act (33 U.S.C. §§1251 et seq., as amended by the Water Quality Act of 1987, P.L. 100-4) and the regulations established by the US Environmental Protection Agency (EPA) for National Pollutant Discharge Elimination System general permits for storm water discharges associated with industrial activity (US EPA, 1992c at 41235). The applicable storm water discharge permit is EPA General Permit Number NMR00A384 (US EPA, 1992c at 41299-41300). The SWPP plan is also intended to meet the requirements of applicable US Department of Energy (DOE) orders, as follows:

- DOE 5400.1, General Environmental Protection Program
- DOE 5400.5, Radiation Protection of the Public and the Environment
- DOE 5480.1B, Environment, Safety, and Health Program for Department of Energy Operations
- DOE 5480.4, Environmental Protection, Safety, and Health Protection Standards
- DOE 5820.2A, Radioactive Waste Management

This SWPP plan applies to discharges of storm water from the construction activities employed to implement the best management practices (BMPs) plan at Material Disposal Area AB located in Technical Area 49. The BMP is designed to improve adverse moisture conditions at Areas 2, 2A, and 2B and will include installation of an interceptor trench, removal of the asphalt pad, redistribution and contouring of the existing fill material, and covering the site with clean fill and gravel mulch.

CONTENTS

1.0 POLLUTION PREVENTION TEAM..... 1

1.1 Designation and Pollution Prevention Team..... 1

1.2 Duties of Pollution Prevention Team Members..... 1

1.3 Appointment of New Team Members 1

2.0 SITE ACTIVITIES AND POTENTIAL POLLUTION SOURCES 1

2.1. Site Activities at MDA AB..... 2

2.1.1 Surface Water Runoff 2

2.1.2 Surface Water Run-on 2

2.2 Inventory of Exposed Materials 2

2.2.1 Other Potential Sources..... 3

2.3 Nonstorm Water Discharges 3

2.4 Documented Spills and Leaks 4

2.5 Site Drainage Maps 4

2.6 Drainage Patterns 4

2.7 Sampling and Analysis of Storm Water Events 5

2.8 Risk Identification and Summary of Potential Pollution Sources in MDA AB..... 5

3.0 BMPs TO PREVENT STORM WATER POLLUTION..... 6

3.1 Good Housekeeping 6

3.2 Preventative Maintenance Program..... 6

3.3 Spill Prevention and Response Procedures 7

3.4 Inspections..... 7

3.5 Employee Training..... 7

3.6 Recordkeeping and Documentation..... 8

4.0 CONTROLS TO REDUCE POLLUTANTS 8

4.1 Sediment and Erosion Controls..... 8

4.2 Management of Storm Water Run-on and Runoff 9

4.3 Other Controls..... 9

4.4 Documentation of Runoff Control Activities 10

5.0 COMPREHENSIVE SITE COMPLIANCE EVALUATION..... 10

5.1 Evaluation Procedures..... 10

5.2 Report on Results of the Comprehensive Site Compliance Evaluation	10
5.3 Implementation of Corrective Actions	11
5.4 Revision of SWPP.....	11
REFERENCES	14
APPENDIX A: POLLUTION PREVENTION TEAM MEMBERS	15
APPENDIX B: DESCRIPTIONS OF PAST SPILLS OR RELEASES.....	17
APPENDIX C: SITE DRAINAGE MAP.....	19
APPENDIX D: SAMPLING AND ANALYTICAL DATA	21
APPENDIX E: RECORD OF INSPECTION AND MAINTENANCE REPORT FORMS.....	23
APPENDIX F: RECORDS OF EMPLOYEE TRAINING RELATED TO STORM WATER POLLUTION PREVENTION	27
APPENDIX G: RECORD OF COMPREHENSIVE SITE COMPLIANCE EVALUATIONS	29

**STORM WATER POLLUTION PREVENTION PLAN
CERTIFICATION STATEMENT OF AUTHORIZATION**

"I certify under penalty of law that this document and all attachments were prepared under my direction or supervision in accordance with a system designed to assure that qualified personnel properly gathered and evaluated the information submitted. Based on my inquiry of the person or persons who manage the system, or those persons directly responsible for gathering the information submitted, the information submitted is, to the best of my knowledge and belief, true, accurate and complete. I am aware that there are significant penalties for submitting false information, including the possibility of fine and imprisonment for knowing violations."

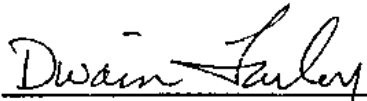
Dwain Farley, EES-1
MDA AB Project Leader
Los Alamos National Laboratory

6/5/88

Signature Date

NONSTORM WATER DISCHARGE ASSESSMENT AND CERTIFICATION		Completed by: ERM/Golder Los Alamos Project Team			
Title:		Nonstorm Water Discharges at TA-49, MDA AB			
Date:		April 1998			
Date of Test or Evaluation	Outfall Directly Observed During the Test (Location)	Method Used to Test or Evaluate Discharge	Describe Results from Test for the Presence of Nonstorm Water Discharge	Identify Potential Significant Sources	Name the Person Conducting the Test or Evaluation
1997	Dust suppression	Knowledge of process	Not expected to result in runoff	Dirt roads and possibly excavated fill; no runoff is anticipated	ER Project
1998	Decontamination water	Knowledge of process	Nonhazardous detergent solution (max. of 6 gals./day)	Sampling activities; will not be discharged unless clean	ER Project
					ER Project
					ER Project
					EH Project
CERTIFICATION					
<p>I, <u>Dwain Fatley</u>, certify under penalty of law that this document and all attachments were prepared under my direction and supervision in accordance with a system designed to ensure that qualified personnel properly gather and evaluate the information submitted. Based on my inquiry of the person or persons who manage the system or those persons directly responsible for gathering the information, the information submitted is, to the best of my knowledge and belief, true, accurate, and completed. I am aware that there are significant penalties for submitting false information, including the possibility of fine and imprisonment for knowing violations.</p>					
A. Name and Official Title		B. Area Code and Telephones No.			
Dwain Fatley		B (505) 667-2415			
MDA AB Project Leader					
Los Alamos National Laboratory					
C. Signature <i>Dwain Fatley</i>		D. Date Signed <i>6/5/98</i>			

1.0 POLLUTION PREVENTION TEAM

This storm water pollution prevention (SWPP) plan applies to operations at Los Alamos National Laboratory (the Laboratory), Technical Area (TA) 49, Material Disposal Area (MDA) AB, on the Frijoles Mesa Site in Los Alamos County, New Mexico. The ERM/Golder Los Alamos Project Team at the Laboratory has established a Pollution Prevention Team whose members are responsible for developing and implementing the SWPP plan.

1.1 Designation and Pollution Prevention Team

The MDA AB project leader appoints at least three members to the Pollution Prevention Team. The members are selected because of their familiarity with facility activities at MDA AB and with the potential impact of these activities on storm water runoff. The Pollution Prevention Team also includes a representative of the Laboratory's Water Quality and Hydrology Group (ESH-18). Each member of the team must receive the annual training described in Section 3.5. A list of current Pollution Prevention Team members is included in Appendix A.

1.2 Duties of Pollution Prevention Team Members

The Pollution Prevention Team will select individual team members to perform specific duties applicable to the implementation of the SWPP plan. These individuals will include

- *Pollution Prevention Team Leader.* One of the Pollution Prevention Team members is designated as the team leader. He or she is responsible for revising and updating the SWPP plan, as required under Section 5.4. The team leader, or qualified designee, will perform the annual comprehensive site compliance evaluation described in Section 5.0. The team leader will also ensure that all team personnel receive the training specified in Section 3.5.
- *Team Members.* Other members of the team are responsible for periodic inspections of MDA AB, as described in Section 3.4. In the event of a spill or release, a team member will also incorporate documentation of the spill and cleanup procedures into Appendix B. Any team member may perform the annual comprehensive site compliance evaluation of MDA AB.

Team members may also be called upon to assist the team leader, especially in the event of a spill or a runoff event that requires a greater than usual level of effort for a short period of time.

1.3 Appointment of New Team Members

The Pollution Prevention Team members are appointed by the MDA AB project leader, and the representative of ESH-18 is appointed by the ESH-18 group leader. Each representative will serve until removed or replaced by the appropriate manager. The list will be revised whenever a member is added to or removed from the team or when the SWPP plan duties of an existing team member are changed.

2.0 SITE ACTIVITIES AND POTENTIAL POLLUTION SOURCES

TA-49, the Frijoles Mesa Site, occupies approximately 1280 acres along the southwestern boundary of the Laboratory. The potential release sites (PRSs) covered under this plan include 49-001 (b, c, d, and g) and 49-003. The PRSs addressed in this SWPP plan are located on the mesa top at an elevation of approximately 7140 feet. These sites are approximately 1650 feet

from an ephemeral stream in the bottom of Water Canyon. The distance to the nearest mesa edge, above a tributary to Water Canyon, is approximately 700 feet. The layout of MDA AB is shown in Appendix C.

TA-49 has been used from the mid-1940s to the present as a buffer zone for firing sites in adjacent TA-15 and TA-39. A period of intense experimental activity at TA-49 took place from late 1959 through mid-1961, during which nuclear safety and related experiments deposited significant amounts of plutonium, uranium, lead, and beryllium in underground shafts. These activities were responsible for almost all of the radioactive and hazardous materials currently present at TA-49.

2.1 Site Activities at MDA AB

A stabilization plan has been prepared as a best management practice (BMP) for MDA AB; the plan includes the following site activities:

- remove the asphalt pad to reduce the moisture buildup that presently occurs beneath it,
- expose and regrade the fill materials underlying the asphalt pad to promote drying and surface runoff,
- construct a diversion channel upgradient of the site to divert surface water run-on from the site,
- complete regrading of the site to eliminate ponding and improve drainage,
- cover the regraded site with a clean layer of crushed tuff,
- cover the clean crushed tuff surface with a layer of soil,
- revegetate the soil layer with shallow-rooting grasses and armor it with gravel to resist erosion,
- locate and remove, or stabilize, surface contaminants that could affect worker health and safety in work areas near the site, and
- monitor the site to determine the effectiveness of the BMPs.

2.1.1 Surface Water Runoff

The site is approximately 1650 feet from an ephemeral stream in the bottom of Water Canyon. The distance to the nearest mesa edge, above a tributary to Water Canyon, is approximately 700 feet. The estimated two-year 24-hour rainfall for the Los Alamos area, including MDA AB, is 1.5 inches. Therefore, the potential runoff from this approximately 4-acre site is 0.5 acre feet of storm water. Additional runoff prevention measures may include, but are not limited to, covering the excavated area during anticipated storm water events and construction of a silt fence downgradient of the construction activities.

2.1.2 Surface Water Run-on

Surface run-on water will be controlled by constructing a diversion channel upgradient of the site to the west to temporarily divert surface storm water run-on during construction. The approximate location is shown in Appendix C.

2.2 Inventory of Exposed Materials

Significant materials, as defined in 40 CFR 122.26(b)(12), are substances related to industrial activities such as process chemicals, raw materials, fuels, and pesticides. When these substances are exposed to storm water runoff, they may be carried to a receiving stream with the

surface water flow. To address this contamination potential, a brief description of materials known to have been disposed at MDA AB is provided below.

The largest potential pollutant sources will be the soils exposed during excavation. The contaminants of potential concern at this site include plutonium, uranium, beryllium, and lead. As contaminated materials are excavated, the loosened soil and debris will become more vulnerable to transport by storm water.

2.2.1 Other Potential Sources

There are several other potential sources of pollutants located at the site that should be mentioned. Exposure of these sources to storm water exists primarily during transfers or if an accidental spill occurs.

Laydown, Stockpile, Parking, and Waste Storage Areas

- Areas free of cultural and other resource conflicts will be identified for material laydown and stockpiling, vehicle parking, and waste asphalt storage areas. The laydown areas have been sited outside the boundaries of any PRSs and will be used for temporary storage of construction supplies and equipment, material processing, and material assembly. The stockpile areas will be used to store such materials as clean fill, soil, and gravel. The parking areas will be used for construction equipment, vehicles, and trailer offices. Waste storage areas would be used primarily for waste asphalt if the asphalt is found to be contaminated. Contaminated asphalt would be stockpiled or stored in rolloff bins. It is anticipated that most of these activities will be conducted in areas already disturbed by past activities along the road leading east from the site toward Area 10.

Heavy Equipment Use

- Heavy equipment will also be in use during construction activities. The possibility of leaks of diesel fuel, hydraulic fluid, gasoline and motor oil from heavy equipment will be mitigated by weekly inspections for worn parts, leaking hoses, and other problems before the equipment is allowed on site.

2.3 Nonstorm Water Discharges

There are few potential sources for nonstorm water discharges at MDA AB, and the discharge of these sources is limited in both quantity and frequency. Known potential sources of nonstorm water discharges include the following:

- During dry periods, unpaved roads are sprinkled with water on a regular basis. On a monthly basis, the contractor may also choose to apply a solution of a commercial dust suppressant, Dust-Ban 8806M Dust Control, consisting mainly of magnesium salts or an approved equivalent. This dust suppressant is not hazardous to human health or the environment but could cause elevated concentrations of magnesium in storm water runoff from areas where it is applied.
- In the case that sampling is performed, the sampling equipment will be decontaminated by washing with a nonhazardous detergent solution and discharged up to 6 gallons per day under the Laboratory notice of intent for decontamination water.

As stated in the Environmental Protection Agency's general permit for storm water discharges associated with industrial activity (EPA, 1992c), the SWPP plan must include a certification that

all storm water outfalls have been evaluated for the presence of nonstorm water discharges. The nonstorm water discharge assessment and certification form (p. vi) meets this requirement.

2.4 Documented Spills and Leaks

No spills or leaks appear to have occurred in this area since October 1, 1989, which may have had the potential to affect the chemical or radiological quality of runoff and sediments. In the event of a future spill, a member of the Pollution Prevention Team will document the spill and associated cleanup activities for inclusion in Appendix B of this SWPP plan.

2.5 Site Drainage Maps

The site drainage maps illustrate the overall site location and indicate property boundaries, buildings, and operation or process areas. They also provide information on drainage, storm water control structures, and receiving streams. These features are located on maps to help assess where potential storm water pollutants are located on the site, where they mix with storm water, and where storm water leaves the site. All of this information is essential in identifying the best opportunities for storm water pollution prevention or control. The site maps include the following features:

- an outline of the drainage area for each storm water outfall and a prediction of the direction of flow, including topography;
- each existing structural control measure to reduce pollutants in storm water runoff (e.g., diversion ditches);
- surface water bodies (e.g., canyon name);
- locations of areas of soil disturbance and areas that will not be disturbed; and
- locations of the following activities where such activities are exposed to precipitation, laydown areas, construction areas, parking areas, stockpile areas, and waste storage areas.

Please consult the MDA AB site drainage map in Appendix C.

2.6 Drainage Patterns

A list of the significant activities occurring at MDA AB and the drainage areas potentially affected by these activities are included in Table 1. The activity locations are also shown on the map in Appendix C.

TABLE 1
DESCRIPTION OF DRAINAGE PATTERNS AND FLOW DIRECTIONS

Drainage Area	Activity Area	Flow Direction	Activities and Potential Contaminants
A	Construction	North	Asphalt removal, fill excavation, soil drying/stockpiling, site regrading plutonium, uranium, beryllium, lead
B	Construction	East	Diversion channel construction, site regrading No contaminants

2.7 Sampling and Analysis of Storm Water Events

In addition to the required sampling of storm water runoff, the Laboratory has implemented an ongoing sampling and analytical program to identify potential radiological and chemical contamination of other media. This program includes sampling and analysis of soils, stream sediment, vegetation, and the atmosphere at various locations throughout TA-49 and adjacent areas. Data collected in this program are available in annual reports prepared and distributed by the Laboratory's Water Quality and Hydrology Group (ESH-18). The pollution prevention team leader will review all environmental data collected in and around MDA AB to identify any potential issues of concern not already addressed in the SWPP plan. Any future data collected for storm water runoff will be included as Appendix D to this plan.

2.8 Risk Identification and Summary of Potential Pollution Sources in MDA AB

The site activities that may contribute to potential storm water pollution are the construction of the trench and berm, removal of the asphalt pad, excavation and redistribution of fill material, the storage of waste, stockpiling of materials, and the refueling of heavy equipment during construction activities. Debris loading will be conducted away from drainage pathways. Heavy equipment will be refueled in a manner that prevents fuel discharge to the environment.

- **Waste Storage Area.** No hazardous substances will be used during the construction activities. It is anticipated that all equipment will be dry decontaminated. In the case that wet decontamination becomes necessary, a decontamination area will be set up including secondary containment for liquids. All liquids would be containerized and stored in the waste storage area awaiting disposal. All waste will be managed in accordance with the approved Waste Characterization Strategy form for these activities (Environmental Restoration Project 1998, 57587). This area will be inspected and documented weekly until all containers are removed.
- **Vehicle and Equipment Parking, Fueling and Maintaining Areas.** Vehicles and equipment used at MDA AB are regularly parked outdoors in both paved and unpaved areas. Fueling and routine maintenance of vehicles also occur in these areas. The possibility that oil, diesel fuel, antifreeze, or other materials could be spilled in these areas cannot be completely eliminated. BMPs have been implemented to minimize the possibility of such a spill. These BMPs may include inspection of all caps, hoses, and nozzles on equipment before fuel transfer. On-site vehicles will receive regular preventive maintenance to reduce the chance of leaks; petroleum products will be stored in tightly sealed containers that are clearly labeled; a spill kit containing absorbent materials will be maintained on site; and a spotter will be used to prevent an overfill when refueling equipment.
- **Roads Used for Transport.** Waste and other materials are moved throughout MDA AB on both paved and unpaved roads. Administrative control practices, including speed limits, warning signs, and personnel training have been implemented to minimize the risk of a spill or release because of a transportation accident. In the event of such an accident, appropriate cleanup procedures will be implemented immediately by on-site personnel. The Emergency Management and Response Group (EM&R) will be contacted at 667-6211 (after hours 667-7080) for further instructions.

If a nonstorm water discharge occurs other than planned decontamination waters, the spill will be reported to the Water Quality & Hydrology Group, ESH-16, Mail Stop K497, or phone 665-0453.

3.0 BMPs TO PREVENT STORM WATER POLLUTION

Standard operating and maintenance procedures for the MDA AB construction activities are designed to minimize the potential for spills, releases, exposure of materials, or any other events that could adversely affect the quality of water and sediment that may be transported out of the area by storm water runoff. Procedures comply with the Laboratory's BMP Program; its Spill Prevention Control and Countermeasure (SPCC) plan; the Environment, Safety and Health section of the Laboratory Manual; and applicable Department of Energy (DOE) directives and orders (see Preface).

3.1 Good Housekeeping

The following good housekeeping practices will be followed on site during the BMP construction operations:

- All materials stored on site will be stored in a neat, orderly manner in accordance with all applicable Laboratory policies and procedures. Appropriate containers will be used and they will be stored (if possible) under a roof, tarpaulin, or other enclosure.
- The on-site waste manager will perform weekly inspections to ensure proper use and disposal of materials on site and will train all site personnel on good housekeeping BMPs and the requirements of this SWPP plan.
- All excavated asphalt will immediately be placed in bulk containers or stockpiled and staged at the waste storage area.
- All containers in the waste storage area will be sealed after operational hours or when full, whichever comes first.
- All containers and control areas will be properly labeled and posted.

3.2 Preventative Maintenance Program

This current plan includes requirements for weekly inspection and documentation that on-site heavy equipment is in good working order and free from leaks or spills. All operations involving heavy equipment (materials handling, decontamination, refueling, parking) will be conducted away from potential drainage pathways to minimize the possibility for leak or spill contamination to leave the site. Problems identified during weekly inspections will be documented and will receive immediate corrective action. A weekly inspection form for MDA AB is provided in Appendix E.

- All containers will be inspected and documented weekly for structural integrity and for stability before movement.
- All storm water control measures, such as diversionary ditches, silt fences, secondary containment, and berms, will be inspected weekly and after significant storm water events for structural integrity. All deficiencies found during inspections will be corrected and documented immediately.
- Records of all equipment inspections and corrective actions will be maintained as part of the permanent project file and will be available upon request.

3.3 Spill Prevention and Response Procedures

Although the probability of spills and releases is minimized by the application of good housekeeping procedures and appropriate operational methods, a spill is conceivable at MDA AB. Specific spill response and cleanup procedures will depend on the nature of the spilled material and the location of the release. In the event of a liquid spill, absorbent materials will be applied to the spill, drummed, and held on site in the waste storage area awaiting characterization. The EM&R Group will be contacted at 667-6211 (after hours 667-7080) for further instructions. A spill report will be completed and submitted to ESH-18.

All loading and unloading of materials will be conducted away from storm water channels and during periods without storm-water-producing events. Drummed liquid wastes (such as decontamination water) will be transferred into containers within secondary containment areas that will block direct discharge from the site.

3.4 Inspections

Qualified personnel shall inspect weekly, while on site, disturbed areas of the project site that have not been finally stabilized, areas used for storage of materials that are exposed to precipitation, structural control measures, and locations where vehicles enter or exit at least once every seven calendar days and within 24 hours of the end of a storm that is 0.5 inches or greater. Where sites have been finally stabilized, such inspection shall be conducted at least once every month for arid months. A set of tracking or follow-up procedures shall be used to ensure that appropriate actions are taken in response to the inspections. Records of inspections shall be maintained. Inspections should include the following:

- Measures to reduce pollutant loading shall be evaluated to determine whether they are adequate and properly implemented in accordance with the terms of the permit or whether additional control measures are needed.
- Structural storm water management measures, sediment and erosion control measures, and other structural pollution prevention measures identified in the plan shall be observed to ensure that they are operating correctly. A visual inspection of equipment needed to implement the plan, such as spill response equipment, shall be made.
- Disturbed areas and areas used for storage of materials that are exposed to precipitation shall be inspected for evidence of or the potential for pollutants entering the drainage system.
- Erosion and sediment control measures identified in the plan shall be observed to ensure that they are operating correctly.
- Where discharge locations or points are accessible, they shall be inspected to ascertain whether erosion control measures are effective in preventing significant impacts to receiving waters.
- Locations where vehicles enter or exit the site shall be inspected for evidence of off-site sediment tracking.

3.5 Employee Training

Employees will be trained on proper decontamination procedures; storage, handling and disposal of generated liquid site wastes; inspection of heavy equipment; secondary containment and erosion control devices; BMPs, including good housekeeping practices; spill response actions; and proper implementation of the SWPP plan and SPCC implementation plan during prefield

work briefings and daily tailgate safety meetings before the start of each day's site activities. Training records are kept in Appendix F.

3.6 Recordkeeping and Documentation

The pollution prevention team leader is responsible for keeping the SWPP plan current so that it accurately reflects present conditions and practices for the MDA AB closure project. The pollution prevention team leader will initiate revision of the SWPP plan whenever changes in operations or other conditions require it. It is the responsibility of each member of the Pollution Prevention Team to bring to the attention of the pollution prevention team leader any changes in conditions or operations at the site that require the revision or incorporation of new material to the SWPP plan. Some conditions that may require revision to the SWPP plan are described in Section 5.3. This SWPP plan will be kept on site during the implementation of the BMP plan, and the original will be sent to the Environmental Restoration (ER) Project's Records Processing Facility (RPF).

Other items that must be documented to ensure adequacy of the SWPP plan include

- results of inspections, including the annual comprehensive site compliance evaluation;
- all MDA AB sampling and analytical data for storm water, soils, and sediment;
- additions to and changes in operational areas and any exposed materials;
- land surface modifications or other structural changes affecting the directions of drainage during storm events;
- the occurrence and cleanup of any spills or releases;
- areas that are susceptible to erosion or sedimentation by storm water runoff; and
- any other factors that may influence the quality of storm water runoff from MDA AB.

Documents relating to these items are quality records, managed according to the DOE's "Records Management System" and the RPF. In general, records related to the SWPP plan and storm water pollution control measures should be retained for at least six years, unless another period is specified in this SWPP plan.

4.0 CONTROLS TO REDUCE POLLUTANTS

Although sediment discharge to the canyons cannot be entirely eliminated, structural controls will be installed, as necessary in areas that are prone to erosion. These controls include diversion ditches, channels, or swales; constructed berms; slope or surface stabilization; and other structures as necessary.

4.1 Sediment and Erosion Controls

Before construction activities begin at MDA AB, a silt fence will be constructed below the construction area. This structure should capture any sediment transfer because of sheet flow runoff. There is currently a drainage channel upgradient of the site to help control run-on. Additional run-on and runoff ditches will be constructed as needed to control erosion and sediment transport.

Upon completion of the construction activities, boundary areas and remaining disturbed soils will be backfilled and revegetated to prevent sheet flow erosion. Specifically, the revegetation process will be as follows.

- Subsoil will be prepared to eliminate uneven surfaces and low spots, while maintaining profiles and contours and blending slopes into level areas. Foreign materials and undesirable plants and weeds will be removed by hand or with an herbicide.
- Topsoil will be added to a minimum depth of four inches, raked smooth, and applied during dry weather on a dry, unfrozen subgrade. Topsoil will be graded to ensure positive drainage. Terry Fox (667-3024) of Ecology Group (ESH-20) should be contacted for a determination of seed content and applications rules.

If evidence of extensive erosion is encountered, the pollution prevention team leader will be notified. The team leader will then examine the affected area to identify the source or sources of the sediment discharge and will recommend the appropriate actions to minimize future erosion and sediment transport.

Specific actions that may be used to control erosion and sediment transport include reshaping contours to eliminate steep slopes, construction of berms, installation of silt fences, riprap or other appropriate water control structures, revegetation of exposed areas, and, if feasible, laying asphalt paving over areas prone to erosion. Tuff that is excavated during the closure activities for use as fill material will be placed in stable piles and surrounded by silt fences or bermed, if necessary, to prevent erosion.

4.2 Management of Storm Water Run-on and Runoff

At this time, the existing controls used for storm water management and the minimization of erosion and sedimentation at MDA AB include an upgradient drainage channel and associated culvert and a downgradient culvert running under the road and draining into the canyon. There is also dense vegetation with a flat terrain to help minimize run-on and runoff.

The plan to manage storm water run-on and runoff at this site includes

- placement of silt fences downgradient to the north and east of the construction area;
- regrade of the fill area to prevent ponding;
- placement of a surface run-on diversion channel upgradient to the south and west of the site;
- placement of riprap, if needed, at the end of discharge points to prevent erosion;
- construction of flow dissipation devices, if needed, within the downstream drainage channels to lessen flow velocities; and
- implementation of site monitoring and maintenance plans.

Site runoff water will be periodically sampled and analyzed for constituents that may have migrated from the site or from upgradient PRSs as part of the Laboratory's National Pollutant Discharge Elimination System general permit.

4.3 Other Controls

In general, the following controls will be implemented under this SWPP plan:

- no solid materials, including building materials, shall be discharged to a watercourse;
- off-site vehicle tracking of sediment and the generation of dust shall be minimized; and
- the plan shall ensure and demonstrate compliance with the Laboratory's permits and requirements for waste disposal sanitary sewer or septic system regulations.

4.4 Documentation of Runoff Control Activities

The BMP field team leader (FTL) is responsible for inspection, maintenance, and repair of the storm water pollution controls described in this plan. This FTL will also produce and maintain inspection, maintenance, and repair records. Original records will be submitted to the ER Project RPF, and copies will be maintained in the ERM/Golder Los Alamos Project office. Additionally, the MDA AB project leader (Dwain Farley) will maintain copies of these records, which are received from ERM/Golder on a weekly basis.

5.0 COMPREHENSIVE SITE COMPLIANCE EVALUATION

A comprehensive site compliance evaluation inspection of the BMP at MDA AB will be performed annually during August or September by the pollution prevention team leader. This time frame was selected for the annual inspection because it falls at the end of the period when intense thunderstorms are common in the Los Alamos area and, therefore, is the time of year when any problems related to precipitation and runoff are most likely to be apparent. Additionally, any problems that may be identified during an inspection in August or early September can be corrected within 12 weeks with a relatively low probability of delay because of snow or ice accumulation because heavy snowfall is infrequent before December.

5.1 Evaluation Procedures

During the comprehensive site compliance evaluation, the pollution prevention team leader will examine all operational areas of MDA AB for any conditions that may contribute to the presence of contaminants in runoff from MDA AB. The pollution prevention team leader will use a Site Compliance Evaluation Checklist to ensure that significant operational areas and relevant conditions are not overlooked during the inspection.

Areas inspected in detail will include all outdoor waste storage areas, material storage areas, equipment and vehicle storage and maintenance areas where sources of nonstorm water runoff are located. Specific items that will be evaluated during the inspection of each area will include

- exposed materials or wastes that may contribute to contamination of storm water runoff,
- any evidence of spills that may have occurred in the operational areas and their potential for contributing contamination to runoff,
- gullies or other evidence of erosion and sediment transport,
- areas that may have been altered by construction or other activities so as to change the direction of storm water runoff, and
- any other factors that may require modification of either operating procedures or the contents of the SWPP plan.

In addition, the pollution team leader will examine all structural features designed to convey runoff and minimize erosion, including culverts, drains, and open channels, to ensure that they are in good working condition and are serving their intended purpose. All observations made during the inspection will be documented on the Site Compliance Evaluation Checklist.

5.2 Report on Results of the Comprehensive Site Compliance Evaluation

Within two weeks after performance of the comprehensive site compliance evaluation, the pollution prevention team leader will prepare a report describing the results of the inspection and

any irregularities that were encountered during the evaluation. The report will include, as a minimum, the following items:

- date(s) on which the inspection was performed;
- the personnel who performed the inspection;
- a copy of the Site Compliance Evaluation Checklist;
- a written summary of major observations relating to implementation of the SWPP plan;
- a summary of all changes made to the SWPP plan, in accordance with Section 5.3; and
- a description of any incidents of noncompliance with SWPP plan that were noted during the inspection and the actions that were taken to correct them.

All reports describing results of the annual Comprehensive Site Compliance Evaluation will be incorporated into Appendix G of the SWPP plan. These reports will be retained as part of the SWPP plan for as long as the SWPP plan remains in effect.

5.3 Implementation of Corrective Actions

This SWPP plan will be amended whenever there is a change in the design, construction, operation, or maintenance procedures at MDA AB that has a significant effect on the potential for discharge of contaminants in storm water runoff from the area. Examples of such a change could include changes in the types of operations performed in any of the facilities or significant change in the direction of runoff because of construction or modification of roads, paved pads, buildings, or other structural features. The SWPP plan will also be amended whenever a comprehensive site compliance evaluation or other inspection identifies any significant changes in operational areas, procedures, or materials handled that may affect the potential for contaminant migration from the site in storm water or sediment.

Any required changes to the SWPP plan sections describing potential pollution sources (Section 2.2 and Appendix G) must be made within two weeks after the need for the change is reported to the Pollution Prevention Team. If the modification of the SWPP plan requires any changes in operational procedures, inspections, or structural features for the control of runoff and sediment, those changes must be implemented within 12 weeks after the modification is incorporated into the SWPP plan.

5.4 Revision of SWPP Plan

This SWPP plan will be amended annually within 60 days after completion of the comprehensive site compliance evaluation. It should also be amended whenever there is a change in the design, construction, operation, or maintenance procedures at MDA AB that has a significant effect on the potential for discharge of contaminants in storm water runoff from the area. Examples of such a change could include changes in the types of operations performed at MDA AB or significant changes in the direction of runoff because of construction or modification of roads, paved pads, buildings, or other structural features. The SWPP plan will also be amended whenever a comprehensive site compliance evaluation or other inspection identifies any significant changes in operational areas, procedures or materials handled that may affect the potential for contaminant migration from the site in storm water or sediment.

Certain specific events trigger requirements for modification of the SWPP plan either by revision of existing sections or by incorporation of new material into the document. Some events requiring modification of the SWPP plan and sections of the SWPP plan that typically would be modified following the event are listed in Table 2. However, Table 2 is not exhaustive, and any event that

has the potential for significantly affecting storm water runoff or sediment transport from MDA AB may require modification of the SWPP plan, whether or not it is listed in Table 2.

The Pollution Prevention Team is responsible for timely amendment of the SWPP plan, whenever required, and is also responsible for evaluating changes in procedures, activities, or other conditions at MDA AB that may require amendment of the SWPP plan. The Pollution Prevention Team will make any required changes to the SWPP plan sections describing potential pollution sources (Section 2.2) within two weeks of being notified of the need for the change.

Amendments to the existing contents of the SWPP plan must be reviewed and approved by both the MDA AB project leader and ESH-18, the same organizations that reviewed and approved the original SWPP plan. Incorporation of new information into Appendixes C and E does not require formal review of the entire SWPP plan. However, all members of the Pollution Prevention Team must review and approve the information before incorporating.

TABLE 2
EVENTS REQUIRING MODIFICATION OF THE SWPP PLAN FOR MDA AB

Event Leading to Modification of the SWPP Plan	Actions Required to Modify the SWPP Plan	Portions of the SWPP Plan Affected by Changes
Change in members or duties of the MDA AB Pollution Prevention Team	Amend the list of team members and their duties in SWPP plan	Appendix A
Significant changes in MDA AB operational procedures or locations of operations	Modify map and text sections of the SWPP plan to reflect the changes	Sections 2.2 and 2.3
Significant changes in the types of materials handled at MDA AB	Review to determine whether changes in SWPP plan procedures are required, add the new materials to the inventory list in the SWPP plan	Sections 2.2 and 2.8
Spill or leak of waste, water, or other materials at MDA AB	Document the release and cleanup procedures, incorporate the documentation in the SWPP plan	Section 2.4, Appendix B
Receipt of laboratory analytical results for storm water discharge, soil, sediment, or other environmental sampling	Review to determine whether there are abnormal values for any constituent, take corrective action if appropriate, incorporate the analytical results in the SWPP plan	Appendix D
Completion of comprehensive site compliance evaluation	Review the entire SWPP plan to ensure that it is still accurate and complete, correct any deficiencies found during the site compliance evaluation, document the evaluation and any follow-up actions	Appendix G, other parts of the SWPP plan as appropriate

REFERENCES

Environmental Restoration Project, March 6, 1998. "Waste Characterization Strategy Form, MDA Focus Area, TA-49, RFI Sampling, BMP Activities, and Asphalt Pad Removal, Material Disposal Area AB - Areas 2, 2A, and 2B," Los Alamos National Laboratory, Los Alamos, New Mexico. (Environmental Restoration Project 1998, ER ID 57587)

LANL, 1996. "Removing Waste from Radiological Controlled Areas," Part 4.3: Terms. Laboratory Standard LS105-05.0, effective date 7/1/96.

LANL (Los Alamos National Laboratory), November 1990. "Solid Waste Management Units Report," Volume I through IV, Los Alamos National Laboratory Report LA-UR-90-3400, prepared by International Technology Corporation under Contract 9-XS8-0062R-1, Los Alamos, New Mexico. (LANL 1990, ER IDs 07511 through 07514)

LANL 1997a. "Spill Prevention Control & Countermeasure Plan," Rev. 4. (Merrick Engineers & Architects)

**APPENDIX A
MEMBERS OF THE STORM WATER
POLLUTION PREVENTION TEAM FOR MDA AB
LOS ALAMOS NATIONAL LABORATORY**

- | | |
|----------------|---|
| 1. Team Leader | John DeJoia, Morrison Knudsen Corporation |
| 2. Team Member | Ray Wright, Project Management Company |
| 3. Team Member | John Crocker, Project Management Company |
| 4. Team Member | Rene Evans, Rocky Mountain Remediation Services, Inc. |
| 5. Team Member | Ken McFadden, Morrison Knudsen Corporation |
| 6. Team Member | Steve Veenis, Merrick & Co. |

**APPENDIX B
DESCRIPTIONS OF PAST SPILLS OR RELEASES**

This section includes data on all reportable spills and releases at MDA AB since October 1, 1989.

DESCRIPTION OF PAST SPILLS OR RELEASES

Date	Spill Location	What Spilled	Quantity Spilled	Corrective Action Taken	Plans to Prevent Recurrence

APPENDIX C
SITE DRAINAGE MAP

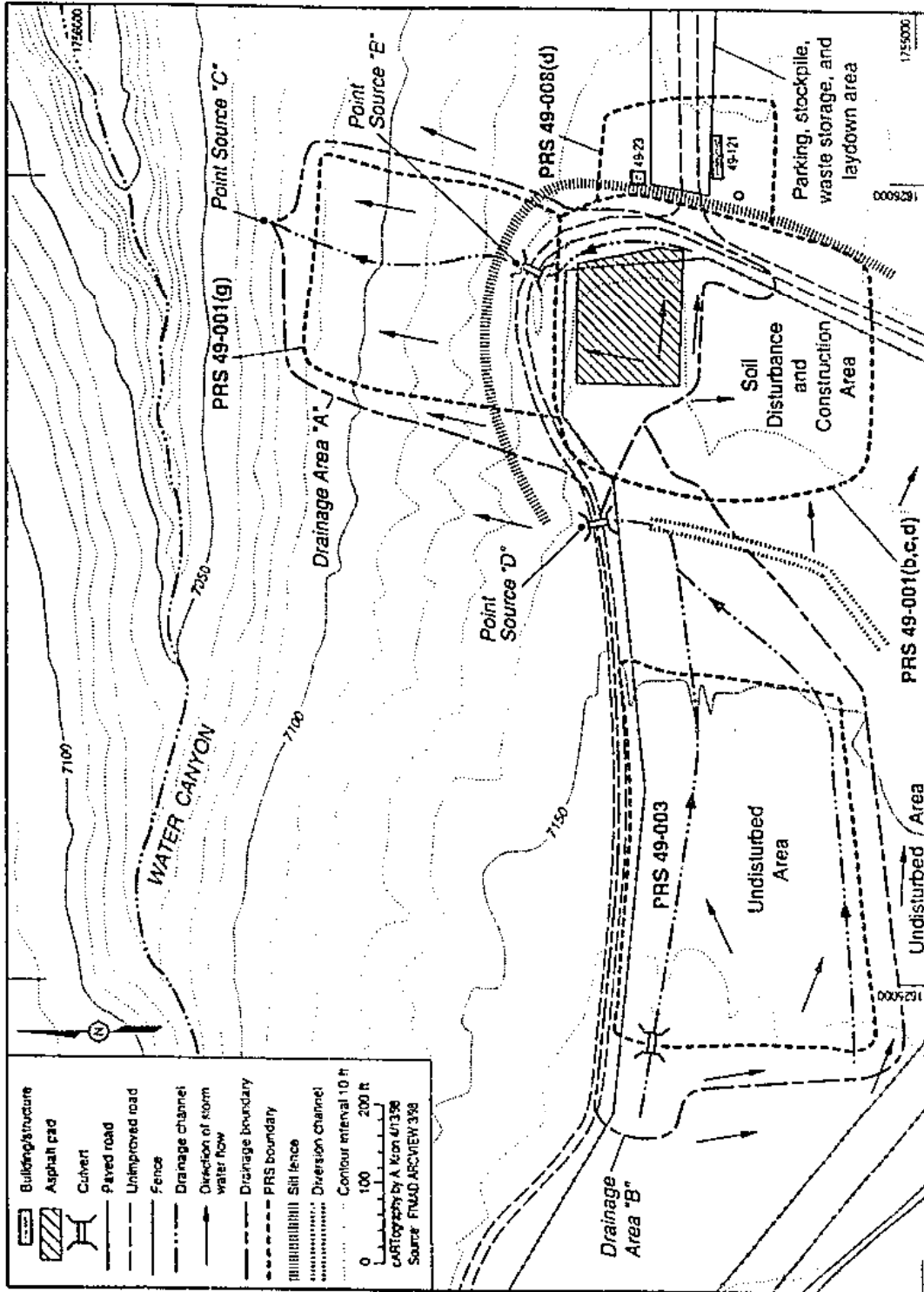

Site drainage map for TA-49 MDA AB.

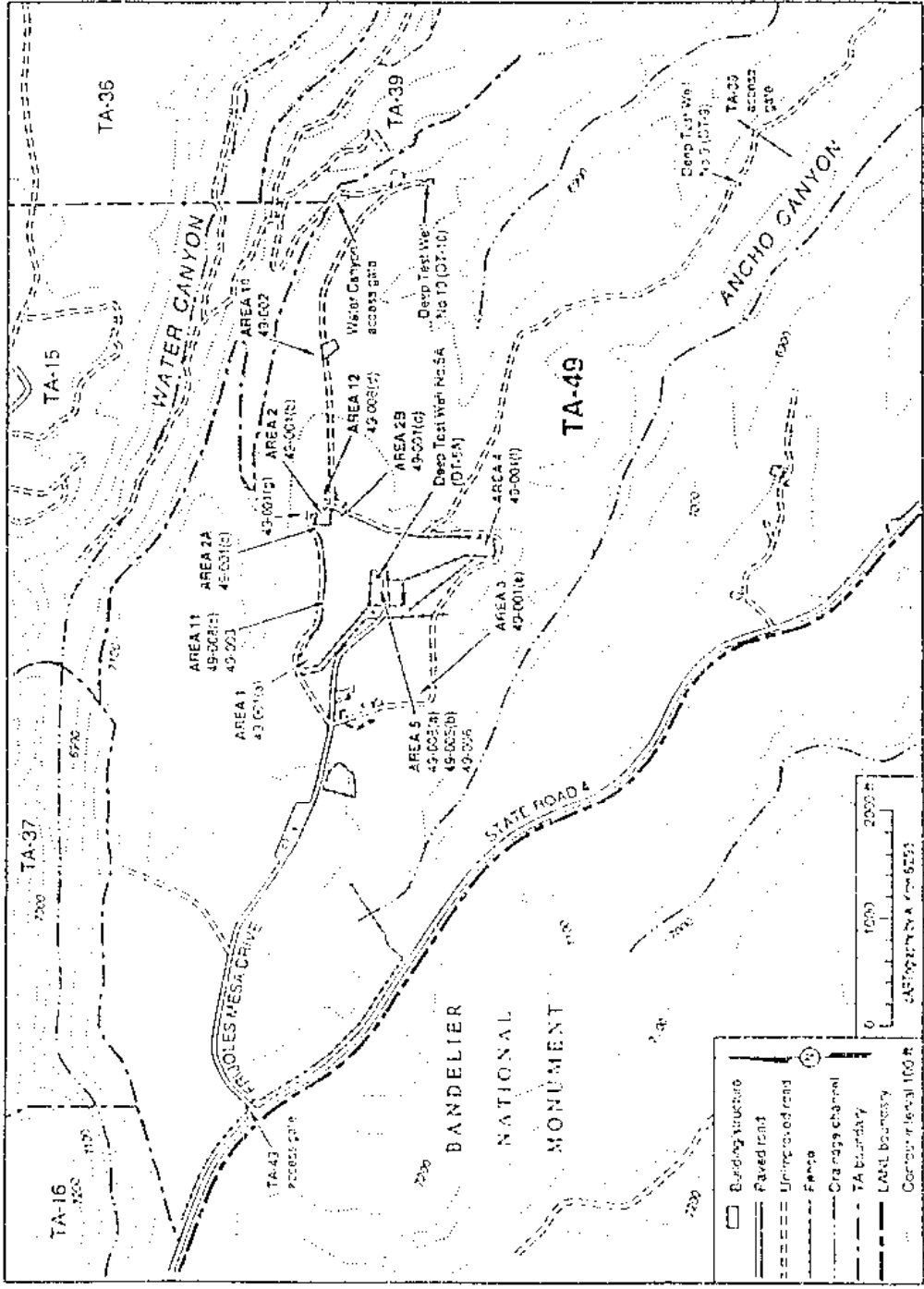

Map of TA-49.

**APPENDIX D
SAMPLING AND ANALYTICAL DATA**

Future analytical data for storm water runoff will be included in here.

2008-06-10 08:10:00

2008-06-10 08:10:00

**APPENDIX E
RECORD OF INSPECTION AND MAINTENANCE REPORT FORMS**

Inspection and Maintenance Report Form

TO BE COMPLETED EVERY 7 DAYS AND WITHIN 24 HOURS
OF A RAINFALL EVENT OF 0.5 INCHES OR MORE

PROJECT NAME: _____

INSPECTOR: _____ DATE: _____

INSPECTOR QUALIFICATIONS: _____

DAYS SINCE LAST RAINFALL: _____ AMOUNT OF LAST RAINFALL: _____ INCHES

Area	Date Last Disturbed	Date of Next Disturbance	Stabilized (Yes/No)	Stabilized With	Condition

STABILIZATION REQUIRED: _____

TO BE PREPARED BY: _____ ON OR BEFORE: _____

Inspection and Maintenance Report Form (cont.)

STRUCTURAL CONTROLS

DATE: _____

From	To	Installed Correctly	Evidence of Washout or Erosion

MAINTENANCE REQUIRED: _____

DATE: _____

From	To	Installed Correctly	Evidence of Washout or Erosion

MAINTENANCE REQUIRED: _____

TO BE PERFORMED BY: _____ ON OR BEFORE: _____

Inspection and Maintenance Report Form (conc.)

CHANGES REQUIRED TO THE SWPP PLAN: _____

REASONS FOR CHANGES: _____

"I certify under penalty of law that this document and all attachments were prepared under my direction or supervision in accordance with a system designed to assure that qualified personnel properly gathered and evaluated the information submitted. Based on my inquiry of the person or persons who manage the system, or those persons directly responsible for gathering the information, the information submitted is, to the best of my knowledge and belief, true, accurate and complete. I am aware that there are significant penalties for submitting false information, including the possibility of fine and imprisonment for knowing violations."

SIGNATURE: _____ **DATE:** _____

**APPENDIX F
RECORDS OF EMPLOYEE TRAINING
RELATED TO STORM WATER POLLUTION PREVENTION**

SWPP TRAINING MATRIX REQUIREMENTS MDA AB FY 1998									
Employee:									
LANL Z No.:									
Definitions: R (Read training), C (Classroom training), F (Field training), AN (As needed training)									
Training Requirement	Personnel Role							Date	Initial
	Project Leader	Pollution Prevention Team Lead	FTL	Team Member	SSO/RCT/RSP	Subcontractor	Comments		
SWPP Plan for TA-49, MDA AB	R	R	R	R	R	R			
SPCC Implementation Plan for TA-49, MDA AB	R	R	R	R	R	R			

SWPP Training Matrix - 1998
 MDA AB FY 1998

**APPENDIX G
RECORD OF COMPREHENSIVE SITE COMPLIANCE EVALUATIONS**

**ANNUAL STORM WATER
SITE COMPLIANCE EVALUATION REPORT**

Name of Facility: _____ Date of Inspection: _____

Name of Inspector(s): _____

Scope:

This evaluation was conducted by reviewing the current SWPP Plan to develop a list of areas that have the potential to contribute pollutants to storm water runoff. This list also contains secondary containment and storm water diversion structures. Facility operations for the past year were reviewed to determine whether new operational areas, or modifications to existing areas, required a plan modification. In addition, all storm water pollution prevention measures were evaluated to ensure that they were accurately identified, in place, and working properly.

This comprehensive site compliance evaluation included

- evaluation of the effectiveness of control measures to reduce pollutant loading in the runoff and whether additional measures are needed.
- observation of the structural storm water management measures, sediment, and erosion control measures and other structural pollution prevention measures and best management practices.
- availability of the equipment needed to implement this SWPP Plan, such as spill prevention, spill response, and waste storage equipment.

Major Observations:

Actions Taken:

Areas of Concern for this Compliance Evaluation:

10/10/05 10:00 AM

**ANNUAL SITE COMPLIANCE EVALUATION
CHECKLIST OF
AREAS REQUIRED TO BE EVALUATED**

I. Areas Potentially Contributing Pollutants to Storm Water Discharges

Yes/No, N/A

- _____ New areas, materials or physical features, including
- _____ Loading/unloading areas
- _____ Outdoor storage
- _____ Outdoor manufacturing or processing
- _____ Dust or particulate generating processes
- _____ On-site waste disposal activities
- _____ PRSs
- _____ Soil erosion
- _____ Inventory of materials exposed to storm water up-to-date
- _____ New nonstorm water discharges
- _____ New spills or leaks since last inspection

Comments:

II. Measures and Controls

Evaluate the effectiveness of existing programs or procedures to reduce pollutant loading into storm water discharges, ensure these are implemented correctly, and determine whether additional programs or procedures are needed. The following programs should be evaluated.

Yes/No, N/A

- _____ Good Housekeeping
- _____ Are areas clean and orderly?
- _____ Are there established protocols/procedures?
- _____ Is training provided?

Measures and Controls (continued)

Yes/No, N/A

- _____ Are there procedures for improvement of
_____ Operation/maintenance of equipment?
_____ Storage practices?
_____ Material inventory?
_____ Routine area cleanup?
_____ Organized work areas?
_____ Educational programs?
- Preventative Maintenance (PM)
_____ Does the PM program include the protection of the environment?
_____ Was the PM program expanded to include storm water?
- Does current PM program include
_____ Identification of equipment or systems to be inspected?
_____ Schedule for inspections
_____ Appropriate/timely repairs, and
_____ Maintenance of records on inspections and equipment?
- Visual Inspections
_____ Is there an existing inspection program?
_____ Do inspections include storm water?
_____ Are inspections documented?
_____ Are there follow-up procedures?
_____ Are there procedures for reporting problems to ESH-18?
- Employee Training
_____ Is training provided on SWPP plan?
_____ Is there a schedule for training?
- Review and Revisions
_____ Are there review/revision procedures for the SWPP plan?
_____ Are the responsibilities of SWPP plan team members assigned?

1
2
3
4
5
6
7
8
9
10
11
12
13
14
15
16
17
18
19
20
21
22
23
24
25
26
27
28
29
30
31
32
33
34
35
36
37
38
39
40
41
42
43
44
45
46
47
48
49
50
51
52
53
54
55
56
57
58
59
60
61
62
63
64
65
66
67
68
69
70
71
72
73
74
75
76
77
78
79
80
81
82
83
84
85
86
87
88
89
90
91
92
93
94
95
96
97
98
99
100

III. Structural Storm Water Management Measures

Observe structural control measures, erosion control measures, and/or other structural pollution prevention measures identified in the plan to ensure that they are adequate and functioning correctly. The following structural controls are to be observed.

Yes/No, N/A

Erosion Controls

- _____ Are there new areas of erosion or the potential for erosion?
- _____ Are erosion controls provided for storm water/other discharges?
- _____ Are containment and diversion structures in place?
- _____ Are vegetated areas maintained?

Management of Runoff

- _____ Are runoff controls described correctly?

IV. Visual Inspection of Equipment

This inspection should include a visual inspection of equipment needed to implement the plan, such as spill response equipment, silt fences, inlet controls, oil/water separators, pumps, etc.

Yes/No, N/A

- _____ Is spill control equipment available?
- _____ Are silt fences being used as an erosion control method?
- _____ If yes, are silt fences in good condition?
- _____ What other equipment is inspected?
- _____
- _____
- _____

**ATTACHMENT 3
TECHNICAL AREA 49,
MATERIAL DISPOSAL AREA AB,
MONITORING WELL AND BOREHOLE
ABANDONMENT PLAN**

MONITORING WELL AND BOREHOLE ABANDONMENT PLAN

Selected monitoring wells at Material Disposal Area AB located at Los Alamos National Laboratory Technical Area 49 may require abandonment and plugging during implementation of stabilization activities designed to improve subsurface moisture conditions in Areas 2, 2A, and 2B. At the time this plan was prepared, only Core Hole 2 were scheduled for abandonment. However, any wells that are abandoned will be abandoned and plugged in accordance with State of New Mexico Environment Department Ground Water Section Monitor Well Construction and Abandonment Guidelines (Ground Water Section, August 15, 1992) and Standard Operating Procedure 5.03, RO, Monitor Well and RFI Borehole Abandonment.

Construction details of each monitoring well will be reviewed before abandonment by reviewing the Core Sample Log, Monitor Well Construction Field Data Log, and/or other applicable records. Each borehole and well will be sounded immediately before abandonment to ensure no obstructions exist in the well bore that could interfere with filling and sealing. All materials within each original borehole and well including, but not limited to, foreign obstructions, the well casing filter pack, and annular seal, should be removed, if possible. If the casing, filter pack, and annular seal materials cannot be removed from any monitoring well, they may be left in place. Casing left in place will be perforated or punctured to allow proper placement of the sealing materials.

Each borehole and well bore will then be filled with a sealing material by pumping the material under pressure through a tremie pipe from the bottom of the well to the top. Cement grout used as a sealing material will have a mixture of 2 to 5 percent bentonite added. The cement/bentonite grout will be thoroughly mixed mechanically in a grout mixer/pump before pumping into the boring or well bore.

Sealing material will be placed in one continuous operation (or *pour*) from the bottom to the top of the well. Whenever work is interrupted by such events as overnight shutdown, poor weather, or other delays, the well opening will be covered at the surface to prevent the entry of foreign material, water, and pollutants. The cover will be held in place or weighted down in such a manner that it cannot be easily removed, except by equipment or tools.

All field work and comments will be recorded in a field logbook and a memorandum to file describing the results of the abandonment. At a minimum, the depth from the surface to the bottom of the borehole, type of cement, amount of bentonite added, amount of cement/bentonite grout used, and ground surface construction details will be recorded.

ATTACHMENT 4
DIVERSION CHANNEL CONSTRUCTION, ASPHALT PAD
REMOVAL, AND SITE REGRADING PLAN AND DESIGN

400 - 00140011 - 001110

400 - 00140011 - 001110

DIVERSION CHANNEL CONSTRUCTION, ASPHALT PAD REMOVAL, AND SITE REGRADING PLAN AND DESIGN

Overview and Site Description

This plan details the construction process and the steps required to remove and dispose of the asphalt pad, to remove and relocate part of the moist to wet fill that underlies the pad, and to construct a surface water diversion channel at Technical Area (TA) 49, Material Disposal Area (MDA) AB, Areas 2, 2A, and 2B, Potential Release Sites (PRS) 49-001 (b, c, d, and g). The work will be done in a manner that protects the health and safety of all involved personnel and protects the environment.

A best management practices (BMP) plan has been prepared to describe the activities required to stabilize this site. The BMP plan describes the rationale and design for the removal of the asphalt pad and for the removal and relocation of part of the underlying fill at this site. This plan addresses the construction activities associated with the removal of the pad, the regrading of fill, and the filling of topographic lows adjacent to the asphalt pad. This work plan accompanies and augments the BMP plan.

Based on the available records, the potential contaminants that might reasonably be expected to be in contact with the asphalt or be present in the underlying moist fill include uranium-235, uranium-238, plutonium, beryllium, and lead. The approach to activities for removing the asphalt and underlying fill with the possible presence of uranium, plutonium, beryllium, and lead is presented below.

The purpose of this plan is to

- supplement the site-specific health and safety plans (SSHASPs) [Environmental Restoration Project, in preparation (b); Environmental Restoration Project 1998, 57912] by providing construction details and standards specifically designed to address the hazards associated with the possible contaminants,
- ensure that each employee is trained and made aware of the safety provisions that are addressed in this work plan, and
- provide details that will aid the workers in implementing these activities.

This plan is designed to enable all involved personnel to recognize the potential hazards on this project and to establish the controls necessary to provide a safe and healthy workplace while protecting the environment and property. Work activities in this plan described using the word *shall* are required to be performed by the subcontractor; work activities described using the word *will* are required to be performed by the contracting party. The work will be accomplished in compliance with this plan, the overall stabilization plan for the asphalt pad site, and the attached specifications and drawings, and quantity estimates (Table 1).

Responsibilities

It is the responsibility of the field team leader (FTL)/field project manager, with the assistance of the site safety officer (SSO), to implement this plan. Work activities described in this plan will be modified by the FTL or his designee, as required to accommodate existing field conditions. An ESH-1-approved radiological control technician (RCT) is responsible for providing technical expertise relevant to radioactive contamination identification and the handling of materials with

potential radioactive constituents. It is the responsibility of each employee to bring to the attention of the FTL, the SSO, the RCT, or any other employee, any unsafe or hazardous conditions or acts of negligence that may cause injury to themselves or others, damage to property, or harm the environment.

TABLE 1
TA-49 STABILIZATION PLAN FOR INSTALLING BMPs
QUANTITY ESTIMATES

Item Description	Unit	Quantity
Asphalt pad	BCY ^a	390
Base tuff	FCY ^b	320
Cover tuff	FCY	470
Cover topsoil	FCY	470
Gravel armor	FCY	40
Diversion channel and berm	LF ^c	320
Asphalt storage area HPDE liner	SY ^d	560
Asphalt storage area general fill	FCY	30
Laydown/parking areas gravel surfacing	FCY	190
Seeding	AC ^e	3.3

- a. BCY = bank cubic yards
- b. FCY = fill cubic yards
- c. LF = linear feet
- d. SY = square yards
- e. AC = acres

Scope of Work

The scope of work covered by this plan includes the activities required to remove the asphalt pad and to regrade and cover the underlying fill and adjacent surface soils. Sedimentation control structures and a surface water run-on diversion channel will be installed before the work begins on the asphalt pad. Site preparation activities, including parking, office, laydown, and storage areas and fence removal shall also occur before asphalt pad activities begin.

Approximately 400 cubic yards of asphalt shall be removed, temporarily stored, crushed, loaded, and transported from the pad. The existing access road may be slightly disturbed to accommodate this stabilization action. If the low areas around the pad are muddy, a layer of tuff material shall be placed in those areas to provide a stable working surface. The fill under the asphalt will be field screened for contaminants and shall be partially recontoured to promote

drainage and drying. Some of the fill will be redistributed to the low areas adjacent to Areas 2, 2A, and 2B. This recontoured fill shall be allowed to dry as a function of regrading. The fill and tuff shall then be recontoured and covered by a temporary, stabilizing cover. This cover shall be revegetated with short-rooted (native) grasses. *Hot spots* downgradient of the pad shall be removed and disposed of off site. A schedule for the planned work is included in the BMP plan.

This plan addresses the activities associated directly with the removal of the asphalt pad and the underlying soil. These activities have been reviewed relative to storm water pollution prevention (SWPP) plan requirements. These requirements include installation of the surface water run-on diversion channel and sedimentation control features (silt fences). The maintenance of the SWPP plan features is included in this scope of work.

SSHASPs [Environmental Restoration Project, in preparation(b); Environmental Restoration Project 1998, 57912] cover this SWPP plan, asphalt pad, and soil removal work scope. The appropriate reviewers and signatories will be identified and included in the SSHASPs. The SSHASPs will be coordinated closely with and will include recommendations by TA-49 Field Management Unit 81 (FMU 81) and ESH-1 personnel. Morrison Knudsen (MK) Corporation and its subcontractors shall adopt and abide by the SSHASPs.

Construction Operations, Work Controls, and Descriptions

There are several preparatory activities that must occur before the actual removal of the asphalt and fill. An Environmental, Safety, and Health Project Summary (ESH ID 98-0014) will be completed. A *facility agreement* for conducting the planned activities will be developed with the facility coordinator. A work/project schedule will be given to the facility coordinator. All site access shall be coordinated with TA-49 personnel. An excavation/soil disturbance permit will be obtained, and the utilities will be located in the field before any surface penetrations are made. The project's National Environmental Protection Act requirements will be identified. A Waste Characterization Strategy (WCS) form has been completed. Various surveys will be completed that will provide data to enable the field implementation of the asphalt and fill removal. These surveys are described in the BMP plan, and the results of these surveys will be available on site.

MK will use only appropriately trained and experienced personnel to accomplish the work described in this plan. Specific personnel training requirements will be defined in the SSHASPs, and MK will coordinate closely with TA-49 and other appropriate Los Alamos National Laboratory (Laboratory) personnel to identify training requirements for work in the area. Before starting any field work, all personnel shall be trained commensurate with the hazards of the involved work. All workers entering the exclusion zone and/or the radiological controlled area (RCA) shall have HAZWOPER training and radiological worker II training. All site personnel shall attend TA-49 site-specific training and any other Laboratory-sponsored training specific to the MDA AB asphalt pad removal. All site personnel shall have the appropriate security clearances and shall abide by TA-49 security and safety requirements. All site workers shall attend and participate in daily tailgate safety meetings before the start of construction activities.

After all required project documents are completed and all involved personnel are trained, a readiness review will be conducted. Once this readiness review has been passed, equipment and personnel shall be mobilized to the area. All equipment shall be inspected before the start of work and regularly thereafter.

Nearby archeological sites will be delineated by a barrier installed by ESH-20 personnel. All project personnel will be instructed not to intrude into these archeological sites. Construction activities shall be limited to daylight hours and no off-road driving shall be permitted. No field disturbances shall occur without a site visit and approval of the area by a representative of ESH-20 for archeological/historical features.

The following general work constraints and assumptions shall be used in the performance of the scope of work included in this plan.

1. Construction activities may be periodically suspended because of TA-49 operations. TA-49 personnel will provide 24 hour notice for scheduled operations requiring the suspension of BMP plan construction activities.
2. All equipment shall be inspected for environment, health, and safety (ES&H) concerns before working on site. All equipment scheduled to be idle for more than six hours shift shall be parked on plastic. All fueling operations shall have spill safeguards in place.
3. All construction activities shall proceed with the constraints required for the potential type of contamination that could reasonably be expected for the concerned area.
4. Personal protective equipment will be used as defined in the SSHASP.
5. When working on or at the base of steep slopes, the condition of the uphill slope and the debris on that slope shall be evaluated before working. Debris that could dislodge and roll into the construction area shall be stabilized or removed.
6. All work within areas defined by an exclusion zone shall be considered a HAZWOPER activity and shall be conducted in compliance with OSHA 29 CFR 1910.120. Exclusion zones, contamination reduction zones, and support zones shall be installed and posted, as required. All personnel and equipment leaving the exclusion zones/contamination reduction zones shall be monitored for contamination and decontaminated as appropriate. All decontamination will be done as described in the SSHASPs.
7. A radiological work permit will be obtained. RCAs will also be established for areas where a reasonable potential exists for surface contamination in excess of the levels required for such designation. No materials originating in an RCA shall leave the site without RCT release.
8. If any unanticipated materials that could potentially affect worker health and safety are discovered during any activity associated with this project, all related operations shall cease. Work in the involved area shall not resume until a resolution is made and operations are authorized to recommence.
9. Before starting daily construction activities where contamination is suspect, the RCT or the SSO shall inspect the area. The results of this daily inspection will be conveyed to all workers at the daily tailgate safety meeting. All ES&H concerns and controls required for that day's activities will be discussed.
10. Hot spots for the purposes of this scope of work shall be defined as those areas or items with radioactivity levels that exceed approximately 100 pCi/g. All radiological controls and monitoring shall be performed by the RCT or the RCT's delegate.
11. Although moist or even wet conditions are expected, if dust becomes a problem, a light water mist shall be used for dust suppression.
12. All work shall be performed in compliance with the SSHASPs and all applicable rules, regulations, drawings, specifications, and project documents.

The requirements of the SWPP plan (Attachment 2 of BMP plan) will be implemented before asphalt removal activities begin. SWPP plan structures will be maintained during the period of field activity.

The existing power line has been relocated to serve the existing facilities and to furnish power to an air-sampling station that is located northwest of Area 2A. This power line relocation was done by Johnson Controls Northern New Mexico and was coordinated with FMU 81 personnel.

Before the construction of the surface water run-on diversion channel, asphalt pad removal, and underlying fill regrading begins, the existing access road shall be modified, as needed, to allow for safe ingress and egress of the area by construction equipment and personnel. Modifications to the existing road are expected to be limited to regrading and some widening. Road modifications will be selected that result in the least amount of tree removal and grading. Appropriate traffic controls shall be implemented. All road work shall be closely coordinated with TA-49 personnel and ESH-20 personnel.

Parking, laydown, storage, and support areas shall be established and constructed. A temporary field office shall be set up in the existing trailer east of Area 2B. Parking and storage areas shall be set up along the existing roads whenever possible. In no case shall parking or storage areas impede the use of the existing roads unless an alternative route is established and TA-49 personnel are notified. An area shall be set aside for an asphalt crushing operation. A portable decontamination area/facility shall be established to support the work in contaminated areas. The design drawings accompanying this attachment should be consulted for proposed facility locations. Portable sanitary facilities shall be set up to comply with the needs of the site work force.

The construction of the surface water run-on diversion channel, the removal of the asphalt pad, the regrading of the fill, cover placement, and all associated activities will be accomplished using MK personnel and subcontractor personnel and equipment. The areas where these activities will occur have the potential to be contaminated, as detailed in the BMP plan. The area of the surface water run-on diversion channel and the underlying fill are assumed to be uncontaminated. The asphalt will be treated as a low-level radioactive material. However, anomalously high areas of radioactive contamination could be present in any of these media. The most elevated radionuclide levels in surface soils/fill at Areas 2, 2A, and 2B are concentrated in the northeast corner of Area 2 and appear to be associated with the exhumation of contaminated soil beneath the asphalt pad by gophers. No field work will be done in potentially contaminated areas without the direct involvement and approval of the RCT or SSO.

FIDLER (radiological) surveys were performed during the Resource Conservation and Recovery Act facility investigation (RFI) sampling activities in the spring of 1998 for Areas 2, 2A, and 2B and adjacent land in downslope drainages toward Water Canyon. Various other surveys of the involved areas were also performed in the spring of 1998. These surveys are described in the RFI sampling and analysis plan [Environmental Restoration Project, in preparation (a)]. These surveys shall be reviewed before starting removal activities in these areas.

Before work begins inside the existing chain link fence, a pre-job briefing will be conducted for all personnel. Areas where contamination could be present and the levels expected will be discussed at this meeting. After this meeting the exclusion zone(s), RCA(s), contamination reduction zone(s), support zone(s) and construction zone(s) will be established for the involved

work areas. After the appropriate zones are established, work may begin. A visual inspection of work areas will be performed by the RCT, the FTL, and the SSO. Any areas identified as hot spots will be delineated at this time. If it is determined that no additional controls are needed, then work shall proceed.

The initial activity shall be the removal of the existing chain link fence and the fence posts. The fence and the fence area will be screened by the RCT or the RCT's delegate before the removal begins. The post anchors will be screened by the RCT or the RCT's delegate after removal. If the concrete and/or steel are determined to be contaminated, they shall be placed in drums or other suitable containers, stored, and subsequently disposed of as stated in the WCS form. Uncontaminated fence components shall be removed, stored nearby, and reinstalled at the end of the project.

All features that are to be preserved will be identified, marked, and protected by tape or barricades/fencing, as required. All surface debris shall be removed from the work area and screened, segregated, and disposed of, as appropriate according to the WCS. Concrete and other materials forming caps over the test shafts shall be left undisturbed. Vegetation shall be cleared from the site after the debris has been removed. Plants shall be trimmed at or above the existing soil level to avoid surface disturbance. The vegetation in the areas of work shall be removed and screened by the RCT or the RCT's delegate. Any vegetation determined to be contaminated will be containerized and stored/disposed of, as defined in the WCS form. All areas adjacent to the asphalt pad should be considered to be wet areas where equipment will get mired. Caution shall be exercised when navigating equipment in these areas.

After the vegetation is removed, an area shall be established to store asphalt and to set up an asphalt crusher. An asphalt crusher will be mobilized as needed to support asphalt disposal activities. All personnel operating the crusher shall receive training specific to that crusher. Barriers shall be installed to restrict access to the crushing area.

Survey markers will be placed to allow for horizontal and vertical control of the site. These markers will allow for (noninstrument) locating of old shaft locations and elevations. Offset grid lines will be established. The buried locations of the shafts under the asphalt pad will be marked on the asphalt. Areas of underlying fill where contamination could exist, based on the 1998 RFI sampling, will be delineated on the asphalt before asphalt removal starts and as required during the excavation process.

A surface water run-on diversion channel shall be constructed upgradient, west and southwest of Areas 2, 2A, and 2B. This diversion channel is designed to intercept surface water run-on from upgradient areas and to divert this run-on to the north with a discharge point at the south end of the existing culvert. The existing culvert shall be relocated vertically, as required, to maintain diversion channel grade. If the culvert is damaged or otherwise unusable, a new culvert will be installed. The area of the diversion channel will be surveyed to mark the channel location and the required excavation limits and grades. The accompanying design drawings should be consulted for details of the surface water run-on diversion channel.

Equipment planned for use in constructing the diversion channel includes a backhoe or a trackhoe (excavator), a motor grader, and a compactor. The diversion channel is planned to be approximately two feet in depth and a minimal width. The width will be a function of the construction equipment capabilities and is expected to be approximately 4 to 6 feet. Excavation of

the diversion channel shall start at the north end and progress to the south end to avoid the possibility of water accumulation in the channel during construction. The materials excavated from the diversion channel shall be placed on the downslope side of the channel and shall be compacted to lessen stabilization problems. The grade of the diversion channel will be checked during construction and at the end of construction. If the survey results indicate elevation (drainage) problems, the channel shall be regraded to ensure positive drainage (flow) to the north.

Once the final grade has been attained, the bottom of the surface water run-on diversion channel shall be compacted to minimize erosion. Then the culvert shall be permanently set, and the road shall be restored to its original condition. Efforts shall be made to limit the aerial extent of disturbance resulting from the construction of the diversion channel.

Following completion of the surface water run-on diversion channel, dry tuff shall be placed in low-lying areas adjacent to the asphalt pad, as needed to provide a stable working surface. The footprint (boundary) of the area where dry tuff fill is to be placed will be surveyed and delineated by the surveyors. This base material shall be compacted and graded smooth. At this time, the existing culvert to the northeast of the asphalt pad shall be cleaned, and drainage shall be established to ensure that no water accumulates during the ensuing removal and regrading operations.

After this base (tuff) pad is completed, asphalt removal can proceed. The asphalt is assumed to be approximately 4 to 8 inches thick. The asphalt removal activities will be performed as shown on Figure 1.

The asphalt pad shall be removed sequentially in approximately 20-ft by 20-ft squares or in sections sized to coincide with possible contamination levels of the underlying fill. A trackhoe is expected to be used to remove the asphalt. The equipment used to excavate the asphalt shall be supported by transfer equipment to take the asphalt either to a storage area or to a disposal facility. Because the fill is assumed to be clean, fill regrading shall occur after the asphalt has been removed. To minimize the possibility of cross contamination, an additional piece of equipment may be used to recontour the underlying fill. The fill material is expected to range from moist to saturated conditions.

Working from the adjacent asphalt surface, the first 20-ft by 20-ft square of asphalt shall be removed in the southwest corner of the site. The asphalt shall be temporarily stored adjacent to the section removed while awaiting field screening. Fill material adhering to the asphalt shall be removed by the trackhoe or by manual means. The undersides of the removed pieces of asphalt will be screened for radionuclides. While the asphalt and soil fill surface are being screened for contamination, the asphalt in the adjacent square to the north shall be removed. This process shall be repeated until all the asphalt in a 20-foot-wide strip along the west side of the pad is removed. When the asphalt removal operation reaches the end of the row, a delay may be experienced while awaiting the screening for radionuclides. This process shall be repeated across the asphalt pad.

Asphalt shall be transported to a nearby storage area, if required, while awaiting final disposition. The asphalt shall be temporarily stored on an HDPE liner incorporating a berm and precipitation cover. Asphalt shall be segregated and stored by expected similarity of possible contaminant constituents. The asphalt storage area shall be inspected for liner and cover integrity on a regular

interval. The integrity of this asphalt storage area shall be maintained until the asphalt has been transported off site.

A 100% FIDLER survey of the exposed fill material surface will be conducted following asphalt removal to identify possible areas of local contamination (hot spots) exceeding the action level for worker safety defined in the SSHASP (Environmental Restoration Project, in preparation (b)). Hot spots in the fill that would be of concern for worker safety and health are expected to be few in number, highly isolated, and small in volume. Any fill identified as hot spots, shall be excavated and drummed to isolate them from normal soil-handling practices. Hot spot removal may be done manually in lieu of using heavy equipment to minimize cross contamination. Hot spot materials shall be stored and then transported to TA-54, Area G, for disposal.

Following hot spot removal, the underlying fill material shall be recontoured to attain a final configuration that will facilitate gradual drainage from the resultant fill *pile*. Care shall be taken to not damage the casings of the boreholes penetrating the pad. A trackhoe shall be used to recontour the fill. The thickness of the fill is expected to average approximately 3 feet. If exceedingly wet fill is encountered, operations may have to be suspended to allow drying before regrading. No regrading of fill shall occur within one vertical foot of elevation of the concrete shaft caps, as determined during the 1998 RFI sampling. Concrete cap (shaft) locations will be surveyed and field located, as necessary, during the regrading process from the offset locations.

Redistribution of the underlying fill will occur incidental to the regrading effort. A trackhoe shall grade and shape the fill, working from the middle outward to the edges. The grooves left by the bucket teeth will aid in the natural drying of the fill. After this initial shaping, the fill shall be allowed to dry naturally for a short period of time.

After the fill materials have been allowed to dry for a sufficient length of time, areas adjacent to the fill shall be regraded to improve surface water drainage and eliminate ponding. The materials used in regrading shall include old fill materials already on the site and new fill materials brought in from off site. Drying of the site fill will occur as a part of the regrading process. The regraded materials shall be compacted to form a firm base for possible future activities at the site and to minimize future subsidence and the subsequent formation of potential ponding areas.

The final surface of the *pile* formed as a result of fill regrading and the subsequent redistribution incidental to grading shall be regraded to allow surface water to flow downslope to the edges without ponding. The regraded site contours are presented in the design drawings. This surface will be land surveyed and an evenly spaced grid of survey grade markers (hubchasers/whiskers) will be installed to mark the surface. At this time, a gross dry decontamination of the equipment used in fill-grading operations shall take place. This decontamination effort shall be done on this potentially contaminated fill surface. Liquids shall not be used in the decontamination process at this time.

After the fill has been recontoured, a comprehensive FIDLER survey of the recontoured fill surface will be performed to document the condition of that surface. Although hot spots may have been removed from that surface as needed for worker safety, this surface may not be free of contamination, and this survey will not be considered confirmatory sampling. Design information on the asphalt pad removal and fill excavation is presented in the design drawings.

Before proceeding with temporary cover construction, removal activities downgradient (north) of the road shall be undertaken. Surface soil contamination at MDA AB is included in PRS 49-001(g)

and has been found in a drainage channel downgradient and north of Areas 2, 2A, and 2B. A FIDLER survey will focus on those parts of PRS 49-001(g) that will be affected by runoff from the site project support areas. The objectives of this focus are to protect worker health and safety by providing areas for project construction and support activities that pose no risk to worker health and safety.

Contamination in PRS 49-001(g) downgradient and north of Areas 2, 2A, and 2B is expected to be minor and large volumes of contaminated soil are not anticipated. Those soils found to exceed the action level defined in the SSHASP (Environmental Restoration Project, in preparation (b)) shall be removed and disposed of accordingly. Before removal, the locations where contaminated soils are found will be reviewed for possible cultural and biological resources. Contaminated soils approved for removal shall be containerized (probably in drums) before disposal. Equipment shall be decontaminated, as appropriate, before moving to the downgradient location. Soils that would pose an unacceptable health and safety risk shall be sent to TA-54, Area G, for disposal. A FIDLER survey of the downgradient areas of activity will be performed to document the site conditions after soil removal is completed.

Following the downgradient removal activities, work shall resume at the fill (former asphalt pad) area. Before starting cover placement activities, the equipment used for the downgradient activities will undergo dry decontamination on the recontoured fill surface. After this decontamination process, temporary cover construction activities shall commence.

A temporary cover consisting of approximately six inches of clean crushed tuff overlain by approximately six inches of imported topsoil shall be placed across the surface of the fill and tuff (emplaced to prevent ponding) to isolate the potentially contaminated fill materials. All equipment engaged in the installation of this clean cover shall be uncontaminated before starting and decontaminated as required during the activity. Placement of the clean crushed tuff cover material shall begin at one edge and proceed in a fashion that eliminates the need to work on potentially contaminated fill. The clean tuff cover shall be compacted for structural integrity.

After the clean crushed tuff cover material has been completed, the approximately six-inch layer of topsoil will be placed. Because the topsoil will be compacted slightly as a function of placement, the topsoil shall be tilled, as necessary, to prepare a seedbed. If at the completion of topsoil placement, the season is appropriate for seeding, then the topsoil area will be seeded with a mix of short-rooted grasses. The anticipated seed mix is approximately 50% Blue Gramma and approximately 50% Western Wheatgrass. If this phase of the operation is completed at a time when seeding is inappropriate, then seeding will be delayed until the time is optimal for seeding. A gopher barrier consisting of a sturdy wire mesh or other devices shall be placed over the surface of the topsoil and fastened in a manner that will preclude gophers from burrowing into the site. The surface of the topsoil shall be armored with gravel to minimize erosion. This gravel armor will be applied manually to approximately 70% visual surface coverage. A land survey of the final surface will be performed and documented. Survey markers will again be installed to allow for visual assessment of possible erosion and cover loss.

The asphalt may be crushed, if required, before disposal, and disposal may occur at any time after removal. However, because of operational logistics, asphalt crushing, transport, and disposal activities are best scheduled to occur after the temporary cover is completed.

Although analysis of the asphalt samples collected during the RFI is expected to provide sufficient characterization for disposal, additional screening of the asphalt for radioactive contamination will be conducted during removal. The removed asphalt shall be segregated based on RFI analyses and operational field radiological screening. After excavation, the handling of the asphalt will be determined by sampling and screening. All clean asphalt meeting release criteria shall be crushed before any potentially contaminated asphalt is processed to minimize cross contamination.

Asphalt may be stored awaiting additional sampling and crushing. This asphalt shall be stored as dictated by the quantity. This asphalt may be stored in rolls, drums, or on plastic and covered. After crushing, if needed, asphalt found to be radioactively contaminated shall be sent to TA-54, Area G, for disposal. Although not expected, asphalt found to be contaminated by other than low levels of radioactivity shall be disposed of as indicated in the WCS form in the BMP plan. Asphalt, wood, and other organic matter will not be disposed of at the site because if the final corrective measure at the site involves an engineered cover, the amount of organic matter beneath the cover should be minimized to avoid gas generation. The assigned waste management coordinator (WMC) will be consulted throughout the removal, sampling, processing, storage, and shipment process. All contaminated materials shall be stored and monitored as directed by the WMC.

After the temporary cover is completed and the asphalt has been transported off site for disposal, site completion activities shall begin. All equipment and materials exposed to possible contamination shall be cleaned or decontaminated, as required. This final decontamination effort may require the installation and use of a decontamination facility that will support a thorough (wet) decontamination procedure. This facility shall be installed in a fashion that will not contaminate the site. This facility shall be removed when decontamination activities are completed. Decontamination products will be properly packaged, labeled, characterized, and disposed of as detailed in the WCS. All personnel, materials, and equipment will leave the site only with release approval by the RCT.

The site fencing, removed earlier, will be reinstalled and augmented as necessary. Appropriate signage will be installed on the fence. The MDA AB perimeter road shall be restored at the conclusion of the BMP plan. Site laydown, stockpile, parking, and waste storage areas will be cleaned of trash and construction materials. All areas disturbed during project activities shall be graded and seeded with an approved seed mix if the season is appropriate. If the season is not appropriate for seeding, the seeding of the site will be delayed until optimal conditions exist.

After all project work is completed, the area shall be inspected, and all trash shall be collected and disposed of. An inspection walk-through will be performed and a punch list of items requiring attention will be developed. Concurrence of satisfactory site condition will be obtained from the facility coordinator. The items on the punch list shall be completed, and project-related construction will be released by the program administrator.

REFERENCES

Environmental Restoration Project, in preparation. "RCRA Facility Investigation Site Screening Plan for Worker Health and Safety, Areas 2, 2A, 2B, Material Disposal Area AB, Technical Area 49," Los Alamos National Laboratory, Los Alamos, New Mexico. [Environmental Restoration Project, in preparation(a)]

Environmental Restoration Project, in preparation. "LANL ER Project Site-Specific Health and Safety Plan (SSHASP), Best Management Practices/Stabilization (BMP/S) at Material Disposal Area (MDA) AB, Areas 2, 2A and 2B - PRSs 49-001(b, c, d and g)," SSHASP No. 204, Los Alamos National Laboratory, Los Alamos, New Mexico. [Environmental Restoration Project, in preparation(b)]

Environmental Restoration Project, May 26, 1998. "LANL ER Project Site-Specific Health and Safety Plan (SSHASP), Construction of the Surface Water Run-on Diversion Channel and Related Features," SSHASP No. 206, Los Alamos National Laboratory, Los Alamos, New Mexico. (Environmental Restoration Project 1998, ER ID 57912)

11
12
13
14
15
16
17
18
19
20
21
22
23
24
25
26
27
28
29
30
31
32
33
34
35
36
37
38
39
40
41
42
43
44
45
46
47
48
49
50
51
52
53
54
55
56
57
58
59
60
61
62
63
64
65
66
67
68
69
70
71
72
73
74
75
76
77
78
79
80
81
82
83
84
85
86
87
88
89
90
91
92
93
94
95
96
97
98
99
100

TA-49 STABILIZATION PLAN FOR INSTALLING BMPs
SPECIFICATIONS

1
2
3
4
5
6
7
8

9
10
11
12
13
14
15



MORRISON KNUDSEN CORPORATION

SPECIFICATION TITLE SHEET

This sheet is a record of each issue or revision to the subject specification.

The exact sheets changed and the nature of the change should be noted under "Remarks." These remarks are not a part of the specification. The revised sheets become part of the original document and shall be compiled with in their entirety.

Issue Date	Author/ Reviser	Checked By	APPROVAL			REMARKS
			Department Manager	Project Engineer	Safety Review	
4/10/98	KLO	<i>[Signature]</i>	CAW	<i>[Signature]</i>	<i>[Signature]</i>	Issue "A" "ISSUED FOR REVIEW"

<i>Client, Project, Location</i> TA-49 STABILIZATION PLAN FOR INSTALLING BMPS PROJECT LOS ALAMOS NATIONAL LABORATORY LOS ALAMOS, NEW MEXICO	<i>Work Order</i> 4865	<i>Specification Title/Description</i> SUMMARY OF WORK
	<i>Specification</i> 01010	

SECTION 01010
SUMMARY OF WORK
TABLE OF CONTENTS

PART 1 GENERAL.....	1
1.1 INTRODUCTION.....	1
1.2 WORK BY SUBCONTRACTOR.....	1
1.3 WORK BY OTHERS.....	1
1.4 WORK SEQUENCE.....	2
1.5 SUBCONTRACTOR USE OF PREMISES.....	4
1.6 OCCUPANCY REQUIREMENTS.....	4
PART 2 PRODUCTS.....	4
PART 3 EXECUTION.....	4

SECTION 01010 - SUMMARY OF WORK

SECTION 01010
SUMMARY OF WORK

PART 1 GENERAL

1.1 INTRODUCTION

This project implements the best management practices (BMPs) that have been selected to stabilize the Technical Area (TA) 49 asphalt pad at Area 2 (Potential Release Site 49-001(b)) at the Los Alamos National Laboratory.

1.2 WORK BY SUBCONTRACTOR

A. The subcontract work consists of

1. site preparation,
2. construction of support areas,
3. clearing of vegetation and removal of surface debris from work areas,
4. removal of the existing asphalt pad,
5. hauling and stockpiling the asphalt,
6. limited regrading of the underlying wet fill,
7. placement of a layer of clean crushed tuff soil over the exposed wet fill and in isolated low areas,
8. placement of topsoil and gravel armor layers,
9. construction of an upstream surface water run-on diversion channel, and
10. site restoration and seeding of disturbed areas.

B. Based on the available records, the potential contaminants that might reasonably be expected to be in contact with the asphalt or be present in the underlying wet fill include uranium-235, uranium- 238, plutonium, beryllium, and lead. The approach to activities for removing the asphalt and regrading the underlying fill with the possible presence of uranium, plutonium, beryllium, and lead is presented herein.

C. The most elevated radionuclide levels in surface soils/fill at Areas 2, 2A, and 2B are concentrated in the northeast corner of Area 2 and appear to be associated with the exhumation of contaminated fill beneath the asphalt pad by gophers. No field work will be done in potentially contaminated areas without the direct involvement and approval of the radiological control technician (RCT) or site safety officer.

1.3 WORK BY OTHERS

Before work starts, existing power poles will be relocated to serve the existing facilities and to furnish power to a proposed air-sampling station located to the north of Area 2. The existing power line will be relocated by others.

1.4 WORK SEQUENCE

The work will be conducted in the following general sequence:

1. Clear vegetation from the construction support area. Trim plants at or above the existing soil level to avoid surface disturbance.
2. Construct parking, laydown, and storage areas.
3. All features that are to be preserved shall be identified, marked, and protected by tape or barricades/fencing, as required.
4. Set up a portable decontamination area/facility.
5. Set up portable sanitary facilities to meet the needs of the site work force.
6. Construct a surface water run-on diversion channel to the west of the work areas as shown on the drawings.
7. Relocate existing culvert at the north end of the diversion channel, as needed to maintain grade.
8. Clean out and inspect the existing culvert near the northeast corner of the asphalt pad. Modify or replace as required.
9. Remove portions of the existing chainlink fence that cross the asphalt pad. The fence and the fence area will be screened by the RCT or the RCT's delegate before the removal begins. The post anchors will be screened by the RCT or the RCT's delegate after removal. If the concrete and/or steel is determined to be contaminated, it shall be placed in drums or other suitable containers and stored and subsequently disposed of as stated on the Waste Characterization Strategy (WCS) form. Uncontaminated fence components shall be removed, stored nearby, and reinstalled at the end of the project. Establish exclusion, contamination reduction, and support zones, as required.
10. All surface debris shall be removed from the work area and screened, segregated, and disposed of, as appropriate according to the WCS.
11. Clear the potentially contaminated work areas. Trim vegetation at or near the existing ground surface without disturbing the subsurface. The vegetation in the areas of work will be removed and screened by the RCT or the RCT's delegate. Any vegetation determined to be contaminated shall be containerized and stored or disposed of as defined on the WCS form.
12. Establish and set up the asphalt stockpile area.
13. Install survey markers for horizontal and vertical control of the site. Areas of underlying fill where contamination is known to exist, based on the 1998 RFI sampling, shall be delineated on the asphalt before asphalt removal starts and as required during the excavation process.
14. Place, spread, and compact fill in isolated low areas as shown on the drawings to provide a stable working surface.
15. Begin asphalt pad removal. The asphalt is approximately 4 inches to 8 inches thick and will be treated as a low-level radioactive material. Working from the adjacent

asphalt surface, the asphalt shall be removed in approximate 20-foot by 20-foot square sections, starting in the southwest (potentially least contaminated) corner of the site. Asphalt shall be temporarily stored adjacent to the section removed while awaiting field screening. Fill material adhering to the asphalt shall be removed by mechanical or manual methods. The undersides of the removed pieces of asphalt shall be screened for radionuclides. While the asphalt and the exposed soil fill surface is being screened for contamination, the asphalt in the adjacent square to the north shall be removed. This process shall be repeated until all the asphalt in a 20-foot-wide strip along the west side of the pad is removed. When the asphalt removal operation reaches the end of the row, a delay may be experienced while awaiting the screening for radionuclides.

16. The removed asphalt shall be segregated, based on RFI analyses and operational field radiological screening. After excavation, the handling of the asphalt shall be determined by sampling and screening.
17. All clean asphalt meeting release criteria shall be hauled and stockpiled in the location shown on the drawings.
18. Asphalt suspected to be contaminated, based on RFI and/or field screening, shall be stored awaiting additional sampling. This asphalt shall be stored as dictated by the quantity and as directed by the contractor. This asphalt may be stored in roll-off containers, drums, or on plastic and covered. Asphalt found to be radioactively contaminated shall be sent to TA-54, Area G, for disposal. Although not expected, asphalt found to be contaminated by other than low levels of radioactivity shall be disposed of as indicated in the WCS form in the BMP plan. All contaminated materials shall be stored and monitored as directed by the WMC.
19. Regrade the underlying fill material by working from the perimeter of the asphalt pad footprint to obtain a smooth, rounded surface that drains to the perimeter. A 100% FIDLER survey of the exposed fill material surface shall be conducted following regrading to identify areas of local contamination (hot spots) exceeding the action level defined in the SSHASP for worker safety. Contaminated fill identified as hot spots shall be excavated and drummed to isolate them from normal soil handling practices. Hot spot removal may be done manually in lieu of using heavy equipment to minimize cross contamination. If exceedingly wet fill is encountered, operations may have to be suspended to allow drying before regrading.
20. Place, spread, and compact a 6-inch-thick layer of crushed tuff over the regraded fill material. Begin at one edge and proceed such that contact with potentially contaminated fill is avoided. Finish to contours and grades shown in the drawings.
21. Place and spread topsoil over the placed crushed tuff.
22. Place wire mesh and spread the gravel armor layer over the topsoil.
23. Reinstall site fencing removed earlier. Augment as necessary. Install signage on the fence.

24. Decontaminate all equipment and materials exposed to possible contamination. All personnel, materials, and equipment shall leave the site only with release approval by the RCT.
25. Clean the site laydown, stockpile, parking, and waste storage areas of trash and construction materials.
26. Restore disturbed areas. Grade and seed all disturbed areas and topsoil/gravel armor areas.

1.5 SUBCONTRACTOR USE OF PREMISES

- A. The subcontractor's use of the premises is limited only by the contractor's right to perform work or to retain other subcontractors on portions of the project.
- B. Limit use of the site to work in areas indicated above. Do not disturb portions of the site beyond the areas in which the work is indicated. Keep driveways and entrances serving the premises clear and available to the contractor, the contractor's employees, and emergency vehicles at all times. Do not use these areas for parking or storage of materials. Schedule deliveries to minimize space and time requirements for storage of materials and equipment on site.
- C. Nearby archeological sites will be delineated by barriers installed by ESH-20 personnel. All subcontractor personnel shall be instructed not to intrude into these archeological sites. Construction activities shall be limited to daylight hours and no off-road driving shall be permitted outside of the work area. No field disturbances shall occur without a site visit and approval of the area by a representative of ESH-20 for archeological/historical features.

1.6 OCCUPANCY REQUIREMENTS

The contractor will occupy the site and construction support area during the entire construction period. Cooperate with the contractor during construction operations to minimize conflicts and facilitate contractor usage. Perform the work so as not to interfere with the contractor's operations.

PART 2 PRODUCTS

Not used

PART 3 EXECUTION



Not used

END OF SECTION 01010

SPECIFICATION TITLE SHEET

This sheet is a record of each issue or revision to the subject specification.

The exact sheets changed and the nature of the change should be noted under "Remarks." These remarks are not a part of the specification. The revised sheets become part of the original document and shall be complied with in their entirety.

Issue Date	Author/ Reviser	Checked By	APPROVAL			REMARKS
			Department Manager	Project Engineer	Safety Review	
4/10/98	KWO		CAW			Issue "A" "ISSUED FOR REVIEW"

Client, Project, Location TA-49 STABILIZATION PLAN FOR INSTALLING BMPS PROJECT LOS ALAMOS NATIONAL LABORATORY LOS ALAMOS, NEW MEXICO	Work Order 4869	Specification Title/Description SUBMITTALS
	Specification 01300	

SECTION 01300
SUBMITTALS

TABLE OF CONTENTS

PART 1 GENERAL..... 1
1.1 SECTION INCLUDES..... 1
1.2 RELATED SECTIONS..... 1
1.3 SUBMITTAL PROCEDURES 1
1.4 CONSTRUCTION PROGRESS SCHEDULES..... 1
1.5 CONSTRUCTION PHOTOGRAPHS 2
PART 2 PRODUCTS..... 2
PART 3 EXECUTION 2

17-0004-01-0000

17-0004-01-0000

SECTION 01300
SUBMITTALS

PART 1 GENERAL

1.1 SECTION INCLUDES

- A. submittal procedures.
- B. construction progress schedules.
- C. construction photographs.

1.2 RELATED SECTIONS

- A. Section 01400, Quality Assurance
- B. Section 02200, Earthwork

1.3 SUBMITTAL PROCEDURES

- A. Transmit each submittal to contractor with a contractor-approved form.
- B. Sequentially number the transmittal forms. Revise submittals with original number and a sequential alphabetic suffix.
- C. Identify on form the project, contractor, subcontractor, pertinent drawing and detail number, and specification section number, as appropriate.
- D. Apply to form the subcontractor's stamp, signed or initialed certifying that review, approval, verification of products required, field dimensions, adjacent construction work, and coordination of information is in accordance with the requirements of the work and subcontract documents.
- E. Schedule submittals to expedite the project, and deliver to contractor. Coordinate submission of related items.
- F. For each submittal for review, allow 15 days excluding delivery time to and from the contractor.
- G. Identify variations from subcontract documents and product or system limitations that may be detrimental to successful performance of the completed work.
- H. Provide space for contractor review stamps.
- I. When a submittal is revised for resubmission, identify all changes made since previous submission.
- J. Distribute copies of reviewed submittals as appropriate. Instruct parties to promptly report any inability to comply with requirements.
- K. Submittals not requested by the contractor will not be recognized or processed.

1.4 CONSTRUCTION PROGRESS SCHEDULES

- A. Submit to contractor initial schedule in duplicate within 15 days after date of notice to proceed.

- B. Revise and resubmit schedule as required.
- C. Submit revised schedules with each application for payment, identifying changes since previous version.
- D. Submit a computer-generated horizontal bar chart with separate line for each major portion of work or operation, identifying first work day of each week.
- E. Show complete sequence of construction by activity, identifying work of separate stages and other logically grouped activities. Indicate the early and late start, early and late finish, float dates, and duration.
- F. Indicate estimated percentage of completion for each item of work at each submission.

1.5 CONSTRUCTION PHOTOGRAPHS

- A. Submit photographs to document work progress and milestones.
- B. Photographs: Two prints; color, glossy 4- by 6-inch size; mounted on 8 1/2- by 11-inch soft card stock, with left edge binding margin for three-hole punch. Also provide digital copy of all photographs.
- C. Take site photographs from differing directions indicating the relative progress of the work, 5 days maximum before submitting.
- D. Identify photographs with date, time, orientation, and project identification.

PART 2 PRODUCTS

Not Used

PART 3 EXECUTION

Not Used

END OF SECTION 01300



MORRISON KNUDSEN CORPORATION

SPECIFICATION TITLE SHEET

This sheet is a record of each issue or revision to the subject specification.

The exact sheets changed and the nature of the change should be noted under "Remarks." These remarks are not a part of the specification. The revised sheets become part of the original document and shall be complied with in their entirety.

Issue Date	Author/ Reviser	Checked By	APPROVAL			REMARKS
			Department Manager	Project Engineer	Safety Review	
4/10/98	KLO	<i>[Signature]</i>	CAW	<i>[Signature]</i>	<i>[Signature]</i>	Issue "A" "ISSUED FOR REVIEW"

<i>Client, Project, Location</i> TA-49 STABILIZATION PLAN FOR INSTALLING BMPs PROJECT LOS ALAMOS NATIONAL LABORATORY LOS ALAMOS, NEW MEXICO	<i>Work Order</i> 4869	<i>Specification Title/Description</i> QUALITY ASSURANCE
	<i>Specification</i> 01400	

**SECTION 01400
QUALITY ASSURANCE**

TABLE OF CONTENTS

PART 1 GENERAL	1
1.1 SECTION INCLUDES	1
1.2 QUALITY ASSURANCE - CONTROL OF INSTALLATION	1
1.3 INSPECTION SERVICES	1
PART 2 PRODUCTS	1
PART 3 EXECUTION	2
3.1 EXAMINATION	2

01400 - QUALITY ASSURANCE

SECTION 01400
QUALITY ASSURANCE

PART 1 GENERAL

1.1 SECTION INCLUDES

- A. quality assurance, control of installation.
- B. inspecting services.

1.2 QUALITY ASSURANCE, CONTROL OF INSTALLATION

- A. Monitor quality control over suppliers, manufacturers, products, services, site conditions, and workmanship, to produce work of specified quality.
- B. Comply with manufacturers' instructions, including each step in sequence.
- C. If manufacturers' instructions conflict with subcontract documents, request clarification from contractor before proceeding.
- D. Comply with specified standards as minimum quality for the work except where more stringent tolerances, codes, or specified requirements indicate higher standards or more precise workmanship.
- E. Perform work by persons qualified to produce required and specified quality.
- F. Verify that field measurements are as indicated on shop drawings or as instructed by the manufacturer.

1.3 INSPECTION SERVICES

- A. Contractor will perform inspection or will appoint, employ, and pay for specified services of an independent firm to perform inspection.
- B. The contractor or the independent firm will perform inspections and other services specified in individual specification sections and as required by the contractor.
- C. Inspecting may occur on or off the project site, as required by the contractor.
- D. Reports will be submitted by the independent firm to the contractor, indicating inspection observations and indicating compliance or noncompliance with subcontract documents.
- E. Cooperate with inspectors. Furnish safe access and assistance by incidental labor as requested.
- F. Notify contractor and independent firm 24 hours before expected time for operations requiring inspection services.
- G. Inspecting does not relieve subcontractor to perform work to subcontract requirements.

PART 2 PRODUCTS

Not used

SPECIFICATION TITLE SHEET

This sheet is a record of each issue or revision to the subject specification.

The exact sheets changed and the nature of the change should be noted under "Remarks." These remarks are not a part of the specification. The revised sheets become part of the original document and shall be compiled with in their entirety.

Issue Date	Author/Reviser	Checked By	APPROVAL			REMARKS
			Department Manager	Project Engineer	Safety Review	
4/10/98	KLO	<i>JJ</i>	CAW	<i>JJ</i>	<i>JJ</i>	Issue "A" "ISSUED FOR REVIEW"

Client, Project, Location TA-49 STABILIZATION PLAN FOR INSTALLING BMPs PROJECT LOS ALAMOS NATIONAL LABORATORY LOS ALAMOS, NEW MEXICO	Work Order 4869	Specification Title/Description CONSTRUCTION FACILITIES AND TEMPORARY CONTROLS
	Specification 01500	

SECTION 01500
CONSTRUCTION FACILITIES AND TEMPORARY CONTROLS

TABLE OF CONTENTS

PART 1 GENERAL	1
1.1 SECTION INCLUDES	1
1.2 TEMPORARY ELECTRICITY	1
1.3 TELEPHONE SERVICE	1
1.4 FACSIMILE SERVICE	1
1.5 TEMPORARY WATER SERVICE	1
1.6 TEMPORARY SANITARY FACILITIES	1
1.7 BARRIERS	1
1.8 FENCING	1
1.9 WATER CONTROL	2
1.10 PROTECTION OF WORK	2
1.11 SECURITY	2
1.12 PARKING	2
1.13 PROJECT IDENTIFICATION	2
1.14 FIELD OFFICES AND SHEDS	2
1.15 REMOVAL OF UTILITIES, FACILITIES, AND CONTROLS	2
PART 2 PRODUCTS	2
PART 3 EXECUTION	2

1000 - 01500 - CONSTRUCTION FACILITIES AND TEMPORARY CONTROLS

SECTION 01500

CONSTRUCTION FACILITIES AND TEMPORARY CONTROLS

PART 1 GENERAL

1.1 SECTION INCLUDES

- A. Temporary Utilities: electricity, telephone service, water, and sanitary facilities.
- B. Temporary Controls: barriers, enclosures and fencing, protection of the work, and water control.
- C. Construction Facilities: access roads, parking, project signage, and temporary buildings.

1.2 TEMPORARY ELECTRICITY

Subcontractor shall provide and pay for power service required.

1.3 TELEPHONE SERVICE

Provide, maintain, and pay for telephone service to subcontractor's field office at time of project mobilization.

1.4 FACSIMILE SERVICE

Provide, maintain and pay for facsimile service and a dedicated telephone line to subcontractor's field office at time of project mobilization.

1.5 TEMPORARY WATER SERVICE

Provide, maintain, and pay for suitable quality water service required for construction operations at time of project mobilization.

1.6 TEMPORARY SANITARY FACILITIES

Provide and maintain required facilities and enclosures for site work force. Existing facility use is not permitted. Provide at time of project mobilization.

1.7 BARRIERS

- A. Provide barriers to prevent unauthorized entry to construction areas and to protect existing facilities and adjacent properties from damage from construction operations.
- B. Provide protection for features designated to remain.
- C. Protect nonowned vehicular traffic, stored materials, site, and structures from damage.

1.8 FENCING

- A. Remove existing fencing as shown on the drawings and store for later reuse. All fencing shall be scanned before beginning work and upon removal. Dispose of contaminated fencing as directed by the contractor.
- B. Fencing shall be 6-foot-high commercial-grade chain link fence.
- C. Reinstall stored fencing at completion of the work. Furnish and install additional fencing as required to complete new fence alignment.

1.9 WATER CONTROL

Grade site to drain. Protect site from ponding or running water. Provide barriers as required to protect site from soil erosion and gophers.

1.10 PROTECTION OF WORK

Protect completed work and provide special protection where specified in individual specification sections.

1.11 SECURITY

Coordinate with Los Alamos National Laboratory site security.

1.12 PARKING

- A. Construct temporary gravel-surface parking areas to accommodate construction personnel.
- B. Do not allow vehicle parking on existing access roads.

1.13 PROJECT IDENTIFICATION

- A. Provide contractor-approved project sign of exterior grade plywood and wood frame construction, painted, with lettering by professional sign painter and corporate logo.
- B. List title of project, names of owner, contractor, and major subcontractors.
- C. Erect sign on site at location approved by contractor.
- D. No other signs are allowed without contractor permission, except those required by law.

1.14 FIELD OFFICES AND SHEDS

Offices and sheds locations shall be approved by contractor.

1.15 REMOVAL OF UTILITIES, FACILITIES, AND CONTROLS

- A. Remove temporary utilities, equipment, facilities, and materials before final application for payment.
- B. Grade site as indicated.

PART 2 PRODUCTS

Not used

PART 3 EXECUTION



Not used

END OF SECTION 01500

SPECIFICATION TITLE SHEET

This sheet is a record of each issue or revision to the subject specification.

The exact sheets changed and the nature of the change should be noted under "Remarks." These remarks are not a part of the specification. The revised sheets become part of the original document and shall be complied with in their entirety.

Issue Date	Author/ Reviser	Checked By	APPROVAL			REMARKS
			Department Manager	Project Engineer	Safety Review	
4/10/98	KLO		CAW			Issue "A" "ISSUED FOR REVIEW"

<p style="text-align: center;"><i>Client, Project, Location</i></p> <p>TA-49 STABILIZATION PLAN FOR INSTALLING BMPs PROJECT LOS ALAMOS NATIONAL LABORATORY LOS ALAMOS, NEW MEXICO</p>	<p style="text-align: center;"><i>Work Order</i></p> <p style="text-align: center;">4869</p> <hr/> <p style="text-align: center;"><i>Specification</i></p> <p style="text-align: center;">02200</p>	<p style="text-align: center;"><i>Specification Title/Description</i></p> <p style="text-align: center;">EARTHWORK</p>
---	---	--

100-000000-0000

**SECTION 02200
EARTHWORK**

TABLE OF CONTENTS

PART 1 GENERAL	1
1.1 SECTION INCLUDES	1
1.2 RELATED SECTIONS	1
1.3 REFERENCES	1
1.4 SUBMITTALS	1
PART 2 PRODUCTS	1
2.1 MATERIALS	1
2.2 EQUIPMENT	2
PART 3 EXECUTION	2
3.1 EXAMINATION AND PREPARATION	2
3.2 CLEARING	2
3.3 REGRADE AREA 2 FILL	2
3.4 CLEAN CRUSHED TUFF PLACEMENT	3
3.5 TOPSOIL PLACEMENT	3
3.6 GRAVEL ARMOR LAYER PLACEMENT	3
3.7 SURFACE WATER RUN-ON DIVERSION CHANNEL	3
3.8 CULVERT INSTALLATION	4
3.9 TOLERANCES	4
3.10 FIELD QUALITY CONTROL	4

SECTION 02200

EARTHWORK

PART 1 GENERAL

1.1 SECTION INCLUDES

- A. clearing
- B. regrading of existing fill
- C. placement of a layer of clean crushed tuff
- D. placement of a layer of topsoil
- E. placement of a gravel armor layer
- F. construction of a surface water run-on diversion channel
- G. installation of culverts

1.2 RELATED SECTIONS

Section 02220, Asphalt Removal and Stockpiling

1.3 REFERENCES

- A. American Society of Testing and Materials (ASTM)
 - ASTM D 422, Standard Test Method for Particle-Size Analysis of Soils
- B. New Mexico State Highway Department Standard Specifications for Road and Bridge Construction
 - Section 206, Excavation and Backfill for Culverts and Minor Structures

1.4 SUBMITTALS

- A. Submit one gradation test result for the gravel armor material for each material source.
- B. Submit equipment specifications for tracked equipment and compactor for contractor approval.
- C. Submit names of proposed topsoil, crushed tuff, and general fill borrow sources for contractor approval.

PART 2 PRODUCTS

2.1 MATERIALS

- A. Topsoil shall be obtained from a contractor-approved source.
- B. Crushed tuff shall be comprised of crushed, uncontaminated tuff obtained from a contractor-approved area. Crushed tuff shall not be placed when frozen.
- C. Gravel armor shall be comprised of hard, durable aggregate. The gravel armor shall be free of debris, trash, frozen materials, and organics. The gravel armor gradation, as determined in accordance with ASTM D 422, shall be within the following limits:

<u>US Std. Sieve Size</u>	<u>Percent Passing</u>
1 inch	100
3/8 inch	0-10

- D. General fill shall be comprised of contractor-approved uncontaminated soils obtained from project excavations and contractor-approved borrow areas.

2.2 EQUIPMENT

- A. Tracked equipment to be used for compacting crushed tuff shall have a minimum ground contact pressure of 6 psi.
- B. Compaction equipment to be used for proofrolling subgrade and for compacting general fill shall be a self-propelled vibratory compactor with a minimum operating weight of 13,000 lbs.

PART 3 EXECUTION

3.1 EXAMINATION AND PREPARATION

- A. Verify site conditions.
- B. Verify that survey bench marks and intended elevations for the work are as indicated.
- C. Identify required lines, levels, contours, and datum.
- D. Locate, identify, and protect from damage utilities, monitoring wells, and features that are to remain.
- E. Utilities requiring relocation will be relocated by others. Coordinate with contractor.
- F. Protect vegetation outside of the immediate work zone.
- G. Protect bench marks, survey control points, existing structures, and fences from equipment and vehicular traffic.

3.2 CLEARING

- A. Clear vegetation from only from those areas approved by the contractor to accommodate site features and construction operations. Trim vegetation at or near the ground surface. Do not grub.
- A. Remove surface debris, trash, excess, and unsuitable materials and dispose of as directed by contractor.

3.3 REGRADING AREA 2 FILL

- A. Equipment shall not be allowed to traffic directly upon the fill exposed by removal of the asphalt pad.
- B. Working from the perimeter of the removed asphalt pad footprint, regrade the fill to produce a smooth, rounded surface that drains away from Area 2 to perimeter ditches and drainages.

3.4 CLEAN CRUSHED TUFF PLACEMENT

- A. Place, spread, and compact a layer of crushed tuff on the regraded fill surface to the lines and grades shown on the drawings. The crushed tuff shall be placed in a single lift with a nominal compacted thickness of 6 inches.
- B. Begin placement at one end and proceed such that contact with potentially contaminated surfaces is avoided.
- C. Place additional crushed tuff lift(s) in isolated areas of potential ponding as shown on the drawings. Place crushed tuff in loose lifts not exceeding 12 inches in thickness.
- D. Each crushed tuff lift shall be compacted by tracking with a minimum of three passes by tracked equipment. Moisture conditioning of crushed tuff before compaction is not required.
- E. Following compaction, grade to produce a smooth, draining surface before placement of the topsoil and gravel armor layers.

3.5 TOPSOIL PLACEMENT

- A. Hand-place the wire mesh gopher barrier over the topsoil and stake using a contractor-approved method.
- B. Place and spread a single lift of topsoil over graded crushed tuff and other disturbed areas.
- C. The topsoil lift shall have a nominal thickness of 6 inches.
- D. Topsoil shall not be compacted.

3.6 GOPHER BARRIER AND GRAVEL ARMOR LAYER PLACEMENT

- A. Hand-place the wire mesh gopher barrier over the topsoil and stake using a contractor-approved method.
- B. Hand-spread the gravel armor layer over the topsoil in a single lift using a contractor-approved method.
- C. Gravel layer shall have areal coverage of approximately 70 percent.
- D. Compaction of the gravel protection layer is not required.

3.7 SURFACE WATER RUN-ON DIVERSION CHANNEL

- A. Proof-roll berm subgrade to identify soft spots. Cut out soft areas of subgrade not capable of compaction in place. Backfill with general fill and compact with a minimum of three passes of contractor-approved compactor. Moisture-condition backfill as needed before compacting to obtain a dense compacted material. Contractor will inspect and may direct subcontractor to alter the moisture content as the contractor deems appropriate.
- B. Overexcavation for the convenience of the subcontractor shall be backfilled as directed by the contractor and at no expense to the contractor.

- C. Excavate diversion channel to the lines and grades shown in the drawings. Overexcavation for the convenience of the subcontractor shall be backfilled as directed by the contractor and at no expense to the contractor.
- D. Use soils excavated from channel to construct adjacent berm. Obtain additional general fill from contractor-approved borrow source as needed.
- E. Place general fill to construct berm in loose lifts not exceeding 8 inches in thickness. Moisture condition fill before compaction as needed to obtain a dense compacted material. Contractor will inspect and may direct subcontractor to alter the moisture content as the contractor deems appropriate.
- F. Compact general fill with at least three passes of contractor-approved compactor.

3.8 CULVERT INSTALLATION

- A. Instal culverts in accordance with New Mexico State Highway Department Standard Specification Section 206.
- A. Minimum cover over culvert shall be 18 inches.

3.9 TOLERANCES

- A. All final graded surfaces shall be within plus or minus 0.1 foot of required elevations.
- A. The diversion channel final invert slope shall be within 0.3 percent of required slope and shall have positive drainage to outlet.
- A. Gravel armor layer coverage may vary depending upon the placement method used.

3.10 FIELD QUALITY CONTROL

- A. Perform the quality control inspections as detailed in Table 1.
- A. Rework or remove and replace work not meeting quality requirements as directed by the contractor.

**TABLE 1
FIELD QUALITY CONTROL INSPECTIONS**

Material	Inspection Item	Method	Frequency
Subgrade	Soft spots	Visual observation	Continuous
Crushed Tuff	Compaction passes	Visual observation	Continuous
	Loose lift thickness	Visual observation	Continuous
General Fill	Compaction passes	Visual observation	Continuous
	Field compaction moisture	Visual observation	Continuous
	Loose lift thickness	Visual observation	Continuous
Gravel Armor	Areal coverage	Visual observation	Continuous

END OF SECTION 02200



MORRISON KNUDSEN CORPORATION

SPECIFICATION TITLE SHEET

This sheet is a record of each issue or revision to the subject specification.

The exact sheets changed and the nature of the change should be noted under "Remarks." These remarks are not a part of the specification. The revised sheets become part of the original document and shall be compiled with in their entirety.

Issue Date	Author/ Reviser	Checked By	APPROVAL			REMARKS
			Department Manager	Project Engineer	Safety Review	
4/10/98	KLO	JB	CAW	JB	JB	Issue "A" "ISSUED FOR REVIEW"

<i>Client, Project, Location</i> TA-49 STABILIZATION PLAN FOR INSTALLING BMP'S PROJECT LOS ALAMOS NATIONAL LABORATORY LOS ALAMOS, NEW MEXICO	<i>Work Order</i> 4869	<i>Specification Title/Description</i> ASPHALT REMOVAL AND STOCKPILING
	<i>Specification</i> 02220	

MORRISON KNUDSEN CORPORATION

**SECTION 02220
ASPHALT REMOVAL AND STOCKPILING**

TABLE OF CONTENTS

PART 1 GENERAL.....	1
1.1 SECTION INCLUDES.....	1
1.2 RELATED SECTIONS.....	1
1.3 EQUIPMENT	1
PART 2 PRODUCTS.....	1
2.1 MATERIALS.....	1
PART 3 EXECUTION	1
3.1 EXAMINATION AND PREPARATION.....	1
3.2 EXCAVATION.....	1
3.3 HAULING, STOCKPILING, AND STORAGE.....	2
3.4 EQUIPMENT DECONTAMINATION	2

02220 - ASPHALT REMOVAL AND STOCKPILING

SECTION 02220
ASPHALT REMOVAL AND STOCKPILING

PART 1 GENERAL

1.1 SECTION INCLUDES

This section includes the requirements for removal and disposal of the existing asphalt pad at Technical Area (TA) 49, Area 2.

1.2 RELATED SECTIONS

Section 02200, Earthwork

1.3 EQUIPMENT

All equipment and tools used in the performance of the work covered by this section shall be subject to approval by the engineer before the work is started and shall be maintained in satisfactory working condition at all times. The equipment shall be adequate and shall have the capability of meeting the grade controls, thickness controls, and smoothness requirements set forth herein.

PART 2 PRODUCTS

2.1 MATERIALS

Asphalt forms a pad at Area 2 with 4-inch to 8-inch thickness.

PART 3 EXECUTION

3.1 EXAMINATION AND PREPARATION

- A. Clear the asphalt pad of all vegetation by trimming close to the asphalt surface.
- B. Prepare the asphalt stockpile area as shown in the project drawings.
- C. Install survey markers to establish vertical and horizontal control of the site.
- D. The contractor will delineate areas of known contamination on the asphalt pad surface before pad removal.

3.2 EXCAVATION

- A. Remove asphalt in sequential sections of approximately 20-foot squares, starting in the southwest corner and proceeding in a planned sequence across the pad.
- B. Reduce size of asphalt rubble during removal, as needed, to accommodate handling by equipment. Avoid intrusion by equipment into the underlying fill.
- C. Perform gross removal of fill adhering to the asphalt by mechanical methods or hand shovel.
- D. Minimize mixing of asphalt rubble into the underlying fill.
- E. Equipment shall not traffic on the exposed underlying fill.

- F. Temporarily store excavated asphalt on an adjacent section of the asphalt pad for field scanning for contamination.

3.3 HAULING, STOCKPILING, AND STORAGE

- A. Asphalt rubble that is not contaminated, as determined by field screening, shall be hauled and placed in the designated asphalt stockpile area.
- B. Asphalt rubble that has suspected contamination, as determined by field screening, shall be stored as directed by the contractor while awaiting confirmation sampling and testing.
- C. Asphalt rubble that has confirmed contamination shall be hauled to TA-54, Area G, for disposal.

3.4 EQUIPMENT DECONTAMINATION

After asphalt removal is completed, perform dry decontamination of equipment over areas that will be covered by clean crushed tuff before moving equipment to the decontamination pad.

END OF SECTION 02220