

**STORM WATER / SURFACE WATER
POLLUTION PREVENTION**

**BEST MANAGEMENT PRACTICES
(BMPS)**

GUIDANCE DOCUMENT

PREPARED BY:

**LOS ALAMOS NATIONAL LABORATORY
WATER QUALITY & HYDROLOGY GROUP (ESH-18)**

&

**MERRICK ENGINEERS & ARCHITECTS
LOS ALAMOS, NEW MEXICO**

Revision 1.0 August 1998

Preface

This guidance document was developed to provide information on the selection, installation, inspection, and maintenance of Best Management Practices (BMPs) designed to control the migration of potential pollutants to surface water. Its intent is to provide a consistent approach in the selection and use of BMPs at Los Alamos National Laboratory (LANL).

Under the National Pollutant Discharge Elimination System (NPDES) Storm Water Program, the Environmental Protection Agency (EPA) defines a BMP as “*schedules of activities, prohibitions of practices, maintenance procedures, and other management practices to prevent or reduce the pollution of waters of the United States. BMPs also include treatment requirements, operating procedures, and practices to control facility site runoff, spillage or leaks, sludge or waste disposal, or drainage from raw material storage.*” Potential pollutants include concentrated storm water runoff, erosion, and sediment transport.

The use of BMPs to minimize pollutant migration is a requirement of several regulatory programs, including the surface water quality standards established by the New Mexico Environment Department. BMP use is also associated with a LANL voluntary program for the control of non-point source pollution.

The BMPs discussed in this document are vegetative and structural controls designed to manage concentrated storm water runoff, minimize erosion and sediment transport, and to prevent a spill or leak from adversely impacting surface water and the environment. These selected BMPs are applicable for the arid climate of the region, and are commonly used in outside industry. The basis for the selection and use of these BMPs should be the environmental site conditions and/or job requirements. The BMPs are organized within the following sections:

- Sediment Retention Controls
- Diversion Structures & Controls
- Conveyance Structures & Controls
- Vegetative Controls
- Channel Stabilization
- Spill Prevention

This document is not intended to be inclusive of all the BMPs that may be applicable at LANL. As new surface water pollution controls are reviewed and used, they may be added to this document. In addition, the information provided in this document is not intended for use as an engineering design standard. Such applicable standards are found in the LANL Civil Standards Manual.

TABLE OF CONTENTS

TABLE OF FIGURES	III
------------------------	-----

SEDIMENT RETENTION CONTROLS

Silt Fence	1
Straw bale barrier	4
Brush barrier	7
Sediment traps & basins	10
Construction entrance/exit	15
Storm drain inlet protection	18

Diversion STRUCTURES & controls

Berms	25
Check dam	28
Waterbar	32
Surface roughening	35

Conveyance structures & controls

Pipe slope drain	39
Level spreader	42
Channels	45

Vegetative controls

Vegetative buffer zone	49
Mulching	52
Matting	54
Temporary Seeding	58
Permanent Seeding	60
Riprap	62
Gabions	65
Storm drain outlet protection	68
Cellular confinement systems	71

Spill prevention

Drum & container storage	74
Electrical Transformers	76
Salvage areas	77

APPENDICES

Appendix A	References
Appendix B	BMP Inspection and Maintenance Form

TABLE OF FIGURES

Silt Fence	3
Straw Bale Barrier	6
Brush Barrier	9
Sediment Traps	13
Typical Sediment Basin	14
Temporary Construction Entrance/Exit	17
Block and Gravel Drop Inlet Sediment Barrier	20
Straw Bale/Gravel Drop Inlet Sediment Barrier	21
Silt Fence Drop Inlet Sediment Barrier	22
Curb Inlet Sediment Barrier (Sandbags)	23
Curb and Gutter Sediment Barrier	24
Earth Berm	27
Rock Check Dam	30
Straw Bale Check Dam	31
Waterbar	34
Surface Roughening	37
Surface Roughening	38
Pipe Slope Drain	41
Level Spreader	44
Rock Lined Channel	47
Vegetation-Lined Channel	48
Vegetative Buffer Zone	51
Matting - Channel Installation	56
Matting - Slope Installation	57
Riprap	64
Gabions	67
Storm Drain Outlet Protection	70
Cellular Confinement System	73

SILT FENCE

GENERAL DESCRIPTION:

A silt fence is a temporary sedimentation control used most commonly on slope contours and within small drainage areas. Its primary function is to detain sediment onsite by creating minimal ponding of storm water runoff and allowing transported sediment to settle out. Traditional silt fence design consists of filter fabric attached to support posts with the lower portion of the fence vertically entrenched and covered by backfill. The fence may also be supported by wire mesh. Additional variations of silt fence design, such as straw bale barriers wrapped in filter fabric, are also used.

PROS:

- Relatively inexpensive for materials and construction
- Minimal clearing or grubbing prior to installation
- Easy to inspect
- Very effective when used with low velocity runoff
- No formal design is required
- Effective where sheet and rill erosion is a problem

CONS:

- Appropriate only for small drainage areas (approximately one acre or less)
- Appropriate only for low velocity flows (approximately less than 0.5 cfs)
- Not designed to support significant ponding
- Upslope grade perpendicular to the fence should not exceed 1:1
- Requires frequent inspection (minimum - after each significant rainfall)
- Requires prompt repair to maintain effectiveness

INSTALLATION GUIDELINES:

Traditional Silt Fence

- The height of a silt fence shall not exceed 36 inches. Ponding and sediment storage height shall not exceed 18 inches.
- The fence line shall follow the contour as closely as possible and maintain a uniform elevation.
- To help ensure maximum life expectancy of the silt fence, the filter fabric should contain ultraviolet ray inhibitors and stabilizers.
- Where possible filter fabric should be cut from a continuous roll to avoid the use of joints. If joints are required, the fabric should be spliced at a support post with a 6-inch minimum overlap. Both ends should be securely fastened to the post.
- Posts shall be spaced a maximum of 10 feet when wire support is used and a maximum of 6 feet apart when used without wire support. Posts should be driven into the ground a minimum of 12 inches.
- The ends of the fence shall be turned uphill.
- Along the line of posts, on the upslope side of the fence, a 4 inch wide trench shall be excavated and the filter fabric buried to a minimum depth of 6 inches. The trench shall be backfilled and the soil compacted over the toe of the filter fabric
- When using standard-strength filter fabric, a wire mesh support fence should be fastened to the upslope side of the posts using heavy duty wire staples at least 1 inch long, tie wires or hog rings. Extend the wire into the trench a minimum of 2 inches and no more than 36 inches above the original ground surface.
- The filter fabric shall then be stapled or wired to the fence with 6 inches of the fabric extending into the trench.

- When using extra-strength filter fabric, a wire mesh support fence is not required. The filter fabric shall then be stapled or wired directly to the posts.
- Silt fences shall be set at least 6 feet from the toe of a slope to increase ponding volume.

Straw Bale Silt Fence

- Bales shall be wrapped in filter fabric.
- Fences should be no more than one bale high.
- Bales should be embedded in a trench that has been excavated to a minimum depth of 4 inches.
- Bales should tightly abut one another.
- Gaps between bale sections should be filled, and backfill material should be tamped to prevent erosional displacement.

INSPECTION AND MAINTENANCE:

- For active field operations, silt fences shall be inspected weekly and within 24 hours, or the next available working day, following each storm event producing greater than 0.5 inches of precipitation.
- When site activity has ceased and significant surface runoff is not likely (arid season), inspections shall be conducted at least every other month and following each storm event producing greater than 0.5 inches of precipitation.
- If an additional inspection frequency is specified within a Storm Water Pollution Prevention (SWPP) Plan, this frequency shall be followed.
- Inspections shall be documented on the BMP Inspection and Maintenance Form.
- Inspectors should identify in particular:
 - ◆ Correct installation
 - ◆ Effectiveness in controlling sediment transport and erosion.
 - ◆ Damage that has occurred since the last inspection. *Most notably:* torn or sagging fences, areas where runoff has eroded a channel beneath or around the fence, and collapsed bales.
 - ◆ Required maintenance
 - ◆ Sediment accumulations and the need to remove the accumulations.
 - ◆ Evidence of erosion or other damage in the surrounding area.
- Accumulated sediment shall be removed when it reaches 1/3 to 1/2 the height of the silt fence.
- Removed sediment accumulations shall not be placed within any drainage, above or below the BMP.
- Removed sediment shall be stabilized to prevent future migration from storm water runoff.
- Required repairs should be conducted immediately and documented in the current or next inspection record.

Environmental media (e.g. soil, sediment, surface and ground water) is not considered waste. However, contaminated environmental media may constitute solid waste and/or hazardous waste. If there is any potential for accumulated sediment to be contaminated, a waste determination must be made and documented. For guidance, see the Laboratory's LIRs on Radioactive Waste, Managing Solid Waste, and Hazardous and Mixed Waste Requirements for Generators.

Inspection plans and records shall be maintained by the owner/operator, and made available for future regulatory inspections.

REMOVAL CRITERIA:

- Silt fences shall not be removed until the upslope area has been permanently stabilized with structural controls or vegetation.
- Final vegetative stabilization is defined as 70% of the vegetative cover that would exist under normal site conditions. The Water Quality & Hydrology Group (ESH-18) shall assist in making this determination.

For assistance with BMP selection, installation, or maintenance, please contact ESH-18 at 665-4752.

SILT FENCE

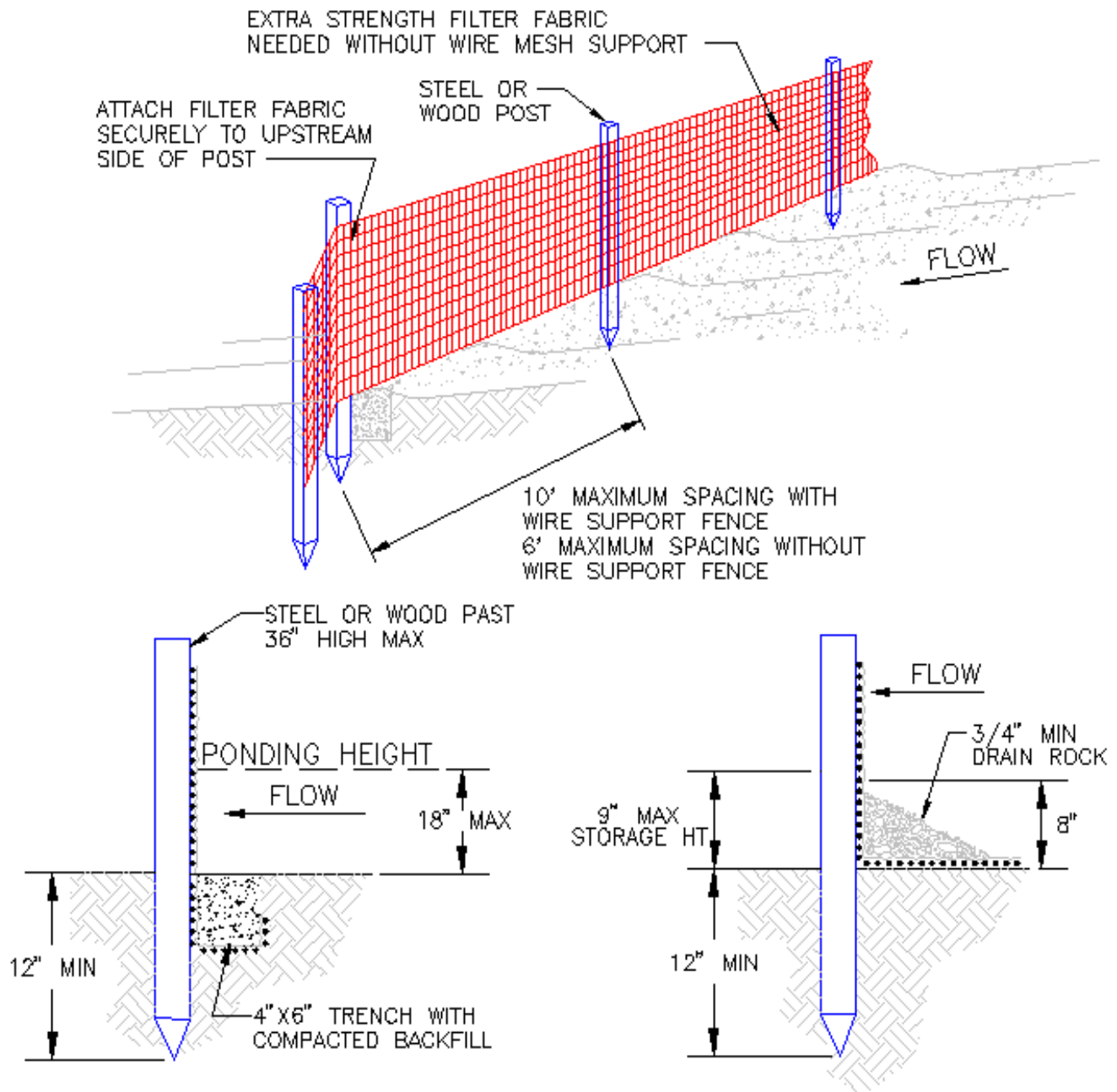

TRENCH DETAIL

INSTALLATION WITHOUT TRENCHING

NOTES:

1. SILT FENCE SHALL BE PLACED ON SLOPE CONTOURS TO MAXIMIZE PONDING EFFICIENCY.
2. WHEN USING WIRE MESH SUPPORT, EXTEND WIRE INTO TRENCH A MINIMUM OF 2 INCHES AND NO MORE THAN 36 INCHES ABOVE THE ORIGINAL GROUND SURFACE.
3. THE ENDS OF THE SILT FENCE SHALL BE TURNED UPHILL.
4. PLACE SILT FENCE AT LEAST 6 FEET FROM THE TOE OF A SLOPE.
5. PONDING HEIGHT SHALL BE A MAXIMUM OF 18₃ INCHES WITH TRENCH INSTALLATION

STRAW BALE BARRIER

GENERAL DESCRIPTION:

A straw bale barrier is a temporary sediment retention control. These barriers are designed for sheet flow runoff and detain sediment by ponding water and allowing sediment particles to settle out. They are also effective in reducing runoff velocity and minimizing erosion. Straw bale barriers are typically placed across a slope, at the toe of a slope, or around the perimeter of construction sites and land disturbing activities.

PROS:

- Inexpensive control
- Easy to install
- Easy to inspect
- Effective in detaining sediment from sheet flow runoff

CONS:

- Appropriate only for small drainage areas (approximately one acre or less)
- Appropriate only for low velocity flows (approximately less than 0.5 cfs)
- Upslope grade perpendicular to the fence should not exceed 2:1
- May require continual maintenance
- Life span is much shorter than that of a silt fence

INSTALLATION GUIDELINES:

- When placed at the toe of a slope, straw bales should be installed a minimum of 5-6 feet from the slope.
- Ponding and sediment storage height shall not exceed one half the height of the bale.
- Barriers should be no more than one bale high.
- Bales should be embedded in a trench that has been excavated to a minimum depth of 4 inches.
- Backfill material shall be firmly compacted.
- Bales should tightly abut one another.
- If the bales are bound with wire, place the bales so the wire does not contact the soil.
- When placed on a slope, anchor the bales in place with two 2 x 2 inch stakes or rebar through each bale. The first stake shall be driven toward the previously laid bale to force the bales tightly together, and stakes shall be driven into the ground a minimum of 18 inches.
- If used on a relatively flat surface in conjunction with regular inspections, the straw bales do not need to be anchored.
- Gaps between bales should be filled, and backfill material should be tamped to prevent erosional displacement.

INSPECTION AND MAINTENANCE:

- For active field operations, straw bale barriers shall be inspected weekly and within 24 hours, or the next available working day, following each storm event producing greater than 0.5 inches of precipitation.
- When site activity has ceased and significant surface runoff is not likely (arid season), inspections shall be conducted at least every other month and following each storm event producing greater than 0.5 inches of precipitation.
- If an additional inspection frequency is specified within a Storm Water Pollution Prevention (SWPP) Plan, this frequency shall be followed.
- Inspections shall be documented on the BMP Inspection and Maintenance Form.

- Inspectors should identify in particular:
 - ◆ Correct installation.
 - ◆ Effectiveness in controlling sediment transport and erosion.
 - ◆ Damage that has occurred since the last inspection.
 - ◆ Required maintenance.
 - ◆ Sediment accumulations and the need to remove the accumulations.
 - ◆ Evidence of erosion or other damage in the surrounding area.
- Closely inspect bales for deterioration.
- Accumulated sediment shall be removed when it reaches 1/2 to 1/3 the height of the bale.
- Removed sediment accumulations shall not be placed within any drainage, either above or below the BMP.
- Removed sediment shall be stabilized to prevent future migration from storm water runoff.
- Required repairs should be conducted immediately and documented in the current or next inspection record.

Environmental media (e.g. soil, sediment, surface and ground water) is not considered waste. However, contaminated environmental media may constitute solid waste and/or hazardous waste. If there is any potential for accumulated sediment to be contaminated, a waste determination must be made and documented. For guidance, see the Laboratory's LIRs on Radioactive Waste, Managing Solid Waste, and Hazardous and Mixed Waste Requirements for Generators.

Inspection plans and records shall be maintained by the owner/operator, and made available for future regulatory inspections.

REMOVAL CRITERIA:

- Straw bale barriers shall be removed when the area has been permanently stabilized with structural controls or vegetation.
- Final vegetative stabilization is defined as 70% of the vegetative cover that would exist under normal site conditions. The Water Quality and Hydrology Group (ESH-18) shall assist in making this determination.

For assistance with BMP selection, installation, or maintenance, please contact ESH-18 at 665-4752.

STRAW BALE BARRIER

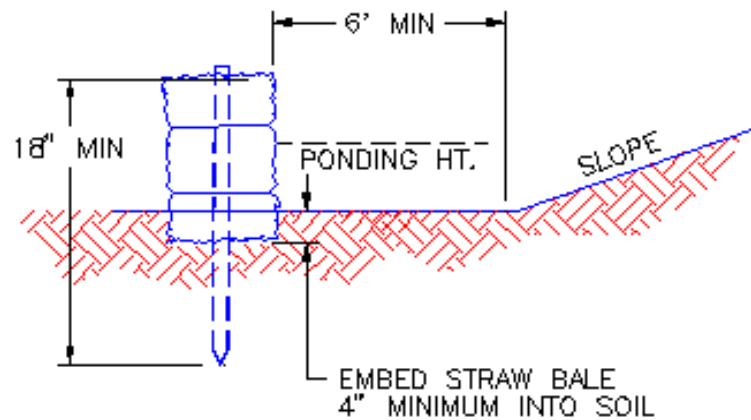

SECTION A - A

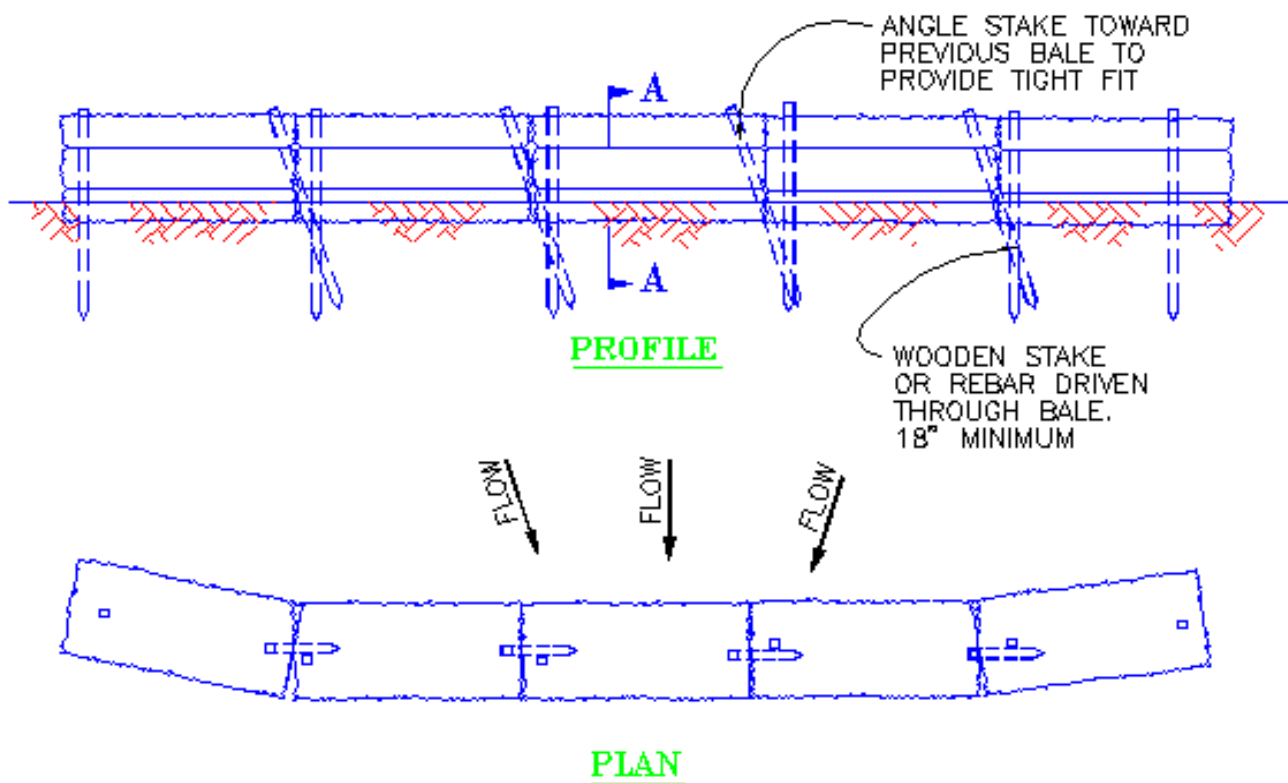

NOTES:

1. THE STRAW BALES SHALL BE PLACED ON SLOPE CONTOUR.
2. BALES TO BE PLACED IN A ROW WITH THE ENDS TIGHTLY ABUTTING.
3. FILL GAPS BETWEEN BALES AND TAMP BACKFILL MATERIAL TO PREVENT EROSION OR FLOW UNDER BALES.

BRUSH BARRIER

GENERAL DESCRIPTION:

A brush barrier is a temporary sediment retention control composed of cleared or grubbed materials such as brush, tree limbs, weeds or grasses, root material, soil and rock. When piled together and placed at the toe of a slope or at the bottom perimeter of a disturbed area, these material reduce runoff velocity and trap and retain sediment. Brush barriers can be constructed by either binding material together with twine or by placing filter fabric over the piled material. The use of filter fabric increases filtering efficiency.

PROS:

- Inexpensive to construct
- Constructed from onsite waste material, minimizing disposal volumes
- Easy to install
- Requires very little maintenance
- If applicable to site conditions, the barrier will naturally decompose over time

CONS:

- Appropriate only for small drainage areas (approximately one acre or less)
- Cannot be placed in drainage channels or at the toe of steep slopes (greater than 2:1)
- Has limited sediment retention and cannot be used in place of a sediment trap
- If constructed without filter fabric, may be unsightly in appearance

INSTALLATION GUIDELINES:

- When placed at the toe of a slope, the barrier should be installed a minimum of 5-6 feet from the slope.
- Pile barrier material uniformly in a row, minimizing voids.
- Minimize the amount of top soil included with the barrier material.
- To minimize the possibility of leaching, do not use wood chips.
- Ensure that brush and tree limbs are not removed from an area of contamination.
- Ponding height should not exceed more than 2/3 the height of the barrier.

Vegetation Only

- Large material such as brush and tree limbs shall bound together with twine or other suitable material.
- Fill gaps with appropriate loose material.
- To anchor the barrier, place wooden stakes along the downhill edge. Stakes shall be driven into the ground a minimum of 12 inches.
- Stakes shall be spaced a maximum of 10 feet apart.

Filter Fabric

- Along the uphill edge of the barrier, excavate a trench 4 inches wide and a minimum of 6 inches deep.
- Drape filter fabric over the barrier, extending the fabric into the trench.
- Bury the filter fabric to a minimum depth of 6 inches.
- Backfill the trench and firmly compact the soil.
- On the downhill side of the barrier, approximately 1-2 feet from the edge, stakes shall be driven into the ground a minimum of 12 inches. Stakes shall be spaced a maximum of 10 feet apart.
- Anchor the downhill edge of the fabric by tying twine, or other suitable material, from the fabric to the stakes.

INSPECTION AND MAINTENANCE:

- For active field operations, brush barriers shall be inspected weekly and within 24 hours, or the next available working day, following each storm event producing greater than 0.5 inches of precipitation.
- When site activity has ceased and significant surface runoff is not likely (arid season), inspections shall be conducted at least every other month and following each storm event producing greater than 0.5 inches of precipitation.
- If an additional inspection frequency is specified within a Storm Water Pollution Prevention (SWPP) Plan, this frequency shall be followed.
- Inspections shall be documented on the BMP Inspection and Maintenance Form.
- Inspectors should identify in particular:
 - ◆ Correct installation.
 - ◆ Effectiveness in controlling sediment transport and erosion.
 - ◆ Damage that has occurred since the last inspection.
 - ◆ Required maintenance.
 - ◆ Sediment accumulations and the need to remove the accumulations.
 - ◆ Evidence of erosion or other damage in the surrounding area.
- Inspect the filter fabric for tears or other damage.
- Inspect the barrier for areas breached by concentrated flows.
- Accumulated sediment shall be removed when it reaches 1/3 to 1/2 the height of the barrier.
- Removed sediment accumulations shall not be placed within any drainage, either above or below the BMP.
- Removed sediment shall be stabilized to prevent future migration from storm water runoff.
- Required repairs should be conducted immediately and documented in the current or next inspection record.

Environmental media (e.g. soil, sediment, surface and ground water) is not considered waste. However, contaminated environmental media may constitute solid waste and/or hazardous waste. If there is any potential for accumulated sediment to be contaminated, a waste determination must be made and documented. For guidance, see the Laboratory's LIRs on Radioactive Waste, Managing Solid Waste, and Hazardous and Mixed Waste Requirements for Generators.

Inspection plans and records shall be maintained by the owner/operator, and made available for future regulatory inspections.

REMOVAL CRITERIA:

- Brush barriers shall not be removed until the area has been permanently stabilized with structural controls or vegetation.
- Final vegetative stabilization is defined as 70% of the vegetative cover that would exist under normal site conditions. The Water Quality and Hydrology Group (ESH-18) shall assist in making this determination.

For assistance with BMP selection, installation, or maintenance, please contact ESH-18 at 665-4752.

BRUSH BARRIER

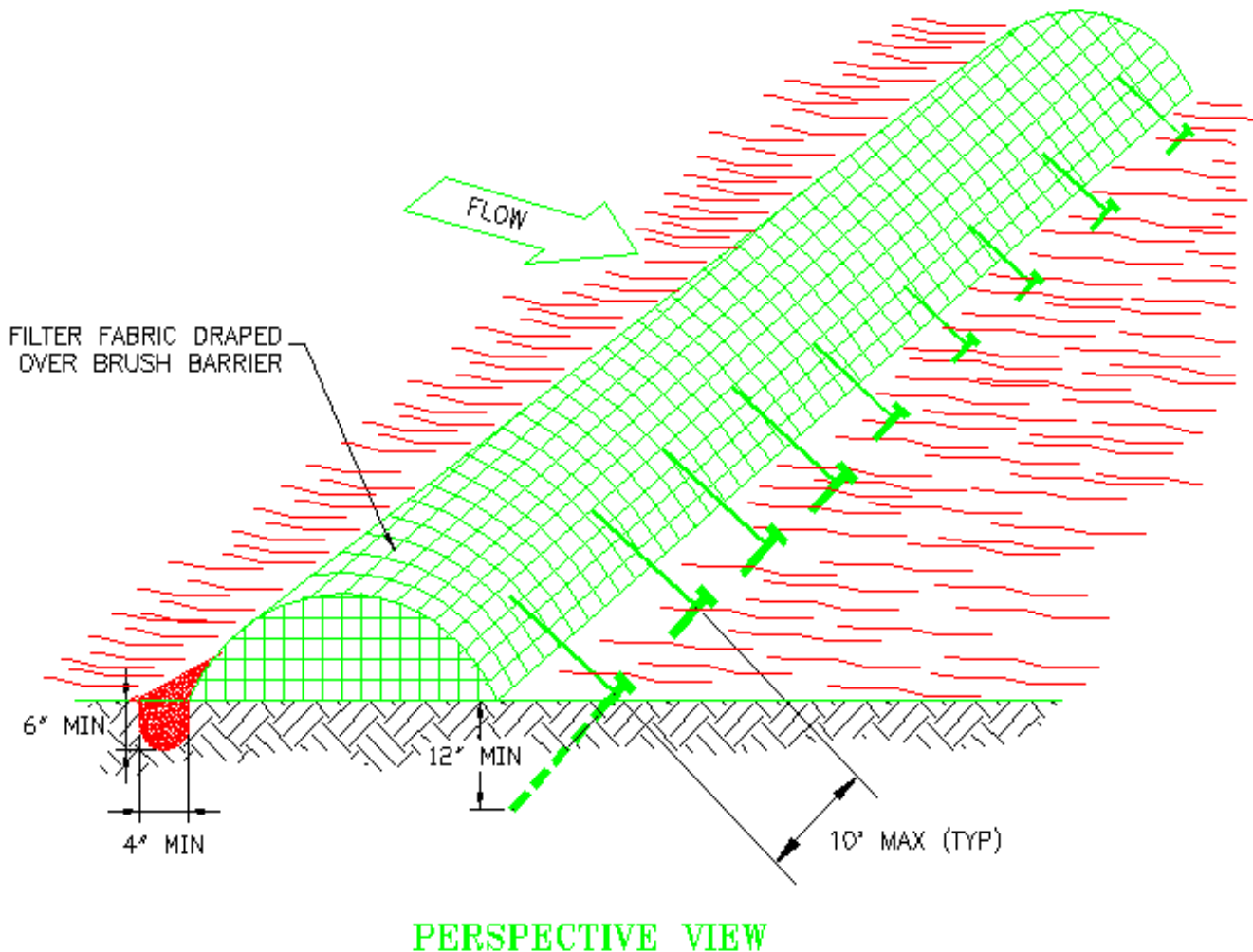

PERSPECTIVE VIEW

NOTES:

1. BARRIER MAY BE CONSTRUCTED WITH CLEARED OR GRUBBED MATERIAL SUCH AS BRUSH, TREE LIMB, ROOT MATERIAL, SOIL, AND ROCK.
2. DRAPE FILTER FABRIC OVER BARRIER, EXTENDING INTO TRENCH ON UPHILL SIDE OF BARRIER. BURY FILTER FABRIC TO A MINIMUM DEPTH OF 6 INCHES.
3. ON THE DOWNHILL SIDE, STAKES SHALL BE DRIVEN INTO THE GROUND APPROXIMATELY 1 TO 2 FEET FROM THE EDGE OF THE BARRIER. EACH STAKE SHALL BE DRIVEN A MINIMUM OF 12 INCHES INTO THE GROUND AND SPACED A MAXIMUM OF 10 FEET APART. FILTER FABRIC SHALL THEN BE ANCHORED BY TYING TWINE OR EQUIVALENT MATERIAL FROM THE FABRIC TO THE STAKES.
4. PONDING HEIGHT SHALL NOT EXCEED 2/3 OF THE HEIGHT OF THE BARRIER.
5. BARRIER SHALL BE INSTALLED A MINIMUM OF 5 TO 6 FEET FROM THE TOE OF A SLOPE.

SEDIMENT TRAPS & BASINS

GENERAL DESCRIPTION:

Sediment traps and basins are excavated depressions, or naturally low areas with an earthen embankment, used to detain sediment laden runoff while excess sediment settles. Runoff is detained within the trap or basin and released through a controlled outlet structure or a spillway that is usually constructed from stone. The amount of sediment retained, as well as the particle size of the retained sediment, is dependent upon runoff detention time. Sediment traps and basins perform the same function but basins are typically larger in size, serve a larger drainage area, and make use of a controlled outlet structure.

PROS:

- Effective in reducing offsite sediment transport
- Depending on size, can be effective in retaining small and fine sediment particles
- Depending on design, may be used with concentrated and high volume flows
- Minimizes sediment accumulations in downstream storm water conveyances

CONS:

- Requires continual maintenance and accessibility for removal of sediment accumulations
- Accumulated sediment may be difficult to remove
- May occupy large areas that must be avoided during construction activities
- Basins may require additional controls to ensure adherence to applicable safety practices

INSTALLATION GUIDELINES:

- Sediment traps and basins should be designed to be used in conjunction with other BMPs.
- Traps and basins should be located where loss of containment would not cause loss of life or property damage.
- Traps and basins shall not be located in a natural watercourse.
- Traps and basins shall be constructed prior to the start of any land disturbing activities.
- Clear or grub the installation area, removing trees, brush, stumps, and other obstructions.
- Remove vegetation within the installation area to facilitate the cleanout of sediment accumulations.
- Ensure that fill material for embankments is free of roots, woody vegetation, and large stones.
- When constructing embankments, place fill material in 6 inch lifts and compact each lift with a compactor or with the appropriate earth moving equipment.
- When compacting with earth moving equipment, construct the embankment 10% higher than the design elevation to allow for settlement. When using a compactor, construct the embankment 5% higher than the design elevation.
- As soon as practicable, stabilize the embankment with seed, mulch, or matting.

Sediment Trap

- Traps should not be used for drainage areas exceeding 5 disturbed acres.
- Traps shall not be used as permanent structures.
- The embankment height for traps should not exceed 5 feet.
- Ensure that sediment trap cut and fill slopes have a maximum slope of 3:1.
- Spillways should be designed to provide the trap with a 1.5 foot settling zone and a 1 foot sediment storage zone.
- The trap outlet area shall be lined with filter fabric prior to placement of stone or gravel.
- Stones used to construct the spillway should be between 6 and 12 inches in diameter.

Sediment Basin

- Basins should be used for drainage areas exceeding 5 disturbed acres.
- Basin geometry and side slope ratios shall conform to design specifications.
- The volume of a basin should include a settling zone of at least 2 feet and a minimum 1.5 foot sediment storage zone.
- A subsurface drain and/or a solid riser pipe with dewatering holes should be used to provide sufficient runoff detention time.
- The basin entrance should be as far as practicable from the outlet to maximize runoff detention time.
- The riser pipe shall be securely attached to the discharge pipe with all connections being watertight.
- Ensure that the riser and discharge pipe are placed on a firm, smooth soil foundation. Sand, gravel, crushed stone, or other pervious materials shall not be used as backfill around the pipe.
- At the discharge pipe spillway, place fill material around the pipe in 4-inch lifts. Compact the material to at least the same density as the adjacent embankment.
- Construct an emergency spillway with the crest elevation being one foot higher than the end of the riser pipe. Ensure that spillway width, and entrance and exit slopes conform to design specifications.
- Ensure that the emergency spillway is not constructed in fill material and, as soon as practicable, stabilize the emergency spillway with seed, mulch, or matting.
- If the basin outlet is a rock lined spillway, line the outlet area with filter fabric prior to placement of stone or gravel.
- Stones used to construct the spillway should be a minimum of 6 inches in diameter.

INSPECTION AND MAINTENANCE:

- For active field operations, sediment traps and basins shall be inspected weekly and within 24 hours, or the next available working day, following each storm event producing greater than 0.5 inches of precipitation.
- When site activity has ceased and significant surface runoff is not likely (arid season), inspections shall be conducted at least every other month and following each storm event producing greater than 0.5 inches of precipitation.
- If an additional inspection frequency is specified within a Storm Water Pollution Prevention (SWPP) Plan, this frequency shall be followed.
- Inspections shall be documented on the BMP Inspection and Maintenance Form.
- Inspectors should identify in particular:
 - ◆ Correct installation.
 - ◆ Effectiveness in controlling runoff and sediment transport.
 - ◆ Damage that has occurred since the last inspection.
 - ◆ Required maintenance.
 - ◆ Sediment accumulations and the need to remove the accumulations.
 - ◆ Evidence of erosion or other damage in the surrounding area.
- Closely inspect embankments for undermining, erosion, or other damage.
- Accumulated sediment shall be removed when it exceeds ½ the design sediment storage volume.
- Removed sediment accumulations shall not be placed within any drainage, either above or below the BMP.
- Removed sediment shall be stabilized to prevent future migration from storm water runoff.
- Required repairs should be conducted immediately and documented in the current or next inspection record.

Environmental media (e.g. soil, sediment, surface and ground water) is not considered waste. However, contaminated environmental media may constitute solid waste and/or hazardous waste. If there is any potential for accumulated sediment to be contaminated, a waste determination must be made and documented. For guidance, see the Laboratory's LIRs on Radioactive Waste, Managing Solid Waste, and Hazardous and Mixed Waste Requirements for Generators.

Inspection plans and records shall be maintained by the owner/operator, and made available for future regulatory inspections.

REMOVAL CRITERIA:

- Traps and basins shall not be removed until the disturbed area has been permanently stabilized with structural controls or vegetation.
- Final vegetative stabilization is defined as 70% of the vegetative cover that would exist under normal site conditions. The Water Quality and Hydrology Group (ESH-18) shall assist in making this determination.

For assistance with BMP selection, installation, or maintenance, please contact ESH-18 at 665-4752.

SEDIMENT TRAP

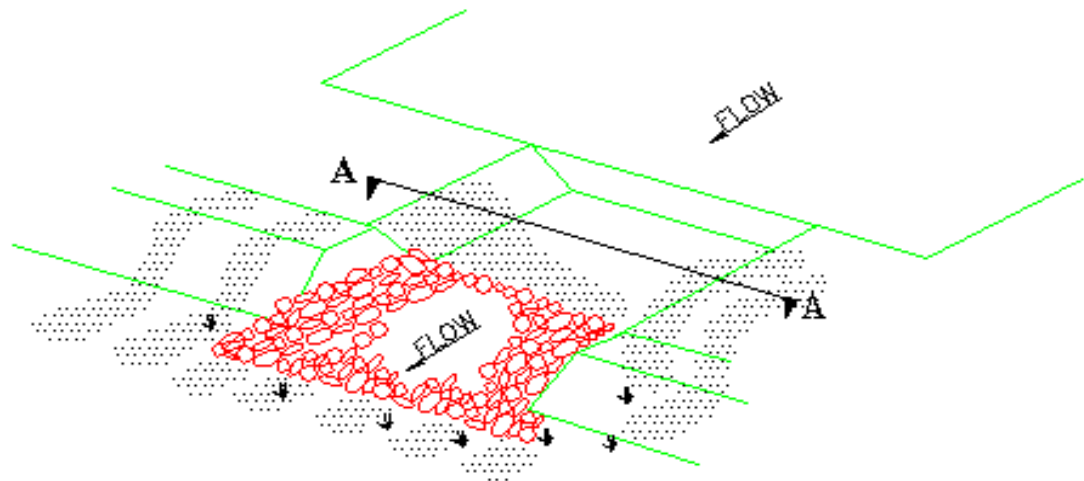

PERSPECTIVE VIEW



SECTION A - A

NOTE:

1. CUT AND FILL SLOPES IN TRAPS SHALL BE 3:1 OR FLATTER.
2. ENSURE THAT FILL MATERIAL FOR EMBANKMENTS IS FREE OF ROOTS, WOODY VEGETATION, AND LARGE STONES.
3. STABILIZE EMBANKMENTS WITH SEED, MULCH, MATTING, OR OTHER APPLICABLE MEASURE.
4. LINE THE TRAP OUTLET AREA WITH FILTER FABRIC PRIOR TO PLACEMENT OF STONE OR GRAVEL.
5. SEDIMENT TRAPS SHALL NOT BE USED FOR DRAINAGE AREAS EXCEEDING 5 ACRES IN SIZE.

TYPICAL SEDIMENT BASIN

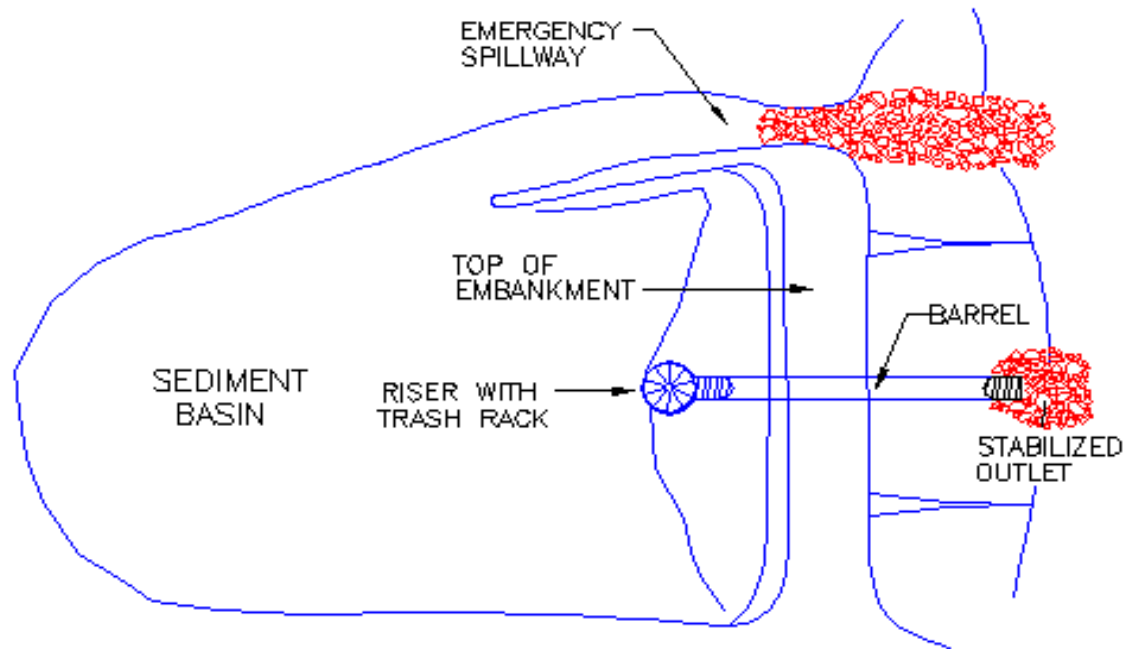

PLAN

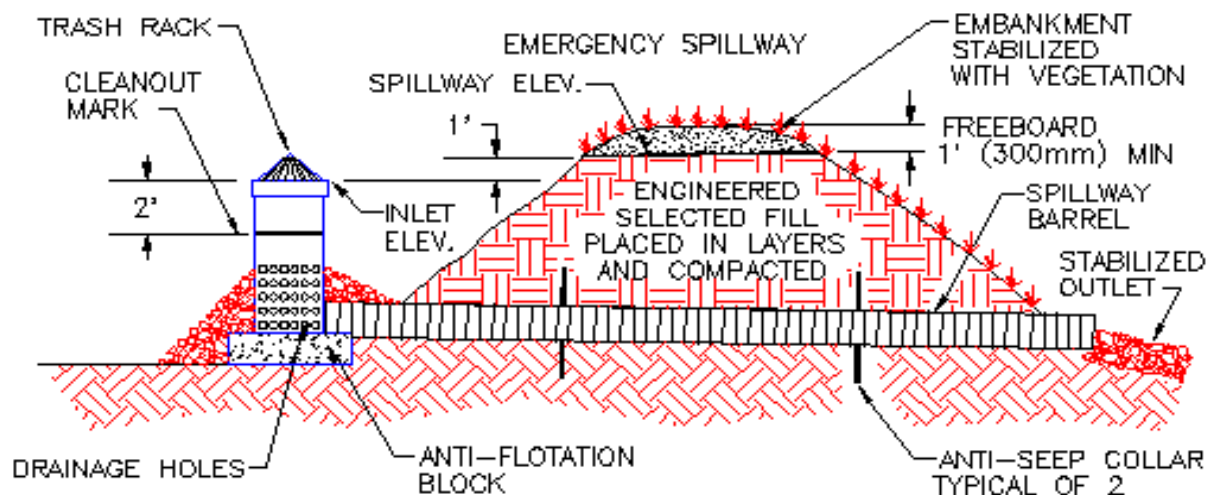

SECTION

NOTES:

1. BASINS SHALL BE USED FOR AREAS GREATER THAN 5 ACRES IN SIZE.
2. ENSURE THAT FILL MATERIAL FOR EMBANKMENTS IS FREE OF ROOTS, WOODY VEGETATION, AND LARGE STONES.
3. LINE THE BASIN OUTLET AREA WITH FILTER FABRIC PRIOR TO PLACEMENT OF STONE OR GRAVEL.
4. ENSURE THAT THE EMERGENCY SPILLWAY IS NOT CONSTRUCTED FROM FILL MATERIAL.
5. STABILIZE EMBANKMENTS AND EMERGENCY SPILLWAY WITH SEED, MULCH, MATTING, OR OTHER APPLICABLE MEASURES.

CONSTRUCTION ENTRANCE/EXIT**GENERAL DESCRIPTION:**

A temporary construction entrance/exit is a small area that has been stabilized with gravel. This pad is located at the location where vehicles enter and exit a construction site. Its purpose is to filter the sediment that collects on vehicles and eliminate off-site tracking of sediment.

PROS:

- Easy to install
- Easy to inspect
- Minimal cost to construct
- Effective in reducing off-site sediment transport

CONS:

- Requires continual maintenance
- Depending upon soil conditions, may be difficult to clean out sediment
- Location is dependent upon proximity to water sources and storm drains

INSTALLATION GUIDELINES:

- The gravel used for pad construction shall be 2-3 inch maximum size aggregate.
- Gravel placement shall conform to the grade and dimensions shown on the design drawings.
- If required, geotextile fabrics should be used to improve the stability of the pad foundation.
- Gravel shall be spread to a minimum thickness of 6 inches.
- The pad shall extend the full width of the entrance/exit. Minimum pad width shall be 12 feet.
- Minimum pad length shall be 50 feet.
- If possible, entrance/exit pads shall not be placed on steep grades or at curves in public roads.
- Controls shall be established to prevent sediment from the pad from entering storm drains or other watercourses.

INSPECTION AND MAINTENANCE:

- For active field operations, temporary construction entrance/exits shall be inspected weekly and within 24 hours, or the next available working day, following each storm event producing greater than 0.5 inches of precipitation.
- When site activity has been reduced to periodic traffic and significant surface runoff is not likely (arid season), inspections shall be conducted at least every other month and following each storm event producing greater than 0.5 inches of precipitation.
- If an additional inspection frequency is specified within a Storm Water Pollution Prevention (SWPP) Plan, this frequency shall be followed.
- Inspections shall be documented on the BMP Inspection and Maintenance Form.
- Inspectors should identify in particular:
 - ◆ Correct installation.
 - ◆ Effectiveness in controlling sediment transport.
 - ◆ Damage that has occurred since the last inspection.
 - ◆ Required maintenance.
 - ◆ Sediment accumulations and the need to remove the accumulations.
 - ◆ Evidence of erosion or other damage in the surrounding area.
- As required, add additional layers of gravel to the pad to prevent off-site tracking of sediment.

Storm Water and Surface Water Pollution Prevention*August 1998*

- Replace gravel as required.
- Removed sediment accumulations shall not be placed within any drainage, either above or below the BMP.
- Removed sediment shall be stabilized to prevent future migration from storm water runoff.
- Required repairs should be conducted immediately and documented in the current or next inspection record.

Environmental media (e.g. soil, sediment, surface, and ground water) is not considered waste. However, contaminated environmental media may constitute solid waste and/or hazardous waste. If there is any potential for accumulated sediment to be contaminated, a waste determination must be made and documented. For guidance, see the Laboratory's LIRs on Radioactive Waste, Managing Solid Waste, and Hazardous and Mixed Waste Requirements for Generators.

Inspection plans and records shall be maintained by the owner/operator, and made available for future regulatory inspections.

REMOVAL CRITERIA:

- Temporary construction entrance/exits shall be removed when the area has been permanently stabilized, or when all construction activities have ceased.
- Final stabilization is defined as 70% of the vegetative cover that would exist under normal site conditions. The Water Quality and Hydrology Group (ESH-18) shall assist in making this determination.

For assistance with BMP selection, installation, or maintenance, please contact ESH-18 at 665-4752.

TEMPORARY GRAVEL CONSTRUCTION ENTRANCE/EXIT

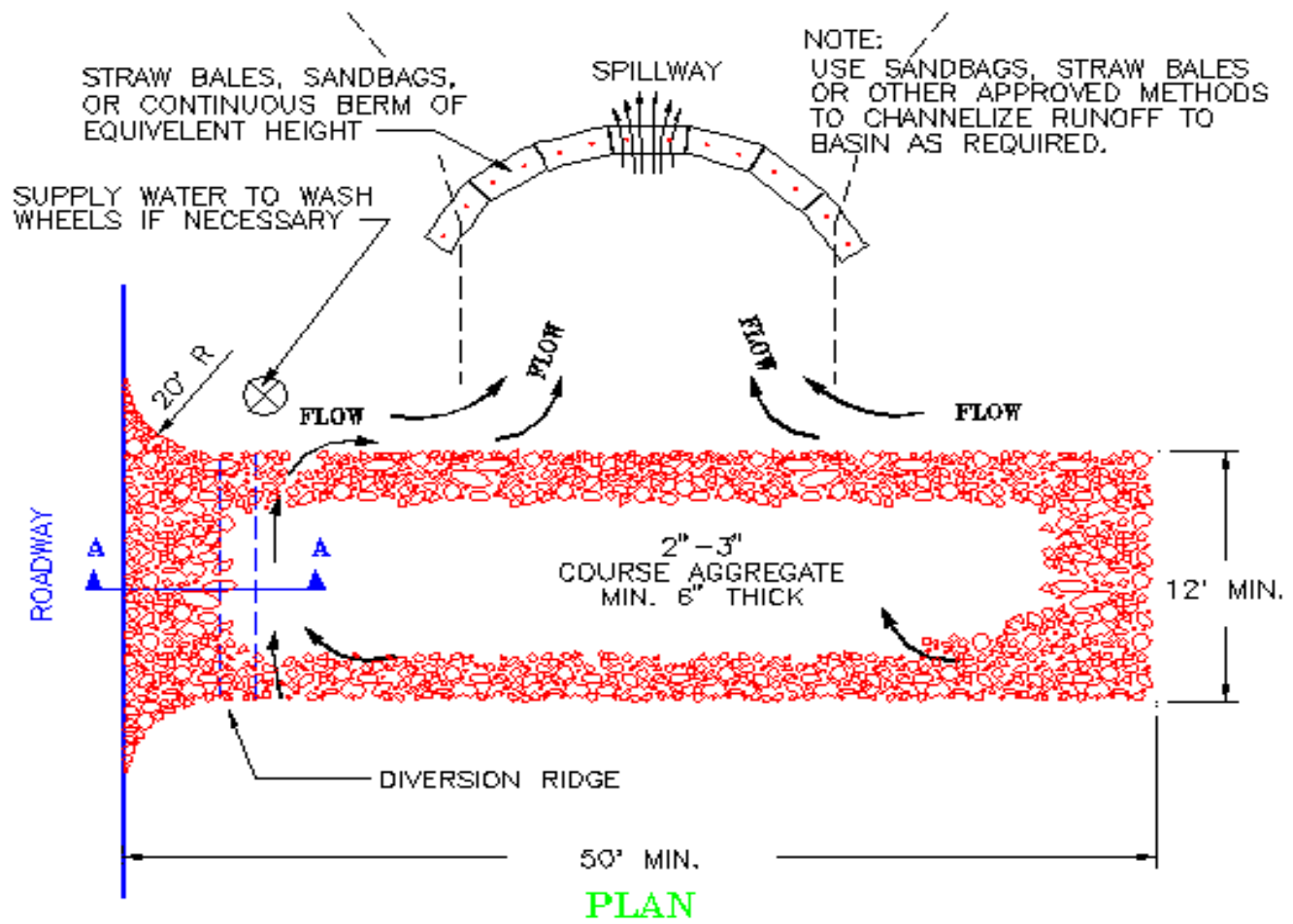
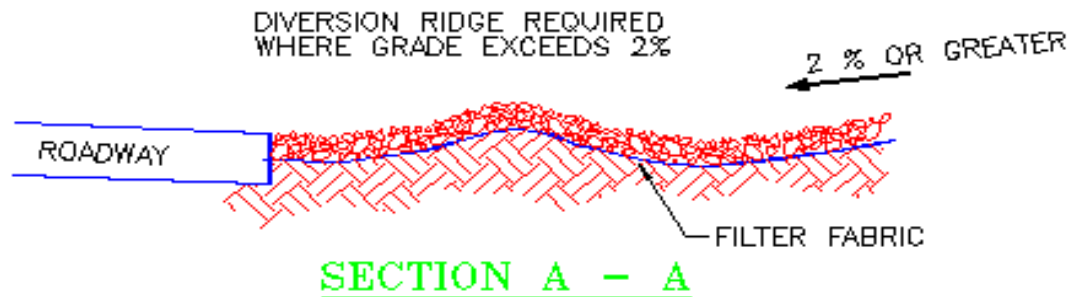

NOTES:

1. THE ENTRANCE SHALL BE MAINTAINED IN A CONDITION THAT WILL MINIMIZE SEDIMENT TRACKING OR TRANSPORT ONTO PUBLIC ROADWAYS. THIS MAY REQUIRE ADDING ADDITIONAL LAYERS OF GRAVEL, REPAIR AND/OR CLEANOUT OF MEASURES USED TO TRAP SEDIMENT.
2. WHEN NECESSARY, WHEELS SHALL BE CLEANED PRIOR TO ENTRANCE ONTO PUBLIC ROADWAYS.
3. VEHICLE WASHING SHALL BE CONDUCTED IN A STABILIZED AREA WITH APPROPRIATE STORM WATER CONTROLS IN PLACE.

STORM DRAIN INLET PROTECTION**GENERAL DESCRIPTION:**

A storm drain inlet protection is a temporary sediment barrier that is placed around either a drop or curb drain inlet. The barriers prevent sediment from entering a storm drain by ponding runoff and allowing sediment to settle out. These barriers are also designed to allow overflow from large storm events. Inlet protection is most commonly constructed from straw bales, sandbags, filter fabric, and concrete blocks and gravel.

PROS:

- Easy to inspect
- Prevents silting-in of storm drain inlets
- Effective in reducing off-site sediment transport

CONS:

- Requires continual maintenance
- Accumulated sediment may be difficult to remove
- Practical only for relatively low volume flows

INSTALLATION GUIDELINES:

- Installation of inlet protection shall precede soil disturbing activities.
- Inlet protection material shall correspond to site conditions and the size of the drainage area.
- Inlet protection should be used in combination with other controls.
- Protection barriers should be placed on gentle slopes to facilitate ponding.
- Barrier placement shall allow for overflow from a large storm event. Overflow shall not be bypassed over the curb.

Sandbags

- Sandbag material shall be a type of geotextile fabric that will not rapidly deteriorate.
- Fill sandbags with 3/4 inch drain rock or 1/4 inch pea gravel.
- Sandbags shall be placed in a curved row with the ends curved and pointing uphill.
- Sandbags should be packed tightly and placed in overlapping layers.
- To allow overflow, form a spillway in the sandbag structure by leaving a one-sandbag gap in the top row.

Straw Bale

- Straw bales shall be embedded within a trench around the inlet. The trench should be as wide as a straw bale and excavated to a minimum depth of 4 inches.
- If the bales are bound with wire, place the bales so the wire does not contact the soil.
- Orient the straw bales lengthwise around the inlet.
- Anchor the bales in place with two 2 x 2 inch stakes or rebar through each bale.
- Fill void spaces between the bales as necessary.

Filter Fabric

- Filter fabric shall be attached to steel or 2 by 4 inch wood support posts. Posts shall have a minimum length of 3 feet and a maximum spacing of 3 feet. A top frame support is recommended.
- Measured from the top of the inlet, the maximum height of the silt fence shall be a 1.5 feet.
- Bury the bottom of the silt fence in 4 inch wide by 6 inch deep trench.
- The excavated trench shall be backfilled with soil and firmly tamped.

Concrete Blocks & Gravel

- Blocks shall be embedded within a trench around the inlet. The trench should be as wide as a block and excavated to a minimum depth of 3 inches.
- Place the blocks around the inlet, tightly abutting the ends.
- If the blocks being used have openings, place wire mesh or filter fabric over the openings.
- To assist in sediment retention, backfill the blocks with $\frac{3}{4}$ - 2 inch gravel. Firmly compact the backfill.

INSPECTION AND MAINTENANCE:

- For active field operations, storm drain inlet protections shall be inspected weekly and within 24 hours, or the next available working day, following each storm event producing greater than 0.5 inches of precipitation.
- When site activity has ceased and significant surface runoff is not likely (arid season), inspections shall be conducted at least every other month and following each storm event producing greater than 0.5 inches of precipitation.
- If an additional inspection frequency is specified within a Storm Water Pollution Prevention (SWPP) Plan, this frequency shall be followed.
- Inspections shall be documented on the BMP Inspection and Maintenance Form.
- Inspectors should identify in particular:
 - ◆ Correct installation.
 - ◆ Effectiveness in controlling sediment transport.
 - ◆ Damage that has occurred since the last inspection.
 - ◆ Required maintenance.
 - ◆ Sediment accumulations and the need to remove the accumulations.
 - ◆ Evidence of erosion or other damage in the surrounding area.
- Inspect inlet barriers for the accumulation of trash.
- Replace materials as required.
- Accumulated sediment shall be removed when it reaches 1/3 to 1/2 the height of the inlet protection.
- Removed sediment accumulations shall not be placed within any drainage, either above or below the BMP.
- Removed sediment shall be stabilized to prevent future migration from storm water runoff.
- Required repairs should be conducted immediately and documented in the current or next inspection record.

Environmental media (e.g. soil, sediment, surface, and ground water) is not considered waste. However, contaminated environmental media may constitute solid waste and/or hazardous waste. If there is any potential for accumulated sediment to be contaminated, a waste determination must be made and documented. For guidance, see the Laboratory's LIRs on Radioactive Waste, Managing Solid Waste, and Hazardous and Mixed Waste Requirements for Generators.

Inspection plans and records shall be maintained by the owner/operator, and made available for future regulatory inspections.

REMOVAL CRITERIA:

- Storm drain inlet protections shall be removed when the area has been permanently stabilized, or when the construction of permanent storm drain structures has been completed.
- Final stabilization is defined as 70% of the vegetative cover that would exist under normal site conditions. The Water Quality and Hydrology Group (ESH-18) shall assist in making this determination.

For assistance with BMP selection, installation, or maintenance, please contact ESH-18 at 665-4752.

BLOCK AND GRAVEL DROP INLET SEDIMENT BARRIER

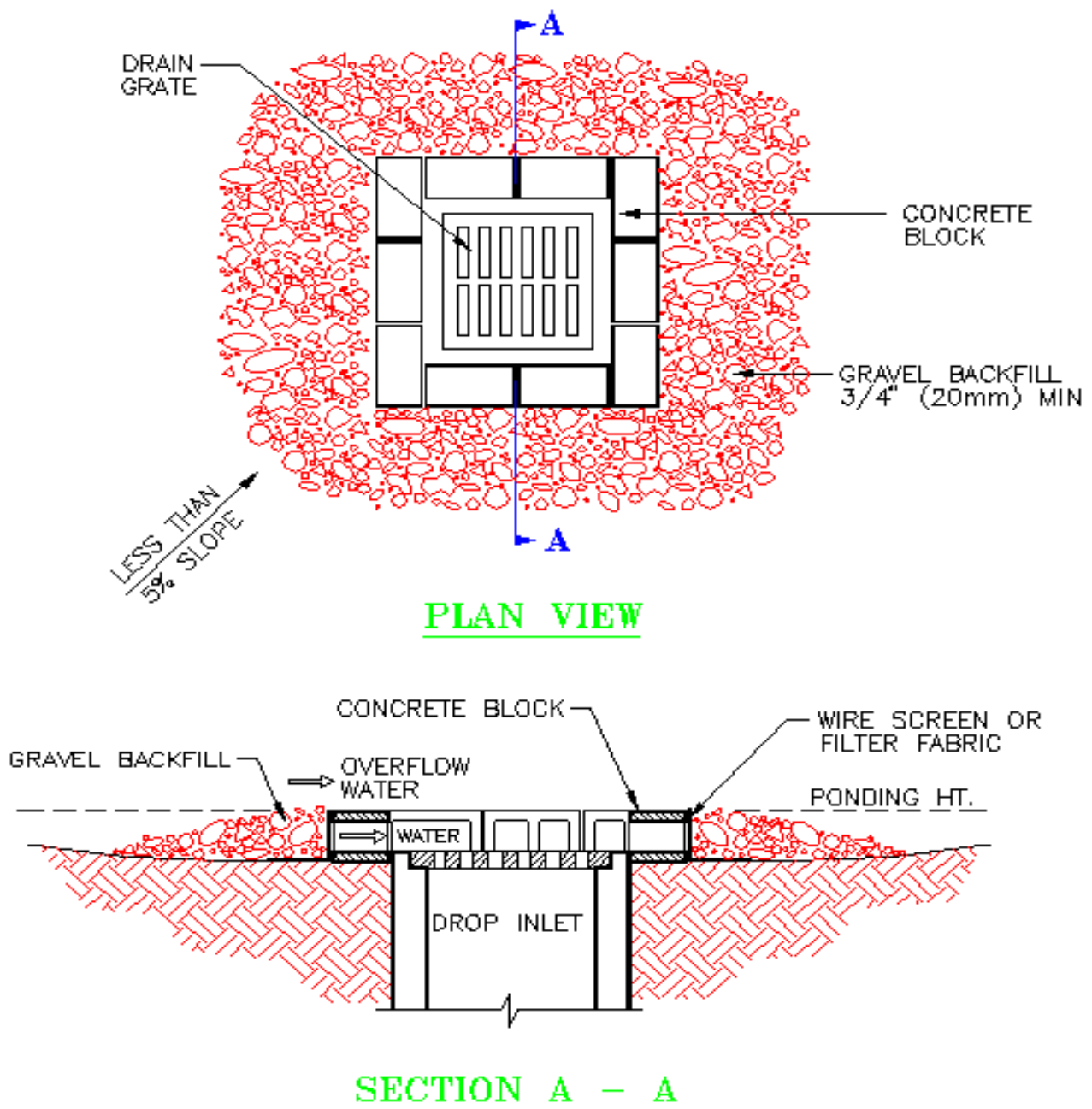

NOTES:

1. DROP INLET SEDIMENT BARRIERS ARE TO BE USED FOR SMALL, NEARLY LEVEL (LESS THAN 5%) DRAINAGE AREAS.
2. BLOCKS SHALL BE EMBEDDED IN A TRENCH AROUND THE INLET TO A MINIMUM DEPTH OF 3", WITH THE ENDS TIGHTLY ABUTTING.
3. BACKFILL THE BLOCKS WITH GRAVEL TO ASSIST IN SEDIMENT RETENTION.
4. THE TOP OF THE STRUCTURE (PONDING HEIGHT) MUST BE WELL BELOW THE GROUND ELEVATION DOWNSLOPE TO PREVENT RUNOFF FROM BYPASSING THE INLET.

STRAW BALE/GRAVEL DROP INLET SEDIMENT BARRIER

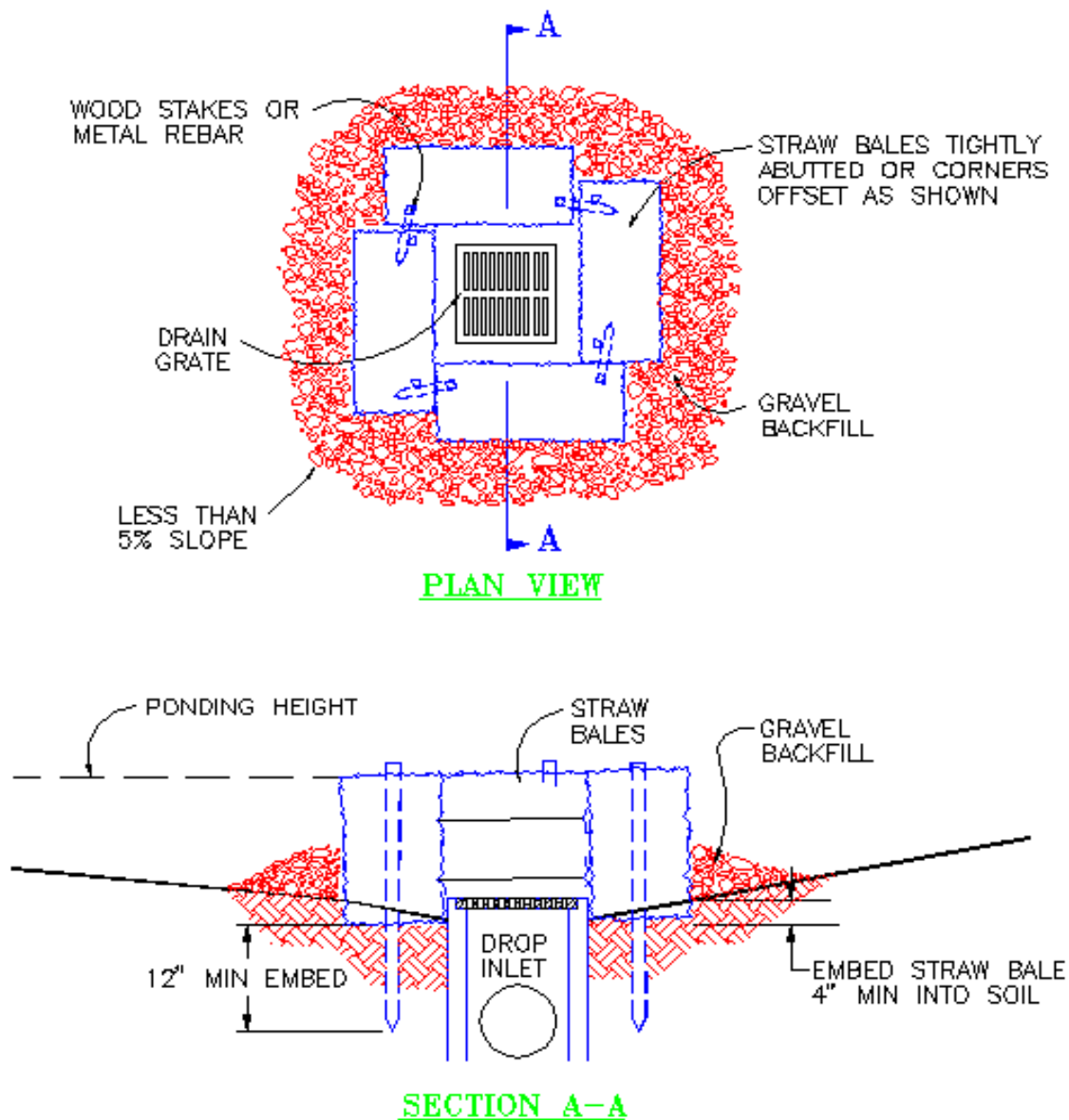

NOTES:

1. DROP INLET SEDIMENT BARRIERS ARE TO BE USED FOR SMALL, NEARLY LEVEL (LESS THAN 5%) DRAINAGE AREAS.
2. ORIENT BALES LENGTHWISE AROUND THE INLET AND EMBED THE BALES 4" INTO THE SOIL. OFFSET CORNERS OR PLACE BALES WITH ENDS TIGHTLY ABUTTING.
3. ANCHOR BALES WITH TWO 2" X 2" STAKES OR REBAR. MINIMUM EMBEDMENT SHALL BE 12".
4. BACKFILL AROUND BALES WITH GRAVEL TO PREVENT EROSION OR FLOW AROUND THE BALES.
5. THE TOP OF THE STRUCTURE (PONDING HEIGHT) MUST BE WELL BELOW THE GROUND ELEVATION DOWNSLOPE TO PREVENT RUNOFF FROM BYPASSING THE INLET.

SILT FENCE DROP INLET SEDIMENT BARRIER

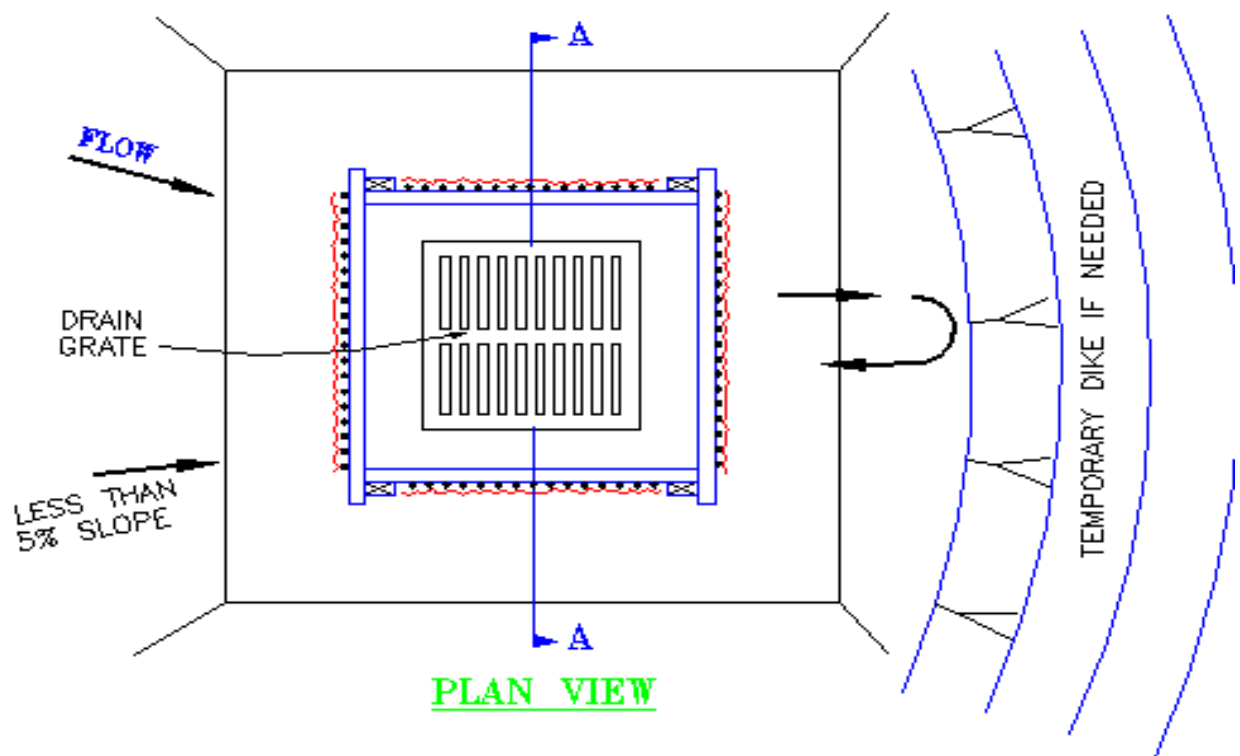

PLAN VIEW

ATTACH FILTER FABRIC SECURELY TO 2X4 WOOD FRAME, OVERLAPPING FABRIC TO NEXT STAKE

TOP FRAME NECESSARY FOR STABILITY

PONDING HT.

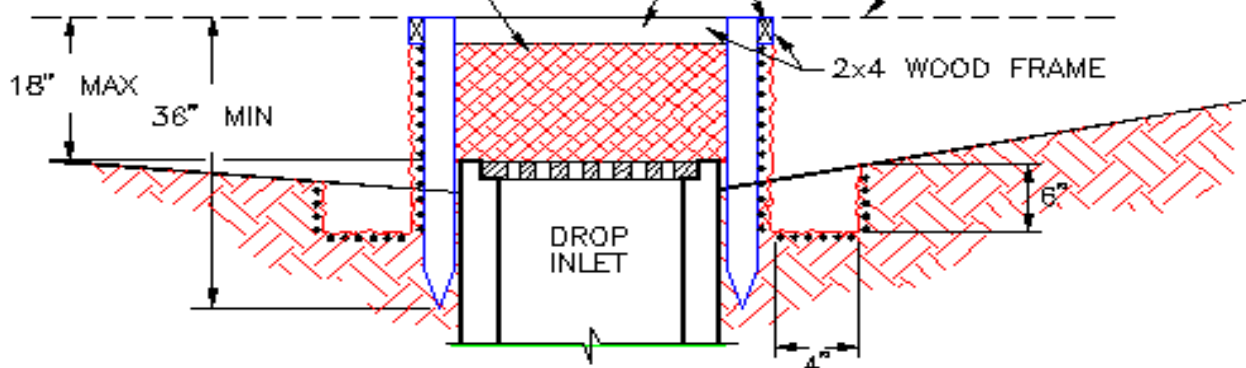

SECTION A-A

NOTES:

1. DROP INLET SEDIMENT BARRIERS ARE TO BE USED FOR SMALL, NEARLY LEVEL (LESS THAN 5%) DRAINAGE AREAS.
2. USE 2" X 4" WOOD OR EQUIVALENT METAL STAKES, 3' MINIMUM LENGTH.
3. MAXIMUM SPACING BETWEEN POSTS SHALL BE 3 FEET.
4. BURY THE BOTTOM OF THE SILT FENCE IN A TRENCH 4" WIDE BY 6" DEEP.
5. INSTALL 2" X 4" WOOD TOP FRAME TO INSURE STABILITY.
6. THE TOP OF THE FRAME (PONDING HEIGHT) MUST BE WELL BELOW THE GROUND ELEVATION DOWNSLOPE TO PREVENT RUNOFF FROM BYPASSING THE INLET.

CURB INLET SEDIMENT BARRIER (SANDBAGS)

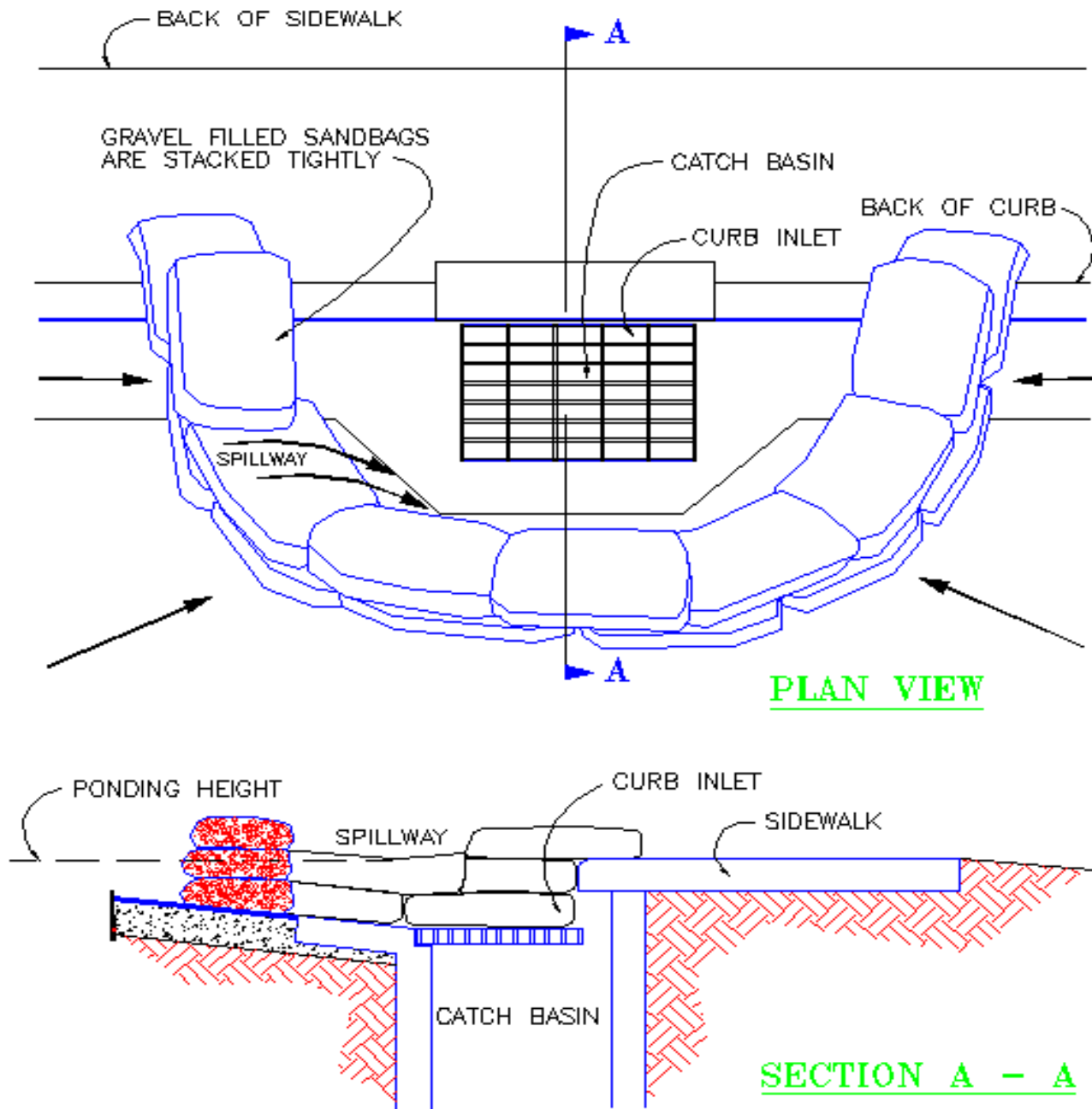

NOTES:

1. PLACE CURB TYPE SEDIMENT BARRIERS ON GENTLY SLOPING STREET SEGMENTS WHERE WATER CAN POND AND ALLOW SEDIMENT TO SEPARATE FROM RUNOFF.
2. SANDBAGS SHALL BE FILLED WITH 3/4" DRAIN ROCK OR 1/4" PEA GRAVEL LAYERED AND PACKED TIGHTLY.
3. ENSURE THAT SANDBAG MATERIAL SHALL BE A TYPE OF GEOTEXTILE FABRIC THAT WILL NOT RAPIDLY DETERIORATE.
4. LEAVE ONE SANDBAG GAP IN THE TOP ROW TO PROVIDE A SPILLWAY FOR OVERFLOW.

CURB AND GUTTER SEDIMENT BARRIER

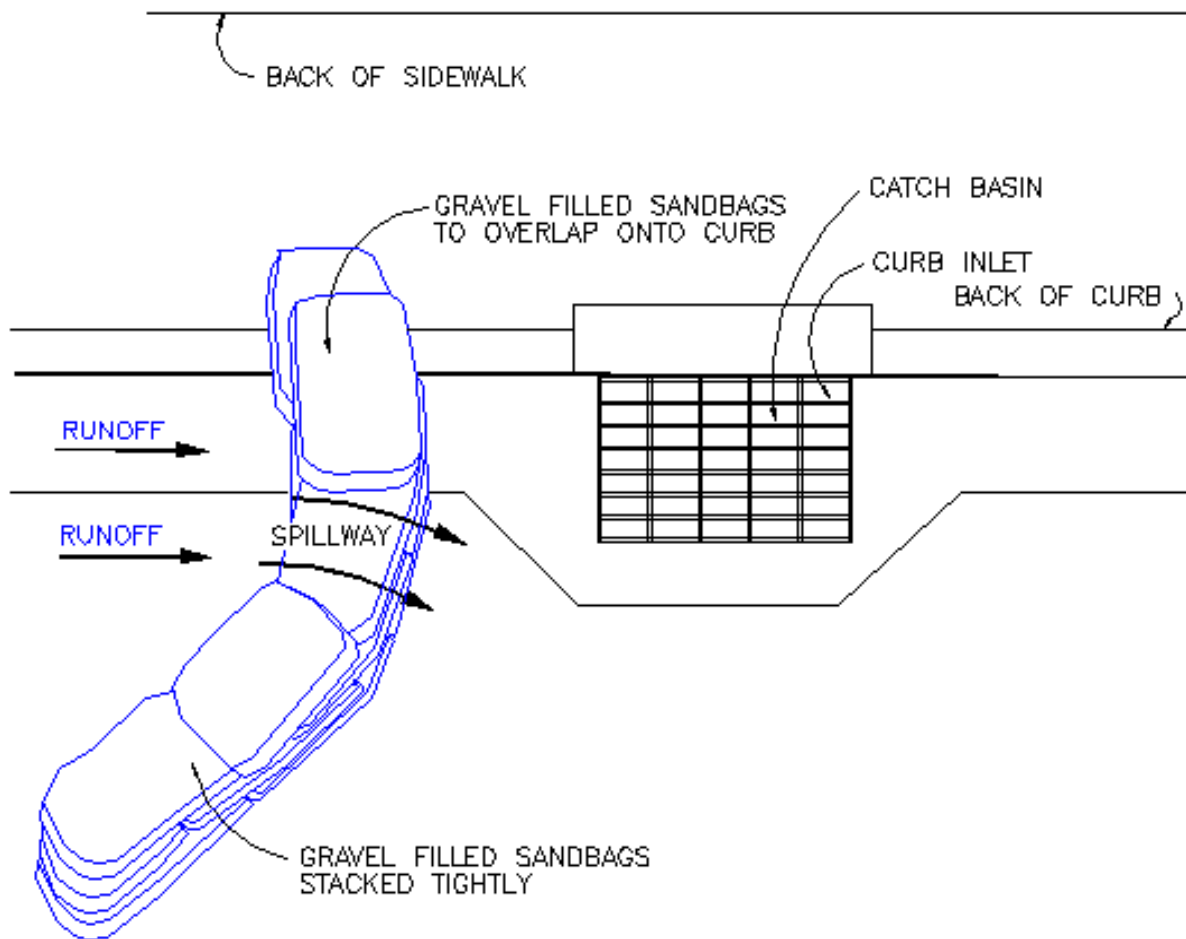

PLAN VIEW

NOTES:

1. PLACE CURB TYPE SEDIMENT BARRIERS ON GENTLY SLOPING SEGMENTS WHERE WATER CAN POND AND ALLOW SEDIMENT TO SEPARATE FROM RUNOFF.
2. SANDBAGS SHOULD BE FILLED WITH 3/4" DRAIN ROCK OR 1/4" PEA GRAVEL LAYERED AND PACKED TIGHTLY. ENSURE THAT SANDBAG MATERIAL SHALL BE A TYPE OF GEOTEXTILE THAT WILL NOT RAPIDLY DETERIORATE.
3. LEAVE ONE SANDBAG GAP IN THE TOP ROW TO PROVIDE A SPILLWAY FOR OVERFLOW.

BERMS

GENERAL DESCRIPTION:

A berm (also referred to as a dike) is a temporary ridge used to divert runoff. Its most common uses include preventing run-on to an exposed or disturbed area, and diverting the sediment-laden runoff from a disturbed area to a sediment trapping control. When used as a temporary control, berms are most often constructed from compacted soil or loose gravel, stone, or crushed rock. Berms may serve as a permanent structural control when constructed from asphalt, concrete, or other similar material. Often times, to facilitate runoff diversion, a small excavated depression is constructed adjacent to the berm. This depression, or small channel, is referred to as a swale. For guidance on the function of a swale, see the section on channels, page 45.

PROS:

- Effective in diverting the runoff from upslope drainages away from unprotected areas
- Efficient method of controlling sediment-laden runoff
- Easy to inspect
- Minimal maintenance costs if installed properly
- If designed properly, may be used as a permanent structure

CONS:

- Cannot be used if the upslope gradient is too great, resulting in high velocity flows
- Earth berms may require vegetative stabilization to prevent erosion of the berm itself
- May be more expensive than other methods if on-site materials cannot be used
- Limited life span if subject to significant vehicular traffic

INSTALLATION GUIDELINES:

- Berms shall be constructed during initial land-disturbing activities and must be operational prior to upslope land disturbance.
- Berms should be constructed in areas with shallow slopes.
- Where applicable, on-site material should be used for berm construction.
- Berms should be adequately compacted to prevent failure.
- When used as a perimeter or downslope control, berms shall divert runoff to a sediment trapping control such as a sediment trap or basin.
- Berms shall be located so as to minimize damage by construction operations and traffic.

Earth Berm

- For areas with little or no construction traffic, earth berms may be constructed.
- For earth berms, temporary or permanent vegetative controls shall be applied upon completion of construction to prevent erosion of the berm itself.

Gravel Berm

- For areas with significant construction traffic, gravel berms should be constructed.
- Well graded gravel or crushed rock shall be used to construct gravel berms.

INSPECTION AND MAINTENANCE:

- For active field operations, berms shall be inspected weekly and within 24 hours, or the next available working day, following each storm event producing greater than 0.5 inches of precipitation.
- When site activity has ceased and significant surface runoff is not likely (arid season), inspections shall be conducted at least every other month and following each storm event producing greater than 0.5 inches of precipitation.
- If an additional inspection frequency is specified within a Storm Water Pollution Prevention (SWPP) Plan, this frequency shall be followed.
- Inspections shall be documented on the BMP Inspection and Maintenance Form.
- Inspectors should identify in particular:
 - ◆ Correct installation.
 - ◆ Effectiveness in controlling storm water runoff, erosion, and sediment transport.
 - ◆ Damage that has occurred since the last inspection. *Most notably:* erosion of the berm from runoff and damage from vehicle traffic.
 - ◆ Required maintenance.
 - ◆ Sediment accumulations and the need to remove the accumulations.
 - ◆ Evidence of erosion or other damage in the surrounding area.
- Berms designed to trap sediment shall, at a minimum, be cleaned out after each significant storm event.
- Damage from vehicle or construction traffic shall be repaired prior to the end of each working day.
- Conduct required repairs immediately and document them in the current or next inspection record.

Environmental media (e.g. soil, sediment, surface, and ground water) is not considered waste. However, contaminated environmental media may constitute solid waste and/or hazardous waste. If there is any potential for accumulated sediment to be contaminated, a waste determination must be made and documented. For guidance, see the Laboratory's LIRs on Radioactive Waste, Managing Solid Waste, and Hazardous and Mixed Waste Requirements for Generators.

Inspection plans and records shall be maintained by the owner/operator, and made available for future regulatory inspections.

REMOVAL CRITERIA:

- Berms shall not be removed until the disturbed or exposed area has been stabilized with permanent structural or vegetative controls.
- Final vegetative stabilization is defined as 70% of the vegetative cover that would exist under normal site conditions. The Water Quality and Hydrology Group (ESH-18) shall assist in making this determination.

For assistance with BMP selection, installation, or maintenance, please contact ESH-18 at 665-4752.

EARTH BERM

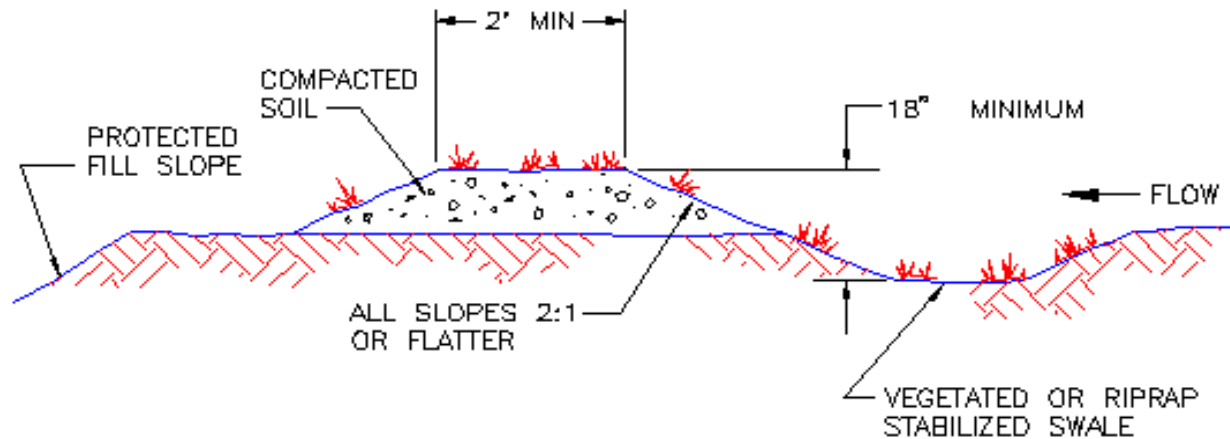

TYPICAL FILL DIVERSION

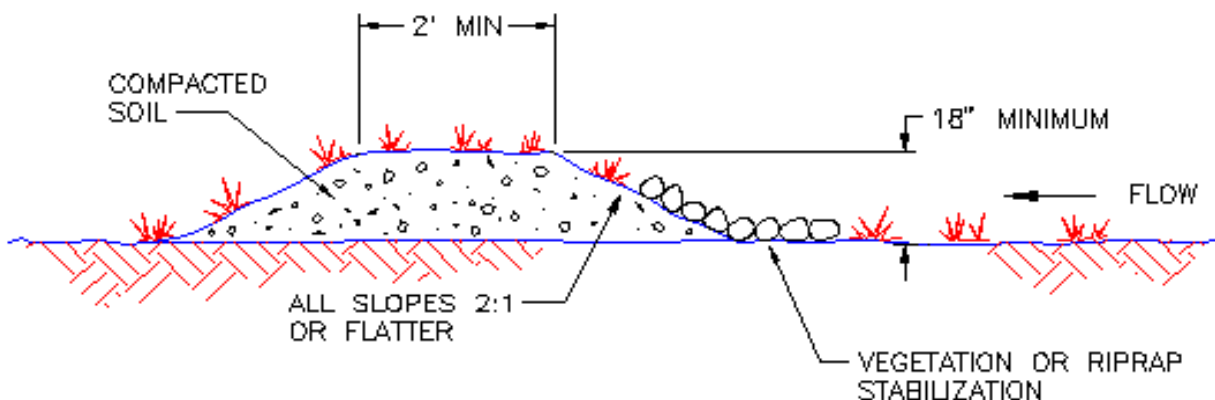

TYPICAL TEMPORARY DIVERSION DIKE

NOTES:

1. THE CHANNEL BEHIND THE BERM SHALL HAVE A POSITIVE GRADE TO A STABILIZED OUTLET.
2. THE BERM SHALL BE ADEQUATELY COMPACTED TO PREVENT FAILURE.
3. THE BERM SHALL BE STABILIZED WITH TEMPORARY OR PERMANENT SEEDING, MATTING, OR OTHER APPLICABLE MEASURES.
4. THE BERM SHALL BE STABILIZED WITH TEMPORARY OR PERMANENT SEEDING, MATTING, OR OTHER APPLICABLE MEASURES.
5. THE TOP OF THE BERM SHALL HAVE A MINIMUM WIDTH OF 2 FEET AND ALL SIDESLOPES SHALL BE 2:1 OR FLATTER.

CHECK DAM**GENERAL DESCRIPTION:**

A check dam is a small dam constructed across a drainage channel. Its purpose is to control runoff, channel erosion, and sediment transport by reducing runoff velocity, providing stabilized drops, and by trapping sediment. These controls are most commonly used in steeply sloped channels or swales, or in areas where adequate vegetation cannot be established. Check dams are usually built from stone, straw bales, or sand bags, and may be either a temporary or permanent structural control.

PROS:

- Reduces runoff velocity and erosion within channels
- Significantly reduces the sediment volume in the runoff
- Inexpensive and easy to install
- Useful where it is not possible to divert the flow to stabilize the channel
- If designed properly, may be used as a permanent structure

CONS:

- Useful only if the drainage area is less than 5 acres
- Significant sedimentation may destroy vegetation lining the channel
- May not be used in a drainage that is a perennial stream

INSTALLATION GUIDELINES:

- Maximum height of the dam, at center, shall be 2 feet.
- The center of the dam shall be a minimum of 6 inches lower than the outer edges.
- Maximum spacing between check dams shall provide that the toe of the upstream dam is at the same elevation as the top of the downstream dam.
- Construct an energy dissipater on the downstream side of the dam to reduce downstream erosion.

Rock Check Dam

- Rock check dams shall be constructed of 2-15 inch maximum size aggregate rock.
- The center of the dam (spillway) shall be at least 6 inches lower than the outer edges.
- If applicable, extend abutments 18 inches into the channel bank.

Straw Bale Check Dam

- Place straw bales lengthwise, in a single row, perpendicular to the flow. Tightly abut the ends of adjacent bales.
- To ensure that sediment-laden runoff flows over the barrier, the bottoms of the bales on the outer edges of the dam shall be higher in elevation than the top of the middle bale (spillway).
- Straw bales shall be embedded in a trench that has been excavated to a minimum depth of 4 inches.
- Gaps between the bales should be filled with straw, rocks, or filter fabric, and backfill material shall be tamped to prevent erosional displacement.
- If wire bound, straw bales shall be oriented so the bindings are around the sides rather than along the top and bottom.
- Bales shall be anchored in place by two 2x2 inch wooden stakes or by rebar driven through the bales. The anchors shall be driven at least 18 inches into the ground and the first anchor driven into each bale shall be driven toward the previously laid bale to force the bales tightly together.

INSPECTION AND MAINTENANCE:

- For active field operations, check dams shall be inspected weekly and within 24 hours, or the next available working day, following each storm event producing greater than 0.5 inches of precipitation.
- When site activity has ceased and significant surface runoff is not likely (arid season), inspections shall be conducted at least every other month and following each storm event producing greater than 0.5 inches of precipitation.
- If an additional inspection frequency is specified within a Storm Water Pollution Prevention (SWPP) Plan, this frequency shall be followed.
- Inspections shall be documented on the BMP Inspection and Maintenance Form.
- Inspectors should identify in particular:
 - ◆ Correct installation.
 - ◆ Effectiveness in controlling storm water runoff and erosion.
 - ◆ Damage that has occurred since the last inspection. *Most notably:* erosion caused by flows around or under the dam structure.
 - ◆ Required maintenance.
 - ◆ Sediment accumulations and the need to remove the accumulations.
 - ◆ Evidence of erosion or other damage in the surrounding area.
- Inspect the dam for collapse or undermining.
- Remove accumulated sediment when it has reached one half the original dam height.
- Removed sediment accumulations shall not be placed within any drainage, either above or below the BMP.
- Removed sediment shall be stabilized to prevent future migration from storm water runoff.
- Conduct required repairs immediately and document them in the current or next inspection record.

Environmental media (e.g. soil, sediment, surface, and ground water) is not considered waste. However, contaminated environmental media may constitute solid waste and/or hazardous waste. If there is any potential for accumulated sediment to be contaminated, a waste determination must be made and documented. For guidance, see the Laboratory's LIRs on Radioactive Waste, Managing Solid Waste, and Hazardous and Mixed Waste Requirements for Generators.

Inspection plans and records shall be maintained by the owner/operator, and made available for future regulatory inspections.

REMOVAL CRITERIA:

- Check dams shall not be removed until the channel has been stabilized with permanent structural controls.
- If a rock check dam is used, all stone should be removed if vegetative erosion controls will be used as permanent stabilization.

For assistance with BMP selection, installation, or maintenance, please contact ESH-18 at 665-4752.

ROCK CHECK DAM

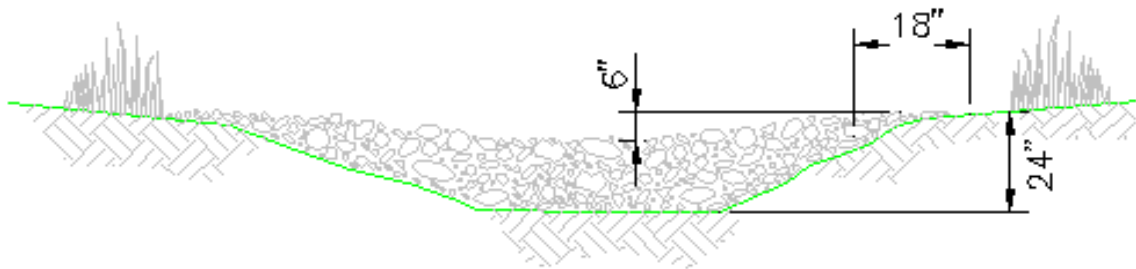

VIEW LOOKING UPSTREAM

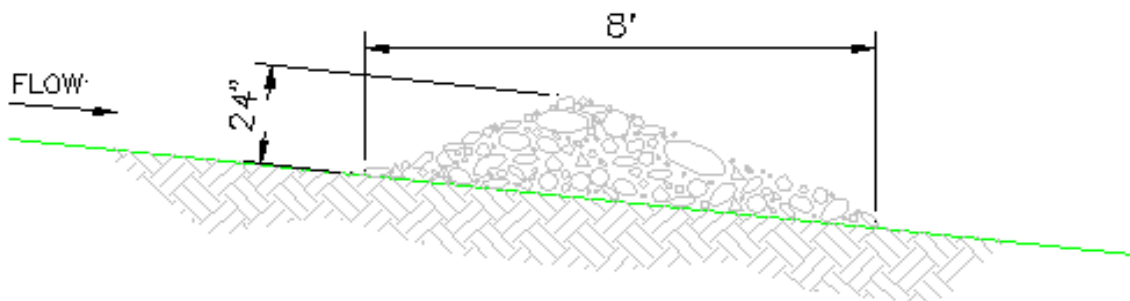

SECTION A

X = THE DISTANCE SUCH THAT POINT A AND B ARE OF EQUAL ELEVATION.

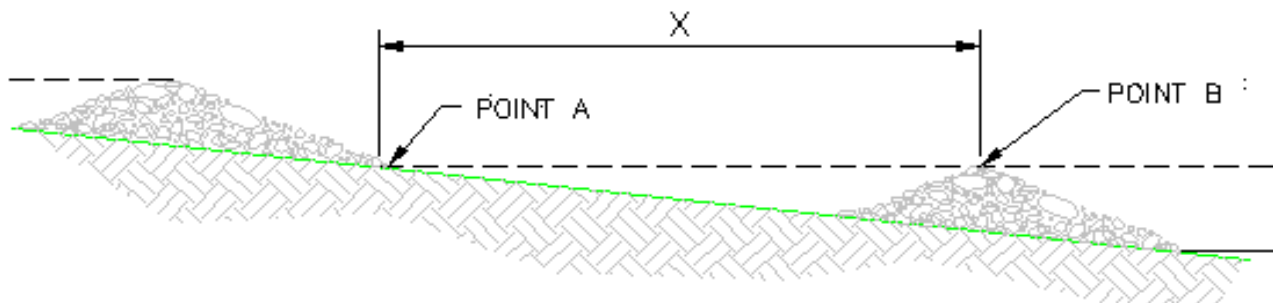

SPACING BETWEEN CHECK DAMS

NOTES:

1. ROCK CHECK DAMS SHALL BE CONSTRUCTED WITH 2-15 INCH MAXIMUM SIZE AGGREGATE ROCK.
2. WHERE APPLICABLE, KEY STONE INTO CHANNEL BANKS AND EXTEND IT BEYOND THE ABUTMENTS A MINIMUM OF 18" TO PREVENT FLOW AROUND DAM.
3. PROVIDE AN ENERGY DISSIPATOR ON THE DOWNSTREAM SIDE OF THE DAM TO REDUCE DOWNSTREAM EROSION.

STRAW BALE CHECK DAM

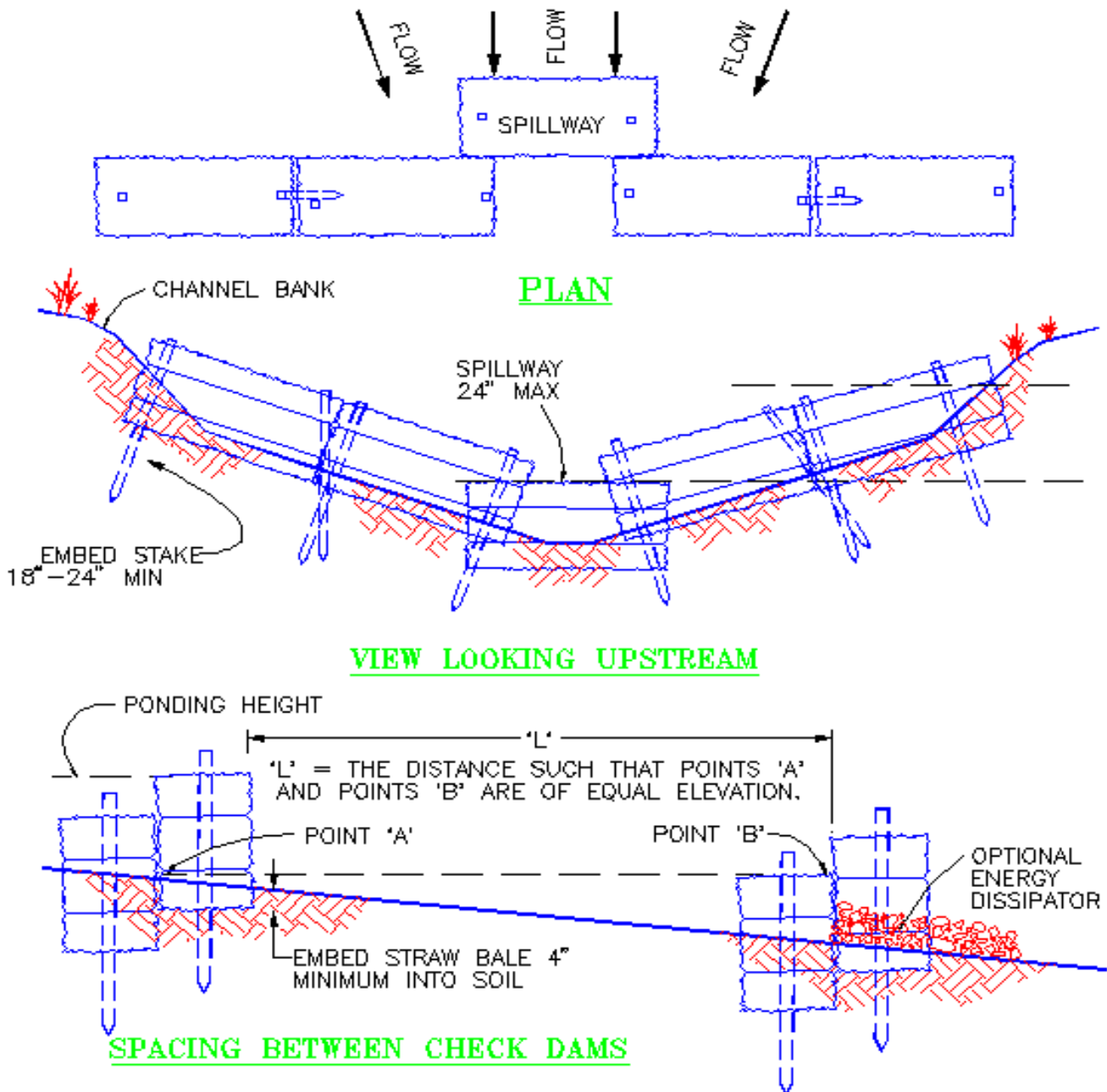

NOTES:

1. PLACE BALES LENGTHWISE, PERPENDICULAR TO THE FLOW, WITH ENDS TIGHTLY ABUTTING.
2. EMBED BALES 4" INTO THE SOIL AND WHERE APPLICABLE, EMBED BALES INTO CHANNEL BANKS.
3. ANCHOR BALES WITH TWO 2" X 2" WOOD STAKES OR METAL REBAR DRIVEN THROUGH THE BALES. STAKES SHALL BE DRIVEN A MINIMUM OF 18" INTO THE GROUND.
4. FILL GAPS BETWEEN BALES AND TAMP BACKFILL MATERIAL TO PREVENT EROSION OR FLOW UNDER THE BALES.
5. SPILLWAY HEIGHT SHALL NOT EXCEED 24"

WATERBAR

GENERAL DESCRIPTION:

A waterbar consists of a berm and excavation that is constructed diagonally across a sloping dirt or gravel road, or utility right-of-way. The purpose of a waterbar is to control erosion on roadways by reducing runoff velocity and by limiting the volume of accumulated water through diversion. At predesigned intervals, runoff is diverted off the roadway onto designated outlet areas.

PROS:

- Reduces runoff and erosion on sloping roadways
- Easy to install
- Requires minimal maintenance
- Easy to inspect

CONS:

- Become less effective when subject to vehicle traffic during wet weather
- May be difficult to cross with low clearance vehicles
- Consideration must be given to each individual outlet area
- Structures should not outlet onto unprotected slopes

INSTALLATION GUIDELINES:

- Waterbars should be constructed immediately upon completion of roadway or right-of-way clearing and grading.
- As measured from the bottom of the excavation to the top of the berm, waterbar height should be a minimum of 18 inches.
- Side slopes should be 2:1 or flatter, and 3:1 or flatter where vehicles cross.
- The diversion shall be constructed at an angle of 45 to 60 degrees from the centerline.
- Diversion should have a minimum positive grade of 2%.
- For areas of significant vehicular traffic, waterbars should be stabilized with gravel.
- Diversions shall outlet onto areas stabilized by either natural or constructed means.
- To approximate the appropriate spacing distance between waterbars, determine the distance it takes for the unrocked, unprotected running surface of a nearby road to develop a 1-inch rill.

INSPECTION AND MAINTENANCE:

- For active field operations, waterbars shall be inspected weekly and within 24 hours, or the next available working day, following each storm event producing greater than 0.5 inches of precipitation.
- When site activity has ceased and significant surface runoff is not likely (arid season), inspections shall be conducted at least every other month and following each storm event producing greater than 0.5 inches of precipitation.
- If an additional inspection frequency is specified within a Storm Water Pollution Prevention (SWPP) Plan, this frequency shall be followed.
- Inspections shall be documented on the BMP Inspection and Maintenance Form.

- Inspectors should identify in particular:
 - ◆ Correct installation.
 - ◆ Effectiveness in controlling storm water runoff and erosion.
 - ◆ Damage that has occurred since the last inspection.
 - ◆ Required maintenance.
 - ◆ Sediment accumulations and the need to remove the accumulations.
 - ◆ Evidence of erosion or other damage in the surrounding area.
- Inspect the diversion outlet area for erosion or other damage.
- Inspect the berm and excavation area for damage.
- Conduct required repairs immediately and document them in the current or next inspection record.

Environmental media (e.g. soil, sediment, surface, and ground water) is not considered waste. However, contaminated environmental media may constitute solid waste and/or hazardous waste. If there is any potential for accumulated sediment to be contaminated, a waste determination must be made and documented. For guidance, see the Laboratory's LIRs on Radioactive Waste, Managing Solid Waste, and Hazardous and Mixed Waste Requirements for Generators.

Inspection plans and records shall be maintained by the owner/operator, and made available for future regulatory inspections.

REMOVAL CRITERIA:

- Waterbars shall not be removed until the slope has been stabilized with permanent structural controls.

For assistance with BMP selection, installation, or maintenance, please contact ESH-18 at 665-4752.

WATERBAR

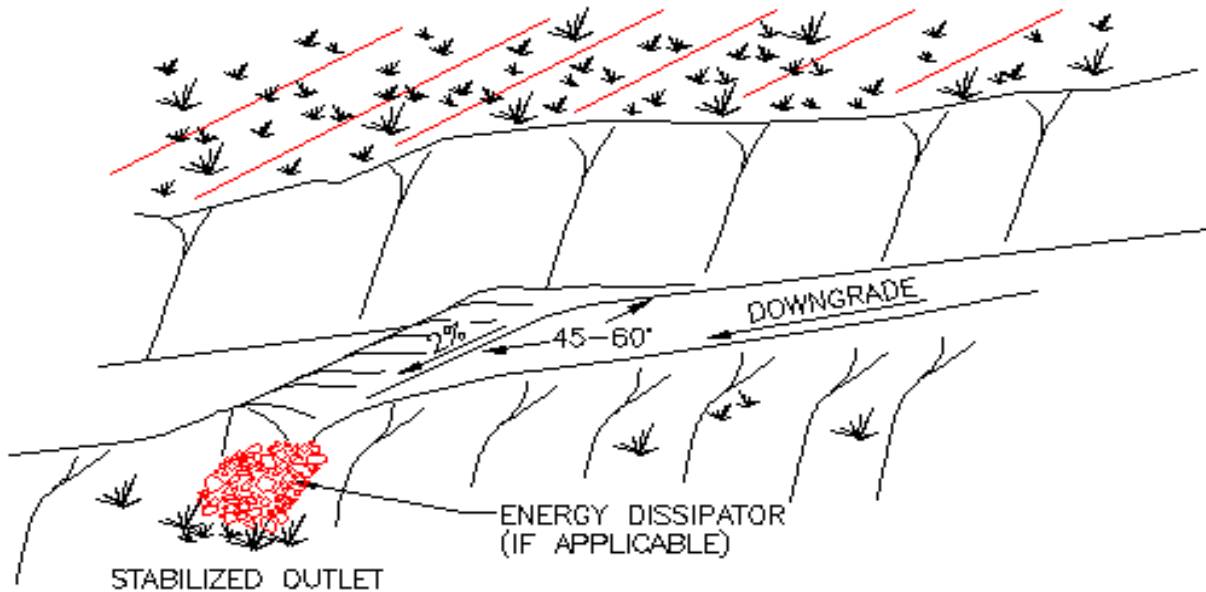

WATERBAR

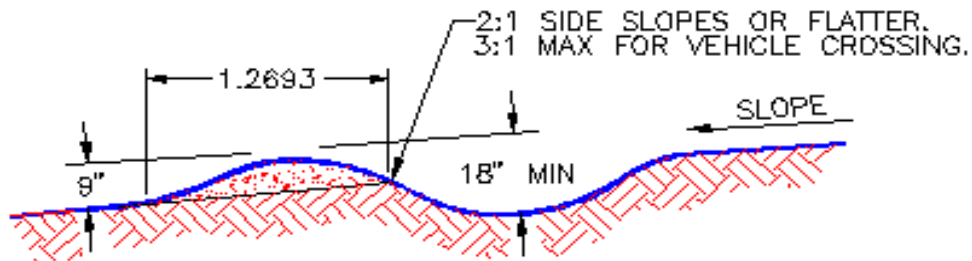

SECTION

NOTES:

1. FOR AREAS OF SIGNIFICANT VEHICULAR TRAFFIC, WATERBARS SHALL BE STABILIZED WITH GRAVEL.
2. DIVERSION BERMS SHOULD HAVE A MINIMUM POSITIVE GRADE OF 2%.
3. WATERBARS SHALL BE CONSTRUCTED AT AN ANGLE OF 46 TO 60 DEGREES FROM THE CENTERLINE.
4. WATERBARS SHALL OUTLET ONTO AREAS STABILIZED BY EITHER NATURAL OR CONSTRUCTED MEANS.

SURFACE ROUGHENING

GENERAL DESCRIPTION:

Surface roughening involves creating, in a bare soil surface, horizontal grooves, depressions, or steps that run parallel to the contour of the land. Roughening methods include grooving or furrowing, stair step grading, and tracking with heavy equipment. These temporary features control erosion by reducing runoff velocity, increasing infiltration, trapping sediment, and aiding in the establishment of vegetative cover, and may be used on all slopes. For steeper slopes, surface roughening should be used in combination with vegetative practices.

PROS:

- Provides immediate erosion protection while vegetative cover is being established
- Easy to construct
- Inexpensive
- Requires minimal maintenance
- Easy to inspect

CONS:

- Limited effectiveness during large storm events
- Temporary control which may have to be reestablished due to storm damage
- Difficult to establish on smooth, hard surfaces

INSTALLATION GUIDELINES:

Cut Slope Roughening

- For slopes steeper than 3:1 but less than 2:1, use stair-step grading or groove cuts.
- For slopes steeper than 2:1, use stair-step grading.
- Use stair-step grading on soils containing large amounts of small rock or any erodible material soft enough to be ripped with a bulldozer.
- Construct stairs wide enough to work with standard earth moving equipment.
- Vertical cuts shall be no more than 2 feet deep in soft materials or no more than 3 feet deep in rocky materials.
- When constructing groove cuts, create a series of ridges and depressions that run across the slope, parallel to the contour.
- Grooves may be constructed using any implement that can be safely operated on the slope.
- Seed roughened areas as quickly as possible.

Fill Slope Roughening

- Slopes with a gradient steeper than 3:1 should be placed in lifts not to exceed 8 inches. Ensure that each lift is properly compacted.
- Slopes with a gradient steeper than 2:1 should be stair-stepped.
- The face of the slope should consist of loose, uncompacted fill 4-6 inches deep.
- Groove the slope in the same manner described in Cut Slope Roughening.
- Seed roughened areas as quickly as possible.
- Do not blade or scrape the final slope face.

Roughening With Tracked Machinery

- Use of tracked machinery should be limited to sandy soils that do not compact easily.
- Avoid tracking on clay soils.
- Operate tracked machinery perpendicular to the contours to leave horizontal depressions in the soil.
- Seed roughened areas as quickly as possible.

INSPECTION AND MAINTENANCE:

- For active field operations, surface roughening shall be inspected weekly and within 24 hours, or the next available working day, following each storm event producing greater than 0.5 inches of precipitation.
- When site activity has ceased and significant surface runoff is not likely (arid season), inspections shall be conducted at least every other month and following each storm event producing greater than 0.5 inches of precipitation.
- If an additional inspection frequency is specified within a Storm Water Pollution Prevention (SWPP) Plan, this frequency shall be followed.
- Inspections shall be documented on the BMP Inspection and Maintenance Form.
- Inspectors should identify in particular:
 - ◆ Correct installation.
 - ◆ Effectiveness in controlling storm water runoff, erosion, and sediment transport.
 - ◆ Damage that has occurred since the last inspection. *Most notably:* rills, washes, and damage to vegetation.
 - ◆ Required maintenance.
 - ◆ Sediment accumulations and the need to remove the accumulations.
 - ◆ Evidence of erosion or other damage in the surrounding area.
- Reseed and conduct required repairs immediately and document the actions in the current or next inspection record.

Environmental media (e.g. soil, sediment, surface, and ground water) is not considered waste. However, contaminated environmental media may constitute solid waste and/or hazardous waste. If there is any potential for accumulated sediment to be contaminated, a waste determination must be made and documented. For guidance, see the Laboratory's LIRs on Radioactive Waste, Managing Solid Waste, and Hazardous and Mixed Waste Requirements for Generators.

Inspection plans and records shall be maintained by the owner/operator, and made available for future regulatory inspections.

REMOVAL CRITERIA:

- Inspection and maintenance of surface roughening shall not cease until the slope has been permanently stabilized with structural controls or vegetation.
- Final vegetative stabilization is defined as 70% of the vegetative cover that would exist under normal site conditions. The Water Quality and Hydrology Group (ESH-18) shall assist in making this determination.

For assistance with BMP selection, installation, or maintenance, please contact ESH-18 at 665-4752.

SURFACE ROUGHENING

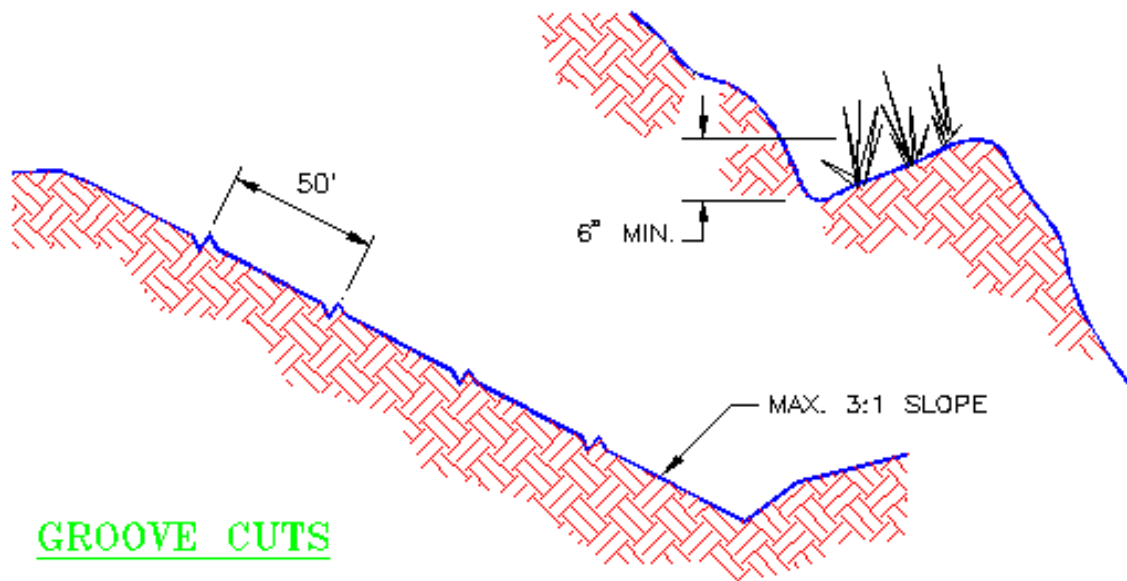
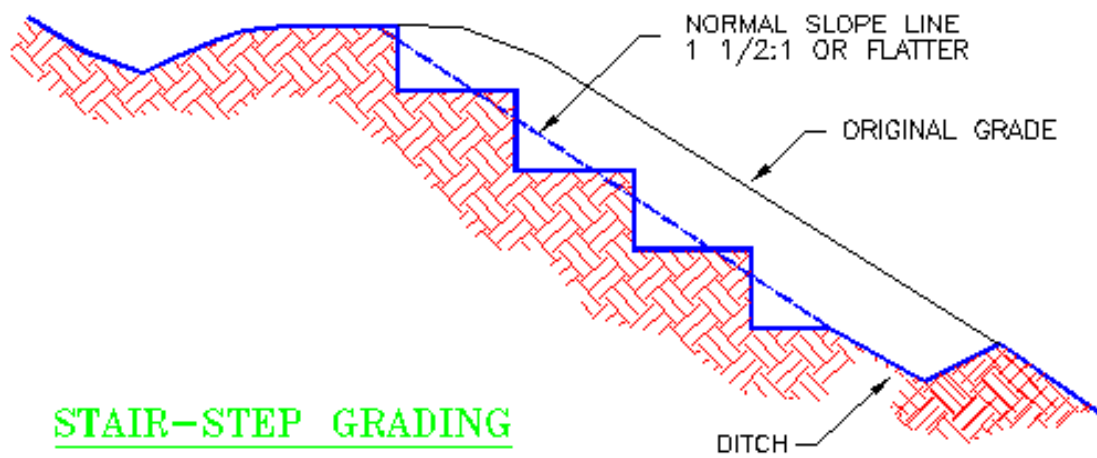

NOTES:

1. STAIR-STEP GRADING SHALL BE USED FOR SLOPES GREATER THAN 2:1.
2. GROOVE CUTS SHALL BE USED ON SLOPES OF 3:1 OR LESS.
3. CONSTRUCT STAIRS WIDE ENOUGH TO WORK WITH STANDARD EARTH MOVING EQUIPMENT.
4. CONSTRUCT CUTS PARALLEL TO THE CONTOURS.
5. VERTICAL CUTS SHALL NOT EXCEED 2 FT IN SOFT MATERIAL AND 3 FT IN ROCKY MATERIAL.

SURFACE ROUGHENING

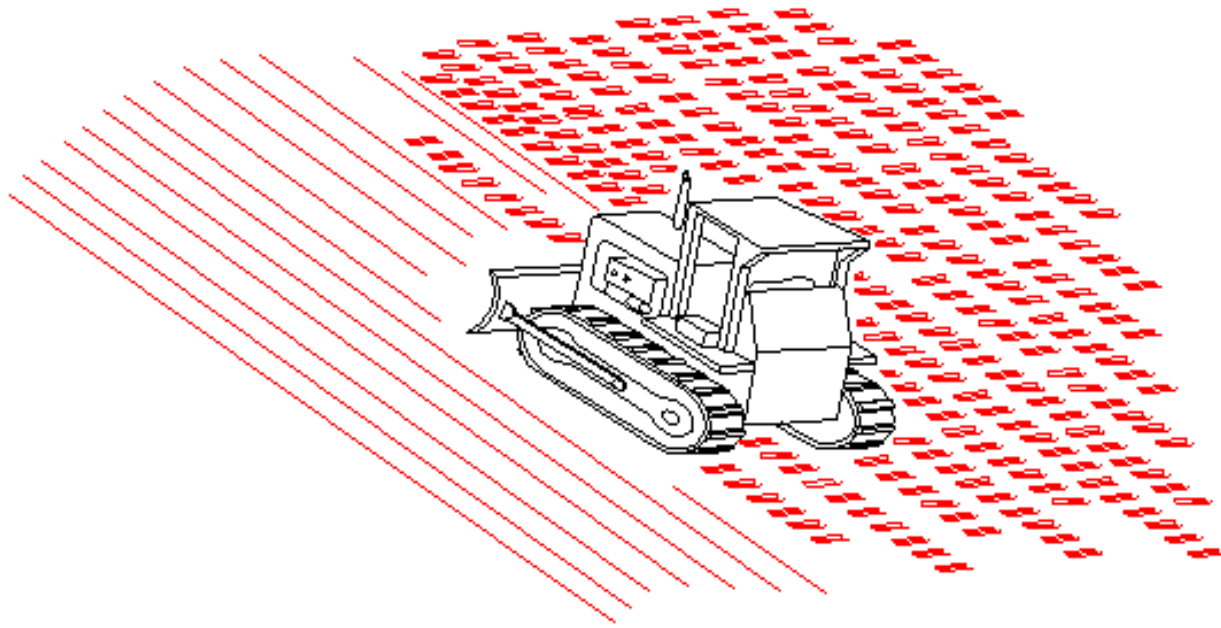

TRACKING

NOTES:

1. USE OF TRACKED MACHINERY SHOULD BE LIMITED TO SANDY SOILS THAT DO NOT EASILY COMPACT.
2. AVOID TRACKING ON CLAY SOILS.
3. OPERATE TRACKED MACHINERY PERPENDICULAR TO THE CONTOURS.
4. SEED AREA FOLLOWING ROUGHENING.

PIPE SLOPE DRAIN

GENERAL DESCRIPTION:

Pipe slope drains are designed to carry concentrated runoff down a slope without causing erosion. They are used most often on cut or fill slopes, areas already damaged by erosion or at high risk for erosion, areas in the process of permanent stabilization, or on saturated slopes at risk for soil slides. This BMP may be constructed with flexible or rigid pipe, sectional downdrains, paved chutes, or clay tiles and may be placed either above or beneath the ground surface.

PROS:

- Reduce or eliminate erosion on steep slopes or in saturated soils
- Especially effective before a slope has been stabilized or before permanent drainage structures are ready for use
- Easy to install
- Requires little maintenance
- Easy to inspect

CONS:

- Requires the area disturbed by installation to be stabilized
- Conduit may clog during a large storm
- Overtopping may occur if pipe inlet capacity is inadequate
- BMP must be sized, installed, and maintained properly or severe erosion of the slope may occur
- Requires formal design

INSTALLATION GUIDELINES:

- Maximum recommended drainage area for a single slope drain is approximately 10 acres.
- Pipe should be sized using the peak runoff from a 10-year storm unless design guidelines specify a larger storm event.
- Place conduit material on undisturbed soil or well-compacted fill. Placement should conform to the locations and elevations shown on the design drawings.
- Anchor the conduit with reinforced, hold-down grommets or stakes. For CMP or corrugated plastic conduit, install one anchor connection for every 20 feet of conduit. Anchor intervals for all other material shall not to exceed 10 feet.
- The pipe slope drain entrance shall be constructed with a standard flared-inlet or tee section of pipe. Ensure that inlet capacity is adequate for the design flow.
- To prevent failure of the slope drain from water saturating the soil and seeping along the pipe, backfill around and under the pipe with stable soil material, hand compacting in 6 inch lifts.
- Fill material over the slope drain, at the top of the slope, shall have a minimum depth of 1.5 feet and a minimum top width of 4 feet. Corresponding side slopes should have a 3:1 slope.
- Ensure that all conduit fittings are watertight.
- Extend conduit beyond the toe of the slope.
- Stabilize the soil at the outlet with riprap or another type of energy dissipater.
- Stabilize all areas disturbed by installation.

INSPECTION AND MAINTENANCE:

- For active field operations, pipe slope drains shall be inspected weekly and within 24 hours, or the next available working day, following each storm event producing greater than 0.5 inches of precipitation.
- When site activity has ceased and significant surface runoff is not likely (arid season), inspections shall be conducted at least every other month and following each storm event producing greater than 0.5 inches of precipitation.
- If an additional inspection frequency is specified within a Storm Water Pollution Prevention (SWPP) Plan, this frequency shall be followed.
- Inspections shall be documented on the BMP Inspection and Maintenance Form.
- Inspectors should identify in particular:
 - ◆ Correct installation
 - ◆ Effectiveness in controlling storm water runoff.
 - ◆ Damage that has occurred since the last inspection.
Most notably: storm water flowing around the conduit entrance, and/or undermining the structure.
 - ◆ Required maintenance
 - ◆ Sediment accumulations and the need to remove the accumulations.
 - ◆ Evidence of erosion or other damage in the surrounding area.
- Accumulated sediment shall be removed when impedes proper conveyance.
- Inspect the outlet point for erosion or other damage.
- Inspect the conduit for breaks or clogs.
- Conducted required repairs immediately and document them in the current or next inspection record.

Environmental media (e.g. soil, sediment, surface, and ground water) is not considered waste. However, contaminated environmental media may constitute solid waste and/or hazardous waste. If there is any potential for accumulated sediment to be contaminated, a waste determination must be made and documented. For guidance, see the Laboratory's LIRs on Radioactive Waste, Managing Solid Waste, and Hazardous and Mixed Waste Requirements for Generators.

Inspection plans and records shall be maintained by the owner/operator, and made available for future regulatory inspections.

REMOVAL CRITERIA:

- Pipe slope drains shall not be removed until the slope has been permanently stabilized with structural controls or vegetation, or permanent drainage structures are ready for use.
- Final vegetative stabilization is defined as 70% of the vegetative cover that would exist under normal site conditions. The Water Quality and Hydrology Group (ESH-18) shall assist in making this determination.

For assistance with BMP selection, installation, or maintenance, please contact ESH-18 at 665-4752.

PIPE SLOPE DRAIN

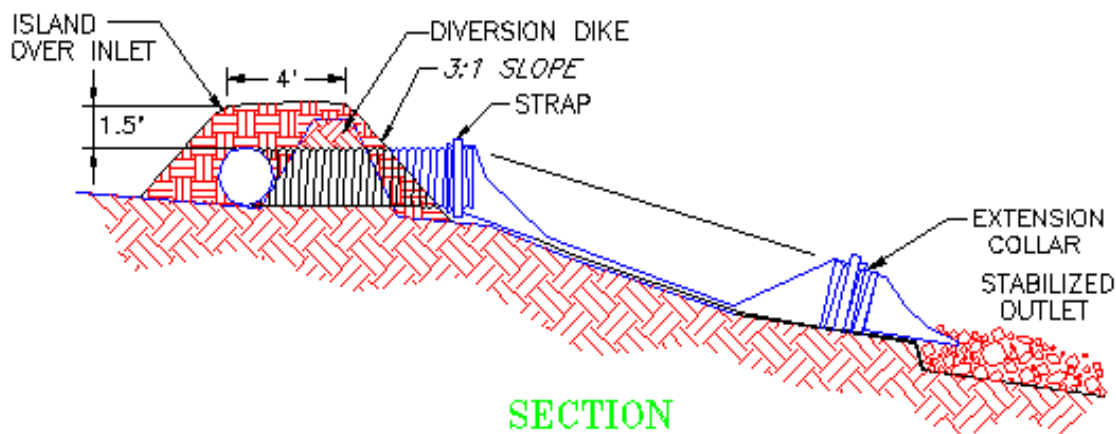
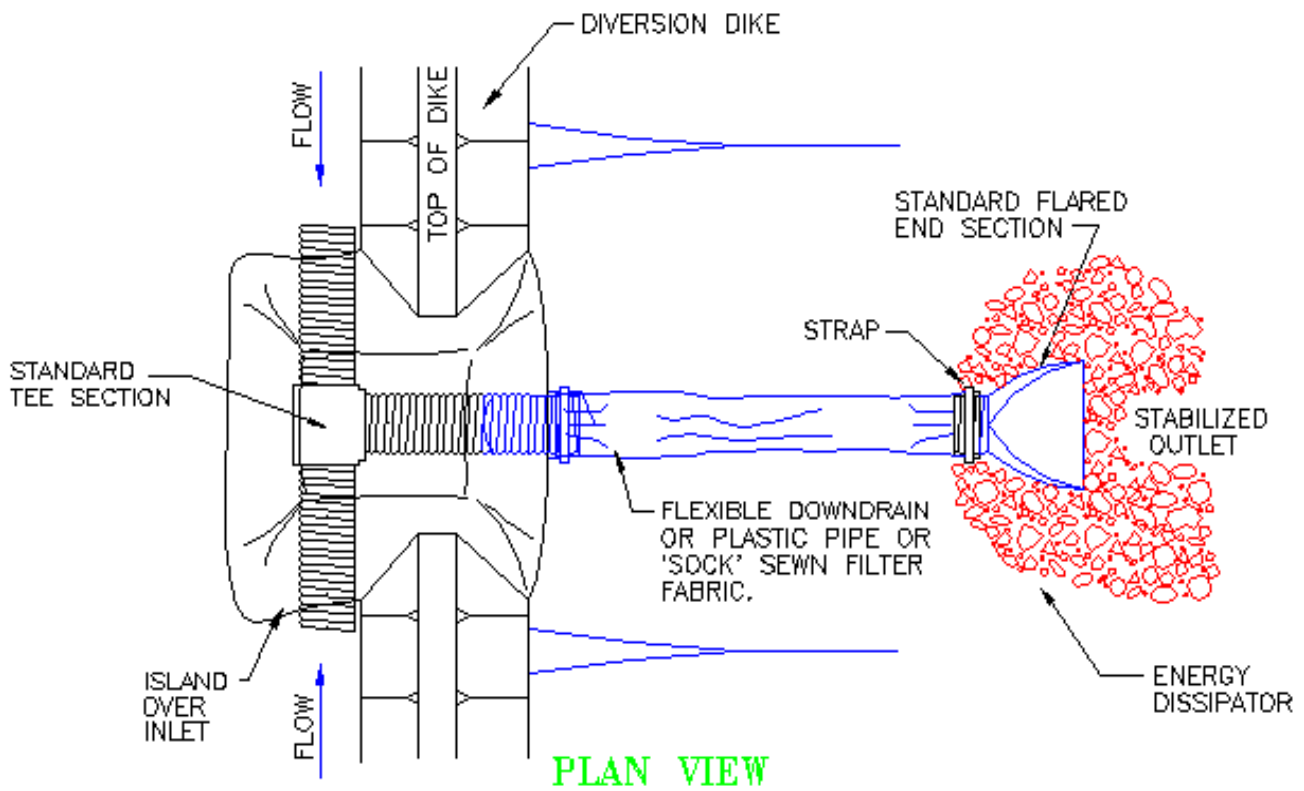

NOTES:

1. MAXIMUM DRAINAGE AREA FOR A SINGLE SLOPE DRAIN IS 10 ACRES.
2. PLACE CONDUIT ON UNDISTURBED SOIL OR WELL COMPACTED FILL.
3. ANCHOR CONDUIT WITH REINFORCED HOLD-DOWN GROMMETS OF STAKES. FOR CMP OR CORRUGATED PLASTIC, INSTALL ONE ANCHOR FOR EVERY 20 FEET OF CONDUIT. ANCHOR INTERVAL SHALL BE 10 FEET FOR ALL OTHER MATERIAL.
4. PIPE SLOPE DRAIN ENTRANCE MAY BE CONSTRUCTED WITH EITHER A STANDARD FLARE-INLET OR TEE SECTION OF PIPE.
5. EXTEND CONDUIT BEYOND THE TEE OF THE SLOPE.

LEVEL SPREADER

GENERAL DESCRIPTION:

A level spreader is an outlet for dikes and diversions that converts concentrated runoff to sheet flow and releases it onto areas stabilized by existing vegetation. The typical level spreader consists of an excavated depression constructed at zero grade across a slope. Concentrated flow enters the spreader and dissipates its energy as it spreads across the flat depression. The ground across the length of both the spreader entrance and outlet are uniform in elevation. Level spreaders are typically placed at the end of dikes that carry sediment free storm runoff away from graded areas and outlet onto undisturbed areas.

PROS:

- Reduces runoff velocity and increases infiltration rates
- Minimal cost to construct
- Easy to inspect

CONS:

- To ensure proper operation, installation requires strict adherence to the design
- Requires regular maintenance and inspection
- Not suitable for large volumes of water
- Should be used on gentle slopes to prevent erosion from spreader discharge
- Can easily develop “short circuiting” because of erosion or other disturbance

INSTALLATION GUIDELINES:

- Level spreaders must be constructed on undisturbed soil (not fill material).
- The slope on the sides of the spreader should be 2:1 or less.
- Excavate the spreader to minimum depth of 6 inches.
- The entrance to the spreader should be level so that the flow can spread out evenly.
- The grade through the spreader channel should be 0%.
- Prior to operation, the depression shall be vegetated. (See the sections on temporary and permanent seeding, pages 58 and 60.)
- The level lip should be of uniform height and zero grade over the length of the spreader.
- Runoff with high sediment loads should be routed through a sediment retention device prior to entrance into the level spreader.
- Stabilize all areas disturbed by spreader installation.

INSPECTION AND MAINTENANCE:

- For active field operations, level spreaders shall be inspected weekly and within 24 hours, or the next available working day, following each storm event producing greater than 0.5 inches of precipitation.
- When site activity has ceased and significant surface runoff is not likely (arid season), inspections shall be conducted at least every other month and following each storm event producing greater than 0.5 inches of precipitation.
- If an additional inspection frequency is specified within a Storm Water Pollution Prevention (SWPP) Plan, this frequency shall be followed.
- Inspections shall be documented on the BMP Inspection and Maintenance Form.

- Inspectors should identify in particular:
 - ◆ Correct installation
 - ◆ Effectiveness in controlling storm water runoff and erosion.
 - ◆ Damage that has occurred since the last inspection. *Most notably:* absence of uniform flow at the spreader outlet and erosion on the slope below the spreader.
 - ◆ Required maintenance
 - ◆ Sediment accumulations and the need to remove the accumulations.
 - ◆ Evidence of erosion or other damage in the surrounding area.
- Inspect the outlet point for erosion or other damage.
- Inspect the spreader depression for adequate and uniform vegetation.
- Removed sediment accumulations shall not be placed within any drainage, either above or below the BMP.
- Removed sediment shall be stabilized to prevent future migration from storm water runoff.
- Conducted required repairs immediately and document them in the current or next inspection record.

Environmental media (e.g. soil, sediment, surface, and ground water) is not considered waste. However, contaminated environmental media may constitute solid waste and/or hazardous waste. If there is any potential for accumulated sediment to be contaminated, a waste determination must be made and documented. For guidance, see the Laboratory's LIRs on Radioactive Waste, Managing Solid Waste, and Hazardous and Mixed Waste Requirements for Generators.

Inspection plans and records shall be maintained by the owner/operator, and made available for future regulatory inspections.

REMOVAL CRITERIA:

- Level spreaders shall not be removed unless the storm water outlet is no longer in use, or until the area being protected by the berm or storm water conveyance has been permanently stabilized with structural controls or vegetation.
- Final vegetative stabilization is defined as 70% of the vegetative cover that would exist under normal site conditions. The Water Quality and Hydrology Group (ESH-18) shall assist in making this determination.

For assistance with BMP selection, installation, or maintenance, please contact ESH-18 at 665-4752.

LEVEL SPREADERS

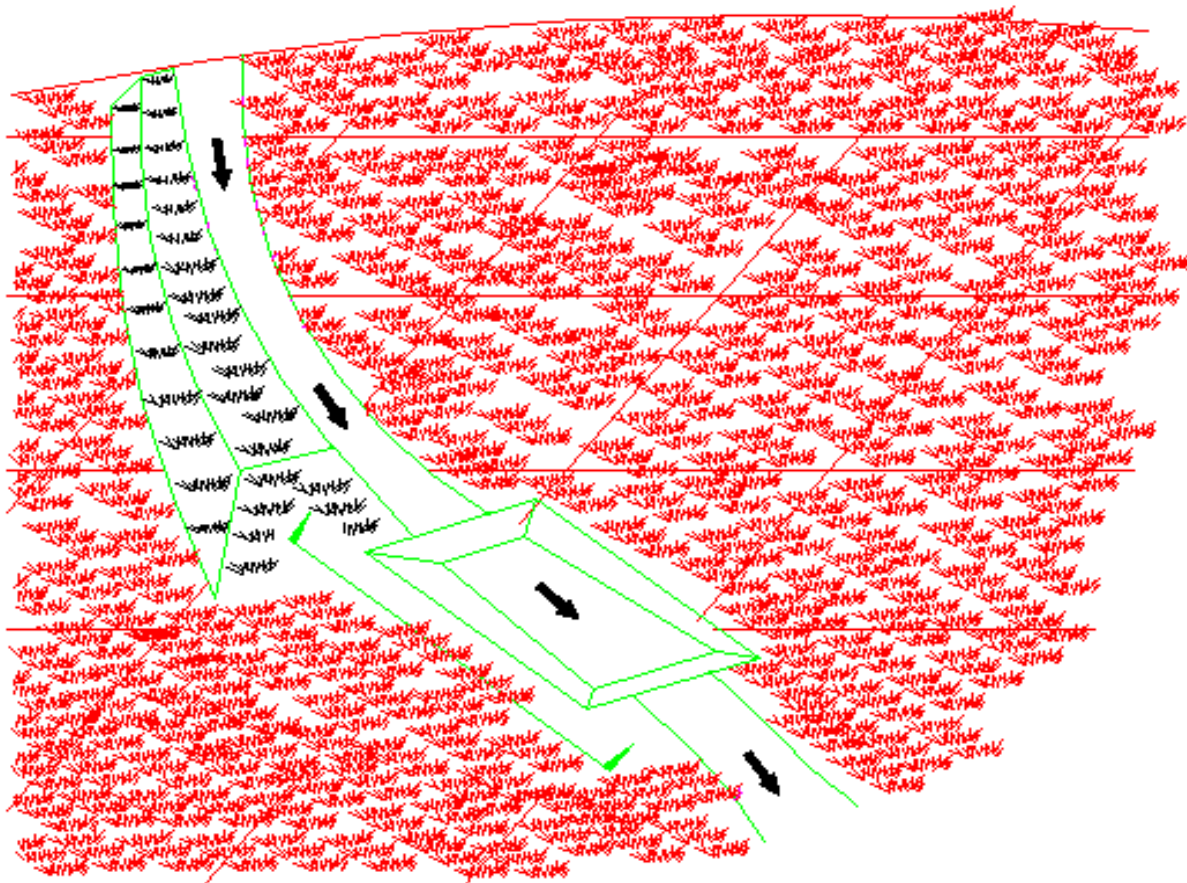

PROFILE

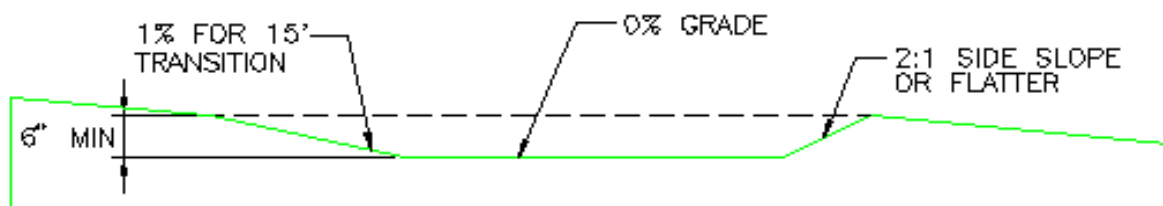

TYPICAL SECTION

NOTES:

1. THE SLOPE BELOW THE LEVEL SPREADER OUTLET SHOULD BE 2:1 OR LESS.
2. EXCAVATE THE SPREADER TO A MINIMUM DEPTH OF 6 INCHES.
3. ENSURE THAT THE GRADE ACROSS THE DEPRESSION IS FLAT OR GRADUALLY SLOPES UPHILL.
4. ENSURE THAT THE GROUND ACROSS THE LENGTH OF THE ENTRANCE AND OUTLET IS UNIFORM IN ELEVATION.

CHANNELS

GENERAL DESCRIPTION:

Channels are defined as natural or constructed waterways designed to collect and convey concentrated flows of storm water runoff. In conveying concentrated flows, channels both minimize erosion and keep runoff from coming in contact with potential pollutants. Channels are typically v-shaped, parabolic, or trapezoidal in shape, and may be lined with vegetation, rock, asphalt, or concrete. A small parabolic or v-shaped channel may also be referred to as a swale. Swales are most commonly used in conjunction with berms.

PROS:

- Ability to direct flows away from construction or industrial activities
- Requires little maintenance
- Provides a long-term storm water control

CONS:

- Cost may not be economical for small facilities or sites
- May increase flow rates
- Conveyed concentrated flows require stabilized structures all the way to the discharge point
- Requires formal design

INSTALLATION GUIDELINES:

- Channel excavation shall conform to the locations and elevations shown on the design drawings.
- Channel material should be placed as the foundation is prepared.
- When constructing rock lined channels, rock shall be placed to form a uniform mass with few voids.
- When constructing vegetation lined channels, use matting (see section on matting, page 54) to establish the lining.
- Channel material shall be based upon flow volumes, channel slope, and soil conditions.
- V-shaped channels should be constructed when flow volumes are relatively small.
- Trapezoidal or parabolic channels should be constructed for large volume flows.
- Channel outlets shall be stabilized with an energy dissipater, and where applicable, sediment trapping controls.
- Stabilize all areas disturbed by channel construction.

INSPECTION AND MAINTENANCE:

- For active field operations, channels shall be inspected weekly and within 24 hours, or the next available working day, following each storm event producing greater than 0.5 inches of precipitation.
- When site activity has ceased and significant surface runoff is not likely (arid season), inspections shall be conducted at least every other month and following each storm event producing greater than 0.5 inches of precipitation.
- If an additional inspection frequency is specified within a Storm Water Pollution Prevention (SWPP) Plan, this frequency shall be followed.
- Inspections shall be documented on the BMP Inspection and Maintenance Form.

- Inspectors should identify in particular:
 - ◆ Correct installation
 - ◆ Effectiveness in controlling storm water runoff.
 - ◆ Damage that has occurred since the last inspection. *Most notably:* scour, vegetation loss, erosion, and rock displacement.
 - ◆ Required maintenance
 - ◆ Sediment accumulations and the need to remove the accumulations.
 - ◆ Evidence of erosion or other damage in the surrounding area.
- Inspect the outlet point for erosion or other damage.
- Inspect the channel for scour, bank stability, and debris build-up.
- Remove debris and sediment accumulations as necessary.
- Removed sediment accumulations shall not be placed within any drainage, either above or below the BMP.
- Removed sediment shall be stabilized to prevent future migration from storm water runoff.
- Conduct required repairs immediately and document them in the current or next inspection record.

Environmental media (e.g. soil, sediment, surface, and ground water) is not considered waste. However, contaminated environmental media may constitute solid waste and/or hazardous waste. If there is any potential for accumulated sediment to be contaminated, a waste determination must be made and documented. For guidance, see the Laboratory's LIRs on Radioactive Waste, Managing Solid Waste, and Hazardous and Mixed Waste Requirements for Generators.

Inspection plans and records shall be maintained by the owner/operator, and made available for future regulatory inspections.

REMOVAL CRITERIA:

- If functioning as a temporary control, channels shall not be removed until the area of concern has been permanently stabilized with structural controls or vegetation.
- Final vegetative stabilization is defined as 70% of the vegetative cover that would exist under normal site conditions. The Water Quality and Hydrology Group (ESH-18) shall assist in making this determination.

For assistance with BMP selection, installation, or maintenance, please contact ESH-18 at 665-4752.

ROCK LINED CHANNEL

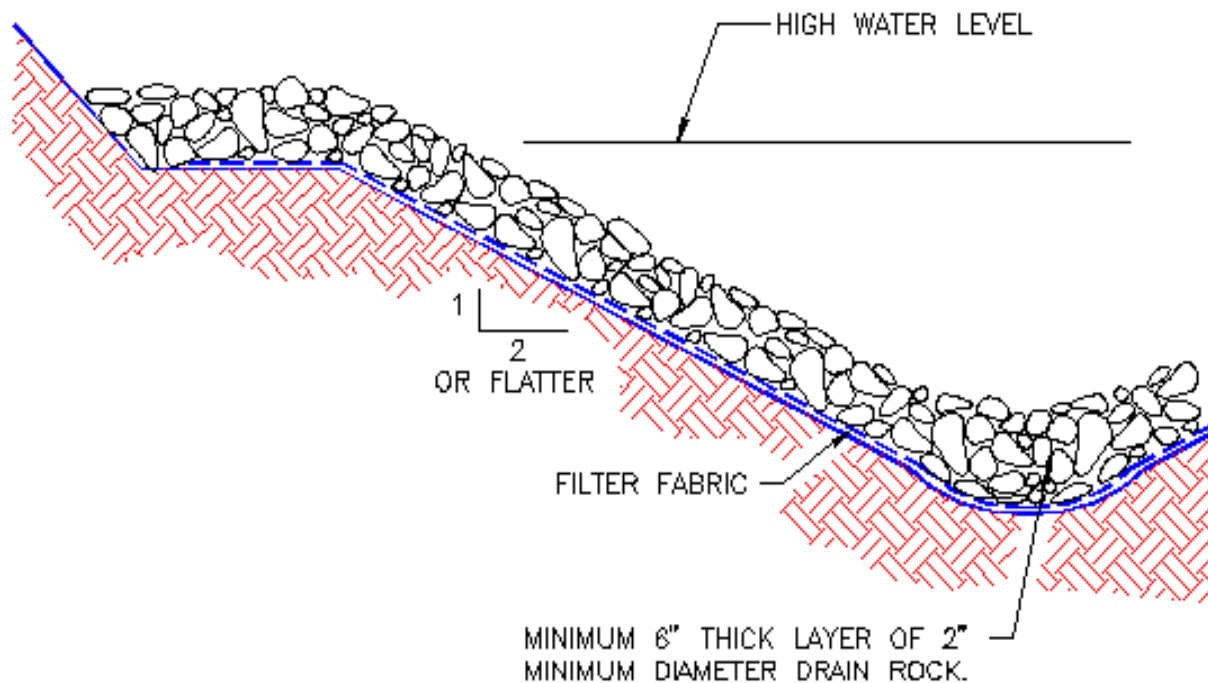

TYPICAL SECTION

NOTES:

1. THE HIGH WATER LEVEL AND OTHER CHANNEL DIMENSIONS SHALL BE BASED ON GRADIENT AND PEAK DESIGN FLOW.
2. V-SHAPED CHANNELS SHALL BE CONSTRUCTED FOR LOW VOLUME FLOWS AND TRAPEZOIDAL OR PARABOLIC SHAPES FOR LARGE VOLUME FLOWS.
3. ROCK SHALL BE PLACED TO FORM A UNIFORM MASS WITH FEW VOIDS.
4. FILTER FABRIC MAY BE INSTALLED PRIOR TO ROCK PLACEMENT TO STABILIZE AND PROTECT THE CHANNEL SURFACE.

VEGETATION-LINED CHANNEL TYPICAL CROSS SECTIONS

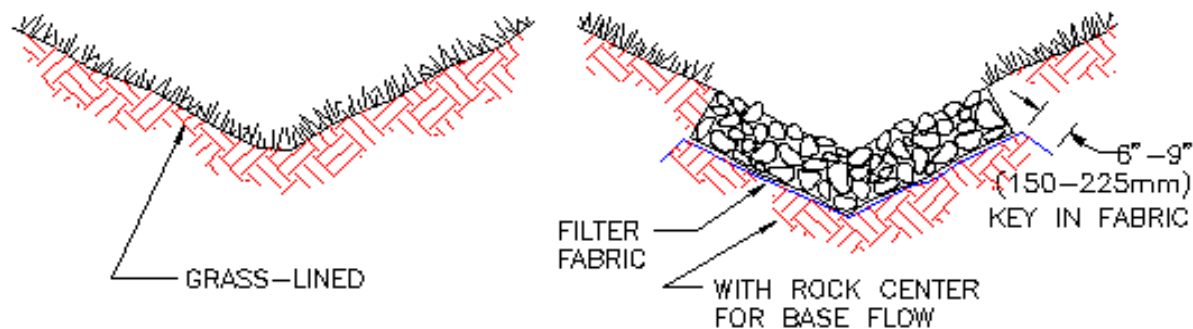

**TYPICAL V-SHAPED CHANNEL
CROSS-SECTION**

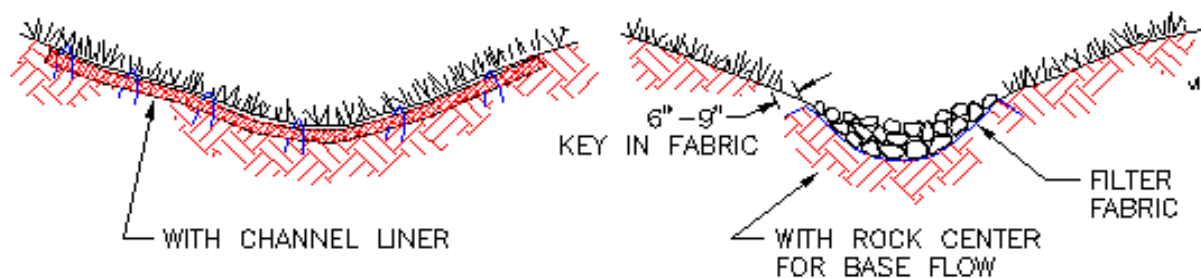

**TYPICAL PARABOLIC CHANNEL
CROSS-SECTION**

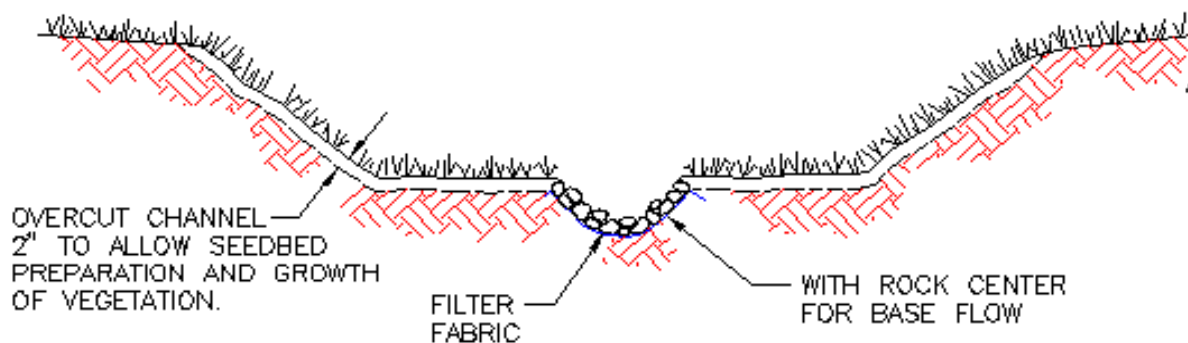

**TYPICAL TRAPEZOIDAL CHANNEL
CROSS-SECTION**

NOTES:

1. THE HIGH WATER LEVEL AND OTHER CHANNEL DIMENSIONS SHALL BE BASED ON GRADIENT AND PEAK DESIGN FLOW.
2. V-SHAPED CHANNELS SHALL BE CONSTRUCTED FOR LOW VOLUME FLOWS AND TRAPEZOIDAL OR PARABOLIC SHAPES FOR LARGE VOLUME FLOWS.

VEGETATIVE BUFFER ZONE

GENERAL DESCRIPTION:

Vegetative buffer zones are vegetated sections of land used to manage storm water runoff. Buffer zones increase infiltration rates and reduce runoff velocity, sediment transport, and runoff on slopes. These areas are particularly effective at the top or bottom of slopes, or adjacent to disturbed or paved areas, wetlands, and watercourses. Buffer zones may be either vegetated areas left undisturbed during construction or newly planted areas.

PROS:

- Inexpensive when using existing vegetation
- Once established, requires minimal maintenance
- Aesthetic control
- Can be used at any site that supports vegetation
- Increases infiltration rate, filters sediment, and reduces runoff velocity

CONS:

- Requires areas that won't limit site activity or the movement of equipment
- Buffer zone is ineffective until vegetation is established
- Area will require additional controls while vegetation is being established

INSTALLATION GUIDELINES:

Existing Vegetation

- Protect existing vegetation, as much as practicable, against damage from excavation and equipment or vehicle traffic.
- Maintain or improve the quality of existing vegetation through routine maintenance activity.
- As applicable, maintenance activities should include irrigating, mowing, pruning, fertilizing, and weed and pest control.

Establishing Vegetation

- Native vegetation appropriate to the season and site conditions shall be used.
- See Section 222.7 of the LANL Architectural Standards Manual, Volume 4, for guidance on applicable seed mixes.
- Storm water diversion and conveyance controls shall be installed to divert concentrated flows away from seeded areas.
- Ensure that seeded areas are protected against disturbances until vegetation is established.

INSPECTION AND MAINTENANCE:

- For active field operations, vegetative buffer zones shall be inspected weekly and within 24 hours, or the next available working day, following each storm event producing greater than 0.5 inches of precipitation.
- When site activity has ceased and significant surface runoff is not likely (arid season), inspections shall be conducted at least every other month and following each storm event producing greater than 0.5 inches of precipitation.
- If an additional inspection frequency is specified within a Storm Water Pollution Prevention (SWPP) Plan, this frequency shall be followed.
- Inspections shall be documented on the BMP Inspection and Maintenance Form.

- Inspectors should identify in particular:
 - ◆ Correct installation or maintenance.
 - ◆ Effectiveness in controlling storm water runoff, erosion, and sediment transport.
 - ◆ Damage that has occurred since the last inspection.
 - ◆ Required maintenance.
 - ◆ Evidence of erosion or other damage in the surrounding area.
- When establishing vegetation, inspect seeded area for uniform growth.
- Conduct required repairs immediately and document them in the current or next inspection record.

Environmental media (e.g. soil, sediment, surface, and ground water) is not considered waste. However, contaminated environmental media may constitute solid waste and/or hazardous waste. If there is any potential for accumulated sediment to be contaminated, a waste determination must be made and documented. For guidance, see the Laboratory's LIRs on Radioactive Waste, Managing Solid Waste, and Hazardous and Mixed Waste Requirements for Generators.

Inspection plans and records shall be maintained by the owner/operator, and made available for future regulatory inspections.

REMOVAL CRITERIA:

- Vegetative buffer zones shall not be removed unless additional controls are implemented, or the area is to be developed.

For assistance with BMP selection, installation, or maintenance, please contact ESH-18 at 665-4752.

VEGETATED BUFFER ZONE

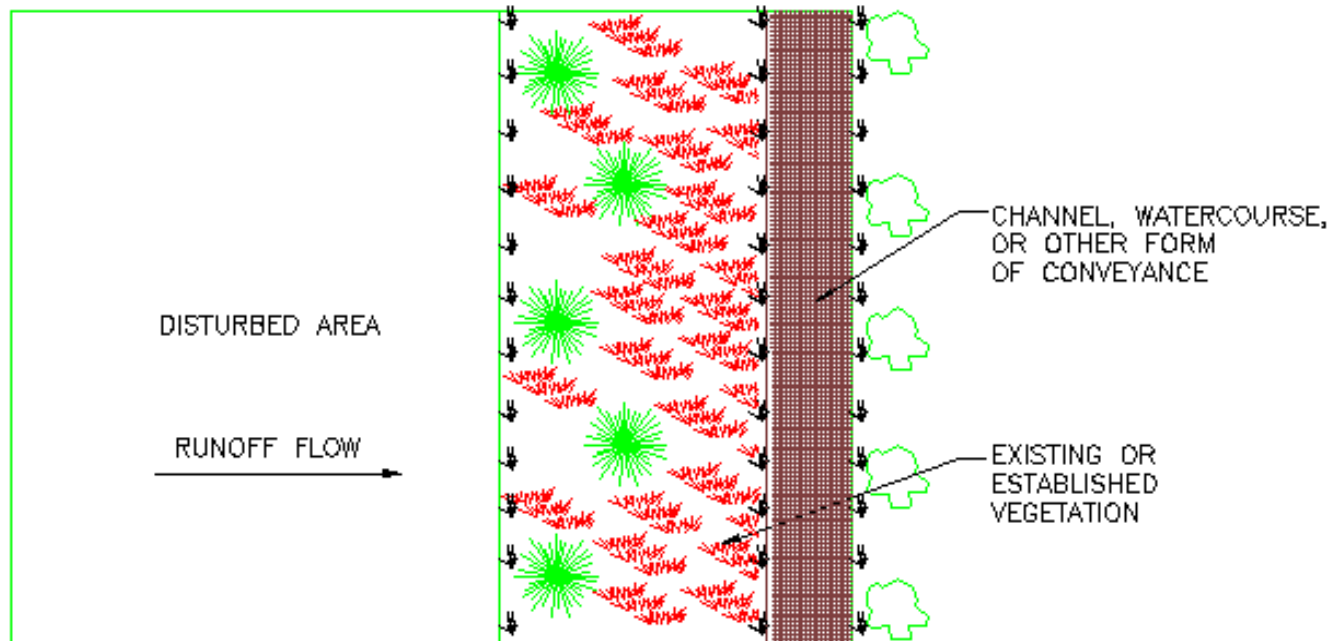

PLAN VIEW

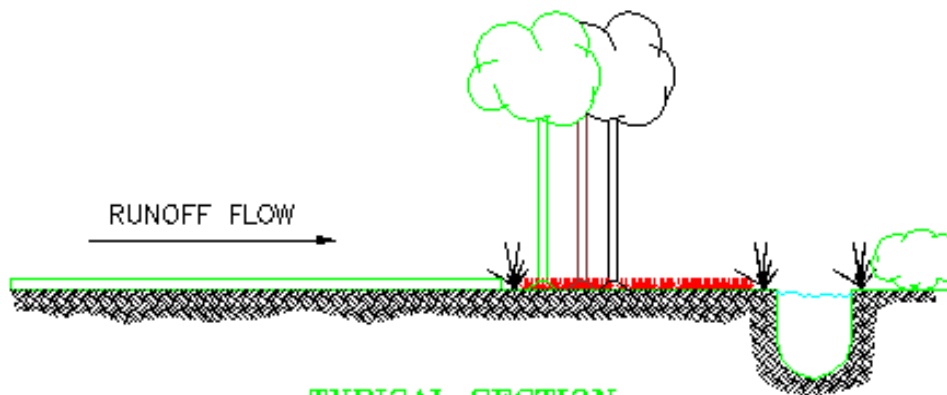

TYPICAL SECTION

NOTES:

1. AS PRACTICABLE, PROTECT EXISTING VEGETATION AGAINST DAMAGE FROM LAND DISTURBING ACTIVITIES.
2. MAINTAIN OR IMPROVE THE QUALITY OF EXISTING VEGETATION THROUGH ROUTINE MAINTENANCE.
3. ESTABLISH NATIVE VEGETATION APPROPRIATE TO THE SEASON AND SITE CONDITIONS.
4. ENSURE THAT SEEDED AREAS ARE PROTECTED AGAINST DISTURBANCES UNTIL VEGETATION IS ESTABLISHED.

MULCHING

GENERAL DESCRIPTION:

Mulching is a temporary soil stabilization practice wherein a protective layer of material is applied to a soil surface. Materials most often used include straw, woodchips, wood fibers, coconut fibers, and excelsior. The purpose of mulch is to stabilize soil and minimize erosion by protecting the soil surface from raindrop impact. Mulch is also effective in increasing infiltration rates, conserving moisture, and aiding in seed germination. Mulch may be applied as loose material or as matting, which is mulch material that is enveloped in biodegradable netting. This section will focus on the application of loose mulch material. Matting is discussed in the following section on page 54.

PROS:

- May be applied by hand or by machinery
- Increases infiltration rates and aids in the germination of vegetation
- Can be applied to any site
- Requires no removal

CONS:

- Due to covering, the germination of some seeds may be delayed
- The application of loose mulch material may have to be repeated due to site activity, wind, or large storm events

INSTALLATION GUIDELINES:

- Mulch shall be applied following the completion of seeding.
- On seeded sites, mulch material shall not be applied more than 2 inches deep, unless incorporated into the soil by tracking, discing, or crimping.
- Storm water diversion and conveyance controls shall be installed to divert concentrated flows away from seeded areas.

Straw

- To prevent the vegetation of noxious weeds, use clean wheat, barley, oat, or rice straw.
- Ensure that the straw is not moldy or compacted.
- Either by hand or machine, evenly distribute straw to a depth of 2-4 inches,
- Cover the exposed area to a uniform depth with the soil surface being barely visible.
- For seeded sites, 80% of the soil surface should be covered.
- For unseeded sites, 90% of the soil surface should be covered.
- One 80 lbs bale of straw will adequately cover approximately 1000 ft².
- Straw shall be anchored immediately to minimize cover loss from wind or water. Anchoring techniques include crimping, tracking, discing, or covering the material with netting.

Straw Anchoring Techniques

- If the straw has been distributed by hand it may be anchored by incorporating it into the soil with a dull, round-nosed shovel. This should be done every 1-2 feet.
- While limited in its operational constraints, tractor drawn tools which incorporate the straw into the top 2-8 inches of soil provide optimum anchoring.
- For slopes of 3:1 or less, tracking with heavy equipment is an effective way to anchor straw. Tracking equipment shall operate perpendicular to the direction of flow.
- Netting is typically made from jute, wood fiber, plastic, paper, or cotton, and may also be used to cover straw mulch.

Wood chips or Bark

- Evenly distribute the material to a surface depth of 2-3 inches.
- The application rate for wood chips or bark is approximately 6 tons/acre or 275 lbs/1,000 ft².

INSPECTION AND MAINTENANCE:

- For active field operations, areas with mulch shall be inspected weekly and within 24 hours, or the next available working day, following each storm event producing greater than 0.5 inches of precipitation.
- When site activity has ceased and significant surface runoff is not likely (arid season), inspections shall be conducted at least every other month and following each storm event producing greater than 0.5 inches of precipitation.
- If an additional inspection frequency is specified within a Storm Water Pollution Prevention (SWPP) Plan, this frequency shall be followed.
- Inspections shall be documented on the BMP Inspection and Maintenance Form.
- Inspectors should identify in particular:
 - ◆ Correct installation.
 - ◆ Effectiveness in controlling storm water runoff, erosion, and sediment transport.
 - ◆ Damage that has occurred since the last inspection.
 - ◆ Required maintenance.
 - ◆ Evidence of erosion or other damage in the surrounding area.
- Inspect mulched areas for adequate and uniform cover.
- Conduct required repairs immediately and document them in the current or next inspection record.

Inspection plans and records shall be maintained by the owner/operator, and made available for future regulatory inspections.

REMOVAL CRITERIA:

None

For assistance with BMP selection, installation, or maintenance, please contact ESH-18 at 665-4752.

MATTING

GENERAL DESCRIPTION:

Matting involves the application of protective mulch matting to a prepared soil surface. Mulch matting is material (most commonly straw, jute, or wood or coconut fibers) that has been formed into sheets of mulch. The material is machine produced and is evenly distributed between biodegradable natural fiber netting. Netting is typically made from jute, wood fiber, plastic, paper or cotton. Matting is used to temporarily stabilize and protect disturbed soil. Its use also increases infiltration rates and aids in the germination of vegetation. Typical applications for matting include disturbed or exposed areas, slopes, and channelized waterways.

PROS:

- Provides immediate soil stabilization and erosion control
- Can aid the establishment of vegetation in waterways
- Increases infiltration rates and aids in the germination of vegetation
- Requires no removal

CONS:

- Due to covering, the germination of some seeds may be delayed
- Netting may interfere with maintenance efforts (mowing, weedeating, etc)
- If mulch material degrades or is washed away prior to the biodegradation of the netting, netting material may have to be removed and properly disposed of.

INSTALLATION GUIDELINES:

Site Preparation

- Grade the installation area as appropriate to ensure firm, continuous contact between the material and the soil.
- Remove all large rocks, clods, or other obstructions that will interfere with the appropriate soil contact.
- For compacted, crusted or hardened soil, loosen with discing, raking or harrowing. For sandy soils, tracking with heavy equipment cleats is effective.
- The seedbed should be approximately 3-5 inches deep. Ensure that the top 3 inches is loose, moist soil.

Seeding

- For erosion control and re-vegetation, seed the area prior to mat installation. Areas disturbed during mat installation may require reseeding.
- For turf reinforcement, seed the area after mat installation.

Anchoring

- Matting shall be anchored to the ground using U-shaped wire staples, metal geotextile stake pins, or wooden stakes. Anchors should be a minimum of 6-8 inches long, having sufficient ground penetration to resist pullout. Wire staples should be a minimum of 11 gauge and stake pins should be a minimum 3/16 inch in diameter steel with a 1 1/2 inch steel washer at the head of the pin. Both shall be driven flush with the ground surface.

Slope Installation

- At the top of the slope anchor the mat in a trench that is a minimum of 6 inches deep x 6 inches wide. Backfill material shall be firmly tamped.
- Ensure the matting is unrolled in the direction of the water flow.
- Maintain direct soil contact during placement.

- Overlap the edges of adjacent parallel rolls a minimum of 4 inches and anchor mats approximately every 3 feet.
- If mat splicing is required, provide a minimum 6 inch overlap between mats and place anchors, approximately 12 inches apart, in the overlapped area.
- Anchor the matting as required to maintain contact with the soil.

Channel Installation

- At the downstream end of the project area, excavate an initial anchor trench approximately 12 inches deep and 6 inches wide.
- Excavate intermittent check slots, 6 inches deep and 6 inches wide across the channel at 25-30 foot intervals along the channel.
- To bury edges of the matting, excavate longitudinal anchor slots 4 inches deep and 4 inches wide along each side of the installation area. Extend the matting 2-3 inches above the crest of channel side slopes.
- The ends of mats shall be secured with anchors at 1 foot intervals. Firmly tamp backfill material.
- Overlap adjacent parallel rolls and splice as is detailed in the previous section.
- Unroll the matting in an upstream direction, stopping at each anchor slot.
- Anchor upstream end of matting in 12 inch deep x 6 inch wide trench. Firmly tamp backfill material.
- Anchor the matting as required to maintain contact with the soil.

INSPECTION AND MAINTENANCE:

- For active field operations, areas with matting shall be inspected weekly and within 24 hours, or the next available working day, following each storm event producing greater than 0.5 inches of precipitation.
- When site activity has ceased and significant surface runoff is not likely (arid season), inspections shall be conducted at least every other month and following each storm event producing greater than 0.5 inches of precipitation.
- If an additional inspection frequency is specified within a Storm Water Pollution Prevention (SWPP) Plan, this frequency shall be followed.
- Inspections shall be documented on the BMP Inspection and Maintenance Form.
- Inspectors should identify in particular:
 - ◆ Correct installation.
 - ◆ Effectiveness in controlling storm water runoff, erosion, and sediment transport.
 - ◆ Damage that has occurred since the last inspection.
 - ◆ Required maintenance.
 - ◆ Evidence of erosion or other damage in the surrounding area.
- Inspect installation area for erosion and undermining.
- Conduct required repairs immediately and document them in the current or next inspection record.

Inspection plans and records shall be maintained by the owner/operator, and made available for future regulatory inspections.

REMOVAL CRITERIA:

None

For assistance with BMP selection, installation, or maintenance, please contact ESH-18 at 665-4752.

MATTING CHANNEL INSTALLATION

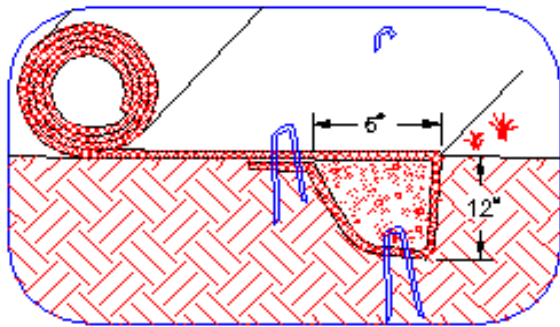

INITIAL CHANNEL ANCHOR TRENCH

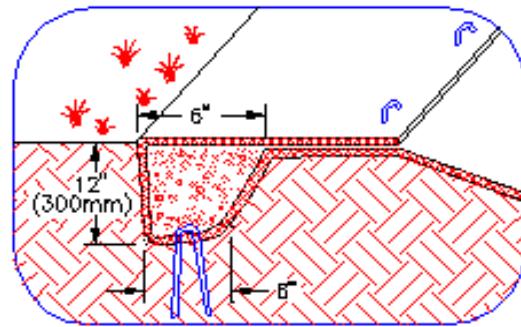

TERMINAL SLOPE AND CHANNEL ANCHOR TRENCH

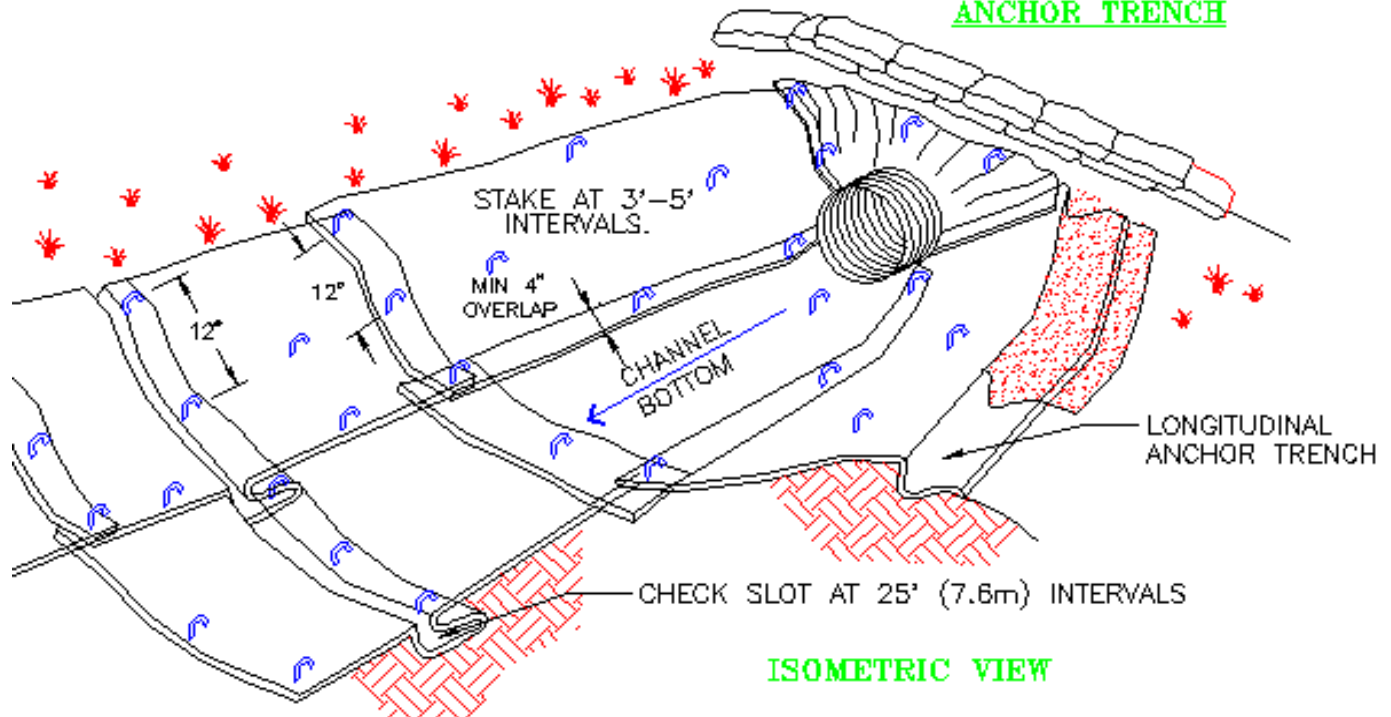

ISOMETRIC VIEW

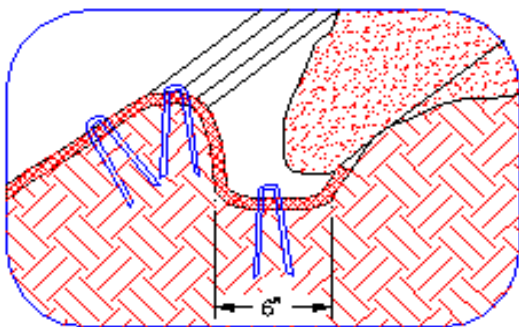

LONGITUDINAL ANCHOR TRENCH

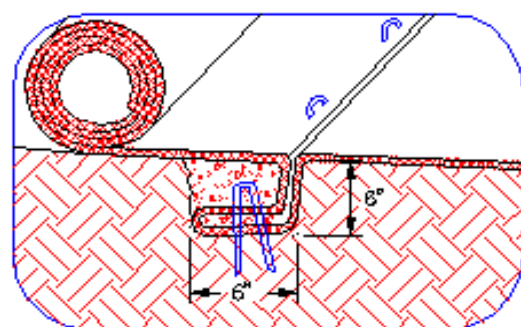

INTERMITTENT CHECK SLOT

NOTES:

1. EXCAVATE INITIAL CHANNEL ANCHOR TRENCH AT THE DOWNSTREAM END OF THE PROJECT.
2. UNROLL MATS IN AN UPSTREAM DIRECTION.
3. ANCHOR MATTING AS REQUIRED TO MAINTAIN SOIL CONTACT.

MATTING SLOPE INSTALLATION

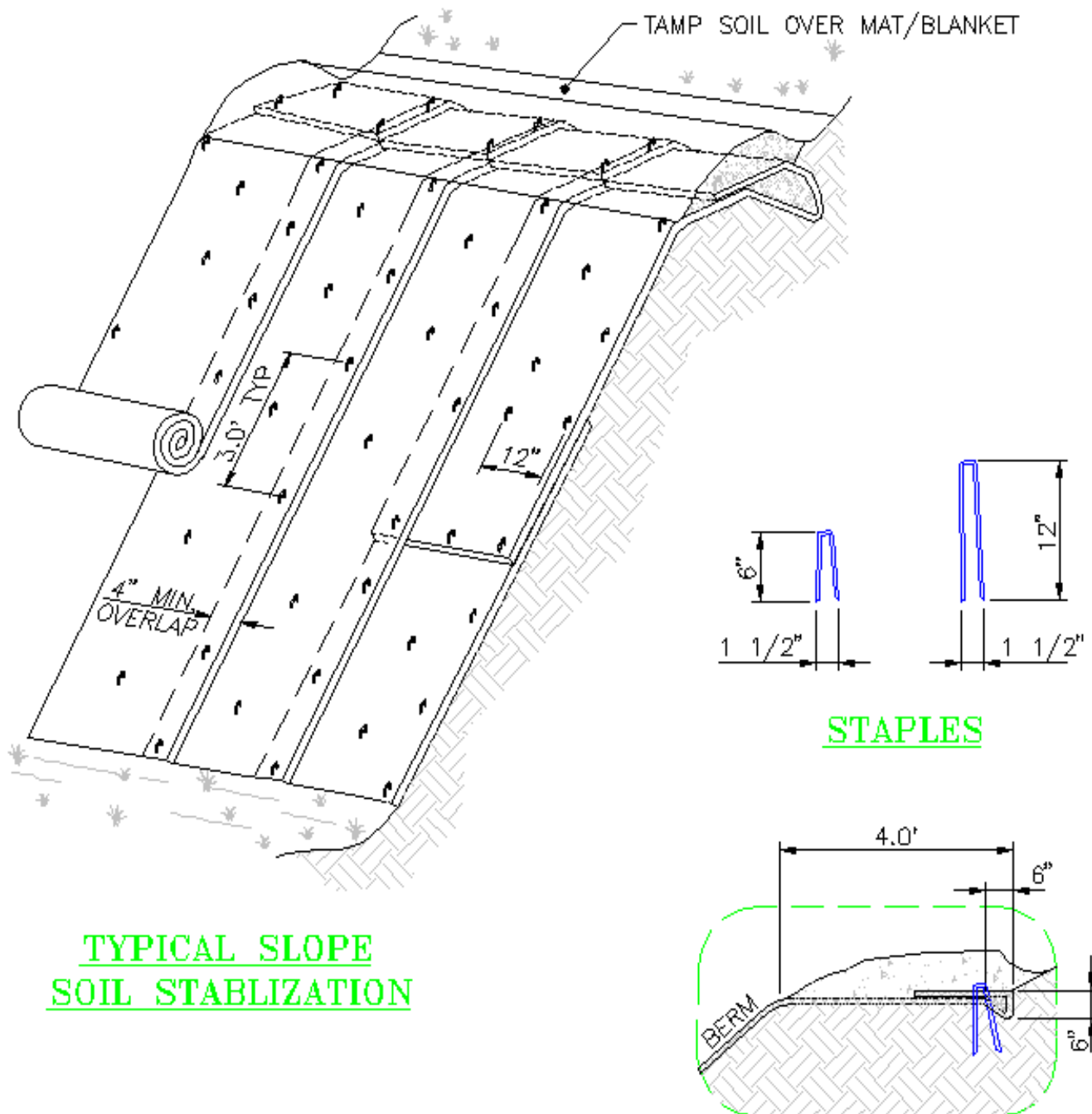

NOTES:

1. SLOPES SURFACE SHALL BE FREE OF ROCKS, CLODS, STICKS AND GRASS. MATS/BLANKETS SHALL HAVE GOOD SOIL CONTACT.
2. APPLY PERMANENT SEEDING BEFORE PLACING BLANKETS. SEEDBED SHALL BE APPROXIMATELY 3-5 INCHES DEEP.
3. UNROLL MATTING IN THE DIRECTION OF WATER FLOW.
4. LAY BLANKETS LOOSELY AND STAKE OR STAPLE TO MAINTAIN DIRECT CONTACT WITH THE SOIL. DO NOT STRETCH.

TEMPORARY SEEDING

GENERAL DESCRIPTION:

Temporary seeding involves providing short-term vegetative cover to disturbed surfaces or other areas that pose a high risk of erosion. The primary difference between temporary and permanent seeding is the use of fast-growing grasses. By quickly stabilizing the area with temporary seeding, erosion and sediment transport can be reduced until permanent stabilization controls can be implemented. Typical areas appropriate for temporary seeding include soil stockpiles, berms, dams, areas adjacent to roadways, and denuded areas exposed to seasonal rains or subject to erosion for more than 30 days.

PROS:

- Inexpensive and easy to install
- Under the right climate conditions, provides rapid vegetative cover
- An aesthetic control
- Increases infiltration rates, reducing storm water runoff
- May reduce the maintenance costs of other erosion controls in the area

CONS:

- Establishment of vegetation is dependent upon the season and rainfall rates
- Following seeding, area requires protection from heavy use
- To effectively control erosion, proper seedbed preparation and the use of quality seed is required
- Once vegetated, the area may require ongoing irrigation and maintenance

INSTALLATION GUIDELINES:

Site Preparation

- Grade the area as needed for proper seedbed preparation.
- If the soil has recently been disturbed, no additional roughening is required.
- For compacted, crusted or hardened soil, loosen with discing, raking or harrowing. For sandy soils, tracking with heavy equipment cleats is effective.
- The seedbed should be approximately 3-5 inches deep. Ensure that the top 3 inches is loose, moist soil free of large clods and stones.
- Storm water diversion and conveyance controls shall be installed to divert concentrated flows away from seeded areas.

Planting

- Seeding should be completed as soon as practicable following completion of land disturbing activities.
- The spreading of mulch should immediately follow seeding when seeding in adverse soil conditions, during excessively hot or dry weather, where heavy rains are expected, or on slopes greater than 2:1.
- Seed shall be applied uniformly using calibrated spreaders, cyclone seeders, mechanical drills, broadcast spreading, or hydroseeders.
- Apply fertilizer and/or lime as soil conditions require.
- To provide adequate seed-soil contact, incorporate the seed into the soil by raking or chain dragging and lightly compact the soil so that the seedbed is firm.

Seed Mixes

- Native vegetation appropriate to the season and site conditions shall be used.
- See Section 222.7 of the LANL Architectural Standards Manual, Volume 4, for guidance on applicable seed mixes.

INSPECTION AND MAINTENANCE:

- For active field operations, areas with temporary seeding shall be inspected weekly and within 24 hours, or the next available working day, following each storm event producing greater than 0.5 inches of precipitation.
- When site activity has ceased and significant surface runoff is not likely (arid season), inspections shall be conducted at least every other month and following each storm event producing greater than 0.5 inches of precipitation.
- If an additional inspection frequency is specified within a Storm Water Pollution Prevention (SWPP) Plan, this frequency shall be followed.
- Inspections shall be documented on the BMP Inspection and Maintenance Form.
- Inspectors should identify in particular:
 - ◆ Correct installation.
 - ◆ Effectiveness in controlling storm water runoff, erosion, and sediment transport.
 - ◆ Damage that has occurred since the last inspection.
 - ◆ Required maintenance.
 - ◆ Evidence of erosion or other damage in the surrounding area.
- Inspect seeded area for uniform growth of vegetation.
- Conduct required repairs immediately and document them in the current or next inspection record.

Inspection plans and records shall be maintained by the owner/operator, and made available for future regulatory inspections.

REMOVAL CRITERIA:

- Seeded areas shall not be disturbed until the area has been stabilized with vegetation.
- Final vegetative stabilization is defined as 70% of the vegetative cover that would exist under normal site conditions. The Water Quality and Hydrology Group (ESH-18) shall assist in making this determination.

For assistance with BMP selection, installation, or maintenance, please contact ESH-18 at 665-4752.

PERMANENT SEEDING

GENERAL DESCRIPTION:

Permanent seeding is the establishment of long-term perennial vegetative cover to disturbed surfaces or other areas that pose a high risk of erosion. Through permanent stabilization, erosion and sediment transport is reduced and the volume of runoff is diminished due to increased infiltration rates. Typical areas appropriate for permanent seeding include denuded areas where long-term vegetative cover is desired, buffer areas, steep slopes, stream banks, and areas where soils are unstable.

PROS:

- Relatively inexpensive
- An aesthetic control
- Increases infiltration rates and reduces erosion and sediment transport
- Very effective in stabilizing the soil

CONS:

- Establishment of vegetation is dependent upon the season and rainfall rates
- Requires site area that is at final grade
- May require ongoing irrigation and maintenance to establish vegetation

INSTALLATION GUIDELINES:

Timing

- Permanent seeding to areas to be void of activity for 1 year or more.
- Permanent seeding should be applied when an area has achieved final grade and no further disturbances are planned.
- Permanent seeding shall be applied prior to seasonal rains or freezing weather.
- For late fall or winter seeding schedules, dormant seeding mixes shall be used.

Site Preparation

- Area to be seeded shall be brought to final grade.
- Storm water diversion and conveyance controls shall be installed to divert concentrated flows away from seeded areas.
- If the soil has recently been disturbed, no additional roughening is required.
- For compacted, crusted or hardened soil, loosen with discing, raking or harrowing. For sandy soils, tracking with heavy equipment cleats is effective.
- The seedbed should be approximately 3-5 inches deep. Ensure that the top 3 inches is loose, moist topsoil free of large clods and stones.

Planting

- Seeding should be initiated as soon as practicable following completion of final grading activities.
- If seeding requires harrowing, tracking, or furrowing, these activities shall be conducted horizontally across the face of the slope.
- The spreading of mulch should immediately follow seeding when seeding in adverse soil conditions, during excessively hot or dry weather, where heavy rains are expected, or on slopes greater than 2:1.
- Seed shall be applied uniformly using calibrated spreaders, cyclone seeders, mechanical drills, broadcast spreading, or hydroseeders.
- Apply fertilizer and/or lime, as soil conditions require.

- To provide adequate seed-soil contact, incorporate broadcast seed into the soil by raking or chain dragging. Lightly compact the soil so that the seedbed is firm.

Seed Mixes

- Native vegetation appropriate to the season and site conditions shall be used.
- Seed mixes shall include annuals, perennials, and legumes.
- See Section 222.7 of the LANL Architectural Standards Manual, Volume 4, for guidance on applicable seed mixes.

INSPECTION AND MAINTENANCE:

- For active field operations, areas with permanent seeding shall be inspected weekly and within 24 hours, or the next available working day, following each storm event producing greater than 0.5 inches of precipitation.
- When site activity has ceased and significant surface runoff is not likely (arid season), inspections shall be conducted at least every other month and following each storm event producing greater than 0.5 inches of precipitation.
- If an additional inspection frequency is specified within a Storm Water Pollution Prevention (SWPP) Plan, this frequency shall be followed.
- Inspections shall be documented on the BMP Inspection and Maintenance Form.
- Inspectors should identify in particular:
 - ◆ Correct installation.
 - ◆ Effectiveness in controlling storm water runoff, erosion, and sediment transport.
 - ◆ Damage that has occurred since the last inspection.
 - ◆ Required maintenance.
 - ◆ Evidence of erosion or other damage in the surrounding area.
- Inspect seeded area for uniform growth of vegetation.
- "Spot" seed small bare areas to increase vegetative cover.
- Conduct required repairs immediately and document them in the current or next inspection record.

Inspection plans and records shall be maintained by the owner/operator, and made available for future regulatory inspections.

REMOVAL CRITERIA:

- Seeded areas shall not be disturbed until the area has been stabilized with vegetation.
- Final vegetative stabilization is defined as 70% of the vegetative cover that would exist under normal site conditions. The Water Quality and Hydrology Group (ESH-18) shall assist in making this determination.

For assistance with BMP selection, installation, or maintenance, please contact ESH-18 at 665-4752.

RIPRAP

GENERAL DESCRIPTION:

Riprap is a foundation of irregularly placed stones designed to stabilize and protect areas subject to erosion. Its uses include cut-and fill slopes, channel sides and bottoms, conveyance inlets and outlets, stream bank stabilization, and shorelines subject to wave action. Riprap is identified as either graded, which includes a mixture of stone sizes, or uniform which constitutes stones of the same size. Stone sizes are designated by mean diameter or weight.

PROS:

- Versatile and erosion resistant material
- Can be used for high velocity flows
- When using graded riprap, provides a dense flexible cover
- Requires minimal maintenance

CONS:

- May be difficult to remove sediment accumulations
- Requires proper slope selection and surface preparation for long term success
- Depending on surrounding conditions, control may be unsightly

INSTALLATION GUIDELINES:

- For areas requiring riprap, schedule land disturbing activities so that riprap placement can immediately follow completion of surface preparation.
- Brush, trees, stumps, and other objects that would interfere with riprap placement shall be removed.
- To prevent soil movement through the riprap, install a filter beneath the riprap. The filter should consist of either a gravel layer or filter fabric.
- Gravel filter design is based on the ratio of particle size in the filter material to that of the subgrade base material.
- Layers of gravel filter material shall be a minimum of 6 inches thick.
- The subgrade for the filter shall conform to the design elevations. Required fill shall be compacted to the density of the surrounding undisturbed material.
- When using filter fabric, connect joints with a minimum overlap of 1 foot and space anchor pins approximately every 3 feet along the overlap. The ends of the fabric shall be buried to a minimum depth of 12 inches.
- Ensure that the fabric material is protected from damage during installation.
- Riprap placement should immediately follow filter installation.
- Riprap shall be either uniform or graded stone.
- Riprap shall not be placed by methods that cause a segregation of stone sizes.
- Riprap placement should form a mass of stones with a minimum of voids.
- Ensure that the filter and underlying layers are not disturbed during placement.
- Following installation, stabilize all disturbed areas.
- For additional information on riprap selection and installation, see Section 602 of the New Mexico State Highway and Transportation Department Standard Specifications for Highway and Bridge Construction.

INSPECTION AND MAINTENANCE:

- For active field operations, riprap shall be inspected weekly and within 24 hours, or the next available working day, following each storm event producing greater than 0.5 inches of precipitation.

- When site activity has ceased and significant surface runoff is not likely (arid season), inspections shall be conducted at least every other month and following each storm event producing greater than 0.5 inches of precipitation.
- If an additional inspection frequency is specified within a Storm Water Pollution Prevention (SWPP) Plan, this frequency shall be followed.
- Inspections shall be documented on the BMP Inspection and Maintenance Form.
- Inspectors should identify in particular:
 - ◆ Correct installation.
 - ◆ Effectiveness in controlling runoff, sediment transport, and erosion.
 - ◆ Damage that has occurred since the last inspection.
 - ◆ Required maintenance.
 - ◆ Sediment accumulations and the need to remove the accumulations.
 - ◆ Evidence of erosion or other damage in the surrounding area.
- Inspect for erosion around the riprap and the dislodgment of stones.
- At a minimum, accumulated sediment shall be removed when stones are no longer visible.
- Removed sediment accumulations shall not be placed within any drainage, either above or below the BMP.
- Removed sediment shall be stabilized to prevent future migration from storm water runoff.
- Required repairs should be conducted immediately and documented in the current or next inspection record.

Environmental media (e.g. soil, sediment, surface, and ground water) is not considered waste. However, contaminated environmental media may constitute solid waste and/or hazardous waste. If there is any potential for accumulated sediment to be contaminated, a waste determination must be made and documented. For guidance, see the Laboratory's LIRs on Radioactive Waste, Managing Solid Waste, and Hazardous and Mixed Waste Requirements for Generators.

Inspection plans and records shall be maintained by the owner/operator, and made available for future regulatory inspections.

REMOVAL CRITERIA:

- Riprap shall not be removed unless the conveyance or channel is no longer in use, or the area is to be stabilized with another type of control.

For assistance with BMP selection, installation, or maintenance, please contact ESH-18 at 665-4752.

RIPRAP

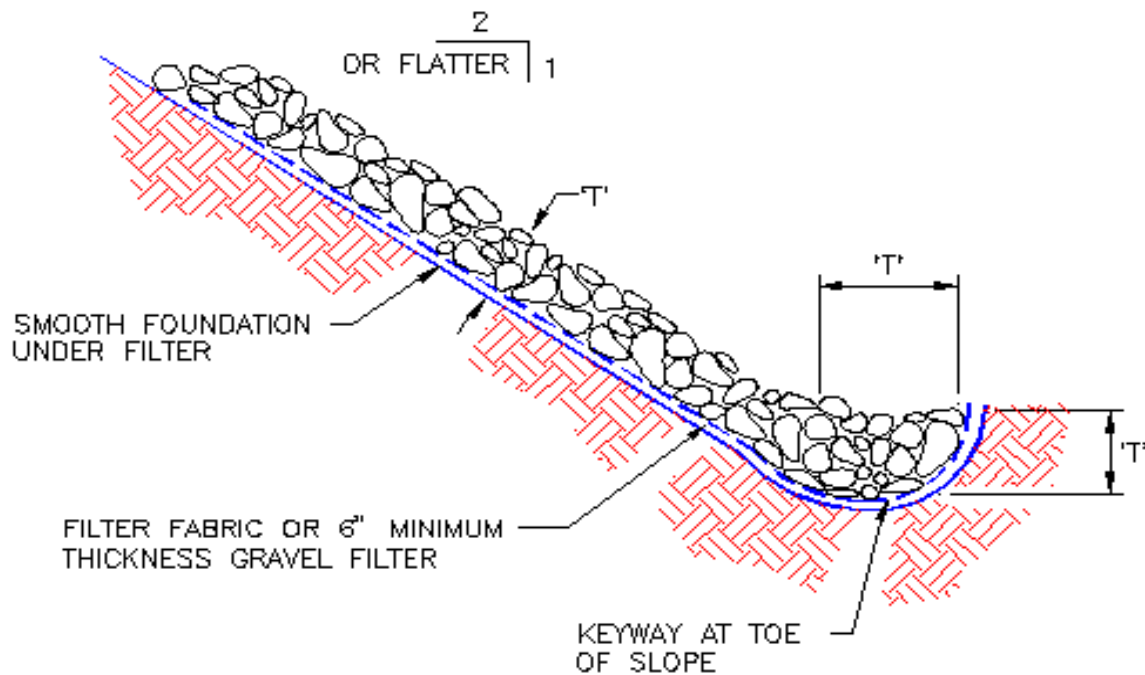

TYPICAL SECTION

NOTES:

1. REMOVE BRUSH, TREES, STUMPS, AND OTHER OBJECTS THAT WOULD INTERFERE WITH RIPRAP PLACEMENT.
2. RIPRAP SHALL BE A MIXTURE OF WELL GRADED STONES.
3. RIPRAP THICKNESS 'T' SHALL BE DETERMINED BY THE ENGINEER. REFER TO SECTION 602 OF THE NEW MEXICO STATE HIGHWAY AND TRANSPORTATION DEPARTMENT STANDARD SPECIFICATIONS OF HIGHWAY AND BRIDGE CONSTRUCTION FOR STONE CLASSIFICATIONS.
4. PLACEMENT SHOULD FORM A WELL GRADED MASS OF STONE WITH A MINIMUM OF VOIDS.
5. ENSURE THAT THE FILTER AND UNDERLYING LAYERS ARE NOT DISTURBED DURING RIPRAP PLACEMENT.

GABIONS

GENERAL DESCRIPTION:

A gabion is wire enclosed riprap that forms a pervious structure designed to stabilize and protect channels and slopes subject to erosion. By trapping sediment between the stones, gabions also facilitate vegetative growth. The traditional gabion is a rectangular basket used as a building block for retaining walls and grade control structures. Gabion mattresses, which are not as thick as traditional gabions, are used to line storm drain outlets and channel side slopes and bottoms. The wire used in gabion construction is typically double-twist, hexagonal mesh, or welded wire.

PROS:

- Versatile and erosion resistant material
- Can be used for high velocity flows
- Supports vegetative growth
- Requires minimal maintenance
- Requires less thickness than an equivalent riprap design

CONS:

- If necessary, may be difficult to remove sediment accumulations
- When used as a retaining wall or grade control structure, requires a formal design
- Depending on surrounding conditions, control may be unsightly

INSTALLATION GUIDELINES:

Gabion installation should be done in accordance with the design requirements and manufacturers' standards and specifications. Additional general information on gabion installation follows:

- Gabions should be of single-unit construction and be fabricated so they can be assembled at the construction site.
- When gabions are assembled, corners should be first joined together. Untied edges shall be assembled by tying with lacing wire or approved fasteners.
- To ensure that erosion does not occur beneath or around the structures, gabions and gabion mattresses shall be secured to the streambank or streambed.
- Excavate loose material as necessary to establish a stable foundation for each structure.
- Gabion baskets should be joined together along adjacent edges, both horizontally and vertically.
- Following filling, the tops of the gabions should be closed along edges with lacing wire or approved fasteners. Voids and bulges in the gabions should be kept to a minimum
- Gabions should be filled with 3-5 inch stone.
- Gabion mattresses should be filled with 4-8 inch stone.
- For additional information on gabion installation, see Section 602 of the New Mexico State Highway and Transportation Department Standard Specifications for Highway and Bridge Construction.

INSPECTION AND MAINTENANCE:

- For active field operations, gabions shall be inspected weekly and within 24 hours, or the next available working day, following each storm event producing greater than 0.5 inches of precipitation.
- When site activity has ceased and significant surface runoff is not likely (arid season), inspections shall be conducted at least every other month and following each storm event producing greater than 0.5 inches of precipitation.

- If an additional inspection frequency is specified within a Storm Water Pollution Prevention (SWPP) Plan, this frequency shall be followed.
- Inspections shall be documented on the BMP Inspection and Maintenance Form.
- Inspectors should identify in particular:
 - ◆ Correct installation.
 - ◆ Effectiveness in controlling runoff, sediment transport, and erosion.
 - ◆ Damage that has occurred since the last inspection.
 - ◆ Required maintenance.
 - ◆ Evidence of erosion or other damage in the surrounding area.
- Inspect for erosion around and beneath the gabions.
- Required repairs should be conducted immediately and documented in the current or next inspection record.

Environmental media (e.g. soil, sediment, surface, and ground water) is not considered waste. However, contaminated environmental media may constitute solid waste and/or hazardous waste. If there is any potential for accumulated sediment to be contaminated, a waste determination must be made and documented. For guidance, see the Laboratory's LIRs on Radioactive Waste, Managing Solid Waste, and Hazardous and Mixed Waste Requirements for Generators.

Inspection plans and records shall be maintained by the owner/operator, and made available for future regulatory inspections.

REMOVAL CRITERIA:

- Gabions shall not be removed unless the conveyance or channel is no longer in use, or the area is to be stabilized with another type of control.

For assistance with BMP selection, installation, or maintenance, please contact ESH-18 at 665-4752.

GABIONS

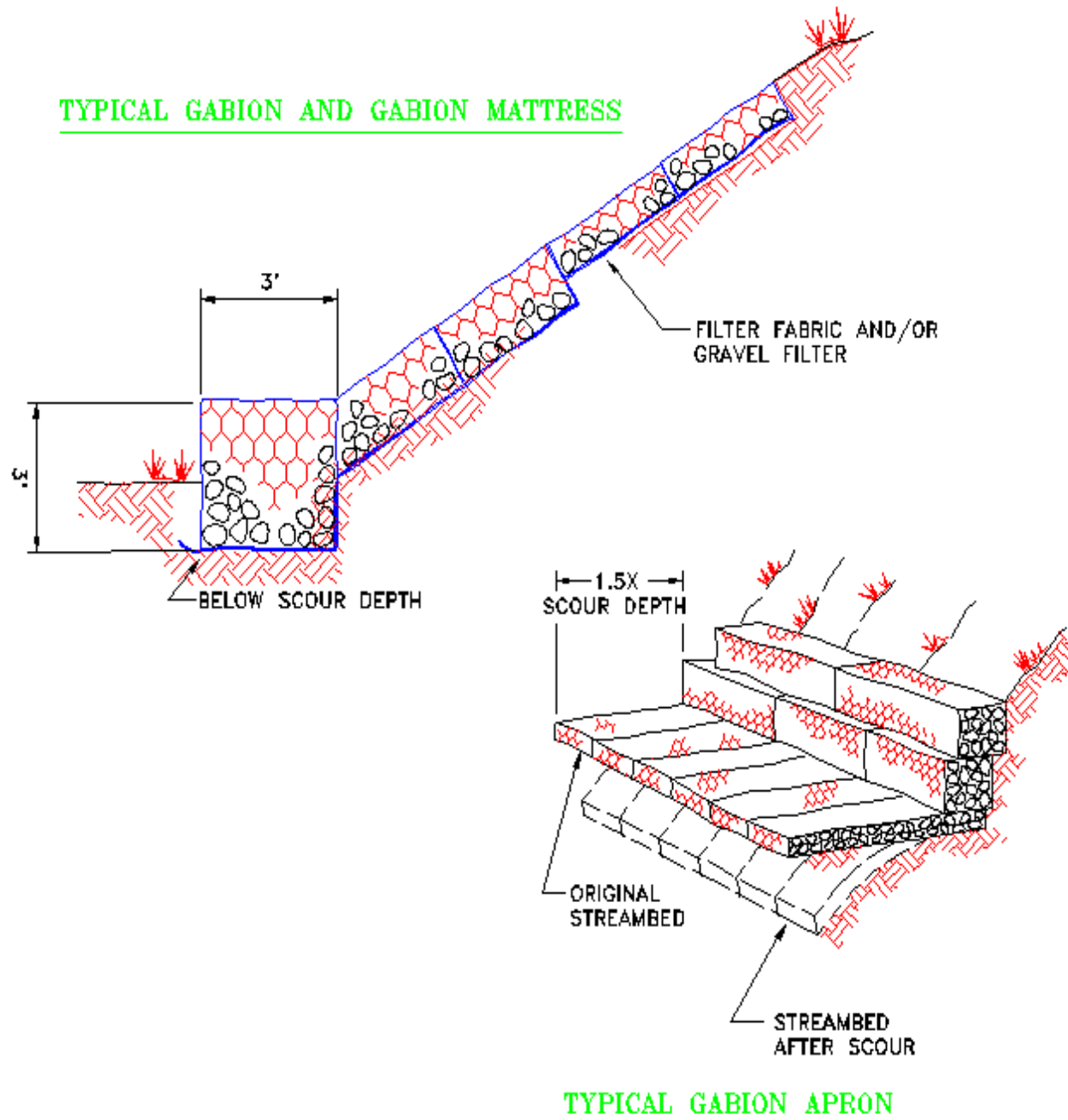

NOTES:

1. WHEN ASSEMBLING GABIONS, FASTEN CORNERS TOGETHER FIRST.
2. SECURE GABIONS TO STREAMBANK OR STREAMBED TO MINIMIZE SCOUR BENEATH OR AROUND THE STRUCTURES.
3. EXCAVATE LOOSE MATERIAL TO ESTABLISH A STABLE FOUNDATION.
4. MINIMIZE VOIDS AND BULGES IN THE GABIONS.

STORM DRAIN OUTLET PROTECTION

GENERAL DESCRIPTION:

Storm drain outlet protection consists of a structural control at a drain outlet that reduces velocity and dissipates energy in concentrated storm water runoff. These controls typically include riprap, concrete aprons, asphalt paved sections, and stilling basins, with riprap being the most common. In reducing velocity and dissipating energy, outlet protections minimize or eliminate scour at the outlet and downstream erosion.

PROS:

- Can be used for high velocity flows
- When using riprap, provides a relatively inexpensive control
- Requires minimal maintenance
- May be designed to remove sediment in addition to reducing velocity
- Minimizes scour and downstream erosion

CONS:

- If necessary, may be difficult to remove sediment accumulations
- Depending on surrounding conditions, control may be unsightly
- If using concrete, may be expensive for design and construction

INSTALLATION GUIDELINES:

- Design factors for outlet protection shall include peak runoff or design discharge of the conveyance, tailwater depth, and apron size.
- For outlets that discharge into a well defined channel, determine the maximum tailwater depth and extend the apron up the channel banks 0.5 feet above this depth.
- For concrete aprons, paved asphalt sections, and stilling basins, a formal design shall be prepared.

Riprap

- Riprap aprons should extend downstream until stable conditions are achieved, even if calculated lengths are exceeded.
- To prevent soil movement through the riprap, install a filter beneath the riprap that consists of a gravel layer or filter fabric.
- The subgrade for the filter shall conform to the design elevations. Required fill shall be compacted to the density of the surrounding undisturbed material.
- When using filter fabric, ensure protection from damage during installation and connect joints with a minimum overlap of 1 foot.
- Riprap shall be a mixture of well graded stones.
- For riprap selection and installation see Section 602 of the New Mexico State Highway and Transportation Department Standard Specifications for Highway and Bridge Construction.
- Ensure that the riprap apron has zero grade and is properly aligned with the receiving stream. No overfall should exist at the end.
- Following installation, stabilize all disturbed areas.

INSPECTION AND MAINTENANCE:

- For active field operations, storm drain outlet protections shall be inspected weekly and within 24 hours, or the next available working day, following each storm event producing greater than 0.5 inches of precipitation.
- When site activity has ceased and significant surface runoff is not likely (arid season), inspections shall be conducted at least every other month and following each storm event producing greater than 0.5 inches of precipitation.
- If an additional inspection frequency is specified within a Storm Water Pollution Prevention (SWPP) Plan, this frequency shall be followed.
- Inspections shall be documented on the BMP Inspection and Maintenance Form.
- Inspectors should identify in particular:
 - ◆ Correct installation.
 - ◆ Effectiveness in controlling runoff, sediment transport, and erosion.
 - ◆ Damage that has occurred since the last inspection.
 - ◆ Required maintenance.
 - ◆ Sediment accumulations and the need to remove the accumulations.
 - ◆ Evidence of erosion or other damage in the surrounding area.
- For riprap aprons, inspect for erosion around the riprap and dislodgment of stones.
- Accumulated sediment shall be removed if it impedes appropriate energy dissipation.
- Removed sediment accumulations shall not be placed within any drainage, either above or below the BMP.
- Removed sediment shall be stabilized to prevent future migration from storm water runoff.
- Required repairs should be conducted immediately and documented in the current or next inspection record.

Environmental media (e.g. soil, sediment, surface, and ground water) is not considered waste. However, contaminated environmental media may constitute solid waste and/or hazardous waste. If there is any potential for accumulated sediment to be contaminated, a waste determination must be made and documented. For guidance, see the Laboratory's LIRs on Radioactive Waste, Managing Solid Waste, and Hazardous and Mixed Waste Requirements for Generators.

Inspection plans and records shall be maintained by the owner/operator, and made available for future regulatory inspections.

REMOVAL CRITERIA:

- Storm drain outlet protections shall not be removed unless the conveyance is no longer in use.

For assistance with BMP selection, installation, or maintenance, please contact ESH-18 at 665-4752.

STORM DRAIN OUTLET PROTECTION

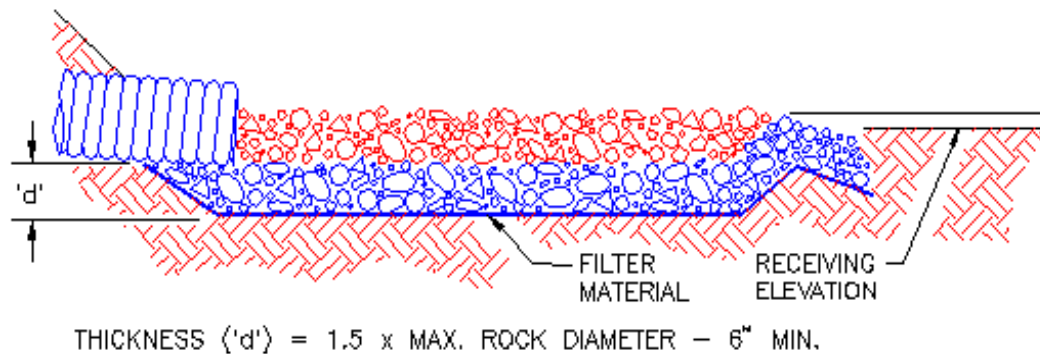

PROFILE

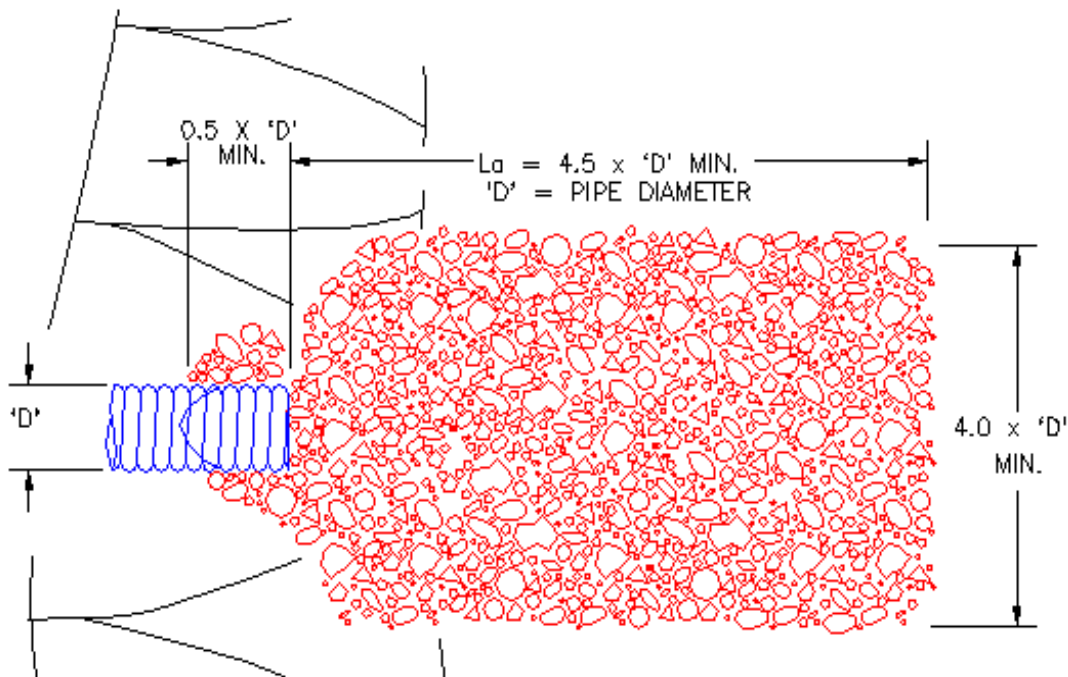

PLAN

NOTES:

1. DESIGN FACTORS FOR OUTLET PROTECTION SHALL INCLUDE PEAK RUNOFF OR DESIGN DISCHARGE OF THE CONVEYANCE, TAILWATER DEPTH, AND APRON SIZE.
2. $'L_a'$ = LENGTH OF APRON. DISTANCE $'L_a'$ SHALL BE OF SUFFICIENT LENGTH TO DISSIPATE ENERGY.
3. ENSURE THAT THE APRON HAS ZERO GRADE AND IS PROPERLY ALIGNED WITH THE RECEIVING STREAM.
4. FILTER MATERIAL SHALL BE FILTER FABRIC OR A 6" MINIMUM THICK GRADED GRAVEL LAYER.
5. WHEN USING RIPRAP, ENSURE THAT THE RIPRAP IS A MIXTURE OF WELL GRADED STONE.

CELLULAR CONFINEMENT SYSTEMS

GENERAL DESCRIPTION:

A cellular confinement system is a flexible, three-dimensional honeycomb structure designed to stabilize soil and prevent erosion. The individual cells in this permanent control confine and reinforce topsoil and all other types of fill material. This reinforcement protects a plant's root zone, permits subsurface drainage, and eliminates the downward movement of soil and the formation of rill erosion. Suitable applications for cellular confinement systems include channel stabilization, erosion control on slopes, the construction of revetments and retaining walls, road stabilization, and temporary low water crossings.

PROS:

- Effective in stabilizing soil and preventing erosion
- Can be used on steep slopes (1:1 or greater)
- Can be placed around large obstacles such as trees and boulders
- Through the reinforcement of fill material, increases load-bearing capacities
- Once established, requires minimal maintenance

CONS:

- More expensive than other stabilization controls
- Installation requires excavation of the area and compaction of the subgrade
- When used to support vegetation, requires surface treatments following the installation and placement of fill material

INSTALLATION GUIDELINES:

- Ensure that the installation area is a level surface. Remove stones and debris as needed. Large obstacles such as trees and boulders may be left in place. (Cellular confinement system may be placed around these objects.)
- Gullies and other large depressions shall be filled and well compacted.
- Excavate as necessary to ensure that, upon installation, the top of the cells are flush with or slightly lower than the surrounding ground or final grade.
- Ensure that the subgrade surface conforms to design elevations and grades.
- For slope stabilization, installation shall begin at the top of the slope a minimum of 2 feet from the edge. Anchor the system and extend the panels down the slope.
- Cellular confinement shall be anchored using J-pins or other approved devices.
- Install anchors in every other cell, repeating this pattern every 6 feet. Ensure that cells are securely anchored to prevent deformation during backfilling. Provide additional anchoring as necessary.
- When joining separate confinement system panels, abut the sections and join with staples, hog rings or other approved fasteners.
- Following completion of installation, place fill material in the cells using suitable equipment.
- When placing fill on steep slopes, infill from the crest to the toe.
- The maximum drop height for fill material shall be 3 feet.
- The depth of overfill and rate of compaction are dependent upon the type of fill material. General guidelines are:
 - ◆ For topsoil, overfill depth should be 1-2 inches. Material should be compacted until it is flush with the top edge of the cell wall.
 - ◆ For loose, granular material, overfill depth should be no more than 1 inch. Material should be compacted until it is flush with the top edge of the cell wall.

- Surface treatments to establish vegetative growth shall immediately follow placement of fill material.
- Areas disturbed during installation shall be stabilized.

INSPECTION AND MAINTENANCE:

- For active field operations, cellular confinement systems shall be inspected weekly and within 24 hours, or the next available working day, following each storm event producing greater than 0.5 inches of precipitation.
- When site activity has ceased and significant surface runoff is not likely (arid season), inspections shall be conducted at least every other month and following each storm event producing greater than 0.5 inches of precipitation.
- If an additional inspection frequency is specified within a Storm Water Pollution Prevention (SWPP) Plan, this frequency shall be followed.
- Inspections shall be documented on the BMP Inspection and Maintenance Form.
- Inspectors should identify in particular:
 - ◆ Correct installation.
 - ◆ Effectiveness in controlling runoff, sediment transport, and erosion.
 - ◆ Damage that has occurred since the last inspection.
 - ◆ Required maintenance.
 - ◆ Evidence of erosion or other damage in the surrounding area.
- Inspect for uniform establishment of vegetation. (70% of the vegetative cover that would exist under normal site conditions constitutes final vegetative stabilization) Reseed areas as necessary.
- Removed sediment accumulations shall not be placed within any drainage, either above or below the BMP.
- Removed sediment shall be stabilized to prevent future migration from storm water runoff.
- Required repairs should be conducted immediately and documented in the current or next inspection record.

Environmental media (e.g. soil, sediment, surface, and ground water) is not considered waste. However, contaminated environmental media may constitute solid waste and/or hazardous waste. If there is any potential for accumulated sediment to be contaminated, a waste determination must be made and documented. For guidance, see the Laboratory's LIRs on Radioactive Waste, Managing Solid Waste, and Hazardous and Mixed Waste Requirements for Generators.

Inspection plans and records shall be maintained by the owner/operator, and made available for future regulatory inspections.

REMOVAL CRITERIA:

NONE (Cellular confinement is a permanent control)

For assistance with BMP selection, installation, or maintenance, please contact ESH-18 at 665-4752.

CELLULAR CONFINEMENT SYSTEM

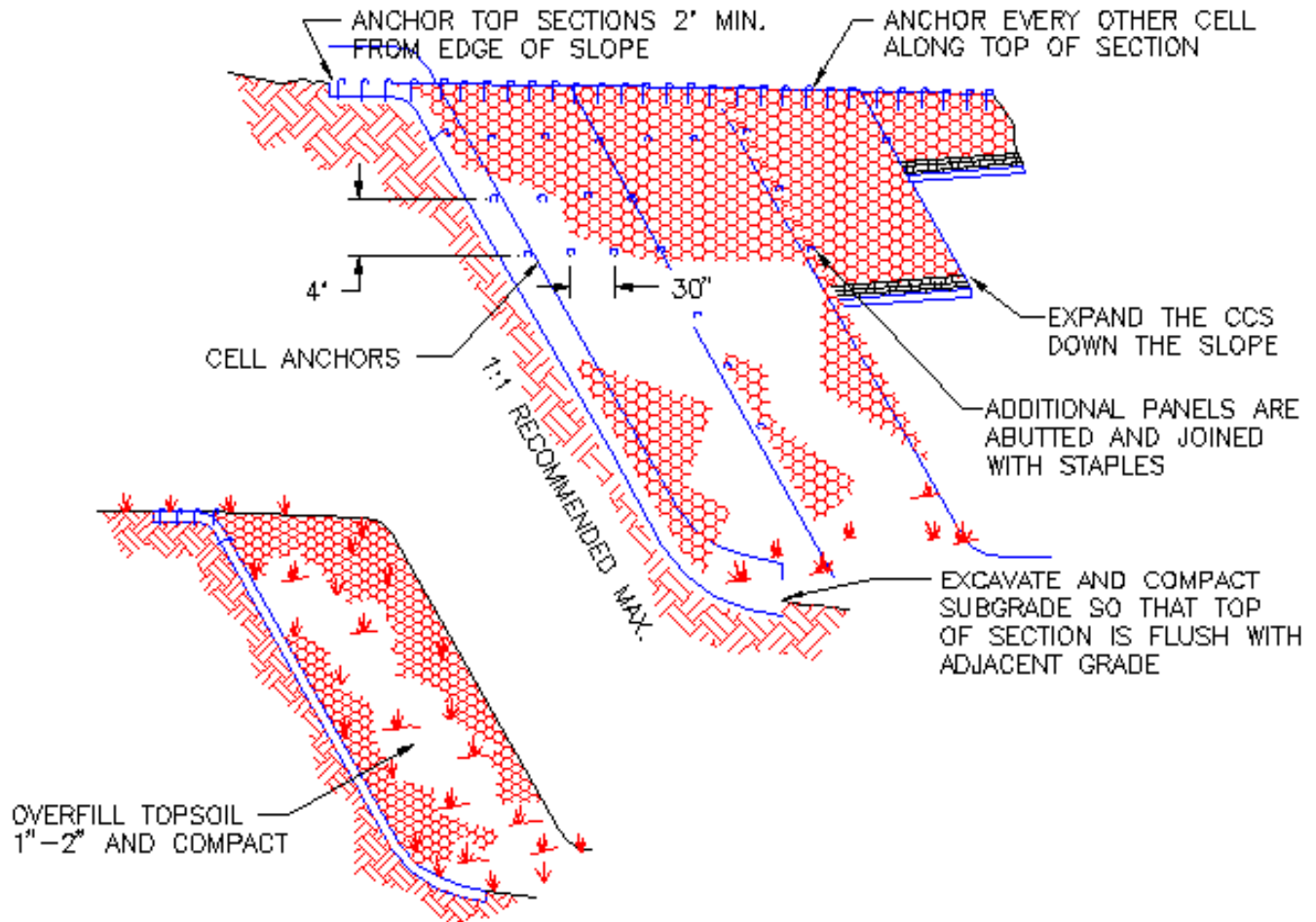

CCS BACKFILLED WITH TOPSOIL AND VEGETATED

NOT TO SCALE

NOTES:

1. ENSURE THAT THE SLOPE IS A LEVEL SURFACE. REMOVE STONES AND DEBRIS AS NEEDED. FILL AND COMPACT GULLIES AND LARGE DEPRESSIONS.
2. ENSURE THAT, UPON INSTALLATION, THE TOP OF THE CELLS ARE FLUSH WITH OR SLIGHTLY LOWER THAN THE SURROUNDING GROUND.
3. SECURELY ANCHOR CELLS TO PREVENT DISPLACEMENT AND DEFORMATION DURING BACKFILLING.
4. FILL CELLS FROM THE CREST OF THE SLOPE TO THE TOE. LIMIT DROP HEIGHT TO 3'.
5. COMPACT TOPSOIL UNTIL IT IS FLUSH WITH THE TOP EDGE OF THE CELL WALL.
6. SEE AREA IMMEDIATELY FOLLOWING PLACEMENT OF FILL.

DRUM & CONTAINER STORAGE

DESCRIPTION:

Drum contents typically include product and waste oils or chemicals. Container storage includes all other types of containers, up to and including above ground storage tanks with a capacity of 660 gallons. Above ground storage tanks with a capacity greater than 660 gallons are subject to the Laboratory's SPCC Plan requirements. Drums and/or containers that are stored where a leak or spill could enter a storm drain, storm water conveyance, arroyo, floor drain, or reach surface water must have spill control provided.

SPILL CONTROL REQUIREMENTS:

Drums are typically stored horizontally in racks or cradles, or vertically off the ground. Racks should be located within a curbed area. Drums stored vertically should be placed on palletized containment units. Drums and containers stored outdoors should be covered to minimize contact with storm water. Typical covers include tarpaulins, plastic sheeting, roofs, buildings, or other enclosures. Drums and containers should not be stored in standing water. Within drum and container storage areas, spill kits with adequate material to contain minor spills should be available.

Secondary containment for drum and container storage may consist of curbing, temporary or permanent berms, prefabricated pallets, or prefabricated storage sheds. Because curbing is typically much smaller than berms, its use should be limited to small areas where the handling and transferring of materials occurs. For drums or containers used for dispensing or transferring materials, drip pans should be placed under the dispensing area. Secondary containment must be large enough to hold the volume of the largest container or 10 percent of the volume of all containers, whichever is greater. If storage is outdoors, the containment volume must also account for the volume of a 3-inch rainfall event.

Periodically, storm events are of such magnitude or frequency that water accumulations in secondary containment structures must be drained or disposed of. Storm water accumulations in secondary containment structures must meet federal and state water quality standards prior to being released. Contact ESH-18 at 665-4752 for assistance.

PROS:

- Prevents a spill or release from reaching surface water and/or the environment
- Easy to install
- Numerous prefabricated units available
- Minimize the area to be cleaned up in the event of a spill
- Cost of containment is typically cheaper than the cost of cleanup and waste disposal
- With exceptions, most spills or releases within a containment unit are not reportable to external agencies

CONS:

- Initial cost
- May impact drum or container accessibility

INSPECTION & MAINTENANCE:

Inspections should include an examination of storage containers for leaks, corrosion, support or foundation failure, and other forms of deterioration. They should also be used to ensure proper labeling and adequate security measures. Secondary containment structures should be inspected for signs of deterioration or damage. Inspections should encompass both informal observations by operating personnel and formal examinations conducted by supervisory personnel. Repairs should be conducted as soon as practicable.

Include and maintain a suitable records system for inspections and maintenance. Make sure records are complete and detailed. Inspection records should, at a minimum, include the following:

- When inspections were done,
- Who conducted the inspection,
- What areas were inspected,
- What problems were found,
- What steps were taken to correct problems, and
- Who was notified about any problems found.

For assistance with spill control requirements, secondary containment selection, inspection, or maintenance please contact ESH-18 at 665-4752.

ELECTRICAL TRANSFORMERS

DESCRIPTION:

Electrical transformers are an integral part of an electronic power distribution network and are widely spread throughout the Laboratory. These units vary in size, type of electrical insulating oil used, and in installation setup. The majority of the transformers at the Laboratory are self-contained, pad-mounted units that do not require additional storage requirements.

Dependent upon its location, a transformer has the potential to impact surface water in the event of a leak or rupture. For all electrical transformers at such locations, spill control is required.

SPILL CONTROL REQUIREMENTS:

The likelihood of containment failure of an individual transformer is relatively low. However, due to their large size and extensive use, transformers are considered a potential spill source. Secondary containment should be provided for pad-mounted units in close proximity to a watercourse, storm drain, or other storm water conveyances.

Secondary containment may consist of curbing, trenching, temporary or permanent berms, or concrete sumps. Secondary containment should be large enough to hold the volume of the largest transformer. If storage is outdoors, the containment volume should also account for the volume of a 3-inch rainfall event.

Periodically, storm events are of such magnitude or frequency that water accumulation in secondary containment structures must be drained or disposed of. Storm water accumulations in secondary containment structures must meet federal and state water quality standards prior to being released. Contact ESH-18 at 665-4752 for assistance.

PROS:

- Prevent a spill or release from reaching surface water and/or the environment
- Easy to install
- Minimize the area to be cleaned up in the event of a spill
- Cost of containment is usually cheaper than the cost of cleanup and waste disposal
- With exceptions, most spills or releases within a containment unit are not reportable to external agencies

CONS:

- Initial cost
- Some installations may impact transformer accessibility
- Retrofitting installations may be expensive

INSPECTION & MAINTENANCE:

Inspections should include an examination of transformers for leaks, corrosion, support or foundation failure, condition of pressure relief devices, and other forms of deterioration. They should also be used to ensure proper labeling and adequate security measures. Secondary containment structures should be inspected for signs of deterioration or damage. Inspections should encompass both informal observations by operating personnel and formal examinations conducted by supervisory personnel. Repairs should be conducted as soon as practicable.

Include and maintain a suitable records system for inspections and maintenance. Make sure records are complete and detailed. Inspection records should, at a minimum, include the following:

- When inspections were done,
- Who conducted the inspection,
- What areas were inspected,
- What problems were found,
- What steps were taken to correct problems, and
- Who was notified about any problems found.

For assistance with spill control requirements, secondary containment selection, inspection or maintenance, please contact ESH-18 at 665-4752.

SALVAGE AREAS

DESCRIPTION:

A salvage area is a geographic location used to store scrap equipment and material. These areas are located throughout the Laboratory and are also referred to as “boneyards”. Salvage areas may house a variety of discarded equipment as well as waste that includes scrap metal, wire, drums, plastics, and lumber. A variety of spill sources may be located within salvage areas since discarded equipment may still contain lubricants, solvents, antifreeze, or other liquids. Leaching may also occur in waste material exposed to storm water.

SPILL CONTROL REQUIREMENTS:

Since salvage areas vary in size, terrain, and type of materials stored, spill control requirements should be applied on an individual basis. However, the following guidelines should be addressed when developing the spill control requirements:

- Identify potential pollutants and hazards within the area
- As appropriate, remove all fluids from discarded equipment
- As appropriate, provide drip pans, covering devices, or other secondary containment for sources of potential pollutants
- Where practicable, provide covering for salvage area materials to minimize contact with storm water
- Provide appropriate secondary containment for the area

The amounts and types of potential pollutants within salvage areas should be identified to determine secondary containment requirements. At a minimum, the salvage area should be bermed around the perimeter to contain runoff and potential pollutant transport. Other BMPs may also be used to divert runoff to either a treatment facility or a controlled area. Equipment that contains residual fluids should be provided with individual secondary containment. This may include drip pans, covering devices, berms, or curbing. Waste material that poses a threat to water quality due to leaching should be covered or stored within a bermed area.

Periodically, storm events are of such magnitude or frequency that water accumulation in secondary containment structures must be drained or disposed of. Storm water accumulations in secondary containment structures must meet federal and state water quality standards prior to being released. Contact ESH-18 at 665-4752 for assistance.

PROS:

- Prevent a spill or release from reaching surface water and/or the environment
- Easy to install
- Minimize the area to be cleaned up after a spill
- Cost of containment is usually cheaper than the cost of cleanup and waste disposal
- With exceptions, most spills or releases within a containment unit are not reportable to external agencies

CONS:

- Initial cost
- Some installations may impact equipment accessibility
- Retrofitting installations may be expensive

INSPECTION & MAINTENANCE:

Inspections should include an examination of salvage areas leaking equipment, soil stains associated with spills, erosion, and other forms of deterioration or damage. They should also be used to ensure adequate safety and security measures. Secondary containment structures should be inspected for signs of deterioration or damage. Inspections should encompass both informal observations by operating personnel and formal examinations conducted by supervisory personnel. Repairs should be conducted as soon as practicable. Include and maintain a suitable records system for inspections and maintenance. Make sure records are complete and detailed. Inspection records should, at a minimum, include the following:

- When inspections were done,
- Who conducted the inspection,
- What areas were inspected,
- What problems were found,
- What steps were taken to correct problems, and
- Who was notified about any problems found.

For assistance with spill control requirements, secondary containment selection, inspection, or maintenance please contact ESH-18 at 665-4752.

HYDRAULIC EQUIPMENT

DESCRIPTION:

Hydraulic equipment is defined as any equipment that uses hydraulic fluids for its operation or maintenance. Such equipment is used extensively throughout the Laboratory and includes vehicles (forklifts, earth moving equipment, etc.), tools, maintenance equipment, and stationary operational and experimental equipment.

SPILL CONTROL REQUIREMENTS:

When not in use, non-stationary hydraulic equipment should be stored in areas that prevent or minimize contact with storm water. Stationary hydraulic equipment should be protected with covering or secondary containment to prevent contact with storm water. When equipment is mounted in rooms with floor drains that drain to the environment or to an industrial or sanitary sewer, floor drains should be protected. Spill kits or other appropriate material should be available within storage areas. Kits should contain material adequate for a minor spill.

The purpose of secondary containment is to contain spilled material for appropriate cleanup to and prevent contact with storm water outside the contained area. Secondary containment for hydraulic equipment storage areas may consist of curbing, temporary or permanent berms, drip pans, or sorbent material. Drip pans and sorbent material are most often used with stationary, indoor equipment. If storage is located outdoors the secondary containment volume should also account for the volume of a 3-inch rainfall event.

Periodically, storm events are of such magnitude or frequency that water accumulations in secondary containment structures must be drained or disposed of. Storm water accumulations in secondary containment structures must meet federal and state water quality standards prior to being released. Contact ESH-18 at 665-4752 for assistance.

PROS:

- Prevent a spill or release from reaching surface water and/or the environment
- Easy to install
- Minimize the area to be cleaned up after a spill
- Cost of containment is usually cheaper than the cost of cleanup and waste disposal
- With exceptions, most spill releases within a containment unit are not reportable to external agencies

CONS:

- Initial cost
- Some installations may impact equipment accessibility
- Retrofitting installations may be expensive

INSPECTION & MAINTENANCE:

Inspections should include an examination of hydraulic equipment for leaks, corrosion, stains on soil and equipment, and other forms of deterioration or damage. They should also be used to ensure proper labeling and adequate safety and security measures. Secondary containment structures should be inspected for signs of deterioration or damage. Inspections should encompass both informal observations by operating personnel and formal examinations conducted by supervisory personnel. Repairs should be conducted as soon as practicable.

Include and maintain a suitable records system for inspections and maintenance. Make sure records are complete and detailed. Inspection records should, at a minimum, include the following:

- When inspections were done,
- Who conducted the inspection,
- What areas were inspected,
- What problems were found,
- What steps were taken to correct problems, and
- Who was notified about any problems found.

For assistance with spill control requirements, secondary containment selection, inspection, or maintenance please contact ESH-18 at 665-4752.

AIR COMPRESSORS

DESCRIPTION:

Air compressors provide pressurized air to varied process equipment. This equipment is used extensively throughout the Laboratory and includes valves; instrumentation; and power tools such as drills, diggers, pile drivers, motors and grinders. Air compressors have receiver tanks that collect and store high-pressure air. As air is compressed, moisture in the air condenses and collects in the receivers. Oil used to lubricate the air compressor leaks into the compressed-air piping and also condenses into the receiver tank. This oil and water mixture must then be drained from the receiver tank and disposed of.

SPILL CONTROL REQUIREMENTS:

Air compressors located outdoors should be covered to minimize contact with storm water. When compressors are mounted indoors in rooms with floor drains that drain to the environment or to an industrial or sanitary sewer, floor drains should be protected.

To contain drain valve discharges and other sources of water and oil condensate, air compressors should be equipped with appropriate secondary containment. This containment may include, but is not limited to, curbing, temporary or permanent berms, drip pans, sorbent material or oil/water separators. Drip pans and sorbent material are most often used with indoor equipment. When located outdoors, the secondary containment volume should also account for the volume of a 3-inch rainfall event.

Storm water and condensate accumulations in secondary containment structures must meet federal and state water quality standards prior to being released. If the condensate is contaminated with oil, the water is a hazardous waste and requires treatment prior to discharge. Contact ESH-18 at 665-4752 for assistance.

To prevent the creation of hazardous waste, use of the Torpedo oil/water separator filter is recommended. This 20 inches long, 2-4 inch diameter filter is constructed from PVC. Within the PVC case is a filter comprised of shredded polypropylene sheets which absorb oil while allowing water to escape. The Torpedo should be attached to the drain valve of the receiver storage tank and to other components in compressed-air systems that collect water condensate. A white polypropylene pad should be placed beneath the discharge outlet of each Torpedo canister to monitor the filter's effectiveness. When the white pad turns yellow from oil in the discharge, the Torpedo requires replacement.

PROS:

- Prevent a spill or release from reaching surface water and/or the environment
- Easy to install
- Minimize the area to be cleaned up in the event of a spill
- Cost of containment is usually cheaper than the cost of cleanup and waste disposal
- With exceptions, most spill releases within a containment unit are not reportable to external agencies
- Torpedo unit prevents the production of hazardous waste.
- Torpedo unit is a relatively inexpensive device
- Spent Torpedo filters are not classified as hazardous waste

CONS:

- Initial cost for some types of secondary containment
- Some installations may impact equipment accessibility
- Retrofitting installations may be expensive (dependent upon type of containment)
- Requires periodic inspection
- Requires periodic replacement

INSPECTION & MAINTENANCE:

Inspections should include an examination of air compressors for leaks, corrosion, stains on soil and equipment, and other forms of deterioration or damage. They should also be used to ensure proper labeling and adequate safety and security measures. Secondary containment structures should be inspected to ensure proper function and to identify signs of deterioration or damage. Inspections should encompass both informal observations by operating personnel and formal examinations conducted by supervisory personnel. Repairs and/or filter replacements should be conducted as soon as practicable.

Include and maintain a suitable records system for inspections and maintenance. Make sure records are complete and detailed. Inspection records should, at a minimum, include the following:

- When inspections were done,
- Who conducted the inspection,
- What areas were inspected,
- What problems were found,
- What steps were taken to correct problems, and
- Who was notified about any problems found.

For assistance with spill control requirements, secondary containment selection, inspection or maintenance, please contact ESH-18 at 665-4752.

APPENDIX A

References

Davis, Mackenzie L. and Cornwell, David A. (1991). Introduction to Environmental Engineering, Second Edition, McGraw-Hill, New York, NY, pp 18-19.

Dewberry, Sidney O., P.E, L.S. (1997). "Land Development: Erosion and Sediment Control", Civil Engineering News, Volume 9, Number 11, pp 45-46.

Environmental Protection Agency (1992). "Developing Pollution Prevention Plans and Best Management Practices", Storm Water Management for Industrial Activities, EPA 832-R-92-006, Office of Water, Washington, DC, pp 4-51 - 4-106.

Environmental Protection Agency (1979). NPDES Best Management Practices Guidance Document, EPA 600/9-79-045, Industrial Environmental Research Laboratory, Cincinnati, OH, pp iv, 1.

Kamber Engineering (1990). (Draft) Sediment and Erosion Control, An Inventory of Current Practices, Gaithersburgh, MD, pp III-27, IV-12 - IV-18, IV-24 - IV-26.

Los Alamos National Laboratory (1995). "Los Alamos Develops New Method of Separating Oil and Water", Dateline: Los Alamos, April Issue, pp 5-7.

Salix Applied Earthcare (1994). Erosion Draw 2.0, Redding, CA, pp 14-15, 23-24, 28-32, 39-40, 44-74, 79-88, 96-102, 106-107, 119-121.

Appendix B

BMP Maintenance and Inspection Form

This inspection form is to be used to document all BMP inspections. For active field operations, inspections shall be conducted weekly and following each storm event producing greater than 0.5 inches of precipitation. When site activity has ceased and significant surface runoff is not likely (arid season), inspections shall be conducted at least every other month and following each storm event producing greater than 0.5 inches of precipitation. Inspection records shall be maintained by the owner/operator, and made available for future regulatory inspections.

BMP Inspection and Maintenance Form

Site or Project Name: _____

Inspector: _____ Date: _____

_____ Days since last rainfall, on _____ Amount of last rainfall _____ (Inches)
 Circle one: Site rain gauge Metrological Tower _____

Complete the table below with the applicable YES, NO, or N/A.

		BMP Installed Correctly	Evidence of -	Storm Water Runoff	Sediment transport	Erosion	Has damage occurred since the last inspection?	Is maintenance required since the last inspection?	Is there accumulated sediment?	Does accumulated sediment require removal?	Is there evidence of other potential pollutant sources?	
List BMP type and location												Comments
1)												
2)												
3)												
4)												
5)												

* All Observations from the table need to be explained below:

Observations: _____

Maintenance Required: _____

Inspector's Signature: _____ Date: _____