



Office of Fissile Materials Disposition

United States Department of Energy

Surplus Plutonium Disposition Final Environmental Impact Statement

Summary

November 1999

For Further Information Contact:
U.S. Department of Energy
Office of Fissile Materials Disposition, P.O. Box 23786, Washington, DC 20026-3786

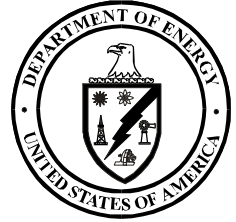

DOE/EIS-0283

Surplus Plutonium Disposition Final Environmental Impact Statement

Summary

**United States Department of Energy
Office of Fissile Materials Disposition**

November 1999

Table of Contents

S.1	Introduction	S-1
	Purpose of and Need for the Proposed Action	S-3
	Issues Identified During the Scoping Period	S-4
	Issues Already Intended for Inclusion in the SPD EIS	S-4
	Additional Issues That Need to Be Addressed in the SPD EIS	S-5
	Issues That Need to Be or Are Already Addressed Elsewhere	S-5
	Other	S-6
	Scope of the SPD EIS	S-6
	Preferred Alternatives	S-9
S.2	Summary of Major Issues Identified During the Comment Periods and Changes to the SPD Draft EIS	S-11
	Public Involvement Process for the SPD Draft EIS and the <i>Supplement to the SPD Draft EIS</i>	S-11
	Summary of Major Issues Raised on the SPD Draft EIS During the Public Comment Period	S-12
	Summary of Major Issues Raised on the <i>Supplement to the SPD Draft EIS</i> During the Public Comment Period	S-14
	Changes to the SPD Draft EIS and the <i>Supplement</i>	S-15
S.3	Alternatives and Materials Analyzed	S-18
	Immobilization Technology Alternatives	S-19
	MOX Fuel Fabrication Alternatives	S-19
	Materials Analyzed	S-21
S.4	Development of the Alternatives	S-22
	Development of Facility Siting Alternatives	S-22
	Alternatives Considered but Eliminated From Detailed Study	S-23
	Amounts of Material to Be Dispositioned	S-23
	Disposition Facility Siting Alternatives	S-23
	Feed Preparation Methods for Immobilization	S-24
	Immobilization Technology Alternatives	S-24
S.5	Overview of Proposed Surplus Plutonium Disposition Facilities and Transportation	S-24
	Pit Disassembly and Conversion	S-26
	Plutonium Conversion and Immobilization	S-27
	MOX Fuel Fabrication	S-27
	Lead Assembly Fabrication	S-28
	Transportation Activities	S-28
S.6	Approach to Environmental Impact Analysis	S-30
S.7	Summary of Impacts of Construction and Operation of Surplus Plutonium Disposition Facilities	S-31
	Summary of Impacts by Alternative and Site	S-32
	Summary of Lead Assembly Fabrication and Postirradiation Examination Impacts	S-35
	Summary of MOX Fuel Integrated Impacts	S-36
	Comparison of Immobilization Technology Impacts	S-39

S.8 Cumulative Impacts	S-42
Hanford	S-42
INEEL	S-45
Pantex	S-46
SRS	S-47
LLNL	S-48
LANL	S-49
ORNL	S-50
Reactor Sites (Catawba, McGuire, and North Anna)	S-51
S.9 References	S-52

List of Figures

Figure S-1. Locations of Surplus Plutonium S-3

Figure S-2. Proposed Locations of Surplus Plutonium Disposition Facilities S-18

Figure S-3. Proposed Surplus Plutonium Disposition Processes S-25

List of Tables

Table S-1. Surplus Plutonium Disposition Facility Alternatives Evaluated in the SPD EIS S-7

Table S-2. Facility Transportation Requirements S-29

Table S-3. Other Past, Present, and Reasonably Foreseeable Actions Considered in the
Cumulative Impact Assessment for Candidate DOE Sites S-43

List of Acronyms

ALARA	as low as is reasonably achievable	NEPA	National Environmental Policy Act
APSF	Actinide Packaging and Storage Facility	NESHAPs	National Emissions Standards for Hazardous Air Pollutants
ANL–W	Argonne National Laboratory–West	NOI	Notice of Intent
CANDU	Canadian Deuterium Uranium	NRC	U.S. Nuclear Regulatory Commission
CAA	Clean Air Act	NWPA	Nuclear Waste Policy Act
CFR	Code of Federal Regulations	ORNL	Oak Ridge National Laboratory
		ORR	Oak Ridge Reservation
D&D	decontamination and decommissioning	PEIS	programmatic environmental impact statement
DCS	Duke Engineering & Services, COGEMA Inc., and Stone & Webster	R&D	research and development
DOE	U.S. Department of Energy	RCRA	Resource Conservation and Recovery Act
DWPF	Defense Waste Processing Facility	RFETS	Rocky Flats Environmental Technology Site
EA	environmental assessment	RFP	Request for Proposals
EIS	environmental impact statement	ROD	Record of Decision
EPA	U.S. Environmental Protection Agency	ROI	region of influence
FFTF	Fast Flux Test Facility	SCSHPO	South Carolina State Historic Preservation Officer
FMEF	Fuels and Materials Examination Facility	SDWA	Safe Drinking Water Act
FR	Federal Register	SPD EIS	<i>Surplus Plutonium Disposition Environmental Impact Statement</i>
HEU	highly enriched uranium	SRS	Savannah River Site
HLW	high-level waste	SST/SGT	safe, secure trailer/SafeGuards Transport
HLWVF	high-level-waste vitrification facility		
INEEL	Idaho National Engineering and Environmental Laboratory	TRU	transuranic
ITP	In-Tank Precipitation	WIPP	Waste Isolation Pilot Plant
LANL	Los Alamos National Laboratory		
LCF	latent cancer fatality		
LEU	low-enriched uranium		
LLNL	Lawrence Livermore National Laboratory		
LLW	low-level waste		
LWR	light water reactor		
MEI	maximally exposed individual		
MOX	mixed oxide		
NAAQS	National Ambient Air Quality Standards		
NAS	National Academy of Sciences		

Chemicals and Units of Measure

cm	centimeter
g	gram
gal	gallon
in	inch
kg	kilogram
km	kilometer
l	liter
lb	pound
m ³	cubic meter
mi	mile
mrem	millirem
MWh	megawatt-hour
rem	roentgen equivalent man
t	metric ton
ton	short ton
UO ₂	uranium dioxide
yd ³	cubic yard
yr	year
°C	degrees Celsius (Centigrade)

Metric Conversion Chart

To Convert Into Metric			To Convert Out of Metric		
If You Know	Multiply By	To Get	If You Know	Multiply By	To Get
Length					
inches	2.54	centimeters	centimeters	0.3937	inches
feet	30.48	centimeters	centimeters	0.0328	feet
feet	0.3048	meters	meters	3.281	feet
yards	0.9144	meters	meters	1.0936	yards
miles	1.60934	kilometers	kilometers	0.6214	miles
Area					
sq. inches	6.4516	sq. centimeters	sq. centimeters	0.155	sq. inches
sq. feet	0.092903	sq. meters	sq. meters	10.7639	sq. feet
sq. yards	0.8361	sq. meters	sq. meters	1.196	sq. yards
acres	0.40469	hectares	hectares	2.471	acres
sq. miles	2.58999	sq. kilometers	sq. kilometers	0.3861	sq. miles
Volume					
fluid ounces	29.574	milliliters	milliliters	0.0338	fluid ounces
gallons	3.7854	liters	liters	0.26417	gallons
cubic feet	0.028317	cubic meters	cubic meters	35.315	cubic feet
cubic yards	0.76455	cubic meters	cubic meters	1.308	cubic yards
Weight					
ounces	28.3495	grams	grams	0.03527	ounces
pounds	0.45360	kilograms	kilograms	2.2046	pounds
short tons	0.90718	metric tons	metric tons	1.1023	short tons
Temperature					
Fahrenheit	Subtract 32, then multiply by 5/9ths	Celsius	Celsius	Multiply by 9/5ths, then add 32	Fahrenheit

Metric Prefixes

Prefix	Symbol	Multiplication Factor
exa-	E	1 000 000 000 000 000 000 = 10 ¹⁸
peta-	P	1 000 000 000 000 000 = 10 ¹⁵
tera-	T	1 000 000 000 000 = 10 ¹²
giga-	G	1 000 000 000 = 10 ⁹
mega-	M	1 000 000 = 10 ⁶
kilo-	k	1 000 = 10 ³
hecto-	h	100 = 10 ²
deka-	da	10 = 10 ¹
deci-	d	0.1 = 10 ⁻¹
centi-	c	0.01 = 10 ⁻²
milli-	m	0.001 = 10 ⁻³
micro-	μ	0.000 001 = 10 ⁻⁶
nano-	n	0.000 000 001 = 10 ⁻⁹
pico-	p	0.000 000 000 001 = 10 ⁻¹²
femto-	f	0.000 000 000 000 001 = 10 ⁻¹⁵
atto-	a	0.000 000 000 000 000 001 = 10 ⁻¹⁸

Summary

S.1 INTRODUCTION

In December 1996, the U.S. Department of Energy (DOE) published the *Storage and Disposition of Weapons-Usable Fissile Materials Final Programmatic Environmental Impact Statement (Storage and Disposition PEIS)* (DOE 1996a). That PEIS analyzes the potential environmental consequences of alternative strategies for the long-term storage of weapons-usable plutonium and highly enriched uranium (HEU) and the disposition of weapons-usable plutonium that has been or may be declared surplus to national security needs.¹ The Record of Decision (ROD) for the *Storage and Disposition PEIS*, issued on January 14, 1997 (DOE 1997a), outlines DOE's decision to pursue an approach to plutonium disposition that would make surplus weapons-usable plutonium inaccessible and unattractive for weapons use. DOE's disposition strategy, consistent with the Preferred Alternative analyzed in the *Storage and Disposition PEIS*, allows for both the immobilization of some (and potentially all) of the surplus plutonium and use of some of the surplus plutonium as mixed oxide (MOX) fuel in existing domestic, commercial reactors. The disposition of surplus plutonium would also involve disposal of both the immobilized plutonium and the MOX fuel (as spent nuclear fuel) in a potential geologic repository.²

On May 22, 1997, DOE published a Notice of Intent (NOI) in the Federal Register (FR) (DOE 1997b) announcing its decision to prepare an environmental impact statement (EIS) that would tier from the analysis and decisions reached in connection with the *Storage and Disposition PEIS*. This EIS, the *Surplus Plutonium Disposition Environmental Impact Statement (SPD EIS)*, addresses the extent to which each of the two plutonium disposition approaches (immobilization and MOX) would be implemented and analyzes candidate sites for plutonium disposition facilities and activities (i.e., lead assembly fabrication and postirradiation examination),⁴ as well as alternative technologies for immobilization. In July 1998, DOE issued the SPD Draft EIS. That draft included a description of the potential environmental impacts of using from three to eight commercial nuclear reactors to irradiate MOX fuel. The potential impacts were based on a generic reactor analysis. In March 1999, DOE awarded a contract for

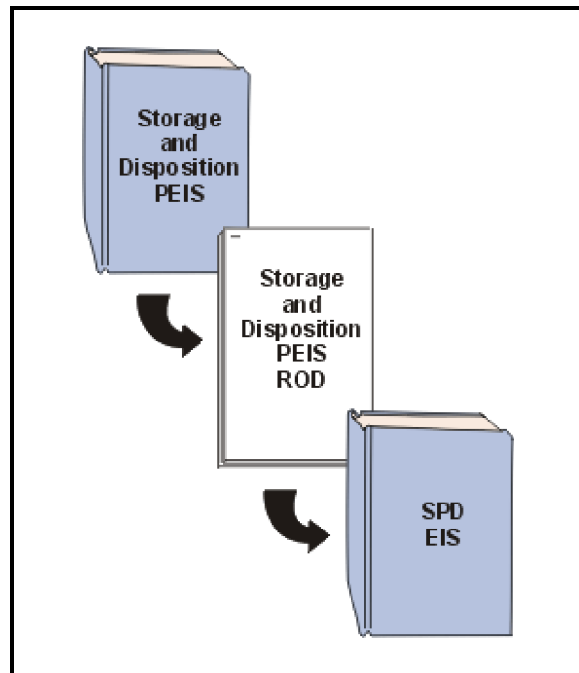

¹ DOE addresses the disposition of surplus HEU in a separate environmental impact statement, the *Disposition of Surplus Highly Enriched Uranium Final Environmental Impact Statement* (DOE 1996b) issued in June 1996, with the ROD (DOE 1996c) issued in August 1996.

² The U.S. Nuclear Regulatory Commission (NRC) has reviewed DOE's plans to place immobilized material into the potential geologic repository and has agreed that with adequate canister and package design features, the immobilized plutonium waste forms can be acceptable for disposal in the repository (Paperiello 1999).

³ Sidebars are used throughout the Summary of the SPD Final EIS to indicate where changes were made since the Summary of the SPD Draft EIS and the *Supplement* were issued. Section S.2 discusses these changes.

⁴ The SPD EIS also analyzes a No Action Alternative, i.e., the possibility of disposition not occurring and, instead, continued storage of surplus plutonium in accordance with the *Storage and Disposition PEIS* ROD.

MOX fuel fabrication and irradiation services.⁵ After this award, DOE issued a *Supplement to the SPD Draft EIS (Supplement)* (April 1999) that describes the potential environmental impacts of using MOX fuel at three proposed reactor sites and provides updated information on the proposed disposition program. These updates and site-specific analyses have been incorporated in the SPD Final EIS.

The SPD EIS analyzes a nominal 50 metric tons (t) (55 tons) of surplus weapons-usable plutonium, which is primarily in the form of pits (the core element of a nuclear weapon's fission component), metals, and oxides.⁶ In addition to 38.2 t (42 tons) of weapons-grade plutonium already declared by the President as excess to national security needs, the material analyzed includes weapons-grade plutonium that may be declared surplus in the future, as well as weapons-usable, reactor-grade plutonium that is surplus to the programmatic and national defense needs of DOE.

As depicted in Figure S-1, there are seven locations of surplus plutonium within the DOE complex: the Hanford Site (Hanford) near Richland, Washington; Idaho National Engineering and Environmental Laboratory (INEEL) near Idaho Falls, Idaho; Lawrence Livermore National Laboratory (LLNL) in Livermore, California;⁷ Los Alamos National Laboratory (LANL) near Los Alamos, New Mexico; the Pantex Plant (Pantex) near Amarillo, Texas; the Rocky Flats Environmental Technology Site (RFETS) near Golden, Colorado; and the Savannah River Site (SRS) near Aiken, South Carolina.

Under the hybrid alternatives, about 34 percent of the surplus plutonium analyzed in the SPD EIS is not suitable for fabrication into MOX fuel due to the complexity, timing, and cost that would be involved in purifying the material. The *Storage and Disposition PEIS* ROD determined that DOE would immobilize at least 8 t (9 tons) of the current surplus plutonium. Since issuance of the ROD, further consideration has indicated that 17 t (19 tons) of the surplus plutonium is not suitable for use in MOX fuel and should be immobilized. Therefore, fabricating all 50 t (55 tons) of surplus plutonium into MOX fuel is not a reasonable alternative and is not analyzed. The SPD EIS does, however, analyze the immobilization of all the surplus plutonium. (Section S.3 of this Summary provides a discussion on the amounts of materials subject to disposition.) Given the variability in purity of the surplus plutonium to be dispositioned, some of the plutonium currently considered for MOX fuel fabrication may also need to be immobilized. The incremental impacts that would be associated with a small shift in materials throughput are discussed in Chapter 4 of the SPD EIS.

In the *Storage and Disposition PEIS* ROD, DOE retained the option to use some of the surplus plutonium as MOX fuel in Canadian Deuterium Uranium (CANDU) reactors, which would have been undertaken only in the event that a multilateral agreement were negotiated among Russia, Canada, and the United States. Since the SPD Draft EIS was issued, DOE determined that adequate reactor capacity is available in the United States to disposition that portion of the U.S. surplus plutonium suitable for MOX fuel and, therefore, while still reserving the CANDU option, DOE is no longer actively pursuing it. DOE, in cooperation with Canada and Russia, proposes to participate in a test and demonstration program using U.S. and Russian MOX fuel in a

⁵ Limited activities may be conducted under this contract including non-site-specific work associated with the development of the initial design for the MOX fuel fabrication facility and plans (paper studies) for outreach, long lead-time procurement, regulatory management, facility quality assurance, safeguards, security, fuel qualifications, and deactivation. Under the contract options, no substantive design work or construction on the proposed MOX facility would begin before a SPD EIS ROD is issued, and any such work would depend on decisions in the ROD.

⁶ Some materials are already in a final disposition form (i.e., irradiated fuel) and will not require further action before disposal. These materials, therefore, are not included in the 50 t (55 tons) analyzed in the SPD EIS.

⁷ Some of the surplus plutonium originally stored at RFETS was shipped to LLNL, where special handling and disassembly processes occurred. The receipt and disassembly of these materials and future processing work will result in the recovery of approximately 1.7 t (1.9 tons) of surplus plutonium at LLNL.

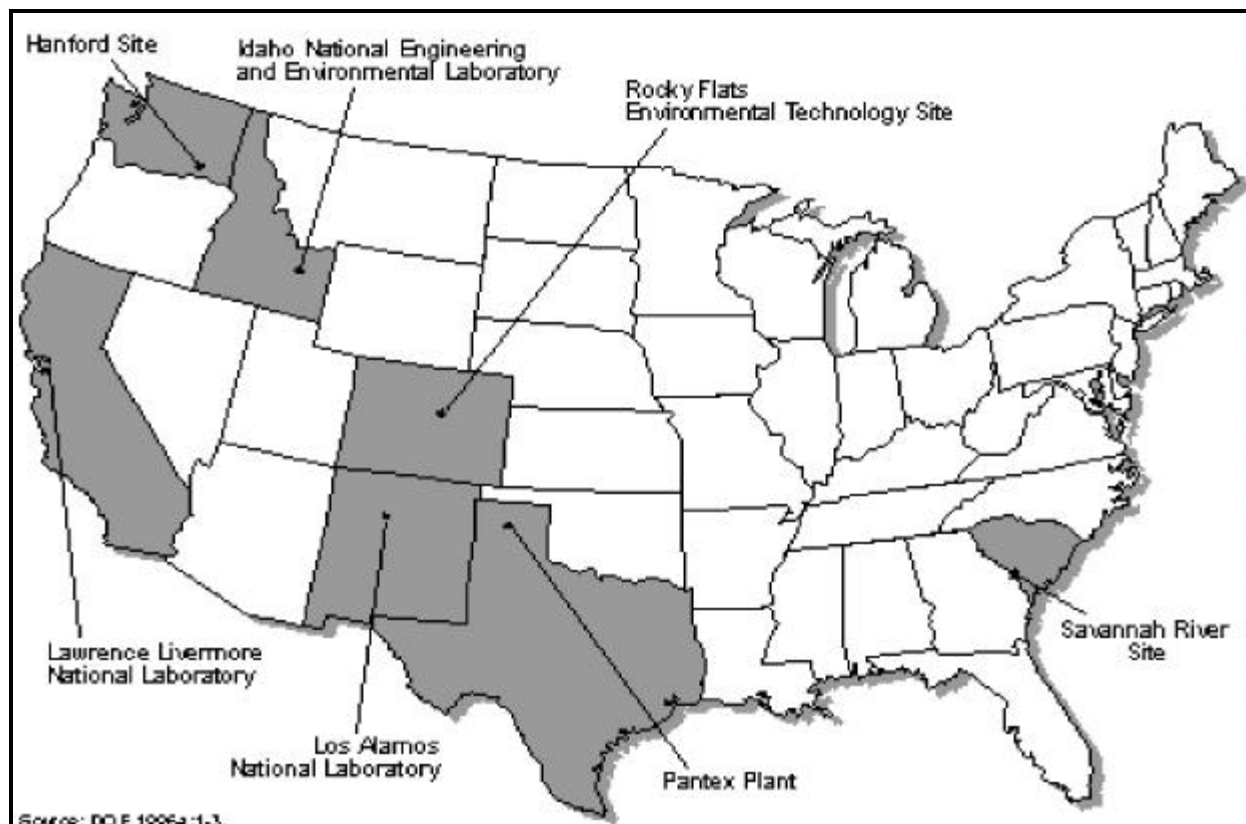

Figure S-1. Locations of Surplus Plutonium

Canadian test reactor.⁸ If Russia and Canada agree to disposition Russian surplus plutonium in CANDU reactors in order to augment Russia's disposition capability, shipments of the Russian MOX fuel would take place directly between Russia and Canada.

Purpose of and Need for the Proposed Action

The purpose of and need for the proposed action is to reduce the threat of nuclear weapons proliferation worldwide by conducting disposition of surplus plutonium in the United States in an environmentally safe and timely manner. Comprehensive disposition actions are needed to ensure that surplus plutonium is converted to proliferation-resistant forms. In September 1993, President Clinton issued the *Nonproliferation and Export Control Policy* (White House 1993) in response to the growing threat of nuclear proliferation. Further, in January 1994, President Clinton and Russia's President Yeltsin issued a *Joint Statement Between the United States and Russia on Non-Proliferation of Weapons of Mass Destruction and the Means of Their Delivery* (White House 1994). In accordance with these policies, the focus of the U.S. nonproliferation efforts includes ensuring the safe, secure, long-term storage and disposition of surplus weapons-usable fissile plutonium. Following publication of the SPD Draft EIS, the United States and Russia signed a 5-year agreement to provide the scientific and technical basis for decisions concerning how surplus plutonium will be managed and a statement of principles with the intention of removing approximately 50 t (55 tons) of plutonium from each country's

⁸ A separate environmental review, the *Environmental Assessment for the Parallel Project Fuel Manufacture and Shipment* (DOE 1999a; Finding of No Significant Impact [FONSI], August 13, 1999), analyzes the fabrication and proposed shipment of MOX fuel for research and development activities involving the use of limited amounts of U.S. MOX fuel in a Canadian test reactor. The FONSI was announced in a press release on September 2, 1999, and made available to the public.

stockpile (see Appendix A). The disposition activities proposed in the SPD EIS will enhance U.S. credibility and flexibility in negotiations on bilateral and multilateral reductions of surplus weapons-usable fissile materials inventories. [Text deleted.] The United States will retain the option to begin certain disposition activities, whenever appropriate, in order to encourage the Russians and set an international example.

The SPD EIS addresses both the immobilization and MOX approaches to surplus plutonium disposition, which include the siting, construction, operation, and ultimate decontamination and decommissioning (D&D) of three types of facilities at one or two of four candidate DOE sites:

- A facility for disassembling pits (a weapons component) and converting the recovered plutonium, as well as plutonium metal from other sources, into plutonium dioxide suitable for disposition. This facility, the pit disassembly and conversion facility, is referred to in this document as the *pit conversion facility*. Candidate sites for this facility are Hanford, INEEL, Pantex, and SRS.
- A facility for immobilizing surplus plutonium for eventual disposal in a geologic repository pursuant to the Nuclear Waste Policy Act (NWPA), the plutonium conversion and immobilization facility, is referred to as the *immobilization facility*. This facility would include a collocated capability for converting nonpit plutonium materials into plutonium dioxide suitable for immobilization. The immobilization facility would be located at either Hanford or SRS. DOE identified SRS as the preferred site for an immobilization facility in the NOI to prepare the SPD EIS, which was issued in May 1997. Technologies for immobilization are also discussed in the SPD EIS.
- A facility for fabricating plutonium dioxide into MOX fuel, the MOX fuel fabrication facility, is referred to as the *MOX facility*. Candidate sites for this facility are Hanford, INEEL, Pantex, and SRS. Also included in the SPD EIS is a separate analysis of MOX lead assembly⁹ activities at five candidate DOE sites: Argonne National Laboratory–West (ANL–W) at INEEL; Hanford; LLNL; LANL; and SRS. DOE would fabricate a limited number of MOX fuel assemblies, referred to as lead assemblies, for testing in a reactor before commencement of fuel irradiation under the proposed MOX fuel program. Postirradiation examination activities at two sites, ANL–W and Oak Ridge National Laboratory (ORNL) in Oak Ridge, Tennessee, are also analyzed in the SPD EIS.

The SPD EIS also analyzes a No Action Alternative, as required by the National Environmental Policy Act (NEPA). In the No Action Alternative, surplus weapons-usable plutonium in storage at various DOE sites would remain at those locations. The vast majority of pits would continue to be stored at Pantex, and the remaining plutonium in various forms would continue to be stored at Hanford, INEEL, LLNL, LANL, RFETS, and SRS.¹⁰

Issues Identified During the Scoping Period

In mid-1997, DOE conducted a public scoping process to solicit comments on its NOI concerning the disposition of surplus plutonium. The following summary describes the major issues identified during the scoping process.

Issues Already Intended for Inclusion in the SPD EIS. Many comments received during the scoping process concern issues that were already intended to be included in the SPD EIS. For example, many commentors expressed concern over the potential environmental impacts of the various technologies at the candidate sites and requested that an in-depth analysis be conducted to determine the potential impacts. A concern was also

⁹ A MOX lead assembly is a prototype reactor fuel assembly that contains MOX fuel.

¹⁰ Should the No Action Alternative be chosen, the ROD pursuant to the SPD EIS would also address the movement of the remaining surplus nonpit plutonium from RFETS in support of its planned closure in 2006.

expressed that making can-in-canister the preferred immobilization technology without an evaluation of alternative technologies circumvents the NEPA process. Other commentors recommended that the SPD EIS include a detailed accounting of the wastes that will be generated and the location of their ultimate disposal. A number of commentors were concerned that existing legal agreements with State governments and other agencies (e.g., triparty agreements) would be overlooked and possibly ignored. Other commentors addressed the quantity of plutonium to be immobilized or fabricated into MOX fuel. DOE is addressing all of these issues in the SPD EIS.

Additional Issues That Need to Be Addressed in the SPD EIS. A few commentors suggested that additional issues be considered in the SPD EIS. [Text deleted.] Some commentors suggested that Pantex be considered as a candidate site for the pit conversion facility under all situations, including the 50-t (55-ton) immobilization option, because most of the surplus pits are currently located there. In response to these comments, DOE added two alternatives to the SPD Draft EIS for the option of immobilizing all 50 t (55 tons) of surplus plutonium. Initially, the alternatives included siting both the pit conversion and immobilization facilities at one site (i.e., Hanford or SRS). The two new alternatives include Pantex as a candidate site for the pit conversion facility.

Issues That Need to Be or Are Already Addressed Elsewhere. Many comments received during the scoping process concern issues that are beyond the scope of the SPD EIS but are being or will be addressed elsewhere. These issues include the relationship of plutonium disposition and tritium production, and use of the Fast Flux Test Facility (FFTF) at Hanford solely for surplus plutonium disposition. The SPD EIS does not address FFTF because the current proposals do not include the use of surplus plutonium as a fuel source for FFTF.¹¹ A question was raised as to the role of the U.S. Nuclear Regulatory Commission (NRC) licensing requirements in regard to plutonium disposition facilities. Suggestions were made to include NRC processes in the SPD EIS. NRC is a “commenting” agency on the SPD EIS. DOE provided copies of the SPD Draft EIS, *Supplement*, and SPD Final EIS to NRC for review and comment, and DOE is conducting regular meetings with NRC on the MOX approach, including fuel design and qualification.¹² In addition, an NRC license would be sought for the MOX facility. Domestic, commercial reactors operate under NRC licenses, and their proposed use of MOX fuel would be subject to review by NRC.

Some questions and concerns were also raised about the MOX fuel fabrication and reactor irradiation services procurement (see Section S.2 for a discussion of the procurement process and associated NEPA activities). Many commentors suggested that DOE, in either the SPD EIS or other program studies, analyze the total cost of each alternative, including facility construction and modification, operations, and D&D, as well as all related site infrastructure costs. At the same time the SPD Draft EIS was issued, DOE released a cost study (DOE 1998a) focusing on site-specific costs to support site selection. As a followup to this study, DOE prepared a second report (DOE 1999b) that compiles life-cycle costs for the Preferred Alternative and addresses cost-related public comments.¹³ These cost studies will be considered, along with the SPD EIS analyses, in the DOE decisionmaking process. Some commentors suggested that the potential impacts of the disposal of spent nuclear fuel generated by MOX fuel use be included in the SPD EIS. This issue has already been addressed in the *Storage and Disposition PEIS*, and disposal of spent nuclear fuel is addressed in the *Draft Environmental Impact Statement*

¹¹ DOE announced in a Notice of Intent (NOI), published September 15, 1999 (64 FR 50064), that it will prepare a programmatic EIS to evaluate the environmental effects associated with, among other options, the restart and operation of FFTF to meet the need for a range of research and development activities, medical isotope production, and plutonium 238 production to fuel National Aeronautics and Space Administration spacecraft.

¹² DOE did not receive comments from NRC on the SPD Draft EIS or the *Supplement*.

¹³ These two cost reports are available on the Office of Fissile Materials Disposition Web site at <http://www.doe-md.com>, in the public reading rooms at the candidate sites, and upon request.

for a Geologic Repository for the Disposal of Spent Nuclear Fuel and High-Level Radioactive Waste at Yucca Mountain, Nye County, Nevada (DOE 1999c).¹⁴

Other. Many of the comments received were expressions of opinion or comments not directly related to issues addressed in the SPD EIS. For example, opposition was expressed by both U.S. and Canadian citizens to using CANDU reactors. Similarly, a number of commentators expressed their support for or opposition to immobilization and MOX technologies. Others expressed support for specific facilities or questioned the viability of site-specific facilities for MOX fuel fabrication, immobilization, or pit conversion. A number of commentators expressed their concern over the market viability of MOX fuel, even though MOX fuel would not be sold on the open market. Some commentators expressed their support for a hybrid disposition approach using both immobilization and MOX fuel fabrication.

Scope of the SPD EIS

Site-specific issues associated with the siting, construction, and operation of the three proposed disposition facilities are analyzed in the SPD EIS. The three facilities would be designed so that they could collectively accomplish disposition of up to 50 t (55 tons) of surplus plutonium over their operating lives, as shown in Table S-1 for the various alternatives under consideration. When the missions of the plutonium disposition facilities are completed, deactivation and stabilization would be performed to reduce the risk of radiological exposure; reduce the need for, and costs associated with, long-term maintenance; and prepare the buildings for potential future use. (Chapter 4 of the SPD EIS provides a discussion on deactivation and stabilization.)

At the end of the useful life of the facilities, DOE would evaluate options for D&D or reuse of the facilities. When DOE is ready to propose D&D of these facilities, an appropriate NEPA review will be conducted. (Chapter 4 of the SPD EIS provides a discussion on D&D.) The SPD EIS also analyzes transportation, including the following (see Section S.5 for a more detailed discussion): plutonium from storage locations to the pit conversion facility or the immobilization facility, depending on the material and the alternative; plutonium dioxide from the pit conversion facility to the immobilization or MOX facilities; recovered HEU from the pit conversion facility to Oak Ridge Reservation (ORR); depleted uranium hexafluoride from a representative DOE site to a representative commercial conversion facility; uranium feed

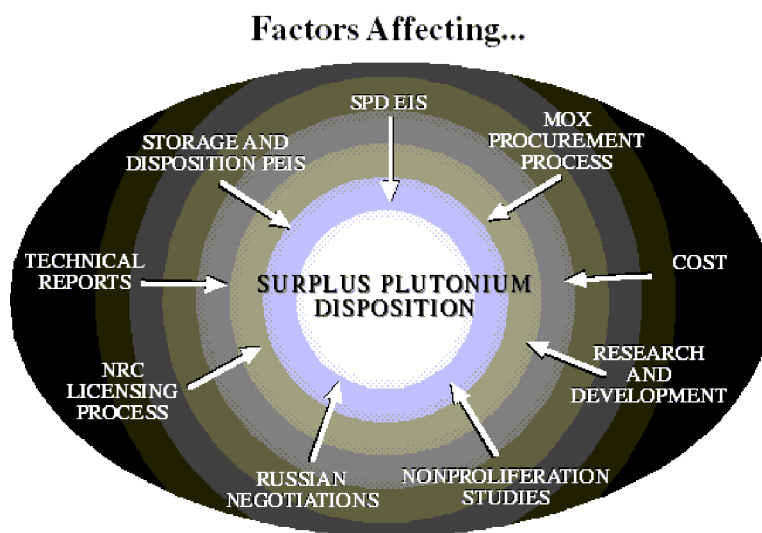

...Surplus Plutonium Disposition Decisions

¹⁴ For purposes of the SPD EIS, a potential geologic repository candidate site at Yucca Mountain, Nevada, was assumed to be the final disposal site for all immobilized plutonium and spent fuel. Currently, Yucca Mountain is the only site being characterized as a potential geologic repository. In August 1999, DOE issued a separate EIS, the *Draft Environmental Impact Statement for a Geologic Repository for the Disposal of Spent Nuclear Fuel and High-Level Radioactive Waste at Yucca Mountain, Nye County, Nevada* (DOE/EIS-0250D) (DOE 1999c), to analyze the site-specific environmental impacts of construction, operation and monitoring, and eventual closure of a potential geologic repository at Yucca Mountain.

Table S-1. Surplus Plutonium Disposition Facility Alternatives Evaluated in the SPD EIS

Alternative	Pit Disassembly and Conversion	Plutonium Conversion and Immobilization	MOX Fuel Fabrication	Disposition Amounts (Plutonium)
1	No Action			
2	Hanford (FMEF)	Hanford (FMEF and HLWVF)	Hanford (New)	17 t Immobilization/ 33 t MOX
3	SRS (New)	SRS (New and DWPF)	SRS (New)	17 t Immobilization/ 33 t MOX
4A	Pantex (New)	Hanford (FMEF and HLWVF)	Hanford (New)	17 t Immobilization/ 33 t MOX
4B	Pantex (New)	Hanford (FMEF and HLWVF)	Hanford (FMEF)	17 t Immobilization/ 33 t MOX
5	Pantex (New)	SRS (New and DWPF)	SRS (New)	17 t Immobilization/ 33 t MOX
6A	Hanford (FMEF)	SRS (New and DWPF)	Hanford (New)	17 t Immobilization/ 33 t MOX
6B	Hanford (FMEF)	SRS (New and DWPF)	Hanford (FMEF)	17 t Immobilization/ 33 t MOX
7	INEEL (FPF)	SRS (New and DWPF)	INEEL (New)	17 t Immobilization/ 33 t MOX
8	INEEL (FPF)	Hanford (FMEF and HLWVF)	INEEL (New)	17 t Immobilization/ 33 t MOX
9	Pantex (New)	SRS (New and DWPF)	Pantex (New)	17 t Immobilization/ 33 t MOX
10	Pantex (New)	Hanford (FMEF and HLWVF)	Pantex (New)	17 t Immobilization/ 33 t MOX
11A	Hanford (FMEF)	Hanford (FMEF and HLWVF)	NA	50 t Immobilization/ 0 t MOX
11B	Pantex (New)	Hanford (FMEF and HLWVF)	NA	50 t Immobilization/ 0 t MOX
12A	SRS (New)	SRS (New and DWPF)	NA	50 t Immobilization/ 0 t MOX
12B	Pantex (New)	SRS (New and DWPF)	NA	50 t Immobilization/ 0 t MOX
[Text deleted.]				
Alternatives 3B, 5B, 6C, 6D, 7B, 9B, 12B, and 12D have been deleted.				
Alternative 12C has been renumbered as 12B. ^a				

^a Section S-4 explains the deletion of these alternatives.

Key: DWPF, Defense Waste Processing Facility; FMEF, Fuels and Materials Examination Facility; FPF, Fuel Processing Facility; HLWVF, high-level-waste vitrification facility (planned); NA, not applicable.

supply (uranium dioxide) from a representative commercial conversion facility to the immobilization and/or MOX fuel fabrication facilities and lead assembly facility; uranium fuel rods from a commercial fuel fabrication facility to the MOX facility and lead assembly facility; plutonium dioxide from LANL to the lead assembly facility; irradiated lead assemblies or rods from a reactor to the postirradiation examination site; spent fuel from the postirradiation examination site to INEEL for storage; MOX fuel to a commercial reactor; and immobilized plutonium to a potential geologic repository.¹⁵ In addition to the various disposition alternatives, a No Action

¹⁵ Shipments of spent fuel to a potential geologic repository are analyzed in the *Draft Environmental Impact Statement for a Geologic Repository for the Disposal of Spent Nuclear Fuel and High-Level Radioactive Waste at Yucca Mountain, Nye County, Nevada* (DOE/EIS-0250D) (DOE 1999c).

Alternative is also analyzed. In this alternative, disposition would not occur, and surplus plutonium would remain in long-term storage in accordance with the storage approach identified in the *Storage and Disposition PEIS* ROD.¹⁶ For all alternatives analyzed in the SPD EIS, it is assumed that storage actions described in the *Storage and Disposition PEIS* ROD, as amended, have been accomplished.¹⁷ Because the SPD EIS tiers from the analyses and decisions reached in association with the *Storage and Disposition PEIS*, information relevant to disposition options or candidate sites is incorporated by reference and summarized; it is not repeated here. [Text deleted.]

As part of the assessment of the MOX alternatives, the SPD EIS analyzes the fabrication of up to 10 lead assemblies that may be needed to support the MOX fuel program, although DOE plans to produce only 2. (See Sections 2.18.2 and 4.27 of the SPD EIS for a discussion of how impacts would be lower if only two lead assemblies were fabricated.) Existing DOE facilities at five candidate sites are analyzed, as is the transportation of feed materials to the lead assembly fabrication sites and the fabricated lead assemblies to a domestic, commercial reactor for test irradiation. Postirradiation examination may be required to support NRC licensing activities related to the use of MOX fuel in domestic, commercial reactors. The SPD EIS discusses postirradiation examination at two candidate sites, ANL–W and ORNL. These two sites are currently the only sites that possess the capability to conduct postirradiation examination activities without major modifications to facility and processing capabilities; only minor modifications for receipt of materials would be required. Other potential facilities, either within the DOE complex or in the commercial sector, would require significant modifications to meet expected requirements for postirradiation examination.

Lead Assembly Candidate Sites

ANL–W
Hanford
LLNL
LANL
SRS

The ceramic immobilization, MOX fuel fabrication, and lead assembly processes require the use of uranium dioxide as a feed material, which can be obtained from either natural or depleted uranium. Because DOE has a large inventory of depleted uranium hexafluoride (the equivalent of 385,000 t [424,385 tons] of depleted uranium dioxide), the SPD EIS analyzes using a small amount of that inventory (about 137 t [151 tons] per year) to produce uranium dioxide (White 1997:1).^{18, 19} Depleted uranium hexafluoride is currently stored at three DOE sites: the East Tennessee Technology Park in Oak Ridge, Tennessee; the Paducah Gaseous Diffusion Plant near Paducah, Kentucky; and the Portsmouth Gaseous Diffusion Plant (Portsmouth) near Piketon, Ohio. For purposes of analysis in the SPD EIS, Portsmouth is used as a representative site for a source of depleted uranium hexafluoride.²⁰ Included for evaluation in the SPD EIS are the activities necessary to package the depleted

¹⁶ Should the No Action Alternative be chosen, the ROD pursuant to the SPD EIS would also address the movement of the remaining surplus nonpit plutonium from RFETS in support of its planned closure in 2006.

¹⁷ Recent studies indicated that cost savings could be realized from the transfer of nonpit materials from RFETS and Hanford to SRS earlier than specified in the *Storage and Disposition PEIS* ROD. A supplemental analysis was prepared and determined that a supplemental PEIS would not be needed; an amended ROD was issued in August 1998 (63 FR43386) and included decisions to accelerate shipment of all nonpit surplus plutonium from RFETS to SRS and the relocation of all Hanford surplus plutonium to SRS, if SRS is selected as the immobilization disposition site.

¹⁸ The contractor chosen by DOE to conduct MOX fuel fabrication has the option of acquiring uranium dioxide from another source.

¹⁹ Potential use of depleted uranium hexafluoride or facilities at the gaseous diffusion plants will be consistent with the *Final Programmatic Environmental Impact Statement for Alternative Strategies for the Long-Term Management and Use of Depleted Uranium Hexafluoride* (DOE/EIS-0269, April 1999; ROD August 1999) and the *Final Plan for Conversion of Depleted Uranium Hexafluoride, As Required by Public Law 105–204* (DOE, July 1999).

²⁰ The Portsmouth Gaseous Diffusion Plant is used as a representative site because it is the only one of the three DOE sites that is currently capable of transferring the depleted uranium hexafluoride from the 12.7-t (14-ton) tails cylinders in which it is currently stored to the 2.28-t (2.5-ton) feed cylinders that are compatible with the processing equipment at a commercial facility (White 1997:5). However, DOE has no preference as to where the depleted uranium is acquired.

uranium hexafluoride for shipment to a representative commercial conversion facility (for purposes of analysis, the SPD EIS uses the General Electric Company's Nuclear Energy Production Facility in Wilmington, North Carolina) for conversion to uranium dioxide,²¹ to transport the depleted uranium hexafluoride from Portsmouth to Wilmington, and to transport the uranium dioxide from Wilmington to the candidate immobilization, MOX fuel fabrication, and lead assembly sites (i.e., ANL-W, Hanford, INEEL, LLNL, LANL, Pantex, and SRS).

DOE's NOI announcing the preparation of the SPD EIS included a table outlining 12 originally proposed disposition alternatives. Each alternative identified the facilities, new or existing, at each candidate site that would be analyzed in the SPD EIS. Since the publication of the NOI, DOE further increased the number of alternatives for SPD EIS analysis to include a new MOX facility at Hanford, in addition to the alternative involving modifying the Fuels and Materials Examination Facility (FMEF). For the option of immobilizing all 50 t (55 tons) of surplus plutonium, DOE also included Pantex as a candidate site for pit disassembly and conversion activities, making a total of four 50-t (55-ton) all-immobilization alternatives in the SPD Draft EIS. Previously, only Hanford and SRS had been considered as sites for pit disassembly and conversion activities for the 50-t (55-ton) all-immobilization case. Eight alternatives using Building 221-F at SRS for the immobilization facility that were analyzed in the SPD Draft EIS have been eliminated from the SPD Final EIS because the amount of space required for the immobilization facility would be significantly larger than originally planned. These eight alternatives are no longer considered reasonable because the construction required for the proposed immobilization facility is now expected to be nearly the same whether the facility is entirely located in a new building or is built in addition to using a portion of Building 221-F at SRS. For clarity, variations of each alternative are presented in the SPD EIS as separate, discrete alternatives. There are now 15 action alternatives presented as 11 sets of alternatives, plus the No Action Alternative (see Table S-1).

As indicated in the ROD for the *Storage and Disposition PEIS*, the SPD EIS analysis provides, in part, the basis for determining a specific immobilization technology. The SPD EIS analyzes in detail the proposed can-in-canister approach and compares the results to the impacts predicted in the *Storage and Disposition PEIS* for the homogenous immobilization approach in new vitrification and ceramic immobilization facilities. In addition, for the can-in-canister approach, the SPD EIS separately analyzes the effects of immobilizing plutonium in either a titanate-based ceramic material or a lanthanide borosilicate glass.

To further define the potential processes to be used for the disposition of surplus plutonium, several research and development (R&D) activities are ongoing. A discussion of these R&D activities is provided in the *Pit Disassembly and Conversion Demonstration Environmental Assessment and Research and Development Activities* (DOE 1998b) (DOE/EA-1207, August 1998; Finding of No Significant Impact [FONSI], August 1998). Several of these R&D activities are likely to continue after the ROD for the SPD EIS is issued.

Preferred Alternatives

DOE's Preferred Alternative for the disposition of surplus weapons-usable plutonium is Alternative 3: to disposition up to 50 t²² (55 tons) of plutonium at SRS using a hybrid approach that involves both the ceramic can-in-canister immobilization approach and the MOX approach. Approximately 17 t (19 tons) would be immobilized in a ceramic form, placed in cans, and embedded in large canisters containing high-level vitrified waste for ultimate disposal in a potential geologic repository pursuant to the NWPA. Approximately 33 t

²¹ Possible existing sites for this conversion include nuclear fuel fabrication facilities in Missouri, North Carolina, South Carolina, and Washington, or a uranium conversion facility in Illinois. For purposes of analysis in the SPD EIS, the commercial nuclear fuel fabrication facility in Wilmington, North Carolina, was used as a representative site. DOE has no preference as to where conversion would occur.

²² Some materials are already in a final disposition form (i.e., irradiated fuel) and will not require further action before disposal. These materials are not included in the SPD EIS.

(36 tons) would be used to fabricate MOX fuel, which would be irradiated in existing, domestic, commercial reactors. The proposed reactors are the Catawba Nuclear Station near York, South Carolina; the McGuire Nuclear Station near Huntersville, North Carolina; and the North Anna Power Station near Mineral, Virginia.²³ The resulting spent fuel would be placed in a potential geologic repository pursuant to the NWP.

Pursuing the hybrid approach provides the best opportunity for U.S. leadership in working with Russia to implement similar options for reducing Russia's excess plutonium in parallel. Further, it sends the strongest possible signal to the world of U.S. determination to reduce stockpiles of surplus weapons-usable plutonium as quickly as possible and in a manner that would make it technically difficult to use the plutonium in weapons again. Pursuing both immobilization and MOX fuel fabrication also provides important insurance against uncertainties of implementing either approach by itself. The construction of new facilities for the disposition of surplus U.S. plutonium would not take place unless there were significant progress on plans for plutonium disposition in Russia.

DOE's preference for siting plutonium disposition facilities is as follows:

- **Pit Disassembly and Conversion at SRS.** Construct and operate a new pit conversion facility at SRS for the purpose of disassembling nuclear weapons pits and converting the plutonium metal to a declassified oxide form suitable for international inspection, and disposition using either immobilization or MOX/reactor approaches. SRS is preferred for the pit conversion facility because the site has extensive experience with plutonium processing, and the pit conversion facility complements existing missions and takes advantage of existing infrastructure. [Text deleted.]
- **Immobilization at SRS (new construction and Defense Waste Processing Facility).**²⁴ Construct and operate a new immobilization facility at SRS using the ceramic can-in-canister technology. This technology would immobilize plutonium in a ceramic form, seal it in cans, and place the cans in canisters filled with borosilicate glass containing radioactive high-level waste (HLW) at the existing Defense Waste Processing Facility (DWPF). This preferred can-in-canister approach at SRS complements existing missions, takes advantage of existing infrastructure and staff expertise, and enables DOE to use an existing facility (DWPF). SRS was previously designated to be part of DOE's Preferred Alternative for immobilization in the NOI issued in May 1997. The ceramic can-in-canister approach would involve slightly lower environmental impacts than the homogenous approach (wherein the plutonium is incorporated into a homogenous mixture of plutonium and fission products in a single waste form). The ceramic can-in-canister approach would involve better performance in a potential geologic repository due to the ceramic form's expected higher durability under repository conditions and its lower potential for long-term criticality. In addition, it would provide greater proliferation resistance than the glass can-in-canister approach because recovery of plutonium from the ceramic form would require a more chemically complex process than has yet been developed.
- **MOX Fuel Fabrication at SRS (new construction).** Construct and operate a new MOX facility at SRS and produce MOX fuel containing surplus weapons-usable plutonium for irradiation in existing

²³ No facility construction or MOX fuel fabrication or irradiation is to occur until the SPD EIS ROD is issued. Additionally, no MOX fuel is to be irradiated until the NRC amends the operating license of each selected reactor prior to the specific reactor receiving the MOX fuel. Such site-specific activities would depend on decisions in the ROD, and DOE's exercise of contract options to allow such activities would be contingent on the ROD.

²⁴ DOE is presently considering replacement alternatives for the In-Tank Precipitation (ITP) process at SRS. The ITP process was intended to separate soluble high-activity radionuclides from liquid HLW before vitrifying the high-level fraction in DWPF. Due to problems experienced with the operation of ITP as configured, DWPF is currently operating with sludge feed only. A supplemental EIS on DWPF operations is being prepared that analyzes three proposed alternatives: small tank precipitation, ion exchange, and direct grout. (Section 2.4.2.1 of the SPD EIS provides a more detailed discussion of these alternatives.)

domestic, commercial reactors. SRS is preferred for the MOX facility because this activity complements existing missions and takes advantage of existing support infrastructure and staff expertise. [Text deleted].

- **Lead Assembly Fabrication at LANL.** Based on consideration of the capabilities of the candidate sites and input from the contractor team chosen for the MOX approach, DOE prefers LANL for lead assembly fabrication. LANL is preferred because it already has fuel fabrication facilities that would not require major modifications, and takes advantage of existing infrastructure and staff experience. Additionally, the surplus plutonium dioxide that would be used to fabricate the lead assemblies would already be in inventory at the site.
- **Postirradiation Examination at ORNL.** If postirradiation examination is necessary for the purpose of qualifying the MOX fuel for commercial reactor use, DOE prefers to perform that task at ORNL. ORNL has the existing facilities and staff expertise needed to perform postirradiation examination as a matter of its routine activities; no major modifications to facilities or processing capabilities would be required. In addition, because ORNL is about 500 km (300 mi) from the McGuire Nuclear Station, the reactor that would irradiate the fuel, it is the closest candidate site for postirradiation examination activities.

S.2 SUMMARY OF MAJOR ISSUES IDENTIFIED DURING THE COMMENT PERIODS AND CHANGES TO THE SPD DRAFT EIS

Public Involvement Process for the SPD Draft EIS and the *Supplement to the SPD Draft EIS*

DOE issued the SPD Draft EIS in July 1998 and received public comments. The comment period ran from July 17, 1998, through September 16, 1998, although DOE considered all comments submitted after the close of the 60-day comment period. In August 1998, DOE held five public hearings at the following locations in the vicinity of the four candidate DOE sites and at one regional location:

Richland, Washington	August 4, 1998
Amarillo, Texas	August 11, 1998
North Augusta, South Carolina	August 13, 1998
Portland, Oregon	August 18, 1998
Idaho Falls, Idaho	August 20, 1998

DOE received comments on the SPD Draft EIS by mail, a toll-free telephone and fax line, the Office of Fissile Materials Disposition Web site, and at the public hearings. Altogether, DOE received approximately 3,400 comment documents from individuals and organizations. All comments are presented in Volume III, Parts A and B, of the Comment Response Document of the SPD Final EIS. Approximately 65 percent of the comments received consisted of mail-in postcard campaigns that expressed either support of or opposition to the use of various sites or technologies. About 12 percent were collected during public hearings, 10 percent were in letters received by mail, 10 percent were received by fax, 2 percent were received by telephone, and 1 percent were received through the Web site.

In April 1999, DOE issued the *Supplement* and received public comments. The comment period ran from May 14, 1999, through June 28, 1999, although DOE considered all comments received after the close of the 45-day comment period. On June 15, 1999, DOE held a public hearing in Washington, D.C. DOE received approximately 77 comment documents from individuals and organizations, which are presented in Volume III, Part B, of the Comment Response Document of the SPD Final EIS. Approximately 21 percent of the comments received were collected during the public hearing, 34 percent were contained in letters received by mail,

26 percent were received by fax, 5 percent were received by telephone, and 14 percent were received through the Web site.

Summary of Major Issues Raised on the SPD Draft EIS During the Public Comment Period

The following paragraphs highlight comments and issues that the public raised concerning information provided in the SPD Draft EIS. These comments were collected during the two separate public comment periods for the SPD Draft EIS and the *Supplement*. (Comments received on information specifically provided in the *Supplement* are summarized in the next section.) Changes made to the SPD EIS in response to a comment are described.

Russian Disposition Program. A number of commentors expressed concern over Russian disposition activities and tying U.S. activities to Russian activities. The United States and Russia recently made progress in the management and disposition of plutonium. In July 1998, Vice President Gore and Russian Prime Minister Sergei Kiriyenko signed a 5-year agreement to provide the scientific and technical basis for decisions concerning how surplus plutonium will be managed. In September 1998, Presidents Clinton and Yeltsin held a Moscow summit and signed a statement of principles with the intention of removing approximately 50 t (55 tons) of plutonium from each country's stockpile. The United States does not currently plan to implement a unilateral program; however, it will retain the option to begin certain disposition activities in order to encourage the Russians and set an international example. DOE has updated the SPD EIS to reflect the agreement and statement of principles and included copies in Appendix A.

Site Selection. A large number of comments were received advocating one candidate site over another for various reasons, including the presence of existing facilities that could prove beneficial to plutonium disposition, skilled workers, safety records, reduced transportation, and perceived economic benefits. DOE has chosen SRS as its preferred site for the three surplus plutonium disposition facilities, as outlined in Section S.1

Approach to Plutonium Disposition. A number of commentors protested DOE's preference for the hybrid approach and the use of MOX fuel for surplus plutonium disposition. Among the comments received on this issue were many advocating the use of the immobilization approach for all of the surplus plutonium. Commentors argued that the immobilization approach was safer, cheaper, and faster. They also pointed out that the immobilization approach resulted in less transportation. Because specific reactors in North Carolina, South Carolina, and Virginia have been proposed for plutonium disposition, the transportation requirements associated with several hybrid alternatives that include the MOX facility at SRS and Pantex have decreased (because the proposed reactors are closer to the sites than the 4,000-km [2,500-mi] bounding distance analyzed in the SPD Draft EIS). As a result, these several hybrid alternatives would require less transportation than some of the 50-t (55-ton) immobilization alternatives. Other commentors viewed the MOX approach as a Federal Government subsidy of the commercial nuclear power industry. Use of MOX fuel in domestic, commercial reactors is not proposed in order to subsidize the commercial nuclear power industry. Rather, the purpose is to safely and securely disposition surplus plutonium by meeting the Spent Fuel Standard.²⁵

Safety and Health. Comments were received that questioned the safety and health aspects of operating the surplus plutonium disposition facilities. Commentors pointed out that DOE's safety record at other nuclear facilities had been poor in the past and questioned DOE's ability to safely operate the disposition facilities. The health and safety of workers and the public is a priority of the surplus plutonium disposition program, regardless

²⁵ "Spent Fuel Standard" is a term coined by the National Academy of Sciences (NAS, 1994, *Management and Disposition of Excess Weapons Plutonium*, National Academy Press, Washington, D.C., pg. 12) and modified by DOE (glossary from Office of Fissile Materials Disposition Web site at <http://www.doe-md.com>) denoting the main objective of alternatives for the disposition of surplus plutonium: that such plutonium be made roughly as inaccessible and unattractive for weapons use as the much larger and growing stock of plutonium in civilian spent nuclear fuel.

of which approach is chosen. Operation of the disposition facilities would comply with applicable Federal, State, and local laws and regulations governing radiological and hazardous chemical releases. Within these limits, DOE believes that the radiation exposure and the level of contamination should be kept as low as is reasonably achievable.

Aqueous Processing of Plutonium. Some commentors questioned DOE's ability to produce clean plutonium dioxide that could be used in MOX fuel using the dry process proposed in the SPD Draft EIS. Questions were raised about the ability of this process to remove gallium and other pit materials from the plutonium before it is fabricated into MOX fuel. On the basis of public comments received on the SPD Draft EIS and the analysis performed as part of the MOX procurement, DOE has included plutonium polishing (a small-scale aqueous process) as a component of the MOX facility to ensure adequate impurity removal from the plutonium dioxide. Appendix N (which addressed plutonium polishing in the SPD Draft EIS) was deleted from the SPD Final EIS, and the impacts discussed therein were included in the impacts presented for the MOX facility in Chapter 4. Section 2.4.3 was also revised to include a discussion of plutonium polishing.

No attempt was made to evaluate the use of DOE's existing aqueous processing lines capable of dissolving pits, as advocated by some commentors. DOE determined that such aqueous processing, while a proven technology, is not a reasonable alternative for pit conversion because current aqueous processes using existing facilities would produce significant amounts of waste, and aqueous processing would complicate international inspection regimes because of classification issues.

Reprocessing. Several comments were received related to the reprocessing of plutonium and the civilian use of plutonium. The use of U.S. surplus plutonium in existing domestic, commercial reactors does not involve reprocessing. The proposed use of MOX fuel is consistent with the U.S. nonproliferation policy and would ensure that plutonium that was produced for nuclear weapons and subsequently declared excess to national security needs is never again used for nuclear weapons. The MOX facility would be built and operated subject to the following strict conditions: construction would take place at a secure DOE site, it would be owned by the U.S. Government, operations would be limited exclusively to the disposition of surplus plutonium, and the MOX facility would be shut down at the completion of the surplus plutonium disposition program. At the end of the useful life of the facility, DOE would evaluate options for D&D or reuse of the facility for other purposes.

Inclusion of Generic Reactor Information in the SPD Draft EIS. Many comments were received on the inclusion of generic reactor information in the SPD Draft EIS. At the time the Draft was released, DOE did not know which specific reactors would be proposed for the MOX program. Subsequently, the Catawba, McGuire, and North Anna reactors were chosen as part of the contractor team that would implement the MOX option should the decision be made in the SPD EIS ROD to go forward with the hybrid approach (i.e., both immobilization and MOX). Specific reactor information provided as part of the procurement process was evaluated by DOE in an Environmental Critique in accordance with DOE's NEPA regulations at 10 CFR 1021.216. The Environmental Critique was considered by DOE before awarding the contract. An Environmental Synopsis, based on the Environmental Critique, was prepared and was released to the public for comment in the *Supplement*. The comments received on the *Supplement* are summarized and responded to in Volume III, Part B, of the Comment Response Document. An opportunity for public comment will likely be provided by NRC during the reactor operating license amendment process.

Transportation Concerns. Commentors raised concerns about the transportation involved with moving the surplus plutonium from storage locations to disposition sites and, in some cases, MOX fuel to reactor sites. Requests were made to limit the transportation where possible, to present the transportation information in a more understandable manner, and to ensure that the transportation was conducted as safely as possible. Additional information has been added to Chapter 2 of the SPD Final EIS, which shows the total transportation associated with each alternative and gives a graphic depiction of the transportation needed for each disposition approach

(immobilization and MOX). As discussed in the SPD EIS, safe transportation is a major concern of DOE. All shipments of surplus plutonium would be accomplished using the safe, secure trailer/SafeGuards Transport (SST/SGT) system.²⁶ Since the establishment of the DOE Transportation Safeguards Division in 1975, the SST/SGT system has transported DOE-owned cargo over more than 151 million km (94 million mi) with no accidents that resulted in a fatality or release of radioactive material.

Cost of Plutonium Disposition. Many commentors focused on the cost of various surplus plutonium disposition facilities. Because cost issues are beyond the scope of the SPD EIS, commentors are referred to DOE's *Cost Analysis in Support of Site Selection for Surplus Weapons-Usable Plutonium Disposition* (DOE 1998a) and *Plutonium Disposition Life Cycle Costs and Cost-Related Comment Resolution Document* (DOE 1999b). Cost comments concerning the basis for DOE's cost estimates or requesting cost information were forwarded to DOE's cost analysis team.

Summary of Major Issues Raised on the *Supplement to the SPD Draft EIS* During the Public Comment Period

Frequency of Reactor Accidents in Reactors Using MOX Fuel. A number of comments argued that the frequency of reactor accidents would be greater due to the use of MOX fuel. The consequences of a beyond-design-basis accident using MOX fuel are generally higher than those expected in the same reactor using low-enriched uranium (LEU) fuel. However, there is no basis for concluding that the frequency of these accidents would increase due to the use of MOX fuel. No change in the frequencies of reactor accidents due to the use of MOX fuel has been made in the SPD Final EIS.

Risk Associated With Reactors Using MOX Fuel. Many commentors were concerned that there is an increase in accident risk from reactors using MOX fuel and that the plutonium in MOX fuel makes a reactor accident more dangerous to human health. There are differences in the expected risk of reactor accidents from the use of MOX fuel. Some accidents would be expected to result in lower consequences to the surrounding population, and thus, lower risks, while others would be expected to result in higher consequences and higher risks. The largest estimated increase in risk to the surrounding population due to the use of MOX fuel is an estimated 14 percent increase in the risk of latent cancer fatalities associated with an interfacing systems loss-of-coolant accident at North Anna. The likelihood of this accident occurring at North Anna is estimated to be 1 chance in 4.2 million per year. Before any MOX fuel is used for plutonium disposition, NRC would perform a comprehensive safety review that would include information prepared by the reactor plant operators as part of their license amendment applications. Expected risk is discussed in Section 4.28 of the SPD EIS.

Environmental Impacts Associated With Using MOX Fuel Versus LEU Fuel. Comments were received expressing a concern that the SPD Draft EIS failed to recognize avoided environmental impacts associated with using MOX fuel versus LEU fuel in existing commercial reactors. While the consequences of a beyond-design-basis accident might be higher and a slight increase in spent fuel could be expected by using MOX fuel, the impacts associated with mining, milling, and enriching uranium are avoided. Section 4.28.3 has been added to the SPD Final EIS to address this issue.

²⁶ The SST/SGT is a specially designed component of an 18-wheel tractor-trailer vehicle. Although the details of the vehicle enhancements are classified, key characteristics are not, and include: enhanced structural supports and a highly reliable tie-down system to protect cargo from impact; heightened thermal resistance to protect the cargo in case of fire; deterrents to protect the unauthorized removal of cargo; couriers who are armed Federal officers and receive rigorous training and are closely monitored through DOE's Personnel Assurance Program; an armored tractor to protect the crew from attack; advanced communications equipment; specially designed escort vehicles containing advance communications and additional couriers; 24-hr-a-day real-time monitoring of the location and status of the vehicle; and significantly more stringent maintenance standards.

Low-Level Waste. Comments were received on the isotopic breakdown of the low-level waste (LLW) that would be generated at the reactors using MOX fuel and the effect of this waste on existing burial grounds. There are differences in fission product inventories and activation products between an LEU and MOX core during a fuel cycle. However, the only time significant quantities of fission products could be released to the environment or end up in LLW would be in the event of a large-scale fuel leak. In regard to normal operations, experience with fabricating MOX fuel indicates a leakage rate of less than one-tenth of one percent. The use of MOX fuel would not be expected to result in any additional LLW because the reactors would continue to operate on the same schedule as if they were using only LEU fuel.

Public Hearings. A number of comments were received regarding the need to hold public hearings near the proposed reactor locations. DOE's NEPA regulations require that at least one public hearing be held to receive comments on a draft EIS (10 CFR Part 1021.313[b]). A public hearing was held in Washington, D.C., to collect public comments on the *Supplement*. No additional hearings were held near the specific reactor sites, but comments were solicited in the areas surrounding the proposed reactors. The *Supplement* was sent to interested groups and individuals near each of the reactors and an informational meeting about the proposed use of MOX fuel, sponsored by a South Carolina State Senator, was attended by DOE during the comment period. The transcript of this meeting is presented as Appendix A of the Comment Response Document.

Changes to the SPD Draft EIS and the *Supplement*

DOE revised the SPD Draft EIS and its *Supplement* in response to comments received from other Federal agencies; tribal, State, and local governments; nongovernmental organizations; the general public; and DOE reviews. The text was changed in the SPD Final EIS to provide additional environmental baseline information, reflect new technical data, make editorial corrections, respond to comments, and clarify text. Some of these changes involved recalculations of the impacts discussed in Chapter 4. In addition, DOE updated information due to events or decisions made since the SPD Draft EIS and *Supplement* were provided for public comment. Sidebars are used throughout the SPD Final EIS to indicate where changes have been made. Below is a brief discussion of significant (i.e., noneditorial) changes.

Revised Preferred Alternative. In the SPD Draft EIS, DOE's Preferred Alternative for siting the proposed facilities was identified as either Alternative 3 (the pit conversion, immobilization and MOX facilities at SRS) or Alternative 5 (the pit conversion facility at Pantex and the immobilization and MOX facilities at SRS). Under either alternative, the hybrid approach (i.e., immobilization and MOX) was preferred with the immobilization technology being the can-in-canister approach. No preference was identified in the SPD Draft EIS for the lead assembly or postirradiation examination activities, nor were the specific reactors that would use MOX fuel identified.

The *Supplement* identified SRS as the preferred site for the construction and operation of the pit conversion, immobilization, and MOX facilities. The *Supplement* also identified LANL as the preferred site for lead assembly activities and ORNL as the preferred site for postirradiation examination activities. Section 1.6 of the SPD Final EIS now identifies Alternative 3 as DOE's Preferred Alternative. In addition, Section 2.1.3 now identifies the three reactor sites that have been named as candidates for using MOX fuel subject to NRC license amendment. They are the Catawba Nuclear Station in York County, South Carolina; the McGuire Nuclear Station in Mecklenburg County, North Carolina; and the North Anna Power Station in Louisa County, Virginia.

Changes to the Immobilization Facility. Since the issuance of the SPD Draft EIS, and as described in the *Supplement*, DOE has developed a more detailed conceptual design for the can-in-canister immobilization facility. Changes in the size of the immobilization facility have been reflected in Chapter 2 of the SPD Final EIS and the associated impact analyses throughout Chapter 4. No changes have been made to the basic processes

proposed in the SPD Draft EIS for immobilization, to the amount of material being considered for immobilization, or to the rate of throughput.

As stated in the *Supplement*, the eight alternatives that included using portions of Building 221–F for immobilization (SPD Draft EIS Alternatives 3B, 5B, 6C, 6D, 7B, 9B, 12B, and 12D) were eliminated. These alternatives are no longer reasonable because the amount of new construction required for the proposed immobilization facility is now nearly the same whether the facility is located entirely in a new building or uses a portion of Building 221–F. Thus, there is no longer any advantage associated with the use of Building 221–F at SRS.

Changes Resulting From the MOX Procurement Process. As stated in the *Supplement*, information provided as part of the MOX procurement process relating to the MOX facility, including the addition of a plutonium-polishing step to the front end of the MOX facility, was analyzed by DOE in an Environmental Critique and summarized in an Environmental Synopsis prepared pursuant to DOE’s NEPA regulations in 10 CFR 1021.216. The Synopsis was included in the *Supplement* and has been added to the SPD Final EIS as Appendix P. Appendix N, *Plutonium Polishing*, has been deleted from the SPD Final EIS, with the information in Appendix N incorporated into the body of the EIS. A description of the polishing step has been added to Section 2.4.3, and the impacts analysis has been incorporated into Chapter 4 of the SPD Final EIS. The polishing step is included in the MOX facility, so plutonium polishing is no longer considered as a contingency for the pit conversion facility.

As described in the *Supplement*, the size of the MOX facility has increased. The larger MOX facility is described in Chapter 2 of the SPD Final EIS, and the associated environmental impacts are presented throughout Chapter 4. No changes have been made in the amount of material proposed to be made into MOX fuel, the facility’s throughput, or in the overall process to be used to fabricate the fuel.

Information related to the affected environment for the specific domestic commercial reactors that would irradiate the MOX fuel was provided in the *Supplement* and has been added to the SPD Final EIS as a new Section 3.7. Environmental impacts analyzed for the actual reactor sites was also provided in the *Supplement* and has been added to Section 4.28 of the SPD Final EIS.

Possible Delay of the Construction of the Actinide Packaging and Storage Facility. As stated in the *Supplement*, the schedule for the Actinide Packaging and Storage Facility (APSF) is uncertain at this time, and therefore, the proposed facilities at SRS analyzed in the SPD Final EIS were modified to disregard any benefit to the proposed facilities as a result of APSF being present. Chapter 4 of the SPD Final EIS presents the environmental impacts that would be associated with the construction and operation of surplus plutonium disposition facilities at SRS that are stand-alone and include no reliance on storage space or other functions at APSF. Throughout the SPD Final EIS, references to APSF have been qualified by the phrase “if built,” and no credit has been taken in the environmental analyses for the presence of APSF.

Pit Repackaging Requirements. The SPD Final EIS was changed to reflect new decisions on the repackaging of pits at Pantex for long-term storage and the impacts of that decision on the need to repackage the pits for offsite transportation.

Pit repackaging for long-term storage. As discussed in the *Supplement*, work is currently under way to repackage all pits at Pantex from the AL–R8 container into the AL–R8 sealed insert (SI) container for long-term storage, described in the *Supplement Analysis for: Final Environmental Impact Statement for the Continued Operation of the Pantex Plant and Associated Storage of Nuclear Weapon Components—AL–R8 Sealed Insert Container* (DOE 1998c). This effort would be completed over 10 years, and the estimated dose to involved workers received from this repackaging activity would be about 104 person-rem. The SPD Draft EIS analyzed

the repackaging of pits in an AT-400A container. The change to the AL-R8 SI changes the undisturbed long-term storage period for pits from 50 to 30 years because of the need to replace a seal in the container after 30 years; the AT-400A does not require that activity. This change has been incorporated into Chapter 4.

Pit repackaging for offsite transportation. The AL-R8 SI is not an offsite shipping container as was the AT-400A analyzed in the SPD Draft EIS. Therefore, if the decision were made to site the pit conversion facility at a site other than Pantex, the surplus pits would have to be taken out of the AL-R8 SI and placed in a shipping container.²⁷ This operation would also require the replacement of some pit-holding fixtures to meet transportation requirements. It is expected that this change would result in a total repackaging dose to involved workers of 208 person-rem. If the decision were made to locate the pit conversion facility at Pantex, then the pits could be moved from their storage location to the pit conversion facility in the AL-R8 SI using onsite transportation vehicles. Under this option, there would be no increased exposures due to repackaging. This change has been incorporated into Chapter 4.

Environmental Impacts Associated With MOX Fuel Versus LEU Fuel. Section 4.28.3 was added to the SPD Final EIS to address the impacts associated with using MOX fuel versus LEU fuel in existing commercial reactors.

Uranium Conversion Impacts. Section 4.30.3, Incremental Impacts Associated With Uranium Conversion, was added to address potential impacts of the conversion of depleted uranium hexafluoride to uranium dioxide. (See Sections 1.5 and 2.4 of the SPD EIS for a discussion on conversion.)

New/Revised Documents and Changes to Cumulative Impacts. Section 1.7 of the SPD Draft EIS, Relationship to Other Actions and Programs (Section 1.8 in the Final), was updated to reflect new or revised planning documents and related NEPA documents, such as the *Environmental Assessment for the Parallel Project Fuel Manufacture and Shipment*, the *ROD for the Department of Energy's Waste Management Program: Treatment of Non-Wastewater Hazardous Waste*, the *Advanced Mixed Waste Treatment Project Final EIS* and *ROD*, and the *Final Environmental Impact Statement on Management of Certain Plutonium Residues and Scrub Alloy Stored at the Rocky Flats Environmental Technology Site* and *RODs*. The information in the most recent programmatic and site documents has been used to update the discussion of cumulative impacts in Section 4.32 of the SPD Final EIS. In addition, cumulative impacts information has been added for LLNL and LANL (two candidate sites for lead assembly fabrication), ORNL (a candidate site for postirradiation examination), and the three reactor sites (Catawba, McGuire, and North Anna).

Affected Environment. Information on the affected environment for ORNL, a candidate site for postirradiation examination, has been added to Chapter 3 of the SPD Final EIS.

Consultations. Appendix O was added to provide the correspondence related to ecological resources, cultural resources, and Native American consultations. Table 5-2 of the SPD EIS provides a summary of these consultations, and Section 4.26 discusses the results of the consultations.

FFTF. Appendix D of the SPD Draft EIS was deleted. The SPD Final EIS does not address using FFTF because the current DOE proposals do not include the use of surplus plutonium as a fuel source for FFTF.

²⁷ At the present time, DOE is using the FL container for the offsite shipment of pits. There are not enough of these containers to meet the plutonium disposition mission. No new FL containers can be manufactured because of certification restrictions. Further, the current FL containers cannot be certified for a specific type of surplus pit. The Defense Nuclear Facilities Safety Board, in its Recommendation 99-1 (August 1999), noted that there is no container suitable for shipping pits from Pantex. Should DOE make any decisions that would require shipment of pits from Pantex, DOE would ensure the availability of a certified shipping container in a timeframe that would support those decisions.

Comment Response. Volume III, the Comment Response Document, was added to the SPD Final EIS. The comments received during the two comment periods and their responses are presented in a side-by-side format.

S.3 ALTERNATIVES AND MATERIALS ANALYZED

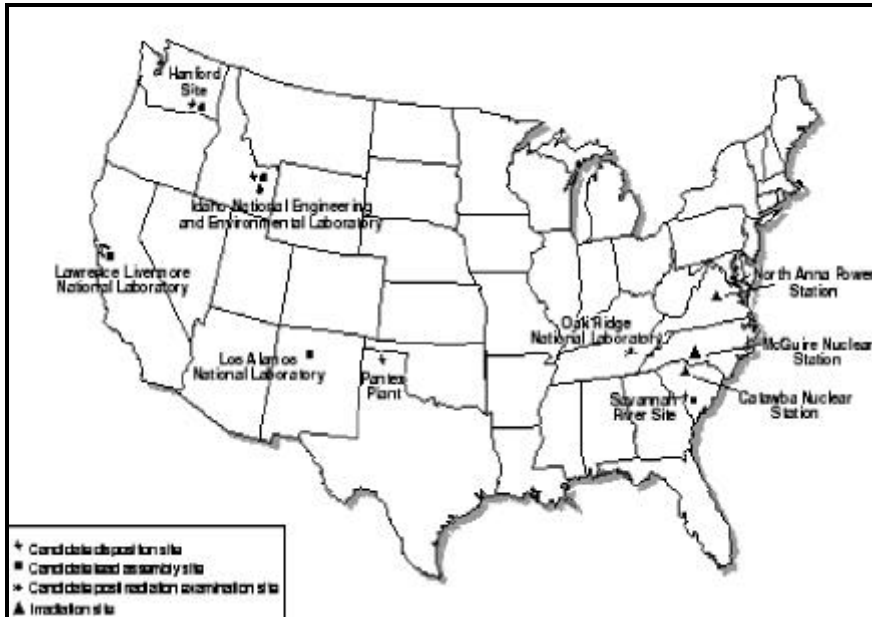

Figure S–2. Proposed Locations of Surplus Plutonium Disposition Facilities

The SPD EIS analyzes the potential environmental impacts associated with implementing pit disassembly and conversion of the recovered plutonium and clean plutonium metal at four candidate sites; conversion and immobilization of plutonium from nonpit sources at two candidate sites, and MOX fuel fabrication activities at four candidate sites. The SPD EIS also evaluates immobilizing plutonium in ceramic or glass forms, and compares the can-in-canister approach with the homogenous ceramic immobilization and vitrification approaches that were evaluated in the *Storage and Disposition PEIS*. As

part of the MOX option, the SPD EIS also evaluates the potential impacts of fabricating MOX fuel lead assemblies (for test irradiation in domestic, commercial nuclear power reactors) at five candidate DOE sites, subsequent postirradiation examination of the lead assemblies at two candidate DOE sites, and addresses the impacts of irradiating MOX fuel in domestic, commercial reactors. Figure S–2 is a map of the United States that identifies the proposed locations of the surplus plutonium disposition facilities.

There are 15 surplus plutonium disposition alternatives and the No Action Alternative, which are shown in Table S–1 and are described in more detail in Chapter 2 of the SPD EIS. The 15 action alternatives are organized into 11 sets of alternatives, reflecting various combinations of facilities and candidate sites, as well as the use of new or existing buildings. For example, Alternative 6, which would locate the pit conversion and MOX facilities at Hanford, and the immobilization facility at SRS, has two variations, denoted as 6A and 6B. The variations occur because the MOX facility could be in new construction or in FMEF at Hanford.

Each of the 15 alternatives includes a pit conversion facility, but additional facilities in each alternative vary depending on the amount of plutonium to be immobilized. Alternatives 2 through 10 involve the hybrid approach of immobilizing 17 t (19 tons) of surplus plutonium and using 33 t (36 tons) for MOX fuel, and therefore require all three facilities. Alternatives 11 and 12 involve immobilizing all 50 t (55 tons), and therefore only include a pit conversion facility and an immobilization facility. Alternative 1, the No Action Alternative, does not involve

disposition of surplus weapons-usable plutonium, but instead addresses continued storage of the plutonium in accordance with the *Storage and Disposition PEIS* ROD, as amended.²⁸

Immobilization Technology Alternatives

The *Storage and Disposition PEIS* discusses several immobilization technologies, including the homogenous ceramic immobilization and vitrification alternatives that were evaluated in detail, as well as the variants of those alternatives, which include the ceramic and glass can-in-canister approaches and another homogenous approach using an adjunct melter (discussed further in Appendix C of the SPD EIS). The ROD for the *Storage and Disposition PEIS* states that DOE would make a determination on the specific technology on the basis of “the follow-on EIS.” The SPD EIS is that follow-on EIS, and it identifies the ceramic can-in-canister approach as the preferred immobilization technology.

In order to bound the estimate of potential environmental impacts associated with ceramic and glass immobilization technologies, the *Storage and Disposition PEIS* analyzes the construction and operation of vitrification and ceramic immobilization facilities that employ a homogenous approach. These facilities are based on generic designs that do not involve the use of existing facilities or specific site locations. These generic designs allow for surplus plutonium to be immobilized in a homogenous form, either within a ceramic matrix and formed into disks, or vitrified as borosilicate glass logs.

In order to support a decision on the immobilization technology and form, the SPD EIS evaluates the potential environmental impacts of the ceramic and glass can-in-canister technologies, and compares those impacts with the impacts of the homogenous facilities evaluated in the *Storage and Disposition PEIS*. This comparison is presented in Chapter 4 of the SPD EIS.

MOX Fuel Fabrication Alternatives

Alternatives that involve the fabrication of MOX fuel include the use of the fuel in existing domestic, commercial nuclear power reactors. The environmental impacts of using MOX fuel in these reactors are evaluated generically in the *Storage and Disposition PEIS*. When the SPD Draft EIS was published, the specific reactors were not known; therefore, that generic analysis was incorporated by reference in the SPD Draft EIS, summarized in Chapter 4, and included in the discussion of the integrated impacts of the MOX fuel alternatives presented in Chapter 2 of that document and Section S.6 of the Draft Summary. This was done with the understanding that by the time the SPD Final EIS was published, the specific reactors would have been identified and reactor-specific analyses would replace the generic analyses.

In May 1998, DOE initiated a procurement process to obtain MOX fuel fabrication and irradiation services. The Request for Proposals (RFP) defined limited activities that may be performed prior to issuance of the SPD EIS ROD. These activities include non-site-specific work primarily associated with the development of the initial conceptual design for the fuel fabrication facility, and plans (paper studies) for outreach, long lead-time procurements, regulatory management, facility quality assurance, safeguards, security, fuel qualifications, and deactivation. In compliance with its NEPA regulations at 10 CFR 1021.216, DOE requested that each offeror provide, as part of its proposal, environmental information specific to its proposed MOX facility design and the domestic, commercial reactors proposed to be used for irradiation of the fuel. That information was analyzed by

²⁸ DOE is considering leaving the repackaged surplus pits in Zone 4 at Pantex for long-term storage. An appropriate environmental review will be conducted when the specific proposal for this change has been determined (e.g., whether additional magazines need to be air-conditioned). The analysis in the SPD EIS assumes that the surplus pits are stored in Zone 12 in accordance with the ROD for the *Storage and Disposition PEIS*. Should the No Action Alternative be chosen, the ROD pursuant to the SPD EIS would also address the movement of the remaining surplus nonpit plutonium from RFETS in support of its planned closure in 2006.

DOE to identify potential environmental impacts of the proposals and documented in an Environmental Critique prepared pursuant to 10 CFR 1021.216(g). That analysis was considered by the selection official as part of the award decision.

DOE awarded a contract to the team of Duke Engineering & Services, COGEMA Inc., and Stone & Webster (DCS) in March 1999 to provide the requested services. These services include design, licensing, construction, operation, and eventual deactivation of the MOX facility, as well as irradiation of the MOX fuel in six domestic, commercial reactors at three sites. The reactors proposed by DCS are Duke Power Company's Catawba Nuclear Station, Units 1 and 2; and McGuire Nuclear Station, Units 1 and 2; and Virginia Power Company's North Anna Power Station, Units 1 and 2. No construction, fabrication, or irradiation of MOX fuel would occur until the SPD EIS ROD is issued. Such site-specific activities, and DOE's exercise of contract options to allow those activities, would be contingent on decisions in the ROD.

"216 Process"

DOE's NEPA Implementing Regulations (10 CFR Part 1021) include special provisions to enable a source selection official to consider, as part of the procurement decision, the environmental impacts of the offerors' proposals. As provided in 10 CFR 1021.216, DOE may require that offerors submit environmental data and analyses as a discrete part of the offeror's proposal. DOE will then:

- independently evaluate and verify the submitted information;
- prepare an environmental critique (subject to confidentiality requirements of the procurement process) for offers in the competitive range, addressing environmental issues pertinent to a decision on the proposals; and
- prepare a publicly available environmental synopsis, based on the environmental critique, to document consideration given to environmental factors in the selection process.

After a selection has been made, the environmental synopsis shall be filed with EPA, made publicly available, and incorporated in an EIS prepared for the action.

If the NEPA process is not completed before the award, the contract work must be made contingent on completion of the NEPA process, and contract work must be phased to allow the NEPA process to be completed in advance of a go/no-go decision.

As provided in 10 CFR 1021.216(h), an Environmental Synopsis, based on the Environmental Critique, was provided to the U.S. Environmental Protection Agency (EPA), made available to the public, and incorporated as Appendix P to the SPD EIS. In addition, Section 3.7 was added to describe the affected environment at the three reactor sites. Section 4.28 was revised to include the reactor-specific impact analyses, and relevant sections of Chapters 2 and 4 were revised as necessary to incorporate information provided by DCS about the proposed MOX facility, where different from that presented in the SPD Draft EIS. Sections of the SPD EIS that were revised or added to include reactor-specific information, including the new Appendix P presenting the Synopsis, were also distributed as the *Supplement to the SPD Draft EIS*.²⁹ An NOA was published in the Federal Register on May 14, 1999 (64 FR 264019), providing a 45-day public comment period on the *Supplement*. This *Supplement* was distributed to interested parties in the local communities surrounding the Catawba, McGuire, and North Anna reactor sites; to stakeholders who received the SPD Draft EIS; and others as requested. Comments are addressed in Volume III, Part B, of the Comment Response Document, and, where appropriate, revisions have been included in the SPD Final EIS.

Under the hybrid alternatives, DOE could produce up to 10 MOX fuel assemblies for testing in domestic, commercial reactors before commencement of full-scale MOX fuel irradiation, although it is likely that only

²⁹ On June 15, 1999, DOE held a public hearing in Washington, D.C., to solicit comments on the *Supplement to the SPD Draft EIS*.

2 lead assemblies would be needed.³⁰ These lead assemblies would be available for irradiation to support NRC licensing and fuel qualification efforts. Potential impacts of MOX fuel lead assembly fabrication are analyzed for three of the candidate sites for MOX fuel fabrication (Hanford, ANL–W at INEEL, and SRS), and two additional sites, LANL and LLNL. Pantex was not considered for lead assembly fabrication because it does not currently have any facilities capable of MOX fuel fabrication. Postirradiation examination of the lead assemblies, if required to support NRC licensing activities, would be conducted. Two potential sites for postirradiation examination are discussed in the SPD EIS: ANL–W and ORNL. As discussed previously, DOE’s preferred locations for lead assembly fabrication and postirradiation examination are LANL and ORNL, respectively.

Materials Analyzed

As described in the following graphic, there are eight general categories used to describe the 50 t (55 tons) of surplus plutonium, which represent the physical and chemical nature of the plutonium. Two of the categories—clean metal (including pits) and clean oxide—could either be fabricated into MOX fuel or immobilized. The remaining six categories of material—impure metals, plutonium alloys, impure oxides, uranium/plutonium oxides, alloy reactor fuel, and oxide reactor fuel—would be immobilized.

DESCRIPTION OF SURPLUS PLUTONIUM BY DISPOSITION FEED CATEGORIES

PLUTONIUM FEED FOR IMMOBILIZATION OR MOX FUEL FABRICATION:

Clean Metal. Pure plutonium metal generally with less than 100 parts per million (ppm) of any given chemical impurity. The metal may have some oxidation or casting residues on the surface. The only major chemical impurities are gallium and radioactive decay products such as americium, neptunium, or uranium. Examples of pure metal items include unalloyed “buttons” of plutonium metal, billets, ingots, castings or rough machined items, finished machined weapon components such as “pits,” and other miscellaneous small metal pieces and parts.

Clean Oxide. Plutonium oxides with less than 3 percent by weight of impurities.

FEED FOR IMMOBILIZATION:

Impure Metal. Items with impurities that are more than 100 ppm, but less than 50 percent by weight.

Plutonium Alloys. Plutonium-containing alloys with impurities that are less than 50 percent by weight. Examples of plutonium alloy items include alloyed plutonium “buttons,” casting products, machined product items, and ingots.

Impure Oxide. Plutonium oxides with at least 3 but less than 50 percent by weight of impurities. Examples in this category include plutonium oxides containing uranium oxides and plutonium oxides containing neptunium, thorium, beryllium, or zirconium.

Uranium/Plutonium Oxide. Plutonium oxides mixed with enriched uranium oxides. Examples include powders or pellets that have been either low-fired (heated at temperatures below 700 °C) or high-fired (heated at temperatures greater than 700 °C).

Alloy Reactor Fuel and Oxide Reactor Fuel. Plutonium-containing reactor fuel that has been manufactured, but not irradiated in a reactor. The plutonium consists of 12 to 26 percent of plutonium 240 with total plutonium compositions being 13 to 27 percent of the material in the fuel. The fuel can be either alloy reactor fuel or reactor fuel containing plutonium oxide mixed with uranium oxide. The majority of alloy reactor fuel in DOE’s plutonium inventory is fuel elements for the Zero Power Physics Reactor at ANL–W. Oxide fuels include experimental capsules, elements, and pins.

³⁰ The potential impacts of fabricating 10 lead assemblies and irradiating 8 of them were analyzed in the SPD EIS. As discussed in Sections 2.18.2 and 4.27 of the SPD EIS, should fewer lead assemblies than analyzed be fabricated or irradiated, the potential impacts would be lower than those described in the SPD EIS.

S.4 DEVELOPMENT OF THE ALTERNATIVES

Development of Facility Siting Alternatives

In the ROD for the *Storage and Disposition PEIS*, DOE identified a large number of possible options to locate three surplus plutonium disposition facilities at four sites, and limited the immobilization options to Hanford and SRS. In addition to the four different sites for potential facility locations, the options were further increased by considering the use of either existing or new facilities at the sites, and by considering whether disposition would occur by the hybrid approach (MOX fuel fabrication and immobilization) or only through immobilization.

The following equally weighted screening criteria were used to reduce the large number of possible facility and site combinations to a range of reasonable alternatives:

- *Worker and public exposure to radiation.* This criterion was used to exclude the site combinations that would involve large amounts of handling, packaging, and repackaging of the surplus plutonium for either intersite or intrasite transportation.
- *Proliferation concerns due to transportation of materials.* Application of this criterion eliminated those options that would increase the transfers of the surplus plutonium, usually involving three sites.
- *Infrastructure.* This criterion was used to exclude the site combinations where a single disposition facility would be located at a site with no benefit for the program or DOE. For example, collocation of two of the three hybrid case disposition facilities at a site would reduce program infrastructure costs such as those associated with safeguards and security features, whereas locating each facility at a separate site would not allow such functions to be shared.

Over 64 options were evaluated, yielding a range of 20 reasonable alternatives that met all of the criteria. Examples of options that were eliminated include all those options placing three facilities at three different sites. In its NOI, DOE proposed to collocate the pit conversion and immobilization facilities for the immobilization-only alternatives. However, during the public scoping process, the comment was made that, under all situations, Pantex should be considered as a candidate site for the pit conversion facility because most of the surplus pits are currently stored there. After confirming that they met all of the screening criteria, three additional immobilization-only alternatives, which place the pit conversion facility at Pantex, were included in the range of reasonable alternatives evaluated in the SPD Draft EIS. The number of reasonable alternatives was reduced to 15 in the *Supplement* when DOE determined that Building 221-F at SRS was no longer a reasonable location for the immobilization facility, as discussed in Section S.2.

[Text deleted.]

Since the issuance of the SPD Draft EIS, DOE has developed a more detailed conceptual design for the can-in-canister immobilization facility. To accommodate design modifications (such as the lengthening of process gloveboxes and the material conveyor), the proposed immobilization facility has increased in size in terms of floor space. The MOX facility has also increased in size since the issuance of the SPD Draft EIS. This increase is due to the inclusion of the plutonium-polishing capability and additional process space proposed by DCS.

Alternatives Considered but Eliminated From Detailed Study

Technology alternatives for surplus plutonium disposition that were evaluated in the *Storage and Disposition PEIS*, but were not selected in the ROD and, therefore, are not being considered in the SPD EIS are: (1) deep-borehole direct disposition; (2) deep-borehole immobilized disposition; (3) electrometallurgical treatment; (4) MOX fuel irradiation in a partially completed light water reactor; and (5) MOX fuel irradiation in an evolutionary (advanced) light water reactor. The reasons why these technologies were not selected are explained in the ROD for the *Storage and Disposition PEIS*.

Alternatives considered for inclusion in the SPD EIS but later eliminated from further analysis fall into four categories: amounts of material to be dispositioned; disposition facility siting; feed preparation methods; and immobilization technologies.

Amounts of Material to Be Dispositioned. In the *Storage and Disposition PEIS* ROD, DOE committed to immobilizing at least 8 t (9 tons) of surplus, low-purity, nonpit plutonium. Since the ROD was issued, however, DOE has determined that because of the level of impurities and additional processing that would be required to meet MOX fuel specifications, an additional 9 t (10 tons) of low-plutonium-content materials would be immobilized. Therefore, the SPD EIS does not evaluate in detail MOX fuel fabrication for all of the nominal 50 t (55 tons) of surplus plutonium.

Disposition Facility Siting Alternatives. In addition to alternatives eliminated by the screening process described earlier, the following facility options were eliminated from further study.

Locating all three surplus plutonium disposition facilities in FMEF at Hanford was listed as Alternative 2 in Table 1 of the NOI for preparation of the SPD EIS. After further evaluation of space requirements, DOE concluded that the available space in FMEF would not be sufficient to accommodate the efficient operation and maintenance of all three facilities. Therefore, Alternative 2 was modified to collocate only the pit conversion and the immobilization facilities in FMEF, with the MOX facility (new construction) adjacent to FMEF.

The *Storage and Disposition PEIS* ROD stated that “to accomplish the plutonium disposition mission, DOE will use, to the extent practical, new as well as modified existing buildings and facilities for portions of the disposition missions.” The subsequent NOI for the SPD EIS further stated that “construction of these facilities would be on previously disturbed land and could include the modification of existing facilities where practicable, to reduce local environmental impacts, reduce costs, and shorten schedules.” As a result, DOE analyzed immobilization alternatives that included Building 221–F at SRS in the SPD Draft EIS. This building was originally built to house operations to chemically separate plutonium from irradiated targets and will be available to support other missions after these activities have been completed. The availability of Building 221–F coincides with the schedule for the proposed surplus plutonium disposition activities.

However, based on revised space requirements for the immobilization facility, the eight alternatives (3B, 5B, 6C, 6D, 7B, 9B, 12B, and 12D) in the SPD Draft EIS that proposed using a portion of Building 221–F for immobilization activities have, as discussed in the *Supplement*, been removed from consideration in the SPD Final EIS. These alternatives are no longer considered reasonable because the amount of new construction required for the proposed immobilization facility is now expected to be nearly the same whether the facility were located entirely in a new building or built in addition to using the available portion of Building 221–F. Deletion of the Building 221–F alternatives does not eliminate SRS from any of the immobilization alternatives under consideration. DOE is still evaluating alternatives that involve construction of a new immobilization facility at SRS.

[Text deleted.]

Feed Preparation Methods for Immobilization. The homogenous ceramic immobilization facility evaluated in the *Storage and Disposition PEIS* was based on a wet-feed preparation process. Although the ceramic form of the can-in-canister approach evaluated in the SPD EIS could also use a wet-feed process, it would require larger quantities of water and generate greater amounts of waste than would a dry-feed process. For these reasons, wet-feed preparation processes for the ceramic can-in-canister approach were not considered to be reasonable, and were not considered further in the SPD EIS.

Immobilization Technology Alternatives. DOE considered locating an adjunct melter adjacent to DWPF at SRS. In the adjunct melter, a mixture of borosilicate glass frit and plutonium would be melted together and added directly to borosilicate glass containing HLW from DWPF. Subsequent evaluations, however, have indicated that the adjunct melter approach would be less technically viable, would take longer to implement, and would cost twice that of the can-in-canister approach. A description of the vitrification process using the adjunct melter is presented in Appendix C of the SPD EIS, but this option is not evaluated as a reasonable alternative.

The technology variants for the new immobilization facilities discussed in the *Storage and Disposition PEIS* considered using either radioactive cesium 137 or HLW as a radiation barrier. However, the *Storage and Disposition PEIS* further identified that, in the can-in-canister approach, the use of HLW to produce a radiation barrier eliminates the need for introducing cesium 137 (from cesium capsules currently in storage at Hanford) into the immobilization process, which in turn reduces radiation shielding requirements and potential exposures to workers and the public. Therefore, the SPD EIS does not include the use of these cesium 137 capsules in the can-in-canister analyses as a reasonable alternative.

S.5 OVERVIEW OF PROPOSED SURPLUS PLUTONIUM DISPOSITION FACILITIES AND TRANSPORTATION

As discussed previously, three facilities are proposed for surplus plutonium disposition: pit conversion, immobilization, and MOX fuel fabrication. The three disposition facilities are proposed for locations where the plutonium would have the levels of protection and control required by applicable DOE safeguards and security directives.³¹ See Figure S-3 for a description of the proposed surplus plutonium disposition processes. Safeguards and security programs would be integrated programs of physical protection, information security, nuclear material control and accountability, and personnel assurance. Security for the facilities would be commensurate with the usability of the material in a nuclear weapon or improvised nuclear device. Each facility would be located at an existing DOE site that has sitewide security measures in place, including access control. In addition to DOE sitewide security services, each facility would have appropriate security features. Physical barriers; access control systems; detection and alarm systems; procedures, including the two-person rule (which requires at least two people to be present when working with special nuclear materials in the facility); and personnel security measures, including security clearance investigations and access authorization levels, would be used to ensure that special nuclear materials stored and processed inside are adequately protected. Nuclear material control and accountability would be ensured through a system that monitors storage, processing, and transfers. Closed-circuit television, intrusion detection, motion detection, and automated materials monitoring methods would be employed as part of the material control and accountability program. At any time, the total amount of special nuclear material in each facility, or in any material balance area within a specific facility, would be known. Physical inventories, measurements, and inspections of

³¹ The physical protection and safeguards and security for the MOX facility would be acceptable to NRC. Physical protection and safeguards and security at the domestic, commercial reactors would meet NRC regulations.

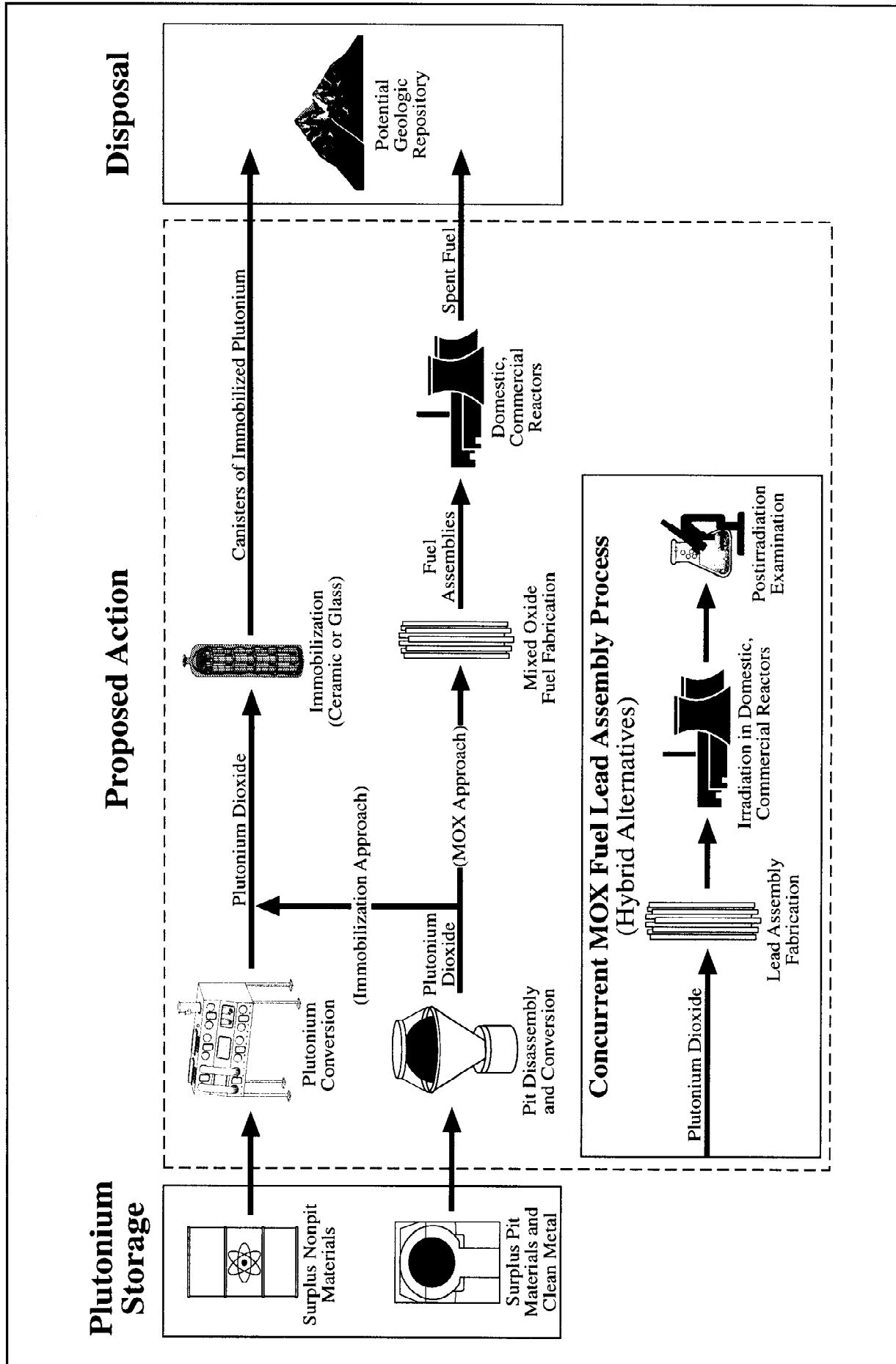

Figure S-3. Proposed Surplus Plutonium Disposition Processes

material both in process and in storage would be used to verify inventory records. In addition, each of the three facilities would need to provide space, and to varying degrees, access for international inspection.

Each of the disposition facilities is proposed to operate for about 10 years. However, the operating life of the facilities may vary somewhat, depending on facility startup experiences and international negotiations regarding the pace of disposition. Also, the MOX facility could operate for as long as 13 years to accommodate the fuel cycles of the reactors in which the MOX fuel would be used. Slightly more or less material could be processed in any given year, potentially extending or shortening the operating period of any of the disposition facilities. Also, for the hybrid approach, it may be necessary, based on feed material quality, to process slightly more material by immobilization than currently envisioned. An analysis of how these adjustments could incrementally affect the potential impacts evaluated in the SPD EIS is provided in Section 4.30.

Because the disposition facilities would operate for about 10 years and would meet stringent safety and natural hazard requirements, they could still be used for other programs or activities. As discussed in Section 4.31 of the SPD EIS, after completion of the surplus plutonium disposition mission, equipment would be removed, decontaminated, and either reused at other DOE facilities or disposed of, and the facilities would be stabilized to a condition suitable for reuse. It is expected that this facility deactivation would take 3 years or less to complete. During this time, DOE would perform engineering evaluations, environmental studies, and further NEPA review to assess the consequences of different courses of action with respect to these facilities.

Pit Disassembly and Conversion

Each surplus plutonium disposition action alternative requires a pit conversion facility to produce appropriate plutonium dioxide feed material. That facility would recover plutonium from pits and process clean plutonium metal; convert the plutonium to an unclassified (i.e., no longer exhibiting any characteristics that are protected for reasons of national security) oxide; and then transfer the oxide to either the immobilization facility or the MOX facility. This process would include the removal of gallium, beryllium, or other materials that may be considered impurities in plutonium dioxide feed for MOX fuel fabrication.³² Given the national security sensitivity of information on pit materials and assembly, pit conversion facility operations would be classified (i.e., access restricted) through the material processing steps, and possibly through the final canning stage.

The pit conversion facility would be designed to process up to 3.5 t (3.8 tons) of plutonium metal into plutonium oxide annually. Facility operations would require a staff of about 400 personnel. The pit conversion facility would be built in a hardened space of thick-walled concrete that meets all of the standards for processing special nuclear material. Areas of the facility in which plutonium would be processed or stored would be designed to survive natural phenomena such as earthquakes, floods, and tornadoes, as well as potential accidents associated with radioactive and fissile materials. In addition to the pit conversion facility, ancillary buildings would also be required for support activities.

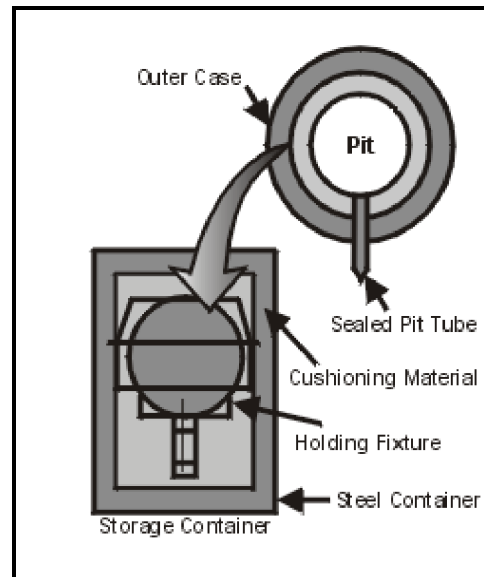

Depiction of Pit

³² Because the plutonium-polishing process evaluated as a contingency in Appendix N of the SPD Draft EIS has been incorporated into the MOX facility, the thermal gallium removal step may no longer be needed in the pit conversion facility. Both the pit conversion and MOX facilities, however, were analyzed in the SPD EIS with their respective gallium (and other impurity) removal processes.

Plutonium Conversion and Immobilization

The immobilization facility would perform two operations on the surplus nonpit plutonium materials: (1) the conversion of miscellaneous surplus plutonium that is not in pit form into plutonium dioxide for immobilization; and (2) the immobilization of this plutonium dioxide, and possibly the plutonium dioxide from pits (if it were decided to also immobilize plutonium from pits), in a ceramic or glass form. This material would then be sealed in cans, and these cans would be placed inside canisters that would subsequently be filled with vitrified HLW from either the HLW vitrification facility at Hanford or DWPF at SRS (i.e., the can-in-canister approach). Filled and sealed waste canisters would be placed into storage for ultimate disposition in a potential geologic repository pursuant to the NWP. The immobilization facility would be open to international inspection.

The immobilization facility would consist of two primary components: a main process building and an HLW vitrification facility (the planned HLW vitrification facility at Hanford, or DWPF at SRS). The facility would be designed to immobilize up to 5 t (5.5 tons) of plutonium metal per year. This annual throughput would consist of up to 1.7 t (1.9 tons) of surplus nonpit plutonium and up to 3.3 t (3.6 tons) of surplus plutonium derived from pits. Operation of the facility would involve three shifts 7 days per week for 10 years and would require a workforce ranging from about 335 to 412 personnel.³³ For 11 of the alternatives considered in the SPD EIS, a total plutonium immobilization throughput of 17 t (19 tons) was assumed. These alternatives involve the hybrid approach of disposition through both immobilization and MOX fuel fabrication. Four alternatives involve disposition only by immobilization, and the facility design for the two candidate sites would accommodate the assumed 50-t (55-ton) throughput of plutonium metal. The lower throughput for the hybrid approach would be reflected in differences in operational employment and resource requirements, but would not affect construction requirements.

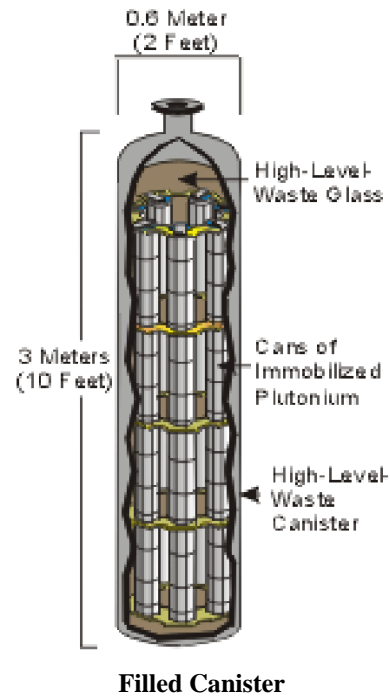

MOX Fuel Fabrication

The MOX facility would produce completed MOX fuel assemblies for use in domestic, commercial nuclear power reactors. Feed materials would be the plutonium dioxide from the pit conversion facility and uranium dioxide made from either the DOE stockpile of depleted uranium hexafluoride from a representative DOE site (i.e., Portsmouth Gaseous Diffusion Plant) or another source selected by the fuel fabricator (DCS) and approved by DOE. MOX fuel fabrication involves blending the plutonium dioxide with uranium dioxide; forming the mixed oxide into pellets; loading the pellets into fuel rods; and assembling the fuel rods into fuel assemblies. Once assembled, each of the fuel assemblies would be transported in SST/SGTs to one of the domestic, commercial reactors for use. Following irradiation, the MOX fuel would be removed from the reactor and managed at the reactor site as spent fuel. Final disposition would be at a potential geologic repository pursuant to the NWP.

³³ Personnel needed to operate the planned HLW vitrification facility at Hanford, or DWPF at SRS, are not included, because these facilities are required regardless of the immobilization alternatives presented in the SPD EIS.

The proposed MOX facility would also include a small-scale aqueous process to remove impurities, in particular gallium, from the plutonium dioxide feed prior to MOX fuel fabrication. This initial plutonium-polishing step would be essentially that described in Appendix N of the SPD Draft EIS. The potential impacts of the MOX facility, including plutonium polishing, are evaluated in Chapter 4 of the SPD EIS and would be the same regardless of the exact location of the plutonium-polishing equipment within the MOX facility.

The MOX facility would be designed to process up to 3.5 t (3.8 tons) of surplus plutonium (as plutonium dioxide from the pit conversion facility) annually. Facility operations would require a staff of about 385 personnel. The MOX facility would be a two-story, hardened, reinforced-concrete structure with a below-grade basement and an at-grade first floor. The facility would meet all applicable standards for processing special nuclear material. The walls, floors, and roof of the building would be constructed of about 46 cm (18 in) thick reinforced concrete. Areas of the facility in which plutonium would be processed or stored would be designed to survive natural phenomena such as earthquakes, floods, and tornadoes, as well as potential accidents associated with processing fissile and radioactive materials. In addition to the MOX facility, ancillary buildings would also be required for support activities.

Lead Assembly Fabrication

Lead assembly fabrication would involve the same basic process as the full-scale fabrication of MOX fuel. Although DOE plans to produce only 2 lead assemblies, as many as 10³⁴ could be fabricated at the lead assembly fabrication facility. The fabrication effort would be implemented in existing facilities at the selected location, and the fabrication phase would be completed in about 3 years. Up to 4 fuel assemblies would be produced in any given year, for a maximum of 10 assemblies at the end of the 3-year fabrication phase. At this rate of production, about 100 kg (220 lb) of plutonium would be made into MOX fuel each year. Including hot startup, a total of about 321 kg (708 lb) of plutonium would be used. The plutonium would come from pits dismantled during the Pit Disassembly and Conversion Demonstration Project or from existing supplies of surplus metal and oxides at LANL. Two extra MOX fuel rods would be fabricated with each lead assembly to be maintained as unirradiated archives. The archived rods would be stored at the lead assembly facility until the completion of all the lead assembly fabrication, irradiation, and testing. The rods would then be shipped to the MOX facility for storage until it was determined that the rods were no longer needed as archived material for fuel qualification purposes. At that time, the archived rods would either be irradiated or dismantled and the materials reused in the MOX fabrication process.

Transportation Activities

The plutonium disposition alternatives examined in the SPD EIS would require DOE to ship surplus plutonium-bearing materials from their current storage locations to the proposed disposition facility locations for processing. Table S-2 is an overview of the different types of shipments that would be required for each proposed disposition facility, and the vehicles in which the shipments would be made.

The overland transportation of any commodity involves a risk to both the transportation crew and members of the public. The risk results directly from transportation-related accidents and indirectly from the increased levels of pollution from vehicle emissions, regardless of the cargo. The transportation of hazardous or

³⁴ Should fewer lead assemblies than analyzed be fabricated or irradiated, the potential impacts would be lower than those described in Sections 2.18.2 and 4.27 of the SPD EIS.

Table S–2. Facility Transportation Requirements

Required Shipment	Vehicle ^{a, b}
Pit Conversion Facility	
Intersite shipment of surplus pits and clean metal to the pit conversion facility	SST/SGT ^c
Recovered HEU from the pit conversion facility to ORR	SST/SGT
[Text deleted.]	
Plutonium dioxide to the immobilization or MOX facility	SST/SGT
Immobilization Facility	
Under Alternatives 11B and 12B, plutonium dioxide from the pit conversion facility ^d	SST/SGT
Surplus nonpit plutonium to the immobilization facility ^e	SST/SGT
DUF ₆ from one of DOE's sites at a gaseous diffusion plant to a conversion facility (ceramic immobilization option only) ^f	Commercial truck
Uranium dioxide from the conversion facility to the immobilization facility (ceramic immobilization option only)	Commercial truck
Immobilized plutonium from immobilization facility to the HLW vitrification facility (intrasite transport)	Special transport vehicle
Vitrified HLW with immobilized plutonium to a potential geologic repository ^g	Commercial truck
MOX Facility^h	
Under Alternatives 4 and 5, plutonium dioxide from the pit conversion facility ⁱ	SST/SGT
DUF ₆ from one of DOE's sites at a gaseous diffusion plant to a commercial conversion facility ^f	Commercial truck
Uranium dioxide from the conversion facility to the MOX facility	Commercial truck
Uranium fuel rods from a commercial fuel fabrication facility to the MOX facility ^j	Commercial truck
MOX fuel bundles to selected domestic, commercial reactors	SST/SGT
MOX spent fuel from domestic, commercial reactors to a potential geologic repository ^k	Commercial truck
Lead Assembly Fabrication Facility	
Plutonium dioxide from LANL to a lead assembly facility at a location other than LANL	SST/SGT
For lead assembly fabrication at LANL, intrasite movement of plutonium materials	Special transport vehicle
DUF ₆ from one of DOE's sites at a gaseous diffusion plant to a commercial conversion facility ^f	Commercial truck
Uranium dioxide from the conversion facility to the lead assembly facility	Commercial truck
Uranium fuel rods from a commercial fuel fabrication facility to the lead assembly facility	Commercial truck
MOX fuel bundles to the selected domestic, commercial reactor	SST/SGT
Irradiated lead assemblies or rods from the reactor to an examination site	Commercial truck
Spent fuel from an examination site to INEEL for storage ^l	Commercial truck
Spent fuel from INEEL to a potential geologic repository ^k	Commercial truck

^a All containers and vehicles will meet Department of Transportation requirements.

^b Commercial trucks will be driven by drivers certified to meet all radioactive materials transportation requirements.

^c SST/SGT is a specially designed semitrailer, pulled by a specially designed tractor, that is used for the safe, secure transportation of cargo containing nuclear weapons or special nuclear material.

^d Under Alternatives 11A and 12A, the two facilities would be collocated; therefore, the transfer of the plutonium dioxide would not require any over-the-road transportation.

^e For cases where the surplus nonpit plutonium requires offsite transportation.

^f DOE is considering building one or more facilities at the gaseous diffusion plant(s) to convert DUF₆ to an oxide form.

^g The *Final Waste Management Programmatic EIS for Managing Treatment, Storage, and Disposal of Radioactive and Hazardous Waste* analyzed a number of options for shipping using either trucks or trains. The SPD EIS has taken the most conservative analytical approach and assumed that all shipments would be made by truck.

^h Some equipment for the MOX facility may be manufactured in Europe and shipped to the United States. No nuclear or radiologically contaminated materials would be transported. Any such shipments would be made by commercial vessel, and no impacts other than those occurring from routine commercial shipping would be expected.

ⁱ Under Alternatives 2, 3, 6A, 6B, 7, 8, 9, and 10, the two facilities would be collocated; therefore, the transfer of the plutonium dioxide would not require any over-the-road transportation.

^j For cases where the fuel assemblies are a combination of MOX and low-enriched uranium fuel rods.

^k Shipments of spent fuel are analyzed in the *Draft EIS for a Geologic Repository for the Disposal of Spent Nuclear Fuel and High-Level Radioactive Waste at Yucca Mountain, Nye County, Nevada*.

^l Shipments of spent fuel within the DOE complex are analyzed in the *DOE Programmatic Spent Nuclear Fuel Management and Idaho National Engineering Laboratory Environmental Restoration and Waste Management Programs Final EIS*.

Key: DUF₆, depleted uranium hexafluoride; HEU, highly enriched uranium; HLW, high-level waste; LANL, Los Alamos National Laboratory; ORR, Oak Ridge Reservation; SST/SGT, safe, secure trailer/SafeGuards Transport.

radioactive materials poses an additional risk due to the unique nature of the material being transported. Chapter 4 and Appendix L of the SPD EIS discuss the risks associated with the transportation of these materials and the steps taken to mitigate these risks.

S.6 APPROACH TO ENVIRONMENTAL IMPACT ANALYSIS

The environmental impact analysis addresses the full range of natural and human resource areas pertinent to the sites considered for the surplus plutonium disposition alternatives. To focus the impact analyses on those areas where the greatest potential exists for effects on the environment, the following topics are discussed in detail: air quality and noise, waste management, socioeconomics, human health risk, facility accidents, transportation, and environmental justice. The remaining resource areas (i.e., geology and soils, water resources, ecological resources, cultural and paleontological resources, land use and visual resources, and infrastructure), analyses have shown that the proposed disposition activities would not have major impacts that varied significantly at each of the candidate sites

Topics Analyzed in the SPD EIS Include:

- Air Quality and Noise
- Waste Management
- Socioeconomics
- Human Health Risk
- Facility Accidents
- Transportation
- Environmental Justice
- Geology and Soils
- Water Resources
- Ecological Resources
- Cultural and Paleontological Resources
- Land Use and Visual Resources
- Infrastructure

regardless of the disposition alternative being considered. Therefore, impacts on these resources were evaluated in detail and discussed in the SPD EIS in terms of the alternative that would have the greatest impact on the resource. The alternative analyzed and discussed is generally that which would locate the largest number of surplus plutonium disposition facilities at a given site. For example, the maximum impact on these resource areas at Pantex would be Alternative 9 or 10, both of which consider building both a pit conversion facility and a MOX facility on the site. In another example, at SRS, the alternative having the greatest impact would be Alternative 3.³⁵ [Text deleted.]

A region of influence (ROI) for each topic or resource area is identified and analyzed for each candidate site for surplus plutonium disposition. Air quality impacts focus on the potential for increases in air pollutant concentrations and discuss those increases relative to the National Ambient Air Quality Standards (NAAQS), National Emissions Standards for Hazardous Air Pollutants (NESHAPs), and State air quality standards. The potential for increases in noise levels is also assessed. Geology and soils are evaluated in terms of site suitability and soil erosion potential. For water resources, the water consumption requirements are compared to the availability of surface and groundwater sources at each site, the potential effects of wastewater discharges on surface and groundwater availability and quality are evaluated, and the site's location relative to floodplains assessed. Biological resources are evaluated in terms of the potential for impacts to terrestrial and aquatic resources, wetlands, and threatened and endangered species. Because most of the facility construction associated with the proposed actions would take place on previously disturbed lands, few impacts would be expected on plant and animal species and the overall biodiversity of the candidate sites. Cultural and paleontological resources address the potential for disturbance to prehistoric, historic, Native American, and paleontological resources. Land resources address land-use compatibility with existing land-use plans, controls, and policies; land requirements for construction and new facilities; and the potential for visual resource impacts. Site

³⁵ During the conduct of the cultural resources impacts analysis, it was determined that construction of surplus plutonium disposition facilities at SRS could produce impacts to archaeological resources requiring mitigation (see Section 4.26.4.4.1 of the SPD EIS). DOE plans to avoid these sites, and it will not be necessary to disturb these areas.

infrastructure impacts are assessed by comparing the electrical power, fuel, water, and transportation network requirements against the existing capacities at each candidate site.

Additional wastes generated by each alternative are compared with existing and planned treatment, storage, and disposal capacities for potential impacts to the waste management infrastructure. Waste management methods are contingent on decisions made based on the *Final Waste Management Programmatic Environmental Impact Statement for Managing Treatment, Storage, and Disposal of Radioactive and Hazardous Waste* (DOE 1997c). Employment and income effects of new job creation and the attendant demands on community services and local transportation are analyzed for socioeconomic impacts.

Maximally Exposed Individual (MEI)

In keeping with standard risk assessment methodology, DOE analyzed the impacts on a “maximally exposed individual.” The MEI is the hypothetical person within a receptor group who has the highest exposure. This individual is assumed to be located at the point of maximum concentration of contaminants 24 hours a day, 7 days a week, for the period of operations analyzed in the SPD EIS.

Both the public and onsite worker exposure to ionizing radiation and hazardous chemicals and the resultant increase in cancer fatality risk are assessed for normal operations and accident conditions. For the public, impacts on individuals (maximally exposed and average exposed) and on the population within 80 km (50 mi) of the site are evaluated; for workers, the focus is on individual workers and on the total facility workforces. The evaluation includes a comparison with health and safety standards established by DOE, EPA, the Occupational Safety and Health Administration, and where appropriate, NRC.

The increased number of potential fatalities from truck accidents during the intersite transportation of surplus plutonium and other materials among the various DOE sites and proposed facilities is evaluated. The evaluation of environmental justice identifies minority and low-income populations that could be affected by implementation of the various alternatives. Populations at risk within 80 km (50 mi) of DOE sites and within 1.6 km (1 mi) of representative transportation routes were evaluated to determine if disproportionately high and adverse effects on minority or low-income populations would result from implementation of the alternatives.

Cumulative impacts can result from individually minor but collectively significant actions taking place over a period of time. The cumulative impact analysis for the SPD EIS involves combining the impacts of the SPD EIS alternatives (including No Action) with the impacts of other past, present, and reasonably foreseeable activities in an ROI. In general, cumulative impacts are calculated by adding the values for the baseline,³⁶ the proposed action, and other reasonably foreseeable future actions. This cumulative value is then weighed against the appropriate impact indicators to determine the potential for impact. For this cumulative impact assessment, it is conservatively assumed that all facilities would operate concurrently at the DOE sites.

Impacts in all resource areas are analyzed consistently. The impact values are estimated using a consistent set of input variables and computations. Moreover, efforts were made to ensure that calculations in all areas use accepted protocols and up-to-date models, as well as the most recent information available. Finally, like presentations were developed to facilitate the comparison of alternatives.

S.7 SUMMARY OF IMPACTS OF CONSTRUCTION AND OPERATION OF SURPLUS PLUTONIUM DISPOSITION FACILITIES

³⁶ The conditions attributable to actions, past and present, by DOE and other public and private entities.

This section summarizes the potential impacts associated with the activities necessary to implement DOE's disposition strategy for surplus plutonium. The summary addresses the environmental information to be considered for each of the decisions contemplated as part of this strategy. A detailed comparison table is provided in Chapter 2 of the SPD EIS that summarizes impacts on key environmental resource areas related to the surplus plutonium disposition facilities and provides that information by alternative, and within each alternative, by site. That comparison of impacts is summarized here. Key resource areas analyzed include air quality, waste management, employment, land disturbance, human health risk, facility accidents, and transportation. Summarized impacts are presented in this section for the No Action Alternative as well as for each of the 15 alternatives that encompass the range of reasonable alternatives for both the 50-t (55-ton) immobilization and the hybrid approaches to plutonium disposition. This section also compares the potential impacts related to implementation of lead assembly fabrication at five candidate sites and postirradiation examination at two candidate sites. To provide an overview of the impacts associated with full implementation of the MOX fuel approach to disposition, this section presents an integrated assessment of the potential impacts of the MOX facility, lead assembly fabrication, postirradiation examination, and use of the MOX fuel at the Catawba, McGuire, and North Anna reactor sites. To facilitate the evaluation of proposed immobilization technologies, this section compares the impacts associated with the can-in-canister immobilization technology with the homogenous technologies described in the *Storage and Disposition PEIS* for the ceramic immobilization and vitrification alternatives.

Summary of Impacts by Alternative and Site

Impacts on air quality are expected to be low for all alternatives. In all cases, the incremental concentrations from surplus plutonium disposition operations would contribute less than 2 percent of the applicable regulatory standard. Total site air concentrations, which also factor in the amount associated with the No Action Alternative,³⁷ would be no more than 21 percent of the applicable annual regulatory standard, with the highest occurring in the alternatives that would have the immobilization facility located at SRS. That particular value represents projected sulfur dioxide concentrations as a percent of the annual NAAQS; the corresponding value for the No Action Alternative is also 21 percent, demonstrating that the increment associated with plutonium disposition facilities would be very small.³⁸

Expected waste generation is estimated for transuranic (TRU) waste, LLW, mixed LLW, hazardous waste, and nonhazardous waste³⁹ from construction activities and 10 years of expected facility operation. As shown in Chapter 4 of the SPD EIS, impacts associated with management of nonhazardous wastes would be minor and would not tend to be a discriminator among alternatives.

Total TRU waste generation for the construction period and 10 years of operation would range from 1,400 m³ (1,832 yd³) to 1,810 m³ (2,368 yd³), and total LLW generation would range from 1,700 m³ (2,224 yd³) to 2,400 m³ (3,140 yd³). The largest amounts of TRU waste and LLW would be generated by the hybrid alternatives. Total mixed LLW generation would range from 20 m³ (26 yd³) for immobilizing all 50 t (55 tons) (Alternatives 11A, 11B, 12A, and 12B) to 50 m³ (65 yd³) for each of the hybrid alternatives. Hazardous waste generation would range from 770 m³ (1,007 yd³) (Alternatives 11A and 11B) to 940 m³ (1,230 yd³) (Alternatives 3, 5, 6A, 6B, 7, and 9).

³⁷ As indicated in Appendix G, the No Action Alternative projects air emissions to the year 2005, when plutonium disposition facility operations under the disposition alternatives would begin, and includes emissions from existing and other planned facilities.

³⁸ This conclusion assumes that activity levels under the No Action Alternative remain the same beyond 2005.

³⁹ Waste type definitions are provided in Appendix F.8 of the SPD EIS.

Impacts on the waste management infrastructure from implementing alternatives for surplus plutonium disposition are expected to be minor. All of the waste expected to be generated from the different alternatives analyzed could be accommodated within existing or planned capacities for waste treatment, storage, and disposal at all of the candidate sites, except for TRU waste at Pantex. At Pantex, a maximum of 860 m³ (1,125 yd³) of TRU waste would be generated under Alternatives 9 or 10. Because TRU waste is not routinely generated and stored at Pantex, TRU waste storage space would be designated within the pit conversion and MOX facilities. TRU waste would be shipped to the Waste Isolation Pilot Plant (WIPP) near Carlsbad, New Mexico, for disposal.

Although the surplus plutonium disposition facilities are still in the early stages of engineering and design, the program would integrate pollution prevention practices that include waste stream minimization, source reduction and recycling, and DOE procurement processes that preferentially procure products made from recycled materials. The surplus plutonium disposition facility designs would minimize the size of radiologically controlled areas, thereby minimizing the generation of radioactive waste. To the extent practical, the DOE facilities would not use solvents or other chemicals that, after use, are regulated by the Resource Conservation and Recovery Act (RCRA), thereby minimizing the amount of hazardous and mixed waste generated. Wastewater would be recycled to the extent possible to minimize effluent discharge.

The number of direct jobs generated by the proposed facilities under each alternative is estimated. All of the action alternatives would generate employment opportunities at the facilities. Expected annual peak construction employment ranges from 463 workers (Alternative 11A) to 2,143 workers (Alternative 5).⁴⁰ Annual employment during operations would range from 751 (Alternatives 12A and 12B) to 1,165 workers (Alternatives 2 and 4B).

Potential effects on human health from facility construction, 10 years of operation, postulated facility accidents, and intersite transportation of radioactive materials are analyzed. Doses to workers from 10 years of routine operation of the three surplus plutonium disposition facilities at DOE sites would result in up to 2.0 latent cancer fatalities (LCFs) for both the hybrid alternatives and the 50-t (55-ton) immobilization alternatives. No LCFs would be expected to occur in the general population during routine operations. Under the No Action Alternative, continued storage of the surplus plutonium also would not be expected to result in any LCFs to the general population during routine operations. Doses to workers from the long-term storage (up to 50 years) of the surplus plutonium would result in up to 2.4 LCFs.

Latent Cancer Fatalities (LCFs)

Fatalities associated with acute and chronic environmental exposures to chemicals or radiation that occur as a result of operational processes specified within the SPD EIS.

The most severe nonreactor design basis accident scenario is also analyzed. For Alternative 4B, a criticality in the MOX facility would result in the most severe consequences. For all other alternatives except the No Action Alternative, a design basis fire in the pit conversion facility resulting in a tritium release would result in the most severe consequences. However, no design basis accident would be expected to result in LCFs in the general population. Under all of the alternatives analyzed in the SPD EIS, the most severe design basis accident would pose a small risk to the public. The risk would also be small for minority and low-income groups within the general population. Thus, implementation of the alternatives for disposition of surplus plutonium disposition would not be expected to pose disproportionately high and adverse risks to minority and low-income populations due to design basis accidents.

⁴⁰ Represents the combined peak annual construction workforces at each site. Peak construction employment under Alternative 11A is composed of the 463 construction workers at Hanford in 2003. Peak construction employment under Alternative 5 is composed of the 451 construction workers at Pantex in 2002 and the 1,692 construction workers at SRS in 2003.

No major consequences for the maximally exposed involved worker would be expected from leaks, spills, and smaller fires. These accidents are such that involved workers would either be able to evacuate immediately or would not be affected by the events. Explosions, on the other hand, could result in immediate injuries from flying debris, as well as the uptake of plutonium and uranium particulates through inhalation. If a criticality were to occur, workers within tens of meters could receive very high to fatal radiation exposures from the initial burst. The dose would strongly depend on the magnitude of the criticality (number of fissions), the distance from the criticality, and the amount of shielding provided by the structures and equipment between the workers and the criticality. Beyond-design-basis earthquakes would also have substantial consequences, ranging from workers being killed by debris from collapsing equipment and structures to high radiation exposures and uptakes of radionuclides. For most accidents, immediate emergency response actions should reduce the consequences to workers near the accident.

Materials transportation is analyzed to determine potential radiological and nonradiological impacts from routine and accident conditions. Transportation includes the movement of surplus plutonium from storage and among the proposed disposition facilities; depleted uranium hexafluoride from, for example, Portsmouth to a conversion facility; uranium dioxide from the conversion facility to the immobilization and MOX facilities; recovered HEU from the pit conversion facility to ORR; MOX fuel to the Catawba, McGuire, and North Anna reactors; spent nuclear fuel resulting from lead assembly irradiation at McGuire to the postirradiation examination site and then to storage at INEEL; and the immobilized plutonium to a potential geologic repository.⁴¹ No traffic fatalities from nonradiological accidents or LCFs from radiological exposures or vehicle emissions would be expected. For the hybrid alternatives, the number of trips would range from 1,917 (Alternative 10) to 2,530 (Alternatives 3, 6A, 6B, and 7), and the cumulative distances traveled would range from 3.6 million km (2.2 million mi) (Alternative 10) to 8.7 million km (5.4 million mi) (Alternatives 6A and 6B). Immobilization-only alternatives would require from 1,877 trips for Alternative 11B to 2,236 trips for Alternative 12B. Cumulative distances traveled for immobilization-only alternatives would range from 2.5 million km (1.5 million mi) (Alternative 11B) to 4.4 million km (2.7 million mi) (Alternative 12A).

Land disturbance relates to impacts on ecological resources, cultural resources, geology and soils, and land use and visual resources. The amount of land that would be disturbed for the hybrid alternatives would range from 19 hectares (47 acres) in Alternative 8, to 32 hectares (79 acres) in Alternatives 3, 5, and 9. Because these land areas are in or adjacent to previously disturbed areas and represent a very small percent of the land available at the candidate sites, the impacts on geology and soil and land use would be minor. Land disturbance associated with immobilizing 50 t (55 tons) of surplus plutonium would range from 9.5 hectares (23 acres) in Alternative 11B to 20 hectares (49 acres) in Alternative 12A or 12B. Construction and operation of the proposed facilities would not effect a significant change in any natural features of visual interest in the area of any of the candidate sites. No major impact is anticipated for any threatened or endangered species because there have been no sightings near the proposed facility locations at the candidate sites. Cultural resource impacts would be minor at all sites except SRS because at all sites except SRS, construction of facilities would be in mostly disturbed or developed areas; at SRS, cultural resource areas would be avoided. Archaeological investigations near F-Area have discovered five sites that could be impacted by construction of surplus plutonium disposition facilities. Two of these sites have been recommended to the South Carolina State Historic Preservation Officer (SCSHPO) as eligible for nomination to the National Register of Historic Places. Potential adverse impacts could be mitigated through either avoidance or data recovery. DOE currently plans to mitigate impacts by avoiding sites that are eligible or potentially eligible for nomination to the National Register of Historic Places. Cultural resource compliance activities would be conducted in accordance with the *Programmatic Memorandum of Agreement for the Savannah River Site* (SRARP 1989:179–188).

⁴¹ Shipments of spent fuel to a potential geologic repository are analyzed in the *Draft Environmental Impact Statement for a Geologic Repository for the Disposal of Spent Nuclear Fuel and High-Level Radioactive Waste at Yucca Mountain, Nye County, Nevada* (DOE/EIS-0250D) (DOE 1999c).

Impacts were also assessed on water availability and quality, and infrastructure including requirements for roads, electricity, and fuel. These evaluations indicated that all impacts would be minor. [Text deleted.] None of the alternatives were found to pose a significant risk (when probability is considered) to the general population, nor would implementation of any of the alternatives result in a significant risk of disproportionately high and adverse impacts to minority or low-income groups within the general population.

Summary of Lead Assembly Fabrication and Postirradiation Examination Impacts

The impacts on key resources from fabrication of lead assemblies at the five candidate sites (ANL–W, Hanford, LLNL, LANL, and SRS) and from postirradiation examination at ANL–W or ORNL, are presented in Chapter 4 of the SPD EIS and summarized here. These areas include waste management, human health risk during normal operations, facility accidents, and transportation.

Impacts from lead assembly and postirradiation examination activities are based on the fabrication of 10 assemblies, although it is likely that only 2 would be needed. If less than 10 lead assemblies were fabricated, the impacts would be lower than those presented in the SPD EIS. Impacts from facility modifications would not be expected to change because the facility modifications would be the same regardless of the number of assemblies produced. Impacts from routine operations, such as resources used, personnel exposure, waste generation, and transportation, would be expected to be reduced in proportion to the number of assemblies produced. The consequences of facility and transportation accidents would be expected to remain the same because the material at risk at any one time would likely not change. However, the risk of these accidents occurring would be reduced as the number of lead assemblies decreased. Because facility modification activities would occur inside existing buildings (i.e., no new buildings would be constructed and no additional land would be disturbed), there should be little increase in air pollutants; land disturbances would be minimal; and the number of construction workers would be low. Little or no impacts are expected on any other resource areas.

There are no appreciable differences in environmental impacts among the five lead assembly candidate sites. There would be little difference in the volume of waste generated at any of the sites. The small differences in TRU waste and LLW would be due to wastes generated during modification of contaminated areas of existing buildings at ANL–W and LANL. No LCFs for either workers or the general population would be expected to result from fabrication of lead assemblies at any of the proposed locations during routine operations. The average annual dose to facility workers would be 500 mrem, for an annual dose to the total facility workforce of 28 person-rem. Impacts on involved workers from facility accidents would be expected to be the same as those described previously for the disposition facilities. No LCFs would be expected in the general population at any site from the postulated bounding design basis accident.

The impacts of postirradiation examination at ANL–W and ORNL, as evaluated in Chapter 4, would be minimal. No construction waste would be generated. With the exception of nonhazardous wastewater at ANL–W, all categories of waste generated during routine operations would use less than 1 percent of either site's applicable treatment, storage, and disposal capacity. Nonhazardous wastewater at ANL–W would use about 6 percent of that site's applicable capacity. No LCFs would be expected to either workers or the public from routine postirradiation examination activities. There would be no routine releases of radioactivity to the environment, and thus no radiological impacts on the public. The average annual dose to facility workers would be 177 mrem, for an annual dose to the total facility workforce of 1.8 person-rem. The most severe accident would be a nuclear criticality. Such an accident could result in high, though probably not fatal, radiological exposures to hot cell workers. No LCFs would be expected in the general population.

The transportation analysis includes the shipment of plutonium dioxide from LANL to the candidate site; depleted uranium hexafluoride from Portsmouth to the representative conversion facility; uranium dioxide from the conversion facility to the lead assembly fabrication facility; MOX fuel rods from the lead assembly facility

to the McGuire reactor for irradiation; and irradiated fuel rods from McGuire to a postirradiation examination facility. Comparison of lead assembly transportation impacts shows little differences among the sites, with no expected traffic fatalities or LCFs. Likewise, there are not expected to be any appreciable differences between the two postirradiation examination sites. Transportation impacts for postirradiation examination at ANL–W are included in lead assembly impacts presented in Chapter 4. Transportation impacts for postirradiation examination at ORNL would be lower than those included for ANL–W because the distance traveled would be less.

If DOE were to decide to immobilize all 50 t (55 tons) of surplus plutonium, no lead assembly activities would be required. If DOE decided to pursue the MOX option, but not fabricate lead assemblies, such activities would not occur at any of the five sites or at the postirradiation examination locations. Under both of these scenarios, current operations would continue at each site and the environmental conditions would remain at baseline levels. Chapter 3 of the SPD EIS provides a description of the current environmental conditions of the sites.

Summary of MOX Fuel Integrated Impacts

The impacts from implementing the MOX fuel fabrication alternatives would not be limited to those associated with the MOX facility, but would also include impacts from lead assembly fabrication, irradiation, and postirradiation examination; and the use of reactors for irradiation of the MOX fuel assemblies. Any new construction would occur at existing DOE sites. MOX-related operations at all sites would be compatible with, or similar to, activities already occurring at those locations.

Section 2.18.3 of the SPD EIS describes the potential impacts of implementation of the MOX alternatives, from fabrication of the MOX fuel assemblies and lead assemblies to irradiation of the assemblies in domestic, commercial nuclear power reactors, and the transportation for all radioactive material movements. While these impacts would be cumulative over the life of the campaign, they would not be concurrent.

Air emissions would result primarily from building heating and vehicular emissions. Releases of criteria pollutants are provided as a range with the lowest emissions at Hanford, where electricity is the method of heating, and the highest at INEEL, where coal-fired boilers produce steam for heating and travel distances for personnel result in vehicular emissions double those estimated for other candidate sites. There are no nonradiological emissions from these facilities that are regulated under NESHAPs. A discussion of radiological emissions relative to NESHAPs may be found in the health effects discussion. Lead assembly fabrication and postirradiation examination activities are relatively small efforts that are not expected to measurably increase air emissions at any of the candidate sites. There would be no incremental difference in the air emissions from Catawba, McGuire, or North Anna related to using MOX fuel. Criteria, toxic, and hazardous pollutant emissions are not related to the type of reactor fuel. Rather, emission of these pollutants from the reactor sites would be related to ancillary processes such as operation of diesel generators, periodic testing of emergency diesel generators, and facility operations.

TRU waste and LLW would be generated during operation of both the lead assembly and full-scale MOX facilities. The amount of waste generated would be process-specific, and would not vary appreciably by site. Lead assembly fabrication is expected to generate a total of 132 m³ (173 yd³) of TRU waste and about 700 m³ (916 yd³) of LLW over a 3-year period. The larger amount of waste generated on an annual basis by lead assembly fabrication, as compared to full-scale fabrication, would be attributed to operational differences between fabricating MOX fuel on a laboratory rather than commercial scale. Similarly, activities such as material recycle may not be implemented to as great an extent on the smaller scale. No increase is expected in the amount of waste generated at the reactor sites as a result of using MOX fuel.

More spent fuel could be generated at the reactor sites as a result of the disposition of surplus plutonium as MOX fuel. It is expected that approximately 5 percent additional spent fuel would be generated as a result of MOX fuel irradiation at the reactor sites. Even so, there would be sufficient space at the reactor sites (in either the spent fuel pools or dry storage) to store the additional spent fuel until it could be sent to a potential geologic repository pursuant to the NWPA. DOE's environmental impact statement for a potential geologic repository (DOE/EIS-0250D, July 1999) includes the MOX fuel that would be generated from this program.

Existing infrastructure would be adequate to support the MOX fuel alternatives, although it has been estimated that 2 km (0.62 mi) of new roads would be needed for the MOX facility. Consumption of coal, natural gas, and electricity vary greatly from site to site, for both the MOX and the lead assembly fabrication facilities, depending on the type of fuel used for heating. For example, electricity needed for MOX fuel fabrication would be 30,000 megawatt hours per year (MWh/yr) at all sites but Hanford. Hanford, which is estimated to use one and one-half times the electricity of the other sites (46,000 MWh/yr), uses electricity to heat its buildings. INEEL and SRS use coal for heating and Pantex uses natural gas. No additional infrastructure needs would result from the use of MOX fuel at the proposed reactors.

The impacts on workers at the MOX facility are based on operating experience at existing MOX facilities in Europe (DOE 1999d). Impacts on workers at the postirradiation facility are based on operating experience at ORNL. The impacts at the lead assembly fabrication facilities are based on an average annual dose rate of 500 mrem/yr. This is an administrative limit that has been set in accordance with ALARA principles. This exposure over the life of the MOX campaign (10 years for the MOX facility, 3 years for lead assembly fabrication, and 3 years for postirradiation examination) would result in an increased risk of fatal cancer of 2.6×10^{-4} at the MOX facility, 6×10^{-4} at the lead assembly site, and 2.2×10^{-4} at the postirradiation examination facility. The corresponding number of LCFs for MOX facility, lead assembly, and postirradiation examination workers from the MOX campaign would be 0.088, 0.033, and 0.002, respectively. No increase in the incremental dose to workers is expected at the proposed reactors from using MOX fuel during routine operations. [Text deleted.]

The potential radiological impacts on the public from routine operations would be very small. Annual doses from the MOX facility to the maximally exposed individual (MEI) range from 1.8×10^{-3} to 1.5×10^{-2} mrem/yr, which translates to an increased risk of fatal cancer of 9.0×10^{-9} to 7.5×10^{-8} for 10 years of exposure. The lowest dose would be received at Hanford; the highest, Pantex. However, the population around Pantex would receive the lowest total population dose, and the lowest annual dose to the average individual. Estimated results at Hanford would be at the high end of the range for both of these parameters, 2.9×10^{-1} person-rem/yr and 7.5×10^{-4} mrem/yr, respectively. The annual dose to the average individual would still be extremely small, and would result in only a 3.8×10^{-9} increased risk of fatal cancer for 10 years of exposure. Offsite dose to the MEI resulting from lead assembly fabrication ranges from a low at SRS of 5.5×10^{-5} to 6.4×10^{-2} mrem/yr at LLNL. The associated risk of fatal cancer would be extremely low for the same MEI, ranging from 8.3×10^{-11} to 9.6×10^{-8} . Annual doses to the average individual at SRS and LLNL would be 8.8×10^{-6} and 1.4×10^{-4} mrem, respectively; risks of LCFs to the same individuals would be 1.3×10^{-11} and 2.1×10^{-10} . Routine

Understanding Scientific Notation

Scientific notation is used in the SPD EIS to express numbers that are so large or so small that they can be difficult to read or write. Scientific notation is based on the use of positive and negative powers (or exponents) of 10. A number written in scientific notation is expressed as the product of a number between 1 and 10 times a positive or negative power of 10. Some positive and negative powers of 10 include:

Positive Powers of 10

$10^1 = 10 \times 1 = 10$
 $10^2 = 10 \times 10 = 100$
 and so on; therefore,
 $10^6 = 1,000,000$ (or
 1 million), etc.

Negative Powers of 10

$10^{-1} = 1/10 = 0.1$
 $10^{-2} = 1/100 = 0.01$
 and so on; therefore,
 $10^{-6} = 0.000001$ (or 1 in
 1 million), etc.

operations under all of the MOX fuel alternatives would pose no significant radiological risk to the public. Nor would routine operations pose a significant risk to groups within the general population, including minority and low-income populations. No change would be expected in the radiation dose to the general population from normal operations associated with the disposition of MOX fuel at the proposed reactors. Offsite dose to the MEI resulting from postirradiation examination would not be expected to change because the activities would not be additive but would displace similar activities already being done in these facilities.

Transportation impacts analyzed include radiological dose to the truck crew and the general population, nonradiological emissions from vehicle operation, potential traffic accident fatalities, and LCFs resulting from an accident involving a breach of containment and release of radioactive materials. Shipments analyzed include all those listed in Table S-4 for the MOX, lead assembly and postirradiation examination facilities, and shipments of fresh MOX fuel to the proposed reactor sites. The analysis shows that no traffic fatalities or LCFs would be expected from routine transportation activities or transportation accidents.

Accidents are unplanned events that would be different for each type of facility needed to implement the MOX approach. The accidents analyzed for the disposition facilities are presented in detail in Appendix K of the SPD EIS, and the consequences summarized by alternative in Chapter 4 of the SPD EIS. The design basis accident with the most severe consequences postulated for the MOX facility is a criticality. This accident would result in an estimated dose at a distance of 1 km (0.62 mi) from the facility of 0.15 rem at Hanford to 0.75 rem at INEEL. This same accident would result in doses at the site boundaries ranging from 1.6×10^{-2} rem at INEEL and SRS to 4.7×10^{-2} rem at Pantex. Population doses and LCFs within 80 km (50 mi) would range from 1.0 person-rem and 5.2×10^{-4} LCF at INEEL to 55 person-rem and 2.8×10^{-2} LCF at Hanford. The frequency of such an accident is estimated to be between 1 in 10,000 and 1 in 1,000,000 per year.

The design basis accident with the most severe consequences postulated for the proposed reactors using MOX fuel is a loss-of-coolant accident. This accident, based on the use of MOX fuel, would result in an increase in the estimated dose at a distance of 640 m (2,100 ft) from the reactor of 0.001 rem at North Anna to 0.15 rem at McGuire. The same accident would result in incremental increases in doses at the site boundaries ranging from 2.0×10^{-4} rem at North Anna to 6.0×10^{-2} rem at McGuire. The incremental change in population doses and LCFs within 80 km (50 mi) of the reactors would range from 0.9 person-rem and 5×10^{-4} LCF at North Anna to 110 person-rem and 0.06 LCF at Catawba. The frequency of such an accident is estimated to be between 1 in 48,000 and 1 in 130,000 per year.

The postulated design basis accident with the most severe consequences for proposed lead assembly operations using MOX fuel would be associated with a nuclear criticality. The accident would result in an incremental increase in estimated dose at the site boundaries ranging from 9.3×10^{-4} rem at SRS to 5.3×10^{-1} rem at LLNL. The same accident would result in incremental changes in population doses and LCF probabilities within 80 km (50 mi) ranging from 3.4×10^{-1} person-rem and 1.6×10^{-4} LCF at ANL-W to 6.6 person-rem and 3.2×10^{-3} LCF at LANL, respectively. The frequency of such an accident is estimated to be between 1 in 10,000 and 1 in 1,000,000 per year. A nuclear criticality would also be the most severe accident at the postirradiation examination facilities, but the amount of spent fuel necessary for such an accident to be physically possible is at least one to two orders of magnitude greater than would normally be available. Under all of the MOX fuel alternatives, the most severe design basis accident would pose no significant radiological risk to the public. Implementation of any of the MOX fuel alternatives would not pose disproportionately high and adverse risks to any group within the general population, including minority and low-income groups.

The SPD EIS also evaluates the potential impacts from a set of postulated highly unlikely accidents with potentially severe consequences at the proposed reactors using both uranium-only and MOX cores. Regarding effects of MOX fuel on accident probabilities, the National Academy of Sciences (NAS) report, *Management and Disposition of Excess Weapons Plutonium Reactor-Related Options*, states, “. . . no important overall

adverse impact of MOX use on the accident probabilities of the light water reactors (LWRs) involved will occur; if there are adequate reactivity and thermal margins in the fuel, as licensing review should ensure, the main remaining determinants of accident probabilities will involve factors not related to fuel composition and hence unaffected by the use of MOX rather than LEU fuel” (NAS 1995:352). Regarding the effects of MOX fuel on accident consequences, the report states, “. . . it seems unlikely that the switch from uranium-based fuel could worsen the consequences of a postulated (and very improbable) severe accident in a LWR by no more than 10 to 20 percent. The influence on the consequences of less severe accidents, which probably dominate the spectrum value of population exposure per reactor-year of operation would be even smaller, because less severe accidents are unlikely to mobilize any significant quantity of plutonium at all” (NAS 1995:355).

The incremental effects of using MOX fuel in the proposed reactors in place of LEU fuel were derived from a quantitative analysis of several highly unlikely severe accident scenarios for MOX and LEU fuel. The analysis considers severe accidents where sufficient damage could occur to cause the release of plutonium or uranium through a breach of the plant’s containment. The consequences of these accident releases on the general population were found to range from minus 4 to plus 14 percent,⁴² compared to LEU fuel, depending on the accident release scenario. This analysis is based on existing probabilistic risk assessments of severe accidents, and the release scenarios were modeled assuming projected population distributions near the proposed reactors in 2015.

The highest consequence accident at all three of the proposed reactors is an interfacing systems loss-of-coolant accident. However, there is an extremely small chance that this beyond-design-basis accident would ever occur. The likelihood of this accident occurring is 1 chance in 15 million at Catawba, 1 chance in 1.6 million at McGuire, and 1 chance in 4.2 million at North Anna. Were this accident to occur, the increase in the estimated dose at the site boundary for MOX fuel as compared with LEU fuel would be 2,000 rem at Catawba, 2,400 rem at McGuire, and 2,200 rem at North Anna. These increases are 14 percent, 12 percent, and 22 percent, respectively, above the doses expected from the same accident using LEU fuel. The incremental changes in population doses and LCFs within 80 km (50 mi) of the reactors have been estimated to be 3.2×10^6 person-rem and 1,300 LCFs (15,600 to 16,900) at Catawba, 1.8×10^6 person-rem and 800 LCFs (11,900 to 12,700) at McGuire, and 7.3×10^5 person-rem and 410 LCFs (2,980 to 3,390) at North Anna. Prompt fatalities from this accident would be expected to increase from 815 to 843 at Catawba, 398 to 421 at McGuire, and from 54 to 60 at North Anna. The increase in risk to the population from this accident as a result of using MOX fuel would be 1.4×10^{-3} at Catawba, 8.0×10^{-3} at McGuire, and 1.6×10^{-3} at North Anna over the estimated 16-year life of the MOX fuel irradiation program.

[Text deleted.]

Comparison of Immobilization Technology Impacts

In order to provide a basis for evaluating alternative immobilization forms and technologies, the environmental impacts associated with operating the ceramic and glass can-in-canister immobilization facilities evaluated in the SPD EIS are compared with the corresponding environmental impacts associated with operating the homogenous ceramic immobilization and vitrification facilities evaluated in the *Storage and Disposition PEIS*.

Chapter 4 of the SPD EIS presents the comparable impacts for key environmental resources (e.g., air quality, waste management, human health risk, and resource requirements) at Hanford and SRS for the homogenous

⁴² Accidents severe enough to cause a release of plutonium involve combinations of events that are highly unlikely. Estimates and analyses presented in the SPD EIS indicate an incremental range of postulated LCFs due to the use of MOX fuel of minus 7 to plus 1,600 (in the population within 80 km [50 mi] of the release point), with incremental attendant risks of LCFs over 16 years of reactor operation with MOX fuel of minus 1.3×10^{-3} and plus 1.7×10^{-3} , respectively.

ceramic immobilization/vitrification and the can-in-canister immobilization facilities. Impacts associated with facility accidents, intersite transportation, and environmental justice are also discussed.

The comparison of impacts is based upon immobilizing the full 50 t (55 tons) of surplus plutonium. The *Storage and Disposition PEIS* impact analyses are based on operating facilities that would convert the plutonium into an oxide in one new facility and immobilize it in a homogenous ceramic or glass form in another new facility. Impacts for a plutonium conversion facility are evaluated and itemized separately from the impacts for a ceramic immobilization or vitrification facility. In contrast, the SPD EIS considers the use of both new and existing facilities, and is based upon evaluating a collocated plutonium conversion and immobilization capability. To compare the impacts, it was therefore necessary to combine the separate *Storage and Disposition PEIS* impact values, as appropriate, to establish a suitable standard of comparison.

Generally, air quality impacts associated with the ceramic or glass can-in-canister technologies would be lower or about the same as those evaluated in the *Storage and Disposition PEIS* for ceramic immobilization or vitrification. With the exception of sulfur dioxide in the ceramic can-in-canister process, all criteria pollutant concentrations associated with either can-in-canister technology would range from being the same to being much lower. Pollutant levels would not be expected to differ between the ceramic and glass can-in-canister processes.

Potential volumes of most waste types resulting from operation of either the ceramic or glass can-in-canister technologies would be considerably less than the waste volumes expected from either ceramic immobilization or vitrification technology evaluated in the *Storage and Disposition PEIS*. For example, operation of a can-in-canister facility using the ceramic process at Hanford or SRS is estimated to result in TRU waste volumes of 126 m³/yr (165 yd³/yr), compared to the 647 m³/yr (846 yd³/yr) of TRU waste estimated in the *Storage and Disposition PEIS* from operation of the homogenous ceramic immobilization facility. Factors contributing to the reduced waste levels associated with the can-in-canister technology would include the use of dry-feed preparation techniques, coordination with existing HLW vitrification operations and the need for a smaller operating work force. Waste volumes would not be expected to differ appreciably between the ceramic and glass can-in-canister processes.

Chapter 4 of the SPD EIS also presents the potential radiological exposure and cancer risk to the public and involved workers from normal operation of the immobilization facilities. The potential risks to the public associated with either can-in-canister technology would be slightly higher than the homogenous technologies at Hanford, but lower at SRS. For example, operation of a can-in-canister facility using the ceramic process at Hanford or SRS is estimated to result in population doses of 1.6×10^{-2} or 5.8×10^{-3} person-rem/yr, respectively, compared to the population doses of 8.4×10^{-3} (at Hanford) or 6.6×10^{-2} (at SRS) person-rem/yr resulting from operation of the homogenous ceramic immobilization facility evaluated in the *Storage and Disposition PEIS*. These variations may be attributable to the incorporation of updated source terms, meteorology, population distribution, and other modeling variables in the analysis of the can-in-canister technologies. A comparison between the ceramic and glass can-in-canister technologies indicates operation of the ceramic process would result in slightly higher potential offsite impacts, regardless of whether it is located at Hanford or SRS. For example, the dose associated with operation of the can-in-canister facility at Hanford would result in a population dose of 1.6×10^{-2} person-rem/yr using the ceramic process and 1.5×10^{-2} person-rem/yr using the glass process; the same facility at SRS would result in a population dose of 5.8×10^{-3} person-rem/yr using the ceramic process, and a dose of 5.3×10^{-3} person-rem/yr using the glass process.

The estimated average worker dose and associated cancer risk for the can-in-canister technologies are slightly higher than estimated in the *Storage and Disposition PEIS* for the homogenous technologies. In all cases, however, the average worker dose would be within the DOE design objective of 1,000 mrem/yr. [Text deleted.] Potential radiological impacts on involved workers are not expected to differ appreciably between the ceramic and glass can-in-canister processes.

Although some potential hazardous chemical impacts were determined for the homogenous ceramic immobilization/vitrification technologies evaluated in the *Storage and Disposition PEIS*, none are expected for either the ceramic or glass can-in-canister technology because no hazardous chemical emissions would occur from operations.

Because of substantial differences between the *Storage and Disposition PEIS* and the SPD EIS in terms of the specific accident scenarios and supporting assumptions used in the determination of facility accident impacts, a standard basis for comparing between homogenous technology and can-in-canister technology accidents is not available. For example, a design basis earthquake scenario was not evaluated in the *Storage and Disposition PEIS* for the plutonium conversion facility, nor were any other design basis accidents evaluated for that facility that could be incorporated with like impacts to the ceramic immobilization or vitrification facility for direct comparison to the accident scenarios presented in the SPD EIS. A design basis earthquake associated with the homogenous approach at Hanford would result in 5.8×10^{-8} and 3.2×10^{-6} LCF in the general population for ceramic immobilization and vitrification, respectively; a design basis earthquake affecting the same facilities at SRS would result in 6.2×10^{-8} and 3.4×10^{-6} LCF, respectively. As discussed above, these values do not reflect the impact of such accidents on a plutonium conversion facility, and are therefore not directly comparable with the results for the can-in-canister approach shown in the SPD EIS. Comparison between the ceramic and glass can-in-canister processes indicates slightly higher impacts would be associated with the ceramic process. For example, a design basis earthquake at Hanford would result in 9.6×10^{-5} LCF in the general population using the ceramic process, and 8.4×10^{-5} LCF using the glass process. Similarly, a design basis earthquake at SRS would result in 3.6×10^{-5} LCF in the general population using a ceramic process, and 3.1×10^{-5} LCF using a glass process.

In terms of resource requirements, operation of the can-in-canister technologies would require lower amounts of electricity, fuel, land area, and water than would the homogenous technologies evaluated in the *Storage and Disposition PEIS*. Fewer workers would be required to operate the can-in-canister technologies, which in turn would result in lower socioeconomic impacts. Resource requirements differ between the ceramic and glass can-in-canister processes in that electricity requirements would be greater to support the ceramic process at either site (i.e., the ceramic process would require 29,000 or 24,000 MWh/yr at Hanford or SRS, respectively, compared with the 28,500 or 23,000 MWh/yr, respectively, required for the glass process).

The *Storage and Disposition PEIS* analysis assumes that canisters of plutonium immobilized with radionuclides would be transported to a potential geologic repository via rail. The SPD EIS analyses, however, conservatively assume that the immobilized canisters would be shipped by truck from the immobilization site to the repository, with one canister being transported per truck shipment.⁴³ The ceramic and glass can-in-canister technologies would result in fewer total potential fatalities from intersite transportation than would the homogenous ceramic immobilization/vitrification technologies evaluated in the *Storage and Disposition PEIS*. Because the ceramic can-in-canister process would produce fewer canisters, it would result in somewhat lower routine and accidental transportation impacts than the glass can-in-canister process.

Evaluations of both the homogenous ceramic immobilization/vitrification technologies and can-in-canister technologies included routine facility operations and transportation as well as accidents. No significant risk to the general population would be expected to occur for normal operations or in the event of a design basis accident. [Text deleted.] Similarly, implementation of these technologies would not result in a significant risk of disproportionately high and adverse impacts on minority or low-income groups within the general population.

⁴³ The *Draft Environmental Impact Statement for a Geologic Repository for the Disposal of Spent Nuclear Fuel and High-Level Radioactive Waste at Yucca Mountain, Nye County, Nevada* (DOE/EIS-0250D) (DOE 1999c) analyzes spent fuel shipments to a potential geologic repository by rail and truck. No decision has been made as to the mode of transportation.

S.8 CUMULATIVE IMPACTS

This section summarizes the potential cumulative impacts from operation of the proposed surplus plutonium disposition facilities. A more detailed analysis is provided in Chapter 4 of the SPD EIS. The incremental impacts of the operation of plutonium disposition facilities were added to the impacts of other past, present, and reasonably foreseeable future actions in the vicinity of the candidate sites.

Impacts from the following are considered in the cumulative impacts assessment:

- Current activities at or in the vicinity of the candidate sites
- Construction and operation of the proposed surplus plutonium disposition facilities
- Other site and offsite Federal and non-Federal activities that are reasonably foreseeable

The related programs considered in the cumulative impact assessment and the seven candidate DOE sites potentially affected are identified in Table S-3 (Section 4.32.8 of the SPD Final EIS discusses the reasonably foreseeable activities considered for the three reactor sites, which is summarized at the end of Section S.8). A bounding alternative was analyzed for each site. The bounding alternative is the alternative that involves the greatest amount of plutonium disposition construction and operation activity at the candidate site. For example, the bounding alternative for Hanford is Alternative 2, all facilities located at Hanford.

[Text deleted.]

In addition to reasonably foreseeable site activities, other activities within the region of the candidate sites were considered in the cumulative impact analysis for selected resources. Because of the distances between many of the candidate DOE sites and other existing and planned non-DOE facilities, there is little opportunity for interactions of facility emissions in terms of impacts to air quality, water quality, or waste management capacity. However, whenever possible, large source contributors have been evaluated for those impacts to human health risk and socioeconomics.

Hanford

Under Alternative 2, all three of the proposed disposition facilities would operate in the 400 Area with the pit conversion and immobilization facilities in FMEF, and a new MOX facility located nearby. In addition to the facilities proposed under Alternative 2, Hanford is being considered for lead assembly work.

Hanford would remain within its site capacity for its major resources. If Alternative 2 is implemented, the proposed surplus plutonium disposition facilities would require about 16 percent of the annual electricity used on the site and about 6 percent of the water; cumulatively, this would be about 24 percent of the site's electricity and 39 percent of the site's water capacity. The proposed activities would not be expected to contaminate the Columbia River or add to existing contamination at Hanford. The land used by these facilities would represent less than 1 percent of the developed land on the site; cumulatively, about 6 percent of the land would be used. Impacts on resource requirements were evaluated for the year 2007 (the peak year) because that would be the first full year in which all three surplus plutonium disposition facilities operate

Table S-3. Other Past, Present, and Reasonably Foreseeable Actions Considered in the Cumulative Impact Assessment for Candidate DOE Sites

Activities	Hanford	INEEL	Pantex	SRS	LLNL	LANL	ORNL
Storage and Disposition of Weapons-Usable Fissile Materials	X	X	X	X			X
Disposition of Surplus Highly Enriched Uranium				X			X
Interim Management of Nuclear Materials at SRS				X			

Activities	Hanford	INEEL	Pantex	SRS	LLNL	LANL	ORNL
[Text deleted.]							
Tritium Supply and Recycling				X			
Waste Management	X	X	X	X		X	
Spent Nuclear Fuel Management and INEL Environmental Restoration and Waste Management	X	X		X			
Foreign Research Reactor Spent Nuclear Fuel	X	X		X			
Tank Waste Remediation System	X						
Shutdown of the River Water System at SRS				X			
Radioactive releases from nuclear power plant sites, Vogtle and WNP ^a	X			X			
Hanford Reach of the Columbia River Comprehensive River Conservation Study	X						
FEIS and Environmental Information Report for Continued Operation of LLNL and SNL					X		
Continued Operation of the Pantex Plant and Associated Storage of Nuclear Weapons Components			X				
Stockpile Stewardship and Management			X	X	X		X
[Text deleted.]							
Management of Plutonium Residues and Scrub Alloy at Rocky Flats				X			
Spent Nuclear Fuel Management (SRS)				X			
DWPF Final Supplemental				X			
Supplemental EIS for In-Tank Precipitation Process Alternatives				X			
Construction and Operation of a Tritium Extraction Facility at SRS				X			
Supplement Analysis for Storing Plutonium in the Actinide Packaging and Storage Facility and Building 105-K at SRS				X			
Los Alamos Site-Wide EIS						X	
Hanford Remedial Action and Comprehensive Land Use Plan	X						
Advanced Mixed Waste Treatment Project		X					
Construction and Operation of the Spallation Neutron Source							X
Long-Term Management and Use of Depleted Uranium Hexafluoride							X

^a NRC, 1996, *Dose Commitments Due to Radioactive Releases from Nuclear Power Plant Sites in 1992*.

Key: DWPF, Defense Waste Processing Facility; LANL, Los Alamos National Laboratory; LLNL, Lawrence Livermore National Laboratory; ORNL, Oak Ridge National Laboratory; SNL, Sandia National Laboratories; WNP, Washington Nuclear Power.

simultaneously, resulting in maximum impacts. While Hanford is also being considered for lead assembly work, lead assembly fabrication operations would be completed by 2006 and, therefore, would not contribute to the maximum impacts for the peak year (2007).

Over the life of the proposed activities, the number of LCFs in the general population from 15 years of Hanford operation would be expected to increase from 0.21 to 0.25 if all the proposed surplus plutonium disposition facilities were located there, including the addition of lead assembly work. Doses to the MEI are based on source location; summing the MEIs for each reasonably foreseeable and current activity would be both misleading and technically incorrect because the hypothetical MEI cannot be in a number of different locations simultaneously. However, to provide some comparative perspective, the hypothetical MEI for all reasonably foreseeable actions would receive an annual dose of 1.9 mrem from other site operations. This corresponds to an LCF risk from 15 years of site operation of 1.4×10^{-5} . The MEI would receive an additional 0.022 mrem/yr for a cumulative annual dose of 1.9 mrem from all activities and a corresponding risk of an LCF of 1.5×10^{-5} from 15 years of operation. The regulatory dose limits for individual members of the public are given in DOE orders and EPA and NRC regulations. The dose limit from airborne emissions is 10 mrem/yr, as required by Clean Air Act (CAA) regulations; the dose limit from drinking water is 4 mrem/yr, as required by Safe Drinking Water Act (SDWA) regulations; and the dose limit from all pathways combined is 100 mrem/yr, as given in DOE Order 5400.5 (DOE 1993) and NRC regulations (10 CFR 20). Thus, the dose to the MEI would be expected to remain well within the regulatory dose limits. Workers on the site would be expected to see an increase in the number of expected LCFs due to radiation from normal site operations over 15 years of 2.0, from about 17 to 19, if all the proposed surplus plutonium disposition activities were sited at Hanford. Doses to individual workers would be kept to minimal levels by instituting badged monitoring, administrative limits, and as-low-as-is-reasonably achievable (ALARA) programs (which would include worker rotations).

It is unlikely that there would be major impacts to the waste management infrastructure at Hanford for hazardous and nonhazardous wastes. Although a few cumulative waste volumes could exceed current storage capacities if the wastes were held in storage and not disposed of, this is not likely. Current schedules for shipment of TRU waste to WIPP indicate that TRU waste generated by the surplus plutonium disposition facilities would need to be stored on the site until 2016. Because Hanford is expected to begin shipping its existing inventory of TRU waste to WIPP in 2000, TRU waste generated by surplus plutonium disposition facilities could be stored in the space vacated by the waste shipped to WIPP. Likewise, it is unlikely that additional LLW storage capacity would be needed because this waste is routinely sent to onsite disposal. Additional mixed LLW disposal capacity could be required, but would likely be augmented by offsite commercial capacity.

Hanford is currently in compliance with all Federal, State, and local air quality regulations and guidelines, and would continue to remain in compliance even with consideration of the cumulative effects of all activities. The surplus plutonium disposition facilities' contribution to overall site concentration is extremely small. As discussed in Section 4.27.2 of the SPD EIS, incremental air pollutant concentrations from lead assembly activities at Hanford would be relatively small, with lead assembly operations completed by 2006. Thus, these emissions would not contribute to the maximum cumulative concentrations for Alternative 2.

Transportation requirements associated with Alternative 2 and the addition of lead assembly work at Hanford would include shipments to and from all of the proposed surplus plutonium disposition facilities. It is estimated that the total number of shipments to and from Hanford associated with site activities other than surplus plutonium disposition would be 416,475 truck shipments during the same timeframe the surplus plutonium disposition facilities would be built and operated. Surplus plutonium disposition activities would add 2,474 truck shipments to this estimate for a total of 418,949. The annual dose to the MEI from these shipments would be expected to increase from 1.68 mrem/yr to about 1.75 mrem/yr. This dose corresponds to an LCF risk from 15 years of transportation of 1.3×10^{-5} and would not represent a significant risk to the public.

INEEL

For INEEL, the bounding alternative for the SPD EIS would be Alternative 7. This alternative calls for the siting of the pit conversion facility in the Fuel Processing Facility and a new MOX facility located nearby. In addition to the facilities proposed under Alternative 7, INEEL is also being considered for lead assembly and postirradiation examination activities.

INEEL would remain within its site capacity for all major resources. If Alternative 7 were implemented at INEEL, the proposed surplus plutonium disposition facilities would require about 13 percent of the annual electricity used on the site and about 2 percent of the water; cumulatively, about 89 percent of the site's electric and 14 percent of the site's water capacity would be used. The land used by these facilities would represent less than 1 percent of the developed land on the site; cumulatively, about 2 percent of the land would be used. Impacts on resource requirements were evaluated for the year 2007 (peak year) because that would be the first full year in which both surplus plutonium disposition facilities operate simultaneously, resulting in maximum impacts. While ANL-W is being considered for lead assembly work, lead assembly fabrication operations would be completed by 2006 and, therefore, would not contribute to the maximum impacts for the peak year (2007). As a candidate for conducting postirradiation examination work, postirradiation examination activities at ANL-W would occur over the timeframe 2006–2009 and concurrently with the startup of surplus plutonium disposition activities. However, there would be no additional cumulative impacts on resource requirements (i.e., employment, electricity, water, land) associated with operation of the postirradiation examination facility at ANL-W, as these activities are routinely conducted at the site with the required infrastructure and workforce already in place.

Over the life of the proposed activities, the number of LCFs in the general population from 15 years of INEEL site operation would be expected to increase from 0.0040 to 0.015 if the proposed surplus plutonium disposition facilities were located there as described in Alternative 7, including the addition of lead assembly and postirradiation examination work. The MEI would receive an annual dose of 0.23 mrem from other site operations. This corresponds to an LCF risk from 15 years of site operation of 1.7×10^{-6} . The MEI would receive an additional 0.018 mrem/yr, for a cumulative annual dose from all activities of 0.25 mrem and a corresponding risk of an LCF of 1.9×10^{-6} from 15 years of operation. The regulatory dose limits for individual members of the public are given in DOE orders and EPA and NRC regulations. The dose limit from airborne emissions is 10 mrem/yr, as required by CAA regulations; the dose limit from drinking water is 4 mrem/yr, as required by SDWA regulations; and the dose limit from all pathways combined is 100 mrem/yr, as given in DOE Order 5400.5 (DOE 1993) and NRC regulations (10 CFR 20). Thus, the dose to the MEI would be expected to remain well within the regulatory dose limits. Workers on the site would be expected to see an increase in the number of expected LCFs due to radiation from normal site operations over 15 years of 0.80, from about 1.2 to 2.0, if the pit conversion and MOX facilities were sited at INEEL and lead assembly and postirradiation examination activities were also conducted at the site. Doses to individual workers would be kept to minimal levels by instituting badged monitoring, administrative limits, and ALARA programs (which would include worker rotations).

It is unlikely that there would be major impacts to the waste management infrastructure at INEEL because sufficient capacity should exist to manage the wastes that could be generated by planned activities. [Text deleted.]

INEEL is currently in compliance with all Federal, State, and local air quality regulations and guidelines, and would continue to remain in compliance even with consideration of the cumulative effects of all activities. The surplus plutonium disposition facilities' contribution to overall site concentration would be extremely small. As discussed in Section 4.27.1 of the SPD EIS, incremental air pollutant concentrations from lead assembly activities at ANL-W would be relatively small, with lead assembly operations completed by 2006. Thus, these emissions would not contribute to the maximum cumulative concentrations for Alternative 7. In addition, should the

postirradiation examination facility be located at ANL–W, there would also be no additional cumulative impact on air pollutant concentrations as these activities are routinely conducted at the site.

Transportation requirements associated with Alternative 7 and the addition of lead assembly and postirradiation examination work at INEEL would include shipments to and from the proposed facilities. It is estimated that the total number of shipments to and from INEEL associated with site activities other than surplus plutonium disposition would be 59,373 truck shipments during the approximately 15-year timeframe the surplus plutonium disposition facilities would be built and operated. Surplus plutonium disposition activities would add 2,565 truck shipments to this estimate for a total of 61,938. The annual dose to the MEI from these shipments would be expected to increase from 1.05 mrem/yr to about 1.12 mrem/yr. This dose corresponds to an LCF risk from 15 years of transportation of 8.4×10^{-6} , which does not significantly increase the risk to the public.

Pantex

For Pantex, the bounding alternative for the SPD EIS would be Alternative 9. This alternative calls for the siting of the new pit conversion and MOX facilities in Zone 4 West.

Pantex would remain within its site capacity for all major resources. If Alternative 9 is implemented, the proposed surplus plutonium disposition facilities would require about 25 percent of the annual electricity used on the site and about 10 percent of the water; cumulatively, this would require about 43 percent of the site's electric and 30 percent of the site's water. For comparison, the estimated maximum cumulative water usage of 1,133 million l/yr (299.3 million gal/yr) would be less than 5 percent of the 23.6 billion l (6.2 billion gal) of water pumped from the Carson County well fields by the city of Amarillo in 1995, and about 1 percent of the 101 billion l (26.7 billion gal) of water applied for irrigation in Carson County in 1995. The land used by these facilities would represent 1 percent of the developed land on the site; cumulatively, about 23 percent of the land would be developed. Impacts on resource requirements were evaluated for the year 2007 (the peak year) because that would be the first full year in which both surplus plutonium disposition facilities operate simultaneously, resulting in maximum impacts.

Over the life of the proposed activities, the number of LCFs in the general population from 15 years of Pantex site operation would be expected to increase from 5.6×10^{-5} to 3.1×10^{-3} if the proposed surplus plutonium disposition facilities were located there as described in Alternative 9. The hypothetical MEI for all reasonably foreseeable actions would receive an annual dose of 7.4×10^{-4} mrem, which corresponds to an LCF risk from 15 years of site operation of 5.5×10^{-9} . The MEI for Alternative 9 would receive an additional 0.077 mrem/yr, for a cumulative annual dose from all activities of 0.078 mrem and a corresponding risk of an LCF of 5.8×10^{-7} from 15 years of operation. The regulatory dose limits for individual members of the public are given in DOE orders and EPA and NRC regulations. The dose limit from airborne emissions is 10 mrem/yr, as required by CAA regulations; the dose limit from drinking water is 4 mrem/yr, as required by SDWA regulations; and the dose limit from all pathways combined is 100 mrem/yr, as given in DOE Order 5400.5 (DOE 1993) and NRC regulations (10 CFR 20). Thus, the dose to the MEI would be expected to remain well within the regulatory limits. Workers on the site would be expected to see an increase in the number of expected LCFs due to radiation from normal site operations over 15 years of 0.86, from about 0.48 to 1.3, if the pit conversion and MOX facilities were sited at Pantex. Doses to individual workers would be kept to minimal levels by instituting badged monitoring, administrative limits, and ALARA programs (which would include worker rotations).

Because there is not any TRU waste currently stored at Pantex, space for storage of TRU waste would be provided within the new surplus plutonium disposition facility. It is unlikely that additional LLW or hazardous waste storage capacity would be needed at Pantex because those wastes are routinely sent to offsite disposal.

Pantex is currently in compliance with all Federal, State, and local air quality regulations and guidelines, and would continue to remain in compliance even with consideration of the cumulative effects of all activities. The surplus plutonium disposition facilities' contribution to overall site concentrations would be extremely small.

Transportation requirements associated with Alternative 9 at Pantex would include shipments to and from the proposed pit conversion and MOX facilities. It is estimated that the total number of shipments to and from Pantex associated with site activities other than surplus plutonium disposition would be 5,460 truck shipments during the approximately 15-year timeframe the surplus plutonium disposition facilities would be built and operated. Alternative 9 would add 2,000 truck shipments to this estimate for a total of 7,460. The annual dose to the MEI from these shipments would be expected to increase from 0.97 mrem/yr to about 1.0 mrem/yr. This dose corresponds to an LCF risk from 15 years of transportation of 7.7×10^{-6} , which does not significantly increase the risk to the public.

SRS

For SRS, the bounding alternative for the SPD EIS would be Alternative 3. Alternative 3 calls for the siting of new pit conversion, immobilization, and MOX facilities near APSF in F-Area, if built. [Text deleted.] SRS is also being considered as a possible lead assembly site.

If Alternative 3 is implemented, the proposed surplus plutonium disposition facilities would require about 9 percent of the annual electricity used on the site and about 3 percent of the water; cumulatively, about 14 percent of the site's electricity and 74 percent of the water would be used. The land used by these facilities would represent less than 1 percent of the developed land on the site; cumulatively, about 9 percent of the land would be used. Impacts on resource requirements were evaluated for the year 2007 because that would be the first full year in which all three surplus plutonium disposition facilities operate simultaneously, resulting in maximum impacts. While SRS is being considered for lead assembly work, lead assembly fabrication operations would be completed by 2006 and, therefore, would not contribute to the maximum impacts for the peak year (2007).

Over the life of the proposed activities, the number of LCFs in the general population from 15 years of SRS operation would be expected to increase from 0.34 to 0.35 if the proposed surplus plutonium disposition facilities were located there as described in Alternative 3, including the addition of lead assembly work. The hypothetical MEI for all reasonably foreseeable actions would receive an annual dose of 1.1 mrem. This corresponds to an LCF risk from 15 years of site operation of 7.9×10^{-6} . The MEI would receive a maximum additional dose of 0.0074 mrem/yr for a cumulative annual dose from all activities, which rounds to 1.1 mrem, and a corresponding risk of an LCF of 8.0×10^{-6} from 15 years of operation. The regulatory dose limits for individual members of the public are given in DOE orders and EPA and NRC regulations. The dose limit from airborne emissions is 10 mrem/yr, as required by CAA regulations; the dose limit from drinking water is 4 mrem/yr, as required by the SDWA regulations; and the dose limit from all pathways combined is 100 mrem/yr, as given in DOE Order 5400.5 (DOE 1993) and NRC regulations (10 CFR 20). Thus, the dose to the MEI would be expected to remain well within the regulatory dose limits. Workers on the site would be expected to see an increase in the number of expected LCFs due to radiation from normal site operations over 15 years of 1.9, from about 2.9 to 4.8, if all the proposed surplus plutonium disposition activities were sited at SRS. Doses to individual workers would be kept to minimal levels by instituting badged monitoring, administrative limits, and ALARA programs (which would include worker rotations).

It is unlikely that there would be major impacts to the waste management infrastructure at SRS for TRU waste and nonhazardous waste. Although the cumulative waste volume for hazardous waste could exceed the storage capacity, it is unlikely that there would be major impacts on the waste management infrastructure at SRS because hazardous waste is generally not held in long-term storage and is disposed of in offsite facilities. [Text deleted.]

Likewise, it is unlikely that additional LLW storage capacity would be needed because this waste is routinely sent to onsite disposal.

SRS is currently in compliance with all Federal, State, and local air quality regulations and guidelines, and would continue to remain in compliance as a result of the cumulative effects of all activities. The surplus plutonium disposition facilities' contribution to overall site concentrations is extremely small. As discussed in Section 4.27.5 of the SPD EIS, incremental air pollutant concentrations from lead assembly activities at SRS would be relatively small, with lead assembly operations completed by 2006. Thus, these emissions would not contribute to the maximum cumulative concentrations for Alternative 3.

Transportation requirements associated with Alternative 3 and the addition of lead assembly work at SRS would include shipments to and from all of the proposed surplus plutonium disposition facilities. The total number of shipments to and from SRS associated with site activities other than surplus plutonium disposition would be 115,187 truck shipments during the approximately 15-year timeframe in which the surplus plutonium disposition facilities would be built and operated. Surplus plutonium disposition activities would add 2,557 truck shipments to this estimate for a total of 117,744. The annual dose to the MEI from these shipments would be expected to increase from 0.59 mrem/yr to about 0.66 mrem/yr. This dose corresponds to an LCF risk from 15 years of transportation of 4.9×10^{-6} , which does not represent a significant increase in risk to the public.

LLNL

The baseline for LLNL includes activities connected to the operation of the National Ignition Facility and the continued operation of the laboratory. Lead assembly alternative impacts discussed in the SPD Final EIS provide bounding conditions for the assessment of cumulative impacts from potential plutonium disposition activities at LLNL. Cumulative impacts have been assessed for the 5-year period, 2001–2005, which represents the time needed to modify facilities to conduct the proposed lead assembly work.

There would be no increase in site employment at LLNL due to surplus plutonium disposition activities as it is expected that existing employees would be used to perform lead assembly tasks. Proposed activities would require less than 1 percent of the annual electricity used on the site and less than 1 percent of the water used annually. Cumulatively, 40 percent of the available electricity and 31 percent of the available water would be used by the laboratory. No change in land development would be required due to lead assembly activities. Impacts on resource requirements were evaluated for the year 2003 because that would be the first full year of lead assembly activities, resulting in maximum impacts.

Over the life of the proposed activities, the cumulative LCFs in the general population from 5 years of LLNL operation would be expected to increase from 0.0045 from other site activities to 0.0062 from the addition of lead assembly activities. The hypothetical MEI for all reasonably foreseeable activities would receive an annual dose of 1.4 mrem, which corresponds to an LCF risk from 5 years of site activities of 3.5×10^{-6} . The MEI for the lead assembly alternative at LLNL would receive an additional annual dose of 0.064 mrem, for a cumulative annual dose of approximately 1.5 mrem, which results in a corresponding risk of an LCF of 3.7×10^{-6} . The regulatory limits for individual members of the public are given in DOE orders and EPA regulations. The dose limit from airborne emissions is 10 mrem/yr, as required by CAA regulations; the dose limit from drinking water is 4 mrem/yr, as required by SDWA regulations; and the dose limit from all pathways is 100 mrem/yr, as given in DOE Order 5400.5 (DOE 1993). Thus, the dose to the MEI would be expected to remain well within the regulatory dose limits. Workers on the site would be expected to see little increase in the number of expected LCFs due to radiation from lead assembly activities, 0.034, making the laboratory's total expected LCFs for the period of the proposed activities 0.088. Doses to individual workers would be kept to minimal levels by instituting badged monitoring, administrative limits, and ALARA programs (which would include worker rotations).

Although some of the cumulative waste volumes could exceed current storage capacities if the wastes were held in storage and not disposed, this is not likely. Wastes are routinely shipped for offsite disposal. In the case of LLW, LLNL ships waste to the Nevada Test Site. Mixed waste would be treated and disposed of in accordance with the LLNL Site Treatment Plan. Hazardous waste would be packaged and shipped off the site to RCRA-permitted treatment, storage, and disposal facilities.

LLNL is currently in compliance with applicable Federal, State, and local regulations and guidelines, with the exception of the 1-hr average nitrogen oxides concentration. The 1-hr standard for ozone may be exceeded on occasion, as indicated by the ozone nonattainment designation for the San Francisco Bay Area Air Quality Management District. Nitrogen oxides and hydrocarbons are precursors in the formation of ozone. Reductions in nitrogen oxide emissions along with a reduction in hydrocarbon emissions can result in a reduction in peak ozone concentrations. Since the production of ozone takes place over a period of time in the presence of sunlight, it is a regional issue and elevated localized concentrations of precursor pollutants do not necessarily correspond to elevated ozone concentrations and exceedances of the ozone standard. Lead assembly activities' contribution to overall site concentrations is extremely small.

Transportation requirements associated with lead assembly activities at LLNL would include shipments of uranium dioxide from a uranium conversion facility to LLNL and shipments of MOX fuel assemblies from LLNL to McGuire for irradiation. The total number of offsite shipments to and from LLNL associated with site activities other than surplus plutonium disposition during the 5-year period of the lead assembly program is estimated to be 2,228. The lead assembly activities proposed for LLNL would add an additional 71 trips to this estimate for a total of 2,299. The annual dose to the MEI from these shipments would be expected to increase from 0.17 mrem/yr to about 0.20 mrem/yr. This dose corresponds to an LCF risk from 5 years of transportation of 5.1×10^{-7} , which would only slightly increase the risk to the public.

LANL

The baseline for LANL includes activities connected to the extended operation of the laboratory. Lead assembly alternative impacts discussed in the SPD Final EIS provide bounding conditions for the assessment of cumulative impacts from potential plutonium disposition activities at LANL. Cumulative impacts have been assessed for the 5-year period, 2001–2005, which represents the time needed to modify facilities to conduct the proposed lead assembly work.

There would be no increase in site employment at LANL due to plutonium disposition activities as it is expected that existing employees would be used to perform lead assembly tasks. The electric power system that serves LANL is near capacity and future projections indicate that electricity demand will exceed capacity. Consideration of options to increase system capacity is complicated by the fact that the systems for major power users in the region are also nearing capacity and demand from these users is also projected to exceed capacity. No specific proposals to rectify this situation have been fully developed. Water use is projected to remain within existing water rights, and no reduction in the discharge volume from springs in the area is foreseen. Lead assembly activities would require less than 1 percent of the annual electricity used on the site and less than 1 percent of the water used annually. Cumulatively, the laboratory would require 157 percent of the available electricity and 96 percent of the available water. Changes to the current overall land-use categories are not expected, with the exception of a change to the land-use designation at TA-67 if that site is chosen for the development of a new LLW disposal facility. Impacts on resource requirements were evaluated for the year 2003 because that would be the first full year of lead assembly activities, resulting in maximum impacts. Doses to individual workers would be kept to minimal levels by instituting badged monitoring, administrative limits, and ALARA programs (which would include worker rotations).

Over the life of the proposed activities, the number of LCFs in the general population from 5 years of LANL operation would not be expected to increase from 0.08 due to lead assembly activities. Thus, no additional LCFs would be expected as a result of these activities. The hypothetical MEI for all reasonably foreseeable activities would receive an annual dose of 5.44 mrem, which corresponds to an LCF risk from 5 years of site activities of 1.4×10^{-5} . The MEI for the lead assembly alternative at LANL would receive an additional annual dose of 0.027 mrem for a cumulative annual dose of 5.47 mrem, which results in a corresponding risk of an LCF of 1.4×10^{-5} . The regulatory limits for individual members of the public are given in DOE orders and EPA regulations. The dose limit from airborne emissions is 10 mrem/yr, as required by CAA regulations; dose limit from drinking water is 4 mrem/yr, as required by SDWA regulations; and the dose limit from all pathways is 100 mrem/yr, as given in DOE Order 5400.5 (DOE 1993). Thus, the dose to the MEI would be expected to remain well within the regulatory dose limits. Workers on the site would be expected to see little increase in the number of expected LCFs due to radiation from lead assembly activities, 0.04, leaving the laboratory's total expected LCFs among the workforce at 1.7 for the period of the proposed activities.

Although some of the cumulative waste volumes could exceed current treatment and storage capacities, this is not likely. Wastes are routinely disposed of on the site or shipped for offsite disposal. Hazardous waste would be packaged and shipped off the site to RCRA-permitted treatment and disposal facilities. Mixed waste would be treated and disposed of in accordance with the LANL site treatment plan. Most LLW would be disposed of on the site without the need for treatment or long-term storage. Alternatives have been evaluated in the LANL Site-Wide EIS for expanding LLW disposal capabilities on the site or shipping LLW for offsite disposal.

LANL is currently in compliance with all Federal, State, and local regulations and guidelines, and would continue to remain in compliance with all projected cumulative activities. Lead assembly activities' contribution to overall site air pollutant concentrations is extremely small.

Transportation requirements associated with lead assembly activities at LANL would include shipments of uranium dioxide from a uranium conversion facility to LANL and shipments of MOX fuel assemblies from LANL to McGuire for irradiation. The total number of offsite hazardous and radioactive material shipments to and from LANL associated with site activities other than surplus plutonium disposition during the 5-year period of the lead assembly program is estimated to be 17,630. The lead assembly activities proposed for LANL would add an additional 15 trips to this estimate for a total of 17,645. The annual dose to the MEI from these shipments would be expected to increase from 0.38 mrem/yr to about 0.39 mrem/yr. This dose corresponds to an LCF risk from 5 years of transportation of 9.5×10^{-7} , which would only slightly increase the risk to the public.

ORNL

The baseline for ORNL includes those activities connected to operation of the Spallation Neutron Source as detailed in the *Final Environmental Impact Statement, Construction and Operation of the Spallation Neutron Source* (DOE 1999e) and continued operation of the laboratory. Postirradiation examination alternative impacts discussed in the SPD Final EIS provide bounding conditions for the assessment of cumulative impacts from potential surplus plutonium disposition activities at ORNL. Cumulative impacts have been assessed for the 3-year period, 2006–2009, which represents the time during which proposed postirradiation examination activities would be conducted.

There would be no additional cumulative impacts on resource requirements (i.e., employment, electricity, water, land) and air quality associated with the normal operation of the postirradiation examination facility at ORNL, as these activities are routinely conducted at the site.

Over the life of the proposed activities, the number of LCFs in the general population from 3 years of ORNL operation would not be expected to increase from 0.029 as a result of the addition of postirradiation examination.

It is not expected that any discernable radiological impacts on the public would be incurred from postirradiation examination activities at ORNL because all the work would be accomplished in heavily shielded hot cells that are built specifically to contain radiation, thereby protecting workers and the public from potential radioactive emissions. Thus, no additional LCFs would be expected as a result of these activities. The hypothetical MEI for all reasonably foreseeable activities would receive an annual dose of about 3.2 mrem, which corresponds to an LCF risk of 4.8×10^{-6} from 3 years of site activities. The MEI would not be expected to receive any additional dose from postirradiation examination activities. The regulatory limits for individual members of the public are given in DOE orders and EPA regulations. The dose limit from airborne emissions is 10 mrem/yr, as required by CAA regulations; the dose limit from drinking water is 4 mrem/yr, as required by SDWA regulations; and the dose limit from all pathways is 100 mrem/yr, as given in DOE Order 5400.5 (DOE 1993). Thus, the dose to the MEI would continue to remain well within the regulatory dose limits. Workers on the site would be expected to see a slight increase in the number of expected LCFs due to radiation from postirradiation examination activities, 0.002, making ORNL's total expected LCFs for the period of the proposed activities 0.13. Doses to individual workers would be kept to minimal levels by instituting badged monitoring, administrative limits, and ALARA programs (which would include worker rotations).

Although some of the LLW and hazardous cumulative waste volumes could exceed current treatment and storage capacities, this is not likely. Additional LLW treatment or storage capacity should not be needed because most LLW would be disposed of off the site, as is the current practice, without the need for treatment or long-term storage. In addition, it is unlikely that further hazardous waste treatment or storage capacity would be needed because these wastes are routinely sent off the site for treatment and disposal.

Transportation requirements associated with postirradiation examination activities at ORNL would include shipments of MOX spent fuel assemblies to ORNL. The total number of offsite hazardous and radioactive material shipments to and from ORNL associated with site activities other than surplus plutonium disposition during the 3-year period of the lead assembly program is estimated to be 24,385. The lead assembly work proposed for LANL would add an additional 8 trips to this estimate for a total of 24,393. The annual dose to the MEI from these shipments would not be expected to increase from 4.4 mrem/yr, which corresponds to an LCF risk from 3 years of transportation of 6.6×10^{-6} .

Reactor Sites (Catawba, McGuire, and North Anna)

Reasonably foreseeable future activities in the areas around Catawba, McGuire, and North Anna that could contribute to cumulative impacts include the potential for continued new home and road development. Activities near Catawba include the widening of the Buster Boyd Bridge on Highway 49 and the widening of a 27-km (17-mi) stretch of Interstate 77 from just south of Rock Hill north to Carowinds. In addition, the extension of water and sewer service in and around the area of the Catawba reactors is planned, along with a 4,000-home development on Highway 49 on the North Carolina side of Lake Wylie. Reasonably foreseeable future activities near McGuire include a 1,500-home development on Mountain Island Lake downstream from Lake Norman. In the areas around North Anna, residential development may include a 540-home subdivision with a golf course, although this project has been on hold since the late 1980s. In addition, Old Dominion Electric is considering building a 300- to 450-MW gas-fired generating station in Louisa County, although other sites are also being considered (Apter 1999).

Only minor modifications would be needed to accommodate using a partial MOX fuel core in place of a 100 percent LEU fuel core at the Catawba, McGuire, and North Anna reactors. Therefore, construction is expected to produce little or no impacts that could add to cumulative effects at these sites.

Normal operations using MOX fuel in place of LEU fuel at the Catawba, McGuire, and North Anna reactors are expected to produce little or no additional impacts at these sites. During normal operations with a partial MOX

fuel core, air and water emissions, waste generation, employment, land use, resource requirements, and utility usage are not expected to change appreciably from those experienced when using a full LEU core. Therefore, impacts related to resource requirements, air quality, waste management, and human health risk are not expected to change from current operations.

Transportation of MOX fuel to the reactors would be in place of a portion of the LEU fuel normally transported to the reactors. Transport of fresh MOX fuel to the reactors is likely to produce minimal additional impacts over the transport of LEU fuel.

Because the contributions to adverse effects of the proposed action would be extremely small, it is expected that activities associated with the proposed action would not exacerbate cumulative effects.

S.9 REFERENCES

Apter, R., 1999, Duke Engineering, Charlotte, NC, personal communication to B. Stevenson, U.S. Department of Energy, Office of Fissile Materials Disposition, Washington, DC, *Reactor Site Development Specifics*, September 20.

DOE (U.S. Department of Energy), 1993, *Radiation Protection of the Public and the Environment*, DOE Order 5400.5, Office of Environment, Safety and Health, January 7.

DOE (U.S. Department of Energy), 1996a, *Storage and Disposition of Weapons-Usable Fissile Materials Final Programmatic Environmental Impact Statement*, DOE/EIS-0229, Office of Fissile Materials Disposition, Washington, DC, December.

DOE (U.S. Department of Energy), 1996b, *Disposition of Surplus Highly Enriched Uranium Final Environmental Impact Statement*, DOE/EIS-0240, Office of Fissile Materials Disposition, Washington, DC, June.

DOE (U.S. Department of Energy), 1996c, *Record of Decision for the Disposition of Surplus Highly Enriched Uranium Final Environmental Impact Statement*, 61 FR 40619, Office of the Federal Register, Washington, DC, August 5.

DOE (U.S. Department of Energy), 1997a, *Record of Decision for the Storage and Disposition of Weapons-Usable Fissile Materials Final Programmatic Environmental Impact Statement*, 62 FR 3014, Office of the Federal Register, Washington, DC, January 14.

DOE (U.S. Department of Energy), 1997b, *Notice of Intent to Prepare a Surplus Plutonium Disposition Environmental Impact Statement*, 62 FR 28009, Office of the Federal Register, Washington, DC, May 22.

DOE (U.S. Department of Energy), 1997c, *Final Waste Management Programmatic Environmental Impact Statement for Managing Treatment, Storage, and Disposal of Radioactive and Hazardous Waste*, DOE/EIS-0200-F, Office of Environmental Management, Washington, DC, May.

DOE (U.S. Department of Energy), 1998a, *Cost Analysis in Support of Site Selection for Surplus Weapons-Usable Plutonium Disposition*, rev. 0, DOE/MD-0009, Office of Fissile Materials Disposition, Washington, DC, July 22.

DOE (U.S. Department of Energy), 1998b, *Pit Disassembly and Conversion Demonstration Environmental Assessment and Research and Development Activities*, DOE/EA-1207, Office of Fissile Materials Disposition, Washington, DC, August.

DOE (U.S. Department of Energy), 1998c, *Supplement Analysis for: Final Environmental Impact Statement for the Continued Operation of the Pantex Plant and Associated Storage of Nuclear Weapon Components—AL-R8 Sealed Insert Container*, Albuquerque Operations Office, Amarillo Area Office, Amarillo, TX, August.

DOE (U.S. Department of Energy), 1999a, *Environmental Assessment for the Parallax Project Fuel Manufacture and Shipment*, DOE/EA-1216, Office of Fissile Materials Disposition, Washington, DC, January.

DOE (U.S. Department of Energy), 1999b, *Plutonium Disposition Life-Cycle Costs and Cost-Related Comment Resolution Document*, MD-0013, Office of Fissile Materials Disposition, Washington, DC, November.

DOE (U.S. Department of Energy), 1999c, *Draft Environmental Impact Statement for a Geologic Repository for the Disposal of Spent Nuclear Fuel and High-Level Radioactive Waste at Yucca Mountain, Nye County, Nevada*, DOE/EIS-0250D, Office of Civilian Radioactive Waste Management, North Las Vegas, NV, July.

DOE (U.S. Department of Energy), 1999d, *MOX Fuel Fabrication Facility and Nuclear Power Reactor Data Report*, MD-0015, Office of Fissile Materials Disposition, Washington, DC, August.

DOE (U.S. Department of Energy), 1999e, *Final Environmental Impact Statement, Construction and Operation of the Spallation Neutron Source*, DOE/EIS-0247, Office of Science, Germantown, MD, April.

NAS (National Academy of Sciences and National Research Council), 1995, *Management and Disposition of Excess Weapons Plutonium, Reactor-Related Options*, National Academy Press, Washington, DC.

[Text deleted.]

NRC (U.S. Nuclear Regulatory Commission), 1996x, *Dose Commitments Due to Radioactive Releases from Nuclear Power Plant Sites in 1992*, NUREG/CR-2850, PNL-4221, vol. 14, Washington, DC, March.

Paperiello, C.J., 1999, U.S. Nuclear Regulatory Commission, Office of Nuclear Material Safety and Safeguards, Washington, DC, personal communication (letter) to L. Barrett, U.S. Department of Energy, Office of Civilian Radioactive Waste Management, Washington, DC, *U.S. Department of Energy Plans for Disposal of Surplus Weapons Plutonium*, January 25.

SRARP (Savannah River Archaeological Research Program), 1989, *Archaeological Resource Management Plan of the Savannah River Archaeological Research Program*, South Carolina Institute of Archaeology and Anthropology, University of South Carolina, Columbia, SC, December.

White, V.S., 1997, *Initial Data Report in Response to the Surplus Plutonium Disposition Environmental Impact Statement Data Call for the UO₂ Supply*, rev. 1, ORNL/TM-13466, Lockheed Martin Energy Research Corporation, Oak Ridge, TN, November.

White House, 1993, *Nonproliferation and Export Control Policy*, Office of the Press Secretary, Washington, DC, September 27.

White House, 1994, *Joint Statement by the President of the Russian Federation and the President of the United States of America on Non-Proliferation of Weapons of Mass Destruction and the Means of Their Delivery*, Office of the Press Secretary, Washington, DC, January 14.



Office of Fissile Materials Disposition

United States Department of Energy

Surplus Plutonium Disposition Final Environmental Impact Statement

Volume I - Part A

November 1999

For Further Information Contact:
U.S. Department of Energy
Office of Fissile Materials Disposition, P.O. Box 23786, Washington, DC 20026-3786

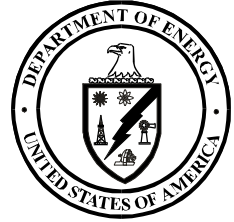

DOE/EIS-0283

Surplus Plutonium Disposition Final Environmental Impact Statement

Volume I - Part A

**United States Department of Energy
Office of Fissile Materials Disposition**

November 1999

Cover Sheet

Responsible Agency: United States Department of Energy (DOE)

Title: *Surplus Plutonium Disposition Final Environmental Impact Statement (SPD EIS)* (DOE/EIS-0283)

Locations of Candidate Sites: California, Idaho, New Mexico, North Carolina, South Carolina, Tennessee, Texas, Virginia, and Washington

Contacts:

For further information on the SPD Final EIS contact: For information on the DOE National Environmental Policy Act (NEPA) process contact:

Mr. G. Bert Stevenson, NEPA Compliance Officer
Office of Fissile Materials Disposition
U.S. Department of Energy
P.O. Box 23786
Washington, DC 20026-3786
Voice: (202) 586-5368

Ms. Carol Borgstrom, Director
Office of NEPA Policy and Assistance
Office of Environment, Safety and Health
U.S. Department of Energy
1000 Independence Ave., SW
Washington, DC 20585
Voice: (202) 586-4600 or (800) 472-2756

Abstract: On May 22, 1997, DOE published a Notice of Intent in the Federal Register (62 Federal Register 28009) announcing its decision to prepare an environmental impact statement (EIS) that would tier from the analysis and decisions reached in connection with the *Storage and Disposition of Weapons-Usable Fissile Materials Final Programmatic EIS*. At that time, the U.S. Environmental Protection Agency decided to be a cooperating agency. The *Surplus Plutonium Disposition Draft Environmental Impact Statement (SPD Draft EIS)* (DOE/EIS-0283-D) was prepared in accordance with NEPA and issued in July 1998. It identified the potential environmental impacts of reasonable alternatives for the proposed siting, construction, and operation of three facilities for the disposition of up to 50 metric tons (55 tons) of surplus plutonium, as well as a No Action Alternative. These three facilities would accomplish pit disassembly and conversion, plutonium conversion and immobilization, and mixed oxide (MOX) fuel fabrication.

For the alternatives that included MOX fuel fabrication, the SPD Draft EIS described the potential environmental impacts of using from three to eight commercial nuclear reactors to irradiate MOX fuel. The potential impacts were based on a generic reactor analysis that used actual reactor data and a range of potential site conditions. In May 1998, DOE initiated a procurement process to obtain MOX fuel fabrication and reactor irradiation services. In March 1999, DOE awarded a contract to Duke Engineering & Services, COGEMA Inc., and Stone & Webster (known as DCS) to provide the requested services. A *Supplement to the SPD Draft EIS* was issued in April 1999, which analyzed the potential environmental impacts of using MOX fuel in six specific reactors named in the DCS proposal. Those reactors are Catawba Nuclear Station Units 1 and 2 in South Carolina, McGuire Nuclear Station Units 1 and 2 in North Carolina, and North Anna Power Station Units 1 and 2 in Virginia.

DOE has identified the hybrid approach as its Preferred Alternative for the disposition of surplus plutonium. This approach allows for the immobilization of 17 metric tons (19 tons) of surplus plutonium and the use of 33 metric tons (36 tons) as MOX fuel. DOE has identified the Savannah River Site near Aiken, South Carolina, as the preferred site for all three disposition facilities (Alternative 3). DOE has also identified Los Alamos National

| Laboratory in New Mexico as the preferred site for lead assembly fabrication, and Oak Ridge National
| Laboratory in Tennessee as the preferred site for postirradiation examination of lead assemblies.

| **Public Involvement:** In preparing the SPD Final EIS, DOE considered comments on the SPD Draft EIS and the
| *Supplement to the SPD Draft EIS* received via mail, fax, and email, and comments recorded by phone and
| transcribed from videotapes. In addition, comments were captured by notetakers during interactive public
| meetings held on the SPD Draft EIS in August 1998 in Amarillo, Texas; Idaho Falls, Idaho; North Augusta,
| South Carolina; Portland, Oregon; and Richland, Washington, as well as during a public meeting on the
| *Supplement to the SPD Draft EIS* held in June 1999 in Washington, D.C. Comments received and DOE's
| responses to these comments are found in Volume III, the Comment Response Document, of the SPD Final EIS.
| Information on the surplus plutonium disposition program can be obtained by visiting the Office of Fissile
| Materials Disposition Web site at <http://www.doe-md.com>.

Table of Contents

Table of Contents	i
List of Figures	xxiii
List of Tables	xxvi
List of Acronyms	xlvii
Chemicals and Units of Measure	lii
Metric Conversion Chart and Metric Prefixes	liii

Volume I - Part A

Chapter 1

Background, Purpose of, and Need for Proposed Action	1-1
1.1 Background	1-1
1.2 Purpose of and Need for the Proposed Action	1-3
1.3 Decisions to Be Made	1-4
1.4 Issues Identified During the Scoping Period	1-4
1.5 Scope of This SPD EIS	1-6
1.6 Preferred Alternatives	1-10
1.7 Summary of Major Issues Identified During the Comment Periods and Changes to the SPD Draft EIS	1-12
1.7.1 Public Involvement Process for the SPD Draft EIS and the <i>Supplement to the SPD Draft EIS</i>	1-12
1.7.2 Summary of Major Issues Raised on the SPD Draft EIS During the Public Comment Period	1-12
1.7.3 Summary of Major Issues Raised on the <i>Supplement to the SPD Draft EIS</i> During the Public Comment Period	1-15
1.7.4 Changes to the SPD Draft EIS and the <i>Supplement</i>	1-16
1.8 Relationship to Other Actions and Programs	1-18
1.8.1 Materials and Disposition Options	1-19
1.8.2 Waste Management	1-20
1.8.3 SPD EIS Candidate Sites	1-21
1.8.4 Cooperating Agencies	1-27
1.9 Organization of This SPD EIS	1-27
1.10 References	1-28

Chapter 2

Alternatives for Disposition of Surplus Weapons-Usable Plutonium	2-1
2.1 Alternatives Analyzed in This SPD EIS	2-1
2.1.1 Surplus Plutonium Disposition Facility Alternatives	2-2
2.1.2 Immobilization Technology Alternatives	2-2
2.1.3 MOX Fuel Fabrication Alternatives	2-8
2.2 Materials Analyzed in This SPD EIS	2-9
2.3 Development of the Alternatives	2-10

2.3.1	Development of Facility Siting Alternatives	2-10
2.3.2	Alternatives Considered but Eliminated From Detailed Study	2-11
2.3.2.1	Amounts of Material to Be Dispositioned	2-11
2.3.2.2	Disposition Facility Siting Alternatives	2-11
2.3.2.3	Feed Preparation Methods for Immobilization	2-12
2.3.2.4	Immobilization Technology Alternatives	2-12
2.4	Overview of Proposed Surplus Plutonium Disposition Facilities and Transportation	2-13
2.4.1	Pit Disassembly and Conversion	2-14
2.4.1.1	Pit Conversion Facility Description	2-15
2.4.1.2	Pit Disassembly and Conversion Process	2-18
2.4.2	Plutonium Conversion and Immobilization	2-21
2.4.2.1	Immobilization Facility Description	2-21
2.4.2.2	Plutonium Conversion and Immobilization Process	2-26
2.4.2.2.1	Plutonium Conversion Process	2-26
2.4.2.2.2	Immobilization Process	2-28
2.4.3	MOX Fuel Fabrication	2-29
2.4.3.1	MOX Facility Description	2-30
2.4.3.2	MOX Fuel Fabrication Process	2-33
2.4.4	Transportation Activities	2-35
2.4.4.1	Pit Conversion Transportation Requirements	2-37
2.4.4.2	Immobilization Transportation Requirements	2-37
2.4.4.3	MOX Transportation Requirements	2-40
2.4.4.4	Lead Assembly and Postirradiation Examination Transportation Requirements	2-40
2.4.4.5	Other Transportation Requirements	2-43
2.5	Alternative 1: No Action	2-44
2.6	Alternative 2: All Facilities at Hanford	2-44
2.7	Alternative 3: All Facilities at SRS	2-48
2.7.1	[Section heading deleted.]	2-48
2.7.2	[Section deleted because alternative deleted.]	2-51
2.8	Alternative 4: Pit Conversion at Pantex; MOX Fuel Fabrication and Immobilization at Hanford	2-51
2.8.1	Alternative 4A	2-51
2.8.2	Alternative 4B	2-53
2.9	Alternative 5: Pit Conversion at Pantex; MOX Fuel Fabrication and Immobilization at SRS	2-54
2.9.1	[Section heading deleted.]	2-54
2.9.2	[Section deleted because alternative deleted.]	2-54
2.10	Alternative 6: Pit Conversion and MOX Fuel Fabrication at Hanford; Immobilization at SRS	2-55
2.10.1	Alternative 6A	2-55
2.10.2	Alternative 6B	2-55
2.10.3	[Section deleted because alternative deleted.]	2-56
2.10.4	[Section deleted because alternative deleted.]	2-56
2.11	Alternative 7: Pit Conversion and MOX Fuel Fabrication at INEEL; Immobilization at SRS	2-56
2.11.1	[Section heading deleted.]	2-56
2.11.2	[Section deleted because alternative deleted.]	2-57
2.12	Alternative 8: Pit Conversion and MOX Fuel Fabrication at INEEL; Immobilization at Hanford	2-57
2.13	Alternative 9: Pit Conversion and MOX Fuel Fabrication at Pantex; Immobilization at SRS	2-59
2.13.1	[Section heading deleted.]	2-59
2.13.2	[Section deleted because alternative deleted.]	2-59
2.14	Alternative 10: Pit Conversion and MOX Fuel Fabrication at Pantex; Immobilization at Hanford	2-61

2.15	Alternative 11: 50-metric-ton Immobilization; Immobilization at Hanford; Pit Conversion at Hanford or Pantex	2-61
2.15.1	Alternative 11A	2-61
2.15.2	Alternative 11B	2-61
2.16	Alternative 12: 50-metric-ton Immobilization; Immobilization at SRS; Pit Conversion at Pantex or SRS	2-62
2.16.1	Alternative 12A	2-62
2.16.2	[Section deleted because alternative deleted.]	2-62
2.16.3	Alternative 12B	2-62
2.16.4	[Section deleted because alternative deleted.]	2-62
2.17	Lead Assembly Fabrication and Postirradiation Examination	2-63
2.17.1	Process Description	2-63
2.17.2	Lead Assembly Fabrication Siting Alternatives	2-64
2.17.2.1	Hanford	2-64
2.17.2.2	ANL-W	2-65
2.17.2.3	SRS	2-65
2.17.2.4	LANL	2-65
2.17.2.5	LLNL	2-69
2.17.3	Postirradiation Examination Siting Alternatives	2-73
2.17.3.1	ANL-W	2-73
2.17.3.2	ORNL	2-74
2.18	Summary of Impacts of Construction and Operation of the Proposed Surplus Plutonium Disposition Facilities	2-74
2.18.1	Summary of Impacts by Alternative and Site	2-74
2.18.2	Summary of Lead Assembly Fabrication and Postirradiation Examination Impacts	2-96
2.18.3	MOX Fuel Integrated Impacts	2-98
2.18.4	Comparison of Immobilization Technology Impacts	2-103
2.19	References	2-106

Chapter 3

3	Affected Environment	3-1
3.1	Approach to Defining the Affected Environment	3-1
3.2	Hanford	3-3
3.2.1	Air Quality and Noise	3-5
3.2.1.1	Air Quality	3-5
3.2.1.1.1	General Site Description	3-5
3.2.1.1.2	Proposed Facility Locations	3-7
3.2.1.2	Noise	3-7
3.2.1.2.1	General Site Description	3-8
3.2.1.2.2	Proposed Facility Locations	3-8
3.2.2	Waste Management	3-8
3.2.2.1	Waste Inventories and Activities	3-9
3.2.2.2	Transuranic and Mixed Transuranic Waste	3-9
3.2.2.3	Low-Level Waste	3-11
3.2.2.4	Mixed Low-Level Waste	3-11
3.2.2.5	Hazardous Waste	3-11
3.2.2.6	Nonhazardous Waste	3-12
3.2.2.7	Waste Minimization	3-12
3.2.2.8	Preferred Alternatives From the WM PEIS	3-12

3.2.3	Socioeconomics	3-13
3.2.3.1	Regional Economic Characteristics	3-13
3.2.3.2	Population and Housing	3-15
3.2.3.3	Community Services	3-15
3.2.3.3.1	Education	3-15
3.2.3.3.2	Public Safety	3-15
3.2.3.3.3	Health Care	3-15
3.2.3.4	Local Transportation	3-15
3.2.4	Existing Human Health Risk	3-19
3.2.4.1	Radiation Exposure and Risk	3-19
3.2.4.1.1	General Site Description	3-19
3.2.4.1.2	Proposed Facility Locations	3-21
3.2.4.2	Chemical Environment	3-21
3.2.4.3	Health Effects Studies	3-22
3.2.4.4	Accident History	3-22
3.2.4.5	Emergency Preparedness	3-23
3.2.5	Environmental Justice	3-23
3.2.6	Geology and Soils	3-24
3.2.6.1	General Site Description	3-24
3.2.6.2	Proposed Facility Locations	3-26
3.2.7	Water Resources	3-27
3.2.7.1	Surface Water	3-27
3.2.7.1.1	General Site Description	3-27
3.2.7.1.2	Proposed Facility Locations	3-31
3.2.7.2	Groundwater	3-31
3.2.7.2.1	General Site Description	3-31
3.2.7.2.2	Proposed Facility Locations	3-32
3.2.8	Ecological Resources	3-33
3.2.8.1	Nonsensitive Habitat	3-33
3.2.8.1.1	General Site Description	3-33
3.2.8.1.2	Proposed Facility Locations	3-35
3.2.8.2	Sensitive Habitat	3-36
3.2.8.2.1	General Site Description	3-36
3.2.8.2.2	Proposed Facility Locations	3-36
3.2.9	Cultural and Paleontological Resources	3-36
3.2.9.1	Prehistoric Resources	3-37
3.2.9.1.1	General Site Description	3-37
3.2.9.1.2	Proposed Facility Locations	3-38
3.2.9.2	Historic Resources	3-38
3.2.9.2.1	General Site Description	3-38
3.2.9.2.2	Proposed Facility Locations	3-39
3.2.9.3	Native American Resources	3-39
3.2.9.3.1	General Site Description	3-39
3.2.9.3.2	Proposed Facility Locations	3-40
3.2.9.4	Paleontological Resources	3-40
3.2.9.4.1	General Site Description	3-40
3.2.9.4.2	Proposed Facility Locations	3-40
3.2.10	Land Use and Visual Resources	3-40
3.2.10.1	Land Use	3-40
3.2.10.1.1	General Site Description	3-40

	3.2.10.1.2	Proposed Facility Locations	3-43
	3.2.10.2	Visual Resources	3-43
	3.2.10.2.1	General Site Description	3-44
	3.2.10.2.2	Proposed Facility Locations	3-44
3.2.11		Infrastructure	3-45
	3.2.11.1	General Site Description	3-45
	3.2.11.1.1	Transportation	3-45
	3.2.11.1.2	Electricity	3-46
	3.2.11.1.3	Fuel	3-46
	3.2.11.1.4	Water	3-46
	3.2.11.1.5	Site Safety Services	3-46
	3.2.11.2	Proposed Facility Locations	3-46
	3.2.11.2.1	Electricity	3-47
	3.2.11.2.2	Fuel	3-47
	3.2.11.2.3	Water	3-47
3.3		INEEL	3-48
	3.3.1	Air Quality and Noise	3-50
	3.3.1.1	Air Quality	3-50
	3.3.1.1.1	General Site Description	3-50
	3.3.1.1.2	Proposed Facility Location	3-52
	3.3.1.2	Noise	3-52
	3.3.1.2.1	General Site Description	3-52
	3.3.1.2.2	Proposed Facility Location	3-52
	3.3.2	Waste Management	3-53
	3.3.2.1	Waste Inventories and Activities	3-53
	3.3.2.2	Transuranic and Mixed Transuranic Waste	3-55
	3.3.2.3	Low-Level Waste	3-56
	3.3.2.4	Mixed Low-Level Waste	3-56
	3.3.2.5	Hazardous Waste	3-57
	3.3.2.6	Nonhazardous Waste	3-57
	3.3.2.7	Waste Minimization	3-57
	3.3.2.8	Preferred Alternatives From the WM PEIS	3-58
	3.3.3	Socioeconomics	3-58
	3.3.3.1	Regional Economic Characteristics	3-58
	3.3.3.2	Population and Housing	3-60
	3.3.3.3	Community Services	3-62
	3.3.3.3.1	Education	3-62
	3.3.3.3.2	Public Safety	3-62
	3.3.3.3.3	Health Care	3-62
	3.3.3.4	Local Transportation	3-62
	3.3.4	Existing Human Health Risk	3-65
	3.3.4.1	Radiation Exposure and Risk	3-65
	3.3.4.1.1	General Site Description	3-65
	3.3.4.1.2	Proposed Facility Location	3-66
	3.3.4.2	Chemical Environment	3-67
	3.3.4.3	Health Effects Studies	3-68
	3.3.4.4	Accident History	3-68
	3.3.4.5	Emergency Preparedness	3-68
	3.3.5	Environmental Justice	3-69
	3.3.6	Geology and Soils	3-69

3.3.6.1	General Site Description	3-69
3.3.6.2	Proposed Facility Location	3-71
3.3.7	Water Resources	3-71
3.3.7.1	Surface Water	3-71
3.3.7.1.1	General Site Description	3-71
3.3.7.1.2	Proposed Facility Location	3-72
3.3.7.2	Groundwater	3-74
3.3.7.2.1	General Site Description	3-74
3.3.7.2.2	Proposed Facility Location	3-75
3.3.8	Ecological Resources	3-75
3.3.8.1	Nonsensitive Habitat	3-75
3.3.8.1.1	General Site Description	3-75
3.3.8.1.2	Proposed Facility Location	3-77
3.3.8.2	Sensitive Habitat	3-77
3.3.8.2.1	General Site Description	3-77
3.3.8.2.2	Proposed Facility Location	3-78
3.3.9	Cultural and Paleontological Resources	3-79
3.3.9.1	Prehistoric Resources	3-79
3.3.9.1.1	General Site Description	3-79
3.3.9.1.2	Proposed Facility Location	3-79
3.3.9.2	Historic Resources	3-80
3.3.9.2.1	General Site Description	3-80
3.3.9.2.2	Proposed Facility Location	3-80
3.3.9.3	Native American Resources	3-80
3.3.9.3.1	General Site Description	3-80
3.3.9.3.2	Proposed Facility Location	3-81
3.3.9.4	Paleontological Resources	3-81
3.3.9.4.1	General Site Description	3-81
3.3.9.4.2	Proposed Facility Location	3-81
3.3.10	Land Use and Visual Resources	3-81
3.3.10.1	Land Use	3-81
3.3.10.1.1	General Site Description	3-81
3.3.10.1.2	Proposed Facility Location	3-84
3.3.10.2	Visual Resources	3-84
3.3.10.2.1	General Site Description	3-84
3.3.10.2.2	Proposed Facility Location	3-84
3.3.11	Infrastructure	3-85
3.3.11.1	General Site Description	3-85
3.3.11.1.1	Transportation	3-85
3.3.11.1.2	Electricity	3-86
3.3.11.1.3	Fuel	3-86
3.3.11.1.4	Water	3-86
3.3.11.1.5	Site Safety Services	3-86
3.3.11.2	Proposed Facility Location	3-86
3.3.11.2.1	Electricity	3-86
3.3.11.2.2	Fuel	3-87
3.3.11.2.3	Water	3-87
3.4	Pantex Plant	3-88
3.4.1	Air Quality and Noise	3-89
3.4.1.1	Air Quality	3-89

	3.4.1.1.1	General Site Description	3–89
	3.4.1.1.2	Proposed Facility Location	3–91
3.4.1.2	Noise		3–91
	3.4.1.2.1	General Site Description	3–91
	3.4.1.2.2	Proposed Facility Location	3–92
3.4.2	Waste Management		3–92
	3.4.2.1	Waste Inventories and Activities	3–93
	3.4.2.2	Transuranic and Mixed Transuranic Waste	3–93
	3.4.2.3	Low-Level Waste	3–93
	3.4.2.4	Mixed Low-Level Waste	3–95
	3.4.2.5	Hazardous Waste	3–95
	3.4.2.6	Nonhazardous Waste	3–96
	3.4.2.7	Waste Minimization	3–96
	3.4.2.8	Preferred Alternatives From the WM PEIS	3–97
3.4.3	Socioeconomics		3–97
	3.4.3.1	Regional Economic Characteristics	3–98
	3.4.3.2	Population and Housing	3–98
	3.4.3.3	Community Services	3–98
	3.4.3.3.1	Education	3–98
	3.4.3.3.2	Public Safety	3–98
	3.4.3.3.3	Health Care	3–102
	3.4.3.4	Local Transportation	3–102
3.4.4	Existing Human Health Risk		3–102
	3.4.4.1	Radiation Exposure and Risk	3–102
	3.4.4.1.1	General Site Description	3–102
	3.4.4.1.2	Proposed Facility Location	3–105
	3.4.4.2	Chemical Environment	3–106
	3.4.4.3	Health Effects Studies	3–106
	3.4.4.4	Accident History	3–107
	3.4.4.5	Emergency Preparedness	3–107
3.4.5	Environmental Justice		3–107
3.4.6	Geology and Soils		3–108
	3.4.6.1	General Site Description	3–108
	3.4.6.2	Proposed Facility Location	3–110
3.4.7	Water Resources		3–110
	3.4.7.1	Surface Water	3–110
	3.4.7.1.1	General Site Description	3–110
	3.4.7.1.2	Proposed Facility Location	3–112
	3.4.7.2	Groundwater	3–114
	3.4.7.2.1	General Site Description	3–114
	3.4.7.2.2	Proposed Facility Location	3–116
3.4.8	Ecological Resources		3–116
	3.4.8.1	Nonsensitive Habitat	3–116
	3.4.8.1.1	General Site Description	3–116
	3.4.8.1.2	Proposed Facility Location	3–118
	3.4.8.2	Sensitive Habitat	3–118
	3.4.8.2.1	General Site Description	3–118
	3.4.8.2.2	Proposed Facility Location	3–118
3.4.9	Cultural and Paleontological Resources		3–119
	3.4.9.1	Prehistoric Resources	3–119

	3.4.9.1.1	General Site Description	3-119
	3.4.9.1.2	Proposed Facility Location	3-120
	3.4.9.2	Historic Resources	3-120
	3.4.9.2.1	General Site Description	3-120
	3.4.9.2.2	Proposed Facility Location	3-120
	3.4.9.3	Native American Resources	3-120
	3.4.9.3.1	General Site Description	3-120
	3.4.9.3.2	Proposed Facility Location	3-121
	3.4.9.4	Paleontological Resources	3-121
	3.4.9.4.1	General Site Description	3-121
	3.4.9.4.2	Proposed Facility Location	3-121
3.4.10		Land Use and Visual Resources	3-121
	3.4.10.1	Land Use	3-121
	3.4.10.1.1	General Site Description	3-121
	3.4.10.1.2	Proposed Facility Location	3-122
	3.4.10.2	Visual Resources	3-124
	3.4.10.2.1	General Site Description	3-124
	3.4.10.2.2	Proposed Facility Location	3-124
3.4.11		Infrastructure	3-124
	3.4.11.1	General Site Description	3-125
	3.4.11.1.1	Transportation	3-125
	3.4.11.1.2	Electricity	3-125
	3.4.11.1.3	Fuel	3-126
	3.4.11.1.4	Water	3-126
	3.4.11.1.5	Site Safety Services	3-126
	3.4.11.2	Proposed Facility Location	3-126
3.5		SRS	3-127
	3.5.1	Air Quality and Noise	3-128
	3.5.1.1	Air Quality	3-128
	3.5.1.1.1	General Site Description	3-128
	3.5.1.1.2	Proposed Facility Locations	3-130
	3.5.1.2	Noise	3-130
	3.5.1.2.1	General Site Description	3-130
	3.5.1.2.2	Proposed Facility Locations	3-131
	3.5.2	Waste Management	3-131
	3.5.2.1	Waste Inventories and Activities	3-131
	3.5.2.2	Transuranic and Mixed Transuranic Waste	3-132
	3.5.2.3	Low-Level Waste	3-133
	3.5.2.4	Mixed Low-Level Waste	3-134
	3.5.2.5	Hazardous Waste	3-134
	3.5.2.6	Nonhazardous Waste	3-135
	3.5.2.7	Waste Minimization	3-135
	3.5.2.8	Preferred Alternatives From the Final WM PEIS	3-135
	3.5.3	Socioeconomics	3-136
	3.5.3.1	Regional Economic Characteristics	3-136
	3.5.3.2	Population and Housing	3-138
	3.5.3.3	Community Services	3-138
	3.5.3.3.1	Education	3-138
	3.5.3.3.2	Public Safety	3-138
	3.5.3.3.3	Health Care	3-138

3.5.3.4	Local Transportation	3-142
3.5.4	Existing Human Health Risk	3-142
3.5.4.1	Radiation Exposure and Risk	3-142
3.5.4.1.1	General Site Description	3-142
3.5.4.1.2	Proposed Facility Locations	3-144
3.5.4.2	Chemical Environment	3-145
3.5.4.3	Health Effects Studies	3-145
3.5.4.4	Accident History	3-145
3.5.4.5	Emergency Preparedness	3-146
3.5.5	Environmental Justice	3-146
3.5.6	Geology and Soils	3-147
3.5.6.1	General Site Description	3-147
3.5.6.2	Proposed Facility Locations	3-149
3.5.7	Water Resources	3-149
3.5.7.1	Surface Water	3-149
3.5.7.1.1	General Site Description	3-149
3.5.7.1.2	Proposed Facility Locations	3-150
3.5.7.2	Groundwater	3-152
3.5.7.2.1	General Site Description	3-152
3.5.7.2.2	Proposed Facility Locations	3-153
3.5.8	Ecological Resources	3-154
3.5.8.1	Nonsensitive Habitat	3-154
3.5.8.1.1	General Site Description	3-154
3.5.8.1.2	Proposed Facility Locations	3-155
3.5.8.2	Sensitive Habitat	3-157
3.5.8.2.1	General Site Description	3-157
3.5.8.2.2	Proposed Facility Locations	3-157
3.5.9	Cultural and Paleontological Resources	3-157
3.5.9.1	Prehistoric Resources	3-158
3.5.9.1.1	General Site Description	3-158
3.5.9.1.2	Proposed Facility Locations	3-159
3.5.9.2	Historic Resources	3-159
3.5.9.2.1	General Site Description	3-159
3.5.9.2.2	Proposed Facility Locations	3-159
3.5.9.3	Native American Resources	3-160
3.5.9.3.1	General Site Description	3-160
3.5.9.3.2	Proposed Facility Locations	3-160
3.5.9.4	Paleontological Resources	3-160
3.5.9.4.1	General Site Description	3-160
3.5.9.4.2	Proposed Facility Locations	3-161
3.5.10	Land Use and Visual Resources	3-161
3.5.10.1	Land Use	3-161
3.5.10.1.1	General Site Description	3-161
3.5.10.1.2	Proposed Facility Locations	3-163
3.5.10.2	Visual Resources	3-164
3.5.10.2.1	General Site Description	3-164
3.5.10.2.2	Proposed Facility Locations	3-164
3.5.11	Infrastructure	3-164
3.5.11.1	General Site Description	3-165
3.5.11.1.1	Transportation	3-165

	3.5.11.1.2	Electricity	3-165
	3.5.11.1.3	Fuel	3-165
	3.5.11.1.4	Water	3-166
	3.5.11.1.5	Site Safety Services	3-166
	3.5.11.2	Proposed Facility Locations	3-166
	3.5.11.2.1	Electricity	3-166
	3.5.11.2.2	Fuel	3-167
	3.5.11.2.3	Water	3-167
3.6		Lead Assembly Fabrication and Postirradiation Examination Sites	3-168
3.6.1		Hanford Overview	3-168
3.6.2		ANL-W Overview	3-168
	3.6.2.1	Air Quality	3-168
	3.6.2.2	Waste Management	3-169
	3.6.2.3	Existing Human Health Risk	3-169
	3.6.2.4	Infrastructure	3-169
3.6.3		LLNL Overview	3-169
	3.6.3.1	Air Quality	3-170
	3.6.3.2	Waste Management	3-171
	3.6.3.3	Existing Human Health Risk	3-172
	3.6.3.4	Infrastructure	3-174
3.6.4		LANL Overview	3-175
	3.6.4.1	Air Quality	3-175
	3.6.4.2	Waste Management	3-175
	3.6.4.3	Existing Human Health Risk	3-177
	3.6.4.4	Infrastructure	3-179
3.6.5		SRS Overview	3-179
	3.6.5.1	Air Quality	3-179
	3.6.5.2	Waste Management	3-179
	3.6.5.3	Existing Human Health Risk	3-180
	3.6.5.4	Infrastructure	3-180
3.6.6		ORR Overview	3-180
	3.6.6.1	Air Quality	3-181
	3.6.6.2	Waste Management	3-181
	3.6.6.3	Existing Human Health Risk	3-183
	3.6.6.4	Infrastructure	3-185
3.7		Reactor Sites for MOX Fuel Irradiation	3-186
3.7.1		Catawba Units 1 and 2 Site Overview	3-186
	3.7.1.1	Air Quality	3-186
	3.7.1.2	Waste Management	3-186
	3.7.1.3	Existing Human Health Risk	3-189
	3.7.1.4	Environmental Justice	3-190
3.7.2		McGuire Units 1 and 2 Site Overview	3-191
	3.7.2.1	Air Quality	3-193
	3.7.2.2	Waste Management	3-193
	3.7.2.3	Existing Human Health Risk	3-194
	3.7.2.4	Environmental Justice	3-196
3.7.3		North Anna Units 1 and 2 Site Overview	3-196
	3.7.3.1	Air Quality	3-198
	3.7.3.2	Waste Management	3-198
	3.7.3.3	Existing Human Health Risk	3-200

3.7.3.4	Environmental Justice	3-201
3.8	References	3-202

Volume I - Part B

Chapter 4

Environmental Consequences		4-1
4.1	Introduction	4-1
4.2	Alternative 1: No Action	4-2
4.2.1	Air Quality and Noise	4-3
4.2.1.1	Hanford	4-3
4.2.1.2	INEEL	4-4
4.2.1.3	Pantex	4-5
4.2.1.4	SRS	4-6
4.2.1.5	LLNL	4-7
4.2.1.6	LANL	4-7
4.2.1.7	RFETS	4-8
4.2.2	Waste Management	4-9
4.2.2.1	Hanford	4-9
4.2.2.2	INEEL	4-10
4.2.2.3	Pantex	4-10
4.2.2.4	SRS	4-11
4.2.2.5	LLNL	4-11
4.2.2.6	LANL	4-12
4.2.2.7	RFETS	4-12
4.2.3	Socioeconomics	4-13
4.2.4	Human Health Risk	4-13
4.2.4.1	Hanford	4-13
4.2.4.2	INEEL	4-14
4.2.4.3	Pantex	4-15
4.2.4.4	SRS	4-17
4.2.4.5	LLNL	4-18
4.2.4.6	LANL	4-19
4.2.4.7	RFETS	4-21
4.2.5	Facility Accidents	4-22
4.2.5.1	Hanford	4-23
4.2.5.2	INEEL	4-23
4.2.5.3	Pantex	4-23
4.2.5.4	SRS	4-24
4.2.5.5	LLNL	4-24
4.2.5.6	LANL	4-24
4.2.5.7	RFETS	4-24
4.2.6	Transportation	4-24
4.2.7	Environmental Justice	4-25
4.2.7.1	Hanford	4-25
4.2.7.2	INEEL	4-25
4.2.7.3	Pantex	4-25

4.2.7.4	SRS	4-25
4.2.7.5	LLNL	4-25
4.2.7.6	LANL	4-26
4.2.7.7	RFETS	4-26
4.2.8	Geology and Soils	4-26
4.2.8.1	Hanford	4-26
4.2.8.2	INEEL	4-26
4.2.8.3	Pantex	4-27
4.2.8.4	SRS	4-27
4.2.8.5	LLNL	4-27
4.2.8.6	LANL	4-28
4.2.8.7	RFETS	4-28
4.2.9	Water Resources	4-28
4.2.9.1	Hanford	4-28
4.2.9.2	INEEL	4-28
4.2.9.3	Pantex	4-29
4.2.9.4	SRS	4-29
4.2.9.5	LLNL	4-29
4.2.9.6	LANL	4-29
4.2.9.7	RFETS	4-29
4.2.10	Ecological Resources	4-29
4.2.10.1	Hanford	4-29
4.2.10.2	INEEL	4-30
4.2.10.3	Pantex	4-30
4.2.10.4	SRS	4-30
4.2.10.5	LLNL	4-30
4.2.10.6	LANL	4-30
4.2.10.7	RFETS	4-30
4.2.11	Cultural and Paleontological Resources	4-31
4.2.11.1	Hanford	4-31
4.2.11.2	INEEL	4-31
4.2.11.3	Pantex	4-31
4.2.11.4	SRS	4-31
4.2.11.5	LLNL	4-31
4.2.11.6	LANL	4-31
4.2.11.7	RFETS	4-32
4.2.12	Land Use and Visual Resources	4-32
4.2.13	Infrastructure	4-32
4.2.13.1	Hanford	4-32
4.2.13.2	INEEL	4-32
4.2.13.3	Pantex	4-32
4.2.13.4	SRS	4-32
4.2.13.5	LLNL	4-32
4.2.13.6	LANL	4-33
4.2.13.7	RFETS	4-33
4.3	Alternative 2	4-34
4.3.1	Construction	4-34
4.3.1.1	Air Quality and Noise	4-34
4.3.1.2	Waste Management	4-35
4.3.1.3	Socioeconomics	4-36

	4.3.1.4	Human Health Risk	4-37
	4.3.1.5	Facility Accidents	4-37
	4.3.1.6	Environmental Justice	4-37
4.3.2	Operations		4-37
	4.3.2.1	Air Quality and Noise	4-37
	4.3.2.2	Waste Management	4-39
	4.3.2.3	Socioeconomics	4-41
	4.3.2.4	Human Health Risk	4-42
	4.3.2.5	Facility Accidents	4-44
	4.3.2.6	Transportation	4-48
	4.3.2.7	Environmental Justice	4-50
4.4	Alternative 3		4-51
4.4.1	Construction		4-51
	4.4.1.1	Air Quality and Noise	4-51
	4.4.1.2	Waste Management	4-52
	4.4.1.3	Socioeconomics	4-53
	4.4.1.4	Human Health Risk	4-54
	4.4.1.5	Facility Accidents	4-54
	4.4.1.6	Environmental Justice	4-54
4.4.2	Operations		4-55
	4.4.2.1	Air Quality and Noise	4-55
	4.4.2.2	Waste Management	4-56
	4.4.2.3	Socioeconomics	4-58
	4.4.2.4	Human Health Risk	4-59
	4.4.2.5	Facility Accidents	4-60
	4.4.2.6	Transportation	4-64
	4.4.2.7	Environmental Justice	4-67
4.5	[Section deleted because alternative deleted.]		4-68
4.6	Alternative 4A		4-69
4.6.1	Construction		4-69
	4.6.1.1	Air Quality and Noise	4-69
	4.6.1.2	Waste Management	4-71
	4.6.1.3	Socioeconomics	4-73
	4.6.1.4	Human Health Risk	4-74
	4.6.1.5	Facility Accidents	4-74
	4.6.1.6	Environmental Justice	4-74
4.6.2	Operations		4-74
	4.6.2.1	Air Quality and Noise	4-74
	4.6.2.2	Waste Management	4-78
	4.6.2.3	Socioeconomics	4-82
	4.6.2.4	Human Health Risk	4-82
	4.6.2.5	Facility Accidents	4-84
	4.6.2.6	Transportation	4-86
	4.6.2.7	Environmental Justice	4-88
4.7	Alternative 4B		4-90
4.7.1	Construction		4-90
	4.7.1.1	Air Quality and Noise	4-90
	4.7.1.2	Waste Management	4-90
	4.7.1.3	Socioeconomics	4-92
	4.7.1.4	Human Health Risk	4-93

	4.7.1.5	Facility Accidents	4-93
	4.7.1.6	Environmental Justice	4-93
4.7.2	Operations		4-93
	4.7.2.1	Air Quality and Noise	4-93
	4.7.2.2	Waste Management	4-95
	4.7.2.3	Socioeconomics	4-95
	4.7.2.4	Human Health Risk	4-96
	4.7.2.5	Facility Accidents	4-97
	4.7.2.6	Transportation	4-99
	4.7.2.7	Environmental Justice	4-99
4.8	Alternative 5		4-101
4.8.1	Construction		4-101
	4.8.1.1	Air Quality and Noise	4-101
	4.8.1.2	Waste Management	4-102
	4.8.1.3	Socioeconomics	4-103
	4.8.1.4	Human Health Risk	4-104
	4.8.1.5	Facility Accidents	4-105
	4.8.1.6	Environmental Justice	4-105
4.8.2	Operations		4-105
	4.8.2.1	Air Quality and Noise	4-105
	4.8.2.2	Waste Management	4-107
	4.8.2.3	Socioeconomics	4-109
	4.8.2.4	Human Health Risk	4-109
	4.8.2.5	Facility Accidents	4-111
	4.8.2.6	Transportation	4-112
	4.8.2.7	Environmental Justice	4-114
4.9	[Section deleted because alternative deleted.]		4-116
4.10	Alternative 6A		4-117
4.10.1	Construction		4-117
	4.10.1.1	Air Quality and Noise	4-117
	4.10.1.2	Waste Management	4-119
	4.10.1.3	Socioeconomics	4-121
	4.10.1.4	Human Health Risk	4-122
	4.10.1.5	Facility Accidents	4-122
	4.10.1.6	Environmental Justice	4-122
4.10.2	Operations		4-123
	4.10.2.1	Air Quality and Noise	4-123
	4.10.2.2	Waste Management	4-126
	4.10.2.3	Socioeconomics	4-129
	4.10.2.4	Human Health Risk	4-130
	4.10.2.5	Facility Accidents	4-132
	4.10.2.6	Transportation	4-133
	4.10.2.7	Environmental Justice	4-135
4.11	Alternative 6B		4-136
4.11.1	Construction		4-136
	4.11.1.1	Air Quality and Noise	4-136
	4.11.1.2	Waste Management	4-136
	4.11.1.3	Socioeconomics	4-138
	4.11.1.4	Human Health Risk	4-139
	4.11.1.5	Facility Accidents	4-139

4.11.1.6	Environmental Justice	4-139
4.11.2	Operations	4-140
4.11.2.1	Air Quality and Noise	4-140
4.11.2.2	Waste Management	4-141
4.11.2.3	Socioeconomics	4-141
4.11.2.4	Human Health Risk	4-142
4.11.2.5	Facility Accidents	4-143
4.11.2.6	Transportation	4-144
4.11.2.7	Environmental Justice	4-144
4.12	[Section deleted because alternative deleted.]	4-146
4.13	[Section deleted because alternative deleted.]	4-147
4.14	Alternative 7	4-148
4.14.1	Construction	4-148
4.14.1.1	Air Quality and Noise	4-148
4.14.1.2	Waste Management	4-149
4.14.1.3	Socioeconomics	4-150
4.14.1.4	Human Health Risk	4-151
4.14.1.5	Facility Accidents	4-151
4.14.1.6	Environmental Justice	4-152
4.14.2	Operations	4-152
4.14.2.1	Air Quality and Noise	4-152
4.14.2.2	Waste Management	4-154
4.14.2.3	Socioeconomics	4-156
4.14.2.4	Human Health Risk	4-156
4.14.2.5	Facility Accidents	4-158
4.14.2.6	Transportation	4-160
4.14.2.7	Environmental Justice	4-163
4.15	[Section deleted because alternative deleted.]	4-164
4.16	Alternative 8	4-165
4.16.1	Construction	4-165
4.16.1.1	Air Quality and Noise	4-165
4.16.1.2	Waste Management	4-166
4.16.1.3	Socioeconomics	4-167
4.16.1.4	Human Health Risk	4-168
4.16.1.5	Facility Accidents	4-169
4.16.1.6	Environmental Justice	4-169
4.16.2	Operations	4-169
4.16.2.1	Air Quality and Noise	4-169
4.16.2.2	Waste Management	4-171
4.16.2.3	Socioeconomics	4-173
4.16.2.4	Human Health Risk	4-174
4.16.2.5	Facility Accidents	4-176
4.16.2.6	Transportation	4-177
4.16.2.7	Environmental Justice	4-179
4.17	Alternative 9	4-180
4.17.1	Construction	4-180
4.17.1.1	Air Quality and Noise	4-180
4.17.1.2	Waste Management	4-181
4.17.1.3	Socioeconomics	4-182
4.17.1.4	Human Health Risk	4-183

4.17.1.5	Facility Accidents	4-184
4.17.1.6	Environmental Justice	4-184
4.17.2	Operations	4-184
4.17.2.1	Air Quality and Noise	4-184
4.17.2.2	Waste Management	4-186
4.17.2.3	Socioeconomics	4-188
4.17.2.4	Human Health Risk	4-188
4.17.2.5	Facility Accidents	4-190
4.17.2.6	Transportation	4-192
4.17.2.7	Environmental Justice	4-194
4.18	[Section deleted because alternative deleted.]	4-196
4.19	Alternative 10	4-197
4.19.1	Construction	4-197
4.19.1.1	Air Quality and Noise	4-197
4.19.1.2	Waste Management	4-197
4.19.1.3	Socioeconomics	4-197
4.19.1.4	Human Health Risk	4-198
4.19.1.5	Facility Accidents	4-198
4.19.1.6	Environmental Justice	4-198
4.19.2	Operations	4-198
4.19.2.1	Air Quality and Noise	4-198
4.19.2.2	Waste Management	4-198
4.19.2.3	Socioeconomics	4-199
4.19.2.4	Human Health Risk	4-199
4.19.2.5	Facility Accidents	4-201
4.19.2.6	Transportation	4-201
4.19.2.7	Environmental Justice	4-204
4.20	Alternative 11A	4-205
4.20.1	Construction	4-205
4.20.1.1	Air Quality and Noise	4-205
4.20.1.2	Waste Management	4-206
4.20.1.3	Socioeconomics	4-207
4.20.1.4	Human Health Risk	4-208
4.20.1.5	Facility Accidents	4-208
4.20.1.6	Environmental Justice	4-208
4.20.2	Operations	4-208
4.20.2.1	Air Quality and Noise	4-208
4.20.2.2	Waste Management	4-210
4.20.2.3	Socioeconomics	4-212
4.20.2.4	Human Health Risk	4-213
4.20.2.5	Facility Accidents	4-214
4.20.2.6	Transportation	4-217
4.20.2.7	Environmental Justice	4-219
4.21	Alternative 11B	4-220
4.21.1	Construction	4-220
4.21.1.1	Air Quality and Noise	4-220
4.21.1.2	Waste Management	4-220
4.21.1.3	Socioeconomics	4-220
4.21.1.4	Human Health Risk	4-221
4.21.1.5	Facility Accidents	4-221

4.21.1.6	Environmental Justice	4-221
4.21.2	Operations	4-221
4.21.2.1	Air Quality and Noise	4-221
4.21.2.2	Waste Management	4-223
4.21.2.3	Socioeconomics	4-225
4.21.2.4	Human Health Risk	4-226
4.21.2.5	Facility Accidents	4-228
4.21.2.6	Transportation	4-229
4.21.2.7	Environmental Justice	4-230
4.22	Alternative 12A	4-232
4.22.1	Construction	4-232
4.22.1.1	Air Quality and Noise	4-232
4.22.1.2	Waste Management	4-233
4.22.1.3	Socioeconomics	4-234
4.22.1.4	Human Health Risk	4-234
4.22.1.5	Facility Accidents	4-235
4.22.1.6	Environmental Justice	4-235
4.22.2	Operations	4-235
4.22.2.1	Air Quality and Noise	4-235
4.22.2.2	Waste Management	4-237
4.22.2.3	Socioeconomics	4-239
4.22.2.4	Human Health Risk	4-239
4.22.2.5	Facility Accidents	4-241
4.22.2.6	Transportation	4-243
4.22.2.7	Environmental Justice	4-245
4.23	[Section deleted because alternative deleted.]	4-246
4.24	Alternative 12B	4-247
4.24.1	Construction	4-247
4.24.1.1	Air Quality and Noise	4-247
4.24.1.2	Waste Management	4-247
4.24.1.3	Socioeconomics	4-247
4.24.1.4	Human Health Risk	4-248
4.24.1.5	Facility Accidents	4-248
4.24.1.6	Environmental Justice	4-249
4.24.2	Operations	4-249
4.24.2.1	Air Quality and Noise	4-249
4.24.2.2	Waste Management	4-250
4.24.2.3	Socioeconomics	4-253
4.24.2.4	Human Health Risk	4-253
4.24.2.5	Facility Accidents	4-255
4.24.2.6	Transportation	4-255
4.24.2.7	Environmental Justice	4-257
4.25	[Section deleted because alternative deleted.]	4-259
4.26	Additional Environmental Resource Analyses	4-260
4.26.1	Hanford	4-260
4.26.1.1	Geology and Soils	4-260
4.26.1.1.1	Construction	4-260
4.26.1.1.2	Operations	4-261
4.26.1.2	Water Resources	4-261
4.26.1.2.1	Construction	4-261

	4.26.1.2.2	Operations	4-262
4.26.1.3		Ecological Resources	4-262
	4.26.1.3.1	Construction	4-262
	4.26.1.3.2	Operations	4-263
4.26.1.4		Cultural and Paleontological Resources	4-264
	4.26.1.4.1	Construction	4-264
	4.26.1.4.2	Operations	4-265
4.26.1.5		Land Use and Visual Resources	4-265
	4.26.1.5.1	Construction	4-265
	4.26.1.5.2	Operations	4-266
4.26.1.6		Infrastructure	4-266
	4.26.1.6.1	Construction	4-266
	4.26.1.6.2	Operations	4-267
4.26.2		INEEL	4-267
4.26.2.1		Geology and Soils	4-267
	4.26.2.1.1	Construction	4-267
	4.26.2.1.2	Operations	4-268
4.26.2.2		Water Resources	4-269
	4.26.2.2.1	Construction	4-269
	4.26.2.2.2	Operations	4-269
4.26.2.3		Ecological Resources	4-270
	4.26.2.3.1	Construction	4-270
	4.26.2.3.2	Operations	4-271
4.26.2.4		Cultural and Paleontological Resources	4-271
	4.26.2.4.1	Construction	4-272
	4.26.2.4.2	Operations	4-272
4.26.2.5		Land Use and Visual Resources	4-272
	4.26.2.5.1	Construction	4-273
	4.26.2.5.2	Operations	4-273
4.26.2.6		Infrastructure	4-274
	4.26.2.6.1	Construction	4-274
	4.26.2.6.2	Operations	4-274
4.26.3		Pantex	4-274
4.26.3.1		Geology and Soils	4-275
	4.26.3.1.1	Construction	4-275
	4.26.3.1.2	Operations	4-276
4.26.3.2		Water Resources	4-276
	4.26.3.2.1	Construction	4-276
	4.26.3.2.2	Operations	4-277
4.26.3.3		Ecological Resources	4-278
	4.26.3.3.1	Construction	4-278
	4.26.3.3.2	Operations	4-279
4.26.3.4		Cultural and Paleontological Resources	4-279
	4.26.3.4.1	Construction	4-279
	4.26.3.4.2	Operations	4-280
4.26.3.5		Land Use and Visual Resources	4-280
	4.26.3.5.1	Construction	4-280
	4.26.3.5.2	Operations	4-281
4.26.3.6		Infrastructure	4-281
	4.26.3.6.1	Construction	4-281

	4.26.3.6.2	Operations	4-281
4.26.4	SRS		4-282
	4.26.4.1	Geology and Soils	4-283
		4.26.4.1.1 Construction	4-283
		4.26.4.1.2 Operations	4-283
	4.26.4.2	Water Resources	4-283
		4.26.4.2.1 Construction	4-283
		4.26.4.2.2 Operations	4-284
	4.26.4.3	Ecological Resources	4-284
		4.26.4.3.1 Construction	4-285
		4.26.4.3.2 Operations	4-285
	4.26.4.4	Cultural and Paleontological Resources	4-286
		4.26.4.4.1 Construction	4-286
		4.26.4.4.2 Operations	4-287
	4.26.4.5	Land Use and Visual Resources	4-287
		4.26.4.5.1 Construction	4-287
		4.26.4.5.2 Operations	4-288
	4.26.4.6	Infrastructure	4-288
		4.26.4.6.1 Construction	4-288
		4.26.4.6.2 Operations	4-288
4.27	Lead Assembly and Postirradiation Examination Alternatives		4-290
	4.27.1	ANL-W	4-290
		4.27.1.1 Air Quality and Noise	4-290
		4.27.1.2 Waste Management	4-291
		4.27.1.3 Infrastructure	4-294
		4.27.1.4 Human Health Risk	4-294
		4.27.1.5 Facility Accidents	4-295
		4.27.1.6 Transportation	4-297
		4.27.1.7 Other Resource Areas	4-297
		4.27.1.8 Environmental Justice	4-298
	4.27.2	Hanford	4-298
		4.27.2.1 Air Quality and Noise	4-298
		4.27.2.2 Waste Management	4-299
		4.27.2.3 Infrastructure	4-301
		4.27.2.4 Human Health Risk	4-302
		4.27.2.5 Facility Accidents	4-303
		4.27.2.6 Transportation	4-304
		4.27.2.7 Other Resource Areas	4-305
		4.27.2.8 Environmental Justice	4-305
	4.27.3	LLNL	4-306
		4.27.3.1 Air Quality and Noise	4-306
		4.27.3.2 Waste Management	4-306
		4.27.3.3 Infrastructure	4-309
		4.27.3.4 Human Health Risk	4-309
		4.27.3.5 Facility Accidents	4-310
		4.27.3.6 Transportation	4-312
		4.27.3.7 Other Resource Areas	4-313
		4.27.3.8 Environmental Justice	4-313
	4.27.4	LANL	4-314
		4.27.4.1 Air Quality and Noise	4-314

4.27.4.2	Waste Management	4-314
4.27.4.3	Infrastructure	4-317
4.27.4.4	Human Health Risk	4-318
4.27.4.5	Facility Accidents	4-319
4.27.4.6	Transportation	4-321
4.27.4.7	Other Resource Areas	4-321
4.27.4.8	Environmental Justice	4-322
4.27.5	SRS	4-322
4.27.5.1	Air Quality and Noise	4-322
4.27.5.2	Waste Management	4-323
4.27.5.3	Infrastructure	4-326
4.27.5.4	Human Health Risk	4-326
4.27.5.5	Facility Accidents	4-327
4.27.5.6	Transportation	4-329
4.27.5.7	Other Resource Areas	4-329
4.27.5.8	Environmental Justice	4-330
4.27.6	Postirradiation Examination Activities	4-330
4.27.6.1	[Text deleted.]	4-330
4.27.6.2	ANL-W	4-330
4.27.6.3	ORNL	4-333
4.28	Impacts of Irradiating MOX Fuel at Reactor Sites	4-337
4.28.1	Construction Impacts	4-338
4.28.2	Operational Impacts	4-338
4.28.2.1	Air Quality and Noise	4-338
4.28.2.2	Waste Management	4-339
4.28.2.3	Socioeconomics	4-339
4.28.2.4	Human Health Risk From Normal Operations	4-339
4.28.2.5	Reactor Accident Analysis	4-340
4.28.2.5.1	Design Basis Accident Analysis	4-341
4.28.2.5.2	Beyond-Design-Basis Accident Analysis	4-347
4.28.2.6	Transportation	4-352
4.28.2.7	Environmental Justice	4-352
4.28.2.8	Spent Fuel	4-353
4.28.2.9	Geology and Soils	4-354
4.28.2.10	Water Resources	4-354
4.28.2.11	Ecological Resources	4-355
4.28.2.12	Cultural and Paleontological Resources	4-355
4.28.2.13	Land Use	4-355
4.28.2.14	Infrastructure	4-355
4.28.3	Avoided Environmental Impacts Associated With Using MOX Fuel From Surplus Plutonium in Commercial Reactors Versus LEU Fuel	4-355
4.29	Comparison of Immobilization Technology Impacts	4-357
4.29.1	Air Quality	4-357
4.29.2	Waste Management	4-358
4.29.3	Human Health Risk	4-358
4.29.4	Facility Accidents	4-361
4.29.5	Resource Requirements	4-362
4.29.6	Intersite Transportation	4-362
4.29.7	Environmental Justice	4-363
4.30	Incremental Impacts	4-364

4.30.1	Incremental Impacts of Reapportioning Materials in the Hybrid Approach	4-364
4.30.1.1	Air Quality	4-364
4.30.1.2	Waste Management	4-364
4.30.1.3	Socioeconomics	4-364
4.30.1.4	Human Health Risk	4-365
4.30.1.5	Facility Accidents	4-366
4.30.1.6	Transportation	4-366
4.30.1.7	Environmental Justice	4-366
4.30.1.8	Other Resource Areas	4-366
4.30.2	Incremental Impacts of Extending or Shortening the Operating Period of Surplus Plutonium Disposition Facilities	4-367
4.30.3	Incremental Impacts Associated With Uranium Conversion	4-367
4.30.3.1	Air Quality	4-368
4.30.3.2	Waste Management	4-368
4.30.3.3	Human Health Risk	4-369
4.30.3.4	Facility Accidents	4-369
4.31	Postoperation Scenarios	4-371
4.31.1	Deactivation and Stabilization	4-371
4.31.2	Decontamination and Decommissioning	4-371
4.32	Cumulative Impacts	4-373
4.32.1	Hanford	4-376
4.32.1.1	Resource Requirements	4-376
4.32.1.2	Air Quality	4-376
4.32.1.3	Waste Management	4-377
4.32.1.4	Human Health Risk	4-377
4.32.1.5	Transportation	4-378
4.32.2	INEEL	4-379
4.32.2.1	Resource Requirements	4-379
4.32.2.2	Air Quality	4-379
4.32.2.3	Waste Management	4-380
4.32.2.4	Human Health Risk	4-380
4.32.2.5	Transportation	4-381
4.32.3	Pantex	4-381
4.32.3.1	Resource Requirements	4-381
4.32.3.2	Air Quality	4-382
4.32.3.3	Waste Management	4-382
4.32.3.4	Human Health Risk	4-382
4.32.3.5	Transportation	4-384
4.32.4	SRS	4-384
4.32.4.1	Resource Requirements	4-384
4.32.4.2	Air Quality	4-385
4.32.4.3	Waste Management	4-385
4.32.4.4	Human Health Risk	4-385
4.32.4.5	Transportation	4-387
4.32.5	LLNL	4-387
4.32.5.1	Resource Requirements	4-387
4.32.5.2	Air Quality	4-388
4.32.5.3	Waste Management	4-388
4.32.5.4	Human Health Risk	4-388
4.32.5.5	Transportation	4-390

4.32.6	LANL	4-390
4.32.6.1	Resource Requirements	4-390
4.32.6.2	Air Quality	4-391
4.32.6.3	Waste Management	4-391
4.32.6.4	Human Health Risk	4-391
4.32.6.5	Transportation	4-393
4.32.7	ORNL	4-393
4.32.7.1	Waste Management	4-394
4.32.7.2	Human Health Risk	4-394
4.32.7.3	Transportation	4-395
4.32.8	Reactor Sites (Catawba, McGuire, North Anna)	4-395
4.33	Irreversible and Irrecoverable Commitments of Resources	4-397
4.33.1	Land Use	4-397
4.33.2	Materials	4-397
4.33.3	Energy	4-399
4.33.4	Waste Minimization, Pollution Prevention, and Energy Conservation	4-399
4.33.4.1	Waste Minimization and Pollution Prevention	4-399
4.33.4.2	Energy Conservation	4-400
4.34	Relationship Between Local Short-term Uses of the Environment and the Maintenance and Enhancement of Long-term Productivity	4-401
4.35	References	4-402

Chapter 5

Environmental Regulations, Permits, and Consultations	5-1
--	-----

5.1	Laws, Regulations, Executive Orders, and DOE Orders	5-1
5.2	Regulatory Activities	5-1
5.2.1	Pit Conversion and Immobilization Facilities	5-2
5.2.2	MOX Facility	5-2
5.2.3	Reactors	5-3
5.3	Consultations	5-3
5.3.1	Native American Consultations	5-4
5.3.2	Archaeological and Historical Resources Consultations	5-4
5.3.3	Endangered Species Act Consultation	5-5

Chapter 6

Glossary	6-1
-----------------	-----

Chapter 7

List of Preparers	7-1
--------------------------	-----

Chapter 8

Distribution List	8-1
--------------------------	-----

Chapter 9

Index	9-1
--------------	-----

List of Figures

Volume I - Part A

Figure 1–1.	Locations of Surplus Plutonium	1–2
Figure 1–2.	Proposed Surplus Plutonium Disposition Processes	1–7
Figure 2–1.	Proposed Locations of Surplus Plutonium Disposition Facilities	2–1
Figure 2–2.	Hanford, Washington	2–4
Figure 2–3.	INEEL, Idaho	2–5
Figure 2–4.	Pantex, Texas	2–6
Figure 2–5.	SRS, South Carolina	2–7
Figure 2–6.	Depiction of a Pit	2–14
Figure 2–7.	General Design of Pit Conversion Facility—Main Processing Level (First Floor)	2–16
Figure 2–8.	General Design of Pit Conversion Facility—Lower (Basement) Level	2–17
Figure 2–9.	Pit Disassembly and Conversion Process	2–19
Figure 2–10.	General Design of Immobilization Facility Main Processing Building—Main Level	2–24
Figure 2–11.	General Design of Immobilization Facility Main Processing Building—Above-Grade Structures	2–25
Figure 2–12.	Cutaway View of Can-in-Canister Approach	2–26
Figure 2–13.	Can-in-Canister Process	2–27
Figure 2–14.	General Design of MOX Facility—Ground Level	2–31
Figure 2–15.	General Design of MOX Facility—Basement Level and Frontal Elevation	2–32
Figure 2–16.	MOX Fuel Fabrication Process	2–34
Figure 2–17.	Transportation Requirements for Plutonium Conversion and Immobilization	2–38
Figure 2–18.	Transportation Requirements for MOX Fuel Fabrication	2–41
Figure 2–19.	Transportation Requirements for Lead Assembly Fabrication	2–42
Figure 2–20.	Proposed Facility Locations in the 400 H-Area at Hanford (Hybrid Alternative Shown) .	2–45
Figure 2–21.	Location of Planned HLW Vitrification Facility in the 200 Area at Hanford (Proposed Location of Canister-Filling Operations)	2–46
Figure 2–22.	Proposed Facility Locations in F-Area at SRS	2–49
Figure 2–23.	Location of DWPF in S-Area at SRS (Proposed Location of Canister-Filling Operations)	2–50
Figure 2–24.	Proposed Pit Conversion Facility Location in Zone 4 West at Pantex	2–52

Figure 2–25.	Proposed Pit Conversion and MOX Facility Locations in INTEC at INEEL	2–58
Figure 2–26.	Proposed Pit Conversion and MOX Facility Locations in Zone 4 West at Pantex	2–60
Figure 2–27.	Proposed MOX Fuel Lead Assembly Fabrication Facilities, ANL–W at INEEL	2–66
Figure 2–28.	Proposed MOX Fuel Lead Assembly Fabrication Facilities, H–Area at SRS	2–67
Figure 2–29.	LANL, New Mexico	2–68
Figure 2–30.	Proposed MOX Fuel Lead Assembly Fabrication Facilities, TA–55 at LANL	2–70
Figure 2–31.	LLNL, California	2–71
Figure 2–32.	Proposed MOX Fuel Lead Assembly Fabrication Facilities, Superblock at LLNL	2–72
Figure 3–1.	Employment and Local Economy for the Hanford Regional Economic Area and the State of Washington	3–14
Figure 3–2.	Population and Housing for the Hanford Region of Influence and the State of Washington	3–16
Figure 3–3.	School District Characteristics for the Hanford Region of Influence	3–17
Figure 3–4.	Public Safety and Health Care Characteristics for the Hanford Region of Influence	3–18
Figure 3–5.	Racial and Ethnic Composition of Minorities Around Hanford	3–25
Figure 3–6.	Flood Area for the Probable Maximum Flood and Columbia River 1948 Flood	3–28
Figure 3–7.	Flood Area of a 50 Percent Breach of the Grand Coulee Dam	3–29
Figure 3–8.	Major Plant Communities at Hanford	3–34
Figure 3–9.	Generalized Land Use at Hanford and Vicinity	3–42
Figure 3–10.	Employment and Local Economy for the INEEL Regional Economic Area and the States of Idaho and Wyoming	3–59
Figure 3–11.	Population and Housing for the INEEL Region of Influence and the State of Idaho	3–61
Figure 3–12.	School District Characteristics for the INEEL Region of Influence	3–63
Figure 3–13.	Public Safety and Health Care Characteristics for the INEEL Region of Influence	3–64
Figure 3–14.	Racial and Ethnic Composition of Minorities Around the Fuel Processing Facility at INEEL	3–70
Figure 3–15.	Flood Area for the Probable Maximum Flood–Induced Overtopping Failure of the Mackay Dam	3–73
Figure 3–16.	Generalized Habitat Types at INEEL	3–76
Figure 3–17.	Generalized Land Use at INEEL and Vicinity	3–83
Figure 3–18.	Employment and Local Economy for the Pantex Regional Economic Area and the States of Texas and New Mexico	3–99
Figure 3–19.	Population and Housing for the Pantex Region of Influence and the State of Texas	3–100
Figure 3–20.	School District Characteristics for the Pantex Region of Influence	3–101

Figure 3–21.	Public Safety and Health Care Characteristics for the Pantex Region of Influence	3–103
Figure 3–22.	Racial and Ethnic Composition of Minorities Around Pantex	3–108
Figure 3–23.	Locations of Floodplains and Playas at Pantex	3–113
Figure 3–24.	Generalized Habitat Types at Pantex (Main Plant Area)	3–117
Figure 3–25.	Generalized Land Use at Pantex and Vicinity	3–123
Figure 3–26.	Employment and Local Economy for the SRS Regional Economic Area and the States of Georgia and South Carolina	3–137
Figure 3–27.	Population and Housing for the SRS Region of Influence and the States of Georgia and South Carolina	3–139
Figure 3–28.	School District Characteristics for the SRS Region of Influence	3–140
Figure 3–29.	Public Safety and Health Care Characteristics for the SRS Region of Influence	3–141
Figure 3–30.	Racial and Ethnic Composition of Minorities Around SRS	3–148
Figure 3–31.	Locations of Floodplains at SRS	3–151
Figure 3–32.	Major Plant Communities at SRS	3–156
Figure 3–33.	Generalized Land Use at SRS and Vicinity	3–162
Figure 3–34.	Catawba Nuclear Power Plant, South Carolina	3–187
Figure 3–35.	McGuire Nuclear Power Plant, North Carolina	3–192
Figure 3–36.	North Anna Nuclear Power Plant, Virginia	3–197

List of Tables

Volume I - Part A

Table 2-1.	Surplus Plutonium Disposition Facility Alternatives Evaluated in This SPD EIS	2-3
Table 2-2.	Potential Impurities in Weapons-Grade Plutonium	2-15
Table 2-3.	Facility Transportation Requirements	2-36
Table 2-4.	Summary of Impacts of Construction and Operation of Surplus Plutonium Disposition Facilities by Alternative and Site	2-78
Table 2-5.	Summary of Impacts of Lead Assembly Fabrication at the Candidate Sites	2-97
Table 2-6.	Potential Impacts on Air Quality of MOX Fuel Fabrication and Irradiation	2-99
Table 2-7.	Potential Impacts on Waste Generation of MOX Fuel Fabrication and Irradiation	2-99
Table 2-8.	Potential Impacts on Infrastructure of MOX Fuel Fabrication and Irradiation	2-100
Table 2-9.	Potential Radiological Impacts on Workers of MOX Fuel Fabrication and Irradiation	2-100
Table 2-10.	Potential Radiological Impacts on the Public of MOX Fuel Fabrication and Irradiation	2-101
Table 2-11.	Potential Overland Transportation Risks of MOX Fuel Fabrication and Irradiation	2-101
Table 3-1.	General Regions of Influence for the Affected Environment	3-2
Table 3-2.	Current Missions at Hanford	3-4
Table 3-3.	Comparison of Ambient Air Concentrations From Hanford Sources With Most Stringent Applicable Standards or Guidelines, 1994	3-6
Table 3-4.	Waste Generation Rates and Inventories at Hanford	3-9
Table 3-5.	Waste Management Capabilities at Hanford	3-10
Table 3-6.	Preferred Alternatives From the WM PEIS	3-13
Table 3-7.	Distribution of Employees by Place of Residence in the Hanford Region of Influence, 1997	3-13
Table 3-8.	Sources of Radiation Exposure to Individuals in the Hanford Vicinity Unrelated to Hanford Operations	3-19
Table 3-9.	Radiation Doses to the Public From Normal Hanford Operations in 1996 (Total Effective Dose Equivalent)	3-20
Table 3-10.	Radiation Doses to Workers From Normal Hanford Operations in 1996 (Total Effective Dose Equivalent)	3-21
Table 3-11.	Threatened and Endangered Species, Species of Concern, and Sensitive Species Occurring or Potentially Occurring in the Vicinity of 200 East Area and 400 Area	3-37
Table 3-12.	Hanford Sitewide Infrastructure Characteristics	3-45

Table 3–13.	Hanford Infrastructure Characteristics for 200 East Area and FMEF	3–46
Table 3–14.	Current Missions at INEEL	3–49
Table 3–15.	Comparison of Ambient Air Concentrations From INEEL Sources With Most Stringent Applicable Standards or Guidelines, 1990	3–51
Table 3–16.	Waste Generation Rates and Inventories at INEEL	3–53
Table 3–17.	Waste Management Capabilities at INEEL	3–54
Table 3–18.	Preferred Alternatives From the WM PEIS	3–60
Table 3–19.	Distribution of Employees by Place of Residence in the INEEL Region of Influence, 1997	3–60
Table 3–20.	Sources of Radiation Exposure to Individuals in the INEEL Vicinity Unrelated to INEEL Operations	3–65
Table 3–21.	Radiation Doses to the Public From Normal INEEL Operations in 1996 (Total Effective Dose Equivalent)	3–66
Table 3–22.	Radiation Doses to Workers From Normal INEEL Operations in 1996 (Total Effective Dose Equivalent)	3–67
Table 3–23.	Threatened and Endangered Species, Species of Concern, and Sensitive Species Occurring or Potentially Occurring in Areas Surrounding INTEC	3–78
Table 3–24.	INEEL Sitewide Infrastructure Characteristics	3–85
Table 3–25.	INEEL Infrastructure Characteristics for INTEC	3–87
Table 3–26.	Current Missions at Pantex	3–88
Table 3–27.	Comparison of Ambient Air Concentrations From Pantex Sources With Most Stringent Applicable Standards or Guidelines, 1993	3–90
Table 3–28.	Waste Generation Rates and Inventories at Pantex	3–93
Table 3–29.	Waste Management Capabilities at Pantex	3–94
Table 3–30.	Preferred Alternatives From the WM PEIS	3–97
Table 3–31.	Distribution of Employees by Place of Residence in the Pantex Region of Influence, 1997	3–98
Table 3–32.	Sources of Radiation Exposure to Individuals in the Pantex Vicinity Unrelated to Pantex Operations	3–104
Table 3–33.	Radiation Doses to the Public From Normal Pantex Operations in 1996 (Total Effective Dose Equivalent)	3–104
Table 3–34.	Radiation Doses to Workers From Normal Pantex Operations in 1996 (Total Effective Dose Equivalent)	3–105
Table 3–35.	Threatened and Endangered Species, Species of Concern, and Sensitive Species Occurring or Potentially Occurring in Areas Surrounding Zone 4 West	3–119
Table 3–36.	Pantex Sitewide Infrastructure Characteristics	3–125
Table 3–37.	Pantex Infrastructure Characteristics for Zone 4	3–126

Table 3–38.	Current Missions at SRS	3–127
Table 3–39.	Comparison of Ambient Air Concentrations From SRS Sources With Most Stringent Applicable Standards or Guidelines, 1994	3–129
Table 3–40.	Waste Generation Rates and Inventories at SRS	3–132
Table 3–41.	Waste Management Capabilities at SRS	3–133
Table 3–42.	Preferred Alternatives From the WM PEIS	3–136
Table 3–43.	Distribution of Employees by Place of Residence in the SRS Region of Influence, 1997	3–136
Table 3–44.	Sources of Radiation Exposure to Individuals in the SRS Vicinity Unrelated to SRS Operations	3–143
Table 3–45.	Radiation Doses to the Public From Normal SRS Operations in 1996 (Total Effective Dose Equivalent)	3–143
Table 3–46.	Radiation Doses to Workers From Normal SRS Operations in 1996 (Total Effective Dose Equivalent)	3–144
Table 3–47.	Threatened and Endangered Species, Species of Concern, and Sensitive Species Occurring or Potentially Occurring in the Vicinity of F-Area and S-Area	3–158
Table 3–48.	SRS Sitewide Infrastructure Characteristics	3–165
Table 3–49.	SRS Infrastructure Characteristics for F-Area and S-Area	3–166
Table 3–50.	Worker Exposure Data for ANL–W, 1994–1996	3–169
Table 3–51.	ANL–W Infrastructure Characteristics	3–170
Table 3–52.	Waste Generation Rates and Inventories at LLNL	3–171
Table 3–53.	Waste Management Facilities at LLNL	3–172
Table 3–54.	Sources of Radiation Exposure to Individuals in the LLNL Vicinity Unrelated to LLNL Operations	3–173
Table 3–55.	Radiation Doses to the Public From Normal LLNL Operations in 1996 (Total Effective Dose Equivalent)	3–173
Table 3–56.	Radiation Doses to Onsite Workers From Normal LLNL Operations in 1997 (Total Effective Dose Equivalent)	3–174
Table 3–57.	LLNL Infrastructure Characteristics	3–174
Table 3–58.	Waste Generation Rates and Inventories at LANL	3–176
Table 3–59.	Selected Waste Management Facilities at LANL	3–176
Table 3–60.	Sources of Radiation Exposure to Individuals in the LANL Vicinity Unrelated to LANL Operations	3–177
Table 3–61.	Radiation Doses to the Public From Normal LANL Operations in 1995 (Total Effective Dose Equivalent)	3–178
Table 3–62.	Radiation Doses to Onsite Workers From Normal Operations at LANL, 1991–1995 (Total Effective Dose Equivalent)	3–178
Table 3–63.	LANL Infrastructure Characteristics	3–179

Table 3–64.	Infrastructure Characteristics of Building 221–H at SRS	3–180
Table 3–65.	Waste Generation Rates and Inventories at ORR	3–182
Table 3–66.	Selected Waste Management Facilities at ORR	3–182
Table 3–67.	Sources of Radiation Exposure to Individuals in the ORR Vicinity Unrelated to ORR Operations	3–183
Table 3–68.	Radiation Doses to the Public From Normal ORR Operations in 1997 (Total Effective Dose Equivalent)	3–184
Table 3–69.	Radiation Doses to Onsite Workers From Normal ORR Operations in 1997 (Total Effective Dose Equivalent)	3–184
Table 3–70.	ORR Infrastructure Characteristics	3–185
Table 3–71.	Comparison of Contribution to Nonradiological Ambient Air Pollutant Concentrations From Catawba Sources With National Ambient Air Quality Standards	3–188
Table 3–72.	Annual Waste Generation for Catawba	3–188
Table 3–73.	Sources of Radiation Exposure to Individuals in the Catawba Vicinity Unrelated to Catawba Operations	3–189
Table 3–74.	Radiological Impacts on the Public From Catawba Operations in 1997 (Total Effective Dose Equivalent)	3–190
Table 3–75.	Radiological Impacts on Involved Workers From Catawba Operations in 1997	3–190
Table 3–76.	Comparison of Contribution to Nonradiological Ambient Air Pollutant Concentrations From McGuire Sources With National Ambient Air Quality Standards	3–193
Table 3–77.	Annual Waste Generation for McGuire	3–194
Table 3–78.	Sources of Radiation Exposure to Individuals in the McGuire Vicinity Unrelated to McGuire Operations	3–195
Table 3–79.	Radiological Impacts on the Public From McGuire Operations in 1997 (Total Effective Dose Equivalent)	3–195
Table 3–80.	Radiological Impacts on Involved Workers From McGuire Operations in 1997	3–196
Table 3–81.	Comparison of Contribution to Nonradiological Ambient Air Pollutant Concentrations From North Anna Sources With National Ambient Air Quality Standards	3–199
Table 3–82.	Annual Waste Generation for North Anna	3–199
Table 3–83.	Sources of Radiation Exposure to Individuals in the North Anna Vicinity Unrelated to North Anna Operations	3–200
Table 3–84.	Radiological Impacts on the Public From North Anna Operations in 1997 (Total Effective Dose Equivalent)	3–200
Table 3–85.	Radiological Impacts on Involved Workers From North Anna Operations in 1997	3–201

Table 4-1.	Evaluation of Hanford Air Pollutant Concentrations Associated With Alternative 1: No Action; Continued Storage of Plutonium at the Site	4-3
Table 4-2.	Evaluation of INEEL Air Pollutant Concentrations Associated With Alternative 1: No Action; Continued Storage of Plutonium at the Site	4-4
Table 4-3.	Evaluation of Pantex Air Pollutant Concentrations Associated With Alternative 1: No Action; Continued Storage of Plutonium at the Site	4-5
Table 4-4.	Evaluation of SRS Air Pollutant Concentrations Associated With Alternative 1: No Action; Continued Storage of Plutonium at the Site	4-6
Table 4-5.	Evaluation of LLNL Air Pollutant Concentrations Associated With Alternative 1: No Action; Continued Storage at the Site	4-7
Table 4-6.	Evaluation of LANL Air Pollutant Concentrations Associated With Alternative 1: No Action; Continued Storage of Plutonium at the Site	4-8
Table 4-7.	Evaluation of RFETS Air Pollutant Concentrations Associated With Alternative 1: No Action; Continued Storage of Plutonium at the Site	4-9
Table 4-8.	Potential Radiological Impacts on the Public of Alternative 1: No Action; Continued Storage of Plutonium at Hanford	4-13
Table 4-9.	Potential Radiological Impacts on Workers of Alternative 1: No Action; Continued Storage of Plutonium at Hanford	4-14
Table 4-10.	Potential Radiological Impacts on the Public of Alternative 1: No Action; Continued Storage of Plutonium at INEEL	4-15
Table 4-11.	Potential Radiological Impacts on Workers of Alternative 1: No Action; Continued Storage of Plutonium at INEEL	4-15
Table 4-12.	Potential Radiological Impacts on the Public of Alternative 1: No Action; Continued Storage of Plutonium at Pantex	4-16
Table 4-13.	Potential Radiological Impacts on Workers of Alternative 1: No Action; Continued Storage of Plutonium at Pantex	4-17
Table 4-14.	Potential Radiological Impacts on the Public of Alternative 1: No Action; Continued Storage of Plutonium at SRS	4-18
Table 4-15.	Potential Radiological Impacts on Workers of Alternative 1: No Action; Continued Storage of Plutonium at SRS	4-18
Table 4-16.	Potential Radiological Impacts on the Public of Alternative 1: No Action; Continued Storage of Plutonium at LLNL	4-19
Table 4-17.	Potential Radiological Impacts on Workers of Alternative 1: No Action; Continued Storage of Plutonium at LLNL	4-20
Table 4-18.	Potential Radiological Impacts on the Public of Alternative 1: No Action; Continued Storage of Plutonium at LANL	4-20
Table 4-19.	Potential Radiological Impacts on Workers of Alternative 1: No Action; Continued Storage of Plutonium at LANL	4-21
Table 4-20.	Potential Radiological Impacts on the Public of Alternative 1: No Action; Continued Storage of Plutonium at RFETS	4-22

Table 4–21.	Potential Radiological Impacts on Workers of Alternative 1: No Action; Continued Storage of Plutonium at RFETS	4–22
Table 4–22.	Evaluation of Air Pollutant Concentrations Associated With Construction Under Alternative 2: Pit Conversion in FMEF, Immobilization in FMEF and HLWVF, and MOX in New Construction at Hanford	4–35
Table 4–23.	Potential Waste Management Impacts of Construction Under Alternative 2: Pit Conversion in FMEF, Immobilization in FMEF and HLWVF, and MOX in New Construction at Hanford	4–36
Table 4–24.	Construction Employment Requirements for Alternative 2: Pit Conversion in FMEF, Immobilization in FMEF and HLWVF, and MOX in New Construction at Hanford	4–37
Table 4–25.	Evaluation of Air Pollutant Concentrations Associated With Operations Under Alternative 2: Pit Conversion in FMEF, Immobilization in FMEF and HLWVF, and MOX in New Construction at Hanford	4–38
Table 4–26.	Evaluation of Air Pollutant Increases Associated With Operations Under Alternative 2: Pit Conversion in FMEF, Immobilization in FMEF and HLWVF, and MOX in New Construction at Hanford	4–39
Table 4–27.	Potential Waste Management Impacts of Operations Under Alternative 2: Pit Conversion in FMEF, Immobilization in FMEF and HLWVF, and MOX in New Construction at Hanford	4–40
Table 4–28.	Potential Radiological Impacts on the Public of Operations Under Alternative 2: Pit Conversion in FMEF, Immobilization in FMEF and HLWVF, and MOX in New Construction at Hanford	4–43
Table 4–29.	Potential Radiological Impacts on Involved Workers of Operations Under Alternative 2: Pit Conversion in FMEF, Immobilization in FMEF and HLWVF, and MOX in New Construction at Hanford	4–43
Table 4–30.	Accident Impacts of Pit Conversion Under Alternative 2: Pit Conversion in FMEF, Immobilization in FMEF and HLWVF, and MOX in New Construction at Hanford	4–44
Table 4–31.	Accident Impacts of Ceramic Immobilization Under Alternative 2: Pit Conversion in FMEF, Immobilization in FMEF and HLWVF, and MOX in New Construction at Hanford	4–45
Table 4–32.	Accident Impacts of Glass Immobilization Under Alternative 2: Pit Conversion in FMEF, Immobilization in FMEF and HLWVF, and MOX in New Construction at Hanford	4–46
Table 4–33.	Accident Impacts of MOX Facility Under Alternative 2: Pit Conversion in FMEF, Immobilization in FMEF and HLWVF, and MOX in New Construction at Hanford	4–47
Table 4–34.	Evaluation of Air Pollutant Concentrations Associated With Construction Under Alternative 3: Pit Conversion and MOX in New Construction and Immobilization in New Construction and DWPF at SRS	4–51
Table 4–35.	Potential Waste Management Impacts of Construction Under Alternative 3: Pit Conversion and MOX in New Construction and Immobilization in New Construction and DWPF at SRS	4–52

Table 4–36. Construction Employment Requirements for Alternative 3: Pit Conversion and MOX in New Construction and Immobilization in New Construction and DWPF at SRS 4–53

Table 4–37. Potential Radiological Impacts on Construction Workers of Alternative 3: Pit Conversion and MOX in New Construction and Immobilization in New Construction and DWPF at SRS 4–54

Table 4–38. Evaluation of Air Pollutant Concentrations Associated With Operations Under Alternative 3: Pit Conversion and MOX in New Construction and Immobilization in New Construction and DWPF at SRS 4–55

Table 4–39. Evaluation of Air Pollutant Increases Associated With Operations Under Alternative 3: Pit Conversion and MOX in New Construction and Immobilization in New Construction and DWPF at SRS 4–56

Table 4–40. Potential Waste Management Impacts of Operations Under Alternative 3: Pit Conversion and MOX in New Construction and Immobilization in New Construction and DWPF at SRS 4–57

Table 4–41. Potential Radiological Impacts on the Public of Operations Under Alternative 3: Pit Conversion and MOX in New Construction and Immobilization in New Construction and DWPF at SRS 4–59

Table 4–42. Potential Radiological Impacts on Involved Workers of Operations Under Alternative 3: Pit Conversion and MOX in New Construction and Immobilization in New Construction and DWPF at SRS 4–60

Table 4–43. Accident Impacts of Pit Conversion Under Alternative 3: Pit Conversion and MOX in New Construction and Immobilization in New Construction and DWPF at SRS 4–61

Table 4–44. Accident Impacts of Ceramic Immobilization Under Alternative 3: Pit Conversion and MOX in New Construction and Immobilization in New Construction and DWPF at SRS 4–62

Table 4–45. Accident Impacts of Glass Immobilization Under Alternative 3: Pit Conversion and MOX in New Construction and Immobilization in New Construction and DWPF at SRS 4–63

Table 4–46. Accident Impacts of MOX Facility Under Alternative 3: Pit Conversion and MOX in New Construction and Immobilization in New Construction and DWPF at SRS 4–64

Table 4–47. Evaluation of Pantex Air Pollutant Concentrations Associated With Construction Under Alternative 4A: Pit Conversion in New Construction at Pantex, and Immobilization in FMEF and HLWVF and MOX in New Construction at Hanford 4–70

Table 4–48. Evaluation at Hanford of Air Pollutant Concentrations Associated With Construction Under Alternative 4A: Pit Conversion in New Construction at Pantex, and Immobilization in FMEF and HLWVF and MOX in New Construction at Hanford 4–71

Table 4–49. Potential Waste Management Impacts of Construction at Pantex Under Alternative 4A: Pit Conversion in New Construction at Pantex, and Immobilization in FMEF and HLWVF and MOX in New Construction at Hanford 4–72

Table 4–50. Potential Waste Management Impacts of Construction at Hanford Under Alternative 4A: Pit Conversion in New Construction at Pantex, and Immobilization in FMEF and HLWVF and MOX in New Construction at Hanford 4–72

Table 4-51.	Construction Employment Requirements for Alternative 4A: Pit Conversion in New Construction at Pantex, and Immobilization in FMEF and HLWVF and MOX in New Construction at Hanford	4-73
Table 4-52.	Evaluation of Pantex Air Pollutant Concentrations Associated With Operations Under Alternative 4A: Pit Conversion in New Construction at Pantex, and Immobilization in FMEF and HLWVF and MOX in New Construction at Hanford	4-75
Table 4-53.	Evaluation of Pantex Air Pollutant Increases Associated With Operations Under Alternative 4A: Pit Conversion in New Construction at Pantex, and Immobilization in FMEF and HLWVF and MOX in New Construction at Hanford	4-76
Table 4-54.	Evaluation of Hanford Air Pollutant Concentrations Associated With Operations Under Alternative 4A: Pit Conversion in New Construction at Pantex, and Immobilization in FMEF and HLWVF and MOX in New Construction at Hanford	4-77
Table 4-55.	Evaluation of Hanford Air Pollutant Increases Associated With Operations Under Alternative 4A: Pit Conversion in New Construction at Pantex, and Immobilization in FMEF and HLWVF and MOX in New Construction at Hanford	4-77
Table 4-56.	Potential Waste Management Impacts of Operations at Pantex Under Alternative 4A: Pit Conversion in New Construction at Pantex, and Immobilization in FMEF and HLWVF and MOX in New Construction at Hanford ^a	4-78
Table 4-57.	Potential Waste Management Impacts of Operations at Hanford Under Alternative 4A: Pit Conversion in New Construction at Pantex, and Immobilization in FMEF and HLWVF and MOX in New Construction at Hanford	4-79
Table 4-58.	Potential Radiological Impacts on the Public of Operations Under Alternative 4A: Pit Conversion in New Construction at Pantex, and Immobilization in FMEF and HLWVF and MOX in New Construction at Hanford	4-83
Table 4-59.	Potential Radiological Impacts on Involved Workers of Operations Under Alternative 4A: Pit Conversion in New Construction at Pantex, and Immobilization in FMEF and HLWVF and MOX in New Construction at Hanford	4-84
Table 4-60.	Accident Impacts of Pit Conversion Under Alternative 4A: Pit Conversion in New Construction at Pantex, and Immobilization in FMEF and HLWVF and MOX in New Construction at Hanford	4-85
Table 4-61.	Evaluation of Hanford Air Pollutant Concentrations Associated With Construction Under Alternative 4B: Pit Conversion in New Construction at Pantex, and Immobilization in FMEF and HLWVF and MOX in FMEF at Hanford	4-91
Table 4-62.	Potential Waste Management Impacts of Construction at Hanford Under Alternative 4B: Pit Conversion in New Construction at Pantex, and Immobilization in FMEF and HLWVF and MOX in FMEF at Hanford	4-91
Table 4-63.	Construction Employment Requirements for Alternative 4B: Pit Conversion in New Construction at Pantex, and Immobilization in FMEF and HLWVF and MOX in FMEF at Hanford	4-92
Table 4-64.	Evaluation of Hanford Air Pollutant Concentrations Associated With Operations Under Alternative 4B: Pit Conversion in New Construction at Pantex, and Immobilization in FMEF and HLWVF and MOX in FMEF at Hanford	4-94

Table 4-65.	Evaluation of Hanford Air Pollutant Increases Associated With Operations Under Alternative 4B: Pit Conversion in New Construction at Pantex, and Immobilization in FMEF and HLWVF and MOX in FMEF at Hanford	4-94
Table 4-66.	Potential Radiological Impacts on the Public of Operations Under Alternative 4B: Pit Conversion in New Construction at Pantex, and Immobilization in FMEF and HLWVF and MOX in FMEF at Hanford	4-96
Table 4-67.	Potential Radiological Impacts on Involved Workers of Operations Under Alternative 4B: Pit Conversion in New Construction at Pantex, and Immobilization in FMEF and HLWVF and MOX in FMEF at Hanford	4-97
Table 4-68.	Accident Impacts of MOX Facility Under Alternative 4B: Pit Conversion in New Construction at Pantex, and Immobilization in FMEF and HLWVF and MOX in FMEF at Hanford	4-98
Table 4-69.	Evaluation of SRS Air Pollutant Concentrations Associated With Construction Under Alternative 5: Pit Conversion in New Construction at Pantex, and Immobilization in New Construction and DWPF and MOX in New Construction at SRS	4-102
Table 4-70.	Potential Waste Management Impacts of Construction at SRS Under Alternative 5: Pit Conversion in New Construction at Pantex, and Immobilization in New Construction and DWPF and MOX in New Construction at SRS	4-103
Table 4-71.	Construction Employment Requirements for Alternative 5: Pit Conversion in New Construction at Pantex, and Immobilization in New Construction and DWPF and MOX in New Construction at SRS	4-104
Table 4-72.	Potential Radiological Impacts on Construction Workers of Alternative 5: Pit Conversion in New Construction at Pantex, and Immobilization in New Construction and DWPF and MOX in New Construction at SRS	4-104
Table 4-73.	Evaluation of SRS Air Pollutant Concentrations Associated With Operations Under Alternative 5: Pit Conversion in New Construction at Pantex, and Immobilization in New Construction and DWPF and MOX in New Construction at SRS	4-106
Table 4-74.	Evaluation of SRS Air Pollutant Increases Associated With Operations Under Alternative 5: Pit Conversion in New Construction at Pantex, and Immobilization in New Construction and DWPF and MOX in New Construction at SRS	4-106
Table 4-75.	Potential Waste Management Impacts of Operations at SRS Under Alternative 5: Pit Conversion in New Construction at Pantex, and Immobilization in New Construction and DWPF and MOX in New Construction at SRS	4-107
Table 4-76.	Potential Radiological Impacts on the Public of Operations Under Alternative 5: Pit Conversion in New Construction at Pantex, and Immobilization in New Construction and DWPF and MOX in New Construction at SRS	4-110
Table 4-77.	Potential Radiological Impacts on Involved Workers of Operations Under Alternative 5: Pit Conversion in New Construction at Pantex, and Immobilization in New Construction and DWPF and MOX in New Construction at SRS	4-111
Table 4-78.	Evaluation of Hanford Air Pollutant Concentrations Associated With Construction Under Alternative 6A: Pit Conversion in FMEF and MOX in New Construction at Hanford, and Immobilization in New Construction and DWPF at SRS	4-118

Table 4-79.	Evaluation of SRS Air Pollutant Concentrations Associated With Construction Under Alternative 6A: Pit Conversion in FMEF and MOX in New Construction at Hanford, and Immobilization in New Construction and DWPF at SRS	4-119
Table 4-80.	Potential Waste Management Impacts of Construction at Hanford Under Alternative 6A: Pit Conversion in FMEF and MOX in New Construction at Hanford, and Immobilization in New Construction and DWPF at SRS	4-120
Table 4-81.	Potential Waste Management Impacts of Construction at SRS Under Alternative 6A: Pit Conversion in FMEF and MOX in New Construction at Hanford, and Immobilization in New Construction and DWPF at SRS	4-120
Table 4-82.	Construction Employment Requirements for Alternative 6A: Pit Conversion in FMEF and MOX in New Construction at Hanford, and Immobilization in New Construction and DWPF at SRS	4-121
Table 4-83.	Potential Radiological Impacts on Construction Workers of Alternative 6A: Pit Conversion in FMEF and MOX in New Construction at Hanford, and Immobilization in New Construction and DWPF at SRS	4-122
Table 4-84.	Evaluation of Hanford Air Pollutant Concentrations Associated With Operations Under Alternative 6A: Pit Conversion in FMEF and MOX in New Construction at Hanford, and Immobilization in New Construction and DWPF at SRS	4-123
Table 4-85.	Evaluation of Hanford Air Pollutant Increases Associated With Operations Under Alternative 6A: Pit Conversion in FMEF and MOX in New Construction at Hanford, and Immobilization in New Construction and DWPF at SRS	4-124
Table 4-86.	Evaluation of SRS Air Pollutant Concentrations Associated With Operations Under Alternative 6A: Pit Conversion in FMEF and MOX in New Construction at Hanford, and Immobilization in New Construction and DWPF at SRS	4-125
Table 4-87.	Evaluation of SRS Air Pollutant Increases Associated With Operations Under Alternative 6A: Pit Conversion in FMEF and MOX in New Construction at Hanford, and Immobilization in New Construction and DWPF at SRS	4-125
Table 4-88.	Potential Waste Management Impacts of Operations at Hanford Under Alternative 6A: Pit Conversion in FMEF and MOX in New Construction at Hanford, and Immobilization in New Construction and DWPF at SRS	4-126
Table 4-89.	Potential Waste Management Impacts of Operations at SRS Under Alternative 6A: Pit Conversion in FMEF and MOX in New Construction at Hanford, and Immobilization in New Construction and DWPF at SRS	4-127
Table 4-90.	Potential Radiological Impacts on the Public of Operations Under Alternative 6A: Pit Conversion in FMEF and MOX in New Construction at Hanford, and Immobilization in New Construction and DWPF at SRS	4-131
Table 4-91.	Potential Radiological Impacts on Involved Workers of Operations Under Alternative 6A: Pit Conversion in FMEF and MOX in New Construction at Hanford, and Immobilization in New Construction and DWPF at SRS	4-132
Table 4-92.	Evaluation of Hanford Air Pollutant Concentrations Associated With Construction Under Alternative 6B: Pit Conversion and MOX Collocated in FMEF at Hanford, and Immobilization in New Construction and DWPF at SRS	4-137

Table 4-93.	Potential Waste Management Impacts of Construction at Hanford Under Alternative 6B: Pit Conversion and MOX Collocated in FMEF at Hanford, and Immobilization in New Construction and DWPF at SRS	4-137
Table 4-94.	Construction Employment Requirements for Alternative 6B: Pit Conversion and MOX Collocated in FMEF at Hanford, and Immobilization in New Construction and DWPF at SRS	4-138
Table 4-95.	Potential Radiological Impacts on Construction Workers of Alternative 6B: Pit Conversion and MOX Collocated in FMEF at Hanford, and Immobilization in New Construction and DWPF at SRS	4-139
Table 4-96.	Evaluation of Hanford Air Pollutant Concentrations Associated With Operations Under Alternative 6B: Pit Conversion and MOX Collocated in FMEF at Hanford, and Immobilization in New Construction and DWPF at SRS	4-140
Table 4-97.	Evaluation of Hanford Air Pollutant Increases Associated With Operations Under Alternative 6B: Pit Conversion and MOX Collocated in FMEF at Hanford, and Immobilization in New Construction and DWPF at SRS	4-141
Table 4-98.	Potential Radiological Impacts on the Public of Operations Under Alternative 6B: Pit Conversion and MOX Collocated in FMEF at Hanford, and Immobilization in New Construction and DWPF at SRS	4-142
Table 4-99.	Potential Radiological Impacts on Involved Workers of Operations Under Alternative 6B: Pit Conversion and MOX Collocated in FMEF at Hanford, and Immobilization in New Construction and DWPF at SRS	4-143
Table 4-100.	Evaluation of INEEL Air Pollutant Concentrations Associated With Construction Under Alternative 7: Pit Conversion in FPF and MOX in New Construction at INEEL, and Immobilization in New Construction and DWPF at SRS	4-148
Table 4-101.	Potential Waste Management Impacts of Construction Under Alternative 7: Pit Conversion in FPF and MOX in New Construction at INEEL	4-150
Table 4-102.	Construction Employment Requirements for Alternative 7: Pit Conversion in FPF and MOX in New Construction at INEEL, and Immobilization in New Construction and DWPF at SRS	4-150
Table 4-103.	Potential Radiological Impacts on Construction Workers of Alternative 7: Pit Conversion in FPF and MOX in New Construction at INEEL, and Immobilization in New Construction and DWPF at SRS	4-151
Table 4-104.	Evaluation of INEEL Air Pollutant Concentrations Associated With Operations Under Alternative 7: Pit Conversion in FPF and MOX in New Construction at INEEL, and Immobilization in New Construction and DWPF at SRS	4-152
Table 4-105.	Evaluation of INEEL Air Pollutant Increases Associated With Operations Under Alternative 7: Pit Conversion in FPF and MOX in New Construction at INEEL, and Immobilization in New Construction and DWPF at SRS	4-153
Table 4-106.	Potential Waste Management Impacts of Operations Under Alternative 7: Pit Conversion in FPF and MOX in New Construction at INEEL	4-154
Table 4-107.	Potential Radiological Impacts on the Public of Operations Under Alternative 7: Pit Conversion in FPF and MOX in New Construction at INEEL, and Immobilization in New Construction and DWPF at SRS	4-157

Table 4–108.	Potential Radiological Impacts on Involved Workers of Operations Under Alternative 7: Pit Conversion in FPF and MOX in New Construction at INEEL, and Immobilization in New Construction and DWPF at SRS	4–158
Table 4–109.	Accident Impacts of Pit Conversion Under Alternative 7: Pit Conversion in FPF and MOX in New Construction at INEEL, and Immobilization in New Construction and DWPF at SRS	4–159
Table 4–110.	Accident Impacts of MOX Facility Under Alternative 7: Pit Conversion in FPF and MOX in New Construction at INEEL, and Immobilization in New Construction and DWPF at SRS	4–160
Table 4–111.	Evaluation of Hanford Air Pollutant Concentrations Associated With Construction Under Alternative 8: Pit Conversion in FPF and MOX in New Construction at INEEL, and Immobilization in FMEF and HLWVF at Hanford	4–166
Table 4–112.	Potential Waste Management Impacts of Construction Under Alternative 8: Immobilization in FMEF and HLWVF at Hanford	4–167
Table 4–113.	Construction Employment Requirements for Alternative 8: Pit Conversion in FPF and MOX in New Construction at INEEL, and Immobilization in FMEF and HLWVF at Hanford	4–168
Table 4–114.	Potential Radiological Impacts on Construction Workers of Alternative 8: Pit Conversion in FPF and MOX in New Construction at INEEL, and Immobilization in FMEF and HLWVF at Hanford	4–168
Table 4–115.	Evaluation of Hanford Air Pollutant Concentrations Associated With Operations Under Alternative 8: Pit Conversion in FPF and MOX in New Construction at INEEL, and Immobilization in FMEF and HLWVF at Hanford	4–170
Table 4–116.	Evaluation of Hanford Air Pollutant Increases Associated With Operations Under Alternative 8: Pit Conversion in FPF and MOX in New Construction at INEEL, and Immobilization in FMEF and HLWVF at Hanford	4–170
Table 4–117.	Potential Waste Management Impacts of Operations Under Alternative 8: Immobilization in FMEF and HLWVF at Hanford	4–172
Table 4–118.	Potential Radiological Impacts on the Public of Operations Under Alternative 8: Pit Conversion in FPF and MOX in New Construction at INEEL, and Immobilization in FMEF and HLWVF at Hanford	4–175
Table 4–119.	Potential Radiological Impacts on Involved Workers of Operations Under Alternative 8: Pit Conversion in FPF and MOX in New Construction at INEEL, and Immobilization in FMEF and HLWVF at Hanford	4–175
Table 4–120.	Evaluation of Pantex Air Pollutant Concentrations Associated With Construction Under Alternative 9: Pit Conversion and MOX in New Construction at Pantex, and Immobilization in New Construction and DWPF at SRS	4–181
Table 4–121.	Potential Waste Management Impacts of Construction at Pantex Under Alternative 9: Pit Conversion and MOX in New Construction at Pantex, and Immobilization in New Construction and DWPF at SRS	4–182
Table 4–122.	Construction Employment Requirements for Alternative 9: Pit Conversion and MOX in New Construction at Pantex, and Immobilization in New Construction and DWPF at SRS	4–183

Table 4–123.	Potential Radiological Impacts on Construction Workers of Alternative 9: Pit Conversion and MOX in New Construction at Pantex, and Immobilization in New Construction and DWPF at SRS	4–183
Table 4–124.	Evaluation of Pantex Air Pollutant Concentrations Associated With Operations Under Alternative 9: Pit Conversion and MOX in New Construction at Pantex, and Immobilization in New Construction and DWPF at SRS	4–185
Table 4–125.	Evaluation of Pantex Air Pollutant Increases Associated With Operations Under Alternative 9: Pit Conversion and MOX in New Construction at Pantex, and Immobilization in New Construction and DWPF at SRS	4–185
Table 4–126.	Potential Waste Management Impacts of Operations at Pantex Under Alternative 9: Pit Conversion and MOX in New Construction at Pantex, and Immobilization in New Construction and DWPF at SRS	4–186
Table 4–127.	Potential Radiological Impacts on the Public of Operations Under Alternative 9: Pit Conversion and MOX in New Construction at Pantex, and Immobilization in New Construction and DWPF at SRS	4–189
Table 4–128.	Potential Radiological Impacts on Involved Workers of Operations Under Alternative 9: Pit Conversion and MOX in New Construction at Pantex, and Immobilization in New Construction and DWPF at SRS	4–190
Table 4–129.	Accident Impacts of MOX Facility Under Alternative 9: Pit Conversion and MOX in New Construction at Pantex, and Immobilization in New Construction and DWPF at SRS	4–191
Table 4–130.	Construction Employment Requirements for Alternative 10: Pit Conversion and MOX in New Construction at Pantex, and Immobilization in FMEF and HLWVF at Hanford	4–197
Table 4–131.	Potential Radiological Impacts on the Public of Operations Under Alternative 10: Pit Conversion and MOX in New Construction at Pantex, and Immobilization in FMEF and HLWVF at Hanford	4–199
Table 4–132.	Potential Radiological Impacts on Involved Workers of Operations Under Alternative 10: Pit Conversion and MOX in New Construction at Pantex, and Immobilization in FMEF and HLWVF at Hanford	4–200
Table 4–133.	Evaluation of Air Pollutant Concentrations Associated with Construction Under Alternative 11A: Pit Conversion in FMEF and Immobilization in FMEF and HLWVF at Hanford	4–206
Table 4–134.	Potential Waste Management Impacts of Construction Under Alternative 11A: Pit Conversion in FMEF and Immobilization in FMEF and HLWVF at Hanford	4–207
Table 4–135.	Construction Employment Requirements for Alternative 11A: Pit Conversion in FMEF and Immobilization in FMEF and HLWVF at Hanford	4–207
Table 4–136.	Evaluation of Air Pollutant Concentrations Associated With Operations Under Alternative 11A: Pit Conversion in FMEF and Immobilization in FMEF and HLWVF at Hanford	4–209
Table 4–137.	Evaluation of Air Pollutant Increases Associated With Operations Under Alternative 11A: Pit Conversion in FMEF and Immobilization in FMEF and HLWVF at Hanford	4–209

Table 4–138.	Potential Waste Management Impacts of Operations Under Alternative 11A: Pit Conversion in FMEF and Immobilization in FMEF and HLWVF at Hanford	4–211
Table 4–139.	Potential Radiological Impacts on the Public of Operations Under Alternative 11A: Pit Conversion in FMEF and Immobilization in FMEF and HLWVF at Hanford	4–213
Table 4–140.	Potential Radiological Impacts on Involved Workers of Operations Under Alternative 11A: Pit Conversion in FMEF and Immobilization in FMEF and HLWVF at Hanford	4–214
Table 4–141.	Accident Impacts of Alternative 11A: Ceramic Immobilization in FMEF at Hanford (50-t Case)	4–215
Table 4–142.	Accident Impacts of Alternative 11A: Glass Immobilization in FMEF at Hanford (50-t Case)	4–216
Table 4–143.	Construction Employment Requirements Under Alternative 11B: Pit Conversion in New Construction at Pantex, and Immobilization in FMEF and HLWVF at Hanford . .	4–220
Table 4–144.	Evaluation of Air Pollutant Concentrations at Hanford Associated With Operations Under Alternative 11B: Pit Conversion in New Construction at Pantex, and Immobilization in FMEF and HLWVF at Hanford	4–222
Table 4–145.	Evaluation of Air Pollutant Increases at Hanford Associated With Operations Under Alternative 11B: Pit Conversion in New Construction at Pantex, and Immobilization in FMEF and HLWVF at Hanford	4–223
Table 4–146.	Potential Waste Management Impacts of Operations at Hanford Under Alternative 11B: Pit Conversion in New Construction at Pantex, and Immobilization in FMEF and HLWVF at Hanford	4–224
Table 4–147.	Potential Radiological Impacts on the Public of Operations Under Alternative 11B: Pit Conversion in New Construction at Pantex, and Immobilization in FMEF and HLWVF at Hanford	4–227
Table 4–148.	Potential Radiological Impacts on Involved Workers of Operations Under Alternative 11B: Pit Conversion in New Construction at Pantex, and Immobilization in FMEF and HLWVF at Hanford	4–227
Table 4–149.	Evaluation of Air Pollutant Concentrations Associated With Construction Under Alternative 12A: Pit Conversion in New Construction and Immobilization in New Construction and DWPF at SRS	4–232
Table 4–150.	Potential Waste Management Impacts of Construction Under Alternative 12A: Pit Conversion in New Construction and Immobilization in New Construction and DWPF at SRS	4–233
Table 4–151.	Construction Employment Requirements for Alternative 12A: Pit Conversion in New Construction and Immobilization in New Construction and DWPF at SRS	4–234
Table 4–152.	Potential Radiological Impacts on Construction Workers of Alternative 12A: Pit Conversion in New Construction and Immobilization in New Construction and DWPF at SRS	4–235
Table 4–153.	Evaluation of Air Pollutant Concentrations Associated with Operations Under Alternative 12A: Pit Conversion in New Construction and Immobilization in New Construction and DWPF at SRS	4–236

Table 4–154.	Evaluation of Air Pollutant Increases Associated With Operations Under Alternative 12A: Pit Conversion in New Construction and Immobilization in New Construction and DWPF at SRS	4–237
Table 4–155.	Potential Waste Management Impacts of Operations Under Alternative 12A: Pit Conversion in New Construction and Immobilization in New Construction and DWPF at SRS	4–238
Table 4–156.	Potential Radiological Impacts on the Public of Operations Under Alternative 12A: Pit Conversion in New Construction and Immobilization in New Construction and DWPF at SRS	4–240
Table 4–157.	Potential Radiological Impacts on Involved Workers of Operations Under Alternative 12A: Pit Conversion in New Construction and Immobilization in New Construction and DWPF at SRS	4–241
Table 4–158.	Accident Impacts of Alternative 12A: Ceramic Immobilization in New Construction at SRS (50-t Case)	4–242
Table 4–159.	Accident Impacts of Alternative 12A: Glass Immobilization in New Construction at SRS (50-t Case)	4–243
Table 4–160.	Construction Employment Requirements Under Alternative 12B: Pit Conversion in New Construction at Pantex, and Immobilization in New Construction and DWPF at SRS	4–247
Table 4–161.	Potential Radiological Impacts on Construction Workers of Alternative 12B: Pit Conversion in New Construction at Pantex, and Immobilization in New Construction and DWPF at SRS	4–248
Table 4–162.	Evaluation of SRS Air Pollutant Concentrations Associated With Operations Under Alternative 12B: Pit Conversion in New Construction at Pantex, and Immobilization in New Construction and DWPF at SRS	4–250
Table 4–163.	Evaluation of Air Pollutant Increases Associated With Operations at SRS Under Alternative 12B: Pit Conversion in New Construction at Pantex, and Immobilization in New Construction and DWPF at SRS	4–250
Table 4–164.	Potential Waste Management Impacts of Operations at SRS Under Alternative 12B: Pit Conversion in New Construction at Pantex, and Immobilization in New Construction and DWPF at SRS	4–251
Table 4–165.	Potential Radiological Impacts on the Public of Operations Under Alternative 12B: Pit Conversion in New Construction at Pantex, and Immobilization in New Construction and DWPF at SRS	4–254
Table 4–166.	Potential Radiological Impacts on Involved Workers of Operations Under Alternative 12B: Pit Conversion in New Construction at Pantex, and Immobilization in New Construction and DWPF at SRS	4–254
Table 4–167.	Maximum New Facility and Construction Area Requirements at Hanford	4–266
Table 4–168.	Maximum Annual Additional Site Infrastructure Requirements for Construction in 400 Area at Hanford	4–267
Table 4–169.	Maximum Annual Additional Site Infrastructure Requirements for Operations in 400 Area at Hanford	4–268

Table 4-170.	Maximum New Facility and Construction Area Requirements at INEEL	4-273
Table 4-171.	Maximum Annual Additional Site Infrastructure Requirements for Construction in INTEC at INEEL	4-274
Table 4-172.	Maximum Annual Additional Site Infrastructure Requirements for Operations in INTEC at INEEL	4-275
Table 4-173.	Maximum New Facility and Construction Area Requirements at Pantex	4-280
Table 4-174.	Maximum Annual Additional Site Infrastructure Requirements for Construction in Zone 4 at Pantex	4-282
Table 4-175.	Maximum Annual Additional Site Infrastructure Requirements for Operations in Zone 4 at Pantex	4-282
Table 4-176.	Maximum New Facility and Construction Area Requirements at SRS	4-287
Table 4-177.	Maximum Annual Additional Site Infrastructure Requirements for Construction in F-Area at SRS	4-289
Table 4-178.	Maximum Annual Additional Site Infrastructure Requirements for Operations in F-Area at SRS	4-289
Table 4-179.	Potential Waste Management Impacts of Modification of Facilities for Lead Assembly Fabrication at ANL-W	4-291
Table 4-180.	Potential Waste Management Impacts of Operation of Lead Assembly Facility at ANL-W	4-292
Table 4-181.	Potential Radiological Impacts on the Public of Operation of Lead Assembly Facility at ANL-W	4-294
Table 4-182.	Potential Radiological Impacts on Involved Workers of Operation of Lead Assembly Facility at ANL-W	4-295
Table 4-183.	Accident Impacts of Lead Assembly Fabrication at ANL-W	4-296
Table 4-184.	Potential Waste Management Impacts of Modification of Facilities for Lead Assembly Fabrication at Hanford	4-299
Table 4-185.	Potential Waste Management Impacts of Operation of Lead Assembly Facility at Hanford	4-300
Table 4-186.	Potential Radiological Impacts on the Public of Operation of Lead Assembly Facility at Hanford	4-302
Table 4-187.	Potential Radiological Impacts on Involved Workers of Operation of Lead Assembly Facility at Hanford	4-303
Table 4-188.	Accident Impacts of Lead Assembly Fabrication at Hanford	4-304
Table 4-189.	Potential Waste Management Impacts of Modification of Facilities for Lead Assembly Fabrication at LLNL	4-307
Table 4-190.	Potential Waste Management Impacts of the Conduct of Lead Assembly Fabrication Activities at LLNL	4-307
Table 4-191.	Potential Radiological Impacts on the Public of Operation of Lead Assembly Facility at LLNL	4-310

Table 4–192.	Potential Radiological Impacts on Involved Workers of Operation of Lead Assembly Facility at LLNL	4–311
Table 4–193.	Accident Impacts of Lead Assembly Fabrication at LLNL	4–311
Table 4–194.	Potential Waste Management Impacts of Modification of Facilities for Lead Assembly Fabrication at LANL	4–315
Table 4–195.	Potential Waste Management Impacts of Operation of Lead Assembly Facility at LANL	4–316
Table 4–196.	Potential Radiological Impacts on Construction Workers of Lead Assembly Facility at LANL	4–318
Table 4–197.	Potential Radiological Impacts on the Public of Operation of Lead Assembly Facility at LANL	4–319
Table 4–198.	Potential Radiological Impacts on Involved Workers of Operation of Lead Assembly Facility at LANL	4–319
Table 4–199.	Accident Impacts of Lead Assembly Fabrication at LANL	4–320
Table 4–200.	Potential Waste Management Impacts of Modification of Facilities for Lead Assembly Fabrication at SRS	4–323
Table 4–201.	Potential Waste Management Impacts of Operation of Lead Assembly Facility at SRS	4–324
Table 4–202.	Potential Radiological Impacts on the Public of Operation of Lead Assembly Facility at SRS	4–326
Table 4–203.	Potential Radiological Impacts on Involved Workers of Operation of Lead Assembly Facility at SRS	4–327
Table 4–204.	Accident Impacts of Lead Assembly Fabrication at SRS	4–328
Table 4–205.	Potential Waste Management Impacts of Postirradiation Examination at ANL–W	4–331
Table 4–206.	Potential Radiological Impacts on Involved Workers of Operation of Postirradiation Examination Facility at ANL–W	4–331
Table 4–207.	Potential Waste Management Impacts of Postirradiation Examination at ORNL	4–334
Table 4–208.	Potential Radiological Impacts on Involved Workers of Operation of Postirradiation Examination Facility at ORNL	4–334
Table 4–209.	Reactor Operating Information	4–337
Table 4–210.	Results of Plant Performance Reviews	4–337
Table 4–211.	Expected Radiological Releases From Continued Operation of the Proposed Reactors	4–339
Table 4–212.	Estimated Dose to the Public From Continued Operation of the Proposed Reactors in the Year 2015 (Partial MOX or LEU Core)	4–340
Table 4–213.	Design Basis Accident Impacts for Catawba With LEU and MOX Fuels	4–344
Table 4–214.	Design Basis Accident Impacts for McGuire With LEU and MOX Fuels	4–345
Table 4–215.	Design Basis Accident Impacts for North Anna With LEU and MOX Fuels	4–346
Table 4–216.	Estimated Prompt Fatalities in the Public From Beyond-Design-Basis Reactor Accidents	4–348

Table 4–217.	Ratio of Accident Impacts for MOX-Fueled and Uranium-Fueled Reactors (MOX Impacts/LEU Impacts)	4–348
Table 4–218.	Beyond-Design-Basis Accident Impacts for Catawba With LEU and MOX Fuels	4–349
Table 4–219.	Beyond-Design-Basis Accident Impacts for McGuire With LEU and MOX Fuels	4–350
Table 4–220.	Beyond-Design-Basis Accident Impacts for North Anna With LEU and MOX Fuels . .	4–351
Table 4–221.	Total Additional Spent Fuel Assemblies Generated by MOX Fuel Irradiation	4–354
Table 4–222.	Estimated Concentrations of Air Pollutants of Immobilization Facilities During Operation at Hanford	4–357
Table 4–223.	Estimated Concentrations of Air Pollutants of Immobilization Facilities During Operation at SRS	4–358
Table 4–224.	Estimated Waste Volumes of Immobilization Facilities During Operation at Hanford and SRS	4–359
Table 4–225.	Potential Radiological Impacts on the Public of Operations for Immobilization Facilities at Hanford	4–359
Table 4–226.	Potential Radiological Impacts on the Public of Operations for Immobilization Facilities at SRS	4–360
Table 4–227.	Potential Radiological Impacts on Involved Workers of Operations for Immobilization Facilities at Hanford and SRS	4–360
Table 4–228.	Potential Hazardous Chemical Impacts on Public and Workers of Operations for Immobilization Facilities at Hanford	4–361
Table 4–229.	Potential Hazardous Chemical Impacts on Public and Workers of Operations for Immobilization Facilities at SRS	4–361
Table 4–230.	Estimated Resource Requirements for Operations at Hanford and SRS	4–362
Table 4–231.	Potential Incremental Changes in Waste Generated From Facility Operations	4–365
Table 4–232.	Potential Incremental Changes in Radiological Impacts on the Public From Normal Operations	4–365
Table 4–233.	Evaluation of Air Pollutant Concentrations Associated With the Conversion of Depleted Uranium Hexafluoride to Uranium Dioxide	4–368
Table 4–234.	Potential Radiological Impacts on the Public From Conversion of Uranium Hexafluoride to Uranium Dioxide	4–369
Table 4–235.	Other Past, Present, and Reasonably Foreseeable Actions Considered in the Cumulative Impact Assessment for Candidate DOE Sites	4–375
Table 4–236.	Maximum Cumulative Resource Use and Impacts at Hanford—2007	4–376
Table 4–237.	Maximum Cumulative Air Pollutant Concentrations at Hanford and Comparison With Standards or Guidelines	4–377
Table 4–238.	Cumulative Impacts on Waste Management Activities at Hanford Over 15-Year Period From 2002–2016	4–378
Table 4–239.	Maximum Cumulative Radiation Doses and Impacts at Hanford Over 15-Year Period From 2002–2016	4–378

Table 4–240.	Maximum Cumulative Resource Use and Impacts at INEEL—2007	4–379
Table 4–241.	Maximum Cumulative Air Pollutant Concentrations at INEEL and Comparison With Standards or Guidelines	4–380
Table 4–242.	Cumulative Impacts on Waste Management Activities at INEEL Over 15-Year Period From 2002–2016	4–380
Table 4–243.	Maximum Cumulative Radiation Doses and Impacts at INEEL Over 15-Year Period From 2002–2016	4–381
Table 4–244.	Maximum Cumulative Resource Use and Impacts at Pantex—2007	4–382
Table 4–245.	Maximum Cumulative Air Pollutant Concentrations at Pantex and Comparison With Standards or Guidelines	4–383
Table 4–246.	Cumulative Impacts on Waste Management Activities at Pantex Over 15-Year Period From 2002–2016	4–383
Table 4–247.	Maximum Cumulative Radiation Doses and Impacts at Pantex Over 15-Year Period From 2002–2016	4–384
Table 4–248.	Maximum Cumulative Resource Use and Impacts at SRS—2007	4–385
Table 4–249.	Maximum Cumulative Air Pollutant Concentrations at SRS and Comparison With Standards or Guidelines	4–386
Table 4–250.	Cumulative Impacts on Waste Management Activities at SRS Over 15-Year Period From 2002–2016	4–386
Table 4–251.	Maximum Cumulative Radiation Doses and Impacts at SRS Over 15-Year Period From 2002–2016	4–387
Table 4–252.	Maximum Cumulative Resource Use and Impacts at LLNL—2003	4–388
Table 4–253.	Maximum Cumulative Air Pollutant Concentrations at LLNL and Comparison With Standards or Guidelines	4–389
Table 4–254.	Cumulative Impacts on Waste Management Activities at LLNL Over 5-Year Period From 2001–2005	4–389
Table 4–255.	Maximum Cumulative Radiation Doses and Impacts at LLNL Over 5-Year Period From 2001–2005	4–390
Table 4–256.	Maximum Cumulative Resource Use and Impacts at LANL—2003	4–391
Table 4–257.	Maximum Cumulative Air Pollutant Concentrations at LANL and Comparison With Standards or Guidelines	4–392
Table 4–258.	Cumulative Impacts on Waste Management Activities at LANL Over 5-Year Period From 2001–2005	4–392
Table 4–259.	Maximum Cumulative Radiation Doses and Impacts at LANL Over 5-Year Period From 2001–2005	4–393
Table 4–260.	Cumulative Impacts on Waste Management Activities at ORNL Over 3-Year Period From 2006–2009	4–394
Table 4–261.	Maximum Cumulative Radiation Exposures and Impacts at ORNL Over 3-Year Period From 2006–2009	4–395

Table 4–262.	Irreversible and Irretrievable Commitments of Construction Resources for Surplus Plutonium Disposition Facilities	4–397
Table 4–263.	Irreversible and Irretrievable Commitments of Construction Resources for Lead Assembly Fabrication Facilities	4–397
Table 4–264.	Irreversible and Irretrievable Commitments of Operations Resources for Surplus Plutonium Disposition Facilities	4–398
Table 4–265.	Irreversible and Irretrievable Commitments of Operations Resources for Lead Assembly Fabrication Facilities	4–399
Table 5–1.	Federal Environmental Statutes, Regulations, and Executive Orders	5–7
Table 5–2.	Summary of Consultations Initiated by DOE	5–14

List of Acronyms

AEA	Atomic Energy Act of 1954	CERCLA	Comprehensive Environmental Response, Compensation, and Liability Act
AECL	Atomic Energy of Canada Limited		
AED	aerodynamic equivalent diameter	CFA	Central Facilities Area
AIRFA	American Indian Religious Freedom Act	CFR	Code of Federal Regulations
ALARA	as low as is reasonably achievable	CPP	Chemical Processing Plant
		CWA	Clean Water Act of 1972, 1987
AMWTP	Advanced Mixed Waste Treatment Project	D&D	decontamination and decommissioning
ANL–W	Argonne National Laboratory–West	DBA	design basis accident
APSF	Actinide Packaging and Storage Facility	DCS	Duke Engineering & Services, COGEMA Inc., and Stone & Webster
AQCR	Air Quality Control Region	DNFSB	Defense Nuclear Facilities Safety Board
ARF	airborne release fraction		
ARIES	Advanced Recovery Integrated Extraction System	DOC	U.S. Department of Commerce
		DoD	U.S. Department of Defense
AVLIS	Atomic Vapor Laser Isotope Separation	DOE	U.S. Department of Energy
		DOL	U.S. Department of Labor
		DOT	U.S. Department of Transportation
BEA	Bureau of Economic Analysis		
BEIR V	Report V of the Committee on the Biological Effects of Ionizing Radiations	DR	damage ratio
		DU PEIS	<i>Final Programmatic Environmental Impact Statement for Alternative Strategies for Long-Term Management and Use of Depleted Uranium Hexafluoride</i>
BIO	Basis for Interim Operation		
BLM	Bureau of Land Management		
BNFL	British Nuclear Fuels		
BWR	boiling water reactor	DWPF	Defense Waste Processing Facility
CAA	Clean Air Act		
CAB	Citizens Advisory Board		
CANDU	Canadian Deuterium Uranium (reactors)	EA	environmental assessment
		EBR	Experimental Breeder Reactor (I or II)
CEQ	Council on Environmental Quality	EIS	environmental impact statement
		EPA	Environmental Protection Agency

ES&H	environment, safety, and health	HHS	Department of Health and Human Services
ESTEEM	Education in Science, Technology, Energy, Engineering, and Math	HIGHWAY	(computer code for distances and populations along U.S. highways)
ETB	Engineering Test Bay	HLW	high-level waste
ETTP	East Tennessee Technology Park	HLWVF	high-level-waste vitrification facility
FAA	Federal Aviation Administration	HMIS	Hazardous Materials Information System
FDP	fluorinel dissolution process	HWTPF	Hazardous Waste Treatment and Processing Facility
FEMA	Federal Emergency Management Agency	HYDOX	hydride oxidation
FFCA	Federal Facility Compliance Agreement	IAEA	International Atomic Energy Agency
FFF	Uranium Fuel Fabrication Facility	ICPP	Idaho Chemical Processing Plant
FFTF	Fast Flux Test Facility	ICRP	International Commission on Radiological Protection
FI	field investigation	ID DHW	Idaho Department of Health and Welfare
FM	Farm-to-Market (road)	INEEL	Idaho National Engineering and Environmental Laboratory
FMF	Fuel Manufacturing Facility	INRAD	Intrinsic Radiation
FMEA	failure modes and effects analysis	INTEC	Idaho Nuclear Technology and Engineering Center
FMEF	Fuels and Materials Examination Facility	IPE	Individual Plant Examination
FONSI	finding of no significant impact	ISC	Industrial Source Complex Model
FPF	Fuel Processing Facility	ISC3	Industrial Source Complex Model, Version 3
FPPA	Farmland Protection Policy Act	ISCST3	Industrial Source Complex Model, Short-Term, Version 3
FR	Federal Register	ISLOCA	interfacing systems loss-of-coolant accident
GAO	General Accounting Office	ITP	In-Tank Precipitation Process
GDP	gaseous diffusion plant		
GE	General Electric Company		
GENII	Generation II, Hanford environmental radiation dosimetry software system		
GPS	global positioning satellite		
HE	high explosive		
HEPA	high-efficiency particulate air (filter)		
HEU	highly enriched uranium		
HFEF	Hot Fuel Examination Facility		

LANL	Los Alamos National Laboratory	NPDES	National Pollutant Discharge Elimination System
LCF	latent cancer fatality		
LDR	Land Disposal Restrictions	NPH	natural phenomena hazard
LEU	low-enriched uranium	NPS	National Park Service
LLNL	Lawrence Livermore National Laboratory	NRC	U.S. Nuclear Regulatory Commission
LLW	low-level waste	NRU	National Research Universal
LOCA	loss-of-coolant accident	NTS	Nevada Test Site
LPF	leak path factor	NWCF	New Waste Calcining Facility
LWR	light water reactor	NWPA	Nuclear Waste Policy Act
		NWS	National Weather Service
M&H	Mason & Hanger Corporation		
MACCS2	Melcor Accident Consequence Code System (computer code)	ORIGEN	ORNL Isotope Generation and Depletion Code
MAR	material at risk	ORNL	Oak Ridge National Laboratory
MD	Office of Fissile Materials Disposition	ORR	Oak Ridge Reservation
MEI	maximally exposed individual	OSHA	Occupational Safety and Health Administration
MIMAS	Micronized Master		
MMI	Modified Mercalli Intensity	PBF	Power Burst Facility
MOX	mixed oxide	PEIS	programmatic environmental impact statement
NAAQS	National Ambient Air Quality Standards	PFP	Plutonium Finishing Plant
NAGPRA	Native American Graves Protection and Repatriation Act	PIE	postirradiation examination
NAS	National Academy of Science	PM _{2.5}	particulate matter with an aerodynamic diameter less than or equal to 2.5 microns
NCRP	National Council on Radiation Protection and Measurements	PM ₁₀	particulate matter with an aerodynamic diameter less than or equal to 10 microns
NDA	nondestructive analysis	PNNL	Pacific Northwest National Laboratory
NEPA	National Environmental Policy Act of 1969	PRA	probabilistic risk assessment
NESHAPs	National Emissions Standards for Hazardous Air Pollutants	PSD	prevention of significant deterioration
NIOSH	National Institute of Occupational Safety and Health	PUREX	Plutonium-Uranium Extraction (Facility)
NOA	Notice of Availability		
NOAA	National Oceanic and Atmospheric Administration	PWR	pressurized water reactor
NOI	Notice of Intent	R&D	research and development

RADTRAN 4	(computer code: risks and consequences of radiological materials transport)	SDWA	Preservation Officer Safe Drinking Water Act, as amended
RANT	Radioactive Assay and Nondestructive Test	SEIS	supplemental environmental impact statement
RAMROD	Radioactive Materials Research, Operations and Demonstration	SHPO	State Historic Preservation Officer
RCRA	Resource Conservation and Recovery Act, as amended	SI	sealed insert
REA	regional economic area	SMC	Specific Manufacturing Complex
RF	respirable fraction	SNF	spent nuclear fuel
RfC	reference concentration	SNM	special nuclear material
RfD	reference dose	SPD	surplus plutonium disposition
RFETS	Rocky Flats Environmental Technology Site	SPD EIS	<i>Surplus Plutonium Disposition Environmental Impact Statement</i>
RFP	Request for Proposal	SPERT	Special Power Excursion Reactor Test
RIA	Reactivity Insertion Accidents	SRS	Savannah River Site
RIMS II	Regional Input-Output Modeling System II (computer code)	SSM PEIS	<i>Final Programmatic Environmental Impact Statement for Stockpile Stewardship and Management</i>
RISKIND	(computer code: risks and consequences of radiological materials transport)	SST/SGT	safe, secure trailer/SafeGuards Transport
ROD	Record of Decision		
ROI	region of influence	SWMU	solid waste management unit
RMF	Radiation Measurements Facility	SWP 1	Service Waste Percolation Pond 1
RWMC	Radioactive Waste Management Complex		
		TA	Technical Area
S/A	Similarity of Appearance (provision of Endangered Species Act)	TCE	trichloroethylene
		TNRCC	Texas Natural Resource Conservation Commission
SAR	safety analysis report	TPBAR-LTA	tritium-producing burnable absorber rod lead test assembly
SARA	Superfund Amendments and Reauthorization Act of 1986	TRA	technical risk assessment
SCDHEC	South Carolina Department of Health and Environmental Control	TRANSCOM	transportation tracking and communications system
		TRU	transuranic
SCE&G	South Carolina Electric & Gas Company	TRUPACT	TRU waste package transporter
		TSCA	Toxic Substances Control Act
SCSHPO	South Carolina State Historic	TSP	total suspended particulates

TVA	Tennessee Valley Authority	WPPSS	Washington Public Power Supply System
TWRS	tank waste remediation system		
TWRS EIS	<i>Tank Waste Remediation System Final Environmental Impact Statement</i>	WROC	Waste Reduction Operations Complex
		WSRC	Westinghouse Savannah River Company
UC	Regents of the University of California	ZPPR	Zero Power Physics Reactor
UFSAR	updated final safety analysis report		
USACE	U.S. Army Corps of Engineers		
USC	United States Code		
USEC	United States Enrichment Corporation		
USFWS	U.S. Fish and Wildlife Service		
UV	ultraviolet		
VOC	volatile organic compounds		
VORTAC	very high frequency omnidirectional range/tactical air navigation (facility)		
VRM	Visual Resource Management		
WAG 3	Waste Area Grouping 3		
WERF	Waste Experimental Reduction Facility		
WIPP	Waste Isolation Pilot Plant		
WM PEIS	<i>Final Waste Management Programmatic Environmental Impact Statement for Managing Treatment, Storage, and Disposal of Radioactive and Hazardous Waste</i>		
WNP-1	Washington Nuclear Plant-1		
WNP-2	Washington Nuclear Plant-2		

Chemicals and Units of Measure

°C	degrees Celsius (Centigrade)	min	minute
°F	degrees Fahrenheit	mph	miles per hour
μCi	microcurie	mrem	millirem
μg	microgram	MTHM	metric tons of heavy metal
μm	micrometer (micron)	MVA	megavolt-ampere
46°26'07"	46 degrees, 26 minutes, 7 seconds	MW	megawatt
Ci	curie	MWe	megawatt electric
cm	centimeter	MWh	megawatt-hour
CO	carbon monoxide	N ₂	nitrogen
CO ₂	carbon dioxide	nCi	nanocurie
dB	decibel	NO ₂	nitrogen dioxide
dba	decibel, A-weighted	pCi	picocurie
DUF ₆	depleted uranium hexafluoride	pcm/F	percent mille/Fahrenheit
eH	oxidation reduction potential	pH	hydrogen ion concentration
ft	foot	PM _{2.5}	particulate matter less than or equal to 2.5 μm in diameter
ft ²	square foot	PM ₁₀	particulate matter less than or equal to 10 μm in diameter
ft ³	cubic foot	ppm	parts per million
g	gram	PuO ₂	plutonium dioxide
g	gravitational acceleration	rad	radiation absorbed dose
gal	gallon	rem	roentgen equivalent man
GWD	gigawatt days (per ton)	s	second
ha	hectare	SO ₂	sulfur dioxide
hr	hour (in compound units)	t	metric ton
in	inch	ton	short ton
kg	kilogram	UF ₆	uranium hexafluoride
km	kilometer	UO ₂	uranium dioxide
km ²	square kilometers	yd	yard
kV	kilovolt	yd ³	cubic yard
l	liter	yr	year (in compound units)
lb	pound	wt %	weight percent
m	meter		
m ²	square meter		
m ³	cubic meter		
mg	milligram		
mi	mile		

Metric Conversion Chart

To Convert Into Metric			To Convert Out of Metric		
If You Know	Multiply By	To Get	If You Know	Multiply By	To Get
Length					
inches	2.54	centimeters	centimeters	0.3937	inches
feet	30.48	centimeters	centimeters	0.0328	feet
feet	0.3048	meters	meters	3.281	feet
yards	0.9144	meters	meters	1.0936	yards
miles	1.60934	kilometers	kilometers	0.6214	miles
Area					
sq. inches	6.4516	sq. centimeters	sq. centimeters	0.155	sq. inches
sq. feet	0.092903	sq. meters	sq. meters	10.7639	sq. feet
sq. yards	0.8361	sq. meters	sq. meters	1.196	sq. yards
acres	0.40469	hectares	hectares	2.471	acres
sq. miles	2.58999	sq. kilometers	sq. kilometers	0.3861	sq. miles
Volume					
fluid ounces	29.574	milliliters	milliliters	0.0338	fluid ounces
gallons	3.7854	liters	liters	0.26417	gallons
cubic feet	0.028317	cubic meters	cubic meters	35.315	cubic feet
cubic yards	0.76455	cubic meters	cubic meters	1.308	cubic yards
Weight					
ounces	28.3495	grams	grams	0.03527	ounces
pounds	0.45360	kilograms	kilograms	2.2046	pounds
short tons	0.90718	metric tons	metric tons	1.1023	short tons
Temperature					
Fahrenheit	Subtract 32 then multiply by 5/9ths	Celsius	Celsius	Multiply by 9/5ths, then add 32	Fahrenheit

Metric Prefixes

Prefix	Symbol	Multiplication Factor
exa-	E	$1\,000\,000\,000\,000\,000\,000 = 10^{18}$
peta-	P	$1\,000\,000\,000\,000\,000 = 10^{15}$
tera-	T	$1\,000\,000\,000\,000 = 10^{12}$
giga-	G	$1\,000\,000\,000 = 10^9$
mega-	M	$1\,000\,000 = 10^6$
kilo-	k	$1\,000 = 10^3$
hecto-	h	$100 = 10^2$
deka-	da	$10 = 10^1$
deci-	d	$0.1 = 10^{-1}$
centi-	c	$0.01 = 10^{-2}$
milli-	m	$0.001 = 10^{-3}$
micro-	μ	$0.000\,001 = 10^{-6}$
nano-	n	$0.000\,000\,001 = 10^{-9}$
pico-	p	$0.000\,000\,000\,001 = 10^{-12}$
femto-	f	$0.000\,000\,000\,000\,001 = 10^{-15}$
atto-	a	$0.000\,000\,000\,000\,000\,001 = 10^{-18}$

Chapter 1

Background, Purpose of, and Need for the Proposed Action

1.1 BACKGROUND

In December 1996, the U.S. Department of Energy (DOE) published the *Storage and Disposition of Weapons-Usable Fissile Materials Final Programmatic Environmental Impact Statement (Storage and Disposition PEIS)* (DOE 1996a). That PEIS analyzes the potential environmental consequences of alternative strategies for the long-term storage of weapons-usable plutonium and highly enriched uranium (HEU) and the disposition of weapons-usable plutonium that has been or may be declared surplus to national security needs.¹ The Record of Decision (ROD) for the *Storage and Disposition PEIS*, issued on January 14, 1997 (DOE 1997a), outlines DOE's decision to pursue a hybrid approach to plutonium disposition that would make surplus weapons-usable plutonium inaccessible and unattractive for weapons use. DOE's disposition strategy, consistent with the Preferred Alternative analyzed in the *Storage and Disposition PEIS*, allows for both the immobilization of some (and potentially all) of the surplus plutonium and use of some of the surplus plutonium as mixed oxide (MOX) fuel in existing domestic, commercial reactors. The disposition of surplus plutonium would also involve disposal of both the immobilized plutonium and the MOX fuel (as spent fuel) in a potential geologic repository.²

On May 22, 1997, DOE published a Notice of Intent (NOI) in the Federal Register (FR) (DOE 1997b) announcing its decision to prepare an environmental impact statement (EIS) that would tier from the analysis and decisions reached in connection with the *Storage and Disposition PEIS*. This EIS, the *Surplus Plutonium Disposition Environmental Impact Statement (SPD EIS)*, addresses the extent to which each of the two plutonium disposition approaches (immobilization and MOX) would be implemented and analyzes candidate sites for plutonium disposition facilities and activities (i.e., lead assembly fabrication and postirradiation examination),⁴ as well as alternative technologies for immobilization. In July 1998, DOE issued the SPD Draft EIS. That draft included a description of the potential environmental impacts of using from three to eight commercial nuclear reactors to irradiate MOX fuel. The potential impacts were based on a generic reactor analysis. In March 1999, DOE awarded a contract for MOX fuel fabrication and irradiation services.⁵ After this award, DOE issued a *Supplement to the SPD Draft EIS (Supplement)* (April 1999) that describes the potential environmental impacts of using MOX fuel at three proposed reactor sites and provides updated information on the proposed disposition program. These updates and site-specific analyses have been incorporated in this SPD Final EIS.

¹ DOE addresses the disposition of surplus HEU in a separate environmental impact statement, the *Disposition of Surplus Highly Enriched Uranium Final Environmental Impact Statement* (DOE 1996b) issued in June 1996, with the ROD (DOE 1996c) issued in August 1996.

² The U.S. Nuclear Regulatory Commission (NRC) has reviewed DOE's plans to place immobilized material into the potential geologic repository and has agreed that with adequate canister and package design features, the immobilized plutonium waste forms can be acceptable for disposal in the repository (Papiello 1999).

³ Sidebars are used throughout this SPD Final EIS to indicate where changes were made since the SPD Draft EIS and *Supplement* were issued. Section 1.7.4 discusses these changes.

⁴ This SPD EIS also analyzes a No Action Alternative, i.e., the possibility of disposition not occurring and instead continued storage of surplus plutonium in accordance with the *Storage and Disposition PEIS* ROD.

⁵ Limited activities may be conducted under this contract, including non-site-specific work associated with the development of the initial design for the MOX fuel fabrication facility and plans (paper studies) for outreach, long lead-time procurements, regulatory management, facility quality assurance, safeguards, security, fuel qualification, and deactivation. Under the contract options, no substantive design work or construction on the proposed MOX facility would begin before a SPD EIS ROD is issued, and any such work would depend on decisions in the ROD.

This SPD EIS analyzes a nominal 50 metric tons (t) (55 tons) of surplus weapons-usable plutonium, which is primarily in the form of pits (the core element of a nuclear weapon's fission component), metal, and oxides.⁶ In addition to 38.2 t (42 tons) of weapons-grade plutonium already declared by the President as excess to national security needs, the material analyzed includes weapons-grade plutonium that may be declared surplus in the future, as well as weapons-usable, reactor-grade plutonium that is surplus to the programmatic and national defense needs of DOE. As depicted in Figure 1-1, there are seven locations of surplus plutonium within the DOE complex: the Hanford Site (Hanford) near Richland, Washington; Idaho National Engineering and Environmental Laboratory (INEEL) near Idaho Falls, Idaho; Lawrence Livermore National Laboratory (LLNL), California;⁷ Los Alamos National Laboratory (LANL) near Los Alamos, New Mexico; the Pantex Plant (Pantex) near Amarillo, Texas; the Rocky Flats Environmental Technology Site (RFETS) near Golden, Colorado; and the Savannah River Site (SRS) near Aiken, South Carolina.

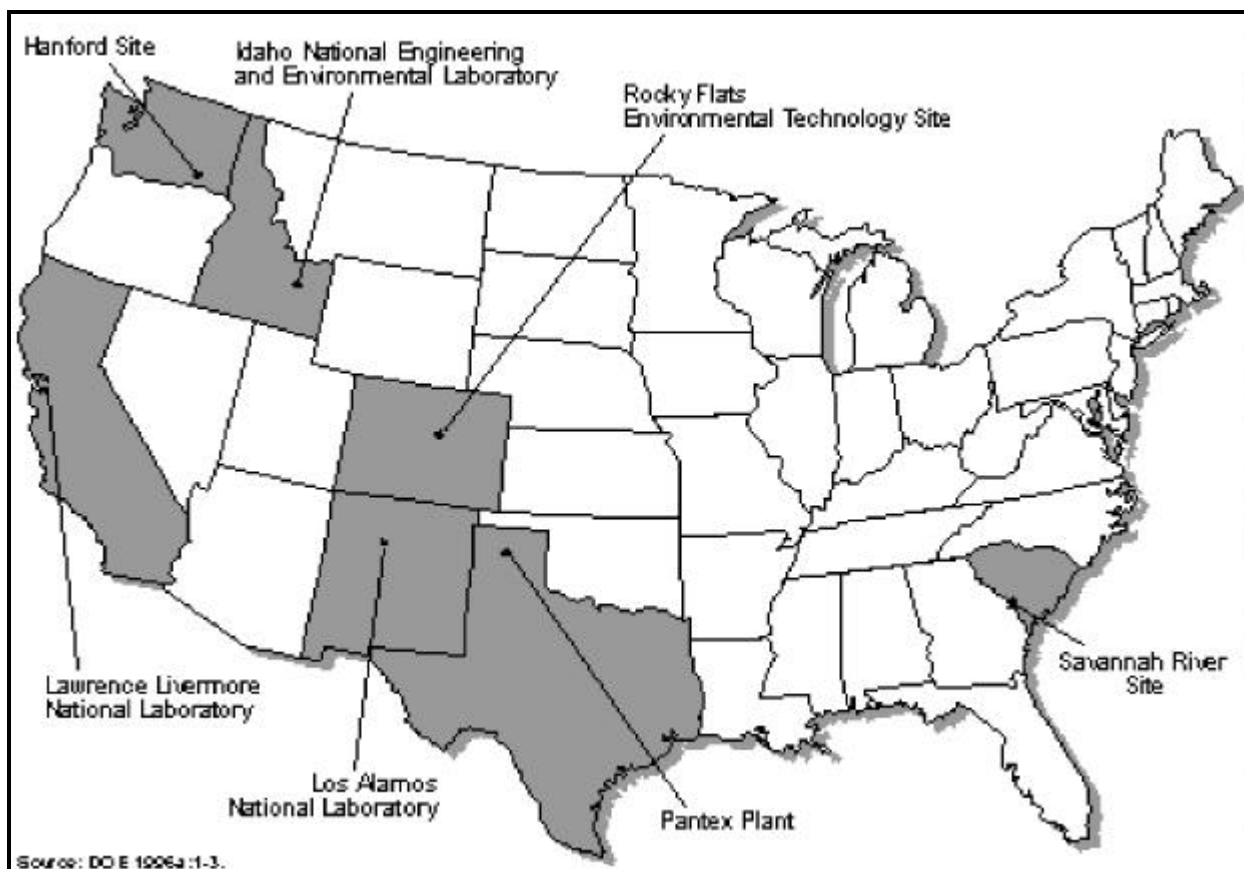

Figure 1-1. Locations of Surplus Plutonium

Under the hybrid alternatives, about 34 percent of the surplus plutonium analyzed in this SPD EIS is not suitable for fabrication into MOX fuel due to the complexity, timing, and cost that would be involved in purifying the materials. The *Storage and Disposition PEIS* ROD determined that DOE would immobilize at least 8 t (9 tons)

⁶ Some materials are already in a final disposition form (i.e., irradiated fuel) and will not require further action before disposal. These materials, therefore, are not included in the 50 t (55 tons) analyzed in this SPD EIS.

⁷ Some of the surplus plutonium originally stored at RFETS was shipped to LLNL, where special handling and disassembly processes occurred. The receipt and disassembly of these materials and future processing work will result in the recovery of approximately 1.7 t (1.9 tons) of surplus plutonium at LLNL.

of the current surplus plutonium. Since issuance of the ROD, further consideration has indicated that 17 t (19 tons) of the surplus plutonium is not suitable for use in MOX fuel and should be immobilized. Therefore, fabricating all 50 t (55 tons) of surplus plutonium into MOX fuel is not a reasonable alternative and is not analyzed. This SPD EIS does, however, analyze the immobilization of all the surplus plutonium. (See Section 2.3.2.1 for a discussion on the amounts of materials subject to disposition.) Given the variability in purity of the surplus plutonium to be dispositioned, some of the plutonium currently considered for MOX fabrication may also need to be immobilized. The incremental impacts that would be associated with a small shift in materials throughput are discussed in Section 4.30.

In the *Storage and Disposition PEIS* ROD, DOE retained the option to use some of the surplus plutonium as MOX fuel in Canadian Deuterium Uranium (CANDU) reactors, which would have been undertaken only in the event that a multilateral agreement were negotiated among Russia, Canada, and the United States. Since the SPD Draft EIS was issued, DOE determined that adequate reactor capacity is available in the United States to disposition that portion of the U.S. surplus plutonium suitable for MOX fuel and, therefore, while still reserving the CANDU option, DOE is no longer actively pursuing it. However, DOE, in cooperation with Canada and Russia, proposes to participate in a test and demonstration program using U.S. and Russian MOX fuel in a Canadian test reactor.⁸ If Russia and Canada agree to disposition Russian surplus plutonium in CANDU reactors in order to augment Russia's disposition capability, shipments of the Russian MOX fuel would take place directly between Russia and Canada.

1.2 PURPOSE OF AND NEED FOR THE PROPOSED ACTION

The purpose of and need for the proposed action is to reduce the threat of nuclear weapons proliferation worldwide by conducting disposition of surplus plutonium in the United States in an environmentally safe and timely manner. Comprehensive disposition actions are needed to ensure that surplus plutonium is converted to proliferation-resistant forms. In September 1993, President Clinton issued the *Nonproliferation and Export Control Policy* (White House 1993) in response to the growing threat of nuclear proliferation. Further, in January 1994, President Clinton and Russia's President Yeltsin issued a *Joint Statement by the President of the Russian Federation and the President of the United States of America on Non-Proliferation of Weapons of Mass Destruction and the Means of Their Delivery* (White House 1994). In accordance with these policies, the focus of the U.S. nonproliferation efforts includes ensuring the safe, secure, long-term storage and disposition of surplus weapons-usable fissile plutonium. Following publication of the SPD Draft EIS, the United States and Russia signed a 5-year agreement to provide the scientific and technical basis for decisions concerning how surplus plutonium will be managed and a statement of principles with the intention of removing approximately 50 t (55 tons) of plutonium from each country's stockpile (see Appendix A). The disposition activities proposed in this SPD EIS will enhance U.S. credibility and flexibility in negotiations on bilateral and multilateral reductions of surplus weapons-usable fissile materials inventories. [Text deleted.] The United States will retain the option to begin certain disposition activities, when appropriate, in order to encourage the Russians and set an international example.

This SPD EIS addresses both the immobilization and MOX approaches to surplus plutonium disposition, which include siting, construction, operation, and ultimate decontamination and decommissioning (D&D) of three types of facilities at one or two of four candidate DOE sites:

⁸ A separate environmental review, the *Environmental Assessment for the Parallax Project Fuel Manufacture and Shipment* (DOE 1999a; Finding of No Significant Impact [FONSI], August 13, 1999), analyzes the fabrication and proposed shipment of MOX fuel rods for research and development activities involving the use of limited amounts of U.S. MOX fuel in a Canadian test reactor. The FONSI was announced in a press release on September 2, 1999, and made available to the public.

- A facility for disassembling pits (a weapons component) and converting the recovered plutonium, as well as plutonium metal from other sources, into plutonium dioxide suitable for disposition. This facility, the pit disassembly and conversion facility, is referred to in this document as the *pit conversion facility*. Candidate sites for this facility are Hanford, INEEL, Pantex, and SRS.
- A facility for immobilizing surplus plutonium for eventual disposal in a geologic repository pursuant to the Nuclear Waste Policy Act (NWPA), the plutonium conversion and immobilization facility, is referred to as the *immobilization facility*. This facility would include a collocated capability for converting nonpit plutonium materials into plutonium dioxide suitable for immobilization. The immobilization facility would be located at either Hanford or SRS. DOE identified SRS as the preferred site for an immobilization facility in the NOI to prepare the SPD EIS, which was issued in May 1997. Technologies for immobilization are also discussed in this SPD EIS.
- A facility for fabricating plutonium dioxide into MOX fuel, the MOX fuel fabrication facility, is referred to as the *MOX facility*. Candidate sites for this facility are Hanford, INEEL, Pantex, and SRS. Also included in this SPD EIS is a separate analysis of MOX lead assembly⁹ activities at five candidate DOE sites: Argonne National Laboratory–West (ANL–W) at INEEL; Hanford; LLNL; LANL; and SRS. DOE would fabricate a limited number of MOX fuel assemblies, referred to as lead assemblies, for testing in a reactor before commencing fuel irradiation under the proposed MOX fuel program. Postirradiation examination activities at two sites, ANL–W and Oak Ridge National Laboratory (ORNL) in Oak Ridge, Tennessee, are also analyzed in this SPD EIS.

This SPD EIS also analyzes a No Action Alternative, as required by the National Environmental Policy Act (NEPA). In the No Action Alternative, surplus weapons-usable plutonium in storage at various DOE sites would remain at those locations. The vast majority of pits would continue to be stored at Pantex, and the remaining plutonium in various forms would continue to be stored at Hanford, INEEL, LLNL, LANL, RFETS, and SRS.¹⁰

1.3 DECISIONS TO BE MADE

DOE will base the following decisions on the analytical results of this SPD EIS and other cost, schedule, and nonproliferation considerations:

- Whether to construct and operate a pit conversion facility, and if so, where.
- Whether to construct and operate an immobilization facility, and if so, where (including selection of a technology for immobilization and the amount of plutonium to be immobilized).
- Whether to construct and operate a MOX facility, and if so, where (including separate selection of a site for fabrication of lead assemblies; a site for postirradiation examination; and the amount of plutonium, if any, to be fabricated into MOX fuel).

1.4 ISSUES IDENTIFIED DURING THE SCOPING PERIOD

In mid-1997, DOE conducted a public scoping process to solicit comments on its NOI concerning the disposition of surplus plutonium. Written comments were requested from the public via U.S. mail, fax, and Web site, and

⁹ A MOX lead assembly is a prototype reactor fuel assembly that contains MOX fuel.

¹⁰ Should the No Action Alternative be chosen, the ROD pursuant to this SPD EIS would also address the movement of the remaining surplus nonpit plutonium from RFETS in support of its planned closure in 2006.

oral comments were collected via telephone and at four public scoping meetings. During June and July 1997, about 640 people attended the scoping meetings held near the candidate sites for disposition facilities. The specific locations of the meetings were Idaho Falls, Idaho (near INEEL); Amarillo, Texas (near Pantex); North Augusta, South Carolina (near SRS); and Richland, Washington (near Hanford). These meetings were designed to provide a forum in which participants could discuss issues directly with DOE program officials, and DOE could solicit relevant input from affected or interested local and regional stakeholders. The meetings were conducted in a workshop format, providing stakeholders with numerous opportunities to learn about the issues and express their comments and concerns. Each workshop consisted of a short plenary session, followed by discussion groups and summarizing remarks. The comments provided at the scoping meetings were documented and used in the development of this SPD EIS.

A database was created to track written and oral comments received during the scoping process. More than 1,400 individual documents, culminating in 2,000 comments, were received and recorded in the database. An analysis was conducted of the comments received during the scoping process. They were initially grouped in the following seven areas: *proposed action, alternatives, facilities/technologies, impact, costs, public involvement, and other*. Comments were further categorized into four major groups according to their relationship to the scope of this SPD EIS: *already intended for inclusion in this SPD EIS, needs to be addressed in this SPD EIS, needs to be or is already addressed elsewhere, and other*. The following summary describes some of the major issues identified during the scoping process.

Issues Already Intended for Inclusion in This SPD EIS. Many comments received during the scoping process concern issues that were already intended to be included in this SPD EIS. For example, many commentors expressed concern over the potential environmental impacts of the various technologies at the candidate sites and requested that an in-depth analysis be conducted to determine the potential impacts. A concern was also expressed that making can-in-canister the preferred immobilization technology without an evaluation of alternative technologies circumvents the NEPA process. Other commentors recommended that this SPD EIS include a detailed accounting of the wastes that will be generated and the location of their ultimate disposal. A number of commentors were concerned that existing legal agreements with State governments and other agencies (e.g., triparty agreements) would be overlooked and possibly ignored. Other commentors addressed the quantity of plutonium to be immobilized or fabricated into MOX fuel. DOE is addressing all of these issues in this SPD EIS.

Additional Issues That Need to Be Addressed in This SPD EIS. A few commentors suggested that additional issues be considered in this SPD EIS. [Text deleted.] Some commentors suggested that Pantex be considered as a candidate site for the pit conversion facility under all situations, including the 50-t (55-ton) immobilization option, because most of the surplus pits are currently located there. In response to these comments, DOE added two alternatives to the SPD Draft EIS for the option of immobilizing all 50 t (55 tons) of surplus plutonium. Initially, the alternatives included siting both the pit conversion and immobilization facilities at one site (i.e., Hanford or SRS). The two new alternatives include Pantex as a candidate site for the pit conversion facility.

Issues That Need to Be or Are Already Addressed Elsewhere. Many comments received during the scoping process concern issues that are beyond the scope of this SPD EIS but are being or will be addressed elsewhere. These issues include the relationship of plutonium disposition and tritium production, and use of the Fast Flux Test Facility (FFTF) at Hanford solely for surplus plutonium disposition. The SPD EIS does not address using FFTF because the current DOE proposals do not include the use of surplus plutonium as a fuel source for FFTF.¹¹

¹¹ DOE announced in a Notice of Intent (NOI) published September 15, 1999 (64 FR 50064), that it will prepare a programmatic EIS to evaluate the environmental effects associated with, among other options, the restart and operation of FFTF to meet the need for a range of research and development activities, medical isotope production, and plutonium 238 production to fuel National Aeronautics and Space Administration spacecraft.

A question was raised as to the role of the U.S. Nuclear Regulatory Commission (NRC) licensing requirements in regard to plutonium disposition facilities. Suggestions were made to include NRC processes in the SPD EIS. The NRC is a “commenting” agency on the SPD EIS. DOE provided copies of the SPD Draft EIS, *Supplement*, and SPD Final EIS to NRC for review and comment, and DOE is conducting regular meetings with NRC on the MOX approach, including fuel design and qualification.¹² In addition, an NRC license would be sought for the MOX facility. Domestic, commercial reactors operate under NRC licenses, and their proposed use of MOX fuel would be subject to review by NRC.

Some questions and concerns were also raised about the MOX fuel fabrication and reactor irradiation services procurement. (See Section 2.1.3 for a discussion of the procurement process and associated NEPA activities.) Many commentors suggested that DOE, in either this SPD EIS or other program studies, analyze the total cost of each alternative, including facility construction and modification, operations, and D&D, as well as all related site infrastructure costs. At the same time the SPD Draft EIS was issued, DOE released a cost study (DOE 1998a) focusing on site-specific costs to support site selection. As a followup to this study, DOE prepared a second report (DOE 1999b) that compiles life-cycle costs for the Preferred Alternative and addresses cost-related public comments.¹³ These cost studies will be considered, along with the SPD EIS analyses, in the DOE decisionmaking process. Some commentors suggested that the potential impacts of the disposal of spent nuclear fuel generated by MOX fuel use be included in this SPD EIS. This issue has already been addressed in the *Storage and Disposition PEIS*, and disposal of spent nuclear fuel is addressed in the *Draft Environmental Impact Statement for a Geologic Repository for the Disposal of Spent Nuclear Fuel and High-Level Radioactive Waste at Yucca Mountain, Nye County, Nevada* (DOE 1999c).¹⁴

Other. Many of the comments received were expressions of opinion or comments not directly related to issues addressed in this SPD EIS. For example, opposition was expressed by both U.S. and Canadian citizens to using CANDU reactors. Similarly, a number of commentors expressed their support for or opposition to immobilization and MOX technologies. Others expressed support for specific facilities or questioned the viability of site-specific facilities for pit conversion, immobilization, or MOX fuel fabrication. A number of commentors expressed their concern over the market viability of MOX fuel, even though MOX fuel would not be sold on the open market. Some commentors expressed their support for a hybrid disposition approach using both immobilization and MOX fuel fabrication.

1.5 SCOPE OF THIS SPD EIS

Site-specific issues associated with siting, construction, and operation of the three surplus plutonium disposition facilities are analyzed in this SPD EIS. The three facilities would be designed so that they could collectively accomplish disposition of up to 50 t (55 tons) of surplus plutonium over their operating lives, as shown in Figure 1–2. When the missions of the plutonium disposition facilities are completed, deactivation

¹² DOE did not receive any comments from NRC on the SPD Draft EIS or *Supplement*.

¹³ These two cost reports are available on the Office of Fissile Materials Disposition Web site at <http://www.doe-md.com>, in the public reading rooms at the candidate sites, and upon request.

¹⁴ For purposes of this SPD EIS, a potential geologic repository candidate site at Yucca Mountain, Nevada, was assumed to be the final disposal site for all immobilized plutonium and spent fuel. Currently, Yucca Mountain is the only site being characterized as a potential geologic repository. In August 1999, DOE issued a separate EIS, the *Draft Environmental Impact Statement for a Geologic Repository for the Disposal of Spent Nuclear Fuel and High-Level Radioactive Waste at Yucca Mountain, Nye County, Nevada* (DOE/EIS-0250D) (DOE 1999c), to analyze the site-specific environmental impacts from construction, operation and monitoring, and eventual closure of a potential geologic repository at Yucca Mountain.

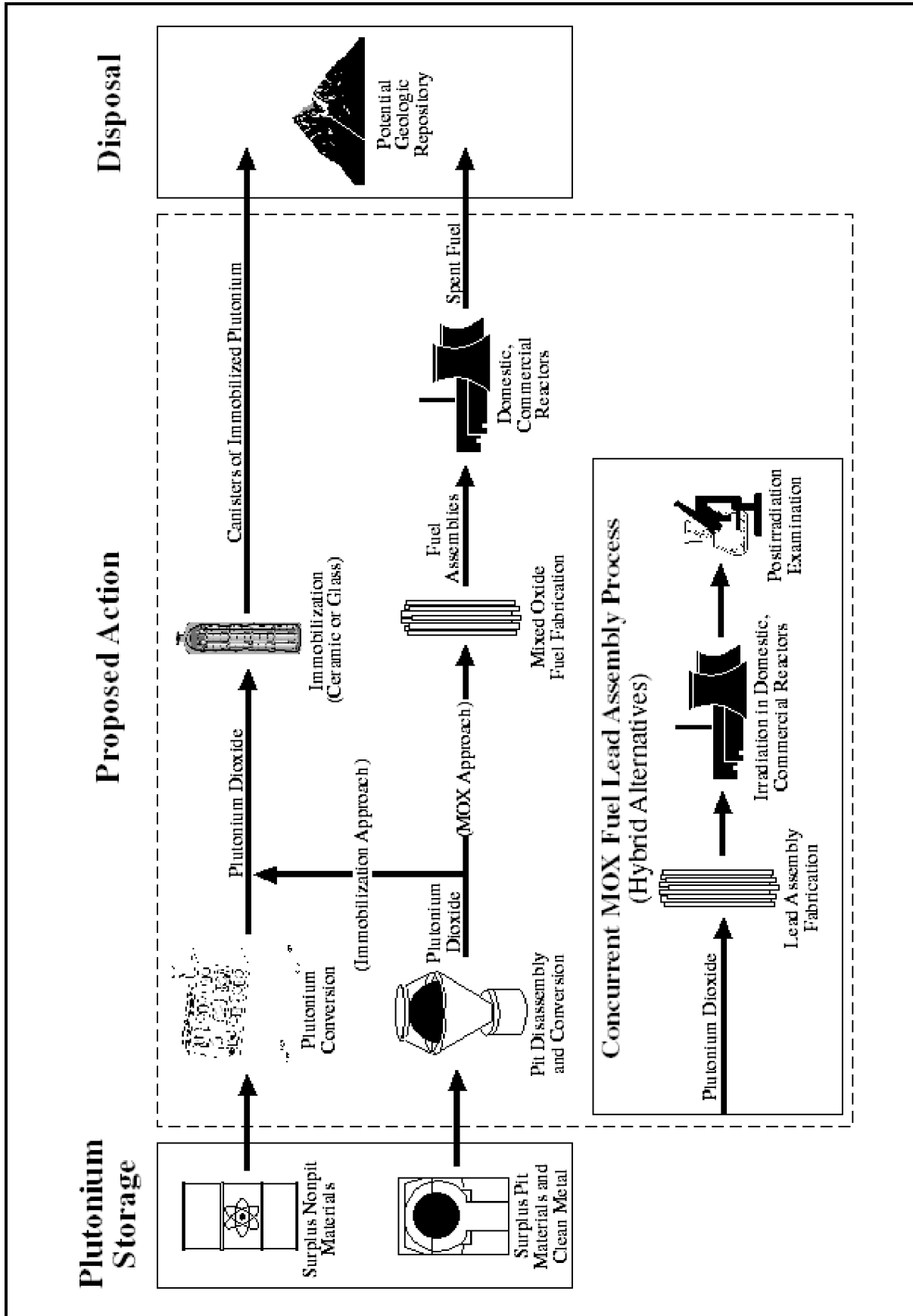

Figure 1-2. Proposed Surplus Plutonium Disposition Processes

and stabilization would be performed to reduce the risk of radiological exposure; reduce the need for and costs associated with long-term maintenance; and prepare the building for potential future use. (See Section 4.31.1 for a discussion on deactivation and stabilization.) At the end of the useful life of the facilities, DOE would evaluate options for D&D or reuse of the facilities. When DOE is ready for D&D of these facilities, an appropriate NEPA review will be conducted. (See Section 4.31.2 for a discussion of D&D.) This SPD EIS also analyzes transportation, including the following (see Section 2.4.4 for a more detailed discussion): plutonium from storage locations to the pit conversion facility or the immobilization facility, depending on the material and the alternative; plutonium dioxide from the pit conversion facility to the immobilization or MOX facility; recovered HEU from the pit conversion facility to Oak Ridge Reservation (ORR); depleted uranium hexafluoride from a representative DOE site to a representative commercial conversion facility (see Sections 2.4.4.2 and 2.4.4.3 for a more detailed discussion); uranium feed supply (uranium dioxide) from a representative commercial conversion facility to the immobilization and/or MOX fuel fabrication facilities and lead assembly facility; uranium fuel rods from a commercial fuel fabrication facility to the MOX facility and lead assembly facility; plutonium dioxide from LANL to the lead assembly facility; irradiated lead assemblies or rods from a reactor to the postirradiation examination site; spent fuel from the postirradiation examination site to INEEL for storage; MOX fuel to a commercial reactor; and immobilized plutonium to a potential geologic repository.¹⁵ In addition to the various disposition alternatives, a No Action Alternative is also analyzed. In this alternative, disposition would not occur, and surplus plutonium would remain in long-term storage in accordance with the storage approach identified in the *Storage and Disposition PEIS* ROD.¹⁶ For all alternatives analyzed in this SPD EIS, it is assumed that storage actions described in the *Storage and Disposition PEIS* ROD, as amended, have been accomplished.¹⁷ Because this SPD EIS tiers from the analyses and decisions reached in association with the *Storage and Disposition PEIS*, information relevant to disposition options or candidate sites is incorporated by reference and summarized; it is not repeated here. [Text deleted.]

As part of the assessment of the MOX alternatives, this SPD EIS analyzes the fabrication of up to 10 lead assemblies that may be needed to support the MOX fuel program, although DOE plans to produce only 2. (See Sections 2.18.2 and 4.27 for a discussion of how impacts would be lower if only two lead assemblies were fabricated.) Existing DOE facilities at five candidate sites are analyzed, as is the transportation of feed materials to the lead assembly fabrication sites and the fabricated lead assemblies to a domestic, commercial reactor for test irradiation. Postirradiation examination may be required to support NRC licensing activities related to the use of MOX fuel in domestic, commercial reactors. This SPD EIS discusses postirradiation examination at two candidate sites, ANL-W and ORNL. These two sites are currently the only sites that possess the capability to conduct postirradiation activities without major modifications to facility and processing capabilities; only minor modifications for receipt of materials would be required. Other potential facilities, either within the DOE complex or in the commercial sector, would require significant modifications to meet expected requirements of the postirradiation examination.

¹⁵ Shipments of spent fuel are analyzed in the *Draft Environmental Impact Statement for a Geologic Repository for the Disposal of Spent Nuclear Fuel and High-Level Radioactive Waste at Yucca Mountain, Nye County, Nevada* (DOE/EIS-0250D) (DOE 1999c).

¹⁶ Should the No Action Alternative be chosen, the ROD pursuant to this SPD EIS would also address the movement of the remaining surplus nonpit plutonium from RFETS in support of its planned closure in 2006.

¹⁷ Recent studies indicated that cost savings could be realized from the transfer of nonpit materials from RFETS and Hanford to SRS earlier than specified in the *Storage and Disposition PEIS* ROD. A Supplement Analysis was prepared, and based on this analysis, DOE determined that a supplemental PEIS would not be needed; an amended ROD was issued in August 1998 (63 FR 43386) and included decisions to accelerate shipment of all nonpit surplus plutonium from RFETS to SRS and to relocate all Hanford surplus plutonium to SRS, if SRS is selected as the immobilization disposition site.

The ceramic immobilization, MOX fuel fabrication, and lead assembly processes require the use of uranium dioxide as a feed material, which can be obtained from either natural or depleted uranium. Because DOE has a large inventory of depleted uranium hexafluoride (the equivalent of 385,000 t [424,385 tons] of depleted uranium dioxide), this SPD EIS analyzes the use of a small amount of that inventory (about 137 t [151 tons] per year) to produce uranium dioxide (White 1997:1).^{18, 19} Depleted uranium hexafluoride is currently stored at three DOE sites: the East Tennessee Technology Park in Oak Ridge, Tennessee; the Paducah Gaseous Diffusion Plant near Paducah, Kentucky; and the Portsmouth Gaseous Diffusion Plant (Portsmouth) near Piketon, Ohio. For purposes of analysis in this SPD EIS, Portsmouth is used as a representative site for a source of depleted uranium hexafluoride.²⁰ Included for evaluation in this SPD EIS are the activities necessary to package the depleted uranium hexafluoride for shipment to a representative commercial conversion facility (for purposes of analysis, this SPD EIS uses the General Electric Company's Nuclear Energy Production Facility in Wilmington, North Carolina) for conversion to uranium dioxide,²¹ to transport the depleted uranium hexafluoride from Portsmouth to Wilmington, and to transport the uranium dioxide from Wilmington to the candidate immobilization, MOX fuel fabrication, and lead assembly sites (i.e., ANL-W, Hanford, INEEL, LLNL, LANL, Pantex, and SRS).

DOE's NOI announcing the preparation of this SPD EIS includes a table outlining 12 originally proposed disposition alternatives. Each alternative identifies the facilities, new or existing, at each candidate site that would be analyzed in this SPD EIS. [Text deleted.] Since the publication of the NOI, DOE further increased the number of alternatives for SPD EIS analysis to include a new MOX facility at Hanford, in addition to the alternative involving modifying the Fuels and Materials Examination Facility. For the option of immobilizing all 50 t (55 tons) of surplus plutonium, DOE also included Pantex as a candidate site for pit disassembly and conversion activities, making a total of four 50-t (55-ton) all-immobilization alternatives in the SPD Draft EIS. Previously, only Hanford and SRS had been considered as sites for pit disassembly and conversion activities for the 50-t (55-ton) all-immobilization case. Eight alternatives using a portion of Building 221-F at SRS for the immobilization facility that were analyzed in the SPD Draft EIS have been eliminated from this SPD Final EIS because the amount of space required for the immobilization facility would be significantly larger than originally planned. These eight alternatives are no longer considered reasonable because the new construction required for the proposed immobilization facility is now expected to be nearly the same whether the facility is entirely located in a new building or is built in addition to using a portion of Building 221-F at SRS. There are now 15 action alternatives presented as 11 sets of alternatives, plus the No Action Alternative. For a more detailed discussion of alternative development, see Section 2.3.

As indicated in the ROD for the *Storage and Disposition PEIS*, this SPD EIS analysis provides, in part, the basis for determining a specific immobilization technology. This SPD EIS analyzes in detail the proposed can-in-canister approach and compares the results with the impacts predicted in the *Storage and Disposition PEIS* for the homogenous immobilization approach in new ceramic immobilization and vitrification facilities.

¹⁸ The contractor chosen by DOE to conduct MOX fuel fabrication has the option of acquiring uranium dioxide from another source.

¹⁹ Potential use of depleted uranium hexafluoride or facilities at the gaseous diffusion plants will be consistent with the *Final Programmatic Environmental Impact Statement for Alternative Strategies for the Long-Term Management and Use of Depleted Uranium Hexafluoride* (DOE/EIS-0269, April 1999; ROD, August 1999) and the *Final Plan for the Conversion of Depleted Uranium Hexafluoride, As Required by Public Law 105-204* (DOE, July 1999).

²⁰ The Portsmouth Gaseous Diffusion Plant is used as a representative site because it is the only one of the three DOE sites that is currently capable of transferring the depleted uranium hexafluoride from the 12.7-t (14-ton) tails cylinders in which it is currently stored to the 2.28-t (2.5-ton) feed cylinders that are compatible with the processing equipment at a commercial facility (White 1997:5). However, DOE has no preference as to where the depleted uranium is acquired.

²¹ Possible existing sites for this conversion facility include nuclear fuel fabrication facilities in Missouri, North Carolina, South Carolina, Washington, or a uranium conversion facility in Illinois. For purposes of analysis in this SPD EIS, the commercial nuclear fuel fabrication facility in Wilmington, North Carolina, is used as a representative site. DOE has no preference as to where conversion would occur.

In addition, for the can-in-canister approach, this SPD EIS separately analyzes the effects of immobilizing plutonium into either a titanate-based ceramic material or a lanthanide borosilicate glass.

To further define the potential processes to be used for the disposition of surplus plutonium, several research and development (R&D) activities are ongoing. A discussion of these R&D activities is provided in the *Pit Disassembly and Conversion Demonstration Environmental Assessment and Research and Development Activities* (DOE 1998b; Finding of No Significant Impact [FONSI], August 1998). Several of these R&D activities are likely to continue after the ROD for this SPD EIS is issued.

1.6 PREFERRED ALTERNATIVES

DOE's Preferred Alternative for the disposition of surplus weapons-usable plutonium is Alternative 3: to disposition up to 50 t (55 tons)²² of plutonium at SRS using a hybrid approach that involves both the ceramic can-in-canister immobilization approach and the MOX approach. Approximately 17 t (19 tons) would be immobilized in a ceramic form, placed in cans, and embedded in large canisters containing high-level vitrified waste for ultimate disposal in a potential geologic repository pursuant to the NWPAs. Approximately 33 t (36 tons) would be used to fabricate MOX fuel, which would be irradiated in existing domestic, commercial reactors. The proposed reactors are the Catawba Nuclear Station near York, South Carolina; the McGuire Nuclear Station near Huntersville, North Carolina; and the North Anna Power Station near Mineral, Virginia.²³ The resulting spent fuel would be placed in a potential geologic repository pursuant to the NWPAs.

Pursuing the hybrid approach provides the best opportunity for U.S. leadership in working with Russia to implement similar options for reducing Russia's excess plutonium in parallel. Further, it sends the strongest possible signal to the world of U.S. determination to reduce stockpiles of surplus weapons-usable plutonium as quickly as possible and in a manner that would make it technically difficult to use the plutonium in weapons again. Pursuing both immobilization and MOX fuel fabrication also provides important insurance against uncertainties of implementing either approach by itself. The construction of new facilities for the disposition of surplus U.S. plutonium would not take place unless there is significant progress on plans for plutonium disposition in Russia.

DOE's preference for siting plutonium disposition facilities is as follows:

- **Pit Disassembly and Conversion at SRS.** Construct and operate a new pit conversion facility at SRS for the purpose of disassembling nuclear weapons pits and converting the plutonium metal to a declassified oxide form suitable for international inspection and disposition using either immobilization or MOX/reactor approaches. SRS is preferred for the pit conversion facility because the site has extensive experience with plutonium processing, and the pit conversion facility complements existing missions and takes advantage of existing infrastructure.

[Text deleted.]

²² Some materials are already in a final disposition form (i.e., irradiated fuel) and will not require further action before disposal. These materials are not included in this SPD EIS.

²³ No facility construction or MOX fuel fabrication or irradiation is to occur until the SPD EIS ROD is issued. Additionally, no MOX fuel is to be irradiated until NRC amends the operating license of each selected reactor prior to the specific reactor receiving the MOX fuel. Such site-specific activities would depend on decisions in the ROD, and DOE's exercise of contract options to allow such activities would be contingent on the ROD.

- **Immobilization at SRS (new construction and Defense Waste Processing Facility).**²⁴ Construct and operate a new immobilization facility at SRS using the ceramic can-in-canister technology. This technology would immobilize plutonium in a ceramic form, seal it in cans, and place the cans in canisters filled with borosilicate glass containing radioactive high-level waste (HLW) at the existing Defense Waste Processing Facility (DWPF). This preferred can-in-canister approach at SRS complements existing missions, takes advantage of existing infrastructure and staff expertise, and enables DOE to use an existing facility (DWPF). SRS was previously designated to be part of DOE's Preferred Alternative for immobilization in the NOI issued in May 1997. The ceramic can-in-canister approach would involve slightly lower environmental impacts than the homogenous approach (wherein the plutonium is incorporated into a homogenous mixture of plutonium and fission products in a single waste form). The ceramic can-in-canister approach would involve better performance in a potential geologic repository due to the ceramic form's expected higher durability under repository conditions and its lower potential for long-term criticality. In addition, it would provide greater proliferation resistance than the glass can-in-canister approach because recovery of plutonium from the ceramic form would require a more chemically complex process than has yet been developed.
- **MOX Fuel Fabrication at SRS (new construction).** Construct and operate a new MOX facility at SRS and produce MOX fuel containing surplus weapons-usable plutonium for irradiation in existing, domestic, commercial reactors. SRS is preferred for the MOX facility because this activity complements existing missions and takes advantage of existing support infrastructure and staff expertise. [Text deleted.]
- **Lead Assembly Fabrication at LANL.** Based on the consideration of capabilities of the candidate sites and input from the contractor team chosen for the MOX approach (the MOX procurement process is discussed in Chapter 2), DOE prefers LANL for lead assembly fabrication. LANL is preferred because it already has fuel fabrication facilities that would not require major modifications, and takes advantage of existing infrastructure and staff expertise. Additionally, the surplus plutonium dioxide that would be used to fabricate the lead assemblies would already be in inventory at the site.
- **Postirradiation Examination at ORNL.** If postirradiation examination is necessary for the purpose of qualifying the MOX fuel for commercial reactor use, DOE prefers to perform that task at ORNL. ORNL has the existing facilities and staff expertise needed to perform postirradiation examination as a matter of its routine activities; no major modifications to facilities or processing capabilities would be required. In addition, because ORNL is about 500 km (300 mi) from the McGuire Nuclear Station, the reactor that would irradiate the fuel, it is the closest candidate site for postirradiation examination activities.

[Text deleted.]

²⁴ DOE is presently considering replacement alternatives for the In-Tank Precipitation (ITP) process at SRS. The ITP process was intended to separate soluble high-activity radionuclides from liquid HLW before vitrifying the high-level fraction in DWPF. Due to problems experienced with the operation of ITP as configured, DWPF is currently operating with sludge feed only. A supplemental EIS on DWPF operation is being prepared that analyzes three proposed alternatives: small tank precipitation, ion exchange, and direct grout. See Section 2.4.2.1 for a more detailed discussion of these alternatives.

1.7 SUMMARY OF MAJOR ISSUES IDENTIFIED DURING THE COMMENT PERIODS AND CHANGES TO THE SPD DRAFT EIS

1.7.1 Public Involvement Process for the SPD Draft EIS and the *Supplement to the SPD Draft EIS*

DOE issued the SPD Draft EIS in July 1998 and received public comments. The comment period ran from July 17, 1998, through September 16, 1998, although DOE considered all comments submitted after the close of the 60-day comment period. In August 1998, DOE held five public hearings at the following locations in the vicinity of the four candidate DOE sites and at one regional location:

Richland, Washington	August 4, 1998
Amarillo, Texas	August 11, 1998
North Augusta, South Carolina	August 13, 1998
Portland, Oregon	August 18, 1998
Idaho Falls, Idaho	August 20, 1998

DOE received comments on the SPD Draft EIS by mail, a toll-free telephone and fax line, the Office of Fissile Materials Disposition Web site, and at the public hearings. Altogether, DOE received approximately 3,400 comment documents from individuals and organizations. All comments are presented in Volume III, Parts A and B, of the Comment Response Document of this SPD Final EIS. Approximately 65 percent of the comments received consisted of mail-in postcard campaigns that expressed either support of or opposition to the use of various sites or technologies. About 12 percent were collected during public hearings, 10 percent were in letters received by mail, 10 percent were received by fax, 2 percent were received by telephone, and 1 percent were received through the Web site.

In April 1999, DOE issued the *Supplement* and received public comments. The comment period ran from May 14, 1999, through June 28, 1999, although DOE considered all comments received after the close of the 45-day comment period. On June 15, 1999, DOE held a public hearing in Washington, D.C. DOE received approximately 77 comment documents from individuals and organizations, which are presented in Volume III, Part B, of the Comment Response Document of this SPD Final EIS. Approximately 21 percent of the comments received were collected during the public hearing, 34 percent were in letters received by mail, 26 percent were received by fax, 5 percent were received by telephone, and 14 percent were received through the Web site.

1.7.2 Summary of Major Issues Raised on the SPD Draft EIS During the Public Comment Period

The following paragraphs highlight comments and issues that the public raised concerning information provided in the SPD Draft EIS. These comments were collected during the two separate public comment periods for the SPD Draft EIS and the *Supplement*. (Comments received on information specifically provided in the *Supplement* are summarized in Section 1.7.3.) Changes made to this SPD EIS in response to a comment are described.

Russian Disposition Program. A number of commentors expressed concern over Russian disposition activities and tying U.S. activities to Russian activities. The United States and Russia recently made progress in the management and disposition of plutonium. In July 1998, Vice President Gore and Russian Prime Minister Sergei Kiriyenko signed a 5-year agreement to provide the scientific and technical basis for decisions concerning how surplus plutonium will be managed. In September 1998, Presidents Clinton and Yeltsin held a Moscow summit and signed a statement of principles with the intention of removing approximately 50 t (55 tons) of plutonium from each country's stockpile. The United States does not currently plan to implement a unilateral program; however, it will retain the option to begin certain disposition activities in order to encourage the Russians and set an international example. DOE has updated this SPD EIS to reflect the agreement and statement of principles and included copies in Appendix A.

Site Selection. A large number of comments were received advocating one candidate site over another for various reasons, including the presence of existing facilities that could prove beneficial to plutonium disposition, skilled workers, safety records, reduced transportation, and perceived economic benefits. DOE has chosen SRS as its preferred site for the three surplus plutonium disposition facilities, as outlined in Section 1.6.

Approach to Plutonium Disposition. A number of commentors protested DOE's preference for the hybrid approach and the use of MOX fuel for surplus plutonium disposition. Among the comments received on this issue were many advocating the use of the immobilization approach for all of the surplus plutonium. Commentors argued that the immobilization approach was safer, cheaper, and faster. They also pointed out that the immobilization approach resulted in less transportation. Because specific reactors in North Carolina, South Carolina, and Virginia have been proposed for plutonium disposition, the transportation requirements associated with several hybrid alternatives that include the MOX facility at SRS and Pantex have decreased (because the proposed reactors are closer to these sites than the 4,000-km [2,500-mi] bounding distance analyzed in the SPD Draft EIS). As a result, these hybrid alternatives would require less transportation than some of the 50-t (55-ton) immobilization alternatives. Other commentors viewed the MOX approach as a Federal Government subsidy of the commercial nuclear power industry. Use of MOX fuel in domestic, commercial reactors is not proposed in order to subsidize the commercial nuclear power industry. Rather, the purpose is to safely and securely disposition surplus plutonium by meeting the Spent Fuel Standard.²⁵

Safety and Health. Comments were received that questioned the safety and health aspects of operating the surplus plutonium disposition facilities. Commentors pointed out that DOE's safety record at other nuclear facilities had been poor in the past and questioned DOE's ability to safely operate the disposition facilities. The health and safety of workers and the public is a priority of the surplus plutonium disposition program, regardless of which approach is chosen. Operation of the disposition facilities would comply with applicable Federal, State, and local laws and regulations governing radiological and hazardous chemical releases. Within these limits, DOE believes that the radiation exposure and the level of contamination should be kept as low as is reasonably achievable.

Aqueous Processing of Plutonium. Some commentors questioned DOE's ability to produce clean plutonium dioxide that could be used in MOX fuel using the dry process proposed in the SPD Draft EIS. Questions were raised about the ability of this process to remove gallium and other pit materials from the plutonium before it is fabricated into MOX fuel. On the basis of public comments received on the SPD Draft EIS and the analysis performed as part of the MOX procurement, DOE has included plutonium polishing (a small-scale aqueous process) as a component of the MOX facility to ensure adequate impurity removal from the plutonium dioxide. Appendix N (which addressed plutonium polishing in the SPD Draft EIS) was deleted from this SPD Final EIS, and the impacts discussed therein were included in the impacts presented for the MOX facility in Chapter 4. Section 2.4.3 was also revised to include a discussion of plutonium polishing.

No attempt was made to evaluate the use of DOE's existing aqueous processing lines capable of dissolving pits, as advocated by some commentors. DOE determined that such aqueous processing, while a proven technology, is not a reasonable alternative for pit conversion because current aqueous processes using existing facilities would produce significant amounts of waste, and aqueous processing would complicate international inspection regimes because of classification issues.

²⁵ "Spent Fuel Standard" is a term coined by the National Academy of Sciences (NAS, 1994, *Management and Disposition of Excess Weapons Plutonium*, National Academy Press, Washington, D.C., pg.12.) and modified by DOE (glossary from Office of Fissile Materials Disposition Web site at <http://www.doe-md.com>) denoting the main objective of alternatives for the disposition of surplus plutonium: that such plutonium be made roughly as inaccessible and unattractive for weapons use as the much larger and growing stock of plutonium in civilian spent nuclear fuel.

Reprocessing. Several comments were received related to the reprocessing of plutonium and the civilian use of plutonium. The use of U.S. surplus plutonium in existing domestic, commercial reactors does not involve reprocessing. The proposed use of MOX fuel is consistent with the U.S. nonproliferation policy and would ensure that plutonium that was produced for nuclear weapons and subsequently declared excess to national security needs is never again used for nuclear weapons. The MOX facility would be built and operated subject to the following strict conditions: construction would take place at a secure DOE site, it would be owned by the U.S. Government, operations would be limited exclusively to the disposition of surplus plutonium, and the MOX facility would be shut down at the completion of the surplus plutonium disposition program. At the end of the useful life of the facility, DOE would evaluate options for D&D or reuse of the facility for other purposes.

Inclusion of Generic Reactor Information in the SPD Draft EIS. Many comments were received on the inclusion of generic reactor information in the SPD Draft EIS. At the time the Draft was released, DOE did not know which specific reactors would be proposed for the MOX program. Subsequently, the Catawba, McGuire, and North Anna reactors were chosen as part of the contractor team that would implement the MOX option should the decision be made in the SPD EIS ROD to go forward with the hybrid approach (i.e., both immobilization and MOX). Specific reactor information provided as part of the procurement process was evaluated by DOE in an Environmental Critique in accordance with DOE's NEPA regulations at 10 CFR 1021.216. The Environmental Critique was considered by DOE before awarding the contract. An Environmental Synopsis based on the Environmental Critique was prepared and released to the public for comment in the *Supplement*. The comments received on the *Supplement* are summarized and responded to in Volume III, Part B, of the Comment Response Document. An opportunity for public comment will also likely be provided by NRC during the reactor operating license amendment process.

Transportation Concerns. Commentors raised concerns about the transportation involved with moving the surplus plutonium from storage locations to disposition sites and, in some cases, MOX fuel to reactor sites. Requests were made to limit the transportation where possible, to present the transportation information in a more understandable manner, and to ensure that the transportation was conducted as safely as possible. Additional information has been added to Chapter 2 of this SPD Final EIS, which shows the total transportation associated with each alternative and gives a graphic depiction of the transportation needed for each disposition approach (immobilization and MOX). As discussed in this SPD EIS, safe transportation is a major concern of DOE. All shipments of surplus plutonium would be accomplished using the safe, secure trailer/SafeGuards Transport (SST/SGT) system.²⁶ Since the establishment of the DOE Transportation Safeguards Division in 1975, the SST/SGT system has transported DOE-owned cargo over more than 151 million km (94 million mi) with no accidents that resulted in a fatality or release of radioactive material.

Cost of Plutonium Disposition. Many commentors focused on the cost of various surplus plutonium disposition facilities. Because cost issues are beyond the scope of this SPD EIS, commentors are referred to DOE's *Cost Analysis in Support of Site Selection for Surplus Weapons-Usable Plutonium Disposition* (DOE 1998a) and *Plutonium Disposition Life-Cycle Costs and Cost-Related Comment Resolution Document* (DOE 1999b). Comments concerning the basis for DOE's cost estimates or requesting cost information were forwarded to DOE's cost analysis team.

²⁶ The SST/SGT is a specially designed component of an 18-wheel tractor-trailer vehicle. Although the details of the vehicle enhancements are classified, key characteristics are not, and include: enhanced structural supports and a highly reliable tie-down system to protect cargo from impact; heightened thermal resistance to protect the cargo in case of fire; deterrents to protect the unauthorized removal of cargo; couriers who are armed Federal officers and receive rigorous training and are closely monitored through DOE's Personnel Assurance Program; an armored tractor to protect the crew from attack; advanced communications equipment; specially designed escort vehicles containing advance communications and additional couriers; 24-hr-a-day real-time monitoring of the location and status of the vehicle; and significantly more stringent maintenance standards.

1.7.3 Summary of Major Issues Raised on the *Supplement to the SPD Draft EIS* During the Public Comment Period

Frequency of Reactor Accidents in Reactors Using MOX Fuel. A number of comments argued that the frequency of reactor accidents would be greater due to the use of MOX fuel. As reflected in the accident analysis included in Section 4.28, the consequences of a beyond-design-basis accident using MOX fuel are generally higher than those expected in the same reactor using low-enriched uranium (LEU) fuel. However, there is no basis for concluding that the frequency of these accidents would increase due to the use of MOX fuel. During the base contract period, the contractor team would work with the utilities to confirm the characteristics of the MOX fuel and whether any design modifications are necessary to maintain safety margins. No change in the frequencies of reactor accidents due to the use of MOX fuel has been made in this SPD Final EIS.

Risk Associated With Reactors Using MOX Fuel. Many commentors were concerned that there is an increase in accident risk from reactors using MOX fuel and that the plutonium in MOX fuel makes a reactor accident more dangerous to human health. There are differences in the expected risk of reactor accidents from the use of MOX fuel. Some accidents would be expected to result in lower consequences to the surrounding population, and thus, lower risks, while others would be expected to result in higher consequences and higher risks. The largest estimated increase in risk to the surrounding population due to the use of MOX fuel is an estimated 14 percent increase in the risk of latent cancer fatalities associated with an interfacing systems loss-of-coolant at North Anna. The likelihood of this accident occurring at North Anna is estimated to be one chance in 4.2 million per year. Before any MOX fuel is used for plutonium disposition, NRC would perform a comprehensive safety review that would include information prepared by the reactor plant operators as part of their license amendment applications. Expected risk is discussed in Section 4.28 of this SPD EIS.

Environmental Impacts Associated With Using MOX Fuel Versus LEU Fuel. Comments were received expressing a concern that the SPD Draft EIS failed to recognize avoided environmental impacts associated with using MOX fuel versus LEU fuel in existing commercial reactors. While the consequences of a beyond-design basis accident might be higher (as discussed above), and a slight increase in spent fuel could be expected by using MOX fuel instead of LEU fuel, the impacts associated with mining, milling, and enriching uranium are avoided. Section 4.28.3 has been added to this SPD Final EIS to address this issue.

Low-Level Waste. Comments were received on the isotopic breakdown of the low-level waste (LLW) that would be generated at the reactors using MOX fuel and the effect of this waste on existing burial grounds. There are differences in fission product inventories and activation products between an LEU and MOX core during a fuel cycle. However, the only time significant quantities of fission products could be released to the environment or end up in LLW would be in the event of a large-scale fuel leak. In regard to normal operations, experience with fabricating MOX fuel indicates a leakage rate of less than one-tenth of one percent. The use of MOX fuel would not be expected to result in any additional LLW because the reactors would continue to operate on the same schedule as if they were using only LEU fuel.

Public Hearings. A number of comments were received regarding the need to hold public hearings near the proposed reactor locations. DOE's NEPA regulations require that at least one public hearing be held to receive comments on a draft EIS (10 CFR Part 1021.313[b]). A public hearing was held in Washington, D.C., to collect public comments on the *Supplement*. No additional hearings were held near the specific reactor sites, but comments were solicited in the areas surrounding the proposed reactors. The *Supplement* was sent to interested groups and individuals near each of the reactors and an informational meeting about the proposed use of MOX fuel, sponsored by a South Carolina State Senator, was attended by DOE during the comment period. The transcript of this meeting is presented as Appendix A of the Comment Response Document.

1.7.4 Changes to the SPD Draft EIS and the *Supplement*

DOE revised the SPD Draft EIS and its *Supplement* in response to comments received from other Federal agencies; tribal, State, and local governments; nongovernmental organizations; the general public; and DOE reviews. The text was changed to provide additional environmental baseline information, reflect new technical data, make editorial corrections, respond to comments, and clarify text. Some of these changes involved recalculations of the impacts discussed in Chapter 4. In addition, DOE updated information due to events or decisions made since the SPD Draft EIS and *Supplement* were provided for public comment. Sidebars are used throughout this SPD Final EIS to indicate where changes have been made. Below is a brief discussion of significant (i.e., noneditorial) changes.

Revised Preferred Alternative. In the SPD Draft EIS, DOE's Preferred Alternative for siting the proposed disposition facilities was identified as either Alternative 3 (the pit conversion, immobilization, and MOX facilities at SRS) or Alternative 5 (the pit conversion facility at Pantex and the immobilization and MOX facilities at SRS). Under either alternative, the hybrid approach (i.e., immobilization and MOX) was preferred with the immobilization technology being the can-in-canister approach. No preference was identified in the SPD Draft EIS for the lead assembly or postirradiation examination activities, nor were the specific reactors that would use MOX fuel identified.

The *Supplement* identified SRS as the preferred site for the construction and operation of the pit conversion, immobilization, and MOX facilities. The *Supplement* also identified LANL as the preferred site for lead assembly activities and ORNL as the preferred site for postirradiation examination activities. Section 1.6 of this SPD Final EIS now identifies Alternative 3 as DOE's Preferred Alternative. In addition, Section 2.1.3 now identifies the three reactor sites that have been named as candidates for using MOX fuel subject to NRC license amendment. They are the Catawba Nuclear Station in York County, South Carolina; the McGuire Nuclear Station in Mecklenburg County, North Carolina; and the North Anna Power Station in Louisa County, Virginia.

Changes to the Immobilization Facility. Since the issuance of the SPD Draft EIS and as described in the *Supplement*, DOE has developed a more detailed conceptual design for the can-in-canister immobilization facility. Changes in the size of the immobilization facility have been reflected in Chapter 2 of this SPD Final EIS and the associated impact analyses throughout Chapter 4. No changes have been made to the basic processes proposed in the SPD Draft EIS for immobilization, to the amount of material being considered for immobilization, or to the rate of throughput.

As stated in the *Supplement*, the eight alternatives that included using portions of Building 221-F for immobilization (SPD Draft EIS Alternatives 3B, 5B, 6C, 6D, 7B, 9B, 12B, and 12D) were eliminated. These alternatives are no longer reasonable because the amount of new construction required for the proposed immobilization facility is now nearly the same whether the facility is located entirely in a new building or uses a portion of Building 221-F. Thus, there is no longer any advantage associated with the use of Building 221-F at SRS.

Changes Resulting From the MOX Procurement Process. As stated in the *Supplement*, information provided as part of the MOX procurement process relating to the MOX facility, including the addition of a plutonium-polishing module to the front end of the MOX facility, was analyzed by DOE in an Environmental Critique and summarized in an Environmental Synopsis prepared pursuant to DOE's NEPA regulations in 10 CFR 1021.216. The Synopsis was included in the *Supplement* and has been added to this SPD Final EIS as Appendix P. Appendix N, *Plutonium Polishing*, has been deleted from this SPD Final EIS, with the information in Appendix N incorporated into the body of the EIS. A description of the polishing module has been added to Section 2.4.3, and the impacts analysis has been incorporated into Chapter 4 of this SPD Final EIS. The polishing step is included in the MOX facility, so plutonium polishing is no longer considered as a contingency for the pit conversion facility.

As described in the *Supplement*, the size of the MOX facility has increased. The larger MOX facility is described in Chapter 2 of this SPD Final EIS, and the associated environmental impacts are presented throughout Chapter 4. No changes have been made in the amount of material proposed to be made into MOX fuel, the facility's throughput, or in the overall process to be used to fabricate the fuel.

Information related to the affected environment for the specific domestic commercial reactors that would irradiate the MOX fuel was provided in the *Supplement* and has been added to this SPD Final EIS as a new Section 3.7. Environmental impacts analyzed for the actual reactor sites was also provided in the *Supplement* and has been added to Section 4.28 of this SPD Final EIS.

Possible Delay of the Construction of the Actinide Packaging and Storage Facility. As stated in the *Supplement*, the schedule for the Actinide Packaging and Storage Facility (APSF) is uncertain at this time, and therefore, the disposition facilities at SRS analyzed in this SPD Final EIS were modified to disregard any benefit to the proposed facilities as a result of APSF being present. Chapter 4 of this SPD Final EIS presents the environmental impacts that would be associated with the construction and operation of surplus plutonium disposition facilities at SRS that are stand-alone and include no reliance on storage space or other functions at APSF. Throughout this SPD Final EIS, references to APSF have been qualified by the phrase "if built," and no credit has been taken in the environmental analyses for the presence of APSF.

Pit Repackaging Requirements. This SPD Final EIS was changed to reflect new decisions on the repackaging of pits at Pantex for long-term storage and the impacts of that decision on the need to repackage the pits for offsite transportation.

Pit repackaging for long-term storage. As discussed in the *Supplement*, work is currently under way to repackage all pits at Pantex from the AL-R8 container into the AL-R8 sealed insert (SI) container for long-term storage,²⁷ as described in the *Supplement Analysis for: Final Environmental Impact Statement for the Continued Operation of the Pantex Plant and Associated Storage of Nuclear Weapon Components—AL-R8 Sealed Insert Container* (DOE 1998c). This effort would be completed over 10 years, and the estimated dose to involved workers received from this repackaging activity would be about 104 person-rem. The SPD Draft EIS analyzed repackaging of the pits in an AT-400A container. The change to the AL-R8 SI changes the undisturbed long-term storage period for pits from 50 to 30 years because of the need to replace a seal in the container after 30 years; the AT-400A does not require that activity. This change has been incorporated into Chapter 4.

Pit repackaging for offsite transportation. The AL-R8 SI is not an offsite shipping container as was the AT-400A analyzed in the SPD Draft EIS. Therefore, if the decision were made to site the pit conversion facility at a site other than Pantex, the surplus pits would have to be taken out of the AL-R8 SI and placed in a shipping container.²⁸ This operation would also require the replacement of some pit-holding fixtures to meet transportation requirements. It is expected that this change would result in a total repackaging dose to involved workers of 208 person-rem. If the decision were made to locate the pit conversion facility at Pantex, then the pits could be moved from their storage location to the pit conversion facility in the AL-R8 SI using onsite transportation

²⁷ DOE is considering leaving the repackaged surplus pits in Zone 4 at Pantex for long-term storage. An appropriate environmental review will be conducted when the specific proposal for this change has been determined (e.g., whether additional magazines need to be air-conditioned). The analysis in this document assumes that the surplus pits are stored in Zone 12 in accordance with the ROD for the *Storage and Disposition PEIS*.

²⁸ At the present time, DOE is using the FL container for the offsite shipment of pits. There are not enough of these containers to meet the plutonium disposition mission. No new FL containers can be manufactured because of certification restrictions. Further, the current FL containers cannot be certified for a specific type of surplus pit. The Defense Nuclear Facilities Safety Board, in its Recommendation 99-1 (August 1999), noted that there is no container suitable for shipping pits from Pantex. Should DOE make any decisions that would require shipment of pits from Pantex, DOE would ensure the availability of a certified shipping container in a timeframe that would support those decisions.

vehicles. Under this option, there would be no increased exposures due to repackaging. This change has been incorporated into Chapter 4.

Environmental Impacts Associated With MOX Fuel Versus LEU Fuel. Section 4.28.3 was added to this SPD Final EIS to address the impacts associated with using MOX fuel versus LEU fuel in existing commercial reactors.

Uranium Conversion Impacts. Section 4.30.3, Incremental Impacts Associated With Uranium Conversion, was added to address potential impacts of the conversion of depleted uranium hexafluoride to uranium dioxide. (See Sections 2.4.4.2 and 2.4.4.3 for a discussion on conversion.)

New/Revised Documents and Changes to Cumulative Impacts. Section 1.7 of the SPD Draft EIS, Relationship to Other Actions and Programs, (Section 1.8 in this Final) was updated to reflect new or revised planning documents and related NEPA documents, such as the *Environmental Assessment for the Parallel Project Fuel Manufacture and Shipment*, the *ROD for the Department of Energy's Waste Management Program: Treatment of Non-Wastewater Hazardous Waste*, the *Advanced Mixed Waste Treatment Project Final EIS* and *ROD*, and the *Final Environmental Impact Statement on Management of Certain Plutonium Residues and Scrub Alloy Stored at the Rocky Flats Environmental Technology Site* and *RODs*. The information in the most recent programmatic and site documents has been used to update the discussion of cumulative impacts in Section 4.32 of this SPD Final EIS. In addition, cumulative impacts information has been added for LLNL and LANL (two candidate sites for lead assembly fabrication), ORNL (a candidate site for postirradiation examination), and the three reactor sites (Catawba, McGuire, and North Anna).

Affected Environment. Information on the affected environment for ORNL, a candidate site for postirradiation examination, has been added to Chapter 3 of this SPD Final EIS.

Consultations. Appendix O was added to provide the correspondence related to ecological resources, cultural resources, and Native American consultations. Table 5–2 provides a summary of these consultations, and Section 4.26 discusses the results of the consultations.

FFTF. Appendix D of the SPD Draft EIS was deleted. This SPD Final EIS does not address using FFTF because the current DOE proposals do not include the use of surplus plutonium as a fuel source for FFTF.

Comment Response. Volume III, the Comment Response Document, was added to this SPD Final EIS. The comments received during the two comment periods and their responses are presented in a side-by-side-format.

1.8 RELATIONSHIP TO OTHER ACTIONS AND PROGRAMS

The proposed plutonium disposition actions would require coordination with other ongoing DOE programs. This section provides brief summaries of NEPA and other planning documents related to these ongoing programs. Section 1.8.1 includes documents that deal directly with other aspects of the surplus plutonium disposition program, as well as documents from other programs that may provide feed materials for disposition activities. Other documents in this section analyze material treatment or stabilization activities at DOE sites that could yield weapons-usable fissile materials that would be dispositioned pursuant to the analysis in this SPD EIS. Section 1.8.2 includes documents that analyze the management of the various waste types across the DOE complex. Waste generated by the construction and operation of the proposed surplus plutonium disposition facilities would be managed in accordance with decisions made pursuant to the NEPA RODs of these documents. Also, some of the waste planning documents will reflect the waste management and environmental implications of the decisions made as a result of this SPD EIS. Section 1.8.3 highlights some of the documents that deal with

activities currently under way or planned for the SPD EIS candidate sites. The information in the most recent and programmatic site documents are considered in the cumulative impact assessment in Section 4.32.

1.8.1 Materials and Disposition Options

The *Storage and Disposition of Weapons-Usable Fissile Materials Final Programmatic Environmental Impact Statement* (DOE/EIS-0229, December 1996) analyzes the environmental impacts of alternatives considered for the long-term storage of weapons-usable fissile materials (HEU and plutonium) and for the disposition of weapons-usable plutonium that has been declared surplus to national security needs. The ROD (January 1997) encompasses two categories of plutonium decisions: (1) the sites and facilities for the storage of nonsurplus plutonium and the storage of surplus plutonium pending disposition; and (2) the programmatic strategy for disposition of surplus plutonium. This ROD does not include the final selection of sites for plutonium disposition facilities or the extent to which the two plutonium disposition approaches (immobilization and MOX) will be ultimately implemented. (Those decisions will be based in part on the analysis in this tiered SPD EIS.) However, DOE does announce in the ROD that the list of candidate sites for plutonium disposition has been narrowed. It also announces the decision to store surplus and nonsurplus HEU in upgraded facilities at the Oak Ridge Reservation. DOE studies indicated that significant cost savings could be realized from the transfer of nonpit materials from RFETS and Hanford earlier than indicated in the *Storage and Disposition PEIS* ROD. DOE issued an amended ROD (August 1998) that supports the early closure of RFETS and the early deactivation of plutonium storage facilities at Hanford. The amended ROD includes decisions to accelerate shipment of all nonpit surplus plutonium from RFETS to SRS and the relocation of all Hanford surplus plutonium to SRS, if SRS were selected as the immobilization site. A supplement analysis to the *Storage and Disposition PEIS*, the *Supplement Analysis for Storing Plutonium in the Actinide Packaging and Storage Facility and Building 105-K at the Savannah River Site*, was issued in July 1998.

The *Pit Disassembly and Conversion Demonstration Environmental Assessment and Research and Development Activities* (DOE/EA-1207, August 1998; FONSI, August 1998) analyzes a proposed demonstration project at LANL to determine the feasibility of an integrated pit disassembly and conversion system as part of the surplus plutonium disposition strategy. This demonstration involves the disassembly of up to 250 pits and conversion of the recovered plutonium to plutonium metal ingots and plutonium oxide. The demonstration started in the fall of 1998 and will last up to 4 years. The results of the demonstration will help “fine-tune” the operational parameters of the pit conversion facility. The environmental assessment (EA) also describes ongoing R&D activities related to the disposition of surplus plutonium.

The *Environmental Assessment for the Parallax Project Fuel Manufacture and Shipment* (DOE/EA-1216, January 1999; FONSI, August 13, 1999) tiers from the *Storage and Disposition PEIS* and analyzes the fabrication and transport of a limited amount of U.S. MOX fuel to a Canadian reactor for test irradiation. Russian MOX fuel would also be irradiated as part of the experiment. The MOX fuel fabricated at LANL would be transported in U.S. Department of Transportation–approved containers by commercial carriers to a Canadian port of entry. At the Canadian border, Atomic Energy of Canada Limited (AECL) would take possession of the fuel and complete the shipment in the U.S. trucks to the National Research Universal (NRU) test reactor at Chalk River Laboratories in Chalk River, Ontario. The AECL would be responsible for conducting all subsequent fuel performance tests in the NRU reactor. All spent fuel resulting from the tests would be disposed of in Canada under the Canadian spent fuel program.

The *Final Environmental Impact Statement on Management of Certain Plutonium Residues and Scrub Alloy Stored at the Rocky Flats Environmental Technology Site* (DOE/EIS-0277F, August 1998; ROD, November 1998; ROD, February 1999; Amended ROD, September 1999) evaluates the potential environmental impacts associated with reasonable management alternatives for certain plutonium residues and all scrub alloy currently stored at RFETS near Golden, Colorado. DOE previously decided to stabilize, if necessary, and

repackage the plutonium residues for safe interim storage at RFETS, as discussed in the *Solid Residue Treatment, Repackaging, and Storage Environmental Assessment* (DOE/EA-1120, April 1996; FONSI, April 1996). The management alternatives analyzed in the EIS are no action (which includes the application of variances to safeguards termination limits), processing without plutonium separation, and processing with plutonium separation. The ROD (November 1998) determined that the preferred alternative would be implemented, which includes (1) processing and packaging plutonium residues at RFETS in preparation for disposal at the Waste Isolation Pilot Plant (WIPP); and (2) packaging and shipping sand, slag, crucible and plutonium fluoride residues, and scrub alloy to SRS, where the materials would be stabilized in F-Canyon by chemically separating the plutonium from the remaining materials in the residues and scrub alloy. In a second ROD (February 1999), DOE decided to implement the preferred alternative specified in the final EIS for the remaining categories of materials. In an amended ROD (September 1999), DOE decided to ship the sand, slag, and crucible residues directly to WIPP and not the residues to SRS.

The *Final Programmatic Environmental Impact Statement for Alternative Strategies for the Long-Term Management and Use of Depleted Uranium Hexafluoride* (DOE/EIS-0269, April 1999; ROD, August 1999) evaluates the environmental impacts of six alternative strategies for the long-term management of DOE-owned depleted uranium hexafluoride currently stored at the East Tennessee Technology Park in Oak Ridge, Tennessee; the Paducah Gaseous Diffusion Plant near Paducah, Kentucky; and the Portsmouth Gaseous Diffusion Plant near Piketon, Ohio. These alternatives involve cylinder technology and design; conversion of depleted uranium hexafluoride to another chemical form; and materials use, storage, disposal, and transportation. As indicated in its ROD, DOE selected the preferred alternative, which is to begin conversion of the depleted uranium hexafluoride as soon as possible, either to uranium oxide, uranium metal, or a combination of both, while allowing for future use of as much of this inventory as possible. This SPD EIS analyzes the conversion of depleted uranium hexafluoride, from a representative site (Portsmouth), to uranium dioxide, which would be used as feedstock for immobilization and MOX fuel and lead assembly fabrication.

[Text deleted.]

1.8.2 Waste Management

The *Final Waste Management Programmatic Environmental Impact Statement for Managing Treatment, Storage, and Disposal of Radioactive and Hazardous Waste* (WM PEIS) (DOE/EIS-0200-F, May 1997; Transuranic [TRU] Waste ROD, January 1998; Hazardous Waste ROD, August 1998) examines the potential environmental and cost impacts of strategic alternatives for managing five types of radioactive and hazardous wastes that have resulted, and will continue to result, from nuclear defense and research activities at a variety of sites around the United States. The WM PEIS provides information on the impacts of various siting configurations that DOE will use to decide at which sites to locate additional treatment, storage, and disposal capacity for each waste configuration. Any waste resulting from actions taken in this SPD EIS would be treated, stored, and disposed of in accordance with the RODs and other decisions resulting from the WM PEIS. To date, three RODs have been issued: for the treatment and storage of TRU waste (January 1998), for the treatment of hazardous waste (August 1998), and for the storage of HLW (August 1999). The TRU waste ROD determined that those DOE sites that currently have or will generate TRU waste will prepare it for storage and store it on the site, the only exception being that Sandia National Laboratory will transfer its TRU waste to LANL. The Hazardous Waste ROD decided that DOE will continue use of offsite facilities for the treatment of nonwastewater hazardous waste based on analysis from the WM PEIS. The Oak Ridge Reservation and SRS will treat some of their own nonwastewater hazardous waste on the site. The HLW ROD decided that immobilized HLW will be stored at Hanford, INEEL, SRS, and the West Valley Demonstration Project in New York until a geologic repository is licensed by NRC.

The *Waste Isolation Pilot Plant Final Environmental Impact Statement* (DOE/EIS-0026, October 1980; ROD, January 1981) and associated supplements (DOE/EIS-0026-S-1, January 1990; ROD, June 1990; and DOE/EIS-0026-S-2, September 1997; ROD, January 1998) analyze the development, operation, and transportation activities associated with WIPP, a mined repository for TRU waste near Carlsbad, New Mexico. TRU waste produced as a result of surplus plutonium disposition activities would be required to meet the WIPP waste acceptance criteria and would ultimately be disposed of at WIPP. This EIS covers transportation from all the SPD EIS candidate sites except Pantex. Therefore, transportation of TRU waste from Pantex to WIPP is analyzed in this SPD EIS.

The *Draft Environmental Impact Statement for a Geologic Repository for the Disposal of Spent Nuclear Fuel and High-Level Radioactive Waste at Yucca Mountain, Nye County, Nevada* (DOE/EIS-0250D, July 1999) analyzes the construction, operation and monitoring, and eventual closure of a potential geologic repository at Yucca Mountain to dispose of commercial and DOE spent nuclear fuel, high-level radioactive waste, and materials that NRC determines by rule require the same degree of isolation. National transportation, Nevada transportation, and waste packaging are evaluated as part of the analysis. Three implementing design alternatives based on thermal load—low, intermediate, and high—are examined. High-level waste with immobilized plutonium and spent fuel produced from SPD EIS plutonium immobilization and MOX alternatives are included in the inventory analyzed in that EIS. This SPD EIS assumes for the purposes of analysis that Yucca Mountain is a potential geologic repository site.

The *Accelerating Cleanup: Paths to Closure* (DOE/EM-0362, June 1998) is DOE's blueprint for cleanup. It provides DOE's detailed projections on the scope, schedules, and costs for the cleanup of contaminated soil, groundwater, and facilities; treatment, storage, and disposal of waste; and effective management of nuclear materials and spent nuclear fuel. Included in the report are site waste and material disposition flow charts that describe each stream, the steps for processing or managing the wastes, and the permanent waste disposal sites that have been designated. This document is not a plan or a decisionmaking document; it describes the status and direction of DOE's draft cleanup strategy. Appropriate NEPA reviews will be conducted before any decisions are made. This SPD EIS reflects the proposals in *Paths to Closure* to the extent possible. Subsequent versions of *Paths to Closure* will reflect the waste management and environmental restoration implications of the decisions made as a result of this SPD EIS.

1.8.3 SPD EIS Candidate Sites

The *Tank Waste Remediation System, Hanford Site, Richland, Washington, Final Environmental Impact Statement* (TWRS EIS) (DOE/EIS-0189, August 1996; ROD, February 1997) satisfies the DOE commitment made in the *Disposal of Hanford Defense High-Level, Transuranic and Tank Waste Final Environmental Impact Statement* (DOE/EIS-0113, December 1987; RODs, March and April 1988) to prepare a supplemental NEPA analysis. The TWRS EIS was prepared in response to several important changes subsequent to the ROD, including a revised strategy for managing and disposing of tank waste and encapsulated cesium and strontium. The TWRS EIS evaluates, as a part of the proposed action: continued operation and management of the tank farms; waste transfer system upgrades; and retrieval and treatment of the tank waste, which would include the construction and operation of a facility to vitrify HLW and vitrify or similarly immobilize the low-activity waste. DOE decided to implement the preferred alternative for retrieval, treatment, and disposal of tank waste and to defer a decision on the disposition of cesium and strontium capsules. Two supplement analyses to the EIS were prepared for the TWRS EIS. The first was the *Proposed Upgrades to the Tank Farm Ventilation, Instrumentation, and Electrical Systems under Project W-314 in Support of Tank Farm Restoration and Safe Operations* (DOE/EIS-0189-SA1, June 1997). Based on this supplement analysis, upgrades or planned upgrades to the tank farm do not pose any additional potential environmental impacts, and therefore no additional NEPA analysis is required. The second supplement analysis was for the *Tank Waste Remediation System* (DOE/EIS-0189-SA2, May 1998). The analysis provides information on the most recent inventory of chemical

and radiological constituents in the tanks and new waste that is to be sent to the tanks for treatment. Based on the new data, it was concluded that there would be minimal changes from the impacts identified in the TWRS EIS, and therefore, no additional NEPA analysis is required.

The *Plutonium Finishing Plant Stabilization Final Environmental Impact Statement* (DOE/EIS-0244F, May 1996; ROD, July 1996) analyzes the potential environmental impacts of alternative approaches to: (1) stabilization of residual plutonium-bearing materials at the Hanford Plutonium Finishing Plant (PFP) to a form suitable for long-term storage; (2) removal of readily retrievable plutonium-bearing materials left behind in process equipment, process areas, and air quality and liquid waste management systems as a result of historic uses; and (3) interim storage of stabilized fissile material in existing PFP vaults pending decisions on ultimate storage and disposition of the material. DOE decided to remove readily retrievable plutonium-bearing materials in holdup at PFP. Following their stabilization, plutonium-bearing materials will be in a form suitable for interim storage in existing vaults at PFP. These materials are included in the plutonium inventory addressed in this SPD EIS. Other plutonium-bearing material having low plutonium content (less than 50 percent by weight) and meeting criteria established by DOE may be treated at PFP using a cementation process.

The *Final Hanford Remedial Action Environmental Impact Statement and Comprehensive Land Use Plan*, (DOE/EIS-0222-F, September 1999) revises the scope of the EIS and alternatives in response to comments received on the original draft. The final EIS focuses on developing an overall strategy for future land use at Hanford and includes a proposed comprehensive land-use plan. The preferred alternative is to consolidate waste management operations in the Central Plateau, allow industrial development in the eastern and southern portions of the site, increase recreational access to the Columbia River, and expand Saddle Mountain National Refuge to include all of the Wahluke Slope, McGee Ranch, and Fitzner-Eberhardt Arid Lands Ecology Reserve.

The *Hanford Reach of the Columbia River Comprehensive River Conservation Study and Environmental Impact Statement* (Final, June 1994, National Park Service) evaluates protecting the Hanford Reach of the Columbia River in terms of its designation as a Wild and Scenic River, provisions for recreation access, and visitor interpretation and education.

The *Department of Energy Programmatic Spent Nuclear Fuel Management and Idaho National Engineering Laboratory Environmental Restoration and Waste Management Programs Final Environmental Impact Statement* (DOE/EIS-0203-F, April 1995; ROD, May 1995) is a complex-wide evaluation of alternatives for managing, through the year 2035, existing and reasonably foreseeable amounts of spent nuclear fuel within the DOE inventory. The EIS contains an analysis of the transportation of spent nuclear fuel, as well as sitewide alternatives for environmental restoration and waste management programs at the Idaho National Engineering Laboratory (INEL, now INEEL). The ROD designated Hanford, INEEL, and SRS for regional spent fuel storage and management, and made decisions for environmental restoration and waste management at INEEL. In March 1996, DOE issued an amendment to the May 1995 ROD to include a decision to regionalize the management of DOE-owned spent nuclear fuel by fuel type, including spent fuel currently stored at Hanford, INEEL, and SRS.

The *Final Environmental Impact Statement on a Proposed Nuclear Weapons Nonproliferation Policy Concerning Foreign Research Reactor Spent Nuclear Fuel* (DOE/EIS-0218F, February 1996; ROD, July 1996) evaluates the adoption of a joint DOE/Department of State policy to manage spent nuclear fuel from foreign research reactors, including HEU provided by the United States to other countries for research reactors. Management alternatives include a number of implementation options for port selection, transportation, and storage at DOE sites. The ROD selected a management policy that provided for the return to the United States of spent fuels from various research reactors, using two designated U.S. ports, and the management at INEEL and SRS. A supplement analysis (DOE/EIS-0218-SA-2, August 1998) was prepared to examine acceptance of foreign research reactor spent nuclear fuel under three scenarios not specifically examined in the EIS: (1)

accepting spent fuel not included in EIS-estimated inventories, (2) accepting spent fuel from countries in quantities greater than those identified in the EIS, and (3) transporting more than eight casks of spent fuel on a single ocean-going vessel. The supplement analysis concluded that the potential environmental impacts of these actions are bounded by the analysis performed in the EIS and, therefore, no supplement to the EIS need be prepared.

The DOE INEEL *Advanced Mixed Waste Treatment Project Final Environmental Impact Statement* (DOE/EIS-0290, January 1999; ROD, April 1999) evaluates four alternatives: (1) No Action Alternative under which existing waste management operations, facilities, and projects would continue; (2) the proposed action/preferred alternative under which BNFL, Inc., would build and operate an Advanced Mixed Waste Treatment Project (AMWTP) facility using proposed thermal and nonthermal treatment technologies for certification and shipment to WIPP or another acceptable disposal facility; (3) nonthermal treatment alternative under which some treatment of transuranic, alpha low-level mixed, and low-level mixed wastes would occur at an AMWTP facility at the same location as the proposed action, and wastes that require thermal treatment would be repackaged for storage; and (4) treatment and storage alternative, which would include the same processes as the proposed action/preferred alternative except treated waste would be placed in Resource Conservation and Recovery Act-permitted storage units at the onsite Radioactive Waste Management Complex for long-term storage. In the ROD, DOE selected the preferred alternative.

The *Final Environmental Impact Statement and Environmental Impact Report for Continued Operation of Lawrence Livermore National Laboratory and Sandia National Laboratories, Livermore* (DOE/EIS-0157, August 1992; ROD, January 27, 1993) evaluates the proposed action of ongoing and proposed facilities and activities at LLNL and Sandia National Laboratories, including near-term (within 5 to 10 years) proposed projects. Three other alternatives analyzed include no action, modification of operations, and shutdown and decommissioning. This EIS updates the sitewide EIS issued in 1982. A decision was made in the ROD to continue operations as outlined in the proposed action. A supplement analysis (DOE/EIS-0157-SA-01, March 1999) was prepared to examine current project and program plans and proposals for operations and identify new or modified projects or operations for the period 1998 to 2002 that were not considered in the 1992 EIS. The supplement analysis concluded that either the projected impacts are within the bounds of the 1992 EIS, the impacts were anticipated by mitigation measures established in the 1992 EIS, or the incremental differences in impacts are not significant; therefore, no supplementation to the 1992 EIS is needed.

The *Site-Wide Environmental Impact Statement for the Continued Operation of the Los Alamos National Laboratory* (DOE/EIS-0238, January 1999; ROD, September 1999) evaluates ongoing and reasonably foreseeable new operations and facilities at LANL in support of DOE missions. This sitewide EIS updates the LANL sitewide EIS issued in 1979. Currently, small-scale R&D activities related to pit disassembly and conversion and MOX fuel fabrication are being conducted at LANL. Chapter 1, Section 1.8, of the sitewide EIS describes the SPD EIS as a related NEPA document. A description of the proposed MOX fuel lead assembly fabrication is included in Chapter 2, Background on Los Alamos National Laboratory Facilities and Activities, in Sections 2.2.2.2 and 2.2.2.15. Impacts of MOX fuel lead assembly fabrication are included in the cumulative impacts section of the LANL sitewide EIS, Sections 5.6.1.3, 5.6.1.7, 5.6.1.8, and 5.6.1.9. A decision was made in the LANL ROD to implement the preferred alternative, which includes expansion of operations, as the need arises, an increase in the level of existing operations to the highest reasonably foreseeable levels, and full implementation of the mission elements assigned to LANL.

The *Final Environmental Impact Statement for the Continued Operation of the Pantex Plant and Associated Storage of Nuclear Weapon Components* (DOE/EIS-0225, November 1996; ROD, January 1997) evaluates all current and proposed facilities and activities at Pantex, including weapons dismantlement and storage of the resulting nuclear materials and classified weapons components in the near term (over a 5- to 10-year period). This sitewide EIS addresses alternative interim storage sites for Pantex plutonium pits, some of which will

ultimately be disposed of as determined in this SPD EIS. A supplement analysis to the Pantex EIS was issued, *Supplement Analysis for: Final Environmental Impact Statement for the Continued Operation of the Pantex Plant and Associated Storage of Nuclear Weapon Components—AL-R8 Sealed Insert Container* (August 1998), to determine the potential impacts associated with repackaging pits into AL-R8 SI containers as opposed to the AT-400A container originally considered. The analysis concluded that the AL-R8 SI met the requirements that were established in the EIS for pit storage at Pantex and that no further NEPA documentation would be required. However, the seals in the AL-R8 SI containers must be changed after 30 years of storage,²⁹ and the pit-holding fixture in many of the AL-R8 SI containers must be modified. New shipping containers are also required to augment the limited number of existing shipping containers.

The *Final Environmental Impact Statement, Construction and Operation of the Spallation Neutron Source* (DOE/EIS-0247, April 1999; ROD, June 1999) analyzes the potential environmental impacts of constructing and operating a state-of-the-art Spallation Neutron Source facility at one of four sites: ORNL (preferred alternative); Argonne National Laboratory in Argonne, Illinois; Brookhaven National Laboratory in Upton, New York; and LANL. The ROD designated ORNL as the chosen site for the facility.

The *Final Environmental Assessment for Wastewater Treatment Capability Upgrade* (DOE/EA-1190, April 1999; FONSI, May 27, 1999) analyzes a proposed action to design, build, and operate a new wastewater treatment facility at Pantex.

The *Final Programmatic Environmental Impact Statement for Stockpile Stewardship and Management* (DOE/EIS-0236, September 1996; ROD, December 1996) evaluates the potential environmental impacts resulting from activities associated with nuclear weapons research, design, development, and testing, as well as the assessment and certification of their safety and reliability. The stewardship portion of the document analyzes the development of three new facilities to provide enhanced experimental capabilities. The stockpile management portion of the EIS concerns producing, maintaining, monitoring, refurbishing, and dismantling the nuclear weapons stockpile at eight sites, including Pantex and SRS. A decision was made in the ROD to downsize a number of facilities for stockpile dismantlement, and to build experimental facilities at LLNL. A draft supplement analysis (DOE/EIS-0236-SA6, June 1999) was prepared to examine the plausibility of a building-wide fire at LANL's plutonium facility and to look at new studies regarding seismic hazards at LANL. The draft supplement analysis was issued for public comment, and a final supplement analysis was issued on September 2, 1999. The supplement analysis concluded that there is no need to prepare a supplemental EIS.

The *Final Environmental Impact Statement, Interim Management of Nuclear Materials* (DOE/EIS-0220, October 1995) analyzes the potential environmental impacts of the management of certain nuclear materials at SRS pending decisions on their future use or ultimate disposition. The EIS includes an analysis of the construction of the SRS Actinide Packaging and Storage Facility. Five RODs have been issued since the Final EIS was published. On December 12, 1995, DOE issued a ROD and Notice of Preferred Alternatives (60 FR 65300) on the interim management of several categories of nuclear materials at SRS. DOE decided to stabilize plutonium and uranium stored in vaults using a combination of management methods. On February 8, 1996, DOE issued a supplemental ROD (61 FR 6633) on the stabilization of two of the remaining categories of nuclear materials (Mark-16 and Mark-22 fuels and other aluminum-clad targets) analyzed in the Final EIS. After considering a DOE staff study and recommendation on canyon facility utilization, DOE issued a second supplemental ROD on September 6, 1996 (61 FR 48474) for stabilization of the neptunium 237 solutions, obsolete neptunium targets, and plutonium 239 solutions. On April 2, 1997, DOE issued a third supplemental ROD (62 FR 17790) on stabilization in the F-Canyon and FB-Line facilities of the remaining

²⁹ This means that the undisturbed storage period changes from 50 to 30 years. See Section 1.7.4 for additional details on the effect of the AL-R8 SI decision on the surplus plutonium disposition program.

Taiwan Research Reactor spent nuclear fuel. In October 1997, DOE issued a fourth supplemental ROD to add an additional method, processing and storage for vitrification in DWPF, to those being used in the management of plutonium and uranium stored in vaults; and to amend its September 6, 1996, ROD to provide for use of the H-Canyon facilities to stabilize, to oxide forms, the plutonium 239 and neptunium 237 solutions stored in H-Canyon and obsolete neptunium 237 targets stored in K-Reactor.

The *Savannah River Site Waste Management Final Environmental Impact Statement* (DOE/EIS-0217, July 1995; ROD, September 1995) analyzes future SRS waste management needs for all waste types over the next 30 years, including the treatment, storage, and disposal of high-level, low-level, mixed, hazardous, and TRU wastes generated from environmental restoration, facility operations, and D&D of buildings. In the ROD, DOE selected phased approaches to waste treatment, storage, and disposal facilities identified in the Final EIS.

The *Spent Nuclear Fuel Management Draft Environmental Impact Statement* (DOE/EIS-0279D, December 1998) evaluates processes for the safe and efficient management of spent nuclear fuel and targets at SRS, including placing these materials in forms suitable for ultimate disposition. Alternatives analyzed include new packaging, new processing, and conventional processing technologies, as well as the No Action Alternative. The preferred alternative for 97 percent of the volume is to use a melt and dilute treatment process. The remaining 3 percent would be managed using conventional processing.

The *Disposition of Surplus Highly Enriched Uranium Final Environmental Impact Statement* (DOE/EIS-0240, June 1996; ROD, July 1996) addresses the disposition of a nominal 200 t (220 tons) of HEU declared surplus to the national security needs of the United States. Alternatives include several approaches to blending down the highly enriched material to make it nonweapons usable and suitable for fabrication into fuel for commercial nuclear reactors. The ROD calls for blending, over time, as much material as possible (up to 85 percent) for commercial use, and blending the remainder for disposal as LLW. Blending sites include SRS.

The *F-Canyon Plutonium Solutions at Savannah River Site Final Environmental Impact Statement* (DOE/EIS-0219, December 1994; ROD, February 1995) evaluates alternatives to stabilize plutonium solutions currently stored in F-Canyon at SRS before their disposition as determined in this SPD EIS. The alternatives examined are taking no action, processing the solutions to plutonium metal, processing the solutions to plutonium dioxide, and transferring the solutions to the HLW tanks for vitrification in DWPF. DOE has processed the plutonium solutions to a metal form using the F-Canyon and FB-Line facilities at SRS.

The *Final Supplemental Environmental Impact Statement, Defense Waste Processing Facility* (DOE/EIS-0082-S, November 1994; ROD, April 1995) assesses the environmental impacts of the construction and operation of DWPF at SRS as modified from the original design addressed in a 1982 EIS. DWPF includes the HLW pretreatment process, the vitrification facility, facilities for the manufacture and disposal of saltstone (LLW resulting from the pretreatment of HLW), radioactive glass waste storage facilities, and associated support facilities. DOE is currently preparing a second supplement, which was announced in the Federal Register on February 22, 1999 (64 FR 8558), on the proposed replacement of the In-Tank Precipitation (ITP) process at SRS. The ITP process as presently configured cannot achieve production goals and safety requirements. Three alternative processes are being evaluated: small tank precipitation, ion exchange, and direct grout. Because replacement of the ITP process constitutes a substantial change to the operation of DWPF as evaluated in the *1994 Supplemental EIS*, DOE is preparing a second supplemental EIS that addresses the potential environmental impacts of ITP process alternatives. DOE's preferred immobilization technology (can-in-canister) and immobilization site (SRS) are dependent on DWPF providing vitrified HLW with sufficient radioactivity.

The *Final Programmatic Environmental Impact Statement for Tritium Supply and Recycling* (DOE/EIS-0161, October 1995; ROD, December 5, 1995) evaluates the siting, construction, and operation of tritium supply technology alternatives and recycling facilities at five candidate sites, as well as the use of a commercial reactor

for producing tritium. The ROD determined that a dual-track approach would be used. One track explores the purchase of an operating or partially complete commercial light water reactor or the purchase of irradiation services from such a reactor. The second track would design, build, and test critical components of an accelerator system for production of tritium. The ROD states that DOE would select one of the alternatives at a later date to serve as the primary source of tritium for the nuclear weapons stockpile, with the other alternative developed as a back-up source, if feasible. SRS was selected as the location for the accelerator. (See Consolidated ROD discussion below.)

The *Final Environmental Impact Statement for Accelerator Production of Tritium at the Savannah River Site* (DOE/EIS-0270, March 1999; Consolidated ROD, May 1999) evaluates the siting, construction, and operation of a linear accelerator at SRS that would produce tritium, a gaseous radioactive isotope of hydrogen considered essential to the operation of U.S. thermonuclear weapons. DOE issued a Consolidated ROD that made the following decisions: (1) the use of commercial light water reactors is the primary source of tritium supply; (2) the accelerator at SRS is the backup tritium supply source, but will not be constructed; (3) the Tennessee Valley Authority's Watts Bar Unit 1 and Sequoyah Unit 1 and 2 reactors are the specific reactors that will provide irradiation services for tritium supply; (4) the H-Area location at SRS is the location for a new tritium extraction facility; and (5) the location and various technologies required to develop the accelerator as a backup to the commercial light water reactors are identified.

The *Final Environmental Impact Statement for the Production of Tritium in a Commercial Light Water Reactor* (DOE/EIS-0288, March 4, 1999; Consolidated ROD, May 1999) evaluates the production of tritium at one or more of five commercial light water reactors, including the transportation of irradiated tritium-producing burnable absorber rods from the reactors to the proposed tritium extraction facility at SRS. (See Consolidated ROD discussion above.)

The *Final Environmental Impact Statement for Construction and Operation of a Tritium Extraction Facility at the Savannah River Site* (DOE/EIS-0271, March 1999; Consolidated ROD, May 1999) evaluates the construction and operation of a facility for the extraction of tritium to support the DOE tritium production capability. (See Consolidated ROD discussion above.)

The *Final Environmental Impact Statement for Shutdown of the River Water System at Savannah River Site* (DOE/EIS-268, May 1997; ROD, January 1998) evaluates the shutdown of the River Water System used to pump large quantities of water from the Savannah River for cooling purposes within SRS. Alternatives for placing all or part of the system in standby mode are also considered. The ROD selected the No Action Alternative, that is, continuing the maintenance and operation of the Savannah River Water System for the foreseeable future.

The *Environmental Assessment for the Proposed Interim Storage of Enriched Uranium Above the Maximum Historical Storage Level at the Y-12 Plant, Oak Ridge, Tennessee* (DOE/EA-0929, September 1994; FONSI, September 1995) analyzes the continued receipt, prestorage processing, and interim storage of enriched uranium in quantities that would exceed the historic maximum storage level. On the basis of this EA, DOE determined that Y-12 would store no more than 500 t (551 tons) of HEU and no more than 6 t (6.6 tons) of LEU. HEU recovered from the SPD EIS pit conversion facility would be shipped to Y-12 for interim storage pending disposition.

The *Notice of Intent to Prepare a Site-Wide Environmental Impact Statement for the Oak Ridge Y-12 Plant* (64 FR 13179) was published March 17, 1999. The EIS will analyze current levels of Y-12 operations and foreseeable new operations and facilities for approximately the next 10 years. The EIS will also provide a baseline of impacts associated with current activities, analyze the potential impacts of constructing a new enriched uranium storage facility, and address siting issues associated with other possible modernization projects. HEU

received from the pit conversion facility would be shipped to Y-12 for interim storage pending disposition. HEU storage at Y-12 could be affected by decisions made in the EIS.

1.8.4 Cooperating Agencies

In May 1997, DOE notified several agencies, including NRC and the U.S. Environmental Protection Agency (EPA), that this SPD EIS was being prepared. On November 10, 1997, NRC informed DOE that it would be a “commenting” rather than “cooperating” agency.³⁰ In keeping with this decision, DOE provided copies of the SPD Draft and Final EIS and *Supplement* to NRC for comment. No agencies other than EPA have decided to be a cooperating agency for this SPD EIS.

1.9 ORGANIZATION OF THIS SPD EIS

This SPD EIS consists of three volumes. Volume I contains the main text of the EIS. Volume II contains technical appendixes that provide supporting details for the analyses in Volume I, as well as additional project information. Volume III contains the comments received on the Draft EIS during the public review periods, along with the DOE responses to these comments. An EIS Summary is also available.

Volume I consists of Chapters 1 through 9. Chapter 2 describes the surplus plutonium disposition alternatives, how the alternatives were developed, and the proposed types of disposition facilities. It also provides a comparison of the alternatives. Chapter 3 describes the potentially affected environments at the candidate sites. Chapter 4 provides summary descriptions of the potential impacts of the proposed action and alternatives on 13 resource areas. This chapter also describes cumulative impacts, D&D and deactivation and stabilization, irreversible and irretrievable commitments of resources, and the relationship between short-term uses of the environment and long-term productivity. Chapter 5 provides a description of the environmental and health and safety compliance requirements governing implementation of the alternatives and includes the status of required consultations with Federal, State, and local agencies. References are included at the end of each chapter. Chapters 6, 7, 8, and 9 are the glossary of terms, the list of SPD EIS preparers, the SPD EIS distribution list, and the index, respectively.

Volumes II and III provide information that supports Volume I. Volume II consists of 16 appendixes and includes background documents, process descriptions, facility data, descriptions of methods used to estimate environmental impacts of the alternatives, and the detailed impact analysis. Volume III includes the comments received on the SPD Draft EIS and the *Supplement*, the responses to the comments, and a brief summary of changes made to the SPD Draft EIS and the *Supplement* in response to the comments.

1.10 REFERENCES

DOE (U.S. Department of Energy), 1996a, *Storage and Disposition of Weapons-Usable Fissile Materials Final Programmatic Environmental Impact Statement*, DOE/EIS-0229, Office of Fissile Materials Disposition, Washington, DC, December.

DOE (U.S. Department of Energy), 1996b, *Disposition of Surplus Highly Enriched Uranium Final Environmental Impact Statement*, DOE/EIS-0240, Office of Fissile Materials Disposition, Washington, DC, June.

³⁰ A cooperating agency participates in the NEPA process at the request of the lead agency developing an EIS. The cooperating agency is involved in the scoping process and may develop information and prepare environmental analyses in its area of special expertise and make available staff support to the lead agency (40 CFR 1501.6, *Regulations for Implementing the Procedural Provisions of the National Environmental Policy Act*). The lead agency may also request other agencies to comment on a draft EIS (40 CFR 1503.1).

DOE (U.S. Department of Energy), 1996c, *Record of Decision for the Disposition of Surplus Highly Enriched Uranium Final Environmental Impact Statement*, 61 FR 40619, Office of the Federal Register, Washington, DC, August 5.

DOE (U.S. Department of Energy), 1997a, *Record of Decision for the Storage and Disposition of Weapons-Usable Fissile Materials Final Programmatic Environmental Impact Statement*, 62 FR 3014, Office of the Federal Register, Washington, DC, January 14.

DOE (U.S. Department of Energy), 1997b, *Notice of Intent to Prepare a Surplus Plutonium Disposition Environmental Impact Statement*, 62 FR 28009, Office of the Federal Register, Washington, DC, May 22.

DOE (U.S. Department of Energy), 1998a, *Cost Analysis in Support of Site Selection for Surplus Weapons-Usable Plutonium Disposition*, rev. 0, DOE/MD-0009, Office of Fissile Materials Disposition, Washington, DC, July 22.

DOE (U.S. Department of Energy), 1998b, *Pit Disassembly and Conversion Demonstration Environmental Assessment and Research and Development Activities*, DOE/EA-1207, Office of Fissile Materials Disposition, Washington, DC, August.

DOE (U.S. Department of Energy), 1998c, *Supplement Analysis for: Final Environmental Impact Statement for the Continued Operation of the Pantex Plant and Associated Storage of Nuclear Weapon Components—AL-R8 Sealed Insert Container*, Albuquerque Operations Office, Amarillo Office, Amarillo, TX, August.

DOE (U.S. Department of Energy), 1999a, *Environmental Assessment for the Paralex Project Fuel Manufacture and Shipment*, DOE/EA-1216, Office of Fissile Materials Disposition, Washington, DC, January.

DOE (U.S. Department of Energy), 1999b, *Plutonium Disposition Life-Cycle Costs and Cost-Related Comment Resolution Document*, MD-0013, Office of Fissile Materials Disposition, Washington, DC, November.

DOE (U.S. Department of Energy), 1999c, *Draft Environmental Impact Statement for a Geologic Repository for the Disposal of Spent Nuclear Fuel and High-Level Radioactive Waste at Yucca Mountain, Nye County, Nevada*, DOE/EIS-0250D, Office of Civilian Radioactive Waste Management, North Las Vegas, NV, July.

Paperiello, C.J., 1999, U.S. Nuclear Regulatory Commission, Office of Nuclear Material Safety and Safeguards, Washington, DC, personal communication (letter) to L. Barrett, U.S. Department of Energy, Office of Civilian Radioactive Waste Management, Washington, DC, *U.S. Department of Energy Plans for Disposal of Surplus Weapons Plutonium*, January 25.

White, V.S., 1997, *Initial Data Report in Response to the Surplus Plutonium Disposition Environmental Impact Statement Data Call for the UO₂ Supply*, rev. 1, ORNL/TM-13466, Lockheed Martin Energy Research Corporation, Oak Ridge, TN, November.

White House, 1993, *Nonproliferation and Export Control Policy*, Office of the Press Secretary, Washington, DC, September 27.

White House, 1994, *Joint Statement by the President of the Russian Federation and the President of the United States of America on Non-Proliferation of Weapons of Mass Destruction and the Means of Their Delivery*, Office of the Press Secretary, Washington, DC, January 14.

Chapter 2 Alternatives for Disposition of Surplus Weapons-Usable Plutonium

2.1 ALTERNATIVES ANALYZED IN THIS SPD EIS

This *Surplus Plutonium Disposition Environmental Impact Statement* (SPD EIS) analyzes the potential environmental impacts associated with implementing the disassembly of pits (a component of nuclear weapons) and conversion of the recovered plutonium and clean plutonium metal at four candidate U.S. Department of Energy (DOE) sites; conversion and immobilization of plutonium from nonpit sources at two candidate DOE sites; and mixed oxide (MOX) fuel fabrication activities at four candidate DOE sites. This SPD EIS also evaluates immobilizing plutonium in ceramic or glass forms, and compares the can-in-canister approach with the homogenous ceramic immobilization and vitrification approaches that were evaluated in the *Storage and Disposition of Weapons-Usable Fissile Materials Final Programmatic Environmental Impact Statement* (*Storage and Disposition PEIS*) (DOE 1996a). As part of the MOX option, this SPD EIS also evaluates the potential impacts of fabricating MOX fuel lead assemblies (for test irradiation in domestic, commercial nuclear power reactors) at five candidate DOE sites, subsequent postirradiation examination of the lead assemblies at two candidate DOE sites, and addresses the impacts of irradiating MOX fuel in domestic, commercial reactors. Figure 2-1 is a map of the United States that identifies the proposed locations of the surplus plutonium disposition facilities.

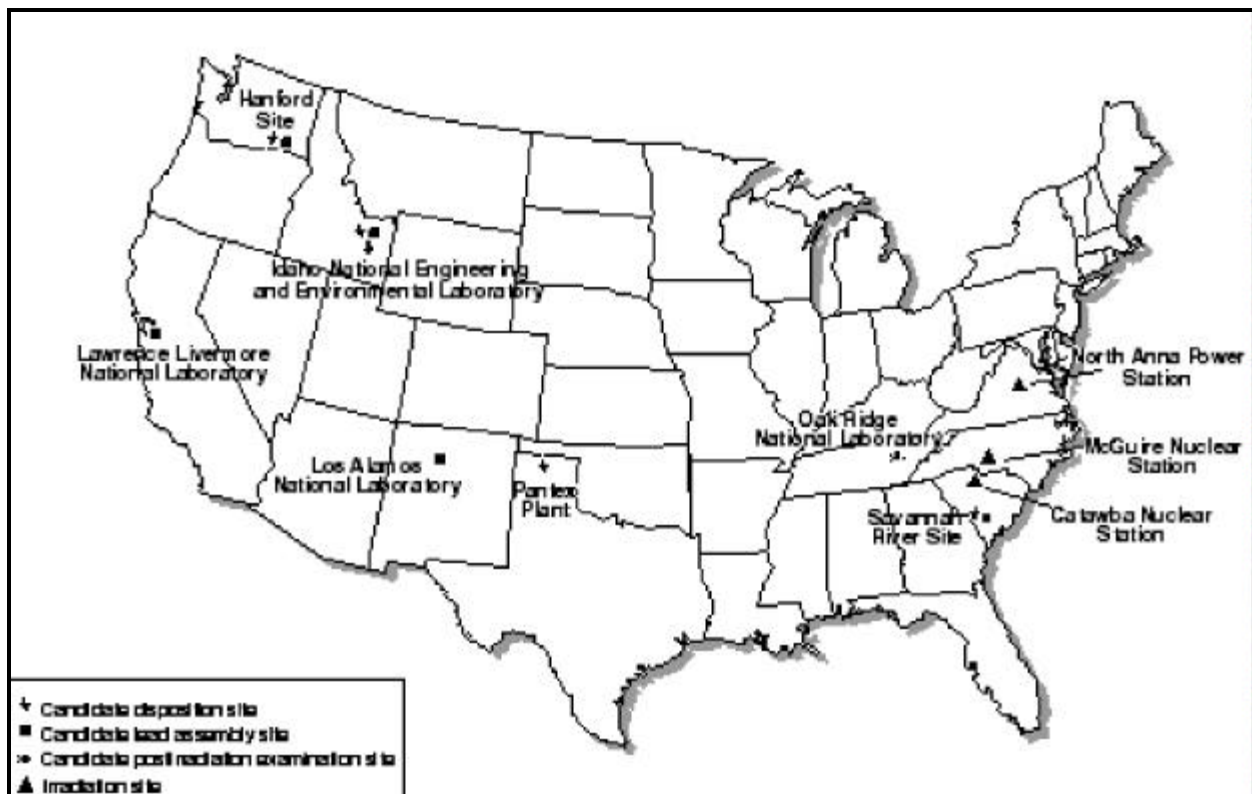

Figure 2-1. Proposed Locations of Surplus Plutonium Disposition Facilities

2.1.1 Surplus Plutonium Disposition Facility Alternatives

The alternatives analyzed in this SPD EIS are based on decisions announced in the Record of Decision (ROD) for the *Storage and Disposition PEIS*, as summarized in Chapter 1. Those decisions include:

- Combining the plutonium conversion and immobilization functions into a single facility,
- Pursuing the siting of a pit disassembly and conversion facility (pit conversion facility), a plutonium conversion and immobilization facility (immobilization facility), and a MOX fuel fabrication facility (MOX facility), and
- Reducing the number of possible disposition sites to be considered from six to four.

Fifteen surplus plutonium disposition alternatives and the No Action Alternative are shown in Table 2–1 and described in detail in Sections 2.5 through 2.16. The 15 action alternatives are organized into 11 sets of alternatives, reflecting various combinations of facilities and candidate sites, as well as the use of new or existing buildings. For example, Alternative 6, which would locate the pit conversion and MOX facilities at the Hanford Site (Hanford), and the immobilization facility at the Savannah River Site (SRS), has two variations, denoted as 6A and 6B. The variations occur because the MOX facility could be in new construction or in the Fuel and Materials Examination Facility (FMEF) at Hanford.

Each of the 15 alternatives includes a pit conversion facility, but additional facilities in each alternative vary depending on the amount of plutonium to be immobilized. Alternatives 2 through 10 involve the hybrid approach of immobilizing 17 t (19 tons) of surplus plutonium and using 33 t (36 tons) for MOX fuel, and therefore, require all three facilities. Alternatives 11 and 12 involve immobilizing all 50 t (55 tons), and therefore, only include a pit conversion facility and an immobilization facility.

Alternative 1, the No Action Alternative, does not involve disposition of surplus weapons-usable plutonium, but instead addresses continued storage of the plutonium in accordance with the *Storage and Disposition PEIS* ROD (DOE 1997a) and amended ROD (DOE 1998a).¹ Figures 2–2, 2–3, 2–4, and 2–5 are regional maps of the four candidate disposition sites: Hanford, Idaho National Engineering and Environmental Laboratory (INEEL), the Pantex Plant (Pantex), and SRS.

2.1.2 Immobilization Technology Alternatives

The *Storage and Disposition PEIS* discusses several immobilization technologies, including the homogenous ceramic and vitrification alternatives that were evaluated in detail, as well as the variants to those alternatives, which included the ceramic and glass can-in-canister approaches and another homogenous approach using an adjunct melter (discussed further in Appendix C of this SPD EIS). The ROD for the *Storage and Disposition PEIS* states that DOE would make a determination on the specific technology on the basis of “the follow-on EIS.” This SPD EIS is that follow-on EIS, and identifies the ceramic can-in-canister approach as the preferred immobilization technology.

In order to bound the estimate of potential environmental impacts associated with ceramic and glass immobilization technologies, the *Storage and Disposition PEIS* analyzes the construction and operation of

¹ Should the No Action Alternative be chosen, the ROD pursuant to this SPD EIS would also address the movement of the remaining surplus nonpit plutonium from RFETS in support of its planned closure in 2006.

vitrification and ceramic immobilization facilities that use a homogenous approach. These facilities are based on generic designs that do not involve the use of existing facilities or specific site locations. These generic

Table 2-1. Surplus Plutonium Disposition Facility Alternatives Evaluated in This SPD EIS

Alternative	Pit Disassembly and Conversion	Plutonium Conversion and Immobilization	MOX Fuel Fabrication	Disposition Amounts (Plutonium)
1	No Action			
2	Hanford (FMEF)	Hanford (FMEF and HLWVF)	Hanford (New)	17 t Immobilization/ 33 t MOX
3	SRS (New)	SRS (New and DWPF)	SRS (New)	17 t Immobilization/ 33 t MOX
4A	Pantex (New)	Hanford (FMEF and HLWVF)	Hanford (New)	17 t Immobilization/ 33 t MOX
4B	Pantex (New)	Hanford (FMEF and HLWVF)	Hanford (FMEF)	17 t Immobilization/ 33 t MOX
5	Pantex (New)	SRS (New and DWPF)	SRS (New)	17 t Immobilization/ 33 t MOX
6A	Hanford (FMEF)	SRS (New and DWPF)	Hanford (New)	17 t Immobilization/ 33 t MOX
6B	Hanford (FMEF)	SRS (New and DWPF)	Hanford (FMEF)	17 t Immobilization/ 33 t MOX
7	INEEL (FPF)	SRS (New and DWPF)	INEEL (New)	17 t Immobilization/ 33 t MOX
8	INEEL (FPF)	Hanford (FMEF and HLWVF)	INEEL (New)	17 t Immobilization/ 33 t MOX
9	Pantex (New)	SRS (New and DWPF)	Pantex (New)	17 t Immobilization/ 33 t MOX
10	Pantex (New)	Hanford (FMEF and HLWVF)	Pantex (New)	17 t Immobilization/ 33 t MOX
11A	Hanford (FMEF)	Hanford (FMEF and HLWVF)	NA	50 t Immobilization/ 0 t MOX
11B	Pantex (New)	Hanford (FMEF and HLWVF)	NA	50 t Immobilization/ 0 t MOX
12A	SRS (New)	SRS (New and DWPF)	NA	50 t Immobilization/ 0 t MOX
12B	Pantex (New)	SRS (New and DWPF)	NA	50 t Immobilization/ 0 t MOX
[Text deleted.]				
Alternatives 3B, 5B, 6C, 6D, 7B, 9B, 12B, and 12D in the SPD Draft EIS have been deleted. Alternative 12C has been renumbered as 12B. ^a				

^a Section 2.3.2.2 explains the deletion of these alternatives.

Key: DWPF, Defense Waste Processing Facility; FMEF, Fuels and Materials Examination Facility; FPF, Fuel Processing Facility; HLWVF, high-level-waste vitrification facility (planned); NA, not applicable.

designs allow for surplus plutonium to be immobilized in a homogenous form, either within a ceramic matrix and formed into disks, or vitrified as borosilicate glass logs.

In order to support a decision on the immobilization technology and form, this SPD EIS evaluates the potential environmental impacts of the ceramic and glass can-in-canister technologies, and compares those impacts with the impacts of the homogenous facilities evaluated in the *Storage and Disposition PEIS*. This comparison is presented in Section 4.29.

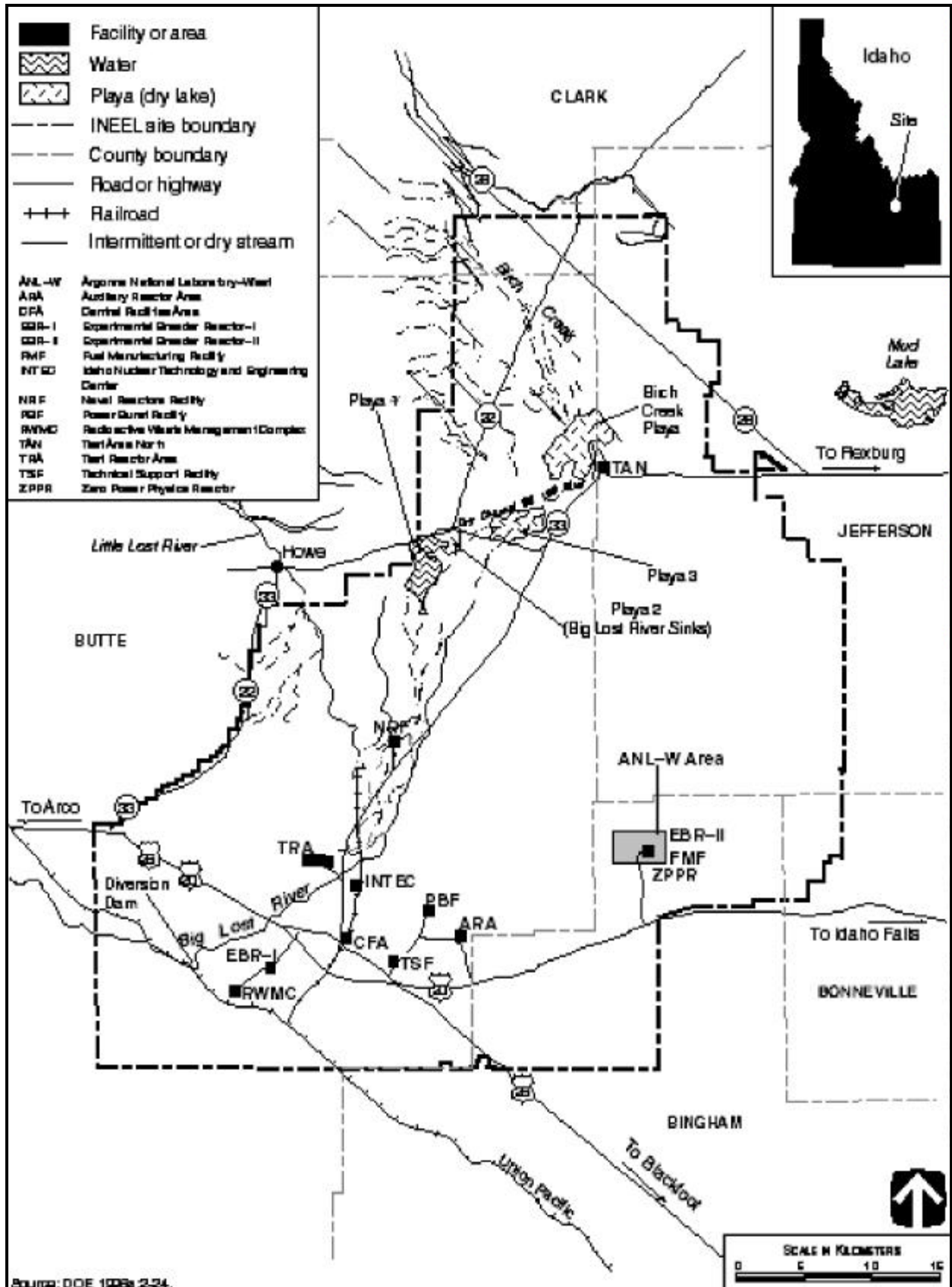

Source: DOE, 1996: 2-24.

Figure 2-3. INEEL, Idaho

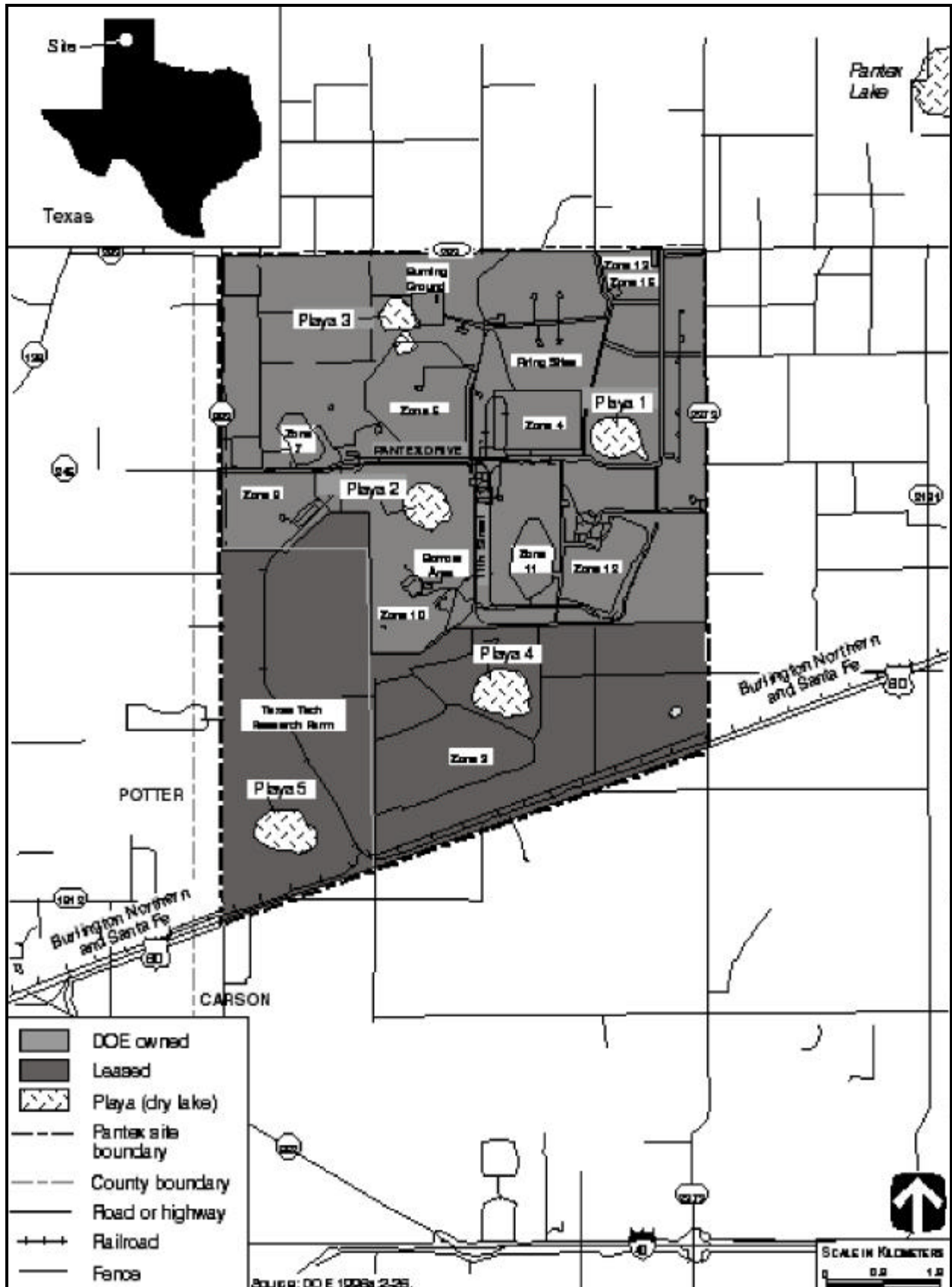

Figure 2-4. Pantex, Texas

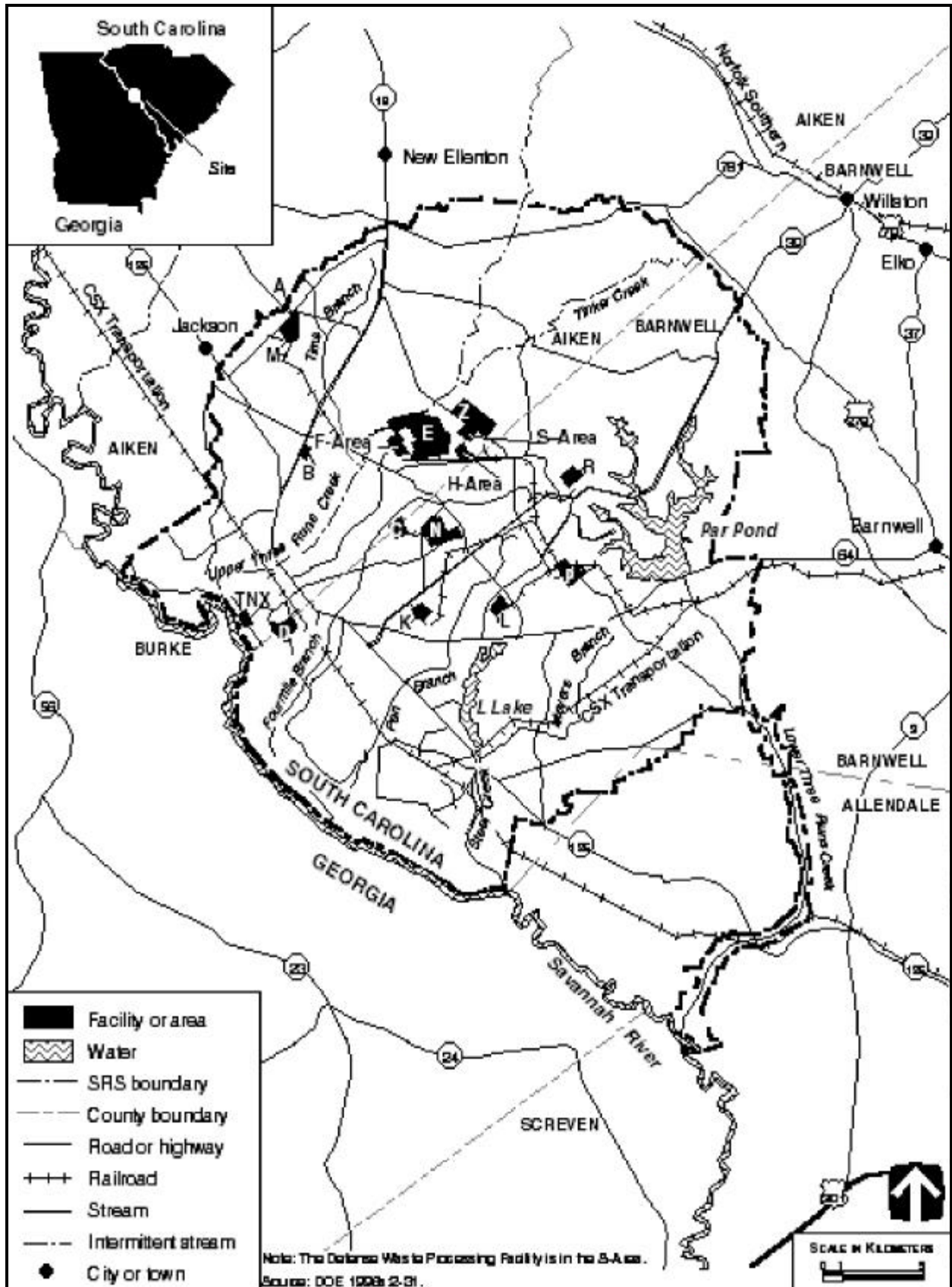

Figure 2-5. SRS, South Carolina

2.1.3 MOX Fuel Fabrication Alternatives

Alternatives that involve the manufacture of MOX fuel include the use of the fuel in existing domestic, commercial reactors. The environmental impacts of using MOX fuel in these reactors are evaluated generically in the *Storage and Disposition PEIS*. When the SPD Draft EIS was published, the specific reactors were not known; therefore, that generic analysis was incorporated by reference in the SPD Draft EIS, summarized in Section 4.28, and included in the discussion of the integrated impacts of the MOX fuel alternatives presented in Section 2.18.3. This was done with the understanding that by the time the SPD Final EIS would be published, the specific reactors would have been identified and reactor-specific analyses would replace the generic analysis.

[Text deleted.] In May 1998, DOE initiated a procurement process to obtain MOX fuel fabrication and irradiation services. The Request for Proposals (RFP) defined limited activities that may be performed prior to issuance of the SPD EIS ROD. These activities include non-site-specific work primarily associated with the development of the initial conceptual design for the fuel fabrication facility; and plans (paper studies) for outreach, long lead-time procurements, regulatory management, facility quality assurance, safeguards, security, fuel qualifications, and deactivation. In compliance with its National Environmental Policy Act (NEPA) regulations at 10 CFR 1021.216, DOE requested that each offeror provide, as part of its proposal, environmental information specific to its proposed MOX facility design and the domestic, commercial reactors proposed to be used for irradiation of the fuel. That information was analyzed by DOE to identify potential environmental impacts of the proposals and documented in an Environmental Critique prepared pursuant to 10 CFR 1021.216(g). That analysis was considered by the selection official as part of the award decision.

DOE awarded a contract to the team of Duke Engineering & Services, COGEMA Inc., and Stone & Webster (DCS) in March 1999 to provide the requested services. These services include design, licensing, construction, operation, and eventual deactivation of the MOX facility as well as irradiation of the MOX fuel in six domestic, commercial reactors at three sites. The reactors proposed by DCS are Duke Power Company's Catawba Nuclear Station, Units 1 and 2; McGuire Nuclear Station, Units 1 and 2; and Virginia Power Company's North Anna Power Station, Units 1 and 2. No facility construction or MOX fuel fabrication or irradiation of MOX fuel is to occur until the SPD EIS ROD is issued. Additionally, no MOX fuel is to be irradiated until NRC amends the operating license of each selected reactor prior to the specific reactor receiving the MOX fuel. Such site-specific activities, and DOE's exercise of contract options to allow those activities, would be contingent on decisions in the ROD.

As provided in 10 CFR 1021.216(h), an Environmental Synopsis (Synopsis), based on the Environmental Critique, was provided to

"216 Process"

DOE's NEPA Implementing Regulations (10 CFR Part 1021) include special provisions to enable a source selection official to consider, as part of the procurement decision, the environmental impacts of the offerors' proposals. As provided in 10 CFR 1021.216, DOE may require that offerors submit environmental data and analyses as a discrete part of the offeror's proposal. DOE will then:

- independently evaluate and verify the submitted information;
- prepare an environmental critique (subject to confidentiality requirements of the procurement process) for offers in the competitive range, addressing environmental issues pertinent to a decision on the proposals; and
- prepare a publicly available environmental synopsis, based on the environmental critique, to document consideration given to environmental factors in the selection process.

After a selection has been made, the environmental synopsis shall be filed with EPA, made publicly available, and incorporated in an EIS prepared for the action.

If the NEPA process is not completed before the award, the contracts shall be made contingent on completion of the NEPA process. DOE shall phase subsequent contract work to allow the NEPA review process to be completed in advance of a go/no-go decision.

the U.S. Environmental Protection Agency (EPA), made available to the public, and incorporated as Appendix P to this SPD EIS. In addition, Section 3.7 was added to describe the affected environment at the three reactor sites, Section 4.28 was revised to include the reactor-specific analyses, and the relevant sections of Chapters 2 and 4 were revised as necessary to incorporate information provided by DCS about the proposed MOX facility, where different from that presented in the SPD Draft EIS. Sections of this SPD EIS that were revised or added to include reactor-specific information, including the new Appendix P presenting the Synopsis, were also distributed as the *Supplement to the SPD Draft EIS*.² A Notice of Availability was published in the Federal Register on May 14, 1999 (EPA 1999), providing a 45-day public comment period on the *Supplement*. This *Supplement* was distributed to interested parties in the local communities surrounding the Catawba, McGuire, and North Anna reactor sites; stakeholders who received the SPD Draft EIS; and others as requested. Comments are addressed in Volume III, the Comment Response Document, and, where appropriate, revisions were made to this SPD EIS.

Under the hybrid alternatives, DOE could produce up to 10 MOX fuel assemblies for testing in domestic, commercial reactors before commencement of full-scale MOX fuel irradiation, although it is likely that only 2 lead assemblies would be needed.³ These lead assemblies would be available for irradiation to support U.S. Nuclear Regulatory Commission (NRC) licensing and fuel qualification efforts. Potential impacts of MOX fuel lead assembly fabrication are analyzed for three of the candidate sites for MOX fuel fabrication (Hanford, Argonne National Laboratory–West [ANL–W] at INEEL, and SRS), and two additional sites, Los Alamos National Laboratory (LANL) in New Mexico, and Lawrence Livermore National Laboratory (LLNL) in California. Pantex was not considered for lead assembly fabrication because it does not currently have any facilities capable of MOX fuel fabrication. Postirradiation examination of the lead assemblies, if required to support NRC licensing activities, would be conducted. Two potential sites for postirradiation examination are discussed in this SPD EIS: ANL–W and Oak Ridge National Laboratory (ORNL). These two sites are currently the only sites that have the capability to conduct postirradiation examination activities without major modifications to facility and processing capabilities; only minor modifications for receipt of materials would be required. Other potential facilities, either within the DOE complex or in the commercial sector, would require significant modifications to meet expected requirements. As discussed in Section 1.6, DOE’s preferred locations for lead assembly fabrication and postirradiation examination are LANL and ORNL, respectively.

2.2 MATERIALS ANALYZED IN THIS SPD EIS

As discussed in the following graphic, there are eight general categories used to describe the 50 t (55 tons) of surplus plutonium, which represent the physical and chemical nature of the plutonium. Two of the categories—clean metal (including pits) and clean oxide—could either be fabricated into MOX fuel or immobilized. The remaining six categories of material—impure metals, plutonium alloys, impure oxides, uranium/plutonium oxides, alloy reactor fuel, and oxide reactor fuel—would be immobilized.

² On June 15, 1999, DOE held a public hearing in Washington, D.C., to solicit comments on the *Supplement to the SPD Draft EIS*.

³ The potential impacts of fabricating 10 lead assemblies and irradiating 8 of them were analyzed in this SPD EIS. As discussed in Sections 2.18.2 and 4.27, should fewer lead assemblies than analyzed be fabricated or irradiated, the potential impacts would be lower than those described.

DESCRIPTION OF SURPLUS PLUTONIUM BY DISPOSITION FEED CATEGORIES

PLUTONIUM FEED FOR IMMOBILIZATION OR MOX FUEL FABRICATION:

Clean Metal. Pure plutonium metal generally with less than 100 parts per million (ppm) of any given chemical impurity. The metal may have some oxidation or casting residues on the surface. The only major chemical impurities are gallium and radioactive decay products such as americium, neptunium, or uranium. Examples of pure metal items include unalloyed "buttons" of plutonium metal, billets, ingots, castings or rough machined items, finished machined weapon components such as "pits," and other miscellaneous small metal pieces and parts.

Clean Oxide. Plutonium oxides with less than 3 percent by weight of impurities.

FEED FOR IMMOBILIZATION:

Impure Metal. Items with impurities that are more than 100 ppm, but less than 50 percent by weight.

Plutonium Alloys. Plutonium-containing alloys with impurities that are less than 50 percent by weight. Examples of plutonium alloy items include alloyed plutonium "buttons," casting products, machined product items, and ingots.

Impure Oxide. Plutonium oxides with at least 3 but less than 50 percent by weight of impurities. Examples in this category include plutonium oxides containing uranium oxides and plutonium oxides containing neptunium, thorium, beryllium, or zirconium.

Uranium/Plutonium Oxide. Plutonium oxides mixed with enriched uranium oxides. Examples include powders or pellets that have been either low-fired (heated at temperatures below 700 °C) or high-fired (heated at temperatures greater than 700 °C).

Alloy Reactor Fuel and Oxide Reactor Fuel. Plutonium-containing reactor fuel that has been manufactured, but not irradiated in a reactor. The plutonium consists of 12 to 26 percent of plutonium 240 with total plutonium compositions being 13 to 27 percent of the material in the fuel. The fuel can be either alloy reactor fuel or reactor fuel containing plutonium oxide mixed with uranium oxide. The majority of alloy reactor fuel in DOE's plutonium inventory is fuel elements for the Zero Power Physics Reactor at ANL-W. Oxide fuels include experimental capsules, elements, and pins.

Source: DOE, *Feed Materials Planning Basis for Surplus Weapons-Usable Plutonium Disposition*, MD-0009, 1997.

2.3 DEVELOPMENT OF THE ALTERNATIVES

This section describes the development process for those SPD EIS alternatives and technical issues that remained to be finalized after issuance of the *Storage and Disposition PEIS* ROD.

2.3.1 Development of Facility Siting Alternatives

In the ROD for the *Storage and Disposition PEIS*, DOE identified a large number of possible options to locate three disposition facilities at four sites, and limited the immobilization options to Hanford and SRS. In addition to the four different sites for potential facility locations, the options were further increased by considering the use of either existing or new facilities at the sites, and by considering whether disposition would occur by the hybrid approach (both MOX fuel and immobilization) or only through immobilization. The following equally weighted screening criteria were used to reduce the large number of possible facility and site combinations to the range of reasonable alternatives:

- *Worker and public exposure to radiation.* This criterion was used to exclude the site combinations that involve large amounts of handling, packaging, and repackaging of the surplus plutonium for either intersite or intrasite transportation.
- *Proliferation concerns due to transportation of materials.* Application of this criterion eliminated those options that increased the transfers of the surplus plutonium, usually involving three sites.
- *Infrastructure.* This criterion was used to exclude the site combinations where a single disposition facility was located at a site with no benefit for the program or DOE. For example, collocation of two of the three hybrid case disposition facilities at a site would reduce program infrastructure costs such as

those associated with safeguards and security features, whereas locating each facility at a separate site would not allow such functions to be shared.

Over 64 options were evaluated, yielding a range of 20 reasonable alternatives that met all the criteria. Examples of options that were eliminated include all those options placing three facilities at three different sites. In its Notice of Intent (NOI), DOE proposed to collocate the pit conversion and immobilization facilities for the immobilization-only alternatives. However, during the public scoping process, the comment was made that, under all situations, Pantex should be considered as a candidate site for the pit conversion facility because most of the surplus pits are currently stored there. After confirming that they met all the screening criteria, three additional immobilization-only alternatives, which placed the pit conversion facility at Pantex, were included in the range of reasonable alternatives evaluated in the SPD Draft EIS. The number of reasonable alternatives was reduced to 15 in the *Supplement* when DOE determined, as discussed in Section 2.3.2.2 of this SPD EIS, that Building 221–F at SRS was no longer a reasonable location for the immobilization facility.

[Text and table deleted.]

2.3.2 Alternatives Considered but Eliminated From Detailed Study

Technology alternatives for surplus plutonium disposition that were evaluated in the *Storage and Disposition PEIS*, but were not selected in the ROD and, therefore, are not being considered in this SPD EIS are: (1) deep-borehole direct disposition; (2) deep-borehole immobilized disposition; (3) electrometallurgical treatment; (4) MOX fuel irradiation in a partially completed light water reactor; and (5) MOX fuel irradiation in an evolutionary advanced light water reactor. The reasons why these technologies were not selected are explained in the ROD for the *Storage and Disposition PEIS*.

Alternatives considered for inclusion in this SPD EIS but later eliminated from further analysis fall into four categories: amounts of material to be dispositioned, disposition facility siting, feed preparation methods, and immobilization technologies.

2.3.2.1 Amounts of Material to Be Dispositioned

In the *Storage and Disposition PEIS* ROD, DOE committed to immobilizing at least 8 t (9 tons) of surplus, low-purity, nonpit plutonium. Since the ROD was issued, however, DOE has determined that because of the level of impurities and additional processing that would be required to meet MOX fuel specifications, an additional 9 t (10 tons) of low-plutonium-content materials would be immobilized.

2.3.2.2 Disposition Facility Siting Alternatives

In addition to alternatives eliminated by the screening process described earlier, the following facility options were eliminated from further study. Several commentors at the public scoping meetings suggested that DOE consider locating the proposed surplus plutonium disposition facilities at three separate sites. As discussed in Section 2.3.1, DOE is striving to minimize worker and public exposure to radiation, minimize proliferation concerns associated with transportation, and reduce infrastructure cost. These goals would not be met if DOE were to build one facility at each of three candidate sites.

Locating all three proposed facilities in FMEF at Hanford was listed as Alternative 2 in Table 1 of the NOI for preparation of this SPD EIS (DOE 1997b). After further evaluation of space requirements, DOE concluded that the available space in FMEF would not be sufficient to accommodate the efficient operation and maintenance of all three facilities. Therefore, Alternative 2 was modified to collocate only the pit conversion and immobilization facilities in FMEF, with the MOX facility in new construction adjacent to FMEF.

The *Storage and Disposition PEIS* ROD stated that “to accomplish the plutonium disposition mission, DOE will use, to the extent practical, new as well as modified existing buildings and facilities for portions of the disposition mission.” The subsequent NOI for the SPD EIS further stated that “construction of these facilities would be on previously disturbed land and could include the modification of existing facilities where practicable, to reduce local environmental impacts, reduce costs, and shorten schedules.” As a result, DOE analyzed immobilization alternatives that included Building 221–F at SRS in the SPD Draft EIS. This building was originally built to house operations to chemically separate plutonium from irradiated targets and will be available to support other missions after these activities have been completed. The availability of Building 221–F coincides with the schedule for the proposed surplus plutonium disposition activities.

However, based on revised space requirements for the immobilization facility, the eight alternatives (3B, 5B, 6C, 6D, 7B, 9B, 12B, and 12D) in the SPD Draft EIS that proposed using a portion of Building 221–F for immobilization activities have, as discussed in the *Supplement*, been removed from consideration. These alternatives are no longer considered reasonable because the amount of new construction required for the proposed immobilization facility is now expected to be nearly the same whether the facility were located entirely in a new building or built in addition to using the available portion of Building 221–F. Deletion of the Building 221–F alternatives does not eliminate SRS from any of the immobilization alternatives under consideration. DOE is still evaluating alternatives that involve construction of a new immobilization facility at SRS.

As described in Section 2.7.2 of the SPD Draft EIS, an immobilization facility using portions of Building 221–F was estimated to require approximately 5,300 m² (57,000 ft²) of space in Building 221–F and an additional 1,400 m² (15,000 ft²) of process space in a new annex for a canister-loading facility, for a total of approximately 6,700 m² (72,000 ft²) of space. As discussed in the *Supplement*, and as shown in Section 2.7.1 of this SPD Final EIS, the immobilization facility is now estimated to require approximately 25,000 m² (269,000 ft²) of space. Because only 5,300 m² (57,000 ft²) of this space could be accommodated in Building 221–F, there is no longer expected to be any advantage associated with the use of Building 221–F in terms of reducing the local environmental impacts, reducing costs, or shortening the construction schedule for this facility.

[Text deleted.]

2.3.2.3 Feed Preparation Methods for Immobilization

The homogenous ceramic immobilization facility evaluated in the *Storage and Disposition PEIS* was based on a wet-feed preparation process. Although the ceramic form of the can-in-canister approach evaluated in this SPD EIS could also use a wet-feed process, it would require larger quantities of water and generate greater amounts of waste than would a dry-feed process. For these reasons, wet-feed preparation processes for the ceramic can-in-canister approach were not considered to be reasonable and were not considered further in this SPD EIS.

2.3.2.4 Immobilization Technology Alternatives

DOE considered locating an adjunct melter adjacent to the Defense Waste Processing Facility (DWPF) at SRS. In the adjunct melter, a mixture of borosilicate glass frit and plutonium would be melted together and added directly to borosilicate glass containing high-level waste (HLW) from DWPF. Subsequent evaluations (UC 1997), however, have indicated that the adjunct melter approach would be less technically viable, would take longer to implement, and would cost twice that of the can-in-canister approach. A description of the vitrification process using the adjunct melter is presented in Appendix C, but this approach is not evaluated as a reasonable alternative.

The technology variants for the new immobilization facilities discussed in the *Storage and Disposition PEIS* considered using either radioactive cesium 137 or HLW as a radiation barrier. However, the *Storage and*

Disposition PEIS further identified that, in the can-in-canister approach, the use of HLW to produce a radiation barrier eliminates the need for introducing cesium 137 (from cesium capsules currently in storage at Hanford) into the immobilization process, which in turn reduces radiation shielding requirements and potential exposures to workers and the public. Therefore, this SPD EIS does not include the use of these cesium 137 capsules in the can-in-canister analyses as a reasonable alternative.

2.4 OVERVIEW OF PROPOSED SURPLUS PLUTONIUM DISPOSITION FACILITIES AND TRANSPORTATION

As discussed previously, three facilities are proposed for surplus plutonium disposition: pit conversion, immobilization, and MOX fuel fabrication. The three disposition facilities are proposed for locations where the plutonium would have the levels of protection and control required by applicable DOE safeguards and security directives.⁴ Safeguards and security programs would be integrated programs of physical protection, information security, nuclear material control and accountability, and personnel assurance. Security for the facilities would be implemented commensurate with the usability of the material in a nuclear weapon or improvised nuclear device. Each facility would be located at an existing DOE site that has sitewide security measures in place, including access control. In addition to DOE sitewide security services, each facility would have appropriate security features. Physical barriers; access control systems; detection and alarm systems; procedures, including the two-person rule (which requires at least two people to be present when working with special nuclear materials in the facility); and personnel security measures, including security clearance investigations and access authorization levels, would be used to ensure that special nuclear materials stored and processed inside are adequately protected. Nuclear material control and accountability would be ensured through a system that monitors storage, processing, and transfers. Closed-circuit television, intrusion detection, motion detection, and other automated material monitoring methods would be employed as part of the material control and accountability program. At any time, the total amount of special nuclear material in each facility, or in any material balance area within a specific facility, would be known. Physical inventories, measurements and inspections of material both in process and in storage would be used to verify inventory records. In addition, each of the three facilities would need to provide space and, to varying degrees, access for international inspection.

Descriptions of the proposed surplus plutonium disposition facilities and process operations are provided in this section. The proposed facility layouts are renderings that show representative equipment layouts that demonstrate functional, but not final designs. These designs are subject to modification during the design and construction process, consistent with any construction project, as may be required to optimize equipment placement and process flow. Sections 2.5 through 2.16 describe, individually, each alternative being considered in this SPD EIS. Because the facilities would be implemented differently at each site and for each alternative, those differences are identified and described. Sections 2.4 through 2.16 were developed using data provided by the Regents of the University of California (UC 1998a–i, 1999a–d). MOX alternatives have also been developed using data provided in the *MOX Fuel Fabrication Facility and Nuclear Power Reactor Data Report* (DOE 1999a) and by ORNL (ORNL 1998, 1999).

Each of the three disposition facility layouts includes accommodations for international inspection. However, the implementation process for international inspection of U.S. and Russian surplus plutonium is not fully defined. Rather, that process is part of ongoing negotiations being conducted to reach a bilateral plutonium disposition agreement between the United States and Russia for their disposition programs in accordance with the *Joint Statement of Principles for Management and Disposition of Plutonium Designated as No Longer Required for Defense Purposes*. This statement was signed by Presidents Clinton and Yeltsin in September 1998

⁴ The physical protection and safeguards and security for the MOX facility would be acceptable to NRC. Physical protection and safeguards and security at the domestic, commercial reactors would meet NRC regulations.

(see Appendix A). The agreement could include provisions for bilateral facility inspections or potential multilateral inspections.

Each of the disposition facilities is proposed to operate for about 10 years. However, the operating life of the facilities may vary somewhat, depending on facility startup experiences and international negotiations regarding the pace of disposition. Also, the MOX facility could operate for as long as 13 years to accommodate the fuel cycles of the reactors in which the MOX fuel would be used. Slightly more or less material could be processed in any given year, potentially extending or shortening the operating period of any of the disposition facilities. Also, for the hybrid approach, it may be necessary, based on feed material quality, to process slightly more material by immobilization than currently envisioned. An analysis of how these adjustments could incrementally affect the potential impacts evaluated in this SPD EIS is provided in Section 4.30.

Because the disposition facilities would operate for about 10 years and would meet stringent safety and natural hazard requirements, they could still be used for other programs or activities. As discussed in Section 4.31, after completion of the surplus plutonium disposition mission, equipment would be removed, decontaminated, and either reused at other DOE facilities or disposed of, and the facilities would be stabilized to a condition suitable for reuse. It is expected that this facility deactivation would take 3 years or less to complete. During this time, DOE would perform engineering evaluations, environmental studies, and further NEPA review to assess the consequences of different courses of action with respect to these facilities.

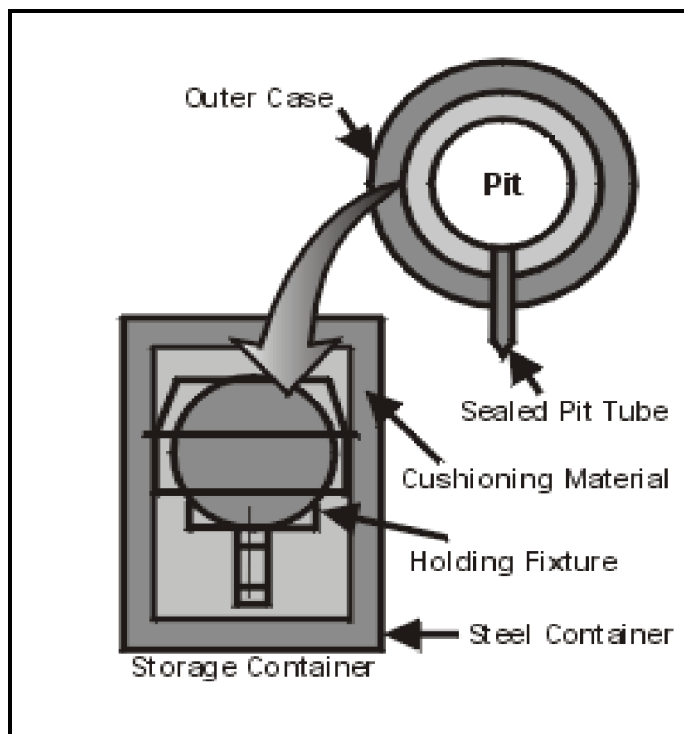

Figure 2-6. Depiction of a Pit

2.4.1 Pit Disassembly and Conversion

Each surplus plutonium disposition action alternative requires a pit conversion facility to produce appropriate plutonium dioxide feed material. That facility would recover plutonium from pits (see Figure 2-6) and process clean plutonium metal (as described in Section 2.2); convert the plutonium to an unclassified (i.e., no longer exhibiting any characteristics that are protected for reasons of national security) oxide; and then transfer the oxide to either the immobilization facility or the MOX facility. This process would include the removal of gallium, beryllium, or other materials that may be considered impurities in plutonium dioxide feed for MOX fuel fabrication. Potential impurities include any of the elements listed in Table 2-2. Given the national security sensitivity of information on pit materials and assembly, pit conversion facility operations

Table 2–2. Potential Impurities in Weapons-Grade Plutonium

Aluminum	Magnesium	
Americium	Manganese	
Boron	Nickel	
Beryllium	Neptunium	
Carbon	Silicon	
Calcium	Tantalum	
Cadmium	Tin	
Chromium	Thorium	
Copper	Titanium	
Gallium	Tungsten	
Iron	Uranium	
Lead	Zinc	

would be classified (i.e., access restricted) through the material-processing steps, and possibly through the final canning stage.

2.4.1.1 Pit Conversion Facility Description

The pit conversion facility would be designed to process up to 3.5 t (3.8 tons) of plutonium metal into plutonium dioxide annually. Facility operations would require a staff of about 400 personnel. The general layout of the pit conversion facility, which approximates how the pit conversion process would be implemented, is presented in Figures 2–7 and 2–8. The specific layout and design of the facility would vary from site to site depending on a number of factors, as discussed in Sections 2.6 through 2.16.

The pit conversion facility would be built in a hardened space of thick-walled concrete that meets all applicable standards for processing special nuclear material. One or possibly both levels of the two-story building would be below grade. Areas of the facility in which plutonium would be processed or stored would be designed to survive natural phenomena such as earthquakes, floods, and tornadoes, as well as potential accidents associated with fissile and radioactive materials. Ancillary buildings would be required for support activities.

Activities involving radioactive materials or externally contaminated containers of radioactive materials would be conducted in gloveboxes. The gloveboxes would be interconnected by a contained conveyor system to move materials from one process step to the next. Gloveboxes would remain completely sealed and operate independently, except during material transfer operations. Built-in safety features would limit the temperature and pressure inside the gloveboxes and ensure that operations remained within criticality safety limits. When dictated by process needs or safety concerns, an inert atmosphere would be maintained in gloveboxes. The exhaust from the gloveboxes would be monitored continuously for radioactive contamination. The atmosphere in the gloveboxes would be kept at a lower pressure than that of the surrounding areas so that any leaks of gaseous or suspended particulate matter would be contained and filtered appropriately. The building ventilation system would include high-efficiency particulate air (HEPA) filters and would be designed to maintain confinement, thus precluding the spread of airborne radioactive particulates or hazardous chemicals within the facility or to the outside environment. Both intake and exhaust air would be filtered, and exhaust gases would be monitored for radioactivity.

Beryllium may be a constituent of some of the pits that would be disassembled in the pit conversion facility. Because inhalation of beryllium dust and particles has been proven to cause a chronic and sometimes fatal lung disease, beryllium is of special interest from a health effects perspective. The process operations in the pit

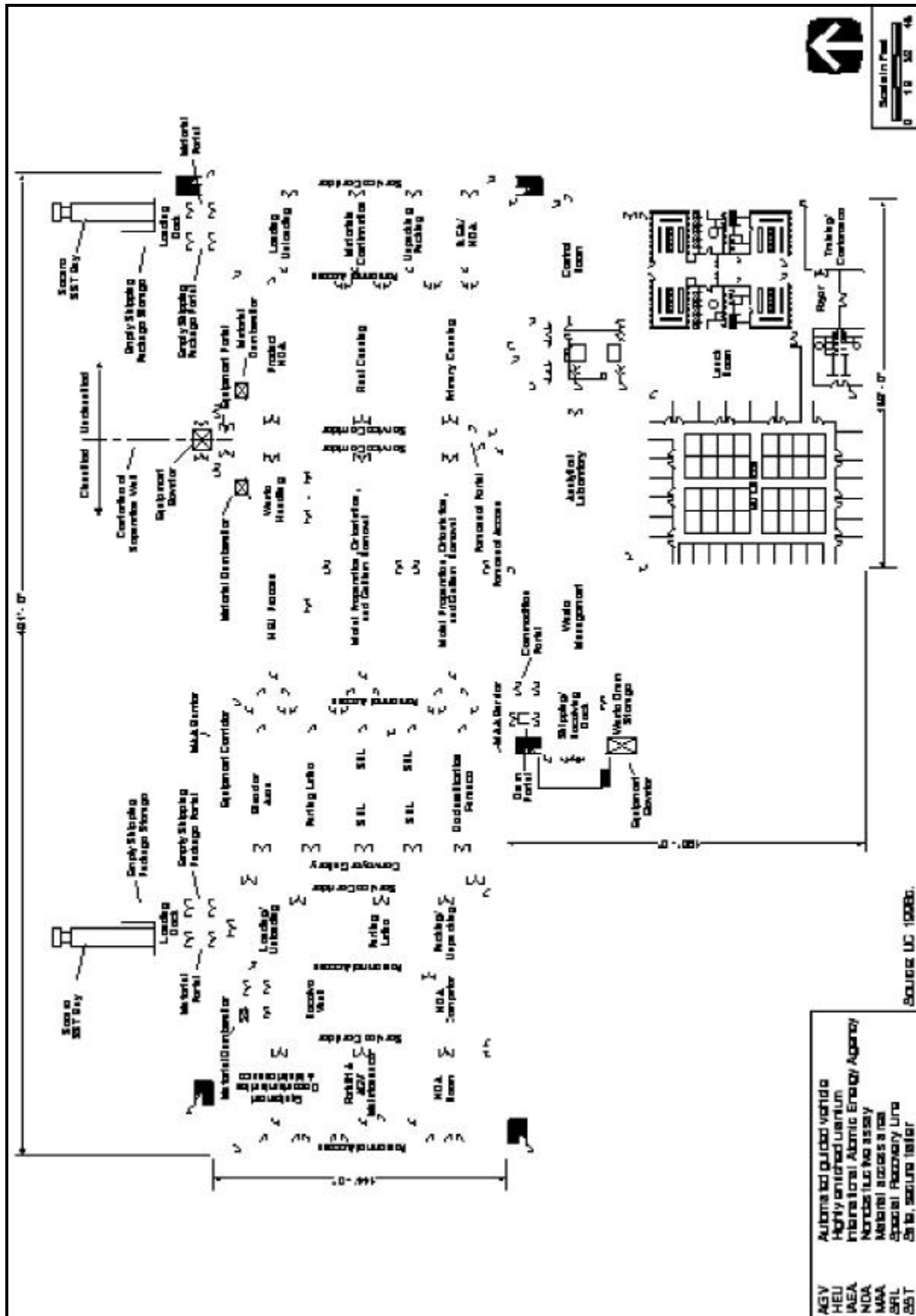

Figure 2-7. General Design of Pit Conversion Facility—Main Processing Level (First Floor)

AGV	Automated guided vehicle
HEU	Highly enriched uranium
IAEA	International Atomic Energy Agency
NDA	Nuclear Design Authority
MAA	Material Access Control
SPIL	Special Recovery Line
SST	Special Storage Tank

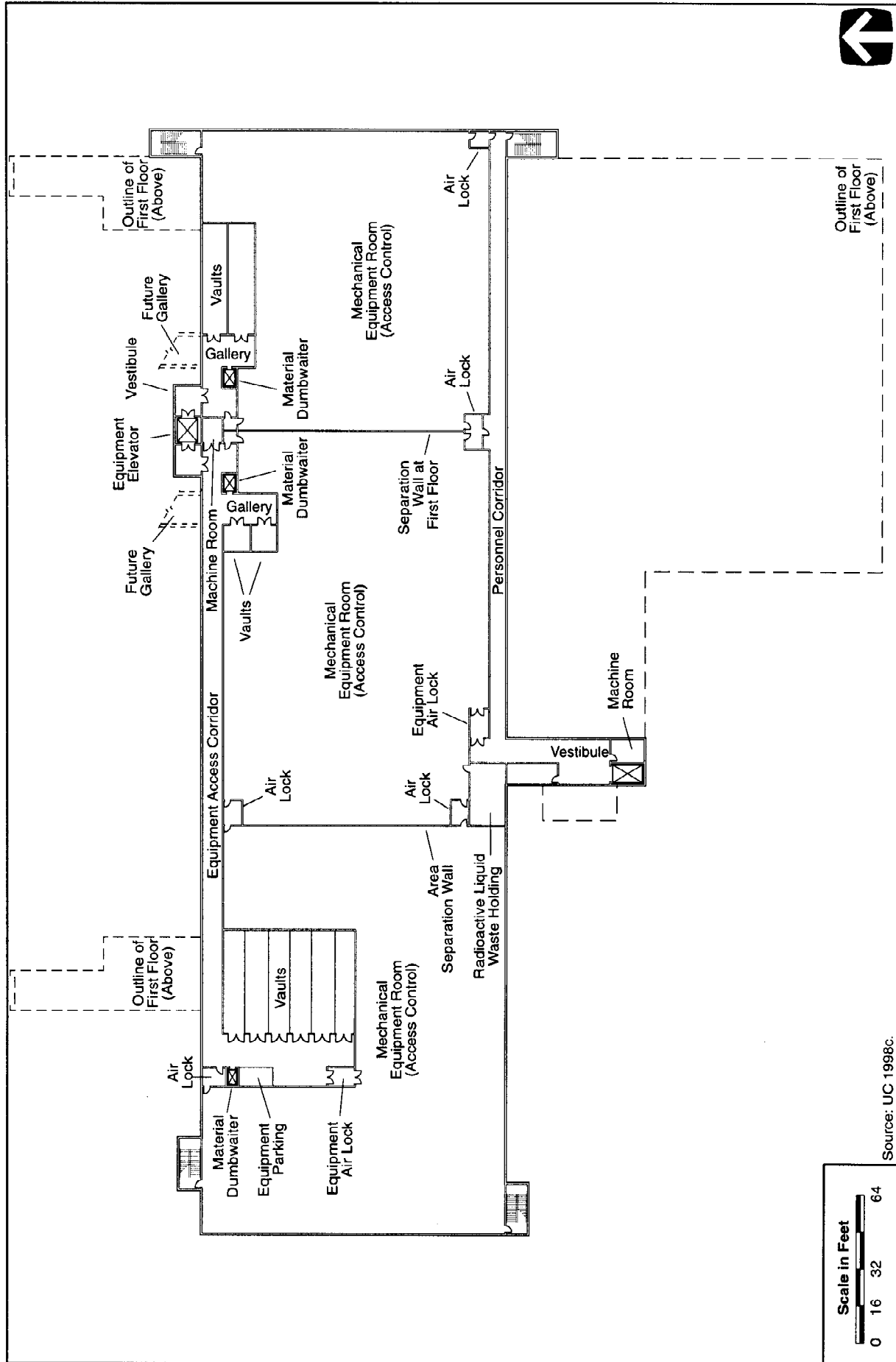

Figure 2-8. General Design of Pit Conversion Facility—Lower (Basement) Level

Source: UC 1998c.

conversion facility are expected to generate only larger, nonrespirable turnings and pieces of metal, and all work would be performed in gloveboxes. No grinding would be done that could cause small pieces of beryllium to become airborne. The beryllium in solid form would be disposed of as low-level waste (LLW) or transuranic (TRU) waste and has been included in the waste estimates presented in Chapter 4. Therefore, exposure to airborne beryllium is not considered a concern for pit disassembly and conversion operations.

The pit conversion facility would accommodate the following surplus plutonium-processing activities: pit receipt, storage, and preparation; pit disassembly; plutonium conversion; gallium removal; oxide blending and sampling; nondestructive assay; product canning; product storage; product inspection and sampling for international inspection; product shipping; declassification of parts not made from special nuclear materials; highly enriched uranium (HEU) decontamination, packaging, storage, and shipping; tritium capture, packaging, and storage; and waste packaging, sampling, and certification. Additional areas for support activities would be needed, including office space, change rooms, a central control room, a laboratory, mechanical equipment rooms, mechanical shops, an emergency generator to supply power to critical safety systems in the event of a power outage, a warehouse, shipping and receiving areas, waste storage, guard stations, entry portals, and parking. Because these facilities would not contain or process special nuclear materials, they would not be required to be in hardened space and thus could be located in other space available at the candidate sites. Separate truck bays in the hardened facility would accommodate DOE safe, secure trailer/SafeGuards Transport (SST/SGTs).

2.4.1.2 Pit Disassembly and Conversion Process

The pit disassembly and conversion process is depicted in Figure 2–9. At the pit conversion facility, the storage containers would be removed from their overpacks (outer shipping containers), the contents verified, and information regarding the material entered into the facility’s material accountability system. Pits and plutonium metal would be placed in a short-term receiving vault, checked for radiological contamination, and transferred to the pit storage vault until processing. Before pits would be fed into the pit disassembly line, they would be segregated based on the potential presence of tritium.⁵ Pits without tritium would go into the pit bisector glovebox, and those containing tritium would start in the Special Recovery Line glovebox.

In the pit bisector glovebox, any external structures would be cut away from the pit, and the pit would be cut in half. Nonbonded pits (pits whose components separate easily) would be separated into plutonium metal, HEU, classified metal shapes, and classified nuclear material parts. The plutonium parts would be assayed as part of the material accountability program. HEU would be sent to the HEU-processing station for material accountability, electrolytic decontamination, and packaging; the classified metal shapes and metal shavings to the declassification furnaces; the nuclear material parts to storage at the pit conversion facility; and the plutonium to the hydride-oxidation (HYDOX) station for the next step of the process. Bonded pits, which cannot be separated prior to processing, would be sent to the HYDOX station intact. For these pits, HEU, classified metal shapes, and classified nuclear material parts would be separated from the plutonium metal during the HYDOX process, then sent to the HEU-processing station, declassification furnaces, and storage at the pit conversion facility, respectively. Recovered HEU would be stored in a vault at the pit conversion facility until shipped to the Oak Ridge Reservation (ORR) for declassification, storage, and eventual disposition. The HEU would meet the Y–12 acceptance criteria prior to shipment to ORR.

Pits with tritium would also be bisected, and the HEU, classified metal shapes, and classified nuclear material parts would be separated from the plutonium; this would occur in the Special Recovery Line glovebox. Under normal circumstances, all the tritium associated with a given pit would be captured and recovered during the

⁵ Tritium can be used as a boosting fuel in high-energy atomic weapons. Although the operators of the pit conversion facility would know which pits contain tritium, the pit types and the number of surplus pits that contain tritium are classified.

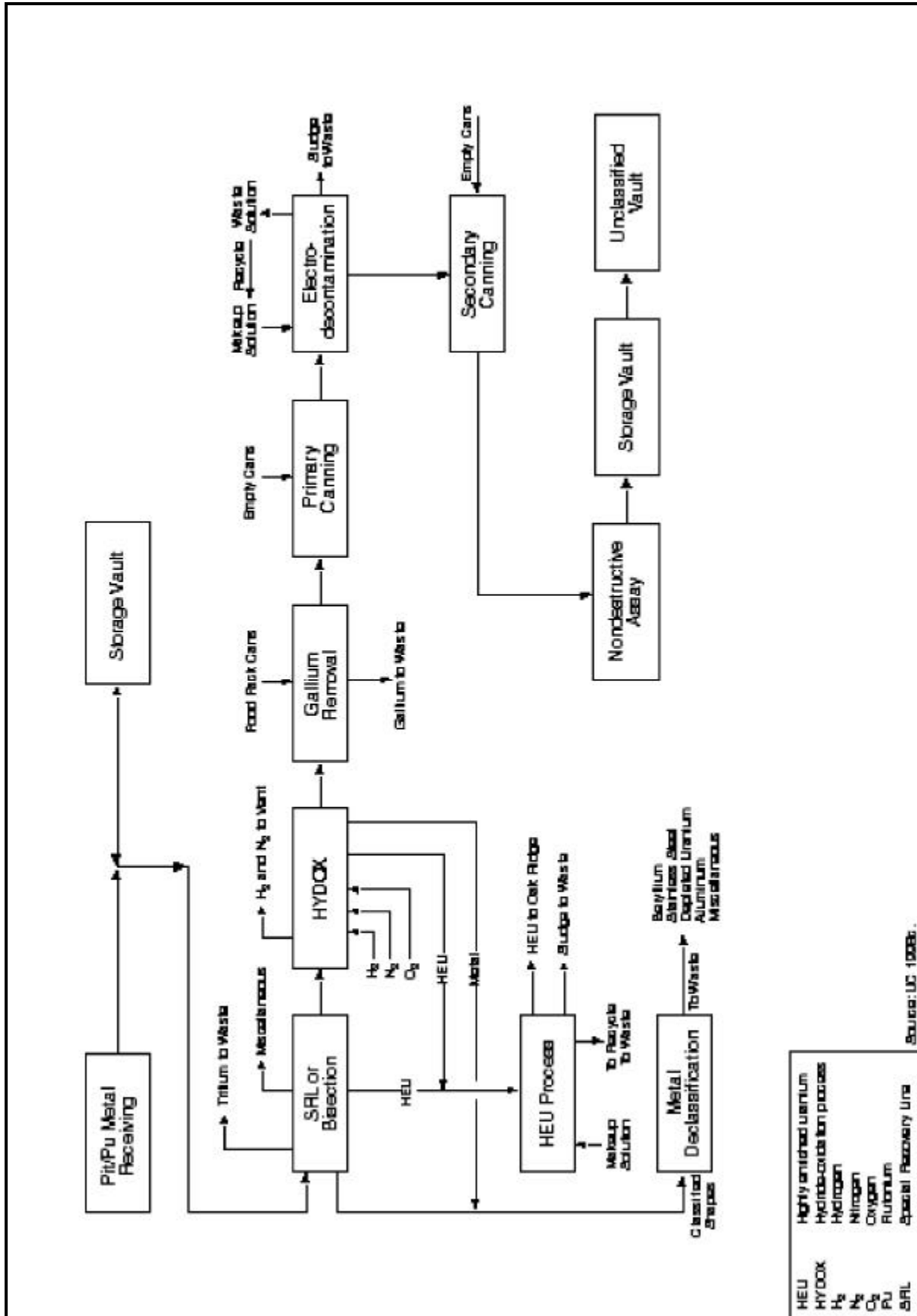

Figure 2-9. Pit Disassembly and Conversion Process

tritium removal process in the Special Recovery Line. It is expected that in a small number of pits, the tritium will have absorbed into the plutonium. For these pits, an additional step would occur in the Special Recovery Line glovebox: the plutonium would be heated in a vacuum furnace to drive off the tritium as a gas. The tritium would then be captured on a catalyst bed and packaged as LLW for treatment and disposal. For purposes of analysis in this SPD EIS, it has been conservatively estimated that 1,100 Ci of tritium would escape to the atmosphere annually through the process building stack. HEU and classified metal shapes would be decontaminated and sent to the HEU-processing station and declassification furnaces, respectively; classified nuclear material parts would be placed in storage at the pit conversion facility. After confirmation that the plutonium metal was free of tritium, the plutonium would be assayed as part of the special nuclear material accountability program and transferred to the HYDOX station. Recovered HEU would be stored in a vault at the pit conversion facility until shipped to the ORR for declassification, storage, and eventual disposition. The HEU would meet the Y-12 acceptance criteria prior to shipment to ORR.

In the HYDOX module, plutonium metal would react with hydrogen, nitrogen, and oxygen at controlled temperatures and pressures in a pressure vessel to produce plutonium dioxide. The plutonium metal would first be reacted with hydrogen gas to form a hydride. Then the vessel would be purged of the hydrogen and the hydride reacted with nitrogen gas to form a nitride. The nitrogen would then be purged and replaced with oxygen for the final reaction forming plutonium dioxide. The plutonium dioxide product would be collected and assayed for the material accountability program to confirm that all the plutonium metal entering the HYDOX process left as an oxide.

Next in this process would be gallium removal. Gallium, a metallic element with a low melting point that is alloyed with plutonium in pits, is considered an impurity in plutonium dioxide feed for MOX fuel fabrication.⁶ As currently proposed and analyzed in this SPD EIS, the pit conversion process includes a gallium removal step in which heat would be used in a controlled manner to separate and collect (for disposal as LLW or TRU waste) gallium oxide from plutonium dioxide. Following gallium removal, the plutonium dioxide would be subjected to a series of tests to verify that it met specifications, sealed in a metal can, and sent to the primary canning module.

This gallium removal process was evaluated in the SPD Draft EIS as meeting the needs of the surplus plutonium disposition program. However, as explained in the *Supplement*, based on public comments, and the responses to the procurement discussed in Section 2.1.3 of this SPD Final EIS, the plutonium-polishing process for gallium removal that was evaluated as a contingency in Appendix N of the SPD Draft EIS has been included in the MOX facility evaluated in this SPD Final EIS. Plutonium polishing consists of a small-scale aqueous process to remove gallium (and the other impurities that can affect the use of the plutonium as reactor fuel) to a greater extent than the dry, thermal process proposed for the pit conversion facility. Because the MOX facility would include the plutonium-polishing component, it may not be necessary to subject the plutonium dioxide to the thermal gallium removal step at the pit conversion facility. Both the pit conversion and MOX facilities, however, are being analyzed with their respective gallium (and other impurity) removal processes. Should it be determined that the thermal process is not needed, the impacts of operating the pit conversion facility, in particular, electrical use and waste generation, would be lower than those estimated in this SPD Final EIS.

In the primary canning module, the cans of plutonium dioxide would be placed into a primary storage can made of stainless steel. This can would then be welded shut and leak tested to ensure that the weld was sound. If the can were to fail the leak test, it would be reopened and rewelded. After passing the leak test, the primary can would be sent to the electrolytic decontamination module. After decontamination, each can would be rinsed, dried, and surveyed to verify decontamination, then sent to the secondary canning module.

⁶ Gallium removal would not be necessary for material that would be immobilized.

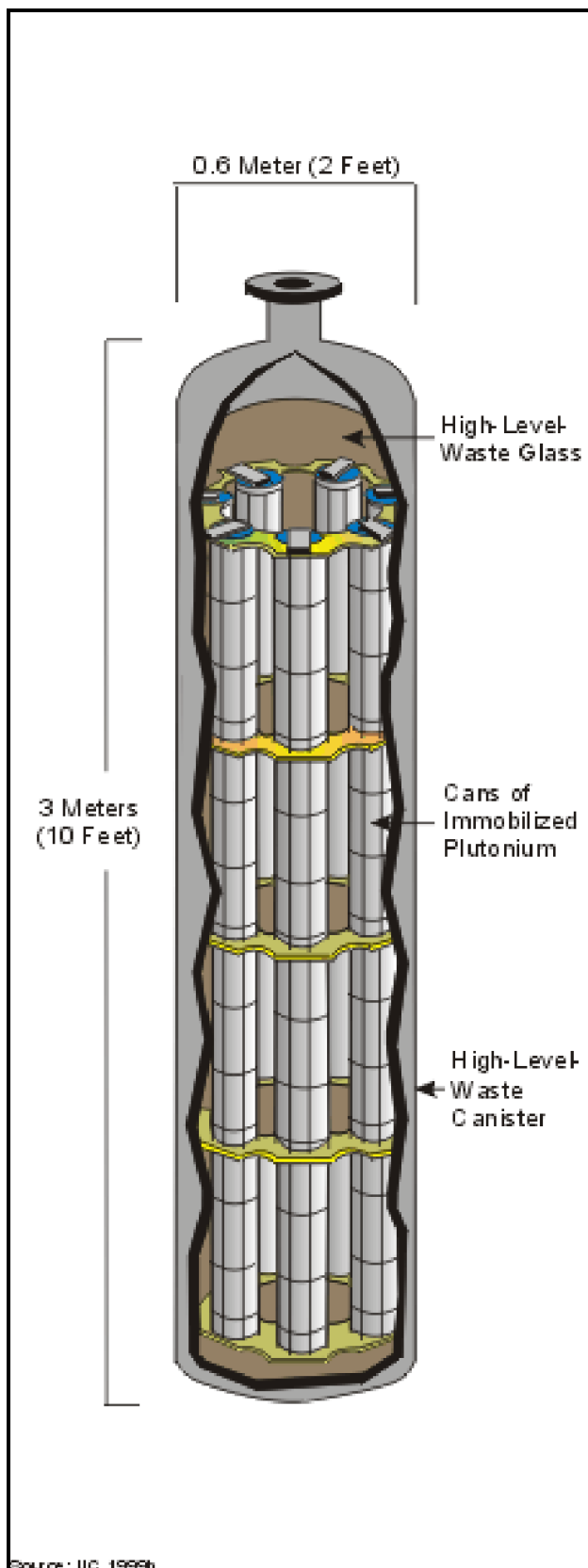

Figure 2-12. Cutaway View of Can-in-Canister Approach

and standby generators would provide backup power for critical systems. This arrangement would ensure that critical systems remain operational during any interruption of offsite power.

2.4.2.2 Plutonium Conversion and Immobilization Process

The plutonium conversion and immobilization process would have the capability to immobilize surplus plutonium material from both pit and nonpit sources. Surplus plutonium derived from pits and already processed by the pit conversion facility would be directly suitable for immobilization, whereas most surplus nonpit plutonium would first have to be converted to a suitable oxide. These oxides would then be incorporated into either a titanate-based ceramic material or a lanthanide borosilicate glass.

The plutonium immobilized in ceramic or glass would be placed inside stainless steel cans, which would be welded shut. The cans would be loaded into an HLW canister (similar to the type currently in use at DWPF at SRS), and filled with HLW to provide a radiation barrier that contributes to the proliferation resistance of the final product. The filled canister, as depicted in Figure 2-12, would then be sealed and stored on the site pending final disposition in a potential geologic repository pursuant to the NWPA. Figure 2-13 provides an overview of the ceramic and glass can-in-canister immobilization processes.

2.4.2.2.1 Plutonium Conversion Process

Plutonium feed materials would be transported in DOE SST/SGTs from the pit conversion facility (if not collocated with the immobilization facility) and the DOE sites storing surplus nonpit plutonium. The shipping containers would be unpacked and the nuclear material assayed at the immobilization facility. Several forms of surplus plutonium materials, all unclassified, would be received by the facility: unirradiated metal reactor fuel in the form of pins and plates clad in stainless steel (from the Zero Power Physics Reactor [ZPPR] at INEEL), unirradiated oxide reactor fuel consisting of fuel pins and bundles (from the Fast Flux Test Facility [FFTF] at Hanford), plutonium alloys, metals, and

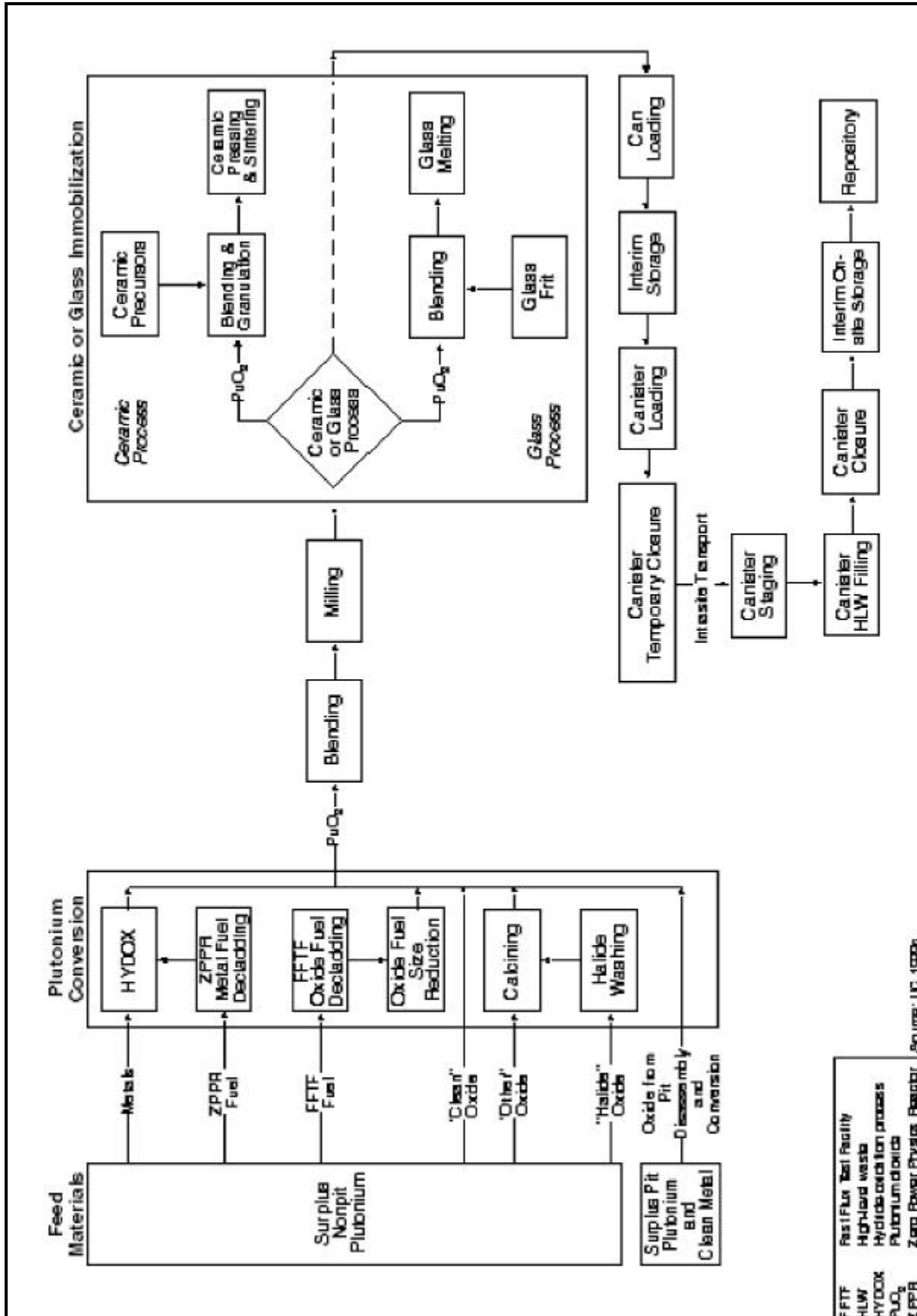

Figure 2-13. Can-in-Canister Process

oxides. Some of these feed materials would also have a uranium component. A feed material storage vault would be available to store up to 6 months of incoming plutonium feed materials. Individual containers would be transferred from the feed material storage vault to a glovebox, unpacked, and inspected to determine the conversion process necessary to render the feed material suitable for immobilization. Metals and alloys would be converted to oxide using the HYDOX process. Metal reactor fuel may require decladding before HYDOX conversion. Oxide reactor fuel would also be decladded, and the individual fuel pellets removed and sorted according to fissile material content. Pellets containing plutonium or enriched uranium would then be ground to an acceptable particle size. Oxides containing moisture or impurities would undergo a calcining process; oxides containing significant concentrations of halide impurities would be “washed” with water to remove the halides before calcining could take place.

Following these conversion processes, the plutonium materials would be stored in the in-process storage vault. Clean oxides—in particular, oxides received from the pit conversion facility, if the decision were made to immobilize all the surplus plutonium—would not require conversion and would be transferred directly to the vault.

2.4.2.2.2 Immobilization Process

Ceramic Process. The ceramic immobilization process would be conducted in a series of glovebox operations that would incorporate the plutonium oxide into ceramic disks, stack the disks inside stainless steel cans, and load the cans into an HLW canister.

In the feed-blending step, plutonium dioxide feed materials would be selected from in-process storage for blending with depleted uranium dioxide. Uranium dioxide would be added to generate a consistent product and reduce criticality concerns, and neutron absorbers (for example, the elements gadolinium or hafnium) would be added to provide criticality safety in the ceramic product. As explained in Section 1.5, uranium dioxide made from depleted uranium hexafluoride in storage at the gaseous diffusion plants previously operated by DOE, such as the Portsmouth Gaseous Diffusion Plant, would be used for this purpose.

After blending, each batch of feed material would be milled to reduce the size of the oxide powder, then blended with ceramic precursors. This mixture would then be granulated with an organic binder to produce a pourable feed that would hold together adequately when compacted into disks. In the press and sinter step, the mixture would be fed into a hydraulic press to form disks, which in turn would be baked in a furnace for reactive sintering to produce the desired mineral phases in the ceramic form. The final product would consist of homogeneous disks about 6.3 cm (2.5 in) in diameter by 2.5 cm (1 in) in height, containing about 10 weight-percent plutonium and 20 weight-percent uranium. These disks would then be stacked and sealed inside stainless steel cans. The cans would be leak tested, assayed, loaded into magazines, and stored in the product vault until removed for canister-filling operations.

As needed, magazines of canned ceramic disks would be removed from storage and inserted and locked into a framework inside an HLW canister. A temporary closure plug would be installed, and following leak testing, the canister would be loaded into a shielded transportation box for intrasite shipment from the main process building to the HLW vitrification facility in a specialized canister transport vehicle.

Glass Process. The glass immobilization process would be conducted in a series of glovebox operations that would incorporate the plutonium oxide into molten lanthanide borosilicate glass, pour it into stainless steel cans, and load the cans into an HLW canister.

In the feed-blending step, plutonium oxide feed materials would be selected from in-process storage for blending to produce individual batches with the desired isotopic composition. Each batch would be milled to reduce the

size of the oxide powder to achieve faster dissolution during the melting process. The milled oxide would then be blended with glass frit (small glass pebbles) containing neutron absorbers (e.g., gadolinium and hafnium) to form a mixture of about 8 weight-percent plutonium and 3 to 8 weight-percent uranium.

This mixture would be fed at a controlled rate into electrically heated melters operating at about 1,500 °C (2,732 °F) to melt the frit and dissolve the plutonium oxide. The homogenous glass melt would be drained into stainless steel cans, which in turn would be sealed, leak tested, assayed, loaded into magazines, and stored in the product vault. As needed, these magazines would be removed from storage and inserted and locked into a framework inside an HLW canister. A temporary closure plug would be installed, and following leak testing, the canister would be loaded into a shielded transportation box for intrasite shipment from the main process building to the HLW vitrification facility in a specialized canister transport vehicle.

Canister Filling. Canister filling, the last major step of the immobilization process, would occur at the HLW vitrification facility. The canisters received from the main process building would be moved individually through an inspection area to the HLW melt cell. In the melt cell, molten, vitrified HLW would be poured into the canister around the stainless steel cans of immobilized plutonium. After removal of any contamination from its outside surface, the canister would be plugged and welded closed. Following inspection and verification that the exterior of the canister was free of contamination, the canister would be transported to an onsite storage vault for interim storage pending final disposition at a potential geologic repository pursuant to the NWPA.

The HLW canisters would measure 0.6 m (2 ft) in diameter by 3 m (10 ft) in height, and, when filled, would weigh up to 2,500 kg (5,500 lb).¹⁰ As each canister of plutonium immobilized in ceramic would contain about 28 kg (61 lb) of plutonium,¹¹ about 1,820 of these canisters would be required to process all 50 t (55 tons) of surplus plutonium. In the ceramic process, the cans, magazines, and internal framework within each canister would displace approximately 15 percent (by volume) of HLW glass. This would result in 272 canisters more than otherwise planned for the DOE HLW vitrification program. Each canister of plutonium immobilized in glass would contain about 26 kg (58 lb) of plutonium.¹¹ As such, about 1,900 canisters would be required to vitrify the 50 t (55 tons) of surplus plutonium. Because the cans, magazines, and internal framework used in the glass process would displace approximately 21 percent (by volume) of HLW glass, this would result in 395 canisters more than otherwise planned for the DOE HLW vitrification program. For the hybrid alternatives, about 670 canisters of plutonium immobilized as a ceramic or 690 canisters of vitrified plutonium would be produced. This would result in 101 or 145 additional canisters, depending on whether the immobilized form were ceramic or glass, respectively, than otherwise planned for the DOE HLW vitrification program.

2.4.3 MOX Fuel Fabrication

The MOX facility would produce completed MOX fuel assemblies for use in domestic, commercial reactors. Feed materials would be the plutonium dioxide from the pit conversion facility and uranium dioxide made from either the DOE stockpile of depleted uranium hexafluoride at a representative DOE site (i.e., the Portsmouth Gaseous Diffusion Plant) or another source selected by the fuel fabricator (DCS) and approved by DOE. MOX fuel fabrication involves blending the plutonium dioxide with uranium dioxide; forming the mixed oxide into pellets; loading the pellets into fuel rods; and assembling the fuel rods into fuel assemblies. Once assembled, each of the fuel assemblies would be transported in SST/SGTs to one of the domestic, commercial reactors for

¹⁰ Consistent with the *Storage and Disposition PEIS* and the WM PEIS, the DWPF HLW canister has been used as the reference canister design for the surplus plutonium immobilization program. Although DOE is considering the possibility of using a larger canister for the Hanford HLW vitrification program, the analyses in this SPD EIS also assume that a DWPF-type canister would be used at Hanford.

¹¹ Plutonium loading in the final design specification and between individual canisters may vary slightly.

use as fuel. Following irradiation, the MOX fuel would be removed from the reactor and managed at the reactor site as spent fuel. Final disposition would be at a potential geologic repository pursuant to the NWPA.

The proposed MOX facility would also include plutonium polishing (a small-scale aqueous process) to remove impurities,¹² in particular gallium, from the plutonium dioxide feed prior to MOX fuel fabrication. This initial plutonium-polishing process would be essentially that described in Appendix N of the SPD Draft EIS, and would add approximately 2,500 m² (27,000 ft²) of process space and about 315 m² (3,400 ft²) of nonhardened space for support functions to the MOX facility. However, the MOX facility layout depicted in Figures 2–14 and 2–15 has not been revised to show this process. This layout approximates how the MOX fuel fabrication process would be implemented. It is a conceptual design that would be updated in subsequent design phases should DOE choose the hybrid approach for surplus plutonium disposition in the ROD. If so, during the design process, the plutonium-polishing component would be integrated into the MOX facility design. The potential impacts of the MOX facility, including plutonium polishing, are evaluated in Chapter 4 and would be the same regardless of where the plutonium-polishing equipment would be located within the MOX facility.

2.4.3.1 MOX Facility Description

The MOX facility would be designed to process up to 3.5 t (3.8 tons) of surplus plutonium (as plutonium dioxide from the pit conversion facility) annually. Facility operations would require a staff of about 385 personnel. The MOX facility has been increased in size from about 11,000 m² (120,000 ft²) in the SPD Draft EIS to about 20,000 m² (215,000 ft²) to include the plutonium-polishing component and additional space proposed by DCS (DOE 1999a). However, about 2,000 m² (21,000 ft²) of administrative space have been relocated from support facilities to the MOX facility, so the net increase in space needed to implement the MOX option is about 7,000 m² (75,000 ft²). As depicted in Figures 2–14 and 2–15, the MOX facility would be a two-story, hardened, reinforced-concrete structure with a below-grade basement and an at-grade first floor. The facility would meet all applicable standards for processing special nuclear material. The walls, floors, and roof of the building would be constructed of about 46 cm (18 in) thick reinforced concrete. Areas of the facility in which plutonium would be processed or stored would be designed to survive natural phenomena such as earthquakes, floods, and tornadoes, as well as potential accidents associated with processing fissile and radioactive materials. Ancillary buildings would be required for support activities.

The fuel fabrication areas, two parallel process lines, would be at ground level. To accommodate the potential for fabricating a different type of fuel, the MOX facility would have sufficient unused space for the installation of another production-scale MOX fuel line. An inert atmosphere would be maintained in gloveboxes where dictated by process needs or safety concerns. The exhaust from the gloveboxes would be monitored continuously for radioactive contamination. The atmosphere in the gloveboxes would be kept at a lower pressure than that of the surrounding areas so that any leaks of gaseous or suspended particulate matter would be contained and filtered appropriately. The building ventilation system would include HEPA filters, and would be designed to maintain confinement, thus precluding the spread of airborne radioactive particulates or hazardous chemicals within the facility and to the outside environment. Both intake and exhaust air would be filtered, and exhaust gases would be monitored for radioactivity. Power would be supplied to the MOX facility by two independent offsite power supplies. An uninterruptible power supply and standby generators

¹² Table 2–2 lists the potential impurities.

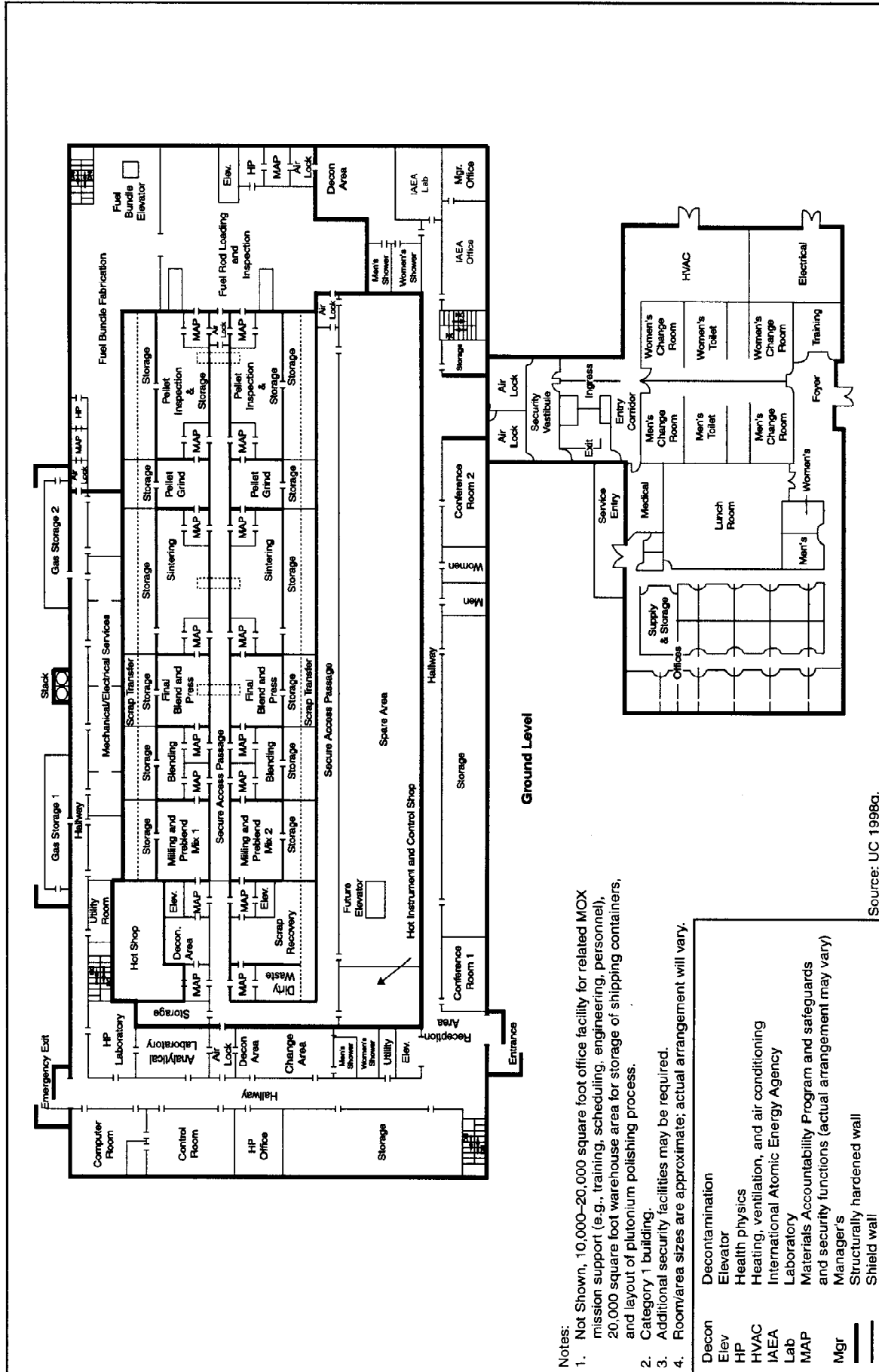

- Notes:
1. Not Shown, 10,000–20,000 square foot office facility for related MOX mission support (e.g., training, scheduling, engineering, personnel), 20,000 square foot warehouse area for storage of shipping containers, and layout of plutonium polishing process.
 2. Category 1 building.
 3. Additional security facilities may be required.
 4. Room/area sizes are approximate; actual arrangement will vary.

Decon	Decontamination
Elev	Elevator
HP	Health physics
HVAC	Heating, ventilation, and air conditioning
IAEA	International Atomic Energy Agency
Lab	Laboratory
MAP	Materials Accountability Program and safeguards and security functions (actual arrangement may vary)
Mgr	Manager's
Shield wall	Structurally hardened wall

Source: UC 1998g.

Figure 2-14. General Design of MOX Facility—Ground Level

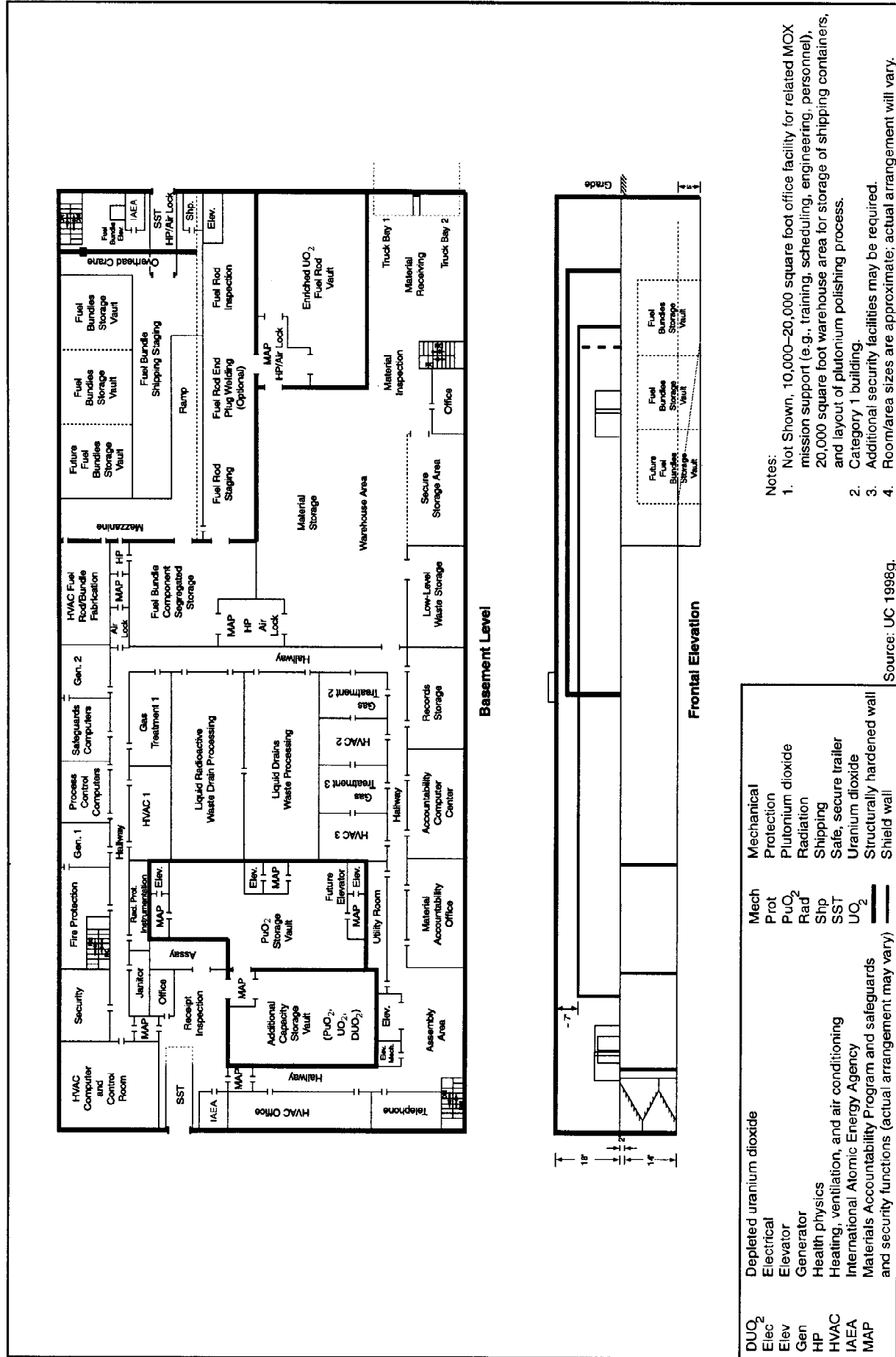

Figure 2-15. General Design of MOX Facility—Basement Level and Frontal Elevation

would provide backup power for critical systems. This arrangement would ensure continued operation of critical systems during any interruption of offsite power.

The basement level of the MOX facility would contain areas for support activities, including special nuclear material vault areas; general shipping and receiving docks; a general warehouse area; radioactive waste storage; assay facilities; emergency generators; heating, ventilation, and air-conditioning equipment; process gas and waste processing and treatment areas; the fuel rod fabrication area; and the fuel bundle assembly, storage, and shipping areas. Separate truck bays would be designed to accommodate the DOE SST/SGTs that would be used to transport the plutonium dioxide powder and the unirradiated fuel assemblies. Access control, office space, and warehouse facilities have been proposed for areas outside the secure MOX facility building. Facilities to support international or bilateral inspection and oversight activities would also be provided. Existing DOE site security and emergency services and environmental monitoring would support the MOX fuel fabrication mission.

MOX fuel is made from a mixture of plutonium dioxide and uranium dioxide. The uranium dioxide would be received from a commercial, NRC-licensed conversion facility. Conversion services for low-enriched uranium hexafluoride are commercially available in the United States at five facilities. As explained in Sections 2.4.4.2 and 2.4.4.3, for purposes of the analyses in this SPD EIS, the Portsmouth Gaseous Diffusion Plant near Piketon, Ohio, was analyzed as the representative facility for the source of depleted uranium hexafluoride to be converted into uranium dioxide.¹³ An NRC-licensed commercial nuclear fuel fabrication facility in Wilmington, North Carolina, was used as a representative conversion facility.

2.4.3.2 MOX Fuel Fabrication Process

Figure 2–16 provides an overview of the MOX fuel fabrication process. The vast majority of the MOX fuel matrix, about 95 percent, is uranium dioxide. MOX fuel fabrication is essentially the same process that is used to produce low-enriched uranium fuel for commercial nuclear power reactors, once the plutonium and uranium dioxide powders are blended together into a mixed oxide. Processing of feed materials would begin with the plutonium-polishing process to remove gallium, but the process would also remove other impurities, including americium, aluminum, and fluorides. This process would include three elements: dissolution of the plutonium in nitric acid, removal of impurities by chemical separation (solvent extraction), and conversion of the plutonium back to an oxide powder by precipitation. Acid recovery steps, by which nearly all the nitric acid would be recovered and reused in the process, would also be included.

To begin the process, plutonium dioxide feedstock would be dissolved in near-boiling nitric acid with a silver nitrate catalyst. This solution would then be transferred to the solvent extraction process. Following solvent extraction, the plutonium would be converted from a nitrate solution back to an oxide powder through an oxalate precipitation, filtration, and calcination process. The resulting plutonium dioxide, verified to meet fabrication requirements, would then be transferred into containers for storage until needed, or transferred directly to the MOX fuel fabrication steps.

MOX fuel fabrication would begin with blending and milling the plutonium dioxide powder to ensure general consistency in enrichment and isotopic concentration. The uranium and plutonium powders would be blended and milled together to ensure uniform distribution of the plutonium in the MOX, and to adjust the particle size of the MOX powder. The MOX powder would then be made into pellets by pressing the powder into shape, sintering (baking at high temperature) the formed pellets, and grinding the sintered pellets to the proper

¹³ In July 1999, DOE submitted its *Final Plan for the Conversion of Depleted Uranium Hexafluoride* to Congress and is finalizing a request for proposals for, among other depleted uranium hexafluoride management activities, construction and operation of a depleted uranium hexafluoride conversion facility at one or more gaseous diffusion plants.

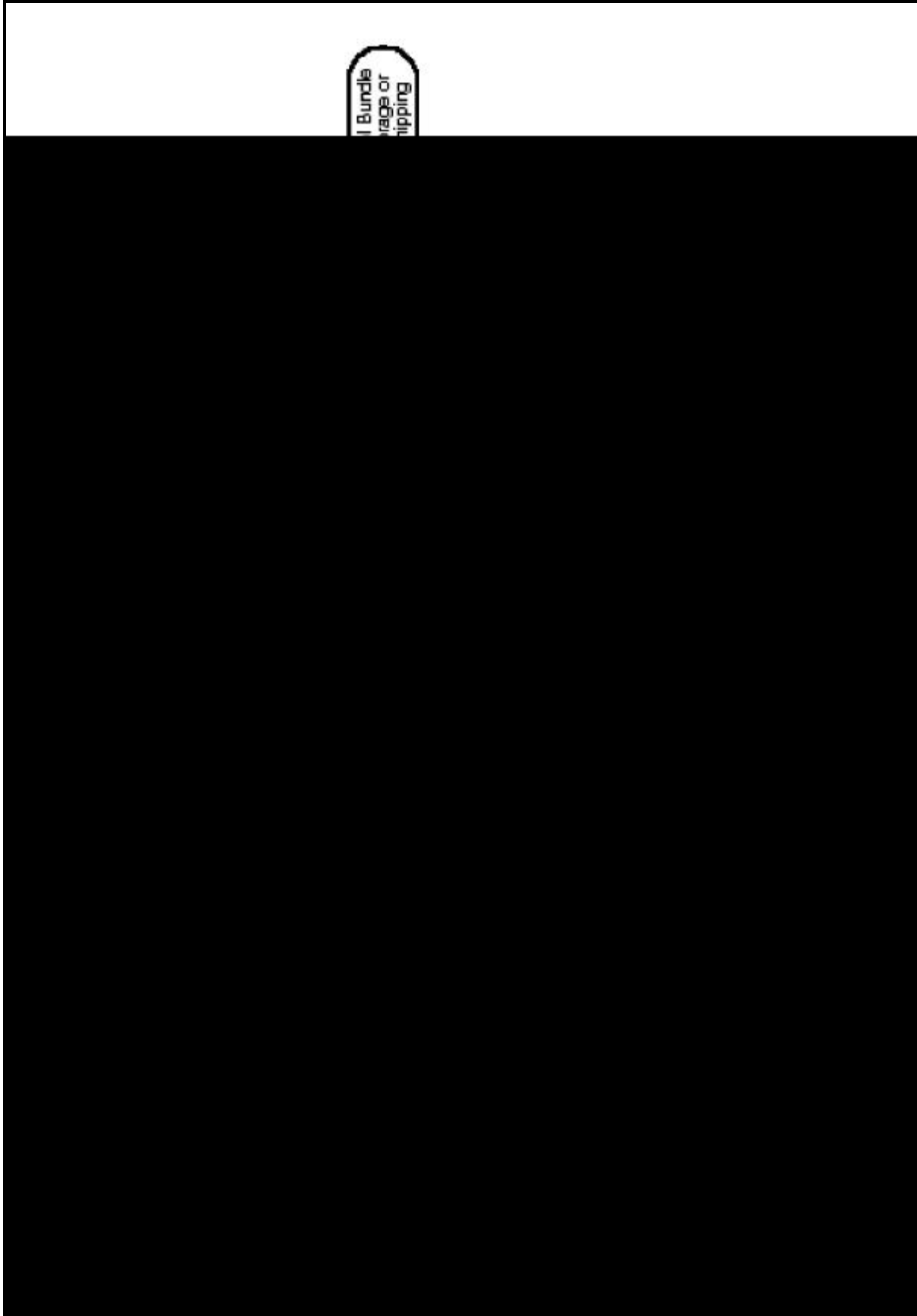

Figure 2-16. MOX Fuel Fabrication Process

dimensions. Materials and pellets would be inspected at each stage, and any rejected materials would be returned to the process for reuse. Most operations would be performed in sealed gloveboxes with inert atmospheres. Sintering furnaces would also be sealed, and offgases would be filtered and monitored prior to release to the atmosphere.

The finished pellets would be moved to the fuel rod fabrication area, where they would be loaded into empty rods. The rods would be sealed, inspected, and decontaminated, then bundled together to form fuel assemblies. Fuel assemblies would consist of only MOX rods or a mixture of MOX and low-enriched uranium rods. Low-enriched uranium rods used in fuel assembly fabrication would be fabricated at another of the fuel fabricator's facilities and brought to the MOX facility for final assembly with the MOX rods. Any rejected fuel bundles would be disassembled, and the materials recycled. Usable rods would be reassembled into new fuel assemblies. Pellets from rods not meeting final product specifications would be crushed and returned to the fabrication process, and decontaminated tubes and hardware would be recycled offsite as scrap metal. Storage for 2 years' production of fuel assemblies would be provided at the MOX facility. Individual fuel assemblies could be stored for that long prior to shipment to the designated domestic, commercial reactor, although production is anticipated to closely follow product need.

The plutonium-polishing process would produce aqueous waste containing the separated impurities (e.g., gallium, americium, aluminum, and fluorides). The liquid wastes from the various impurity removal processes would be transferred to a waste feed tank for evaporation and chemical treatment as required. The evaporator condensate would be treated to produce concentrated acid and acidified water for reuse. The evaporator concentrate would be chemically denitrated, and the offgas from the denitrator scrubbed to produce concentrated nitric acid for reuse. The impurities removed during these processes would be concentrated and solidified for disposal as TRU waste.

Solid wastes generated from process operations would include glovebox gloves, equipment, tools, wipes, and glovebox and HEPA filters. These materials would be removed from the process glovebox lines and transferred to a waste packaging glovebox. Nonprocess materials would be decontaminated to remove residual plutonium. The plutonium would be returned to the dissolution step, and the waste materials would be packaged, assayed, and disposed of as either TRU or LLW, as appropriate.

2.4.4 Transportation Activities

The plutonium disposition alternatives examined in this SPD EIS would require DOE to ship surplus plutonium-bearing materials from their current storage locations, shown in Figure 1-1, to the proposed disposition facility locations for processing. Table 2-3 is an overview of the different types of shipments that would be required for each proposed disposition facility and the vehicles in which the shipments would be made.

The overland transportation of any commodity involves a risk to both the transportation crew and members of the public. The risk results directly from transportation-related accidents and indirectly from the increased levels of pollution from vehicle emissions, regardless of the cargo. The transportation of hazardous or radioactive materials poses an additional risk due to the unique nature of the material being transported. Chapter 4 and Appendix L discuss the risks associated with the transportation of these materials and the steps that would be taken to mitigate these risks as they relate to this SPD EIS.

Table 2–3. Facility Transportation Requirements

Required Shipment	Vehicle ^{a, b}
Pit Conversion Facility	
Intersite shipment of surplus pits and clean metal to the pit conversion facility	SST/SGT
Recovered HEU from the pit conversion facility to ORR	SST/SGT
[Text deleted.]	
Plutonium dioxide to the immobilization or MOX facility	SST/SGT
Immobilization Facility	
Under Alternatives 11B and 12B, plutonium dioxide from the pit conversion facility ^c	SST/SGT
Surplus nonpit plutonium to the immobilization facility ^d	SST/SGT
Depleted uranium hexafluoride from one of DOE’s sites at a gaseous diffusion plant to a conversion facility (ceramic immobilization option only) ^e	Commercial truck
Uranium dioxide from the conversion facility to the immobilization facility (ceramic immobilization option only)	Commercial truck
Immobilized plutonium from immobilization facility to the HLW vitrification facility (intrasite transport)	Special transport vehicle
Vitrified HLW with immobilized plutonium to a potential geologic repository	Commercial truck
MOX Facility^f	
Under Alternatives 4 and 5, plutonium dioxide from the pit conversion facility ^g	SST/SGT
Depleted uranium hexafluoride from one of DOE’s sites at a gaseous diffusion plant to a commercial conversion facility ^e	Commercial truck
Uranium dioxide from the conversion facility to the MOX facility	Commercial truck
Uranium fuel rods from a commercial fuel fabrication facility to the MOX facility ^h	Commercial truck
MOX fuel bundles to selected domestic, commercial reactors	SST/SGT
MOX spent fuel from domestic, commercial reactors to a potential geologic repository ⁱ	Commercial truck
Lead Assembly Fabrication Facility	
Plutonium dioxide from LANL to a lead assembly facility at a location other than LANL	SST/SGT
For lead assembly fabrication at LANL, intrasite movement of plutonium materials	Special transport vehicle
Depleted uranium hexafluoride from one of DOE’s sites at a gaseous diffusion plant to a commercial conversion facility ^e	Commercial truck
Uranium dioxide from the conversion facility to the lead assembly facility	Commercial truck
Uranium fuel rods from a commercial fuel fabrication facility to the lead assembly facility	Commercial truck
MOX fuel bundles to the selected domestic, commercial reactor	SST/SGT
Irradiated lead assemblies or rods from the reactor to an examination site	Commercial truck
Spent fuel from an examination site to INEEL for storage ^j	Commercial truck
Spent fuel from INEEL to a potential geologic repository ⁱ	Commercial truck

^a All containers and vehicles will meet Department of Transportation requirements.

^b Commercial trucks will be driven by drivers certified to meet all radioactive materials transportation requirements.

^c Under Alternatives 11A and 12A, the two facilities would be collocated; therefore, the transfer of the plutonium dioxide would not require any over-the-road transportation.

^d For cases where the surplus nonpit plutonium requires offsite transportation.

^e DOE is considering building one or more facilities at the gaseous diffusion plant(s) to convert depleted uranium hexafluoride to an oxide form.

^f Some equipment for the MOX facility may be manufactured in Europe and shipped to the United States. No nuclear or radiologically contaminated materials would be transported. Any such shipments would be made by commercial vessel, and no impacts other than those occurring from routine commercial shipping would be expected.

^g Under Alternatives 2, 3, 6A, 6B, 7, 8, 9, and 10, the two facilities would be collocated; therefore, the transfer of the plutonium dioxide would not require any over-the-road transportation.

^h For cases where the fuel assemblies are a combination of MOX and low-enriched uranium fuel rods.

ⁱ Shipments of spent fuel are analyzed in the *Draft EIS for a Geologic Repository for the Disposal of Spent Nuclear Fuel and High-Level Radioactive Waste at Yucca Mountain, Nye County, Nevada*.

^j Shipments of spent fuel within the DOE complex are analyzed in the *DOE Programmatic Spent Nuclear Fuel Management and Idaho National Engineering Laboratory Environmental Restoration and Waste Management Programs Final EIS*.

Key: HEU, highly enriched uranium; HLW, high-level waste; LANL, Los Alamos National Laboratory; ORR, Oak Ridge Reservation; SST/SGT, safe, secure trailer/SafeGuards Transport.

2.4.4.1 Pit Conversion Transportation Requirements

To implement any of the disposition alternatives being considered in this SPD EIS, clean plutonium metal and surplus pits would need to be shipped from current storage locations around the DOE complex to the proposed location of the pit conversion facility. Due to the attractiveness of these materials for use in constructing nuclear weapons, all intersite shipments would be made in DOE SST/SGTs.¹⁴ In the alternatives that include locating the pit conversion facility at Pantex, where surplus pits are stored, the transfer of the surplus pits from onsite storage to the pit conversion facility would be made in specially designed transport vehicles that are routinely used to transport pits around the site. This would reduce the number of intersite trips and the distance that would have to be traveled to transport pits to the pit conversion facility. Also, as discussed in Appendix L, the dose associated with transferring the pits from storage to the pit conversion facility at Pantex could be reduced because the pits would be transferred from current storage locations to the pit conversion facility without being repackaged into the shipping containers that would be required for intersite transport.

After conversion, the plutonium from the pit conversion facility would be in the form of plutonium dioxide. For most of the alternatives, this material would be transferred from the pit conversion facility to either the immobilization or MOX facility through a secure underground tunnel. In Alternatives 6B and 11A, where the pit conversion facility is collocated in the same building with another disposition facility, the plutonium dioxide would be transferred within the building. However, several alternatives (4A, 4B, 5, 11B, and 12B) locate the pit conversion facility at Pantex and immobilization and/or MOX facilities at another site. The reason for including these alternatives is that the vast majority of the surplus pits are stored at Pantex. Less intersite transportation would be required to move these pits to the pit conversion facility, and the doses associated with repackaging pits into shipping containers at Pantex would be avoided. Under these alternatives, the plutonium dioxide from the pit conversion facility would be shipped in SST/SGTs to the other proposed disposition facilities.

HEU recovered during the pit disassembly process would be shipped via SST/SGT to ORR for declassification, storage, and eventual disposition.¹⁵ The HEU would be decontaminated at the pit conversion facility, and would meet Y-12 acceptance criteria prior to shipment.

2.4.4.2 Immobilization Transportation Requirements

Figure 2-17 shows the transportation requirements for the proposed immobilization disposition activities. Surplus nonpit plutonium in various forms would be moved from current storage locations (i.e., Hanford, INEEL, LLNL, LANL, the Rocky Flats Environmental Technology Site [RFETS], and SRS) to the proposed immobilization facility location, either Hanford or SRS. The quantity of plutonium contained in these materials dictates that they be subjected to the same safeguards and security requirements as materials that could be used in nuclear weapons. Therefore, intersite shipments would be made in SST/SGTs.

¹⁴ The SST/SGT is a specially designed component of an 18-wheel tractor-trailer vehicle. Although the details of the vehicle enhancements are classified, key characteristics are not, and include: enhanced structural supports and a highly reliable tie-down system to protect cargo from impact; heightened thermal resistance to protect the cargo in case of fire; deterrents to protect the unauthorized removal of cargo; couriers who are armed federal officers and receive rigorous training and are closely monitored through DOE's Personnel Assurance Program; an armored tractor to protect the crew from attack and advanced communications equipment; specially designed escort vehicles containing advance communications and additional couriers; 24-hr-a-day real-time monitoring of the location and status of the vehicle; and significantly more stringent maintenance standards.

¹⁵ Shipments would be in accordance with the *Environmental Assessment for the Proposed Interim Storage of Enriched Uranium Above the Maximum Historical Storage Level at the Y-12 Plant, Oak Ridge, Tennessee* (DOE/EA-0929, September 1994; FONSI, September 1995). Storage would be in accordance with the ROD for the *Storage and Disposition PEIS*; disposition would be in accordance with the ROD for the *Disposition of Surplus Highly Enriched Uranium Final Environmental Impact Statement* (61 FR 40619, August 5, 1996).

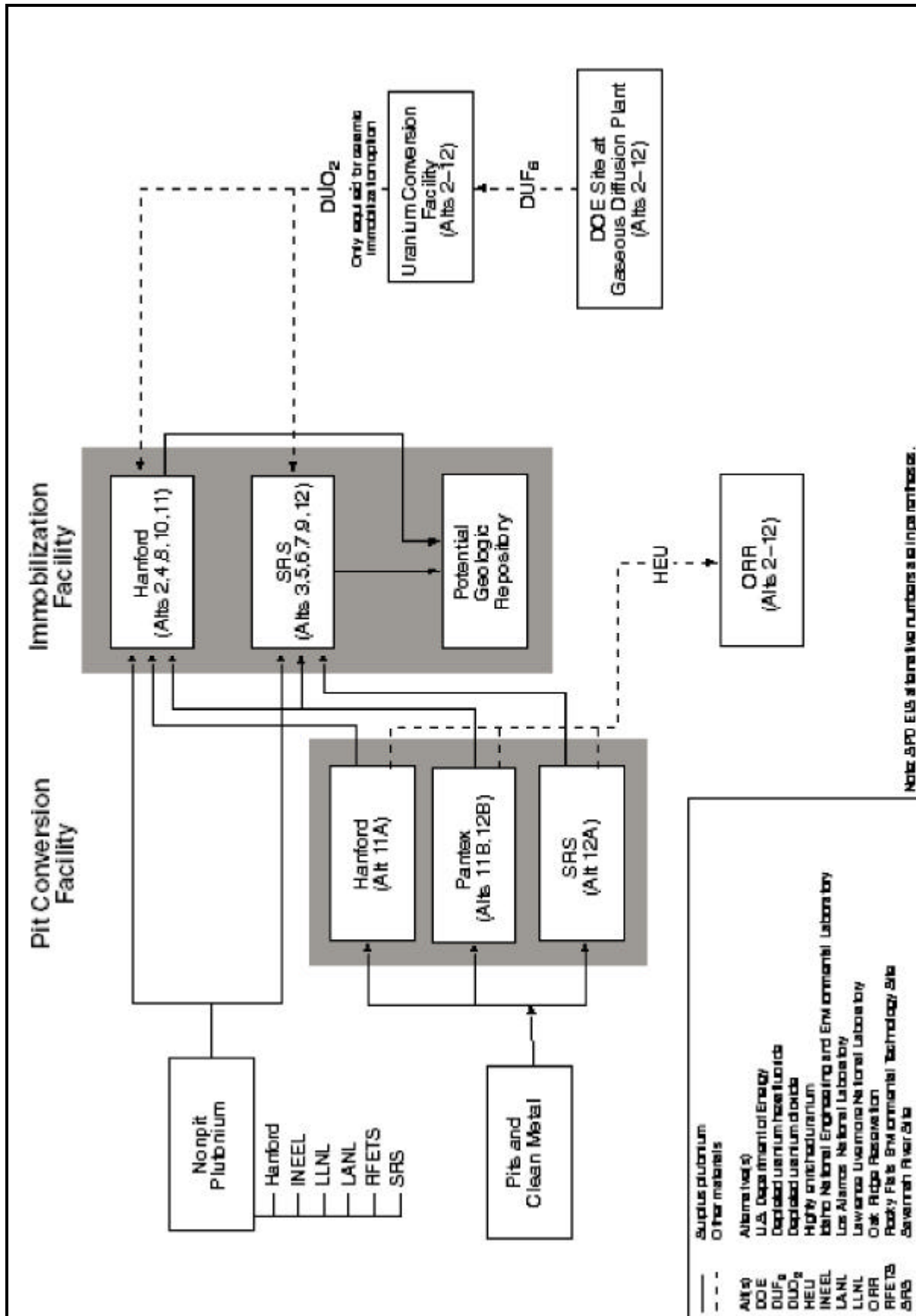

Figure 2-17. Transportation Requirements for Plutonium Conversion and Immobilization

For Alternatives 11 and 12, where all the surplus plutonium would be immobilized, the plutonium dioxide from the pit conversion facility would also be transferred to the immobilization facility. For Alternative 11A, both facilities would be collocated in FMEF and the transfer would take place within the same building. For Alternative 12A, the transfer would be made between the two facilities at SRS through a secure underground tunnel and would not require any vehicular transportation. [Text deleted.] However, as discussed in Section 2.4.4.1, for Alternatives 11B and 12B, the plutonium dioxide would be shipped from the pit conversion facility at Pantex to the immobilization facility at either Hanford or SRS in SST/SGTs.

Surplus plutonium destined for immobilization would be immobilized in either a ceramic or glass form, placed in small stainless steel cans and then into HLW canisters at the immobilization facility. The canisters would then be transported in specially designed intrasite transport vehicles to an HLW vitrification facility (either DWPF at SRS, or the planned HLW vitrification facility at Hanford). In keeping with the current practice at these sites for this type of shipment, this intrasite transportation could require roads at Hanford or SRS to be closed temporarily while the material would be transported from one area of the site to another. This practice would provide all needed security measures and mitigate potential risk to the public, without requiring the use of SST/SGTs for intrasite transfers.

Immobilization alternatives at Hanford could involve the transfer of plutonium between FMEF and the immobilization annex. This transfer would occur either through an underground tunnel or by surface vehicle within the protected security zone.

Immobilization of the plutonium as a ceramic material also requires a small amount of depleted uranium dioxide (i.e., less than 10 t/yr [11 tons/yr]) as discussed in Section 2.4.2.2.2. This depleted uranium dioxide could be produced by shipping depleted uranium hexafluoride from one of DOE's storage areas at a gaseous diffusion plant in Kentucky, Ohio, or Tennessee via commercial truck to a commercial site for conversion to depleted uranium dioxide. Possible sites for this conversion include nuclear fuel fabrication facilities in Missouri, North Carolina, South Carolina, or Washington, or a uranium conversion facility in Illinois. After conversion at one of these sites, the uranium dioxide would be shipped on a commercial truck to either Hanford or SRS for use in the immobilization facility. Because the risks associated with transporting either depleted uranium hexafluoride or depleted uranium dioxide are extremely low, the shipments could be made to or from any of the locations discussed above and not significantly affect the overall risks associated with the transportation required in this SPD EIS. For the purposes of quantifying the transportation analysis in this SPD EIS, it was assumed that the depleted uranium hexafluoride would be shipped from the DOE facility at the Portsmouth Gaseous Diffusion Plant near Piketon, Ohio, to an NRC-licensed commercial nuclear fuel fabrication facility in Wilmington, North Carolina, for conversion.

After the immobilized plutonium would be encased by HLW at the HLW vitrification facility, it would eventually be shipped to a potential geologic repository for ultimate disposal. Because the cans of immobilized plutonium would displace some of the HLW that would otherwise fill the canister, additional canisters would have to be filled over the life of the immobilization program to address this displaced HLW. It is estimated that up to 395 additional canisters of HLW would result from the decision to immobilize all 50 t (55 tons) of surplus plutonium. The *Draft Environmental Impact Statement for a Geologic Repository for the Disposal of Spent Nuclear Fuel and High-Level Radioactive Waste at Yucca Mountain, Nye County, Nevada (Yucca Mountain Draft EIS)*, (DOE 1999b) analyzed a number of different options for the shipment of these canisters using either trucks or trains. The analysis in the *Yucca Mountain Draft EIS* indicated that the risks would be lower if the canisters were shipped by train. However, no ROD has been issued regarding these shipments. To bound the risks, this SPD EIS has taken the most conservative analytical approach (i.e., the approach that results in the highest risk to the public) and assumed that all of these shipments would be made by truck to the potential geologic repository, with one canister being loaded on each truck.

2.4.4.3 MOX Transportation Requirements

To implement the MOX disposition alternatives being considered in this SPD EIS, plutonium dioxide from the pit conversion facility would have to be transferred to the MOX facility. Under all the MOX alternatives except Alternatives 4A, 4B, and 5, the pit conversion and MOX facilities would be located at the same site. Figure 2–18 shows the transportation requirements for the proposed MOX disposition activities. For Alternative 6B, the transfer would take place within the same building (FMEF). Under Alternatives 2, 3, 6A, 7, 8, 9, and 10, current designs assume that facility materials would be transferred between the two facilities through a secure, underground tunnel. No vehicular transportation over public roads would be required for any of these alternatives. However, as discussed in Section 2.4.4.1, for Alternatives 4A, 4B, and 5, the plutonium dioxide would be shipped in SST/SGTs from the pit conversion facility at Pantex to the MOX facility at either Hanford or SRS.

MOX fuel fabrication also requires uranium dioxide. Depleted uranium dioxide could be produced by shipping depleted uranium hexafluoride from one of DOE's storage areas at a gaseous diffusion plant in Kentucky, Ohio, or Tennessee via commercial truck to a commercial site for conversion to depleted uranium dioxide. Possible sites for this conversion include nuclear fuel fabrication facilities in Missouri, North Carolina, South Carolina, or Washington, or a uranium conversion facility in Illinois. After conversion at one of these sites, the uranium dioxide would be shipped on a commercial truck to Hanford, INEEL, Pantex, or SRS for use in the MOX facility. Because the radiological risks associated with transporting either depleted uranium hexafluoride or depleted uranium dioxide are extremely low, the shipments could be made from or to any of the locations discussed above and not significantly change the overall risks associated with the transportation required in this SPD EIS. For the purposes of quantifying the transportation analysis in this SPD EIS, representative sites for obtaining the depleted uranium dioxide were chosen. The Portsmouth Gaseous Diffusion Plant near Piketon, Ohio, represents the source of the depleted uranium hexafluoride and an NRC-licensed commercial nuclear fuel fabrication facility in Wilmington, North Carolina, represents the conversion facility.

After conversion, the depleted uranium dioxide would be shipped on a commercial truck from the conversion facility to the MOX facility. After fabrication, the MOX fuel would be shipped to Catawba, McGuire, or North Anna where it would be inserted into the reactor and irradiated. These shipments would be made in SST/SGTs because unirradiated MOX fuel in large enough quantities is subject to security concerns similar to those associated with weapons-grade plutonium. [Text deleted.]

It is also possible that some equipment for the MOX facility may be manufactured in Europe and shipped to the United States. No nuclear or radiologically contaminated materials would be transported. Any such shipments would be made by commercial vessel, and no impacts other than those occurring from routine commercial shipping would be expected.

2.4.4.4 Lead Assembly and Postirradiation Examination Transportation Requirements

To implement the MOX disposition alternatives being considered in this SPD EIS, MOX fuel assemblies would be fabricated, irradiated, and tested before the actual production of MOX fuel. Figure 2–19 shows the transportation requirements for the proposed lead assembly activities. As described in Section 2.17, plutonium dioxide from the Pit Disassembly and Conversion Demonstration Project at LANL would be shipped in SST/SGTs to one of four candidate DOE facilities (Hanford, ANL–W, LLNL, or SRS), or remain at LANL, for fabrication into lead assemblies. If the lead assemblies were to be fabricated at LANL, the plutonium dioxide would be transferred from the pit conversion demonstration to the lead assembly fabrication area within the same plutonium processing building (PF–4), in Technical Area 55 (TA–55), for MOX pellet production. Any intrasite transfers of plutonium outside of TA–55 would be in special vehicles in accordance

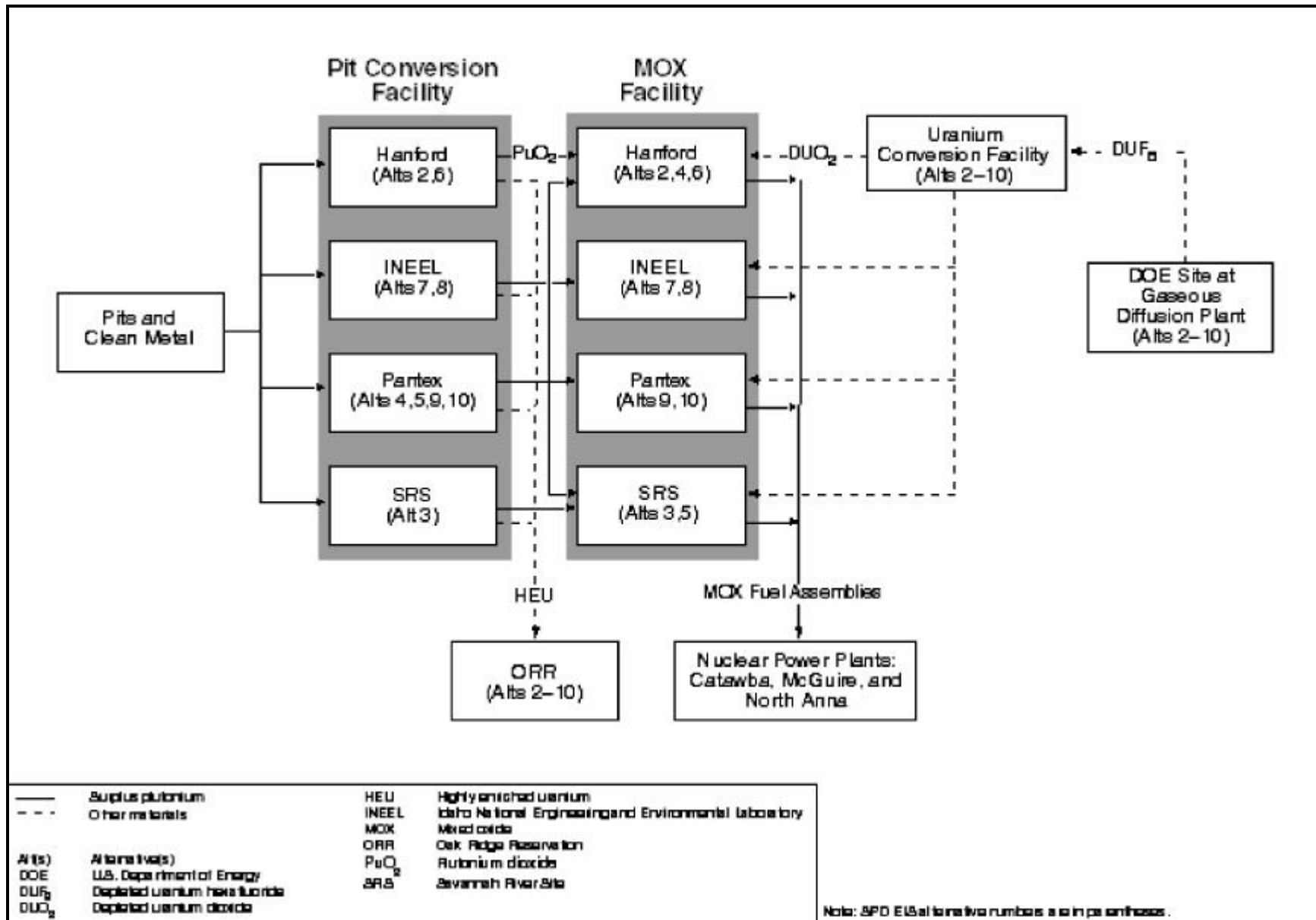

Figure 2-18. Transportation Requirements for MOX Fuel Fabrication

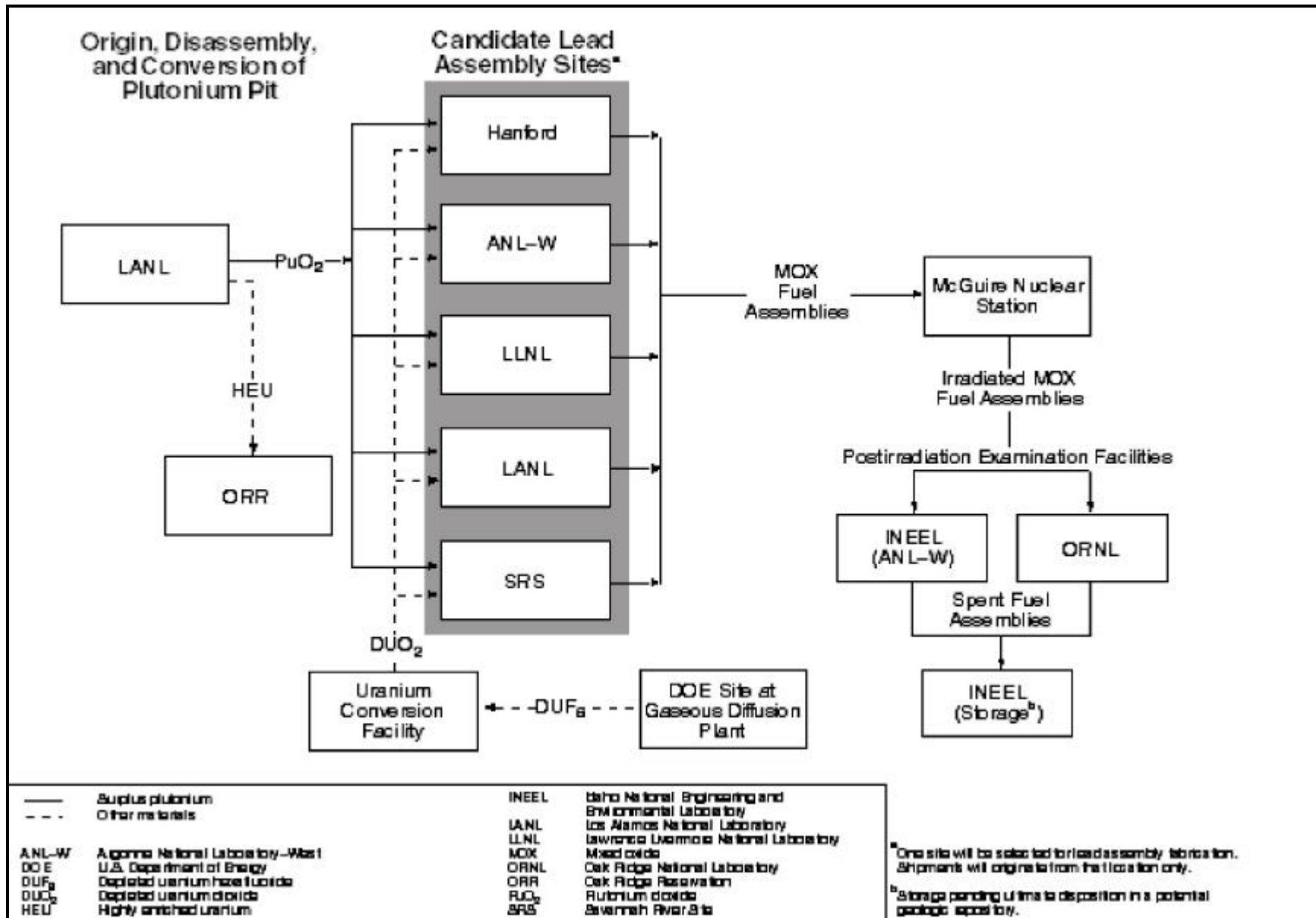

Figure 2-19. Transportation Requirements for Lead Assembly Fabrication

with site practices for this type of shipment. This intrasite transportation could require temporary road closures while the material would be moved from one area of the site to another. This practice would provide all needed security and mitigate potential risk to the public, without requiring the use of SST/SGTs for intrasite transfers.

The depleted uranium needed to support this effort is assumed to be shipped from one of DOE's storage areas at the Portsmouth Gaseous Diffusion Plant near Piketon, Ohio, to the nuclear fuel fabrication facility in Wilmington, North Carolina, for conversion, and then to the lead assembly fabrication site. All the transportation associated with depleted uranium would be via commercial truck.

After fabrication, the lead assemblies would be shipped to McGuire Nuclear Station¹⁶ near Huntersville, North Carolina, for irradiation. These shipments would be made in SST/SGTs because unirradiated MOX fuel in large enough quantities is subject to security concerns similar to those associated with weapons-grade plutonium. Although the Preferred Alternative would fabricate lead assemblies at LANL, the lead assemblies could be fabricated as far away from McGuire as Hanford. Because transportation impacts are proportional to distance, the transportation analysis assumes, in order to evaluate the maximum potential impact, that the reactor will be 5,000 km (3,100 mi) from the lead assembly fabrication facility, the approximate distance between Hanford and McGuire. Transportation impacts would be proportionally less for other sites closer to McGuire.

After irradiation, the lead assemblies may be shipped from the reactor site to a postirradiation examination facility for analysis. Postirradiation examination, if required, would occur at one of two DOE sites, ANL-W or ORNL. As discussed in Section 2.1.3, these are the only two sites that have the capability to conduct postirradiation examination without major modifications to facility and processing capabilities. These shipments would be via commercial truck because the MOX fuel would be irradiated, thereby removing the proliferation concerns associated with plutonium. Because the actual postirradiation facility that would be used has not been selected (ORNL has been identified as the preferred location), the transportation analysis assumes that it will be 4,000 km (2,500 mi) from the reactor site where the lead assemblies were irradiated. This is the approximate distance between McGuire and ANL-W, the maximum distance that the irradiated lead assemblies would be transported. Any postirradiation examination activities and shipments of spent fuel remaining after postirradiation examination would comply with the Consent Order and Settlement Agreement in Public Service Company of Colorado v. Batt and all other applicable agreements and orders, including provisions concerning removal of the material from the applicable examination site and limits on the number of truck shipments to the site.

2.4.4.5 Other Transportation Requirements

All the alternatives being considered in this SPD EIS require some overland transportation of wastes from the proposed disposition facilities to treatment, storage, or disposal facilities. The proposed action does not result in a large increase in waste generation at any of the candidate sites, and transportation would be handled in the same manner as other site waste shipments. In addition, the shipments would not represent any new, different, or additional risks beyond those associated with existing waste shipments at these sites, as analyzed in the WM PEIS. The possible exceptions are the alternatives that consider siting disposition facilities at Pantex and the alternative that considers placing the lead assembly fabrication facility at LLNL. Because Pantex does not currently generate any TRU waste and does not have any TRU waste in storage, the WM PEIS did not consider TRU waste being shipped from Pantex to the Waste Isolation Pilot Plant (WIPP). Therefore, a small number of shipments of TRU waste to WIPP via commercial truck have been included in the transportation analysis in this SPD EIS. In addition, the projected amount of LLW generated by the proposed action would represent a large percentage of this waste type at both Pantex and LLNL, as analyzed in the WM PEIS. Because these sites ship

¹⁶ Based on information provided by DCS, DOE has identified McGuire as its preference for irradiating lead assemblies.

LLW to the Nevada Test Site (NTS) for disposal, the transportation analysis in this SPD EIS includes a small number of shipments of LLW from Pantex and LLNL to NTS via commercial carrier.

2.5 ALTERNATIVE 1: NO ACTION

In the No Action Alternative, surplus weapons-usable plutonium materials in storage at various DOE sites shown in Figure 1–1 would remain at those locations. The vast majority of pits would continue to be stored at Pantex, and the remaining plutonium in various forms would continue to be stored at Hanford, INEEL, LLNL, LANL, RFETS, and SRS. The No Action Alternative would not satisfy the purpose and need for the proposed action because DOE's disposition decisions in the *Storage and Disposition PEIS* ROD would not be implemented. The ROD announced that, consistent with the Preferred Alternative in the *Storage and Disposition PEIS*, DOE had decided to reduce, over time, the number of locations where the various forms of plutonium are stored, through a combination of storage and disposition alternatives. Implementation of much of this decision requires the movement of surplus materials to disposition facility locations. Pits that have been moved from RFETS to Pantex would be relocated in accordance with the *Storage and Disposition PEIS* ROD, as amended.¹⁷ Other surplus materials would continue to be stored indefinitely at their current locations, with the exception that DOE is considering leaving the repackaged surplus pits in Zone 4 at Pantex for long-term storage.¹⁸ An appropriate environmental review will be conducted when the specific proposal for this change has been determined (e.g., whether additional magazines need to be air-conditioned). The analysis in this SPD EIS assumes that the surplus pits are stored in Zone 12 in accordance with the ROD for the *Storage and Disposition PEIS*.

2.6 ALTERNATIVE 2: ALL FACILITIES AT HANFORD

Pit Conversion in FMEF; Immobilization in FMEF and the HLW Vitrification Facility; MOX Fuel Fabrication in New Construction

This alternative would involve locating the three proposed surplus plutonium disposition facilities in the 400 Area at Hanford, combining the use of an existing building, FMEF, with new construction (see Figure 2–20). Canister filling would be accomplished at the planned HLW vitrification facility in the 200 East Area¹⁹ (see Figure 2–21), about 24 km (15 mi) northwest of the 400 Area. FMEF, completed in 1984, is a reinforced concrete process building with an attached mechanical equipment wing on the west side, and an entry wing with administrative space across the south side. The building has six levels, two of which are below grade. FMEF was designed and constructed to fabricate fast breeder reactor fuel, but it has not been used for any major projects to date. The building has been modified since 1984, and the utility systems and support systems, including the ventilation system, have been completed. Designed to handle highly radioactive materials, FMEF includes a number of thick-walled cells surrounded by corridors. Space for offices,

¹⁷ Recent studies have indicated that cost savings could be realized from the transfer of nonpit materials from RFETS and Hanford to SRS earlier than specified in the *Storage and Disposition PEIS* ROD. A Supplement Analysis was prepared, and based on this analysis, DOE determined that a supplemental PEIS would not be needed; an amended ROD was issued in August 1998 (63 FR 43386) and included decisions to accelerate shipment of all nonpit surplus plutonium from RFETS to SRS and to relocate all Hanford surplus plutonium to SRS, should SRS be selected as the immobilization disposition site.

¹⁸ Should the No Action Alternative be chosen, the ROD pursuant to this SPD EIS would also address movement of the remaining surplus nonpit plutonium from RFETS in support of its planned closure in 2006.

¹⁹ The planned HLW vitrification facility is described in the *Tank Waste Remediation System Final Environmental Impact Statement* and is currently scheduled to be available in a timeframe that would meet the needs of the surplus plutonium disposition program.

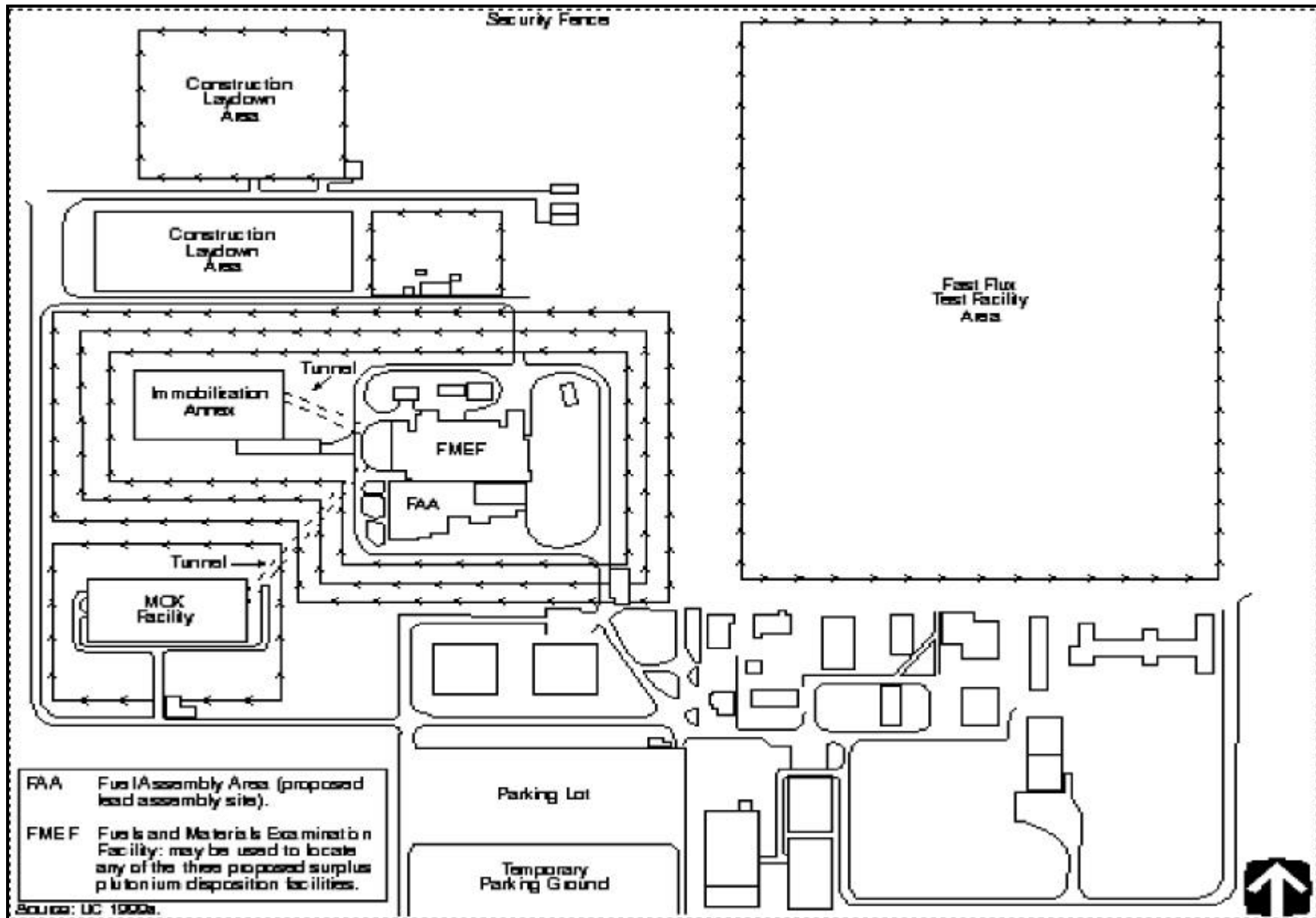

Figure 2-20. Proposed Facility Locations in the 400 H-Area at Hanford (Hybrid Alternative Shown)

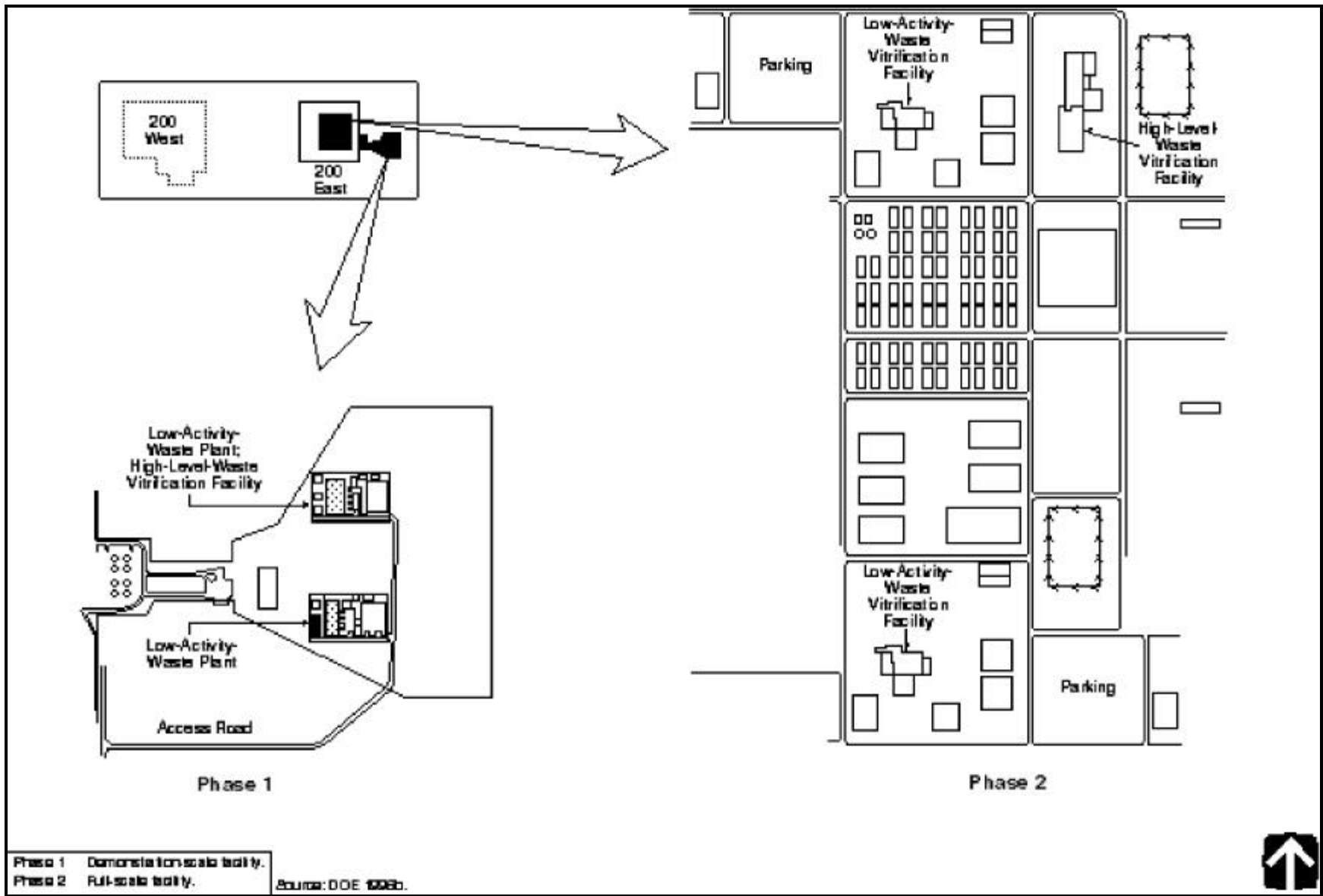

Figure 2-21. Location of Planned HLW Vitrification Facility in the 200 Area at Hanford (Proposed Location of Canister-Filling Operations)



laboratories, control rooms, utilities, and other activities is available around the interior perimeter of the building. Modification to the interior spaces would be required to use the building for surplus plutonium disposition activities. No radioactive materials have been introduced into the building, so the modification would neither generate radioactive waste nor contribute radiological dose to the construction workforce. The building is large enough to house facilities for only two of the three proposed disposition activities. Therefore, this alternative calls for collocation of the pit conversion and immobilization facilities in FMEF, and the construction of a new building close to FMEF to house the MOX facility.

In this alternative, the pit conversion facility would occupy the lower floors of FMEF, and the immobilization facility, the upper two floors. About 13,000 m² (140,000 ft²) of space on the -35-ft, -17-ft, ground, and +21-ft levels would be modified to support pit disassembly and conversion activities. Not all the space on every floor would be required for pit disassembly and conversion activities, but the floors would be predominately associated with that process.

Plutonium conversion and immobilization activities would primarily occupy the +42- and +70-ft levels. While a portion of the +42-ft level would be shared by the two facilities, most of the floor would be dedicated to the immobilization facility, which would occupy about 17,000 m² (183,000 ft²). Both facilities would share utilities, loading docks, and security assets. The large shipping and receiving area of FMEF would allow for housing a number of SST/SGTs.

The immobilization facility would also require the construction of a two-story annex northwest of FMEF. This building would provide approximately 4,600 m² (49,000 ft²) of space for canister-loading activities and some analytical laboratory operations. The security fence surrounding FMEF would be extended to include this additional area. Material movement between FMEF and the annex would occur either by surface vehicle or through an underground tunnel between the two facilities within the protected security zone.

For the MOX facility, a new two-story building of about 20,000 m² (215,000 ft²) would be constructed west of FMEF. A secure underground tunnel would connect the two buildings for special nuclear material transfers. This tunnel would be locked and alarmed under normal operating conditions and subject to the same security measures on both sides as the building perimeters, both to ensure the protection of the special nuclear materials and to maintain the independence of the MOX facility. The tunnel would be opened in accordance with safeguards and security procedures for the transfer of plutonium dioxide from the pit conversion facility to the MOX facility, and would be closed immediately upon completion of transfer activities. Other than being joined to it by this tunnel, the MOX facility would be independent of FMEF, and would be inside its own fenced security area. Various nonhardened support buildings totaling about 2,300 m² (25,000 ft²) would be needed to support the MOX mission. The proposed facilities would use such existing Hanford services as sitewide security (although there would be additional security assigned to each of the three disposition facilities), emergency services, environmental monitoring, and waste management.

Construction would begin in about 2001, with modifications to FMEF for the pit conversion facility, and would continue through completion of the MOX facility in about 2006. Operations would commence in about 2004 with pit disassembly and conversion, and would continue until about 2019 when the MOX and immobilization facilities have completed their missions. Operation of the MOX facility would not begin until the pit conversion facility had been operating for a year, so that feed material would be available for MOX fuel fabrication.

2.7 ALTERNATIVE 3: ALL FACILITIES AT SRS

Pit Conversion and MOX Fuel Fabrication in New Construction; Immobilization in New Construction and DWPF

2.7.1 [Section heading deleted.]

This alternative would involve locating the three proposed surplus plutonium disposition facilities in newly constructed buildings near the area currently designated for APSF in F-Area at SRS (see Figure 2–22). In addition, the canister receipt area at DWPF in S-Area, about 6 km (3.7 mi) east of F-Area (see Figures 2–5 and 2–23), would be modified as described in Section 2.4.2.1 to accommodate receipt and processing of the canisters transferred from the immobilization facility for filling with vitrified HLW. [Text deleted.]

In the SPD Draft EIS, alternatives that considered locating the disposition facilities in new construction at SRS used the proposed APSF as a receiving facility for SST/SGT shipments; storage vaults for plutonium dioxide and metal; and for the pit conversion and immobilization facilities, nondestructive assay facilities. Therefore, the SPD Draft EIS analyzed somewhat smaller disposition facilities at SRS than at the other candidate sites. DOE has recently decided to delay the construction of APSF. Because the schedule for APSF is uncertain, this SPD Final EIS has been modified to disregard any benefit to the proposed facilities as a result of APSF being present at SRS. This SPD EIS now presents the environmental impacts that would be associated with construction and operation of disposition facilities at SRS that are stand-alone and include no reliance on APSF for storage space or other functions. Throughout this SPD EIS, references to APSF have been qualified by the phrase “if built” or a similar phrase, and no credit has been taken in the environmental analyses for the use of APSF.

The pit conversion facility now analyzed at SRS is identical to that proposed in the Pantex alternatives, where it has always been considered a stand-alone facility. In the current immobilization facility design, some space would be available to partially offset the use of APSF for functions such as storage or accountability measurements. However, without APSF, construction of truck bays and other minor modifications (up to approximately 980 m² [10,500 ft²]) would be necessary. The MOX facility proposed for SRS has also been replaced with the larger stand-alone facility that has been proposed for the other candidate sites. Should DOE decide to collocate all three disposition facilities at SRS, as indicated in the Preferred Alternative (see Section 1.6), the final design of these facilities would coordinate potential common functions among the facilities to the extent practical as a means to reduce space requirements and the associated environmental impacts.

As shown in Figure 2–22, the immobilization facility would be east of the area currently designated for APSF, the pit conversion facility due south of the immobilization facility, and the MOX facility due south of the pit conversion facility.²⁰ To accommodate all three disposition facilities at this location, it would be necessary to move the F-Area fence line to incorporate more area. These facilities would be connected to each other by material transfer tunnels. These tunnels would be locked and alarmed under normal operating conditions and subject to the same security measures on both sides as the building perimeters, both to ensure the protection of the special nuclear materials and to maintain the independence of the MOX facility. The tunnels would be opened in accordance with safeguards and security procedures for the transfer of special nuclear materials and would be closed immediately upon completion of transfer activities. Other than being joined by the tunnel, the MOX

²⁰ As discussed in Section 4.26.4.4.1, facility construction would avoid any cultural resource areas eligible or potentially eligible for nomination to the National Register of Historic Places.

facility would be independent of the other plutonium disposition facilities and would be inside its own fenced security area. |

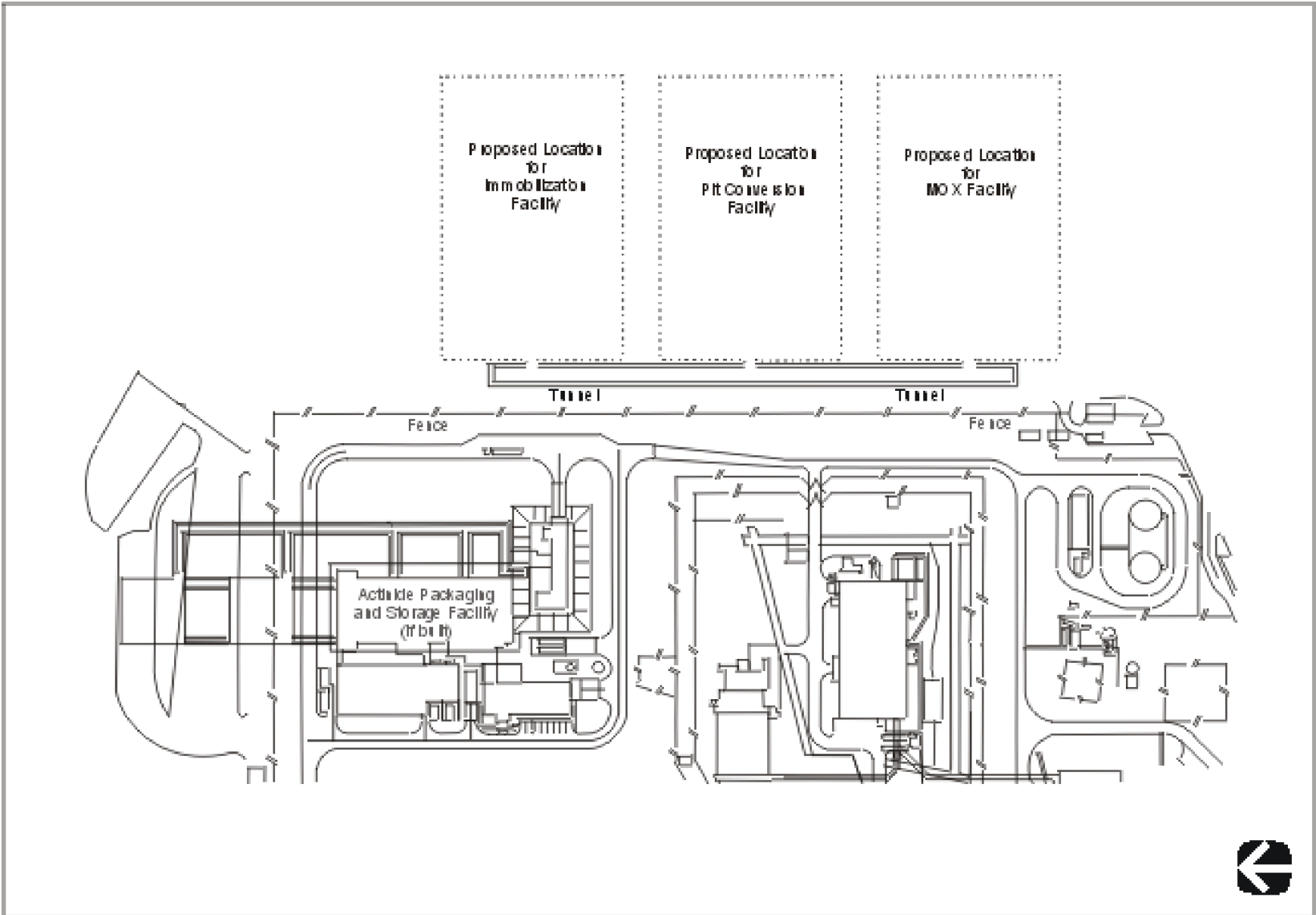

Figure 2-22. Proposed Facility Locations in F-Area at SRS

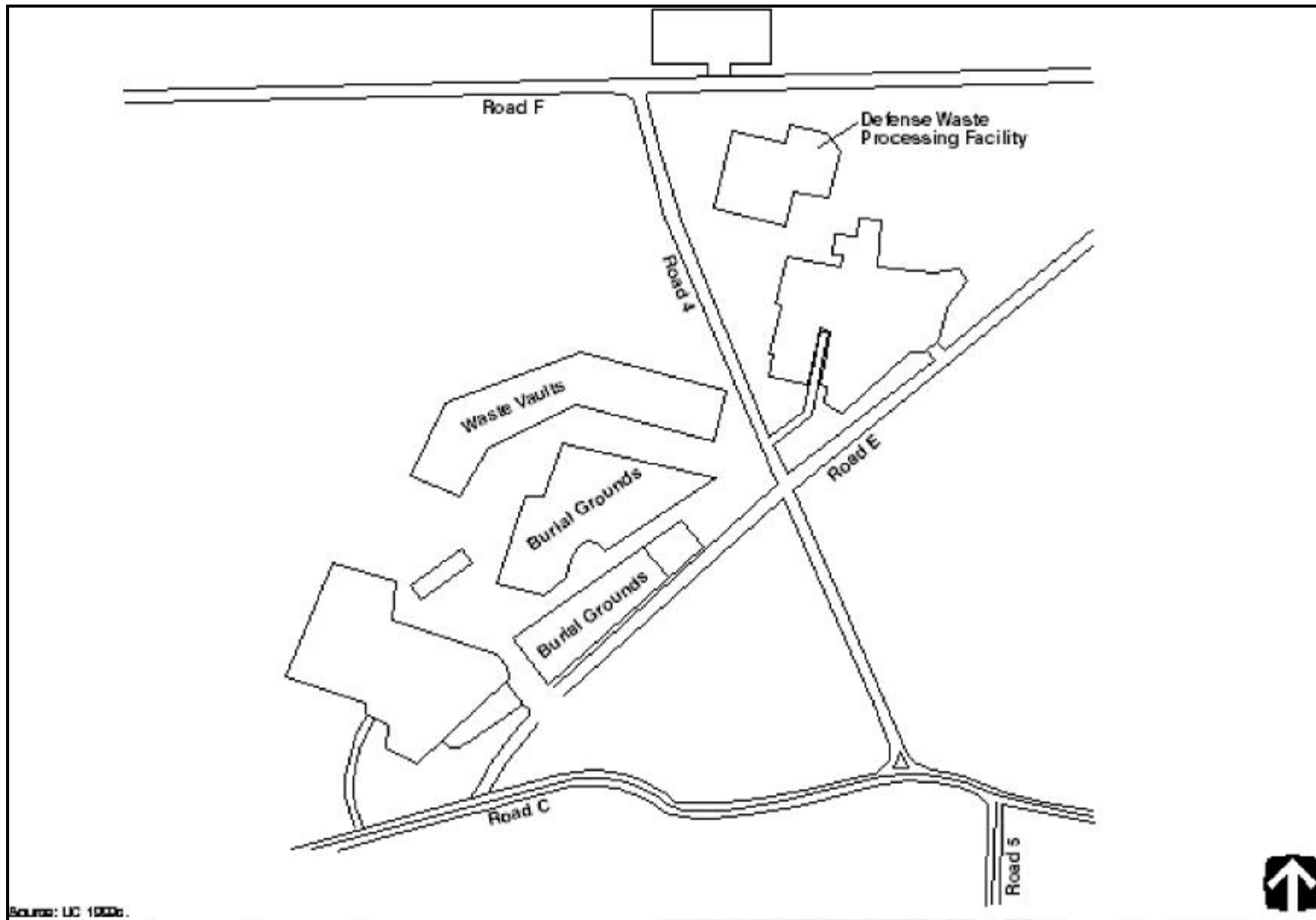

Figure 2-23. Location of DWPF in S-Area at SRS (Proposed Location of Canister-Filling Operations)

The pit conversion facility would occupy about 18,600 m² (200,000 ft²) on two levels, one or both of which may be below grade. Another 2,400 m² (26,000 ft²) would be required for a utility building, standby generator, and an electrical substation in F-Area. The total space required for the immobilization facility would be about 25,000 m² (269,000 ft²). Of that, 23,000 m² (248,000 ft²) would be in new facilities in F-Area; the remainder would be space in existing facilities that would not require further modification. The immobilization facility would have four levels, three of which would be above grade. The main process area would be at grade level, below which a small basement level would contain transfer corridors and a fire-water collection facility. The third level would house support equipment such as heating, ventilation, and air-conditioning systems, and electrical and mechanical utilities. In the center of the facility, a core “stack” or shaft would extend from the main processing level up to the small fourth level for vertical processing of materials. Two smaller, two-level structures immediately adjacent and connected to the main processing building would serve as entry control and provide administrative space. The MOX facility would occupy about 20,000 m² (215,000 ft²) on two levels, one below grade. Another 2,300 m² (25,000 ft²) would be required for new support buildings in F-Area. The proposed facilities would use such existing SRS services as sitewide security (although there would be additional security assigned to each of the three disposition facilities), emergency services, environmental monitoring, and waste management.

Construction would commence in about 2001 with the pit conversion facility, and would continue through completion of the MOX facility in about 2006. Operations would commence in about 2004 with pit conversion, and would continue until about 2019, when the MOX and immobilization facilities have completed their missions. Operation of the MOX facility would not begin until the pit conversion facility had been operating for a year, so that feed material would be available for MOX fuel fabrication.

2.7.2 [Section deleted because alternative deleted.]

2.8 ALTERNATIVE 4: PIT CONVERSION AT PANTEX; MOX FUEL FABRICATION AND IMMOBILIZATION AT HANFORD

2.8.1 Alternative 4A

Pantex: Pit Conversion in New Construction

Hanford: MOX Fuel Fabrication in New Construction; Immobilization in FMEF and HLW Vitrification Facility

This alternative would involve locating the pit conversion facility at Pantex and the immobilization and MOX facilities at Hanford. The pit conversion and MOX facilities would be in new construction, and FMEF would be modified to house the immobilization facility. Canister filling would be accomplished at the planned HLW vitrification facility scheduled for construction in the 200 East Area, about 24 km (15 mi) northwest of the 400 Area (see Figures 2–20 and 2–21).

At Pantex, the pit conversion facility would be in a new building in Zone 4 West, with some support facilities to the west of, and adjacent to, Zone 4 West (see Figure 2–24). Utilities and storage vaults would be on the ground floor of the pit conversion facility; and the main processing and loading areas, offices, and support areas, in a below-grade basement. The building would occupy about 18,600 m² (200,000 ft²). New buildings totaling 5,300 m² (57,000 ft²) would have to be constructed to support the pit conversion facility. Additional space in existing buildings in Zone 4 West would be used for administration, access control, warehousing, and other services. New or upgraded electrical, water, and gas supply lines would be constructed from existing trunk lines. The proposed pit conversion facility would use such existing Pantex services as sitewide security (although there would be an additional security assigned to the facility), emergency services, environmental monitoring, and waste management. TRU waste storage would be provided in the main pit conversion facility

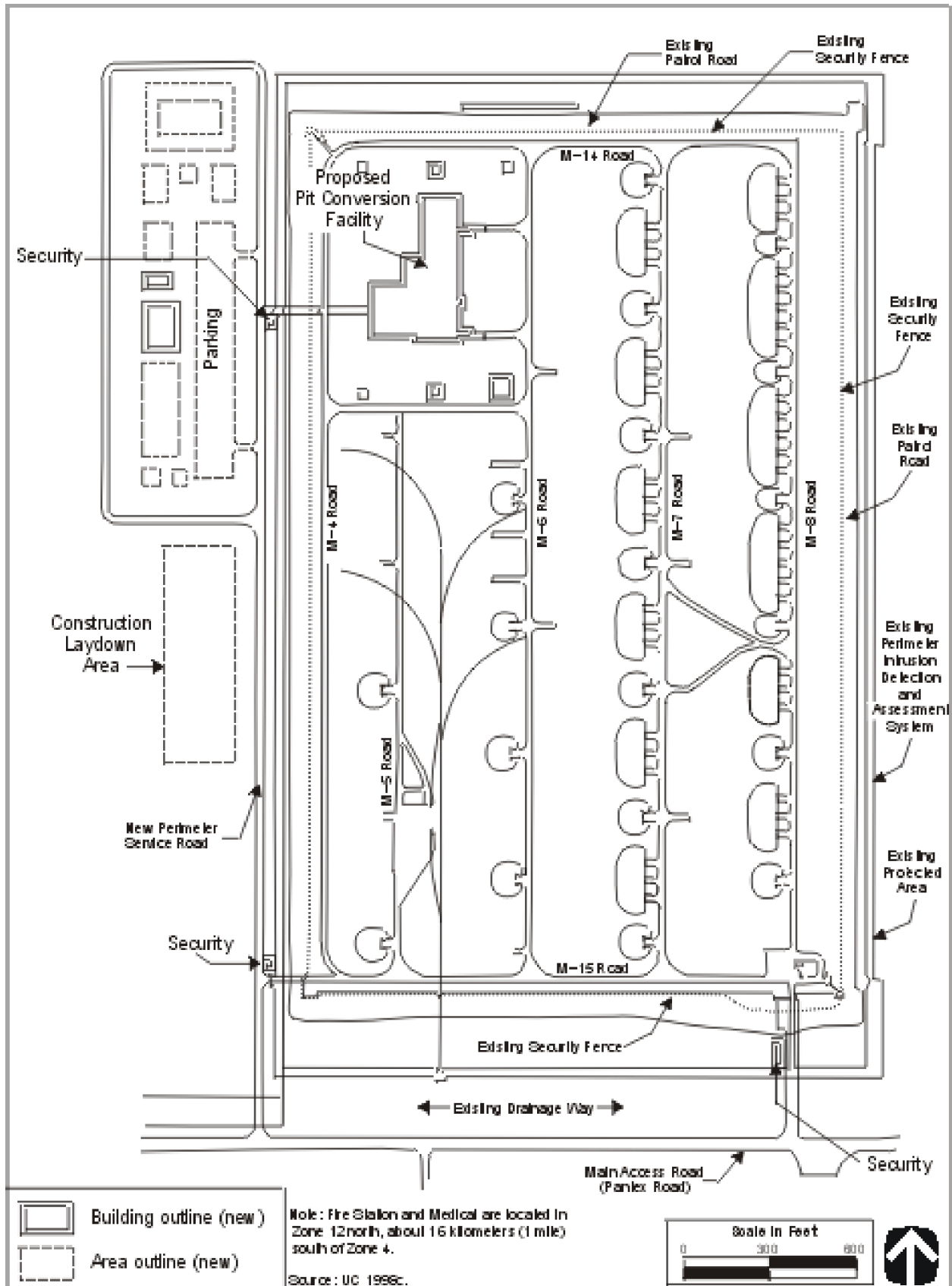

Figure 2-24. Proposed Pit Conversion Facility Location in Zone 4 West at Pantex

or in ancillary facilities. Construction would commence in about 2001 and continue through about 2003. Operations would commence in about 2004 and continue until about 2014.

Facilities at Hanford would be in the 400 Area, the immobilization facility in the FMEF and the MOX facility in new construction near FMEF. Immobilization would be concentrated on the +42- and +70-ft levels of FMEF, although process support functions would be conducted on all six floors of the building. The total space required for the immobilization facility would be about 20,000 m² (215,000 ft²); the remainder of FMEF would be available for other missions.

For the MOX facility, a new two-story building of about 20,000 m² (215,000 ft²) would be constructed west of FMEF. This facility would be independent of FMEF and inside its own fenced security area. In addition to the main process building, the MOX facility would require 2,300 m² (25,000 ft²) of new support buildings throughout the 400 Area. The proposed disposition facilities would use such existing Hanford services as sitewide security (although there would be additional security assigned to each of the disposition facilities), emergency services, environmental monitoring, and waste management.

Modification and new construction at Hanford would commence in about 2002 and continue through about 2006. The immobilization facility would commence operations in about 2005; the MOX facility, in about 2006. The MOX facility would operate until about 2019; the immobilization facility until 2016. Operation of the MOX facility would not begin until the pit conversion facility had been operating for at least a year, so that feed material would be available for MOX fuel fabrication.

2.8.2 Alternative 4B

Pantex: Pit Conversion in New Construction

Hanford: Plutonium Conversion and Immobilization in FMEF and HLW Vitrification Facility; and MOX Fuel Fabrication in FMEF

This alternative would involve locating the pit conversion facility in new construction at Pantex and the immobilization and MOX facilities in FMEF at Hanford. Canister filling would be accomplished at the planned HLW vitrification facility scheduled for construction in the 200 East Area, about 24 km (15 mi) northwest of the 400 Area. At Pantex, the pit conversion facility would be the same as the one described for Alternative 4A in Section 2.8.1. This alternative differs from Alternative 4A in that the MOX facility would be located in FMEF rather than in new construction.

At Hanford, FMEF would be modified to contain both the MOX and immobilization facilities. While these facilities would share the building, they would be totally separate from each other to accommodate NRC regulation of the MOX facility. The immobilization facility would occupy about 14,000 m² (150,000 ft²), primarily on the ground and +21-ft levels. Only the receiving area would be shared by the two facilities, but the area would be modified to physically separate the two sides and provide independent access to the two facilities.

The immobilization facility would also require the construction of a two-story annex northwest of FMEF. This building would provide approximately 6,700 m² (72,000 ft²) of space for canister-loading activities and most analytical laboratory operations. The security fence surrounding FMEF would be extended to include this additional area. Material movement between FMEF and the annex would occur either by surface vehicle or through an underground tunnel between the two facilities within the protected security zone.

To implement the MOX mission at FMEF, the building would be remodeled and annexes added to accommodate the functions and processes required for MOX fuel fabrication. The MOX facility would occupy about 8,200 m² (88,000 ft²) on the ground, +42-ft, and +70-ft levels of FMEF. New annex areas on the north and east sides of

the building for utilities and an entrance area with office space would add another 1,900 m² (20,000 ft²) to the FMEF structure. Partition walls and other isolation mechanisms would be used to completely segregate the MOX portion of the building from the other portions. In addition to the main process building, the MOX facility would require 4,200 m² (45,000 ft²) of new support buildings throughout 400 Area. The proposed disposition facilities would use such existing Hanford services as sitewide security (although there would be additional security assigned to each of the disposition facilities), emergency services, environmental monitoring, and waste management.

Modification of FMEF would commence in about 2002 and continue through about 2006. The immobilization facility would commence operations in about 2005; the MOX facility, in about 2006. The MOX facility would operate until about 2019; the immobilization facility until 2016. Operation of the MOX facility would not begin until the pit facility had been operating for at least a year, so that feed material would be available for MOX fuel fabrication.

2.9 ALTERNATIVE 5: PIT CONVERSION AT PANTEX; MOX FUEL FABRICATION AND IMMOBILIZATION AT SRS

Pantex: Pit Conversion in New Construction

SRS: MOX Fuel Fabrication in New Construction; and Immobilization in New Construction and DWPF

2.9.1 [Section heading deleted.]

This alternative would involve locating the pit conversion facility at Pantex and the immobilization and MOX facilities in new construction near the area currently designated for APSF at SRS. In addition, the canister receipt area at DWPF in S-Area would be modified as described in Section 2.4.2.1 to accommodate receipt and processing of the canisters transferred from the immobilization facility for filling with vitrified HLW. At Pantex, the pit conversion facility would be the same as the one described for Alternative 4A in Section 2.8.1.

As shown in Figure 2–22, the immobilization facility would be east of the area currently designated for APSF, and the MOX facility south of the immobilization facility. (The pit conversion facility, shown on this map, would not be located at SRS.) To accommodate both the immobilization and MOX facilities, it would be necessary to move the F-Area fence line to incorporate more area. These facilities would be constructed as described for Alternative 3 in Section 2.7.

Construction at SRS would commence in about 2002 and continue through about 2006. The immobilization facility would commence operations in about 2005; the MOX facility, in about 2006. The MOX facility would operate until about 2019; the immobilization facility until 2016. Operation of the MOX facility would not begin until the pit facility had been operating for at least a year, so that feed material would be available for MOX fuel fabrication.

2.9.2 [Section deleted because alternative deleted.]

2.10 ALTERNATIVE 6: PIT CONVERSION AND MOX FUEL FABRICATION AT HANFORD; IMMOBILIZATION AT SRS

2.10.1 Alternative 6A

Hanford: Pit Conversion in FMEF; MOX Fuel Fabrication in New Construction
SRS: Immobilization in New Construction and DWPF

This alternative would involve locating the pit conversion and MOX facilities at Hanford, in FMEF and new construction, respectively; and the immobilization facility in new construction near the area currently designated for APSF at SRS. In addition, the canister receipt area at DWPF in S-Area would be modified as described in Section 2.4.2.1 to accommodate receipt and processing of the canisters transferred from the immobilization facility for filling with vitrified HLW. In this alternative, the pit conversion facility would occupy about 13,000 m² (140,000 ft²) of space on the -35-ft, -17-ft, ground, and +21-ft levels of FMEF, as described in Section 2.6; the remainder of FMEF would be available for other missions. A new two-story building would be constructed for the MOX facility, as described in Section 2.6. The proposed disposition facilities would use such existing Hanford services as sitewide security (although there would be additional security assigned to each of the disposition facilities), emergency services, environmental monitoring, and waste management.

Construction would commence in about 2001, with modifications to FMEF for the pit conversion facility, and would continue through completion of the MOX facility in about 2006. The pit conversion facility would commence operations in about 2004; the MOX facility, in about 2006. Operations would continue until about 2019, when the MOX facility has completed its mission. Operation of the MOX facility would not begin until the pit conversion facility had been operating for at least a year, so that feed material would be available for MOX fuel fabrication.

The new immobilization facility at SRS would be east of the area currently designated for APSF, as described in Section 2.7. The total space required for that facility would be about 25,000 m² (269,000 ft²). Of that, 23,000 m² (248,000 ft²) would be in new facilities; the remainder would be space in existing facilities that would not require further modification. To accommodate the immobilization facility, it would be necessary to move the F-Area fence line out to incorporate more area. The immobilization facility would use such existing SRS services as sitewide security (although there would be an additional security assigned to the facility), emergency services, environmental monitoring, and waste management. Construction would commence in about 2002 and continue through about 2005. Operations would commence in about 2005 and continue until about 2016.

2.10.2 Alternative 6B

Hanford: Pit Conversion and MOX Fuel Fabrication Collocated in FMEF
SRS: Immobilization in New Construction and DWPF

This alternative would involve locating both the pit conversion and MOX facilities in FMEF at Hanford, and the immobilization facility in new construction near the area currently designated for APSF at SRS. In addition, the canister receipt area at DWPF in S-Area would be modified as described in Section 2.4.2.1 to accommodate receipt and processing of the canisters transferred from the immobilization facility for filling with vitrified HLW. In this alternative, the immobilization facility would be constructed and operated at SRS as described for Alternative 6A in Section 2.10.1.

FMEF would be modified to contain both the pit conversion and MOX facilities. While these facilities would share the building, they would be totally separate from each other to accommodate NRC regulation of the MOX facility. The pit conversion facility would occupy about 13,000 m² (140,000 ft²) of space on the -35-ft, -17-ft,

ground, and +21-ft levels of FMEF, as described in Section 2.6. Plutonium dioxide would be moved from the pit conversion facility to the MOX facility in a secure elevator.

To implement the MOX mission at FMEF, the building would be remodeled and annexes added to accommodate all the functions and processes required for MOX fuel fabrication. The MOX facility would occupy about 8,200 m² (88,000 ft²) on the ground, +42-ft, and +70-ft levels of FMEF. The new annex areas on the north and east sides of the building for utilities and an entrance area with office space would add another 1,900 m² (20,000 ft²) to the FMEF structure. Partition walls and other isolation mechanisms would be used to completely segregate the MOX portion of the building from the other portions. In addition to the main process building, the MOX facility would require 4,200 m² (45,000 ft²) of new support buildings throughout 400 Area. The proposed disposition facilities would use such existing Hanford services as sitewide security (although there would be additional security assigned to each of the disposition facilities), emergency services, environmental monitoring, and waste management.

Modification of FMEF would commence in about 2001 and would continue through about 2006. The pit conversion facility would commence operations in about 2004; the MOX facility, in about 2006. Operations would cease when the MOX facility has shut down in about 2019. Operation of the MOX facility would not begin until the pit facility had been operating for at least a year, so that feed material would be available for MOX fuel fabrication.

2.10.3 [Section deleted because alternative deleted.]

2.10.4 [Section deleted because alternative deleted.]

2.11 ALTERNATIVE 7: PIT CONVERSION AND MOX FUEL FABRICATION AT INEEL; IMMOBILIZATION AT SRS

INEEL: Pit Conversion in the Fuel Processing Facility; MOX Fuel Fabrication in New Construction
SRS: Immobilization in New Construction and DWPF

2.11.1 [Section heading deleted.]

This alternative would involve locating the pit conversion facility in the Fuel Processing Facility (FPF) and the MOX facility in new construction in the Idaho Nuclear Technology and Energy Center (INTEC) area at INEEL, and the immobilization facility in new construction near the area currently designated for APSF at SRS. In addition, the canister receipt area at DWPF in S-Area would be modified as described in Section 2.4.2.1 to accommodate receipt and processing of the canisters transferred from the immobilization facility for filling with vitrified HLW. The immobilization facility would be implemented at SRS as described for Alternative 6A in Section 2.10.1.

FPF has six levels, three below grade. It is structurally complete, but has never been used. Construction was started in 1986, but discontinued in 1993, leaving essentially a concrete shell with temporary lighting and ventilation. As the building was designed to handle highly radioactive materials, it includes a number of interior thick-walled cells surrounded by corridors and access ways. Building utility areas and office space surround the corridors of the above-grade stories. Modification to the interior spaces would be required to accommodate surplus plutonium disposition activities. No radioactive materials have been introduced into the building, so the modification would neither generate radioactive waste nor contribute a radiological dose to the construction workforce. In this alternative, the pit conversion facility would occupy about 14,000 m² (150,000 ft²) on four levels of FPF. No new support buildings would have to be built, as the facility's needs would be met by existing facilities at INTEC.

A new two-story building of about 20,000 m² (215,000 ft²) would be constructed for the MOX facility. As shown in Figure 2–25, this building would be south of FPF. A secure underground tunnel would connect the two buildings for special nuclear material transfers. This tunnel would be locked and alarmed under normal operating conditions, and subject to the same security measures on both sides as the building perimeters, both to ensure protection of the special nuclear materials and to maintain the independence of the MOX facility. The tunnel would be opened in accordance with safeguards and security procedures for the transfer of plutonium dioxide from the pit conversion facility to the MOX facility, and would be closed immediately upon completion of transfer activities. Other than being joined to it by this tunnel, the MOX facility would be independent of FPF, and would be inside its own fenced security area. In addition to the main process building, the MOX facility would require 2,300 m² (25,000 ft²) of new support buildings throughout the INTEC Area. The proposed disposition facilities would use such existing INEEL services as sitewide security (although there would be additional security assigned to each of the disposition facilities), emergency services, environmental monitoring, and waste management.

Construction would commence in about 2001, with modifications to FPF for the pit conversion facility, and would continue through completion of the MOX facility in about 2006. Operations would commence in about 2004, with pit conversion, and would continue until about 2019, when the MOX facility has completed its mission. Operation of the MOX facility would not begin until the pit conversion facility had been operating for at least a year, so that feed material would be available for MOX fuel fabrication.

2.11.2 [Section deleted because alternative deleted.]

2.12 ALTERNATIVE 8: PIT CONVERSION AND MOX FUEL FABRICATION AT INEEL; IMMOBILIZATION AT HANFORD

INEEL: Pit Conversion in FPF; MOX Fuel Fabrication in New Construction

Hanford: Immobilization in FMEF and HLW Vitrification Facility

This alternative would involve locating the pit conversion facility in FPF and the MOX facility in new construction in the INTEC area at INEEL; and the immobilization facility in FMEF at Hanford. The pit conversion and MOX facilities would be implemented at INEEL as described for Alternative 7 in Section 2.11.

At Hanford, FMEF would be modified to house the immobilization facility as described for Alternative 4A in Section 2.8.1. Canister filling would be accomplished at the planned HLW vitrification facility scheduled for construction in the 200 East Area, about 24 km (15 mi) northwest of the 400 Area. Modification of FMEF would commence in about 2002 and continue through about 2004. Operation of the immobilization facility would commence in about 2005 and continue until about 2016.

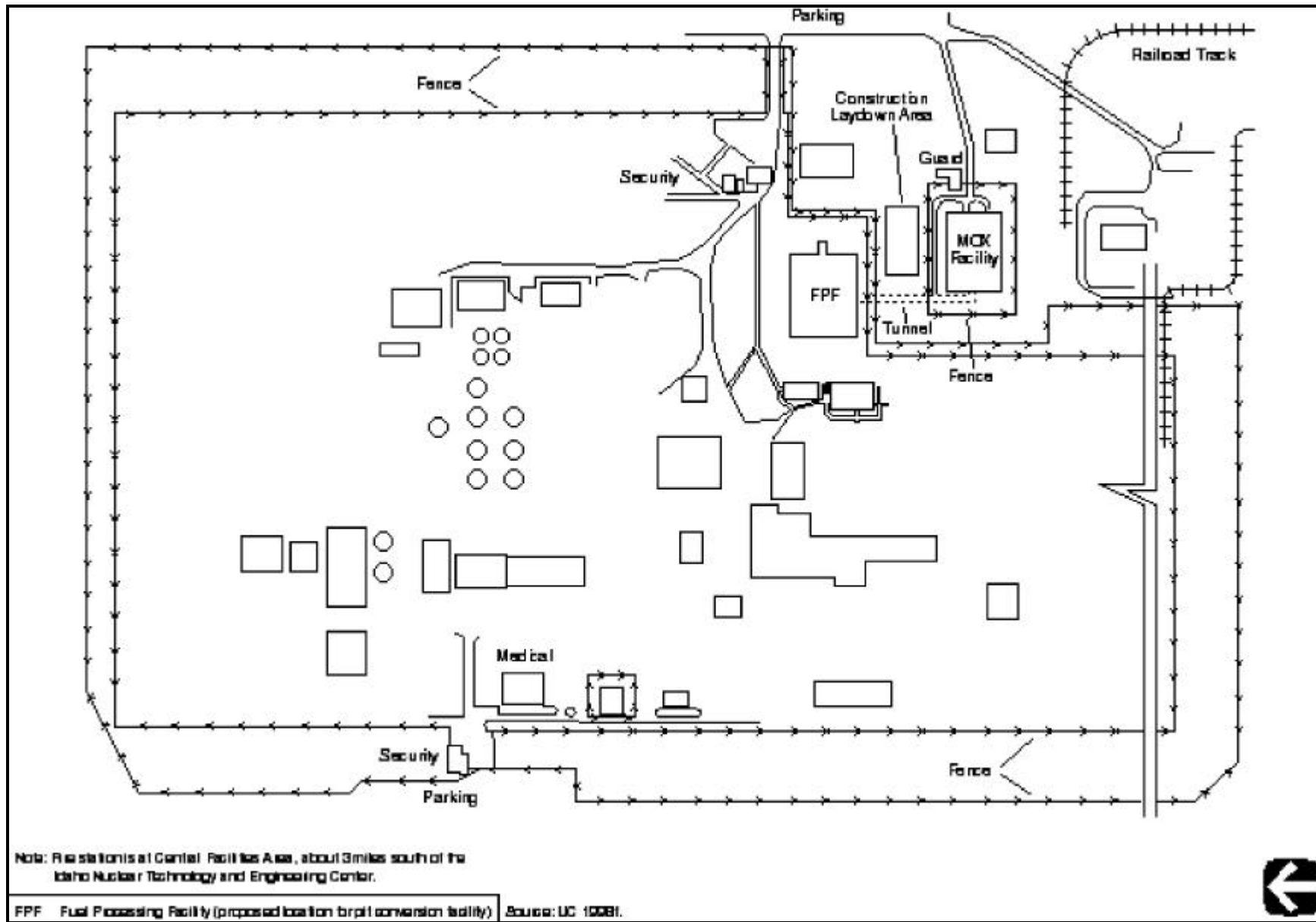

Figure 2-25. Proposed Pit Conversion and MOX Facility Locations in INTEC at INEEL

2.13 ALTERNATIVE 9: PIT CONVERSION AND MOX FUEL FABRICATION AT PANTEX; IMMOBILIZATION AT SRS

Pantex: Pit Conversion and MOX Fuel Fabrication in New Construction
SRS: Immobilization in New Construction and DWPF

2.13.1 [Section heading deleted.]

This alternative would involve locating both the pit conversion and the MOX facilities at Pantex, and the immobilization facility in new construction near the area currently designated for APSF at SRS. In addition, the canister receipt area at DWPF in S-Area would be modified as described in Section 2.4.2.1 to accommodate receipt and processing of the canisters transferred from the immobilization facility for filling with vitrified HLW. The immobilization facility would be as described in Section 2.10.1.

At Pantex, the pit conversion and MOX facilities would be in new construction in Zone 4 West (see Figure 2–26). The pit conversion facility in this alternative would be the same as that described in Section 2.8.1. For the MOX facility, a new two-story building of about 20,000 m² (215,000 ft²) would be constructed south of the pit conversion facility. A secure underground tunnel would connect the two buildings for special nuclear material transfers.²¹ This tunnel would be locked and alarmed under normal operating conditions, and subject to the same security measures on both sides as the building perimeters, both to ensure protection of the special nuclear materials and to maintain the independence of the MOX facility. The tunnel would be opened in accordance with safeguards and security procedures for the transfer of plutonium oxide from the pit conversion facility to the MOX facility, and would be closed immediately upon completion of transfer activities. Other than being joined by this tunnel, the MOX facility would be independent of the pit conversion facility, and would be inside its own fenced security area. In addition to the main process building, the MOX facility would require 2,300 m² (25,000 ft²) of new support buildings throughout Zone 4 West. TRU waste storage would be provided in the main pit conversion and MOX facilities or in ancillary facilities. The proposed disposition facilities would use such existing Pantex services as sitewide security (although there would be additional security assigned to each of the disposition facilities), emergency services, environmental monitoring, and waste management.

Construction at Pantex would commence in about 2001 with the pit conversion facility, and continue through completion of the MOX facility in about 2006. Operations would commence in about 2004 with pit conversion, and continue until about 2019, when the MOX facility has completed its mission. Operation of the MOX facility would not begin until the pit conversion facility had been operating for at least a year, so that feed material would be available for MOX fuel fabrication.

2.13.2 [Section deleted because alternative deleted.]

²¹ Current facility design includes a tunnel for material transfers. Intrasite transfers of special nuclear materials in accordance with current site practices may be considered in lieu of a tunnel in the facility design.

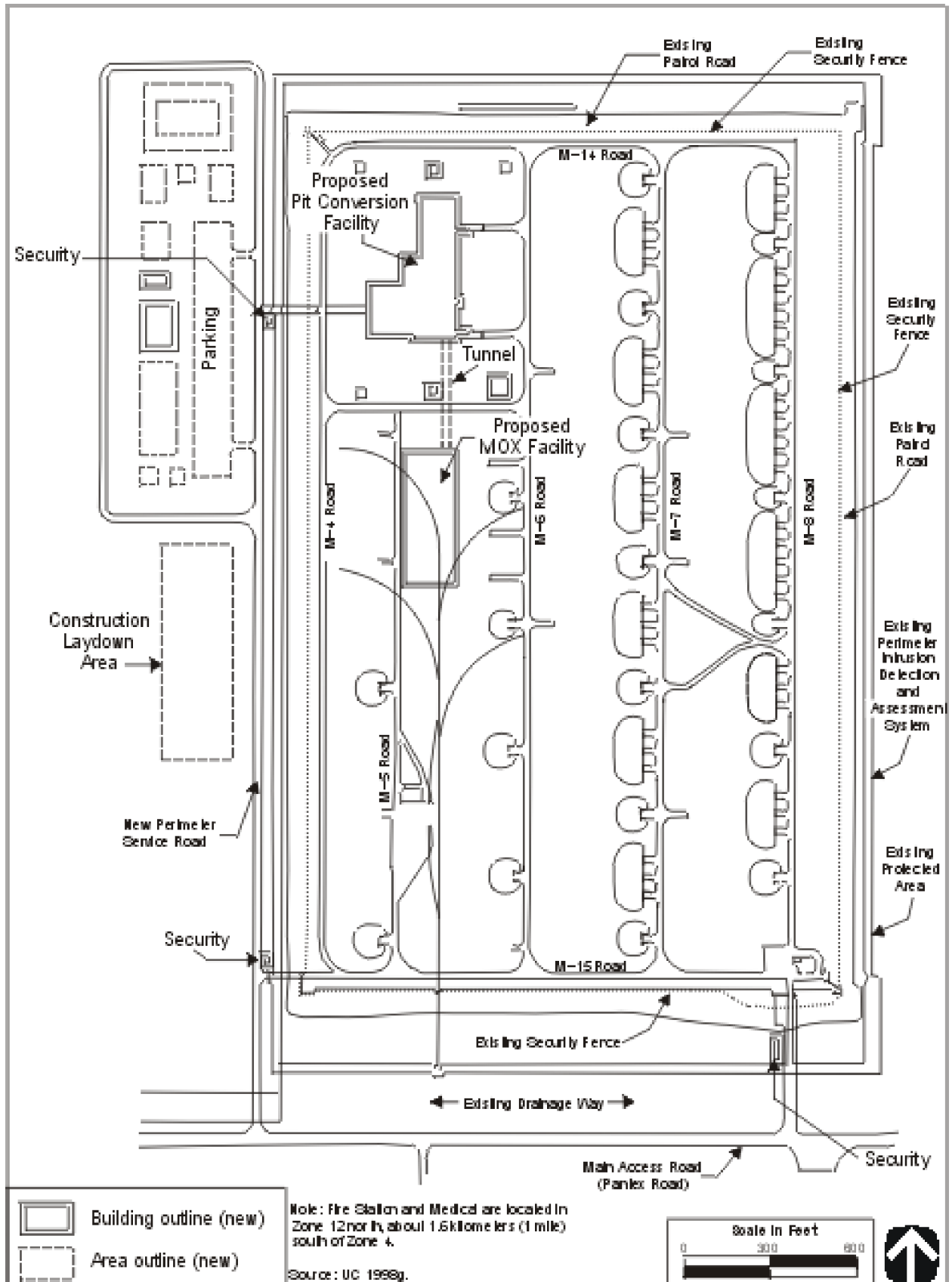

Figure 2-26. Proposed Pit Conversion and MOX Facility Locations in Zone 4 West at Pantex

2.14 ALTERNATIVE 10: PIT CONVERSION AND MOX FUEL FABRICATION AT PANTEX; IMMOBILIZATION AT HANFORD

Pantex: Pit Conversion and MOX Fuel Fabrication in New Construction
Hanford: Immobilization in FMEF and HLW Vitrification Facility

This alternative would involve locating both the pit conversion and MOX facilities in new construction at Pantex, as described for Alternative 9 in Section 2.13. The immobilization facility would be in FMEF at Hanford, and canister filling would be accomplished at the planned HLW vitrification facility scheduled for construction in the 200 East Area, about 24 km (15 mi) northwest of the 400 Area. Immobilization would be implemented as described for Alternative 8 in Section 2.12.

2.15 ALTERNATIVE 11: 50-METRIC-TON IMMOBILIZATION; IMMOBILIZATION AT HANFORD; PIT CONVERSION AT HANFORD OR PANTEX

2.15.1 Alternative 11A

Hanford: Pit Conversion in FMEF; Immobilization in FMEF and the HLW Vitrification Facility

This alternative would involve immobilizing all the nominal 50 t (55 tons) of surplus plutonium at Hanford. Therefore, only two facilities, the pit conversion and the immobilization facilities, would be needed to accomplish the surplus plutonium disposition mission. The pit conversion facility would be collocated with the immobilization facility in FMEF, as described for Alternative 2 in Section 2.6. However, all the plutonium dioxide produced in the pit conversion facility would be transferred to the immobilization facility, which would be operated at a higher throughput (5 t [5.5 tons] rather than 1.7 t [1.9 tons]) to accommodate the additional approximately 33 t (36 tons) of plutonium that would be received from the pit conversion facility. Also, the operating workforce at the immobilization facility would be increased as discussed in Section 4.20.2.3 to process the additional amount of material. Construction would commence around 2001 with the pit conversion facility, and would continue through completion of the modifications to the FMEF for the immobilization facility about 2005. Operations would commence in about 2004 with the pit conversion facility, and continue until about 2016, when the immobilization facility has completed its mission.

2.15.2 Alternative 11B

Pantex: Pit Conversion in New Construction
Hanford: Immobilization in FMEF and the HLW Vitrification Facility

This alternative would involve immobilizing all the nominal 50 t (55 tons) of surplus plutonium. Therefore, only two facilities, the pit conversion facility and the immobilization facility, would be needed to accomplish the surplus plutonium disposition mission. The pit conversion facility would be located at Pantex as described in Alternative 4A, Section 2.8.1, and the immobilization facility would be located at Hanford as described for Alternative 11A, in Section 2.15.1. All the plutonium dioxide produced in the pit conversion facility would be shipped to the immobilization facility, which would be operated as described in Section 2.15.1.

Construction would commence in about 2001 with the pit conversion facility at Pantex, and would continue through completion of the modifications to the FMEF at Hanford for the immobilization facility in about 2005. Operations would commence in about 2004 with the pit conversion facility, and continue until about 2016, when the immobilization facility has completed its mission.

2.16 ALTERNATIVE 12: 50-METRIC-TON IMMOBILIZATION; IMMOBILIZATION AT SRS; PIT CONVERSION AT PANTEX OR SRS

2.16.1 Alternative 12A

SRS: Pit Conversion in New Construction; Immobilization in New Construction and DWPF

This alternative would involve immobilizing all 50 t (55 tons) of surplus plutonium at SRS. Therefore, only two facilities, the pit conversion facility and the immobilization facility, would be needed to accomplish the surplus plutonium disposition mission. Both the pit conversion and immobilization facilities would be in new construction near the area currently designated for APSF in F-Area, as described in Section 2.7. In addition, the canister receipt area at DWPF in S-Area would be modified to accommodate receipt and processing of the canisters transferred from the immobilization facility for filling with vitrified HLW. The pit conversion and immobilization facilities would be the same as those described for Alternative 3 in Section 2.7, except that all the plutonium dioxide produced in the pit conversion facility would be transferred to the immobilization facility. To accommodate the additional 33 t (36 tons) of plutonium that would be received from the pit conversion facility, the immobilization facility would be operated at a higher throughput (5 t [5.5 tons] rather than 1.7 t [1.9 tons]), and the operating workforce at the immobilization facility would be increased as discussed in Section 4.22.2.3.

Construction would commence in about 2001 with the pit conversion facility, and continue through completion of the immobilization facility in about 2005. Operations would commence in about 2004 with the pit conversion facility, and continue until about 2016, when the immobilization facility has completed its mission.

2.16.2 [Section deleted because alternative deleted.]

2.16.3 Alternative 12B²²

Pantex: Pit Conversion in New Construction

SRS: Immobilization in New Construction and DWPF

This alternative would involve immobilizing all the nominal 50 t (55 tons) of surplus plutonium. Therefore, only two facilities, the pit conversion facility and the immobilization facility, would be needed to accomplish the surplus plutonium disposition mission. The pit conversion facility would be located at Pantex as described in Alternative 4A, Section 2.8.1, and the immobilization facility would be located at SRS as described for Alternative 12A, in Section 2.16.1. All the plutonium dioxide produced in the pit conversion facility would be shipped to the immobilization facility, which would be operated as described in Section 2.16.1.

Construction would commence in about 2001 with the pit conversion facility at Pantex, and continue through completion of the immobilization facility at SRS in about 2005. Operations would commence in about 2004 with the pit conversion facility, and continue until about 2016, when the immobilization facility has completed its mission.

2.16.4 [Section deleted because alternative deleted.]

²² This alternative was analyzed as Alternative 12C in the SPD Draft EIS; it has been renumbered as Alternative 12B because SPD Draft EIS Alternative 12B has been deleted.

2.17 LEAD ASSEMBLY FABRICATION AND POSTIRRADIATION EXAMINATION

Five sites are proposed for the fabrication of lead assemblies. They are LLNL, LANL, and three of the four candidate sites for the proposed surplus weapons-grade plutonium disposition activities: Hanford, INEEL (ANL–W facilities), and SRS.²³ These sites have the experience and facilities with safeguards Category I²⁴ and natural phenomenon hazards protection to handle the plutonium for fabricating the lead assemblies. After irradiation at McGuire, the lead assemblies may be examined at either ANL–W or ORNL. Sites considered for lead assembly activities are shown in Figure 2–1. Lead assembly fabrication and postirradiation examination would be implemented only if required to support NRC licensing activities and fuel qualification efforts. If the MOX fuel approach could be implemented without fabricating lead assemblies, or if DOE decides to immobilize all 50 t (55 tons) of surplus plutonium, then these activities would not occur. This section was developed using data provided by ORNL (O'Connor et al. 1998a–e).

2.17.1 Process Description

Lead assembly fabrication would involve the same basic process described for the full-scale fabrication of MOX fuel in Section 2.4.3.2. Although DOE plans to produce only 2 lead assemblies, as many as 10 could be produced at the lead assembly fabrication facility.²⁵ The fabrication effort would be implemented in existing facilities at the selected location, and the fabrication phase would be completed in about 3 years. Up to 4 fuel assemblies would be produced in any given year, for a maximum of 10 assemblies at the end of the 3-year fabrication phase. At this rate of production, about 100 kg (220 lb) plutonium would be made into MOX fuel each year. Including hot startup, a total of about 321 kg (708 lb) plutonium would be used. The plutonium would come from pits dismantled during the Pit Disassembly and Conversion Demonstration Project or from existing supplies of surplus metal and oxide at LANL. Two extra MOX fuel rods would be fabricated with each lead assembly to be maintained as unirradiated archives. The archived rods would be stored at the lead assembly facility until the completion of all the lead assembly fabrication, irradiation, and testing. The rods would then be shipped to the MOX facility for storage until it was determined that the rods were no longer needed as archived material for fuel qualification purposes. At that time, the archived rods would either be irradiated, or dismantled and the materials reused in the MOX fabrication process.

At the lead assembly fabrication site, plutonium dioxide would be blended with uranium dioxide originating from depleted uranium hexafluoride in DOE storage at, for example, the Portsmouth Gaseous Diffusion Plant, then formed into pellets, sintered, and loaded into rods. After fabrication, the rods would either be assembled into fuel assemblies and transported to the reactor, or transported as rods to the reactor site for insertion into special assemblies prior to irradiation. The lead assemblies would be inserted into the reactor during a refueling outage and left in the reactor for up to three fuel cycles. After removal from the reactor, the irradiated assemblies would be managed at the reactor site as spent fuel while cooling down for approximately 6 months. After the cooldown period, several fuel rods removed from the lead assemblies at the reactor site would be transported to ANL–W or ORNL for postirradiation examination. The rest of the rods would remain in the spent fuel pool and would be managed as spent nuclear fuel.

²³ Pantex was not considered for lead assembly fabrication because it does not currently have any facilities capable of MOX fuel fabrication.

²⁴ DOE protects nuclear materials based on the relative attractiveness of the materials in constructing a weapon and/or improvised nuclear device. Category I facilities provide the highest level of safeguards and security.

²⁵ As discussed in Sections 2.18.2 and 4.27, should fewer lead assemblies than analyzed be fabricated or irradiated, the potential impacts would be lower than those described.

During postirradiation examination, several of the fuel rods would be subjected to a series of nondestructive and destructive tests to evaluate the physical and chemical changes to the fuel material and cladding resulting from irradiation. Activities would be conducted remotely, with the irradiated fuel rods inside a hot cell. Operators would remain outside the hot cell and would be shielded by the walls and windows of that cell. Any postirradiation examination activities and shipments would comply with the Consent Order and Settlement Agreement in *Public Service Company of Colorado vs. Batt* (if the work were performed at ANL-W) and all other applicable agreements and orders, including provisions concerning removal of the material from the applicable examination site and limits on the number of truck shipments to the site.

The lead assembly fabrication facility would be operational by October 2002, with the first lead assemblies available for insertion by late 2003. After lead assembly fabrication is completed, deactivation would take about 3 years and could involve conversion of the space for another mission or missions.

2.17.2 Lead Assembly Fabrication Siting Alternatives

If required, lead assembly fabrication and postirradiation examination would be conducted at operating DOE sites in facilities that can accommodate the proposed activities with minimal alteration of interior spaces, are authorized to handle plutonium, and are situated in hardened spaces of thick-walled concrete that meet the standards for processing special nuclear material. Areas of the buildings in which plutonium would be handled are designed to survive natural phenomena such as earthquakes, floods, and tornadoes, as well as potential accidents associated with the processing of fissile and radioactive materials.

Security at these facilities, implemented at several levels, would provide maximum protection for the special nuclear materials. Each facility would be on an existing DOE site that has safeguards and security measures in place, including access control. In addition to DOE sitewide security services, each building in which special nuclear materials are handled has physical security and procedures commensurate with the amount and type of material authorized in the area. Physical barriers; access control systems; detection and alarm systems; procedures, including the two-person rule (requiring at least two people to be present during work with special nuclear materials in the facility); and personnel security measures, including security clearance investigations and access authorization levels—all ensure that special nuclear materials are adequately protected. Nuclear material control and accountability are ensured through a system for monitoring storage, processing, and transfers. At any time, the total amount of special nuclear material in each facility, or in any material balance area within a facility, would be known. As appropriate, closed-circuit television, intrusion detection, motion detection, and other automated methods are used as part of the material control and accountability program. Physical measurements and inspections of material are used to verify inventory records.

2.17.2.1 Hanford

The Fuel Assembly Area of FMEF, within Hanford's 400 Area (see Figures 2-2 and 2-20) has been proposed as a location for lead assembly fabrication. FMEF, also proposed as a candidate location for the pit conversion, immobilization, and MOX facilities, is described in detail in Section 2.6.

FMEF consists of several connected buildings. Building 427, the main part of the facility, is a six-level processing building with an attached mechanical wing on the west side and an emergency power wing on the northwest corner. The Fuel Assembly Area (Building 4862) is appended to the southeastern end of FMEF. This area is divided into two sections, the entry (administrative) wing, and the lower-level operations portion, the Fuel Assembly Area, designed for the fabrication of fuel assemblies for FFTF. The lower level of the Fuel Assembly Area would be used for fuel rod and assembly fabrication. The upper level contains independent ventilation equipment. Storage of plutonium feed materials would occur in the operating vaults of Building 427, or in reconfigured below-grade storage tubes in the Fuel Assembly Area.

2.17.2.2 ANL–W

ANL–W is in the southeast portion of INEEL (see Figure 2–3). Established in the mid-1950s, the facility had as its primary mission the support of advanced liquid metal reactor research. In 1995, ANL–W began conducting research in the treatment of DOE spent nuclear fuel and in technologies for reactor decontamination and decommissioning. The ZPPR Vault and Workroom (Building 775), ZPPR Reactor Cell (Building 776), Fuel Manufacturing Facility (FMF, Building 704), and Fuel Assembly and Storage Building, (FASB, Building 787) within ANL–W have been proposed to support lead assembly fabrication (see Figure 2–27). As discussed in Sections 2.17.3 and 2.17.3.1, postirradiation examination could also be conducted at ANL–W.

ZPPR began operations at ANL–W in 1969 and was placed on standby in 1989. The facility is large enough to enable core physics studies of full-scale breeder reactors. The principal experimental area has a very thick foundation and thick concrete walls covered with an earthen mound, and a sand/gravel/HEPA filter roof. FMF, adjacent to the ZPPR facility, is buried under an earthen mound similar to that of ZPPR. This facility is currently supporting a furnace and glovebox operation for the dismantlement of damaged ZPPR fuel plates and the packaging of recovered plutonium oxide for shipment. FMF is also used as a test site for the development of safeguards and security systems. ZPPR and FMF share security assets, including a common security area surrounded by security fences, perimeter intrusion detection, and alarm systems. ZPPR and FMF are both Safeguards Category I, hardened buildings which meet natural phenomenon protection requirements currently approved for handling special nuclear materials.

The ZPPR Workroom has been proposed for fuel manufacture and storage, and the ZPPR Reactor Cell, as the high-bay fuel assembly and inspection area. Space within FMF would be used for fuel storage. The FASB would also be used for lead assembly fabrication. This facility was constructed to provide space, equipment, and services for manufacturing fuel elements and components for an experimental breeder reactor. A metallurgical laboratory is housed in the building's west end. The FASB would provide controlled vault storage for special nuclear materials, including fuel assemblies.

2.17.2.3 SRS

SRS is in the southern portion of South Carolina, approximately 19 km (12 mi) south of Aiken (see Figure 2–5). Chemical processing facilities are situated within the F- and H-Canyon areas at SRS. Their primary mission was to separate special nuclear materials from spent reactor fuels and irradiated targets. A portion of the 221–H Canyon facility, located within the H-Area, has been proposed for the fabrication of lead assemblies (see Figure 2–28). This unused space originally constructed for the Uranium Solidification Facility (USF), was never completed. The 221–H facility is entirely within a protected safeguards and security area. Existing USF utilities, access control, administrative and laboratory space, and waste management systems would also be used for the proposed lead assembly fabrication activities.

2.17.2.4 LANL

LANL, in northern New Mexico, was established in 1943 to design, develop, and test nuclear weapons (see Figure 2–29). Its mission has expanded from the primary task of designing nuclear weapons to include nonnuclear defense programs and a broad array of nondefense programs. Current programs include research and development of nuclear safeguards and security, medium-energy physics, space nuclear systems, biomedicine, computational science, and lasers. As discussed in Section 2.17.1, the plutonium dioxide feed material for the lead assembly fabrication effort is expected to be produced at LANL.

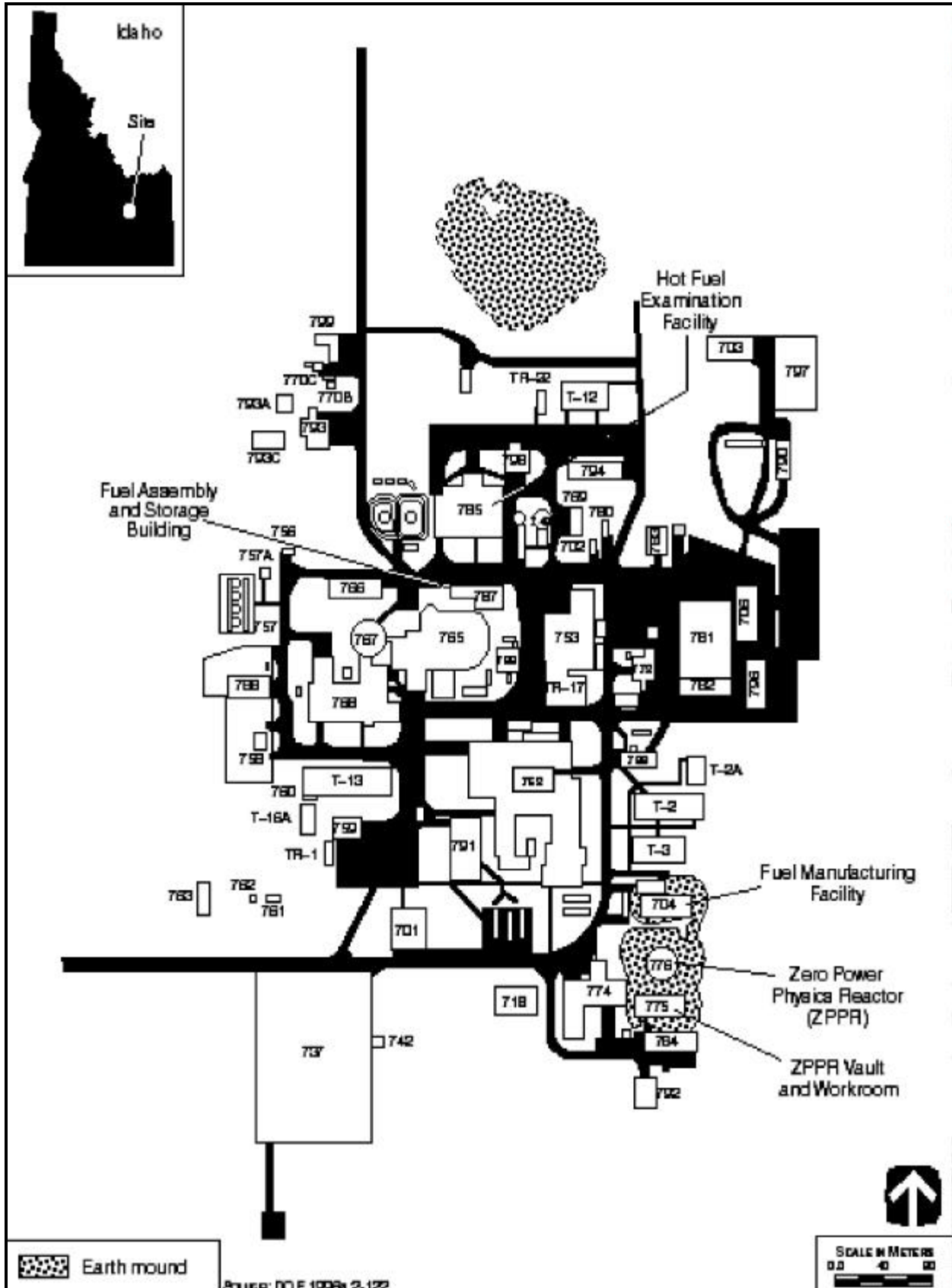
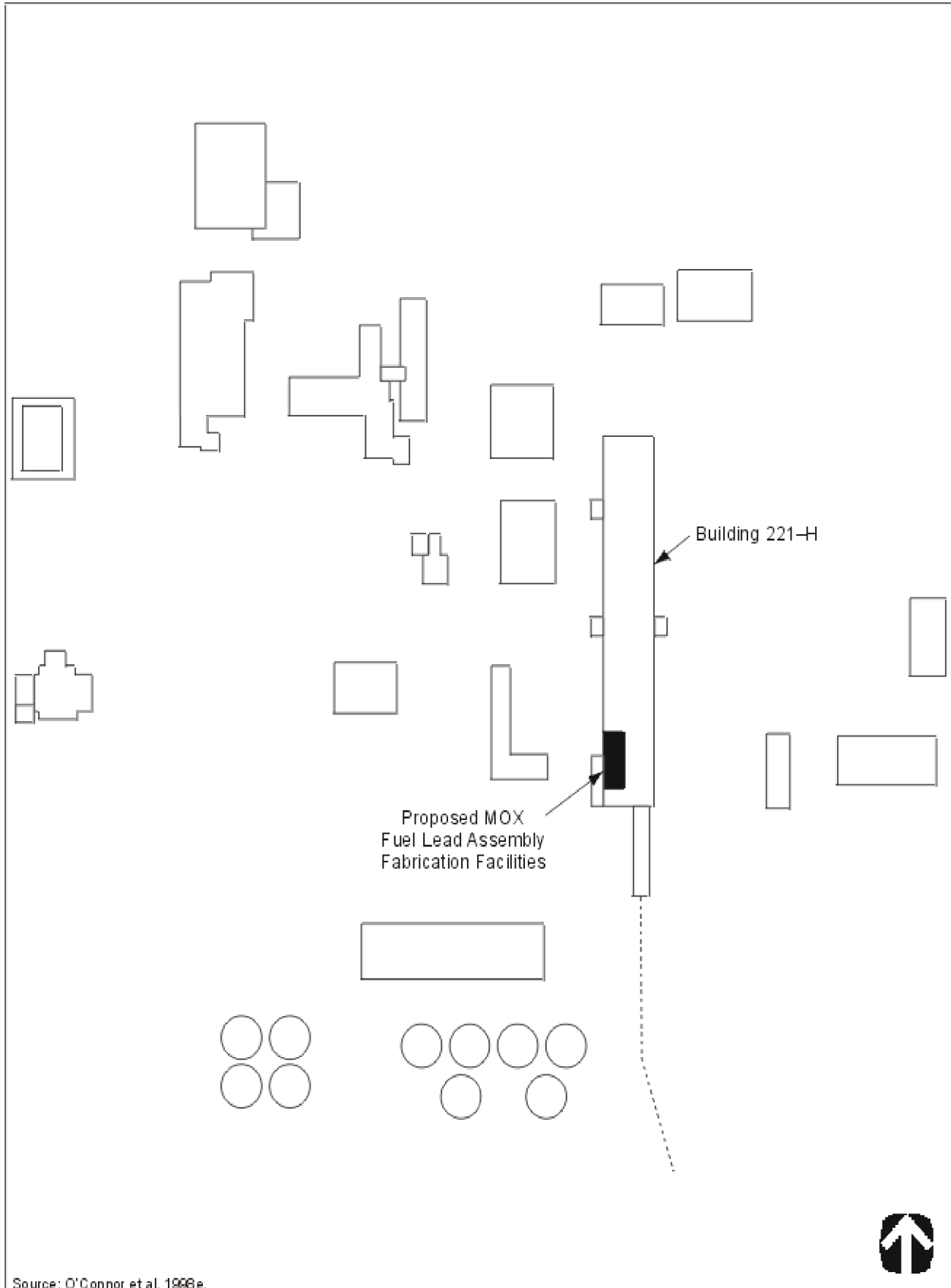

Figure 2-27. Proposed MOX Fuel Lead Assembly Fabrication Facilities, ANL-W at INEEL



Source: O'Connor et al. 1998e.

Figure 2-28. Proposed MOX Fuel Lead Assembly Fabrication Facilities, H-Area at SRS

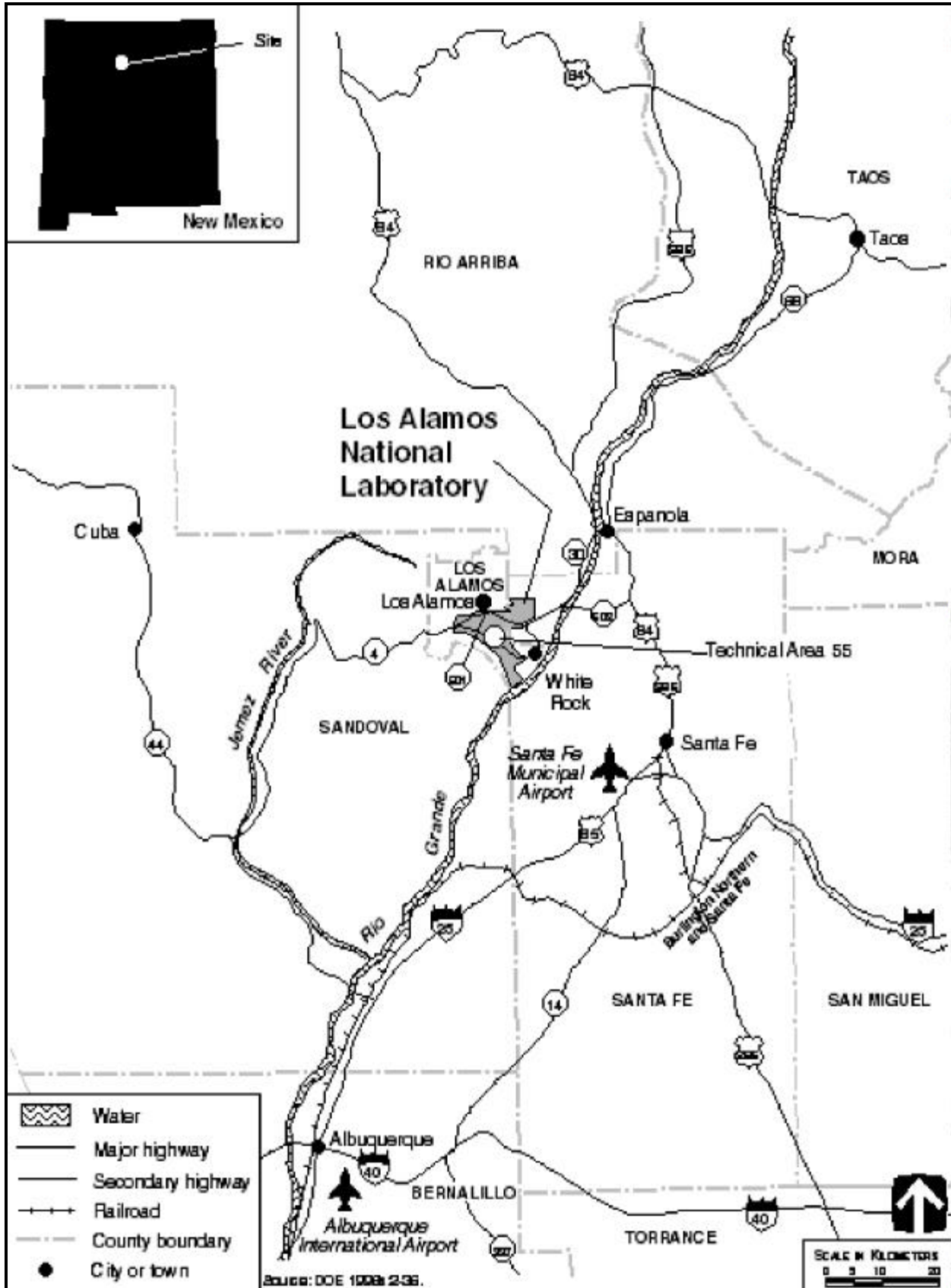

Figure 2-29. LANL, New Mexico

LANL consists primarily of Technical Areas, of which 49 are actively in use. With the exception of the bundle assembly and inspection activities proposed for the Radioactive Materials Research, Operations and Demonstration Facility in TA-50, the facilities proposed for lead assembly fabrication and storage of archived fuel rods are in Building PF-4 within TA-55 (see Figure 2-30). Most of TA-55, including the main complex, is inside a restricted area surrounded by a double security fence. In addition to Building PF-4, the TA-55 main complex consists of the Administration Building (PF-1), Support Office Building (PF-2), Support Building (PF-3), Warehouse (PF-5), and other miscellaneous support buildings.

Fuel fabrication activities have been proposed for currently operational fuel fabrication laboratories in Building PF-4, which became operational in 1978 for conducting state-of-the-art plutonium processing. Current activities in the building include plutonium recovery, fabrication of plutonium components, weapons disassembly, plutonium 238 and actinide processing, and fabrication of ceramic-based reactor fuels.

2.17.2.5 LLNL

The main LLNL site, originally a naval air training station, is approximately 80 km (50 mi) east of San Francisco and 6.4 km (4 mi) from downtown Livermore (see Figure 2-31). LLNL was established in 1952 to conduct nuclear weapons research. Its current mission is research, testing, and development focusing on national defense and security, energy, the environment, and biomedicine. Within recent years, LLNL's mission has broadened to include global security, ecology, and mathematics and science education.

Buildings 332, 334, and 335 are the three primary facilities proposed to support fabrication of lead assemblies. The Plutonium Facility (Building 332) is inside LLNL's Superblock, a 500-ft by 700-ft protected area surrounded by an alarmed double security fence (see Figure 2-32). Building 332 comprises several buildings constructed over the past three decades, including the Plenum Building, an office structure, plutonium-handling laboratories, mechanical shops, office space, a small nonradioactive materials laboratory, two plutonium storage vaults, and a cold machine shop. Current activities in the Plutonium Facility include the receipt, storage, and shipping of special nuclear materials; plutonium and fissile uranium operations and experiments; special nuclear material control and accountability; scrap recovery; and waste operations. For the lead assembly fabrication effort, Building 332 would be used to receive and store bulk plutonium dioxide powder, fabricate MOX pellets, and assemble fuel rods.

Building 334, adjacent to Building 332 in the Superblock, can handle maximum quantities of encapsulated special nuclear materials. This three-floor facility comprises the Engineering Test Bay (ETB) and the Radiation Measurements Facility (RMF). The ETB is used to conduct thermal and dynamic tests on weapon components; the RMF, located in the Intrinsic Radiation (INRAD) bay, to make intrinsic radiation measurements of various components. The INRAD and ETB bays provide primary and secondary confinement of radioactive material. For the proposed lead assembly fabrication, the ETB would be used for assembling, storing, packaging, and shipping fuel assemblies. Building 334 also contains analytical, metallography, scrap recovery, and other equipment to support the proposed activities.

Building 335, also adjacent to Building 332, is used as a staging area for nonradioactive equipment and systems being readied to move into Building 332. There are also areas for training, document storage, and change rooms, as well as access into the radioactive materials area of Building 332. For the lead assembly fabrication effort, Building 335 would be used for assembly and testing of equipment, storage of spare parts and supplies, and electrical and mechanical shop areas. The proposed activities can be accomplished within LLNL's administrative limits for uranium and plutonium inventory as identified in the *Supplement Analysis for Continued Operation of Lawrence Livermore National Laboratory and Sandia National Laboratories, Livermore* (DOE 1999c).

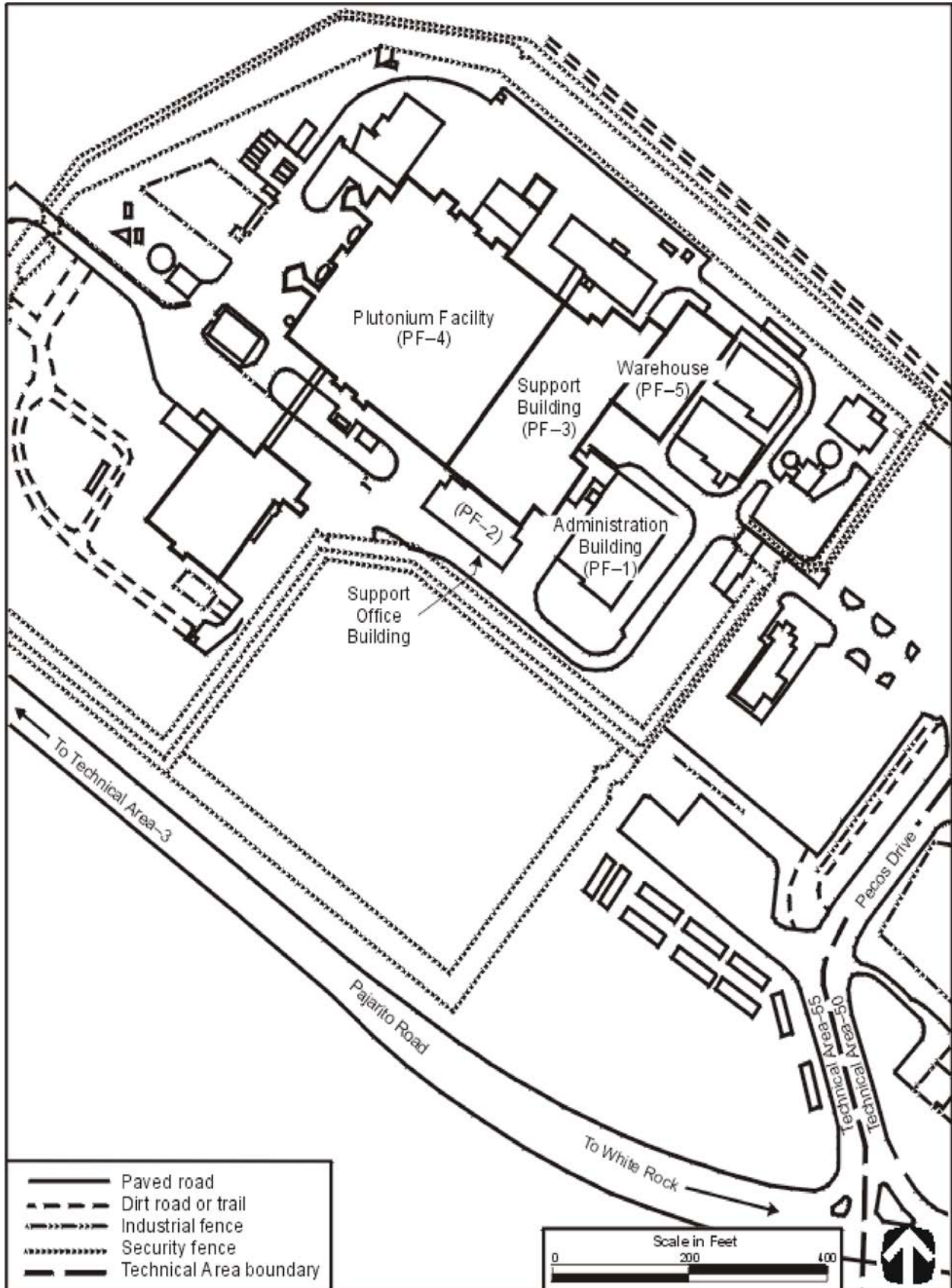

Figure 2-30. Proposed MOX Fuel Lead Assembly Fabrication Facilities, TA-55 at LANL

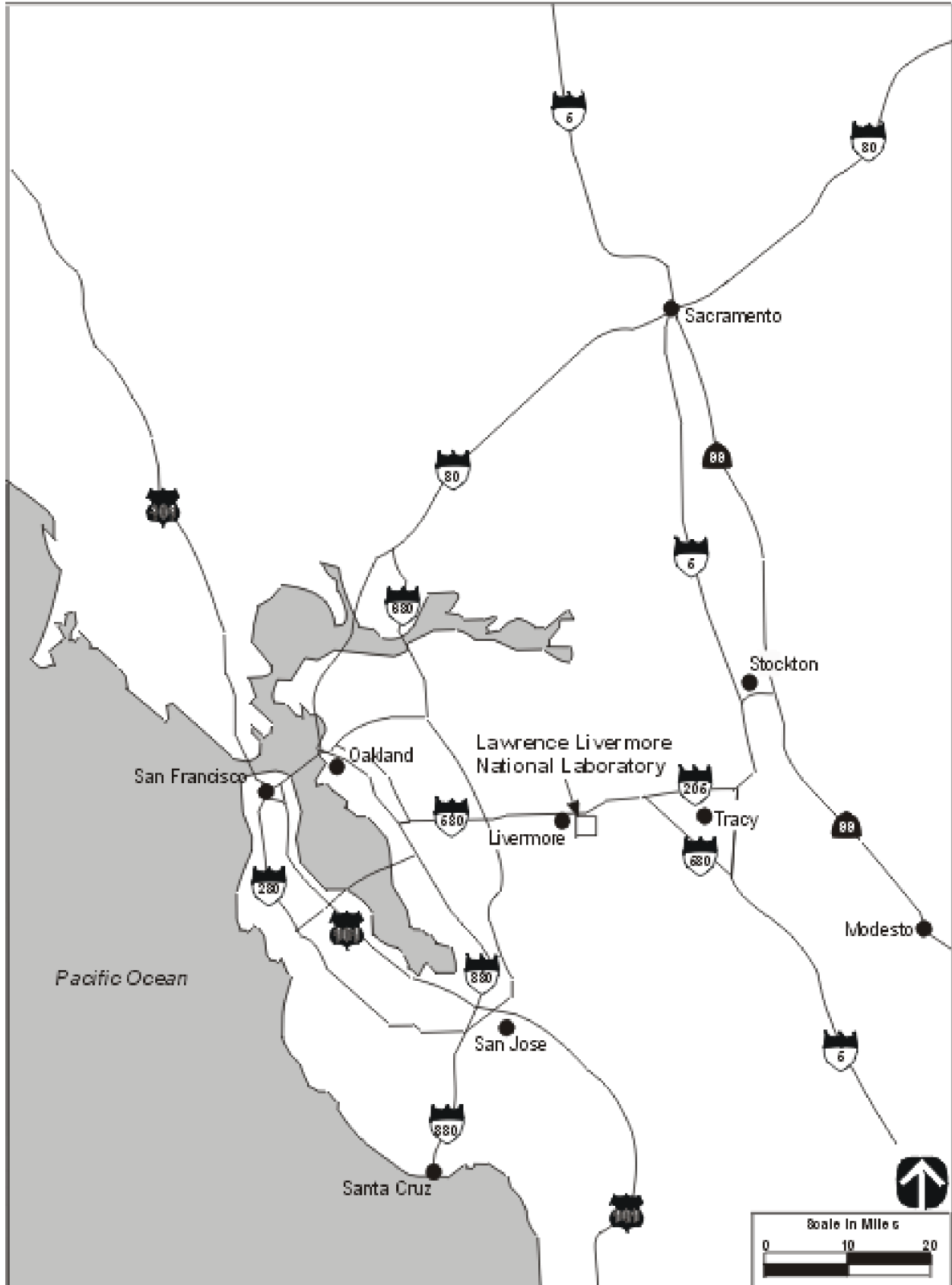

Figure 2-31. LLNL, California

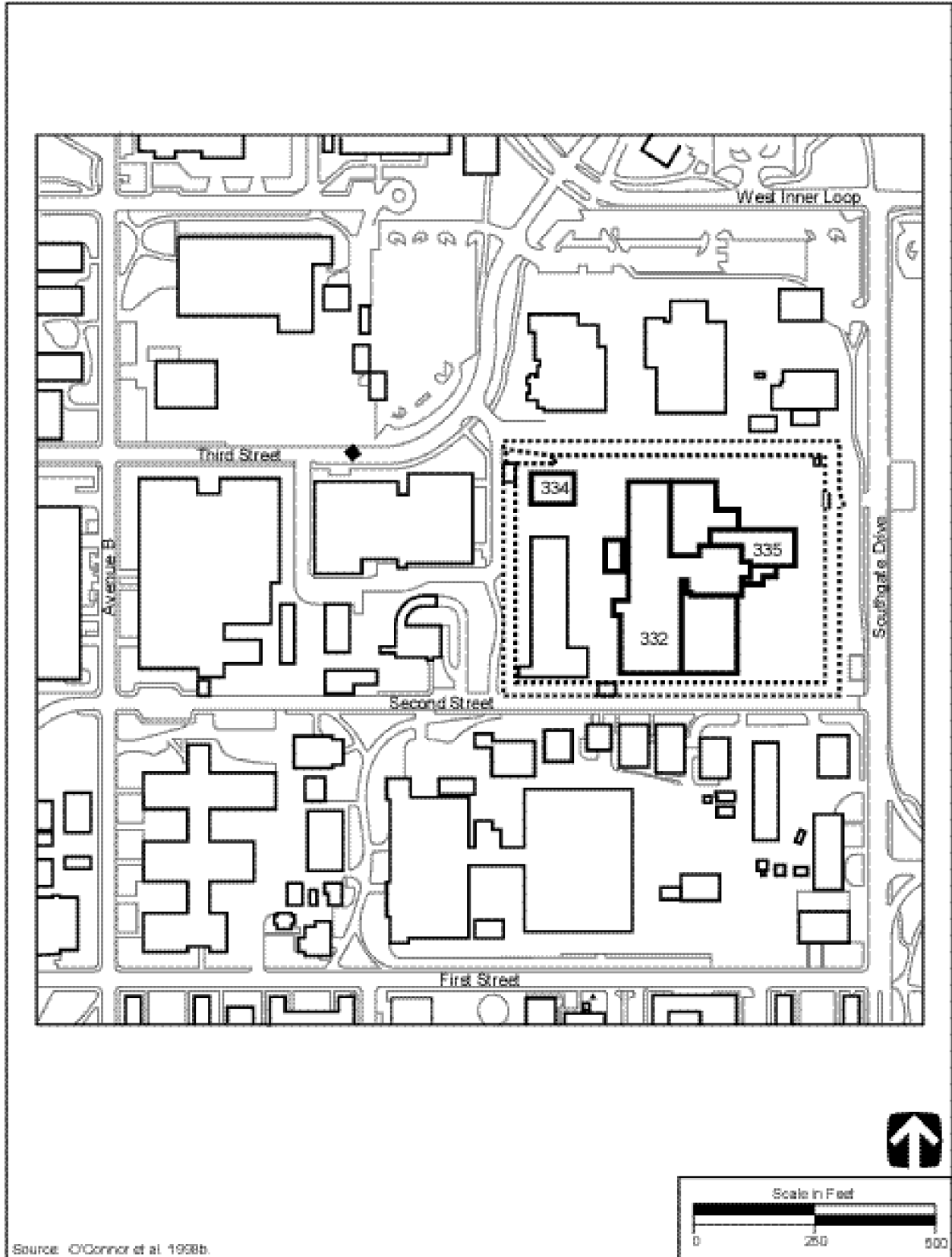

Figure 2–32. Proposed MOX Fuel Lead Assembly Fabrication Facilities, Superblock at LLNL

2.17.3 Postirradiation Examination Siting Alternatives

Postirradiation examination is used to collect information about fuel assemblies after irradiation. Tests on the lead assemblies would begin with remote nondestructive examination, which typically involves a visual examination of the fuel rods to detect signs of damage or wear, as well as the measurement of physical parameters such as length, diameter, and weight. The nondestructive tests would continue with more rigorous tests such as ultrasonic tests, x- or gamma spectroscopy, and neutron radiography. After completion of the nondestructive testing, which does not compromise the integrity of the material being examined, the rods would be subjected to destructive testing: they would be punctured to collect contained gases, then cut into segments for metallurgical and ceramographic testing, chemical analysis, electron microscopy, and other physical testing. Such tests, standard industry and research activities, would provide information on how the fuel material and the cladding responded to being inside the operating reactor. DOE proposes to conduct any required postirradiation examination at either ANL-W or ORNL because these facilities have hot cells (special facilities which are heavily shielded and have remote-handling equipment for working with highly radioactive materials) and testing equipment that are routinely required for these activities. Both sites currently process materials equivalent to those that would be handled during postirradiation examination of these lead assemblies. At either site, only minimal modifications to existing equipment would be required for acceptance of commercial-sized, full-length fuel rods.

Waste generated by destructive testing of the lead assemblies would be managed at the postirradiation examination site as TRU waste. Irradiated fuel rods sent to the postirradiation examination facility that are not destroyed in testing would be managed at the postirradiation examination site as spent fuel, in accordance with the site's spent fuel program. This spent fuel from the lead assembly program may be stored at the postirradiation examination site until transported to INEEL, where it would remain in storage pending disposition at a potential geologic repository pursuant to the NWPA.²⁶

2.17.3.1 ANL-W

The Hot Fuel Examination Facility (HFEF) is a hot cell complex for the preparation and examination of irradiated experiments and the characterization and testing of waste forms from conditioning of spent fuel and waste. HFEF is located in a double-fenced compound on the ANL-W site at INEEL (see Figure 2-27). HFEF consists of two adjacent shielded hot cells, a shielded metallographic loading box, an unshielded Hot Repair Area and a Waste Characterization Area. The building is a three-story structure with a basement support area, and has a gross floor area of about 5,200 m² (56,000 ft²).

The HFEF main cell is 21 m (70 ft) long by 9 m (30 ft) wide by 7.5 m (25 ft) high, and has an argon gas atmosphere. The cell is serviced by two electro-mechanical manipulators rated for 340 kg (750 lb) and two 5-ton bridge cranes. There are 15 workstations, each equipped with two master/slave manipulators.

The primary program at HFEF, since October 1994, has been the support of the Experimental Breeder Reactor II (EBR-II) defueling and decommissioning. HFEF was responsible for receiving all the fuel and blanket material from EBR-II and preparing the material for storage in the Radioactive Scrap and Waste Facility.

In addition to the handling of the EBR-II fuel, HFEF is the examination facility for both the metal and ceramic waste form experiments from the Fuel Conditioning Facility. In addition, equipment is being installed and

²⁶ Transportation and storage at INEEL would be in accordance with decisions made in the ROD for the *Department of Energy Programmatic Spent Nuclear Fuel Management and Idaho National Engineering Laboratory Environmental Restoration and Waste Management Programs Environmental Impact Statement*.

processes tested for the disposal of the plutonium and fission product waste from the conditioning of EBR-II fuel. The testing and characterization of the ceramic waste forms will be performed in HFEF.

HFEF is presently being modified to accept commercial-sized fuel assemblies. All the examination equipment in the cell and the cask handling systems are being modified to handle commercial sized casks and fuel rods for examination. These modification are expected to be complete in mid-1999.

2.17.3.2 ORNL

The Irradiated Fuels Examination Laboratory (IFEL), Building 3525, has been used for fuel research and examination. It is part of ORNL approximately 14 km (8 mi) southwest of the city of Oak Ridge, Tennessee. Over a period of three decades, this facility has handled a wide variety of fuels including aluminum clad research reactor fuel, both stainless and zircaloy clad LWR fuel, coated-particle gas cooled reactor fuel, and numerous one of a kind fuel test specimens. In addition, the facility has also done iridium isotope processing and irradiated capsule disassembly.

The IFEL contains a large horseshoe-shaped array of hot cells which are divided into three work areas. The hot cells are constructed of 3-ft thick concrete walls with oil-filled lead glass viewing windows. The inside of surfaces of the cell bank are lined with stainless steel to provide containment of particulate matter and to facilitate decontamination. Special penetrations are provided for the sealed entry of services such as instrument lines, lights, and electrical power. A pair of manipulators are located at each of 15 window stations for remote cell operations and periscopes allow for magnified views of in-cell objects. Heavy objects within each cell bank can be moved by electromechanical manipulators or a 3-ton crane. Fuel materials enter and leave the cells through three shielded transfer stations provided at the rear face of the North cell.

2.18 SUMMARY OF IMPACTS OF CONSTRUCTION AND OPERATION OF THE PROPOSED SURPLUS PLUTONIUM DISPOSITION FACILITIES

This section summarizes the potential impacts associated with the activities necessary to implement DOE's disposition strategy for surplus plutonium. The summary addresses the environmental information to be considered for each of the decisions contemplated as part of this strategy. This information is compiled from the analyses presented in Chapter 4 of this SPD EIS. Section 2.18.1 summarizes impacts related to the proposed surplus plutonium disposition facilities and provides that information by alternative, and within each alternative, by site. Summarized impacts are presented for the No Action Alternative as well as for each of the 15 alternatives that encompass the range of reasonable alternatives for both the 50-t (55-ton) immobilization and the hybrid approaches to plutonium disposition. Section 2.18.2 compares the potential impacts related to implementation of lead assembly fabrication at five candidate sites and postirradiation examination at two candidate sites. To provide an overview of the impacts associated with full implementation of the MOX fuel approach to disposition, Section 2.18.3 presents an integrated assessment of the potential impacts of the MOX facility, lead assembly fabrication, postirradiation examination, and use of the MOX fuel in domestic, commercial reactors. To facilitate the evaluation of proposed immobilization technologies, the final section compares the impacts associated with the can-in-canister immobilization technology with those described in the *Storage and Disposition PEIS* for the ceramic immobilization and vitrification alternatives.

2.18.1 Summary of Impacts by Alternative and Site

Table 2-4 summarizes the potential impacts of the No Action and surplus plutonium disposition facility alternatives on key environmental resource areas. In addition, the amount of land that would be disturbed and the potential impacts from facility accidents and transportation are summarized. Impacts are presented by

alternative, and within each alternative, by the affected site. For the No Action Alternative, sites that currently store surplus plutonium are included in the table.

Impacts on air quality are expected to be low for all alternatives. Table 2–4 provides the incremental criteria pollutant concentrations from surplus plutonium disposition operations for each alternative. In all cases, the incremental concentrations would contribute less than 2 percent of the applicable regulatory standard. Total site air concentrations, which also factor in the amount associated with the No Action Alternative,²⁷ would be no more than 21 percent of the annual applicable regulatory standard, with the highest occurring in the alternatives that would have the immobilization facility located at SRS. That particular value represents projected sulfur dioxide concentrations as a percent of the annual National Ambient Air Quality Standards; the corresponding value for the No Action Alternative is also 21 percent, demonstrating that the increment associated with plutonium disposition facilities would be very small.²⁸

Expected waste generation by alternative is estimated for TRU waste, LLW, mixed LLW, hazardous waste, and nonhazardous waste²⁹ from construction activities and 10 years of expected facility operation. As shown in Chapter 4, impacts associated with management of nonhazardous wastes would be minor and would not tend to be a discriminator among alternatives.

TRU waste generation would range from 1,400 m³ (1,832 yd³) to 1,810 m³ (2,368 yd³), and LLW generation would range from 1,700 m³ (2,224 yd³) to 2,400 m³ (3,140 yd³). Mixed waste generation would range from 20 m³ (26 yd³) for immobilizing all 50 t (55 tons) (Alternatives 11A, 11B, 12A, and 12B) to 50 m³ (65 yd³) for each of the hybrid alternatives. Hazardous waste generation would range from 770 m³ (1,007 yd³) (Alternatives 11A and 11B) to 940 m³ (1,230 yd³) (Alternatives 3, 5, 6A, 6B, 7, and 9).

Impacts on the waste management infrastructure from implementing alternatives for surplus plutonium disposition are expected to be minor. All of the waste expected to be generated from the different alternatives analyzed could be accommodated within existing or planned capacities for waste treatment, storage, and disposal at all of the candidate sites, except for TRU waste at Pantex. At Pantex, a maximum of 860 m³ (1,125 yd³) of TRU waste would be generated under Alternative 9 or 10. Because TRU waste is not routinely generated and stored at Pantex, TRU waste storage space would be designated within the pit conversion and MOX facilities. TRU waste would be shipped to WIPP near Carlsbad, New Mexico, for disposal.

Although the proposed facilities are still in the early stages of engineering and design, the surplus plutonium disposition program would integrate pollution prevention practices that include waste stream minimization, source reduction, and recycling, as well as DOE procurement processes that preferentially procure products made from recycled materials. The proposed facility designs would minimize the size of radiologically controlled areas, thereby minimizing the generation of radioactive waste. To the extent practical, solvents or other chemicals which, after use, are regulated by the Resource Conservation and Recovery Act would not be used at the DOE facilities, thereby minimizing the amount of hazardous and mixed waste generated. Wastewater would be recycled to the extent possible to minimize effluent discharge.

The employment column of Table 2–4 summarizes the number of direct jobs that would be generated by the proposed facilities under each alternative. All the action alternatives would generate employment opportunities

²⁷ As indicated in Appendix G, the No Action Alternative projects air emissions to the year 2005, when plutonium disposition facility operations under the disposition alternatives would begin, and includes emissions from existing and other planned facilities.

²⁸ This conclusion assumes that activity levels under the No Action Alternative remain the same beyond 2005.

²⁹ Waste type definitions may be found in Appendix F.8.

at the facilities. Expected annual peak construction employment ranges from 463 workers (Alternative 11A) to 2,143 workers (Alternative 5).³⁰ Annual employment during operations would range from 751 workers (Alternatives 12A and 12B) to 1,165 workers (Alternatives 2 and 4B).

Potential effects on human health from facility construction, 10 years of operation, postulated facility accidents and intersite transportation of radioactive materials are also summarized in Table 2–4. Doses to workers from the construction and 10 years of routine operation of the three surplus plutonium disposition facilities at DOE sites would result in up to 2.0 latent cancer fatalities (LCFs) for both the hybrid alternatives and the 50-t (55-ton) immobilization alternatives. No LCFs would be expected to occur in the general population during routine operations. Under the No Action Alternative, continued storage of the surplus plutonium would also not result in any LCFs to the general population during routine operations. Doses to workers from the long-term storage (up to 50 years) of the surplus plutonium would result in up to 2.4 LCFs.

Table 2–4 presents the results of the analysis of the most severe nonreactor design basis accident scenario. For Alternative 4B, a criticality in the MOX facility would result in the most severe consequences. For all other alternatives except the No Action Alternative, a design basis fire in the pit conversion facility resulting in a tritium release would result in the most severe consequences. However, no design basis accident would be expected to result in LCFs in the general population.

No major consequences for the maximally exposed involved worker would be expected from leaks, spills, and smaller fires. These accidents are such that involved workers would either be able to evacuate immediately or would not be affected by the events. Explosions, on the other hand, could result in immediate injuries from flying debris, as well as the uptake of plutonium and uranium particulates through inhalation. If a criticality were to occur, workers within tens of meters could receive very high to fatal radiation exposures from the initial burst. The dose would strongly depend on the magnitude of the criticality (number of fissions), the distance from the criticality, and the amount of shielding provided by the structures and equipment between the workers and the criticality. Beyond-design-basis earthquakes would also have substantial consequences, ranging from workers being killed by debris from collapsing equipment and structures to high radiation exposures and uptakes of radionuclides. For most accidents, immediate emergency response actions should reduce the consequences to workers near the accident.

Materials transportation is analyzed to determine potential radiological and nonradiological impacts from routine and accident conditions. These results are summarized in Table 2–4. Transportation includes the movement of surplus plutonium from storage and among the proposed disposition facilities; depleted uranium hexafluoride from, for example, Portsmouth to a conversion facility; uranium dioxide from the conversion facility to the immobilization and/or MOX facilities; recovered HEU from the pit conversion facility to ORR; MOX fuel to Catawba, McGuire, and North Anna; spent nuclear fuel resulting from lead assembly irradiation at McGuire to the postirradiation examination site and then to storage at INEEL; and the immobilized plutonium to a potential geologic repository.³¹ No traffic fatalities from nonradiological accidents or LCFs from radiological exposures or vehicle emissions would be expected. For the hybrid alternatives, the number of trips would range from 1,917 (Alternative 10) to 2,530 (Alternatives 3, 6A, 6B, and 7), and the cumulative distances traveled would range from 3.6 million km (2.2 million mi) (Alternative 10) to 8.7 million km (5.4 million mi) (Alternatives 6A and 6B).

³⁰ These values represent the combined peak annual construction workforce at each site. Peak construction employment under Alternative 11A is composed of the 463 construction workers at Hanford in 2003. Peak construction employment under Alternative 5 is composed of the 451 construction workers at Pantex in 2002 and the 1,692 construction workers at SRS in 2003.

³¹ Shipments of spent fuel to the potential geologic repository are analyzed in the *Draft Environmental Impact Statement for a Geologic Repository for the Disposal of Spent Nuclear Fuel and High-Level Radioactive Waste at Yucca Mountain, Nye County, Nevada* (DOE/EIS-0250D) (DOE 1999b).

Immobilization-only alternatives would require from 1,877 trips for Alternative 11B to 2,236 trips for Alternative 12A. Cumulative distances traveled for the immobilization-only alternatives would range from 2.5 million km (1.5 million mi) (Alternative 11B) to 4.4 million km (2.7 million mi) (Alternative 12A).

Table 2–4 also provides the total land area that would be disturbed at each site for each alternative. Land disturbance relates directly to impacts on ecological resources, cultural resources, geology and soils, and land use and visual resources. The amount of land that would be disturbed for the hybrid alternatives would range from 19 hectares (47 acres) in Alternative 8, to 32 hectares (79 acres) in Alternatives 3, 5, and 9. Because these land areas are in or adjacent to previously disturbed areas and represent a very small percent of the land available at the candidate sites, the impacts on geology and soils and land use would be minor. Land disturbance associated with immobilizing approximately 50 t (55 tons) of surplus plutonium would range from 9.5 hectares (23 acres) in Alternative 11B, to 20 hectares (49 acres) in Alternative 12A or 12B. Construction and operation of the proposed facilities would not effect a significant change in any natural features of visual interest in the area of any of the candidate sites. No major impact is anticipated for any threatened or endangered species because there have been no sightings near the proposed facility locations at the candidate sites. Cultural resource impacts would be minor at all sites because at all sites except SRS, construction of facilities would be in mostly disturbed or developed areas; at SRS, cultural resource areas would be avoided. Archaeological investigations near F-Area have discovered five sites that could be impacted by construction of surplus plutonium disposition facilities. Two of these sites have been recommended to the South Carolina State Historic Preservation Officer (SHPO) as eligible for nomination to the National Register of Historic Places. Potential adverse impacts could be mitigated through either avoidance or data recovery. DOE currently plans to mitigate impacts by avoiding sites that are eligible or potentially eligible for nomination to the National Register. Cultural resource compliance activities would be conducted in accordance with the *Programmatic Memorandum of Agreement for the Savannah River Site* (SRARP 1989:179–188).

Impacts were also assessed on water availability and quality and infrastructure including requirements for roads, electricity, and fuel. These evaluations indicated that all impacts would be minor. [Text deleted.] None of the alternatives were found to pose a significant risk (when probability is considered) to the general population, nor would implementation of any of the alternatives result in a significant risk of disproportionately high and adverse impacts on minority or low-income groups within the general population.

Table 2–4. Summary of Impacts of Construction and Operation of Surplus Plutonium Disposition Facilities by Alternative and Site

Site	Air Quality ^a (incremental pollutant concentrations in $\mu\text{g}/\text{m}^3$)	Waste Management ^b (m^3)	Employment ^c (direct)	Land Disturbance ^d (ha)	Human Health Risk ^e (dose in person-rem)	Facility Accidents ^f	Transportation ^g
Alternative 1: No Action							
Hanford	No change	No change	No change	None	Dose Public: 4.7×10^{-2} Workers: 46 LCFs Public: 1.2×10^{-3} Workers: 0.92	NA	None
INEEL	No change	No change	No change	None	Dose Public: 7.6×10^{-5} Workers: 1.5 LCFs Public: 1.9×10^{-6} Workers: 2.9×10^{-2}	NA	None
Pantex	No change	No change	No change	None	Dose Public: 6.3×10^{-6} Storage Workers: 3 Packaging Workers: 16 LCFs Public: 1.6×10^{-7} Storage Workers: 6.0×10^{-2} Packaging Workers: 6.4×10^{-2}	NA	None

Alternatives for Disposition of Surplus Weapons-Usable Plutonium

Table 2-4. Summary of Impacts of Construction and Operation of Surplus Plutonium Disposition Facilities by Alternative and Site

Site	Air Quality ^a (incremental pollutant concentrations in $\mu\text{g}/\text{m}^3$)	Waste Management ^b (m^3)	Employment ^c (direct)	Land Disturbance ^d (ha)	Human Health Risk ^e (dose in person-rem)	Facility Accidents ^f	Transportation ^g
SRS	No change	No change	No change	None	Dose Public: 2.9×10^{-4} Workers: 7.5 LCFs Public: 7.2×10^{-6} Workers: 0.15	NA	None
LLNL	No change	No change	No change	None	Dose Public: 6.7×10^{-3} Workers: 25 LCFs Public: 1.7×10^{-4} Workers: 0.50	NA	None
LANL	No change	No change	No change	None	Dose Public: 2.7 Workers: 12.5 LCFs Public: 6.8×10^{-2} Workers: 0.25	NA	None
RFETS	No change	No change	No change	None	Dose Public: 0.10 Workers: 25 LCFs Public: 2.5×10^{-3} Workers: 0.50	NA	None

Table 2-4. Summary of Impacts of Construction and Operation of Surplus Plutonium Disposition Facilities by Alternative and Site

Site	Air Quality ^a (incremental pollutant concentrations in $\mu\text{g}/\text{m}^3$)	Waste Management ^b (m^3)	Employment ^c (direct)	Land Disturbance ^d (ha)	Human Health Risk ^e (dose in person-rem)	Facility Accidents ^f	Transportation ^g
SRS	No change	No change	No change	None	Dose Public: 2.9×10^{-4} Workers: 7.5 LCFs Public: 7.2×10^{-6} Workers: 0.15	NA	None
LLNL	No change	No change	No change	None	Dose Public: 6.7×10^{-3} Workers: 25 LCFs Public: 1.7×10^{-4} Workers: 0.50	NA	None
LANL	No change	No change	No change	None	Dose Public: 2.7 Workers: 12.5 LCFs Public: 6.8×10^{-2} Workers: 0.25	NA	None
RFETS	No change	No change	No change	None	Dose Public: 0.10 Workers: 25 LCFs Public: 2.5×10^{-3} Workers: 0.50	NA	None

Table 2-4. Summary of Impacts of Construction and Operation of Surplus Plutonium Disposition Facilities by Alternative and Site

Site	Air Quality ^a (incremental pollutant concentrations in $\mu\text{g}/\text{m}^3$)	Waste Management ^b (m^3)	Employment ^c (direct)	Land Disturbance ^d (ha)	Human Health Risk ^e (dose in person-rem)	Facility Accidents ^f	Transportation ^g
Alternative 2: Pit Conversion in FMEF, Immobilization in FMEF and HLWVF, and MOX in New Construction at Hanford							
Hanford	CO: 0.651 NO ₂ : 0.0873 PM ₁₀ : 0.00541 SO ₂ : 0.00496	TRU: 1,800 LLW: 2,300 MLLW: 50 Haz: 800	Construction: 1,235 Operations: 1,165	22	Construction (workforce) Dose: 0 LCFs: 0 Operations Dose Public: 7.2 Workers: 488 LCFs Public: 3.6×10^{-2} Workers: 2.0	Tritium release at pit conversion facility: 0.11 LCF	LCFs: 6.1×10^{-2} Traffic fatalities: 7.4×10^{-2} Kilometers traveled: 7.5M Additional risk of LCFs at Pantex: 8.3×10^{-2}

Table 2-4. Summary of Impacts of Construction and Operation of Surplus Plutonium Disposition Facilities by Alternative and Site

Site	Air Quality ^a (incremental pollutant concentrations in $\mu\text{g}/\text{m}^3$)	Waste Management ^b (m^3)	Employment ^c (direct)	Land Disturbance ^d (ha)	Human Health Risk ^e (dose in person-rem)	Facility Accidents ^f	Transportation ^g
Alternative 3: Pit Conversion, Immobilization, and MOX in New Construction at SRS							
SRS	CO: 0.37 NO ₂ : 0.0634 PM ₁₀ : 0.00423 SO ₂ : 0.124	TRU: 1,800 LLW: 2,400 MLLW: 50 Haz: 940	Construction: 1,968 Operations: 1,120	32 Disturbance could impact a site potentially eligible for the National Register of Historic Places	Construction (workforce) Dose: 4.1 LCFs: 1.6×10^{-3} Operations Dose Public: 1.8 Workers: 456 LCFs Public: 9.0×10^{-3} Workers: 1.8	Tritium release at pit conversion facility: 5.0×10^{-2} LCF	LCFs: 8.1×10^{-2} Traffic fatalities: 5.3×10^{-2} Kilometers traveled: 4.3M Additional risk of LCFs at Pantex: 8.3×10^{-2}
[Text deleted because alternative deleted.] ^h							

Table 2-4. Summary of Impacts of Construction and Operation of Surplus Plutonium Disposition Facilities by Alternative and Site

Site	Air Quality ^a (incremental pollutant concentrations in $\mu\text{g}/\text{m}^3$)	Waste Management ^b (m^3)	Employment ^c (direct)	Land Disturbance ^d (ha)	Human Health Risk ^e (dose in person-rem)	Facility Accidents ^f	Transportation ^g
Alternative 4A: Pit Conversion in New Construction at Pantex, and Immobilization in FMEF and HLWVF and MOX in New Construction at Hanford							
Pantex	CO: 0.381 NO ₂ : 0.0374 PM ₁₀ : 0.00215 SO ₂ : 0.00064	TRU: 180 LLW: 600 MLLW: 10 Haz: 20	Construction: 451 Operations: 400	5.0	Construction (workforce) Dose: 0 LCFs: 0 Operations Dose Public: 0.58 Workers: 192 LCFs Public: 2.9×10^{-3} Workers: 0.77	Tritium release at pit conversion facility: 1.8×10^{-2} LCF	LCFs: 5.7×10^{-2} Traffic fatalities: 6.5×10^{-2} Kilometers traveled: 6.3M Additional risk of LCFs at Pantex: 0
Hanford	CO: 0.374 NO ₂ : 0.052 PM ₁₀ : 0.00367 SO ₂ : 0.00343	TRU: 1,600 LLW: 1,700 MLLW: 40 Haz: 780	Construction: 1,148 Operations: 720	16	Construction (workforce) Dose: 0 LCFs: 0 Operations Dose Public: 0.30 Workers: 264 LCFs Public: 1.5×10^{-3} Workers: 1.1	Nuclear criticality at MOX facility: 1.9×10^{-2} LCF	

Alternatives for Disposition of Surplus Weapons-Usable Plutonium

Table 2-4. Summary of Impacts of Construction and Operation of Surplus Plutonium Disposition Facilities by Alternative and Site

Site	Air Quality ^a (incremental pollutant concentrations in $\mu\text{g}/\text{m}^3$)	Waste Management ^b (m^3)	Employment ^c (direct)	Land Disturbance ^d (ha)	Human Health Risk ^e (dose in person-rem)	Facility Accidents ^f	Transportation ^g
Alternative 4B: Pit Conversion in New Construction at Pantex, and Immobilization in FMEF and HLWVF and MOX in FMEF at Hanford							
Pantex	CO: 0.381 NO ₂ : 0.0374 PM ₁₀ : 0.00215 SO ₂ : 0.00064	TRU: 180 LLW: 600 MLLW: 10 Haz: 20	Construction: 451 Operations: 400	5.0	Construction (workforce) Dose: 0 LCFs: 0 Operations Dose Public: 0.58 Workers: 192 LCFs Public: 2.9×10^{-3} Workers: 0.77	Tritium release at pit conversion facility: 1.8×10^{-2} LCF	LCFs: 5.7×10^{-2} Traffic fatalities: 6.5×10^{-2} Kilometers traveled: 6.3M Additional risk of LCFs at Pantex: 0
Hanford	CO: 0.507 NO ₂ : 0.0707 PM ₁₀ : 0.00499 SO ₂ : 0.00468	TRU: 1,600 LLW: 1,700 MLLW: 40 Haz: 780	Construction: 1,064 Operations: 765	17.4	Construction (workforce) Dose: 0 LCFs: 0 Operations Dose Public: 0.15 Workers: 296 LCFs Public: 7.3×10^{-4} Workers: 1.2	Nuclear criticality at MOX or immobilization facility: 1.9×10^{-2} LCF	

Table 2-4. Summary of Impacts of Construction and Operation of Surplus Plutonium Disposition Facilities by Alternative and Site

Site	Air Quality ^a (incremental pollutant concentrations in $\mu\text{g}/\text{m}^3$)	Waste Management ^b (m^3)	Employment ^c (direct)	Land Disturbance ^d (ha)	Human Health Risk ^e (dose in person-rem)	Facility Accidents ^f	Transportation ^g
Alternative 5: Pit Conversion in New Construction at Pantex, and Immobilization in New Construction and DWPF and MOX in New Construction at SRS							
Pantex	CO: 0.381 NO ₂ : 0.0374 PM ₁₀ : 0.00215 SO ₂ : 0.00064	TRU: 180 LLW: 600 MLLW: 10 Haz: 20	Construction: 451 Operations: 400	5.0	Construction (workforce) Dose: 0 LCFs: 0 Operations Dose Public: 0.58 Workers: 192 LCFs Public: 2.9×10^{-3} Workers: 0.77	Tritium release at pit conversion facility: 1.8×10^{-2} LCF	LCFs: 7.7×10^{-2} Traffic fatalities: 5.0×10^{-2} Kilometers traveled: 3.8M Additional risk of LCFs at Pantex: 0
SRS	CO: 0.275 NO ₂ : 0.0347 PM ₁₀ : 0.0024 SO ₂ : 0.0829	TRU: 1,600 LLW: 1,800 MLLW: 40 Haz: 920	Construction: 1,692 Operations: 720	27 Disturbance could impact a site potentially eligible for the National Register of Historic Places	Construction (workforce) Dose: 2.7 LCFs: 1.1×10^{-3} Operations Dose Public: 1.8×10^{-2} Workers: 264 LCFs Public: 9.2×10^{-4} Workers: 1.1	Nuclear criticality at MOX facility: 8.0×10^{-3} LCF	

Alternatives for Disposition of Surplus Weapons-Usable Plutonium

Table 2-4. Summary of Impacts of Construction and Operation of Surplus Plutonium Disposition Facilities by Alternative and Site

Site	Air Quality ^a (incremental pollutant concentrations in $\mu\text{g}/\text{m}^3$)	Waste Management ^b (m^3)	Employment ^c (direct)	Land Disturbance ^d (ha)	Human Health Risk ^e (dose in person-rem)	Facility Accidents ^f	Transportation ^g
Alternative 6A: Pit Conversion in FMEF and MOX in New Construction at Hanford, and Immobilization in New Construction and DWPF at SRS							
Hanford	CO: 0.247 NO ₂ : 0.031 PM ₁₀ : 0.00143 SO ₂ : 0.00123	TRU: 860 LLW: 1,500 MLLW: 40 Haz: 50	Construction: 844 Operations: 785	14	Construction (workforce) Dose: 0 LCFs: 0 Operations Dose Public: 7.2 Workers: 214 LCFs Public: 3.6×10^{-2} Workers: 0.86	Tritium release at pit conversion facility: 0.11 LCF	LCFs: 9.6×10^{-2} Traffic fatalities: 9.1×10^{-2} Kilometers traveled: 8.6M Additional risk of LCFs at Pantex: 8.3×10^{-2}
SRS	CO: 0.152 NO ₂ : 0.0242 PM ₁₀ : 0.00181 SO ₂ : 0.0442	TRU: 950 LLW: 810 MLLW: 10 Haz: 890	Construction: 1,014 Operations: 335	15 Disturbance could impact a site potentially eligible for the National Register of Historic Places	Construction (workforce) Dose: 1.5 LCFs: 6.0×10^{-4} Operations Dose Public: 2.8×10^{-3} Workers: 242 LCFs Public: 1.4×10^{-5} Workers: 0.97	Nuclear criticality at immobilization facility: 8.0×10^{-4} LCF	

Table 2-4. Summary of Impacts of Construction and Operation of Surplus Plutonium Disposition Facilities by Alternative and Site

Site	Air Quality ^a (incremental pollutant concentrations in $\mu\text{g}/\text{m}^3$)	Waste Management ^b (m^3)	Employment ^c (direct)	Land Disturbance ^d (ha)	Human Health Risk ^e (dose in person-rem)	Facility Accidents ^f	Transportation ^g
Alternative 6B: Pit Conversion and MOX Collocated in FMEF at Hanford, and Immobilization in New Construction and DWPF at SRS							
Hanford	CO: 0.247 NO ₂ : 0.031 PM ₁₀ : 0.00143 SO ₂ : 0.00123	TRU: 860 LLW: 1,500 MLLW: 40 Haz: 50	Construction: 655 Operations: 785	14	Construction (workforce) Dose: 0 LCFs: 0 Operations Dose Public: 7.0 Workers: 214 LCFs Public: 3.5×10^{-2} Workers: 0.86	Tritium release at pit conversion facility: 0.11 LCF	LCFs: 9.6×10^{-2} Traffic fatalities: 9.1×10^{-2} Kilometers traveled: 8.6M Additional risk of LCFs at Pantex: 8.3×10^{-2}
SRS	CO: 0.152 NO ₂ : 0.0242 PM ₁₀ : 0.00181 SO ₂ : 0.0442	TRU: 950 LLW: 810 MLLW: 10 Haz: 890	Construction: 1,014 Operations: 335	15 Disturbance could impact a site potentially eligible for the National Register of Historic Places	Construction (workforce) Dose: 1.5 LCFs: 6.0×10^{-4} Operations Dose Public: 2.8×10^{-3} Workers: 242 LCFs Public: 1.4×10^{-5} Workers: 0.97	Nuclear criticality at immobilization facility: 8.0×10^{-4} LCF	

Alternatives for Disposition of Surplus Weapons-Usable Plutonium

Table 2-4. Summary of Impacts of Construction and Operation of Surplus Plutonium Disposition Facilities by Alternative and Site

Site	Air Quality ^a (incremental pollutant concentrations in $\mu\text{g}/\text{m}^3$)	Waste Management ^b (m^3)	Employment ^c (direct)	Land Disturbance ^d (ha)	Human Health Risk ^e (dose in person-rem)	Facility Accidents ^f	Transportation ^g
Alternative 7: Pit Conversion in FPF and MOX in New Construction at INEEL, and Immobilization in New Construction and DWPF at SRS							
INEEL	CO: 0.762 NO ₂ : 0.144 PM ₁₀ : 0.00833 SO ₂ : 0.345	TRU: 860 LLW: 1,500 MLLW: 40 Haz: 50	Construction: 866 Operations: 743	14	Construction (workforce) Dose: 2.0 LCFs: 7.7×10^{-4} Operations Dose Public: 2.2 Workers: 192 LCFs Public: 1.1×10^{-2} Workers: 0.77	Tritium release at pit conversion facility: 4.4×10^{-3} LCF	LCFs: 9.4×10^{-2} Traffic fatalities: 8.3×10^{-2} Kilometers traveled: 7.5M Additional risks of LCFs at Pantex: 8.3×10^{-2}
SRS	CO: 0.152 NO ₂ : 0.0242 PM ₁₀ : 0.00181 SO ₂ : 0.0442	TRU: 950 LLW: 810 MLLW: 10 Haz: 890	Construction: 1,014 Operations: 335	15 Disturbance could impact a site potentially eligible for the National Register of Historic Places	Construction (workforce) Dose: 1.5 LCFs: 6.0×10^{-4} Operations Dose Public: 2.8×10^{-3} Workers: 242 LCFs Public: 1.4×10^{-5} Workers: 0.97	Nuclear criticality at immobilization facility: 8.0×10^{-4} LCF	

Table 2-4. Summary of Impacts of Construction and Operation of Surplus Plutonium Disposition Facilities by Alternative and Site

Site	Air Quality ^a (incremental pollutant concentrations in $\mu\text{g}/\text{m}^3$)	Waste Management ^b (m^3)	Employment ^c (direct)	Land Disturbance ^d (ha)	Human Health Risk ^e (dose in person-rem)	Facility Accidents ^f	Transportation ^g
Alternative 8: Pit Conversion in FPF and MOX in New Construction at INEEL, and Immobilization in FMEF and HLWVF at Hanford							
INEEL	CO: 0.762 NO ₂ : 0.144 PM ₁₀ : 0.00833 SO ₂ : 0.345	TRU: 860 LLW: 1,500 MLLW: 40 Haz: 50	Construction: 866 Operations: 743	14	Construction (workforce) Dose: 2.0 LCFs: 7.7×10^{-4} Operations Dose Public: 2.2 Workers: 192 LCFs Public: 1.1×10^{-2} Workers: 0.77	Tritium release at pit conversion facility: 4.4×10^{-3} LCF	LCFs: 5.9×10^{-2} Traffic fatalities: 6.5×10^{-2} Kilometers traveled: 6.3M Additional risks of LCFs at Pantex: 8.3×10^{-2}
Hanford	CO: 0.271 NO ₂ : 0.0376 PM ₁₀ : 0.00265 SO ₂ : 0.00249	TRU: 950 LLW: 800 MLLW: 10 Haz: 750	Construction: 414 Operations: 335	4.5	Construction (workforce) Dose: 0 LCFs: 0 Operations Dose Public: 7.8×10^{-3} Workers: 242 LCFs Public: 3.9×10^{-5} Workers: 0.97	Nuclear criticality at immobilization facility: 2.7×10^{-3} LCF	

Alternatives for Disposition of Surplus Weapons-Usable Plutonium

Table 2-4. Summary of Impacts of Construction and Operation of Surplus Plutonium Disposition Facilities by Alternative and Site

Site	Air Quality ^a (incremental pollutant concentrations in $\mu\text{g}/\text{m}^3$)	Waste Management ^b (m^3)	Employment ^c (direct)	Land Disturbance ^d (ha)	Human Health Risk ^e (dose in person-rem)	Facility Accidents ^f	Transportation ^g
Alternative 9: Pit Conversion and MOX in New Construction at Pantex, and Immobilization in New Construction and DWPF at SRS							
Pantex	CO: 0.705 NO ₂ : 0.0736 PM ₁₀ : 0.00531 SO ₂ : 0.00265	TRU: 860 LLW: 1,500 MLLW: 40 Haz: 50	Construction: 1,048 Operations: 785	17	Construction (workforce) Dose: 0 LCFs: 0 Operations Dose Public: 0.61 Workers: 214 LCFs Public: 3.0×10^{-3} Workers: 0.86	Tritium release at pit conversion facility: 1.8×10^{-2} LCF	LCFs: 8.1×10^{-2} Traffic fatalities: 5.2×10^{-2} Kilometers traveled: 4.8M Additional risk of LCFs at Pantex: 0
SRS	CO: 0.152 NO ₂ : 0.0242 PM ₁₀ : 0.00181 SO ₂ : 0.0442	TRU: 950 LLW: 810 MLLW: 10 Haz: 890	Construction: 1,014 Operations: 335	15 Disturbance could impact a site potentially eligible for the National Register of Historic Places	Construction (workforce) Dose: 1.5 LCFs: 6.0×10^{-4} Operations Dose Public: 2.8×10^{-3} Workers: 242 LCFs Public: 1.4×10^{-5} Workers: 0.97	Nuclear criticality at immobilization facility: 8.0×10^{-4} LCF	

Table 2-4. Summary of Impacts of Construction and Operation of Surplus Plutonium Disposition Facilities by Alternative and Site

Site	Air Quality ^a (incremental pollutant concentrations in $\mu\text{g}/\text{m}^3$)	Waste Management ^b (m^3)	Employment ^c (direct)	Land Disturbance ^d (ha)	Human Health Risk ^e (dose in person-rem)	Facility Accidents ^f	Transportation ^g
Alternative 10: Pit Conversion and MOX in New Construction at Pantex, and Immobilization in FMEF and HLWVF at Hanford							
Pantex	CO: 0.705 NO ₂ : 0.0736 PM ₁₀ : 0.00531 SO ₂ : 0.00265	TRU: 860 LLW: 1,500 MLLW: 40 Haz: 50	Construction: 1,048 Operations: 785	17	Construction (workforce) Dose: 0 LCFs: 0 Operations Dose Public: 0.61 Workers: 214 LCFs Public: 3.0×10^{-3} Workers: 0.86	Tritium release at pit conversion facility: 1.8×10^{-2} LCF	LCFs: 4.6×10^{-2} Traffic fatalities: 4.3×10^{-2} Kilometers traveled: 3.6M Additional risk of LCFs at Pantex: 0
Hanford	CO: 0.271 NO ₂ : 0.0376 PM ₁₀ : 0.00265 SO ₂ : 0.00249	TRU: 950 LLW: 800 MLLW: 10 Haz: 750	Construction: 414 Operations: 335	4.5	Construction (workforce) Dose: 0 LCFs: 0 Operations Dose Public: 7.8×10^{-3} Workers: 242 LCFs Public: 3.9×10^{-5} Workers: 0.97	Nuclear criticality at immobilization facility: 2.7×10^{-3} LCF	

Alternatives for Disposition of Surplus Weapons-Usable Plutonium

Table 2-4. Summary of Impacts of Construction and Operation of Surplus Plutonium Disposition Facilities by Alternative and Site

Site	Air Quality ^a (incremental pollutant concentrations in $\mu\text{g}/\text{m}^3$)	Waste Management ^b (m^3)	Employment ^c (direct)	Land Disturbance ^d (ha)	Human Health Risk ^e (dose in person-rem)	Facility Accidents ^f	Transportation ^g
Alternative 11A: Pit Conversion in FMEF and Immobilization in FMEF and HLWVF at Hanford (No MOX)							
Hanford	CO: 0.548 NO ₂ : 0.0729 PM ₁₀ : 0.0044 SO ₂ : 0.00401	TRU: 1,400 LLW: 1,700 MLLW: 20 Haz: 770	Construction: 463 Operations: 812	11	Construction (workforce) Dose: 0 LCFs: 0 Operations Dose Public: 6.9 Workers: 490 LCFs Public: 3.4×10^{-2} Workers: 2.0	Tritium release at pit conversion facility: 0.11 LCF	LCFs: 7.4×10^{-2} Traffic fatalities: 5.4×10^{-2} Kilometers traveled: 3.7M Additional risk of LCFs at Pantex: 8.3×10^{-2}

Table 2-4. Summary of Impacts of Construction and Operation of Surplus Plutonium Disposition Facilities by Alternative and Site

Site	Air Quality ^a (incremental pollutant concentrations in $\mu\text{g}/\text{m}^3$)	Waste Management ^b (m^3)	Employment ^c (direct)	Land Disturbance ^d (ha)	Human Health Risk ^e (dose in person-rem)	Facility Accidents ^f	Transportation ^g
Alternative 11B: Pit Conversion in New Construction at Pantex and Immobilization in FMEF and HLWVF at Hanford (No MOX)							
Pantex	CO: 0.381 NO ₂ : 0.0374 PM ₁₀ : 0.00215 SO ₂ : 0.00064	TRU: 180 LLW: 600 MLLW: 10 Haz: 20	Construction: 451 Operations: 400	5.0	Construction (workforce) Dose: 0 LCFs: 0 Operations Dose Public: 0.58 Workers: 192 LCFs Public: 2.9×10^{-3} Workers: 0.77	Tritium release at pit conversion facility: 1.8×10^{-2} LCF	LCFs: 7.07×10^{-2} Traffic fatalities: 4.5×10^{-2} Kilometers traveled: 2.5M Additional risk of LCFs at Pantex: 0
Hanford	CO: 0.271 NO ₂ : 0.0376 PM ₁₀ : 0.00265 SO ₂ : 0.00249	TRU: 1,300 LLW: 1,100 MLLW: 10 Haz: 750	Construction: 414 Operations: 367	4.5	Construction (workforce) Dose: 0 LCFs: 0 Operations Dose Public: 1.6×10^{-2} Workers: 266 LCFs Public: 8.0×10^{-5} Workers: 1.1	Nuclear criticality at immobilization facility: 2.7×10^{-3} LCF	

Alternatives for Disposition of Surplus Weapons-Usable Plutonium

Table 2-4. Summary of Impacts of Construction and Operation of Surplus Plutonium Disposition Facilities by Alternative and Site

Site	Air Quality ^a (incremental pollutant concentrations in $\mu\text{g}/\text{m}^3$)	Waste Management ^b (m^3)	Employment ^c (direct)	Land Disturbance ^d (ha)	Human Health Risk ^e (dose in person-rem)	Facility Accidents ^f	Transportation ^g
Alternative 12A: Pit Conversion in New Construction and Immobilization in New Construction and DWPF at SRS (No MOX)							
SRS	CO: 0.246 NO ₂ : 0.0529 PM ₁₀ : 0.00364 SO ₂ : 0.0852	TRU: 1,500 LLW: 1,700 MLLW: 20 Haz: 910	Construction: 1,196 Operations: 751	20 Disturbance could impact a site potentially eligible for the National Register of Historic Places	Construction (workforce) Dose: 2.9 LCFs: 1.2×10^{-3} Operations Dose Public: 1.6 Workers: 446 LCFs Public: 8.0×10^{-3} Workers: 1.8	Tritium release at pit conversion facility: 5.0×10^{-2} LCF	LCFs: 0.152 Traffic fatalities: 8.1×10^{-2} Kilometers traveled: 4.4M Additional risk of LCFs at Pantex: 8.3×10^{-2}

Table 2-4. Summary of Impacts of Construction and Operation of Surplus Plutonium Disposition Facilities by Alternative and Site

Site	Air Quality ^a (incremental pollutant concentrations in $\mu\text{g}/\text{m}^3$)	Waste Management ^b (m^3)	Employment ^c (direct)	Land Disturbance ^d (ha)	Human Health Risk ^e (dose in person-rem)	Facility Accidents ^f	Transportation ^g
Alternative 12B: Pit Conversion in New Construction at Pantex, and Immobilization in New Construction and DWPF at SRS (No MOX)							
Pantex	CO: 0.381 NO ₂ : 0.0374 PM ₁₀ : 0.00215 SO ₂ : 0.00064	TRU: 180 LLW: 600 MLLW: 10 Haz: 20	Construction: 451 Operations: 400	5.0	Construction (workforce) Dose: 0 LCFs: 0 Operations Dose Public: 0.58 Workers: 192 LCFs Public: 2.9×10^{-3} Workers: 0.77	Tritium release at pit conversion facility: 1.8×10^{-2} LCF	LCFs: 0.148 Traffic fatalities: 7.8×10^{-2} Kilometers traveled: 3.9M Additional risk of LCFs at Pantex: 0
SRS	CO: 0.152 NO ₂ : 0.0242 PM ₁₀ : 0.00181 SO ₂ : 0.0442	TRU: 1,300 LLW: 1,100 MLLW: 10 Haz: 890	Construction: 1,014 Operations: 351	15 Disturbance could impact a site potentially eligible for the National Register of Historic Places	Construction (workforce) Dose: 1.5 LCFs: 6.0×10^{-4} Operations Dose Public: 5.8×10^{-3} Workers: 254 LCFs Public: 2.9×10^{-5} Workers: 1.0	Nuclear criticality at immobilization facility: 8.0×10^{-4} LCF	

Alternatives for Disposition of Surplus Weapons-Usable Plutonium

Table 2-4. Summary of Impacts of Construction and Operation of Surplus Plutonium Disposition Facilities by Alternative and Site

- ^a Values represent the incremental criteria pollutant concentrations associated with surplus plutonium disposition operations for the annual averaging period for nitrogen dioxide (NO₂), particulate matter with an aerodynamic diameter smaller than or equal to 10 microns (PM₁₀), and sulfur dioxide (SO₂), and for the 8-hour averaging period for carbon monoxide.
- ^b Values are based on a construction period of approximately 3 years and 10 years of operation.
- ^c Values are for the peak year of construction for each site and for the annual operation of all facilities for each alternative. Personnel needed to operate the planned HLW vitrification facility at Hanford, or DWPF at SRS, are not included.
- ^d Values represent the total land disturbance at each site from construction and operations.
- ^e Values for Alternative 1 represent impacts over 50 years of operation under No Action. Those for the remaining alternatives are for the period of construction and 10 years of operation. Public dose values represent the annual radiological dose (in person-rem) to the population within 80 km (50 mi) of the facility location for the year 2030 under Alternative 1, or for 2010 under Alternatives 2 through 12. Worker dose values represent the total radiological dose to involved workers at the facility (in person-rem/year). Public LCFs represent the 50-year LCFs estimated to occur in the population within 80 km (50 mi) for the year 2030 under Alternative 1, or the 10-year LCFs estimated to occur for the year 2010 under Alternatives 2 through 12. Worker LCFs represent the associated 50-year or 10-year LCFs estimated to occur in the involved workforce.
- ^f The most severe of the design basis accidents (based on 95 percent meteorological conditions) is used to obtain the population LCF. Higher LCFs would be associated with postulated beyond-design-basis accidents as presented in Chapter 4 and described in detail in Appendix K.
- ^g For alternatives that involve more than one site, the transportation impacts for the entire alternative are shown in the first site listed in the alternative. LCFs are from the radiological exposure associated with incident-free operations, radiological accidents, and fatalities expected as a result of vehicle emissions. Traffic fatalities are from nonradiological vehicle accidents. LCFs at Pantex are associated with repackaging requirements if the pit conversion facility were located elsewhere.
- ^h Alternatives 3B, 5B, 6C, 6D, 7B, 9B, 12B, and 12D in the SPD Draft EIS have been deleted. Alternative 12C has been renumbered as 12B. Table entries for deleted alternatives have likewise been deleted.
- Key:** DWPF, Defense Waste Processing Facility; FMEF, Fuels and Materials Examination Facility; FPF, Fuel Processing Facility; Haz, hazardous; HLWVF, high-level-waste vitrification facility; LCF, latent cancer fatality; LLW, low-level waste; MLLW, mixed low-level waste; NA, not applicable; TRU, transuranic.

2.18.2 Summary of Lead Assembly Fabrication and Postirradiation Examination Impacts

The impacts on key resources from fabrication of lead assemblies at the five candidate sites (ANL–W, Hanford, LLNL, LANL, and SRS) evaluated in Section 4.27 are summarized in Table 2–5. These areas include waste management, human health risk during normal operations, facility accidents, and transportation. The transportation analysis includes the shipment of plutonium dioxide from LANL to the candidate site; depleted uranium hexafluoride from the representative DOE storage site at the Portsmouth Gaseous Diffusion Plant to the representative conversion facility in Wilmington, North Carolina; uranium dioxide from the conversion facility to the lead assembly fabrication facility; MOX fuel rods from the lead assembly facility to the McGuire reactor for irradiation; and irradiated fuel rods from McGuire to a postirradiation examination facility.³² Total distance traveled, in kilometers, is provided for each proposed fabrication site. Because facility modification activities would occur inside existing buildings (i.e., no new buildings would be constructed and no additional land would be disturbed), there should be little increase in air pollutants; land disturbances would be minimal; and the number of construction workers would be low. Little or no impacts are expected on any other resources areas.

Impacts from lead assembly and postirradiation examination activities are based on the fabrication of 10 assemblies, although it is likely that only 2 would be needed. If less than 10 lead assemblies were fabricated, the impacts would be lower than those presented in this SPD EIS. Impacts from facility modifications would not be expected to change because the facility modifications would be the same regardless of the number of assemblies produced. Impacts from routine operations, such as resources used, personnel exposure, waste generation, and transportation, would be expected to be reduced in proportion to the number of assemblies produced. The consequences of facility and transportation accidents would be expected to remain the same because the material at risk at any one time would likely not change. However, the risk of these accidents occurring would be reduced as the number of lead assemblies decreased.

There are no appreciable differences in environmental impacts among the five lead assembly candidate sites. There would be little difference in the volume of waste generated at any of the sites. The small differences in TRU waste and LLW would be due to wastes generated during modification of contaminated areas of existing buildings at ANL–W and LANL. In addition, less than 5 m³ (6.5 ft³) of hazardous waste would be generated during facility modification and lead assembly fabrication. The total amount of nonhazardous waste generated, primarily sanitary wastewater, would range from 8,700 to 13,500 m³ (11,380 to 17,658 yd³). No LCFs for either workers or the public would be expected to result from fabrication of lead assemblies at any of the proposed locations during routine operations. Impacts from facility accidents also show that no LCFs would be expected in the general population at any site from the postulated bounding design basis accident. Comparison of transportation impacts shows little differences among the sites, with no expected traffic fatalities or LCFs. Likewise, there are not expected to be any appreciable differences between the two postirradiation examination sites.

No major consequences for the maximally exposed involved worker would be expected from leaks, spills, and smaller fires. These accidents are such that involved workers would either be able to evacuate immediately or would not be affected by the events. Explosions, on the other hand, could result in immediate injuries from flying debris, as well as the uptake of plutonium and uranium particulates through inhalation. If a criticality were to occur, workers within tens of meters could receive very high to fatal radiation exposures from the initial burst. The dose would strongly depend on the magnitude of the criticality (number of fissions), the distance from the criticality, and the amount of shielding provided by the structures and equipment between the workers and the criticality. Beyond-design-basis earthquakes would also have substantial consequences, ranging from workers

³² Shipments of spent fuel to the potential geologic repository are analyzed in the *Draft Environmental Impact Statement for a Geologic Repository for the Disposal of Spent Nuclear Fuel and High-Level Radioactive Waste at Yucca Mountain, Nye County, Nevada* (DOE/EIS-0250D) (DOE 1999b).

being killed by debris from collapsing equipment and structures to high radiation exposures and uptakes of radionuclides. For most accidents, immediate emergency response actions should reduce the consequences to workers near the accident.

The impacts of postirradiation examination at ANL–W and ORNL, as evaluated in Section 4.27.6, would be minimal. No construction waste would be generated. With the exception of nonhazardous wastewater at ANL–W, all categories of waste generated during routine operations would use less than 1 percent of either site’s applicable treatment, storage, and disposal capacity. Nonhazardous wastewater at ANL–W would use about 6 percent of that site’s applicable capacity. Transportation impacts for postirradiation examination at ANL–W are included in the lead assembly impacts presented in Table 2–5. Transportation impacts for postirradiation examination at ORNL would be lower than those listed in Table 2–5 because the distance traveled would be less.

Table 2–5. Summary of Impacts of Lead Assembly Fabrication at the Candidate Sites^a

Candidate Site	Waste Management ^b (m ³)	Human Health Risk ^c (dose in person-rem)	Facility Accidents ^d	Transportation ^e
ANL–W	Total TRU waste: 132 Total LLW: 736 Total MLLW: 4 Total Haz: 0	Dose Public: 0.011 Workers: 28 LCFs Public: 5.5×10 ⁻⁶ Workers: 0.011	Nuclear criticality LCFs: 1.7×10 ⁻⁴	Radiological LCFs: 8.1×10 ⁻³ Traffic fatalities: 1.8×10 ⁻³ Kilometers traveled: 77,000
Hanford	Total TRU waste: 132 Total LLW: 700 Total MLLW: 4 Total Haz: 0	Dose Public: 0.025 Workers: 28 LCFs Public: 1.2×10 ⁻⁵ Workers: 0.011	Nuclear criticality LCFs: 2.7×10 ⁻³	Radiological LCFs: 8.1×10 ⁻³ Traffic fatalities: 1.9×10 ⁻³ Kilometers traveled: 89,000
LLNL	Total TRU waste: 132 Total LLW: 700 Total MLLW: 4 Total Haz: 0	Dose Public: 1.1 Workers: 28 LCFs Public: 5.5×10 ⁻⁴ Workers: 0.011	Nuclear criticality LCFs: 3.2×10 ⁻²	Radiological LCFs: 8.4×10 ⁻³ Traffic fatalities: 1.8×10 ⁻³ Kilometers traveled: 73,000
LANL	Total TRU waste: 137 Total LLW: 705 Total MLLW: 4 Total Haz: 0	Dose Public: 0.025 Workers: 28 LCFs Public: 1.2×10 ⁻⁵ Workers: 0.011	Nuclear criticality LCFs: 3.2×10 ⁻³	Radiological LCFs: 8.1×10 ⁻³ Traffic fatalities: 1.6×10 ⁻³ Kilometers traveled: 49,000
SRS	Total TRU waste: 132 Total LLW: 700 Total MLLW: 4 Total Haz: 2	Dose Public: 6.6×10 ⁻³ Workers: 28 LCFs Public: 3.3×10 ⁻⁶ Workers: 0.011	Nuclear criticality LCFs: 6.5×10 ⁻⁴	Radiological LCFs: 8.3×10 ⁻³ Traffic fatalities: 1.6×10 ⁻³ Kilometers traveled: 67,000

^a Impacts are based on the fabrication of 10 lead assemblies and irradiation of 8. Should only two lead assemblies be fabricated and irradiated, impacts would be lower than indicated.

^b Totals for 2-year modification and 3-year operation of lead assembly facility.

^c Annual dose for public residing within 80 km (50 mi) of the candidate site. Worker dose is the same at all five facilities because estimated number of workers and estimated dose to worker does not vary by site. Estimated dose to public varies based on projected population within 80 km (50 mi) of candidate site.

^d The most severe of the design basis accidents is listed.

^e LCFs are from the radiological exposure associated with incident-free operations and radiological accidents; traffic fatalities, from nonradiological traffic accidents.

Key: ANL–W, Argonne National Laboratory–West; LANL, Los Alamos National Laboratory; LCF, latent cancer fatality; LLNL, Lawrence Livermore National Laboratory; LLW, low-level waste; MLLW, mixed-low-level waste; TRU, transuranic.

No LCFs would be expected to either workers or the public from routine postirradiation examination activities. There would be no routine releases of radioactivity to the environment, and thus, radiological impacts on the public. The average annual dose to facility workers would be 177 mrem, for an annual dose to the total facility

workforce of 1.8 person-rem. The most severe accident would be a nuclear criticality. Such an accident could result in high, though probably not fatal, radiological exposures to hot cell workers. No LCFs would be expected in the general population.

If DOE were to decide to immobilize all 50 t (55 tons) of surplus plutonium, no lead assembly activities would be required. Should DOE decide to pursue the MOX option, but to not fabricate lead assemblies, such activities would not occur at any of the five sites. Under both of these scenarios, current operations would continue at the sites and the environmental conditions would remain at baseline levels. (See Chapter 3 for a description of the current environmental conditions at the sites.)

2.18.3 MOX Fuel Integrated Impacts

The impacts from implementing the MOX fuel fabrication alternatives would not be limited to those associated with the MOX facility, but would also include impacts from lead assembly fabrication, irradiation, and postirradiation examination, and the use of reactors for irradiation of the MOX fuel assemblies. Any new construction would occur at existing DOE sites. MOX-related operations at all sites would be compatible with, or similar to, activities already occurring at those locations.

Tables 2–6 through 2–11 describe the potential impacts of implementation of the MOX alternatives, from fabrication of the MOX fuel assemblies and lead assemblies to irradiation of the assemblies in domestic, commercial reactors, and the transportation for all radioactive material movements. While these impacts would be cumulative over the life of the campaign, they would not all be concurrent. The data presented are those reported in Chapter 4.

Air emissions, presented in Table 2–6, would result primarily from building heating and vehicular emissions. Releases of criteria pollutants are provided as a range, with the lowest emissions at Hanford, where electricity is the method of heating, and the highest at INEEL, where coal-fired boilers produce steam for heating and travel distances for personnel result in vehicular emissions double those estimated for other candidate sites. Lead assembly fabrication and postirradiation examination activities are relatively small efforts that are not expected to measurably increase air emissions at any of the candidate sites. There are no nonradiological emissions from these facilities that are regulated under the National Emission Standards for Hazardous Air Pollutants (NESHAPs). As discussed in Section 4.32, radiological NESHAPs emissions would be monitored and maintained as part of the total site limit of 10 mrem/yr from all sources. There would be no incremental difference in the air emissions from Catawba, McGuire, or North Anna related to using MOX fuel. Criteria, toxic, and hazardous pollutant emissions are not related to the type of reactor fuel. Rather, emission of these pollutants from the reactor sites would be related to ancillary processes such as operation of diesel generators, periodic testing of emergency diesel generators, and facility operations.

TRU waste and LLW would be generated during operation of both the lead assembly and full-scale MOX facilities (see Table 2–7). The amount of waste generated would be process-specific, and would not vary appreciably by site. Lead assembly fabrication would result in a total of 132 m³ (173 yd³) of TRU waste and 700 m³ (916 yd³) of LLW waste. The larger amount of waste generated on an annual basis by lead assembly fabrication, as compared to full-scale fabrication, would be attributed to operational differences between fabricating MOX fuel on a laboratory rather than commercial scale. Similarly, activities such as material recycle may not be implemented to as great an extent on the smaller scale. No increase is expected in the amount of waste generated at the reactor sites as a result of using MOX fuel.

Table 2–6. Potential Impacts on Air Quality of MOX Fuel Fabrication and Irradiation

Criteria Pollutant	MOX Facility ^a (kg/yr)	L.A. Fab. and Postirrad. Exam. (kg/yr)	Reactor Operation Increment (kg/yr)	Total MOX Fuel Increment (kg/yr)
Carbon monoxide	35K to 83K	0	0	35K to 83K
Nitrogen dioxide	11K to 32K	0	0	11K to 32K
PM ₁₀	31K to 60K	0	0	31K to 60K
Sulfur dioxide	0.1K to 73K	0	0	0.1K to 73K
Volatile organic compounds	4K to 10K	0	0	4K to 10K
Total suspended particulates ^b	31K to 60K	0	0	31K to 60K

^a Includes vehicle emissions.

^b Total suspended particulates assumed to be the same as PM₁₀.

[Text deleted.]

Table 2–7. Potential Impacts on Waste Generation of MOX Fuel Fabrication and Irradiation

Waste Type	MOX Facility (m ³)	L.A. Fab. and Postirrad. Exam. (m ³)	Reactor Operation Increment	Total MOX Fuel Increment ^a (m ³)
TRU waste	680	143	0	823
Low-level waste	940	840	0	1,780
Mixed LLW	30	5	0	35
Hazardous	30	1	0	31
Nonhazardous				
Liquid ^b	260K	7.9K	0	268K
Solid	4.4K	5.3K	0	9.7K

^a Total contribution of MOX effort; based on total lead assembly and postirradiation examination activities and 10 years of MOX fuel fabrication.

^b Primary contributor is sanitary use, not process-related activities.

More spent fuel would be generated at the reactor sites as a result of the proposed disposition of surplus plutonium as MOX fuel. As discussed in Section 4.28, it is expected that approximately 5 percent additional spent fuel would be generated as a result of MOX fuel irradiation at the proposed reactor sites. Even so, there would be sufficient space at the reactor sites (in either the spent fuel pools or dry storage) to store the additional spent fuel until it could be sent to a potential geologic repository pursuant to the NWPA. DOE's draft environmental impact statement for a potential geologic repository (DOE/EIS-0250D, July 1999) includes the MOX fuel that would be generated from this program.

Existing infrastructure would be adequate to support the MOX fuel alternatives, although it has been estimated that up to 2 km (0.62 mi) of new roads would be needed for the MOX facility (see Table 2–8). Consumption of coal, natural gas, and electricity vary greatly from site to site, for both the MOX and the lead assembly fabrication facilities, depending on the type of fuel used for heating. For example, electricity needed for MOX fuel fabrication would be 30,000 MWh/yr at all sites but Hanford. Hanford, which is estimated to use one and one-half times the electricity of the other sites (46,000 MWh/yr), uses electricity to heat its buildings. INEEL and SRS use coal for heating, and Pantex, natural gas. No additional infrastructure needs would result from the use of MOX fuel at the proposed reactors.

Table 2–9 compiles information about expected radiological impacts on workers during routine operations. The impacts on workers at the MOX facility are based on operating experience at existing MOX facilities in

Table 2–8. Potential Impacts on Infrastructure of MOX Fuel Fabrication and Irradiation

Requirement	MOX Facility	L.A. Fab. and Postirrad. Exam.	Reactor Operation Increment
Electricity (MWh/yr)	30K to 46K	0.7K to 1.2K	0
Water (l/yr)	68M	1.6M	0
Fuel			
Oil (l/yr)	63K	12K to 61K	0
Natural gas (m ³ /yr)	0 to 1.1M	0 to 55K	0
Coal (t/yr)	0 to 2.1K	0 to 0.06K	0
Transportation			
Roads (km)	1.0 to 2.0	0	0
Rail (km)	0	0	0

Table 2–9. Potential Radiological Impacts on Workers of MOX Fuel Fabrication and Irradiation

Impact	MOX Facility (over 10 years)	L.A. Fab. and Postirrad. Exam. (over 6 years)	Reactor Operation Increment (over 16 years)
Average worker dose (mrem/yr)	65	451	0
Latent fatal cancer risk	2.6×10^{-4}	1.1×10^{-3}	0
Total dose (person-rem/yr)	22	15	0
Latent fatal cancers	0.088	0.035	0

Europe (DOE 1999a). Impacts on workers at the postirradiation examination facility are based on operating experience at ORNL (O’Connor et al. 1998a). The impacts at the lead assembly fabrication facilities are based on an average annual dose rate of 500 mrem/yr. (This is an administrative limit that has been set in accordance with as-low-as-is-reasonably-achievable principles.) The exposure over the life of the MOX campaign (10 years for the MOX facility, 3 years for lead assembly fabrication and 3 years for postirradiation examination) would result in an increased risk of fatal cancer of 2.6×10^{-4} at the MOX facility, 6.0×10^{-4} at the lead assembly site, and 2.2×10^{-4} at the postirradiation examination facility. The corresponding number of LCFs for MOX facility, lead assembly, and postirradiation examination workers from the MOX campaign would be 0.088, 0.033, and 0.002, respectively. No increase in the incremental dose to workers is expected at the proposed reactors from using MOX fuel.

The potential radiological impacts on the general population from routine operations would be very small. Table 2–10 shows that from routine operations annual doses from the MOX facility to the maximally exposed individual (MEI) range from 1.8×10^{-3} to 1.5×10^{-2} mrem/yr, which translates to an increased risk of fatal cancer of 9.0×10^{-9} to 7.5×10^{-8} for 10 years of exposure. The lowest dose would be received at Hanford; the highest, Pantex. However, the population around Pantex would receive the lowest total population dose, and the lowest annual dose to the average individual. Estimated results at Hanford would be at the high end of the range for both of these parameters, 2.9×10^{-1} person-rem/yr and 7.5×10^{-4} mrem/yr, respectively. The annual dose to the average individual would still be extremely small, and would result in only a 3.8×10^{-9} increased risk of fatal cancer for 10 years of exposure. Offsite dose to the MEI resulting from lead assembly fabrication ranges from a low at SRS of 5.5×10^{-5} to 6.4×10^{-2} mrem/yr at LLNL. The associated risk of fatal cancer would be extremely low for the same MEI, ranging from 8.3×10^{-11} to 9.6×10^{-8} . Annual doses to the average individual at SRS and LLNL would be 8.8×10^{-6} and 1.4×10^{-4} mrem, respectively; risk of LCFs to the same individuals would be 1.3×10^{-11} and 2.1×10^{-10} . Offsite dose to the MEI resulting from postirradiation examination would not be expected to change because the activities would not be additive, but would displace similar activities already being done in these facilities. No change would be expected in the radiation dose to the general population from normal operations associated with the disposition of MOX fuel at the proposed reactors (see Table 2–10).

Table 2–10. Potential Radiological Impacts on the Public of MOX Fuel Fabrication and Irradiation

Impact	MOX Facility (over 10 years)	L.A. Fab. and Postirrad. Exam. (over 6 years)	Reactor Operation Increment (over 16 years)
Annual dose to MEI (mrem)	1.8×10^{-3} to 1.5×10^{-2}	0 to 6.4×10^{-2}	0
Fatal cancer risk	9.0×10^{-9} to 7.5×10^{-8}	0 to 9.6×10^{-8}	0
Annual population dose (person-rem)	0.027 to 0.29	0 to 1.1	0
Fatal cancers	1.4×10^{-4} to 1.5×10^{-3}	0 to 1.7×10^{-3}	0
Annual dose to average ind. (mrem)	8.8×10^{-5} to 7.5×10^{-4}	0 to 1.4×10^{-4}	0
Fatal cancer risk	4.4×10^{-10} to 3.8×10^{-9}	0 to 2.1×10^{-10}	0

Transportation impacts are summarized in Table 2–11, and include radiological dose to the truck crew and the general population, nonradiological emissions from vehicle operation, potential traffic accident fatalities, and LCFs resulting from an accident involving a breach of containment and release of radioactive materials. Shipments analyzed include all those listed in Table 2–3 for the MOX, lead assembly, and postirradiation examination facilities, and shipments of fresh MOX fuel to the proposed reactor sites. The analysis shows that no traffic fatalities or LCFs would be expected from either routine transportation activities or accidents.

Table 2–11. Potential Overland Transportation Risks of MOX Fuel Fabrication and Irradiation

Impact	MOX Facility	L.A. Fab. and Postirrad. Exam.	Total MOX Fuel Increment
Routine radiological			
Crew (LCFs)	6.7×10^{-4} to 1.1×10^{-3}	7.1×10^{-5} to 5.6×10^{-4}	7.4×10^{-4} to 1.6×10^{-3}
Public (LCFs)	5.3×10^{-3} to 7.2×10^{-3}	6.0×10^{-4} to 4.8×10^{-3}	5.9×10^{-3} to 1.2×10^{-2}
Routine nonradiological, emissions (LCFs)	6.2×10^{-3} to 2.3×10^{-2}	7.7×10^{-5} to 3.7×10^{-4}	6.2×10^{-3} to 2.4×10^{-2}
Accidental, traffic (fatalities)	1.7×10^{-2} to 5.9×10^{-2}	4.7×10^{-4} to 1.9×10^{-3}	1.8×10^{-2} to 6.1×10^{-2}
Accidental, radiological (LCFs)	3.2×10^{-3} to 3.8×10^{-3}	5.6×10^{-4} to 3.0×10^{-3}	3.8×10^{-3} to 6.8×10^{-3}

Key: LCFs, latent cancer fatalities.

Accidents are unplanned events which would be different for each type of facility needed to implement the MOX approach. The accidents analyzed for the disposition facilities are presented in detail in Appendix K and the consequences summarized by alternative in Chapter 4 (Sections 4.3 through 4.19 for Alternative 2 through 10, respectively, Section 4.27 for the lead assembly and postirradiation examination alternatives, and Section 4.28 for the reactors). The design basis accident with the most severe consequences postulated for the MOX facility is a criticality. This accident would result in an estimated dose at a distance of 1 km (0.62 mi) from the facility of from 0.15 rem at Hanford to 0.75 rem at INEEL. This same accident would result in doses at the site boundaries ranging from 1.6×10^{-2} rem at INEEL and SRS to 4.7×10^{-2} rem at Pantex. Population doses and LCFs within 80 km (50 mi) would range from 1.0 person-rem and 5.2×10^{-4} LCF at INEEL to 55 person-rem and 2.8×10^{-2} LCF at Hanford. The frequency of such an accident is estimated to be between 1 in 10,000 and 1 in 1,000,000 per year.

The postulated design basis accident with the most severe consequences for proposed lead assembly operations using MOX fuel would be associated with a nuclear criticality. The accident would result in an incremental increase in estimated dose at the site boundaries ranging from 9.3×10^{-4} rem at SRS to 5.3×10^{-1} rem at LLNL. The same accident would result in incremental changes in population doses and LCF probabilities within 80 km (50 mi), ranging from 3.4×10^{-1} person-rem and 1.6×10^{-4} LCF at ANL–W to 6.6 person-rem and 3.2×10^{-3} LCF at LANL, respectively. The frequency of such an accident is estimated to be between 1 in 10,000 and 1 in 1,000,000 per year. A nuclear criticality would also be the most severe accident at the postirradiation

examination facilities, but the amount of spent fuel necessary for such an accident to be physically possible is at least one to two orders of magnitude greater than would normally be available.

The design basis accident with the most severe consequences postulated for the proposed reactors using MOX fuel is a loss-of-coolant accident. This accident would result in an increase in the estimated dose at a distance of 640 m (2,100 ft) from the reactor of 0.001 rem at North Anna to 0.15 rem at McGuire. The same accident would result in incremental increases in doses at the site boundaries ranging from 2.0×10^{-4} rem at North Anna to 0.06 rem at McGuire. The incremental change in population doses and LCFs within 80 km (50 mi) of the reactors would range from 0.9 person-rem and 5×10^{-4} LCF at North Anna to 110 person-rem and 0.06 LCF at Catawba. The frequency of such an accident is estimated to be between 1 in 48,000 and 1 in 130,000 per year.

This SPD EIS also evaluates the potential impacts from a set of postulated highly unlikely accidents with potentially severe consequences at the proposed reactors using both uranium-only and MOX cores. [Text deleted.] Regarding effects of MOX fuel on accident probabilities, the National Academy of Sciences states, “. . . no important overall adverse impact of MOX use on the accident probabilities of the LWRs involved will occur; if there are adequate reactivity and thermal margins in the fuel, as licensing review should ensure, the main remaining determinants of accident probabilities will involve factors not related to fuel composition and hence unaffected by the use of MOX rather than LEU fuel” (NAS 1995:352). Regarding the effects of MOX fuel on accident consequences, the report states, “. . . it seems unlikely that the switch from uranium-based fuel could worsen the consequences of a postulated (and very improbable) severe accident in a LWR by no more than 10 to 20 percent. The influence on the consequences of less severe accidents, which probably dominate the spectrum value of population exposure per reactor-year of operation would be even smaller, because less severe accidents are unlikely to mobilize any significant quantity of plutonium at all” (NAS 1995:355).

The incremental effects of using MOX fuel in the proposed reactors in place of LEU fuel were derived from a quantitative analysis of several highly unlikely severe accident scenarios for MOX and LEU fuel. The analysis considers severe accidents where sufficient damage could occur to cause the release of plutonium or uranium through a breach of the plant’s containment. The consequences of these accident releases on the general population were found to range from minus 4 to plus 14 percent³³ compared with LEU fuel, depending on the accident release scenario. This analysis was based on existing probabilistic risk assessments of severe accidents, and the release scenarios were modeled assuming projected population distributions near the proposed reactors in 2015.

The highest consequence accident at all three of the proposed reactors is an interfacing systems loss-of-coolant accident. However, there is an extremely small chance that this beyond-design-basis accident would ever occur. The likelihood of this accident occurring is 1 chance in 15 million at Catawba, 1 chance in 1.6 million at McGuire, and 1 chance in 4.2 million at North Anna. Were this accident to occur, the increases in the estimated dose at the site boundary for MOX fuel as compared to LEU fuel would be 2,000 rem at Catawba; 2,400 rem at McGuire; and 2,200 rem at North Anna. These increases are 14 percent, 12 percent, and 22 percent, respectively, above the doses expected from the same accident using LEU fuel. The incremental change in population doses and LCFs within 80 km (50 mi) of the reactors have been estimated to be 3.2×10^6 person-rem and 1,300 LCFs (from 15,600 to 16,900 LCFs) at Catawba; 1.8×10^6 person-rem and 800 LCFs (from 11,900 to 12,700) at McGuire; and 7.3×10^5 person-rem and 410 LCFs (from 2,980 to 3,390 LCFs) at North Anna. Prompt fatalities from this accident would be expected to increase from 815 to 843 at Catawba, from 398 to 421 at McGuire, and from 54 to 60 at North Anna. The increase in risk to the population from this accident as a result of using MOX

³³ Accidents severe enough to cause a release of plutonium involve combinations of events that are highly unlikely. Estimates and analyses presented in Section 4.28 indicate an incremental range of postulated LCFs due to the use of MOX fuel of minus 7 to plus 1,300 (in the population within 80 km [50 mi] of the release point), with incremental attendant risks of LCFs over 16 years of reactor operation with MOX fuel of minus 1.3×10^{-3} and plus 1.4×10^{-3} , respectively.

fuel would be 1.4×10^{-3} at Catawba, 8.0×10^{-3} at McGuire, and 1.6×10^{-3} at North Anna over the estimated 16-year life of the MOX fuel irradiation program.

[Text deleted.]

2.18.4 Comparison of Immobilization Technology Impacts

To provide a basis for evaluating alternative immobilization forms and technologies, the environmental impacts associated with operating the ceramic and glass can-in-canister immobilization facilities evaluated in this SPD EIS were compared with the corresponding environmental impacts associated with operating the homogenous ceramic immobilization and vitrification facilities evaluated in the *Storage and Disposition PEIS* (DOE 1996a).

Section 4.29 presents the comparable impacts for key environmental resources (e.g., air quality, waste management, human health risk, and resource requirements) at Hanford and SRS for the homogenous ceramic immobilization/vitrification facilities and the can-in-canister immobilization facilities. Impacts associated with facility accidents, intersite transportation, and environmental justice are also discussed. The results of the comparative analysis are summarized here.

The comparison of impacts is based on immobilizing the full 50 t (55 tons) of surplus plutonium. The *Storage and Disposition PEIS* impact analyses are based on operating facilities that would convert the plutonium into an oxide in one new facility and immobilize it into a homogenous ceramic or glass form in another new facility. Impacts for a plutonium conversion facility are evaluated and itemized separately from the impacts for a ceramic immobilization or vitrification facility. In contrast, this SPD EIS considers the use of both new and existing facilities, and is based on a collocated plutonium conversion and immobilization capability. To compare the impacts, it was therefore necessary to combine the separate *Storage and Disposition PEIS* impact values, as appropriate, to establish a suitable standard of comparison.

Generally, air quality impacts associated with the ceramic or glass can-in-canister technologies would be lower or about the same as those evaluated in the *Storage and Disposition PEIS* for ceramic immobilization or vitrification. With the exception of sulfur dioxide in the ceramic can-in-canister process, all criteria pollutant concentrations associated with either can-in-canister technology would range from being the same to being much lower. Pollutant levels would not be expected to differ between the ceramic and glass can-in-canister processes.

Potential volumes of most waste types resulting from operation of the ceramic or glass can-in-canister technologies would be considerably less than the waste volumes expected from either ceramic immobilization or vitrification technology evaluated in the *Storage and Disposition PEIS*. For example, operation of a can-in-canister facility using the ceramic process at Hanford or SRS is estimated to result in TRU waste volumes of 126 m³/yr (165 yd³/yr), compared to the 647 m³/yr (846 yd³/yr) of TRU waste estimated in the *Storage and Disposition PEIS* from operation of the homogenous ceramic immobilization facility. Factors contributing to the reduced waste levels associated with the can-in-canister technology would include the use of dry-feed preparation techniques, coordination with existing HLW vitrification operations and the need for a smaller operating work force. Waste volumes would not be expected to differ appreciably between the ceramic and glass can-in-canister processes.

Section 4.29 also presents the potential radiological exposure and cancer risk to the public and involved workers from normal operation of the immobilization facilities. The potential risks to the public associated with either can-in-canister technology would be slightly higher than the homogeneous technologies at Hanford, but lower at SRS. For example, operation of a can-in-canister facility using the ceramic process at Hanford or SRS is estimated to result in population doses of 1.6×10^{-2} or 5.8×10^{-3} person-rem/yr, respectively, compared to the

population doses of 8.4×10^{-3} (at Hanford) or 6.6×10^{-2} person-rem/yr (at SRS) resulting from operation of the homogenous ceramic immobilization facility evaluated in the *Storage and Disposition PEIS*. These variations may be attributable to the incorporation of updated source terms, meteorology, population distribution, and other modeling variables in the analysis of the can-in-canister technologies. A comparison between the ceramic and glass can-in-canister technologies indicates operation of the ceramic process would result in slightly higher potential offsite impacts, regardless of whether it is located at Hanford or SRS. For example, the dose associated with operation of the can-in-canister facility at Hanford would result in a population dose of 1.6×10^{-2} person-rem/yr using the ceramic process and 1.5×10^{-2} person-rem/yr using the glass process; the same facility at SRS would result in a population dose of 5.8×10^{-3} person-rem/yr using the ceramic process, and a dose of 5.3×10^{-3} person-rem/yr using the glass process.

The estimated average worker dose and associated cancer risk for the can-in-canister technologies are slightly higher than estimated in the *Storage and Disposition PEIS* for the homogenous technologies. In all cases, however, worker dose would be within the DOE design objective of 1,000 mrem/yr. Potential radiological impacts on involved workers are not expected to differ appreciably between the ceramic and glass can-in-canister processes.

Although some potential hazardous chemical impacts were determined for the homogenous ceramic immobilization/vitrification technologies evaluated in the *Storage and Disposition PEIS*, none are expected for either the ceramic or glass can-in-canister technology because no hazardous chemical emissions would occur from operations.

Because of substantial differences between the *Storage and Disposition PEIS* and the SPD EIS in terms of the specific accident scenarios and supporting assumptions used in the determination of facility accident impacts, a standard basis for comparing homogenous technology and can-in-canister technology accidents is not available. For example, a design basis earthquake scenario was not evaluated in the *Storage and Disposition PEIS* for the plutonium conversion facility, nor were any other design basis accidents evaluated for that facility that could be incorporated with like impacts to the ceramic immobilization or vitrification facility for direct comparison to the accident scenarios presented in this SPD EIS. A design basis earthquake associated with the homogenous approach at Hanford would result in 5.8×10^{-8} and 3.2×10^{-6} LCF in the general population for ceramic immobilization and vitrification, respectively; a design basis earthquake affecting the same facilities at SRS would result in 6.2×10^{-8} and 3.4×10^{-6} LCF, respectively. As discussed earlier in this paragraph these values do not reflect the impact of such accidents on a plutonium conversion facility, and are therefore not directly comparable with the results for the can-in-canister approach shown in this SPD EIS. Comparison of the ceramic and glass can-in-canister processes indicates slightly higher impacts would be associated with the ceramic process. For example, a design basis earthquake at Hanford would result in 9.6×10^{-5} LCF in the general population using the ceramic process, and 8.4×10^{-5} LCF using the glass process. Similarly, a design basis earthquake at SRS would result in 3.6×10^{-5} LCF in the general population using a ceramic process, and 3.1×10^{-5} LCF using a glass process.

In terms of resource requirements, operation of the can-in-canister technologies would require lower amounts of electricity, fuel, land area, and water than would the homogenous technologies evaluated in the *Storage and Disposition PEIS*. Fewer workers would be required to operate the can-in-canister technologies, which in turn would result in lower socioeconomic impacts. Resource requirements differ between the ceramic and glass can-in-canister processes in that electricity requirements would be greater to support the ceramic process at either site (i.e., the ceramic process would require 29,000 or 24,000 MWh/yr at Hanford or SRS, respectively, compared to the 28,500 or 23,000 MWh/yr, respectively, required for the glass process).

The *Storage and Disposition PEIS* analysis assumes that canisters of plutonium immobilized with radionuclides would be transported to a potential geologic repository via rail. This SPD EIS analysis, however, conservatively

assumes that the immobilized canisters would be shipped by truck from the immobilization site to the repository, with one canister being transported per truck shipment.³⁴ The ceramic and glass can-in-canister technologies would result in fewer total potential fatalities from intersite transportation than would the homogenous ceramic immobilization/vitrification technologies evaluated in the *Storage and Disposition PEIS*. Because the ceramic can-in-canister process would produce fewer canisters, it would result in somewhat lower routine and accidental transportation impacts than the glass can-in-canister process.

Evaluations of both the homogenous ceramic immobilization/vitrification technologies and can-in-canister technologies included routine facility operations and transportation as well as accidents. No significant risk to the general population would be expected to occur for normal operations or in the event of a design basis accident. [Text deleted.] Similarly, implementation of these technologies would not result in a significant risk of disproportionately high and adverse impacts on minority or low-income groups within the general population.

³⁴ The *Draft Environmental Impact Statement for a Geologic Repository for the Disposal of Spent Nuclear Fuel and High-Level Radioactive Waste at Yucca Mountain, Nye County, Nevada* (DOE/EIS-0250D) (DOE 1999b) analyzes spent fuel shipments by rail and truck. No decision has been made as to the mode of transportation.

2.19 REFERENCES

DOE (U.S. Department of Energy), 1996a, *Storage and Disposition of Weapons-Usable Fissile Materials Final Programmatic Environmental Impact Statement*, DOE/EIS-0229, Office of Fissile Materials Disposition, Washington, DC, December.

DOE (U.S. Department of Energy), 1996b, *Tank Waste Remediation System, Hanford Site, Richland, Washington, Final Environmental Impact Statement*, DOE/EIS-0189, Richland Operations Office, Richland, WA, August.

DOE (U.S. Department of Energy), 1997a, *Record of Decision for the Storage and Disposition of Weapons-Usable Fissile Materials Final Programmatic Environmental Impact Statement*, 62 FR 3014, Office of the Federal Register, Washington, DC, January 14.

DOE (U.S. Department of Energy), 1997b, *Notice of Intent to Prepare a Surplus Plutonium Disposition Environmental Impact Statement*, 62 FR 28009, Office of the Federal Register, Washington, DC, May 22.

DOE (U.S. Department of Energy), 1998a, *Amended Record of Decision for the Storage and Disposition of Weapons-Usable Fissile Materials*, 63 FR 43386, Office of the Federal Register, Washington, DC, August 13.

DOE (U.S. Department of Energy), 1998b, *Environmental Assessment for the Transfer of 1100 Area Southern Rail Connection and Rolling Stock, Hanford Site, Richland, Washington*, DOE/EA-1260, Richland Operations Office, Richland, WA, August.

DOE (U.S. Department of Energy), 1998c, *Independent Assessment of the Savannah River Site High Level Waste Salt Disposition Alternative Evaluation*, DOE/ID-10672, December.

DOE (U.S. Department of Energy), 1999a, *MOX Fuel Fabrication Facility and Nuclear Power Reactor Data Report*, MD-0015, Office of Fissile Materials Disposition, Washington, DC, August.

DOE (U.S. Department of Energy), 1999b, *Draft Environmental Impact Statement for a Geologic Repository for the Disposal of Spent Nuclear Fuel and High-Level Radioactive Waste at Yucca Mountain, Nye County, Nevada*, DOE/EIS-0250D, Office of Civilian Radioactive Waste Management, North Las Vegas, NV, July.

DOE (U.S. Department of Energy), 1999c, *Supplement Analysis for Continued Operation of Lawrence Livermore National Laboratory and Sandia National Laboratories, Livermore*, DOE/EIS-0157-SA-01, Oakland Operations Office, Oakland, CA, March.

EPA (U.S. Environmental Protection Agency), 1999, *Notice of Availability for the Draft Supplement for Surplus Plutonium Disposition*, 64 FR 26410, Office of the Federal Register, Washington, DC, May 14.

NAS (National Academy of Sciences), 1995, *Management and Disposition of Excess Weapons Plutonium Reactor-Related Option*, National Academy Press, Washington, DC.

NC (National Research Council), 1999, *Interim Report on Processing Alternatives for High-Level Radioactive Waste Salt Solutions at the Savannah River Site*, transmitted by letter from Milt Levenson, Chair and Greg Choppin, Vice Chair to Ernest J. Moniz, Under Secretary, U.S. Department of Energy, October 14.

O'Connor, D.G., et al., 1998a, *ANL-W MOX Fuel Lead Assemblies Data Report for the Surplus Plutonium Disposition Environmental Impact Statement*, ORNL/TM-13478, Lockheed Martin Energy Research Corporation, Oak Ridge, TN, August.

O'Connor, D.G., et al., 1998b, *LLNL MOX Fuel Lead Assemblies Data Report for the Surplus Plutonium Disposition Environmental Impact Statement*, ORNL/TM-13480, Lockheed Martin Energy Research Corporation, Oak Ridge, TN, August.

O'Connor, D.G., et al., 1998c, *Hanford MOX Fuel Lead Assemblies Data Report for the Surplus Plutonium Disposition Environmental Impact Statement*, ORNL/TM-13481, Lockheed Martin Energy Research Corporation, Oak Ridge, TN, August.

O'Connor, D.G. et al., 1998d, *LANL MOX Fuel Lead Assemblies Data Report for the Surplus Plutonium Disposition Environmental Impact Statement*, ORNL/TM-13482, Lockheed Martin Energy Research Corporation, Oak Ridge, TN, August.

O'Connor, D.G., et al., 1998e, *SRS MOX Fuel Lead Assemblies Data Report for the Surplus Plutonium Disposition Environmental Impact Statement*, ORNL/TM-13483, Lockheed Martin Energy Research Corporation, Oak Ridge, TN, August.

ORNL (Oak Ridge National Laboratory), 1998, *Final Data Report Response to the Draft Surplus Plutonium Disposition Environmental Impact Statement Data Call for Generic Site Add-On Facility for Plutonium Polishing*, ORNL/TM-13669, Oak Ridge, TN, June.

ORNL (Oak Ridge National Laboratory), 1999, *MOX/LEU Core Inventory Ratios*, Oak Ridge, TN.

| SRARP (Savannah River Archaeological Research Program), 1989, *Archaeological Resource Management Plan of the Savannah River Archaeological Research Program*, South Carolina Institute of Archaeology and Anthropology, University of South Carolina, Columbia, SC, December.

UC (Regents of the University of California), 1997, *Immobilization Technology Down-Selection Radiation Barrier Approach*, UCRL-ID-127320, Lawrence Livermore National Laboratory, Livermore, CA, May 23.

UC (Regents of the University of California), 1998a, *Pit Disassembly and Conversion Facility, Environmental Impact Statement Data Report—Hanford Site*, LA-UR-97-2907, Los Alamos National Laboratory, Los Alamos, NM, June 1.

UC (Regents of the University of California), 1998b, *Pit Disassembly and Conversion Facility, Environmental Impact Statement Data Report—Idaho National Engineering and Environmental Laboratory*, LA-UR-97-2908, Los Alamos National Laboratory, Los Alamos, NM, June 1.

UC (Regents of the University of California), 1998c, *Pit Disassembly and Conversion Facility, Environmental Impact Statement Data Report—Pantex Plant*, LA-UR-97-2909, Los Alamos National Laboratory, Los Alamos, NM, June 1.

UC (Regents of the University of California), 1998d, *Pit Disassembly and Conversion Facility, Environmental Impact Statement Data Report—Savannah River Site*, LA-UR-97-2910, Los Alamos National Laboratory, Los Alamos, NM, June 1.

UC (Regents of the University of California), 1998e, *Response to the Surplus Plutonium Disposition Environmental Impact Statement Data Call for a Mixed Oxide Fuel Fabrication Facility Located at the Hanford Site*, rev. 3, LA-UR-97-2064, Los Alamos National Laboratory, Los Alamos, NM, June 22.

UC (Regents of the University of California), 1998f, *Response to the Surplus Plutonium Disposition Environmental Impact Statement Data Call for a Mixed Oxide Fuel Fabrication Facility Located at the Idaho National Engineering and Environmental Laboratory*, rev. 3, LA-UR-97-2065, Los Alamos National Laboratory, Los Alamos, NM, June 22.

UC (Regents of the University of California), 1998g, *Response to the Surplus Plutonium Disposition Environmental Impact Statement Data Call for a Mixed Oxide Fuel Fabrication Facility Located at the Pantex Plant*, rev. 3, LA-UR-97-2067, Los Alamos National Laboratory, Los Alamos, NM, June 22.

UC (Regents of the University of California), 1998h, *Response to the Surplus Plutonium Disposition Environmental Impact Statement Data Call for a Mixed Oxide Fuel Fabrication Facility Located at the Savannah River Site*, rev. 3, LA-UR-97-2066, Los Alamos National Laboratory, Los Alamos, NM, June 22.

UC (Regents of the University of California), 1998i, *Cost Estimates of Pit Disassembly and Conversion Facility Siting Alternatives*, LA-13485-MS, Los Alamos National Laboratory, Los Alamos, NM, July.

[Text deleted.]

UC (Regents of the University of California), 1999a, *Fissile Materials Disposition Program, EIS Data Call Report: Plutonium Immobilization Plant Using Ceramic in Existing Facilities at Hanford*, rev. 1, UCRL-ID-128275, Lawrence Livermore National Laboratory, Livermore, CA, September.

UC (Regents of the University of California), 1999b, *Fissile Materials Disposition Program, EIS Data Call Report: Plutonium Immobilization Plant Using Glass in Existing Facilities at Hanford*, rev. 1, UCRL-ID-128276, Lawrence Livermore National Laboratory, Livermore, CA, September.

UC (Regents of the University of California), 1999c, *Fissile Materials Disposition Program, EIS Data Call Report: Plutonium Immobilization Plant Using Glass in New Facilities at the Savannah River Site*, rev. 1, UCRL-ID-128271, Lawrence Livermore National Laboratory, Livermore, CA, September.

UC (Regents of the University of California), 1999d, *Fissile Materials Disposition Program, EIS Data Call Report: Plutonium Immobilization Plant Using Ceramic in New Facilities at the Savannah River Site*, rev. 1, UCRL-ID-128273, Lawrence Livermore National Laboratory, Livermore, CA, September.

Chapter 3 Affected Environment

3.1 APPROACH TO DEFINING THE AFFECTED ENVIRONMENT

In accordance with the Council on Environmental Quality National Environmental Policy Act (NEPA) regulations (CEQ 1986) on preparing an environmental impact statement (EIS), the affected environment is “interpreted comprehensively to include the natural and physical environment and the relationship of people with that environment.” The affected environment descriptions presented in this chapter provide the context for understanding the environmental consequences described in Chapter 4. As such, they serve as a baseline from which any environmental changes that may be brought about by implementing the proposed action and alternatives can be identified and evaluated. For this *Surplus Plutonium Disposition Environmental Impact Statement* (SPD EIS), the baseline conditions are the existing conditions.

The candidate sites for the proposed surplus plutonium disposition facilities are the Hanford Site (Hanford), Idaho National Engineering and Environmental Laboratory (INEEL), the Pantex Plant (Pantex), and the Savannah River Site (SRS). As described in Chapter 2, areas within the boundaries of the sites that are potential locations for the proposed facilities include the

Site	Area (km ²)	Population		Dose per Year ^a		
		Health Risk ROI ^a	Socio-economic ROI	Site Work Force	MEI (mrem)	Population (person-rem)
Hanford	1,450	380,000	179,949	12,882	0.0074	0.20
INEEL	2,300	121,500	213,547	8,291	0.031	0.24
Pantex	60	275,000	212,729	2,944	0.000088	0.0021
SRS	800	620,100	453,778	15,032	0.20	8.6

^a For 1996.
Key: MEI, maximally exposed individual; ROI, region of influence.

200 East and 400 Areas at Hanford, the Idaho Nuclear Technology and Engineering Center (INTEC)¹ at INEEL, Zone 4 West at Pantex, and F- and S-Areas at SRS. The resources that are described for the candidate sites are air quality and noise, waste management, socioeconomic, human health risk, environmental justice, geology and soils, water resources, ecological resources, cultural and paleontological resources, land use and visual resources, and infrastructure.

Candidate sites for mixed oxide (MOX) fuel lead assembly fabrication and postirradiation examination are described in Section 3.6. These sites are Hanford, INEEL (at Argonne National Laboratory–West [ANL–W]), Lawrence Livermore National Laboratory (LLNL), Los Alamos National Laboratory (LANL), Oak Ridge Reservation (ORR) (at Oak Ridge National Laboratory [ORNL]), and SRS. These additional sites are evaluated for related plutonium disposition activities only; therefore, they are not described in detail. Sites that would supply uranium dioxide are not described in this section because these activities are routinely performed at these locations, would be conducted in existing buildings with existing personnel, and would not be expected to result in additional impacts at these sites. See Figure 2–1 for the location of these sites.

Proposed reactor sites where the irradiation of MOX fuel would be performed are described in Section 3.7. The reactors that would be used are Catawba Nuclear Station Units 1 and 2, McGuire Nuclear Station Units 1 and 2, and North Anna Power Station Units 1 and 2. As described in Section 2.4.3, these reactors would be used for the irradiation of MOX fuel only.

¹ Formerly known as the Idaho Chemical Processing Plant (ICPP).

The U.S. Department of Energy (DOE) evaluated the environmental impacts of the surplus plutonium disposition alternatives within defined regions of influence (ROI) at each of the four candidate sites and along transportation routes. The ROIs are specific to the type of effect evaluated and encompass geographic areas within which any significant impact would be expected to occur. For example, human health risks to the general public from exposure to airborne contaminant emissions were assessed for an area within an 80 km (50 mi) radius of the proposed facilities. The human health risks of shipping materials among sites were evaluated for populations living along the roadways linking the DOE sites. Economic effects such as job and income growth were evaluated within a socioeconomic ROI that includes the county in which the site is located and nearby counties in which a substantial portion of the site’s workforce resides. Brief descriptions of the ROIs are given in Table 3–1. More detailed descriptions of the ROI and the methods used to evaluate impacts are presented in Appendix F.

Table 3–1. General Regions of Influence for the Affected Environment

Environmental Feature	Region of Influence
Air quality and noise	The site and nearby offsite areas within local air quality control regions and the transportation corridors between the sites
Waste management	Waste management facilities on the site
Socioeconomics	The counties where at least 90 percent of site employees reside
Human health risk	The site and nearby offsite areas (within 80 km of the site and the transportation corridors between the sites) where worker and general population radiation, radionuclide, and hazardous chemical exposures may occur
Environmental justice	The minority and low-income populations within 80 km of the site and along the transportation corridors between the sites
Geology and soils	Geologic and soil resources within the site and nearby offsite areas
Water resources	Onsite and adjacent surface water bodies and groundwater
Ecological resources	The site and adjacent areas where ecological communities exist including nonsensitive and sensitive habitats and species
Cultural and paleontological resources	The area within the site and adjacent to the site boundary
Land use and visual resources	The site and the areas immediately adjacent to the site
Infrastructure	Power, fuel supply, water supply, and road systems on the site

At each of the four candidate sites, baseline conditions for each environmental resource area were determined from information provided in previous environmental studies, relevant laws and regulations, and other government reports and databases. More detailed information on the affected environment at the candidate sites can be found in annual site environmental reports and site NEPA documents.

For More Detailed Information on Environmental Conditions at the Candidate Sites for the Proposed Surplus Plutonium Disposition Facilities^a

Draft Hanford Remedial Action EIS and Comprehensive Land Use Plan, 1996

DOE Programmatic Spent Nuclear Fuel Management and INEL Environmental Restoration and Waste Management Final EIS, 1995

Final EIS for the Continued Operation of the Pantex Plant and Associated Storage of Nuclear Weapon Components, 1996

SRS Waste Management Final EIS, 1995

^a Also consult annual site environmental reports.

3.2 HANFORD

Hanford, established in 1943 as one of the three original Manhattan Project sites, is in Washington State just north of Richland (Figure 2–2). Hanford was a U.S. Government nuclear materials production site that included nuclear reactor operation, storage and reprocessing of spent nuclear fuel, and management of radioactive and dangerous wastes. Present Hanford programs are diversified and include management of radioactive wastes, research and development (R&D) for advanced reactors, renewable energy technologies, waste disposal technologies and contamination cleanup, and plutonium stabilization and storage (DOE 1996a:3-20).

Hanford is owned and used primarily by DOE, but portions of it are owned, leased, or administered by other government agencies. Public access is limited to travel on the Route 4 and Route 10 access roads as far as the Wye Barricade, State Routes 24 and 240, and the Columbia River. By restricting access to the site, the public is buffered from the areas formerly used for production of nuclear materials and currently used for waste storage and disposal. Only about 6 percent of the land area has been disturbed and is actively used, leaving mostly vacant land with widely scattered facilities. The entire Hanford Site has been designated a National Environmental Research Park (DOE 1996a:3-20).

Hanford includes extensive production, service, and R&D areas. Onsite programmatic and general purpose facilities total approximately 799,000 m² (8.6 million ft²) of space. Fifty-one percent (408,000 m² [4.4 million ft²]) is general purpose space, including offices, laboratories, shops, warehouses, and other support facilities. The remaining 392,000 m² (4.2 million ft²) of space are programmatic facilities comprising processing, evaporation, filtration, waste recovery, waste treatment, waste storage facilities, and R&D laboratories. More than half of the general purpose and programmatic facilities are more than 30 years old. Facilities designed to perform previous missions are being evaluated for reuse in the cleanup mission. The existing facilities are grouped into the following numbered operational areas (DOE 1996a:3-20, 3-21).

- C The 100 Areas, in the northern part of the site on the southern shore of the Columbia River, are the site of eight retired plutonium production reactors and the dual-purpose N Reactor, all of which have been permanently shut down since 1991. The 100 Areas cover about 1,100 ha (2,720 acres).
- C The 200 West and 200 East Areas are in the center of the site and are about 8 and 11 km (5 and 6.8 mi), respectively, south of the Columbia River. Historically, these areas have been used for fuel reprocessing; plutonium processing, fabrication, and storage; and waste management and disposal activities. The 200 Areas cover about 1,600 ha (3,950 acres).
- C The 300 Area is in the southern part of the site, just north of the city of Richland. A few of the facilities continue to support nuclear and nonnuclear R&D to include the Pacific Northwest National Laboratory (PNNL). Many of the facilities in the 300 Area are in the process of being deactivated. This area covers 150 ha (370 acres).
- C The 400 Area, about 8 km (5 mi) northwest of the 300 Area, is the location of the recently shut down Fast Flux Test Facility (FFTF) and Fuels and Materials Examination Facility (FMEF). FFTF is an advanced liquid-metal-cooled research reactor that was used in the testing of breeder reactor systems. The six-level process building (427 Building) is the main structure of FMEF and encloses about 17,000 m² (183,000 ft²) of operating area. FMEF also consists of several connected buildings. This building has never been operated and is free of contamination. The exterior walls are reinforced concrete, and the cell walls are constructed of high-density concrete. The facility was designed and constructed for spent fuel examination and was subsequently partially converted for MOX fuel fabrication.

- C The 600 Area comprises the remainder of Hanford, which includes most of the undisturbed land and support facilities and infrastructure (e.g., roads, railroads, telecommunications, water treatment and distribution, electrical transmission lines and substations, fire and ambulance, access control facilities, borrow pits, and a landfill).
- C The 700 Area is the administrative center in downtown Richland and consists of government-owned buildings (e.g., the Federal Building).
- C The 3000 Area is a support area in north Richland that is being vacated but still contains some administrative and support facilities.

In addition, there are DOE-leased facilities and DOE contractor-owned facilities that support Hanford operations. These facilities are on private land south of the 300 Area and outside of the 3000 Area (DOE 1996a:3-21).

DOE Activities. The Hanford mission is to clean up the site, provide scientific and technological excellence to meet global needs, and partner the economic diversification of the region. Current DOE activities that support Hanford’s mission are shown in Table 3–2. In the area of waste management, Hanford has embarked on a long-range cleanup program in compliance with the Hanford Federal Facility Agreement and Consent Order (Tri-Party Agreement) and applicable Federal, State, and local laws. DOE has set a goal of cleaning up Hanford’s waste sites and bringing its facilities into compliance with Federal, State, and local environmental laws by the year 2028. In addition, as part of the cleanup mission, DOE has the responsibility to safely store, handle, and stabilize plutonium materials and spent fuel (DOE 1996a:3-21, 3-22).

Table 3–2. Current Missions at Hanford

Mission	Description	Sponsor
Waste management	Store defense wastes and handle, store, and dispose of radioactive, hazardous, mixed, or sanitary wastes from current operations	Assistant Secretary for Environmental Management
Environmental restoration	Restore approximately 1,100 inactive radioactive, hazardous, and mixed waste sites and about 100 surplus facilities	Assistant Secretary for Environmental Management
Research and development	Conduct research in the fields of energy, health, safety, environmental sciences, molecular sciences, environmental restoration and waste management R&D, and national security activities	Various DOE Program Managers
Technology development	Develop new technologies for environmental restoration and waste management, including site characterization and assessment methods, and waste minimization	Various DOE Program Managers

Source: DOE 1996a:3-22.

Non-DOE Activities. In addition to the DOE mission-related activities, Hanford has some unique and diverse assets and non-DOE missions that include the following (DOE 1996a:3-22):

- C The Fitzner-Eberhardt Arid Lands Ecology Reserve, 31,100 ha (76,800 acres), established in 1967, managed by the U.S. Fish and Wildlife Service (USFWS) for DOE as a habitat and wildlife reserve and nature research center (Sandberg 1998a).

- C The area north of the Columbia River, managed in part by the Washington State Department of Wildlife as the Wahluke Slope Wildlife Recreation Area and in part by the USFWS as the Saddle Mountain National Wildlife Refuge.
- C The Washington Nuclear Plant-2 (WNP-2), 1,100-MWe reactor operated by Energy Northwest (formerly Washington Public Power Supply System [WPPSS]) and also the partially completed WNP-1 reactor.
- C The Laser Interferometer Gravitational-Wave Observatory, operated by the National Science Foundation as one of two widely separated installations (within the United States) that are operated in unison as a single gravitational-wave observatory.
- C The Hanford Meteorological Station and towers.
- C An observatory and radio telescope facilities on Rattlesnake Mountain.
- C The U.S. Ecology commercial low-level radioactive waste disposal site on State-leased lands south of the 200 Areas near the center of Hanford.

3.2.1 Air Quality and Noise

3.2.1.1 Air Quality

Air pollution refers to any substance in the air that could harm human or animal populations, vegetation, or structures, or that unreasonably interferes with the comfortable enjoyment of life and property. Air pollutants are transported, dispersed, or concentrated by meteorological and topographical conditions. Air quality is affected by air pollutant emission characteristics, meteorology, and topography.

3.2.1.1.1 General Site Description

The climate at Hanford and the surrounding region is characterized as that of a semiarid steppe. The humidity is low, and winters are mild. The average annual temperature is 11.8 EC (53.3 EF); average monthly temperatures range from a minimum of -1.5 EC (29.3 EF) in January to a maximum of 24.7 EC (76.5 EF) in July. The average annual precipitation is 16 cm (6.3 in). Prevailing winds at the Hanford Meteorological Station are from the west-northwest. The average annual windspeed is 3.4 m/s (7.6 mph) (DOE 1996a:3-29). Additional information related to meteorology and climatology at Hanford is presented in Appendix F of the *Storage and Disposition of Weapons-Usable Fissile Materials Final Programmatic Environmental Impact Statement (Storage and Disposition PEIS)* (DOE 1996a:F-2-F-5) and in the *Hanford Site National Environmental Policy Act (NEPA) Characterization* (Neitzel 1996).

Most of Hanford is within the South-Central Washington Intrastate Air Quality Control Region (AQCR) #230, but a small portion of the site is in the Eastern Washington-Northern Idaho Interstate AQCR #62. None of the areas within Hanford and its surrounding counties are designated as nonattainment areas with respect to National Ambient Air Quality Standards (NAAQS) for criteria air pollutants (EPA 1997a). Applicable NAAQS and Washington State ambient air quality standards are presented in Table 3-3.

There are no prevention of significant deterioration (PSD) Class I areas within 100 km (62 mi) of Hanford. Hanford operates under a PSD permit issued in 1980 that limits emissions of nitrogen dioxide from the Plutonium-Uranium Extraction (PUREX) and Uranium Trioxide Plants in the 200 Area (DOE 1996a:3-29). These facilities have not been operated since 1994 and have been deactivated and transferred to the

Table 3–3. Comparison of Ambient Air Concentrations From Hanford Sources With Most Stringent Applicable Standards or Guidelines, 1994

Pollutant	Averaging Period	Most Stringent Standard or Guideline (Fg/m ³) ^a	Concentration (Fg/m ³)
Criteria pollutants			
Carbon monoxide	8 hours	10,000 ^b	0.7
	1 hour	40,000 ^b	2.6
Nitrogen dioxide	Annual	100 ^b	0.2
Ozone	8 hours	157 ^c	(d)
PM ₁₀	Annual	50 ^b	0.01
	24 hours	150 ^b	0.1
PM _{2.5}	3-year annual	15 ^c	(e)
	24 hours (98th percentile over 3 years)	65 ^c	(e)
Sulfur dioxide	Annual	50 ^f	0.8
	24 hours	260 ^f	6.6
	3 hours	1,300 ^b	22.9
	1 hour	1,000 ^f	47.9
	1 hour	660 ^{f,g}	47.9
Other regulated pollutants			
Gaseous fluoride	30 days	0.84 ^f	(i)
	7 days	1.7 ^f	(i)
	24 hours	2.9 ^f	(i)
	12 hours	3.7 ^f	(i)
	8 months (Mar-Oct)	0.50 ^f	(i)
Total suspended particulates	Annual	60 ^f	0.01
	24 hours	150 ^f	0.1
Hazardous and other toxic compounds			
Benzene	24 hours	0.12 ^h	(i)
[Text deleted.]			

^a The more stringent of the Federal and State standards is presented if both exist for the averaging period. The National Ambient Air Quality Standards (NAAQS) (EPA 1997a), other than those for ozone, particulate matter, and lead, and those based on annual averages, are not to be exceeded more than once per year. The 1-hr ozone standard is attained when the expected number of days per year with maximum hourly average concentrations above the standard is #1. The 1-hr ozone standard applies only to nonattainment areas. The 8-hr ozone standard is attained when the 3-year average of the annual fourth-highest daily maximum 8-hr average concentration is less than or equal to 157 Fg/m³. The 24-hr particulate matter standard is attained when the expected number of days with a 24-hr average concentration above the standard is #1. The annual arithmetic mean particulate matter standard is attained when the expected annual arithmetic mean concentration is less than or equal to the standard.

^b Federal and State standard.

^c Federal standard.

^d Not directly emitted or monitored by the site.

^e No data is available with which to assess PM_{2.5} concentrations.

^f State standard.

^g Not to be exceeded more than twice in any 7 consecutive days.

^h State's risk-based acceptable source impact levels.

ⁱ No sources identified at the site.

Note: NAAQS also include standards for lead. No sources of lead emissions have been identified at the site. Emissions of other air pollutants not listed here have been identified at Hanford, but are not associated with any alternatives evaluated. These other air pollutants are quantified in the *Storage and Disposition PEIS* (DOE 1996a). EPA recently revised

ambient air quality standards for particulate matter and ozone. The new standards, finalized on July 18, 1997, changed the ozone primary and secondary standards from a 1-hr concentration of 235 Fg/m³ (0.12 ppm) to an 8-hr concentration of 157 Fg/m³ (0.08 ppm). During a transition period while States are developing State implementation plan revisions for attaining and maintaining these standards, the 1-hr ozone standard will continue to apply in nonattainment areas (EPA 1997b:38855). For particulate matter, the current PM₁₀ annual standard is retained, and two PM_{2.5} (particulate matter with an aerodynamic diameter less than or equal to 2.5 Fm) standards are added. These standards are set at a 15-Fg/m³ 3-year annual arithmetic mean based on community-oriented monitors and a 65-Fg/m³ 3-year average of the 98th percentile of 24-hr concentrations at population-oriented monitors. The revised 24-hr PM₁₀ standard is based on the 99th percentile of 24-hr concentrations. The existing PM₁₀ standards will continue to apply in the interim period (EPA 1997c:38652).

Source: DOE 1996a:3-30; EPA 1997a; WDEC 1994.

DOE Office of Environmental Restoration for continued surveillance and maintenance awaiting eventual decommissioning.

Ambient air quality near the Hanford boundary is currently monitored for particulate matter. Particulate concentrations can reach rather high levels in eastern Washington because of extreme natural events (dust storms, volcanic eruptions, and large brush fires [DOE 1996b:4-46–4-50]). The 24-hr standard for particulate matter with an aerodynamic diameter less than or equal to 10 Fm (PM₁₀) was exceeded in 1993 at Columbia Center in Kennewick, about 10 km (6.2 mi) southeast of Hanford, likely as a result of windblown dust. Ambient air quality at Hanford is discussed in more detail in the *Hanford Site 1995 Environmental Report* (Dirkes and Hanf 1996:56, 61, 62, 95–108). Routine monitoring of most nonradiological pollutants is not conducted at the site. Monitoring of nitrogen oxides and total suspended particulates at Hanford has been discontinued as a result of phasing out programs for which the monitoring was required. Carbon monoxide, sulfur dioxide, and nitrogen dioxide have been monitored periodically in communities and commercial areas southeast of Hanford. In 1995, air samples of semivolatile organic compounds were collected on the site and at an offsite location, and the results are discussed in the annual environmental report (Dirkes and Hanf 1996:95–108). All concentrations of these compounds were below the applicable risk-based concentrations.

The primary sources of air pollutants at Hanford include process emissions, vehicular emissions, and construction activities. Table 3–3 presents the existing ambient air pollutant concentrations at the site boundary attributable to sources at Hanford. These concentrations are based on emissions for the year 1994. The emissions were modeled using meteorological data from 1989–1990 (DOE 1996a:3-30). Only those pollutants that would be emitted by any of the surplus plutonium disposition alternatives are presented. With the exception of particulate matter, as discussed previously, the concentrations of these pollutants—concentrations from Hanford combined with those from background (non-Hanford) sources—are in compliance with the ambient air quality standards. All coal-fired steam generation facilities have been shut down at Hanford. The conversion to oil, natural gas, and electric energy sources was completed in 1998. This will result in a significant reduction in air pollutant emissions from the site. Detailed information on emissions of other pollutants at Hanford is discussed in the *Hanford Site NEPA Characterization* (Neitzel 1996:4.28–4.32, 6.12).

3.2.1.1.2 Proposed Facility Locations

Prevailing winds in the 200 Areas (Hanford Meteorological Station) are from the west-northwest (Neitzel 1996:4.3, 4.6; Hoitink and Burk 1996:2.10). The 200 East Area has emissions of various air pollutants from oil-fired steam generation and releases of various toxic pollutants from tank farms, waste processing, and laboratories. Emissions from these sources are quantified in the *Tank Waste Remediation System EIS* (DOE 1996c:G-35–G-111).

Prevailing winds in the 400 Area are from the south-southwest, with a secondary maximum from the northwest (Neitzel 1996:4.6; Hoitink and Burk 1996:2.10). The 400 Area has no nonradioactive air pollutant emission sources of concern (Neitzel 1996:4.30).

3.2.1.2 Noise

Noise is unwanted sound that interferes or interacts negatively with the human or natural environment. Noise may disrupt normal activities or diminish the quality of the environment.

3.2.1.2.1 General Site Description

Major noise sources within Hanford include various facilities, equipment, and machines (e.g., cooling systems, transformers, engines, pumps, boilers, steam vents, paging systems, construction and materials-handling equipment, and vehicles). Data from two noise surveys indicate that background noise levels (measured as the 24-hr equivalent sound level) at Hanford range from 30 to 60.5 decibels A-weighted (dBA) (DOE 1996a:3-29). The 24-hr background sound level in undeveloped areas at Hanford ranges from 24 to 36 dBA, except when high winds elevate sound levels (Neitzel 1996:4.127). The primary source of noise at the site and nearby residences is traffic. Most Hanford industrial facilities are far enough from the site boundary that noise levels from these sources at the boundary are not measurable or are barely distinguishable from background noise levels (DOE 1996a:3-29). Hanford is currently in compliance with the State noise regulations (DOE 1996a:3-29–3-31). Noise sources, existing noise levels at Hanford, and noise standards are described in the *Storage and Disposition PEIS* (DOE 1996a:3-29–3-31, F-31, F-32) and in the *Hanford Site NEPA Characterization* (Neitzel 1996:4.125–4.130).

The potential impact of traffic noise resulting from Hanford activities was evaluated for a draft EIS addressing the siting of the proposed New Production Reactor. Estimates were made of baseline traffic noise along two major access routes: State Route 24, leading from the Hanford Site west to Yakima, and State Route 240, south of the site and west of Richland, where it handles maximum traffic volume. Modeled traffic noise levels (equivalent sound level [1-hr]) at 15 m (50 ft) from State Route 24 for both peak and offpeak periods were 62 dBA. Traffic noise levels from State Route 240 for both peak and offpeak periods were 70 dBA (Neitzel 1996:4.127, 4.130). These traffic noise levels were projections based on employment levels about 30 percent higher than actual levels at Hanford in 1997. About 9 percent of Hanford's employees commute by vanpool or bus (Mecca 1997a). Existing traffic noise levels may be different as a result of changes in site employment and ride-sharing activities.

The U.S. Environmental Protection Agency (EPA) guidelines for environmental noise protection recommend an average day-night average sound level of 55 dBA as sufficient to protect the public from the effects of broadband environmental noise in typically quiet outdoor and residential areas (EPA 1974:29). Land-use compatibility guidelines adopted by the Federal Aviation Administration and the Federal Interagency Committee on Urban Noise indicate that yearly day-night average sound levels less than 65 dBA are compatible with residential land uses and levels up to 75 dBA are compatible with residential uses if suitable noise reduction features are incorporated into structures (DOT 1995). It is expected that for most residences near Hanford, the day-night average sound level is less than 65 dBA and is compatible with the residential land use, although for some residences along major roadways noise levels may be higher.

3.2.1.2.2 Proposed Facility Locations

No distinguishing noise characteristics have been identified at either the 200 East Area or the 400 Area. Both are far enough from the site boundary—the 200 East Area is 12.6 km (7.8 mi) and the 400 Area is 6.1 km (3.8 mi)

away—that noise levels from the facilities at the boundary are not measurable or are barely distinguishable from background levels.

3.2.2 Waste Management

Waste management includes minimization, characterization, treatment, storage, transportation, and disposal of waste generated from ongoing DOE activities. The waste is managed using appropriate treatment, storage, and disposal technologies and in compliance with all applicable Federal and State statutes and DOE orders.

3.2.2.1 Waste Inventories and Activities

Hanford manages the following types of waste: high-level waste (HLW), transuranic (TRU), mixed TRU, low-level waste (LLW), mixed LLW, hazardous, and nonhazardous. HLW would not be generated by surplus plutonium disposition activities at Hanford, and thus is not discussed further. Waste generation rates and the inventory of stored waste from activities at Hanford are provided in Table 3–4. Table 3–5 summarizes the Hanford waste management capabilities. More detailed descriptions of the waste management system capabilities at Hanford are included in the *Storage and Disposition PEIS* (DOE 1996a:3-61, E-12).

Table 3–4. Waste Generation Rates and Inventories at Hanford

Waste Type	Generation Rate (m ³ /yr)	Inventory (m ³)
TRU^a		
Contact handled	450	11,450
Remotely handled	72	273
LLW	3,902	0
Mixed LLW		
RCRA	840	8,170
TSCA	7	103
Hazardous	560	NA ^b
Nonhazardous		
Liquid	200,000	NA ^b
Solid	43,000	NA ^b

^a Includes mixed TRU waste.

^b Generally, hazardous and nonhazardous wastes are not held in long-term storage.

Key: LLW, low-level waste; NA, not applicable; RCRA, Resource Conservation and Recovery Act; TRU, transuranic; TSCA, Toxic Substances Control Act.

Source: DOE 1996d:15, 16, except hazardous and nonhazardous solid wastes (DOE 1996a:3-62, E-19), and nonhazardous liquid wastes (Teal 1997).

EPA placed Hanford on the National Priorities List on November 3, 1989. In accordance with the Comprehensive Environmental Response, Compensation, and Liability Act (CERCLA), DOE entered into a Tri-Party Agreement with EPA and the State of Washington to govern the environmental compliance and cleanup of Hanford. That agreement meets the legal requirements specified under the Federal Facility Compliance Agreement (FFCA). An aggressive environmental restoration program is under way using priorities established in the Tri-Party Agreement (DOE 1996a:3-61). More information on regulatory requirements for waste disposal is provided in Chapter 5.

3.2.2.2 Transuranic and Mixed Transuranic Waste

All currently generated contact-handled TRU waste is being placed in above-grade storage buildings at the Hanford Central Waste Complex and the TRU Waste Storage and Assay Facility (DOE 1996a:3-64). TRU waste will be maintained in storage until shipped to the Waste Isolation Pilot Plant (WIPP) in Carlsbad, New Mexico, for disposal, beginning in 2000 (Aragon 1999). The new Waste Receiving and Processing Facility has the capability to process retrieved suspect TRU waste and certify newly generated and stored TRU waste for shipment to WIPP (Dirkes and Hanf 1996:10). Treatment of TRU waste will be provided in the future at the Stabilization Facility and Thermal Treatment Facility. TRU waste will be treated to meet WIPP waste acceptance criteria, packaged in accordance with DOE and U.S. Department of Transportation (DOT) requirements, and transported to WIPP for disposal (DOE 1996a:3-144). Mixed TRU

Table 3-5. Waste Management Capabilities at Hanford

Facility Name/Description	Capacity	Status	Applicable Waste Type					
			Mixed TRU		Mixed LLW		Haz	Non-Haz
			TRU	TRU	LLW	LLW		
Treatment Facility (m³/yr except as otherwise specified)								
242-A Evaporator, m ³ /day	265	Online	X	X	X	X		
Waste Receiving and Processing Facility	1,820	Online	X	X	X	X		
Stabilization Facility Contract	1,860	Planned for 1999	X	X		X		
Thermal Treatment Facility Contract	5,135	Planned for 2001	X	X		X		
Grout Treatment Facility	15,000	Online				X		
Shielded Analytical Lab Waste Treatment Unit, kg/hr	4	Online				X		
Maintenance & Storage Facility, batch/yr	26	Online				X		
200 Area Effluent Treatment Facility, m ³ /min	0.57	Online			X	X		
200 East Area Sanitary Wastewater Treatment Facility	120,000	Online						X
Storage Facility (m³)								
Central Waste Complex	16,800	Online	X	X	X	X		
TRU Waste Storage and Assay Facility	416	Standby	X	X	X	X		
305-B Storage Facility	20	Online			X	X	X	
B-Plant Canyon Waste Pile	5	Online			X			
B-Plant Container Storage	51	Online				X		
PUREX Tunnel 1	4,141	Online			X	X		
PUREX Tunnel 2	19,528	Online			X	X		
PUREX Canyon Waste Pile	432	Online				X		
200 Area Liquid Effluent Retention Facility	59,000	Online			X	X		
4843 Alkali Metal Storage Facility	95	Standby				X	X	
Disposal Facility (m³ except as otherwise specified)								
Grout Vaults	230,000	Online			X			
LLW Burial Ground	1,740,000	Online			X			
Radioactive Mixed Waste Disposal Facility	14,200	Standby			X	X		
200 Area Treated Effluent Disposal Facility, m ³ /min	8.7	Online						X
Energy Northwest Sewage Treatment Facility, m ³ /yr	235,000	Online						X

Key: Haz, hazardous; LLW, low-level waste; PUREX, Plutonium-Uranium Extraction (Plant); TRU, transuranic.

Source: Dirkes and Hanf 1996:46; Kovacs 1997; Rhoderick 1998; Sandberg 1998a; Teal 1997.

wastes are included in the TRU waste category because these wastes are expected to go to WIPP for ultimate disposal (DOE 1996a:3-64).

3.2.2.3 Low-Level Waste

Solid LLW is compacted and sent to the LLW Burial Ground in the 200 West Area for disposal in trenches. Additional LLW is received from offsite generators and disposed of at the LLW Burial Ground. LLW resulting from the tank waste remediation system waste pretreatment program will be vitrified; as a contingency, the Grout Facility will be maintained in standby condition. The vitrified LLW will be disposed of on the site in the 200 Area under the tank waste remediation system program (DOE 1996a:3-64).

U.S. Ecology operates a licensed commercial LLW Burial Ground on a site southwest of the 200 East Area that is leased to the State of Washington. The facility is not a DOE facility and is not considered part of DOE's Hanford operations (DOE 1996a:E-17).

3.2.2.4 Mixed Low-Level Waste

One of the existing treatment facilities for mixed LLW is the 242-A Evaporator in the 200 East Area, which reduces the volume of these wastes and removes cesium via ion exchange (DOE 1996a:3-64). The process condensate from the evaporator is temporarily stored in the Liquid Effluent Retention Facility until it is treated in the Liquid Effluent Treatment Facility. The Liquid Effluent Retention Facility consists of three Resource Conservation and Recovery Act (RCRA)-compliant surface impoundments for storing process condensate from the 242-A Evaporator. This facility provides equalization of the flow and pH to the Liquid Effluent Treatment Facility. The Liquid Effluent Treatment Facility provides ultraviolet light/peroxide destruction of organic compounds, reverse osmosis to remove dissolved solids, and ion exchange to remove the last traces of contaminants. Discharge of the treated effluent is via a dedicated pipeline to an underground drain field. The effluent treatment process produces a mixed LLW sludge that is concentrated, dried, packaged in 208-l (55-gal) drums, and transferred to the Central Waste Complex. This secondary waste is stored prior to treatment (if necessary) and disposal in the Mixed Waste Trench (Dirkes and Hanf 1996:10, 45, 46). In a recent modification to the Tri-Party Agreement, DOE has agreed to begin designing a vitrification facility to treat liquid mixed LLW (DOE 1996a:E-17; E-18).

The Waste Receiving and Processing Facility, near the Central Waste Complex in the 200 West Area, eventually will provide size reduction, decontamination, condensation, melting, amalgamation, incineration, ash stabilization, and shipping for Hanford mixed waste. The Waste Receiving and Processing Facility is being constructed in two phases: module 1 and module 2 (2A and 2B) and is designed to process 6,800 drums of waste annually (Dirkes and Hanf 1996:40). Module 1 will be designed to prepare retrieved and stored TRU waste and will be operational in 1999. Module 2A is designed to process LLW, TRU waste, mixed LLW, and mixed TRU waste, and is operational. Module 2B, if authorized, will be designed to process LLW, TRU waste, mixed LLW, and mixed TRU waste with a dose rate greater than 200 mrem/hr. Module 2B has an undetermined startup date (DOE 1996a:E-18).

The Radioactive Mixed Waste Disposal Facilities are in the Hanford LLW Burial Ground and are designated as 218-W-5, Trench 31, and Trench 34. The facilities consist of rectangular trenches with approximate dimensions of 76 by 30 m (250 by 100 ft). These facilities are RCRA compliant, with double liners and leachate collection and removal systems (Dirkes and Hanf 1996:40).

3.2.2.5 Hazardous Waste

There are no treatment facilities for hazardous waste at Hanford; therefore, the wastes are accumulated in satellite storage areas (for less than 90 days) or at interim RCRA-permitted facilities such as the 305-B Waste Storage Facility. The common practice for newly generated hazardous waste is to ship it off the site by truck using

DOT-approved transporters for treatment, recycling, recovery, and disposal at RCRA-permitted facilities (DOE 1996a:3-65, E-18; Sandberg 1998a).

3.2.2.6 Nonhazardous Waste

Sanitary wastewater is discharged to onsite treatment facilities such as septic tanks, subsurface soil adsorption systems, and wastewater treatment plants. These facilities treat an average of 600,000 l/day (159,000 gal/day) of sewage (DOE 1996a:E-19).

The 200 Area Treated Effluent Disposal Facility industrial sewer collects the treated wastewater streams from various plants in the 200 Areas and disposes of the clean effluent at two 2-ha (5-acre) ponds permitted by the State of Washington (DOE 1996a:E-19). The design capacity of the facility is approximately 8,700 l/min (2,300 gal/min), although the discharge permit presently limits the average monthly flow to about 2,400 l/min (640 gal/min) (Dirkes and Hanf 1996:46).

Nonhazardous solid wastes include construction debris, office trash, cafeteria wastes, furniture and appliances, nonradioactive friable asbestos, powerhouse ash, and nonradioactive/nonhazardous demolition debris. Until 1997, nonhazardous solid wastes were disposed of in the 600 Area central landfill. Under an agreement between DOE and the city of Richland, most of the site's nonregulated and nonradioactive solid wastes are now sent to the Richland Sanitary Landfill for disposal (DOE 1996a:3-65, E-19). The Richland Sanitary Landfill is at the southern edge of the Hanford Site boundary. Nonradioactive friable asbestos and medical waste are shipped off the site for disposal (Dirkes and Hanf 1996:83; Sandberg 1998a).

3.2.2.7 Waste Minimization

The Hanford Site Pollution Prevention Program is a comprehensive and continual effort to systematically reduce the quantity and toxicity of hazardous, radioactive, mixed, and sanitary wastes; conserve resources and energy; reduce hazardous substance use; and prevent or minimize pollutant releases to all environmental media from all operations and site cleanup activities. In accordance with sound environmental management, preventing pollution through source reduction is the first priority in the Hanford Site Pollution Prevention Program, and the second priority is environmentally safe recycling. For instance, Hanford pollution prevention efforts in 1995 helped to prevent the generation of approximately 2,900 m³ (3,790 yd³) of radioactive mixed waste, 207 t (228 tons) of RCRA waste, 30,000 m³ (39,200 yd³) of process wastewater, and 4,400 t (4,850 tons) of sanitary waste. Also during 1995, Hanford recycled approximately 632 t (697 tons) of office paper, 20 t (22 tons) of cardboard, 3,600 t (3,970 tons) of ferrous metal, 215 t (237 tons) of nonferrous metal, 57 t (63 tons) of lead, 16 t (18 tons) of solid chemicals, and 78,000 l (20,600 gal) of liquid chemicals. In addition, Hanford's new centralized recycling center collects aerosol cans, fluorescent light ballasts, fluorescent light tubes, and lead acid batteries (Dirkes and Hanf 1996:44, 45).

3.2.2.8 Preferred Alternatives From the WM PEIS

Preferred alternatives from the *Waste Management Programmatic Environmental Impact Statement* (WM PEIS) (DOE 1997a:summary, 95) are shown in Table 3-6 for the four waste types analyzed in this SPD EIS. A decision on the future management of these wastes could result in the construction of new waste management facilities at Hanford and the closure of other facilities. Decisions on the various waste types are expected to be announced in a series of records of decision (RODs) to be issued on this WM PEIS. In fact, the TRU waste ROD was issued on January 20, 1998 (DOE 1998a) with the hazardous waste ROD issued on August 5, 1998 (DOE 1998b). The TRU waste ROD states that DOE will develop and operate mobile and fixed facilities to characterize and prepare TRU waste for disposal at WIPP. Each DOE site that has, or will

Table 3–6. Preferred Alternatives From the WM PEIS

Waste Type	Preferred Action
TRU and mixed TRU	DOE prefers onsite treatment and storage of Hanford’s TRU waste pending disposal at WIPP. ^a
LLW	DOE prefers to treat Hanford’s LLW on the site. Hanford could be selected as one of the regional disposal sites for LLW.
Mixed LLW	DOE prefers regionalized treatment at Hanford. This includes the onsite treatment of Hanford’s wastes and could include treatment of some mixed LLW generated at other sites. Hanford could be selected as one of the regional disposal sites for mixed LLW.
Hazardous	DOE prefers to continue to use commercial facilities for hazardous waste treatment. ^a

^a ROD for TRU waste (DOE 1998a) and ROD for hazardous waste (DOE 1998b) selected the preferred alternatives for these waste types at Hanford.

Key: LLW, low-level waste; ROD, record of decision; TRU, transuranic; WIPP, Waste Isolation Pilot Plant.

Source: DOE 1997a:summary, 95.

generate, TRU waste will, as needed, prepare and store its TRU waste on the site. The hazardous waste ROD states that most DOE sites will continue to use offsite facilities for the treatment and disposal of major portions of the nonwastewater hazardous waste, with ORR and SRS continuing to treat some of their own hazardous waste on the site in existing facilities where this is economically favorable. More detailed information and DOE’s alternatives for the future configuration of waste management facilities at Hanford is presented in the WM PEIS and the hazardous waste and TRU waste RODs.

3.2.3 Socioeconomics

Statistics for employment and regional economy are presented for the regional economic area (REA) as defined in Appendix F.9, which encompasses nine counties surrounding Hanford in Washington. Statistics for population, housing, community services, and local transportation are presented for the ROI, a two-county area in which 91 percent of all Hanford employees reside as shown in Table 3–7. In 1997, Hanford employed about 12,882 persons (about 3.7 percent of the REA civilian labor force) (Mecca 1997b).

Table 3–7. Distribution of Employees by Place of Residence in the Hanford Region of Influence, 1997

County	Number of Employees	Total Site Employment (Percent)
Benton	10,563	82
Franklin	1,159	9
ROI total	11,722	91

Source: Mecca 1997b.

3.2.3.1 Regional Economic Characteristics

Selected employment and regional economy statistics for the Hanford REA and Washington are summarized in Figure 3–1. Between 1990 and 1996, the civilian labor force in the REA increased 35.3 percent to 344,611. In 1996, the unemployment rate in the REA was 11.1 percent, significantly higher than the rate of 6.5 percent in Washington State (DOL 1999).

In 1995, service activities represented the largest sector of employment in the REA (22.3 percent). This was followed by agriculture (19.6 percent) and government (17.4 percent). Overall, the State total for these employment sectors was 25.0 percent, 3.7 percent, and 18.0 percent, respectively (DOL 1997).

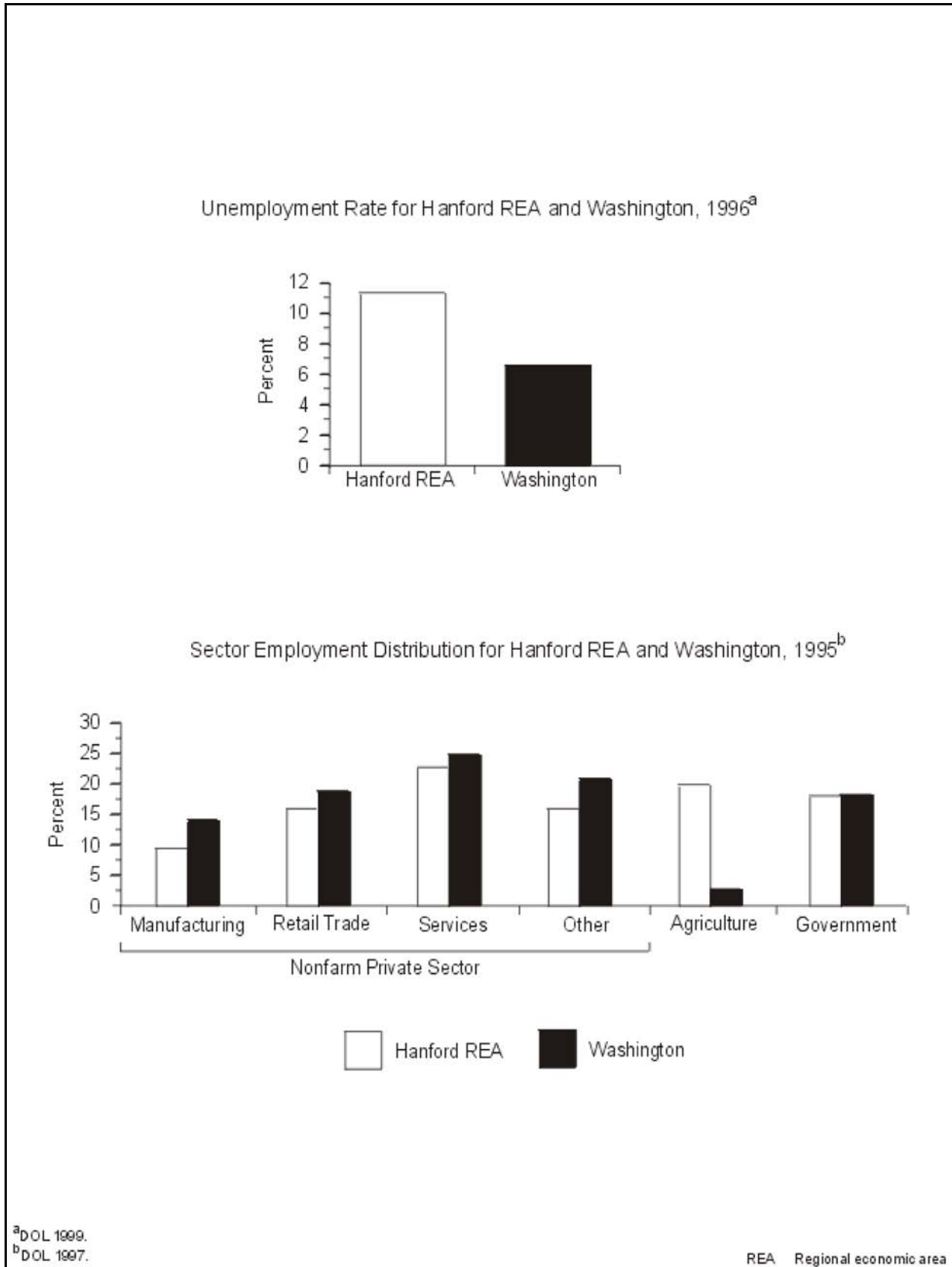

Figure 3-1. Employment and Local Economy for the Hanford Regional Economic Area and the State of Washington

3.2.3.2 Population and Housing

In 1996, the ROI population totaled 179,949. Between 1990 and 1996, the ROI population increased 18.9 percent compared with the 12.9 percent increase experienced in Washington (DOC 1997). Between 1980 and 1990, the number of housing units in the ROI increased by about 4.6 percent, compared with a 20.3 percent increase in Washington. The total number of housing units within the ROI for 1990 was 58,541 (DOC 1994). The 1990 homeowner vacancy rates for the ROI was 1.4 percent compared with the State's rate of 1.3 percent. The ROI renter vacancy rate was 5.5 percent compared with 5.8 percent for the State (DOC 1990a). Population and housing trends in the ROI and Washington are summarized in Figure 3-2.

3.2.3.3 Community Services

3.2.3.3.1 Education

Ten school districts provide public education in the Hanford ROI. As shown in Figure 3-3, school districts in 1997 were operating at capacities ranging from 65 to 100 percent. In 1997, the student-to-teacher ratio in the ROI averaged 16:1 (Nemeth 1997a). In 1990, the average student-to-teacher ratio for Washington was 11.4:1 (DOC 1990b; 1994).

3.2.3.3.2 Public Safety

In 1997, a total of 281 sworn police officers were serving the ROI. The ROI average officer-to-population ratio was 1.6 officers per 1,000 persons (Nemeth 1997b). This compares with the 1990 State average of 1.7 police officers per 1,000 persons (DOC 1990b). In 1997, 616 paid and volunteer firefighters provided fire protection services in the Hanford ROI. The average firefighter-to-population ratio in 1997 in the ROI was 3.4 firefighters per 1,000 persons (Nemeth 1997b). This compares with the 1990 State average of 1 firefighter per 1,000 persons (DOC 1990b). Figure 3-4 displays the ratio of sworn police officers and firefighters to population for the two counties in the Hanford ROI.

3.2.3.3.3 Health Care

In 1996, a total of 257 physicians served the ROI. The average physician-to-population ratio in the ROI was 1.4 physicians per 1,000 persons compared with the 1996 State average of 3.7 per 1,000 persons (Randolph 1997). In 1997, there were four hospitals serving the ROI. The hospital bed-to-population ratio averaged 2.1 beds per 1,000 persons (Nemeth 1997c). This compares with a State 1991 average of 2.4 beds per 1,000 persons (DOC 1996:128). Figure 3-4 displays the ratio of physicians-to-population and hospital bed-to-population for the two counties in the Hanford ROI.

3.2.3.4 Local Transportation

Vehicular access to Hanford is provided by State Routes 240, 243, 24, and Stevens Drive. State Route 240 connects to the Richland bypass highway, which interconnects with I-182. State Route 243 exits the site's northwestern boundary and serves as a primary link between the site and I-90. State Route 24 enters the site from the west and continues eastward across the northernmost portion of the site and intersects State Route 26 about 16 km (10 mi) east of the site boundary. Stevens Drive out of north Richland is the favored route to Hanford (see Figure 2-2).

One current road improvement project that could affect vehicular access to Hanford is repaving and signal work at the intersection of State Route 240 and Stevens Drive. Two projects, currently in the planning stage, could affect vehicular access to Hanford in the future: a realignment of State Route 240 from Stevens Drive

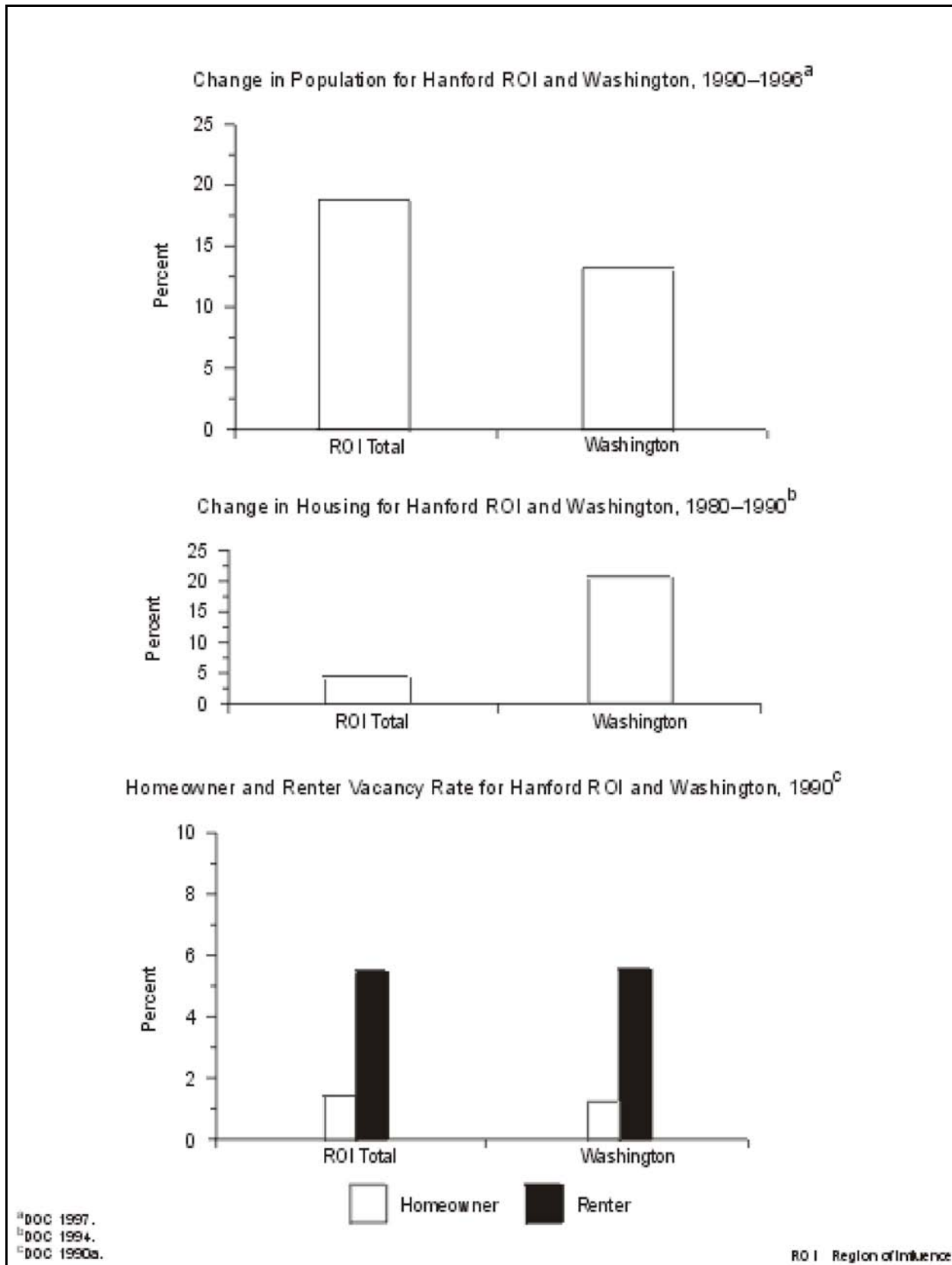

Figure 3–2. Population and Housing for the Hanford Region of Influence and the State of Washington

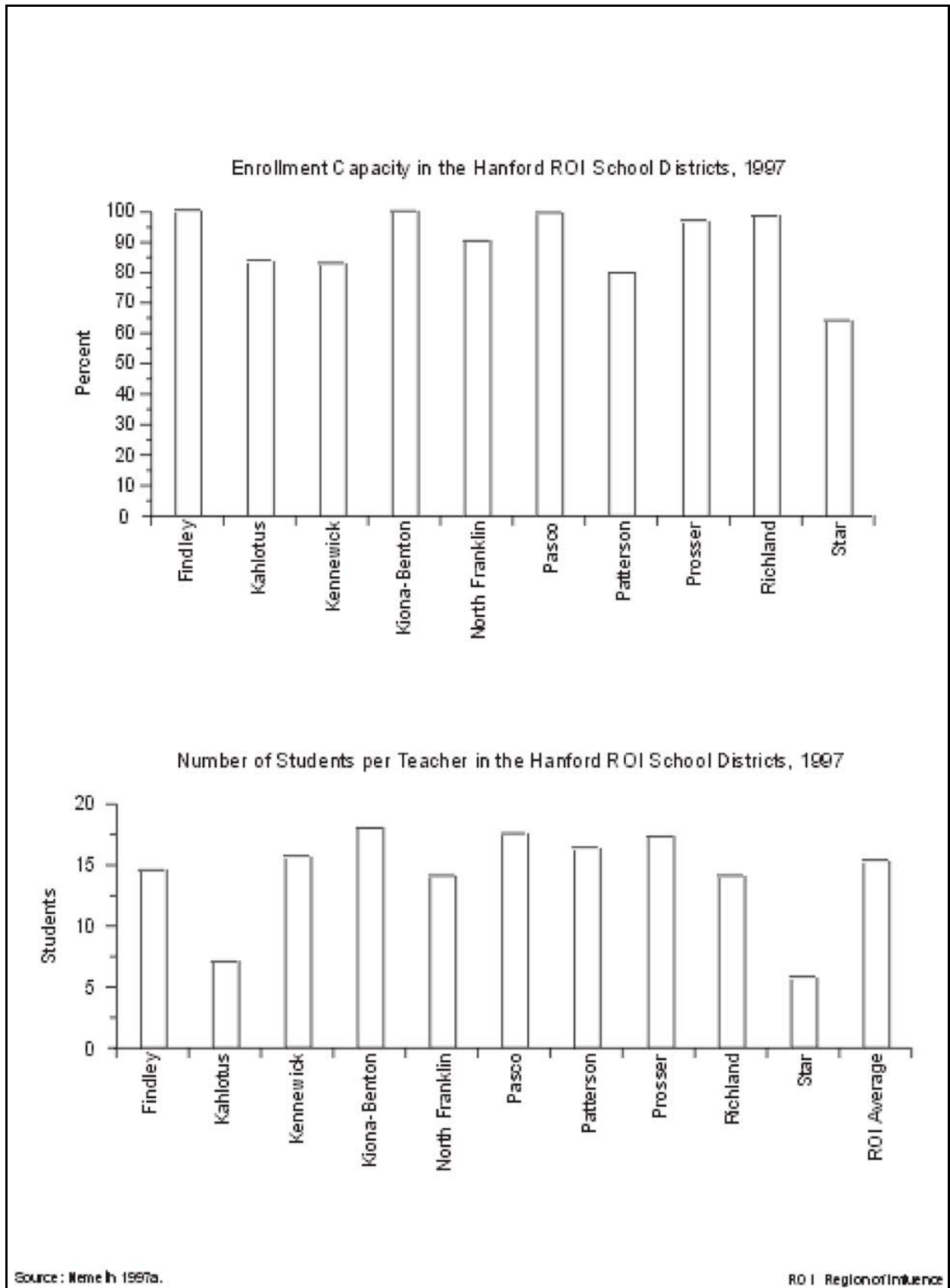

Figure 3-3. School District Characteristics for the Hanford Region of Influence

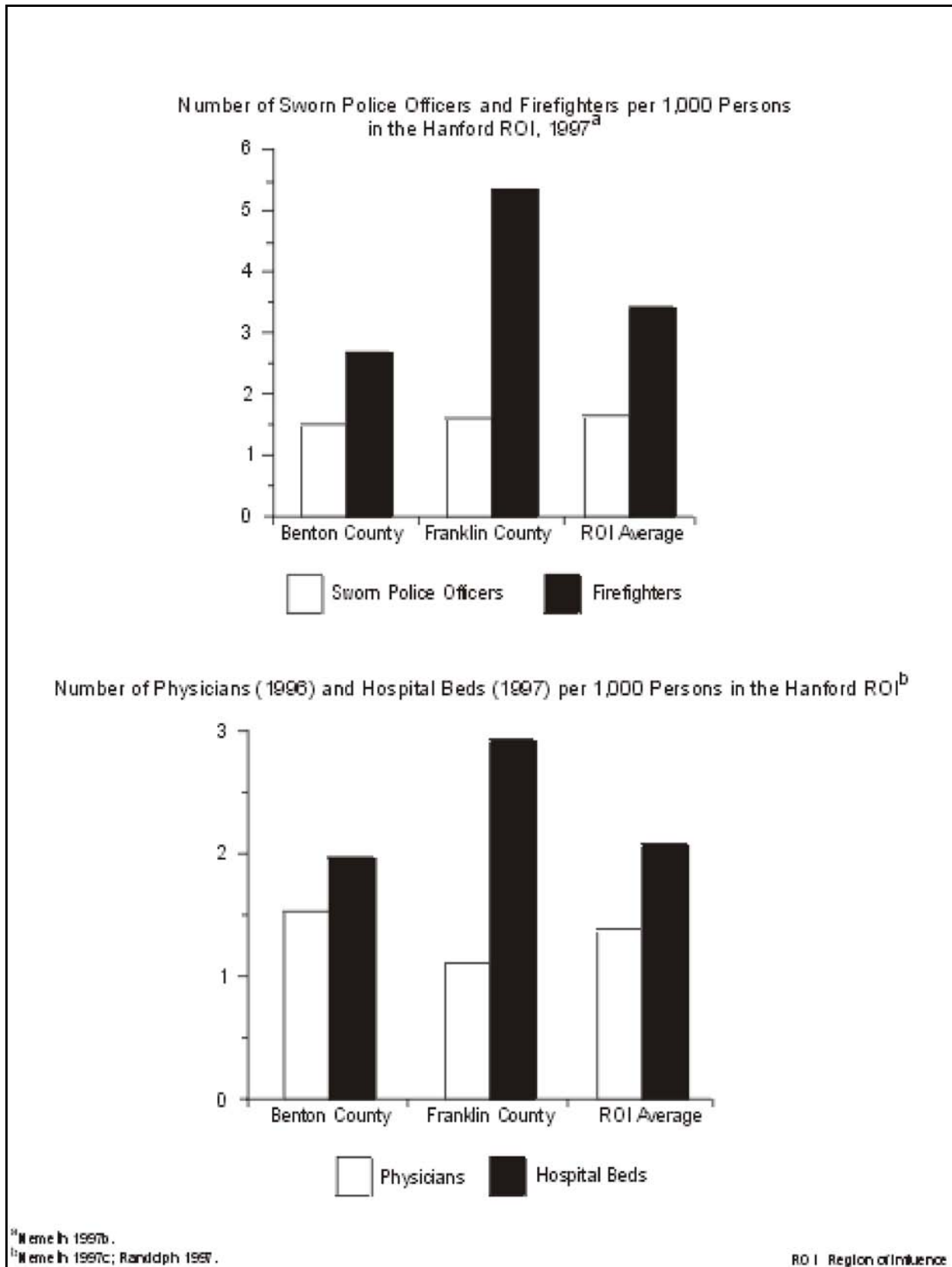

Figure 3-4. Public Safety and Health Care Characteristics for the Hanford Region of Influence

to State Route 224 and the paving of asphalt overlay of State Route 224 from West Richland to State Route 240 in the year 2000 (MacNeil 1997). However, an improvement project on Grosscup Road would provide relief of congestion due to State Route 224 paving activities.

The local intercity transit system, Ben Franklin Transit, supplies bus service between the Tri-Cities and Hanford. Both private interests and Ben Franklin Transit provide vanpooling opportunities in the ROI.

Onsite rail transport is provided by a short-line railroad that connects with the Union Pacific line just south of the Yakima River. The Union Pacific line interchanges with the Washington Central and Burlington Northern and Santa Fe at the city of Kennewick. There is no passenger rail service at Hanford (see Section 3.2.11.1.1 for more information).

In the ROI, the Columbia River is used as an inland waterway for barge transportation from the Pacific Ocean. The Port of Benton provides a barge slip where shipments arriving at Hanford may be off-loaded.

Tri-Cities Airport, near the city of Pasco, provides jet air passenger and cargo service by both national and local carriers. Numerous smaller private airports are located throughout the ROI (DOE 1996a).

3.2.4 Existing Human Health Risk

Public and occupational health and safety issues include the determination of potentially adverse effects on human health that result from acute and chronic exposures to ionizing radiation and hazardous chemicals.

3.2.4.1 Radiation Exposure and Risk

3.2.4.1.1 General Site Description

Major sources and levels of background radiation exposure to individuals in the vicinity of Hanford are shown in Table 3–8. Annual background radiation doses to individuals are expected to remain constant over time. The total dose to the population, in terms of person-rem, changes as the population size changes. Background radiation doses are unrelated to Hanford operations.

Table 3–8. Sources of Radiation Exposure to Individuals in the Hanford Vicinity Unrelated to Hanford Operations

Source	Effective Dose Equivalent (mrem/yr)
Natural background radiation^a	
Cosmic radiation	30
External terrestrial radiation	30
Internal terrestrial radiation	40
Radon in homes (inhaled)	200 ^b
Other background radiation^c	
Diagnostic x rays and nuclear medicine	53
Weapons test fallout	<1
Air travel	1
Consumer and industrial products	10
Total	365

^a Dirkes and Hanf 1997:264.

^b An average for the United States.

^c NCRP 1987:11, 40, 53.

Releases of radionuclides to the environment from Hanford operations provide another source of radiation exposure to individuals in the vicinity of Hanford. Types and quantities of radionuclides released from Hanford operations in 1996 are listed in the *Hanford Site Environmental Report for Calendar Year 1996* (Dirkes and Hanf 1997:65–71). Doses to the public resulting from these releases are presented in Table 3–9. These doses fall within radiological limits per DOE Order 5400.5 (DOE 1993a:II-1–II-5) and are much lower than those of background radiation.

Table 3–9. Radiation Doses to the Public From Normal Hanford Operations in 1996 (Total Effective Dose Equivalent)

Members of the Public	Atmospheric Releases ^a		Liquid Releases		Total	
	Standard ^b	Actual	Standard ^b	Actual	Standard ^b	Actual
Maximally exposed individual (mrem)	10	4.6×10 ⁻³	4	2.8×10 ^{-3(c)}	100	7.4×10 ⁻³
Population within 80 km (person-rem) ^d	None	0.13	None	0.072	100	0.20
Average individual within 80 km (mrem) ^e	None	3.4×10 ⁻⁴	None	1.9×10 ⁻⁴	None	5.3×10 ⁻⁴

^a Includes direct radiation dose from surface deposits of radioactive material.

^b The standards for individuals are given in DOE Order 5400.5 (DOE 1993a:II-1–II-5). As discussed in that order, the 10-mrem/yr limit from airborne emissions is required by the Clean Air Act, and the 4-mrem/yr limit is required by the Safe Drinking Water Act; for this SPD EIS, the 4-mrem/yr value is conservatively assumed to be the limit for the sum of doses from all liquid pathways. The total dose of 100 mrem/yr is the limit from all pathways combined. The 100-person-rem value for the population is given in proposed 10 CFR 834, as published in 58 FR 16268 (DOE 1993b:para. 834.7). If the potential total dose exceeds the 100 person-rem value, it is required that the contractor operating the facility notify DOE.

^c Includes the drinking water dose.

^d About 380,000 in 1996.

^e Obtained by dividing the population dose by the number of people living within 80 km (50 mi) of the site.

Source: Dirkes and Hanf 1997:chap. 5.

Using a risk estimator of 500 cancer deaths per 1 million person-rem (5×10^{-4} fatal cancer per person-rem) to the public (see Appendix F.10), the fatal cancer risk to the maximally exposed member of the public due to radiological releases from Hanford operations in 1996 is estimated to be 3.7×10^{-9} . That is, the estimated probability of this person dying of cancer at some point in the future from radiation exposure associated with 1 year of Hanford operations is less than 4 in 1 billion. (It takes several to many years from the time of radiation exposure for a cancer to manifest itself.)

According to the same risk estimator, 1×10^{-4} excess fatal cancers are projected in the population living within 80 km (50 mi) of Hanford from normal operations in 1996. To place this number in perspective, it may be compared with the number of fatal cancers expected in the same population from all causes. The 1996 mortality rate associated with cancer for the entire U.S. population was 0.2 percent per year (Famighetti 1998:964). Based on this mortality rate, the number of fatal cancers expected during 1996 from all causes in the population living within 80 km (50 mi) of Hanford was 760. This expected number of fatal cancers is much higher than the 1×10^{-4} fatal cancer estimated from Hanford operations in 1996.

Hanford workers receive the same dose as the general public from background radiation, but they also receive an additional dose from working in facilities with nuclear materials. Table 3–10 presents the average dose to the individual worker and the cumulative dose to all workers at Hanford from operations in 1996. These doses fall within the radiological regulatory limits of 10 CFR 835 (DOE 1995a:para. 835.202). According to a risk

Table 3–10. Radiation Doses to Workers From Normal Hanford Operations in 1996 (Total Effective Dose Equivalent)

Occupational Personnel	Onsite Releases and Direct Radiation	
	Standard ^a	Actual
Average radiation worker (mrem)	None ^b	19
Total workers (person-rem) ^c	None	266

^a The radiological limit for an individual worker is 5,000 mrem/yr (DOE 1995a:para. 835.202). However, DOE’s goal is to maintain radiological exposure as low as is reasonably achievable. It has therefore established an administrative control level of 2,000 mrem/yr (DOE 1994a:2-3); the site must make reasonable attempts to maintain individual worker doses below this level.

^b No standard is specified for an “average radiation worker”; however, the maximum dose that this worker may receive is limited to that given in footnote “a.”

^c About 14,000 (badged) in 1996.

Source: Lyon 1997.

estimator of 400 fatal cancers per 1 million person-rem among workers² (Appendix F.10), the number of projected fatal cancers among Hanford workers from normal operations in 1996 is 0.11.

A more detailed presentation of the radiation environment, including background exposures and radiological releases and doses, is presented in the *Hanford Site Environmental Report for Calendar Year 1996* (Dirkes and Hanf 1997). The concentrations of radioactivity in various environmental media (including air, water, and soil) in the site region (on and off the site) are also presented in that report.

3.2.4.1.2 Proposed Facility Locations

External radiation doses have been measured in the 200 and 400 Areas. In 1996, the annual doses in the 200 and 400 Areas were roughly the same, about 85 mrem. This is 10 mrem higher than the value measured at the offsite control locations. The concentration of plutonium 239/240 in air in the 200 Area in 1996 was about 1×10^{-5} pCi/m³. Although this was about 100 times higher than the value at the control location, it was still very small. No measurements of plutonium concentrations in air were reported for the 400 Area (Dirkes and Hanf 1997:75, 76, 124, 185, 186).

3.2.4.2 Chemical Environment

The background chemical environment important to human health consists of the atmosphere, which may contain hazardous chemicals that can be inhaled; drinking water, which may contain hazardous chemicals that can be ingested; and other environmental media through which people may come in contact with hazardous chemicals (e.g., surface water during swimming, soil through direct contact, or food). Hazardous chemicals can cause cancer and noncancer health effects. The baseline data for assessing potential health impacts from the chemical environment are addressed in Section 3.2.1.

² The risk estimator for workers is lower than the estimator for the public because of the absence from the workforce of the more radiosensitive infant and child age groups.

Effective administrative and design controls that decrease hazardous chemical releases to the environment and help achieve compliance with permit requirements (e.g., air emissions and National Pollutant Discharge Elimination System [NPDES] permit requirements) contribute to minimizing health impacts on the public. The effectiveness of these controls is verified through the use of monitoring information and inspection of mitigation measures. Health impacts on the public may occur via inhalation of air containing hazardous chemicals released to the atmosphere during normal Hanford operations. Risks to public health from other possible pathways, such as ingestion of contaminated drinking water or direct exposure, are lower than those via the inhalation pathway.

Baseline air emission concentrations and applicable standards for hazardous chemicals are addressed in Section 3.2.1. The baseline concentrations are estimates of the highest existing offsite concentrations and represent the highest concentrations to which members of the public could be exposed. These concentrations are in compliance with applicable guidelines and regulations. Information on estimating the health impacts of hazardous chemicals is presented in Appendix F.10.

Exposure pathways to Hanford workers during normal operations may include the inhalation of contaminants in the workplace atmosphere and direct contact with hazardous materials. The potential for health impacts varies among facilities and workers, and available information is insufficient for a meaningful estimate of impacts. However, workers are protected from workplace hazards through appropriate training, protective equipment, monitoring, substitution, and engineering and management controls. They are also protected by adherence to Occupational Safety and Health Administration (OSHA) and EPA standards that limit workplace atmospheric and drinking water concentrations of potentially hazardous chemicals. Appropriate monitoring that reflects the frequency and amounts of chemicals used in the operational processes ensures that these standards are not exceeded. Additionally, DOE requires that conditions in the workplace be as free as possible from recognized hazards that cause, or are likely to cause, illness or physical harm. Therefore, workplace conditions at Hanford are substantially better than required by standards.

3.2.4.3 Health Effects Studies

Three epidemiological studies and a feasibility study have been conducted on communities around Hanford to determine whether there are excess cancers in the general population. One study found no excess cancers but identified an elevated rate of neural tube defects in progeny. This elevated rate was not attributed to parental employment at Hanford. A second study suggested that neural tube defects were associated with cumulative radiation exposure, and showed other defects statistically associated with parental employment at Hanford, but not with parental radiation exposure. The third study did not show any cancer risk associated with living near the facility.

Many epidemiological studies have been carried out on the Hanford workers over the years. The studies have consistently shown a statistically significant elevated risk of death from multiple myeloma associated with radiation exposure among Hanford male workers. The elevated risk was observed only among workers exposed to 10 rads (-10 rem) or more. Other studies have also identified an elevated risk of death from pancreatic cancers, but a recent reanalysis did not conclude there was an elevated risk. Studies of female Hanford workers have shown an elevated risk of deaths from musculoskeletal system and connective tissue conditions. For a more detailed description of the studies reviewed and their findings, and for a discussion of the epidemiologic surveillance program implemented by DOE to monitor the health of current workers, refer to Appendix M.4.2 of the *Storage and Disposition PEIS* (DOE 1996a:M-224–M-230).

3.2.4.4 Accident History

Prior to 1997, there were 128 nuclear-process-related incidents with some degree of safety significance at Hanford over its period of operation. These do not include less-significant instances of radioactivity release or

contamination during normal operations, which have been the subject of other reviews. The 128 incidents fall into three significant categories, based on the seriousness of the actual or potential consequences.

Fifteen of the incidents were Category 1, indicating that serious injury, radiation release or exposure above limits, substantial actual plant damage, or a significant challenge to safety resulted. Forty-six events were Category 2, less severe than Category 1, but involving significant cost or a less significant threat to safety. The remaining 67 incidents were Category 3, causing minor radiation exposure or monetary cost, or involving a violation of operating standards without a serious threat to safety (DOE 1996a:3-60).

On May 14, 1997, a chemical explosion occurred at the Hanford Plutonium Reclamation Plant in a room where nonradioactive bulk chemicals were mixed for the now-discontinued plutonium recovery process. The reclamation plant was designed to concentrate liquid feeds, dissolve and process solid material, and perform solvent-extraction recovery of plutonium from aqueous streams. Eight workers outside the plant at the time of the explosion complained of various symptoms, including headaches, light-headedness, and a strange metallic taste. All eight workers were transported to a nearby medical center, where they were examined and released. A small fire protection water line ruptured during the explosion, resulting in the release of water from the building. No one was injured and no radioactive materials were released to the environment. The explosion caused significant localized damage to the facility.

3.2.4.5 Emergency Preparedness

Each DOE site has established an emergency management program that would be activated in the event of an accident. This program has been developed and maintained to ensure adequate response to most accident conditions and to provide response efforts for accidents not specifically considered. The emergency management program includes emergency planning, preparedness, and response.

Accordingly, the DOE Richland Operations Office has developed and maintains a comprehensive set of emergency preparedness plans and procedures for Hanford to support onsite and offsite emergency management actions in the event of an accident. The DOE Richland Operations Office also provides technical assistance to other Federal agencies and to State and local governments. Hanford contractors are responsible for ensuring that emergency plans and procedures are prepared and maintained for all facilities, operations, and activities under their jurisdiction, and for directing implementation of those plans and procedures during emergency conditions. The DOE Richland Operations Office, contractor, and State and local government plans are fully coordinated and integrated. Emergency control centers have been established by the DOE Richland Operations Office and its contractors for the principal work areas to provide oversight and support to emergency response actions within those areas.

Following the May 1997 explosion at Hanford (discussed previously), a review of the emergency management response indicated that multiple programs and systems failed in the hours following the accident. In a letter to Secretarial Offices, Secretary of Energy Federico Peña identified actions to be taken at all DOE sites to implement lessons learned from the emergency response (Peña 1997). The actions involve the following elements:

1. Improve training for facility and site emergency personnel
2. Ensure that equipment and qualified personnel are ready for the wide variety of potential radiological and chemical hazards
3. Improve coordination with local medical communities
4. Have in place comprehensive procedures to attend to personnel who are potentially affected by an accident

3.2.5 Environmental Justice

Environmental justice concerns the environmental impacts that proposed actions may have on minority and low-income populations, and whether such impacts are disproportionate to those on the population as a whole in the potentially affected area. In the case of Hanford, the potentially affected area includes parts of Washington and Oregon.

The potentially affected area around the 200 East Area is defined by a circle with an 80-km (50-mi) radius centered at the planned HLW vitrification facility (lat. 46E33'03.64" N, long. 119E30'13.95" W). The total population residing within that area in 1990 was 346,031. The proportion of the population that was considered minority was 26.2 percent. The potentially affected area surrounding the 400 Area is defined by a circle with an 80-km (50-mi) radius centered at FMEF (lat. 46E26'07" N, long. 119E21'55" W). The total population residing within that area in 1990 was 277,515, and the proportion of the population deemed minority was 25.4 percent. The same census data show that the percentage of minorities for the contiguous United States was 24.1, and the percentages for the States of Washington and Oregon were 13.3 and 9.2, respectively (DOC 1992).

Figure 3-5 illustrates the racial and ethnic composition of the minority population in the potentially affected area around the 200 East Area. At the time of the 1990 census, Hispanics were the largest minority group within the potentially affected area, constituting 21.5 percent of the total population. Native Americans contributed about 2 percent, and Asians, about 1.4 percent. Blacks made up about 1.2 percent of the population (DOC 1992).

As for the racial and ethnic composition of the minority population in the potentially affected area around the 400 Area, Hispanics were the largest minority group, constituting 21.5 percent of the total population during the 1990 census. Asians contributed about 1.4 percent, and Native Americans, about 2.0 percent. Blacks were about 1.2 percent of the population (DOC 1992).

A breakdown of incomes in the potentially affected area is also available from the 1990 census data (DOC 1992). At that time, the poverty threshold was \$9,981 for a family of three with one related child under 18 years of age. A total of 64,780 persons (19.0 percent of the total population) residing within the potentially affected area around the 200 East Area reported incomes below that threshold. The data also show that 47,310 persons (17.3 percent of the total population) residing within the potentially affected area around the 400 Area reported incomes below the poverty threshold. Data obtained during the 1990 census also show that of the total population of the contiguous United States, 13.1 percent reported incomes below the poverty threshold, and that the figures for Washington and Oregon were 10.9 and 12.4 percent, respectively.

3.2.6 Geology and Soils

Geologic resources are consolidated or unconsolidated earth materials, including ore and aggregate materials, fossil fuels, and significant landforms. Soil resources are the loose surface materials of the earth in which plants grow, usually consisting of disintegrated rock, organic matter, and soluble salts.

3.2.6.1 General Site Description

The rocks beneath Hanford consist of Miocene-age and younger rocks that overlay older Cenozoic sedimentary and volcanic basement rocks. The major geologic units underlying Hanford are, in ascending order: subbasalt (basement) rocks, the Columbia River Basalt Group (with alluvial interbeds of sand, gravel, or silt of the Ellensburg Formation), the Ringold Formation, the Plio-Pleistocene unit, early "Palouse" soil, and the Hanford Formation (DOE 1996a:3-38; DOE 1996c:4-5).

Basalt outcrops are exposed on ridges at Gable Mountain, Gable Butte, and the Saddle Mountains in the northern part of Hanford, and on Rattlesnake Hills and Yakima Ridge, overlapping the western and southwestern edges

of Hanford (DOE 1996a:3-38). Other than crushed rock, sand, and gravel, no economically viable geologic resources have been identified at Hanford (DOE 1996c:4-10).

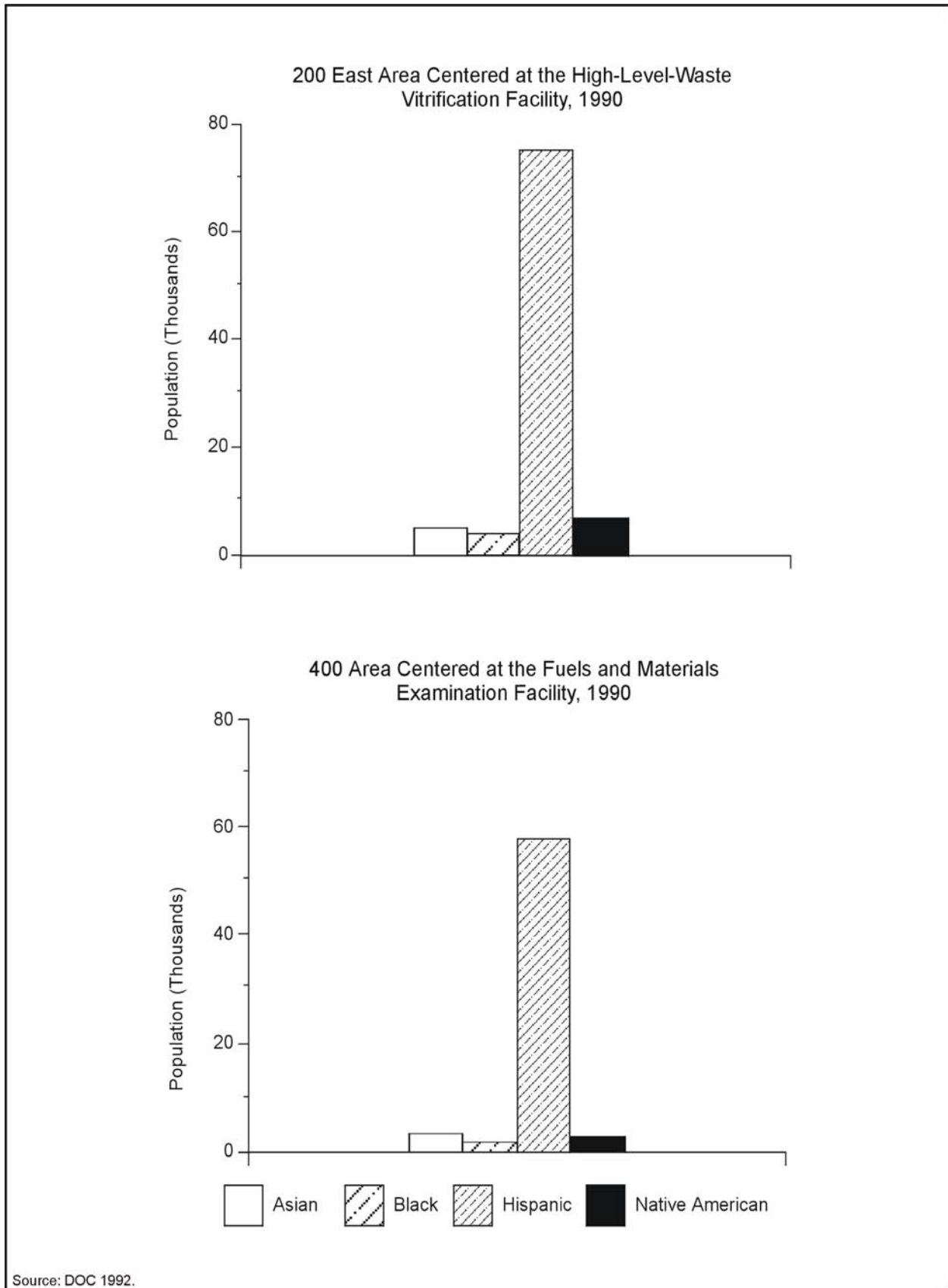

Figure 3-5. Racial and Ethnic Composition of Minorities Around Hanford

Known faults in the Hanford area include those on Gable Mountain and the Rattlesnake-Wallula alignment. The faults in Central Gable Mountain are considered capable, although there is no observed seismicity on or near Gable Mountain. The Rattlesnake-Wallula alignment is interpreted as possibly being capable because there appear to be active portions of the fault system 56 km (35 mi) southwest of the central part of Hanford. A capable fault is one that has had movement at or near the ground surface at least once within the past 35,000 years or recurrent movement within the past 500,000 years (Barghusen and Feit 1995:2.2-13, 2.2-14).

According to the Uniform Building Code, Hanford is in Seismic Zone 2B, meaning that moderate damage could occur as a result of an earthquake. Seismicity of the Columbia Plateau, as determined by the rate of earthquakes per area and the historical magnitude of these events, is lower than that of other regions in the Pacific Northwest (DOE 1996a:3-38, 3-39). The two largest earthquakes near Hanford occurred in 1918 and 1973; each had an approximate Richter magnitude of 4.5 and a Modified Mercalli Intensity of V. They occurred in the central portion of the Columbia Plateau north of Hanford (Neitzel 1996:4.49). An earthquake with a maximum horizontal acceleration of 0.25g is calculated to have an annual probability of occurrence of 1 in 10,000 at Hanford (Barghusen and Feit 1995:2.2-14).

There is some potential for slope failure at Hanford, although only the slopes of Gable Mountain and White Bluffs are steep enough to warrant landslide concern. White Bluffs, east of the Columbia River, poses the greatest concern because of the clay-rich nature of some beds above the river level, the discharge of large quantities of irrigation water into the ground atop the cliffs, the surface incline toward the Columbia River, and the eastward channel migration of the Columbia and its undercutting of the adjacent bluffs. A large landslide along White Bluffs could fill the Columbia River channel and divert water onto Hanford (DOE 1996a:3-40). Calculations of the potential impacts of such a landslide indicate a flood area similar to the probable maximum flood (Neitzel 1996:4.58–4.61).

Several major volcanoes are in the Cascade Range west of Hanford, including Mount Adams, 164 km (102 mi) from Hanford, and Mount St. Helens, 218 km (135 mi) west-southwest of the site (DOE 1996a:3-40). Ashfalls from at least three Cascade volcanoes have blanketed the central Columbia Plateau since the late Pleistocene epoch. Generally, ashfall layers have not exceeded more than a few centimeters in thickness, with the exception of the Mount Mazama (Crater Lake, Oregon) eruption, when as much as 10 cm (3.9 in) of ash fell over western Washington (Barghusen and Feit 1995:2.2-14).

Fifteen different soil types occur at Hanford. These soils vary from sand to silty and sandy loam. The dominant soil types are the Quincy (Rupert) sand, Burbank loamy sand, Ephrata sandy loam, and the Warden silt loam. No soils at Hanford are currently classified as prime farmlands because there are no current soil surveys, and the only prime farmland soils in the region are irrigated (DOE 1996b:4-15). The soils at Hanford are considered acceptable for standard construction techniques (DOE 1996a:3-40). More detailed descriptions of the geology and the soil conditions at Hanford are included in the *Storage and Disposition PEIS* (DOE 1996a:3-38–3-40) and the *Hanford Remedial Action EIS* (DOE 1996b).

3.2.6.2 Proposed Facility Locations

The nearest capable fault to the 200 East Area is about 10 km (6.2 mi) away (Mecca 1997a:6). The predominant soils of the 200 East Area are the Burbank loamy sand and the Ephrata sandy loam, and the soils are not subject to liquefaction or other instabilities (Mecca 1997a:6; Neitzel 1996:4-46).

The nearest capable fault to the 400 Area is about 19 km (12 mi) away (Mecca 1997a:6). The predominant soil type in the 400 Area is the Rupert sand, and the soils are not subject to liquefaction or other instabilities (Mecca 1997a:6; Neitzel 1996:4-46).

3.2.7 Water Resources

3.2.7.1 Surface Water

Surface water includes marine or freshwater bodies that occur above the ground surface, including rivers, streams, lakes, ponds, rainwater catchments, embayments, and oceans.

3.2.7.1.1 General Site Description

The major surface water features at Hanford are the Columbia River, the Yakima River, the springs along the Columbia River and on Rattlesnake Mountain, and onsite ponds. Flow of the Columbia River is regulated by several dams upstream and downstream from the site. The nearest dam upstream from Hanford is the Priest Rapids Dam, and the closest downstream dam is the McNary Dam. The Hanford Reach is the portion of the Columbia River that extends from Priest Rapids Dam to the upstream edge of the pool behind McNary Dam. Because the flows are regulated, flow rates in the Hanford Reach can vary considerably; it is the last remaining free-flowing, nontidal section of the river (DOE 1996a:3-32). The average flow rate at the Priest Rapids Dam is about 3,360 m³/s (118,700 ft³/s). About one-third of the Hanford Site drains into the Yakima River, which forms a portion of the southern site boundary (Neitzel 1996:4.53–4.55). The average annual flow rate for the Yakima River is about 104 m³/s (3,670 ft³/s). Rattlesnake Springs and Snively Springs are in the southwestern portion of the site and flow into intermittent streams. Flows received by these streams infiltrate rapidly into the surface sediments thereof (DOE 1996a:3-32).

Waters of the Columbia River are used primarily for hydroelectric power, transportation, irrigation and other agricultural purposes, recreation, and municipal domestic water. Hanford uses water from the river for domestic and industrial purposes (DOE 1996a:3-32).

Flooding of the site has occurred along the Columbia River, but chances of recurrence have been greatly reduced by the construction of dams to regulate river flow. No maps of flood-prone areas have been produced by the Federal Emergency Management Agency (FEMA). FEMA produces these maps for areas capable of being developed, and the Hanford Site is not designated for commercial or residential development (DOE 1996b:4-22). However, analyses have been completed to determine the potential for the probable maximum flood. This is determined through hydrologic factors, including the amount of precipitation within the drainage basin, snow melt, and tributary conditions. The probable maximum flood for the Columbia River below the Priest Rapids Dam has been calculated at 39,600 m³/s (1.4 million ft³/s). Figure 3–6 shows the elevations of the highest flood of record, the river at normal flow, the 1948 flood, and the probable maximum flood (DOE 1996b:4-23).

Potential flooding due to dam failure has been evaluated by the U.S. Army Corps of Engineers (USACE). Upstream failures could have any number of causes, the magnitude of the resultant flooding depending on the size of the breach in the dam. USACE evaluated various scenarios for failure of the Grand Coulee Dam and assumed flow conditions of about 11,300 m³/s (400,000 ft³/s). The worst-case scenario assumed a 50 percent breach in the dam (Figure 3–7). The flood wave from an instantaneous 50 percent breach was calculated to be 595,000 m³/s (21 million ft³/s). In addition to the areas affected by the probable maximum flood, the remainder of the 100 Area, the 300 Area, and nearly all of Richland, Washington, would be flooded. Determinations were not made for larger instantaneous breaches in the Grand Coulee Dam, because the 50 percent scenario was believed to be the largest conceivable flow from a natural or manmade breach. It was not considered credible that a structure as large as the Grand Coulee Dam could be 100 percent destroyed instantaneously. The analysis also assumed that the 50 percent breach would occur only as the result of direct explosive detonation, and not because of some natural event such as an earthquake (DOE 1996b:4-24).

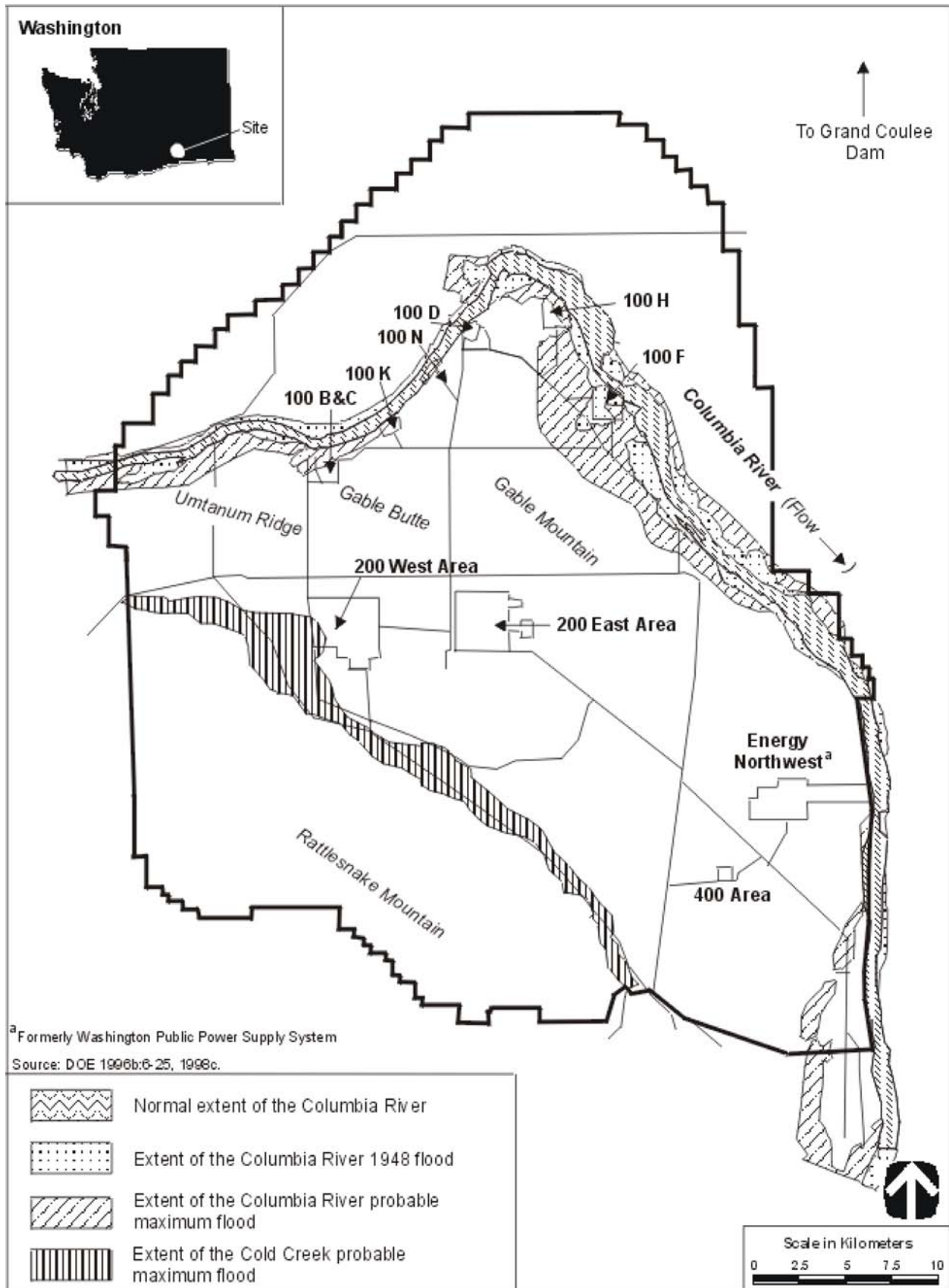

Figure 3-6. Flood Area for the Probable Maximum Flood and Columbia River 1948 Flood

3.3.3.3 Community Services

3.3.3.3.1 Education

Thirteen school districts provide public education services and facilities in the INEEL ROI. As shown in Figure 3–12, they operated at between 50 percent (Swan Valley District) and 100 percent (Shelley District) capacity in 1997. In 1997, the average student-to-teacher ratio for the INEEL ROI was 18.8:1 (Nemeth 1997a). In 1990, the average student-to-teacher ratio for Idaho was 12.8:1 (DOC 1990b, 1994).

3.3.3.3.2 Public Safety

In 1997, a total of 475 sworn police officers were serving the four-county ROI. In 1997, the average ROI officer-to-population ratio was 2.2 officers per 1,000 persons (Nemeth 1997b). This compares with the 1990 State average of 1.6 officers per 1,000 persons (DOC 1990b). In 1997, 560 paid and volunteer firefighters provided fire protection services in the INEEL ROI. The average firefighter-to-population ratio in the ROI in 1997 was 2.6 firefighters per 1,000 persons (Nemeth 1997b). This compares with the 1990 State average of 1.2 firefighters per 1,000 persons (DOC 1990b). Figure 3–13 displays the ratio of sworn police officers and firefighters to the population for the INEEL ROI.

3.3.3.3.3 Health Care

In 1996, a total of 329 physicians served the ROI. The average ROI physician-to-population ratio was 1.5 physicians per 1,000 persons as compared with a 1996 State average of 1.7 physicians per 1,000 persons (Randolph 1997). In 1997, there were five hospitals serving the four-county ROI. The hospital bed-to-population ratio averaged 4.6 hospital beds per 1,000 persons (Nemeth 1997c). This compares with the 1990 State average of 3.3 beds per 1,000 persons (DOC 1996:128). Figure 3–13 displays the ratio of hospital beds and physicians to the population for all the counties in the INEEL ROI.

3.3.3.4 Local Transportation

Vehicular access to INEEL is provided by U.S. Routes 20 and 26 to the south and State Routes 22 and 33 to the north. U.S. Routes 20 and 26 and State Routes 22 and 33 all share rights-of-way west of INEEL (see Figure 2–3).

There are two road segments that could be affected by the disposition alternatives: U.S. Route 20 from U.S. Routes 26 and 91 at Idaho Falls to U.S. Route 26 East and U.S. Routes 20 and 26 from U.S. Route 26 East to State Routes 22 and 33.

There are no current road improvement projects affecting access to INEEL; however, there are two planned road improvement projects that could affect future access to INEEL. There are plans to resurface State Route 33 from the intersection of State Routes 28 and 33 to 13 km (8.1 mi) east of this intersection. There are also plans for routine paving of segments along State Route 28 from now until the year 2000 (Bala 1997).

DOE shuttle vans provide transportation between INEEL facilities and Idaho Falls for DOE and contractor personnel. The major railroad in the ROI is the Union Pacific Railroad. The railroad's Blackfoot-to-Arco Branch provides rail service to the southern portion of INEEL. A DOE-owned spur connects the Union Pacific Railroad to INEEL by a junction at Scovill Siding. There are no navigable waterways within the ROI capable of accommodating waterborne transportation of material shipments to INEEL. Fanning Field in Idaho Falls

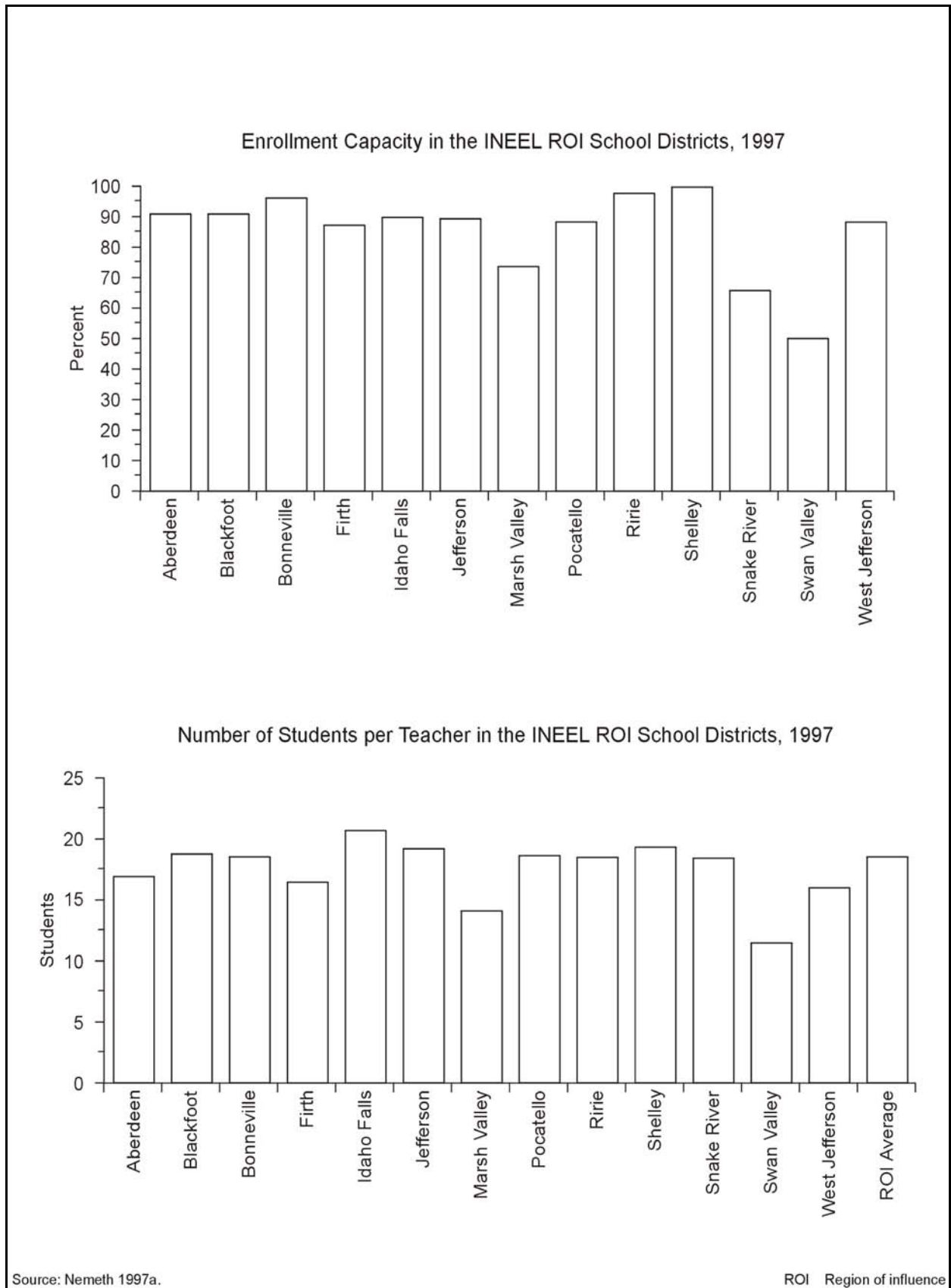

Figure 3-12. School District Characteristics for the INEEL Region of Influence

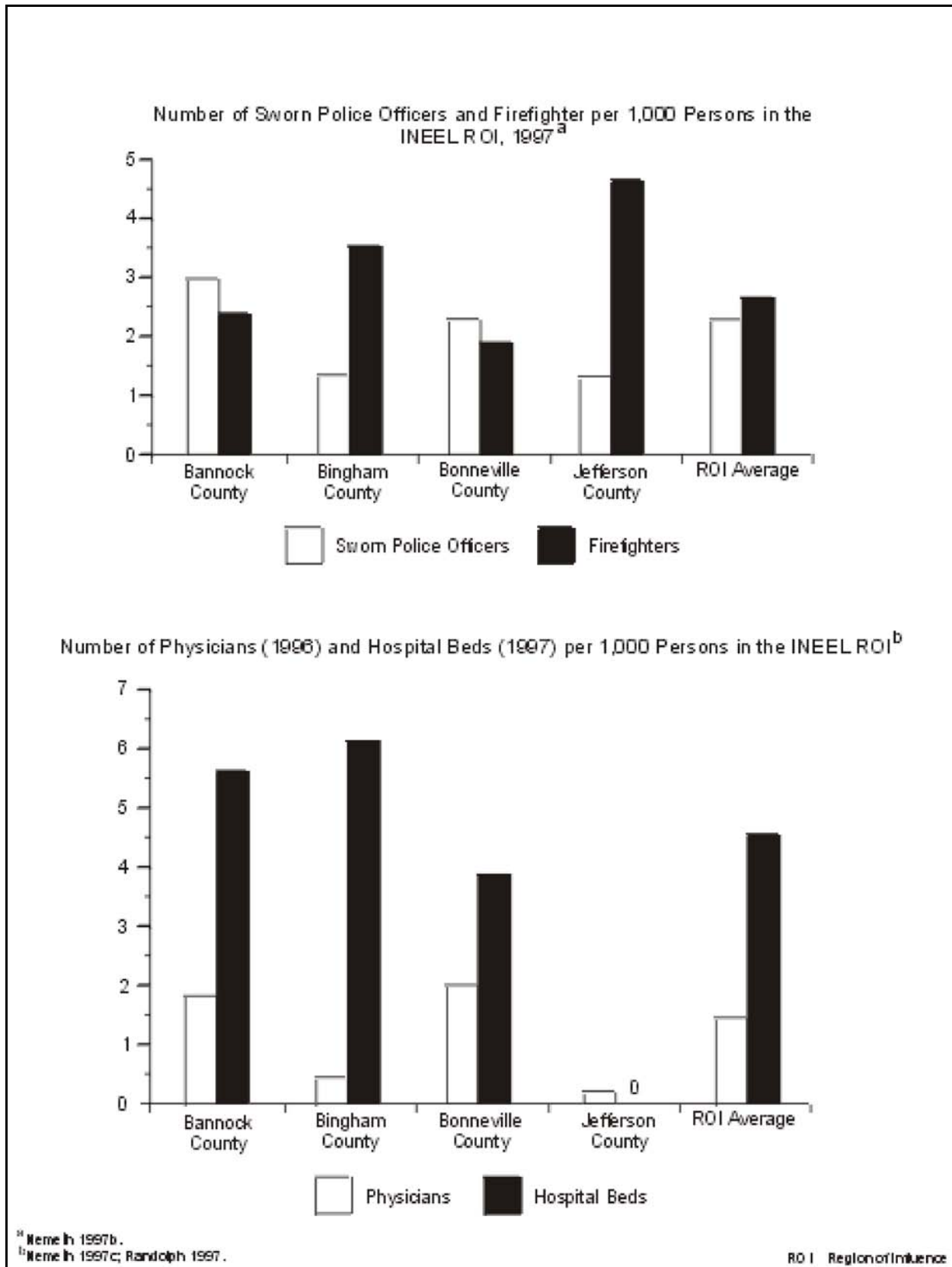

Figure 3-13. Public Safety and Health Care Characteristics for the INEEL Region of Influence

and Pocatello Municipal Airport in Pocatello provide jet air passenger and cargo service for both national and local carriers. Numerous smaller private airports are located throughout the ROI (DOE 1996a).

3.3.4 Existing Human Health Risk

Public and occupational health and safety issues include the determination of potentially adverse effects on human health that result from acute and chronic exposures to ionizing radiation and hazardous chemicals.

3.3.4.1 Radiation Exposure and Risk

3.3.4.1.1 General Site Description

Major sources and levels of background radiation exposure to individuals in the vicinity of INEEL are shown in Table 3–20. Annual background radiation doses to individuals are expected to remain constant over time. The total dose to the population, in terms of person-rem, changes as the population size changes. Background radiation doses are unrelated to INEEL operations.

Table 3–20. Sources of Radiation Exposure to Individuals in the INEEL Vicinity Unrelated to INEEL Operations

Source	Effective Dose Equivalent (mrem/yr)
Natural background radiation^a	
Cosmic radiation	48
External terrestrial radiation	73
Internal terrestrial/cosmogenic radiation	40
Radon in homes (inhaled)	200 ^b
Other background radiation^c	
Diagnostic x rays and nuclear medicine	53
Weapons test fallout	<1
Air travel	1
Consumer and industrial products	10
Total	426

^a Mitchell et al. 1997:4-21.

^b An average for the United States.

^c NCRP 1987:11, 40, 53.

Releases of radionuclides to the environment from INEEL operations provide another source of radiation exposure to individuals in the vicinity of INEEL. Types and quantities of radionuclides released from INEEL operations in 1996 are listed in *Idaho National Engineering Laboratory Site Environmental Report for Calendar Year 1996* (Mitchell et al. 1997:7-4, 7-5). The doses to the public resulting from these releases are presented in Table 3–21. These doses fall within radiological limits per DOE Order 5400.5 (DOE 1993a:II-1–II-5) and are much lower than those of background radiation.

Using a risk estimator of 500 cancer deaths per 1 million person-rem (5×10^{-4} fatal cancer per person-rem) to the public (see Appendix F.10), the fatal cancer risk to the maximally exposed member of the public due to radiological releases from INEEL operations in 1996 is estimated to be 1.6×10^{-8} . That is, the estimated probability of this person dying of cancer at some point in the future from radiation exposure associated with 1 year of INEEL operations is less than 2 in 100 million. (It takes several to many years from the time of radiation exposure for a cancer to manifest itself.)

Table 3–21. Radiation Doses to the Public From Normal INEEL Operations in 1996 (Total Effective Dose Equivalent)

Members of the Public	Atmospheric Releases		Liquid Releases		Total	
	Standard ^a	Actual	Standard ^a	Actual	Standard ^a	Actual
Maximally exposed individual (mrem)	10	0.031	4	0	100	0.031
Population within 80 km (person-rem) ^b	None	0.24	None	0	100	0.24
Average individual within 80 km (mrem) ^c	None	0.0020	None	0	None	0.0020

^a The standards for individuals are given in DOE Order 5400.5 (DOE 1993a:II-1–II-5). As discussed in that order, the 10-mrem/yr limit from airborne emissions is required by the Clean Air Act, and the 4-mrem/yr limit is required by the Safe Drinking Water Act; for this SPD EIS, the 4-mrem/yr value is conservatively assumed to be the limit for the sum of doses from all liquid pathways. The total dose of 100 mrem/yr is the limit from all pathways combined. The 100-person-rem value for the population is given in proposed 10 CFR 834, as published in 58 FR 16268 (DOE 1993b:para. 834.7). If the potential total dose exceeds the 100-person-rem value, it is required that the contractor operating the facility notify DOE.

^b About 121,500 in 1996.

^c Obtained by dividing the population dose by the number of people living within 80 km (50 mi) of the site.

Source: Mitchell, Peterson, and Hoff 1996:4-48.

According to the same risk estimator, 1.2×10^{-4} excess fatal cancer is projected in the population living within 80 km (50 mi) of INEEL from normal operations in 1996. To place this number in perspective, it may be compared with the number of fatal cancers expected in the same population from all causes. The 1996 mortality rate associated with cancer for the entire U.S. population was 0.2 percent per year (Famighetti 1998:964). Based on this mortality rate, the number of fatal cancers expected during 1995 from all causes in the population living within 80 km (50 mi) of INEEL was 243. This expected number of fatal cancers is much higher than the 1.2×10^{-4} fatal cancer estimated from INEEL operations in 1996.

INEEL workers receive the same doses as the general public from background radiation, but they also receive an additional dose from working in facilities with nuclear materials. Table 3–22 presents the average dose to the individual worker and the cumulative dose to all workers at INEEL from operations in 1996. These doses fall within the radiological regulatory limits of 10 CFR 835 (DOE 1995a:para. 835.202). According to a risk estimator of 400 fatal cancers per 1 million person-rem among workers⁴ (Appendix F.10), the number of projected fatal cancers among INEEL workers from normal operations in 1996 is 0.082.

A more detailed presentation of the radiation environment, including background exposures and radiological releases and doses, is presented in the *Idaho National Engineering Laboratory Site Environmental Report for Calendar Year 1996* (Mitchell et al. 1997). The concentrations of radioactivity in various environmental media (including air, water, and soil) in the site region (on and off the site) are also presented in that report.

3.3.4.1.2 Proposed Facility Location

External radiation doses and concentrations of gross alpha, plutonium, and americium in air have been measured in the INTEC area. In 1996, the annual average dose along the boundary of INTEC was about 180 mrem. If radiation from the “hot spots” along this boundary (e.g., the tree farm) is not included, the dose is reduced to about 150 mrem. This is about 20 mrem higher than the average dose measured at the offsite control locations. Concentrations in air of gross alpha, plutonium 239/240, and americium 241 in 1995 were 5×10^{-4} pCi/m³, 2.1×10^{-4}

⁴ The risk estimator for workers is lower than the estimator for the public because of the absence from the workforce of the more radiosensitive infant and child age groups.

⁵ pCi/m³, and 6×10⁻⁶ pCi/m³, respectively. The gross alpha value was about three times lower than that measured at the offsite control locations, and the plutonium 239/240 and americium 241

Table 3–22. Radiation Doses to Workers From Normal INEEL Operations in 1996 (Total Effective Dose Equivalent)

Occupational Personnel	Onsite Releases and Direct Radiation	
	Standard ^a	Actual
Average radiation worker (mrem)	None ^b	125 ^c
Total workers (person-rem) ^d	None	205 ^c

^a The radiological limit for an individual worker is 5,000 mrem/yr (DOE 1995a:para. 835.202). However, DOE’s goal is to maintain radiological exposure as low as is reasonably achievable. It has therefore established an administrative control level of 2,000 mrem/yr (DOE 1994a:2-3); the site must make reasonable attempts to maintain individual worker doses below this level.

^b No standard is specified for an “average radiation worker”; however, the maximum dose that this worker may receive is limited to that given in footnote “a.”

^c Does not include doses received at the Naval Reactors Facility. The impacts associated with this facility fall under the jurisdiction of the Navy as part of the Nuclear Propulsion Program.

^d About 1,650 (badged) in 1995.

Source: Abbott, Crockett, and Moor 1997.

values were each about 50 percent higher. In 1996, the concentration of gross alpha was about 1×10⁻³ pCi/m³ in the INTEC area. No measurements of plutonium or americium in air were reported in this area in 1996 (Mitchell, Peterson, and Hoff 1996:4-10, 4-17, 4-18, 4-28, 4-31; Mitchell et al.1997:4-4, 4-19, 4-21, 4-23).

3.3.4.2 Chemical Environment

The background chemical environment important to human health consists of the atmosphere, which may contain hazardous chemicals that can be inhaled; drinking water, which may contain hazardous chemicals that can be ingested; and other environmental media through which people may come in contact with hazardous chemicals (e.g., surface water during swimming, soil through direct contact, or food). Hazardous chemicals can cause cancer and noncancer health effects. The baseline data for assessing potential health impacts from the chemical environment are addressed in Section 3.3.1.

Effective administrative and design controls that decrease hazardous chemical releases to the environment and help achieve compliance with permit requirements (e.g., air emissions and NPDES permit requirements) contribute to minimizing health impacts on the public. The effectiveness of these controls is verified through the use of monitoring information and inspection of mitigation measures. Health impacts on the public may occur via inhalation of air containing hazardous chemicals released to the atmosphere during normal INEEL operations. Risks to public health from other possible pathways, such as ingestion of contaminated drinking water or direct exposure, are lower than those via the inhalation pathway. At INEEL, the risk to public health from water ingestion and direct exposure pathways is low because surface water is not used for drinking or as a receptor for wastewater discharges.

Baseline air emission concentrations and applicable standards for hazardous chemicals are addressed in Section 3.3.1. These baseline concentrations are estimates of the highest existing offsite concentrations and represent the highest concentrations to which members of the public could be exposed. These concentrations

are in compliance with applicable guidelines and regulations. Information on estimating the health impacts of hazardous chemicals is presented in Appendix F.10.

Exposure pathways to INEEL workers during normal operation may include the inhalation of contaminants in the workplace atmosphere and direct contact with hazardous materials. The potential for health impacts varies among facilities and workers, and available information is insufficient for a meaningful estimate of impacts. However, workers are protected from workplace hazards through appropriate training, protective equipment, monitoring, substitution, and engineering and management controls. INEEL workers are also protected by adherence to OSHA and EPA standards that limit workplace atmospheric and drinking water concentrations of potentially hazardous chemicals. Appropriate monitoring that reflects the frequency and amounts of chemicals used in the operational processes ensures that these standards are not exceeded. Additionally, DOE requires that conditions in the workplace be as free as possible from recognized hazards that cause, or are likely to cause, illness or physical harm. Therefore, workplace conditions at INEEL are substantially better than required by standards.

3.3.4.3 Health Effects Studies

Epidemiological studies were conducted on communities surrounding INEEL to determine whether there are excess cancers in the general population. Two of these are described in more detail in Appendix M.4.4 of the *Storage and Disposition PEIS* (DOE 1996a:M-233, M-234). No excess cancer mortality was reported, and although excess cancer incidence was observed, no association thereof with INEEL was established. A study by the State of Idaho completed in June 1996 found excess brain cancer incidence in the six counties surrounding INEEL, but a follow-up survey concluded that “there was nothing that clearly linked all these cases to one another or any one thing.”

No occupational epidemiological studies have been completed at INEEL to date, but several worker health studies were initiated recently at INEEL and another is almost complete. Researchers from the Boston University School of Public Health in cooperation with the National Institute of Occupational Safety and Health (NIOSH), are investigating the effects of workforce restructuring (downsizing) in the nuclear weapons industry. The health of displaced workers will be studied. Under a NIOSH cooperative agreement, the epidemiologic evaluation of childhood leukemia and paternal exposure to ionizing radiation now includes INEEL as well as other DOE sites. Another study began in October 1997, *Medical Surveillance for Former Workers at INEEL*, is being carried out by a group of investigators consisting of the Oil, Chemical, and Atomic Workers International Union, Mt. Sinai School of Medicine, the University of Massachusetts at Lowell, and the Alice Hamilton College. A cohort mortality study of the workforce at INEEL being conducted by NIOSH is not expected to be released until December 1998. DOE has implemented an epidemiologic surveillance program to monitor the health of current INEEL workers. A discussion of this program is given in Appendix M.4.4 of the *Storage and Disposition PEIS* (DOE 1996a:M-233, M-234).

3.3.4.4 Accident History

DOE conducted a study, the *Idaho National Engineering Laboratory Historical Dose Evaluation* (DOE/ID-12119), to estimate the potential offsite radiation doses for the entire operating history of INEEL (DOE 1996a:3-139). Releases resulted from a variety of tests and experiments as well as a few accidents at INEEL. The study concluded that these releases contributed to the total radiation dose during test programs of the 1950s and early 1960s. The frequency and size of releases has declined since that time. There have been no serious unplanned or accidental releases of radioactivity or other hazardous substance at INEEL facilities in the last 10 years of operation.

3.3.4.5 Emergency Preparedness

Each DOE site has established an emergency management program that would be activated in the event of an accident. This program has been developed and maintained to ensure adequate response to most accident conditions and to provide response efforts for accidents not specifically considered. The emergency management program includes emergency planning, preparedness, and response.

Government agencies whose plans are interrelated with the INEEL emergency plan for action include the State of Idaho, Bingham County, Bonneville County, Butte County, Clark County, Jefferson County, the Bureau of Indian Affairs, and the Fort Hall Indian Reservation. INEEL contractors are responsible for responding to emergencies at their facilities. Specifically, the emergency action director is responsible for recognition, classification, notifications, and protective action recommendations. At INEEL, emergency preparedness resources include fire protection from onsite and offsite locations and radiological and hazardous chemical material response. Emergency response facilities include an emergency control center at each facility, at the INEEL warning communication center, and at the INEEL site emergency operations center. Seven INEEL medical facilities are also available to provide routine and emergency service.

DOE has specified actions to be taken at all DOE sites to implement lessons learned from the emergency response to an accidental explosion at Hanford in May 1997. These actions and the timeframe in which they must be implemented are presented in Section 3.2.4.5.

3.3.5 Environmental Justice

Environmental justice concerns the environmental impacts that proposed actions may have on minority and low-income populations, and whether such impacts are disproportionate to those on the population as a whole in the potentially affected area. In the case of INEEL, the potentially affected area includes only parts of central Idaho.

The potentially affected area surrounding INTEC is defined by a circle with an 80-km (50-mi) radius centered at FPF (lat. 43E34'12.5" N, long. 112E55' 55.4" W). The total population residing within that area in 1990 was 119,138. The proportion of the population there that was considered minority was 9.9 percent. The same census data show that the percentage of minorities for the contiguous United States was 24.1, and for the State of Idaho, 7.8 (DOC 1992).

Figure 3–14 illustrates the racial and ethnic composition of the minority population in the potentially affected area centered at FPF. At the time of the 1990 census, Hispanics and Native Americans were the largest minority groups within that area, constituting 6 percent and 2.6 percent of the total population, respectively, during the 1990 census. Asians constituted about 1 percent, and blacks, about 0.3 percent (DOC 1992).

A breakdown of incomes in the potentially affected area is also available from the 1990 census data (DOC 1992). At that time, the poverty threshold was \$9,981 for a family of three with one related child under 18 years of age. A total of 14,386 persons (12.2 percent of the total population) residing within the potentially affected area around INTEC reported incomes below that threshold. Data obtained during the 1990 census also show that of the total population of the contiguous United States, 13.1 percent reported incomes below the poverty threshold, and that Idaho reported 13.3 percent.

3.3.6 Geology and Soils

Geologic resources are consolidated or unconsolidated earth materials, including ore and aggregate materials, fossil fuels, and significant landforms. Soil resources are the loose surface materials of the earth in which plants grow, usually consisting of disintegrated rock, organic matter, and soluble salts.

3.3.6.1 General Site Description

The upper 1 to 2 km (0.6 to 1.2 mi) of the crust beneath INEEL is composed of interlayered basalt and sediment. The sediments are composed of fine-grained silts that were deposited by wind; silts, sands, and

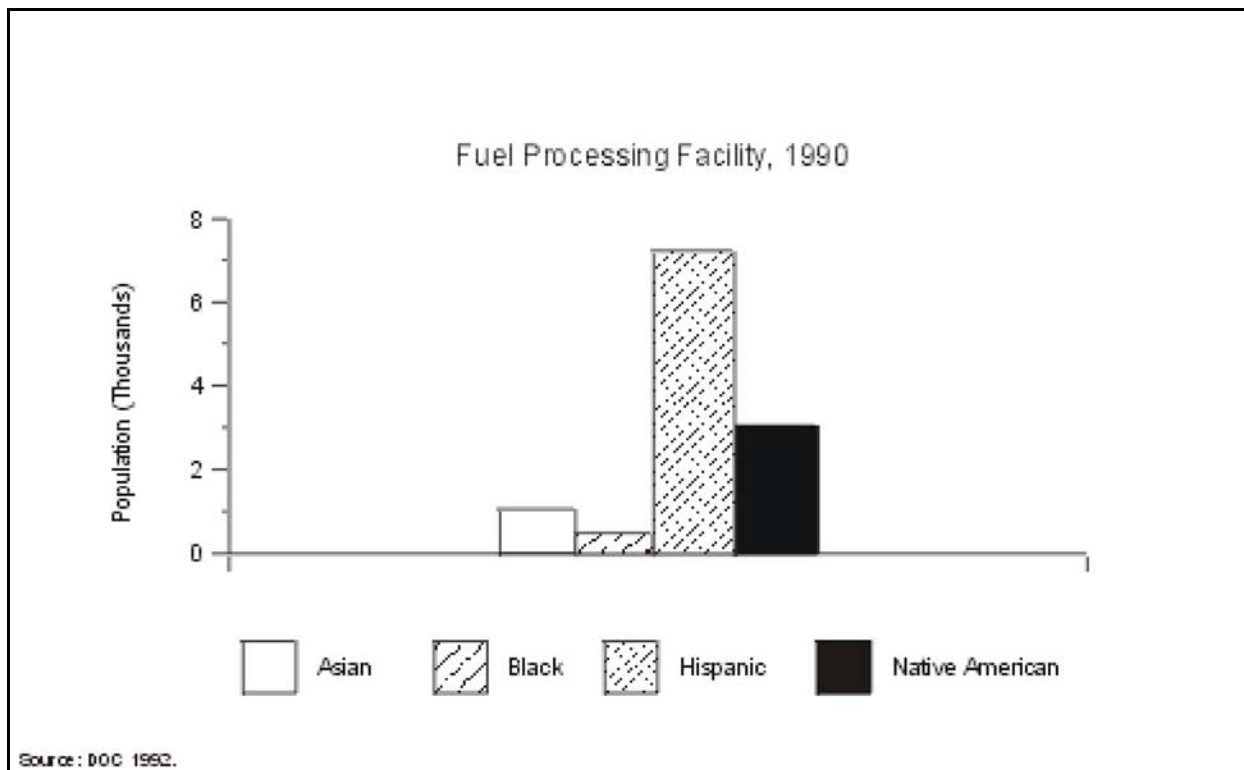

Figure 3-14. Racial and Ethnic Composition of Minorities Around the Fuel Processing Facility at INEEL

gravels deposited by streams; and clays, silts, and sands deposited in lakes. Rhyolitic (granite-like) volcanic rocks of unknown thickness lie beneath the basalt sediment sequence. The rhyolitic volcanic rocks were erupted between 6.5 and 4.3 million years ago (Barghusen and Feit 1995:2.3-17).

Within INEEL, economically viable sand, gravel, and pumice resources have been identified. Several quarries have supplied these materials to various onsite construction projects (DOE 1996a:3-121). Geothermal resources are potentially available in parts of the Eastern Snake River Plain, but neither of two boreholes—INEEL-1 (drilled to a depth of 3,048 m [10,000 ft] to explore for geothermal resources 8 km [5 mi] north of INTEC) and WO-2 (drilled to a depth of 1,524 m [5,000 ft] 4.8 km [3 mi] east of INTEC)—encountered rocks with significant geothermal potential (Abbott, Crockett, and Moor 1997:11).

There is no potential for sinkholes or unstable conditions at INTEC. Lava tubes, which could have adverse effects similar to those of sinkholes, do occur in the INEEL area, but extensive drilling and foundation excavation in the INTEC area over the past few decades has revealed no lava tubes beneath the site. Drilling for foundation engineering investigations at FPF has also revealed no lava tubes (Abbott, Crockett, and Moor 1997:10).

The Arco Segment of the Lost River Fault and the Howe Segment of the Lemhi Fault terminate about 30 km (19 mi) from the INEEL boundary and are considered capable. A capable fault is one that has had movement at or near the ground surface at least once within the past 35,000 years or recurrent movement within the past 500,000 years (DOE 1996a:3-121).

According to the Uniform Building Code, INEEL, located on the Eastern Snake River Plain, is in Seismic Zone 2B, meaning that moderate damage could occur as a result of an earthquake. Historic and recent seismic data cataloged by NOAA, the National Earthquake Information Center, the University of Utah, and the INEEL Seismic Network indicate that earthquakes in the region occur primarily in the Intermountain Seismic Belt and the

Centennial Tectonic Belt. The seismic characteristics of the Eastern Snake River Plain and the adjacent Basin and Range Province are different; the plain has historically experienced few and small earthquakes. No earthquakes have been recorded within about 48 km (30 mi) of the site (DOE 1996a:3-121). An earthquake with a maximum horizontal acceleration of 0.15g is calculated to have an annual probability of occurrence of 1 in 5,000 at a central INEEL location (Barghusen and Feit 1995:2.3-17).

The largest historic earthquake near INEEL took place in 1983 about 107 km (66 mi) to the northwest, near Borah Peak in the Lost River Range. The earthquake had a surface wave magnitude of 7.3 with a resulting peak horizontal ground acceleration of 0.022g to 0.078g at INEEL (Jackson 1985:385). An earthquake of greater than 5.5 magnitude can be expected about every 10 years within a 322-km (200-mi) radius of INEEL (DOE 1996a:3-121).

Volcanic hazards at INEEL can come from sources inside or outside the Snake River Plain. Most of the basaltic volcanic activity occurred at the Craters of the Moon National Monument 20 km (12 mi) southwest of INEEL between 4 million and 2,100 years ago. The probability of volcanic activity affecting facilities at INEEL is very low. In fact, the Volcanism Working Group for the *Storage and Disposition PEIS* (DOE 1996a) estimated that the conditional probability of basaltic volcanism affecting a south-central INEEL location is at most once per 40,000 years. The rhyolite domes along the Axial Volcanic Zone formed between 1.2 million and 300,000 years ago and have a recurrence interval of about 200,000 years. Therefore, the probability of future dome formation affecting INEEL facilities is also very low (DOE 1996a:3-121–3-123).

INEEL soils are derived from volcanic and clastic rocks from nearby highlands. In the southern part of the site, the soils are gravelly to rocky and generally shallow. The northern portion is composed mostly of unconsolidated clay, silt, and sand. No prime farmland lies within the INEEL boundaries. Generally, the soils are acceptable for standard construction techniques (DOE 1996a:3-107, 3-123). More detailed descriptions of the geology and the soil conditions at INEEL are included in the *Storage and Disposition PEIS* (DOE 1996a:3-121–3-123).

3.3.6.2 Proposed Facility Location

The nearest capable fault is in the South Creek Segment of the Lemhi Fault, about 26 km (16 mi) north of INTEC. All soil near INTEC was originally fine loam over a sand or sand-cobble mix deposited in the floodplain of the Big Lost River. However, all soils within the INTEC fences have been disturbed. The soils beneath the INTEC area are not subject to liquefaction because of the high content of gravel mixed with the alluvial sands and silts. In addition, the sediments are not saturated (Abbott, Crockett, and Moor 1997:10).

3.3.7 Water Resources

3.3.7.1 Surface Water

Surface water includes marine or freshwater bodies that occur above the ground surface, including rivers, streams, lakes, ponds, rainwater catchments, embayments, and oceans.

3.3.7.1.1 General Site Description

Three intermittent streams drain the mountains near INEEL: Big Lost River, Little Lost River, and Birch Creek. These intermittent streams carry snowmelt in the spring and are usually dry by midsummer. Several years can pass before any offsite waters enter DOE property. Big Lost River and Birch Creek are the only streams that regularly flow onto INEEL. Little Lost River is usually dry by the time it reaches the site because of upstream use of the flow for irrigation. None of the rivers flow from the site to offsite areas. Big Lost River discharges

into the Big Lost River sinks, and there is no surface discharge from these sinks (Barghusen and Feit 1995:2.3-2, 2.3-21; DOE 1996a:3-115).

Big Lost River has been classified by the State of Idaho for domestic and agricultural use, cold water biota development, salmon spawning, primary and secondary recreation, and other special resource uses. Surface waters, however, are not used for drinking water on the site, nor is any wastewater discharged directly to them. Moreover, there are no surface water rights issues at INEEL, because INEEL facilities currently neither discharge directly to, nor make withdrawals from, these water bodies. None of the rivers have been classified as a Wild and Scenic River. Flood diversion facilities constructed in 1958 secured INEEL from the 300-year flood (DOE 1995b:4.8-1–4.8-5; 1996a:3-115).

3.3.7.1.2 Proposed Facility Location

There are no named streams within INTEC—only unnamed drainage ditches to carry storm flows away from buildings and facilities at the site. Outside INTEC, the only surface water is a stretch of Big Lost River. This is an intermittent stream that flows only after rainfall events or in the spring, when it carries snowmelt from the nearby mountains (Abbott, Crockett, and Moor 1997:5). A summary of water quality data for Big Lost River in the vicinity of INEEL is provided in the *Storage and Disposition PEIS* and shows no unusual concentrations of the parameters analyzed (DOE 1996a:3-115–3-117).

Flooding scenarios that involve the failure of McKay Dam and high flows in the Big Lost River have been evaluated. The results indicate that in the event of a failure of this dam, flooding would occur at INTEC and other facilities at INEEL. The low velocity and shallow depth of the water, however, would not pose a threat of structural damage to the facilities. Localized flooding can occur due to rapid snowmelt and frozen ground conditions, but none has been reported at INTEC (Barghusen and Feit 1995:2.3-21, 2.3-23). A study of the 100-year flood has been completed by the U.S. Geological Survey. The study indicates that the only INEEL facility that would be flooded is the northern part of INTEC and its entrance road. The depth of water over Lincoln Boulevard near its intersection with Monroe Boulevard is estimated at 0.12 to 0.70 m (0.4 to 2.3 ft) (Berenbrock and Kjelstrom 1998:11, 12). The 500-year flood has not been studied (Abbott, Crockett, and Moor 1997:7). However, the probable maximum flood has been calculated, as shown on Figure 3–15 (DOE 1997b).

Purgeable organics such as 1,1-dichloroethylene, toluene, and 1,1,1-trichloroethane have been detected in wells near INTEC. Metals, including arsenic, barium, lead, mercury, selenium, and silver, were also found in samples from wells. Inorganic chemicals such as sodium and chloride have been found in these samples. Maximum values for tritium in samples from three wells averaged 23,700 pCi/l; and maximum strontium 90 values averaged 53 pCi/l (Abbott, Crockett, and Moor 1997:11, 12). These values exceed the drinking water standards for tritium and strontium 90 of 20,000 pCi/l and 8 pCi/l, respectively. The results of groundwater modeling and baseline risk assessment will be used to identify the release sites requiring further evaluation. If necessary, removal actions may be taken to prevent further migration of contaminants to the Snake River Plain Aquifer (Mitchell et al. 1997:3-5). Sanitary waste with no potential for radioactive contamination is treated in the INTEC Sewage Treatment Facility (CPP–615). This facility has a Wastewater Land Application Permit from the State of Idaho and does not discharge to surface waters, but allows land application of treated sanitary sewage. The only effluent criteria associated with flows to the sewage ponds are the amounts of total suspended solids and nitrogen released to the ponds. All compliance points for the ponds are in wells downgradient from the ponds, and the maximum allowable concentrations are similar to those in the National Primary and Secondary Drinking Water Standards (Abbott, Crockett, and Moor 1997:9, 10). Drainage from corridors, roof and floor drains, and condensate from process heating, and heating, ventilation, and air

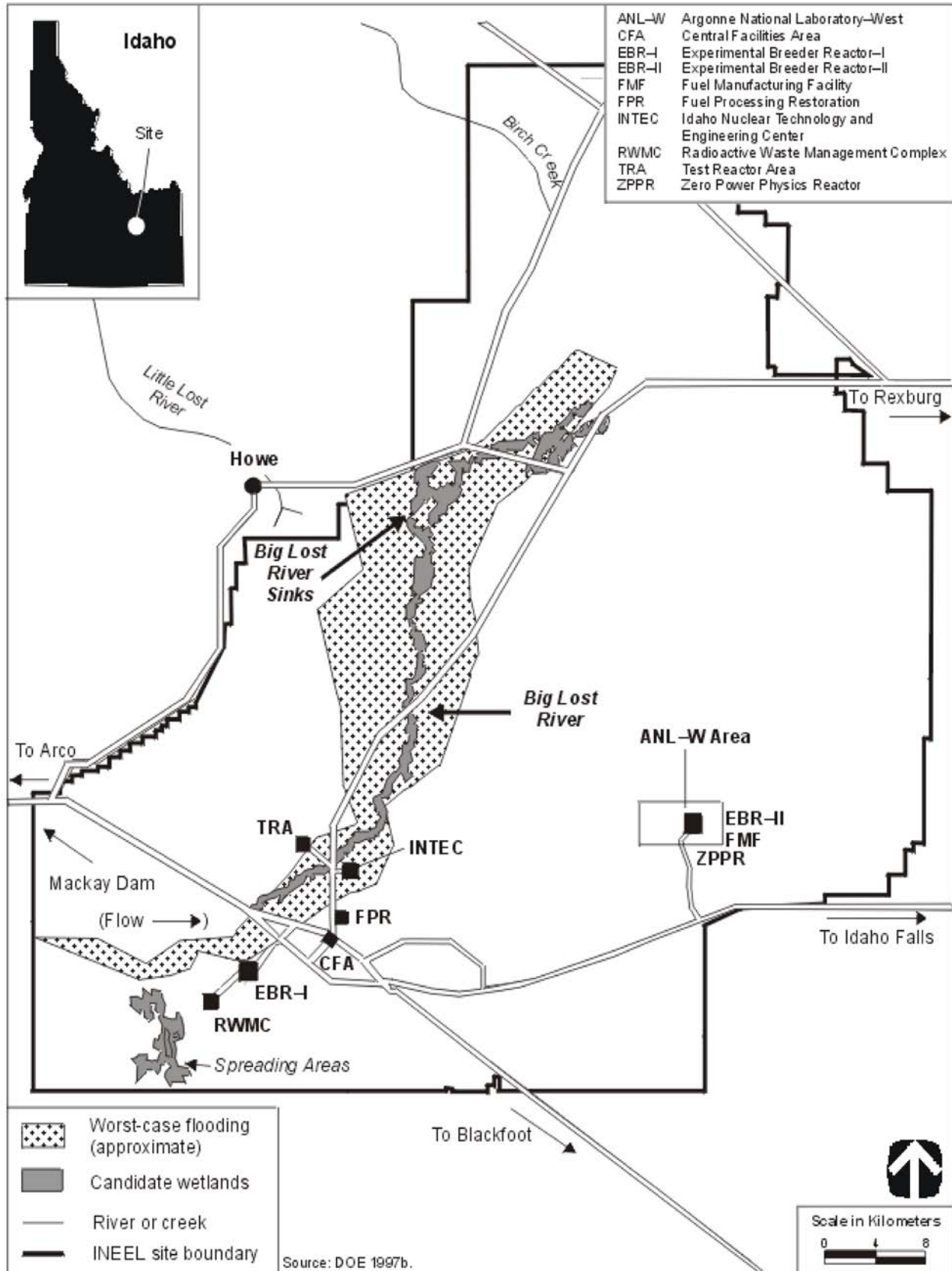

Figure 3-15. Flood Area for the Probable Maximum Flood-Induced Overtopping Failure of the Mackay Dam

conditioning systems with very low potential for radiological contamination are routed to the INTEC service waste system. Service Waste Percolation Pond 1 (SWP-1), southeast of Building CPP-603, has a surface area about of 18,400 m² (198,000 ft²) and is 4.9 m (16 ft) deep. Service Waste Pond 2, immediately west of SWP-1, has a surface area of 46 m² (495 ft²). Both ponds are fenced to keep out wildlife (Abbott, Crockett, and Moor 1997:9).

Consideration is being given to relocating the percolation pond to reduce the potential impacts on a contaminated perched water zone. Consideration is also being given to obtaining an NPDES permit to allow direct discharge into Big Lost River. These actions are independent of the proposed action analyzed in this SPD EIS and would be preceded by appropriate NEPA documentation (Abbott, Crockett, and Moor 1997:10).

3.3.7.2 Groundwater

Aquifers are classified by Federal and State authorities according to use and quality. The Federal classifications include Class I, II, and III groundwater. Class I groundwater is either the sole source of drinking water or is ecologically vital. Class IIA and IIB are current or potential sources of drinking water (or other beneficial use), respectively. Class III is not considered a potential source of drinking water and is of limited beneficial use.

3.3.7.2.1 General Site Description

The Snake River Plain aquifer is classified by EPA as a Class I sole source aquifer. It lies below the INEEL site and covers about 24,860 km² (9,600 mi²) in southeastern Idaho. This aquifer serves as the primary drinking water source in the Snake River Basin and is believed to contain 1.2 quadrillion to 2.5 quadrillion l (317 trillion to 660 trillion gal) of water. Recharge of the groundwater comes from Henry's Fork of the Snake River, Big Lost River, Little Lost River, and Birch Creek. Rainfall and snowmelt also contribute to the aquifer's recharge (DOE 1996a:3-115-3-117).

Groundwater generally flows laterally at a rate of 1.5 to 6.1 m/day (5 to 20 ft/day). It emerges in springs along the Snake River from Milner to Bliss, Idaho. Depth to the groundwater table ranges from about 60 m (200 ft) below ground in the northeast corner of the site to about 300 m (1,000 ft) in the southeast corner (DOE 1995b:4.8-5; 1996a:3-117).

Perched water tables occur below the site. These perched water tables tend to slow the migration of pollutants that might otherwise reach the Snake River Plain aquifer (DOE 1996a:3-117).

INEEL has a large network of monitoring wells—about 120 in the Snake River Plain aquifer and another 100 drilled in the perched zone. The wells are used for monitoring to determine the compliance of specific actions with requirements of RCRA and CERCLA, as well as routine monitoring to evaluate the quality of the water in the aquifer. The aquifer is known to have been contaminated with tritium; however, the concentration dropped 93 percent between 1961 and 1994, possibly due to the elimination of tritium disposal, radioactive decay, and dispersion throughout the aquifer. Other known contaminants include cesium 137, iodine 129, strontium 90, and nonradioactive compounds such as TCE. Components of nonradioactive waste entered the aquifer as a result of past waste disposal practices. Elimination of groundwater injection exemplifies a change in disposal practices that has reduced the amount of these constituents in the groundwater (DOE 1996a:3-117, 3-119).

From 1982 to 1985, INEEL used about 7.9 billion l/yr (2.1 billion gal/yr) from the Snake River Plain aquifer, the only source of water at INEEL. This represents less than 0.3 percent of the groundwater withdrawn from that aquifer. DOE holds a Federal Reserved Water Right for the INEEL site that permits a pumping capacity of approximately 2.3 m³/s (80 ft³/s) with a maximum water consumption of 43 billion l/yr (11 billion gal/yr). INEEL's priority on water rights dates back to its establishment in 1950 (DOE 1996a:3-119).

3.3.7.2.2 Proposed Facility Location

Generally, the groundwater near INEEL, including INTEC, flows from the north and northeast to the south and southwest (Barghusen and Feit 1995:2.3-23).

Water for the INTEC is supplied by two deep wells located in the northwest corner of the INTEC. The wells are about 180 m (590 ft) deep and about 36 cm (14 in) in diameter (Abbott, Crockett, and Moor 1997:9). These wells can each supply up to approximately 11,000 l/min (3,000 gal/min) of water for use in the INTEC fire water, potable water, treated water, and demineralized water systems (Werner 1997). Pumping has little effect on the level of the groundwater, because the withdrawals are so small relative to the volume of water in the aquifer and the amount of recharge available. The production wells at INTEC have historically contained measurable quantities of strontium 90. In 1992, the highest concentration was 1 pCi/l, compared with the EPA maximum Primary Drinking Water Standard of 8 pCi/l. Sampling has yielded similar results over time (Barghusen and Feit 1995:2.3-23–2.3-29).

3.3.8 Ecological Resources

Ecological resources are defined as terrestrial (predominantly land) and aquatic (predominantly water) ecosystems characterized by the presence of native and naturalized plants and animals. For the purposes of this SPD EIS, those ecosystems are differentiated in terms of habitat support of threatened, endangered, and other special-status species—that is, “nonsensitive” versus “sensitive” habitat.

3.3.8.1 Nonsensitive Habitat

Nonsensitive habitat comprises those terrestrial and aquatic areas of the site that typically support the region’s major plant and animal species.

3.3.8.1.1 General Site Description

INEEL is dominated by fairly undisturbed shrub-steppe vegetation that provides important habitat for nearly 400 plant species and numerous animal species native to the region’s cool desert environment. Facilities and operating areas occupy 2 percent of INEEL, and approximately 60 percent of the surrounding area is used by sheep and cattle for grazing (DOE 1996a:3-125). Six broad vegetative categories representing nearly 20 distinct habitats have been identified on the INEEL site. Approximately 90 percent of INEEL is covered by shrub-steppe vegetation, which is dominated by big sagebrush, saltbrush, rabbitbrush, and native grasses, and contains a diversity of forbs (Figure 3–16) (DOE 1997b:44).

The large, undeveloped tracts of land used by INEEL for safety and security buffers also provide important habitat for plants and animals. Because INEEL is at the mouth of several mountain valleys, large numbers of mammals and migratory birds of prey are funneled onto the site. During some winters, thousands of pronghorn antelope and sage grouse can be found in the low and big sagebrush communities in the northern region. The juniper communities in the northwestern and southwestern regions provide important nesting areas for raptors and songbirds (DOE 1996a:3-125; 1997b:42).

Animal species found at INEEL include 2 species of amphibians, more than 225 species of birds, 6 species of fish, 44 species of mammals, and 11 species of reptiles (Reynolds 1999). Commonly observed animals include the short-horned lizard, gopher snake, sage sparrow, Townsend’s ground squirrel, and black-tailed

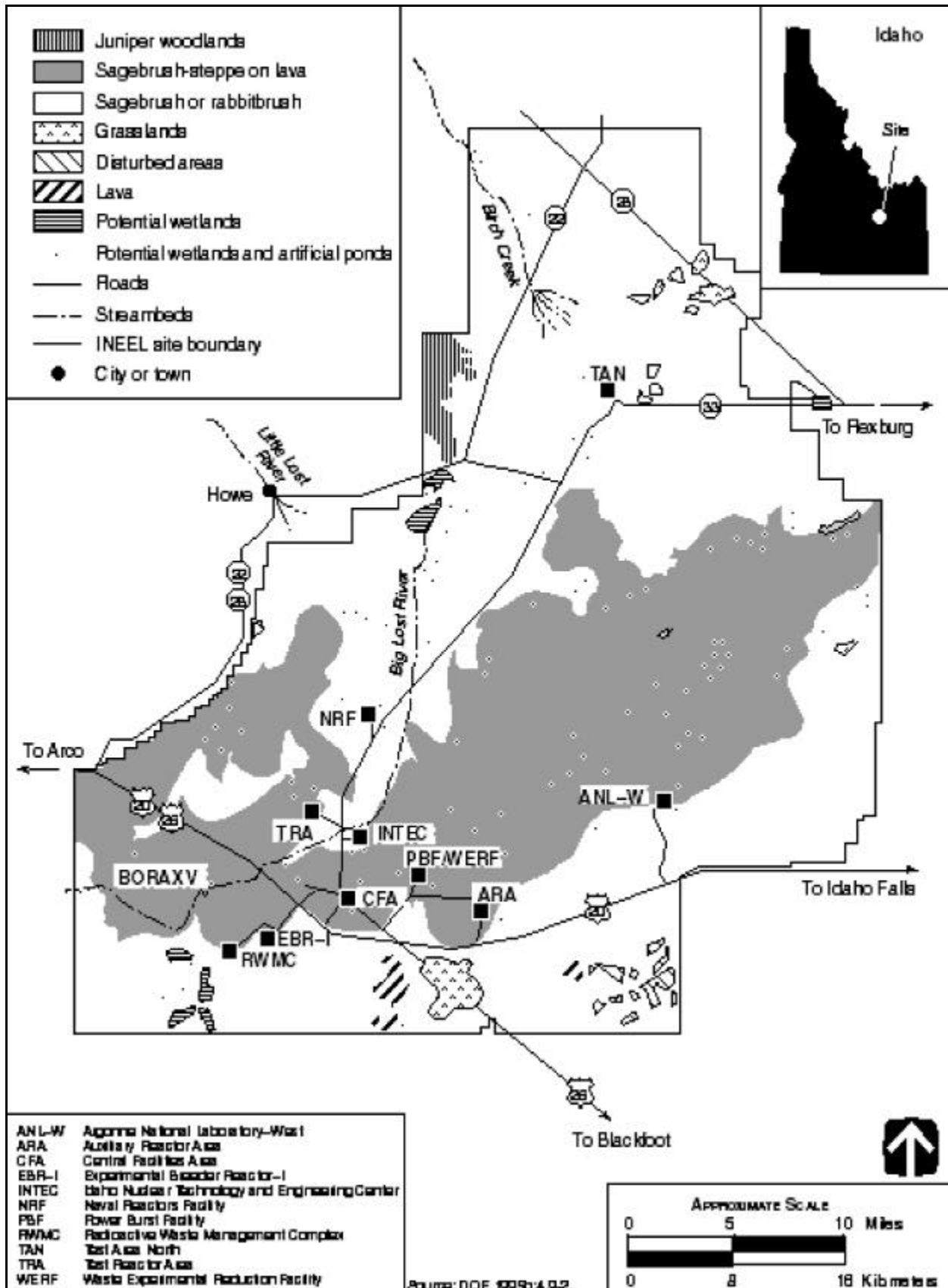

Figure 3-16. Generalized Habitat Types at INEEL

jackrabbit (DOE 1996a:3-125). Important game animals that reside at INEEL include sage grouse, mule deer, and elk. Roughly 30 percent of Idaho's pronghorn antelope population uses INEEL as winter range. Hunting of pronghorn antelope and elk is permitted under controlled conditions to reduce damage to crops on private lands and is restricted to within about 0.8 km (0.5 mi) inside the property boundary of INEEL (DOE 1995b:4.2-1; 1996a:3-125). Predators observed on the INEEL site include bobcats, mountain lions, badgers, and coyotes (DOE 1997b:42).

Aquatic habitat is limited to three intermittent streams (Big Lost River, Little Lost River, and Birch Creek) that drain into four sinks in the north-central portion of INEEL and to a number of liquid-waste disposal ponds. When water from the Big Lost River does flow on the site, several species of fish are observed: brook trout, rainbow trout, mountain whitefish, speckled dace, shorthead sculpin, and kokanee salmon (DOE 1996a:3-125).

3.3.8.1.2 Proposed Facility Location

INTEC is an industrial facility with most land surfaces being disturbed, bare ground (85 percent) or facilities and pavement (13 percent). Natural areas are limited to those areas outside the fenced boundary, mainly sagebrush-steppe on lava, sagebrush, rabbitbrush, and grasslands. The onsite areas are not vegetated except for grasses, shrubs, and trees associated with lawns and landscaping, and weedy annuals and grasses commonly found in disturbed areas. These areas, as well as buildings and wastewater treatment ponds, are used by a number of species. Accordingly, animal species potentially present in the immediate area surrounding FPF are primarily limited to those species adapted to disturbed industrial areas, such as small mammals (e.g., mice, rabbits, and ground squirrels), birds (e.g., sparrows and finches), and reptiles (e.g., lizards). A comprehensive list of species potentially present within INTEC and the surrounding area is presented in the Waste Area Grouping 3 (WAG3) risk assessment work plan developed by Rodriguez et al. (1997) (Werner 1997:WAG3 Report Summary). There are no known aquatic species or habitat within the immediate environs of FPF (Abbott, Crockett, and Moor 1997:15).

3.3.8.2 Sensitive Habitat

Sensitive habitat comprises those terrestrial and aquatic (including designated wetlands) areas of the site that support threatened and endangered, State-protected, and other special-status plant and animal species.⁵

3.3.8.2.1 General Site Description

Nearly all INEEL wetland habitats, with the exception of playa wetlands, are impacted by water management and diversion activities on and off the site. Agricultural demands and flood control diversions, combined with low regional precipitation, prevent permanent water in the Big Lost River and Birch Creek drainages, thus limiting the "classic" wetlands to inordinately wet periods. The Big Lost River and Birch Creek drainages support unique riparian habitats that are important to a diversity of desert animals and breeding birds (DOE 1997b:43, 44). Riparian vegetation, primarily willow and cottonwood, provides nesting habitat for hawks, owls, and songbirds (DOE 1996a:3-125). The only permanent source of surface water on INEEL is manmade ponds where flows are sustained through facility operations. These ponds represent important habitat on INEEL that would not exist otherwise (DOE 1997b:43, 44).

Nineteen threatened, endangered, and other special-status species listed by the Federal Government or the State of Idaho may be found in the vicinity of INEEL, as shown in Table 3.4.6-1 in the *Storage and Disposition PEIS* (DOE 1996a:3-128).

⁵ The Federal Government defines threatened and endangered species in the Endangered Species Act, and wetlands in 33 CFR 328.3.

3.3.8.2.2 Proposed Facility Location

There are no known wetlands within the immediate environs of INTEC (Abbott, Crockett, and Moor 1997:15). Manmade percolation ponds that receive permitted facility effluent and hold water intermittently are known to support the boreal chorus frog and aquatic invertebrates when water is present. Several wetland plant species have been identified in percolation ponds south of INTEC (Werner 1997:WAG3 Report Summary). INTEC does not provide critical habitat for any of the 14 threatened, endangered, or other special-status species listed in Table 3–23 that may occur in the area (Werner 1997:WAG3 Report Summary).

Table 3–23. Threatened and Endangered Species, Species of Concern, and Sensitive Species Occurring or Potentially Occurring in Areas Surrounding INTEC

Common Name	Scientific Name	Federal Status	State Status
Birds			
Bald eagle	<i>Haliaeetus leucocephalus</i>	Threatened	Endangered
Black tern	<i>Chlidonias niger</i>	Species of Concern	Not listed
Burrowing owl	<i>Athene cucularia</i>	Species of Concern	Not listed
Ferruginous hawk	<i>Buteo regalis</i>	Species of Concern	Protected
Loggerhead shrike	<i>Lanius ludovicianus</i>	Species of Concern	Not listed
Northern goshawk	<i>Accipiter gentilis</i>	Species of Concern	Sensitive
Peregrine falcon	<i>Falco peregrinus</i>	Endangered	Endangered
Trumpeter swan	<i>Cygnus buccinator</i>	Species of Concern	Species of Special Concern
White-faced ibis	<i>Plegadis chihi</i>	Species of Concern	Not listed
Mammals			
Long-eared myotis	<i>Myotis evotis</i>	Species of Concern	Not listed
Pygmy rabbit	<i>Brachylagus (Sylvilagus) idahoensis</i>	Species of Concern	Species of Special Concern
Small-footed myotis	<i>Myotis subulatus</i>	Species of Concern	Not listed
Townsend’s western big-eared bat	<i>Plecotus townsendii</i>	Species of Concern	Species of Special Concern
Plants			
Lemhi milkvetch	<i>Astragalus aquilonius</i>	Not listed	Global (Rare) Priority 3
Sepal-tooth dodder	<i>Cuscuta denticulata</i>	Not listed	State Priority 1
Spreading gilia	<i>Ipomopsis polycladon</i>	Not listed	State Priority 2
Unknown	<i>Catapyrenium congestum</i>	Not listed	Sensitive
Winged-seed evening primrose	<i>Camissonia pterosperma</i>	Not listed	Sensitive
Reptiles			
Northern sagebrush lizard	<i>Sceloporus graciosus</i>	Species of Concern	Not listed

Key: INTEC, Idaho Nuclear Technology and Engineering Center.

Source: Ruesink 1998; Stephens 1998, 1999; Werner 1997:WAG3 Report Summary.

The northern sagebrush lizard and three bat species of special concern are believed to have the greatest potential for occurrence within the environs of INTEC. This is based on a survey conducted in 1996 to evaluate the presence of suitable habitat for threatened and endangered species and species of concern. Bat usage of the area is likely to be limited to aerial hunting activities around the INTEC sewage disposal and percolation ponds. The sewage disposal and percolation ponds are routinely used by wildlife, and these facilities and a portion of the Big

Lost River are within 1 km (0.6 mi) of FPF. The extent of potential usage of facility habitats by the northern sagebrush lizard is unknown (Werner 1997:WAG3 Report Summary).

3.3.9 Cultural and Paleontological Resources

Cultural resources are human imprints on the landscape and are defined and protected by a series of Federal laws, regulations, and guidelines. INEEL has a well-documented record of cultural and paleontological resources. Guidance for the identification, evaluation, recordation, curation, and management of these resources is included in the *Final Draft Idaho National Engineering Laboratory Management Plan for Cultural Resources* (Miller 1995). There have been 1,506 cultural resource sites and isolated finds identified, including 688 prehistoric sites, 38 historic sites, 753 prehistoric isolates, and 27 historic isolates (DOE 1996a:3-129). While many significant cultural resources have been identified, only about 4 percent of the area within the INEEL site has been surveyed (DOE 1996a:3-129). Most surveys have been conducted near major facility areas in conjunction with major modification, demolition, or abandonment of site facilities.

Cultural sites are often occupied continuously or intermittently over substantial time spans. For this reason, a single location (sites) may contain evidence of use during both historic and prehistoric periods. In the discussions that follow, the numbers of prehistoric and historic resources are presented; the sum of these resources may be greater than the total number of sites reported due to this dual-use history at sites. Therefore, where the total number of sites reported is less than the sum of prehistoric and historic sites certain locations were used during both periods.

3.3.9.1 Prehistoric Resources

Prehistoric resources are physical properties that remain from human activities that predate written records.

3.3.9.1.1 General Site Description

Prehistoric resources identified at INEEL are generally reflective of Native American hunting and gathering activities. Resources appear to be concentrated along the Big Lost River and Birch Creek, atop buttes, and within craters or caves. They include residential bases, campsites, caves, hunting blinds, rock alignments, and limited-activity locations such as lithic and ceramic scatters, hearths, and concentrations of fire-affected rock. Most sites have not been formally evaluated for nomination to the National Register, but are considered to be potentially eligible. Given the rather high density of prehistoric sites at INEEL, additional sites are likely to be identified as surveys continue (DOE 1996a:3-129).

3.3.9.1.2 Proposed Facility Location

The INTEC area has been subject to a number of archaeological survey projects over the past two decades. Most of these investigations have been concentrated around the perimeter of the site and along existing roadways or power line corridors. Survey coverage in the area around Building 691 is complete. The inventory of identified resources includes campsites and isolated artifacts reflecting Native American hunting and gathering activities, as well as resources reflective of more recent attempts at homesteading and agriculture (Abbott, Crockett, and Moor 1997:16).

Most of the area near FPF has been surveyed, except for a small area east of the railroad tracks. Six archaeological resources have been identified within the surveyed area. Most of the sites are prehistoric and historic isolates that are not likely to yield additional information and are therefore not likely to be potentially eligible for National Register nomination (Abbott, Crockett, and Moor 1997:16).

3.3.9.2 Historic Resources

Historic resources consist of physical properties that postdate the existence of written records. In the United States, historic resources are generally considered to be those that date no earlier than 1492.

3.3.9.2.1 General Site Description

Thirty-eight historic sites and 27 historic isolates have been identified at INEEL. These resources are representative of European-American activities, including fur trapping and trading, immigration, transportation, mining, agriculture, and homesteading, as well as more recent military and scientific/engineering R&D activities. Examples of historic resources include Goodale's Cutoff (a spur of the Oregon Trail), remnants of homesteads and ranches, irrigation canals, and a variety of structures from the World War II era. Experimental Breeder Reactor I, the first reactor to achieve a self-sustaining chain reaction using plutonium instead of uranium as the principal fuel component, is listed on the National Register and is designated a National Historic Landmark. Many other INEEL structures built between 1949 and 1974 are considered eligible for the National Register because of their exceptional scientific and engineering significance and their major role in the development of nuclear science and engineering since World War II. According to current studies, additional historic sites are likely to exist in unsurveyed portions of INEEL (DOE 1996a:3-129).

3.3.9.2.2 Proposed Facility Location

In the study area near INTEC are two historic sites, a homestead and nearby trash dump, that may be eligible for nomination to the National Register. These sites are potential sources of information on Carey Land Act-sponsored agricultural activities in the region (Abbott, Crockett, and Moor 1997:16).

A historic resource inventory of all buildings within INTEC is being conducted and will likely identify additional historic structures built between 1949 and 1974. Because it was constructed after 1974, FPF is not considered to be historic (Abbott, Crockett, and Moor 1997:16).

3.3.9.3 Native American Resources

Native American resources are sites, areas, and materials important to Native Americans for religious or heritage reasons. In addition, cultural values are placed on natural resources such as plants, which have multiple purposes within various Native American groups. Of primary concern are concepts of sacred space that create the potential for land-use conflicts.

3.3.9.3.1 General Site Description

Native American resources at INEEL are associated with the two groups of nomadic hunters and gatherers that used the region at the time of European-American contact: the Shoshone and Bannock. Both of these groups used the area that now encompasses INEEL as they harvested floral and faunal resources and obsidian from Big Southern Butte or Howe Point. Because INEEL is considered part of the Shoshone-Bannock Tribes' ancestral homeland, it contains many localities that are important for traditional, cultural, educational, and religious reasons. This includes not only prehistoric archaeological sites, which are important in a religious or cultural heritage context, but also features of the natural landscape and air, plant, water, or animal resources that have special significance (DOE 1996a:3-129).

3.3.9.3.2 Proposed Facility Location

INTEC and the surrounding area may contain Native American resources. The existence and significance of any resources near INTEC would be established in direct consultation with the Shoshone and Bannock Tribes. INEEL recently initiated general consultation with the Shoshone and Bannock Tribes, and a working agreement was established (Abbott, Crockett, and Moor 1997:16, B-1, B-2). Consultations (see Chapter 5 and Appendix O) were initiated with appropriate Native American groups to determine any concerns associated with the actions evaluated in this SPD EIS.

3.3.9.4 Paleontological Resources

Paleontological resources are the physical remains, impressions, or traces of plants or animals from a former geological age.

3.3.9.4.1 General Site Description

Paleontological remains consist of fossils and their associated geologic information. The region encompassing INEEL has abundant and varied paleontological resources, including plant, vertebrate, and invertebrate remains from soils and lake and river sediments, and organic materials found in caves and archaeological sites (DOE 1995b:4.4-5).

3.3.9.4.2 Proposed Facility Location

Vertebrate fossils recovered from the Big Lost River floodplain consist of isolated bones or teeth from large mammals of the Pleistocene or Ice Age. These fossils were discovered during excavations and well-drilling operations. A single mammoth tooth was salvaged during the excavation of a percolation pond immediately south of INTEC. Other fossils have been recorded in the vicinities of the Test Reactor Area and Naval Reactors Facility. Occasional skeletal elements of fossil mammoth, horse, and camel have been retrieved from the Big Lost River diversion dam and Radioactive Waste Management Complex on the southwestern side of INEEL, and from river and alluvial fan gravels and Lake Terreton sediments near Test Area North (Abbott, Crockett, and Moor 1997:16).

3.3.10 Land Use and Visual Resources

3.3.10.1 Land Use

Land may be characterized by its potential for the location of human activities (land use). Natural resource attributes and other environmental characteristics could make a site more suitable for some land uses than for others. Changes in land use may have both beneficial and adverse effects on other resources (biological, cultural, geological, aquatic, and atmospheric).

INEEL is situated on approximately 2,300 km² (890 mi²) of land in southeastern Idaho (DOE 1997b). INEEL is owned by the Federal Government and administered, managed, and controlled by DOE (DOE 1996a:3-107). It is primarily within Butte County, but portions of the site are also in Bingham, Jefferson, Bonneville, and Clark Counties. The site is roughly equidistant from Salt Lake City, Utah, and Boise, Idaho.

3.3.10.1.1 General Site Description

Lands surrounding INEEL are owned by the Federal Government, the State of Idaho, and private parties. Regional land uses include grazing, wildlife management, rangeland, mineral and energy production, recreation, and crop

production. Approximately 60 percent of the surrounding area is used by sheep and cattle for grazing. Small communities and towns near the INEEL boundaries include Mud Lake to the east; Arco, Butte City, and Howe to the west; and Atomic City to the south (DOE 1995b:4.2-5). Two National Natural Landmarks border INEEL: Big Southern Butte (2.4 km [1.5 mi] south) and Hell's Half Acre (2.6 km [1.6 mi] southeast) (DOE 1996a:3-107). A portion of Hell's Half Acre National Natural Landmark is designated as a Wilderness Study Area. The Black Canyon Wilderness Study Area is also adjacent to INEEL (DOE 1996a:3-107).

Land-use categories at INEEL include facility operations, grazing, general open space, and infrastructure such as roads. Generalized land uses at INEEL and vicinity are shown in Figure 3-17. Facility operations include industrial and support operations associated with energy research and waste management activities. Land is also used for recreation and environmental research associated with the designation of INEEL as a National Environmental Research Park. Much of INEEL is open space that has not been designated for specific use. Some of this space serves as a buffer zone between INEEL facilities and other land uses. About 2 percent of the total INEEL site area (46 km² [18 mi²]) is used for facilities and operation (DOE 1995b:4.2-1). Approximately 9,000 ha (22,240 acres) or 4 percent of the total acreage at INEEL is available for radioactive waste management facilities (DOE 1997a:vol. I, 4-20). Public access to most facilities is restricted. Approximately 6 percent of the INEEL site, or 140 km² (54 mi²), is public roads and utilities that cross the site. Recreational uses include public tours of general facility areas and Experimental Breeder Reactor I (a National Historic Landmark), and controlled hunting, which is generally restricted to 0.8 km (0.5 mi) within the INEEL boundary. Between 1,210 km² (467 mi²) and 1,420 km² (548 mi²) are used for cattle and sheep grazing. A 3.6-km² (1.4-mi²) portion of this land, at the junction of Idaho State Highways 28 and 33, is used by the U.S. Sheep Experiment Station as a winter feedlot for about 6,500 sheep (DOE 1995b:4.2-1).

INTEC is about 4.8 km (3 mi) north of the Central Facilities Area. The plant is situated on approximately 85 ha (210 acres) within the perimeter fence. An additional 22 ha (54 acres) of the plant area lie outside the fence (DOE 1997b). The INTEC complex houses reprocessing facilities for Government-owned defense and research spent fuels. Facilities at INTEC include spent fuel storage and reprocessing areas, a waste solidification facility and related waste storage bins, remote analytical laboratories, and a coal-fired steam-generating plant.

DOE land-use plans and policies applicable to INEEL include the *INEL Institutional Plan for FY 1994-1999* and the *INEL Technical Site Information Report* (DOE 1995b:vol. 2, part A, 4.2-1). The *Institutional Plan* provides a general overview of INEEL facilities, strategic program descriptions, and major construction projects, and identifies specific technical programs and capital equipment needs. The *Information Report* (DOE 1995b:vol. 2, part A) presents a 20-year master plan for development activities at the site. Land-use planning for INEEL administrative and laboratory facilities located in the city of Idaho Falls is subject to Idaho Falls planning and zoning restrictions (DOE 1996a:3-107).

All county plans and policies encourage development adjacent to previously developed areas to minimize the need for infrastructure improvements and to avoid urban sprawl. Because INEEL is remote from most developed areas, INEEL lands and adjacent areas are not likely to experience residential and commercial development, and no new development is planned near the site. Recreational and agricultural uses, however, are expected to increase in the surrounding area in response to greater demand for recreational areas and the conversion of rangeland to cropland (DOE 1995b:4.2-5).

The Fort Bridger Treaty of July 3, 1868, secured the Fort Hall Reservation as the permanent homeland of the Shoshone-Bannock Peoples. According to the treaty, tribal members reserved rights to hunting, fishing, and gathering on surrounding unoccupied lands of the United States. While INEEL is considered occupied land, it was recognized that certain areas on the INEEL site have significant cultural and religious significance to

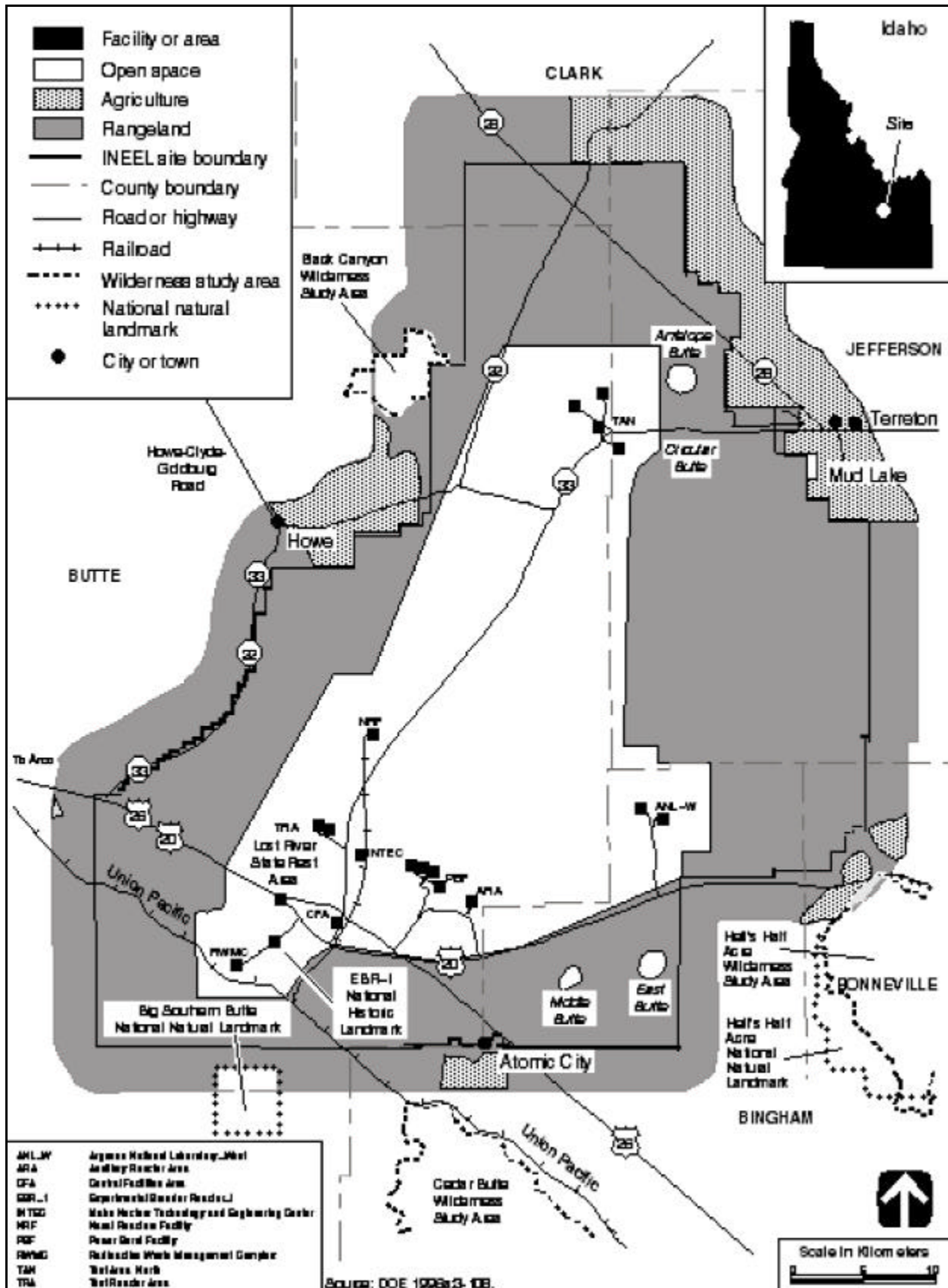

Figure 3-17. Generalized Land Use at INEEL and Vicinity

the tribes. A 1994 Memorandum of Agreement with the Shoshone-Bannock Tribes (DOE 1994b:1) provides tribal members access to the Middle Butte to perform sacred or religious ceremonies or other educational or cultural activities.

3.3.10.1.2 Proposed Facility Location

FPF is not currently being used and is being maintained on standby. This building, the largest at INTEC, is in the middle of an area of several warehouse and administrative facilities. The land, currently disturbed, is designated for waste-processing operations. FPF is 12 km (7.5 mi) from the nearest site boundary.

3.3.10.2 Visual Resources

Visual resources are natural and human-created features that give a particular landscape its character and aesthetic quality. Landscape character is determined by the visual elements of form, line, color, and texture. All four elements are present in every landscape; however, they exert varying degrees of influence. The stronger the influence exerted by these elements in a landscape, the more interesting the landscape. The more visual variety that exists with harmony, the more aesthetically pleasing the landscape.

3.3.10.2.1 General Site Description

The INEEL site is bordered on the north and west by the Bitterroot, Lemhi, and Lost River mountain ranges. Volcanic buttes near the southern boundary of INEEL can be seen from most locations on the site. INEEL generally consists of open desert land predominantly covered by large sagebrush and grasslands. Pasture and farmland border much of the site.

Ten facility areas are on the INEEL site. Although INEEL has a master plan, no specific visual resource standards have been established. INEEL facilities have the appearance of low-density commercial/industrial complexes widely dispersed throughout the site. Structure heights range from about 3 to 30 m (10 to 100 ft); a few stacks and towers reach 76 m (250 ft). Although many INEEL facilities are visible from highways, most facilities are more than 0.8 km (0.5 mi) from public roads (DOE 1995b:4.5-1). The operational areas are well defined at night by the security lights.

The Craters of the Moon National Monument is about 20 km (12 mi) southwest of INEEL's western boundary. It includes a designated Wilderness Area, which must maintain Class I air quality standards. Lands adjacent to the site, under BLM jurisdiction, are designated as VRM Class II areas (DOE 1995b:4.5-2). This designation obliges preservation and retention of the existing character of the landscape. Lands within the INEEL site are designated as VRM Classes III and IV, the most lenient classes in terms of modification (DOE 1995b:4.5-2). The Black Canyon Wilderness Study Area, adjacent to INEEL, is under consideration by BLM for Wilderness Area designation, approval of which would result in an upgrade of its VRM class from Class II to Class I (DOE 1995b:4.5-2; DOI 1986a, 1986b). The Hell's Half Acre Wilderness Study Area is about 2.6 km (1.6 mi) southeast of INEEL's eastern boundary. This area, famous for its lava flows and hiking trails, is managed by BLM.

3.3.10.2.2 Proposed Facility Location

While FPF is the largest building on the site, the tallest structure is the stack connected to INTEC; it is 76 m (250 ft) tall. INTEC is visible in the middle ground from State Highways 20 and 26, with Saddle Mountain in the background. The character of INTEC is consistent with a VRM Class IV designation (DOI 1986a, 1986b). Natural features of visual interest within a 40-km (25-mi) radius include Big Lost River at 0.8 km (0.5 mi), Big Southern Butte National Natural Landmark at 20 km (12 mi), Saddle Mountain at 40 km (25 mi), Middle Butte

at 18 km (11 mi), Hell's Half Acre Wilderness Study area at 35 km (22 mi) and East Butte at 23 km (14 mi) (Abbott, Crockett, and Moor 1997:4).

3.3.11 Infrastructure

Site infrastructure includes those utilities and other resources required to support construction and continued operation of mission-related facilities identified under the various proposed alternatives.

3.3.11.1 General Site Description

INEEL has extensive production, service, and research facilities. An extensive infrastructure supports these facilities, as shown in Table 3–24.

Table 3–24. INEEL Sitewide Infrastructure Characteristics

Resource	Current Usage	Site Capacity
Transportation		
Roads (km)	445 ^a	445 ^a
Railroads (km)	48	48
Electricity		
Energy consumption (MWh/yr)	232,500	394,200
Peak load (MW)	42	124
Fuel		
Natural gas (m ³ /yr)	NA	NA
Oil (l/yr) ^b	5,820,000	16,000,000 ^c
Coal (t/yr)	11,340	11,340 ^c
Water (l/yr)	6,000,000,000 ^d	43,000,000,000 ^e

^a Includes paved and unpaved roads.

^b Includes fuel oil and propane.

^c As supplies get low, more can be supplied by truck or rail.

^d See Werner 1997:2.

^e See DOE 1995b:vol. II, part A, 4.13-1.

Key: NA, not applicable.

Source: DOE 1996a:3-110.

3.3.11.1.1 Transportation

The road network at INEEL provides for onsite transportation; the railroads for deliveries of large volumes of coal and oversized structural components. Commercial shipments are by truck and plane, but some bulk materials are transported by train, and waste by truck and train (DOE 1995b:vol. I, 4.11-1).

About 140 km (87 mi) of paved surface has been developed out of the 445 km (277 mi) of roads on the site, including about 29 km (18 mi) of service roads that are closed to the public. Most of the roads are adequate for the current level of normal transportation activity and could handle increased traffic volume (DOE 1995b:vol. I, 4.11-1).

Idaho Falls receives railroad freight service from Butte, Montana, to the north, and from Pocatello, Idaho, and Salt Lake City, Utah, to the south. The Union Pacific Railroad's Blackfoot-to-Arco Branch crosses the southern portion of INEEL and provides rail service to the site. This branch connects with a DOE spur line at the Scoville

Siding, then links with developed areas within INEEL. Rail shipments to and from INEEL usually are limited to bulk commodities, spent nuclear fuel, and radioactive waste (DOE 1995b:vol. I, 4.11-3).

3.3.11.1.2 Electricity

Commercial electric power is supplied to INEEL from the Antelope substation through two feeders to the federally owned Scoville substation, which supplies electric power directly to the site electric power distribution system. Electric power supplied by Idaho Power Company is generated by hydroelectric generators along the Snake River in southern Idaho and by the Bridger and Valmy coal-fired thermal electric generation plants in southwestern Wyoming and northern Nevada (DOE 1995b:vol. II, part A, 4.13-2). Characteristics of this power pool are summarized in Table 3.4.2-2 of the *Storage and Disposition PEIS* (DOE 1996a:3-111).

The average electrical availability at INEEL is about 394,200 MWh/yr; the average usage, about 232,500 MWh/yr. The peak load capacity for INEEL is 124 MW; the current peak load usage, about 42 MW (DOE 1996a:3-110).

3.3.11.1.3 Fuel

Fuels consumed at INEEL include several liquid petroleum fuels, coal, and propane gas. All fuels are transported to the site for storage and use. Fuel storage is provided for each facility, and the inventories are restocked as necessary (DOE 1995b:vol. II, part A, 4.13-2). The current site usage is about 5.8 million l/yr (1.5 million gal/yr). The current site usage of coal is about 11,340 t/yr (12,500 tons/yr) (DOE 1996a:3-110). If additional coal or fuel oil were needed during the year, it could be shipped onto the site.

3.3.11.1.4 Water

The Snake River Plain Aquifer is the source of all water at INEEL (DOE 1996a:3-119). The water is provided by a system of about 30 wells, together with pumps and storage tanks. That system is administered by DOE, which holds the Federal Reserved Water Right for the site of 43 billion l/yr (11 billion gal/yr) (DOE 1995b:vol. II, part A, 4.13-1). The current site usage is 6 billion l/yr (1.6 billion gal/yr) (Werner 1997:2).

3.3.11.1.5 Site Safety Services

DOE operates three fire stations at INEEL. These stations are at the north end of Test Area North, at ANL-W, and in the Central Facilities Area. Each station has a minimum of one engine company capable of supporting any fire emergency in its assigned area. The fire department also provides the site with ambulance, emergency medical technician, and hazardous material response services (DOE 1995b:vol. II, part A, 4.13-3).

3.3.11.2 Proposed Facility Location

A separate utility tunnel running off the main INTEC utility tunnel was completed and water, steam condensate, air, and other lines have been completed up to, and in some cases into, FPF when this facility was built. A summary of the infrastructure characteristics of INTEC is presented as Table 3-25.

3.3.11.2.1 Electricity

Electric power for INTEC is routed into the main electrical room from a 14-kV feeder in Unit Substation 2, north of the building. The current capacity available for INTEC is 262,800 MWh/yr (Abbott, Crockett, and Moor 1997:20).

Table 3–25. INEEL Infrastructure Characteristics for INTEC

Resource	Current Usage	Capacity
Electricity		
Energy consumption (MWh/yr)	60,000	262,800
Peak load (MW)	9.2 ^a	31.4 ^{b,c}
Fuel		
Natural gas (m ³ /yr)	NA	NA
Oil (l/yr)	757,000	1,112,720 ^{d,e}
Coal (t/yr)	13,000	NA ^e
Water (l/yr)	45,420,000	227,100,000

^a Demand.

^b Equivalent to 30 MW continuous use per year.

^c Based on a 95 percent power factor.

^d Available capacity is INTEC tank storage capacity in liters.

^e As supplies get low, more can be supplied by truck or rail.

Key: INTEC, Idaho Nuclear Technology and Engineering Center; NA, not applicable.

Source: Abbott, Crockett, and Moor 1997:20; Werner 1997:1.

3.3.11.2.2 Fuel

Fuel oil and propane are supplied from INTEC. The current capacity of fuel oil and propane is approximately 1.1 million l/yr (291,000 gal/yr); the usage, approximately 757,000 l/yr (200,000 gal/yr) (Abbott, Crockett, and Moor 1997:20).

3.3.11.2.3 Water

Water service is available through connection to the INTEC water supply system, which obtains its water from two deep wells located north of the INTEC main process area. The water withdrawn from the Snake River Plain Aquifer is a small fraction of the available supply (Abbott, Crockett, and Moor 1997:9). The current annual capacity of water available for FPF is about 230 million l/yr (61 million gal/yr); and the current usage for the facility is about 45 million l/yr (12 million gal/yr) (Werner 1997:1).

3.4 PANTEX PLANT

Pantex is in Carson County along U.S. Highway 60 and lies about 27 km (17 mi) northeast of downtown Amarillo, Texas (Figure 2–4). Pantex lies in the Texas Panhandle on the Llano Estacado (staked plains) portion of the Great Plains. The topography at Pantex is relatively flat, characterized by rolling grassy plains and natural playa basins. The term “playa” is used to describe the more than 17,000 ephemeral lakes in the Texas Panhandle, usually less than 1 km (0.6 mi) in diameter, that receive water runoff from the surrounding area. The region is a semiarid farming and ranching area. Pantex is surrounded by agricultural land, but several significant industrial facilities are also nearby (DOE 1996a:3-146).

Pantex was first used by the U.S. Army for loading conventional ammunition shells and bombs from 1942 to 1945. In 1951, the Atomic Energy Commission arranged to begin rehabilitating portions of the original plant and constructing new facilities for nuclear weapons operations. The current missions are shown in Table 3–26. Weapons assembly, disassembly, and stockpile surveillance activities involve handling (but not processing) of encapsulated uranium, plutonium, and tritium, as well as a variety of nonradioactive hazardous or toxic chemicals (DOE 1996a:3-146).

Table 3–26. Current Missions at Pantex

Mission	Description	Sponsor
Plutonium storage	Provide storage of pits from dismantled nuclear weapons	Assistant Secretary for Defense Programs
High explosive(s) components	Manufacture for use in nuclear weapons	Assistant Secretary for Defense Programs
Weapons assembly	Assemble new nuclear weapons for the stockpile	Assistant Secretary for Defense Programs
Weapons maintenance	Retrofit, maintain, and repair stockpile weapons	Assistant Secretary for Defense Programs
Quality assurance	Stockpile quality assurance testing and evaluation	Assistant Secretary for Defense Programs
Weapons disassembly	Disassemble stockpile weapons as required	Assistant Secretary for Defense Programs
Test and training programs	Assemble nuclear weapon-like devices for training	Assistant Secretary for Defense Programs
Weapons dismantlement	Dismantle nuclear weapons no longer required	Assistant Secretary for Defense Programs
Development support	Provide support to design agencies as requested	Assistant Secretary for Defense Programs
Waste management	Waste treatment, storage, and disposal	Assistant Secretary for Defense Programs
Environmental management	Environmental restoration activities	Assistant Secretary for Environmental Management

Source: DOE 1996a:3-146.

DOE Activities. All DOE activities at Pantex, except for environmental restoration programs, fall under the DOE Office of the Assistant Secretary for Defense Programs. Historically, DOE’s mission for Pantex primarily included assembly and delivery to the U.S. Department of Defense (DoD) of a variety of nuclear weapons. Today, the primary roles of Pantex are the disassembly of U.S. nuclear weapons being returned to DOE by DoD, maintenance and repair of nuclear weapons, and storage of plutonium pits. These operations are in compliance with the negotiated downsizing of the U.S. and the former Soviet nuclear forces (DOE 1996a:3-147).

Other activities that have been, and will continue to be, conducted under DOE's national security mission include certain maintenance and monitoring activities of the remaining nuclear weapons stockpile, modification and assembly of existing nuclear weapons systems, and production of high-explosive components for nuclear weapons. DOE also conducts quality evaluation of weapons, quality assurance testing of weapons components, and R&D supporting nuclear weapons activities at the plant. DOE's national security responsibilities are mandated by statutes, Presidential directives, and congressional authorization and appropriations (DOE 1996a:3-147).

The change in mission emphasis from assembly to disassembly of nuclear weapons has caused an increase in some waste streams. Waste management operations at Pantex in the near term would add facilities to enhance capabilities to adequately handle existing waste streams. Improved facilities for hazardous waste staging, treatment, and storage would be coupled with increased use of commercial offsite facilities to treat mixed waste streams. Upon completion of the current backlog of dismantlements due to stockpile reduction, waste generation is likely to decrease (DOE 1996a:3-147).

Non-DOE Activities. Texas Tech University pursues agricultural activities on both DOE-owned and DOE-leased property (DOE 1996a:3-147).

3.4.1 Air Quality and Noise

3.4.1.1 Air Quality

Air pollution refers to any substance in the air that could harm human or animal populations, vegetation, or structures, or that unreasonably interferes with the comfortable enjoyment of life and property. Air pollutants are transported, dispersed, or concentrated by meteorological and topographical conditions. Air quality is affected by air pollutant emission characteristics, meteorology, and topography.

3.4.1.1.1 General Site Description

The climate at Pantex and the surrounding region is characterized as semiarid with hot summers and rather cold winters. The average annual temperature in the Amarillo region is 13.8 EC (56.9 EF); temperatures range from an average daily minimum of -5.7 EC (21.8 EF) in January to an average daily maximum of 32.8 EC (91.1 EF) in July. The average annual precipitation is 49.8 cm (19.6 in). Prevailing winds at Pantex are from the south. The average annual windspeed is 6 m/s (13.5 mph) (NOAA 1994a). Additional information related to meteorology and climatology at Pantex is presented in Appendix F of the *Storage and Disposition PEIS* (DOE 1996a:F-11, F-12) and in the site environmental information document (M&H 1996a:6-1-6-19).

Pantex is within the Amarillo-Lubbock Intrastate AQCR #211. None of the areas within Pantex and this AQCR are designated as nonattainment areas with respect to the NAAQS for criteria air pollutants (EPA 1997e). Applicable NAAQS and Texas State ambient air quality standards are presented in Table 3-27.

There are no PSD Class I areas within 100 km (62 mi) of Pantex. None of the facilities at Pantex have been required to obtain a PSD permit (DOE 1996f:4-118-4-120).

The primary emission sources of criteria pollutants at Pantex are the steam plant boilers, the explosives-burning operation, and emissions from onsite vehicles. Emission sources of hazardous or toxic air pollutants include the high-explosives synthesis facility, the explosives-burning operation, paint spray booths, miscellaneous laboratories, and other small operations (DOE 1996f:4-134). The boilers and high-explosives synthesis facility operate under air permits from the Texas Natural Resource Conservation Commission (TNRCC). The paint

Table 3–27. Comparison of Ambient Air Concentrations From Pantex Sources With Most Stringent Applicable Standards or Guidelines, 1993

Pollutant	Averaging Period	Most Stringent	Concentration
		Standard or Guideline (Fg/m ³) ^a	(Fg/m ³)
Criteria pollutants			
Carbon monoxide	8 hours	10,000 ^b	161
	1 hour	40,000 ^b	924
Nitrogen dioxide	Annual	100 ^b	0.90
Ozone	8 hours	157 ^c	(d)
PM ₁₀	Annual	50 ^b	8.73
	24 hours	150 ^b	88.5
PM _{2.5}	3-year annual	15 ^c	(e)
	24 hours	65 ^c	(e)
	(98th percentile over 3 years)		
Sulfur dioxide	Annual	80 ^b	<0.01
	24 hours	365 ^b	<0.01
	3 hours	1,300 ^b	<0.01
	30 minutes	1,048 ^f	<0.01
Other regulated pollutants			
Hydrogen sulfide	30 minutes	112 ^f	(g)
Total suspended particulates	3 hours	200 ^f	(h)
	1 hour	400 ^f	(h)
Hazardous and other toxic compounds			
Benzene	1 hour	75 ⁱ	19.4 ^j
	Annual	3 ⁱ	0.0547
[Text deleted.]			

^a The more stringent of the Federal and State standards is presented if both exist for the averaging period. The National Ambient Air Quality Standards (NAAQS) (EPA 1997a), other than those for ozone, particulate matter, lead, and those based on annual averages, are not to be exceeded more than once per year. The 1-hr ozone standard is attained when the expected number of days per year with maximum hourly average concentrations above the standard is #1. The 1-hr ozone standard applies only to nonattainment areas. The 8-hr ozone standard is attained when the 3-year average of the annual fourth-highest daily maximum 8-hr average concentration is less than or equal to 157 Fg/m³. The 24-hr particulate matter standard is attained when the expected number of days with a 24-hr average concentration above the standard is #1. The annual arithmetic mean particulate matter standard is attained when the expected annual arithmetic mean concentration is less than or equal to the standard.

^b Federal and State standard.

^c Federal standard.

^d Not directly emitted or monitored by the site.

^e No data is available with which to assess PM_{2.5} concentrations.

^f State standard.

^g No sources identified at the site.

^h No site boundary concentrations from Pantex facilities presented in the *Final EIS for the Continued Operation of the Pantex Plant and Associated Storage of Nuclear Weapon Components*.

ⁱ TNRCC effects-screening levels are “tools” used by the Toxicology and Risk Assessment Staff to evaluate impacts of air pollutant emissions. They are not ambient air standards. If ambient levels of air contaminants exceed the screening levels, it does not necessarily indicate a problem, but would trigger a more indepth review. The levels are set where no adverse effect is expected.

^j Concentration reported as a 30-min average.

Note: The NAAQS also includes standards for lead. No sources of lead emissions have been identified for any of the alternatives presented in Chapter 4. Emissions of other air pollutants not listed here have been identified at Pantex, but are not associated with any of the alternatives evaluated. These other air pollutants are quantified in the *Final EIS for the Continued Operation of the Pantex Plant and Associated Storage of Nuclear Weapon Components* (DOE 1996f). EPA recently revised the ambient air

quality standards for particulate matter and ozone. The new standards, finalized on July 18, 1997, changed the ozone primary and secondary standards from a 1-hr concentration of 235 Fg/m³ (0.12 ppm) to an 8-hr concentration of 157 Fg/m³ (0.08 ppm). During a transition period while States are developing State implementation plan revisions for attaining and maintaining these standards, the 1-hr ozone standard will continue to apply in nonattainment areas (EPA 1997b:38855). For particulate matter, the current PM₁₀ annual standard is retained, and two PM_{2.5} standards are added. These standards are set at a 15-Fg/m³ 3-year annual arithmetic mean based on community-oriented monitors and a 65 Fg/m³ 3-year average of the 98th percentile of 24-hr concentrations at population-oriented monitors. The revised 24-hr PM₁₀ standard is based on the 99th percentile of 24-hr concentrations. The existing PM₁₀ standards will continue to apply in the interim period (EPA 1997c:38652).

Source: DOE 1996f:4-127-4-133; EPA 1997a; TNRCC 1997a, 1997b.

spray booths, miscellaneous laboratories, and other small operations are allowed under TNRCC standard exemptions. The explosive-burning operation is allowed under the TNRCC hazardous waste permit (DOE 1997c:21, 22).

With the exception of thermal treatment of high explosives at the burning ground, most stationary sources of nonradioactive atmospheric releases are fume hoods and building exhaust systems, some of which have HEPA filters for control of particulate emissions. Table 3-27 presents the ambient air concentrations attributable to sources at Pantex, which are based on emissions for the year 1993. These emissions were modeled using meteorological data from 1988 (DOE 1996f:4-123) and represent maximum output conditions. Actual annual emissions for some pollutants are somewhat less than these levels, and the estimated concentrations bound the actual Pantex contribution to ambient levels. Only those pollutants that would be emitted for any of the surplus plutonium disposition alternatives are presented. Additional information on ambient air quality at Pantex and detailed information on emissions of other pollutants at Pantex are discussed in the *Final EIS for the Continued Operation of Pantex* (DOE 1996f:4-117-4-135, B-3-B-61) and the 1996 *Environmental Report for Pantex Plant* (DOE 1997c:21, 22, 78-84). Concentrations of nonradiological air pollutants shown in Table 3-27 are in compliance with applicable regulations or are below applicable health effects-screening levels, the concentration of hazardous air pollutants determined by TNRCC to have minimal effect on human health and the environment.

Measurements of PM₁₀ and various volatile organic compounds are made at Pantex. During 1993, only one 24-hr PM₁₀ measurement exceeded the NAAQS level, while in 1994 the PM₁₀ NAAQS level was exceeded 1 day in January and 1 day in June. Windblown dust is indicated as a major contributor to some of these exceedances. The concentrations of carbon monoxide, sulfur dioxide, and nitrogen dioxide from Pantex—combined with those from background (non-Pantex) sources—are expected to be in compliance with the ambient air quality standards. Measured concentrations of 1-2-dibromoethane exceeded the effects-screening levels once in 1995. However, monitoring in the last quarter of 1995 and 1996 showed that all organic compounds measured were below their respective effects-screening levels (DOE 1996f:4-121-4-123; M&H 1997:8, 12, 35-37). 1-2-dibromoethane is not emitted at Pantex. The air quality monitoring program is described in the annual site environmental monitoring reports (DOE 1997c).

Annual PM₁₀ measured concentrations during 1995 were less than 24 Fg/m³ at all monitoring locations, and except one measurement of 170 Fg/m³ during a grass fire, 24-hr PM₁₀ measured concentrations were below 129 Fg/m³ (TNRCC 1997c:13-15).

3.4.1.1.2 Proposed Facility Location

The meteorological conditions described for Pantex are considered to be representative of the Zone 4 West area. Primary sources of pollutants in Zone 4 West include a standby diesel electric generator, drum sampling, and bulk handling of chemicals (DOE 1996f:B-10-B-29).

3.4.1.2 Noise

Noise is unwanted sound that interferes or interacts negatively with the human or natural environment. Noise may disrupt normal activities or diminish the quality of the environment.

3.4.1.2.1 General Site Description

Major noise emission sources within Pantex include various industrial facilities, equipment, and machines (e.g., cooling systems, transformers, engines, pumps, boilers, steam vents, construction and materials-handling equipment, vehicles), as well as small arms firing, alarms, and explosives detonation. Most Pantex industrial

facilities are far enough from the site boundary that noise levels from these sources at the boundary are barely distinguishable from background noise. However, some noise from explosives detonation can be heard at residences north of the site, and small arms weapons firing can be heard at residences to the west (DOE 1996a:3-153, 1996f:4-161-4-170).

The acoustic environment along the Pantex boundary and at nearby residences away from traffic noise is typical of a rural location. The day-night average sound levels are in the range, 35 to 50 dBA, that is typical of rural areas (EPA 1974:B-4). Noise survey results in areas adjacent to Pantex indicate that ambient sound levels are generally low, with natural sounds and distant traffic being the primary sources. Traffic, aircraft, trains, and agricultural activities result in higher short-term levels (M&H 1996a:11-1-11-19). Traffic is the primary source of noise at the site boundary and at residences near roads. Traffic noise is expected to dominate sound levels along major roads in the area, such as U.S. Route 60. The residents most likely to be affected by noise from plant traffic along Pantex access routes are those living along Farm-to-Market (FM) 2373 and FM 683 (DOE 1996a:3-153).

Measurements of equivalent sound levels for traffic noise and other sources along the roads bounding Pantex are 53 to 62 dBA for FM 2373 at about 400 m (1300 ft) from the road; 51 to 58 dBA for FM 293 at about 70 m (230 ft); 44 to 65 dBA for FM 683 at about 40 m (130 ft); and 51 dBA for U.S. Route 60 at about 225 m (740 ft). These levels are based on a limited number of 30-min samples taken during peak and offpeak traffic periods; mostly at locations within the site boundary (M&H 1996a:11-11-11-15). The levels represent the range of daytime traffic noise levels at residences near the site.

Other sources of noise include aircraft, wind, insect activity, and agricultural activity. Except for the prohibition of nuisance noise, neither the State of Texas nor local governments have established any regulations that specify acceptable community noise levels applicable to Pantex (DOE 1996a:F-32).

The EPA guidelines for environmental noise protection recommend an average day-night sound level of 55 dBA as sufficient to protect the public from the effects of broadband environmental noise in typically quiet outdoor and residential areas (EPA 1974:29). Land-use compatibility guidelines adopted by the Federal Aviation Administration and the Federal Interagency Committee on Urban Noise indicate that yearly day-night average sound levels less than 65 dBA are compatible with residential land uses and levels up to 75 dBA are compatible with residential uses if suitable noise reduction features are incorporated into structures (DOT 1995). It is expected that for most residences near Pantex, the day-night average sound level is less than 65 dBA and is compatible with the residential land use.

3.4.1.2.2 Proposed Facility Location

No distinguishing noise characteristics of Zone 4 West have been identified. Zone 4 West is far enough—1.8 km (1.1 mi)—from the site boundary that noise levels from the facilities are barely distinguishable from background levels.

3.4.2 Waste Management

Waste management includes minimization, characterization, treatment, storage, transportation, and disposal of waste generated from ongoing DOE activities. The waste is managed using appropriate treatment, storage, and disposal technologies and in compliance with all applicable Federal and State statutes and DOE orders.

3.4.2.1 Waste Inventories and Activities

Pantex manages the following types of waste: LLW, mixed LLW, hazardous, and nonhazardous. TRU waste and mixed TRU waste are not normally generated and no HLW is currently generated at Pantex. Waste generation rates and the inventory of stored waste from activities at Pantex are provided in Table 3–28. Table 3–29 summarizes Pantex waste management capabilities. More detailed descriptions of the waste management system capabilities at Pantex are included in the *Storage and Disposition PEIS* (DOE 1996a:3-180–3-183, E-49–E-62) and the *Final EIS for the Continued Operation of the Pantex Plant and Associated Storage of Nuclear Weapons Components* (DOE 1996f:4-229).

Table 3–28. Waste Generation Rates and Inventories at Pantex

Waste Type	Generation Rate (m ³ /yr)	Inventory (m ³)
TRU^a		
Contact handled	0	0 ^b
Remotely handled	0	0
LLW	139	208
Mixed LLW	24 ^c	135
Hazardous	486 ^{c,d}	153 ^{e,f}
Nonhazardous		
Liquid	473,125 ^g	NA ^f
Solid	8,007 ^c	311 ^{e,f,h}

^a Includes mixed TRU waste.

^b DOE 1997d:1-2.

^c DOE 1997c:19.

^d Includes TSCA-regulated wastes.

^e DOE 1996f:4-233.

^f Generally, hazardous and nonhazardous wastes are not held in long-term storage.

^g King 1997a.

^h Largely composed of asbestos waste.

Key: LLW, low-level waste; NA, not applicable; TRU, transuranic; TSCA, Toxic Substances Control Act.

Source: DOE 1996e:15, 16, except as notes.

EPA placed Pantex on the National Priorities List on May 31, 1994. Currently, environmental restoration activities are conducted in compliance with CERCLA and a RCRA permit issued in April 1991, and modified in February 1996. Environmental restoration activities are expected to be completed in 2000 (DOE 1996a:3-180). More information on regulatory requirements for waste disposal is provided in Chapter 5.

3.4.2.2 Transuranic and Mixed Transuranic Waste

Pantex does not generate or manage TRU waste as a result of normal operations, although there are procedures in place to manage TRU waste if it is generated. The small quantity of TRU waste (<1 m³) that was stored in Building 12-24 was moved to LANL pending disposal at WIPP (DOE 1997d:1-2).

3.4.2.3 Low-Level Waste

Compactible solid LLW is processed at the LLW Compactor and stored along with the noncompactible materials for shipment to the Nevada Test Site (NTS), where most LLW is disposed of, or to a commercial vendor. Some liquid LLW has been solidified, but more development is required in this area. Much liquid

Table 3–29. Waste Management Capabilities at Pantex

Facility Name/Description	Capacity	Status	Applicable Waste Type					
			Mixed TRU	Mixed TRU	Mixed LLW	Mixed LLW	Haz	Non-Haz
Treatment Facility (m³/yr)								
11-09 South - Scintillation Vial Crusher/Segregator	Variable ^a	Online ^b			X			
11-09 South - Sort/Segregation and Decontamination Activities	Variable ^a	Online ^b			X	X		
11-09 South - Fluorescent Bulb Crusher	Variable ^a	Online ^b					X	
12-17 - Evaporator for Tritiated Water	Campaign	Online			X			
12-19 East - Rotary Evaporator Vacuum Distillation Units (2)	Campaign	Online						X
12-19 East - Fractional Distillation Unit	Campaign	Online						X
12-19 East - HE Precipitation Process	Campaign	Online						X
12-42 - Compactor/Drum Crusher	Variable ^a	Online ^b			X			
16-18 - HWTPF	750	Planned for 1999			X	X	X	
16-18 - HWTPF Waste Compacting	90	Planned for 1999			X	X	X	X
16-18 - HWTPF Drum Crushing	208	Planned for 1999			X	X	X	X
16-18 - HWTPF Wastewater Evaporation System	45	Planned for 1999			X			
16-18 - HWTPF Misc Drum Operations (including neutralization and filtration)	Various	Planned for 1999			X	X	X	
16-18 - HWTPF Drum Rinsing System	45	Planned for 1999					X	
16-18 - HWTPF Fluorescent Bulb Crusher	12	Planned for 1999					X	
16-18A - Solvent Recovery Unit	348	Planned for 1999					X	
16-18A - Scintillation Vial Crushing	90	Planned for 1999			X			X
Burning Ground Thermal Processing Units	Variable ^c	Online				X	X	
Wastewater Treatment Facility	946,250	Online						X

Facility Name/Description	Capacity	Status	Applicable Waste Type					
			Mixed		Mixed		Haz	Non-Haz
			TRU	TRU	LLW	LLW		
Storage Facility (m³)								
11-07A & B Pads - Container Storage Areas	402	Online			X	X	X	X
11-07 North Pad - Container Storage Unit	125	Online			X	X	X	X

Table 3–29. Waste Management Capabilities at Pantex (Continued)

Facility Name/Description	Capacity	Status	Applicable Waste Type					
			Mixed		Mixed		Haz	Non-Haz
			TRU	TRU	LLW	LLW		
Disposal Facility (m³)								
11-09 North Building - Container Storage Area	379	Online			X	X	X	X
16-16 Building - Hazardous Waste Staging Facility	1,047	Online			X	X	X	X
Construction Debris Landfill (Zone 10)	21,208	Online						X

^a Capacity included in HWTPF.

^b Unit will move to HWTPF when operational in 1999.

^c Permit limitations are per burning event.

Key: Haz, hazardous; HE, high explosives; HWTPF, Hazardous Waste Treatment and Processing Facility; LLW, low-level waste; TRU, transuranic.

Source: King 1997b; Lemming 1998; M&H 1997:28.

LLW is currently being evaporated. The remaining liquid LLW is being stored on the site awaiting a treatment process (Jones 1999).

Pantex is presently approved to ship seven LLW streams to NTS for disposal. Previous approvals of two waste streams were deactivated due to changes in the characterization of the wastes, but the requests for approval are being updated and reviewed and approval is expected. Requests for the approval of two additional waste streams are being prepared for submittal, and several other waste streams are being studied and considered for submittal. These wastes are currently stored on the site. Soil contaminated with depleted uranium has been disposed of at a commercial facility, and the possibility for disposal of other LLW at commercial facilities is being pursued where technically and economically advisable. Radioactively contaminated classified weapon components that cannot be demilitarized and sanitized are sent to the classified LLW repository at NTS (Jones 1999).

3.4.2.4 Mixed Low-Level Waste

Pantex treats mixed LLW in three areas: the Burning Ground, Building 11-9, and Building 12-17 (King 1997b). The Burning Ground is an open-burning area where explosives, explosive-contaminated waste, and explosive-contaminated spent solvents are burned. A large-volume reduction is attained by this treatment, and some wastes are rendered nonhazardous due to elimination of the high-explosive reactivity hazard (DOE 1996a:E-50). Building 11-9 in Zone 11 is permitted for the treatment and processing of mixed LLW and hazardous waste in tanks and containers (DOE 1996f:4-236).

Pantex has developed the *Pantex Plant Federal Facility Compliance Act Compliance Plan* to provide mixed waste treatment capability for all mixed waste streams in accordance with the FFCA of 1992 (DOE 1996a:3-180). Currently, some mixed LLW is stored on the site until it can be profiled and accepted by offsite treatment and disposal facilities, in accordance with the Pantex site treatment plan (DOE 1997c:sec. 2.3.1). The Hazardous Waste Treatment and Processing Facility is being planned to treat mixed waste (DOE 1996a:E-50).

3.4.2.5 Hazardous Waste

Pantex stores some hazardous waste on the site. Most hazardous waste generated at Pantex is shipped off the site for recycle, treatment, or disposal at commercial facilities. High explosives, high-explosive contaminated materials, and high-explosive contaminated solid wastes are burned under controlled conditions at the Burning Ground. Ash, debris, and residue resulting from this burning are transported off the site for approved disposal at a commercial RCRA-permitted facility (DOE 1996a:3-183, E-51). Polychlorinated biphenyls waste is transported to offsite permitted facilities for treatment and disposal (DOE 1996f:4-238).

3.4.2.6 Nonhazardous Waste

Management of solid waste is regulated by TNRCC. Nonhazardous waste generated at Pantex falls into Texas Class 1 or Class 2 designation. Some solid waste (inert and insoluble materials like certain scrap metals, bricks, concrete, glass, dirt, and certain plastics and rubber items that are not readily degradable) is designated as Class 2 nonhazardous waste and is disposed on the site in the Construction Debris Landfill in Zone 10. The onsite landfill is approved for both Class 2 and Class 3 wastes. The remainder of the Class 2 nonhazardous waste generated at Pantex is sanitary waste such as cafeteria and lunchroom waste, paper towels, and office waste. Most of this waste is disposed off the site at permitted landfills (such as the city of Amarillo landfill), although some goes to offsite commercial incinerators (DOE 1997c:sec. 2.3.1).

Class 1 nonhazardous waste (such as asbestos), though not hazardous by EPA's definition relative to RCRA, is handled in much the same manner as hazardous waste and is sent to offsite treatment or disposal facilities (DOE 1997c:sec. 2.3.1). Medical waste is dispositioned through a commercial vendor who picks up and transports the waste (DOE 1996f:4-238).

Sanitary sewage and some pretreated industrial wastewater are treated by the Wastewater Treatment Facility and discharged to Playa 1 (DOE 1996f:4-238). The treated effluent from the system either evaporates or infiltrates into the ground. Upgrades to the facility and associated collection/conveyance system will help to ensure that effluent limitations are met. Included in this project is the upgrade of the existing sewage treatment lagoon, repair and replacement of deteriorated sewer lines, construction of a closed system to eliminate the use of open ditches for conveyance of industrial wastewater discharges, and improvements to the plant storm-water management system (DOE 1996a:3-183, E-51). Conceptual design of the Wastewater Treatment Facility was completed on January 26, 1998, and the Title I detailed design was scheduled to be completed by June 30, 1999. Award of the actual facility construction contract is scheduled for January 31, 2001; completion of construction of all treatment facility upgrades is scheduled for November 30, 2003 (DOE 1999a).

An environmental assessment (EA) was recently completed for the wastewater treatment plant upgrade (DOE 1999d) and a FONSI was issued (DOE 1999e). As selected in the FONSI, the project to upgrade the existing Wastewater Treatment Facility will essentially involve the construction of a new, zero-discharge facility south of the current facility and outside the 100-year floodplain of Playa 1. Specifically, two new lagoons will be constructed, one serving as a facultative treatment lagoon and the second as an irrigation water storage reservoir and alternate treatment lagoon. The existing Wastewater Treatment Facility lagoon will be retained as a supplemental storage facility for treated wastewater effluent.

Beginning in 2003, instead of being discharged to Playa 1, treated effluents will be disposed of via land application for the irrigation of crops in cooperation with the Texas Tech University Research Farm. Either a subsurface flow system, a center-pivot system, or an overland flow irrigation system will be used to apply effluents (DOE 1999d, 1999e).

3.4.2.7 Waste Minimization

The goals of the Pantex pollution prevention and waste minimization program are to minimize the volume of waste generated to the extent that it is technologically and economically practical; reduce the hazard of waste through substitution or process modification; minimize contamination of real property and facilities; minimize exposure and associated risk to human health and the environment; and ensure safe, efficient, and compliant long-term management of all wastes (DOE 1996a:3-180).

Although an overall increase in waste generation of 49 percent occurred in 1996, this was largely a result of the removal of contaminated soil from ditches as part of the environmental restoration program. In fact, from 1987 to 1996, the generation of routine hazardous waste decreased by more than 99 percent. The generation of other waste types has also been reduced. The goal of reducing the generation of mixed LLW by 50 percent from 1992 levels has already been met. Another goal is to halve the generation of LLW and State-regulated (Class 1) wastes by 1999 (DOE 1997c:sec. 3.5). Pantex also participates in the Clean Texas 2000 pollution prevention program and has committed to a 50 percent reduction in 1987 chemical releases and hazardous waste generation by the year 2000 (DOE 1996f:4-232). Currently, telephone directories, paper, certain plastics, and some steel and aluminum cans are being recycled (DOE 1996a:E-51).

3.4.2.8 Preferred Alternatives From the WM PEIS

Preferred alternatives from the WM PEIS (DOE 1997a:summary, 109) are shown in Table 3-30 for the four waste types analyzed in this SPD EIS. A decision on the future management of these wastes could result in the construction of new waste management facilities at Pantex, and the closure of other facilities. Decisions on the various waste types are expected to be announced in a series of RODs to be issued on this WM PEIS. In fact, the TRU waste ROD was issued on January 20, 1998 (DOE 1998a), with the hazardous waste ROD issued on August 5, 1998 (DOE 1998b). The TRU waste ROD states that DOE will develop and operate mobile and fixed facilities to characterize and prepare TRU waste for disposal at WIPP. Each DOE site that has, or will generate, TRU waste will, as needed, prepare and store its TRU waste on the site. The hazardous waste ROD states that most DOE sites will continue to use offsite facilities for the treatment and disposal of major portions of the nonwastewater hazardous waste, with ORR and SRS continuing to treat some of their own hazardous waste on the site in existing facilities where this is economically favorable. More detailed information on DOE's alternatives for the future configuration of waste management facilities at Pantex is presented in the WM PEIS, and the hazardous waste and TRU waste RODs.

Table 3–30. Preferred Alternatives From the WM PEIS

Waste Type	Preferred Action
TRU and mixed TRU	DOE prefers treatment and storage of Pantex TRU waste at LANL. ^a
LLW	DOE prefers to treat Pantex LLW on the site. DOE prefers to ship Pantex LLW to one of two or three regional disposal sites.
Mixed LLW	DOE prefers to treat mixed LLW generated at Pantex on the site consistent with Pantex’s site treatment plan. DOE prefers to ship Pantex mixed LLW to one of two or three regional disposal sites.
Hazardous	DOE prefers to continue to use commercial facilities for hazardous waste treatment. ^b

^a ROD for TRU waste (DOE 1998a) states that “each of the Department’s sites that currently has or will generate TRU waste will prepare and store its TRU waste on site. . . .” The ROD did not specifically address TRU waste generated at Pantex, since there is currently no TRU waste in inventory at Pantex.

^b ROD for hazardous waste (DOE 1998b) selected the preferred alternative at Pantex.

Key: LANL, Los Alamos National Laboratory; LLW, low-level waste; TRU, transuranic.

Source: DOE 1997a:summary, 26, 109.

3.4.3 Socioeconomics

Statistics for employment and regional economy are presented for the REA as defined in Appendix F.9, which encompasses 32 counties surrounding Pantex in Texas and New Mexico. Statistics for population, housing, community services, and local transportation are presented for the ROI, a three-county area (in Texas) in which 93.8 percent of all Pantex employees reside as shown in Table 3–31. In 1997, Pantex employed 2,944 persons (about 1.3 percent of the REA civilian labor force) (King 1997a).

Table 3–31. Distribution of Employees by Place of Residence in the Pantex Region of Influence, 1997

County	Number of Employees	Total Site Employment (Percent)
Randall	1,629	55.3
Potter	965	32.8
Carson	167	5.7
ROI total	2,761	93.8

Source: King 1997a.

3.4.3.1 Regional Economic Characteristics

Selected employment and regional economy statistics for the Pantex REA are summarized in Figure 3–18. Between 1990 and 1996, the civilian labor force increased 11.6 percent to 234,072. In 1996, the unemployment rate in the REA was 4.6 percent, which was lower than the 5.6 percent unemployment rate in Texas and the 8.1 percent unemployment rate in New Mexico (DOL 1999). In 1995, government activities represented the largest sector of the employment in the REA (21.9 percent). This was followed by retail trade (19.6 percent) and services (18.8 percent). The totals for these employment sectors in Texas were 18.0 percent, 18.7 percent, and 24.7 percent, respectively. The totals for these employment sectors in New Mexico were 22 percent, 20.3 percent, and 26.7 percent, respectively (DOL 1997).

3.4.3.2 Population and Housing

In 1996, the ROI population totaled 212,729. Between 1990 and 1996, the ROI population increased 9.6 percent compared with the 12.2 percent increase in Texas (DOC 1997). Between 1980 and 1990, the number of housing

units in the ROI increased by about 15.8 percent, compared with the 26.3 percent increase in Texas. The total number of housing units within the ROI for 1990 was 83,590 (DOC 1994). The 1990 homeowner vacancy rate for the ROI, 3.3 percent, was similar to the Texas rate of 3.2 percent. The renter vacancy rate, 14.2 percent, was also similar to Texas' 13 percent (DOC 1990a). Population and housing trends in the Pantex ROI are summarized in Figure 3–19.

3.4.3.3 Community Services

3.4.3.3.1 Education

Eight school districts provide public education in the Pantex ROI. As shown in Figure 3–20, school districts were operating between 56 and 100 percent of capacity in 1997. In 1997, the average student-to-teacher ratio for the ROI was 15:1 (Nemeth 1997a). In 1990, the average student-to-teacher ratio for Texas was 11.3:1 (DOC 1990b; 1994).

3.4.3.3.2 Public Safety

In 1997, a total of 542 sworn police officers were serving the ROI. The 1997 ROI average officer-to-population ratio was 2.5 officers per 1,000 persons (Nemeth 1997b). This compares with the 1990 State average of 2.0 officers per 1,000 persons (DOC 1990b). In 1997, 487 paid and volunteer firefighters provided fire protection services to the Pantex ROI. The 1997 average ROI firefighter-to-population ratio was 2.3 firefighters per 1,000 persons (Nemeth 1997b). This compares with the 1990 State average of 0.9 firefighters per

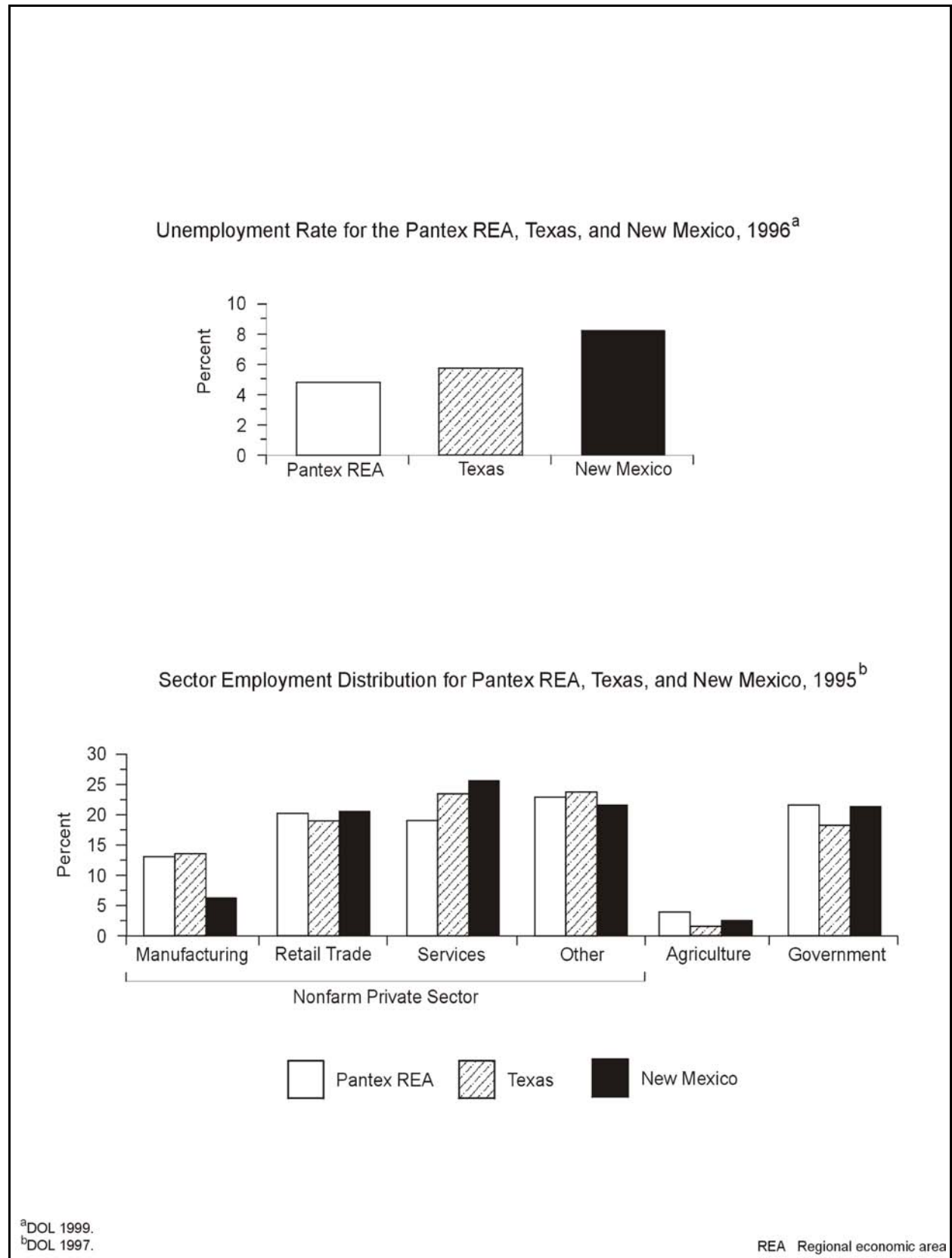

Figure 3-18. Employment and Local Economy for the Pantex Regional Economic Area and the States of Texas and New Mexico

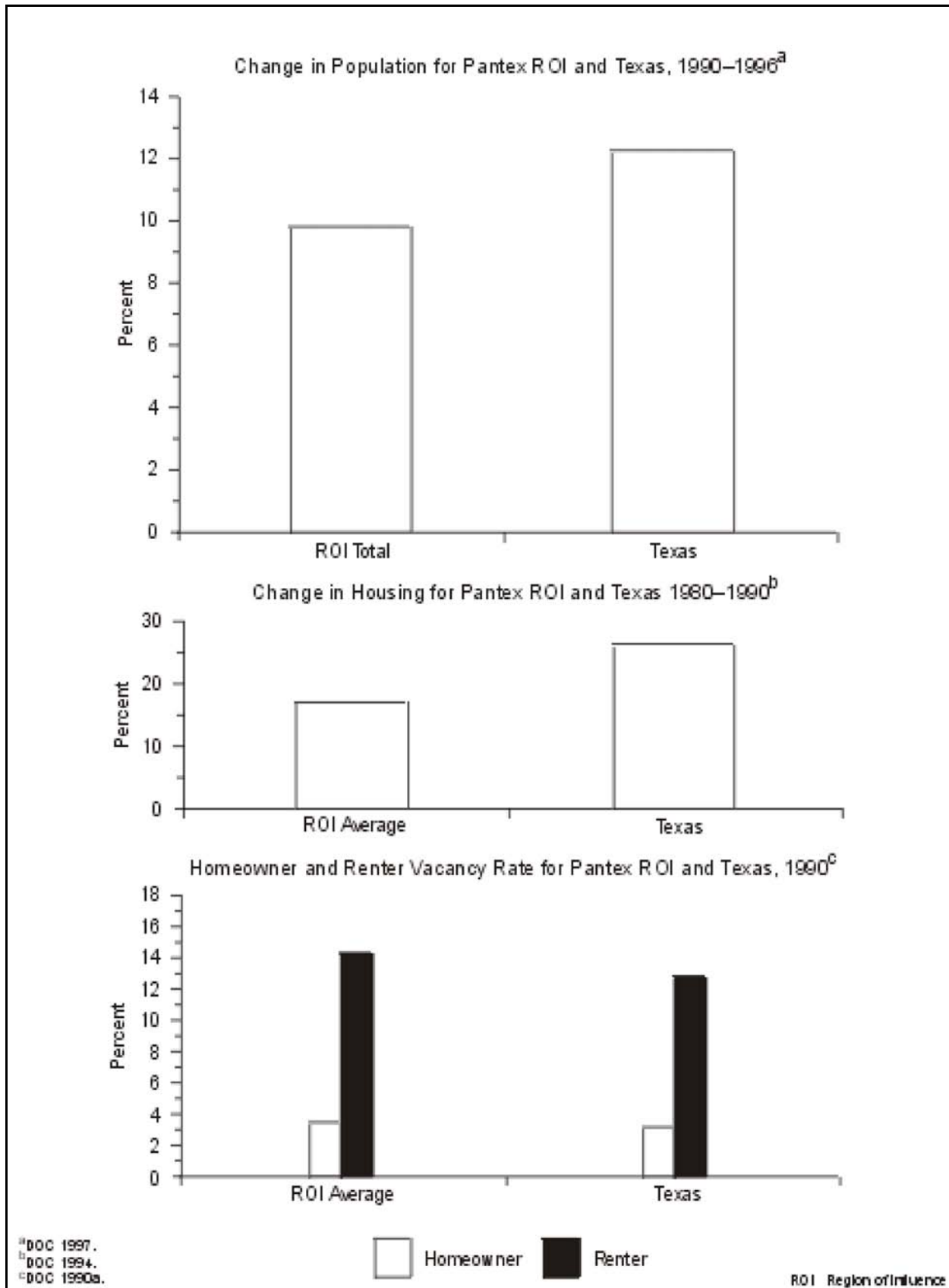

Figure 3–19. Population and Housing for the Pantex Region of Influence and the State of Texas

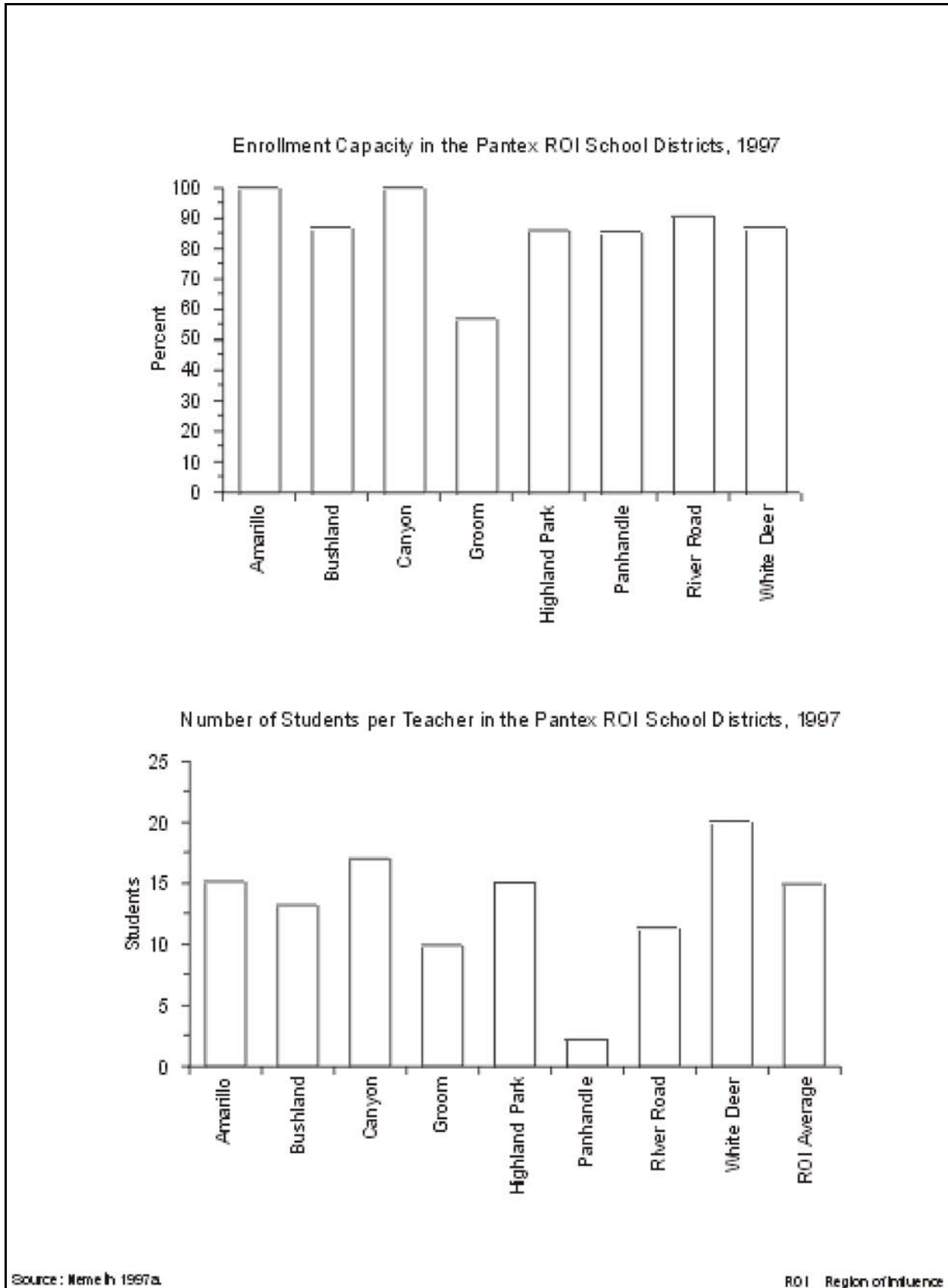

Figure 3-20. School District Characteristics for the Pantex Region of Influence

1,000 persons (DOC 1990b). Figure 3–21 displays the ratio of sworn police officers and firefighters to the population for the Pantex ROI.

3.4.3.3 Health Care

In 1996, a total of 531 physicians served the ROI. The 1996 average physician-to-population ratio in the ROI of 2.5 physicians per 1,000 persons compares with the 1996 State average of 2.2 physicians per 1,000 persons (Randolph 1997). In 1997, six hospitals served the three-county ROI. The 1997 hospital bed-to-population ratio was 5.9 beds per 1,000 persons in the ROI (Nemeth 1997c). This compares with the 1990 State average of 3.4 beds per 1,000 persons (DOC 1996:128). Figure 3–21 displays the ratio of hospital beds and physicians to the population for the Pantex ROI.

3.4.3.4 Local Transportation

Vehicular access to Pantex is provided by FM 683 to the west and FM 2373 to the east. Both roads connect with FM 293 to the north and U.S. Route 60 to the south (see Figure 2–4). Four road segments in the ROI could be affected by route disposition alternatives: I–27 from Local Route 335 at Amarillo to I–40 at Amarillo and FM 683 from U.S. Route 60 to FM 293. The third is FM 2373 from I–40 to U.S. Route 60. The fourth is FM 2373 from U.S. Route 60 to FM U.S. Route 60 (DOE 1996a).

Aside from routine minor preventive maintenance paving, there was one planned road improvement project in 1998 that could affect access onto the Pantex site. This includes the construction of a bridge along FM 1912 over U.S. Route 60. There are also long-range plans to build a bridge at the intersection of FM 2373 and U.S. Route 60. Both of these projects are not expected to be initiated until the year 2000 or beyond (Nipp 1997). Even without these improvements, the road system is more than adequate for current Pantex workloads. Amarillo City Transit provides public transport service to Amarillo, but the service does not extend to Pantex. The major railroad in the Pantex ROI is the Burlington Northern and Santa Fe Railroad, a mainline that forms the southern boundary of Pantex and provides direct access to the site. There are no navigable waterways within the ROI capable of accommodating material transports to the plant.

Amarillo International Airport provides jet air passenger and cargo service from national and local carriers. Several smaller private airports are located throughout the ROI (DOE 1996a).

3.4.4 Existing Human Health Risk

Public and occupational health and safety issues include the determination of potentially adverse effects on human health that result from acute and chronic exposures to ionizing radiation and hazardous chemicals.

3.4.4.1 Radiation Exposure and Risk

3.4.4.1.1 General Site Description

Major sources and levels of background radiation exposure to individuals in the vicinity of Pantex are shown in Table 3–32. Annual background radiation doses to individuals are expected to remain constant over time. The total dose to the population, in terms of person-rem, changes as the population size changes. Background radiation doses are unrelated to Pantex operations.

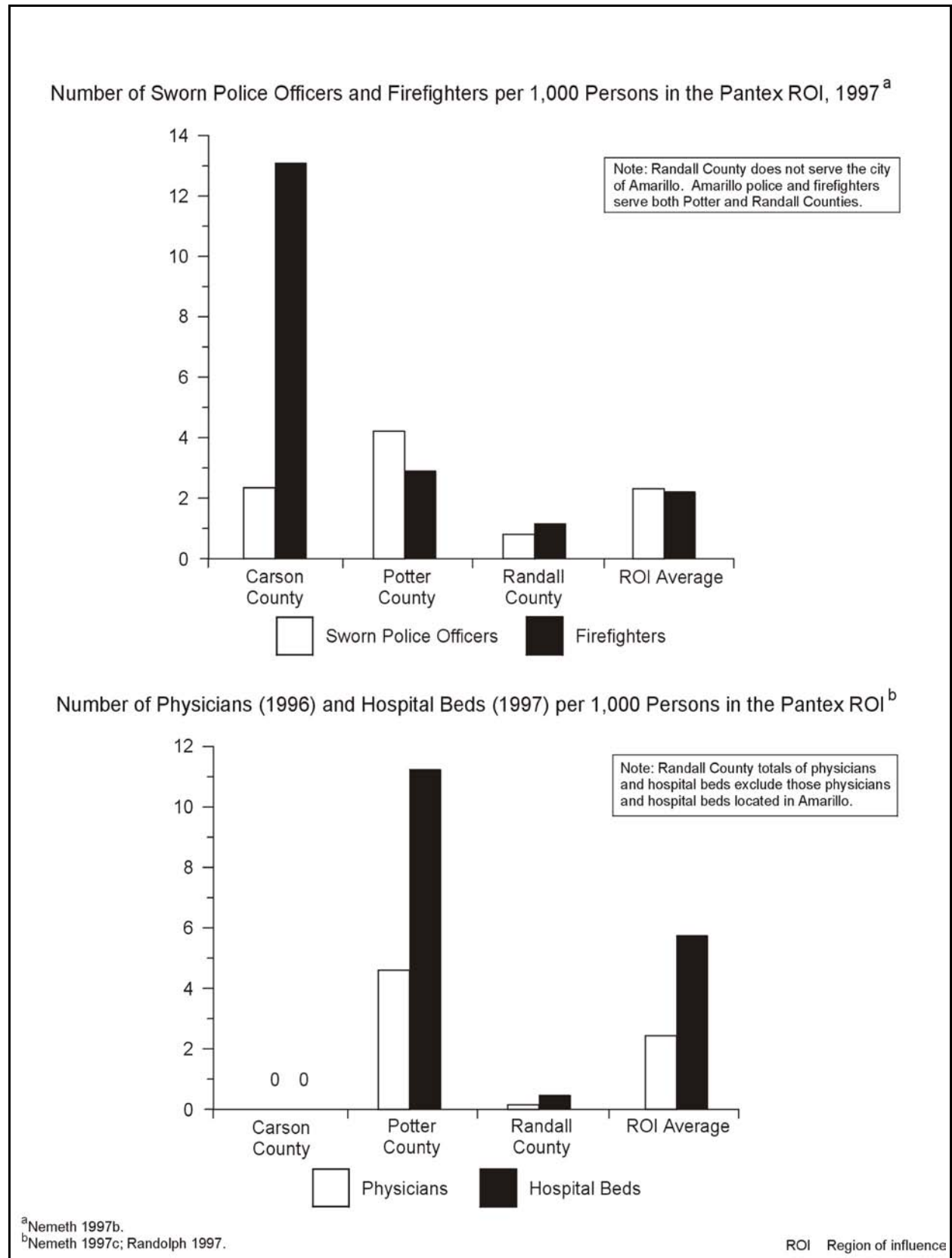

Figure 3-21. Public Safety and Health Care Characteristics for the Pantex Region of Influence

Table 3–32. Sources of Radiation Exposure to Individuals in the Pantex Vicinity Unrelated to Pantex Operations

Source	Effective Dose Equivalent (mrem/yr)
Natural background radiation	
Cosmic and external terrestrial radiation ^a	93
Internal terrestrial radiation ^b	39
Radon in homes (inhaled) ^b	200 ^c
Other background radiation^b	
Diagnostic x rays and nuclear medicine	53
Weapons test fallout	<1
Air travel	1
Consumer and industrial products	10
Total	397

^a DOE 1997c:65.^b NCRP 1987:11, 40, 53.^c An average for the United States.

Releases of radionuclides to the environment from Pantex operations provide another source of radiation exposure to people in the vicinity of Pantex. Types and quantities of radionuclides released from Pantex operations in 1996 are listed in the *1996 Environmental Report for Pantex Plant* (DOE 1997c:64). Doses to the public resulting from these releases are given in Table 3–33. These doses fall within radiological limits per DOE Order 5400.5 (DOE 1993a:II-1–II-5) and are much lower than those of background radiation.

Table 3–33. Radiation Doses to the Public From Normal Pantex Operations in 1996 (Total Effective Dose Equivalent)

	Atmospheric Releases		Liquid Releases		Total	
	Standard ^a	Actual	Standard ^a	Actual	Standard ^a	Actual
Members of the Public						
Maximally exposed individual (mrem)	10	8.8×10^{-5}	4	0	100	8.8×10^{-5}
Population within 80 km (person-rem) ^b	None	2.1×10^{-3}	None	0	100	2.1×10^{-3}
Average individual within 80 km (mrem) ^c	None	7.6×10^{-6}	None	0	None	7.6×10^{-6}

^a The standards for individuals are given in DOE Order 5400.5 (DOE 1993a:II-1–II-5). As discussed in that order, the 10-mrem/yr limit from airborne emissions is required by the Clean Air Act, and the 4-mrem/yr limit is required by the Safe Drinking Water Act; for this SPD EIS, the 4-mrem/yr value is conservatively assumed to be the limit for the sum of doses from all liquid pathways. The total dose of 100 mrem/yr is the limit from all pathways combined. The 100-person-rem value for the population is given in proposed 10 CFR 834, as published in 58 FR 16268 (DOE 1993b:para. 834.7). If the potential total dose exceeds the 100-person-rem value, it is required that the contractor operating the facility notify DOE.

^b About 275,000 in 1996.

^c Obtained by dividing the population dose by the number of people living within 80 km (50 mi) of the site.

Source: DOE 1997c:65.

Using a risk estimator of 500 cancer deaths per 1 million person-rem (5×10^{-4} fatal cancer per person-rem) to the public (see Appendix F.10), the fatal cancer risk to the maximally exposed member of the public due to radiological releases from Pantex operations in 1996 is estimated to be 4.4×10^{-11} . That is, the estimated probability of this person dying of cancer at some point in the future from radiation exposure associated with 1 year of Pantex operations is less than 5 in 100 billion. (It takes several to many years from the time of radiation exposure for a cancer to manifest itself.)

According to the same risk estimator, 1.1×10^{-6} excess fatal cancer is projected in the population living within 80 km (50 mi) of Pantex from normal operations in 1996. To place this number into perspective, it may be compared with the number of fatal cancers expected in the same population from all causes. The 1996 mortality rate associated with cancer for the U.S. population was 0.2 percent per year (Famighetti 1998:964). Based on this mortality rate, the number of fatal cancers expected to occur during 1996 from all causes in the population living within 80 km (50 mi) of Pantex was 550. This expected number of fatal cancers is much higher than the 1.1×10^{-6} fatal cancer estimated from Pantex operations in 1996.

Pantex workers receive the same dose as the general public from background radiation, but they also receive an additional dose from working in facilities with nuclear materials. Table 3–34 presents the average dose to the individual worker and the cumulative dose to all workers at Pantex from operations in 1996. These doses fall within the radiological regulatory limits of 10 CFR 835 (DOE 1995a:para. 835.202). According to a risk estimator of 400 fatal cancers per 1 million person-rem among workers⁶ (Appendix F.10), the number of projected fatal cancers among Pantex workers from normal operations in 1996 is 0.011.

Table 3–34. Radiation Doses to Workers From Normal Pantex Operations in 1996 (Total Effective Dose Equivalent)

Occupational Personnel	Onsite Releases and Direct Radiation	
	Standard ^a	Actual
Average radiation worker (mrem)	None ^b	8.7
Total workers (person-rem) ^c	None	28

^a The radiological limit for an individual worker is 5,000 mrem/yr (DOE 1995a:para. 835.202). However, DOE's goal is to maintain radiological exposure as low as is reasonably achievable. It has therefore established an administrative control level of 2,000 mrem/yr (DOE 1994a:2-3); the site must make reasonable attempts to maintain individual worker doses below this level.

^b No standard is specified for an "average radiation worker"; however, the maximum dose that this worker may receive is limited to that given in footnote "a."

^c About 3,160 in 1996 of which approximately 2,400 were badged.

Source: M&H 1997.

A more detailed presentation of the radiation environment, including background exposures and radiological releases and doses, is presented in the *1996 Environmental Report for Pantex Plant* (DOE 1997c). In addition, the concentrations of radioactivity in various environmental media (including air, water, and soil) in the site region (on and off the site) are presented in that same report.

3.4.4.1.2 Proposed Facility Location

External radiation doses and concentrations of gross alpha and plutonium in air have been measured in Zone 4. In 1996, the annual dose in Zone 4 was about 100 mrem. This is the same as measured at the offsite control location, which indicates that there is no additional dose to workers above background. In that same year, the

⁶ The risk estimator for workers is lower than the estimator for the public because of the absence from the workforce of the more radiosensitive infant and child age groups.

Zone 4 concentration in air of plutonium 239/240 was 3.2×10^{-7} pCi/m³. This value was about one-third less than that measured at the offsite locations (DOE 1997c:67, 77, 79).

3.4.4.2 Chemical Environment

The background chemical environment important to human health consists of the atmosphere, which may contain hazardous chemicals that can be inhaled; drinking water, which may contain hazardous chemicals that can be ingested; and other environmental media through which people may come in contact with hazardous chemicals (e.g., surface water during swimming, soil through direct contact, or food). Hazardous chemicals can cause cancer and noncancer health effects. The baseline data for assessing potential health impacts from the chemical environment are addressed in Section 3.4.1.

Effective administrative and design controls that decrease hazardous chemical releases to the environment and help achieve compliance with permit requirements (e.g., air emissions and NPDES permit requirements) contribute to minimizing health impacts on the public. The effectiveness of these controls is verified through the use of monitoring information and inspection of mitigation measures. Health impacts on the public may occur via inhalation of air containing hazardous chemicals released to the atmosphere during normal Pantex operations. Risks to public health from other possible pathways, such as ingestion of contaminated drinking water or by direct exposure, are lower than those from the inhalation pathway.

Baseline air emission concentrations and applicable standards for hazardous chemicals are addressed in Section 3.4.1. The baseline concentrations are estimates of the highest existing offsite concentrations and represent the highest concentrations to which members of the public could be exposed. All annual concentrations are in compliance with applicable guidelines and regulations. Information on estimating the health impacts of hazardous chemicals is presented in Appendix F.10.

Exposure pathways to Pantex workers during normal operations may include the inhalation of contaminants in the workplace atmosphere and direct contact with hazardous materials. The potential for health impacts varies among facilities and workers, and available information is insufficient for a meaningful estimate of impacts. However, workers are protected from workplace hazards through appropriate training, protective equipment, monitoring, substitution, and engineering and management controls. They are also protected by adherence to OSHA and EPA standards that limit workplace atmospheric and drinking water concentrations of potentially hazardous chemicals. Appropriate monitoring that reflects the frequency and amounts of chemicals used in the operational processes ensures that these standards are not exceeded. Additionally, DOE requires that conditions in the workplace be as free as possible from recognized hazards that cause, or are likely to cause, illness or physical harm. Therefore, workplace conditions at Pantex are substantially better than required by standards.

3.4.4.3 Health Effects Studies

Only one cancer incidence and mortality study was conducted on the general population in communities surrounding Pantex for the period 1981 to 1992, and only one study of workers (employed between 1951 and 1978) has been done. There were no statistically significant increases in mortality among females in the general population during this period, but significant increases in prostate cancer mortality occurred among Potter County and Randall County males, and in leukemia mortality among Carson County males. No statistically significant increases in other types of cancer among males occurred during this period. Significantly fewer deaths were observed in the workforce than would be expected judging from U.S. death rates for cancer, arteriosclerotic heart disease, and digestive diseases. No specific causes of death occurred more frequently than expected. Workers were reported to show a nonstatistically significant excess of brain cancer and leukemia in the study conducted; the small number of cases could be attributed to chance alone. For a more detailed description of the studies reviewed and the findings, and for a discussion of the epidemiologic surveillance program

implemented by DOE to monitor the health of current Pantex workers, refer to Appendix M.4.5 of the *Storage and Disposition PEIS* (DOE 1996a).

3.4.4.4 Accident History

In 1989, during a weapon disassembly and retirement operation, a release of tritium in the assembly cell occurred. Four workers received negligible doses, and a fifth, a somewhat higher, but still low dose of 1.4 mrem. No other incidents involving the accidental release of radioactivity from Pantex have taken place in more than 30 years.

3.4.4.5 Emergency Preparedness

Each DOE site has established an emergency management program that would be activated in the event of an accident. This program has been developed and maintained to ensure adequate response to most accident conditions and to provide response efforts for accidents not specifically considered. The emergency management program includes planning, preparedness, and response.

Pantex has an emergency management plan to protect life and property within the facility, the health and welfare of surrounding areas, and the defense interests of the nation during any credible emergency situation. Formal mutual assistance agreements have been made with the Amarillo fire department, the National Guard, and St. Anthony's Hospital. Under accident conditions, an emergency coordinating team of DOE and Pantex contractor management personnel would initiate the Pantex emergency plan and coordinate all onsite actions.

If offsite areas could be affected, the Texas Department of Public Safety would be notified immediately and would make emergency announcements to the public and local governmental agencies in accordance with Annex R of the *State of Texas Emergency Management Plan*. Pantex has Radiological Assistance Teams equipped and trained to respond to an accident involving radioactive contamination on or off the site. In addition, the Joint Nuclear Accident Coordination Center in Albuquerque, New Mexico, can be called on if needed to mobilize radiation emergency response teams from DOE, DoD, and other participating Federal agencies.

DOE has specified actions to be taken at all DOE sites to implement lessons learned from the emergency response to an accidental explosion at Hanford in May 1997. These actions and the timeframe in which they must be implemented are presented in Section 3.2.4.5.

3.4.5 Environmental Justice

Environmental justice concerns the environmental impacts that proposed actions may have on minority and low-income populations, and whether such impacts are disproportionate to those on the population as a whole in the potentially affected area. In the case of Pantex, the potentially affected area includes only parts of northwestern Texas.

| The potentially affected area around Zone 4 West is defined by a circle with an 80-km (50-mi) radius centered at Pantex (lat. 35E20'0.4" N, long. 101E34'22.5" W). The total population residing within that area in 1990 was 266,004. The proportion of the population there that was considered minority was 19.1 percent. The same census data show that the percentage of minorities for the contiguous United States was 24.1, and for the State of Texas, 39.3 (DOC 1992).

| Figure 3–22 illustrates the racial and ethnic composition of the minority population in the potentially affected area. At the time of the 1990 census, Hispanics were the largest minority group within that area, constituting 12.8 percent of the population. Blacks constituted about 4.2 percent, and Asians, about 1.3 percent. Native Americans were the smallest group, constituting about 0.8 percent (DOC 1992).

A breakdown of incomes in the potentially affected area is also available from the 1990 census data (DOC 1992). At that time, the poverty threshold was \$9,981 for a family of three with one related child under 18 years of age. A total of 39,578 persons (15.2 percent of the total population) residing within the potentially affected area around Zone 4 West reported incomes below that threshold. Data obtained during the 1990 census also show that of

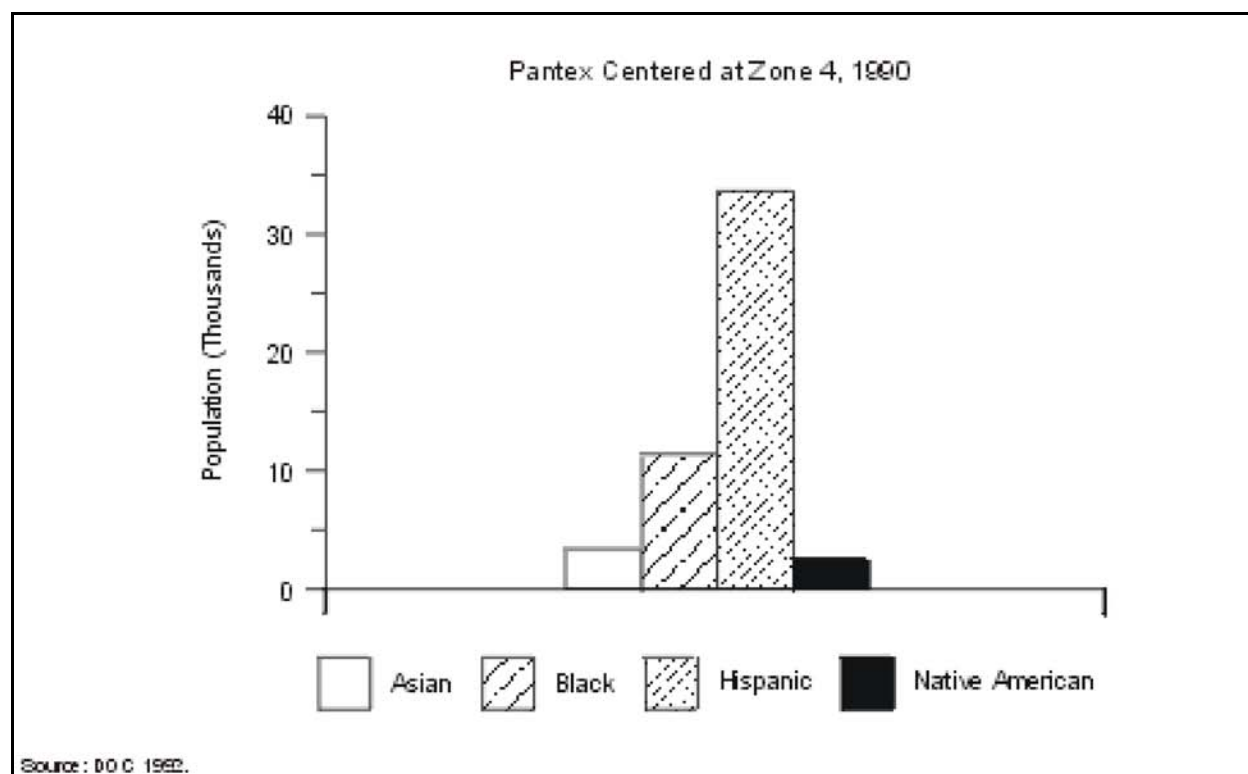

Figure 3-22. Racial and Ethnic Composition of Minorities Around Pantex

the total population of the contiguous United States, 13.1 percent reported incomes below the poverty threshold, and that Texas reported 18.1 percent.

3.4.6 Geology and Soils

Geologic resources are consolidated or unconsolidated earth materials, including ore and aggregate materials, fossil fuels, and significant landforms. Soil resources are the loose surface materials of the earth in which plants grow, usually consisting of disintegrated rock, organic matter, and soluble salts.

3.4.6.1 General Site Description

Pantex is rather flat and includes four playas on DOE property and two playas on land leased from Texas Tech University (M&H 1996a:5-5). The playas are frequently dry, with clay bottoms and depths to about 9 m (30 ft)(DOE 1996a:3-165). (See Section 3.4.7.1 for additional information on these playas.) The primary surface deposits at Pantex are Pullman soils on the Southern High Plains surface and Randall soils in the playas (M&H 1996a:3-1).

The Pullman soils are the soil horizon in the uppermost section of the Quaternary-aged Blackwater Draw Formation. This formation consists of a sequence of buried soil horizons, the upper unit of mostly clay loam and caliche about 3 m (10 ft) thick and a lower unit of silty sand with caliche 10 to 24 m (30 to 80 ft) thick. The Blackwater Draw Formation overlies the Ogallala Formation (M&H 1996a:3-1).

The Ogallala Formation of Tertiary Age regionally consists of alluvial sediments partly occupying paleovalleys, with eolian sediments capping paleouplands and most fluvial deposits. More specifically, the basal, paleovalley

fill materials consist of sands and gravels deposited in a high-energy fluvial environment along with fine sand and silt and laminated-to-massive clay resulting from overbank or floodplain deposition. Eolian sediments overlie and are interbedded with the fluvial deposits and consist of dune sand deposits as well as deposits ranging from fine sand to coarse silt thought to have been deposited as thin sand sheets and loess. Overall, a total of seven distinct lithofacies have been identified in the Ogallala Formation, including gravel; sand and gravel; fluvial sand; fine sand and mud; laminated fine sand and silt; and laminated-to-massive clay, eolian sand, and fine sand to coarse silt (Gustavson 1996:1, 5, 17, 34, 48). The top of the formation is capped by the Caprock caliche. Depths to the base of the Ogallala vary considerably, from about 90 m (300 ft) at the southwest corner of the site to about 220 m (720 ft) at the northeast corner of the site (M&H 1996a:3-1). Underlying the Ogallala Formation are sedimentary rocks of the Triassic Dockum Group. This rock is as much as 30 m (100 ft) thick and consists of sandstone, siltstone, and mudstone. The portion of the Triassic Dockum Group near the northeastern corner of Pantex was eroded before the Ogallala was deposited directly on Permian strata (M&H 1996a:19). The Permian strata consist of deposits of salt, shale, limestone, argillaceous (clay-bearing) limestone, and dolomite. No economically viable geologic resources have been identified at Pantex (DOE 1996a:3-165).

Dissolution of salt beds within the Permian strata has resulted in sinkholes and fractures in nearby Armstrong and Hutchinson Counties in Texas. No sinkholes or fractures have been identified in Carson County, where the site is located. Recent work using shallow seismic data has determined that the structure beneath the playas at Pantex and adjacent areas shows the displacement of Ogallala strata. This displacement is attributed to the dissolution of underlying salt beds, an active geologic process in the region (DOE 1996a:3-165). In terms of the life of Pantex, the effects of that process are negligible (M&H 1997:19).

There are no capable faults in the vicinity of Pantex. A capable fault is one that has had movement at or near the ground surface at least once within the past 35,000 years or recurrent movement within the past 500,000-years (DOE 1996a:3-165). No tectonic faulting younger than late Permian is recognized at or near Pantex. An assessment of natural hazards at Pantex found three major subsurface faults and one minor surface fault. The subsurface faults range from 64 to 250 km (40 to 155 mi) in length and are 8 to 40 km (5 to 25 mi) from the plant site. The surface fault is estimated to be 6.4 km (4 mi) long and 32 km (20 mi) northwest of Pantex (M&H 1996a:3-8–3-10).

According to the Uniform Building Code, Pantex is on the boundary zone between Seismic Zones 0 and 1, meaning that little or no damage could occur as a result of an earthquake. This area is fairly free of earthquakes (DOE 1996a:3-165). Between 1906 and 1986, as few as 36 earthquakes were felt by persons in the Texas Panhandle. The strongest reported had a Modified Mercalli Intensity of VI. An earthquake of intensity VI is felt by everyone but causes little damage to competent structures. Many of the earthquake epicenters are associated with the Amarillo Uplift, about 32 km (20 mi) north of Pantex. An earthquake with a maximum horizontal acceleration of 0.17g is calculated to have an annual probability of occurrence of 1 in 5,000 at Pantex (Barghusen and Feit 1995:2.10–14).

There are no volcanic hazards at Pantex because there are no known areas of active volcanism in the Texas Panhandle (DOE 1996a:3-165). The nearest volcanic activity occurred 4,000 to 10,000 years ago in northeast New Mexico (M&H 1996a:3-8).

Pantex is underlain by soils of the Pullman-Randall association, which consists of nearly level to gently sloping, deep noncalcareous clays (i.e., clays containing no calcium carbonate [calcite]) and clay loams. Pullman soils underlie most of the Pantex area, but Randall soils occur in the vicinity of the playas and depressions (DOE 1996a:3-165). The Pullman soil is classified as prime farmland soil (M&H 1997:17). Soils at Pantex are acceptable for standard construction techniques (DOE 1996a:3-165). More detailed descriptions of the geology and the soil conditions at Pantex are included in the *Storage and Disposition PEIS* (DOE 1996a:3-165, 3-166) and the *Environmental Information Document for the Pantex Plant EIS* (M&H 1996a:3-1–3-53).

3.4.6.2 Proposed Facility Location

The soil types near Zone 4 West are Pullman clay loam (0 to 1 percent and 1 to 3 percent slopes) and Osteocyte clay loam (1 to 3 percent slopes). Neither of these soils is subject to liquefaction or is unstable (M&H 1997:17).

3.4.7 Water Resources

3.4.7.1 Surface Water

Surface water includes marine or freshwater bodies that occur above the ground surface, including rivers, streams, lakes, ponds, rainwater catchments, embayments, and oceans.

3.4.7.1.1 General Site Description

Pantex is situated on a flat portion of the Southern High Plains of Texas. No streams or rivers flow through Pantex. Major surface water in the vicinity includes the Canadian River, 27 km (17 mi) north of the plant, Sweetwater Creek and the Salt Fork of the Red River, respectively 80 km (50 mi) and 32 km (20 mi) to the east, and the Prairie Dog Fork of the Red River, 56 km (35 mi) to the south. The Canadian River flows into Lake Meredith about 40 km (25 mi) north of the plant. Water from Lake Meredith is mixed with water pumped from the Ogallala aquifer for use as drinking water for several Southern High Plains cities. No hydrologic connections exist to transport contaminants from Pantex into either the Canadian River or Lake Meredith (M&H 1996a:5-4, 5-5).

The only naturally occurring bodies of water on the plant site are the playas and very small, unnamed, intermittent channels and ditches that may feed storm water into them. There are three playas (Playas 1, 2, and 3) on Pantex property, two (Playas 4 and 5) on the Texas Tech University property, several adjacent to Pantex, and one, called Pantex Lake, on DOE-owned property about 4 km (2.5 mi) northeast of the main portion of Pantex. Pantex Lake received discharges from the old sewage treatment facility from 1942 until the early 1970s; however, flows from the wastewater treatment facility are now discharged to Playa 1 as permitted by the State of Texas and the EPA. Currently, there are no industrial discharges diverted to Pantex Lake, Playa 3, or Playa 5, although all of the playas receive surface water runoff from precipitation events (Barghusen and Feit 1995:2.10-17–2.10-20).

Studies have suggested that most of the recharge of the underlying Ogallala aquifer within the Southern High Plains originates from water stored in the playas. However, the playas are frequently dry because of the high, naturally occurring evaporation rate combined with a rate of infiltration that normally exceeds the rate of inflow. Playas in the area of the plant may be as large as 1,220 m (4,000 ft) in diameter and more than 9 m (30 ft) deep. Most of the playas are floored with a clay accumulation at the bottom that is lens shaped, being thickest in the middle and thinning out toward the edges. These clay floors may contain desiccation cracks up to 1.8 m (6 ft) deep when the floor is dry (Barghusen and Feit 1995:2.10-17).

The only surface waterway that flows throughout the year is the one that receives flow from the Wastewater Treatment Facility and discharges into Playa 1. In 1996, discharge to the waterway was 1,242,400 l/day (328,200 gal/day). The Wastewater Treatment Facility receives and treats sanitary waste flows and some process wastewater flows. Effluent from the Wastewater Treatment Facility is monitored pursuant to the plant's NPDES permit and TNRCC permits. The remaining channels and ditches contain flows only after storm events (DOE 1997c:112).

Industrial and storm-water discharges are authorized by State and Federal permits. Pantex is authorized to discharge wastewater into Playas 1, 2, and 4 under NPDES Permit TX0107107, issued June 1, 1996, and TNRCC Wastewater Discharge Permit 02296, issued June 14, 1996. These permits define the volume and quality

of effluent flows that may be discharged to the playas. Storm water from industrial activities is permitted to be discharged into Playas 1, 2, 3, and 4 by general NPDES Permit TXR00G138, issued February 15, 1995. Pollution prevention plans are required by this permit, which establishes 10 outfalls throughout Pantex where effluent samples are to be taken (M&H 1997:15). Pantex is currently transitioning to the new Multi-Sector General Permit for Storm Water. This permit will require monitoring at 8 storm water outfalls (Weinreich 1997). Pantex is also authorized to discharge storm water from construction activities that disturb more than 2 ha (5 acres) under the “Final NPDES General Permits for Storm Water Discharges from Construction Sites” (57 Federal Register 41176). A notice of intent is filed for each individual construction project and a pollution prevention plan is prepared and implemented. No sampling requirements are associated with these permitted activities (M&H 1997:15). On September 14, 1998 (63 Federal Register 51164), the State of Texas was authorized by EPA to assume administration of the NPDES permit program. While permits already issued by EPA will remain in effect until they expire or are replaced by a TNRCC-issued permit, this will ultimately result in consolidation of the industrial and storm-water discharge permits held by Pantex under the Texas Pollutant Discharge Elimination System (EPA 1998a).

The playas are considered by the State of Texas to be “waters of the State.” The Pantex playas have been designated as jurisdictional wetlands, and therefore are also waters of the United States (DOE 1996a:3-157). Including monitoring required by NPDES and TNRCC permits, surface water is monitored for radioactive and nonradioactive parameters at 37 onsite locations, including the playas (DOE 1997c:iii).

Sampling data for surface waters at the site in 1996 showed that concentrations of radionuclides were similar to historical levels and lower than the derived concentration guides for ingested water (DOE 1997c:table 10.2). Moreover, little concern emerged during the monitoring of surface waters, and discharges to them, for a variety of other parameters, including organics, metals, explosives, polychlorinated biphenyls, and pesticides. Toluene was detected twice at the wastewater treatment plant effluent outfall (Outfall 001); however, it was not detected in the plant influent 30 days prior to sampling. No noncompliances were reported at any of the other monitored outfalls or sampling points on the site. Throughout the 1996 sampling season, Pantex Lake was dry, and no samples could be collected (DOE 1997c:116).

On December 2, 1997, EPA issued Mason & Hanger Corporation at Pantex an Administrative Order regarding its NPDES Permit No. TX107107. During 1997, Pantex periodically exceeded some discharge limits set by the permit. The exceedances included ammonia, oil and grease, total suspended solids, and total metals. Although Pantex exceeded the limits set by the EPA permit, based on all available data, the levels of constituents found in the wastewater do not pose a threat to public health or the environment. The Administrative Order required correction of exceedances within 30 days, and for those exceedances that could not be corrected within 30 days, submittal of a corrective action plan. A comprehensive plan was submitted to EPA on December 22, 1997. EPA indicated that it intended to use the plan to develop a negotiated compliance agreement. The compliance agreement was signed on November 24, 1998 by DOE (Battley 1999). Pantex is proceeding with implementation of its corrective action plan. Corrective actions include upgrading the Wastewater Treatment Facility; soil stabilization and erosion control measures; and operational, maintenance, and monitoring program modifications. These engineered solutions are scheduled for completion in the year 2003 (Nava 1998; DOE 1999a).

An EA was recently completed for the wastewater treatment plant upgrade (DOE 1999d) and a FONSI was issued (DOE 1999e). As selected in the FONSI, the project to upgrade the existing Wastewater Treatment Facility will essentially involved the construction of a new, zero-discharge facility south of the current facility and outside the 100-year floodplain of Playa 1. Specifically, two new lagoons will be constructed, one serving as a facultative treatment lagoon and the second as an irrigation water storage reservoir and alternate treatment lagoon. The existing Wastewater Treatment Facility lagoon will be retained as a supplemental storage facility for treated wastewater effluent.

Beginning in 2003, instead of being discharged to Playa 1, treated effluents will be disposed of via land application for the irrigation of crops in cooperation with the Texas Tech University Research Farm. Either a subsurface flow system, a center-pivot system, or an overland flow irrigation system will be used to apply effluents (DOE 1999d, 1999e).

Water rights in Texas fall under the Doctrine of Prior Appropriations. Under this doctrine, the user who first appropriates water for a beneficial use has priority in the use of available water supplies over a user claiming rights at a later time. Courts also recognize riparian rights legally granted in Spanish-American Agreements. TNRCC is the administrator for water rights and the permit-issuing authority (DOE 1996a:3-160). Because Pantex does not use any surface water, it exerts no surface water rights.

Figure 3–23 shows the surface water drainage basins for each of the playas (DOE 1996f:4-76). Storm-water runoff from the industrialized areas of Pantex collects within the playas and the tailwater pit and does not flow offsite. Storm water that is collected in the tailwater pit at the northeast boundary of the site is pumped to a ditch that flows to Playa 1 (M&H 1996a:5-7). General flooding of some low-lying portions of Pantex could occur as a result of runoff associated with precipitation and the subsequent filling of the playas. Historically, there has been no major flooding at the Pantex site (M&H 1996a:5-17–5-24; 1996b:2-11). There are no federally designated Wild and Scenic Rivers on the site (Barghusen and Feit 1995:2.10-2).

3.4.7.1.2 Proposed Facility Location

Most surface runoff near Zone 4 West flows to Playa 1 (M&H 1996b:2-11; 1997:24). However, a very small portion of this area flows to Playa 2. The distance between the proposed surplus plutonium disposition facilities and the drainage basin divide is sufficient to prevent storm-water flows from the proposed facilities from entering Playa 2. Playa 1 has a surface area of 32 ha (79 acres) and Playa 2, 30 ha (74 acres) (M&H 1996a:5-6). A review of flooding maps of the playas indicates that the 100-year flood elevation for Playa 1 is 1,073.4 m (3,522 ft) and for Playa 2 it is 1,074.7 m (3,526 ft). The elevation of the proposed facilities is 1,084 m (3,556 ft) (DOE 1996f:4-77).

Playa 3 is upgradient from the proposed surplus plutonium disposition facilities and the 100-year flood elevation is 1,086.5 m (3,565 ft). The maps indicate that water elevations above that of the 100-year flood would result in sheet overflow at shallow depths in the direction of the proposed facilities. Figure 3–23 shows the approximate extent of the floodplains at Pantex (DOE 1996b:4-76).

Results of surface water quality sampling from 1994 confirm that Pantex was in compliance with all water quality regulations for Playa 1 and that, with the exception of a high water level in Playa 1 in July 1994 attributable to a rainfall event, all permit requirements were met (DOE 1996a:3-157).

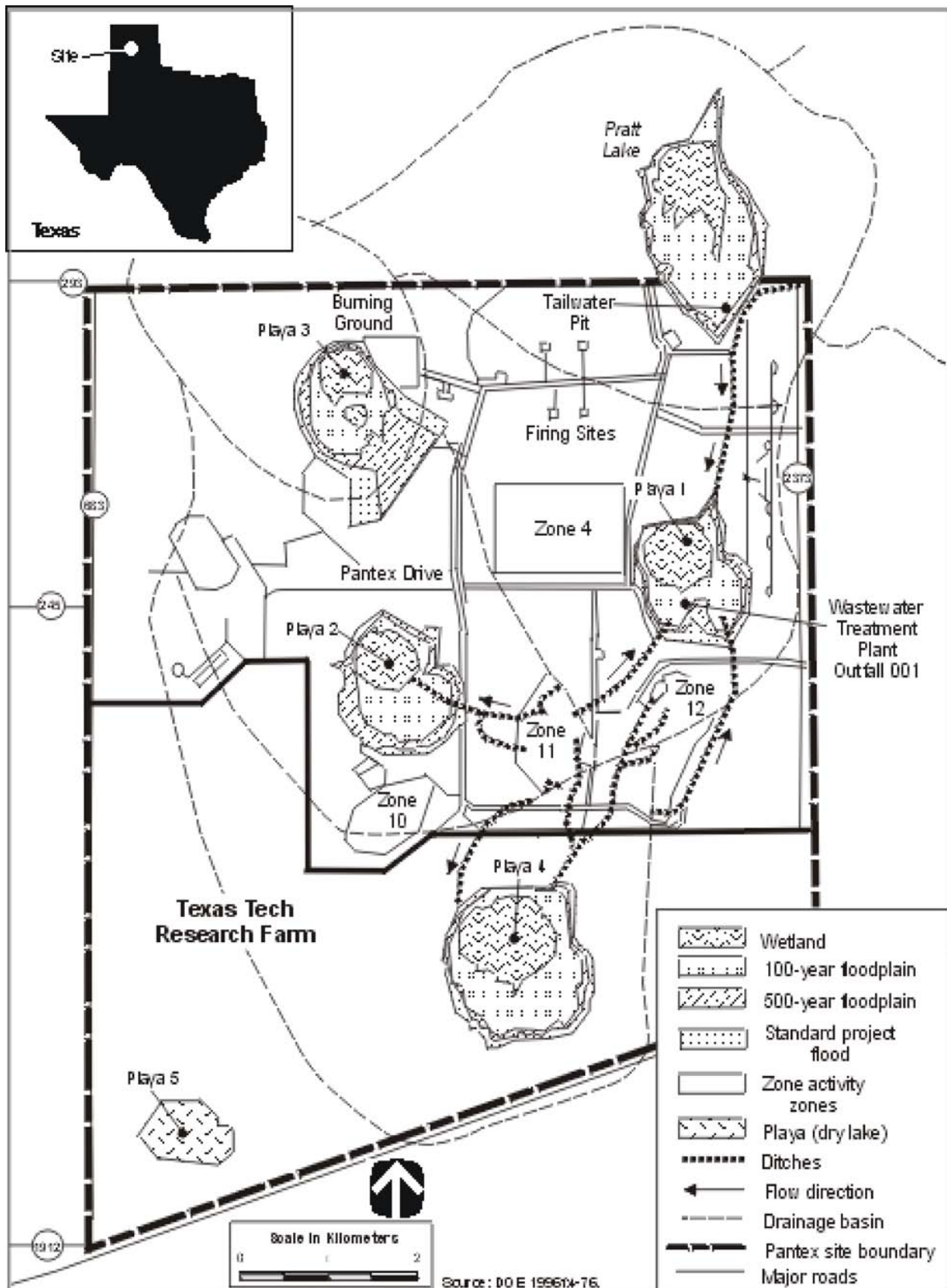

Figure 3-23. Locations of Floodplains and Playas at Pantex

3.4.7.2 Groundwater

Aquifers are classified by Federal and State authorities according to use and quality. The Federal classifications include Class I, II, and III groundwater. Class I groundwater is either the sole source of drinking water or is ecologically vital. Class IIA and IIB are current or potential sources of drinking water (or other beneficial use), respectively. Class III is not considered a potential source of drinking water and is of limited beneficial use.

3.4.7.2.1 General Site Description

The three primary hydrostratigraphic units, (i.e., separate layers of water), in the vicinity of Pantex are the Blackwater Draw Formation, the Ogallala Formation, and the Triassic Dockum Group. The units as a whole constitute the vadose (unsaturated) zone, the saturated perched aquifer zone, and the lower, saturated main aquifer below the site (M&H 1996a:4-1).

The Blackwater Draw Formation has been identified as the most widespread post-Ogallala unit throughout the Southern High Plains. It consists of modified eolian sands and silts interbedded with numerous caliches composed of variably cemented carbonate layers and nodules. The thickness of the Blackwater Draw Formation at Pantex is variable, ranging from 15 to 24 m (50 to 80 ft) (M&H 1996a:4-4).

The High Plains aquifer, commonly referred to as the Ogallala aquifer, underlies the southern part of the Great Plains physiographic province. It is the primary water source for the Texas Panhandle and eastern New Mexico. The Ogallala aquifer in the vicinity of Pantex consists primarily of the saturated lower Ogallala Formation, although water is also produced from strata as old as Permian (M&H 1996a:4-4).

The Ogallala aquifer exists in unconfined conditions. Recharge occurs from precipitation and subsequent infiltration of surface water either through surface soils or through focused recharge from the numerous playas that occur across the area. Direct recharge of the aquifer can occur in those limited areas where the aquifer formation is at the surface, but no outcrops exist at Pantex. Recent evidence supports significant recharge of the aquifer below the playas in the Southern High Plains; however, evidence of such recharge has not been determined for the Ogallala aquifer at Pantex (M&H 1996a:4-1).

Depths to the Ogallala aquifer generally run parallel to the regional land surface, which dips gently from northwest to southeast (M&H 1996a:3-36, 4-15). The depth to the Ogallala aquifer at Pantex varies from about 104 m (341 ft) at the southern boundary to 140 m (459 ft) at the northern boundary (M&H 1997:14). This south-to-north groundwater flow contrasts with the regional northwest-to-southeast trend of the remaining portion of the Southern High Plains. Localized disruption of these generalized flow patterns can occur where significant withdrawals are made, such as near the city of Amarillo Carson County well field about 3.2 km (2 mi) northeast of Pantex (M&H 1996a:4-1).

The Triassic Dockum Group underlying the Ogallala Formation is believed to be as thick as 30 m (100 ft) under Pantex. The lateral extent, thickness, and hydraulic characteristics of this group have not been established beneath Pantex, and well logs usually identify these only as Triassic or red beds (M&H 1996a:4-4, 4-5). However, limited data from regional hydrogeologic studies of the Dockum Group divide it into an upper and a lower section, with only the Lower Dockum Group inferred to exist beneath portions of Carson County, including the southwest portion where Pantex is located. The Lower Dockum Group consists predominantly of fine to coarse-grained sandstones and granular and pebble conglomerate along with mudstone sequences of alluvial, deltaic, and lacustrine origin. It has a thickness of less than 61 m (200 ft) beneath southwestern Carson County, consistent with site-specific data (Dutton and Simpkins 1986:3-4).

The water-bearing stratum of the Lower Dockum Group is the Lower Dockum aquifer. Regionally, the surface of the aquifer lies 91 to 213 m (300 to 700 ft) below the water table of the Ogallala aquifer and below the base of the Ogallala Formation (Dutton and Simpkins 1986:13). Any interconnection between the High Plains (Ogallala) aquifer system and the Lower Dockum aquifer across most of the Southern High Plains is thought to be poor at best, with little current recharge occurring (having ended during the Pleistocene epoch) (Dutton and Simpkins 1986:13, 24). Although at Pantex the upper confining layer of the Lower Dockum aquifer is absent, there are indications that it may be hydraulically connected to the overlying Ogallala aquifer. (M&H 1996a:4-7, 4-15-16).

The two main water-bearing units beneath the plant are the Tertiary Ogallala Formation and the Triassic Dockum Group. Two water-bearing zones in the Ogallala Formation are present beneath the plant. The first is a perched water zone above the main zone of saturation. One of these is present beneath Playa 1. The perched water zones consist of discontinuous perched water lenses, the lateral extent of which has not been fully determined. The second and deeper water-bearing zone is the Ogallala aquifer, which is the primary source of water for drinking, irrigation, and commercial uses (M&H 1996a:4-5). In general, factors such as well yield, depth to water, and high solids content limit production of the Lower Dockum Group aquifer for potable purposes. Irrigation water is supplied by the Dockum Group rather than the Ogallala Formation in locations to the west and south of Pantex, but Ogallala water is reportedly mixed with groundwater from the Dockum Group to meet the potable water needs of a few municipalities (Dutton and Simpkins 1986:3, 21, 22). There are no designated sole source aquifers near Pantex (Barghusen and Feit 1995:2.10-2).

Five production wells in the northeast corner of Pantex provide water for the plant's needs (DOE 1996a:3-162). Pantex water use has decreased during the period from 1991 to 1995 by 231 million l (61 million gal), from a maximum of 848 million l (224 million gal) of water in 1991, to 617 million l (163 million gal) of water in 1995 (M&H 1996a:4-33, 9-8). In 1995, the city of Amarillo produced 23.6 billion l (6.2 billion gal) of water from the Ogallala aquifer via the Carson County well fields. In addition, approximately 101 billion l (27 billion gal) of water were applied for irrigation in Carson County in 1995 (DOE 1996f:4-104).

Groundwater is controlled by the individual landowner in Texas through the Doctrine of Prior Appropriations (DOE 1996a:3-160). TNRCC and the Texas Water Development Board are the two State agencies with major involvement in groundwater fact finding, data gathering, and analysis. Groundwater management is the responsibility of local jurisdictions through Groundwater Management Districts. Pantex is in Panhandle Groundwater District 3, which has the authority to require permits and limit the quantity of water pumped. Historically, the Panhandle Groundwater Conservation District has not limited the quantity of water pumped. However, for wells drilled after July 19, 1995, that produce more than 1,300,000 l/yr (350,000 gal/yr) per acre owned, landowners will be required to obtain a High Production Permit from the Panhandle Groundwater Conservation District (DOE 1996f:4-105).

As described in Section 3.4.10.1, the DOE-owned portion of Pantex is approximately 41 km² (4,100 ha or 10,100 acres) in area. Therefore, a High Production Permit would be required if DOE were to exceed approximately 13 billion l/yr (3.4 billion gal/yr) of groundwater withdrawals. As shown in Table 3-36, the current usage is about 850 million l/yr (225 million gal/yr), with a system capacity of about 3.8 billion l/yr (1 billion gal/yr). Further detail on the groundwater resources at Pantex may be found in the *Storage and Disposition PEIS* (DOE 1996a) and the *Environmental Information Document: The Continued Operation of the Pantex Plant and Associated Storage of Nuclear Weapon Components EIS* (M&H 1996a).

3.4.7.2.2 Proposed Facility Location

Given the nature and extent of the Ogallala aquifer, the general site description is believed to be representative of conditions beneath Zone 4 West. Water for the proposed facilities would be supplied from the existing site water system, which uses groundwater; no surface water would be used (M&H 1997:13).

3.4.8 Ecological Resources

Ecological resources are defined as terrestrial (predominantly land) and aquatic (predominantly water) ecosystems characterized by the presence of native and naturalized plants and animals. For the purposes of this SPD EIS, those ecosystems are differentiated in terms of habitat support of threatened, endangered, and other special-status species—that is, “sensitive” versus “nonsensitive” habitat.

3.4.8.1 Nonsensitive Habitat

Nonsensitive habitat comprises those terrestrial and aquatic areas of the site that typically support the region’s major plant and animal species.

3.4.8.1.1 General Site Description

Pantex is on a treeless portion of the High Plains where 229 plant species and numerous animal species thrive (DOE 1996a:3-166). Short-grass prairie grasslands were the native vegetation until the prairie was converted to agricultural use for crops, grazing, or protective vegetative cover under the Conservation Reserve Program. The few remaining native grassland areas are heavily grazed by livestock. Such grazing has transformed much of the rangeland from the native blue grama-buffalo grass to brush, forbs, or cacti. Essentially all land at Pantex has been managed or disturbed to some degree. The following five basic habitat types have been identified: operational areas, grasslands, mowed areas, agricultural croplands, and playas as shown in Figure 3–24 (Battelle and M&H 1996:8, 11).

Animal species found at Pantex include 7 species of amphibians, 43 species of birds, 19 species of mammals, and 8 species of reptiles. Common bird species known to exist in the vicinity of Pantex include the western meadowlark, mourning dove, horned lark, and several species of sparrows. Raptors on the site include the Swainson’s hawk, American kestrel, and burrowing owl. Frequently sighted mammals include the black-tailed jackrabbit, black-tailed prairie dog, and hispid cotton rat. Although hunting is not permitted on the site, game animals include the desert cottontail, northern bobwhite, scaled quail, and numerous waterfowl. Predators present include the badger and coyote (DOE 1996a:3-166).

Aquatic habitats are limited to Playa 1, several wastewater treatment lagoons, and ditches, and five playas that contain water after precipitation events (Playas 2, 3, 4, and 5, and Pantex Lake). Vegetation in these areas is quite variable. Playa 1 receives treated effluent from the wastewater treatment facility, and because of this year round flow supports extensive stands of barewaist cattail, tule, or soft-stemmed bulrush. Playa 2 is nearly covered with smartweeds, while longspike spikerush is the most abundant species at Playa 3. Pantex Lake, the largest playa, supports a large number of species, longspike spikerush and wooly bursage being the most common, as is the case for Playa 4. Playa 5 is on Texas Tech University property and is not influenced by Pantex activities. The diversity of macroinvertebrates is playa-specific, and more than 80 species have been recorded (Battelle and M&H 1996:20–22).

Birds are the most conspicuous animal associated with the playas in terms of numbers, diversity, and biomass. Situated along the central flyway migratory route, the playas provide valuable habitat for migration, wintering, and nesting. The most common wintering ducks are mallards, northern pintails, green-winged teals, and

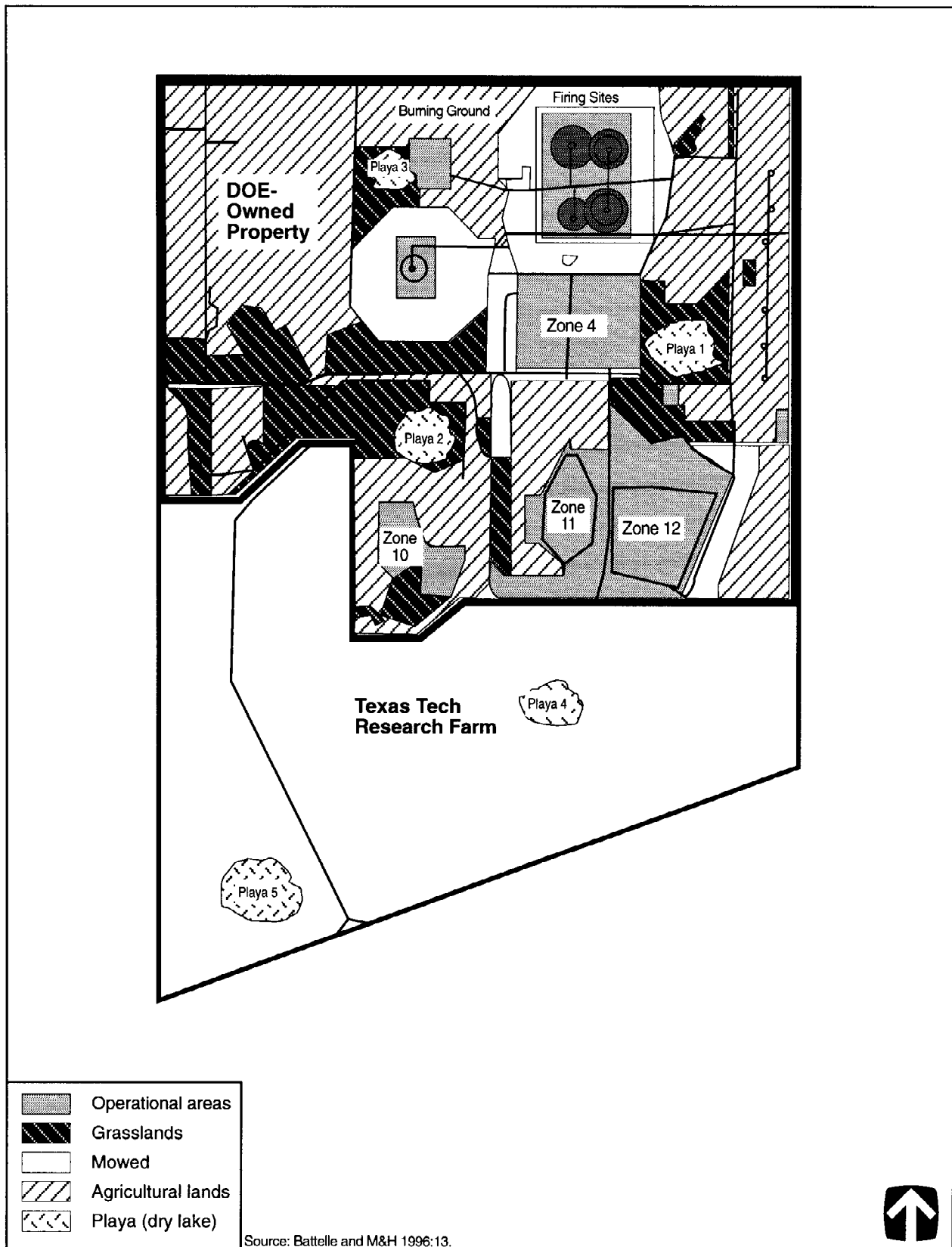

Figure 3-24. Generalized Habitat Types at Pantex (Main Plant Area)

American wigeons. Species known to breed in playas include the mallard, northern pintail, blue-winged teal, cinnamon teal, northern bobwhite, western meadowlark, yellow-headed blackbird, red-winged blackbird, and ring-necked pheasant (Battelle and M&H 1996:22).

3.4.8.1.2 Proposed Facility Location

The immediate environs of Zone 4 West are mowed for security and fire protection purposes. The security fencing system around Zone 4 West contains bare ground, whereas the interior of the zone contains areas of buffalo grass between structures (M&H 1997:20). An agricultural area northwest of Zone 4 West is regularly planted with winter wheat. South of the zone is a previously cultivated area that has been revegetated with native grass species of buffalo grass, blue grama, and sideoats grama (King 1997a:8). Several animal species could be present in and around Zone 4 West. Mammals sighted in this area include the cottontail rabbit, black-tailed jackrabbit, striped skunk, coyote, and thirteen-lined ground squirrel. Reptiles and amphibians known to inhabit the area include the prairie rattlesnake, Texas horned lizard, Great Plains skink, bull snake, Great Plains toad, plains spadefoot toad, and tiger salamander. Birds found in the area include the western burrowing owl, western meadowlark, western kingbird, eastern kingbird, American kestrel, horned lark, mourning dove, pigeon, grasshopper sparrow, and numerous waterfowl and other species associated with wetlands (King 1997a:8; M&H 1997:20).

3.4.8.2 Sensitive Habitat

Sensitive habitat comprises those terrestrial and aquatic (including designated wetlands) areas of the site that support threatened and endangered, State-protected, and other special-status plant and animal species.⁷

3.4.8.2.1 General Site Description

Playas 1, 2, 3, and 4 and Pantex Lake have been designated by USACE as jurisdictional wetlands and are therefore regulated pursuant to Section 404 of the Clean Water Act (Battelle and M&H 1996:20).

Ten threatened, endangered, or other special-status species listed by the Federal Government or the State of Texas may be found in the vicinity of Pantex, as shown in Table 3.5.6-1 in the *Storage and Disposition PEIS* (DOE 1996a:3-166).

3.4.8.2.2 Proposed Facility Location

Portions of the drainage basins for Playas 1, 2, and 3 lie in or near Zone 4 (see Figure 3-23). Some shorebirds and waterfowl (e.g., grebes, blackbirds, teals, ducks, and heron) nest or feed within the grasslands and cultivated fields associated with these playas (King 1997a; M&H 1997:21).

Although there is no critical habitat for any threatened or endangered species at Pantex, four special-status species may be found within the environs of Zone 4 West, as shown in Table 3-35. The ferruginous hawk is a common winter resident that feeds on prairie dogs and cottontail rabbits. The area west of Zone 4 West is a potential feeding location because of its prairie dog towns. The prairie dogs are removed from this area at least annually. Also associated with the prairie dog towns is the western burrowing owl. Up to 10 pairs have been identified as nesting in the area just west of Zone 4 West. Although not observed anywhere on Pantex since 1996, the swift fox (*Vulpes velox*), a candidate for Federal listing as a threatened or endangered species, may be present

⁷ The Federal Government defines threatened and endangered species in the Endangered Species Act, and wetlands in 33 CFR 328.3.

on the site, judging from the historical observation of field indicators in areas adjacent to Zone 4 and Zone 4 West. The Texas horned lizard is fairly common and is seen most frequently around the

Table 3–35. Threatened and Endangered Species, Species of Concern, and Sensitive Species Occurring or Potentially Occurring in Areas Surrounding Zone 4 West

Common Name	Scientific Name	Federal Status	State Status
Birds			
Ferruginous hawk	<i>Buteo regalis</i>	Species of Concern	Not listed
Western burrowing owl	<i>Athene cunicularia hypugea</i>	Species of Concern	Not listed
Mammals			
Swift fox	<i>Vulpes velox</i>	Candidate species	Not listed
Reptiles			
Texas horned lizard	<i>Phrynosoma cornutum</i>	Species of Concern	Threatened

Source: M&H 1997:21, 22.

playas. Because it feeds mainly on harvester ants found throughout Pantex, there is a high probability of its occurrence in and around Zone 4 West (M&H 1997:21, 22).

3.4.9 Cultural and Paleontological Resources

Cultural resources are human imprints on the landscape and are defined and protected by a series of Federal laws, regulations, and guidelines. Pantex has a well-documented record of cultural resources. These resources include 69 archaeological sites indicating prehistoric Native American and historic European-American occupation and use. They also include the standing structures, foundations, and other extant features once part of the Pantex Ordnance Plant (1942-1945), the World War II predecessor of Pantex. In addition, many structures and features associated with Cold War era (1951-1991) operations at the plant are included in the cultural resource inventory. Pantex also maintains valuable historic documents, records, and artifacts pertinent to interpretation of the prehistoric and historic human activities conducted on the site (M&H 1996a).

Cultural sites are often occupied continuously or intermittently over substantial time spans. For this reason, a single location (sites) may contain evidence of use during both historic and prehistoric periods. In the discussions that follow, the numbers of prehistoric and historic resources are presented; the sum of these resources may be greater than the total number of sites reported due to this dual-use history at sites. Therefore, where the total number of sites reported is less than the sum of prehistoric and historic sites certain locations were used during both periods.

Approximately 50 percent of Pantex, including DOE-leased and -owned property, has been surveyed for archaeological resources. Both the Texas State Historic Preservation Officer and the Advisory Council on Historic Preservation have agreed that additional archaeological surveys are not required. All World War II buildings, structures, and remains at Pantex have been surveyed and recorded. A building survey and an oral history program on the Cold War period are ongoing. By calendar year 1999, all the plant’s cultural resources will be managed under a comprehensive Cultural Resource Management Plan required by the National Historic Preservation Act. Until that time, resources will be effectively managed through existing case-by-case procedures and interim agreements that comply with the act (M&H 1997:26, 27).

3.4.9.1 Prehistoric Resources

Prehistoric resources are physical properties that remain from human activities that predate written records.

3.4.9.1.1 General Site Description

Prehistoric site types identified at Pantex include small temporary campsites and limited-activity locations characterized by surface scatters of artifacts. Archaeological surveys at Pantex have systematically covered about one-half of the facility. About 60 prehistoric sites have been recorded to date on DOE and Texas Tech University property. In consultation with the Texas State Historic Preservation Officer and the Advisory Council on Historic Preservation, DOE has determined that only two prehistoric archaeological sites are potentially eligible for inclusion on the National Register.

3.4.9.1.2 Proposed Facility Location

There are no National Register-eligible sites near Zone 4 West (M&H 1997:26, 27).

3.4.9.2 Historic Resources

Historic resources consist of physical properties that postdate the existence of written records. In the United States, historic resources are generally considered to be those that date no earlier than 1492.

3.4.9.2.1 General Site Description

Historic resources at Pantex include European-American farmstead sites represented by foundations and artifact scatters; World War II era buildings, structures, and foundations; and Cold War era buildings and structures. To date, 12 European-American farmstead sites have been surveyed and recorded. In consultation with the Texas State Historic Preservation Officer and the Advisory Council on Historic Preservation, DOE has determined that these sites are not eligible for inclusion on the National Register. All remaining World War II era buildings, structures, and foundations have been surveyed and recorded. Under the terms of the programmatic agreement executed in October 1996 among DOE, the Texas State Historic Preservation Officer, and the Advisory Council on Historic Preservation (DOE 1996g), plant properties requiring modification are reviewed by plant staff, and appropriate mitigation is completed.

3.4.9.2.2 Proposed Facility Location

According to existing information, it is unlikely that unrecorded historic sites exist within Zone 4 West. If required, additional reviews by the State Historic Preservation Office are expected to be minimal (M&H 1997:27). Inadvertent discoveries will be addressed as discussed in Chapter 5.

3.4.9.3 Native American Resources

Native American resources are sites, areas, and materials important to Native Americans for religious or heritage reasons. In addition, cultural values are placed on natural resources such as plants, which have multiple purposes within various Native American groups. Of primary concern are concepts of sacred space that create the potential for land-use conflicts. The identification of these resources is determined through consultations with potentially affected Native American groups (see Chapter 5 and Appendix O).

3.4.9.3.1 General Site Description

A treaties search has been completed, indicating that four federally recognized Native American tribes, the Kiowa, Comanche, Apache, and Cheyenne-Arapaho Tribes of Oklahoma, are culturally affiliated with the Texas Panhandle region. Pantex staff have contacted these four and six additional tribes: the Mescalero and Jicarilla Apache Tribes, the Caddo Tribe of Oklahoma, the Delaware Tribe of Western Oklahoma, the Wichita and

affiliated tribes, and the Fort Sill Apache Tribe. As a result of these consultations no mortuary remains, associated artifacts, or traditional cultural properties have been identified at Pantex, nor are they likely to be (M&H 1997:27).

3.4.9.3.2 Proposed Facility Location

Zone 4 West does not contain any recognized Native American resources. Consultations (see Chapter 5 and Appendix O) were initiated with appropriate Native American groups to determine any concerns associated with the actions evaluated in this SPD EIS.

3.4.9.4 Paleontological Resources

Paleontological resources are the physical remains, impressions, or traces of plants or animals from a former geological age.

3.4.9.4.1 General Site Description

The surficial geology of the Pantex area consists of silts, clays, and sands of the Blackwater Draw Formation. In other areas of the Southern High Plains, this formation contains Late Pleistocene vertebrate remains including bison, camel, horse, mammoth, and mastodon, with occasional evidence of their use by humans (M&H 1997:27).

3.4.9.4.2 Proposed Facility Location

No paleontological resources have been reported for Zone 4 West.

3.4.10 Land Use and Visual Resources

3.4.10.1 Land Use

Land may be characterized by its potential for the location of human activities (land use). Natural resource attributes and other environmental characteristics could make a site more suitable for some land uses than for others. Changes in land use may have both beneficial and adverse effects on other resources (biological, cultural, geological, aquatic, and atmospheric).

Pantex is in Carson County, approximately 27 km (17 mi) northeast of downtown Amarillo. The operational activities of the site are confined to 60 km² (23 mi²) of land, of which approximately 37 km² (14 mi²) are owned by the Federal Government. The remaining lands are leased from Texas Tech University to provide a safety and security buffer zone. In addition to the Pantex site, DOE owns a 4.4 km² (1.7 mi²) portion of a large playa approximately 6.4 km (4 mi) northeast of the plant (DOE 1996a:3-148).

3.4.10.1.1 General Site Description

Regional land use within an 80-km (50-mi) radius of Pantex is predominately agricultural (DOE 1996f:4-26). Most of this expanse is devoted to rangeland along the Canadian River drainage north of Pantex and in the tributary drainage of the Red River to the south (DOE 1996f:4-26). Cropland, for both irrigated and dry-land crops, is the second largest land-use category behind rangeland. Some private property owners have enrolled their land in the Federal Conservation Reserve Program. Under terms of the program, the land cannot be cultivated or grazed for 10 years (DOE 1996f:4-22). However, most of the land is cultivated. The land surrounding Pantex is rural private property. The closest offsite residences are approximately 48 m (160 ft) from the plant boundary in the western and northeastern sectors (DOE 1996a:3-148).

Commercial, residential, industrial, institutional, and public lands constitute a small part of the total land use within an 80-km (50-mi) radius. These areas are associated mainly with the towns and cities of the region (DOE 1996f:4-26). Amarillo, which is primarily residential, is the largest urban area in the region.

Land-use categories at Pantex include industrial, agricultural, rangeland, open space, and playa areas. Generalized land uses at Pantex and the vicinity are shown in Figure 3–25. Several areas of land not actively committed to Pantex operations are used by Texas Tech University for agricultural purposes. Agricultural activities generally consist of dry farming and livestock grazing. The soil at Pantex contains several types that, according to the Natural Resources Conservation Service have been classified as prime farmland soils (DOE 1996a:3-148).

Approximately 23 percent of the Pantex site has been developed for industrial use (DOE 1996f:4-21). Pantex is divided into four major working areas: manufacturing, high-explosives development, test firing sites, and support facilities. The manufacturing area is devoted to the fabrication of high-explosives components and weapons assembly and disassembly operations. The area in which nuclear weapons operations are conducted covers approximately 80 ha (200 acres) and contains more than 100 buildings (DOE 1983:3-1). This area is surrounded by a security zone.

DOE will manage future land and facility use at Pantex through the land- and facility-use planning process. Guidance for future site development and reuse is based on long-term goals and objectives shared by DOE and stakeholders (DOE 1996f:4-24). Pantex has a *Site Development Plan* that depicts the plant upon completion of the projects outlined in the *Technical Site Information Five Year Plan*. Land resources at Pantex are expected to remain constant with continued leasing of Texas Tech University land for security and safety reasons (M&H 1996a:10-31). *The Integrated Plan for Playa Management at Pantex Plant* provides land-use guidelines for the playas and surrounding areas. This plan is being implemented as a best management plan to protect cultural and natural resources (M&H 1996c:10-41).

Within the State of Texas, land-use planning occurs only at the municipal level. The *1995 City of Amarillo Comprehensive Plan* has designated land for future growth within the city limits (DOE 1996f:4-33). Future residential development is expected to the southwest, away from the Pantex site. The East Planning Area of the city, which extends to within 3.2 km (2 mi) of Pantex, has historically been one of the slower growing residential areas. Because of the presence of the airport and industrial land use in the area, the comprehensive plan encourages compatible rather than residential use (DOE 1996a:3-148). No future land use has been projected by the city of Amarillo or county planning agencies (M&H 1996a:10-31).

No onsite areas are subject to Native American Treaty Rights.

3.4.10.1.2 Proposed Facility Location

| Existing land use within Zone 4 West is designated as industrial. It contains the weapons/high-explosives magazines and interim pit storage area (DOE 1996f:4-21). It also supports various DOE nuclear weapons design agencies. The land is currently disturbed and is designated for high-explosives development. Zone 4 is 1.8 km (1.1 mi) from the nearest site boundary.

Areas immediately adjacent to the zone to the north, south, and west are designated as open space. Lands to the east are primarily designated as rangeland and agricultural land. About 0.4 km (0.2 mi) to the east of Zone 4 is the Playa 1 Management Unit. Playa 1 currently receives permitted industrial and sanitary sewage effluents from the wastewater treatment facility as well as storm-water runoff from Zones 4, 11, and 12 (M&H 1996c:4). According to the *Facility Assessment Visual Site Inspection Report* prepared under RCRA (M&H 1996c:4), previous discharges of industrial pollutants into the playa have resulted in its classification as a solid

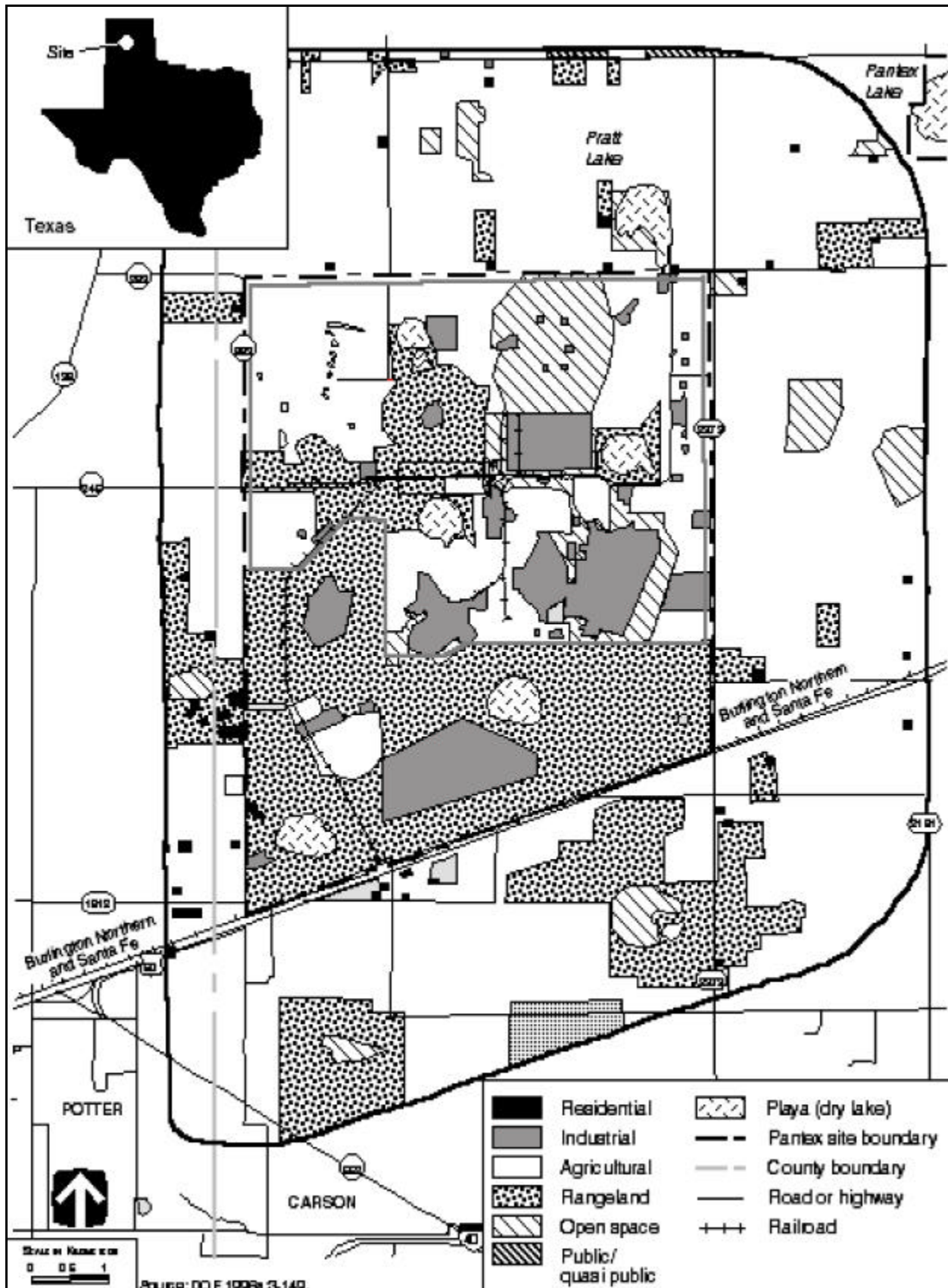

Figure 3-25. Generalized Land Use at Pantex and Vicinity

waste management unit (SWMU). Any activities disturbing the soils within an SWMU, including remedial activities, are regulated under RCRA and require additional management (M&H 1996c:4).

3.4.10.2 Visual Resources

Visual resources are natural and human-created features that give a particular landscape its character and aesthetic quality. Landscape character is determined by the visual elements of form, line, color, and texture. All four elements are present in every landscape; however, they exert varying degrees of influence. The stronger the influence exerted by these elements in a landscape, the more interesting the landscape. The more visual variety that exists with harmony, the more aesthetically pleasing the landscape.

3.4.10.2.1 General Site Description

Pantex is in the treeless Southern High Plains of Texas. It lies in the transition zone between the North Central Plains and the Llano Estacado (staked plains) to the south. The landscape typically consists of cultivated cropland and rangeland. The plant consists of operational facilities and the inactive facilities of the former World War II ammunition plant. These industrial uses are surrounded by cropland and rangeland that blend into the offsite viewscape. The developed areas of Pantex are consistent with a VRM Class IV designation. The remainder of Pantex is consistent with VRM Class III or IV (DOE 1996a:3-148; DOI 1986a, 1986b).

Public access to the plant is strictly controlled. Access to the plant perimeter is limited to three Texas FM roads and U.S. Route 60. The most visible and sensitive vantage point for Pantex facilities is located 2.4 km (1.5 mi) southeast at the intersection of U.S. Route 60 and FM 2373. U.S. Route 60 is part of the Texas Plains Trail, a scenic road on which Pantex is a designated point of interest. From this road, parts of the plant are visible as low clusters of buildings on a flat landscape. The most visible structures include a new water tower in Zone 11, with a height of 45 m (148 ft), and the twin stacks of the steam plant, each with a height of 20 m (65 ft). The tallest structure at Pantex is a 60-m (197-ft) meteorological tower in the northeast corner of the site (Greenly 1999). This tower would normally be visible as a pencil-thin line from a distance of 1.6 km (1 mi) or less. The operations areas are well defined at night by the security lights. Plant facilities are also visible from I-40, a motorist rest area approximately 10 km (6.2 mi) away being the closest vantage point. The view from this point is similar to that described for U.S. Route 60, but because of the greater distance, the plant facilities are more obscure (DOE 1996a:3-148).

3.4.10.2.2 Proposed Facility Location

Zone 4 West, which houses existing industrial facilities, is not visible from U.S. Route 60, including the intersection of U.S. Route 60 and FM 2373. The new water tower and the twin stacks of the steam plant are the features most visible from offsite. Operations areas are well defined at night by the security lights. The closest natural feature of visual interest is Palo Duro Canyon State Park, 45 km (28 mi) to the south. Open space immediately to the west of Zone 4 West is consistent with a VRM Class III or IV designation. Zone 4 West is a developed area consistent with VRM Class IV (DOE 1996a:3-148; DOI 1986a, 1986b; Greenly 1999).

3.4.11 Infrastructure

Site infrastructure includes those utilities and other resources required to support construction and continued operation of mission-related facilities identified under the various proposed alternatives.

3.4.11.1 General Site Description

Pantex has the extensive infrastructure necessary to support operations at the plant. The key components of this infrastructure are summarized in Table 3–36.

Table 3–36. Pantex Sitewide Infrastructure Characteristics

Resource	Current Usage	Site Capacity
Transportation		
Roads (km)	76	76
Railroads (km)	27	27
Electricity		
Energy consumption (MWh/yr)	81,850	420,500
Peak load (MW)	13.6	124
Fuel		
Natural gas (m ³ /yr)	12,910,000	248,000,000
Oil (l/yr)	59,960	NA ^a
Coal (t/yr) ^b	NA ^b	NA ^b
Water (l/yr)	851,600,000	3,785,000,000

^a As supplies get low, more can be supplied by truck or rail.

^b Coal is not used at Pantex.

Key: NA, not applicable.

Source: King 1997a:5.

3.4.11.1.1 Transportation

An onsite road system of about 76 km (47 mi) of paved surface has been developed (DOE 1996a:3-151). Roads within the plant are classified as either “primary,” “secondary,” or “tertiary.” Primary roads are the main distribution arteries for all traffic outside and within the plant. Secondary roads supplement the primary roads and serve as collector roadways. Both the primary and secondary roads are two-lane, paved arteries. Tertiary roads are frequently single lanes, but some have two lanes when the extra width is justified by traffic volume (M&H 1996a:9-17).

Amarillo is a major rail center on the main lines of the Burlington Northern and Santa Fe, which has internodal facilities in Amarillo. Pantex is connected to the Burlington Northern and Santa Fe system via a spur that enters the plant from the southwest. This spur provides access to the entire system as well as to other railroads (M&H 1996a:9-17, 9-19).

3.4.11.1.2 Electricity

Electrical service for the nine-county region surrounding Pantex is supplied by the Southwestern Public Service Company except for Donley County which is serviced by West Texas Utilities (M&H 1996a:9-1). Generation is mainly from coal, oil, and gas (produced by gas turbines), in order of capacity. The rest comes from nuclear, hydroelectric, and other sources. Pantex draws its power from the West Central Power Pool, characteristics of which are summarized in Table 3.5.2–2 of the *Storage and Disposition PEIS* (DOE 1996a:3-151).

The average electrical availability at Pantex is about 420,500 MWh/yr; the average annual usage, about 81,850 MWh/yr. The peak load capacity for the plant is 124 MW; the current peak load usage, about 13.6 MW (King 1997a:5).

3.4.11.1.3 Fuel

Fuels consumed at Pantex include liquid petroleum fuels and natural gas. Natural gas is supplied by Energas (King 1997a:3). Oil is used as a backup for the Building 16-13 steam boiler. Oil capacity is only limited by the number of deliveries of oil by truck. There is a 89,300-l (23,600-gal) fuel oil storage tank on the site. The current annual site availability of natural gas is about 248 million m³/yr (8.8 billion ft³/yr); and the current usage, about 12.9 million m³/yr (456 million ft³/yr) (King 1997a:5).

3.4.11.1.4 Water

Water for Pantex is provided by a system of five wells, together with pumps and storage tanks. The volume used by the plant between 1989 and 1995 ranged from 689 million l (182 million gal) to 946 million l (250 million gal) (M&H 1996a:9-7). The water supply system capacity is about 3.8 billion l/yr (1 billion gal/yr); the average usage of domestic water, about 850 million l/yr (225 million gal/yr) (King 1997a:5).

3.4.11.1.5 Site Safety Services

Plant fire protection is provided by the Pantex fire department, which has one onsite fire station. Personnel in the fire department maintain a high level of readiness. A minimum of eight firefighters, three of whom are certified paramedics, are on duty at all times. The fire department maintains two advanced life-support ambulances on the site (M&H 1996a:9-25).

3.4.11.2 Proposed Facility Location

Little current utility usage occurs in Zone 4 West. Given the current usage level of each utility type at Pantex, excess capacity available for Zone 4 West would be as indicated in Table 3-37. There would be an electrical capacity of 338,634 MWh/yr, with a peak load of 110.4 MW; a natural gas capacity of about 235 million m³/yr (8.3 billion ft³/yr); and a water capacity of about 3 billion l/yr (775 million gal/yr), with a peak supply of about 8 million l/day (2 million gal/day) (King 1997a:6).

Table 3-37. Pantex Infrastructure Characteristics for Zone 4

Resource	Current Usage	Excess Site Capacity
Electrical		
Energy consumption (MWh/yr)	Negligible	338,634
Peak load (MW)	Negligible	110.4
Fuel		
Natural gas (m ³ /yr)	Negligible	235,181,309
Oil (l/yr)	NA	NA ^a
Coal (t/yr) ^b	NA ^b	NA ^b
Water (l/yr)	Negligible	2,933,000,000

^a As supplies get low, more can be supplied by truck or rail.

^b Coal is not used at Pantex.

Key: NA, not applicable.

Source: King 1997a:6.

3.5 SRS

SRS is about 19 km (12 mi) south of Aiken, South Carolina (Figure 2–5). First established in 1950, SRS has been involved for more than 40 years in tritium operations and nuclear material production. Today the site includes 16 major production, service, and R&D areas, not all of which are currently in operation (DOE 1996a:3-228).

There are more than 3,000 facilities at SRS, including 740 buildings with 511,000 m² (5.5 million ft²) of floor area. Major nuclear facilities at SRS include fuel and plutonium storage facilities and target fabrication facilities, nuclear material production reactors, chemical separation plants, a uranium fuel processing area, liquid HLW tank farms, a waste vitrification facility, and the Savannah River Technology Center. SRS processes nuclear materials into forms suitable for continued safe storage, use, or transportation to other DOE sites. Tritium recycling facilities at SRS empty tritium from expired reservoirs, purify it to eliminate the helium decay product, and fill replacement reservoirs for nuclear weapons. Filled reservoirs are delivered to Pantex for weapons assembly and directly to DoD to replace expired reservoirs. Historically, DOE has produced tritium at SRS, but none has been produced since 1988 (DOE 1996a:3-228).

DOE Activities. The current missions at SRS are shown in Table 3–38. In the past, the SRS complex produced nuclear materials. The complex consisted of various plutonium storage facilities, five reactors (the C-, K-, L-, P-, and R-Reactors) (all inactive), a fuel and target fabrication plant, two chemical separation plants, a tritium-target processing facility, a heavy water rework facility, and waste management facilities. The K-Reactor (the last operational reactor) has been shut down with no planned provision for restart. SRS is still conducting tritium recycling operations in support of stockpile requirements using retired weapons as the tritium supply source. The separations facilities and F- and H-Canyons are planned to be used through the year 2002 to complete DOE's commitment to the Defense Nuclear Facilities Safety Board regarding stabilization of inventories of unstable nuclear materials (DOE 1996a:3-228).

Table 3–38. Current Missions at SRS

Mission	Description	Sponsor
Plutonium storage	Maintain F-Area plutonium storage facilities	Assistant Secretary for Environmental Management
Tritium recycling	Operate H-Area tritium facilities	Assistant Secretary for Defense Programs
Stabilize targets, spent nuclear fuels, and other nuclear materials	Operate F- and H-Canyons	Assistant Secretary for Environmental Management
Waste management	Operate waste management facilities	Assistant Secretary for Environmental Management
Environmental monitoring and restoration	Operate remediation facilities	Assistant Secretary for Environmental Management
Research and development	Savannah River Technology Center technical support of Defense Programs, Environmental Management, and Nuclear Energy programs	Assistant Secretary for Defense Programs; Assistant Secretary for Environmental Management; Office of Nuclear Energy

Source: DOE 1996a:3-229.

DOE Office of Environmental Management is pursuing a 10-year plan to achieve full compliance with all applicable laws, regulations, and agreements to treat, store, and dispose of existing wastes; reduce generation of new wastes; clean up inactive waste sites; remedied contaminated groundwater; and dispose of surplus facilities (DOE 1996a:3-228).

The Savannah River Technology Center provides technical support to all DOE operations at SRS. In this role, it provides process engineering development to reduce costs, waste generation, and radiation exposure. SRS has an expanding mission to transfer unique technologies developed at the site to industry. SRS is also an active participant in the Strategic Environmental R&D Program formulated to develop technologies to mitigate environmental hazards at DoD and DOE sites (DOE 1996a:3-228).

Non-DOE Activities. Non-DOE facilities and operations at SRS include the Savannah River Forest Station, the Savannah River Ecology Laboratory, and the Institute of Archaeology and Anthropology. The Savannah River Forest Station is an administrative unit of the U.S. Forest Service, which provides timber management, research support, soil and water protection, wildlife management, secondary roads management, and fire management to DOE. The Savannah River Forest Station manages 62,300 ha (154,000 acres), comprising approximately 80 percent of the site area. It has been responsible for reforestation and manages an active timber business. The Savannah River Forest Station assists with the development and updating of sitewide land use plans and provides continual support with site layout and vegetative management. It also assists in long-term wildlife management and soil rehabilitation projects (DOE 1996a:3-228).

The Savannah River Ecology Laboratory is operated for DOE by the Institute of Ecology of the University of Georgia. It has established a center of ecological field research where faculty, staff, and students perform interdisciplinary field research and gain an understanding of the impact of energy technologies on the ecosystems of the southeastern United States. This information is communicated to the scientific community, government agencies, and the general public. In addition to Savannah River Ecology Laboratory studies, the Institute of Archaeology and Anthropology is operated by the University of South Carolina to survey the archaeological resources of SRS. These surveys are used by DOE when planning new facility additions or modifications (DOE 1996a:3-229).

3.5.1 Air Quality and Noise

3.5.1.1 Air Quality

Air pollution refers to any substance in the air that could harm human or animal populations, vegetation, or structures, or that unreasonably interferes with the comfortable enjoyment of life and property. Air pollutants are transported, dispersed, or concentrated by meteorological and topographical conditions. Air quality is affected by air pollutant emission characteristics, meteorology, and topography.

3.5.1.1.1 General Site Description

The SRS region has a temperate climate with short, mild winters and long, humid summers. Throughout the year, the climate is frequently affected by warm, moist maritime air masses. The average annual temperature at SRS is 17.3 EC (63.2 EF); temperatures vary from an average daily minimum of 0 EC (32 EF) in January to an average daily maximum of 33.2 EC (91.7 EF) in July. The average annual precipitation at SRS is about 114 cm (45 in). Precipitation is distributed fairly evenly throughout the year, with the highest in summer and the lowest in autumn. There is no predominant wind direction at SRS. The average annual wind speed at Augusta National Weather Service Station is 2.9 m/s (6.5 mph) (NOAA 1994b). Additional information related to meteorology and climatology at SRS is presented in Appendix F of the *Storage and Disposition PEIS* (DOE 1996a:F-16, F-17) and in the *Savannah River Site Waste Management Environmental Impact Statement* (DOE 1995c:3-21–3-25).

SRS is near the center of the Augusta-Aiken Interstate AQCR #53. None of the areas within SRS and its surrounding counties are designated as nonattainment areas with respect to the NAAQS for criteria air pollutants (EPA 1997f; 1997g). Applicable NAAQS and the ambient air quality standards for the States of South Carolina and Georgia are presented in Table 3–39.

**Table 3–39. Comparison of Ambient Air Concentrations From SRS Sources
With Most Stringent Applicable Standards or Guidelines, 1994**

Pollutant	Averaging Period	Most Stringent Standard or Guideline (Fg/m ³) ^a	Concentration (Fg/m ³)
Criteria pollutants			
Carbon monoxide	8 hours	10,000 ^b	632
	1 hour	40,000 ^b	5,010
Nitrogen dioxide	Annual	100 ^b	8.8
Ozone	8 hours	157 ^c	(d)
PM ₁₀	Annual	50 ^b	4.8
	24 hours	150 ^b	80.6
PM _{2.5}		15 ^c	(e)
	3-year annual	65 ^c	(e)
	24 hours (98th percentile over 3 years)		
Sulfur dioxide	Annual	80 ^b	16.3
	24 hours	365 ^b	215
	3 hours	1,300 ^b	690
Lead	Calendar quarter	1.5 ^b	<0.01
Other regulated pollutants			
Gaseous fluoride	30 days	0.8 ^f	(g)
	7 days	1.6 ^f	0.11
	24 hours	2.9 ^f	0.60
	12 hours	3.7 ^f	241
Total suspended particulates	Annual	75 ^f	43.3
Hazardous and other toxic compounds			
Benzene	24 hours	150 ^f	20.7
[Text deleted.]			

^a The more stringent of the Federal and State standards is presented if both exist for the averaging period. The National Ambient Air Quality Standards (NAAQS) (EPA 1997a), other than those for ozone, particulate matter, and lead, and those based on annual averages, are not to be exceeded more than once per year. The 1-hr ozone standard is attained when the expected number of days per year with maximum hourly average concentrations above the standard is #1. The 1-hr ozone standard applies only to nonattainment areas. The 8-hr ozone standard is attained when the 3-year average of the annual fourth-highest daily maximum 8-hr average concentration is less than or equal to 157 Fg/m³. The 24-hr particulate matter standard is attained when the expected number of days with a 24-hr average concentration above the standards is #1. The annual arithmetic mean particulate matter standard is attained when the expected annual arithmetic mean concentration is less than or equal to the standard.

^b Federal and State standard.

^c Federal standard.

^d Not directly emitted or monitored by the site.

^e No data is available with which to assess PM_{2.5} concentrations.

^f State standard.

^g No concentration reported.

Note: The NAAQS also includes standards for lead. No sources of lead emissions have been identified for any of the alternatives presented in Chapter 4. Emissions of other air pollutants not listed here have been identified at SRS, but are not associated with any of the alternatives evaluated. These other air pollutants are quantified in the *Storage and Disposition PEIS* (DOE 1996a). EPA recently revised the ambient air quality standards for particulate matter and ozone. The new standards, finalized on July 18, 1997, changed the ozone primary and secondary standards from a 1-hr concentration of 235 Fg/m³ (0.12 ppm) to an 8-hr concentration of 157 Fg/m³ (0.08 ppm). During a transition period while States are developing State implementation plan revisions for attaining and maintaining these standards, the 1-hr ozone standard will continue to apply in nonattainment areas (EPA 1997b:38855). For

particulate matter, the current PM_{10} annual standard is retained, and two $PM_{2.5}$ standards are added. These standards are set at a 15-Fg/m^3 3-year annual arithmetic mean based on community-oriented monitors and a 65-Fg/m^3 3-year average of the 98th percentile of 24-hr concentrations at population-oriented monitors. The revised 24-hr PM_{10} standard is based on the 99th percentile of 24-hr concentrations. The existing PM_{10} standards will continue to apply in the interim period (EPA 1997c:38652). Values may differ from those of the source document due to rounding.

Source: DOE 1998e:3-14, 1998f:3-26; EPA 1997a; SCDHEC 1996.

There are no PSD Class I areas within 100 km (62 mi) of SRS. None of the facilities at SRS have been required to obtain a PSD permit (DOE 1996a:3-233).

The primary emission sources of criteria air pollutants at SRS are the nine coal-burning boilers and four fuel-oil-burning package boilers that produce steam and electricity, diesel engine-powered equipment, the Defense Waste Processing Facility (DWPF), the In-Tank Precipitation process, groundwater air strippers, the Consolidated Incineration Facility, and various other process facilities. Other emissions and sources include fugitive particulates from coal piles and coal-processing facilities, vehicles, controlled burning of forestry areas, and temporary emissions from various construction-related activities (DOE 1996a:F-17, F-18).

Table 3–39 presents the ambient air concentrations attributable to sources at SRS. These concentrations are based on emissions for the year 1994 (DOE 1998e:3-14; DOE 1998f:3-26). Only those hazardous pollutants that would be emitted for any of the surplus plutonium disposition alternatives are presented. Additional information on ambient air quality at SRS is in the *SRS Environmental Report for 1995* (Arnett and Mamatey 1996:111–114). Concentrations shown in Table 3–39 attributable to SRS are in compliance with applicable guidelines and regulations. Data for 1995 from nearby South Carolina monitors at Beech Island, Jackson, and Barnwell indicate that the NAAQS for particulate matter, lead, ozone, sulfur dioxide, and nitrogen dioxide are not exceeded in the area around SRS (SCDHEC 1995:1, 25, 28, 37–39). Air pollutant measurements at these monitoring locations during 1995 showed for nitrogen dioxide an annual average concentration of 9.4 Fg/m^3 ; for sulfur dioxide concentrations of 99 Fg/m^3 for 3-hr averaging, 24 Fg/m^3 for 24-hr averaging, and 5 Fg/m^3 for the annual average; for total suspended particulates an annual average concentration of 37 Fg/m^3 ; and for PM_{10} concentrations of 62 Fg/m^3 for 24-hr averaging and 19 Fg/m^3 for the annual average.

3.5.1.1.2 Proposed Facility Locations

The meteorological conditions described for SRS are considered representative of F-Area. Information on air pollutant emissions from F-Area is included in the overall site emissions discussed previously.

The meteorological conditions described for SRS are considered representative of S-Area. Information on air pollutant emissions from S-Area is included in the previous discussion of overall site emissions. The air pollutant sources in this area include process and diesel generator emissions.

3.5.1.2 Noise

Noise is unwanted sound that interferes or interacts negatively with the human or natural environment. Noise may disrupt normal activities or diminish the quality of the environment.

3.5.1.2.1 General Site Description

Major noise sources at SRS are primarily in developed or active areas and include various industrial facilities, equipment, and machines (e.g., cooling systems, transformers, engines, pumps, boilers, steam vents, paging systems, construction and materials-handling equipment, and vehicles). Major noise emission sources outside of these active areas consist primarily of vehicles and rail operations. Existing SRS-related noise sources of

importance to the public are those related to transportation of people and materials to and from the site, including trucks, private vehicles, helicopters, and trains (DOE 1996a:3-233–3-235).

Another important contributor to noise levels is traffic to and from SRS operations along access highways through the nearby towns of New Ellenton, Jackson, and Aiken. Noise measurements recorded during 1989 and 1990 along State Route 125 in the town of Jackson at a point about 15 m (50 ft) from the roadway indicate that the 1-hr equivalent sound level from traffic ranged from 48 to 72 dBA. The estimated day-night average sound levels along this route were 66 dBA for summer and 69 dBA for winter. Similarly, noise measurements along State Route 19 in the town of New Ellenton at a point about 15 m (50 ft) from the roadway indicate that the 1-hr equivalent sound level from traffic ranged from 53 to 71 dBA. The estimated average day-night average sound levels along this route were 68 dBA for summer and 67 dBA for winter (NUS 1990:3-2–3-6, app. C and F).

Most industrial facilities at SRS are far enough from the site boundary that noise levels from these sources at the boundary would not be measurable or would be barely distinguishable from background levels.

The States of Georgia and South Carolina, and the counties in which SRS is located, have not established any noise regulations that specify acceptable community noise levels, with the exception of a provision in the Aiken County Zoning and Development Standards Ordinance that limits daytime and nighttime noise by frequency band (DOE 1996a:F-33).

The EPA guidelines for environmental noise protection recommend an average day-night average sound level of 55 dBA as sufficient to protect the public from the effects of broadband environmental noise in typically quiet outdoor and residential areas (EPA 1974:29). Land-use compatibility guidelines adopted by the Federal Aviation Administration and the Federal Interagency Committee on Urban Noise indicate that yearly day-night average sound levels less than 65 dBA are compatible with residential land uses and levels up to 75 dBA are compatible with residential uses if suitable noise reduction features are incorporated into structures (DOT 1995). It is expected that for most residences near SRS, the day-night average sound level is less than 65 dBA and is compatible with the residential land use, although for some residences along major roadways noise levels may be higher.

3.5.1.2.2 Proposed Facility Locations

No distinguishing noise characteristics at F-Area have been identified. F-Area is far enough—7.9 km (4.9 mi)—from the site boundary that noise levels from the facilities are not measurable or are barely distinguishable from background levels.

No distinguishing noise characteristics at S-Area have been identified. Observations of sound sources during a summer sound level survey near the fence line of S-Area indicate that typical sources include vehicles, turbines, locomotives, paging systems, and fans (NUS 1990:app. B). S-Area is far enough—9.6 km (6 mi)—from the site boundary that noise levels from these facilities are not measurable or are barely distinguishable from background levels.

3.5.2 Waste Management

Waste management includes minimization, characterization, treatment, storage, transportation, and disposal of waste generated from ongoing DOE activities. The waste is managed according to appropriate treatment, storage, and disposal technologies and in compliance with all applicable Federal and State statutes and DOE orders.

3.5.2.1 Waste Inventories and Activities

SRS manages the following types of waste: HLW, TRU, mixed TRU, LLW, mixed LLW, hazardous, and nonhazardous. HLW would not be generated by surplus plutonium disposition activities at SRS, and therefore, will not be discussed further. Waste generation rates and the inventory of stored waste from activities at SRS are provided in Table 3–40. Table 3–41 summarizes the SRS waste management capabilities. More detailed

Table 3–40. Waste Generation Rates and Inventories at SRS

Waste Type	Generation Rate (m ³ /yr)	Inventory (m ³)
TRU^a		
Contact handled	427	6,977
Remotely handled	4	0
LLW	10,043	1,616
Mixed LLW		
RCRA	1,135	6,940
TSCA	0	110
Hazardous	74	1,416 ^b
Nonhazardous		
Liquid	416,100	NA ^c
Solid	6,670	NA ^c

^a Includes mixed TRU wastes.

^b Sessions 1997a.

^c Generally, nonhazardous wastes are not held in long-term storage.

Key: LLW, low-level waste; NA, not applicable; RCRA, Resource Conservation and Recovery Act; TRU, transuranic; TSCA, Toxic Substances Control Act.

Source: DOE 1996d:15, 16, except for hazardous and nonhazardous solid waste (DOE 1996a:3-262, 3-263) and nonhazardous liquid waste (Sessions 1997a).

descriptions of the waste management system capabilities at SRS are included in the *Storage and Disposition PEIS* (DOE 1996a:3-261–3-265, E-97) and the *Savannah River Site Waste Management Final EIS* (DOE 1995c:3-66).

EPA placed SRS on the National Priorities List in December 1989. In accordance with CERCLA, DOE entered into an FFCA with EPA and the State of South Carolina to coordinate cleanup activities at SRS under one comprehensive strategy. The FFCA combines the RCRA Facility Investigation Program Plan with a CERCLA cleanup program titled the *RCRA Facility Investigation/Remedial Investigation Program Plan* (DOE 1996a:3-261). More information on regulatory requirements for waste disposal is provided in Chapter 5.

3.5.2.2 Transuranic and Mixed Transuranic Waste

TRU waste generated between 1974 and 1986 is stored on five concrete pads and one asphalt pad that have been covered with approximately 1.2 m (4 ft) of soil. TRU waste generated since 1986 is stored on 13 concrete pads that are not covered with soil. The TRU waste storage pads are in the Low-Level Radioactive Waste Disposal Facility (DOE 1995c:3-80, 3-81).

A TRU Waste Characterization and Certification Facility is planned and would provide extensive containerized waste certification capabilities. The facility is needed to prepare TRU waste for treatment and to certify TRU waste for disposal at WIPP. Drums that are certified for shipment to WIPP will be placed in interim storage

on concrete pads in E-Area (DOE 1996a:3-264). LLW containing concentrations of TRU nuclides between 10 and 100 nCi (referred to as alpha-contaminated LLW) is managed like TRU waste because its physical and chemical properties are similar and similar procedures will be used to determine its final disposition (DOE 1996a:3-264). WIPP is expected to begin receiving waste from SRS in 2000 (Aragon 1999). |

Table 3–41. Waste Management Capabilities at SRS

Facility Name/Description	Capacity	Status	Applicable Waste Type					
			TRU	Mixed TRU	LLW	Mixed LLW	Haz	Non-Haz
Treatment Facility (m³/yr)								
TRU Waste Characterization/ Certification Facility	1,720	Planned for 2007	X	X				
Consolidated Incineration Facility & Ashcrete Stabilization Facility	4,630 liquid 17,830 solid	Online			X	X	X	
F- and H-Area Effluent Treatment Facility	1,930,000	Online			X	X		
M-, L-, and H-Area Compactors	3,983	Online			X			
Non-Alpha Vitrification Facility	3,090	Planned			X	X	X	
M-Area Liquid Effluent Treatment Facility	999,000	Online				X		
M-Area Vendor Treatment Facility	2,470	Planned				X		
Savannah River Technology Center Ion Exchange Treatment Probe	11,200	Online				X		
E-Area Supercompactor	5,700	Planned			X			
Z-Area Saltstone Facility	28,400	Online				X		
Central Sanitary Wastewater Treatment Facility	1,449,050	Online						X
Storage Facility (m³)								
TRU Storage Pads	34,400	Online	X	X				
DWPF Organic Waste Storage Tank	568	Online				X		
Liquid Waste Solvent Tanks	454	Planned				X		
M-Area Process Waste Interim Treatment/Storage Facility	8,300	Online				X		
Mixed Waste Storage Facilities (645- 2N, -295, -43E)	1,905	Online				X		
Savannah River Technology Center Mixed Waste Storage Tanks	198	Online				X		
Long-Lived Waste Storage Building	1,064	Planned			X			
Solid Waste Storage Pads	2,657	Online				X	X	
Buildings 316-M, 710-B, 645-N, and 645-4N	2,515	Online				X	X	
M-Area Storage Pad	2,160	Online				X		
Disposal Facility (m³)								
Intermediate-Level Waste Vaults	3,665	Online			X			
Low-Activity Waste Vaults	30,500	Online			X			
LLW Disposal Facility Slit Trenches	26,000	Planned			X			
Z-Area Saltstone Vaults	1,110,000	Online			X			

Key: DWPF, Defense Waste Processing Facility; Haz, hazardous; LLW, low-level waste; TRU, transuranic.

Source: DOE 1996a:E-108–E-112; Miles 1998; Rhoderick 1998; Sessions 1997a, 1997b.

3.5.2.3 Low-Level Waste

Both liquid and solid LLW are treated at SRS. Most aqueous LLW streams are sent to the F- and H-Area Effluent Treatment Facility and treated by filtration, reverse osmosis, and ion exchange to remove the radionuclide contaminants. After treatment, the effluent is discharged to Upper Three Runs Creek. The treatment residuals are concentrated by evaporation and stored in the H-Area tank farm for eventual treatment in the Z-Area Saltstone Facility. In that facility, wastes are immobilized with grout for onsite disposal (DOE 1996a:E-98).

After completion of a series of extensive readiness tests, the Consolidated Incineration Facility began radioactive operations in 1997. The Consolidated Incineration Facility is designed to incinerate both solid and liquid LLW, mixed LLW, and hazardous waste (WSRC 1997a).

Solid LLW is segregated into several categories to facilitate proper treatment, storage, and disposal. Solid LLW that radiates less than 200 mrem/hr at 5 cm (2 in) from the unshielded container is considered low-activity waste. If it radiates greater than 200 mrem/hr at 5 cm (2 in), it is considered intermediate-activity waste. Intermediate-activity tritium waste is intermediate-activity waste with more than 10 Ci of tritium per container. Long-lived waste is contaminated with long-lived isotopes that exceed the waste acceptance criteria for onsite disposal (DOE 1996a:E-99).

Four basic types of vaults and buildings are used for storing the different waste categories: low-activity waste vaults, intermediate-level nontritium vaults, intermediate-level tritium vaults, and the long-lived waste storage building. The vaults are below-grade concrete structures, and the storage building is a metal building on a concrete pad (DOE 1996a:E-99).

Currently, DOE places low-activity LLW in carbon steel boxes and deposits them in the low-activity waste vaults in E-Area. Intermediate-activity LLW is packaged according to waste form and disposed of in the intermediate-level waste vaults in E-Area. Long-lived wastes are stored in the Long-Lived Waste Storage Building in E-Area until treatment and disposal technologies are developed (DOE 1995c:3-75).

Saltstone generated in the solidification of LLW salts extracted from HLW is disposed of in the Z-Area Saltstone Vaults. Saltstone is solidified grout formed by mixing the LLW salt with cement, fly ash, and furnace slag. Saltstone is the highest volume of solid LLW disposed of at SRS. SRS disposal facilities are projected to meet solid LLW disposal requirements, including LLW from off the site, for the next 20 years (DOE 1996a:3-261, 3-264).

3.5.2.4 Mixed Low-Level Waste

The FFCA addresses SRS compliance with RCRA LDR. The FFCA requires DOE facilities storing mixed waste to develop site-specific treatment plans and to submit them for approval (DOE 1996a:3-264, 3-265). The site treatment plan for mixed waste specifies treatment technologies or technology development schedules for all SRS mixed waste (Arnett and Mamatey 1996:50). SRS is allowed to continue to generate and store mixed waste, subject to LDR. Schedules to provide compliance through treatment in the Consolidated Incineration Facility are included in the FFCA (DOE 1996a:3-264).

The SRS mixed waste program consists primarily of safely storing waste until treatment and disposal facilities are available. Mixed LLW is stored in the A-, E-, M-, N-, and S-Areas in various tanks and buildings. These facilities include burial ground solvent tanks, the M-Area Process Waste Interim Treatment/Storage Facility, the Savannah River Technology Center Mixed Waste Storage Tanks, and the DWPF Organic Waste Storage Tank (DOE 1995c:3-81). These South Carolina Department of Health and Environmental Control permitted facilities will remain in use until appropriate treatment and disposal is performed on the waste (DOE 1996a:E-99).

3.5.2.5 Hazardous Waste

Hazardous waste is accumulated at the generating facility for a maximum of 90 days, or stored in DOT-approved containers in three RCRA-permitted hazardous waste storage buildings and on three interim status storage pads in B- and N-Areas. Most of the waste is shipped off the site to commercial RCRA-permitted treatment and disposal facilities using DOT-certified transporters. DOE plans to incinerate up to 9 percent of the hazardous waste (organic liquids, sludge, and debris) in the Consolidated Incineration Facility (DOE 1996a:3-265). In 1995, 72 m³ (2,538 ft³) of hazardous waste were sent to onsite storage. Of this amount, 20 m³ (712 ft³) were shipped off the site for commercial treatment or disposal (Arnett and Mamatey 1996:48).

3.5.2.6 Nonhazardous Waste

In 1994, the centralization and upgrading of the sanitary wastewater collection and treatment systems at SRS were completed. The program included the replacement of 14 (of 20) aging treatment facilities scattered across the site with a new 3,975 m³/day (1.1 million gal/day) central treatment facility and connecting them with a new 29 km (18 mi) sanitary sewer system. The central treatment facility treats sanitary wastewater by the extended aeration activated sludge process. The treatment facility separates the wastewater into two forms, clarified effluent and sludge. The liquid effluent is further treated by the nonchemical method of ultraviolet (UV) light disinfection to meet NPDES discharge limitations for the outfall to Fourmile Branch. The sludge is further treated to reduce pathogen levels to meet proposed land application criteria. The remaining sanitary wastewater treatment facilities are being upgraded as necessary by replacing existing chlorination treatment systems with nonchemical UV light disinfection systems to meet NPDES limitations (DOE 1996a:3-265).

SRS has privatized the collection, hauling, and disposal of its sanitary waste (Arnett and Mamatey 1996:48). SRS-generated solid sanitary waste is sent to the Three Rivers Landfill (DOE 1998f:3-42). SRS disposes of other nonhazardous waste that consists of scrap metal, powerhouse ash, domestic sewage, scrap wood, construction debris, and used railroad ties in a variety of ways. Scrap metal is sold to salvage vendors for reclamation. Powerhouse ash and domestic sewage sludge are used for land reclamation. Scrap wood is burned on the site or chipped for mulch. Construction debris is used for erosion control. Railroad ties are shipped off the site for disposal (DOE 1996a:E-100).

3.5.2.7 Waste Minimization

The total amount of waste generated and disposed of at SRS has been and continues to be reduced through the efforts of the pollution prevention and waste minimization program at the site. This program is designed to achieve continuous reduction of waste and pollutant releases to the maximum extent feasible and in accordance with regulatory requirements while fulfilling national security missions (DOE 1996a:E-97). The program focuses mainly on source reduction, recycling, and increasing employee participation in pollution prevention. For example, 1995 nonhazardous solid waste generation was 32 percent below that of 1994, and the disposal volume of other solid waste, including radioactive and hazardous wastes, was 38 percent below 1994 levels. In 1995, SRS achieved a 9 percent reduction in its radioactive waste generation volume compared with 1994. Total solid waste volumes have declined by more than 70 percent since 1991. Radioactive solid waste volumes have declined by about 63 percent, or more than 17,000 m³ (600,000 ft³) from 1991 through 1995. In 1995, more than 2,990 t (3,300 tons) of nonradioactive materials were recycled at SRS, including 963 t (1,062 tons) of paper and cardboard (Arnett and Mamatey 1996:16, 41).

3.5.2.8 Preferred Alternatives From the Final WM PEIS

Preferred alternatives from the WM PEIS (DOE 1997a:summary, 117) are shown in Table 3-42 for the four waste types analyzed in this SPD EIS. A decision on the future management of these wastes could result in the

construction of new waste management facilities at SRS and the closure of other facilities. Decisions on the various waste types are expected to be announced in a series of RODs to be issued on this WM PEIS. In fact, the TRU waste ROD was issued on January 20, 1998 (DOE 1998a), with the hazardous waste ROD issued on August 5, 1998 (DOE 1998b). The TRU waste ROD states that DOE will develop and operate mobile and fixed facilities to characterize and prepare TRU waste for disposal at WIPP. Each DOE site that has, or will generate, TRU waste will, as needed, prepare and store its TRU waste on the site. The hazardous waste ROD states that

Table 3–42. Preferred Alternatives From the WM PEIS

Waste Type	Preferred Action
TRU and mixed TRU	DOE prefers the regionalized alternative for onsite treatment and storage of SRS contact-handled TRU waste. Under this alternative, some contact-handled TRU waste could be received from ORR for treatment and storage. ^a
LLW	DOE prefers to treat SRS LLW on the site. SRS could be selected as one of the regional disposal sites for LLW.
Mixed LLW	DOE prefers regionalized treatment at SRS. This includes the onsite treatment of SRS waste and could include treatment of some mixed LLW generated at other sites. SRS could be selected as one of the regional disposal sites for mixed LLW.
Hazardous	DOE prefers to continue to use commercial facilities for hazardous waste treatment. ^b

^a ROD for TRU waste (DOE 1998a) states that “each of the Department’s sites that currently has or will generate TRU waste will prepare and store its TRU waste on site. . . .”

^b ROD for hazardous waste (DOE 1998b) selected a modified preferred alternative that includes continued onsite treatment at SRS where this is economically favorable.

Key: LLW, low-level waste; ORR, Oak Ridge Reservation; TRU, transuranic.

Source: DOE 1997a:summary, 117.

most DOE sites will continue to use offsite facilities for the treatment and disposal of major portions of the nonwastewater hazardous waste, with ORR and SRS continuing to treat some of their own hazardous waste on the site in existing facilities where this is economically favorable. More detailed information and DOE’s alternatives for the future configuration of waste management facilities at SRS is presented in the WM PEIS and the hazardous waste and TRU waste RODs.

3.5.3 Socioeconomics

Statistics for employment and regional economy are presented for the REA as defined in Appendix F.9, which encompasses 15 counties around SRS located in Georgia and South Carolina. Statistics for population, housing, community services, and local transportation are presented for the ROI, a five-county area in which 90.7 percent of all SRS employees reside as shown in Table 3–43. In 1997, SRS employed 15,032 persons (about 5.8 percent of the REA civilian labor force) (Knox 1997).

Table 3–43. Distribution of Employees by Place of Residence in the SRS Region of Influence, 1997

County	Number of Employees	Total Site Employment (Percent)
Aiken	6,981	53.9
Columbia	1,881	14.5
Richmond	1,755	13.5
Barnwell	932	7.2
Edgefield	210	1.6
ROI total	11,759	90.7

Source: Knox 1997.

3.5.3.1 Regional Economic Characteristics

Selected employment and regional economy statistics for the SRS REA are summarized in Figure 3–26. Between 1990 and 1996, the civilian labor force in the REA increased 3.6 percent to the 1996 level of 257,101. In 1996, the unemployment rate in the REA was 7.6 percent, which is greater than the unemployment rates for Georgia (4.6 percent) and South Carolina (6 percent) (DOL 1999).

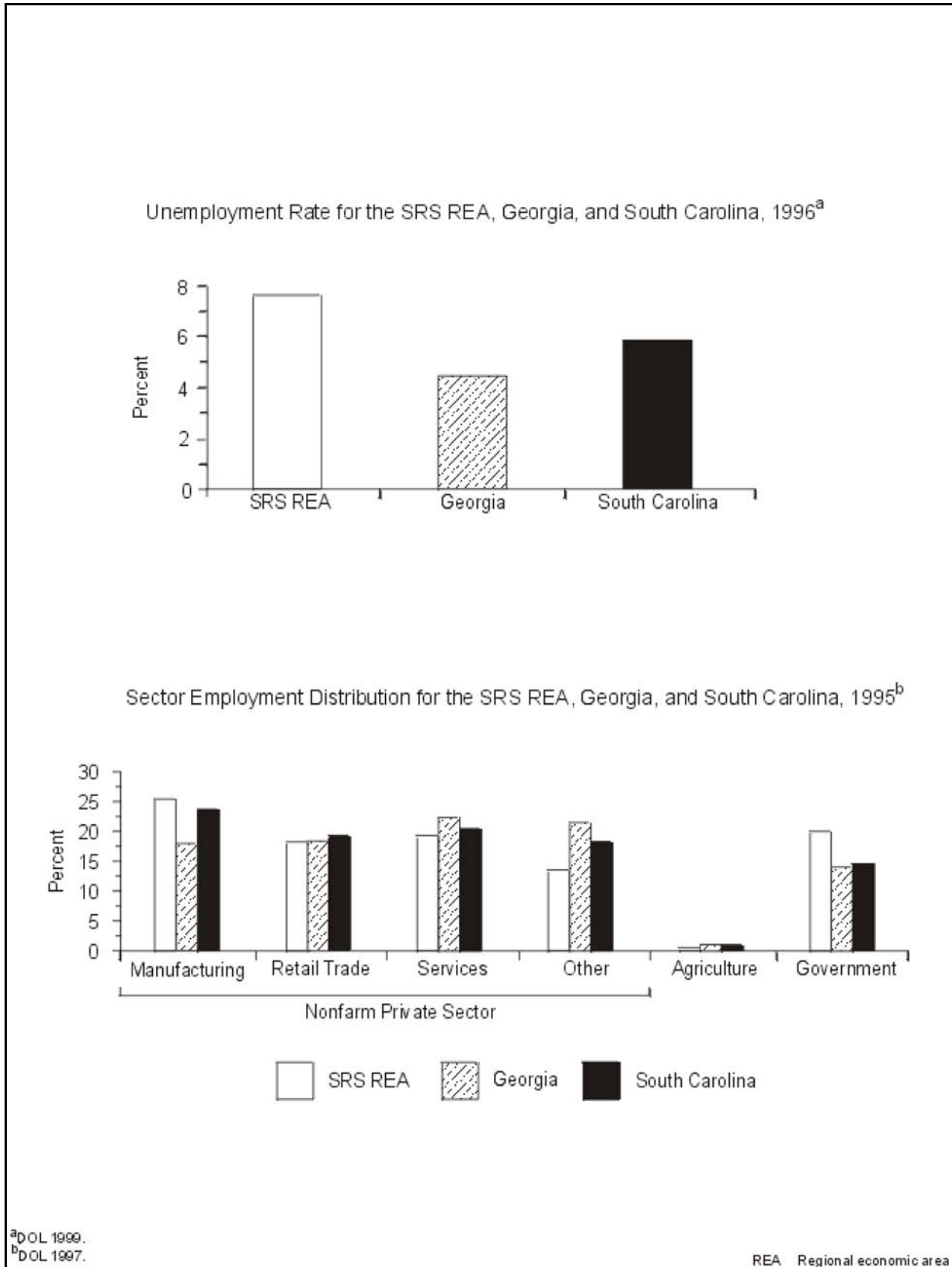

Figure 3-26. Employment and Local Economy for the SRS Regional Economic Area and the States of Georgia and South Carolina

In 1995, manufacturing represented the largest sector of employment in the REA (25.6 percent). This was followed by government (20.9 percent) and service (19.9 percent) activities. The total for these employment sectors in Georgia was 17.5 percent, 16.8 percent, and 23 percent, respectively. The total for these employment sectors in South Carolina was 23.3 percent, 17.3 percent, and 20.5 percent, respectively (DOL 1997).

3.5.3.2 Population and Housing

In 1996, the ROI estimated population totaled 453,778. From 1990 to 1996, the ROI population increased by 8.6 percent, compared with a 13 percent increase in Georgia's population and a 5.7 percent increase in South Carolina's population (DOC 1997). Between 1980 and 1990, the number of housing units in the ROI increased by 25.1 percent, compared with the 30.1 percent increase in Georgia and the 23.5 percent increase in South Carolina. The total number of housing units within the ROI for 1990 was 165,443 (DOC 1994). The 1990 homeowner vacancy rate for the ROI was 2.2 percent, compared with the statewide rates of 2.5 percent for Georgia and 1.7 percent for South Carolina. The renter vacancy rate for the ROI counties was 10 percent compared with the statewide rates of 12.2 percent for Georgia and 11.5 percent for South Carolina (DOC 1990a). Population and housing trends are summarized in Figure 3-27.

3.5.3.3 Community Services

3.5.3.3.1 Education

Seven school districts provided public education services and facilities in the SRS ROI. As shown in Figure 3-28, these school districts operated at between 85 percent (Barnwell County, District 19) and 125 percent (Richmond County School District) capacity in 1997. In 1997, the average student-to-teacher ratio for the SRS ROI was 17:1 (Nemeth 1997a). In 1990, the average student-to-teacher ratios were 10.8:1 for Georgia and 11.5:1 for South Carolina (DOC 1990b; 1994).

3.5.3.3.2 Public Safety

In 1997, a total of 973 sworn police officers were serving the five-county ROI. The average ROI officer-to-population ratio was 2.1 officers per 1,000 persons (Nemeth 1997b). This compares with the 1990 State averages of 2.0 officers per 1,000 persons for Georgia and 1.8 officers per 1,000 persons for South Carolina (DOC 1990b). In 1997, 1,712 paid and volunteer firefighters provided fire protection services in the SRS ROI. The average firefighter-to-population ratio in the ROI was 3.8 firefighters per 1,000 persons (Nemeth 1997b). This compares with the 1990 State averages of 1.0 firefighters per 1,000 persons for Georgia and 0.8 firefighters per 1,000 persons for South Carolina (DOC 1990b). Figure 3-29 displays the ratio of sworn police officers and firefighters to the population for all the counties in the ROI.

3.5.3.3.3 Health Care

In 1996, a total of 1,722 physicians served the ROI. The average physician-to-population ratio in the ROI was 3.8 physicians per 1,000 persons. This compares with a 1996 State average of 2.3 physicians per 1,000 persons for Georgia and 2.2 physicians per 1,000 persons for South Carolina (Randolph 1997). In 1997, there were 10 hospitals serving the five-county ROI. The hospital bed-to-population ratio averaged 7.7 beds per 1,000 persons (Nemeth 1997c). This compares with a 1990 State average of 4.1 beds per 1,000 persons for Georgia and 3.3 beds per 1,000 persons for South Carolina (DOC 1996:128). Figure 3-29 displays the hospital bed-to-population and physician-to-population ratios for the SRS ROI counties.

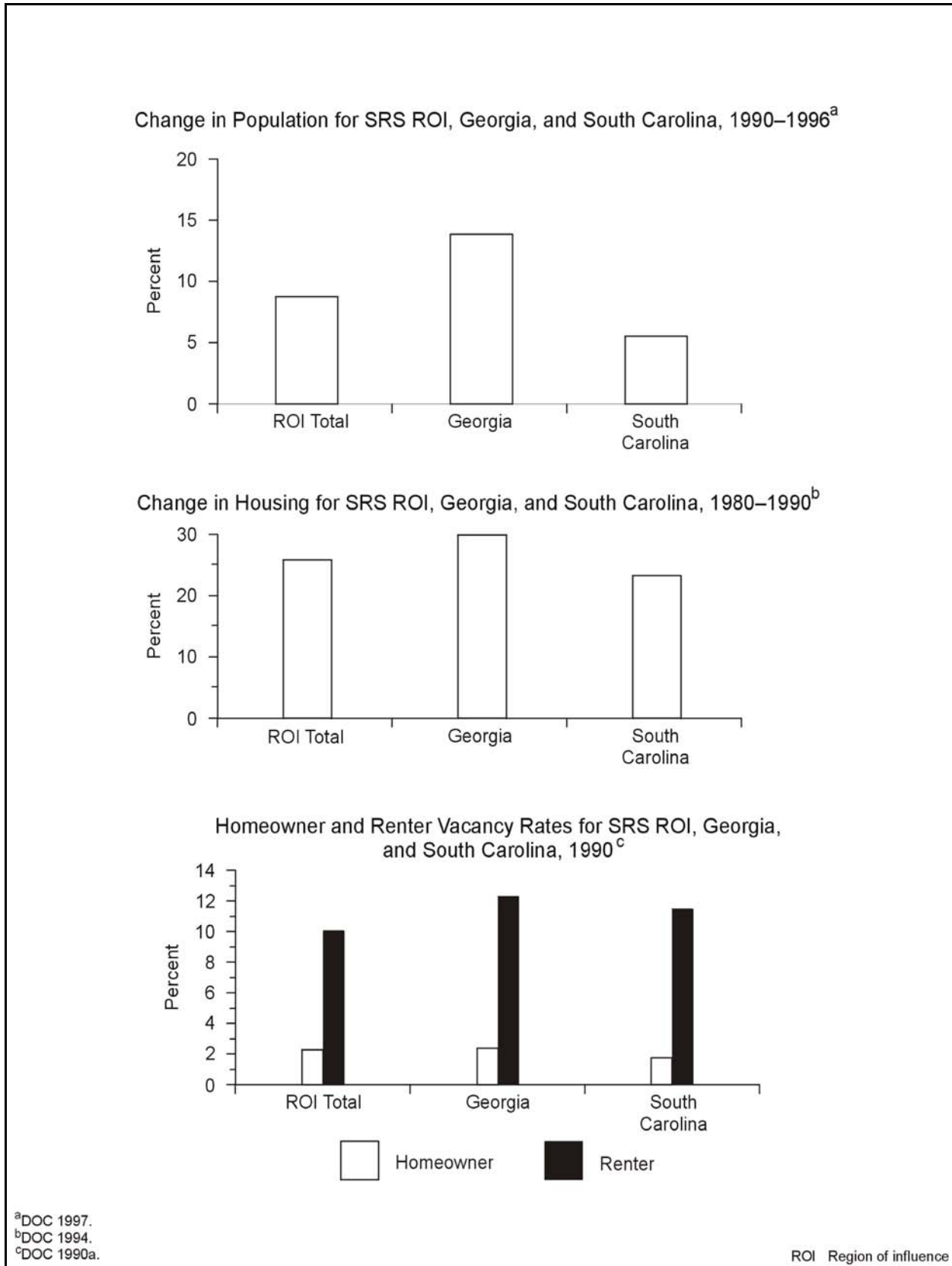

Figure 3–27. Population and Housing for the SRS Region of Influence and the States of Georgia and South Carolina

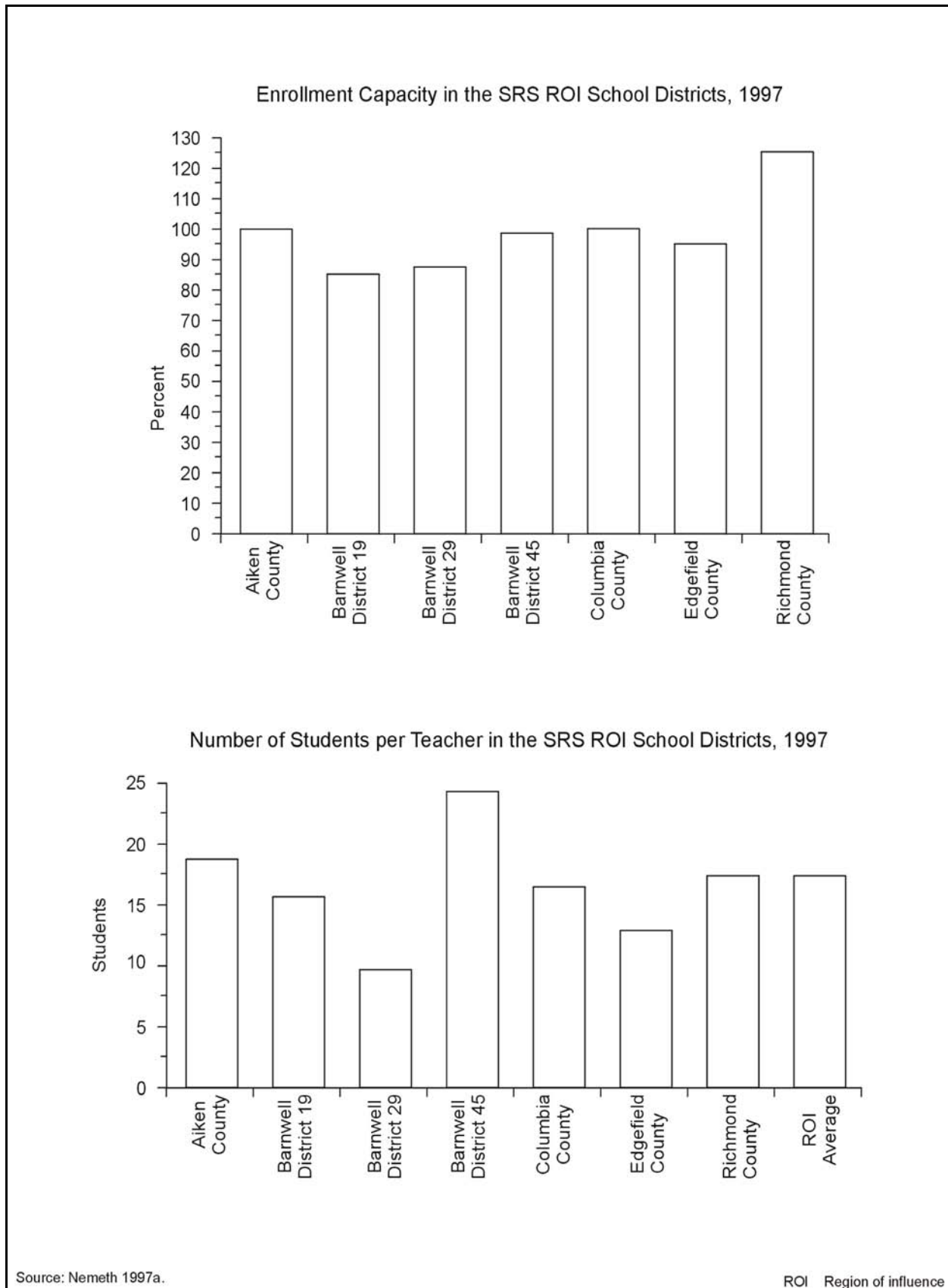

Figure 3-28. School District Characteristics for the SRS Region of Influence

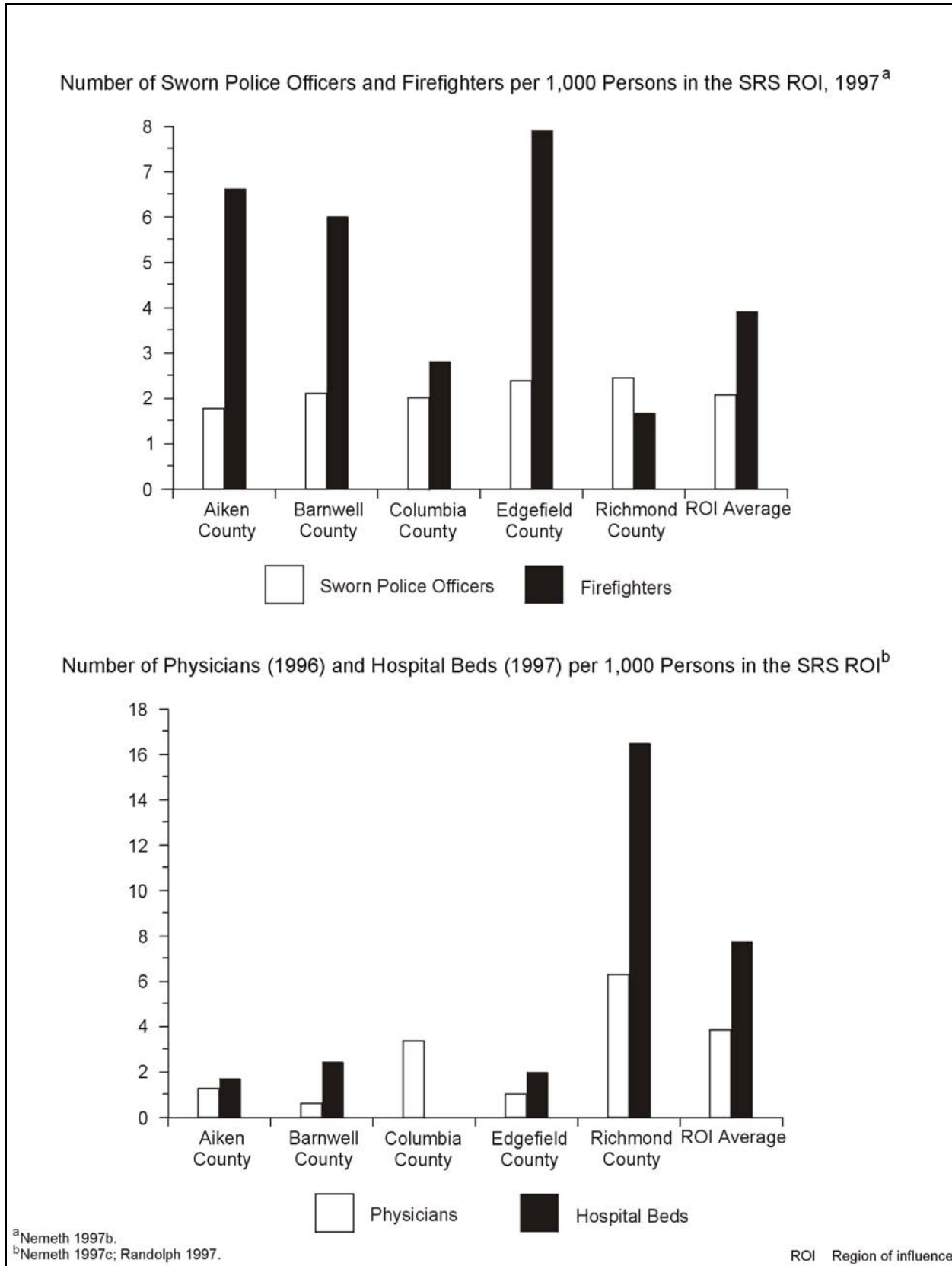

Figure 3–29. Public Safety and Health Care Characteristics for the SRS Region of Influence

3.5.3.4 Local Transportation

Vehicular access to SRS is provided by South Carolina State Routes 19, 64, and 125 (see Figure 2–5). Two road segments in the ROI could be affected by the disposition alternatives: South Carolina State Route 19 from U.S. I–78 at Aiken to U.S. 278 and South Carolina State Route 230 from U.S. 25 Business at North Augusta to U.S. I–25, I–78, and I–278. Three road improvement projects are planned that would alleviate traffic congestion leading into SRS.

The first improvement project is the widening of South Carolina State Route 302, Pine Log Road, from U.S. Route 78 and the construction of new segments to extend the route to South Carolina State Route 19. U.S. Route 25 is also being widened for one-half mile south of I–20. The widening project will be in conjunction with the second improvement project, the new construction of the Bobby Jones Expressway. The expressway will head in a southwest direction crossing South Carolina State Routes 126 and 125 and U.S. Route 1 and continue over the Savannah River to connect with the Georgia portion of the Bobby Jones Expressway, which is already constructed. The third improvement project is the completion of the South Carolina State Route 118 around Aiken. South Carolina State Route 118 will be widened with the construction of new segments to complete the by-pass (Sullivan 1997).

There is no public transportation to SRS. Rail service in the ROI is provided by the Norfolk Southern Corporation and CSX Transportation. SRS is provided rail access via Robbins Station on the CSX Transportation line.

Waterborne transportation is available via the Savannah River. Currently, the Savannah River is used primarily for recreation. SRS has no commercial docking facilities, but it has a boat ramp that has accepted large transport barge shipments.

Columbia Metropolitan Airport in the city of Columbia, South Carolina, and Bush Field in the city of Augusta, Georgia, receive jet air passenger and cargo service from both national and local carriers. Numerous smaller private airports are located in the ROI (DOE 1996a).

3.5.4 Existing Human Health Risk

Public and occupational health and safety issues include the determination of potentially adverse effects on human health that result from acute and chronic exposures to ionizing radiation and hazardous chemicals.

3.5.4.1 Radiation Exposure and Risk

3.5.4.1.1 General Site Description

Major sources and levels of background radiation exposure to individuals in the vicinity of SRS are shown in Table 3–44. Annual background radiation doses to individuals are expected to remain constant over time. The total dose to the population, in terms of person-rem, changes as the population size changes. Background radiation doses are unrelated to SRS operations.

Releases of radionuclides to the environment from SRS operations provide another source of radiation exposure to individuals in the vicinity of SRS. Types and quantities of radionuclides released from SRS operations in 1996 are listed in the *Savannah River Site Environmental Report for 1996* (Arnett and Mamatey 1997a:71–73). Doses to the public resulting from these releases are presented in Table 3–45. These doses fall within radiological limits per DOE Order 5400.5 (DOE 1993a:II-1–II-5) and are much lower than those of background radiation.

Table 3–44. Sources of Radiation Exposure to Individuals in the SRS Vicinity Unrelated to SRS Operations

Source	Effective Dose Equivalent (mrem/yr)
Natural background radiation^a	
Cosmic radiation	27
External radiation	28
Internal terrestrial radiation	40
Radon in homes (inhaled)	200 ^b
Other background radiation^c	
Diagnostic x rays and nuclear medicine	53
Weapons test fallout	<1
Air travel	1
Consumer and industrial products	10
Total	360

^a Arnett and Mamatey 1997a:116.

^b An average for the United States.

^c NCRP 1987:11, 40, 53.

Table 3–45. Radiation Doses to the Public From Normal SRS Operations in 1996 (Total Effective Dose Equivalent)

Members of the Public	Atmospheric Releases		Liquid Releases		Total	
	Standard ^a	Actual	Standard ^a	Actual ^b	Standard ^a	Actual
Maximally exposed individual (mrem)	10	0.06	4	0.14	100	0.20
Population within 80 km (person-rem) ^c	None	6.4	None	2.2	100	8.6
Average individual within 80 km (mrem) ^d	None	1.0×10^{-2}	None	3.2×10^{-3}	None	1.4×10^{-2}

^a The standards for individuals are given in DOE Order 5400.5 (DOE 1993a:II-1–II-5). As discussed in that order, the 10-mrem/yr limit from airborne emissions is required by the Clean Air Act, and the 4-mrem/yr limit is required by the Safe Drinking Water Act; for this SPD EIS the 4-mrem/yr value is conservatively assumed to be the limit for the sum of doses from all liquid pathways. The total dose of 100 mrem/yr is the limit from all pathways combined. The 100-person-rem value for the population is given in proposed 10 CFR 834, as published in 58 FR 16268 (DOE 1993b:para. 834.7). If the potential total dose exceeds the 100-person-rem value, it is required that the contractor operating the facility notify DOE.

^b Conservatively includes all water pathways, not just the drinking water pathway. The population dose includes contributions to Savannah River users downstream of SRS to the Atlantic Ocean.

^c About 620,100 in 1996. For liquid releases, an additional 70,000 water users in Port Wentworth, Georgia, and Beaufort, South Carolina (about 160 km [98 mi] downstream), are included in the assessment.

^d Obtained by dividing the population dose by the number of people living within 80 km (50 mi) of the site for atmospheric releases; for liquid releases the number of people includes water users who live more than 80 km (50 mi) downstream of the site.

Source: Arnett and Mamatey 1997a:108, 111, 112, 115.

Using a risk estimator of 500 cancer deaths per 1 million person-rem (5×10^{-4} fatal cancer per person-rem) to the public (see Appendix F.10), the fatal cancer risk to the maximally exposed member of the public due to radiological releases from SRS operations in 1996 is estimated to be 1.0×10^{-7} . That is, the estimated probability of this person dying of cancer at some point in the future from radiation exposure associated with 1 year of SRS operations is 1 in 10 million. (It takes several to many years from the time of radiation exposure for a cancer to manifest itself.)

According to the same risk estimator, 0.0043 excess fatal cancer is projected in the population living within 80 km (50 mi) of SRS from normal operations in 1996. To place this number in perspective, it may be compared with the number of fatal cancers expected in the same population from all causes. The 1996 mortality rate

associated with cancer for the entire U.S. population was 0.2 percent per year (Famighetti 1998:964). Based on this national mortality rate, the number of fatal cancers from all causes expected during 1996 in the population living within 80 km (50 mi) of SRS was 1,240. This expected number of fatal cancers is much higher than the 0.0043 fatal cancers estimated from SRS operations in 1996.

SRS workers receive the same dose as the general public from background radiation, but also receive an additional dose from working in facilities with nuclear materials. Table 3–46 presents the average worker and cumulative worker dose to SRS workers from operations in 1996. These doses fall within the radiological regulatory limits of 10 CFR 835 (DOE 1995b:paragraph 835.202). According to a risk estimator of 400 fatal cancers per 1 million person-rem among workers⁸ (Appendix F.10), the number of projected fatal cancers to SRS workers from normal operations in 1996 is 0.095.

Table 3–46. Radiation Doses to Workers From Normal SRS Operations in 1996 (Total Effective Dose Equivalent)

Occupational Personnel	Onsite Releases and Direct Radiation	
	Standard ^a	Actual
Average radiation worker (mrem)	None ^b	19.0
Total workers (person-rem) ^c	None	237

^a The radiological limit for an individual worker is 5,000 mrem/yr (DOE 1995a:para. 835.202). However, DOE’s goal is to maintain radiological exposure as low as reasonably achievable. It has therefore established an administrative control level of 2,000 mrem/yr (DOE 1994a:2-3); DOE must make reasonable attempts to maintain worker doses below this level.

^b No standard is specified for an “average radiation worker”; however, the maximum dose that this worker may receive is limited to that given in footnote “a.”

^c About 12,500 (badged) in 1996.

Source: Sessions 1997c.

A more detailed presentation of the radiation environment, including background exposures and radiological releases and doses, is presented in the *Savannah River Site Environmental Report for 1996* (Arnett and Mamatey 1997a). The concentrations of radioactivity in various environmental media (including air, water, and soil) in the site region (on and off the site) are also presented in that report.

3.5.4.1.2 Proposed Facility Locations

External radiation doses and concentrations of gross alpha, plutonium, and americium in air have been measured in F- and S-Areas. In 1996, the annual doses in the F- and S-Areas were 106 and 111 mrem, respectively. Both are higher than the dose of 87 mrem measured at the offsite control location. In the same year, the concentrations of gross alpha were about 1.3×10^{-3} pCi/m³ and 9.8×10^{-4} pCi/m³ in the F- and S-Areas, respectively, compared with the approximately 9.4×10^{-4} pCi/m³ measured at the offsite control location. The concentrations of plutonium 239 in the F- and S-Areas were about 8.4×10^{-7} and 0 pCi/m³, respectively. Offsite controls did not detect any plutonium 239 in the air in 1996 (Arnett and Mamatey 1997a:80; 1997b:31, 33, 40, 42).

⁸ The risk estimator for workers is lower than the estimator for the public because of the absence from the workforce of the more radiosensitive infant and child age groups.

3.5.4.2 Chemical Environment

The background chemical environment important to human health consists of the atmosphere, which may contain hazardous chemicals that can be inhaled; drinking water, which may contain hazardous chemicals that can be ingested; and other environmental media through which people may come in contact with hazardous chemicals (e.g., surface water during swimming, soil through direct contact, or food). Hazardous chemicals can cause cancer and noncancer health effects. The baseline data for assessing potential health impacts from the chemical environment are addressed in Section 3.5.1.

Effective administrative and design controls that decrease hazardous chemical releases to the environment and help achieve compliance with permit requirements (e.g., air emissions and NPDES permit requirements) contribute to minimizing health impacts on the public. The effectiveness of these controls is verified through the use of monitoring information and inspection of mitigation measures. Health impacts on the public may occur via inhalation of air containing hazardous chemicals released to the atmosphere during normal SRS operations. Risks to public health from other possible pathways, such as ingestion of contaminated drinking water or direct exposure, are lower than those via the inhalation pathway.

Baseline air emission concentrations and applicable standards for hazardous chemicals are addressed in Section 3.5.1. The baseline concentrations are estimates of the highest existing offsite concentrations and represent the highest concentrations to which members of the public could be exposed. These concentrations are in compliance with applicable guidelines and regulations. Information on estimating the health impacts of hazardous chemicals is presented in Appendix F.10.

Exposure pathways to SRS workers during normal operations may include inhaling contaminants in the workplace atmosphere and direct contact with hazardous materials. The potential for health impacts varies among facilities and workers, and available information is insufficient for a detailed estimate of impacts. Workers are protected from workplace hazards through appropriate training, protective equipment, monitoring, substitution, and engineering and management controls. They are also protected by adherence to OSHA and EPA standards that limit workplace atmospheric and drinking water concentrations of potentially hazardous chemicals. Appropriate monitoring that reflects the frequency and amounts of chemicals used in the operational processes ensures that these standards are not exceeded. Additionally, DOE requires that conditions in the workplace be as free as possible from recognized hazards that cause or are likely to cause illness or physical harm. Therefore, workplace conditions at SRS are substantially better than required by standards.

3.5.4.3 Health Effects Studies

One epidemiological study on the general population in communities surrounding SRS has been conducted and published. No evidence of excess cancer mortality, congenital anomalies, birth defects, early infancy deaths, strokes, or cardiovascular deaths was reported. The epidemiological literature on the facility reflects an excess of leukemia deaths among hourly workers; no other health effects for workers are reported. For a more detailed description of the studies reviewed and their findings, and for a discussion of the epidemiologic surveillance program implemented by DOE to monitor the health of current SRS workers, refer to Appendix M.4.7 of the *Storage and Disposition PEIS* (DOE 1996a:M-242, M-243).

3.5.4.4 Accident History

Between 1974 and 1988, there were 13 inadvertent tritium releases from the SRS tritium facilities. These releases were attributed to aging equipment in the tritium-processing facility and are one of the reasons for the construction of the Replacement Tritium Facility at SRS. A detailed description and study of these incidents and the consequences thereof for the offsite population have been documented by SRS. The most significant were

in 1981, 1984, and 1985, when, respectively, 32,934, 43,800, and 19,403 Ci of tritiated water vapor were released (DOE 1996a:3-259). From 1989 through 1992, there were 20 inadvertent releases, all with little or no offsite dose consequences. The largest of the recent releases occurred in 1992 when 12,000 Ci of tritium were released (Arnett, Karapatakis, and Mamatey 1993:260).

In 1993, an inadvertent release of 0.18 microcurie (mCi) of plutonium 238 and plutonium 239 took place. Westinghouse Savannah River Company emergency response models estimated an exposure of 0.0019 mrem to a hypothetical person at the site boundary (Arnett, Karapatakis, and Mamatey 1994:178).

3.5.4.5 Emergency Preparedness

Each DOE site has established an emergency management program that would be activated in the event of an accident. This program has been developed and maintained to ensure adequate response to most accident conditions and to provide response efforts for accidents not specifically considered. The emergency management program includes emergency planning, preparedness, and response.

The Emergency Preparedness Facility at SRS provides overall direction and control for onsite responses to emergencies and coordinates with Federal, State, and local agencies and officials on the technical aspects of the emergency. Emergency plans have been prepared for specific areas at SRS. Participating government agencies whose plans are interrelated with the SRS emergency plan for action include the States of South Carolina and Georgia, the City of Aiken, and the various counties in the general region of the site. Emergency response support, including firefighting and medical assistance, would be provided by these jurisdictions.

DOE has specified actions to be taken at all DOE sites to implement lessons learned from the emergency response to an accidental explosion at Hanford in May 1997. These actions and the timeframe in which they must be implemented are presented in Section 3.2.4.5.

3.5.5 Environmental Justice

Environmental justice concerns the environmental impacts that proposed actions may have on minority and low-income populations, and whether such impacts are disproportionate to those on the population as a whole in the potentially affected area. In the case of SRS, the potentially affected area includes parts of Georgia and South Carolina.

The potentially affected area around the location of the proposed surplus plutonium disposition facilities in F-Area is defined by a circle with an 80-km (50-mi) radius centered at the Actinide Packaging and Storage Facility (APSF), if built, (lat. 33E17'32" N, long. 81E40'26" W). The total population residing within that area in 1990 was 614,095. The proportion of the population there that was considered minority was 38.0 percent.

Figure 3-30 illustrates the racial and ethnic composition of the minority population in the potentially affected area surrounding APSF, if built. At the time of the 1990 census, Blacks were the largest minority group within that area, constituting 35.7 percent of the total population. Hispanics constituted about 1.1 percent, and Asians, about 1 percent. Native Americans comprised about 0.2 percent of the population (DOC 1992).

[Text deleted.]

The potentially affected area around S-Area is defined by a circle with an 80-km (50-mi) radius centered at DWPF (lat. 33E17'43" N, long. 81E38'25" W). The total population residing within that area in 1990 was 626,317. The proportion of the population around this facility that was considered minority was 38.5 percent.

Figure 3–30 illustrates the racial and ethnic composition of the minority population in the potentially affected area around the S-Area. At the time of the 1990 census, Blacks were the largest minority group within the potentially affected area, constituting 36.3 percent of the total population. Hispanics constituted about 1.0 percent, and Asians, about 1 percent. Native Americans constituted about 0.2 percent of the population (DOC 1992). The same census data show that the percentage of minorities for the contiguous United States was 24.1, and the percentages for the States of Georgia and South Carolina, 29.8 and 31.4, respectively (DOC 1992).

A breakdown of incomes in the potentially affected area is also available from the 1990 census data (DOC 1992). At that time, the poverty threshold was \$9,981 for a family of three with one related child under 18 years of age. A total of 107,057 persons (18.0 percent of the total population) residing within the potentially affected area around F-Area at APSF, if built, reported incomes below the poverty threshold. [Text deleted.] The low-income population around S-Area at DWPF was 109,217 (18.0 percent of the total population).

Data obtained during the 1990 census also show that of the total population of the contiguous United States, 13.1 percent reported incomes below the poverty threshold, and that Georgia and South Carolina reported 14.7 and 15.4 percent, respectively.

3.5.6 Geology and Soils

Geologic resources are consolidated or unconsolidated earth materials, including ore and aggregate materials, fossil fuels, and significant landforms. Soil resources are the loose surface materials of the earth in which plants grow, usually consisting of disintegrated rock, organic matter, and soluble salts.

3.5.6.1 General Site Description

Coastal Plain sediments beneath SRS overlie a basement complex composed of Paleocene crystalline and Triassic sedimentary formations of the Dunbarton Basin. Small and discontinuous zones of calcareous sand (i.e., sand containing calcium carbonate [calcite]), potentially subject to dissolution by water, are beneath some parts of SRS. If dissolution occurs in these zones, potential underground subsidence resulting in settling of the ground surface could occur. No settling as a result of dissolution of these zones has been identified. No economically viable geologic resources have been identified at SRS (DOE 1996a:3-241).

In the immediate region of SRS, there are no known capable faults. A capable fault is one that has had movement at or near the ground surface at least once within the past 35,000 years or recurrent movement within the past 500,000 years. Several faults have been identified from subsurface mapping and seismic surveys within the Paleozoic and Triassic basement beneath SRS. The largest of these is the Pen Branch Fault. There is no evidence of movement within the last 38 million years along this fault (DOE 1996a:3-241).

According to the Uniform Building Code, SRS is in Seismic Zone 2, meaning that moderate damage could occur as a result of an earthquake (DOE 1996a:3-241). Two earthquakes occurred during recent years inside the SRS boundary. On June 8, 1985, an earthquake with a local Richter scale magnitude of 2.6 and a focal depth of about 1 km (0.6 mi) occurred at SRS. Its epicenter was west of C- and K-Areas. The acceleration produced by the earthquake did not activate seismic monitoring instruments in the reactor areas. (These instruments have detection limits of 0.002g.) On August 5, 1988, another earthquake with a local Richter scale magnitude of 2.0 and a focal depth of about 2.7 km (1.7 mi) occurred at SRS. Its epicenter was northwest of K-Area. The seismic alarms in SRS facilities were not triggered. Existing information does not conclusively correlate the two earthquakes with any of the known faults on the site (DOE 1995c:3-7). Earthquakes capable of producing structural damage are not likely to occur in the vicinity of SRS (DOE 1996a:3-241).

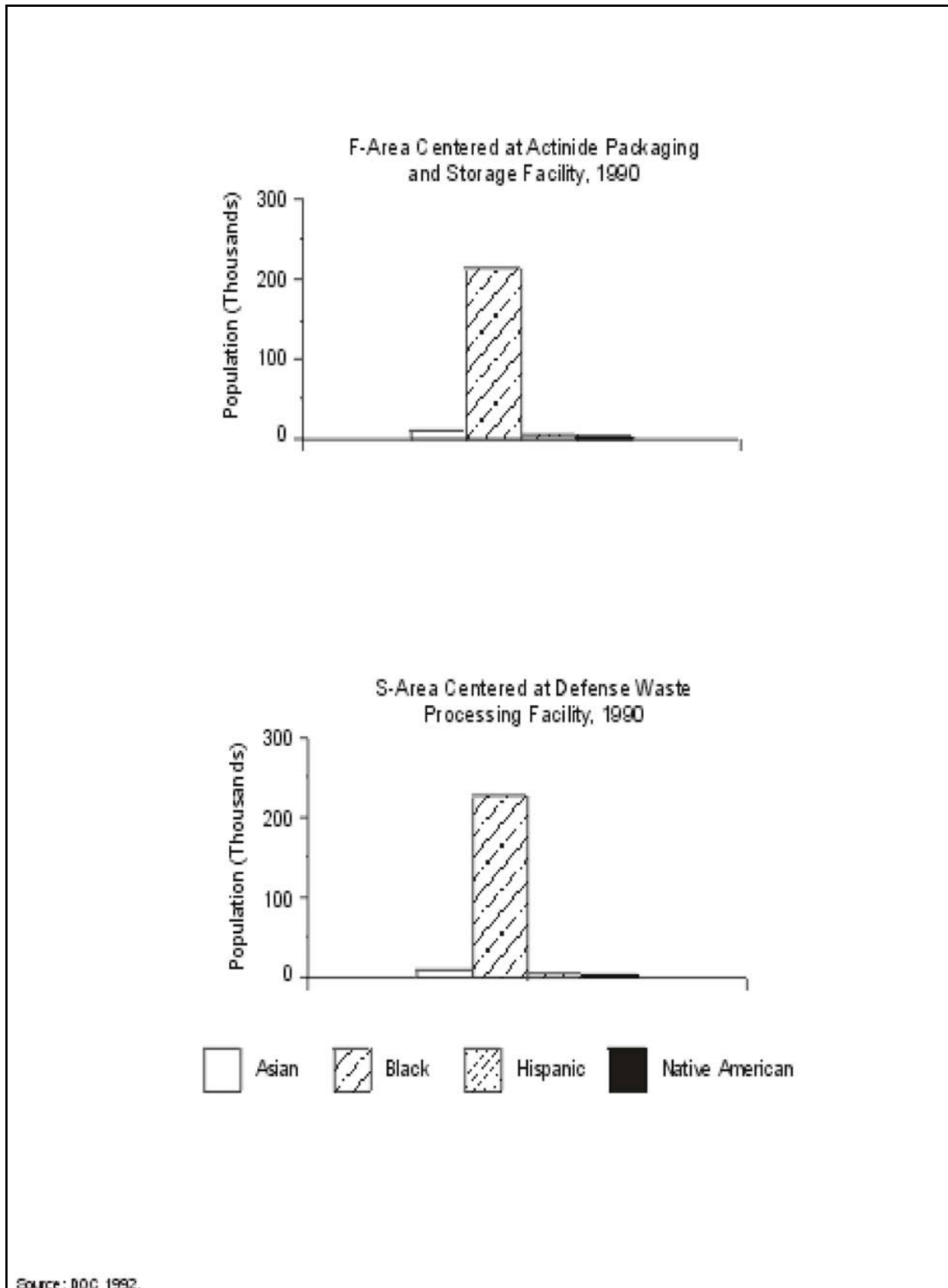

Figure 3-30. Racial and Ethnic Composition of Minorities Around SRS

Historically, two large earthquakes have occurred within 300 km (186 mi) of SRS. The largest of these, the Charleston earthquake of 1886, had an estimated Richter scale magnitude ranging from 6.5 to 7.5 (DOE 1996a:3-241). The SRS area experienced an estimated peak horizontal acceleration of 0.10g during this earthquake (DOE 1995c:3-6). An earthquake with a maximum horizontal acceleration of 0.19g is estimated to have an annual probability of occurrence of 1 in 5,000 at SRS (Barghusen and Feit 1995:2.13–16).

There are no volcanic hazards at SRS. The area has not experienced volcanic activity within the last 230 million years (DOE 1996a:3-241). Future volcanism is not expected because SRS is along the passive continental margin of North America (Barghusen and Feit 1995:2.13–16).

The soils at SRS are primarily sands and sandy loams. The somewhat excessively drained soils have a thick, sandy surface layer that extends to a depth of 2 m (6.6 ft) or more in some areas. Soil units that meet the soil requirements for prime farmland soils exist on SRS. However, the U.S. Department of Agriculture, Natural Resources Conservation Service, does not identify these lands as prime farmland due to the nature of site use; that is, the lands are not available for the production of food or fiber. The soils at SRS are considered acceptable for standard construction techniques (DOE 1996a:3-230, 3-241). Detailed descriptions of the geology and the soil conditions at SRS are included in the *Storage and Disposition PEIS* (DOE 1996a:3-241) and the *Savannah River Site Waste Management Final EIS* (DOE 1995c:3-4–3-6).

3.5.6.2 Proposed Facility Locations

Soils in F-Area are predominantly of the Fuquay-Blanton-Dothan association, consisting of nearly level to sloping, well-drained soils. Other soils include the Troup-Pickney-Lucy association, consisting of nearly level soils formed along, and parallel to, the floodplains of streams (Barghusen and Feit 1995:2.13–16).

Several subsurface investigations conducted on SRS waste management areas encountered soft sediments classified as calcareous sands. These sands were encountered in borings in S-Area between 33 and 35 m (108 to 115 ft) below ground surface. Preliminary information indicates that these calcareous zones are not continuous over large areas, nor are they very thick. No settling as a result of dissolution of these zones has been identified (DOE 1995c:3-6). Soils in S-Area are predominantly the same as those in F-Area (Barghusen and Feit 1995:2.13–16).

3.5.7 Water Resources

3.5.7.1 Surface Water

Surface water includes marine or freshwater bodies that occur above the ground surface, including rivers, streams, lakes, ponds, rainwater catchments, embayments, and oceans.

3.5.7.1.1 General Site Description

The largest river in the area of SRS is the Savannah River, which borders the site on the southwest. Six streams flow through SRS and discharge into the Savannah River: Upper Three Runs Creek, Beaver Dam Creek, Fourmile Branch, Pen Branch, Steel Creek, and Lower Three Runs Creek. Upper Three Runs Creek has two tributaries, Tims Branch and Tinker Creek; Pen Branch has one, Indian Grave Branch; and Steel Creek, one, Meyers Branch (DOE 1996a:3-236).

There are two manmade lakes at SRS: L-Lake, which discharges to Steel Creek, and Par Pond, which discharges to Lower Three Runs Creek. Also, about 299 Carolina bays—i.e., closed depressions capable of holding

water—occur throughout the site. While these bays receive no direct effluent discharges, they do receive storm-water runoff (DOE 1996a:3-236; WSRC 1997b:6-124).

Water has historically been withdrawn from the Savannah River for use mainly as cooling water; some, however, has been used for domestic purposes (DOE 1996a:3-236). SRS currently withdraws about 140 billion l/yr (37 billion gal/yr) from the river. Most of this water is returned to the river through discharges to various tributaries (DOE 1996a:3-236).

The average flow of the Savannah River is 283 m³/s (10,000 ft³/s). Three large upstream reservoirs, Hartwell, Richard B. Russell, and Strom Thurmond/Clarks Hill, regulate the flow in the Savannah River, thereby lessening the impacts of drought and flooding on users downstream (DOE 1995c:3-14).

Several communities in the area use the Savannah River as a source of domestic water. The nearest downstream water intake is the Beaufort-Jasper Water Authority in South Carolina, which withdraws about 0.23 m³/s (8.1 ft³/s) to service about 51,000 people. Treated effluent is discharged to the Savannah River from upstream communities and from treatment facilities at SRS. The average annual volume of flow discharged by the sewage treatment facilities at SRS is about 700 million l (185 million gal) (DOE 1996a:3-236; Barghusen and Feit 1995:2.13-18).

It is clear that the surplus plutonium disposition facilities would not be located within a 100-year floodplain, but there is no information concerning 500-year floodplains (DOE 1996a:3-236). No federally designated Wild and Scenic Rivers occur within the site (Barghusen and Feit 1995:2.13-2). A map showing the 100-year floodplain is presented as Figure 3–31 (Noah 1995:52).

The Savannah River is classified as a freshwater source that is suitable for primary and secondary contact recreation; drinking, after appropriate treatment; fishing; balanced indigenous aquatic community development and propagation; and industrial and agricultural uses. A comparison of Savannah River water quality upstream (river mile 160) and downstream (river mile 120) of SRS showed no significant differences for nonradiological parameters (Arnett and Mamatey 1996:73, 119, 120). A comparison of current and historical data shows that the coliform data are within normal fluctuations for river water in this area. For the different river locations, however, there has been an increase in the number of analyses in which standards were not met. The data for the river's monitoring locations generally met the freshwater standards set by the State; a comparison of the 1995 and earlier measurements for river samples showed no abnormal deviations. As for radiological constituents, tritium is the predominant radionuclide detected above background levels in the Savannah River (Arnett and Mamatey 1996:80, 120).

Surface water rights for SRS are determined by the Doctrine of Riparian Rights, which allows owners of land adjacent to or under the water to use the water beneficially (DOE 1996a:3-239). SRS has five NPDES permits, two (SC0000175 and SC0044903) for industrial wastewater discharges, two (SCR000000 and SCR100000) for general storm-water discharges, and one (ND0072125) for land application. Permit SC0000175 regulates 76 outfalls; permit SC0044903, another 7. The 1995 compliance rate for these outfalls was 99.8 percent. The 48 storm-water-only outfalls regulated by the storm-water permits are monitored as required. A pollution prevention plan has been developed to identify where best available technology and best management practices must be used. For storm-water runoff from construction activities extending over 2 ha (5 acres), a sediment reduction and erosion plan is required (Arnett and Mamatey 1996:24, 114, 115, 226).

3.5.7.1.2 Proposed Facility Locations

The land around F-Area drains to Upper Three Runs Creek and Fourmile Branch (DOE 1995c:3-17). Upper Three Runs Creek is a large, cool blackwater stream that flows into the Savannah River. It drains about

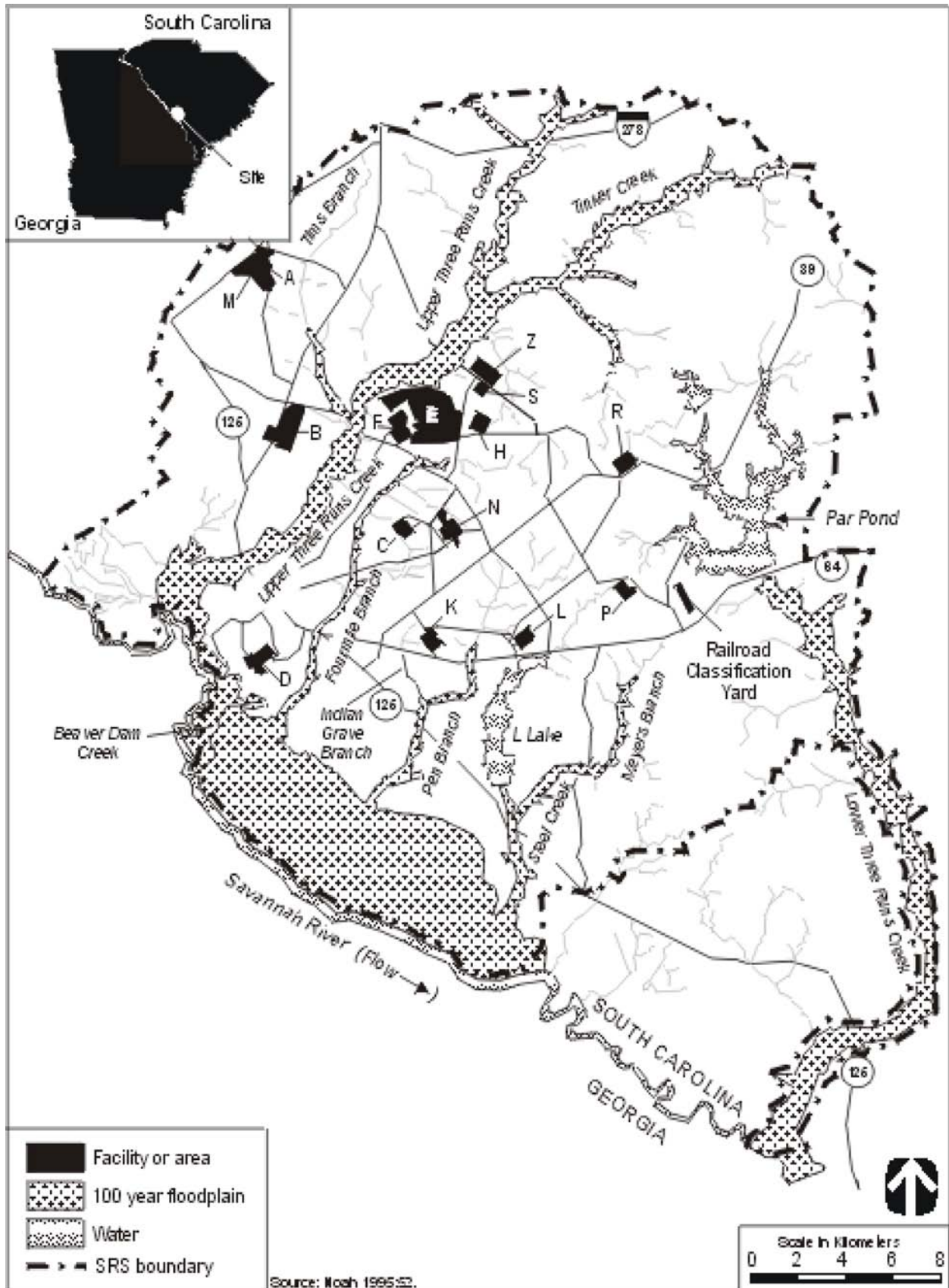

Figure 3-31. Locations of Floodplains at SRS

544 km² (210 mi²), and during water year 1991, had a mean discharge of 6.8 m³/s (240 ft³/s) near its mouth. The 7-day, 10-year low flow, which is the lowest flow over any 7 days within any 10-year period, is about 2.8 m³/s (100 ft³/s). The stream is about 40 km (25 mi) long and only its lower reaches extend through SRS. It receives more water from underground sources than any other SRS stream, and therefore has lower dissolved solids, hardness, and pH values. It is the only major stream on the site that has not received thermal discharges. It receives permitted discharges from several areas at SRS, including F-Area, S-Area, S-Area sewage treatment plant, and treated industrial wastewater from the Chemical Waste Treatment Facility steam condensate. Flow from the sanitary wastewater discharge averages less than 0.001 m³/s (0.035 ft³/s or 16 gal/min). A comparison with the 7-day, 10-year low flow of 2.8 m³/s (100 ft³/s) in Upper Three Runs Creek shows that the present discharges are very small. The analytical results for the active outfalls show the constituents of concern are maintained within permit limitations (DOE 1994c:3-12-3-15; 1995c:3-15, 3-19).

Fourmile Branch is a blackwater stream affected by past operational practices at SRS. Its headwaters are near the center of the site, and it flows southwesterly before discharging into the Savannah River. The watershed is about 54 km² (21 mi²) and receives permitted effluent discharges from F-Area and H-Area. This stream received cooling water discharges from C-Reactor while it was operating. Since those discharges ceased in 1985, the maximum recorded temperature in the stream has been 32 EC (90 EF), as opposed to ambient water temperatures that exceeded 60 EC (140 EF) when the reactor was operating. The average flow in the stream during C-Reactor operation was about 11.3 m³/s (400 ft³/s); since then flows have averaged about 1.8 m³/s (64 ft³/s) (DOE 1995c:3-19). In its lower reaches, this stream widens and flows via braided channels through a delta. Downstream of this delta area, it re-forms into one main channel, and most of the flow discharges into the Savannah River at river mile 152.1. When the Savannah River floods, water from Fourmile Branch flows along the northern boundary of the floodplain and joins with other site streams to exit the swamp via Steel Creek instead of flowing directly into the Savannah River (DOE 1995c:3-19).

The land surrounding S-Area also drains to Upper Three Runs Creek and Fourmile Branch. (Except for the differences noted in this section, stream information for F-Area is also relevant to S-Area.) Storm-water runoff from most of the area near DWPF is collected and discharged into a retention basin north of S-Area. Effluent from this basin is discharged at Outfall DW-005 to Crouch Branch, then to Upper Three Runs Creek (Arnett and Mamatey 1996:167; DOE 1994c:3-15). Analyses of samples from this outfall show a minimal impact of storm water on the water quality of Upper Three Runs Creek. Construction of DWPF adversely affected the water quality of Crouch Branch and McQueen Branch; however, enhanced erosion and sedimentation controls have been instituted at DWPF and in Z-Area. Also, startup of DWPF and the concurrent reduction in construction activities have assisted in reducing sediment loads to these streams (DOE 1994c:3-15).

3.5.7.2 Groundwater

Aquifers are classified by Federal and State authorities according to use and quality. The Federal classifications include Class I, II, and III groundwater. Class I groundwater is either the sole source of drinking water or is ecologically vital. Class IIA and IIB are current or potential sources of drinking water (or other beneficial use), respectively. Class III is not considered a potential source of drinking water and is of limited beneficial use.

3.5.7.2.1 General Site Description

Although many different systems have been used to describe groundwater systems at SRS, for this SPD EIS the same system used in the *Storage and Disposition PEIS* has been adopted. The uppermost aquifer is referred to as the water table aquifer. It is supported by the leaky "Green Clay" aquitard, which confines the Congaree aquifer. Below the Congaree aquifer is the leaky Ellenton aquitard, which confines the Cretaceous aquifer, also known as the Tuscaloosa aquifer. In general, groundwater in the water table aquifer flows downward to the Congaree aquifer or discharges to nearby streams. Flow in the Congaree aquifer is downward to the Cretaceous

aquifer or horizontal to stream discharge or the Savannah River, depending on the location within SRS (DOE 1996a:3-239).

Groundwater in the area is used extensively for domestic and industrial purposes. Most municipal and industrial water supplies are withdrawn from the Cretaceous or water table aquifer, while small domestic supplies are withdrawn from the Congaree or water table aquifer. It is estimated that about 13 billion l/yr (3.4 billion gal/yr) are withdrawn from the aquifers within a 16-km (10-mi) radius of the site, which is similar to the volume used by SRS (DOE 1996a:3-239). The Cretaceous aquifer is an important water resource for the SRS region. The water is generally soft, slightly acidic, and low in dissolved and suspended solids (DOE 1995c:3-11, 3-13). Aiken, South Carolina, for example, uses the Cretaceous aquifer for drinking water.

Groundwater is the only source of domestic water at SRS (DOE 1995c:3-13). All groundwater at SRS is classified by EPA as a Class II water source, and depth to groundwater ranges from near the surface to about 46 m (150 ft). In 1993, SRS withdrew about 13 billion l/yr (3.4 billion gal/yr) of groundwater to support site operations (DOE 1996a:3-239). There are no designated sole source aquifers in the area (Barghusen and Feit 1995:2.13-2).

Groundwater ranges in quality across the site: in some areas it meets drinking water quality standards, while in areas near some waste sites it does not. The Cretaceous aquifer is generally unaffected except for an area near A-Area, where TCE has been reported. TCE has also been reported in the A- and M-Areas in the Congaree aquifer. Tritium has been reported in the Congaree aquifer in the Separations Area. The water table aquifer is contaminated with solvents, metals, and low levels of radionuclides at several SRS sites and facilities. Groundwater eventually discharges into onsite streams or the Savannah River (DOE 1996a:3-239), but groundwater contamination has not been detected beyond SRS boundaries (DOE 1995c:3-13).

Groundwater rights in South Carolina are associated with the absolute ownership rule. Owners of land overlying a groundwater source are allowed to withdraw as much water as they desire; however, the State requires users who withdraw more than 379,000 l/day (100,000 gal/day) to report their withdrawals. SRS is required to report because its usage is above the reporting level (DOE 1996a:3-239).

3.5.7.2.2 Proposed Facility Locations

Groundwater in the shallow, intermediate, and deep aquifers flows in different directions, depending on the depths of the streams that cut the aquifers. The shallow aquifer discharges to Upper Three Runs Creek and Fourmile Branch. Shallow groundwater in the vicinity of S-Area flows toward Upper Three Runs Creek, McQueen Branch, or Fourmile Branch. Groundwater in the intermediate and deep aquifers flows horizontally toward the Savannah River and southeast toward the coast (DOE 1994c:3-4, 3-6).

Groundwater also moves vertically. In the shallow aquifer, it moves downward until its movement is obstructed by impermeable material. Operating under a different set of physical conditions, groundwater in the intermediate and deep aquifers flows mostly horizontally. Near F-Area it moves upward due to higher water pressure below the confining unit between the upper and lower aquifers. This upward movement helps to protect the lower aquifers from contaminants found in the shallow aquifer. The depth to groundwater in F-Area varies from about 1 to 20 m (3.3 to 66 ft) (DOE 1994c:3-6).

Groundwater quality in F-Area is not significantly different from that for the site as a whole. It is abundant, usually soft, slightly acidic, and low in dissolved solids. High dissolved iron concentrations occur in some aquifers. Where needed, groundwater is treated to raise the pH and remove iron. Results of sampling in the shallow aquifer have indicated excursions from drinking water standards for lead, tetrachloroethylene, and tritium in S-Area wells (DOE 1994c:3-6, 3-9).

F-Area groundwater quality can exceed drinking water standards for several contaminants. Near the F-Area seepage basins and inactive process sewer line, radionuclide contamination is widespread. Most of these wells contain tritium above drinking water standards. Other wells exhibit gross alpha, gross beta, strontium 90, and iodine 129 above their standards. Other radionuclides found above proposed standards in several wells include americium 241; curium 243 and 244; radium 226 and 228; strontium 90; total alpha-emitting radium; and uranium 233, 234, 235, and 238. Cesium 137, curium 245 and 246, and plutonium 238 were also found (Arnett and Mamatey 1996:143, 144).

Near the F-Area Tank Farm, tritium, mercury, nitrate-nitrite as nitrogen, cadmium, gross alpha, and lead were detected above drinking water standards in one or more wells. The pH exceeded the basic standard, and trichlorofluoromethane (Freon 11), which has no drinking water standard, was present in elevated levels (Arnett and Mamatey 1996:153).

At the F-Area Sanitary Sludge Land Application Site, tritium, specific conductance, lead, and copper were found to exceed their drinking water standards in one or more wells (Arnett and Mamatey 1996:154). Groundwater near the F-Area Acid/Caustic Basin consistently exceeded drinking water standards for gross alpha. Total alpha-emitting radium, alkalinity, gross beta, nitrate as nitrogen, and pH were above their respective standards in one or more wells (Arnett and Mamatey 1996:138). The groundwater near the F-Area Coal Pile Runoff Containment Basin did not exceed any chemical or radiological standard during 1995 (Arnett and Mamatey 1996:141).

Groundwater flow and conditions in S-Area are not significantly different from those in F-Area. Tritium, tetrachloroethylene, and TCE exceeded the drinking water standards near the S-Area facilities. The groundwater in one well near the S-Area Low-Point Pump Pit also contained tritium in excess of drinking water standards. No other radiological or chemical constituents have been detected above standards since 1989 (Arnett and Mamatey 1996:149). Near the S-Area vitrification building, also known as the S-Area Canyon, tritium exceeded drinking water standards, and specific conductance and alkalinity were elevated (Arnett and Mamatey 1996:149).

3.5.8 Ecological Resources

Ecological resources are defined as terrestrial (predominantly land) and aquatic (predominantly water) ecosystems characterized by the presence of native and naturalized plants and animals. For the purposes of this SPD EIS, those ecosystems are differentiated in terms of habitat support of threatened, endangered, and other special-status species—that is, “nonsensitive” versus “sensitive” habitat.

3.5.8.1 Nonsensitive Habitat

Nonsensitive habitat comprises those terrestrial and aquatic areas of the site that typically support the region’s major plant and animal species.

3.5.8.1.1 General Site Description

At least 90 percent of the SRS land cover is composed of upland pine and bottomland hardwood forests (DOE 1997a:4-97). Five major plant communities have been identified at SRS: bottomland hardwood (most commonly sweetgum and yellow poplar); upland hardwood-scrub oak (predominantly oaks and hickories); pine/hardwood; loblolly, longleaf, and slash pine; and swamp. The loblolly, longleaf, and slash pine community covers about 65 percent of the upland areas of the site. Swamp forests and bottomland hardwood forests occur along the Savannah River and the numerous streams found on the site (Figure 3–32) (DOE 1995a:vol. 1, app. C, 4-47; 1996a:3-242).

The biodiversity of the region is extensive due to the variety of plant communities and the mild climate. Animal species known to inhabit SRS include 44 species of amphibians, 255 species of birds, 54 species of mammals, and 59 species of reptiles. Common species include the eastern box turtle, Carolina chickadee, common crow, eastern cottontail, and gray fox (DOE 1996a:3-242; WSRC 1997b:3-3). Game animals include a number of species, two of which, the white-tailed deer and feral hogs, are hunted on the site (DOE 1996d:3-56). Raptors, such as the Cooper's hawk and black vulture, and carnivores, such as the gray fox are ecologically important groups at SRS (DOE 1996a:3-242).

Aquatic habitat includes manmade ponds, Carolina bays, reservoirs, and the Savannah River and its tributaries. There are more than 50 manmade impoundments throughout the site that support populations of bass and sunfish. Carolina bays, a type of wetland unique to the southeastern United States, are natural shallow depressions that occur in interstream areas. These bays can range from lakes to shallow marshes, herbaceous bogs, shrub bogs, or swamp forests. Among the 299 Carolina bays found throughout SRS, fewer than 20 have permanent fish populations. Redfin pickerel, mud sunfish, lake chubsucker, and mosquito fish are present in these bays. Although sport and commercial fishing is not permitted at SRS, the Savannah River is used extensively for both. Important commercial species are the American shad, hickory shad, and striped bass, all of which are anadromous. The most important warm-water game fish are bass, pickerel, crappie, bream, and catfish (DOE 1996a:3-244; WSRC 1997b:6-124).

3.5.8.1.2 Proposed Facility Locations

F-Area and S-Area are situated on an upland plateau between the drainage areas of Upper Three Runs Creek and Fourmile Branch. These heavily industrialized areas are dominated by buildings, paved parking lots, graveled construction areas, and laydown yards; little natural vegetation remains inside the fenced areas. Grassed areas occur around the administration buildings, and some vegetation is present along drainage ditches, but most of the developed areas have no vegetation (DOE 1994c:3-24; 1995b:vol. 1, app. C, 4-47). The most common plant communities in the vicinities of F-Area and S-Area include loblolly, longleaf, and slash pine; upland hardwood-scrub oak; pine/hardwood; and bottomland hardwood (DOE 1995c:3-34, 3-35; DOE 1996a:3-242). Cleared fields are also common in F-Area, and a roughly 6-ha (15-acre) oak-hickory forest area designated as a National Environmental Research Park set aside is northwest of F-Area (DOE 1996a:3-242).

A recent (1994–1997) study was conducted to document the composition and diversity of urban wildlife, those species of amphibians, birds, mammals and reptiles that inhabit or temporarily use the developed areas on SRS. Results indicate that the use of the developed areas by wildlife species is more common than has been previously reported (Mayer and Wike 1997:8, 52). A total of 41 wildlife species were observed in and around F-Area, including 18 species of birds, 11 species of mammals, and 12 species of reptiles. Similarly, S-Area produced sightings of 36 wildlife species, including 19 species of birds, 9 species of mammals, and 8 species of reptiles. Bird species commonly seen include the bufflehead (F-Area only), turkey vulture, black vulture, killdeer, rock dove, mourning dove, chimney swift (F-Area only), great crested flycatcher (F-Area only), barn swallow, common crow, fish crow, northern mockingbird, American robin, loggerhead shrike (S-Area only), European starling, house sparrow (S-Area only), red-winged blackbird (S-Area only), and common grackle. Frequently sighted mammals include the Virginia opossum, eastern cottontail (F-Area only), house mouse, feral cat, striped skunk, and raccoon. The only reptile commonly observed is the banded water snake (Mayer and Wike 1997:9–14).

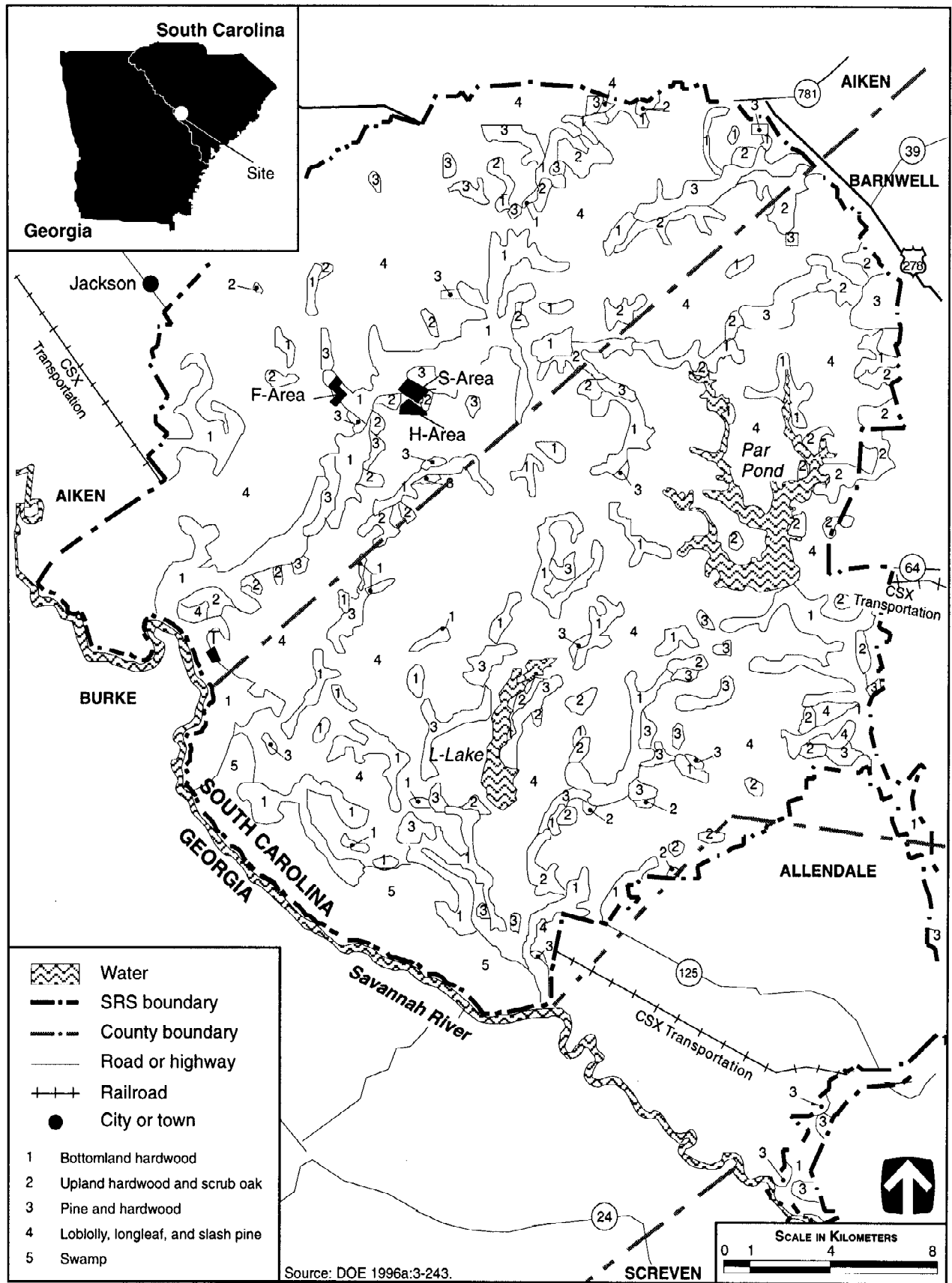

Figure 3-32. Major Plant Communities at SRS

Upper Three Runs Creek and its tributaries and three Carolina bays constitute the aquatic habitat in the vicinity of F-Area and S-Area. Streams support largemouth bass, black crappie, and various species of pan fish. Upper Three Runs Creek has a rich fauna; more than 551 species of aquatic insects have been collected (DOE 1996a:3-244; WSRC 1997b:5-32). It is important as a spawning area for blueback herring, and as a seasonal nursery habitat for American shad, striped bass, and other Savannah River species. Aquatic resources information on the three Carolina bays is unavailable (DOE 1996a:3-244).

3.5.8.2 Sensitive Habitat

Sensitive habitat comprises those terrestrial and aquatic (including wetlands) areas of the site that support threatened and endangered, State-protected, and other special-status plant and animal species.⁹

3.5.8.2.1 General Site Description

SRS wetlands, most of which are associated with floodplains, streams, and impoundments, include bottomland hardwood, cypress-tupelo, scrub-shrub, and emergent vegetation, as well as open water. Swamp forest along the Savannah River is the most extensive wetlands vegetation type (DOE 1996a:3-242).

Sixty-one threatened, endangered, and other special-status species listed by the Federal Government or the State of South Carolina may be found in the vicinity of SRS, as shown in Table 3.7.6-1 in the *Storage and Disposition PEIS*. No critical habitat for threatened or endangered species exists on SRS (DOE 1996a:3-245).

3.5.8.2.2 Proposed Facility Locations

No federally listed threatened or endangered species are known to occur in F-Area or S-Area, but several species that may exist in the general vicinity of these areas are listed in Table 3-47. The American alligator, although listed as threatened (by virtue of similarity in appearance to the endangered crocodile) is fairly abundant on SRS. It was recently observed near F-Area, but its occurrence there is seen as uncommon. Furthermore, no State-listed protected species have been found in any developed area on SRS, and of the State-listed organisms known to occur, none would be expected to use any of the disturbed areas for extended periods (Mayer and Wike 1997:42).

The Pen Branch area, about 14 km (8.7 mi) southwest of the proposed sites, and an area south of Par Pond, about 12 km (7.5 mi) to the southeast, support active bald eagle nests. Wood storks have been observed about 21 km (13 mi) from the proposed site, near the Fourmile Branch delta. The closest colony of red-cockaded woodpeckers is about 5 km (3.1 mi) away, but suitable forage habitat exists on the proposed sites. The smooth purple coneflower, the only endangered plant species found on SRS, could be found on the proposed sites (DOE 1996a:3-245). Botanical surveys conducted by the Savannah River Forest Station in 1992 and 1994 identified three populations of Oconee azalea in the area northwest of F-Area. This State-listed rare plant species, was found on the steep slopes adjacent to the Upper Three Runs Creek floodplain (DOE 1995c:3-37).

3.5.9 Cultural and Paleontological Resources

Cultural resources are human imprints on the landscape and are defined and protected by a series of Federal laws, regulations, and guidelines. Field studies conducted over the past two decades by the South Carolina Institute of Archaeology and Anthropology of the University of South Carolina have provided considerable information about the distribution and content of cultural resources at SRS. About 60 percent of SRS has been surveyed, and 858 archaeological (historic and prehistoric) sites have been identified (DOE 1995c). There are 67 sites considered potentially eligible for listing on the National Register; most of the sites have not yet been

⁹ The Federal Government defines threatened and endangered species in the Endangered Species Act, and wetlands in 33 CFR 328.3.

Table 3–47. Threatened and Endangered Species, Species of Concern, and Sensitive Species Occurring or Potentially Occurring in the Vicinity of F-Area and S-Area

Common Name	Scientific Name	Federal Status	State Status
Birds			
Bald eagle	<i>Haliaeetus leucocephalus</i>	Threatened	Endangered
Red-cockaded woodpecker	<i>Picoides borealis</i>	Endangered	Endangered
Wood stork	<i>Mycteria americana</i>	Endangered	Endangered
Plants			
Oconee azalea	<i>Rhododendron flammeum</i>	Not listed	Species of Concern
Smooth purple coneflower	<i>Echinacea laevigata</i>	Endangered	Endangered
Reptiles			
American alligator	<i>Alligator mississippiensis</i>	Threatened (S/A) ^a	Not listed

^a Protected under the Similarity of Appearance Provision of the Endangered Species Act.

Source: DOE 1996a:3-245–3-248; EuDaly 1998; Mayer and Wike 1997:9–14, 42.

evaluated (DOE 1996a:3-249). No SRS nuclear production facilities have been nominated for the National Register, and there are no plans for nominations. Existing SRS facilities lack architectural integrity and do not contribute to the broad historic theme of the Manhattan Project and the production of World War II era nuclear materials (DOE 1995c:vol. I, 3-53, 3-54).

Cultural sites are often occupied continuously or intermittently over substantial time spans. For this reason, a single location (sites) may contain evidence of use during both historic and prehistoric periods. In the discussions that follow, the numbers of prehistoric and historic resources are presented; the sum of these resources may be greater than the total number of sites reported due to this dual-use history at sites. Therefore, where the total number of sites reported is less than the sum of prehistoric and historic sites certain locations were used during both periods.

Cultural resources at SRS are managed under the terms of a programmatic memorandum of agreement among the DOE Savannah River Operations Office, the South Carolina State Historic Preservation Officer, and the Advisory Council on Historic Preservation, dated August 24, 1990 (WSRC 1997b:sec. 2.6). Guidance on the management of cultural resources at SRS is included in the *Archaeological Resources Management Plan of the Savannah River Archaeological Research Program* (SRARP 1989).

3.5.9.1 Prehistoric Resources

Prehistoric resources are physical properties that remain from human activities that predate written records.

3.5.9.1.1 General Site Description

Prehistoric resources at SRS consist of villages, base camps, limited-activity sites, quarries, and workshops. An extensive archaeological survey program begun at SRS in 1974 includes numerous field studies such as reconnaissance surveys, shovel test transects, and intensive site testing and excavation. There is prehistoric evidence of more than 800 sites, some of which may fall in the vicinity of the proposed facilities. Fewer than 8 percent of these sites have been evaluated for National Register eligibility (DOE 1996a:3-249).

3.5.9.1.2 Proposed Facility Locations

Within F-Area, land areas have been disturbed over the past 46 years by activities associated with construction and operation of the extant facilities. Although no archaeological surveys have been conducted within the

boundary of F-Area, no prehistoric cultural materials have been, or are expected to be, identified within this industrial area.

The proposed construction area adjacent to F-Area has been surveyed for prehistoric and historic archaeological resources. A number of archaeological sites within this area contain prehistoric materials considered potentially eligible for nomination to the National Register (Cabak, Sassaman, and Gillam 1996:199–312; SRARP 1997; Stephenson and King 1999). Prior to any activity with potential impact on the sites in this area, a consultation process would be initiated with the South Carolina State Historic Preservation Officer to formally determine the eligibility of specific sites and to determine necessary and appropriate mitigation measures.

A survey of S-Area prior to construction of DWPF revealed no archaeological resources potentially eligible for nomination to the National Register.

3.5.9.2 Historic Resources

Historic resources consist of physical properties that postdate the existence of written records. In the United States, historic resources are generally considered to be those that date no earlier than 1492.

3.5.9.2.1 General Site Description

Types of historic sites include farmsteads, tenant dwellings, mills, plantations and slave quarters, rice farm dikes, dams, cattle pens, ferry locations, towns, churches, schools, cemeteries, commercial building locations, and roads. About 400 historic sites or sites with historic components have been identified within SRS, and some of these may fall within the locations of the proposed facilities. To date, about 10 percent of the historic sites have been evaluated for National Register eligibility. Most pre-SRS era historic structures were demolished during the initial establishment of SRS in 1950. Two SRS era buildings built in 1951 remain in use. From a Cold War perspective, SRS has been involved in tritium operations and other nuclear material production for more than 40 years; therefore, some existing facilities and engineering records may have significant historical and scientific content (DOE 1996a:3-249).

3.5.9.2.2 Proposed Facility Locations

Within F-Area, land areas have been disturbed over the past 46 years by activities associated with the construction and operation of the extant facilities. Although no surveys have been conducted within the boundary of F-Area, no historic resources are expected to be identified with the possible exception of surviving facilities and engineering records from the Cold War era (DOE 1996a:3-249).

The proposed construction area adjacent to and northeast of F-Area has been surveyed for prehistoric and historic archaeological resources. Four known archaeological resources containing historic materials are considered potentially eligible for nomination to the National Register (Cabak, Sassaman, and Gillam 1996:199–312). Prior to any activity with potential impact on the sites in this area, a consultation process would be initiated with the South Carolina State Historic Preservation Officer to formally determine the eligibility of specific sites and to determine necessary and appropriate mitigation measures.

A survey of S-Area in conjunction with the 1982 DWPF EIS revealed no archaeological resources potentially eligible for nomination to the National Register (DOE 1994c:3–37).

3.5.9.3 Native American Resources

Native American resources are sites, areas, and materials important to Native Americans for religious or heritage reasons. In addition, cultural values are placed on natural resources such as plants, which have multiple purposes within various Native American groups. Of primary concern are concepts of sacred space that create the potential for land-use conflicts.

3.5.9.3.1 General Site Description

Native American groups with traditional ties to the area include the Apalachee, Cherokee, Chickasaw, Creek, Shawnee, Westo, and Yuchi. At different times, each of these groups was encouraged by the English to settle in the area to provide protection from the French, Spanish, or other Native American groups. Main villages of both the Cherokee and Creek were located southwest and northwest of SRS, respectively, but both groups may have used the area for hunting and gathering activities. During the early 1800s, most of the remaining Native Americans residing in the region were relocated to the Oklahoma Territory (DOE 1996a:3-249).

Native American resources in the region include remains of villages or townsites, ceremonial lodges, burials, cemeteries, and natural areas containing traditional plants used in religious ceremonies. Literature reviews and consultations with Native American representatives have revealed concerns related to the American Indian Religious Freedom Act within the central Savannah River valley, including some sensitive Native American resources and several plants traditionally used in ceremonies (DOE 1996a:3-249).

3.5.9.3.2 Proposed Facility Locations

In 1991, DOE conducted a survey of Native American concerns about religious rights in the central Savannah River valley. During this study, three Native American groups, the Yuchi Tribal Organization, the National Council of Muskogee Creek, and the Indian People's Muskogee Tribal Town Confederacy, expressed continuing interest in the SRS region with regard to the practice of their traditional religious beliefs. The Yuchi Tribal Organization and the National Council of Muskogee Creek have expressed concerns that several plant species—for example, redroot (*Lachnanthese carolinianum*), button snakeroot (*Erynglum yuccifolium*), and American ginseng (*Panax quinquefolium*)—traditionally used in tribal ceremonies could exist on SRS. Redroot and button snakeroot are known to occur on SRS, but are typically found in wet, sandy areas such as evergreen shrub bogs and savannas. Neither species is likely to be found in F-Area or S-Area due to clearing prior to the establishment of SRS in the 1950s (DOE 1994c:3-37). Consultations (see Chapter 5 and Appendix O) were initiated with appropriate Native American groups to determine any concerns associated with the actions evaluated in this SPD EIS.

3.5.9.4 Paleontological Resources

Paleontological resources are the physical remains, impressions, or traces of plants or animals from a former geological age.

3.5.9.4.1 General Site Description

Paleontological materials from the SRS area date largely from the Eocene Age (54 to 39 million years ago) and include fossil plants, numerous invertebrate fossils, giant oysters (*Crassostrea gigantissima*), other mollusks, and bryozoa. With the exception of the giant oysters, all other fossils are fairly widespread and common; therefore, the assemblages have low research potential or scientific value (DOE 1996a:3-249).

3.5.9.4.2 Proposed Facility Locations

No paleontological resources have been recorded for either F-Area or S-Area.

3.5.10 Land Use and Visual Resources

3.5.10.1 Land Use

Land may be characterized by its potential for the location of human activities (land use). Natural resource attributes and other environmental characteristics could make a site more suitable for some land uses than for others. Changes in land use may have both beneficial and adverse effects on other resources (biological, cultural, geological, aquatic, and atmospheric).

Located in southwestern South Carolina, SRS occupies an area of about 800 km² (310 mi²) in a generally rural area about 40 km (25 mi) southeast of Augusta, Georgia, and 19 km (12 mi) south of Aiken, South Carolina, the nearest population centers (DOE 1996a:3-228). The site is owned by the Federal Government and is administered, managed, and controlled by DOE (DOE 1996a:3-230). It is bordered by the Savannah River to the southwest and includes portions of three South Carolina counties: Aiken, Allendale, and Barnwell (DOE 1996a:3-230).

3.5.10.1.1 General Site Description

Forest and agricultural land predominate in the areas bordering SRS. There are also significant open water and nonforested wetlands along the Savannah River Valley. Incorporated and industrial areas are the only other significant land uses. There is limited urban and residential development bordering SRS. The three counties in which SRS is located have not zoned any of the site land. The only adjacent area with any zoning is the town of New Ellenton, which has lands in two zoning categories bordering SRS: urban development and residential development. The closest residences are to the west, north, and northeast, within 60 m (200 ft) of the site boundary (DOE 1996a:3-230).

Various industrial, manufacturing, medical, and farming operations are conducted in areas around the site. Major industrial and manufacturing facilities in the area include textile mills, plants producing polystyrene foam and paper products, chemical processing plants, and a commercial nuclear power plant. Farming is diversified in the region; it includes crops such as peaches, watermelon, cotton, soybeans, corn, and small grains (DOE 1995b:vol. 1, app. C, 4-2).

Outdoor public recreation facilities are plentiful and varied in the SRS region. Included are the Sumter National Forest, 75 km (47 mi) to the northwest; Santee National Wildlife Refuge, 80 km (50 mi) to the east; and Clarks Hill/Strom Thurmond Reservoir, 70 km (43 mi) to the northwest. There are also a number of State, county, and local parks in the region, most notably Redcliffe Plantation, Rivers Bridge, Barnwell and Aiken County State Parks in South Carolina, and Mistletoe State Park in Georgia (DOE 1995b:vol. I, app. C, 4-2). The Crackerneck Wildlife Management Area, which extends over 1,930 ha (4,770 acres) of SRS adjacent to the Savannah River, is open to the public for hunting and fishing. Public hunts are allowed under DOE Order 4300.1C, which states that “all installations having suitable land and water areas will have programs for the harvesting of fish and wildlife by the public” (Noah 1995:48). SRS is a controlled area, public access being limited to through traffic on South Carolina Highway 125 (SRS Road A), U.S. Highway 278 (SRS Road 1), and the CSX railway line (DOE 1995b:vol. 1, app. C, 4-2).

Land use at SRS can be classified into three major categories: forest/undeveloped, water/wetlands, and developed facilities. Generalized land uses at SRS and vicinity are shown on Figure 3–33. Approximately

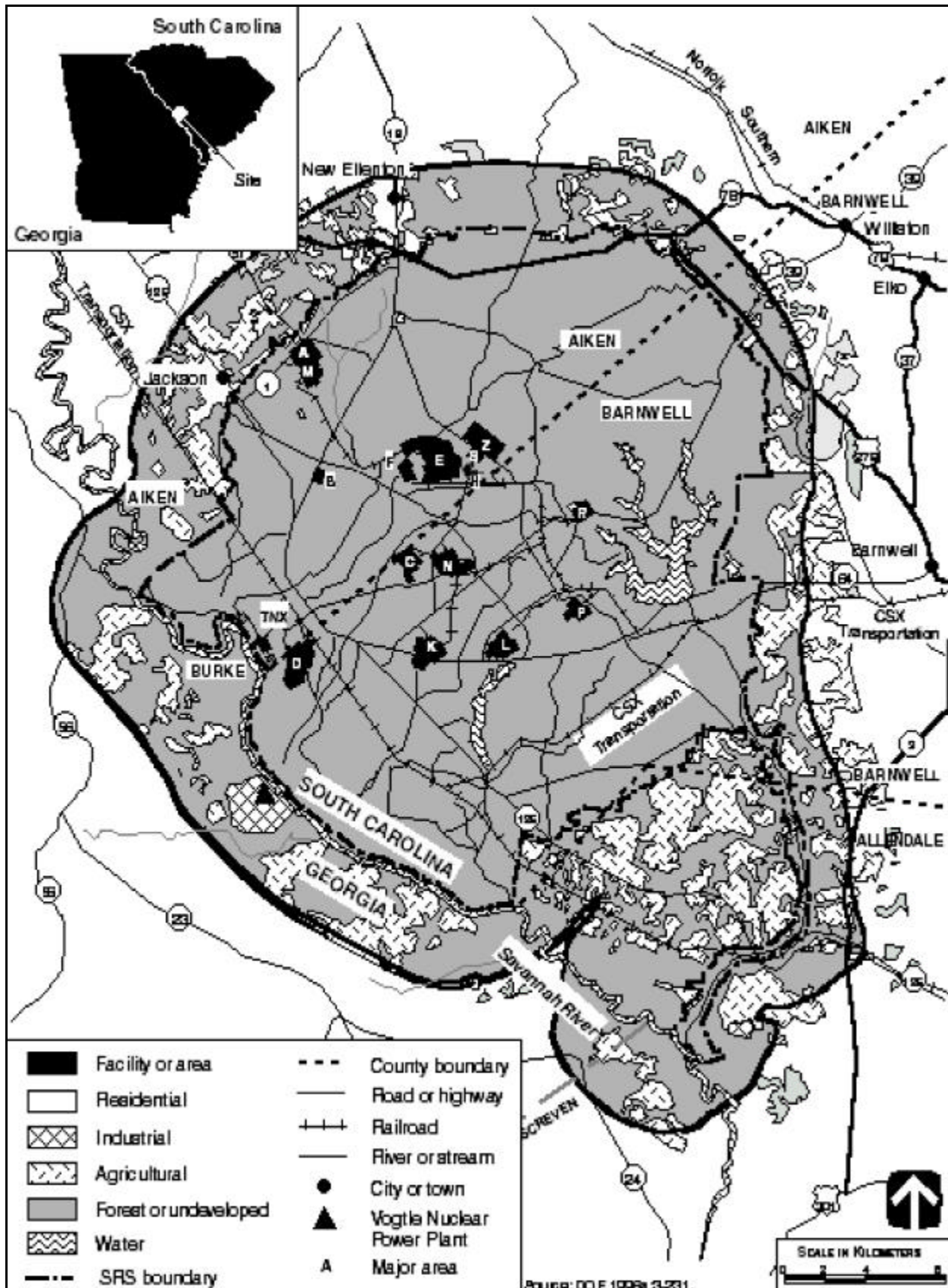

Figure 3-33. Generalized Land Use at SRS and Vicinity

585 km² (226 mi²) of SRS—i.e., 73 percent of the area—is undeveloped (DOE 1996a:3-230). Wetlands, streams, and lakes account for 180 km² (70 mi²) or 22 percent of the site, while developed facilities including production and support areas, roads, and utility corridors only make up approximately 5 percent or 40 km² (15 mi²) of SRS (DOE 1996a:3-230). The woodlands area is primarily in revenue-producing, managed timber production. The U.S. Forest Service, under an interagency agreement with DOE, harvests about 7.3 km² (2.8 mi²) of timber from SRS each year (DOE 1997e:4-57). Soil map units that meet the requirements for prime farmland soils exist on the site. However, the U.S. Department of Agriculture, Natural Resources Conservation Service, does not identify these as prime farmlands because the land is not available for agricultural production (DOE 1996a:3-230).

In 1972, DOE designated all of SRS as a National Environmental Research Park. The National Environmental Research Park is used by the national scientific community to study the impacts of human activities on the cypress swamp and hardwood forest ecosystems (DOE 1996a:3-230). DOE has set aside approximately 57 km² (22 mi²) of SRS exclusively for nondestructive environmental research (DOE 1997e:4-57). A portion of SRS is open to the public for hunting and fishing.

Decisions on future land uses at SRS are made by DOE through the site development, land use, and future planning processes. SRS has established a Land Use Technical Committee composed of representatives from DOE, Westinghouse Savannah River Company, and other SRS organizations. DOE prepared the *FY 1994 Draft Site Development Plan*, which describes the current SRS mission and facilities, evaluates possible future missions and requirements, and outlines a master development plan that is now being prepared. In January 1996a, DOE published the *SRS Future Use Project Report*, which summarizes stakeholder-preferred future use recommendations that DOE considers throughout future planning and decisionmaking activities (DOE 1997e:4-57).

The State of South Carolina, through Act 489, as amended in 1994, requires local jurisdictions to undertake comprehensive planning. Regional-level planning also occurs within the State, with the State divided into 10 planning districts guided by regional advisory councils (DOE 1996a:3-230). The counties of Aiken, Allendale, and Barnwell together constitute part of the Lower Savannah River Council of Governments. Private lands bordering SRS are subject to the planning regulations of these three counties.

No onsite areas are subject to Native American Treaty Rights. However, five Native American groups, the Yuchi Tribal Organization, the National Council of Muskogee Creek, the Indian Peoples Muskogee Tribal Town Confederacy, the Pee Dee Indian Association, and the Ma Chis Lower Alabama Creek Indian Tribe, have expressed concern over sites and items of religious significance on SRS. DOE routinely notifies these organizations about major planned actions at SRS and asks them to comment on SRS documents prepared in accordance with NEPA.

3.5.10.1.2 Proposed Facility Locations

Many buildings are situated within F-Area. Included is Building 221-F, one of the canyons where plutonium was recovered from targets during DOE's plutonium production phase. Land use at Building 221-F in F-Area is classified as heavy industrial. This 30-m (100-ft) concrete structure is designed for plutonium immobilization. F-Area occupies approximately 160 ha (395 acres) of the site; S-Area, 110 ha (272 acres). These areas are about 14 km (8.7 mi) and 10 km (6.2 mi), respectively, from the site boundary.

Also within F-Area will be the Actinide Packaging and Storage Facility (if built), a planned below-grade facility for receiving and storing Category I quantities of special nuclear material (UC 1999). For those alternatives that involve installing the plutonium conversion and immobilization facilities at SRS, DWPF in S-Area would provide the second-stage immobilization services (DOE 1994c:3-29).

3.5.10.2 Visual Resources

Visual resources are natural and human-created features that give a particular landscape its character and aesthetic quality. Landscape character is determined by the visual elements of form, line, color, and texture. All four elements are present in every landscape; however, they exert varying degrees of influence. The stronger the influence exerted by these elements in a landscape, the more interesting the landscape. The more visual variety that exists with harmony, the more aesthetically pleasing the landscape.

3.5.10.2.1 General Site Description

The dominant viewshed in the vicinity of SRS consists mainly of agricultural land and forest, with some limited residential and industrial areas. The SRS landscape is characterized by wetlands and upland hills. Vegetation is composed of bottomland hardwood forests, scrub oak and pine woodlands, and wetland forests. DOE facilities are scattered throughout SRS and are brightly lit at night. These facilities are generally not visible offsite, as views are limited by rolling terrain, normally hazy atmospheric conditions, and heavy vegetation. The only areas visually impacted by the DOE facilities are those within the view corridors of State Highway 125 and SRS Road 1.

The developed areas and utility corridors (transmission lines and aboveground pipelines) of SRS are consistent with a VRM Class IV designation. The remainder of SRS is consistent with VRM Class III or IV (DOE 1996a:3-230; DOI 1986a, 1986b).

3.5.10.2.2 Proposed Facility Locations

Industrial facilities within F-Area consist of large concrete structures, smaller administrative and support buildings, and parking lots (DOE 1994c:3-38). The structures range in height from 3 to 30 m (10 to 100 ft), with a few stacks and towers that reach 60 m (200 ft). The facilities in this area are brightly lit at night and visible when approached via SRS access roads. Visual resource conditions in F-Area are consistent with VRM Class IV (DOI 1986a, 1986b; Sessions 1997c:sec. 2.1, table 2-1). F-Area is about 7 km (4.3 mi) from State Highway 125 and 8.5 km (5.3 mi) from SRS Road 1. Public view of F-Area facilities is restricted by heavily wooded areas bordering segments of the SRS Road 1 system and site-crossing State Highway 125. Moreover, those facilities are not visible from the Savannah River, which is about 10 km (6.2 mi) to the west.

Industrial facilities within S-Area consist of large concrete buildings, smaller administrative and support buildings, and parking lots (DOE 1994c:3-38). The facilities in this area are brightly lit at night and visible when approached via SRS access roads. Visual resource conditions in S-Area are consistent with a VRM Class IV designation (DOI 1986a, 1986b; Sessions 1997c:sec. 2.1, table 2-1). S-Area is about 10 km (6.2 mi) from State Highway 125 and 11 km (6.8 mi) from SRS Road 1. Public view of S-Area facilities is restricted by heavily wooded areas bordering segments of the SRS Road 1 system and site-crossing State Highway 125. Moreover, those facilities are not visible from the Savannah River, which is about 15 km (9.3 mi) to the west.

3.5.11 Infrastructure

Site infrastructure includes those utilities and other resources required to support construction and continued operation of mission-related facilities identified under the various alternative actions.

3.5.11.1 General Site Description

SRS comprises numerous research, processing, and administrative facilities. An extensive infrastructure system supports these facilities, as shown in Table 3-48.

Table 3–48. SRS Sitewide Infrastructure Characteristics

Resource	Current Usage	Site Capacity
Transportation		
Roads (km)	230	230
Railroads (km)	103	103
Electricity		
Energy consumption (MWh/yr)	420,000	5,200,000
Peak load (MW)	70	330
Fuel		
Natural gas (m ³ /yr)	NA	NA
Oil (l/yr)	28,400,000	NA ^a
Coal (t/yr)	210,000	NA ^a
Water (l/yr)	1,780,000,000	3,870,000,000

^a As supplies get low, more can be supplied by truck or rail.

Key: NA, not applicable.

Source: Sessions 1997a:2.

3.5.11.1.1 Transportation

SRS has an extensive network—230 km (143 mi)—of roads to meet its onsite intrasite transportation requirements. The railroad infrastructure, which consists of 103 km (64 mi) of track, provides for deliveries of large volumes of coal and oversized structural components (Table 3–48).

3.5.11.1.2 Electricity

The SRS electrical grid is a 115-kV system in a ring arrangement that supplies power to operating areas, administrative areas, and independent and support function areas. That system includes about 160 km (100 mi) of transmission lines. Power is supplied to the grid by three South Carolina Electric & Gas Company (SCE&G) transmission lines. SRS is situated in, and draws its power from, the Virginia-Carolina Sub-Region, an electric power pool area that is a part of the Southeastern Electrical Reliability Council. Most of that power comes from offsite coal-fired and nuclear-powered generating plants (Sessions 1997c:sec. 2.8).

Current site electricity consumption is about 420,000 MWh/yr. Site capacity is about 5.2 million MWh/yr. The peak load capacity is 330 MW; the peak load usage, 70 MW (Sessions 1997c:sec. 2.8).

3.5.11.1.3 Fuel

Coal and oil are used at SRS primarily to power the steam plants. Steam generation facilities at SRS include coal-fired powerhouses at A-, D-, and H-Areas and two package steam boilers, which use number 2 fuel oil, in K-Area. Coal is delivered by rail and is stored in coal piles in A-, D- and H-Areas. Oil is delivered by truck to K-Area. Coal is used to fuel A-Area powerhouse that provides process and heating steam for the main administrative area at SRS. D-Area powerhouse provides most of the steam for the SRS process area (Sessions 1998a). Natural gas is not used at SRS.

3.5.11.1.4 Water

A new central domestic water system serves the majority of the site. The system includes three wells and a 17-million-l/day (4.5-million-gal/day) water treatment plant in A-Area; two wells and an 8.3-million-l/day (2.2-million-gal/day) backup water treatment plant in B-Area; three elevated storage tanks; and a 43-km (27-mi)

pipings loop (Sessions 1997c:sec. 2.8). The system’s available flow capacity is approximately 13,060 l/min (3,450 gal/min) (DOE 1997f:3-35). Process water is provided to individual site areas. See Section 3.5.11.2.3 for more information.

3.5.11.1.5 Site Safety Services

The SRS fire department operates under a 12-hr rotational shift schedule, with three fire stations. Among the firefighters and officers are members of the SRS Hazardous Materials Response Team and the Rescue Team, responsible for rescues of all types. The fire department is supported by a fleet of 20 vehicles, including six pumpers, one pumper-tanker, one tanker, one aerial platform ladder truck, one light duty rescue vehicle, one mini-pumper for grass fires, one specially prepared emergency response step van and trailer for hazardous materials response, and two boats for waterway spill response and control. Inspections are performed periodically according to National Fire Protection Codes and Standards (WSRC 1994).

3.5.11.2 Proposed Facility Locations

A summary of the infrastructure characteristics for F-Area and S-Area is provided in Table 3–49.

Table 3–49. SRS Infrastructure Characteristics for F-Area and S-Area

Resource	F-Area		S-Area	
	Current Usage	Capacity	Current Usage	Capacity
Electricity				
Energy consumption (MWh/yr)	78,300	561,000	37,400	385,000
Peak load (MW)	14.5	64.0	6.0	14.5
Fuel				
Natural gas (m ³ /yr)	NA	NA	NA	NA
Oil (l/yr)	NA	NA	NA	NA
Coal (t/yr)	NA	NA	NA	NA
Water (l/yr)	374,000,000	1,590,000,000	49,800,000	797,000,000

Key: NA, not applicable.

Source: Sessions 1997a.

3.5.11.2.1 Electricity

Electric power for F-Area is provided by the 200–F Power Loop, which is supplied by the 251–F electrical substation. This substation consists of two 115/13.8-kV, 24/32-MVA transformers and associated switchgear. The 13.8-kV power is distributed through a 2,000-A–rated bus (Sessions 1997c:sec. 2.8). F-Area electrical energy consumption is about 78,300 MWh/yr; F-Area electrical capacity, about 561,000 MWh/yr (Sessions 1997a).

Electric power for S-Area is provided by two 13.8-kV feeders supplied by the 251–H electrical substation. This substation consists of two 115/13.8-kV, 24/32-MVA transformers and associated switchgear. The 13.8-kV power is distributed through two 2,000-A–rated buses. The 13.8-kV bus tie breaker is normally closed. S-Area electrical energy consumption is about 37,400 MWh/yr; electrical capacity in S-Area, about 385,000 MWh/yr (Sessions 1997a; 1997c:sec. 2.8).

3.5.11.2.2 Fuel

Coal and oil are not required in F- or S-Area because steam is supplied from the central facility, and electricity is supplied from the site electrical grid system (Sessions 1998b).

3.5.11.2.3 Water

F-Area water usage of domestic water is about 374 million l/yr (100 million gal/yr) from the new central domestic water system. Currently available capacity for F-Area is about 1.6 billion l/yr (420 million gal/yr) (Sessions 1997a; 1997c:sec. 2.8). |

S-Area has managed its supply of water until recently and has used an average of 50 million l/yr (13 million gal/yr). Now that it is connected to the new central domestic water system, the area has access to the system's excess capacity of 797 million l/yr (211 million gal/yr) (Sessions 1997a; 1997c:sec. 2.8). |

Process and service water are supplied through deep-well systems within site areas. Wells 905-100F and 905-102F supply process and service water to F-Area; wells 905-1S and 905-2S to S-Area's DWPF. These wells are screened in the McQueen Branch (Lower Tuscaloosa) aquifer (Sessions 1997c:sec. 2.8). Each of these process water systems is capable of delivering 1,987 million l/yr (525 million gal/yr) of water (Sessions 1997a; 1997c:sec 2.8). Current usage of process and service water in F-Area is 481 million l/yr (127 million gal/yr) and about 3.79 million l/yr (1 million gal/yr) in S-Area (Sessions 1997a). |

3.6 LEAD ASSEMBLY FABRICATION AND POSTIRRADIATION EXAMINATION SITES

3.6.1 Hanford Overview

Hanford is located in the southeast portion of Washington State, occupying about 1,450 km² (560 mi²). The 400 Area occupies 0.6 km² (0.2 km²). Additional information on Hanford and the 400 Area is provided in Section 3.2.

[Text deleted.]

The options proposed for lead assembly fabrication at Hanford would use existing employees and buildings; therefore, major facility modifications would not be required. For this reason, detailed descriptions of environmental resources such as geology and soils, water, ecological, cultural and paleontological, land use and visual, socioeconomics, and environmental justice are not required for the 400 Area. For additional information on the resource areas that could be impacted by lead assembly fabrication activities in the 400 Area, refer to Sections 3.2.1, 3.2.2, 3.2.4, and 3.2.11.

3.6.2 ANL-W Overview

Located in the southeast portion of INEEL is ANL-W. ANL-W is about 328 ha (820 acres). Atomic City, 29 km (18 mi) southwest, is the closest populated area to ANL-W; it has a population of 25. Idaho Falls, population of about 45,000, is 63 km (39 mi) east of ANL-W (see Figure 2-3). In 1997, about 700 employees worked at ANL-W (O'Connor et al. 1998b).

Established in the mid-1950s, the primary mission of the ANL-W was to support advanced liquid metal reactor research (DOE 1996h:Idaho 4). In 1995, ANL-W began a Redirected Nuclear Research and Development Program to conduct research in the treatment of DOE spent nuclear fuel and reactor decontamination and decommissioning technologies (O'Connor et al. 1998b).

[Text deleted.]

The options proposed for lead assembly fabrication and postirradiation examination at ANL-W would occur in existing facilities that would not require major modifications and would use existing employees. For this reason, detailed descriptions of environmental resources such as geology and soils, water, ecological, cultural and paleontological, land use and visual, socioeconomics, and environmental justice are not provided. For more information on these resource areas, refer to Section 3.3. The resource areas that could be impacted by lead assembly fabrication activities are air quality, waste management, existing human health risk, and infrastructure. These resource areas are described below.

3.6.2.1 Air Quality

The meteorological conditions at INEEL are considered to be representative for ANL-W. Emissions of criteria pollutants at ANL-W result from the ongoing operation of onsite boilers used to produce steam for heating. Existing ambient air pollutant concentrations at INEEL are in compliance with applicable guidelines and regulations. See Section 3.3.1 for additional information on air quality for areas surrounding INEEL.

3.6.2.2 Waste Management

ANL-W analyzes, stores, and ships TRU waste, hazardous waste, mixed waste, LLW, and nonhazardous waste generated by the numerous research and support facilities at INEEL (O'Connor et al. 1998b).

The Waste Characterization Area, in the ANL–W Hot Fuels Examination Facility, is a glovebox facility used for characterization of TRU. The Radioactive Scrap and Waste Facility, in the northeast corner of ANL–W, provides underground vault storage for remote-handled LLW, mixed LLW, and TRU waste. The Radioactive Scrap and Waste Facility is a State of Idaho RCRA-permitted facility (O’Connor et al. 1998b).

The Radioactive Sodium Storage Facility is in an ANL–W controlled access area. The Radioactive Sodium Storage Facility is a RCRA-permitted storage facility used to store radioactive and heavy metal contaminated debris along with sodium and sodium-potassium alloy mixed waste (O’Connor et al. 1998b).

The sanitary wastewater treatment facility, 6,057-m³/yr (21,390-ft³/yr) capacity, is the only waste treatment facility at ANL–W. Other forms of waste generated at ANL–W are treated and disposed of at INEEL waste facilities or shipped off the site (O’Connor et al. 1998b). More information on waste management activities at INEEL can be found in Section 3.3.2.

3.6.2.3 Existing Human Health Risk

See Section 3.3.4 for major sources and levels of background radiation, mean concentrations of radiological releases, and offsite estimated dose rates to individuals within the vicinity of INEEL. Site worker radiological exposure data at ANL–W for 1994–1996 is provided in Table 3–50. Worker exposure limits at ANL–W remain within applicable limits.

Table 3–50. Worker Exposure Data for ANL–W, 1994–1996

Year	Radiation Worker Dose		All Workers	
	(mrem)	(person-rem)	(mrem)	(person-rem)
1994	34	28	19	34
1995	50	41	27	43
1996	56	45	31	45

Key: ANL–W, Argonne National Laboratory–West.

Source: O’Connor et al. 1998b.

3.6.2.4 Infrastructure

The site infrastructure at ANL–W includes those utilities and other resources required to support construction and continued operation of mission-related facilities. Table 3–51 shows facility infrastructure information for the proposed facility location. An adequate infrastructure exists at ANL–W to support current activities. See Section 3.3.11 for more detailed information on INEEL’s infrastructure.

3.6.3 LLNL Overview

LLNL is composed of two sites: Livermore Site and Site 300 (see Figure 2–31). The Livermore Site is about 80 km (50 mi) east of San Francisco and 6.4 km (4 mi) from downtown Livermore. It occupies about 332 ha (821 acres) of flat terrain in the Livermore Valley. Site 300 is about 24 km (15 mi) southeast of the Livermore Site (DOE 1996h:California 67; 1996i:4-328).

Table 3–51. ANL–W Infrastructure Characteristics

Resource	Current Usage
Electricity	
Energy consumption (MWh/yr)	4,200
Peak load (MWe)	5,088
Fuel	
Natural gas (m ³ /yr)	0
Liquid (m ³)	0
Coal (t/yr)	0
Steam (kg/h)	690
Water	
Annual (l/yr)	1,500,000
Peak (l/yr)	2,000,000

Key: ANL–W, Argonne National Laboratory–West.

Source: O’Connor et al. 1998b:S-10.

Originally used as a naval air training station, the Livermore Site was established in 1952 to conduct nuclear weapons research. Site 300 is a remote high-explosives testing facility. The current mission of LLNL is research, testing, and development that focuses on national defense and security, energy, the environment, and biomedicine (DOE 1996h:California 69). Within recent years, LLNL’s mission has broadened to include global security, ecology, and mathematics and science education. In early 1998, LLNL had about 7,700 employees (O’Connor et al. 1998c).

[Text deleted.]

The options proposed for lead assembly fabrication at LLNL would occur in existing facilities that would not require major modifications and would use existing employees. For this reason, detailed descriptions of environmental resources such as geology and soils, water, ecological, cultural and paleontological, land use and visual, socioeconomic, and environmental justice are not provided. For a detailed discussion of these resource areas, refer to the *Stockpile Stewardship and Management Final PEIS* (DOE 1996i). The resource areas that could be impacted by lead assembly fabrication activities are air quality, waste management, existing human health risk, and infrastructure. These resource areas are described below.

3.6.3.1 Air Quality

The Livermore Site is in the San Francisco Bay Area Air Quality Management District. This area is designated as attainment for all criteria pollutants with respect to attainment of the NAAQS (EPA 1998b); however, EPA has recently redesignated the area as nonattainment for ozone (EPA 1998c). The emissions of criteria air pollutants at the Livermore Site result from the ongoing operation of numerous boilers for heating; solvent cleaning operations; emergency generators; and various experimental, testing, and process sources. The Bay Area Air Quality Management District and the San Joaquin Valley Unified Air Pollution Control District requested that the Livermore Site assess the impact of toxic air emissions on the surrounding area. The risks at the Livermore Site were found to be below the threshold values used to determine the need for additional evaluation (DOE 1996i:4-334). For a detailed discussion of this resource area, refer to Section 4.7.2.3 of the *Stockpile Stewardship and Management Final PEIS* (DOE 1996i:4-333).

3.6.3.2 Waste Management

LLNL was added to EPA's National Priorities List in July 1987 based on the presence of volatile organic compounds in the groundwater. In November 1988, DOE, EPA, the California Department of Health Services, and the Bay Area Regional Water Quality Control Board signed an FFCA to facilitate compliance with CERCLA, the Superfund Amendments and Reauthorization Act, and applicable State laws. In a remedial investigation/feasibility study prepared pursuant to CERCLA, DOE outlined its cleanup strategy for the LLNL Livermore Site. A ROD issued on July 15, 1992, included an announcement of DOE's decision to pump and treat contaminated groundwater and construct approximately seven small treatment facilities. The selected remedies address the principal concerns at LLNL by removing the contaminants from soil and groundwater and treating the effluents to the extent necessary for protection of human health and the environment (O'Connor et al. 1998c:3).

Through its research and operation activities, LLNL treats, stores, packages, and prepares TRU, low-level, mixed low-level, hazardous, and nonhazardous wastes for transport. Waste is treated and stored on the site and then shipped off the site for additional treatment and disposal. No disposal of waste occurs at the Livermore Site (DOE 1996h:California 78). LLNL waste generation rates and inventories are shown in Table 3-52. Table 3-53 provides information on waste management facilities at LLNL.

Table 3-52. Waste Generation Rates and Inventories at LLNL

Waste Type	Generation Rate (m ³ /yr)	Inventory (m ³)
TRU ^a	27	257
Contact-handled		
LLW	124	644
Mixed LLW ^b	353	454
Hazardous	579	NA ^c
Nonhazardous		
Liquid	456,000	NA ^c
Solid	4,280	NA ^c

^a Includes mixed TRU waste.

^b Includes TSCA mixed LLW.

^c Generally, hazardous and nonhazardous wastes are not held in long-term storage.

Key: LLNL, Lawrence Livermore National Laboratory; LLW, low-level waste; NA, not applicable; TRU, transuranic; TSCA, Toxic Substances Control Act.

Source: DOE 1996i:4-400 for hazardous and nonhazardous waste; DOE 1996d:15, 16 for all other wastes.

For a more detailed discussion of waste management activities at the Livermore Site, refer to Section 4.7.2.10 of the *Stockpile Stewardship and Management Final PEIS* (DOE 1996i:4-358) or Section 4.15.2 of the *Final EIS and Environmental Impact Report for Continued Operation of LLNL and Sandia National Laboratories, Livermore* (DOE 1992:4-239).

Table 3–53. Waste Management Facilities at LLNL

Facility Name/Description	Capacity	Status	Applicable Waste Types				
			TRU	LLW	Mixed LLW	Haz	Non-Haz
Treatment facilities (m³/yr)							
LLW size reduction	771	Online		X			
Building 513 and 514 Waste Treatment Facility ^a	2,012	Online		X	X	X	X
Decontamination and waste treatment facility	Not determined	Planned	X	X	X	X	X
Storage facilities (m³)							
Building 233, 625	217	Online	X	X	X	X	X
Building 280	513	Online	X	X			X
Building 513, 514, area 612–2	222	Online		X	X	X	X
Area 612–1	1,086	Online	X	X	X	X	X
Area 612–4	169	Online	X	X	X	X	X
Area 612–5	760	Online	X	X	X	X	X
Area 612 tanks	57	Online		X	X	X	X
Building 612 lab packaging unit	16	Online		X	X	X	X
Building 614, 693	298	Online	X	X	X	X	X
612 yard, area 612–3	1,327	Online		X			X
Building 696	590	Online	X	X			X
Disposal facilities (m³/yr)							
LLNL sanitary sewer	2,327,800	Online					X

^a Treatment methods employed in Building 513 are solidification and shredding. Methods used in Building 514 are evaporation, blending, separation, gas adsorption, silver recovery, and wastewater treatment (Kielusiak 1998a).

Key: Haz, hazardous; LLNL, Lawrence Livermore National Laboratory; LLW, low-level waste; TRU, transuranic.

Source: Kielusiak 1998b.

3.6.3.3 Existing Human Health Risk

Major sources and levels of background radiation exposure to individuals in the vicinity of LLNL are shown in Table 3–54. Annual background radiation doses to individuals are expected to remain constant over time. Total dose to the population changes as population size changes. Background radiation doses are unrelated to LLNL operations.

Release of radionuclides to the environment from LLNL operations provides another source of radiation exposure to the population in the vicinity. Doses to the public resulting from these releases are shown in Table 3–55. These doses fall within regulatory limits (DOE 1993a) and are small when compared with background radiation exposure.

Using a risk estimator of 500 cancer deaths per 1 million person-rem (5×10^{-4} fatal cancer per person-rem) to the public (see Appendix F.10), the fatal cancer risk to the maximally exposed member of the public due to radiological releases from LLNL operations in 1996 is estimated to be 4.7×10^{-8} . That is, the estimated probability of this person dying from cancer from radiation exposure from 1 year of LLNL operations is slightly less than 5 chances in 100 million.

Table 3–54. Sources of Radiation Exposure to Individuals in the LLNL Vicinity Unrelated to LLNL Operations

Source	Effective Dose Equivalent (mrem/yr)
Natural background radiation	
Internal terrestrial radiation	40
Cosmic radiation	30
External terrestrial radiation	30
Radon in homes (inhaled)	200
Other background radiation	
Diagnostic x rays and nuclear medicine	53
Weapons test fallout	<1
Nuclear fuel cycle	<1
Total	354

Key: LLNL, Lawrence Livermore National Laboratory.

Note: Values for radon and weapons test fallout are averages for the United States.

Source: Harrach et al.:12-18.

Table 3–55. Radiation Doses to the Public From Normal LLNL Operations in 1996 (Total Effective Dose Equivalent)

Members of the Public	Atmospheric Releases		Liquid Releases		Total	
	Standard ^a	Actual	Standard ^a	Actual	Standard ^a	Actual
Maximally exposed individual (mrem) ^a	10	0.093	4	0	100	0.093
Population within 80 km (person-rem) ^b	None	1.1	None	0	100	1.1
Average exposed individual within 80 km (mrem) ^c	None	0.000175	None	0	None	0.000175

^a The standards for individuals are given in DOE Order 5400.5. As discussed in that order, the 10-mrem/yr limit for airborne emissions is required by the Clean Air Act. The 4-mrem/yr limit is required by the Safe Drinking Water Act; for this SPD EIS, the 4-mrem/yr value is conservatively assumed to be the limit for the sum of doses from all liquid pathways. The total dose of 100 mrem/yr is the limit from all combined pathways. The 100-person-rem value for the population is given in proposed 10 CFR 834 (DOE 1993b).

^b In 1996, this population was about 6.3 million.

^c Obtained by dividing the population dose by the number of people living within 80 km (50 mi) of the site.

Key: LLNL, Lawrence Livermore National Laboratory.

Source: Harrach et al.:12-18.

According to the same risk estimator, 5.5×10^{-4} excess fatal cancer per year is projected in the population living within 80 km (50 mi) of LLNL. For perspective, this number can be compared with the number of fatal cancers expected in this population from all causes. The 1996 mortality rate associated with cancer for the entire population was 0.2 percent per year. Based on this national rate, the number of fatal cancers from all causes expected during 1996 in the population living within 80 km (50 mi) of LLNL was 13,000. This number of expected fatal cancers is much higher than the estimated 5.5×10^{-4} fatal cancer that could result from LLNL operations in 1996.

Workers at LLNL receive the same dose as the general public from background radiation; however, they receive an additional dose from normal operations. Table 3–56 includes average, maximally exposed, and total

occupational doses to LLNL workers from operations in 1997. These doses fall within radiological limits. Based on a dose-to-risk conversion factor of 400 fatal cancers per 1 million person-rem (4×10^{-4} fatal cancer

Table 3–56. Radiation Doses to Onsite Workers From Normal LLNL Operations in 1997 (Total Effective Dose Equivalent)

Occupational Personnel	Onsite Releases and Direct Radiation	
	Standard ^a	Actual
Average radiation worker (mrem)	None ^b	2.5
Maximally exposed worker (mrem)	5,000	1,144
Total workers (person-rem) ^c	None	18.2

^a The radiological limit for an individual worker is 5,000 mrem/yr (DOE 1995a:para. 835.202); however, DOE's goal is to maintain radiological exposures as low as is reasonably achievable. Therefore, DOE has established an administrative control level of 2,000 mrem/yr (DOE 1994a:2-3); DOE must make reasonable attempts to maintain worker doses below this level.

^b No standard is specified for an "average radiation worker"; however, the maximum dose that this worker may receive is limited to that given in footnote "a."

^c The total number of badged workers at the site in 1997 was 7,300.

Key: LLNL, Lawrence Livermore National Laboratory.

Source: Zahn 1998.

per person-rem) among workers (see Appendix F), the number of excess fatal cancers to LLNL workers from normal operations in 1997 is estimated to be 0.0073.

More detailed information of the radiation environment, including background exposures and radiological releases and doses, is presented in the *LLNL Environmental Report for 1996* (Harrach et al. 1997). Concentrations of radioactivity in various environmental media (e.g., air and water) and animal tissues in the site region are also presented in the same reference.

3.6.3.4 Infrastructure

A summary of the infrastructure characteristics of LLNL is presented in Table 3–57. An adequate infrastructure exists at LLNL to support current activities.

Table 3–57. LLNL Infrastructure Characteristics

Resource	Current Usage ^a	Site Capacity
Electricity		
Energy consumption (MWh/yr)	295,919	100 MW peak
Fuel		
Natural gas (m ³ /yr)	13,017,173	4,400 m ³ /hr peak
Liquid (l/yr)	1,257,699	NA ^b
Coal (t/yr)	0	0
Water		
Annual (l/yr)	874,138,983	10,977,660 l/day peak

^a Five-year average for FY93–97.

^b As supplies get low, more can be supplied by truck.

Key: LLNL, Lawrence Livermore National Laboratory; NA, not applicable.

Source: O'Connor et al. 1998c.

3.6.4 LANL Overview

LANL occupies 11,300 ha (28,000 acres) of land in northern New Mexico (see Figure 2–29). Situated on the Pajarito plateau in the Jemez mountains, the closest population centers are the city of Los Alamos (population 12,000) and White Rock (population 8,000). The closest metropolitan area is Santa Fe (population 50,000), about 40 km (25 mi) southeast of LANL. In 1997, LANL had about 9,200 workers (DOE 1996a:3-304).

The laboratory was established in 1943 to design, develop, and test nuclear weapons. LANL's mission has expanded from the primary task of designing nuclear weapons to include nonnuclear defense programs and a broad array of nondefense programs. Current programs include R&D of nuclear safeguards and security, space nuclear systems, biomedicine, computational science, and lasers (DOE 1996a:3-304). LANL consists primarily of Technical Areas (TAs), of which 49 are actively in use (DOE 1997g:1).

[Text deleted.]

The options proposed for lead assembly fabrication at LANL would occur in existing facilities that would not require major modifications and would use existing employees. For this reason, detailed descriptions of environmental resources such as geology and soils, water, ecological, cultural and paleontological, land use and visual, socioeconomic, and environmental justice are not provided. For more information on these resource areas, refer to the *Storage and Disposition PEIS* (DOE 1996a). The resource areas that could be impacted by lead assembly fabrication activities are air quality, waste management, existing human health risk, and infrastructure. These resource areas are described below.

3.6.4.1 Air Quality

LANL is within the New Mexico Intrastate AQCR 157. None of the areas within LANL and its surrounding communities are designated as nonattainment areas with respect to any of the NAAQS (EPA 1997h). The criteria pollutants, nitrogen dioxide, carbon monoxide, volatile organic hydrocarbons, particulate matter, and sulphur dioxide make up about 79 percent of the stationary source emissions at LANL. The sources of these criteria pollutants are power plants, steam plants, asphalt plants, and space heaters. Toxic and other hazardous pollutants comprise the remaining 21 percent of emissions from stationary sources at LANL. These emissions are generated by equipment cleaning, coating processes, and acid baths. Concentrations of criteria and hazardous and toxic air pollutants are in compliance with applicable guidelines and regulations (DOE 1996a:3-310). For a detailed discussion of this resource area, refer to Section 3.9.3 of the *Storage and Disposition PEIS* (DOE 1996a:3-310).

3.6.4.2 Waste Management

Although not listed on the National Priorities List, LANL adheres to the CERCLA guidelines for environmental restoration projects that involve certain hazardous substances not covered by RCRA. LANL's environmental restoration program originally consisted of approximately 2,100 potential release sites. At the end of FY97, there remained only about 756 sites requiring investigation or remediation and 118 buildings awaiting decontamination and decommissioning. LANL's environmental restoration program is scheduled for completion in 2006 (LANL 1998:21).

Through its research and operation activities, LANL manages the following waste categories generated at 33 technical areas: TRU, low-level, mixed low-level, hazardous, and nonhazardous wastes (DOE 1996h:New Mexico 38; 1996i:4-272). LANL waste generation rates and inventories are presented in Table 3-58.

Table 3-58. Waste Generation Rates and Inventories at LANL

Waste Type	Generation Rate (m ³ /yr)	Inventory (m ³)
TRU^a		
Contact-handled	262	11,262
LLW	1,585	NA ^c
Mixed LLW^b	90	6,801
Hazardous	942	NA ^c
Nonhazardous		
Liquid	692,857	
Solid	5,453	NA ^c

^a Includes mixed TRU waste.

^b Includes TSCA mixed LLW.

^c Generally, LLW, hazardous, and nonhazardous wastes are not held in long-term storage.

Key: LANL, Los Alamos National Laboratory; LLW, low-level waste; NA, not applicable; TRU, transuranic; TSCA, Toxic Substances Control Act.

Source: DOE 1996a:3-339 for hazardous and nonhazardous waste; DOE 1996d:15, 16 for all other wastes.

LANL currently stores TRU waste on the site pending shipment to WIPP for disposal. The site also treats and disposes of LLW on the site. Mixed LLW is stored on the site pending treatment at a combination of onsite and offsite facilities. Hazardous waste is treated and stored on the site for offsite disposal. Nonhazardous solid wastes are shipped off the site for treatment and disposal. Nonhazardous liquid wastes are treated and disposed of on the site (DOE 1996a:3-337, 3-340, 3-341). See Table 3-59 for information on selected treatment, storage, and disposal facilities at LANL.

Table 3–59. Selected Waste Management Facilities at LANL

Facility Name/Description	Capacity	Status	Applicable Waste Types					
			Mixed		Mixed		Haz	Non-Haz
			TRU	TRU	LLW	LLW		
Treatment facilities (m³/yr)								
TRU waste volume reduction	1,080	Online	X	X				
RAMROD & RANT facilities	1,050	Online	X	X				
LLW compaction	76	Online			X			
Sanitary Wastewater Treatment Plant	1,060,063	Online						X
Storage facilities (m³)								
TA–54 TRU waste storage	24,355	Online	X	X				
LLW storage	663	Online			X			
Mixed LLW storage	583	Online				X		
Hazardous waste storage	1,864	Online					X	
Disposal facilities (m³)								
TA–54 Area G LLW Disposal	252,500 ^a	Online			X			
Sanitary tile fields (m ³ /yr)	567,750	Online						X

^a Current inventory of 250,000 m³ (8.8 million ft³), therefore, capacity will be exhausted in the next 2 to 5 years (O'Connor et al. 1998d). The *LANL Site-Wide Final EIS* (DOE 1999b) evaluates alternatives for LLW disposal.

Key: Haz, hazardous; LANL, Los Alamos National Laboratory; LLW, low-level waste; RAMROD, Radioactive Materials Research, Operations, and Demonstration; RANT, Radioactive Assay and Nondestructive Test; TRU, transuranic.

Source: DOE 1996a:3-337–3-341; Triay 1999.

For a more detailed description of this resource area, see Section 3.9.10 of the *Storage and Disposition PEIS* (DOE 1996a), or Sections 2.2.2.14 and 2.2.2.15 of the *Site-Wide Environmental Impact Statement for Continued Operation of the Los Alamos National Laboratory* (DOE 1999b).

3.6.4.3 Existing Human Health Risk

Major sources and levels of background radiation exposure to individuals within the vicinity of LANL are shown in Table 3–60. Annual background radiation doses to individuals are expected to remain constant over time. Total dose to the population changes as population size changes. Background radiation doses are unrelated to LANL operations (DOE 1996a:3-334).

Table 3–60. Sources of Radiation Exposure to Individuals in the LANL Vicinity Unrelated to LANL Operations

Source	Effective Dose Equivalent (mrem/yr)
Natural background radiation	
Cosmic radiation	48
External terrestrial radiation	44
Neutron cosmic radiation	10
Internal terrestrial	40
Radon in homes (inhaled)	200
Other background radiation	
Diagnostic x rays and nuclear medicine	53
Weapons test fallout	<1
Air travel	1
Consumer and industrial products	10
Total	407

Key: LANL, Los Alamos National Laboratory.

Note: Value for radon is an average for the United States.

Source: DOE 1996a:3-333.

Release of radionuclides to the environment from LANL operations provides another source of radiation exposure to the population in the vicinity. The doses to the public resulting from these releases are shown in Table 3–61. These doses fall within regulatory limits (DOE 1993a) and are small when compared with background radiation exposure.

Using a risk estimator of 500 cancer deaths per 1 million person-rem (5×10^{-4} fatal cancer per person-rem) to the public (see Appendix F.10), the fatal cancer risk to the maximally exposed member of the public due to radiological releases from LANL operations in 1995 is estimated to be 2.9×10^{-6} . That is, the estimated probability of this person dying from cancer from radiation exposure from 1 year of LANL operations is about three chances in one million (DOE 1998g:3-77).

According to the same risk estimator, 1.6×10^{-3} excess fatal cancer per year is projected in the population living within 80 km (50 mi) of LANL in 1995. For perspective, this number can be compared with the number of fatal cancers expected in this population from all causes. The 1996 mortality rate associated with cancer for the entire population was 0.2 percent per year. Based on this national rate, the number of fatal cancers from all causes expected during 1995 in the population living within 80 km (50 mi) of LANL was 482. This number of expected fatal cancers is much higher than the estimated 1.6×10^{-3} fatal cancers that could result from LANL operations in 1995 (DOE 1998g:3-77).

**Table 3–61. Radiation Doses to the Public From Normal LANL Operations in 1995
(Total Effective Dose Equivalent)**

Members of the Public	Atmospheric Releases		Liquid Releases		Total	
	Standard ^a	Actual	Standard ^a	Actual ^b	Standard ^a	Actual ^b
Maximally exposed individual (mrem)	10	5.1	4	0.58	100	5.7
Population within 80 km (person-rem) ^c	None	3.2	None	Negligible	100	3.2
Average individual within 80 km (mrem) ^d	None	0.013	None	Negligible	None	0.013

^a The standards for individuals are given in DOE Order 5400.5. As discussed in that order, the 10-mrem/yr limit from airborne emissions is required by the Clean Air Act. The 4-mrem/yr limit is required by the Safe Drinking Water Act; for this SPD EIS, the 4-mrem/yr value is conservatively assumed to be the limit for the sum of doses from all liquid pathways. The total dose of 100 mrem/yr is the limit from all combined pathways. The 100-person-rem value for the population is given in proposed 10 CFR 834 (DOE 1993b).

^b Actual dose values given in this column conservatively include all water pathways, not just drinking water.

^c In 1995, this population was about 241,000.

^d Obtained by dividing the population dose by the number of people living within 80 km (50 mi) of the site.

Key: LANL, Los Alamos National Laboratory.

Source: DOE 1998g:3-77.

Workers at LANL receive the same dose as the general public from background radiation; however, they receive an additional dose from normal operations. Table 3–62 includes average, maximally exposed, and total occupational doses to LANL workers from operations in 1991–1995. Based on a risk estimator of 400 fatal cancers per 1 million person-rem (4×10^{-4} fatal cancer per person-rem) among workers (see Appendix F), the average annual number of fatal cancers to LANL workers from normal operations during the 1991–1995 timeframe is estimated to be 0.066 (DOE 1998g:3-77).

**Table 3–62. Radiation Doses to Onsite Workers From
Normal Operations at LANL, 1991–1995
(Total Effective Dose Equivalent)**

Occupational Personnel	Onsite Releases and Direct Radiation	
	Standard ^a	Actual ^b
Average radiation worker (mrem)	None ^c	16
Maximally exposed worker (mrem)	5,000	2,000
Total workers (person-rem)	None	165

^a The radiological limit for an individual worker is 5,000 mrem/yr (DOE 1995a:para. 835.202); however, DOE's goal is to maintain radiological exposures as low as is reasonably achievable. Therefore, DOE has established an administrative control level of 2,000 mrem/yr (DOE 1994a:2-3); DOE must make reasonable attempts to maintain worker doses below this level.

^b Annual doses are averaged over the 5-year period.

^c No standard is specified for an "average radiation worker"; however, the maximum dose that this worker may receive is limited to that given in footnote "a."

Key: LANL, Los Alamos National Laboratory.

Source: DOE 1998g:3-77.

More detailed information of the radiation environment at LANL is presented in *Environmental Surveillance at Los Alamos During 1995* (UC 1996). Concentrations of radioactivity in various environmental media (e.g., air and water) and animal tissues in the site region are also presented in the same reference.

3.6.4.4 Infrastructure

A summary of the infrastructure characteristics of LANL is presented in Table 3–63. An adequate infrastructure exists at LANL to support current activities.

Table 3–63. LANL Infrastructure Characteristics

Resource	Current Usage
Electricity	
Energy consumption (MWh/yr)	372,145
Fuel	
Natural gas (m ³ /yr)	43,414,560
Fuel oil (l/yr)	0
Steam (kg/h)	33,554
Water	
Annual (l/yr) ^a	5,490,000,000

^a In 1994, LANL’s water system had an annual demand of 80 percent of its current allotment of 6,830 million l/yr (1,804 million gal/yr) (DOE 1999b:4-182). Demand includes use by Los Alamos County and National Park Service. LANL alone used 1,843 million l (approximately 487 million gal).

Key: LANL, Los Alamos National Laboratory.

Source: DOE 1996a:3-308, 1999b:4-181, 4-182.

3.6.5 SRS Overview

SRS occupies about 806 km² (310 mi²) in the southern portion of South Carolina, about 19 km (12 mi) south of Aiken, South Carolina (see Figure 2–5) (DOE 1996a:3-228). Additional information on SRS is presented in Section 3.5.

[Text deleted.]

The options proposed for lead assembly fabrication at SRS would use existing employees and buildings; therefore, major facility modifications would not be required. For this reason, detailed descriptions of environmental resources such as geology and soils, water, ecological, cultural and paleontological, land use and visual, socioeconomic, and environmental justice are not provided. The resource areas that could be impacted by lead assembly fabrication activities are air quality, waste management, existing human health risk, and infrastructure. These resource areas are described below.

3.6.5.1 Air Quality

The meteorological conditions at H-Area are considered to be representative for SRS. Existing ambient air pollutant concentrations at SRS are in compliance with applicable guidelines and regulations. See Section 3.5.1 for additional information on air quality for areas surrounding SRS.

3.6.5.2 Waste Management

TRU, low-level, mixed low-level, hazardous, and nonhazardous wastes are generated by R&D, production, and decontamination activities in H-Area. These wastes are managed at SRS facilities and at offsite locations, as

appropriate. The total quantities of waste generated and the inventories in storage at SRS are presented in Section 3.5.2. Three of the major waste management facilities located in H-Area are described below. Additional SRS waste management facilities are described in Section 3.5.2.

The Consolidated Incineration Facility is designed to incinerate solid and liquid LLW, mixed LLW, and hazardous waste. This H-Area facility has a capacity of 4,630 m³/yr (6,056 yd³/yr) of liquid waste and 17,830 m³/yr (23,322 yd³/yr) of solid waste (DOE 1996a:E-109).

Liquid LLW and mixed LLW generated in H-Area are conveyed to the F- and H-Area Effluent Treatment Facility for treatment. This facility has a capacity of 1,930,000 m³/yr (2,524,000 yd³/yr). Treated effluents are discharged to Upper Three Runs Creek in compliance with permit limits. Treatment residuals are concentrated by evaporation and stored in the H-Area tank farm for eventual treatment in the Z-Area Saltstone Facility. In that facility, wastes are immobilized with grout for onsite disposal (DOE 1996a:E-98, E-109).

Sanitary wastewater from H-Area is conveyed to the Central Sanitary Wastewater Treatment Facility for treatment and disposal. The H-Area sanitary sewer has a capacity of 136,274 m³/yr (178,246 yd³/yr) (O'Connor et al. 1998e), and the Central Sanitary Wastewater Treatment Facility has a capacity of 1,030,000 m³/yr (1,347,000 yd³/yr) (Sessions 1997a). More information on waste management activities at SRS is presented in Section 3.5.2.

3.6.5.3 Existing Human Health Risk

See Section 3.5.4 for major sources and levels of background radiation, mean concentrations of radiological releases, and offsite estimated dose rates to individuals within the vicinity of SRS.

3.6.5.4 Infrastructure

The site infrastructure at Building 221–H includes those utilities and other resources required to conduct mission-related activities. A summary of the infrastructure characteristics at Building 221–H is presented in Table 3–64. An adequate infrastructure exists at this facility to support current activities. See Section 3.5.11 for more detailed information on the infrastructure at SRS.

Table 3–64. Infrastructure Characteristics of Building 221–H at SRS

Resource	Current Usage
Electricity	
Energy consumption (MWh/yr)	120,000
Fuel	
Natural gas (m ³ /yr)	NA
Fuel oil (l/yr)	NA
Coal (t/yr)	0
Water (l/yr)	380,000,0000

Key: NA, not applicable.
Source: O'Connor et al. 1998e.

3.6.6 ORR Overview

ORR, established in 1943 as one of the three original Manhattan Project sites, occupies about 13,974 ha (34,516 acres) west of Knoxville, Tennessee, in and around the city of Oak Ridge, Tennessee (DOE 1999g:S-9). ORR is composed of three separate operations areas: East Tennessee Technology Park

(ETTP), ORNL, and Y-12. ETTP serves as an operations center for ORR's environmental restoration and waste management programs. Y-12 engages in national security activities and manufacturing outreach to U.S. industries.

ORNL is one of the country's largest multidisciplinary laboratories and research facilities. Its primary mission is to perform leading-edge nonweapons R&D in energy, health, and the environment. Other missions include production of radioactive and stable isotopes not available from other production sources; fundamental research in a variety of sciences; research involving hazardous and radioactive materials; and radioactive waste disposal. The facilities that would be used for postirradiation examination are located at ORNL.

The options proposed for postirradiation examination at ORNL would occur in existing facilities that would not require major modifications and would use existing employees. For this reason, detailed descriptions of environmental resources such as geology and soils, water, ecological, cultural and paleontological, land use and visual, socioeconomic, and environmental justice are not provided. For a detailed discussion of these resource areas, refer to the *Storage and Disposition PEIS* (DOE 1996a) and the *Final EIS, Construction and Operation of the Spallation Neutron Source* (DOE 1999g). The resource areas that are discussed include air quality, waste management, existing human health risk, and infrastructure.

3.6.6.1 Air Quality

ORR is in the Eastern Tennessee and Southwestern Virginia Interstate AQCR (DOE 1996a:3-192). This area is designated as attainment for all criteria pollutants with respect to the NAAQS (DOE 1999g:4-17). The primary sources of criteria air pollutants at ORR are the steam plants at ETTP, ORNL, and Y-12. Other emissions sources include the Toxic Substances Control Act incinerator, various process sources, vehicles, temporary emissions from construction activities, and fugitive particulate emissions from coal piles (DOE 1996a:3-192). For a detailed discussion of this resource area, refer to Section 4.1.3 of the *Final EIS, Construction and Operation of the Spallation Neutron Source* (DOE 1999g:4-14).

3.6.6.2 Waste Management

ORR was added to EPA's National Priorities List on November 21, 1989. In January 1, 1992, DOE, EPA, and the Tennessee Department of Environmental Conservation signed an FFCA to facilitate compliance with RCRA and applicable State laws. This agreement coordinates ORR inactive site assessment and remedial actions. In addition, portions of the FFCA are applicable to operating waste management systems (DOE 1996a:3-219).

Through its research and operation activities, ORR treats, stores, packages, and prepares for transport TRU, low-level, mixed low-level, hazardous, and nonhazardous wastes and spent nuclear fuel. Most waste is treated and stored on the site and then shipped off the site for additional treatment and disposal (DOE 1996a:3-219-3-227). ORR waste generation rates and inventories are shown in Table 3-65. Table 3-66 provides information on waste management facilities at ORR. For a more detailed discussion of waste management activities at ORR, refer to Sections 3.6.10 and E.2.5 of the *Storage and Disposition PEIS* (DOE 1996a:3-219, E-63).

Table 3–65. Waste Generation Rates and Inventories at ORR^a

Waste Type	Generation Rate (m³/yr)	Inventory (m³)
TRU^b		
Contact-handled	9	1,339
LLW	5,181	18,414
Mixed LLW^c	1,122	48,763
Hazardous	34,048	NA ^d
Nonhazardous		
Liquid	2,406,300	NA ^d
Solid	49,470	NA ^d

^a Includes ETTP, ORNL, and Y-12.

^b Includes mixed TRU waste.

^c Includes TSCA mixed LLW.

^d Generally, hazardous and nonhazardous wastes are not held in long-term storage.

Key: ETTP, East Tennessee Technology Park; ORNL, Oak Ridge National Laboratory; ORR, Oak Ridge Reservation; LLW, low-level waste; NA, not applicable; TRU, transuranic; TSCA, Toxic Substances Control Act.

Source: DOE 1996a:3-220–3-225 for hazardous and nonhazardous waste; DOE 1996d:15, 16 for all other wastes.

Table 3–66. Selected Waste Management Facilities at ORR

Facility Name/Description	Capacity	Status	Applicable Waste Types				
			TRU	LLW	Mixed LLW	Haz	Non-Haz
Treatment facilities (m³/yr)							
TRU Waste Treatment Plant (ORNL)	620	Planned for 2001	X				
Waste Compactor Facility (ORNL)	11,300	Online		X			
TSCA Incinerator (ETTP)	15,700	Online			X	X	
Bldg K–1203 Sewage Treatment Plant	829,000	Online					X
Oak Ridge Sewage Treatment Plant	1,934,500	Online					X
Sanitary Wastewater Treatment Facility (ORNL)	414,000	Online					X
Storage facilities (m³)							
TRU Waste Storage (ORNL)	1,760	Online	X				
LLW Storage (ETTP and ORNL)	51,850	Online		X			
Mixed Waste Storage (ETTP, ORNL, and Y–12)	231,753	Online			X		
Hazardous Waste Storage (ORNL and Y–12)	1,051	Online				X	
Disposal facilities (m³)							
Industrial & sanitary landfill (Y–12)	1,100,000	Online					X

Key: ETTP, East Tennessee Technology Park; Haz, hazardous; ORNL, Oak Ridge National Laboratory; ORR, Oak Ridge Reservation; LLW, low-level waste; TRU, transuranic; TSCA, Toxic Substances Control Act.

Source: DOE 1996a:3-219–3-225, E-78–E-95.

3.6.6.3 Existing Human Health Risk

Major sources and levels of background radiation exposure to individuals in the vicinity of ORR are shown in Table 3–67. Annual background radiation doses to individuals are expected to remain constant over time. Total dose to the population changes as population size changes. Background radiation doses are unrelated to ORR operations.

Table 3–67. Sources of Radiation Exposure to Individuals in the ORR Vicinity Unrelated to ORR Operations

Source	Effective Dose Equivalent (mrem/yr)
Natural background radiation ^a	
Internal terrestrial radiation	40
Cosmic radiation	27
External terrestrial radiation	28
Radon in homes (inhaled)	200
Other background radiation ^b	
Diagnostic x rays and nuclear medicine	53
Weapons test fallout	<1
Air travel	1
Consumer and industrial products	10
Total	360

Source	Effective Dose Equivalent (mrem/yr)
^a Hamilton et al. 1998.	
^b NCRP 1987.	
Key: ORR, Oak Ridge Reservation.	
Note: Value for radon is an average for the United States.	

Release of radionuclides to the environment from ORR operations provides another source of radiation exposure to the population in the vicinity. Doses to the public resulting from these releases are shown in Table 3–68. These doses fall within regulatory limits (DOE 1993a) and are small when compared with background radiation exposure.

Using a risk estimator of 500 cancer deaths per 1 million person-rem (5×10^{-4} fatal cancer per person-rem) to the public (see Appendix F.10), the fatal cancer risk to the maximally exposed member of the public due to radiological releases from ORR operations in 1997 is estimated to be 1.4×10^{-6} . That is, the estimated probability of this person dying from cancer from radiation exposure from 1 year of ORR operations is slightly more than one chance in one million.

According to the same risk estimator, 0.0079 excess fatal cancer per year is projected in the population living within 80 km (50 mi) of ORR. For perspective, this number can be compared with the number of fatal cancers expected in this population from all causes. The 1996 mortality rate associated with cancer for the entire population was 0.2 percent per year. Based on this national rate, the number of fatal cancers from all causes expected during 1996 in the population living within 80 km (50 mi) of ORR was 1,760. This number of expected fatal cancers is much higher than the estimated 0.0079 fatal cancers that could result from ORR operations in 1997.

Table 3–68. Radiation Doses to the Public From Normal ORR Operations in 1997 (Total Effective Dose Equivalent)

Members of the Public	Atmospheric Releases		Liquid Releases		Total	
	Standard ^a	Actual	Standard ^a	Actual	Standard ^a	Actual
Maximally exposed individual (mrem)	10	0.41	4	1.4 ^b	100	2.8 ^c
Population within 80 km (person-rem) ^d	None	10.0	None	5.7	100	15.7
Average exposed individual within 80 km (mrem) ^e	None	0.011	None	0.0065	None	0.018

^a The standards for individuals are given in DOE Order 5400.5. As discussed in that order, the 10-mrem/yr limit for airborne emissions is required by the Clean Air Act. The 4-mrem/yr limit is required by the Safe Drinking Water Act; for this SPD EIS, the 4-mrem/yr value is conservatively assumed to be the limit for the sum of doses from all liquid pathways. The total dose of 100 mrem/yr is the limit from all combined pathways. The 100-person-rem value for the population is given in proposed 10 CFR 834 (DOE 1993b).

^b These doses are mainly from drinking water and eating fish from the Clinch River section of Poplar Creek.

^c This total dose includes a conservative value of 1 mrem/yr from direct radiation exposure to a cesium field near the Clinch River.

^d In 1997, this population was about 880,000.

^e Obtained by dividing the population dose by the number of people living within 80 km (50 mi) of the site.

Key: ORR, Oak Ridge Reservation.

Source: Hamilton et al. 1998.

Workers at ORR receive the same dose as the general public from background radiation; however, they receive an additional dose from normal operations. Table 3–69 includes average, maximally exposed, and total

occupational doses to ORR workers from operations in 1997. These doses fall within radiological limits. Based on a dose-to-risk conversion factor of 400 fatal cancers per 1 million person-rem (4×10^{-4} fatal cancer per person-rem) among workers (see Appendix F), the number of excess fatal cancers to ORR workers from normal operations in 1997 is estimated to be 0.031.

Table 3–69. Radiation Doses to Onsite Workers From Normal ORR Operations in 1997 (Total Effective Dose Equivalent)

Occupational Personnel	Onsite Releases and Direct Radiation	
	Standard ^a	Actual
Average radiation worker (mrem)	None ^b	48
Total workers (person-rem) ^c	None	78

^a The radiological limit for an individual worker is 5,000 mrem/yr (DOE 1995a:para. 835.202); however, DOE’s goal is to maintain radiological exposures as low as is reasonably achievable. Therefore, DOE has established an administrative control level of 2,000 mrem/yr (DOE 1994a:2-3); DOE must make reasonable attempts to maintain worker doses below this level.

^b No standard is specified for an “average radiation worker”; however, the maximum dose that this worker may receive is limited to that given in footnote “a.”

^c The total number of badged workers at the site in 1997 was 1,614.

Key: ORR, Oak Ridge Reservation.

Source: DOE 1999h.

More detailed information of the radiation environment, including background exposures and radiological releases and doses, is presented in the *ORR Annual Site Environmental Report for 1997* (Hamilton et al. 1998), and Section 4.1.9.1 of the *Final EIS, Construction and Operation of the Spallation Neutron Source* (DOE 1999g:4-60). Concentrations of radioactivity in various environmental media (e.g., air and water) and animal tissues in the site region are also presented in the *ORR Annual Site Environmental Report for 1997*.

3.6.6.4 Infrastructure

A summary of the infrastructure characteristics of ORR is presented in Table 3–70. An adequate infrastructure exists at ORR to support current activities. For a more detailed discussion of the site infrastructure, refer to Section 4.2.10.2 of the *Final EIS, Construction and Operation of the Spallation Neutron Source* (DOE 1999g:4-144), and Sections 3.6.2 and 3.6.4 of the *Storage and Disposition PEIS* (DOE 1996a:3-190,3-194).

Table 3–70. ORR Infrastructure Characteristics

Resource	Current Usage^a	Site Capacity
Electricity		
Energy consumption (MWh/yr)	726,000	13,880,000
Fuel		
Natural gas (m ³ /yr)	95,000,000	250,760,000
Liquid (l/yr)	416,000	416,000 ^a
Coal (t/yr)	16,300	16,300 ^a
Water		
Annual (l/yr)	14,210,000,000	44,347,500,000

^a As supplies get low, more can be supplied by truck.

Key: ORR, Oak Ridge Reservation.

Source: DOE 1996a:3-190, 3-194.

3.7 REACTOR SITES FOR MOX FUEL IRRADIATION

3.7.1 Catawba Units 1 and 2 Site Overview

The Catawba nuclear power plant occupies 158 ha (391 acres) in York County, South Carolina, 9.3 km (5.8 mi) north-northwest of Rock Hill, South Carolina, and 16.9 km (10.5 mi) west-southwest of Charlotte, North Carolina (see Figure 3–34). The site is on a peninsula bounded by Beaver Dam Creek to the north, Big Allison Creek to the south, Lake Wylie to the east, and private property to the west (Duke Power 1997:2-3). Lake Wylie has a surface area of 5,040 ha (12,455 acres), a shoreline of approximately 523 km (325 mi), and a volume of 3.46×10^8 m³ (281,900 acre-ft). The towns of Mount Holly and Belmont, North Carolina, take their raw water supplies from Lake Wylie. The communities of Chester, Fort Lawn, Fort Mill, Great Falls, Lancaster, Mitford, Riverview, and Rock Hill, South Carolina, obtain at least a portion of their municipal water supplies from the Catawba River within 80 km (50 mi) downstream from the site (Duke Power 1997:2-41, table 2-52).

In 1997, the plant employed 1,232 persons (DOE 1999f). The Catawba reactors are operated by Duke Power Company. The operating licenses (Nos. NPF–35 and NPF–52) for Units 1 and 2 were granted in 1985 and 1986 and expire in 2024 and 2026, respectively (NRC 1997). The population within an 80-km (50-mi) radius of these reactors is estimated to be 1,656,093 (Duke Power 1997:table 2-13).

Reactor cooling is accomplished using mechanical draft cooling towers, with water obtained from Lake Wylie (Duke Power 1997). During normal operations of Catawba, cooling water is pumped from the Beaver Dam Creek arm of Lake Wylie at a rate of 266,680 million l/yr (70,450 million gal/yr) and returned to Big Allison Creek at a rate of 172,902 million l/yr (45,676 million gal/yr). The net difference in water (93,779 million l/yr [24,774 million gal/yr]) is due to evaporation in the cooling towers (DOE 1999f).

New (unirradiated) fuel assemblies are dry stored in racks located in the two New Fuel Storage Buildings. Each New Fuel Storage Building is designed to accommodate 98 fuel assemblies (a total of 196 assemblies). Spent (irradiated) fuel assemblies are stored in two spent fuel pools in the two fuel buildings. The spent fuel storage pools have a total capacity of 2,836 assemblies (Duke Power 1997:9-3–9-6). Security at the site is provided in accordance with U.S. Nuclear Regulatory Commission (NRC) regulations and includes security checkpoints, barbed wire fencing, surveillance cameras, and intruder detection. More information about these reactors can be found at the NRC Web site at <http://www.nrc.gov/OPA/finder.htm> (NRC 1999) and in NRC Docket Nos. 50–413 and 50–414.

3.7.1.1 Air Quality

Catawba is within the Metropolitan Charlotte, North Carolina, AQCR #167. None of the areas within the site or York County are designated as nonattainment areas with respect to the NAAQS for criteria air pollutants (EPA 1998d).

Sources of criteria air pollutants from Catawba include five emergency diesel generators, a safe shutdown facility generator, and miscellaneous equipment such as trucks and forklifts. Table 3–71 provides a summary of criteria pollutant concentrations from operations of Catawba. The concentrations resulting from operations are well below the applicable ambient air quality standards even when background concentrations from other offsite sources are considered.

3.7.1.2 Waste Management

Table 3–72 presents the 5-year average annual waste generation rates for Catawba.

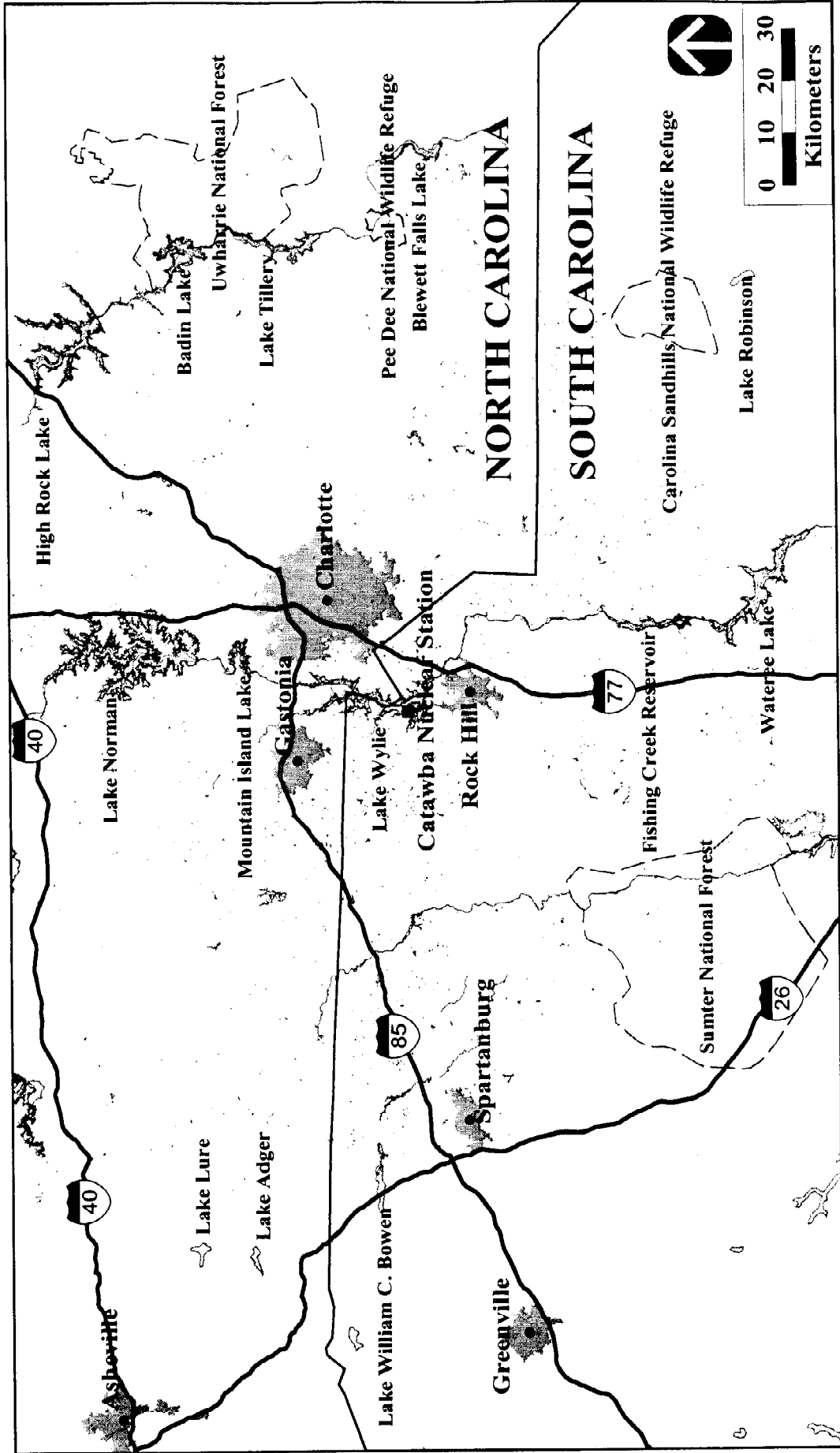

Figure 3-34. Catawba Nuclear Power Plant, South Carolina

Table 3–71. Comparison of Contribution to Nonradiological Ambient Air Pollutant Concentrations From Catawba Sources With National Ambient Air Quality Standards

Pollutant	Averaging Period	NAAQS (Fg/m ³)	Catawba (Fg/m ³)
Carbon monoxide	8 hours	10,000	978
	1 hour	40,000	1,400
Nitrogen dioxide	Annual	100	3.26
PM ₁₀	Annual	50	0.102
	24 hours	150	65.9
PM _{2.5}	3-year annual	15	(a)
	24 hours (98th percentile over 3 years)	65	(a)
Sulfur dioxide	Annual	80	0.0418
	24 hours	365	26.9
	3 hours	1,300	60.4

^a No data is available with which to assess PM_{2.5} concentrations.

Key: NAAQS, National Ambient Air Quality Standards.

Note: Based on 1994–1995 emissions data for diesel generators.

Source: Modeled concentrations based on DOE 1999f; EPA 1997a.

Table 3–72. Annual Waste Generation for Catawba (m³)

Waste Type	Generation Rate
LLW	50
Mixed LLW	0.6 ^a
Hazardous waste	29 ^a
Nonhazardous waste	
Liquid	60,794 ^b
Solid	455 ^a

^a Values converted from kilograms assuming a waste density such that 1 m³ = 1,000 kg.

^b Assuming sanitary wastewater is generated at the same rate 365 days per year.

Key: LLW, low-level waste.

Source: DOE 1999f.

The waste disposal systems provide all equipment necessary to collect, process, store, and prepare for disposal of all radioactive liquid and solid wastes produced as a result of reactor operations. Potentially radioactive liquids may originate from a variety of sources, including the steam generator blowdown system, ventilation unit condensate system, drainage system sumps, laboratory drains, personnel decontamination area drains, decontamination system, sampling system, and laundry drains. Potentially radioactive liquid wastes are collected and characterized as to the level of contamination present. If contamination is below regulated levels, liquids may be discharged to the circulating water discharge outfall in accordance with the National Pollutant Discharge Elimination System (NPDES) permit. If liquids are determined to be radioactively contaminated, they are treated by filtration, evaporation, or mixing and settling, or are sent to the demineralizers, before being discharged. Continuous radiation monitoring is provided for treated liquid waste before its release to the circulating water discharge outfall. Liquid waste is analyzed and monitored to ensure that radionuclide concentrations are maintained as low as practical and well within the limits of applicable regulations and permits (Duke Power 1997:11-9–11-27).

The radioactive solid waste disposal system provides facilities for holdup, packaging, and storage of wastes before shipment to offsite licensed treatment and disposal facilities. Radioactive solid waste may include evaporator concentrates, spent demineralizer resins, spent filters, laboratory wastes, rags, gloves, boots, brooms, and other miscellaneous tools and apparel that become contaminated during normal plant operations and maintenance. Treatment on the site may include dewatering and compaction, or solidification using a contractor-supplied mobile unit. Materials that are compressible are placed in 208-l (55-gal) drums for compaction. Spent radioactive filter cartridges are packaged in either 114-l (30-gal) or 208-l (55-gal) drums. Packaged wastes are stored in the filter cartridge storage bunker, low-activity-waste storage room, high-activity-waste storage room, solidification area, and waste shipping area before being shipped to an offsite treatment or disposal facility (Duke Power 1997:11-53–11-61).

The small quantities of mixed low-level and hazardous wastes generated are accumulated on the site before being shipped for commercial treatment and disposal in offsite permitted facilities. Nonhazardous solid wastes are generated by typical industrial processes and housekeeping activities and are collected on the site and managed off the site at the local permitted sanitary landfill. Nonhazardous sanitary wastewater is treated in the onsite sanitary wastewater treatment facility and then discharged to Lake Wylie (Sadler 1997:6).

3.7.1.3 Existing Human Health Risk

Major sources and levels of background radiation exposure to individuals within the vicinity of Catawba are shown in Table 3–73. Annual background radiation doses to individuals are expected to remain constant over time. Total dose to the population changes as population size changes. Background radiation doses are unrelated to reactor operations.

Table 3–73. Sources of Radiation Exposure to Individuals in the Catawba Vicinity Unrelated to Catawba Operations

Source	Effective Dose Equivalent (mrem/yr)
Natural background radiation	
Cosmic and external and internal terrestrial radiation ^a	125
Radon in homes (inhaled) ^b	200 ^c
Other background radiation^b	
Diagnostic x rays and nuclear medicine	53
Weapons test fallout	<1
Air travel	1
Consumer and industrial products	10
Total	390

^a Virginia Power 1998:11B-3.

^b NCRP 1987:11, 40, 53.

^c An average for the United States.

Releases of radionuclides to the environment from normal reactor operations provide another source of radiation exposure to populations within the vicinity of the site. The doses to the public resulting from these releases are shown in Table 3–74. These doses fall within regulatory limits and are small when compared with background exposure.

Using a risk estimator of 500 cancer deaths per 1 million person-rem (5×10^{-4} fatal cancer per person-rem) to the public (see Appendix F.10), the fatal cancer risk to the maximally exposed member of the public due to radiological releases from normal reactor operations in 1997 is estimated to be 7.8×10^{-8} . That is, the estimated

Table 3–74. Radiological Impacts on the Public From Catawba Operations in 1997 (Total Effective Dose Equivalent)

Members of the Public	Atmospheric Releases		Liquid Releases		Total	
	Standard ^a	Actual	Standard ^a	Actual	Standard ^a	Actual
Maximally exposed individual (mrem)	5	0.045	3	0.11	25	0.16
Population within 80 km (person-rem) ^b	NA	4.0	NA	4.3	NA	8.3

^a The standards for individuals are given in 10 CFR 50, Appendix I. The standard for the maximally exposed offsite individual (25 mrem/yr total body from all pathways) is given in 40 CFR 190.

^b Population used: 1,656,093; this population dose was estimated for the year 2000 and is assumed to be representative for the year 1997.

Key: NA, not applicable.

Source: DOE 1999f; Duke Power 1997:tables 2-13, 11-12, and 11-15.

probability of this person dying from cancer from radiation exposure from 1 year of normal reactor operations is about 1 chance in 13 million.

According to the same risk estimator, 0.0042 excess fatal cancer is projected among the population living within 80 km (50 mi) of Catawba in 1997. For perspective, this number can be compared with the number of fatal cancers expected in this population from all causes. The 1996 mortality rate associated with cancer for the entire population was 0.2 percent per year (Famighetti 1998:964). Based on this national rate, the number of fatal cancers from all causes expected during 1997 in the population living within 80 km (50 mi) of Catawba was about 3,300. This number of expected fatal cancers is much higher than the estimated 0.0042 fatal cancer that could result from normal reactor operations in 1997.

Workers at the reactors receive the same background radiation dose as the general public; however, they receive an additional dose from normal operations of the reactors. Table 3–75 includes average, maximally exposed, and total occupational doses to reactor workers from operations in 1997. Based on a risk estimator of 400 cancer deaths per 1 million person-rem (4×10^{-4} fatal cancer per person-rem) among workers, the number of fatal cancers to reactor workers from 1997 normal operations is estimated to be 0.11.

Table 3–75. Radiological Impacts on Involved Workers From Catawba Operations in 1997

Number of badged workers ^a	3,420
Total dose (person-rem/yr)	265
Annual latent fatal cancers	0.11
Average worker dose (mrem/yr)	78
Annual risk of latent fatal cancer	3.1×10^{-5}

^a A badged worker is equipped with an individual dosimeter.

Note: The radiological limit for an individual worker is 5,000 mrem/yr (10 CFR 20). An effective ALARA program would ensure that doses are reduced to levels that are as low as is reasonably achievable.

Source: DOE 1999f.

3.7.1.4 Environmental Justice

Environmental justice concerns the environmental impacts that proposed actions may have on minority and low-income populations, and whether such impacts are disproportionately high and adverse (CEQ 1997). In the case of Catawba, the potentially affected area includes parts of North Carolina and South Carolina.

The potentially affected area around Catawba is defined by a circle with an 80-km (50-mi) radius centered at these reactors (lat. 35E03M050 N, long. 81E04W100 W). The total population residing within that area in 1990 was 1,519,392. The proportion of the population that was considered minority was 20.7 percent. The same census data show that the percentage of minorities for the contiguous United States was 24.1, and the percentages of the States of North Carolina and South Carolina were 25.0 and 31.5, respectively (DOC 1992).

At the time of the 1990 census, Blacks were the largest minority group within the potentially affected area, constituting 19.0 percent of the total population. Asians and Hispanics contributed about 0.7 percent, and Native Americans made up about 0.3 percent of the population (DOC 1992).

A breakdown of incomes in the potentially affected area is also available from the 1990 census data (DOC 1992). At that time, the poverty threshold was \$9,981 for a family of three with one related child under 18 years of age. A total of 159,956 persons (10.5 percent of the total population) residing within the potentially affected area around Catawba reported incomes below that threshold. Data obtained during the 1990 census also show that of the total population of the contiguous United States, 13.1 percent reported incomes below the poverty threshold and that the figures for North Carolina and South Carolina were 13.0 and 15.4 percent, respectively (DOC 1992).

3.7.2 McGuire Units 1 and 2 Site Overview

The McGuire nuclear power plant occupies 280 ha (700 acres) in northwestern Mecklenburg County, North Carolina, 27.4 km (17 mi) northwest of Charlotte, North Carolina (see Figure 3–35). The site is bounded to the west by the Catawba River and to the north by Lake Norman. Surrounding land is generally rural nonfarmland. Lake Norman, with a surface area of 13,156 ha (32,510 acres), a volume of 1,349 million m³ (1,093,600 acre-ft) and a shoreline of 837 km (520 mi), stretches 54.7 km (34 mi) from Cowans Ford Dam to the tailrace of Lookout Lake. The Charlotte municipal water intake is 18 km (11.2 mi) downstream from the site (Duke Power 1996:2-3, 2-27, 2-28; Nesbit 1999; Ritchey 1996). In addition, the communities of Belmont, Gastonia, and Mount Holly, North Carolina, and Chester, Fort Lawn, Fort Mill, Lancaster, Mitford, Riverview, and Rock Hill, South Carolina, obtain at least a portion of their municipal water supplies from the Catawba River within 80 km (50 mi) downstream from the site (Duke Power 1997:2-41, table 2-52).

In 1997, the plant employed 1,238 persons (DOE 1999f). The McGuire reactors are operated by Duke Power Company. The operating licenses (Nos. NPF–9 and NPF–17) for these reactors were granted in 1981 and 1983, and expire in 2021 and 2023, respectively (NRC 1997). The population within an 80-km (50-mi) radius of these reactors is estimated to be 2,140,720 (Duke Power 1996:table 2-1). Reactor cooling is accomplished using a once-through cooling system. Cooling water is withdrawn from Lake Norman at a rate of 7,025,937 million l/yr (1,856,062 million gal/yr) and discharged back into Lake Norman at a rate of 6,966,567 million l/yr (1,840,378 million gal/yr). The net difference in water (59,370 million l/yr [15,684 million gal/yr]) is due to evaporation (DOE 1999f).

New (unirradiated) fuel assemblies are dry stored in racks located in the two New Fuel Storage Vaults. Each New Fuel Storage Vault is designed to accommodate 96 fuel assemblies (a total of 192 assemblies). Spent (irradiated) fuel assemblies are stored in two spent fuel pools in the two Auxiliary Buildings. The two spent fuel storage pools have a total capacity of 2,926 assemblies. New fuel can also be stored in the spent fuel pools (Duke Power 1996:9-3–9-8). Security at the site is provided in accordance with NRC regulations and includes security checkpoints, barbed wire fencing, surveillance cameras, and intruder detection. More information about these reactors can be found at the NRC Web site at <http://www.nrc.gov/OPA/finder.htm> (NRC 1999) and in NRC Docket Nos. 50–369 and 50–370.

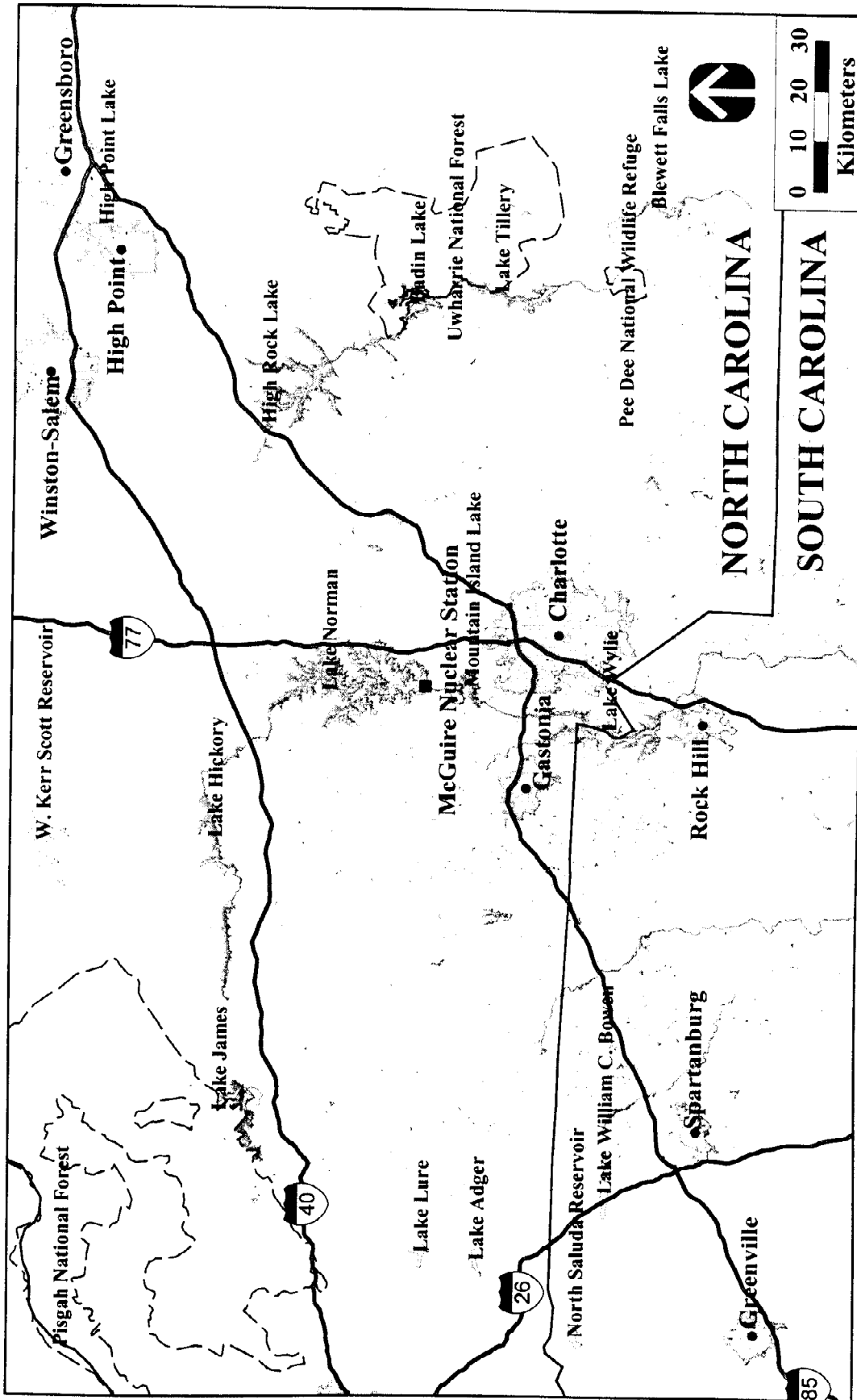

Figure 3-35. McGuire Nuclear Power Plant, North Carolina

3.7.2.1 Air Quality

McGuire is within the Metropolitan Charlotte AQCR #167. None of the areas within the site or Mecklenberg County are designated as nonattainment areas with respect to the NAAQS for criteria air pollutants (EPA 1998e).

Sources of criteria air pollutants from McGuire include five emergency diesel generators, a safe shutdown facility generator, and miscellaneous equipment such as trucks and forklifts. Table 3–76 provides a summary of criteria pollutant concentrations from operations of McGuire. The concentrations resulting from operations are well below the applicable ambient air quality standards even when background concentrations from other offsite sources are considered.

Table 3–76. Comparison of Contribution to Nonradiological Ambient Air Pollutant Concentrations From McGuire Sources With National Ambient Air Quality Standards

Pollutant	Averaging Period	NAAQS (Fg/m ³)	McGuire (Fg/m ³)
Carbon monoxide	8 hours	10,000	1,060
	1 hour	40,000	1,510
Nitrogen dioxide	Annual	100	2.55
	PM ₁₀	50	0.0799
PM _{2.5}	24 hours	150	71.2
	3-year annual	15	(a)
Sulfur dioxide	24 hours (98th percentile over 3 years)	65	(a)
	Annual	80	0.0336
	24 hours	365	29.9
	3 hours	1,300	67.4

^a No data is available with which to assess PM_{2.5} concentrations.

Key: NAAQS, National Ambient Air Quality Standards.

Note: Based on 1994–1997 emissions data for diesel generators.

Source: Modeled concentrations based on DOE 1999f; EPA 1997a.

3.7.2.2 Waste Management

Table 3–77 presents the 5-year average annual waste generation rates for McGuire.

The waste disposal systems provide all equipment necessary to collect, process, store, and prepare for disposal of all radioactive liquid and solid wastes produced as a result of reactor operations. Potentially radioactive liquids may originate from a variety of sources, including the steam generator blowdown system, ventilation unit condensate system, drainage system sumps, laboratory drains, personnel decontamination area drains, decontamination system, sampling system, and laundry drains. Potentially radioactive liquid wastes are collected and characterized as to the level of contamination present. If contamination is below regulated levels, liquids may be discharged to the circulating water discharge outfall in accordance with the NPDES permit. If liquids are determined to be radioactively contaminated, they are treated by filtration, evaporation, or mixing and settling, or are sent to the demineralizers, before being discharged. Continuous radiation monitoring is provided for treated waste before its release to the circulating water discharge outfall. Liquid waste is analyzed and monitored to ensure that radionuclide concentrations are maintained as low as practical and well within the limits of applicable regulations and permits (Duke Power 1996:11-9–11-26).

Table 3–77. Annual Waste Generation for McGuire (m³)

Waste Type	Generation Rate
LLW	42.2
Mixed LLW	0.19 ^a
Hazardous waste	28.6 ^a
Nonhazardous waste	
Liquid	49,740 ^b
Solid	568 ^a

^a Values converted from kilograms assuming a waste density such that 1 m³ = 1,000 kg.

^b Assuming sanitary wastewater is generated at the same rate 365 days per year.

Key: LLW, low-level waste.

Source: DOE 1999f.

The radioactive solid waste disposal system provides facilities for holdup, packaging, and storage of wastes before shipment to offsite licensed treatment and disposal facilities. Radioactive solid waste may include evaporator concentrates, spent demineralizer resins, spent filters, laboratory wastes, contaminated oils, rags, gloves, boots, sweepings, brooms, and other miscellaneous tools and apparel that become contaminated during normal plant operations and maintenance. Treatment on the site may include dewatering, or solidification using a contractor-supplied mobile unit. Low-activity solid wastes, such as rags, clothing, and sweepings, are loaded directly into storage containers for shipment to an offsite treatment or disposal facility. Spent radioactive filter cartridges are packaged in drums or other waste containers, with spent resin solidified, if required. The disposal of slightly contaminated sludge from the wastewater treatment plant is carried out by landspreading the sludge on a site contiguous to McGuire using a method approved by the State of North Carolina and NRC. Packaged wastes are stored in the filter storage bunker, solidified liner storage bunker, and the shielded storage bunker before being shipped to an offsite treatment or disposal facility (Duke Power 1996:11-49–11-56).

The small quantities of mixed LLW and hazardous waste generated are accumulated on the site before being shipped for commercial treatment and disposal in offsite permitted facilities. Nonhazardous solid wastes are generated by typical industrial processes and housekeeping activities and are collected on the site and managed off the site at the local permitted sanitary landfill. Nonhazardous sanitary wastewater is discharged to the Charlotte Mecklenburg Utility Department sanitary sewer system (Duke Power 1994).

3.7.2.3 Existing Human Health Risk

Major sources and levels of background radiation exposure to individuals within the vicinity of McGuire are shown in Table 3–78. Annual background radiation doses to individuals are expected to remain constant over time. Total dose to the population changes as population size changes. Background radiation doses are unrelated to reactor operations.

Releases of radionuclides to the environment from normal reactor operations provide another source of radiation exposure to populations within the vicinity of the site. The doses to the public resulting from these releases are shown in Table 3–79. These doses fall within regulatory limits and are small when compared with background exposure.

Using a risk estimator of 500 cancer deaths per 1 million person-rem (5×10^{-4} fatal cancer per person-rem) to the public (see Appendix F.10), the fatal cancer risk to the maximally exposed member of the public due to radiological releases from normal reactor operations in 1997 is estimated to be 4.9×10^{-8} . That is, the estimated

Table 3–78. Sources of Radiation Exposure to Individuals in the McGuire Vicinity Unrelated to McGuire Operations

Source	Effective Dose Equivalent (mrem/yr)
Natural background radiation	
Cosmic and external and internal terrestrial radiation ^a	125
Radon in homes (inhaled) ^b	200 ^c
Other background radiation^b	
Diagnostic x rays and nuclear medicine	53
Weapons test fallout	<1
Air travel	1
Consumer and industrial products	10
Total	390

^a Virginia Power 1998:11B-3.

^b NCRP 1987:11, 40, 53.

^c An average for the United States.

Table 3–79. Radiological Impacts on the Public From McGuire Operations in 1997 (Total Effective Dose Equivalent)

Members of the Public	Atmospheric Releases		Liquid Releases		Total	
	Standard ^a	Actual	Standard ^a	Actual	Standard ^a	Actual
Maximally exposed individual (mrem)	5	0.033	3	0.065	25	0.098
Population within 80 km (person-rem) ^b	NA	2.8	NA	93	NA	96

^a The standards for individuals are given in 10 CFR 50, Appendix I. The standard for maximally exposed offsite individual (25 mrem/yr total body from all pathways) is given in 40 CFR 190.

^b Population used: 2,140,720; this population dose was estimated for the year 2000 and is assumed to be representative for the year 1997.

Key: NA, not applicable.

Source: DOE 1999f; Duke Power 1974:5.3-7, table 5.3.5-1; 1996:table 2-1.

probability of this person dying from cancer from radiation exposure from 1 year of normal reactor operations is about 1 chance in 20 million.

According to the same risk estimator, 0.048 excess fatal cancer is projected among the population living within 80 km (50 mi) of McGuire in 1997. For perspective, this number can be compared with the number of fatal cancers expected in this population from all causes. The 1996 mortality rate associated with cancer for the entire population was 0.2 percent per year (Famighetti 1998:964). Based on this national rate, the number of fatal cancers from all causes expected during 1997 in the population living within 80 km (50 mi) of McGuire was about 4,300. This number of expected fatal cancers is much higher than the estimated 0.048 fatal cancer that could result from normal reactor operations in 1997.

Workers at the reactors receive the same background radiation dose as the general public; however, they receive an additional dose from normal operations of the reactors. Table 3–80 includes average, maximally exposed, and total occupational doses to reactor workers from operations in 1997. Based on a risk estimator of 400 cancer deaths per 1 million person-rem (4×10^{-4} fatal cancer per person-rem) among workers, the number of fatal cancers to reactor workers from 1997 normal operations is estimated to be 0.20.

Table 3–80. Radiological Impacts on Involved Workers From McGuire Operations in 1997

Number of badged workers ^a	3992
Total dose (person-rem/yr)	492
Annual latent fatal cancers	0.20
Average worker dose (mrem/yr)	123
Annual risk of latent fatal cancer	4.9×10^{-5}

^a A badged worker is equipped with an individual dosimeter.

Note: The radiological limit for an individual worker is 5,000 mrem/yr (10 CFR 20). An effective ALARA program would ensure that doses are reduced to levels that are as low as is reasonably achievable.

Source: DOE 1999f.

3.7.2.4 Environmental Justice

Environmental justice concerns the environmental impacts that proposed actions may have on minority and low-income populations, and whether such impacts are disproportionately high and adverse (CEQ 1997). In the case of McGuire, the potentially affected area includes parts of North Carolina and South Carolina.

The potentially affected area around McGuire is defined by a circle with an 80-km (50-mi) radius centered at these reactors (lat. 35E25N590 N, long. 80E56W550 W). The total population residing within that area in 1990 was 1,738,966. The proportion of the population that was considered minority was 17.6 percent. The same census data show that the percentage of minorities for the contiguous United States was 24.1, and the percentages of the States of North and South Carolina were 25.0 and 31.5, respectively (DOC 1992).

At the time of the 1990 census, Blacks were the largest minority group within the potentially affected area, constituting 15.9 percent of the total population. Hispanics and Asians contributed about 0.7 percent, and Native Americans made up about 0.3 percent of the population (DOC 1992).

A breakdown of incomes in the potentially affected area is also available from the 1990 census data (DOC 1992). At that time, the poverty threshold was \$9,981 for a family of three with one related child under 18 years of age. A total of 170,956 persons (9.8 percent of the total population) residing within the potentially affected area around McGuire reported incomes below that threshold. Data obtained during the 1990 census also show that of the total population of the contiguous United States, 13.1 percent reported incomes below the poverty threshold, and that the figures for North Carolina and South Carolina were 13.0 and 15.4 percent, respectively (DOC 1992).

3.7.3 North Anna Units 1 and 2 Site Overview

The North Anna nuclear power plant occupies 422 ha (1,043 acres) in Louisa County, Virginia, approximately 64.4 km (40 mi) north-northwest of Richmond, Virginia, and 113 km (70 mi) southwest of Washington, D.C. (see Figure 3–36). The largest community within 16 km (10 mi) of the site is the town of Mineral in Louisa County. The site is on a peninsula on the southern shore of Lake Anna. Lake Anna is approximately 27.4 km (17 mi) long, with a surface area of 5,260 ha (13,000 acres) and 322 km (200 mi) of shoreline. The reservoir contains approximately 380 billion l (100 billion gal) of water (Virginia Power 1998:2.1-1, 2.1-2).

In 1997, the plant employed 552 persons (DOE 1999f). The North Anna reactors are operated by the Virginia Power Company. The operating licenses (Nos. NPF–4 and NPF–7) for these reactors were granted in 1978 and 1980, and expire in 2018 and 2020, respectively (NRC 1997). It is estimated that the population within an 80-km (50-mi) radius of the reactor is 1,614,983 (Virginia Power 1998:2.1-21).

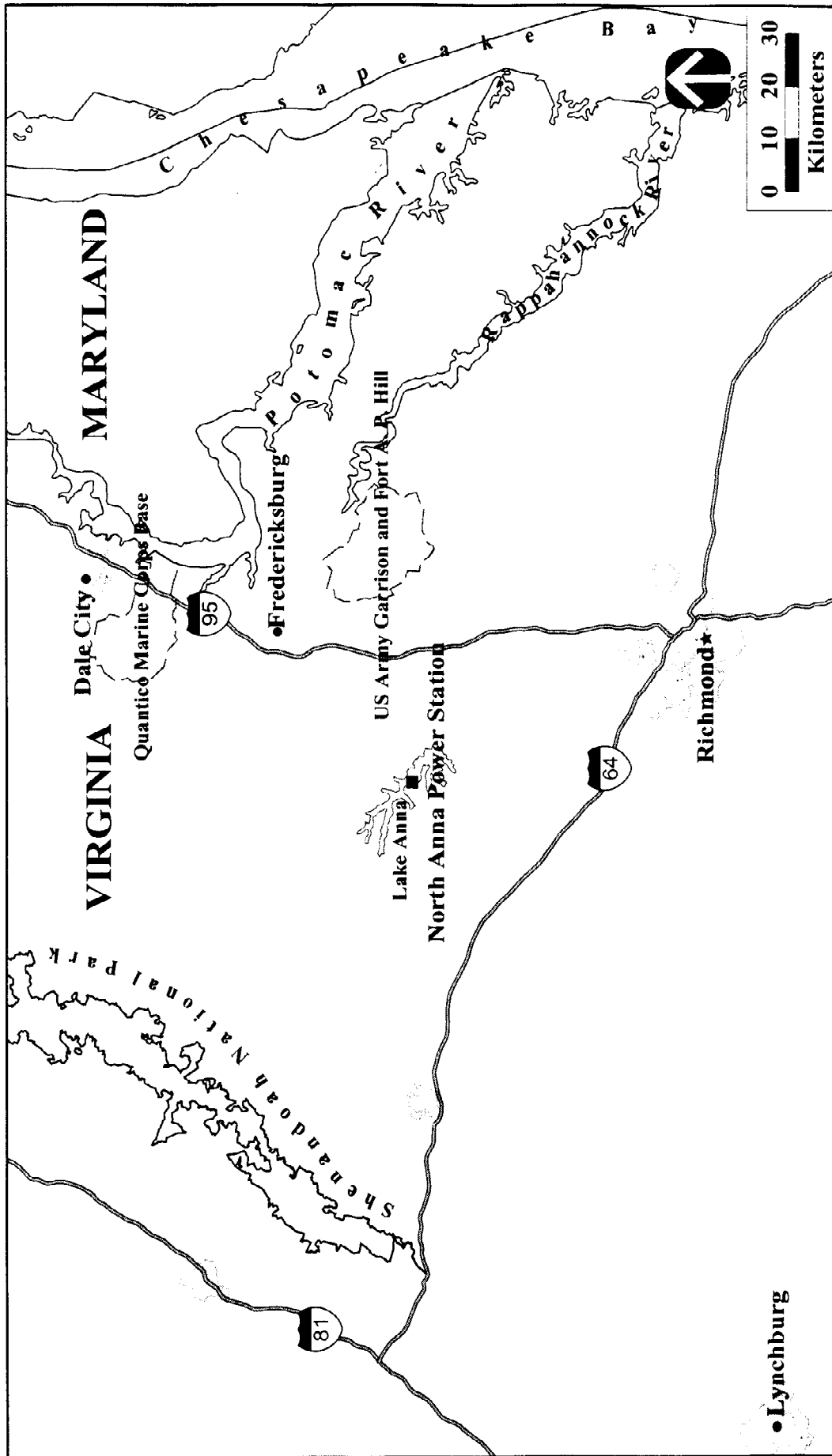

Figure 3-36. North Anna Nuclear Power Plant, Virginia

Reactor cooling is accomplished using a once-through cooling system with water obtained from Lake Anna (Virginia Power 1998:2.1-2). The rate of cooling water withdrawal is 5,564,000 million l/yr (1,470,000 million gal/yr), with all water returned to Lake Anna (DOE 1999f). There are no known industrial users downstream from the site until some 97 km (60 mi) downstream at West Point, where a large pulp and paper manufacturing plant is located. There are no known potable water withdrawals along the entire stretch of the river downstream to West Point, where the river becomes brackish (Virginia Power 1998:2.4-3).

New (unirradiated) fuel assemblies are dry stored in the new fuel storage area of the fuel building. The new fuel storage area has a capacity of 126 fuel assemblies. Spent (irradiated) fuel assemblies are stored under water in the spent fuel pit in the fuel building. The spent fuel storage pit has a capacity of 1,737 fuel assemblies (Virginia Power 1998:9.1-1, 9.1-2). Dry cask storage is being developed and is expected to have a capacity of an additional 1,824 assemblies (NRC 1998). Security at the site is provided in accordance with NRC regulations and includes security checkpoints, barbed wire fencing, surveillance cameras, and intruder detection. More information about these reactors can be found at the NRC Web site at <http://www.nrc.gov/OPA/finder.htm> (NRC 1999) and in NRC Docket Nos. 50-338 and 50-339.

3.7.3.1 Air Quality

North Anna is within the Northeastern Virginia AQCR #224. None of the areas within the site or Louisa County are designated as nonattainment areas with respect to the NAAQS for criteria air pollutants (EPA 1998f).

Sources of criteria air pollutants from North Anna include two auxiliary boilers, four emergency diesel generators, a station blackout generator, and miscellaneous equipment such as trucks and forklifts. Table 3-81 provides a summary of criteria pollutant concentrations from operations of North Anna. The concentrations resulting from operations are well below the applicable ambient air quality standards even when background concentrations from other offsite sources are considered.

3.7.3.2 Waste Management

Table 3-82 presents the 5-year average annual waste generation rates for North Anna.

The waste disposal systems provide all equipment necessary to collect, process, store, and prepare for disposal of all radioactive liquid and solid wastes produced as a result of reactor operations. Potentially radioactive liquids may originate from a variety of sources, including the boron recovery system, steam generator blowdown system, drainage system sumps, laboratory drains, personnel decontamination area drains, decontamination system, sampling system, laundry drains, and spent resin flush system. Potentially radioactive liquid wastes are collected and characterized as to the level of contamination present. If contamination is below regulated levels, liquids may be discharged to the circulating water discharge outfall in accordance with the NPDES permit. If liquids are determined to be radioactively contaminated, they are treated by the ion exchange filtration system or demineralizers to reduce contamination before being discharged. Continuous radiation monitoring is provided for treated liquid waste before its release to the circulating water discharge outfall. Liquid waste is analyzed and monitored to ensure that radionuclide concentrations are maintained as low as practical and well within the limits of applicable regulations and permits (Virginia Power 1998:11.2-1, 11.2-2).

The radioactive solid waste disposal system provides facilities for holdup, packaging, and storage of wastes before shipment to offsite treatment and disposal facilities. Radioactive solid waste may include spent resin slurries, spent filter cartridges, rags, gloves, boots, brooms, and other miscellaneous tools and apparel that become contaminated during normal plant operations and maintenance. Contaminated solid materials resulting

Table 3–81. Comparison of Contribution to Nonradiological Ambient Air Pollutant Concentrations From North Anna Sources With National Ambient Air Quality Standards

Pollutant	Averaging Period	NAAQS (Fg/m ³)	North Anna (Fg/m ³)
Carbon monoxide	8 hours	10,000	416
	1 hour	40,000	594
Nitrogen dioxide	Annual	100	0.00504
PM ₁₀	Annual	50	0.00407
	24 hours	150	15.4
PM _{2.5}	3-year annual	15	(a)
	24 hours (98th percentile over 3 years)	65	(a)
Sulfur dioxide	Annual	80	0.0167
	24 hours	365	63
	3 hours	1,300	142

^a No data is available with which to assess PM_{2.5} concentrations.

Key: NAAQS, National Ambient Air Quality Standards.

Note: Based on 1997 emissions data for diesel generators.

Source: Modeled concentrations based on DOE 1999f; EPA 1997a.

Table 3–82. Annual Waste Generation for North Anna (m³)

Waste Type	Generation Rate
LLW	236.6 ^a
Mixed LLW	0
Hazardous waste	11.4
Nonhazardous waste	
Liquid	681
Solid	10,400

^a Two-year average (1996–1997).

Key: LLW, low-level waste.

Source: DOE 1999f.

from station maintenance are stored in specified areas of the auxiliary building and the decontamination building. Materials that are compressible are placed in 208-l (55-gal) drums for compaction at the bailing facility. Compressible materials and other contaminated solid materials that are not placed in drums are placed in 6.1-m (20-ft) seavans for shipment to offsite licensed treatment and disposal facilities. Contaminated metallic materials and highly contaminated solid objects are placed inside disposable containers for shipment to a disposal facility (Virginia Power 1998:11.5-1–11.5-3).

The small quantities of mixed LLW and hazardous waste generated are accumulated on the site before being shipped for commercial treatment and disposal in offsite permitted facilities. Nonhazardous solid wastes are generated by typical industrial processes and housekeeping activities and are collected on the site and managed off the site at the local permitted sanitary landfill. Nonhazardous sanitary wastewater is treated in the onsite sanitary wastewater treatment facility and then discharged to Lake Anna (VADEQ 1997:9, 28).

3.7.3.3 Existing Human Health Risk

Major sources and levels of background radiation exposure to individuals within the vicinity of North Anna are shown in Table 3–83. Annual background radiation doses to individuals are expected to remain constant over time. Total dose to the population changes as population size changes. Background radiation doses are unrelated to reactor operations.

Table 3–83. Sources of Radiation Exposure to Individuals in the North Anna Vicinity Unrelated to North Anna Operations

Source	Effective Dose Equivalent (mrem/yr)
Natural background radiation	
Cosmic and external and internal terrestrial radiation ^a	125
Radon in homes (inhaled) ^b	200 ^c
Other background radiation^b	
Diagnostic x rays and nuclear medicine	53
Weapons test fallout	<1
Air travel	1
Consumer and industrial products	10
Total	390

^a Virginia Power 1998:11B-3.

^b NCRP 1987:11, 40, 53.

^c An average for the United States.

Releases of radionuclides to the environment from normal reactor operations provide another source of radiation exposure to populations within the vicinity of the site. The doses to the public resulting from these releases are shown in Table 3–84. These doses fall within regulatory limits and are small when compared with background exposure.

Table 3–84. Radiological Impacts on the Public From North Anna Operations in 1997 (Total Effective Dose Equivalent)

Members of the Public	Atmospheric Releases		Liquid Releases		Total	
	Standard ^a	Actual	Standard ^a	Actual	Standard ^a	Actual
Maximally exposed individual (mrem)	5	6.1×10^{-4}	3	0.28	25	0.28
Population within 80 km (person-rem) ^b	NA	6.0	NA	9.0	NA	15.0

^a The standards for individuals are given in 10 CFR 50, Appendix I. The standard for the maximally exposed offsite individual (25 mrem/yr total body from all pathways) is given in 40 CFR 190.

^b Population used: 1,614,983; this population dose was estimated for the year 2000 and is assumed to be representative for the year 1997. Population doses were ratioed to reflect latest census data projections.

Key: NA, not applicable.

Source: DOE 1999f; Virginia Power 1998:2.1-21, 11B-3, 11.3-13.

Using a risk estimator of 500 cancer deaths per 1 million person-rem (5×10^{-4} fatal cancer per person-rem) to the public (see Appendix F.10), the fatal cancer risk to the maximally exposed member of the public due to radiological releases from normal reactor operations in 1997 is estimated to be 1.4×10^{-7} . That is, the estimated probability of this person dying from cancer from radiation exposure from 1 year of normal reactor operations is about one chance in seven million.

According to the same risk estimator, 0.0075 excess fatal cancer is projected among the population living within 80 km (50 mi) of North Anna in 1997. For perspective, this number can be compared with the number of fatal cancers expected in this population from all causes. The 1996 mortality rate associated with cancer for the entire population was 0.2 percent per year (Famighetti 1998:964). Based on this national rate, the number of fatal cancers from all causes expected during 1997 in the population living within 80 km (50 mi) of North Anna was about 3,200. This number of expected fatal cancers is much higher than the estimated 0.0075 fatal cancer that could result from normal reactor operations in 1997.

Workers at the reactors receive the same background radiation dose as the general public, however, they receive an additional dose from normal operations of the reactors. Table 3–85 includes average, maximally exposed, and total occupational doses to reactor workers from operations in 1997. Based on a risk estimator of 400 cancer deaths per 1 million person-rem (4×10^{-4} fatal cancer per person-rem) among workers, the number of fatal cancers to reactor workers from 1997 normal operations is estimated to be 0.041.

Table 3–85. Radiological Impacts on Involved Workers From North Anna Operations in 1997

Number of badged workers ^a	2,243
Total dose (person-rem/yr)	103
Annual latent fatal cancers	0.041
Average worker dose (mrem/yr)	46
Annual risk of latent fatal cancer	1.8×10^{-5}

^a A badged worker is equipped with an individual dosimeter.

Note: The radiological limit for an individual worker is 5,000 mrem/yr (10 CFR 20). An effective ALARA program would ensure that doses are reduced to levels that are as low as is reasonably achievable.

Source: DOE 1999f.

3.7.3.4 Environmental Justice

Environmental justice concerns the environmental impacts that proposed actions may have on minority and low-income populations, and whether such impacts are disproportionately high and adverse (CEQ 1997). In the case of North Anna, the potentially affected area includes parts of Maryland and Virginia.

The potentially affected area around North Anna is defined by a circle with an 80-km (50-mi) radius centered around these reactors (lat. 38E03N370 N, long. 77E47N240 W). The total population residing within that area in 1990 was 1,286,156. The proportion of the population that was considered minority was 21.9 percent. The same census data show that the percentages of minorities for the contiguous United States was 24.1, and the percentage of the States of Maryland and Virginia were 30.4 and 24.0, respectively (DOC 1992).

At the time of the 1990 census, Blacks were the largest minority group within the potentially affected area, constituting 18.8 percent of the total population. Asians contributed about 1.5 percent, and Hispanics, about 1.4 percent. Native Americans made up about 0.3 percent of the population (DOC 1992).

A breakdown of incomes in the potentially affected area is also available from the 1990 census data (DOC 1992). At that time, the poverty threshold was \$9,981 for a family of three with one related child under 18 years of age. A total of 88,162 persons (6.9 percent of the total population) residing within the potentially affected area around North Anna reported incomes below that threshold. Data obtained during the 1990 census also show that of the total population of the contiguous United States, 13.1 percent reported incomes below the poverty threshold, and that the figures for Maryland and Virginia were 8.3 and 10.3 percent, respectively (DOC 1992).

3.8 REFERENCES

Abbott, D.G., 1998, Lockheed Martin Idaho Technologies Company, Idaho Falls, ID, personal communication to J. DiMarzio, Science Applications International Corporation, Germantown, MD, *SPD EIS - Additional Questions on Affected Environment*, January 28.

Abbott, D.G., A.B. Crockett, and K.S. Moor, 1997, *INEEL Affected Environment: Supplemental Data Report in Support of the Preparation of the Surplus Plutonium Disposition Environmental Impact Statement (Predecisional Draft)*, INEL/EXT-97-00563, Lockheed Martin Idaho Technologies Company, Idaho Falls, ID, June.

Abbott, M.L., J.M. Brooks, and K.L. Martin, 1991, *NPR Environmental Impact at the INEL: Air Quality, Cooling Towers, and Noise*, rev. A, NPRD-90-059, EG&G Idaho, Inc., Idaho Falls, ID, March.

| Aragon, K., 1999, U.S. Department of Energy, Carlsbad Area Office, Carlsbad, NM, personal communication
| (facsimile) to J. DiMarzio, Science Applications International Corporation, Germantown, MD, *Schedule for TRU*
| *Waste Shipments Sent from Generator Sites*, February 4.

Arnett, M.W., and A.R. Mamatey, eds., 1996, *Savannah River Site Environmental Report for 1995*, WSRC-TR-96-0075, Westinghouse Savannah River Company, Aiken, SC.

Arnett, M.W., and A.R. Mamatey, eds., 1997a, *Savannah River Site Environmental Report for 1996*, WSRC-TR-97-0171, Westinghouse Savannah River Company, Aiken, SC.

Arnett, M.W., and A.R. Mamatey, eds., 1997b, *Savannah River Site Environmental Data for 1996*, WSRC-TR-97-0077, Westinghouse Savannah River Company, Aiken, SC.

Arnett, M.W., L.K. Karapatakis, and A.R. Mamatey, eds., 1993, *Savannah River Site Environmental Report for 1992*, WSRC-TR-93-075, Westinghouse Savannah River Company, Aiken, SC.

Arnett, M.W., L.K. Karapatakis, and A.R. Mamatey, eds., 1994, *Savannah River Site Environmental Report for 1993*, WSRC-TR-94-075, Westinghouse Savannah River Company, Aiken, SC.

Bala, E., 1997, Idaho Transportation Department, Rigby, ID, personal communication to D.M. Nemeth, Science Applications International Corporation, Germantown, MD, *Transportation Improvements in Idaho*, September 11.

Barghusen, J., and R. Feit, 1995, *Technical Report on Affected Environment for the DOE Sites Considered in the DOE Waste Management Programmatic Environmental Impact Statement*, META/Berger-SR-01, META/Berger, Gaithersburg, MD, July.

Battelle (Battelle Memorial Institute), 1989, *Hanford Cultural Resources Management Plan*, PNL-6942, Pacific Northwest National Laboratory, Richland, WA, June.

Battelle and M&H (Battelle Pantex and Mason & Hanger Corporation), 1996, *Biological Assessment of Continued Operation of Pantex Plant and Associated Storage of Nuclear Weapon Components*, Amarillo, TX, April 26.

| Battley, V.L., 1999, U.S. Department of Energy, Amarillo Area Office, Amarillo, TX, personal communication
| (facsimile) to K. Folk, Science Applications International Corporation, Germantown, MD, *Signed FFCA for*
| *Pantex*, January 25.

Berenbrock, C., and L.C. Kjelstrom, 1998, *Preliminary Water-Surface Elevations and Boundaries of the 100-Year Peak Flow in the Big Lost River at the Idaho National Engineering and Environmental Laboratory, Idaho*, Water-Resources Investigations Report 98-4065, U.S. Geological Survey, Boise, ID.

Cabak, M.A, K.E. Sassaman, and J.C. Gillam, 1996, "Distributional Archaeology in the Aiken Plateau: Intensive Survey of E Area, Savannah River Site, Aiken County, South Carolina," *Savannah River Archaeological Research Papers 8, Occasional Papers of the Savannah River Archaeological Research Program*, South Carolina Institute of Archaeology and Anthropology, University of South Carolina, Aiken, SC.

CEQ (Council on Environmental Quality), 1986, *Regulations for Implementing the Procedural Provisions of the National Environmental Policy Act*, "Human Environment," 40 CFR 1508.14, Washington, DC, July 1.

CEQ (Council on Environmental Quality), 1997, *Environmental Justice, Guidance Under the National Environmental Policy Act*, Executive Office of the President, Washington, DC, December 10.

Clawson, K.L., G.E. Start, and N.R. Ricks, eds., 1989, *Climatology of the Idaho National Engineering Laboratory*, 2nd ed., DOE/ID-12118, U.S. Department of Energy, Idaho Operations Office, Idaho Falls, ID, December.

Depperschmidt, J., 1999, U.S. Department of Energy, Idaho Operations Office, Idaho Falls, ID, personal communication (fax) to S. Lesica, U.S. Department of Energy, Office of Nuclear Facilities Management, Germantown, MD, *Comments from DOE-ID HLW Program Office*, June 29.

Dirkes, R.L., and R.W. Hanf, eds., 1996, *Hanford Site 1995 Environmental Report*, PNNL-11139, Battelle, Pacific Northwest National Laboratory, Richland, WA, June.

Dirkes, R.L., and R.W. Hanf, eds., 1997, *Hanford Site 1996 Environmental Report*, PNNL-11472, Battelle, Pacific Northwest National Laboratory, Richland, WA, August.

DOC (U.S. Department of Commerce), 1990a, *1990 Census Look Up*, Summary Tape File 1C, Bureau of the Census, Washington, DC.

DOC (U.S. Department of Commerce), 1990b, *1990 EEO File: Detailed Occupations by Sex by Hispanic Origin and Race*, Bureau of the Census, Housing and Household Economic Statistics Division, Washington, DC.

DOC (U.S. Department of Commerce), 1992, *Census of Population and Housing, 1990: Summary Tape File 3 on CD-ROM*, Bureau of the Census, May.

DOC (U.S. Department of Commerce), 1994, *County and City Data Book: 1994, Washington, DC*, Bureau of the Census, Washington, DC, 1994.

DOC (U.S. Department of Commerce), 1996, *Statistical Abstract of the United States: 1996*, 116th Edition, Bureau of the Census, Washington, DC, October.

DOC (U.S. Department of Commerce), 1997, *Estimates of the Population of Counties and Demographic Components of Population Change: Annual Time Series, July 1, 1990 to July 1, 1996*, www.census.gov/population/estimates/county/CO-96-08, Bureau of the Census, Population Estimates Program, Population Division, Washington, DC.

DOE (U.S. Department of Energy), 1983, *Final Environmental Impact Statement Pantex Plant Site, Amarillo, Texas*, DOE/EIS-0098, Washington, DC, October.

DOE (U.S. Department of Energy), 1992, *Final Environmental Impact Statement and Environmental Impact Report for Continued Operation of Lawrence Livermore National Laboratory and Sandia National Laboratories, Livermore*, DOE/EIS-0157, San Francisco Field Office, Oakland, CA, August.

DOE (U.S. Department of Energy), 1993a, *Radiation Protection of the Public and the Environment*, DOE Order 5400.5, Office of Environment, Safety and Health, January 7.

DOE (U.S. Department of Energy), 1993b, *Radiation Protection of the Public and the Environment*, proposed rule 10 CFR 834, 58 FR 16268, Office of the Federal Register, Washington, DC, March 23.

DOE (U.S. Department of Energy), 1994a, *Radiological Control Manual*, rev. 1, DOE/EH-0256T, Office of Environment, Safety and Health, Washington, DC, April.

DOE (U.S. Department of Energy), 1994b, *Memorandum of Agreement Between the United States Department of Energy Idaho Operations Office and the Shoshone-Bannock Tribes*, OID-OC-RAK-94-11, Idaho Operations Office, Idaho Falls, ID, February 2.

DOE (U.S. Department of Energy), 1994c, *Final Supplemental Environmental Impact Statement, Defense Waste Processing Facility*, DOE/EIS-0082-S, Savannah River Operations Office, Aiken, SC, November.

DOE (U.S. Department of Energy), 1995a, *Occupational Radiation Protection*, 10 CFR 835, Washington, DC, January 1.

DOE (U.S. Department of Energy), 1995b, *Department of Energy Programmatic Spent Nuclear Fuel Management and Idaho National Engineering Laboratory Environmental Restoration and Waste Management Programs Final Environmental Impact Statement*, DOE/EIS-0203-F, Office of Environmental Management, Idaho Operations Office, Idaho Falls, ID, April.

DOE (U.S. Department of Energy), 1995c, *Savannah River Site Waste Management Final Environmental Impact Statement*, DOE/EIS-0217, Savannah River Operations Office, Aiken, SC, July.

DOE (U.S. Department of Energy), 1996a, *Storage and Disposition of Weapons-Usable Fissile Materials Final Programmatic Environmental Impact Statement*, DOE/EIS-0229, Office of Fissile Materials Disposition, Washington, DC, December.

DOE (U.S. Department of Energy), 1996b, *Draft Hanford Remedial Action Environmental Impact Statement and Comprehensive Land Use Plan*, DOE/EIS-0222D, Richland Operations Office, Richland, WA, August.

DOE (U.S. Department of Energy), 1996c, *Tank Waste Remediation System, Hanford Site, Richland, Washington, Final Environmental Impact Statement*, DOE/EIS-0189, Richland Operations Office, Richland, WA, August.

DOE (U.S. Department of Energy), 1996d, *Integrated Data Base Report - 1995: U.S. Spent Nuclear Fuel and Radioactive Waste Inventories, Projections, and Characteristics*, rev. 12, DOE/RW-0006, Office of Environmental Management, Germantown, MD, December.

DOE (U.S. Department of Energy), 1996e, *Final Environmental Impact Statement on a Proposed Nuclear Weapons Nonproliferation Policy Concerning Foreign Research Reactor Spent Nuclear Fuel*, DOE/EIS-0218F, Office of Environmental Management, Washington, DC, February.

DOE (U.S. Department of Energy), 1996f, *Final Environmental Impact Statement for the Continued Operation of the Pantex Plant and Associated Storage of Nuclear Weapon Components*, DOE/EIS-0225, Albuquerque Operations Office, Albuquerque, NM, November.

DOE (U.S. Department of Energy), 1996g, *Programmatic Agreement Among the U.S. Department of Energy/Amarillo Area Office, the Texas State Historic Preservation Officer, and the Advisory Council on Historic Preservation*, Amarillo Area Office, Amarillo, TX, October.

DOE (U.S. Department of Energy), 1996h, *The 1996 Baseline Environmental Management Report*, DOE/EM-0290, Office of Environmental Management, Washington, DC, June.

DOE (U.S. Department of Energy), 1996i, *Final Programmatic Environmental Impact Statement for Stockpile Stewardship and Management*, DOE/EIS-0236, Office of Fissile Materials Disposition, Washington, DC, September.

[Text deleted.]

DOE (U.S. Department of Energy), 1997a, *Final Waste Management Programmatic Environmental Impact Statement for Managing Treatment, Storage, and Disposal of Radioactive and Hazardous Waste*, DOE/EIS-0200-F, Office of Environmental Management, Washington, DC, May.

DOE (U.S. Department of Energy), 1997b, *Idaho National Engineering and Environmental Laboratory, Comprehensive Facility and Land Use Plan*, DOE/ID-10514, Idaho Operations Office, Idaho Falls, ID, April 30.

DOE (U.S. Department of Energy), 1997c, *1996 Environmental Report for Pantex Plant*, DOE/AL/65030-9704, Albuquerque Operations Office, Amarillo Area Office, Amarillo, TX, May.

DOE (U.S. Department of Energy), 1997d, *Waste Isolation Pilot Plant Disposal Phase Final Supplemental Environmental Impact Statement*, DOE/EIS-0026-S-2, Carlsbad Area Office, Carlsbad, NM, September.

DOE (U.S. Department of Energy), 1997e, *Shutdown of the River Water System at the Savannah River Site Final Environmental Impact Statement*, DOE/EIS-0268, Savannah River Operations Office, Aiken, SC, May.

DOE (U.S. Department of Energy), 1997f, *Accelerator for Production of Tritium at the Savannah River Site Environmental Impact Statement*, DOE/EIS-0270D, Savannah River Operations Office, Aiken, SC, December.

DOE (U.S. Department of Energy), 1997g, *Site Profile, Los Alamos National Laboratory*, Office of Oversight, Environment, Safety and Health, Washington, DC, October.

DOE (U.S. Department of Energy), 1998a, *Record of Decision for the Department of Energy's Waste Management Program: Treatment and Storage of Transuranic Waste*, 63 FR 3629, Office of the Federal Register, Washington, DC, January 23.

DOE (U.S. Department of Energy), 1998b, *Record of Decision for the Department of Energy's Waste Management Program: Treatment of Nonwastewater Hazardous Waste*, 63 FR 41810, Office of the Federal Register, Washington, DC, August 5.

DOE (U.S. Department of Energy), 1998c, *Environmental Assessment for the Transfer of 1100 Area, Southern Rail Connection and Rolling Stock, Hanford Site, Richland, Washington*, DOE/EA-1260, Richland Operations Office, Richland, WA, August.

| DOE (U.S. Department of Energy), 1998d, *Accelerating Cleanup, Paths to Closure*, DOE/EM-0362, Office of Environmental Management, Washington, DC, June.

| DOE (U.S. Department of Energy), 1998e, *Draft Environmental Impact Statement for the Construction and Operation of a Tritium Extraction Facility at the Savannah River Site*, DOE/EIS-0271D, Savannah River Operations Office, Aiken, SC, May.

| DOE (U.S. Department of Energy), 1998f, *Savannah River Site Spent Nuclear Fuel Management Draft Environmental Impact Statement*, DOE/EIS-0279D, Savannah River Operations Office, Aiken, SC, December.

| DOE (U.S. Department of Energy), 1998g, *Final Environmental Impact Statement on Management of Certain Plutonium Residues and Scrub Alloy Stored at the Rocky Flats Environmental Technology Site*, DOE/EIS-0277F, Office of Environmental Management, Washington, DC, August.

| DOE (U.S. Department of Energy), 1999a, *Semi-Annual Progress Report, NPDES Permit No. TX0107107, Federal Facilities Compliance Agreement (FFCA) Docket No. VI-98-1210, Administrative Order (AO) Docket No. VI-98-0401*, Amarillo Area Office, Amarillo, TX, January 12.

| DOE (U.S. Department of Energy), 1999b, *Final Site-Wide Environmental Impact Statement for Continued Operation of the Los Alamos National Laboratory*, DOE/EIS-0238, Albuquerque Operations Office, Albuquerque, NM, January.

| DOE (U.S. Department of Energy), 1999c, *INEEL Shipment Arrives Safely at Waste Isolation Pilot Plant*, Press Release, Idaho Operations Office, Idaho Falls, ID, April 28.

| DOE (U.S. Department of Energy), 1999d, *Final Environmental Assessment for Wastewater Treatment Capability Upgrade*, DOE/EA-1190, Amarillo Area Office, Amarillo, TX, April.

| DOE (U.S. Department of Energy), 1999e, *Finding of No Significant Impact, Wastewater Treatment Facility Upgrade, Pantex Plant*, May 27.

| DOE (U.S. Department of Energy), 1999f, *MOX Fuel Fabrication Facility and Nuclear Power Reactor Data Report*, MD-0015, Office of Fissile Materials Disposition, Washington, DC, August.

| DOE (U.S. Department of Energy), 1999g, *Final Environmental Impact Statement, Construction and Operation of the Spallation Neutron Source*, DOE/EIS-0247, Office of Science, Germantown, MD, April.

| DOE (U.S. Department of Energy), 1999h, *REMS Query Results for Oak Ridge for 1997*, rems.eh.doe.gov/rems/, Office of Environment, Safety and Health Web site.

| DOI (U.S. Department of the Interior), 1986a, *Visual Resource Inventory, BLM Manual Handbook H-8410-1*, Bureau of Land Management, Washington, DC, January 17.

| DOI (U.S. Department of the Interior), 1986b, *Visual Resource Contrast Rating, BLM Manual Handbook H-8431-1*, Bureau of Land Management, Washington, DC, January 17.

| DOL (U.S. Department of Labor), 1997, *Employment and Wages, Annual Averages, 1995*, Bureau of Labor Statistics, Office of Employment and Unemployment Statistics, Washington, DC.

DOL (U.S. Department of Labor), 1999, *Local Area Unemployment Statistics for Year 1996*, www.bls.gov/sahome.html, Bureau of Labor Statistics, Office of Employment and Unemployment Statistics, Local Area Unemployment Statistics Division, Washington, DC, April 8.

DOT (U.S. Department of Transportation), 1995, *Airport Noise Compatibility Planning*, 14 CFR 150, July 18.

Duke Power (Duke Power Company), 1974, *McGuire Environmental Report, Operating Stage*, Docket No. 50369-58, Atomic Energy Commission, Washington, DC.

Duke Power (Duke Power Company), 1994, *NPDES Permit Renewal, NC0024392, McGuire Nuclear Station, Mecklenburg County*, letter from J. Carter (Technical Systems Manager, GSD/Environmental Division) to C. Sullins (North Carolina Department of Environment, Health and Natural Resources), Huntersville, NC, June 30.

Duke Power (Duke Power Company), 1996, *McGuire Nuclear Station Updated Final Safety Analysis Report*, Charlotte, NC, May 14.

Duke Power (Duke Power Company), 1997, *Catawba Nuclear Station Updated Final Safety Analysis Report*, Charlotte, NC, May 2.

Dutton, A.R., and W.W. Simpkins, 1986, *Hydrogeochemistry and Water Resources of the Triassic Lower Dockum Group in the Texas Panhandle and Eastern New Mexico*, Report of Investigations No. 161, Bureau of Economic Geology, Austin, TX.

EPA (U.S. Environmental Protection Agency), 1974, *Information on Levels of Environmental Noise Requisite To Protect Public Health and Welfare With an Adequate Margin of Safety*, EPA/550/9-74-004, Office of Noise Abatement and Control, Washington, DC, March.

[Text deleted.]

EPA (U.S. Environmental Protection Agency), 1997a, *National Primary and Secondary Ambient Air Quality Standards*, 40 CFR 50, March 31.

EPA (U.S. Environmental Protection Agency), 1997b, *National Ambient Air Quality Standards for Ozone*, 62 FR 38855, Office of the Federal Register, Washington, DC, July 18.

EPA (U.S. Environmental Protection Agency), 1997c, *National Ambient Air Quality Standards for Particulate Matter*, 62 FR 38652, Office of the Federal Register, Washington, DC, July 18.

EPA (U.S. Environmental Protection Agency), 1997d, *Designation of Areas for Air Quality Planning Purposes*, "Idaho," 40 CFR 81.313, March 31.

EPA (U.S. Environmental Protection Agency), 1997e, *Designation of Areas for Air Quality Planning Purposes*, "Texas," 40 CFR 81.344, March 31.

EPA (U.S. Environmental Protection Agency), 1997f, *Designation of Areas for Air Quality Planning Purposes*, "Georgia," 40 CFR 81.311, March 31.

EPA (U.S. Environmental Protection Agency), 1997g, *Designation of Areas for Air Quality Planning Purposes*, "South Carolina," 40 CFR 81.341, March 31.

EPA (U.S. Environmental Protection Agency), 1997h, *Designation of Areas for Air Quality Planning Purposes*, “New Mexico,” 40 CFR 81.332, March 31.

| EPA (U.S. Environmental Protection Agency), 1998a, *State Program Requirements; Approval of Application to Administer the National Pollutant Discharge Elimination System (NPDES) Program; Texas*, 63 FR 51164, Office of the Federal Register, Washington, DC, September 24.

| EPA (U.S. Environmental Protection Agency), 1998b, *Designation of Areas for Air Quality Planning Purposes*, “California,” 40 CFR 81.305, July 1.

| EPA (U.S. Environmental Protection Agency), 1998c, *Designation of Areas for Air Quality Planning Purposes, State of California: Redesignation of the San Francisco Bay Area to Nonattainment for Ozone*, final rule, 63 FR 37258, Office of the Federal Register, Washington, DC, July 10.

EPA (U.S. Environmental Protection Agency), 1998d, *Designation of Areas for Air Quality Planning Purposes*, “South Carolina,” 40 CFR 81.341, July 1.

EPA (U.S. Environmental Protection Agency), 1998e, *Designation of Areas for Air Quality Planning Purposes*, “North Carolina,” 40 CFR 81.334, July 1.

EPA (U.S. Environmental Protection Agency), 1998f, *Designation of Areas for Air Quality Planning Purposes*, “Virginia,” 40 CFR 81.347, July 1.

ERDA (U.S. Energy Research Development Administration), 1976, *Evaluation of Impact of Potential Flooding Criteria on the Hanford Project*, RLO-76-4, Richland Operations Office, Richland, WA.

| EuDaly, E.M., 1998, U.S. Department of the Interior, Fish and Wildlife Service, Charleston, SC, personal communication to M. Jones, U.S. Department of Energy, Office of Fissile Materials Disposition, Washington, DC, FWS Log No. 4-6-98-364, *Surplus Plutonium Disposition, Savannah River Site (SRS), Aiken County, South Carolina*, September 8.

Famighetti, R., ed., 1998, *The World Almanac and Book of Facts 1998*, K-III Reference Corporation, Mahwah, NJ.

| Greenly, G.D., 1999, Waste and Environmental Management Department, DOE Pantex Plant, Amarillo, TX, personal communication to K. Folk, Science Applications International Corporation, Germantown, MD, *Buildings/Towers on the Pantex Plant Site*, June 18.

| Gustavson, T.C., 1996, *Fluvial and Eolian Depositional Systems, Paleosols, and Paleoclimate of the Upper Cenozoic Ogallala and Blackwater Draw Formations, Southern High Plains, Texas and New Mexico*, Report of Investigations No. 239, Bureau of Economic Geology, Austin, TX.

| Hamilton, L.V., et al., 1998, *Oak Ridge Reservation Annual Site Environmental Report for 1997*, ES/ESH-78, Oak Ridge National Laboratory, Oak Ridge, TN, October.

Harrach, R.J., et al., 1997, *Environmental Report 1996, Lawrence Livermore National Laboratory*, UCRL-50027-26, Lawrence Livermore National Laboratory, Livermore, CA, September 1.

Hartman, M.J., and P.F. Dresel, eds., 1997, *Hanford Site Groundwater Monitoring for Fiscal Year 1996*, PNNL-11470, Battelle, Pacific Northwest National Laboratory, Richland, WA, February.

Hoitink, D.J., and K.W. Burk, 1996, *Hanford Site Climatological Data Summary 1995 With Historical Data*, PNNL-11107, Battelle, Richland, WA, May.

ID DHW (Idaho Department of Health and Welfare), 1995, *Rules for the Control of Air Pollution in Idaho*: 577, “Ambient Standards for Specific Air Pollutants”; 585, “Toxic Air Pollutants Non-Carcinogenic Increments”; 586, “Toxic Air Pollutants Carcinogenic Increments,” IDAPA 16, Title 01, Chapter 01, Boise, ID.

Jackson, S.M., 1985, “Acceleration Data from the 1983 Borah Peak, Idaho, Earthquake Recorded at the Idaho National Engineering Laboratory,” in *Proceedings of Workshop XXVIII on the Borah Peak, Idaho, Earthquake*, R.S. Stein and R.C. Bucknam (eds.), Open-File Report 85-290, U.S. Geological Survey, Idaho Falls, ID, pp. 385-400.

Jones, M., 1999, U.S. Department of Energy, Washington, DC, personal communication (electronic mail) to J. DiMarzio and J. Eichner, Science Applications International Corporation, Germantown, MD, *Pantex Comments*, January 27.

Kielusiak, C., 1998a, Lawrence Livermore National Laboratory, Livermore, CA, personal communication to J. DiMarzio, Science Applications International Corporation, Germantown, MD, *Additional Waste Treatment Information*, April 21.

Kielusiak, C., 1998b, Lawrence Livermore National Laboratory, Livermore, CA, personal communication to J. DiMarzio, Science Applications International Corporation, Germantown, MD, *Revised Table 3.7.3.3-2*, April 23.

King, H.H., 1997a, Mason & Hanger Corporation, Amarillo, TX, personal communication (electronic mail) to J. DiMarzio, Science Applications International Corporation, Germantown, MD, *Additional Information for Pantex AE Data Call*, August 1.

King, H.H., 1997b, Mason & Hanger Corporation, Amarillo, TX, personal communication to J. DiMarzio, Science Applications International Corporation, Germantown, MD, *Waste Management Information for Pantex*, October 21.

Knox, J., 1997, U.S. Department of Energy, Savannah River Operations Office, personal communication (facsimile) to K. Gandee, U.S. Department of Energy, Office of Fissile Materials Disposition, Washington, DC, July 2.

Kovacs, J., 1997, B&W Hanford Company, Richland, WA, personal communication to J. DiMarzio, Science Applications International Corporation, Germantown, MD, *Waste Management Facilities at the Hanford Site*, October 23.

LANL (Los Alamos National Laboratory), 1998, *Environmental Surveillance at Los Alamos During 1997*, LA-13487-ENV, Los Alamos, NM.

Lemming, J.F., 1998, Mason & Hanger Corporation, Amarillo, TX, personal communication to J. DiMarzio, Science Applications International Corporation, Germantown, MD, *SPD EIS - Additional Questions on Affected Environment*, January 30.

Lyon, M., 1997, Battelle, Pacific Northwest National Laboratory, personal communication to J. Teal, Science Applications International Corporation, Richland, WA, *Hanford Calendar Year Manrem Data for 1996, 1995, and 1994*, April 30.

M&H (Mason & Hanger Corporation), 1996a, *Environmental Information Document: The Continued Operation of the Pantex Plant and Associated Storage of Nuclear Weapon Components Environmental Impact Statement*, ES:96:0156, Amarillo, TX, September.

M&H (Mason & Hanger Corporation), 1996b, *Safety Information Document: The Continued Operation of the Pantex Plant and Associated Storage of Nuclear Weapon Components Environmental Impact Statement*, ES:96:0155, Amarillo, TX, September.

M&H (Mason & Hanger Corporation), 1996c, *Integrated Plan for Playa Management at Pantex Plant*, Environmental Protection Department, Environmental, Safety and Health, Pantex Plant, Amarillo, TX, December.

M&H (Mason & Hanger Corporation), 1997, *Pantex Plant Affected Environment Data Report for the Surplus Plutonium Disposition Environmental Impact Statement*, Amarillo, TX, June 12.

MacNeil, R., 1997, Washington Department of Transportation, Union Gap, WA, personal communication to D.M. Nemeth, Science Applications International Corporation, Germantown, MD, *Transportation Improvements in Washington*, September 9.

Mayer, J.J., and L.D. Wike, 1997, *SRS Urban Wildlife: Environmental Information Document*, WSRC-TR-97-0093, Westinghouse Savannah River Company, Aiken, SC, May.

McConnaughey, J., 1998, State of Washington Department of the Fish and Wildlife, Department of Ecology, Kennewick, WA, personal communication to M. Jones, U.S. Department of Energy, Office of Fissile Materials Disposition, Washington, DC, *Comments on the Surplus Plutonium Disposition Draft Environmental Impact Statement, July 1998, DOE/EIS-0283-D*, December 7.

Mecca, J.E., 1997a, U.S. Department of Energy, Richland Operations Office, Richland, WA, personal communication to K.R. Gandee, U.S. Department of Energy, Office of Fissile Materials Disposition, Washington, DC, *Hanford Site Response to Site Environmental Data Call for Preparation of the Draft Surplus Plutonium Disposition Environmental Impact Statement*, June 11.

Mecca, J.E., 1997b, U.S. Department of Energy, Richland Operations Office, Richland, WA, personal communication to K.R. Gandee, U.S. Department of Energy, Office of Fissile Materials Disposition, Washington, DC, *Affected Environment Data Reports for the Surplus Plutonium Disposition EIS*, July 31.

Miles, M., 1998, U.S. Department of Energy, Savannah River Operations Office, Aiken, SC, personal communication to J. DiMarzio, Science Applications International Corporation, Germantown, MD, *Volume Capacities for SRS*, May 28.

Miller, S., 1995, *Idaho National Engineering Laboratory Management Plan for Cultural Resources (Final Draft)*, rev. 1, DOE/ID-10361, Lockheed Martin Idaho Technologies Company, Idaho Falls, ID, July.

Mitchell, R.G., D. Peterson, and D.L. Hoff, 1996, *Idaho National Engineering Laboratory Site Environmental Report for Calendar Year 1995*, DOE/ID-12082(95), U.S. Department of Energy, Idaho Operations Office, Idaho Falls, ID, August.

Mitchell, R.G., D. Peterson, D. Roush, R.W. Brooks, L.R. Paulus, and D.B. Martin, 1997, *Idaho National Engineering Laboratory Site Environmental Report for Calendar Year 1996*, DOE/ID-12082(96), U.S. Department of Energy, Idaho Operations Office, Idaho Falls, ID, August.

Moor, K., 1998, Lockheed Martin Idaho Technologies Company, Idaho Falls, ID, personal communication to J. DiMarzio, Science Applications International Corporation, Germantown, MD, *Waste Management Facilities at the Idaho National Engineering and Environmental Laboratory*, January.

Nava, B., 1998, Battelle-Pantex, Amarillo, TX, personal communication to J. DiMarzio, Science Applications International Corporation, Germantown, MD, *Administrative Order for Pantex*, May 28.

NCRP (National Council on Radiation Protection and Measurements), 1987, *Ionizing Radiation Exposure of the Population of the United States*, NCRP Report No. 93, Pergamon Press, Elmsford, NY, September 1.

Neitzel, D.A., ed., 1996, *Hanford Site National Environmental Policy Act (NEPA) Characterization*, rev. 8, PNL-6415, Battelle, Pacific Northwest National Laboratory, Richland, WA, August.

Nemeth, D.M., 1997a, *List of School Districts Contacted for Current Operating Capacities, Student Enrollment, and Number of Teachers Employed Within the Hanford, INEEL, Pantex, and SRS ROIs*, Memorandum to SPD EIS Administrative Record, December 15.

Nemeth, D.M., 1997b, *List of Sheriff Offices, Police Departments, and Fire Departments Contacted for Number of Sworn Police Officers Employed and Firefighters (Both Employed and Volunteer) in the Hanford, INEEL, Pantex, and SRS ROIs*, Memorandum to SPD EIS Administrative Record, December 15.

Nemeth, D.M., 1997c, *List of Hospitals and Hospital Associations Contacted for Current Number of Hospitals and Hospital Beds Located in Hanford, INEEL, Pantex, and SRS ROIs*, Memorandum to SPD EIS Administrative Record, December 17.

Nesbit, S., 1999, Duke Energy, Charlotte, NC, personal communication to P. Wherley, Science Applications International Corporation, Germantown, MD, *Duke Power Comments on the April 1999 Supplement to the SPD Draft EIS*, June 21.

Nipp, B., 1997, Texas Department of Transportation, Amarillo, TX, personal communication to D.M. Nemeth, Science Applications International Corporation, Germantown, MD, *Transportation Improvements in Texas*, September 10.

NOAA (National Oceanic and Atmospheric Administration), 1994a, *Local Climatological Data, Annual Summary With Comparative Data, 1993*, "Amarillo, Texas (AMA)" National Environmental Satellite, Data, and Information Service, National Climatic Data Center, Asheville, NC, November 29.

NOAA (National Oceanic and Atmospheric Administration), 1994b, *Local Climatological Data, Annual Summary With Comparative Data, 1993*, "Augusta, Georgia" National Environmental Satellite, Data, and Information Service, National Climatic Data Center, Asheville, NC, November 29.

Noah, J.C., compiler, 1995, *Land-Use Baseline Report, Savannah River Site*, WSRC-TR-95-0276, Westinghouse Savannah River Company, Aiken, SC, June.

NPS (U.S. National Park Service), 1994, *Hanford Reach of the Columbia River Comprehensive River Conservation Study and Environmental Impact Statement*, Final, Pacific Northwest Regional Office, Seattle, WA, June.

[Text deleted.]

NRC (U.S. Nuclear Regulatory Commission), 1997, *NRC Information Digest: 1997 Edition*, NUREG-1350, vol. 9, Division of Budget and Analysis, Office of the Chief Financial Officer, Washington, DC, http://www.nrc.gov/NRC/NUREGS/SR1350/V9/sr1350.html#_1_1.

NRC (U.S. Nuclear Regulatory Commission), 1998, *NRC Issues License for Spent Fuel Storage Installation at North Anna Nuclear Power Plant*, Press Release No. 98-110, Office of Public Affairs, Washington, DC, July 2.

NRC (U.S. Nuclear Regulatory Commission), 1999, *Nuclear Plant Information Books*, Washington, DC, <http://www.nrc.gov/OPA/finder.htm#pib>.

NUS (NUS Corporation), 1990, *Sound-Level Characterization of the Savannah River Site*, NUS-5251, Aiken, SC, August.

O'Connor, D.G., et al., 1998a, *Hanford MOX Fuel Lead Assemblies Data Report for the Surplus Plutonium Disposition Environmental Impact Statement*, ORNL/TM-13481, Lockheed Martin Energy Research Corporation, Oak Ridge, TN.

O'Connor, D.G., et al., 1998b, *ANL-W MOX Fuel Lead Assemblies Data Report for the Surplus Plutonium Disposition Environmental Impact Statement*, ORNL/TM-13478, Lockheed Martin Energy Research Corporation, Oak Ridge, TN.

O'Connor, D.G., et al., 1998c, *LLNL MOX Fuel Lead Assemblies Data Report for the Surplus Plutonium Disposition Environmental Impact Statement*, ORNL/TM-13480, Lockheed Martin Energy Research Corporation, Oak Ridge, TN.

O'Connor, D.G., et al., 1998d, *LANL MOX Fuel Lead Assemblies Data Report for the Surplus Plutonium Disposition Environmental Impact Statement*, ORNL/TM-13482, Lockheed Martin Energy Research Corporation, Oak Ridge, TN.

O'Connor, D.G., et al., 1998e, *SRS MOX Fuel Lead Assemblies Data Report for the Surplus Plutonium Disposition Environmental Impact Statement*, ORNL/TM-13483, Lockheed Martin Energy Research Corporation, Oak Ridge, TN.

Peña, F., 1997, U.S. Department of Energy, personal communication to Secretarial Officers and Heads of Field Elements, U.S. Department of Energy, *Lessons Learned From the Emergency Management of the May 14, 1997 Explosion at Hanford's Plutonium Reclamation Facility*, August.

Randolph, L., 1997, American Medical Association, Chicago, IL, personal communication to D.M. Nemeth, Science Applications International Corporation, Germantown, MD, *Information on Physicians by State and County, 1996*, August.

| Reynolds, T.D., 1999, Environmental Science and Research Foundation, Idaho Falls, ID, personal communication to J.R. Schinner, Science Applications International Corporation, Germantown, MD, June 22.

Rhoderick, J., 1998, U.S. Department of Energy, Office of Environmental Management, Washington, DC, personal communication to M. Jones, U.S. Department of Energy, Office of Fissile Materials Disposition, Washington, DC, *Review of Waste Management Facilities for Surplus Plutonium Disposition (SPD) EIS*, April 30.

| Ritchey, K., 1996, *First Impressions Newcomer's Guide, Charlotte Metro*, "Lake Norman Area Services and Attractions," RE/MAX Lake and Land, Cornelius, NC.

Rohl, D.A., 1994, *Hanford Site Water Systems Plan, Site Utilities Program*, RL-WSP-94-01, U.S. Department of Energy, Richland Operations Office, Richland, WA, April.

Roy, R., 1998, U.S. Department of the Interior, Fish and Wildlife Service, Moses Lake, WA, personal communication to M. Jones, U.S. Department of Energy, Office of Fissile Materials Disposition, Washington, DC, *Surplus Plutonium Disposition Environmental Impact Statement FWS Reference: I-9-99-SP-052*, December 3.

Ruesink, R., 1998, U.S. Department of the Interior, Fish and Wildlife Service, Snake River Basin Office, Boise, ID, personal communication to M. Jones, U.S. Department of Energy, Office of Fissile Materials Disposition, Washington, DC, *Surplus Plutonium Disposition--Section 7 Consultation File #506.0000, SP #1-4-98-SP-247*, August 18.

Sadler, M., 1997, South Carolina Department of Health and Environmental Control, Columbia, SC, personal communication to A. Grooms, Duke Energy, *Duke Energy/Catawba Nuclear NPDES Permit #SC0004278*, September 29.

Sandberg, D., 1998a, B&W Hanford Company, Richland, WA, personal communication to J. DiMarzio, Science Applications International Corporation, Germantown, MD, *Some Answers to Additional Questions of the Affected Environments at the Sites*, April 30.

Sandberg, D., 1998b, B&W Hanford Company, Richland, WA, personal communication to J. DiMarzio, Science Applications International Corporation, Germantown, MD, *300 Area Treated Effluent Disposal Facility*, April 2.

Sandberg, D., 1998c, B&W Hanford Company, Richland, WA, personal communication to J. DiMarzio, Science Applications International Corporation, Germantown, MD, *200 Area Fuel Usage*, February 25.

SCDHEC (South Carolina Department of Health and Environmental Control), 1995, *South Carolina Air Quality Annual Report*, vol. XV.

SCDHEC (South Carolina Department of Health and Environmental Control), 1996, *Regulation 61-62, Air Pollution Control Regulations and Standards*, Standard 2, "Ambient Air Quality Standards"; Standard 8, "Toxic Air Pollutants," Air Pollution Control, Columbia, SC.

Sessions, J., 1997a, Westinghouse Savannah River Company, Aiken, SC, personal communication to K. Gandee, U.S. Department of Energy, Office of Fissile Materials Disposition, Washington, DC, *Surplus Pu Disposition EIS Savannah River Site Affected Environment*, August 4.

Sessions, J., 1997b, Westinghouse Savannah River Company, Aiken, SC, personal communication to J. DiMarzio, Science Applications International Corporation, Germantown, MD, *Request for Waste Management Information*, October 1.

Sessions, J., 1997c, Westinghouse Savannah River Company, Aiken, SC, personal communication to K. Gandee, U.S. Department of Energy, Office of Fissile Materials Disposition, Washington, DC, *Surplus Pu Disposition EIS Savannah River Site Affected Environmental Data Call*, ESH-EAP-97-0057, June 9.

Sessions, J., 1998a, Westinghouse Savannah River Company, Aiken, SC, personal communication to J. DiMarzio, Science Applications International Corporation, Germantown, MD, *Coal & Oil*, February 2.

Sessions, J., 1998b, Westinghouse Savannah River Company, Aiken, SC, personal communication to John DiMarzio, Science Applications International Corporation, Germantown, MD, *Reply to Additional Questions on Affected Environment*, January 26.

SRARP (Savannah River Archaeological Research Program), 1989, *Archaeological Resource Management Plan of the Savannah River Archaeological Research Program*, South Carolina Institute of Archaeology and Anthropology, University of South Carolina, Columbia, SC, December.

| SRARP (Savannah River Archaeological Research Program), 1997, *Preliminary Archaeological Assessment of the Proposed Plutonium Immobilization Plant, Savannah River Site, Aiken County, South Carolina*, South Carolina Institute of Archaeology and Anthropology, University of South Carolina, Columbia, SC, November 24.

| Stephens, G., 1998, Idaho Department of Fish and Game, Idaho Conservation Data Center, Boise, ID, personal communication to M. Jones, U.S. Department of Energy, Office of Fissile Materials Disposition, Washington, DC, *Input Relative to Special Status Species Associated with INEEL and Construction at the Idaho Nuclear Technology and Energy Center (INTEC)*, August 12.

| Stephens, G., 1999, Idaho Department of Fish and Game, Idaho Conservation Data Center, Boise, ID, personal communication (facsimile) to K. Folk, Science Applications International Corporation, Germantown, MD *INTEC Area at INEEL*, Reply to Questions Relative to the Database Search for Information on Special-Status Species, February 12.

| Stephenson, K., and A. King, 1999, Savannah River Archaeological Research Program, South Carolina Institute of Archaeology and Anthropology, Aiken, SC, personal communication to D. Ryan, U.S. Department of Energy, Savannah River Operations Office, Aiken, SC, *Surplus Plutonium Disposition Facility Survey Update*, August 26.

Sullivan, M., 1997, South Carolina Highway Administration, Columbia, SC, personal communication to D.M. Nemeth, Science Applications International Corporation, Germantown, MD, *Transportation Improvements in South Carolina*, September 11.

Teal, J., 1997, Science Applications International Corporation, Richland, WA, personal communication to J. DiMarzio, Science Applications International Corporation, Germantown, MD, *Reply to "Hanford Infrastructure – Unresolved Issues,"* September 24.

TNRCC (Texas Natural Resource Conservation Commission), 1997a, *TNRCC Rules*: 101, "General Rules (Air Quality)"; 112, "Control of Air Pollution from Sulfur Compounds (Reg. II)"; 113, "Control of Air Pollution from Toxic Materials (Reg. III)," Austin, TX.

TNRCC (Texas Natural Resource Conservation Commission), 1997b, Toxicology and Risk Assessment (TARA) Section Staff, memo to Interested Parties, *Effects Screening Levels (ESLs) List*, Austin, TX, September 5.

TNRCC (Texas Natural Resource Conservation Commission), 1997c, *Pantex Nuclear Weapons Facility Ambient Air Monitoring Annual 1995 Report*, AS-70, Monitoring Operations Division, Austin, TX, January.

| Triay, I., 1999, U.S. Department of Energy, Los Alamos National Laboratory, Los Alamos, NM, personal communication (telephone conversation) with John DiMarzio, Science Applications International Corporation, Germantown, MD, *TRU Waste Processing Capacity*, April 7.

UC (Regents of the University of California), 1996, *Environmental Surveillance at Los Alamos During 1995*, LA-13210-ENV, October.

UC (Regents of the University of California), 1999, *Fissile Materials Disposition Program, EIS Data Call Report: Plutonium Immobilization Plant Using Glass in New Facilities at the Savannah River Site*, rev. 1, UCRL-ID-128271, Lawrence Livermore National Laboratory, Livermore, CA, September.

VADEQ (Commonwealth of Virginia, Department of Environmental Quality), 1997, *Authorization to Discharge Under the Virginia Pollutant Discharge Elimination System and the Virginia State Water Control Law*, Permit No. VA0052451, November 18.

Virginia Power (Virginia Electric & Power Company), 1998, *North Anna Power Station Updated Final Safety Analysis Report*, rev. 32, Richmond, VA, February 11.

WDEC (Washington Department of Ecology), 1994, *Washington Administrative Code, Title 173*: Chapter 173-460, "Controls for New Sources of Toxic Air Pollutants"; Chapter 173-470, "Standards for Particulate Matter"; Chapter 173-474, "Ambient Air Quality Standards for Sulfur Oxides"; Chapter 173-475, "Ambient Air Quality Standards for Carbon Monoxide, Ozone, and Nitrogen Dioxide"; Chapter 173-481, "Ambient Air Quality and Environmental Standards for Fluorides."

Weinreich, W.A., 1997, Mason & Hanger Corporation, Amarillo, TX, personal communication to J.S. Johnson, U.S. Department of Energy, Amarillo Area Office, Amarillo, TX, *Visual Examination of Storm Water Runoff per the Multi-Sector Permit; WAD Deliverable No. 10-13d*, December 30.

Werner, J., 1997, U.S. Department of Energy, Idaho Operations Office, Idaho Falls, ID, personal communication to K. Gandee, U.S. Department of Energy, Office of Fissile Materials Disposition, Washington, DC, *Data Call for the INEEL Affected Environments*, August 4.

WSRC (Westinghouse Savannah River Company), 1994, *Fact Sheet on Savannah River Site Fire Department*, www.srs.gov/general/aboutsrs/pub_rel/factsheets/fact_sheet_27.html, Administration and Infrastructure Division, Aiken, SC, May 3.

WSRC (Westinghouse Savannah River Company), 1997a, *SRS News Highlights, This Month's Top Stories, CIF: Starting a New Era of Waste Management at SRS*, from www.srs.gov/general/aboutsrs/pub_rel/srsnews.html#STORYONE, Public Relations Department, Aiken, SC, September 2.

WSRC (Westinghouse Savannah River Company), 1997b, *SRS Ecology Environmental Information Document*, WSRC-TR-97-0223, Aiken, SC.

Zahn, K.C., 1998, Lawrence Livermore National Laboratory, Livermore, CA, personal communication to C. Groome, Science Applications International Corporation, Germantown, MD, *Revisions to March 1998 Preliminary Draft Surplus Plutonium Disposition EIS*, April 3.



Office of Fissile Materials Disposition

United States Department of Energy

Surplus Plutonium Disposition Final Environmental Impact Statement

Volume I - Part B

November 1999

For Further Information Contact:
U.S. Department of Energy
Office of Fissile Materials Disposition, P.O. Box 23786, Washington, DC 20026-3786

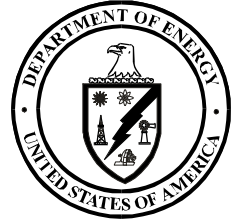

DOE/EIS-0283

Surplus Plutonium Disposition Final Environmental Impact Statement

Volume I - Part B

**United States Department of Energy
Office of Fissile Materials Disposition**

November 1999

Cover Sheet

Responsible Agency: United States Department of Energy (DOE)

Title: *Surplus Plutonium Disposition Final Environmental Impact Statement* (SPD EIS) (DOE/EIS-0283)

Locations of Candidate Sites: California, Idaho, New Mexico, North Carolina, South Carolina, Tennessee, Texas, Virginia, and Washington

Contacts:

For further information on the SPD Final EIS contact: For information on the DOE National Environmental Policy Act (NEPA) process contact:

Mr. G. Bert Stevenson, NEPA Compliance Officer
Office of Fissile Materials Disposition
U.S. Department of Energy
P.O. Box 23786
Washington, DC 20026-3786
Voice: (202) 586-5368

Ms. Carol Borgstrom, Director
Office of NEPA Policy and Assistance
Office of Environment, Safety and Health
U.S. Department of Energy
1000 Independence Ave., SW
Washington, DC 20585
Voice: (202) 586-4600 or (800) 472-2756

Abstract: On May 22, 1997, DOE published a Notice of Intent in the Federal Register (62 Federal Register 28009) announcing its decision to prepare an environmental impact statement (EIS) that would tier from the analysis and decisions reached in connection with the *Storage and Disposition of Weapons-Usable Fissile Materials Final Programmatic EIS*. At that time, the U.S. Environmental Protection Agency decided to be a cooperating agency. The *Surplus Plutonium Disposition Draft Environmental Impact Statement* (SPD Draft EIS) (DOE/EIS-0283-D) was prepared in accordance with NEPA and issued in July 1998. It identified the potential environmental impacts of reasonable alternatives for the proposed siting, construction, and operation of three facilities for the disposition of up to 50 metric tons (55 tons) of surplus plutonium, as well as a No Action Alternative. These three facilities would accomplish pit disassembly and conversion, plutonium conversion and immobilization, and mixed oxide (MOX) fuel fabrication.

For the alternatives that included MOX fuel fabrication, the SPD Draft EIS described the potential environmental impacts of using from three to eight commercial nuclear reactors to irradiate MOX fuel. The potential impacts were based on a generic reactor analysis that used actual reactor data and a range of potential site conditions. In May 1998, DOE initiated a procurement process to obtain MOX fuel fabrication and reactor irradiation services. In March 1999, DOE awarded a contract to Duke Engineering & Services, COGEMA Inc., and Stone & Webster (known as DCS) to provide the requested services. A *Supplement to the SPD Draft EIS* was issued in April 1999, which analyzed the potential environmental impacts of using MOX fuel in six specific reactors named in the DCS proposal. Those reactors are Catawba Nuclear Station Units 1 and 2 in South Carolina, McGuire Nuclear Station Units 1 and 2 in North Carolina, and North Anna Power Station Units 1 and 2 in Virginia.

DOE has identified the hybrid approach as its Preferred Alternative for the disposition of surplus plutonium. This approach allows for the immobilization of 17 metric tons (19 tons) of surplus plutonium and the use of 33 metric tons (36 tons) as MOX fuel. DOE has identified the Savannah River Site near Aiken, South Carolina, as the preferred site for all three disposition facilities (Alternative 3). DOE has also identified Los Alamos National

| Laboratory in New Mexico as the preferred site for lead assembly fabrication, and Oak Ridge National
| Laboratory in Tennessee as the preferred site for postirradiation examination of lead assemblies.

| **Public Involvement:** In preparing the SPD Final EIS, DOE considered comments on the SPD Draft EIS and the
| *Supplement to the SPD Draft EIS* received via mail, fax, and email, and comments recorded by phone and
| transcribed from videotapes. In addition, comments were captured by notetakers during interactive public
| meetings held on the SPD Draft EIS in August 1998 in Amarillo, Texas; Idaho Falls, Idaho; North Augusta,
| South Carolina; Portland, Oregon; and Richland, Washington, as well as during a public meeting on the
| *Supplement to the SPD Draft EIS* held in June 1999 in Washington, D.C. Comments received and DOE's
| responses to these comments are found in Volume III, the Comment Response Document, of the SPD Final EIS.
| Information on the surplus plutonium disposition program can be obtained by visiting the Office of Fissile
| Materials Disposition Web site at <http://www.doe-md.com>.

Chapter 5

Environmental Regulations, Permits, and Consultations

5.1 LAWS, REGULATIONS, EXECUTIVE ORDERS, AND DOE ORDERS

The major Federal laws, regulations, Executive orders, and other compliance actions that potentially apply to surplus plutonium disposition activities, depending on the various alternatives, are identified in Table 5–1.¹ There are a number of Federal environmental statutes dealing with environmental protection, compliance, or consultation that affect compliance at every U.S. Department of Energy (DOE) location. In addition, certain environmental requirements have been delegated to State authorities for enforcement and implementation. It is DOE policy to conduct its operations in an environmentally safe manner in compliance with all applicable statutes, regulations, and standards. Although this chapter does not address pending legislation or future regulations, DOE recognizes that the regulatory environment is in transition, and subject to many changes, and that the construction, operation, and decommissioning of any surplus plutonium disposition facility must be conducted in compliance with all applicable regulations and standards.

The Atomic Energy Act of 1954 authorizes DOE to establish standards to protect health or minimize dangers to life or property for activities under DOE's jurisdiction. Through a series of DOE orders and regulations, an extensive system of standards and requirements has been established to ensure safe operation of facilities. DOE regulations are generally found in Title 10 of the Code of Federal Regulations (CFR). For purposes of this *Surplus Plutonium Disposition Environmental Impact Statement* (SPD EIS), relevant regulations include 10 CFR 820, *Procedural Rules for DOE Nuclear Activities*; 10 CFR 830, *Nuclear Safety Management*; 10 CFR 834, *Radiation Protection of the Public and the Environment (Draft)*; 10 CFR 835, *Occupational Radiation Protection*; 10 CFR 1021, *National Environmental Policy Act Implementing Procedures*; and 10 CFR 1022, *Compliance with Floodplains/Wetlands Environmental Review Requirements*. The DOE orders have been revised and reorganized to reduce duplication and eliminate obsolete provisions (though some older orders remain in effect during the transition). The new organization is by Series and is generally intended to include all DOE policies, orders, manuals, requirements documents, notices, and guides. Relevant DOE orders include those in the new Series 400, which deals with Work Process. Within this Series, DOE Order 420.1 addresses *Facility Safety*; 425.1A, *Startup and Restart of Nuclear Facilities*; 452.1A, *Nuclear Explosive and Weapons Surety Programs*; 452.2A, *Safety of Nuclear Explosives Operations*; 452.4, *Security and Control of Nuclear Explosives and Nuclear Weapons*; 460.1A, *Packaging and Transportation Safety*; 470.1, *Safeguards and Security Program*; and Manual 474.1, *Nuclear Materials Management and Safeguards System Reporting and Data Submission*. In addition, DOE (older number) Series 5400 addresses environmental, safety, and health programs for DOE operations.

5.2 REGULATORY ACTIVITIES

It is likely that new or modified permits would be needed before surplus plutonium disposition facilities could be constructed or operated. Permits regulate many aspects of facility construction and operations, including the quality of construction, treatment and storage of hazardous waste, and discharges of effluents to the environment. These permits would be obtained as required from appropriate Federal, State, and local agencies. Permits for constructing or operating surplus plutonium disposition facilities would not be obtained or modified before a Record of Decision was issued on this SPD EIS.

¹ It should be noted that not all of these statutes, regulations, and orders apply to all aspects of the surplus plutonium disposition program and that the descriptions provided represent only a broad summary of each listed requirement.

5.2.1 Pit Conversion and Immobilization Facilities

The pit conversion and immobilization facilities would be designed, constructed, and operated in accordance with DOE regulations and requirements, although the facilities may, as a matter of policy, take into account any appropriate NRC standards. These facilities are categorized as nonreactor nuclear facilities. The major DOE design criteria may be found in DOE Order 6430.1A, *General Design Criteria*, and its successor Orders 420.1A, *Facility Safety*, and 430.1, *Life Cycle Asset Management*, which delineate applicable regulatory and industrial codes and standards for both conventional facilities designed to industrial standards and “special facilities” (defined as nonreactor nuclear facilities and explosive facilities). The design of the facilities would be accomplished in stages that allow for adequate review and assurance that all required standards are met. Prior to operation, the facilities would undergo cold and hot startup testing and an operational readiness review in accordance with the requirements of DOE Order 425.1. Startup of these facilities would require the approval of the Secretary of Energy.

While there are a number of areas or buildings that would be designed to conventional codes and standards, plutonium processing and storage areas, and other areas where quantities of plutonium or other special nuclear materials in excess of a minimum quantity could be present, would be required to meet the more stringent requirements for facility integrity and safeguards and security. Other applicable regulations and standards would be related to worker health and safety and environmental protection, such as DOE’s radiation protection standards found in 10 CFR 835. In addition, Federal or State regulations implementing the Clean Water Act (CWA), Clean Air Act (CAA), and Resource Conservation and Recovery Act (RCRA) are applicable. These regulations are implemented through permits, and DOE would require evaluations to determine whether the pit conversion or immobilization facility emissions and activities would necessitate modification of any of these permits. Analyses in Chapter 4 have shown that there would be minimal impact from construction and operation of these facilities.

5.2.2 MOX Facility

The mixed oxide (MOX) fuel fabrication facility would be licensed to operate by the U.S. Nuclear Regulatory Commission (NRC) under its regulations in 10 CFR 70, *Domestic Licensing of Special Nuclear Material*. Because the facility would be located at a DOE site, however, certain DOE requirements affecting site interfaces and infrastructure would also be applicable. In addition, as would be the case regardless of where the facility was built, certain Federal or State regulations implementing the CWA, the CAA, and RCRA would be applicable. These regulations are implemented through permits. Evaluation would be required to determine whether MOX facility emissions and activities necessitated modification of any of these permits. Analyses in Chapter 4 have shown that there would be minimal impacts from construction and operation of the MOX facility.

MOX facility design and operating parameters would be imposed by requirements of 10 CFR 70. Facility robustness, and worker health and safety, for example, are all specified by 10 CFR 70. This regulation incorporates and refers the licensee to provisions of other NRC regulations such as those found in 10 CFR 20, *Protection Against Radiation*. Safety and environmental analyses would be required to support the license application for the MOX facility.

Integral to the National Environmental Policy Act (NEPA) process is consideration of how the proposed action might affect biotic, cultural, and Native American resources and of the need for mitigation of any potential impacts. Required consultations with agencies and recognized Native American groups have been initiated as part of the NEPA process for this SPD EIS.

5.2.3 Reactors

Nuclear power reactors undergo a lengthy licensing process under 10 CFR 50, *Domestic Licensing of Production and Utilization Facilities*, beginning before facility construction. This process includes preparation of safety analysis and environmental reports. The safety analysis report remains a living document that serves as the licensing basis for the plant and is updated throughout the life of the plant. Public hearings before a licensing board are conducted before a license is issued. Once issued, operating licenses may be amended only with proper evaluation, review, and approval as specified in 10 CFR 50.90. This prescriptive process requires demonstration that a proposed change does not involve an unreviewed environmental or safety question and provides for public notice and opportunity to comment before issuance of the license amendment. Minor license amendments can be processed fairly expeditiously, but more involved amendments can require multiple submittals before NRC is assured that the proposed action will not reduce the margin of safety of the plant. All submittals, except the portions that contain proprietary information, are available to the public.

The six reactors proposed to use MOX fuel have been operating for many years. Revisions to each of their operating licenses would be required prior to MOX fuel being brought to the reactor sites and loaded into the reactors. The regulatory process for requesting reactor license amendments to use MOX fuel would be the same as that for any 10 CFR 50 operating license amendment request. This process is initiated by the reactor licensee submitting an operating license amendment request in accordance with 10 CFR 50.90. The license amendment request would need to include a discussion of all potential impacts and changes in reactor operation that could be important to safety or the environment.

The need for modifications to site permits would be evaluated by the individual plants. The contractor team of Duke Engineering & Services, COGEMA Inc., and Stone & Webster has indicated that there would be minimal changes in effluents, emissions, and wastes (radiological or nonradiological).

5.3 CONSULTATIONS

Certain statutes and regulations require DOE to consider consultations with Federal, State, and local agencies and federally recognized Native American groups regarding the potential for alternatives for surplus plutonium disposition to disturb sensitive resources. The needed consultations must occur on a timely basis and are generally required before any land disturbance can begin. Most of these consultations are related to biotic, cultural, and Native American resources. Biotic resource consultations generally pertain to the potential for activities to disturb sensitive species or habitats. Cultural resource consultations relate to the potential for disruption of important cultural resources and archaeological sites. Finally, Native American consultations are concerned with the potential for disturbance of ancestral Native American sites and the traditional practices of Native Americans.

DOE has initiated consultations with Federal and State agencies and federally recognized Native American groups regarding the potential for alternatives for surplus plutonium disposition to disturb sensitive resources. Table 5-2 presents a summary of the consultations initiated by DOE. Appendix O contains copies of the consultation letters sent by DOE to agencies and Native American groups, and any written responses provided by those agencies or groups. Attachments to responses are not included in Appendix O but are, nevertheless, part of the public record. All agencies and Native American groups were also sent a copy of the SPD Draft EIS. Information from the agencies and Native American group responses has been incorporated into Chapters 3 and 4 as appropriate.

5.3.1 Native American Consultations

Upon publication of the SPD Draft EIS, DOE initiated the government-to-government consultation process with federally recognized Native American groups for the proposed action and alternatives discussed herein. The consultations were conducted consistent with the direction outlined in DOE Order 1230.2, *American Indian Tribal Government Policy*. A copy of the SPD Draft EIS was presented to each federally recognized tribe that has acknowledged potential concern for resources at the Hanford Site, Idaho National Engineering and Environmental Laboratory (INEEL), Pantex Plant, and Savannah River Site (SRS) during prior consultations initiated for compliance with statutes such as the National Historic Preservation Act (16 USC 470 et seq.) and the Native American Graves Protection and Repatriation Act (NAGPRA) (25 USC 3001).

The consultation process was initiated by DOE through a formal letter identifying the potential actions at the DOE site accompanied by a copy of the SPD Draft EIS. The letter requested a response from each Native American group regarding concerns, including any concerns under the American Indian Religious Freedom Act (42 USC 1996) and NAGPRA. Among the areas of specific concern that may be identified by Native American groups are religious and sacred places and resources, Native American human remains, associated funerary objects, unassociated funerary objects, sacred objects, and cultural patrimony objects. [Text deleted.] The intent of these consultations was to identify all potential Native American concerns associated with each action discussed in the SPD Draft EIS and to consider the results of the consultation processes in this SPD Final EIS.

Consultations were requested with the Native American groups listed in Table 5–2, which included four groups related to Hanford, one to INEEL, four to Pantex and six to SRS. Consultations with the Native American groups indicate that there are no significant concerns related to the proposed action and alternatives evaluated in this SPD EIS.

In the event of inadvertent discovery of potential important materials such as human remains, associated funerary objects, unassociated funerary objects, sacred objects, and cultural patrimony during construction and operation, another consultation process will be initiated. Each DOE site considered in this SPD EIS has plans and procedures that address inadvertent discoveries of cultural material. In each case, the ground-disturbing activities would be immediately suspended upon recognition of human remains or potential cultural materials. DOE would be notified and qualified cultural resource specialists would evaluate the materials to determine potential Native American origin. If the remains or materials are determined to be of potential Native American origin and within the criteria of applicable statutes such as NAGPRA, DOE would immediately initiate consultation with Native American groups with interest in the locations, as determined during the SPD Draft EIS consultation process described above. Based on the results of the consultations, DOE would take appropriate action prior to resuming ground-disturbing activities.

5.3.2 Archaeological and Historical Resources Consultations

Each DOE site evaluated in this SPD EIS has cultural (archaeological and historical) resource management plans that prescribe consultation processes for activities that have the potential to adversely affect sites and properties eligible for nomination, or listed, on the National Register of Historic Places. The management plans have been developed consistent with archaeological and historical resource laws (see Table 5–1) as implemented under 36 CFR 800, *Protection of Historic and Cultural Properties*.

Upon publication of the SPD Draft EIS, DOE initiated consultation with the State Historic Preservation Officers (SHPOs) of Idaho, Washington, and South Carolina as appropriate under each site’s programmatic agreement and management plan (see Table 5–2). Consultation with the SHPO in Texas was not required because extensive surveys of Pantex have shown that significant cultural resources are not likely to be present, and both the Texas SHPO and the Advisory Council on Historic Preservation have agreed that additional archaeological surveys are

not required. The intent of each consultation was to determine potential eligibility for nomination to the National Register of Historic Places of archaeological and historic resources that may be associated with the proposed actions and alternatives. As discussed in Section 5.3.1, DOE also initiated consultation with Native Americans. [Text deleted.] The consultation process was initiated by DOE through a formal letter to the appropriate SHPO identifying the potential actions at the DOE site accompanied by a copy of the SPD Draft EIS. In all cases, the consultation process was conducted in conformance with 36 CFR 800 requirements and programmatic agreements for the management of archaeological and historic resources and properties.

The letters sent by DOE solicited specific concerns the SHPOs may have about the DOE proposal. Consultations with the SHPOs indicate that only the South Carolina SHPO had significant concerns related to the proposed action and alternatives evaluated in this SPD EIS. The South Carolina SHPO response noted that if Alternative 3 (DOE's preferred alternative) is selected, further consultations would be required. In response to the SHPO's concerns about cultural resources present near the F-Area, additional surveys were performed. Investigations identified archaeological sites near this portion of F-Area that have been recommended to the South Carolina SHPO as eligible for nomination to the National Register. DOE currently plans to mitigate impact by avoiding these sites.

In the event that potential archaeological and historic materials are discovered during construction and operation, another consultation process will be initiated. Each DOE site considered in this SPD EIS has plans and procedures that address inadvertent discoveries of cultural material. In each case, the ground-disturbing activities would be immediately suspended upon recognition of human remains or potential archaeological and historical materials. DOE would be notified and qualified cultural resource specialists would evaluate the materials to identify and determine their potential archaeological and historical value under 36 CFR 800. If the materials are determined to be potentially eligible for nomination to the National Register of Historic places, DOE would immediately initiate an expedited formal consultation process with the appropriate SHPO, as appropriate under the programmatic agreement. Based on the results of the consultations, DOE would take appropriate action to ensure mitigation of any adverse effects to resources determined eligible for the National Register of Historic Places.

5.3.3 Endangered Species Act Consultation

Upon publication of the SPD Draft EIS, DOE conducted consultations with the appropriate regional and field offices of the U.S. Department of the Interior, Fish and Wildlife Service (USFWS) and the equivalent State agencies. The consultations were conducted to solicit input on the potential for impacts on ecological resources, especially Federal threatened, endangered, and other species of concern or their critical habitat and/or State-protected species. These consultations were conducted in accordance with Sections 7(a)-(d) of the Endangered Species Act of 1973 (16 USC Sections 1536(a)-(d)) and its implementing regulations under 50 CFR 402, *Interagency Cooperation-Endangered Species Act of 1973, As Amended*, and relevant State statutes and regulations (see Table 5-1).

The consultation process was initiated by DOE through formal letters that identified the potential actions at each DOE site and was accompanied by a copy of the SPD Draft EIS. Each letter also summarized the preliminary analysis of the potential impacts on ecological resources at each site, including any known Federal- or State-listed species with the potential for occurrence. As shown in Table 5-2, letters were sent to each respective USFWS regional or field office with primary jurisdiction over the four DOE surplus plutonium disposition candidate sites. The letters requested that the USFWS offices provide any available information on Federal threatened and endangered animal and plant species (listed or proposed) and their habitats in the vicinity of the specific project areas. Each office was also asked to identify any other issues or concerns that should be considered in this SPD EIS. A similar written request for comment was also sent to each equivalent State agency including: the Washington Department of Fish and Wildlife, Department of Ecology; Idaho Department of Fish and Game,

| Conservation Data Center; Texas Parks and Wildlife Department; and the South Carolina Department of Natural Resources, Lower Coastal Wildlife Diversity.

| Of the four consultations initiated with the USFWS, three of the offices provided written responses, with the resulting information considered in the preparation of this SPD Final EIS. Additional species information was provided by the USFWS Moses Lake, Washington, and Charleston, South Carolina offices. The USFWS Charleston office also indicated in its response that the proposed facilities at SRS do not appear to present a substantial risk to federally protected ecological resources and that DOE has satisfied its obligations under Section 7 of the *Endangered Species Act*. The USFWS Boise, Idaho, office indicated that the information provided in the SPD Draft EIS was accurate. In the absence of receipt of a written response, telephone communication was initiated with the USFWS office in Arlington, Texas, with officials indicating that the office had no additional information to provide or comment on the SPD Draft EIS.

| Three of the four State agencies contacted also provided written responses, with one agency (i.e., South Carolina Department of Natural Resources) verbally responding that it had no additional information to provide or other comment on the SPD Draft EIS. Additional information was provided by the Washington State Department of Fish and Wildlife and the Idaho Department of Fish and Game, which was considered in development of this SPD Final EIS.

| Prior to any project implementation activities at any site, additional consultations with Federal and State agencies would be conducted, as appropriate. Additionally, site-specific surveys and assessments would be conducted, as necessary, to determine the potential for impacts to protected or other sensitive animal and plant species and sensitive habitats and to identify any required mitigation measures.

Table 5–1. Federal Environmental Statutes, Regulations, and Executive Orders

Statute, Regulation, Executive Order	Citation	Potential Requirements
Air Quality and Noise		
Clean Air Act of 1970 (CAA)	42 USC 7401 et seq.	Requires sources to meet standards and obtain permits to satisfy: National Ambient Air Quality Standards (NAAQS), State implementation plans, Standards of Performance for New Stationary Sources, National Emission Standards for Hazardous Air Pollutants, and Prevention of Significant Deterioration (PSD). Public radiological dose limits for DOE facilities are outlined in 40 CFR 61.92, under the authority of this act.
National Ambient Air Quality Standards	42 USC 7409; 40 CFR 50	Establishes primary and secondary ambient air quality standards governing carbon monoxide, lead, nitrogen dioxide, ozone, sodium dioxide, and particulate matter with an aerodynamic diameter less than or equal to 10 microns.
Standards of Performance for New Stationary Sources	42 USC 7411; 40 CFR 60	Establishes control/emission standards and recordkeeping requirements for new or modified sources specifically addressed by a standard.
National Emission Standards for Hazardous Air Pollutants	42 USC 7412; 40 CFR 61, 63	Establishes emission levels for carcinogenic or mutagenic pollutants or operation requirements; may require a preconstruction approval, depending on the process being considered and the level of emissions that will result from the new or modified source.
Prevention of Significant Deterioration	42 USC 7470 et seq.; 40 CFR 51.166	Establishes requirements for the State implementation plans for PSD programs. Applies to areas that are in compliance with NAAQS. Requires comprehensive preconstruction review and the application of Best Available Control Technology to major stationary sources (emissions of 100 tons per year [tons/yr]) and major modifications; requires a preconstruction review of air quality impacts and the issuance of a construction permit from the responsible State agency setting forth emission limitations to protect the PSD increment.
Determining conformity of Federal actions to State or Federal implementation plans	40 CFR 93	Requires Federal facilities to demonstrate compliance with State or Federal implementation plans for applicable actions in nonattainment areas.
Executive Order 12843, Procurement Requirements and Policies for Federal Agencies for Ozone-Depleting Substances	April 21, 1993	Requires Federal agencies to minimize procurement of ozone-depleting substances and conform their practices to comply with Title VI of CAA Amendments regarding stratospheric ozone protection and to recognize the increasingly limited availability of Class I substances until final phaseout.
Noise Control Act of 1972	42 USC 4901 et seq.	Requires facilities to maintain noise levels that do not jeopardize the health and safety of the public.
Water Resources		
Clean Water Act (CWA)	33 USC 1251 et seq.	Requires U.S. Environmental Protection Agency (EPA)- or State-issued permits and compliance with provisions of permits regarding discharge of effluents to waters of the United States.

Table 5–1. Federal Environmental Statutes, Regulations, and Executive Orders (Continued)

Statute, Regulation, Executive Order	Citation	Potential Requirements
Water Resources (Continued)		
National Pollutant Discharge Elimination System	33 USC 1342	Requires permit to discharge effluents (pollutants) and storm water to waters of the United States; permit modifications are required if discharge effluents are altered.
Wild and Scenic Rivers Act of 1968	16 USC 1271 et seq.	Requires consultation before construction of any new Federal project associated with a river designated as wild and scenic or under study in order to minimize and mitigate any adverse effects on the physical and biological properties of the river.
Safe Drinking Water Act of 1974	42 USC 300f et seq.; 40 CFR 141	Requires certification of any plant water treatment facility constructed on a site to ensure that the quality of public drinking water is protected and that maximum radioactive contaminant levels do not exceed 4 mrem dose equivalents.
Executive Order 11990, Protection of Wetlands	May 24, 1977	Requires Federal agencies to avoid the long- and short-term adverse impacts associated with the destruction or modification of wetlands.
Executive Order 11988, Floodplain Management	May 29, 1977	Directs Federal agencies to establish procedures to ensure that the potential effects of flood hazards and floodplain management are considered for any action undertaken in a floodplain and that floodplain impacts be avoided to the extent practical. Requires consultation if project impacts a floodplain.
Compliance with Floodplain/ Wetlands Environmental Review Requirements	10 CFR 1022	DOE’s floodplain and wetlands environmental review requirements.
Civilian Use of Nuclear Materials		
Standards for Protection Against Radiation	10 CFR 20	Establishes standards for protection against ionizing radiation resulting from activities conducted by NRC licensees for both radiation workers and the public.
Domestic Licensing of Production and Utilization Facilities	10 CFR 50	Provides for the licensing of production and utilization facilities, which includes commercial nuclear power reactors. This part describes in detail the information needed to support an operational license application, a license amendment request, design criteria, enforcement actions, and other specifics of the licensing process.
Environmental Protection Regulations for Domestic Licensing and Related Regulatory Functions	10 CFR 51	Implements NRC’s NEPA requirements.
Domestic Licensing of Special Nuclear Material	10 CFR 70	Establishes procedures and criteria for issuance of licenses to receive title to, own, possess, use, and initially transfer special nuclear material; and establishes and provides for the terms and conditions upon which NRC will issue such licenses.

Table 5–1. Federal Environmental Statutes, Regulations, and Executive Orders (Continued)

Statute, Regulation, Executive Order	Citation	Potential Requirements
Waste Management and Pollution Prevention		
Resource Conservation and Recovery Act; Hazardous and Solid Waste Amendments of 1984 (RCRA)	42 USC 6901 et seq.	Requires notification and permits for operations involving hazardous waste treatment, storage, or disposal facilities; changes to site hazardous waste operations could require amendments to RCRA hazardous waste permits involving public hearings.
Comprehensive Environmental Response, Compensation, and Liability Act of 1980 (CERCLA); Superfund Amendments and Reauthorization Act of 1986	42 USC 9601 et seq.	Requires cleanup and notification if there is a release or threatened release of a hazardous substance; requires DOE to enter into Interagency Agreements with EPA and State to control the cleanup of each DOE site on the National Priorities List.
Nuclear Waste Policy Act of 1982	42 USC 10101 et seq.	Establishes a schedule for the siting, construction, and operation of a geologic repository that will provide a reasonable assurance that the public and the environment will be protected from the hazards posed by disposal of high-level radioactive waste (HLW) and spent nuclear fuel; establishes Federal responsibility and a Federal policy for the disposal of HLW and spent nuclear fuel; defines the relationship between Federal and State governments with respect to the disposal of HLW and spent nuclear fuel; and establishes a Nuclear Waste Fund.
Pollution Prevention Act of 1990	42 USC 13101 et seq.	Establishes a national policy that pollution should be reduced at the source and requires a toxic chemical source reduction and recycling report for an owner or operator of a facility required to file an annual toxic chemical release form under Section 313 of the Superfund Amendments and Reauthorization Act.
Toxic Substances Control Act of 1976 (TSCA)	15 USC 2601 et seq.	Requires compliance with inventory reporting and chemical control provisions of TSCA to protect the public from the risks of exposure to chemicals; TSCA imposes strict limitations on use and disposal of equipment contaminated with polychlorinated biphenyls.
Federal Facility Compliance Act of 1992	42 USC 6961	Waives sovereign immunity for Federal facilities under RCRA and requires DOE to develop plans and enter into agreements with States as to specific management actions for specific mixed waste streams.
Executive Order 12088, Federal Compliance with Pollution Control Standards	October 13, 1978	Requires Federal agency landlords to submit to the Office of Management and Budget an annual plan for the control of environmental pollution and to consult with EPA and State agencies regarding the best techniques and methods.

Table 5–1. Federal Environmental Statutes, Regulations, and Executive Orders (Continued)

Statute, Regulation, Executive Order	Citation	Potential Requirements
Waste Management and Pollution Prevention (Continued)		
Executive Order 12856, Federal Compliance with Right-To-Know Laws and Pollution Prevention Requirements	August 3, 1993	Requires Federal agencies to achieve 50 percent reduction of agency’s total releases of toxic chemicals to the environment and offsite transfers, to prepare a written facility pollution prevention plan not later than 1995, and to publicly report toxic chemicals entering any waste stream from Federal facilities, including any releases to the environment, and to improve local emergency planning, response and accident notification.
[Text deleted.]		
Executive Order 12580, Superfund Implementation	January 23, 1987	Delegates to the heads of Executive departments and agencies the responsibility for undertaking remedial actions for releases, or threatened releases, that are not on the National Priorities List and removal actions other than emergencies where the release is from any facility under the jurisdiction or control of Executive departments and agencies.
Biotic Resources		
Fish and Wildlife Coordination Act	16 USC 661 et seq.	Requires consultation on the possible effects on wildlife of construction, modification, or control of bodies of water in excess of 10 acres in surface area.
Bald and Golden Eagle Protection Act of 1972	16 USC 668 et seq.	Requires consultations to determine if any protected birds are found to inhabit the area. If so, must obtain a permit prior to moving any nests due to construction or operation of disposition facilities.
Migratory Bird Treaty Act of 1918	16 USC 703 et seq.	Requires consultation to determine if there are any impacts on migrating bird populations due to construction or operation of disposition facilities. If so, must develop mitigation measures to avoid adverse effects.
Anadromous Fish Conservation Act of 1965	16 USC 757	Requires consultation to determine if there are any impacts on anadromous fish that spawn in fresh water or estuaries and migrate to ocean waters and on anadromous fishery resources that are subject to depletion from water resource development.
Wilderness Act of 1964	16 USC 1131 et seq.	Requires consultation with the Department of Commerce and the Department of Interior to minimize impacts.
Wild Free-Roaming Horses and Burros Act of 1971	16 USC 1331 et seq.	Requires consultation with the Department of Interior to minimize impacts.

Table 5–1. Federal Environmental Statutes, Regulations, and Executive Orders (Continued)

Statute, Regulation, Executive Order	Citation	Potential Requirements
Biotic Resources (Continued)		
Endangered Species Act of 1973	16 USC 1531 et seq.	Requires consultation to identify endangered or threatened species and their habitats, assess impacts thereon, obtain biological opinions and, if necessary, develop mitigation measures to reduce or eliminate adverse effects of construction or operation.
Cultural Resources		
Antiquities Act of 1906	16 USC 431 et seq.	Requires protection of historic, prehistoric, and paleontological objects in federal lands from appropriation, excavation, injury, and destruction without permission.
DOE American Indian Tribal Government Policy	DOE Order 1230.2	Establishes government-to-government protocols for DOE interactions with tribal governments.
National Historic Preservation Act of 1966	16 USC 470 et seq.	Requires consultation with the State Historic Preservation Office prior to undertaking construction to ensure that no historical resources will be affected.
Archaeological and Historical Preservation Act of 1974	16 USC 469	Requires obtaining authorization for any disturbance of archaeological resources.
Archaeological Resources Protection Act of 1979	16 USC 470aa et seq.	Requires obtaining authorization for any excavation or removal of archaeological resources.
American Indian Religious Freedom Act of 1978	42 USC 1996 et seq.	Requires consultation with local Native American tribes to ensure that their religious customs, traditions, and freedoms are preserved.
Native American Graves Protection and Repatriation Act of 1990	25 USC 3001 et seq.	Requires repatriation of cultural items to Native Americans.
Executive Order 13007, Indian Sacred Sites	May 24, 1996	Requires the protection and preservation of Native American religious practices.
Executive Order 11593, Protection and Enhancement of the Cultural Environment	May 13, 1971	Requires the preservation of historic and archaeological data that may be lost during construction activities.
Worker Safety and Health		
Occupational Safety and Health Act of 1970	5 USC 5108 et seq.	Requires compliance with all applicable worker safety and health regulations.
Hazard Communication	29 CFR 1910.1200	Ensures that workers are informed of, and trained to handle, all chemical hazards in the workplace.
Transportation		
Transportation regulations	49 CFR 171, 172, 173, 174, 176, 177, 178, 397	Establishes standards for materials transportation including: packaging, marking and labeling, placarding, monitoring, routes, accident reporting, and manifesting. Includes requirements for transport by rail, air, and public highway.

Table 5–1. Federal Environmental Statutes, Regulations, and Executive Orders (Continued)

Statute, Regulation, Executive Order	Citation	Potential Requirements
Transportation (Continued)		
Packaging and Transportation of Radioactive Materials	10 CFR 71	Establishes requirements for packaging, preparation for shipment, and transportation of licensed radioactive material, and standards for approval of packaging and shipping procedures for fissile material and for a quantity of other licensed material in excess of a Type A quantity. This part establishes the certification process, including the required documentation for and testing of shipping containers, and quality assurance program that must be in place for vendors and users of approved shipping containers.
Hazardous Materials Transportation Act of 1974 [Text deleted.]	49 USC 1801 et seq.	Requires compliance with hazardous materials and waste transportation requirements.
Regulations of the International Atomic Energy Agency	IAEA Safety Series 6	Establishes standards for radioactive materials transportation.
International Maritime Organization Regulations	International Maritime Dangerous Goods Code, 1994	Requires segregation of radioactive materials packages from other dangerous goods and other aspects of stowage.
Other		
Atomic Energy Act of 1954	42 USC 2011 et seq.	Authorizes DOE to establish standards to protect health or minimize dangers to life or property for activities under DOE's jurisdiction.
Price Anderson Act	42 USC 2210	Allows DOE to indemnify its contractors if the contract involves the risk of public liability from a nuclear incident.
Department of Energy Orders	Parts 100–500	Establishes standards and requirements to ensure safe operation of facilities.
National Environmental Policy Act (NEPA)	42 USC 4321 et seq.	Requires Federal agency to prepare an environmental impact statement for any major Federal action with significant environmental impact.
NEPA Implementing Procedures	10 CFR 1021	Requires DOE to follow its own implementing regulations to ensure environmental quality.
Emergency Planning and Community Right-To-Know Act of 1986	42 USC 11001 et seq.	Requires the development of emergency response plans and reporting requirements for chemical spills and other emergency releases, and imposes right-to-know reporting requirements covering storage and use of chemicals that are reported on toxic chemical release forms.
Executive Order 11514, Protection and Enhancement of Environmental Quality	March 6, 1970	Requires Federal agencies to demonstrate leadership in achieving the environmental quality goals of NEPA; provides for DOE consultation with appropriate Federal, State, and local agencies in carrying out their activities as they affect the environment.

Table 5–1. Federal Environmental Statutes, Regulations, and Executive Orders (Continued)

Statute, Regulation, Executive Order	Citation	Potential Requirements
Other (Continued)		
Farmland Protection Policy Act of 1981	7 USC 4201 et seq.	Requires avoidance of any adverse effects to prime and unique farmlands.
Executive Order 12114, Environmental Effects Abroad of Major Federal Actions	January 4, 1979	Requires officials of Federal agencies having ultimate responsibility for authorizing and approving actions encompassed by this order to be informed of pertinent environmental considerations and to take such considerations into account, along with other pertinent considerations of national policy, in making decisions regarding such actions. While based on independent authority, this order furthers the purpose of NEPA.
Executive Order 12898, Federal Actions to Address Environmental Justice in Minority and Low-Income Populations	February 11, 1994	Requires Federal agencies to identify and address as appropriate, disproportionately high and adverse human health or environmental effects of its programs, policies, and activities on minority populations and low-income populations.
Executive Order 12656, Assignment of Emergency Preparedness Responsibilities	November 18, 1988	Assigns emergency preparedness responsibilities to Federal departments and agencies.

Table 5–2. Summary of Consultations Initiated by DOE

DOE Site	Subject	DOE Consultation Letter		Agency/Group Response	
		Addressed To (Date of Letter)	Page No.	From (Date of Response or Last Contact)	Page No.
Hanford	Cultural Resources	Mr. David Hansen State Historic Preservation Officer (October 30, 1998)	O–2	Mr. Robert Whitlam (March 2, 1999)	NA ^a
	Native American	Mr. Russell Jim Confederated Tribes and Bands of the Yakima Indian Nation (October 30, 1998)	O–4	Ms. Nancy Peters (March 5, 1999)	NA ^b
	Native American	Ms. Donna L. Powaukee Nez Perce Tribe (October 30, 1998)	O–6	Mr. Pat Sobotta (March 2, 1999)	NA ^b
	Native American	Ms. Lenora Seelatsee Wanapum Band (October 30, 1998)	O–8	Ms. Lenora Seelatsee (March 5, 1999)	NA ^b
	Native American	Mr. J.R. Wilkinson Confederated Tribes of the Umatilla Indian Reservation (October 30, 1998)	O–10	Mr. J.R. Wilkinson (March 2, 1999)	NA ^b
	Ecological Resources	Mr. Richard Roy U.S. Fish and Wildlife Service (July 28, 1998)	O–12	Mr. Richard Roy (December 3, 1998)	O–14
	Ecological Resources	Mr. Jay McConnaughey Washington Department of Fish and Wildlife (July 28, 1998)	O–16	Mr. Jay McConnaughey (December 7, 1998)	O–18
INEEL	Cultural Resources	Mr. Robert Yohe State Historic Preservation Officer (October 30, 1998)	O–21	Mr. Robert Yohe (March 2, 1999)	NA ^a
	Native American	Mr. Keith Tinno Fort Hall Reservation (October 30, 1998)	O–23	Mr. Jim Reed (March 2, 1999)	NA ^b
	Ecological Resources	Ms. Susan Burch U.S. Fish and Wildlife Service (July 28, 1998)	O–25	Mr. Robert Kuesink (August 18, 1998)	O–27
	Ecological Resources	Mr. George Stephens Idaho Department of Fish and Game (July 28, 1998)	O–29	Mr. George Stephens (August 12, 1998 and February 12, 1999)	O–31 O–32
Pantex	Native American	Mr. Virgil Franklin Sr. Cheyenne-Arapaho Tribe of Oklahoma (October 30, 1998)	O–33	Mr. Gordon Yellowman (March 2, 1999)	NA ^b
	Native American	Mr. Billy Evans Horse Kiowa Tribe of Oklahoma (October 30, 1998)	O–35	Mr. William Hensley (March 2, 1999)	NA ^b
	Native American	Mr. D.J. Mowatt Apache Tribe of Oklahoma (October 30, 1998)	O–37	Mr. D.J. Mowatt (March 2, 1999)	NA ^b
	Native American	Mr. Don Wauahdooh Comanche Tribe of Oklahoma (October 30, 1998)	O–39	Ms. Phyllis Attocknie (March 2, 1999)	NA ^b
	Ecological Resources	Mr. Robert Short U.S. Fish and Wildlife Service (July 28, 1998)	O–41	Agency office had no comment based on personal communication with Mr. Clayton Napier (December 2, 1998)	NA ^a
	Ecological Resources	Mr. Pat Martin Texas Parks and Wildlife Department (July 28, 1998)	O–43	Ms. Shannon Breslin (March 22, 1999)	O–45

Table 5-2. Summary of Consultations Initiated by DOE (Continued)

DOE Site	Subject	DOE Consultation Letter		Agency/Group Response	
		Addressed To (Date of Letter)	Page No.	From (Date of Response or Last Contact)	Page No.
SRS	Cultural Resources	Dr. Rodger Stroup State Historic Preservation Officer (October 30, 1998)	O-46	Ms. Nancy Brock (November 12, 1998)	O-48
	Native American	Mr. Tom Berryhill National Council of the Muskogee Creek (October 30, 1998)	O-49	Mr. Ken Childers (March 2, 1999)	NA ^b
	Native American	Ms. Nancy Carnley Ma Chis Lower Alabama Creek Indian Tribe (October 30, 1998)	O-51	Ms. Nancy Carnley (March 2, 1999)	NA ^b
	Native American	Miko Tony Hill Indian People's Muskogee Tribal Town Confederacy (October 30, 1998)	O-53	Miko Tony Hill (March 2, 1999)	NA ^b
	Native American	Ms. Virginia Montoya Pee Dee Indian Association (October 30, 1998)	O-55	Ms. Virginia Montoya (March 2, 1999)	NA ^b
	Native American	Mr. Al Rolland Yuchi Tribal Organization, Inc. (October 30, 1998)	O-57	Mr. Al Rolland (March 2, 1999)	NA ^b
	Native American	Mr. John Ross United Keetoowah Band (October 30, 1998)	O-59	Ms. Julie Moss (March 2, 1999)	NA ^b
	Ecological Resources	Mr. Roger Banks U.S. Fish and Wildlife Service (July 28, 1998)	O-61	Mr. Edwin EuDaly (September 8, 1998)	O-63
	Ecological Resources	Mr. Tom Murphy South Carolina Department of Natural Resources	O-67	Agency office had no comment based on personal communication with Mr. Tom Murphy (December 2, 1998)	NA ^a

^a No written response was received. Response obtained via telephone conversation.

^b No response was received.

Chapter 7

List of Preparers

Bagley, Anubhav, *Land Use and Visual Resources, SAIC*

M.E.P., Environmental Planning (1997), Arizona State University, Tempe, AZ
B.P.P., Physical Planning (1990), School of Planning and Architecture, New Delhi, India
Years of Experience: 5

Borghi, Louis C., *Ecological Resources, SAIC*

M.S., Ecology (1977), The Pennsylvania State University, State College, PA
B.A., Biology (1975), LaSalle University, Philadelphia, PA
Years of Experience: 21

Brown, Tracy L., *Crosscutting Functions, SAIC*

B.A., Environmental Engineering Science (1994), Dartmouth College, Hanover, NH
Years of Experience: 5

DeMoss, Gary M., *Transportation Accidents, SAIC*

M.A., Engineering Administration (1991), Virginia Polytechnic Institute and State University, Blacksburg, VA
B.S., Mechanical Engineering (1981), University of Virginia, Charlottesville, VA
Years of Experience: 17

DiMarzio, John A., *Waste Management, SAIC*

M.S., Geology (1984), The George Washington University, Washington, DC
B.S., Geology (1981), University of Maryland, College Park, MD
Years of Experience: 15

Eichner, John M., *Deputy Project Manager, SAIC*

B.S., Accounting and Finance (1980), Syracuse University, Syracuse, NY
Years of Experience: 18

Elia, Ellen D., *Socioeconomics, SAIC*

B.A., Mathematics (1988), College of the Holy Cross, Worcester, MA
Years of Experience: 9

Everett, H. Christopher, *Facility Accidents, SAIC*

B.S., Physics (1985), Tufts University, Medford, MA
Years of Experience: 13

Folk, Kevin T., *Additional Environmental Resource Analyses, SAIC*

M.S., Environmental Biology (1997), Hood College, Frederick, MD
B.A., Geoenvironmental Studies (1989), Shippensburg University of Pennsylvania, Shippensburg, PA
Years of Experience: 10

Gandee, Kitty B., *Impact Analysis, SAIC*

M.S., Nuclear Engineering (1978), Oregon State University, Corvallis, OR
M.L.S., Library Science (1975), University of Pittsburgh, Pittsburgh, PA
M.S., Materials Engineering (1974), University of Maryland, College Park, MD
B.S., Metallurgical Engineering (1972), Chen Kung University, Tainan, Taiwan
Years of Experience: 21

Groome, Chadi D., *MOX Fuel Options, SAIC*

M.S., Environmental Engineering Sciences (1977), University of Florida, Gainesville, FL
B.S., Zoology (1973), Clemson University, Clemson, SC
Years of Experience: 19

Gross, Lorraine S., *Cultural and Paleontological Resources, SAIC*

M.A., Anthropology (1986), Washington State University, Pullman, WA
B.A., Anthropology (1975), Pomona College, Claremont, CA
Years of Experience: 22

Haley, Timothy A., *Transportation Analysis, SAIC*

M.S., Reliability Engineering (1998), University of Maryland, College Park, MD
B.S., Engineering, Nuclear Engineering (1989), University of Cincinnati, Cincinnati, OH
Years of Experience: 7

Hirrlinger, Diana N., *Crosscutting Functions/Quality Assurance, SAIC*

M.B.A., Marketing and Organizational Behavior (1987), University of Maryland, College Park, MD
B.S., Conservation of Natural Resources (1980), University of California, Berkeley, CA
Years of Experience: 18

Hoffman, Robert G., *Immobilization Options, SAIC*

B.S., Environmental Resource Management (1986), The Pennsylvania State University,
State College, PA
Years of Experience: 13

Holian, O. James, *Summary of Impacts, SAIC*

M.S., Meteorology (1984), The Pennsylvania State University, State College, PA
B.S., Meteorology (1982), The Pennsylvania State University, State College, PA
Years of Experience: 17

Jones, Marcus E., *EIS Document Manager (through April 1999), Reactors Group, Office of Fissile Materials Disposition (MD-4), U.S. Department of Energy*

M.S.E., Environmental Engineering (1986), University of Alabama, Tuscaloosa, AL
B.S., Biology (1980), University of Alabama, Tuscaloosa, AL
Years of Experience: 16

Kumar, Prasanna N., *Environmental Engineer, NEPA Compliance and Outreach, Office of Fissile Materials Disposition (MD-13), U.S. Department of Energy*

M.S., Mining Engineering (1963), University of Arizona, Tucson, AZ
B.Sc., Applied Sciences (1955), Mysore University, Bangalore, India
Years of Experience: 36

Mancino, Frank P., *Comment Response Systems Manager, SAIC*

M.S., Natural Resources Management and Policy (1979), University of Michigan, Ann Arbor, MI
B.S., Environmental Studies (1976), Florida International University, Miami, FL
Years of Experience: 21

Martin, James F., *Technical Editor, SAIC*

M.S., Theoretical Linguistics (1969), Georgetown University, Washington, DC
B.S., Modern Languages (1959), University of Memphis, Memphis, TN
Years of Experience: 39

Martin, Karen L., *Impact Analysis, SAIC*

B.A., Conservation and Resource Development (1981), University of Maryland, College Park, MD
Years of Experience: 16

Nemeth, Diane M., *Socioeconomics, SAIC*

M.S., Urban Planning (1978), Columbia University, New York, NY
B.A., Economics (1973), Miami University, Oxford, OH
Years of Experience: 25

Nestor, Barry, *Document Production, SAIC*

M.A., American Government and Urban Affairs (1970), American University, Washington, DC
B.A., Economics (1960), Providence College, Providence, RI
Years of Experience: 20

Nulton, J. David, *Director, Reactors Group, Office of Fissile Materials Disposition (MD-4), U.S. Department of Energy*

M.S., Mechanical Engineering (1970), Stanford University, Stanford, CA
B.S., Mechanical Engineering (1968), Drexel University, Philadelphia, PA
Years of Experience: 30

Outlaw, Douglas A., *Facility Accidents, SAIC*

Ph.D., Nuclear Physics (1974), North Carolina State University, Raleigh, NC
M.S., Nuclear Physics (1970), North Carolina State University, Raleigh, NC
B.S., Physics (1969), North Carolina State University, Raleigh, NC
Years of Experience: 21

Pietzyk, Sharon M., *Ecological Resources, SAIC*

M.S., Systems Management (1988), University of Southern California, Los Angeles, CA
B.S., Biology (1981), James Madison University, Harrisonburg, VA
Years of Experience: 17

Rhone, Jacquelyn L., *Document Production, SAIC*

A.Sc., Radiological Health Technology (1972), Central Florida Community College, Ocala, FL
Years of Experience: 26

Randolph, James L., *Cultural and Paleontological Resources, SAIC*

Ph.D., Anthropology (1994), University of California, Santa Barbara, CA
M.A., Anthropology (1977), Southern Illinois University at Carbondale, IL
B.A., Anthropology (1972), University of Georgia, Athens, GA
Years of Experience: 31

Sawyer, Cheri A., *Document Production Manager, SAIC*

B.S., Journalism (1977), University of Maryland, College Park, MD

Years of Experience: 22

Schlegel, Robert L., *Human Health Risk, SAIC*

Degree of Nuclear Engineer (1964), Columbia University, New York, NY

M.S., Nuclear Engineering (1961), Columbia University, New York, NY

B.S., Chemical Engineering (1959), Massachusetts Institute of Technology, Cambridge, MA

Years of Experience: 36

Snyder, Carl A., *Reactor Accidents, SAIC*

B.S., Nuclear Engineering (1992), University of Maryland, College Park, MD

B.S., Mathematics (1987), University of Maryland, College Park, MD

Years of Experience: 7

Stevenson, G. Bert, *NEPA Compliance Officer and EIS Document Manager, Office of Fissile Materials Disposition (MD-4), U.S. Department of Energy*

B.S., Physics (1963), Marshall University, Huntington, WV

Years of Experience: 35

Updike, Paul J., *Infrastructure, Impact Summary, SAIC*

M.A., International Affairs (1997), University of Pittsburgh, Pittsburgh, PA

B.S., Economics (1985), Clarion University, Clarion, PA

Years of Experience: 10

Waldman, Gilbert H., *Human Health Risk, SAIC*

M.S., Technical Management (1999), The John Hopkins University, Baltimore, MD

B.S., Nuclear Engineering (1991), University of Florida, Gainesville, FL

Years of Experience: 7

Werth, Robert H., *Air Quality and Noise, SAIC*

B.A., Physics (1973), Gordon College, Wenham, MA

Years of Experience: 25

Wherley, Patricia L., *EIS Project Manager, SAIC*

B.A., Geography (1980), The George Washington University, Washington, DC

Years of Experience: 22

Williams, John W., *Environmental Justice, SAIC*

Ph.D., Physics (1972), New Mexico State University, Las Cruces, NM

M.S., Physics (1970), New Mexico State University, Las Cruces, NM

B.S., Mathematics (1962), North Texas State University, Denton, TX

Years of Experience: 23

Chapter 8 Distribution List

The U.S. Department of Energy is providing copies of the *Surplus Plutonium Disposition Final Environmental Impact Statement* to Federal, State, and local elected and appointed government officials and agencies; Native American groups; and other organizations and individuals listed below. Copies will be distributed in bulk to some individuals and organizations for further distribution (e.g., the State single points of contact for the National Environmental Policy Act [NEPA]). Copies will be provided to other organizations and individuals on request.

ELECTED OFFICIALS

Federal Elected Officials

- Senators and Representatives from the States of California, Georgia, Idaho, New Mexico, North Carolina, Oregon, South Carolina, Tennessee, Texas, Virginia, and Washington
- Congressional Committees:
 - Senate: Committee on Appropriations, Committee on Armed Services, and Energy and Natural Resources Committee
 - House of Representatives: Committee on Appropriations and Committee on National Security

State Elected Officials

- Governors from the States of California, Georgia, Idaho, New Mexico, North Carolina, Oregon, South Carolina, Tennessee, Texas, Virginia, and Washington
- State Senators and Representatives from the States of California, Georgia, Idaho, New Mexico, North Carolina, Oregon, South Carolina, Tennessee, Texas, Virginia, and Washington

Local Elected Officials

- Mayors, council members, etc., from areas near the Catawba Nuclear Station, Hanford Site, Idaho National Engineering and Environmental Laboratory, Lawrence Livermore National Laboratory, Los Alamos National Laboratory, McGuire Nuclear Station, North Anna Power Station, Oak Ridge National Laboratory, Pantex Plant, and Savannah

River
Site

APPOINTED OFFICIALS

Federal Appointed Officials

- Agencies that are members of the Interagency Working Group for Plutonium Disposition—Arms Control and Disarmament Agency, Central Intelligence Agency, Council on Environmental Quality, Defense Nuclear Facilities Safety Board, Department of Defense, National Security Council, Nuclear Regulatory Commission, Office of Management and Budget, State Department, and Environmental Protection Agency
- Other Federal agencies including: General Accounting Office, National Academy of Sciences, National Oceanic and Atmospheric Administration, National Science Foundation, U.S. Bureau of Indian Affairs, and U.S. National Park Service

Resources Conservation Commission; State of Texas’ Department of Health; State of Washington’s Department of Ecology; State of Washington’s Energy Office; Tennessee Department of Environment and Conservation/DOE

Oversight Division; Virginia Department of Health, State Commissioner; Virginia State Corporation Commission, Division of Energy Regulation; and U.S. Nuclear Regulatory Commission, Region 2

State Appointed Officials

- NEPA single points of contact for the States of California, Georgia, Idaho, New Mexico, North Carolina, Oregon, South Carolina, Tennessee, Texas, Virginia, and Washington
- State agencies including: Commonwealth of Virginia, Office of Attorney General; Georgia Emergency Management Agency; South Carolina Nuclear Waste Program; Southern States Energy Board; State of Idaho’s Idaho National Engineering and Environmental Laboratory Oversight Program; State of Texas’ Division of Emergency Management; State of Texas’ Office of the Attorney General; Texas Natural

NATIVE AMERICAN GROUPS

Federally recognized Native American tribes from
the States of California, Georgia, Idaho, New
Mexico, North Carolina, Oregon, South Carolina, |
Tennessee, Texas, Virginia, and Washington |

DEPARTMENT OF ENERGY

Department of Energy Reading Rooms in the
States of California, Idaho, New Mexico, North |
Carolina, Oregon, South Carolina, Tennessee, |
Texas, Virginia, Washington, and the District of |
Columbia |

ORGANIZATIONS AND INDIVIDUALS

Organizations and individuals who have requested
copies of the *Surplus Plutonium Disposition* |
Final Environmental Impact Statement |

Chapter 9 Index

100-year flood, 3-72, 3-112

500-year flood, 3-72

700 Area, 3-4

A

Actinide Packaging and Storage Facility, 1-17, 1-19, 1-25, 2-21, 2-48, 2-54–2-56, 2-59, 2-62, 3-146, 3-147, 3-163, 4-2, 4-11, 4-24, 4-30, 4-54, 4-59, 4-104, 4-110, 4-122, 4-131, 4-139, 4-142, 4-151, 4-157, 4-183, 4-189, 4-235, 4-240, 4-248, 4-254, 4-285, 4-288, 4-374, 4-375, 4-384, 4-405

administrative control level, 3-21, 3-67, 3-105, 3-144, 3-174, 3-178, 3-184, 4-43, 4-60, 4-84, 4-97, 4-111, 4-132, 4-143, 4-158, 4-175, 4-190, 4-200, 4-214, 4-227, 4-241, 4-254, 4-295, 4-303, 4-311, 4-318, 4-319, 4-327, 4-331, 4-334

Advisory Council on Historic Preservation, 3-119, 3-120, 3-158, 3-205, 4-279, 5-5

Air Quality Control Region, 3-5, 3-50, 3-89, 3-128, 3-175, 3-181, 3-186, 3-193, 3-198

aircraft crash, 4-23, 4-24, 4-85, 4-191

ALARA program, 3-190, 3-196, 3-201, 4-14, 4-15, 4-17, 4-18, 4-20–4-22, 4-43, 4-54, 4-60, 4-84, 4-97, 4-104, 4-110, 4-111, 4-122, 4-131, 4-132, 4-139, 4-143, 4-151, 4-157, 4-158, 4-168, 4-175, 4-183, 4-190, 4-200, 4-214, 4-227, 4-235, 4-240, 4-241, 4-248, 4-254, 4-295, 4-302, 4-303, 4-310, 4-311, 4-318, 4-319, 4-327, 4-331, 4-334, 4-369, 4-378, 4-381, 4-383, 4-387, 4-390, 4-393, 4-395

American Indian Religious Freedom Act, 3-160, 5-4, 5-11

americium, 2-9, 2-15, 2-33, 2-35, 3-66, 3-67, 3-144, 3-154

Apache Tribe, 3-120, 5-14

aquatic habitat, 3-35, 3-77, 3-116, 3-155, 3-157, 4-263, 4-270, 4-278, 4-279, 4-285, 4-401

archaeological survey, 3-38, 3-79, 3-119, 3-158, 3-159, 4-272, 5-5

Atomic Energy Act, 5-1, 5-12

average exposed member of the public, 4-13–4-15, 4-17, 4-20, 4-21, 4-42, 4-59, 4-82, 4-96, 4-109, 4-130, 4-142, 4-156, 4-174, 4-189, 4-199, 4-213, 4-226, 4-240, 4-253, 4-294, 4-302, 4-310, 4-318, 4-326

average worker dose, 2-100, 2-104, 3-190, 3-196, 3-201, 4-14, 4-15, 4-17, 4-18, 4-20–4-22, 4-43, 4-54, 4-60, 4-84, 4-97, 4-104, 4-111, 4-122, 4-132, 4-139, 4-143, 4-151, 4-158, 4-168, 4-175, 4-183, 4-190, 4-200, 4-214, 4-227, 4-235, 4-241, 4-248, 4-254, 4-295, 4-303, 4-311, 4-318, 4-319, 4-327, 4-331, 4-334, 4-359, 4-360

B

background radiation, 3-19, 3-20, 3-65, 3-66, 3-102, 3-104, 3-105, 3-142, 3-144, 3-169, 3-172, 3-173, 3-177, 3-178, 3-180, 3-183, 3-184, 3-189, 3-190, 3-194, 3-195, 3-200, 3-201, 4-13–4-22, 4-42, 4-43, 4-59, 4-82, 4-83, 4-96, 4-109, 4-110, 4-130, 4-131, 4-142, 4-151, 4-156, 4-157, 4-168, 4-174, 4-175, 4-189, 4-199, 4-213, 4-226, 4-227, 4-240, 4-253, 4-254, 4-261, 4-268, 4-276, 4-283, 4-294, 4-302, 4-310, 4-318, 4-319, 4-326, 4-339

Beaver Dam Creek, 3-149, 3-186

benzene, 3-6, 3-51, 3-90, 3-129, 4-3–4-6, 4-35, 4-37, 4-51, 4-54, 4-70, 4-71, 4-74, 4-91, 4-93, 4-102, 4-104, 4-118, 4-119, 4-122, 4-137, 4-139, 4-148, 4-151, 4-166, 4-169, 4-180, 4-181, 4-184, 4-198, 4-206, 4-232

beyond-design-basis accident, 2-102, 4-44, 4-144, 4-158, 4-176, 4-192, 4-201, 4-305, 4-322, 4-330, 4-341, 4-347, 4-349–4-352

Big Allison Creek, 3-186

Big Lost River, 3-71, 3-72, 3-74, 3-77, 3-79, 3-81, 3-84, 3-203

Bonneville Power Administration, 3-46, 3-47

borosilicate glass, 1-10, 1-11, 2-3, 2-12, 2-26, 2-28

Building 221-F, 1-9, 1-16, 2-11, 2-12, 3-163

C

calcining furnace, 4-45, 4-46, 4-62, 4-63, 4-215, 4-216, 4-242, 4-243

Canadian Deuterium Uranium Reactor, 1-3, 1-6

cancer risk, 2-100, 2-101, 2-103, 2-104, 3-20, 3-22, 3-65, 3-104, 3-143, 3-172, 3-177, 3-183, 3-189, 3-194, 3-200, 4-13–4-22, 4-42, 4-43, 4-54, 4-59, 4-60, 4-83, 4-84, 4-96, 4-97, 4-104, 4-110, 4-111, 4-122, 4-131, 4-132, 4-139, 4-142, 4-143, 4-151, 4-157, 4-158, 4-168, 4-175, 4-183, 4-189, 4-190, 4-199, 4-200, 4-213, 4-214, 4-227, 4-235, 4-240, 4-241, 4-248, 4-254, 4-294, 4-295, 4-302, 4-303, 4-310, 4-311, 4-318, 4-319, 4-326, 4-327, 4-331, 4-334, 4-340, 4-358–4-361, 4-365, 4-369

can-in-canister process, 2-27, 2-103, 2-105, 4-357

carbon dioxide, 4-38, 4-56, 4-78, 4-95, 4-107, 4-126, 4-141, 4-154, 4-171, 4-186, 4-198, 4-210, 4-223, 4-236, 4-250

carbon monoxide, 2-95, 2-99, 3-6, 3-7, 3-51, 3-52, 3-90, 3-91, 3-129, 3-175, 3-188, 3-193, 3-199, 3-215, 4-3–4-9, 4-35, 4-38, 4-51, 4-55, 4-70, 4-71, 4-75, 4-77, 4-91, 4-94, 4-102, 4-106, 4-118, 4-119, 4-123, 4-125, 4-137, 4-140, 4-148, 4-152, 4-166, 4-170, 4-181, 4-185, 4-206, 4-209, 4-222, 4-232, 4-236, 4-250, 4-290, 4-298, 4-306, 4-314, 4-322, 4-356–4-358, 4-368, 4-377, 4-380, 4-383, 4-386, 4-389, 4-392, 4-410, 5-7

Catawba Nuclear Station, 1-10, 1-14, 1-16, 1-18, 2-8, 2-9, 2-40, 2-76, 2-98, 2-102, 2-103, 3-1 3-186–3-191, 3-207, 3-213, 4-49, 4-337–4-339, 4-342, 4-344, 4-348–4-351, 4-353, 4-354, 4-395, 4-396, 4-406

Catawba River, 3-186, 3-191

Centennial Tectonic Belt, 3-71

ceramic and glass, 2-2, 2-3, 2-26, 2-103–2-105, 4-35, 4-38, 4-39, 4-43, 4-52, 4-55, 4-56, 4-59, 4-72, 4-76, 4-78, 4-90, 4-93, 4-102, 4-107, 4-119, 4-124, 4-126, 4-166, 4-169, 4-171,

4-206, 4-208, 4-210, 4-213, 4-221, 4-223, 4-233, 4-235, 4-237, 4-240, 4-251, 4-268, 4-289, 4-357–4-359, 4-362

ceramic immobilization, 1-9, 2-1, 2-2, 2-12, 2-28, 2-36, 2-74, 2-103–2-105, 4-1, 4-45, 4-62, 4-215, 4-242, 4-357–4-363, 4-367–4-369

ceramic or glass, 2-1, 2-21, 2-23, 2-26, 2-29, 2-39, 2-103, 2-104, 4-43, 4-54, 4-60, 4-84, 4-97, 4-104, 4-110, 4-111, 4-122, 4-132, 4-139, 4-143, 4-151, 4-158, 4-168, 4-175, 4-183, 4-190, 4-200, 4-214, 4-227, 4-235, 4-241, 4-248, 4-250, 4-254, 4-357, 4-358, 4-360, 4-363

City of Livermore Water Reclamation Plant, 4-309

Clean Air Act, 3-20, 3-66, 3-104, 3-143, 3-173, 3-178, 3-184, 4-9, 4-42, 4-59, 4-83, 4-97, 4-110, 4-131, 4-143, 4-157, 4-174, 4-189, 4-200, 4-214, 4-226, 4-240, 4-253, 4-306, 4-377, 4-381, 4-382, 4-387, 4-390, 4-393, 4-394, 5-2, 5-7

Columbia River, 1-22, 3-3, 3-5, 3-19, 3-24, 3-26–3-28, 3-30–3-32, 3-35, 3-37–3-41, 3-43–3-46, 3-212, 4-28, 4-261, 4-262, 4-264, 4-373, 4-375

Committee on the Biological Effects of Ionizing Radiation, 4-54, 4-104, 4-122, 4-139, 4-151, 4-168, 4-183, 4-235, 4-248, 4-318, 4-407

Comprehensive Environmental Response Compensation, and Liability Act, 3-9, 3-53, 3-74, 3-93, 3-132, 3-171, 3-175, 5-9

Congaree aquifer, 3-152, 3-153

consultations, 1-18, 1-27, 3-39, 3-40, 3-41, 3-81, 3-120, 3-121, 3-159, 3-160, 3-213, 4-263–4-265, 4-271, 4-272, 4-278, 4-280, 4-285, 4-287, 4-401, 4-402, 4-408, 5-1, 5-3–5-6, 5-8, 5-10–5-12, 5-14, 5-15

contact-handled TRU waste, 3-9, 3-136, 4-39, 4-40, 4-56, 4-57, 4-79, 4-80, 4-107, 4-108, 4-127, 4-128, 4-154, 4-155, 4-171, 4-172, 4-187, 4-210, 4-211, 4-223, 4-224, 4-237, 4-238, 4-251, 4-252, 4-292, 4-293, 4-299, 4-300, 4-308, 4-314–4-317, 4-324, 4-325

Council on Environmental Quality, 3-1, 3-190, 3-196, 3-201, 3-203, 4-399, 4-400, 4-402

- Cowans Ford Dam, 3-191
- Craters of the Moon, 3-50, 3-71, 3-84, 4-152
- C-Reactor, 3-152
- Cretaceous aquifer, 3-152, 3-153
- critical habitat, 3-78, 3-118, 3-157, 4-34, 4-39, 4-52, 4-56, 4-69, 4-76, 4-101, 4-106, 4-117, 4-124, 4-126, 4-149, 4-153, 4-165, 4-171, 4-180, 4-185, 4-205, 4-210, 4-223, 4-233, 4-237, 4-249, 4-263, 4-270, 4-278, 4-285, 5-5
- criticality, 1-11, 2-15, 2-28, 2-76, 2-82–2-90, 2-92, 2-94, 2-96–2-98, 2-101, 4-23, 4-44–4-47, 4-60–4-64, 4-85, 4-86, 4-97–4-99, 4-112, 4-132, 4-133, 4-144, 4-158–4-160, 4-176, 4-190–4-192, 4-201, 4-215–4-217, 4-228, 4-242, 4-243, 4-255, 4-295, 4-296, 4-303, 4-304, 4-311, 4-312, 4-319–4-321, 4-327, 4-328, 4-332, 4-335
- cumulative air pollutant concentration, 4-377, 4-380, 4-383, 4-386, 4-389, 4-392
- cumulative impact, 1-18, 1-19, 1-24, 1-27, 4-42, 4-59, 4-83, 4-96, 4-110, 4-131, 4-142, 4-157, 4-174, 4-189, 4-200, 4-213, 4-226, 4-240, 4-253, 4-373–4-375, 4-376–4-395
- cumulative radiation exposure, 3-22, 4-395
- ## D
- DCS, 2-8, 2-9, 2-29, 2-30, 2-43, 4-297, 4-304, 4-312, 4-321, 4-329, 4-332, 4-335, 4-337, 4-338, 4-371
- deactivation and stabilization, 1-8, 1-27, 4-371
- decontamination and decommissioning, 1-3, 1-6, 1-8, 1-14, 1-25, 1-27, 2-65, 3-48, 3-168, 3-175, 4-371, 4-372
- Defense Nuclear Facilities Safety Board, 1-18, 3-127, 4-31, 4-32
- Defense Waste Processing Facility, 1-11, 1-25, 1-26, 2-3, 2-12, 2-21–2-23, 2-26, 2-29, 2-39, 2-48, 2-50, 2-54–2-56, 2-59, 2-62, 2-84–2-87, 2-89, 2-93–2-95, 3-130, 3-133, 3-134, 3-146, 3-147, 3-152, 3-159, 3-163, 3-167, 3-204, 4-51–4-57, 4-59–4-66, 4-102–4-104, 4-106, 4-107, 4-110, 4-111, 4-113, 4-118–4-127, 4-131, 4-132, 4-134, 4-137–4-143, 4-148, 4-150–4-153, 4-157–4-162, 4-181–4-183, 4-185, 4-186, 4-189–4-191, 4-193, 4-232–4-238, 4-240, 4-241, 4-244, 4-247, 4-248, 4-250, 4-251, 4-254, 4-256, 4-287, 4-288, 4-363, 4-374, 4-375, 4-403
- depleted uranium, 1-8, 1-9, 1-18, 1-20, 2-28, 2-29, 2-33, 2-36, 2-39, 2-40, 2-43, 2-63, 2-76, 2-96, 3-95, 4-48, 4-49, 4-65, 4-66, 4-87, 4-113, 4-133, 4-134, 4-161, 4-162, 4-177, 4-178, 4-193, 4-202, 4-203, 4-218, 4-229, 4-256, 4-366–4-369, 4-374, 4-375, 4-405
- design basis accident, 1-15, 2-76, 2-96, 2-101, 2-102, 2-105, 3-8, 3-52, 3-92, 3-131, 4-45, 4-60, 4-84, 4-97, 4-111, 4-132, 4-143, 4-158, 4-176, 4-190, 4-201, 4-228, 4-241, 4-295, 4-303, 4-311, 4-319, 4-327, 4-341–4-346, 4-363
- disposal land usage factor, 4-41, 4-58, 4-80, 4-108, 4-128, 4-155, 4-172, 4-187, 4-211, 4-224, 4-238, 4-252, 4-291, 4-293, 4-300, 4-308, 4-315, 4-317, 4-325
- disposal technology, 3-3, 3-8, 3-53, 3-92, 3-131, 3-134
- disturbed land, 2-12, 4-32, 4-265, 4-273, 4-280, 4-287
- DOE enrichment facility, 4-48, 4-65, 4-87, 4-113, 4-133, 4-161, 4-177, 4-193, 4-202
- DOE order, 3-8, 3-20, 3-53, 3-65, 3-66, 3-92, 3-104, 3-131, 3-142, 3-143, 3-161, 3-173, 3-178, 3-184, 3-204, 4-22, 4-24, 4-42, 4-59, 4-83, 4-97, 4-110, 4-131, 4-143, 4-157, 4-174, 4-189, 4-200, 4-214, 4-226, 4-240, 4-253, 4-377, 4-378, 4-381, 4-382, 4-383, 4-386, 4-387, 4-390, 4-393, 4-394, 4-395, 4-403, 5-1, 5-2, 5-4, 5-11
- DOE regulations, 5-1, 5-2
- drum-gas testing, 4-40, 4-57, 4-79, 4-108, 4-127, 4-155, 4-172, 4-187, 4-210, 4-224, 4-238, 4-251, 4-292, 4-300, 4-308, 4-315, 4-316, 4-324
- dry cask storage, 3-198
- dry-feed process, 2-12
- Duke Engineering, 2-8, 4-337, 4-402, 5-3

Duke Power, 2-8, 3-186, 3-188–3-191, 3-193–3-195, 3-207, 3-211, 4-337

E

Eastern Snake River, 3-70, 3-71

electrical consumption, 4-376, 4-379, 4-382, 4-385, 4-388, 4-391

Ellenton aquitard, 3-152

emergency planning, 3-23, 3-68, 3-146, 4-400, 5-10, 5-12

emergency response, 2-76, 2-97, 3-23, 3-69, 3-107, 3-146, 3-166, 4-48, 4-62, 4-86, 4-99, 4-112, 4-133, 4-144, 4-159, 4-176, 4-192, 4-201, 4-217, 4-228, 4-242, 4-255, 4-296, 4-304, 4-312, 4-321, 4-328, 4-347, 4-370, 5-12

energy conservation, 4-399, 4-400

energy consumption, 3-45, 3-46, 3-85, 3-87, 3-125, 3-126, 3-165, 3-166, 3-170, 3-174, 3-179, 3-180, 3-185, 4-267, 4-268, 4-274, 4-275, 4-282, 4-289, 4-400

enriched uranium, 1-1, 1-15, 1-25, 1-27, 1-28, 2-9, 2-18, 2-28, 2-33, 2-35–2-37, 3-48, 4-48, 4-65, 4-87, 4-113, 4-133, 4-161, 4-177, 4-193, 4-202, 4-340, 4-344–4-346, 4-348–4-351, 4-355, 4-356, 4-367, 4-373, 4-375, 4-403

Envirocare, 3-57, 4-80, 4-155, 4-188, 4-293

Environmental Critique, 1-14, 1-16, 2-8, 2-9

Environmental Synopsis, 1-14, 1-16, 2-8, 2-9

ethylene glycol, 4-398

F

F-Area, 2-48, 2-51, 2-54, 2-55, 2-62, 2-77, 3-127, 3-130, 3-131, 3-146, 3-150, 3-152–3-155, 3-163, 3-164, 3-166, 3-167, 4-113, 4-122, 4-139, 4-148, 4-151, 4-161, 4-180, 4-183, 4-193, 4-232, 4-234, 4-238, 4-239, 4-244, 4-247, 4-248, 4-251, 4-252, 4-256, 4-284–4-289, 5-5

Farmland Protection Policy Act, 4-27, 4-275, 5-13

Fast Flux Test Facility, 1-5, 1-6, 1-18, 2-26, 2-64, 3-3, 3-32, 3-43, 3-47

FB-Line, 1-25

F-Canyon, 1-20, 1-25

Federal Aviation Administration, 3-8, 3-52, 3-92, 3-131

Federal Conservation Reserve Program, 3-121

Federal Emergency Management Agency, 3-27

Federal Facility Compliance Agreement, 3-9, 3-57, 3-95, 3-132, 3-134, 3-171, 3-181, 3-203, 3-206

feed preparation methods, 2-11, 2-12

Finding of No Significant Impact, 1-3, 1-10, 1-19, 1-20, 1-24, 1-27, 2-37, 3-96, 3-112, 3-206

Fort Hall Reservation, 3-82, 5-14

Fort Sill Apache Tribe, 3-120

Fourmile Branch, 3-135, 3-149, 3-150, 3-152, 3-153, 3-155, 3-157

Fuel Manufacturing Facility, 2-65, 3-49, 4-2, 4-23, 4-31, 4-291

Fuel Processing Facility, 2-3, 2-56, 2-57, 2-87, 2-88, 2-95, 3-48, 3-50, 3-69, 3-70, 3-77, 3-79, 3-80, 3-84, 3-86, 3-87, 4-148, 4-150–4-154, 4-156–4-160, 4-165, 4-166, 4-168, 4-170, 4-175, 4-176, 4-267, 4-268, 4-270, 4-273, 4-379

fuel rods, 1-3, 1-8, 2-30, 2-33, 2-35, 2-36, 2-63, 2-64, 2-69, 2-73, 2-74, 2-96, 4-49, 4-65, 4-87, 4-113, 4-134, 4-161, 4-177, 4-193, 4-202, 4-297, 4-332, 4-333, 4-335, 4-338, 4-342, 4-366

fuel-handling accident, 4-341, 4-342, 4-344–4-346

Fuels and Materials Examination Facility, 1-9, 2-2, 2-3, 2-11, 2-12, 2-21, 2-39, 2-40, 2-44, 2-47, 2-51, 2-53–2-57, 2-61, 2-64, 3-3, 3-24, 3-43, 3-44, 3-47, 4-34, 4-69, 4-84, 4-90, 4-92, 4-94, 4-97, 4-98, 4-117, 4-132, 4-136, 4-138, 4-143, 4-165–4-167, 4-197, 4-199, 4-200, 4-205–4-207, 4-211, 4-216, 4-218, 4-220, 4-228, 4-260, 4-262, 4-264–4-267, 4-301, 4-303, 4-376, 4-408

G

gallium, 1-13, 2-9, 2-14, 2-15, 2-18, 2-20, 2-30, 2-33, 2-35

geologic repository, 1-1, 1-4, 1-6, 1-8, 1-10, 1-11, 1-21, 1-28, 2-21, 2-22, 2-26, 2-29, 2-30, 2-36, 2-39, 2-73, 2-76, 2-96, 2-99, 2-105, 2-106, 4-49, 4-66, 4-87, 4-113, 4-134, 4-162, 4-178, 4-193, 4-203, 4-218, 4-229, 4-244, 4-256, 4-332, 4-333, 4-335, 4-338, 4-352, 4-354, 4-362, 4-366, 4-405, 5-9

glass immobilization, 2-2, 2-28, 4-35, 4-39, 4-43, 4-46, 4-52, 4-56, 4-59, 4-63, 4-72, 4-78, 4-90, 4-102, 4-107, 4-119, 4-126, 4-166, 4-171, 4-206, 4-210, 4-213, 4-216, 4-223, 4-233, 4-237, 4-240, 4-243, 4-251

Grand Coulee Dam, 3-27, 3-29–3-31

H

Hanford Reach, 1-22, 3-27, 3-30, 3-33, 3-35, 3-36, 3-38, 3-39, 3-41, 3-43, 3-212, 4-264, 4-373, 4-375

H-Area, 1-26, 2-65, 3-127, 3-133, 3-152, 3-179, 3-180, 4-323–4-325

Hazardous and Solid Waste Amendments of 1984, 4-399, 5-9

H-Canyon, 1-25, 2-65

HEPA filter, 2-15, 2-23, 2-30, 2-35, 2-65 3-54, 3-55, 3-57, 3-91, 4-332, 4-335

high explosive, 3-88, 3-89, 3-91, 3-95, 3-96, 4-5

High Plains aquifer, 3-114

high-level waste, 1-11, 1-21, 1-22, 1-25, 1-26, 2-12, 2-13, 2-21–2-23, 2-26, 2-28, 2-29, 2-36, 2-39, 2-44, 2-46, 2-48, 2-51, 2-53–2-57, 2-59, 2-61, 2-62, 2-95, 2-103, 3-9, 3-24, 3-48, 3-49, 3-53–3-55, 3-93, 3-127, 3-131, 3-134, 3-203, 4-39, 4-49, 4-56, 4-65, 4-66, 4-78, 4-87, 4-107, 4-113, 4-126, 4-134, 4-154, 4-161, 4-162, 4-171, 4-178, 4-186, 4-193, 4-202, 4-203, 4-210, 4-218, 4-223, 4-229, 4-237, 4-244, 4-251, 4-256, 4-265, 4-292, 4-299, 4-307, 4-316, 4-324, 4-358, 4-363, 4-366, 5-9

high-level-waste canister, 2-26, 2-28, 2-29, 4-49, 4-66, 4-87, 4-113, 4-134, 4-162, 4-178,

4-193, 4-203, 4-218, 4-229, 4-244, 4-256, 4-363

highly enriched uranium, 1-1, 1-8, 1-19, 1-23, 1-25, 1-27, 1-28, 2-18, 2-20, 2-36, 2-37, 2-76, 4-48, 4-65, 4-86, 4-87, 4-112, 4-113, 4-133, 4-161, 4-177, 4-192, 4-193, 4-202, 4-217, 4-229, 4-244, 4-256, 4-356, 4-373, 4-375, 4-403

homogenous ceramic immobilization/vitrification, 2-103–2-105

hot cell, 2-64, 2-73, 2-74, 2-98, 3-48, 4-330–4-335, 4-394

HYDOX, 2-18, 2-20, 2-28, 4-45, 4-46, 4-62, 4-63, 4-215, 4-216, 4-242, 4-243

hydrogen sulfide, 3-90, 4-9

I

Idaho Nuclear Technology and Engineering Center, 2-56–2-58, 3-1, 3-48, 3-49, 3-50, 3-52, 3-54–3-57, 3-66, 3-67, 3-69–3-72, 3-74, 3-75, 3-77–3-82, 3-84, 3-86, 3-87, 3-214, 4-150, 4-151, 4-154, 4-156, 4-168, 4-269, 4-270, 4-272–4-275, 4-409

Indian Peoples Muskogee Tribal Town, 3-163

interfacing systems loss-of-coolant accident, 2-102, 4-341, 4-347–4-353

Intermountain Seismic Belt, 3-71

International Atomic Energy Agency, 5-12

L

Lake Anna, 3-196, 3-198, 3-199

Lake Norman, 3-191, 4-395

Lake Wylie, 3-186, 3-189, 4-395

land disturbance, 2-77, 2-95, 2-96, 4-265, 4-287, 5-3

large-break loss-of-coolant accident, 4-341

leak testing, 2-21, 2-28, 2-29

leukemia, 3-68, 3-106, 3-145

light water reactor, 1-26, 2-11, 2-74, 2-102, 4-332, 4-335, 4-337, 4-340, 4-355

Lookout Lake, 3-191

- Lost River Fault, 3-70
- low-enriched uranium, 1-15, 1-18, 1-27, 2-33, 2-35, 2-36, 2-102, 2-107, 4-337–4-346, 4-348–4-356, 4-395, 4-396
- low-income population, 3-2, 3-147, 4-25, 4-26, 4-37, 4-50, 4-54, 4-67, 4-74, 4-89, 4-93, 4-100, 4-105, 4-115, 4-122, 4-135, 4-139, 4-145, 4-152, 4-163, 4-169, 4-179, 4-184, 4-195, 4-198, 4-204, 4-208, 4-219, 4-221, 4-231, 4-235, 4-245, 4-249, 4-258, 4-298, 4-305, 4-313, 4-322, 4-330, 4-333, 4-336, 4-353, 4-366, 5-13
- M**
- Ma Chis Lower Alabama Creek Indian Tribe, 3-163, 5-15
- maximally exposed involved worker, 2-76, 2-96, 4-47, 4-61, 4-86, 4-99, 4-112, 4-132, 4-144, 4-159, 4-176, 4-192, 4-201, 4-217, 4-228, 4-242, 4-255, 4-296, 4-303, 4-312, 4-320, 4-328
- maximally exposed member of the public, 3-20, 3-65, 3-104, 3-143, 3-172, 3-177, 3-183, 3-189, 3-194, 3-200, 4-13–4-15, 4-17–4-21, 4-37, 4-42, 4-54, 4-59, 4-74, 4-82, 4-83, 4-93, 4-96, 4-104, 4-109, 4-110, 4-122, 4-130, 4-139, 4-142, 4-151, 4-156, 4-157, 4-169, 4-174, 4-184, 4-189, 4-198–4-200, 4-213, 4-226, 4-240, 4-253, 4-294, 4-295, 4-302, 4-310, 4-318, 4-326, 4-327
- McGuire Nuclear Station, 1-10, 1-11, 1-14, 1-16, 1-18, 2-8, 2-9, 2-40, 2-43, 2-63, 2-76, 2-96, 2-98, 2-102, 2-103, 3-1, 3-191–3-196, 3-207, 4-49, 4-297, 4-304, 4-312, 4-321, 4-329, 4-332, 4-335, 4-337–4-339, 4-342, 4-343, 4-345, 4-348–4-351, 4-353, 4-354, 4-390, 4-393, 4-395, 4-396, 4-408
- McNary Dam, 3-27
- McQueen Branch, 3-152, 3-153, 3-167
- melter spill, 4-46, 4-63, 4-214, 4-216, 4-243
- Migratory Bird Treaty Act, 4-263, 4-270, 4-278, 4-285, 5-10
- minority population, 2-77, 2-105, 3-2, 3-23–3-25, 3-69, 3-70, 3-107, 3-108, 3-146–3-148, 3-190, 3-191, 3-196, 3-201, 4-25, 4-26, 4-37, 4-50, 4-54, 4-67, 4-74, 4-89, 4-93, 4-100, 4-105, 4-115, 4-122, 4-135, 4-139, 4-145, 4-152, 4-163, 4-169, 4-179, 4-184, 4-195, 4-198, 4-204, 4-208, 4-219, 4-221, 4-231, 4-235, 4-245, 4-249, 4-258, 4-298, 4-305, 4-313, 4-322, 4-330, 4-333, 4-336, 4-352, 4-353, 4-363, 4-366, 5-13
- mixed transuranic waste, 3-9, 3-11, 3-53, 3-55, 3-56, 3-93, 3-132, 3-171, 3-176, 3-182, 4-10–4-12, 4-39, 4-40, 4-56, 4-57, 4-78, 4-79, 4-107, 4-126, 4-127, 4-154, 4-171, 4-172, 4-186, 4-187, 4-210, 4-211, 4-223, 4-224, 4-237, 4-238, 4-251, 4-292, 4-299, 4-300, 4-307, 4-308, 4-314, 4-316, 4-324, 4-331, 4-334
- mixed waste, 1-18, 1-23, 2-75, 3-4, 3-10–3-12, 3-48, 3-49, 3-54, 3-56, 3-57, 3-89, 3-95, 3-133, 3-134, 3-169, 3-182, 4-10, 4-11, 4-40, 4-41, 4-57, 4-58, 4-79, 4-81, 4-108, 4-127–4-129, 4-154, 4-155, 4-171, 4-173, 4-210, 4-212, 4-225, 4-237, 4-239, 4-251, 4-252, 4-292, 4-293, 4-300, 4-301, 4-308, 4-314, 4-324, 4-325, 4-374, 4-375, 4-388, 4-391, 4-400, 4-405, 5-9
- Modified Mercalli Intensity, 3-26, 3-109
- MOX fuel pellets, 4-48, 4-49, 4-65, 4-87, 4-112, 4-113, 4-133, 4-134, 4-161, 4-177, 4-193, 4-202, 4-244
- MOX fuel rods, 1-3, 2-63, 2-96, 4-49, 4-65, 4-87, 4-113, 4-134, 4-161, 4-177, 4-193, 4-202, 4-366
- multilateral agreement, 1-3
- municipal water, 3-186, 3-191
- N**
- National Academy of Sciences, 1-13, 2-102, 2-106, 4-54, 4-104, 4-122, 4-139, 4-151, 4-168, 4-183, 4-235, 4-248, 4-318, 4-340, 4-341, 4-407
- National Ambient Air Quality Standards, 2-75, 3-5, 3-6, 3-50, 3-51, 3-89–3-91, 3-128–3-130, 3-170, 3-175, 3-181, 3-186, 3-188, 3-193, 3-198, 3-199, 3-207, 5-7
- National Council of Muskogee Creek, 3-160, 3-163

- National Emission Standards for Hazardous Air Pollutants, 2-98, 4-38, 5-7
- National Environmental Policy Act, 1-4-1-6, 1-8, 1-14-1-16, 1-18, 1-19, 1-21-1-24, 1-27, 2-8, 2-14, 3-1, 3-2, 3-5, 3-7, 3-8, 3-56, 3-74, 3-163, 3-203, 3-211, 4-44, 4-372, 4-400, 4-402, 5-1, 5-2, 5-8, 5-12, 5-13
- National Institute of Occupational Safety and Health, 3-68
- national park, 1-22, 3-179, 3-212
- National Pollutant Discharge Elimination System, 3-21, 3-30, 3-67, 3-74, 3-106, 3-111, 3-135, 3-145, 3-150, 3-188, 3-193, 3-198, 3-206-3-208, 3-213, 4-261, 4-262, 4-269, 4-284, 4-354, 5-8
- National Priorities List, 3-9, 3-41, 3-53, 3-93, 3-132, 3-171, 3-175, 3-181, 5-9, 5-10
- National Register of Historic Places, 2-48, 2-77, 2-81, 2-84-2-87, 2-89, 2-93, 2-94, 3-36-3-39, 3-79, 3-80, 3-120, 3-157-3-159, 4-272, 4-279, 4-286, 5-4, 5-5
- National Research Universal Test Reactor, 1-20
- Native American Graves Protection and Repatriation Act, 5-4, 5-11
- Native American Treaty Rights, 3-122, 3-163
- Native Americans, 1-18, 3-24, 3-39, 3-40, 3-69, 3-79-3-81, 3-107, 3-119-3-122, 3-146, 3-147, 3-160, 3-163, 3-191, 3-196, 3-201, 4-264-4-266, 4-271-4-273, 4-279-4-281, 4-286-4-288, 4-355, 5-2-5-5, 5-11, 5-14, 5-15
- Nevada Test Site, 2-44, 3-93, 3-95, 4-11, 4-78, 4-80, 4-88, 4-114, 4-186, 4-187, 4-194, 4-203, 4-230, 4-257, 4-307, 4-308, 4-334, 4-383 4-388, 4-389, 4-394, 4-403
- Nez Perce Tribe, 3-39, 5-14
- nonattainment, 3-5, 3-6, 3-50, 3-51, 3-89, 3-90, 3-128, 3-129, 3-170, 3-175, 3-186, 3-193, 3-198, 3-208, 4-9, 4-306, 4-388, 4-406, 5-7
- nonpit plutonium, 1-4, 1-8, 2-2, 2-11, 2-21, 2-26, 2-36, 2-37, 2-44, 4-2, 4-12, 4-24, 4-49, 4-65, 4-87, 4-113, 4-134, 4-161, 4-178, 4-193, 4-194, 4-202, 4-203, 4-214, 4-218, 4-229, 4-230, 4-244, 4-245, 4-256, 4-257
- Nonproliferation and Export Control Policy, 1-3, 1-29
- nonsensitive habitat, 3-33, 3-75, 3-116, 3-154, 4-262, 4-263, 4-270, 4-271, 4-278, 4-279, 4-285
- North Anna Power Station, 1-10, 1-14-1-16, 1-18, 2-8, 2-9, 2-40, 2-76, 2-98, 2-102, 2-103, 3-1, 3-196-3-201, 3-212, 3-215, 4-49, 4-65, 4-87, 4-113, 4-134, 4-161, 4-178, 4-193, 4-202, 4-337-4-339, 4-342, 4-343, 4-346, 4-348, 4-351-4-354, 4-395, 4-396, 4-406
- Notice of Intent, 1-1, 1-4, 1-6, 1-9, 1-11, 1-27, 1-28, 2-11, 2-12, 2-106, 3-111, 4-404
- NRC license, 1-6, 1-8, 1-16, 2-9, 2-63, 4-371
- nuclear fuel fabricator, 4-297, 4-304, 4-312, 4-321, 4-329
- nuclear material control and accountability, 2-13, 2-64, 2-69
- Nuclear Regulatory Commission, 1-1, 1-6, 1-8, 1-10, 1-14-1-16, 1-21, 1-27, 1-29, 2-8, 2-9, 2-13, 2-33, 2-39, 2-40, 2-53, 2-56, 2-63, 3-186, 3-191, 3-194, 3-196, 3-198, 3-212, 4-42, 4-43, 4-59, 4-83, 4-84, 4-97, 4-110, 4-111, 4-131, 4-132, 4-143, 4-157, 4-158, 4-174, 4-175, 4-189, 4-190, 4-200, 4-337, 4-340-4-342, 4-347, 4-371, 4-377, 4-378, 4-381-4-383, 4-387, 4-406 4-407, 4-408, 5-2, 5-3, 5-8
- Nuclear Waste Policy Act, 1-4, 1-10, 2-21, 2-26, 2-29, 2-30, 2-73, 2-99, 4-333, 5-9
- ## O
- Occupational Safety and Health Administration, 3-22, 3-68, 3-106, 3-145, 4-34, 4-39, 4-52, 4-56, 4-69, 4-71, 4-76, 4-78, 4-101, 4-107, 4-119, 4-126, 4-149, 4-153, 4-165, 4-171, 4-180, 4-186, 4-205, 4-210, 4-233, 4-237, 4-408
- Ogallala aquifer, 3-110, 3-114-3-116, 4-29, 4-277
- ozone, 3-6, 3-51, 3-90, 3-129, 3-130, 3-170, 3-207, 3-208, 3-215, 4-9, 4-306, 4-357, 4-358, 4-388, 4-406, 4-410, 5-7

P

Pacific Northwest National Laboratory, 3-3, 3-202, 3-203, 3-209–3-211, 4-402

Paducah Gaseous Diffusion Plant, 1-9, 1-20

Pantex Lake, 3-110, 3-111, 3-116, 3-118

Parallex Project, 1-3, 1-18, 1-19, 1-28

Pee Dee Indian Association, 3-163, 5-15

Pit Disassembly and Conversion Demonstration, 1-10, 1-19, 1-28, 2-40, 2-63

Playa 1 Management Unit, 3-122, 4-281

Plutonium Finishing Plant, 1-22, 4-2, 4-23, 4-31, 4-32

plutonium polishing, 1-13, 1-16, 1-17, 2-20, 2-30, 2-33, 2-35, 2-107, 4-408

pollution prevention, 2-75, 3-12, 3-30, 3-57, 3-96, 3-97, 3-111, 3-135, 3-150, 4-399, 4-400, 4-402, 5-9, 5-10

Pollution Prevention Act of 1990, 4-399, 5-9

Portsmouth Gaseous Diffusion Plant, 1-9, 1-20, 2-28, 2-29, 2-33, 2-39, 2-40, 2-43, 2-63, 2-96

Prevention of Significant Deterioration, 3-5, 3-50, 3-89, 3-130, 4-38, 4-39, 4-55, 4-56, 4-75–4-77, 4-94, 4-105, 4-106, 4-123–4-125, 4-141, 4-152, 4-153, 4-170, 4-184, 4-185, 4-209, 4-222, 4-223, 4-236, 4-237, 4-249, 4-250, 5-7

Priest Rapids Dam, 3-27, 3-36, 3-41

prompt fatalities, 2-103, 4-22, 4-24, 4-45, 4-341, 4-347–4-353

R

radioactive waste, 1-6, 1-8, 1-21, 1-23, 1-28, 1-29, 2-22, 2-33, 2-36, 2-39, 2-47, 2-56, 2-75, 2-76, 2-96, 2-105, 2-106, 3-3, 3-5, 3-32, 3-41, 3-48, 3-49, 3-55, 3-56, 3-81, 3-82, 3-85, 3-132, 3-135, 3-181, 3-205, 4-49, 4-155, 4-367, 4-405, 5-9

radiography, 2-73, 4-40, 4-57, 4-79, 4-108, 4-127, 4-155, 4-172, 4-187, 4-210, 4-224, 4-238, 4-251, 4-292, 4-300, 4-308, 4-315, 4-316, 4-324

radiological consequences, 4-44, 4-46, 4-47, 4-60, 4-61, 4-84, 4-86, 4-99, 4-111, 4-132, 4-144, 4-158, 4-159, 4-192, 4-228, 4-255, 4-295, 4-303, 4-311, 4-312, 4-319, 4-320, 4-327

radiological exposure, 1-8, 1-13, 2-76, 2-95–2-98, 2-103, 3-19–3-23, 3-65, 3-67, 3-102, 3-104, 3-105, 3-128, 3-142–3-144, 3-169, 3-172–3-174, 3-177, 3-178, 3-183, 3-184, 3-189, 3-190, 3-194, 3-195, 3-200, 3-211, 4-14, 4-17, 4-21, 4-22, 4-47, 4-48, 4-61, 4-62, 4-74, 4-86, 4-93, 4-99, 4-104, 4-112, 4-133, 4-144, 4-159, 4-176, 4-183, 4-192, 4-198, 4-201, 4-217, 4-221, 4-228, 4-242, 4-248, 4-255, 4-264, 4-271, 4-279, 4-286, 4-296, 4-297, 4-303–4-305, 4-312, 4-313, 4-320, 4-321, 4-328, 4-329, 4-332, 4-333, 4-335, 4-336, 4-358, 4-359, 4-370, 4-371, 4-377, 4-380, 4-382, 4-385, 4-388, 4-391, 4-394, 4-395

radiological monitoring, 3-50, 3-188, 3-193, 3-198, 4-408

radiological risk, 2-40, 4-37, 4-54, 4-74, 4-93, 4-104, 4-122, 4-139, 4-151, 4-168, 4-183, 4-198, 4-208, 4-221, 4-234, 4-248, 4-294, 4-302, 4-309, 4-318, 4-326, 4-330, 4-333

radon, 3-19, 3-65, 3-104, 3-143, 3-173, 3-177, 3-183, 3-189, 3-195, 3-200

Recommendation 94-1, 4-31, 4-32

Recommendation 99-1, 1-18

Resource Conservation and Recovery Act, 2-75, 3-9, 3-11, 3-12, 3-32, 3-53, 3-56, 3-57, 3-74, 3-93, 3-96, 3-122, 3-124, 3-132, 3-134, 3-169, 3-175, 3-181, 4-388, 4-391, 4-400, 5-2, 5-9

riparian habitat, 3-36, 3-77

Rocky Flats Environmental Technology, 1-2, 1-4, 1-8, 1-18–1-20, 2-2, 2-37, 2-44, 2-79, 3-55, 3-59, 3-206, 4-2, 4-8, 4-9, 4-12, 4-16, 4-17, 4-21, 4-22, 4-24, 4-26, 4-28–4-30, 4-32, 4-33, 4-49, 4-65, 4-87, 4-113, 4-134, 4-161, 4-178, 4-193, 4-202, 4-218, 4-229, 4-244, 4-256, 4-374, 4-405

S

- safe, secure trailer/SafeGuards Transport, 1-14, 2-18, 2-36, 2-37, 2-48, 4-48, 4-49, 4-65, 4-86, 4-87, 4-112, 4-113, 4-133, 4-134, 4-161, 4-177, 4-192, 4-193, 4-202, 4-217, 4-218, 4-229, 4-244, 4-256
- safeguards category, 2-63, 2-65
- San Francisco Bay Area, 3-170, 3-208, 4-306, 4-388, 4-406
- sanitary sewer system, 3-57, 3-135, 3-194, 4-41, 4-58, 4-81, 4-109, 4-129, 4-156, 4-173, 4-212, 4-225, 4-239, 4-252, 4-301, 4-307, 4-309, 4-317, 4-325
- sanitary wastewater, 2-96, 3-10, 3-12, 3-133, 3-135, 3-152, 3-169, 3-176, 3-180, 3-182, 3-188, 3-189, 3-194, 3-199, 4-52, 4-53, 4-57, 4-58, 4-103, 4-107, 4-109, 4-120, 4-121, 4-127, 4-129, 4-212, 4-233, 4-234, 4-237-4-239, 4-251-4-253, 4-269, 4-277, 4-284, 4-309, 4-315-4-317, 4-323-4-325
- S-Area, 2-48, 2-54-2-56, 2-59, 2-62, 3-130, 3-131, 3-146, 3-147, 3-149, 3-152-3-155, 3-157, 3-159-3-161, 3-163, 3-164, 3-166, 3-167, 4-52, 4-56, 4-65, 4-101, 4-106, 4-113, 4-126, 4-134, 4-161, 4-193, 4-233, 4-237, 4-244, 4-249, 4-256, 4-287, 4-288
- scoping meeting, 1-4, 1-5, 2-11
- scoping process, 1-4, 1-5, 1-27, 2-11
- scrap metal segregation, 4-400
- security clearance, 2-13, 2-64
- seismic event, 4-46, 4-60, 4-84, 4-98, 4-111, 4-132, 4-143, 4-158, 4-176, 4-190, 4-216, 4-241, 4-296, 4-303, 4-320, 4-328
- sensitive habitat, 3-2, 3-36, 3-77, 3-118, 3-157, 4-262, 4-263, 4-270, 4-271, 4-278, 4-279, 4-284, 4-285, 5-6
- sensitive species, 3-37, 3-119, 4-263, 4-271, 4-278, 4-285, 4-401, 5-3
- sintering, 2-28, 2-33, 2-35, 4-45, 4-47, 4-62, 4-64, 4-98, 4-160, 4-191, 4-215, 4-242
- source reduction and recycling, 4-400, 5-9
- special-status species, 3-36, 3-77, 3-78, 3-118, 3-157, 3-214, 4-263, 4-270, 4-271, 4-278, 4-279, 4-286, 5-5
- species of concern, 3-36, 3-37, 3-78, 3-119, 3-158, 4-285
- Spent Fuel Standard, 1-13, 2-22
- spent nuclear fuel, 1-6, 1-8, 1-13, 1-21-1-23, 1-25, 1-28, 2-22, 2-36, 2-39, 2-63, 2-65, 2-73, 2-76, 2-96, 2-105, 2-106, 3-2, 3-3, 3-49, 3-53, 3-85, 3-168, 3-181, 3-204-3-206, 4-10, 4-49, 4-154, 4-292, 4-332, 4-333, 4-335, 4-353, 4-373-4-375, 4-386, 4-403-4-405, 5-9
- special nuclear material, 2-13, 2-15, 2-18, 2-23, 2-30, 2-33, 2-47, 2-48, 2-57, 2-59, 2-64, 2-65, 2-69, 3-48, 3-163, 5-2, 5-8
- special nuclear material control and accountability, 2-69
- State Historic Preservation Officer, 2-77, 3-36, 3-39, 3-119, 3-120, 3-158, 3-159, 3-205, 4-265, 4-272, 4-279, 4-280, 4-286, 4-287, 5-4, 5-5, 5-14, 5-15
- stream minimization, 2-75, 4-400
- strontium, 1-21, 1-22, 2-22, 3-30, 3-32, 3-72, 3-74, 3-75, 3-154
- Superfund, 3-41, 3-171, 5-9, 5-10
- surveillance and maintenance, 3-7, 4-371
- ## T
- tank waste remediation system, 1-21, 1-22, 2-21, 2-44, 2-106, 3-7, 3-11, 3-204, 4-3, 4-42, 4-82, 4-95, 4-130, 4-173, 4-212, 4-226, 4-373, 4-375, 4-403
- technology transfer, 4-400
- threatened and endangered species, 3-36, 3-37, 3-77, 3-78, 3-118, 3-119, 3-157, 3-158, 4-29, 4-30, 4-71, 4-78, 4-118, 4-297, 4-305, 4-313, 4-321, 4-329, 4-332, 4-335
- transportation accidents, 2-96, 4-48, 4-50, 4-64, 4-66, 4-67, 4-86, 4-88, 4-89, 4-99, 4-112, 4-114, 4-115, 4-133, 4-135, 4-145, 4-160, 4-162, 4-163, 4-177-4-179, 4-192, 4-194, 4-195, 4-201, 4-203, 4-204, 4-217, 4-219, 4-229-4-231, 4-243, 4-245, 4-255, 4-257,

4-258, 4-290, 4-297, 4-305, 4-312, 4-321, 4-329, 4-332, 4-335, 4-352, 4-353, 4-366

transportation requirements, 1-13, 1-18, 2-36–2-38, 2-40–2-43, 3-165, 4-48, 4-65, 4-87, 4-113, 4-133, 4-161, 4-177, 4-193, 4-202, 4-217, 4-244, 4-366, 4-378, 4-381, 4-384, 4-387, 4-390, 4-393, 4-395, 5-12

transuranic waste, 1-20, 1-21, 1-25, 2-20, 2-35, 2-43, 2-51, 2-59, 2-73, 2-75, 2-96–2-99, 2-103, 3-9–3-13, 3-48, 3-53, 3-55, 3-56, 3-58, 3-59, 3-93, 3-97, 3-132, 3-133, 3-135, 3-136, 3-169, 3-171, 3-176, 3-182, 3-202, 3-206, 3-215, 4-10–4-12, 4-35, 4-39–4-41, 4-52, 4-56, 4-57, 4-72, 4-78–4-81, 4-88, 4-90, 4-102, 4-107, 4-108, 4-114, 4-119, 4-126–4-128, 4-136, 4-149, 4-154, 4-155, 4-166, 4-171–4-173, 4-181, 4-186, 4-187, 4-194, 4-203, 4-206, 4-210–4-212, 4-223–4-225, 4-230, 4-233, 4-237, 4-238, 4-251, 4-252, 4-257, 4-292, 4-293, 4-299–4-301, 4-306–4-308, 4-314–4-317, 4-323–4-325, 4-331, 4-334, 4-358, 4-377, 4-382, 4-389, 4-392, 4-394, 4-400, 4-402, 4-404

treaty-reserved privileges, 3-43

trichloroethylene, 3-30, 3-74, 3-153, 3-154

tritium production, 1-5, 1-26

tritium releases, 2-76, 2-80–2-94, 3-145, 4-44–4-46, 4-60, 4-61, 4-84, 4-85, 4-99, 4-144, 4-158, 4-159, 4-216, 4-217, 4-228, 4-241, 4-255

tritium supply, 1-26, 3-127, 4-373, 4-375

Tuscaloosa aquifer, 3-152

U

Umatilla Indian Reservation, 3-39, 3-43, 5-14

Uniform Building Code, 3-26, 3-70, 3-109, 3-147

Upper Three Runs Creek, 3-133, 3-149, 3-150, 3-152, 3-153, 3-155, 3-157, 3-180

uranium conversion, 1-9, 1-18, 2-39, 2-40, 4-48, 4-65, 4-87, 4-113, 4-133, 4-134, 4-161, 4-177, 4-193, 4-202, 4-218, 4-229, 4-256, 4-364, 4-367–4-370, 4-390, 4-393, 4-397

U.S. Army Corps of Engineers, 3-27, 3-118

U.S. Department of Agriculture, 3-149, 3-163

U.S. Department of Defense, 3-88, 3-107, 3-127, 3-128

U.S. Department of Transportation, 3-8, 3-9, 3-12, 3-52, 3-55, 3-92, 3-131, 3-134, 3-207, 4-35, 4-41, 4-53, 4-72, 4-81, 4-92, 4-102, 4-119, 4-129, 4-137, 4-149, 4-155, 4-167, 4-173, 4-182, 4-188, 4-206, 4-212, 4-225, 4-234, 4-293, 4-301, 4-309, 4-317, 4-323

U.S. Fish and Wildlife Service, 3-4, 3-5, 3-41, 4-263, 4-264, 4-271, 4-278, 4-285, 5-5, 5-6, 5-14, 5-15

V

Virginia Power, 2-8, 3-189, 3-195, 3-196, 3-198–3-200, 3-215, 4-337

Visual Resource Management Class, 3-44, 3-84, 3-124, 3-164, 4-266, 4-273, 4-281, 4-288

Visual Resource Management Methodology, 4-273, 4-280, 4-287

vitrification process, 2-13, 2-22

W

waste acceptance criteria, 1-21, 3-9, 3-55, 3-56, 3-134, 4-10–4-12, 4-39, 4-40, 4-56, 4-57, 4-79, 4-80, 4-107, 4-108, 4-127, 4-128, 4-154, 4-155, 4-171, 4-172, 4-187, 4-210, 4-211, 4-223, 4-224, 4-237, 4-238, 4-251, 4-252, 4-292, 4-299, 4-300, 4-308, 4-314–4-316, 4-324

weapons-grade plutonium, 1-2, 2-15, 2-40, 2-43, 2-63, 4-49, 4-65, 4-87, 4-113, 4-134, 4-161, 4-178, 4-193, 4-202

weapons-usable fissile material, 1-1, 1-3, 1-19, 1-28, 2-1, 2-106, 3-5, 3-204, 4-1, 4-340, 4-348, 4-373, 4-375, 4-403, 4-404

weapons-usable plutonium, 1-1, 1-2, 1-4, 1-10, 1-11, 1-14, 1-19, 1-28, 2-1, 2-2, 2-9, 2-44, 4-2, 4-32, 4-352

wet-feed preparation process, 2-12

wetlands, 3-36, 3-77, 3-78, 3-111, 3-118, 3-157, 3-161, 3-163, 3-164, 4-29, 4-30, 4-263,

4-270, 4-271, 4-278, 4-279,
4-285, 4-297, 4-305, 4-313,
4-321, 4-329, 4-332, 4-335, 5-1,
5-8

wildlife, 3-4, 3-5, 3-30, 3-33, 3-35, 3-36, 3-41,
3-74, 3-78, 3-81, 3-128, 3-155, 3-161, 3-208,
3-210, 3-213, 4-7-4-9, 4-34, 4-39, 4-52,
4-56, 4-69, 4-71, 4-76, 4-78, 4-101, 4-106,
4-117, 4-118, 4-124, 4-126, 4-149, 4-153,
4-165, 4-171, 4-180, 4-185, 4-205, 4-210,
4-223, 4-233, 4-237, 4-249, 4-263, 4-264,
4-271, 4-278, 4-279, 4-285, 4-286, 4-297,
4-305, 4-313, 4-321, 4-329, 4-332, 4-335,
4-401, 4-402, 4-406-4-408, 5-5, 5-6, 5-10,
5-14, 5-15

worker injuries, 4-37, 4-48, 4-54, 4-62, 4-74, 4-86,
4-93, 4-99, 4-105, 4-112, 4-122, 4-133,
4-139, 4-144, 4-151, 4-160, 4-169, 4-177,
4-184, 4-192, 4-198, 4-201, 4-208, 4-217,
4-221, 4-228, 4-235, 4-243, 4-248, 4-255



Office of Fissile Materials Disposition

United States Department of Energy

Surplus Plutonium Disposition Final Environmental Impact Statement

Volume II

November 1999

For Further Information Contact:
U.S. Department of Energy
Office of Fissile Materials Disposition, P.O. Box 23786, Washington, DC 20026-3786

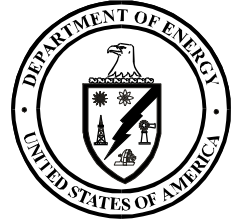

DOE/EIS-0283

Surplus Plutonium Disposition Final Environmental Impact Statement

Volume II

**United States Department of Energy
Office of Fissile Materials Disposition**

November 1999

Cover Sheet

Responsible Agency: United States Department of Energy (DOE)

Title: *Surplus Plutonium Disposition Final Environmental Impact Statement (SPD EIS)* (DOE/EIS-0283)

Locations of Candidate Sites: California, Idaho, New Mexico, North Carolina, South Carolina, Tennessee, Texas, Virginia, and Washington

Contacts:

For further information on the SPD Final EIS contact: For information on the DOE National Environmental Policy Act (NEPA) process contact:

Mr. G. Bert Stevenson, NEPA Compliance Officer
Office of Fissile Materials Disposition
U.S. Department of Energy
P.O. Box 23786
Washington, DC 20026-3786
Voice: (202) 586-5368

Ms. Carol Borgstrom, Director
Office of NEPA Policy and Assistance
Office of Environment, Safety and Health
U.S. Department of Energy
1000 Independence Ave., SW
Washington, DC 20585
Voice: (202) 586-4600 or (800) 472-2756

Abstract: On May 22, 1997, DOE published a Notice of Intent in the Federal Register (62 Federal Register 28009) announcing its decision to prepare an environmental impact statement (EIS) that would tier from the analysis and decisions reached in connection with the *Storage and Disposition of Weapons-Usable Fissile Materials Final Programmatic EIS*. At that time, the U.S. Environmental Protection Agency decided to be a cooperating agency. The *Surplus Plutonium Disposition Draft Environmental Impact Statement (SPD Draft EIS)* (DOE/EIS-0283-D) was prepared in accordance with NEPA and issued in July 1998. It identified the potential environmental impacts of reasonable alternatives for the proposed siting, construction, and operation of three facilities for the disposition of up to 50 metric tons (55 tons) of surplus plutonium, as well as a No Action Alternative. These three facilities would accomplish pit disassembly and conversion, plutonium conversion and immobilization, and mixed oxide (MOX) fuel fabrication.

For the alternatives that included MOX fuel fabrication, the SPD Draft EIS described the potential environmental impacts of using from three to eight commercial nuclear reactors to irradiate MOX fuel. The potential impacts were based on a generic reactor analysis that used actual reactor data and a range of potential site conditions. In May 1998, DOE initiated a procurement process to obtain MOX fuel fabrication and reactor irradiation services. In March 1999, DOE awarded a contract to Duke Engineering & Services, COGEMA Inc., and Stone & Webster (known as DCS) to provide the requested services. A *Supplement to the SPD Draft EIS* was issued in April 1999, which analyzed the potential environmental impacts of using MOX fuel in six specific reactors named in the DCS proposal. Those reactors are Catawba Nuclear Station Units 1 and 2 in South Carolina, McGuire Nuclear Station Units 1 and 2 in North Carolina, and North Anna Power Station Units 1 and 2 in Virginia.

DOE has identified the hybrid approach as its Preferred Alternative for the disposition of surplus plutonium. This approach allows for the immobilization of 17 metric tons (19 tons) of surplus plutonium and the use of 33 metric tons (36 tons) as MOX fuel. DOE has identified the Savannah River Site near Aiken, South Carolina, as the preferred site for all three disposition facilities (Alternative 3). DOE has also identified Los Alamos National

| Laboratory in New Mexico as the preferred site for lead assembly fabrication, and Oak Ridge National
| Laboratory in Tennessee as the preferred site for postirradiation examination of lead assemblies.

| **Public Involvement:** In preparing the SPD Final EIS, DOE considered comments on the SPD Draft EIS and the
| *Supplement to the SPD Draft EIS* received via mail, fax, and email, and comments recorded by phone and
| transcribed from videotapes. In addition, comments were captured by notetakers during interactive public
| meetings held on the SPD Draft EIS in August 1998 in Amarillo, Texas; Idaho Falls, Idaho; North Augusta,
| South Carolina; Portland, Oregon; and Richland, Washington, as well as during a public meeting on the
| *Supplement to the SPD Draft EIS* held in June 1999 in Washington, D.C. Comments received and DOE's
| responses to these comments are found in Volume III, the Comment Response Document, of the SPD Final EIS.
| Information on the surplus plutonium disposition program can be obtained by visiting the Office of Fissile
| Materials Disposition Web site at <http://www.doe-md.com>.

Table of Contents

Table of Contents i
 List of Figures xii
 List of Tables xiii
 List of Acronyms xxix
 Chemicals and Units of Measure xxxiv
 Metric Conversion Chart and Metric Prefixes xxxv

Volume II

**Appendix A
 Federal Register Notices and Joint Statement**

**Appendix B
 Contractor Disclosure Statement**

**Appendix C
 Adjunct Melter Vitrification Process C-1**

C.1 Adjunct Melter as an Immobilization Technology Variant C-1
 C.2 Evaluation of Immobilization Technology Variants C-1
 C.3 Adjunct Melter Vitrification Process C-2
 C.4 References C-4

**Appendix D
 Deleted**

**Appendix E
 Facility Data E-1**

E.1 Pit Conversion Facility E-1
 E.2 Immobilization Facility E-4
 E.3 MOX Facility E-11
 E.4 Lead Assembly Fabrication Facility E-14
 E.5 References E-16

**Appendix F
 Impact Assessment Methods F-1**

F.1 Air Quality And Noise F-1
 F.1.1 Description of Affected Resources F-1
 F.1.1.1 Air Quality F-1
 F.1.1.2 Noise F-3
 F.1.2 Description of Impact Assessment F-4
 F.1.2.1 Air Quality F-4
 F.1.2.2 Noise F-6

F.2	Geology And Soils	F-7
F.2.1	Description of Affected Resources	F-7
F.2.2	Description of Impact Assessment	F-7
F.3	Water Resources	F-8
F.3.1	Description of Affected Resources	F-8
F.3.2	Description of Impact Assessment	F-8
F.4	Ecological Resources	F-11
F.4.1	Description of Affected Resources	F-11
F.4.2	Description of Impact Assessment	F-11
F.4.2.1	Nonsensitive Habitat Impacts	F-11
F.4.2.2	Sensitive Habitat Impacts	F-12
F.5	Cultural And Paleontological Resources	F-12
F.5.1	Description of Affected Resources	F-12
F.5.2	Description of Impact Assessment	F-12
F.6	Land Resources	F-14
F.6.1	Description of Affected Resources	F-14
F.6.2	Description of Impact Assessment	F-14
F.6.2.1	Land-Use Analysis	F-14
F.6.2.2	Visual Resources Analysis	F-15
F.7	Infrastructure	F-15
F.7.1	Description of Affected Resources	F-15
F.7.2	Description of Impact Assessment	F-16
F.8	Waste Management	F-16
F.8.1	Description of Affected Resources	F-16
F.8.2	Description of Impact Assessment	F-18
F.9	Socioeconomics	F-18
F.9.1	Description of Affected Resources	F-18
F.9.2	Description of Impact Assessment	F-19
F.10	Human Health Risk During Normal Operations	F-19
F.10.1	Description of Affected Resources	F-19
F.10.2	Description of Impact Assessment	F-21
F.10.2.1	Public Health Risks	F-21
F.10.2.1.1	Radiological Risks	F-21
F.10.2.1.2	Chemical Risks	F-21
F.10.2.2	Occupational Health Risks	F-25
F.10.2.2.1	Radiological Risks	F-25
F.10.2.2.2	Hazardous Chemical Risks	F-25
F.11	Facility Accidents	F-25
F.11.1	Description of Affected Resources	F-25
F.11.2	Description of Impact Assessment	F-25
F.12	Transportation	F-26
F.12.1	Description of Affected Resources	F-26
F.12.2	Description of Impact Assessment	F-26
F.13	Environmental Justice	F-29
F.13.1	Description of Affected Resources	F-29
F.13.2	Description of Impact Assessment	F-29
F.14	Cumulative Impacts	F-31
F.15	References	F-34

Appendix G		
Air Quality		G-1
G.1	Hanford	G-1
G.1.1	Assessment Data	G-1
G.1.2	Facilities	G-2
G.1.2.1	Pit Conversion Facility	G-2
G.1.2.1.1	Construction of Pit Conversion Facility	G-2
G.1.2.1.2	Operation of Pit Conversion Facility	G-3
G.1.2.2	Immobilization Facility	G-4
G.1.2.2.1	Construction of Immobilization Facility	G-4
G.1.2.2.2	Operation of Immobilization Facility	G-5
G.1.2.3	MOX Facility	G-6
G.1.2.3.1	Construction of MOX Facility	G-6
G.1.2.3.2	Operation of MOX Facility	G-7
G.1.2.4	Pit Conversion and Immobilization Facilities	G-8
G.1.2.4.1	Construction of Pit Conversion and Immobilization Facilities	G-8
G.1.2.4.2	Operation of Pit Conversion and Immobilization Facilities	G-10
G.1.2.5	Pit Conversion and MOX Facilities	G-11
G.1.2.5.1	Construction of Pit Conversion and MOX Facilities	G-11
G.1.2.5.2	Operation of Pit Conversion and MOX Facilities	G-13
G.1.2.6	Immobilization and MOX Facilities	G-14
G.1.2.6.1	Construction of Immobilization and MOX Facilities	G-14
G.1.2.6.2	Operation of Immobilization and MOX Facilities	G-16
G.1.2.7	Pit Conversion, Immobilization, and MOX Facilities	G-17
G.1.2.7.1	Construction of Pit Conversion, Immobilization, and MOX Facilities	G-17
G.1.2.7.2	Operation of Pit Conversion, Immobilization, and MOX Facilities	G-18
G.2	INEEL	G-20
G.2.1	Assessment Data	G-20
G.2.2	Facilities	G-20
G.2.2.1	Pit Conversion Facility	G-20
G.2.2.1.1	Construction of Pit Conversion Facility	G-20
G.2.2.1.2	Operation of Pit Conversion Facility	G-21
G.2.2.2	MOX Facility	G-22
G.2.2.2.1	Construction of MOX Facility	G-22
G.2.2.2.2	Operation of MOX Facility	G-23
G.2.2.3	Pit Conversion and MOX Facilities	G-24
G.2.2.3.1	Construction of Pit Conversion and MOX Facilities	G-24
G.2.2.3.2	Operation of Pit Conversion and MOX Facilities	G-25
G.3	Pantex	G-27
G.3.1	Assessment Data	G-27
G.3.2	Facilities	G-27
G.3.2.1	Pit Conversion Facility	G-27
G.3.2.1.1	Construction of Pit Conversion Facility	G-27
G.3.2.1.2	Operation of Pit Conversion Facility	G-28
G.3.2.2	MOX Facility	G-29
G.3.2.2.1	Construction of MOX Facility	G-29
G.3.2.2.2	Operation of MOX Facility	G-30

	G.3.2.3	Pit Conversion and MOX Facilities	G-31
	G.3.2.3.1	Construction of Pit Conversion and MOX Facilities	G-31
	G.3.2.3.2	Operation of Pit Conversion and MOX Facilities	G-33
G.4	SRS		G-34
	G.4.1	Assessment Data	G-34
	G.4.2	Facilities	G-34
	G.4.2.1	Pit Conversion Facility	G-34
	G.4.2.1.1	Construction of Pit Conversion Facility	G-34
	G.4.2.1.2	Operation of Pit Conversion Facility	G-35
	G.4.2.2	[Text deleted.]	G-36
	G.4.2.3	Immobilization Facility	G-36
	G.4.2.3.1	Construction of Immobilization Facility	G-36
	G.4.2.3.2	Operation of Immobilization Facility	G-37
	G.4.2.4	MOX Facility	G-38
	G.4.2.4.1	Construction of MOX Facility	G-38
	G.4.2.4.2	Operation of MOX Facility	G-39
	G.4.2.5	Pit Conversion and Immobilization Facilities	G-40
	G.4.2.5.1	Construction of Pit Conversion and Immobilization Facilities	G-40
	G.4.2.5.2	Operation of Pit Conversion and Immobilization Facilities	G-41
	G.4.2.6	Pit Conversion and MOX Facilities	G-42
	G.4.2.6.1	Construction of Pit Conversion and MOX Facilities	G-42
	G.4.2.6.2	Operation of Pit Conversion and MOX Facilities	G-44
	G.4.2.7	Immobilization and MOX Facilities	G-45
	G.4.2.7.1	Construction of Immobilization and MOX Facilities	G-45
	G.4.2.7.2	Operation of Immobilization and MOX Facilities	G-46
	G.4.2.8	Pit Conversion, Immobilization, and MOX Facilities	G-47
	G.4.2.8.1	Construction of Pit Conversion, Immobilization, and MOX Facilities	G-47
	G.4.2.8.2	Operation of Pit Conversion, Immobilization, and MOX Facilities	G-48
G.5	References		G-50

Appendix H

Waste Management	H-1
-------------------------	-----

H.1	Hanford	H-2	
	H.1.1	Assessment Data	H-2
	H.1.2	Facilities	H-2
	H.1.2.1	Pit Conversion Facility	H-2
	H.1.2.1.1	Construction of Pit Conversion Facility	H-2
	H.1.2.1.2	Operation of Pit Conversion Facility	H-3
	H.1.2.2	Immobilization Facility	H-6
	H.1.2.2.1	Construction of Immobilization Facility	H-6
	H.1.2.2.2	Operation of Immobilization Facility	H-7
	H.1.2.3	MOX Facility	H-9
	H.1.2.3.1	Construction of MOX Facility	H-9
	H.1.2.3.2	Operation of MOX Facility	H-10
	H.1.2.4	Pit Conversion and Immobilization Facilities	H-13
	H.1.2.4.1	Construction of Pit Conversion and Immobilization Facilities	H-13
	H.1.2.4.2	Operation of Pit Conversion and Immobilization Facilities	H-14

	H.1.2.5	Pit Conversion and MOX Facilities	H-16
	H.1.2.5.1	Construction of Pit Conversion and MOX Facilities	H-16
	H.1.2.5.2	Operation of Pit Conversion and MOX Facilities	H-17
	H.1.2.6	Immobilization and MOX Facilities	H-20
	H.1.2.6.1	Construction of Immobilization and MOX Facilities	H-20
	H.1.2.6.2	Operation of Immobilization and MOX Facilities	H-21
	H.1.2.7	Pit Conversion, Immobilization, and MOX Facilities	H-23
	H.1.2.7.1	Construction of Pit Conversion, Immobilization, and MOX Facilities	H-23
	H.1.2.7.2	Operation of Pit Conversion, Immobilization, and MOX Facilities	H-25
H.2	INEEL		H-28
	H.2.1	Assessment Data	H-28
	H.2.2	Facilities	H-28
	H.2.2.1	Pit Conversion Facility	H-28
	H.2.2.1.1	Construction of Pit Conversion Facility	H-28
	H.2.2.1.2	Operation of Pit Conversion Facility	H-29
	H.2.2.2	MOX Facility	H-31
	H.2.2.2.1	Construction of MOX Facility	H-31
	H.2.2.2.2	Operation of MOX Facility	H-32
	H.2.2.3	Pit Conversion and MOX Facilities	H-35
	H.2.2.3.1	Construction of Pit Conversion and MOX Facilities	H-35
	H.2.2.3.2	Operation of Pit Conversion and MOX Facilities	H-36
H.3	Pantex		H-39
	H.3.1	Assessment Data	H-39
	H.3.2	Facilities	H-39
	H.3.2.1	Pit Conversion Facility	H-39
	H.3.2.1.1	Construction of Pit Conversion Facility	H-39
	H.3.2.1.2	Operation of Pit Conversion Facility	H-40
	H.3.2.2	MOX Facility	H-42
	H.3.2.2.1	Construction of MOX Facility	H-42
	H.3.2.2.2	Operation of MOX Facility	H-43
	H.3.2.3	Pit Conversion and MOX Facilities	H-46
	H.3.2.3.1	Construction of Pit Conversion and MOX Facilities	H-46
	H.3.2.3.2	Operation of Pit Conversion and MOX Facilities	H-47
H.4	SRS		H-50
	H.4.1	Assessment Data	H-50
	H.4.2	Facilities	H-50
	H.4.2.1	Pit Conversion Facility	H-50
	H.4.2.1.1	Construction of Pit Conversion Facility	H-50
	H.4.2.1.2	Operation of Pit Conversion Facility	H-51
	H.4.2.2	Immobilization Facility	H-53
	H.4.2.2.1	Construction of Immobilization Facility	H-53
	H.4.2.2.2	Operation of Immobilization Facility	H-54
	H.4.2.3	MOX Facility	H-57
	H.4.2.3.1	Construction of MOX Facility	H-57
	H.4.2.3.2	Operation of MOX Facility	H-58
	H.4.2.4	Pit Conversion and Immobilization Facilities	H-60
	H.4.2.4.1	Construction of Pit Conversion and Immobilization Facilities	H-60
	H.4.2.4.2	Operation of Pit Conversion and Immobilization Facilities	H-61

H.4.2.5	Pit Conversion and MOX Facilities	H-64
H.4.2.5.1	Construction of Pit Conversion and MOX Facilities	H-64
H.4.2.5.2	Operation of Pit Conversion and MOX Facilities	H-65
H.4.2.6	Immobilization and MOX Facilities	H-67
H.4.2.6.1	Construction of Immobilization and MOX Facilities	H-67
H.4.2.6.2	Operation of Immobilization and MOX Facilities	H-68
H.4.2.7	Pit Conversion, Immobilization, and MOX Facilities	H-71
H.4.2.7.1	Construction of Pit Conversion, Immobilization, and MOX Facilities	H-71
H.4.2.7.2	Operation of Pit Conversion, Immobilization, and MOX Facilities	H-72
H.5	Lead Assembly Fabrication	H-75
H.5.1	ANL-W	H-75
H.5.1.1	Construction	H-75
H.5.1.2	Operations	H-76
H.5.2	Hanford	H-78
H.5.2.1	Construction	H-78
H.5.2.2	Operations	H-78
H.5.3	LLNL	H-80
H.5.3.1	Construction	H-80
H.5.3.2	Operations	H-81
H.5.4	LANL	H-83
H.5.4.1	Construction	H-83
H.5.4.2	Operations	H-85
H.5.5	SRS	H-87
H.5.5.1	Construction	H-87
H.5.5.2	Operations	H-88
H.6	Postirradiation Examination	H-90
H.6.1	ANL-W	H-90
H.6.1.1	Construction	H-90
H.6.1.2	Operations	H-90
H.6.2	ORNL	H-92
H.6.2.1	Construction	H-92
H.6.2.2	Operations	H-92
H.7	References	H-95

Appendix I

Socioeconomics	I-1	
I.1	Hanford	I-1
I.2	Ineel	I-4
I.3	Pantex	I-7
I.4	SRS	I-10
I.5	References	I-13

Appendix J

Human Health Risks	J-1	
J.1	Hanford	J-1
J.1.1	Assessment Data	J-1

	J.1.1.1	Meteorological Data	J-1
	J.1.1.2	Population Data	J-1
	J.1.1.3	Agricultural Data	J-1
	J.1.1.4	Source Term Data	J-4
	J.1.1.5	Other Calculational Assumptions	J-5
J.1.2	Facilities		J-6
	J.1.2.1	Pit Conversion Facility	J-6
	J.1.2.1.1	Construction of Pit Conversion Facility	J-6
	J.1.2.1.2	Operation of Pit Conversion Facility	J-6
	J.1.2.2	Immobilization Facility	J-7
	J.1.2.2.1	Construction of Immobilization Facility	J-7
	J.1.2.2.2	Operation of Immobilization Facility	J-7
	J.1.2.3	MOX Facility	J-8
	J.1.2.3.1	Construction of MOX Facility	J-8
	J.1.2.3.2	Operation of MOX Facility	J-9
	J.1.2.4	Pit Conversion and Immobilization Facilities	J-9
	J.1.2.4.1	Construction of Pit Conversion and Immobilization Facilities ...	J-9
	J.1.2.4.2	Operation of Pit Conversion and Immobilization Facilities	J-10
	J.1.2.5	Pit Conversion and MOX Facilities	J-11
	J.1.2.5.1	Construction of Pit Conversion and MOX Facilities	J-11
	J.1.2.5.2	Operation of Pit Conversion and MOX Facilities	J-11
	J.1.2.6	Immobilization and MOX Facilities	J-12
	J.1.2.6.1	Construction of Immobilization and MOX Facilities	J-12
	J.1.2.6.2	Operation of Immobilization and MOX Facilities	J-12
	J.1.2.7	Pit Conversion, Immobilization, and MOX Facilities	J-14
	J.1.2.7.1	Construction of Pit Conversion, Immobilization, and MOX Facilities	J-14
	J.1.2.7.2	Operation of Pit Conversion, Immobilization, and MOX Facilities	J-14
J.2	INEEL		J-16
	J.2.1	Assessment Data	J-16
	J.2.1.1	Meteorological Data	J-16
	J.2.1.2	Population Data	J-16
	J.2.1.3	Agricultural Data	J-16
	J.2.1.4	Source Term Data	J-19
	J.2.1.5	Other Calculational Assumptions	J-19
	J.2.2	Facilities	J-20
	J.2.2.1	Pit Conversion Facility	J-20
	J.2.2.1.1	Construction of Pit Conversion Facility	J-20
	J.2.2.1.2	Operation of Pit Conversion Facility	J-20
	J.2.2.2	MOX Facility	J-21
	J.2.2.2.1	Construction of MOX Facility	J-21
	J.2.2.2.2	Operation of MOX Facility	J-21
	J.2.2.3	Pit Conversion and MOX Facilities	J-22
	J.2.2.3.1	Construction of Pit Conversion and MOX Facilities	J-22
	J.2.2.3.2	Operation of Pit Conversion and MOX Facilities	J-22
J.3	Pantex		J-23
	J.3.1	Assessment Data	J-23
	J.3.1.1	Meteorological Data	J-23
	J.3.1.2	Population Data	J-24

	J.3.1.3	Agricultural Data	J-24
	J.3.1.4	Source Term Data	J-26
	J.3.1.5	Other Calculational Assumptions	J-27
J.3.2	Facilities		J-28
	J.3.2.1	Pit Conversion Facility	J-28
		J.3.2.1.1 Construction of Pit Conversion Facility	J-28
		J.3.2.1.2 Operation of Pit Conversion Facility	J-28
	J.3.2.2	MOX Facility	J-29
		J.3.2.2.1 Construction of MOX Facility	J-29
		J.3.2.2.2 Operation of MOX Facility	J-29
	J.3.2.3	Pit Conversion and MOX Facilities	J-30
		J.3.2.3.1 Construction of Pit Conversion and MOX Facilities	J-30
		J.3.2.3.2 Operation of Pit Conversion and MOX Facilities	J-30
J.4	SRS		J-32
	J.4.1	Assessment Data	J-32
		J.4.1.1 Meteorological Data	J-32
		J.4.1.2 Population Data	J-32
		J.4.1.3 Agricultural Data	J-32
		J.4.1.4 Source Term Data	J-35
		J.4.1.5 Other Calculational Assumptions	J-36
	J.4.2	Facilities	J-37
		J.4.2.1 Pit Conversion Facility	J-37
		J.4.2.1.1 Construction of Pit Conversion Facility	J-37
		J.4.2.1.2 Operation of Pit Conversion Facility	J-37
	J.4.2.2	Immobilization Facility	J-38
		J.4.2.2.1 Construction of Immobilization Facility	J-38
		J.4.2.2.2 Operation of Immobilization Facility	J-39
	J.4.2.3	MOX Facility	J-40
		J.4.2.3.1 Construction of MOX Facility	J-40
		J.4.2.3.2 Operation of MOX Facility	J-40
	J.4.2.4	Pit Conversion and Immobilization Facilities	J-41
		J.4.2.4.1 Construction of Pit Conversion and Immobilization Facilities	J-41
		J.4.2.4.2 Operation of Pit Conversion and Immobilization Facilities	J-42
	J.4.2.5	Pit Conversion and MOX Facilities	J-43
		J.4.2.5.1 Construction of Pit Conversion and MOX Facilities	J-43
		J.4.2.5.2 Operation of Pit Conversion and MOX Facilities	J-43
	J.4.2.6	Immobilization and MOX Facilities	J-44
		J.4.2.6.1 Construction of Immobilization and MOX Facilities	J-44
		J.4.2.6.2 Operation of Immobilization and MOX Facilities	J-45
	J.4.2.7	Pit Conversion, Immobilization, and MOX Facilities	J-46
		J.4.2.7.1 Construction of Pit Conversion, Immobilization, and MOX Facilities	J-46
		J.4.2.7.2 Operation of Pit Conversion, Immobilization, and MOX Facilities	J-47
J.5	Lead Assembly Fabrication		J-48
	J.5.1	ANL-W	J-48
		J.5.1.1 Assessment Data	J-48
		J.5.1.1.1 Meteorological Data	J-48
		J.5.1.1.2 Population Data	J-48
		J.5.1.1.3 Agricultural Data	J-48

	J.5.1.1.4	Source Term Data	J-48
	J.5.1.1.5	Other Calculational Assumptions	J-49
J.5.2	J.5.1.2	Human Health Impacts	J-50
	J.5.2	Hanford	J-50
	J.5.2.1	Assessment Data	J-50
	J.5.2.1.1	Meteorological Data	J-50
	J.5.2.1.2	Population Data	J-50
	J.5.2.1.3	Agricultural Data	J-51
	J.5.2.1.4	Source Term Data	J-51
	J.5.2.1.5	Other Calculational Assumptions	J-52
	J.5.2.2	Human Health Impacts	J-53
J.5.3	LLNL		J-53
	J.5.3.1	Assessment Data	J-53
	J.5.3.1.1	Meteorological Data	J-53
	J.5.3.1.2	Population Data	J-53
	J.5.3.1.3	Agricultural Data	J-53
	J.5.3.1.4	Source Term Data	J-55
	J.5.3.1.5	Other Calculational Assumptions	J-56
	J.5.3.2	Human Health Impacts	J-57
J.5.4	LANL		J-57
	J.5.4.1	Assessment Data	J-57
	J.5.4.1.1	Meteorological Data	J-57
	J.5.4.1.2	Population Data	J-57
	J.5.4.1.3	Agricultural Data	J-57
	J.5.4.1.4	Source Term Data	J-59
	J.5.4.1.5	Other Calculational Assumptions	J-60
	J.5.4.2	Human Health Impacts	J-60
J.5.5	SRS		J-60
	J.5.5.1	Assessment Data	J-60
	J.5.5.1.1	Meteorological Data	J-61
	J.5.5.1.2	Population Data	J-61
	J.5.5.1.3	Agricultural Data	J-61
	J.5.5.1.4	Source Term Data	J-63
	J.5.5.1.5	Other Calculational Assumptions	J-64
	J.5.5.2	Human Health Impacts	J-64
J.6	References		J-65

Appendix K

	Facility Accidents	K-1
K.1	Impact Assessment Methods for Facility Accidents	K-1
	K.1.1 Introduction	K-1
	K.1.1.1 Risk	K-1
	K.1.1.2 Uncertainties and Conservatism	K-3
	K.1.2 Safety Design Process	K-3
	K.1.3 DOE Facility Accident Identification and Quantification	K-4
	K.1.3.1 Background	K-4
	K.1.3.2 Identification of Accident Scenarios and Frequencies	K-5
	K.1.3.3 Identification of Material at Risk	K-6
	K.1.3.4 Identification of Material Potentially Released to the Environment	K-7

K.1.4	Evaluation of Consequences of Accidents	K-8
K.1.4.1	Potential Receptors	K-8
K.1.4.2	Modeling of Dispersion of Releases to the Environment	K-8
K.1.4.3	Modeling of Consequences of Releases to the Environment	K-10
K.1.5	Accident Scenarios for Surplus Plutonium Disposition Facilities	K-11
K.1.5.1	Accident Scenario Consistency	K-11
K.1.5.2	Facility Accident Scenarios	K-16
K.1.5.2.1	Pit Conversion Facility	K-16
K.1.5.2.2	Immobilization Facility	K-18
K.1.5.2.3	MOX Facility Accident Scenarios	K-21
K.1.5.2.4	Lead Assembly Accident Scenarios	K-23
K.2	Facility Accident Impacts at Hanford	K-27
K.3	Facility Accident Impacts at INEEL	K-35
K.4	Facility Accident Impacts at Pantex	K-38
K.5	Facility Accident Impacts at SRS	K-41
K.6	Lead Assembly Accident Impacts	K-48
K.7	Commercial Reactor Accident Analysis	K-54
K.7.1	Introduction	K-54
K.7.2	Reactor Accident Identification and Quantification	K-54
K.7.2.1	MOX Source Term Development	K-55
K.7.2.2	Meteorological Data	K-56
K.7.2.3	Population Data	K-56
K.7.2.4	Design Basis Events	K-58
K.7.2.5	Beyond-Design-Basis Events	K-61
K.7.2.6	Accident Impacts	K-69
K.7.2.6.1	Catawba	K-75
K.7.2.6.2	McGuire	K-76
K.7.2.6.3	North Anna	K-76
K.8	References	K-77

Appendix L

Evaluation of Human Health Effects From Transportation		L-1
L.1	Introduction	L-1
L.2	Scope of Assessment	L-1
L.3	Packaging and Representative Shipment Configurations	L-2
L.3.1	Packaging Overview	L-2
L.3.1.1	Uranium Hexafluoride Packaging	L-3
L.3.1.2	Uranium Dioxide Packaging	L-3
L.3.1.3	MOX Fuel Packaging	L-3
L.3.1.4	Highly Enriched Uranium Packaging	L-4
L.3.1.5	Plutonium Packaging	L-4
L.3.1.6	Overview of Type B Containers	L-4
L.3.2	Safe, Secure Transportation	L-5
L.3.3	Ground Transportation Route Selection Process	L-6
L.4	Methods for Calculating Transportation Risks	L-7
L.5	Alternatives, Parameters, and Assumptions	L-9
L.5.1	Transportation Alternatives	L-9
L.5.2	Representative Routes and Populations	L-16
L.5.3	Distance Traveled by Alternative	L-16

L.5.4	Shipment External Dose Rates	L-16
L.5.5	Health Risk Conversion Factors	L-19
L.5.6	Accident Involvement Rates	L-19
L.5.7	Container Accident Response Characteristics and Release Fractions	L-20
L.6	Risk Analysis Results	L-20
L.6.1	Per-Shipment Risk Factors	L-20
L.6.2	Evaluation of Shipment Risks	L-20
L.6.3	Maximally Exposed Individuals	L-21
L.6.4	Waste Transportation	L-24
L.6.5	Consequences of Sabotage or Terrorist Attack During Transportation	L-25
L.7	Cumulative Impacts of Transportation	L-26
L.7.1	Radiological Impacts	L-26
L.7.2	Accident Impacts	L-30
L.8	Uncertainty and Conservatism in Estimated Impacts	L-30
L.8.1	Uncertainties in Material Inventory and Characterization	L-30
L.8.2	Uncertainties in Containers, Shipment Capacities, and Number of Shipments	L-31
L.8.3	Uncertainties in Route Determination	L-31
L.8.4	Uncertainties in the Calculation of Radiation Doses	L-31
L.9	References	L-33

Appendix M

Analysis of Environmental Justice	M-1
--	-----

M.1	Introduction	M-1
M.2	Definitions and Approach	M-1
M.3	Spatial Resolution	M-2
M.4	Population Projections	M-3
M.5	Results for the Candidate DOE Sites	M-5
M.5.1	Population Estimates	M-5
M.5.2	Geographical Dispersion of Minority and Low-Income Populations	M-8
M.5.3	Environmental Effects on Minority and Low-Income Populations Residing Near Candidate DOE Sites	M-8
M.6	Results for Transportation Routes	M-17
M.7	Results for the Reactor Sites	M-20
M.7.1	Minority and Low-Income Population Estimates	M-20
M.7.2	Environmental Effects on Minority and Low-Income Populations Residing Near Proposed Reactor Sites	M-22
M.8	References	M-22

Appendix N

Deleted

Appendix O

Consultations	O-1
----------------------------	-----

Appendix P

Environmental Synopsis	P-1
-------------------------------------	-----

List of Figures

Volume II

Figure C-1. Adjunct Melter Vitrification Process C-3

Figure L-1. Overland Transportation Risk Assessment L-8

Figure L-2. Transportation Requirements for Plutonium Conversion and Immobilization L-12

Figure L-3. Transportation Requirements for MOX Fuel Fabrication L-13

Figure L-4. Transportation Requirements for Lead Assembly Fabrication L-14

Figure M-1. Block Group Structure Near Idaho Falls, Idaho M-4

Figure M-2. Geographical Distribution of the Minority Population Residing Within 80 km
of Proposed Facilities at Hanford M-9

Figure M-3. Geographical Distribution of the Low-Income Population Residing Within
80 km of Proposed Facilities at Hanford M-10

Figure M-4. Geographical Distribution of the Minority Population Residing Within 80 km of Fuel
Processing Facility at INEEL M-11

Figure M-5. Geographical Distribution of the Low-Income Population Residing Within 80 km
of Fuel Processing Facility at INEEL M-12

Figure M-6. Geographical Distribution of the Minority Population Residing Within 80 km
of Potentially Affected Area at Pantex M-13

Figure M-7. Geographical Distribution of the Low-Income Population Residing Within 80 km
of Potentially Affected Area at Pantex M-14

Figure M-8. Geographical Distribution of the Minority Population Residing Within 80 km of
Proposed Facilities at SRS M-15

Figure M-9. Geographical Distribution of the Low-Income Population Residing Within 80 km
of Proposed Facilities at SRS M-16

Figure M-10. Geographical Distribution of the Minority Population Residing Within 80 km
of Catawba Nuclear Station M-23

Figure M-11. Geographical Distribution of the Low-Income Population Residing Within 80 km
of Catawba Nuclear Station M-24

Figure M-12. Geographical Distribution of the Minority Population Residing Within 80 km
of McGuire Nuclear Station M-25

Figure M-13. Geographical Distribution of the Low-Income Population Residing Within 80 km
of McGuire Nuclear Station M-26

Figure M-14. Geographical Distribution of the Minority Population Residing Within 80 km
of North Anna Power Station M-27

Figure M-15. Geographical Distribution of the Low-Income Population Residing Within 80 km
of North Anna Power Station M-28

List of Tables
Volume II

Table E-1.	Pit Conversion Facility Schedule	E-1
Table E-2.	Pit Conversion Facility Construction Area Requirements	E-1
Table E-3.	Pit Conversion Facility Operation Area Requirements	E-2
Table E-4.	Pit Conversion Facility Construction Employment Requirements (2001-2003)	E-2
Table E-5.	Pit Conversion Facility Major Construction Resource Requirements (2001-2003)	E-2
Table E-6.	Pit Conversion Facility Annual Employment Operation Requirements	E-2
Table E-7.	Pit Conversion Facility Annual Operation Resource Requirements	E-3
Table E-8.	Ceramic or Glass Immobilization Facility Schedule	E-4
Table E-9.	Ceramic or Glass Immobilization Facility Construction Area Requirements	E-4
Table E-10.	Ceramic or Glass Immobilization Facility Operation Area Requirements	E-5
Table E-11.	Ceramic or Glass Immobilization Facility Construction Employment Requirements (2001-2005)	E-5
Table E-12.	Ceramic or Glass Immobilization Facility Major Construction Resource Requirements (2001-2005)	E-6
Table E-13.	Ceramic or Glass Immobilization Facility Annual Employment Operation Requirements	E-6
Table E-14.	Immobilization Facility Annual Operation Resource Requirements at Hanford	E-7
Table E-15.	Immobilization Facility Annual Operation Resource Requirements Collocated With Pit Conversion Facility at Hanford	E-8
Table E-16.	Immobilization Facility Annual Operation Resource Requirements Collocated With MOX Facility at Hanford	E-9
Table E-17.	Immobilization Facility Annual Operation Resource Requirements at SRS	E-10
Table E-18.	MOX Facility Schedule	E-11
Table E-19.	MOX Facility Construction Area Requirements	E-11
Table E-20.	MOX Facility Operation Area Requirements	E-11
Table E-21.	MOX Facility Construction Employment Requirements (2002-2004)	E-12
Table E-22.	MOX Facility Major Construction Resource Requirements (2002-2004)	E-12
Table E-23.	MOX Facility Annual Employment Operation Requirements	E-12
Table E-24.	MOX Facility Annual Operation Resource Requirements	E-13
Table E-25.	Lead Assembly Fabrication Facility Schedule	E-14
Table E-26.	Lead Assembly Fabrication Annual Employment Operation Requirements	E-14
Table E-27.	Lead Assembly Fabrication Construction Resource Requirements	E-14
Table E-28.	Lead Assembly Fabrication Annual Operation Resource Requirements	E-15

Table F-1.	Impact Assessment Protocol for Air Quality and Noise	F-5
Table F-2.	Impact Assessment Protocol for Geology and Soils	F-7
Table F-3.	Impact Assessment Protocol for Water Resources	F-9
Table F-4.	Impact Assessment Protocol for Ecological Resources	F-11
Table F-5.	Impact Assessment Protocol for Cultural and Paleontological Resources	F-13
Table F-6.	Impact Assessment Protocol for Land Resources	F-15
Table F-7.	Impact Assessment Protocol for Infrastructure	F-16
Table F-8.	Impact Assessment Protocol for Waste Management	F-18
Table F-9.	Impact Assessment Protocol for Socioeconomics	F-20
Table F-10.	Impact Assessment Protocol for Human Health Risk	F-22
Table F-11.	Impact Assessment Protocol for Facility Accidents	F-26
Table F-12.	Impact Assessment Protocol for Transportation	F-28
Table F-13.	Impact Assessment Protocol for Environmental Justice	F-30
Table F-14.	Selected Indicators of Cumulative Impact	F-31
Table F-15.	Other Past, Present, and Reasonably Foreseeable Actions Considered in the Cumulative Impact Assessment for Candidate DOE Sites	F-32
Table F-16.	Recent Comprehensive National Environmental Policy Act Documents for the DOE Sites	F-33
Table G-1.	Estimated Concentrations From No Action at Hanford	G-1
Table G-2.	Emissions From Construction of Pit Conversion Facility in FMEF at Hanford	G-2
Table G-3.	Concentrations From Construction of Pit Conversion Facility in FMEF at Hanford	G-3
Table G-4.	Emissions From Operation of Pit Conversion Facility in FMEF at Hanford	G-3
Table G-5.	Concentrations From Operation of Pit Conversion Facility in FMEF at Hanford	G-4
Table G-6.	Emissions From Construction of Immobilization Facility in FMEF at Hanford	G-5
Table G-7.	Concentrations From Construction of Immobilization Facility in FMEF at Hanford	G-5
Table G-8.	Emissions From Operation of Immobilization Facility in FMEF at Hanford	G-6
Table G-9.	Concentrations From Operation of Immobilization Facility in FMEF at Hanford	G-6
Table G-10.	Emissions From Construction of New MOX Facility at Hanford	G-7
Table G-11.	Concentrations From Construction of New MOX Facility at Hanford	G-7
Table G-12.	Emissions From Operation of New MOX Facility at Hanford	G-8
Table G-13.	Concentrations From Operation of New MOX Facility at Hanford	G-8
Table G-14.	Emissions From Construction of Pit Conversion and Immobilization Facilities in FMEF at Hanford	G-9

Table G-15.	Concentrations From Construction of Pit Conversion and Immobilization Facilities in FMEF at Hanford	G-9
Table G-16.	Emissions From Operation of Pit Conversion and Immobilization Facilities in FMEF at Hanford	G-10
Table G-17.	Concentrations From Operation of Pit Conversion and Immobilization Facilities in FMEF at Hanford	G-11
Table G-18.	Emissions From Construction of Pit Conversion and MOX Facilities in FMEF at Hanford	G-12
Table G-19.	Concentrations From Construction of Pit Conversion and MOX Facilities in FMEF at Hanford	G-12
Table G-20.	Emissions From Operation of Pit Conversion and MOX Facilities in FMEF at Hanford	G-13
Table G-21.	Concentrations From Operation of Pit Conversion and MOX Facilities in FMEF at Hanford	G-14
Table G-22.	Emissions From Construction of Immobilization and MOX Facilities Collocated in FMEF at Hanford	G-15
Table G-23.	Concentrations From Construction of Immobilization and MOX Facilities Collocated in FMEF at Hanford	G-15
Table G-24.	Emissions From Operation of Immobilization and MOX Facilities Collocated in FMEF at Hanford	G-16
Table G-25.	Concentrations From Operation of Immobilization and MOX Facilities Collocated in FMEF at Hanford	G-17
Table G-26.	Emissions From Construction of Pit Conversion and Immobilization Facilities in FMEF and MOX in New Construction at Hanford	G-18
Table G-27.	Concentrations From Construction of Pit Conversion and Immobilization Facilities in FMEF and MOX in New Construction at Hanford	G-18
Table G-28.	Emissions From Operation of Pit Conversion and Immobilization Facilities in FMEF and MOX in New Construction at Hanford	G-19
Table G-29.	Concentrations From Operation of Pit Conversion and Immobilization Facilities in FMEF and MOX in New Construction at Hanford	G-19
Table G-30.	Estimated Concentrations From No Action at INEEL	G-20
Table G-31.	Emissions From Construction of Pit Conversion Facility in FPF at INEEL	G-21
Table G-32.	Concentrations From Construction of Pit Conversion Facility in FPF at INEEL	G-21
Table G-33.	Emissions From Operation of Pit Conversion Facility in FPF at INEEL	G-22
Table G-34.	Concentrations From Operation of Pit Conversion Facility in FPF at INEEL	G-22
Table G-35.	Emissions From Construction of New MOX Facility at INEEL	G-23
Table G-36.	Concentrations From Construction of New MOX Facility at INEEL	G-23
Table G-37.	Emissions From Operation of New MOX Facility at INEEL	G-24
Table G-38.	Concentrations From Operation of New MOX Facility at INEEL	G-24

Table G-39.	Emissions From Construction of Pit Conversion Facility in FPF and New MOX Facility at INEEL	G-25
Table G-40.	Concentrations From Construction of Pit Conversion Facility in FPF and New MOX Facility at INEEL	G-25
Table G-41.	Emissions From Operation of Pit Conversion Facility in FPF and New MOX Facility at INEEL	G-26
Table G-42.	Concentrations From Operation of Pit Conversion Facility in FPF and New MOX Facility at INEEL	G-26
Table G-43.	Estimated Concentrations From No Action at Pantex	G-27
Table G-44.	Emissions From Construction of New Pit Conversion Facility at Pantex	G-28
Table G-45.	Concentrations From Construction of New Pit Conversion Facility at Pantex	G-28
Table G-46.	Emissions From Operation of New Pit Conversion Facility at Pantex	G-29
Table G-47.	Concentrations From Operation of New Pit Conversion Facility at Pantex	G-29
Table G-48.	Emissions From Construction of New MOX Facility at Pantex	G-30
Table G-49.	Concentrations From Construction of New MOX Facility at Pantex	G-30
Table G-50.	Emissions From Operation of New MOX Facility at Pantex	G-31
Table G-51.	Concentrations From Operation of New MOX Facility at Pantex	G-31
Table G-52.	Emissions From Construction of New Pit Conversion and MOX Facilities at Pantex ...	G-32
Table G-53.	Concentrations From Construction of New Pit Conversion and MOX Facilities at Pantex	G-32
Table G-54.	Emissions From Operation of New Pit Conversion and MOX Facilities at Pantex	G-33
Table G-55.	Concentrations From Operation of New Pit Conversion and MOX Facilities at Pantex ..	G-33
Table G-56.	Estimated Concentrations From No Action at SRS	G-34
Table G-57.	Emissions From Construction of New Pit Conversion Facility at SRS	G-35
Table G-58.	Concentrations From Construction of New Pit Conversion Facility at SRS	G-35
Table G-59.	Emissions From Operation of New Pit Conversion Facility at SRS	G-36
Table G-60.	Concentrations From Operation of New Pit Conversion Facility at SRS	G-36
Table G-61.	Emissions From Construction of New Immobilization Facility at SRS	G-37
Table G-62.	Concentrations From Construction of New Immobilization Facility at SRS	G-37
Table G-63.	Emissions From Operation of New Immobilization Facility at SRS	G-38
Table G-64.	Concentrations From Operation of New Immobilization Facility at SRS	G-38
Table G-65.	Emissions From Construction of New MOX Facility at SRS	G-39
Table G-66.	Concentrations From Construction of New MOX Facility at SRS	G-39
Table G-67.	Emissions From Operation of New MOX Facility at SRS	G-40
Table G-68.	Concentrations From Operation of New MOX Facility at SRS	G-40

Table G-69.	Emissions From Construction of New Pit Conversion and Immobilization Facilities at SRS	G-41
Table G-70.	Concentrations From Construction of New Pit Conversion and Immobilization Facilities at SRS	G-41
Table G-71.	Emissions From Operation of New Pit Conversion and Immobilization Facilities at SRS	G-42
Table G-72.	Concentrations From Operation of New Pit Conversion and Immobilization Facilities at SRS	G-42
Table G-73.	Emissions From Construction of New Pit Conversion and MOX Facilities at SRS	G-43
Table G-74.	Concentrations From Construction of New Pit Conversion and MOX Facilities at SRS	G-43
Table G-75.	Emissions From Operation of New Pit Conversion and MOX Facilities at SRS	G-44
Table G-76.	Concentrations From Operation of New Pit Conversion and MOX Facilities at SRS	G-44
Table G-77.	Emissions From Construction of New Immobilization and MOX Facilities at SRS	G-45
Table G-78.	Concentrations From Construction of New Immobilization and MOX Facilities at SRS	G-45
Table G-79.	Emissions From Operation of New Immobilization and MOX Facilities at SRS	G-46
Table G-80.	Concentrations From Operation of New Immobilization and MOX Facilities at SRS	G-47
Table G-81.	Emissions From Construction of New Pit Conversion, Immobilization, and MOX Facilities at SRS	G-47
Table G-82.	Concentrations From Construction of New Pit Conversion, Immobilization, and MOX Facilities at SRS	G-48
Table G-83.	Emissions From Operation of New Pit Conversion, Immobilization, and MOX Facilities at SRS	G-48
Table G-84.	Concentrations From Operation of New Pit Conversion, Immobilization, and MOX Facilities at SRS	G-49
Table H-1.	Potential Waste Management Impacts of Construction of Pit Conversion Facility in FMEF at Hanford	H-3
Table H-2.	Potential Waste Management Impacts of Operation of Pit Conversion Facility in FMEF at Hanford	H-4
Table H-3.	Potential Waste Management Impacts of Construction of Immobilization Facility in FMEF at Hanford	H-6
Table H-4.	Potential Waste Management Impacts of Operation of Immobilization Facility in FMEF at Hanford	H-7
Table H-5.	Potential Waste Management Impacts of Construction of MOX Facility in FMEF or New Construction at Hanford	H-10
Table H-6.	Potential Waste Management Impacts of Operation of MOX Facility in FMEF or New Construction at Hanford	H-11

Table H-7.	Potential Waste Management Impacts of Construction of Pit Conversion and Immobilization Facilities in FMEF at Hanford	H-13
Table H-8.	Potential Waste Management Impacts of Operation of Pit Conversion and Facilities in Immobilization FMEF at Hanford	H-15
Table H-9.	Potential Waste Management Impacts of Construction of Pit Conversion and MOX Facilities in FMEF or New MOX Facility at Hanford	H-17
Table H-10.	Potential Waste Management Impacts of Operation of Pit Conversion and MOX in FMEF Facilities or New MOX Facility at Hanford	H-18
Table H-11.	Potential Waste Management Impacts of Construction of Collocating Immobilization and MOX Facilities in FMEF or New MOX Facility at Hanford	H-20
Table H-12.	Potential Waste Management Impacts of Operation of Collocating Immobilization and MOX Facilities in FMEF or New MOX Facility at Hanford	H-22
Table H-13.	Potential Waste Management Impacts of Construction of Pit Conversion and Immobilization Facilities in FMEF and New MOX Facility at Hanford	H-24
Table H-14.	Potential Waste Management Impacts of Operation of Pit Conversion and Immobilization Facilities in FMEF and New MOX Facilities at Hanford	H-25
Table H-15.	Potential Waste Management Impacts of Construction of Pit Conversion Facility in FPF at INEEL	H-28
Table H-16.	Potential Waste Management Impacts of Operation of Pit Conversion Facility in FPF at INEEL	H-30
Table H-17.	Potential Waste Management Impacts of Construction of New MOX Facility at INEEL	H-32
Table H-18.	Potential Waste Management Impacts of Operation of New MOX Facility at INEEL	H-33
Table H-19.	Potential Waste Management Impacts of Construction of Pit Conversion Facility in FPF and New MOX Facility at INEEL	H-35
Table H-20.	Potential Waste Management Impacts of Operation of Pit Conversion Facility in FPF and New MOX Facility at INEEL	H-37
Table H-21.	Potential Waste Management Impacts of Construction of New Pit Conversion Facility at Pantex	H-39
Table H-22.	Potential Waste Management Impacts of Operation of New Pit Conversion Facility at Pantex	H-40
Table H-23.	Potential Waste Management Impacts of Construction of New MOX Facility at Pantex	H-43
Table H-24.	Potential Waste Management Impacts of Operation of New MOX Facility at Pantex	H-44
Table H-25.	Potential Waste Management Impacts of Construction of New Pit Conversion and MOX Facilities at Pantex	H-46
Table H-26.	Potential Waste Management Impacts of Operation of New Pit Conversion and MOX Facilities at Pantex	H-47
Table H-27.	Potential Waste Management Impacts of Construction of New Pit Conversion Facility at SRS	H-50

Table H-28.	Potential Waste Management Impacts of Operation of New Pit Conversion Facility at SRS	H-51
Table H-29.	Potential Waste Management Impacts of Construction of New Immobilization Facility at SRS	H-53
Table H-30.	Potential Waste Management Impacts of Operation of New Immobilization Facility at SRS	H-55
Table H-31.	Potential Waste Management Impacts From Construction of New MOX Facility at SRS	H-57
Table H-32.	Potential Waste Management Impacts From Operation of New MOX Facility at SRS ..	H-58
Table H-33.	Potential Waste Management Impacts of Construction of New Pit Conversion and Immobilization Facilities at SRS	H-60
Table H-34.	Potential Waste Management Impacts of Operation of New Pit Conversion and Immobilization Facilities at SRS	H-62
Table H-35.	Potential Waste Management Impacts of Construction of New Pit Conversion and MOX Facilities at SRS	H-64
Table H-36.	Potential Waste Management Impacts of Operation of New Pit Conversion and MOX Facilities at SRS	H-65
Table H-37.	Potential Waste Management Impacts of Construction of New Immobilization and MOX Facilities at SRS	H-67
Table H-38.	Potential Waste Management Impacts of Operation of New Immobilization and MOX Facilities at SRS	H-69
Table H-39.	Potential Waste Management Impacts of Construction of New Pit Conversion, Immobilization, and MOX Facilities at SRS	H-71
Table H-40.	Potential Waste Management Impacts of Operation of New Pit Conversion, Immobilization, and MOX Facilities at SRS	H-72
Table H-41.	Potential Waste Management Impacts of Modification of Facilities for Lead Assembly Fabrication at ANL-W	H-75
Table H-42.	Potential Waste Management Impacts of Operation of Facilities for Lead Assembly Fabrication at ANL-W	H-76
Table H-43.	Potential Waste Management Impacts of Modification of Facilities for Lead Assembly Fabrication at Hanford	H-78
Table H-44.	Potential Waste Management Impacts of Operation of Facilities for Lead Assembly Fabrication at Hanford	H-79
Table H-45.	Potential Waste Management Impacts of Modification of Facilities for Lead Assembly Fabrication at LLNL	H-81
Table H-46.	Potential Waste Management Impacts of Operation of Facilities for Lead Assembly Fabrication at LLNL	H-82
Table H-47.	Potential Waste Management Impacts of Modification of Facilities for Lead Assembly Fabrication at LANL	H-84

Table H-48.	Potential Waste Management Impacts of Operation of Facilities for Lead Assembly Fabrication at LANL	H-85
Table H-49.	Potential Waste Management Impacts of Modification of Facilities for Lead Assembly Fabrication at SRS	H-87
Table H-50.	Potential Waste Management Impacts of Operation of Facilities for Lead Assembly Fabrication at SRS	H-88
Table H-51.	Potential Waste Management Impacts at INEEL of Conducting Postirradiation Examination at ANL-W	H-90
Table H-52.	Potential Waste Management Impacts of Conducting Postirradiation Examination at ORNL	H-93
Table I-1.	Hanford Projected Site Employment	I-1
Table I-2.	Hanford Regional Economic Area Projected Employment and Economy, 1996-2010	I-1
Table I-3.	Hanford Region of Influence Projected Population, 1996-2010	I-1
Table I-4.	Hanford Region of Influence Projected Number of Owner and Renter Housing Units, 1990-2010	I-2
Table I-5.	Hanford Region of Influence Projected Student Enrollment, 1997-2010	I-2
Table I-6.	Hanford Region of Influence Projected Number of Teachers, 1997-2010	I-2
Table I-7.	Hanford Region of Influence Projected Number of Sworn Police Officers, 1997-2010	I-3
Table I-8.	Hanford Region of Influence Projected Number of Firefighters, 1997-2010	I-3
Table I-9.	Hanford Region of Influence Projected Number of Hospital Beds, 1997-2010	I-3
Table I-10.	Hanford Region of Influence Projected Number of Doctors, 1996-2010	I-3
Table I-11.	INEEL Projected Site Employment	I-4
Table I-12.	INEEL Regional Economic Area Projected Employment and Economy, 1996-2010	I-4
Table I-13.	INEEL Region of Influence Projected Population, 1996-2010	I-4
Table I-14.	INEEL Region of Influence Projected Number of Owner and Renter Housing Units, 1990-2010	I-4
Table I-15.	INEEL Region of Influence Projected Student Enrollment, 1997-2010	I-5
Table I-16.	INEEL Region of Influence Projected Number of Teachers, 1997-2010	I-5
Table I-17.	INEEL Region of Influence Projected Number of Sworn Police Officers, 1997-2010	I-6
Table I-18.	INEEL Region of Influence Projected Number of Firefighters, 1997-2010	I-6
Table I-19.	INEEL Region of Influence Projected Number of Hospital Beds, 1997-2010	I-6
Table I-20.	INEEL Region of Influence Projected Number of Doctors, 1996-2010	I-6
Table I-21.	Pantex Projected Site Employment	I-7
Table I-22.	Pantex Regional Economic Area Projected Employment and Economy, 1996-2010	I-7
Table I-23.	Pantex Region of Influence Projected Population, 1996-2010	I-7

Table I-24.	Pantex Region of Influence Projected Number of Owner and Renter Housing Units, 1990–2010	I-7
Table I-25.	Pantex Region of Influence Projected Student Enrollment, 1997–2010	I-8
Table I-26.	Pantex Region of Influence Projected Number of Teachers, 1997–2010	I-8
Table I-27.	Pantex Region of Influence Projected Number of Sworn Police Officers, 1997–2010	I-8
Table I-28.	Pantex Region of Influence Projected Number of Firefighters, 1997–2010	I-9
Table I-29.	Pantex Region of Influence Projected Number of Hospital Beds, 1997–2010	I-9
Table I-30.	Pantex Region of Influence Projected Number of Doctors, 1996–2010	I-9
Table I-31.	SRS Projected Employment	I-10
Table I-32.	SRS Regional Economic Area Projected Employment and Economy, 1996–2010	I-10
Table I-33.	SRS Region of Influence Projected Population, 1996–2010	I-10
Table I-34.	SRS Region of Influence Projected Number of Owner and Renter Housing Units, 1990–2010	I-10
Table I-35.	SRS Region of Influence Projected Student Enrollment, 1997–2010	I-11
Table I-36.	SRS Region of Influence Projected Number of Teachers, 1997–2010	I-11
Table I-37.	SRS Region of Influence Projected Number of Sworn Police Officers, 1997–2010	I-11
Table I-38.	SRS Region of Influence Projected Number of Firefighters, 1997–2010	I-12
Table I-39.	SRS Region of Influence Projected Number of Hospital Beds, 1997–2010	I-12
Table I-40.	SRS Region of Influence Projected Number of Doctors, 1996–2010	I-12
Table J-1.	Hanford 1983–1991 Joint Frequency Distributions at 61-m Height	J-2
Table J-2.	Projected Hanford Population Surrounding FMEF for Year 2010	J-4
Table J-3.	Estimated Incident-Free Annual Radiological Releases From the Pit Conversion Facility at Hanford	J-4
Table J-4.	Estimated Incident-Free Annual Radiological Releases From the Immobilization Facility at Hanford	J-5
Table J-5.	Estimated Incident-Free Annual Radiological Releases From the MOX Facility at Hanford	J-5
Table J-6.	Potential Radiological Impacts on the Public of Operation of Pit Conversion Facility in FMEF at Hanford	J-7
Table J-7.	Potential Radiological Impacts on Involved Workers of Operation of Pit Conversion Facility in FMEF at Hanford	J-7
Table J-8.	Potential Radiological Impacts on the Public of Operation of Immobilization Facility in FMEF at Hanford	J-8
Table J-9.	Potential Radiological Impacts on Involved Workers of Operation of Immobilization Facility in FMEF at Hanford	J-8

Table J-10.	Potential Radiological Impacts on the Public of Operation of MOX Facility in FMEF or New Construction at Hanford	J-9
Table J-11.	Potential Radiological Impacts on Involved Workers of Operation of MOX Facility in FMEF or New Construction at Hanford	J-9
Table J-12.	Potential Radiological Impacts on the Public of Operation of Pit Conversion and Immobilization Facilities in FMEF at Hanford	J-10
Table J-13.	Potential Radiological Impacts on Involved Workers of Operation of Pit Conversion and Immobilization Facilities in FMEF at Hanford	J-10
Table J-14.	Potential Radiological Impacts on the Public of Operation of Pit Conversion and MOX Facilities in FMEF or New MOX Facility at Hanford	J-11
Table J-15.	Potential Radiological Impacts on Involved Workers of Operation of Pit Conversion and MOX Facilities in FMEF or New MOX Facility at Hanford	J-12
Table J-16.	Potential Radiological Impacts on the Public of Operation of Collocating Immobilization and MOX Facilities in FMEF or New MOX Facility at Hanford	J-13
Table J-17.	Potential Radiological Impacts on Involved Workers of Operation of Collocating Immobilization and MOX Facilities in FMEF or New MOX Facility at Hanford	J-13
Table J-18.	Potential Radiological Impacts on the Public of Operation of Pit Conversion and Immobilization Facilities in FMEF and New MOX Facility at Hanford	J-14
Table J-19.	Potential Radiological Impacts on Involved Workers of Operation of Pit Conversion and Immobilization Facilities in FMEF and New MOX Facility at Hanford	J-15
Table J-20.	INEEL 1987-1991 Joint Frequency Distributions at 61-m Height	J-17
Table J-21.	Projected INEEL Population Surrounding INTEC for Year 2010	J-18
Table J-22.	Estimated Incident-Free Annual Radiological Releases From the Pit Conversion Facility at INEEL	J-19
Table J-23.	Estimated Incident-Free Annual Radiological Releases From the MOX Facility at INEEL	J-19
Table J-24.	Potential Radiological Impacts on the Public of Operation of Pit Conversion Facility in FPF at INEEL	J-21
Table J-25.	Potential Radiological Impacts on Involved Workers of Operation of Pit Conversion Facility in FPF at INEEL	J-21
Table J-26.	Potential Radiological Impacts on the Public of Operation of New MOX Facility at INEEL	J-22
Table J-27.	Potential Radiological Impacts on Involved Workers of Operation of New MOX Facility at INEEL	J-22
Table J-28.	Potential Radiological Impacts on the Public of Operation of Pit Conversion Facility in FPF and New MOX Facility at INEEL	J-23
Table J-29.	Potential Radiological Impacts on Involved Workers of Operation of Pit Conversion Facility in FPF and New MOX Facility at INEEL	J-23
Table J-30.	1985-1989 Joint Frequency Distributions at 7-m Height for Pantex	J-25

Table J-31.	Projected Pantex Population Surrounding Zone 4 for Year 2010	J-26
Table J-32.	Estimated Incident-Free Annual Radiological Releases From the New Pit Conversion Facility at Pantex	J-26
Table J-33.	Estimated Incident-Free Annual Radiological Releases From the New MOX Facility at Pantex	J-27
Table J-34.	Potential Radiological Impacts on the Public of Operation of New Pit Conversion Facility at Pantex	J-28
Table J-35.	Potential Radiological Impacts on Involved Workers of Operation of New Pit Conversion Facility at Pantex	J-28
Table J-36.	Potential Radiological Impacts on the Public of Operation of New MOX Facility at Pantex	J-29
Table J-37.	Potential Radiological Impacts on Involved Workers of Operation of New MOX Facility at Pantex	J-29
Table J-38.	Potential Radiological Impacts on the Public of Operation of New Pit Conversion and MOX Facilities at Pantex	J-30
Table J-39.	Potential Radiological Impacts on Involved Workers of Operation of New Pit Conversion and MOX Facilities at Pantex	J-31
Table J-40.	SRS 1987-1991 Joint Frequency Distributions at 61-m Height	J-33
Table J-41.	Projected SRS Population Surrounding APSF (Pit Conversion and MOX Facilities) for Year 2010	J-34
Table J-42.	Projected SRS Population Surrounding APSF (Immobilization Facility) for Year 2010	J-34
Table J-43.	Estimated Incident-Free Annual Radiological Releases From the Pit Conversion Facility at SRS	J-35
Table J-44.	Estimated Incident-Free Annual Radiological Releases From the New Immobilization Facility at SRS	J-35
Table J-45.	Estimated Incident-Free Annual Radiological Releases From the New MOX Facility at SRS	J-36
Table J-46.	Potential Radiological Impacts on Construction Workers of New Pit Conversion Facility at SRS	J-37
Table J-47.	Potential Radiological Impacts on the Public of Operation of New Pit Conversion Facility at SRS	J-38
Table J-48.	Potential Radiological Impacts on Involved Workers of Operation of New Pit Conversion Facility at SRS	J-38
Table J-49.	Potential Radiological Impacts on Construction Workers of New Immobilization Facility at SRS	J-39
Table J-50.	Potential Radiological Impacts on the Public of Operation of New Immobilization Facility at SRS	J-39
Table J-51.	Potential Radiological Impacts on Involved Workers of Operation of New Immobilization Facility at SRS	J-40

Table J-52.	Potential Radiological Impacts on Construction Workers of New MOX Facility at SRS .	J-40
Table J-53.	Potential Radiological Impacts on the Public of Operation of New MOX Facility at SRS	J-41
Table J-54.	Potential Radiological Impacts on Involved Workers of Operation of New MOX Facility at SRS	J-41
Table J-55.	Potential Radiological Impacts on Construction Workers of New Pit Conversion and Immobilization Facilities at SRS	J-42
Table J-56.	Potential Radiological Impacts on the Public of Operation of New Pit Conversion and Immobilization Facilities at SRS	J-42
Table J-57.	Radiological Impacts on Involved Workers of Operation of New Pit Conversion and Immobilization Facilities at SRS	J-43
Table J-58.	Potential Radiological Impacts on Construction Workers of New Pit Conversion and MOX Facilities at SRS	J-43
Table J-59.	Potential Radiological Impacts on the Public of Operation of New Pit Conversion and MOX Facilities at SRS	J-44
Table J-60.	Potential Radiological Impacts on Involved Workers of Operation of New Pit Conversion and MOX Facilities at SRS	J-44
Table J-61.	Potential Radiological Impacts on Construction Workers of New Immobilization and MOX Facilities at SRS	J-45
Table J-62.	Potential Radiological Impacts on the Public of Operation of New Immobilization and MOX Facilities at SRS	J-45
Table J-63.	Potential Radiological Impacts on Involved Workers of Operation of New Immobilization and MOX Facilities at SRS	J-46
Table J-64.	Potential Radiological Impacts on Construction Workers of New Pit Conversion, Immobilization, and MOX Facilities at SRS	J-46
Table J-65.	Potential Radiological Impacts on the Public of Operation of New Pit Conversion, Immobilization, and MOX Facilities at SRS	J-47
Table J-66.	Potential Radiological Impacts on Involved Workers of Operation of New Pit Conversion, Immobilization, and MOX Facilities at SRS	J-47
Table J-67.	Projected INEEL Population Surrounding ANL-W for Year 2005	J-49
Table J-68.	Estimated Incident-Free Annual Radiological Releases From the MOX Lead Assembly Facility at ANL-W	J-49
Table J-69.	Projected Hanford Population Surrounding FMEF for Year 2005	J-51
Table J-70.	Estimated Incident-Free Annual Radiological Releases From the MOX Lead Assembly Facility at Hanford	J-52
Table J-71.	LLNL 1993 Joint Frequency Distributions at 10-m Height	J-54
Table J-72.	Projected LLNL Population Surrounding Building 332 for Year 2005	J-55
Table J-73.	Estimated Incident-Free Annual Radiological Releases From the MOX Lead Assembly Facility at LLNL	J-56

Table J-74.	LANL 1993–1996 Joint Frequency Distributions at 11-m Height	J-58
Table J-75.	Projected LANL Population Surrounding TA-55 for Year 2005	J-59
Table J-76.	Estimated Incident-Free Annual Radiological Releases From the MOX Lead Assembly Facility at LANL	J-59
Table J-77.	SRS 1987–1991 Joint Frequency Distributions at 61-m Height	J-62
Table J-78.	Projected SRS Population Surrounding H-Area for Year 2005	J-63
Table J-79.	Estimated Incident-Free Annual Radiological Releases From the MOX Lead Assembly Facility at SRS	J-63
Table K-1.	Isotopic Composition of Plutonium Used in Accident Analysis	K-7
Table K-2.	Isotopic Composition of Plutonium Used in Lead Assembly Accident Analysis	K-24
Table K-3.	Accident Impacts of Pit Conversion Facility in FMEF at Hanford	K-28
Table K-4.	Accident Impacts of Ceramic Immobilization Facility in FMEF and HLWVF at Hanford (Hybrid Case)	K-29
Table K-5.	Accident Impacts of Glass Immobilization Facility in FMEF and HLWVF at Hanford (Hybrid Case)	K-30
Table K-6.	Accident Impacts of Ceramic Immobilization Facility in FMEF and HLWVF at Hanford (50-t Case)	K-31
Table K-7.	Accident Impacts of Glass Immobilization Facility in FMEF and HLWVF at Hanford (50-t Case)	K-32
Table K-8.	Accident Impacts of MOX Facility in FMEF at Hanford	K-33
Table K-9.	Accident Impacts of New MOX Facility at Hanford	K-34
Table K-10.	Accident Impacts of Pit Conversion Facility in FPF at INEEL	K-36
Table K-11.	Accident Impacts of New MOX Facility at INEEL	K-37
Table K-12.	Accident Impacts of New Pit Conversion Facility at Pantex	K-39
Table K-13.	Accident Impacts of New MOX Facility at Pantex	K-40
Table K-14.	Accident Impacts of New Pit Conversion Facility at SRS	K-42
Table K-15.	Accident Impacts of Ceramic Immobilization Facility in New Construction and DWPF at SRS (Hybrid Case)	K-43
Table K-16.	Accident Impacts of Glass Immobilization Facility in New Construction and DWPF at SRS (Hybrid Case)	K-44
Table K-17.	Accident Impacts of Ceramic Immobilization Facility in New Construction and DWPF at SRS (50-t Case)	K-45
Table K-18.	Accident Impacts of Glass Immobilization Facility in New Construction and DWPF at SRS (50-t Case)	K-46
Table K-19.	Accident Impacts of New MOX Facility at SRS	K-47
Table K-20.	Accident Impacts of Lead Assembly Fabrication at ANL-W	K-48

Table K-21.	Accident Impacts of Lead Assembly Fabrication at Hanford (27-m Stack Height)	K-49
Table K-22.	Accident Impacts of Lead Assembly Fabrication at Hanford (36-m Stack Height)	K-50
Table K-23.	Accident Impacts of Lead Assembly Fabrication at LLNL	K-51
Table K-24.	Accident Impacts of Lead Assembly Fabrication at LANL	K-52
Table K-25.	Accident Impacts of Lead Assembly Fabrication at SRS H-Area	K-53
Table K-26.	Isotopic Breakdown of Plutonium	K-55
Table K-27.	MOX/LEU Core Inventory Isotopic Ratios	K-56
Table K-28.	Projected Catawba Population for Year 2015	K-57
Table K-29.	Projected McGuire Population for Year 2015	K-57
Table K-30.	Projected North Anna Population for Year 2015	K-58
Table K-31.	Catawba and McGuire LOCA Source Term	K-59
Table K-32.	North Anna LOCA Source Term	K-60
Table K-33.	Catawba and McGuire Fuel-Handling Accident Source Term	K-61
Table K-34.	North Anna Fuel-Handling Accident Source Term	K-61
Table K-35.	Catawba and McGuire End-of-Cycle Core Activities	K-64
Table K-36.	North Anna End-of-Cycle Core Activities	K-65
Table K-37.	Beyond-Design-Basis Accident Source Terms	K-66
Table K-38.	Design Basis Accident Impacts for Catawba With LEU and MOX Fuels	K-70
Table K-39.	Beyond-Design-Basis Accident Impacts for Catawba With LEU and MOX Fuels	K-71
Table K-40.	Design Basis Accident Impacts for McGuire With LEU and MOX Fuels	K-72
Table K-41.	Beyond-Design-Basis Accident Impacts for McGuire With LEU and MOX Fuels	K-73
Table K-42.	Design Basis Accident Impacts for North Anna With LEU and MOX Fuels	K-74
Table K-43.	Beyond-Design-Basis Accident Impacts for North Anna With LEU and MOX Fuels	K-75
Table K-44.	Ratio of Accident Impacts for MOX-Fueled and LEU-Fueled Reactors (MOX Impacts/Uranium Impacts)	K-75
Table K-45.	Prompt Fatalities for MOX-Fueled and LEU-Fueled Reactors	K-76
Table L-1.	Summary of Material Shipments	L-15
Table L-2.	Potential Shipping Legs Evaluated in the SPD EIS	L-17
Table L-3.	Summary of SPD EIS Transportation Requirements	L-19
Table L-4.	Human Health Risks of Transport to Lead Assembly Facilities	L-21
Table L-5.	Maximum Human Health Risks of Transport to Lead Assembly Facilities	L-21
Table L-6.	Total Risks for All SPD EIS Alternatives	L-22

Table L-7.	Estimated Dose to Maximally Exposed Individuals During Incident-Free Transportation Conditions	L-22
Table L-8.	Estimated Dose to the Population and to Maximally Exposed Individuals During the Most Severe Accident Conditions (Plutonium Dioxide)	L-23
Table L-9.	Estimated Dose to the Population and to Maximally Exposed Individuals During the Most Severe Accident Conditions (Plutonium Pits)	L-24
Table L-10.	Impacts of Transporting LLW and Transuranic Waste	L-25
Table L-11.	Cumulative Transportation-Related Radiological Collective Doses and Latent Cancer Fatalities (1943 to 2048) (person-rem)	L-27
Table M-1.	Racial and Ethnic Composition of Minority Populations Residing Within 80 km of Candidate DOE Sites in 1990	M-6
Table M-2.	Projected Racial and Ethnic Composition of Minority Populations Residing Within 80 km of Candidate DOE Sites in 1997	M-6
Table M-3.	Projected Racial and Ethnic Composition of Minority Populations Residing Within 80 km of Candidate DOE Sites in 2010	M-7
Table M-4.	Uncertainties in Estimates of Total and Minority Populations for the Year 2010	M-7
Table M-5.	Minority Populations Residing Along Transportation Routes for Surplus Plutonium . .	M-18
Table M-6.	Low-Income Populations Residing Along Transportation Routes for Surplus Plutonium	M-19
Table M-7.	Racial and Ethnic Composition of Minority Populations Residing Within 80 km of Proposed Reactor Sites in 1990	M-21
Table M-8.	Projected Racial and Ethnic Composition of Minority Populations Residing Within 80 km of Proposed Reactor Sites in 2015	M-21
Table M-9.	Uncertainties in Estimates of Total and Minority Populations for the Year 2015	M-21

List of Acronyms

AEA	Atomic Energy Act of 1954	CERCLA	Comprehensive Environmental Response, Compensation, and Liability Act
AECL	Atomic Energy of Canada Limited		
AED	aerodynamic equivalent diameter	CFA	Central Facilities Area
AIRFA	American Indian Religious Freedom Act	CFR	Code of Federal Regulations
ALARA	as low as is reasonably achievable	CPP	Chemical Processing Plant
		CWA	Clean Water Act of 1972, 1987
AMWTP	Advanced Mixed Waste Treatment Project	D&D	decontamination and decommissioning
ANL–W	Argonne National Laboratory–West	DBA	design basis accident
APSF	Actinide Packaging and Storage Facility	DCS	Duke Engineering & Services, COGEMA Inc., and Stone & Webster
AQCR	Air Quality Control Region	DNFSB	Defense Nuclear Facilities Safety Board
ARF	airborne release fraction		
ARIES	Advanced Recovery Integrated Extraction System	DOC	U.S. Department of Commerce
		DoD	U.S. Department of Defense
AVLIS	Atomic Vapor Laser Isotope Separation	DOE	U.S. Department of Energy
		DOL	U.S. Department of Labor
		DOT	U.S. Department of Transportation
BEA	Bureau of Economic Analysis		
BEIR V	Report V of the Committee on the Biological Effects of Ionizing Radiations	DR	damage ratio
		DU PEIS	<i>Final Programmatic Environmental Impact Statement for Alternative Strategies for Long-Term Management and Use of Depleted Uranium Hexafluoride</i>
BIO	Basis for Interim Operation		
BLM	Bureau of Land Management		
BNFL	British Nuclear Fuels		
BWR	boiling water reactor		
		DWPF	Defense Waste Processing Facility
CAA	Clean Air Act		
CAB	Citizens Advisory Board		
CANDU	Canadian Deuterium Uranium (reactors)	EA	environmental assessment
		EBR	Experimental Breeder Reactor (I or II)
CEQ	Council on Environmental Quality	EIS	environmental impact statement
		EPA	Environmental Protection Agency

ES&H	environment, safety, and health	HHS	Department of Health and Human Services
ESTEEM	Education in Science, Technology, Energy, Engineering, and Math	HIGHWAY	(computer code for distances and populations along U.S. highways)
ETB	Engineering Test Bay	HLW	high-level waste
ETTP	East Tennessee Technology Park	HLWVF	high-level-waste vitrification facility
FAA	Federal Aviation Administration	HMIS	Hazardous Materials Information System
FDP	fluorinel dissolution process	HWTPF	Hazardous Waste Treatment and Processing Facility
FEMA	Federal Emergency Management Agency	HYDOX	hydride oxidation
FFCA	Federal Facility Compliance Agreement	IAEA	International Atomic Energy Agency
FFF	Uranium Fuel Fabrication Facility	ICPP	Idaho Chemical Processing Plant
FFTF	Fast Flux Test Facility	ICRP	International Commission on Radiological Protection
FI	field investigation	ID DHW	Idaho Department of Health and Welfare
FM	Farm-to-Market (road)	INEEL	Idaho National Engineering and Environmental Laboratory
FMF	Fuel Manufacturing Facility	INRAD	Intrinsic Radiation
FMEA	failure modes and effects analysis	INTEC	Idaho Nuclear Technology and Engineering Center
FMEF	Fuels and Materials Examination Facility	IPE	Individual Plant Examination
FONSI	finding of no significant impact	ISC	Industrial Source Complex Model
FPF	Fuel Processing Facility	ISC3	Industrial Source Complex Model, Version 3
FPPA	Farmland Protection Policy Act	ISCST3	Industrial Source Complex Model, Short-Term, Version 3
FR	Federal Register	ISLOCA	interfacing systems loss-of-coolant accident
GAO	General Accounting Office	ITP	In-Tank Precipitation Process
GDP	gaseous diffusion plant		
GE	General Electric Company		
GENII	Generation II, Hanford environmental radiation dosimetry software system		
GPS	global positioning satellite		
HE	high explosive		
HEPA	high-efficiency particulate air (filter)		
HEU	highly enriched uranium		
HFEF	Hot Fuel Examination Facility		

LANL	Los Alamos National Laboratory	NPDES	National Pollutant Discharge Elimination System
LCF	latent cancer fatality		
LDR	Land Disposal Restrictions	NPH	natural phenomena hazard
LEU	low-enriched uranium	NPS	National Park Service
LLNL	Lawrence Livermore National Laboratory	NRC	U.S. Nuclear Regulatory Commission
LLW	low-level waste	NRU	National Research Universal
LOCA	loss-of-coolant accident	NTS	Nevada Test Site
LPF	leak path factor	NWCF	New Waste Calcining Facility
LWR	light water reactor	NWPA	Nuclear Waste Policy Act
		NWS	National Weather Service
M&H	Mason & Hanger Corporation		
MACCS2	Melcor Accident Consequence Code System (computer code)	ORIGEN	ORNL Isotope Generation and Depletion Code
MAR	material at risk	ORNL	Oak Ridge National Laboratory
MD	Office of Fissile Materials Disposition	ORR	Oak Ridge Reservation
MEI	maximally exposed individual	OSHA	Occupational Safety and Health Administration
MIMAS	Micronized Master		
MMI	Modified Mercalli Intensity	PBF	Power Burst Facility
MOX	mixed oxide	PEIS	programmatic environmental impact statement
NAAQS	National Ambient Air Quality Standards	PFP	Plutonium Finishing Plant
NAGPRA	Native American Graves Protection and Repatriation Act	PIE	postirradiation examination
NAS	National Academy of Science	PM _{2.5}	particulate matter with an aerodynamic diameter less than or equal to 2.5 microns
NCRP	National Council on Radiation Protection and Measurements	PM ₁₀	particulate matter with an aerodynamic diameter less than or equal to 10 microns
NDA	nondestructive analysis	PNNL	Pacific Northwest National Laboratory
NEPA	National Environmental Policy Act of 1969	PRA	probabilistic risk assessment
NESHAPs	National Emissions Standards for Hazardous Air Pollutants	PSD	prevention of significant deterioration
NIOSH	National Institute of Occupational Safety and Health	PUREX	Plutonium-Uranium Extraction (Facility)
NOA	Notice of Availability		
NOAA	National Oceanic and Atmospheric Administration	PWR	pressurized water reactor
NOI	Notice of Intent	R&D	research and development

RADTRAN 4	(computer code: risks and consequences of radiological materials transport)	SDWA	Preservation Officer Safe Drinking Water Act, as amended
RANT	Radioactive Assay and Nondestructive Test	SEIS	supplemental environmental impact statement
RAMROD	Radioactive Materials Research, Operations and Demonstration	SHPO	State Historic Preservation Officer
RCRA	Resource Conservation and Recovery Act, as amended	SI	sealed insert
REA	regional economic area	SMC	Specific Manufacturing Complex
RF	respirable fraction	SNF	spent nuclear fuel
RfC	reference concentration	SNM	special nuclear material
RfD	reference dose	SPD	surplus plutonium disposition
RFETS	Rocky Flats Environmental Technology Site	SPD EIS	<i>Surplus Plutonium Disposition Environmental Impact Statement</i>
RFP	Request for Proposal	SPERT	Special Power Excursion Reactor Test
RIA	Reactivity Insertion Accidents	SRS	Savannah River Site
RIMS II	Regional Input-Output Modeling System II (computer code)	SSM PEIS	<i>Final Programmatic Environmental Impact Statement for Stockpile Stewardship and Management</i>
RISKIND	(computer code: risks and consequences of radiological materials transport)	SST/SGT	safe, secure trailer/SafeGuards Transport
ROD	Record of Decision		
ROI	region of influence	SWMU	solid waste management unit
RMF	Radiation Measurements Facility	SWP 1	Service Waste Percolation Pond 1
RWMC	Radioactive Waste Management Complex		
		TA	Technical Area
S/A	Similarity of Appearance (provision of Endangered Species Act)	TCE	trichloroethylene
		TNRCC	Texas Natural Resource Conservation Commission
SAR	safety analysis report	TPBAR-LTA	tritium-producing burnable absorber rod lead test assembly
SARA	Superfund Amendments and Reauthorization Act of 1986	TRA	technical risk assessment
SCDHEC	South Carolina Department of Health and Environmental Control	TRANSCOM	transportation tracking and communications system
		TRU	transuranic
SCE&G	South Carolina Electric & Gas Company	TRUPACT	TRU waste package transporter
		TSCA	Toxic Substances Control Act
SCSHPO	South Carolina State Historic	TSP	total suspended particulates

TVA	Tennessee Valley Authority	WPPSS	Washington Public Power Supply System
TWRS	tank waste remediation system		
TWRS EIS	<i>Tank Waste Remediation System Final Environmental Impact Statement</i>	WROC	Waste Reduction Operations Complex
		WSRC	Westinghouse Savannah River Company
UC	Regents of the University of California	ZPPR	Zero Power Physics Reactor
UFSAR	updated final safety analysis report		
USACE	U.S. Army Corps of Engineers		
USC	United States Code		
USEC	United States Enrichment Corporation		
USFWS	U.S. Fish and Wildlife Service		
UV	ultraviolet		
VOC	volatile organic compounds		
VORTAC	very high frequency omnidirectional range/tactical air navigation (facility)		
VRM	Visual Resource Management		
WAG 3	Waste Area Grouping 3		
WERF	Waste Experimental Reduction Facility		
WIPP	Waste Isolation Pilot Plant		
WM PEIS	<i>Final Waste Management Programmatic Environmental Impact Statement for Managing Treatment, Storage, and Disposal of Radioactive and Hazardous Waste</i>		
WNP-1	Washington Nuclear Plant-1		
WNP-2	Washington Nuclear Plant-2		

Chemicals and Units of Measure

°C	degrees Celsius (Centigrade)	min	minute
°F	degrees Fahrenheit	mph	miles per hour
μCi	microcurie	mrem	millirem
μg	microgram	MTHM	metric tons of heavy metal
μm	micrometer (micron)	MVA	megavolt-ampere
46°26'07"	46 degrees, 26 minutes, 7 seconds	MW	megawatt
Ci	curie	MWe	megawatt electric
cm	centimeter	MWh	megawatt-hour
CO	carbon monoxide	N ₂	nitrogen
CO ₂	carbon dioxide	nCi	nanocurie
dB	decibel	NO ₂	nitrogen dioxide
dba	decibel, A-weighted	pCi	picocurie
DUF ₆	depleted uranium hexafluoride	pcm/F	percent mille/Fahrenheit
eH	oxidation reduction potential	pH	hydrogen ion concentration
ft	foot	PM _{2.5}	particulate matter less than or equal to 2.5 μm in diameter
ft ²	square foot	PM ₁₀	particulate matter less than or equal to 10 μm in diameter
ft ³	cubic foot	ppm	parts per million
g	gram	PuO ₂	plutonium dioxide
g	gravitational acceleration	rad	radiation absorbed dose
gal	gallon	rem	roentgen equivalent man
GWD	gigawatt days (per ton)	s	second
ha	hectare	SO ₂	sulfur dioxide
hr	hour (in compound units)	t	metric ton
in	inch	ton	short ton
kg	kilogram	UF ₆	uranium hexafluoride
km	kilometer	UO ₂	uranium dioxide
km ²	square kilometers	yd	yard
kV	kilovolt	yd ³	cubic yard
l	liter	yr	year (in compound units)
lb	pound	wt %	weight percent
m	meter		
m ²	square meter		
m ³	cubic meter		
mg	milligram		
mi	mile		

Metric Conversion Chart

To Convert Into Metric			To Convert Out of Metric		
If You Know	Multiply By	To Get	If You Know	Multiply By	To Get
Length					
inches	2.54	centimeters	centimeters	0.3937	inches
feet	30.48	centimeters	centimeters	0.0328	feet
feet	0.3048	meters	meters	3.281	feet
yards	0.9144	meters	meters	1.0936	yards
miles	1.60934	kilometers	kilometers	0.6214	miles
Area					
sq. inches	6.4516	sq. centimeters	sq. centimeters	0.155	sq. inches
sq. feet	0.092903	sq. meters	sq. meters	10.7639	sq. feet
sq. yards	0.8361	sq. meters	sq. meters	1.196	sq. yards
acres	0.40469	hectares	hectares	2.471	acres
sq. miles	2.58999	sq. kilometers	sq. kilometers	0.3861	sq. miles
Volume					
fluid ounces	29.574	milliliters	milliliters	0.0338	fluid ounces
gallons	3.7854	liters	liters	0.26417	gallons
cubic feet	0.028317	cubic meters	cubic meters	35.315	cubic feet
cubic yards	0.76455	cubic meters	cubic meters	1.308	cubic yards
Weight					
ounces	28.3495	grams	grams	0.03527	ounces
pounds	0.45360	kilograms	kilograms	2.2046	pounds
short tons	0.90718	metric tons	metric tons	1.1023	short tons
Temperature					
Fahrenheit	Subtract 32 then multiply by 5/9ths	Celsius	Celsius	Multiply by 9/5ths, then add 32	Fahrenheit

Metric Prefixes

Prefix	Symbol	Multiplication Factor
exa-	E	1 000 000 000 000 000 000 = 10^{18}
peta-	P	1 000 000 000 000 000 = 10^{15}
tera-	T	1 000 000 000 000 = 10^{12}
giga-	G	1 000 000 000 = 10^9
mega-	M	1 000 000 = 10^6
kilo-	k	1 000 = 10^3
hecto-	h	100 = 10^2
deka-	da	10 = 10^1
deci-	d	0.1 = 10^{-1}
centi-	c	0.01 = 10^{-2}
milli-	m	0.001 = 10^{-3}
micro-	μ	0.000 001 = 10^{-6}
nano-	n	0.000 000 001 = 10^{-9}
pico-	p	0.000 000 000 001 = 10^{-12}
femto-	f	0.000 000 000 000 001 = 10^{-15}
atto-	a	0.000 000 000 000 000 001 = 10^{-18}

Appendix A
Federal Register Notices
and
Joint Statement

**A.1 RECORD OF DECISION FOR THE STORAGE AND DISPOSITION OF WEAPONS-USABLE
FISSILE MATERIALS FINAL PROGRAMMATIC ENVIRONMENTAL IMPACT
STATEMENT**

Responses: 18,620 Burden Hours: 64,310.

Abstract: The LESCOP is being conducted in response to the legislative requirement in P.L. 103-382, Section 1501 to assess the implementation of Title I and related education reforms. The information will be used to examine changes—over a 3-year period—that are occurring in schools and classrooms. Teachers and teacher aides will complete a mail survey, and district Title I administrators, principals, school-based staff, and parents will be interviewed during on-site field work.

[FR Doc. 97-1307 Filed 1-17-97; 8:45 am]

BILLING CODE 4000-01-P

DEPARTMENT OF ENERGY

Record of decision for the Storage and Disposition of Weapons-Usable Fissile Materials Final Programmatic Environmental Impact Statement

AGENCY: Department of Energy.

ACTION: Record of Decision.

SUMMARY: The Department of Energy (DOE) has decided to implement a program to provide for safe and secure storage of weapons-usable fissile materials (plutonium and highly enriched uranium [HEU]) and a strategy for the disposition of surplus weapons-usable plutonium, as specified in the Preferred Alternative in the Storage and Disposition of Weapons-Usable Fissile Materials Final Programmatic Environmental Impact Statement (S&D Final PEIS, DOE/EIS-0229, December 1996). The fundamental purpose of the program is to maintain a high standard of security and accounting for these materials while in storage, and to ensure that plutonium produced for nuclear weapons and declared excess to national security needs (now, or in the future) is never again used for nuclear weapons.

DOE will consolidate the storage of weapons-usable plutonium by upgrading and expanding existing and planned facilities at the Pantex Plant in Texas and the Savannah River Site (SRS) in South Carolina, and continue the storage of weapons-usable HEU at DOE's Y-12 Plant at the Oak Ridge Reservation (ORR) in Tennessee, in upgraded and, as HEU is dispositioned, consolidated facilities. After certain conditions are met, most plutonium now stored at the Rocky Flats Environmental Technology Site (RFETS) in Colorado will be moved to Pantex and SRS. Plutonium currently stored at the Hanford Site (Hanford), the Idaho

National Engineering Laboratory (INEL), and the Los Alamos National Laboratory (LANL) will remain at those sites until disposition (or movement to lag storage at the disposition facilities).

DOE's strategy for disposition of surplus plutonium is to pursue an approach that allows immobilization of surplus plutonium in glass or ceramic material for disposal in a geologic repository pursuant to the Nuclear Waste Policy Act, and burning of some of the surplus plutonium as mixed oxide (MOX) fuel in existing, domestic, commercial reactors, with subsequent disposal of the spent fuel in a geologic repository pursuant to the Nuclear Waste Policy Act. DOE may also burn MOX fuel in Canadian Deuterium Uranium [CANDU] reactors in the event of an appropriate agreement among Russia, Canada, and the United States, as discussed below. The timing and extent to which either or both of these disposition approaches (immobilization or MOX) are ultimately deployed will depend upon the results of future technology development and demonstrations, follow-on (tiered) site-specific environmental review, contract negotiations, and detailed cost reviews, as well as nonproliferation considerations, and agreements with Russia and other nations. DOE's program will be subject to the highest standards of safeguards and security throughout all aspects of storage, transportation, and processing, and will include appropriate International Atomic Energy Agency verification.

Due to technology, complexity, timing, cost, and other factors that would be involved in purifying certain plutonium materials to make them suitable for potential use in MOX fuel, approximately 30 percent of the total quantity of plutonium (that has or may be declared surplus to defense needs) would require extensive purification to use in MOX fuel, and therefore will likely be immobilized. DOE will immobilize at least 8 metric tons (MT) of currently declared surplus plutonium materials that DOE has already determined are not suitable for use in MOX fuel. DOE reserves the option of using the immobilization approach for all of the surplus plutonium.

The exact locations for disposition facilities will be determined pursuant to a follow-on, site-specific disposition environmental impact statement (EIS) as well as cost, technical and nonproliferation studies. However, DOE has decided to narrow the field of candidate disposition sites. DOE has decided that a vitrification or immobilization facility (collocated with a plutonium conversion facility) will be

located at either Hanford or SRS, that a potential MOX fuel fabrication facility will be located at Hanford, INEL, Pantex, or SRS (only one site), and that a "pit" disassembly and conversion facility will be located at Hanford, INEL, Pantex, or SRS (only one site). ("Pits" are weapons components containing plutonium.) The specific reactors, and their locations, that may be used to burn the MOX fuel will depend on contract negotiations, licensing, and environmental reviews. Because there are a number of technology variations that could be used for immobilization, DOE will also determine the specific immobilization technology based on the follow-on EIS, technology developments, cost information, and nonproliferation considerations. Based on current technological and cost information, DOE anticipates that the follow-on EIS will identify, as part of the proposed action, immobilizing a portion of the surplus plutonium using the "can-in-canister" technology at the Defense Waste Processing Facility (DWPF) at the Savannah River Site.

The use of MOX fuel in existing reactors would be undertaken in a manner that is consistent with the United States' policy objective on the irreversibility of the nuclear disarmament process and the United States' policy discouraging the civilian use of plutonium. To this end, implementing the MOX alternative would include government ownership and control of the MOX fuel fabrication facility at a DOE site, and use of the facility only for the surplus plutonium disposition program. There would be no reprocessing or subsequent reuse of spent MOX fuel. The MOX fuel would be used in a once-through fuel cycle in existing reactors, with appropriate arrangements, including contractual or licensing provisions, limiting use of MOX fuel to surplus plutonium disposition.

The Department of Energy also retains the option of using MOX fuel in Canadian Deuterium Uranium (CANDU) reactors in Canada in the event a multilateral agreement is negotiated among Russia, Canada, and the United States to use CANDU reactors for surplus United States' and Russian plutonium. DOE will engage in a test and demonstration program for CANDU MOX fuel as appropriate and consistent with future cooperative efforts with Russia and Canada.

These efforts will provide the basis and flexibility for the United States to initiate disposition efforts either multilaterally or bilaterally through negotiations with other nations, or unilaterally as an example to Russia and

other nations. Disposition of the surplus plutonium will serve as a nonproliferation and disarmament example, encourage similar actions by Russia and other nations, and foster multilateral or bilateral disposition efforts and agreements.

EFFECTIVE DATE: The decisions set forth in this Record of Decision (ROD) are effective upon issuance of this document, in accordance with DOE's National Environmental Policy Act (NEPA) Implementing Procedures and Guidelines (10 CFR Part 1021) and the Council on Environmental Quality (CEQ) regulations implementing NEPA (40 CFR Parts 1500-1508).

ADDRESSES: Copies of the S&D Final PEIS, the Technical Summary Report For Long-Term Storage of Weapons-Usable Fissile Materials, the Technical Summary Report for Surplus Weapons-Usable Plutonium Disposition, the Nonproliferation and Arms Control Assessment of Weapons-Usable Fissile Material Storage and Plutonium Disposition, and this ROD may be obtained by writing to the U.S. Department of Energy, Office of Fissile Materials Disposition, MD-4, 1000 Independence Avenue, SW., Washington, DC 20585, or by calling (202) 586-4513. The 56-page Summary of the S&D Final PEIS, the other documents noted above (other than the full PEIS), and this ROD are also available on the Fissile Materials Disposition World Wide Web Page at: <http://web.fie.com/htdoc/fed/DOE/fsl/pub/menu/any/>

FOR FURTHER INFORMATION CONTACT: For information on the storage and disposition of weapons-usable fissile materials program or this ROD contact: Mr. J. David Nulton, Director, NEPA Compliance and Outreach, Office of Fissile Materials Disposition (MD-4), U.S. Department of Energy, 1000 Independence Avenue, SW., Washington, DC 20585, telephone (202) 586-4513.

For information on the DOE NEPA process, contact: Carol M. Borgstrom, Director, Office of NEPA Policy and Assistance (EH-42), U.S. Department of Energy, 1000 Independence Ave., SW, Washington, DC 20585, telephone (202) 586-4600 or leave a message at (800) 472-2756.

SUPPLEMENTARY INFORMATION:

I. Background

The end of the Cold War has created a legacy of surplus weapons-usable fissile materials both in the United States and the former Soviet Union. Further agreements on disarmament may increase the surplus quantities of

these materials. The global stockpiles of weapons-usable fissile materials pose a danger to national and international security in the form of potential proliferation of nuclear weapons and the potential for environmental, safety, and health consequences if the materials are not properly safeguarded and managed.

In September 1993, President Clinton issued a Nonproliferation and Export Control Policy in response to the growing threat of nuclear proliferation. Further, in January 1994, President Clinton and Russia's President Yeltsin issued a Joint Statement Between the United States and Russia on Nonproliferation of Weapons of Mass Destruction and the Means of Their Delivery. In accordance with these policies, the focus of the U.S. nonproliferation efforts in this regard is five-fold: (i) To secure nuclear materials in the former Soviet Union; (ii) to assure safe, secure, long-term storage and disposition of surplus weapons-usable fissile materials; (iii) to establish transparent and irreversible nuclear arms reductions; (iv) to strengthen the nuclear nonproliferation regime; and (v) to control nuclear exports. The policy also states that the United States will not encourage the civil use of plutonium and that the United States does not engage in plutonium reprocessing for either nuclear power or nuclear explosive purposes.

To demonstrate the United States' commitment to these objectives, President Clinton announced on March 1, 1995, that approximately 200 metric tons of U.S.-origin weapons-usable fissile materials, of which 165 metric tons are HEU and 38 metric tons are weapons-grade plutonium, had been declared surplus to the United States' defense needs.¹ The safe and secure storage of weapons-usable plutonium and HEU, and the disposition of surplus weapons-usable plutonium, consistent with the Preferred Alternative in the S&D Final PEIS and the decisions described in section V of this ROD, are consistent with the President's nonproliferation policy.

¹ The Secretary of Energy's Openness Initiative announcement of February 6, 1996, announced that the United States has about 213 metric tons of surplus fissile materials, including the 200 metric tons the President announced in March, 1995. Of the 213 metric tons of surplus materials, the Openness Initiative announcement indicated that about 174.3 metric tons are HEU and about 38.2 metric tons are weapons-grade plutonium. Additional quantities of plutonium may be declared surplus in the future; therefore, the S&D Final PEIS analyzes the disposition of a nominal 50 metric tons of plutonium, as well as the storage of 89 metric tons of plutonium and 994 metric tons of HEU.

II. Decisions Made in This ROD

This ROD encompasses two categories of decisions: (1) The sites and facilities for storage of non-surplus weapons-usable plutonium and HEU, and storage of surplus plutonium and HEU pending disposition; and (2) the programmatic strategy for disposition of surplus weapons-usable plutonium. This ROD does not encompass the final selection of sites for plutonium disposition facilities, nor the extent to which the two plutonium disposition approaches (immobilization or MOX) will ultimately be implemented. Those decisions will be made pursuant to a follow-on EIS. However, DOE does announce in this ROD that the slate of candidate sites for plutonium disposition has been narrowed. This ROD does not include decisions about the disposition of surplus HEU, which were made in July 1996 in the separate ROD for the Disposition of Surplus Highly Enriched Uranium Final Environmental Impact Statement, 61 FR 40619 (Aug. 5, 1996).²

III. NEPA Process

A. S&D Draft PEIS

On June 21, 1994, DOE published a Notice of Intent (NOI) in the Federal Register (59 FR 31985) to prepare a Storage and Disposition of Weapons-Usable Fissile Materials Programmatic Environmental Impact Statement (S&D PEIS), which was originally to address the storage and disposition of both plutonium and HEU. DOE subsequently concluded that a separate EIS on surplus HEU disposition would be appropriate. Accordingly, DOE published a notice in the Federal Register (60 FR 17344) on April 5, 1995, to inform the public of the proposed plan to prepare a separate EIS for the disposition of surplus HEU.

DOE published an implementation plan (IP) for the S&D PEIS in March 1995 (DOE/EIS-0229-IP). The IP recorded the issues identified during the scoping process, indicated how they would be addressed in the S&D PEIS, and provided guidance for the preparation of the S&D PEIS. DOE issued the Storage and Disposition of Weapons-Usable Fissile Materials Draft Programmatic Environmental Impact Statement (S&D Draft PEIS, DOE/EIS-0229-D) for public comment in February 1996. On March 8, 1996, both DOE and the Environmental Protection

² The material considered in the S&D Final PEIS, and covered by the decisions in this ROD, does not include spent nuclear fuel, irradiated targets, uranium-233, plutonium-238, plutonium residues of less than 50-percent plutonium by weight, or weapons program materials-in-use.

Agency (EPA) published Notices of Availability of the S&D Draft PEIS in the Federal Register (61 FR 9443 and 61 9450), announcing a public comment period from March 8 until May 7, 1996. In response to requests from the public, DOE on May 13, 1996 published another Notice in the Federal Register (61 FR 22038) announcing an extension of the comment period until June 7, 1996. Eight public meetings on the S&D Draft PEIS were held during March and April 1996 in Washington, DC and in the vicinity of the DOE sites under consideration for the proposed actions.

During the 92-day public comment period, the public was encouraged to provide comments via mail, toll-free fax, electronic bulletin board (Internet), and toll-free telephone recording device. By these means, DOE received 8,442 comments from 6,543 individuals and organizations for consideration. In addition, 250 oral comments were recorded from some of the 734 individuals who attended the eight public meetings. All of the comments received, and the Department's responses to them, are presented in Volume IV (the Comment Response Document) of the S&D Final PEIS. All of the comments were considered in preparation of the S&D Final PEIS, and in many cases resulted in changes to the document. The Notice of Availability for the S&D Final PEIS was published by EPA in the Federal Register on December 13, 1996 (61 FR 65572). DOE published its own Notice of Availability for the S&D Final PEIS in the Federal Register on December 19, 1996 (61 FR 67001).

B. Alternatives Considered

The S&D PEIS analyzes the reasonable action alternatives in addition to the Preferred Alternative and the No Action Alternative. The Preferred Alternative, which is described below in section V, Decisions, and which DOE has decided to implement, represents a combination of alternatives for both storage and disposition.

1. The Proposed Action

The proposed action, as described in the S&D PEIS, would involve the following actions for U.S. weapons-usable fissile materials:

- Storage—provide a long-term storage system (for up to 50 years) for non-surplus plutonium and HEU that meets the Stored Weapons Standard³

³The "Stored Weapons Standard" for weapons-usable fissile materials storage was initially defined in Management and Disposition of Excess Weapons Plutonium, National Academy of Sciences, 1994. DOE defines the Stored Weapons Standard as follows: The high standards of security and

and applicable environmental, safety, and health standards while reducing storage and infrastructure costs.

- Storage Pending Disposition—provide storage that meets the Stored Weapons Standard for inventories of weapons-usable plutonium and HEU⁴ that have been or may be declared surplus.

- Disposition—convert surplus plutonium and plutonium that may be declared surplus in the future to forms that meet the Spent Fuel Standard,⁵ thereby providing evidence of irreversible disarmament and setting a model for proliferation resistance.

2. Long-Term Storage Alternatives and Related Activities

a. *No Action.* Under the No Action Alternative, all weapons-usable fissile materials would remain at existing storage sites. Maintenance at existing storage facilities would be done as required to ensure safe operation for the balance of the facility's useful life. Sites covered under the No Action Alternative included Hanford, INEL, Pantex, the ORR, SRS, RFETS, and LANL. Although there are no weapons-usable fissile materials within the scope of the S&D PEIS stored currently at Nevada Test Site (NTS), it was also analyzed under No Action to provide an environmental baseline against which impacts of the storage and disposition action alternatives were analyzed.

b. *Upgrade at Multiple Sites.* Under this alternative for storage, DOE would either modify certain existing facilities or build new facilities, depending on the site's ability to meet standards for nuclear material storage facilities, and would utilize existing site infrastructure to the extent possible. These modified or new facilities would be designed to operate for up to 50 years. Plutonium

accounting for the storage of intact nuclear weapons should be maintained, to the extent practical, for weapons-usable fissile materials throughout dismantlement, storage, and disposition.

⁴The S&D PEIS covers long-term storage of non-surplus HEU and storage of surplus HEU pending disposition. Until storage decisions are implemented, surplus HEU that has not gone to disposition will continue to be stored pursuant to, and not to exceed the 10-year interim storage time period evaluated in, the Environmental Assessment for the Proposed Interim Storage of Enriched Uranium Above the Maximum Historical Storage Level at the Y-12 Plant, Oak Ridge, Tennessee (Y-12 EA) (DOE/EA-0929, September 1994) and Finding of No Significant Impact (FONSI).

⁵The "Spent Fuel Standard" for disposition was also initially defined in Management and Disposition of Excess Weapons Plutonium, National Academy of Sciences, 1994. DOE defines the Spent Fuel Standard as follows: The surplus weapons-usable plutonium should be made as inaccessible and unattractive for weapons use as the much larger and growing quantity of plutonium that exists in spent nuclear fuel from commercial power reactors.

materials currently stored at Hanford, INEL, Pantex, and SRS would remain at those four sites (in upgraded or new facilities), and HEU would remain at ORR (in upgraded, consolidated facilities). This alternative does not apply to NTS because NTS does not currently store weapons-usable fissile materials.

A sub-alternative of relocating portions of the plutonium inventory (a total of 14.4 metric tons according to DOE's Openness Initiative announcements of December 7, 1993, and February 6, 1996, respectively) from RFETS and LANL to one or more of the four existing plutonium storage sites is analyzed. Storage of surplus materials without strategic reserve and weapons research and development (R&D) materials is also included as a sub-alternative. Within some of the five candidate storage sites under this alternative, there are also multiple storage options.

c. *Consolidation of Plutonium.* Under this alternative, plutonium materials at existing sites would be removed, and the entire DOE inventory of plutonium would be consolidated at one site, while the HEU inventory would remain at ORR. Again, Hanford, INEL, Pantex and SRS would be candidate sites for plutonium consolidation. In addition, NTS would be a candidate site for this alternative. Consolidation of plutonium at ORR would result in a situation in which inventories of plutonium and HEU were collocated at one site; this alternative was therefore analyzed as one option under the Collocation Alternative (see below). A sub-alternative to account for the separate storage of surplus materials without strategic reserve and weapons R&D materials was also included.

d. *Collocation of Plutonium and Highly Enriched Uranium.* Under the Collocation Alternative, the entire DOE inventory of plutonium and HEU would be consolidated and collocated at the same site. The six candidate sites would be Hanford, NTS, INEL, Pantex, ORR, and SRS. A sub-alternative for the separate storage of surplus materials without strategic reserve and weapons R&D materials was also included.

3. Plutonium Disposition Alternatives and Related Activities

The disposition technologies analyzed in the S&D PEIS were those that would convert surplus plutonium into a form that would meet the Spent Fuel Standard. For the purpose of environmental impact analyses of the various disposition alternatives, both generic and specific sites were used to provide perspective on these

alternatives. Under each alternative, there are various ways to implement the alternative. These "variants" (such as the can-in-canister⁶ approach) are shown in Table 1 to provide a range of available options for consideration.

TABLE 1.—DESCRIPTION OF VARIANTS UNDER PLUTONIUM DISPOSITION ALTERNATIVES

Alternatives analyzed	Possible variants
<ul style="list-style-type: none"> • Deep Borehole Direct Disposition • Deep Borehole Immobilized Disposition 	<ul style="list-style-type: none"> • Arrangement of plutonium in different types of emplacement canisters. • Emplacement of pellet-group mix.
<ul style="list-style-type: none"> • New Vitrification Facilities 	<ul style="list-style-type: none"> • Pumped emplacement of pellet-grout mix. • Plutonium concentration loading, size and shape of ceramic pellets. • Collocated pit disassembly/conversion, plutonium conversion, and immobilization facilities. • Use of either Cs-137 from capsules or HLW as a radiation barrier. • Wet or dry feed preparation technologies. • An adjunct melter adjacent to the DWPF at SRS, in which borosilicate glass frit with plutonium (without highly radioactive radionuclides) is added to borosilicate glass containing HLW from the DWPF. • A can-in-canister approach at SRS in which cans of plutonium glass (without highly radioactive radionuclides) are placed in DWPF canisters which are then filled with borosilicate glass containing HLW in the DWPF (see Appendix O of the Final PEIS). • A can-in-canister approach similar to above but using new facilities at sites other than SRS. • Collocated pit disassembly/plutonium conversion, and immobilization facilities.
<ul style="list-style-type: none"> • New Ceramic Immobilization Facilities 	<ul style="list-style-type: none"> • Use of either Cs-137 from capsules or HLW as a radiation barrier. • Wet or dry feed preparation technologies. • A can-in-canister approach at SRS in which the plutonium is immobilized without highly radioactive radionuclides in a ceramic matrix and then placed in the DWPF canisters that are then filled with borosilicate glass containing HLW (See Appendix O of the Final PEIS). • A can-in-canister approach similar to above but using new facilities at sites other than SRS. • Immobilize plutonium into metal ingot form.
<ul style="list-style-type: none"> • Electrometallurgical Treatment (glass-bonded zeolite form) 	<ul style="list-style-type: none"> • Locate at DOE sites other than ANL-W at INEL. • Pressurized or Boiling Water Reactors.
<ul style="list-style-type: none"> • Existing LWR With New MOX Facilities 	<ul style="list-style-type: none"> • Different numbers of reactors. • European MOX fuel fabrication. • Modification/completion of existing facilities for MOX fabrication. • Collocated pit disassembly/conversion, plutonium conversion, and MOX facilities. • Reactors with different core management schemes (plutonium loadings, refueling intervals). • Same as for existing LWR (except that MOX fuel would not be fabricated in Europe).
<ul style="list-style-type: none"> • Partially Completed LWR With New MOX Facilities • Evolutionary LWR With New MOX Facilities • Existing CANDU Reactor With New MOX Facilities 	<ul style="list-style-type: none"> • Same as for partially completed LWR. • Different numbers of reactors. • Modification/completion of existing facilities for MOX fabrication. • Collocated pit disassembly/conversion, plutonium conversion, and MOX facilities. • Reactors with different core management schemes (plutonium loadings, refueling intervals).

Note: ANL-W=Argonne National Laboratory-West; Cs-137=cesium-137; HLW=high-level waste; LWR=light water reactor

The first step in plutonium disposition is to remove the surplus plutonium from storage, then process this material in a pit disassembly/conversion facility (for pits) or in a plutonium conversion facility (for non-pit materials). The processing would convert the plutonium material into a form suitable for each of the disposition alternatives described in the following sections. The pit disassembly/conversion facility and the plutonium conversion facility would be built at a DOE site. The six candidate sites for long-term storage were evaluated for the potential environmental impacts of constructing and operating these facilities.

a. No Disposition Action. A "No Plutonium Disposition" action means disposition would not occur, and surplus plutonium-bearing weapon components (pits) and other forms, such as metal and oxide, would remain in storage in accordance with decisions on the long-term storage of weapons-usable fissile materials.

b. Deep Borehole Category. Under this category of alternatives, surplus weapons-usable plutonium would be disposed of in deep boreholes that would be drilled at least 4 kilometers (km) (2.5 miles [mi]) into ancient, geologically stable rock formations beneath the water table. The deep borehole would provide a geologic

barrier against potential proliferation. A generic site was evaluated for the construction and operation of a borehole complex where the surplus plutonium would be prepared for emplacement in the borehole. This complex would consist of five major facilities: Processing; drilling; emplacing/sealing; waste management; and support (security, maintenance, and utilities).

(1) Direct Disposition (Borehole). Under the Direct Disposition Alternative, surplus plutonium would be removed from storage, processed as necessary, converted to a form suitable for emplacement, packaged, and placed in a deep borehole. The deep borehole would be sealed to isolate the

⁶In the can-in-canister variant, cans of plutonium in a glass or ceramic matrix would be placed in a canister. This canister would then be filled with

borosilicate glass containing high-level radioactive waste (HLW) or highly radioactive material such as cesium. This variant, at an existing facility (the

Defense Waste Processing Facility [DWPF] at SRS), is described in Appendix O of the S&D Final PEIS.

plutonium from the accessible environment. Long-term performance of the deep borehole would depend on the stability of the geologic system. A generic site was used for the borehole complex to analyze the environmental impact of this alternative.

(2) **Immobilized Disposition (Borehole).** Under the Immobilized Disposition Alternative, the surplus plutonium would be removed from storage, processed, and converted to a suitable form for shipment to a ceramic immobilization facility. The output of this facility would be spherical ceramic pellets containing plutonium, facilitating handling during transportation and emplacement. The ceramic pellets (about 2.54 centimeters [cm] [1 inch {in}] in diameter and containing 1 percent plutonium by weight) would then be placed in drums and shipped to the borehole complex. At the deep borehole site, the ceramic pellets would be mixed with non-plutonium ceramic pellets and fixed with grout during emplacement. The deep borehole would be sealed to isolate the plutonium from the accessible environment. Long-term performance of the deep borehole would depend on the stability of the geologic system.

Although a generic site was used for analyses of the borehole complex in this alternative, the ceramic immobilization facility would be built at a DOE site. Therefore, the six candidate sites for long-term storage were used to evaluate the environmental impacts of the borehole immobilization facility.

c. Immobilization Category. Under this category of alternatives, surplus plutonium would be immobilized to create a chemically stable form for disposal in a geologic repository pursuant to the Nuclear Waste Policy Act (NWPA).⁷ The plutonium material would be mixed with or surrounded by high-level waste (HLW) or other radioactive isotopes and immobilized to create a radiation field that could serve as a proliferation deterrent, along with safeguards and security comparable to those of commercial spent nuclear fuel,

⁷ Also referred to as a permanent, or HLW repository. Pursuant to the Nuclear Waste Policy Act, DOE is currently characterizing the Yucca Mountain Site in Nevada as a potential repository for spent nuclear fuel and HLW. Legislative clarification, or a determination by the Nuclear Regulatory Commission that the immobilized plutonium should be isolated as HLW, may be required before the material could be placed in Yucca Mountain should DOE and the President recommend, and Congress approve, its operation. No Resource Conservation and Recovery Act (RCRA) wastes would be immobilized unless the immobilization would constitute adequate treatment under RCRA. The immobilized product would be consistent with the repository's waste acceptance criteria.

thereby achieving the Spent Fuel Standard. All immobilized plutonium would be encased in stainless steel canisters and would remain in onsite vault-type storage until a geologic repository pursuant to the NWPA is operational.

(1) **Vitrification.** Under the Vitrification Alternative, surplus plutonium would be removed from storage, processed, packaged, and transported to the vitrification facility. In this facility, the plutonium would be mixed with glass frit and highly radioactive cesium-137 (Cs-137) or HLW to produce borosilicate glass logs (a slightly different process, using HLW, would be used for the can-in-canister variant, as discussed in Appendix O of the S&D Final PEIS). The Cs-137 isotope could come from the cesium chloride (CsCl) capsules currently stored at Hanford or from existing HLW if the site selected for vitrification already manages HLW. Each glass log produced from the vitrification facility would contain about 84 kilograms (kg) (185 pounds [lb]) of plutonium. The vitrification facility would be built at a DOE site. The six candidate sites for long-term storage were analyzed for this alternative.

(2) **Ceramic Immobilization.** Under the Ceramic Immobilization Alternative, surplus plutonium would be removed from storage, processed, packaged, and transported to a ceramic immobilization facility. In this facility, the plutonium would be mixed with nonradioactive ceramic materials and Cs-137 or HLW to produce ceramic disks (a slightly different process, using HLW, would be used for the can-in-canister variant, as discussed in Appendix O of the S&D Final PEIS). Each disk would be approximately 30 cm (12 in) in diameter and 10 cm (4 in) thick, and would contain approximately 4 kg (9 lb) of plutonium. The Cs-137 or HLW would be provided as previously described. The ceramic immobilization facility would be built at a DOE site. The six candidate sites for long-term storage were analyzed for this alternative.

(3) **Electrometallurgical Treatment.** Under the Electrometallurgical Treatment Alternative, surplus plutonium would be removed from storage, processed, packaged, and transported to new or modified facilities for electrometallurgical treatment. This process could immobilize surplus fissile materials into a glass-bonded zeolite (GBZ) form. With the GBZ material, the plutonium would be in the form of a stable, leach-resistant mineral that is

incorporated in durable glass materials.⁸ Existing electrometallurgical facilities at INEL were used as a representative site for analysis of potential environmental impacts.

d. Reactor Category. Under the reactor alternatives considered in the S&D PEIS, DOE would fabricate surplus plutonium into MOX fuel for use in reactors. The irradiated MOX fuel would reduce the proliferation risks of the plutonium material, and the reactors would also generate electricity. MOX fuel would be used in a once-through fuel cycle, with no reprocessing or subsequent reuse of spent fuel. The spent nuclear fuel generated by the reactors would then be sent to a geologic repository pursuant to the NWPA.

Because the United States does not have a MOX fuel fabrication facility or capability, a new dedicated MOX fuel fabrication facility would be built at a DOE or commercial site.⁹ The surplus plutonium from storage would be processed, converted to plutonium dioxide (PuO₂), and transferred to the MOX fuel fabrication facility. In this facility, PuO₂ and uranium dioxide (UO₂) (from existing domestic sources) would be blended and fabricated into MOX pellets, loaded into fuel rods, and assembled into fuel bundles suitable for use in the reactor alternatives under consideration.

(1) **Existing Light Water Reactors.** Under the Existing Light Water Reactor (LWR) Alternative, the MOX fuel containing surplus plutonium would be fabricated and transported to existing commercial LWRs in the United States, where the MOX fuel would be used instead of conventional UO₂ fuel. The LWRs employed for domestic electric power generation are pressurized water reactors (PWRs) and boiling water reactors (BWRs). Both types of reactors use the heat produced from nuclear fission reactions to generate steam that drives turbines and generates electricity. Three to five reactor units would be needed.¹⁰

⁸ In May 1996, the Department issued a Finding of No Significant Impact (FONSI) (61 Fed. Reg. 25647) and decision to proceed with the limited demonstration of the electrometallurgical treatment process at Argonne National Laboratory-West (ANL-W) at INEL for processing up to 125 spent fuel assemblies from the Experimental Breeder Reactor II (100 drivers and 25 blanket assemblies). Although this alternative could be conducted at other DOE sites, ANL-W is described in the S&D PEIS as the representative site for analysis.

⁹ Although a generic commercial site was evaluated in the S&D PEIS, it is not part of the Preferred Alternative or the decisions in this ROD.

¹⁰ It is possible that an existing LWR can be configured to produce tritium, consume plutonium as fuel, and generate revenue through the production of electricity. This configuration is called a multipurpose reactor. Environmental

(2) Partially Completed Light Water Reactors. Under the Partially Completed LWR Alternative, commercial LWRs on which construction has been halted would be completed. The completed reactors would use MOX fuel containing surplus plutonium. The characteristics of these LWRs would be the same as those of the existing LWRs discussed in the Existing LWR Alternative. The Bellefonte Nuclear Plant located along the west bank of the Tennessee River in Alabama was used as a representative site for the environmental analysis of this alternative. Two reactor units (such as those at the Bellefonte Nuclear Plant) would be needed to implement this alternative.

(3) Evolutionary Light Water Reactors. The evolutionary LWRs are improved versions of existing commercial LWRs. Two design approaches were considered in the S&D PEIS. The first is a large PWR or BWR similar to the size of the existing PWR and BWR. The second is a small PWR approximately one-half the size of the large PWR. Two large or four small evolutionary LWRs would be needed to implement this alternative.

Under each design approach for this alternative, evolutionary LWRs would be built at a DOE site. Therefore, the six candidate sites for long-term storage were used to evaluate the environmental impacts of this alternative.

(4) Canadian Deuterium Uranium Reactor. Under the CANDU Reactor Alternative, the MOX fuel containing surplus plutonium would be fabricated in a U.S. facility, then transported for use in one or more commercial heavy water reactors in Canada. The Ontario Hydro Bruce-A Nuclear Generating Station identified by the Government of Canada was used as a representative site for evaluation of this alternative. This station is located on Lake Huron about 300 km (186 mi) northeast of Detroit, Michigan. Environmental analysis of domestic activities up to the U.S./Canadian border is presented in the S&D PEIS. The use of CANDU reactors would be subject to the policies, regulations, and approval of the Federal and Provincial Canadian Governments. Pursuant to Section 123 of the Atomic

analysis of the multipurpose reactor is included in Chapter 4 of the Final Programmatic Environmental Impact Statement for Tritium Supply and Recycling (TSR PEIS) (DOE/EIS-0161, October 1995) and Appendix N of the S&D PEIS. In the TSR PEIS ROD (December 1995), the multipurpose reactor was preserved as an option for future consideration. The Fast Flux Test Facility (FFTF) at Hanford has been under consideration for tritium production, and could also use surplus plutonium as reactor fuel if it were shown to be useful for tritium production. This ROD does not preclude use of the FFTF for tritium production or the potential use of surplus plutonium as fuel for the FFTF.

Energy Act, any export of MOX fuel from the United States to Canada must be made under the agreement for cooperation between the two countries. Spent fuel generated by a CANDU reactor would be disposed under the Canadian spent fuel program.

C. Preferred Alternative

The S&D Final PEIS presented the Department's Preferred Alternative for both storage and disposition. DOE has decided to implement the Preferred Alternative as described in the S&D Final PEIS. Thus, the Preferred Alternative is described in Section V of this ROD, Decisions.

D. Environmental Impacts

Chapter 4 and the appendices of the S&D Final PEIS analyzed the potential environmental impacts of the storage and disposition alternatives in detail. The S&D Final PEIS also evaluated the maximum site impacts that would result at Hanford, INEL, Pantex, and SRS from combining the Preferred Alternative for storage with the Preferred Alternative for disposition. Consistent with the Preferred Alternative, Hanford, INEL, Pantex, and SRS are each a possible location for all or some plutonium disposition activities. The siting, construction, and operation of disposition facilities will be covered in a separate, follow-on EIS. The S&D Final PEIS described the total life cycle impacts that would result from the Preferred Alternative at the DOE sites identified for potential placement of the disposition facilities.

Based on analyses in the S&D Final PEIS, the areas where impacts might be significant are as follows:

- The use of groundwater at the Pantex Plant for storage and disposition facilities could contribute to the overall declining water levels of the Ogallala Aquifer. The projected No Action Alternative water usage at Pantex in the year 2005 reflects a reduction from current usage due to planned downsizing over the next few years. The Preferred Alternative would require a 72-percent increase in the projected No Action Alternative water use; the total amount (428 million liters per year) is considerably less than what is currently being withdrawn (836 million liters per year) at Pantex.

- A set of postulated accidents was used for each plutonium disposition alternative over the life of the campaign to obtain potential radiological impacts at the four DOE sites where disposition facilities could be built. The PEIS analyzes the risk of latent cancer fatalities (reflecting the probability of accident occurrence and the latent

cancer fatalities potentially caused by the accident) for accidents that have low probabilities of occurrence and severe consequences, as well as those that have higher probabilities and low consequences. For potential severe accidents, the risk of latent cancer fatalities to the population located within 80 kilometers (50 miles) of the accident for the "front-end" disposition process campaign would range from 4.5×10^{-16} (that is, approximately 1 chance in 2 quadrillion) to 1.7×10^{-4} (approximately 1 chance in 6,000) for the pit disassembly/conversion facility, and from 1.5×10^{-16} to 1.3×10^{-4} for the plutonium conversion facility. This risk would range from 2.8×10^{-14} to 1.8×10^{-5} for the vitrification facility, from 7.0×10^{-16} to 1.9×10^{-7} for the ceramic immobilization facility, and from 4.6×10^{-16} to 4.3×10^{-4} for the MOX fuel fabrication facility. To estimate the change in risk associated with using MOX fuel instead of uranium fuel in existing LWRs, the severe accident scenarios assumed a large population distribution near a generic existing LWR and extreme meteorological conditions for dispersal, leading to large doses that were not necessarily reflective of actual site conditions. The resultant change in risk of cancer fatalities to a generic population located within 80 km (50 mi) of the severe accidents was estimated to range from -2.0×10^{-4} to 3.0×10^{-5} per year¹¹, reflecting a postulated risk of using MOX fuel that ranges from seven percent lower to eight percent higher than the risk of using uranium fuel. Under the Preferred Alternative, the estimated risk of cancer fatalities under severe accident conditions using MOX fuel in existing LWRs ranges from 0.01 to 0.098 for an 11-year campaign.

- Under the Preferred Alternative, HEU would continue to be stored at the Y-12 Plant at ORR in existing facilities that would be upgraded to meet requirements for withstanding natural phenomena, including earthquakes and tornadoes. This upgrade would reduce the expected risk for the design basis accidents analyzed in the Y-12 EA (for example, Building 9212) by approximately 80 percent, resulting in a latent cancer fatality risk of 7.4×10^{-6} (approximately 7 in a million) to the maximally exposed individual, 5.7×10^{-8} (approximately 6 in 100

¹¹ Accidents severe enough to cause a release of plutonium involved combinations of events that are highly unlikely. Estimates and analyses presented in Chapter 4 and summarized in Table 2.5-3 of the PEIS indicate a range of latent cancer fatalities of 5,900 to 7,300 and a risk of 0.016 to 0.15 of a fatality in the population for the 17-year campaign analyzed under the Existing LWR Alternative.

million) to a non-involved worker, and 5.1×10^{-7} (approximately 5 in 10 million) to the 80-km offsite population.

- Under the Preferred Alternative, safe, secure storage would continue for materials at Hanford, INEL, and ORR, pending disposition. Therefore, there would be no transportation impact at these sites until disposition. The storage transportation impact would come from movement of the RFETS materials to Pantex and SRS. If, following the EIS for construction and operation of plutonium disposition facilities, potential plutonium disposition activities were added to Hanford, INEL, Pantex, and SRS, the estimated total health effects for the life of the project from transportation of surplus plutonium (including transportation of those materials from RFETS to Pantex and SRS) would range from 0.193 fatalities for transportation to Pantex, to 1.87 fatalities for transportation to SRS (primarily from normal expected traffic accidents, not from radiological releases). In addition to the disposition activities at DOE sites, there would be transportation of the MOX fuel from the DOE fuel fabrication site to existing LWRs. The location of the LWRs and the destination of the MOX fuel could be either the eastern or western United States. For 4,000 km (2,486 mi) of such transportation, there could be up to an additional 3.61 potential fatalities (primarily from normal expected traffic accidents, not from radiological releases) for the life of the campaign, assuming 100 percent of the surplus plutonium would be used in commercial reactors. The actual amount would be smaller, and therefore potential fatalities would be lower, under the Preferred Alternative.

- At Hanford, INEL, Pantex, and SRS the Preferred Alternative would slightly increase regional employment and income. At RFETS, phaseout of plutonium storage would result in the loss of approximately 2,200 direct jobs. Compared to the total employment in the area, the loss of these jobs and the impacts to the regional economy would not be severe.

DOE has fully considered all of the environmental analyses in the S&D Final PEIS in reaching the decisions set forth in Section V, below.

E. Avoidance/Minimization of Environmental Harm

For the long-term storage of fissile material, there are four sites (Hanford, NTS, INEL, and LANL) where the Preferred Alternative is "no action"; that is, no plutonium would be stored at NTS, and at Hanford, INEL, and LANL, DOE would continue storage at

existing facilities, using proven nuclear materials safeguards and security procedures, until disposition. These existing facilities would be maintained to ensure their safe operation and compliance with applicable environmental, safety and health requirements. At RFETS, the Preferred Alternative is to phase out storage of weapons-usable fissile materials, thus mitigating environmental impacts at RFETS. There are three sites (Pantex, ORR, and SRS) where the Preferred Alternative is to upgrade existing and planned new facilities. Site-specific mitigation measures for storage at these sites have been described in the S&D Final PEIS, and are summarized as follows:

- At Pantex, to alleviate the effects from using groundwater from the Ogallala Aquifer, the city of Amarillo is considering supplying treated wastewater to Pantex from the Hollywood Road Wastewater Treatment Plant for industrial use; the Department will use such treated wastewater to the extent possible. Radiation doses to individual workers will be kept low by maintaining comprehensive badged monitoring and programs to keep worker exposures "as low as reasonably achievable" (ALARA).

- At ORR, radiation doses to individual workers will be kept low by maintaining comprehensive badged monitoring and ALARA programs, including worker rotations. Upgrades for HEU storage to meet performance requirements will include seismic structural modifications as documented in Natural Phenomena Upgrade of the Downsized/Consolidated Oak Ridge Uranium/Lithium Plant Facilities. These modifications will reduce the risk of accidents to workers and the public.

- At SRS, to minimize soil erosion impacts during construction, storm water management and erosion control measures will be employed. Mitigation measures for potential Native American resources will be identified through consultation with the potentially affected tribes. Radiation doses to individual workers will be kept low by maintaining comprehensive badged monitoring and ALARA programs including worker rotations. The modified Actinide Packaging and Storage Facility (APSF) will be designed and operated in accordance with contemporary DOE Orders and regulations to reduce risks to workers and the public.

From a nonproliferation standpoint, the highest standards for safeguards and security will be employed during transportation, storage, and disposition.

With respect to transportation, DOE will coordinate the transport of plutonium and HEU with State officials, consistent with current policy. Although the actual routes will be classified, they will be selected to circumvent populated areas, maximize the use of interstate highways, and avoid bad weather. DOE will continue to coordinate emergency preparedness plans and responses with involved states through a liaison program. The packaging, vehicles, and transport procedures being used are specifically designed and tested to prevent a radiological release under all credible accident scenarios.

For the Preferred Alternative for disposition, site-specific mitigation measures will be addressed in the follow-on, site-specific EIS. In the Nonproliferation and Arms Control Assessment of Weapons-Usable Fissile Material Storage and Plutonium Disposition Alternatives, measures are proposed to reduce the possibility of the theft or loss of material. For both immobilization and MOX fuel fabrication, bulk processing is the point in the disposition process when the material is most vulnerable to covert attempts to steal or divert it. A variety of opportunities for improving safeguards, some of which are already implemented at large, modern facilities, include near real-time accounting, increased automation in the process design, and improved containment and surveillance.

The security risks posed by transportation can be reduced by minimizing the amount of transportation required (for example, putting the plutonium processing and MOX fabrication operations at the same site), minimizing the number of sites to which material has to be shipped, and minimizing the distance between those sites.

F. Environmentally Preferable Alternatives

The environmental analyses in Chapter 4 of the S&D Final PEIS indicate that the environmentally preferable alternative (the alternative with the lowest environmental impacts over the 50 years considered in the PEIS) for storage of weapons-usable fissile materials would be the Preferred Alternative, which consists of No Action at Hanford, NTS, INEL, and LANL pending disposition, phaseout of storage at RFETS, and upgrades that would ultimately reduce environmental vulnerabilities at ORR, SRS, and Pantex.

For disposition of surplus plutonium, the environmentally preferable alternative would be the No Disposition Action alternative, because the

plutonium would remain in storage in accordance with decisions on the long-term storage of weapons-usable fissile materials, and there would be no new Federal actions that could impact the environment. For normal operations, analyses show that immobilization would be somewhat preferable to the existing LWR and preferred alternatives, although these alternatives, with the exception of waste generated, would be essentially environmentally comparable.¹²

Severe facility accident considerations indicate that immobilization options would be environmentally preferable to the existing reactor and preferred alternatives, although the likelihood of occurrence of severe accidents and the risk to the public are expected to be fairly low. Although No Disposition Action would be environmentally preferable, it would not satisfy the purpose and need for the Proposed Action, because the stockpile of surplus plutonium would not be reduced, and the Nonproliferation and Export Control Policy would not be implemented.

The hybrid approach (pursuing both reactors/MOX and immobilization) is being chosen over immobilization alone because of the increased flexibility it will provide by ensuring that plutonium disposition can be initiated promptly should one of the approaches ultimately fail or be delayed. Establishing the means for expeditious plutonium disposition will also help provide the basis for an international cooperative effort that can result in reciprocal, irreversible plutonium disposition actions by Russia. (See discussion in sections IV and V, below.)

IV. Non-Environmental Considerations

A. Technical Summary Reports

To assist in the preparation of this ROD, DOE's Office of Fissile Materials Disposition prepared and in July 1996 issued a *Technical Summary Report for Surplus Weapons-Usable Plutonium Disposition and a Technical Summary Report for Long-Term Storage of Weapons-Usable Fissile Materials*. These Technical Summary Reports (TSRs) summarize technical, cost, and schedule data for the storage and disposition alternatives that are considered in the S&D PEIS. After receiving comments on each of the

TSRs, DOE issued revised versions of the reports in October and November, 1996, respectively.

1. Storage Technical Summary Report

This report provides technical, cost and schedule information for long-term storage alternatives analyzed in the S&D PEIS. The cost information for each alternative is presented in constant 1996 dollars and also discounted or present value dollars. It identifies both capital costs and life cycle costs. The following costs are in 1996 dollars.

The cost analyses show that the combination (preferred) alternative for the storage of plutonium would provide advantages to the Department with respect to implementing disposition technologies and would be the least expensive compared to other storage alternatives. The cost of the combination (preferred) alternative would be approximately \$30 million in investment and \$360 million in operating costs from inception until disposition occurs. The cost of the upgrade at multiple sites alternative would be approximately \$380 million in investment and \$3.2 billion in operating costs for 50 years. The costs for the consolidation alternative could range from approximately \$40 million to \$360 million in investment and \$600 million to \$1.1 billion for operating costs for 50 years, depending on the extent to which existing facilities and capabilities can be shared with other programs at the sites.

The schedule analysis shows that the upgraded storage facilities for plutonium under the combination (preferred) alternative could be operational by 2004 at Pantex (Zone 12), and by 2001 at SRS. The upgrade for the storage of HEU could be completed by 2004 (or earlier). RFETS pits could be received at Pantex beginning in 1997 in Zone 4 on a temporary basis until Zone 12 upgrades are completed. The other analyzed alternatives (upgrade and consolidation) would require about six years to complete.

2. Disposition Technical Summary Report

This report provides technical viability, cost, and schedule information for plutonium disposition alternatives and variants analyzed in the S&D PEIS. The variants analyzed in the report are based on pre-conceptual design information in most cases.

a. Technical Viability Estimates. The report indicates that each of the alternatives appears to be technically viable, although each is currently at a different level of technical maturity. There is high confidence that the technologies are sufficiently mature to

allow procurement and/or construction of facilities and equipment to meet plutonium disposition technical requirements and to begin disposition in about a decade.¹³

Reactor Alternatives—Light water reactors (LWRs) can be readily converted to enable the use of MOX fuels. Many European LWRs currently operate on MOX fuel cycles. Although some technical risks exist, they are all amenable to engineering resolution. Sufficient existing domestic reactor capacity exists, unless significant delays occur in the disposition mission. CANDU reactors appear to be capable of operating on MOX fuel cycles, but this has never been demonstrated on any industrial scale. Therefore, additional development would be required to achieve the level of maturity for the CANDU reactors that exists for light water reactors. Partially complete and evolutionary LWRs would involve increased technical risk relative to existing LWRs, as well as the need to complete or build (and license) new reactor facilities. The spent MOX fuel waste form that results from reactor disposition of surplus plutonium will have to satisfy waste acceptance criteria for the geologic repository.

Immobilization Alternatives—All vitrification alternatives require additional research and development prior to implementation of immobilization of weapons-usable plutonium. However, a growing experience base exists relating to the vitrification of high-level waste. These existing technologies can be adapted to the plutonium disposition mission, though different equipment designs and glass formulations will generally be necessary due to criticality considerations and chemical differences between plutonium and HLW that may affect the stability of the glass matrix. Vitrification and ceramic immobilization alternatives are similar with regard to the technical maturity of incorporating plutonium in their respective matrices. The technical viability of electrometallurgical treatment has not yet been established for the plutonium disposition mission. The experimental data base for this alternative is limited, and critical questions on waste form performance are not yet resolved. This alternative is considered practical only if the underlying technology is further

¹² The potential risk of latent cancer fatality for a maximally exposed individual of the public from lifetime accident-free operation under the various alternatives are: 1.2×10^{-9} to 1.2×10^{-7} for boreholes, 1.2×10^{-9} to 1.2×10^{-7} for immobilization (vitrification or ceramic immobilization), 1.3×10^{-6} to 2.6×10^{-6} for existing LWRs, and 9.0×10^{-7} to 1.7×10^{-6} for the Preferred Alternative.

¹³ Actual timing would depend on technical demonstrations, follow-on site-specific environmental review, detailed cost estimates, and international agreements.

developed for spent nuclear fuels.¹⁴ All of the immobilization alternatives will require qualification (to meet acceptance criteria) of the waste form for the geologic repository, and may require legislative clarification or NRC rulemaking.

Deep Borehole Alternatives—Uncertainties for the deep borehole alternatives relate to selecting and qualifying a site; additional legislation and regulations, or legislative and regulatory clarification, may be required. The front-end feed processing operations for the deep borehole alternatives are much simpler than for other alternatives because no highly radioactive materials are processed, thus avoiding the need for remote handling operations. Emplacement technologies are comprised of largely low-technology operations which would be adaptations from existing hardware and processes used in the oil and gas industry.

Hybrid Approaches—Two hybrid approaches that combine technologies were considered as illustrative examples, using existing LWR or CANDU reactors in conjunction with a can-in-canister (immobilization) approach. Hybrids provide insurance against technical or institutional hurdles which could arise for a single technology approach for disposition. If any significant roadblock is encountered in any one area of a hybrid, it would be possible to simply divert the feed material to the more viable technology. In the case of a single technology, such roadblocks would be more problematic.

b. **Cost Estimates.** The following discussion is in constant 1996 dollars unless otherwise stated.

(1) **Investment Costs.**

- The investment costs for existing reactor variants tends to be about \$1 billion; completing or building new reactors increases the investment cost to between \$2 billion and \$6 billion.

- The investment cost for the immobilization alternatives ranges from approximately \$0.6 billion for the can-in-canister variants to approximately \$2 billion for new greenfield variants.¹⁵

- Hybrid alternatives (combining both immobilization and reactor alternatives) require approximately \$200 million additional investment over the existing

light water reactor stand-alone alternatives.

- Investment costs for the deep borehole alternatives range from about \$1.1 billion for direct emplacement to about \$1.4 billion for immobilized emplacement.

- Alternatives that utilize existing facilities for plutonium processing, immobilization, or fuel fabrication would realize significant investment cost savings over building new facilities for the same function.

- Large uncertainties in the cost estimates exist, relating to both engineering and institutional factors.

- A significant fraction of the investment cost for an alternative/variant is related to the front-end facilities for the extraction of the plutonium from pits and other plutonium-bearing materials and for other functions that are common to all alternatives.

(2) **Life Cycle Costs.**

- The life cycle costs for hybrid alternatives are similar to the stand-alone reactor alternatives. For the existing LWR/immobilization hybrid alternative (preferred alternative), the cost is \$260 million higher than the stand-alone reactor alternative; for the CANDU/immobilization hybrid alternative, the cost is \$70 million higher.

- The combined investment and net operating costs for MOX fuel are higher than for commercial uranium fuel; thus, the cost of MOX fuel cannot compete economically with low-enriched uranium fuel for LWRs or natural uranium fuel for CANDU reactors.

- The can-in-canister approaches are the most attractive variants for immobilization based on cost considerations.

- The deep borehole alternatives are more expensive than the can-in-canister and existing reactor alternatives. The immobilized borehole alternative life cycle cost is \$1 billion greater than that for the direct emplacement alternative (\$3.6 billion vs. \$2.6 billion).

- Large uncertainties in the cost estimates exist, relating to engineering, regulatory, and policy considerations.

c. **Schedule Estimates.** The key conclusions of the Disposition Technical Summary Report with respect to schedules are as follows:

- Significant schedule uncertainties exist, relating to both engineering and institutional factors.

- Opportunities for compressing or expanding schedules exist.

(1) **Reactor Alternatives.** • The rate at which MOX fuel is consumed in reactors will depend on the rate that MOX fuel is provided and fabricated,

and the rate that plutonium oxide is provided to the MOX fuel fabrication facility.

- The time to attain production scale operation in existing LWRs and CANDU reactors could be about 8–12 years, depending on the need for and source of test assemblies that might be required.

- The time to complete the disposition mission is a function of the number of reactors committed to the mission, among other factors. For the variants considered, the time to complete varies from about 24 to 31 years.

(2) **Immobilization Alternatives.**

- The time to start the disposition mission ranges from 7 to 13 years, depending on the technology used and whether existing facilities are used.

- The operating campaign for the immobilization alternatives at full-scale operation would be about 10 years; it is possible to compress or expand the operating schedule by several years, if desired, by resizing the immobilization facility designs selected for analysis in this study. The overall mission duration (including research and development, construction, and operation) is expected to be about 18 to 24 years.

- Potential delays for start-up of the immobilization alternatives involve completing process development and demonstration, and qualifying the waste form for a geologic repository.

(3) **Deep Borehole Alternatives.** • The time to start-up is expected to be 10 years.

- The operating duration of the mission would be about 10 years, although completing all burial operations at the borehole site in 3 years is possible. Therefore, the overall mission duration is estimated to be 20 years with accelerated emplacement reducing the duration by about 7 years.

- The schedule for the deep borehole alternatives would depend in part on selecting and qualifying a site, and obtaining legislative and regulatory clarification as well as any necessary permits.

(4) **Hybrid Approaches.** • In general, the schedule data that apply to the component technologies apply to the hybrid alternatives as well.

- Confidence in an early start-up and an earlier completion can both be improved with a hybrid approach, relative to stand-alone alternatives.

- Hybrid alternatives provide an inherent back-up technology approach to enhance confidence in attaining schedule goals.

¹⁴ A recent study by the National Research Council concludes that the electrometallurgical treatment technology is not sufficiently mature to provide a reliable basis for timely plutonium disposition. "An Evaluation of the Electrometallurgical Approach for Treatment of Excess Weapons Plutonium" (National Academy Press, Washington, D.C., 1996).

¹⁵ "Greenfield" means a variant involving a new facility, with no existing plutonium-handling infrastructure.

B. Nonproliferation Assessment

To assist in the development of this ROD, DOE's Office of Arms Control and Nonproliferation, with support from the Office of Fissile Materials Disposition, prepared a report, Nonproliferation and Arms Control Assessment of Weapons-Usable Fissile Material Storage and Plutonium Disposition Alternatives. The report was issued in draft form in October 1996, and following a public comment period, was issued in final form in January 1997. It analyzes the nonproliferation and arms reduction implications of the alternatives for storage of plutonium and HEU, and disposition of excess plutonium. It is based in part on a Proliferation Vulnerability Red Team Report prepared for the Office of Fissile Materials Disposition by Sandia National Laboratory. The assessment describes the benefits and risks associated with each option. Some of the "options" and "alternatives" discussed in the Nonproliferation Assessment are listed as "variants" (such as can-in-canister) in the S&D Final PEIS. The key conclusions of the report, as presented in its Executive Summary, are reproduced below.

1. Storage. • Each of the options under consideration for storage of U.S. weapons-usable fissile materials has the potential to support U.S. nonproliferation and arms reduction goals, if implemented appropriately.

- Each of the storage options could provide high levels of security to prevent theft of nuclear materials, and could provide access to excess materials for international monitoring.

- Making excess plutonium and HEU available for bilateral U.S.-Russian monitoring and International Atomic Energy Agency (IAEA) safeguards, while protecting proliferation-sensitive information, would help demonstrate the U.S. commitment never to return this material to nuclear weapons, providing substantial arms reduction and nonproliferation benefits in the near-term.

2. Disposition of U.S. Excess Plutonium

a. *In General.* • Each of the options for disposition of excess weapons plutonium that meets the Spent Fuel Standard would, if implemented appropriately, offer major nonproliferation and arms reduction benefits compared to leaving the material in storage in directly weapons-usable form. Taking into account the likely impact on Russian disposition activities, the no-action alternative appears to be by far the least desirable of the plutonium disposition options

from a nonproliferation and arms reduction perspective.

- Carrying out disposition of excess U.S. weapons plutonium, using options that ensured effective nonproliferation controls and resulted in forms meeting the Spent Fuel Standard, would:

- reduce the likelihood that current arms reductions would be reversed, by significantly increasing the difficulty, cost, and observability of returning this plutonium to weapons;

- increase international confidence in the arms reduction process, strengthening political support for the nonproliferation regime and providing a base for additional arms reductions, if desired;

- reduce long-term proliferation risks posed by this material by further helping to ensure that weapons-usable material does not fall into the hands of rogue states or terrorist groups; and

- lay the essential foundation for parallel disposition of excess Russian plutonium, reducing the risks that Russia might threaten U.S. security by rebuilding its Cold War nuclear weapons arsenal, or that this material might be stolen for use by potential proliferators.

- Choosing the "no-action alternative" of leaving U.S. excess plutonium in storage in weapons-usable form indefinitely, rather than carrying out disposition:

- would represent a clear reversal of the U.S. position seeking to reduce excess stockpiles of weapons-usable materials worldwide;

- would make it impossible to achieve disposition of Russian excess plutonium;

- could undermine international political support for nonproliferation efforts by leaving open the question of whether the United States was maintaining an option for rapid reversal of current arms reductions; and

- could undermine progress in nuclear arms reductions.

- The benefits of placing U.S. excess plutonium under international monitoring and then transforming it into forms that met the Spent Fuel Standard would be greatly increased, and the risks of these steps significantly decreased, if Russia took comparable steps with its own excess plutonium on a parallel track. The two countries need not use the same plutonium disposition technologies, however.

- As the 1994 NAS committee report¹⁶ concluded, options for disposition of U.S. excess weapons plutonium will provide maximum

nonproliferation and arms control benefits if they:

- minimize the time during which the excess plutonium is stored in forms readily usable for nuclear weapons;

- preserve material safeguards and security during the disposition process, seeking to maintain to the extent possible the same high standards of security and accounting applied to stored nuclear weapons (the Stored Weapons Standard);

- result in a form from which the plutonium would be as inaccessible and unattractive for weapons use as the larger and growing quantity of plutonium in commercial spent fuel (the Spent Fuel Standard).

- In order to achieve the benefits of plutonium disposition as rapidly as possible, and to minimize the risks and negative signals resulting from leaving the excess plutonium in storage, it is important for disposition options to begin, and to complete the mission as soon as practicable taking into account nonproliferation, environment, safety, and health, and economic constraints. Timing should be a key criterion in judging disposition options. Beginning the disposition quickly is particularly important to establishing the credibility of the process, domestically and internationally.

- Each of the options under consideration for plutonium disposition has its own advantages and disadvantages with respect to nonproliferation and arms control, but none is clearly superior to the others.

- Each of the options under consideration for plutonium disposition can potentially provide high levels of security and safeguards for nuclear materials during the disposition process, mitigating the risk of theft of nuclear materials.

- Each of the options under consideration for plutonium disposition can potentially provide for effective international monitoring of the disposition process.

- Plutonium disposition can only reduce, not eliminate, the security risks posed by the existence of excess plutonium, and will involve some risks of its own:

- Because all plutonium disposition options would take decades to complete, disposition is not a near-term solution to the problem of nuclear theft and smuggling. While disposition will make a long-term contribution, the near-term problem must be addressed through programs to improve security and safeguarding for nuclear materials, and to ensure adequate police, customs, and intelligence capabilities to interdict nuclear smuggling.

¹⁶ See footnote 3, above.

- All plutonium disposition options under consideration would involve processing and transport of plutonium, which will involve more risk of theft in the short term than if the material had remained in heavily guarded storage, in return for the long-term benefit of converting the material to more proliferation-resistant forms.

- Both the United States and Russia will still retain substantial stockpiles of nuclear weapons and weapons-usable fissile materials even after disposition of the fissile materials currently considered excess is complete. These weapons and materials will continue to pose a security challenge regardless of what is done with excess plutonium.

- None of the disposition options under consideration would make it impossible to recover the plutonium for use in nuclear weapons, or make it impossible to use other plutonium to rebuild a nuclear arsenal. Therefore, disposition will only reduce, not eliminate, the risk of reversal of current nuclear arms reductions.

- A U.S. decision to choose reactor alternatives for plutonium disposition could offer additional arguments and justifications to those advocating plutonium reprocessing and recycle in other countries. This could increase the proliferation risk if it in fact led to significant additional separation and handling of weapons-usable plutonium. On the other hand, if appropriately implemented, plutonium disposition might also offer an opportunity to develop improved procedures and technologies for protecting and safeguarding plutonium, which could reduce proliferation risks and would strengthen U.S. efforts to reduce the stockpiles of separated plutonium in other countries.

- Large-scale bulk processing of plutonium, including processes to convert plutonium pits to oxide and prepare other forms for disposition, as well as fuel fabrication or immobilization processes, represents the stage of the disposition process when material is most vulnerable to covert theft by insiders or covert diversion by the host state. Such bulk processing is required for all options, however; in particular, initial processing of plutonium pits and other forms is among the most proliferation-sensitive stages of the disposition process, but is largely common to all the options. More information about the specific process designs is needed to determine whether there are significant differences between the various immobilization and reactor options in the overall difficulty of providing effective assurance against theft or

diversion during the different types of bulk processing involved, and if so, which approach is superior in this respect.

- Transport of plutonium is the point in the disposition process when the material is most vulnerable to overt armed attacks designed to steal plutonium. With sufficient resources devoted to security, however, high levels of protection against such overt attacks can be provided. International, and particularly overseas, shipments would involve greater transportation concerns than domestic shipments.¹⁷

b. Conclusions Relating to Specific Disposition Options.

- The reactor options, homogeneous immobilization¹⁸ options, and deep borehole immobilized emplacement option can all meet the Spent Fuel Standard. The can-in-canister options are being refined to increase the resistance to separation of the plutonium cans from the surrounding glass, with the goal of meeting the Spent Fuel Standard. The deep borehole direct emplacement option substantially exceeds the Spent Fuel Standard with respect to recovery by sub-national groups, but could be more accessible and attractive for recovery by the host state than spent fuel.

- The reactor options have some advantage over the immobilization options with respect to perceived irreversibility, in that the plutonium would be converted from weapons-grade to reactor-grade, even though it is possible to produce nuclear weapons with both weapons and reactor-grade plutonium. The immobilization and deep borehole options have some advantage over the reactor options in avoiding the perception that they could potentially encourage additional separation and civilian use of plutonium, which itself poses proliferation risks.

- Options that result in accountable "items" (for purposes of international safeguards) whose plutonium content can be accurately measured (such as

¹⁷ International shipments would be involved (from the United States to Canada) if the CANDU option were pursued as a result of international agreements among the U.S., Canada, and Russia. Overseas shipments would be involved if European MOX fuel fabrication were utilized in the interim before a domestic MOX fabrication facility were completed. The Preferred Alternative and the decisions in this ROD do not involve European MOX fuel fabrication.

¹⁸ The term "homogeneous immobilization" refers to mixing of solutions of plutonium and either HLW or cesium in liquid form, followed by solidification of the mixture in either glass or ceramic matrices. This contrasts with the "can-in-canister" variant, in which the plutonium and HLW or cesium materials are never actually mixed together.

fuel assemblies or immobilized cans without fission products in the "can-in-canister" option) offer some advantage in accounting to ensure that the output plutonium matches the input plutonium from the process. Other options (such as homogeneous immobilization or immobilized emplacement in deep boreholes) would require greater reliance on containment and surveillance to provide assurance that no material was stolen or diverted—but in some cases could involve simpler processing, easing the task of providing such assurance.

- The principal uncertainty with respect to using excess weapons plutonium as MOX in U.S. LWRs relates to the potential difficulty of gaining political and regulatory approvals for the various operations required.

- Compared to the LWR option, the CANDU option would involve more transport and more safeguarding issues at the reactor sites themselves (because of the small size of the CANDU fuel bundles and the on-line refueling of the CANDU reactors). Demonstrating the use of MOX in CANDU reactors by carrying out this option for excess weapons plutonium disposition could somewhat detract from U.S. efforts to convince nations operating CANDU reactors in regions of proliferation concern not to pursue MOX fuel cycles, but these nations are likely to base their fuel cycle decisions primarily on factors independent of disposition of this material. Disposing of excess weapons plutonium in another country long identified with disarmament could have significant symbolic advantages, particularly if carried out in parallel with Russia. Disposition of Russian plutonium in CANDU reactors, however, would require resolving additional transportation issues and additional questions relating to the likely Russian desire for compensation for the energy value of the plutonium.

- The immobilization options have the potential to be implemented more quickly than the reactor options. They face somewhat less political uncertainty but somewhat more technical uncertainty than the reactor options.

- The likelihood of very long delays in gaining approval for siting and construction of deep borehole sites represents a very serious arms reduction and nonproliferation disadvantage of the borehole option, in either of its variants. While the deep borehole direct-emplacement option requires substantially less bulk processing than the other disposition options, that option may not meet the Spent Fuel Standard for retrievability by the host state, as mentioned above. Any potential

advantage from the reduced processing is small compared to the large timing uncertainty and the potential retrievability disadvantage.

- Similarly, the electrometallurgical treatment option, because it is less developed than the other immobilization options, involves more uncertainty in when it could be implemented, which represents a significant arms reduction and nonproliferation disadvantage. It does not appear to have major compensating advantages compared to the other immobilization options.

- The "can-in-canister" immobilization options have a timing advantage over the homogeneous immobilization options, in that, by potentially relying on existing facilities, they could begin several years sooner. As noted above, however, modified systems intended to allow this option to meet the Spent Fuel Standard are still being designed.

C. Comments on the S&D Final PEIS

After issuing the Final PEIS, DOE received approximately 100 letters from organizations and individuals commenting on the alternatives addressed in the PEIS. Many of these letters expressed opposition to the MOX fuel approach for surplus plutonium disposition. The major concern raised in these letters was the contention that the use of MOX fuel is associated with proliferation risk as well as additional delays, costs, and safety and environmental risks. One of these letters was from a coalition of 14 national organizations recommending that the Department decide to utilize immobilization for the disposition of all surplus plutonium and that MOX be retained for use, if at all, only as an "insurance policy" if immobilization should prove infeasible. Several of those 14 organizations also wrote separately making similar points. Conversely, many of the letters provided comments in support of the use of MOX fuel and/or a dual path, while a few expressed opposition to the immobilization alternatives.

Seven of the letters received suggested the use of disposition approaches that were not analyzed in the PEIS. Three of these approaches (dropping plutonium into volcanoes, burying it in the sea at the base of a volcano, and storing it in large granite or marble structures) are similar to options that were either considered (but found to be unreasonable) in a screening process that preceded the PEIS, or were addressed in the PEIS Comment Response Document. These approaches were considered to be potentially

damaging to the environment, among other things, and were therefore dismissed as unreasonable. Three other alternatives (plasma technology, binding and neutralizing plutonium with a new organic material, and use in rocket engines) recommended in these letters would require a substantial amount of development and could not be accomplished in the same time frame as alternatives analyzed in the PEIS. One commentator suggested adding the plutonium to the radioactive sludge being stored at Hanford for eventual disposal. The Department views this as unreasonable because of delays and increased costs that would be incurred in the program to manage the wastes in the Hanford tanks. One commentator was opposed to the utilization of Hanford's Fuels and Materials Examination Facility for MOX fuel fabrication and the Fast Flux Test Facility for MOX fuel burning.

All of the issues raised in these letters are covered in the body of the Final PEIS, in the Comment Response Document, the Summary Report of the Screening Process (DOE/MD-0002, March 19, 1995), the Technical Summary Report for Surplus Weapons-Usable Plutonium Disposition, or the Nonproliferation and Arms Control Assessment of Weapons-Usable Fissile Material Storage and Plutonium Disposition Alternatives, which have each been considered in reaching this ROD.

The Department's decision for surplus plutonium disposition is to pursue both the existing LWR (MOX fuel) and immobilization approaches. DOE recognizes that the estimated life-cycle cost of immobilization alone would be less than that of the hybrid approach (pursuing both), but the additional expense would be warranted by the increased flexibility should one of the approaches ultimately fail, and the increased ability to influence Russian plutonium disposition actions. (The lowest cost approach would be the No Disposition Action alternative; however, as noted in section III.F, above, that option would not satisfy the purpose and need for this program.) DOE also recognizes that analyses in the PEIS indicated that, for normal operation, the environmental and health impacts would be somewhat lower for immobilization, although, with the exception of waste generation, impacts for the preferred, immobilization, and existing LWR (MOX) alternatives would be essentially comparable (see prior discussion).

Potential latent cancer fatalities for members of the public under the MOX approach would be significantly higher

than under the immobilization approach only under highly unlikely facility accident scenarios; the risk (taking into account accident probabilities) to the public of latent cancer fatalities from accidents would be fairly low for both approaches.

From the nonproliferation standpoint, results of the Nonproliferation and Arms Control Assessment of Weapons-Usable Fissile Material Storage and Plutonium Disposition Alternatives (see section IV.B) indicated that each of the options under consideration for plutonium disposition has its own advantages and disadvantages, and each can potentially provide high levels of security and safeguards for nuclear materials during the disposition process, mitigating the risk of theft of nuclear materials. Initial processing of plutonium pits and other forms is among the most proliferation-sensitive stages of the disposition process, but is largely common to all the options. Although the Assessment also concluded that none of the approaches is clearly superior to the others, both the Nonproliferation Assessment and a letter from the Secretary of Energy Advisory Board Task Force on the Nonproliferation and Arms Control Implications of Weapons-Usable Fissile Materials Disposition Alternatives (included as Appendix B to the Nonproliferation Assessment) concluded that the hybrid approach (both reactors/MOX and immobilization) is preferable because of uncertainties in each approach and because it would minimize potential delays should problems develop with either approach. Numerous comment letters have made similar points.

One such letter was received from five individuals who were the U.S. participants on the U.S.-Russian Independent Scientific Commission on Disposition of Excess Weapons Plutonium. This letter supported the dual-track approach on the grounds that "ruling out reactors and thus depending solely on vitrification as the only approach to plutonium disposition that might be implementable anytime soon, would have far bigger nonproliferation liabilities than would the two-track approach." These commentators argued that designating only immobilization as the preferred approach, with MOX as a back-up, would have essentially all the nonproliferation and arms reduction liabilities of a one-track approach, which would weaken the U.S. position and have severe consequences for the likely success of programs to carry out permanent disposition of weapons plutonium in Russia, and therefore jeopardize the success of programs to

carry out U.S. disposition. These commentors stated that without the dual-track approach, the U.S. will lose any leverage it might have over the conditions and safeguards accompanying the use of Russian plutonium in their reactors. They also pointed out that pursuing both the MOX option and immobilization in the U.S. may be the best way to convince Russia, which currently favors converting its own plutonium to MOX fuel, of the value of immobilization for a portion of its excess plutonium. These commentors argued that the dual-track approach would not undermine U.S. nonproliferation policy, would not increase the risk of nuclear theft and terrorism, and would not lead to a new domestic plutonium recycle industry since it would not significantly affect the huge economic barriers to using MOX fuel on a commercial basis.

Two commentors expressed opposition to plutonium recycling (reprocessing), citing the Final Generic Environmental Statement on the Use of Recycle Plutonium in Mixed Oxide Fuel in Light Water Cooled Reactors (GESMO), NUREG-0002, which was issued by the NRC in 1976, and President Carter's decision to ban plutonium recycling. DOE notes that plutonium recycling is not part of the plutonium disposition program or the decisions in this ROD; on the contrary, this ROD includes conditions on the use of MOX fuel that are intended to prevent the use of recycled plutonium.

The use of MOX fuel in existing reactors would be undertaken in a manner that is consistent with the United States' policy objective on the irreversibility of the nuclear disarmament process and the United States' policy discouraging the use of plutonium for civil purposes. To this end, implementing the MOX alternative would include government ownership and control of the MOX fuel fabrication facility at a DOE site, and use of the facility only for the surplus plutonium disposition program. There would be no reprocessing or subsequent reuse of spent MOX fuel. The MOX fuel would be used in a once-through fuel cycle in existing reactors, with appropriate arrangements, including contractual or licensing provisions, limiting use of MOX fuel to surplus plutonium disposition.

One commentor, who opposed MOX fuel use, urged DOE not to use European MOX fuel fabrication capability if the MOX approach is pursued. In this ROD, DOE has not decided to use European MOX fuel fabrication.

V. Decisions

A. Storage of Weapons-Usable Fissile Materials

Consistent with the Preferred Alternative in the S&D Final PEIS, the Department has decided to reduce, over time, the number of locations where the various forms of plutonium are stored, through a combination of storage alternatives in conjunction with a combination of disposition alternatives. DOE will begin implementing this decision by moving surplus plutonium from RFETS as soon as possible, transporting the pits to Pantex beginning in 1997, and non-pit plutonium materials to SRS upon completion of the expanded Actinide Packing and Storage Facility (APSF), anticipated in 2001. Over time, DOE will store this plutonium in upgraded facilities at Pantex and in the expanded APSF. Surplus and non-surplus HEU will be stored in upgraded facilities at ORR. Storage facilities for the surplus HEU will also be modified, as needed, to accommodate international inspection requirements consistent with the President's Nonproliferation and Export Control Policy. Accordingly, DOE has decided to pursue the following actions for storage:

- Phase out storage of all weapons-usable plutonium at RFETS beginning in 1997; move pits to Pantex, and non-pit materials to SRS upon completion of the expanded APSF. At Pantex, DOE will repackage pits from RFETS in Zone 12, then place them in existing storage facilities in Zone 4, pending completion of facility upgrades in Zone 12. At SRS, DOE will expand the planned new APSF, and move separated and stabilized non-pit plutonium materials from RFETS to the expanded APSF upon completion. The small number of pits currently at RFETS that are not in shippable form will be placed in a shippable condition in accordance with existing procedures prior to shipment to Pantex. Additionally, some pits and non-pit plutonium materials from RFETS could be used at SRS, LANL, and Lawrence Livermore National Laboratory (LLNL) for tests and demonstrations of aspects of disposition technologies (see disposition decision, below). All non-pit weapons-usable plutonium materials currently stored at RFETS are surplus.

The Department's decision to remove plutonium from RFETS is based on the cleanup agreement among DOE, EPA, and the State of Colorado for RFETS, the proximity of RFETS to the Denver metropolitan area, and the fact that some of the RFETS plutonium is currently stored in buildings 371 and

376, two of the most vulnerable facilities as defined by and identified in DOE's Plutonium Working Group Report on Environmental, Safety, and Health Vulnerabilities Associated With the Department's Plutonium Storage (DOE/EH-0414, November, 1994).

- Upgrade storage facilities at Zone 12 South (to be completed by 2004) at Pantex to store those surplus pits currently stored at Pantex, and surplus pits from RFETS, pending disposition. Storage facilities at Zone 4 will continue to be used for these pits prior to completion of the upgrade.

- In accordance with the preferred alternative in the Final Programmatic Environmental Impact Statement for Stockpile Stewardship and Management (Stockpile Stewardship and Management PEIS), store Strategic Reserve pits at Pantex in other upgraded facilities in Zone 12.

The Department's decision to consolidate pit storage at Pantex places the pits at a central location where most of the pits already reside and where the expertise and infrastructure are already in place to accommodate pit storage.¹⁹ Pantex has more than 40 years of experience with the handling of pits. Zone 12 facilities would be modified for long-term storage of the Pantex plutonium inventory and the small number of pits transferred from RFETS and SRS for a modest cost (about \$10 million capital cost). Pursuant to the Final EIS for the Continued Operation of the Pantex Plant and Associated Storage of Nuclear Weapon Components (DOE/EIS-0225), DOE is proposing to continue nuclear weapons stockpile management operations and related activities at the Pantex Plant, including interim storage of up to 20,000 pits.²⁰ Consequently, the storage of surplus pits at Pantex would offer the opportunity to share trained people and other resources, and a decreased cost could be realized over other sites without similar experience. Using the Pantex Plant for pit storage would also involve the lowest cost and the least new construction relative to other sites.

- Expand the planned APSF at SRS (Upgrade Alternative) to store those surplus, non-pit plutonium materials currently at SRS and surplus non-pit plutonium materials from RFETS, pending disposition (see disposition decision, below). DOE analyzed the

¹⁹ A small number of research and development pits located at RFETS that have been and will continue to be packaged and returned to LANL and LLNL are outside the scope of the S&D PEIS and this ROD.

²⁰ The pits that are to be moved to Pantex pursuant to this ROD fall within the 20,000 pit limit.

potential impacts of constructing and operating the APSF in the Final Environmental Impact Statement, Interim Management of Nuclear Materials (DOE/EIS-0220) and announced the decision to build the facility in the associated ROD (60 FR 65300, December 19, 1995). DOE, pursuant to the decisions announced here to store surplus non-pit plutonium at SRS, will likely design and build the APSF and the expanded space to accommodate the RFETS material as one building,²¹ which DOE plans to complete in 2001. The RFETS surplus non-pit plutonium materials²² will be moved to SRS after stabilization is performed at RFETS under corrective actions in response to Defense Nuclear Facilities Safety Board Recommendation 94-1; and after the material is packaged in DOE-approved storage and shipping containers pursuant to existing procedures. The surplus plutonium already on-site at SRS and the movement of separated and stabilized non-pit plutonium from RFETS would result in the storage of a maximum of 10 metric tons of surplus plutonium in the new, expanded APSF at SRS. In addition, shipment of the non-pit plutonium from RFETS to SRS, after stabilization, would only be implemented if the subsequent ROD for a plutonium disposition site (see Section V.B., below) calls for immobilization of plutonium at SRS. Placement of surplus, non-pit plutonium materials in a new storage facility at SRS will allow utilization of existing expertise and plutonium handling capabilities in a location where disposition activities could occur (see disposition decision, below). The decision to store non-pit plutonium from RFETS at SRS places most non-pit material at a plutonium-competent site with the most modern, state-of-the-art storage and processing facilities, and at a site with the only remaining large-scale chemical separation and processing capability in the DOE

complex.²³ Pits currently located at SRS will be moved to Pantex for storage consistent with the Preferred Alternative in the Stockpile Stewardship and Management PEIS. There are no strategic non-pit materials currently located at SRS.

- Continue current storage (No Action) of surplus plutonium at Hanford and INEL, pending disposition (or movement to lag storage²⁴ at disposition facilities when selected).²⁵ This action will allow surplus plutonium to remain at the sites with existing expertise and plutonium handling capabilities, and where potential disposition activities could occur (see disposition decision, below). There are no non-surplus weapons-usable plutonium materials currently stored at either site.

- Continue current storage (No Action) of plutonium at LANL, pending disposition (or movement to lag storage at the disposition facilities). This plutonium will be stored in stabilized form with the non-surplus plutonium in the upgraded Nuclear Material Storage Facility pursuant to the No Action alternative for the site.

- Take No Action at the NTS. DOE will not introduce plutonium to sites that do not currently have plutonium in storage.

- Upgrade storage facilities at the Y-12 Plant (Y-12) (to be completed by 2004 or earlier) at ORR to store non-surplus HEU and surplus HEU pending disposition. Existing storage facilities at Y-12 will be modified to meet natural phenomena requirements, as documented in Natural Phenomena Upgrade of the Downsized/Consolidated Oak Ridge Uranium/Lithium Plant Facilities (Y/EN-5080, 1994). Storage facilities will be consolidated, and the storage footprint will be reduced, as surplus HEU is dispositioned and blended to low-enriched uranium, pursuant to the ROD for the Disposition of Surplus Highly Enriched Uranium Final Environmental Impact Statement (61 FR 40619, August 5, 1996). Consistent with the Preferred

Alternative in the Stockpile Stewardship and Management PEIS, HEU strategic reserves will be stored at the Y-12 Plant.

B. Plutonium Disposition

Consistent with the Preferred Alternative in the S&D Final PEIS, DOE has decided to pursue a strategy for plutonium disposition that allows for immobilization of surplus weapons plutonium in glass or ceramic forms and burning of the surplus plutonium as mixed oxide fuel (MOX) in existing reactors. The decision to pursue disposition of the surplus plutonium using these approaches is supported by the analyses in the Disposition Technical Summary Report (section IV.A.2 above) and the Nonproliferation Assessment (section IV.B above), as well as the S&D Final PEIS. The results of additional technology development and demonstrations, site-specific environmental review, detailed cost proposals, nonproliferation considerations, and negotiations with Russia and other nations will ultimately determine the timing and extent to which MOX as well as immobilization is deployed. These efforts will provide the basis and flexibility for the United States to initiate disposition efforts either multilaterally or bilaterally through negotiations with other nations, or unilaterally as an example to Russia and other nations.

Pursuant to this decision, the United States policy not to encourage the civil use of plutonium and, accordingly, not to itself engage in plutonium reprocessing for either nuclear power or nuclear explosive purposes, does not change. Although under this decision some plutonium may ultimately be burned in existing reactors, extensive measures will be pursued (see below) to ensure that federal support for this unique disposition mission does not encourage other civil uses of plutonium or plutonium reprocessing. The United States will maintain its commitments regarding the use of plutonium in civil nuclear programs in western Europe and Japan.

The Disposition Technical Summary Report (section IV.A.2 above) concluded that the lowest cost option for plutonium disposition would be immobilization using the can-in-canister variant and existing facilities to the maximum extent possible, with a net life-cycle cost of about \$1.8 billion. The Disposition Technical Summary Report also estimated that the net life-cycle cost of the hybrid immobilization/MOX approach would be about \$2.2 billion. The additional expense of pursuing the hybrid approach would be warranted by

²¹ Building the APSF in this way, rather than as originally configured plus an expansion, will not increase the potential impacts of constructing and operating the facility beyond those analyzed in the S&D Final PEIS in conjunction with the analyses in the Final Environmental Impact Statement, Interim Management of Nuclear Materials.

²² This decision does not include residues at RFETS that are less than 50-percent plutonium by weight, or scrub alloys. The management and disposition of those materials has been or is being considered in separate NEPA reviews. See Environmental Assessment for Solid Residue Treatment, Repackaging, and Storage (DOE/EA-1120, April 1996); Notice of Intent to Prepare an EIS on the Management of Certain Plutonium Residues and Scrub Alloy Stored at the Rocky Flats Environmental Technology Site (61 FR 58866, November 19, 1996).

²³ SRS is one of the preferred candidate sites for plutonium disposition facilities, including the potential for the early start of disposition by immobilization using the can-in-canister option at the DWPF.

²⁴ Lag storage is temporary storage at the applicable disposition facility.

²⁵ Lawrence Livermore National Laboratory (LLNL) currently stores 0.3 metric tons of plutonium, which are primarily research and development and operational feedstock materials not surplus to government needs. Adequate storage facilities for this material currently exist at LLNL, where it will be stored and used for research and development activities. None of the plutonium stored at LLNL falls within the scope of the disposition alternatives in the S&D Final PEIS or the disposition decisions in this ROD.

the increased flexibility it would provide, as noted in the Nonproliferation Assessment, to ensure that plutonium disposition could be initiated promptly should one of the approaches ultimately fail or be delayed. Establishing the means for expeditious plutonium disposition will also help provide the basis for an international cooperative effort that can result in reciprocal, irreversible plutonium disposition actions by Russia. This disposition strategy signals a strong U.S. commitment to reducing its stockpile of surplus plutonium, thereby effectively meeting the purpose of and need for the Proposed Action.

To accomplish the plutonium disposition mission, DOE will use, to the extent practical, new as well as modified existing buildings and facilities for portions of the disposition mission. DOE will analyze and compare existing and new buildings and facilities, and technology variations, in a subsequent, site-specific EIS. In addition, all disposition facilities will be designed or modified, as needed, to accommodate international inspection requirements consistent with the President's Nonproliferation and Export Control Policy. Accordingly, DOE has decided to pursue the following strategy and supporting actions for plutonium disposition:

- Immobilize plutonium materials using vitrification or ceramic immobilization at either Hanford or SRS, in new or existing facilities. Immobilization could be used for pure or impure forms of plutonium. In the subsequent EIS (referenced above), DOE anticipates that the preferred alternative for vitrification or ceramic immobilization will include the can-in-canister variant, utilizing the existing HLW and the DWPF at SRS (see below). Alternatively, new immobilization facilities could be built at Hanford or SRS. The immobilized material would be disposed of in a geologic repository. Pursuant to appropriate NEPA review, DOE will continue the research and development leading to the demonstration of the can-in-canister variant at the DWPF using surplus plutonium and the development of vitrification and ceramic formulations.

- Convert surplus plutonium materials into mixed oxide (MOX) fuel for use in existing reactors. Pure surplus plutonium materials including pits, pure metal, and oxides could be converted without extensive processing into MOX fuel for use in existing commercial reactors. Other, already separated forms of surplus plutonium would require additional purification. (This purification would not involve

reprocessing of spent nuclear fuel.) The Government-produced MOX fuel (from plutonium declared surplus to defense needs) would be used in existing LWRs with a once-through fuel cycle, with no reprocessing or subsequent reuse of the spent fuel. In addition, DOE will explore appropriate contractual limits to ensure that any reactor license modification for use of the MOX fuel is limited to governmental purposes involving the disposition of surplus, weapons-usable plutonium, so as to discourage general civil use of plutonium-based fuel. The spent MOX fuel would be disposed of in a geologic repository. If partially completed LWRs were to be completed by other parties, they would be considered for this mission. The MOX fuel would be fabricated in a domestic, government-owned facility at one of four DOE sites (SRS, Hanford, INEL, or Pantex).

The Department reserves as an option the potential use of some MOX fuel in CANDU reactors in Canada in the event that a multilateral agreement to deploy this option is negotiated among Russia, Canada, and the United States. DOE will engage in a test and demonstration program for CANDU MOX fuel consistent with ongoing and potential future cooperative efforts with Russia and Canada.

The test and demonstration activities could occur at LANL and at sites in Canada, potentially beginning in 1997, and will be based on appropriate NEPA review. Fabrication of MOX fuel for CANDU reactors would occur in a DOE facility, as would be true in the case of domestic LWRs. Strict security and safeguards would be employed in the fabrication and transport of MOX fuel to CANDU reactors, as well as domestic reactors. Whether, and the extent to which, the CANDU option is implemented will depend on multi-national agreements and the results of the test and demonstration activities.

Due to technology, complexity, timing, cost, and other factors that would be involved in purifying certain plutonium materials to make them suitable for potential use in MOX fuel, approximately 30 percent of the total quantity of plutonium that has been or may be declared surplus to defense needs would require extensive purification for use in MOX fuel, and therefore will likely be immobilized. Of the plutonium that is currently surplus, DOE will immobilize at least 8 metric tons that it has determined are not suitable for use in MOX fuel.²⁶ DOE

²⁶The S&D Final PEIS, for purposes of analysis of impacts of the preferred alternative (using both reactors and immobilization), assumed that about

reserves the option of using the immobilization approach for all of the surplus plutonium.

The timing and extent to which either option is ultimately utilized will depend on the results of international agreements, future technology development and demonstrations, site-specific environmental review, detailed cost proposals, and negotiations with Russia and other nations. In the event both technologies are utilized, because the time required for plutonium disposition using reactors would be longer than that for immobilization, it is probable that some surplus plutonium would be immobilized initially, prior to completion of reactor irradiation for other surplus plutonium. Implementation of this strategy will involve some or all of the following supporting actions:

- Construct and operate a plutonium vitrification facility or ceramic immobilization facility at either Hanford or SRS. DOE will analyze alternative locations at these two sites for constructing new buildings or using modified existing buildings in subsequent, site-specific NEPA review. SRS has existing facilities (the DWPF) and infrastructure to support an immobilization mission, and at Hanford, DOE has proposed constructing and operating immobilization facilities for the wastes in Hanford tanks.²⁷ DOE will not create new infrastructure for immobilizing plutonium with HLW or cesium at INEL, NTS, ORR, or Pantex. Due to the substantial timing and cost advantages associated with the can-in-canister option, as discussed in the Technical Summary Report For Surplus Weapons-Usable Plutonium Disposition and summarized in section IV.A.2, above, DOE anticipates that the proposed action for immobilization in the follow-on plutonium disposition EIS will include the use of the can-in-canister option at the DWPF at SRS for immobilizing a portion of the surplus, non-pit plutonium material.²⁸

30 percent (approximately 17 MT) of the surplus plutonium materials might be immobilized because they are impure. DOE's decision here that immobilization will be used for at least 8 MT currently located at SRS and RFETS is based on DOE's current assessment that that quantity of material is so low in quality that its purification for use in MOX fuel would not be cost-effective. This decision does not preclude immobilizing all of the surplus plutonium, but it does preclude using the MOX/reactor approach for all of the material.

²⁷See Final Environmental Impact Statement for the Tank Waste Remediation System, Hanford Site, Richland, Washington (DOE/EIS-0189, August 1996); ROD expected early in 1997.

²⁸DOE expects to issue a Notice of Intent to prepare the follow-on EIS shortly following this ROD. Reasonable alternatives for the proposed

- Construct and operate a plutonium conversion facility for non-pit plutonium materials at either Hanford or SRS. DOE will collocate the plutonium conversion facility with the vitrification or ceramic immobilization facility discussed above. In subsequent, site-specific NEPA review, DOE will analyze alternative locations at Hanford and SRS for constructing new buildings or using modified existing buildings for the plutonium conversion facility.

- Construct and operate a pit disassembly/conversion facility at Hanford, INEL, Pantex, or SRS (only one site). DOE will not introduce plutonium to sites that do not currently have plutonium in storage. Therefore, two sites analyzed in the S&D PEIS, NTS and ORR, will not be considered further for plutonium disposition activities. DOE will analyze alternative locations at Hanford, INEL, Pantex, and SRS for constructing new buildings or using modified existing buildings in subsequent, site-specific NEPA review. Based on appropriate NEPA review, DOE anticipates demonstrating the Advanced Recovery and Integrated Extraction System (ARIES) concept at LANL for pit disassembly/conversion beginning in fiscal year 1997.

- Construct and operate a domestic, government-owned, limited-purpose MOX fuel fabrication facility at Hanford, INEL, Pantex, or SRS (only one site). As noted above, NTS and ORR will not be considered further for plutonium disposition activities. In follow-on NEPA review, DOE will analyze alternative locations at Hanford, INEL, Pantex, and SRS, for constructing new buildings or using modified existing buildings. The MOX fuel fabrication facility will serve only the limited mission of fabricating MOX fuel from plutonium declared surplus to U.S. defense needs, with shut-down and decontamination and decommissioning of the facility upon completion of this mission.²⁹

DOE's program for surplus plutonium disposition will be subject to the highest standards of safeguards and security for storage, transportation, and processing

action will be considered in the follow-on disposition EIS.

²⁹ DOE supports external regulation of its facilities, and in the Report of Department of Energy Working Group on External Regulation (DOE/UF-0001, December 1996), DOE proposed to seek legislation that would generally require NRC licenses for new DOE facilities. Therefore, DOE anticipates seeking an NRC license for the MOX fuel fabrication facility, which would be limited to a license to fabricate MOX fuel from plutonium declared surplus to defense needs. DOE may also seek legislation that would by statute limit the MOX fuel fabrication facility to disposition of surplus plutonium.

(particularly during operations that involve the greatest proliferation vulnerability, such as during MOX fuel preparation and transportation), and will include International Atomic Energy Agency verification as appropriate. Transportation of all plutonium-bearing materials under this program, including the transportation of prepared MOX fuel to reactors, will be accomplished using the DOE Transportation Safeguards Division's "Safe Secure Transports" (SSTs), which affords these materials the same level of transportation safety, security, and safeguards as is used for nuclear weapons.

Pursuant to appropriate NEPA review(s), DOE will continue research and development and engage in further testing and demonstrations of plutonium disposition technologies which may include: dissolution of small quantities of plutonium in both glass and ceramic formulation; experiments with immobilization equipment and systems; fabrication of MOX fuel pellets for demonstrations of reactor irradiation at INEL; mechanical milling and mixing of plutonium and uranium feed; and testing of shipping and storage containers for certification, in addition to the testing and demonstrations previously described for the can-in-canister immobilization variant, the ARIES system, and other plutonium processes.

DOE has decided not to pursue several disposition alternatives that were evaluated in the S&D PEIS: two deep borehole alternatives, electrometallurgical treatment, evolutionary reactors, and partially-completed reactors (unless they were completed by others, in which case they would qualify as existing reactors). Although the deep borehole options are technically attractive, the institutional uncertainties associated with siting of borehole facilities make timely implementation of this alternative unlikely. To implement the borehole alternatives, new legislation and regulations, or clarification of existing regulations, may be necessary. DOE has decided not to pursue the electrometallurgical treatment option for immobilization because its technology is less mature than vitrification or ceramic immobilization.³⁰ DOE has decided not to pursue evolutionary reactors or partially-completed reactors because they offer no advantages over existing reactors for plutonium

³⁰ An evaluation by the National Research Council in a recent report (see footnote 12, above) concluded that the electrometallurgical treatment process is not sufficiently mature to provide a reliable basis for timely plutonium disposition.

disposition and would involve higher costs, greater regulatory uncertainties, higher environmental impacts from construction, and less timely commencement of disposition actions.

VI. Conclusion

DOE has decided to implement a program to provide for safe and secure storage of weapons-usable fissile materials and for disposition of weapons-usable plutonium that is declared excess to national security needs (now or in the future), as specified in the Preferred Alternative in the S&D Final PEIS. DOE will consolidate the storage of weapons-usable plutonium by upgrading and expanding existing facilities at the Pantex Plant in Texas and SRS in South Carolina, continuing storage of surplus plutonium currently onsite at Hanford, LANL, and INEL pending disposition, and continuing storage of weapons-usable HEU at DOE's Y-12 Plant in Tennessee, in upgraded and, as surplus HEU is down-blended under the ROD for Disposition of Surplus Highly Enriched Uranium Final Environmental Impact Statement, consolidated facilities. DOE will provide for disposition of surplus plutonium by pursuing a strategy that allows: (1) Immobilization of surplus plutonium for disposal in a repository pursuant to the Nuclear Waste Policy Act, and (2) fabrication of surplus plutonium into MOX fuel, for use in existing domestic commercial reactors (and potentially CANDU reactors, depending on future agreements with Russia and Canada). The timing and extent to which each of these disposition technologies is deployed will depend upon the results of future technology development and demonstrations, site-specific environmental review, detailed cost proposals, and the results of negotiations with Russia, Canada, and other nations. This programmatic decision is effective upon being made public, in accordance with DOE's regulations implementing NEPA (10 CFR 1021.315). The goals of this program are to support U.S. nuclear weapons nonproliferation policy by reducing global stockpiles of excess fissile materials so that they may never be used in weapons again. This program will demonstrate the United States' commitment to its nonproliferation goals, as specified in the President's Nonproliferation and Export Control Policy of 1993, and provide an example for other nations, where stockpiles of surplus weapons-usable fissile materials may be less secure from potential theft or diversion than those in the United

States, to encourage them to take similar actions.

The decision process reflected in this Notice complies with the requirements of the National Environmental Policy Act (42 U.S.C. § 4321 et seq.) and its implementing regulations at 40 CFR Parts 1500-1508 and 10 CFR Part 1021.

Issued in Washington, D.C., January 14, 1997.

Hazel R. O'Leary,
Secretary.

[FR Doc. 97-1355 Filed 1-17-97; 8:45 am]

BILLING CODE 6450-01-P

Energy Information Administration

Agency Information Collection Activities: Proposed Collection; Comment Request

SUMMARY: The Energy Information Administration (EIA) is soliciting comments concerning the proposed three-year extension of existing form DOE-887, "Department of Energy Customer Surveys."

DATES: Written comments must be submitted on or before March 24, 1997. If you anticipate that you will be submitting comments, but find it difficult to do so within the period of time allowed by this notice, you should advise the contact listed below of your intention to do so as soon as possible.

ADDRESSES: Send comments to Herbert T. Miller, Office of Statistical Standards, EI-73, Forrestal Building, U.S. Department of Energy, Washington, D.C. 20585, (Phone 202-426-1103, FAX 202-426-1081, or e-mail hmiller@eia.doe.gov).

FOR FURTHER INFORMATION: Requests for additional information should be directed to Herbert Miller at the address listed above.

SUPPLEMENTARY INFORMATION:

- I. Background
- II. Current Actions
- III. Request for Comments

I. Background

In order to fulfill its responsibilities under the Federal Energy Administration Act of 1974 (Pub. L. No. 93-275) and the Department of Energy Organization Act (Pub. L. No. 95-91), the Energy Information Administration is obliged to carry out a central, comprehensive, and unified energy data and information program. As part of this program, EIA collects, evaluates, assembles, analyzes, and disseminates data and information related to energy resource reserves, production, demand, and technology, and related economic and statistical information relevant to

the adequacy of energy resources to meet demands in the near and longer term future for the Nation's economic and social needs.

The Energy Information Administration, as part of its continuing effort to reduce paperwork and respondent burden (required by the Paperwork Reduction Act of 1995 (Pub. L. 104-13)), conducts a presurvey consultation program to provide the general public and other Federal agencies with an opportunity to comment on proposed and/or continuing reporting forms. This program helps to ensure that requested data can be provided in the desired format, reporting burden is minimized, reporting forms are clearly understood, and the impact of collection requirements on respondents can be properly assessed. Also, EIA will later seek approval by the Office of Management and Budget (OMB) for the collections under Section 3507(h) of the Paperwork Reduction Act of 1995 (Pub. L. No. 104-13, Title 44, U.S.C. Chapter 35).

On September 11, 1993, the President signed Executive Order No. 12862 aimed at "* * * ensuring the Federal government provides the highest quality service possible to the American people." The Order discusses surveys as a means for determining the kinds and qualities of service desired by Federal Government customers and for determining satisfaction levels for existing services. These voluntary customer surveys will be used to ascertain customer satisfaction with the Department of Energy in terms of services and products. Respondents will be individuals and organizations that are the recipients of the Department's services and products. Previous customer surveys have provided useful information to the Department for assessing how well the Department is delivering its services and products and for making improvements. The results are used internally and summaries are provided to the Office of Management and Budget on an annual basis, and are used to satisfy the requirements and the spirit of Executive Order No. 12862.

II. Current Actions

The request to OMB will be for a three-year extension of the expiration date of approval for DOE to conduct customer surveys. During the past clearance cycle, over 20 customer surveys have been conducted by telephone and mail. (Examples of previously conducted customer surveys are available upon request.) Our planned activities in the next 3 fiscal years reflect our increased emphasis on

and expansion of these activities, including an increased use of electronic means for obtaining customer input (CD-ROM and World Wide Web).

III. Request for Comments

Prospective respondents and other interested parties should comment on the actions discussed in item II. The following guidelines are provided to assist in the preparation of responses.

General Issues

A. Is the proposed collection of information necessary, taking into account its accuracy, adequacy, and reliability, and the agency's ability to process the information it collects in a useful and timely fashion?

B. What enhancements can EIA make to the quality, utility, and clarity of the information to be collected?

As a Potential Respondent

A. Average public reporting burden for a customer survey is estimated to be .25 hours per response (8,333 respondents per year x 15 minutes per response = 2,083 hours annually). Burden includes the total time, effort, or financial resources expended to generate, maintain, retain, or disclose or provide the information including: (1) reviewing instructions; (2) developing, acquiring, installing, and utilizing technology and systems for the purposes of collecting, validating, verifying, processing, maintaining, disclosing and providing information; (3) adjusting the existing ways to comply with any previously applicable instructions and requirements; (4) training personnel to respond to a collection of information; (5) searching data sources; (6) completing and reviewing the collection of information; and (7) transmitting, or otherwise disclosing the information.

Please comment on (1) the accuracy of our estimate and (2) how the agency could minimize the burden of the collection of information, including the use of automated collection techniques or other forms of information technology.

B. EIA estimates that respondents will incur no additional costs for reporting other than the hours required to complete the collection. What is the estimated (1) total dollar amount annualized for capital and start-up costs and (2) recurring annual dollar amount of operation and maintenance and purchase of services costs associated with this data collection? The estimates should take into account the costs associated with generating, maintaining, and disclosing or providing the information.

**A.2 NOTICE OF INTENT—SURPLUS PLUTONIUM DISPOSITION ENVIRONMENTAL
IMPACT STATEMENT**

collection on the respondents, including through the use of information technology.

Dated: May 16, 1997.

Gloria Parker,

Director, Information Resources Management Group.

Office of Management

Type of Review: New.

Title: Department of Education Federal Cash Award Certification Statement and Department of Education Federal Cash Quarterly Confirmation Statement.

Frequency: Annually.

Affected Public: Business or other for-profit; Not for Profit institutions; Federal Government; State, Local or Tribal Government, SEAs or LEAs.

Annual Reporting and Recordkeeping Hour Burden:

Responses: 12,000.

Burden Hours: 38,160.

Abstract: The collection of the Federal Cash Award Statement is necessary for the Agency to monitor cash advanced to grantees and to obtain expenditure information for each grant from grantees. Information collection is used to report total outlays to the Office of Management and Budget and the Department of the Treasury and is used to project the Federal government's and the Department's financial condition. This information collection also enables the Department to provide Treasury with outlay information to facilitate Treasury's estimation of future borrowing requirements. Respondents include over 12,000 State, local, college, university, proprietary school and non-profit grantees who draw funds from the Department.

The collection of Federal cash quarterly confirmation statement enables grantees to identify discrepancies in grant authorizations, and funds drawn and funds refunded. Action is required only if a grantee's records do not agree with the information contained on the statement. This information will be used to help grantees report and initiate resolution of discrepancies. Respondents include over 12,000 State, local, college, university, proprietary school and non-profit grantees who draw funds from the Department.

Office of Special Education and Rehabilitative Services

Type of Review: New.

Title: Grantee Reporting Form.

Frequency: Annually.

Affected Public: Business or other for-profit; Not-for-profit institutions; State, local or Tribal Gov't, SEAs or LEAs.

Annual Reporting and Recordkeeping Hour Burden:

Responses: 165.

Burden Hours: 330.

Abstract: Rehabilitation Services Administration (RSA) training grants provide stipends to "RSA Scholars" in order to train skilled rehabilitation personnel. Grantees are required to "track" scholars, relative to the "payback" provision in the Rehabilitation Act. Data collection is reported annually to RSA in order to monitor performance and report progress to Congress.

[FR Doc. 97-13413 Filed 5-21-97; 8:45 am]

BILLING CODE 4000-01-M

DEPARTMENT OF ENERGY

Surplus Plutonium Disposition Environmental Impact Statement

AGENCY: Department of Energy

ACTION: Notice of intent

SUMMARY: The Department of Energy (DOE) announces its intent to prepare an Environmental Impact Statement (EIS) pursuant to the National Environmental Policy Act (NEPA) on the disposition of United States' weapons-usable surplus plutonium. This EIS is tiered from the Storage and Disposition of Weapons-Usable Fissile Materials Programmatic Environmental Impact Statement (Storage and Disposition PEIS) (DOE/EIS-0229), issued in December 1996, and the associated Record of Decision (62 FR 3014), issued on January 14, 1997.

The EIS will examine reasonable alternatives and potential environmental impacts for the proposed siting, construction, and operation of three types of facilities for plutonium disposition. The first is a facility to disassemble and convert pits (a nuclear weapons component) into plutonium oxide suitable for disposition. As explained in the January 1997 Record of Decision, this pit disassembly and conversion facility will be located at either DOE's Hanford Site, Idaho National Engineering and Environmental Laboratory (INEEL), Pantex Plant, or Savannah River Site (SRS). The second is a facility to immobilize surplus plutonium in a glass or ceramic form for disposition in a geologic repository pursuant to the Nuclear Waste Policy Act. This second facility will be located at either Hanford or SRS, and include a collocated capability to convert non-pit plutonium materials into a form suitable for immobilization. The EIS will discuss various technologies for immobilization.

The third type of facility would fabricate plutonium oxide into mixed oxide (MOX) fuel. The MOX fuel fabrication facility would be located at either Hanford, INEEL, Pantex or SRS. MOX fuel would be used in existing commercial light water reactors in the United States, with subsequent disposal of the spent fuel in accordance with the Nuclear Waste Policy Act. Some MOX fuel could also be used in Canadian deuterium uranium (CANDU) reactors depending upon negotiation of a future international agreement between Canada, Russia, and the United States. The EIS will also discuss decommissioning and decontamination (D&D) of the three facilities.

This Notice of Intent describes the Department's proposed action, solicits public input, and announces the schedule for the public scoping meetings.

DATES: Comments on the proposed scope of the Surplus Plutonium Disposition EIS (SPD EIS) are invited from the public. To ensure consideration in the draft EIS, written comments should be postmarked by July 18, 1997. Comments received after that date will be considered to the extent practicable. DOE will hold interactive scoping meetings near sites that may be affected by the proposed action to discuss issues and receive oral and written comments on the scope of the EIS. The locations, dates and times for these public meetings are included in the Supplementary Information section of this notice and will be announced by additional appropriate means.

ADDRESSES: Comments and questions concerning the plutonium disposition program can be submitted by calling (answering machine) or faxing them to the toll free number 1-800-820-5156, or by mailing them to: Bert Stevenson, NEPA Compliance Officer, Office of Fissile Materials Disposition, U.S. Department of Energy, Post Office Box 23786, Washington, DC 20026-3786.

Comments may also be submitted electronically by using the Office of Fissile Materials Disposition's web site. The address is <http://web.fie.com/fedix/fisl.html>.

FOR FURTHER INFORMATION CONTACT: For general information on the DOE NEPA process, please contact: Carol Borgstrom, Director, Office of NEPA Policy and Assistance, U.S. Department of Energy 1000, Independence Avenue, S.W., Washington, DC 20585, 202-586-4600 or 1-800-472-2756.

SUPPLEMENTARY INFORMATION:

Background

The Storage and Disposition Programmatic Environmental Impact Statement (PEIS) analyzed the potential environmental consequences of alternatives for the long-term storage (up to 50 years) of weapons-usable fissile materials and the disposition of surplus plutonium. Surplus plutonium for disposition refers to that weapons-usable plutonium that the President has declared surplus to national security needs, as well as such plutonium that may be declared surplus in the future. As stated in the Record of Decision for the Storage and Disposition PEIS, the Department decided to pursue a hybrid

approach that allows immobilization of surplus plutonium in glass or ceramic form and burning of some of the surplus plutonium as MOX fuel in existing, commercial light water reactors in the United States (and potentially in Canadian Deuterium Uranium (CANDU) reactors in Canada depending on future international agreement). The Department decided that the extent to which either or both of these disposition approaches would ultimately be deployed would depend in part upon future NEPA review, although the Department committed to immobilize at least 8 metric tons (tonnes) of currently declared surplus plutonium and reserved the option of immobilizing all surplus weapons plutonium. In the

Record of Decision for the Storage and Disposition PEIS, the Department further decided to: (1) locate the immobilization facility (collocated with a plutonium conversion facility) at either Hanford or SRS; (2) locate a potential MOX fuel fabrication facility at either Hanford, INEEL, Pantex, or SRS; (3) locate a pit disassembly and conversion facility at either Hanford, INEEL, Pantex, or SRS; and (4) determine the specific technology for immobilization based in part on this follow-on disposition EIS.

The processes, materials and technologies involved in surplus plutonium disposition are depicted in Figure 1.

BILLING CODE 6450-01-P

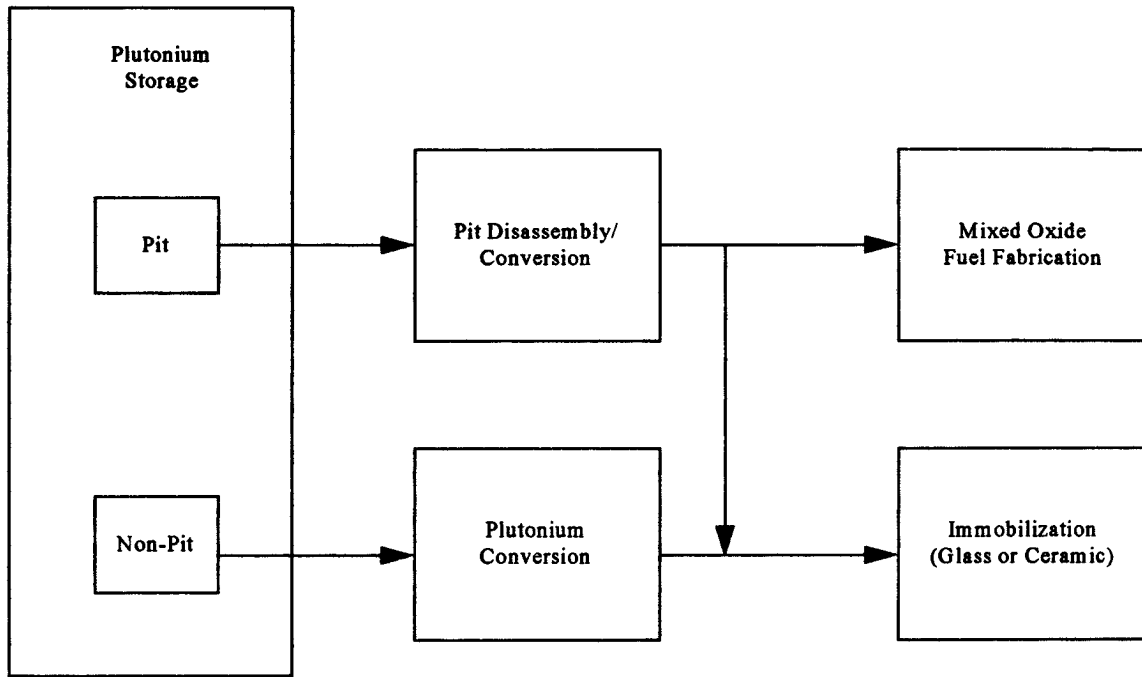

Figure 1. Plutonium Disposition Processes in DOE's Proposed Action

Proposed Action

The Department proposes to determine whether to continue with both the immobilization and MOX approaches for surplus plutonium disposition and if so, to site, construct, and operate and ultimately D&D three types of facilities for plutonium disposition at one or more of four DOE sites, as follows:

- A collocated non-pit plutonium conversion and immobilization facility at either Hanford, near Richland, Washington, or SRS, near Aiken, South Carolina, with sub-alternatives for the technology and facilities used to form the immobilized plutonium.
- A pit disassembly/conversion facility at either Hanford; SRS; INEEL, near Idaho Falls, Idaho; or the Pantex Plant, near Amarillo, Texas.
- A MOX fuel fabrication facility at either Hanford, INEEL, Pantex, or SRS, with sub-alternatives for fabrication of Lead Test Assemblies for use in fuel qualification demonstrations.

Construction of these facilities would be on previously disturbed land and could include the modification of existing facilities where practicable, to reduce local environmental impacts, reduce costs, and shorten schedules. In the pit disassembly and conversion facility, the Department proposes to disassemble surplus pits and convert the plutonium in them to an unclassified oxide form suitable for disposition. The Department also proposes to convert most non-pit plutonium materials to plutonium oxide at the plutonium conversion facility, which will be collocated with the immobilization facility.

Plutonium Disposition Decisions

The Department expects to make the following decisions based upon the results of this EIS and other information and considerations:

- Whether to construct and operate collocated plutonium conversion and immobilization facilities, and if so, where (including selection of the specific immobilization technology).
- Whether to construct and operate a pit disassembly/conversion facility, and if so, where.
- Whether to construct and operate a MOX fuel fabrication facility, and if so, where (including selection of the site for fabrication of Lead Test Assemblies).

The exact extent to which the MOX approach would ultimately be deployed will depend on a number of factors, in addition to environmental impacts. These are likely to include cost, contract negotiations, and international agreements.

Alternatives

No Action

A No Action alternative will be analyzed (Alternative 1) in the SPD EIS. Implementation of the No Action alternative would mean that disposition would not occur, and surplus weapons-usable plutonium, including pits, metals and oxides, would remain in storage in accordance with the Storage and Disposition PEIS Record of Decision.

Plutonium Disposition Alternatives

The SPD EIS will analyze alternatives for the siting, construction and operation of the three facilities at various candidate sites as described in the Proposed Action. These facilities would be designed so that they could collectively disposition surplus plutonium (existing and future) over their operating lives. Although the exact quantity of plutonium that may be declared surplus over time is not known, for purposes of analysis a nominal 50 tonnes of surplus plutonium will be used for assessing the environmental impacts of plutonium disposition activities at the various candidate sites. Under alternatives involving the "hybrid" (immobilization and MOX) approach selected in the Storage and Disposition Record of Decision, the SPD EIS will analyze the same distribution of surplus plutonium that was analyzed in the Storage and Disposition PEIS, which is fabrication of pits and pure plutonium metal or oxide (approximately 33 tonnes) into MOX fuel, and immobilization of the remaining non-pit plutonium (approximately 17 tonnes). The Record of Decision on the Storage and Disposition PEIS states, "DOE will immobilize at least eight tonnes of currently declared surplus plutonium materials that DOE has already determined are not suitable for use in MOX fuel." Since the issuance of that decision, the Department has further determined that a total of about 17 tonnes of surplus plutonium is not suitable for use in MOX fuel without extensive processing. Thus, an alternative for fabricating all surplus plutonium into MOX fuel will not be analyzed. However, converting the full 50 tonnes of surplus plutonium into an immobilized form will be analyzed as a reasonable alternative.

Under each disposition approach, DOE could in principle locate one, two, or all three facilities at a candidate site. However, locating one facility at each of three sites would mean conducting disposition activities at three widely separated locations around the country. This would substantially increase

transportation cost, unnecessarily increase exposure of workers and the public, and increase transportation risks, without any apparent compensating benefit. Therefore, the Department is proposing to consider only alternatives that locate two or more facilities at one site, with the possibility of one facility at a separate site. Further, certain combinations of facilities and sites are not being considered as reasonable alternatives, because they would also substantially increase transportation cost, unnecessarily increase exposure to workers and the public, and increase transportation risks, without any apparent compensating benefit.

Based on the above considerations and the candidate site selections in the Storage and Disposition Record of Decision, the following alternatives have been developed in addition to the No Action alternative. Table 1 summarizes the alternatives by site. Alternatives 2 through 10 (see Table 1) would involve immobilization of approximately 17 tonnes of low purity (non-pit) plutonium, and fabrication of approximately 33 tonnes of high purity plutonium (pits and plutonium metal) into MOX fuel. The differences among alternatives 2 through 10 are the locations of the proposed facilities. Alternatives 11 and 12 would involve immobilization of all 50 tonnes of plutonium at either Hanford or SRS.

The Department has identified existing facilities that can be modified for use in plutonium disposition at various candidate sites. A summary of the existing and new facilities (shown in the parentheses in Table 1) to be used in the SPD EIS analyses is given in Table 1, where FMEF is the Fuel and Materials Examination Facility, FPF is the Fuel Processing Facility, and DWPF is the Defense Waste Processing Facility.

Lead Test Assemblies

With respect to the MOX alternatives, the Department would qualify MOX fuel forms for use in existing commercial reactors. DOE will analyze two sub-alternatives for the fabrication of the lead test assemblies needed to qualify the fuel. In one sub-alternative, the lead test assemblies would be fabricated in the United States. Fabrication in the United States would involve constructing a pilot capability in conjunction with the fuel fabrication facility. Therefore, the potential sites include the candidate sites for the fuel fabrication facility (i.e., Hanford, INEEL, Pantex, and SRS). The pilot capability could also be located in an existing small facility at the Los Alamos National Laboratory (LANL). The

second alternative would be for fabrication in existing European facilities; three potential fabrication

sites exist (Belgium, France, and the United Kingdom) that would allow fabrication of the Lead Test Assemblies

sooner than with any facility under the United States alternative.

TABLE 1.—DISPOSITION ALTERNATIVES

Alternative/Site/Disposition Facility				
Alt. No.	Pit disassembly	MOX plant	Plutonium conversion and immobilization	Amounts of plutonium
1			No Action	
2	Hanford (FMEF)	Hanford (FMEF)	Hanford (FMEF)	17t Immobilization / 33t MOX.
3	SRS (New)	SRS (New)	SRS (New, or Bldg 221F, and DWPF)	17t Immobilization / 33t MOX.
4	Pantex (New)	Hanford (FMEF)	Hanford (FMEF)	17t Immobilization / 33t MOX.
5	Pantex (New)	SRS (New)	SRS (New, or Bldg 221F, and DWPF)	17t Immobilization / 33t MOX.
6	Hanford (FMEF)	Hanford (FMEF)	SRS (New, or Bldg 221F, and DWPF)	17t Immobilization / 33t MOX.
7	INEEL (FPF)	INEEL (New)	SRS (New, or Bldg 221F, and DWPF)	17t Immobilization / 33t MOX.
8	INEEL (FPF)	INEEL (New)	Hanford (FMEF)	17t Immobilization / 33t MOX.
9	Pantex (New)	Pantex (New)	SRS (New, or Bldg 221F, and DWPF)	17t Immobilization / 33t MOX.
10	Pantex (New)	Pantex (New)	Hanford (FMEF)	17t Immobilization / 33t MOX.
11	Hanford (FMEF)	N/A	Hanford (FMEF)	50t Immobilization / 0t MOX.
12	SRS (New)	N/A	SRS (New, or Bldg 221F, and DWPF)	50t Immobilization / 0t MOX.

Immobilization Technology

The Record of Decision on the Storage and Disposition PEIS stated, "Because there are a number of technology variations that could be used for immobilization, DOE will also determine the specific immobilization technology based upon the follow-on EIS * * *" (i.e., the SPD EIS). The technologies to be considered are those identified as variants in the Storage and Disposition PEIS.

Preferred Alternative

For immobilization, the Department prefers to use the "can-in-canister" technology at the DWPF at SRS. Under the can-in-canister approach, cans containing plutonium in glass or ceramic form would be placed in DWPF canisters, which would be filled with borosilicate glass containing high-level waste.

Classified Information

The Department plans to prepare the SPD EIS as an unclassified document with a classified appendix. The classified information in the SPD EIS will not be available for public review. However, the classified information will be considered by DOE in reaching a decision on the disposition of surplus plutonium. DOE will provide as much information as possible in unclassified form to assist public understanding and comment.

Research and Development Activities

The Department recently announced its intent to prepare two environmental assessments (EAs) for proposed research and development activities that DOE would conduct prior to completion of the SPD EIS and ROD. One EA will

analyze the potential environmental impacts of a proposed pit disassembly and conversion integrated systems test at LANL. In addition, to further the purposes of NEPA, this EA will describe other research and development activities currently on-going at various sites, including work related to immobilization and to MOX fuel fabrication. The other EA will be prepared for the proposed shipment of special MOX fuel to Canada for an experiment involving the use of United States and Russian fuel in a Canadian test reactor, for development of fuel for the CANDU reactors. This EA will analyze the prior and future fabrication and proposed shipment of the fuel pellets needed for the experiment.

Relationships With Other DOE NEPA Activities

In addition to the SPD EIS and the EAs discussed above, the Department is currently conducting NEPA reviews of other activities that have a potential relationship with the SPD EIS. They include:

1. *Waste Management Programmatic Environmental Impact Statement for Managing Treatment, Storage and Disposal of Radioactive and Hazardous Waste* (DOE/EIS-0200D) (Draft issued: September 22, 1995; 60 FR 49264).

2. *Management of Certain Plutonium Residues and Scrub Alloy Stored at the Rocky Flats Environmental Technology Site EIS* (Notice of Intent to Prepare an Environmental Impact Statement: November 19, 1996; 61 FR 58866).

Invitation To Comment

DOE invites comments on the scope of this EIS from all interested parties, including potentially affected Federal, State, and local agencies, and Indian

tribes. Comments can be provided by any of the means listed in the Address Section of this notice and by providing oral and written comments at the scoping meetings.

The Department is requesting, by separate correspondence, that Federal agencies¹ desiring to be designated as cooperating agencies on the SPD EIS inform DOE by July 18, 1997.

Scoping Meetings

Public scoping meetings will be held near each site that may be affected by the proposed action. The interactive scoping meetings will provide the public with the opportunity to present comments, ask questions, and discuss concerns regarding plutonium disposition activities with DOE officials, and for the Department to receive oral and written comments on the scope of the EIS. Written and oral comments will be given equal weight in the scoping process. Input from the scoping meetings along with comments received by other means (phone, mail, fax, website) will be used by the Department in refining the scope of the EIS. The locations and dates for these public meetings are as shown below. All meetings will consist of two sessions (1:00 pm to 4:00 pm and 6:00 pm to 9:00 pm).

Hanford Site:

July 1, 1997
Shilo Inn
50 Comstock
Richland, WA 99352
509-946-4661

¹ Arms Control and Disarmament Agency; Department of Defense; Department of State; Environmental Protection Agency; and Nuclear Regulatory Commission.

Idaho National Engineering and Environmental Laboratory

June 10, 1997

Shilo Inn
780 Lindsay Boulevard
Idaho Fall, ID 83402
208-523-0088*Pantex Plant*

June 12, 1997

Radisson Inn Airport
7909 I-40 East at Lakeside
Amarillo, TX 79104
806-373-3303*Savannah River Site*

June 19, 1997

North Augusta Community Center
495 Brookside Avenue
North Augusta, SC 29841
803-441-4290

Advanced registration for the public meetings is requested but not required. Please call 1-800-820-5134 and leave your name and the location of the meeting(s) you plan to attend. This information will be used to determine the size and number of rooms needed for the meeting.

Scoping Meeting Format:

The Department intends to hold a plenary session at the beginning of each scoping meeting in which DOE officials will more fully explain the framework for the plutonium disposition program, the proposed action, preliminary alternatives for accomplishing the proposed action and public participation in the NEPA process. Following the plenary session, the Department intends to discuss relevant issues in more detail, answer questions, and receive comments. Each scoping meeting for the Surplus Plutonium Disposition EIS will have two sessions, with each session lasting approximately three to four hours.

Issued in Washington, DC this 16 day of May, 1997, for the United States Department of Energy.

Peter N. Brush,

*Principal Deputy Assistant Secretary,
Environment, Safety and Health.*

[FR Doc. 97-13494 Filed 5-21-97; 8:45 am]

BILLING CODE 6450-01-P

DEPARTMENT OF ENERGY**Federal Energy Regulatory Commission**

[Docket No. RP97-165-003]

Alabama-Tennessee Natural Gas Company; Notice of Compliance Filing

May 16, 1997.

Take notice that on May 12, 1997, Alabama-Tennessee Natural Gas

Company (Alabama-Tennessee) tendered for filing the tariff sheets listed in Appendix A to the filing, to be effective June 1, 1997.

Alabama-Tennessee states that the tariff sheets are submitted in compliance with Order No. 587 and the Commission's order issued on May 1, 1997 FERC ¶ 61,117).

Any person desiring to protest said filing should file a protest with the Federal Energy Regulatory Commission, 888 First Street, NE., Washington, DC 20426, in accordance with Section 385.211 of the Commission's Regulations. All such protests must be filed as provided in Section 154.210 of the Commission's Regulations. Protests will be considered by the Commission in determining appropriate action to be taken, but will not serve to make protestants parties to the proceedings. Copies of this filing are on file with the Commission and are available for public inspection.

Lois D. Cashell,

Secretary.

[FR Doc. 97-13441 Filed 5-21-97; 8:45 am]

BILLING CODE 6717-01-M

DEPARTMENT OF ENERGY**Federal Energy Regulatory Commission**

[Docket No. ES97-32-000]

Citizens Utilities Company; Notice of Application

May 16, 1997.

Take notice that on May 9, 1997, Citizens Utilities Company (Applicant) filed an application with the Federal Energy Regulatory Commission under § 204 of the Federal Power Act requesting orders (a) extending the effectiveness of the order in Docket No. ES95-34-000 until the close of business on June 30, 1997, and (b) authorizing the issuance, from time to time, of up to 50,000,000 shares of common stock as stock dividends on shares of its outstanding common stock during a two-year period ending July 1, 1999.

Any person desiring to be heard or to protest said application should file a motion to intervene or protest with the Federal Energy Regulatory Commission, 888 1st Street, NE, Washington, D.C. 20426 in accordance with Rules 211 and 214 of the Commission's Rules of Practice and Procedure (18 CFR 385.211 and 385.214). All such motions or protests should be filed on or before May 20, 1997. Protests will be considered by the Commission in determining the appropriate action to be taken, but will not serve to make the

protestants parties to the proceeding. Any person wishing to become a party must file a motion to intervene. Copies of this filing are on file with the Commission and are available for public inspection.

Lois D. Cashell,

Secretary.

[FR Doc. 97-13437 Filed 5-21-97; 8:45 am]

BILLING CODE 6717-01-M

DEPARTMENT OF ENERGY**Federal Energy Regulatory Commission**

[Docket No. CP96-712-000]

Discovery Gas Transmission LLC; Notice of Site Visit

May 16, 1997.

On May 22, 1997, beginning at 9:30 a.m., the Office of Pipeline Regulation (OPR) staff will conduct a compliance inspection of the onshore facilities of the Discovery Gas Transmission LLC Pipeline Construction Project in Lafourche Parish, Louisiana, beginning at the Larose Gas Processing Plant site (off state highway 24) in Larose.

All parties may attend. Those planning to attend must provide their own transportation (an air boat is required for most of the pipeline route).

For further information, please contact Paul McKee at (202) 208-1088.

Warren C. Edmunds,

Acting Director, Office of Pipeline Regulation.

[FR Doc. 97-13434 Filed 5-21-97; 8:45 am]

BILLING CODE 6717-01-M

DEPARTMENT OF ENERGY**Federal Energy Regulatory Commission**

[Docket No. ER97-2846-000]

Florida Power Corporation; Notice of Filing

May 16, 1997.

Take notice that on May 5, 1997, Florida Power Corporation (Florida Power) filed an Application for an Order Approving Market-Based Rates for Sales Outside of Florida. In its Application, Florida Power requests authorization to engage in wholesale, bulk power sales outside of Florida at market-determined prices, including sales not involving Florida Power's generation or transmission. Florida Power requests an effective date of 60 days after this filing, or the date on which the Commission issues an order approving Florida Power's application for market-based rates, whichever is earlier.

**A.3 AMENDED NOTICE OF AVAILABILITY—SURPLUS PLUTONIUM DISPOSITION
DRAFT ENVIRONMENTAL IMPACT STATEMENT, 45-DAY NEPA REVIEW PERIOD**

Dated: July 16, 1998.
 Richard D. Wilson,
Acting Assistant Administrator.
 [FR Doc. 98-19832 Filed 7-23-98; 8:45 am]
 BILLING CODE 6560-50-P

ENVIRONMENTAL PROTECTION AGENCY

[ER-FRL-5494-1]

Environmental Impact Statements and Regulations; Availability of EPA Comments

Availability of EPA comments prepared July 6, 1998 Through July 10, 1998 pursuant to the Environmental Review Process (ERP), under Section 309 of the Clean Air Act and Section 102(2)(c) of the National Environmental Policy Act as amended. Requests for copies of EPA comments can be directed to the Office of Federal Activities AT (202) 564-5076. An explanation of the ratings assigned to draft environmental impact statements (EISs) was published in FR dated April 10, 1998 (63 FR 17856).

Draft EISs

ERP No. D-FRC-J05078-MT Rating EO2, Missouri-Madison Hydroelectric (FERC No. 2188) Project, Issuing a New licence (Relicence) for Nine Dams and Associated Facilities, MT.

Summary: EPA expressed environmental objections regarding FERC's rejection of Section 10 (j) recommendations; inadequacies in the analysis of thermal issues; the potential for impairment to the beneficial uses; and the rejection of some State Clean Water Act 401 conditions. EPA believes FERC should ensure license conditions that require hydropower operations be done in the best practicable manner to minimize harm to beneficial uses. License conditions also need to incorporate thermal success criteria and appropriate language to reopen the license if success criteria are not adequately attained by proposed mitigation. EPA believes additional information is needed to fully assess and mitigate all potential impacts of the management actions.

ERP No. D-IBR-J28020-UT Rating EO2, Narrows Dam and Reservoir Project, Construction of Supplemental Water Supply for Agricultural and Municipal Water Use, Gooseberry Creek, Sanpete and Carbon Counties, UT.

Summary: EPA expressed environmental objections to the proposed project, and stated that it believes additional, less damaging alternatives are available which would reduce the project related impacts. EPA

requested additional detail on mitigation, project impacts, and alternatives.

ERP No. D-IBR-K39045-CA Rating EC2, Programmatic EIS—Central Valley Project Improvement Act (CVPIA) of 1992 Implementation, Central Valley, Trinity, Contra Costa, Alameda, Santa Clara and San Benito Counties, CA.

Summary: EPA expressed strong support for the overall intent of CVPIA implementation; alternatives which provide a strong two-pronged commitment to ecosystem restoration and flexible, efficient use of developed water supplies; and use of CVPIA tools to provide efficient management of existing, developed water supplies. EPA requested additional information and explanation on the range of implementation, relationship between PEIS and subsequent rules and regulations, and to the relationship of the PEIS to interim implementation programs and the "Garamendi process"

ERP No. DR-DOI-K40222-TT Rating EO2, Palau Compact Road Construction, Revision to Major Transportation and Communication Link on the Island of Babeldaob, Implementation, Funding, Republic of Palau, Babeldaob Island, Trust Territory of the Pacific Islands.

Summary: EPA expressed environmental objections because the RDEIS did not provide sufficient documentation that all practicable means have been undertaken by the Corps and the Republic of Palau to avoid and minimize adverse impacts associated with placing dredged or fill material in wetlands and other aquatic resources protected under CWA Section 404.

Final EISs

ERP No. F-AFS-L65285-AK, Chasina Timber Sale, Harvesting Timber and Road Construction, Tongass National Forest, Craig Ranger District, Ketchikan Administrative Area, AK.

Summary: Review of the Final EIS was not deemed necessary. No formal comment letter was sent to the preparing agency.

ERP No. F-AFS-L65300-AK, Canal Hoya Timber Sale, Implementation, Stikine Area, Tongass National Forest, Value Comparison Unit (VCU), AK.

Summary: Review of the Final EIS was not deemed necessary. No formal comment letter was sent to the preparing agency.

Dated: July 21, 1998.
 William D. Dickerson,
Director, NEPA Compliance Division, Office of Federal Activities.

[FR Doc. 98-19884 Filed 7-23-98; 8:45 am]
 BILLING CODE 6560-50-U

ENVIRONMENTAL PROTECTION AGENCY

[ER-FRL-5493-9]

Environmental Impact Statements; Notice of Availability

Responsible Agency: Office of Federal Activities, General Information (202) 564-7167 OR (202) 564-7153.

Weekly receipt of Environmental Impact Statements
 Filed July 13, 1998 Through July 17, 1998

Pursuant to 40 CFR 1506.9

EIS No. 980269, Draft EIS, AFS, ID, Eagle Bird Project Area, Timber Harvesting and Road Construction, Idaho Panhandle National Forests, St. Joe Ranger District, Shoshone County, ID, Due: September 07, 1998, Contact: Cameo Flood (208) 245-4517.

EIS No. 980270, Final EIS, FHW, NC, US 70 Improvements Project, I-40 to the Intersection of US 70 and US 70 Business, Funding and COE Section 404 Permit, Wake and Johnston Counties, NC, Due: August 24, 1998, Contact: Nicholas L. Graf, P.E. (919) 733-7842 ext. 260.

EIS No. 980271, Draft EIS, FHW, IN, US 231 Transportation Project, New Construction from CR-200 N to CR-1150'1, Funding, Right-of-Way Permit and COE Section 404 Permit, Spencer and Dubois Counties, IN, Due: October 15, 1998, Contact: Douglas N. Head (317) 226-7487.

EIS No. 980272, Draft EIS, NOA, MS, Grand Bay National Estuarine Research Reserve (NERR), Designation, To Conduct Research, Educational Project and Construction, East of the City of Biloxi, Jackson County, MS, Due: September 07, 1998, Contact: Stephanie Thornton (301) 713-3125 ext. 110

EIS No. 980273, Draft Supplement, FTA, PR, Tren Urbano Transit Project, Updated Information for the Minillas Extension, Construction and Operation, San Juan Metropolitan Area, Funding, NPDES Permit, US Coast Guard Bridge Permit and COE Section 10 and 404 Permits, PR, Due: September 07, 1998, Contact: Alex McNeil (404) 562-3511.

EIS No. 980274, Final EIS, FRC, NB, Kingsley Dam Project (FERC. No. 1417) and North Platte/Keystone Diversion Dam (FERC. No. 1835) Hydroelectric Project, Application for Licenses, Near the confluence of the North/South Platte Rivers, Keith, Lincoln, Garden, Dawson and Gasper Counties, NB, August 24, 1998, Contact: Frankie Green (202) 501-7704.

EIS No. 980275, Draft EIS, FAA, NC, Charlotte/Douglas International Airport, Construction and Operation, New Runway 17/35 (Future 18L/36R Associated Taxiway Improvements, Master Plan Development, Approval Airport Layout Plan (ALP) and COE Section 404 Permit, Mecklenburg County, NC, Due: September 07, 1998, Contact: Thomas M. Roberts (404) 305-7153.

EIS No. 980276, Draft EIS, BOP, PA, Greater Scranton Area, United States Penitentiary (USP) Construction and Operation, Site Selection, Lackawanna and Wayne Counties, PA, Due: September 8, 1998, Contact: David J. Dorworth (202) 514-6470.

EIS No. 980277, Draft EIS, DOE, ID, Advanced Mixed Waste Treatment Project, Construction and Operation, Site Selected, Idaho National Engineering and Environmental Laboratory (INEEL), Eastern Snake River Plain, ID, Due: September 11, 1998, Contact: John Medema (208) 526-1407.

EIS No. 980278, Final EIS, AFS, ID, North Round Valley Timber Sales and Road Construction, Implementation, Payette National Forest, New Meadows Ranger District, Adams County, ID, Due: August 24, 1998, Contact: Kimberly Brandel (208) 347-0300.

Amended Notices

EIS No. 980171, Draft EIS, COE, TX, Dallas Floodway Extension, Implementation, Trinity River Basin, Flood Damage Reduction and Environmental Restoration, Dallas County, TX, Due: August 14, 1998, Contact: Gene T. Rice, Jr. (817) 978-2110. Published FR 05-15-98—Review Period extended.

EIS No. 980267, Draft EIS, DOE, CA, NM, TX, ID, C, WA, Surplus Plutonium Disposition (DOE/EIS-0283) for Siting, Construction and Operation of three facilities for Plutonium Disposition, Possible Sites Hanford, Idaho National Engineering and Environmental Laboratory, Pantex Plant and Savannah River, CA, ID, NM, SC, TX and WA, Due: September 16, 1998, Contact: G. Bert Stevenson (202) 586-5368. This EIS was inadvertently omitted from the 07-17-98 Federal Register. The official 45 days NEPA review period is calculated from 07-17-98.

Dated: July 21, 1998.

William D. Dickerson,
Director, NEPA Compliance Division, Office of Federal Activities.

[FR Doc. 98-19885 Filed 7-23-98; 8:45 am]

BILLING CODE 6560-50-P

FEDERAL COMMUNICATIONS COMMISSION

Notice of Public Information Collection(s) Submitted to OMB for Review and Approval

July 17, 1998.

SUMMARY: The Federal Communications Commissions, as part of its continuing effort to reduce paperwork burden invites the general public and other Federal agencies to take this opportunity to comment on the following information collection, as required by the Paperwork Reduction Act of 1995, Public Law 104-13. An agency may not conduct or sponsor a collection of information unless it displays a currently valid control number. No person shall be subject to any penalty for failing to comply with a collection of information subject to the Paperwork Reduction Act (PRA) that does not display a valid control number. Comments are requested concerning (a) whether the proposed collection of information is necessary for the proper performance of the functions of the Commission, including whether the information shall have practical utility; (b) the accuracy of the Commission's burden estimate; (c) ways to enhance the quality, utility, and clarity of the information collected; and (d) ways to minimize the burden of the collection of information on the respondents, including the use of automated collection techniques or other forms of information technology.

DATES: Written comments should be submitted on or before August 24, 1998. If you anticipate that you will be submitting comments, but find it difficult to do so within the period of time allowed by this notice, you should advise the contact listed below as soon as possible.

ADDRESSES: Direct all comments to Les Smith, Federal Communications Commissions, Room 234, 1919 M St., N.W., Washington, DC 20554 or via internet to lesmith@fcc.gov.

FOR FURTHER INFORMATION CONTACT: For additional information or copies of the information collections contact Les Smith at 202-418-0217 or via internet at lesmith@fcc.gov.

SUPPLEMENTARY INFORMATION:

OMB Approval Number: 3060-0089.

Title: Application for Land Radio Station Authorization in the Maritime Services.

Form No.: FCC 503.

Type of Review: Revision of a currently approved collection.

Respondents: Individuals or households; Businesses or other for-

profit entities; Not-for-profit institutions; State, Local or Tribal Government.

Number of Respondents: 700.

Estimated Time Per Response: 45 minutes.

Frequency of Response: On occasion reporting requirements.

Cost to Respondents: \$76,224 (\$115 application fee for a new station; \$90 application fee to modify an existing land station; postage).

Total Annual Burden: 525 hours.

Needs and Uses: FCC Rules require that applicants file FCC Form 503 when applying for a new station or when modifying an existing land radio station in the Maritime Mobile Service or an Alaska Public Fixed Station. This form is required by the Communications Act of 1934, as amended, International Treaties, and FCC Rules—47 CFR Parts 1.922, 80.19, and 80.29. The data collected are necessary to evaluate a request for station authorization in the Maritime Services or an Alaska Public Fixed Station, to issue licenses, and to update the database to allow proper management of the frequency spectrum. FCC Form 503 is being revised to collect Antenna Structure Registration Number/ or FCC Form 854 File Number, and Internet or E-mail address of the applicant. Due to changes in the antenna clearance procedures, we no longer need to collect certain antenna information, such as the name of the nearest aircraft landing area and the distance and the direction to the nearest runway. The instructions are being edited accordingly.

Federal Communications Commission.

Magalie Roman Salas,

Secretary.

[FR Doc. 98-19715 Filed 7-23-98; 8:45 am]

BILLING CODE 6712-01-P

FEDERAL COMMUNICATIONS COMMISSION

Notice of Public Information Collection(s) Submitted to OMB for Review and Approval

July 18, 1998.

SUMMARY: The Federal Communications Commission, as part of its continuing effort to reduce paperwork burden invites the general public and other Federal agencies to take this opportunity to comment on the following information collection, as required by the Paperwork Reduction Act of 1995, Pub. L. 104-13. An agency may not conduct or sponsor a collection of information unless it displays a currently valid control number. No person shall be subject to any penalty

**A.4 AMENDED NOTICE OF AVAILABILITY—SURPLUS PLUTONIUM DISPOSITION
DRAFT ENVIRONMENTAL IMPACT STATEMENT, 60-DAY NEPA REVIEW PERIOD**

Burden Statement: The annual burden for this collection of information is estimated to average fourteen work weeks of professional effort at \$840 per week, and seven work weeks of clerical support at \$360 per week for the government. Approximately 210 requests may be made annually with an average of one hour spent on each request by both entities. The total costs are attributed to labor hours and overhead since there is no capital investment required for this collection of information. Burden means the total time, effort, or financial resources expended by persons to generate, maintain, retain, or disclose or provide information to or for a Federal agency. This includes the time needed to review instruction; develop, acquire, install, and utilize technology and systems for the purposes of collecting, validating, and verifying information, processing and maintaining information, and disclosing and providing information; adjust the existing ways to comply with any previously applicable instruction and requirements; train personnel to be able to respond to a collection of information; search data sources; complete and review the collection information; and transmit or otherwise disclose the information.

Dated: August 3, 1998.

Robert Perciasepe,

Assistant Administrator for Air and Radiation.

[FR Doc. 98-21210 Filed 8-6-98; 8:45 am]

BILLING CODE 6560-50-P

ENVIRONMENTAL PROTECTION AGENCY

[FRL-6139-8]

Agency Information Collection Activities: Comment Request Up for Renewal

AGENCY: Environmental Protection Agency (EPA).

ACTION: Notice.

SUMMARY: In compliance with the Paperwork Reduction Act (44 U.S.C. 3501 *et seq.*), this document announces that EPA is planning to submit the following continuing Information Collection Request (ICR) to the Office of Management and Budget (OMB): EPA Worker Protection Standard for Hazardous Waste Operations and Emergency Response, EPA ICR #1426.03, OMB Control #2050-0105, Expiration 1/31/99. Before submitting ICR to OMB and Budget (OMB) for review and approval, EPA is soliciting

comments on specific aspects of the collection as described below.

DATES: Comments must be submitted on or before October 3, 1998.

ADDRESSES: Office of Solid Waste and Emergency Response, 401 M. Street, SW, MS 5101, Washington, DC 20460.

Remit Comments to: Sella M. Burchette, S EPA/ERT, 2890 Woodbridge Ave., Bldg 18, MS 101, Edison, NJ 08837-3679.

To obtain a copy at no charge, please contact Sella Burchette at (732) 321-6726/FAX: (732) 321-6724/or electronically at burchette.sella@epamail.epa.gov.

SUPPLEMENTARY INFORMATION:

Affected entities: Entities affected by this action are those State and local employees engaged in hazardous waste operations and emergency response in the 27 States that do not have Occupational Safety and Health Administration (OSHA) approved State plans.

Title: EPA Worker Protection Standard for Hazardous Waste Operations and Emergency Response, EPA ICR #1426.03, OMB Control #2050-0105, Expiration 1-31-99. This is a request for renewal, without change, of a currently approved collection.

Abstract: Section 126 (f) of the Superfund Amendments and Reauthorization Act of 1986 (SARA) require EPA to set worker protection standards for State and local employees engaged in hazardous waste operations and emergency response in the 27 States that do not have Occupational Safety and Health Administration approved State plans. The EPA coverage, required to be identical to the OSHA standards, extends to three categories of employees: those in clean-ups at uncontrolled hazardous waste sites, including corrective actions at Treatment, Storage and Disposal (TSD) facilities regulated under the Resource Conservation and Recovery Act (RCRA); employees working at routine hazardous waste operations at RCRA TSD facilities; and employees involved in emergency response operations without regard to location. This ICR renews the existing mandatory recordkeeping collection of ongoing activities including monitoring of any potential employee exposure at uncontrolled hazardous waste site, maintaining records of employee training, refresher training, medical exams, and reviewing emergency response plans.

An agency may not conduct or sponsor, and a person is not required to respond to, a collection of information unless it displays a currently valid OMB control number. The OMB control

numbers for EPA's regulations are listed in 40 CFR part 9 and 48 CFR Chapter 15.

The EPA would like to solicit comments to:

(i) evaluate whether the proposed collection of information is necessary for the proper performance of the functions of the agency, including whether the information will have practical utility;

(ii) evaluate the accuracy of the agency's estimates of the burden of the proposed collection of information;

(iii) enhance the quality, utility and clarity of the information to be collected; and

(iv) minimize the burden of the collection of information on those who are to respond, including though the use of appropriate automated electronic, mechanical, or other technology collection techniques or other forms of information technology, e.g. permitting electronic submission of responses.

Burden Statement: The annual recordkeeping burden for this collection is estimated to average 10.64 hours per site or event. The estimated number of respondents is approximated at 100 RCRA regulated TSD facilities or uncontrolled hazardous waste sites; 23,900 State and local police departments, fire departments or hazardous materials response teams. The estimated total burden hours on respondents: 255,427. The frequency of collection: continuous maintenance or records.

Send comments regarding these matters, or any other aspect of the information collection, including suggestions for reducing the burden, to the address listed above.

Dated: July 30, 1998.

Larry Reed,

Acting Office Director, Office of Emergency and Remedial Response.

[FR Doc. 98-21211 Filed 8-6-98; 8:45 am]

BILLING CODE 6560-50-P

ENVIRONMENTAL PROTECTION AGENCY

[ER-FRL-5494-3]

Environmental Impact Statements; Notice of Availability

RESPONSIBLE AGENCY: Office of Federal Activities, General Information (202) 564-7167 OR (202) 564-7153.

Weekly receipt of Environmental Impact Statements, Filed July 27, 1998 Through July 31, 1998, Pursuant to 40 CFR 1506.9.

EIS No. 980287, DRAFT EIS, COE, CA, Los Angeles County Drainage Area

- (LACDA) Water Conservation and Supply and Santa Fe-Whittier Narrows Dams Feasibility Study, Implementation, Los Angeles County, CA, Due: September 21, 1998, Contact: Ms. Debbie Lamb (213) 452-3798.
- EIS No. 980288, FINAL EIS, AFS, CA, Eight Eastside Rivers, Wild and Scenic River Study, Suitability or Nonsuitability, Tahoe National Forest and Lake Tahoe Management Unit, Land and Resource Management Plans, Alpine, El Dorado, Placer, Nevada and Sierra Counties, CA, Due: September 8, 1998, Contact: Phil Horning (530) 478-6210.
- EIS No. 980289, FINAL EIS, FHW, TX, Loop 49 Southern Section Construction, TX-155 to TX-110, Funding, Tyler, Smith County, TX, Due: September 8, 1998, Contact: Walter C. Waidelich (512) 916-5988.
- EIS No. 980290, DRAFT EIS, NPS, CA, Redwood National and State Parks General Management Plan, Implementation, Humboldt and Del Norte Counties, CA, Due: October 9, 1998, Contact: Alan Schmierer (414) 427-1441.
- EIS No. 980291, DRAFT EIS, FHW, MN, TH-23 Reconstruction, MN-TH-22 in Richmond extending through the Cities of Richmond, Cold Spring and Rockville to I-94, Funding, Stearns County, MN, Due: September 22, 1998, Contact: Cheryl Martin (612) 291-6120.
- EIS No. 980292, DRAFT EIS, FHW, MO, MO-63 Corridor Project, Transportation Improvement extending from south of the Phelps/Maries County Line and South of Route W near Vida, Funding and COE Section 404 Permit, City of Rolla, Phelps and Maries Counties, MO, Due: October 3, 1998, Contact: Don Neumann (573) 636-7104.
- EIS No. 980293, FINAL EIS, FHW, TN, Shelby Avenue/Demonbreum Street Corridor, from I-65 North to I-40 West in Downtown Nashville, Funding, U.S. Coast Guard Permit and COE Section 404 Permit, Davidson County, TN, Due: September 8, 1998, Contact: James E. Scapellato (615) 736-5394.
- EIS No. 980294, DRAFT EIS, NOA, MN, Minnesota's Lake Superior Costal Program, Approval and Implementation, St. Louis and Cook Counties, MN, Due: September 21, 1998, Contact: Joseph A. Uravitch (301) 713-3155.
- EIS No. 980295, DRAFT EIS, BLM, WY, Carbon Basin Coal Project Area, Coal Lease Application for Elk Mountain/Saddleback Hills, Carbon County, WY, Due: October 6, 1998, Contact: Jon Johnson (307) 775-6116.
- EIS No. 980296, FINAL EIS, BLM, AK, Northeast National Petroleum Reserve-Alaska (NPR-A), Integrate Activity Plan, Multiple-Use Management, for Land within the North Slope Borough, AK, Due: September 8, 1998, Contact: Gene Terland (907) 271-3344.
- EIS No. 980297, FINAL SUPPLEMENT, AFS, MT, Helena National Forest and Elkhorn Mountain portion of the Deerlodge National Forest Land and Resource Management Plan, Updated Information on Oil and Gas Leasing, Implementation several counties, MT, Due: September 08, 1998, Contact: Tom Andersen (Ext 277) (406) 446-5201.
- EIS No. 980298, FINAL EIS, COE, CA, Montezuma Wetlands Project, Use of Cover and Non-cover Dredged Materials to restore Wetland, Implementation, Conditional-Use-Permit, NPDES and COE Section 10 and 404 Permit, Suisum Marsh in Collinsville, Solano County, CA, Due: September 08, 1998, Contact: Liz Varnhagen (415) 977-8451.
- EIS No. 980299, FINAL EIS, USA, MD, Aberdeen Proving Ground, Pilot Testing of Neutralization/Biotreatment of Mustard Agent (HD), Design, Construction and Operation, NPDES and COE Section 404 Permit, Harford County, MD, Due: September 08, 1998, Contact: Mr. Matt Hurlburt (410) 612-7027.
- EIS No. 980300, DRAFT EIS, COE, AR, Grand Prairie Area Demonstration Project, Implementation, Water Conservation, Groundwater Management and Irrigation Water Supply, Prairie, Arkansas, Monroe and Lonoke Counties, AR, Due: September 21, 1998, Contact: Edward P. Lambert (901) 544-0707.
- Amended Notices
- EIS No. 980267, DRAFT EIS, DOE, CA, NM, TX, ID, SC, WA, Surplus Plutonium Disposition (DOE/EIS-0283) for Siting, Construction and Operation of three facilities for Plutonium Disposition, Possible Sites Hanford, Idaho National Engineering and Environmental Laboratory, Pantex Plant and Savannah River, CA, ID, NM, SC, TX and WA, Due: September 16, 1998, Contact: G. Bert Stevenson (202) 586-5368. The DOE granted a 60-Day review period for the above project.
- EIS No. 980269, DRAFT EIS, AFS, ID, Eagle Bird Project Area, Timber Harvesting and Road Construction, Idaho Panhandle National Forests, St. Joe Ranger District, Shoshone County, ID, Due: September 07, 1998, Contact: Cameo Flood (208) 245-4517.
- Published FR-07-24-98—Due Date Correction.
- Dated: August 4, 1998.
- Joseph C. Montgomery,
Environmental Specialist, Office of Federal Activities.
[FR Doc. 98-21235 Filed 8-7-98; 8:45 am]
- BILLING CODE 6560-50-U

ENVIRONMENTAL PROTECTION AGENCY

[FRL-6139-5]

Notice of Proposed CERCLA Section 122(h)(1) Administrative Cost Recovery Settlement

AGENCY: Environmental Protection Agency (EPA).

ACTION: Proposal of CERCLA section 106 abatement action and section 122(h)(1) administrative cost recovery settlement for the Cecil's Transmission Repair site.

SUMMARY: U.S. EPA proposes to address the potential liability of Buhl and Laura Smith ("Settling Parties") under the Comprehensive Environmental Response, Compensation, and Liability Act of 1980, as amended ("CERCLA"), 42 U.S.C. 9601 *et seq.*, by providing for performance of removal actions to abate an imminent and substantial endangerment to the public health, welfare or the environment resulting from the actual or threatened release of hazardous substances at or from the Cecil's Transmission Repair Site ("the Site"), located at 197 and 209 Collier Road, Doylestown, Wayne County, Ohio. U.S. EPA proposes to address the potential liability of the Settling Parties by execution of a CERCLA section 122(h)(1) Administrative Order on Consent ("AOC"), prepared pursuant to 42 U.S.C. 9622(h)(1). The key terms and conditions of the AOC may be briefly summarized as follows: (1) The Settling Parties agree to remove and dispose of all hazardous waste located on the portion of the Site they own, including drums; (2) U.S. EPA provides the Settling Parties a covenant not to sue for recovery of response costs (past and oversight costs) pursuant to section 107(a) of CERCLA, 42 U.S.C. 9607(a), and contribution protection as provided by CERCLA sections 113(f)(2) and 122(h)(4), 42 U.S.C. 9613(f)(2) and 9622(h)(4), conditioned upon satisfactory completion of obligations under the AOC. The Site is not on the NPL, and no further response activities at the Site are anticipated at this time. The total response costs connected with

A.5 NOTICE OF AN AMENDED RECORD OF DECISION FOR THE STORAGE AND DISPOSITION OF WEAPONS-USABLE FISSILE MATERIALS

responsibilities are to (1) evaluate the standards of accreditation applied to applicant foreign medical schools; and (2) determine the comparability of those standards to standards for accreditation applied to United States medical schools.

For Further Information Contact: Bonnie LeBold, Executive Director, National Committee on Foreign Medical Education and Accreditation, 7th and D Streets, S.W., Room 3082, ROB #3, Washington, D.C. 20202-7563. Telephone: (202) 260-3636. Beginning September 28, 1998, you may call to obtain the identity of the countries whose standards are to be evaluated during this meeting.

Dated: August 6, 1998.

David A. Longanecker,

Assistant Secretary for Postsecondary Education.

[FR Doc. 98-21757 Filed 8-12-98; 8:45 am]

BILLING CODE 4000-01-M

DEPARTMENT OF ENERGY

Storage and Disposition of Weapons-Usable Fissile Materials

AGENCY: Department of Energy.

ACTION: Notice of an amended Record of Decision.

SUMMARY: The U.S. Department of Energy (DOE) prepared a final programmatic environmental impact statement, Storage and Disposition of Weapons-Usable Fissile Materials (Storage and Disposition PEIS) (DOE/EIS-0229, December 1996) in accordance with the National Environmental Policy Act (NEPA), Council on Environmental Quality NEPA implementing regulations, and DOE implementing procedures. The Storage and Disposition PEIS, among other things, assesses the potential environmental impacts of alternatives and locations for storing weapons-usable fissile materials (plutonium and highly enriched uranium).

On January 14, 1997, DOE issued a Record of Decision (Storage and Disposition ROD), 62 FR 3014, (January 21, 1997), selecting weapons-usable fissile materials storage and surplus plutonium disposition strategies. For plutonium storage, DOE decided to consolidate part of its weapons-usable plutonium storage by upgrading and expanding existing and planned facilities at the Pantex Plant (Pantex) near Amarillo, Texas and the Savannah River Site (SRS) near Aiken, South Carolina. For plutonium currently stored at the Hanford Site (Hanford) near Richland, Washington, and other DOE sites, DOE decided that surplus weapons-usable plutonium would remain at these sites until disposition

(or move to lag storage at a disposition facility). The weapons-usable plutonium stored at the Rocky Flats Environmental Technology Site (RFETS), near Golden, Colorado, would be moved to Pantex and the SRS. However, the plutonium destined for the SRS, i.e., non-pit, weapons-usable surplus plutonium, would be moved only if: (1) the plutonium had been stabilized under corrective actions in response to the Defense Nuclear Facilities Safety Board (DNFSB) Recommendation 94-1 and packaged to meet the DOE storage Standard 3013-96, Criteria for Safe Storage of Plutonium Metals and Oxides, (2) the construction and expansion of the Actinide Packaging and Storage Facility (APSF) at the SRS had been completed, and (3) the SRS had been selected in the upcoming Record of Decision for the Surplus Plutonium Disposition Environmental Impact Statement as the immobilization disposition site for surplus weapons-usable plutonium.

In order to support the early closure of the RFETS and the early deactivation of plutonium storage facilities at the Hanford site, DOE is modifying, contingent upon the satisfaction of certain conditions, some of the decisions made in its Storage and Disposition ROD associated with surplus plutonium storage pending disposition. Namely, DOE will take steps that allow: (1) the accelerated shipment of all non-pit surplus weapons-usable plutonium from the RFETS (about 7 metric tons) to the SRS beginning in about 2000, in advance of completion of the APSF in 2001, and (2) the relocation of all Hanford surplus weapons-usable plutonium (about 4.6 metric tons) to the SRS, between about 2002 and 2005, pending disposition. However, consistent with the Storage and Disposition PEIS ROD, DOE will only implement the movement of RFETS and Hanford non-pit, surplus weapons-usable plutonium inventories to the SRS if the SRS is selected as the immobilization disposition site. DOE is preparing the Surplus Plutonium Disposition Environmental Impact Statement (SPD EIS), draft issued July 1998, as part of the decision making process for determining an immobilization site.¹

To accommodate the storage of Hanford surplus weapons-usable plutonium, DOE will expand the APSF as planned in the Storage and Disposition ROD. In addition, to accommodate the early receipt and storage of the RFETS surplus

plutonium, the Department will prepare additional suitable storage space in Building 105-K (i.e., K-Reactor) in the K-Area at the SRS. Portions of Building 105-K will be modified to provide safe and secure plutonium storage. Safeguards and security features will be upgraded, criticality monitoring devices will be installed, structural features will be inspected and repaired, roof vents will be added, and doors will be modified. Several areas in the facility will be decontaminated and excess equipment will be removed to provide additional floor space.

Modifications will also include dismantling and removing unused process equipment in four building areas: Stack Area, Crane Maintenance Area, Crane Wash Area, and Process Room.

Security systems in the four building areas will be reactivated and upgraded to support using them for plutonium storage. Existing systems including the K-Area security perimeter, security control system and building water/power ventilation support systems will be used. Building modifications will provide for truck loading and unloading, material conformation, shipping accountability measurements, and storage. The Department will also declassify (process the metal to produce unclassified "buttons") some of the RFETS plutonium materials using SRS's FB-Line (in the F-Area) and after declassification, package this material in the APSF to meet the DOE storage Standard 3013-96, Criteria for Safe Storage of Plutonium Metals and Oxides.

All plutonium materials shipped to SRS will be stable and, except for classified metal and/or parts, will be packaged to meet the requirements of the DOE Standard 3013-96, Criteria for Safe Storage of Plutonium Metals and Oxides, before shipment. All shipments of plutonium to SRS will be by Safe Secure Transport (SST) in accordance with applicable DOE, U.S. Department of Transportation and U.S. Nuclear Regulatory Commission requirements and regulations. Some of the RFETS plutonium material packaged and shipped will be less than 50% plutonium by weight; as a result, there will be approximately 3% more total weight of material and a corresponding increase in the number of shipments than considered in the Storage and Disposition PEIS, although the total amount of plutonium in the material will remain about the same.

Under the previous ROD, a maximum of 10 metric tons of surplus plutonium, including plutonium from RFETS and existing onsite plutonium, would be

¹ SRS has been identified by DOE as the preferred site for the immobilization disposition facility.

stored at SRS in the APSF, pending disposition, provided that SRS is selected as the immobilization site following completion of the Surplus Plutonium Disposition EIS. Transfer of plutonium from RFETS to SRS would begin when the APSF is completed in 2001.

With this amended ROD, a total of approximately 11.6 metric tons of surplus weapons-usable plutonium from Hanford and RFETS (in addition to existing onsite SRS surplus plutonium, for a total of approximately 14 metric tons of surplus plutonium) could be stored at SRS in the APSF and Building 105-K, pending disposition, provided that SRS is selected as the immobilization site. Transfer of plutonium from RFETS to SRS would begin when the modifications to Building 105-K are completed, i.e., in about 2000; shipments of plutonium from Hanford to SRS would begin in about 2002.

This amended ROD only alters DOE's previous decision (Storage and Disposition ROD) for the storage of non-pit, surplus weapons-usable plutonium currently located at the RFETS and Hanford sites. No changes are being made to other storage decisions or any decisions associated with surplus fissile material disposition.

In accordance with 10 CFR 1021.314, DOE has prepared a Supplement Analysis to determine if these changes require a supplement to the Storage and Disposition PEIS under the Council on Environmental Quality Regulations at 40 CFR 1502.9(c). The Supplement Analysis shows that the new proposed action does not result in a substantial change to environmental concerns evaluated in the Storage and Disposition PEIS. Also, the Supplement Analysis shows that the proposed action does not present significant new circumstances or information relevant to the environmental concerns evaluated in the Storage and Disposition PEIS. Therefore, based on the Supplement Analysis, DOE has determined that a supplement to the Storage and Disposition PEIS is not required, and DOE has decided not to prepare such a supplement.

FOR FURTHER INFORMATION CONTACT: For further information on the long-term storage or the disposition of weapons-usable fissile materials, or to receive a copy of the final Storage and Disposition PEIS, the Storage and Disposition EIS ROD or the Supplement Analysis, contact: G. Bert Stevenson, NEPA Compliance Officer, Office of Fissile Materials Disposition (MD-4), U.S. Department of Energy, 1000

Independence Avenue, SW.,
1 Washington, DC 20585, (202) 586-5368.

For further information on the DOE NEPA process, contact: Carol M. Borgstrom, Director, Office of NEPA Policy and Assistance (EH-42), U.S. Department of Energy, 1000 Independence Avenue, SW., Washington, DC 20585, (202) 586-4600, or leave a message at (800) 472-2756.

SUPPLEMENTARY INFORMATION:

I. Background

A. Current Storage Program and Original Decision for Surplus Weapons-Usable Plutonium

DOE is currently phasing out the storage of all weapons-usable plutonium at RFETS. The phaseout involves shipping all RFETS pits to Pantex, and shipping all RFETS surplus non-pit, weapons-usable plutonium to the SRS (subject to certain conditions) starting in about 2001. As decided in the January 1997 Storage and Disposition PEIS ROD, the stabilized non-pit, surplus weapons-usable plutonium would not be moved unless and until: expansion of the APSF² at the SRS had been completed; the RFETS material had been stabilized and packaged to meet the Criteria for Safe Storage of Plutonium Metals and Oxides for long-term storage under corrective actions in response to the Defense Nuclear Facilities Safety Board Recommendation 94-1; and DOE had decided to immobilize plutonium at the SRS. The Department also decided to continue the current storage of surplus plutonium at Hanford, the Idaho National Engineering and Environmental Laboratory (INEEL), and Los Alamos National Laboratory (LANL) pending disposition (or movement to lag storage); and to pursue a strategy for plutonium disposition that would immobilize surplus weapons-usable plutonium in glass or ceramic forms and would allow the burning of some of the surplus weapons-usable plutonium (mostly from pits) as mixed oxide fuel in existing commercial light-water reactors.

B. Need to Change Storage Program

Recently, DOE has estimated that accelerating the closure of RFETS from 2010 to 2006 could save as much as \$1.3 billion. Integral to achieving an accelerated closure of the site would be

² The APSF has been designed but not built. Construction is scheduled to start in October 1998 and the facility is scheduled to be in operation by October 2001. Expansion of the APSF refers to increasing the vault capacity of the facility to the current design of 5,000 storage positions (sufficient storage space for current SRS materials and RFETS materials).

removal of the non-pit, surplus weapons-usable plutonium to SRS two years earlier than the current plan. Removal of the surplus plutonium at RFETS is only one of several steps to realize the savings. Other steps are proposed or ongoing pursuant to separate NEPA review. DOE also expects that the transfer of non-pit, surplus weapons-usable plutonium from Hanford to Savannah River could save as much as \$150 million in upgrade and operating costs for plutonium storage facilities at the Hanford Site. As with the RFETS plutonium, the transfer would not be accomplished unless DOE decided to locate the plutonium immobilization facility at the Savannah River Site. The implementation cost for the proposed action is estimated to be approximately \$93 million.

Closing RFETS by 2006 would, among other things, require the removal of non-pit, surplus weapons-usable plutonium metal and oxide from RFETS by 2002. In order to remove all the non-pit, surplus weapons-usable plutonium from RFETS by 2002, DOE would have to begin transferring the material to the SRS by January 2000, prior to completing the construction of the APSF.

DOE has also reevaluated plutonium storage operations at Hanford and determined that transferring all (about 4.6 metric tons) non-pit, surplus weapons-usable plutonium from that site for storage could save the Department as much as \$150 million by avoiding upgrade and operating costs for plutonium storage facilities at the Hanford Site. DOE is considering the early transfer of plutonium from Hanford to the SRS as a means of achieving this savings.

These transfers would not occur unless DOE decides to immobilize plutonium at the SRS. A ROD to select the immobilization site is anticipated in early 1999 in the SPD EIS.

C. Proposed Action

The Department of Energy is proposing to accelerate the movement of all (about 7 metric tons) of non-pit, surplus weapons-usable plutonium at the RFETS and to move all (about 4.6 metric tons) of the surplus weapons-usable plutonium at Hanford to the SRS for storage pending disposition. The RFETS plutonium would be shipped to the SRS from about January 2000 through 2002. The Hanford plutonium would be shipped to the SRS from about 2002 through 2005.

The plutonium would not be moved to SRS unless the Department decides to disposition (immobilize) the non-pit,

surplus weapons-usable plutonium at SRS, after completion of the final Surplus Plutonium Disposition Environmental Impact Statement. In addition, the plutonium would not be shipped until it were stabilized and packaged to meet DOE Standard 3013-96, *Criteria for Safe Storage of Plutonium Metals and Oxides* in response to Defense Nuclear Facilities Safety Board Recommendation 94-1. This proposed action is consistent with DOE's objective, as explained in the ROD for the Storage and Disposition PEIS, to reduce over time the number of locations where plutonium is stored in the DOE complex.

Starting in about January 2000, all non-pit, surplus weapons-usable plutonium (except for classified plutonium) would be shipped to Building 105-K. At Building 105-K, the shipping containers³ would be unloaded using a battery powered forklift truck. Material control and accountability measurements would be made at Building 105-K. The shipping containers would then be loaded onto metal pallets and transferred to a storage location in the building. DOE would not open any of the shipping containers in Building 105-K. While in storage, the containers would be inspected on a regular basis to assure external container integrity.³ DOE has successfully used (and continues to use) shipping containers for plutonium storage at the SRS. No problems with a loss of material confinement have been experienced to date.

Portions of Building 105-K will be modified to facilitate plutonium storage. Safeguards and security features will be upgraded, criticality monitoring devices will be installed, structural features will be inspected and repaired, and roof vents will be added and doors will be modified. Several areas in the facility will be decontaminated and excess equipment will be removed to provide additional floor space.⁴

Modifications will include dismantling and removing unused process equipment in four building areas: Stack Area, Crane Maintenance Area, Crane Wash Area, and Process Room. These areas total approximately 30,000 square feet, are within the

security areas that existed for reactor operations, and are adjacent to a currently active highly enriched uranium storage area. Security systems in the four building areas will be reactivated and upgraded to support using them for plutonium storage. Existing systems including the K-Area security perimeter, security control system and building water/power ventilation support systems will be used. Building modifications will provide for truck loading and unloading, material conformation, shipping accountability measurements, and storage.

Some of the RFETS plutonium is in a classified form, which would restrict the International Atomic Energy Agency (IAEA) from access to the material. DOE intends to make the APSF vault, and potentially Building 105-K, available for IAEA inspection. As a result, the RFETS plutonium needs to be declassified. To accomplish this objective, DOE would transfer the classified RFETS plutonium to F-Area for processing (declassifying) in the FB-Line facility at SRS. In the FB-Line facility, the plutonium would be melted using existing facilities and equipment that are part of the plutonium metal production process for which the FB-Line facility was designed. The declassification work would not be done on a continuous basis, but rather whenever processing capabilities were available. The RFETS plutonium would be fashioned into metal "buttons" that are the traditional FB-Line product. After the "buttons" are fabricated, the material would be transferred to the APSF and packaged to meet the requirements of DOE's plutonium storage standard. Then, the material would be placed in type B shipping containers and transported to Building 105-K for storage. Alternatively, the material could remain in the APSF vault, if space is available to allow for operational flexibility.

Some of the RFETS plutonium materials would be less than 50% plutonium by weight and would involve approximately 3% more total weight of material and a corresponding increase in the number of shipments than considered in the S&D PEIS.

Beginning in about 2002, SRS would begin to receive from Hanford stabilized plutonium packaged to meet DOE's long-term standard for placement in the APSF. Once APSF is operating, DOE could transfer a portion of the RFETS material from Building 105-K to the APSF in order to provide for operational flexibility. The plutonium from RFETS and Hanford would remain in storage at the APSF and Building 105-K pending

disposition along with existing SRS surplus plutonium.

The plutonium would be transferred in type B shipping containers by truck using methods and routes described in the Storage and Disposition PEIS (i.e., the Department of Energy's Safe Secure Transport System).

If DOE decides to pursue the No Action alternative for the disposition of surplus plutonium in the SPD EIS Record of Decision, the SRS, RFETS, and Hanford materials would remain in storage at their current sites in accordance with the No Action alternative. If the DOE decides to immobilize surplus plutonium at Hanford, the SRS and RFETS materials would be shipped to Hanford in accordance with the decisions reached in the SPD EIS Record of Decision.

II. NEPA Process for Amending ROD

A. Supplement Analysis

Pursuant to DOE regulations in 10 CFR 1021.314, DOE has prepared a Supplement Analysis, Supplement Analysis for Storing Plutonium in the Actinide Packaging and Storage Facility and Building 105-K at the Savannah River Site (July 1998), to help determine whether a supplement to the Storage and Disposition PEIS is required under the Council on Environmental Quality Regulations, 40 CFR 1502.9(c). The Supplement Analysis compares the potential impacts of the new proposed action to the impacts discussed for the plutonium storage alternatives in the Storage and Disposition PEIS. The Supplement Analysis shows that the new proposed action does not make a substantial change to environmental concerns evaluated in the Storage and Disposition PEIS. Furthermore, the Supplement Analysis shows that there are no new significant circumstances or information relevant to environmental concerns and bearing on the proposed action or its impact.

B. Comparison of Potential Impacts

The facilities involved (i.e., Building 105-K and the APSF) are or will be located in existing industrial areas at the SRS.

- Land Resources, Site Infrastructure, Geology and Soils, Biology Resources and Cultural and Paleontological Resources. There are no aquatic habitats or wetlands in these areas nor are there any threatened or endangered species. None of the affected facilities have been nominated for inclusion in the National Register of Historic Places, and there are no plans for such nominations.

Based on evaluations in the Storage and Disposition PEIS and information

³To support the proposed action, DOE would purchase additional Type 9975 shipping containers, which are Type B containers and would also be used for storage. This would be done so that storing the RFETS materials in shipping containers pending disposition will not impact the Department's supply of Type B shipping containers.

⁴A portion of these activities could be completed as part of maintenance, clean-up, and decontamination activities at SRS that DOE has determined are categorically excluded from further NEPA review.

incorporated in the Supplement Analysis from the Final Environmental Impact Statements on the Interim Management of Nuclear Materials (DOE/EIS-0220, October, 1995)(IMNMS EIS) there would be little or no impact to land resources, site infrastructure, geology and soils, biology resources and cultural and Paleontological resources by the construction, operation and expansion of the APSF. This is equally true for Building 105-K since all storage operations would occur within the existing Building 105-K structure.

- It is expected that declassification of the RFETS material would require 100 Mw hrs/yr of electricity. This work would not require modification to the FB-line's electrical system and is well within the capacity of the facility and the site.

- Packaging and Transportation. The transportation routes to the SRS would be the same as those assumed in the Storage and Disposition PEIS (i.e., overland truck routes on interstate highways and state roads). Transportation operations would not change. DOE estimates that the total inter-site transportation impact associated with transferring plutonium from the RFETS and Hanford to the SRS would be 0.07 potential latent cancer fatalities, which would be approximately the same as for the Preferred Alternative in the Storage and Disposition PEIS.⁵ DOE estimates that the intra-site transportation activities could add an additional 0.01 latent cancer fatalities to the worker population.⁶

- Air Quality and Noise. Storage: Accomplishing the proposed action, including the modifications to Building 105-K, would add no significant air quality and noise impacts above the existing site baseline. Therefore, air quality and noise impacts from the plutonium storage aspects of the proposed action would be essentially the same as the air quality and noise impacts from the Preferred Alternative of the Storage and Disposition PEIS (i.e., the Upgrade With RFETS Non-Pit Material alternative).

⁵The impact is the sum of the impact of transportation of RFETS non-pit plutonium under the Preferred Alternative in the Storage and Disposition PEIS and the incremental impact for shipping the Hanford plutonium.

⁶In inter-site transportation analyses, non-radiological accidents would be the greatest contributor to fatalities. In the case of intra-site transportation, impacts would be due primarily to radiation doses received from normal transportation operations. Effects from intra-site accidents, if any, would likely be negligible. Historically, certified containers maintain their integrity in accident situations.

Declassification/Repackaging: DOE estimates there would be a small increase in non-radiological air emissions for declassification operations (i.e., metal conversion operations in FB-Line) above the non-radiological air emissions estimated for the No Action and the Upgrade alternatives in the Storage and Disposition PEIS. Non-radiological air emissions would be well within State and Federal regulatory limits. Repackaging activities are not expected to involve the use of chemicals, beyond a very small amount of decontamination liquid.

- Water Resources. *Storage:* The maximum impact to water resources, above existing site baseline usage and discharges, expected from plutonium storage aspects of DOE's proposed action would be about the same as presented in the Upgrade With RFETS and LANL Material alternative of the Storage and Disposition PEIS,⁷ i.e., there would be a 0.01% increase in water use and a 0.1% increase in waste water discharges. The water impacts from the proposed action would have a negligible effect on site water or waste treatment capacity.

The impacts of radiological liquid discharges from Building 105-K are included as part of the No Action alternative in the Storage and Disposition PEIS. DOE expects there would be no significant increase above the No Action alternative discharge levels since, during normal operations, water is not in contact with plutonium storage containers.

Declassification/Repackaging: DOE estimates declassification operations would cause a small and insignificant increase in water usage beyond the water requirement estimated for other site operations.

Repackaging activities in the APSF are expected to have essentially no impact to water resources beyond the site base line operations presented in the No Action alternative of the Storage and Disposition PEIS.⁸ Repackaging operations would not significantly increase the use of water resources beyond that required to operate the industrial systems associated with the APSF, e.g., chillers for air conditioning, sanitary sewer, potable water, etc., because additional water is not used in repackaging operations.

- Socioeconomics. *Storage:* The socioeconomic impact of operating Building 105-K for plutonium storage would be essentially the same as the

impact described for the Preferred Alternative of the Storage and Disposition PEIS. The socioeconomic impact of modifying Building 105-K and operating both APSF and Building 105-K would be well within the impacts described for the Consolidation alternative of the Storage and Disposition PEIS.

The socioeconomic impacts at RFETS and Hanford of moving surplus plutonium to SRS were analyzed in the Storage and Disposition PEIS. The analysis concluded that this action would phase out plutonium storage at RFETS and Hanford. Approximately 200 direct job losses at Hanford, in addition to the 2000 at RFETS, would result. Compared to the total employment in those areas, the loss of these jobs and the impacts to the regional economies would not be significant. The proposed action would not change the magnitude of these impacts at RFETS, but cause them to occur sooner.

Declassification/Repackaging: DOE estimates there would be negligible additional socioeconomic effects due to operating the APSF for repackaging of RFETS plutonium or operating FB-Line for declassification purposes because the existing site workforce would be used.

- Public and Occupational Health and Safety (normal operations). *Storage. Public and Non-Involved Workers:* Plutonium storage operations in Building 105-K would not result in any additional air or water radiological impacts (beyond those currently associated with other operations in Building 105-K) because no shipping containers or storage containers would be opened in Building 105-K. Since air and water emissions create impacts that affect the non-involved workers and the public, there would be no significant additional radiological impact to the public or non-involved workers from normal operations in Building 105-K. Therefore, the impact from the proposed action to the public and non-involved workers would be essentially the same as the impact from the Preferred Alternative in the Storage and Disposition PEIS.

Involved Workers: DOE estimated that the potential health impact from 50 years of APSF storage to individual involved workers for the Preferred Alternative in the Storage and Disposition PEIS was a latent cancer fatality risk of 5×10^{-3} and that 1.5×10^{-1} latent cancer fatalities could occur in the involved worker population. DOE estimates that the potential health impacts from 10 years of operating Building 105-K to store plutonium could result in a risk of latent cancer

⁷ Table 4.2.6.4-1 of the Storage and Disposition PEIS.

⁸ Table 4.2.6.4-1 of the Storage and Disposition PEIS.

fatality for the average Building 105-K involved worker of 1.5×10^{-3} and 2.6×10^{-2} latent cancer fatalities in the Building 105-K involved worker population. Since the Storage and Disposition PEIS bases health impacts on 50 years of storage, for comparison purposes, the impacts from 50 years of plutonium storage in the APSF are added to the impacts from 10 years of plutonium storage in Building 105-K. Using this approach, the health impacts from storing plutonium in the APSF and in Building 105-K would be 0.18 latent cancer fatalities in the involved worker population of both facilities.

Health impacts to involved workers for the plutonium storage aspects of the proposed action in this Supplement Analysis (0.18 latent cancer fatalities) would be essentially the same as the health impact estimated in the Preferred Alternative of the Storage and Disposition PEIS (0.15 latent cancer fatalities).

Declassification/Repackaging Radiological Impacts. Public, Non-involved Workers, Involved Workers: For declassification operations the potential health effect from the postulated radiation dose to the maximally exposed member of the public at the Site boundary would be 1.7×10^{-6} latent cancer fatalities. The potential health effect from the postulated radiation dose to the population surrounding the SRS and to workers would be 0.068 latent cancer fatalities and 0.078 latent cancer fatalities, respectively, above those predicted in the Preferred Alternative in the Storage and Disposition PEIS.

For repackaging operations (i.e., repackaging all plutonium from the RFETS in the APSF for 2 years) the potential health effect from the postulated radiation dose to the maximally exposed member of the public at the site boundary would be 7.5×10^{-12} latent cancer fatalities. The potential health effect from the postulated radiation dose to the population surrounding the SRS and to workers would be 1.5×10^{-7} latent cancer fatalities and 2.5×10^{-2} latent cancer fatalities, respectively, above those predicted in the Preferred Alternative in the Storage and Disposition PEIS. The impacts from repackaging, only the RFETS plutonium that would be declassified in the FB-Line would be less.

Building 105-K Modification. Public, Non-Involved Workers, Involved Workers: No impacts to non-involved workers or the public would be expected from the decontamination, modification, removal, and construction work because this work is not expected to generate significant air or water

emissions. Work activities are confined to the interior of Building 105-K and airborne radioactivity levels are routinely monitored during work. Liquid sources would not be released from the building during normal decontamination, removal, or construction work. The potential health impact to workers, in the form of the risk of latent cancer fatality, would be 4×10^{-4} for 18 months of decontamination and construction work and the number of latent cancer fatalities that could be expected in the worker population was estimated to be 2×10^{-2} . The risks associated with the modification of Building 105-K are approximately ten percent of the risks estimated for storage of the plutonium in the Preferred Alternative of the Storage and Disposition PEIS.

Summary

Public: In the Storage and Disposition PEIS, DOE estimated the potential health impact to the population surrounding the SRS from existing site operations and for the Upgrade Alternative over 50 years was 1.1 latent cancer fatalities. Accomplishing the new proposed action would slightly increase that potential health impact to about 1.2 latent cancer fatalities. Emissions would remain within the limits of the National Emission Standards for Hazardous Air Pollutants permits for the APSF and Building 105-K.

Workers: In the Storage and Disposition PEIS, DOE estimated that the potential health impact to the total site workforce from existing site operations over 50 years would be 5.3 latent cancer fatalities. Accomplishing the proposed action would increase the potential health impact to the site workforce by 0.3 to 5.6 latent cancer fatalities. This new estimate in total site workforce health impact is slightly greater than the health impact of 5.3 latent cancer fatalities estimated for the Preferred Alternative in the Storage and Disposition PEIS and is slightly lower than the health impact of 5.7 latent cancer fatalities that DOE estimated for the Consolidation alternative in the Storage and Disposition PEIS.

Storage Chemical Impacts. There would be no significant impact to the public or workers from hazardous chemicals due to plutonium storage operations in Building 105-K. There are no industrial systems or other operations involved in the plutonium storage operations that would add to existing Building 105-K chemical impacts.

• *Waste Management.* Modifications to Building 105-K: DOE estimates that

decontamination and removal activities which would make Building 105-K available for storage operations would generate 750 cubic meters of low level waste, which is less than 1% of the low-level waste DOE expects to be generated by SRS activities as described in the No Action alternative of the Storage and Disposition PEIS. DOE does not expect to generate any significant quantities of other wastes in order to modify Building 105-K. No high-level radioactive waste would be generated.

Storage: DOE estimated that storing plutonium in the APSF, as described in the Preferred Alternative of the Storage and Disposition PEIS, would not generate any of the following radioactive wastes: high-level, transuranic, mixed transuranic, low-level, mixed low-level or hazardous (other than minor quantities). DOE estimates that storing plutonium in Building 105-K would not significantly change the estimate for the Preferred Alternative in the Storage and Disposition PEIS.

Declassification/Repackaging: DOE estimates that declassifying RFETS plutonium would generate about: 88 m³ of transuranic waste; 4 m³ of mixed waste; and 44 m³ of low-level radioactive waste. No high-level waste is expected. These additional amounts of waste represent a small fraction of these types of waste that are generated at the site by other operations. The site has sufficient capacity to accommodate this increase in waste volume.

• *Accidents. Storage:* For the Building 105-K design basis accidents, DOE estimated that the maximum impact to the population surrounding the SRS could be 0.34 latent cancer fatalities in the unlikely event that plutonium were released to the 105-K Building as a result of corrosion of a storage container. This risk is greater than the risk estimated for storage of plutonium in the Preferred Alternative and other alternatives of the S&D PEIS; however, the risk would be comparable to the same type of accident for the storage of plutonium at SRS in existing storage vaults as analyzed in the Continuing Storage Alternative for the Storage of Plutonium and Uranium in the IMNM EIS. (The IMNM accident analysis showed 0.31 latent cancer fatalities for the population surrounding SRS.) DOE will implement administrative controls (including scheduled surveillances) to limit actions or conditions that might lead to a release of radioactive materials under accident conditions. The risk to the maximally exposed member of the public and non-involved worker would also be greater than the risk for storage

of plutonium estimated in the Preferred Alternative and other alternatives of the Storage and Disposition PEIS but would be low (less than 3×10^{-3} latent cancer fatalities).

For the postulated beyond design basis accidents, DOE estimated that the maximum impact to the population could be 2.7×10^{-4} latent cancer fatalities in the event of a vault fire. This risk is greater than the risk estimated for storage of plutonium in the Preferred Alternative of the Storage and Disposition PEIS, but low. The risks to the maximally exposed public and the non-involved worker would also be greater than the risks for the storage of plutonium estimated in the Preferred Alternative of the Storage and Disposition PEIS but would be extremely small (less than 2×10^{-8} latent cancer fatalities). DOE estimated that the involved worker may be subject to injury and, in some cases, fatality as a result of potential beyond design basis accidents.

Declassification/Repackaging: DOE estimates that for declassification operation in the FB-Line, the risk to the public would be 1.2×10^{-3} latent cancer fatalities, 2.6×10^{-4} latent cancer fatalities to the maximally exposed off-site individual and 4.5×10^{-3} latent cancer fatalities/yr to the non-involved worker. These risks are slightly greater than the risks for storage of plutonium estimated in the Upgrade Alternative of the Storage and Disposition PEIS, but are low. For repackaging operations in the APSF, the risks are low and similar to the impacts presented for storage of plutonium in the Preferred Alternative of the Storage and Disposition PEIS (less than 2×10^{-4} latent cancer fatalities).

- **Environmental Justice.** For environmental justice impacts to occur, there must be significant and adverse human health or environmental impacts that disproportionately affect minority populations and/or low-income populations. The Supplement Analysis shows that accomplishing the proposed action would be within regulatory limits and the impacts would be very low during routine operations.

The same Supplement Analyses also shows that accidents would not result in a significant risk of adverse human health or environmental impacts to the population who reside within 80 kilometers of the SRS. Therefore, such accidents would not have disproportionately high or adverse risk of impacts on minority or low-income populations.

Based on the analysis in this supplement analysis, no disproportionate, high or adverse

impact would be expected on minority or low-income populations.

C. Environmentally Preferable Alternative

The environmental analyses in Chapter 4 of the Storage and Disposition PEIS indicate that the environmentally preferable alternative (the alternative with the lowest environmental impacts over the 50 years considered in the PEIS) for storage of weapons-usable fissile materials would be the Storage and Disposition PEIS Preferred Alternative, which consists of No Action at Hanford, Idaho National Engineering and Environmental Laboratory, Los Alamos National Laboratory, Argonne National Laboratory, and Nevada Test Site (NTS) (no fissile materials are or would be stored at the NTS) pending disposition, phaseout of storage at RFETS, and upgrades at the Oak Ridge Reservation, SRS, and Pantex. The proposed action as modified by this amended decision is still the environmentally preferred alternative.

III. Non-Environmental Considerations

A. Economic Analysis

DOE has estimated that accelerating the closure of RFETS from 2010 to 2006 in accordance with the DOE Closure 2006 Rocky Flats Closure Project Management Plan could save as much as \$1.3 billion. Closing RFETS by 2006 would require the removal of non-pit, surplus weapons-usable plutonium metal and oxide from RFETS by 2002. The early removal of the RFETS non-pit, surplus weapons-usable plutonium supports the early deactivation, decontamination, and decommissioning of the RFETS plutonium storage and packaging facilities.

DOE also expects that the transfer of non-pit, surplus weapons-usable plutonium from Hanford to the SRS, could save as much as \$150 million in upgrade and operating costs for plutonium storage facilities at the Hanford Site. As with the RFETS plutonium, the transfer would not be accomplished unless DOE decided to locate the plutonium immobilization disposition facility at the SRS.

The implementation cost for the proposed action is estimated to be approximately \$93 million.

B. Nonproliferation

From a nonproliferation standpoint, the highest standards for safeguards and security will be employed during transportation and storage. There is no change in this regard from the original PEIS ROD.

IV. Amended Decision

Consistent with the Preferred Alternative in the Storage and Disposition PEIS, and the Supplement Analysis, Storing Plutonium in the Actinide Packaging and Storage Facility and Building 105-K at the Savannah River Site (July 1998), the Department has decided to reduce, over time, the number of locations where the various forms of plutonium are stored, through a combination of storage alternatives in conjunction with a combination of disposition alternatives.

The Department has decided to modify those aspects of the Storage and Disposition ROD (62 FR 3014) concerning the storage of weapons-usable plutonium at RFETS and Hanford, pending disposition. Other aspects of the Storage and Disposition ROD remain unaltered. DOE has decided to:

- Modify an existing building (105-K) at SRS to allow the receipt and storage of RFETS non-pit, surplus weapons-usable plutonium.

If the Department decides to select SRS as the immobilization site in the SPD EIS ROD, then the Department will:

- Ship all RFETS non-pit, surplus weapons-usable plutonium (about 7 MT) to SRS beginning in about 2000 through about 2002;
- Store RFETS non-classified plutonium metal and/or parts in shipping containers in Building 105-K at SRS beginning in about 2000;
- For RFETS classified surplus metal and/or parts, declassify the material in the FB-Line facility and repackage the material in the APSF (after construction of the APSF in about 2001). In the FB-Line, the plutonium will be melted using existing facilities and equipment that are part of the plutonium metal production process for which FB-Line was designed;
- Store the declassified material in Building 105-K in shipping containers or the APSF vault if space is available;
- Ship all Hanford non-pit, surplus weapons-usable plutonium (approximately 4.6 metric tons) from about 2002 through 2005 and store this material in the APSF;
- Before shipment, all plutonium transported from RFETS (except for the classified metal and/or parts) and Hanford will be stabilized⁹ and packaged in accordance with DOE Standard-3013-96, Criteria for Safe Storage of Plutonium Metals and Oxides for long-term storage. All shipments of plutonium, including the classified metal and parts, will be by SST in

⁹Hanford plutonium fuel that is stable would not need to be stabilized.

accordance with applicable DOE, U.S. Department of Transportation and U.S. Nuclear Regulatory Commission requirements and regulations. Plutonium will be packaged in certified Type B accident resistant packages for transport; and

- The RFETS and Hanford Material stored at SRS may be moved between Building 105-K and the APSF to allow for operational flexibility.

Some of the surplus plutonium at RFETS and Hanford, approximately 1 metric ton at each site, is currently under International Atomic Energy Agency (IAEA) safeguards as a component of the United States nonproliferation policy to remove weapons-usable fissile materials from use for defense purposes. DOE has designed the APSF for IAEA safeguards and intends that plutonium stored in the APSF will be available for IAEA safeguards. Surplus plutonium under IAEA safeguards at RFETS and Hanford that may be shipped to the SRS, will remain available for IAEA safeguards in the APSF. Since plutonium that may be stored in Building 105-K will remain in shipping containers and not be accessible for full IAEA safeguards controls (e.g., physical sampling, destructive analyses), DOE is considering, with the IAEA, the application of IAEA verification controls to ensure the plutonium stored in Building 105-K is not diverted for defense purposes. In addition, DOE intends, as indicated in the Storage and Disposition ROD, that DOE's program for surplus plutonium disposition will include IAEA verification as appropriate.

If the DOE decides to pursue the No Action alternative for the disposition of surplus plutonium, the SRS, RFETS, and Hanford materials would remain in storage at their current sites in accordance with the No Action alternative in the Storage and Disposition PEIS ROD. If the DOE decides to immobilize surplus plutonium at Hanford, the SRS and RFETS materials would be shipped to Hanford in accordance with the decisions reached in the SPD EIS ROD.

V. Conclusion

Under the previous ROD, a maximum of 10 metric tons of surplus plutonium, including plutonium from RFETS and existing onsite plutonium, would be stored at SRS in the APSF, pending disposition, provided that SRS is selected as the immobilization site following completion of the SPD EIS. Transfer of plutonium from RFETS to SRS would begin when the APSF is completed in 2001.

With this amended ROD, a total of approximately 11.6 metric tons of surplus plutonium from both Hanford and RFETS (in addition to existing onsite SRS surplus plutonium, for a total of approximately 14 metric tons of surplus plutonium) would be stored at SRS in the APSF and Building 105-K, pending disposition, provided SRS is selected as the immobilization site. Transfer of plutonium from RFETS to SRS would begin when the modifications to Building 105-K are completed, i.e., in about 2000; shipments of plutonium from Hanford to SRS would begin in about 2002.

DOE has decided to implement a revised program to provide for safe and secure storage of weapons-usable fissile materials. DOE will prepare to advance the consolidation of the storage of weapons-usable plutonium by modifying existing facilities at the SRS in South Carolina, and phasing out surplus plutonium storage at RFETS in Colorado and Hanford in Washington. Consistent with the Storage and Disposition PEIS ROD, this Amended ROD supports the Department's objectives to phase out the storage of all weapons-usable plutonium at the RFETS and Hanford as soon as possible and to reduce the number of sites where surplus weapons-usable plutonium is stored.

The decision process reflected in this Notice complies with the requirements of the National Environmental Policy Act (NEPA) (42 U.S.C. 4321 *et seq.*) and its implementing regulations in 40 CFR Parts 1500-1508 and 10 CFR Part 1021.

Issued in Washington, D.C., August 6, 1998.

Laura S. H. Holgate,
Director, Office of Fissile Materials
Disposition.

[FR Doc. 98-21744 Filed 8-12-98; 8:45 am]

BILLING CODE 6450-01-P

DEPARTMENT OF ENERGY

Environmental Management Site-Specific Advisory Board, Pantex Plant, Amarillo, Texas

AGENCY: Department of Energy.

ACTION: Notice of open meeting.

SUMMARY: Pursuant to the provisions of the Federal Advisory Committee Act (Pub. L. No. 92-463, 86 Stat. 770) notice is hereby given of the following Advisory Committee meeting: Environmental Management Site-Specific Advisory Board (EM SSAB), Pantex Plant, Amarillo, Texas.

DATE AND TIME: Tuesday, August 25, 1998: 1:30 p.m.-5:30 p.m.

ADDRESSES: Amarillo Association of Realtors, Amarillo, Texas.

FOR FURTHER INFORMATION CONTACT: Jerry S. Johnson, Assistant Area Manager, Department of Energy, Amarillo Area Office, P.O. Box 30030, Amarillo, TX 79120 (806) 477-3125.

SUPPLEMENTARY INFORMATION: *Purpose of the Committee:* The Board provides input to the Department of Energy on Environmental Management strategic decisions that impact future use, risk management, economic development, and budget prioritization activities.

Tentative Agenda

1:30 p.m. Welcome—Agenda Review—Approval of Minutes
1:45 p.m. Co-Chair Comments
2:00 p.m. Immobilization
3:00 p.m. Break
3:15 p.m. Updates—Occurrence Reports—DOE
3:45 p.m. Ex-Officio Reports
4:00 p.m. Low-Level Waste Seminar Update
5:00 p.m. Task Force/Subcommittee Minutes
5:30 p.m. Closing Remarks/Adjourn

Public Participation: The meeting is open to the public, and public comment will be invited throughout the meeting. Written statements may be filed with the Committee either before or after the meeting. Written comments will be accepted at the address above for 15 days after the date of the meeting. Individuals who wish to make oral statements pertaining to agenda items should contact Jerry Johnson's office at the address or telephone number listed above. Requests must be received 5 days prior to the meeting and reasonable provision will be made to include the presentation in the agenda. The Designated Federal Official is empowered to conduct the meeting in a fashion that will facilitate the orderly conduct of business. Each individual wishing to make public comment will be provided a maximum of 5 minutes to present their comments at any time throughout the meeting.

Minutes: The minutes of this meeting will be available for public review and copying at the Pantex Public Reading Rooms located at the Amarillo College Lynn Library and Learning Center, 2201 South Washington, Amarillo, TX phone (806) 371-5400. Hours of operation are from 7:45 am to 10:00 pm, Monday through Thursday; 7:45 am to 5:00 pm on Friday; 8:30 am to 12:00 noon on Saturday; and 2:00 pm to 6:00 pm on Sunday, except for Federal holidays. Additionally, there is a Public Reading Room located at the Carson County Public Library, 401 Main Street,

**A.6 NOTICE OF INTENT—SUPPLEMENT TO THE DRAFT SURPLUS PLUTONIUM
DISPOSITION ENVIRONMENTAL IMPACT STATEMENT**

Dated: March 30, 1999.

Judith Johnson,

Acting Assistant Secretary, Elementary and Secondary Education.

[FR Doc. 99-8394 Filed 4-5-99; 8:45 am]

BILLING CODE 4000-01-P

DEPARTMENT OF ENERGY

Office of Arms Control and Nonproliferation Policy; Proposed Subsequent Arrangement

AGENCY: Department of Energy.

ACTION: Subsequent arrangement.

SUMMARY: This notice is being issued under the authority of Section 131 of the Atomic Energy Act of 1954, as amended (42 U.S.C. 2160). The Department is providing notice of a "subsequent arrangement" under the Agreement for Cooperation in the Peaceful Uses of Nuclear Energy Between the United States of America and the European Atomic Energy Community (EURATOM) and the Agreement for Cooperation Between the Government of the United States of America and the Government of Canada Concerning the Civil Uses of Atomic Energy.

This subsequent arrangement concerns the transfer of 90,552,300 grams of natural uranium in the form of hexafluoride from Cameco Corporation in Canada to Urenco Limited in the United Kingdom for toll enrichment. The enrichment will not exceed 20%. The material will then be transferred to Northern States Power in Minneapolis, MN for use in their commercial power reactor.

In accordance with Section 131 of the Atomic Energy Act of 1954, as amended, we have determined that this subsequent arrangement will not be inimical to the common defense and security.

This subsequent arrangement will take effect no sooner than fifteen days after the date of publication of this notice.

Dated: March 30, 1999.

For the Department of Energy.

Edward T. Fei,

Deputy Director, International Policy and Analysis Division, Office of Arms Control and Nonproliferation.

[FR Doc. 99-8451 Filed 4-5-99; 8:45 am]

BILLING CODE 6450-01-P

DEPARTMENT OF ENERGY

Office of Arms Control and Nonproliferation Policy; Proposed Subsequent Arrangement

AGENCY: Department of Energy.

ACTION: Subsequent Arrangement.

SUMMARY: This notice is being issued under the authority of Section 131 of the Atomic Energy Act of 1954, as amended (42 U.S.C. 2160). The Department is providing notice of a "subsequent arrangement" under the Agreement for Cooperation in the Peaceful Uses of Nuclear Energy Between the United States of America and the European Atomic Energy Community (EURATOM) and the Agreement for Cooperation Between the Government of the United States of America and the Government of Canada Concerning the Civil Uses of Atomic Energy.

This subsequent arrangement concerns the transfer of 3,078,600 grams of natural uranium in the form of hexafluoride from Cameco Corporation in Canada to Urenco Limited in the United Kingdom for toll enrichment. The enrichment will not exceed 20%. The material will then be transferred to Wolf Creek Nuclear Operation Corporation in Burlington, KS for use in their commercial power reactor.

In accordance with Section 131 of the Atomic Energy Act of 1954, as amended, we have determined that this subsequent arrangement will not be inimical to the common defense and security.

This subsequent arrangement will take effect no sooner than fifteen days after the date of publication of this notice.

Dated: March 30, 1999.

For the Department of Energy.

Edward T. Fei,

Deputy Director, International Policy and Analysis Division Office of Arms Control and Nonproliferation.

[FR Doc. 99-8452 Filed 4-5-99; 8:45 am]

BILLING CODE 6450-01-P

DEPARTMENT OF ENERGY

Supplement to the Draft Surplus Plutonium Disposition Environmental Impact Statement

AGENCY: Department of Energy.

ACTION: Notice of Intent.

SUMMARY: The Department of Energy (DOE) announces its intent to prepare a supplement to the Surplus Plutonium Disposition Draft Environmental Impact Statement (SPD EIS) pursuant to the National Environmental Policy Act

(NEPA). The SPD Draft EIS (DOE/EIS-0283D) was issued for public comment in July 1998. The Supplement will update the SPD Draft EIS by examining the potential environmental impacts of using mixed oxide (MOX) fuel in six specific commercial nuclear reactors at three sites for the disposition of surplus weapons-grade plutonium. DOE identified these reactors through a competitive procurement process. The Department is planning to issue the Supplement to the SPD Draft EIS in April 1999. DOE will publish a separate Notice of Availability in the Federal Register at that time. This Notice of Intent describes the content of the Supplement to the SPD Draft EIS, solicits public comment on the Supplement, and announces DOE's intention to conduct a public hearing. Consistent with 40 CFR 1502.9(c)(4) and 10 CFR 1021.314(d), DOE has determined not to conduct scoping for the Supplement.

ADDRESSES: Requests for information concerning the plutonium disposition program can be submitted by calling (answering machine) or faxing them to the toll free number 1-800-820-5156, or by mailing them to: Bert Stevenson, NEPA Compliance Officer, Office of Fissile Materials Disposition, U.S. Department of Energy, Post Office Box 23786, Washington, DC 20026-3786. **FOR FURTHER INFORMATION CONTACT:** For general information on the DOE NEPA process, please contact: Carol Borgstrom, Director, Office of NEPA Policy and Assistance, U.S. Department of Energy, 1000 Independence Avenue, S.W., Washington, DC 20585, 202-586-4600 or leave a message at 1-800-472-2756.

Additional information regarding the DOE NEPA process and activities is available on the Internet through the NEPA Home Page at <http://www.eh.doe.gov/nepa>.

SUPPLEMENTARY INFORMATION:

Background

In October 1994, the Secretary of Energy and the Congress created the Office of Fissile Materials Disposition (MD) within the Department of Energy (DOE) to focus on the elimination of surplus highly enriched uranium (HEU) and plutonium surplus to national defense needs. As one of its major responsibilities, MD is tasked with determining how to disposition surplus weapons—usable plutonium. In January 1997, DOE issued a Record of Decision (ROD) for the Storage and Disposition of Weapons—Usable Fissile Materials Final Programmatic Environmental Impact Statement (S&D PEIS) (DOE/EIS-

0229; December 1996). In that ROD, DOE decided to pursue a strategy that would allow for the possibility of both the immobilization of surplus plutonium and the use of surplus plutonium as mixed oxide (MOX) fuel in existing domestic, commercial reactors. DOE is in the process of completing the Surplus Plutonium Disposition Environmental Impact Statement (SPD Draft EIS) (DOE/EIS-0283D; July 1998) to choose a site(s) for plutonium disposition activities and to determine the technology(ies) that will be used to support this effort.

Related Procurement Action

To support the timely undertaking of the surplus plutonium disposition program, DOE initiated a procurement action to contract for MOX fuel fabrication and reactor irradiation services. The services requested in this procurement process include design, licensing, construction, operation, and eventual deactivation of a MOX facility, as well as irradiation of the MOX fuel in three to eight existing domestic, commercial reactors, should the decision be made by DOE to go forward with the MOX program.

On May 19, 1998, DOE issued a Request for Proposal (RFP) (Solicitation Number DE-RP02-98CH10888) that defined limited activities that may be performed prior to issuance of the SPD EIS ROD. These activities include non-site-specific work primarily associated with the development of the initial conceptual design for the fuel fabrication facility, and plans (paper studies) for outreach, long lead-time procurements, regulatory management, facility quality assurance, safeguards, security, fuel qualifications, and deactivation. No construction would be started on a MOX fuel fabrication facility until the SPD EIS ROD is issued. The MOX facility, if built, would be DOE-owned, licensed by the Nuclear Regulatory Commission, and located at one of four candidate DOE sites. DOE has designated the Savannah River Site as the preferred alternative for the MOX fuel fabrication facility.

Based on a review of proposals received in response to the RFP, DOE determined in January 1999 that one proposal was in the competitive range. Under this proposal, MOX fuel would be fabricated at a DOE site and then irradiated in one of six domestic commercial nuclear reactors.

Environmental Review During Procurement Action

An environmental critique was prepared in accordance with DOE's National Environmental Policy Act

(NEPA) regulations at 10 CFR 1021.216. Because an EIS is in progress on this action, DOE required offerors to submit reasonably available environmental data and analyses as a part of their proposals. DOE independently evaluated and verified the accuracy of the data provided by the offeror in the competitive range, and prepared an environmental critique for consideration before the selection was made. The Environmental Critique was used by DOE to determine:

(1) if there are any important environmental issues in the offeror's proposal that may affect the selection process; and

(2) if the potential environmental impacts of the offeror's proposal were bounded by impacts presented in the S&D PEIS and SPD Draft EIS or whether additional analysis was required in the SPD Final EIS.

As required by Section 216, the Environmental Critique included a discussion of the purpose of the procurement; the salient characteristics of the offeror's proposal; any licenses, permits or approvals needed to support the program; and an evaluation of the potential environmental impacts of the offer. The Environmental Critique is a procurement-sensitive document and subject to all associated restrictions. DOE then prepared a synopsis, which summarizes the Environmental Critique and reduces business-sensitive information to a level that will not compromise the procurement process. The Synopsis will be filed with the Environmental Protection Agency and made available to the public.

Contract Award

As a result of the procurement process described above, in March 1999, the Department of Energy contracted with Duke Engineering & Services, COGEMA, Inc., and Stone & Webster to provide mixed oxide fuel fabrication and reactor irradiation services. The team, known as DUKE COGEMA STONE & WEBSTER or DCS, has its corporate headquarters in Charlotte, NC. Subcontractors to DCS include Duke Power Company, Charlotte, NC and Virginia Power Company, Richmond, VA, who will provide the reactor facilities in which mixed oxide fuel will be used upon receipt of Nuclear Regulatory Commission license amendments. Other major subcontractors include Nuclear Fuel Services, Inc., Erwin, TN; Belgonucleaire, Brussels, Belgium; and Framatome Cogema Fuels of Lynchburg, VA. Under the contract, the team will also modify six existing U.S. commercial light water reactors at three sites to irradiate mixed oxide fuel

assemblies. These reactor sites are Catawba in York, SC; McGuire in Huntersville, NC; and North Anna in Mineral, VA. The team will be responsible for obtaining a license to operate the fuel fabrication facility and the license modifications for the reactors from the Nuclear Regulatory Commission. Full execution of this contract is contingent on DOE's completion of the SPD EIS, as provided by 40 CFR 1021.216(i).

Supplement to the Surplus Plutonium Disposition Draft Environmental Impact Statement

The purpose of the Supplement to the SPD Draft EIS is to update the Draft by including specific information available as a result of the award of the DCS contract. The Supplement to the SPD Draft EIS will contain background information on the SPD Draft EIS; changes made to the SPD Draft EIS (Section 1.7.2); a description of the reactor sites (Section 3.7); impacts of irradiating mixed oxide fuel in existing light water reactors (Section 4.28); Facility Accidents (Appendix K); Analysis of Environmental Justice (Appendix M); and the Environmental Synopsis (Appendix O).

DOE anticipates that the Supplement to the SPD Draft EIS will be available in April. DOE intends to hold an interactive hearing in Washington, DC in May 1999 to discuss issues and receive oral and written comments on the Supplement to the Draft SPD EIS. The Notice of Availability will provide specific information concerning the date, time and location for the public hearing.

Issued in Washington, DC this 31st day of March 1999, for the United States Department of Energy.

David Michaels,

Assistant Secretary, Environment, Safety and Health.

[FR Doc. 99-8455 Filed 4-5-99; 8:45 am]

BILLING CODE 6450-01-P

DEPARTMENT OF ENERGY

Office of Science; Biological and Environmental Research Advisory Committee

AGENCY: Department of Energy.

ACTION: Notice of open meeting.

SUMMARY: This notice announces a meeting of the Biological and Environmental Research Advisory Committee. Federal Advisory Committee Act (Public Law 92-463, 86 Stat. 770) requires that public notice of

**A.7 NOTICE OF AVAILABILITY—SUPPLEMENT TO THE SURPLUS PLUTONIUM
DISPOSITION DRAFT ENVIRONMENTAL IMPACT STATEMENT**

technological collection techniques or other forms of information technology, e.g., permitting electronic submission of responses.

Burden Statement: The annual public reporting and recordkeeping burden for this collection of information is estimated to average 3.03 hours per response. It is estimated that any individual may respond to synopses or market research questions 5 times per year. EPA anticipates publicizing approximately 260 contract actions per year, and conducting 3790 market research inquiries. Burden means the total time, effort, or financial resources expended by persons to generate, maintain, retain, or disclose or provide information to or for a Federal agency. This includes the time needed to review instructions; develop, acquire, install, and utilize technology and systems for the purposes of collecting, validating, and verifying information, processing and maintaining information, and disclosing and providing information; adjust the existing ways to comply with any previously applicable instructions and requirements; train personnel to be able to respond to a collection of information; search data sources; complete and review the collection of information; and transmit or otherwise disclose the information.

Dated: May 7, 1999.

Lawrence G. Wyborski,

Acting Manager, Policy Service Center.

[FR Doc. 99-12249 Filed 5-13-99; 8:45 am]

BILLING CODE 6560-50-U

ENVIRONMENTAL PROTECTION AGENCY

[ER-FRL-6242-6]

Environmental Impact Statements and Regulations; Availability of EPA Comments

Availability of EPA comments prepared April 19, 1999 Through April 23, 1999 pursuant to the Environmental Review Process (ERP), under Section 309 of the Clean Air Act and Section 102(2)(c) of the National Environmental Policy Act as amended. Requests for copies of EPA comments can be directed to the Office of FEDERAL ACTIVITIES AT (202) 564-7167.

An explanation of the ratings assigned to draft environmental impact statements (EISs) was published in FR dated April 09, 1999 (64 FR 17362).

Draft EISs

ERP No. D-AFS-L65207-OR Rating *LO, Young'n Timber Sales, Implementation, Willamette National

Forest Land and Resource Management Plan, Middle Fork Ranger District, Lane County, OR.

Summary: EPA used a screening tool to conduct a limited review of this action. Based upon the screen, EPA does not foresee having any environmental objections to the proposed project. Therefore, EPA will not be conducting a detailed review.

ERP No. D-AFS-L65304-OR Rating EC2, Moose Subwatershed Timber Harvest and Other Vegetation Management Actions, Central Cascade Adaptive Management (CCAMA), Willamette National Forest, Sweet Home Ranger District, Linn County, OR.

Summary: EPA expressed environmental concerns with the proposed timber harvest due to entry into roadless area and the potential for impact to water quality and recommended that the Forest Service continue to monitor for water quality impacts.

ERP No. D-COE-J36050-ND Rating EO2, Maple River Dam and Reservoir, Construction and Operation, Flood Control, Cass County Joint Water Resource District, Cass County, ND.

Summary: EPA expressed environmental objections to the project on the basis of: (1) the lack of adequate provisions to identify and protect aquatic habitats, (2) exceedances of water quality standards, (3) the uncertainty of the mitigation, restoration and conservation efforts, (4) the lack of information on future flood control activities, (5) future growth and development impacts in the lower watershed area, (6) a cumulative impacts analysis that was limited to water chemistry, (7) a substantial need to address the watershed as a unit.

Final EISs

ERP No. F-AFS-L65255-AK, Control Lake Timber Sale, Implementation, Prince of Wales Island, Tongass National Forest, AK.

Summary: Review of the Final EIS was not deemed necessary. No formal comment letter was sent to the preparing agency.

ERP No. F-BLM-L65294-OR, Beaty Butte Allotment Management Plan, Implementation, Lakeview District, Hart Mountain National Antelope Refuge, Lake and Harney Counties, OR.

Summary: The Final EIS has addressed the issues EPA raised in the draft EIS.

ERP No. FS-COE-G32054-00, Red River Waterway, Louisiana, Texas, Arkansas and Oklahoma and Related Projects, New and Updated Information, Red River Below Denison Dam Levee Rehabilitation, Implementation,

Hempstead, Lafayette and Miller Counties, AR.

Summary: EPA has no objection to the selection of the preferred alternative described in the FSEIS.

Dated: May 11, 1999.

William D. Dickerson,

Director, Office of Federal Activities.

[FR Doc. 99-12265 Filed 5-13-99; 8:45 am]

BILLING CODE 6560-50-U

ENVIRONMENTAL PROTECTION AGENCY

[ER-FRL-6242-5]

Environmental Impact Statements; Notice of Availability

Responsible Agency: Office of Federal Activities, General Information (202) 564-7167 or (202) 564-7153.

Weekly receipt of Environmental Impact Statements

Filed May 03, 1999 Through May 07, 1999.

Pursuant to 40 CFR 1506.9.

EIS No. 990148, Final Supplement, AFS, CO, Lakewood Raw Water Pipeline for Continued Operation, Maintenance, Reconstruction and/or Replacement, Application for Easement, Roosevelt National Forest, Boulder Ranger District, in the City of Boulder, CO, Due: June 07, 1999, Contact: Jean Thomas (970) 498-1267. The above DOA EIS should have appeared in the 05/07/99 Federal Register. The 30-day Comment Period is Calculated from 05/07/99.

EIS No. 990149, Draft EIS, AFS, MT, Bridger Bowl Ski Area, Permit Renewal and Master Development Plan Update, Implementation, Special Use Permit and COE Section 404 Permit, Gallatin National Forest, in the City of Bozeman, MT, Due: June 28, 1999, Contact: Nancy Halstom (406) 587-6920.

EIS No. 990150, Final EIS, NPS, TX, Lyndon B. Johnson National Historical Park, Package 227, General Management Plan, Implementation, Blanco and Gillespie Counties, TX, Due: June 14, 1999, Contact: Leslie Starhart (830) 868-7128.

EIS No. 990151, Final EIS, FHW, MO, IA, US 61, US 218 and IA-394

Highway Improvements, Construction, Funding, US Army COE Section 404 Permit, Lewis and Clark Counties, MO and Lee and Henry Counties, IA, Due: June 14, 1999, Contact: Donald Neumann (573) 636-7104.

EIS No. 990152, Draft EIS, FTA, VA, Norfolk-Virginia Beach Light Rail Transit System East/West Corridor

- Project, Transportation Improvements, Tidewater Transportation District Commission, COE Section 404 Permit, City of Norfolk and City of Virginia Beach, VA, Due: June 28, 1999, Contact: Michael McCollum (215) 656-7100.
- EIS No. 990153, Legislative Final EIS, USA, AK, Alaska Army Lands Withdrawal Renewal for Fort Wainwright and Fort Greely West Training Area, Approval of Permits and Licenses, City of Fairbanks, City of North Pole and City of Delta Junction, North Star Borough, AK, Due: June 14, 1999, Contact: Cindy Herdrich (970) 491-5347.
- EIS No. 990154, Draft Supplement, DOE, CA, NM, TX, ID, SC, WA, Surplus Plutonium Disposition (DOE/EIS-0283-S) for Siting, New and Revised Information, Construction and Operation of three facilities for Plutonium Disposition, Possible Sites Hanford, Idaho National Engineering and Environmental Laboratory, Pantex Plant and Savannah River, CA, ID, NM, SC, TX and WA, Due: June 28, 1999, Contact: G. Bert Stevenson (202) 586-5368.
- EIS No. 990155, Draft EIS, BLM, WY, Wyodak Coal Bed Methane Project, Road Construction, Drilling Operation, Electrical Distribution Line, Powder River Basin, Campbell and Converse Counties, WY, Due: June 28, 1999, Contact: Richard Zander (307) 684-1161.
- EIS No. 990156, Final EIS, UAF, ND, Minuteman III Missile System Dismantlement, Intercontinental Ballistic Missile (ICBM) Launch Facilities (LFs) and Missile Alert Facilities (MAFs), Deployment Areas, Grand Forks Air Forces Base, ND, Due: June 14, 1999, Contact: Jonathan D. Farthing (210) 536-3069.

Amended Notices

- EIS No. 990103, Draft Supplement, FHWA, CA, CA-125 South Route Location, Adoption and Construction, between CA-905 on Otay Mesa to CA-54 in Spring Valley, Updated and Additional Information, Funding and COE Section 404 Permit, San Diego County, CA, Due: May 24, 1999, Contact: C. Glenn Clinton (916) 498-5037. Published FR-04-09-99—Due Date Correction.
- EIS No. 990108, Draft Supplement EIS, AFS, ID, Grade-Dukes Timber Sale, Proposal to Harvest and Regenerate Timber, Implementation, Cuddy Mountain Roadless Area, Payette National Forest, Weiser Ranger District, Washington County, Idaho, Due: June 01, 1999, Contact: Dautis

Pearson (208) 253-0134. Published FR 04-09-99 Review Period Extended. EIS No. 990143, Draft EIS, TPT, CA, Presidio of San Francisco General Management Plan, Implementation, New Development and Uses within the Letterman Complex, Golden Gate National Recreation Area, City and County of San Francisco, CA, Due: June 14, 1999, Contact: John Pelka (415) 561-5300. Published FR-04-30-99—Correction to Document Status from a Draft Supplement to Draft.

Dated: May 11, 1999.

William D. Dickerson,
Director, Office of Federal Activities.
 [FR Doc. 99-12264 Filed 5-13-99; 8:45 am]
BILLING CODE 6560-50-U

ENVIRONMENTAL PROTECTION AGENCY

[FRL-6342-1]

RIN 2060-AH52

Public Meetings To Discuss Air Quality Modeling and Infrastructure Issues Associated With Alternative-Fueled Vehicles

AGENCY: Environmental Protection Agency (EPA).

ACTION: Notice of public meetings.

SUMMARY: The Environmental Protection Agency intends to hold two public workshops to discuss issues associated with alternative fuel vehicles (AFVs) (i.e., vehicles powered by fuels other than gasoline). The first workshop (which EPA will hold May 26, 1999, in Louisville, Kentucky), will focus on issues associated with air quality modeling of AFVs. The purpose of this workshop is to facilitate an exchange of information that will help EPA determine which areas of its modeling, if any, should be enhanced to better estimate the air quality impacts of alternative-fueled vehicles. The second workshop will focus on issues related to infrastructure development and creating a sustainable market for AFVs.

DATES: The first workshop (on modeling and AFVs) will be held on May 26, 1999, in Louisville, Kentucky, following the Department of Energy's National Clean Cities Conference. The date for the second workshop (on infrastructure development and creating a sustainable market for AFVs) will be announced later. Members of the public are invited to attend as observers.

ADDRESSES: Questions about the workshop should be addressed to: Barry Garelick (202-564-9028; garelick.barry@epa.gov) or Christine

Hawk (202-564-9672; hawk.christine@epa.gov), 401 M Street, S.W. (6406J), Washington, D.C. (20460). The workshop will be held at the Sellbach Hilton Hotel, 500 4th St, Louisville, Kentucky 40202, 800 333-3399 or 502-585-3200.

FOR FURTHER INFORMATION CONTACT: Barry Garelick (202) 564-9028.

SUPPLEMENTARY INFORMATION: As this Administration has long recognized, one of the keys to moving forward environmentally is moving forward technologically. Progress towards sustainable reductions in emissions from the mobile source sector is inextricably linked to technological advancement. Motor vehicles are significant contributors to ground-level ozone, the principal harmful ingredient in smog. They also emit other pollutants, including particulate matter and air toxics. Motor vehicle emissions contribute to public health problems such as asthma and other respiratory problems, especially in children.

History has shown that the rise in vehicle sales and vehicle miles traveled every year has consistently led to increases in the aggregate emissions from the mobile source sector, despite progress in reducing emissions from gasoline-powered, conventional motor vehicles. This places increasing importance on technological developments, including vehicles powered by fuels other than gasoline. There is particular interest in the creation of vehicles whose emissions do not increase as the vehicle ages. There are a number of types of alternative fuel vehicles (AFVs) in production and under development. In the United States, manufacturers are already selling various types of AFVs, including vehicles powered by electricity, compressed natural gas, methanol, and ethanol. The last year has also seen dramatic developments in hybrid-electric vehicle and fuel cell technology.

Congress and the Administration have already recognized that they have an important role to play regarding AFVs. As part of the 1990 Amendments to the Clean Air Act, Congress included sections promoting increased numbers of clean fuel fleet vehicles. The Clean Fuel Fleet program, which began on September 1, 1998, requires certain nonattainment areas to adopt and implement a program requiring certain centrally-fueled fleets to include a specified percentage of clean-fuel vehicles in their new fleet vehicle purchases. Additionally, Congress passed the Energy Policy Act of 1992 (EPAct), which includes numerous provisions designed to increase the

**A.8 JOINT STATEMENT OF PRINCIPLES FOR MANAGEMENT AND DISPOSITION OF
PLUTONIUM DESIGNATED AS NO LONGER REQUIRED FOR DEFENSE PURPOSES**

**AGREEMENT
BETWEEN
THE GOVERNMENT
OF THE UNITED STATES OF AMERICA
AND
THE GOVERNMENT
OF THE RUSSIAN FEDERATION
ON SCIENTIFIC AND TECHNICAL COOPERATION
IN THE MANAGEMENT OF PLUTONIUM
THAT HAS BEEN WITHDRAWN
FROM NUCLEAR MILITARY PROGRAMS**

The Government of the United States of America and the Government of the Russian Federation, hereafter referred to as the Parties.

Taking into account:

- The January 14, 1994, Declaration of the Presidents of the United States and the Russian Federation on "Nonproliferation of Weapons of Mass Destruction and the Means of Their Delivery";
- The Declaration of the April 19-20, 1996, Summit on Nuclear Safety and Security in Moscow;
- The Conclusions of the International Meeting of Experts in Paris, on October 28-31, 1996, concerning the safe and efficient management of fissile materials designated as no longer required for defense purposes;
- The statement regarding fissile materials in the June 22, 1997, Final Communiqué of the Denver Summit of the Eight;
- The statement of the President of the United States on March 1, 1995, that 200 tons of fissile material will be withdrawn from the U.S. nuclear stockpile and directing that these materials will never again be used to build a nuclear weapon; and
- The message of the President of the Russian Federation to the participants of the 41st General Conference of the IAEA, September 26, 1997, on step by step removal from nuclear defense programs of up to 500 tonnes of highly enriched uranium and up to 50 tonnes of plutonium released in the process of nuclear disarmament;

Have agreed as follows:

ARTICLE 1

The purposes of this Agreement are to:

- a) Provide the scientific and technical basis for decisions on how plutonium, subject to this Agreement, shall be managed; and
- b) Establish a framework for continued and expanded scientific and technical cooperation for the accomplishment of the objective in paragraph a.

ARTICLE 2

For purposes of this Agreement:

1. "Plutonium" means plutonium that has been withdrawn from nuclear military programs and is no longer required for defense purposes.
2. "Management of plutonium" means the transformation of plutonium into spent fuel or other forms equally unusable for nuclear weapons or other nuclear explosive devices, and may include conversion of plutonium and its manufacture into MOX fuel, use of MOX fuel in nuclear reactors, and immobilization of plutonium in various forms.

ARTICLE 3

1. The Parties shall:
 - a) Continue to cooperate with small-scale tests and demonstrations relating to management of plutonium; and
 - b) As soon as is practicable, also proceed to pilot-scale demonstrations of technologies for plutonium management.
2. The principal subject areas for the Parties' cooperative efforts shall be:
 - a) Conversion of metallic plutonium into oxide suitable for the manufacture of MOX fuel for nuclear power reactors of various types;
 - b) Stabilization of unstable forms of plutonium;
 - c) Use of plutonium in the form of MOX fuel in various types of nuclear power reactors;
 - d) Immobilization of plutonium, including wastes and hard-to-process forms; and
 - e) Disposal of immobilized forms of materials containing plutonium in deep geological formations.

ARTICLE 4

1. The Parties shall designate Executive Agents to carry out the provisions of this Agreement. The Executive Agent for the United States of America shall be the U.S. Department of Energy and the Executive Agent for the Russian Federation shall be the Russian Ministry for Atomic Energy.

2. The Parties shall have the right, consistent with their respective laws and regulations, and following written notification to the other Party, to obtain participation, as necessary, in the implementation of this Agreement, by other agencies, departments, and units of their respective governments.
3. To accomplish the objectives of this Agreement, the Parties shall establish a U.S.-Russian Joint Steering Committee on Plutonium Management, which shall coordinate and agree upon work undertaken under this Agreement. Each Party shall designate its members on the Joint Steering Committee. Decisions of the Joint Steering Committee shall be taken by consensus.
4. The tasks of the Joint Steering Committee shall include:
 - a) Development of overall work programs and areas of cooperation within the scope of this Agreement;
 - b) Prioritization, coordination, review and approval of the cooperative projects under this Agreement within the resources made available by the Parties;
 - c) Resolution of any disputes that may arise with respect to the scientific and technical work performed under this Agreement; and
 - d) Such other matters, as the Parties may agree, that are within the scope of this Agreement.
5. When agreement is reached on the performance of joint research, projects, or experiments under this Agreement, detailed procedures for performing the activities involved shall be officially drawn up in the form of implementing arrangements, to be reviewed and approved by the Joint Steering Committee.

ARTICLE 5

Cooperation between the Parties within the framework of this Agreement may include the following:

- a) Sharing of scientific and technical information;
- b) Development of conceptual approaches;
- c) Research, experiments and small-scale demonstrations of technological solutions;
- d) Design, construction, and operation of pilot-scale facilities for demonstrating and testing technological solutions obtained as a result of research;
- e) Transfer of equipment and non-nuclear materials;
- f) Meetings, seminars, conferences, personnel assignments, and workshops for the sharing of information;
- g) Feasibility studies; and
- h) Such other forms of cooperation within the scope of this Agreement as the Executive Agents may agree upon in writing.

ARTICLE 6

1. In the implementation of this Agreement, only unclassified information shall be exchanged.
2. In order to prevent access to it by people and organizations not participating in the implementation of this Agreement, information provided by the Parties pursuant to, or produced as a result of, this Agreement which is considered sensitive by the Parties is to be held in confidence and must be clearly designated and marked. The Party transmitting the information will designate information as sensitive in accordance with its internal laws and regulations. The Party receiving this information shall assign it a designation that provides a degree of protection at least equivalent to that required by the Party that furnished the information.
3. Sensitive information shall be handled in accordance with the laws and regulations of the Party receiving the information, and shall not be disclosed or transmitted to a third party not participating in implementation of this Agreement without the written consent of the Party transmitting the information. According to the regulations of the United States, such information shall be treated as foreign government information provided in confidence and shall be protected appropriately. According to the norms and regulations of the Russian Federation, such information shall be treated as official information with limited distribution and shall be protected appropriately.
4. The Parties shall assure effective protection and allocation of rights to intellectual property transmitted or created under this Agreement, as set forth in this Article and in the Annex to this Agreement, which forms an integral part of this Agreement.
5. Information transmitted under this Agreement must be used solely in accordance with this Agreement.
6. The number of people having access to sensitive information must be limited to the number necessary to implement this Agreement and other programs associated with this Agreement, and shall be determined by the Parties' Executive Agents.

ARTICLE 7

1. Materials, equipment and technologies, transferred under the terms of this Agreement, shall not be used for the production of nuclear weapons, any nuclear explosive devices, or for research or development of such devices or for the furtherance of any military purpose.
2. Materials, equipment and technologies, transferred under the terms of this Agreement, shall not be exported, re-exported, or transferred from the jurisdiction of the recipient without the written consent of the Parties.
3. Prior to the export under the terms of this Agreement to a third party of any equipment, materials or technologies, the Parties by mutual agreement in writing shall define the conditions in accordance with which such items shall be exported, re-exported, or transferred from the jurisdiction of the third party.
4. The Parties' Executive Agents shall take all measures necessary to ensure adequate physical protection of nuclear materials, equipment, installations, and nuclear technologies in its jurisdiction, and shall apply criteria and levels of physical

protection not lower than those identified in the Convention on the Physical Protection of Nuclear Material and in recommendations of the IAEA.

ARTICLE 8

Equipment, supplies, materials, services and activities provided or acquired by the United States of America, its contractors, subcontractors, and their personnel for the implementation of this Agreement are free technical assistance and are thus exempt from customs duties and taxes. The Russian Federation shall take all necessary measures to exempt this equipment, shipments, materials, services, and work from all taxes, tariffs, customs duties, and levies of the Russian Federation and its instrumentalities.

ARTICLE 9

1. With the exception of claims for damage or injury against individuals arising from their premeditated actions, the Government of the Russian Federation shall bring no claims or other legal proceedings against the Government of the United States of America and its personnel or its contractors, sub-contractors, consultants, suppliers or sub-suppliers of equipment or services at any tier and their personnel, in any court or forum, for any damage, including indirect, direct or consequential damage, arising from activities undertaken pursuant to this Agreement, to property owned by the Russian Federation. This paragraph shall not apply to legal actions brought by the Government of the Russian Federation to enforce the provisions of contracts to which it or a Russian national or other legal entity is a party.

2. With the exception of claims for damage or injury against individuals arising from their premeditated actions, the Government of the Russian Federation shall provide for the adequate defense of, shall indemnify, and shall bring no claims or other legal proceedings against, the Government of the United States of America and its personnel or its contractors, sub-contractors, consultants, suppliers or sub-suppliers of equipment or services at any tier and their personnel, in connection with third-party claims, in any court or forum, for any injury or damage, including indirect, direct, or consequential injury or damage, arising from activities undertaken pursuant to this Agreement, occurring within or outside the territory of the Russian Federation. Nothing in this paragraph shall be construed as acknowledging the jurisdiction of any court or forum over third-party claims to which this paragraph applies, nor shall it be construed as waiving the sovereign immunity of either Party with respect to third-party claims that may be brought against it.

3. The Parties may, as necessary, conduct consultations regarding claims and legal proceedings concerning this Article.

4. The provisions of this Article shall not prevent the Parties from providing compensation in accordance with their national laws.

5. Nothing in this Article shall be interpreted to prevent legal proceedings or claims against nationals of the Russian Federation or permanent residents of the Russian Federation.

ARTICLE 10

1. Joint activities under this Agreement shall be supported by funds and in-kind contributions of equipment, material, and labor provided on a non-reimbursable basis for these purposes by the United States of America and the Russian Federation.

Joint activities may also be supported, in whole or in part, from funds directly from other sources, including non-government funds and funds from the private sector.

2. In all cases, the activities of, and financial support provided by, the United States of America under this Agreement are subject to the availability of appropriated funds. In all cases, the activities of, and financial support provided by, the Russian Federation under this Agreement are subject to the availability of appropriated funds.

ARTICLE 11

In the event that a Party awards contracts for the acquisition of articles and services, including construction, to implement this Agreement, such contracts shall be awarded in accordance with the laws and regulations of that Party.

ARTICLE 12

1. Representatives of the U.S. Department of Energy shall have the right upon reasonable notice to examine and audit the use of any support or assistance provided by the U.S. Government in connection with cooperation under this Agreement during the life of this Agreement and for three years thereafter. Such examinations may be conducted at sites or locations as agreed to by the Parties' Executive Agents.

2. The Parties' Executive Agents shall develop appropriate arrangements for conducting audits and examinations for all work performed within the framework of this Agreement.

ARTICLE 13

All questions regarding the interpretation or application of this Agreement shall be resolved by means of consultation between the Parties.

ARTICLE 14

1. This Agreement shall enter into force on the date of signature, and shall remain in force for five years. The Agreement may be extended for successive five-year periods with the written consent of both Parties after joint review before the end of each five-year period. The Agreement may be amended by written agreement of the Parties.

2. This Agreement may be terminated by either Party by sending written notice through diplomatic channels of its intent to terminate the Agreement, in which case the Agreement shall terminate six months from the date of the notification.

3. In the event that either Party exercises its right to terminate this Agreement, the Parties may agree upon the implementation of existing contracts and projects until their completion, and will settle any outstanding costs by mutual agreement. If this Agreement is terminated or expires, the Parties agree that all sensitive information and intellectual property that was made available in the course of the Agreement shall continue to be treated in conformance with Article 6 of this Agreement, unless other arrangements are made by written agreement of the Parties.

Done at Moscow this twenty-fourth day of July, 1998, in duplicate in the English and Russian languages, both texts being equally authentic.

FOR THE GOVERNMENT OF THE
UNITED STATES OF AMERICA:

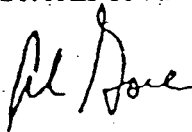

FOR THE GOVERNMENT OF THE
RUSSIAN FEDERATION:



**ANNEX
TO THE
AGREEMENT
BETWEEN
THE GOVERNMENT
OF THE UNITED STATES OF AMERICA
AND
THE GOVERNMENT
OF THE RUSSIAN FEDERATION
ON SCIENTIFIC AND TECHNICAL COOPERATION
IN THE MANAGEMENT OF PLUTONIUM
THAT HAS BEEN WITHDRAWN
FROM NUCLEAR MILITARY PROGRAMS**

INTELLECTUAL PROPERTY

Pursuant to Article 6 of this Agreement:

The Parties shall ensure adequate and effective protection of intellectual property created or furnished under this Agreement and relevant implementing agreements. The Parties agree to notify one another in a timely fashion of any inventions or copyrighted works resulting from scientific and technological work performed under this Agreement and to seek protection for such intellectual property in a timely fashion. Rights to such intellectual property shall be allocated as provided in this Annex.

I. Scope

- A. This Annex is applicable to all cooperative activities undertaken pursuant to this Agreement, except as otherwise specifically agreed by the Parties or their Executive Agents.
- B. For purposes of this Agreement, "intellectual property" shall have the meaning found in Article 2 of the Convention Establishing the World Intellectual Property Organization, done at Stockholm, July 14, 1967.
- C. This Annex addresses the allocation of rights and interests between the Parties. Each Party shall ensure that the other Party can obtain the rights to intellectual property allocated in accordance with this Annex, by obtaining those rights from its own participants through contracts, license agreements or other legal documents, if necessary. This Annex does not otherwise alter or prejudice the allocation between a Party and its nationals or other legal entities, which shall be determined by that Party's laws and practices.
- D. Disputes concerning intellectual property arising under this Agreement should be resolved through discussions between the concerned participating institutions, or, if necessary, the Parties or their Executive Agents. Upon mutual agreement of the Parties, a dispute shall be submitted to an arbitral tribunal for binding arbitration in accordance with the Agreement and with the applicable rules of international law.
- E. Termination or expiration of this Agreement shall not affect rights or obligations under this Annex.

II. Allocation of Rights

A. Each Party shall be entitled to a non-exclusive, irrevocable, royalty-free license in all countries to translate, reproduce, and publicly distribute scientific and technical journal articles, papers, reports, and books directly arising from cooperation under this Agreement. All publicly distributed copies of a copyrighted work prepared under this provision shall indicate the names of the authors of the work unless an author explicitly declines to be named.

B. Rights to all forms of intellectual property, other than those rights described in Paragraph II.A above, shall be allocated as follows:

(1) Visiting researchers shall receive intellectual property rights under the policies of the host institution. In addition, each visiting researcher named as an inventor or author shall be entitled to awards, bonuses, benefits, or any other rewards in accordance with the policies of the host institution.

(2) (a) For intellectual property created during joint research, for example, when the Parties, participating institutions, or participating personnel have agreed in advance on the scope of work, each Party shall be entitled to obtain all rights and interests in its own country. Rights and interests in third countries will be determined in implementing agreements. If research is not designated as "joint research" in the relevant implementing agreement, rights to intellectual property arising from the research will be allocated in accordance with paragraph II.B.(1) above. In addition, each person named as an inventor or author shall be entitled to receive awards in accordance with the policies of the participating institutions.

(b) Notwithstanding paragraph II.B.(2)(a) above, if a type of intellectual property is available under the laws of one Party but not the other Party, the Party whose laws provide for this type of protection shall be entitled to all rights and interests worldwide. Persons named as inventors or authors of the property shall nonetheless be entitled to awards, bonuses, benefits, or any other rewards in accordance with the policies of the participating institution of the Party obtaining rights.

III. Business Confidential Information

In the event that information identified in a timely fashion as business-confidential is furnished or created under this Agreement, each Party and its participants shall protect such information in accordance with applicable laws, regulations, and administrative practices. Information may be identified as "business-confidential" if a person having the information may derive an economic benefit from it or may obtain a competitive advantage over those who do not have it, the information is not generally known or publicly available from other sources, and the owner has not previously made the information available without imposing in a timely manner an obligation to keep it confidential.

СОГЛАШЕНИЕ

между Правительством Соединенных Штатов Америки и
Правительством Российской Федерации о научно-техническом
сотрудничестве в области обращения с плутоном, изъятым из ядерных
военных программ

Правительство Соединенных Штатов Америки и Правительство
Российской Федерации, именуемые в дальнейшем Сторонами,

Принимая во внимание:

Заявление Президентов Соединенных Штатов Америки и Российской
Федерации от 14 января 1994 года « О нераспространении оружия массового
уничтожения и средств его доставки»;

Декларацию встречи на высшем уровне в Москве по ядерной
безопасности 19-20 апреля 1996 года;

Заключения Международной встречи экспертов в Париже 28-31
октября 1996 года о безопасном и эффективном обращении с делящимися
материалами, определенными как более не требующиеся для военных целей;

Положение, касающееся делящихся материалов, Заключительного
Коммюнике Встречи на высшем уровне в Денвере стран Большой Восьмерки
от 22 июня 1997 года;

Заявление Президента Соединенных Штатов Америки от 1 марта 1995
года о том, что 200 тонн делящихся материалов будут выведены из ядерного
арсенала США и никогда более не будут использованы для создания
ядерного оружия; и

Обращение Президента Российской Федерации к участникам 41-ой
сессии Генеральной конференции МАГАТЭ 26 сентября 1997 года о
постепенном изъятии из ядерных военных программ до 500 тонн
высокообогащенного урана и до 50 тонн плутония, высвобождаемых в
процессе ядерного разоружения;

Согласились о нижеследующем:

Статья 1

Целью настоящего Соглашения является:

- а). выработка научно-технического обоснования для принятия решения об использовании плутония, являющегося предметом данного Соглашения.
- б). определение основных направлений продолжения и расширения научно-технического сотрудничества для выполнения положения параграфа а).

Статья 2

Для целей настоящего Соглашения:

1. Термин «плутоний» означает плутоний, изъятый из ядерных военных программ и более не требуемый для военных целей.
2. Термин «обращение с плутонием» означает перевод плутония в отработавшее топливо или в другие формы, в равной степени не пригодные для использования в ядерном оружии или других ядерных взрывных устройствах и может включать конверсию плутония, производство из плутония смешанного оксидного топлива (МОКС-топлива), использование МОКС-топлива в ядерных реакторах и иммобилизацию плутония в различных формах.

Статья 3

1. Стороны будут:

- а) продолжать сотрудничество в области маломасштабных испытаний и демонстраций в области обращения с плутонием; а также
- б) так скоро, как это представляется практически возможным, переходить к опытно-промышленным демонстрациям технологий по обращению с плутонием.

2. Основными направлениями сотрудничества Сторон будут:

- а) конверсия металлического плутония в оксид, пригодный для изготовления МОКС-топлива для энергетических ядерных реакторов различных типов;
- б) стабилизация нестабильных форм плутония;

- в) использование плутония в виде МОКС-топлива в энергетических ядерных реакторах различных типов;
- г) иммобилизация плутония, включая отходы и трудно перерабатываемые формы; и
- д) захоронение иммобилизованных материалов, содержащих плутоний, в глубоких геологических формациях.

Статья 4

1. Для выполнения положений настоящего Соглашения Стороны назначают исполнительные органы. От Соединенных Штатов Америки - Министерство энергетики Соединенных Штатов Америки, в Российской Федерации исполнительным органом является Министерство Российской Федерации по атомной энергии.

2. В соответствии с законодательством и правилами Сторон и после письменного уведомления другой Стороны, каждая Сторона при необходимости имеет право привлекать к осуществлению данного Соглашения другие правительственные агентства, департаменты и организации своей страны.

3. Для выполнения целей настоящего Соглашения Стороны создают российско-американский Объединенный Координационный Комитет по обращению с плутонием, который координирует и согласовывает работы, проводимые в рамках настоящего Соглашения. Каждая Сторона назначает своих представителей в Объединенном Координационном Комитете. Решения Объединенного Координационного Комитета принимаются на основе консенсуса.

4. Задачами Объединенного Координационного Комитета являются:

а) Определение областей сотрудничества и разработка общего плана работ в рамках настоящего Соглашения;

б) Определение приоритетов, координация, рассмотрение и одобрение совместных проектов, осуществляемых в рамках настоящего Соглашения и в пределах ресурсов, предоставленных Сторонами;

в) Разрешение любых споров, которые могут возникнуть в процессе научно-технической работы в рамках настоящего Соглашения; и

г) Рассмотрение иных вопросов по согласию Сторон, находящихся в рамках настоящего Соглашения.

5. При достижении договоренности о проведении совместных исследований, проектов или экспериментов в рамках настоящего Соглашения, детальный план выполнения этих работ официально составляется в виде исполнительных договоренностей, подлежащих рассмотрению и одобрению Объединенным Координационным Комитетом.

Статья 5

Сотрудничество Сторон в рамках настоящего Соглашения может включать следующие направления:

а) Обмен научной и технической информацией;

б) Разработка концептуальных подходов;

в) Исследовательские, экспериментальные работы и маломасштабные демонстрации технологических решений;

г) Проектирование, создание и эксплуатация опытно-промышленных установок с целью демонстрации и проверки технологических решений, полученных в результате исследований;

д) Передачу оборудования и неядерных материалов;

е) Встречи, семинары, конференции, командировки и рабочие совещания с целью обмена информацией;

ж) Техничко-экономические обоснования;

з) Другие формы сотрудничества в рамках настоящего Соглашения по совместному согласию исполнительных органов, выраженному в письменном виде.

Статья 6

1. В рамках настоящего Соглашения осуществляется обмен только несекретной информацией.

2. С целью предотвращения доступа лиц и организаций, не участвующих в выполнении настоящего Соглашения, к информации, передаваемой Сторонами в рамках настоящего Соглашения или полученной в результате его осуществления, и считающейся Сторонами конфиденциальной, с этой информацией следует обращаться как с конфиденциальной информацией. Такая информация должна быть четко определена и обозначена. Определение информации в качестве конфиденциальной осуществляется Стороной, передающей информацию, в соответствии с ее законами и правилами. Сторона, принимающая эту информацию, присваивает ей классификацию, обеспечивающую ей такую степень защищенности, которая, по крайней мере, равноценна защищенности, требуемой Стороной, которая предоставила эту информацию.

3. Обращение с конфиденциальной информацией осуществляется в соответствии с законами и правилами Стороны, получающей информацию, причем эта информация не разглашается и не передается третьей стороне, не участвующей в реализации настоящего Соглашения, без письменного согласия Стороны, передавшей информацию. В соответствии с нормами и правилами Соединенных Штатов Америки, с такой информацией обращаются как с информацией, принадлежащей иностранному правительству, переданной конфиденциально. Эта информация обеспечивается соответствующей защитой. В соответствии с нормами и правилами Российской Федерации с этой информацией обращаются как со служебной информацией ограниченного распространения, и эта информация обеспечивается соответствующей защитой.

4. Стороны обеспечивают эффективную защиту интеллектуальной собственности и распределение прав на интеллектуальную собственность, переданную или созданную в рамках настоящего Соглашения, как это указано в настоящей Статье и в Приложении к настоящему Соглашению, которое является неотъемлемой частью настоящего Соглашения.

5. Информация, передаваемая в рамках настоящего Соглашения, должна использоваться исключительно в целях, установленных настоящим Соглашением.

6. Число лиц, имеющих доступ к конфиденциальной информации, должно быть ограничено числом, необходимым для реализации настоящего Соглашения и других связанных с ним программ и определяется исполнительными органами Сторон.

Статья 7

1. Материалы, оборудование и технологии, передаваемые по настоящему Соглашению, не будут использоваться для производства ядерного оружия, любых ядерных взрывных устройств или для исследований или разработки таких устройств, а также для использования в военных целях.

2. Материалы, оборудование и технологии, передаваемые по настоящему Соглашению, не являются предметом экспорта, реэкспорта или передачи из-под юрисдикции получателя без письменного согласия Сторон.

3. До начала экспортных поставок третьей стороне какого-либо оборудования, материалов или технологий в рамках настоящего Соглашения, Стороны по взаимному согласию в письменном виде определяют условия, в соответствии с которыми эти предметы экспорта могут экспортироваться, реэкспортироваться или передаваться из-под юрисдикции третьей стороны.

4. Исполнительные органы Сторон должны предпринимать все необходимые меры для обеспечения соответствующей физической защиты ядерных материалов, оборудования, установок и ядерных технологий, находящихся под их юрисдикцией, а также применяют такие критерии и уровни физической защиты, которые не ниже критериев и уровней,

определенных в Конвенции по физической защите ядерных материалов и в рекомендациях МАГАТЭ.

Статья 8

Оборудование, поставки, материалы, услуги и работы, предоставляемые или приобретаемые Соединенными Штатами Америки, их подрядчиками, субподрядчиками и их персоналом в целях реализации настоящего Соглашения, являются безвозмездной технической помощью, в отношении которых применяется освобождение от уплаты таможенных пошлин и налогов. Российская Федерация предпринимает все необходимые меры для освобождения такого оборудования, поставок, материалов, услуг и работ от всех налогов, тарифов, таможенных пошлин и сборов Российской Федерации и ее органов.

Статья 9

1. За исключением претензий к отдельным лицам за ущерб или телесное повреждение, явившихся результатом их преднамеренных действий, Правительство Российской Федерации не предъявляет претензий и не возбуждает судебных разбирательств в связи с деятельностью, осуществляемой во исполнение настоящего Соглашения, против Правительства Соединенных Штатов Америки и его персонала или его подрядчиков, субподрядчиков, консультантов, поставщиков или субпоставщиков оборудования или услуг на любом уровне и их персонала за любой ущерб, включая косвенный, прямой или вторичный ущерб имуществу, принадлежащему Российской Федерации. Настоящий пункт не применяется к правовым действиям, осуществляемым Правительством Российской Федерации для обеспечения выполнения положений контрактов, стороной которых является оно, российский гражданин или юридическое лицо.

2. За исключением претензий к отдельным лицам за ущерб или телесное повреждение, явившихся результатом их преднамеренных действий, Правительство Российской Федерации обеспечивает надлежащую защиту, освобождает от материальной ответственности, не предъявляет

претензий и не возбуждает судебных разбирательств против Правительства Соединенных Штатов Америки и его персонала, подрядчиков, субподрядчиков, консультантов, поставщиков или субпоставщиков оборудования или услуг на любом уровне и их персоналу по претензиям третьих сторон в связи с деятельностью во исполнение настоящего Соглашения в любом суде за телесное повреждение или ущерб, включая косвенное, прямое или вторичное телесное повреждение или ущерб, причиненные в пределах и за пределами территории Российской Федерации. Ничто в настоящем пункте не истолковывается как признание юрисдикции любого суда над претензиями третьих сторон, к которым применяется настоящий пункт, ни как отказ от иммунитета государства любой из Сторон в отношении возможных претензий к ним третьих сторон.

3. Стороны могут в случае необходимости проводить консультации в связи с претензиями и судебными разбирательствами, касающимися настоящей Статьи.

4. Положения настоящей Статьи не исключают возможности предоставления Сторонами компенсации в соответствии с их национальным законодательством.

5. Ничто в настоящей Статье не истолковывается как препятствующее судебным разбирательствам или претензиям к гражданам Российской Федерации или лицам, постоянно проживающим на территории Российской Федерации.

Статья 10

1. Совместная деятельность в рамках данного Соглашения финансируется из фондов, выделенных на эти цели Соединенными Штатами Америки и Российской Федерацией и в виде предоставления ими материалов, оборудования и услуг экспертов на безвозмездной основе. Совместная деятельность также может быть профинансирована частично или полностью непосредственно из других источников, включая неправительственные фонды и частный сектор.

2. Во всех случаях деятельность в рамках настоящего соглашения и ее финансовая поддержка Соединенными Штатами Америки зависит от наличия ассигнованных средств. Во всех случаях деятельность в рамках

настоящего Соглашения и ее финансовая поддержка Российской Федерацией зависит от наличия ассигнованных средств

Статья 11

В случае заключения контракта со Стороной на приобретение предметов и услуг, включая строительство, с целью выполнения настоящего Соглашения, эти контракты заключаются в соответствии с законами и правилами этой Стороны.

Статья 12

1. Представители Министерства энергетики США имеют право при уведомлении в разумные сроки проводить проверки и ревизию использования любой помощи и содействия, представленной Правительством Соединенных Штатов Америки в рамках сотрудничества, предусмотренного настоящим Соглашением, в течение всего срока действия настоящего Соглашения и трех лет по истечении его срока действия. Подобные проверки могут проводиться на территории или местах Сторон, определенных по взаимной договоренности между исполнительными органами Сторон.

3. Исполнительные органы сторон разрабатывают соответствующие процедуры для проведения проверок и ревизий всех работ, выполняемых в рамках настоящего Соглашения.

Статья 13

Все вопросы, относящиеся к толкованию или применению положений данного Соглашения, решаются путем проведения консультаций между Сторонами.

Статья 14

1. Настоящее Соглашение вступает в силу с даты подписания и действует в течение 5 лет. Срок его действия может быть продлен на очередные 5-летние периоды с письменного согласия обеих Сторон после совместного рассмотрения до окончания каждого 5-летнего периода. Настоящее Соглашение может быть изменено по взаимному согласию Сторон в письменном виде.

2. Действие настоящего Соглашения может быть прекращено любой из Сторон путем направления письменного уведомления о таком намерении по дипломатическим каналам. В этом случае настоящее Соглашение прекращает действие по истечении шести месяцев со дня направления уведомления.

3. В случае прекращения действия данного Соглашения по инициативе одной из Сторон, Стороны могут договориться о выполнении существующих контрактов и проектов в полном объеме и по взаимной договоренности урегулировать вопрос о неоплаченных счетах. Стороны согласны, что в случае прекращения или окончания срока действия настоящего Соглашения, обращение со всей конфиденциальной информацией и интеллектуальной собственностью, полученной в ходе осуществления настоящего Соглашения, будет и впредь осуществляться в соответствии со Статьей 6 настоящего Соглашения, если Сторонами не будет достигнуто иных договоренностей в письменной форме.

СОВЕРШЕНО в _____ 199 г., в двух экземплярах, каждый на английском и русском языках, причем оба текста имеют одинаковую силу.

ЗА ПРАВИТЕЛЬСТВО
СОЕДИНЕННЫХ ШТАТОВ
АМЕРИКИ



ЗА ПРАВИТЕЛЬСТВО
РОССИЙСКОЙ ФЕДЕРАЦИИ



ПРИЛОЖЕНИЕ

к Соглашению
между Правительством Соединенных Штатов Америки и
Правительством Российской Федерации о научно-техническом
сотрудничестве в области обращения с плутонием, изъятим из ядерных
военных программ

Интеллектуальная собственность

В соответствии со Статьей 6 настоящего Соглашения:

Стороны обеспечивают адекватную и эффективную защиту интеллектуальной собственности, создаваемой или предоставленной в рамках настоящего Соглашения и соответствующих исполнительных соглашений.

Стороны договорились своевременно уведомлять друг друга о всех изобретениях, результатах научно-технической, научно-информационной деятельности и работах, выполняемых в рамках настоящего Соглашения, на которые распространяются авторские права, а также стремиться к своевременной защите объектов интеллектуальной собственности. Распределение прав на такую интеллектуальную собственность осуществляется в соответствии с положениями настоящего Приложения.

I. Область применения

А. Настоящее Приложение распространяется на всю совместную деятельность, осуществляемую в соответствии с Соглашением, если Стороны или их исполнительные органы не договорились иначе.

Б. Для целей настоящего Соглашения "интеллектуальная собственность" имеет значение, определенное в Статье 2 Конвенции, учреждающей Всемирную организацию интеллектуальной собственности, заключенной в Стокгольме 14 июля 1967 г.

В. Настоящее Приложение касается распределения прав и учета интересов Сторон. Каждая Сторона обеспечивает получение другой Стороной прав на интеллектуальную собственность, переданную в соответствии с настоящим Приложением, путем приобретения этих прав от

ее собственных участников посредством заключения контрактов, лицензионных договоров или составления при необходимости иных юридических документов. Настоящее Приложение никоим иным образом не изменяет и не наносит ущерба порядку в распределении прав на интеллектуальную собственность между Стороной и ее гражданами или юридическими лицами, который определяется законами и практикой этой Стороны.

Г. Спорные вопросы относительно интеллектуальной собственности, возникающие в рамках настоящего Соглашения, должны разрешаться путем проведения обсуждений между соответствующими участвующими в его выполнении учреждениями либо, если это необходимо, между Сторонами или их исполнительными органами. По взаимному согласию Сторон спорный вопрос передается на рассмотрение арбитражного суда для его разрешения, обязательного для Сторон, в соответствии с Соглашением и применяемыми положениями международного права.

Д. Прекращение или окончание срока действия настоящего Соглашения не влияет на права или обязательства, вытекающие из настоящего Приложения.

II. Распределение прав

А. Каждой Стороне предоставляется неисключительная, безотзывная, безвозмездная лицензия во всех странах на перевод, воспроизведение и публичное распространение научных и технических журнальных статей, докладов, отчетов и книг, непосредственно подготовленных в результате совместной работы в рамках настоящего Соглашения. Во всех публично распространяемых экземплярах охраняемых авторским правом работ, подготовленных в соответствии с настоящим положением, указываются имена их авторов, за исключением тех случаев, когда автор определенно выразил желание остаться анонимным.

Б. Права на все виды интеллектуальной собственности, помимо тех прав, которые изложены выше в параграфе II.А, распределяются следующим образом:

(1) Приглашенные исследователи получают права на интеллектуальную собственность в соответствии с правилами принимающей их организации. В дополнение к этому, каждый приглашенный

исследователь, признанный как изобретатель или автор, имеет право на получение вознаграждений, премий, прибыли или любых иных вознаграждений в соответствии с правилами принимающей организации.

(2) (а) В отношении интеллектуальной собственности, созданной в ходе совместных исследований, если Стороны, участвующие организации или сотрудники предварительно согласовали объем работ, каждой Стороне предоставляются права и выгоды в ее стране. Права и выгоды в третьих странах определяются в исполнительных соглашениях. Если исследовательская работа не определена как "совместные исследования" в соответствующем исполнительном соглашении, то права на интеллектуальную собственность, созданную в рамках такой исследовательской работы, распределяются в соответствии с приведенным выше параграфом II.Б (1). В дополнение к этому, каждое лицо, признанное как изобретатель или автор, имеет право на вознаграждения в соответствии с правилами участвующих организаций.

(б) Несмотря на положения приведенного выше параграфа 2а), если право на какой-либо вид интеллектуальной собственности действительно согласно законодательству государства одной Стороны, но не действительно согласно законодательству государства другой Стороны, то Сторона, законодательство которой обеспечивает такую защиту, получает все права и выгоды во всех странах мира. Тем не менее, лица, признанные как изобретатели или авторы интеллектуальной собственности, имеют право на получение вознаграждений, премий, прибыли или любых иных вознаграждений в соответствии с правилами участвующих организаций.

III. Деловая конфиденциальная информация

В том случае, если в рамках настоящего Соглашения предоставляется или создается информация, своевременно определенная как деловая конфиденциальная, то каждая Сторона и ее участники осуществляют защиту такой информации в соответствии с применимыми законами, правилами и административной практикой. Информация может определяться как "деловая конфиденциальная", если какое-либо лицо, располагающее информацией, может извлечь из нее экономическую выгоду или получить конкурентные преимущества перед теми, кто такой информацией не обладает, если информация широко не известна либо не доступна из других источников и если владелец ранее не предоставлял эту информацию без своевременного введения обязательства сохранять ее конфиденциальность.

Appendix B
CONTRACTOR DISCLOSURE STATEMENT

**NEPA DISCLOSURE STATEMENT FOR PREPARATION OF EIS FOR DOE
SURPLUS PLUTONIUM DISPOSITION**

The Council on Environmental Quality (CEQ) Regulations at 40 CFR 1506.5(c), which have been adopted by the the U.S. Department of Energy (DOE) (10 CFR 1021), require contractors who will prepare an EIS to execute a disclosure specifying that they have no financial or other interest in the outcome of the project. The term "financial interest or other interest in the outcome of the project" for purposes of this disclosure is defined in the March 23, 1981, guidance "Forty Most Asked Questions Concerning CEQ's National Environmental Policy Act Regulations," 46 FR 18026-18038 at Question 17a and b.

"Financial or other interest in the outcome of the project" includes "any financial benefit such as a promise of future construction or design work in the project, as well as indirect benefits the contractor is aware of (e.g., if the project would aid proposals sponsored by the firm's other clients)." 46 FR 18026-18038 at 18031.

In accordance with these requirements, the offerer and any proposed subcontractors hereby certify as follows: (check either (a) or (b) to assure of your proposal).

- (a) Offerer and any proposed subcontractors have no financial or other interest in the outcome of the project.
- (b) Offerer and any proposed subcontractor have the following financial or other interest in the outcome of the project and hereby agree to divest themselves of such interest prior to award of this contract.

Financial or Other Interests

- 1.
- 2.
- 3.

Certified by:

Signature

Casey Koontz
Name

Contract Representative
Title

Science Applications International Corporation
Company

August 14, 1997
Date

Appendix C

Adjunct Melter Vitrification Process

C.1 ADJUNCT MELTER AS AN IMMOBILIZATION TECHNOLOGY VARIANT

The adjunct melter vitrification process was identified in the *Storage and Disposition of Weapons-Usable Fissile Materials Final Programmatic Environmental Impact Statement (Storage and Disposition PEIS)* (DOE 1996) as a possible technology variant for immobilizing surplus plutonium. It is a homogenous immobilization approach similar to the new, stand-alone vitrification facility evaluated in the *Storage and Disposition PEIS*, except that the approach would use some existing facilities and infrastructure at the Savannah River Site (SRS).

In the adjunct melter approach, plutonium would be immobilized, using modified facilities in Building 221-F, into a borosilicate glass frit that would be temporarily stored in individual cans. This frit would be mixed in the new adjunct melter facility with high-level waste (HLW) supplied from the Defense Waste Processing Facility (DWPF). The blended feed would be melted and poured into DWPF canisters to produce a radiation field in the final product that would meet the Spent Fuel Standard (UC 1996).

C.2 EVALUATION OF IMMOBILIZATION TECHNOLOGY VARIANTS

The U.S. Department of Energy (DOE) examined six immobilization technology variants to determine the more promising variants for further development. The six variants were divided into two categories—the external radiation barrier approach and internal radiation barrier approach—as follows:

- | | |
|---|---|
| I. External barrier
(Can-in-canister variants) | 1. Ceramic immobilization in existing facilities
2. Glass immobilization in existing facilities |
| II. Internal barrier
(Homogenous variants) | 3. Vitrification in new, stand-alone facilities
4. Vitrification with an adjunct melter in existing (DWPF at SRS) and new facilities
5. Ceramic immobilization in new, stand-alone facilities
6. Electrometallurgical treatment in existing and new facilities |

Nine evaluation criteria, similar to those used in the screening of alternatives for analysis in the *Storage and Disposition PEIS*, were used to qualitatively evaluate the six immobilization technology variants:

1. Resistance to theft and diversion by unauthorized parties
2. Resistance to retrieval, extraction, and reuse by host nation
3. Technical viability
4. Environmental, safety, and health compliance
5. Cost effectiveness
6. Timeliness
7. Fostering progress and cooperation with Russia and other countries
8. Public and institutional acceptance
9. Additional benefits

The evaluation concluded that the external barrier variants would be superior to the internal barrier variants in terms of timeliness, higher technical viability, much lower costs, and, to a lesser extent, slightly lower

environmental and health risks (UC 1997). As a result of this evaluation, the can-in-canister variants (1 and 2) were considered reasonable alternatives for analysis in the *Surplus Plutonium Disposition Environmental Impact Statement* (SPD EIS) and are compared with the homogenous vitrification and ceramic immobilization facilities (3 and 5) evaluated in the *Storage and Disposition PEIS*. DOE decided, in the Record of Decision for the *Storage and Disposition PEIS*, not to pursue the electrometallurgical treatment option (6) because its technology is less mature than vitrification or ceramic immobilization. Although use of the adjunct melter (4) may be viable from a technical standpoint, it would cost twice as much as the can-in-canister approach and would take 1 to 5 years longer to implement. Based on the relative sizes of the facilities, their use of existing facilities and infrastructure, and the processing steps associated with their operation, specific environmental impacts associated with the adjunct melter approach would be expected to result in environmental impacts ranging between those of the new facility (homogenous) variants and the two can-in-canister variants. The adjunct melter's lack of an environmental advantage combined with its timeliness, cost, and technical shortcomings make it less reasonable than the can-in-canister approach. Thus, it is not included as a reasonable alternative for detailed environmental analysis in the SPD EIS. For completeness, a description of the vitrification process using the adjunct melter with DWPF at SRS is provided below.

C.3 ADJUNCT MELTER VITRIFICATION PROCESS

A simplified flow diagram using a new adjunct melter at SRS is shown in Figure C-1. The disposition process would begin with the conversion of feed materials to plutonium oxide at Building 221-F. This oxide would be blended by a dry feed preparation process to prepare a consistent feedstock and fed into a melter along with glass frit to initiate the first stage of vitrification. The first-stage melter would dissolve the plutonium oxide into the borosilicate glass and convert the mixture to a frit containing about 10 percent plutonium by weight. The assumed nominal feed of plutonium over the life of the adjunct melter vitrification process would be 50 t (55 tons) over a 10-year period.

The plutonium glass frit would then be stored in small steel cans and transported as needed to the new adjunct melter facility adjacent to DWPF. Standard DWPF operations receive two main feedlines from the SRS HLW tank farms to be vitrified—a washed tank sludge and an aqueous HLW precipitate that contains highly radioactive cesium 137. In the adjunct melter process, some of the aqueous HLW precipitate would be diverted from the DWPF, via an interarea pipeline, to the adjunct melter facility. At the adjunct melter facility, the plutonium glass frit would be mixed with DWPF frit and the aqueous HLW precipitate in a melter feed tank, and slurry fed to the melter, producing a homogenous glass melt that would then be poured into DWPF canisters. The surplus plutonium contained in the canisters would be dissolved in the glass and uniformly integrated with fission products. The canisters would then be stored on the site awaiting final disposal at a geologic repository pursuant to the Nuclear Waste Policy Act.

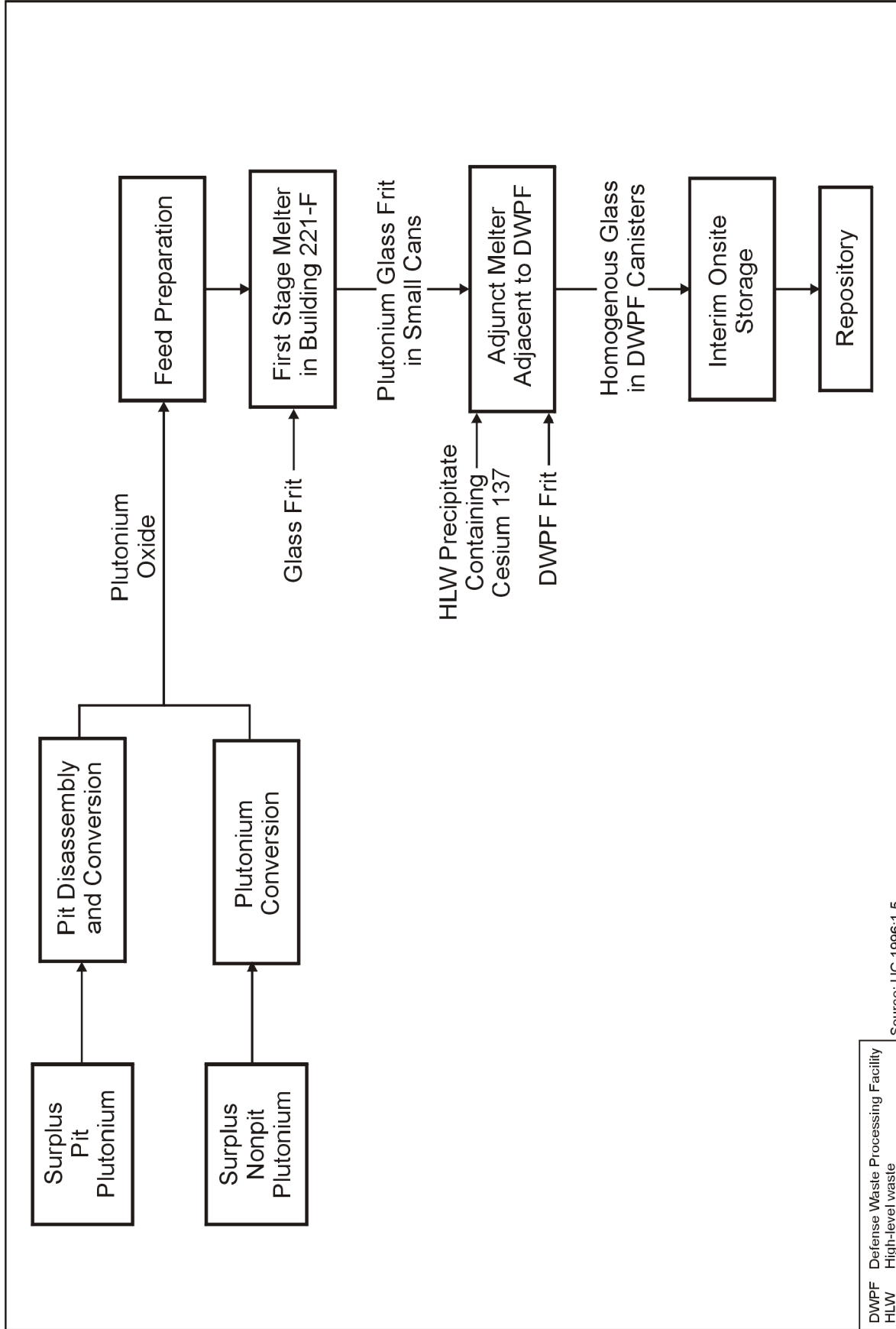

DWPF Defense Waste Processing Facility
 HLW High-level waste

Source: UC, 1996:1-5

Figure C-1. Adjunct Melter Vitrification Process

C.4 REFERENCES

DOE (U.S. Department of Energy), 1996, *Storage and Disposition of Weapons-Usable Fissile Materials Final Programmatic Environmental Impact Statement*, DOE/EIS-0229, Office of Fissile Materials Disposition, Washington, DC, December.

UC (Regents of the University of California), 1996, *Alternative Technical Summary Report: Vitrification Adjunct Melter to DWPF Variant*, UCRL-ID-122660, L-120217-1, Lawrence Livermore National Laboratory, Livermore, CA, August 26.

UC (Regents of the University of California), 1997, *Immobilization Technology Down-Selection Radiation Barrier Approach*, UCRL-ID-127320, Lawrence Livermore National Laboratory, Livermore, CA, May 23.

Table of Contents

Appendix C

Adjunct Melter Vitrification Process	C-1
C.1 ADJUNCT MELTER AS AN IMMOBILIZATION TECHNOLOGY VARIANT	C-1
C.2 EVALUATION OF IMMOBILIZATION TECHNOLOGY VARIANTS	C-1
C.3 ADJUNCT MELTER VITRIFICATION PROCESS	C-2
C.4 REFERENCES	C-4

List of Figures

Figure C-1. Adjunct Melter Vitrification Process C-3

Appendix E Facility Data

This appendix presents predesign data on the construction and operations requirements for the proposed surplus plutonium disposition facilities. Tables E-1 through E-24 present data on schedule, construction area requirements, operation area requirements, construction employment requirements, major construction resource requirements, operation employment requirements, and operation resource requirements for each of the four candidate U.S. Department of Energy sites (the Hanford Site [Hanford], Idaho National Engineering and Environmental Laboratory [INEEL], the Pantex Plant [Pantex], and the Savannah River Site [SRS]). For the candidate lead assembly fabrication facilities at Argonne National Laboratory-West, Hanford, Lawrence Livermore National Laboratory, Los Alamos National Laboratory, and SRS, the schedule, operation employment requirements, and operation resource requirements are presented in Tables E-25 through E-28.

The alternatives addressed in the *Surplus Plutonium Disposition Environmental Impact Statement* (SPD EIS) provide options for the collocation of facilities at Hanford in the Fuels and Materials Examination Facility. Resource requirements for the pit conversion facility are the same whether the facility is collocated with the other facilities or is installed alone. There are differences, however, in such requirements for the immobilization and mixed oxide (MOX) facilities as indicated in Tables E-8 through E-24.

E.1 PIT CONVERSION FACILITY

Table E-1. Pit Conversion Facility Schedule

Activity	Calendar Year
Research and development	1995-2002
Integrated-process demonstrations	1998-2002
Facility design	1999-2001
Construction	2001-2003
Permitting and licensing	1999-2004
Startup and operation	2004-2014
Deactivation and stabilization	2015-2017

Note: Schedule dates are approximate based on latest information. Actual timing may cause some activities to start later in the reference year and end sometime past the end year shown here.

Source: UC 1998a-d.

Table E-2. Pit Conversion Facility Construction Area Requirements

Function	Hanford	INEEL	Pantex	SRS
Laydown area, ha (acres) (including spoils, topsoils, etc.)	2 (4.94)	2 (4.94)	2 (4.94)	2 (4.94)
Warehouse area, ha (acres)	0 (0)	0 (0)	0 (0)	0 (0)
Staging area, ha (acres)	0 (0)	0 (0)	0 (0)	0 (0)
Temporary parking, ha (acres)	0 (0)	0 (0)	0 (0)	0 (0)
New roads, km (mi)	0.13 (0.08)	1.3 (0.81)	3.1 (1.93)	1.8 (1.12)

Note: For purposes of the SPD EIS, metric values provided in the data reports were rounded to two significant figures and converted to the English values.

Source: UC 1998a-d.

Table E-3. Pit Conversion Facility Operation Area Requirements

Land-Use Area	Hanford	INEEL	Pantex	SRS
New process facilities, ha (acres)	0 (0)	0 (0)	1.1 (2.72)	1.1 (2.72)
New support facilities, ha (acres)	0.09 (0.22)	0.09 (0.22)	1.5 (3.71)	1.5 (3.71)
Security area, ha (acres)	0 (0)	0 (0)	0 (0)	0 (0)
New parking lots, ha (acres)	0.4 (0.99)	0.4 (0.99)	0.4 (0.99)	0.4 (0.99)

Note: For purposes of the SPD EIS, metric values provided in the data reports were rounded to two significant figures and converted to the English values.

Source: UC 1998a-d.

Table E-4. Pit Conversion Facility Construction Employment Requirements (2001-2003)

Employees	Hanford	INEEL	Pantex	SRS
Craft workers	220	290	853	853
Management and administrative	<u>44</u>	<u>58</u>	<u>171</u>	<u>171</u>
Total employment	264	348	1,024	1,024

Note: Includes construction staff data provided in the data reports.

Source: UC 1998a-d.

Table E-5. Pit Conversion Facility Major Construction Resource Requirements (2001-2003)

Resource Requirements	Hanford	INEEL	Pantex	SRS
Electricity (MWh)	5,100	5,100	5,100	5,100
Fuel, l (gal)	260,000 (68,684)	330,000 (87,176)	990,000 (261,528)	990,000 (261,528)
Water, l (gal)	6,000,000 (1,585,020)	12,000,000 (3,170,040)	36,000,000 (9,510,120)	36,000,000 (9,510,120)
Concrete, m ³ (yd ³)	4,200 (5,494)	5,700 (7,456)	18,000 (23,544)	18,000 (23,544)
Steel, t (tons)	140 (154)	190 (209)	1,900 (2,094)	1,900 (2,094)

Note: For purposes of the SPD EIS, metric values provided in the data reports were rounded to two significant figures and converted to the English values.

Source: UC 1998a-d.

Table E-6. Pit Conversion Facility Annual Employment Operation Requirements

Employees	Hanford	INEEL	Pantex	SRS
Officials and managers	6	6	6	6
Professionals	65	65	65	65
Technicians	179	179	179	179
Office and clerical	14	14	14	14
Craft workers	42	42	42	42
Operatives	22	22	22	22
Laborers	5	5	5	5
Service workers	<u>67</u>	<u>25</u>	<u>67</u>	<u>67</u>
Total employment	400	358	400	400

Source: UC 1998a-d.

Table E-7. Pit Conversion Facility Annual Operation Resource Requirements

Resource Requirements	Hanford	INEEL	Pantex	SRS
Electricity (MWh)	28,000	15,000	16,000	16,000
Coal, t (tons)	NA	2,100 (2,315)	NA	2,400 (2,646)
Natural gas, m ³ (ft ³)	NA	NA	1,300,000 (45,909,500)	NA
Fuel oil, ^a l (gal)	38,000 (10,038)	38,000 (10,038)	38,000 (10,038)	38,000 (10,038)
Water, l (gal)	62,000,000 (16,378,540)	49,000,000 (12,944,330)	48,000,000 (12,680,160)	48,000,000 (12,680,160)
Hydrogen, m ³ (ft ³)	450 (15,892)	450 (15,892)	450 (15,892)	450 (15,892)
Nitrogen, m ³ (ft ³)	2,200 (77,693)	2,200 (77,693)	2,200 (77,693)	2,200 (77,693)
Oxygen, m ³ (ft ³)	330 (11,654)	330 (11,654)	330 (11,654)	330 (11,654)
Argon, m ³ (ft ³)	14,000 (494,410)	14,000 (494,410)	14,000 (494,410)	14,000 (494,410)
Chlorine, m ³ (ft ³)	62 (2,190)	63 (2,225)	62 (2,190)	62 (2,190)
Helium, m ³ (ft ³)	4,800 (169,512)	4,800 (169,512)	4,800 (169,512)	4,800 (169,512)
Sulfuric acid, kg (lb)	570 (1,257)	100 (220)	470 (1,036)	470 (1,036)
Phosphoric acid, kg (lb)	240 (529)	240 (529)	240 (529)	240 (529)
Oils and lubricants, kg (lb)	1,600 (3,527)	1,600 (3,527)	1,600 (3,527)	1,600 (3,527)
Cleaning solvents, kg (lb)	140 (309)	140 (309)	140 (309)	140 (309)
Polyphosphate, kg (lb)	67 (148)	0 (0)	70 (154)	0 (0)
Polyelectrolyte, kg (lb)	240 (529)	240 (529)	240 (529)	240 (529)
Liquid nitrogen, kg (lb)	1,100 (2,425)	1,100 (2,425)	1,100 (2,425)	1,100 (2,425)
Aluminum sulfate, kg (lb)	940 (2,072)	970 (2,138)	960 (2,116)	960 (2,116)
Bentonite, kg (lb)	470 (1,036)	490 (1,080)	480 (1,058)	480 (1,058)

^a Fuel oil includes gasoline, diesel, and lube oil.

Key: NA, not applicable.

Note: For purposes of the SPD EIS, metric values provided in the data reports were rounded to two significant figures and converted to the English values. Resource requirements less than 50 kg/yr (110 lb/yr) are not listed.

Source: UC 1998a-d.

E.2 IMMOBILIZATION FACILITY

Table E–8. Ceramic or Glass Immobilization Facility Schedule

Activity	Calendar Year
Research and development	1995–2002
Integrated-process demonstrations	1997–2003
Design and construction	1999–2005
Permitting and licensing	1999–2005
Startup and operation	2005–2016
Deactivation and stabilization	2016–2019

Note: Schedule dates are approximate based on latest information. Actual timing may cause some activities to start later in the reference year and end sometime past the end year shown here.

Source: UC 1999a–d.

Table E–9. Ceramic or Glass Immobilization Facility Construction Area Requirements

Function	Hanford			SRS
	Alone	Collocation		New
		with PDCF	with MOX	
Laydown area, ha (acres) (including spoils, topsoils, etc.)	1.8 (4.45)	4.5 (11.1)	4.5 (11.1)	9.7 (24.0)
Warehouse area, ha (acres)	2.6 (6.4)	2.6 (6.4)	2.6 (6.4)	2.6 (6.4)
Staging area, ha (acres)	0 (0)	0 (0)	0 (0)	0 (0)
Temporary parking, ha (acres)	0 (0)	0 (0)	0 (0)	0 (0)
Waste storage area, ha (acres)	0.1 (0.25)	0.1 (0.25)	0.1 (0.25)	0.1 (0.25)
New roads, km (mi)	0 (0)	0.25 (0.16)	0.3 (0.19)	0.6 (0.37)

Key: MOX, mixed oxide fuel fabrication facility; PDCF, pit disassembly and conversion facility.

Note: For purposes of the SPD EIS, metric values provided in the data reports were rounded to two significant figures and converted to the English values.

Source: UC 1999a–d.

**Table E–10. Ceramic or Glass Immobilization Facility
Operation Area Requirements**

Land-Use Area	Hanford			SRS
	Alone	Collocation		New
		with PDCF	with MOX	
New process facilities, ha (acres)	0 (0)	0 (0)	0 (0)	0.55 (1.36)
New support facilities, ha (acres)	0 (0)	0.23 (0.57)	0.34 (0.84)	0.16 (0.40)
Security area, ha (acres)	0 (0)	0 (0)	0 (0)	0 (0)
New parking, ha (acres)	0 (0)	0.6 (1.5)	0.72 (1.8)	2 (4.94)

Key: MOX, mixed oxide fuel fabrication facility; PDCF, pit disassembly and conversion facility.

Note: For purposes of the SPD EIS, metric values provided in the data reports were rounded to two significant figures and converted to the English values.

Source: UC 1999a–d.

**Table E–11. Ceramic or Glass Immobilization Facility
Construction Employment Requirements (2001–2005)**

Employees	Hanford			SRS
	Alone	Collocation		New
		with PDCF	with MOX	
Craft workers	1,049	1,063	1,306	2,564
Management and administrative	174	176	218	428
Total employment	1,223	1,239	1,524	2,992

Key: MOX, mixed oxide fuel fabrication facility; PDCF, pit disassembly and conversion facility.

Source: UC 1999a–d.

**Table E–12. Ceramic or Glass Immobilization Facility
Major Construction Resource Requirements (2001–2005)**

Resource Requirements	Hanford			SRS
	Alone	Collocation		New
		with PDCF	with MOX	
Electricity (MWh)	91,000	74,000	77,000	32,000
Fuel, 1 (gal)	290,000 (76,609)	750,000 (198,128)	960,000 (253,603)	4,700,000 (1,241,599)
Coal, t (tons)	NA	NA	NA	1,800 (1,984)
Water, 1 (gal)	220,000,000 (58,117,400)	230,000,000 (60,759,100)	250,000,000 (66,042,500)	330,000,000 (87,176,100)
Concrete, m ³ (yd ³)	1,900 (2,485)	17,000 (22,236)	22,000 (28,776)	77,000 (100,716)
Steel, t (tons)	420 (463)	3,100 (3,417)	4,000 (4,409)	25,000 (27,558)

Key: MOX, mixed oxide fuel fabrication facility; NA, not applicable; PDCF, pit disassembly and conversion facility.

Note: For purposes of the SPD EIS, metric values provided in the data reports were rounded to two significant figures and converted to the English values.

Source: UC 1999a–d.

**Table E–13. Ceramic or Glass Immobilization Facility
Annual Employment Operation Requirements**

Employees	Hanford					SRS	
	Alone		Collocation			New	
	17 t	50 t	17 t	50 t	17 t	17 t	50 t
Officials and managers	14	14	16	16	16	14	14
Professionals	29	29	33	33	33	29	29
Technicians	188	220	200	232	200	196	212
Office and clerical	12	12	15	15	15	12	12
Craft workers	32	32	36	36	36	32	32
Service workers	<u>60</u>	<u>60</u>	<u>80</u>	<u>80</u>	<u>80</u>	<u>52</u>	<u>52</u>
Total employment	335	367	380	412	380	335	351

Key: MOX, mixed oxide fuel fabrication facility; PDCF, pit disassembly and conversion facility.

Source: UC 1999a–d.

Table E–14. Immobilization Facility Annual Operation Resource Requirements at Hanford

Resource Requirements	Ceramic		Glass	
	17 t	50 t	17 t	50 t
Electricity (MWh)	28,000	29,000	28,000	29,000
Coal, t (tons)	NA	NA	NA	NA
Natural gas, m ³ (ft ³)	NA	NA	NA	NA
Fuel oil, ^a l (gal)	69,000 (18,228)	69,000 (18,228)	69,000 (18,228)	69,000 (18,228)
Water, l (gal)	58,000,000 (15,321,860)	62,000,000 (16,378,540)	55,000,000 (14,529,350)	60,000,000 (15,850,200)
Hydrogen, m ³ (ft ³)	290 (10,241)	320 (11,301)	290 (10,241)	320 (11,301)
Oxygen, m ³ (ft ³)	350 (12,360)	400 (14,126)	350 (12,360)	400 (14,126)
Nitrogen, ^b m ³ (ft ³)	990,000 (34,961,850)	1,400,000 (49,441,000)	990,000 (34,961,850)	1,400,000 (49,441,000)
Argon, ^b m ³ (ft ³)	200,000 (7,063,000)	330,000 (11,653,950)	130,000 (4,590,950)	130,000 (4,590,950)
Helium, ^b m ³ (ft ³)	8,600 (303,709)	10,000 (353,150)	8,600 (303,709)	10,000 (353,150)
[Text deleted.]				
Process water, l (gal)	110 (29)	110 (29)	110 (29)	110 (29)
Precursor, kg (lb)	11,000 (24,251)	31,000 (68,343)	NA	NA
Binder, kg (lb)	350 (772)	960 (2,116)	NA	NA
[Text deleted.]				
Frit, kg (lb)	NA	NA	29,000 (63,933)	55,000 (121,253)
Stainless steel canisters, kg (lb)	50,000 (110,230)	140,000 (308,644)	62,000 (136,685)	170,000 (374,782)
Absorbents, kg (lb)	1,100 (2,425)	1,100 (2,425)	1,100 (2,425)	1,100 (2,425)
Hydraulic fluid, l (gal)	400 (106)	400 (106)	400 (106)	400 (106)
Oil, ^c l (gal)	1,400 (370)	1,400 (370)	1,400 (370)	1,400 (370)
Sodium hypochlorite, kg (lb)	57 (126)	57 (126)	57 (126)	57 (126)
Polyphosphate, kg (lb)	84 (185)	84 (185)	84 (185)	84 (185)
Corrosion inhibitor, kg (lb)	100 (220)	100 (220)	100 (220)	100 (220)

^a Fuel oil includes gasoline, diesel, and oil.

^b Includes process and nonprocess chemicals.

^c Includes cutting oil and lubricating oil.

Key: NA, not applicable.

Note: For purposes of the SPD EIS, metric values provided in the data reports were rounded to two significant figures and converted to the English values. Resource requirements less than 50 kg/yr (110 lb/yr) are not listed, except for lubricants.

Source: UC 1999a, 1999b.

Table E-15. Immobilization Facility Annual Operation Resource Requirements Collocated With Pit Conversion Facility at Hanford

Resource Requirements	Ceramic		Glass	
	17 t	50 t	17 t	50 t
Electricity (MWh)	23,000	24,000	23,000	24,000
Coal, t (tons)	NA	NA	NA	NA
Natural gas, m ³ (ft ³)	NA	NA	NA	NA
Fuel oil, ^a l (gal)	100,000 (26,417)	100,000 (26,417)	100,000 (26,417)	100,000 (26,417)
Water, l (gal)	68,000,000 (17,963,560)	72,000,000 (19,020,240)	68,000,000 (17,963,560)	72,000,000 (19,020,240)
Hydrogen, m ³ (ft ³)	290 (10,241)	320 (11,301)	290 (10,241)	320 (11,301)
Oxygen, m ³ (ft ³)	350 (12,360)	400 (14,126)	350 (12,360)	400 (14,126)
Nitrogen, ^b m ³ (ft ³)	990,000 (34,961,850)	1,400,000 (49,441,000)	990,000 (34,961,850)	1,400,000 (49,441,000)
Argon, ^b m ³ (ft ³)	200,000 (7,063,000)	330,000 (11,653,950)	130,000 (4,590,950)	130,000 (4,590,950)
Helium, ^b m ³ (ft ³)	8,600 (303,709)	10,000 (353,150)	8,600 (303,709)	10,000 (353,150)
[Text deleted.]				
Process water, l (gal)	110 (29)	110 (29)	110 (29)	110 (29)
Precursor, kg (lb)	11,000 (24,251)	31,000 (68,343)	NA	NA
Binder, kg (lb)	350 (772)	960 (2,116)	NA	NA
[Text deleted.]				
Frit, kg (lb)	NA	NA	29,000 (63,933)	55,000 (121,253)
Stainless steel canisters, kg (lb)	50,000 (110,230)	140,000 (308,644)	62,000 (136,685)	170,000 (374,782)
Absorbents, kg (lb)	1,100 (2,425)	1,100 (2,425)	1,100 (2,425)	1,100 (2,425)
Hydraulic fluid, l (gal)	400 (106)	400 (106)	400 (106)	400 (106)
Oil, ^c l (gal)	1,400 (370)	1,400 (370)	1,400 (370)	1,400 (370)
Sodium hypochlorite, kg (lb)	74 (163)	74 (163)	74 (63)	74 (63)
Polyphosphate, kg (lb)	110 (243)	110 (243)	110 (243)	110 (243)
Corrosion inhibitor, kg (lb)	130 (287)	130 (287)	130 (287)	130 (287)

^a Fuel oil includes gasoline, diesel, and oil.

^b Includes process and nonprocess chemicals.

^c Includes cutting oil and lubricating oil.

Key: NA, not applicable.

Note: For purposes of the SPD EIS, metric values provided in the data reports were rounded to two significant figures and converted to the English values. Resource requirements less than 50 kg/yr (110 lb/yr) are not listed, except for lubricants.

Source: UC 1999a, 1999b.

Table E-16. Immobilization Facility Annual Operation Resource Requirements Collocated With MOX Facility at Hanford

Resource Requirements	17 t	
	Ceramic	Glass
Electricity (MWh)	24,000	24,000
Coal, t (tons)	NA	NA
Natural gas, m ³ (ft ³)	NA	NA
Fuel oil, ^a l (gal)	100,000 (26,417)	100,000 (26,417)
Water, l (gal)	70,000,000 (18,491,900)	70,000,000 (18,491,900)
Hydrogen, m ³ (ft ³)	290 (10,241)	290 (10,241)
Oxygen, m ³ (ft ³)	350 (12,360)	350 (12,360)
Nitrogen, ^b m ³ (ft ³)	990,000 (34,961,850)	990,000 (34,961,850)
Argon, ^b m ³ (ft ³)	200,000 (7,063,000)	130,000 (4,590,950)
Helium, ^b m ³ (ft ³)	8,600 (303,709)	8,600 (303,709)
[Text deleted.]		
Process water, l (gal)	110 (29)	110 (29)
Precursor, kg (lb)	11,000 (24,251)	NA
Binder, kg (lb)	350 (772)	NA
[Text deleted.]		
Frit, kg (lb)	NA	29,000 (63,933)
Stainless steel canisters, kg (lb)	50,000 (110,230)	62,000 (136,685)
Absorbents, kg (lb)	1,100 (2,425)	1,100 (2,425)
Hydraulic fluid, l (gal)	400 (106)	400 (106)
Oil, ^c l (gal)	1,400 (370)	1,400 (370)
Sodium hypochlorite, kg (lb)	81 (179)	81 (179)
Polyphosphate, kg (lb)	120 (265)	120 (265)
Corrosion inhibitor, kg (lb)	140 (309)	140 (309)

^a Fuel oil includes gasoline, diesel, and oil.

^b Includes process and nonprocess chemicals.

^c Includes cutting oil and lubricating oil.

Key: NA, not applicable.

Note: For purposes of the SPD EIS, metric values provided in the data reports were rounded to two significant figures and converted to the English values. Resource requirements less than 50 kg/yr (110 lb/yr) are not listed, except for lubricants.

Source: UC 1999a, 1999b.

Table E-17. Immobilization Facility Annual Operation Resource Requirements at SRS

Resource Requirements	Ceramic		Glass	
	17 t	50 t	17 t	50 t
Electricity (MWh)	23,000	24,000	23,000	23,000
Coal, t (tons)	1,200 (1,323)	1,200 (1,323)	1,200 (1,323)	1,200 (1,323)
Natural gas, m ³ (ft ³)	NA	NA	NA	NA
Fuel oil, ^a l (gal)	69,000 (18,228)	69,000 (18,228)	69,000 (18,228)	69,000 (18,228)
Water, l (gal)	100,000,000 (26,417,000)	110,000,000 (29,058,700)	100,000,000 (26,417,000)	110,000,000 (29,058,700)
Hydrogen, m ³ (ft ³)	290 (10,241)	320 (11,301)	290 (10,241)	320 (11,301)
Oxygen, m ³ (ft ³)	350 (12,360)	400 (14,126)	350 (2,360)	400 (14,126)
Nitrogen, ^b m ³ (ft ³)	990,000 (34,961,850)	1,400,000 (49,441,000)	990,000 (34,961,850)	1,400,000 (49,441,000)
Argon, ^b m ³ (ft ³)	200,000 (7,063,000)	330,000 (11,653,950)	130,000 (4,590,950)	130,000 (4,590,950)
Helium, ^b m ³ (ft ³)	8,600 (303,709)	10,000 (353,150)	8,600 (303,709)	10,000 (353,150)
[Text deleted.]				
Process water, l (gal)	110 (29)	110 (29)	110 (29)	110 (29)
Precursor, kg (lb)	11,000 (24,251)	31,000 (68,343)	NA	NA
Binder, kg (lb)	350 (772)	960 (2,116)	NA	NA
[Text deleted.]				
Frit, kg (lb)	NA	NA	29,000 (63,933)	55,000 (121,253)
Stainless steel canisters, kg (lb)	50,000 (110,230)	140,000 (308,644)	62,000 (136,685)	174,000 (383,600)
Absorbents, kg (lb)	1,100 (2,425)	1,100 (2,425)	1,100 (2,425)	1,100 (2,425)
Hydraulic fluid, l (gal)	400 (106)	400 (106)	400 (106)	400 (106)
Oil, ^c l (gal)	1,400 (370)	1,400 (370)	1,400 (370)	1,400 (370)
Sodium hypochlorite, kg (lb)	130 (287)	130 (287)	130 (287)	130 (287)
Polyphosphate, kg (lb)	190 (419)	190 (419)	190 (419)	190 (419)
Corrosion inhibitor, kg (lb)	230 (507)	230 (507)	230 (507)	230 (507)

^a Fuel oil includes gasoline, diesel, and oil.

^b Includes process and nonprocess chemicals.

^c Includes cutting oil and lubricating oil.

Key: NA, not applicable.

Note: For purposes of the SPD EIS, metric values provided in the data reports were rounded to two significant figures and converted to the English values. Resource requirements less than 50 kg/yr (110 lb/yr) are not listed, except for lubricants.

Source: UC 1999c, 1999d.

E.3 MOX FACILITY

Table E–18. MOX Facility Schedule

Activity	Calendar Year
MOX team selection and contract negotiation	1999
Design	2000–2001
Permitting and licensing	2000–2006
Construction	2002–2004
Cold startup	2005
Hot startup	2006
Operation	2006–2015
Deactivation and stabilization	2015–2019 (nominal 3 years)

Note: Schedule dates are approximate based on latest information. Actual timing may cause some activities to start later in the reference year and end sometime past the end year shown here.

Source: UC 1998e–h.

Table E–19. MOX Facility Construction Area Requirements

Function	Hanford				
	FMEF	New	INEEL	Pantex	SRS
Laydown area, ha (acres) (including spoils, topsoils, etc.)	2 (4.94)	2 (4.94)	2 (4.94)	2 (4.94)	2 (4.94)
Warehouse area, ha (acres)	0 (0)	0 (0)	0 (0)	0 (0)	0 (0)
Staging area, ha (acres)	0.65 (1.61)	0.65 (1.61)	0.65 (1.61)	0.65 (1.61)	0.65 (1.61)
Temporary parking, ha (acres)	2 (4.94)	2 (4.94)	2 (4.94)	2 (4.94)	2 (4.94)
Waste storage area, ha (acres)	1 (2.47)	1 (2.47)	1 (2.47)	1 (2.47)	1 (2.47)
New roads, km (mi)	1 (0.62)	1 (0.62)	1 (0.62)	2 (1.24)	2 (1.24)

Key: FMEF, Fuels and Materials Examination Facility.

Note: For purposes of the SPD EIS, metric values provided in the data reports were rounded to two significant figures and converted to the English values.

Source: UC 1998e–h.

Table E–20. MOX Facility Operation Area Requirements

Land-Use Area	Hanford				
	FMEF	New	INEEL	Pantex	SRS
New process facilities, ha (acres)	0 (0)	1.0 (2.47)	1.0 (2.47)	1.0 (2.47)	1.0 (2.47)
New support facilities, ha (acres)	0.47 (1.16)	0.24 (0.59)	0.24 (0.59)	0.24 (0.59)	0.24 (0.59)
Security area, ha (acres)	3 (7.41)	3 (7.41)	3 (7.41)	3 (7.41)	3 (7.41)
New parking, ha (acres)	2 (4.94)	2(4.94)	2 (4.94)	2 (4.94)	2 (4.94)

Key: FMEF, Fuels and Materials Examination Facility.

Note: For purposes of the SPD EIS, metric values provided in the data reports were rounded to two significant figures and converted to the English values.

Source: DOE 1999; UC 1998e–h.

Table E-21. MOX Facility Construction Employment Requirements (2002-2004)

Employees	Hanford				
	FMEF	New	INEEL	Pantex	SRS
Craft workers	1,263	1,471	1,471	1,471	1,471
Management and administrative	<u>641</u>	<u>679</u>	<u>679</u>	<u>679</u>	<u>679</u>
Total employment	1,904	2,150	2,150	2,150	2,150

Key: FMEF, Fuels and Materials Examination Facility.

Note: Total employment includes construction workers during cold and hot startup years.

Source: DOE 1999; ORNL 1998.

Table E-22. MOX Facility Major Construction Resource Requirements (2002-2004)

Resource Requirements	Hanford				
	FMEF	New	INEEL	Pantex	SRS
Electricity (MWh)	74,000	6,000	6,000	6,000	6,000
[Text deleted.]					
Fuel, l (gal)	330,000 (87,176)	1,000,000 (264,170)	1,000,000 (264,170)	1,000,000 (264,170)	1,000,000 (264,170)
Water, l (gal)	50,000,000 (13,208,500)	69,000,000 (18,227,730)	69,000,000 (18,227,730)	69,000,000 (18,227,730)	69,000,000 (18,227,730)
Concrete, m ³ (yd ³)	6,300 (8,240)	15,000 (19,620)	15,000 (19,620)	15,000 (19,620)	15,000 (19,620)
Steel, t (tons)	2,400 (2,646)	6,100 (6,724)	6,100 (6,724)	6,100 (6,724)	6,100 (6,724)

[Text deleted.]

Key: FMEF, Fuels and Materials Examination Facility.

Note: For purposes of the SPD EIS, metric values provided in the data reports were rounded to two significant figures and converted to the English values. Resource requirements less than 50 kg/yr (110 lb/yr) are not listed.

Source: DOE 1999; ORNL 1998.

Table E-23. MOX Facility Annual Employment Operation Requirements

Employees	Hanford				
	FMEF	New	INEEL	Pantex	SRS
Office managers and professionals	86	86	86	86	86
Technicians, operatives, laborers, and service workers	268	268	268	268	268
Office and clerical	12	12	12	12	12
Craft workers	<u>19</u>	<u>19</u>	<u>19</u>	<u>19</u>	<u>19</u>
Total employment	385	385	385	385	385

Key: FMEF, Fuels and Materials Examination Facility.

Note: Total employment during normal operations, after cold and hot startup years.

Source: DOE 1999; ORNL 1998; UC 1998e-h.

Table E–24. MOX Facility Annual Operation Resource Requirements

Resource Requirements	Hanford				
	FMEF	New	INEEL	Pantex	SRS
Electricity (MWh)	46,000	46,000	30,000	30,000	30,000
Coal, t (tons)	NA	NA	2,100 (2,315)	NA	890 (983)
Natural gas, m ³ (ft ³)	NA	NA	NA	1,100,000 (38,846,500)	NA
Fuel oil, ^a l (gal)	63,000 (16,643)	63,000 (16,643)	63,000 (16,643)	63,000 (16,643)	63,000 (16,643)
Water, l (gal)	68,000,000 (17,963,560)	68,000,000 (17,963,560)	68,000,000 (17,963,560)	68,000,000 (17,963,560)	68,000,000 (17,963,560)
Hydrogen, m ³ (ft ³)	23,000 (812,245)	23,000 (812,245)	23,000 (812,245)	23,000 (812,245)	23,000 (812,245)
Nitrogen, m ³ (ft ³)	10,000,000 (353,150,000)	10,000,000 (353,150,000)	10,000,000 (353,150,000)	10,000,000 (353,150,000)	10,000,000 (353,150,000)
Oxygen, m ³ (ft ³)	74 (2,613)	74 (2,613)	74 (2,613)	74 (2,613)	74 (2,613)
Argon, m ³ (ft ³)	500,000 (17,657,500)	500,000 (17,657,500)	500,000 (17,657,500)	500,000 (17,657,500)	500,000 (17,657,500)
Helium, m ³ (ft ³)	21,000 (741,615)	21,000 (741,615)	21,000 (741,615)	21,000 (741,615)	21,000 (741,615)
Phosphoric acid, kg (lb)	100 (220)	100 (220)	100 (220)	100 (220)	100 (220)
Sodium nitrate, kg (lb)	500 (1,102)	500 (1,102)	500 (1,102)	500 (1,102)	500 (1,102)
Sodium hydroxide, kg (lb)	76 (168)	76 (168)	76 (168)	76 (168)	76 (168)
Ethylene glycol, kg (lb)	300 (661)	300 (661)	300 (661)	300 (661)	300 (661)
Lubricant zinc stearate, kg (lb)	300 (661)	300 (661)	300 (661)	300 (661)	300 (661)
[Text deleted.]					
Nitric acid, m ³ (ft ³)	180 (6,357)	180 (6,357)	180 (6,357)	180 (6,357)	180 (6,357)
Silver nitrate kg (lb)	140 (309)	140 (309)	140 (309)	140 (309)	140 (309)
Solvent, l (gal)	15 (3.97)	15 (3.97)	15 (3.97)	15 (3.97)	15 (3.97)
[Text deleted.]					
Hydroxylamine nitrate, kg (lb)	660 (1,455)	660 (1,455)	660 (1,455)	660 (1,455)	660 (1,455)
[Text deleted.]					
Oxalic acid dihydrate, kg (lb)	7,000 (15,432)	7,000 (15,432)	7,000 (15,432)	7,000 (15,432)	7,000 (15,432)
Reillex HPG resin (wet basis), kg (lb)	160 (353)	160 (353)	160 (353)	160 (353)	160 (353)

^a Fuel oil includes gasoline and oil.

Key: FMEF, Fuels and Materials Examination Facility; NA, not applicable.

Note: For purposes of the SPD EIS, metric values provided in the data reports were rounded to two significant figures and converted to the English values.

Source: DOE 1999; ORNL 1998; UC 1998e–h.

E.4 LEAD ASSEMBLY FABRICATION FACILITY

Table E–25. Lead Assembly Fabrication Facility Schedule

Activity	Calendar Year
Equipment procured	2000–2001
Facility design	1999–2001
Facility permitting	2000–2002
Facility modification	2001–2002
Lead assembly fabrication (operation)	2003–2006
Deactivation and stabilization	2010–2013

Note: Schedule dates are approximate based on latest information. Actual timing may cause some activities to start later in the reference year and end sometime past the end year shown here.

Source: O’Connor et al. 1998a–e.

Table E–26. Lead Assembly Fabrication Annual Employment Operation Requirements

Employees	Number of Employees
Officials and managers	1
Professionals	4
Technicians	31
Office and clerical	2
Craft workers	5
Operatives	8
Service workers	9
Total employment	60

Source: O’Connor et al. 1998a–e.

Table E–27. Lead Assembly Fabrication Construction Resource Requirements

Resource Requirement	ANL–W	Hanford	LLNL	LANL	SRS
Electricity (MWh)	NR	NR	NR	NR	2,800
Fuel oil, ^a 1 (gal)	NR	NR	NR	NR	45,000 (11,888)
Water, 1 (gal)	NR	NR	NR	NR	15,000,000 (3,962,550)
Industrial gases, m ³ (ft ³)	NR	NR	NR	NR	57 (2,013)
Concrete, m ³ (yd ³)	NR	NR	NR	NR	19 (25)
Steel, t (tons)	NR	NR	NR	NR	45 (50)

^a Fuel oil includes gasoline, diesel, and oil.

Key: ANL–W, Argonne National Laboratory–West; LANL, Los Alamos National Laboratory; LLNL, Lawrence Livermore National Laboratory; NR, not reported.

Note: ANL–W, Hanford, LLNL, and LANL require minor modifications to existing buildings; therefore, no significant construction resource requirements are expected.

Source: O’Connor et al. 1998a–e.

Table E-28. Lead Assembly Fabrication Annual Operation Resource Requirements

Resource Requirement	ANL-W	Hanford	LLNL	LANL	SRS
Electricity (MWh)	720	1,200	720	720	720
Coal, t (tons)	NA	NA	NA	NA	60 (66)
Natural gas, m ³ (ft ³)	NA	NA	55,000 (1,942,325)	55,000 (1,942,325)	NA
Fuel oil, ^a l (gal)	61,000 (16,114)	12,000 (3,170)	12,000 (3,170)	12,000 (3,170)	12,000 (3,170)
Water, l (gal)	1,600,000 (422,672)	1,600,000 (422,672)	1,600,000 (422,672)	1,600,000 (422,672)	1,600,000 (422,672)
Argon, m ³ (ft ³)	16,000 (565,040)	16,000 (565,040)	16,000 (565,040)	16,000 (565,040)	16,000 (565,040)
Helium, m ³ (ft ³)	10 (353)	10 (353)	10 (353)	10 (353)	10 (353)
Hydrogen, m ³ (ft ³)	1,000 (35,315)	1,000 (35,315)	1,000 (35,315)	1,000 (35,315)	1,000 (35,315)
Nitrogen, m ³ (ft ³)	5,300 (187,170)	5,300 (187,170)	5,300 (187,170)	5,300 (187,170)	5,300 (187,170)
Oxygen, m ³ (ft ³)	5,000 (176,575)	5,000 (176,575)	5,000 (176,575)	5,000 (176,575)	5,000 (176,575)
Sodium nitrate, kg (lb)	85 (187)	85 (187)	85 (187)	85 (187)	85 (187)
Alcohol, l (gal)	230 (61)	230 (61)	230 (61)	230 (61)	230 (61)
General cleaning fluids, l (gal)	230 (61)	230 (61)	230 (61)	230 (61)	230 (61)

^a Fuel oil includes gasoline, diesel, and oil.

Key: ANL-W, Argonne National Laboratory-West; LANL, Los Alamos National Laboratory; LLNL, Lawrence Livermore National Laboratory; NA, not applicable.

Note: For purposes of the SPD EIS, metric values provided in the data reports were rounded to two significant figures and converted to the English values. Resource requirements less than 50 kg/yr (110 lb/yr) are not listed.

Source: O'Connor et al. 1998a-e.

E.5 REFERENCES

DOE (U.S. Department of Energy), 1999, *MOX Fuel Fabrication Facility and Nuclear Power Reactor Data Report*, MD-0015, Office of Fissile Materials Disposition, Washington, DC, August.

O'Connor, D.G., et al., 1998a, *ANL-W MOX Fuel Lead Assemblies Data Report for the Surplus Plutonium Disposition Environmental Impact Statement*, ORNL/TM-13478, Lockheed Martin Energy Research Corporation, Oak Ridge, TN, August.

O'Connor, D.G., et al., 1998b, *Hanford MOX Fuel Lead Assemblies Data Report for the Surplus Plutonium Disposition Environmental Impact Statement*, ORNL/TM-13481, Lockheed Martin Energy Research Corporation, Oak Ridge, TN, August.

O'Connor, D.G., et al., 1998c, *LANL MOX Fuel Lead Assemblies Data Report for the Surplus Plutonium Disposition Environmental Impact Statement*, ORNL/TM-13482, Lockheed Martin Energy Research Corporation, Oak Ridge, TN, August.

O'Connor, D.G., et al., 1998d, *LLNL MOX Fuel Lead Assemblies Data Report for the Surplus Plutonium Disposition Environmental Impact Statement*, ORNL/TM-13480, Lockheed Martin Energy Research Corporation, Oak Ridge, TN, August.

O'Connor, D.G., et al., 1998e, *SRS MOX Fuel Lead Assemblies Data Report for the Surplus Plutonium Disposition Environmental Impact Statement*, ORNL/TM-13483, Lockheed Martin Energy Research Corporation, Oak Ridge, TN, August.

ORNL (Oak Ridge National Laboratory), 1998, *Final Data Report Response to the Draft Surplus Plutonium Disposition Environmental Impact Statement Data Call for Generic Site Add-On Facility for Plutonium Polishing*, ORNL/TM-13669, Oak Ridge, TN, June.

UC (Regents of the University of California), 1998a, *Pit Disassembly and Conversion Facility, Environmental Impact Statement Data Report—Hanford Site*, LA-UR-97-2907, Los Alamos National Laboratory, Los Alamos, NM, June 1.

UC (Regents of the University of California), 1998b, *Pit Disassembly and Conversion Facility, Environmental Impact Statement Data Report—Idaho National Engineering and Environmental Laboratory*, LA-UR-97-2908, Los Alamos National Laboratory, Los Alamos, NM, June 1.

UC (Regents of the University of California), 1998c, *Pit Disassembly and Conversion Facility, Environmental Impact Statement Data Report—Pantex Plant*, LA-UR-97-2909, Los Alamos National Laboratory, Los Alamos, NM, June 1.

UC (Regents of the University of California), 1998d, *Pit Disassembly and Conversion Facility, Environmental Impact Statement Data Report—Savannah River Site*, LA-UR-97-2910, Los Alamos National Laboratory, Los Alamos, NM, June 1.

UC (Regents of the University of California), 1998e, *Response to the Surplus Plutonium Disposition Environmental Impact Statement Data Call for a Mixed Oxide Fuel Fabrication Facility Located at the Hanford Site*, rev. 3, LA-UR-97-2064, Los Alamos National Laboratory, Los Alamos, NM, June 22.

UC (Regents of the University of California), 1998f, *Response to the Surplus Plutonium Disposition Environmental Impact Statement Data Call for a Mixed Oxide Fuel Fabrication Facility Located at the Idaho National Engineering and Environmental Laboratory*, rev. 3, LA-UR-97-2065, Los Alamos National Laboratory, Los Alamos, NM, June 22.

UC (Regents of the University of California), 1998g, *Response to the Surplus Plutonium Disposition Environmental Impact Statement Data Call for a Mixed Oxide Fuel Fabrication Facility Located at the Pantex Plant*, rev. 3, LA-UR-97-2067, Los Alamos National Laboratory, Los Alamos, NM, June 22.

UC (Regents of the University of California), 1998h, *Response to the Surplus Plutonium Disposition Environmental Impact Statement Data Call for a Mixed Oxide Fuel Fabrication Facility Located at the Savannah River Site*, rev. 3, LA-UR-97-2066, Los Alamos National Laboratory, Los Alamos, NM, June 22.

[Text deleted.]

UC (Regents of the University of California), 1999a, *Fissile Materials Disposition Program, EIS Data Call Report: Plutonium Immobilization Plant Using Ceramic in Existing Facilities at Hanford*, rev. 1, UCRL-ID-128275, Lawrence Livermore National Laboratory, Livermore, CA, September.

UC (Regents of the University of California), 1999b, *Fissile Materials Disposition Program, EIS Data Call Report: Plutonium Immobilization Plant Using Glass in Existing Facilities at Hanford*, rev. 1, UCRL-ID-128276, Lawrence Livermore National Laboratory, Livermore, CA, September.

UC (Regents of the University of California), 1999c, *Fissile Materials Disposition Program, EIS Data Call Report: Plutonium Immobilization Plant Using Ceramic in New Facilities at the Savannah River Site*, rev. 1, UCRL-ID-128273, Lawrence Livermore National Laboratory, Livermore, CA, September.

UC (Regents of the University of California), 1999d, *Fissile Materials Disposition Program, EIS Data Call Report: Plutonium Immobilization Plant Using Glass in New Facilities at the Savannah River Site*, rev. 1, UCRL-ID-128271, Lawrence Livermore National Laboratory, Livermore, CA, September.

Appendix F

Impact Assessment Methods

This appendix briefly describes the methods used to evaluate the potential direct, indirect, and cumulative effects of the alternatives for surplus plutonium disposition. The same methodologies were also applied to the assessment of impacts at each of the proposed lead assembly and postirradiation examination sites. Included are impact assessment methods for air quality and noise, geology and soils, water resources, ecological resources, cultural and paleontological resources, land use and visual resources, infrastructure, waste management, socioeconomics, human health risk and hazardous chemicals, facility accidents, transportation, environmental justice, and cumulative impacts. Each section is organized so that first the affected resource is described and then the impact assessment method is presented. Detailed descriptions of the methods for facility accident and transportation impact analyses are presented as Appendixes K and L, respectively.

Although impacts were generally described as either major or minor, this assignment was made in different ways, depending on the resource. For air quality, for example, estimated pollutant emissions from the proposed surplus plutonium disposition facilities were compared with the appropriate regulatory standards or guidelines. For human health risk, estimated radionuclide exposure to humans from the proposed facilities were compared with applicable dose limits. Comparison with regulatory standards is a commonly used method for benchmarking environmental impact and is done here to provide perspective on the magnitude of identified impacts.

Other indicators of impact were also established to focus the analysis on impacts that could be major. The analysis of waste management impacts, for example, focused on alternatives where additional waste generation would be a large percentage of current site waste generation, although a major impact was suggested only where waste generation would exceed the capacity of existing waste management facilities. Cumulative impacts were also evaluated with a view to ensuring that actions with minor impacts individually could not have major impacts collectively.

Impacts in all resource areas were analyzed consistently; that is, the impact values were estimated using a consistent set of input variables and computations. Moreover, efforts were made to ensure that calculations in all areas used accepted protocols and up-to-date models. Finally, like presentations were developed to facilitate the comparison of alternatives.

The impact assessment methods used to evaluate the effects of irradiating mixed oxide (MOX) fuel at the proposed domestic, commercial reactor sites (see Section 4.28) are generally the same as those applied to assess the impacts of the surplus plutonium disposition alternatives at each of the candidate U.S. Department of Energy (DOE) sites. Where there is a difference in the impact assessment method, the nature of the deviation and a discussion of the impact assessment methods used for the reactor sites are provided. Otherwise, if no specific exception is noted, the impact assessment methods applied to the candidate DOE sites were also applied to the proposed reactor sites.

F.1 AIR QUALITY AND NOISE

F.1.1 Description of Affected Resources

F.1.1.1 Air Quality

Air pollution refers to any substance in the air that could harm human or animal populations, vegetation, or structures, or that unreasonably interferes with the comfortable enjoyment of life and property. For purposes of the *Surplus Plutonium Disposition Environmental Impact Statement* (SPD EIS), only outdoor air pollutants were addressed. They may be in the form of solid particles, liquid droplets, gases, or a combination of these

forms. Generally, they can be categorized as primary pollutants (those emitted directly from identifiable sources) and secondary pollutants (those produced in the air by interaction between two or more primary pollutants or by reaction with normal atmospheric constituents, which may be influenced by sunlight). Air pollutants are transported, dispersed, or concentrated by meteorological and topographical conditions. Thus, air quality is affected by air pollutant emission characteristics, meteorology, and topography.

Ambient air quality in a given location can be described by comparing the concentrations of various pollutants in the atmosphere with the appropriate standards. Ambient air quality standards have been established by Federal and State agencies, allowing an adequate margin of safety for protection of public health and welfare from the adverse effects of pollutants in the ambient air. Pollutant concentrations higher than the corresponding standards are considered unhealthy; those below such standards, acceptable.

The pollutants of concern are primarily those for which Federal and State ambient air quality standards have been established, including criteria air pollutants, hazardous air pollutants, and other toxic air compounds. Criteria air pollutants are those listed in 40 CFR 50, *National Primary and Secondary Ambient Air Quality Standards* (EPA 1997a). Hazardous air pollutants and other toxic compounds are those listed in Title I of the 1990 Clean Air Act (CAA) as amended, those regulated by the National Emissions Standards for Hazardous Air Pollutants (NESHAPs), and those that have been proposed or adopted for regulation by the respective State or are listed in State guidelines. Also of concern are air pollutant emissions that may contribute to the depletion of stratospheric ozone or global warming. Construction activities, particularly those that involve modification of existing facilities, may be subject to certain NESHAPs requirements, for example, the reporting, training, and work practice requirements for asbestos renovation (EPA 1997b). Provisions of other NESHAPs requirements, such as those for benzene (EPA 1997c), would likely not apply because the amounts stored and used for construction and operation of these facilities would be small. Provisions of NESHAPs for radionuclides are discussed in Chapter 5 and Appendix F.10.

Areas with air quality better than the National Ambient Air Quality Standards (NAAQS) for criteria air pollutants are designated as being in attainment; areas with air quality worse than the NAAQS for such pollutants, as nonattainment areas. Areas may be designated as unclassified when sufficient data for attainment status designation are lacking. Attainment status designations are assigned by county, metropolitan statistical area, consolidated metropolitan statistical area, or portions thereof. Air Quality Control Regions designated by the U.S. Environmental Protection Agency (EPA) are listed in 40 CFR 81, *Designation of Areas for Air Quality Planning Purposes*.

For locations that are in an attainment area for criteria air pollutants, prevention of significant deterioration (PSD) regulations limit pollutant emissions from new sources and establish allowable increments of pollutant concentrations. Three PSD classifications are specified with the criteria established in the CAA amendments. Class I areas include national wilderness areas, memorial parks larger than 2,020 ha (5,000 acres), and national parks larger than 2,430 ha (6,000 acres), and areas that have been redesignated as Class I. Class II areas are all areas not designated as Class I. No Class III areas have been designated.

Designation as a nonattainment area for criteria air pollutants triggers control requirements designated to achieve attainment status by specified dates. In addition, facilities that constitute major new emission sources cannot be constructed in a nonattainment area without permits that impose stringent pollution control requirements to ensure progress toward compliance.

The region of influence (ROI) for air quality is that area around a site potentially affected by air pollutant emissions caused by the surplus plutonium disposition alternatives. The air quality impact area normally evaluated is the area in which concentrations of criteria air pollutants would increase more than a significant amount in a Class II area. Significance varies according to the averaging period: 2,000 $\mu\text{g}/\text{m}^3$ for 1 hr for carbon

monoxide; $25 \mu\text{g}/\text{m}^3$ for 3 hr for sulfur dioxide; $5 \mu\text{g}/\text{m}^3$ for 24 hr for sulfur dioxide and particulate matter with an aerodynamic diameter less than or equal to 10 microns (PM_{10}); and $1 \mu\text{g}/\text{m}^3$ annually for sulfur dioxide, PM_{10} , and nitrogen dioxide (EPA 1997d). Generally, this covers a few kilometers downwind from the source. For sources within 100 km (62 mi) of a Class I area, the air quality impact area evaluated would include the Class I area if the average 24-hr increase in concentration were greater than $1 \mu\text{g}/\text{m}^3$. The size of the ROI depends on emission source characteristics, pollutant types, emission rates, and meteorological and topographical conditions. For purposes of this analysis, where most of the sites are large, impacts were evaluated at the site boundary, along roads within the sites to which the public has access, and anywhere else the contributions to pollutant concentrations could exceed the established significance levels.

Baseline air quality is typically described in terms of pollutant concentrations modeled for existing sources at each site and background air pollutant concentrations measured near the sites. For this analysis, concentrations for existing sources were obtained from existing source documents or by modeling recent emissions data. Data from the *Storage and Disposition PEIS* (DOE 1996a) were incorporated where appropriate.

The maximum concentrations of toxic air pollutants at or beyond the site boundary were compared with Federal and State regulations or limits. To determine human health risk (see Appendix F.10), modeling outputs on chemical concentrations in air were weighed against chemical-specific toxicity values. Emissions of radionuclides to the air (see Appendix F.10) were evaluated in terms of a total dosage standard.

F.1.1.2 Noise

Sound results from the compression and expansion of air or some other medium when an impulse is transmitted through it. Sound requires a source of energy and a medium for transmitting the sound wave. Propagation of sound is affected by various factors, including meteorology, topography, and barriers. Noise is undesirable sound that interferes or interacts negatively with the human or natural environment. Noise may disrupt normal activities (e.g., hearing, sleep), damage hearing, or diminish the quality of the environment.

Sound-level measurements used to evaluate the effects of nonimpulsive sound on humans are compensated by an A-weighting scale that accounts for the hearing response characteristics (i.e., frequency) of the human ear. Sound levels are expressed in decibels, or in the case of A-weighted measurements, decibels A-weighted. The EPA has developed noise-level guidelines for different land-use classifications. Some States and localities have established noise control regulations or zoning ordinances that specify acceptable noise levels by land-use category.

Noise from facility operations and associated traffic could affect human and animal populations. Because most nontraffic noise associated with construction and operation of the proposed facilities would be distant from offsite noise-sensitive receptors, the contribution to offsite noise levels should be small. Impacts associated with transportation access routes, including noise from increased traffic, could result in small increases in noise along these routes. The ROI for each of the sites includes the site and surrounding areas, including transportation corridors, where proposed activities might increase noise levels. Transportation corridors most likely to experience increased noise levels are those roads within a few miles of the site boundary that carry most of the site's employee and shipping traffic.

Sound-level data representative of site environs were obtained from existing reports and from calculations of the sound levels typical of prevailing traffic volumes along the transportation corridors. The acoustic environment was further described in terms of existing noise sources for each site.

F.1.2 Description of Impact Assessment

F.1.2.1 Air Quality

Potential air quality impacts of pollutant emissions from construction and normal operations were evaluated for each alternative (see Table F-1). That assessment included a comparison of effects of each alternative with applicable Federal and State ambient air quality standards and concentration limits. The more stringent standards, EPA or State, served as the assessment criteria. Criteria for hazardous and toxic air pollutants include those listed in Title III of the 1990 CAA Amendments, NESHAPs, and standards and guidelines adopted by the respective states. The State ambient standards are the same as or more stringent than the Federal ambient standards. The Federal primary ambient standards define levels of air quality that EPA “judges are necessary with an adequate margin of safety, to protect the public health” (EPA 1997a). The Federal secondary ambient standards define levels of air quality that EPA “judges are necessary to protect the public welfare from any known or anticipated adverse effects of a pollutant” (EPA 1997a). The surplus plutonium disposition incremental change in concentrations of pollutants was compared with the PSD Class II allowable increments. Impacts on Class I PSD areas were evaluated where there was a Class I area within 100 km (62 mi) of the site.

Operational air pollutant emissions data for each alternative (other than No Action) were based on engineering design reports; construction emissions data for each alternative, on engineering design reports, emission factors for construction equipment listed in *Compilation of Air Pollutant Emission Factors: Mobile Sources* (EPA 1991:vol. II, 7-1-7-7), and emission factors for fugitive dust from construction listed in *Compilation of Air Pollutant Emission Factors* (EPA 1996a:13.2-1; 13.2-2; 13.2.2-1-13.2.2-8; 13.2.3-1-13.2.3-7; 13.2.4-1-13.2.4-9; 13.2.5-1-13.2.5-21). Traffic emissions were estimated using EPA’s MOBILE5b and PART 5 emissions calculation models.

For each alternative, contributions to offsite air pollutant concentrations were modeled on the basis of guidance presented in the *Guideline on Air Quality Models* (EPA 1997e). The EPA-recommended Industrial Source Complex Model, Version 3 (ISC3), was selected as the most appropriate model to perform the air dispersion modeling, because it is designed to support the EPA regulatory modeling program and is capable of handling multiple sources and source types. The short-term version of ISC3, ISCST3, was used to calculate concentrations with averaging times of 1 to 24 hours and annual average concentrations. Concentrations for the No Action Alternative were based on information provided in the *Storage and Disposition PEIS* (DOE 1996a).

For each reactor site proposed for irradiation of MOX fuel, the contributions to offsite air pollutant concentrations were modeled using the EPA long-term version of the ISC3 model, ISCLT3, for annual average concentrations, and the SCREEN3 model, for short-term average concentrations. Emissions were based on information provided by Duke Engineering and Services, COGEMA Inc., and Stone and Webster as summarized in the *MOX Fuel Fabrication Facility and Nuclear Power Reactor Data Report* (DOE 1999).

The modeling analysis incorporated conservative assumptions, which tend to overestimate the pollutant concentrations. The “highest-high” concentration for each pollutant and averaging time was selected for comparison with the applicable assessment criterion, instead of the less conservative EPA-recommended “highest-high” and “highest second-highest” concentration for long-term and short-term averaging times, respectively. The concentrations evaluated were the maximum occurring at or beyond the site boundary or a public access road, and included the contribution of the alternative and that of existing onsite sources. Available monitoring data, which reflect both onsite and offsite sources, were also taken into consideration. Concentrations of the criteria air pollutants, hazardous air pollutants, and toxic air compounds were presented for each alternative. Construction equipment activity emissions were evaluated as a volume source for each

Table F-1. Impact Assessment Protocol for Air Quality and Noise

Resource	Required Data		Measure of Impact
	Affected Environment	Facility Design	
Air quality			
Criteria air pollutants and other regulated pollutants ^a	Ambient concentration ($\mu\text{g}/\text{m}^3$) of air pollutants, and concentrations of pollutants from existing sources at site	Emission (kg/yr) of air pollutants from facility and facility construction or modification; source characteristics (e.g., stack height and diameter, exit temperature and velocity); shipments and workforce estimates	Contribution of proposed alternative to concentrations of each pollutant at or beyond site boundary; total concentration of each pollutant at or beyond site boundary; percent of applicable standard
Toxic/hazardous air pollutants ^b	Ambient concentrations ($\mu\text{g}/\text{m}^3$) of toxic air pollutants; concentrations of pollutants from existing sources at site	Emission rate (kg/yr) of toxic air pollutants from facility; source characteristics (e.g., stack height and diameter, exit temperature and velocity)	Contribution of proposed alternative to concentrations of each pollutant at or beyond the site boundary; total concentration of each pollutant at or beyond site boundary; percent of applicable standard
Noise	Sound levels at sensitive offsite receptors (e.g., at nearby residences, along major access routes); sound levels at noise-sensitive wildlife habitat (nearby threatened and endangered wildlife habitat)	Descriptions of major construction and operation sources; shipment and workforce estimates	Increase in day/night average sound level at sensitive receptors

^a Carbon monoxide; hydrogen fluoride; lead; nitrogen oxides; ozone; particulate matter with an aerodynamic diameter less than or equal to $10 \mu\text{g}$; sulfur dioxide; total suspended particulates.

^b Title III pollutants, pollutants regulated under the National Emissions Standard for Hazardous Air Pollutants, and other State-regulated pollutants.

alternative using the ISC3 model. The total concentration, including the contribution from each alternative and the percent of the applicable standard, were presented. This percentage reflects the variability of the No Action concentrations, the standards and guidelines among sites and the differences among the alternatives.

The effects of traffic related to construction and operation for each alternative were evaluated by calculating the emissions of criteria pollutants from worker vehicles and shipping activities.

One year of sequential hourly onsite meteorological data from the sites and upper-air data for appropriate locations from the National Climactic Data Center were used in the air quality modeling. For consistency, the data were for the same year considered in the *Storage and Disposition PEIS* (DOE 1996a).

Additional assumptions were incorporated in the air quality modeling at each site. For example, to model emissions from a generic process stack for MOX fuel fabrication, a single source within the facility was used, assuming a stack height of 8 m (26 ft), a stack diameter of 0.3 m (1 ft), a stack exit temperature equal to the

ambient temperature, and a stack exit velocity of 0.03 m/s (0.1 ft/s). Where they could be obtained, however, actual stack locations and stack parameters were used to model pollutant concentrations.

The analysis tends to overestimate pollutant concentrations, since the location of the maximum site boundary concentrations due to surplus plutonium disposition facilities was assumed to be the same as the location of maximum concentrations of other pollutant sources at the site.

Ozone is typically formed as a secondary pollutant in the ambient air (troposphere). It is formed from such primary pollutants as nitrogen oxides and volatile organic compounds, which emanate from vehicular (mobile), natural, and other stationary sources. It is not emitted directly as a pollutant from the sites. Although ozone may thus be regarded appropriately as a regional issue, specific ozone precursors, notably nitrogen dioxide and volatile organic compounds, were analyzed as applicable to the alternatives under consideration.

The CAA, as amended, required that Federal actions conform to the host State's "State Implementation Plan." A State Implementation Plan provides for the implementation, maintenance, and enforcement of NAAQS for the six criteria pollutants: sulfur dioxide; PM₁₀; carbon monoxide; ozone; nitrogen dioxide; and lead. Its purpose is to eliminate or reduce the severity and number of violations of NAAQS and to expedite the attainment of these standards. No department, agency, or instrumentality of the Federal Government shall engage in or support in any way (i.e., provide financial assistance for, license or permit, or approve) any activity that does not conform to an applicable implementation plan. The final rule for *Determining Conformity of General Federal Actions to State or Federal Implementation Plans* (EPA 1993) took effect on January 31, 1994. Hanford, Pantex, the Idaho National Engineering and Environmental Laboratory, the Savannah River Site, and Los Alamos National Laboratory are within areas currently designated as attainment for criteria air pollutants. Therefore, the surplus plutonium disposition alternatives being considered at these sites are not affected by the provisions of the conformity rule. Rocky Flats Environmental Technology Site (RFETS) is in an area designated nonattainment for ozone, PM₁₀, and carbon monoxide. Lawrence Livermore National Laboratory is in an area designated nonattaining for ozone. Applicability of the conformity rule to the RFETS is discussed in Section 4.2.1.7 on No Action.

Emissions of potential stratospheric ozone-depleting compounds such as chlorofluorocarbons were not evaluated because no emissions of these pollutants were identified in the engineering design reports.

Emissions of pollutants that are potential contributors to global warming (e.g., carbon dioxide, nitrous oxide, chlorofluorocarbons, and methane) were evaluated using emission data in the engineering design reports. These emissions were compared with annual releases of these pollutants from other sources (EPA 1997f).

F.1.2.2 Noise

Also addressed in the SPD EIS assessment were the onsite and offsite acoustic impacts of construction and operation of the proposed facilities (see Table F-1). That analysis drew from available information (e.g., engineering design reports) on the types of noise sources and the locations of the proposed facilities relative to the site boundary and noise-sensitive locations. Its focus was the degree of change in noise levels at sensitive receptors (e.g., residences near the site boundary and along access routes, and schools along access routes) with respect to ambient conditions. (A change in noise level of less than 3 decibels is generally not detectable by the human ear. An increase of 10 decibels is roughly equivalent to a doubling of the perceived sound.) Most nontraffic noise sources associated with construction and operation of the surplus plutonium disposition facilities are far enough from offsite noise-sensitive receptors that the contribution to offsite noise levels should be small. Projections of traffic noise during construction and operations were based on the employment and shipment projections provided in the engineering design reports.

F.2 GEOLOGY AND SOILS

F.2.1 Description of Affected Resources

Geologic resources include consolidated and unconsolidated earth materials, including mineral assets such as ore and aggregate materials, and fossil fuels such as coal, oil, and natural gas. Geologic conditions include hazards such as earthquakes, faults, volcanoes, landslides, and land subsidence. Soil resources include the loose surface materials of the earth in which plants grow, usually consisting of mineral particles from disintegrating rock, organic matter, and soluble salts.

The ROI for geology and soils includes all areas subject to disturbance by construction and operation of surplus plutonium disposition facilities, and those areas beneath these facilities that would remain inaccessible for the life of the facilities.

Geology and soils were considered with respect to natural conditions that could affect the alternative, as well as those portions of the resource that could be affected by the alternative. Geology and soil conditions that could affect the integrity and safety of the surplus plutonium disposition alternatives include large-scale geologic hazards and attributes of the soil beneath the proposed facility. Geology and soil resources that could be affected by the surplus plutonium disposition alternatives include economically valuable mineral resources and prime farmland soils.

F.2.2 Description of Impact Assessment

Facility construction and operations for the surplus plutonium disposition alternatives were considered from the perspective of impacts on specific geologic resources and soil attributes. Construction impacts would predominate in effects on geologic and soil resources; hence, key factors in the analysis were the land area to be disturbed during construction and occupied during operations (see Table F-2). The main objective was avoidance of the siting of facilities over unstable soils (i.e., soils prone to liquefaction, shrink-swell, or erosion).

Table F-2. Impact Assessment Protocol for Geology and Soils

Resource	Required Data		Measure of Impact
	Affected Environment	Facility Design	
Soil attributes	Presence of any unstable soils at proposed facility location	Location of proposed facility on the site	Location of facility on unstable soils
Valuable mineral and energy resources	Presence of any valuable mineral or energy resources at proposed facility location	Location of proposed facility on the site	Destruction or rendering inaccessible of valuable mineral or energy resources
Prime farmland soils	Presence of prime farmland soils at proposed facility location	Location of proposed facility on the site	Conversion of prime farmland soils to nonagricultural use

Included in the geology and soil impact analysis was consideration of the risks to the proposed facilities of large-scale geologic hazards such as faulting and earthquakes, lava extrusions and other volcanic activity, landslides, sinkholes, and salt dissolution (i.e., conditions that tend to affect broad expanses of land). In the *Storage and Disposition PEIS* (DOE 1996a:4-45-47, 4-148-150, 4-204-206, 4-309-311), hazards from the large-scale geologic conditions at each candidate site were assessed for proposed long-term storage facilities. The

supporting data and findings of that analysis, which focused on the presence of the hazard and the distance of the facilities from it, were reviewed and accepted as generally applicable to the surplus plutonium disposition facilities and therefore are incorporated by reference. Efforts were also made to determine if locating the surplus plutonium disposition facilities at a specific site could destroy, or preclude the use of, valuable mineral or energy resources.

Pursuant to the Farmland Protection Policy Act (FPPA) (7 USC 4201 et seq.), and the regulations (7 CFR 658) promulgated as result thereof, the presence of prime farmland was also evaluated. This act requires agencies to make FPPA evaluations part of the National Environmental Policy Act (NEPA) process, the main purpose being to reduce the conversion of farmland to nonagricultural uses by Federal projects and programs. Prime farmland, as defined in 7 CFR 657, is land that contains the best combination of physical and chemical characteristics for producing crops. It includes cropland, pasture land, rangeland, and forest land. Potential prime farmlands not acquired prior to June 22, 1982, the effective date of the FPPA, are exempt from its provisions (DOE 1996b:4-22).

F.3 WATER RESOURCES

F.3.1 Description of Affected Resources

Water resources are the surface and subsurface waters that are suitable for human consumption, agricultural purposes, or irrigation or industrial/commercial purposes, and that could be impacted by the proposed action. This analysis involved the review of engineering estimates of expected water use and effluent discharges from proposed construction, operation, maintenance, and decontamination and decommissioning (D&D) of the proposed facilities, and ultimately the impacts of the activities on the local surface water and groundwater.

F.3.2 Description of Impact Assessment

The water resources evaluation for the SPD EIS tiers from the corresponding analysis presented in the *Storage and Disposition PEIS* (DOE 1996a). Its purpose was to evaluate the differences in the impacts where changes would be incurred in the assumed water usage to accommodate the facilities involved in the planned disposition activities. Determination of the impacts of the alternatives on water resources (see Table F-3) consisted of a comparison of field-generated data with regulatory standards, design parameters commonly used in the water and wastewater design industry, and accepted industry standards.

Certain assumptions were integral to this analysis: (1) that all water and sewage treatment facilities would be approved by the appropriate permitting authority, and thus that the impacts of project-specific withdrawals from the water treatment plants and effluent discharges from the sewage treatment plant would be in accordance with established standards; (2) that the sewage treatment facilities would meet the effluent limitations imposed by their respective National Pollutant Discharge Elimination System (NPDES) permits; and (3) that any storm-water runoff from construction or operation activities would be handled in accordance with the regulations of the appropriate permitting authority. It was also assumed that, during construction, siltation fencing or other erosion control devices would be used to mitigate short-term adverse impacts from siltation, and that, as appropriate, storm-water holding ponds would be constructed to lessen the impacts of rainfall events on the receiving streams.

Table F-3. Impact Assessment Protocol for Water Resources^a

Resource	Required Data		Measure of Impact
	Affected Environment	Facility Design	
Surface water quality	Surface waters near the facilities in terms of stream classifications and changes in water quality	Anticipated effluent quantity and quality	Noncompliance of surface water quality with relevant standards of Clean Water Act or with State regulations
Groundwater quality	Groundwater near the facilities in terms of classification, presence of designated sole source aquifers, and changes in quality of groundwater	Quantity and quality of anticipated withdrawals from, or discharges to, groundwater	Concentrations of contaminants in groundwater exceeding standards established in accordance with Safe Drinking Water Act or State regulations
Surface water availability	Surface waters near the facilities, including average flow; 7-day, 10-year low flow; and numbers of downstream users	Volume of withdrawals from, and discharges to, surface waters	Changes in availability to downstream users of water for drinking, irrigation, or animal feeding ^b
Groundwater availability	Groundwater near the facilities, including numbers of all groundwater users, existing water rights for major water users, and contractual agreements for water supply use within impacted area	Volume of withdrawals and discharges to groundwater	Changes in availability of groundwater for human consumption, irrigation, or animal feeding
Flooding impacts	Locations of 100- and 500-year floodplains	Facility location on the site	Construction of facilities in a floodplain ^c

^a For flows above the design capacity of existing water and sewage treatment systems.

^b An impact is assumed if withdrawals exceed 10 percent of the 7-day, 10-year low flow of the receiving stream.

^c A floodplain assessment is a prerequisite to construction on a floodplain.

Further assumptions regarding water resources impacts were based in part on results of the analysis. The first step in the analysis was to determine whether any revisions in project water and wastewater flows had occurred between the time of the *Storage and Disposition PEIS* (DOE 1996a) and the collection of data for the SPD EIS. If no revisions were necessary, and if no evidence of an impact on water resources was presented in the *Storage and Disposition PEIS* (DOE 1996a), then it was assumed that no such impact would be incurred. If the analysis reflected a revision downward in the assumed water use for a proposed activity, and there was no impact for that activity in the *Storage and Disposition PEIS* (DOE 1996a), then no impact was attributed to that activity. If the analysis reflected an increase in water use, then an evaluation of the design capacity of the water and wastewater treatment facilities was made to determine whether their design capacity would be exceeded by the additional flows. If the combined flow (i.e., the existing flow plus those from the proposed activities) were less than the design capacity of the water and sewage treatment plants, then it was assumed that there would be no impact on water availability for local users or on the receiving stream from sewage treatment plant effluent discharges. If the flows from the proposed facilities were found to exceed the design capacity of the existing water or sewage treatment facilities, then the following extensive analyses of the impact of these flows were conducted.

Surface Water Availability. The analysis of the potential impacts on water availability entailed comparing the rate of surface water use for the specific alternative, the associated effluent discharges, and the use and classification of water in downstream waterways. For facilities intending to use surface water, an evaluation was

made of the total use and the 7-day, 10-year low-flow conditions of the receiving stream. Discharges of effluent back into the receiving stream were included in the evaluation. If net losses were found to exceed 10 percent of the 7-day, 10-year low flow, an impact was assumed. Where groundwater was the source of water, discharges to surface water were interpreted as adding to the flow in the receiving stream. If the increases exceeded 200 percent of the 7-day, 10-year low flow, then an impact was assumed.

Surface Water Quality. The evaluation of the surface water quality impacts focused on the quality and quantity of the effluent to be discharged and the quality of the receiving stream upstream and downstream from the proposed facilities. The evaluation of effluent quality featured review of the expected design parameters, such as the design average and maximum flows, as well as the effluent parameters reflected in the existing or expected NPDES permit. Those parameters include biochemical oxygen demand, total suspended solids, metals, coliform bacteria, organic and inorganic chemicals, radionuclides, and any other parameters that affect the local environment. Water quality management practices were reviewed to ensure that NPDES permit limitations would be met. Factors that currently degrade water quality were also identified.

During construction, the receiving stream could be affected by construction site runoff and sedimentation. Such impacts relate to the amount of land disturbed, the type of soil at the site, the topography, and weather conditions. They would be minimized by application of standard management practices for storm-water and erosion control.

During operations, receiving waters could be affected by increased runoff from parking lots, buildings, or other cleared areas. Storm water from these areas could be contaminated with materials deposited by airborne pollutants, automobile exhaust and residues, and process effluents. Impacts of storm-water discharges could be highly specific, and mitigation would depend on management practices, the design of holding facilities, the topography, and adjacent land use. Data from the existing water quality database were compared with expected flows from the new facilities to determine the relative impacts on the quality of the water in the receiving stream.

Groundwater Availability. Effects of the proposed action on groundwater supplies were determined by analyzing potential withdrawal rates for the construction and operation phases of the action. Estimates of withdrawal from the affected aquifers were provided. Additionally, instances in which groundwater use could exceed a large portion of the locally developed groundwater supplies were identified.

Groundwater Quality. Potential groundwater quality impacts associated with effluent discharges during the construction and operation phases were examined. The groundwater quality projections were then weighed against Federal and State groundwater quality standards, effluent limitations, and drinking water standards to determine the impacts of each alternative. Also evaluated were the effects of construction and operation activities on the movement of existing groundwater contamination plumes, and the consequences thereof for groundwater use in the area.

Floodplain Impacts. Once the regional 100- and 500-year floodplains were identified from maps and other existing documents, the likely impacts of proposed surplus plutonium disposition facility construction and operation activities were analyzed. For any facilities proposed for location in a floodplain, a floodplain assessment would be prepared, as necessary. Where possible, the surplus plutonium disposition facilities were sited to ensure compliance with Executive Order 11988, *Floodplain Management*, and 10 CFR 1022, *Compliance With Floodplain/Wetlands Environmental Review Requirements*.

F.4 ECOLOGICAL RESOURCES

F.4.1 Description of Affected Resources

Ecological resources include terrestrial and aquatic resources (plants and animals), wetlands, and threatened and endangered species that could be affected by proposed construction and operations at the proposed surplus plutonium disposition sites. In accordance with the *Storage and Disposition PEIS* (DOE 1996a), the ROI for habitat impacts from facility construction and operations is the area within a 1.6-km (1-mi) radius of the proposed facilities.

F.4.2 Description of Impact Assessment

The proposed alternatives would involve, at a minimum, land disturbance during modifications to existing facilities and may require site clearing for construction of new facilities (see Table F-4). Accordingly, ecological impacts were assessed in terms of potential disturbances or loss of nonsensitive terrestrial and aquatic habitats and the potential effects on nearby sensitive habitats. For purposes of the SPD EIS, sensitive habitats include those areas occupied by threatened and endangered species, State-protected species, and wetlands.

Table F-4. Impact Assessment Protocol for Ecological Resources

Resource	Required Data		Measure of Impact
	Affected Environment	Facility Design	
Nonsensitive terrestrial and aquatic habitats	Vegetation and wildlife within a 1.6-km (1-mi) radius of proposed facility locations	Area disturbed by construction of proposed facility	Decrease in acreage of undisturbed local and regional nonsensitive habitats
Sensitive terrestrial and aquatic habitats, including wetlands	Sensitive species habitats within a 1.6-km (1-mi) radius of proposed facility locations	Area disturbed by construction of proposed facility	Decrease in extent of sensitive habitats in ROI Determination by USFWS and State agencies that facility construction could disturb sensitive habitats

Key: ROI, region of influence; USFWS, U.S. Fish and Wildlife Service.

F.4.2.1 Nonsensitive Habitat Impacts

During the construction phase, ecological resources could be affected through disturbance or loss of habitat resulting from site clearing, land disturbance, human intrusion, and noise. Terrestrial resources could be directly affected through changes in vegetative cover important to individual animals of certain species with limited home ranges, such as small mammals and songbirds. Likely impacts include increased direct mortality and susceptibility to predation. Activities associated with the construction and operation of facilities (e.g., human intrusion and noise) could also compel the migration of the wildlife to adjacent areas with similar habitat. If the receiving areas were already supporting the maximum sustainable wildlife, competition for limited resources and habitat degradation could be fatal to some species. Therefore, the analysis of impacts on terrestrial wildlife was based largely on the extent of plant community loss or modification.

Construction or modification of facilities, and the operation thereof, could directly affect aquatic resources through increased runoff and sedimentation, increased flows, and the introduction of thermal and chemical changes to the water. However, various mitigation techniques should minimize construction impacts, and discharges of contaminants to surface waters from routine operations are expected to be limited by engineering control practices. Therefore, impacts are expected to be minimal.

F.4.2.2 Sensitive Habitat Impacts

Impacts on threatened and endangered species, State-protected species, and their habitats during construction of the proposed surplus plutonium disposition facilities were determined in a manner similar to that for nonsensitive habitats. A list of sensitive species that could be present at each site was compiled. Informal consultations were initiated with the appropriate U.S. Fish and Wildlife Service (USFWS) offices and State-equivalent agencies as part of the impacts assessment for sensitive species. Plans were developed for preconstruction surveys, as necessary, to determine the presence of any Federal- or State-listed species within the ROI. Those plans call for consulting the USFWS and various State agencies to confirm that potential impacts on sensitive habitats are acceptable or can be mitigated.

Most construction impacts on wetlands are related to the displacement of wetlands by filling, draining, or dredging activities. Operational impacts thereon could result from effluents, surface water or groundwater withdrawals, or the creation of new wetlands. Loss of wetlands resulting from construction and operation of the surplus plutonium disposition facilities was addressed by comparing data on the location and areal extent of wetlands in the ROI with the land area requirements for the proposed facilities.

F.5 CULTURAL AND PALEONTOLOGICAL RESOURCES

F.5.1 Description of Affected Resources

Cultural resources are the indications of human occupation and use of the landscape as defined and protected by a series of Federal laws, regulations, and guidelines. For the SPD EIS, the potential impacts of proposed surplus plutonium disposition activities were assessed separately for each of the three general categories of cultural resources: prehistoric, historic, and Native American. Paleontological resources are the physical remains, impressions, or traces of plants or animals from a former geological age, and may be sources of information on paleoenvironments and the evolutionary development of plants and animals. Although not governed by the same historic preservation laws as cultural resources, they could be affected by the proposed surplus plutonium disposition activities in much the same manner.

Prehistoric resources are physical remains of human activities that predate written records; they generally consist of artifacts that may alone or collectively yield otherwise inaccessible information about the past. Historic resources consist of physical remains that postdate the emergence of written records; in the United States, they are architectural structures or districts, archaeological objects, and archaeological features dating from 1492 and later. Ordinarily, sites less than 50 years old are not considered historic, but exceptions can be made for such properties if they are of particular importance, such as structures associated with Cold War themes. Native American resources are sites, areas, and materials important to Native Americans for religious or heritage reasons. Such resources may include geographical features, plants, animals, cemeteries, battlefields, trails, and environmental features.

The primary ROI used for the cultural and paleontological resource analyses encompasses the land areas directly disturbed by construction and operation of the proposed facilities. The natural setting of those resources was considered a contextual component thereof.

F.5.2 Description of Impact Assessment

The SPD EIS study addressed the potential direct and indirect impacts on cultural resources at each of the candidate sites from the proposed action and alternatives (see Table F-5). The assessment of direct impacts focused on ground-disturbing activities and alterations to existing resources, particularly those listed or eligible for listing on the National Register of Historic Places (National Register), and those considered important to

Table F-5. Impact Assessment Protocol for Cultural and Paleontological Resources

Resource	Required Data		Measure of Impact
	Affected Environment	Facility Design	
Prehistoric resources	Site cultural resource inventory/management plan reflecting listing or eligibility for listing on National Register Existing programmatic agreements	Location of proposed facility on the site Areas to be disturbed	Potential for physical destruction, damage, or alteration; isolation or alteration of the character of the property; introduction of visual, audible, or atmospheric elements out of character; and neglect of resources listed or eligible for listing on the National Register Noncompliance with existing laws, regulations, and programmatic agreements
Historic resources	Site cultural resource inventory/management plan reflecting listing or eligibility for listing on National Register Existing programmatic agreements	Location of proposed facility on the site Areas to be disturbed	Potential for physical destruction, damage, or alteration; isolation or alteration of the character of the property; introduction of visual, audible, or atmospheric elements out of character; and neglect of resources listed or eligible for listing on the National Register Noncompliance with existing laws, regulations, and programmatic agreements
Native American resources	Site cultural resource inventory/management plan reflecting listing or eligibility for listing on National Register Existing programmatic agreements Resources identified through consultations with Native American tribal governments	Location of proposed facility on the site Areas to be disturbed	Potential for disturbance of Native American resources as determined through consultations with potentially affected Native American tribal governments (per DOE Order 1230.2) Noncompliance with existing laws, regulations, and programmatic agreements
Paleontological resources	Site cultural resource inventory/management plan Existing programmatic agreements	Location of proposed facility on the site Areas to be disturbed	Potential for appropriation, excavation, injury, or destruction of resources without permission (per Antiquities Act of 1906) Noncompliance with existing laws, regulations, and programmatic agreements

Native Americans. Potential indirect impacts of surplus plutonium disposition activities were also assessed—impacts associated with reduced access to a resource site, as well as impacts associated with increased traffic and visitation in sensitive areas.

For specific sites, depending on the alternative, more detailed information was required (e.g., file investigations, Native American consultations, implementation of the Native American policy of DOE, predictive modeling) to determine the types, numbers, and locations, as well as the National Register eligibility or importance in other respects of resources in the proposed project area.

Plans were drawn up for consultation with each State Historic Preservation Officer and reviews of existing DOE site cultural resource surveys and management plans to determine the National Register eligibility and importance of the resources, and to assess measures designed to mitigate the impacts of the proposed actions.

The measure of impact on a particular resource will depend largely on specific cultural resource management agreements with the candidate sites, the consultations with State Historic Preservation Officers and affected Native American tribes, and overall compliance with Section 106 of the National Historic Preservation Act.

F.6 LAND RESOURCES

F.6.1 Description of Affected Resources

Land resources include the land on and contiguous to each candidate site; the physical features that influence current or proposed uses; local urban and rural population density; pertinent State, county, and municipal land-use plans and regulations; land ownership and availability; and the aesthetic characteristics of the site and surrounding areas.

Land resources analysis for the SPD EIS determined the potential beneficial or adverse impacts on land use and visual resources for the defined ROI. The ROI for land use at each candidate site varies due to disparities in population density and growth trends, the extent of Federal land ownership, adjacent land-use patterns and trends, and other geographic or safety considerations. The ROI for visual resources includes those lands within the viewshed of the proposed action and alternatives.

F.6.2 Description of Impact Assessment

F.6.2.1 Land-Use Analysis

Requirements for the SPD EIS included estimating the impacts of the alternatives on land use within each DOE site, adjacent Federal or State lands, adjacent communities, and wildlife or resource areas. At issue were the net land area affected; its relationship to conforming and nonconforming land uses; current growth trends, land values, and other socioeconomic factors pertaining to land use; and the projected modifications to other facility activities and missions consistent with the proposed alternatives (see Table F-6). Land-use impacts could vary considerably from site to site, depending on existing facility land-use configurations, adjoining land uses, plans for transportation security, proximity to residential areas, and other environmental and containment factors.

Evaluation of existing land uses at each of the potentially affected sites required review of existing and future facility land-use plans. Where land adjacent to the proposed site is managed by local government, applicable community general plans, zoning ordinances, and population growth trend data were reviewed. Where such land is managed or under the jurisdiction of a Federal or State land management agency, the respective agency resource management plans and policies were reviewed. Total land area requirements include those areas to be occupied by the footprint of each building and nonbuilding support area in conjunction with all paved roads, parking areas, graveled areas, and construction laydown areas, and any land graded and cleared of vegetation. Land area requirements were identified using proposed facility data reports.

Table F–6. Impact Assessment Protocol for Land Resources

Resource	Required Data		Measure of Impact
	Affected Environment	Facility Design	
Land use; area used	Total site acreage; available acreage	Location of proposed facility on the site; total land area requirements	Facility land requirements greater than 30% of available acreage
Compatibility with existing or future land-use plans, policies, or regulations	Existing facility and regional land-use configurations; applicable plans, policies, or regulations	Location of proposed facility on the site; facility D&D procedures; expected modifications of other facility activities and missions to accommodate proposed alternatives	Incompatibility with existing facility or adjacent land use; encroachment by disturbed area onto sensitive lands protected by existing management plans or policies; significant long-term or permanent loss of land use resulting from facility construction, operation, or D&D
Visual resources	Delineation of nearby visual resources and viewsheds, including Class I areas	Location of proposed facility on the site; facility dimensions and appearance	Significant reduction of assigned VRM classification for a notable viewshed

Key: D&D, decontamination and decommissioning; VRM, Visual Resource Management.

F.6.2.2 Visual Resources Analysis

Visual resource impacts are changes in the physical features of the landscape attributable to the proposed action. Visual resource assessment was based on the Bureau of Land Management Visual Resource Management (VRM) classification scheme (DOI 1986a, 1986b). Impacts on scenic or visual resources were analyzed by identifying existing VRM classifications and documenting any potential reductions therein at each of the alternative locations as a result of the proposed action or alternatives (see Table F–6). Existing class designation was derived from an inventory of scenic qualities, sensitivity levels, and distance zones for particular areas. The elements of scenic quality are landforms, vegetation, water, color, adjacent scenery, scarcity, and cultural modification. Scenic value is determined by the variety and harmonious composition of the elements of scenic quality. Sensitivity levels are determined by user volumes and user attention. Distance zones concern the visibility from travel routes or observation points.

Important concerns of the visual resources analysis were the degree of contrast between the proposed action and the surrounding landscape, the location and sensitivity levels of public vantage points, and the visibility of the proposed action from the vantage points. The distance from a vantage point to the affected area and atmospheric conditions were also taken into consideration, as distance and haze can diminish the degree of contrast and visibility. A qualitative assessment of the degree of contrast between the proposed facilities or activities and the existing visual landscape was also presented. Reduction of an assigned VRM classification could result if the affected area could be seen from the vantage point with a high sensitivity level.

F.7 INFRASTRUCTURE

F.7.1 Description of Affected Resources

Site infrastructure includes physical resources required to support the construction and operation of facilities. It includes the capacities of the onsite road and rail transportation networks; electric power and electrical load capacities; natural gas, coal, and fuel oil capacities; and water supply system capacities.

The ROI is generally limited to the boundaries of DOE sites. However, should infrastructure requirements exceed site capacities, the ROI would be expanded (for analysis) to include the sources of additional supply. For example, if electrical demand (with added facilities) exceeded site availability, then the ROI would be expanded to include the likely source of additional power: the power pool currently supplying the site.

F.7.2 Description of Impact Assessment

In general, infrastructure impacts were assessed by evaluating the requirements of each alternative against the site capacities. An impact assessment was made for each resource (road networks, rail interfaces, electricity, fuel, and water) for the various alternatives (see Table F-7). Tables reflecting site availability and infrastructure requirements were developed for each alternative. Data for these tables were obtained from reports describing the existing infrastructure at the sites, and from the data reports for each facility. If necessary, design mitigation considerations conducive to reduction of the infrastructure demand were also identified.

Table F-7. Impact Assessment Protocol for Infrastructure

Resource	Required Data		Measure of Impact
	Affected Environment	Facility Design	
Transportation Roads (km) Railroads (km)	Site capacity and current usage	Facility requirements	Additional requirement (with added facilities) exceeding site capacity
Electricity Energy consumption (MWh/yr) Peak load (MW)	Site capacity and current usage	Facility requirements	Additional requirement (with added facilities) exceeding site capacity
Fuel Natural gas (m ³ /yr) Oil (l/yr) Coal (t/yr)	Site capacity and current usage	Facility requirements	Additional requirement (with added facilities) exceeding site capacity
Water (l/yr)	Site capacity and current usage	Facility requirements	Additional requirement (with added facilities) exceeding site capacity

Any projected demand for infrastructure resources exceeding site availability can be regarded as an indicator of environmental impact. Whenever projected demand approaches or exceeds capacity, further analysis for that resource is warranted. Often, design changes can mitigate the impact of additional demand for a given resource. For example, substituting fuel oil for natural gas (or vice versa) for heating or industrial processes can be accomplished at little cost during the design of a facility, provided the potential for impact is identified early. Similarly, a dramatic “spike” in peak demand for electricity can sometimes be mitigated by changes to operational procedures or parameters.

F.8 WASTE MANAGEMENT

F.8.1 Description of Affected Resources

The operation of surplus plutonium disposition support facilities would generate several types of waste, depending on the alternative. Such wastes include the following:

- **Transuranic:** Waste containing more than 100 nCi of alpha-emitting transuranic (TRU) isotopes with half-lives greater than 20 year per gram of waste, except for (1) high-level waste; (2) waste that DOE has determined, with the concurrence of EPA, does not need the degree of isolation required by 40 CFR 191, and (3) waste that the U.S. Nuclear Regulatory Commission (NRC) has approved for

disposal, case by case in accordance with 10 CFR 61. Mixed transuranic waste contains hazardous components regulated under the Resource Conservation and Recovery Act (RCRA).

- **Low-level:** Waste that contains radioactivity and is not classified as high-level waste, TRU waste, or spent nuclear fuel,¹ or the tailings or wastes produced by the extraction or concentration of uranium or thorium from any ore processed primarily for its source material. Test specimens of fissionable material irradiated for research and development only, and not for the production of power or plutonium, may be classified as low-level waste, provided the TRU concentration is less than 100 nCi/g of waste.
- **Mixed low-level:** Low-level waste that also contains hazardous components regulated under RCRA.
- **Hazardous:** Under RCRA, a solid waste that, because of its characteristics, may (1) cause or significantly contribute to an increase in mortality or an increase in serious irreversible, or incapacitating reversible illness, or (2) pose a substantial present or potential hazard to human health or the environment when improperly treated, stored, transported, disposed of, or otherwise managed. Hazardous wastes appear on special EPA lists or possess at least one of the following characteristics: ignitability, corrosivity, reactivity, or toxicity. This category does not include source, special nuclear, or byproduct material as defined by the Atomic Energy Act.
- **Nonhazardous:** Discarded material including solid, liquid, semisolid, or contained gaseous material resulting from industrial, commercial, mining, and agricultural operations, and from community activities. This category does not include source, special nuclear, or byproduct material as defined by the Atomic Energy Act.

The alternatives for surplus plutonium disposition could have an impact on existing site facilities devoted to the treatment, storage, and disposal of these categories of waste.

For new facilities, construction wastes would be similar to those generated by any construction project of comparable scale. Wastes generated during the modification of existing nuclear facilities, however, could produce additional radioactive or hazardous demolition debris.

For all but nonhazardous wastes, DOE chose to combine the liquid and solid waste generation estimates into one waste generation rate for ease of comparison to site waste generation rates. Liquid waste was converted from liters to cubic meters using a conversion factor of 1,000 liters per cubic meter. This is likely to be conservative because it includes the volume of the liquid waste before treatment.

Waste management activities in support of the disposition of surplus plutonium would be contingent on Records of Decision (RODs) issued for the *Final Waste Management Programmatic Environmental Impact Statement for Managing Treatment, Storage, and Disposal of Radioactive and Hazardous Waste* (DOE 1997a). Depending on future waste-type-specific RODs, in accordance with that EIS, wastes could be treated and disposed of on the site or at regionally or centrally located waste management centers. The ROD for hazardous waste issued on August 5, 1998, states that most DOE sites will continue to use offsite facilities for the treatment and disposal of major portions of nonwastewater hazardous waste, with the Oak Ridge Reservation and SRS continuing to treat some of their own hazardous waste on the site in existing facilities where this is economically favorable. According to the TRU Waste ROD issued on January 20, 1998, TRU and TRU mixed waste would be treated on the site according to the current planning-basis Waste Isolation Pilot Plant (WIPP) Waste Acceptance Criteria and shipped to WIPP for disposal. The impacts of disposing of TRU waste at WIPP are

¹ Fuel withdrawn from a nuclear reactor following irradiation, the constituent elements of which have not been separated by reprocessing.

described in the *Waste Isolation Pilot Plant Disposal Phase Final Supplemental Environmental Impact Statement* (DOE 1997b). Current schedules for shipment of TRU waste to WIPP would accommodate shipment of contact-handled TRU waste from surplus plutonium disposition facilities beginning in 2016 (DOE 1997c:17). Therefore, it is assumed TRU waste would be stored on the site until 2016.

F.8.2 Description of Impact Assessment

As shown in Table F–8, impacts were assessed by comparing the projected waste stream volumes generated from the proposed activities at each site with current site waste generation rates and storage volumes.² Furthermore, projected waste generation rates for the proposed activities were compared with processing rates and capacities of those existing treatment, storage, and disposal facilities likely to be involved in managing the additional waste. Most likely, each waste type would be managed at many different facilities; for simplicity, however, it was assumed that the entire waste volume would be managed at one treatment facility, one storage facility, and one disposal facility.

Table F–8. Impact Assessment Protocol for Waste Management

Resource	Required Data		Measure of Impact
	Affected Environment	Facility Design	
Waste management capacity	Site generation rates (m ³ /yr) for each waste type	Construction and operation generation rates (m ³ /yr) for each waste type	SPD facility waste generation rates are a large percentage of existing site generation rates and a large percentage of capacities of applicable waste management facilities
TRU waste	Site management capacities (m ³) or rates (m ³ /yr) for potentially affected treatment, storage, and disposal facilities for each waste type		
Low-level waste			
Mixed low-level waste			
Hazardous waste			
Nonhazardous waste			
Disposal capacity for transuranic waste (including mixed TRU waste)	TRU waste volume (m ³) expected to be disposed of at WIPP Capacity at WIPP (m ³)	Total TRU waste generated (m ³) for SPD facilities	Combination of SPD facility TRU waste generation and existing TRU waste generation exceeds capacity of WIPP

Key: SPD, surplus plutonium disposition; TRU, transuranic; WIPP, Waste Isolation Pilot Plant.

F.9 SOCIOECONOMICS

F.9.1 Description of Affected Resources

Socioeconomic impacts may be defined as the environmental consequences of a proposed action in terms of demographic and economic changes. Two types of jobs would be created as a result of DOE’s adopting any of the surplus plutonium disposition alternatives: (1) construction-related jobs, transient in nature and short in duration, and thus less likely to impact public services; and (2) jobs related to plant operations, required for a decade or more and thus possibly creating additional service requirements in the ROI.

² For the SPD EIS, only the impacts relative to the capacities of waste management facilities were considered. Environmental impacts of waste management facility operation are evaluated in other facility-specific or sitewide NEPA documents.

F.9.2 Description of Impact Assessment

Before the socioeconomic analyses could begin, the socioeconomic environment had to be defined for two geographic regions, the regional economic area (REA) and ROI. The REA is used to assess potential effects of an action on the regional economy. REAs are the broad markets defined by the economic linkages among and between the regional industrial and service sectors and the communities within a region. These linkages determine the nature and magnitude of any multiplier effect associated with a change in economic activity.

For example, as work expands at a given site, the money spent on accomplishing this work flows into the local economy; it is spent on additional jobs, goods, and services within the REA. Using the Regional Input-Output Modeling System developed by the Bureau of Economic Analysis of the U.S. Department of Commerce, the regional economic impacts of a proposed project can be estimated over the life of the project.

Similarly, potential demographic impacts were assessed for the ROI. The ROI could represent a smaller geographic area—one in which only the housing market and local community services would be significantly affected by a given alternative. Site-specific ROIs were identified as those counties in which at least 90 percent of the site's workforce reside. This distribution reflects existing residential preferences for people currently employed at the sites and was used to estimate the distribution of new workers required to support the alternatives.

For each REA, data were compiled on the current socioeconomic conditions, including unemployment rates, economic sector activities, and the civilian labor force. For each ROI, statistics were compiled on the housing demand and community services. These data were combined with population forecasts developed using Census Bureau data to project changes to reflect the various siting alternatives being considered. Site-specific data were then used to help determine whether the overall workforce would be increased by the alternatives being considered (see Table F-9).

In some cases, a site's overall workforce was projected to decrease at the same time additional workers would be needed to support an alternative under consideration in the SPD EIS. In these cases, there would be little change in the site's overall workforce from current levels, and thus very little change in requirements for community services would be expected from a particular alternative. In the alternative, where the projected increases in the site workforce were greater than current levels, the impacts on community services were assessed by determining the increase in community services required to maintain the current status.

F.10 HUMAN HEALTH RISK DURING NORMAL OPERATIONS

F.10.1 Description of Affected Resources

Assessments for the SPD EIS aimed in part at enhancing public understanding of the potential impacts of each of the alternatives on their own health and that of workers. Included was a description of the radiological and chemical releases resulting from construction activities and normal operations for each alternative, including No Action, and the impacts on public and occupational health.

The risks from radiation were not added to those from hazardous chemicals, given the considerable uncertainty as to their combined effects. Impacts of some chemicals are enhanced by radiation, while those of others are not affected or can even be reduced. The reverse also holds true: chemicals can increase, decrease, or not influence radiological effects.

For the public, impacts on individuals (maximally exposed and average exposed) and on the population within 80 km (50 mi) of the site were evaluated; for workers, the focus was impacts on individuals and on the total

Table F-9. Impact Assessment Protocol for Socioeconomics

Resource	Required Data		Measure of Impact
	Affected Environment	Facility Design	
Workforce requirements	Site workforce projections from DOE sites	Estimated construction and operating staff requirements and timeframes	Workforce requirements added to sites' workforce projections
REA civilian labor force	Labor force projections based on State population projections	Estimated construction and operating staff requirements and timeframes	Workforce requirements as a percentage of the civilian labor force
Unemployment rate	1996 unemployment rates in counties surrounding sites and in host States	Estimated construction and operating staff requirements	Projected change in unemployment rates
Health care services Number of hospital beds per 100,000 residents	Latest available rates based on telephone interviews with area hospitals and State hospital associations	Estimated influx of new health care facilities to meet construction and operating staff requirements	Projected change in numbers to maintain current rates
Number of physicians per 100,000 residents	Latest available rates based on AMA data	Estimated influx of new health care employees to meet construction and operating staff requirements	Projected change in numbers to maintain current rates
Housing—Percent of occupied housing units	Latest available rates from the Census Bureau	Estimated influx of new housing units needed for influx of construction and operating staff requirements	Projected change in numbers to maintain current rates
Schools			
Percent operating capacity for school districts in ROI	Latest available rates based on telephone interviews with school districts	Estimated influx of new students generated by movement of employees and their families into ROI	Projected change in operating capacity for school districts in ROI
Teacher-to-student ratio	Latest available rates based on telephone interviews with school districts	Estimated influx of new students generated by movement of employees and their families into ROI	Projected change in number of teachers to maintain current teacher-to-student ratio
Community services			
Ratio of police to 100,000 residents	Latest number of sworn officers based on telephone interviews with police departments	Estimated influx of new officers to meet construction and operating staff requirements	Projected change in number of officers to maintain current police-to-resident ratio
Ratio of firefighters to 100,000 residents	Latest number of firefighters based on telephone interviews with fire departments	Estimated influx of new firefighters to meet construction and operating requirements	Projected change in number of firefighters to maintain current firefighter-to-resident ratio

Key: AMA, American Medical Association; REA, regional economic area; ROI, region of influence.

facility workforce. The basic health risk issue addressed was whether any of the alternatives would result in undue numbers of health effects (e.g., cancers among workers or the public). Because protection of human health is regulated by DOE, EPA, NRC, and the Occupational Safety and Health Administration (OSHA), estimates

of public and worker doses and associated health risks are also necessary to demonstrate that surplus plutonium disposition facilities are being designed in compliance with the applicable standards issued by these agencies.

F.10.2 Description of Impact Assessment

F.10.2.1 Public Health Risks

The health risks to the general public were determined in the following ways: (1) for present operations, doses stated in the most recent environmental or safety reports were used to calculate health risks; and (2) for operations of the proposed facilities, incremental radiological and chemical doses were modeled using specific facility data and site-dependent parameters and converted into their associated health risks.

Radiological and chemical impacts associated with the No Action Alternative were estimated from projected releases from all site facilities that are expected to be operating at the time the actions assessed in the SPD EIS are under way. For each of the other alternatives, radiological and chemical effluents were obtained from facility data reports specific to each surplus plutonium disposition process.

F.10.2.1.1 Radiological Risks

Public health risk assessments from radiological releases during normal operations of the proposed facilities at the candidate sites were performed using the Generation II computer code, to calculate doses from inhalation, ingestion of terrestrial foods, drinking water, fish, and direct exposure to radiation in plumes or on the ground. This type of assessment uses site-dependent factors, including meteorology, population distributions, agricultural production, and facility locations on a given site. As reflected in Table F-10, doses were calculated for the maximally exposed individual (MEI) member of the public, for the average exposed member of the public, and for the total population living within 80 km (50 mi) of a given release location (NRC 1977:1.109.30).

Total site doses were compared with regulatory limits and, for perspective, with background radiation levels in the vicinity of the site. These doses were also converted into a projected number of fatal cancers using a risk estimator of 500 fatal cancers per 1 million person-rem derived from data prepared by the National Research Council's Committees on the Biological Effects of Ionizing Radiations and by the International Commission on Radiological Protection (ICRP 1991). The calculated health effects were compared with those arising among the same population groups from other causes.

[Text deleted.]

F.10.2.1.2 Chemical Risks

The potential impacts on the offsite public from exposure to hazardous chemicals released to the atmosphere as a result of the construction or routine operation of the proposed facilities were evaluated. The receptor considered in these evaluations was the MEI member of the offsite population at each candidate site. The MEI is the hypothetical individual in the population who has the highest potential exposure.

Table F-10. Impact Assessment Protocol for Human Health Risk

Risk	Required Data		Measure of Impact
	Affected Environment	Facility Design	
Radiation: public			
Offsite MEI dose via airborne pathways	Current annual dose (mrem) to MEI via all airborne pathways at site	Annual radionuclide release rates (Ci) to air from proposed facility. Stack height. Location of proposed facility on the site.	Annual dose greater than 10 mrem via airborne releases (NESHAPs limit), and 5 mrem (airborne external [10 CFR 50]).
Offsite MEI dose via liquid pathways	Current annual dose (mrem) to MEI via all liquid pathways at site	Annual radionuclide release rates (Ci) to liquid pathways.	Annual dose via liquid releases greater than 4 mrem (SDWA) and 3 mrem (10 CFR 50).
Offsite MEI dose via all pathways, including air, water, and others (e.g., direct radiation)	Current annual dose (mrem) to MEI via all pathways at site Annual radionuclide release rates to air and water from site release locations Joint frequency meteorological data Water dilution factors Distances from radionuclide release points to site boundary for 16 cardinal directions Exposure information associated with other potential pathways (e.g., direct radiation from each site area)	Annual radionuclide releases to air and via any other pathway (e.g., direct radiation) from proposed facility. Stack height. Location of proposed facility on the site. Exposure information associated with other potential pathways (e.g., direct radiation).	Annual dose greater than 100 mrem via all pathways (DOE 5400.5 and 10 CFR 20)
Dose to population within 80 km (50 mi) of site via all pathways	Current annual population dose (person-rem) via all pathways at site Projected population distribution within an 80-km (50-mi) radius from radionuclide release points Latest available milk, meat, and vegetable distributions within an 80-km (50-mi) radius from radionuclide release points Joint frequency meteorological data Water usage values (e.g., fish harvest, number of water drinkers) Water dilution factors	Annual radionuclide release rates (Ci) to air and liquid from proposed facility. Stack height. Location of proposed facility on the site.	Annual population dose greater than 100 person-rem via all pathways (proposed 10 CFR 834).

Table F-10. Impact Assessment Protocol for Human Health Risk (Continued)

Risk	Required Data		Measure of Impact
	Affected Environment	Facility Design	
Radiation: occupational			
Average dose to involved (facility) worker ^a	Not applicable	Annual average dose (mrem) to the facility worker.	Annual dose of more than 750 mrem. This value represents 15% of 10 CFR 835 and 10 CFR 20 limit of 5,000 mrem/yr and 37.5% of DOE administrative control level of 2,000 mrem/yr, and has been chosen to ensure that dose received by average worker is well below dose limits and administrative control level. Annual dose of more than 5,000 mrem/yr for commercial plants (10 CFR 20).
Average dose to noninvolved (site) worker ^a	Current annual average dose (mrem) among all noninvolved workers at site	Not applicable.	Annual dose of more than 250 mrem. This value represents 5% of 10 CFR 835 limit of 5,000 mrem/yr and 12.5% of the DOE administrative control level of 2,000 mrem/yr, and has been chosen to ensure that dose received by average worker is well below dose limits and administrative control level.
Total dose to involved (facility) workers	Not applicable	Annual total dose (person-rem) among all facility workers. Number of facility workers.	Annual dose of more than 750 mrem times number of involved workers. Annual dose of more than 5,000 mrem/yr for commercial plants (10 CFR 20).
Total dose to noninvolved (site) workers	Current annual total dose (person-rem) among all workers at site Number of noninvolved workers	Not applicable.	Annual dose of more than 250 mrem times number of noninvolved workers at site.
Radiation: construction workers			
Average dose to construction worker ^a	Level of existing contamination and dose expected from working in that area of site	Annual average and total dose to construction worker.	For average worker, 50% of values given above for public's MEI. This is based on interpretation of a construction worker as a member of the public and application of a reduction factor of 2 in going to an average rather than a maximally exposed worker.
Total dose to construction workers		Numbers of construction workers.	For total workforce, number of workers in workforce times doses for an average worker.

Table F-10. Impact Assessment Protocol for Human Health Risk (Continued)

Risk	Required Data		Measure of Impact
	Affected Environment	Facility Design	
Hazardous chemicals: public			
Offsite MEI latent cancer incidence risk	Distribution of population in ROI Joint frequency meteorological data	Airborne release (kg/yr) of hazardous chemicals.	Probability of latent cancer incidence for MEI.
[Text deleted.]			

^a More meaningful in determining health risk than dose to maximally exposed worker, which varies significantly each year. Monitoring, however, will ensure that dose to the maximally exposed worker remains within regulatory limits.

Key: CFR, Code of Federal Regulations; MEI, maximally exposed individual; NESHAPs, National Emission Standards for Hazardous Air Pollutants; ROI, region of influence; SDWA, Safe Drinking Water Act.

As a result of releases from construction and routine operation of facilities, receptors are expected to be potentially exposed to concentrations of hazardous chemicals that are below those that could cause acutely toxic health effects. Acutely toxic health effects result from short-term exposure to relatively high concentrations of contaminants, such as those that may be encountered during facility accidents. Long-term exposure to relatively lower concentrations of hazardous chemicals can produce adverse chronic health effects that may include both carcinogenic and noncarcinogenic effects. However, the health effect endpoint evaluated in this analysis is limited to the probability of an excess latent cancer incidence for the offsite population MEI because only carcinogenic chemicals are expected to be released from the proposed actions.

Estimates of airborne concentrations of hazardous chemicals were developed using the ISC air dispersion model. This model was developed by EPA for regulatory air-dispersion-modeling applications (EPA 1996b). ISC3 is the most recent version of the model and is approved for use for a wide variety of emission sources and conditions. The ISC model estimates atmospheric concentrations based on the airborne emissions from the facility for each block in a circular grid comprising 16 directional sectors (e.g., north, north-northeast, northeast) at radial distances out to 80 km (50 mi) from the point of release, producing a distribution of atmospheric concentrations. The offsite population MEI is located in the block with the highest estimated concentration.

For carcinogenic chemicals, risk is estimated by the following equation:

$$\text{Risk} = \text{CA} \times \text{URF}$$

where

Risk = unitless probability of cancer incidence

CA = contaminant concentration in air (in $\mu\text{g}/\text{m}^3$)

URF = cancer inhalation unit risk factor (in units of cancers per $\mu\text{g}/\text{m}^3$)

Cancer unit risk factors are used in risk assessments to estimate an upper-bound lifetime probability of an individual developing cancer as a result of exposure to a particular concentration of a potential carcinogen.

For the proposed actions, benzene is the only potential carcinogen that may be released to the atmosphere during facility construction activities (UC 1998a, 1998b, 1998c, and 1998d). EPA considers benzene to be a human carcinogen based on several studies that show increased incidence of nonlymphocytic leukemia from occupational exposure, increased incidence of neoplasia in rats and mice exposed by inhalation and gavage, and increases in chromosomal aberrations of bone marrow cells and peripheral lymphocytes in workers exposed to benzene and in laboratory studies with rabbits and rats (EPA 1997g).

F.10.2.2 Occupational Health Risks

F.10.2.2.1 Radiological Risks

Health risks from radiological exposure were determined for two types of workers: the facility worker, (i.e., the worker inside one of the plutonium-processing facilities or one of the commercial plants); and the site worker (i.e., the worker elsewhere on the site but not involved in plutonium processing). Health risks to individual workers and to total workforces were assessed.

The facility worker's dose was based on data from design reports on specific surplus plutonium disposition facilities or from the commercial plant historical data. It was assumed that the noninvolved site worker only receives a dose that results from his or her primary onsite activities. No additional dose to these workers would be expected from surplus plutonium disposition facility operation.

Worker doses were converted into the number of projected fatal cancers using the risk estimator of 400 fatal cancers per 1 million person-rem given in the International Commission on Radiological Protection Publication 60 (ICRP 1991). This risk estimator, compared with that for members of the public, reflects the absence of the most radiosensitive age groups (i.e., infants and children) in the workforce.

F.10.2.2.2 Hazardous Chemical Risks

Impacts of exposures to hazardous chemicals for workers directly involved in the proposed actions were not quantitatively evaluated. The use of personal protective equipment by the workers, as well as the use of engineering process controls, will limit worker exposure to levels within OSHA *Permissible Exposure Limits* (in 29 CFR 1910) or American Conference of Governmental Industrial Hygienists *Threshold Limit Values*.

F.11 FACILITY ACCIDENTS

F.11.1 Description of Affected Resources

Processing any hazardous material poses a risk of accidents impacting involved workers (workers directly involved in facility processes), noninvolved workers (workers on the site but not directly involved in facility processes), and members of the public. The consequences of such accidents could involve the release of radioactive or chemical material or the release of hazardous (e.g., explosive) energy, beyond the intended confines of the process. Risk is determined by the development of a representative spectrum of accidents, each of which is conservatively characterized by a likelihood (i.e., expected frequency of occurrence) and a consequence.

For the purpose of this analysis, involved workers were defined as workers in the immediate vicinity of the process involved in the accident; noninvolved workers, as workers located at the closer of 1,000 m (3,281 ft) from the accident (emission) source or the site boundary; and members of the public, as persons residing outside the site boundary and within 80 km (50 mi) of the facility.

F.11.2 Description of Impact Assessment

To avoid duplication, the analysis of potential accidents performed for the SPD EIS took full cognizance of the corresponding analyses in the *Storage and Disposition PEIS* (DOE 1996a), including accident sequence development, source term definition, and consequence analysis. The analysis focused on the likelihoods and consequences of a variety of a bounding spectrum of accidents postulated for each alternative, from high-consequence, low-frequency accidents to low-consequence, high-frequency accidents.

One objective of the accident analysis, a follow-on to a hazard analysis, was to translate each source term into a probabilistic distribution of consequences based on site-specific modeling of meteorological dispersion of the hazardous material and resulting uptake of that material by members of the human population. To predict the impacts of postulated accidents on the health of workers and the public, source terms were translated into consequences using the Melcor Accident Consequence Code System (MACCS2).

Metrics used to measure the impact of each accident include the accident frequency, the mean and 95th percentile doses for the noninvolved worker at the closer of 1,000 m (3,281 ft) or the site boundary, the mean and 95th percentile doses for the MEI at the site boundary, and the mean and 95th percentile doses for members of the general public within 80 km (50 mi) of the facility. Additionally, the individual doses were translated into the probability of latent cancer fatality, and the dose to the general public into the expected number of latent cancer fatalities (see Table F-11). Additional information on the development of accident sequences, source term definition, and consequence analysis can be found in Appendix K.

Table F-11. Impact Assessment Protocol for Facility Accidents

Accident	Required Data		Measure of Impact
	Affected Environment	Facility Design	
Operational events	Meteorological data	Accident source terms	Radiological dose at 1,000 m (3,281 ft) from accident source
External events	Data on population within 80 km (50 mi) of facility	Accident frequencies	Probability of latent cancer fatality given dose at 1,000 m (3,281 ft)
NPH events	Site boundary data	Facility location	Radiological dose to offsite MEI Probability of latent cancer fatality given dose at site boundary Dose to general public within 80 km (50 mi) of facility Latent cancer fatalities among general public within 80 km (50 mi) of facility

Key: MEI, maximally exposed individual; NPH, natural phenomena hazard.

F.12 TRANSPORTATION

F.12.1 Description of Affected Resources

Overland transportation of any commodity involves a risk to both transportation crew members and members of the public. This risk results directly from transportation-related accidents and indirectly from the increased levels of pollution from vehicle emissions, regardless of cargo. The transportation of plutonium, radioactive waste, or other nuclear materials can pose additional risks owing to the unique properties of the material.

Accordingly, DOE, NRC, and the U.S. Department of Transportation have instituted strict policies and regulations governing the transport of such materials. The requirements are applicable throughout a shipment's ROI, which encompasses the onsite roadways, as well as the public roads between DOE sites and between DOE sites and commercial sites. For site-to-site transport, for example, shippers are required to use interstate highways predominantly.

F.12.2 Description of Impact Assessment

The risk from incident-free transportation was assessed for persons living within 0.8 km (0.5 mi) of the route; the risk from hypothetical accidents, for persons living within 80 km (50 mi) of the route. Assessment of the

human health risks of overland transportation is crucial to a complete appraisal of the environment impacts of transportation associated with the surplus plutonium disposition alternatives.

The impacts associated with overland transportation were calculated per shipment, and then multiplied by the number of shipments. This approach allowed for maximum flexibility in determining the risk for a variety of alternatives (see Table F-12).

Fundamental assumptions of this analysis were consistent with those of the *Storage and Disposition PEIS* (DOE 1996a), and the same computer codes, release data, and accident scenarios were used. The HIGHWAY computer program was used for selecting highway routes for transporting radioactive materials by truck. The HIGHWAY database is a computerized road atlas that currently describes approximately 386,242 km (240,000 mi) of roads. A complete description of the interstate system and all U.S. highways is included in the database. Most of the principal State highways and many local and community roadways are also identified. The code is updated periodically to reflect current road conditions, and has been benchmarked against the reported mileages and observations of commercial trucking firms.

The first analytic step in the ground transportation analysis was to determine the incident-free and accident risk factors per shipment for transportation of the various types of hazardous materials. As with any risk estimate, the risk factors were calculated as the product of the probability and the magnitude of the exposure. Accident risk factors were calculated for radiological and nonradiological traffic accidents. The probabilities (much lower than unity [i.e., 1]) and the magnitudes of exposure were multiplied, yielding risk numbers. Incident-free risk factors were calculated for crew and public exposure to radiation emanating from the package and for public exposure to the chemical toxicity of the transportation vehicle exhaust. The probability of incident-free exposure is unity.

The RADTRAN 4 computer code (Neuhauser and Kanipe 1995) was used for the incident-free and accident risk assessments to estimate the impacts on collective populations. RADTRAN 4 was developed by Sandia National Laboratories to calculate population risk associated with the transportation of radioactive materials by a variety of modes: truck, rail, air, ship, and barge. Calculations are in terms of the probabilities and consequences of potential exposure events.

The RISKIND computer code (Yuan et al. 1995) was used to estimate the incident-free doses to MEIs and to develop impact estimates for use in the accident consequence assessment. This code was developed for DOE's Office of Civilian Radioactive Waste Management to analyze the exposure of individuals during incident-free transportation. It also allows for a detailed assessment of the consequences for individuals and population subgroups of severe transportation accidents in various environmental settings.

RISKIND calculations supplemented the collective risk results achieved with RADTRAN 4; they addressed areas of specific concern to individuals and population subgroups. Essentially, the RISKIND analyses answered the "what if" questions, such as, "What if I live next to a site access road?" or "What if an accident happens near my town?"

Radiological doses, expressed in units of rem, were multiplied by the ICRP 60 (ICRP 1991) conversion factors and the estimated numbers of shipments to produce risk estimates in units of latent cancer fatalities. The vehicle emission risk factors were calculated in terms of latent fatalities; the vehicle accident risk factors, in fatalities. The nonradiological risk factors were multiplied by the number of shipments.

For each alternative, risks of both incident-free and accident conditions were assessed. For the incident-free assessment, risks were calculated for "collective populations" of potentially exposed individuals and for MEIs. (The collective population risk is a measure of the radiological risk posed to society as a whole by the

Table F-12. Impact Assessment Protocol for Transportation

Risk	Required Data		Measure of Impact
	Affected Environment	Facility Design	
Incident-free transportation			
Radiation dose to crew		Origin and destination of shipments Characterization of vehicles and material shipped	Dose and latent cancer fatalities to crew
Radiation dose to public	Population within 0.8 km (0.5 mi) of route	Origin and destination of shipments	Dose and latent cancer fatalities to public
On-link	Number of persons using a highway	Characterization of vehicles and material shipped	
Off-link			
During stops	Traffic conditions along route		
Maximally exposed crew member		Origin and destination of shipments Characterization of vehicles and material shipped Location of workers	Radiation doses compared with 10 CFR 20 limits (2 mrem/hr and 100 mrem/yr)
Maximally exposed member of public		Origin and destination of shipments Characterization of vehicles and material shipped	Radiation doses compared with 10 CFR 20 limits (2 mrem/hr and 100 mrem/yr)
Health risks from vehicle emissions		Origin and destination of shipments Characterization of vehicles	Fatalities
Transportation accidents			
Radiological risk to public	Population within 80 km (50 mi) of route	Origin and destination of shipments Characterization of vehicles and material shipped	Doses and latent cancer fatalities
Nonradiological risk to public (nonradiological)	Traffic conditions along route	Origin and destination of shipments	Fatalities
Maximally exposed individual		Origin and destination of shipments Characterization of vehicles and material shipped	Doses and latent cancer fatalities

Key: CFR, Code of Federal Regulations.

alternative being considered. It was the primary means of comparing the various alternatives.) The accident assessment had two components: (1) a probabilistic risk assessment, which addressed the probabilities and consequences of a range of possible transportation accident environments, including low-probability accidents with high consequences and high-probability accidents with low consequences; and (2) an accident consequence assessment, which concerned only the consequences of the most severe transportation accidents postulated.

F.13 ENVIRONMENTAL JUSTICE

F.13.1 Description of Affected Resources

Constituting the affected environment are the low-income and minority populations residing in the potentially affected area. For the analysis of environmental justice relative to incident-free transportation, that area was defined as a corridor 1.6 km (1 mi) wide centered on rail or truck routes. For analyses pertaining to transportation accidents and evaluations of environmental justice in facility environs, it consisted of the geographical area within an 80 km (50 mi) distance of the accident site or facility.

Minority populations were split among four groups: Asians, Blacks, Hispanics, and Native Americans. The population group designated as Hispanic includes all persons who identified themselves as having Hispanic origins, regardless of race. For example, a person self-identified as Asian and of Hispanic origin was included among Hispanics. Persons self-identified as Asian and not of Hispanic origin were included in the Asian population.

Block group spatial resolution was used throughout the analysis (see Table F-13). The Census Bureau defines block group to include 250–500 housing units with 400 being typical. The minority population residing in the affected area was determined from data contained in Table P12 of Standard Tape File 3A published by the Census Bureau (DOC 1992). Low-income populations were estimated from data in Table P121 (DOC 1992:B-28, B-29), which provides statistical data characterizing income status relative to the poverty threshold for each block group.

F.13.2 Description of Impact Assessment

Formal requirements for inclusion of environmental justice concerns in environmental documentation were initiated by Executive Order 12898, *Federal Actions to Address Environmental Justice in Minority Populations and Low Income Populations*, issued in February 1994. The Council on Environmental Quality has oversight responsibility for implementation of the Executive order in documentation prepared under the provisions of NEPA. The Council issued draft guidance for environmental justice in May 1996 (CEQ 1997). These guidelines provide the foundation for evaluation of environmental justice in the SPD EIS.

Analysis of environmental justice for the SPD EIS focused on the “block group,” one of the geographical aggregations of demographic data typically provided by the Census Bureau (DOC 1992). Block groups provide the finest spatial resolution available for evaluation of low-income populations. It is rare, however, that the boundaries of block groups coincide with those of affected areas. Uniform population distribution within block groups is also uncommon. Such uniformity was assumed, however, for purposes of SPD EIS population estimates. Thus, for each block group, the percentage of the population included in the population count equaled the percentage of the geographical area of the block group that lay within the affected area. An upper bound for the potentially affected population was obtained by including the total population of partially included block groups in the population count; a lower bound, by excluding the total population of such block groups from the count.

The following definitions were used in the evaluation:

- **Minority individuals:** Persons who are members of any of the following population groups: Asian or Pacific Islander, Black, Hispanic, or Native Americans (American Indian, Eskimo, or Aleut). This definition includes all persons except those self-designated as not of Hispanic origin and as either White or “Other Race” (one of the classifications used by the Census Bureau in the 1990 census).

Table F-13. Impact Assessment Protocol for Environmental Justice

Resource	Required Data		Measure of Impact
	Affected Environment	Health Effects	
Minority population	Minority population data at block group spatial resolution from Table P12 of STF3A (DOC 1992)		Disproportionately high annual population dose to minority population (CEQ 1997:app. A)
	Distribution within 80 km (50 mi) of each candidate site	Population dose for sectors within 80-km (50-mi) radius of candidate site	
	Distribution within 1.6 km (1 mi) of transportation corridors	Population dose for areas within 1.6-km (1-mi) radius of transportation corridor	
Low-income population	Low-income population data at block group spatial resolution from Table P121 of STF3A (DOC 1992)		Disproportionately high annual population dose to low-income population (CEQ 1997:app. A)
	Distribution within 80 km (50 mi) of each candidate site	Population dose for sectors within 80-km (50-mi) radius of candidate site	
	Distribution within 1.6 km (1 mi) of transportation corridor	Population dose for areas within 1.6-km (1-mi) radius of transportation corridor	

Key: CEQ, Council on Environmental Quality; DOC, U.S. Department of Commerce; STF, Standard Tape File.

- **Minority population:** The total number of minority individuals residing within a potentially affected area.
- **Low-income individuals:** All persons whose self-reported income is below the poverty threshold as adopted by the Census Bureau (DOC 1992:app. B, B-28).
- **Low-income population:** The total number of low-income individuals residing within a potentially affected area.

If the analysis of health or other environmental effects showed that the actions consistent with the proposed alternatives would have significant impacts on the general population, then additional analysis of impacts on the minority and low-income populations was conducted. The analysis method was identical to that described for the evaluation of radiological impacts on the general population. Given the impracticality of extrapolating block level population and income data, minority and low-income populations within each block group were assumed to increase in direct proportion to the increase in general population from the year 1990 to the year of interest.

F.14 CUMULATIVE IMPACTS

Cumulative impacts can result from individually minor but collectively significant actions taking place over a period of time (40 CFR 1508.7). The cumulative impact analysis for the SPD EIS involved combining the impacts of the SPD EIS alternatives (including No Action) with the impacts of other past, present, and reasonably foreseeable activities.

[Text deleted.]

In general, cumulative impacts were calculated by adding the values for the baseline,³ the maximum impacts from the proposed activities at the candidate sites, and other future actions. This cumulative value was then weighed against the appropriate impact indicators to determine the potential for impact. Table F-14 shows the selected indicators of cumulative impacts evaluated in the SPD EIS. The analysis focused on the potential for cumulative impacts at each candidate site from DOE actions under detailed consideration at the time of the SPD EIS (see Table F-15). Non-DOE actions were also considered where information was readily available. Public documents prepared by agencies of Federal, State, and local government were the primary sources of information for the non-DOE actions.

Table F-14. Selected Indicators of Cumulative Impact

Category	Indicator
Resource use	Land occupied
	Electricity use
	Water use
	Workers required
[Text deleted.]	
Air quality	Percent of NAAQS for criteria pollutants
Human health	Offsite population
	MEI dose
	Total dose
	Latent cancer fatalities
	Workers
	Average dose
Waste generation	Total dose
	Latent cancer fatalities
	Site waste generation rate versus capacity
	TRU waste
	LLW
	Mixed LLW
Transportation	Hazardous waste
	Nonhazardous waste
	Number of offsite trips
	MEI dose
	Risk of latent cancer fatality

Key: LLW, low-level waste; MEI, maximally exposed individual; NAAQS, National Ambient Air Quality Standards; TRU, transuranic.

It is assumed that construction impacts would not be cumulative because such construction is typically of short duration and construction impacts are generally temporary. However, waste created during construction as well as any radiation doses received by construction workers have been added to the cumulative totals for all

³ The conditions attributable to actions, past and present, by DOE and other public and private entities.

Table F–15. Other Past, Present, and Reasonably Foreseeable Actions Considered in the Cumulative Impact Assessment for Candidate DOE Sites

Activities	Hanford	INEEL	Pantex	SRS	LLNL	LANL	ORNL
Storage and Disposition of Weapons-Usable Fissile Materials	X	X	X	X			X
Disposition of Surplus Highly Enriched Uranium				X			X
Interim Management of Nuclear Materials at SRS				X			
[Text deleted.]							
Tritium Supply and Recycling				X			
Waste Management	X	X	X	X		X	X
Spent Nuclear Fuel Management and INEL Environmental Restoration and Waste Management	X	X		X			
Foreign Research Reactor Spent Nuclear Fuel	X	X		X			
Tank Waste Remediation System	X						
Shutdown of the River Water System at SRS				X			
Radioactive releases from nuclear power plant sites, Vogtle and WNP	X			X			
Hanford Reach of the Columbia River Comprehensive River Conservation Study	X						
FEIS and Environmental Information Report for Continued Operation of LLNL and SNL					X		
Continued Operation of the Pantex Plant and Associated Storage of Nuclear Weapons Components			X				
Stockpile Stewardship and Management			X	X	X		X
[Text deleted.]							
Management of Plutonium Residues and Scrub Alloy at Rocky Flats				X			
Spent Nuclear Fuel Management (SRS)				X			
DWPF Final Supplemental				X			
Supplemental EIS for In-Tank Precipitation Process Alternatives				X			
Construction and Operation of a Tritium Extraction Facility at SRS				X			
Supplement Analysis for Storing Plutonium in the Actinide Packaging and Storage Facility and Building 105–K at SRS				X			
Los Alamos Site-Wide EIS						X	
Hanford Remedial Action and Comprehensive Land Use Plan	X						
Advanced Mixed Waste Treatment Project		X					
Construction and Operation of the Spallation Neutron Source							X
Long-Term Management and Use of Depleted Uranium Hexafluoride							X

Key: DWPF, Defense Waste Processing Facility; LANL, Los Alamos National Laboratory; LLNL, Lawrence Livermore National Laboratory; ORNL, Oak Ridge National Laboratory; SNL, Sandia National Laboratories; WNP, Washington Nuclear Power.

proposed surplus plutonium disposition activities. D&D of the proposed facilities was not addressed in the cumulative impact estimates. Given the uncertainty regarding the timing of D&D, any impact estimate at this time would be highly speculative. A detailed evaluation of D&D will be provided in follow-on NEPA documentation closer to the actual time of those actions.

Recent sitewide NEPA documents (see Table F-16) provide the latest comprehensive evaluation of cumulative impacts for the sites.

Table F-16. Recent Comprehensive National Environmental Policy Act Documents for the DOE Sites

Site	Document	Year	ROD Issued ^a
Hanford	<i>Tank Waste Remediation System, Hanford Site, Richland, Washington, Final Environmental Impact Statement</i>	1996	February 1997
INEEL	<i>DOE Programmatic Spent Nuclear Fuel Management and Idaho National Engineering Laboratory Environmental Restoration and Waste Management Programs Final Environmental Impact Statement</i>	1995	March 1996
Pantex	<i>Final Environmental Impact Statement for the Continued Operation of the Pantex Plant and Associated Storage of Nuclear Weapon Components</i>	1996	January 1997
SRS	<i>Savannah River Site Waste Management Final Environmental Impact Statement</i>	1995	October 1995
LLNL	<i>Final Site-Wide Environmental Impact Statement for Continued Operation of the Lawrence Livermore National Laboratory</i>	1992	January 1993
LANL	<i>Final Site-Wide Environmental Impact Statement for Continued Operation of the Los Alamos National Laboratory</i>	1999	Pending

^a Date of the first ROD issued.

Key: ROD, Record of Decision.

F.15 REFERENCES

CEQ (Council on Environmental Quality), 1997, *Environmental Justice, Guidance Under the National Environmental Policy Act*, Executive Office of the President, Washington, DC, December 10.

DOC (U.S. Department of Commerce), 1992, *Census of Population and Housing, 1990: Summary Tape File 3 on CD-ROM*, Bureau of the Census, May.

DOE (U.S. Department of Energy), 1996a, *Storage and Disposition of Weapons-Usable Fissile Materials Final Programmatic Environmental Impact Statement*, DOE/EIS-0229, Office of Fissile Materials Disposition, Washington, DC, December.

DOE (U.S. Department of Energy), 1996b, *Final Environmental Impact Statement for the Continued Operation of the Pantex Plant and Associated Storage of Nuclear Weapon Components*, DOE/EIS-0225, Albuquerque Operations Office, Albuquerque, NM, November.

DOE (U.S. Department of Energy), 1997a, *Final Waste Management Programmatic Environmental Impact Statement for Managing Treatment, Storage, and Disposal of Radioactive and Hazardous Waste*, DOE/EIS-0200-F, Office of Environmental Management, Washington, DC, May.

DOE (U.S. Department of Energy), 1997b, *Waste Isolation Pilot Plant Disposal Phase Final Supplemental Environmental Impact Statement*, DOE/EIS-0026-S-2, Carlsbad Area Office, Carlsbad, NM, September.

DOE (U.S. Department of Energy), 1997c, *The National TRU Waste Management Plan*, rev. 1, DOE/NTP-96-1204, Carlsbad Area Office, Carlsbad, NM, December.

| DOE (U.S. Department of Energy), 1999, *MOX Fuel Fabrication Facility and Nuclear Power Reactor Data Report*, MD-0015, Office of Fissile Materials Disposition, Washington, DC, August.

| DOI (U.S. Department of the Interior), 1986a, *Visual Resource Inventory*, BLM Manual Handbook H-8410-1, Bureau of Land Management, Washington, DC, January 17.

| DOI (U.S. Department of the Interior), 1986b, *Visual Resource Contrast Rating*, BLM Manual Handbook H-8431-1, Bureau of Land Management, Washington, DC, January 17.

EPA (U.S. Environmental Protection Agency), 1991, *Compilation of Air Pollutant Emission Factors: Mobile Sources*, 4th ed., vol. II, AP-42, supp. A, Office of Mobile Source Air Pollution Control, Ann Arbor, MI, January.

EPA (U.S. Environmental Protection Agency), 1993, *Determining Conformity of General Federal Actions to State or Federal Implementation Plans*, 58 FR 63214, Office of the Federal Register, Washington, DC, November 30.

EPA (U.S. Environmental Protection Agency), 1996a, *Compilation of Air Pollutant Emission Factors: Stationary Point and Area Sources*, 5th ed., vol. I, AP-42, supp. B, Office of Air Quality Planning and Standards, Office of Air and Radiation, Research Triangle Park, NC, November.

EPA (U.S. Environmental Protection Agency), 1996b, *40 CFR Parts 51 and 52, Requirements for Preparation, Adoption, and Submittal of Implementation Plans*, final rule, 61 FR 41838–41894, Office of the Federal Register, Washington, DC, August 12.

EPA (U.S. Environmental Protection Agency), 1997a, *National Primary and Secondary Ambient Air Quality Standards*, 40 CFR 50, March 31.

EPA (U.S. Environmental Protection Agency), 1997b, *National Emission Standards for Hazardous Air Pollutants*, “Subpart M–National Emission Standard for Asbestos, Standard for Waste Disposal for Manufacturing, Fabricating, Demolition, Renovation, and Spraying Operations,” 40 CFR 61.150, July 1.

EPA (U.S. Environmental Protection Agency), 1997c, *National Emission Standards for Hazardous Air Pollutants*, “Subpart Y–National Emission Standard for Benzene Emissions from Benzene Storage Vessels,” 40 CFR 61.270 and 61.276, July 1.

EPA (U.S. Environmental Protection Agency), 1997d, *Requirements for Preparation, Adoption, and Submittal of Implementation Plans*, “Permit Requirements,” 40 CFR 51.165.

EPA (U.S. Environmental Protection Agency), 1997e, *Guideline on Air Quality Models (Revised)*, 40 CFR 51, app. W, July 1.

EPA (U.S. Environmental Protection Agency), 1997f, *Recent Trends in U.S. Greenhouse Gas Emissions*, www.epa.gov/globalwarming/inventory/trends.html, November 19.

EPA (U.S. Environmental Protection Agency), 1997g, *Integrated Risk Information System, Benzene*, CASRN 71-43-2, Substance File No. 0276, online version, April 1.

ICRP (International Commission on Radiological Protection), 1991, *1990 Recommendations of the International Commission on Radiological Protection*, ICRP Publication 60, Elmsford, NY.

Neuhauser, K.S., and F.L. Kanipe, 1995, *RADTRAN 4, Volume II: Technical Manual*, SAND89-2370, Sandia National Laboratories, Albuquerque, NM, March.

NRC (U.S. Nuclear Regulatory Commission), 1977, *Calculation of Annual Doses to Man From Routine Releases of Reactor Effluents for the Purpose of Evaluating Compliance With 10 CFR 50, Appendix I*, Regulatory Guide 1.109, Office of Standards Development, Washington, DC, October.

UC (Regents of the University of California), 1998a, *Response to the Surplus Plutonium Disposition Environmental Impact Statement Data Call for a Mixed Oxide Fuel Fabrication Facility Located at the Hanford Site*, rev. 3, LA-UR-97-2064, Los Alamos National Laboratory, Los Alamos, NM, June 22.

UC (Regents of the University of California), 1998b, *Response to the Surplus Plutonium Disposition Environmental Impact Statement Data Call for a Mixed Oxide Fuel Fabrication Facility Located at the Idaho National Engineering and Environmental Laboratory*, rev. 3, LA-UR-97-2065, Los Alamos National Laboratory, Los Alamos, NM, June 22.

UC (Regents of the University of California), 1998c, *Response to the Surplus Plutonium Disposition Environmental Impact Statement Data Call for a Mixed Oxide Fuel Fabrication Facility Located at the Pantex Plant*, rev. 3, LA-UR-97-2067, Los Alamos National Laboratory, Los Alamos, NM, June 22.

UC (Regents of the University of California), 1998d, *Response to the Surplus Plutonium Disposition Environmental Impact Statement Data Call for a Mixed Oxide Fuel Fabrication Facility Located at the Savannah River Site*, rev. 3, LA-UR-97-2066, Los Alamos National Laboratory, Los Alamos, NM, June 22.

Yuan, Y.C., S.Y. Chen, B.M. Riwer, and D.J. LePoire, 1995, *RISKIND—A Computer Program for Calculating Radiological Consequences and Health Risks from Transportation of Spent Nuclear Fuel*, ANL/EAD-1, Argonne National Laboratory, Argonne, IL, November.

Appendix G Air Quality

This appendix presents detailed information that support the air quality impact assessments in Chapter 4. Data are provided for the four candidate U.S. Department of Energy sites: the Hanford Site (Hanford), Idaho National Engineering and Environmental Laboratory (INEEL), the Pantex Plant (Pantex), and the Savannah River Site (SRS).

G.1 HANFORD

G.1.1 Assessment Data

Emission rates for criteria, hazardous, and toxic air pollutants at Hanford are presented in Table F.1.2.2–1 of the *Storage and Disposition of Weapons-Usable Fissile Materials Final Programmatic Environmental Impact Statement (Storage and Disposition PEIS)* (DOE 1996a:F-6). These emission rates were used as input into the modeled No Action Alternative pollutant concentrations presented in that environmental impact statement (EIS) and reflect projected Hanford facility emissions for 2005. The storage alternative selected for Hanford results in no change in these concentrations (DOE 1996a:4-34). In addition to the concentrations projected for 2005, the concentrations for the Phased Implementation Alternative—Phase II Operation of the vitrification facilities presented in the *Tank Waste Remediation System Final EIS* (DOE 1996b:5-68) were included in the estimate of the No Action concentration for surplus plutonium disposition as shown in Table G–1. Other onsite activities related to programs analyzed in EISs for spent nuclear fuel and waste management are also included. Other activities at Hanford that may occur during the time period 2005–2015 are discussed in the cumulative impacts section. Radiological impacts, including those from emissions to the air, are discussed in Appendix J.

Table G–1. Estimated Concentrations ($\mu\text{g}/\text{m}^3$) From No Action at Hanford

Pollutant	Averaging Period	PEIS Estimated Base Year (2005)	Tank Waste Remediation	Other Onsite From PEIS	No Action
Carbon monoxide	8 hours	0.08	34	0	34.1
	1 hour	0.30	48	0	48.3
Nitrogen dioxide	Annual	0.03	0.12	0.1	0.25
	24 hours	<0.01	0.0079	0	0.0179
Sulfur dioxide	Annual	0.02	0.75	0	0.77
	24 hours	<0.01	0.02	1.6	1.63
Total suspended particulates	24 hours	<0.01	1.6	7.3	8.91
	3 hours	0.01	3.6	26	29.6
	1 hour	0.02	4.0	29	32.9
Benzene	Annual	<0.01	0.0079	0	0.0179
	24 hours	<0.02	0.75	0	0.77
Benzene	Annual	(a)	0.000006	0	0.000006
[Text deleted.]					

^a No sources of this pollutant have been identified at the site.

Key: PEIS, *Storage and Disposition PEIS*.

Source: DOE 1996a:4-34, 4-912; 1996b:5-68.

G.1.2 Facilities

G.1.2.1 Pit Conversion Facility

G.1.2.1.1 Construction of Pit Conversion Facility

Potential air quality impacts from modification of the Fuels and Materials Examination Facility (FMEF) and construction of support facilities for pit disassembly and conversion at Hanford were analyzed using the Industrial Source Complex Model, Short-Term, Version 3 (ISCST3) as described in Appendix F.1. Construction impacts result from emissions from diesel fuel-burning construction equipment, particulate matter emissions from soil disturbance by construction equipment and other vehicles (construction fugitive emissions), operation of a concrete batch plant, employee vehicles, and trucks moving materials and wastes. Emissions from these sources are summarized in Table G-2.

Table G-2. Emissions (kg/yr) From Construction of Pit Conversion Facility in FMEF at Hanford

Pollutant	Diesel Equipment and Construction Fugitive	
	Emissions	Vehicles
Carbon monoxide	1,000	11,300
Nitrogen dioxide	2,400	3,040
PM ₁₀	3,500	10,300
Sulfur dioxide	160	0
Volatile organic compounds	200	1,400
Total suspended particulates	9,300	10,300

Key: FMEF, Fuels and Materials Examination Facility.
Source: UC 1998a.

Maximum air pollutant concentrations from construction activities are summarized in Table G-3.

Table G–3. Concentrations ($\mu\text{g}/\text{m}^3$) From Construction of Pit Conversion Facility in FMEF at Hanford

Pollutant	Averaging Period	Most Stringent			
		Standard or Guideline ^a	No Action	Contribution	Total
Carbon monoxide	8 hours	10,000	34.1	0.277	34.4
	1 hour	40,000	48.3	1.88	50.2
Nitrogen dioxide	Annual	100	0.25	0.0199	0.27
PM ₁₀	Annual	50	0.0179	0.029	0.047
	24 hours	150	0.77	0.323	1.09
Sulfur dioxide	Annual	50	1.63	0.00133	1.63
	24 hours	260	8.91	0.0148	8.93
	3 hours	1,300	29.6	0.1	29.7
	1 hour	660 ^b	32.9	0.301	33.2
Total suspended particulates	Annual	60	0.0179	0.0771	0.095
	24 hours	150	0.77	0.857	1.63

^a The more stringent of the Federal and State standards is presented if both exist for the averaging period.

^b At Hanford, the level is not to be exceeded more than twice in any 7 consecutive days.

Key: FMEF, Fuels and Materials Examination Facility.

Source: EPA 1997; WDEC 1994.

G.1.2.1.2 Operation of Pit Conversion Facility

Potential air quality impacts from operation of the pit conversion and support facilities at Hanford were analyzed using ISCST3 as described in Appendix F.1. Operational impacts result from emissions from emergency diesel generators, process emissions, employee vehicles, and trucks moving materials and wastes. Emissions from these sources are summarized in Table G–4. Emergency generators were modeled as a volume source. The process stack for radiological emissions was modeled with a 36 m (118 ft) height, 3.88 m (12.7 ft) diameter, stack exit temperature of 20 °C (68 °F), and an exit velocity of 3.3 m/s (10.8 ft/s). There was no boiler modeled because heating requirements would be met using electric power (UC 1998a).

Table G–4. Emissions (kg/yr) From Operation of Pit Conversion Facility in FMEF at Hanford

Pollutant	Emergency		
	Generator	Process	Vehicles
Carbon monoxide	520	0	41,800
Nitrogen dioxide	2,000	0	11,200
PM ₁₀	50	0	38,100
Sulfur dioxide	34	0	0
Volatile organic compounds	58	0	5,150
Total suspended particulates	50	0	38,100

Key: FMEF, Fuels and Materials Examination Facility.

Source: UC 1998a.

Maximum air pollutant concentrations resulting from the emergency diesel generators and process sources, plus the No Action concentrations, are summarized in Table G-5. Radiological impacts, including those from emissions to the air, are discussed in Appendix J.

Table G-5. Concentrations ($\mu\text{g}/\text{m}^3$) From Operation of Pit Conversion Facility in FMEF at Hanford

Pollutant	Averaging Period	Most Stringent	No Action	Contribution	Total
		Standard or Guideline ^a			
Carbon monoxide	8 hours	10,000	34.1	0.144	34.2
	1 hour	40,000	48.3	0.978	49.3
Nitrogen dioxide	Annual	100	0.25	0.0166	0.267
PM ₁₀	Annual	50	0.0179	0.000415	0.0183
	24 hours	150	0.77	0.00461	0.775
Sulfur dioxide	Annual	50	1.63	0.000282	1.63
	24 hours	260	8.91	0.00313	8.91
	3 hours	1,300	29.6	0.0213	29.6
	1 hour	660 ^b	32.9	0.064	33.0
Total suspended particulates	Annual	60	0.0179	0.000415	0.0183
	24 hours	150	0.77	0.00461	0.775

^a The more stringent of the Federal and State standards is presented if both exist for the averaging period.

^b At Hanford, the level is not to be exceeded more than twice in any 7 consecutive days.

Key: FMEF, Fuels and Materials Examination Facility.

Source: EPA 1997; WDEC 1994.

G.1.2.2 Immobilization Facility

G.1.2.2.1 Construction of Immobilization Facility

Potential air quality impacts from modification of FMEF and construction of support facilities for plutonium conversion and immobilization (ceramic or glass) at Hanford were analyzed using ISCST3 as described in Appendix F.1. Construction impacts result from emissions from diesel fuel-burning construction equipment, particulate matter emissions from soil disturbance by construction equipment and other vehicles (construction fugitive emissions), operation of a concrete batch plant, employee vehicles, and trucks moving materials and wastes. Emissions from these sources are summarized in Table G-6.

Table G–6. Emissions (kg/yr) From Construction of Immobilization Facility in FMEF at Hanford

Pollutant	Diesel	Construction	Concrete	Vehicles
	Equipment	Fugitive Emissions ^a	Batch Plant	
Carbon monoxide	1,170	0	0	39,900
Nitrogen dioxide	3,010	0	0	10,700
PM ₁₀	230 ^b	193 ^b	65 ^b	36,400
Sulfur dioxide	310	0	0	0
Volatile organic compounds	240	0	0	4,920
Total suspended particulates	230	193	65	36,400

^a Does not include fugitive emissions from the concrete batch plant.

^b PM₁₀ emissions were assumed to be the same as total suspended particulate emissions for the purpose of this analysis resulting in some overestimate of PM₁₀ concentrations.

Key: FMEF, Fuels and Materials Examination Facility.

Source: UC 1999a, 1999b.

Maximum air pollutant concentrations from construction activities are summarized in Table G–7.

Table G–7. Concentrations ($\mu\text{g}/\text{m}^3$) From Construction of Immobilization Facility in FMEF at Hanford

Pollutant	Averaging Period	Most Stringent Standard or Guideline ^a			Total
		No Action	Ceramic or Glass		
Carbon monoxide	8 hours	10,000	34.1	0.324	34.4
	1 hour	40,000	48.3	2.2	50.5
Nitrogen dioxide	Annual	100	0.25	0.025	0.275
	PM ₁₀	50	0.0179	0.00405	0.022
Sulfur dioxide	24 hours	150	0.77	0.158	0.928
	Annual	50	1.63	0.00257	1.63
Total suspended particulates	24 hours	260	8.91	0.0286	8.94
	3 hours	1,300	29.6	0.194	29.8
	1 hour	660 ^b	32.9	0.583	33.5
Total suspended particulates	Annual	60	0.0179	0.00405	0.022
	24 hours	150	0.77	0.158	0.928

^a The more stringent of the Federal and State standards is presented if both exist for the averaging period.

^b At Hanford, the level is not to be exceeded more than twice in any 7 consecutive days.

Key: FMEF, Fuels and Materials Examination Facility.

Source: EPA 1997; WDEC 1994.

G.1.2.2.2 Operation of Immobilization Facility

Potential air quality impacts from operation of immobilization (ceramic or glass) and support facilities at Hanford were analyzed using ISCST3 as described in Appendix F.1. Operational impacts result from emissions from emergency diesel generators, process emissions, employee vehicles, and trucks moving materials and wastes. Emissions from these sources are summarized in Table G–8. Emergency generators were modeled as a volume source. The process stack for radiological emissions was modeled with a 35.6 m (116.8 ft) height, 3.88 m (12.7 ft) diameter, stack exit temperature of 20 °C (68 °F), and an exit velocity of 3.3 m/s (10.8 ft/s). There was no boiler modeled because heating requirements would be met using electric power (UC 1999a, 1999b).

Table G–8. Emissions (kg/yr) From Operation of Immobilization Facility in FMEF at Hanford

Pollutant	Emergency Generator	Ceramic or Glass Process	Vehicles
Carbon monoxide	980	0	46,400
Nitrogen dioxide	4,530	0	12,500
PM ₁₀	320	0	42,400
Sulfur dioxide	300	0	0
Volatile organic compounds	370	0	5,720
Total suspended particulates	320	0	42,400

Key: FMEF, Fuels and Materials Examination Facility.

Source: UC 1999a, 1999b.

Maximum air pollutant concentrations resulting from the emergency diesel generators and process sources, plus the No Action concentrations, are summarized in Table G–9. Radiological impacts, including those from emissions to the air, are discussed in Appendix J.

Table G–9. Concentrations ($\mu\text{g}/\text{m}^3$) From Operation of Immobilization Facility in FMEF at Hanford

Pollutant	Averaging Period	Most Stringent			Total
		Standard or Guideline ^a	No Action	Ceramic or Glass	
Carbon monoxide	8 hours	10,000	34.1	0.271	34.4
	1 hour	40,000	48.3	1.84	50.1
Nitrogen dioxide	Annual	100	0.25	0.0376	0.288
	PM ₁₀	50	0.0179	0.00265	0.021
Sulfur dioxide	24 hours	150	0.77	0.0295	0.799
	Annual	50	1.63	0.00249	1.63
Sulfur dioxide	24 hours	260	8.91	0.0277	8.94
	3 hours	1,300	29.6	0.188	29.8
	1 hour	660 ^b	32.9	0.564	33.5
Total suspended particulates	Annual	60	0.0179	0.00265	0.021
	24 hours	150	0.77	0.0295	0.799

^a The more stringent of the Federal and State standards is presented if both exist for the averaging period.

^b At Hanford, the level is not to be exceeded more than twice in any 7 consecutive days.

Key: FMEF, Fuels and Materials Examination Facility.

Source: EPA 1997; WDEC 1994.

G.1.2.3 MOX Facility

G.1.2.3.1 Construction of MOX Facility

Potential air quality impacts from construction of new mixed oxide (MOX) and support facilities at Hanford were analyzed using ISCST3 as described in Appendix F.1. Construction impacts result from emissions from diesel fuel-burning construction equipment, particulate matter emissions from soil disturbance by construction equipment and other vehicles (construction fugitive emissions), operation of a concrete batch plant, employee vehicles, and trucks moving materials and wastes. Emissions from these sources are summarized in Table G–10.

Table G–10. Emissions (kg/yr) From Construction of New MOX Facility at Hanford

Pollutant	Diesel	Construction	Concrete Batch	
	Equipment	Fugitive Emissions ^a	Plant	Vehicles
Carbon monoxide	3,840	0	0	37,600
Nitrogen dioxide	10,080	0	0	10,100
PM ₁₀	768 ^b	6,880	1,460 ^b	34,400
Sulfur dioxide	1,020	0	0	0
Volatile organic compounds	792	0	0	4,640
Total suspended particulates	768	13,600	1,460	34,400
Toxics ^c	0	<1	0	0

^a Does not include fugitive emissions from the concrete batch plant.

^b PM₁₀ emissions were assumed to be the same as total suspended particulate emissions for the purpose of this analysis, resulting in some overestimate of PM₁₀ concentrations.

^c Various toxic air pollutants (e.g., lead, benzene, hexane) could be emitted during construction.

Source: UC 1998b.

Maximum air pollutant concentrations from construction activities are summarized in Table G–11.

Table G–11. Concentrations ($\mu\text{g}/\text{m}^3$) From Construction of New MOX Facility at Hanford

Pollutant	Most Stringent Standard				
	Averaging Period	or Guideline ^a	No Action	Contribution	Total
Carbon monoxide	8 hours	10,000	34.1	1.06	35.1
	1 hour	40,000	48.3	7.22	55.5
Nitrogen dioxide	Annual	100	0.25	0.0836	0.334
	PM ₁₀	50	0.0179	0.0744	0.092
Sulfur dioxide	24 hours	150	0.77	3.27	4.03
	Annual	50	1.63	0.00846	1.64
	24 hours	260	8.91	0.094	9.
	3 hours	1,300	29.6	0.64	30.3
Total suspended particulates	1 hour	660 ^b	32.9	1.92	34.8
	Annual	60	0.0179	0.132	0.15
Toxics ^c	24 hours	150	0.77	5.88	6.66
	Annual	0.12	0.000006	0.000008	0.000014

^a The more stringent of the Federal and State standards is presented if both exist for the averaging period.

^b At Hanford, the level is not to be exceeded more than twice in any 7 consecutive days.

^c Various toxic air pollutants (e.g., lead, benzene, hexane) may be emitted during construction and were analyzed as benzene.

Source: EPA 1997; WDEC 1994.

G.1.2.3.2 Operation of MOX Facility

Potential air quality impacts from operation of the new MOX and support facilities at Hanford were analyzed using ISCST3 as described in Appendix F.1. Operational impacts result from emissions from emergency diesel generators, process emissions, employee vehicles, and trucks moving materials and wastes. Emissions from these sources are summarized in Table G–12. Emergency generators were modeled as a volume source. The process stack for radiological emissions was modeled with a 35.6 m (116.8 ft) height, 0.3048 m (1.0 ft) diameter, stack exit temperature of 20 °C (68 °F), and an exit velocity of 0.03 m/s (0.1 ft/s). There was no boiler modeled because heating requirements would be met using electric power (UC 1998b).

Table G–12. Emissions (kg/yr) From Operation of New MOX Facility at Hanford

Pollutant	Emergency		
	Generator	Process	Vehicles
Carbon monoxide	374	0	34,200
Nitrogen dioxide	1,738	0	9,170
PM ₁₀	122	0	31,200
Sulfur dioxide	114	0	0
Volatile organic compounds	142	0	4,210
Total suspended particulates	122	0	31,200
[Text deleted.]			
[Text deleted.]			

Source: UC 1998b.

Maximum air pollutant concentrations resulting from the emergency diesel generators and process sources, plus the No Action concentrations, are summarized in Table G–13. Radiological impacts, including those from emissions to the air, are discussed in Appendix J.

Table G–13. Concentrations (μg/m³) From Operation of New MOX Facility at Hanford

Pollutant	Averaging Period	Most Stringent		No Action	Contribution	Total
		Standard or Guideline ^a				
Carbon monoxide	8 hours	10,000		34.1	0.103	34.2
	1 hour	40,000		48.3	0.704	49.0
Nitrogen dioxide	Annual	100		0.25	0.0144	0.264
	PM ₁₀	50		0.0179	0.00101	0.0189
Sulfur dioxide	24 hours	150		0.77	0.0113	0.781
	Annual	50		1.63	0.000946	1.63
	24 hours	260		8.91	0.0105	8.92
	3 hours	1,300		29.6	0.0715	29.7
Total suspended particulates	1 hour	660 ^b		32.9	0.214	33.1
	Annual	60		0.0179	0.00101	0.0189
	24 hours	150		0.77	0.0113	0.781
[Text deleted.]						

^a The more stringent of the Federal and State standards is presented if both exist for the averaging period.

^b At Hanford, the level is not to be exceeded more than twice in any 7 consecutive days.

[Text deleted.]

Source: EPA 1997; WDEC 1994.

G.1.2.4 Pit Conversion and Immobilization Facilities

G.1.2.4.1 Construction of Pit Conversion and Immobilization Facilities

Potential air quality impacts from modification of FMEF and construction of support facilities for pit disassembly and conversion and plutonium conversion and immobilization (ceramic or glass) at Hanford were analyzed using ISCST3 as described in Appendix F.1. Construction impacts result from emissions from diesel fuel-burning construction equipment, particulate matter emissions from soil disturbance by construction

equipment and other vehicles (construction fugitive emissions), operation of a concrete batch plant, employee vehicles, and trucks moving materials and wastes. Emissions from these sources are summarized in Table G-14.

Table G-14. Emissions (kg/yr) From Construction of Pit Conversion and Immobilization Facilities in FMEF at Hanford

Pollutant	Pit Conversion		Immobilization			
	Diesel Equipment and Construction Fugitive Emissions	Vehicles	Diesel Equipment	Construction Fugitive Emissions ^a	Concrete Batch Plant	Vehicles
Carbon monoxide	1,000	11,300	3,060	0	0	40,000
Nitrogen dioxide	2,400	3,040	7,890	0	0	10,700
PM ₁₀	3,500	10,300	600 ^b	6,770	560 ^b	36,500
Sulfur dioxide	160	0	800	0	0	0
Volatile organic compounds	200	1,400	620	0	0	4,930
Total suspended particulates	9,300	10,300	600	13,100	560	36,500

^a Does not include fugitive emissions from the concrete batch plant.

^b PM₁₀ emissions were assumed to be the same as total suspended particulate emissions for the purpose of this analysis resulting in some overestimate of PM₁₀ concentrations.

Key: FMEF, Fuels and Materials Examination Facility.

Source: UC 1998a, 1999a, 1999b.

Maximum air pollutant concentrations from construction activities are summarized in Table G-15.

Table G-15. Concentrations ($\mu\text{g}/\text{m}^3$) From Construction of Pit Conversion and Immobilization Facilities in FMEF at Hanford

Pollutant	Averaging Period	Most Stringent		Pit Conversion	Immobilization (Ceramic or Glass)	Total
		Standard or Guideline ^a	No Action			
Carbon monoxide	8 hours	10,000	34.1	0.277	0.846	35.2
	1 hour	40,000	48.3	1.88	5.76	55.9
Nitrogen dioxide	Annual	100	0.25	0.0199	0.0654	0.335
	24 hours	150	0.77	0.323	2.96	4.05
Sulfur dioxide	Annual	50	1.63	0.00133	0.00664	1.64
	24 hours	260	8.91	0.0148	0.0737	9.
[Text deleted.]	3 hours	1,300	29.6	0.1	0.502	30.2
	1 hour	660 ^b	32.9	0.301	1.5	34.7
Total suspended particulates	Annual	60	0.0179	0.0771	0.117	0.212
	24 hours	150	0.77	0.857	5.58	7.21

^a The more stringent of the Federal and State standards is presented if both exist for the averaging period.

^b At Hanford, the level is not to be exceeded more than twice in any 7 consecutive days.

Key: FMEF, Fuels and Materials Examination Facility.

Source: EPA 1997; WDEC 1994.

G.1.2.4.2 Operation of Pit Conversion and Immobilization Facilities

Potential air quality impacts from operation of pit conversion, immobilization (ceramic or glass), and support facilities at Hanford were analyzed using ISCST3 as described in Appendix F.1. Operational impacts result from emissions from emergency diesel generators, process emissions, employee vehicles, and trucks moving materials and wastes. Emissions from these sources are summarized in Table G–16. Stack parameters used for modeling were as stated previously.

Table G–16. Emissions (kg/yr) From Operation of Pit Conversion and Immobilization Facilities in FMEF at Hanford

Pollutant	Pit Conversion			Immobilization		
	Emergency Generator	Process	Vehicles	Emergency Generator	Ceramic or Glass Process	Vehicles ^a
Carbon monoxide	520	0	41,800	1,460	0	57,100
Nitrogen dioxide	2,000	0	11,200	6,790	0	15,300
PM ₁₀	50	0	38,100	480	0	52,100
Sulfur dioxide	34	0	0	450	0	0
Volatile organic compounds	58	0	5,150	550	0	7,040
Total suspended particulates	50	0	38,100	480	0	52,100

^a For 50-t (55-ton) case.

Key: FMEF, Fuels and Materials Examination Facility.

Source: UC 1998a, 1999a, 1999b.

Maximum air pollutant concentrations resulting from the emergency diesel generators and process sources, plus No Action concentrations, are summarized in Table G–17. Radiological impacts, including those from emissions to the air, are discussed in Appendix J.

Table G–17. Concentrations ($\mu\text{g}/\text{m}^3$) From Operation of Pit Conversion and Immobilization Facilities in FMEF at Hanford

Pollutant	Averaging Period	Most Stringent		No Action	Pit Conversion	Immobilization (Ceramic or Glass)	Total ^b
		Standard or Guidelines ^a					
Carbon monoxide	8 hours	10,000	34.1	0.144	0.404	34.6	
	1 hour	40,000	48.3	0.978	2.75	52.	
Nitrogen dioxide	Annual	100	0.25	0.0166	0.0563	0.323	
PM ₁₀	Annual	50	0.0179	0.000415	0.00398	0.0223	
	24 hours	150	0.77	0.00461	0.0443	0.819	
Sulfur dioxide	Annual	50	1.63	0.000282	0.00373	1.63	
	24 hours	260	8.91	0.00313	0.0415	8.95	
	3 hours	1,300	29.6	0.0213	0.282	29.9	
	[Text deleted.] 1 hour	660 ^c	32.9	0.064	0.847	33.8	
Total suspended particulates	Annual	60	0.0179	0.000415	0.00398	0.0223	
	24 hours	150	0.77	0.00461	0.0443	0.819	

^a The more stringent of the Federal and State standards is presented if both exist for the averaging period.

^b The concentrations for ceramic and glass are the same for both 17-t and 50-t cases.

^c At Hanford, the level is not to be exceeded more than twice in any 7 consecutive days.

Key: FMEF, Fuels and Materials Examination Facility.

Source: EPA 1997; WDEC 1994.

G.1.2.5 Pit Conversion and MOX Facilities

G.1.2.5.1 Construction of Pit Conversion and MOX Facilities

Potential air quality impacts from modification of FMEF and construction of support facilities for pit disassembly and conversion and MOX fuel fabrication at Hanford were analyzed using ISCST3 as described in Appendix F.1. Construction impacts result from emissions from diesel fuel-burning construction equipment, particulate matter emissions from disturbance of soil by construction equipment and other vehicles (construction fugitive emissions), operation of a concrete batch plant, employee vehicles, and trucks moving materials and wastes. Emissions from these sources are summarized in Table G–18.

Table G–18. Emissions (kg/yr) From Construction of Pit Conversion and MOX Facilities in FMEF at Hanford

Pollutant	Pit Conversion		MOX			
	Diesel Equipment and Construction Fugitive Emissions	Vehicles	Diesel Equipment	Construction Fugitive Emissions ^a	Concrete Batch Plant	Vehicles
Carbon monoxide	1,000	11,300	778	0	0	37,300
Nitrogen dioxide	2,400	3,040	2,009	0	0	10,000
PM ₁₀	3,500	10,300	154 ^b	2,830	435 ^b	34,100
Sulfur dioxide	160	0	204	0	0	0
Volatile organic compounds	200	1,400	160	0	0	4,600
Total suspended particulates	9,300	10,300	154	5,590	435	34,100
Toxics ^c	0	0	0	<1	0	0

^a Does not include fugitive emissions from the concrete batch plant.

^b PM₁₀ emissions were assumed to be the same as total suspended particulate emissions for the purpose of this analysis resulting in some overestimate of PM₁₀ concentrations.

^c Various toxic air pollutants (e.g., lead, benzene, hexane) could be emitted during construction.

Key: FMEF, Fuels and Materials Examination Facility.

Source: UC 1998a, 1998b.

Maximum air pollutant concentrations from construction activities are summarized in Table G–19.

Table G–19. Concentrations (µg/m³) From Construction of Pit Conversion and MOX Facilities in FMEF at Hanford

Pollutant	Averaging Period	Most Stringent	No Action	Pit Conversion	MOX	Total
		Standard or Guideline ^a				
Carbon monoxide	8 hours	10,000	34.1	0.277	0.215	34.6
	1 hour	40,000	48.3	1.88	1.46	51.6
Nitrogen dioxide	Annual	100	0.25	0.0199	0.0167	0.287
	24 hours	50	0.0179	0.029	0.0274	0.0743
Sulfur dioxide	Annual	150	0.77	0.323	1.32	2.41
	24 hours	50	1.63	0.00133	0.00169	1.63
Total suspended particulates	24 hours	260	8.91	0.0148	0.0188	8.94
	3 hours	1,300	29.6	0.1	0.128	29.8
	[Text deleted.]					
Toxics ^c	1 hour	660 ^b	32.9	0.301	0.384	33.6
	Annual	60	0.0179	0.0771	0.051	0.146
Total suspended particulates	24 hours	150	0.77	0.857	2.4	4.03
	Annual	0.12	0.000006	0	0.000008	0.000014

^a The more stringent of the Federal and State standards is presented if both exist for the averaging period.

^b At Hanford, the level is not to be exceeded more than twice in any 7 consecutive days.

^c Various toxic air pollutants (e.g., lead, benzene, hexane) could be emitted during construction and were analyzed as benzene.

Key: FMEF, Fuels and Materials Examination Facility.

Source: EPA 1997; WDEC 1994.

G.1.2.5.2 Operation of Pit Conversion and MOX Facilities

Potential air quality impacts from operation of pit conversion, MOX, and support facilities at Hanford were analyzed using ISCST3 as described in Appendix F.1. Operational impacts result from emissions from emergency diesel generators, process emissions, employee vehicles, and trucks moving materials and wastes. Emissions from these sources are summarized in Table G–20. Stack parameters used for modeling were as stated previously.

Table G–20. Emissions (kg/yr) From Operation of Pit Conversion and MOX Facilities in FMEF at Hanford

Pollutant	Pit Conversion			MOX		
	Emergency Generator	Process	Vehicles	Emergency Generator	Process	Vehicles
Carbon monoxide	520	0	41,800	374	0	34,200
Nitrogen dioxide	2,000	0	11,200	1,738	0	9,170
PM ₁₀	50	0	38,100	122	0	31,200
Sulfur dioxide	34	0	0	114	0	0
Volatile organic compounds	58	0	5,150	142	0	4,210
Total suspended particulates	50	0	38,100	122	0	31,200
[Text deleted.]						

[Text deleted.]

Key: FMEF, Fuels and Materials Examination Facility.

Source: UC 1998a, 1998b.

Maximum air pollutant concentrations resulting from the emergency diesel generators and process sources, plus the No Action concentrations, are summarized in Table G–21. Radiological impacts, including those from emissions to the air, are discussed in Appendix J.

Table G–21. Concentrations ($\mu\text{g}/\text{m}^3$) From Operation of Pit Conversion and MOX Facilities in FMEF at Hanford

Pollutant	Most Stringent			Pit Conversion	MOX	Total
	Averaging Period	Standard or Guideline ^a	No Action			
Carbon monoxide	8 hours	10,000	34.1	0.144	0.103	34.3
	1 hour	40,000	48.3	0.978	0.704	50.0
Nitrogen dioxide	Annual	100	0.25	0.0166	0.0144	0.281
PM ₁₀	Annual	50	0.0179	0.000415	0.00101	0.0193
	24 hours	150	0.77	0.00461	0.0113	0.786
Sulfur dioxide	Annual	50	1.63	0.000282	0.000946	1.63
	24 hours	260	8.91	0.00313	0.0105	8.92
	3 hours	1,300	29.6	0.0213	0.0715	29.7
	[Text deleted.]					
	1 hour	660 ^b	32.9	0.064	0.214	33.2
Total suspended particulates	Annual	60	0.0179	0.000415	0.00101	0.0193
	24 hours	150	0.77	0.00461	0.0113	0.786
[Text deleted.]						

^a The more stringent of the Federal and State standards is presented if both exist for the averaging period.

^b At Hanford, the level is not to be exceeded more than twice in any 7 consecutive days.

[Text deleted.]

Key: FMEF, Fuels and Materials Examination Facility.

Source: EPA 1997; WDEC 1994.

G.1.2.6 Immobilization and MOX Facilities

G.1.2.6.1 Construction of Immobilization and MOX Facilities

Potential air quality impacts from modification of FMEF and construction of support facilities for collocating immobilization (ceramic or glass) and MOX facilities at Hanford were analyzed using ISCST3 as described in Appendix F.1. Construction impacts result from emissions from diesel fuel-burning construction equipment, particulate matter emissions from disturbance of soil by construction equipment and other vehicles (construction fugitive emissions), operation of a concrete batch plant, employee vehicles, and trucks moving materials and wastes. Emissions from these sources are summarized in Table G–22.

Table G–22. Emissions (kg/yr) From Construction of Immobilization and MOX Facilities Collocated in FMEF at Hanford

Pollutant	Immobilization (Ceramic or Glass)				MOX			
	Diesel Equipment	Construction Fugitive Emissions ^a	Concrete Batch Plant	Vehicles	Diesel Equipment	Construction Fugitive Emissions ^a	Concrete Batch Plant	Vehicles
Carbon monoxide	3,900	0	0	49,000	778	0	0	37,300
Nitrogen dioxide	10,100	0	0	13,100	2,009	0	0	10,000
PM ₁₀	770 ^b	8,860 ^b	733 ^b	44,700	154	2,830	435 ^b	34,100
Sulfur dioxide	1,020	0	0	0	204	0	0	0
Volatile organic compounds	800	0	0	6,040	160	0	0	4,600
Total suspended particulates	770	16,900	733	44,700	154	5,590	435	34,100
Toxics ^c	0	0	0	0	0	<1	0	0

^a Does not include fugitive emissions from the concrete batch plant.

^b PM₁₀ emissions were assumed to be the same as total suspended particulate emissions for the purpose of this analysis resulting in some overestimate of PM₁₀ concentrations.

^c Various toxic air pollutants (e.g., lead, benzene, hexane) could be emitted during construction.

Key: FMEF, Fuels and Materials Examination Facility.

Source: UC 1998b, 1999a, 1999b.

Maximum air pollutant concentrations from construction activities are summarized in Table G–23.

Table G–23. Concentrations ($\mu\text{g}/\text{m}^3$) From Construction of Immobilization and MOX Facilities Collocated in FMEF at Hanford

Pollutant	Averaging Period	Most Stringent	No Action	Immobilization		Total
		Standard or Guideline ^a		(Ceramic or Glass)	MOX	
Carbon monoxide	8 hours	10,000	34.1	1.08	0.215	35.4
	1 hour	40,000	48.3	7.34	1.46	57.1
Nitrogen dioxide	Annual	100	0.25	0.0838	0.0167	0.351
PM ₁₀	Annual	50	0.0179	0.0849	0.0274	0.13
	24 hours	150	0.77	3.85	1.32	5.94
Sulfur dioxide	Annual	50	1.63	0.00846	0.00169	1.64
	24 hours	260	8.91	0.094	0.0188	9.02
	3 hours	1,300	29.6	0.64	0.128	30.4
	[Text deleted.]					
Total suspended particulates	1 hour	660 ^b	32.9	1.92	0.383	35.2
	Annual	60	0.0179	0.153	0.051	0.222
	24 hours	150	0.77	7.05	2.4	10.2
Toxics ^c	Annual	0.12	0.000006	0	0.000008	0.000014

^a The more stringent of the Federal and State standards is presented if both exist for the averaging period.

^b At Hanford, the level is not to be exceeded more than twice in any 7 consecutive days.

^c Various toxic air pollutants (e.g., lead, benzene, hexane) could be emitted during construction and were analyzed as benzene.

Key: FMEF, Fuels and Materials Examination Facility.

Source: EPA 1997; WDEC 1994.

G.1.2.6.2 Operation of Immobilization and MOX Facilities

Potential air quality impacts from operation of the collocated immobilization (ceramic or glass) and MOX and support facilities at Hanford were analyzed using ISCST3 as described in Appendix F.1. Operational impacts result from emissions from emergency diesel generators, process emissions, employee vehicles, and trucks moving materials and wastes. Emissions from these sources are summarized in Table G–24. Stack parameters used for modeling were as stated previously.

Table G–24. Emissions (kg/yr) From Operation of Immobilization and MOX Facilities Collocated in FMEF at Hanford

Pollutant	Immobilization			MOX		
	Emergency Generator	Ceramic or Glass Process	Vehicles	Emergency Generator	Process	Vehicles
Carbon monoxide	1,460	0	52,700	374	0	34,200
Nitrogen dioxide	6,790	0	14,100	1,738	0	9,170
PM ₁₀	480	0	48,100	122	0	31,200
Sulfur dioxide	450	0	0	114	0	0
Volatile organic compounds	550	0	6,490	142	0	4,210
Total suspended particulates	480	0	48,100	122	0	31,200
[Text deleted.]						

[Text deleted.]

Key: FMEF, Fuels and Materials Examination Facility.

Source: UC 1998b, 1999a, 1999b.

Maximum air pollutant concentrations resulting from the emergency diesel generators and process sources are summarized in Table G–25. Radiological impacts, including those from emissions to the air, are discussed in Appendix J.

Table G–25. Concentrations ($\mu\text{g}/\text{m}^3$) From Operation of Immobilization and MOX Facilities Collocated in FMEF at Hanford

Pollutant	Averaging Period	Most Stringent		Immobilization (Ceramic or Glass)	MOX	Total With Ceramic or Glass
		Standard or Guideline ^a	No Action			
Carbon monoxide	8 hours	10,000	34.1	0.404	0.103	34.6
	1 hour	40,000	48.3	2.75	0.704	51.8
Nitrogen dioxide	Annual	100	0.25	0.0563	0.0144	0.321
PM ₁₀	Annual	50	0.0179	0.00398	0.00101	0.023
	24 hours	150	0.77	0.0443	0.0113	0.825
Sulfur dioxide	Annual	50	1.63	0.00373	0.000946	1.64
	24 hours	260	8.91	0.0415	0.0105	8.96
	3 hours	1,300	29.6	0.282	0.0715	30
	[Text deleted.]					
	1 hour	660 ^b	32.9	0.847	0.214	34
Total suspended particulates	Annual	60	0.0179	0.00398	0.00101	0.0229
	24 hours	150	0.77	0.0443	0.0113	0.825
[Text deleted.]						

^a The more stringent of the Federal and State standards is presented if both exist for the averaging period.

^b At Hanford, the level is not to be exceeded more than twice in any 7 consecutive days.

[Text deleted.]

Key: FMEF, Fuels and Materials Examination Facility.

Source: EPA 1997; WDEC 1994.

G.1.2.7 Pit Conversion, Immobilization, and MOX Facilities

G.1.2.7.1 Construction of Pit Conversion, Immobilization, and MOX Facilities

Potential air quality impacts from modification of FMEF for pit disassembly and conversion and plutonium conversion and immobilization (ceramic or glass), and new construction of MOX and support facilities at Hanford were analyzed using ISCST3 as described in Appendix F.1. Construction impacts result from emissions from diesel fuel-burning construction equipment, particulate matter emissions from soil disturbance by construction equipment and other vehicles (construction fugitive emissions), operation of a concrete batch plant, employee vehicles, and trucks moving materials and wastes. Emissions from these sources are summarized in Table G–26.

Maximum air pollutant concentrations from construction activities are summarized in Table G–27.

Table G–26. Emissions (kg/yr) From Construction of Pit Conversion and Immobilization Facilities in FMEF and MOX in New Construction at Hanford

Pollutant	Pit Conversion		Immobilization				MOX			
	Diesel Equipment & Construction Fugitive		Diesel Equipment	Construction Fugitive Emissions ^a	Concrete Batch Plant		Diesel Equipment	Construction Fugitive Emissions ^a		Concrete Batch Plant
	Emissions	Veh			Veh	Veh		Emissions ^a	Veh	
CO	1,000	11,300	3,060	0	0	40,000	3,840	0	0	37,600
NO ₂	2,400	3,040	7,890	0	0	10,700	10,080	0	0	10,100
PM ₁₀	3,500	10,300	600 ^b	6,770	560 ^b	36,500	768 ^b	6,880	1,460 ^b	34,400
SO ₂	160	0	800	0	0	0	1,020	0	0	0
VOC	200	1,400	620	0	0	4,930	792	0	0	4,640
TSP	9,300	10,300	600	13,100	560	36,500	768	13,600	1,460	34,400
Toxics ^c	0	0	0	0	0	0	0	<1	0	0

^a Does not include fugitive emissions from the concrete batch plant.

^b PM₁₀ emissions were assumed to be the same as TSP emissions for the purpose of this analysis resulting in some overestimate of PM₁₀ concentrations.

^c Various toxic air pollutants (e.g., lead, benzene, hexane) could be emitted during construction.

Key: CO, carbon monoxide; FMEF, Fuels and Materials Examination Facility; NO₂, nitrogen dioxide; SO₂, sulfur dioxide; TSP, total suspended particulates; Veh, vehicles; VOC, volatile organic compounds.

Source: UC 1998a, 1998b, 1999a, 1999b.

Table G–27. Concentrations (µg/m³) From Construction of Pit Conversion and Immobilization Facilities in FMEF and MOX in New Construction at Hanford

Pollutant	Most Stringent			Immobilization			Total
	Averaging Period	Standard or Guideline ^a	No Action	Pit Conversion	(Ceramic or Glass)	MOX	
Carbon monoxide	8 hours	10,000	34.1	0.277	0.846	1.06	36.3
	1 hour	40,000	48.3	1.88	5.76	7.22	63.2
Nitrogen dioxide	Annual	100	0.25	0.0199	0.0654	0.0836	0.419
	24 hours	50	0.0179	0.029	0.0651	0.0744	0.186
Sulfur dioxide	Annual	150	0.77	0.323	2.96	3.27	7.32
	24 hours	50	1.63	0.00133	0.00664	0.00846	1.65
Total suspended particulates	24 hours	260	8.91	0.0148	0.0737	0.094	9.09
	3 hours	1,300	29.6	0.1	0.502	0.64	30.9
	[Text deleted.]						
Toxics ^c	1 hour	660 ^b	32.9	0.301	1.5	1.92	36.6
	Annual	60	0.0179	0.0771	0.117	0.132	0.344
Toxics ^c	24 hours	150	0.77	0.857	5.58	5.88	13.1
	Annual	0.12	0.000006	0	0	0.000008	0.000014

^a The more stringent of the Federal and State standards is presented if both exist for the averaging period.

^b At Hanford, the level is not to be exceeded more than twice in any 7 consecutive days.

^c Various toxic air pollutants (e.g., lead, benzene, hexane) could be emitted during construction and were analyzed as benzene.

Key: FMEF, Fuels and Materials Examination Facility.

Source: EPA 1997; WDEC 1994.

G.1.2.7.2 Operation of Pit Conversion, Immobilization, and MOX Facilities

Potential air quality impacts from operation of the three surplus plutonium disposition and support facilities at Hanford were analyzed using ISCST3 as described in Appendix F.1. Operational impacts result from emissions from emergency diesel generators, process emissions, employee vehicles, and trucks moving materials and wastes. Emissions from these sources are summarized in Table G–28. Stack parameters used for modeling were as stated previously.

Table G–28. Emissions (kg/yr) From Operation of Pit Conversion and Immobilization Facilities in FMEF and MOX in New Construction at Hanford

Pollutant	Pit Conversion			Immobilization			MOX		
	EG	Process	Veh	EG	Process ^a	Veh	EG	Process	Veh
Carbon monoxide	520	0	41,800	1,460	0	52,700	374	0	34,200
Nitrogen dioxide	2,000	0	11,200	6,790	0	14,100	1,738	0	9,170
PM ₁₀	50	0	38,100	480	0	48,100	122	0	31,200
Sulfur dioxide	34	0	0	450	0	0	114	0	0
Volatile organic compounds	58	0	5,150	550	0	6,490	142	0	4,210
Total suspended particulates	50	0	38,100	480	0	48,100	122	0	31,200

[Text deleted.]

^a Ceramic or glass.**Key:** EG, emergency generator; FMEF, Fuels and Materials Examination Facility; Veh, vehicle.**Source:** UC 1998a, 1998b, 1999a, 1999b.

Maximum air pollutant concentrations resulting from the emergency diesel generators and process sources, plus the No Action concentrations, are summarized in Table G–29. Radiological impacts, including those from emissions to the air, are discussed in Appendix J.

Table G–29. Concentrations ($\mu\text{g}/\text{m}^3$) From Operation of Pit Conversion and Immobilization Facilities in FMEF and MOX in New Construction at Hanford

Pollutant	Averaging Period	Most Stringent Standard or Guideline ^a		Pit Conversion	Immobilization (Ceramic or Glass)		MOX	Total
		No Action						
Carbon monoxide	8 hours	10,000	34.1	0.144	0.404	0.103	34.7	
	1 hour	40,000	48.3	0.978	2.75	0.704	52.7	
Nitrogen dioxide	Annual	100	0.25	0.0166	0.0563	0.0144	0.337	
	24 hours	50	0.0179	0.000415	0.00398	0.00101	0.023	
PM ₁₀	Annual	150	0.77	0.00461	0.0442	0.0113	0.83	
	24 hours	50	1.63	0.000282	0.00373	0.000946	1.64	
Sulfur dioxide	24 hours	260	8.91	0.00313	0.0415	0.0105	8.97	
	3 hours	1,300	29.6	0.0213	0.282	0.0715	30	
	[Text deleted.]							
Total suspended particulates	1 hour	660 ^b	32.9	0.064	0.847	0.214	34	
	Annual	60	0.0179	0.000415	0.00398	0.00101	0.023	
Total suspended particulates	24 hours	150	0.77	0.00461	0.0443	0.0113	0.83	

[Text deleted.]

^a The more stringent of the Federal and State standards is presented if both exist for the averaging period.^b At Hanford, the level is not to be exceeded more than twice in any 7 consecutive days.

[Text deleted.]

Key: FMEF, Fuels and Materials Examination Facility.**Source:** EPA 1997; WDEC 1994.

G.2 INEEL

G.2.1 Assessment Data

Emission rates for criteria, hazardous, and toxic pollutants at INEEL are presented in Table F.1.2.4–1 of the *Storage and Disposition PEIS* (DOE 1996a:F-10). These emission rates were used as input into the modeled No Action pollutant concentrations presented in that document and reflect INEEL facility emissions for 1990, which were assumed to be representative of No Action for 2005. The storage alternative selected for INEEL results in no change in these concentrations (DOE 1996a:4-138). Other onsite activities related to programs analyzed in EISs for spent nuclear fuel and waste management are also included in the estimates of the No Action concentration for surplus plutonium disposition shown in Table G–30. For the cumulative impacts analysis, additional emissions from the proposed Advanced Mixed Waste Treatment Project are also considered. Radiological impacts, including those from emissions to the air, are discussed in Appendix J.

Table G–30. Estimated Concentrations ($\mu\text{g}/\text{m}^3$) From No Action at INEEL

Pollutant	Averaging Period	PEIS Estimated Base Year (2005)	Other Onsite From PEIS	No Action	AMWTP ^a
Carbon monoxide	8 hours	284	18	302	0.85
	1 hour	614	605	1,219	115
Nitrogen dioxide	Annual	4	7	11	0.34
PM ₁₀	Annual	3	0	3	0.006
	24 hours	33	6	39	4.6
Sulfur dioxide	Annual	6	0	6	0.012
	24 hours	135	2	137	4.5
	3 hours	579	12	591	25
Benzene	Annual	0.029	0	0.029	0.0001
[Text deleted.]					

^a Contribution from the Advanced Mixed Waste Treatment Project proposed action with microencapsulation or vitrification (included in cumulative impacts analysis).

Key: AMWTP, *INEEL Advanced Mixed Waste Treatment Project Final EIS*; PEIS, *Storage and Disposition PEIS*.

Source: DOE 1996a:4-138, 4-928, 4-929; DOE 1999.

G.2.2 Facilities

G.2.2.1 Pit Conversion Facility

G.2.2.1.1 Construction of Pit Conversion Facility

Potential air quality impacts from modification of the Fuel Processing Facility (FPF) and construction of new support facilities at INEEL for pit disassembly and conversion were analyzed using ISCST3 as described in Appendix F.1. Construction impacts result from emissions from diesel fuel-burning construction equipment, particulate matter emissions from soil disturbance by construction equipment and other vehicles (construction fugitive emissions), operation of a concrete batch plant, employee vehicles, and trucks moving materials and wastes. Emissions from construction of a new facility are higher than for modification of an existing facility described previously. Emissions from these sources are summarized in Table G–31.

Maximum air pollutant concentrations from construction activities are summarized in Table G–32 but are not expected to result in the exceedance of the ambient air quality standards.

Table G–31. Emissions (kg/yr) From Construction of Pit Conversion Facility in FPF at INEEL

Pollutant	Diesel Equipment and Construction Fugitive	
	Emissions	Vehicles
Carbon monoxide	1,300	44,100
Nitrogen dioxide	5,600	11,100
PM ₁₀	3,900	33,300
Sulfur dioxide	370	0
Volatile organic compounds	460	5,390

Key: FPF, Fuel Processing Facility.

Source: UC 1998c.

Table G–32. Concentrations ($\mu\text{g}/\text{m}^3$) From Construction of Pit Conversion Facility in FPF at INEEL

Pollutant	Averaging Period	Most Stringent			
		Standard or Guideline ^a	No Action	Contribution	Total
Carbon monoxide	8 hours	10,000	302	0.524	303
	1 hour	40,000	1,219	1.42	1,220
Nitrogen dioxide	Annual	100	11	0.0658	11.1
	24 hours	150	39	0.585	39.6
PM ₁₀	Annual	50	3	0.0458	3.05
	24 hours	150	39	0.585	39.6
Sulfur dioxide	Annual	80	6	0.00434	6
	24 hours	365	137	0.0555	137
	3 hours	1,300	591	0.223	591

^a The more stringent of the Federal and State standards is presented if both exist for the averaging period.

Key: FPF, Fuel Processing Facility.

Source: EPA 1997; ID DHW 1995.

G.2.2.1.2 Operation of Pit Conversion Facility

Potential air quality impacts from operation of the pit conversion and support facilities at INEEL were analyzed using ISCST3 as described in Appendix F.1. Operational impacts result from emissions from boilers, emergency diesel generators, process emissions, employee vehicles, and trucks moving materials and wastes. Emissions from these sources are summarized in Table G–33. Emergency generators were modeled as a volume source. The process stack for radiological emissions was modeled with a 35 m (115 ft) height, 1.82 m (6.0 ft) diameter, stack exit temperature of 11 °C (52 °F), and an exit velocity of 0.03 m/s (0.1 ft/s). The boiler stack was modeled with a 45.7 m (150 ft) height, 1.85 m (6.1 ft) diameter, stack exit temperature of 174 °C (345 °F), and an exit velocity of 3.25 m/s (10.7 ft/s) (UC 1998c).

Table G–33. Emissions (kg/yr) From Operation of Pit Conversion Facility in FPF at INEEL

Pollutant	Emergency			
	Boilers	Generator	Process	Vehicles
Carbon monoxide	580	520	0	74,100
Nitrogen dioxide	18,000	2,000	0	18,600
PM ₁₀	1,250	50	0	56,000
Sulfur dioxide	30,000	34	0	0
Volatile organic compounds	62	58	0	9,050

Key: FPF, Fuel Processing Facility.

Source: UC 1998c.

Maximum air pollutant concentrations resulting from the boilers, emergency diesel generators, and process sources, plus the No Action concentrations, are summarized in Table G–34.

Table G–34. Concentrations ($\mu\text{g}/\text{m}^3$) From Operation of Pit Conversion Facility in FPF at INEEL

Pollutant	Averaging Period	Most Stringent Standard or Guideline ^a			
		No Action	Contribution	Total	
Carbon monoxide	8 hours	10,000	302	0.253	302
	1 hour	40,000	1,219	0.80	1,220
Nitrogen dioxide	Annual	100	11	0.0838	11.1
	24 hours	50	3	0.00477	3.00
PM ₁₀	Annual	150	39	0.0494	39.1
	24 hours	80	6	0.101	6.10
Sulfur dioxide	Annual	365	137	1.01	138
	3 hours	1,300	591	5.42	596

^a The more stringent of the Federal and State standards is presented if both exist for the averaging period.

Key: FPF, Fuel Processing Facility.

Source: EPA 1997; ID DHW 1995.

At the nearest prevention of significant deterioration (PSD) Class I area, Craters of the Moon National Monument, the contribution to air pollutant concentrations is less than $0.01 \mu\text{g}/\text{m}^3$ for nitrogen dioxide, particulate matter with an aerodynamic diameter less than or equal to $10 \mu\text{m}$ (PM₁₀), and sulfur dioxide, except for the 24-hr sulfur dioxide value, which is $0.05 \mu\text{g}/\text{m}^3$, and the 3-hr sulfur dioxide value, which is $0.23 \mu\text{g}/\text{m}^3$. Radiological impacts, including those from emissions to the air, are discussed in Appendix J.

G.2.2.2 MOX Facility

G.2.2.2.1 Construction of MOX Facility

Potential air quality impacts from construction of new MOX and support facilities at INEEL were analyzed using ISCST3 as described in Appendix F.1. Construction impacts result from emissions from diesel fuel-burning construction equipment, particulate matter emissions from disturbance of soil by construction equipment and other vehicles (construction fugitive emissions), operation of a concrete batch plant, employee vehicles, and trucks moving materials and wastes. Emissions from construction of a new facility are higher than for modification of an existing facility described previously. Emissions from these sources are summarized in Table G–35.

Table G–35. Emissions (kg/yr) From Construction of New MOX Facility at INEEL

Pollutant	Construction			Vehicles
	Diesel Equipment	Fugitive Emissions ^a	Concrete Batch Plant	
Carbon monoxide	3,840	0	0	114,000
Nitrogen dioxide	10,080	0	0	28,600
PM ₁₀	768	6,860	1,460	85,900
Sulfur dioxide	1,020	0	0	0
Volatile organic compounds	792	0	0	13,900
Toxics ^b	0	<1	0	0

^a Does not include fugitive emissions from the concrete batch plant.

^b Various toxic air pollutants (e.g., lead, benzene, hexane) could be emitted during construction.

Source: UC 1998d.

Maximum air pollutant concentrations from construction activities are summarized in Table G–36.

Table G–36. Concentrations ($\mu\text{g}/\text{m}^3$) From Construction of New MOX Facility at INEEL

Pollutant	Averaging Period	Most Stringent	No Action	Contribution	Total
		Standard or Guideline ^a			
Carbon monoxide	8 hours	10,000	302	1.54	304
	1 hour	40,000	1,219	4.18	1,220
Nitrogen dioxide	Annual	100	11	0.118	11.1
	24 hours	50	3	0.105	3.11
PM ₁₀	Annual	150	39	5.32	44.3
	24 hours	80	6	0.012	6.01
Sulfur dioxide	Annual	365	137	0.153	137
	24 hours	1,300	591	0.614	592
Toxics ^b	Annual	0.12	0.029	0.00001	0.029

^a The more stringent of the Federal and State standards is presented if both exist for the averaging period.

^b Various toxic air pollutants (e.g., lead, benzene, hexane) could be emitted during construction and were analyzed as benzene.

Source: EPA 1997; ID DHW 1995.

G.2.2.2.2 Operation of MOX Facility

Potential air quality impacts from operation of the new MOX and support facilities at INEEL were analyzed using ISCST3 as described in Appendix F.1. Operational impacts result from emissions from boilers, emergency diesel generators, process emissions, employee vehicles, and trucks moving materials and wastes. Emissions from these sources are summarized in Table G–37. Emergency generators were modeled as a volume source. The process stack for radiological emissions was modeled with a 8 m (26 ft) height, 0.3048 m (1.0 ft) diameter, stack exit temperature of 11 °C (52 °F), and an exit velocity of 0.03 m/s (0.1 ft/s). The boiler stack was modeled with a 45.7 m (150 ft) height, 1.85 m (6.1 ft) diameter, stack exit temperature of 174 °C (345 °F), and exit velocity of 3.25 m/s (10.7 ft/s) (UC 1998d).

Maximum air pollutant concentrations resulting from the boilers, emergency diesel generators, and process sources, plus the No Action concentrations, are summarized in Table G–38.

Table G-37. Emissions (kg/yr) From Operation of New MOX Facility at INEEL

Pollutant	Emergency			
	Boilers	Generator	Process	Vehicles
Carbon monoxide	4,800	374	0	77,600
Nitrogen dioxide	12,000	1,738	0	19,500
PM ₁₀	636	122	0	58,600
Sulfur dioxide	72,600	114	0	0
Volatile organic compounds	0	142	0	9,470
[Text deleted.]				
[Text deleted.]				

Source: UC 1998d.

Table G-38. Concentrations ($\mu\text{g}/\text{m}^3$) From Operation of New MOX Facility at INEEL

Pollutant	Averaging Period	Most Stringent			
		Standard or Guideline ^a	No Action	Contribution	Total
Carbon monoxide	8 hours	10,000	302	0.509	303
	1 hour	40,000	1,219	2.34	1,220
Nitrogen dioxide	Annual	100	11	0.0606	11.1
	24 hours	50	3	0.00356	3.
PM ₁₀	Annual	150	39	0.0396	39.
	24 hours	80	6	0.244	6.24
Sulfur dioxide	Annual	365	137	2.45	139
	24 hours	1,300	591	13.2	604
	3 hours				
[Text deleted.]					

^a The more stringent of the Federal and State standards is presented if both exist for the averaging period.

[Text deleted.]

Source: EPA 1997; ID DHW 1995.

At the nearest PSD Class I area, Craters of the Moon National Monument, the contribution to air pollutant concentrations is less than $0.01 \mu\text{g}/\text{m}^3$ for nitrogen dioxide and PM₁₀. For sulfur dioxide the annual value is $0.01 \mu\text{g}/\text{m}^3$, the 24-hr value is $0.11 \mu\text{g}/\text{m}^3$, and the 3-hr value is $0.46 \mu\text{g}/\text{m}^3$. Radiological impacts, including those from emissions to the air, are discussed in Appendix J.

G.2.2.3 Pit Conversion and MOX Facilities

G.2.2.3.1 Construction of Pit Conversion and MOX Facilities

Potential air quality impacts from modification of FPF for pit disassembly and conversion and construction of new MOX and support facilities at INEEL were analyzed using ISCST3 as described in Appendix F.1. Construction impacts result from emissions from diesel fuel-burning construction equipment, particulate matter emissions from disturbance of soil by construction equipment and other vehicles (construction fugitive emissions), operation of a concrete batch plant, employee vehicles, and trucks moving materials and wastes. Emissions from construction of a new facility are higher than for modification of an existing facility described previously. Emissions from these sources are summarized in Table G-39.

Table G–39. Emissions (kg/yr) From Construction of Pit Conversion Facility in FPF and New MOX Facility at INEEL

Pollutant	Pit Conversion		MOX			
	Diesel Equipment and Construction Fugitive Emissions	Vehicles	Diesel Equipment	Construction Fugitive Emissions ^a	Concrete Batch Plant	Vehicles
Carbon monoxide	1,300	44,100	3,840	0	0	114,000
Nitrogen dioxide	5,600	11,100	10,080	0	0	28,600
PM ₁₀	3,900	33,300	768	6,860	1,460	85,900
Sulfur dioxide	370	0	1,020	0	0	0
Volatile organic compounds	460	5,390	792	0	0	13,900
Toxics ^b	0	0	0	<1	0	0

^a Does not include fugitive emissions from the concrete batch plant.

^b Various toxic air pollutants (e.g., lead, benzene, hexane) could be emitted during construction.

Key: FPF, Fuel Processing Facility.

Source: UC 1998c, 1998d.

Maximum air pollutant concentrations from construction activities are summarized in Table G–40.

Table G–40. Concentrations ($\mu\text{g}/\text{m}^3$) From Construction of Pit Conversion Facility in FPF and New MOX Facility at INEEL

Pollutant	Averaging Period	Most Stringent		Pit Conversion	MOX	Total
		Standard or Guideline ^a	No Action			
Carbon monoxide	8 hours	10,000	302	0.524	1.55	304
	1 hour	40,000	1,219	1.42	4.18	1,220
Nitrogen dioxide	Annual	100	11	0.0658	0.118	11.2
	24 hours	50	3	0.0458	0.105	3.15
PM ₁₀	Annual	150	39	0.585	5.32	44.9
	24 hours	80	6	0.00434	0.012	6.02
Sulfur dioxide	Annual	365	137	0.0555	0.153	137
	3 hours	1,300	591	0.223	0.614	592
Toxics ^b	Annual	0.12	0.029	0	0.00001	0.029

^a The more stringent of the Federal and State standards is presented if both exist for the averaging period.

^b Various toxic air pollutants (e.g., lead, benzene, hexane) could be emitted during construction and were analyzed as benzene.

Key: FPF, Fuel Processing Facility.

Source: EPA 1997; ID DHW 1995.

G.2.2.3.2 Operation of Pit Conversion and MOX Facilities

Potential air quality impacts from operation of the new pit conversion, MOX, and support facilities at INEEL were analyzed using ISCST3 as described in Appendix F.1. Operational impacts result from boilers, emissions from emergency diesel generators, process emissions, employee vehicles, and trucks moving materials and wastes. Emissions from these sources are summarized in Table G–41. Stack parameters used for modeling were as stated previously.

Table G–41. Emissions (kg/yr) From Operation of Pit Conversion Facility in FPF and New MOX Facility at INEEL

Pollutant	Pit Conversion				MOX			
	Boilers	Emergency			Boilers	Emergency		
		Generator	Process	Vehicles		Generator	Process	Vehicles
Carbon monoxide	580	520	0	74,100	4,800	374	0	77,600
Nitrogen dioxide	18,000	2,000	0	18,600	12,000	1,738	0	19,500
PM ₁₀	1,250	50	0	56,000	636	122	0	58,600
Sulfur dioxide	30,000	34	0	0	72,600	114	0	0
Volatile organic compounds	62	58	0	9,050	0	142	0	9,470
[Text deleted.]								

[Text deleted.]

Key: FPF, Fuel Processing Facility.
Source: UC 1998c, 1998d.

Maximum air pollutant concentrations resulting from the boilers, emergency diesel generators, and process sources, plus the No Action concentrations, are summarized in Table G–42.

Table G–42. Concentrations ($\mu\text{g}/\text{m}^3$) From Operation of Pit Conversion Facility in FPF and New MOX Facility at INEEL

Pollutant	Most Stringent			Pit Conversion ^a	MOX	Total
	Averaging Period	Standard or Guideline ^a	No Action			
Carbon monoxide	8 hours	10,000	302	0.253	0.509	303
	1 hour	40,000	1,219	0.80	2.34	1,220
Nitrogen dioxide	Annual	100	11	0.0838	0.0606	11.1
	24 hours	50	3	0.00477	0.00356	3.01
Sulfur dioxide	Annual	150	39	0.0494	0.0396	39.1
	24 hours	80	6	0.101	0.244	6.35
	3 hours	365	137	1.01	2.45	140
		1,300	591	5.42	13.2	610
[Text deleted.]						

[Text deleted.]

^a The more stringent of the Federal and State standards is presented if both exist for the averaging period.

[Text deleted.]

Key: FPF, Fuel Processing Facility.
Source: EPA 1997; ID DHW 1995.

At the nearest PSD Class I area, Craters of the Moon National Monument, the contribution to air pollutant concentrations are $0.01 \mu\text{g}/\text{m}^3$ or less for nitrogen dioxide and PM₁₀. For sulfur dioxide the annual value is $0.01 \mu\text{g}/\text{m}^3$, the 24-hr value is $0.16 \mu\text{g}/\text{m}^3$, and the 3-hr value is $0.69 \mu\text{g}/\text{m}^3$. Radiological impacts, including those from emissions to the air, are discussed in Appendix J.

G.3 PANTEX

G.3.1 Assessment Data

Emission rates for criteria, hazardous, and toxic air pollutants at Pantex are presented in Table 4.7.2.1–3 of the *Final Environmental Impact Statement for the Continued Operation of Pantex* (DOE 1996c:4-147). These emission rates were used as input into the modeled pollutant concentrations presented in that document and reflect Pantex facility emissions for over a 10-year period to about 2006. These concentrations are assumed to be representative of No Action for 2005 and include the upgrade storage alternative selected for Pantex and discussed in the *Storage and Disposition PEIS* (DOE 1996a:4-190). Other onsite activities related to programs analyzed in EISs for stockpile stewardship management and waste management are added to these concentrations as shown in Table G–43. Radiological impacts, including those from emissions to the air, are discussed in Appendix J.

Table G–43. Estimated Concentrations ($\mu\text{g}/\text{m}^3$) From No Action at Pantex

Pollutant	Averaging Period	PEIS	Other Onsite	
		No Action ^a	From PEIS	No Action
Carbon monoxide	8 hours	602	17.5	620
	1 hour	2,900	92.8	2,990
Nitrogen dioxide	Annual	0.542	1.4	1.94
PM ₁₀	Annual	8.73	0.06	8.79
	24 hours	88.5	0.93	89.4
Sulfur dioxide	Annual	0	0	0
	24 hours	0.00002	0	0.00002
	3 hours	0.00008	0	0.00008
	30 minutes	0.00016	0	0.00016
Total suspended particulates	3 hours	(a)	(a)	(a)
	1 hour	(a)	(a)	(a)
Benzene	Annual	0.0547	0	0.0547
	1 hour	19.4	0	19.4

[Text deleted.]

^a Three- and 1-hr concentrations for total suspended particulates were not reported in the source document.

[Text deleted.]

Key: PEIS, *Storage and Disposition PEIS*.

Source: DOE 1996a:4-936, 4-937; 1996c:4-139.

G.3.2 Facilities

G.3.2.1 Pit Conversion Facility

G.3.2.1.1 Construction of Pit Conversion Facility

Potential air quality impacts from construction of new pit conversion and support facilities at Pantex were analyzed using ISCST3 as described in Appendix F.1. Construction impacts result from emissions from diesel fuel-burning construction equipment, particulate matter emissions from disturbance of soil by construction equipment and other vehicles (construction fugitive emissions), operation of a concrete batch plant, employee vehicles, and trucks moving materials and wastes. Emissions from these sources are summarized in Table G–44.

Maximum air pollutant concentrations from construction activities are summarized in Table G–45.

Table G–44. Emissions (kg/yr) From Construction of New Pit Conversion Facility at Pantex

Pollutant	Diesel Equipment and Construction Fugitive	
	Emissions	Vehicles
Carbon monoxide	6,400	40,500
Nitrogen dioxide	29,200	11,200
PM ₁₀	20,300	38,900
Sulfur dioxide	1,900	0
Volatile organic compounds	2,400	5,140
Total suspended particulates	47,500	38,900

Source: UC 1998e.

Table G–45. Concentrations ($\mu\text{g}/\text{m}^3$) From Construction of New Pit Conversion Facility at Pantex

Pollutant	Averaging Period	Most Stringent	No Action	Contribution	Total
		Standard or Guideline ^a			
Carbon monoxide	8 hours	10,000	620	3.77	623
	1 hour	40,000	2,990	23.5	3,020
Nitrogen dioxide	Annual	100	1.94	0.501	2.44
	24 hours	50	8.79	0.349	9.14
PM ₁₀	Annual	150	89.4	4.18	93.6
	24 hours	80	0	0.0326	0.0326
Sulfur dioxide	24 hours	365	0.00002	0.392	0.392
	3 hours	1,300	0.00008	1.71	1.71
Total suspended particulates	30 minutes	1,048	0.00016	6.98	6.98
	3 hours	200	(b)	42.7	42.7
	1 hour	400	(b)	174	174

^a The more stringent of the Federal and State standards is presented if both exist for the averaging period.

^b Three- and 1-hr concentrations for total suspended particulates were not listed in the source document.

Source: EPA 1997; TNRC 1997a, 1997b.

G.3.2.1.2 Operation of Pit Conversion Facility

Potential air quality impacts from operation of the new pit conversion and support facilities at Pantex were analyzed using ISCST3 as described in Appendix F.1. Operational impacts result from emissions from boilers, emergency diesel generators, process emissions, employee vehicles, and trucks moving materials and wastes. Emissions from these sources are summarized in Table G–46. Emergency generators were modeled as a volume source. The process stack for radiological emissions was modeled with a 35 m (115 ft) height, 1.82 m (6.0 ft) diameter, stack exit temperature of 20 °C (68 °F), and an exit velocity of 0.03 m/s (0.1 ft/s). The boiler stack was modeled with a 19.8 m (65 ft) height, 1.7 m (5.6 ft) diameter, stack exit temperature of 124 °C (255 °F), and an exit velocity of 6.2 m/s (20 ft/s) (UC 1998e).

Maximum air pollutant concentrations resulting from the boilers, emergency diesel generators and process sources, plus the No Action concentrations, are summarized in Table G–47. Radiological impacts, including those from emissions to the air, are discussed in Appendix J.

Table G-46. Emissions (kg/yr) From Operation of New Pit Conversion Facility at Pantex

Pollutant	Emergency			
	Boilers	Generator	Process	Vehicles
Carbon monoxide	780	520	0	38,800
Nitrogen dioxide	700	2,000	0	10,800
PM ₁₀	300	50	0	37,300
Sulfur dioxide	13	34	0	0
Volatile organic compounds	132	58	0	4,920
Total suspended particulates	300	50	0	37,300

Source: UC 1998e.

Table G-47. Concentrations ($\mu\text{g}/\text{m}^3$) From Operation of New Pit Conversion Facility at Pantex

Pollutant	Averaging Period	Most Stringent			
		Standard or Guideline ^a	No Action	Contribution	Total
Carbon monoxide	8 hours	10,000	620	0.381	620
	1 hour	40,000	2,990	2.14	2,990
Nitrogen dioxide	Annual	100	1.94	0.0374	1.98
	24 hours	50	8.79	0.00215	8.79
Sulfur dioxide	Annual	150	89.4	0.0225	89.5
	24 hours	80	0	0.00064	0.00064
Total suspended particulates	24 hours	365	0.00002	0.00753	0.00755
	3 hours	1,300	0.00008	0.0327	0.0328
	30 minutes	1,048	0.00016	0.129	0.129
Total suspended particulates	3 hours	200	(b)	0.0937	0.0937
	1 hour	400	(b)	0.273	0.273

^a The more stringent of the Federal and State standards is presented if both exist for the averaging period.^b Three- and 1-hr concentrations for total suspended particulates were not listed in the source document.

Source: EPA 1997; TNRCC 1997a, 1997b.

G.3.2.2 MOX Facility

G.3.2.2.1 Construction of MOX Facility

Potential air quality impacts from construction of new MOX and support facilities at Pantex were analyzed using ISCST3 as described in Appendix F.1. Construction impacts result from emissions from diesel fuel-burning construction equipment, particulate matter emissions from disturbance of soil by construction equipment and other vehicles (construction fugitive emissions), operation of a concrete batch plant, employee vehicles, and trucks moving materials and wastes. Emissions from these sources are summarized in Table G-48.

Maximum air pollutant concentrations from construction activities are summarized in Table G-49.

Table G-48. Emissions (kg/yr) From Construction of New MOX Facility at Pantex

Pollutant	Construction			
	Diesel Equipment	Fugitive Emissions ^a	Concrete Batch Plant	Vehicles
Carbon monoxide	3,840	0	0	35,800
Nitrogen dioxide	10,080	0	0	9,930
PM ₁₀	768 ^b	6,890	1,460 ^b	34,400
Sulfur dioxide	1,020	0	0	0
Volatile organic compounds	792	0	0	4,540
Total suspended particulates	768	13,700	1,460	34,400
Toxics ^c	0	<1	0	0

^a Does not include fugitive emissions from the concrete batch plant.

^b PM₁₀ emissions were assumed to be the same as total suspended particulate emissions for the purpose of this analysis resulting in some overestimate of PM₁₀ concentrations.

^c Various toxic air pollutants (e.g., lead, benzene, hexane) could be emitted during construction.

Source: UC 1998f.

Table G-49. Concentrations (μg/m³) From Construction of New MOX Facility at Pantex

Pollutant	Averaging Period	Most Stringent			
		Standard or Guideline ^a	No Action	Contribution	Total
Carbon monoxide	8 hours	10,000	620	2.26	622
	1 hour	40,000	2,990	14.1	3,010
Nitrogen dioxide	Annual	100	1.94	0.173	2.12
	PM ₁₀	50	8.79	0.154	8.94
Sulfur dioxide	24 hours	150	89.4	7.31	96.7
	Annual	80	0	0.0175	0.018
	24 hours	365	0.00002	0.21	0.21
	3 hours	1,300	0.00008	0.917	0.918
Total suspended particulates	30 minutes	1,048	0.00016	3.75	3.75
	3 hours	200	(b)	57.4	57.4
	1 hour	400	(b)	234	234
Toxics ^c	Annual	3 ^d	0.0547	0.00002	0.0547
	1 hour	75 ^d	19.4	0.0162	19.4

^a The more stringent of the Federal and State standards is presented if both exist for the averaging period.

^b Three- and 1-hr concentrations for total suspended particulates were not listed in the source document.

^c Various toxic air pollutants (e.g., lead, benzene, hexane) could be emitted during construction and were analyzed as benzene.

^d Effects-screening level of the Texas Natural Resource Conservation Commission. Such levels are not ambient air standards, but merely “tools” used by the Toxicology and Risk Assessment staff to evaluate impacts of air pollutant emissions. Thus, exceedance of the screening levels by ambient air contaminants does not necessarily indicate a problem. That circumstance, however, would prompt a more thorough evaluation.

[Text deleted.]

Source: EPA 1997; TNRCC 1997a, 1997b.

G.3.2.2.2 Operation of MOX Facility

Potential air quality impacts from operation of the new MOX and support facilities at Pantex were analyzed using ISCST3 as described in Appendix F.1. Operational impacts result from emissions from boilers, emergency diesel generators, process emissions, employee vehicles, and trucks moving materials and wastes. Emissions from these sources are summarized in Table G-50. Emergency generators were modeled as a volume source. The process stack for radiological emissions was modeled with a 8 m (26 ft) height, 0.3048 m

Table G–50. Emissions (kg/yr) From Operation of New MOX Facility at Pantex

Pollutant	Emergency			
	Boilers	Generator	Process	Vehicles
Carbon monoxide	1,080	374	0	34,800
Nitrogen dioxide	1,470	1,738	0	9,660
PM ₁₀	247	122	0	33,400
Sulfur dioxide	11	114	0	0
Volatile organic compounds	102	142	0	4,410
Total suspended particulates	247	122	0	33,400
[Text deleted.]				

Source: UC 1998f.

(1.0 ft) diameter, stack exit temperature of 20 °C (68 °F), and an exit velocity of 0.03 m/s (0.1 ft/s). The boiler stack was modeled with a 19.8 m (65 ft) height, 1.7 m (5.6 ft) diameter, stack exit temperature of 124 °C (255 °F), and an exit velocity of 6.2 m/s (20 ft/s) (UC 1998f).

Maximum air pollutant concentrations resulting from the boilers, emergency diesel generators and process sources, plus the No Action concentrations, are summarized in Table G–51. Radiological impacts, including those from emissions to the air, are discussed in Appendix J.

Table G–51. Concentrations ($\mu\text{g}/\text{m}^3$) From Operation of New MOX Facility at Pantex

Pollutant	Averaging Period	Most Stringent			
		Standard or Guideline ^a	No Action	Contribution	Total
Carbon monoxide	8 hours	10,000	620	0.324	620
	1 hour	40,000	2,990	1.70	2,990
Nitrogen dioxide	Annual	100	1.94	0.0362	1.98
	Annual	50	8.79	0.00316	8.79
PM ₁₀	24 hours	150	89.4	0.0352	89.5
	Annual	80	0	0.00201	0.002
Sulfur dioxide	24 hours	365	0.00002	0.0239	0.0239
	3 hours	1,300	0.00008	0.104	0.104
	30 minutes	1,048	0.00016	0.422	0.422
	Annual	80	0	0.00201	0.002
Total suspended particulates	3 hours	200	(b)	0.15	0.15
	1 hour	400	(b)	0.522	0.522
[Text deleted.]					

^a The more stringent of the Federal and State standards is presented if both exist for the averaging period.

^b Three- and 1-hr concentrations for total suspended particulates were not listed in the source document.

[Text deleted.]

Source: EPA 1997; TNRCC 1997a, 1997b.

G.3.2.3 Pit Conversion and MOX Facilities

G.3.2.3.1 Construction of Pit Conversion and MOX Facilities

Potential air quality impacts from construction of new pit conversion, MOX, and support facilities at Pantex were analyzed using ISCST3 as described in Appendix F.1. Construction impacts result from emissions from diesel fuel-burning construction equipment, particulate matter emissions from disturbance of soil by construction

equipment and other vehicles (construction fugitive emissions), operation of a concrete batch plant, employee vehicles, and trucks moving materials and wastes. Emissions from these sources are summarized in Table G-52.

Table G-52. Emissions (kg/yr) From Construction of New Pit Conversion and MOX Facilities at Pantex

Pollutant	Pit Conversion		MOX			
	Diesel Equipment and Construction Fugitive Emissions	Vehicles	Diesel Equipment	Construction Fugitive Emissions ^a	Concrete Batch Plant	Vehicles
Carbon monoxide	6,400	40,500	3,840	0	0	35,800
Nitrogen dioxide	29,200	11,200	10,080	0	0	9,930
PM ₁₀	20,300	38,900	768 ^b	6,890	1,460 ^b	34,400
Sulfur dioxide	1,900	0	1,020	0	0	0
Volatile organic compounds	2,400	5,140	792	0	0	4,540
Total suspended particulates	47,500	38,900	768	13,700	1,460	34,400
Toxics ^c	0	0	0	<1	0	0

^a Does not include fugitive emissions from the concrete batch plant.

^b PM₁₀ emissions were assumed to be the same as total suspended particulate emissions for MOX for the purpose of this analysis resulting in some overestimate of PM₁₀ concentrations.

^c Various toxic air pollutants (e.g., lead, benzene, hexane) could be emitted during construction.

Source: UC 1998e, 1998f.

Maximum air pollutant concentrations from construction activities are summarized in Table G-53.

Table G-53. Concentrations (μm^3) From Construction of New Pit Conversion and MOX Facilities at Pantex

Pollutant	Averaging Period	Most Stringent		Pit Conversion	MOX	Total
		Standard or Guideline ^a	No Action			
Carbon monoxide	8 hours	10,000	620	3.77	2.26	626
	1 hour	40,000	2,990	23.5	14.1	3,030
Nitrogen dioxide	Annual	100	1.94	0.501	0.173	2.62
	PM ₁₀	Annual	50	8.79	0.349	0.154
Sulfur dioxide	24 hours	150	89.4	4.18	7.31	100
	Annual	80	0	0.0326	0.0175	0.0501
	24 hours	365	0.00002	0.392	0.21	0.602
	3 hours	1,300	0.00008	1.71	0.917	2.63
Total suspended particulates	30 minutes	1,048	0.00016	6.98	3.75	10.7
	3 hours	200	(b)	42.7	57.4	100
	1 hour	400	(b)	174	234	409
Toxics ^c	Annual	3	0.0547	0.00	0.00002	0.0547
	1 hour	75	19.4	0.00	0.0162	19.4

^a The more stringent of the Federal and State standards is presented if both exist for the averaging period.

^b Three- and 1-hr concentrations for total suspended particulates were not listed in the source document.

^c Various toxic air pollutants (e.g., lead, benzene, hexane) could be emitted during construction and were analyzed as benzene.

[Text deleted.]

Source: EPA 1997; TNRC 1997a, 1997b.

G.3.2.3.2 Operation of Pit Conversion and MOX Facilities

Potential air quality impacts from operation of the new pit conversion, MOX, and support facilities at Pantex were analyzed using ISCST3 as described in Appendix F.1. Operational impacts result from emissions from boilers, emergency diesel generators, process emissions, employee vehicles, and trucks moving materials and wastes. Emissions from these sources are summarized in Table G–54. Stack parameters used for modeling were as stated previously.

Table G–54. Emissions (kg/yr) From Operation of New Pit Conversion and MOX Facilities at Pantex

Pollutant	Pit Conversion				MOX			
	Boilers	Emergency Generator	Process	Vehicles	Boilers	Emergency Generator	Process	Vehicles
Carbon monoxide	780	520	0	38,800	1,080	374	0	34,800
Nitrogen dioxide	700	2,000	0	10,800	1,470	1,738	0	9,660
PM ₁₀	300	50	0	37,300	247	122	0	33,400
Sulfur dioxide	13	34	0	0	11	114	0	0
Volatile organic compounds	132	58	0	4,920	102	142	0	4,410
Total suspended particulates	300	50	0	37,300	247	122	0	33,400

[Text deleted.]

[Text deleted.]

Source: UC 1998e, 1998f.

Maximum air pollutant concentrations resulting from the boilers, emergency diesel generators, and process sources, plus the No Action concentrations, are summarized in Table G–55. Radiological impacts, including those from emissions to the air, are discussed in Appendix J.

Table G–55. Concentrations ($\mu\text{g}/\text{m}^3$) From Operation of New Pit Conversion and MOX Facilities at Pantex

Pollutant	Averaging Period	Most Stringent Standard or Guideline ^a		No Action	Pit Conversion		MOX	Total
Carbon monoxide	8 hours	10,000		620	0.381	0.324		620
	1 hour	40,000		2,990	2.14	1.7		3,000
Nitrogen dioxide	Annual	100		1.94	0.0374	0.0362		2.02
	24 hours	150		89.4	0.0225	0.0352		89.5
PM ₁₀	Annual	50		8.79	0.00215	0.00316		8.80
	24 hours	150		89.4	0.0225	0.0352		89.5
Sulfur dioxide	Annual	80		0	0.00064	0.00201		0.00265
	24 hours	365		0.00002	0.00753	0.0239		0.0315
	3 hours	1,300		0.00008	0.0327	0.104		0.137
	30 minutes	1,048		0.00016	0.129	0.422		0.551
Total suspended particulates	3 hours	200		(b)	0.0937	0.15		0.244
	1 hour	400		(b)	0.273	0.522		0.796

[Text deleted.]

^a The more stringent of the Federal and State standards is presented if both exist for the averaging period.

^b Three- and 1-hr concentrations for total suspended particulates were not listed in the source document.

[Text deleted.]

Source: EPA 1997; TNRC 1997a, 1997b.

G.4 SRS

G.4.1 Assessment Data

Emission rates for 1994 for criteria, hazardous, and toxic air pollutants at SRS were used as input into the modeling of pollutant concentrations presented in the *Savannah River Site Spent Nuclear Fuel Management Draft Environmental Impact Statement* (DOE 1998a:3-26). Presented in Table G-56 are concentration estimates assumed to be representative of the No Action Alternative at SRS for 2005. These estimates take into account the storage upgrade to accommodate nonpit material from the Rocky Flats Environmental Technology Site (DOE 1996a:4-299), as well as other onsite activities responsive to EIS Records of Decision in various program areas, specifically, foreign research reactor spent nuclear fuel, highly enriched uranium disposition, interim management of nuclear materials, stockpile stewardship and management, tritium supply and recycling, and waste management (DOE 1996a:4-953, 4-954). Other activities at SRS, which may occur during the time period 2005–2015, including operation of the Tritium Extraction Facility and spent nuclear fuel processing, are discussed in the cumulative impacts section. Radiological impacts, including those from emissions to the air, are discussed in Appendix J.

Table G-56. Estimated Concentrations ($\mu\text{g}/\text{m}^3$) From No Action at SRS

Pollutant	Averaging Period	1994 Baseline Concentration ^a	Other Onsite Sources			
			No Action	TEF	SNF	
Carbon monoxide	8 hours	632	39.1	671	0.45	1.3
	1 hour	5,010	82.2	5,100	3.6	9.8
Nitrogen dioxide	Annual	8.8	2.57	11.4	0.0055	3.4
PM ₁₀	Annual	4.8	0.14	4.94	0.00009	0.02
	24 hours	80.6	5.13	85.7	0.01	0.13
Sulfur dioxide	Annual	16.3	0.39	16.7	0.00009	0.02
	24 hours	215	6.96	222	0.001	0.13
	3 hours	690	34.9	725	0.088	0.98
Total suspended particulates	Annual	43.3	2.08	45.4	0.00016	0.02
Benzene	24 hours	20.7	0	20.7	0	0
[Text deleted.]						

^a DOE 1998a:3-26.

Key: SNF, SRS Spent Nuclear Fuel Management Draft EIS; TEF, Construction and Operation of a Tritium Extraction Facility at SRS Draft EIS.

Source: DOE 1995a:E-10–E-13; 1995b:5-3; 1995c: vol. 1, app. C, 5-9; 1995d:4-408; 1996a:4-299; 1996d:4-26; 1998a:5-4; 1998b:4-6.

G.4.2 Facilities

G.4.2.1 Pit Conversion Facility

G.4.2.1.1 Construction of Pit Conversion Facility

Potential air quality impacts from construction of new pit conversion and support facilities at SRS were analyzed using ISCST3 as described in Appendix F.1. Construction impacts result from emissions from diesel fuel-burning construction equipment, particulate matter emissions from disturbance of soil by construction equipment and other vehicles (construction fugitive emissions), operation of a concrete batch plant, employee vehicles, and trucks moving materials and wastes. Emissions from construction of a new facility are higher than for modification of an existing facility described previously. Emissions from these sources are summarized in Table G-57.

Table G-57. Emissions (kg/yr) From Construction of New Pit Conversion Facility at SRS

Pollutant	Diesel Equipment and Construction Fugitive	
	Emissions	Vehicles
Carbon monoxide	6,400	38,600
Nitrogen dioxide	29,200	11,200
PM ₁₀	20,300	39,500
Sulfur dioxide	1,900	0
Volatile organic compounds	2,400	5,160
Total suspended particulates	47,500	39,500

Source: UC 1998g.

Maximum air pollutant concentrations from construction activities are summarized in Table G-58.

Table G-58. Concentrations ($\mu\text{g}/\text{m}^3$) From Construction of New Pit Conversion Facility at SRS

Pollutant	Averaging Period	Most Stringent Standard or Guideline ^a			
		No Action	Contribution	Total	
Carbon monoxide	8 hours	10,000	671	0.911	672
	1 hour	40,000	5,100	4.14	5,100
Nitrogen dioxide	Annual	100	11.4	0.0601	11.4
	PM ₁₀	50	4.94	0.0418	4.98
Sulfur dioxide	24 hours	150	85.7	1.03	86.8
	Annual	80	16.7	0.00391	16.7
	24 hours	365	222	0.0964	222
Total suspended particulates	3 hours	1,300	725	0.578	726
	Annual	75	45.4	0.0977	45.5

^a The more stringent of the Federal and State standards is presented if both exist for the averaging period.

Source: EPA 1997; SCDHEC 1996.

G.4.2.1.2 Operation of Pit Conversion Facility

Potential air quality impacts from operation of the new pit conversion and support facilities at SRS were analyzed using ISCST3 as described in Appendix F.1. Operational impacts result from emissions from boilers, emergency diesel generators, process emissions, employee vehicles, and trucks moving materials and wastes. Emissions from these sources are summarized in Table G-59. Emergency generators were modeled as a volume source. The process stack for radiological emissions was modeled with a 35 m (115 ft) height, 1.82 m (6 ft) diameter, stack exit temperature of 20 °C (68 °F), and an exit velocity of 0.03 m/s (0.1 ft/s). The boiler stack was modeled with a 38.1 m (125 ft) height, 3.01 m (9.9 ft) diameter, stack exit temperature of 160 °C (320 °F), and an exit velocity of 10.67 m/s (35 ft/s) (UC 1998g).

Maximum air pollutant concentrations resulting from the boilers, emergency diesel generators, and process sources, plus the No Action concentrations, are summarized in Table G-60. Radiological impacts, including those from emissions to the air, are discussed in Appendix J.

**Table G–59. Emissions (kg/yr) From Operation of
New Pit Conversion Facility at SRS**

Pollutant	Emergency			
	Boilers	Generator	Process	Vehicles
Carbon monoxide	587	520	0	39,600
Nitrogen dioxide	20,000	2,000	0	11,500
PM ₁₀	1,400	50	0	40,500
Sulfur dioxide	33,300	34	0	0
Volatile organic compounds	69	58	0	5,300
Total suspended particulates	1,400	50	0	40,500

Source: UC 1998g.

**Table G–60. Concentrations ($\mu\text{g}/\text{m}^3$) From Operation of
New Pit Conversion Facility at SRS**

Pollutant	Averaging Period	Most Stringent			
		Standard or Guideline ^a	No Action	Contribution	Total
Carbon monoxide	8 hours	10,000	671	0.0942	672
	1 hour	40,000	5,100	0.373	5,100
Nitrogen dioxide	Annual	100	11.4	0.0287	11.4
	PM ₁₀	50	4.94	0.00182	4.94
Sulfur dioxide	Annual	150	85.7	0.026	85.8
	24 hours	80	16.7	0.041	16.7
	24 hours	365	222	0.56	223
Total suspended particulates	3 hours	1,300	725	1.46	726
	Annual	75	45.4	0.00182	45.4

^a The more stringent of the Federal and State standards is presented if both exist for the averaging period.

Source: EPA 1997; SCDHEC 1996.

G.4.2.2 [Text deleted.]

G.4.2.3 Immobilization Facility

G.4.2.3.1 Construction of Immobilization Facility

Potential air quality impacts from construction of new immobilization (ceramic or glass) and support facilities at SRS were analyzed using ISCST3 as described in Appendix F.1. Construction impacts result from emissions from diesel fuel-burning construction equipment, particulate matter emissions from disturbance of soil by construction equipment and other vehicles (construction fugitive emissions), operation of a concrete batch plant, employee vehicles, and trucks moving materials and wastes. Emissions from construction of a new facility are higher than for modification of an existing facility described previously. Emissions from these sources are summarized in Table G–61.

Maximum air pollutant concentrations from construction activities are summarized in Table G–62.

Table G–61. Emissions (kg/yr) From Construction of New Immobilization Facility at SRS

Pollutant	Construction			
	Diesel Equipment	Fugitive Emissions ^a	Concrete Batch Plant	Vehicles
Carbon monoxide	20,300	0	0	48,700
Nitrogen dioxide	52,700	0	0	14,100
PM ₁₀	3,930 ^b	11,300	2,610 ^b	49,900
Sulfur dioxide	24,400	0	0	0
Volatile organic compounds	3,900	0	0	6,520
Total suspended particulates	3,930	21,600	2,610	49,900

^a Does not include fugitive emissions from the concrete batch plant.

^b PM₁₀ emissions were assumed to be the same as total suspended particulate emissions for this analysis, resulting in some overestimate of PM₁₀ concentrations.

Source: UC 1999c, 1999d.

Table G–62. Concentrations (μg/m³) From Construction of New Immobilization Facility at SRS

Pollutant	Averaging Period	Most Stringent			Total
		Standard or Guideline ^a	No Action	Ceramic or Glass	
Carbon monoxide	8 hours	10,000	671	2.89	674
	1 hour	40,000	5,100	13.1	5,110
Nitrogen dioxide	Annual	100	11.4	0.108	11.5
	PM ₁₀	50	4.94	0.0366	4.98
Sulfur dioxide	24 hours	150	85.7	3.56	89.3
	Annual	80	16.7	0.0502	16.7
	24 hours	365	222	1.24	223
Total suspended particulates	3 hours	1,300	725	7.42	732
	Annual	75	45.4	0.0581	45.4

^a The more stringent of the Federal and State standards is presented if both exist for the averaging period.

Source: EPA 1997; SCDHEC 1996.

G.4.2.3.2 Operation of Immobilization Facility

Potential air quality impacts from operation of new immobilization (ceramic or glass) and support facilities at SRS were analyzed using ISCST3 as described in Appendix F.1. Operational impacts result from emissions from boilers, emergency diesel generators, process emissions, employee vehicles, and trucks moving materials and wastes. Emissions from these sources are summarized in Table G–63. Emergency generators were modeled as a volume source. The process stack for radiological emissions was modeled with a 41 m (135 ft) height, 5.1 m (17 ft) diameter, stack exit temperature of 20 °C (68 °F), and an exit velocity of 7 m/s (23 ft/s). The boiler stack was modeled with a 38.1 m (125 ft) height, 3.01 m (9.9 ft) diameter, stack exit temperature of 160 °C (320 °F), and an exit velocity of 10.67 m/s (35 ft/s) (UC 1999c, 1999d).

Maximum air pollutant concentrations resulting from the boilers, emergency diesel generators, and process sources, plus the No Action concentrations, are summarized in Table G–64. Radiological impacts, including those from emissions to the air, are discussed in Appendix J.

Table G–63. Emissions (kg/yr) From Operation of New Immobilization Facility at SRS

Pollutant	Boilers	Emergency Generator	Ceramic or Glass	
			Process	Vehicles ^a
Carbon monoxide	370	980	0	46,500
Nitrogen dioxide	12,100	4,530	0	13,500
PM ₁₀	940	320	0	47,600
Sulfur dioxide	35,500	300	0	0
Volatile organic compounds	80	370	0	6,220
Total suspended particulates	940	320	0	47,600

^a For 50-t (55-ton) case.

Source: UC 1999c, 1999d.

Table G–64. Concentrations ($\mu\text{g}/\text{m}^3$) From Operation of New Immobilization Facility at SRS

Pollutant	Averaging Period	Most Stringent		Ceramic or Glass	Total
		Standard or Guideline ^a	No Action		
Carbon monoxide	8 hours	10,000	671	0.152	671
	1 hour	40,000	5,100	0.657	5,100
Nitrogen dioxide	Annual	100	11.4	0.0242	11.4
	24 hours	50	4.94	0.00181	4.94
PM ₁₀	Annual	150	85.7	0.032	85.8
	24 hours	80	16.7	0.0442	16.7
Sulfur dioxide	Annual	365	222	0.61	223
	24 hours	1,300	725	1.63	727
Total suspended particulates	Annual	75	45.4	0.00181	45.4

^a The more stringent of the Federal and State standards is presented if both exist for the averaging period.

Source: EPA 1997; SCDHEC 1996.

G.4.2.4 MOX Facility

G.4.2.4.1 Construction of MOX Facility

Potential air quality impacts from construction of new MOX and support facilities at SRS were analyzed using ISCST3 as described in Appendix F.1. Construction impacts result from emissions from diesel fuel-burning construction equipment, particulate matter emissions from disturbance of soil by construction equipment and other vehicles (construction fugitive emissions), operation of a concrete batch plant, employee vehicles, and trucks moving materials and wastes. Emissions from construction of a new facility are higher than for modification of an existing facility described previously. Emissions from these sources are summarized in Table G–65.

Maximum air pollutant concentrations from construction activities are summarized in Table G–66.

Table G–65. Emissions (kg/yr) From Construction of New MOX Facility at SRS

Pollutant	Construction			
	Diesel Equipment	Fugitive Emissions ^a	Concrete Batch Plant	Vehicles
Carbon monoxide	3,840	0	0	33,600
Nitrogen dioxide	10,100	0	0	9,740
PM ₁₀	768 ^b	6,870	1,310 ^b	34,400
Sulfur dioxide	1,020	0	0	0
Volatile organic compounds	792	0	0	4,490
Total suspended particulates	768	13,600	1,310	34,400
Toxics ^c	0	<1	0	0

^a Does not include fugitive emissions from the concrete batch plant.

^b PM₁₀ emissions were assumed to be the same as total suspended particulate emissions for this analysis resulting in some overestimate of PM₁₀ concentrations.

^c Various toxic air pollutants (e.g., lead, benzene, hexane) could be emitted during construction.

Source: UC 1998h.

Table G–66. Concentrations (μg/m³) From Construction of New MOX Facility at SRS

Pollutant	Averaging Period	Most Stringent			
		Standard or Guideline ^a	No Action	Contribution	Total
Carbon monoxide	8 hours	10,000	671	0.547	672
	1 hour	40,000	5,100	2.48	5,100
Nitrogen dioxide	Annual	100	11.4	0.0207	11.4
	PM ₁₀	50	4.94	0.0185	4.96
Sulfur dioxide	24 hours	150	85.7	1.8	87.5
	Annual	80	16.7	0.0021	16.7
Total suspended particulates	24 hours	365	222	0.0517	222
	3 hours	1,300	725	0.31	725
Toxics ^b	Annual	75	45.4	0.0321	45.4
	24 hours	150	20.7	0.000224	20.7

^a The more stringent of the Federal and State standards is presented if both exist for the averaging period.

^b Various toxic air pollutants (e.g., lead, benzene, hexane) could be emitted during construction and were analyzed as benzene.

Source: EPA 1997; SCDHEC 1996.

G.4.2.4.2 Operation of MOX Facility

Potential air quality impacts from operation of the new MOX and support facilities at SRS were analyzed using ISCST3 as described in Appendix F.1. Operational impacts result from emissions from boilers, emergency diesel generators, process emissions, employee vehicles, and trucks moving materials and wastes. Emissions from these sources are summarized in Table G–67. Emergency generators were modeled as a volume source. The process stack for radiological emissions was modeled with a 8 m (26 ft) height, 0.3048 m (1.0 ft) diameter, stack exit temperature of 20 °C (68 °F), and an exit velocity of 0.03 m/s (0.1 ft/s). The boiler stack was modeled with a 38.1 m (125 ft) height, 3.01 m (9.9 ft) diameter, stack exit temperature of 160 °C (320 °F), and an exit velocity of 10.67 m/s (35 ft/s) (UC 1998h).

Table G-67. Emissions (kg/yr) From Operation of New MOX Facility at SRS

Pollutant	Emergency			
	Boilers	Generator	Process	Vehicles
Carbon monoxide	2,040	374	0	32,700
Nitrogen dioxide	5,640	1,740	0	9,470
PM ₁₀	276	122	0	33,400
Sulfur dioxide	31,300	114	0	0
Volatile organic compounds	0	142	0	4,370
Total suspended particulates	276	122	0	33,400
[Text deleted.]				
[Text deleted.]				

Source: UC 1998h.

Maximum air pollutant concentrations resulting from the boilers, emergency diesel generators, and process sources, plus the No Action concentrations, are summarized in Table G-68. Radiological impacts, including those from emissions to the air, are discussed in Appendix J.

Table G-68. Concentrations ($\mu\text{g}/\text{m}^3$) From Operation of New MOX Facility at SRS

Pollutant	Averaging Period	Most Stringent			
		Standard or Guideline ^a	No Action	Contribution	Total
Carbon monoxide	8 hours	10,000	671	0.123	671
	1 hour	40,000	5,100	0.371	5,100
Nitrogen dioxide	Annual	100	11.4	0.0105	11.4
	PM ₁₀	Annual	50	4.94	0.00059
Sulfur dioxide	24 hours	150	85.7	0.0108	85.7
	Annual	80	16.7	0.0387	16.7
	24 hours	365	222	0.531	222
Total suspended particulates	3 hours	1,300	725	1.39	726
	Annual	75	45.4	0.00059	45.4
[Text deleted.]					

^a The more stringent of the Federal and State standards is presented if both exist for the averaging period.

[Text deleted.]

Source: EPA 1997; SCDHEC 1996.

G.4.2.5 Pit Conversion and Immobilization Facilities

G.4.2.5.1 Construction of Pit Conversion and Immobilization Facilities

Potential air quality impacts from construction of new pit conversion, immobilization (ceramic or glass), and support facilities at SRS were analyzed using ISCST3 as described in Appendix F.1. [Text deleted.] Construction impacts result from emissions from fuel-burning construction equipment, particulate matter emissions from soil disturbance by construction equipment and other vehicles (construction fugitive emissions), operation of a concrete batch plant, employee vehicles, and trucks moving materials and wastes. Emissions from these sources are summarized in Table G-69.

Table G-69. Emissions (kg/yr) From Construction of New Pit Conversion and Immobilization Facilities at SRS

Pollutant	Pit Conversion		Immobilization (Ceramic or Glass)			
	Diesel Equipment and Construction Fugitive Emissions	Veh	Diesel Equipment	Construction Fugitive Emissions ^a	Concrete Batch Plant	Veh
Carbon monoxide	6,400	38,600	20,300	0	0	48,700
Nitrogen dioxide	29,200	11,200	52,700	0	0	14,100
PM ₁₀	20,300	39,500	3,930 ^b	11,300	2,610 ^b	49,900
Sulfur dioxide	1,900	0	24,400	0	0	0
Volatile organic compounds	2,400	5,160	3,900	0	0	6,520
Total suspended particulates	47,500	39,500	3,930	21,600	2,610	49,900

^a Does not include fugitive emissions from concrete batch plant.

^b PM₁₀ emissions were assumed to be the same as total suspended particulate emissions for this analysis, resulting in some overestimate of PM₁₀ concentrations.

Key: Veh, vehicles.

Source: UC 1998g, 1999c, 1999d.

Maximum air pollutant concentrations from construction activities are summarized in Table G-70.

Table G-70. Concentrations ($\mu\text{g}/\text{m}^3$) From Construction of New Pit Conversion and Immobilization Facilities at SRS

Pollutant	Averaging Period	Most Stringent	No Action	Pit Conversion	Immobilization (Ceramic or Glass)	Total
		Standard or Guideline ^a				
Carbon monoxide	8 hours	10,000	671	0.911	2.89	675
	1 hour	40,000	5,100	4.14	13.1	5,110
Nitrogen dioxide	Annual	100	11.4	0.0601	0.108	11.5
PM ₁₀	Annual	50	4.94	0.0418	0.0366	5.02
	24 hours	150	85.7	1.03	3.56	90.3
Sulfur dioxide	Annual	80	16.7	0.00391	0.0502	16.7
	24 hours	365	222	0.0964	1.24	223
Total suspended particulates	3 hours	1,300	725	0.578	7.42	733
	Annual	75	45.4	0.0977	0.0581	45.5

^a The more stringent of the Federal and state standards is presented if both exist for the averaging period.

Source: EPA 1997; SCDHEC 1996.

G.4.2.5.2 Operation of Pit Conversion and Immobilization Facilities

Potential air quality impacts from operation of new pit conversion, immobilization (ceramic or glass), and support facilities at SRS were analyzed using ISCST3 as described in Appendix F.1. Operational impacts result from emissions from boilers, emergency diesel generators, process emissions, employee vehicles, and trucks moving

materials and wastes. Emissions from these sources are summarized in Table G-71. Stack parameters used for modeling were as stated previously.

Table G-71. Emissions (kg/yr) From Operation of New Pit Conversion and Immobilization Facilities at SRS

Pollutant	Pit Conversion				Immobilization			
	Boilers	EG	Process	Veh	Boilers	EG	Process	Veh ^a
Carbon monoxide	587	520	0	39,600	370	980	0	46,500
Nitrogen dioxide	20,000	2,000	0	11,500	12,100	4,530	0	13,500
PM ₁₀	1,400	50	0	40,500	940	320	0	47,600
Sulfur dioxide	33,300	34	0	0	35,500	300	0	0
Volatile organic compounds	69	58	0	5,300	80	370	0	6,220
Total suspended particulates	1,400	50	0	40,500	940	320	0	47,600

^a For 50-t (55-ton) case.

[Text deleted.]

Key: EG, emergency generator; Veh, vehicles.

Source: UC 1998g, 1999c, 1999d.

Maximum air pollutant concentrations resulting from the boilers, emergency diesel generators, and process sources, plus the No Action concentrations, are summarized in Table G-72. Radiological impacts, including those from emissions to the air, are discussed in Appendix J.

Table G-72. Concentrations ($\mu\text{g}/\text{m}^3$) From Operation of New Pit Conversion and Immobilization Facilities at SRS

Pollutant	Averaging Period	Most Stringent	No Action	Pit Conversion	Immobilization (Ceramic or Glass)	Total
		Standard or Guideline ^a				
Carbon monoxide	8 hours	10,000	671	0.0942	0.152	671
	1 hour	40,000	5,100	0.373	0.657	5,100
Nitrogen dioxide	Annual	100	11.4	0.0287	0.0242	11.4
PM ₁₀	Annual	50	4.94	0.00182	0.00181	4.94
	24 hours	150	85.7	0.026	0.032	85.8
Sulfur dioxide	Annual	80	16.7	0.041	0.0442	16.8
	24 hours	365	222	0.56	0.61	223
	3 hours	1,300	725	1.46	1.63	728
Total suspended particulates	Annual	75	45.4	0.00182	0.00181	45.4

^a The more stringent of the Federal and State standards is presented if both exist for the averaging period.

[Text deleted.]

Source: EPA 1997; SCDHEC 1996.

G.4.2.6 Pit Conversion and MOX Facilities

G.4.2.6.1 Construction of Pit Conversion and MOX Facilities

Potential air quality impacts from construction of new pit conversion, MOX, and support facilities at SRS were analyzed using ISCST3 as described in Appendix F.1. Construction impacts result from emissions from diesel

fuel-burning construction equipment, particulate matter emissions from soil disturbance by construction equipment and other vehicles (construction fugitive emissions), operation of a concrete batch plant, employee vehicles, and trucks moving materials and wastes. Emissions from these sources are summarized in Table G-73.

Table G-73. Emissions (kg/yr) From Construction of New Pit Conversion and MOX Facilities at SRS

Pollutant	Pit Conversion		MOX			
	Diesel Equipment and Construction Fugitive Emissions	Vehicles	Diesel Equipment	Construction Fugitive Emissions ^a	Concrete Batch Plant	Vehicles
Carbon monoxide	6,400	38,600	3,840	0	0	33,600
Nitrogen dioxide	29,200	11,200	10,100	0	0	9,740
PM ₁₀	20,300	39,500	768 ^b	6,870	1,310 ^b	34,400
Sulfur dioxide	1,900	0	1,020	0	0	0
Volatile organic compounds	2,400	5,160	792	0	0	4,490
Total suspended particulates	47,500	39,500	768	13,600	1,310	34,400
Toxics ^c	0	0	0	<1	0	0

^a Does not include fugitive emissions from the concrete batch plant.

^b PM₁₀ emissions were assumed to be the same as total suspended particulate emissions for this analysis, resulting in some overestimate of PM₁₀ concentrations.

^c Various toxic air pollutants (e.g., lead, benzene, hexane) could be emitted during construction.

Source: UC 1998g, 1998h.

Maximum air pollutant concentrations from construction activities are summarized in Table G-74.

Table G-74. Concentrations ($\mu\text{g}/\text{m}^3$) From Construction of New Pit Conversion and MOX Facilities at SRS

Pollutant	Averaging Period	Most Stringent		Pit Conversion	MOX	Total
		Standard or Guideline ^a	No Action			
Carbon monoxide	8 hours	10,000	671	0.911	0.547	672
	1 hour	40,000	5,100	4.14	2.48	5,110
Nitrogen dioxide	Annual	100	11.4	0.0601	0.0207	11.5
	PM ₁₀	Annual	50	4.94	0.0418	0.0185
24 hours		150	85.7	1.03	1.8	88.5
Sulfur dioxide	Annual	80	16.7	0.00391	0.0021	16.7
	24 hours	365	222	0.0964	0.0517	222
	3 hours	1,300	725	0.578	0.31	726
Total suspended particulates	Annual	75	45.4	0.0977	0.0321	45.5
Toxics ^b	24 hours	150	20.7	0	0.000224	20.7

^a The more stringent of the Federal and State standards is presented if both exist for the averaging period.

^b Various toxic air pollutants (e.g., lead, benzene, and hexane) could be emitted during construction and were analyzed as benzene.

Source: EPA 1997; SCDHEC 1996.

G.4.2.6.2 Operation of Pit Conversion and MOX Facilities

Potential air quality impacts from operation of the new pit conversion and MOX facilities at SRS were analyzed using ISCST3 as described in Appendix F.1. Operational impacts result from emissions from boilers, emergency diesel generators, process emissions, employee vehicles, and trucks moving materials and wastes. Emissions from these sources are summarized in Table G-75. Stack parameters used for modeling were as stated previously.

Table G-75. Emissions (kg/yr) From Operation of New Pit Conversion and MOX Facilities at SRS

Pollutant	Pit Conversion				MOX			
	Boilers	EG	Process	Vehicles	Boilers	EG	Process	Vehicles
Carbon monoxide	587	520	0	39,600	2,040	374	0	32,700
Nitrogen dioxide	20,000	2,000	0	11,500	5,640	1,740	0	9,470
PM ₁₀	1,400	50	0	40,500	276	122	0	33,400
Sulfur dioxide	33,300	34	0	0	31,300	114	0	0
Volatile organic compounds	69	58	0	5,300	0	142	0	4,370
Total suspended particulates	1,400	50	0	40,500	276	122	0	33,400
[Text deleted.]								

[Text deleted.]

Key: EG, emergency generator.

Source: UC 1998g, 1998h.

Maximum air pollutant concentrations resulting from the boilers, emergency diesel generators, and process sources, plus the No Action concentrations, are summarized in Table G-76. Radiological impacts, including those from emissions to the air, are discussed in Appendix J.

Table G-76. Concentrations ($\mu\text{g}/\text{m}^3$) From Operation of New Pit Conversion and MOX Facilities at SRS

Pollutant	Averaging Period	Most Stringent				
		Standard or Guideline ^a	No Action	Pit Conversion	MOX	Total
Carbon monoxide	8 hours	10,000	671	0.0942	0.123	671
	1 hour	40,000	5,100	0.373	0.371	5,100
Nitrogen dioxide	Annual	100	11.4	0.0287	0.0105	11.4
	24 hours	50	4.94	0.00182	0.00059	4.94
Sulfur dioxide	Annual	80	16.7	0.041	0.0387	16.8
	24 hours	365	222	0.56	0.531	223
Total suspended particulates	3 hours	1,300	725	1.46	1.39	728
	Annual	75	45.4	0.00182	0.00059	45.4
[Text deleted.]						

^a The more stringent of the Federal and State standards is presented if both exist for the averaging period.

[Text deleted.]

Source: EPA 1997; SCDHEC 1996.

G.4.2.7 Immobilization and MOX Facilities

G.4.2.7.1 Construction of Immobilization and MOX Facilities

Potential air quality impacts from construction of new immobilization (ceramic or glass), MOX, and support facilities at SRS were analyzed using ISCST3 as described in Appendix F.1. [Text deleted.] Construction impacts result from emissions from diesel fuel-burning construction equipment, particulate matter emissions from disturbance of soil by construction equipment and other vehicles (construction fugitive emissions), operation of a concrete batch plant, employee vehicles, and trucks moving materials and wastes. Emissions from these sources are summarized in Table G-77.

Table G-77. Emissions (kg/yr) From Construction of New Immobilization and MOX Facilities at SRS

Pollutant	Immobilization (Ceramic or Glass)				MOX			
	DE	CFE ^a	CBP	Veh	DE	CFE ^a	CBP	Veh
Carbon monoxide	20,300	0	0	48,700	3,840	0	0	33,600
Nitrogen dioxide	52,700	0	0	14,100	10,100	0	0	9,740
PM ₁₀	3,930 ^b	11,300	2,610 ^b	49,900	768 ^b	6,810	1,310 ^b	34,400
Sulfur dioxide	24,400	0	0	0	1,020	0	0	0
Volatile organic compounds	3,900	0	0	6,520	792	0	0	4,490
Total suspended particulates	3,930	21,600	2,610	49,900	768	13,600	1,310	34,400
Toxics ^c	0	0	0	0	0	<1	0	0

^a Does not include fugitive emissions from concrete batch plant.

^b PM₁₀ emissions were assumed to be the same as total suspended particulate emissions for this analysis, resulting in some overestimate of PM₁₀ concentrations.

^c Various toxic air pollutants (e.g., lead, benzene, hexane) could be emitted during construction.

Key: CBP, concrete batch plant; CFE, construction fugitive emissions; DE, diesel equipment; Veh, vehicles.

Source: UC 1998h, 1999c, 1999d.

Maximum air pollutant concentrations from construction activities are summarized in Table G-78.

Table G-78. Concentrations (μg/m³) From Construction of New Immobilization and MOX Facilities at SRS

Pollutant	Averaging Period	Most Stringent	No Action	Immobilization	MOX	Total
		Standard or Guideline ^a		(Ceramic or Glass)		
Carbon monoxide	8 hours	10,000	671	2.89	0.547	675
	1 hour	40,000	5,100	13.1	2.48	5,110
Nitrogen dioxide	Annual	100	11.4	0.108	0.0207	11.5
PM ₁₀	Annual	50	4.94	0.0366	0.0185	5
	24 hours	150	85.7	3.56	1.8	91.1
Sulfur dioxide	Annual	80	16.7	0.0502	0.0021	16.7
	24 hours	365	222	1.24	0.0517	223
	3 hours	1,300	725	7.42	0.31	733
Total suspended particulates	Annual	75	45.4	0.0581	0.0321	45.5
Toxics ^b	24 hours	150	20.7	0	0.000224	20.7

^a The more stringent of the Federal and State standards is presented if both exist for the averaging period.

^b Various toxic air pollutants (e.g., lead, benzene, hexane) could be emitted during construction and were analyzed as benzene.

Source: EPA 1997; SCDHEC 1996.

G.4.2.7.2 Operation of Immobilization and MOX Facilities

Potential air quality impacts from operation of new immobilization (ceramic or glass), MOX, and support facilities at SRS were analyzed using ISCST3 as described in Appendix F.1. Operational impacts result from emissions from boilers, emergency diesel generators, process emissions, employee vehicles, and trucks moving materials and wastes. Emissions from these sources are summarized in Table G-79. Stack parameters used for modeling were as stated previously.

Table G-79. Emissions (kg/yr) From Operation of New Immobilization and MOX Facilities at SRS

Pollutant	Immobilization				MOX			
	Boilers	Emergency Generator	Process ^a	Vehicles	Boilers	Emergency Generator	Process	Vehicles
Carbon monoxide	370	980	0	44,400	2,040	374	0	32,700
Nitrogen dioxide	12,100	4,530	0	12,900	5,640	1,740	0	9,470
PM ₁₀	940	320	0	45,400	276	122	0	33,400
Sulfur dioxide	35,500	300	0	0	31,300	114	0	0
Volatile organic compounds	80	370	0	5,940	0	142	0	4,370
Total suspended particulates	940	320	0	45,400	276	122	0	33,400

[Text deleted.]

^a Ceramic or glass.

[Text deleted.]

Source: UC 1998h, 1999c, 1999d.

Maximum air pollutant concentrations resulting from the boilers, emergency diesel generators, and process sources, plus the No Action concentrations, are summarized in Table G-80. Radiological impacts, including those from emissions to the air, are discussed in Appendix J.

Table G–80. Concentrations ($\mu\text{g}/\text{m}^3$) From Operation of New Immobilization and MOX Facilities at SRS

Pollutant	Averaging Period	Most Stringent				
		Standard or Guideline ^a	No Action	Immobilization	MOX	Total
Carbon monoxide	8 hours	10,000	671	0.152	0.123	671
	1 hour	40,000	5,100	0.657	0.371	5,100
Nitrogen dioxide	Annual	100	11.4	0.0242	0.0105	11.4
PM ₁₀	Annual	50	4.94	0.00181	0.00059	4.94
	24 hours	150	85.7	0.032	0.0108	85.8
Sulfur dioxide	Annual	80	16.7	0.0442	0.0388	16.8
	24 hours	365	222	0.61	0.531	223
	3 hours	1,300	725	1.63	1.39	728
Total suspended particulates	Annual	75	45.4	0.00181	0.00059	45.4

[Text deleted.]

^a The more stringent of the Federal and State standards is presented if both exist for the averaging period.

[Text deleted.]

Source: EPA 1997; SCDHEC 1996.

G.4.2.8 Pit Conversion, Immobilization, and MOX Facilities

G.4.2.8.1 Construction of Pit Conversion, Immobilization, and MOX Facilities

Potential air quality impacts from construction of new pit conversion, immobilization (ceramic or glass), MOX, and support facilities at SRS were analyzed using ISCST3 as described in Appendix F.1. [Text deleted.] Construction impacts result from emissions from diesel fuel-burning construction equipment, particulate matter emissions from soil disturbance by construction equipment and other vehicles (construction fugitive emissions), operation of a concrete batch plant, employee vehicles, and trucks moving materials and wastes. Emissions from these sources are summarized in Table G–81.

Table G–81. Emissions (kg/yr) From Construction of New Pit Conversion, Immobilization, and MOX Facilities at SRS

Pollutant	Pit Conversion		Immobilization (Ceramic or Glass)				MOX			
	DE & CFE	Veh	DE	CFE ^a	CBP	Veh	DE	CFE ^a	CBP	Veh
Carbon monoxide	6,400	38,600	20,300	0	0	48,700	3,840	0	0	33,600
Nitrogen dioxide	29,200	11,200	52,700	0	0	14,100	10,080	0	0	9,740
PM ₁₀	20,300	39,500	3,930 ^b	11,300	2,610 ^b	49,900	768 ^b	6,870	1,310 ^b	34,400
Sulfur dioxide	1,900	0	24,400	0	0	0	1,020	0	0	0
Volatile organic compounds	2,400	5,160	3,900	0	0	6,520	792	0	0	4,490
Total suspended particulates	47,500	39,500	3,930	21,600	2,610	49,900	768	13,600	1,310	34,400
Toxics ^c	0	0	0	0	0	0	0	<1	0	0

^a Does not include fugitive emissions from the concrete batch plant.

^b PM₁₀ emissions were assumed to be the same as total suspended particulate emissions for this analysis, resulting in some overestimate of PM₁₀ concentrations.

^c Various toxic air pollutants (e.g., lead, benzene, hexane) could be emitted during construction.

Key: CBP, concrete batch plant; CFE, construction fugitive emissions; DE, diesel equipment; Veh, vehicles.

Source: UC 1998g, 1998h, 1999c, 1999d.

Maximum air pollutant concentrations from construction activities are summarized in Table G–82.

Table G–82. Concentrations ($\mu\text{g}/\text{m}^3$) From Construction of New Pit Conversion, Immobilization, and MOX Facilities at SRS

Pollutant	Averaging Period	Most Stringent					Total
		Standard or Guideline ^a	No Action	Pit Conversion	Immobilization (Ceramic or Glass)	MOX	
Carbon monoxide	8 hours	10,000	671	0.911	2.89	0.547	675
	1 hour	40,000	5,100	4.14	13.1	2.48	5,120
Nitrogen dioxide	Annual	100	11.4	0.0601	0.108	0.0207	11.6
PM ₁₀	Annual	50	4.94	0.0418	0.0366	0.0185	5.04
	24 hours	150	85.7	1.03	3.56	1.8	92.1
Sulfur dioxide	Annual	80	16.7	0.00391	0.0502	0.0021	16.7
	24 hours	365	222	0.0964	1.24	0.0517	223
	3 hours	1,300	725	0.578	7.42	0.31	733
Total suspended particulates	Annual	75	45.4	0.0977	0.0581	0.0321	45.6
Toxics ^b	24 hours	150	20.7	0	0	0.000224	20.7

^a The more stringent of the Federal and State standards is presented if both exist for the averaging period.

^b Various toxic air pollutants (e.g., lead, benzene, hexane) could be emitted during construction and were analyzed as benzene.

Source: EPA 1997; SCDHEC 1996.

G.4.2.8.2 Operation of Pit Conversion, Immobilization, and MOX Facilities

Potential air quality impacts from operation of the three surplus plutonium disposition and support facilities at SRS were analyzed using ISCST3 as described in Appendix F.1. Operational impacts result from emissions from emergency diesel generators, process emissions, steam boilers, employee vehicles, and trucks moving materials and wastes. Emissions from these sources are summarized in Table G–83. Stack parameters used for modeling were as stated previously.

Table G–83. Emissions (kg/yr) From Operation of New Pit Conversion, Immobilization, and MOX Facilities at SRS

Pollutant	Pit Conversion				Immobilization				MOX			
	Boilers	EG	Process	Veh	Boilers	EG	Process ^a	Veh	Boilers	EG	Process	Veh
CO	587	520	0	39,600	370	980	0	44,400	2,040	374	0	32,700
NO ₂	20,000	2,000	0	11,500	12,100	4,530	0	12,900	5,640	1,740	0	9,470
PM ₁₀	1,400	50	0	40,500	940	320	0	45,400	276	122	0	33,400
SO ₂	33,300	34	0	0	35,500	300	0	0	31,300	114	0	0
VOC	69	58	0	5,300	80	370	0	5,940	0	142	0	4,370
TSP	1,400	50	0	40,500	940	320	0	45,400	276	122	0	33,400

[Text deleted.]

^a Ceramic or glass.

[Text deleted.]

Key: CO, carbon monoxide; EG, emergency generator; NO₂, nitrogen dioxide; SO₂, sulfur dioxide; TSP, total suspended particulates; Veh, vehicles; VOC, volatile organic compounds.

Source: UC 1998g, 1998h, 1999c, 1999d.

Maximum air pollutant concentrations resulting from the boilers, emergency diesel generators, and process sources, plus the No Action concentrations, are summarized in Table G–84. Radiological impacts, including those emissions to the air, are discussed in Appendix J.

Table G-84. Concentrations ($\mu\text{g}/\text{m}^3$) From Operation of New Pit Conversion, Immobilization, and MOX Facilities at SRS

Pollutant	Averaging Period	Most Stringent		Immobilization			Total
		Standard or Guideline ^a	No Action	Pit Conversion	(Ceramic or Glass)	MOX	
Carbon monoxide	8 hours	10,000	671	0.0942	0.152	0.123	671
	1 hour	40,000	5,100	0.373	0.657	0.371	5,100
Nitrogen dioxide	Annual	100	11.4	0.0287	0.0242	0.0105	11.4
PM ₁₀	Annual	50	4.94	0.00182	0.00181	0.00059	4.94
	24 hours	150	85.7	0.0261	0.032	0.0108	85.8
Sulfur dioxide	Annual	80	16.7	0.041	0.0442	0.0387	16.8
	24 hours	365	222	0.56	0.61	0.531	224
	3 hours	1,300	725	1.46	1.63	1.39	729
Total suspended particulates	Annual	75	45.4	0.00182	0.00181	0.00059	45.4

[Text deleted.]

^a The more stringent of the Federal and State standards is presented if both exist for the averaging period.

[Text deleted.]

Source: EPA 1997; SCDHEC 1996.

G.5 REFERENCES

DOE (U.S. Department of Energy), 1995a, *Savannah River Site Waste Management Final Environmental Impact Statement*, DOE/EIS-0217, Savannah River Operations Office, Aiken, SC, July.

DOE (U.S. Department of Energy), 1995b, *Final Environmental Impact Statement, Interim Management of Nuclear Materials*, DOE/EIS-0220, Savannah River Operations Office, Aiken, SC, October.

DOE (U.S. Department of Energy), 1995c, *Department of Energy Programmatic Spent Nuclear Fuel Management and Idaho National Engineering Laboratory Environmental Restoration and Waste Management Programs Final Environmental Impact Statement*, DOE/EIS-0203-F, Office of Environmental Management, Idaho Operations Office, Idaho Falls, ID, April.

DOE (U.S. Department of Energy), 1995d, *Final Programmatic Environmental Impact Statement for Tritium Supply and Recycling*, DOE/EIS-0161, Office of Reconfiguration, Washington, DC, October 19.

DOE (U.S. Department of Energy), 1996a, *Storage and Disposition of Weapons-Usable Fissile Materials Final Programmatic Environmental Impact Statement*, DOE/EIS-0229, Office of Fissile Materials Disposition, Washington, DC, December.

DOE (U.S. Department of Energy), 1996b, *Tank Waste Remediation System, Hanford Site, Richland, Washington, Final Environmental Impact Statement*, DOE/EIS-0189, Richland Operations Office, Richland, WA, August.

DOE (U.S. Department of Energy), 1996c, *Final Environmental Impact Statement for the Continued Operation of the Pantex Plant and Associated Storage of Nuclear Weapon Components*, DOE/EIS-0225, Albuquerque Operations Office, Albuquerque, NM, November.

DOE (U.S. Department of Energy), 1996d, *Disposition of Surplus Highly Enriched Uranium Final Environmental Impact Statement*, DOE/EIS-0240, Office of Fissile Materials Disposition, Washington, DC, June.

DOE (U.S. Department of Energy), 1998a, *Savannah River Site Spent Nuclear Fuel Management Draft Environmental Impact Statement*, DOE/EIS-0279D, Savannah River Operations Office, Aiken, SC, December.

DOE (U.S. Department of Energy), 1998b, *Draft Environmental Impact Statement for the Construction and Operation of a Tritium Extraction Facility at the Savannah River Site*, DOE/EIS-0271D, Savannah River Operations Office, Aiken, SC, May.

DOE (U.S. Department of Energy), 1999, *Advanced Mixed Waste Treatment Project Final Environmental Impact Statement*, DOE/EIS-0290, Idaho Operations Office, Idaho Falls, ID, January.

EPA (U.S. Environmental Protection Agency), 1997, *National Primary and Secondary Ambient Air Quality Standards*, 40 CFR 50, March 31.

ID DHW (Idaho Department of Health and Welfare), 1995, *Rules for the Control of Air Pollution in Idaho*, 577, "Ambient Standards for Specific Air Pollutants"; 585, "Toxic Air Pollutants Non-Carcinogenic Increments"; 586, "Toxic Air Pollutants Carcinogenic Increments," IDAPA 16, Title 01, Chapter 01, Boise, ID.

SCDHEC (South Carolina Department of Health and Environmental Control), 1996, *Regulation 61-62, Air Pollution Control Regulations and Standards*, Standard 2, “Ambient Air Quality Standards”; Standard 8, “Toxic Air Pollutants,” Air Pollution Control, Columbia, SC.

TNRCC (Texas Natural Resource Conservation Commission), 1997a, Toxicology and Risk Assessment (TARA) Section Staff, memo to Interested Parties, *1997 Effects Screening Levels (ESLs) List*, Austin, TX, September 5.

TNRCC (Texas Natural Resource Conservation Commission), 1997b, *TNRCC Rules: 101, “General Rules (Air Quality)”*; 112, “Control of Air Pollution from Sulfur Compounds (Reg. II)”; 113, “Control of Air Pollution from Toxic Materials (Reg. III),” Austin, TX.

UC (Regents of the University of California), 1998a, *Pit Disassembly and Conversion Facility, Environmental Impact Statement Data Report—Hanford Site*, LA-UR-97-2907, Los Alamos National Laboratory, Los Alamos, NM, June 1.

UC (Regents of the University of California), 1998b, *Response to the Surplus Plutonium Disposition Environmental Impact Statement Data Call for a Mixed Oxide Fuel Fabrication Facility Located at the Hanford Site*, rev. 3, LA-UR-97-2064, Los Alamos National Laboratory, Los Alamos, NM, June 22.

UC (Regents of the University of California), 1998c, *Pit Disassembly and Conversion Facility, Environmental Impact Statement Data Report—Idaho National Engineering and Environmental Laboratory*, LA-UR-97-2908, Los Alamos National Laboratory, Los Alamos, NM, June 1.

UC (Regents of the University of California), 1998d, *Response to the Surplus Plutonium Disposition Environmental Impact Statement Data Call for a Mixed Oxide Fuel Fabrication Facility Located at the Idaho National Engineering and Environmental Laboratory*, rev. 3, LA-UR-97-2065, Los Alamos National Laboratory, Los Alamos, NM, June 22.

UC (Regents of the University of California), 1998e, *Pit Disassembly and Conversion Facility, Environmental Impact Statement Data Report—Pantex Plant*, LA-UR-97-2909, Los Alamos National Laboratory, Los Alamos, NM, June 1.

UC (Regents of the University of California), 1998f, *Response to the Surplus Plutonium Disposition Environmental Impact Statement Data Call for a Mixed Oxide Fuel Fabrication Facility Located at the Pantex Plant*, rev. 3, LA-UR-97-2067, Los Alamos National Laboratory, Los Alamos, NM, June 22.

UC (Regents of the University of California), 1998g, *Pit Disassembly and Conversion Facility, Environmental Impact Statement Data Report—Savannah River Site*, LA-UR-97-2910, Los Alamos National Laboratory, Los Alamos, NM, June 1.

UC (Regents of the University of California), 1998h, *Response to the Surplus Plutonium Disposition Environmental Impact Statement Data Call for a Mixed Oxide Fuel Fabrication Facility Located at the Savannah River Site*, rev. 3, LA-UR-97-2066, Los Alamos National Laboratory, Los Alamos, NM, June 22.

| [Text deleted.]

UC (Regents of the University of California), 1999a, *Fissile Materials Disposition Program, EIS Data Call Report: Plutonium Immobilization Plant Using Ceramic in Existing Facilities at Hanford*, rev. 1, UCRL-ID-128275, Lawrence Livermore National Laboratory, Livermore, CA, September.

UC (Regents of the University of California), 1999b, *Fissile Materials Disposition Program, EIS Data Call Report: Plutonium Immobilization Plant Using Glass in Existing Facilities at Hanford*, rev. 1, UCRL-ID-128276, Lawrence Livermore National Laboratory, Livermore, CA, September.

UC (Regents of the University of California), 1999c, *Fissile Materials Disposition Program, EIS Data Call Report: Plutonium Immobilization Plant Using Ceramic in New Facilities at the Savannah River Site*, rev. 1, UCRL-ID-128273, Lawrence Livermore National Laboratory, Livermore, CA, September.

UC (Regents of the University of California), 1999d, *Fissile Materials Disposition Program, EIS Data Call Report: Plutonium Immobilization Plant Using Glass in New Facilities at the Savannah River Site*, rev. 1, UCRL-ID-128271, Lawrence Livermore National Laboratory, Livermore, CA, September.

WDEC (Washington Department of Ecology), 1994, *Washington Administrative Code, Title 173*, Chapter 173-460, "Controls for New Sources of Toxic Air Pollutants"; Chapter 173-470, "Standards for Particulate Matter"; Chapter 173-474, "Ambient Air Quality Standards for Sulfur Oxides"; Chapter 173-475, "Ambient Air Quality Standards for Carbon Monoxide, Ozone, and Nitrogen Dioxide"; Chapter 173-481, "Ambient Air Quality and Environmental Standards for Fluorides," January 14.

Appendix I Socioeconomics

This appendix presents detailed information on the potential socioeconomic impacts associated with the influx of construction workers during the construction of the proposed surplus plutonium disposition facilities as well as the workers needed to operate the proposed facilities. This information supports the socioeconomic assessments described in Chapter 4. Site-specific input data used in the evaluation of these socioeconomic impacts are provided or referenced where appropriate, including projections for employment, unemployment, population, housing units, student enrollment, teachers employed, police officers, firefighters, hospital beds, and doctors. Tables I-1 through I-40 present data¹ for the four candidate U.S. Department of Energy sites: the Hanford Site (Hanford), Idaho National Engineering and Environmental Laboratory (INEEL), the Pantex Plant (Pantex), and the Savannah River Site (SRS).

I.1 HANFORD

Table I-1. Hanford Projected Site Employment

Year	Employment	Change From Previous (%)	Change From 1997 (%)
1997	12,882	-	-
2000	10,800	-16.16	-16.16
2005	11,000	1.85	-14.61
2010	20,600	87.27	59.91
2015	12,100	-41.26	-6.07
2020	11,900	-1.65	-7.62

Source: Mecca 1997a, 1997b; Teal memo.

**Table I-2. Hanford Regional Economic Area Projected
Employment and Economy, 1996-2010**

Regional Economic Area	1996	2000	2005	2010
Civilian labor force	344,611	369,570	393,230	418,465
Total employment	306,396	328,709	349,790	372,278
Unemployment rate (%)	11.1	11.1	11.0	11.0

Source: DOL 1999; Washington State Office of Financial Management 1995.

Table I-3. Hanford Region of Influence Projected Population, 1996-2010

County	1996	2000	2005	2010
Benton	134,359	149,100	157,549	166,476
Franklin	45,590	50,683	54,562	58,738
ROI total	179,949	199,783	212,111	225,214

Source: DOC 1997; Washington State Office of Financial Management 1995.

¹ Table totals may not add precisely due to rounding.

Table I-4. Hanford Region of Influence Projected Number of Owner and Renter Housing Units, 1990-2010

County	1990	1996	2000	2005	2010
Benton	44,877	52,462	58,217	61,516	65,002
Franklin	13,664	16,016	17,806	19,168	20,635
ROI total	58,541	68,478	76,023	80,684	85,637

Source: DOC 1994; Washington State Office of Financial Management 1995.

Table I-5. Hanford Region of Influence Projected Student Enrollment, 1997-2010

County	1997	Capacity		2000	2005	2010
			(%)			
Benton County	28,142		90.7	30,427	32,151	33,973
Findley	1,130		100.0	1,222	1,291	1,364
Kennewick	13,462		83.0	14,555	15,380	16,251
Kiona-Benton	1,701		100.0	1,839	1,943	2,053
Patterson	73		80.0	79	83	88
Prosser	2,794		98.0	3,021	3,192	3,373
Richland	8,982		99.5	9,711	10,262	10,843
Franklin County	10,064		97.7	10,896	11,730	12,628
Kahlotus	98		85.0	106	114	123
North Franklin	1,905		90.0	2,062	2,220	2,390
Pasco	8,048		100.0	8,713	9,380	10,098
Star School	13		65.0	14	15	16
ROI total	38,206		92.5	41,323	43,881	46,601

Source: Nemeth 1997a; Washington State Office of Financial Management 1995.

Table I-6. Hanford Region of Influence Projected Number of Teachers, 1997-2010

County	1997	Student/Teacher		2000	2005	2010
			Ratio			
Benton County	1,785		15.8	1,930	2,039	2,154
Findley	76		14.9	82	87	92
Kennewick	822		16.4	889	939	992
Kiona-Benton	94		18.1	102	107	113
Patterson	4.5		16.2	5	5	5
Prosser	164		17.0	177	187	198
Richland	624		14.4	675	713	753
Franklin County	598		16.8	647	697	750
Kahlotus	14		7.0	15	16	18
North Franklin	132		14.4	143	154	166
Pasco	450		17.9	487	524	565
Star School	2		6.5	2	2	3
ROI total	2,383		16.0	2,577	2,736	2,905

Source: Nemeth 1997a; Washington State Office of Financial Management 1995.

Table I-7. Hanford Region of Influence Projected Number of Sworn Police Officers, 1997–2010

County	1997	2000	2005	2010
Benton	208	225	238	251
Franklin	73	79	85	92
ROI total	281	304	323	343

Source: Nemeth 1997b; Washington State Office of Financial Management 1995.

Table I-8. Hanford Region of Influence Projected Number of Firefighters, 1997–2010

County	1997	2000	2005	2010
Benton	369	399	422	445
Franklin	247	267	288	310
ROI total	616	666	710	755

Source: Nemeth 1997b; Washington State Office of Financial Management 1995.

Table I-9. Hanford Region of Influence Projected Number of Hospital Beds, 1997–2010

County	1997	2000	2005	2010
Benton	251	271	287	303
Franklin	132	143	154	166
ROI total	383	414	441	469

Source: Nemeth 1997c; Washington State Office of Financial Management 1995.

Table I-10. Hanford Region of Influence Projected Number of Doctors, 1996–2010

County	1996	2000	2005	2010
Benton	208	225	238	251
Franklin	49	53	57	61
ROI total	257	278	295	313

Source: Randolph 1997; Washington State Office of Financial Management 1995.

I.2 INEEL

Table I-11. INEEL Projected Site Employment

Year	Employment	Change From Previous (%)	Change From 1997 (%)
1997	8,291	–	–
2000	7,250	-12.56	-12.56
2005	7,250	0.00	-12.56
2010	7,250	0.00	-12.56
2015	7,250	0.00	-12.56
2020	7,250	0.00	-12.56

Source: Abbott et al. 1997.

Table I-12. INEEL Regional Economic Area Projected Employment and Economy, 1996–2010

Regional Economic Area	1996	2000	2005	2010
Civilian labor force	150,403	161,149	168,979	177,199
Total employment	143,182	153,440	169,884	168,784
Unemployment rate (%)	4.8	4.8	4.8	4.7

Source: DOL 1999; Idaho Power 1996; State of Wyoming, Administration and Information 1996.

Table I-13. INEEL Region of Influence Projected Population, 1996–2010

County	1996	2000	2005	2010
Bannock	73,608	78,600	81,808	85,147
Bingham	41,366	44,426	46,236	48,120
Bonneville	79,670	85,650	89,154	92,802
Jefferson	18,903	20,609	21,646	22,736
ROI total	213,547	229,285	238,844	248,804

Source: DOC 1997; Idaho Power 1996; State of Wyoming, Administration and Information 1996.

Table I-14. INEEL Region of Influence Projected Number of Owner and Renter Housing Units, 1990–2010

County	1990	1996	2000	2005	2010
Bannock	25,694	28,352	30,275	31,510	32,796
Bingham	12,664	14,095	15,138	15,754	16,396
Bonneville	26,049	29,036	31,215	32,493	33,822
Jefferson	5,353	6,094	6,643	6,978	7,329
ROI total	69,760	77,576	83,271	86,735	90,344

Source: DOC 1994; Idaho Power 1996; State of Wyoming, Administration and Information 1996.

Table I–15. INEEL Region of Influence Projected Student Enrollment, 1997–2010

County	Capacity				
	1997	(%)	2000	2005	2010
Bannock County	14,673	86.5	15,413	16,042	16,697
Marsh Valley	1,609	74.0	1,690	1,759	1,831
Pocatello	13,064	88.3	13,723	14,283	14,866
Bingham County	11,248	84.7	11,867	12,350	12,853
Aberdeen	1,019	90.0	1,075	1,119	1,164
Blackfoot	4,510	90.0	4,758	4,952	5,154
Firth	1,044	88.0	1,101	1,146	1,193
Shelley	2,300	100.0	2,426	2,525	2,628
Snake River	2,375	65.0	2,506	2,608	2,714
Bonneville County	18,737	91.8	19,782	20,592	21,434
Bonneville	7,750	95.0	8,182	8,517	8,866
Idaho Falls	10,927	90.0	11,536	12,009	12,500
Swan Valley	60	50.0	63	66	69
Jefferson County	5,510	90.6	5,879	6,175	6,486
Jefferson	4,033	90.0	4,303	4,520	4,747
Ririe	750	97.0	800	840	883
West Jefferson	727	88.0	776	815	856
ROI total	50,168	88.4	52,941	55,158	57,470

Source: Idaho Power 1996; Nemeth 1997a; State of Wyoming, Administration and Information 1996.

Table I–16. INEEL Region of Influence Projected Number of Teachers, 1997–2010

County	Student/Teacher				
	1997	Ratio	2000	2005	2010
Bannock County	822	17.9	863	899	935
Marsh Valley	113	14.2	119	124	129
Pocatello	709	18.4	745	775	807
Bingham County	619	18.2	653	680	707
Aberdeen	61	16.7	64	67	70
Blackfoot	240	18.8	253	264	274
Firth	65	16.1	69	71	74
Shelley	121	19.0	128	133	138
Snake River	132	18.0	139	145	151
Bonneville County	930	20.1	982	1,022	1,064
Bonneville	425	18.2	449	467	486
Idaho Falls	500	21.9	528	549	572
Swan Valley	5	12.0	5	5	6
Jefferson County	299	18.4	319	335	352
Jefferson	212	19.0	226	238	250
Ririe	41	18.3	44	46	48
West Jefferson	46	15.8	49	52	54
ROI total	2,670	18.8	2,817	2,936	3,059

Source: Idaho Power 1996; Nemeth 1997a; State of Wyoming, Administration and Information 1996.

**Table I–17. INEEL Region of Influence Projected
Number of Sworn Police Officers, 1997–2010**

County	1997	2000	2005	2010
Bannock	214	225	234	244
Bingham	53	56	58	61
Bonneville	181	191	199	207
Jefferson	27	29	30	32
ROI total	475	501	521	544

Source: Idaho Power 1996; Nemeth 1997b; State of Wyoming, Administration and Information 1996.

**Table I–18. INEEL Region of Influence Projected
Number of Firefighters, 1997–2010**

County	1997	2000	2005	2010
Bannock	179	188	196	204
Bingham	144	152	158	165
Bonneville	149	157	164	170
Jefferson	88	94	99	104
ROI total	560	591	616	643

Source: Idaho Power 1996; Nemeth 1997b; State of Wyoming, Administration and Information 1996.

**Table I–19. INEEL Region of Influence Projected
Number of Hospital Beds, 1997–2010**

County	1997	2000	2005	2010
Bannock	413	434	451	470
Bingham	254	268	279	290
Bonneville	312	329	343	357
Jefferson	–	–	–	–
ROI total	978	1,031	1,073	1,117

Source: Idaho Power 1996; Nemeth 1997c; State of Wyoming, Administration and Information 1996.

**Table I–20. INEEL Region of Influence Projected
Number of Doctors, 1996–2010**

County	1996	2000	2005	2010
Bannock	139	146	152	158
Bingham	22	23	24	25
Bonneville	163	172	179	186
Jefferson	5	5	6	6
ROI total	329	347	361	375

Source: Idaho Power 1996; Randolph 1997; State of Wyoming, Administration and Information 1996.

I.3 PANTEX

Table I–21. Pantex Projected Site Employment

Year	Employment	Change From Previous (%)	Change From 1997 (%)
1997	2,944	–	–
2000	2,500	-15.08	-15.08
2005	1,750	-30.00	-40.56
2010	1,750	0.00	-40.56
2015	1,750	0.00	-40.56
2020	1,750	0.00	-40.56

Source: Mason & Hanger Corporation 1997.

Table I–22. Pantex Regional Economic Area Projected Employment and Economy, 1996–2010

Regional Economic Area	1996	2000	2005	2010
Civilian labor force	234,702	243,043	253,140	263,768
Total employment	223,237	231,799	241,453	251,614
Unemployment rate (%)	4.6	4.6	4.6	4.6

Source: DOC 1997; DOL 1999; Texas State Data Center 1996; University of New Mexico 1997.

Table I–23. Pantex Region of Influence Projected Population, 1996–2010

County	1996	2000	2005	2010
Carson	6,714	6,758	6,843	6,929
Potter	108,636	113,692	119,023	124,603
Randall	97,379	102,841	108,810	115,126
ROI total	212,729	223,291	234,676	246,658

Source: DOC 1997; Texas State Data Center 1996; University of New Mexico 1997.

Table I–24. Pantex Region of Influence Projected Number of Owner and Renter Housing Units, 1990–2010

County	1990	1996	2000	2005	2010
Carson	2,856	2,884	2,903	2,939	2,976
Potter	42,927	45,959	48,098	50,353	52,173
Randall	37,807	41,032	43,333	45,849	48,510
ROI total	83,590	89,875	94,334	99,141	104,200

Source: DOC 1994, 1997; Texas State Data Center 1996; University of New Mexico 1997.

Table I–25. Pantex Region of Influence Projected Student Enrollment, 1997–2010

County	Capacity				
	1997	(%)	2000	2005	2010
Carson County	860	76.4	864	875	886
Groom	195	55.7	196	198	201
Panhandle	125	85.0	126	127	129
White Deer	540	86.0	543	549	556
Potter County	31,707	98.8	32,807	34,346	35,956
Amarillo	29,023	100.0	30,030	31,458	32,912
Bushland	447	85.1	463	484	507
Highland Park	787	85.0	814	852	892
River Road	1,450	90.0	1,500	1,571	1,644
Randall County	7,249	100.0	7,552	7,990	8,454
Canyon	7,249	100.0	7,552	7,990	8,454
ROI total	39,816	98.4	41,224	43,211	45,296

Source: DOC 1997; Nemeth 1997a; Texas State Data Center 1996; University of New Mexico 1997.

Table I–26. Pantex Region of Influence Projected Number of Teachers, 1997–2010

County	Student/Teacher				
	1997	Ratio	2000	2005	2010
Carson County	106	8.2	108	111	115
Groom	20	10.0	20	20	20
Panhandle	59	2.1	61	64	67
White Deer	27	20.0	27	27	28
Potter County	2,122	14.9	2,196	2,299	2,406
Amarillo	1,913	15.2	1,979	2,072	2,169
Bushland	35	12.8	36	38	40
Highland Park	54	14.6	56	58	61
River Road	120	12.1	124	130	136
Randall County	436	16.6	454	481	508
Canyon	436	16.6	454	481	508
ROI total	2,664	14.9	2,758	2,890	3,030

Source: DOC 1997; Nemeth 1997a; Texas State Data Center 1996; University of New Mexico 1997.

Table I–27. Pantex Region of Influence Projected Number of Sworn Police Officers, 1997–2010

County	1997	2000	2005	2010
Carson	16	16	16	16
Potter	445	460	482	505
Randall	81	84	89	94
ROI total	542	560	587	615

Source: DOC 1997; Nemeth 1997b; Texas State Data Center 1996; University of New Mexico 1997.

**Table I–28. Pantex Region of Influence Projected
Number of Firefighters, 1997–2010**

County	1997	2000	2005	2010
Carson	88	88	90	91
Potter	288	298	312	327
Randall	111	116	122	129
ROI total	487	502	524	547

Source: DOC 1997; Nemeth 1997b; Texas State Data Center 1996; University of New Mexico 1997.

**Table I–29. Pantex Region of Influence Projected
Number of Hospital Beds, 1997–2010**

County	1997	2000	2005	2010
Carson	–	–	–	–
Potter	1,208	1,250	1,309	1,370
Randall	52	54	57	61
ROI total	1,260	1,304	1,366	1,431

Source: DOC 1997; Nemeth 1997c; Texas State Data Center 1996; University of New Mexico 1997.

**Table I–30. Pantex Region of Influence Projected
Number of Doctors, 1996–2010**

County	1996	2000	2005	2010
Carson	–	–	–	–
Potter	515	533	558	584
Randall	16	17	18	19
ROI total	531	550	576	603

Source: DOC 1997; Randolph 1997; Texas State Data Center 1996; University of New Mexico 1997.

I.4 SRS

Table I-31. SRS Projected Employment

Year	Employment	Change From Previous (%)	Change From 1997 (%)
1997	15,032	–	–
2000	14,000	-6.87	-6.87
2005	12,000	-14.29	-20.17
2010	10,000	-16.67	-33.48
2015	10,000	0.00	-33.48
2020	10,000	0.00	-33.48

Source: Knox 1997.

Table I-32. SRS Regional Economic Area Projected Employment and Economy, 1996–2010

Regional Economic Area	1996	2000	2005	2010
Civilian labor force	257,101	272,378	287,049	302,663
Total employment	237,611	251,830	265,486	280,022
Unemployment rate (%)	7.6	7.5	7.5	7.5

Source: DOC 1997; DOL 1999; Georgia Institute of Technology 1997; South Carolina Budget & Control Board 1997.

Table I-33. SRS Region of Influence Projected Population, 1996–2010

County	1996	2000	2005	2010
Aiken	133,130	143,167	154,965	167,735
Barnwell	21,640	22,512	23,107	23,718
Columbia	86,173	97,936	104,636	111,795
Edgefield	19,051	19,786	20,318	20,864
Richmond	193,784	202,466	213,133	224,363
ROI total	453,778	485,867	516,159	548,475

Source: DOC 1997; Georgia Institute of Technology 1997; South Carolina Budget & Control Board 1997.

Table I-34. SRS Region of Influence Projected Number of Owner and Renter Housing Units, 1990–2010

County	1990	1996	2000	2005	2010
Aiken	49,266	54,941	59,083	63,952	69,222
Barnwell	7,854	8,334	8,669	8,899	9,134
Columbia	23,745	28,769	32,697	34,933	37,323
Edgefield	7,290	7,716	8,014	8,229	8,450
Richmond	77,288	82,540	86,238	90,781	95,564
ROI total	165,433	182,300	194,701	206,795	219,694

Source: DOC 1994, 1997; Georgia Institute of Technology 1997; South Carolina Budget & Control Board 1997.

Table I–35. SRS Region of Influence Projected Student Enrollment, 1997–2010

County	Capacity				
	1997	(%)	2000	2005	2010
Aiken County	24,830	100.0	26,221	28,382	30,721
Barnwell County	5,055	92.6	5,207	5,345	5,486
District 45	2,770	99.0	2,854	2,929	3,007
District 19	1,230	85.0	1,267	1,300	1,335
District 29	1,055	87.0	1,087	1,115	1,145
Columbia County	18,178	100.0	20,009	21,378	22,840
Edgefield County	4,100	95.0	4,218	4,331	4,448
Richmond County	36,841	125.0	38,072	40,078	42,190
ROI total	89,004	108.2	93,728	99,514	105,685

Source: DOC 1997; Georgia Institute of Technology 1997; Nemeth 1997a; South Carolina Budget & Control Board 1997.

Table I–36. SRS Region of Influence Projected Number of Teachers, 1997–2010

County	Student/Teacher				
	1997	Ratio	2000	2005	2010
Aiken County	1,343	18.5	1,418	1,535	1,662
Barnwell County	304	16.6	313	321	330
District 45	115	24.1	118	122	125
District 19	82	15.0	84	87	89
District 29	107	9.9	110	113	116
Columbia County	1,085	16.8	1,194	1,276	1,363
Edgefield County	312	13.1	321	330	338
Richmond County	2,159	17.1	2,231	2,349	2,472
ROI total	5,203	17.1	5,478	5,811	6,166

Source: DOC 1997; Georgia Institute of Technology 1997; Nemeth 1997a; South Carolina Budget & Control Board 1997.

Table I–37. SRS Region of Influence Projected Number of Sworn Police Officers, 1997–2010

County	1997	2000	2005	2010
Aiken	243	257	278	301
Barnwell	45	46	48	49
Columbia	170	187	200	214
Edgefield	43	44	45	47
Richmond	472	488	513	541
ROI total	973	1,022	1,084	1,150

Source: DOC 1997; Georgia Institute of Technology 1997; Nemeth 1997b; South Carolina Budget & Control Board 1997.

**Table I-38. SRS Region of Influence Projected
Number of Firefighters, 1997-2010**

County	1997	2000	2005	2010
Aiken	875	924	1,000	1,083
Barnwell	130	134	137	141
Columbia	245	270	288	308
Edgefield	150	154	158	163
Richmond	312	322	339	357
ROI total	1,712	1,804	1,924	2,052

Source: DOC 1997; Georgia Institute of Technology 1997; Nemeth 1997b; South Carolina Budget & Control Board 1997.

**Table I-39. SRS Region of Influence Projected
Number of Hospital Beds, 1997-2010**

County	1997	2000	2005	2010
Aiken	225	238	257	278
Barnwell	53	55	56	58
Columbia	-	-	-	-
Edgefield	40	41	42	43
Richmond	3,190	3,297	3,470	3,653
ROI total	3,508	3,630	3,826	4,032

Source: DOC 1997; Georgia Institute of Technology 1997; Nemeth 1997c; South Carolina Budget & Control Board 1997.

**Table I-40. SRS Region of Influence Projected
Number of Doctors, 1996-2010**

County	1996	2000	2005	2010
Aiken	179	189	205	221
Barnwell	11	11	12	12
Columbia	297	327	349	373
Edgefield	13	13	14	14
Richmond	1,222	1,263	1,329	1,399
ROI total	1,722	1,803	1,909	2,020

Source: DOC 1997; Georgia Institute of Technology 1997; Randolph 1997; South Carolina Budget & Control Board 1997.

I.5 REFERENCES

Abbott, D.G., A.B. Crockett, and K.S. Moor, 1997, *INEEL Affected Environment: Supplemental Data Report in Support of the Preparation of the Surplus Plutonium Disposition Environmental Impact Statement (Predecisional Draft)*, Idaho National Engineering Laboratory, Spent Fuel High-Level Waste and Related Programs Directorate, INEL/EXT-97-00563, Lockheed Martin Idaho Technologies Company, Idaho Falls, ID, June.

DOC (U.S. Department of Commerce), 1994, *County and City Data Book: 1994*, Bureau of the Census, Washington, DC.

DOC (U.S. Department of Commerce), 1997, *Estimates of the Population of Counties and Demographic Components of Population Change: Annual Time Series, July 1, 1990 to July 1, 1996*, <http://www.census.gov/population/estimates/county/>, CO-96-8, Bureau of the Census, Population Estimates Program, Population Division, Washington, DC, March 20.

DOL (U.S. Department of Labor), 1999, *Local Area Unemployment Statistics for Year 1996*, <http://www.bls.gov/sahome.html>, Bureau of Labor Statistics, Office of Employment and Unemployment Statistics, Local Area Unemployment Statistics Division, Washington, DC, April 8.

Georgia Institute of Technology, 1997, *Total Population, 1980, 1990, 1996 Estimates, 2000 and 2010 Projections*, School of Public Policy State Data and Research Center, Atlanta, GA.

Idaho Power (Idaho Power Company), 1996, *1997 County Economic Forecast (1996–2015)*, Boise, ID, November.

Knox, J., 1997, U.S. Department of Energy, Savannah River Operations Office, Savannah River, SC, personal communication (facsimile) to K. Gandee, U.S. Department of Energy, Office of Fissile Materials Disposition, Washington, DC, *Site Figures for DOE-HQ, Surplus Pu Disposition EIS*, July 1.

M&H (Mason & Hanger Corporation), 1997, *Pantex Plant Affected Environment Data Report for the Surplus Plutonium Disposition Environmental Impact Statement*, Amarillo, TX, June 12.

Mecca, J.E., 1997a, U.S. Department of Energy, Richland Operations Office, Richland, WA, personal communication to K.R. Gandee, U.S. Department of Energy, Office of Fissile Materials Disposition, Washington, DC, *Hanford Site Response to Site Environmental Data Call for Preparation of the Draft Surplus Plutonium Disposition Environmental Impact Statement*, June 11.

Mecca, J.E., 1997b, U.S. Department of Energy, Richland Operations Office, Richland, WA, personal communication to K.R. Gandee, U.S. Department of Energy, Office of Fissile Materials Disposition, Washington, DC, *Affected Environment Data Reports for the Surplus Plutonium Disposition EIS*, July 31.

Nemeth, D.M., 1997a, *List of School Districts Contacted for Current Operating Capacities, Student Enrollment, and Number of Teachers Employed Within the Hanford, INEEL, Pantex, and SRS ROIs*, Memorandum to SPD EIS Administrative Record, December 15.

Nemeth, D.M., 1997b, *List of Sheriff Offices, Police Departments, and Fire Departments Contacted for Number of Sworn Police Officers Employed and Firefighters (Both Employed and Volunteer) in the Hanford, INEEL, Pantex, and SRS ROIs*, Memorandum to SPD EIS Administrative Record, December 15.

Nemeth, D.M., 1997c, *List of Hospitals and Hospital Associations Contacted for Current Number of Hospitals and Hospital Beds Located in the Hanford, INEEL, Pantex, and SRS ROIs*, Memorandum to SPD EIS Administrative Record, December 15.

Randolph, L., 1997, American Medical Association, Chicago, IL, personal communication to D.M. Nemeth, Science Applications International Corporation, Germantown, MD, *Information on Physicians by State and County, 1996*, August.

South Carolina Budget & Control Board, 1997, *SC Population Projections: 2005–2015*, Office of Research and Statistics, Columbia, SC.

State of Wyoming, Administration and Information, 1996, *Wyoming and County Population Estimates and Projections*, Economic Analysis Division, Cheyenne, WY, November.

Texas State Data Center (Texas Agricultural Experiment Station, Texas A&M University System), 1996, *Projections of the Population of Texas and Counties in Texas by Age, Sex and Race/Ethnicity for 1990-2030*, Population Estimates and Projections Program and The Center for Demographic and Socioeconomic Research and Education, Department of Rural Sociology, College Station, TX, February.

University of New Mexico, 1997, *New Mexico Population Projections by County*, Bureau of Business and Economic Research Data Bank, Albuquerque, NM, April.

Washington State Office of Financial Management, 1996, *Washington State County Population Projections by Age and Sex: 1990–2020*, Forecasting Division, Olympia, WA, January 19.

Appendix J

Human Health Risks

This appendix presents detailed information on the potential impacts to humans associated with incident-free (normal) releases of radioactivity from the proposed surplus plutonium disposition facilities. This information supports the human health risk assessments described in Chapter 4. In addition, site-specific input data used in the evaluation of these human health impacts are also provided or referenced where appropriate. The proposed facilities would be at one or more of four candidate U.S. Department of Energy (DOE) sites: the Hanford Site (Hanford), Idaho National Engineering and Environmental Laboratory (INEEL), the Pantex Plant (Pantex), and the Savannah River Site (SRS). Information is also presented on the human health impacts of mixed oxide (MOX) fuel lead assembly fabrication activities at five potential DOE sites: Argonne National Laboratory–West (ANL–W) at INEEL, Hanford, Lawrence Livermore National Laboratory (LLNL), Los Alamos National Laboratory (LANL), and SRS.

J.1 HANFORD

J.1.1 Assessment Data

To perform the dose assessments for the *Surplus Plutonium Disposition Environmental Impact Statement* (SPD EIS), different types of data were collected and generated. In addition, calculational assumptions were made. Appendix F.10 provides a summary of the methods and tools (e.g., the GENII computer code) used for the assessments.

J.1.1.1 Meteorological Data

The meteorological data used for the Hanford dose assessments was in the form of a joint frequency data (JFD) file. A JFD file is a table that lists the percentages of time the wind blows in a certain direction, at a certain speed, and within a certain stability class. The JFD file was based on measurements taken over a period of several years at a specific location and height. Average annual meteorological conditions, averaged over the measurement period, were used for normal operations. Table J–1 presents the JFD used in the dose assessments for Hanford.

J.1.1.2 Population Data

The Hanford population distribution was based on the *1990 Census of Population and Housing Data* (DOC 1992). Projections were determined for the year 2010 (about midlife of operations) for areas within 80 km (50 mi) of the locations for the proposed surplus plutonium disposition facilities. The site population in 2010 was assumed to be representative of the population over the operational period evaluated. The population was spatially distributed on a circular grid with 16 directions and 10 radial distances out to an 80-km (50-mi) distance. The grid was centered at the Fuels and Materials Examination Facility (FMEF) in the 400 Area, the location from which radionuclides are assumed to be released during incident-free operations. Table J–2 presents the population data used for the dose assessments at Hanford.

J.1.1.3 Agricultural Data

The 1987 Census of Agriculture was the source used to generate site-specific data for food production. Food production was spatially distributed on a circular grid similar to that used for the population distribution described previously. This food grid (or wheel) was generated by combining the fraction of a county in each segment (e.g., south, southwest, north-northeast) and the county production of the eight food categories analyzed by GENII—leafy vegetables, root vegetables, fruits, grains, beef, poultry, milk, and eggs. Each

Table J-1. Hanford 1983–1991 Joint Frequency Distributions at 61-m Height

Wind Speed (m/s)	Stability Class	Wind Blows Toward															
		S	SSW	SW	WSW	W	WNW	NW	NNW	N	NNE	NE	ENE	E	ESE	SE	SSE
0.89	A	0.12	0.1	0.08	0.11	0.14	0.15	0.1	0.08	0.14	0.08	0.05	0.06	0.07	0.05	0.05	0.07
	B	0.05	0.05	0.05	0.05	0.06	0.05	0.04	0.03	0.07	0.03	0.02	0.02	0.03	0.02	0.03	0.03
	C	0.06	0.04	0.04	0.04	0.06	0.04	0.07	0.05	0.04	0.04	0.03	0.01	0.05	0.03	0.04	0.04
	D	0.32	0.23	0.2	0.18	0.25	0.26	0.24	0.28	0.36	0.26	0.19	0.15	0.22	0.19	0.22	0.21
	E	0.19	0.14	0.1	0.1	0.13	0.13	0.14	0.19	0.37	0.22	0.18	0.17	0.23	0.19	0.19	0.19
	F	0.22	0.14	0.1	0.09	0.13	0.11	0.15	0.2	0.34	0.2	0.2	0.12	0.2	0.14	0.16	0.16
	G	0.13	0.08	0.06	0.03	0.06	0.07	0.07	0.18	0.22	0.13	0.09	0.07	0.12	0.09	0.12	0.09
2.7	A	0.32	0.28	0.28	0.28	0.39	0.37	0.37	0.34	0.55	0.32	0.16	0.09	0.17	0.13	0.13	0.15
	B	0.12	0.09	0.08	0.06	0.12	0.07	0.1	0.11	0.15	0.12	0.05	0.05	0.05	0.04	0.06	0.07
	C	0.13	0.08	0.08	0.05	0.09	0.08	0.1	0.11	0.16	0.08	0.04	0.03	0.05	0.03	0.06	0.08
	D	0.58	0.41	0.37	0.26	0.38	0.33	0.46	0.59	0.85	0.49	0.25	0.15	0.33	0.36	0.47	0.41
	E	0.32	0.2	0.19	0.12	0.21	0.21	0.25	0.45	0.68	0.46	0.31	0.24	0.37	0.29	0.38	0.33
	F	0.35	0.23	0.15	0.07	0.12	0.09	0.18	0.36	0.64	0.31	0.23	0.16	0.18	0.18	0.23	0.22
	G	0.18	0.12	0.06	0.03	0.04	0.04	0.08	0.2	0.3	0.16	0.1	0.04	0.08	0.1	0.15	0.16
4.7	A	0.39	0.31	0.21	0.1	0.13	0.13	0.15	0.19	0.77	0.51	0.17	0.13	0.19	0.15	0.16	0.17
	B	0.14	0.09	0.06	0.04	0.04	0.04	0.04	0.07	0.2	0.16	0.06	0.04	0.03	0.02	0.06	0.06
	C	0.1	0.1	0.06	0.03	0.03	0.03	0.04	0.06	0.16	0.16	0.04	0.02	0.05	0.04	0.06	0.07
	D	0.59	0.38	0.26	0.14	0.16	0.14	0.32	0.55	0.97	0.75	0.27	0.15	0.34	0.46	0.63	0.55
	E	0.41	0.21	0.15	0.09	0.1	0.11	0.28	0.6	1.02	0.71	0.37	0.27	0.5	0.53	0.6	0.43
	F	0.37	0.22	0.11	0.06	0.07	0.06	0.17	0.48	0.73	0.44	0.21	0.11	0.16	0.2	0.37	0.29
	G	0.19	0.11	0.05	0.02	0.02	0.01	0.04	0.19	0.26	0.14	0.06	0.02	0.04	0.07	0.19	0.13
7.2	A	0.22	0.17	0.08	0.02	0.02	0.01	0.03	0.05	0.32	0.63	0.28	0.17	0.23	0.11	0.19	0.15
	B	0.07	0.05	0.01	0.01	0	0	0.02	0.01	0.1	0.22	0.06	0.05	0.05	0.03	0.07	0.03
	C	0.04	0.05	0.02	0.01	0	0.01	0.02	0.02	0.07	0.18	0.06	0.04	0.03	0.03	0.05	0.04
	D	0.27	0.19	0.09	0.04	0.02	0.04	0.1	0.25	0.65	0.86	0.37	0.2	0.29	0.5	0.75	0.4
	E	0.27	0.18	0.07	0.02	0.02	0.04	0.15	0.43	0.73	0.74	0.34	0.2	0.39	0.73	0.94	0.44
	F	0.21	0.14	0.06	0.02	0.02	0.01	0.09	0.33	0.52	0.39	0.14	0.07	0.09	0.16	0.45	0.26
	G	0.13	0.08	0.04	0.01	0.01	0.01	0.03	0.11	0.19	0.13	0.04	0.02	0.01	0.04	0.14	0.13

Table J-1. Hanford 1983–1991 Joint Frequency Distributions at 61-m Height (Continued)

Wind Speed (m/s)	Stability Class	Wind Blows Toward															
		S	SSW	SW	WSW	W	WNW	NW	NNW	N	NNE	NE	ENE	E	ESE	SE	SSE
9.8	A	0.05	0.05	0.03	0.01	0	0	0	0.01	0.08	0.29	0.21	0.12	0.12	0.08	0.12	0.04
	B	0.02	0.01	0.01	0	0	0	0	0	0.02	0.08	0.04	0.04	0.04	0.02	0.03	0.02
	C	0.02	0.02	0.01	0	0	0	0	0.01	0.02	0.08	0.06	0.03	0.03	0.03	0.03	0.01
	D	0.09	0.08	0.02	0.01	0	0.01	0.03	0.04	0.24	0.58	0.32	0.16	0.19	0.33	0.57	0.14
	E	0.1	0.12	0.04	0.01	0	0.01	0.06	0.17	0.37	0.51	0.26	0.13	0.17	0.43	0.73	0.22
	F	0.1	0.11	0.03	0.01	0.01	0	0.03	0.14	0.21	0.2	0.07	0.02	0.03	0.08	0.23	0.16
	G	0.05	0.04	0.02	0	0	0	0.01	0.07	0.09	0.05	0.03	0	0	0.02	0.1	0.07
13.0	A	0.01	0.02	0	0	0	0	0	0	0.02	0.09	0.1	0.1	0.08	0.03	0.07	0.01
	B	0	0.01	0	0	0	0	0	0	0.01	0.03	0.04	0.04	0.02	0.01	0.03	0.01
	C	0	0.01	0	0	0	0	0	0	0.01	0.02	0.04	0.02	0.02	0.01	0.02	0.01
	D	0.03	0.03	0.01	0	0	0	0.01	0.02	0.07	0.27	0.24	0.12	0.09	0.19	0.32	0.05
	E	0.04	0.08	0.03	0.01	0	0	0.02	0.05	0.13	0.32	0.25	0.1	0.07	0.2	0.33	0.07
	F	0.04	0.05	0.02	0.01	0	0	0.02	0.06	0.08	0.13	0.05	0.01	0.01	0.02	0.1	0.06
	G	0.01	0.01	0	0	0	0	0	0.02	0.02	0.03	0.01	0	0	0.01	0.05	0.04
16.0	A	0	0.01	0	0	0	0	0	0	0	0.02	0.06	0.03	0.02	0.01	0.01	0
	B	0	0.01	0	0	0	0	0	0	0	0.01	0.02	0.01	0	0	0	0
	C	0	0	0	0	0	0	0	0	0	0.01	0.02	0.01	0.01	0	0.01	0
	D	0.02	0.03	0.01	0.01	0	0	0	0.01	0.01	0.11	0.19	0.06	0.03	0.06	0.1	0.01
	E	0.01	0.04	0.03	0	0	0	0.01	0.02	0.05	0.16	0.16	0.04	0.02	0.04	0.09	0.01
	F	0.01	0.03	0	0	0	0	0	0.03	0.04	0.05	0.02	0	0.01	0	0.01	0.02
	G	0	0	0	0	0	0	0	0.02	0.02	0.02	0	0	0	0	0.02	0
19.0	A	0.02	0.03	0	0	0	0	0	0	0	0.01	0.05	0.01	0.01	0	0.01	0
	B	0	0.03	0	0	0	0	0	0	0	0	0.02	0	0	0	0	0
	C	0.01	0.02	0	0	0	0	0	0	0	0	0.03	0	0	0	0	0
	D	0.03	0.09	0	0	0	0	0	0	0	0.09	0.22	0.04	0.03	0.01	0.02	0
	E	0.03	0.1	0.02	0	0	0	0	0.02	0.02	0.1	0.14	0.02	0.01	0.01	0.01	0
	F	0.02	0.04	0.01	0	0	0	0	0.03	0.03	0.04	0.02	0	0	0	0.01	0
	G	0	0.01	0	0	0	0	0	0.02	0.02	0.02	0	0	0	0	0.01	0

Source: Neitzel 1996.

county’s food production was assumed to be distributed uniformly over the given county’s land area. These categorized food wheels were then used in the assessment of doses to the Hanford population from the ingestion pathway. The consumption rates used in the dose assessments were those for the maximally exposed individual (MEI) and average exposed individual. People living within the 80-km (50-mi) assessment area were assumed to consume only food grown in that area. Hanford food production and consumption data used for the dose assessments in the SPD EIS were obtained from the *Health Risk Data for Storage and Disposition Final PEIS* (HNUS 1996).

Table J-2. Projected Hanford Population Surrounding FMEF for Year 2010

Direction	Distance (mi)										Total
	0-1	1-2	2-3	3-4	4-5	5-10	10-20	20-30	30-40	40-50	
S	0	0	0	0	0	4,265	44,747	1,141	7,041	19,608	76,802
SSW	0	0	0	0	2	1,515	2,758	438	2,976	3,951	11,640
SW	0	0	0	0	42	1,388	4,788	316	227	2,047	8,808
WSW	0	0	0	0	0	54	2,387	17,154	3,588	325	23,508
W	0	0	0	0	0	0	766	6,201	28,142	15,966	51,075
WNW	0	0	0	0	0	0	5	879	1,233	9,074	11,191
NW	0	0	0	0	0	0	0	645	411	178	12,34
NNW	0	0	0	0	0	0	0	1,097	1,437	1,491	4,025
N	0	0	0	0	0	0	0	1,153	3,773	2,749	7,675
NNE	0	0	0	0	0	18	468	5,523	1,514	25,879	33,402
NE	0	0	0	0	0	95	827	7,348	3,019	1,256	12,545
ENE	0	0	0	0	0	345	1,544	3,737	423	446	6,495
E	0	0	0	0	0	425	948	451	351	327	2,502
ESE	0	0	0	0	0	434	655	347	266	326	2,028
SE	0	0	0	0	0	419	1,313	1,736	396	1,459	5,323
SSE	0	0	0	0	0	6,989	87,249	33,689	608	986	129,521
Total	0	0	0	0	44	15,947	148,455	81,855	55,405	86,068	387,774

Key: FMEF, Fuels and Materials Examination Facility.

Source: DOC 1992.

J.1.1.4 Source Term Data

Estimated incident-free radiological releases associated with the pit conversion, immobilization, and MOX facilities are presented in Tables J-3 through J-5. Stack heights and release locations are provided in the facility data reports (DOE 1999; UC 1998a, 1998b, 1999a, 1999b).

Table J-3. Estimated Incident-Free Annual Radiological Releases From the Pit Conversion Facility at Hanford

Isotope	($\mu\text{Ci/yr}$)
Plutonium 236	9.3×10^{-11}
Plutonium 238	0.065
Plutonium 239	0.69
Plutonium 240	0.18
Plutonium 241	0.69
Plutonium 242	4.8×10^{-5}
Americium 241	0.37
Hydrogen 3	1.1×10^9

Source: UC 1998a.

Table J-4. Estimated Incident-Free Annual Radiological Releases From the Immobilization Facility at Hanford

Isotope	Ceramic (17 t) ($\mu\text{Ci/yr}$)	Ceramic (50 t) ($\mu\text{Ci/yr}$)	Glass (17 t) ($\mu\text{Ci/yr}$)	Glass (50 t) ($\mu\text{Ci/yr}$)
Plutonium 236	–	–	–	–
Plutonium 238	–	0.57	–	0.52
Plutonium 239	3.7	9.5	3.4	8.6
Plutonium 240	1.7	3.1	1.6	2.8
Plutonium 241	110	100	98	93
Plutonium 242	1.3×10^{-3}	1.6×10^{-3}	1.2×10^{-3}	1.5×10^{-3}
Americium 241	2.3	5.4	2.2	5.0
Uranium 234	–	–	–	–
Uranium 235	1.1×10^{-5}	4.5×10^{-5}	2.3×10^{-6}	2.3×10^{-6}
Uranium 238	8.8×10^{-5}	3.5×10^{-4}	1.9×10^{-5}	1.9×10^{-5}

Source: UC 1999a, 1999b.

Table J-5. Estimated Incident-Free Annual Radiological Releases From the MOX Facility at Hanford

Isotope	($\mu\text{Ci/yr}$)
Plutonium 236	1.3×10^{-8}
Plutonium 238	8.5
Plutonium 239	91
Plutonium 240	23
Plutonium 241	101
Plutonium 242	6.1×10^{-3}
Americium 241	48
Uranium 234	5.1×10^{-3}
Uranium 235	2.1×10^{-4}
Uranium 238	0.012

Source: UC 1998b.

J.1.1.5 Other Calculational Assumptions

To estimate radiological impacts of incident-free operation of the proposed facilities at Hanford, the following additional assumptions and factors were considered, in accordance with the guidelines established in U.S. Nuclear Regulatory Commission (NRC) Regulatory Guide 1.109 (NRC 1977).

- Ground surfaces were assumed to have no previous deposition of radionuclides for the purposes of modeling the incremental radiological impacts associated with surplus plutonium disposition activities. However, doses associated with true instances of prior deposition are accounted for in the Affected Environment and Cumulative Impacts sections.
- The annual external exposure time to the plume and to soil contamination was 0.7 year for the MEI (NRC 1977).
- The annual external exposure time to the plume and to soil contamination was 0.5 year for the population (NRC 1977).

- The annual inhalation exposure time to the plume was 1 year for the MEI and general population (NRC 1977).
- The exposed individual or population was assumed to have the characteristics and habits (e.g., inhalation and ingestion rates) of the adult human.
- A semi-infinite/finite plume model was used for air immersion doses. Other pathways evaluated were ground exposure, inhalation, ingestion of food crops, and ingestion of contaminated animal products. Drinking water, aquatic food ingestion, and any other pathway that may involve liquid exposure were not examined because all releases are to the air.
- Reported stack heights were used for atmospheric releases. The resultant doses were conservative as use of the actual stack height instead of the effective stack height negates plume rise.
- The calculated doses are 50-year committed doses from 1 year of intake.

J.1.2 Facilities

The following sections present all viable radiological impact scenarios that could be associated with different combinations of incident-free facility operations at Hanford.

J.1.2.1 Pit Conversion Facility

J.1.2.1.1 Construction of Pit Conversion Facility

No radiological risk would be incurred by members of the public from construction and modification of a pit conversion facility at Hanford. According to recent surveys conducted in the 400 Area, a construction worker would not be expected to receive any additional dose above natural background levels (Antonio 1998). Nonetheless, if deemed necessary, workers may be monitored (badged) as a precautionary measure.

J.1.2.1.2 Operation of Pit Conversion Facility

Tables J-6 and J-7 present the incident-free radiological impacts of the operation of a pit conversion facility at Hanford.

**Table J–6. Potential Radiological Impacts on the Public
of Operation of Pit Conversion Facility in FMEF at Hanford**

Population within 80 km for year 2010	
Dose (person-rem)	6.9
Percent of natural background ^a	5.9×10^{-3}
10-year latent fatal cancers	0.034
Maximally exposed individual	
Annual dose (mrem)	0.017
Percent of natural background ^a	5.7×10^{-3}
10-year latent fatal cancer risk	8.5×10^{-8}
Average exposed individual within 80 km^b	
Annual dose (mrem)	0.017
10-year latent fatal cancer risk	8.5×10^{-8}

^a The annual natural background radiation level at Hanford is 300 mrem for the average individual; the population within 80 km (50 mi) in 2010 would receive 116,300 person-rem.

^b Obtained by dividing the population dose by the number of people projected to live within 80 km (50 mi) of Hanford in 2010 (387,800).

Key: FMEF, Fuels and Materials Examination Facility.

Source: Model results.

**Table J–7. Potential Radiological Impacts on Involved Workers
of Operation of Pit Conversion Facility in FMEF at Hanford**

Number of badged workers	383
Total dose (person-rem/yr)	192
10-year latent fatal cancers	0.77
Average worker dose (mrem/yr)	500
10-year latent fatal cancer risk	2.0×10^{-3}

Key: FMEF, Fuels and Materials Examination Facility.

Note: The radiological limit for an individual worker is 5,000 mrem/yr (DOE 1995). However, the maximum dose to a worker involved in operations would be kept below the DOE administrative control level of 2,000 mrem/yr (DOE 1994). An effective ALARA program would ensure that doses are reduced to levels that are as low as is reasonably achievable.

J.1.2.2 Immobilization Facility

J.1.2.2.1 Construction of Immobilization Facility

No radiological risk would be incurred by members of the public from the construction and modification of an immobilization (ceramic or glass) facility at Hanford. According to recent radiation surveys conducted in the 400 Area, a construction worker would not be expected to receive any additional dose above natural background levels (Antonio 1998). Nonetheless, if deemed necessary, workers may be monitored (badged) as a precautionary measure.

J.1.2.2.2 Operation of Immobilization Facility

Tables J–8 and J–9 present all possible incident-free radiological impact scenarios for the operation of a ceramic or glass immobilization facility at Hanford.

Table J–8. Potential Radiological Impacts on the Public of Operation of Immobilization Facility in FMEF at Hanford

Impact	17 t		50 t	
	Ceramic	Glass	Ceramic	Glass
Population within 80 km for year 2010				
Dose (person-rem)	7.8×10^{-3}	7.1×10^{-3}	0.016	0.015
Percent of natural background ^a	6.7×10^{-6}	6.1×10^{-6}	1.4×10^{-5}	1.3×10^{-5}
10-year latent fatal cancers	3.9×10^{-5}	3.6×10^{-5}	8.0×10^{-5}	7.5×10^{-5}
Maximally exposed individual				
Annual dose (mrem)	1.1×10^{-4}	9.7×10^{-5}	2.2×10^{-4}	2.0×10^{-4}
Percent of natural background ^a	3.7×10^{-5}	3.2×10^{-5}	7.3×10^{-5}	6.7×10^{-5}
10-year latent fatal cancer risk	5.5×10^{-10}	4.9×10^{-10}	1.1×10^{-9}	1.0×10^{-9}
Average exposed individual within 80 km^b				
Annual dose (mrem)	2.0×10^{-5}	1.8×10^{-5}	4.1×10^{-5}	3.9×10^{-5}
10-year latent fatal cancer risk	1.0×10^{-10}	9.0×10^{-11}	2.1×10^{-10}	2.0×10^{-10}

^a The annual natural background radiation level at Hanford is 300 mrem for the average individual; the population within 80 km (50 mi) in 2010 would receive 116,300 person-rem.

^b Obtained by dividing the population dose by the number of people projected to live within 80 km (50 mi) of Hanford in 2010 (387,800).

Key: FMEF, Fuels and Materials Examination Facility.

Source: Model results.

Table J–9. Potential Radiological Impacts on Involved Workers of Operation of Immobilization Facility in FMEF at Hanford^a

Impact	17 t		50 t	
	Ceramic	Glass	Ceramic	Glass
Number of badged workers	365	365	397	397
Total dose (person-rem/yr)	274	274	298	298
10-year latent fatal cancers	1.1	1.1	1.2	1.2
Average worker dose (mrem/yr)	750	750	750	750
10-year latent fatal cancer risk	3.0×10^{-3}	3.0×10^{-3}	3.0×10^{-3}	3.0×10^{-3}

^a The presented values are representative of the largest possible number of workers regardless of collocation considerations.

Key: FMEF, Fuels and Materials Examination Facility.

Note: The radiological limit for an individual worker is 5,000 mrem/yr (DOE 1995). However, the maximum dose to a worker involved in operations would be kept below the DOE administrative control level of 2,000 mrem/yr (DOE 1994). An effective ALARA program would ensure that doses are reduced to levels that are as low as is reasonably achievable.

Source: UC 1999a, 1999b.

J.1.2.3 MOX Facility

J.1.2.3.1 Construction of MOX Facility

No radiological risk would be incurred by members of the public from the construction and modification of a MOX facility at Hanford. According to recent radiation surveys conducted in the 400 Area, a construction worker would not be expected to receive any additional dose above natural background levels (Antonio 1998). Nonetheless, if deemed necessary, workers may be monitored (badged) as a precautionary measure.

J.1.2.3.2 Operation of MOX Facility

Tables J–10 and J–11 present the incident-free radiological impacts of the operation of a MOX facility at Hanford. The facility would either be located within the existing FMEF or a new facility would be built adjacent to FMEF.

Table J–10. Potential Radiological Impacts on the Public of Operation of MOX Facility in FMEF or New Construction at Hanford

Impact	FMEF ^a	New ^a
Population dose within 80 km for year 2010		
Dose (person-rem)	0.14	0.29
Percent of natural background ^b	1.2×10^{-4}	2.5×10^{-4}
10-year latent fatal cancers	6.9×10^{-4}	1.5×10^{-3}
Maximally exposed individual		
Annual dose (mrem)	1.8×10^{-3}	4.8×10^{-3}
Percent of natural background ^b	6.1×10^{-4}	1.6×10^{-3}
10-year latent fatal cancer risk	9.3×10^{-9}	2.4×10^{-8}
Average exposed individual within 80 km^c		
Annual dose (mrem)	3.5×10^{-4}	7.5×10^{-4}
10-year latent fatal cancer risk	1.7×10^{-9}	3.7×10^{-9}

^a The difference in impacts is attributable to different stack heights. As described in Section 4.26.1.2.2, Water Resources, no component was attributed to liquid pathways because it is not expected that significant contamination could reach these pathways given the site's groundwater and surface-water characteristics.

^b The annual natural background radiation level at Hanford is 300 mrem for the average individual; the population within 80 km (50 mi) in 2010 would receive 116,300 person-rem.

^c Obtained by dividing the population dose by the number of people projected to live within 80 km (50 mi) of Hanford in 2010 (387,800).

Key: FMEF, Fuels and Materials Examination Facility.

Source: Model results.

Table J–11. Potential Radiological Impacts on Involved Workers of Operation of MOX Facility in FMEF or New Construction at Hanford

Number of badged workers	331
Total dose (person-rem/yr)	22
10-year latent fatal cancers	0.088
Average worker dose (mrem/yr)	65
10-year latent fatal cancer risk	2.6×10^{-4}

Key: FMEF, Fuels and Materials Examination Facility.

Note: The radiological limit for an individual worker is 5,000 mrem/yr (DOE 1995). However, the maximum dose to a worker involved in operations would be kept below the DOE administrative control level of 2,000 mrem/yr (DOE 1994). An effective ALARA program would ensure that doses are reduced to levels that are as low as is reasonably achievable.

Source: DOE 1999; UC 1998b.

J.1.2.4 Pit Conversion and Immobilization Facilities

J.1.2.4.1 Construction of Pit Conversion and Immobilization Facilities

No radiological risk would be incurred by members of the public from the construction and modification of pit conversion and immobilization (ceramic or glass) facilities at Hanford. According to recent radiation surveys conducted in the 400 Area, a construction worker would not be expected to receive any additional dose above

natural background levels (Antonio 1998). Nonetheless, if deemed necessary, workers may be monitored (badged) as a precautionary measure.

J.1.2.4.2 Operation of Pit Conversion and Immobilization Facilities

Tables J–12 and J–13 present all possible incident-free radiological impact scenarios for the operation of the pit conversion and immobilization facilities at Hanford.

Table J–12. Potential Radiological Impacts on the Public of Operation of Pit Conversion and Immobilization Facilities in FMEF at Hanford

Impact	Pit Conversion	Immobilization (50 t)		Total ^a
		Ceramic	Glass	
Population within 80 km for year 2010				
Dose (person-rem)	6.9	0.016	0.015	6.9
Percent of natural background ^b	5.9×10^{-3}	1.4×10^{-5}	1.3×10^{-5}	5.9×10^{-3}
10-year latent fatal cancers	0.034	8.0×10^{-5}	7.5×10^{-5}	0.034
Maximally exposed individual				
Annual dose (mrem)	0.017	2.2×10^{-4}	2.0×10^{-4}	0.017
Percent of natural background ^b	5.7×10^{-3}	7.3×10^{-5}	6.7×10^{-5}	5.8×10^{-3}
10-year latent fatal cancer risk	8.5×10^{-8}	1.1×10^{-9}	1.0×10^{-9}	8.6×10^{-8}
Average exposed individual within 80 km^c				
Annual dose (mrem)	0.017	4.1×10^{-5}	3.9×10^{-5}	0.017
10-year latent fatal cancer risk	8.5×10^{-8}	2.1×10^{-10}	2.0×10^{-10}	8.5×10^{-8}

^a Totals represent the largest possible sums for each public category. Totals are additive in all cases because the same groups or individuals would receive doses from both facilities.

^b The annual natural background radiation level at Hanford is 300 mrem for the average individual; the population within 80 km (50 mi) in 2010 would receive 116,300 person-rem.

^c Obtained by dividing the population dose by the number of people projected to live within 80 km (50 mi) of Hanford in 2010 (387,800).

Key: FMEF, Fuels and Materials Examination Facility.

Source: Model results.

Table J–13. Potential Radiological Impacts on Involved Workers of Operation of Pit Conversion and Immobilization Facilities in FMEF at Hanford

Impact	Pit Conversion	Immobilization (50 t) ^a		Total
		Ceramic or Glass		
Number of badged workers	383	397		780
Total dose (person-rem/yr)	192	298		490
10-year latent fatal cancers	0.77	1.2		2.0
Average worker dose (mrem/yr)	500	750		628 ^b
10-year latent fatal cancer risk	2.0×10^{-3}	3.0×10^{-3}		2.5×10^{-3}

^a The presented values are representative of the largest possible number of workers regardless of collocation considerations.

^b Represents an average of the doses for both facilities.

Key: FMEF, Fuels and Materials Examination Facility.

Note: The radiological limit for an individual worker is 5,000 mrem/yr (DOE 1995). However, the maximum dose to a worker involved in operations would be kept below the DOE administrative control level of 2,000 mrem/yr (DOE 1994). An effective ALARA program would ensure that doses are reduced to levels that are as low as is reasonably achievable.

Source: UC 1998a, 1999a, 1999b.

J.1.2.5 Pit Conversion and MOX Facilities

J.1.2.5.1 Construction of Pit Conversion and MOX Facilities

No radiological risk would be incurred by members of the public from the modification of FMEF for pit disassembly and conversion and MOX fuel fabrication or construction of new MOX facility at Hanford. According to recent radiation surveys conducted in the 400 Area, a construction worker would not be expected to receive any additional dose above natural background levels (Antonio 1998). Nonetheless, if deemed necessary, workers may be monitored (badged) as a precautionary measure.

J.1.2.5.2 Operation of Pit Conversion and MOX Facilities

Tables J–14 and J–15 present the incident-free radiological impacts of the operation of the pit conversion and MOX facilities at Hanford.

Table J–14. Potential Radiological Impacts on the Public of Operation of Pit Conversion and MOX Facilities in FMEF or New MOX Facility at Hanford

Impact	Pit Conversion	MOX ^a		Total ^b
		FMEF	New	
Population within 80 km for year 2010				
Dose (person-rem)	6.9	0.14	0.29	7.2
Percent of natural background ^c	5.9×10^{-3}	1.2×10^{-4}	2.5×10^{-4}	6.2×10^{-3}
10-year latent fatal cancers	0.034	7.0×10^{-4}	1.5×10^{-3}	0.036
Maximally exposed individual				
Annual dose (mrem)	0.017	1.8×10^{-3}	4.8×10^{-3}	0.022
Percent of natural background ^c	5.7×10^{-3}	6.1×10^{-4}	1.6×10^{-3}	7.3×10^{-3}
10-year latent fatal cancer risk	8.5×10^{-8}	9.3×10^{-9}	2.4×10^{-8}	1.1×10^{-7}
Average exposed individual within 80 km^d				
Annual dose (mrem)	0.017	3.5×10^{-4}	7.5×10^{-4}	0.018
10-year latent fatal cancer risk	8.5×10^{-8}	1.7×10^{-9}	3.7×10^{-9}	8.9×10^{-8}

^a As described in Section 4.26.1.2.2, Water Resources, no component was attributed to liquid pathways because it is not expected that significant contamination could reach these pathways given the site's groundwater and surface-water characteristics.

^b Totals represent the largest possible sums for each public category. Totals are additive in all cases because the same groups or individuals would receive doses from both facilities.

^c The annual natural background radiation level at Hanford is 300 mrem for the average individual; the population within 80 km (50 mi) in 2010 would receive 116,300 person-rem.

^d Obtained by dividing the population dose by the number of people projected to live within 80 km (50 mi) of Hanford in 2010 (387,800).

Key: FMEF, Fuels and Materials Examination Facility.

Source: Model results.

Table J–15. Potential Radiological Impacts on Involved Workers of Operation of Pit Conversion and MOX Facilities in FMEF or New MOX Facility at Hanford

Impact	Pit Conversion	MOX (FMEF or New)	Total
Number of badged workers	383	331	714
Total dose (person-rem/yr)	192	22	214
10-year latent fatal cancers	0.77	0.088	0.86
Average worker dose (mrem/yr)	500	65	300 ^a
10-year latent fatal cancer risk	2.0×10^{-3}	2.6×10^{-4}	1.2×10^{-3}

^a Represents an average of the doses for both facilities.

Key: FMEF, Fuels and Materials Examination Facility.

Note: The radiological limit for an individual worker is 5,000 mrem/yr (DOE 1995). However, the maximum dose to a worker involved in operations would be kept below the DOE administrative control level of 2,000 mrem/yr (DOE 1994). An effective ALARA program would ensure that doses are reduced to levels that are as low as is reasonably achievable.

| **Source:** DOE 1999; UC 1998a, 1998b.

J.1.2.6 Immobilization and MOX Facilities

J.1.2.6.1 Construction of Immobilization and MOX Facilities

No radiological risk would be incurred by members of the public from the modification of FMEF for collocating plutonium conversion and immobilization (ceramic or glass) and MOX fuel fabrication or construction of a new MOX facility at Hanford. According to recent radiation surveys conducted in the 400 Area, a construction worker would not be expected to receive any additional dose above natural background levels (Antonio 1998). Nonetheless, if deemed necessary, workers may be monitored (badged) as a precautionary measure.

J.1.2.6.2 Operation of Immobilization and MOX Facilities

Tables J–16 and J–17 present the incident-free radiological impacts of the operation of the immobilization and MOX facilities at Hanford.

Table J–16. Potential Radiological Impacts on the Public of Operation of Collocating Immobilization and MOX Facilities in FMEF or New MOX Facility at Hanford

Impact	Immobilization (17 t)		MOX ^a		Total ^b
	Ceramic	Glass	FMEF	New	
Population within 80 km for year 2010					
Dose (person-rem)	7.8×10 ⁻³	7.1×10 ⁻³	0.14	0.29	0.30
Percent of natural background ^c	6.7×10 ⁻⁶	6.1×10 ⁻⁶	1.2×10 ⁻⁴	2.5×10 ⁻⁴	2.6×10 ⁻⁴
10-year latent fatal cancers	3.9×10 ⁻⁵	3.6×10 ⁻⁵	6.9×10 ⁻⁴	1.5×10 ⁻³	1.5×10 ⁻³
Maximally exposed individual					
Annual dose (mrem)	1.1×10 ⁻⁴	9.7×10 ⁻⁵	1.8×10 ⁻³	4.8×10 ⁻³	4.9×10 ⁻³
Percent of natural background ^c	3.7×10 ⁻⁵	3.2×10 ⁻⁵	6.1×10 ⁻⁴	1.6×10 ⁻³	1.6×10 ⁻³
10-year latent fatal cancer risk	5.5×10 ⁻¹⁰	4.9×10 ⁻¹⁰	9.3×10 ⁻⁹	2.4×10 ⁻⁸	2.5×10 ⁻⁸
Average exposed individual within 80 km^d					
Annual dose (mrem)	2.0×10 ⁻⁵	1.8×10 ⁻⁵	3.5×10 ⁻⁴	7.5×10 ⁻⁴	7.7×10 ⁻⁴
10-year latent fatal cancer risk	1.0×10 ⁻¹⁰	9.0×10 ⁻¹¹	1.7×10 ⁻⁹	3.7×10 ⁻⁹	3.9×10 ⁻⁹

^a As described in Section 4.26.1.2.2, Water Resources, no component was attributed to liquid pathways because it is not expected that significant contamination could reach these pathways given the site's groundwater and surface-water characteristics.

^b Totals represent the largest possible sums for each public category. Totals are additive in all cases because the same groups or individuals would receive doses from both facilities.

^c The annual natural background radiation level at Hanford is 300 mrem for the average individual; the population within 80 km (50 mi) in 2010 would receive 116,300 person-rem.

^d Obtained by dividing the population dose by the number of people projected to live within 80 km (50 mi) of Hanford in 2010 (387,800).

Key: FMEF, Fuels and Materials Examination Facility.

Source: Model results.

Table J–17. Potential Radiological Impacts on Involved Workers of Operation of Collocating Immobilization and MOX Facilities in FMEF or New MOX Facility at Hanford

Impact	Immobilization (17 t) ^a	MOX	Total
	Ceramic or Glass	(FMEF or New)	
Number of badged workers	365	331	696
Total dose (person-rem/yr)	274	22	296
10-year latent fatal cancers	1.1	0.088	1.2
Average worker dose (mrem/yr)	750	65	425 ^b
10-year latent fatal cancer risk	3.0×10 ⁻³	2.6×10 ⁻⁴	1.7×10 ⁻³

^a The presented values are representative of the largest possible number of workers regardless of collocation considerations.

^b Represents an average of the doses for both facilities.

Key: FMEF, Fuels and Materials Examination Facility.

Note: The radiological limit for an individual worker is 5,000 mrem/yr (DOE 1995). However, the maximum dose to a worker involved in operations would be kept below the DOE administrative control level of 2,000 mrem/yr (DOE 1994). An effective ALARA program would ensure that doses are reduced to levels that are as low as is reasonably achievable.

Source: DOE 1999; UC 1998b, 1999a, 1999b.

J.1.2.7 Pit Conversion, Immobilization, and MOX Facilities

J.1.2.7.1 Construction of Pit Conversion, Immobilization, and MOX Facilities

No radiological risk would be incurred by members of the public from the modification of FMEF for pit disassembly and conversion and plutonium conversion and immobilization (ceramic or glass) and construction of a new MOX facility at Hanford. According to recent radiation surveys conducted at the 400 Area, a construction worker would not be expected to receive any additional dose above natural background levels (Antonio 1998). Nonetheless, if deemed necessary, workers may be monitored (badged) as a precautionary measure.

J.1.2.7.2 Operation of Pit Conversion, Immobilization, and MOX Facilities

Tables J-18 and J-19 present all possible incident-free radiological impact scenarios for operating all three facilities at Hanford.

Table J-18. Potential Radiological Impacts on the Public of Operation of Pit Conversion and Immobilization Facilities in FMEF and New MOX Facility at Hanford

Impact	Pit Conversion	Immobilization (17 t)		MOX ^a		Total ^b
		Ceramic	Glass	FMEF	New	
Population within 80 km for year 2010						
Dose (person-rem)	6.9	7.8×10 ⁻³	7.1×10 ⁻³	0.14	0.29	7.2
Percent of natural background ^c	5.9×10 ⁻³	6.7×10 ⁻⁶	6.1×10 ⁻⁶	1.2×10 ⁻⁴	2.5×10 ⁻⁴	6.2×10 ⁻³
10-year latent fatal cancers	0.034	3.9×10 ⁻⁵	3.6×10 ⁻⁵	6.9×10 ⁻⁴	1.5×10 ⁻³	0.036
Maximally exposed individual						
Annual dose (mrem)	0.017	1.1×10 ⁻⁴	9.7×10 ⁻⁵	1.8×10 ⁻³	4.8×10 ⁻³	0.022
Percent of natural background ^c	5.7×10 ⁻³	3.7×10 ⁻⁵	3.2×10 ⁻⁵	6.1×10 ⁻⁴	1.6×10 ⁻³	7.3×10 ⁻³
10-year latent fatal cancer risk	8.5×10 ⁻⁸	5.5×10 ⁻¹⁰	4.9×10 ⁻¹⁰	9.3×10 ⁻⁹	2.4×10 ⁻⁸	1.1×10 ⁻⁷
Average exposed individual within 80 km^d						
Annual dose (mrem)	0.017	2.0×10 ⁻⁵	1.8×10 ⁻⁵	3.5×10 ⁻⁴	7.5×10 ⁻⁴	0.018
10-year latent fatal cancer risk	8.5×10 ⁻⁸	1.0×10 ⁻¹⁰	9.0×10 ⁻¹¹	1.7×10 ⁻⁹	3.7×10 ⁻⁹	8.9×10 ⁻⁸

^a As described in Section 4.26.1.2.2, Water Resources, no component was attributed to liquid pathways because it is not expected that significant contamination could reach these pathways given the site's groundwater and surface-water characteristics.

^b Totals represent the largest possible sums for each public category. Totals are additive in all cases because the same groups or individuals would receive doses from all three facilities.

^c The annual natural background radiation level at Hanford is 300 mrem for the average individual; the population within 80 km (50 mi) in 2010 would receive 116,300 person-rem.

^d Obtained by dividing the population dose by the number of people projected to live within 80 km (50 mi) of Hanford in 2010 (387,800).

Key: FMEF, Fuels and Materials Examination Facility.

Source: Model results.

Table J–19. Potential Radiological Impacts on Involved Workers of Operation of Pit Conversion and Immobilization Facilities in FMEF and New MOX Facility at Hanford

Impact	Pit Conversion	Immobilization (17 t) ^a		MOX (FMEF or New)	Total
		Ceramic or Glass			
Number of badged workers	383	365		331	1,079
Total dose (person-rem/yr)	192	274		22	488
10-year latent fatal cancers	0.77	1.1		0.088	2.0
Average worker dose (mrem/yr)	500	750		65	452 ^b
10-year latent fatal cancer risk	2.0×10^{-3}	3.0×10^{-3}		2.6×10^{-4}	1.8×10^{-3}

^a The presented values are representative of the largest possible number of workers regardless of collocation considerations.

^b Represents an average of the doses for all three facilities.

Key: FMEF, Fuels and Materials Examination Facility.

Note: The radiological limit for an individual worker is 5,000 mrem/yr (DOE 1995). However, the maximum dose to a worker involved in operations would be kept below the DOE administrative control level of 2,000 mrem/yr (DOE 1994). An effective ALARA program would ensure that doses are reduced to levels that are as low as is reasonably achievable.

Source: DOE 1999; UC 1998b, 1999a, 1999b.

J.2 INEEL

J.2.1 Assessment Data

To perform the dose assessments for the SPD EIS, different types of data were collected and generated. In addition, calculational assumptions were made. Appendix F.10 provides a summary of the methods and tools (e.g., the GENII computer code) that were used for the assessments.

J.2.1.1 Meteorological Data

The meteorological data used for the INEEL dose assessments was in the form of JFD file. A JFD file is a table listing the percentages of time the wind blows in a certain direction, at a certain speed, and within a certain stability class. The JFD file was based on measurements taken over a period of several years at a specific location and height. Average annual meteorological conditions, averaged over the measurement period, were used for normal operations. Table J-20 presents the JFD used in the dose assessments for INEEL.

J.2.1.2 Population Data

The INEEL population distribution was based on the *1990 Census of Population and Housing Data* (DOC 1992). Projections were determined for the year 2010 (about midlife of operations) for areas within 80 km (50 mi) of the locations for the proposed surplus plutonium disposition facilities. The site population in 2010 was assumed to be representative of the population over the operational period evaluated. The population was spatially distributed on a circular grid with 16 directions and 10 radial distances out to an 80-km (50-mi) distance. The grid was centered at the Idaho Nuclear Technology and Engineering Center (INTEC), the location from which radionuclides are assumed to be released during incident-free operations. Table J-21 presents the population data used for the dose assessments at INEEL.

J.2.1.3 Agricultural Data

The 1987 Census of Agriculture was the source used to generate site-specific data for food production. Food production was spatially distributed on a circular grid similar to that used for the population distribution described previously. This food grid (or wheel) was generated by combining the fraction of a county in each segment (e.g., south, southwest, north-northeast) and the county production of the eight food categories analyzed by GENII—leafy vegetables, root vegetables, fruits, grains, beef, poultry, milk, and eggs. Each county's food production was assumed to be distributed uniformly over the given county's land area. These categorized food wheels were then used in the assessment of doses to the INEEL population from the ingestion pathway. The consumption rates used in the dose assessments were those for the MEI and average exposed individual. People living within the 80-km (50-mi) assessment area were assumed to consume only food grown in that area. INEEL food production and consumption data used for the dose assessments in the SPD EIS were obtained from the *Health Risk Data for Storage and Disposition Final PEIS* (HNUS 1996).

Table J-20. INEEL 1987-1991 Joint Frequency Distributions at 61-m Height

Wind Speed (m/s)	Stability Class	Wind Blows Toward															
		S	SSW	SW	WSW	W	WNW	NW	NNW	N	NNE	NE	ENE	E	ESE	SE	SSE
1.0	A	0.2	0.31	0.28	0.21	0.2	0.19	0.24	0.22	0.17	0.16	0.11	0.11	0.1	0.11	0.09	0.15
	B	0.04	0.06	0.03	0.01	0.01	0.01	0.01	0.02	0.03	0.02	0.01	0.01	0.01	0	0	0.01
	C	0.04	0.07	0.07	0.02	0.01	0.01	0.01	0.01	0.01	0.01	0.01	0.02	0.01	0.01	0.01	0.01
	D	0.15	0.26	0.15	0.08	0.03	0.05	0.04	0.07	0.07	0.07	0.04	0.05	0.05	0.05	0.05	0.08
	E	0.14	0.17	0.15	0.08	0.07	0.07	0.04	0.06	0.05	0.07	0.06	0.04	0.04	0.05	0.06	0.06
	F	0.4	0.46	0.44	0.3	0.23	0.2	0.16	0.18	0.13	0.16	0.15	0.16	0.17	0.16	0.18	0.27
2.5	A	0.25	0.45	0.58	0.49	0.4	0.34	0.31	0.49	0.63	0.66	0.57	0.32	0.24	0.14	0.18	0.18
	B	0.06	0.18	0.21	0.11	0.03	0.02	0.02	0.05	0.08	0.12	0.08	0.05	0.03	0.01	0.01	0.02
	C	0.15	0.35	0.4	0.09	0.02	0.01	0.02	0.05	0.11	0.1	0.12	0.03	0.04	0.02	0.01	0.03
	D	0.55	1.78	1.05	0.2	0.07	0.04	0.08	0.1	0.17	0.3	0.32	0.2	0.1	0.07	0.08	0.12
	E	0.32	0.75	0.52	0.15	0.07	0.04	0.06	0.09	0.09	0.17	0.15	0.18	0.07	0.06	0.07	0.09
	F	0.77	1.65	1.38	0.67	0.34	0.24	0.21	0.27	0.31	0.51	0.47	0.48	0.35	0.32	0.34	0.38
4.5	A	0.02	0.05	0.05	0.03	0.02	0.01	0.02	0.04	0.08	0.1	0.09	0.08	0.02	0.02	0.02	0.01
	B	0.07	0.12	0.16	0.09	0.04	0.03	0.04	0.12	0.2	0.39	0.4	0.2	0.1	0.05	0.08	0.06
	C	0.07	0.19	0.33	0.13	0.02	0.02	0.02	0.08	0.14	0.33	0.58	0.21	0.07	0.05	0.03	0.06
	D	0.45	2.59	2.36	0.33	0.07	0.05	0.08	0.22	0.36	0.91	1.18	0.7	0.22	0.12	0.12	0.21
	E	0.34	1.26	0.93	0.17	0.04	0.03	0.06	0.11	0.21	0.34	0.49	0.38	0.15	0.08	0.12	0.17
	F	0.35	1.2	1.25	0.37	0.12	0.06	0.04	0.15	0.17	0.33	0.43	0.34	0.18	0.08	0.12	0.16
6.9	A	0	0	0	0	0	0	0	0	0	0	0	0	0	0	0	0
	B	0	0	0	0	0	0	0	0	0	0.01	0	0	0	0	0	0
	C	0.06	0.07	0.08	0.03	0.02	0.01	0.02	0.07	0.1	0.23	0.46	0.27	0.1	0.04	0.05	0.04
	D	0.67	1.47	1.6	0.35	0.06	0.03	0.08	0.26	0.4	1.28	2.95	1.78	0.44	0.16	0.08	0.4
	E	0.15	0.8	0.8	0.16	0.03	0.01	0.06	0.13	0.13	0.33	0.88	0.69	0.11	0.02	0.01	0.08
	F	0.05	0.2	0.25	0.07	0.01	0.01	0	0.02	0.02	0.01	0.1	0.11	0.01	0.01	0	0.01
9.6	A	0	0	0	0	0	0	0	0	0	0	0	0	0	0	0	0
	B	0	0	0	0	0	0	0	0	0	0	0	0	0	0	0	0
	C	0	0	0	0	0	0	0	0	0	0	0.01	0.01	0.01	0	0	0
	D	0.64	0.61	0.74	0.16	0.02	0.01	0.04	0.16	0.29	1.1	3.53	1.98	0.38	0.12	0.07	0.26
	E	0.03	0.12	0.17	0.07	0	0	0.01	0.03	0.03	0.06	0.37	0.28	0.04	0.01	0	0
	F	0	0	0.01	0	0	0	0	0	0	0	0	0	0	0	0	0
13.2	A	0	0	0	0	0	0	0	0	0	0	0	0	0	0	0	0
	B	0	0	0	0	0	0	0	0	0	0	0	0	0	0	0	0
	C	0	0	0	0	0	0	0	0	0	0	0	0	0	0	0	0
	D	0.25	0.25	0.18	0.05	0	0	0.02	0.08	0.16	0.55	2.88	2.13	0.18	0.11	0.01	0.05
	E	0	0	0	0	0	0	0	0	0	0	0.01	0.01	0	0	0	0
	F	0	0	0	0	0	0	0	0	0	0	0	0	0	0	0	0

Table J-20. INEEL 1987-1991 Joint Frequency Distributions at 61-m Height (Continued)

Wind Speed (m/s)	Stability Class	Wind Blows Toward																
		S	SSW	SW	WSW	W	WNW	NW	NNW	N	NNE	NE	ENE	E	ESE	SE	SSE	
19.0	A	0	0	0	0	0	0	0	0	0	0	0	0	0	0	0	0	
	B	0	0	0	0	0	0	0	0	0	0	0	0	0	0	0	0	
	C	0	0	0	0	0	0	0	0	0	0	0	0	0	0	0	0	
	D	0.01	0.05	0.01	0.01	0	0	0	0	0	0	0.04	0.47	0.48	0.01	0.01	0	0
	E	0	0	0	0	0	0	0	0	0	0	0	0	0	0	0	0	0
	F	0	0	0	0	0	0	0	0	0	0	0	0	0	0	0	0	0
25.0	A	0	0	0	0	0	0	0	0	0	0	0	0	0	0	0	0	
	B	0	0	0	0	0	0	0	0	0	0	0	0	0	0	0	0	
	C	0	0	0	0	0	0	0	0	0	0	0	0	0	0	0	0	
	D	0	0	0	0	0	0	0	0	0	0	0	0	0.01	0	0	0	0
	E	0	0	0	0	0	0	0	0	0	0	0	0	0	0	0	0	0
	F	0	0	0	0	0	0	0	0	0	0	0	0	0	0	0	0	0

Source: Sagendorf 1992.

Table J-21. Projected INEEL Population Surrounding INTEC for Year 2010

Direction	Distance (mi)										Total
	0-1	1-2	2-3	3-4	4-5	5-10	10-20	20-30	30-40	40-50	
S	0	0	0	0	0	32	204	340	1,222	3,624	5,422
SSW	0	0	0	0	0	22	92	182	335	445	1,076
SW	0	0	0	0	0	22	87	117	163	304	693
WSW	0	0	0	0	0	0	87	136	149	262	634
W	0	0	0	0	0	0	87	180	392	280	939
WNW	0	0	0	0	0	0	269	519	445	311	1,544
NW	0	0	0	0	0	6	384	620	772	720	2,502
NNW	0	0	0	0	0	6	96	97	315	173	687
N	0	0	0	0	0	0	25	45	77	100	247
NNE	0	0	0	0	0	0	25	48	170	161	404
NE	0	0	0	0	0	0	0	285	652	342	1,279
ENE	0	0	0	0	0	0	0	332	575	1,057	1,964
E	0	0	0	0	0	0	0	506	1,203	12,055	13,764
ESE	0	0	0	0	0	0	208	947	1,536	103,127	105,818
SE	0	0	0	0	0	0	219	374	16,764	11,931	29,288
SSE	0	0	0	0	0	20	212	346	7,427	8,500	16,505
Total	0	0	0	0	0	108	1,995	5,074	32,197	143,392	182,766

Key: INTEC, Idaho Nuclear Technology and Engineering Center.

Source: DOC 1992.

J.2.1.4 Source Term Data

Estimated incident-free radiological releases associated with the pit conversion and MOX facilities are presented in Tables J-22 and J-23. Stack heights and release locations are provided in the facility data reports (DOE 1999; UC 1998c, 1998d).

Table J-22. Estimated Incident-Free Annual Radiological Releases From the Pit Conversion Facility at INEEL

Isotope	($\mu\text{Ci/yr}$)
Plutonium 236	9.3×10^{-11}
Plutonium 238	0.065
Plutonium 239	0.69
Plutonium 240	0.18
Plutonium 241	0.69
Plutonium 242	4.8×10^{-5}
Americium 241	0.37
Hydrogen 3	1.1×10^9

Source: UC 1998c.

Table J-23. Estimated Incident-Free Annual Radiological Releases From the MOX Facility at INEEL

Isotope	($\mu\text{Ci/yr}$)
Plutonium 236	1.3×10^{-8}
Plutonium 238	8.5
Plutonium 239	91
Plutonium 240	23
Plutonium 241	101
Plutonium 242	6.1×10^{-3}
Americium 241	48
Uranium 234	5.1×10^{-3}
Uranium 235	2.1×10^{-4}
Uranium 238	0.012

Source: UC 1998d.

J.2.1.5 Other Calculational Assumptions

To estimate radiological impacts of incident-free operation of the proposed facilities at INEEL, the following additional assumptions and factors were considered, in accordance with the guidelines established in NRC Regulatory Guide 1.109 (NRC 1977).

- Ground surfaces were assumed to have no previous deposition of radionuclides for the purposes of modeling the incremental radiological impacts associated with surplus plutonium disposition activities. However, doses associated with true instances of prior deposition are accounted for in the Affected Environment and Cumulative Impacts sections.
- The annual external exposure time to the plume and to soil contamination was 0.7 year for the MEI (NRC 1977).

- The annual external exposure time to the plume and to soil contamination was 0.5 year for the population (NRC 1977).
- The annual inhalation exposure time to the plume was 1 year for the MEI and general population (NRC 1977).
- The exposed individual or population was assumed to have the characteristics and habits (e.g., inhalation and ingestion rates) of the adult human.
- A semi-infinite/finite plume model was used for air immersion doses. Other pathways evaluated were ground exposure, inhalation, ingestion of food crops, and ingestion of contaminated animal products. Drinking water, aquatic food ingestion, and any other pathway that may involve liquid exposure were not examined because all releases are to the air.
- Reported stack heights were used for atmospheric releases. The resultant doses were conservative as use of the actual stack height instead of the effective stack height negates plume rise.
- The calculated doses are 50-year committed doses from 1 year of intake.

J.2.2 Facilities

The following sections present all viable radiological impact scenarios that could be associated with different combinations of incident-free facility operations at INEEL.

J.2.2.1 Pit Conversion Facility

J.2.2.1.1 Construction of Pit Conversion Facility

No radiological risk would be incurred by members of the public from construction and modification of a pit conversion facility in the Fuel Processing Facility (FPF) at INEEL. According to a recent radiation survey (Mitchell et al. 1997) conducted in the INTEC area, a construction worker could receive about 5 mrem/yr above natural background levels from exposure to radiation deriving from other activities, past or present, at the site. Construction worker exposures would be kept as low as is reasonably achievable, and workers would be monitored (badged) as appropriate.

J.2.2.1.2 Operation of Pit Conversion Facility

Tables J-24 and J-25 present the incident-free radiological impacts of the operation of a pit conversion facility at INEEL.

Table J–24. Potential Radiological Impacts on the Public of Operation of Pit Conversion Facility in FPF at INEEL

Population within 80 km for year 2010	
Dose (person-rem)	2.2
Percent of natural background ^a	3.3×10^{-3}
10-year latent fatal cancers	0.011
Maximally exposed individual	
Annual dose (mrem)	0.015
Percent of natural background ^a	4.2×10^{-3}
10-year latent fatal cancer risk	7.5×10^{-8}
Average exposed individual within 80 km^b	
Annual dose (mrem)	0.012
10-year latent fatal cancer risk	6.0×10^{-8}

^a The annual natural background radiation level at INEEL is 361 mrem for the average individual; the population within 80 km (50 mi) in 2010 would receive 66,000 person-rem.

^b Obtained by dividing the population dose by the number of people projected to live within 80 km (50 mi) of INEEL in 2010 (182,800).

Key: FPF, Fuel Processing Facility.

Source: Model results.

Table J–25. Potential Radiological Impacts on Involved Workers of Operation of Pit Conversion Facility in FPF at INEEL

Number of badged workers	341
Total dose (person-rem/yr)	170
10-year latent fatal cancers	0.68
Average worker dose (mrem/yr)	500
10-year latent fatal cancer risk	2.0×10^{-3}

Key: FPF, Fuel Processing Facility.

Note: The radiological limit for an individual worker is 5,000 mrem/yr (DOE 1995). However, the maximum dose to a worker involved in operations would be kept below the DOE administrative control level of 2,000 mrem/yr (DOE 1994). An effective ALARA program would ensure that doses are reduced to levels that are as low as is reasonably achievable.

Source: UC 1998c.

J.2.2.2 MOX Facility

J.2.2.2.1 Construction of MOX Facility

No radiological risk would be incurred by members of the public from the construction of a new MOX facility at INEEL. According to a recent radiation survey (Mitchell et al. 1997) conducted in the INTEC area, a construction worker could receive about 5 mrem/yr above natural background levels from exposure to radiation deriving from other activities, past or present, at the site. Construction worker exposures would be kept as low as is reasonably achievable, and workers would be monitored (badged) as appropriate.

J.2.2.2.2 Operation of MOX Facility

Tables J–26 and J–27 present the incident-free radiological impacts of the operation of a new MOX facility at INEEL.

Table J–26. Potential Radiological Impacts on the Public of Operation of New MOX Facility at INEEL^a

Population within 80 km for year 2010	
Dose (person-rem)	0.037
Percent of natural background ^b	5.6×10^{-5}
10-year latent fatal cancers	1.9×10^{-4}
Maximally exposed individual	
Annual dose (mrem)	3.2×10^{-3}
Percent of natural background ^b	8.8×10^{-4}
10-year latent fatal cancer risk	1.6×10^{-8}
Average exposed individual within 80 km^c	
Annual dose (mrem)	2.1×10^{-4}
10-year latent fatal cancer risk	1.0×10^{-9}

^a As described in Section 4.26.2.2.2, Water Resources, no component was attributed to liquid pathways because it is not expected that significant contamination could reach these pathways given the site’s groundwater and surface-water characteristics.

^b The annual natural background radiation level at INEEL is 361 mrem for the average individual; the population within 80 km (50 mi) in 2010 would receive 66,000 person-rem.

^c Obtained by dividing the population dose by the number of people projected to live within 80 km (50 mi) of INEEL in 2010 (182,800).

Source: Model results.

Table J–27. Potential Radiological Impacts on Involved Workers of Operation of New MOX Facility at INEEL

Number of badged workers	331
Total dose (person-rem/yr)	22
10-year latent fatal cancers	0.088
Average worker dose (mrem/yr)	65
10-year latent fatal cancer risk	2.6×10^{-4}

Note: The radiological limit for an individual worker is 5,000 mrem/yr (DOE 1995). However, the maximum dose to a worker involved in operations would be kept below the DOE administrative control level of 2,000 mrem/yr (DOE 1994). An effective ALARA program would ensure that doses are reduced to levels that are as low as is reasonably achievable.

Source: DOE 1999; UC 1998d.

J.2.2.3 Pit Conversion and MOX Facilities

J.2.2.3.1 Construction of Pit Conversion and MOX Facilities

No radiological risk would be incurred by members of the public from the construction and modification of a pit conversion facility in FPF and construction of a new MOX facility at INEEL. According to a recent radiation survey (Mitchell et al. 1997) conducted in the INTEC area, a construction worker could receive about 5 mrem/yr above natural background levels from exposure to radiation deriving from other activities, past or present, at the site. Construction worker exposures would be kept as low as is reasonably achievable, and workers would be monitored (badged) as appropriate.

J.2.2.3.2 Operation of Pit Conversion and MOX Facilities

Tables J–28 and J–29 present the incident-free radiological impacts of operation of pit conversion and MOX facilities at INEEL.

Table J–28. Potential Radiological Impacts on the Public of Operation of Pit Conversion Facility in FPF and New MOX Facility at INEEL

Impact	Pit Conversion	MOX ^a	Total ^b
Population within 80 km for year 2010			
Dose (person-rem)	2.2	0.037	2.2
Percent of natural background ^c	3.3×10^{-3}	5.6×10^{-5}	3.4×10^{-3}
10-year latent fatal cancers	0.011	1.9×10^{-4}	0.011
Maximally exposed individual			
Annual dose (mrem)	0.015	3.2×10^{-3}	0.018
Percent of natural background ^c	4.2×10^{-3}	8.8×10^{-4}	5.1×10^{-3}
10-year latent fatal cancer risk	7.5×10^{-8}	1.6×10^{-8}	9.1×10^{-8}
Average exposed individual within 80 km^d			
Annual dose (mrem)	0.012	2.1×10^{-4}	0.012
10-year latent fatal cancer risk	6.0×10^{-8}	1.0×10^{-9}	6.1×10^{-8}

^a As described in Section 4.26.2.2.2, Water Resources, no component was attributed to liquid pathways because it is not expected that significant contamination could reach these pathways given the site's groundwater and surface-water characteristics.

^b Totals are additive in all cases because the same groups or individuals would receive doses from both facilities.

^c The annual natural background radiation level at INEEL is 361 mrem for the average individual; the population within 80 km (50 mi) in 2010 would receive 66,000 person-rem.

^d Obtained by dividing the population dose by the number of people projected to live within 80 km (50 mi) of INEEL in 2010 (182,800).

Key: FPF, Fuel Processing Facility.

Source: Model results.

Table J–29. Potential Radiological Impacts on Involved Workers of Operation of Pit Conversion Facility in FPF and New MOX Facility at INEEL

Impact	Pit Conversion	MOX	Total
Number of badged workers	341	331	672
Total dose (person-rem/yr)	170	22	192
10-year latent fatal cancers	0.68	0.088	0.77
Average worker dose (mrem/yr)	500	65	286 ^a
10-year latent fatal cancer risk	2.0×10^{-3}	2.6×10^{-4}	1.1×10^{-3}

^a Represents an average of the doses for both facilities.

Key: FPF, Fuel Processing Facility.

Note: The radiological limit for an individual worker is 5,000 mrem/yr (DOE 1995). However, the maximum dose to a worker involved in operations would be kept below the DOE administrative control level of 2,000 mrem/yr (DOE 1994). An effective ALARA program would ensure that doses are reduced to levels that are as low as is reasonably achievable.

Source: DOE 1999; UC 1998c, 1998d.

J.3 PANTEX

J.3.1 Assessment Data

To perform the dose assessments for the SPD EIS, different types of data were collected and generated. In addition, calculational assumptions were made. Appendix F.10 provides a summary of the methods and tools (e.g., the GENII computer code) that were used for the assessments.

J.3.1.1 Meteorological Data

The meteorological data used for the Pantex dose assessments was in the form of a JFD file. A JFD file is a table listing the percentages of time the wind blows in a certain direction, at a certain speed, and within a certain stability class. The JFD file was based on measurements taken over a period of several years at a specific location

and height. Average annual meteorological conditions, averaged over the measurement period, were used for normal operations. Table J-30 presents the JFD used in the dose assessments for Pantex.

J.3.1.2 Population Data

The Pantex population distribution was based on the *1990 Census of Population and Housing Data* (DOC 1992). Projections were determined for the year 2010 (about midlife of operations) for areas within 80 km (50 mi) of the locations for the proposed plutonium disposition facilities. The site population in 2010 was assumed to be representative of the population over the operational period evaluated. The population was spatially distributed on a circular grid with 16 directions and 10 radial distances out to an 80-km (50-mi) distance. The grid was centered at Zone 4, the location from which radionuclides are assumed to be released during incident-free operations. Table J-31 presents the population data used for the dose assessments at Pantex.

J.3.1.3 Agricultural Data

The 1987 Census of Agriculture was the source used to generate site-specific data for food production. Food production was spatially distributed on a circular grid similar to that used for the population distribution described previously. This food grid (or wheel) was generated by combining the fraction of a county in each segment (e.g., south, southwest, north-northeast) and the county production of the eight food categories analyzed by GENII—leafy vegetables, root vegetables, fruits, grains, beef, poultry, milk, and eggs. Each county's food production was assumed to be distributed uniformly over the given county's land area. These categorized food wheels were then used in the assessment of doses to the Pantex population from the ingestion pathway. The consumption rates used in the dose assessments were those for the MEI and average exposed individual. People living within the 80-km (50-mi) assessment area were assumed to consume only food grown in that area. Pantex food production and consumption data used for the dose assessments in the SPD EIS were obtained from the *Health Risk Data for Storage and Disposition Final PEIS* (HNUS 1996).

Table J-30. 1985–1989 Joint Frequency Distributions at 7-m Height for Pantex^a

Wind Speed (m/s)	Stability Class	Wind Blows Toward															
		S	SSW	SW	WSW	W	WNW	NW	NNW	N	NNE	NE	ENE	E	ESE	SE	SSE
0.89	A	0.02	0	0.01	0.01	0.01	0.01	0.01	0.01	0.01	0.01	0.01	0.01	0.01	0.02	0.01	0.01
	B	0.02	0.01	0.01	0.02	0.03	0.02	0.02	0.02	0.05	0.01	0.03	0.02	0.04	0.02	0.03	0.02
	C	0.02	0	0.01	0.01	0.01	0	0.01	0	0.01	0.01	0.01	0.01	0.02	0.01	0.01	0.01
	D	0.03	0.01	0.03	0.02	0.02	0.02	0.02	0.03	0.02	0.02	0.01	0.02	0.03	0.02	0.02	0.03
	E	0	0	0	0	0	0	0	0	0	0	0	0	0	0	0	0
	F	0.12	0.04	0.04	0.05	0.04	0.04	0.07	0.08	0.17	0.11	0.16	0.09	0.13	0.13	0.11	0.08
2.5	A	0.03	0.01	0.02	0.02	0.03	0.02	0.02	0.01	0.02	0.02	0.01	0.03	0.02	0.02	0.02	0.01
	B	0.12	0.06	0.08	0.06	0.14	0.06	0.07	0.05	0.13	0.06	0.09	0.05	0.11	0.09	0.11	0.07
	C	0.12	0.05	0.07	0.07	0.06	0.05	0.04	0.05	0.12	0.11	0.09	0.11	0.13	0.13	0.15	0.09
	D	0.22	0.12	0.13	0.14	0.18	0.12	0.12	0.16	0.19	0.16	0.12	0.14	0.18	0.13	0.16	0.16
	E	0.23	0.1	0.09	0.1	0.12	0.14	0.16	0.14	0.31	0.21	0.23	0.18	0.21	0.15	0.19	0.12
	F	0.41	0.16	0.13	0.14	0.18	0.2	0.25	0.23	0.62	0.49	0.64	0.39	0.48	0.49	0.43	0.28
4.5	A	0	0	0	0	0	0	0	0	0	0	0	0	0	0	0	0
	B	0.08	0.04	0.07	0.07	0.07	0.06	0.06	0.09	0.17	0.13	0.13	0.09	0.1	0.08	0.07	0.08
	C	0.45	0.21	0.18	0.2	0.27	0.16	0.22	0.22	0.63	0.45	0.54	0.39	0.47	0.37	0.48	0.32
	D	1.14	0.72	0.64	0.59	0.72	0.66	1.02	1.1	2.19	1.21	1	0.5	0.41	0.32	0.6	0.5
	E	0.72	0.33	0.28	0.27	0.41	0.39	0.79	1.16	2.75	1.85	1.83	0.93	0.55	0.56	0.79	0.38
	F	0	0	0	0	0	0	0	0	0	0	0	0	0	0	0	0
6.9	A	0	0	0	0	0	0	0	0	0	0	0	0	0	0	0	0
	B	0	0	0	0	0	0	0	0	0	0	0	0	0	0	0	0
	C	0.13	0.1	0.07	0.05	0.04	0.04	0.05	0.13	0.52	0.5	0.39	0.22	0.16	0.08	0.05	0.04
	D	3.07	1.76	1	0.67	0.9	0.83	1.73	2.59	7.3	4.2	3.32	1.83	1.19	0.57	0.89	0.95
	E	0	0	0	0	0	0	0	0	0	0	0	0	0	0	0	0
	F	0	0	0	0	0	0	0	0	0	0	0	0	0	0	0	0
9.6	A	0	0	0	0	0	0	0	0	0	0	0	0	0	0	0	0
	B	0	0	0	0	0	0	0	0	0	0	0	0	0	0	0	0
	C	0.03	0.02	0.03	0.01	0	0.01	0.01	0.03	0.18	0.19	0.09	0.04	0.03	0.01	0	0.01
	D	1.49	0.82	0.29	0.13	0.11	0.13	0.33	0.48	2.24	1.48	1.01	0.76	0.49	0.12	0.15	0.34
	E	0	0	0	0	0	0	0	0	0	0	0	0	0	0	0	0
	F	0	0	0	0	0	0	0	0	0	0	0	0	0	0	0	0
12.1	A	0	0	0	0	0	0	0	0	0	0	0	0	0	0	0	0
	B	0	0	0	0	0	0	0	0	0	0	0	0	0	0	0	0
	C	0.01	0.01	0	0	0	0	0	0	0.04	0.01	0.01	0.02	0.01	0	0	0
	D	0.73	0.32	0.05	0.03	0.01	0.02	0.05	0.1	0.41	0.22	0.2	0.25	0.24	0.05	0.09	0.2
	E	0	0	0	0	0	0	0	0	0	0	0	0	0	0	0	0
	F	0	0	0	0	0	0	0	0	0	0	0	0	0	0	0	0

^a Joint frequency distribution data was compiled by the National Weather Service Station at Amarillo Airport; it was assumed that this data satisfactorily represented the atmospheric conditions at the Pantex site.

Source: NWS 1997.

Table J-31. Projected Pantex Population Surrounding Zone 4 for Year 2010

Direction	Distance (mi)										Total
	0-1	1-2	2-3	3-4	4-5	5-10	10-20	20-30	30-40	40-50	
S	0	0	0	4	5	41	100	96	104	268	618
SSW	0	0	0	0	5	117	441	1,095	361	1,013	3,032
SW	0	0	0	3	3	901	18,330	14,816	13,199	1,137	48,389
WSW	0	0	3	2	3	49	88,209	65,959	1,189	528	15,5942
W	0	0	2	2	3	25	3,372	683	227	897	5,211
WNW	0	0	3	2	3	25	148	360	517	834	1,892
NW	0	2	3	3	3	25	98	253	547	542	1,476
NNW	0	2	3	4	5	30	88	344	519	16,924	17,919
N	0	2	3	4	5	41	151	5,476	176	225	6,083
NNE	0	2	3	4	5	41	162	18,764	2,998	233	22,212
NE	0	2	3	4	5	41	163	396	295	165	1,074
ENE	0	2	3	4	5	41	324	724	22,852	176	24,131
E	0	2	3	4	5	961	2,016	884	372	1,085	5,332
ESE	0	2	3	4	5	41	273	512	248	401	1,489
SE	0	0	3	4	5	41	303	370	115	2,182	3,023
SSE	0	0	0	4	5	41	677	311	69	109	1,216
Total	0	16	35	52	70	2,461	114,855	111,043	43,788	26,719	299,039

Source: DOC 1992.

J.3.1.4 Source Term Data

Estimated incident-free radiological releases associated with the new pit conversion and MOX facilities at Pantex are presented in Tables J-32 and J-33. Stack heights and release locations are provided in the facility data reports (DOE 1999; UC 1998e, 1998f).

Table J-32. Estimated Incident-Free Annual Radiological Releases From the New Pit Conversion Facility at Pantex

Isotope	($\mu\text{Ci/yr}$)
Plutonium 236	9.3×10^{-11}
Plutonium 238	0.065
Plutonium 239	0.69
Plutonium 240	0.18
Plutonium 241	0.69
Plutonium 242	4.8×10^{-5}
Americium 241	0.37
Hydrogen 3	1.1×10^9

Source: UC 1998e.

Table J-33. Estimated Incident-Free Annual Radiological Releases From the New MOX Facility at Pantex

Isotope	($\mu\text{Ci/yr}$)
Plutonium 236	1.3×10^{-8}
Plutonium 238	8.5
Plutonium 239	91
Plutonium 240	23
Plutonium 241	101
Plutonium 242	6.1×10^{-3}
Americium 241	48
Uranium 234	5.1×10^{-3}
Uranium 235	2.1×10^{-4}
Uranium 238	0.012

Source: UC 1998f.

J.3.1.5 Other Calculational Assumptions

To estimate radiological impacts of incident-free operation of the proposed facilities at Pantex, the following additional assumptions and factors were considered, in accordance with the guidelines established in NRC Regulatory Guide 1.109 (NRC 1977).

- Ground surfaces were assumed to have no previous deposition of radionuclides for the purposes of modeling the incremental radiological impacts associated with surplus plutonium disposition activities. However, doses associated with true instances of prior deposition are accounted for in the Affected Environment and Cumulative Impacts sections.
- The annual external exposure time to the plume and to soil contamination was 0.7 year for the MEI (NRC 1977).
- The annual external exposure time to the plume and to soil contamination was 0.5 year for the population (NRC 1977).
- The annual inhalation exposure time to the plume was 1 year for the MEI and general population (NRC 1977).
- The exposed individual or population was assumed to have the characteristics and habits (e.g., inhalation and ingestion rates) of the adult human.
- A semi-infinite/finite plume model was used for air immersion doses. Other pathways evaluated were ground exposure, inhalation, ingestion of food crops, and ingestion of contaminated animal products. Drinking water, aquatic food ingestion, and any other pathway that may involve liquid exposure were not examined because all releases were to the air.
- Reported stack heights were used for atmospheric releases. The resultant doses were conservative as use of the actual stack height instead of the effective stack height negates plume rise.
- The calculated doses are 50-year committed doses from 1 year of intake.

J.3.2 Facilities

The following sections present all viable radiological impact scenarios that could be associated with different combinations of incident-free facility operations at Pantex.

J.3.2.1 Pit Conversion Facility

J.3.2.1.1 Construction of Pit Conversion Facility

No radiological risk would be incurred by members of the public from the construction of a new pit conversion facility at Pantex. According to a recent radiation survey (DOE 1997) conducted in Zone 4, a construction worker would not be expected to receive any additional radiation exposure above natural background levels in the area. Nonetheless, construction workers may be monitored (badged) as a precautionary measure.

J.3.2.1.2 Operation of Pit Conversion Facility

Tables J-34 and J-35 present the incident-free radiological impacts of the operation of a new pit conversion facility at Pantex.

Table J-34. Potential Radiological Impacts on the Public of Operation of New Pit Conversion Facility at Pantex

Population within 80 km for year 2010	
Dose (person-rem)	0.58
Percent of natural background ^a	5.8×10^{-4}
10-year latent fatal cancers	2.9×10^{-3}
Maximally exposed individual	
Annual dose (mrem)	0.062
Percent of natural background ^a	0.019
10-year latent fatal cancer risk	3.1×10^{-7}
Average exposed individual within 80 km^b	
Annual dose (mrem)	1.9×10^{-3}
10-year latent fatal cancer risk	9.5×10^{-9}

^a The annual natural background radiation level at Pantex is 332 mrem for the average individual; the population within 80 km (50 mi) in 2010 would receive 99,300 person-rem.

^b Obtained by dividing the population dose by the number of people projected to live within 80 km (50 mi) of Pantex in 2010 (299,000).

Source: Model results.

Table J-35. Potential Radiological Impacts on Involved Workers of Operation of New Pit Conversion Facility at Pantex

Number of badged workers	383
Total dose (person-rem/yr)	192
10-year latent fatal cancers	0.77
Average worker dose (mrem/yr)	500
10-year latent fatal cancer risk	2.0×10^{-3}

Note: The radiological limit for an individual worker is 5,000 mrem/yr (DOE 1995). However, the maximum dose to a worker involved in operations would be kept below the DOE administrative control level of 2,000 mrem/yr (DOE 1994). An effective ALARA program would ensure that doses are reduced to levels that are as low as is reasonably achievable.

Source: UC 1998e.

J.3.2.2 MOX Facility

J.3.2.2.1 Construction of MOX Facility

No radiological risk would be incurred by members of the public from construction of a new MOX facility at Pantex. According to a recent radiation survey (DOE 1997) conducted in Zone 4, a construction worker would not be expected to receive any additional radiation exposure above natural background levels in the area. Nonetheless, construction workers may be monitored (badged) as a precautionary measure.

J.3.2.2.2 Operation of MOX Facility

Tables J–36 and J–37 present the incident-free radiological impacts of the operation of a new MOX facility at Pantex.

Table J–36. Potential Radiological Impacts on the Public of Operation of New MOX Facility at Pantex^a

Population within 80 km for year 2010	
Dose (person-rem)	0.027
Percent of natural background ^b	2.7×10^{-5}
10-year latent fatal cancers	1.3×10^{-4}
Maximally exposed individual	
Annual dose (mrem)	0.015
Percent of natural background ^b	4.5×10^{-3}
10-year latent fatal cancer risk	7.5×10^{-8}
Average exposed individual within 80 km^c	
Annual dose (mrem)	8.8×10^{-5}
10-year latent fatal cancer risk	4.5×10^{-10}

^a As described in Section 4.26.3.2.2, Water Resources, no component was attributed to liquid pathways because it is not expected that significant contamination could reach these pathways given the site's groundwater and surface-water characteristics.

^b The annual natural background radiation level at Pantex is 332 mrem for the average individual; the population within 80 km (50 mi) in 2010 would receive 99,300 person-rem.

^c Obtained by dividing the population dose by the number of people projected to live within 80 km (50 mi) of Pantex in 2010 (299,000).

Source: Model results.

Table J–37. Potential Radiological Impacts on Involved Workers of Operation of New MOX Facility at Pantex

Number of badged workers	331
Total dose (person-rem/yr)	22
10-year latent fatal cancers	0.088
Average worker dose (mrem/yr)	65
10-year latent fatal cancer risk	2.6×10^{-4}

Note: The radiological limit for an individual worker is 5,000 mrem/yr (DOE 1995). However, the maximum dose to a worker involved in operations would be kept below the DOE administrative control level of 2,000 mrem/yr (DOE 1994). An effective ALARA program would ensure that doses are reduced to levels that are as low as is reasonably achievable.

Source: DOE 1999; UC 1998f.

J.3.2.3 Pit Conversion and MOX Facilities

J.3.2.3.1 Construction of Pit Conversion and MOX Facilities

No radiological risk would be incurred by members of the public from the construction of new pit conversion and MOX facilities at Pantex. According to a recent radiation survey (DOE 1997) conducted in Zone 4, a construction worker would not be expected to receive any additional radiation exposure above natural background levels in the area. Nonetheless, construction workers may be monitored (badged) as a precautionary measure.

J.3.2.3.2 Operation of Pit Conversion and MOX Facilities

Tables J-38 and J-39 present the incident-free radiological impacts of operation of the new pit conversion and MOX facilities at Pantex.

Table J-38. Potential Radiological Impacts on the Public of Operation of New Pit Conversion and MOX Facilities at Pantex

Impact	Pit Conversion	MOX ^a	Total ^b
Population within 80 km for year 2010			
Dose (person-rem)	0.58	0.027	0.61
Percent of natural background ^c	5.8×10^{-4}	2.7×10^{-5}	6.1×10^{-4}
10-year latent fatal cancers	2.9×10^{-3}	1.3×10^{-4}	3.0×10^{-3}
Maximally exposed individual			
Annual dose (mrem)	0.062	0.015	0.077
Percent of natural background ^c	0.019	4.5×10^{-3}	0.024
10-year latent fatal cancer risk	3.1×10^{-7}	7.5×10^{-8}	3.9×10^{-7}
Average exposed individual within 80 km^d			
Annual dose (mrem)	1.9×10^{-3}	8.8×10^{-5}	2.0×10^{-3}
10-year latent fatal cancer risk	9.5×10^{-9}	4.4×10^{-10}	9.9×10^{-9}

^a As described in Section 4.26.3.2.2, Water Resources, no component was attributed to liquid pathways because it is not expected that significant contamination could reach these pathways given the site's groundwater and surface-water characteristics.

^b Totals are additive in all cases because the same groups or individuals would receive doses from both facilities.

^c The annual natural background radiation level at Pantex is 332 mrem for the average individual; the population within 80 km (50 mi) in 2010 would receive 99,300 person-rem.

^d Obtained by dividing the population dose by the number of people projected to live within 80 km (50 mi) of Pantex in 2010 (299,000).

Source: Model results.

Table J-39. Potential Radiological Impacts on Involved Workers of Operation of New Pit Conversion and MOX Facilities at Pantex

Impact	Pit Conversion	MOX	Total
Number of badged workers	383	331	714
Total dose (person-rem/yr)	192	22	214
10-year latent fatal cancers	0.77	0.088	0.86
Average worker dose (mrem/yr)	500	65	300 ^a
10-year latent fatal cancer risk	2.0×10^{-3}	2.6×10^{-4}	1.2×10^{-3}

^a Represents an average of the doses for both facilities.

Note: The radiological limit for an individual worker is 5,000 mrem/yr (DOE 1995). However, the maximum dose to a worker involved in operations would be kept below the DOE administrative control level of 2,000 mrem/yr (DOE 1994). An effective ALARA program would ensure that doses are reduced to levels that are as low as is reasonably achievable.

Source: DOE 1999; UC 1998e, 1998f.

J.4 SRS

J.4.1 Assessment Data

To perform the dose assessments for the SPD EIS, different types of data were collected and generated. In addition, calculational assumptions were made. Appendix F.10 provides a summary of the methods and tools (e.g., the GENII computer code) that were used for the assessments.

J.4.1.1 Meteorological Data

The meteorological data used for the SRS dose assessments was in the form of a JFD file. A JFD file is a table listing the percentages of time the wind blows in a certain direction, at a certain speed, and within a certain stability class. The JFD data file was based on measurements taken over a period of several years at a specific location (F-Area) and height. Average annual meteorological conditions, averaged over the measurement period, were used for normal operations. Table J-40 presents the JFD data used in the dose assessments for SRS.

J.4.1.2 Population Data

The SRS population distribution was based on the *1990 Census of Population and Housing Data* (DOC 1992). Projections were determined for the year 2010 (about midlife of operations) for areas within 80 km (50 mi) of the locations for the proposed surplus plutonium disposition facilities. The site population in 2010 was assumed to be representative of the population over the operational period evaluated. The population was spatially distributed on a circular grid with 16 directions and 10 radial distances out to an 80-km (50-mi) distance. The grids were centered at the Actinide Packaging and Storage Facility in F-Area, the locations from which radionuclides are assumed to be released during incident-free operations. Tables J-41 and J-42 present the population data used for the dose assessments at SRS.

J.4.1.3 Agricultural Data

The 1987 Census of Agriculture was the source used to generate site-specific data for food production. Food production was spatially distributed on a circular grid similar to that used for the population distributions described previously. This food grid (or wheel) was generated by combining the fraction of a county in each segment (e.g., south, southwest, north-northeast) and the county production of the eight food categories analyzed by GENII (leafy vegetables, root vegetables, fruits, grains, beef, poultry, milk, and eggs). Each county's food production was assumed to be distributed uniformly over the given county's land area. These categorized food wheels are then used in the assessment of doses to the SRS population from the ingestion pathway. The consumption rates used in the dose assessments were those for the MEI and average exposed individual. People living within the 80-km (50-mi) assessment area were assumed to consume only food grown in that area. SRS food production and consumption data used for the dose assessments in the SPD EIS were obtained from the *Health Risk Data for Storage and Disposition Final PEIS* (HNUS 1996).

Table J-40. SRS 1987–1991 Joint Frequency Distributions at 61-m Height

Wind Speed (m/s)	Stability Class	Wind Blows Toward															
		S	SSW	SW	WSW	W	WNW	NW	NNW	N	NNE	NE	ENE	E	ESE	SE	SSE
2.0	A	0.27	0.35	0.39	0.42	0.34	0.31	0.28	0.31	0.31	0.3	0.32	0.34	0.5	0.32	0.29	0.26
	B	0.04	0.05	0.06	0.08	0.05	0.05	0.04	0.05	0.05	0.04	0.06	0.07	0.06	0.06	0.06	0.04
	C	0.02	0.03	0.1	0.07	0.02	0.04	0.03	0.06	0.05	0.05	0.07	0.07	0.09	0.06	0.03	0.02
	D	0.01	0.03	0.07	0.02	0.02	0.03	0.05	0.05	0.04	0.04	0.05	0.05	0.03	0.02	0.04	0.03
	E	0	0	0.02	0	0	0.01	0.02	0.01	0.01	0.02	0.02	0.02	0.02	0.01	0.01	0.02
	F	0	0	0.01	0	0	0	0	0	0	0	0	0	0	0	0	0
4.0	A	0.64	0.63	0.7	0.77	0.76	0.63	0.54	0.66	0.58	0.64	0.73	1.15	1	0.69	0.52	0.44
	B	0.22	0.3	0.33	0.4	0.33	0.26	0.21	0.22	0.28	0.26	0.51	0.67	0.59	0.3	0.16	0.2
	C	0.08	0.52	0.57	0.77	0.51	0.37	0.33	0.39	0.44	0.45	0.7	0.77	0.69	0.33	0.28	0.15
	D	0.06	0.52	1.49	1.12	0.5	0.51	0.62	0.78	0.77	0.62	0.7	0.75	0.77	0.47	0.31	0.15
	E	0.04	0.2	0.8	0.35	0.18	0.28	0.42	0.55	0.57	0.43	0.51	0.42	0.49	0.33	0.25	0.15
	F	0.02	0.02	0.1	0.05	0.03	0.03	0.07	0.09	0.06	0.07	0.09	0.06	0.06	0.07	0.06	0.04
6.0	A	0.49	0.15	0.1	0.09	0.1	0.09	0.08	0.14	0.11	0.14	0.17	0.17	0.19	0.18	0.1	0.21
	B	0.12	0.22	0.17	0.22	0.19	0.09	0.08	0.15	0.17	0.2	0.3	0.42	0.37	0.28	0.11	0.08
	C	0.08	0.4	0.42	0.63	0.35	0.18	0.19	0.34	0.38	0.43	0.6	0.77	0.64	0.39	0.17	0.11
	D	0.06	0.8	2.28	1.39	0.62	0.44	0.67	1.31	1.21	0.75	0.94	0.87	1.01	0.66	0.29	0.18
	E	0.06	0.51	1.36	1.07	0.56	0.48	0.64	1.25	1.29	0.97	1.08	1.14	1.22	0.77	0.38	0.21
	F	0.02	0.04	0.18	0.28	0.23	0.21	0.2	0.23	0.23	0.26	0.25	0.26	0.21	0.19	0.1	0.08
8.0	A	0.11	0.03	0.01	0.01	0.01	0.01	0	0.02	0.01	0.04	0.02	0.02	0.03	0.03	0.02	0.03
	B	0	0.06	0.02	0.01	0	0	0	0.01	0.03	0.04	0.08	0.06	0.04	0.08	0.03	0.01
	C	0.01	0.11	0.11	0.13	0.06	0.04	0.05	0.07	0.13	0.17	0.27	0.28	0.33	0.29	0.06	0.01
	D	0.04	0.3	0.6	0.41	0.08	0.03	0.1	0.25	0.21	0.15	0.2	0.24	0.63	0.35	0.05	0.02
	E	0.02	0.29	0.25	0.16	0.06	0.02	0.02	0.06	0.08	0.05	0.16	0.12	0.15	0.06	0.02	0.02
	F	0	0.01	0.04	0.06	0.04	0.01	0.02	0.02	0.04	0.05	0.02	0.01	0.01	0	0	0
12.0	A	0.01	0	0	0	0	0	0	0	0	0	0.01	0.01	0	0.01	0	0.01
	B	0	0	0	0	0	0	0	0	0	0	0	0	0.01	0.02	0	0
	C	0	0.01	0	0	0	0	0	0.02	0.03	0.03	0.04	0.06	0.2	0.18	0.01	0
	D	0.01	0.06	0.08	0.08	0.01	0.01	0.01	0.03	0.05	0.03	0.06	0.03	0.39	0.2	0.01	0
	E	0	0.01	0.02	0.01	0	0	0	0	0	0	0	0	0	0	0	0
	F	0	0	0	0	0	0	0	0	0	0	0	0	0	0	0	0
14.1	A	0	0	0	0	0	0	0	0	0	0	0	0	0	0	0	0
	B	0	0	0	0	0	0	0	0	0	0	0	0	0	0	0	0
	C	0	0	0	0	0	0	0	0	0	0	0	0.01	0	0.01	0	0
	D	0	0	0	0	0	0	0	0	0	0	0	0	0.01	0	0	0
	E	0	0	0	0	0	0	0	0	0	0	0	0	0	0	0	0
	F	0	0	0	0	0	0	0	0	0	0	0	0	0	0	0	0

Source: Simpkins 1997.

Table J-41. Projected SRS Population Surrounding APSF (Pit Conversion and MOX Facilities) for Year 2010

Direction	Distance (mi)										Total
	0-1	1-2	2-3	3-4	4-5	5-10	10-20	20-30	30-40	40-50	
S	0	0	0	0	0	0	600	2,109	3,312	3,447	9,468
SSW	0	0	0	0	0	36	935	1,853	4,732	2,501	10,057
SW	0	0	0	0	0	73	1,239	8,333	2,023	4,318	15,986
WSW	0	0	0	0	0	228	3,762	4,014	3,742	7,194	18,940
W	0	0	0	0	0	355	7,786	47,484	21,880	18,192	95,697
WNW	0	0	0	0	0	2,439	11,335	205,958	53,232	6,694	279,658
NW	0	0	0	0	0	1,455	18,694	38,351	2,884	3,123	64,507
NNW	0	0	0	0	0	3,279	40,843	20,468	9,466	5,766	79,822
N	0	0	0	0	0	1,012	7,787	6,010	5,928	20,994	41,731
NNE	0	0	0	0	0	145	1,934	2,959	6,794	20,775	32,607
NE	0	0	0	0	0	0	3,168	3,786	5,985	11,236	24,175
ENE	0	0	0	0	0	0	3,077	5,828	7,625	33,477	50,007
E	0	0	0	0	0	0	6,188	5,442	7,342	3,952	22,924
ESE	0	0	0	0	0	0	996	3,497	4,455	7,253	16,201
SE	0	0	0	0	0	0	572	2,555	4,695	7,667	15,489
SSE	0	0	0	0	0	0	390	648	4,122	2,975	8,135
Total	0	0	0	0	0	9,022	109,306	359,295	148,217	159,564	785,404

Key: APSF, Actinide Packaging and Storage Facility.

Source: DOC 1992.

Table J-42. Projected SRS Population Surrounding APSF (Immobilization Facility) for Year 2010

Direction	Distance (mi)										Total
	0-1	1-2	2-3	3-4	4-5	5-10	10-20	20-30	30-40	40-50	
S	0	0	0	0	0	0	576	2,124	3,368	3,437	9,505
SSW	0	0	0	0	0	33	914	1,849	4,750	2,508	10,054
SW	0	0	0	0	0	59	1,204	8,412	2,043	4,640	16,358
WSW	0	0	0	0	0	241	3,930	4,188	3,771	6,887	19,017
W	0	0	0	0	0	543	7,632	51,313	22,422	18,246	100,156
WNW	0	0	0	0	0	2,344	11,777	204,567	51,659	6,581	276,928
NW	0	0	0	0	0	1,479	19,053	36,367	2,990	3,123	63,012
NNW	0	0	0	0	0	3,394	43,236	17,846	9,567	5,783	79,826
N	0	0	0	0	0	961	7,818	5,691	6,005	21,037	41,512
NNE	0	0	0	0	0	171	1,936	3,000	6,811	21,327	33,245
NE	0	0	0	0	0	0	3,137	3,756	6,043	11,279	24,215
ENE	0	0	0	0	0	0	3,202	5,735	7,434	34,686	51,057
E	0	0	0	0	0	0	6,264	5,509	7,575	3,991	23,339
ESE	0	0	0	0	0	0	1,023	2,892	4,016	7,077	15,008
SE	0	0	0	0	0	0	569	3,116	5,213	7,848	16,746
SSE	0	0	0	0	0	0	380	636	3,953	3,002	7,971
Total	0	0	0	0	0	9,225	112,651	357,001	147,620	161,452	787,949

Key: APSF, Actinide Packaging and Storage Facility.

Source: DOC 1992.

J.4.1.4 Source Term Data

Estimated incident-free radiological releases associated with the new pit conversion, immobilization, and MOX facilities are presented in Tables J-43 through J-45. Stack heights and release locations are provided in the facility data reports (DOE 1999; UC 1998g, 1998h, 1999c, 1999d).

Table J-43. Estimated Incident-Free Annual Radiological Releases From the Pit Conversion Facility at SRS

Isotope	($\mu\text{Ci/yr}$)
Plutonium 236	9.3×10^{-11}
Plutonium 238	0.065
Plutonium 239	0.69
Plutonium 240	0.18
Plutonium 241	0.69
Plutonium 242	4.8×10^{-5}
Americium 241	0.37
Hydrogen 3	1.1×10^9

Source: UC 1998g.

Table J-44. Estimated Incident-Free Annual Radiological Releases From the New Immobilization Facility at SRS

Isotope	Ceramic (17 t)	Ceramic (50 t)	Glass (17 t)	Glass (50 t)
	($\mu\text{Ci/yr}$)	($\mu\text{Ci/yr}$)	($\mu\text{Ci/yr}$)	($\mu\text{Ci/yr}$)
Plutonium 236	–	–	–	–
Plutonium 238	–	0.57	–	0.52
Plutonium 239	3.7	9.5	3.4	8.6
Plutonium 240	1.7	3.1	1.6	2.8
Plutonium 241	110	100	98	93
Plutonium 242	1.3×10^{-3}	1.6×10^{-3}	1.2×10^{-3}	1.5×10^{-3}
Americium 241	2.3	5.4	2.2	5.0
Uranium 234	–	–	–	–
Uranium 235	1.1×10^{-5}	4.5×10^{-5}	2.3×10^{-6}	2.3×10^{-6}
Uranium 238	8.8×10^{-5}	3.5×10^{-4}	1.9×10^{-5}	1.9×10^{-5}

Source: UC 1999c, 1999d.

Table J-45. Estimated Incident-Free Annual Radiological Releases From the New MOX Facility at SRS

Isotope	Airborne ($\mu\text{Ci/yr}$)	Liquid ($\mu\text{Ci/yr}$)
Plutonium 236	1.3×10^{-8}	9.3×10^{-8}
Plutonium 238	8.5	64
Plutonium 239	91	670
Plutonium 240	23	170
Plutonium 241	101	750
Plutonium 242	6.1×10^{-3}	0.046
Americium 241	48	350
Uranium 234	5.1×10^{-3}	0.037
Uranium 235	2.1×10^{-4}	1.6×10^{-3}
Uranium 238	0.012	0.089

Source: UC 1998h.

J.4.1.5 Other Calculational Assumptions

To estimate radiological impacts of incident-free operation of the facilities at SRS, the following additional assumptions and factors were considered, in accordance with the guidelines established in NRC Regulatory Guide 1.109 (NRC 1977).

Ground surfaces were assumed to have no previous deposition of radionuclides for the purposes of modeling the incremental radiological impacts associated with surplus plutonium disposition activities. However, doses associated with true instances of prior deposition are accounted for in the Affected Environment and Cumulative Impacts sections.

- The annual external exposure time to the plume and to soil contamination was 0.7 year for the MEI (NRC 1977).
- The annual external exposure time to the plume and to soil contamination was 0.5 year for the population (NRC 1977).
- The annual inhalation exposure time to the plume was 1 year for the MEI and general population (NRC 1977).
- The exposed individual or population was assumed to have the characteristics and habits (e.g., inhalation and ingestion rates) of the adult human.
- A semi-infinite/finite plume model was used for air immersion doses. Other pathways evaluated were ground exposure, inhalation, ingestion of food crops, and ingestion of contaminated animal products. Drinking water, aquatic food ingestion, and any other pathway that may involve liquid exposure were also examined for the MOX facility because it is the only facility with expected liquid releases at SRS.
- Reported stack heights were used for atmospheric releases. The resultant doses were conservative as use of the actual stack height instead of the effective stack height negates plume rise.
- The calculated doses are 50-year committed doses from 1 year of intake.

J.4.2 Facilities

The following sections present all viable radiological impact scenarios that could be associated with different combinations of incident-free facility operations at SRS.

J.4.2.1 Pit Conversion Facility

J.4.2.1.1 Construction of Pit Conversion Facility

No radiological risk would be incurred by members of the public from the construction of a new pit conversion facility at SRS. Construction worker exposures to radiation that derives from other activities at the site, past and present, would also be kept as low as is reasonably achievable. Construction workers would be monitored (badged) as appropriate. Summaries of radiological impacts of these activities are presented in Table J-46 for workers at risk.

Table J-46. Potential Radiological Impacts on Construction Workers of New Pit Conversion Facility at SRS

Annual average number of workers	341	
Total dose (person-rem/yr)	1.4	
Annual latent fatal cancers ^a	5.6×10^{-4}	
Average worker dose (mrem/yr)	4	
Annual latent fatal cancer risk	1.6×10^{-6}	

^a Values are based on a risk factor of 400 latent fatal cancers per million person-rem set by the National Research Council's Committee on the Biological Effects of Ionizing Radiations.

Note: The radiological limit for a construction worker is 100 mrem/yr because they are categorized as members of the public (DOE 1993). An effective ALARA program would ensure that doses are reduced to levels that are as low as is reasonably achievable.

Source: ICRP 1991; NAS 1990; UC 1998g.

J.4.2.1.2 Operation of Pit Conversion Facility

Tables J-47 and J-48 present the incident-free radiological impacts of the operation of a new pit conversion facility at SRS.

Table J–47. Potential Radiological Impacts on the Public of Operation of New Pit Conversion Facility at SRS

Population within 80 km for year 2010	
Dose (person-rem)	1.6
Percent of natural background ^a	6.9×10^{-4}
10-year latent fatal cancers	8.0×10^{-3}
Maximally exposed individual	
Annual dose (mrem)	3.7×10^{-3}
Percent of natural background ^a	1.3×10^{-3}
10-year latent fatal cancer risk	1.9×10^{-8}
Average exposed individual within 80 km^b	
Annual dose (mrem)	2.0×10^{-3}
10-year latent fatal cancer risk	1.0×10^{-8}

^a The annual natural background radiation level at SRS is 295 mrem for the average individual; the population within 80 km (50 mi) in 2010 would receive about 232,000 person-rem.

^b Obtained by dividing the population dose by the number of people projected to live within 80 km (50 mi) of SRS in 2010 (about 790,000).

Source: Model results.

Table J–48. Potential Radiological Impacts on Involved Workers of Operation of New Pit Conversion Facility at SRS

Number of badged workers	383
Total dose (person-rem/yr)	192
10-year latent fatal cancers	0.77
Average worker dose (mrem/yr)	500
10-year latent fatal cancer risk	2.0×10^{-3}

Note: The radiological limit for an individual worker is 5,000 mrem/yr (DOE 1995). However, the maximum dose to a worker involved in operations would be kept below the DOE administrative control level of 2,000 mrem/yr (DOE 1994). An effective ALARA program would ensure that doses are reduced to levels that are as low as is reasonably achievable.

Source: UC 1998g.

J.4.2.2 Immobilization Facility

J.4.2.2.1 Construction of Immobilization Facility

No radiological risk would be incurred by members of the public from the construction of a new immobilization facility at SRS. Construction worker exposures to radiation that derives from other activities at the site, past or present, would also be kept as low as is reasonably achievable. Construction workers would be monitored (badged) as appropriate. Summaries of radiological impacts of these activities are presented in Table J–49 for workers at risk.

Table J-49. Potential Radiological Impacts on Construction Workers of New Immobilization Facility at SRS^a

Annual average number of workers	374
Total dose (person-rem/yr)	1.5
Annual latent fatal cancers ^b	6.0×10^{-4}
Average worker dose (mrem/yr)	4
Annual latent fatal cancer risk	1.6×10^{-6}

^a The values would be the same for immobilization in either ceramic or glass.

^b Values are based on a risk factor of 400 latent fatal cancers per million person-rem set by the National Research Council's Committee on the Biological Effects of Ionizing Radiations.

Note: The radiological limit for a construction worker is 100 mrem/yr because they are categorized as members of the public (DOE 1993). An effective ALARA program would ensure that doses are reduced to levels that are as low as is reasonably achievable.

Source: ICRP 1991; NAS 1990; UC 1999c, 1999d.

J.4.2.2.2 Operation of Immobilization Facility

Tables J-50 and J-51 present all possible incident-free radiological impact scenarios of the operation of a new immobilization facility at SRS.

Table J-50. Potential Radiological Impacts on the Public of Operation of New Immobilization Facility at SRS

Impact	17 t		50 t	
	Ceramic	Glass	Ceramic	Glass
Population within 80 km for year 2010				
Dose (person-rem)	2.8×10^{-3}	2.6×10^{-3}	5.8×10^{-3}	5.3×10^{-3}
Percent of natural background ^a	1.2×10^{-6}	1.1×10^{-6}	2.5×10^{-6}	2.3×10^{-6}
10-year latent fatal cancers	1.4×10^{-5}	1.3×10^{-5}	2.9×10^{-5}	2.7×10^{-5}
Maximally exposed individual				
Annual dose (mrem)	2.8×10^{-5}	2.6×10^{-5}	5.8×10^{-5}	5.3×10^{-5}
Percent of natural background ^a	9.5×10^{-6}	8.8×10^{-6}	2.0×10^{-5}	1.8×10^{-5}
10-year latent fatal cancer risk	1.4×10^{-10}	1.3×10^{-10}	2.9×10^{-10}	2.7×10^{-10}
Average exposed individual within 80 km^b				
Annual dose (mrem)	3.6×10^{-6}	3.3×10^{-6}	7.4×10^{-6}	6.7×10^{-6}
10-year latent fatal cancer risk	1.8×10^{-11}	1.6×10^{-11}	3.7×10^{-11}	3.4×10^{-11}

[Text deleted.]

^a The annual natural background radiation level at SRS is 295 mrem for the average individual; the population within 80 km (50 mi) in 2010 would receive about 232,000 person-rem.

^b Obtained by dividing the population dose by the number of people projected to live within 80 km (50 mi) of the SRS facilities in 2010 (about 790,000).

Source: Model results.

Table J-51. Potential Radiological Impacts on Involved Workers of Operation of New Immobilization Facility at SRS^a

Impact	17 t	50 t
Number of badged workers	323	339
Total dose (person-rem/yr)	242	254
10-year latent fatal cancers	0.97	1.0
Average worker dose (mrem/yr)	750	750
10-year latent fatal cancer risk	3.0×10^{-3}	3.0×10^{-3}

^a The values would be the same for immobilization in either ceramic or glass.

Note: The radiological limit for an individual worker is 5,000 mrem/yr (DOE 1995). However, the maximum dose to a worker involved in operations would be kept below the DOE administrative control level of 2,000 mrem/yr (DOE 1994). An effective ALARA program would ensure that doses are reduced to levels that are as low as is reasonably achievable.

Source: UC 1999c, 1999d.

J.4.2.3 MOX Facility

J.4.2.3.1 Construction of MOX Facility

No radiological risk would be incurred by members of the public from the construction of a new MOX facility at SRS. Construction worker exposures to radiation that derives from other activities at the site, past or present, would also be kept as low as is reasonably achievable. Construction workers would be monitored (badged) as appropriate. Summaries of radiological impacts of these activities are presented in Table J-52 for workers at risk.

Table J-52. Potential Radiological Impacts on Construction Workers of New MOX Facility at SRS

Annual average number of workers	292
Total dose (person-rem/yr)	1.2
Annual latent fatal cancers ^a	4.8×10^{-4}
Average worker dose (mrem/yr)	4
Annual latent fatal cancer risk	1.6×10^{-6}

^a Values are based on a risk factor of 400 latent fatal cancers per million person-rem set by the National Research Council's Committee on the Biological Effects of Ionizing Radiations.

Note: The radiological limit for a construction worker is 100 mrem/yr because they are categorized as members of the public (DOE 1993). An effective ALARA program would ensure that doses are reduced to levels that are as low as is reasonably achievable.

Source: ICRP 1991; NAS 1990; UC 1998h.

J.4.2.3.2 Operation of MOX Facility

Tables J-53 and J-54 present the incident-free radiological impacts of the operation of a new MOX facility at SRS.

**Table J-53. Potential Radiological Impacts on the Public of
Operation of New MOX Facility at SRS^a**

Population within 80 km for year 2010	
Dose (person-rem)	0.18
Percent of natural background ^b	7.8×10^{-5}
10-year latent fatal cancers	9.1×10^{-4}
Maximally exposed individual	
Annual dose (mrem)	3.7×10^{-3}
Percent of natural background ^b	1.3×10^{-3}
10-year latent fatal cancer risk	1.9×10^{-8}
Average exposed individual within 80 km^c	
Annual dose (mrem)	2.3×10^{-4}
10-year latent fatal cancer risk	1.2×10^{-9}

^a Includes a dose component from liquid pathways because it is possible that liquid releases could reach these pathways at SRS.

^b The annual natural background radiation level at SRS is 295 mrem for the average individual; the population within 80 km (50 mi) in 2010 would receive about 232,000 person-rem.

^c Obtained by dividing the population dose by the number of people projected to live within 80 km (50 mi) of SRS in 2010 (about 790,000).

Source: Model results.

**Table J-54. Potential Radiological Impacts on Involved
Workers of Operation of New MOX Facility at SRS**

Number of badged workers	331
Total dose (person-rem/yr)	22
10-year latent fatal cancers	0.088
Average worker dose (mrem/yr)	65
10-year latent fatal cancer risk	2.6×10^{-4}

Note: The radiological limit for an individual worker is 5,000 mrem/yr (DOE 1995). However, the maximum dose to a worker involved in operations would be kept below the DOE administrative control level of 2,000 mrem/yr (DOE 1994). An effective ALARA program would ensure that doses are reduced to levels that are as low as is reasonably achievable.

Source: DOE 1999; UC 1998h.

J.4.2.4 Pit Conversion and Immobilization Facilities

J.4.2.4.1 Construction of Pit Conversion and Immobilization Facilities

No radiological risk would be incurred by members of the public from construction of new pit conversion and immobilization facilities at SRS. Construction worker exposures to radiation that derives from other activities at the site, past or present, would also be kept as low as is reasonably achievable. Construction workers would be monitored (badged) as appropriate. Summaries of radiological impacts of these activities are presented in Table J-55 for workers at risk.

Table J–55. Potential Radiological Impacts on Construction Workers of New Pit Conversion and Immobilization Facilities at SRS

Impact	Pit Conversion	Immobilization ^a	Total
Annual average number of workers	316	374	690
Total dose (person-rem/yr)	1.3	1.5	2.8
Annual latent fatal cancers ^b	5.2×10^{-4}	6.0×10^{-4}	1.1×10^{-3}
Average worker dose (mrem/yr)	4	4	4 ^c
Annual latent fatal cancer risk	1.6×10^{-6}	1.6×10^{-6}	1.6×10^{-6}

^a The values would be the same for immobilization in either ceramic or glass.

^b Values are based on a risk factor of 400 latent fatal cancers per million person-rem set by the National Research Council's Committee on the Biological Effects of Ionizing Radiations.

^c Represents an average of the doses for both facilities.

Note: The radiological limit for a construction worker is 100 mrem/yr because they are categorized as members of the public (DOE 1993). An effective ALARA program would ensure that doses are reduced to levels that are as low as is reasonably achievable.

Source: ICRP 1991; NAS 1990; UC 1998g, 1999c, 1999d.

J.4.2.4.2 Operation of Pit Conversion and Immobilization Facilities

Tables J–56 and J–57 present all possible incident-free radiological impact scenarios of operation of the new pit conversion and immobilization facilities at SRS.

Table J–56. Potential Radiological Impacts on the Public of Operation of New Pit Conversion and Immobilization Facilities at SRS

Impact	Pit Conversion	Immobilization (50 t)		Total ^a
		Ceramic	Glass	
Population within 80 km for year 2010				
Dose (person-rem)	1.6	5.8×10^{-3}	5.3×10^{-3}	1.6
Percent of natural background ^b	6.9×10^{-4}	2.5×10^{-6}	2.3×10^{-6}	6.9×10^{-4}
10-year latent fatal cancers	8.0×10^{-3}	2.9×10^{-5}	2.7×10^{-5}	8.0×10^{-3}
Maximally exposed individual				
Annual dose (mrem)	3.7×10^{-3}	5.8×10^{-5}	5.3×10^{-5}	3.8×10^{-3}
Percent of natural background ^b	1.3×10^{-3}	2.0×10^{-5}	1.8×10^{-5}	1.3×10^{-3}
10-year latent fatal cancer risk	1.9×10^{-8}	2.9×10^{-10}	2.7×10^{-10}	1.9×10^{-8}
Average exposed individual within 80 km^c				
Annual dose (mrem)	2.0×10^{-3}	7.4×10^{-6}	6.7×10^{-6}	2.0×10^{-3}
10-year latent fatal cancer risk	1.0×10^{-8}	3.7×10^{-11}	3.4×10^{-11}	1.0×10^{-8}

[Text deleted.]

^a Totals represent the largest possible sums for each public category. Totals are additive in all cases because the same groups or individuals would receive doses from both facilities.

^b The annual natural background radiation level at SRS is 295 mrem for the average individual; the population within 80 km (50 mi) in 2010 would receive about 232,000 person-rem.

^c Obtained by dividing the population dose by the number of people projected to live within 80 km (50 mi) of the SRS facilities in 2010 (about 790,000).

Source: Model results.

Table J–57. Radiological Impacts on Involved Workers of Operation of New Pit Conversion and Immobilization Facilities at SRS

Impact	Pit Conversion	Immobilization (50 t) ^a	Total
Number of badged workers	383	339	772
Total dose (person-rem/yr)	192	254	446
10-year latent fatal cancers	0.77	1.0	1.8
Average worker dose (mrem/yr)	500	750	618 ^b
10-year latent fatal cancer risk	2.0×10^{-3}	3.0×10^{-3}	2.5×10^{-3}

^a The values would be the same for immobilization in either ceramic or glass.

^b Represents an average of the doses for both facilities.

Note: The radiological limit for an individual worker is 5,000 mrem/yr (DOE 1995). However, the maximum dose to a worker involved with operations would be kept below the DOE administrative control level of 2,000 mrem/yr (DOE 1994). An effective ALARA program would ensure that doses are reduced to levels that are as low as is reasonably achievable.

Source: UC 1998g, 1999c, 1999d.

J.4.2.5 Pit Conversion and MOX Facilities

J.4.2.5.1 Construction of Pit Conversion and MOX Facilities

No radiological risk would be incurred by members of the public from the construction of new pit conversion and MOX facilities at SRS. Construction worker exposures to radiation that derives from other activities at the site, past or present, would also be kept as low as is reasonably achievable. Construction workers would be monitored (badged) as appropriate. Summaries of radiological impacts of these activities are presented in Table J–58 for workers at risk.

Table J–58. Potential Radiological Impacts on Construction Workers of New Pit Conversion and MOX Facilities at SRS

Impact	Pit Conversion	MOX	Total
Annual average number of workers	341	292	633
Total dose (person-rem/yr)	1.4	1.2	2.6
Annual latent fatal cancers ^a	5.6×10^{-4}	4.8×10^{-4}	1.0×10^{-3}
Average worker dose (mrem/yr)	4	4	4 ^b
Annual latent fatal cancer risk	1.6×10^{-6}	1.6×10^{-6}	1.6×10^{-6}

^a Values are based on a risk factor of 400 latent fatal cancers per million person-rem set by the National Research Council's Committee on the Biological Effects of Ionizing Radiations.

^b Represents an average of the doses for both facilities.

Note: The radiological limit for a construction worker is 100 mrem/yr because they are categorized as members of the public (DOE 1993). An effective ALARA program would ensure that doses are reduced to levels that are as low as is reasonably achievable.

Source: ICRP 1991; NAS 1990; UC 1998g, 1998h.

J.4.2.5.2 Operation of Pit Conversion and MOX Facilities

Tables J–59 and J–60 present the incident-free radiological impacts of operation of the new pit conversion and MOX facilities at SRS.

Table J–59. Potential Radiological Impacts on the Public of Operation of New Pit Conversion and MOX Facilities at SRS

Impact	Pit Conversion	MOX ^a	Total ^b
Population within 80 km for year 2010			
Dose (person-rem)	1.6	0.18	1.8
Percent of natural background ^c	6.9×10^{-4}	7.8×10^{-5}	7.7×10^{-4}
10-year latent fatal cancers	8.0×10^{-3}	9.1×10^{-4}	8.9×10^{-3}
Maximally exposed individual			
Annual dose (mrem)	3.7×10^{-3}	3.7×10^{-3}	7.4×10^{-3}
Percent of natural background ^c	1.3×10^{-3}	1.3×10^{-3}	2.5×10^{-3}
10-year latent fatal cancer risk	1.9×10^{-8}	1.9×10^{-8}	3.7×10^{-8}
Average exposed individual within 80 km^d			
Annual dose (mrem)	2.0×10^{-3}	2.3×10^{-4}	2.2×10^{-3}
10-year latent fatal cancer risk	1.0×10^{-8}	1.2×10^{-9}	1.1×10^{-8}

^a Includes a dose component from liquid pathways because it is possible that liquid releases could reach these pathways at SRS.

^b Totals are additive in all cases because the same groups or individuals would receive doses from both facilities.

^c The annual natural background radiation level at SRS is 295 mrem for the average individual; the population within 80 km (50 mi) in 2010 would receive about 232,000 person-rem.

^d Obtained by dividing the population dose by the number of people projected to live within 80 km (50 mi) of SRS in 2010 (about 790,000).

Source: Model results.

Table J–60. Potential Radiological Impacts on Involved Workers of Operation of New Pit Conversion and MOX Facilities at SRS

Impact	Pit Conversion	MOX	Total
Number of badged workers	383	331	714
Total dose (person-rem/yr)	192	22	214
10-year latent fatal cancers	0.77	0.088	0.86
Average worker dose (mrem/yr)	500	65	300 ^a
10-year latent fatal cancer risk	2.0×10^{-3}	2.6×10^{-4}	1.2×10^{-3}

^a Represents an average of the doses for both facilities.

Note: The radiological limit for an individual worker is 5,000 mrem/yr (DOE 1995). However, the maximum dose to a worker involved in operations would be kept below the DOE administrative control level of 2,000 mrem/yr (DOE 1994). An effective ALARA program would ensure that doses are reduced to levels that are as low as is reasonably achievable.

Source: DOE 1999; UC 1998g, 1998h.

J.4.2.6 Immobilization and MOX Facilities

J.4.2.6.1 Construction of Immobilization and MOX Facilities

No radiological risk would be incurred by members of the public from the construction of new immobilization and MOX facilities at SRS. Construction worker exposures to radiation deriving from other activities, past or present, at the site would also be kept as low as is reasonably achievable. Construction workers would be monitored (badged) as appropriate. Summaries of radiological impacts of these activities are presented in Table J–61 for workers at risk.

Table J–61. Potential Radiological Impacts on Construction Workers of New Immobilization and MOX Facilities at SRS

Impact	Immobilization ^a	MOX	Total
Annual average number of workers	374	292	666
Total dose (person-rem/yr)	1.5	1.2	2.7
Annual latent fatal cancers ^b	6.0×10^{-4}	4.8×10^{-4}	1.1×10^{-3}
Average worker dose (mrem/yr)	4	4	4 ^c
Annual latent fatal cancer risk	1.6×10^{-6}	1.6×10^{-6}	1.6×10^{-6}

^a The values would be the same for immobilization in either ceramic or glass.

^b Values are based on a risk factor of 400 latent fatal cancers per million person-rem set by the National Research Council's Committee on the Biological Effects of Ionizing Radiations.

^c Represents an average of the doses for both facilities.

Note: The radiological limit for a construction worker is 100 mrem/yr because they are categorized as members of the public (DOE 1993). An effective ALARA program would ensure that doses are reduced to levels that are as low as is reasonably achievable.

Source: ICRP 1991; NAS 1990; UC 1998h, 1999c, 1999d.

J.4.2.6.2 Operation of Immobilization and MOX Facilities

Tables J–62 and J–63 present the incident-free radiological impacts of operation of the new immobilization and MOX facilities at SRS.

Table J–62. Potential Radiological Impacts on the Public of Operation of New Immobilization and MOX Facilities at SRS

Impact	Immobilization (17 t)			Total ^b
	Ceramic	Glass	MOX ^a	
Population within 80 km for year 2010				
Dose (person-rem)	2.8×10^{-3}	2.6×10^{-3}	0.18	0.18
Percent of natural background ^c	1.2×10^{-6}	1.1×10^{-6}	7.8×10^{-5}	7.9×10^{-5}
10-year latent fatal cancers	1.4×10^{-5}	1.3×10^{-5}	9.1×10^{-4}	9.2×10^{-4}
Maximally exposed individual				
Annual dose (mrem)	2.8×10^{-5}	2.6×10^{-5}	3.7×10^{-3}	3.7×10^{-3}
Percent of natural background ^c	9.5×10^{-6}	8.8×10^{-6}	1.3×10^{-3}	1.3×10^{-3}
10-year latent fatal cancer risk	1.4×10^{-10}	1.3×10^{-10}	1.9×10^{-8}	1.9×10^{-8}
Average exposed individual within 80 km^d				
Annual dose (mrem)	3.6×10^{-6}	3.3×10^{-6}	2.3×10^{-4}	2.3×10^{-4}
10-year latent fatal cancer risk	1.8×10^{-11}	1.6×10^{-11}	1.2×10^{-9}	1.2×10^{-9}

[Text deleted.]

^a Includes a dose component from liquid pathways because it is possible that liquid releases could reach these pathways at SRS.

^b Totals represent the largest possible sums for each public category. Totals are additive in all cases because the same groups or individuals would receive doses from both facilities.

^c The annual natural background radiation level at SRS is 295 mrem for the average individual; the population within 80 km (50 mi) in 2010 would receive about 232,000 person-rem.

^d Obtained by dividing the population dose by the number of people projected to live within 80 km (50 mi) of the SRS facilities in 2010 (about 790,000).

Source: Model results.

Table J–63. Potential Radiological Impacts on Involved Workers of Operation of New Immobilization and MOX Facilities at SRS

Impact	Immobilization (17 t) ^a	MOX	Total
Number of badged workers	323	331	654
Total dose (person-rem/yr)	242	22	264
10-year latent fatal cancers	0.97	0.088	1.1
Average worker dose (mrem/yr)	750	65	404 ^b
10-year latent fatal cancer risk	3.0×10^{-3}	2.6×10^{-4}	1.6×10^{-3}

^a The values would be the same for immobilization in either ceramic or glass.

^b Represents an average of the doses for both facilities.

Note: The radiological limit for an individual worker is 5,000 mrem/yr (DOE 1995). However, the maximum dose to a worker involved in operations would be kept below the DOE administrative control level of 2,000 mrem/yr (DOE 1994). An effective ALARA program would ensure that doses are reduced to levels that are as low as is reasonably achievable.

Source: DOE 1999; UC 1998h, 1999c, 1999d.

J.4.2.7 Pit Conversion, Immobilization, and MOX Facilities

J.4.2.7.1 Construction of Pit Conversion, Immobilization, and MOX Facilities

No radiological risk would be incurred by members of the public from the construction of new pit conversion, immobilization, and MOX facilities at SRS. Construction worker exposures to radiation that derives from other activities at the site, past or present, would also be kept as low as is reasonably achievable. Construction workers would be monitored (badged) as appropriate. Summaries of radiological impacts of these activities are presented in Table J–64 for workers at risk.

Table J–64. Potential Radiological Impacts on Construction Workers of New Pit Conversion, Immobilization, and MOX Facilities at SRS

Impact	Pit Conversion	Immobilization ^a	MOX	Total
Annual average number of workers	341	374	292	1,007
Total dose (person-rem/yr)	1.4	1.5	1.2	4.1
Annual latent fatal cancers ^b	5.6×10^{-4}	6.0×10^{-4}	4.8×10^{-4}	1.6×10^{-3}
Average worker dose (mrem/yr)	4	4	4	4 ^c
Annual latent fatal cancer risk	1.6×10^{-6}	1.6×10^{-6}	1.6×10^{-6}	1.6×10^{-6}

^a The values would be the same for immobilization in either ceramic or glass.

^b Values are based on a risk factor of 400 latent fatal cancers per million person-rem set by the National Research Council's Committee on the Biological Effects of Ionizing Radiations.

^c Represents an average of the doses for all three facilities.

Note: The radiological limit for construction workers is 100 mrem/yr because they are categorized as members of the public (DOE 1993). An effective ALARA program would ensure that doses are reduced to levels that are as low as is reasonably achievable.

Source: ICRP 1991; NAS 1990; UC 1998g, 1998h, 1999c, 1999d.

J.4.2.7.2 Operation of Pit Conversion, Immobilization, and MOX Facilities

Tables J–65 and J–66 present all possible incident-free radiological impact scenarios of operation of all three new facilities at SRS.

Table J–65. Potential Radiological Impacts on the Public of Operation of New Pit Conversion, Immobilization, and MOX Facilities at SRS

Impact	Pit Conversion	Immobilization (17 t)		MOX ^a	Total ^b
		Ceramic	Glass		
Population within 80 km for year 2010					
Dose (person-rem)	1.6	2.8×10^{-3}	2.6×10^{-3}	0.18	1.8
Percent of natural background ^c	6.9×10^{-4}	1.2×10^{-6}	1.1×10^{-6}	7.8×10^{-5}	7.8×10^{-4}
10-year latent fatal cancers	8.0×10^{-3}	1.4×10^{-5}	1.3×10^{-5}	9.1×10^{-4}	9.0×10^{-3}
Maximally exposed individual					
Annual dose (mrem)	3.7×10^{-3}	2.8×10^{-5}	2.6×10^{-5}	3.7×10^{-3}	7.4×10^{-3}
Percent of natural background ^c	1.3×10^{-3}	9.5×10^{-6}	8.8×10^{-6}	1.3×10^{-3}	2.5×10^{-3}
10-year latent fatal cancer risk	1.9×10^{-8}	1.4×10^{-10}	1.3×10^{-10}	1.9×10^{-8}	3.7×10^{-8}
Average exposed individual within 80 km^d					
Annual dose (mrem)	2.0×10^{-3}	3.6×10^{-6}	3.3×10^{-6}	2.3×10^{-4}	2.2×10^{-3}
10-year latent fatal cancer risk	1.0×10^{-8}	1.8×10^{-11}	1.6×10^{-11}	1.2×10^{-9}	1.1×10^{-8}

[Text deleted.]

^a Includes a dose component from liquid pathways because it is possible that liquid releases could reach these pathways at SRS.

^b Totals represent the largest possible sums for each public category. Totals are additive in all cases because the same groups or individuals would receive doses from all three facilities.

^c The annual natural background radiation level at SRS is 295 mrem for the average individual; the population within 80 km (50 mi) in the year 2010 receives about 232,000 person-rem.

^d Obtained by dividing the population dose by the number of people projected to live within 80 km (50 mi) of the SRS facilities in 2010 (about 790,000).

Source: Model results.

Table J–66. Potential Radiological Impacts on Involved Workers of Operation of New Pit Conversion, Immobilization, and MOX Facilities at SRS

Impact	Pit Conversion	Immobilization (17 t) ^a	MOX	Total
Number of badged workers	383	323	331	1,037
Total dose (person-rem/yr)	192	242	22	456
10-year latent fatal cancers	0.77	0.97	0.088	1.8
Average worker dose (mrem/yr)	500	750	65	440 ^b
10-year latent fatal cancer risk	2.0×10^{-3}	3.0×10^{-3}	2.6×10^{-4}	1.8×10^{-3}

^a The values would be the same for immobilization in either ceramic or glass.

^b Represents an average of the doses for all three facilities.

Note: The radiological limit for an individual worker is 5,000 mrem/yr (DOE 1995). However, the maximum dose to a worker involved in operations would be kept below the DOE administrative control level of 2,000 mrem/yr (DOE 1994). An effective ALARA program would ensure that doses are reduced to levels that are as low as is reasonably achievable.

Source: DOE 1999; UC 1998g, 1998h, 1999c, 1999d.

J.5 LEAD ASSEMBLY FABRICATION

J.5.1 ANL–W

J.5.1.1 Assessment Data

This section presents applicable data and assumptions used in the assessment of lead assembly human health risks at ANL–W at INEEL. Appendix F.10 provides a summary of the methods and tools (e.g., the GENII computer code) used for the assessment.

J.5.1.1.1 Meteorological Data

The meteorological data used for the ANL–W dose assessments was in the form of a JFD file. A JFD file is a table listing the percentages of time the wind blows in a certain direction, at a certain speed, and within a certain stability class. The JFD file was based on measurements taken over a period of several years at a specific location and height. Average annual meteorological conditions, averaged over the measurement period, were used for normal operations. Table J–20 presents the JFD used in the dose assessments for ANL–W.

J.5.1.1.2 Population Data

The INEEL population distribution was based on the *1990 Census of Population and Housing Data* (DOC 1992). Projections were determined for the year 2005 for areas within 80 km (50 mi) of the proposed facility location. The site population in 2005 was assumed to be representative of the population over the operational period evaluated. The population was spatially distributed on a circular grid with 16 directions and 10 radial distances out to an 80-km (50-mi) distance. The grid was centered at ANL–W, the location from which radionuclides are assumed to be released during incident-free operations. Table J–67 presents the population data used for the lead assembly dose assessments at ANL–W.

J.5.1.1.3 Agricultural Data

The 1987 Census of Agriculture was the source used to generate site-specific data for food production. Food production was spatially distributed on a circular grid similar to that used for the population distributions described previously. This food grid (or wheel) was generated by combining the fraction of a county in each segment (e.g., south, southwest, north-northeast) and the county production of the eight food categories analyzed by GENII—leafy vegetables, root vegetables, fruits, grains, beef, poultry, milk, and eggs. Each county's food production was assumed to be distributed uniformly over the given county's land area. These categorized food wheels were then used in the assessment of doses to the population from the ingestion pathway. The consumption rates used in the dose assessments were those for the MEI and average exposed individual. People living within the 80-km (50-mi) assessment area were assumed to consume only food grown in that area. ANL–W food production and consumption data used for the dose assessments in the SPD EIS were obtained from the *Health Risk Data for Storage and Disposition Final PEIS* (HNUS 1996).

J.5.1.1.4 Source Term Data

| Estimated incident-free radiological releases associated with the MOX fuel lead assembly facility are presented
| in Table J–68. Stack height and release location are provided in the Oak Ridge National Laboratory (ORNL)
| *ANL-W MOX Fuel Lead Assemblies Data Report for the Surplus Plutonium Disposition Environmental Impact
| Statement* (O'Connor et al. 1998a).

Table J-67. Projected INEEL Population Surrounding ANL-W for Year 2005

Direction	Distance (mi)										Total
	0-1	1-2	2-3	3-4	4-5	5-10	10-20	20-30	30-40	40-50	
S	0	0	0	0	0	0	277	2,086	6,173	30,883	39,419
SSW	0	0	0	0	0	0	273	323	906	3,267	4,769
SW	0	0	0	0	0	0	246	247	224	334	1,051
WSW	0	0	0	0	0	0	0	238	177	181	596
W	0	0	0	0	0	0	0	179	224	528	931
WNW	0	0	0	0	0	0	35	474	824	467	1,800
NW	0	0	0	0	0	0	36	57	280	929	1,302
NNW	0	0	0	0	0	0	0	81	76	76	233
N	0	0	0	0	0	0	0	254	140	146	540
NNE	0	0	0	0	0	0	252	450	266	158	1,126
NE	0	0	0	0	0	0	252	443	515	98	1,308
ENE	0	0	0	0	0	0	253	706	1,411	5,196	7,566
E	0	0	0	0	0	0	367	1,405	18,570	32,506	52,848
ESE	0	0	0	0	0	103	509	4,197	90,875	756	96,440
SE	0	0	0	0	17	80	589	3,523	11,502	411	16,122
SSE	0	0	0	0	17	52	279	4,816	19,230	1,068	25,462
Total	0	0	0	0	34	235	3,368	19,479	151,393	77,004	251,513

Key: ANL-W, Argonne National Laboratory-West.

Source: DOC 1992.

Table J-68. Estimated Incident-Free Annual Radiological Releases From the MOX Lead Assembly Facility at ANL-W

Isotope	($\mu\text{Ci/yr}$)
Plutonium 236	–
Plutonium 238	0.85
Plutonium 239	23
Plutonium 240	5.3
Plutonium 241	58
Plutonium 242	9.3×10^{-4}
Americium 241	2.0
Uranium 234	1.3×10^{-3}
Uranium 235	5.4×10^{-5}
Uranium 238	3.1×10^{-3}

Source: O'Connor et al. 1998a.

J.5.1.1.5 Other Calculational Assumptions

To estimate radiological impacts of incident-free operation of the lead assembly facility at ANL-W, the following additional assumptions and factors were considered, in accordance with the guidelines established in NRC Regulatory Guide 1.109 (NRC 1977).

- Ground surfaces were assumed to have no previous deposition of radionuclides for the purposes of modeling the incremental radiological impacts associated with surplus plutonium disposition activities.

However, doses associated with true instances of prior deposition are accounted for in the Affected Environment and Cumulative Impacts sections.

- The annual external exposure time to the plume and to soil contamination was 0.7 year for the MEI (NRC 1977).
- The annual external exposure time to the plume and to soil contamination was 0.5 year for the population (NRC 1977).
- The annual inhalation exposure time to the plume was 1 year for the MEI and general population (NRC 1977).
- The exposed individual or population was assumed to have the characteristics and habits (e.g., inhalation and ingestion rates) of the adult human.
- A semi-infinite/finite plume model was used for air immersion doses. Other pathways evaluated were ground exposure, inhalation, ingestion of food crops, and ingestion of contaminated animal products. Drinking water, aquatic food ingestion, and any other pathway that may involve liquid exposure were not examined because all releases are to the air.
- Reported stack heights were used for atmospheric releases and were assumed to be the effective stack height. The resultant doses were conservative because use of the actual stack height negates plume rise.
- The calculated doses are 50-year committed doses from 1 year of intake.

J.5.1.2 Human Health Impacts

Potential radiological impacts on the public and workers resulting from normal lead assembly operations are presented in Section 4.27.1.4. Potential impacts on postirradiation examination facility workers are presented in Section 4.27.6.2.

J.5.2 Hanford

J.5.2.1 Assessment Data

This section presents applicable data and assumptions used in the assessment of lead assembly human health risks at Hanford. Appendix F.10 provides a summary of the methods and tools (e.g., the GENII computer code) used for the assessment.

J.5.2.1.1 Meteorological Data

The meteorological data used for the Hanford dose assessments was in the form of a JFD file. A JFD file is a table listing the percentages of time the wind blows in a certain direction, at a certain speed, and within a certain stability class. The JFD file was based on measurements taken over a period of several years at a specific location and height. Average annual meteorological conditions, averaged over the measurement period, were used for normal operations. Table J-1 presents the JFD used in the dose assessments for Hanford.

J.5.2.1.2 Population Data

The Hanford population distribution was based on the *1990 Census of Population and Housing Data* (DOC 1992). Projections were determined for the year 2005 for areas within 80 km (50 mi) of the proposed facility location. The site population in 2005 was assumed to be representative of the population over the operational period evaluated. The population was spatially distributed on a circular grid with 16 directions and 10 radial distances out to an 80-km (50-mi) distance. The grid was centered at FMEF in the 400 Area, the location from which radionuclides are assumed to be released during incident-free operations. Table J-69 presents the population data used for lead assembly dose assessments at Hanford.

Table J-69. Projected Hanford Population Surrounding FMEF for Year 2005

Direction	Distance (mi)										Total
	0-1	1-2	2-3	3-4	4-5	5-10	10-20	20-30	30-40	40-50	
S	0	0	0	0	0	3,886	40,763	1,039	7,050	19,641	72,379
SSW	0	0	0	0	2	1,380	2,513	399	2,888	3,828	11,010
SW	0	0	0	0	38	1,265	4,361	288	207	1,923	8,082
WSW	0	0	0	0	0	50	2,175	15,734	3,338	300	21,597
W	0	0	0	0	0	0	698	5,764	26,190	14,858	47,510
WNW	0	0	0	0	0	0	5	813	1,147	8,446	10,411
NW	0	0	0	0	0	0	0	592	377	163	1,132
NNW	0	0	0	0	0	0	0	1,034	1,317	1,362	3,713
N	0	0	0	0	0	0	0	1,224	3,458	2,520	7,202
NNE	0	0	0	0	0	16	425	5,074	1,388	23,720	30,623
NE	0	0	0	0	0	86	751	6,743	2,769	1,153	11,502
ENE	0	0	0	0	0	313	1,401	3,391	385	410	5,900
E	0	0	0	0	0	386	861	410	319	300	2,276
ESE	0	0	0	0	0	393	595	315	245	302	1,850
SE	0	0	0	0	0	381	1,191	1,604	366	1,364	4,906
SSE	0	0	0	0	0	6,366	79,333	30,715	565	979	117,958
Total	0	0	0	0	40	14,522	135,072	75,139	52,009	81,269	358,051

Key: FMEF, Fuels and Materials Examination Facility.

Source: DOC 1992.

J.5.2.1.3 Agricultural Data

The 1987 Census of Agriculture was the source used to generate site-specific data for food production. Food production was spatially distributed on a circular grid similar to that used for the population distributions described previously. This food grid (or wheel) was generated by combining the fraction of a county in each segment (e.g., south, southwest, north-northeast) and the county production of the eight food categories analyzed by GENII—leafy vegetables, root vegetables, fruits, grains, beef, poultry, milk, and eggs. Each county's food production was assumed to be distributed uniformly over the given county's land area. These categorized food wheels were then used in the assessment of doses to the population from the ingestion pathway. The consumption rates used in the dose assessments were those for the MEI and average exposed individual. People living within the 80-km (50-mi) assessment area were assumed to consume only food grown in that area. Hanford food production and consumption data used for the dose assessments in the SPD EIS were obtained from the *Health Risk Data for Storage and Disposition Final PEIS* (HNUS 1996).

J.5.2.1.4 Source Term Data

Estimated incident-free radiological releases associated with the MOX fuel lead assembly facility are presented in Table J-70. Stack height and release location are reported in the ORNL *Hanford MOX Fuel Lead*

Table J-70. Estimated Incident-Free Annual Radiological Releases From the MOX Lead Assembly Facility at Hanford

Isotope	($\mu\text{Ci/yr}$)
Plutonium 236	–
Plutonium 238	0.85
Plutonium 239	23
Plutonium 240	5.3
Plutonium 241	58
Plutonium 242	9.3×10^{-4}
Americium 241	2.0
Uranium 234	1.3×10^{-3}
Uranium 235	5.4×10^{-5}
Uranium 238	3.1×10^{-3}

Source: O'Connor et al. 1998b.

Assemblies Data Report for the Surplus Plutonium Disposition Environmental Impact Statement (O'Connor et al. 1998b).

J.5.2.1.5 Other Calculational Assumptions

To estimate radiological impacts of incident-free operation of the lead assembly facility at Hanford, the following additional assumptions and factors were considered, in accordance with the guidelines established in NRC Regulatory Guide 1.109 (NRC 1977).

- Ground surfaces were assumed to have no previous deposition of radionuclides for the purposes of modeling the incremental radiological impacts associated with surplus plutonium disposition activities. However, doses associated with true instances of prior deposition are accounted for in the Affected Environment and Cumulative Impacts sections.
- The annual external exposure time to the plume and to soil contamination was 0.7 year for the MEI (NRC 1977).
- The annual external exposure time to the plume and to soil contamination was 0.5 year for the population (NRC 1977).
- The annual inhalation exposure time to the plume was 1 year for the MEI and general population (NRC 1977).
- The exposed individual or population was assumed to have the characteristics and habits (e.g., inhalation and ingestion rates) of the adult human.
- A semi-infinite/finite plume model was used for air immersion doses. Other pathways evaluated were ground exposure, inhalation, ingestion of food crops, and ingestion of contaminated animal products. Drinking water, aquatic food ingestion, and any other pathway that may involve liquid exposure were not examined because all releases are to the air.

- Reported stack heights were used for atmospheric releases and were assumed to be the effective stack height. The resultant doses were conservative because use of the actual stack height negates plume rise.
- The calculated doses are 50-year committed doses from 1 year of intake.

J.5.2.2 Human Health Impacts

Potential radiological impacts on the public and workers resulting from normal lead assembly operations are presented in Section 4.27.2.4.

J.5.3 LLNL

J.5.3.1 Assessment Data

This section presents applicable data and assumptions used in the assessment of lead assembly human health risks at LLNL. Appendix F.10 provides a summary of the methods and tools (e.g., the GENII computer code) used for the assessment.

J.5.3.1.1 Meteorological Data

The meteorological data used for the LLNL dose assessments was in the form of a JFD file. A JFD file is a table listing the percentages of time the wind blows in a certain direction, at a certain speed, and within a certain stability class. The JFD file was based on measurements taken at a specific location and height. Annual meteorological conditions were used for normal operations. Table J-71 presents the JFD used in the dose assessments for LLNL.

J.5.3.1.2 Population Data

The LLNL population distribution was based on the *1990 Census of Population and Housing Data* (DOC 1992). Projections were determined for the year 2005 for areas within 80 km (50 mi) of the proposed facility location. The site population in 2005 was assumed to be representative of the population over the operational period evaluated. The population was spatially distributed on a circular grid with 16 directions and 10 radial distances out to an 80-km (50-mi) distance. The grid was centered at Building 332, the location from which radionuclides are assumed to be released during incident-free operations. Table J-72 presents the population data that were used for lead assembly dose assessments at LLNL.

J.5.3.1.3 Agricultural Data

The 1992 Census of Agriculture (DOC 1992) was the source used to generate site-specific data for food production. Food production was spatially distributed on a circular grid similar to that used for the population distributions described previously. This food grid (or wheel) was generated by combining the fraction of a county in each segment (e.g., south, southwest, north-northeast) and the county production of the eight food categories analyzed by GENII—leafy vegetables, root vegetables, fruits, grains, beef, poultry, milk, and eggs. Each county's food production was assumed to be distributed uniformly over the given county's land area. These categorized food wheels were then used in the assessment of doses to the population from the ingestion pathway. The consumption rates used in the dose assessments were those for the MEI and average exposed individual. People living within the 80-km (50-mi) assessment area were assumed to consume only food grown in that area. LLNL food production and consumption data used for the dose assessments in the SPD EIS were obtained from the 1992 census data for LLNL (DOC 1992).

Table J-71. LLNL 1993 Joint Frequency Distributions at 10-m Height

Wind Speed (m/s)	Stability Class	Wind Blows Toward															
		S	SSW	SW	WSW	W	WNW	NW	NNW	N	NNE	NE	ENE	E	ESE	SE	SSE
0.89	A	0.45	0.41	0.4	0.33	0.27	0.17	0.14	0.11	0.13	0.34	0.62	1.14	1.53	0.78	0.57	0.45
	B	0.22	0.11	0.1	0.11	0.1	0.03	0.03	0.01	0.07	0.05	0.27	0.41	0.17	0.17	0.14	0.09
	C	0.13	0.09	0.15	0.03	0.02	0.01	0	0.03	0.08	0.14	0.16	0.22	0.16	0.09	0.08	0.07
	D	0.17	0.33	0.45	0.53	0.65	0.67	0.23	0.34	1.05	1.86	1.21	0.7	0.27	0.13	0.05	0.03
	E	0.18	0.33	0.86	0.99	1.01	1.13	0.39	0.48	1.07	1.7	0.74	0.41	0.25	0.06	0.09	0.03
	F	0.11	0.16	0.61	0.93	0.8	0.63	0.55	0.31	0.35	0.38	0.39	0.14	0.1	0.08	0.11	0.07
	G	0.62	0.74	1.06	1.64	1.97	1.78	1.53	0.97	0.73	0.75	0.49	0.48	0.34	0.27	0.35	0.37
2.86	A	0.3	0.37	0.24	0.18	0.03	0.02	0.02	0.01	0	0.02	0.26	0.81	0.89	0.31	0.21	0.16
	B	0.4	0.39	0.77	0.16	0	0.03	0.02	0.01	0.02	0.08	0.39	1.26	1.15	0.22	0.07	0.21
	C	0.07	0.59	1.21	0	0	0	0	0.01	0.02	0.09	0.7	1.28	1.17	0.23	0.01	0.03
	D	0.03	0.82	1.04	0.03	0	0	0.03	0.09	0.25	1.14	4.88	2.71	1.81	0.21	0.02	0
	E	0.07	0.13	0.27	0.07	0	0	0.05	0.06	0.63	1.91	0.93	0.16	0.03	0	0	0.02
	F	0.03	0.03	0.16	0.1	0.01	0.02	0.01	0.02	0.03	0.02	0.06	0.02	0.01	0.02	0.01	0.01
	G	0.01	0.05	0.07	0.06	0.05	0.02	0.03	0.02	0.05	0.03	0.06	0	0	0	0.01	0.01
4.71	A	0	0	0	0	0	0	0	0	0	0	0	0	0	0	0	0
	B	0	0	0	0	0	0	0	0	0	0	0	0	0	0	0	0
	C	0.34	0.71	0.23	0.02	0	0.02	0	0.05	0.01	0.03	0.3	1.22	1.62	0.16	0.01	0
	D	0.08	0.72	0.56	0	0	0	0	0.06	0.09	0.61	3.64	1.51	2.04	0.11	0.01	0.02
	E	0	0.02	0	0	0	0	0	0	0	0.15	0.17	0.01	0	0	0	0
	F	0	0	0	0	0	0	0	0	0	0	0	0	0	0	0	0
	G	0	0	0	0	0	0	0	0	0	0	0	0	0	0	0	0
6.69	A	0	0	0	0	0	0	0	0	0	0	0	0	0	0	0	0
	B	0	0	0	0	0	0	0	0	0	0	0	0	0	0	0	0
	C	0	0	0	0	0	0	0	0	0	0	0	0	0	0	0	0
	D	0.15	0.24	0.02	0	0	0	0	0	0.03	0.45	1.25	0.32	0.13	0.03	0	0
	E	0	0	0	0	0	0	0	0	0	0	0	0	0	0	0	0
	F	0	0	0	0	0	0	0	0	0	0	0	0	0	0	0	0
	G	0	0	0	0	0	0	0	0	0	0	0	0	0	0	0	0
8.68	A	0	0	0	0	0	0	0	0	0	0	0	0	0	0	0	0
	B	0	0	0	0	0	0	0	0	0	0	0	0	0	0	0	0
	C	0	0	0	0	0	0	0	0	0	0	0	0	0	0	0	0
	D	0.07	0.08	0	0	0	0	0	0	0.02	0.07	0.02	0	0.01	0	0	0
	E	0	0	0	0	0	0	0	0	0	0	0	0	0	0	0	0
	F	0	0	0	0	0	0	0	0	0	0	0	0	0	0	0	0
	G	0	0	0	0	0	0	0	0	0	0	0	0	0	0	0	0

Table J-71. LLNL 1993 Joint Frequency Distributions at 10-m Height (Continued)

Wind Speed (m/s)	Stability Class	Wind Blows Toward															
		S	SSW	SW	WSW	W	WNW	NW	NNW	N	NNE	NE	ENE	E	ESE	SE	SSE
10.5	A	0	0	0	0	0	0	0	0	0	0	0	0	0	0	0	0
	B	0	0	0	0	0	0	0	0	0	0	0	0	0	0	0	0
	C	0	0	0	0	0	0	0	0	0	0	0	0	0	0	0	0
	D	0	0	0	0	0	0	0	0	0	0	0.01	0	0	0	0	0
	E	0	0	0	0	0	0	0	0	0	0	0	0	0	0	0	0
	F	0	0	0	0	0	0	0	0	0	0	0	0	0	0	0	0
	G	0	0	0	0	0	0	0	0	0	0	0	0	0	0	0	0

Key: LLNL, Lawrence Livermore National Laboratory.

Source: Gouveia 1997.

Table J-72. Projected LLNL Population Surrounding Building 332 for Year 2005

Direction	Distance (mi)										Total
	0-1	1-2	2-3	3-4	4-5	5-10	10-20	20-30	30-40	40-50	
S	5	14	6	8	10	84	178	157	15,286	56,124	71,872
SSW	5	15	13	8	10	47	1,080	301,887	190,271	27,874	521,210
SW	31	538	25	18	16	91	42,723	589,979	350,562	52,017	1,036,000
WSW	228	1,283	660	982	1,885	644	146,903	239,224	184,580	4,845	581,234
W	302	1,316	3,338	6,379	9,931	24,309	112,488	123,480	333,290	64,111	678,944
WNW	311	1,316	4,567	6,337	8,349	20,051	92,859	476,610	570,787	545,627	1,726,814
NW	272	1,316	1,770	2,274	212	677	78,366	170,569	454,881	135,688	846,025
NNW	109	1,423	2,850	2,109	53	404	8,150	275,850	117,234	154,923	563,105
N	5	49	1,094	324	39	367	4,555	139,309	1,444	230,332	377,518
NNE	5	15	25	35	45	283	13,831	24,535	7,317	5,523	51,614
NE	5	15	16	25	21	127	8,403	12,091	128,594	36,124	185,421
ENE	5	11	6	8	10	111	2,218	130,249	211,561	11,360	355,539
E	5	14	8	8	10	249	54,523	86,577	30,047	47,622	219,063
ESE	5	15	17	8	10	103	1,898	7,484	230,939	242,714	483,193
SE	5	15	10	8	10	91	512	902	18,290	23,344	43,187
SSE	5	12	6	8	10	85	314	83	26	1,063	1,612
Total	1,303	7,367	14,411	18,539	20,621	47,723	569,001	2,578,986	2,845,109	1,639,291	7,742,351

Key: LLNL, Lawrence Livermore National Laboratory.

Source: DOC 1992.

J.5.3.1.4 Source Term Data

Estimated incident-free radiological releases associated with the MOX fuel lead assembly facility are presented in Table J-73. Stack height and release location are provided in the ORNL *LLNL MOX Fuel Lead Assemblies Data Report for the Surplus Plutonium Disposition Environmental Impact Statement* (O'Connor et al. 1998c).

Table J-73. Estimated Incident-Free Annual Radiological Releases From the MOX Lead Assembly Facility at LLNL

Isotope	($\mu\text{Ci/yr}$)
Plutonium 236	–
Plutonium 238	0.85
Plutonium 239	23
Plutonium 240	5.3
Plutonium 241	58
Plutonium 242	9.3×10^{-4}
Americium 241	2.0
Uranium 234	1.3×10^{-3}
Uranium 235	5.4×10^{-5}
Uranium 238	3.1×10^{-3}

Source: O'Connor et al. 1998c.

J.5.3.1.5 Other Calculational Assumptions

To estimate radiological impacts of incident-free operation of the lead assembly facility at LLNL, the following additional assumptions and factors were considered, in accordance with the guidelines established in NRC Regulatory Guide 1.109 (NRC 1977).

- Ground surfaces were assumed to have no previous deposition of radionuclides for the purposes of modeling the incremental radiological impacts associated with surplus plutonium disposition activities. However, doses associated with true instances of prior deposition are accounted for in the Affected Environment and Cumulative Impacts sections.
- The annual external exposure time to the plume and to soil contamination was 0.7 year for the MEI (NRC 1977).
- The annual external exposure time to the plume and to soil contamination was 0.5 year for the population (NRC 1977).
- The annual inhalation exposure time to the plume was 1 year for the MEI and general population (NRC 1977).
- The exposed individual or population was assumed to have the characteristics and habits (e.g., inhalation and ingestion rates) of the adult human.
- A semi-infinite/finite plume model was used for air immersion doses. Other pathways evaluated were ground exposure, inhalation, ingestion of food crops, and ingestion of contaminated animal products. Drinking water, aquatic food ingestion, and any other pathway that may involve liquid exposure were not examined because all releases are to the air.
- Reported stack heights were used for atmospheric releases and were assumed to be the effective stack height. The resultant doses were conservative because use of the actual stack height negates plume rise.
- The calculated doses are 50-year committed doses from 1 year of intake.

J.5.3.2 Human Health Impacts

Potential radiological impacts on the public and workers resulting from normal lead assembly operations are presented in Section 4.27.3.4.

J.5.4 LANL

J.5.4.1 Assessment Data

This section presents applicable data and assumptions used in the assessment of lead assembly human health risks at LANL. Appendix F.10 provides a summary of the methods and tools (e.g., the GENII computer code) used for the assessment.

J.5.4.1.1 Meteorological Data

The meteorological data used for the LANL dose assessments was in the form of a JFD file. A JFD file is a table listing the percentages of time the wind blows in a certain direction, at a certain speed, and within a certain stability class. The JFD file was based on measurements taken at a specific location and height. Annual meteorological conditions were used for normal operations. Table J-74 presents the JFD used in the dose assessments for LANL.

J.5.4.1.2 Population Data

The LANL population distribution was based on the *1990 Census of Population and Housing Data* (DOC 1992). Projections were determined for the year 2005 for areas within 80 km (50 mi) of the proposed facility location. The site population in 2005 was assumed to be representative of the population over the operational period evaluated. The population was spatially distributed on a circular grid with 16 directions and 10 radial distances out to an 80-km (50-mi) distance. The grid was centered at Technical Area 55 (TA-55), the location from which radionuclides are assumed to be released during incident-free operations. Table J-75 presents the population data used for lead assembly dose assessments at LANL.

J.5.4.1.3 Agricultural Data

The 1992 Census of Agriculture was the source used to generate site-specific data for food production. Food production was spatially distributed on a circular grid similar to that used for the population distributions described previously. This food grid (or wheel) was generated by combining the fraction of a county in each segment (e.g., south, southwest, north-northeast) and the county production of the eight food categories analyzed by GENII—leafy vegetables, root vegetables, fruits, grains, beef, poultry, milk, and eggs. Each county's food production was assumed to be distributed uniformly over the given county's land area. These categorized food wheels were then used in the assessment of doses to the population from the ingestion pathway. The consumption rates used in the dose assessments were those for the MEI and average exposed individual. People living within the 80-m (50-mi) assessment area were assumed to consume only food grown in that area. LANL food production and consumption data used for the dose assessments in the SPD EIS were obtained from the *Final Environmental Impact Statement on Management of Certain Plutonium Residues and Scrub Alloy Stored at the Rocky Flats Environmental Technology Site* (DOE 1998).

Table J-74. LANL 1993-1996 Joint Frequency Distributions at 11-m Height

Wind Speed (m/s)	Stability Class	Wind Blows Toward															
		S	SSW	SW	WSW	W	WNW	NW	NNW	N	NNE	NE	ENE	E	ESE	SE	SSE
0.78	A	0.12	0.26	0.5	0.84	0.74	0.54	0.45	0.32	0.18	0.11	0.08	0.05	0.06	0.06	0.07	0.07
	B	0.03	0.05	0.12	0.19	0.16	0.09	0.08	0.07	0.04	0.01	0.02	0.01	0.02	0.02	0.01	0.02
	C	0.05	0.09	0.14	0.2	0.16	0.09	0.09	0.09	0.07	0.04	0.03	0.03	0.02	0.03	0.02	0.03
	D	0.86	0.69	0.57	0.45	0.47	0.34	0.33	0.33	0.38	0.35	0.33	0.31	0.35	0.4	0.57	0.72
	E	0.59	0.45	0.33	0.23	0.22	0.15	0.13	0.13	0.17	0.24	0.32	0.28	0.29	0.4	0.51	0.62
	F	0.26	0.28	0.27	0.19	0.18	0.17	0.2	0.25	0.3	0.32	0.22	0.17	0.15	0.2	0.24	0.25
2.5	A	0.03	0.07	0.17	0.45	0.56	0.43	0.33	0.22	0.18	0.08	0.06	0.05	0.04	0.03	0.03	0.03
	B	0.02	0.05	0.2	0.39	0.42	0.31	0.27	0.22	0.16	0.1	0.06	0.05	0.05	0.04	0.03	0.02
	C	0.05	0.15	0.46	0.68	0.65	0.45	0.46	0.59	0.59	0.26	0.16	0.12	0.16	0.12	0.07	0.05
	D	0.95	1.09	0.94	0.72	0.56	0.34	0.47	1.3	2.12	1.89	1.93	0.95	1.08	0.81	0.56	0.63
	E	0.87	0.59	0.34	0.19	0.11	0.1	0.13	0.24	0.67	1.82	2.41	1.72	1.84	1.41	0.8	0.8
	F	0.09	0.07	0.05	0.03	0.01	0.01	0.05	0.1	0.25	0.33	0.11	0.36	0.39	0.39	0.12	0.07
4.5	A	0	0	0	0	0	0	0	0	0	0	0	0	0	0	0	0
	B	0	0	0	0	0	0	0	0	0	0	0.01	0.01	0.01	0.02	0.01	0
	C	0.02	0.04	0.07	0.04	0.02	0.01	0.01	0.03	0.15	0.09	0.11	0.19	0.31	0.19	0.09	0.02
	D	0.81	0.8	0.42	0.16	0.07	0.04	0.11	0.99	3.24	3.52	2.59	1.61	1.86	1.05	0.54	0.44
	E	0.21	0.2	0.08	0.01	0	0	0.01	0.07	0.32	1.74	1.08	1.32	1.31	0.32	0.23	0.22
	F	0	0.01	0	0	0	0	0	0	0.02	0.04	0	0.05	0.05	0.01	0.01	0
6.9	A	0	0	0	0	0	0	0	0	0	0	0	0	0	0	0	0
	B	0	0	0	0	0	0	0	0	0	0	0	0	0	0	0	0
	C	0	0	0	0	0	0	0	0	0	0	0	0.01	0.01	0.01	0	0
	D	0.19	0.2	0.05	0	0	0	0.01	0.31	0.96	1.42	0.87	0.93	0.62	0.48	0.31	0.15
	E	0	0	0	0	0	0	0	0	0	0	0	0	0	0	0	0
	F	0	0	0	0	0	0	0	0	0	0	0	0	0	0	0	0
9.6	A	0	0	0	0	0	0	0	0	0	0	0	0	0	0	0	0
	B	0	0	0	0	0	0	0	0	0	0	0	0	0	0	0	0
	C	0	0	0	0	0	0	0	0	0	0	0	0	0	0	0	0
	D	0.01	0.01	0	0	0	0	0	0.05	0.03	0.08	0.09	0.19	0.08	0.05	0.04	0.02
	E	0	0	0	0	0	0	0	0	0	0	0	0	0	0	0	0
	F	0	0	0	0	0	0	0	0	0	0	0	0	0	0	0	0
105	A	0	0	0	0	0	0	0	0	0	0	0	0	0	0	0	0
	B	0	0	0	0	0	0	0	0	0	0	0	0	0	0	0	0
	C	0	0	0	0	0	0	0	0	0	0	0	0	0	0	0	0
	D	0	0	0	0	0	0	0	0.01	0	0	0.01	0.01	0	0	0	0
	E	0	0	0	0	0	0	0	0	0	0	0	0	0	0	0	0
	F	0	0	0	0	0	0	0	0	0	0	0	0	0	0	0	0

Key: LANL, Los Alamos National Laboratory.

Source: LANL 1997.

Table J-75. Projected LANL Population Surrounding TA-55 for Year 2005

Direction	Distance (mi)										Total
	0-1	1-2	2-3	3-4	4-5	5-10	10-20	20-30	30-40	40-50	
S	0	0	25	26	44	221	701	1,606	1,125	2,962	6,710
SSW	0	0	26	20	56	21	1,373	4,464	4,949	43,596	54,505
SW	0	0	26	22	80	29	155	1,767	817	30,893	33,789
WSW	0	0	26	21	56	302	159	1,187	2,500	61	4,312
W	0	0	27	20	26	457	190	1,084	135	350	2,289
WNW	0	12	39	135	90	532	73	138	1,755	1,306	4,080
NW	0	152	1,287	2,379	1,500	720	102	195	248	274	6,857
NNW	0	427	844	224	126	421	169	211	174	220	2,816
N	500	585	264	107	137	560	609	688	659	289	4,398
NNE	0	480	61	57	56	463	958	919	658	143	3,795
NE	0	101	12	17	22	378	12,856	2,950	1,954	3,236	21,526
ENE	0	10	12	17	22	618	13,270	3,439	2,869	1,938	22,195
E	0	10	12	17	22	684	3,598	590	719	1,161	6,813
ESE	0	10	12	17	33	220	1,602	3,608	316	834	6,652
SE	0	0	0	0	4,488	952	6,143	76,455	4,503	742	93,283
SSE	0	0	0	117	85	224	5,021	10,633	2,091	483	18,654
Total	500	1,787	2,673	3,196	6,843	6,802	46,979	109,934	25,472	88,488	292,674

Key: LANL, Los Alamos National Laboratory; TA-55, Technical Area 55.

Source: DOC 1992.

J.5.4.1.4 Source Term Data

Estimated incident-free radiological releases associated with the MOX fuel lead assembly facility are presented in Table J-76. Stack height and release location are provided in the ORNL *LANL MOX Fuel Lead Assemblies Data Report for the Surplus Plutonium Disposition Environmental Impact Statement* (O'Connor et al. 1998d).

Table J-76. Estimated Incident-Free Annual Radiological Releases From the MOX Lead Assembly Facility at LANL

Isotope	($\mu\text{Ci}/\text{yr}$)
Plutonium 236	–
Plutonium 238	0.85
Plutonium 239	23
Plutonium 240	5.3
Plutonium 241	58
Plutonium 242	9.3×10^{-4}
Americium 241	2.0
Uranium 234	1.3×10^{-3}
Uranium 235	5.4×10^{-5}
Uranium 238	3.1×10^{-3}

Source: O'Connor et al. 1998d.

J.5.4.1.5 Other Calculational Assumptions

To estimate radiological impacts of incident-free operation of the lead assembly facility at LANL, the following additional assumptions and factors were considered, in accordance with the guidelines established in NRC Regulatory Guide 1.109 (NRC 1977).

- Ground surfaces were assumed to have no previous deposition of radionuclides for the purposes of modeling the incremental radiological impacts associated with surplus plutonium disposition activities. However, doses associated with true instances of prior deposition are accounted for in the Affected Environment and Cumulative Impacts sections.
- The annual external exposure time to the plume and to soil contamination was 0.7 year for the MEI (NRC 1977).
- The annual external exposure time to the plume and to soil contamination was 0.5 year for the population (NRC 1977).
- The annual inhalation exposure time to the plume was 1 year for the MEI and general population (NRC 1977).
- The exposed individual or population was assumed to have the characteristics and habits (e.g., inhalation and ingestion rates) of the adult human.
- A semi-infinite/finite plume model was used for air immersion doses. Other pathways evaluated were ground exposure, inhalation, ingestion of food crops, and ingestion of contaminated animal products. Drinking water, aquatic food ingestion, and any other pathway that may involve liquid exposure were not examined because all releases are to the air.
- Reported stack heights were used for atmospheric releases and were assumed to be the effective stack height. The resultant doses were conservative, because use of the actual stack height negates plume rise.
- The calculated doses are 50-year committed doses from 1 year of intake.

J.5.4.2 Human Health Impacts

Potential radiological impacts on the public and workers resulting from normal lead assembly operations are presented in Section 4.27.4.4.

J.5.5 SRS

J.5.5.1 Assessment Data

This section presents applicable data and assumptions used in the assessment of lead assembly human health risks at SRS. Appendix F.10 provides a summary of the methods and tools (e.g., the GENII computer code) used for the assessment.

J.5.5.1.1 Meteorological Data

The meteorological data used for the SRS dose assessments was in the form of a JFD file. A JFD file is a table listing the percentages of time the wind blows in a certain direction, at a certain speed, and within a certain

stability class. The JFD file was based on measurements taken over a period of several years at a specific location (H-Area) and height. Average annual meteorological conditions, averaged over the measurement period, were used for normal operations. Table J-77 presents the JFD used in the dose assessments for SRS.

J.5.5.1.2 Population Data

The SRS population distribution was based on the *1990 Census of Population and Housing Data* (DOC 1992). Projections were determined for the year 2005 for areas within 80 km (50 mi) of the proposed facility location. The site population in 2005 was assumed to be representative of the population over the operational period evaluated. The population was spatially distributed on a circular grid with 16 directions and 10 radial distances out to an 80-km (50-mi) distance. The grid was centered within H-Area, the location from which radionuclides are assumed to be released during incident-free operations. Table J-78 presents the population data used for the lead assembly dose assessments at SRS.

J.5.5.1.3 Agricultural Data

The 1987 Census of Agriculture was the source used to generate site-specific data for food production. Food production was spatially distributed on a circular grid similar to that used for the population distributions described previously. This food grid (or wheel) was generated by combining the fraction of a county in each segment (e.g., south, southwest, north-northeast) and the county production of the eight food categories analyzed by GENII—leafy vegetables, root vegetables, fruits, grains, beef, poultry, milk, and eggs. Each county's food production was assumed to be distributed uniformly over the given county's land area. These categorized food wheels were then used in the assessment of doses to the population from the ingestion pathway. The consumption rates used in the dose assessments were those for the MEI and average exposed individual. People living within the 80-km (50-mi) assessment area were assumed to consume only food grown in that area. SRS food production and consumption data used for the dose assessments in the SPD EIS were obtained from the *Health Risk Data for Storage and Disposition of Final PEIS* (HNUS 1996).

Table J-77. SRS 1987–1991 Joint Frequency Distributions at 61-m Height

Wind Speed (m/s)	Stability Class	Wind Blows Toward															
		S	SSW	SW	WSW	W	WNW	NW	NNW	N	NNE	NE	ENE	E	ESE	SE	SSE
2.0	A	0.37	0.41	0.37	0.42	0.4	0.37	0.4	0.36	0.36	0.35	0.45	0.39	0.45	0.43	0.37	0.41
	B	0.08	0.08	0.09	0.1	0.05	0.06	0.06	0.05	0.08	0.07	0.05	0.05	0.05	0.08	0.05	0.07
	C	0.03	0.06	0.09	0.07	0.06	0.05	0.06	0.05	0.07	0.05	0.06	0.05	0.08	0.05	0.05	0.05
	D	0.02	0.05	0.06	0.04	0.06	0.03	0.06	0.07	0.06	0.03	0.07	0.05	0.04	0.03	0.05	0.04
	E	0.01	0.02	0.04	0.01	0.01	0.03	0.03	0.03	0.02	0.02	0.01	0.01	0.02	0.01	0.02	0.02
	F	0	0.01	0.01	0.01	0.01	0.01	0	0.01	0.01	0.01	0.02	0.01	0.01	0.01	0.01	0.01
4.0	A	0.87	0.74	0.88	1	0.94	0.94	0.65	0.62	0.74	0.72	1	1.28	1.29	0.94	0.53	0.6
	B	0.27	0.41	0.58	0.62	0.43	0.34	0.24	0.22	0.32	0.33	0.48	0.67	0.56	0.37	0.25	0.21
	C	0.17	0.57	1.13	1.03	0.6	0.41	0.41	0.37	0.48	0.52	0.59	0.79	0.53	0.45	0.3	0.24
	D	0.1	0.44	1.07	0.89	0.55	0.5	0.71	0.69	0.92	0.91	0.8	0.81	0.72	0.57	0.43	0.27
	E	0.06	0.27	0.69	0.48	0.3	0.33	0.46	0.7	0.67	0.57	0.54	0.47	0.43	0.43	0.33	0.3
	F	0.02	0.05	0.09	0.04	0.02	0.08	0.09	0.09	0.11	0.08	0.12	0.09	0.03	0.05	0.05	0.07
6.0	A	0.57	0.26	0.16	0.19	0.15	0.07	0.07	0.09	0.14	0.14	0.21	0.24	0.27	0.24	0.14	0.24
	B	0.14	0.39	0.38	0.31	0.16	0.11	0.07	0.08	0.19	0.21	0.32	0.51	0.51	0.36	0.13	0.09
	C	0.12	0.54	1.3	0.74	0.35	0.19	0.22	0.25	0.47	0.46	0.56	0.69	0.64	0.56	0.21	0.12
	D	0.12	0.43	0.85	0.58	0.4	0.44	0.65	1.16	1.45	0.78	0.9	0.77	0.78	0.65	0.32	0.09
	E	0.07	0.53	0.69	0.71	0.6	0.45	0.65	1.01	1.18	0.94	0.91	0.89	0.48	0.4	0.19	0.14
	F	0.01	0.26	0.21	0.14	0.14	0.19	0.13	0.16	0.22	0.21	0.24	0.23	0.07	0.04	0.02	0.04
8.0	A	0.09	0.05	0.01	0.01	0.01	0	0.01	0.01	0.02	0.02	0.02	0.04	0.03	0.02	0.01	0.06
	B	0.01	0.08	0.03	0.01	0.01	0.01	0	0.01	0.05	0.04	0.05	0.1	0.17	0.21	0.06	0.01
	C	0.01	0.1	0.2	0.08	0.02	0.03	0.03	0.06	0.16	0.16	0.21	0.26	0.45	0.43	0.1	0.02
	D	0.01	0.05	0.1	0.02	0.01	0.01	0.05	0.18	0.22	0.15	0.1	0.09	0.03	0.05	0.03	0
	E	0	0.05	0.03	0.04	0.01	0.01	0	0.03	0.04	0.02	0.04	0.01	0.01	0	0	0
	F	0	0.03	0.02	0.02	0	0.01	0	0.01	0.02	0.01	0.02	0.01	0	0	0	0
12.0	A	0.01	0	0	0	0	0	0	0	0	0.01	0.01	0.01	0	0.01	0	0.01
	B	0	0.01	0	0	0	0	0	0	0	0	0.01	0.01	0.06	0.06	0.01	0
	C	0	0.01	0	0	0	0.01	0	0.03	0.04	0.04	0.05	0.06	0.16	0.17	0.02	0.01
	D	0	0.02	0.02	0	0	0	0	0.01	0.02	0.04	0	0	0.01	0	0	0
	E	0	0	0	0	0	0	0	0	0	0	0	0	0	0	0	0
	F	0	0	0	0	0	0	0	0	0	0	0	0	0	0	0	0
14.1	A	0	0	0	0	0	0	0	0	0	0	0	0	0	0	0	0
	B	0	0	0	0	0	0	0	0	0	0	0	0	0	0	0	0
	C	0	0	0	0	0	0	0	0	0	0	0	0	0	0	0	0
	D	0	0	0	0	0	0	0	0	0	0	0	0	0	0	0	0
	E	0	0	0	0	0	0	0	0	0	0	0	0	0	0	0	0
	F	0	0	0	0	0	0	0	0	0	0	0	0	0	0	0	0

Source: Simpkins 1997.

Table J-78. Projected SRS Population Surrounding H-Area for Year 2005

Direction	Distance (mi)										Total
	0-1	1-2	2-3	3-4	4-5	5-10	10-20	20-30	30-40	40-50	
S	0	0	0	0	0	0	485	1,807	5,207	3,545	11,044
SSW	0	0	0	0	0	0	629	1,906	5,070	2,361	9,966
SW	0	0	0	0	0	25	895	7,586	1,939	2,953	13,398
WSW	0	0	0	0	0	71	2,428	4,529	3,330	8,327	18,685
W	0	0	0	0	0	683	4,586	54,394	22,338	13,086	95,087
WNW	0	0	0	0	0	1,384	7,849	172,996	76,767	6,917	265,913
NW	0	0	0	0	0	1,026	14,508	34,759	4,044	3,629	57,966
NNW	0	0	0	0	0	2,691	30,598	23,544	8,243	6,184	71,260
N	0	0	0	0	0	363	4,049	3,790	4,887	20,832	33,921
NNE	0	0	0	0	0	89	1,790	3,016	6,535	21,457	32,887
NE	0	0	0	0	0	15	3,754	3,684	6,147	9,896	23,496
ENE	0	0	0	0	0	9	3,723	6,246	6,956	43,139	60,073
E	0	0	0	0	0	113	7,647	3,844	6,830	4,084	22,518
ESE	0	0	0	0	0	3	1,329	2,551	3,551	5,933	13,367
SE	0	0	0	0	0	0	552	4,950	4,962	8,342	18,806
SSE	0	0	0	0	0	0	374	597	1,940	2,703	5,614
Total	0	0	0	0	0	6,472	85,196	330,199	168,746	163,388	754,001

Source: DOC 1992.

J.5.5.1.4 Source Term Data

Estimated incident-free radiological releases associated with the MOX fuel lead assembly facility are presented in Table J-79. Stack height and release location are provided in the ORNL *SRS MOX Fuel Lead Assemblies Data Report for the Surplus Plutonium Disposition Environmental Impact Statement* (O'Connor et al. 1998e).

Table J-79. Estimated Incident-Free Annual Radiological Releases From the MOX Lead Assembly Facility at SRS

Isotope	($\mu\text{Ci/yr}$)
Plutonium 236	–
Plutonium 238	0.85
Plutonium 239	23
Plutonium 240	5.3
Plutonium 241	58
Plutonium 242	9.3×10^{-4}
Americium 241	2.0
Uranium 234	1.3×10^{-3}
Uranium 235	5.4×10^{-5}
Uranium 238	3.1×10^{-3}

Source: O'Connor et al. 1998e.

J.5.5.1.5 Other Calculational Assumptions

To estimate radiological impacts of incident-free operation of the facilities at SRS, the following additional assumptions and factors were considered, in accordance with the guidelines established in NRC Regulatory Guide 1.109 (NRC 1977).

- Ground surfaces were assumed to have no previous deposition of radionuclides for the purposes of modeling the incremental radiological impacts associated with surplus plutonium disposition activities. However, doses associated with true instances of prior deposition are accounted for in the Affected Environment and Cumulative Impacts sections.
- The annual external exposure time to the plume and to soil contamination was 0.7 year for the MEI (NRC 1977).
- The annual external exposure time to the plume and to soil contamination was 0.5 year for the population (NRC 1977).
- The annual inhalation exposure time to the plume was 1 year for the MEI and general population (NRC 1977).
- The exposed individual or population was assumed to have the characteristics and habits (e.g., inhalation and ingestion rates) of the adult human.
- A semi-infinite/finite plume model was used for air immersion doses. Other pathways evaluated were ground exposure, inhalation, ingestion of food crops, and ingestion of contaminated animal products. Drinking water, aquatic food ingestion, and any other pathway that may involve liquid exposure were not examined because all releases are to the air.
- Reported stack heights were used for atmospheric releases and were assumed to be the effective stack height. The resultant doses were conservative because use of the actual stack height negates plume rise.
- The calculated doses are 50-year committed doses from 1 year of intake.

J.5.5.2 Human Health Impacts

Potential radiological impacts on the public and workers resulting from normal lead assembly operations are presented in Section 4.27.5.4.

J.6 REFERENCES

Antonio, E., 1998, Battelle Pacific Northwest National Laboratory, Richland, WA, personal communication (facsimile) to R. Schlegel, Science Applications International Corporation, Germantown, MD, *Doses at 400 Area*, March 23.

DOC (U.S. Department of Commerce), 1992, *Census of Population and Housing, 1990: Summary Tape File 3 on CD-ROM*, Bureau of the Census, Washington, DC, May.

DOE (U.S. Department of Energy), 1993, *Radiation Protection of the Public and the Environment*, DOE Order 5400.5, Office of Environment, Safety and Health, January 7.

DOE (U.S. Department of Energy), 1994, *Radiological Control Manual*, rev. 1, DOE/EH-0256T, Office of Environment, Safety and Health, Washington, DC, April.

DOE (U.S. Department of Energy), 1995, *Occupational Radiation Protection*, 10 CFR 835, Washington, DC, January 1.

DOE (U.S. Department of Energy), 1997, *1996 Environmental Report for Pantex Plant*, DOE/AL/65030-9704, Albuquerque Operations Office, Amarillo Area Office, Amarillo, TX, May.

DOE (U.S. Department of Energy), 1998, *Final Environmental Impact Statement on Management of Certain Plutonium Residues and Scrub Alloy Stored at the Rocky Flats Environmental Technology Site*, DOE/EIS-0277F, Office of Environmental Management, Washington, DC, August.

DOE (U.S. Department of Energy), 1999, *MOX Fuel Fabrication Facility and Nuclear Power Reactor Data Report*, MD-0015, Office of Fissile Materials Disposition, Washington, DC, August.

Gouveia, F., 1997, Los Alamos National Laboratory, Los Alamos, NM, personal communication to R. Schlegel, Science Applications International Corporation, Germantown, MD, *1993 LLNL Star Data*, February.

HNU S (Halliburton NUS Corporation), 1996, *Health Risk Data for Storage and Disposition of Weapons-Usable Fissile Materials Programmatic Environmental Impact Statement*, Gaithersburg, MD, October.

ICRP (International Commission on Radiological Protection), 1991, *1990 Recommendations of the International Commission on Radiological Protection*, ICRP Publication 60, Elmsford, NY.

LANL (Los Alamos National Laboratory), 1997, *LANL Joint Frequency Distribution Data*, www.lanl.gov/public/welcome.html, February.

Mitchell, R.G., D. Peterson, D. Roush, R.W. Brooks, L.R. Paulus, and D.B. Martin, 1997, *Idaho National Engineering Laboratory Site Environmental Report for Calendar Year 1996*, DOE/ID-12082(96), U.S. Department of Energy, Idaho Operations Office, Idaho Falls, ID, August.

NAS (National Academy of Sciences and National Research Council), 1990, *Health Effects of Exposure to Low Levels of Ionizing Radiation, BEIR V*, Committee on the Biological Effects of Ionizing Radiations, Board of Radiation Effects Research, Commission on Life Sciences, National Academy Press, Washington, DC.

Neitzel, D.A., ed., 1996, *Hanford Site National Environmental Policy Act (NEPA) Characterization*, rev. 8, PNL-6415, Battelle, Pacific Northwest National Laboratory, Richland, WA, August.

NRC (U.S. Nuclear Regulatory Commission), 1977, *Calculation of Annual Doses to Man From Routine Releases of Reactor Effluents for the Purpose of Evaluating Compliance With 10 CFR 50, Appendix I*, Regulatory Guide 1.109, Office of Standards Development, Washington, DC, October.

NWS (National Weather Service), 1997, *Meteorological Data for Pantex Site*, Texas Natural Resource Conservation Commission, Amarillo, TX.

O'Connor, D.G., et al., 1998a, *ANL-W MOX Fuel Lead Assemblies Data Report for the Surplus Plutonium Disposition Environmental Impact Statement*, ORNL/TM-13478, Lockheed Martin Energy Research Corporation, Oak Ridge, TN, August.

O'Connor, D.G., et al., 1998b, *Hanford MOX Fuel Lead Assemblies Data Report for the Surplus Plutonium Disposition Environmental Impact Statement*, ORNL/TM-13481, Lockheed Martin Energy Research Corporation, Oak Ridge, TN, August.

O'Connor, D.G., et al., 1998c, *LLNL MOX Fuel Lead Assemblies Data Report for the Surplus Plutonium Disposition Environmental Impact Statement*, ORNL/TM-13480, Lockheed Martin Energy Research Corporation, Oak Ridge, TN, August.

O'Connor, D.G., et al., 1998d, *LANL MOX Fuel Lead Assemblies Data Report for the Surplus Plutonium Disposition Environmental Impact Statement*, ORNL/TM-13482, Lockheed Martin Energy Research Corporation, Oak Ridge, TN, August.

O'Connor, D.G., et al., 1998e, *SRS MOX Fuel Lead Assemblies Data Report for the Surplus Plutonium Disposition Environmental Impact Statement*, ORNL/TM-13483, Lockheed Martin Energy Research Corporation, Oak Ridge, TN, August.

Sagendorf, J., 1992, U.S. Department of Commerce, National Oceanic and Atmospheric Administration, Washington, DC, personal communication to S. Maheras, Idaho National Engineering and Environmental Laboratory, Idaho Falls, ID, *Meteorological Joint Frequency Data Sets for INEL*, January.

Simpkins, A.A., 1997, Westinghouse Savannah River Company, Aiken, SC, personal communication to J.R. Sessions, Westinghouse Savannah River Company, Aiken, SC, *Meteorological and Worker Dose Data for Plutonium Residues EIS*, May.

UC (Regents of the University of California), 1998a, *Pit Disassembly and Conversion Facility, Environmental Impact Statement Data Report—Hanford Site*, LA-UR-97-2907, Los Alamos National Laboratory, Los Alamos, NM, June 1.

UC (Regents of the University of California), 1998b, *Response to the Surplus Plutonium Disposition Environmental Impact Statement Data Call for a Mixed Oxide Fuel Fabrication Facility Located at the Hanford Site*, rev. 3, LA-UR-97-2064, Los Alamos National Laboratory, Los Alamos, NM, June 22.

UC (Regents of the University of California), 1998c, *Pit Disassembly and Conversion Facility, Environmental Impact Statement Data Report—Idaho National Engineering and Environmental Laboratory*, LA-UR-97-2908, Los Alamos National Laboratory, Los Alamos, NM, June 1.

UC (Regents of the University of California), 1998d, *Response to the Surplus Plutonium Disposition Environmental Impact Statement Data Call for a Mixed Oxide Fuel Fabrication Facility Located at the Idaho National Engineering and Environmental Laboratory*, rev. 3, LA-UR-97-2065, Los Alamos National Laboratory, Los Alamos, NM, June 1.

UC (Regents of the University of California), 1998e, *Pit Disassembly and Conversion Facility, Environmental Impact Statement Data Report—Pantex Plant*, LA-UR-97-2909, Los Alamos National Laboratory, Los Alamos, NM, June 1.

UC (Regents of the University of California), 1998f, *Response to the Surplus Plutonium Disposition Environmental Impact Statement Data Call for a Mixed Oxide Fuel Fabrication Facility Located at the Pantex Plant*, rev. 3, LA-UR-97-2067, Los Alamos National Laboratory, Los Alamos, NM, June 22.

UC (Regents of the University of California), 1998g, *Pit Disassembly and Conversion Facility, Environmental Impact Statement Data Report—Savannah River Site*, LA-UR-97-2910, Los Alamos National Laboratory, Los Alamos, NM, June 1.

UC (Regents of the University of California), 1998h, *Response to the Surplus Plutonium Disposition Environmental Impact Statement Data Call for a Mixed Oxide Fuel Fabrication Facility Located at the Savannah River Site*, rev. 3, LA-UR-97-2066, Los Alamos National Laboratory, Los Alamos, NM, June 22.

[Text deleted.]

UC (Regents of the University of California), 1999a, *Fissile Materials Disposition Program, EIS Data Call Report: Plutonium Immobilization Plant Using Ceramic in Existing Facilities at Hanford*, rev. 1, UCRL-ID-128275, Lawrence Livermore National Laboratory, Livermore, CA, September.

UC (Regents of the University of California), 1999b, *Fissile Materials Disposition Program, EIS Data Call Report: Plutonium Immobilization Plant Using Glass in Existing Facilities at Hanford*, rev. 1, UCRL-ID-128276, Lawrence Livermore National Laboratory, Livermore, CA, September.

UC (Regents of the University of California), 1999c, *Fissile Materials Disposition Program, EIS Data Call Report: Plutonium Immobilization Plant Using Ceramic in New Facilities at the Savannah River Site*, rev. 1, UCRL-ID-128273, Lawrence Livermore National Laboratory, Livermore, CA, September.

UC (Regents of the University of California), 1999d, *Fissile Materials Disposition Program, EIS Data Call Report: Plutonium Immobilization Plant Using Glass in New Facilities at the Savannah River Site*, rev. 1, UCRL-ID-128271, Lawrence Livermore National Laboratory, Livermore, CA, September.

Appendix K

Facility Accidents

K.1 IMPACT ASSESSMENT METHODS FOR FACILITY ACCIDENTS

K.1.1 Introduction

The potential for facility accidents and the magnitude of their consequences are important factors for making reasonable choices among the various surplus plutonium disposition alternatives analyzed in the *Surplus Plutonium Disposition Environmental Impact Statement* (SPD EIS). Guidance on the implementation of 40 CFR 1502.22, as amended (EPA 1992), requires the evaluation of impacts that have a low frequency of occurrence but high consequences. Further, public comments received during the scoping process have clearly indicated the public's concern with facility safety and health risks and the need to address these concerns in the decisionmaking process.

For the No Action Alternative, potential accidents are defined in existing facility documentation, such as safety analysis reports (SARs), hazards assessment documents, National Environmental Policy Act (NEPA) documents, and probabilistic risk assessments (PRAs). The accidents include radiological and chemical accidents that have a low frequency of occurrence but high consequences, and a spectrum of other accidents that have a higher frequency of occurrence and lesser consequences. The data in these documents include accident scenarios, materials at risk, source terms (quantities of hazardous materials released to the environment), and consequences.

For each facility, a hazards analysis document identifying and estimating the effects of all major hazards that could affect the environment, workers, and the public would be issued in conjunction with the conceptual design package. Additional accident analyses for identified major hazards would be provided in a preliminary SAR issued during the period of definitive design (Title II) review. A final SAR would be prepared during the construction period and issued before testing began as final documented evidence that the new facility could be operated in a manner that did not pose any undue risk to the health and safety of workers and the public.

In determining the potential for facility accidents and the magnitude of their consequences, the SPD EIS considers two important concepts in the presentation of results: (1) risk and (2) uncertainties and conservatism.

K.1.1.1 Risk

One type of metric that can be obtained from the accident analysis results presented in the SPD EIS is accident risk. Risk is usually defined as the product of the consequences and estimated frequency of a given accident. Accident consequences may be presented in terms of dose (e.g., person-rem) or health effects (e.g., latent cancer fatalities [LCFs]). The accident frequency is the number of times the accident is expected to occur over a given period of time (e.g., per year). In general, the frequency of design basis and beyond-design-basis accidents is much lower than 1 per year, and therefore is approximately equal to the probability of the accident during 1 year. If an accident is expected to occur once every 1,000 years (i.e., a frequency of 1.0×10^{-3} per year) and the consequences of the accident is five LCFs, then the risk is $1.0 \times 10^{-3} \times 5 = 5.0 \times 10^{-3}$ LCF per year.

A number of specific types of risk can be directly calculated from the Melcor Accident Consequence Code System (MACCS2) results reported in the SPD EIS (SNL 1997). One type of risk, average individual risk, is the product of the total consequences experienced by the population and the accident frequency, divided by the population.¹ For example, if an accident has a frequency of 1.0×10^{-3} per year, the consequence thereof is 5 LCFs, and the

¹ Population data for each facility considered in the SPD EIS can be found in Appendix J.

population in which the fatalities are experienced is 100,000, then the average individual risk is $1.0 \times 10^{-3} \times 5/100,000 = 5.0 \times 10^{-8}$ LCF per year. This metric is meaningful only when the mean value for consequence is used because risk itself is not a random parameter, even though it involves underlying randomness. It is noteworthy that the value of the average individual risk depends on the size of the area for which the population is defined. In general, the larger the area considered, the smaller the average individual risk for a given accident. The choice of an 80-km (50-mi) radius is common practice.

The average individual risk is a measure of the risk that an average individual (in this case within 80 km [50 mi] of the accident) experiences from specified accidents at the facility. This risk can be compared with other average individual risks, such as the risk of dying from a motor vehicle accident (about 1 in 80), the risk of death from fires (about 1 in 500), or the risk of accidental poisoning (about 1 in 1,000). These comparisons are not meant to imply that risks of an LCF caused by U.S. Department of Energy (DOE) operations are trivial, but only to show how they compare with other, more common risks. Radiological risks to the general public from DOE operations are considered to be involuntary risks as opposed to voluntary risks, such as operating a motor vehicle.

It is also possible to calculate population risk, which is the product of the total consequences experienced by the population and accident frequency. For example, if an accident has a frequency of 1.0×10^{-3} per year and the consequences of the accident is 5 LCFs, then the population risk is $1.0 \times 10^{-3} \times 5 = 5.0 \times 10^{-3}$ LCF per year. Population risk is a measure of the expected number of consequences experienced by the population as a whole over the course of a year.

It would be inappropriate, however, to simply take the LCFs given the dose at 1,000 m (3,281 ft) or the LCFs given the dose at the site boundary and multiply them by the corresponding accident frequencies in an attempt to obtain the maximum individual risk to the noninvolved worker or the maximally exposed individual (MEI) member of the public. The reasons for this are discussed in the following paragraphs.

The distribution of centerline consequences from which the reported doses are obtained is constructed by modeling the accidental release many times using different weather conditions (i.e., windspeed, wind direction, stability class, and rainfall) each time. For each weather condition, the centerline consequences at 1,000 m (3,281 ft) and at the site boundary are calculated, and those values contribute to their respective distributions. Thus, given the accidental release, there is a 95 percent chance that the centerline consequences at 1,000 m (3,281 ft) and at the site boundary will fall below the reported 95th percentile consequences, and the expected consequences would be equal to the reported mean consequences. It is noteworthy, however, that the actual locations of the centerline consequences vary with wind direction, so the reported consequences are not associated with a specific point at 1,000 m (3,281 ft) or the site boundary. It is known only that the centerline consequences, wherever they might be, are characterized by the reported values.

A problem arises when these consequences are used to characterize individual risk. Although there is always some location that is exposed to the centerline consequences, no location is associated with the risk obtained by multiplying the centerline consequences by the accident frequency, because the direction of the plume centerline changes for each set of weather conditions. As a result, the risk to an individual at the location of maximum risk is likely to be much lower than the risk calculated by multiplying the centerline consequences by the accident frequency. In fact, because there are 16 sectors, and because doses decrease with lateral movement away from the centerline even within a sector, risk values generated in this way would tend to overstate the risk by a factor of as much as 100, and possibly more. The values are bounding, but have a potentially misleading degree of conservatism. Ultimately, MACCS2 is capable of calculating individual consequences at the point of maximum consequence (as reported in the SPD EIS), but it is not configured to calculate individual risk at the point of maximum risk.

K.1.1.2 Uncertainties and Conservatism

The analyses of accidents are based on calculations relevant to hypothetical sequences of events and models of their effects. The models provide estimates of the frequencies, source terms, pathways for dispersion, exposures, and the effects on human health and the environment that are as realistic as possible within the scope of the analysis. In many cases, a paucity of experience with the accidents postulated leads to uncertainty in the calculation of their consequences and frequencies. This fact has prompted the use of models or input values that yield conservative estimates of consequence and frequency. All alternatives have been evaluated using uniform methods and data, allowing for a fair comparison of all alternatives.

Although average individual and population risks can be calculated from the information in the SPD EIS, the equations for such calculations involve accident frequency, a parameter whose calculation is subject to considerable uncertainty. The uncertainty in estimates of the frequency of highly unlikely events can be several orders of magnitude. This is the reason accident frequencies are reported in the SPD EIS qualitatively, in terms of broad frequency bins, as opposed to numerically. Similarly, any metric that includes frequency as a factor will have at least as much, and generally more, uncertainty associated with it. Therefore, the consequence metrics have been preserved as the primary accident analysis results, and accident frequencies identified qualitatively, to provide a perspective on risk that does not imply an unjustified level of precision.

K.1.2 Safety Design Process

The proposed surplus plutonium disposition facilities would be designed to comply with current Federal, State, and local laws, DOE orders, and industrial codes and standards. This would result in a plant that is highly resistant to the effects of natural phenomena, including earthquake, flood, tornado, and high wind, as well as credible events as appropriate to the site, such as fire, explosions, and man-made threats.

The design process for the proposed facilities would comply with the requirements for safety analysis and evaluation in DOE Orders 430.1 and 5480.23. These orders require that the safety assessment be an integral part of the design process to ensure compliance with all DOE construction and operation safety criteria by the time the facilities are constructed and in operation.

The safety analysis process begins early in conceptual design with the identification of hazards that could produce unintended adverse safety consequences to workers or the public. As the design develops, failure modes and effects analyses (FMEAs) are performed to identify events capable of releasing hazardous material. The kinds of events considered include equipment failures, spills, human errors, fires, explosions, criticality, earthquakes, electrical storms, tornadoes, floods, and aircraft crashes. These postulated events become focal points for design changes or improvements to prevent unacceptable accidents. The analyses continue as the design progresses, the object being to assess the need for safety equipment and the performance of such equipment. Eventually, the safety analyses are formally documented in a SAR and, if appropriate, a PRA. The PRA documents the estimated frequency and consequences of a complete spectrum of accidents and helps to identify where design improvements could make meaningful safety improvements.

The first SAR, completed at the conclusion of conceptual design, includes identification of hazards and some limited assessment of a few enveloping design basis accidents. It includes deterministic safety analysis and FMEA of major systems. A comprehensive preliminary SAR, completed by the end of the preliminary design, provides a broad assessment of the range of design basis accident scenarios and the performance of equipment provided in the facility specifically for accident consequence mitigation. A limited PRA may be included in that analysis.

The SAR continues to be developed during detailed design. The safety review of the report and any supporting PRA are completed and safety issues resolved before the initiation of facility construction. Also, a final SAR is produced that includes documentation of safety-related design changes made during construction and the impact of those changes on the safety assessment. It also includes the results of any safety-related research and development that was performed to support the safety assessment of the facility. Approval of the final SAR is required before the facility is allowed to commence operation.

K.1.3 DOE Facility Accident Identification and Quantification

K.1.3.1 Background

Identification of accident scenarios for the proposed facilities is fairly straightforward. The proposed facilities are simple, and their processes have been used in other facilities for other purposes. From an accident identification and quantification perspective, therefore, these processes are well known and understood. Very few of the proposed activities would differ from activities at other facilities.

New facilities would likely be designed, constructed, and operated to provide an even lower accident risk than other facilities that have used these types of processes. The new facilities would benefit from lessons learned in the operation of similar processes. They would be designed to surpass existing plutonium facilities in the ability to reduce the frequency of accidents and to mitigate the consequences thereof.

A large experience base exists for the design of the proposed facilities and processes. Because the principal hazard to workers and the public from plutonium is the inhalation of very small particles, the safety management approach that has evolved is centered on control of those particles. The control approach is to perform all operations that could release airborne plutonium particles in a glovebox. The glovebox protects workers from inhalation of the particles and provides a convenient means for the collection of any particle that becomes airborne on filters. Air from the gloveboxes, operating areas, and buildings is exhausted through multiple stages of high-efficiency particulate air (HEPA) filters and monitored for radioactivity prior to release from the building. These exhaust systems are designed for effective performance even under the severe conditions of design basis accidents, such as major fires involving an entire process line.

While the new processes and facilities would be designed to reduce the risks of a wide range of possible accidents to a level deemed acceptable, some such risks would remain. As with all engineered structures—e.g., houses, bridges, dams—there is some level of earthquake or high wind the structure could not survive. While new plutonium facilities must be designed to very high standards—for instance, they must survive, with little plutonium release, a 1-in-10,000-year earthquake—an accident more severe than the design basis can always be postulated. Current DOE standards require that new facilities be designed to prevent to the extent possible, and then withstand, control, and mitigate, all credible process-related accidents. For safety analysis purposes, credible accidents are generally defined as accidents with frequencies greater than 1 in 1 million per year, including such natural-phenomena-induced accidents as earthquakes, high winds, and flooding. The accidents considered in the design, construction, and operation of these facilities are generally called design basis accidents.

In addition to the accident risks from the design basis accidents, the new facilities would face risks from beyond-design-basis accidents. For most plutonium facilities, the design basis includes all types of process-related accidents that have occurred in past operations: major spills, leaks, transfer errors, process-related fires, explosions, and nuclear criticalities. Certain natural-phenomena-initiated accidents also meet the DOE design basis criteria. While extremely unlikely, all new plutonium facilities, as essentially all manmade structures, could collapse under the influence of an earthquake. For most new plutonium facilities, the worst possible accident is a beyond-design-basis earthquake that results in partial or total collapse of the structure, spills, possibly fires, and loss of confinement of the plutonium powder. Also conceivable are such external events

as the crash of a large aircraft onto the structure with an ensuing fuel-fed fire. At most locations away from major airports, however, the likelihood is less than 1 in 10 million per year. For some locations, such as Pantex, the frequency is higher, so aircraft crash-initiated accidents are a basic consideration.

The accident analysis reported in the SPD EIS is less detailed than a formal PRA or facility safety analysis because it addresses bounding accidents (accidents with low frequency of occurrence and high consequence) and a representative spectrum of possible operational accidents (accidents with high frequency of occurrence and low consequence). The technical approach for the selection of accidents is consistent with the DOE Office of NEPA Oversight's *Recommendations for the Preparation of Environmental Assessments and Environmental Impact Statements* (DOE 1993), which recommends consideration of two major categories of accidents: design basis accidents and beyond-design-basis accidents.²

K.1.3.2 Identification of Accident Scenarios and Frequencies

A range of design basis and beyond-design-basis accident scenarios have been identified for each of the surplus plutonium disposition technologies (UC 1998a–h, 1999a–d). For each technology, the wide range of process-related accidents possible during construction and operation of the facility have been evaluated to ensure that their consequences are low or the frequency of occurrence, extremely low.

All of the analyzed accidents would involve a release of small, respirable plutonium particles or direct gamma and neutron radiation, and to a lesser extent, fission products from a nuclear criticality. Analyses of each proposed operation for accidents involving hazardous chemicals are reflected in the data reports supporting the SPD EIS. However, as the quantities of hazardous chemicals to be handled are small relative to those of many industrial facilities, no major chemical accidents were identified. The general categories of process-related accidents considered include:

- Drops or spills of materials within and outside the gloveboxes
- Fires involving process equipment or materials, and room or building fires
- Explosions initiated by the process equipment or materials or by conditions or events external to the process
- Nuclear criticalities

The analyses considered synergistic effects and determined that the only significant source of such effects would be a seismic event (i.e., a design basis seismic event or a seismically induced total collapse). The synergy would be due to the common-cause initiator (i.e., seismic ground motion). This was accounted for by summing population doses and LCFs for alternatives in which facilities would be located at the same site. MEI doses were not summed because an individual would only receive a summed dose if he or she were located along the line connecting the release points from two facilities and the wind were blowing along the same line at the time of the accident.

For each of these accident categories, a conservative preliminary assessment of consequence was made, and where consequences were significant, one or more bounding accident scenarios were postulated. The building confinement and fire suppression systems would be adequate to reduce the risks of most spills and minor fires. The systems would be designed to prevent, to the extent practicable, larger fires and explosions. Great efforts have always been made to prevent nuclear criticalities, which have the potential to kill workers in their immediate

² Some of the data reports supporting the SPD EIS use the terms “evaluation basis” and “beyond-evaluation-basis” to denote the two major categories of accidents. For clarity, the SPD EIS uses the terms “design basis” and “beyond-design-basis” throughout.

vicinity. In all cases, standard practice is expected to keep the frequency of accidental nuclear criticalities as low as possible.

The proposed surplus plutonium disposition facilities would be expected to meet or exceed the requirements of DOE Order 420.1, *Facility Safety*, and *Natural Phenomena Hazards Design and Evaluation Criteria for Department of Energy Facilities* (DOE-STD-1020-94) (DOE 1994a), or the requirements of 10 CFR 70, *Domestic Licensing of Special Nuclear Material*, if the proposed facility were to be licensed by the U.S. Nuclear Regulatory Commission (NRC). Because the DOE and, if applicable, NRC design criteria require that new plutonium-processing buildings be of very robust, reinforced-concrete construction, very few events outside the building would have sufficient energy to threaten the building confinement. The principal concern would be the crash of a large commercial or military aircraft into the facility. Such an event, however, is highly unlikely. Only those crashes with a frequency greater than 10^{-7} per year are addressed in the SPD EIS.

Design basis and beyond-design-basis natural-phenomena-initiated accidents are also considered. Because of the robust nature of construction of new plutonium facilities, the only design basis natural-phenomena-initiated accidents with the potential to impact the facility interior are seismic events. Similarly, seismic events also bound the consequences and risks posed by beyond-design-basis natural phenomena.

The suite of generic accidents in the *Storage and Disposition PEIS* (DOE 1996a) was considered in the analysis of accidents for the SPD EIS. However, the more detailed design information in the surplus plutonium disposition data reports was the primary basis for the identification of accidents because it most accurately represents the expected facility configuration. The fire on the loading dock and the oxyacetylene explosion in a process cell were unsupported by this information, so were not included in the SPD EIS.

Accident frequencies are generally grouped into the bins of “anticipated,” “unlikely,” and “extremely unlikely,” with estimated frequencies of greater than 10^{-2} , 10^{-2} to 10^{-4} , and 10^{-4} to 10^{-6} per year, respectively. The accidents evaluated represent a spectrum of accident frequencies and consequences ranging from low-frequency/high-consequence to high-frequency/low-consequence events. However, given the preliminary nature of the designs under consideration, it was not possible to assess quantitatively the frequency of occurrence of all the events addressed. The evaluation does not indicate the total risk of operating the facility, but does provide information on high-risk events that could be used to develop an accident risk ranking of the various alternatives.

K.1.3.3 Identification of Material at Risk

For each accident scenario, the material at risk—generally plutonium—was identified. Plutonium to be disposed of has a wide range of chemical and isotopic forms. The sources of plutonium vary among the various candidate facilities, and for specific facilities among various alternatives. Table K-1 presents the isotopic compositions that were used in the development of accident consequences in the SPD EIS. The vulnerability of material generally depends on the form of that material, the degree and robustness of containment, and the energetics of the potential accident scenario (UC 1998a:table 6-6; 1998c:tables 9-2 and A-7; 1998d:table B-1). For example, plutonium stored in strong, tight storage containers is not generally vulnerable to simple drops or spills, but may be vulnerable in a total collapse earthquake scenario.

Table K-1. Isotopic Composition of Plutonium Used in Accident Analysis (wt %)

Isotope	Pit Disassembly and MOX	Immobilization: Plutonium Conversion	Immobilization: First Stage, Hybrid Case	Immobilization: First Stage, 50-t Case
Plutonium 238	3.00×10^{-2}	0.0	0.0	2.0×10^{-2}
Plutonium 239	92.2	86.9	86.9	91.0
Plutonium 240	6.46	11.1	11.1	8.2
Plutonium 241	5.00×10^{-2}	1.5	1.5	5.80×10^{-1}
Plutonium 242	1.00×10^{-1}	5.0×10^{-1}	5.0×10^{-1}	2.50×10^{-1}
Americium 241	9.00×10^{-1}	1.0	1.0	9.4×10^{-1}

On an industrial scale, the quantities of hazardous chemicals are generally small. The occupational risks are generally limited to material handling and are managed under the required industrial hygiene program. No substantial hazardous chemical releases are expected.

K.1.3.4 Identification of Material Potentially Released to the Environment

The amount and particle size distribution of material aerosolized in an accident generally depends on the form of that material, the degree and robustness of containment, and the energetics of the potential accident scenario. Once the material is aerosolized, it must still travel through building confinement and filtration systems or bypass the systems before being released to the environment.

A standard DOE formula was used to estimate the source term for each accident at each of the proposed surplus plutonium facilities:

$$\text{Source Term} = \text{MAR} \times \text{DR} \times \text{ARF} \times \text{RF} \times \text{LPF}$$

where:

- MAR = material at risk (curies or grams)
- DR = damage ratio
- ARF = airborne release fraction
- RF = respirable fraction³
- LPF = leak path factor

The value of each of these factors depends on the details of the specific accident scenario postulated. ARF and RF were estimated according to reference material in *Airborne Release Fractions/Rates and Respirable Fractions for Nonreactor Nuclear Facilities* (DOE-HDBK-3010-94) (DOE 1994b). Conservative HEPA filter efficiencies of 0.999 and 0.99 were assumed, based on two stages of filtration, for a total LPF of 1.0×10^{-5} ; however, actual efficiencies would likely be 0.999 and 0.998 or better. [Text deleted.]

No accident scenarios were identified that would result in a substantial release of plutonium or other radionuclides via liquid pathways.

³ Respirable fractions are not applied in the assessment of doses based on noninhalation pathways, such as criticality.

K.1.4 Evaluation of Consequences of Accidents

K.1.4.1 Potential Receptors

For each potential accident, information is provided on accident consequences and frequencies to three types of receptors: (1) a noninvolved worker, (2) the maximally exposed member of the public, and (3) the offsite population. The first receptor, a noninvolved worker, is a hypothetical individual working on the site but not involved in the proposed activity. The worker is assumed to be downwind at a point 1,000 m (3,281 ft) from the accident. Although other distances closer to the accident could have been assumed, the calculations break down at distances of about 200 m (656 ft) or less due to limitations in modeling the effects of building wake and local terrain on dispersion of the released radioactive substances. A worker closer than 1,000 m (3,281 ft) to the accident would generally receive a higher dose; a worker farther away, a lower dose. At some sites where the distance from the accident to the nearest site boundary is less than 1,000 m (3,281 ft), the worker is assumed to be at the site boundary. The second receptor, a maximally exposed member of the public, is a hypothetical individual assumed to be downwind at the site boundary. Exposures received by this individual are intended to represent the highest doses to a member of the public. The third receptor, the offsite population, is all members of the public within 80 km (50 mi) of the accident location.

Consequences to workers directly involved in the processes under consideration are addressed generically, without attempt at a scenario-specific quantification of consequences. This approach to in-facility consequences was selected for two reasons. First, the uncertainties involved in quantifying accident consequences become overwhelming for most radiological accidents due to the high sensitivity of dose values to assumptions about the details of the release and the location and behavior of the impacted worker. Also, the dominant accident risks to the worker of facility operations are from standard industrial accidents, as opposed to bounding radiological accidents. The accident fatality risk for DOE has been reported as 2.7×10^{-5} per person per year (DOE 1999a). According to historical data on standard industrial accidents, the national average fatality risk from manufacturing operations is 3.5×10^{-5} per person per year (DOL 1997).

Consequences for potential receptors as a result of plume passage were determined without regard for emergency response measures, and thus are more conservative than would be expected if evacuation and sheltering were explicitly modeled. Instead, it is assumed that potential receptors are fully exposed in fixed positions for the duration of plume passage, thereby maximizing their exposure to the plume. As discussed in Appendix K.1.4.2, a conservative estimate of total risk was obtained by assuming that all released radionuclides contributed to the inhalation dose rather than being removed from the plume by surface deposition, which is a less significant contributor to overall risk and is controllable through interdiction.

K.1.4.2 Modeling of Dispersion of Releases to the Environment

The MACCS2 computer code (version 1.12) was used to estimate the consequences of accidents for the proposed facilities. A detailed description of the MACCS2 model is available in NUREG/CR-4691 (NRC 1990). Originally developed to model the radiological consequences of nuclear reactor accidents, this code has been used for the analysis of accidents for many EISs and other safety documentation, and is considered applicable to the analysis of accidents associated with the disposition of plutonium.

MACCS2 models the offsite consequences of an accident that releases a plume of radioactive materials into the atmosphere, specifically, the degree of dispersion versus distance as a function of historical wind direction, speed, and atmospheric conditions. Were such an accidental release to occur, the radioactive gases and aerosols in the plume would be transported by the prevailing wind and dispersed in the atmosphere, and the population would be exposed to radiation. MACCS2 generates the distribution of downwind doses at specified distances, as well as the distribution of population doses out to 80 km (50 mi).

As implemented, the MACCS2 model evaluates doses due to inhalation of aerosols, such as respirable plutonium, as well as exposure to the passing plume. This represents the major portion of the dose that a noninvolved worker or member of the public would receive as a result of a plutonium disposition facility accident. The longer-term effects of plutonium deposited on the ground and surface waters after the accident, including the resuspension and inhalation of plutonium and the ingestion of contaminated crops, were not modeled for the SPD EIS. These pathways have been studied and been found not to contribute as significantly to dosage as inhalation, and they are controllable through interdiction. Instead, the deposition velocity of the radioactive material was set to zero, so that material that might otherwise be deposited on surfaces remained airborne and available for inhalation. This adds a conservatism to inhalation doses that can become considerable at large distances (as much as two orders of magnitude at the 80-km [50-mi] limit). Thus, the method used in the SPD EIS is conservative compared with dose results that would be obtained if deposition and resuspension were taken into account.

Longer-term effects of fission products released in a nuclear criticality accident have been extensively studied. The principal concern is ingestion of iodine 131 via milk that becomes contaminated due to the ingestion of contaminated grains by milk cows. This pathway can be controlled if necessary. In terms of the effects of an accidental criticality, doses from this pathway are small.

The potential for tritium contamination of the Ogallala aquifer as a consequence of an accident at Pantex involving tritium was identified as a specific concern during the development of the SPD EIS. The assessment of consequences of accidental tritium releases in the SPD EIS is consistent with the method used in the *Final Programmatic Environmental Impact Statement for Tritium Supply and Recycling* (DOE 1995a). Unlike plutonium, oxidized tritium (i.e., water vapor) is not significantly deposited on the ground for subsequent percolation into the local groundwater except under conditions of rain or dew. Pantex has a rather arid climate, so the chance of these weather conditions at the time of an accident is slight. Moreover, even if it were to happen as indicated in Section 4.6.1.2 of the *Final Environmental Impact Statement for the Continued Operation of the Pantex Plant and Associated Storage of Nuclear Weapon Components* (DOE 1996b), actual movement of contaminated groundwater off the site would require about 10 to 20 years. In fact, current test data show that it could take as long as 50 or more years for a contaminant plume to move off the site. The half-life of tritium is 12 years; therefore, any hypothetical contamination deposited on the ground surface and carried into the groundwater regime would be reduced by a factor of roughly 2 to 16 by the time it moved off the site. Because of these considerations, health consequences of contamination of the Ogallala aquifer were not considered to be a significant contributor to health risks from a tritium release accident.

The region around the facility is divided by a polar-coordinate grid centered on the facility itself. The user specifies the number of radial divisions and their endpoint distances. The angular divisions used to define the spatial grid correspond to the 16 directions of the compass.

MACCS2 was applied in a probabilistic manner using a weather bin–sampling technique. Centerline doses, as a function of distance, were calculated for each of 1,460 meteorological sequence samples, resulting in a distribution of doses reflecting variations in weather conditions at the time of the postulated accidental release. The code outputs the conditional probability of exceeding a dose as a function of distance. The mean and 95th percentile consequences are reported in the SPD EIS. Doses higher than the 95th percentile values would be expected only 5 percent of the time.

MACCS2 cannot be used to calculate directly the distribution of maximum doses (resulting from meteorological variations) around irregular contours, such as a site boundary. As a result, analyses that use MACCS2 to calculate site boundary doses usually default to calculating doses at the distance corresponding to the shortest distance to the site boundary. In effect, the site boundary is treated as if it were circular, with a radius equal to the shortest distance from the facility to the actual site boundary. While this approximation is conservative with respect to dose (with the possible exception of doses from elevated plumes), it eliminates the use of some

site-specific information, namely the site boundary location (other than the nearest point), wind direction, and any correlation between wind direction and other meteorological parameters. Because the primary purpose of the SPD EIS is to aid in decisions about facility locations, and because differences in dose values among the various options are largely a function of site-specific variations, a different approach was taken to more accurately characterize the potential for maximum doses at the site boundary.

For the SPD EIS, MACCS2 was used to generate intermediate results that could be further processed to obtain the distribution of doses around the site boundary, accounting for variations in site boundary distance as a function of direction. The specific instrument was the Type B result option of MACCS2, which renders the distribution of doses at a specified radial distance within a specified compass sector, given a release. Type B results were requested for the site boundary distance for each of the 16 compass sectors over which the meteorological data is defined. This resulted in 16 separate dose distributions; one for each specific location around the site boundary. The distribution of maximum doses around the site boundary was constructed by first summing the values of the Type B distributions for each dose value. The resulting distribution was then truncated for low dose values to the point where the remainder of the distribution was normalized. This produced the distribution of maximum doses around the site boundary, which is the distribution from which the mean and 95th percentile doses are reported.

Radiological consequences may vary somewhat as a result of variations in the duration of release. For longer releases, there is a greater chance of plume meander (i.e., variations in wind direction over the duration of release). MACCS2 models plume meander by increasing the lateral dispersion coefficient of the plume for longer release durations, thus lowering the dose. For perspective, doses from an homogenous, 1-hr release would be 30 percent lower than those of a 10-min release as a result of plume meander; doses from a 2-hr release, 46 percent lower. The other effect of longer release durations is involvement of a greater variety of meteorological conditions in a given release, which reduces the variance of the resulting dose distributions. This would tend to lower high-percentile doses, raise low-percentile doses, and have no effect on the mean dose.

For the SPD EIS accident analysis, a duration of 10 min was assumed for all releases. This is consistent with the accident phenomenology expected for all scenarios, with the possible exception of fire. Depending on the circumstances, the time between fire ignition and extinction may be considerably longer, particularly for the larger, beyond-design-basis fires. However, even in a fire of long duration, it is possible to release substantial fractions of the total radiological source term in fairly short periods, as the fire consumes areas of high MAR concentrations. The assumption of a 10-min release duration for fire is intended to generically account for this circumstance.

K.1.4.3 Modeling of Consequences of Releases to the Environment

The mean and 95th percentile consequences of accidental radiological releases, given variations in meteorological conditions at the time of the accident, are calculated as radiological doses in terms of rem. The mean consequences, or the expected consequences of the accident, are an appropriate statistic for use in risk estimates. The 95th percentile consequences represent bounding consequences of the accident; that is, if the accident were to occur and release the stated source term, there would be a 95 percent probability of lower than the stated consequences. This statistic is thus useful for characterizing the bounding consequence potential of the proposed activity under the stated accident condition. The consequences are also expressed as the additional potential or likelihood of death from cancer for the noninvolved worker and the maximally exposed member of the public, and the expected number of incremental LCFs among the exposed population.

The probability coefficients for determining the likelihood of fatal cancer, given a dose, are taken from the *1990 Recommendations of the International Commission on Radiological Protection* (ICRP 1991). For low doses or low dose rates, respective probability coefficients of 4.0×10^{-4} and 5.0×10^{-4} fatal cancers per rem are applied

for workers and the general public.⁴ For high doses received at a high rate, respective probability coefficients of 8.0×10^{-4} and 1.0×10^{-3} fatal cancers per rem are applied for noninvolved workers and the public. These higher probability coefficients apply where doses are above 20 rem and dose rates above 10 rem/hr.

K.1.5 Accident Scenarios for Surplus Plutonium Disposition Facilities

Bounding design basis and beyond-design-basis accident scenarios have been developed from accident scenarios presented in each of the surplus plutonium disposition data reports (UC 1998a–h, 1999a–d). These scenarios are discussed in detail, along with specific assumptions for each facility and site, in these documents.

K.1.5.1 Accident Scenario Consistency

In preparing the accident analysis for the SPD EIS, the primary objective was to ensure consistency between the data reports so that results of the analyses for the proposed surplus plutonium disposition alternatives could be compared on as equal a footing as possible. In spite of efforts by all parties, some inconsistencies exist between the data reports. This does not imply technical inaccuracy in any analysis; it merely reflects the uncertainties and reliance on convention that are inherent in accident analyses in general. In order to provide a consistent analytical basis, information in the data reports has been modified or augmented as described below.

Aircraft Crash. It was decided early in the process of developing accident scenarios that aircraft crash scenarios would not be provided in the data reports, but would be developed, as appropriate, directly for the SPD EIS.

Frequencies of an aircraft crash into each facility for each alternative were developed in accordance with DOE-STD-3014 (DOE 1996c). The frequency of crashes involving aircraft capable of penetrating the subject facility (assumed to be all aircraft except those in general aviation) would be below 1.0×10^{-7} per year for all facilities except those at Pantex. For facilities at Pantex, the frequency of impact would be 1.7×10^{-6} per year.

Of the variety of impact conditions accounted for in the above frequency values (e.g., impact angle, direction, lateral distance from building center, speed) only a fraction would have the potential to produce consequences comparable to those reported in the SPD EIS, while other impacts (grazing impacts, impacts into office areas, etc.) would not result in significant radiological impacts. [Text deleted.] Aircraft crashes at Pantex with the potential for significant consequences could occur more frequently than 1.0×10^{-7} per year, so these scenarios were analyzed further.

For the facilities at Pantex, the potential for an aircraft crash into vaults containing large quantities of plutonium powder was examined in relation to the potential for a crash into the facility as a whole. For the pit conversion and mixed oxide (MOX) facilities, the footprint of the vault would be considerably less than one-tenth that of the facility as a whole, indicating that vault impact frequencies would be on the order of, and perhaps less than, one-tenth the facility impact frequencies. Moreover, fewer types of aircraft would have the potential to penetrate the vault due to the robustness of the reinforced-concrete vault structures and their location in the basements of the facilities. Inside the vault, the storage containers would provide additional protection against the release of material. The protection provided by the vault structure and the storage containers can be regarded as conducive to a further reduction in the frequency of aircraft crashes into vault areas.

In response to public concern over the risk of an aircraft crash at Pantex, and consistent with a Memorandum of Understanding between the DOE Amarillo Area Office and the Federal Aviation Administration (FAA), an

⁴ Probability coefficients for the likelihood of nonfatal cancer are 8.0×10^{-5} for adult workers and 1.0×10^{-4} for the public. The probability coefficients for severe hereditary effects are 8.0×10^{-5} for adult workers and 1.3×10^{-4} for the public.

Overflight Working Group was established. This working group provided a number of recommendations for reducing the risk of an aircraft crash into any facility at Pantex. DOE supplemented the Memorandum of Understanding with an Interagency Agreement with the FAA. These actions resulted in the following recommendations:

- Modifying the vectoring of approaching aircraft to preclude extended flying over plant boundaries and reducing the number of aircraft turning on final approach over the plant
- Modifying holding patterns so that they are away from the plant
- Developing a new global positioning satellite (GPS), nonprecision approach to runway 22
- Replacing the backcourse localizer approach to runway 22 with an offset localizer approach
- Upgrading the lighting system for the approach to runway 4
- Establishing a hotline between the FAA and DOE
- Establishing new very high frequency omnidirection radio tactical (VORTAC) air navigation device locations
- Installing a GPS ground differential station, and commissioning a new GPS precision approach to runway 22

As of this date, all the recommendations except the last two have been implemented. The recommendation to install a precision approach is on hold until the FAA develops the standards for the augmentation system. While these changes cannot be quantitatively reflected in the frequency of aircraft crash as calculated by DOE-STD-3014, the improvements have been acknowledged as representing a reduction in the exposure of Pantex to aircraft, which translates to a reduction in the aircraft crash frequency at that site.

As a result of these considerations, it was qualitatively estimated that the overall scenario frequency of an aircraft crash into a plutonium powder vault associated with either the pit conversion or MOX facility was below the threshold frequency of 1.0×10^{-7} per year. Additionally, it was qualitatively estimated that in light of these considerations, the overall frequency of aircraft impact into the pit conversion or MOX facility at Pantex was below 1×10^{-6} per year, or “beyond extremely unlikely.” The development of consequences of an aircraft crash was therefore refocused on the MAR that could be in process areas at the time of the crash. To develop representative consequences, it was assumed that the aircraft impact would involve the process area containing the largest amount of material in the most dispersible form. For the MOX facility, the impact was assumed to involve the unloading vessel and hopper storage, powder-blending process, and MOX powder storage areas. These processes would contain the bulk of process plutonium in powder form. The total quantity of plutonium in powder form would be 1.8×10^5 g (6.3×10^3 oz) (UC 1998d:table B-13), assuming that one-third of the plutonium in MOX powder storage was in powder form, one-third in green pellet form, and one-third in the form of sintered pellets. However, given the potentially high-energy densities associated with an aircraft crash, it was assumed that the green pellets would be equally vulnerable to release as powder, for a total effective powder quantity of 3.5×10^5 g (1.2×10^4 oz). For the pit conversion facility, the impact was assumed to involve the bisector, blending, canning, nondestructive analysis, and temporary storage areas, for a total of 6.0×10^4 g (2.1×10^3 oz) (UC 1998a:table 7-3) of plutonium in powder form.

The initial effect of the impact would be to disperse the material in a manner consistent with DOE-HDBK-3010-94 values for debris impact in powder. For this phenomenon, DOE-HDBK-3010-94

recommends bounding ARF and RF values of 1.0×10^{-2} and 0.2 (DOE 1994a:4-10), respectively, resulting in an initial source term of 117 g (4.1 oz) for the pit conversion facility and 690 g (24 oz) for the MOX facility. An aircraft crash could also induce a fire capable of entraining additional material in a lofted plume. The ARF and RF values for thermal stress, 6.0×10^{-3} and 1.0×10^{-2} (DOE 1994a:4-7), respectively, would result in a 3 percent increase in the source term. This additional source term should not contribute significantly to the noninvolved worker dose or the MEI dose, given the trajectory of the plume. However, it would contribute to the population dose. For simplicity, the source term was included in the ground-level release, yielding a total plutonium release of 124 g (4.4 oz) for the pit conversion facility and 710 g (25 oz) for the MOX facility.

The same source terms would result from postulated aircraft crashes into the pit conversion and MOX facilities regardless of their location. As discussed above, inclusion of the consequence analysis for Pantex, but not for other sites such as SRS, was solely due to differences in accident frequency.

Criticality. All of the data reports provide technically defensible information on criticality, but the analytical assumptions vary among the reports. To assess the significance of the variations, MACCS2 runs were performed for each criticality source term. The resulting doses varied by a factor of about 15 for all criticalities except the natural phenomena hazard (NPH) vault criticality in the immobilization data report. Doses from this criticality were roughly 100 times larger than any other doses and were dominated by aerosolized plutonium from the vault.

For the SPD EIS, it was decided to discard the NPH vault criticality on the grounds that it is, at most, an improbable event that is conditional on the occurrence of a beyond-design-basis earthquake and does not represent the potential consequences of an isolated criticality. Beyond-design-basis earthquakes have been addressed via a total collapse scenario in all data reports, and the additional assumption of a criticality occurring in addition to the total collapse does not significantly increase doses beyond those resulting from the collapse itself.

Of the remaining criticalities, the criticality in the rotary splitter tumbler in the glass immobilization data report produced the highest doses, dominated by fission products as opposed to plutonium. The source term for this criticality is based on a fission yield from 1.0×10^{19} fissions in an oxide powder.

For the SPD EIS, it was decided to use this source term for criticality for all facilities, because all facilities would handle oxide powder in quantities sufficient for criticality. For the aqueous plutonium-polishing process at the MOX facility, a solution criticality of 10^{19} fissions was also postulated, which bounds the powder criticality due to the greater release potential of fission products from solution. The estimated frequency of extremely unlikely (i.e., 10^{-6} to 10^{-4} per year) reported in the immobilization data report was also used because it is the bounding estimate.

The criticality source term provided in the immobilization data report neglects some very short-lived isotopes that would be expected in a criticality, namely bromine 85, iodine 136, krypton 89 and 90, and xenon 137. Since the half-lives of these isotopes are all less than 4 min, they do not have a significant direct impact on radiological consequences. However, the daughters of some of the isotopes are themselves radioactive; in particular, krypton 89 decays to rubidium 89, which has a half-life of 15 min. The significance of the daughters for overall consequences has been assessed for Pantex, which is considered bounding because Pantex has the highest windspeeds and tends to carry the daughters the farthest for a given level of decay. As expected, the increase in dose is greatest for the noninvolved worker; approximately 25 percent higher for both the mean and 95th percentile. The dose increase decreases to 3 and 13 percent, respectively, for the mean and 95th percentile doses to the population within 80 km (50 mi). Dose increases at other sites are expected to be lower than corresponding increases at Pantex. Because these increases are small considering the great uncertainty inherent in the estimate of the total number of fissions, the source term in the immobilization data report remains a conservative estimate of the potential release from a criticality accident, and no modification of the source term has been made.

Design Basis Earthquake. Each data report presents an analysis of the design basis earthquake. The immobilization and MOX data reports provide source terms for that earthquake, while the pit conversion data reports indicate no release as a result of a design basis earthquake because the facility would be designed to withstand the event.

For the SPD EIS, a nonzero source term for pit conversion was generated by applying a building ventilation LPF of 1.0×10^{-5} , accounting for a HEPA filtered release, to the beyond-design-basis earthquake source term. It is recognized that this is a conservative procedure, in that the beyond-design-basis earthquake would release more material into the air within the building than a design basis earthquake. The combined ARF \times RF for powder under beyond-design-basis earthquake conditions has been assessed as three times that for design basis earthquake conditions, and the total amount of vulnerable material may be somewhat greater. (For perspective, it resulted in a ratio of design basis earthquake to beyond-design-basis earthquake source term values that is somewhat higher than the corresponding ratio for MOX fuel fabrication, but lower than for plutonium conversion and immobilization.)

Beyond-Design-Basis Earthquake. All of the proposed operations would be in either existing or new facilities that would be expected to meet or exceed the requirements of DOE O 420.1 (DOE 1995b) and DOE-STD-1020-94 for reducing the risks associated with natural phenomena hazards. The proposed facilities would be characterized as Performance Category 3 facilities. Such facilities would have to be designed or evaluated for a design basis earthquake with a mean annual exceedance probability of 5×10^{-4} , corresponding to a return period of 2,000 years. For sites such as Lawrence Livermore National Laboratory (LLNL), which are near tectonic plate boundaries, the requirements would include a mean annual seismic hazard exceedance probability of 1.0×10^{-3} , or a return period of 1,000 years.

The numerical seismic design requirements detailed in DOE-STD-1020-94 are structured such that there is assurance that specific performance goals are met. For plutonium facilities (Performance Category 3), the performance goal is that occupant safety, continued operation, and hazard confinement would be ensured for earthquakes with an annual probability exceeding approximately 1×10^{-4} . There is sufficient conservatism in the design of buildings and the structures, systems, and components important to safety that these goals should be met given that they are designed against earthquakes with an estimated mean annual probability of 5×10^{-4} .

| [Text deleted.]

By contrast, nonnuclear structures at these sites and the surrounding community would be constructed to the standards of the Uniform Building Code for that region. These peak acceleration values are 50 to 82 percent of the peak acceleration design requirements for plutonium facilities in the same area and correspond approximately to DOE Performance Category 1 facilities with 500-year return intervals. During major earthquakes, structures built to these Uniform Building Code requirements would be expected to suffer significantly more damage than reinforced-concrete structures designed for plutonium operations.

At sites far from tectonic plate boundaries, deterministic techniques such as those used by NRC in evaluating safe-shutdown earthquakes for the siting of nuclear reactors have also been used to determine the maximum seismic ground motion requirements for facility designs. These techniques involve estimating the ground acceleration at the proposed facility either by assuming the largest historical earthquake within the tectonic province or by assessing the maximum earthquake potential of the appropriate tectonic structure or capable fault closest to the facility. For NRC-licensed reactors, this technique resulted in safe-shutdown earthquakes with estimated return periods in the 1,000- to 100,000-year range (DOE 1994a:C-17).

All the existing facilities under consideration in the SPD EIS have had seismic evaluations demonstrating that they meet the seismic evaluation requirements for the design basis earthquake. Some facilities, such as

Building 332 at LLNL under consideration for preparation of the lead test assemblies, have had extensive evaluations of the ability of the structures, systems, and components important to safety to survive a range of seismic loadings. Evaluations reported in the *Final Environmental Impact Statement and Environmental Impact Report for Continued Operation of Lawrence Livermore National Laboratory and Sandia National Laboratories, Livermore* (DOE 1992) indicate that Building 332 would survive a postulated 0.8g earthquake and retain those features essential for the safe containment of radioactive materials. The estimated return interval for this level of ground accelerations is about 10,000 years. The facility was also examined for damage due to a 0.9g earthquake and found to be survivable (DOE 1992:app. D.5.2.1), albeit with some potential for loss of confinement due to equipment damage in safety systems (DOE 1992:table I-14).

The magnitude of potential earthquakes with return periods greater than 10,000 years is highly uncertain. For purposes of the SPD EIS, it was assumed that at all the candidate sites, earthquakes with return periods in the 100,000- to 10-million-year range might result in sufficient ground motion to cause major damage to even a modern, well-engineered and well-constructed plutonium facility. Therefore, in the absence of convincing evidence otherwise, a total collapse of the plutonium facilities was assumed to be scientifically credible and within the rule of reason for return intervals in this range.

Each data report presents an analysis of total collapse. The immobilization and MOX data reports are fairly consistent in their use of damage estimates and release fractions. They assume that material in storage containers in vault storage would be adequately protected from the scenario energetics, for a damage ratio of zero in the vault. They also assume powder ARF and RF values of 1.0×10^{-3} and 0.3 (UC 1998c:tables 8-14 and 8-15; 1998d:169), respectively. The pit conversion data reports assume a damage ratio of 50 percent for material held in storage containers, applies cumulative ARF and RF values of 2.7×10^{-3} to powder subject to seismic vibration, free-fall spill, and turbulent air currents; and also presents a resuspension source term (UC 1998a:79–81).

For the SPD EIS, the pit conversion source term was modified by adjusting the damage ratio in the vault from 0.5 to 0 based on the corresponding analyses in the immobilization and MOX data reports, and adjusting the ARF and RF values for powder to 1.0×10^{-3} and 0.3, respectively. The assumption of vault survival in the beyond-design-basis earthquake was based on the fact that the vaults would be designed with significantly more robustness than the balance of the proposed facilities. The requirements for the additional robustness of the vault derive from the desire for increased protection of vault contents against external events such as aircraft crash or proliferation concerns, as well as increased earthquake survivability. It is expected that the vaults would survive the most likely seismic events of sufficient magnitude to collapse the processing areas of the proposed facilities. While there may be even more intense seismic events capable of compromising the protection afforded by the vaults, such events are expected to be beyond extremely unlikely.

The value of 2.7×10^{-3} , used in the pit conversion data report, is based on seismic-induced collapse of large structures into loose bulk powder; this assumption is considered unnecessarily conservative given the expectation of containerized storage for the majority of the powder inventory at any given time. The resuspension source term was kept (and was not applied to either immobilization or MOX). Although worth noting, this difference between the data reports is not considered particularly significant, for the resuspension source term constitutes only 30 percent of the total.

The frequency for all beyond-design-basis earthquakes for all facilities is reported in the SPD EIS as extremely unlikely to beyond extremely unlikely (the pit conversion facility data report estimated a frequency of less than 1×10^{-6} per year.) They are reported as such because the uncertainties inherent in associating damage levels with earthquake frequencies become overwhelming below frequencies of about 1.0×10^{-5} per year.

Filtration Efficiency. The immobilization and MOX data reports use a building filtration efficiency of 1.0×10^{-5} for particulate releases (UC 1998c:8-3; 1998d:tables B-18–B-20). The pit conversion data report uses a building

filtration efficiency of 2.0×10^{-6} (UC 1998a:73). For consistency, the pit conversion source terms have been adjusted to reflect an LPF of 1.0×10^{-5} . This is reasonable because it is expected that the ventilation efficiencies of all HEPA-filtered buildings would be essentially the same.

Beyond-Design-Basis Fire. The MOX data report presents an analysis of a beyond-design-basis fire whose basis in terms of scenario definition was from the *Data Report for Plutonium Conversion Facility* (Smith, Wilkey, and Siebe 1996), which was produced for the *Storage and Disposition PEIS* (DOE 1996a). Neither the pit conversion nor the immobilization data reports contain analyses of a beyond-design-basis fire.

For the SPD EIS, beyond-design-basis fires were developed for pit conversion and immobilization by replacing the building filtration LPF with an LPF of 1.4 percent, in accordance with the beyond-design-basis scenario definition presented in the *Data Report for Plutonium Conversion Facility* (Smith, Wilkey, and Siebe 1996) and adapted for the MOX fuel fabrication analysis. (For perspective, it resulted in a ratio of design basis fire to beyond-design-basis fire source term values that are within a factor of 2 of the corresponding ratio for MOX fuel fabrication.)

It is understood that the LPF of 1.4 percent is based on a facility-specific analysis of the Plutonium Finishing Building (PF-4) in Technical Area 55 at LANL, and that an analysis of other facilities using the same phenomenological assumptions might yield somewhat different results. However, for the purpose of this analysis, and considering the degree of similarity expected between facilities as a result of required plutonium-handling practices, this value was used generically in the assessment of beyond-design-basis fire.

K.1.5.2 Facility Accident Scenarios

K.1.5.2.1 Pit Conversion Facility

A wide range of potential accident scenarios were considered for the pit conversion facility. These scenarios are considered in detail in the pit conversion facility data reports (UC 1998a, 1998c, 1998e, 1998f). The analysis assumes that the pit conversion facility is located in a new or upgraded existing building designed to withstand design basis natural phenomena hazards such as earthquakes, winds, tornadoes, and floods such that no unfiltered releases would be expected. Also, no site-specific accidents conducive to releases are identified. Therefore, the potential accident scenarios apply to all four candidate sites.

Analysis of the proposed process operations for the pit conversion facility identified the following broad categories of accidents: aircraft crash, criticality, design basis earthquake, beyond-design-basis earthquake, explosion, fire, leaks or spills, and tritium release. Basic characteristics of each of these postulated accidents are described below. Additional discussion of scenario development based on consistency concerns can be found in Appendix K.1.5.1.

Aircraft Crash. A crash of a large, heavy commercial or military aircraft directly into a reinforced-concrete facility could damage the structure sufficient to breach confinement and disperse material into the environment. A subsequent fuel-fed fire could provide energy to further damage structures and equipment, aerosolize material, and drive materials into the environment. Source terms are highly speculative but would be expected to exceed those from the beyond-design-basis earthquake. At all sites except Pantex, the frequency of such a crash is below 10^{-7} per year.

Criticality. Engineered and administrative controls should be available to ensure that the double-contingency principles are in place for all portions of the process. It is assumed that human error results in multiple failures leading to an inadvertent nuclear criticality. The estimated frequency of this accident is in the range of 10^{-4} to 10^{-6} per year. A bounding source term resulting from 10^{19} fissions is assumed.

Design Basis Earthquake. The principal design basis natural phenomena event that could release material to the environment is the design basis earthquake. While the major safety systems, including building confinement and the building HEPA filtration system should continue to function, the vibratory motion would be expected to resuspend loose plutonium powder within gloveboxes and cause some minor spills. These would be picked up by the ventilation system and filtered by the HEPA filters before release from the building. Although highly uncertain, the source term should be much lower than that postulated for the beyond-design-basis earthquake. Based on an LPF of 1.0×10^{-5} for two HEPA filters, a stack release of 3.9×10^{-4} g (1.4×10^{-5} oz) is postulated. The estimated frequency of this accident is in the range of 10^{-4} to 10^{-2} per year.

Beyond-Design-Basis Earthquake. The postulated beyond-design-basis earthquake is assumed to be of sufficient magnitude to cause total collapse of the process equipment, building walls, roof, and floors, and loss of the containment function of the building. The material in the building is assumed to be driven airborne by the seismic vibrations, free-fall during the collapse, and impact. Molten metal in furnaces is also assumed to burn in the aftermath of the collapse. An instantaneous plus-resuspension ground-level release of 39 g (1.4 oz) of respirable plutonium is estimated for the process area. While the release of an additional 2,529 g (89 oz) from the vault would be possible, it would be unlikely given the expected packaging of materials in the vault. The estimated frequency of this accident is in the range of 10^{-5} to 10^{-7} per year.

Explosion. The bounding explosion is a deflagration of a hydrogen gas mixture inside the hydride oxidation (HYDOX) furnace. The deflagration is assumed to result from multiple equipment failures and operator errors that lead to a buildup of hydrogen and a flow of oxygen into the inert-atmosphere glovebox used in the HYDOX process. Also assumed is an MAR of 4.5 kg (9.9 lb) of plutonium powder, and given the venting of pressurized gas through the powder, bounding ARF and RF of 0.1 and 0.7, respectively. The explosive energy would be sufficient to damage glovebox windows but insufficient to threaten the building HEPA filter system. Based on an LPF of 1.0×10^{-5} for two HEPA filters, a stack release of 3.2×10^{-3} g (1.1×10^{-4} oz) is postulated. The estimated frequency of this accident is in the range of 10^{-2} to 10^{-4} per year.

Fire. According to the several safety analyses of the plutonium facility at LANL, the bounding fire within the pit conversion facility is a fire involving all of the gloves in a glovebox used for blending plutonium powder. A flammable cleaning liquid is assumed to be brought into the glovebox, in violation of procedure, then to spill and ignite. The gloves are assumed to be stowed outside the glovebox but to be ignited by the fire and completely consumed. An MAR of 2 g (0.07 oz) of plutonium dust is assumed for each of 12 gloves, with all of the 24 g (0.85 oz) assumed to be aerosolized. The sprinkler system is assumed to function and protect the room and remainder of the building. Also assumed are an ARF of 0.05 and an RF of 1.0, resulting in a 1.2-g (0.04-oz) release to the building ventilation system. Based on an LPF of 1.0×10^{-5} for two HEPA filters, a stack release of 1.2×10^{-5} g (4.2×10^{-7} oz) is postulated. The estimated frequency of this accident is in the range of 10^{-2} to 10^{-4} per year.

Leaks or Spills of Nuclear Material. The most catastrophic leak or spill postulated would result from a forklift or other large vehicle running over a package of nuclear material and breaching the storage container. If a 4-kg (8.8-lb) package of plutonium oxide were breached, a total airborne release of 0.44 g (0.016 oz) to the room would occur, and after HEPA filtration of the facility exhaust, a total release of 4.4×10^{-6} . This accident has an estimated frequency in the range of 10^{-4} to 10^{-6} per year.

Tritium Release. A major glovebox fire is assumed to heat multiple parts contaminated with up to 20 g (0.71 oz) of tritium and convert all of it into tritiated water vapor. Very conservatively, the ARF, RF, and LPF are all assumed to be 1.0, resulting in a release of 20 g (0.71 oz) (1.9×10^{-5} Ci) through the stack to the atmosphere. The estimated frequency of this accident is in the range of 10^{-4} to 10^{-6} per year.

K.1.5.2.2 Immobilization Facility

A wide range of potential accident scenarios are reflected in the immobilization facility data reports (UC 1999a–d). The analysis assumes that the immobilization facility is located in a new or upgraded existing building designed to withstand design basis natural phenomena hazards such as earthquakes, winds, tornadoes, and floods such that no unfiltered releases would be expected. Also, no site-specific accidents conducive to releases are identified. Therefore, the potential accident scenarios apply to all four candidate sites. Additional discussion of scenario development based on consistency concerns can be found in Appendix K.1.5.1.

Analysis of the proposed process operations identified specific scenarios for the conversion process, each of the immobilization options (ceramic and glass), and the canister-handling portion of the process. Design basis and beyond-design-basis earthquakes were identified for the overall facility. Identified as accidents specific to the plutonium conversion processes were a criticality, an explosion in HYDOX furnace, a calcining furnace–glovebox fire, and a hydrogen explosion in the plutonium conversion room. For the ceramic immobilization option, moreover, a sintering furnace–glovebox fire was identified; for the glass immobilization option, a melter eruption and a melter spill. All of the scenarios identified with the canister-handling phase were negligible compared with the conversion and immobilization scenarios.

PLUTONIUM CONVERSION OPERATIONS

Criticality. Review of the possibility of accidents attributable to plutonium conversion operations indicated that the principal processes of concern include the halide wash operations, the HYDOX furnace, and the sorting/unpacking glovebox. Engineered and administrative controls should be available to ensure that the double-contingency principles are in place for all portions of the process. It is assumed that human error could result in multiple failures leading to an inadvertent nuclear criticality. The estimated frequency of this accident is in the range of 10^{-4} to 10^{-6} per year. A bounding source term resulting from 10^{19} fissions is assumed.

Explosion in HYDOX Furnace. The bounding explosion is a deflagration of a hydrogen gas mixture inside the HYDOX furnace. The deflagration is assumed to result from multiple equipment failures and operator errors that lead to a buildup of hydrogen and a flow of oxygen into the inert-atmosphere glovebox used in the HYDOX process. Also assumed is an MAR of 4.8 kg (11 lb) of plutonium powder, and given the venting pressurized gas through the powder, bounding ARF and RF of 0.1 and 0.7, respectively. The explosive energy would be sufficient to damage glovebox windows but insufficient to threaten the building HEPA filter system. Based on an LPF of 1.0×10^{-5} for two HEPA filters, a stack release of 3.4×10^{-3} g (1.2×10^{-4} oz) is postulated. The estimated frequency of this accident is approximately 10^{-3} per year or in the unlikely range.

Hydrogen Explosion in Plutonium Conversion Room. A supply pipe leak in the plutonium conversion room could result in a hydrogen explosion. Conversion of plutonium metal is accomplished using the HYDOX process, which entails the introduction of hydrogen gas. Were the hydrogen supply piping to leak into the operating/maintenance room, the gas could be ignited by an electrical short or operating mechanical equipment, causing an explosion. Depending on the volume of the leak, the structural integrity of the glovebox glove ports could fail and disperse the plutonium oxide. It is assumed that the building ventilation does not fail, and that the two HEPA filters provide filtration prior to discharge of the powder to the stack. An entire day's inventory of 25 kg (55 lb) of plutonium oxide powder is assumed present in the plutonium conversion gloveboxes. Based on an ARF of 5×10^{-3} , an RF of 0.3, and an LPF of 1.0×10^{-5} for two HEPA filters, a stack release of 3.8×10^{-4} g (1.3×10^{-5} oz) of plutonium is postulated. The estimated frequency of this accident is approximately 10^{-3} per year or in the unlikely range.

Furnace-Initiated Glovebox Fire (Calcining Furnace). It is assumed that a fault in the calcining furnace results in the ignition of any combustibles (e.g., bags) left inside the glovebox. The fire would be self-limiting, but would cause suspension of the radioactive material. It is also assumed that the glovebox (including the window) maintains its structural integrity, but that the internal glovebox HEPA filter fails. All of the loose

surface contamination within the glovebox, assumed to be 10 percent of the daily inventory (4.5 kg [9.9 lb] of plutonium) of the calcining furnace, is assumed to be involved. Based on an ARF of 6×10^{-3} , an RF of 0.01, and an LPF of 1.0×10^{-5} for two HEPA filters, a stack release of 2.7×10^{-7} g (9.5×10^{-9} oz) of plutonium is postulated. The estimated frequency of this accident is in the range of 10^{-4} to 10^{-6} per year.

CERAMIC IMMOBILIZATION OPTION

Criticality. Review of the possibility of accidents attributable to the ceramic immobilization operations indicated that the principal operation of concern is the rotary splitter tumbler. Engineered and administrative controls should be available to ensure that the double-contingency principles are in place for all portions of the process. It is assumed that human error results in multiple failures leading to an inadvertent nuclear criticality. The estimated frequency of this accident is in the range of 10^{-4} to 10^{-6} per year. A bounding source term resulting from 10^{19} fissions is assumed.

Design Basis Earthquake. The principal design basis natural phenomena event that could release material to the environment is the design basis earthquake. While the major safety systems, including building confinement and the building HEPA filtration system should continue to function, the vibratory motion would be expected to suspend loose plutonium powder within gloveboxes and cause some minor spills. These would be picked up by the ventilation system and filtered by the HEPA filters before release from the building. Most material storage containers are assumed to be engineered to withstand design basis earthquakes without failing. For plutonium conversion, it is assumed that at the time of the event the entire day's inventory (25 kg [55 lb] of plutonium) is present in the form of oxide powder. For the ceramic immobilization portion, this includes the oxide inventories from the rotary splitter, oxide grinding, blend and granulate feed storage, drying and storage, pressing, inspection, and load trays and weigh areas. Although the source term is highly uncertain, an assessment of the MAR, ARF, and RF for each of the process areas indicated a potential for the release of 38 g (1.3 oz) of plutonium to the still-functioning building ventilation system and 3.8×10^{-4} g (1.3×10^{-5} oz) from the stack. The nominal frequency estimate for a design basis earthquake affecting new DOE plutonium facilities is 5×10^{-4} per year, or in the unlikely range.

Beyond-Design-Basis Earthquake. The postulated beyond-design-basis earthquake is assumed to be of sufficient magnitude to cause total collapse of the process equipment, building walls, roof, and floors, and loss of the containment function of the building. The material in the building is assumed to be driven airborne by the seismic vibrations, free-fall during the collapse, and impact. Material in storage containers in vaults would be adequately protected from the scenario energetics. Although the source term is highly uncertain, an assessment of the MAR, ARF, and RF for each of the process areas indicated a potential for the release of 19 g (0.67 oz) of plutonium at ground level. The estimated frequency of this accident is in the range of 10^{-5} to 10^{-7} per year.

Furnace-Initiated Glovebox Fire (Sintering Furnace). It is assumed that the sintering gas supplied to the furnace gloveboxes is a safe gas mixture—hydrogen and argon. Human errors are at issue—either a vendor/supplier that causes a supply of air or noninerting gas to be supplied to the furnace glovebox, or a piping error at the facility itself, in which oxygen is inadvertently substituted for the inert gas. Any combustibles (e.g., bags) left inside the glovebox could ignite, causing a glovebox fire. It is assumed that the fire is self-limiting, but causes suspension of the radioactive material. It is also assumed that the glovebox (including the window) maintains its structural integrity, but that the internal glovebox HEPA filter fails. All of the loose surface contamination within the glovebox, assumed to be 10 percent of the daily inventory (25 kg [55 lb] of plutonium) of the calcining furnace, is assumed to be involved. Based on an ARF of 6×10^{-3} , an RF of 0.01, and an LPF of 1.0×10^{-5} for two HEPA filters, a stack release of 1.5×10^{-6} g (5.3×10^{-8} oz) of plutonium is postulated. The estimated frequency of this accident is in the range of 10^{-4} to 10^{-6} per year.

GLASS IMMOBILIZATION OPTION

Design Basis Earthquake. The principal design basis natural phenomena event that could release material to the environment is the design basis earthquake. While the major safety systems, including building confinement and the building HEPA filtration system should continue to function, the vibratory motion would be expected to suspend loose plutonium powder within gloveboxes and cause some minor spills. These would be picked up by the ventilation system and filtered by the HEPA filters before release from the building. Most material storage containers are assumed to be engineered to withstand design basis earthquakes without failing. For plutonium conversion, it is assumed that at the time of the event the entire day's inventory (25 kg [55 lb] of plutonium) is present in the form of oxide powder. For the glass immobilization portion, this includes oxide inventories from the rotary splitter, oxide grinding, blend melter, and feed storage. Although the source term is highly uncertain, an assessment of the MAR, ARF, and RF for each of the process areas indicated a potential for the release of 33 g (1.2 oz) of plutonium to the still-functioning building ventilation system and 3.3×10^{-4} g (1.2×10^{-5} oz) from the stack. The nominal frequency estimate for a design basis earthquake affecting new DOE plutonium facilities is 5×10^{-4} per year, or in the unlikely range.

Beyond-Design-Basis Earthquake. The postulated beyond-design-basis earthquake is assumed to be of sufficient magnitude to cause total collapse of the process equipment, building walls, roof, and floors, and loss of the containment function of the building. The material in the building is assumed to be driven airborne by the seismic vibrations, free-fall during the collapse, and impact. Material in storage containers in vaults storage would be adequately protected from the scenario energetics. Although the source term is highly uncertain, an assessment of the MAR, ARF, and RF for each of the process areas indicated a potential for the release of 17 g (0.60 oz) of plutonium released at ground level. The estimated frequency of this accident is in the range of 10^{-5} to 10^{-7} per year.

Melter Eruption. A melter eruption could result from the buildup of impurities in, or addition of impurities to, the glass frit or melt. Impurities range from water, which could cause a steam eruption, to chemical contaminants, which could react at elevated temperatures and produce a highly exothermic reaction (eruption or deflagration). The resulting sudden pressure increase could eject the fissile material bearing melt liquid into the processing glovebox structure. However the energy release would likely be insufficient to challenge the glovebox structure. It is assumed that the entire contents of the melter, about 1.4 kg (3.1 lb) of plutonium, are ejected into the glovebox. Based on an ARF of 4×10^{-4} , an RF of 1, and an LPF of 1.0×10^{-5} for two HEPAs, a stack release of 1.4×10^{-6} g (4.9×10^{-8} oz) of plutonium is postulated. The estimated frequency of this accident is approximately 2.5×10^{-3} per year, or in the unlikely range.

Melter Spill. A melter spill into the glovebox could occur due to improper alignment of the product glass cans during pouring operations. The melter glovebox enclosure and the off-gas exhaust ventilation system would confine radioactive material released in the spill. The glovebox structure and its associated filtered exhaust ventilation system would not be impacted by this event. It is assumed that the entire contents of the melter, about 1.4 kg (3.1 lb) of plutonium, are spilled into the glovebox. On the basis of an ARF of 2.4×10^{-5} , a RF of 1, and an LPF of 1.0×10^{-5} for two HEPAs, a stack release of 3.3×10^{-7} g (1.2×10^{-8} oz) of plutonium is postulated. The estimated frequency of this accident is approximately 3×10^{-4} per year, or in the unlikely range.

CAN-IN-CANISTER OPERATIONS

Can-Handling Accident (Before Shipment to Vitrification Facility). A can-handling accident would involve a can containing either ceramic pellets or a vitrified glass log of plutonium material. Studies supporting the Defense Waste Processing Facility (DWPF) SAR (UC 1999a–d) indicate that the source term resulting from dropping or tipping a log of vitrified waste, even without credit for the steel canister, would be negligible. Both surplus plutonium immobilization technologies (ceramic and glass) result in a form with a durability that is comparable to that of the DWPF vitrified waste form. Consequently, no postulated can-handling event would result in a radioactive release to the environment.

Melter Spill (Melt Pour at Vitrification Facility). Analysis of a spill of melt material was included in studies performed in support of the DWPF SAR. According to that analysis, the source term resulting from the dropping or tipping a log of vitrified waste, even without credit for the steel canister, would be negligible. Both surplus plutonium immobilization technologies (ceramic and glass) result in a form with a durability that is comparable to the DWPF vitrified waste form. Consequently, it is postulated that no melter spill event results in a radioactive release to the environment.

Canister-Handling Accident (After Melt Pour at DWPF). Analysis of events involving the handling and storage of vitrified waste canisters was included in studies performed in support of the DWPF SAR. Results of that analysis indicate that the source term resulting from the dropping or tipping of a log of vitrified waste, even without credit for the steel canister, would be negligible. Both surplus plutonium immobilization technologies (ceramic and glass) result in a form with a durability that is comparable to the DWPF vitrified waste form. Consequently, it is postulated that no canister-handling event results in a radioactive release to the environment.

K.1.5.2.3 MOX Facility Accident Scenarios

A wide range of potential accident scenarios were considered in the analysis reflected in the MOX facility data reports (UC 1998b, 1998d, 1998g, 1998h). The analysis assumes that the MOX facility is located in a new or upgraded existing building designed to withstand design basis natural phenomena hazards such as earthquakes, winds, tornadoes, and floods such that no unfiltered releases would be expected. The MOX facility includes an aqueous plutonium-polishing process by which impurities, in particular gallium, are removed from the plutonium feed for MOX fuel fabrication. Bounding accidents for this process were developed separately from the accidents reflected in the MOX facility data reports and are documented in a stand-alone, process-specific data report (ORNL 1998).

Analysis of the proposed process operations for the MOX facility identified the following broad categories of accidents: aircraft crash (Pantex only), criticality, design basis earthquake, beyond-design-basis earthquake, explosion in sintering furnace, fire, and beyond-design-basis fire. Basic characteristics of each of these postulated accidents are described below. Additional discussion of scenario development based on consistency concerns can be found in Appendix K.1.5.1.

Aircraft Crash. A crash of a large, heavy commercial or military aircraft directly into a reinforced-concrete facility could damage the structure sufficiently to breach confinement and disperse material into the environment. A subsequent fuel-fed fire could provide energy to further damage structures and equipment, aerosolize material, and drive materials into the environment. Source terms are highly speculative but would be expected to exceed those from the beyond-design-basis earthquake. At all sites except Pantex, the frequency of such a crash is below 10^{-7} per year.

Criticality. Review of the possibility of accidents for the MOX facility indicated no undue criticality risk associated with the proposed operations. Engineered and administrative controls should be available to ensure that the double-contingency principles are in place for all portions of the process. It is assumed that human error could result in multiple failures leading to an inadvertent nuclear criticality. The estimated frequency of this accident is in the range of 10^{-4} to 10^{-6} per year. A bounding source term resulting from 10^{19} fissions in solution is assumed.

Design Basis Earthquake. The principal design basis natural phenomena event that could release material to the environment is the design basis earthquake. While the major safety systems, including building confinement and the building HEPA filtration system should continue to function, the vibratory motion would be expected to resuspend loose plutonium powder within gloveboxes and cause some minor spills. These would be picked up by the ventilation system and filtered by the HEPA filters before to release from the building. Material storage

containers including cans, hoppers, and bulk storage vessels are assumed to be engineered to withstand design basis earthquakes without failing. Although the source term is highly uncertain, an assessment of the MAR, ARF, and RF for each of the process areas indicated a potential for the release of 4 g (0.14 oz) of plutonium (in the form of MOX powder) to the still-functioning building ventilation system and 4.0×10^{-5} g (3.5×10^{-7} oz) from the stack. The nominal frequency estimate for a design basis earthquake for new DOE plutonium facilities is 5×10^{-4} per year, or in the unlikely range.

Beyond-Design-Basis Earthquake. The postulated beyond-design-basis earthquake is assumed to be of sufficient magnitude to cause total collapse of the process equipment, building walls, roof, and floors, and loss of the containment function of the building. The material in the building is assumed to be driven airborne by the seismic vibrations, free-fall during the collapse, and impact. Although the source term is highly uncertain, an assessment of the MAR, ARF, and RF for each of the process areas indicated a potential for the release of 124 g (4.4 oz) of plutonium (in the form of MOX powder) at ground level. The estimated frequency of this accident is in the range of 10^{-5} to 10^{-7} per year.

Explosion in Sintering Furnace. The several furnaces proposed for the MOX fuel fabrication process all use nonexplosive mixtures of 6 percent hydrogen and 94 percent argon. Given the physical controls on the piping for nonexplosive and explosive gas mixtures, operating procedures, and other engineered safety controls, accidental use of an explosive gas is extremely unlikely, though not impossible. A bounding explosion or deflagration is postulated to occur in one of the three sintering furnaces in the MOX facility building. Multiple equipment failures and operator errors would be required to lead to a buildup of hydrogen and an inflow of oxygen into the inert furnace atmosphere. As much as 5.6 kg (12.3 lb) of plutonium in the form of MOX powder would be at risk, and a bounding ARF of 0.01 and RF of 1.0 is assumed. Based on an LPF of 1.0×10^{-5} for two HEPA filters, a stack release of 5.6×10^{-4} g (2.0×10^{-5} oz) of plutonium (in the form of MOX powder) is postulated. It is estimated that the frequency of this accident is in the range of 10^{-4} to 10^{-6} per year.

Ion Exchange Column Exotherm. A thermal excursion within an ion exchange column is postulated to result from offnormal operations, degraded resin, or a glovebox fire. It is also assumed that the column venting/pressure relief valve fails to vent the overpressure, causing the column to rupture violently. The overpressure releases plutonium nitrate solution as an aerosol within the affected glovebox, which in turn is processed through the ventilation system. If the overpressure also breaches the glovebox, a fraction of the aerosol is released within the room as well. The combined ARF and RF values for this scenario are 9.0×10^{-3} for burning resin and 6.0×10^{-3} for liquid behaving as a flashing spray on depressurization. Additionally, 10 percent of the resin is assumed to burn, yielding a combined ARF and RF value of 9.0×10^{-3} for loaded plutonium. The LPF for the ventilation system is 1.0×10^{-5} .

With regard to probability, process controls are used to ensure that nitrated anion exchange resins are maintained in a wet condition, that the maximum nitric acid concentration and the operating temperature are limited to safe values, and that the time for absorption of plutonium in the resin is minimized. With these controls in place, the frequency of this accident is estimated to be in the unlikely range.

Fire. It is assumed that the liquid organic solvent containing the maximum plutonium concentration leaks as a spray into the glovebox, builds to a flammable concentration, and is contacted by an ignition source. The combined ARF and RF value for this scenario is 1.0×10^{-2} for quiescent burning to self-extinguishment. The LPF for the ventilation system is 1.0×10^{-5} . Scenario frequency is assessed as unlikely.

Spill. Leakage of liquids from process equipment must be considered as an anticipated event. However, with multiple containment barriers, a release from the process room would be extremely unlikely. A bounding scenario involved a liquid spill of concentrated aqueous plutonium solution, with 50 l (13.2 gal) accumulating before the

leak is stopped. The ARF and RF values used for this scenario are 2.0×10^{-4} and 0.5, respectively. The LPF for the building ventilation system is 1.0×10^{-5} .

Beyond-Design-Basis Fire. The MOX facility would be built and operated such that there would be insufficient combustible materials to support a large fire. To bound the possible consequences of a major fire, a large quantity of combustible materials are assumed to be introduced into the process area near the blending area, which contains a fairly large amount of plutonium. A major fire is assumed to occur that causes the building ventilation and filtration systems to fail, possibly due to clogged HEPA filters. A total of 11 kg (24 lb) of plutonium in the form of MOX powder is assumed at risk. Based on an ARF of 6×10^{-3} , a RF of 0.01, and an LPF of 1.4×10^{-2} for two damaged, clogged HEPA filters, a stack release of 9.4×10^{-3} g (3.3×10^{-4} oz) of plutonium (in the form of MOX powder) is postulated. It is estimated that the frequency of this accident is less than 10^{-6} per year.

K.1.5.2.4 Lead Assembly Accident Scenarios

Design basis and beyond-design-basis accident scenarios have been developed for the fabrication of MOX fuel lead assemblies. These scenarios are discussed in detail, with specific assumptions for each facility and site, in the site data reports (O'Connor et al. 1998a–e). In spite of efforts by all parties, however, some inconsistencies exist between the data reports. This does not imply technical inaccuracy in any analysis; it merely reflects the uncertainties and reliance on convention inherent in accident analyses in general. In preparing the accident analysis for the SPD EIS, therefore, information in the data reports was modified or augmented to ensure the consistency, as appropriate, that is necessary for a reliable comparison of lead assembly fabrication accidents and the other accidents analyzed herein. Modifications were made to ensure that, to the extent practical, differences in analytical results were based on actual differences in facility conditions, as opposed to arbitrary differences in analytical methods or assumptions. One change, reflected in Table K–2, involved the assumption for all accidents of an isotopic composition of plutonium identical to that assumed in the analyses of pit disassembly and conversion and MOX fuel fabrication.

Table K–2. Isotopic Composition of Plutonium Used in Lead Assembly Accident Analysis

Isotope	Weight Percent
Plutonium 238	3.0×10^{-2}
Plutonium 239	92.2
Plutonium 240	6.46
Plutonium 241	5.0×10^{-2}
Plutonium 242	1.0×10^{-1}
Americium 241	9.0×10^{-1}

Criticality. Criticalities could be postulated in several areas (e.g., powder storage, the gloveboxes involved in mixing, the furnace, the fuel rod storage area). The estimated frequencies associated with these events would vary depending on the controls in place, the number of operator movements, and the amount of fissile material present. A generic approach was taken with respect to the selection of the specifics of this event, rather than selection of a criticality scenario associated with a specific operation in the lead assembly fabrication.

The criticality source term stipulated in the data reports was modified to make it identical to the corresponding source term used in the assessment of criticality in the pit conversion, immobilization, and MOX facilities. That source term is based on a fission yield from 1.0×10^{19} fissions in an oxide powder. The discussion provided in Appendix K.1.5 on criticality is also applicable here.

Design Basis Earthquake. An earthquake appropriate with the facility's design basis was selected. For this event, major portions of the process line gloveboxes are assumed to be breached, making the contents available for release. The storage vault and receiving area are assumed to have suitable storage containers for plutonium oxide that would survive the earthquake (storage containers with double containment). In-process material in gloveboxes is, however, more vulnerable, as are powder storage areas that may exist. Of particular concerns are the dispersible powders at the powder-blending stations. Finished pellets and fuel rods are thought to be generally nondispersible, even though they could escape the gloveboxes. In this earthquake, some non-seismically qualified process equipment could fail, and some process material spill. It is also conservatively assumed that glovebox filtration would fail.

The lead assembly data reports use ARF and RF values of 1.0×10^{-2} and 0.2, respectively, for plutonium oxide in cans involved in a design basis earthquake. These values are based on DOE-HDBK-3010-94 recommendations for the suspension of bulk powder by debris impact and air turbulence from falling objects. For consistency with the design basis accident analyses for the other facilities, these values were changed to 1.0×10^{-3} and 0.1, values based on DOE-HDBK-3010-94 recommendations for the suspension of bulk powder due to vibration of substrate from shock-impact to powder confinement (e.g., gloveboxes, cans) due to external energy (e.g., seismic vibrations). Such values are appropriate for earthquakes in which structural integrity is largely maintained and there is not a significant amount of debris or falling objects.

Beyond-Design-Basis Earthquake. For this analysis an event much more severe in consequences than would be expected from the design basis earthquake was examined. For some existing DOE facilities, the estimated seismic frequencies of beyond-design-basis events can be greater than 1.0×10^{-6} per year. The design basis for every building in the complex varies considerably depending on site specifics, including the type of construction used in the building. A damage assessment of the facility is further complicated by the fact that seismic considerations could also be incorporated in the glovebox design of the facility. In reality, such a catastrophic event may or may not demolish the building and the gloveboxes. However, for the purposes of illustrating a high-consequence accident, total demolition of the building is assumed. In this event, no credit is taken for the building, filters, or gloveboxes.

In the data report, an estimated frequency of 1.0×10^{-6} per year is cited as appropriate. To acknowledge the high degree of uncertainty in assessing a frequency of this scenario, a range of extremely unlikely to beyond extremely unlikely has been assigned to this event.

The source term for the beyond-design-basis earthquake includes a contribution from the plutonium storage vault, the assumed DR being 5 percent. The values used for the ARF, RF and vault DR— 1.0×10^{-3} , 0.3, and 0, respectively—derive from adjustments consistent with the analysis of the corresponding scenario in the MOX facility data report. This results in a reduction of the source term for this accident by a factor of 2, to 11 g (0.39 oz) plutonium.

Extensive analyses have been performed on the seismic hazard at LLNL and the response of the plutonium facility, Building 332, to that hazard. According to the geology and seismology studies characterizing the nature and magnitude of the seismic threat, there is no physiographic basis for postulating earthquake magnitudes and ground accelerations higher than Richter magnitude 6.9 and 1.1g, respectively. Building 332, Increment III, has been evaluated for resistance to earthquakes and ground accelerations of these magnitudes and found to be adequate. Events of significantly higher magnitude and ground acceleration would be required to collapse Increment III. The frequency of these larger events would most likely be extremely low (1.0×10^{-6} per year or less), as the physiography of the dominant fault systems is such that they are thought incapable of producing the required magnitudes of ground accelerations (Coats 1998). Results of a number of reviews of Increment III indicate that the actual ground motion needed to cause collapse of the structure is above 1.5g. Based on the current LLNL hazard curve and various estimates of the fragility curves for collapse of Increment III, the

frequency of collapse is estimated at 1.0×10^{-7} per year or less (Murray 1998). The frequency of a total collapse of Building 332 at LLNL is thus considered sufficiently low that additional examination is unnecessary.

Explosion. An explosion event was postulated in the sintering furnace in the lead assembly fabrication facility. A nonexplosive mixture of 6 percent hydrogen and 94 percent argon is used in the furnace. Multiple equipment and operator errors would have to occur to enable the buildup of an explosive mixture of hydrogen and air in the box. It is assumed that green pellets are subjected to the direct force of the shock waves resulting from such an explosion. It is further assumed that the gloveboxes involved in powder blending are damaged indirectly by the explosion. It is not expected that the shock wave impacting this area would be severe enough to significantly damage all of the storage inventory because interim storage containers would provide some mitigation.

Fire. A moderate-size room fire is assumed. Combustible material such as hydraulic fluid, alcohol, or contaminated combustibles is assumed to be present in the room. Adjoining facilities such as offices conceivably add to the risk of fires in the building. The gloveboxes are assumed to fail in the fire. The MOX powder in interim storage is assumed to be at risk and subjected to the thermal stress of the fire, given failure of the gloveboxes. Because of the limited combustible material and mitigation features such as fire protection systems and a firefighting unit, the event is assumed to be terminated. This fire is not severe enough to jeopardize the overall confinement characteristics of the building.

The source term for the design basis fire analyzed in the lead assembly data reports is dominated by the explosive release of high pressure from two plutonium oxide cans as they are heated to the point of failure. The ARF and RF values for this phenomenon are 0.1 and 0.7, respectively, and reflect burst pressures on the order of 25 to 500 psig. The potential for this kind of release is highly uncertain, and a valid design basis fire may be defined without including it, as is the case with the data reports for the other facilities. Therefore, for greater consistency between the design basis fire for the lead assembly and those for the other facilities, it is assumed that the two plutonium oxide cans are already open and vulnerable to the same phenomena as the rest of the analyzed powder. This results in a reduction of the data report source term by a factor of 38.

It is noteworthy that the lead assembly data report assumes a room fire, and the other data reports, a process fire. This is not considered inconsistent: the lead assembly processes are expected to be closer to one another other than the MOX processes, so the potential for propagation of fire may be somewhat greater.

Beyond-Design-Basis Fire. Fuel-manufacturing operations do not involve the use of significant amounts of combustible material. For the purpose of analysis, the lead assembly data reports define a beyond-design-basis fire that results in building collapse, the breach of material in the plutonium storage vault, and a lofted plume. These assumptions, however, are inconsistent with the beyond-design-basis fires analyzed for the other facilities. The beyond-design-basis fire has therefore been modified to reflect a room fire or building fire that clogs the building HEPA filters, resulting in a ground-level, unfiltered release. The assumed LPF is 1.4×10^{-2} (Smith, Wilkey, and Siebe 1996), consistent with the other analyses. Additionally, it is assumed that the fire does not involve the vault or that the storage canisters in the vault provide adequate protection for the duration of the fire.

K.2 FACILITY ACCIDENT IMPACTS AT HANFORD

The potential source terms and consequences of postulated bounding facility accidents for each facility option at Hanford are presented in Tables K-3 through K-9. Accident scenarios and source terms were developed from data reports prepared for each technology. Consequences were estimated using the MACCS2 computer code and local population and meteorology data. The consequences are presented for mean and 95th percentile meteorological conditions.

Meteorological data are based on 10-m (33-ft) weather readings at Hanford for the 1996 calendar year.⁵ In accordance with the MACCS2 format requirements, the data set consists of 8,760 consecutive hourly readings of windspeed, wind direction, Pasquill-Gifford stability class, and accumulated rainfall.

Population estimates for Hanford are for the year 2010, are based on the *Census of Population and Housing, 1990* (DOC 1992), and are identical to the estimates used for the analysis of normal operations in the SPD EIS. Population values are formatted into 16 sectors centered around the 16 standard compass directions, which are further subdivided into 10 radial distance intervals out to 80 km (50 mi).

⁵ The choice of calendar year was based primarily on data quality. For some combinations of site and calendar year, the data set contains significant gaps, making that data undesirable for use in dispersion modeling. As a result, not all sites were analyzed using meteorological data for the same calendar year.

Table K-3. Accident Impacts of Pit Conversion Facility in FMEF at Hanford

Accident	Source Term (g)	Frequency (per year)	Meteorology	Impacts on Noninvolved Worker		Impacts at Site Boundary		Impacts on Population Within 80 km	
				Dose (rem)	Probability of Cancer Fatality ^a	Dose (rem)	Probability of Cancer Fatality ^a	Dose (person-rem)	Latent Cancer Fatalities ^b
Fire	1.2×10 ⁻⁵	Unlikely	Mean	2.8×10 ⁻⁶	1.1×10 ⁻⁹	5.2×10 ⁻⁷	2.6×10 ⁻¹⁰	8.7×10 ⁻⁴	4.3×10 ⁻⁷
			95th percentile	1.1×10 ⁻⁵	4.3×10 ⁻⁹	1.6×10 ⁻⁶	8.1×10 ⁻¹⁰	5.3×10 ⁻³	2.6×10 ⁻⁶
Explosion	3.2×10 ⁻³	Unlikely	Mean	7.3×10 ⁻⁴	2.9×10 ⁻⁷	1.4×10 ⁻⁴	6.8×10 ⁻⁸	2.3×10 ⁻¹	1.1×10 ⁻⁴
			95th percentile	2.8×10 ⁻³	1.1×10 ⁻⁶	4.2×10 ⁻⁴	2.1×10 ⁻⁷	1.4	6.8×10 ⁻⁴
Leaks/spills of nuclear material	4.4×10 ⁻⁶	Extremely unlikely	Mean	1.0×10 ⁻⁶	4.1×10 ⁻¹⁰	1.9×10 ⁻⁷	9.6×10 ⁻¹¹	3.2×10 ⁻⁴	1.6×10 ⁻⁷
			95th percentile	3.9×10 ⁻⁶	1.6×10 ⁻⁹	5.9×10 ⁻⁷	3.0×10 ⁻¹⁰	1.9×10 ⁻³	9.5×10 ⁻⁷
Tritium release	2.0×10 ¹	Extremely unlikely	Mean	1.2×10 ⁻¹	4.7×10 ⁻⁵	2.2×10 ⁻²	1.1×10 ⁻⁵	3.7×10 ¹	1.8×10 ⁻²
			95th percentile	4.5×10 ⁻¹	1.8×10 ⁻⁴	6.8×10 ⁻²	3.4×10 ⁻⁵	2.2×10 ²	1.1×10 ⁻¹
Criticality	1.0×10 ¹⁹ Fissions	Extremely unlikely	Mean	1.1×10 ⁻²	4.4×10 ⁻⁶	1.2×10 ⁻³	6.0×10 ⁻⁷	8.5×10 ⁻¹	4.3×10 ⁻⁴
			95th percentile	3.3×10 ⁻²	1.3×10 ⁻⁵	3.4×10 ⁻³	1.7×10 ⁻⁶	5.4	2.7×10 ⁻³
Design basis earthquake	3.9×10 ⁻⁴	Unlikely	Mean	9.0×10 ⁻⁵	3.6×10 ⁻⁸	1.7×10 ⁻⁵	8.4×10 ⁻⁹	2.8×10 ⁻²	1.4×10 ⁻⁵
			95th percentile	3.5×10 ⁻⁴	1.4×10 ⁻⁷	5.2×10 ⁻⁵	2.6×10 ⁻⁸	1.7×10 ⁻¹	8.4×10 ⁻⁵
Beyond-design-basis fire	1.7×10 ⁻²	Beyond extremely unlikely	Mean	2.9×10 ⁻²	1.1×10 ⁻⁵	1.1×10 ⁻³	5.6×10 ⁻⁷	1.5	7.7×10 ⁻⁴
			95th percentile	1.1×10 ⁻¹	4.3×10 ⁻⁵	4.1×10 ⁻³	2.0×10 ⁻⁶	9.9	4.9×10 ⁻³
Beyond-design-basis earthquake	3.9×10 ¹	Extremely unlikely to beyond extremely unlikely	Mean	6.6×10 ¹	2.6×10 ⁻²	2.6	1.3×10 ⁻³	3.6×10 ³	1.8
			95th percentile	2.5×10 ²	9.9×10 ⁻²	9.4	4.7×10 ⁻³	2.3×10 ⁴	11

^a Increased likelihood (or probability) of cancer fatality to a hypothetical individual (a single noninvolved worker at a distance of 1,000 m [3,281 ft] or at the site boundary, whichever is smaller, or to a hypothetical individual in the offsite population located at the site boundary) if exposed to the indicated dose. The value assumes that the accident has occurred.

^b Estimated number of cancer fatalities in the entire offsite population out to a distance of 80 km (50 mi) if exposed to the indicated dose. The value assumes that the accident has occurred.

Key: FMEF, Fuels and Materials Examination Facility.

Note: Calculated using the source terms in the pit conversion data report, as modified in Appendix K.1.5.1, site meteorology, projected regional population, and the MACCS2 computer code.

Source: UC 1998a.

Table K-4. Accident Impacts of Ceramic Immobilization Facility in FMEF and HLWVF at Hanford (Hybrid Case)

Accident	Source Term (g)	Frequency (per year)	Meteorology	Impacts on Noninvolved Worker		Impacts at Site Boundary		Impacts of Population Within 80 km	
				Dose (rem)	Probability of Cancer Fatality ^a	Dose (rem)	Probability of Cancer Fatality ^a	Dose (person-rem)	Latent Cancer Fatalities ^b
Criticality	1.0×10 ¹⁹ fissions	Extremely unlikely	Mean	1.1×10 ⁻²	4.4×10 ⁻⁶	1.2×10 ⁻³	6.0×10 ⁻⁷	8.5×10 ⁻¹	4.3×10 ⁻⁴
			95th percentile	3.3×10 ⁻²	1.3×10 ⁻⁵	3.4×10 ⁻³	1.7×10 ⁻⁶	5.4	2.7×10 ⁻³
Explosion in HYDOX furnace	3.4×10 ⁻³	Unlikely	Mean	1.0×10 ⁻³	4.0×10 ⁻⁷	1.9×10 ⁻⁴	9.4×10 ⁻⁸	3.1×10 ⁻¹	1.6×10 ⁻⁴
			95th percentile	3.8×10 ⁻³	1.5×10 ⁻⁶	5.8×10 ⁻⁴	2.9×10 ⁻⁷	1.9	9.4×10 ⁻⁴
Glovebox fire (calcining furnace)	2.7×10 ⁻⁷	Extremely unlikely	Mean	8.0×10 ⁻⁸	3.2×10 ⁻¹¹	1.5×10 ⁻⁸	7.4×10 ⁻¹²	2.5×10 ⁻⁵	1.2×10 ⁻⁸
			95th percentile	3.0×10 ⁻⁷	1.2×10 ⁻¹⁰	4.6×10 ⁻⁸	2.3×10 ⁻¹¹	1.5×10 ⁻⁴	7.4×10 ⁻⁸
Hydrogen explosion	3.8×10 ⁻⁴	Unlikely	Mean	1.1×10 ⁻⁴	4.4×10 ⁻⁸	2.1×10 ⁻⁵	1.0×10 ⁻⁸	3.4×10 ⁻²	1.7×10 ⁻⁵
			95th percentile	4.2×10 ⁻⁴	1.7×10 ⁻⁷	6.4×10 ⁻⁵	3.2×10 ⁻⁸	2.1×10 ⁻¹	1.0×10 ⁻⁴
Glovebox fire (sintering furnace)	1.5×10 ⁻⁶	Extremely unlikely	Mean	4.4×10 ⁻⁷	1.8×10 ⁻¹⁰	8.3×10 ⁻⁸	4.1×10 ⁻¹¹	1.4×10 ⁻⁴	6.9×10 ⁻⁸
			95th percentile	1.7×10 ⁻⁶	6.8×10 ⁻¹⁰	2.6×10 ⁻⁷	1.3×10 ⁻¹⁰	8.3×10 ⁻⁴	4.1×10 ⁻⁷
Design basis earthquake	3.8×10 ⁻⁴	Unlikely	Mean	1.1×10 ⁻⁴	4.5×10 ⁻⁸	2.1×10 ⁻⁵	1.0×10 ⁻⁸	3.5×10 ⁻²	1.7×10 ⁻⁵
			95th percentile	4.3×10 ⁻⁴	1.7×10 ⁻⁷	6.4×10 ⁻⁵	3.2×10 ⁻⁸	2.1×10 ⁻¹	1.0×10 ⁻⁴
Beyond-design-basis fire	2.1×10 ⁻³	Beyond extremely unlikely	Mean	4.5×10 ⁻³	1.8×10 ⁻⁶	1.8×10 ⁻⁴	8.9×10 ⁻⁸	2.4×10 ⁻¹	1.2×10 ⁻⁴
			95th percentile	1.7×10 ⁻²	6.8×10 ⁻⁶	6.5×10 ⁻⁴	3.2×10 ⁻⁷	1.6	7.8×10 ⁻⁴
Beyond-design-basis earthquake	1.9×10 ¹	Extremely unlikely to beyond extremely unlikely	Mean	4.1×10 ¹	1.6×10 ⁻²	1.6	8.1×10 ⁻⁴	2.2×10 ³	1.1
			95th percentile	1.5×10 ²	1.6×10 ⁻²	5.8	2.9×10 ⁻³	1.4×10 ⁴	7.1

^a Increased likelihood (or probability) of cancer fatality to a hypothetical individual (a single noninvolved worker at a distance of 1,000 m [3,281 ft] or at the site boundary, whichever is smaller, or to a hypothetical individual in the offsite population located at the site boundary) if exposed to the indicated dose. The value assumes that the accident has occurred.

^b Estimated number of cancer fatalities in the entire offsite population out to a distance of 80 km (50 mi) if exposed to the indicated dose. The value assumes that the accident has occurred.

Key: FMEF, Fuels and Materials Examination Facility; HLWVF, high-level-waste vitrification facility, HYDOX, hydride oxidation.

Note: Calculated using the source terms in the immobilization data report, as modified in Appendix K.1.5.1, site meteorology, projected regional population, and the MACCS2 computer code.

Source: UC 1999a.

Table K–5. Accident Impacts of Glass Immobilization Facility in FMEF and HLWVF at Hanford (Hybrid Case)

Accident	Source Term (g)	Frequency (per year)	Meteorology	Impacts on Noninvolved Worker		Impacts at Site Boundary		Impacts on Population Within 80 km	
				Dose (rem)	Probability of Cancer Fatality ^a	Dose (rem)	Probability of Cancer Fatality ^a	Dose (person-rem)	Latent Cancer Fatalities ^b
Criticality	1.0×10 ¹⁹ fissions	Extremely unlikely	Mean	1.1×10 ⁻²	4.4×10 ⁻⁶	1.2×10 ⁻³	6.0×10 ⁻⁷	8.5×10 ⁻¹	4.3×10 ⁻⁴
			95th percentile	3.3×10 ⁻²	1.3×10 ⁻⁵	3.4×10 ⁻³	1.7×10 ⁻⁶	5.4	2.7×10 ⁻³
Explosion in HYDOX furnace	3.4×10 ⁻³	Unlikely	Mean	1.0×10 ⁻³	4.0×10 ⁻⁷	1.9×10 ⁻⁴	9.4×10 ⁻⁸	3.1×10 ⁻¹	1.6×10 ⁻⁴
			95th percentile	3.8×10 ⁻³	1.5×10 ⁻⁶	5.8×10 ⁻⁴	2.9×10 ⁻⁷	1.9	9.4×10 ⁻⁴
Glovebox fire (calcining furnace)	2.7×10 ⁻⁷	Extremely unlikely	Mean	8.0×10 ⁻⁸	3.2×10 ⁻¹¹	1.5×10 ⁻⁸	7.4×10 ⁻¹²	2.5×10 ⁻⁵	1.2×10 ⁻⁸
			95th percentile	3.0×10 ⁻⁷	1.2×10 ⁻¹⁰	4.6×10 ⁻⁸	2.3×10 ⁻¹¹	1.5×10 ⁻⁴	7.4×10 ⁻⁸
Hydrogen explosion	3.8×10 ⁻⁴	Unlikely	Mean	1.1×10 ⁻⁴	4.4×10 ⁻⁸	2.1×10 ⁻⁵	1.0×10 ⁻⁸	3.4×10 ⁻²	1.7×10 ⁻⁵
			95th percentile	4.2×10 ⁻⁴	1.7×10 ⁻⁷	6.4×10 ⁻⁵	3.2×10 ⁻⁸	2.1×10 ⁻¹	1.0×10 ⁻⁴
Melter eruption	1.4×10 ⁻⁶	Unlikely	Mean	4.1×10 ⁻⁷	1.6×10 ⁻¹⁰	7.6×10 ⁻⁸	3.8×10 ⁻¹¹	1.3×10 ⁻⁴	6.4×10 ⁻⁸
			95th percentile	1.6×10 ⁻⁶	6.3×10 ⁻¹⁰	2.4×10 ⁻⁷	1.2×10 ⁻¹⁰	7.7×10 ⁻⁴	3.8×10 ⁻⁷
Melter spill	3.3×10 ⁻⁷	Unlikely	Mean	9.6×10 ⁻⁸	3.9×10 ⁻¹¹	1.8×10 ⁻⁸	9.0×10 ⁻¹²	3.0×10 ⁻⁵	1.5×10 ⁻⁸
			95th percentile	3.7×10 ⁻⁷	1.5×10 ⁻¹⁰	5.6×10 ⁻⁸	2.8×10 ⁻¹¹	1.8×10 ⁻⁴	9.0×10 ⁻⁸
Design basis earthquake	3.3×10 ⁻⁴	Unlikely	Mean	9.7×10 ⁻⁵	3.9×10 ⁻⁸	1.8×10 ⁻⁵	9.1×10 ⁻⁹	3.0×10 ⁻²	1.5×10 ⁻⁵
			95th percentile	3.7×10 ⁻⁴	1.5×10 ⁻⁷	5.6×10 ⁻⁵	2.8×10 ⁻⁸	1.8×10 ⁻¹	9.1×10 ⁻⁵
Beyond-design-basis fire	3.8×10 ⁻⁴	Beyond extremely unlikely	Mean	8.1×10 ⁻⁴	3.3×10 ⁻⁷	3.2×10 ⁻⁵	1.6×10 ⁻⁸	4.4×10 ⁻²	2.2×10 ⁻⁵
			95th percentile	3.1×10 ⁻³	1.2×10 ⁻⁶	1.2×10 ⁻⁴	5.8×10 ⁻⁸	2.8×10 ⁻¹	1.4×10 ⁻⁴
Beyond-design-basis earthquake	1.7×10 ¹	Extremely unlikely to beyond extremely unlikely	Mean	3.6×10 ¹	1.4×10 ⁻²	1.4	7.1×10 ⁻⁴	1.9×10 ³	9.7×10 ⁻¹
			95th percentile	1.4×10 ²	5.4×10 ⁻²	5.1	2.6×10 ⁻³	1.2×10 ⁴	6.2

^a Increased likelihood (or probability) of cancer fatality to a hypothetical individual (a single noninvolved worker at a distance of 1,000 m [3,281 ft] or at the site boundary, whichever is smaller, or to a hypothetical individual in the offsite population located at the site boundary) if exposed to the indicated dose. The value assumes that the accident has occurred.

^b Estimated number of cancer fatalities in the entire offsite population out to a distance of 80 km (50 mi) if exposed to the indicated dose. The value assumes that the accident has occurred.

Key: FMEF, Fuels and Materials Examination Facility; HLWVF, high-level-waste vitrification facility; HYDOX, hydride oxidation.

Note: Calculated using the source terms in the immobilization data report, as modified in Appendix K.1.5.1, site meteorology, projected regional population, and the MACCS2 computer code.

Source: UC 1999b.

Table K–6. Accident Impacts of Ceramic Immobilization Facility in FMEF and HLWVF at Hanford (50-t Case)

Accident	Source Term (g)	Frequency (per year)	Meteorology	Impacts on Noninvolved Worker		Impacts at Site Boundary		Impacts on Population Within 80 km	
				Dose (rem)	Probability of Cancer Fatality ^a	Dose (rem)	Probability of Cancer Fatality ^a	Dose (person-rem)	Latent Cancer Fatalities ^b
Criticality	1.0×10 ¹⁹ fissions	Extremely unlikely	Mean	1.1×10 ⁻²	4.4×10 ⁻⁶	1.2×10 ⁻³	6.0×10 ⁻⁷	8.5×10 ⁻¹	4.3×10 ⁻⁴
			95th percentile	3.3×10 ⁻²	1.3×10 ⁻⁵	3.4×10 ⁻³	1.7×10 ⁻⁶	5.4	2.7×10 ⁻³
Explosion in HYDOX furnace	3.4×10 ⁻³	Unlikely	Mean	1.0×10 ⁻³	4.0×10 ⁻⁷	1.9×10 ⁻⁴	9.4×10 ⁻⁸	3.1×10 ⁻¹	1.6×10 ⁻⁴
			95th percentile	3.8×10 ⁻³	1.5×10 ⁻⁶	5.8×10 ⁻⁴	2.9×10 ⁻⁷	1.9	9.4×10 ⁻⁴
Glovebox fire (calcining furnace)	2.7×10 ⁻⁷	Extremely unlikely	Mean	8.0×10 ⁻⁸	3.2×10 ⁻¹¹	1.5×10 ⁻⁸	7.4×10 ⁻¹²	2.5×10 ⁻⁵	1.2×10 ⁻⁸
			95th percentile	3.0×10 ⁻⁷	1.2×10 ⁻¹⁰	4.6×10 ⁻⁸	2.3×10 ⁻¹¹	1.5×10 ⁻⁴	7.4×10 ⁻⁸
Hydrogen explosion	3.8×10 ⁻⁴	Unlikely	Mean	1.1×10 ⁻⁴	4.4×10 ⁻⁸	2.1×10 ⁻⁵	1.0×10 ⁻⁸	3.4×10 ⁻²	1.7×10 ⁻⁵
			95th percentile	4.2×10 ⁻⁴	1.7×10 ⁻⁷	6.4×10 ⁻⁵	3.2×10 ⁻⁸	2.1×10 ⁻¹	1.0×10 ⁻⁴
Glovebox fire (sintering furnace)	1.5×10 ⁻⁶	Extremely unlikely	Mean	4.4×10 ⁻⁷	1.8×10 ⁻¹⁰	8.3×10 ⁻⁸	4.1×10 ⁻¹¹	1.4×10 ⁻⁴	6.9×10 ⁻⁸
			95th percentile	1.7×10 ⁻⁶	6.8×10 ⁻¹⁰	2.6×10 ⁻⁷	1.3×10 ⁻¹⁰	8.3×10 ⁻⁴	4.1×10 ⁻⁷
Design basis earthquake	3.8×10 ⁻⁴	Unlikely	Mean	1.0×10 ⁻⁴	4.1×10 ⁻⁸	1.9×10 ⁻⁵	9.6×10 ⁻⁹	3.2×10 ⁻²	1.6×10 ⁻⁵
			95th percentile	3.9×10 ⁻⁴	1.6×10 ⁻⁷	5.9×10 ⁻⁵	3.0×10 ⁻⁸	1.9×10 ⁻¹	9.6×10 ⁻⁵
Beyond-design-basis fire	2.1×10 ⁻³	Beyond extremely unlikely	Mean	4.5×10 ⁻³	1.8×10 ⁻⁶	1.8×10 ⁻⁴	8.9×10 ⁻⁸	2.4×10 ⁻¹	1.2×10 ⁻⁴
			95th percentile	1.7×10 ⁻²	6.8×10 ⁻⁶	6.5×10 ⁻⁴	3.2×10 ⁻⁷	1.6	7.8×10 ⁻⁴
Beyond-design-basis earthquake	1.9×10 ¹	Unlikely to beyond extremely unlikely	Mean	3.8×10 ¹	1.5×10 ⁻²	1.5	7.4×10 ⁻⁴	2.0×10 ³	1.0
			95th percentile	1.4×10 ²	5.7×10 ⁻²	5.4	2.7×10 ⁻³	1.3×10 ⁴	6.5

^a Increased likelihood (or probability) of cancer fatality to a hypothetical individual (a single noninvolved worker at a distance of 1,000 m [3,281 ft] or at the site boundary, whichever is smaller, or to a hypothetical individual in the offsite population located at the site boundary) if exposed to the indicated dose. The value assumes that the accident has occurred.

^b Estimated number of cancer fatalities in the entire offsite population out to a distance of 80 km (50 mi) if exposed to the indicated dose. The value assumes that the accident has occurred.

Key: FMEF, Fuels and Materials Examination Facility; HLWVF, high-level-waste vitrification facility, HYDOX, hydride oxidation.

Note: Calculated using the source terms in the immobilization data report, as modified in Appendix K.1.5.1, site meteorology, projected regional population, and the MACCS2 computer code.

Source: UC 1999a.

Table K-7. Accident Impacts of Glass Immobilization Facility in FMEF and HLWVF at Hanford (50-t Case)

Accident	Source Term (g)	Frequency (per year)	Meteorology	Impacts on Noninvolved Worker		Impacts at Site Boundary		Impacts on Population Within 80 km	
				Dose (rem)	Probability of Cancer Fatality ^a	Dose (rem)	Probability of Cancer Fatality ^a	Dose (person-rem)	Latent Cancer Fatalities ^b
Criticality	1.0×10 ¹⁹ fissions	Extremely unlikely	Mean	1.1×10 ⁻²	4.4×10 ⁻⁶	1.2×10 ⁻³	6.0×10 ⁻⁷	8.5×10 ⁻¹	4.3×10 ⁻⁴
			95th percentile	3.3×10 ⁻²	1.3×10 ⁻⁵	3.4×10 ⁻³	1.7×10 ⁻⁶	5.4	2.7×10 ⁻³
Explosion in HYDOX furnace	3.4×10 ⁻³	Unlikely	Mean	1.0×10 ⁻³	4.0×10 ⁻⁷	1.9×10 ⁻⁴	9.4×10 ⁻⁸	3.1×10 ⁻¹	1.6×10 ⁻⁴
			95th percentile	3.8×10 ⁻³	1.5×10 ⁻⁶	5.8×10 ⁻⁴	2.9×10 ⁻⁷	1.9	9.4×10 ⁻⁴
Glovebox fire (calcining furnace)	2.7×10 ⁻⁷	Extremely unlikely	Mean	8.0×10 ⁻⁸	3.2×10 ⁻¹¹	1.5×10 ⁻⁸	7.4×10 ⁻¹²	2.5×10 ⁻⁵	1.2×10 ⁻⁸
			95th percentile	3.0×10 ⁻⁷	1.2×10 ⁻¹⁰	4.6×10 ⁻⁸	2.3×10 ⁻¹¹	1.5×10 ⁻⁴	7.4×10 ⁻⁸
Hydrogen explosion	3.8×10 ⁻⁴	Unlikely	Mean	1.1×10 ⁻⁴	4.4×10 ⁻⁸	2.1×10 ⁻⁵	1.0×10 ⁻⁸	3.4×10 ⁻²	1.7×10 ⁻⁵
			95th percentile	4.2×10 ⁻⁴	1.7×10 ⁻⁷	6.4×10 ⁻⁵	3.2×10 ⁻⁸	2.1×10 ⁻¹	1.0×10 ⁻⁴
Melter eruption	1.4×10 ⁻⁶	Unlikely	Mean	4.1×10 ⁻⁷	1.6×10 ⁻¹⁰	7.6×10 ⁻⁸	3.8×10 ⁻¹¹	1.3×10 ⁻⁴	6.4×10 ⁻⁸
			95th percentile	1.6×10 ⁻⁶	6.3×10 ⁻¹⁰	2.4×10 ⁻⁷	1.2×10 ⁻¹⁰	7.7×10 ⁻⁴	3.8×10 ⁻⁷
Melter spill	3.3×10 ⁻⁷	Unlikely	Mean	9.6×10 ⁻⁸	3.9×10 ⁻¹¹	1.8×10 ⁻⁸	9.0×10 ⁻¹²	3.0×10 ⁻⁵	1.5×10 ⁻⁸
			95th percentile	3.7×10 ⁻⁷	1.5×10 ⁻¹⁰	5.6×10 ⁻⁸	2.8×10 ⁻¹¹	1.8×10 ⁻⁴	9.0×10 ⁻⁸
Design basis earthquake	3.3×10 ⁻⁴	Unlikely	Mean	9.0×10 ⁻⁵	3.6×10 ⁻⁸	1.7×10 ⁻⁵	8.4×10 ⁻⁹	2.8×10 ⁻²	1.4×10 ⁻⁵
			95th percentile	3.5×10 ⁻⁴	1.4×10 ⁻⁷	5.2×10 ⁻⁵	2.6×10 ⁻⁸	1.7×10 ⁻¹	8.4×10 ⁻⁵
Beyond-design-basis fire	3.8×10 ⁻⁴	Beyond extremely unlikely	Mean	8.1×10 ⁻⁴	3.3×10 ⁻⁷	3.2×10 ⁻⁵	1.6×10 ⁻⁸	4.4×10 ⁻²	2.2×10 ⁻⁵
			95th percentile	3.1×10 ⁻³	1.2×10 ⁻⁶	1.2×10 ⁻⁴	5.8×10 ⁻⁸	2.8×10 ⁻¹	1.4×10 ⁻⁴
Beyond-design-basis earthquake	1.7×10 ¹	Extremely unlikely to beyond extremely unlikely	Mean	3.3×10 ¹	1.3×10 ⁻²	1.3	6.6×10 ⁻⁴	1.8×10 ³	9.0×10 ⁻¹
			95th percentile	1.3×10 ²	5.0×10 ⁻²	4.8	2.4×10 ⁻³	1.2×10 ⁴	5.8

^a Increased likelihood (or probability) of cancer fatality to a hypothetical individual (a single noninvolved worker at a distance of 1,000 m [3,281 ft] or at the site boundary, whichever is smaller, or to a hypothetical individual in the offsite population located at the site boundary) if exposed to the indicated dose. The value assumes that the accident has occurred.

^b Estimated number of cancer fatalities in the entire offsite population out to a distance of 80 km (50 mi) if exposed to the indicated dose. The value assumes that the accident has occurred.

Key: FMEF, Fuels and Materials Examination Facility; HLWVF, high-level-waste vitrification facility; HYDOX, hydride oxidation.

Note: Calculated using the source terms in the immobilization data report, as modified in Appendix K.1.5.1, site meteorology, projected regional population, and the MACCS2 computer code.

Source: UC 1999b.

Table K–8. Accident Impacts of MOX Facility in FMEF at Hanford

Accident	Source Term (g)	Frequency (per year)	Meteorology	Impacts on Noninvolved Worker		Impacts at Site Boundary		Impacts on Population Within 80 km	
				Dose (rem)	Probability of Cancer Fatality ^a	Dose (rem)	Probability of Cancer Fatality ^a	Dose (person-rem)	Latent Cancer Fatalities ^b
Criticality	1.0×10 ¹⁹ fissions	Extremely unlikely	Mean	5.1×10 ⁻²	2.0×10 ⁻⁵	6.5×10 ⁻³	3.3×10 ⁻⁶	6.2	3.1×10 ⁻³
			95th percentile	1.5×10 ⁻¹	6.0×10 ⁻⁵	1.9×10 ⁻²	9.4×10 ⁻⁶	3.9×10 ¹	1.9×10 ⁻²
Explosion in sintering furnace	5.5×10 ⁻⁴	Extremely unlikely	Mean	1.3×10 ⁻⁴	5.1×10 ⁻⁸	2.4×10 ⁻⁵	1.2×10 ⁻⁸	4.0×10 ⁻²	2.0×10 ⁻⁵
			95th percentile	4.9×10 ⁻⁴	2.0×10 ⁻⁷	7.4×10 ⁻⁵	3.7×10 ⁻⁸	2.4×10 ⁻¹	1.2×10 ⁻⁴
Ion exchange exotherm	2.4×10 ⁻⁵	Unlikely	Mean	5.6×10 ⁻⁶	2.2×10 ⁻⁹	1.0×10 ⁻⁶	5.2×10 ⁻¹⁰	1.7×10 ⁻³	8.7×10 ⁻⁷
			95th percentile	2.1×10 ⁻⁵	8.6×10 ⁻⁹	3.2×10 ⁻⁶	1.6×10 ⁻⁹	1.1×10 ⁻²	5.2×10 ⁻⁶
Fire	4.0×10 ⁻⁶	Unlikely	Mean	9.3×10 ⁻⁷	3.7×10 ⁻¹⁰	1.7×10 ⁻⁷	8.7×10 ⁻¹¹	2.9×10 ⁻⁴	1.4×10 ⁻⁷
			95th percentile	3.6×10 ⁻⁶	1.4×10 ⁻⁹	5.4×10 ⁻⁷	2.7×10 ⁻¹⁰	1.8×10 ⁻³	8.7×10 ⁻⁷
Spill	5.0×10 ⁻⁶	Extremely unlikely	Mean	1.2×10 ⁻⁶	4.7×10 ⁻¹⁰	2.2×10 ⁻⁷	1.1×10 ⁻¹⁰	3.6×10 ⁻⁴	1.8×10 ⁻⁷
			95th percentile	4.5×10 ⁻⁶	1.8×10 ⁻⁹	6.7×10 ⁻⁷	3.4×10 ⁻¹⁰	2.2×10 ⁻³	1.1×10 ⁻⁶
Design basis earthquake	7.9×10 ⁻⁵	Unlikely	Mean	1.8×10 ⁻⁵	7.3×10 ⁻⁹	3.4×10 ⁻⁶	1.7×10 ⁻⁹	5.7×10 ⁻³	2.8×10 ⁻⁶
			95th percentile	7.0×10 ⁻⁵	2.8×10 ⁻⁸	1.1×10 ⁻⁵	5.3×10 ⁻⁹	3.4×10 ⁻²	1.7×10 ⁻⁵
Beyond-design-basis fire	6.0×10 ⁻²	Beyond extremely unlikely	Mean	1.0×10 ⁻¹	4.1×10 ⁻⁵	4.0×10 ⁻³	2.0×10 ⁻⁶	5.5	2.8×10 ⁻³
			95th percentile	3.8×10 ⁻¹	1.5×10 ⁻⁴	1.5×10 ⁻²	7.3×10 ⁻⁶	3.5×10 ¹	1.8×10 ⁻²
Beyond-design-basis earthquake	9.5×10 ¹	Extremely unlikely to beyond extremely unlikely	Mean	1.6×10 ²	6.5×10 ⁻²	6.4	3.2×10 ⁻³	8.7×10 ³	4.4
			95th percentile	6.1×10 ²	2.4×10 ⁻¹	2.3×10 ¹	1.2×10 ⁻²	5.6×10 ⁴	2.8×10 ¹

^a Increased likelihood (or probability) of cancer fatality to a hypothetical individual (a single noninvolved worker at a distance of 1,000 m [3,281 ft] or at the site boundary, whichever is smaller, or to a hypothetical individual in the offsite population located at the site boundary) if exposed to the indicated dose. The value assumes that the accident has occurred.

^b Estimated number of cancer fatalities in the entire offsite population out to a distance of 80 km (50 mi) if exposed to the indicated dose. The value assumes that the accident has occurred.

Key: FMEF, Fuels and Materials Examination Facility.

Note: Calculated using the source terms in the MOX data report, as modified in Appendix K.1.5.1, site meteorology, projected regional population, and the MACCS2 computer code.

Source: UC 1998b.

Table K–9. Accident Impacts of New MOX Facility at Hanford

Accident	Source Term (g)	Frequency (per year)	Meteorology	Impacts on Noninvolved Worker		Impacts at Site Boundary		Impacts on Population Within 80 km	
				Dose (rem)	Probability of Cancer Fatality ^a	Dose (rem)	Probability of Cancer Fatality ^a	Dose (person-rem)	Latent Cancer Fatalities ^b
Criticality	1.0×10 ¹⁹ fissions	Extremely unlikely	Mean	1.8×10 ⁻¹	7.2×10 ⁻⁵	9.9×10 ⁻³	4.9×10 ⁻⁶	8.2	4.1×10 ⁻³
			95th percentile	6.1×10 ⁻¹	2.5×10 ⁻⁴	3.5×10 ⁻²	1.7×10 ⁻⁵	5.5×10 ¹	2.8×10 ⁻²
Explosion in sintering furnace	5.5×10 ⁻⁴	Extremely unlikely	Mean	8.0×10 ⁻⁴	3.2×10 ⁻⁷	3.5×10 ⁻⁵	1.8×10 ⁻⁸	5.0×10 ⁻²	2.5×10 ⁻⁵
			95th percentile	2.9×10 ⁻³	1.2×10 ⁻⁶	1.1×10 ⁻⁴	5.7×10 ⁻⁸	3.2×10 ⁻¹	1.6×10 ⁻⁴
Ion exchange exotherm	2.4×10 ⁻⁵	Unlikely	Mean	3.5×10 ⁻⁵	1.4×10 ⁻⁸	1.5×10 ⁻⁶	7.7×10 ⁻¹⁰	2.2×10 ⁻³	1.1×10 ⁻⁶
			95th percentile	1.3×10 ⁻⁴	5.1×10 ⁻⁸	5.0×10 ⁻⁶	2.5×10 ⁻⁹	1.4×10 ⁻²	7.0×10 ⁻⁶
Fire	4.0×10 ⁻⁶	Unlikely	Mean	5.8×10 ⁻⁶	2.3×10 ⁻⁹	2.6×10 ⁻⁷	1.3×10 ⁻¹⁰	3.6×10 ⁻⁴	1.8×10 ⁻⁷
			95th percentile	2.1×10 ⁻⁵	8.4×10 ⁻⁹	8.3×10 ⁻⁷	4.2×10 ⁻¹⁰	2.3×10 ⁻³	1.2×10 ⁻⁶
Spill	5.0×10 ⁻⁶	Extremely unlikely	Mean	7.3×10 ⁻⁶	2.9×10 ⁻⁹	3.2×10 ⁻⁷	1.6×10 ⁻¹⁰	4.5×10 ⁻⁴	2.3×10 ⁻⁷
			95th percentile	2.6×10 ⁻⁵	1.1×10 ⁻⁸	1.0×10 ⁻⁶	5.2×10 ⁻¹⁰	2.9×10 ⁻³	1.5×10 ⁻⁶
Design basis earthquake	7.9×10 ⁻⁵	Unlikely	Mean	1.1×10 ⁻⁴	4.6×10 ⁻⁸	5.0×10 ⁻⁶	2.5×10 ⁻⁹	7.1×10 ⁻³	3.6×10 ⁻⁶
			95th percentile	4.1×10 ⁻⁴	1.7×10 ⁻⁷	1.6×10 ⁻⁵	8.2×10 ⁻⁹	4.6×10 ⁻²	2.3×10 ⁻⁵
Beyond-design-basis fire	6.0×10 ⁻²	Beyond extremely unlikely	Mean	1.0×10 ⁻¹	4.1×10 ⁻⁵	4.0×10 ⁻³	2.0×10 ⁻⁶	5.5	2.8×10 ⁻³
			95th percentile	3.8×10 ⁻¹	1.5×10 ⁻⁴	1.5×10 ⁻²	7.3×10 ⁻⁶	3.5×10 ¹	1.8×10 ⁻²
Beyond-design-basis earthquake	9.5×10 ¹	Extremely unlikely to beyond extremely unlikely	Mean	1.6×10 ²	6.5×10 ⁻²	6.4	3.2×10 ⁻³	8.7×10 ³	4.4
			95th percentile	6.1×10 ²	2.4×10 ⁻¹	2.3×10 ¹	1.2×10 ⁻²	5.6×10 ⁴	2.8×10 ¹

^a Increased likelihood (or probability) of cancer fatality to a hypothetical individual (a single noninvolved worker at a distance of 1,000 m [3,281 ft] or at the site boundary, whichever is smaller, or to a hypothetical individual in the offsite population located at the site boundary) if exposed to the indicated dose. The value assumes that the accident has occurred.

^b Estimated number of cancer fatalities in the entire offsite population out to a distance of 80 km (50 mi) if exposed to the indicated dose. The value assumes that the accident has occurred.

Note: Calculated using the source terms in the MOX data report, as modified in Appendix K.1.5.1, site meteorology, projected regional population, and the MACCS2 computer code.

Source: UC 1998b.

K.3 FACILITY ACCIDENT IMPACTS AT INEEL

The potential source terms and consequences of postulated bounding facility accidents for each facility option for INEEL are presented in Tables K-10 and K-11. Accident scenarios and source terms were developed from data reports prepared for each technology. Consequences were estimated using the MACCS2 computer code and local population and meteorology data. The consequences are presented for mean and 95th percentile meteorological conditions.

Meteorological data are based on 10-m (33-ft) weather readings at INEEL for the 1993 calendar year.⁶ In accordance with MACCS2 format requirements, the data set consists of 8,760 consecutive hourly readings of windspeed, wind direction, Pasquill-Gifford stability class, and accumulated rainfall.

Population estimates for INEEL are for the year 2010, are based on the *Census of Population and Housing, 1990* (DOC 1992), and are identical to the estimates used for the analysis of normal operations in the SPD EIS. Population values are formatted into 16 sectors centered around the 16 standard compass directions, which are further subdivided into 10 radial distance intervals out to 80 km (50 mi).

⁶ The choice of calendar year was based primarily on data quality. For some combinations of site and calendar year, the data set contains significant gaps, making that data undesirable for use in dispersion modeling. As a result, not all sites were analyzed using meteorological data for the same calendar year.

Table K–10. Accident Impacts of Pit Conversion Facility in FPF at INEEL

Accident	Source Term (g)	Frequency (per year)	Meteorology	Impacts on Noninvolved Worker		Impacts at Site Boundary		Impacts on Population Within 80 km	
				Dose (rem)	Probability of Cancer Fatality ^a	Dose (rem)	Probability of Cancer Fatality ^a	Dose (person-rem)	Latent Cancer Fatalities ^b
Fire	1.2×10 ⁻⁵	Unlikely	Mean	2.5×10 ⁻⁶	1.0×10 ⁻⁹	3.0×10 ⁻⁷	1.5×10 ⁻¹⁰	5.6×10 ⁻⁵	2.8×10 ⁻⁸
			95th percentile	6.4×10 ⁻⁶	2.5×10 ⁻⁹	1.1×10 ⁻⁶	5.3×10 ⁻¹⁰	2.1×10 ⁻⁴	1.0×10 ⁻⁷
Explosion	3.2×10 ⁻³	Unlikely	Mean	6.5×10 ⁻⁴	2.6×10 ⁻⁷	7.8×10 ⁻⁵	3.9×10 ⁻⁸	1.5×10 ⁻²	7.4×10 ⁻⁶
			95th percentile	1.7×10 ⁻³	6.7×10 ⁻⁷	2.8×10 ⁻⁴	1.4×10 ⁻⁷	5.5×10 ⁻²	2.7×10 ⁻⁵
Leaks/spills of nuclear material	4.4×10 ⁻⁶	Extremely unlikely	Mean	9.1×10 ⁻⁷	3.6×10 ⁻¹⁰	1.1×10 ⁻⁷	5.4×10 ⁻¹¹	2.1×10 ⁻⁵	1.0×10 ⁻⁸
			95th percentile	2.3×10 ⁻⁶	9.3×10 ⁻¹⁰	3.9×10 ⁻⁷	1.9×10 ⁻¹⁰	7.7×10 ⁻⁵	3.8×10 ⁻⁸
Tritium release	2.0×10 ¹	Extremely unlikely	Mean	1.0×10 ⁻¹	4.2×10 ⁻⁵	1.2×10 ⁻²	6.2×10 ⁻⁶	2.4	1.2×10 ⁻³
			95th percentile	2.7×10 ⁻¹	1.1×10 ⁻⁴	4.5×10 ⁻²	2.2×10 ⁻⁵	8.8	4.4×10 ⁻³
Criticality	1.0×10 ¹⁹	Extremely unlikely	Mean	1.1×10 ⁻²	4.4×10 ⁻⁶	4.8×10 ⁻⁴	2.4×10 ⁻⁷	2.2×10 ⁻²	1.1×10 ⁻⁵
			95th percentile	3.3×10 ⁻²	1.3×10 ⁻⁵	1.6×10 ⁻³	7.9×10 ⁻⁷	8.5×10 ⁻²	4.2×10 ⁻⁵
Design basis earthquake	3.9×10 ⁻⁴	Unlikely	Mean	8.0×10 ⁻⁵	3.2×10 ⁻⁸	9.5×10 ⁻⁶	4.8×10 ⁻⁹	1.8×10 ⁻³	9.1×10 ⁻⁷
			95th percentile	2.1×10 ⁻⁴	8.2×10 ⁻⁸	3.4×10 ⁻⁵	1.7×10 ⁻⁸	6.8×10 ⁻³	3.4×10 ⁻⁶
Beyond-design-basis fire	1.7×10 ⁻²	Beyond extremely unlikely	Mean	3.0×10 ⁻²	1.2×10 ⁻⁵	8.1×10 ⁻⁴	4.1×10 ⁻⁷	9.6×10 ⁻²	4.8×10 ⁻⁵
			95th percentile	1.1×10 ⁻¹	4.5×10 ⁻⁵	2.9×10 ⁻³	1.5×10 ⁻⁶	3.6×10 ⁻¹	1.8×10 ⁻⁴
Beyond-design-basis earthquake	3.9×10 ¹	Extremely unlikely to beyond extremely unlikely	Mean	7.0×10 ¹	2.8×10 ⁻²	1.9	9.3×10 ⁻⁴	2.2×10 ²	1.1×10 ⁻¹
			95th percentile	2.6×10 ²	1.0×10 ⁻¹	6.7	3.3×10 ⁻³	8.4×10 ²	4.2×10 ⁻¹

^a Increased likelihood (or probability) of cancer fatality to a hypothetical individual (a single noninvolved worker at a distance of 1,000 m [3,281 mi] or at the site boundary, whichever is smaller, or to a hypothetical individual in the offsite population located at the site boundary) if exposed to the indicated dose. The value assumes that the accident has occurred.

^b Estimated number of cancer fatalities in the entire offsite population out to a distance of 80 km (50 mi) if exposed to the indicated dose. The value assumes that the accident has occurred.

Key: FPF, Fuel Processing Facility.

Note: Calculated using the source terms in the pit conversion data report, as modified in Appendix K.1.5.1, site meteorology, projected regional population, and the MACCS2 computer code.

Source: UC 1998f.

Table K–11. Accident Impacts of New MOX Facility at INEEL

Accident	Source Term (g)	Frequency (per year)	Meteorology	Impacts on Noninvolved Worker		Impacts at Site Boundary		Impacts on Population Within 80 km	
				Dose (rem)	Probability of Cancer Fatality ^a	Dose (rem)	Probability of Cancer Fatality ^a	Dose (person-rem)	Latent Cancer Fatalities ^b
Criticality	1.0×10 ¹⁹ fissions	Extremely unlikely	Mean	1.9×10 ⁻¹	7.4×10 ⁻⁵	4.3×10 ⁻³	2.1×10 ⁻⁶	2.7×10 ⁻¹	1.4×10 ⁻⁴
			95th percentile	7.5×10 ⁻¹	3.0×10 ⁻⁴	1.6×10 ⁻²	8.2×10 ⁻⁶	1.0	5.2×10 ⁻⁴
Explosion in sintering furnace	5.5×10 ⁻⁴	Extremely unlikely	Mean	8.3×10 ⁻⁴	3.3×10 ⁻⁷	2.2×10 ⁻⁵	1.1×10 ⁻⁸	3.1×10 ⁻³	1.5×10 ⁻⁶
			95th percentile	3.6×10 ⁻³	1.4×10 ⁻⁶	8.4×10 ⁻⁵	4.2×10 ⁻⁸	1.2×10 ⁻²	5.8×10 ⁻⁶
Ion exchange exotherm	2.4×10 ⁻⁵	Unlikely	Mean	3.6×10 ⁻⁵	1.4×10 ⁻⁸	9.5×10 ⁻⁷	4.8×10 ⁻¹⁰	1.3×10 ⁻⁴	6.7×10 ⁻⁸
			95th percentile	1.6×10 ⁻⁴	6.3×10 ⁻⁸	3.7×10 ⁻⁶	1.8×10 ⁻⁹	5.1×10 ⁻⁴	2.5×10 ⁻⁷
Fire	4.0×10 ⁻⁶	Unlikely	Mean	6.0×10 ⁻⁶	2.4×10 ⁻⁹	1.6×10 ⁻⁷	7.9×10 ⁻¹¹	2.2×10 ⁻⁵	1.1×10 ⁻⁸
			95th percentile	2.6×10 ⁻⁵	1.0×10 ⁻⁸	6.1×10 ⁻⁷	3.1×10 ⁻¹⁰	8.5×10 ⁻⁵	4.2×10 ⁻⁸
Spill	5.0×10 ⁻⁶	Extremely unlikely	Mean	7.5×10 ⁻⁶	3.0×10 ⁻⁹	2.0×10 ⁻⁷	9.9×10 ⁻¹¹	2.8×10 ⁻⁵	1.4×10 ⁻⁸
			95th percentile	3.3×10 ⁻⁵	1.3×10 ⁻⁸	7.7×10 ⁻⁷	3.8×10 ⁻¹⁰	1.1×10 ⁻⁴	5.3×10 ⁻⁸
Design basis earthquake	7.9×10 ⁻⁵	Unlikely	Mean	1.2×10 ⁻⁴	4.7×10 ⁻⁸	3.1×10 ⁻⁶	1.6×10 ⁻⁹	4.4×10 ⁻⁴	2.2×10 ⁻⁷
			95th percentile	5.1×10 ⁻⁴	2.1×10 ⁻⁷	1.2×10 ⁻⁵	6.0×10 ⁻⁹	1.7×10 ⁻³	8.3×10 ⁻⁷
Beyond-design-basis fire	6.0×10 ⁻²	Beyond extremely unlikely	Mean	1.1×10 ⁻¹	4.3×10 ⁻⁵	2.9×10 ⁻³	1.4×10 ⁻⁶	3.4×10 ⁻¹	1.7×10 ⁻⁴
			95th percentile	4.1×10 ⁻¹	1.6×10 ⁻⁴	1.0×10 ⁻²	5.2×10 ⁻⁶	1.3	6.5×10 ⁻⁴
Beyond-design-basis earthquake	9.5×10 ¹	Extremely unlikely to beyond extremely unlikely	Mean	1.7×10 ²	6.8×10 ⁻²	4.6	2.3×10 ⁻³	5.4×10 ²	2.7×10 ⁻¹
			95th percentile	6.5×10 ²	2.6×10 ⁻¹	1.6×10 ¹	8.2×10 ⁻³	2.1×10 ³	1.0
			95th percentile						

^a Increased likelihood (or probability) of cancer fatality to a hypothetical individual (a single noninvolved worker at a distance of 1,000 m [3,281 ft] or at the site boundary, whichever is smaller, or to a hypothetical individual in the offsite population located at the site boundary) if exposed to the indicated dose. The value assumes that the accident has occurred.

^b Estimated number of cancer fatalities in the entire offsite population out to a distance of 80 km (50 mi) if exposed to the indicated dose. The value assumes that the accident has occurred.

Note: Calculated using the source terms in the MOX data report, as modified in Appendix K.1.5.1, site meteorology, projected regional population, and the MACCS2 computer code.

Source: UC 1998g.

K.4 FACILITY ACCIDENT IMPACTS AT PANTEX

The potential source terms and consequences of postulated bounding facility accidents for each facility option for Pantex are presented in Tables K-12 and K-13. Accident scenarios and source terms were developed from data reports prepared for each technology. Consequences were estimated using the MACCS2 computer code and local population and meteorology data. The consequences are presented for mean and 95th percentile meteorological conditions.

Meteorological data are based on 10-m (33-ft) weather readings from the Pantex Tower for the 1996 calendar year.⁷ In accordance with MACCS2 format requirements, the data set consists of 8,760 consecutive hourly readings of windspeed, wind direction, Pasquill-Gifford stability class, and accumulated rainfall.

Population estimates for Pantex are for the year 2010, are based on the *Census of Population and Housing, 1990* (DOC 1992), and are identical to the estimates used for the analysis of normal operations in the SPD EIS. Population values are formatted into 16 sectors centered around the 16 standard compass directions, which are further subdivided into 10 radial distance intervals out to 80 km (50 mi).

⁷ The choice of calendar year was based primarily on data quality. For some combinations of site and calendar year, the data set contains significant gaps, making that data undesirable for use in dispersion modeling. As a result, not all sites were analyzed using meteorological data for the same calendar year.

Table K–12. Accident Impacts of New Pit Conversion Facility at Pantex

Accident	Source Term (g)	Frequency (per year)	Meteorology	Impacts on Noninvolved Worker		Impacts at Site Boundary		Impacts on Population Within 80 km	
				Dose (rem)	Probability of Cancer Fatality ^a	Dose (rem)	Probability of Cancer Fatality ^a	Dose (person-rem)	Latent Cancer Fatalities ^b
Fire	1.2×10 ⁵	Unlikely	Mean	2.3×10 ⁻⁶	9.1×10 ⁻¹⁰	7.6×10 ⁻⁷	3.8×10 ⁻¹⁰	1.8×10 ⁻⁴	9.1×10 ⁻⁸
			95th percentile	5.2×10 ⁻⁶	2.1×10 ⁻⁹	2.1×10 ⁻⁶	1.0×10 ⁻⁹	8.6×10 ⁻⁴	4.3×10 ⁻⁷
Explosion	3.2×10 ³	Unlikely	Mean	6.0×10 ⁻⁴	2.4×10 ⁻⁷	2.0×10 ⁻⁴	9.9×10 ⁻⁸	4.8×10 ⁻²	2.4×10 ⁻⁵
			95th percentile	1.4×10 ⁻³	5.4×10 ⁻⁷	5.4×10 ⁻⁴	2.7×10 ⁻⁷	2.2×10 ⁻¹	1.1×10 ⁻⁴
Leaks/spills of nuclear material	4.4×10 ⁶	Extremely unlikely	Mean	8.4×10 ⁻⁷	3.3×10 ⁻¹⁰	2.8×10 ⁻⁷	1.4×10 ⁻¹⁰	6.7×10 ⁻⁵	3.3×10 ⁻⁸
			95th percentile	1.9×10 ⁻⁶	7.6×10 ⁻¹⁰	7.6×10 ⁻⁷	3.8×10 ⁻¹⁰	3.1×10 ⁻⁴	1.6×10 ⁻⁷
Tritium release	2.0×10 ¹	Extremely unlikely	Mean	9.6×10 ⁻²	3.8×10 ⁻⁵	3.2×10 ⁻²	1.6×10 ⁻⁵	7.7	3.8×10 ⁻³
			95th percentile	2.2×10 ⁻¹	8.7×10 ⁻⁵	8.7×10 ⁻²	4.4×10 ⁻⁵	3.6×10 ¹	1.8×10 ⁻²
Criticality	1.0×10 ¹⁹	Extremely unlikely	Mean	6.1×10 ⁻³	2.5×10 ⁻⁶	2.7×10 ⁻³	1.3×10 ⁻⁶	2.7×10 ⁻¹	1.4×10 ⁻⁴
			95th percentile	1.5×10 ⁻²	6.0×10 ⁻⁶	6.0×10 ⁻³	3.0×10 ⁻⁶	1.6	7.9×10 ⁻⁴
Design basis earthquake	3.9×10 ⁻⁴	Unlikely	Mean	7.4×10 ⁻⁵	2.9×10 ⁻⁸	2.4×10 ⁻⁵	1.2×10 ⁻⁸	5.9×10 ⁻³	2.9×10 ⁻⁶
			95th percentile	1.7×10 ⁻⁴	6.7×10 ⁻⁸	6.7×10 ⁻⁵	3.3×10 ⁻⁸	2.8×10 ⁻²	1.4×10 ⁻⁵
Beyond-design-basis fire	1.7×10 ²	Beyond extremely unlikely	Mean	9.6×10 ⁻³	3.8×10 ⁻⁶	1.5×10 ⁻³	7.5×10 ⁻⁷	2.8×10 ⁻¹	1.4×10 ⁻⁴
			95th percentile	2.8×10 ⁻²	1.1×10 ⁻⁵	4.4×10 ⁻³	2.2×10 ⁻⁶	1.3	6.3×10 ⁻⁴
Beyond-design-basis earthquake	3.9×10 ¹	Extremely unlikely to beyond extremely unlikely	Mean	2.2×10 ¹	8.8×10 ⁻³	3.5	1.7×10 ⁻³	6.4×10 ²	3.2×10 ⁻¹
			95th percentile	6.4×10 ¹	2.6×10 ⁻²	1.0×10 ¹	5.1×10 ⁻³	3.0×10 ³	1.5
Aircraft crash	1.2×10 ²	Beyond extremely unlikely	Mean	6.8×10 ¹	2.7×10 ⁻²	1.1×10 ¹	5.4×10 ⁻³	2.0×10 ³	1.0
			95th percentile	2.0×10 ²	7.9×10 ⁻²	3.1×10 ¹	1.6×10 ⁻²	9.2×10 ³	4.5

^a Increased likelihood (or probability) of cancer fatality to a hypothetical individual (a single noninvolved worker at a distance of 1,000 m [3,281 ft] or at the site boundary, whichever is smaller, or to a hypothetical individual in the offsite population located at the site boundary) if exposed to the indicated dose. The value assumes that the accident has occurred.

^b Estimated number of cancer fatalities in the entire offsite population out to a distance of 80 km (50 mi) if exposed to the indicated dose. The value assumes that the accident has occurred.

Note: Calculated using the source terms in the pit conversion data report, as modified in Appendix K.1.5.1, site meteorology, projected regional population, and the MACCS2 computer code.

Source: UC 1998e.

Table K–13. Accident Impacts of New MOX Facility at Pantex

Accident	Source Term (g)	Frequency (per year)	Meteorology	Impacts on Noninvolved Worker		Impacts at Site Boundary		Impacts on Population Within 80 km	
				Dose (rem)	Probability of Cancer Fatality ^a	Dose (rem)	Probability of Cancer Fatality ^a	Dose (person-rem)	Latent Cancer Fatalities ^b
Criticality	1.0×10 ¹⁹ fissions	Extremely unlikely	Mean	7.5×10 ⁻²	3.0×10 ⁻⁵	1.9×10 ⁻²	9.3×10 ⁻⁶	1.9	9.4×10 ⁻⁴
			95th percentile	2.4×10 ⁻¹	9.5×10 ⁻⁵	4.7×10 ⁻²	2.3×10 ⁻⁵	1.1×10 ¹	5.4×10 ⁻³
Explosion in sintering furnace	5.5×10 ⁻⁴	Extremely unlikely	Mean	2.8×10 ⁻⁴	1.1×10 ⁻⁷	4.8×10 ⁻⁵	2.4×10 ⁻⁸	9.1×10 ⁻³	4.5×10 ⁻⁶
			95th percentile	8.9×10 ⁻⁴	3.5×10 ⁻⁷	1.3×10 ⁻⁴	6.6×10 ⁻⁸	4.2×10 ⁻²	2.1×10 ⁻⁵
Ion exchange exotherm	2.4×10 ⁻⁵	Unlikely	Mean	1.2×10 ⁻⁵	5.0×10 ⁻⁹	2.1×10 ⁻⁶	1.0×10 ⁻⁹	4.0×10 ⁻⁴	2.0×10 ⁻⁷
			95th percentile	3.9×10 ⁻⁵	1.5×10 ⁻⁸	5.8×10 ⁻⁶	2.9×10 ⁻⁹	1.8×10 ⁻³	9.0×10 ⁻⁷
Fire	4.0×10 ⁻⁶	Unlikely	Mean	2.1×10 ⁻⁶	8.3×10 ⁻¹⁰	3.5×10 ⁻⁷	1.7×10 ⁻¹⁰	6.6×10 ⁻⁵	3.3×10 ⁻⁸
			95th percentile	6.4×10 ⁻⁶	2.6×10 ⁻⁹	9.6×10 ⁻⁷	4.8×10 ⁻¹⁰	3.0×10 ⁻⁴	1.5×10 ⁻⁷
Spill	5.0×10 ⁻⁶	Extremely unlikely	Mean	2.6×10 ⁻⁶	1.0×10 ⁻⁹	4.4×10 ⁻⁷	2.2×10 ⁻¹⁰	8.3×10 ⁻⁵	4.1×10 ⁻⁸
			95th percentile	8.1×10 ⁻⁶	3.2×10 ⁻⁹	1.2×10 ⁻⁶	6.0×10 ⁻¹⁰	3.8×10 ⁻⁴	1.9×10 ⁻⁷
Design basis earthquake	7.9×10 ⁻⁵	Unlikely	Mean	4.1×10 ⁻⁵	1.6×10 ⁻⁸	6.8×10 ⁻⁶	3.4×10 ⁻⁹	1.3×10 ⁻³	6.5×10 ⁻⁷
			95th percentile	1.3×10 ⁻⁴	5.1×10 ⁻⁸	1.9×10 ⁻⁵	9.4×10 ⁻⁹	5.9×10 ⁻³	3.0×10 ⁻⁶
Beyond-design-basis fire	6.0×10 ⁻²	Beyond extremely unlikely	Mean	3.4×10 ⁻²	1.4×10 ⁻⁵	5.4×10 ⁻³	2.7×10 ⁻⁶	1.0	5.0×10 ⁻⁴
			95th percentile	9.9×10 ⁻²	4.0×10 ⁻⁵	1.6×10 ⁻²	7.8×10 ⁻⁶	4.6	2.3×10 ⁻³
Beyond-design-basis earthquake	9.5×10 ¹	Extremely unlikely to beyond extremely unlikely	Mean	5.4×10 ¹	2.2×10 ⁻²	8.5	4.3×10 ⁻³	1.6×10 ³	7.9×10 ⁻¹
			95th percentile	1.6×10 ²	6.3×10 ⁻²	2.5×10 ¹	1.2×10 ⁻²	7.3×10 ³	3.6
Aircraft crash	7.1×10 ²	Beyond extremely unlikely	Mean	4.0×10 ²	1.6×10 ⁻¹	6.3×10 ¹	3.2×10 ⁻²	1.2×10 ⁴	5.9
			95th percentile	1.2×10 ³	4.7×10 ⁻¹	1.9×10 ²	9.3×10 ⁻²	5.4×10 ⁴	2.7×10 ¹

^a Increased likelihood (or probability) of cancer fatality to a hypothetical individual (a single noninvolved worker at a distance of 1,000 m [3,281 ft] or at the site boundary, whichever is smaller, or to a hypothetical individual in the offsite population located at the site boundary) if exposed to the indicated dose. The value assumes that the accident has occurred.

^b Estimated number of cancer fatalities in the entire offsite population out to a distance of 80 km (50 mi) if exposed to the indicated dose. The value assumes that the accident has occurred.

Note: Calculated using the source terms in the MOX data report, as modified in Appendix K.1.5.1, site meteorology, projected regional population, and the MACCS2 computer code.

Source: UC 1998h.

K.5 FACILITY ACCIDENT IMPACTS AT SRS

The potential source terms and consequences of postulated bounding facility accidents for each facility option for SRS are presented in Tables K-14 through K-19. Accident scenarios and source terms were developed from data reports prepared for each technology. Consequences were estimated using the MACCS2 computer code and local population and meteorology data. The consequences are presented for both mean and 95th percentile meteorological conditions.

Meteorological data are based on 10-m (33-ft) weather readings at SRS, are identical to the data used in *F-Canyon Plutonium Solutions Environmental Impact Statement*, and included in Sample Problem D of the MACCS2 User's Guide (Chanin and Young 1997:4-4). In accordance with MACCS2 format requirements, the data set consists of 8,760 consecutive hourly readings of windspeed, wind direction, Pasquill-Gifford stability class, and accumulated rainfall.

Population estimates for SRS are for the year 2010, are based on the *Census of Population and Housing, 1990* (DOC 1992), and are identical to the estimates used for the analysis of normal operations in the SPD EIS. Population values are formatted into 16 sectors centered around the 16 standard compass directions, which are further subdivided into 10 radial distance intervals out to 80 km (50 mi).

| [Tables deleted.]

Table K–14. Accident Impacts of New Pit Conversion Facility at SRS

Accident	Source Term (g)	Frequency (per year)	Meteorology	Impacts on Noninvolved Worker		Impacts at Site Boundary		Impacts on Population Within 80 km	
				Dose (rem)	Probability of Cancer Fatality ^a	Dose (rem)	Probability of Cancer Fatality ^a	Dose (person-rem)	Latent Cancer Fatalities ^b
Fire	1.2×10 ⁻⁵	Unlikely	Mean	2.6×10 ⁻⁶	1.1×10 ⁻⁹	2.1×10 ⁻⁷	1.0×10 ⁻¹⁰	5.4×10 ⁻⁴	2.7×10 ⁻⁷
			95th percentile	6.2×10 ⁻⁶	2.5×10 ⁻⁹	6.7×10 ⁻⁷	3.3×10 ⁻¹⁰	2.4×10 ⁻³	1.2×10 ⁻⁶
Explosion	3.2×10 ⁻³	Unlikely	Mean	6.9×10 ⁻⁴	2.8×10 ⁻⁷	5.4×10 ⁻⁵	2.7×10 ⁻⁸	1.4×10 ⁻¹	7.0×10 ⁻⁵
			95th percentile	1.6×10 ⁻³	6.5×10 ⁻⁷	1.8×10 ⁻⁴	8.8×10 ⁻⁸	6.2×10 ⁻¹	3.1×10 ⁻⁴
Leaks/spills of nuclear material	4.4×10 ⁻⁶	Extremely unlikely	Mean	9.6×10 ⁻⁷	3.9×10 ⁻¹⁰	7.5×10 ⁻⁸	3.8×10 ⁻¹¹	2.0×10 ⁻⁴	9.8×10 ⁻⁸
			95th percentile	2.3×10 ⁻⁶	9.1×10 ⁻¹⁰	2.5×10 ⁻⁷	1.2×10 ⁻¹⁰	8.7×10 ⁻⁴	4.3×10 ⁻⁷
Tritium release	2.0×10 ¹	Extremely unlikely	Mean	1.1×10 ⁻¹	4.4×10 ⁻⁵	8.6×10 ⁻³	4.3×10 ⁻⁶	2.3×10 ¹	1.1×10 ⁻²
			95th percentile	2.6×10 ⁻¹	1.0×10 ⁻⁴	2.8×10 ⁻²	1.4×10 ⁻⁵	1.0×10 ²	5.0×10 ⁻²
Criticality	1.0×10 ¹⁹ fissions	Extremely unlikely	Mean	7.9×10 ⁻³	3.2×10 ⁻⁶	5.8×10 ⁻⁴	2.9×10 ⁻⁷	4.2×10 ⁻¹	2.1×10 ⁻⁴
			95th percentile	1.7×10 ⁻²	6.7×10 ⁻⁶	1.8×10 ⁻³	9.2×10 ⁻⁷	1.8	9.0×10 ⁻⁴
Design basis earthquake	3.9×10 ⁻⁴	Unlikely	Mean	8.5×10 ⁻⁵	3.4×10 ⁻⁸	6.6×10 ⁻⁶	3.3×10 ⁻⁹	1.7×10 ⁻²	8.6×10 ⁻⁶
			95th percentile	2.0×10 ⁻⁴	8.0×10 ⁻⁸	2.2×10 ⁻⁵	1.1×10 ⁻⁸	7.7×10 ⁻²	3.8×10 ⁻⁵
Beyond-design-basis fire	1.7×10 ⁻²	Beyond extremely unlikely	Mean	1.1×10 ⁻²	4.4×10 ⁻⁶	4.8×10 ⁻⁴	2.4×10 ⁻⁷	8.8×10 ⁻¹	4.4×10 ⁻⁴
			95th percentile	4.0×10 ⁻²	1.6×10 ⁻⁵	1.6×10 ⁻³	7.8×10 ⁻⁷	3.7	1.9×10 ⁻³
Beyond-design-basis earthquake	3.9×10 ¹	Extremely unlikely to beyond extremely unlikely	Mean	2.5×10 ¹	1.0×10 ⁻²	1.1	5.5×10 ⁻⁴	2.0×10 ³	1.0
			95th percentile	9.2×10 ¹	3.7×10 ⁻²	3.6	1.8×10 ⁻³	8.5×10 ³	4.3

^a Increased likelihood (or probability) of cancer fatality to a hypothetical individual (a single noninvolved worker at a distance of 1,000 m [3,281 ft] (or at the site boundary, whichever is smaller, or to a hypothetical individual in the offsite population located at the site boundary) if exposed to the indicated dose. The value assumes that the accident has occurred.

^b Estimated number of cancer fatalities in the entire offsite population out to a distance of 80 km (50 mi) if exposed to the indicated dose. The value assumes that the accident has occurred.

Note: Calculated using the source terms in the pit conversion data report, as modified in Appendix K.1.5.1, site meteorology, projected regional population, and the MACCS2 computer code.

Source: UC 1998c.

Table K–15. Accident Impacts of Ceramic Immobilization Facility in New Construction and DWPF at SRS (Hybrid Case)

Accident	Source Term (g)	Frequency (per year)	Meteorology	Impacts on Noninvolved Worker		Impacts at Site Boundary		Impacts on Population Within 80 km	
				Dose (rem)	Probability of Cancer Fatality ^a	Dose (rem)	Probability of Cancer Fatality ^a	Dose (person-rem)	Latent Cancer Fatalities ^b
Criticality	1.0×10 ¹⁹ fissions	Extremely unlikely	Mean	5.3×10 ⁻³	2.1×10 ⁻⁶	4.6×10 ⁻⁴	2.3×10 ⁻⁷	3.5×10 ⁻¹	1.8×10 ⁻⁴
			95th percentile	1.0×10 ⁻²	4.2×10 ⁻⁶	1.6×10 ⁻³	7.8×10 ⁻⁷	1.5	7.5×10 ⁻⁴
Explosion in HYDOX furnace	3.4×10 ⁻³	Unlikely	Mean	3.9×10 ⁻⁴	1.6×10 ⁻⁷	5.3×10 ⁻⁵	2.7×10 ⁻⁸	1.6×10 ⁻¹	7.8×10 ⁻⁵
			95th percentile	8.6×10 ⁻⁴	3.4×10 ⁻⁷	1.6×10 ⁻⁴	8.1×10 ⁻⁸	7.1×10 ⁻¹	3.5×10 ⁻⁴
Glovebox fire (calcining furnace)	2.7×10 ⁻⁷	Extremely unlikely	Mean	3.1×10 ⁻⁸	1.2×10 ⁻¹¹	4.2×10 ⁻⁹	2.1×10 ⁻¹²	1.2×10 ⁻⁵	6.2×10 ⁻⁹
			95th percentile	6.8×10 ⁻⁸	2.7×10 ⁻¹¹	1.3×10 ⁻⁸	6.5×10 ⁻¹²	5.6×10 ⁻⁵	2.8×10 ⁻⁸
Hydrogen explosion	3.8×10 ⁻⁴	Unlikely	Mean	4.3×10 ⁻⁵	1.7×10 ⁻⁸	5.9×10 ⁻⁶	2.9×10 ⁻⁹	1.7×10 ⁻²	8.6×10 ⁻⁶
			95th percentile	9.5×10 ⁻⁵	3.8×10 ⁻⁸	1.8×10 ⁻⁵	9.0×10 ⁻⁹	7.8×10 ⁻²	3.8×10 ⁻⁵
Glovebox fire (sintering furnace)	1.5×10 ⁻⁶	Extremely unlikely	Mean	1.7×10 ⁻⁷	6.9×10 ⁻¹¹	2.4×10 ⁻⁸	1.2×10 ⁻¹¹	6.9×10 ⁻⁵	3.4×10 ⁻⁸
			95th percentile	3.8×10 ⁻⁷	1.5×10 ⁻¹⁰	7.2×10 ⁻⁸	3.6×10 ⁻¹¹	3.1×10 ⁻⁴	1.5×10 ⁻⁷
Design basis earthquake	3.8×10 ⁻⁴	Unlikely	Mean	4.4×10 ⁻⁵	1.7×10 ⁻⁸	5.9×10 ⁻⁶	3.0×10 ⁻⁹	1.7×10 ⁻²	8.7×10 ⁻⁶
			95th percentile	9.6×10 ⁻⁵	3.8×10 ⁻⁸	1.8×10 ⁻⁵	9.1×10 ⁻⁹	7.9×10 ⁻²	3.9×10 ⁻⁵
Beyond-design-basis fire	2.1×10 ⁻³	Beyond extremely unlikely	Mean	1.7×10 ⁻³	6.9×10 ⁻⁷	7.6×10 ⁻⁵	3.8×10 ⁻⁸	1.4×10 ⁻¹	7.0×10 ⁻⁵
			95th percentile	6.3×10 ⁻³	2.5×10 ⁻⁶	2.5×10 ⁻⁴	1.2×10 ⁻⁷	5.8×10 ⁻¹	2.9×10 ⁻⁴
Beyond-design-basis earthquake	1.9×10 ¹	Extremely unlikely to beyond extremely unlikely	Mean	1.6×10 ¹	6.3×10 ⁻³	6.8×10 ⁻¹	3.4×10 ⁻⁴	1.3×10 ³	6.3×10 ⁻¹
			95th percentile	5.7×10 ¹	2.3×10 ⁻²	2.2	1.1×10 ⁻³	5.3×10 ³	2.7

^a Increased likelihood (or probability) of cancer fatality to a hypothetical individual (a single noninvolved worker at a distance of 1,000 m [3,281 ft] or at the site boundary, whichever is smaller, or to a hypothetical individual in the offsite population located at the site boundary) if exposed to the indicated dose. The value assumes that the accident has occurred.

^b Estimated number of cancer fatalities in the entire offsite population out to a distance of 80 km (50 mi) if exposed to the indicated dose. The value assumes that the accident has occurred.

Key: DWPF, Defense Waste Processing Facility; HYDOX, hydride oxidation.

Note: Calculated using the source terms in the immobilization data report, as modified in Appendix K.1.5.1, site meteorology, projected regional population, and the MACCS2 computer code.

Source: UC 1999c.

Table K–16. Accident Impacts of Glass Immobilization Facility in New Construction and DWPF at SRS (Hybrid Case)

Accident	Source Term (g)	Frequency (per year)	Meteorology	Impacts on Noninvolved Worker		Impacts at Site Boundary		Impacts on Population Within 80 km	
				Dose (rem)	Probability of Cancer Fatality ^a	Dose (rem)	Probability of Cancer Fatality ^a	Dose (person-rem)	Latent Cancer Fatalities ^b
Criticality	1.0×10 ¹⁹ fissions	Extremely unlikely	Mean	5.3×10 ⁻³	2.1×10 ⁻⁶	4.6×10 ⁻⁴	2.3×10 ⁻⁷	3.5×10 ⁻¹	1.8×10 ⁻⁴
			95th percentile	1.0×10 ⁻²	4.2×10 ⁻⁶	1.6×10 ⁻³	7.8×10 ⁻⁷	1.5	7.5×10 ⁻⁴
Explosion in HYDOX furnace	3.4×10 ⁻³	Unlikely	Mean	3.9×10 ⁻⁴	1.6×10 ⁻⁷	5.3×10 ⁻⁵	2.7×10 ⁻⁸	1.6×10 ⁻¹	7.8×10 ⁻⁵
			95th percentile	8.6×10 ⁻⁴	3.4×10 ⁻⁷	1.6×10 ⁻⁴	8.1×10 ⁻⁸	7.1×10 ⁻¹	3.5×10 ⁻⁴
Glovebox fire (calcining furnace)	2.7×10 ⁻⁷	Extremely unlikely	Mean	3.1×10 ⁻⁸	1.2×10 ⁻¹¹	4.2×10 ⁻⁹	2.1×10 ⁻¹²	1.2×10 ⁻⁵	6.2×10 ⁻⁹
			95th percentile	6.8×10 ⁻⁸	2.7×10 ⁻¹¹	1.3×10 ⁻⁸	6.5×10 ⁻¹²	5.6×10 ⁻⁵	2.8×10 ⁻⁸
Hydrogen explosion	3.8×10 ⁻⁴	Unlikely	Mean	4.3×10 ⁻⁵	1.7×10 ⁻⁸	5.9×10 ⁻⁶	2.9×10 ⁻⁹	1.7×10 ⁻²	8.6×10 ⁻⁶
			95th percentile	9.5×10 ⁻⁵	3.8×10 ⁻⁸	1.8×10 ⁻⁵	9.0×10 ⁻⁹	7.8×10 ⁻²	3.8×10 ⁻⁵
Melter eruption	1.4×10 ⁻⁶	Unlikely	Mean	1.6×10 ⁻⁷	6.4×10 ⁻¹¹	2.2×10 ⁻⁸	1.1×10 ⁻¹¹	6.4×10 ⁻⁵	3.2×10 ⁻⁸
			95th percentile	3.5×10 ⁻⁷	1.4×10 ⁻¹⁰	6.7×10 ⁻⁸	3.3×10 ⁻¹¹	2.9×10 ⁻⁴	1.4×10 ⁻⁷
Melter spill	3.3×10 ⁻⁷	Unlikely	Mean	3.8×10 ⁻⁸	1.5×10 ⁻¹¹	5.1×10 ⁻⁹	2.6×10 ⁻¹²	1.5×10 ⁻⁵	7.5×10 ⁻⁹
			95th percentile	8.3×10 ⁻⁸	3.3×10 ⁻¹¹	1.6×10 ⁻⁸	7.8×10 ⁻¹²	6.8×10 ⁻⁵	3.3×10 ⁻⁸
Design basis earthquake	3.3×10 ⁻⁴	Unlikely	Mean	3.8×10 ⁻⁵	1.5×10 ⁻⁸	5.2×10 ⁻⁶	2.6×10 ⁻⁹	1.5×10 ⁻²	7.6×10 ⁻⁶
			95th percentile	8.3×10 ⁻⁵	3.3×10 ⁻⁸	1.6×10 ⁻⁵	7.9×10 ⁻⁹	6.9×10 ⁻²	3.4×10 ⁻⁵
Beyond-design-basis fire	3.8×10 ⁻⁴	Beyond extremely unlikely	Mean	3.1×10 ⁻⁴	1.2×10 ⁻⁷	1.4×10 ⁻⁵	6.8×10 ⁻⁹	2.5×10 ⁻²	1.3×10 ⁻⁵
			95th percentile	1.1×10 ⁻³	4.6×10 ⁻⁷	4.4×10 ⁻⁵	2.2×10 ⁻⁸	1.0×10 ⁻¹	5.3×10 ⁻⁵
Beyond-design-basis earthquake	1.7×10 ¹	Extremely unlikely to beyond extremely unlikely	Mean	1.4×10 ¹	5.5×10 ⁻³	6.0×10 ⁻¹	3.0×10 ⁻⁴	1.1×10 ³	5.5×10 ⁻¹
			95th percentile	5.0×10 ¹	2.0×10 ⁻²	2.0	9.8×10 ⁻⁴	4.6×10 ³	2.3

^a Increased likelihood (or probability) of cancer fatality to a hypothetical individual (a single noninvolved worker at a distance of 1,000 m [3,281 ft] or at the site boundary, whichever is smaller, or to a hypothetical individual in the offsite population located at the site boundary) if exposed to the indicated dose. The value assumes that the accident has occurred.

^b Estimated number of cancer fatalities in the entire offsite population out to a distance of 80 km (50 mi) if exposed to the indicated dose. The value assumes that the accident has occurred.

Key: DWPF, Defense Waste Processing Facility; HYDOX, hydride oxidation.

Note: Calculated using the source terms in the immobilization data report, as modified in Appendix K.1.5.1, site meteorology, projected regional population, and the MACCS2 computer code.

Source: UC 1999d.

Table K–17. Accident Impacts of Ceramic Immobilization Facility in New Construction and DWPF at SRS (50-t Case)

Accident	Source Term (g)	Frequency (per year)	Meteorology	Impacts on Noninvolved Worker		Impacts at Site Boundary		Impacts on Population Within 80 km	
				Dose (rem)	Probability of Cancer Fatality ^a	Dose (rem)	Probability of Cancer Fatality ^s	Dose (person-rem)	Latent Cancer Fatalities ^b
Criticality	1.0×10 ¹⁹ fissions	Extremely unlikely	Mean	5.3×10 ⁻³	2.1×10 ⁻⁶	4.6×10 ⁻⁴	2.3×10 ⁻⁷	3.5×10 ⁻¹	1.8×10 ⁻⁴
			95th percentile	1.0×10 ⁻²	4.2×10 ⁻⁶	1.6×10 ⁻³	7.8×10 ⁻⁷	1.5	7.5×10 ⁻⁴
Explosion in HYDOX furnace	3.4×10 ³	Unlikely	Mean	3.9×10 ⁻⁴	1.6×10 ⁻⁷	5.3×10 ⁻⁵	2.7×10 ⁻⁸	1.6×10 ⁻¹	7.8×10 ⁻⁵
			95th percentile	8.6×10 ⁻⁴	3.4×10 ⁻⁷	1.6×10 ⁻⁴	8.1×10 ⁻⁸	7.1×10 ⁻¹	3.5×10 ⁻⁴
Glovebox fire (calcining furnace)	2.7×10 ⁷	Extremely unlikely	Mean	3.1×10 ⁻⁸	1.2×10 ⁻¹¹	4.2×10 ⁻⁹	2.1×10 ⁻¹²	1.2×10 ⁻⁵	6.2×10 ⁻⁹
			95th percentile	6.8×10 ⁻⁸	2.7×10 ⁻¹¹	1.3×10 ⁻⁸	6.5×10 ⁻¹²	5.6×10 ⁻⁵	2.8×10 ⁻⁸
Hydrogen explosion	3.8×10 ⁴	Unlikely	Mean	4.3×10 ⁻⁵	1.7×10 ⁻⁸	5.9×10 ⁻⁶	2.9×10 ⁻⁹	1.7×10 ⁻²	8.6×10 ⁻⁶
			95th percentile	9.5×10 ⁻⁵	3.8×10 ⁻⁸	1.8×10 ⁻⁵	9.0×10 ⁻⁹	7.8×10 ⁻²	3.8×10 ⁻⁵
Glovebox fire (sintering furnace)	1.5×10 ⁶	Extremely unlikely	Mean	1.7×10 ⁻⁷	6.9×10 ⁻¹¹	2.4×10 ⁻⁸	1.2×10 ⁻¹¹	6.9×10 ⁻⁵	3.4×10 ⁻⁸
			95th percentile	3.8×10 ⁻⁷	1.5×10 ⁻¹⁰	7.2×10 ⁻⁸	3.6×10 ⁻¹¹	3.1×10 ⁻⁴	1.5×10 ⁻⁷
Design basis earthquake	3.8×10 ⁴	Unlikely	Mean	4.0×10 ⁻⁵	1.6×10 ⁻⁸	5.5×10 ⁻⁶	2.7×10 ⁻⁹	1.6×10 ⁻²	8.0×10 ⁻⁶
			95th percentile	8.8×10 ⁻⁵	3.5×10 ⁻⁸	1.7×10 ⁻⁵	8.3×10 ⁻⁹	7.2×10 ⁻²	3.6×10 ⁻⁵
Beyond-design-basis fire	2.1×10 ³	Beyond extremely unlikely	Mean	1.7×10 ⁻³	6.9×10 ⁻⁷	7.6×10 ⁻⁵	3.8×10 ⁻⁸	1.4×10 ⁻¹	7.0×10 ⁻⁵
			95th percentile	6.3×10 ⁻³	2.5×10 ⁻⁶	2.5×10 ⁻⁴	1.2×10 ⁻⁷	5.8×10 ⁻¹	2.9×10 ⁻⁴
Beyond-design-basis earthquake	1.9×10 ¹	Extremely unlikely to beyond extremely unlikely	Mean	1.4×10 ¹	5.7×10 ⁻³	6.3×10 ⁻¹	3.1×10 ⁻⁴	1.2×10 ³	5.8×10 ⁻¹
			95th percentile	5.3×10 ¹	2.1×10 ⁻²	2.1	1.0×10 ⁻³	4.8×10 ³	2.5

^a Increased likelihood (or probability) of cancer fatality to a hypothetical individual (a single noninvolved worker at a distance of 1,000 m [3,281 ft] or at the site boundary, whichever is smaller, or to a hypothetical individual in the offsite population located at the site boundary) if exposed to the indicated dose. The value assumes that the accident has occurred.

^b Estimated number of cancer fatalities in the entire offsite population out to a distance of 80 km (50 mi) if exposed to the indicated dose. The value assumes that the accident has occurred.

Key: DWPF, Defense Waste Processing Facility; HYDOX, hydride oxidation.

Note: Calculated using the source terms in the immobilization data report, as modified in Appendix K.1.5.1, site meteorology, projected regional population, and the MACCS2 computer code.

Source: UC 1999c.

Table K–18. Accident Impacts of Glass Immobilization Facility in New Construction and DWPF at SRS (50-t Case)

Accident	Source Term (g)	Frequency (per year)	Meteorology	Impacts on Noninvolved Worker		Impacts at Site Boundary		Impacts on Population Within 80 km	
				Dose (rem)	Probability of Cancer Fatality ^a	Dose (rem)	Probability of Cancer Fatality ^a	Dose (person-rem)	Latent Cancer Fatalities ^b
Criticality	1.0×10 ¹⁹ fissions	Extremely unlikely	Mean	5.3×10 ⁻³	2.1×10 ⁻⁶	4.6×10 ⁻⁴	2.3×10 ⁻⁷	3.5×10 ⁻¹	1.8×10 ⁻⁴
			95th percentile	1.0×10 ⁻²	4.2×10 ⁻⁶	1.6×10 ⁻³	7.8×10 ⁻⁷	1.5	7.5×10 ⁻⁴
Explosion in HYDOX furnace	3.4×10 ⁻³	Unlikely	Mean	3.9×10 ⁻⁴	1.6×10 ⁻⁷	5.3×10 ⁻⁵	2.7×10 ⁻⁸	1.6×10 ⁻¹	7.8×10 ⁻⁵
			95th percentile	8.6×10 ⁻⁴	3.4×10 ⁻⁷	1.6×10 ⁻⁴	8.1×10 ⁻⁸	7.1×10 ⁻¹	3.5×10 ⁻⁴
Glovebox fire (calcining furnace)	2.7×10 ⁻⁷	Extremely unlikely	Mean	3.1×10 ⁻⁸	1.2×10 ⁻¹¹	4.2×10 ⁻⁹	2.1×10 ⁻¹²	1.2×10 ⁻⁵	6.2×10 ⁻⁹
			95th percentile	6.8×10 ⁻⁸	2.7×10 ⁻¹¹	1.3×10 ⁻⁸	6.5×10 ⁻¹²	5.6×10 ⁻⁵	2.8×10 ⁻⁸
Hydrogen explosion	3.8×10 ⁻⁴	Unlikely	Mean	4.3×10 ⁻⁵	1.7×10 ⁻⁸	5.9×10 ⁻⁶	2.9×10 ⁻⁹	1.7×10 ⁻²	8.6×10 ⁻⁶
			95th percentile	9.5×10 ⁻⁵	3.8×10 ⁻⁸	1.8×10 ⁻⁵	9.0×10 ⁻⁹	7.8×10 ⁻²	3.8×10 ⁻⁵
Melter eruption	1.4×10 ⁻⁶	Unlikely	Mean	1.6×10 ⁻⁷	6.4×10 ⁻¹¹	2.2×10 ⁻⁸	1.1×10 ⁻¹¹	6.4×10 ⁻⁵	3.2×10 ⁻⁸
			95th percentile	3.5×10 ⁻⁷	1.4×10 ⁻¹⁰	6.7×10 ⁻⁸	3.3×10 ⁻¹¹	2.9×10 ⁻⁴	1.4×10 ⁻⁷
Melter spill	3.3×10 ⁻⁷	Unlikely	Mean	3.8×10 ⁻⁸	1.5×10 ⁻¹¹	5.1×10 ⁻⁹	2.6×10 ⁻¹²	1.5×10 ⁻⁵	7.5×10 ⁻⁹
			95th percentile	8.3×10 ⁻⁸	3.3×10 ⁻¹¹	1.6×10 ⁻⁸	7.8×10 ⁻¹²	6.8×10 ⁻⁵	3.3×10 ⁻⁸
Design basis earthquake	3.3×10 ⁻⁴	Unlikely	Mean	3.5×10 ⁻⁵	1.4×10 ⁻⁸	4.8×10 ⁻⁶	2.4×10 ⁻⁹	1.4×10 ⁻²	7.0×10 ⁻⁶
			95th percentile	7.7×10 ⁻⁵	3.1×10 ⁻⁸	1.5×10 ⁻⁵	7.3×10 ⁻⁹	6.4×10 ⁻²	3.1×10 ⁻⁵
Beyond-design-basis fire	3.8×10 ⁻⁴	Beyond extremely unlikely	Mean	3.1×10 ⁻⁴	1.2×10 ⁻⁷	1.4×10 ⁻⁵	6.8×10 ⁻⁹	2.5×10 ⁻²	1.3×10 ⁻⁵
			95th percentile	1.1×10 ⁻³	4.6×10 ⁻⁷	4.4×10 ⁻⁵	2.2×10 ⁻⁸	1.0×10 ⁻¹	5.3×10 ⁻⁵
Beyond-design-basis earthquake	1.7×10 ¹	Extremely unlikely to beyond extremely unlikely	Mean	1.3×10 ¹	5.1×10 ⁻³	5.6×10 ⁻¹	2.8×10 ⁻⁴	1.0×10 ³	5.1×10 ⁻¹
			95th percentile	4.7×10 ¹	1.9×10 ⁻²	1.8	9.1×10 ⁻⁴	4.3×10 ³	2.2

^a Increased likelihood (or probability) of cancer fatality to a hypothetical individual (a single noninvolved worker at a distance of 1,000 m [3,281 ft] or at the site boundary, whichever is smaller, or to a hypothetical individual in the offsite population located at the site boundary) if exposed to the indicated dose. The value assumes that the accident has occurred.

^b Estimated number of cancer fatalities in the entire offsite population out to a distance of 80 km (50 mi) if exposed to the indicated dose. The value assumes that the accident has occurred.

Key: DWPF, Defense Waste Processing Facility; HYDOX, hydride oxidation.

Note: Calculated using the source terms in the immobilization data report, as modified in Appendix K.1.5.1, site meteorology, projected regional population, and the MACCS2 computer code.

Source: UC 1999d.

Table K-19. Accident Impacts of New MOX Facility at SRS

Accident	Source Term (g)	Frequency (per year)	Meteorology	Impacts on Noninvolved Worker		Impacts at Site Boundary		Impacts on Population Within 80 km	
				Dose (rem)	Probability of Cancer Fatality ^a	Dose (rem)	Probability of Cancer Fatality ^a	Dose (person-rem)	Latent Cancer Fatalities ^b
Criticality	1.0×10 ¹⁹ fissions	Extremely unlikely	Mean	8.8×10 ⁻²	3.5×10 ⁻⁵	4.0×10 ⁻³	2.0×10 ⁻⁶	3.9	1.9×10 ⁻³
			95th percentile	3.0×10 ⁻¹	1.2×10 ⁻⁴	1.6×10 ⁻²	8.0×10 ⁻⁶	1.6×10 ¹	8.0×10 ⁻³
Explosion in sintering furnace	5.5×10 ⁻⁴	Extremely unlikely	Mean	3.3×10 ⁻⁴	1.3×10 ⁻⁷	1.2×10 ⁻⁵	6.1×10 ⁻⁹	2.9×10 ⁻²	1.4×10 ⁻⁵
			95th percentile	1.2×10 ⁻³	4.6×10 ⁻⁷	4.8×10 ⁻⁵	2.4×10 ⁻⁸	1.2×10 ⁻¹	6.1×10 ⁻⁵
Ion exchange exotherm	2.4×10 ⁻⁵	Unlikely	Mean	1.4×10 ⁻⁵	5.7×10 ⁻⁹	5.3×10 ⁻⁷	2.7×10 ⁻¹⁰	1.2×10 ⁻³	6.2×10 ⁻⁷
			95th percentile	5.1×10 ⁻⁵	2.0×10 ⁻⁸	2.1×10 ⁻⁶	1.1×10 ⁻⁹	5.3×10 ⁻³	2.7×10 ⁻⁶
Fire	4.0×10 ⁻⁶	Unlikely	Mean	2.4×10 ⁻⁶	9.5×10 ⁻¹⁰	8.9×10 ⁻⁸	4.4×10 ⁻¹¹	2.1×10 ⁴	1.0×10 ⁷
			95th percentile	8.4×10 ⁻⁶	3.4×10 ⁻⁹	3.5×10 ⁻⁷	1.8×10 ⁻¹⁰	8.8×10 ⁴	4.4×10 ⁷
Spill	5.0×10 ⁻⁶	Extremely unlikely	Mean	3.0×10 ⁻⁶	1.2×10 ⁻⁹	1.1×10 ⁻⁷	5.6×10 ⁻¹¹	2.6×10 ⁴	1.3×10 ⁷
			95th percentile	1.1×10 ⁻⁵	4.2×10 ⁻⁹	4.4×10 ⁻⁷	2.2×10 ⁻¹⁰	1.1×10 ⁻³	5.5×10 ⁷
Design basis earthquake	7.9×10 ⁻⁵	Unlikely	Mean	4.6×10 ⁻⁵	1.9×10 ⁻⁸	1.7×10 ⁻⁶	8.7×10 ⁻¹⁰	4.1×10 ⁻³	2.0×10 ⁻⁶
			95th percentile	1.7×10 ⁻⁴	6.6×10 ⁻⁸	6.9×10 ⁻⁶	3.5×10 ⁻⁹	1.7×10 ⁻²	8.7×10 ⁻⁶
Beyond-design-basis fire	6.0×10 ⁻²	Beyond extremely unlikely	Mean	3.9×10 ⁻²	1.6×10 ⁻⁵	1.7×10 ⁻³	8.5×10 ⁻⁷	3.2	1.6×10 ⁻³
			95th percentile	1.4×10 ⁻¹	5.7×10 ⁻⁵	5.6×10 ⁻³	2.8×10 ⁻⁶	1.3×10 ¹	6.7×10 ⁻³
Beyond-design-basis earthquake	9.5×10 ¹	Extremely unlikely to beyond extremely unlikely	Mean	6.2×10 ¹	2.5×10 ⁻²	2.7	1.4×10 ⁻³	5.0×10 ³	2.5
			95th percentile	2.3×10 ²	9.1×10 ⁻²	8.8	4.4×10 ⁻³	2.1×10 ⁴	1.1×10 ¹

^a Increased likelihood (or probability) of cancer fatality to a hypothetical individual (a single noninvolved worker at a distance of 1,000 m [3,281 ft] or at the site boundary, whichever is smaller, or to a hypothetical individual in the offsite population located at the site boundary) if exposed to the indicated dose. The value assumes that the accident has occurred.

^b Estimated number of cancer fatalities in the entire offsite population out to a distance of 80 km (50 mi) if exposed to the indicated dose. The value assumes that the accident has occurred.

Note: Calculated using the source terms in the MOX data report, as modified in Appendix K.1.5.1, site meteorology, projected regional population, and the MACCS2 computer code.

Source: UC 1998d.

K.6 LEAD ASSEMBLY ACCIDENT IMPACTS

Tables K–20 through K–25 present the source terms and accident impacts of fabrication of lead assemblies for the candidate sites.

Table K–20. Accident Impacts of Lead Assembly Fabrication at ANL–W

Accident	Source Term (g)	Frequency (per year)	Meteorology	Impacts on Noninvolved Worker		Impacts at Site Boundary		Impacts on Population Within 80 km	
				Dose (rem)	Probability of Cancer Fatality ^a	Dose (rem)	Probability of Cancer Fatality ^a	Dose (person-rem)	Latent Cancer Fatalities ^b
Criticality	1.0×10 ¹⁹ fissions	Extremely unlikely	Mean	2.5×10 ⁻²	9.9×10 ⁻⁶	1.3×10 ⁻³	6.4×10 ⁻⁷	6.8×10 ⁻²	3.4×10 ⁻⁵
			95th percentile	7.7×10 ⁻²	3.1×10 ⁻⁵	4.9×10 ⁻³	2.5×10 ⁻⁶	3.4×10 ⁻¹	1.7×10 ⁻⁴
Design basis earthquake	3.9×10 ⁻⁵	Unlikely	Mean	5.0×10 ⁻⁵	2.0×10 ⁻⁸	2.0×10 ⁻⁶	1.0×10 ⁻⁹	5.1×10 ⁻⁴	2.6×10 ⁻⁷
			95th percentile	1.7×10 ⁻⁴	6.8×10 ⁻⁸	7.7×10 ⁻⁶	3.9×10 ⁻⁹	2.7×10 ⁻³	1.4×10 ⁻⁶
Design basis fire	1.7×10 ⁻⁵	Unlikely	Mean	2.2×10 ⁻⁵	8.6×10 ⁻⁹	8.7×10 ⁻⁷	4.4×10 ⁻¹⁰	2.2×10 ⁻⁴	1.1×10 ⁻⁷
			95th percentile	7.4×10 ⁻⁵	2.9×10 ⁻⁸	3.3×10 ⁻⁶	1.7×10 ⁻⁹	1.2×10 ⁻³	5.9×10 ⁻⁷
Design basis explosion	2.7×10 ⁻⁴	Extremely unlikely	Mean	3.5×10 ⁻⁴	1.4×10 ⁻⁷	1.4×10 ⁻⁵	7.1×10 ⁻⁹	3.6×10 ⁻³	1.8×10 ⁻⁶
			95th percentile	1.2×10 ⁻³	4.8×10 ⁻⁷	5.4×10 ⁻⁵	2.7×10 ⁻⁸	1.9×10 ⁻²	9.6×10 ⁻⁶
Beyond-design-basis earthquake	1.1×10 ¹	Extremely unlikely to beyond extremely unlikely	Mean	2.0×10 ¹	7.9×10 ⁻³	7.7×10 ⁻¹	3.8×10 ⁻⁴	1.5×10 ²	7.4×10 ⁻²
			95th percentile	7.4×10 ¹	3.0×10 ⁻²	2.8	1.4×10 ⁻³	7.9×10 ²	3.9×10 ⁻¹
Beyond-design-basis fire	2.4×10 ⁻²	Beyond extremely unlikely	Mean	4.4×10 ⁻²	1.8×10 ⁻⁵	1.7×10 ⁻³	8.5×10 ⁻⁷	3.3×10 ⁻¹	1.6×10 ⁻⁴
			95th percentile	1.7×10 ⁻¹	6.6×10 ⁻⁵	6.2×10 ⁻³	3.1×10 ⁻⁶	1.8	8.7×10 ⁻⁴

^a Increased likelihood (or probability) of cancer fatality to a hypothetical individual (a single noninvolved worker at a distance of 1,000 m [3,281 ft] or the site boundary, whichever is smaller, or to a hypothetical individual in the offsite population located at the site boundary) if exposed to the indicated dose. The value assumes that the accident has occurred.

^b Estimated number of cancer fatalities in the entire offsite population out to a distance of 80 km (50 mi) if exposed to the indicated dose. The value assumes that the accident has occurred.

Key: ANL–W, Argonne National Laboratory–West.

Source: O’Connor et al. 1998a.

**Table K–21. Accident Impacts of Lead Assembly Fabrication at Hanford
(27-m Stack Height)**

Accident	Source Term (g)	Frequency (per year)	Meteorology	Impacts on Noninvolved Worker		Impacts at Site Boundary		Impacts on Population Within 80 km	
				Dose (rem)	Probability of Cancer Fatality ^a	Dose (rem)	Probability of Cancer Fatalities ^a	Dose (person-rem)	Latent Cancer Fatalities ^b
Criticality	1.0×10 ¹⁹ fissions	Extremely unlikely	Mean	1.4×10 ⁻²	5.6×10 ⁻⁶	1.4×10 ⁻³	6.8×10 ⁻⁷	8.7×10 ⁻¹	4.3×10 ⁻⁴
			95th percentile	4.0×10 ⁻²	1.6×10 ⁻⁵	4.2×10 ⁻³	2.1×10 ⁻⁶	5.5	2.7×10 ⁻³
Design basis earthquake	3.9×10 ⁻⁵	Unlikely	Mean	1.6×10 ⁻⁵	6.5×10 ⁻⁹	1.9×10 ⁻⁶	9.6×10 ⁻¹⁰	2.9×10 ⁻³	1.4×10 ⁻⁶
			95th percentile	4.8×10 ⁻⁵	1.9×10 ⁻⁸	6.3×10 ⁻⁶	3.2×10 ⁻⁹	1.7×10 ⁻²	8.6×10 ⁻⁶
Design basis fire	1.7×10 ⁻⁵	Unlikely	Mean	7.1×10 ⁻⁶	2.8×10 ⁻⁹	8.4×10 ⁻⁷	4.2×10 ⁻¹⁰	1.2×10 ⁻³	6.2×10 ⁻⁷
			95th percentile	2.1×10 ⁻⁵	8.4×10 ⁻⁹	2.7×10 ⁻⁶	1.4×10 ⁻⁹	7.4×10 ⁻³	3.7×10 ⁻⁶
Design basis explosion	2.7×10 ⁻⁴	Extremely unlikely	Mean	1.1×10 ⁻⁴	4.6×10 ⁻⁸	1.4×10 ⁻⁵	6.8×10 ⁻⁹	2.0×10 ⁻²	1.0×10 ⁻⁵
			95th percentile	3.4×10 ⁻⁴	1.4×10 ⁻⁷	4.4×10 ⁻⁵	2.2×10 ⁻⁸	1.2×10 ⁻¹	6.0×10 ⁻⁵
Beyond-design-basis earthquake	1.1×10 ¹	Extremely unlikely to beyond extremely unlikely	Mean	1.9×10 ¹	7.5×10 ⁻³	7.4×10 ⁻¹	3.7×10 ⁻⁴	1.0×10 ³	5.1×10 ⁻¹
			95th percentile	7.1×10 ¹	8×10 ⁻²	2.7	1.3×10 ⁻³	6.5×10 ³	3.2
Beyond-design-basis fire	2.4×10 ⁻²	Beyond extremely unlikely	Mean	4.1×10 ⁻²	1.7×10 ⁻⁵	1.6×10 ⁻³	8.2×10 ⁻⁷	2.2	1.1×10 ⁻³
			95th percentile	1.6×10 ⁻¹	6.3×10 ⁻⁵	5.9×10 ⁻³	3.0×10 ⁻⁶	1.4×10 ¹	7.2×10 ⁻³

^a Increased likelihood (or probability) of cancer fatality to a hypothetical individual (a single noninvolved worker at a distance of 1,000 m [3,281 ft] or the site boundary, whichever is smaller, or to a hypothetical individual in the offsite population located at the site boundary) if exposed to the indicated dose. The value assumes that the accident has occurred.

^b Estimated number of cancer fatalities in the entire offsite population out to a distance of 80 km (50 mi) if exposed to the indicated dose. The value assumes that the accident has occurred.

Source: O'Connor et al. 1998b.

**Table K–22. Accident Impacts of Lead Assembly Fabrication at Hanford
(36-m Stack Height)**

Accident	Source Term (g)	Frequency (per year)	Meteorology	Impacts on Noninvolved Worker		Impacts at Site Boundary		Impacts on Population Within 80 km	
				Dose (rem)	Probability of Cancer Fatality ^a	Dose (rem)	Probability of Cancer Fatalities ^a	Dose (person-rem)	Latent Cancer Fatalities ^b
Criticality	1.0×10 ¹⁹ fissions	Extremely unlikely	Mean	1.1×10 ⁻²	4.4×10 ⁻⁶	1.2×10 ⁻³	6.0×10 ⁻⁷	8.5×10 ⁻¹	4.3×10 ⁻⁴
			95th percentile	3.3×10 ⁻²	1.3×10 ⁻⁵	3.4×10 ⁻³	1.7×10 ⁻⁶	5.4	2.7×10 ⁻³
Design basis earthquake	3.9×10 ⁻⁵	Unlikely	Mean	9.1×10 ⁻⁶	3.6×10 ⁻⁹	1.7×10 ⁻⁶	8.5×10 ⁻¹⁰	2.8×10 ⁻³	1.4×10 ⁻⁶
			95th percentile	3.5×10 ⁻⁵	1.4×10 ⁻⁸	5.2×10 ⁻⁶	2.6×10 ⁻⁹	1.7×10 ⁻²	8.5×10 ⁻⁶
Design basis fire	1.7×10 ⁻⁵	Unlikely	Mean	3.9×10 ⁻⁶	1.6×10 ⁻⁹	7.3×10 ⁻⁷	3.7×10 ⁻¹⁰	1.2×10 ⁻³	6.1×10 ⁻⁷
			95th percentile	1.5×10 ⁻⁵	6.0×10 ⁻⁹	2.3×10 ⁻⁶	1.1×10 ⁻⁹	7.4×10 ⁻³	3.7×10 ⁻⁶
Design basis explosion	2.7×10 ⁻⁴	Extremely unlikely	Mean	6.4×10 ⁻⁵	2.5×10 ⁻⁸	1.2×10 ⁻⁵	5.9×10 ⁻⁹	2.0×10 ⁻²	9.9×10 ⁻⁶
Beyond-design-basis earthquake	1.1×10 ¹	Extremely unlikely to beyond extremely unlikely	Mean	1.9×10 ¹	7.5×10 ⁻³	7.4×10 ⁻¹	3.7×10 ⁻⁴	1.0×10 ³	5.1×10 ⁻¹
			95th percentile	7.1×10 ¹	2.8×10 ⁻²	2.7	1.3×10 ⁻³	6.5×10 ³	3.2
Beyond-design-basis fire	2.4×10 ⁻²	Beyond extremely unlikely	Mean	4.1×10 ⁻²	1.7×10 ⁻⁵	1.6×10 ⁻³	8.2×10 ⁻⁷	2.2	1.1×10 ⁻³
			95th percentile	1.6×10 ⁻¹	6.3×10 ⁻⁵	5.9×10 ⁻³	3.0×10 ⁻⁶	1.4×10 ¹	7.2×10 ⁻³

^a Increased likelihood (or probability) of cancer fatality to a hypothetical individual (single noninvolved worker at a distance of 1,000 m [3,281 ft] or the site boundary, whichever is smaller, or to a hypothetical individual in the offsite population located at the site boundary) if exposed to the indicated dose. The value assumes that the accident has occurred.

^b Estimated number of cancer fatalities in the entire offsite population out to a distance of 80 km (50 mi) if exposed to the indicated dose. The value assumes that the accident has occurred.

Source: O'Connor et al. 1998b.

Table K–23. Accident Impacts of Lead Assembly Fabrication at LLNL

Accident	Source Term (g)	Frequency (per year)	Meteorology	Impacts on Noninvolved Worker		Impacts at Site Boundary		Impacts on Population Within 80 km	
				Dose (rem)	Probability of Cancer Fatality ^a	Dose (rem)	Probability of Cancer Fatalities ^a	Dose (person-rem)	Latent Cancer Fatalities ^b
Criticality	1.0×10 ¹⁹ fissions	Extremely unlikely	Mean	7.0×10 ⁻²	2.8×10 ⁻⁵	6.7×10 ⁻²	3.3×10 ⁻⁵	1.1×10 ¹	5.7×10 ⁻³
			95th percentile	5.3×10 ⁻¹	2.1×10 ⁻⁴	5.3×10 ⁻¹	2.7×10 ⁻⁴	6.4×10 ¹	3.2×10 ⁻²
Design basis earthquake	3.9×10 ⁻⁵	Unlikely	Mean	1.8×10 ⁻⁴	7.2×10 ⁻⁸	2.2×10 ⁻⁴	1.1×10 ⁻⁷	5.5×10 ⁻²	2.8×10 ⁻⁵
			95th percentile	1.3×10 ⁻³	5.3×10 ⁻⁷	1.7×10 ⁻³	8.5×10 ⁻⁷	2.8×10 ⁻¹	1.4×10 ⁻⁴
Design basis fire	1.7×10 ⁻⁵	Unlikely	Mean	7.8×10 ⁻⁵	3.1×10 ⁻⁸	9.3×10 ⁻⁵	4.7×10 ⁻⁸	2.4×10 ⁻²	1.2×10 ⁻⁵
			95th percentile	5.7×10 ⁻⁴	2.3×10 ⁻⁷	7.4×10 ⁻⁴	3.7×10 ⁻⁷	1.2×10 ⁻¹	6.0×10 ⁻⁵
Design basis explosion	2.7×10 ⁻⁴	Extremely unlikely	Mean	1.3×10 ⁻³	5.0×10 ⁻⁷	1.5×10 ⁻³	7.6×10 ⁻⁷	3.9×10 ⁻¹	1.9×10 ⁻⁴
			95th percentile	9.3×10 ⁻³	3.7×10 ⁻⁶	1.2×10 ⁻²	6.0×10 ⁻⁶	1.9	9.7×10 ⁻⁴
Beyond-design-basis fire	2.4×10 ⁻²	Beyond extremely unlikely	Mean	1.4×10 ⁻¹	5.7×10 ⁻⁵	1.3×10 ⁻¹	6.7×10 ⁻⁵	3.5×10 ¹	1.8×10 ⁻²
			95th percentile	1.1	4.3×10 ⁻⁴	1.1	5.3×10 ⁻⁴	1.7×10 ²	8.7×10 ⁻²

^a The closest point to the site boundary is 563 m (1,847 ft), which is less than 1,000 m (3,281 ft). Therefore, doses to the onsite worker are assessed at 1,000 m [3,281 ft] only in those directions where the site boundary is greater than 1,000 m (3,281 ft) away. For other directions, doses are assessed at the site boundary.

^b Increased likelihood (or probability) of cancer fatality to a hypothetical individual (a single noninvolved worker at a distance of 1,000 m (3,281 ft) or the site boundary, whichever is smaller, or to a hypothetical individual in the offsite population located at the site boundary) if exposed to the indicated dose. The value assumes that the accident has occurred.

Key: LLNL, Lawrence Livermore National Laboratory.

Note: A beyond-design-basis earthquake was not evaluated for Building 332 at LLNL because extensive analyses of the seismic hazard at the site and the response of the building to those hazards indicate that the scenario is beyond the range of “reasonably foreseeable.” Current estimates are that the frequency of collapse is on the order of 1.0×10⁻⁷ per year or less.

Source: Murray 1998; O’Connor et al. 1998c.

Table K–24. Accident Impacts of Lead Assembly Fabrication at LANL

Accident	Source Term (g)	Frequency (per year)	Meteorology	Impacts on Noninvolved Worker		Impacts at Site Boundary		Impacts on Population Within 80 km	
				Dose (rem)	Probability of Cancer Fatality ^a	Dose (rem)	Probability of Cancer Fatalities ^a	Dose (person-rem)	Latent Cancer Fatalities ^b
Criticality	1.0×10 ¹⁹ fissions	Extremely unlikely	Mean	2.2×10 ⁻²	8.7×10 ⁻⁶	1.1×10 ⁻²	5.7×10 ⁻⁶	1.5	7.5×10 ⁻⁴
			95th percentile	6.5×10 ⁻²	2.6×10 ⁻⁵	2.8×10 ⁻²	1.4×10 ⁻⁵	6.6	3.2×10 ⁻³
Design basis earthquake	3.9×10 ⁻⁵	Unlikely	Mean	3.4×10 ⁻⁵	1.4×10 ⁻⁸	1.3×10 ⁻⁵	6.5×10 ⁻⁹	3.1×10 ⁻³	1.5×10 ⁻⁶
			95th percentile	1.1×10 ⁻⁴	4.3×10 ⁻⁸	4.1×10 ⁻⁵	2.1×10 ⁻⁸	1.4×10 ⁻²	6.8×10 ⁻⁶
Design basis fire	1.7×10 ⁻⁵	Unlikely	Mean	1.5×10 ⁻⁵	6.0×10 ⁻⁹	5.7×10 ⁻⁶	2.8×10 ⁻⁹	1.3×10 ⁻³	6.7×10 ⁻⁷
			95th percentile	4.7×10 ⁻⁵	1.9×10 ⁻⁸	1.8×10 ⁻⁵	9.0×10 ⁻⁹	5.9×10 ⁻³	2.9×10 ⁻⁶
Design basis explosion	2.7×10 ⁻⁴	Extremely unlikely	Mean	2.4×10 ⁻⁴	9.7×10 ⁻⁸	9.2×10 ⁻⁵	4.6×10 ⁻⁸	2.2×10 ⁻²	1.1×10 ⁻⁵
			95th percentile	7.6×10 ⁻⁴	3.0×10 ⁻⁷	2.9×10 ⁻⁴	1.5×10 ⁻⁷	9.5×10 ⁻²	4.8×10 ⁻⁵
Beyond-design-basis earthquake	1.1×10 ¹	Extremely unlikely to beyond extremely unlikely	Mean	1.3×10 ¹	5.3×10 ⁻³	4.4	2.2×10 ⁻³	9.5×10 ²	4.8×10 ⁻¹
			95th percentile	5.1×10 ¹	2.1×10 ⁻²	1.4×10 ¹	7.0×10 ⁻³	4.2×10 ³	2.1
Beyond-design-basis fire	2.4×10 ⁻²	Beyond extremely unlikely	Mean	2.9×10 ⁻²	1.2×10 ⁻⁵	9.7×10 ⁻³	4.9×10 ⁻⁶	2.1	1.1×10 ⁻³
			95th percentile	1.1×10 ⁻¹	4.6×10 ⁻⁵	3.1×10 ⁻²	1.6×10 ⁻⁵	9.2	4.6×10 ⁻³

^a Increased likelihood (or probability) of cancer fatality to a hypothetical individual (a single noninvolved worker at a distance of 1,000 m [3,281 ft] or the site boundary, whichever is smaller, or to a hypothetical individual in the offsite population located at the site boundary) if exposed to the indicated dose. The value assumes that the accident has occurred.

^b Estimated number of cancer fatalities in the entire offsite population out to a distance of 80 km (50 mi) if exposed to the indicated dose. The value assumes that the accident has occurred.

Key: LANL, Los Alamos National Laboratory.

Source: O'Connor et al. 1998d.

Table K-25. Accident Impacts of Lead Assembly Fabrication at SRS H-Area

Accident	Source Term (g)	Frequency (per year)	Meteorology	Impacts on Noninvolved Worker		Impacts at Site Boundary		Impacts on Population Within 80 km	
				Dose (rem)	Probability of Cancer Fatality ^a	Dose (rem)	Probability of Cancer Fatalities ^a	Dose (person-rem)	Latent Cancer Fatalities ^b
Criticality	1.0×10 ¹⁹ fissions	Extremely unlikely	Mean	5.2×10 ⁻³	2.1×10 ⁻⁶	3.4×10 ⁻⁴	1.7×10 ⁻⁷	3.0×10 ⁻¹	1.5×10 ⁻⁴
			95th percentile	1.0×10 ⁻²	4.0×10 ⁻⁶	9.3×10 ⁻⁴	4.6×10 ⁻⁷	1.3	6.5×10 ⁻⁴
Design basis earthquake	3.9×10 ⁻⁵	Unlikely	Mean	3.5×10 ⁻⁶	1.4×10 ⁻⁹	4.4×10 ⁻⁷	2.2×10 ⁻¹⁰	1.3×10 ⁻³	6.3×10 ⁻⁷
			95th percentile	7.8×10 ⁻⁶	3.1×10 ⁻⁹	1.3×10 ⁻⁶	6.7×10 ⁻¹⁰	5.6×10 ⁻³	2.8×10 ⁻⁶
Design basis fire	1.7×10 ⁻⁵	Unlikely	Mean	1.5×10 ⁻⁶	6.1×10 ⁻¹⁰	1.9×10 ⁻⁷	9.5×10 ⁻¹¹	5.4×10 ⁻⁴	2.7×10 ⁻⁷
			95th percentile	3.4×10 ⁻⁶	1.3×10 ⁻⁹	5.8×10 ⁻⁷	2.9×10 ⁻¹⁰	2.4×10 ⁻³	1.2×10 ⁻⁶
Design basis explosion	2.7×10 ⁻⁴	Extremely unlikely	Mean	2.5×10 ⁻⁵	9.9×10 ⁻⁹	3.1×10 ⁻⁶	1.5×10 ⁻⁹	8.8×10 ⁻³	4.4×10 ⁻⁶
			95th percentile	5.5×10 ⁻⁵	2.2×10 ⁻⁸	9.5×10 ⁻⁶	4.7×10 ⁻⁹	3.9×10 ⁻²	2.0×10 ⁻⁵
Beyond-design-basis earthquake	1.1×10 ¹	Extremely unlikely to beyond extremely unlikely	Mean	7.1	2.9×10 ⁻³	2.0×10 ⁻¹	9.8×10 ⁻⁵	5.1×10 ²	2.6×10 ⁻¹
			95th percentile	2.6×10 ¹	1.0×10 ⁻²	8.8×10 ⁻¹	4.4×10 ⁻⁴	2.2×10 ³	1.1
Beyond-design-basis fire	2.4×10 ⁻²	Beyond extremely unlikely	Mean	1.6×10 ⁻²	6.3×10 ⁻⁶	4.4×10 ⁻⁴	2.2×10 ⁻⁷	1.1	5.7×10 ⁻⁴
			95th percentile	5.8×10 ⁻²	2.3×10 ⁻⁵	2.0×10 ⁻³	9.8×10 ⁻⁷	4.9	2.4×10 ⁻³

^a Increased likelihood (or probability) of cancer fatality to a hypothetical individual (a single noninvolved worker at a distance of 1,000 m [3,281 ft] or the site boundary, whichever is smaller, or to a hypothetical individual in the offsite population located at the site boundary) if exposed to the indicated dose. The value assumes that the accident has occurred.

^b Estimated number of cancer fatalities in the entire offsite population out to a distance of 80 km (50 mi) if exposed to the indicated dose. The value assumes that the accident has occurred.

Source: O'Connor et al. 1998e.

K.7 COMMERCIAL REACTOR ACCIDENT ANALYSIS

K.7.1 Introduction

Postulated design basis and beyond-design-basis accidents were analyzed using the MACCS2 computer code for each of the three proposed reactor sites, Catawba Nuclear Station, McGuire Nuclear Station, and North Anna Power Station (NRC 1990, SNL 1997). Only those accidents with the potential for substantial radiological releases to the environment were evaluated. Two design basis accidents (a loss-of-coolant accident [LOCA] and a fuel-handling accident) and four beyond-design-basis accidents (a steam generator tube rupture, an early containment failure, a late containment failure, and an interfacing systems loss-of-coolant accident [ISLOCA]) meet this criteria. Each of these accidents was analyzed twice, once using the current low-enriched uranium (LEU) core, and again, assuming a partial (40 percent) MOX core. Doses (consequences) and risks to a noninvolved worker, the offsite MEI, and the general public within 80 km (50 mi) of each plant from each accident scenario were calculated. These results were then compared, by plant, for each postulated accident.

The MEI dose is calculated at the exclusion area boundary of each plant. The exclusion area boundary is that area surrounding the reactor in which the reactor licensee has the authority to determine all activities, including exclusion or removal of personnel and property from the area. This area may be traversed by a highway, railroad, or waterway, provided any one of these is not so close to the facility that it interferes with normal operation of the facility, and appropriate and effective arrangements are made to control traffic and protect public health and safety on the highway, railroad, or waterway in an emergency. There are generally no residences within an exclusion area. However, if there were residents, they would be subject to ready removal in case of necessity. Activities unrelated to operation of the reactor may be permitted in an exclusion area under appropriate limitations, provided that no significant hazards to the public health and safety would result.

K.7.2 Reactor Accident Identification and Quantification

Catawba and McGuire are similar plants, both with two 3,411-MWt Westinghouse pressurized water reactors (PWRs) with ice condenser containments. Because of these similarities, the release paths and mitigating mechanisms for the two plants are almost identical. The conservative assumptions of the NRC regulatory guidance produce identical radiological releases to the environment (source terms) for the two plants. However, site-specific population and meteorological inputs result in different consequences from the two plants. The North Anna site has two 2,893 MWt Westinghouse PWRs with subatmospheric containments.

Both the design basis and beyond-design-basis accidents were identified from plant documents. Design basis accidents were selected by reviewing the Updated Final Safety Analysis Report (UFSAR) for each plant (Duke Power 1996, 1997; Virginia Power 1998). Beyond-design-basis accidents were identified from the submittals (Duke Power 1991, 1992; Virginia Power 1992) in response to the NRC's Generic Letter 88-20 (NRC 1988), which required reactor licensees to perform Individual Plant Examinations (IPEs) for severe accident vulnerabilities. Source terms for each accident for LEU-only cores were identified from these documents, source terms for partial MOX cores were developed based on these LEU source terms, and analyses were performed assuming both the current LEU-only cores and partial MOX cores containing 40 percent MOX fuel and 60 percent LEU fuel. After the source term is developed, the consequences (in terms of LCFs and prompt fatalities) can be determined. To determine the risk, however, the frequency (probability) of occurrence of the accident must be determined. Then the consequences are multiplied by the frequency to determine the risk.

For this analysis, the frequencies of occurrence for the accidents with a 40 percent MOX core are assumed to be the same as those with an LEU core. The National Academy of Sciences reported (NAS 1995) that "any approach to the use of MOX fuel in U.S. power reactors must and will receive a thorough, formal safety review before it is licensed. While we are not in a position to predict what if any modifications to existing reactor types

will be required as a result of such licensing reviews, we expect that the final outcome will be certification that whatever LWR type is chosen will be able, with modifications if appropriate, to operate within prevailing reactivity and thermal margins using sufficient plutonium loadings to accomplish the disposition mission in a small number of reactors. We believe, further, that under these circumstances no important overall adverse impact of MOX use on the accident probabilities of the LWRs involved will occur; if there are adequate reactivity and thermal margins in the fuel, as licensing review should ensure, the main remaining determinants of accident probabilities will involve factors not related to fuel composition and hence unaffected by the use of MOX rather than LEU fuel.” Considering the National Academy of Sciences statements, the lack of empirical data, and the degree of uncertainty associated with accident frequencies, this analysis assumes that the accident frequencies are the same for a 40 percent MOX core as those for a 100 percent LEU core.

K.7.2.1 MOX Source Term Development

MOX source terms were developed by applying the calculated ratio for individual radioisotopes present in both the MOX and LEU cores to the source term for each of the LEU accidents. MOX source term development required several steps. The analysis assumes that the initial isotopic composition of the plutonium is that delivered to the MOX facility for fabrication into MOX fuel. The MOX facility includes a polishing step that removes impurities, including americium 241, a major contributor to the dose from plutonium 235. This analysis conservatively assumes that the polishing step reduces the americium 241 to 1 part per million (ppm), then ages the plutonium for 1 year after polishing prior to being loaded into a reactor. Table K–26 provides the assumed isotopic composition for the plutonium source material.

Table K–26. Isotopic Breakdown of Plutonium

Isotope	Prior to Polishing (wt %)	After Polishing and Aging (wt %)
Plutonium 236	<1 ppb	1 ppb
Plutonium 238	0.03	0.03
Plutonium 239	92.2	93.28
Plutonium 240	6.46	6.54
Plutonium 241	0.05	0.05
Plutonium 242	0.1	0.1
Americium 241	0.9	25 ppm

Key: ppb, parts per billion; ppm, parts per million; wt %, weight percent.

The SPD EIS assumes that MOX fuel would be fabricated using depleted uranium (0.25 weight percent uranium 235) (White 1997). The MOX assemblies are assumed to be 4.37 percent plutonium/amerium and the LEU assemblies are assumed to be 4.37 percent uranium 235. To simulate a normal plant refueling cycle, the MOX portion was assumed to be 50 percent once-burned and 50 percent twice-burned assemblies. The LEU portion of the MOX was assumed to be 33.3 percent once-burned, 33.3 percent twice-burned, and 33.3 percent thrice-burned assemblies. The LEU-only cores were assumed to be equally divided between once-, twice-, and thrice-burned assemblies. All analyses assumed end-of-cycle inventories to produce the highest consequences. Fuel cycles were based on an 18-month refueling schedule with a 40-day downtime between cycles. The source terms for the LEU-only accident analyses were those identified in plant documents. Source terms for the partial MOX cores were developed using the isotopic ratios in Table K–27 provided by Oak Ridge National Laboratory (ORNL 1999). The MOX core inventory for each isotope was divided by the LEU core inventory for that isotope to provide a MOX/LEU ratio for each isotope. These ratios were then applied to LEU releases for each accident to estimate the MOX releases.

Table K–27. MOX/LEU Core Inventory Isotopic Ratios

Isotope	Ratio	Isotope	Ratio	Isotope	Ratio
Americium 241	2.06	Krypton 85m	0.86	Strontium 91	0.86
Antimony 127	1.15	Krypton 87	0.85	Strontium 92	0.89
Antimony 129	1.07	Krypton 88	0.84	Technetium 99m	0.99
Barium 139	0.97	Lanthanum 140	0.97	Tellurium 127	1.16
Barium 140	0.98	Lanthanum 141	0.97	Tellurium 127m	1.20
Cerium 141	0.98	Lanthanum 142	0.97	Tellurium 129	1.08
Cerium 143	0.95	Molybdenum 99	0.99	Tellurium 129m	1.09
Cerium 144	0.91	Neodymium 147	0.98	Tellurium 131m	1.11
Cesium 134	0.85	Neptunium 239	0.99	Tellurium 132	1.01
Cesium 136	1.09	Niobium 95	0.94	Tritium	0.95
Cesium 137	0.91	Plutonium 238	0.76	Xenon 131m	1.02
Cobalt 58	0.86	Plutonium 239	2.06	Xenon 133	1.00
Cobalt 60	0.72	Plutonium 240	2.20	Xenon 133m	1.01
Curium 242	1.43	Plutonium 241	1.79	Xenon 135	1.28
Curium 244	0.94	Praseodymium 143	0.95	Xenon 135m	1.04
Iodine 131	1.03	Rhodium 105	1.19	Xenon 138	0.96
Iodine 132	1.02	Rubidium 86	0.77	Yttrium 90	0.76
Iodine 133	1.00	Ruthenium 103	1.11	Yttrium 91	0.85
Iodine 134	0.98	Ruthenium 105	1.18	Yttrium 92	0.89
Iodine 135	1.00	Ruthenium 106	1.28	Yttrium 93	0.91
Krypton 83m	0.89	Strontium 89	0.83	Zirconium 95	0.94
Krypton 85	0.78	Strontium 90	0.75	Zirconium 97	0.98

The NRC licensing process will thoroughly review precise enrichments and fuel management schemes. The enrichments and fuel management schemes analyzed in the SPD EIS were chosen as realistic upper bounds. The accidents also assumed a maximum 40 percent MOX core. Taken together, these assumptions are sufficiently conservative to account for uncertainties associated with the MOX/LEU ratios.

K.7.2.2 Meteorological Data

Meteorological data for each specific reactor site were used. The meteorological data characteristic of the site region are described by 1 year of hourly data (8,760 measurements). This data includes wind speed, wind direction, atmospheric stability, and rainfall (DOE 1999b).

K.7.2.3 Population Data

The population distribution around each plant was determined using 1990 census data extrapolated to the year 2015. The population was then split into segments that correspond to the chosen polar coordinate grid. The polar coordinate grid for this analysis consists of 12 radial intervals aligned with the 16 compass directions. For Catawba and McGuire, the distances (in kilometers) of the 12 radial intervals are: 0.64, 0.762, 1.61, 3.22, 4.83, 6.44, 8.05, 16.09, 32.18, 48.27, 64.36, 80.45. For North Anna, these distances (in kilometers) are: 0.64, 1.350, 1.61, 3.22, 4.83, 6.44, 8.05, 16.09, 32.18, 48.27, 64.36, 80.45. The first of the 12 segments represents the location of the noninvolved worker and the second is the location of the site boundary. Projected population data for the year 2015 corresponding to the grid segments at Catawba, McGuire, and North Anna are presented in Tables K–28, K–29, and K–30, respectively.

Table K-28. Projected Catawba Population for Year 2015

Direction	Distance in Kilometers From Release Point											
	0.64	0.762	1.61	3.22	4.83	6.44	8.05	16.09	32.18	48.27	64.36	80.45
N	0	0	6	14	73	469	800	2,642	51,540	31,112	49,551	33,306
NNE	0	0	6	112	250	334	362	9,394	173,036	135,229	102,558	66,298
NE	0	0	7	119	239	394	595	6,442	212,814	143,650	22,571	20,108
ENE	0	0	11	81	504	1,409	1,042	5,842	72,488	52,784	32,588	10,919
E	0	0	21	5	863	1,059	570	7,959	12,144	27,800	22,844	10,995
ESE	0	0	23	47	295	388	679	7,449	8,607	18,196	12,293	9,290
SE	0	0	20	25	284	893	1,060	37,300	14,279	14,657	12,776	3,692
SSE	0	0	6	80	278	706	891	16,458	10,249	4,190	1,599	11,376
S	0	0	24	165	275	606	819	4,529	4,457	15,062	1,579	1,874
SSW	0	0	17	137	245	238	346	2,268	3,563	2,093	12,970	4,245
SW	0	0	20	114	162	208	267	5,538	9,559	2,040	11,272	12,302
WSW	0	0	21	84	159	205	257	2,493	4,756	8,947	31,712	80,518
W	0	0	23	113	202	272	345	4,979	6,978	17,182	26,070	35,091
WNW	0	0	23	103	199	283	363	3,011	17,814	32,751	29,031	8,706
NW	0	0	23	96	165	274	363	3,099	65,856	28,474	33,819	45,793
NNW	0	0	21	85	125	1,153	1,296	3,404	48,431	24,219	32,537	52,530

Table K-29. Projected McGuire Population for Year 2015

Direction	Distance in Kilometers From Release Point											
	0.64	0.762	1.61	3.22	4.83	6.44	8.05	16.09	32.18	48.27	64.36	80.45
N	0	0	44	0	269	110	203	3,153	14,870	28,254	12,987	15,726
NNE	0	0	28	0	124	569	1,728	9,493	21,903	12,317	24,826	43,937
NE	0	0	30	0	5	832	1,016	6,944	30,939	44,064	55,186	44,691
ENE	0	0	184	144	405	684	591	4,289	51,928	37,373	13,039	28,160
E	0	0	217	180	448	381	493	7,575	26,495	21,992	16,957	14,635
ESE	0	0	65	69	271	381	507	7,423	119,345	79,039	36,221	26,552
SE	0	0	15	59	130	244	273	8,387	219,183	204,614	46,100	24,527
SSE	0	0	15	59	99	138	100	9,530	90,900	95,688	79,859	15,954
S	0	0	14	83	165	182	165	6,429	35,178	21,241	41,638	9,071
SSW	0	0	18	101	169	240	221	3,261	61,514	29,814	10,774	9,327
SW	0	0	26	101	169	236	305	5,338	20,195	31,064	47,641	43,067
WSW	0	0	19	101	169	236	296	2,741	20,873	17,334	15,815	15,077
W	6	0	14	112	184	252	312	2,048	24,932	11,715	12,705	43,357
WNW	0	0	3	101	444	811	338	2,187	14,985	57,262	74,708	60,953
NW	0	0	0	224	200	1,005	793	4,260	8,528	22,380	26,093	12,511
NNW	0	0	0	0	4	0	36	1,989	8,570	40,993	13,101	10,686

Table K-30. Projected North Anna Population for Year 2015

Direction	Distance in Kilometers From Release Point											
	0.64	1.35	1.61	3.22	4.83	6.44	8.05	16.09	32.18	48.27	64.36	80.45
N	0	0	0	39	98	122	153	576	7,816	5,149	17,803	42,233
NNE	0	0	2	37	58	160	206	1,236	7,634	10,765	25,976	172,658
NE	0	0	2	30	43	94	100	1,122	38,833	90,820	34,429	77,097
ENE	0	0	0	15	103	40	64	1,373	5,822	6,693	11,426	17,324
E	0	0	0	17	112	42	34	1,183	6,128	5,175	1,839	4,296
ESE	0	0	2	7	17	97	135	950	5,595	5,454	5,161	7,909
SE	0	0	1	18	77	9	12	575	2,989	19,343	59,057	76,396
SSE	0	0	3	50	29	27	40	919	5,051	15,259	443,326	392,420
S	0	0	0	42	20	30	40	669	4,413	11,763	20,254	34,375
SSW	0	0	0	10	12	54	65	554	3,098	5,803	5,616	6,222
SW	0	0	0	4	14	54	86	1,186	2,678	2,845	5,482	4,576
WSW	0	0	0	19	42	31	63	1,381	4,402	6,729	8,905	8,094
W	0	0	0	31	24	24	29	466	2,883	4,529	109,205	21,748
WNW	0	0	0	30	79	52	29	606	2,725	8,371	17,931	9,934
NW	0	0	1	35	52	92	81	662	3,327	11,604	11,816	3,090
NNW	0	0	0	28	64	13	25	771	4,725	9,040	25,534	10,041

K.7.2.4 Design Basis Events

Design basis events are defined by the American Nuclear Society as Condition IV occurrences or limiting faults. Condition IV occurrences are faults which are not expected to take place, but are postulated because their consequences would include the potential for the release of substantial radioactive material. These are the most serious events which must be designed against and represent limiting design cases.

The accident analyses presented in the UFSARs are conservative design basis analyses and therefore the dose consequences are bounding (i.e., a realistically based analysis would result in lower doses). The results, however, provide a comparison of the potential consequences resulting from design basis accidents. The consequences also provide insight into which design basis accidents should be analyzed in an environmental impact statement, such as the SPD EIS. After reviewing the UFSAR accident analyses, the design basis accidents chosen for evaluation in the SPD EIS are a large-break LOCA and a fuel-handling accident.

LOCA. A design basis large-break LOCA was chosen for evaluation because it is the limiting reactor design basis accident at each of the three plants. The analysis was performed in accordance with the methodology and assumptions in Regulatory Guide 1.4 (NRC 1974). The large-break LOCA is defined as a break equivalent in size to a double-ended rupture of the largest pipe of the reactor coolant system. Following a postulated double-ended rupture of a reactor coolant pipe, the emergency core cooling system keeps cladding temperatures well below melting, ensuring that the core remains intact and in a coolable geometry. As a result of the increase in cladding temperature and rapid depressurization of the core, however, some cladding failure may occur in the hottest regions of the core. Thus, a fraction of the fission products accumulated in the pellet-cladding gap may be released to the reactor coolant system and thereby to the containment. Although no core melting would occur for the design basis LOCA, a gross release of fission products is evaluated. The only postulated mechanism for such a release would require a number of simultaneous and extended failures to occur in the engineered safety feature systems, producing severe physical degradation of core geometry and partial melting of the fuel.

Development of the LOCA source term is based on the conservative assumptions specified in Regulatory Guide 1.4. Consistent with this Regulatory Guide, 100 percent of the noble gas inventory and 25 percent of the iodine inventory in the core are assumed to be immediately available for leakage from the primary containment.

However, all of this radioactivity is not released directly to the environment because there are a number of mitigating mechanisms which can delay or retain radioisotopes. The principal mechanism, the primary containment, substantially restricts the release rate of the radioisotopes. Following a postulated LOCA, another potential source of fission product release to the environment is the leakage of radioactive water from engineered safety feature equipment located outside containment. The fission products could then be released from the water into the atmosphere, resulting in offsite radiological consequences that contribute to the total dose from the LOCA.

The LOCA radiological consequence analysis for the LEU cores was performed assuming a ground-level release based on offeror-supplied plant-specific radioisotope release data. All possible leak paths (containment, bypass, and the emergency core cooling system) were included. Were a LOCA to occur, a substantial percentage of the releases would be expected to be elevated, which would be expected to reduce the consequences from those calculated in this analysis. To analyze the accident for a partial MOX core, the LEU isotopic activity was multiplied by the MOX/LEU ratios (from Table K-27) to provide a MOX core activity for each isotope. The LEU and MOX LOCA releases for Catawba and McGuire are provided in Table K-31 and for North Anna in Table K-32.

Table K-31. Catawba and McGuire LOCA Source Term

Isotope	LEU LOCA	MOX/LEU	40% MOX Core
	Release (Ci)	Ratio	Release (Ci)
Iodine 131	2.42×10 ⁴	1.03	2.49×10 ⁴
Iodine 132	7.76×10 ²	1.02	7.92×10 ²
Iodine 133	3.22×10 ³	1.00	3.22×10 ³
Iodine 134	6.55×10 ²	0.98	6.42×10 ²
Iodine 135	2.51×10 ³	1.00	2.51×10 ³
Krypton 83m	3.62×10 ³	0.89	3.22×10 ³
Krypton 85	1.96×10 ⁴	0.78	1.53×10 ⁴
Krypton 85m	1.96×10 ⁴	0.86	1.68×10 ⁴
Krypton 87	1.04×10 ⁴	0.85	8.82×10 ³
Krypton 88	3.23×10 ⁴	0.84	2.72×10 ⁴
Xenon 131m	2.79×10 ⁴	1.02	2.84×10 ⁴
Xenon 133	2.33×10 ⁶	1.00	2.33×10 ⁶
Xenon 133m	3.45×10 ⁴	1.01	3.49×10 ⁴
Xenon 135	2.90×10 ⁵	1.28	3.71×10 ⁵
Xenon 135m	1.40×10 ³	1.04	1.46×10 ³
Xenon 138	7.21×10 ³	0.96	6.92×10 ³

Key: LEU, low-enriched uranium; LOCA, loss-of-coolant accident.

Fuel-Handling Accident. The fuel-handling accident analysis was performed in a conservative manner, in accordance with Regulatory Guide 1.25 methodology (NRC 1972). In the fuel-handling accident scenario, a spent fuel assembly is dropped. The drop results in a breach of the fuel rod cladding, and a portion of the volatile fission gases from the damaged fuel rods is released. A fuel-handling accident would realistically result in only a fraction of the fuel rods being damaged. However, consistent with NRC methodology, all the fuel rods in the assembly are assumed to be damaged.

Table K–32. North Anna LOCA Source Term

Isotope	LEU LOCA	MOX/LEU	40% MOX Core
	Release (Ci)	Ratio	Release (Ci)
Iodine 131	3.68×10^2	1.03	3.79×10^2
Iodine 132	3.45×10^2	1.02	3.52×10^2
Iodine 133	5.87×10^2	1.00	5.87×10^2
Iodine 134	5.10×10^2	0.98	5.00×10^2
Iodine 135	5.01×10^2	1.00	5.01×10^2
Krypton 83m	4.26×10^2	0.89	3.79×10^2
Krypton 85	5.06×10^1	0.78	3.95×10^1
Krypton 85m	1.48×10^3	0.86	1.27×10^3
Krypton 87	2.22×10^3	0.85	1.89×10^3
Krypton 88	3.50×10^3	0.84	2.94×10^3
Xenon 131m	3.20×10^1	1.02	3.26×10^1
Xenon 133	6.91×10^3	1.00	6.91×10^3
Xenon 133m	1.70×10^2	1.01	1.72×10^2
Xenon 135	6.37×10^3	1.28	8.15×10^3
Xenon 135m	6.72×10^2	1.04	6.99×10^2
Xenon 138	1.90×10^3	0.96	1.82×10^3

Key: LEU, low-enriched uranium; LOCA, loss-of-coolant accident.

The accident is assumed to occur at the earliest time fuel-handling operations may begin after shutdown as identified in each plant's Technical Specifications.⁸ The assumed accident time is 72 hr after shutdown at Catawba and McGuire. North Anna Technical Specifications require a minimum of 150 hr between shutdown and the initiation of fuel movement, but assumed an accident time of 100 hr.

As assumed in Regulatory Guide 1.25, the damaged assembly is the highest powered assembly being removed from the reactor. The values for individual fission product inventories in the damaged assembly are calculated assuming full power operation at the end of core life immediately preceding shutdown. All of the gap activity in the damaged rods is assumed to be released to the spent fuel pool. Noble gases released to the spent fuel pool are immediately released at ground level to the environment, but the water in the spent fuel pool greatly reduces the iodine available for release to the environment. It is assumed that all of the iodine escaping from the spent fuel pool is released to the environment at ground level over a 2-hr time period through the fuel-handling building ventilation system. The Catawba and McGuire UFSARs assume iodine filter efficiencies of 95 percent for both the inorganic and organic species. The North Anna UFSAR assumes a filter efficiency of 90 percent for the inorganic iodine and 70 percent for the organic iodine. The LEU and MOX source terms for Catawba and McGuire are provided in Table K–33 and the source terms for North Anna are provided in Table K–34.

The frequencies for the design basis LOCAs, obtained from the IPEs, are Catawba, 7.50×10^{-6} ; McGuire, 1.50×10^{-5} ; and North Anna, 2.10×10^{-5} . The frequencies of the fuel-handling accidents were estimated in lieu of plant-specific data. For conservatism, a frequency of 1×10^{-4} was chosen for the analysis.

⁸ Technical Specifications are plant-specific operating conditions that control safety-related parameters of plant operation. Technical Specifications are part of the operating license and require an operating license amendment to change.

Table K–33. Catawba and McGuire Fuel-Handling Accident Source Term

Nuclide	LEU	MOX/LEU	40% MOX Core
	Release (Ci)	Ratio	Release
Iodine 131	3.83×10 ¹	1.03	3.94×10 ¹
Iodine 132	5.55×10 ¹	1.02	5.66×10 ¹
Iodine 133	8.00×10 ¹	1.00	8.00×10 ¹
Iodine 134	8.80×10 ¹	0.98	8.62×10 ¹
Iodine 135	7.55×10 ¹	1.00	7.55×10 ¹
Krypton 83m	9.47×10 ³	0.89	8.43×10 ³
Krypton 85	1.11×10 ³	0.78	8.66×10 ²
Krypton 85m	2.16×10 ⁴	0.86	1.86×10 ⁴
Krypton 87	4.04×10 ⁴	0.85	3.43×10 ⁴
Krypton 88	5.58×10 ⁴	0.84	4.69×10 ⁴
Xenon 133	1.60×10 ⁵	1.00	1.60×10 ⁵
Xenon 133m	4.81×10 ³	1.01	4.86×10 ³
Xenon 135	1.65×10 ⁵	1.28	2.11×10 ⁵
Xenon 135m	2.96×10 ⁴	1.04	3.08×10 ⁴
Xenon 138	1.34×10 ⁵	0.96	1.29×10 ⁵

Key: LEU, low-enriched uranium; LOCA, loss-of-coolant accident.

Table K–34. North Anna Fuel-Handling Accident Source Term

Nuclide	LEU	MOX/LEU	40% MOX Core
	Release (Ci)	Ratio	Release
Iodine 131	9.05×10 ¹	1.03	9.32×10 ¹
Iodine 132	1.37×10 ²	1.02	1.40×10 ²
Iodine 133	2.01×10 ²	1.00	2.01×10 ²
Iodine 134	2.36×10 ²	0.98	2.31×10 ²
Iodine 135	1.82×10 ²	1.00	1.82×10 ²
Krypton 85	2.60×10 ³	0.78	2.03×10 ³
Krypton 85m	2.65×10 ⁴	0.86	2.28×10 ⁴
Krypton 87	5.10×10 ⁴	0.85	4.34×10 ⁴
Krypton 88	7.25×10 ⁴	0.84	6.09×10 ⁴
Xenon 131m	4.56×10 ²	1.02	4.65×10 ²
Xenon 133	1.36×10 ⁵	1.00	1.36×10 ⁵
Xenon 133m	3.46×10 ³	1.01	3.49×10 ³
Xenon 135	3.70×10 ⁴	1.28	4.74×10 ⁴
Xenon 135m	3.74×10 ⁴	1.04	3.89×10 ⁴
Xenon 138	1.22×10 ⁵	0.96	1.17×10 ⁵

Key: LEU, low-enriched uranium; LOCA, loss-of-coolant accident.

K.7.2.5 Beyond-Design-Basis Events

Beyond-design-basis accidents (severe reactor accidents) are less likely to occur than reactor design basis accidents. In the reactor design basis accidents, the mitigating systems are assumed to be available. In the severe reactor accidents, even though the initiating event could be a design basis event (e.g., large-break LOCA), additional failures of mitigating systems would cause some degree of physical deterioration of the fuel in the

reactor core and a possible breach of the containment structure leading to the direct release of radioactive materials to the environment.

The beyond-design-basis accident evaluation in the SPD EIS included a review of each plant's IPE. In 1988, the NRC required all licensees of operating plants to perform IPEs for severe accident vulnerabilities (Generic Letter 88-20) (NRC 1988), and indicated that a Probabilistic Risk Assessment (PRA) would be an acceptable approach to performing the IPE. A PRA evaluates, in full detail (quantitatively), the consequences of all potential events caused by the operating disturbances (known as internal initiating events) within each plant. The state-of-the-art PRA uses realistic criteria and assumptions in evaluating the accident progression and the systems required to mitigate each accident.

A plant-specific PRA for severe accident vulnerabilities starts with identification of initiating events (i.e., challenges to normal plant operation or accidents) that require successful mitigation to prevent core damage. These events are grouped into initiating event classes that have similar characteristics and require the same overall plant response.

Event trees are developed for each initiating event class. These event trees depict the possible sequence of events that could occur during the plant's response to each initiating event class. The trees delineate the possible combinations (sequences) of functional and/or system successes and failures that lead to either successful mitigation of the initiating event or core damage. Functional and/or system success criteria are developed based on the plant response to the class of accident sequences. Failure modes of systems that are functionally important to preventing core damage are modeled. This modeling process is usually done with fault trees that define the combinations of equipment failures, equipment outages, and human errors that could cause the failure of systems to perform the desired functions.

Quantification of the event trees leads to hundreds, or even thousands, of different end states representing various accident sequences that are either mitigated or lead to core damage. Each accident sequence and its associated end state has a unique "signature" because of the particular combination of system successes and failures. These end states are grouped together into plant damage states, each of which collects sequences for which the progression of core damage, the release of fission products from the fuel, the status of containment and its systems, and the potential for mitigating source terms are similar. The sum of all core damage accident sequences will then represent an estimate of plant core damage frequency. The analysis of core damage frequency calculations is called a Level 1 PRA, or front-end analysis.

Next, an analysis of accident progression, containment loading⁹ resulting from the accident, and the structural response to the accident loading is performed. The primary objective of this analysis, which is called a Level 2 PRA, is to characterize the potential for, and magnitude of, a release of radioactive material from the reactor fuel to the environment, given the occurrence of an accident that damages the core. The analysis includes an assessment of containment performance in response to a series of severe accidents. Analysis of the progression of an accident (an accident sequence within a plant damage state) generates a time history of loads imposed on the containment pressure boundary. These loads would then be compared against the containment's structural performance limits. If the loads exceed the performance limits, the containment would be expected to fail; conversely, if the containment performance limits exceed the calculated loads, the containment would be expected to survive. Four modes of containment failure are defined: containment isolation failure, containment bypass, early containment failure, and late containment failure.

⁹ Challenges to containment integrity such as elevated temperature or pressure are referred to as containment loading.

The magnitude of the radioactive release to the atmosphere in an accident is dependent on the timing of the reactor vessel failure and the containment failure. To determine the magnitude of the release, a containment event tree representing the time sequence of major phenomenological events that could occur during the formation and relocation of core debris (after core melt), availability of the containment heat removal system, and the expected mode of containment failures (i.e., bypass, early, and late), is developed. A reduced set of plant damage states is defined by culling the lower frequency plant damage states into higher frequency ones that have relatively similar severity and consequence potential. This condensed set is known as the key plant damage states. These key plant damage states would then become the initiating events for the containment event tree. The outcome of each sequence in this event tree represents a specific release category. Release categories that can be represented by similar source terms are grouped. Source terms associated with various release categories describe the fractional releases for representative radionuclide groups, as well as the timing, duration, and energy of release.

Beyond-design-basis accidents evaluated in the SPD EIS included only those scenarios that lead to containment bypass or failure because the public and environmental consequences would be significantly less for accident scenarios that do not lead to containment bypass or failure. The accidents evaluated consisted of a steam generator tube rupture, an early containment failure, a late containment failure, and an ISLOCA.

Steam Generator Tube Rupture. A beyond-design-basis steam generator tube rupture induced by high temperatures represents a containment bypass event. Analyses have indicated a potential for very high gas temperatures in the reactor coolant system during accidents involving core damage when the primary system is at high pressure. The high temperature could fail the steam generator tubes. As a result of the tube rupture, the secondary side may be exposed to full Reactor Coolant System pressures. These pressures are likely to cause relief valves to lift on the secondary side as they are designed to do. If these valves fail to close after venting, an open pathway from the reactor vessel to the environment can result.

Early Containment Failure. This accident is defined as the failure of containment prior to or very soon (within a few hours) after breach of the reactor vessel. A variety of mechanisms such as direct contact of core debris with the containment, rapid pressure and temperature loads, hydrogen combustion, and fuel-coolant interactions can cause structural failure of the containment. Early containment failure can be important because it tends to result in shorter warning times for initiating public protective measures, and because radionuclide releases would generally be more severe than if the containment fails late.

Late Containment Failure. A late containment failure involves structural failure of the containment several hours after breach of the reactor vessel. A variety of mechanisms such as gradual pressure and temperature increase, hydrogen combustion, and basemat melt-through by core debris can cause late containment failure.

ISLOCA. An ISLOCA refers to a class of accidents in which the reactor coolant system pressure boundary interfacing with a supporting system of lower design pressure is breached. If this occurs, the lower pressure system will be overpressurized and could rupture outside the containment. This failure would establish a flow path directly to the environment or, sometimes, to another building of small-pressure capacity.

For each of the proposed reactors, an assessment was made of the pre-accident inventories of each radioactive species in the reactor fuel, using information on the thermal power and refueling cycles. For the source term and offsite consequence analysis, the radioactive species were collected into groups that exhibit similar chemical behavior. The following groups represent the radionuclides considered to be most important to offsite consequences: noble gases, iodine, cesium, tellurium, strontium, ruthenium, lanthanum, cerium, and barium.

The LEU end-of-cycle isotopic activities (inventories) were multiplied by the MOX/LEU ratio to provide a MOX end-of-cycle activity for each isotope. The LEU and MOX core activities for Catawba and McGuire are provided in Table K-35. The activities for North Anna are provided in Table K-36.

Table K-35. Catawba and McGuire End-of-Cycle Core Activities

Isotope	LEU Core Activity (Ci)	MOX/LEU Ratio	40% MOX Core Activity (Ci)	Isotope	LEU Core Activity (Ci)	MOX/LEU Ratio	40% MOX Core Activity (Ci)
Americium 241	3.13×10 ³	2.06	6.45×10 ³	Niobium 95	1.41×10 ⁸	0.94	1.33×10 ⁸
Antimony 127	7.53×10 ⁶	1.15	8.66×10 ⁶	Plutonium 238	9.90×10 ⁴	0.76	7.53×10 ⁴
Antimony 129	2.67×10 ⁷	1.07	2.85×10 ⁷	Plutonium 239	2.23×10 ⁴	2.06	4.60×10 ⁴
Barium 139	1.70×10 ⁸	0.97	1.65×10 ⁸	Plutonium 240	2.82×10 ⁴	2.20	6.20×10 ⁴
Barium 140	1.68×10 ⁸	0.98	1.65×10 ⁸	Plutonium 241	4.74×10 ⁶	1.79	8.49×10 ⁶
Cerium 141	1.53×10 ⁸	0.98	1.50×10 ⁸	Praseodymium 143	1.46×10 ⁸	0.95	1.39×10 ⁸
Cerium 143	1.48×10 ⁸	0.95	1.41×10 ⁸	Rhodium 105	5.53×10 ⁷	1.19	6.58×10 ⁷
Cerium 144	9.20×10 ⁷	0.91	8.37×10 ⁷	Rubidium 86	5.10×10 ⁴	0.77	3.93×10 ⁴
Cesium 134	1.17×10 ⁷	0.85	9.93×10 ⁶	Ruthenium 103	1.23×10 ⁸	1.11	1.36×10 ⁸
Cesium 136	3.56×10 ⁶	1.09	3.88×10 ⁶	Ruthenium 105	7.98×10 ⁷	1.18	9.42×10 ⁷
Cesium 137	6.53×10 ⁶	0.91	5.94×10 ⁶	Ruthenium 106	2.79×10 ⁷	1.28	3.57×10 ⁷
Cobalt 58	8.71×10 ⁵	0.86	7.49×10 ⁵	Strontium 89	9.70×10 ⁷	0.83	8.05×10 ⁷
Cobalt 60	6.66×10 ⁵	0.72	4.80×10 ⁵	Strontium 90	5.24×10 ⁶	0.75	3.93×10 ⁶
Curium 242	1.20×10 ⁶	1.43	1.71×10 ⁶	Strontium 91	1.25×10 ⁸	0.86	1.07×10 ⁸
Curium 244	7.02×10 ⁴	0.94	6.60×10 ⁴	Strontium 92	1.30×10 ⁸	0.89	1.16×10 ⁸
Iodine 131	8.66×10 ⁷	1.03	8.92×10 ⁷	Technetium 99m	1.42×10 ⁸	0.99	1.41×10 ⁸
Iodine 132	1.28×10 ⁸	1.02	1.30×10 ⁸	Tellurium 127	7.28×10 ⁶	1.16	8.44×10 ⁶
Iodine 133	1.83×10 ⁸	1.00	1.83×10 ⁸	Tellurium 127m	9.63×10 ⁵	1.20	1.16×10 ⁶
Iodine 134	2.01×10 ⁸	0.98	1.97×10 ⁸	Tellurium 129	2.50×10 ⁷	1.08	2.70×10 ⁷
Iodine 135	1.73×10 ⁸	1.00	1.73×10 ⁸	Tellurium 129m	6.60×10 ⁶	1.09	7.20×10 ⁶
Krypton 85	6.69×10 ⁵	0.78	5.22×10 ⁵	Tellurium 131m	1.26×10 ⁷	1.11	1.40×10 ⁷
Krypton 85m	3.13×10 ⁷	0.86	2.69×10 ⁷	Tellurium 132	1.26×10 ⁸	1.01	1.27×10 ⁸
Krypton 87	5.72×10 ⁷	0.85	4.87×10 ⁷	Xenon 133	1.83×10 ⁸	1.00	1.83×10 ⁸
Krypton 88	7.74×10 ⁷	0.84	6.50×10 ⁷	Xenon 135	3.44×10 ⁷	1.28	4.40×10 ⁷
Lanthanum 140	1.72×10 ⁸	0.97	1.67×10 ⁸	Yttrium 90	5.62×10 ⁶	0.76	4.27×10 ⁶
Lanthanum 141	1.57×10 ⁸	0.97	1.53×10 ⁸	Yttrium 91	1.18×10 ⁸	0.85	1.00×10 ⁸
Lanthanum 142	1.52×10 ⁸	0.97	1.47×10 ⁸	Yttrium 92	1.30×10 ⁸	0.89	1.16×10 ⁸
Molybdenum 99	1.65×10 ⁸	0.99	1.63×10 ⁸	Yttrium 93	1.47×10 ⁸	0.91	1.34×10 ⁸
Neodymium 147	6.52×10 ⁷	0.98	6.39×10 ⁷	Zirconium 95	1.49×10 ⁸	0.94	1.40×10 ⁸
Neptunium 239	1.75×10 ⁹	0.99	1.73×10 ⁹	Zirconium 97	1.56×10 ⁸	0.98	1.53×10 ⁸

Key: LEU, low-enriched uranium.

Table K-36. North Anna End-of-Cycle Core Activities

Isotope	LEU Core Activity (Ci)	MOX/LEU Ratio	40% MOX Core Activity (Ci)	Isotope	LEU Core Activity (Ci)	MOX/LEU Ratio	40% MOX Core Activity (Ci)
Americium 241	1.03×10 ⁴	2.06	2.13×10 ⁴	Plutonium 238	1.99×10 ⁵	0.76	1.51×10 ⁵
Antimony 127	6.36×10 ⁶	1.15	7.31×10 ⁶	Plutonium 239	2.70×10 ⁴	2.06	5.57×10 ⁴
Antimony 129	2.41×10 ⁷	1.07	2.58×10 ⁷	Plutonium 240	3.43×10 ⁴	2.20	7.54×10 ⁴
Barium 139	1.39×10 ⁸	0.97	1.35×10 ⁸	Plutonium 241	9.82×10 ⁶	1.79	1.76×10 ⁷
Barium 140	1.37×10 ⁸	0.98	1.34×10 ⁸	Praseodymium 143	1.17×10 ⁸	0.95	1.11×10 ⁸
Cerium 141	1.25×10 ⁸	0.98	1.22×10 ⁸	Rhodium 105	7.22×10 ⁷	1.19	8.59×10 ⁷
Cerium 143	1.18×10 ⁸	0.95	1.12×10 ⁸	Rubidium 86	1.45×10 ⁴	0.77	1.12×10 ⁴
Cerium 144	9.70×10 ⁷	0.91	8.82×10 ⁷	Rubidium 103	1.16×10 ⁸	1.11	1.28×10 ⁸
Cesium 134	1.28×10 ⁷	0.85	1.09×10 ⁷	Rubidium 105	7.84×10 ⁷	1.18	9.25×10 ⁷
Cesium 136	3.42×10 ⁶	1.09	3.72×10 ⁶	Rubidium 106	3.83×10 ⁷	1.28	4.90×10 ⁷
Cesium 137	8.41×10 ⁶	0.91	7.66×10 ⁶	Strontium 89	7.48×10 ⁷	0.83	6.21×10 ⁷
Curium 242	2.72×10 ⁶	1.43	3.88×10 ⁶	Strontium 90	6.22×10 ⁶	0.75	4.66×10 ⁶
Curium 244	2.75×10 ⁵	0.94	2.58×10 ⁵	Strontium 91	9.36×10 ⁷	0.86	8.05×10 ⁷
Iodine 131	7.33×10 ⁷	1.03	7.55×10 ⁷	Strontium 92	1.04×10 ⁸	0.89	9.23×10 ⁷
Iodine 132	1.07×10 ⁸	1.02	1.09×10 ⁸	Technetium 99m	1.26×10 ⁸	0.99	1.25×10 ⁸
Iodine 133	1.52×10 ⁸	1.00	1.52×10 ⁸	Tellurium 127	6.21×10 ⁶	1.16	7.21×10 ⁶
Iodine 134	1.75×10 ⁸	0.98	1.71×10 ⁸	Tellurium 127m	9.87×10 ⁵	1.20	1.18×10 ⁶
Iodine 135	1.49×10 ⁸	1.00	1.49×10 ⁸	Tellurium 129	2.29×10 ⁷	1.08	2.47×10 ⁷
Krypton 85	3.51×10 ⁶	0.78	2.74×10 ⁶	Tellurium 129m	4.20×10 ⁶	1.09	4.58×10 ⁶
Krypton 85m	8.69×10 ⁵	0.86	7.48×10 ⁵	Tellurium 132	1.07×10 ⁸	1.01	1.08×10 ⁸
Krypton 87	3.86×10 ⁷	0.85	3.28×10 ⁷	Xenon 133	1.59×10 ⁸	1.00	1.59×10 ⁸
Krypton 88	5.46×10 ⁷	0.84	4.59×10 ⁷	Xenon 133m	4.69×10 ⁶	1.01	4.73×10 ⁶
Lanthanum 140	1.42×10 ⁸	0.97	1.37×10 ⁸	Xenon 135	4.47×10 ⁷	1.28	5.72×10 ⁷
Lanthanum 141	1.28×10 ⁸	0.97	1.24×10 ⁸	Yttrium 90	6.21×10 ⁶	0.76	4.72×10 ⁶
Lanthanum 142	1.24×10 ⁸	0.97	1.21×10 ⁸	Yttrium 91	9.93×10 ⁷	0.85	8.44×10 ⁷
Molybdenum 99	1.43×10 ⁸	0.99	1.42×10 ⁸	Yttrium 92	1.01×10 ⁸	0.89	8.97×10 ⁷
Neodymium 147	5.12×10 ⁷	0.98	5.02×10 ⁷	Yttrium 93	1.16×10 ⁸	0.91	1.05×10 ⁸
Neptunium 239	1.51×10 ⁹	0.99	1.50×10 ⁹	Zirconium 95	1.27×10 ⁸	0.94	1.20×10 ⁸
Niobium 95	1.31×10 ⁸	0.94	1.23×10 ⁸	Zirconium 97	1.28×10 ⁸	0.98	1.26×10 ⁸

Key: LEU, low-enriched uranium.

The source term for each accident, taken from each plant’s PRA, is described by the release height, timing, duration, and heat content of the plume, the fraction of each isotope group released, and the warning time (time when offsite officials are warned that an emergency response should be initiated). The PRAs included several release categories for each bypass and failure scenario. These release categories were screened for each accident scenario to determine which release category resulted in the highest risk. The risk was determined by multiplying the consequences by the frequency for each release category. The release category with the highest risk for each scenario was used in the SPD EIS analysis. The highest risk release category source terms for Catawba, McGuire, and North Anna are presented in Table K-37. Also included in each release category characterization is the frequency of occurrence.

The overall risk from beyond-design-basis accidents can be described by the sum of risks from all beyond-design-basis accidents. The group of accidents derived from the screening process results in the highest risks from the containment bypass and failure scenarios. The screened-out accidents in these categories not only

Table K-37. Beyond-Design-Basis Accident Source Terms

Accident	Parameters	Release		Release Fractions								
		Category	Frequency	Xe/Kr	I	Cs/Rb	Te/Sb	Sr	Ru/Mo	La	Ce	Ba
CATAWBA												
SG tube rupture^a	Time: 20 hr Duration: 1.0 hr Energy: 1.0×10 ⁴ cal/sec (4.2×10 ⁴ W) Elevation: 10.0 m Warning time: 7.5 hr	1.04	6.31×10 ⁻¹⁰	1.0	7.7×10 ⁻¹	7.9×10 ⁻¹	7.3×10 ⁻¹	5.0×10 ⁻³	9.4×10 ⁻²	1.3×10 ⁻⁴	NA	4.0×10 ⁻²
Early containment failure	Time: 6.0 hr Duration: 0.5 hr Energy: 2.0×10 ⁷ cal/sec (8.37×10 ⁷ W) Elevation: 10.0 m Warning time: 5.5 hr	5.01	3.42×10 ⁻⁸	1.0	5.5×10 ⁻²	4.8×10 ⁻²	3.0×10 ⁻²	2.5×10 ⁻⁴	2.2×10 ⁻³	1.2×10 ⁻⁴	NA	1.7×10 ⁻³
Late containment failure	Time: 18.5 hr Duration: 0.5 hr Energy: 1.0×10 ⁷ cal/sec (4.2×10 ⁷ W) Elevation: 10.0 m Warning time: 18.0 hr	6.01	1.21×10 ⁻⁵	1.0	3.6×10 ⁻³	3.9×10 ⁻³	1.8×10 ⁻³	5.2×10 ⁻⁵	3.8×10 ⁻⁴	2.6×10 ⁻⁵	NA	1.6×10 ⁻⁴
Interfacing systems LOCA	Time: 6.0 hr Duration: 1.0 hr Energy: 1.0×10 ⁴ cal/sec (4.2×10 ⁴ W) Elevation: 10.0 m Warning time: 5.5 hr	2.04	6.9×10 ⁻⁸	1.0	8.2×10 ⁻¹	8.2×10 ⁻¹	7.9×10 ⁻¹	5.8×10 ⁻²	2.1×10 ⁻¹	3.1×10 ⁻²	NA	1.4×10 ⁻¹

Table K-37. Beyond-Design-Basis Accident Source Terms (Continued)

Accident	Parameters	Release		Release Fractions								
		Category	Frequency	Xe/Kr	I	Cs/Rb	Te/Sb	Sr	Ru/Mo	La	Ce	Ba
McGUIRE												
SG tube rupture	Time: 20.0 hr Duration: 1.0 hr Energy: 1.0×10 ⁴ cal/sec (4.2×10 ⁴ W) Elevation: 10.0 m Warning time: 7.5 hr	1.04	5.81×10 ⁻⁹	1.0	7.7×10 ⁻¹	7.9×10 ⁻¹	7.3×10 ⁻¹	5.0×10 ⁻³	9.4×10 ⁻²	1.3×10 ⁻⁴	NA	4.0×10 ⁻²
Early containment failure	Time: 6.0 hr Duration: 0.5 hr Energy: 2.0×10 ⁷ cal/sec (8.37×10 ⁷ W) Elevation: 10.0 m Warning time: 5.5 hr	5.01	9.89×10 ⁻⁸	1.0	4.4×10 ⁻²	3.5×10 ⁻²	2.1×10 ⁻²	1.4×10 ⁻⁴	4.3×10 ⁻³	2.0×10 ⁻⁵	NA	1.4×10 ⁻³
Late containment failure	Time: 32.0 hr Duration: 0.5 hr Energy: 1.0×10 ⁷ cal/sec (4.2×10 ⁷ W) Elevation: 10.0 m Warning time: 31.5 hr	6.01	7.21×10 ⁻⁶	1.0	3.2×10 ⁻³	2.4×10 ⁻³	3.3×10 ⁻³	1.0×10 ⁻⁸	5.8×10 ⁻⁸	1.0×10 ⁻⁹	NA	1.8×10 ⁻⁷
Interfacing systems LOCA	Time: 3.0 hr Duration: 1.0 hr Energy: 1.0×10 ⁴ cal/sec (4.2×10 ⁴ W) Elevation: 10.0 m Warning time: 2.0 hr	2.04	6.35×10 ⁻⁷	1.0	7.5×10 ⁻¹	7.5×10 ⁻¹	6.6×10 ⁻¹	4.2×10 ⁻²	1.5×10 ⁻¹	2.0×10 ⁻²	NA	9.8×10 ⁻²

Table K-37. Beyond-Design-Basis Accident Source Terms (Continued)

Accident	Parameters	Release Category	Frequency	Release Fractions								
				Xe/Kr	I	Cs/Rb	Te/Sb	Sr	Ru/Mo	La	Ce	Ba
NORTH ANNA												
SG tube rupture	Time: 20.3 hr Duration: 1.0 hr Energy: 8.48×10 ³ cal/sec (3.55×10 ⁴ W) Elevation: 10.0 m Warning time: 7.8 hr	24	7.38×10 ⁻⁶	9.96×10 ⁻¹	5.2×10 ⁻¹	5.4×10 ⁻¹	2.6×10 ⁻³ / 6.8×10 ⁻¹	3.4×10 ⁻²	1.4×10 ⁻¹	5.5×10 ⁻⁵	5.2×10 ⁻³	2.1×10 ⁻²
Early containment failure	Time: 3.056 hr Duration: 0.5 hr Energy: 1.696×10 ⁷ cal/sec (7.1×10 ⁷ W) Elevation: 10.0 m Warning time: 2.556 hr	7	1.60×10 ⁻⁷	9.0×10 ⁻¹	7.4×10 ⁻²	9.7×10 ⁻²	1.4×10 ⁻² / 1.3×10 ⁻¹	1.5×10 ⁻²	2.5×10 ⁻²	8.1×10 ⁻⁶	9.7×10 ⁻⁵	8.7×10 ⁻³
Late containment failure	Time: 8.33 hr Duration: 0.5 hr Energy: 8.48×10 ⁶ cal/sec (3.55×10 ⁷ W) Elevation: 10.0 m Warning time: 7.83 hr	9	2.46×10 ⁻⁶	8.2×10 ⁻¹	2.3×10 ⁻⁶	1.4×10 ⁻⁵	1.6×10 ⁻⁵ / 1.2×10 ⁻⁴	3.2×10 ⁻⁴	3.9×10 ⁻⁴	1.8×10 ⁻¹¹	1.4×10 ⁻¹¹	1.3×10 ⁻⁵
Interfacing systems LOCA^b	Time: 5.56 hr Duration: 1.0 hr Energy: 8.48×10 ³ cal/sec (3.55×10 ⁴ W) Elevation: 10.0 m Warning time: 4.56 hr	23	2.40×10 ⁻⁷	9.4×10 ⁻¹	2.9×10 ⁻¹	3.1×10 ⁻¹	1.6×10 ⁻⁵ / 5.0×10 ⁻¹	2.3×10 ⁻¹	2.8×10 ⁻¹	3.6×10 ⁻⁴	3.7×10 ⁻²	1.5×10 ⁻¹

^a McGuire data was used for the Catawba steam generator tube rupture event to compare similar scenarios.

^b McGuire release duration, elevation, and warning time span were used for North Anna in lieu of plant-specific information.

Key: LOCA, loss-of-coolant accident; NA, not applicable; SG, steam generator.

result in lower consequences, but also have much lower probabilities, often resulting in risks several orders of magnitude lower. The other type of severe accident scenario for these reactors results in an intact containment. The risks from these events are several orders of magnitude lower than the risks from the bypass and failure scenarios. Therefore, a summation of the severe accident risks presented in the SPD EIS is a good indicator of overall risk.

Evacuation Information. This analysis conservatively assumes that 95 percent of the population within the 16-km (10-mi) emergency planning zone participated in an evacuation. It was also assumed that the five percent of the population that did not participate in the initial evacuation was relocated within 12 to 24 hr after plume passage, based on the measured concentrations of radioactivity in the surrounding area and the comparison of projected doses with Environmental Protection Agency (EPA) guidelines. Longer term countermeasures (e.g., crop or land interdiction) were based on EPA Protective Action Guides.

Each beyond-design-basis accident scenario has a warning time and a subsequent release time. The warning time is the time at which notification is given to offsite emergency response officials to initiate protective measures for the surrounding population. The release time is the time when the release to the environment begins. The minimum time between the warning time and the release time is one-half hour. The minimum time of one-half hour is enough time to evacuate onsite personnel (i.e., noninvolved workers). This also conservatively assumes that an onsite emergency has not been declared prior to initiating an offsite notification. Intact containment severe accident scenarios, which were not analyzed because of their insignificant offsite consequences, take place on an even longer time frame.

K.7.2.6 Accident Impacts

Accident impacts are presented in terms of increased risk. Increased risk is defined as the additional risk resulting from using a partial MOX core rather than an LEU core. For example, if the risk of an LCF from an accident with an LEU core is 1.0×10^{-6} and the risk of an LCF from the same accident with a MOX core is 1.1×10^{-6} , then the increased risk of an LCF is 1.0×10^{-7} ($1.1 \times 10^{-6} - 1.0 \times 10^{-6} = 1.0 \times 10^{-7}$).

Tables K-38 through K-43 present the consequences and risks of the postulated set of accidents at Catawba, McGuire, and North Anna, respectively. The receptors include a noninvolved worker located 640 m (0.4 mi) from the release point, the MEI, and the population within an 80-km (50-mi) radius of the reactor site. The consequences and risks are presented for both the current LEU-only and the proposed 40 percent MOX core configurations.

Table K-44 shows the ratios of accident impacts with the proposed 40 percent MOX core to the impacts with the current LEU core. This table shows that the increased risk from accidents to the surrounding population from a MOX core is, on average, less than 5 percent. For the fuel-handling accident at all three plants, the risk is reduced when using MOX fuel.

Severe accident scenarios that postulate large abrupt releases could result in prompt fatalities if the radiation dose is sufficiently high. Of the accidents analyzed in the SPD EIS, the ISLOCA and steam generator tube rupture at Catawba and McGuire, and the ISLOCA at North Anna were the only accidents that resulted in doses high enough to cause prompt fatalities. However, the number of prompt fatalities is expected to increase only for the ISLOCA scenarios. Table K-45 shows the estimated number of prompt fatalities estimated to result from these accidents.

Table K-38. Design Basis Accident Impacts for Catawba With LEU and MOX Fuels

Accident	Frequency (per year)	LEU or MOX Core	Impacts on Noninvolved Worker			Impacts at Site Boundary			Impacts on Population Within 80 km		
			Dose (rem)	Probability of Latent Cancer Fatality ^a	Risk of Latent Cancer Fatality (over campaign) ^b	Dose (rem)	Probability of Latent Cancer Fatality ^a	Risk of Latent Cancer Fatality (over campaign) ^b	Dose (person-rem)	Latent Cancer Fatalities ^c	Risk of Latent Cancer Fatalities (over campaign) ^d
Loss-of-coolant accident	7.50×10 ⁻⁶	LEU	3.78	1.51×10 ⁻³	1.81×10 ⁻⁷	1.44	7.20×10 ⁻⁴	8.64×10 ⁻⁸	3.64×10 ³	1.82	2.19×10 ⁻⁴
		MOX	3.85	1.54×10 ⁻³	1.86×10 ⁻⁷	1.48	7.40×10 ⁻⁴	8.88×10 ⁻⁸	3.75×10 ³	1.88	2.26×10 ⁻⁴
Spent-fuel-handling accident ^e	1.00×10 ⁻⁴	LEU	0.275	1.10×10 ⁻⁴	1.78×10 ⁻⁷	0.138	6.90×10 ⁻⁵	1.10×10 ⁻⁷	1.12×10 ²	5.61×10 ⁻²	8.98×10 ⁻⁵
		MOX	0.262	1.05×10 ⁻⁴	1.68×10 ⁻⁷	0.131	6.55×10 ⁻⁵	1.05×10 ⁻⁷	1.10×10 ²	5.48×10 ⁻²	8.77×10 ⁻⁵

^a Likelihood (or probability) of cancer fatality for a hypothetical individual—a noninvolved worker at a distance of 640 m (2,100 ft) or the maximally exposed offsite individual at the site boundary—given exposure (762 m [2,500 ft]) to the indicated dose.

^b Risk of cancer fatality over the estimated 16-year campaign to a hypothetical individual—a noninvolved worker at a distance of 640 m (2,100 ft) or the maximally exposed offsite individual at the site boundary (762 m [2,500 ft]).

^c Estimated number of cancer fatalities in the entire offsite population out to a distance of 80 km (50 mi) given exposure to the indicated dose.

^d Risk of a cancer fatality over the estimated 16-year campaign in the entire offsite population out to a distance of 80 km (50 mi).

^e Postulated design basis accidents at commercial reactors are considered extremely unlikely events. They are estimated to have a frequency of between 1.0×10⁻⁴ and 1.0×10⁻⁶ per year. Because a spent-fuel-handling accident does not have a calculated frequency associated with it, it has been estimated to have the highest frequency for the purposes of this analysis.

Key: LEU, low-enriched uranium.

Table K-39. Beyond-Design-Basis Accident Impacts for Catawba With LEU and MOX Fuels

Accident	Frequency (per year)	LEU or MOX Core	Impacts at Site Boundary			Impacts on Population Within 80 km		
			Dose (rem)	Probability of Latent Cancer Fatality ^a	Risk of Latent Cancer Fatality (over campaign) ^b	Dose (person-rem)	Latent Cancer Fatalities ^c	Risk of Latent Cancer Fatalities (over campaign) ^d
SG tube rupture ^e	6.31×10 ⁻¹⁰	LEU	3.46×10 ²	0.346	3.49×10 ⁻⁹	5.71×10 ⁶	5.20×10 ³	5.25×10 ⁻⁵
		MOX	3.67×10 ²	0.367	3.71×10 ⁻⁹	5.93×10 ⁶	5.42×10 ³	5.47×10 ⁻⁵
Early containment failure	3.42×10 ⁻⁸	LEU	5.97	2.99×10 ⁻³	1.63×10 ⁻⁹	7.70×10 ⁵	4.62×10 ²	2.53×10 ⁻⁴
		MOX	6.01	3.01×10 ⁻³	1.65×10 ⁻⁹	8.07×10 ⁵	4.84×10 ²	2.66×10 ⁻⁴
Late containment failure	1.21×10 ⁻⁵	LEU	3.25	1.63×10 ⁻³	3.15×10 ⁻⁷	3.93×10 ⁵	1.97×10 ²	3.81×10 ⁻²
		MOX	3.48	1.74×10 ⁻³	3.38×10 ⁻⁷	3.78×10 ⁵	1.90×10 ²	3.68×10 ⁻²
ISLOCA	6.90×10 ⁻⁸	LEU	1.40×10 ⁴	1	1.10×10 ⁻⁶	2.64×10 ⁷	1.56×10 ⁴	1.73×10 ⁻²
		MOX	1.60×10 ⁴	1	1.10×10 ⁻⁶	2.96×10 ⁷	1.69×10 ⁴	1.87×10 ⁻²

^a Likelihood (or probability) of cancer fatality to a hypothetical individual—the maximally exposed offsite individual at the site boundary (762 m [2,500 ft])—given exposure to the indicated dose.

^b Risk of cancer fatality over the estimated 16-year campaign to a hypothetical individual—the maximally exposed offsite individual at the site boundary (762 m [2,500 ft]).

^c Estimated number of cancer fatalities in the entire offsite population out to a distance of 80 km (50 mi) given exposure to the indicated dose.

^d Risk of cancer fatality over the estimated 16-year campaign in the entire offsite population out to a distance of 80 km (50 mi).

^e McGuire timing and release fractions were used to compare like scenarios.

Key: ISLOCA, interfacing systems loss-of-coolant accident; LEU, low-enriched uranium; SG, steam generator.

Table K-40. Design Basis Accident Impacts for McGuire With LEU and MOX Fuels

Accident	Frequency (per year)	LEU or MOX Core	Impacts on Noninvolved Worker			Impacts at Site Boundaries			Impacts on Population Within 80 km		
			Dose (rem)	Probability of Latent Cancer Fatality ^a	Risk of Latent Cancer Fatality (over campaign) ^b	Dose (rem)	Probability of Latent Cancer Fatality ^a	Risk of Latent Cancer Fatality (over campaign) ^b	Dose (person-rem)	Latent Cancer Fatalities ^c	Risk of Latent Cancer Fatalities (over campaign) ^d
Loss-of-coolant accident	1.50×10 ⁻⁵	LEU	5.31	2.12×10 ⁻³	5.10×10 ⁻⁷	2.28	1.14×10 ⁻³	2.74×10 ⁻⁷	3.37×10 ³	1.69	4.06×10 ⁻⁴
		MOX	5.46	2.18×10 ⁻³	5.25×10 ⁻⁷	2.34	1.17×10 ⁻³	2.82×10 ⁻⁷	3.47×10 ³	1.74	4.18×10 ⁻⁴
Spent-fuel-handling accident ^e	1.00×10 ⁻⁴	LEU	0.392	1.57×10 ⁻⁴	2.51×10 ⁻⁷	0.212	1.06×10 ⁻⁴	1.70×10 ⁻⁷	99.1	4.96×10 ⁻²	7.94×10 ⁻⁵
		MOX	0.373	1.49×10 ⁻⁴	2.38×10 ⁻⁷	0.201	1.01×10 ⁻⁴	1.62×10 ⁻⁷	97.3	4.87×10 ⁻²	7.79×10 ⁻⁵

^a Likelihood (or probability) of cancer fatality for a hypothetical individual—a noninvolved worker at a distance of 640 m (2,100 ft) or the maximally exposed offsite individual at the site boundary (762 m [2,500 ft])—given exposure to the indicated dose.

^b Risk of cancer fatality over the estimated 16-year campaign to a hypothetical individual—a noninvolved worker at a distance of 640 m (2,100 ft) or the maximally exposed offsite individual at the site boundary (762 m [2,500 ft]).

^c Estimated number of cancer fatalities in the entire offsite population out to a distance of 80 km (50 mi) given exposure to the indicated dose.

^d Risk of a cancer fatality over the estimated 16-year campaign in the entire offsite population out to a distance of 80 km (50 mi).

^e Postulated design basis accidents at commercial reactors are considered extremely unlikely events. They are estimated to have a frequency of between 1.0×10⁻⁴ and 1.0×10⁻⁶ per year. Because a spent-fuel-handling accident does not have a calculated frequency associated with it, it has been estimated to have the highest frequency for the purposes of this analysis.

Key: LEU, low-enriched uranium.

Table K-41. Beyond-Design-Basis Accident Impacts for McGuire With LEU and MOX Fuels

Accident	Frequency (per year)	LEU or MOX Core	Impacts at Site Boundary			Impacts on Population Within 80 km		
			Dose (rem)	Probability of Latent Cancer Fatality ^a	Risk of Latent Cancer Fatality (over campaign) ^b	Dose (person-rem)	Latent Cancer Fatalities ^c	Risk of Latent Cancer Fatalities (over campaign) ^d
SG tube rupture ^e	5.81×10 ⁻⁹	LEU	6.10×10 ²	0.610	5.66×10 ⁻⁸	5.08×10 ⁶	4.65×10 ³	4.32×10 ⁻⁴
		MOX	6.47×10 ²	0.647	6.02×10 ⁻⁸	5.28×10 ⁶	4.85×10 ³	4.51×10 ⁻⁴
Early containment failure	9.89×10 ⁻⁸	LEU	12.2	6.10×10 ⁻³	9.65×10 ⁻⁹	7.90×10 ⁵	4.57×10 ²	7.23×10 ⁻⁴
		MOX	12.6	6.30×10 ⁻³	9.97×10 ⁻⁹	8.04×10 ⁵	4.67×10 ²	7.39×10 ⁻⁴
Late containment failure	7.21×10 ⁻⁶	LEU	2.18	1.09×10 ⁻³	1.26×10 ⁻⁷	3.04×10 ⁵	1.52×10 ²	1.76×10 ⁻²
		MOX	2.21	1.11×10 ⁻³	1.28×10 ⁻⁷	2.96×10 ⁵	1.48×10 ²	1.71×10 ⁻²
ISLOCA	6.35×10 ⁻⁷	LEU	1.95×10 ⁴	1	1.02×10 ⁻⁵	1.79×10 ⁷	1.19×10 ⁴	0.121
		MOX	2.19×10 ⁴	1	1.02×10 ⁻⁵	1.97×10 ⁷	1.27×10 ⁴	0.129

^a Likelihood (or probability) of cancer fatality to a hypothetical individual—the maximally exposed offsite individual at the site boundary (762 m [2,500 ft])—given exposure to the indicated dose.

^b Risk of cancer fatality over the estimated 16-year campaign to a hypothetical individual—the maximally exposed offsite individual at the site boundary (762 m [2,500 ft]).

^c Estimated number of cancer fatalities in the entire offsite population out to a distance of 80 km (50 mi) given exposure to the indicated dose.

^d Risk of cancer fatalities over the estimated 16-year campaign in the entire offsite population out to a distance of 80 km (50 mi).

^e McGuire timing and release fractions were used to compare like scenarios.

Key: ISLOCA, interfacing systems loss-of-coolant accident; LEU, low-enriched uranium; SG, steam generator.

Table K-42. Design Basis Accident Impacts for North Anna With LEU and MOX Fuels

Accident	Frequency (per year)	LEU or MOX Core	Impacts on Noninvolved Worker			Impacts at Site Boundary			Impacts on Population Within 80 km		
			Dose (rem)	Probability of Latent Cancer Fatality ^a	Risk of Latent Cancer Fatality (over campaign) ^b	Dose (rem)	Probability of Latent Cancer Fatality ^a	Risk of Latent Cancer Fatality (over campaign) ^b	Dose (person-rem)	Latent Cancer Fatalities ^c	Risk of Latent Cancer Fatalities (over campaign) ^d
Loss-of-coolant accident	2.10×10 ⁻⁵	LEU	0.114	4.56×10 ⁻⁵	1.53×10 ⁻⁸	3.18×10 ⁻²	1.59×10 ⁻⁵	5.34×10 ⁻⁹	39.4	1.97×10 ⁻²	6.62×10 ⁻⁶
		MOX	0.115	4.60×10 ⁻⁵	1.55×10 ⁻⁸	3.20×10 ⁻²	1.60×10 ⁻⁵	5.38×10 ⁻⁹	40.3	2.02×10 ⁻²	6.78×10 ⁻⁶
Spent-fuel-handling accident ^e	1.00×10 ⁻⁴	LEU	0.261	1.04×10 ⁻⁴	1.66×10 ⁻⁷	9.54×10 ⁻²	4.77×10 ⁻⁵	7.63×10 ⁻⁸	29.4	1.47×10 ⁻²	2.35×10 ⁻⁵
		MOX	0.239	9.56×10 ⁻⁵	1.53×10 ⁻⁷	8.61×10 ⁻²	4.31×10 ⁻⁵	6.90×10 ⁻⁸	27.5	1.38×10 ⁻²	2.21×10 ⁻⁵

^a Likelihood (or probability) of cancer fatality for a hypothetical individual—a noninvolved worker at a distance of 640 m (2,100 ft) or the maximally exposed offsite individual at the site boundary (1,349 m [4,426 ft])—given exposure to the indicated dose.

^b Risk of cancer fatality over the estimated 16-year campaign to a hypothetical individual—a noninvolved worker at a distance of 640 m (2,100 ft) or the maximally exposed offsite individual at the site boundary (1,349 m [4,426 ft]).

^c Estimated number of cancer fatalities in the entire offsite population out to a distance of 80 km (50 mi) given exposure to the indicated dose.

^d Risk of a cancer fatality over the estimated 16-year campaign in the entire offsite population out to a distance of 80 km (50 mi).

^e Postulated design basis accidents at commercial reactors are considered extremely unlikely events. They are estimated to have a frequency of between 1.0×10⁻⁴ and 1.0×10⁻⁶ per year. Because a spent-fuel-handling accident does not have a calculated frequency associated with it, it has been estimated to have the highest frequency for the purposes of this analysis.

Key: LEU, low-enriched uranium.

Table K–43. Beyond-Design-Basis Accident Impacts for North Anna With LEU and MOX Fuels

Accident	Frequency (per year)	LEU or MOX Core	Impacts on Site Boundary			Impacts on Population Within 80 km		
			Dose (rem)	Probability of Latent Cancer Fatality ^a	Risk of Latent Cancer Fatality (over campaign) ^b	Dose (person-rem)	Latent Cancer Fatalities ^c	Risk of Latent Cancer Fatalities (over campaign) ^d
SG tube rupture ^e	7.38×10 ⁻⁶	LEU	2.09×10 ²	0.209	2.46×10 ⁻⁵	1.73×10 ⁶	1.22×10 ³	0.144
		MOX	2.43×10 ²	0.243	2.86×10 ⁻⁵	1.84×10 ⁶	1.33×10 ³	0.157
Early containment failure ^e	1.60×10 ⁻⁷	LEU	19.6	1.96×10 ⁻²	5.02×10 ⁻⁸	8.33×10 ⁵	4.52×10 ²	1.16×10 ⁻³
		MOX	21.6	2.16×10 ⁻²	5.54×10 ⁻⁸	8.42×10 ⁵	4.61×10 ²	1.18×10 ⁻³
Late containment failure ^e	2.46×10 ⁻⁶	LEU	1.12	5.60×10 ⁻⁴	2.21×10 ⁻⁸	4.04×10 ⁴	20.2	7.95×10 ⁻⁴
		MOX	1.15	5.75×10 ⁻⁴	2.26×10 ⁻⁸	4.43×10 ⁴	22.1	8.70×10 ⁻⁴
ISLOCA ^e	2.40×10 ⁻⁷	LEU	1.00×10 ⁴	1	3.84×10 ⁻⁶	4.68×10 ⁶	2.98×10 ³	1.14×10 ⁻²
		MOX	1.22×10 ⁴	1	3.84×10 ⁻⁶	5.41×10 ⁶	3.39×10 ³	1.30×10 ⁻²

^a Likelihood (or probability) of cancer fatality to a hypothetical individual—the maximally exposed offsite individual at the site boundary (1,349 m [4,426 ft])—given exposure to the indicated dose.

^b Risk of cancer fatality over the estimated 16-year campaign to a hypothetical individual—the maximally exposed offsite individual at the site boundary (1,349 m [4,426 ft]).

^c Estimated number of cancer fatalities in the entire offsite population out to a distance of 80 km (50 mi) given exposure to the indicated dose.

^d Risk of cancer fatalities over the estimated 16-year campaign in the entire offsite population out to a distance of 80 km (50 mi).

^e McGuire release durations and warning times were used in lieu of site specific data.

Key: ISLOCA, interfacing systems loss-of-coolant accident; LEU, low-enriched uranium; SG, steam generator.

Table K–44. Ratio of Accident Impacts for MOX-Fueled and LEU-Fueled Reactors (MOX Impacts/Uranium Impacts)

Accident	Catawba			McGuire			North Anna		
	Worker	MEI	Population	Worker	MEI	Population	Worker	MEI	Population
LOCA	1.019	1.028	1.033	1.028	1.026	1.030	1.009	1.006	1.025
FHA	0.953	0.949	0.977	0.952	0.948	0.982	0.916	0.903	0.939
SGTR	NA	1.061	1.042	NA	1.061	1.043	NA	1.163	1.090
Early	NA	1.007	1.048	NA	1.033	1.022	NA	1.102	1.020
Late	NA	1.071	0.964	NA	1.014	0.974	NA	1.027	1.094
ISLOCA	NA	1.143	1.083	NA	1.123	1.067	NA	1.220	1.138

Key: Early, early containment; FHA, fuel-handling accident; ISLOCA, interfacing systems loss-of-coolant accident; Late, late containment; LEU, low-enriched uranium; LOCA, loss-of-coolant accident; MEI, maximally exposed individual; NA, not applicable; SGTR, steam generator tube rupture.

K.7.2.6.1 Catawba

Design Basis Accidents. Table K–38 shows the risks and consequences associated with a LOCA and spent-fuel-handling accident at Catawba. The greatest risk increase to the surrounding population for a design basis accident with a MOX core configuration is approximately 3.3 percent from the LOCA. If this accident were to occur, the consequences in terms of LCFs in the surrounding population within 80 km (50 mi) would be 1.82 LCFs for an LEU core and 1.88 LCFs for a partial MOX core. The increased risk, in terms of an LCF, to the noninvolved worker is 1 in 200 million (5.0×10⁻⁹) per 16-year campaign; the MEI, one 1 in 420 million (2.4×10⁻⁹) per 16-year campaign; and the population, 1 in 140,000 (7.0×10⁻⁶) per 16-year campaign.

Table K-45. Prompt Fatalities for MOX-Fueled and LEU-Fueled Reactors

Accident Scenario	LEU	MOX
Steam generator tube rupture		
Catawba	1	1
McGuire	1	1
North Anna	0	0
Interfacing systems loss-of-coolant accident		
Catawba	815	843
McGuire	398	421
North Anna	54	60

Key: LEU, low-enriched uranium.

Beyond-Design-Basis Accidents. Table K-39 shows the risks and consequences associated with four beyond-design-basis accidents at Catawba. Table K-45 shows prompt fatalities. The greatest risk increase to the surrounding population from a beyond-design-basis accident with a MOX core configuration is approximately 8.3 percent from the ISLOCA. If this accident were to occur, the consequences in terms of LCFs and prompt fatalities in the surrounding population within 80 km (50 mi) would be approximately 16,400 fatalities for an LEU core and 17,700 fatalities for a partial MOX core. The increased risk, in terms of an LCF, to the population is 1 in 710 (1.4×10^{-3}) per 16-year campaign. The increased risk of a prompt fatality is 1 in 32,000 (3.1×10^{-5}) per 16-year campaign.

K.7.2.6.2 McGuire

Design Basis Accidents. Table K-40 shows the risks and consequences associated with a LOCA and spent-fuel-handling accident at McGuire. The greatest risk increase to the surrounding population for a design basis accident with a MOX core configuration is 3.0 percent from the LOCA. If this accident were to occur, the consequences in terms of LCFs in the surrounding population within 80 km (50 mi) would be 1.69 LCFs for an LEU core and 1.74 LCFs for a partial MOX core. The increased risk, in terms of an LCF, to the noninvolved worker is 1 in 67 million (1.5×10^{-8}) per 16-year campaign; the MEI, 1 in 120 million (8.0×10^{-9}) per 16-year campaign; and the population, 1 in 83,000 (1.2×10^{-5}) per 16-year campaign.

Beyond-Design-Basis Accidents. Table K-41 shows the risks and consequences associated with four beyond-design-basis accidents at McGuire. Table K-45 shows prompt fatalities. The greatest risk increase to the surrounding population for a beyond-design-basis accident with a MOX core configuration is approximately 6.6 percent from the ISLOCA. If this accident were to occur, the consequences in terms of LCFs and prompt fatalities in the surrounding population within 80 km (50 mi) would be approximately 12,300 fatalities with an LEU core and 13,100 with a partial MOX core. The increased risk of an LCF to the population is 1 in 120 (8.0×10^{-3}) per 16-year campaign. The increased risk of a prompt fatality is 1 in 4,300 (2.3×10^{-4}) per 16-year campaign.

K.7.2.6.3 North Anna

Design Basis Accidents. Table K-42 shows the risks and consequences associated with a LOCA and spent-fuel-handling accident at North Anna. The greatest risk increase to the surrounding population for a design-basis-accident with a MOX core configuration is approximately 2.5 percent from the LOCA. If this accident were to occur, the consequences in terms of LCFs in the surrounding population within 80 km (50 mi) would be 1.97×10^{-2} LCF for an LEU core and 2.02×10^{-2} LCF for a partial MOX core. The increased risk, in

terms of an LCF, to the noninvolved worker is 1 in 5.0 billion (2.0×10^{-10}) per 16-year campaign; the MEI, 1 in 25 billion (4.0×10^{-11}) per 16-year campaign; and the population, 1 in 6.2 million (1.6×10^{-7}) per 16-year campaign.

Beyond-Design-Basis Accidents. Table K-43 shows the risks and consequences associated with four beyond-design-basis accidents at North Anna. Table K-45 shows prompt fatalities. The greatest risk increase to the surrounding population from a beyond-design-basis accident with a MOX core configuration is approximately 14 percent from the ISLOCA. If this accident were to occur, the consequences in terms of LCFs and prompt fatalities in the surrounding populations within 80 km (50 mi) would be approximately 3,000 fatalities for an LEU core and 3,450 fatalities for a partial MOX core. The increased risk of an LCF to the population is 1 in 620 (1.6×10^{-3}) per 16-year campaign. The increased risk of a prompt fatality is 1 in 43,000 (2.3×10^{-5}) per 16-year campaign.

K.8 REFERENCES

Chanin, D.I., and M.L. Young, 1997, *Code Manual for MACCS2: Volume 1, User's Guide*, SAND97-0594, Sandia National Laboratories, Albuquerque, NM, March.

Coats, D.W. Jr., 1998, University of California, Lawrence Livermore National Laboratory, Plant Engineering, Livermore, CA, personal communication to B. Meyers, Lawrence Livermore National Laboratory, Livermore, CA, *B-332 Inc. III Seismic Safety*, April 2.

DOC (U.S. Department of Commerce), 1992, *Census of Population and Housing, 1990: Summary Tape File 3 on CD-ROM*, Bureau of the Census, Washington, DC, May.

DOE (U.S. Department of Energy), 1992, *Final Environmental Impact Statement and Environmental Impact Report for Continued Operation of Lawrence Livermore National Laboratory and Sandia National Laboratories, Livermore*, DOE/EIS-0157, San Francisco Field Office, Oakland, CA, August.

DOE (U.S. Department of Energy), 1993, *Recommendations for the Preparation of Environmental Assessments and Environmental Impact Statements*, Office of Environment, Safety and Health, Office of NEPA Oversight, Washington, DC, May.

DOE (U.S. Department of Energy), 1994a, *Natural Phenomena Hazards Design and Evaluation Criteria for Department of Energy Facilities*, DOE-STD-1020-94, Washington, DC, April.

DOE (U.S. Department of Energy), 1994b, *Airborne Release Fractions/Rates and Respirable Fractions for Nonreactor Nuclear Facilities*, vol. I and II, DOE Handbook DOE-HDBK-3010-94, Washington, DC, October.

DOE (U.S. Department of Energy), 1995a, *Final Programmatic Environmental Impact Statement for Tritium Supply and Recycling*, DOE/EIS-0161, Office of Reconfiguration, Washington, DC, October 19.

DOE (U.S. Department of Energy), 1995b, *Facility Safety*, DOE O 420.1, Washington, DC, October 13.

DOE (U.S. Department of Energy), 1996a, *Storage and Disposition of Weapons-Usable Fissile Materials Final Programmatic Environmental Impact Statement*, DOE/EIS-0229, Office of Fissile Materials Disposition, Washington, DC, December.

DOE (U.S. Department of Energy), 1996b, *Final Environmental Impact Statement for the Continued Operation of the Pantex Plant and Associated Storage of Nuclear Weapon Components*, DOE/EIS-0225, Albuquerque Operations Office, Albuquerque, NM, November.

DOE (U.S. Department of Energy), 1996c, *Accident Analysis for Aircraft Crash Into Hazardous Facilities*, DOE-STD-3014-96, Washington, DC, October.

DOE (U.S. Department of Energy), 1999a, *DOE and Contractor Fatality Incidence Rates*, <http://tis.eh.doe.gov/cairs/cairs/summary/oipds984/fatrate.gif>, Office of Environment, Safety and Health, Washington, DC, August 5.

DOE (U.S. Department of Energy), 1999b, *MOX Fuel Fabrication Facility and Nuclear Power Reactor Data Report*, MD-0015, Office of Fissile Materials Disposition, Washington, DC, August.

DOL (U.S. Department of Labor), 1997, *National Census of Fatal Occupational Injuries, 1996*, USDL 97266, Bureau of Labor Statistics, Washington, DC, August 7.

Duke Power Company, 1991, *McGuire Individual Plant Examination (IPE) Submittal Report and McGuire Nuclear Station Unit 1 Probabalistic Risk Assessment (PRA)*, vol. 1–3, November 4.

Duke Power Company, 1992, *Catawba Individual Plant Examination (IPE) Submittal Report and Catawba Nuclear Station Unit 1 Probabalistic Risk Assessment (PRA)*, vol. 1–3, September 10.

Duke Power Company, 1996, *Updated Final Safety Analysis Report for McGuire Nuclear Station*, May 14.

Duke Power Company, 1997, *Updated Final Safety Analysis Report for Catawba Nuclear Station*, May 2.

EPA (U.S. Environmental Protection Agency), 1992, *Environmental Impact Statement*, “Incomplete or Unavailable Information,” 40 CFR 1502.22, Washington, DC, July 1.

ICRP (International Commission on Radiological Protection), 1991, *1990 Recommendations of the International Commission on Radiological Protection*, ICRP Publication 60, Elmsford, NY.

[Text deleted.]

Murray, R.C., 1998, Lawrence Livermore National Laboratory, Hazards Mitigation Center, Livermore, CA, personal communication to B. Myers, Lawrence Livermore National Laboratory, Livermore, CA, *Collapse Probability of Building 332 Increment III Due to an Earthquake*, April 20.

NAS (National Academy of Sciences and National Research Council), 1995, *Management and Disposition of Excess Weapons Plutonium, Reactor-Related Options*, National Academy Press, Washington, DC.

NRC (U.S. Nuclear Regulatory Commission), 1972, *Assumptions Used for Evaluating the Potential Radiological Consequences of a Fuel Handling Accident in the Fuel Handling Storage Facility for Boiling and Pressurized Water Reactors*, Regulatory Guide 1.25, Washington, DC, March 23.

NRC (U.S. Nuclear Regulatory Commission), 1974, *Assumptions Used for Evaluating the Potential Radiological Consequences of a Loss of Coolant Accident for Pressurized Water Reactors*, rev. 2, Regulatory Guide 1.4, Washington, DC, June.

NRC (U.S. Nuclear Regulatory Commission), 1988, *Individual Plant Examination for Severe Accident Vulnerabilities—10 CFR 50.54(f) (Generic Letter 88-20)*, Washington, DC, November 23.

NRC (U. S. Nuclear Regulatory Commission), 1990, *MELCOR Accident Consequence Code System (MACCS)*, NUREG/CR-4691, Office of Nuclear Regulatory Research, Division of Systems Research, Washington, DC, February.

O'Connor, D.G., et al., 1998a, *ANL-W MOX Fuel Lead Assemblies Data Report for the Surplus Plutonium Disposition Environmental Impact Statement*, ORNL/TM-13478, Lockheed Martin Energy Research Corporation, Oak Ridge, TN, August.

O'Connor, D.G., et al., 1998b, *Hanford MOX Fuel Lead Assemblies Data Report for the Surplus Plutonium Disposition Environmental Impact Statement*, ORNL/TM-13481, Lockheed Martin Energy Research Corporation, Oak Ridge, TN, August.

O'Connor, D.G., et al., 1998c, *LLNL MOX Fuel Lead Assemblies Data Report for the Surplus Plutonium Disposition Environmental Impact Statement*, ORNL/TM-13480, Lockheed Martin Energy Research Corporation, Oak Ridge, TN, August.

O'Connor, D.G., et al., 1998d, *LANL MOX Fuel Lead Assemblies Data Report for the Surplus Plutonium Disposition Environmental Impact Statement*, ORNL/TM-13482, Lockheed Martin Energy Research Corporation, Oak Ridge, TN, August.

O'Connor, D.G., et al., 1998e, *SRS MOX Fuel Lead Assemblies Data Report for the Surplus Plutonium Disposition Environmental Impact Statement*, ORNL/TM-13483, Lockheed Martin Energy Research Corporation, Oak Ridge, TN, August.

| ORNL (Oak Ridge National Laboratory), 1998, *Final Data Report Response to the Draft Surplus Plutonium Disposition Environmental Impact Statement Data Call for Generic Site Add-On Facility for Plutonium Polishing*, ORNL/TM-13669, Oak Ridge, TN, June.

ORNL (Oak Ridge National Laboratory), 1999, *MOX/LEU Core Inventory Ratios*, Oak Ridge TN.

Smith, W.B., O. Wilkey, and D. Siebe, 1996, *Data Report for Plutonium Conversion Facility*, LA-UR-95-1721, Los Alamos National Laboratory, Los Alamos, NM, February 14.

SNL (Sandia National Laboratory), 1997, *Code Manual for MACCS2: Volume 1, User's Guide*, SAND97-0594, Albuquerque, NM, March.

UC (Regents of the University of California), 1998a, *Pit Disassembly and Conversion Facility, Environmental Impact Statement Data Report—Hanford Site*, LA-UR-97-2907, Los Alamos National Laboratory, Los Alamos, NM, June 1.

UC (Regents of the University of California), 1998b, *Response to the Surplus Plutonium Disposition Environmental Impact Statement Data Call for a Mixed Oxide Fuel Fabrication Facility Located at the Hanford Site*, rev. 3, LA-UR-97-2064, Los Alamos National Laboratory, Los Alamos, NM, June 22.

UC (Regents of the University of California), 1998c, *Pit Disassembly and Conversion Facility, Environmental Impact Statement Data Report—Savannah River Site*, LA-UR-97-2910, Los Alamos National Laboratory, Los Alamos, NM, June 1.

UC (Regents of the University of California), 1998d, *Response to the Surplus Plutonium Disposition Environmental Impact Statement Data Call for a Mixed Oxide Fuel Fabrication Facility Located at the Savannah River Site*, rev. 3, LA-UR-97-2066, Los Alamos National Laboratory, Los Alamos, NM, June 22.

UC (Regents of the University of California), 1998e, *Pit Disassembly and Conversion Facility, Environmental Impact Statement Data Report—Pantex Plant*, LA-UR-97-2909, Los Alamos National Laboratory, Los Alamos, NM, June 1.

UC (Regents of the University of California), 1998f, *Pit Disassembly and Conversion Facility, Environmental Impact Statement Data Report—Idaho National Engineering and Environmental Laboratory*, LA-UR-97-2908, Los Alamos National Laboratory, Los Alamos, NM, June 1.

UC (Regents of the University of California), 1998g, *Response to the Surplus Plutonium Disposition Environmental Impact Statement Data Call for a Mixed Oxide Fuel Fabrication Facility Located at the Idaho National Engineering and Environmental Laboratory*, rev. 3, LA-UR-97-2065, Los Alamos National Laboratory, Los Alamos, NM, June 22.

UC (Regents of the University of California), 1998h, *Response to the Surplus Plutonium Disposition Environmental Impact Statement Data Call for a Mixed Oxide Fuel Fabrication Facility Located at the Pantex Plant*, rev. 3, LA-UR-97-2067, Los Alamos National Laboratory, Los Alamos, NM, June 22.

[Text deleted.]

UC (Regents of the University of California), 1999a, *Fissile Materials Disposition Program, EIS Data Call Report: Plutonium Immobilization Plant Using Ceramic in Existing Facilities at Hanford*, rev. 1, UCRL-ID-128275, Lawrence Livermore National Laboratory, Livermore, CA, September.

UC (Regents of the University of California), 1999b, *Fissile Materials Disposition Program, EIS Data Call Report: Plutonium Immobilization Plant Using Glass in Existing Facilities at Hanford*, rev. 1, UCRL-ID-128276, Lawrence Livermore National Laboratory, Livermore, CA, September.

UC (Regents of the University of California), 1999c, *Fissile Materials Disposition Program, EIS Data Call Report: Plutonium Immobilization Plant Using Ceramic in New Facilities at the Savannah River Site*, rev. 1, UCRL-ID-128273, Lawrence Livermore National Laboratory, Livermore, CA, September.

UC (Regents of the University of California), 1999d, *Fissile Materials Disposition Program, EIS Data Call Report: Plutonium Immobilization Plant Using Glass in New Facilities at the Savannah River Site*, rev. 1, UCRL-ID-128271, Lawrence Livermore National Laboratory, Livermore, CA, September.

Virginia Power, 1992, *North Anna Units 1 & 2 Probabilistic Risk Assessment (PRA), Individual Plant Examination in Response to GL-88-20, Supplement 1*, December 14.

Virginia Power, 1998, *North Anna Power Station Updated Final Safety Analysis Report*, rev. 32, Richmond, VA, February 11.

White, V.S., 1997, *Initial Data Report in Response to the Surplus Plutonium Disposition Environmental Impact Statement Data Call for the UO₂ Supply*, rev. 1, ORNL/TM-13466, Lockheed Martin Energy Research Corporation, Oak Ridge, TN, November.

Appendix L

Evaluation of Human Health Effects From Transportation

L.1 INTRODUCTION

The overland transportation of any commodity involves a risk to both transportation crew members and members of the public. This risk results directly from transportation-related accidents and indirectly from the increased levels of pollution from vehicle emissions, regardless of the cargo. The transportation of certain materials, such as hazardous or radioactive waste, can pose an additional risk due to the unique nature of the material. In order to permit a complete appraisal of the environmental impacts of the proposed action and alternatives, the human health risks associated with the overland transportation of plutonium and other hazardous materials have been assessed.

This appendix provides an overview of the approach used to assess the human health risks that may result from the overland transportation. The appendix includes a discussion of the scope of the assessment, analytical methods used for the risk assessment (i.e., computer models), important assessment assumptions, and a determination of potential transportation routes. It also presents the results of the assessment. In addition, to aid in the understanding and interpretation of the results, specific areas of uncertainty are described, with an emphasis on how the uncertainties may affect comparisons of the alternatives.

The approach used in this appendix is modeled after that used in the *Storage and Disposition of Weapons-Usable Fissile Materials Final Programmatic Environmental Impact Statement* (PEIS) (DOE 1996a). The fundamental assumptions used in the analysis for the *Surplus Plutonium Disposition Environmental Impact Statement* are consistent with those used in the PEIS, and the same computer codes and generic release and accident data are used.

The risk assessment results are presented in this appendix in terms of “per-shipment” risk factors, as well as for the total risks associated with each alternative. Per-shipment risk factors provide an estimate of the risk from a single hazardous material shipment between a specific origin and destination. The total risks for a given alternative are found by multiplying the expected number of shipments by the appropriate per-shipment risk factors.

L.2 SCOPE OF ASSESSMENT

The scope of the overland transportation human health risk assessment, including the alternatives and options, transportation activities, potential radiological and nonradiological impacts, transportation modes considered, and receptors, is described below. Additional details of the assessment are provided in the remaining sections of the appendix.

- Proposed Action and Alternatives—The transportation risk assessment conducted for the SPD EIS estimates the human health risks associated with the transportation of plutonium and other hazardous materials for a number of disposition alternatives.
- Radiological Impacts—For each alternative, radiological risks (i.e., those risks that result from the radioactive nature of the plutonium and other hazardous materials) are assessed for both incident-free (i.e., normal) and accident transportation conditions. The radiological risk associated with incident-free transportation conditions would result from the potential exposure of people to external radiation in the vicinity of a loaded shipment. The radiological risk from transportation accidents would come from the potential release and dispersal of radioactive material into the environment during an accident and the

subsequent exposure of people through multiple exposure pathways (i.e., exposure to contaminated ground or air, or ingestion of contaminated food).

- All radiological impacts are calculated in terms of effective dose and associated health effects in the exposed populations. The radiation dose calculated is the total effective dose equivalent, which is the sum of the effective dose equivalent from external radiation exposure and the 50-year committed effective dose equivalent from internal radiation exposure (NRC 1998). Radiation doses are presented in units of roentgen equivalent man (rem) for individuals and person-rem for collective populations. The impacts are further expressed as health risks in terms of latent cancer fatalities (LCFs) and cancer incidence in exposed populations. The health risk conversion factors (expected health effects per dose absorbed) were taken from the *1990 Recommendations of the International Commission on Radiological Protection* (ICRP 1991).
- Nonradiological Impacts—In addition to the radiological risks posed by overland transportation activities, vehicle-related risks are also assessed for nonradiological causes (i.e., related to the transport vehicles and not the radioactive cargo) for the same transportation routes. The nonradiological transportation risks are independent of the radioactive nature of the cargo and would be incurred for similar shipments of any commodity. The nonradiological risks are assessed for both incident-free and accident conditions. Nonradiological risks during incident-free transportation conditions would be caused by potential exposure to increased vehicle exhaust emissions. The nonradiological accident risk refers to the potential occurrence of transportation accidents that directly result in fatalities unrelated to the cargo. State-specific transportation fatality rates are used in the assessment. Nonradiological risks are presented in terms of estimated fatalities.
- Transportation Modes—All overland shipments were assumed to take place by truck.
- Receptors—Transportation-related risks are calculated and presented separately for workers and members of the general public. The workers considered are truck crew members involved in the actual overland transportation. The general public includes all persons who could be exposed to a shipment while it is moving or stopped enroute. Potential risks are estimated for the collective populations of exposed people, as well as for the hypothetical maximally exposed individual. The collective population risk is a measure of the radiological risk posed to society as a whole by the alternative being considered. As such, the collective population risk is used as the primary means of comparing various alternatives.

L.3 PACKAGING AND REPRESENTATIVE SHIPMENT CONFIGURATIONS

Regulations that govern the transportation of radioactive materials are designed to protect the public from the potential loss or dispersal of radioactive materials as well as from routine radiation doses during transit. The primary regulatory approach to promote safety is through the specification of standards for the packaging of radioactive materials. Because packaging represents the primary barrier between the radioactive material being transported and radiation exposure to the public and the environment, packaging requirements are an important consideration for the transportation risk assessment. Regulatory packaging requirements are discussed briefly below and in Chapter 5. In addition, the representative packaging and shipment configurations assumed for the SPD EIS are described.

L.3.1 Packaging Overview

Although several Federal and State organizations are involved in the regulation of radioactive materials transportation, primary regulatory responsibility resides with the U.S. Department of Transportation (DOT) and the U.S. Nuclear Regulatory Commission (NRC). All transportation activities must take place in accordance with

the applicable regulations of these agencies specified in Title 49 of the Code of Federal Regulations (CFR) Part 173 (DOT 1992a) and 10 CFR 71 (NRC 1996).

Transportation packaging for small quantities of radioactive materials must be designed, constructed, and maintained to contain and shield their contents during normal transport conditions. For large quantities and for more highly radioactive material, such as spent nuclear fuel or plutonium, they must contain and shield their contents in the event of severe accident conditions. The type of packaging used is determined by the total radioactive hazard presented by the material within the packaging; 10 CFR 71 (NRC 1996) provides the rules for this determination. Four basic types of packaging are used: Excepted, Industrial, Type A, and Type B. Another packaging option, Strong and Tight, is still available for some domestic shipments.

Excepted packagings are limited to transporting materials with extremely low levels of radioactivity. Industrial packagings are used to transport materials that, because of their low concentration of radioactive materials, present a limited hazard to the public and the environment. Type A packagings are designed to protect and retain their contents under normal transport conditions and must maintain sufficient shielding to limit radiation exposure to handling personnel. These packagings are used to transport radioactive materials with higher concentrations or amounts of radioactivity than Excepted or Industrial packagings. Strong and Tight packagings are used in the United States for shipment of certain materials with low levels of radioactivity, such as natural uranium and rubble from the decommissioning of nuclear reactors. Type B packages are described in detail in Appendix L.3.1.6.

L.3.1.1 Uranium Hexafluoride Packaging

DOE would ship uranium hexafluoride in a commercial vehicle from the Portsmouth Gaseous Diffusion Plant to a fuel fabrication facility in Model 30B cylinders, which are Type A packages (for the purposes of the SPD EIS). Uranium hexafluoride shipments are regulated under 49 CFR 173.420, which requires the packaging to be in accordance with ANSI N14.1, *Uranium Hexafluoride—Packaging for Transport*. Because uranium hexafluoride breaks down into hydrofluoric acid and uranyl fluoride when exposed to air, packages would be marked with the primary hazard label as “Radioactive Yellow-II” and a secondary hazard label as “Corrosive.” The transport vehicle would be required to show the primary placard “Radioactive” and the secondary placard “Corrosive.”

L.3.1.2 Uranium Dioxide Packaging

DOE would ship uranium dioxide in a commercial vehicle from the fuel fabrication facility to DOE’s mixed oxide (MOX) facility in gasketed, open-head, 208-l (55-gal) drums with heavy plastic liners, which are Industrial Package Type 1 packages. Uranium dioxide shipments are regulated under 49 CFR 173.425. Because uranium dioxide is a low-specific-activity material, no primary hazard label would be required, and because it is chemically stable, no secondary hazard label would be required. The transport vehicle would be required to show the primary placard “Radioactive” and no secondary placard.

L.3.1.3 MOX Fuel Packaging

DOE will design the container for the MOX fuel assemblies. For analysis purposes, it is assumed that DOE would ship the unirradiated MOX fuel bundles in a safe, secure trailer/SafeGuards Transport (SST/SGT) to the reactor site(s) in Type B packages. Two conceptual packaging ideas are end-loading and lateral-loading packages (Ludwig et al. 1997). The fuel assembly weight per container is approximately 2800 kg (6,000 lb) for either pressurized water reactor (PWR) or boiling water reactor (BWR) fuel. The container could hold either four PWR or eight BWR assemblies.

L.3.1.4 Highly Enriched Uranium Packaging

DOE would ship highly enriched uranium (HEU) in an SST/SGT from the pit conversion facility to the Y-12 facility near Oak Ridge, Tennessee. The DOE-approved container type for these shipments is the DT-22.

L.3.1.5 Plutonium Packaging

DOE would ship all plutonium in Type B containers. DOE would ship nonpit plutonium in an SST/SGT from DOE sites (Hanford, Idaho National Engineering and Environmental Laboratory [INEEL], Lawrence Livermore National Laboratory [LLNL], Los Alamos National Laboratory [LANL], Rocky Flats Environmental Technology Site [RFETS], and Savannah River Site [SRS]) to the immobilization facility (Hanford or SRS) in a variety of containers, such as Type 3013, Type 2R, and Foodpac containers, which would be transported inside various casks, such as radial reflector, SAFEKEG (Type 9517), Model 60 FFTA DFA pins shipping or Specification 6M packages. DOE would ship plutonium pits from DOE sites to the pit conversion facility in DOE-approved FL containers and the piece parts resulting from pit disassembly in DOE-approved UC-609 and USA/9975 containers. Plutonium dioxide produced at the pit conversion facility would be loaded into packaging that meets DOE-STD-3013-96, *Criteria for Preparing and Packaging Plutonium Metals and Oxides for Long-Term Storage* (DOE 1996b) or equivalent. This package provides for safe storage of plutonium oxides for at least 50 years or until final disposition and serves as the primary containment vessel for shipping. DOE-STD-3013-96 specifies a design goal that the Type 3013 container could be shipped in a qualified shipping container without further reprocessing or repackaging. The Type 3013 primary containment vessel is designed for shipping and would be compatible with a Type B package. No Type B package has been specifically constructed or licensed for shipping DOE-STD-3013-96 primary containment vessels.

A Type B package is required when transporting commercial quantities of plutonium materials, including unirradiated MOX fuel assemblies. DOE is developing a conceptual design for a MOX container that optimizes SST/SGT load-carrying capacity and ensures compatibility with fuel-handling systems at commercial reactors (Ludwig et al. 1997).

L.3.1.6 Overview of Type B Containers

The transportation of highway-route controlled quantities of plutonium (more than a few grams, depending on activity level) requires the use of Type B packaging. In addition to meeting the standards for Type A packaging, Type B packaging must provide a high degree of assurance that, even in severe accidents, the integrity of the package will be maintained with essentially no loss of the radioactive contents or serious impairment of the shielding and maintain subcriticality capability. Type B packaging must satisfy stringent testing criteria specified in 10 CFR 71 (NRC 1996). The testing criteria were developed to simulate severe accident conditions, including impact, puncture, fire, and water immersion.

Beyond meeting DOT standards showing it can withstand normal conditions of transport without loss or dispersal of its radioactive contents or allowance of significant radiation fields, Type B packaging must also meet the 10 CFR 71 requirements administered by the NRC. The complete sequence of tests is listed below:

- Free-Drop Test—A 9-m (30-ft) free-drop onto a flat, essentially unyielding, horizontal surface, striking the surface in a position for which maximum damage to the package is expected.
- Puncture Test—A 1-m (40-in) drop onto the upper end of a 15-cm (6-in) diameter solid, vertical, cylindrical, mild steel bar (at least 20-cm [8-in] long) mounted on an essentially unyielding, horizontal surface.

- Thermal Test—Exposure to a heat flux of no less than that of a thermal radiation environment of 800 °C (1,475 °F) with an emissivity coefficient of at least 0.9 for a period of 30 minutes.
- Water Immersion Test—A separate, undamaged package specimen is subjected to water pressure equivalent to immersion under a head of water of at least 15-m (50-ft) for no less than 8 hours.

Effective April 1, 1996, 10 CFR 71 was revised to require an additional immersion test in 200 m (660 ft) of water for Type B casks designed to contain material with activity levels greater than 1 million curies (Ci) (NRC 1996). Containers used for shipping plutonium will not necessarily be subject to this test because they will contain much less than one million curies. The packaging may also be required to undergo the crush test if it is considered a light-weight, low-density package as most drum-type packages are. The crush test consists of dropping a 500-kg (1100-lb) steel plate from 9 m (30 ft) onto the package, which is resting on an essentially unyielding surface.

Additional restrictions apply to package surface contamination levels, but these restrictions are not limiting for the transportation radiological risk assessment. For risk assessment purposes, it is important to note that all packaging of a given type is designed to meet the same performance criteria. Therefore, two different Type B designs would be expected to perform similarly during incident-free and accident transportation conditions. The specific containers selected, however, will determine the total number of shipments necessary to transport a given quantity of plutonium.

External radiation from a package must be below specified limits that minimize the exposure of the handling personnel and general public. For these types of shipments, the external radiation dose rate during normal transportation conditions must be maintained below the following limits of 49 CFR 173 (DOT 1992a):

- 10 mrem/hr at any point 2 m (6.6 ft) from the vertical planes projected by the outer lateral surfaces of the transport vehicle (referred to as the regulatory limit throughout this document)
- 2 mrem/hr in any normally occupied position in the transport vehicle

L.3.2 Safe, Secure Transportation

DOE anticipates that any transportation of plutonium pits, nonpit plutonium, plutonium dioxide, MOX fuel, or HEU would be required to be made through use of the Transportation Safeguards System and shipped using SST/SGTs. The SST/SGT is a fundamental component of the Transportation Safeguards System. The Transportation Safeguards System is operated by the DOE Transportation Safeguards Division of the Albuquerque Operations Office for the DOE Headquarters Office of Defense Programs. Based on operational experience between FY84 and FY98, the mean probability of an accident requiring the tow-away of the SST/SGT was 0.058 accident per million kilometers (0.096 accident per million miles). By contrast, the rate for commercial trucking in 1989 was about 0.3 accident per million kilometers (0.5 accident per million miles). Commercial trucking accident rates (Saricks and Kvitek 1994) were used in the human health effects analysis. Since its establishment in 1975, the Transportation Safeguards Division has accumulated more than 151 million km (94 million mi) of over-the-road experience transporting DOE-owned cargo with no accidents resulting in a fatality or release of radioactive material.

The SST/SGT is a specially designed component of an 18-wheel tractor-trailer vehicle. Although details of vehicle enhancements and some operational aspects are classified, key characteristics of the SST/SGT system include the following:

- Enhanced structural characteristics and a highly reliable tie-down system to protect cargo from impact
- Heightened thermal resistance to protect the cargo in case of fire (newer SST/SGT models)
- Established operational and emergency plans and procedures governing the shipment of nuclear materials
- Various deterrents to prevent unauthorized removal of cargo
- An armored tractor component that provides courier protection against attack and contains advanced communications equipment
- Specially designed escort vehicles containing advanced communications and additional couriers
- 24-hour-a-day real-time communications to monitor the location and status of all SST/SGT shipments via DOE's Security Communication system
- Couriers who are armed Federal Officers, receive rigorous specialized training, and who are closely monitored through DOE's Personnel Assurance Program
- Significantly more stringent maintenance standards than those for commercial transport equipment
- Conduct of periodic appraisals of the Transportation Safeguards System operations by the DOE Office of Defense Programs to ensure compliance with DOE orders and management directives, and continuous improvement in transportation and emergency management programs

L.3.3 Ground Transportation Route Selection Process

According to DOE guidelines, plutonium shipments must comply with both NRC and DOT regulatory requirements. Commercial shipments are also required by law to comply with both NRC and DOT requirements. NRC regulations cover the packaging and transport of plutonium, whereas DOT specifically regulates the carriers and the conditions of transport, such as routing, handling and storage, and vehicle and driver requirements. The highway routing of nuclear material is systematically determined according to DOT regulations 49 CFR 171–179 and 49 CFR 397 for commercial shipments. The dates and times that specific transportation routes would be used are classified information and would not be publicized before a shipment.

The DOT routing regulations require that a shipment of a “highway route-controlled quantity” of radioactive material be transported over a preferred highway network including interstate highways, with preference toward interstate system bypasses around cities, and State-designated preferred routes. A State or tribe may designate a preferred route to replace or supplement the interstate highway system in accordance with DOT guidelines (DOT 1992b).

Carriers of highway route-controlled quantities are required to use the preferred network, unless moving from origin to the nearest interstate or from the interstate to the destination, when making necessary repair or rest stops, or when emergency conditions render the interstate unsafe or impassible. The primary criterion for selecting the preferred route for a shipment is travel time. Preferred routing takes into consideration accident rate, transit time, population density, activities, time of day, and day of week.

The HIGHWAY computer code (Johnson et al. 1993) may be used for selecting highway routes in the United States. The HIGHWAY database is a computerized road atlas that currently describes about 386,400 km (240,000 mi) of roads. The Interstate System and all U.S. (U.S.-designated) highways are completely described in the database. In addition, most of the principal State highways and many local and community roads are also identified. The code is updated periodically to reflect current road conditions and has been benchmarked against reported mileages and observations of commercial truck firms. Features in the HIGHWAY code allow the user to select routes that conform to DOT regulations. Additionally, the HIGHWAY code contains data on the population densities along the routes. The distance and population data from the HIGHWAY code are part of the information used for the transportation impact analysis in the SPD EIS.

L.4 METHODS FOR CALCULATING TRANSPORTATION RISKS

The overland transportation risk assessment methodology is summarized in Figure L-1. After the alternatives were identified and goals of the shipping campaign were understood, the first step was to collect data on material characteristics and accident parameters. Physical, radiological, and packaging data were provided in reports from the DOE national laboratories. Accident parameters are largely based on the DOE-funded study of transportation accidents (Saricks and Kvittek 1994).

Representative routes that may be used for the shipment of plutonium were selected using the HIGHWAY code. These routes were selected for risk assessment purposes. They do not necessarily represent the actual routes that would be used to transport nuclear materials. Specific routes cannot be identified in advance because the routes would not be finalized until DOE has actually planned the shipping campaign. The selection of the actual route would be responsive to environmental and other conditions that would be in effect or could be predicted at the time of shipment. Such conditions could include adverse weather conditions, road conditions, bridge closures, and local traffic problems. For security reasons, details about a planned shipment would not be publicized before the shipment.

The first analytic step in the ground transportation analysis was to determine the incident-free and accident risk factors, on a per-shipment basis, for transportation. Risk factors, as any risk estimate, are the product of the probability of exposure and the magnitude of the exposure. Accident risk factors were calculated for radiological and nonradiological traffic accidents. The probabilities, which are much lower than 1, and the magnitudes of exposure were multiplied, yielding risk numbers. Incident-free risk factors were calculated for crew and public exposure to radiation emanating from the shipping container (cask) and public exposure to the chemical toxicity of the transportation vehicle exhaust. The probability of incident-free exposure is unity (one).

Radiological risk factors are expressed in units of rem. Later in the analysis, they are multiplied by the *1990 Recommendations of the International Commission on Radiological Protection* (ICRP 1991) conversion factors and estimated number of shipments to give risk estimates in units of LCFs. The vehicle emission risk factors are calculated in LCFs, and the vehicle accident risk factors are calculated in fatalities.

For each alternative, risks were assessed for both incident-free transportation and accident conditions. For the incident-free assessment, risks were calculated for collective populations of potentially exposed individuals and for maximally exposed individuals. The accident assessment consists of two components: (1) a probabilistic accident risk assessment that considers the probabilities and consequences of a range of possible transportation accident environments, including low-probability accidents that have high consequences and

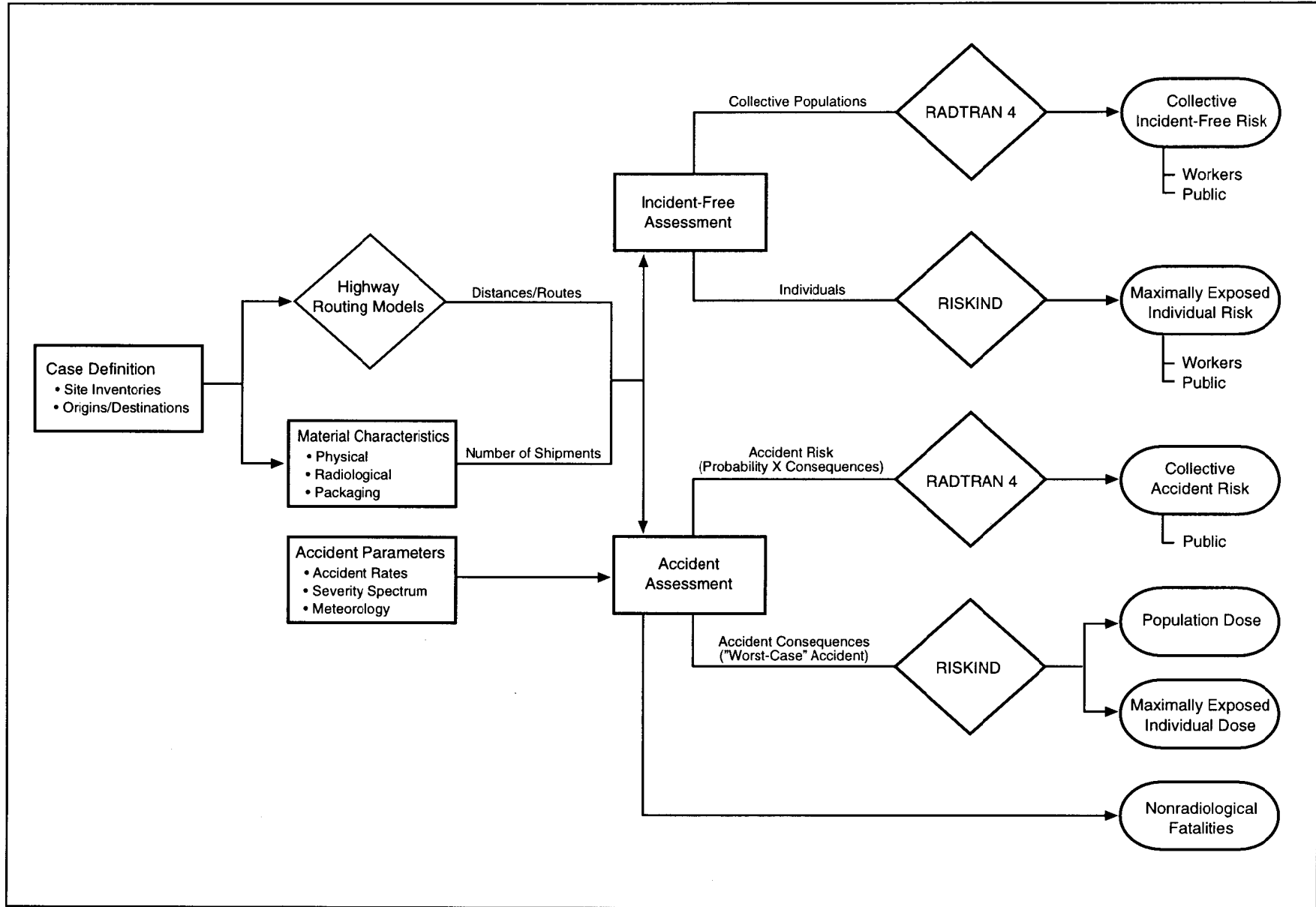

Figure L-1. Overland Transportation Risk Assessment

high-probability accidents that have low consequences, and (2) an accident consequence assessment that considers only the consequences of the most severe transportation accidents postulated.

The RADTRAN 4 computer code (Neuhauser and Kanipe 1995) is used for incident-free and accident risk assessments to estimate the impacts on collective populations. RADTRAN 4 was developed by Sandia National Laboratories to calculate population risks associated with the transportation of radioactive materials by a variety of modes, including truck, rail, air, ship, and barge.

The RADTRAN 4 population risk calculations take into account both the consequences and probabilities of potential exposure events. The collective population risk is a measure of the total radiological risk posed to society as a whole by the alternative being considered. As such, the collective population risk is used as the primary means of comparing the various alternatives. The RISKIND computer code (Yuan et al. 1995) is used to estimate the incident-free doses to maximally exposed individuals and for estimating impacts for the accident consequence assessment. The RISKIND computer code was developed for DOE's Office of Civilian Radioactive Waste Management to analyze the exposure of individuals during incident-free transportation. In addition, the RISKIND code was designed to allow a detailed assessment of the consequences to individuals and population subgroups from severe transportation accidents under various environmental settings.

The RISKIND calculations were conducted to supplement the collective risk results calculated with RADTRAN 4. Whereas the collective risk results provide a measure of the overall risks of each alternative, the RISKIND calculations are meant to address areas of specific concern to individuals and population subgroups. Essentially, the RISKIND analyses are meant to address "What if" questions, such as "What if I live next to a site access road?" or "What if an accident happens near my town?"

If highly specialized analytic codes had been used to model SST/SGT behavior in an accident (*DOE-Developed Analysis of Dispersal Risk Occurring in Transportation* or ADROIT [Clauss et al. 1995:689–696]), the code would have provided a probabilistic risk analysis of special nuclear materials shipped in an SST/SGT. ADROIT is designed to provide a focused analysis of a release caused by partial detonation of explosive material. The approach and the code could be tailored for the materials shipped as part of the surplus plutonium disposition program. However, detailed thermal and mechanical models have not been created for most of the packages used in the SPD EIS.

L.5 ALTERNATIVES, PARAMETERS, AND ASSUMPTIONS

The transportation risk assessment is designed to ensure—through uniform and judicious selection of models, data, and assumptions—that relative comparisons of risk among the various alternatives are meaningful. The major input parameters and assumptions used in the transportation risk assessment are discussed below.

L.5.1 Transportation Alternatives

The proposed action would involve transporting plutonium and other nuclear materials between DOE and commercial sites. Except for the No Action Alternative, each alternative in the SPD EIS has extensive and unique requirements for the transportation of hazardous materials. In this section, the assumptions and logic used to model the intersite transportation requirements are described.

Alternatives 2 through 12 require transporting plutonium metal and pits from various DOE sites to the pit conversion facility at Hanford, INEEL, Pantex, or SRS. The pit conversion facility would disassemble pits and convert the plutonium metal into plutonium dioxide. During the pit disassembly process, HEU would be recovered and shipped from the pit conversion facility to the Y-12 facility at Oak Ridge. In addition, some pit parts would be recovered and shipped to LANL. The plutonium dioxide would be shipped to the MOX facility

or the immobilization facility depending on the alternative. In many of the alternatives, the pit conversion facility is located on the same site as the MOX facility or immobilization facility, limiting the need for intersite transportation of the plutonium dioxide. In these alternatives, the plutonium dioxide would be transported between the facilities via a secure tunnel between the facilities.

In addition to reducing the number of trips required and the distance that would have to be traveled to transport surplus pits to the pit conversion facility, by placing the pit conversion facility at Pantex the dose associated with repackaging pits for intersite shipment could be reduced by nearly 40 percent. This is because pits can be transferred to the pit conversion facility at Pantex in their current storage containers (mainly the AL-R8 container) without having to be repackaged. If the pits are transported to another site, they have to be moved to a shipping container (e.g., FL-type, 9975).

Based on estimates presented in the *Final EIS for the Continued Operation of Pantex and Associated Storage of Nuclear Weapons Components (Pantex Sitewide EIS)* (DOE 1996c), about 50 workers would be needed to repackage approximately 13,000 pits from their current storage containers into containers that could also be used for shipping.¹ Work is currently under way to repackage pits from the AL-R8 container into the AL-R8 sealed insert (SI) container as discussed in the *Supplement Analysis for the Final Environmental Impact Statement for the Continued Operation of the Pantex Plant and Associated Storage of Nuclear Weapons Components—AL-R8 Sealed Insert Container* (DOE 1998). This effort could be completed over 10 years, and the estimated annual dose received from repackaging activities would be about 208 mrem per worker (Low 1999). By locating the pit conversion facility at Pantex, it is expected that the additional dose associated with repackaging the surplus pits into shipping containers could be avoided. This would effectively reduce the total expected dose for these activities by 50 percent. If the pit conversion facility were sited at Pantex, the pits would be slowly moved from storage locations in storage containers on specially designed vehicles to the pit conversion facility instead of having to be put into offsite shipping containers. Over the 10-year operating life of the pit conversion facility, this would reduce the total estimated dose to involved Pantex transportation and staging workers by 104 person-rem from 208 person-rem to 104 person-rem.² Under either scenario, the estimated number of excess cancer fatalities associated with repackaging activities would be 0.1 or less.

In August 1998, DOE prepared a supplement analysis (DOE 1998) for the *Pantex Sitewide EIS* that compares all environmental impact parameters to those analyzed in the *Pantex Sitewide EIS* and final determinations made in the Record of Decision that was signed on January 17, 1997, with respect to the use of the AL-R8 SI. Results of the analysis indicated that both the AT-400A container and the modified AL-R8 container, or AL-R8 SI, comply with the latest pit storage specifications to provide an improved storage environment for the pits and would be considered feasible solutions to long-term pit storage at Pantex. The containers were further analyzed with respect to the parameters established in the *Pantex Sitewide EIS* for public, personnel, and environmental impact potential. Based on conclusions drawn from this analysis, DOE concluded that the use of the AL-R8 SI containers does not constitute new circumstances or information or substantial change in the proposed action relevant to environmental concerns; therefore, no supplemental EIS, no new EIS, nor further NEPA documentation is required.

¹ In the analysis presented in the *Pantex Sitewide EIS* (DOE 1996c), pits are assumed to be repackaged in AT-400A containers. The amount of effort involved in repackaging a pit in an AT-400A container is more intense than the effort needed to repackage a pit in an FL-type container or equivalent; therefore, the doses would be expected to be higher. Since the *Pantex Sitewide EIS* was completed, it has been decided that surplus pits would not be repackaged in AT-400A containers. As a result, the dose estimates associated with repackaging pits as presented in the *Pantex Sitewide EIS* are conservatively high for the SPD EIS. No effort has been made to reestimate the dose associated with repackaging pits. The doses presented in the SPD EIS are based on using the AT-400A container, and therefore represent upper bounds on the expected dose to involved workers.

² Extremity doses are estimated to be approximately nine times higher than the whole body dose, but would be expected to stay within DOE's administrative limit of 2 rem/yr, or in the case at Pantex, 5 rem/yr (Low 1999).

Alternatives 2 through 12 involve immobilization of nonpit plutonium at Hanford (Alternative 2, 4, 8, 10, or 11) or SRS (Alternative 3, 5, 6, 7, 9, or 12). This material would be transported from its current location at various DOE sites to the chosen immobilization facility. If the immobilization facility uses a ceramic process, uranium oxide would be required. One of the United States Enrichment Corporation's gaseous diffusion plants would fill cylinders with depleted uranium hexafluoride, which would be transported to a commercial facility for conversion to uranium oxide. (For the purpose of this analysis, the gaseous diffusion plant in Portsmouth, Ohio, and the nuclear fuel fabrication facility in Wilmington, North Carolina, were chosen as representative sites for these activities.) The uranium oxide would be transported to the immobilization facility at Hanford or SRS. After the material is immobilized, it is assumed that the additional canisters of high level waste would be shipped to a potential geologic repository consistent with the assumptions made in the *Final Waste Management Programmatic Environmental Impact Statement for Managing Treatment, Storage, and Disposal of Radioactive and Hazardous Waste* (WM PEIS) (DOE 1997a). Figure L-2 shows the transportation requirements for the proposed immobilization disposition activities.

The production of MOX fuel (Alternatives 2 through 10) requires transporting plutonium dioxide from the pit conversion facility to the MOX facility at Hanford, INEEL, Pantex, or SRS. However, in every alternative except Alternatives 4 and 5, the pit conversion facility and MOX facility are collocated so there would not be any intersite transportation required for the plutonium dioxide as discussed above. In the case of Alternative 4, the pit conversion facility would be located at Pantex and the plutonium dioxide would be shipped to Hanford. Under Alternative 5, the pit conversion facility would also be at Pantex but the plutonium dioxide would be shipped to SRS. Uranium oxide needed to produce MOX fuel would be converted from uranium hexafluoride, originally from Portsmouth, at Wilmington, and then transported to the MOX facility. If MOX fuel rods are bundled with low-enriched uranium fuel rods, the uranium fuel rods may come from a separate fabrication facility. Transportation of the uranium fuel rods to the MOX facility is equivalent to transportation of uranium fuel to a commercial reactor site. This transportation activity is covered under the *Final Environmental Statement on the Transportation of Radioactive Material by Air and Other Modes* (NRC 1977). The MOX fuel would be transported to a domestic, commercial reactor for power production. For the purposes of this analysis, all MOX fuel was assumed to be transported to North Anna, the commercial reactor farthest from the MOX facility. Because the proposed reactor sites are in the same general area of the country, this approach closely models the risk of implementing each alternative. Figure L-3 shows the transportation requirements for the proposed MOX disposition activities.

Alternatives 2 through 10 include the production of MOX fuel. If this alternative is chosen by DOE, lead assembly fabrication and irradiation may precede the actual production of MOX fuel. Plutonium dioxide at LANL would be shipped to one of five DOE facilities (Argonne National Laboratory-West [ANL-W], Hanford, LLNL, LANL, or SRS). Low-enriched uranium (LEU) oxide would be produced from LEU hexafluoride, originally from Portsmouth, at Wilmington, and then transported to the lead assembly fabrication facility. From the fabrication facility, the MOX fuel lead assemblies would be transported overland to the McGuire reactor. After irradiation in the reactor, the MOX spent fuel lead assemblies would be transported to a DOE site (either ANL-W or Oak Ridge National Laboratory) for postirradiation examination. Figure L-4 shows the transportation requirements for the proposed lead assembly activities.

Table L-1 shows the container type, vehicle type, and number of shipments required for each material form. This table can be used along with Figures L-2 through L-4 to determine which shipments and how many shipments are required for each alternative. The container type and vehicle type are based on currently available containers, and current practices, regulations, and DOE Orders. If a MOX production alternative is selected, DOE would have to design and construct a container to transport MOX fuel to the commercial, domestic reactor. The estimated number of shipments is based on the best available information and could change slightly as material is prepared for transportation.

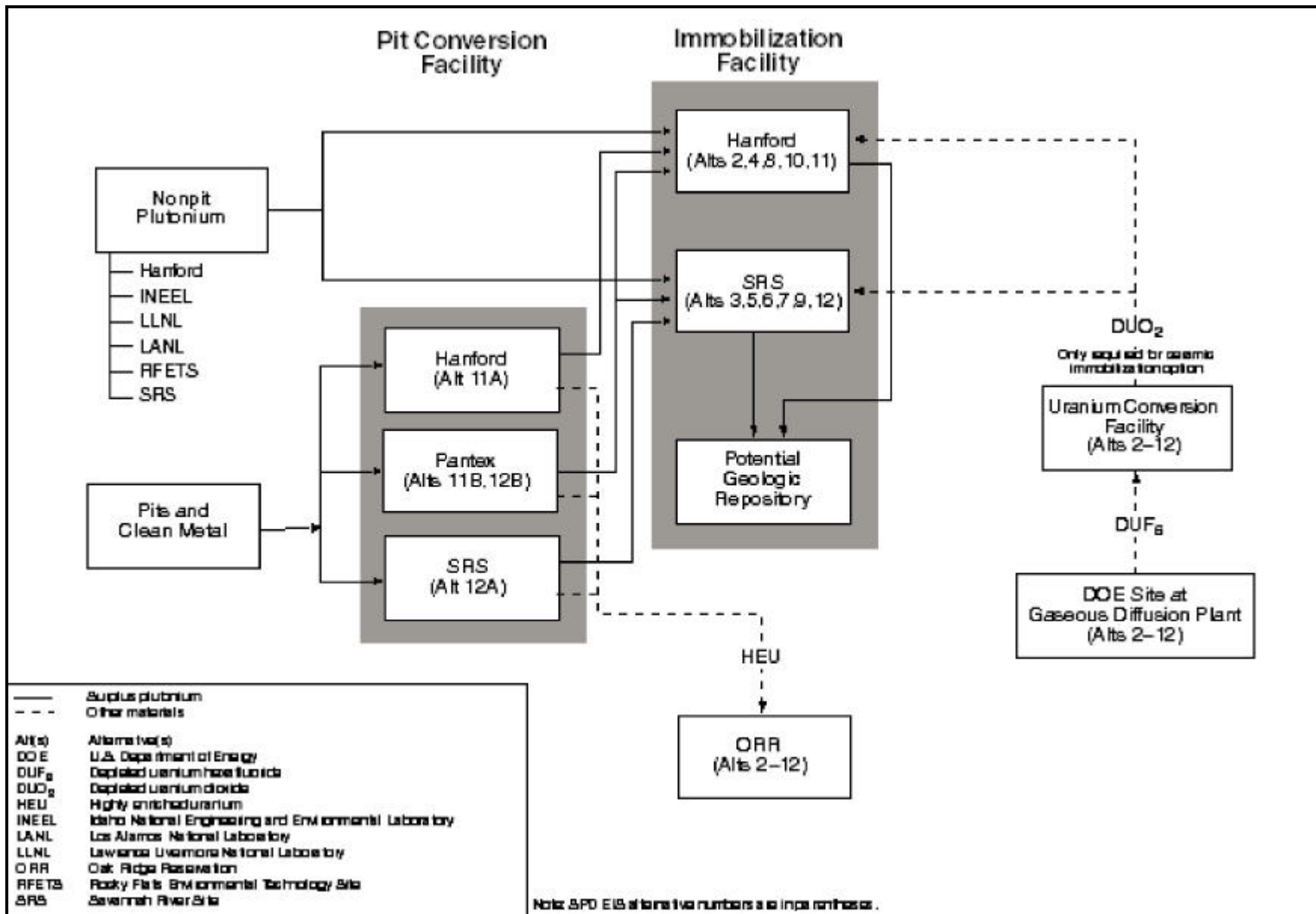

Figure L-2. Transportation Requirements for Plutonium Conversion and Immobilization

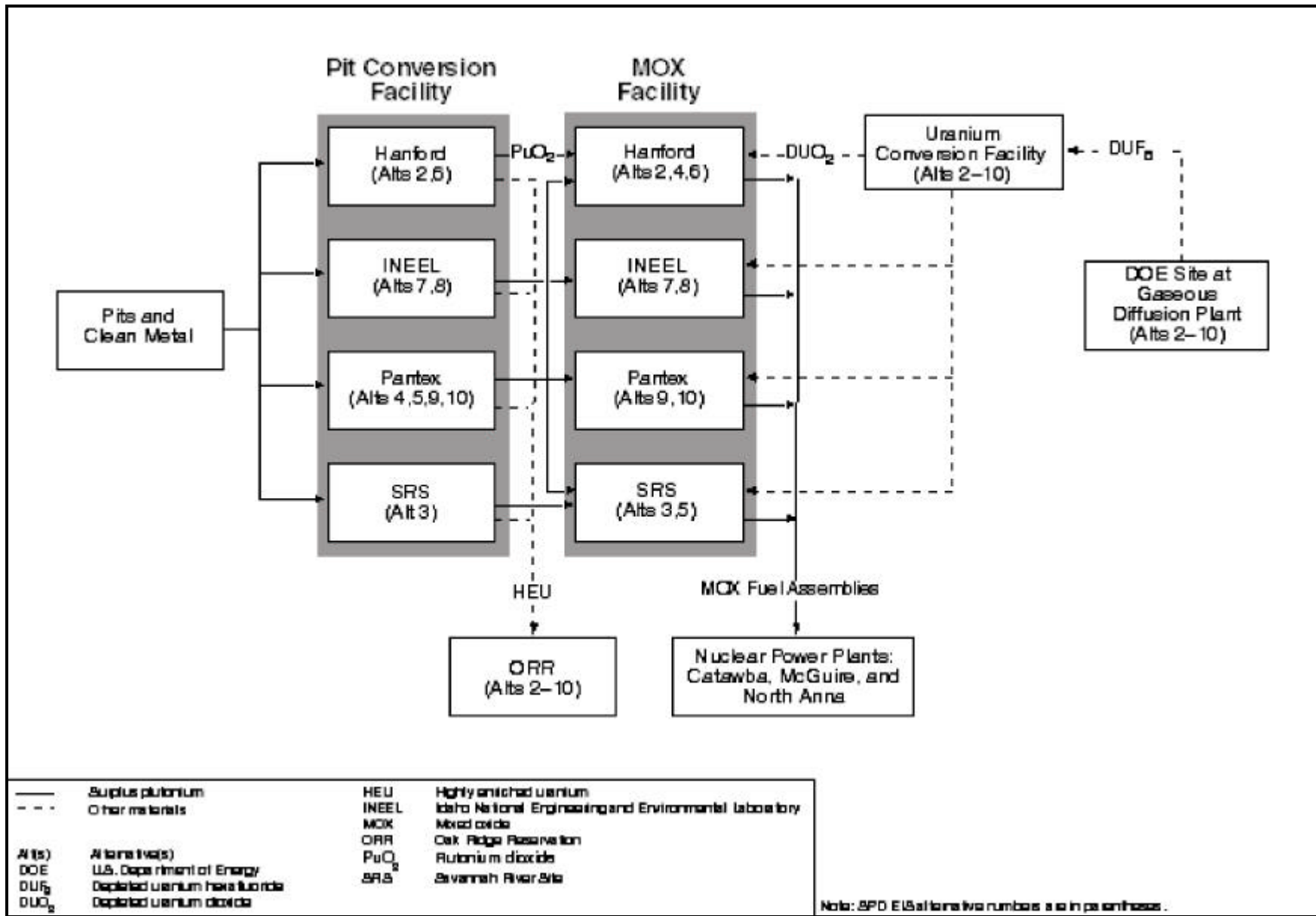

Figure L-3. Transportation Requirements for MOX Fuel Fabrication

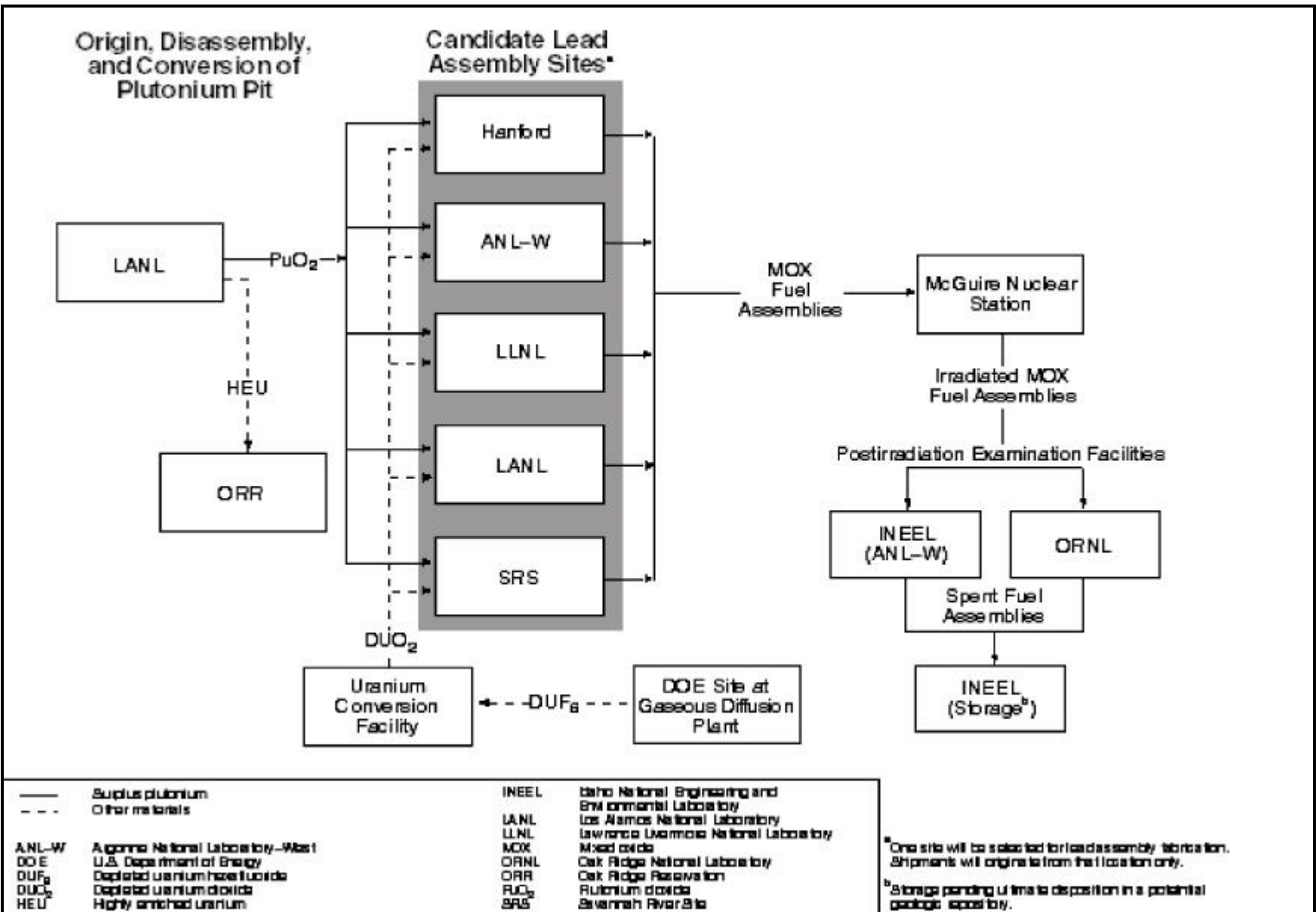

Figure L-4. Transportation Requirements for Lead Assembly Fabrication

Table L-1. Summary of Material Shipments

Origin	Destination	Material Form	Container	Vehicle	No. of Shipments
Surplus plutonium^{a,b}					
Pantex	PDCF	Pits	To be designed	SST/SGT	530
Hanford	Immobilization	Oxide	9975	SST/SGT	104
		FFTF pins	M60	SST/SGT	13
		FFTF assemblies	RRSC	SST/SGT	14
		ZPPR plates	9975	SST/SGT	116
ANL-W	Immobilization	ZPPR pins	9975	SST/SGT	40
		SRS material	9975	SST/SGT	48
SRS	Immobilization	SRS material	9975	SST/SGT	48
LANL	Immobilization	Oxide	SAFEKEG	SST/SGT	7
		Metal	SAFEKEG	SST/SGT	4
LLNL	Immobilization	Various	9975	SST/SGT	8
RFETS	Immobilization	Oxide	9975	SST/SGT	104
Pit conversion facility^{a,b}					
PDCF	Y-12	HEU	DT-22	SST/SGT	160
PDCF	LANL	Piece parts	UC-609	SST/SGT	20
PDCF	LANL	Piece parts	9968	SST/SGT	10
PDCF	Immobilization or MOX facility	Oxide	SAFEKEG	SST/SGT	254
Immobilization facility					
GDP	UO ₂ facility	UF ₆ ^(c)	30B cylinder	Commercial	2/2 ^(d)
UO ₂ facility	Immobilization	UO ₂ ^(c)	55-gal drum	Commercial	2/5 ^(d)
Immobilization	Potential geologic repository	Vitrified HLW ^b	TRUPACT	Commercial	145/395 ^(d)
MOX facility^e					
GDP	UO ₂ facility	UF ₆ ^(c)	30B	Commercial	80
UO ₂ facility	MOX facility	UO ₂ ^(c)	55-gal drum	Commercial	60
MOX facility	Reactors	MOX fuel bundles ^{a,b}	To be designed	SST/SGT	830
Lead assembly fabrication facility^f					
LANL	Lead assembly	Pu oxide	SAFEKEG	SST/SGT	12
GDP	UO ₂ facility	UF ₆	30B cylinder	Commercial	1
UO ₂ facility	MOX facility	UO ₂	55-gal drum	Commercial	2
MOX facility	Reactors	MOX fuel bundles	MO-1	SST/SGT	4
Reactor	Examination site	Irradiated fuel	Type -B	Commercial	8

^a From Didlake 1998.

^b From UC 1998a-h, 1999a-d.

^c From White 1997.

^d 17-ton cases/50-ton cases.

^e Some equipment for the MOX facility may be manufactured in Europe and shipped to the United States. No nuclear or radiologically contaminated materials would be transported. Any such shipments would be made by commercial vessel, and no impacts other than those occurring from routine commercial shipping would be expected.

^f From O'Connor et al. 1998a-e.

Key: ANL-W, Argonne National Laboratory-W; FFTF, Fast Flux Test Facility; GDP, Gaseous Diffusion Plant; HEU, highly enriched uranium; HLW, high-level waste; LANL, Los Alamos National Laboratory; LLNL, Lawrence Livermore National Laboratory; PDCF, pit disassembly and conversion facility; Pu, plutonium; RFETS, Rocky Flats Environmental Technology Site; SST/SGT, safe, secure trailer/SafeGuards Transport; UF₆, uranium hexafluoride; UO₂, uranium dioxide; ZPPR, Zero Power Physics Reactor.

L.5.2 Representative Routes and Populations

Representative overland truck routes were selected for the origin and destination points identified in Figures L-2, L-3, and L-4 are shown in Table L-2. The routes (which were determined for risk assessment purposes) were

selected consistent with current routing practices and all applicable routing regulations and guidelines. They do not necessarily represent the actual routes that would be used to transport plutonium and other hazardous materials in the future. Details about a planned shipment cannot be identified in advance, as explained in Appendix L.3.3.

Route characteristics that are important to the radiological risk assessment include the total shipment distance and the population distribution along the route. The specific route selected determines both the total potentially exposed population and the expected frequency of transportation-related accidents. Route characteristics are summarized in Table L-2. The population densities along each route are derived from 1990 U.S. Bureau of the Census data and projected forward to the year 2010 using State-specific projections. Rural, suburban, and urban areas are characterized according to the following breakdown: rural population densities range from 0 to 54 persons per square kilometer (0 to 139 person per square mile); the suburban range is from 55 to 1,284 persons per square kilometer (140 to 3,326 persons per square mile); and the urban includes all population densities greater than 1,284 persons per square kilometer (3,326 persons per square mile). The exposed population includes all persons living within 800 m (0.5 mi) of each side of the road.

L.5.3 Distance Traveled by Alternative

Table L-3 shows the number of shipments, the total mileage traveled by the trucks carrying nuclear materials, and the affected populations. The affected population is designed to show the number of people potentially exposed to nuclear material shipments. The measure is calculated by multiplying the number of shipments by the number of people living within 800 m (0.5 mi) of the route used to transport the material. The highest possible lead test assembly mileages and populations from Table L-3 are used in the alternative totals. The number of trips in Table L-3 comes from the SPD EIS data reports (UC 1998a-h, 1999a-d).

[Text deleted.]

L.5.4 Shipment External Dose Rates

The dose and corresponding risk to populations and maximally exposed individuals during incident-free transportation conditions are directly proportional to the assumed shipment external dose rate. The Federal regulations for maximum allowable dose rates for exclusive-use shipments were presented in Appendix L.3.1.

The actual shipment dose rate is a complex function of the composition and configuration of shielding and containment used in the cask, the geometry of the loaded shipments, and characteristics of the material shipped. DOE has years of experience handling the materials that would be required to be shipped under the alternatives assessed in the SPD EIS, and has regularly conducted radiation level measurements while handling these materials. The maximum predicted dose from individual packages, based on experience at DOE facilities, would yield a dose rate less than the Federal regulatory limit in every case. Spent nuclear fuel and nonpit plutonium were conservatively assumed to have dose rates equal to the regulatory limit of 10 mrem/hr at 2 m (6.6 ft) from the vehicle. This DOE experience was used in the preparation of the dose rates given in the data reports (UC 1998a-h, 1999a-d) and used in the analysis.

Table L–2. Potential Shipping Legs Evaluated in the SPD EIS

From	To	Distance (km)	Percentage in Zones			Population Density (person/km ²)			Affected Population
			Rural	Suburban	Urban	Rural	Suburban	Urban	
ANL–W	INEEL	34	100	0	0	2	0	0	84
ANL–W	Hanford	1,035	91.7	7.6	0.6	9	570	2,883	113,482
ANL–W	Pantex	2,395	90.1	8.3	1.6	6	561	2,963	380,038
ANL–W	SRS	3,756	82.8	15.4	1.8	9	453	2,787	767,529
Hanford	INEEL	967	91.6	7.9	0.6	8	559	2,898	107,214
Hanford	ORR	3,981	87.6	11.1	1.3	8	461	2,830	604,916
Hanford	Pantex	3,032	90.6	8.0	1.4	6	574	2,979	450,511
Hanford	Onsite	24	100	0	0	10	0	0	538
Hanford	Geologic repository ^a	1,907	87.8	10.3	1.9	4	485	2,098	397,534
Hanford	LANL	2,511	90.2	8.6	1.2	6	569	2,952	361,442
INEEL	SRS	3,719	82.7	15.4	1.8	9	450	2,788	757,940
INEEL	ORR	3,312	86.7	11.9	1.4	8	437	2,778	518,875
INEEL	LANL	1,841	89.6	9.1	1.4	6	553	2,962	286,387
LANL	Pantex	647	90.7	6.8	2.5	6	676	3,061	132,446
LANL	LLNL	1,218	88.8	7.8	3.4	5	634	3,634	346,679
LANL	INEEL	1,841	89.6	9.1	1.4	6	553	2,962	286,387
LANL	Hanford	2,511	90.2	8.6	1.2	6	569	2,952	361,442
LANL	SRS	2,787	80.8	16.9	2.4	12	455	2,786	684,441
LANL	ORR	2,390	85.8	12.3	1.9	10	435	2,764	439,696
LANL	ANL–W	1,873	89.1	9.5	1.4	4.5	386	2,085	296,222
LLNL	Hanford	1,429	76.0	20.5	3.5	12	487	2,868	478,115
LLNL	INEEL	1,566	85.7	10.3	4.0	6	713	3,546	552,834
LLNL	Pantex	2,327	89.8	6.7	3.5	5	674	3,525	643,591
LLNL	SRS	4,416	80.6	16.4	3.0	10	482	3,165	1,284,987
LLNL	NTS	1,143	85.8	8.6	5.6	5	716	3,771	506,575
Pantex	ORR	1,762	84.4	14.0	1.6	12	392	2,657	302,418
Pantex	SRS	2,169	78.1	19.6	2.3	14	426	2,706	543,092
Pantex	INEEL	2,363	90.2	8.2	1.6	6	561	2,988	373,420
Pantex	WIPP	713	93.1	6.0	0.8	4	697	2,631	75,392
Pantex	NTS	1,997	94.0	4.8	1.2	4	634	3,086	228,159
Pantex	LANL	647	90.7	6.8	2.5	6	676	3,061	132,446
Portsmouth, OH	Fuel fabrication ^b	1,014	63.5	34.6	1.7	20	380	2,446	301,445
RFETS	INEEL	1,178	91.4	7.4	1.2	6	505	3,329	156,394
RFETS	Pantex	1,255	87.2	10.0	2.9	5	634	3,143	319,338
RFETS	Hanford	1,848	91.6	7.4	1.0	6	547	3,228	232,380
RFETS	SRS	2,609	78.1	19.3	2.5	11	439	2,741	674,965
SRS	ORR	575	68.7	30.5	0.8	18	374	2,306	132,959
SRS	Hanford	4,389	84.2	14.2	1.6	9	467	2,823	835,727
SRS	Onsite	6	100	0	0	10	0	0	134
SRS	Geologic repository ^a	3,936	83.2	19.9	1.9	9	510	3,069	893,080
SRS	LANL	2,787	80.8	16.9	2.4	12	455	2,786	684,441
Fuel fabrication ^b	SRS	581	72.8	26.8	0.3	23	301	2,202	97,034
Fuel fabrication ^b	Pantex	2,577	76.2	22.4	1.4	14	392	2,690	651,769
Fuel fabrication ^b	Hanford	4,796	82.6	16.1	1.2	10	435	2,806	856,223

Table L-2. Potential Shipping Legs Evaluated in the SPD EIS (Continued)

From	To	Distance (km)	Percentage in Zones			Population Density (person/km ²)			Affected Population
			Rural	Suburban	Urban	Rural	Suburban	Urban	
Fuel fabrication ^b	ANL-W	4,165	81.0	17.7	1.3	10	418	2,769	787,474
Fuel fabrication ^b	LLNL	4,880	82.5	15.1	2.4	10	457	3,192	1,199,169
Fuel fabrication ^b	LANL	3,201	78.0	19.8	1.6	13	413	2,766	696,023
Generic 4,000 km		4,000	84.0	15.0	1.0	6	719	3,861	969,600
Generic 5,000 km		5,000	84.0	15.0	1.0	6	719	3,861	1,212,000
Hanford	Catawba	4,498	84.5	14.1	1.3	9	447	2,776	765,850
INEEL/ANL	Catawba	3,793	83.0	15.5	1.5	9	429	2,737	697,959
SRS	Catawba	251	69.0	29.8	1.2	17	418	2,373	66,154
LANL	Catawba	2,844	81.1	17.0	1.8	11	428	2,722	595,856
LLNL	Catawba	4,539	84.3	13.1	2.6	9	477	3,167	1,105,526
Pantex	Catawba	2,243	78.6	19.7	1.7	13	397	2,626	477,319
Catawba	ORR	497	58.3	39.8	2.0	20	405	2,546	177,922
Hanford	McGuire	4,458	84.8	13.9	1.2	9	428	2,802	716,024
INEEL/ANL-W	McGuire	3,753	83.4	15.3	1.3	9	409	2,767	636,712
SRS	McGuire	296	66.4	31.6	2.1	15	441	2,438	94,828
LANL	McGuire	2,821	81.5	16.9	1.7	11	401	2,753	559,307
LLNL	McGuire	4,500	84.6	12.9	2.5	9	458	3,207	1,055,765
Pantex	McGuire	2,203	79.3	19.3	1.4	13	370	2,661	419,295
McGuire	ORR	457	59.5	39.9	0.5	21	343	2,504	118,268
Hanford	N. Anna	4,575	86.1	12.4	1.4	9	449	2,717	744,228
INEEL/ANL-W	N. Anna	3,870	85.0	13.4	1.6	10	429	2,666	671,048
SRS	N. Anna	837	72.7	26.8	0.5	21	306	2,167	145,069
LANL	N. Anna	3,117	83.6	14.7	1.7	13	397	2,711	574,877
LLNL	N. Anna	4,797	84.7	12.7	2.7	9	492	2,886	1,134,405
Pantex	N. Anna	2,499	82.0	16.6	1.4	14	364	2,619	435,744
N. Anna	ORR	753	76.3	22.7	1.0	22	317	2,503	137,224

^a Potential geologic repository assumed to be located at Yucca Mountain, Nevada, for the purposes of analysis.

^b Assumed to be located at Wilmington, North Carolina, for the purposes of analysis.

Key: ANL-W, Argonne National Laboratory-W; LANL, Los Alamos National Laboratory; LLNL, Lawrence Livermore National Laboratory; NTS, Nevada Test Site; ORR, Oak Ridge Reservation; RFETS, Rocky Flats Environmental Technology Site; WIPP, Waste Isolation Pilot Plant.

Table L-3. Summary of SPD EIS Transportation Requirements

Alternative	Number of Trips	Cumulative Distance (km)	Affected Population (millions)
2	2,447	7.5 M	5.4
3	2,530	4.3 M	7.0
4	2,171	6.3 M	4.9
5	2,254	3.8 M	6.7
6	2,530	8.7 M	8.5
7	2,530	7.6 M	8.1
8	2,447	6.4 M	5.3
9	2,000	4.8 M	6.4
10	1,917	3.6 M	4.2
11A	2,153	3.7 M	4.7
11B	1,877	2.5 M	4.1
12A	2,236	4.4 M	6.8
12B	1,960	3.9 M	6.4
Lead assembly			
ANL-W	27	77 K	2.5
Hanford	27	89 K	2.7
LLNL	27	73 K	3.4
LANL	15	49 K	2.1
SRS	27	67 K	1.7

Key: ANL-W, Argonne National Laboratory-W; K, thousands; LANL, Los Alamos National Laboratory; LLNL, Lawrence Livermore National Laboratory; M, million.

L.5.5 Health Risk Conversion Factors

The health risk conversion factors used to estimate expected cancer fatalities were taken from the *1990 Recommendations of the International Commission on Radiological Protection* (ICRP 1991): 0.0005 and 0.0004 fatal cancer cases per person-rem for members of the public and workers, respectively. Cancer fatalities occur during the lifetimes of the exposed populations and, thus, are called LCFs.

L.5.6 Accident Involvement Rates

For the calculation of accident risks, vehicle accident and fatality rates are taken from data provided in other reports (Saricks and Kvitek 1994). Accident rates are generically defined as the number of accident involvements (or fatalities) in a given year per unit of travel in that same year. Therefore, the rate is a fractional value, with the accident-involvement count as the numerator of the fraction and vehicular activity (total travel distance) as its denominator. Accident rates are generally determined for a multiyear period. For assessment purposes, the total number of expected accidents or fatalities is calculated by multiplying the total shipment distance for a specific case by the appropriate accident or fatality rate.

For truck transportation, the rates presented are specifically for heavy combination trucks involved in interstate commerce (Saricks and Kvitek 1994). Heavy combination trucks are rigs composed of a separable tractor unit containing the engine and one to three freight trailers connected to each other. Heavy combination trucks are typically used for radioactive waste shipments. The truck accident rates are computed for each State based on statistics compiled by the DOT Office of Motor Carriers for 1986 to 1988. Saricks and Kvitek present accident involvement and fatality counts; estimated kilometers of travel by State; and the corresponding average accident involvement, fatality, and injury rates for the 3 years investigated. Fatalities are deaths (including crew members)

attributable to the accident or that occurred at any time within 30 days thereafter. SST/SGT accident rates are based on operational experience (Claus and Shyr 1999) and influence factors (Phillips et al. 1994).

L.5.7 Container Accident Response Characteristics and Release Fractions

The transportation accident model assigns accident probabilities to a set of accident categories. Eight accident-severity categories defined in the NRC's *Final Environmental Statement on the Transportation of Radioactive Material by Air and Other Modes*, NUREG-0170 (NRC 1977), were used. The least severe categories (Categories I and II) represent low magnitudes of crush force, accident-impact velocity, fire duration, and puncture-impact speed. The most severe category (Category VIII) represents a large crush force, high accident-impact velocity, long fire duration, and a high puncture-impact speed. The fraction of material released and material aerosolized, and the fraction of that material that is respirable (particles smaller than 10 microns), was assigned based on the accident categories and container types. Because all plutonium shipments will use the previously described Type B containers and the SST/SGT system, even severe accidents release, at the most, a portion of the material being transported. The risks associated with other materials are significantly lower.

L.6 RISK ANALYSIS RESULTS

L.6.1 Per-Shipment Risk Factors

Per-shipment risk factors have been calculated for the collective populations of exposed persons and the crew for all anticipated routes and shipment configurations. The radiological risks are presented in doses per shipment for each unique route, material, and container combination. Doses are calculated for the crew, off-link public (i.e., people living along the route), on-link public (i.e., pedestrians and drivers along the route), and public at rest and fueling stops (i.e., stopped cars, buses, and trucks, workers, and other bystanders). The accident risk factors are called "dose risk" because the values incorporate the spectrum of accident severity probabilities and associated consequences. Separate risk factors are provided for fatalities resulting from hydrocarbon emissions (known to contain carcinogens) and transportation accidents (fatalities resulting from impact).

L.6.2 Evaluation of Shipment Risks

Tables L-4 and L-5 show the human health risks and maximum human health risks, respectively, of transporting materials for the lead assembly alternatives. As shown, the risks include the risk of transporting uranium dioxide, uranium hexafluoride, plutonium dioxide, fuel assemblies, and spent fuel. Table L-6 shows the results of similar calculations that give the risks for each alternative. The risk estimates in Table L-6 include the maximum risk for the lead assembly transportation (Alternatives 2 through 10), plutonium pit shipments, pit material shipments (HEU and nonplutonium bearing pit parts), uranium hexafluoride, uranium dioxide, fuel assemblies, and nonpit plutonium. The risks are calculated by multiplying the per-shipment factors by the number of shipments and, in the case of the radiological doses, by the health risk conversion factors.

Table L-4. Human Health Risks of Transport to Lead Assembly Facilities

Site	DUO ₂ and LEU Fuel Assemblies From FFF					PuO ₂ From LANL				
	Routine Transport Impacts			Accident Risks		Routine Transport Impacts			Accident Risks	
	Radiological			Rad	Nonrad	Radiological			Rad	Nonrad
	Crew	Public	Nonrad ^a	Rad	Nonrad	Crew	Public	Nonrad ^a	Rad	Nonrad
LANL	5.6E-6	4.5E-5	2.0E-5	3.8E-4	2.5E-4	–	–	–	–	–
ANL–W	7.3E-6	5.8E-5	2.2E-5	1.6E-4	3.2E-4	2.1E-6	2.2E-6	8.2E-5	2.3E-4	1.6E-4
SRS	9.8E-7	7.9E-6	1.3E-6	1.2E-5	4.3E-5	3.2E-6	4.2E-6	2.1E-4	5.3E-4	2.3E-4
Hanford	8.4E-6	6.7E-5	2.3E-5	1.7E-4	3.7E-4	2.8E-6	2.9E-6	9.4E-5	2.8E-4	2.1E-4
LLNL	8.5E-6	6.8E-5	4.7E-5	3.4E-4	3.8E-4	1.4E-6	1.4E-6	1.3E-4	2.9E-4	1.0E-4

^a Toxic emissions.

Key: ANL–W, Argonne National Laboratory–West; DUO₂, depleted uranium dioxide; FFF, Uranium Fuel Fabrication Facility; LANL, Los Alamos National Laboratory; LEU, low-enriched uranium; LLNL, Lawrence Livermore National Laboratory; Rad, radiological; Nonrad, nonradiological; PuO₂, plutonium dioxide; UO₂, uranium dioxide.

Note: All risks are expressed in latent cancer fatalities during the implementation of the proposed action, except for the Nonrad Accident Risks column, which is the number of fatalities.

Table L-5. Maximum Human Health Risks of Transport to Lead Assembly Facilities

Shipment	Routine Transport Impacts				
	Radiological			Accident Risks	
	Crew	Public	Nonradiological ^a	Radiological	Nonradiological
Depleted UO ₂ and LEU fuel assemblies from FFF and PuO ₂ from LANL	1.1E-5	7.0E-5	2.1E-4	6.3E-4	5.8E-4
Depleted UF ₆ from gaseous diffusion plant to FFF	2.5E-8	2.0E-7	3.4E-6	5.2E-5	4.0E-5
Lead assemblies to reactor site	3.7E-7	2.2E-7	1.2E-4	2.1E-6	1.3E-4
Spent fuel to postirradiation examination site	5.5E-4	4.8E-3	7.8E-5	2.3E-3	1.2E-3

^a Toxic emissions.

Key: FFF, Uranium Fuel Fabrication Facility; LANL, Los Alamos National Laboratory; LEU, low-enriched uranium; PuO₂, plutonium dioxide; UF₆, uranium hexafluoride; UO₂, uranium dioxide.

Note: All risks are expressed in latent cancer fatalities during the implementation of the proposed action, except for the Nonradiological Accident Risks column, which is the number of fatalities.

L.6.3 Maximally Exposed Individuals

The risks to maximally exposed individuals under incident-free transportation conditions were estimated for hypothetical exposure scenarios. The estimated dose to inspectors and the public is presented in Table L-7 on a per-event basis (person-rem per event). Note that the potential exists for individual exposures if multiple exposure events occur. For instance, the dose to a person stuck in traffic next to a shipment for 30 minutes is calculated to be 11 mrem. (This conservatively assumes the person in a car is 1.2 m [4 ft] from the edge of the truck.) If the exposure duration was longer, the dose would rise proportionally. In addition, a person working at a truck service station could receive a significant dose if trucks were to use the same stops repeatedly. The dose to a person fueling a truck could be as much as 1 mrem. Administrative controls could be instituted to control the location and duration of truck stops if multiple exposures were to occur routinely. However, it is DOE's normal practice to have SST/SGT guard force members (trained, monitored radiation workers) perform fueling and routine on-road maintenance checks (i.e., check oil or windshield wiper fluid).

Table L-6. Total Risks for All SPD EIS Alternatives

Alter- native	Pit Conversion	MOX Immobilization			Routine Transport Impacts		Accident Risks		
					Radiological		Nonradiological	Radiological	
					Crew	Public	Emission	Traffic	Accident
2	Hanford	Hanford	Hanford	0.012	0.020	0.025	0.074	0.004	
3	SRS	SRS	SRS	0.024	0.034	0.019	0.053	0.004	
4	Pantex	Hanford	Hanford	0.012	0.020	0.021	0.065	0.004	
5	Pantex	SRS	SRS	0.024	0.033	0.016	0.050	0.004	
6	Hanford	Hanford	SRS	0.024	0.035	0.033	0.091	0.004	
7	INEEL	INEEL	SRS	0.024	0.035	0.032	0.083	0.004	
8	INEEL	INEEL	Hanford	0.012	0.020	0.024	0.065	0.003	
9	Pantex	Pantex	SRS	0.024	0.034	0.019	0.052	0.004	
10	Pantex	Pantex	Hanford	0.012	0.019	0.012	0.043	0.003	
11A	Hanford	NA	Hanford	0.027	0.036	0.011	0.054	0.0003	
11B	Pantex	NA	Hanford	0.027	0.036	0.007	0.045	0.0007	
12A	SRS	NA	SRS	0.057	0.074	0.021	0.081	0.0006	
12B	Pantex	NA	SRS	0.057	0.073	0.018	0.078	0.0012	

Key: NA, not applicable.

Note: All risks are expressed in latent cancer fatalities during the implementation of the proposed action, except for the Nonradiological Accident Risks column, which is the number of fatalities.

Table L-7. Estimated Dose to Maximally Exposed Individuals During Incident-Free Transportation Conditions^{a,b}

Receptor	Dose to Maximally Exposed Individual
Workers	
Crew member	0.1 rem/yr ^c
Inspector	0.0029 rem/event
Public	
Resident	4.0×10 ⁻⁷ rem/event
Person in traffic construction	0.011 rem/event
Person at service station	0.001 rem/event

^a The exposure scenario assumptions are described in Appendix L.6.3.

^b Doses are calculated assuming that the shipment external dose rate is equal to the maximum expected dose 10 mrem/hr at 2 m (6.6 ft) from the package.

^c Dose to truck drivers could exceed the legal limit of 100 mrem/yr in the absence of administrative controls.

The cumulative dose to a resident was calculated assuming all shipments passed his or her home. The cumulative doses assume that the resident is present for every shipment and is unshielded at a distance of 30 m (98 ft) from the route. Therefore, the cumulative dose is only a function of the number of shipments passing a particular point and is independent of the actual route being considered. The maximum dose to this resident, would be about 1 mrem. The annual individual dose can be estimated by assuming that shipments would occur uniformly over a 15-year time period.

The accident consequence assessment is intended to provide an estimate of the maximum potential impacts posed by the most severe potential transportation accidents involving a shipment. The accident consequence results are presented in Table L-8 for the maximum severity accidents involving plutonium dioxide shipments,

Table L-8. Estimated Dose to the Population and to Maximally Exposed Individuals During the Most Severe Accident Conditions (Plutonium Dioxide)^{a, b}

Mode and Accident Location	Neutral Conditions ^c				Stable Conditions ^f			
	Population ^d		Maximally Exposed Individual ^e		Population ^d		Maximally Exposed Individual ^e	
	Dose (person-rem)	Consequences (Cancer Fatalities)	Dose (rem)	Consequences (Probability of Cancer Fatality)	Dose (person-rem)	Consequences (Cancer Fatalities)	Dose (rem)	Consequences (Probability of Cancer Fatality)
Truck								
Urban	228,760	114	684	0.68	40,420	20.2	23.2	0.023
Suburban	49,880	25	684	0.68	8,815	4.4	23.2	0.023
Rural	624	0.31	684	0.68	581	0.29	23.2	0.023

^a The most severe accidents correspond to the NUREG-0170 accident severity Category VIII (NRC 1977).

^b Buoyant plume rise resulting from fire for a severe accident was included in the exposure model.

^c Neutral weather conditions result in moderate dispersion and dilution of the release plume. Neutral conditions were taken to be Pasquill stability Class D with a wind speed of 4 m/sec (9 mph). Neutral conditions occur approximately 50 percent of the time in the United States.

^d Populations extend at a uniform density to a radius of 80 km (50 mi) from the accident site. Population exposure pathways include acute inhalation, acute cloudshine, groundshine, resuspended inhalation, resuspended cloudshine, and ingestion of food, including initially contaminated food (RISKIND assumes that all food is grown in rural areas) (Yuan et al. 1995). It is assumed that decontamination or mitigative actions are taken.

^e The maximally exposed individual is assumed to be at the location of maximum exposure. The locations of maximum exposure would be 100 m (330 ft) and 500 m (1,650 ft) from the accident site under neutral and stable atmospheric conditions, respectively. Individual exposure pathways include acute inhalation, acute cloudshine, and groundshine during passage of the plume. No ingested dose is considered. Note that the maximally exposed individual receives more dose than the population in a rural location. This analytic phenomena is caused by probabilistic calculations. It is very unlikely that an individual will be nearby in a rural population zone.

^f Stable weather conditions result in minimal dispersion and dilution of the release plume and are thus unfavorable. Stable conditions were taken to be Pasquill stability Class F with a wind speed of 1 m/sec (2.2 mph). Stable conditions occur approximately one-third of the time in the United States.

and Table L-9 for maximum severity accidents involving plutonium pits. Table L-8 applies to alternatives in which the pit conversion facility is located at Pantex, and large amounts of plutonium dioxides are shipped to a MOX or conversion facility. Table L-9 applies to alternatives in which plutonium pits and metals are shipped to a pit conversion facility at a site other than Pantex. In either table, the accident frequency in rural locations is about 1×10^{-7} per year (once in 10 million years). The frequency of accidents in urban and suburban zones was evaluated. Accidents are much less likely to occur in urban and suburban zones because the total distance traveled is much lower than in rural zones. The impacts represent the most severe accidents hypothesized.

The hypothetical accidents described in Tables L-8 and L-9 involve either a long-term fire or tremendous impact or crushing forces. In the case of crushing forces, a fire would have to be burning in order to spread the plutonium as modeled. These accidents are assumed to cause a ground-level release of 10 percent of the radioactive material in the truck. These accidents are more likely on rural interstates where speeds are higher and where the vehicles spend most of their travel time. NUREG-0170 (NRC 1977) describes the analytic approach in more detail.

The population doses are for a uniform population density within an 80-km (50-mi) radius (Neuhauser and Kanipe 1995). The location of the maximally exposed individual is determined based on atmospheric conditions

at the time of the accident and the buoyant characteristics of the released plume. The locations of maximum exposure would be 100 m (330 ft) and 500 m (1,650 ft) from the accident site for neutral (average)

Table L-9. Estimated Dose to the Population and to Maximally Exposed Individuals During the Most Severe Accident Conditions (Plutonium Pits)^{a, b}

Mode and Accident Location	Neutral Conditions ^c				Stable Conditions ^f			
	Population ^d		Maximally Exposed Individual ^e		Population ^d		Maximally Exposed Individual ^e	
	Dose (person-rem)	Consequences (Cancer Fatalities)	Dose (rem)	Consequences (Probability of Cancer Fatality)	Dose (person-rem)	Consequences (Cancer Fatalities)	Dose (rem)	Consequences (Probability of Cancer Fatality)
Truck								
Urban	31,920	16	96	0.096	5,640	2.8	3.3	0.0016
Suburban	6,960	3.5	96	0.096	1,230	0.62	3.3	0.0016
Rural	87	0.044	96	0.096	81	0.041	3.3	0.0016

^a The most severe accidents correspond to the NUREG-0170 accident severity Category VIII (NRC 1977).

^b Buoyant plume rise resulting from fire for a severe accident was included in the exposure model.

^c Neutral weather conditions result in moderate dispersion and dilution of the release plume. Neutral conditions were taken to be Pasquill stability Class D with a wind speed of 4 m/sec (9 mph). Neutral conditions occur approximately 50 percent of the time in the United States.

^d Populations extend at a uniform density to a radius of 80 km (50 mi) from the accident site. Population exposure pathways include acute inhalation, acute cloudshine, groundshine, resuspended inhalation, resuspended cloudshine, and ingestion of food, including initially contaminated food (RISKIND assumes that all food is grown in rural areas) (Yuan et al. 1995). It is assumed that decontamination or mitigative actions are taken.

^e The maximally exposed individual is assumed to be at the location of maximum exposure. The locations of maximum exposure would be 100 m (330 ft) and 500 m (1,650 ft) from the accident site under neutral and stable atmospheric conditions, respectively. Individual exposure pathways include acute inhalation, acute cloudshine, and groundshine during passage of the plume. No ingested dose is considered. Note that the maximally exposed individual receives more dose than the population in a rural location. This analytic phenomena is caused by probabilistic calculations. It is very unlikely that an individual will be nearby in a rural population zone.

^f Stable weather conditions result in minimal dispersion and dilution of the release plume and are thus unfavorable. Stable conditions were taken to be Pasquill stability Class F with a wind speed of 1 m/sec (2.2 mph). Stable conditions occur approximately one-third of the time in the United States.

and stable conditions, respectively. The dose to the maximally exposed individual is independent of the location of the accident. No acute or early fatalities would be expected from radiological causes.

L.6.4 Waste Transportation

Under all of the alternatives being considered in the SPD EIS, some transportation would be required to support routine shipments of wastes from the proposed surplus plutonium disposition facilities to treatment, storage, or disposal facilities located on the sites. All DOE sites have plans and procedures for handling and transporting waste. This transportation would be handled in the same manner as other site waste shipments and would not represent a large increase in the amount of wastes generated at these sites. The shipments would not represent any additional risks beyond the ordinary waste shipments at these sites, as analyzed in the WM PEIS (DOE 1997a).

However, in four specific cases, waste would be generated that is not covered in the WM PEIS (DOE 1997a): (1) transuranic (TRU) waste generated at Pantex from the pit conversion facility; (2) low-level waste (LLW) generated at Pantex from the pit conversion facility; (3) LLW generated at Pantex from the MOX facility, and (4) LLW generated at LLNL during lead assembly fabrication.

TRU waste generated at Pantex was not covered by the WM PEIS Record of Decision (ROD) because there was no TRU waste at Pantex at the time the ROD was issued, and none was anticipated to be generated by ongoing

site operations. Location of the pit conversion and MOX facilities at Pantex would result in the generation of TRU waste as described in Section 4.17.2.2 of the SPD EIS. Shipment of TRU waste to WIPP was analyzed using the methodology and parameters found in Appendix E of the Waste Isolation Pilot Plant *Disposal Phase Final Supplemental Environmental Impact Statement* (DOE 1997b). In order to support the transportation of TRU waste from Pantex to WIPP, 76 additional shipments were analyzed in the SPD EIS.

A fairly large increase in the amount of LLW (i.e., 25 percent of the site’s current storage capacity) would be expected if the pit conversion facility were located at Pantex. Currently, this type of waste is shipped to the Nevada Test Site (NTS) for disposal. In order to support the transportation of pit conversion facility LLW from Pantex to NTS, 21 additional shipments were analyzed in the SPD EIS. The impacts were calculated from LLW transportation impacts presented in the WM PEIS (DOE 1997a).

An additional increase in the amount of LLW (i.e., 14 percent, for a total of 39 percent of the site’s current storage capacity) would be expected if the pit conversion and MOX facilities are located at Pantex. Currently, this type of waste is shipped to NTS for disposal. In order to support the transportation of MOX LLW from Pantex to NTS, 38 additional shipments have been analyzed in the SPD EIS. The impacts were calculated from LLW transportation impacts presented in the WM PEIS (DOE 1997a).

Further, an increase in the LLW at LLNL would be expected if the lead assembly were done at LLNL. Currently, this type of waste is shipped to NTS for disposal. In order to support transportation of lead assembly LLW from LLNL to NTS, 44 additional shipments were analyzed in the SPD EIS. The impacts were calculated from LLW transportation impacts presented in the WM PEIS (DOE 1997a). Table L–10 shows the impacts of transporting LLW and TRU waste. The radiological risks to the public are larger for TRU than for LLW because of the larger amount of radioactive material in TRU. The dose to the crew are about the same, because the truck carrying TRU would require some shielding or spacing to ensure that the dose rate to the truck crew is less than 2 mrem/hr.

Table L–10. Impacts of Transporting LLW and Transuranic Waste

Waste Type	Origin	Destination	Trips	Kilometers Traveled	Routine Transport Impacts		Accidental Risks		
					Crew	Public	Emission	Traffic	Radiological
LLW	Pantex, pit conversion facility	NTS	38	76,000	0.0011	0.0015	0.00018	0.0029	5.8×10 ⁻⁷
LLW	Pantex, MOX	NTS	21	42,000	0.0006	0.0008	0.00010	0.0016	3.2×10 ⁻⁷
LLW	LLNL	NTS	44	50,000	0.0007	0.0010	0.00056	0.0020	3.8×10 ⁻⁷
TRU	Pantex, pit conversion facility	WIPP	76	54,000	0.0008	0.0025	0.00013	0.0015	1.1×10 ⁻⁶

Key: LLNL, Lawrence Livermore National Laboratory; LLW, low-level waste; NTS, Nevada Test Site; TRU, transuranic; WIPP, Waste Isolation Pilot Plant.

Note: All risks are expressed in latent cancer fatalities during the implementation of the proposed actions except for the Nonradiological Accidental Traffic column, which is the number of fatalities.

L.6.5 Consequences of Sabotage or Terrorist Attack During Transportation

This section provides an evaluation of impacts that could potentially result from a malicious act on a shipment of hazardous or radioactive material during transportation. In no instance, even in severe cases such as those discussed below, could a nuclear explosion or permanent contamination of the environment leading to condemnation of land occur. Because of the Transportation Safeguards System described in Appendix L.3.2,

DOE considers sabotage or terrorist attack on an SST/SGT to be unlikely enough such that no further risk analysis is required.

DOE analyzed the nonproliferation aspects (DOE 1997c) of the transportation associated with the alternatives in the SPD EIS. In this study, DOE realized that all plutonium disposition alternatives under consideration would involve processing and transport of plutonium, which will involve more risk of theft in the short term than if the material had remained in heavily guarded storage, in return for the long-term benefit of converting the material to more proliferation-resistant forms. DOE intends to use the same SST/SGTs for these shipments that are used for shipment of intact nuclear weapons, with similar security forces and other measures. The level of assurance against possible attack during transportation can be increased to essentially any desired level by applying more resources such as money, security forces, or technology. DOE concluded that transport of plutonium is the point in the disposition process when the material is most vulnerable to overt, armed attacks designed to steal plutonium. With sufficient resources devoted to security, high levels of protection against such overt attacks can be provided. International, and particularly overseas, shipments would involve greater transportation concerns than domestic shipments (DOE 1997c).

The *Final Environmental Impact Statement on a Proposed Nuclear Weapons Nonproliferation Policy Concerning Foreign Research Reactor Spent Nuclear Fuel* (DOE 1996d) analyzed the spectrum of attacks on spent nuclear fuel casks. They fall into three categories or scenarios: (1) exploding a bomb near a shipping cask, (2) attacking a cask with a shaped charge or an armor-piercing weapon (i.e., an antitank weapon), and (3) hijacking (stealing) a shipping cask. None of the scenarios considered would lead to a criticality accident. DOE determined that, due to the security measures that would be in place for any spent nuclear fuel shipments, such attacks would be unlikely to occur. At a minimum, the extent or effects of any such attacks would be mitigated by the security measures. Additionally, the SPD EIS considered a comparatively few shipments (if the lead assembly program is implemented) of spent nuclear fuel. Other materials, including uranium hexafluoride, uranium dioxide, TRU waste, and LLW, are commonly shipped and do not represent particularly attractive targets for sabotage or terrorist attacks.

L.7 CUMULATIVE IMPACTS OF TRANSPORTATION

L.7.1 Radiological Impacts

The cumulative impacts of the transportation of radioactive material consist of impacts from (a) historical shipments of radioactive waste and spent nuclear fuel, (b) reasonably foreseeable actions that include transportation of radioactive material, (c) general radioactive materials transportation that is not related to a particular action, and (d) the alternatives evaluated in the SPD EIS. The assessment of cumulative transportation impacts concentrates on the cumulative impacts of offsite transportation because offsite transportation yields potential radiation doses to a greater portion of the general population than does onsite transportation. The collective dose to the general population and workers was the measure used to quantify cumulative transportation impacts. This measure of impact was chosen because it may be directly related to LCFs using a cancer risk coefficient and because of the difficulty in identifying a maximally exposed individual for shipments throughout the United States spanning the period 1943 through 2048 (106 years). The year 1943 corresponds to the start of operations at Hanford and the Oak Ridge Reservation.

Collective doses from historical shipments of spent nuclear fuel to NTS were summarized in *Summary of Doses and Health Effects* (Jones and Maheras 1994). Data for these shipments were available for 1971 through 1993 and were linearly extrapolated back to 1951, the start of operations at NTS, because data before 1971 were not available. The results of this analysis are summarized in Table L-11. Collective doses from historical shipments of low-level waste, mixed low-level waste, and TRU waste were also estimated (DOE 1996e). Over the time period 1974 through 1994, there were about 8,400 of these shipments. These

Table L–11. Cumulative Transportation-Related Radiological Collective Doses and Latent Cancer Fatalities (1943 to 2048) (person-rem)

Category	Collective Dose	
	Occupational Dose	General Population Dose
Historical shipments (DOE 1995a)	250	130
Radioactive waste to Nevada Test Site (DOE 1996e)	82	100
Reasonably foreseeable actions		
Nevada Test Site expanded use (DOE 1996e)	–	150 ^a
Spent nuclear fuel management (DOE 1995a, 1996d)	360	810
Waste Management PEIS (DOE 1997a) ^b	16,000	20,000
Waste Isolation Pilot Plant (DOE 1997b)	790	5,900
Molybdenum-99 production (DOE 1996f)	240	520
Tritium supply and recycling (DOE 1995b)	–	–
Surplus highly enriched uranium disposition (DOE 1996g)	400	520
Storage and Disposition PEIS (DOE 1996a)	–	2,400 ^a
Stockpile Stewardship (DOE 1996h)	–	38 ^a
Pantex (DOE 1996c)	250 ^c	490 ^c
West Valley (DOE 1996i)	1,400	12,000
S3G and D1G prototype reactor plant disposal (DOE 1997d)	2.9–6.8	2.2–5.4
S1C prototype reactor plant disposal (DOE 1996j)	6.7	1.9
Container system for naval spent nuclear fuel (USN 1996a)	11	15
Cruiser and submarine reactor plant disposal (USN 1996b)	5.8	5.8
Submarine reactor compartment disposal (USN 1984)	–	0.053
Return of cesium 137 capsules (DOE 1994)	0.42	5.7
Uranium billets (DOE 1992)	0.50	0.014
Nitric acid (DOE 1995c)	0.43	3.1
General transportation		
1943 to 1982 (NRC 1977)	220,000	170,000
1983 to 2048 (Weiner, LaPlante, and Hageman 1991a:661–666; 1991b:655–660)	110,000	120,000
Shipments for alternatives evaluated in the SPD EIS	10	50
Summary		
Historical	330	230
Reasonably foreseeable actions	19,000	43,000
General transportation (1943 to 2048)	330,000	290,000
Shipments for alternatives evaluated in the SPD EIS	10	50
Total collective dose (rounded to nearest thousand)	349,000	333,000
Total latent cancer fatalities	140	170

^a Includes public and occupational collective doses.

^b Includes mixed low-level waste and low-level waste; transuranic waste included in DOE 1997b.

^c Includes all highly enriched uranium shipped to Y–12.

shipments were estimated to result in a collective occupational dose of 82 person-rem and a collective dose for the general population of 100 person-rem.

Collective doses from other historical shipments of radioactive material were evaluated in the *Programmatic Spent Nuclear Fuel Management and Idaho National Engineering Laboratory Environmental Restoration and Waste Management Programs Final Environmental Impact Statement* (DOE 1995a). These include historical shipments associated with Hanford, INEEL, Oak Ridge, SRS, and Naval spent nuclear fuel and test specimens.

There are considerable uncertainties in these historical estimates of collective dose. For example, the population densities and transportation routes used in the dose assessments were based on census data for 1990 and the U.S. highway and rail system as it existed in the 1990s. Using census data for 1990 tends to overestimate historical collective doses because the U.S. population has continuously increased over the time covered in these assessments. Basing collective dose estimates on the U.S. highway and rail system as it existed in the 1990s may slightly underestimate doses for shipments that occurred in the 1940s, 1950s, and 1960s, because a larger portion of the transport routes would have been on non-interstate highways where the population may have been closer to the road. Data were not available that correlated transportation routes and population densities for the 1940s, 1950s, 1960s, and 1970s; therefore, it was necessary to use more recent data to make dose estimates. By the 1970s, the structure of the interstate highway system was largely fixed and most shipments would have been made on interstates.

Shipment data were linearly extrapolated for years when data were unavailable, which also results in uncertainty. However, this technique was validated by linearly extrapolating the data in the *Historical Overview of Domestic Spent Fuel Shipments—Update* (SAIC 1991) for 1973 through 1989 to estimate the number of shipments that took place during the time period 1964 through 1972 (also contained in SAIC 1991). The data in the historical overview could not be used directly because only shipment counts are presented for 1964 through 1982, and no origins or destinations were listed for years before 1983. Based on the data in the historical overview, linearly extrapolating the data for 1973 through 1989 overestimates the shipments for 1964 through 1972 by 20 percent when compared to the actual shipment counts for 1964 through 1972.

Transportation impacts may also result from reasonably foreseeable projects, such as the transportation impacts contained in other DOE National Environmental Policy Act analyses. The results of these analyses are summarized in Table L-11. For some of these analyses, a preferred alternative was not identified nor a ROD issued. In those cases, the alternative that was estimated to result in the largest transportation impact was included in Table L-11.

There are also reasonably foreseeable projects that involve limited transportation of radioactive material: (a) shipment of submarine reactor compartments from the Puget Sound Naval Shipyard to Hanford for burial, (b) return of cesium 137 isotope capsules to Hanford, (c) shipment of uranium billets from Hanford to the United Kingdom, and (d) shipment of low-specific-activity nitric acid from Hanford to the United Kingdom. While this is not an exhaustive list of projects that may involve limited transportation of radioactive material, it does illustrate that the transportation impacts associated with these types of projects are extremely low when compared to major projects or general transportation.

There are also general transportation activities that take place that are unrelated to the alternatives evaluated in the SPD EIS or to reasonably foreseeable actions. Examples of these activities are shipments of radiopharmaceuticals to nuclear medicine laboratories and shipments of commercial low-level radioactive waste to commercial disposal facilities. The NRC evaluated these types of shipments based on a survey of radioactive materials transportation published in NUREG-0170 (NRC 1977). Categories of radioactive material evaluated in NUREG-0170 included: (a) limited quantity shipments, (b) medical, (c) industrial, (d) fuel cycle, and (e) waste.

The NRC estimated that the annual collective worker dose for these shipments was 5,600 person-rem. The annual collective general population dose for these shipments was estimated to be 4,200 person-rem. Because comprehensive transportation doses were not available, these collective dose estimates were used to estimate

transportation collective doses for 1943 through 1982 (40 years). These dose estimates included spent nuclear fuel and radioactive waste shipments made by truck and rail.

Based on the transportation dose assessments in NUREG-0170, the cumulative transportation collective doses for 1943 through 1982 were estimated to be 220,000 person-rem for workers and 170,000 person-rem for the general population.

In 1983, another survey of radioactive materials transportation in the United States was conducted (Javitz et al. 1985). This survey included NRC and Agreement State licensees. Both spent nuclear fuel and radioactive waste shipments were included in the survey. Weiner, LaPlante, and Hageman (1991a:661–666, 1991b:665–660) used the survey by Javitz et al. (1985) to estimate collective doses from general transportation. The transportation dose assessments in Weiner, LaPlante, and Hageman (1991a:661–666, 1991b:665–660) were used to estimate transportation doses for 1983 through 2048 (66 years). Weiner, LaPlante, and Hageman (1991a:661–666) evaluated eight categories of radioactive material shipments by truck: (a) industrial, (b) radiography, (c) medical, (d) fuel cycle, (e) research and development, (f) unknown, (g) waste, and (h) other. Based on a median external exposure rate, an annual collective worker dose of 1,400 person-rem and an annual collective general population dose of 1,400 person-rem were estimated. Over the 66-year time period from 1983 through 2048, both the collective worker and general population doses were estimated to be 92,000 person-rem.

Weiner, LaPlante, and Hageman (1991b:655–660) also evaluated six categories of radioactive material shipments by plane: (a) industrial, (b) radiography, (c) medical, (d) research and development, (e) unknown, and (f) waste. Based on a median external exposure rate, an annual collective worker dose of 290 person-rem and an annual collective general population dose of 450 person-rem were estimated. Over the 66-year time period from 1983 through 2048, the collective worker dose was estimated to be 19,000 person-rem and the general population collective dose was estimated to be 30,000 person-rem.

Like the historical transportation dose assessments, the estimates of collective doses from general transportation also exhibit considerable uncertainty. For example, data for 1975 were applied to general transportation activities from 1943 through 1982. This approach probably overestimates doses because the amount of radioactive material that was transported in the 1950s and 1960s was less than the amount shipped in the 1970s. For example, in 1968, the shipping rate for radioactive material packages was estimated to be 300,000 packages per year (Patterson 1968:199–209); in 1975, this rate was estimated to be 2,000,000 packages per year (NRC 1977). However, because comprehensive data that would enable a more realistic transportation dose assessment are not available, the dose estimates developed by NRC were used.

Total collective worker doses from all types of shipments (historical, reasonably foreseeable actions, and general transportation) were estimated to be approximately 350,000 person-rem (140 LCFs), for the period of time 1943 through 2048 (106 years). Total general population collective doses were also estimated to be 330,000 person-rem (170 LCFs). The majority of the collective dose for workers and the general population was because of general transportation of radioactive material. The total number of LCFs over the time period 1943 through 2048 was estimated to be 310. Over this same period of time (106 years), about 54,060,000 people would die from cancer, based on 510,000 LCFs per year (DOC 1993). It should be noted that the estimated number of transportation-related LCFs would be indistinguishable from other LCFs, and the transportation-related LCFs would be 0.0000057 percent of the total number of expected LCFs during this timeframe.

L.7.2 Accident Impacts

For transportation accidents involving radioactive material, the dominant risk is from accidents that are unrelated to the cargo (i.e., traffic or vehicular accidents). Fatalities involving the shipment of radioactive materials were surveyed for 1971 through 1993 using the Radioactive Material Incident Report database. For 1971 through 1993, 21 vehicular accidents involving 36 fatalities occurred. These fatalities resulted from vehicular accidents

and were not associated with the radioactive nature of the cargo; no radiological fatalities because of transportation accidents have ever occurred in the United States. During the same period of time, over 1,100,000 persons were killed in vehicular accidents in the United States (National Safety Council 1994). About 100 additional vehicular accident fatalities were estimated to result from the transportation of radioactive material (i.e., the transportation associated with reasonably foreseeable actions and general radioactive materials transportation). During the 39-year time period from 2010 through 2048, approximately 1,600,000 people would be expected to be killed in vehicular accidents in the United States. The vehicular accident fatalities associated with radioactive materials transportation would be expected to be 0.006 percent of the total number of vehicular accident fatalities.

L.8 UNCERTAINTY AND CONSERVATISM IN ESTIMATED IMPACTS

The sequence of analyses performed to generate the estimates of radiological risk for the transportation includes: (1) determination of the inventory and characteristics, (2) estimation of shipment requirements, (3) determination of route characteristics, (4) calculation of radiation doses to exposed individuals (including estimation of environmental transport and uptake of radionuclides), and (5) estimation of health effects. Uncertainties are associated with each of these steps. Uncertainties exist in the way that the physical systems being analyzed are represented by the computational models, in the data required to exercise the models (due to measurement errors, sampling errors, natural variability, or unknowns simply caused by the future nature of the actions being analyzed), and in the calculations themselves (e.g., approximate algorithms used by the computers).

In principle, the uncertainty associated with each input or computational source can be estimated and the resultant uncertainty in each set of calculations can be predicted. Thus, the uncertainties from one set of calculations to the next can be propagated and the uncertainty in the final or absolute result can be estimated; however, conducting such a full-scale quantitative uncertainty analysis is often impractical and sometimes impossible, especially for actions to be initiated at an unspecified time in the future. Instead, the risk analysis is designed to ensure, through uniform and judicious selection of scenarios, models, and input parameters, that relative comparisons of risk among the various alternatives are meaningful. In the transportation risk assessment, this design is accomplished by uniformly applying common input parameters and assumptions to each alternative. Therefore, although considerable uncertainty is inherent in the absolute magnitude of the transportation risk for each alternative, much less uncertainty is associated with the relative differences among the alternatives in a given measure of risk.

In the following sections, areas of uncertainty are discussed for the assessment steps enumerated above. Special emphasis is placed on identifying whether the uncertainties affect relative or absolute measures of risk. The degree of conservatism of the assumption is addressed. Where practical, the parameters that most significantly affect the risk assessment results are identified.

L.8.1 Uncertainties in Material Inventory and Characterization

The inventories and the physical and radiological characteristics are important input parameters to the transportation risk assessment. The potential amount of transportation for any alternative is determined primarily by the projected nuclear material inventory and assumptions concerning shipment capacities. The physical and radiological characteristics are important in determining the amount of material released during accidents and the subsequent doses to exposed individuals through multiple environmental exposure pathways.

Uncertainties in the inventory and characterization will be reflected to some degree in the transportation risk results. If the inventory is overestimated (or underestimated), the resulting transportation risk estimates also will be overestimated (or underestimated) by roughly the same factor. However, the same inventory estimates are used to analyze the transportation impacts of each of the SPD EIS alternatives. Therefore, for comparative

purposes, the observed differences in transportation risks among alternatives are believed to represent unbiased, reasonably accurate estimates from current information in terms of relative risk comparisons.

No detailed characterization of surplus nonpit plutonium was included in the evaluation of each shipment of this material. Such information typically would not be compiled until actual shipments were being planned. Only global, conservative assumptions were used in the impact analysis. For the purpose of analysis, DOE assumed a maximum of 4.5 kg (9.9 lb) of plutonium per package, and 40 packages per SST/SGT. Actual SST/SGT shipments could handle more material. This leads to a conservative estimate of radiological accident risks for shipment of surplus nonpit plutonium for each alternative. However, since such shipments have been shown to have lower radiological accident risks than shipments of either plutonium dioxides from pits or lead assembly spent fuel, the overall effect would be very small.

L.8.2 Uncertainties in Containers, Shipment Capacities, and Number of Shipments

The amount of transportation required for each alternative is based, in part, on assumptions concerning the packaging characteristics and shipment capacities for commercial trucks and safe, secure transports. Changes in loading, tiedown, or packaging practices could affect estimates. Representative shipment capacities were defined for assessment purposes based on probable future shipment capacities. In reality, the actual shipment capacities may differ from the predicted capacities, so the projected number of shipments, and consequently the total transportation risk, would change. However, although the predicted transportation risks would increase or decrease accordingly, the relative differences in risks among alternatives would remain about the same. The maximum amount of material allowed in Type B containers is set by conservative safety analyses.

L.8.3 Uncertainties in Route Determination

Representative routes were determined between all origin and destination sites considered in the SPD EIS. The routes were determined consistent with current guidelines, regulations, and practices, but may not be the actual routes that would be used in the future. In reality, the actual routes could differ from the representative ones in terms of distances and total population along the routes. Moreover, since radioactive materials could be transported over an extended period of time starting at some time in the future, the highway infrastructures and the demographics along routes could change. These effects were not accounted for in the transportation assessment; however, it is not anticipated that these changes would significantly affect relative comparisons of risk among the alternatives considered in the SPD EIS. The dates and times that specific transportation routes would be used are classified.

L.8.4 Uncertainties in the Calculation of Radiation Doses

The models used to calculate radiation doses from transportation activities introduce a further uncertainty in the risk assessment process. It is generally difficult to estimate the accuracy or absolute uncertainty of the risk assessment results. The accuracy of the calculated results is closely related to the limitations of the computational models and the uncertainties in each of the input parameters that the model requires. The single greatest limitation facing users of RADTRAN, or any computer code of this type, is the scarcity of data for certain input parameters.

Uncertainties associated with the computational models are minimized by using state-of-the-art computer codes that have undergone extensive review. Because there are numerous uncertainties that are recognized but difficult to quantify, assumptions are made at each step of the risk assessment process that are intended to produce conservative results (i.e., overestimate the calculated dose and radiological risk). Because parameters and assumptions are applied to all alternatives, this model bias is not expected to affect the meaningfulness of relative comparisons of risk; however, the results may not represent risks in an absolute sense.

The single largest contributor to the collective population doses calculated with RADTRAN was found to be the dose to members of the public at truck stops. Currently, RADTRAN uses a simple point-source approximation for truck-stop exposures and assumes that the total stop time for a shipment is proportional to the shipment distance. The parameters used in the stop model were based on a survey of a very limited number of radioactive material shipments that examined a variety of shipment types in different areas of the country. It was assumed that stops occur as a function of distance, with a stop rate of 0.011 hr/km (0.018 hr/mi). For non-SST/SGT shipments, it was further assumed that an average of 50 people at each stop are exposed at a distance of 20 m (66 ft). In RADTRAN, the population dose is directly proportional to the external shipment dose rate and the number of people exposed, and inversely proportional to the square of the distance. For this assessment, it was assumed that many shipments (nonpit plutonium and spent nuclear fuel) would have external dose rates at the regulatory limit of 10 mrem/hr at 2 m (6.6 ft). In practice, the external dose rates would vary from shipment to shipment. The stop rate assumed results in an hour of stop time per 100 km (62 mi) of travel.

Based on the qualitative discussion with shippers, the parameter values used in the assessment appear to be conservative. However, data do not exist to quantitatively assess the degree of control, location, frequency, and duration of truck stops. However, based on the regulatory requirements of 10 CFR 73 for continuous escort of the material and the requirement for two drivers, it is clear that the trucks would be on the move much of the time until arrival at the destination. Therefore, the calculated impacts are extremely conservative. By using these conservative parameters, the calculations in the SPD EIS are consistent with the RADTRAN published values.

Shielding exposed populations is not considered. For all incident-free exposure scenarios, no credit has been taken for shielding exposed individuals. In reality, shielding would be afforded by trucks and cars sharing the transport routes, rural topography, and the houses and buildings in which people reside. Incident-free exposure to external radiation could be reduced significantly depending on the type of shielding present. For residential houses, shielding factors (i.e., the ratio of shielded to unshielded exposure rates) were estimated to range from 0.02 to 0.7, with a recommended value of 0.33. If shielding were to be considered for the maximally exposed resident living near a transport route, the calculated doses and risks would be reduced by approximately 70 percent. Similar levels of shielding may be provided to individuals exposed in vehicles.

Postaccident mitigative actions were not considered for dispersal accidents. For severe accidents involving the release and dispersal of radioactive materials in the environment, no postaccident mitigative actions, such as interdiction of crops or evacuation of the accident vicinity, were considered in this risk assessment. Postaccident mitigative measures to reduce groundshine doses (evacuation and/or decontamination) are assumed to occur 24 hours after the accident in RADTRAN analyses. Additionally, RADTRAN assumes that highly contaminated crops are not ingested (Neuhauser and Knipe 1995). Since RISKIND is modeling the worst credible accident, these measures were not considered. In reality, mitigative actions would take place following an accident in accordance with U.S. Environmental Protection Agency radiation protection guides for nuclear incidents (EPA 1992). The effects of mitigative actions on population accident doses are highly dependent on the severity, location, and timing of the accident. For this risk assessment, ingestion doses were only calculated for accidents occurring in rural areas (the calculated ingestion doses; however, it assumed, all food grown on contaminated ground is consumed and is not limited to the rural population). Interdiction of foodstuffs would act to reduce, but not eliminate, this contribution.

L.9 REFERENCES

Claus, J.M., and L.J. Shyr, 1999, *Defense Programs Transportation Risk Assessment*, Sandia National Laboratories, Albuquerque, NM, draft dated April 1999 (to be published in fall 1999).

Clauss, David B., et al., 1995, *Proceedings of the 11th International Conference on Packaging and Transportation of Radioactive Materials* (PATRAM 1995), "ADROIT: A New Model for Analyzing Risk Associated with Transportation of Nuclear Explosives and Nuclear Materials," vol. II.

Didlake, J., 1998, *Fissile Materials Disposition Program SST/SGT Transportation Estimation*, SAND98-8244, Sandia Corporation, Livermore, CA, June.

DOC (U.S. Department of Commerce), 1993, *Statistical Abstract of the United States: 1993*, 113th ed., Bureau of the Census, Washington, DC.

DOE (U.S. Department of Energy), 1992, *Environmental Assessment for the Shipment of Low Enriched Uranium Billets to the United Kingdom from the Hanford Site, Richland, Washington*, DOE/EA-0787, Richland, WA, August.

DOE (U.S. Department of Energy), 1994, *Environmental Assessment for Return of Isotope Capsules to the Waste Encapsulation and Storage Facility*, DOE/EA-0942, Washington, DC, May.

DOE (U.S. Department of Energy), 1995a, *Department of Energy Programmatic Spent Nuclear Fuel Management and Idaho National Engineering Laboratory Environmental Restoration and Waste Management Programs Final Environmental Impact Statement*, DOE/EIS-0203-F, Office of Environmental Management, Idaho Operations Office, Idaho Falls, ID, April.

DOE (U.S. Department of Energy), 1995b, *Final Programmatic Environmental Impact Statement for Tritium Supply and Recycling*, DOE/EIS-0161, Office of Reconfiguration, Washington, DC, October 19.

DOE (U.S. Department of Energy), 1995c, *Environmental Assessment: Disposition and Transportation of Surplus Radioactive Low Specific Activity Nitric Acid, Hanford Site, Richland, Washington*, DOE/EA-1005, Washington, DC, May.

DOE (U.S. Department of Energy), 1996a, *Storage and Disposition of Weapons-Usable Fissile Materials Final Programmatic Environmental Impact Statement*, DOE/EIS-0229, Office of Fissile Materials Disposition, Washington, DC, December.

DOE (U.S. Department of Energy), 1996b, *Criteria for Preparing and Packaging Plutonium Metals and Oxides for Long-Term Storage*, DOE-STD-3013-96, Washington, DC, September.

DOE (U.S. Department of Energy), 1996c, *Final Environmental Impact Statement for the Continued Operation of the Pantex Plant and Associated Storage of Nuclear Weapon Components*, DOE/EIS-0225, Albuquerque Operations Office, Albuquerque, NM, November.

DOE (U.S. Department of Energy), 1996d, *Final Environmental Impact Statement on a Proposed Nuclear Weapons Nonproliferation Policy Concerning Foreign Research Reactor Spent Nuclear Fuel*, DOE/EIS-0218F, Office of Environmental Management, Washington, DC, February.

DOE (U.S. Department of Energy), 1996e, *Final Environmental Impact Statement for the Nevada Test Site and Off-Site Locations in the State of Nevada*, DOE/EIS-0243, Nevada Operations Office, Las Vegas, NV, August.

DOE (U.S. Department of Energy), 1996f, *Medical Isotopes Production Project: Molybdenum-99 and Related Isotopes, Environmental Impact Statement*, DOE/EIS-0249F, Washington, DC, April.

DOE (U.S. Department of Energy), 1996g, *Disposition of Surplus Highly Enriched Uranium Final Environmental Impact Statement*, DOE/EIS-0240, Office of Fissile Materials Disposition, Washington, DC, June.

DOE (U.S. Department of Energy), 1996h, *Final Programmatic Environmental Impact Statement for Stockpile Stewardship and Management*, DOE/EIS-0236, Office of Technical and Environmental Support, Reconfiguration Group, Washington, DC, September.

DOE (U.S. Department of Energy), 1996i, *Draft Environmental Impact Statement for Completion of the West Valley Demonstration Project and Closure or Long-Term Management of Facilities at the Western New York Nuclear Service Center*, DOE/EIS-0226-D, Washington, DC, January.

DOE (U.S. Department of Energy), 1996j, *Final Environmental Impact Statement SIC Prototype Reactor Plant Disposal*, DOE/EIS-0275, Office of Naval Reactors, Windsor, CT, November.

DOE (U.S. Department of Energy), 1997a, *Final Waste Management Programmatic Environmental Impact Statement for Managing Treatment, Storage, and Disposal of Radioactive and Hazardous Waste*, DOE/EIS-0200-F, Office of Environmental Management, Washington, DC, May.

DOE (U.S. Department of Energy), 1997b, *Waste Isolation Pilot Plant Disposal Phase Final Supplemental Environmental Impact Statement*, DOE/EIS-0026-S-2, Carlsbad Area Office, Carlsbad, NM, September.

| DOE (U.S. Department of Energy), 1997c, *Nonproliferation and Arms Control Assessment of Weapons-Usable Fissile Material Storage and Excess Plutonium Disposition Alternatives*, DOE/NN-0007, Office of Nonproliferation and National Security, Washington, DC, January.

DOE (U.S. Department of Energy), 1997d, *Final Environmental Impact Statement, Disposal of the S3G and DIG Prototype Reactor Plants*, DOE/EIS-0274, Office of Naval Reactors, Schenectady, NY, November.

| DOE (U.S. Department of Energy), 1998, *Supplement Analysis for: Final Environmental Impact Statement for the Continued Operation of the Pantex Plant and Associated Storage of Nuclear Weapon Components—AL-R8 Sealed Insert Container*, Albuquerque Operations Office, Amarillo Area Office, Amarillo, TX, August.

DOT (U.S. Department of Transportation), 1992a, *Shippers—General Requirements for Shipments and Packagings*, 49 CFR 173, Washington, DC, October 1.

DOT (U.S. Department of Transportation), 1992b, *Guidelines for Selecting Preferred Highway Routes for Highway Route Controlled Quantity Shipments of Radioactive Materials*, DOT/RSPA/HMS/92-02, August.

EPA (U.S. Environmental Protection Agency), 1992, *Manual of Protective Actions for Nuclear Incidents*, EPA/400-R-92-001, Washington, DC, May.

ICRP (International Commission on Radiological Protection), 1991, *1990 Recommendations of the International Commission on Radiological Protection*, ICRP, Publication 60, Elmsford, NY.

Javitz, H.S., T.R. Lyman, C. Maxwell, E.L. Myers, and C.R. Thompson, 1985, *Transport of Radioactive Material in the United States: Results of a Survey to Determine the Magnitude and Characteristics of Domestic, Unclassified Shipments of Radioactive Materials*, SAND84-7174, Sandia National Laboratories.

Johnson, P.E., D.S. Joy, D.B. Clark, and J.M. Jacobi, 1993, *HIGHWAY 3.1, An Enhanced Transportation Routing Model: Program Description, Methodology, and Revised User's Manual*, ORNL/TM-12124, Oak Ridge National Laboratory, Oak Ridge, TN, March.

Jones, S., and S.J. Maheras, 1994, *Summary of Doses and Health Effects From Historical Offsite Spent Nuclear Fuel Shipments to the Nevada Test Site*, Engineering Design File (EDF) EIS-TRANS-31.

Low, J., 1999, U.S. Department of Energy, Albuquerque Operations Office, Albuquerque, NM, personal communication to J. Bozik, U.S. Department of Energy, Office of Fissile Materials Disposition, Washington, DC, *Response on MD NEPA Questions*, April 9.

Ludwig, S.B., R.E. Best, S.P. Schmid, and B.E. Welch, 1997, *Transportation and Packaging Issues Involving the Disposition of Surplus Plutonium as MOX Fuel in Commercial LWRs*, ORNL/TM-13427, Oak Ridge National Laboratory, Oak Ridge, TN, August.

National Safety Council, 1994, *Accident Facts, 1994 Edition*, Itasca, IL.

Neuhauser, K.S., and F.L. Kanipe, 1995, *RADTRAN 4, Volume II: Technical Manual*, SAND89-2370, Sandia National Laboratories, Albuquerque, NM, March.

NRC (U.S. Nuclear Regulatory Commission), 1977, *Final Environmental Statement on the Transportation of Radioactive Material by Air and Other Modes*, vol. 1, NUREG-0170, Office of Standards Development, Washington, DC, December.

NRC (U.S. Nuclear Regulatory Commission), 1996, *Packaging and Transportation of Radioactive Material*, 10 CFR 71, Washington, DC, January 1.

NRC (U.S. Nuclear Regulatory Commission), 1998, *Standards for Protection Against Radiation*, 10 CFR 20, Washington, DC, January 1.

O'Connor, D.G., et al., 1998a, *Hanford MOX Fuel Lead Assemblies Data Report for the Surplus Plutonium Disposition Environmental Impact Statement*, ORNL/TM-13481, Lockheed Martin Energy Research Corporation, Oak Ridge, TN, August.

O'Connor, D.G., et al., 1998b, *ANL-W MOX Fuel Lead Assemblies Data Report for the Surplus Plutonium Disposition Environmental Impact Statement*, ORNL/TM-13478, Lockheed Martin Energy Research Corporation, Oak Ridge, TN, August.

O'Connor, D.G., et al., 1998c, *LLNL MOX Fuel Lead Assemblies Data Report for the Surplus Plutonium Disposition Environmental Impact Statement*, ORNL/TM-13480, Lockheed Martin Energy Research Corporation, Oak Ridge, TN, August.

O'Connor, D.G., et al., 1998d, *LANL MOX Fuel Lead Assemblies Data Report for the Surplus Plutonium Disposition Environmental Impact Statement*, ORNL/TM-13482, Lockheed Martin Energy Research Corporation, Oak Ridge, TN, August.

O'Connor, D.G., et al., 1998e, *SRS MOX Fuel Lead Assemblies Data Report for the Surplus Plutonium Disposition Environmental Impact Statement*, ORNL/TM-13483, Lockheed Martin Energy Research Corporation, Oak Ridge, TN, August.

Patterson, D.E., 1968, *Proceedings of the Second International Symposium on Packaging and Transportation of Radioactive Materials, October 14-18, 1968, Gatlinburg, Tennessee*, “The Accident Experience of the USAEC in the Shipment of Radioactive Material,” CONF-681001.

Phillips, J.S., et al., 1994, *Determination of Influence Factors and Accident Rates for the Armored Tractor/Safe Secure Trailer*, SAND93-0111, Sandia National Laboratories, Albuquerque, NM, April.

SAIC (Science Applications International Corporation), 1991, *Historical Overview of Domestic Spent Fuel Shipments—Update*, DE91 016051.

Saricks, C., and T. Kvitek, 1994, *Longitudinal Review of State-Level Accident Statistics for Carriers of Intrastate Freight*, ANL/ESD/TM-68, Argonne National Laboratory, Argonne, IL, March.

UC (Regents of the University of California), 1998a, *Pit Disassembly and Conversion Facility, Environmental Impact Statement Data Report—Hanford Site*, LA-UR-97-2907, Los Alamos National Laboratory, Los Alamos, NM, June 1.

UC (Regents for the University of California) 1998b, *Response to the Surplus Plutonium Disposition Environmental Impact Statement Data Call for a Mixed Oxide Fuel Fabrication Facility Located at the Hanford Site*, rev. 3, LA-UR-97-2064, Los Alamos National Laboratory, Los Alamos, NM, June 22.

UC (Regents for the University of California) 1998c, *Pit Disassembly and Conversion Facility, Environmental Impact Statement Data Report—Savannah River Site*, LA-UR-97-2910, Los Alamos National Laboratory, Los Alamos, NM, June 1.

UC (Regents for the University of California) 1998d, *Response to the Surplus Plutonium Disposition Environmental Impact Statement Data Call for a Mixed Oxide Fuel Fabrication Facility Located at the Savannah River Site*, rev. 3, LA-UR-97-2066, Los Alamos National Laboratory, Los Alamos, NM, June 22.

UC (Regents for the University of California) 1998e, *Pit Disassembly and Conversion Facility, Environmental Impact Statement Data Report—Pantex*, LA-UR-97-2909, Los Alamos National Laboratory, Los Alamos, NM, June 1.

UC (Regents for the University of California) 1998f, *Pit Disassembly and Conversion Facility, Environmental Impact Statement Data Report—Idaho National Engineering and Environmental Laboratory*, LA-UR-97-2908, Los Alamos National Laboratory, Los Alamos, NM, June 1.

UC (Regents for the University of California) 1998g, *Response to the Surplus Plutonium Disposition Environmental Impact Statement Data Call for a Mixed Oxide Fuel Fabrication Facility Located at the Idaho National Engineering and Environmental Laboratory*, rev. 3, LA-UR-97-2065, Los Alamos National Laboratory, Los Alamos, NM, June 22.

UC (Regents for the University of California) 1998h, *Response to the Surplus Plutonium Disposition Environmental Impact Statement Data Call for a Mixed Oxide Fuel Fabrication Facility Located at the Pantex Plant*, rev. 3, LA-UR-97-2067, Los Alamos National Laboratory, Los Alamos, NM, June 22.

| [Text deleted.]

UC (Regents for the University of California) 1999a, *Fissile Materials Disposition Program, EIS Data Call Report: Plutonium Immobilization Plant Using Ceramic in Existing Facilities at Hanford*, rev. 1, UCRL-ID-128275, Lawrence Livermore National Laboratory, Livermore, CA, September.

UC (Regent of the University of California) 1999b, *Fissile Materials Disposition Program, EIS Data Call Report: Plutonium Immobilization Plant Using Glass in Existing Facilities at Hanford*, rev. 1, UCRL-ID-128276, Lawrence Livermore National Laboratory, Livermore, CA, September.

UC (Regents for the University of California) 1999c, *Fissile Materials Disposition Program, EIS Data Call Report: Plutonium Immobilization Plant Using Ceramic in New Facilities at the Savannah River Site*, rev. 1, UCRL-ID-128273, Lawrence Livermore National Laboratory, Livermore, CA, September.

UC (Regents for the University of California) 1999d, *Fissile Materials Disposition Program, EIS Data Call Report: Plutonium Immobilization Plant Using Glass in New Facilities at the Savannah River Site*, rev. 1, UCRL-ID-128271, Lawrence Livermore National Laboratory, Livermore, CA, September.

USN (U.S. Department of the Navy), 1984, *Final Environmental Impact Statement on the Disposal of Decommissioned, Defueled Naval Submarine Reactor Plants*, PB90-193855, Washington, DC, May.

USN (U.S. Department of the Navy), 1996a, *Department of the Navy Final Environmental Impact Statement for a Container System for the Management of Naval Spent Nuclear Fuel*, DOE/EIS-0251, Arlington, VA, November.

USN (U.S. Department of the Navy), 1996b, *Final Environmental Impact Statement on the Disposal of Decommissioned, Defueled Cruiser, Ohio Class, and Los Angeles Class Naval Reactor Plants*, Bremerton, WA, April.

Weiner, R.F., P.A. LaPlante, and J.P. Hageman, 1991a, *Risk Analysis*, “An Approach to Assessing the Impacts of Incident-Free Transportation of Radioactive Materials: II. Highway Transportation,” vol. 11, no. 4.

Weiner, R.F., P.A. LaPlante, and J.P. Hageman, 1991b, *Risk Analysis*, “An Approach to Assessing the Impacts of Incident-Free Transportation of Radioactive Materials: I. Air Transportation,” vol. 11, no. 4.

White, V.S., 1997, *Initial Data Report in Response to the Surplus Plutonium Disposition Environmental Impact Statement Data Call for the UO₂ Supply*, rev. 1, ORNL/TM-13466, Lockheed Martin Energy Research Corporation, Oak Ridge, TN, November. |

Yuan, Y.C., S.Y. Chen, B.M. Riwer, and D.J. LePoire, 1995, *RISKIND—A Computer Program for Calculating Radiological Consequences and Health Risks from Transportation of Spent Nuclear Fuel*, ANL/EAD-1, Argonne National Laboratory, Argonne, IL, November.

Table M-1. Racial and Ethnic Composition of Minority Populations Residing Within 80 km of Candidate DOE Sites in 1990

Candidate Site	Total Pop.	Minority Pop.	Percent Minority Pop.	Asian or Pacific Islander Pop.	Percent Asian or Pacific Islander Pop.	Black Pop.	Percent Black Pop.	Hispanic Pop.	Percent Hispanic Pop.	Native American Pop.	Percent Native American Pop.	Other Race	Percent Other Race Pop.	White Pop.	Percent White Pop.
Hanford 400 Area	277,515	70,493	25.4	3,989	1.4	2,788	1.0	59,736	21.5	3,981	1.4	372	0.1	206,651	74.5
Hanford 200 East	346,031	90,526	26.2	4,852	1.4	4,144	1.2	74,490	21.5	7,040	2.0	556	0.2	254,949	73.7
INEEL	119,138	11,757	9.9	1,166	1.0	385	0.3	7,154	6.0	3,052	2.6	135	0.1	107,246	90.0
Pantex	266,004	50,778	19.1	3,450	1.3	11,130	4.2	33,977	12.8	2,220	0.8	363	0.1	214,864	80.7
[Text deleted.]															
SRS APSF, if built	614,095	232,781	37.9	5,888	1.0	219,136	35.7	6,456	1.1	1,300	0.2	175	0.0	381,139	62.1
SRS DWPF	626,317	241,168	38.5	5,951	1.0	227,378	36.3	6,521	1.0	1,319	0.2	175	0.0	384,974	61.5

Key: APSF, Actinide Packaging and Storage Facility; DWPF, Defense Waste Processing Facility.

Table M-2. Projected Racial and Ethnic Composition of Minority Populations Residing Within 80 km of Candidate DOE Sites in 1997

Candidate Site	Total Pop.	Minority Pop.	Percent Minority Pop.	Asian or Pacific Islander Pop.	Percent Asian or Pacific Islander Pop.	Black Pop.	Percent Black Pop.	Hispanic Pop.	Percent Hispanic Pop.	Native American Pop.	Percent Native American Pop.	Other Race	Percent Other Race Pop.	White Pop.	Percent White Pop.
Hanford 400 Area	324,640	98,586	30.4	5,640	1.7	3,153	1.0	85,642	26.4	4,151	1.3	418	0.1	225,636	69.5
Hanford 200 East	396,420	126,166	31.8	6,885	1.7	4,666	1.2	106,551	26.9	8,064	2.0	631	0.2	269,623	68.0
INEEL	145,117	16,785	11.6	1,627	1.1	590	0.4	10,793	7.4	3,775	2.6	166	0.1	128,166	88.3
Pantex	292,004	62,845	21.5	5,107	1.7	12,801	4.4	42,490	14.6	2,447	0.8	414	0.1	228,745	78.3
[Text deleted.]															
SRS APSF, if built	694,891	274,985	39.6	9,276	1.3	254,807	36.7	9,456	1.4	1,447	0.2	201	0.0	419,704	60.4
SRS DWPF	688,352	275,654	40.0	9,332	1.4	255,459	37.1	9,422	1.4	1,441	0.2	201	0.0	412,497	59.9

Key: APSF, Actinide Packaging and Storage Facility; DWPF, Defense Waste Processing Facility.

Table M-3. Projected Racial and Ethnic Composition of Minority Populations Residing Within 80 km of Candidate DOE Sites in 2010

Candidate Site	Total Pop.	Minority Pop.	Percent Minority Pop.	Asian or Pacific Islander Pop.	Percent Asian or Pacific Islander Pop.	Black Pop.	Percent Black Pop.	Hispanic Pop.	Percent Hispanic Pop.	Native American Pop.	Percent Native American Pop.	Other Race	Percent Other Race Pop.	White Pop.	Percent White Pop.
Hanford 400 Area	426,473	163,767	38.4	9,287	2.2	3,907	0.9	144,750	33.9	5,824	1.4	508	0.1	262,198	61.5
Hanford 200 East	532,179	207,732	39.0	11,341	2.1	5,763	1.1	180,345	33.9	10,283	1.9	761	0.1	323,686	60.8
INEEL	185,748	27,887	15.0	2,426	1.3	960	0.5	18,887	10.2	5,615	3.0	210	0.1	157,651	84.9
Pantex	332,001	84,418	25.4	7,626	2.3	15,916	4.8	58,101	17.5	2,775	0.8	490	0.1	247,093	74.4
[Text deleted.]															
SRS APSF, if built	802,140	336,549	42.0	13,974	1.7	306,706	38.2	14,271	1.8	1,598	0.2	235	0.0	465,356	58.0
SRS DWPF	815,380	345,527	42.4	14,093	1.7	315,444	38.7	14,374	1.8	1,617	0.2	235	0.0	469,617	57.6

Key: APSF, Actinide Packaging and Storage Facility; DWPF, Defense Waste Processing Facility.

Table M-4. Uncertainties in Estimates of Total and Minority Populations for the Year 2010

Candidate Site	No. of Partially Included Block Groups		No. of Fully Included Block Groups		T/P	Upper Bound for Total Population	Estimate of Total Population	Lower Bound for Total Population	Upper Bound for Minority Population	Estimate of Minority Population	Lower Bound for Minority Population
Hanford 400 Area	8(OR)	39(WA)	31(OR)	233(WA)	5.6	422,872	415,828	397,570	161,697	159,713	153,854
200 East	13(OR)	42(WA)	6(OR)	365(WA)	6.7	519,364	509,136	482,861	205,420	202,832	196,212
INEEL	39		91		2.3	215,134	183,565	155,726	32,443	27,650	23,498
Pantex	22		483		22.0	338,218	330,300	321,477	85,566	83,963	82,332
SRS											
[Text deleted.]											
APSF, if built	27(GA)	55(SC)	245(GA)	277(SC)	6.4	865,698	807,583	753,569	365,148	339,708	318,908
DWPF	31(GA)	57(SC)	232(GA)	291(SC)	5.9	815,864	800,530	758,866	347,365	340,704	324,062

Key: APSF, Actinide Packaging and Reprocessing Facility; DWPF, Defense Waste Processing Facility; GA, Georgia; OR, Oregon; SC, South Carolina; WA, Washington.

block groups that are partly within the circle of 80-km (50-mi) radius centered at the various facilities. Column 3 shows the number of block groups that lie completely within the circle. Potentially affected areas surrounding Hanford and SRS include two States. Columns 2 and 3 show the number of partial or total inclusions for the affected States. Column 4 of the table, denoted as “T/P,” shows the number of totally included block groups divided by the number of partially included block groups. In order to minimize the uncertainties in the population estimate, it is desirable that this ratio be as large as possible. Column 5 shows upper bounds for the estimates of the total population listed in column 6. As discussed above, upper bounds were obtained by including the total population of all block groups that lie at least partially within the affected area. Lower bounds for the estimate of total population shown in column 7 were obtained by including only the populations of totally included block groups. Analogous statements apply to columns 8 through 10.

As would be expected from the value of T/P shown in column 4, uncertainties in the total population estimate for Pantex were the smallest among the four sites (+2.4 percent and -2.7 percent), as were the uncertainties in the estimate of the minority population at risk near Pantex (+1.9 percent and -1.9 percent). Uncertainties in the population estimates for INEEL were the largest among the four sites (+17.2 percent and -15.2 percent for total population; +17.3 percent and -15.0 percent for minority population). None of the uncertainties shown in Table M-4 are large enough to noticeably affect the conclusions regarding radiological health effects or environmental justice.

M.5.2 Geographical Dispersion of Minority and Low-Income Populations

Figures M-2 through M-9 show the geographical distributions of minority and low-income populations at risk in the vicinity of the candidate DOE sites. Distributions shown in these figures are based on baseline population data for 1990. Even-numbered figures show the geographical distribution of minority populations in potentially affected areas within a distance of 80 km (50 mi) of candidate facilities. Block groups are shaded to indicate the percentage of the total population comprised of minorities. According to the decennial census of 1990, minorities comprised 24.2 percent of the total population of the contiguous United States. Block groups unshaded in the even-numbered figures are those for which the percentage of minority residents is less than the national percentage minority population. Areas shaded in gray show block groups for which the percentage of minority residents exceeds the national minority percentage by less than a factor of two. Diagonally hatched block groups shown in the even-numbered figures are those for which the percentage of minority residents exceeds the national minority percentage by a factor of two or more.

Odd-numbered figures show the geographical distribution of low-income populations potentially at risk from implementation of the proposed action or alternatives. According to the decennial census of 1990, 13.4 percent of the population of the contiguous United States reported incomes less than the poverty threshold. Block groups unshaded in Figures M-1, M-5, M-7, and M-9 are those for which the percentage of low-income residents is less than the national percentage of persons reporting an income less than the poverty threshold. Areas shaded in gray show block groups for which the percentage of low-income residents exceeds the national low-income percentage by less than a factor of two. Diagonally hatched block groups shown in the odd-numbered figures are those for which the percentage of low-income residents exceeds the national low-income percentage by a factor of two or more.

M.5.3 Environmental Effects on Minority and Low-Income Populations Residing Near Candidate DOE Sites

The analysis of environmental effects on populations residing within 80 km (50 mi) of proposed facilities is presented in Chapter 4 of the SPD EIS. This analysis shows that no radiological fatalities are likely to result from implementation of the proposed action or alternatives. Radiological risks to the public are small regardless of the racial and ethnic composition of the population, and regardless of the economic status of

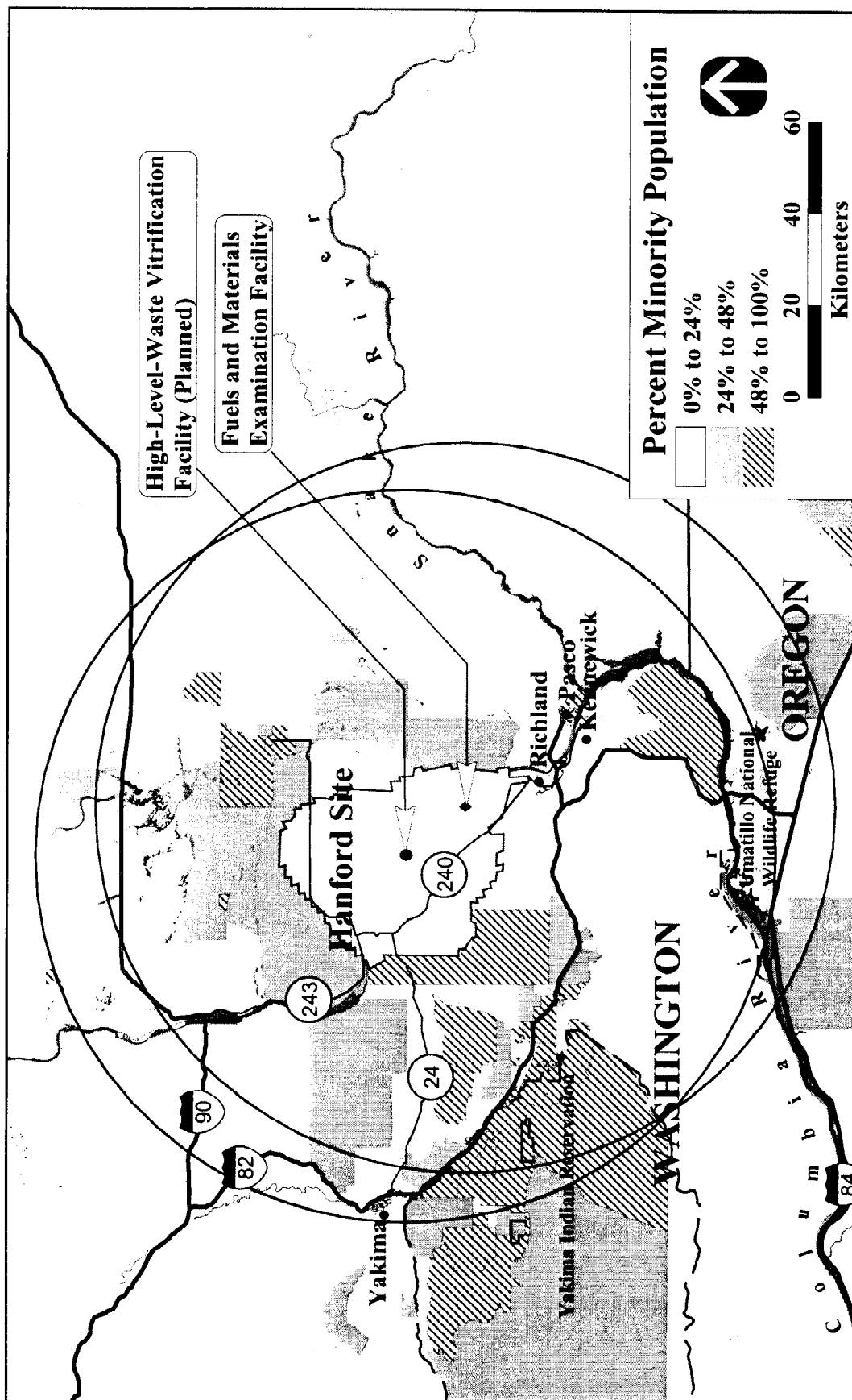

Figure M-2. Geographical Distribution of the Minority Population Residing Within 80 km (50 mi) of Proposed Facilities at Hanford

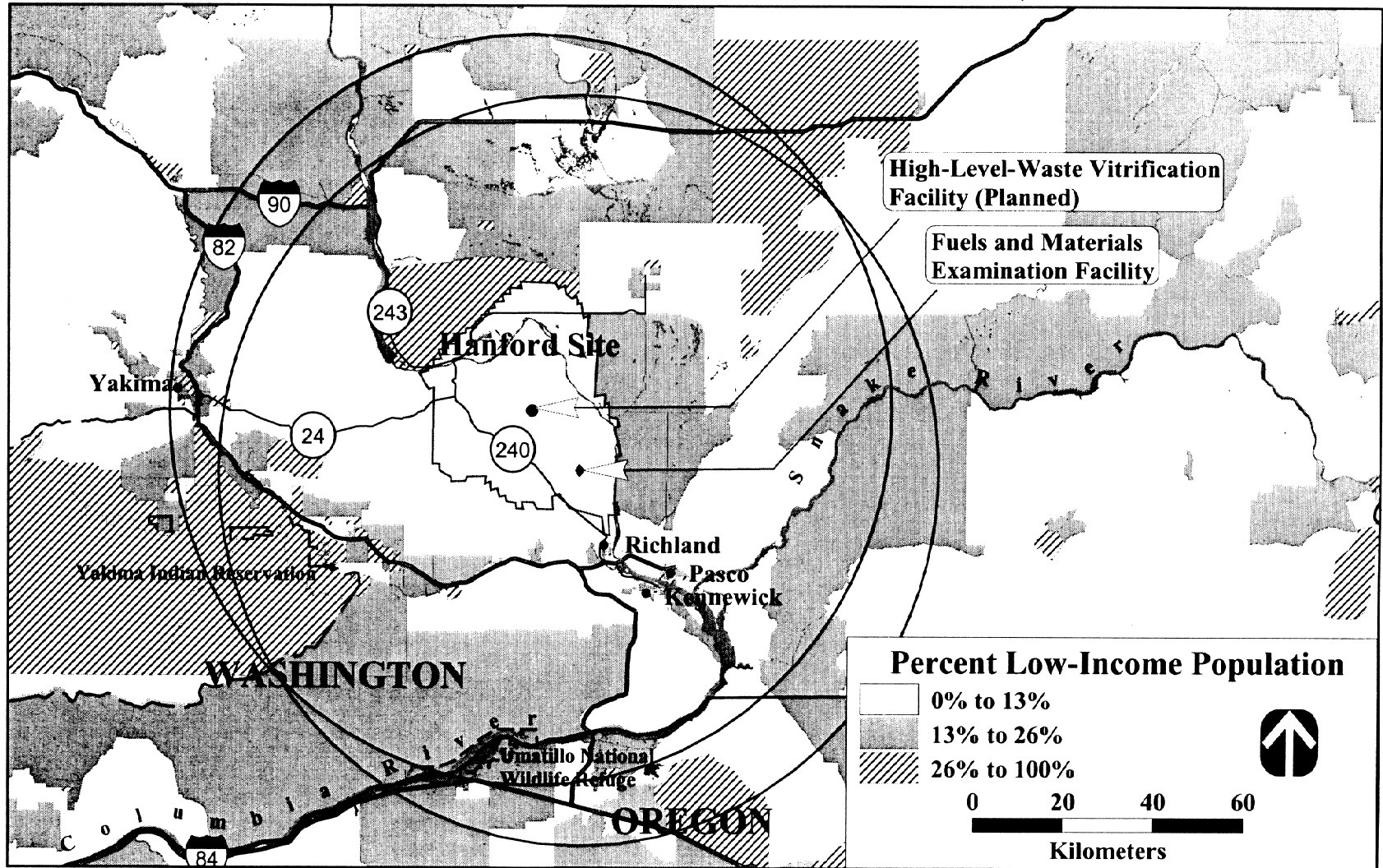

Figure M-3. Geographical Distribution of the Low-Income Population Residing Within 80 km (50 mi) of Proposed Facilities at Hanford

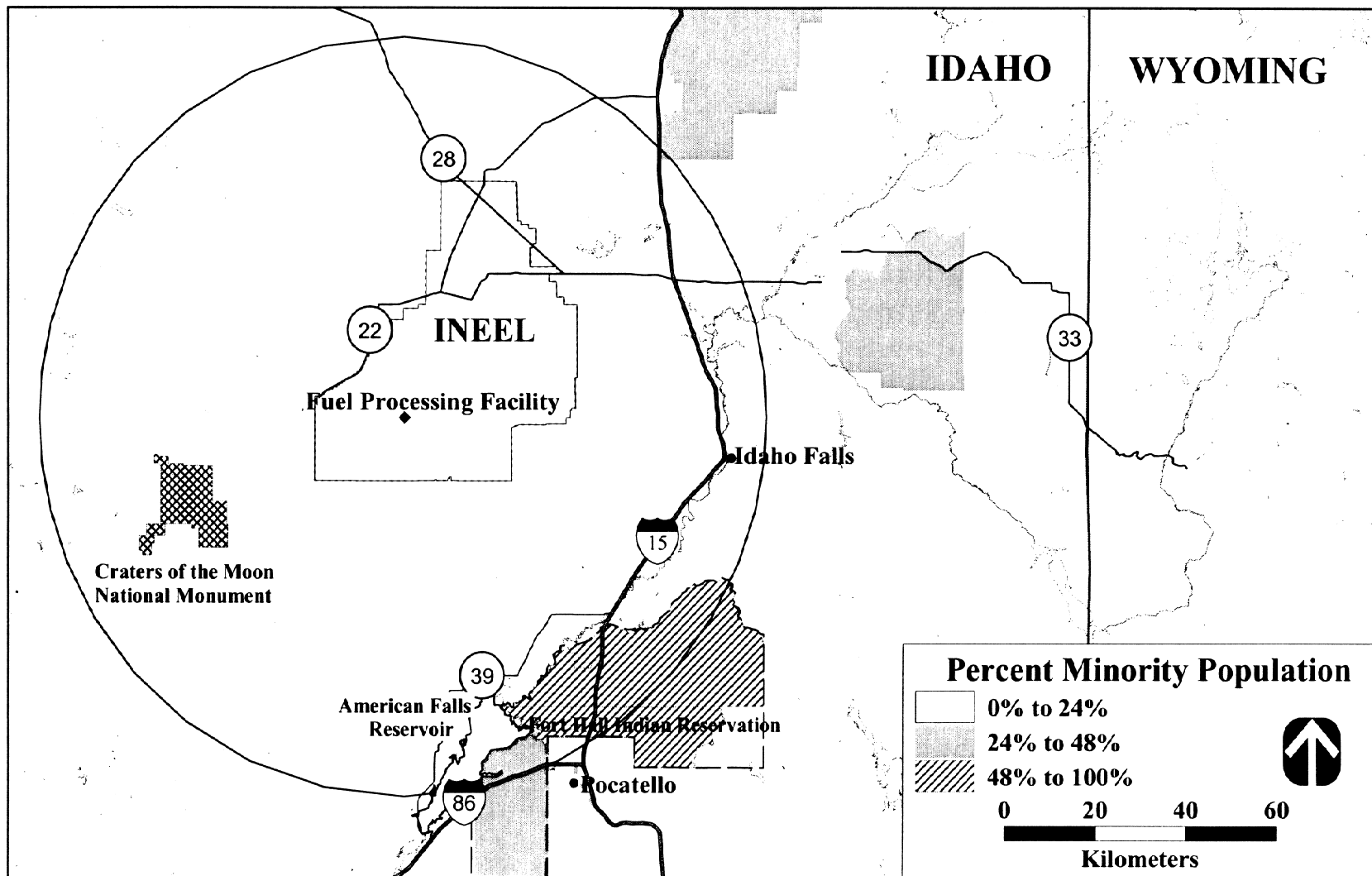

Figure M-4. Geographical Distribution of the Minority Population Residing Within 80 km (50 mi) of Fuel Processing Facility at INEEL

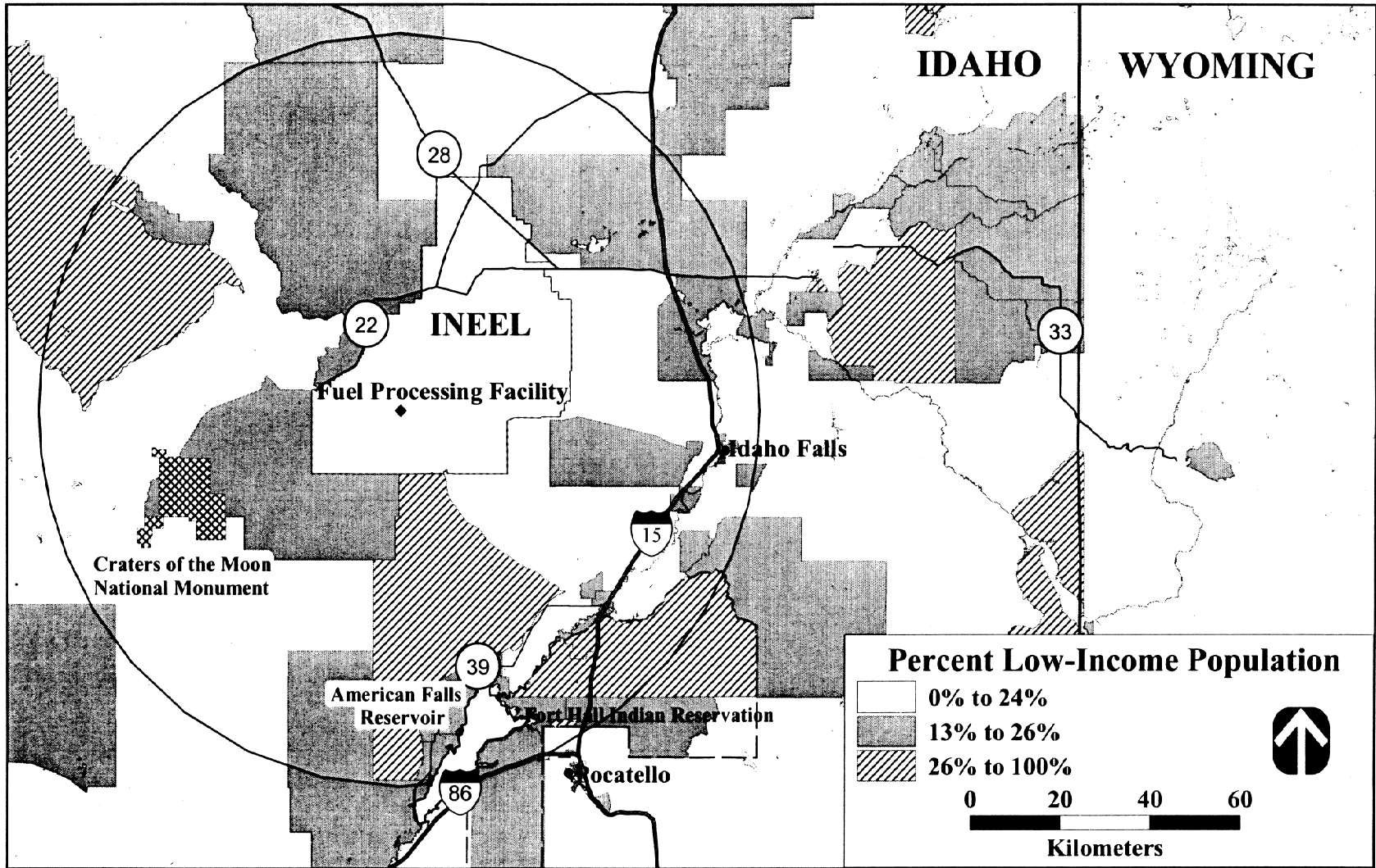

Figure M-5. Geographical Distribution of the Low-Income Population Residing Within 80 km (50 mi) of Fuel Processing Facility at INEEL

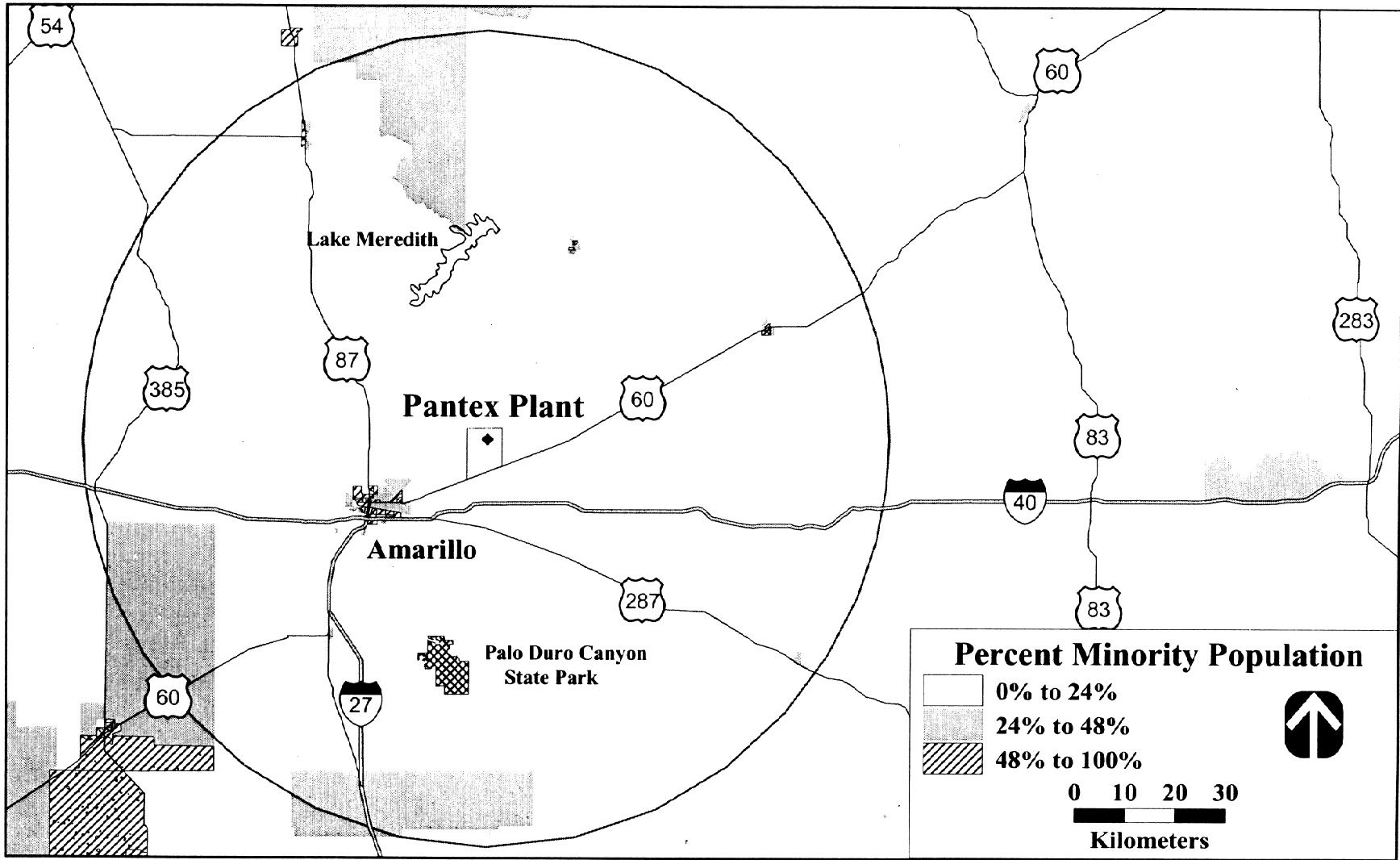

Figure M-6. Geographical Distribution of the Minority Population Residing Within 80 km (50 mi) of Potentially Affected Area at Pantex

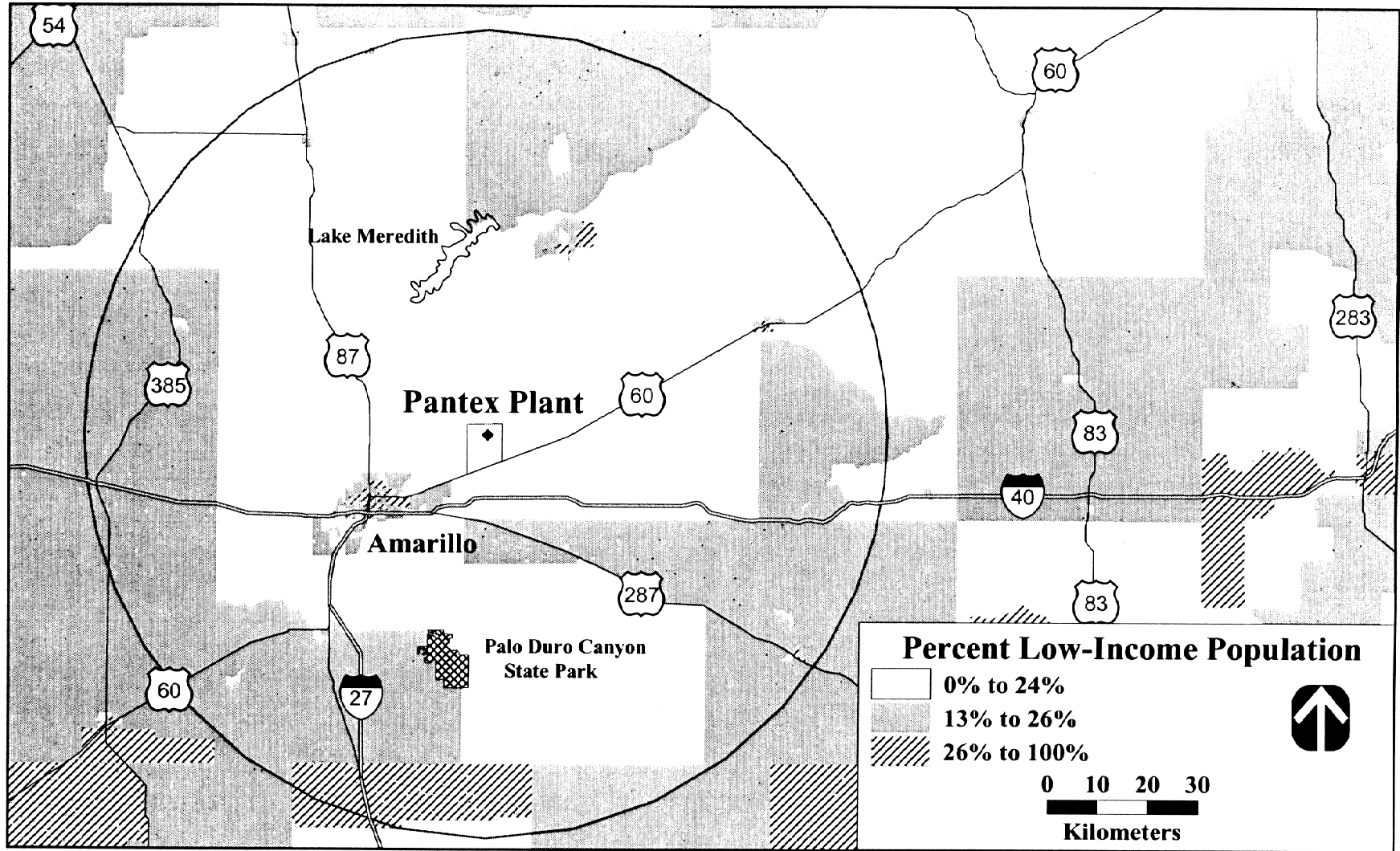

Figure M-7. Geographical Distribution of the Low-Income Population Residing Within 80 km (50 mi) of Potentially Affected Area at Pantex

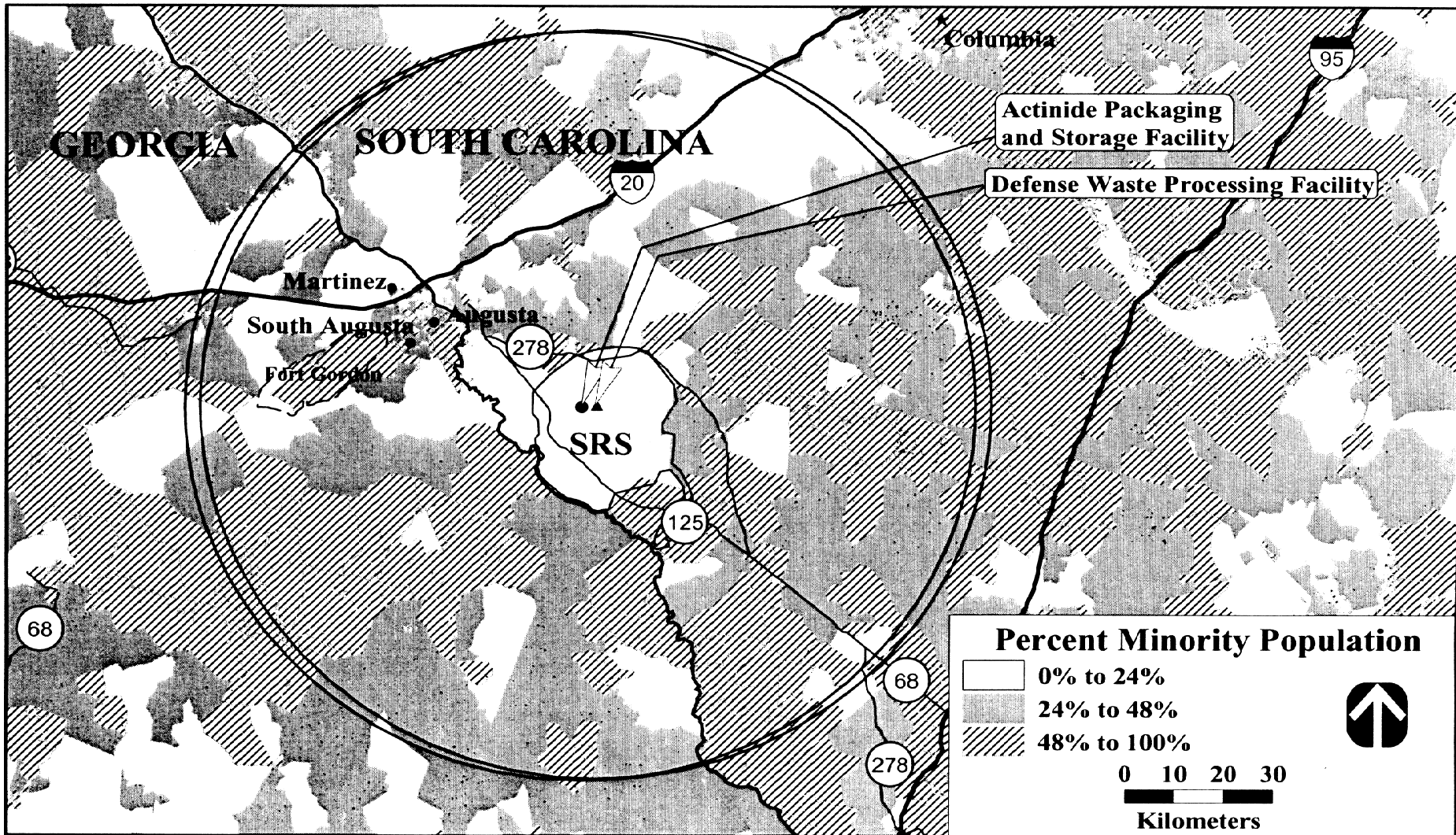

Figure M-8. Geographical Distribution of the Minority Population Residing Within 80 km (50 mi) of Proposed Facilities at SRS

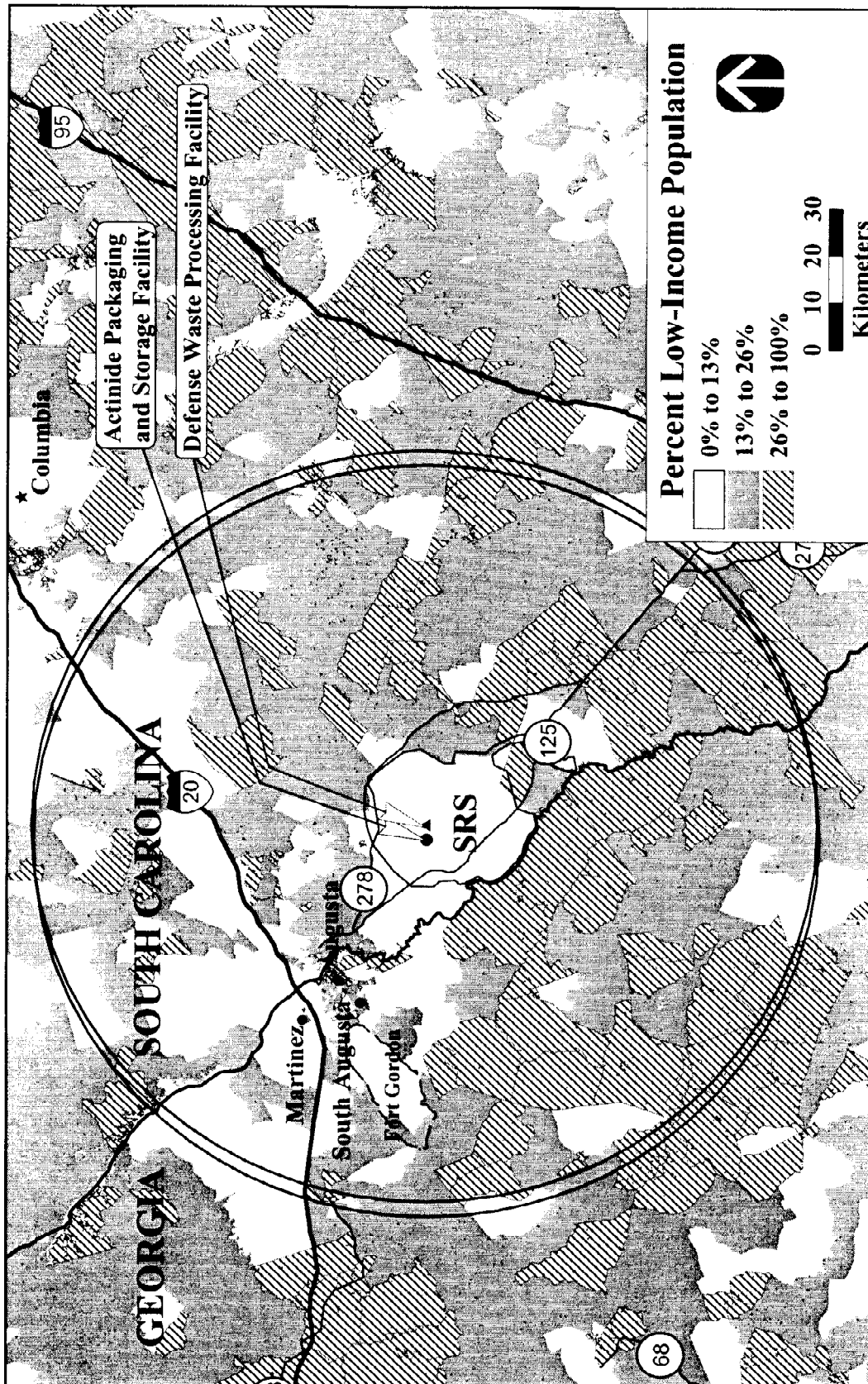

Figure M-9. Geographical Distribution of the Low-Income Population Residing Within 80 km (50 mi) of Proposed Facilities at SRS

individuals comprising the population. Nonradiological risks to the general population are also small regardless of the racial and ethnic composition or economic status of the population. Thus, disproportionately high and adverse impacts on minority and low-income populations residing near the various facilities are not likely to result from implementation of the proposed action or alternatives.

M.6 RESULTS FOR TRANSPORTATION ROUTES

Table M-5 shows minority populations residing along 1.6-km (1-mi) corridors centered on routes that are representative of those that could be used for the transportation of nuclear materials under the proposed action or alternatives. Table M-6 shows similar data for low-income populations. Population data for Tables M-5 and M-6 were extracted from Tables P-12 and P-121 of the STF-3A files (DOC 1992). Distances from a given origin to a given destination are similar but not identical to corresponding distances shown in Appendix L. This is because distances listed in Appendix L were calculated with the HIGHWAY computer code, while distances shown in Tables M-5 and M-6 were obtained from a Geographical Information System analysis using TigerLine data and STF3A files prepared by the Census Bureau. Both techniques use block group spatial resolution, and the differences are generally less than 5 percent.

Total and minority populations residing in the highway corridors are listed in Columns 4 and 5, respectively, of Table M-5. Column 6 shows minority populations residing within highway corridors as a percentage of the total population. Although total and minority populations residing within the corridors generally tend to increase with increasing distance, the relationship is clearly route dependent.

As discussed in Appendix L of the SPD EIS, implementation of the proposed action or alternatives would not result in significant radiological or nonradiological risks to populations residing along highway transportation routes. Although the percentage minority or low-income populations residing along highway routes can vary by as much as a factor of four, results of the analysis presented in Chapter 4 are independent of the racial and ethnic composition of populations within the corridors, as well as the economic status of populations at risk within the corridors. Implementation of the proposed action or alternatives is not likely to result in disproportionately high and adverse effects on minority or low-income populations residing within representative transportation corridors.

Table M-5. Minority Populations Residing Along Transportation Routes for Surplus Plutonium

Origin	Destination	Distance (km)	Total Population Along Route	Minority Population Along Route	Percentage Minority Population Along Route
ANL-W	Hanford	1,035	82,418	9,356	11.4
ANL-W	Pantex	2,395	281,386	82,566	29.3
ANL-W	SRS	3,756	580,985	122,415	21.1
Fuel fabrication	Hanford	4,760	601,233	95,417	15.9
Fuel fabrication	INEEL	4,092	556,388	88,331	15.9
Fuel fabrication	LANL	3,201	506,962	126,460	24.9
Fuel fabrication	Pantex	2,563	430,359	87,635	20.4
Fuel fabrication	SRS	578	75,050	30,702	40.9
Hanford	Geological repository	1,888	248,006	31,424	12.7
Hanford	INEEL	949	74,624	8,927	12.0
Hanford	LANL	2,515	276,768	71,860	26.0
Hanford	ORR	3,993	434,235	62,000	14.3
Hanford	Pantex	3,040	342,903	92,151	26.9
INEEL	ORR	3,316	389,496	59,174	15.2
INEEL	SRS	3,702	574,433	123,656	21.5
LANL	ANL-W	1,868	230,510	60,265	26.1
LANL	INEEL	1,840	227,759	65,563	28.8
LANL	LLNL	1,218	454,603	224,303	49.3
LANL	Pantex	647	85,252	35,326	41.4
LANL	SRS	2,779	521,907	163,376	31.3
LLNL	Fuel fabrication	4,838	771,701	257,880	33.4
LLNL	Geological repository	1,140	414,432	192,001	46.3
LLNL	Hanford	1,428	380,755	50,764	13.3
LLNL	INEEL	1,559	373,040	72,575	19.5
LLNL	Pantex	2,302	476,701	226,661	47.5
LLNL	SRS	4,395	856,464	403,622	47.1
Pantex	Geological repository	1,986	186,981	66,118	35.4
Pantex	INEEL	2,365	293,805	85,783	29.2
Pantex	ORR	1,753	245,038	59,671	24.4
Pantex	SRS	2,165	441,441	126,441	28.6
Pantex	WIPP	538	121,377	37,477	30.9
Portsmouth, OH	Fuel fabrication	977	239,221	40,636	17.0
RFETS	Hanford	1,848	141,585	23,178	16.4
RFETS	INEEL	1,170	104,960	17,791	17.0
RFETS	Pantex	1,252	252,177	81,450	32.3
RFETS	SRS	2,954	540,944	123,248	22.8
SRS	Hanford	4,377	615,204	126,016	20.5
SRS	ORR	568	109,074	15,614	14.3

Key: ANL-W, Argonne National Laboratory-West; LANL, Los Alamos National Laboratory; LLNL, Lawrence Livermore National Laboratory; ORR, Oak Ridge Reservation; RFETS, Rocky Flats Environmental Technology Site; WIPP, Waste Isolation Pilot Plant.

Table M-6. Low-Income Populations Residing Along Transportation Routes for Surplus Plutonium

Origin	Destination	Distance (km)	Total Population Along Route	Low-Income Population Along Route	Percentage Low-Income Population Along Route
ANL-W	Hanford	1,035	82,418	10,016	12.2
ANL-W	Pantex	2,395	281,386	44,102	15.7
ANL-W	SRS	3,756	580,985	60,473	10.4
Fuel fabrication	Hanford	4,760	601,233	61,518	10.2
Fuel fabrication	INEEL	4,092	556,388	55,229	9.9
Fuel fabrication	LANL	3,201	506,962	73,801	14.6
Fuel fabrication	Pantex	2,563	430,359	64,909	15.1
Fuel fabrication	SRS	578	75,050	10,673	14.2
Hanford	Geological repository	1,888	248,006	28,699	11.6
Hanford	INEEL	949	74,624	9,468	12.7
Hanford	LANL	2,515	276,768	42,384	15.3
Hanford	ORR	3,993	434,235	42,696	9.8
Hanford	Pantex	3,040	342,903	53,293	15.5
INEEL	ORR	3,316	389,496	39,171	10.1
INEEL	SRS	3,702	574,433	61,713	10.7
LANL	ANL-W	1,868	230,510	35,476	15.4
LANL	INEEL	1,840	227,759	35,984	15.8
LANL	LLNL	1,218	454,603	59,814	13.2
LANL	Pantex	647	85,252	12,635	14.8
LANL	SRS	2,779	521,907	80,398	15.4
LLNL	Fuel fabrication	4,838	771,701	103,519	13.4
LLNL	Geological repository	1,140	414,732	48,663	11.7
LLNL	Hanford	1,428	380,755	38,761	10.2
LLNL	INEEL	1,559	373,040	34,078	9.1
LLNL	Pantex	2,302	476,701	62,602	13.1
LLNL	SRS	4,395	856,464	136,322	15.9
Pantex	Geological repository	1,986	186,981	30,207	16.2
Pantex	INEEL	2,365	293,805	46,898	16.0
Pantex	ORR	1,753	245,038	44,137	18.0
Pantex	SRS	2,165	441,441	68,339	15.5
Pantex	WIPP	538	121,377	26,269	21.6
Portsmouth, OH	Fuel fabrication	977	239,221	33,268	13.9
RFETS	Hanford	1,848	141,585	15,985	11.3
RFETS	INEEL	1,170	104,960	10,424	9.9
RFETS	Pantex	1,252	252,177	41,478	16.4
RFETS	SRS	2,954	540,944	58,752	10.9
SRS	Hanford	4,377	615,204	65,311	10.6
SRS	ORR	568	109,074	13,061	12.0

Key: ANL-W, Argonne National Laboratory-West; LANL, Los Alamos National Laboratory; LLNL, Lawrence Livermore National Laboratory; ORR, Oak Ridge Reservation; RFETS, Rocky Flats Environmental Technology Site; WIPP, Waste Isolation Pilot Plant.

M.7 RESULTS FOR THE REACTOR SITES

M.7.1 Minority and Low-Income Population Estimates

Table M-7 shows total populations, minority populations, and percentage minority populations that resided within 80 km (50 mi) of the various sites at the time of the 1990 census. The 80-km (50-mi) distance defines the radius of potential radiological effects for calculations of radiation dose to the general population. Table M-8 shows similar data for projected populations in 2015. As discussed in Appendix M.4, minority populations residing in potentially affected areas in 1990 were adopted as a baseline. Populations in 2015 were then projected from the baseline data under the assumption that percentage changes in the majority and minority populations residing in the affected areas will be identical to those projected for State populations. The Census Bureau estimates that the national minority percentage will increase from approximately 24 percent in 1990 to nearly 34 percent by 2015 (Census 1996). [Text deleted.] In Tables M-7 and M-8, the sum of percentages of the different populations may total slightly more or less than 100 percent due to roundoff.

Table M-9 illustrates the uncertainties in the population estimates for the year 2015 due to the partial inclusion of block groups within the boundaries of potentially affected areas. Column 2 of the table lists the number of block groups that are partly within the circle of 80-km (50-mi) radius centered at the various facilities. Column 3 shows the number of block groups that lie completely within the circle. Potentially affected areas surrounding all three of the proposed reactor sites include two States. Columns 2 and 3 show the number of partial or total inclusions for the affected States. Column 4 of the table, denoted as "T/P," shows the number of totally included block groups divided by the number of partially included block groups. In order to minimize the uncertainties in the population estimate, it is desirable that this ratio be as large as possible. Column 5 shows upper bounds for the estimates of the total population listed in column 6. As discussed above, upper bounds were obtained by including the total population of all block groups that lie at least partially within the affected area. Lower bounds for the estimate of total population shown in column 7 were obtained by including only the populations of totally included block groups. Analogous statements apply to columns 8 through 10.

As would be expected from the value of T/P shown in column 4, uncertainties in the total population estimate for McGuire were the smallest among the three proposed reactor sites (+3.7 percent and -2.4 percent), as were the uncertainties in the estimate of the minority population at risk near Catawba (+5.7 percent and -3.3 percent). Uncertainties in the population estimates for North Anna were the largest among the three sites (+6.5 percent and -4.5 percent for total population; +5.9 percent and -4.2 percent for minority population). None of the uncertainties shown in Table M-9 are large enough to noticeably affect the conclusions regarding radiological health effects or environmental justice.

An estimate of the percentage of low-income persons living within 80 km (50 mi) of the proposed reactor sites in 2015 was obtained using a linear projection of low-income data from the 1980 census and the 1990 census. In 1990, the percentage of low-income persons (i.e., those with reported incomes below the poverty threshold) residing in the contiguous United States was 13.1 percent. The percentage of low-income persons living within 80 km (50 mi) of the proposed reactor sites was lower than the national average in every case. Around Catawba, the percentage of low-income persons living within 80 km (50 mi), in 1990, was 10.5 percent. At McGuire, the percentage was 9.8 percent, and around North Anna, the percentage was 6.9 percent.

The estimated number of low-income persons living within 80 km (50 mi) of Catawba in 2015 is 157,477 or 7.0 percent of the projected population. The estimated number of low-income persons living within 80 km (50 mi) of McGuire in 2015 is 171,182 or 6.6 percent of the projected population. The estimated number of

Table M-7. Racial and Ethnic Composition of Minority Populations Residing Within 80 km of Proposed Reactor Sites in 1990

Reactor Site	Total Pop.	Minority Pop.	Percent Minority Pop.	Asian or Pacific Islander Pop.	Percent Asian or Pacific Islander Pop.	Black Pop.	Percent Black Pop	Hispanic Pop.	Percent Hispanic Pop.	Native American Pop.	Percent Native American Pop.	Other Race	Percent Other Race Pop.	White Pop.	Percent White Pop.
Catawba	1,519,392	315,089	20.7	10,942	0.7	288,382	19.0	10,666	0.7	5,098	0.3	442	0.0	1,203,861	79.2
McGuire	1,738,966	305,717	17.6	12,007	0.7	275,789	15.9	12,094	0.7	5,828	0.3	479	0.0	1,432,770	82.4
North Anna	1,286,156	281,652	21.9	18,783	1.5	241,619	18.8	17,550	1.4	3,686	0.3	947	0.1	1,003,557	78.0

Table M-8. Projected Racial and Ethnic Composition of Minority Populations Residing Within 80 km of Proposed Reactor Sites in 2015

Reactor Site	Total Pop.	Minority Pop.	Percent Minority Pop.	Asian or Pacific Islander Pop.	Percent Asian or Pacific Islander Pop.	Black Pop.	Percent Black Pop	Hispanic Pop.	Percent Hispanic Pop.	Native American Pop.	Percent Native American Pop.	Other Race	Percent Other Race Pop.	White Pop.	Percent White Pop.
Catawba	2,265,495	597,376	26.4	37,756	1.7	507,810	22.4	40,504	1.8	10,700	0.5	606	0.0	1,668,119	73.6
McGuire	2,575,369	620,701	24.1	43,333	1.7	517,577	20.1	46,486	1.8	12,635	0.5	670	0.0	1,954,668	75.9
North Anna	2,042,200	731,773	35.8	106,086	5.2	508,719	24.9	111,992	5.5	4,976	0.2	1,165	0.1	1,309,262	64.1

Table M-9. Uncertainties in Estimates of Total and Minority Populations for the Year 2015

Reactor Site	No. of Partially Included Block Groups	No. of Fully Included Block Groups	T/P	Upper Bound for Total Population	Estimate of Total Population	Lower Bound for Total Population	Upper Bound for Minority Population	Estimate of Minority Population	Lower Bound for Minority Population
Catawba	54 (NC) 52 (SC)	851 (NC) 314 (SC)	11.0	2,395,224	2,265,495	2,191,319	627,435	597,376	579,620
McGuire	64 (NC) 24 (SC)	1,190 (NC) 129 (SC)	15.0	2,672,795	2,575,369	2,513,292	636,842	620,701	611,521
North Anna	84 (VA) 10 (MD)	710 (VA) 5 (MD)	7.6	2,175,504	2,042,200	1,949,928	775,277	731,773	700,983

low-income persons living within 80 km (50 mi) of North Anna in 2015 is 110,531 or 5.4 percent of the projected population. [Text deleted.] Figures M-10 through M-15 show geographical distributions of minority and low-income populations residing within 80 km (50 mi) of the proposed reactor sites.

M.7.2 Environmental Effects on Minority and Low-Income Populations Residing Near Proposed Reactor Sites

The analysis of environmental effects on populations residing within 80 km (50 mi) of the proposed reactor sites is presented in Chapter 4 of the SPD EIS. This analysis shows that no radiological fatalities are likely to result from implementation of the proposed action or alternatives. Radiological risks to the public are small regardless of the racial and ethnic composition of the population, and regardless of the economic status of individuals comprising the population. Nonradiological risks to the general population are also small regardless of the racial and ethnic composition or economic status of the population. Thus, disproportionately high and adverse impacts on minority and low-income populations residing near the various facilities are not likely to result from implementation of the proposed action or alternatives.

M.8 REFERENCES

Campbell, P., 1996, *Population Projections: 1995–2025*, U.S. Department of Commerce, Bureau of the Census, Washington, DC, October.

CEQ (Council on Environmental Quality), 1997, *Environmental Justice, Guidance Under the National Environmental Policy Act*, Executive Office of the President, Washington, DC, December 10.

DOC (U.S. Department of Commerce), 1992, *Census of Population and Housing, 1990: Summary Tape File 3 on CD-ROM*, Bureau of the Census, Washington, DC, May.

DOC (U.S. Department of Commerce), 1996, *Resident Population of the United States: Middle Series Projections, 2015–2030, by Sex, Race, and Hispanic Origin, with Median Age*, Bureau of the Census, Washington, DC, March.

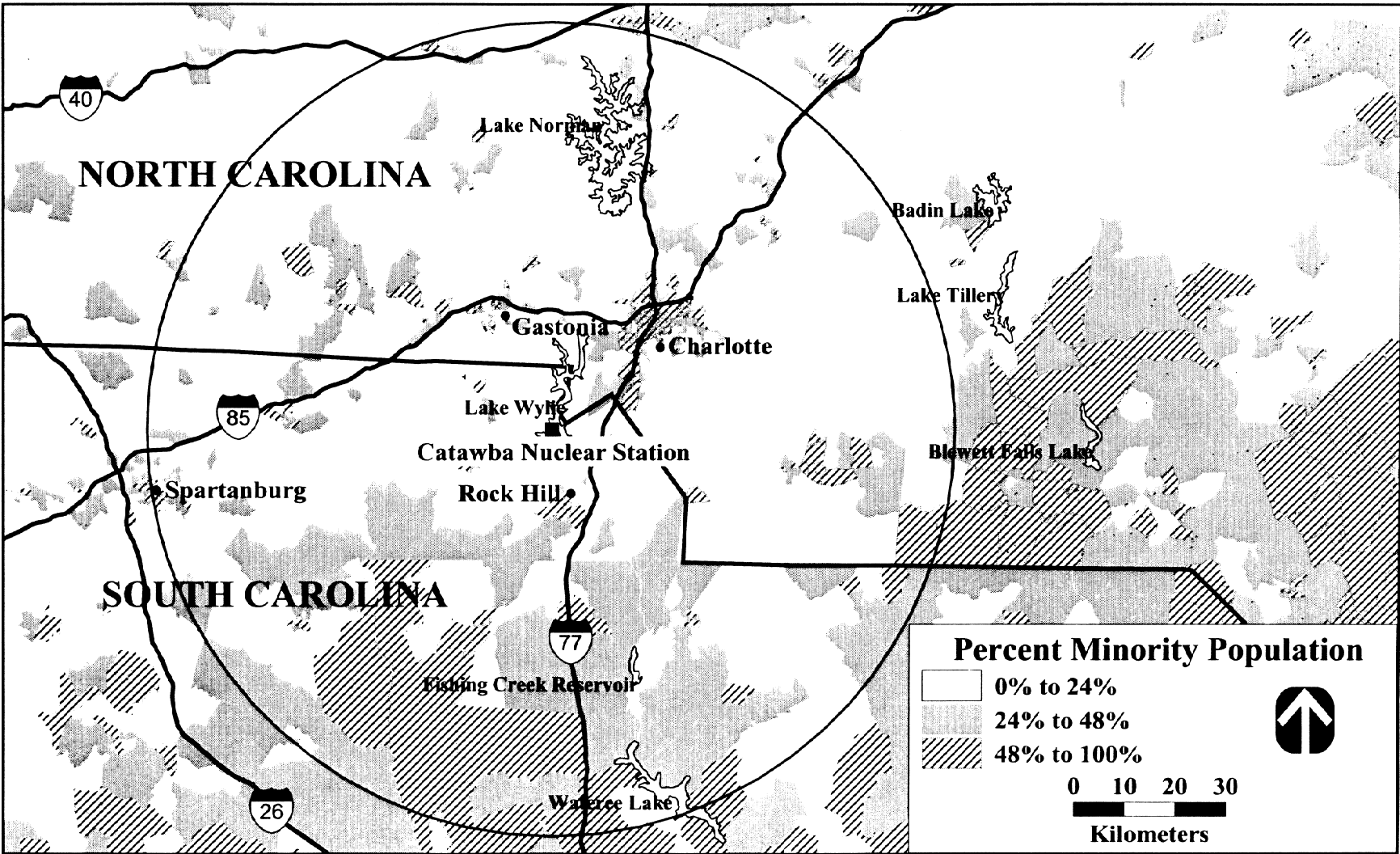

Figure M-10. Geographical Distribution of the Minority Population Residing Within 80 km (50 mi) of Catawba Nuclear Station

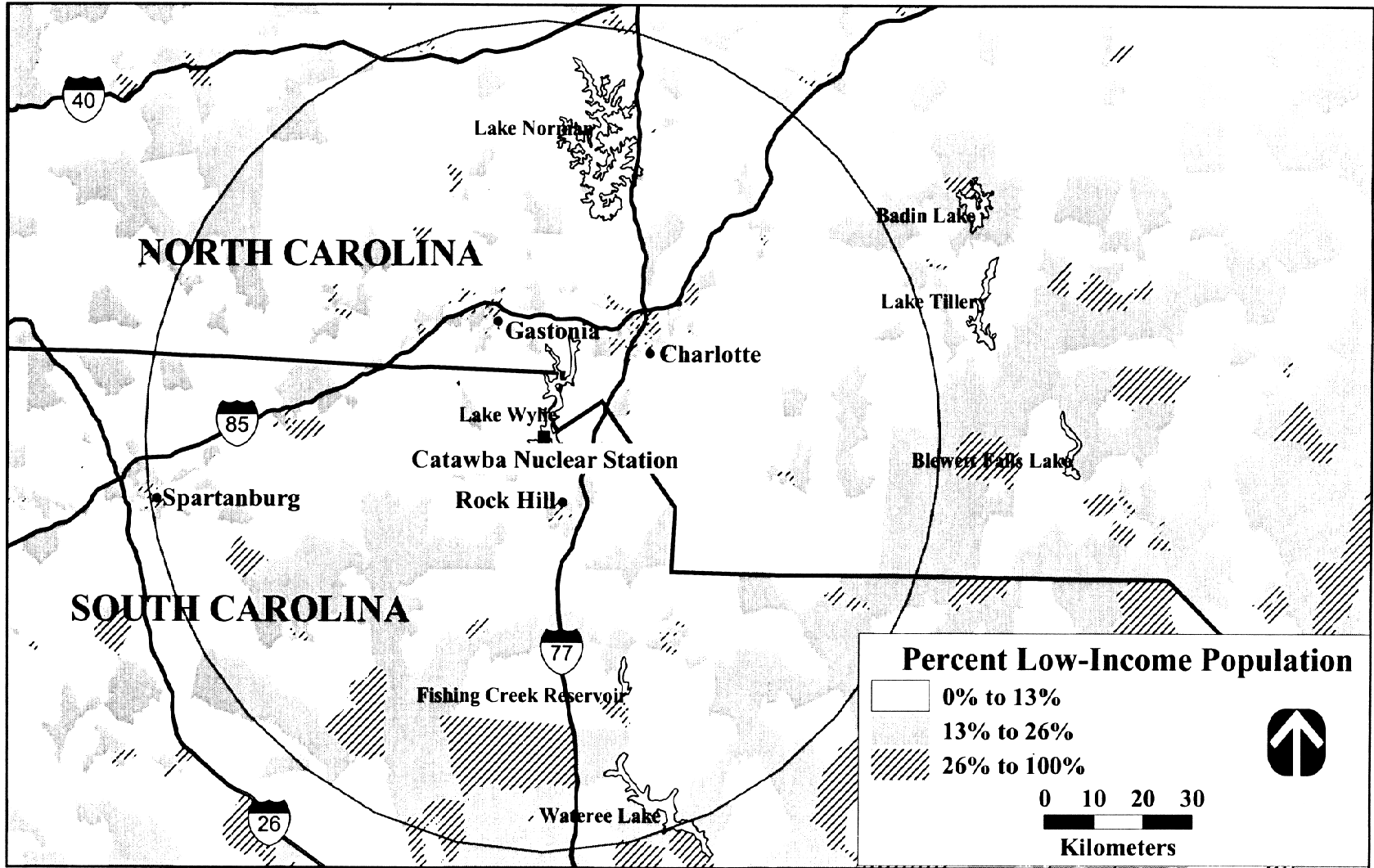

Figure M-11. Geographical Distribution of the Low-Income Population Residing Within 80 km (50 mi) of Catawba Nuclear Station

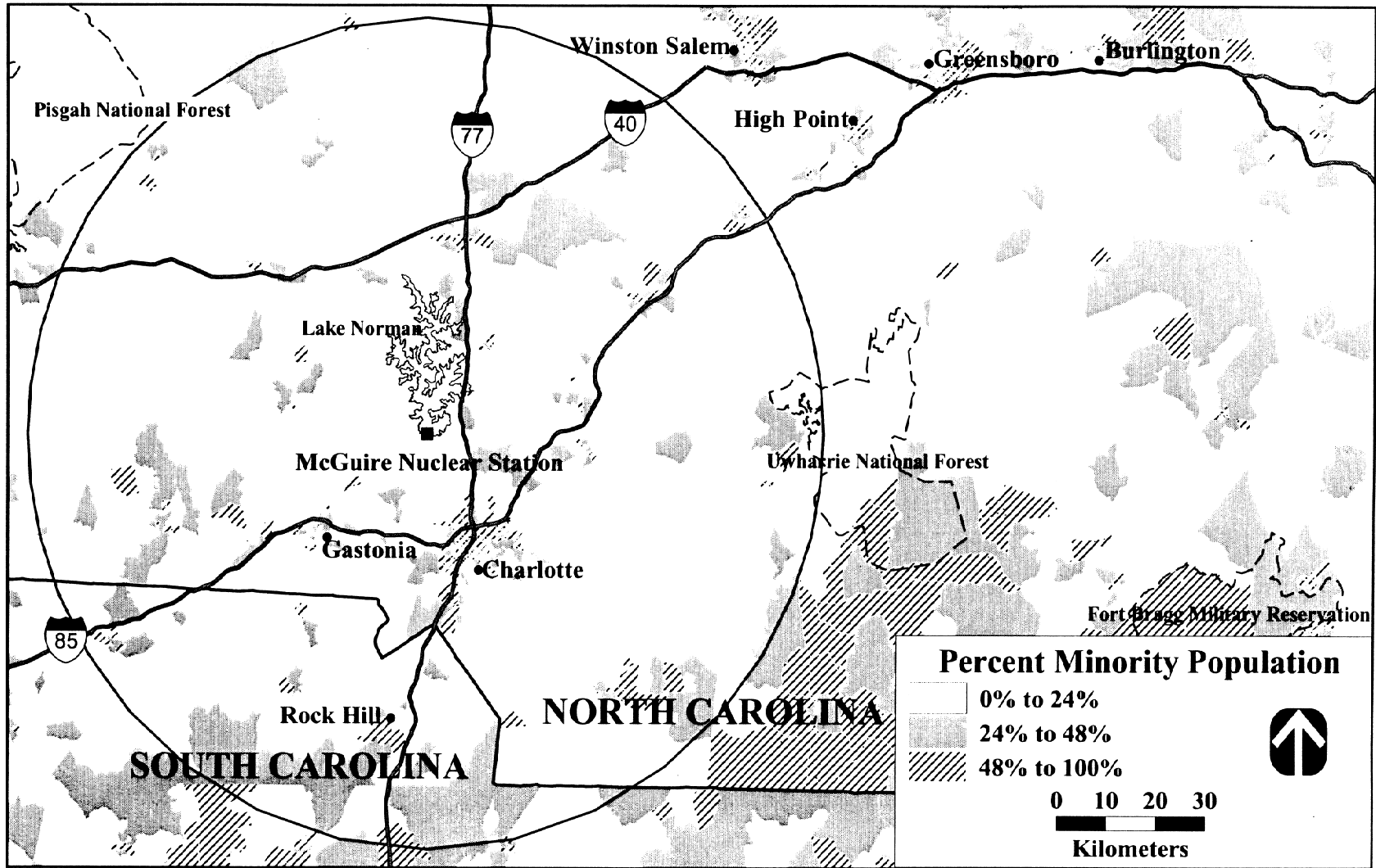

Figure M-12. Geographical Distribution of the Minority Population Residing Within 80 km (50 mi) of McGuire Nuclear Station

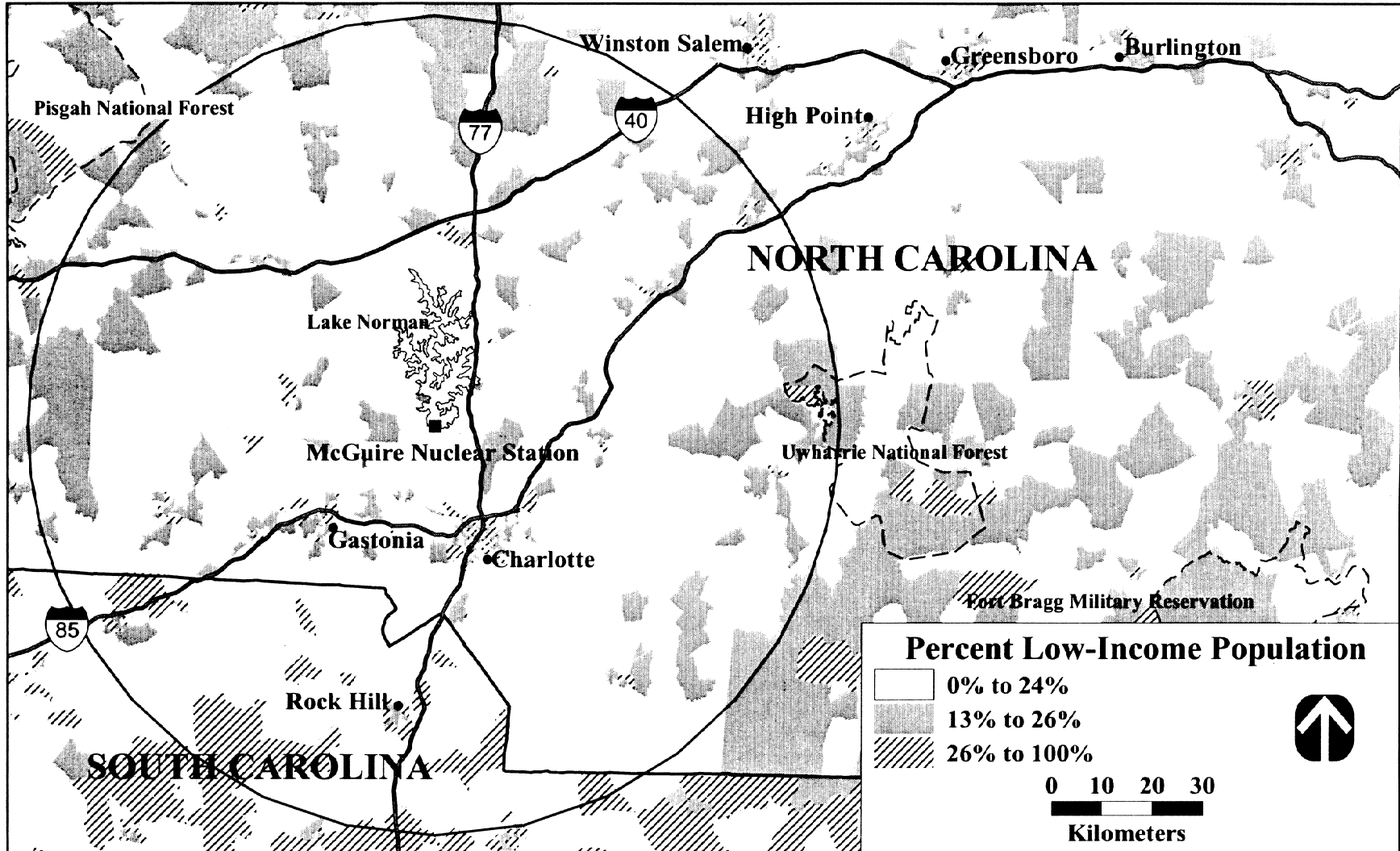

Figure M-13. Geographical Distribution of the Low-Income Population Residing Within 80 km (50 mi) of McGuire Nuclear Station

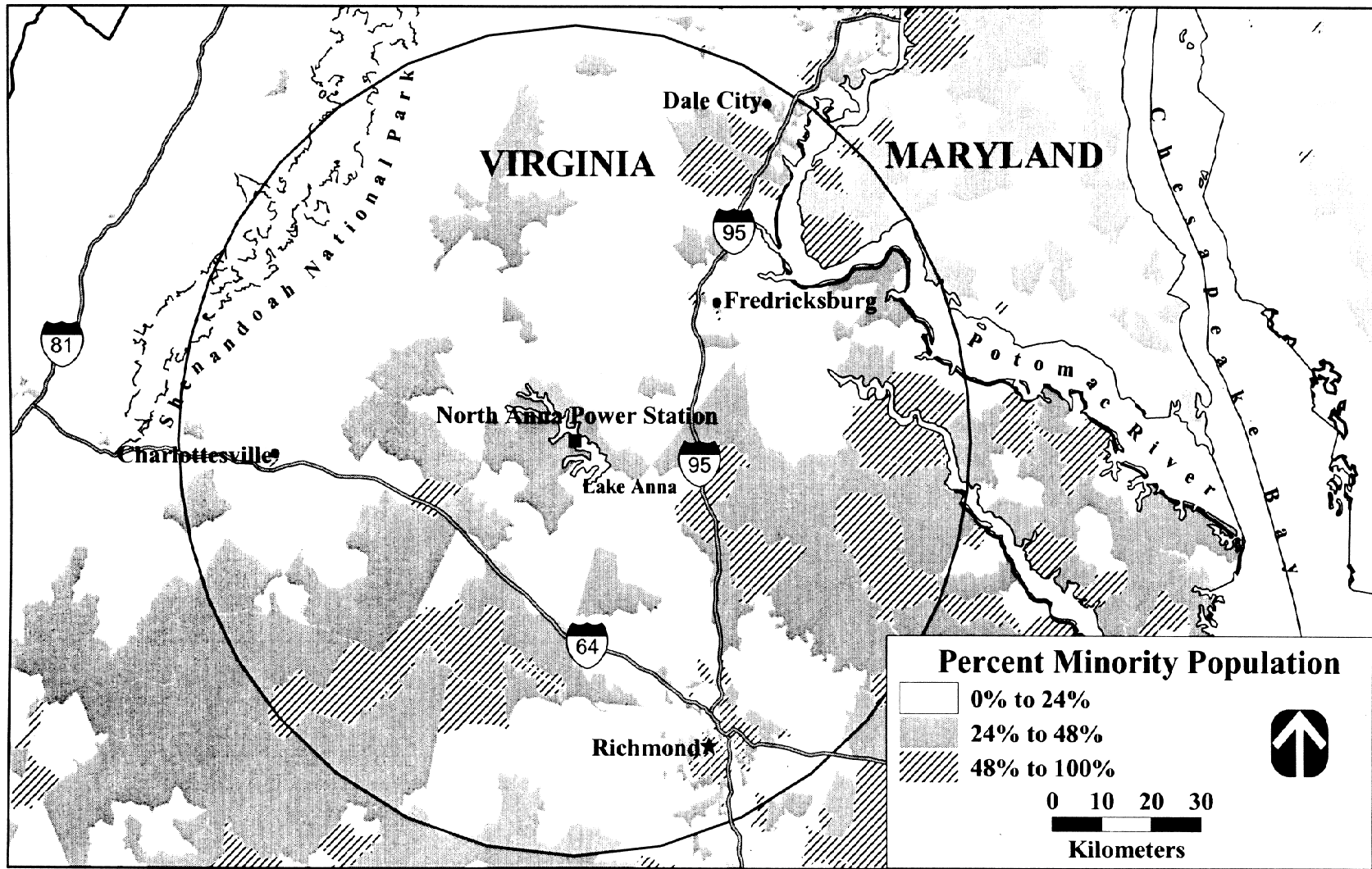

Figure M-14. Geographical Distribution of the Minority Population Residing Within 80 km (50 mi) of North Anna Power Station

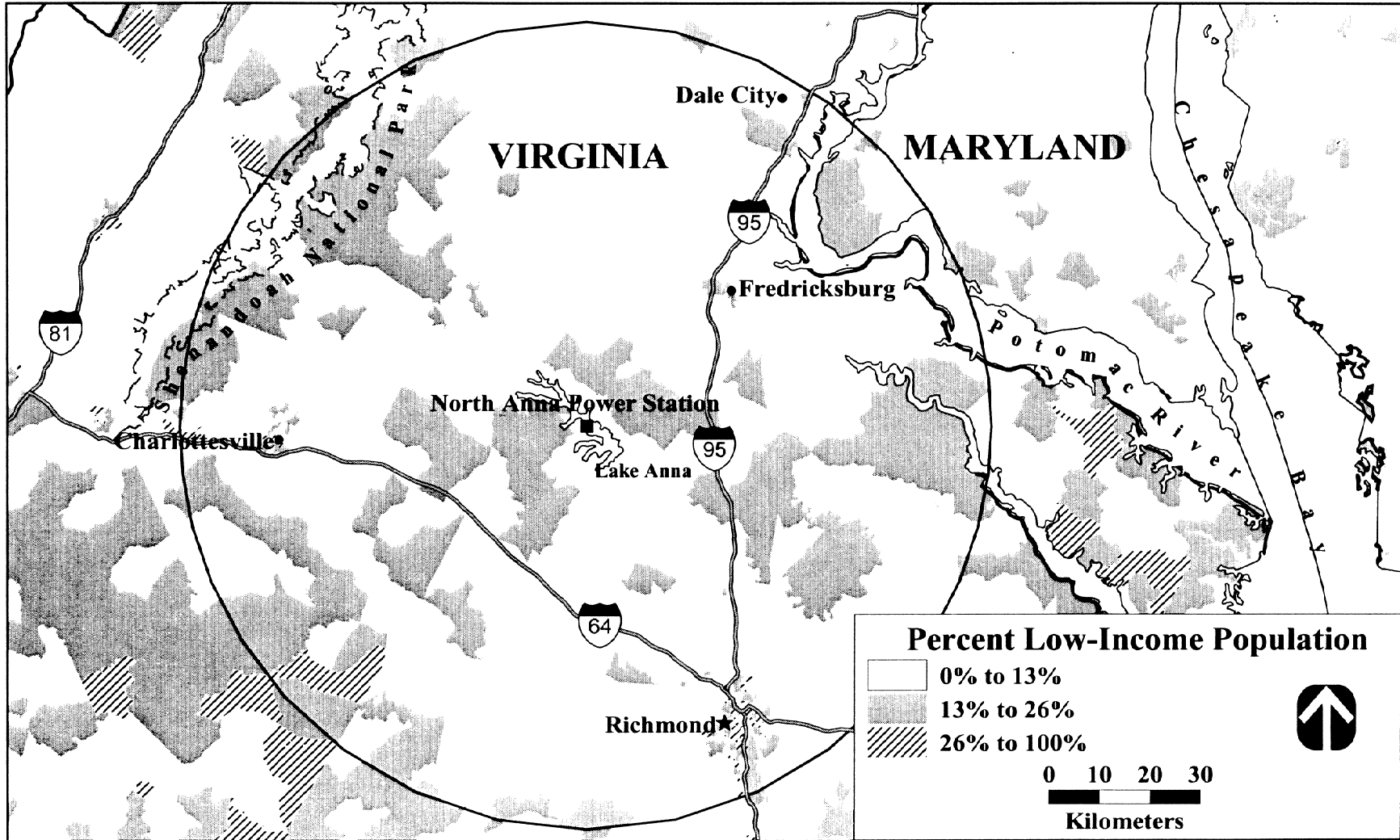

Figure M-15. Geographical Distribution of the Low-Income Population Residing Within 80 km (50 mi) of North Anna Power Station

Appendix O Consultations

Certain statutes and regulations require the U.S. Department of Energy (DOE) to consider consultations with Federal, State, and local agencies and federally recognized Native American groups regarding the potential for alternatives for surplus plutonium disposition to disturb sensitive resources. These consultations are related to biotic, cultural, and Native American resources. DOE has initiated applicable consultations with Federal and State agencies and federally recognized Native American groups. Appendix O contains copies of the consultation letters sent by DOE to agencies and Native American groups, and any written responses provided by those agencies or groups. Attachments to responses are not included in Appendix O but are, nevertheless, part of the public record.



Department of Energy
Washington, DC 20585

October 30, 1998

David Hansen
State Historic Preservation Officer
Office of Archaeology & Historical Preservation
420 Golf Club Road SE, Suite 201
Lacey, Washington 98503

Subject: Consultation for Surplus Plutonium Disposition Environmental Impact Analysis Process, Under Executive Memorandum Concerning Government-to-Government Relations

Dear Mr. Hansen:

The purpose of this letter is to notify you that the United States Department of Energy (DOE) is in the process of conducting an Environmental Impact Analysis concerning the disposition of surplus plutonium.

With this letter we are soliciting specific concerns the Office of Archaeology and Historical Preservation may have about the proposal. This consultation is in accordance with the National Environmental Policy Act and Section 106 of the National Historic Preservation Act.

The *Surplus Plutonium Disposition Environmental Impact Statement* (SPD EIS) is tiered from the *Storage and Disposition of Weapons-Usable Fissile Materials Final Programmatic EIS* (DOE/EIS-0229), issued in December 1996, and the associated Record of Decision (62 FR 3014), issued on January 14, 1997. DOE is producing the SPD EIS in compliance with the National Environmental Policy Act (NEPA) and Council on Environmental Quality regulations implementing NEPA, DOE's NEPA Implementing Regulations (10 CFR 1021), and other applicable federal and state environmental legislation.

The purpose and need for the proposed action is to reduce the threat of nuclear weapons proliferation worldwide by disposing of surplus plutonium in the United States in an environmentally safe and timely manner. The SPD Draft EIS, a copy of which is attached for your review, examines the potential environmental impacts for 24 alternatives for the proposed siting, construction, and operation of three types of facilities: pit disassembly and conversion; mixed oxide (MOX) fuel fabrication; and plutonium conversion and immobilization.

If an alternative is selected that includes siting of surplus plutonium disposition facilities at the Hanford site (e.g., Alternative 2), a maximum of about 15 hectares

David Hansen, Washington SHPO
10/30/98
Page 2

(37 acres) of land in the 400 Area would be impacted. No prehistoric or historic archaeological resources have been identified within the proposed construction areas, and no architectural resources in the 200 East of 400 Area. Preconstruction surveys (as required) and construction monitoring for previously unknown resources would be conducted within the framework of the *Hanford Cultural Resources Management Plan* (Battelle 1989; revised draft edition 1998).

If you have any specific concerns about the SPD EIS proposal, we would like to hear from you. Please contact me with your concerns or questions at:

Marcus Jones
SPD EIS Document Manager
U.S. Department of Energy
Office of Fissile Materials Disposition
P.O. Box 23786
Washington, DC 20026-3786
(202) 586-0149.

You may also contact Dee Lloyd, Hanford Cultural Resources Program Manager, at (509) 372-2299.

Sincerely,

Marcus Jones
SPD EIS Document Manager

cc: Dee Lloyd, Cultural Resource Manager, Hanford
Lois Thompson, Federal Preservation Officer, DOE HQ

SPD EIS enclosure

**Department of Energy**

Washington, DC 20585

October 30, 1998

Mr. Russell Jim, Manager
Environmental Restoration/Waste Management Program
Confederated Tribes and Bands of the Yakama Indian Nation
2808 Main Street
Union Gap, Washington 98903

*Subject: Consultation for Surplus Plutonium Disposition Environmental Impact
Analysis Process, Under Executive Memorandum Concerning Government-
to-Government Relations*

Dear Mr. Jim:

The purpose of this letter is to notify you that the United States Department of Energy (DOE) is in the process of conducting an Environmental Impact Analysis concerning the disposition of surplus plutonium.

With this letter we are soliciting specific concerns the Confederated Tribes and Bands of the Yakama Indian Nation may have about the proposal. This consultation is in accordance with the Executive Memorandum (29 April 1994) entitled, "Government-to-Government Relations with Native American Tribal Governments", and DOE Order 1230.2. It also follows prior consultation initiated for compliance with the American Indian Religious Freedom Act (AIRFA) (PL 95-341) and the Native American Graves Protection and Repatriation Act (NAGPRA) (PL 101-601).

The *Surplus Plutonium Disposition Environmental Impact Statement* (SPD EIS) is tiered from the *Storage and Disposition of Weapons-Usable Fissile Materials Final Programmatic EIS* (DOE/EIS-0229), issued in December 1996, and the associated Record of Decision (62 FR 3014), issued on January 14, 1997. DOE is producing the SPD EIS in compliance with the National Environmental Policy Act (NEPA) and Council on Environmental Quality regulations implementing NEPA, DOE's NEPA Implementing Regulations (10 CFR 1021), and other applicable federal and state environmental legislation.

The purpose and need for the proposed action is to reduce the threat of nuclear weapons proliferation worldwide by disposing of surplus plutonium in the United States in an environmentally safe and timely manner. The SPD Draft EIS, a copy of which is attached for your review, examines the potential environmental impacts for 24 alternatives for the proposed siting, construction, and operation of three types of facilities: pit disassembly and conversion; mixed oxide (MOX) fuel fabrication; and plutonium conversion and immobilization.

Mr. Russell Jim, Manager, Confederated Tribes and Bands of the Yakama Indian Nation
10/30/98
Page 2

If an alternative is selected that includes siting of surplus plutonium disposition facilities at the Hanford site (e.g., Alternative 2), a maximum of 15 hectares (37 acres) of land in previously disturbed portions of the 400 Area would be impacted. Based on previous investigations, no traditional cultural properties have been identified in the 400 Area or immediately adjacent areas.

If you have any specific concerns about the SPD EIS proposal, we would like to hear from you. Please contact me with your concerns or questions at:

Marcus Jones
SPD EIS Document Manager
U.S. Department of Energy
Office of Fissile Materials Disposition
P.O. Box 23786
Washington, DC 20026-3786
(202) 586-0149.

You may also contact Kevin Clark, Hanford Indian Nation Program Manager, at (509) 376-6332.

Sincerely,

Marcus Jones
SPD EIS Document Manager

cc: Tom Woods, YIN
Nanci Peters, YIN
Kevin V. Clark, Indian Nation Program Manager, Hanford
Brandt Petrasek, EM-20, DOE HQ

SPD EIS enclosure

**Department of Energy**

Washington, DC 20585

October 30, 1998

Ms. Donna L. Powaukee, Director
Environmental Restoration/Waste Management Program
Nez Perce Tribe
P.O. Box 365
Lapwai, Idaho 83540

Subject: Consultation for Surplus Plutonium Disposition Environmental Impact Analysis Process, Under Executive Memorandum Concerning Government-to-Government Relations

Dear Ms. Powaukee:

The purpose of this letter is to notify you that the United States Department of Energy (DOE) is in the process of conducting an Environmental Impact Analysis concerning the disposition of surplus plutonium.

With this letter we are soliciting specific concerns the Nez Perce Tribe may have about the proposal. This consultation is in accordance with the Executive Memorandum (29 April 1994) entitled, "Government-to-Government Relations with Native American Tribal Governments", and DOE Order 1230.2. It also follows prior consultation initiated for compliance with the American Indian Religious Freedom Act (AIRFA) (PL 95-341) and the Native American Graves Protection and Repatriation Act (NAGPRA) (PL 101-601).

The *Surplus Plutonium Disposition Environmental Impact Statement* (SPD EIS) is tiered from the *Storage and Disposition of Weapons-Usable Fissile Materials Final Programmatic EIS* (DOE/EIS-0229), issued in December 1996, and the associated Record of Decision (62 FR 3014), issued on January 14, 1997. DOE is producing the SPD EIS in compliance with the National Environmental Policy Act (NEPA) and Council on Environmental Quality regulations implementing NEPA, DOE's NEPA Implementing Regulations (10 CFR 1021), and other applicable federal and state environmental legislation.

The purpose and need for the proposed action is to reduce the threat of nuclear weapons proliferation worldwide by disposing of surplus plutonium in the United States in an environmentally safe and timely manner. The SPD Draft EIS, a copy of which is attached for your review, examines the potential environmental impacts for 24 alternatives for the proposed siting, construction, and operation of three types of facilities: pit disassembly and conversion; mixed oxide (MOX) fuel fabrication; and plutonium conversion and immobilization.

Ms. Donna L. Powaukee, Nez Perce Tribe
10/30/98
Page 2

If an alternative is selected that includes siting of surplus plutonium disposition facilities at the Hanford site (e.g., Alternative 2), a maximum of 15 hectares (37 acres) of land in previously disturbed portions of the 400 Area would be impacted. Based on previous investigations, no traditional cultural properties have been identified in the 400 Area or immediately adjacent areas.

If you have any specific concerns about the SPD EIS proposal, we would like to hear from you. Please contact me with your concerns or questions at:

Marcus Jones
SPD EIS Document Manager
U.S. Department of Energy
Office of Fissile Materials Disposition
P.O. Box 23786
Washington, DC 20026-3786
(202) 586-0149.

You may also contact Kevin Clark, Hanford Indian Nation Program Manager, at (509) 376-6332.

Sincerely,

Marcus Jones
SPD EIS Document Manager

cc: Stan Sobczyk, NPT
Pat Sobotta, NPT
Kevin Clark, Indian Nations Program Manager, Hanford
Brandt Petrasek, EM-20, DOE HQ

SPD EIS enclosure



Department of Energy
Washington, DC 20585

October 30, 1998

Ms. Lenora Seelatsee
Wanapum Band
Grant County P.U.D
30 "C" Street, S.W.
P.O. Box 878
Ephrata, Washington 98823

Subject: Consultation for Surplus Plutonium Disposition Environmental Impact Analysis Process, Under Executive Memorandum Concerning Government-to-Government Relations

Dear Ms. Seelatsee:

The purpose of this letter is to notify you that the United States Department of Energy (DOE) is in the process of conducting an Environmental Impact Analysis concerning the disposition of surplus plutonium.

With this letter we are soliciting specific concerns the Wanapum Band may have about the proposal. This consultation is in accordance with the Executive Memorandum (29 April 1994) entitled, "Government-to-Government Relations with Native American Tribal Governments", and DOE Order 1230.2. It also follows prior consultation initiated for compliance with the American Indian Religious Freedom Act (AIRFA) (PL 95-341) and the Native American Graves Protection and Repatriation Act (NAGPRA) (PL 101-601).

The *Surplus Plutonium Disposition Environmental Impact Statement* (SPD EIS) is tiered from the *Storage and Disposition of Weapons-Usable Fissile Materials Final Programmatic EIS* (DOE/EIS-0229), issued in December 1996, and the associated Record of Decision (62 FR 3014), issued on January 14, 1997. DOE is producing the SPD EIS in compliance with the National Environmental Policy Act (NEPA) and Council on Environmental Quality regulations implementing NEPA, DOE's NEPA Implementing Regulations (10 CFR 1021), and other applicable federal and state environmental legislation.

The purpose and need for the proposed action is to reduce the threat of nuclear weapons proliferation worldwide by disposing of surplus plutonium in the United States in an environmentally safe and timely manner. The SPD Draft EIS, a copy of which is attached for your review, examines the potential environmental impacts for 24 alternatives for the proposed siting, construction, and operation of three types of

Ms. Lenora Seelatsee, Wanapum Band
10/30/98
Page 2

facilities: pit disassembly and conversion; mixed oxide (MOX) fuel fabrication; and plutonium conversion and immobilization.

If an alternative is selected that includes siting of surplus plutonium disposition facilities at the Hanford site (e.g., Alternative 2), a maximum of 15 hectares (37 acres) of land in previously disturbed portions of the 400 Area would be impacted. Based on previous investigations, no traditional cultural properties have been identified in the 400 Area or immediately adjacent areas.

If you have any specific concerns about the SPD EIS proposal, we would like to hear from you. Please contact me with your concerns or questions at:

Marcus Jones
SPD EIS Document Manager
U.S. Department of Energy
Office of Fissile Materials Disposition
P.O. Box 23786
Washington, DC 20026-3786
(202) 586-0149.

You may also contact Kevin Clark, Hanford Indian Nation Program Manager, at (509) 376-6332.

Sincerely,

Marcus Jones
SPD EIS Document Manager

cc: Rex Buck, Jr., Wanapum
Robert Tomanawash, Wanapum
Kevin V. Clark, Indian Nation Program Manager, Hanford
Brandt Petrasek, EM-20, DOE HQ

SPD EIS enclosure

**Department of Energy**

Washington, DC 20585

October 30, 1998

Mr. J. R. Wilkinson, Manager
Special Sciences and Resources Program
Confederated Tribes of the Umatilla Indian Reservation
P.O. Box 638
Pendleton, Oregon 97801

Subject: Consultation for Surplus Plutonium Disposition Environmental Impact Analysis Process, Under Executive Memorandum Concerning Government-to-Government Relations

Dear Mr. Wilkinson:

The purpose of this letter is to notify you that the United States Department of Energy (DOE) is in the process of conducting an Environmental Impact Analysis concerning the disposition of surplus plutonium.

With this letter we are soliciting specific concerns the Confederated Tribes of the Umatilla Indian Reservation may have about the proposal. This consultation is in accordance with the Executive Memorandum (29 April 1994) entitled, "Government-to-Government Relations with Native American Tribal Governments", and DOE Order 1230.2. It also follows prior consultation initiated for compliance with the American Indian Religious Freedom Act (AIRFA) (PL 95-341) and the Native American Graves Protection and Repatriation Act (NAGPRA) (PL 101-601).

The *Surplus Plutonium Disposition Environmental Impact Statement* (SPD EIS) is tiered from the *Storage and Disposition of Weapons-Usable Fissile Materials Final Programmatic EIS* (DOE/EIS-0229), issued in December 1996, and the associated Record of Decision (62 FR 3014), issued on January 14, 1997. DOE is producing the SPD EIS in compliance with the National Environmental Policy Act (NEPA) and Council on Environmental Quality regulations implementing NEPA, DOE's NEPA Implementing Regulations (10 CFR 1021), and other applicable federal and state environmental legislation.

The purpose and need for the proposed action is to reduce the threat of nuclear weapons proliferation worldwide by disposing of surplus plutonium in the United States in an environmentally safe and timely manner. The SPD Draft EIS, a copy of which is attached for your review, examines the potential environmental impacts for 24 alternatives for the proposed siting, construction, and operation of three types of facilities: pit disassembly and conversion; mixed oxide (MOX) fuel fabrication; and plutonium conversion and immobilization.

Mr. J. R. Wilkinson, Manager, Confederated Tribes of the Umatilla Reservation
10/30/98
Page 2

If an alternative is selected that includes siting of surplus plutonium disposition facilities at the Hanford site (e.g., Alternative 2), a maximum of 15 hectares (37 acres) of land in previously disturbed portions of the 400 Area would be impacted. Based on previous investigations, no traditional cultural properties have been identified in the 400 Area or immediately adjacent areas.

If you have any specific concerns about the SPD EIS proposal, we would like to hear from you. Please contact me with your concerns or questions at:

Marcus Jones
SPD EIS Document Manager
U. S. Department of Energy
Office of Fissile Materials Disposition
P.O. Box 23786
Washington, DC 20026-3786
(202) 586-0149.

You may also contact Kevin Clark, Hanford Indian Nation Program Manager, at (509) 376-6332.

Sincerely,

Marcus Jones
SPD EIS Document Manager

cc: Jo Marie Tessman, CTUIR
Kevin V. Clark, Indian Nation Program Manager, Hanford
Brandt Petrasek, EM-20, DOE HQ

SPD EIS enclosure



Department of Energy

Washington, DC 20585
July 28, 1998

Mr. Richard Roy
U.S. Department of Interior
Fish and Wildlife Service
Post Office Box 1157
Moses Lake, WA 98837

Dear Mr. Roy:

INFORMAL CONSULTATION UNDER SECTION 7 OF THE ENDANGERED SPECIES ACT FOR SURPLUS PLUTONIUM DISPOSITION

The Department of Energy (DOE) published its Notice of Intent to prepare the *Surplus Plutonium Disposition Environmental Impact Statement* (SPD EIS) in the Federal Register (Vol. 92, No. 99) on May 22, 1997. This SPD EIS is tiered from the *Storage and Disposition of Weapons-Usable Fissile Materials Programmatic EIS* (DOE/EIS-0229), issued in December 1996, and the associated Record of Decision (62 FR 3014), issued on January 14, 1997. To summarize, the purpose of the proposed action is to reduce the threat of nuclear weapons proliferation worldwide in an environmentally safe and timely manner by conducting disposition of surplus plutonium in the United States, thus setting a nonproliferation example for other nations.

The SPD Draft EIS, a copy of which is attached for your review, examines twenty-four alternatives and analyzes the potential environmental impacts for the proposed siting, construction, and operation of three types of facilities: pit disassembly and conversion, mixed oxide (MOX) fuel fabrication, and plutonium conversion and immobilization. The Hanford Site near Richland, Washington is a candidate site for all three facilities. The candidate sites and alternatives are shown in Table 2-1 of the SPD Draft EIS. Please note that where practical, the modification of existing buildings is being considered.

Alternative 2 proposes locating pit disassembly and conversion, and plutonium conversion and immobilization facilities in the Fuels and Materials Examination Facility (FMEF) and the MOX fuel fabrication facility in new construction adjacent to FMEF in the 400 Area. In addition, the planned high-level waste vitrification facility in the 200 East Area would be used to process the canisters from the plutonium conversion and immobilization facility. Although several alternatives include locating facilities at Hanford, Alternative 2 has the greatest potential for impacts on ecological resources.

Preliminary analyses suggest that overall impacts on ecological resources from constructing and operating the proposed surplus plutonium disposition facilities would be limited because the land area required (15 hectares [37 acres]) is relatively small in comparison to regionally available habitat; habitat disturbance would be minimized because construction would take place in previously disturbed or developed areas; and operational impacts would be minimized because



Printed with soy ink on recycled paper

facility releases of airborne and aqueous effluents would be controlled and permitted. Section 4.26.1.3 of the SPD Draft EIS presents the ecological resources analysis for the Hanford Site.

Although sources indicate that no critical habitat for any threatened and endangered species exists near the proposed construction area, there may be Washington State-classified special status species associated with shrub-steppe habitat that could be affected due to land disturbance and noise. Animal species include burrowing owl, ferruginous hawk, golden eagle, long-billed curlew, sage thrasher, Swainson's hawk, pygmy rabbit, desert night snake, and striped whipsnake. It is doubtful the loggerhead shrike and sage sparrow would be affected because a fire in the 400 Area previously destroyed most of their habitat. Plant species include crouching milkvetch, piper's daisy, squill onion, and stalked-pod milkvetch.

Consistent with the Endangered Species Act, DOE requests that the Fish and Wildlife Service provide any additional information on the presence of threatened and endangered animal and plant species, both listed and proposed, in the vicinity of the 200 East and 400 Areas at Hanford. Information on the habitats of these species would also be appreciated. DOE also requests information on any other species of concern that are known to occur or potentially occur in the vicinity of the 200 East and 400 Areas.

As part of DOE's National Environmental Policy Act process, DOE encourages the Fish and Wildlife Service to identify any concerns or issues that it believes should be addressed in the SPD EIS. To facilitate incorporation of your input into the SPD Final EIS, please provide a written response by September 16, 1998.

Please mail your response to:

Marcus Jones
SPD EIS Document Manager
U.S. Department of Energy
Office of Fissile Materials Disposition
1000 Independence Avenue, SW
Washington, DC 20585

If you have any questions, please contact me at (202) 586-0149.

Sincerely,

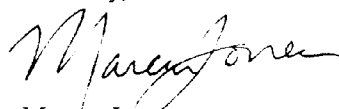

Marcus Jones
SPD EIS Document Manager

cc: Charles A. Brandt, PNNL
Dana Ward, DOE



United States Department of the Interior

FISH AND WILDLIFE SERVICE
517 South Buchanan
Moses Lake, Washington 98837
Phone: 509-765-6125 FAX: 509-765-9043

December 3, 1998

Department of Energy
Office of Fissile Materials Disposition
Attn: Marcus Jones
SPD EIS Document Manager
1000 Independence Avenue, SW
Washington, DC 20585

RE: Surplus Plutonium Disposition Environmental Impact Statement
FWS Reference: 1-9-99-SP-052

Dear Mr. Jones:

Thank you for your request of December 3, 1998. Enclosed is a list of threatened and endangered species, candidate species and species of concern (Enclosure A), that may be present at the Hanford Reservation. We are enclosing a list of the whole site, due to the limited site-specific information provided in your December 3, 1998 letter. This list fulfills the requirements of the U. S. Fish and Wildlife Service (Service) under Section 7(c) of the Endangered Species Act of 1973, as amended (Act).

The Service has included aquatic species due to the possibilities of groundwater transmission of radioactive materials. Thus, we are giving you the opportunity to make an initial evaluation of possible effects to each species, as provided in the Federal Register (Vol. 51, No. 106, pg. 19946) on June 3, 1986. We are enclosing a copy of the requirements for federal agency compliance under the Act (Enclosure B).

Should the biological assessment for the proposed project determine that a listed species is likely to be affected (adversely or beneficially) by the project, the federal agency should request Section 7 consultation through this office. If the biological assessment determines that the proposed action is "not likely to adversely affect" a listed species, the federal agency should request Service concurrence with that determination through the informal consultation process. If the biological assessment determines the project to have "no effect," we would appreciate receiving a copy for our information.

Candidate species and species of concern are included simply as advance notice to federal agencies of species which may be proposed and listed in the future. Protection provided to these species now may preclude possible listing in the future. If early evaluation of your project indicates that it is likely to adversely impact a candidate species, or species of concern, the federal agency may wish to request technical assistance from this office.

There are other species, including anadromous fishes that have been federally listed by the National Marine Fisheries Service (NMFS). Some of these species may occur in the vicinity of your project. Please contact NMFS in Lacey, WA at (360) 753-5828, or in Portland, OR at (503) 231-2319, to request a species list.

Thank you for your efforts to protect our nation's species and their habitats. If you have additional questions regarding your responsibilities under the Act, please contact Richard Smith of this office at (509) 765-6125.

Sincerely,

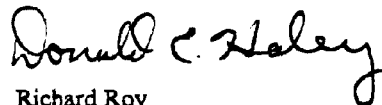

Richard Roy
Acting Assistant Field Supervisor

ENCLOSURES



Department of Energy

Washington, DC 20585

July 28, 1998

Mr. Jay McConnaughey
 Washington Department of Fish and Wildlife
 1315 West 4th
 Kennewick, WA 99336

Dear Mr. McConnaughey:

The Department of Energy (DOE) published its Notice of Intent to prepare the *Surplus Plutonium Disposition Environmental Impact Statement* (SPD EIS) in the Federal Register (Vol. 92, No. 99) on May 22, 1997. This SPD EIS is tiered from the *Storage and Disposition of Weapons-Usable Fissile Materials Programmatic EIS* (DOE/EIS-0229), issued in December 1996, and the associated Record of Decision (62 FR 3014), issued on January 14, 1997. To summarize, the purpose of the proposed action is to reduce the threat of nuclear weapons proliferation worldwide in an environmentally safe and timely manner by conducting disposition of surplus plutonium in the United States, thus setting a nonproliferation example for other nations.

The SPD Draft EIS, a copy of which is attached for your review, examines twenty-four alternatives and analyzes the potential environmental impacts for the proposed siting, construction, and operation of three types of facilities: pit disassembly and conversion, mixed oxide (MOX) fuel fabrication, and plutonium conversion and immobilization. The Hanford Site near Richland, Washington is a candidate site for all three facilities. The candidate sites and alternatives are shown in Table 2-1 of the SPD Draft EIS. Please note that where practical, the modification of existing buildings is being considered.

Alternative 2 proposes locating pit disassembly and conversion, and plutonium conversion and immobilization facilities in the Fuels and Materials Examination Facility (FMEF) and the MOX fuel fabrication facility in new construction adjacent to FMEF in the 400 Area. In addition, the planned high-level waste vitrification facility in the 200 East Area would be used to process the canisters from the plutonium conversion and immobilization facility. Although several alternatives include locating facilities at Hanford, Alternative 2 has the greatest potential for impacts on ecological resources.

Preliminary analyses suggest that overall impacts on ecological resources from constructing and operating the proposed surplus plutonium disposition facilities would be limited because the land area required (15 hectares [37 acres]) is relatively small in comparison to regionally available habitat; habitat disturbance would be minimized because construction would take place in previously disturbed or developed areas; and operational impacts would be minimized because



Printed with soy ink on recycled paper

facility releases of airborne and aqueous effluents would be controlled and permitted. Section 4.26.1.3 of the SPD Draft EIS presents the ecological resources analysis for the Hanford Site.

Although sources indicate that no critical habitat for any threatened and endangered species exists near the proposed construction area, there may be Washington State-classified special status species associated with shrub-steppe habitat that could be affected due to land disturbance and noise. Animal species include burrowing owl, ferruginous hawk, golden eagle, long-billed curlew, sage thrasher, Swainson's hawk, pygmy rabbit, desert night snake, and striped whipsnake. It is doubtful the loggerhead shrike and sage sparrow would be affected because a fire in the 400 Area previously destroyed most of their habitat. Plant species include crouching milkvetch, piper's daisy, squill onion, and stalked-pod milkvetch.

As part of DOE's National Environmental Policy Act process, DOE encourages the Washington Department of Fish and Wildlife to identify any concerns or issues that it believes should be addressed in the SPD EIS. To facilitate incorporation of your input into the SPD Final EIS, please provide a written response by September 16, 1998.

Please mail your response to:

Marcus Jones
SPD EIS Document Manager
U. S. Department of Energy
Office of Fissile Materials Disposition
1000 Independence Avenue, SW
Washington, DC 20585

If you have any questions, please contact me at (202) 586-0149.

Sincerely,

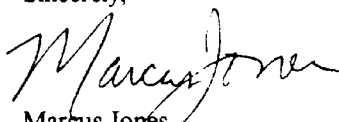
Marcus Jones
SPD EIS Document Manager

cc: Charles A. Brandt, PNNL
Dana Ward, DOE



STATE OF WASHINGTON
DEPARTMENT OF FISH AND WILDLIFE

1701 S 24th Avenue • Yakima, Washington 98902-5720 • (509) 575-2740 FAX (509) 575-2474

c/o Department of Ecology
1315 W 4th Ave, Kennewick, WA 99336

7 December, 1998

Marcus Jones
SPD EIS Document Manager
U.S. Department of Energy
Office of Fissile Materials Disposition
1000 Independence Ave. SW
Washington, DC 20585

Dear Mr. Jones:

Subject: Comments on the *Surplus Plutonium Disposition Draft Environmental Impact Statement, July 1998*, DOE/EIS-0283-D.

Upon a recent request for comments on the aforementioned document by U.S. Department of Energy (USDOE) Washington DC staff, the Washington Department of Fish and Wildlife (WDFW) is providing comments and greatly appreciates the invitation to submit comments even after the official closing of the comment period.

The WDFW supports the identified preferred alternatives in the draft EIS for siting plutonium disposition facilities (i.e. Immobilization at SRS, MOX Fuel Fabrication at SRS and Pit Disassembly and Conversion at SRS or Pantex). We concur with USDOE's determination as stated in the *Summary* "that Hanford's cleanup mission is critical, therefore ... prefers that the cleanup mission remain the site's top priority..." It is important that cleanup continue to remain the focus of the Hanford Site to be protective of the Columbia River ecosystem.

The Hanford Site ecosystem contains biological resources of regional, national, and international significance. The Hanford Reach supports a healthy stock of upriver bright fall chinook salmon (*Oncorhynchus tshawytscha*) and provides essential habitat for the federally listed Upper Columbia River steelhead (*Oncorhynchus mykiss*) which has been listed as endangered. The Nature Conservancy of Washington findings from a multi-year biodiversity inventory confirm the importance of the Hanford Site, and the 1997 annual report states "Findings from the biodiversity inventory to date show that the Hanford Site,

Mr. Jones
7 December, 1998
Page 2 of 3

including the Hanford Reach, is home to an irreplaceable natural legacy¹." Over the duration of the inventory, TNC scientists discovered 40 species new to science. Other biological studies support the significance of these resources as well. The significance of shrub steppe is accurately reflected in the *draft Hanford Site Biological Resource Management Plan* by the following: "...the percentage that Hanford contributes to the existence of shrub steppe within the ecoregion has increased by about 250% since European settlement". The WDFW has designated nearly 80% of the site as Priority Shrub Steppe Habitat including the post-fire habitat. Finally, the National Biological Service (currently known as the National Biological Division of the U.S. Geological Service) has listed native shrub and grassland steppe in Washington and Oregon as an endangered ecosystem².

The Hanford Site has been identified in several alternatives with alternative 2 having the greatest potential for impacts on ecological resources. Impacts would include the loss of 37 acres of habitat and effluent discharge to the Columbia River. The WDFW provides the following comments in the event that the facilities are actually sited at the Hanford Site.

The draft EIS mentions that effluent discharges would occur to the Columbia River. Given this information, the USDOE should enter into consultation with the National Marine Fisheries Service under Section 7 of the Endangered Species Act to ensure that the action is not likely to jeopardize the continued existence of any listed species (16 U.S.C. Sec.1536 (a)(2)) (i.e. Upper Columbia River steelhead). Consultation requirements of Section 7 are nondiscretionary and are effective at the time of species' listing regardless of whether critical habitat is designated. Our concerns are with the release of contaminants and thermal discharge that may adversely affect anadromous fish. Again, as in our comments on DOE/EA-1259, we would expect an aquatic biological review to occur given the evidence that suggest Upper Columbia River steelhead spawn where fall chinook salmon have been previously observed spawning in the Hanford Reach.

We commend USDOE for first looking at the modification of existing buildings before constructing new ones. This action is consistent with the mitigation hierarchy as defined in 40CFR§1508.20. As stated earlier, WDFW designated post-fire shrub steppe habitat located in the southeast portion of the Hanford Site as Priority Shrub Steppe Habitat. Our concerns with this habitat are captured in a letter dated 1 July, 1998 to Mr. Dana Ward,

¹ The Nature Conservancy of Washington. Biodiversity Inventory and analysis of the Hanford Site, 1997 Annual report, May 1998.

² Noss, Reed F., E.T. Laroe III, and J.M. Scott. Endangered ecosystems of the United States: A preliminary assessment of loss and degradation. Biological Report 28, Feb. 1995, National Biological Service, U.S. Department of the Interior.

Mr. Jones
7 December, 1998
Page 3 of 3

USDOE-RL. We believe every effort should be made to protect this habitat from further fragmentation and degradation which would occur from habitat disturbances, and that any adverse impacts that could not be mitigated through minimization and rectification should be compensated for at a 3:1 ratio. This would be consistent with USDOE's steward role of sustaining the natural ecosystems as stated in the Land and Facility Use Policy. Also, a commitment to fully mitigate adverse impacts to Priority Shrub Steppe Habitat would be consistent with past actions, such as, the Safe Interim Storage EIS, Tank Waste Remediation System EIS, and Solid Waste Retrieval Complex, Enhanced Radioactive and Mixed Waste Storage Facility, Infrastructure Upgrades, and Central Waste, Support Complex EA where adverse impacts were compensated.

We would request language be included in the final EIS that states "The project will be reviewed with the Washington Department of Fish and Wildlife and a mitigation action plan be developed and implemented to compensate for the destruction of Priority Shrub Steppe habitat from this project".

Again, thank you for the opportunity to comment. If you have any questions on these comments, please contact me at (509) 736-3095.

Sincerely,

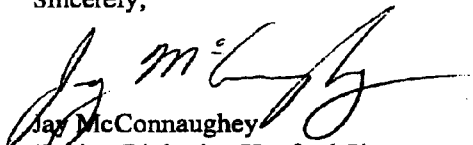

Jay McConaughy
Habitat Biologist, Hanford Site

Enclosures (2)

cc w/o enc:
USDOE

Paul Dunigan, Jr.
Washington Department of Ecology
Rebecca Inman
Ron Skinnarland

WDFW
Ted Clausing
Neil Rikard



Department of Energy
Washington, DC 20585

October 30, 1998

Robert Yohe
State Historic Preservation Officer
100 Main
Boise, Idaho 83702

Subject: Consultation for Surplus Plutonium Disposition Environmental Impact Analysis Process

Dear Mr Yohe:

The purpose of this letter is to notify you that the United States Department of Energy (DOE) is in the process of conducting an Environmental Impact Analysis concerning the disposition of surplus plutonium.

With this letter we are soliciting specific concerns the Idaho State Historic Preservation Office may have about the proposal. This consultation is in accordance with National Environmental Policy Act and Section 106 of the National Historic Preservation Act.

The *Surplus Plutonium Disposition Environmental Impact Statement* (SPD EIS) is tiered from the *Storage and Disposition of Weapons-Usable Fissile Materials Final Programmatic EIS* (DOE/EIS-0229), issued in December 1996, and the associated Record of Decision (62 FR 3014), issued on January 14, 1997. DOE is producing the SPD EIS in compliance with the National Environmental Policy Act (NEPA) and Council on Environmental Quality regulations implementing NEPA, DOE's NEPA Implementing Regulations (10 CFR 1021), and other applicable federal and state environmental legislation.

The purpose and need for the proposed action is to reduce the threat of nuclear weapons proliferation worldwide by disposing of surplus plutonium in the United States in an environmentally safe and timely manner. The SPD Draft EIS, a copy of which is attached for your review, examines the potential environmental impacts for 24 alternatives for the proposed siting, construction, and operation of three types of facilities: pit disassembly and conversion; mixed oxide (MOX) fuel fabrication; and plutonium conversion and immobilization.

If an alternative is selected that includes siting of surplus plutonium disposition facilities at the Idaho National Environmental and Engineering Laboratory (INEEL) site (e.g., Alternative 7A), a maximum of about 13 hectares (32 acres) of land inside the Idaho Nuclear Technology and Engineering Center (INTEC) protected area adjacent to

Robert Yohe, State Historic Preservation Officer
10/30/98
Page 2

the Fuel Processing Facility (FPF) would be impacted. Six prehistoric resources within the vicinity of the proposed construction area have been identified, but none are eligible for nomination to the National Register. A homestead and a trash dump may be eligible for the National Register, and a historic building survey being conducted within INTEC is likely to identify structures potentially eligible for the National Register based on their Cold War associations. Direct impact of the proposed construction would be unlikely; however, consistent with the *INEL Management Plan for Cultural Resources*, surveys and monitoring would be conducted to ensure against impact to National Register-eligible resources.

If you have any specific concerns about the SPD EIS proposal, we would like to hear from you. Please contact me with your concerns or questions at:

Marcus Jones
SPD EIS Document Manager
U.S. Department of Energy
Office of Fissile Materials Disposition
P.O. Box 23786
Washington, DC 20026-3786
(202) 586-0149.

You may also contact Bob Stark, the INEEL Technical Lead for Cultural Resources, at (208) 526-1122.

Sincerely,

Marcus Jones
SPD EIS Document Manager

cc: Bob Stark, Technical Lead for Cultural Resources, INEEL
Lois Thompson, Federal Preservation Officer, DOE HQ

SPD EIS enclosure



Department of Energy

Washington, DC 20585

October 30, 1998

Mr. Keith Tinno, Tribal Chairman
Fort Hall Reservation
P.O. Box 306
Fort Hall, Idaho 83203

Subject: Consultation for Surplus Plutonium Disposition Environmental Impact Analysis Process, Under Executive Memorandum Concerning Government-to-Government Relations

Dear Mr. Tinno:

The purpose of this letter is to notify you that the United States Department of Energy (DOE) is in the process of conducting an Environmental Impact Analysis concerning the disposition of surplus plutonium.

With this letter we are soliciting specific concerns the Shoshone and Bannock Tribes may have about the proposal. This consultation is in accordance with the Executive Memorandum (29 April 1994) entitled, "Government-to-Government Relations with Native American Tribal Governments", and DOE Order 1230.2. It also follows prior consultation initiated for compliance with the American Indian Religious Freedom Act (AIRFA) (PL 95-341) and the Native American Graves Protection and Repatriation Act (NAGPRA) (PL 101-601).

The *Surplus Plutonium Disposition Environmental Impact Statement* (SPD EIS) is tiered from the *Storage and Disposition of Weapons-Usable Fissile Materials Final Programmatic EIS* (DOE/EIS-0229), issued in December 1996, and the associated Record of Decision (62 FR 3014), issued on January 14, 1997. DOE is producing the SPD EIS in compliance with the National Environmental Policy Act (NEPA) and Council on Environmental Quality regulations implementing NEPA, DOE's NEPA Implementing Regulations (10 CFR 1021), and other applicable federal and state-delegated environmental legislation.

The purpose and need for the proposed action is to reduce the threat of nuclear weapons proliferation worldwide by disposing of surplus plutonium in the United States in an environmentally safe and timely manner. The SPD Draft EIS, a copy of which is attached for your review, examines the potential environmental impacts for 24 alternatives for the proposed siting, construction, and operation of three types of facilities: pit disassembly and conversion; mixed oxide (MOX) fuel fabrication; and plutonium conversion and immobilization.

Mr. Keith Tinno, Tribal Chairman, Fort Hall Reservation
10/30/98
Page 2

If an alternative is selected that includes siting of surplus plutonium disposition facilities at the INEEL site (e.g., Alternative 7A), a maximum of about 13 hectares (32 acres) of land inside the Idaho nuclear Technology and Engineering Center (INTEC) protected area adjacent to the Fuel Processing Facility (FPF) would be impacted. Specific Native American resources have not been identified within the proposed construction area, but operations could result in indirect impacts, such as access restrictions. DOE would conduct direct consultation with the Shoshone and Bannock Tribes, consistent with a working agreement between DOE and the tribes, to ensure there are no direct construction-related impacts.

If you have any specific concerns about the SPD EIS proposal, we would like to hear from you. Please contact me with your concerns or questions at:

Marcus Jones
SPD EIS Document Manager
U.S. Department of Energy
Office of Fissile Materials Disposition
P.O. Box 23786
Washington, DC 20026-3786
(202) 586-0149.

You may also contact Bob Pence, the INEEL American Indian Program Manager, at (208) 526-6518.

Sincerely,

Marcus Jones
SPD EIS Document Manager

cc: Diana Yupe, Fort Hall
Bob Pence, American Indian Program Manager, INEEL
Brandt Petrasek, EM-20, DOE HQ

SPD EIS enclosure



Department of Energy

Washington, DC 20585
July 28, 1998

Ms. Susan Burch
U. S. Department of Interior
Fish and Wildlife Service
Snake River Basin Office
Columbia River Basin Ecological Region
1387 South Vinnell Way
Room 368
Boise, ID 83709

Dear Ms. Burch:

INFORMAL CONSULTATION UNDER SECTION 7 OF THE ENDANGERED SPECIES ACT FOR SURPLUS PLUTONIUM DISPOSITION

The Department of Energy (DOE) published its Notice of Intent to prepare the *Surplus Plutonium Disposition Environmental Impact Statement* (SPD EIS) in the Federal Register (Vol. 92, No. 99) on May 22, 1997. This SPD EIS is tiered from the *Storage and Disposition of Weapons-Usable Fissile Materials Programmatic EIS* (DOE/EIS-0229), issued in December 1996, and the associated Record of Decision (62 FR 3014), issued on January 14, 1997. To summarize, the purpose of the proposed action is to reduce the threat of nuclear weapons proliferation worldwide in an environmentally safe and timely manner by conducting disposition of surplus plutonium in the United States, thus setting a nonproliferation example for other nations.

The SPD Draft EIS, a copy of which is attached for your review, examines twenty-four alternatives and analyzes the potential environmental impacts for the proposed siting, construction, and operation of three types of facilities: pit disassembly and conversion, mixed oxide (MOX) fuel fabrication, and plutonium conversion and immobilization. The Idaho National Engineering and Environmental Laboratory (INEEL) near Idaho Falls, Idaho is a candidate site for the pit disassembly and MOX facilities. Alternatives 7A, 7B, and 8 propose locating pit disassembly and conversion in the Fuel Processing Facility (FPF) and MOX fuel fabrication in new construction in the Idaho Nuclear Technology and Energy Center (INTEC) area. The candidate sites and alternatives are shown in Table 2-1 of the SPD Draft EIS. Please note that where practical, the modification of existing buildings is being considered.

Preliminary analyses suggest that overall impacts on ecological resources from constructing and operating the proposed surplus plutonium disposition facilities would be limited because the land area required (13 hectares [32 acres]) is relatively small in comparison to regionally available habitat; habitat disturbance would be minimized because construction would take place in previously disturbed or developed areas; and operational impacts would be minimized because facility releases of airborne and aqueous effluents would be controlled and permitted. Section



Printed with soy ink on recycled paper

4.26.2.3 of the SPD Draft EIS presents the ecological resources analysis for INEEL.

Although sources indicate that no critical habitat for any threatened and endangered species exists near the proposed construction area, there may be Federal or State-classified special status species in the area surrounding INTEC. These species include bald eagle, black tern, burrowing owl, ferruginous hawk, loggerhead shrike, long-eared and small-footed myotis, northern goshawk, northern sagebrush lizard, peregrine falcon, pygmy rabbit, Townsend's western big-eared bat, trumpeter swan, and white-faced ibis. Noise disturbance is probably the most important impact affecting local wildlife populations.

Consistent with the Endangered Species Act, DOE requests that the Fish and Wildlife Service provide any additional information on the presence of threatened and endangered animal and plant species, both listed and proposed, in the vicinity of the INTEC area at INEEL. Information on the habitats of these species would also be appreciated. DOE also requests information on any other species of concern that are known to occur or potentially occur in the vicinity of INTEC.

As part of DOE's National Environmental Policy Act process, DOE encourages the Fish and Wildlife Service to identify any concerns or issues it believes should be addressed in the SPD EIS. To facilitate incorporation of your input into the SPD Final EIS, please provide a written response by September 16, 1998.

Please mail your response to:

Marcus Jones
SPD EIS Document Manager
U.S. Department of Energy
Office of Fissile Materials Disposition
1000 Independence Avenue, SW
Washington, DC 20585

If you have any questions, please contact me at (202) 586-0149.

Sincerely,

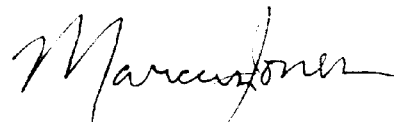

Marcus Jones
SPD EIS Document Manager

cc: Roger Twitchell, DOE
Tim Reynolds, ESRF



United States Department of the Interior

FISH AND WILDLIFE SERVICE

Snake River Basin Office, Columbia River Basin Ecoregion
1387 South Vinnell Way, Room 368
Boise, Idaho 83709

August 18, 1998

Marcus Jones
SPD EIS Document Manager
U.S. Department of Energy
Office of Fissile Materials Disposition
1000 Independence Avenue S.W.
Washington, D.C. 20585

Subject: Surplus Plutonium Disposition--Section 7 Consultation
File #506.0000 SP #1-4-98-SP-247

Dear Mr. Jones:

The U.S. Fish and Wildlife Service (Service) has received your letter announcing your Notice of Intent to prepare the Surplus Plutonium Disposition Environmental Impact Statement. Your letter to us, dated July 28 1998 and received here August 10, 1998 dealt specifically with issues related to species listed under the Endangered Species Act of 1973 (Act). Your letter noted a number of rare and sensitive species that could occur at the Idaho National Engineering and Environmental Laboratory site. Two listed species, the threatened bald eagle and peregrine falcon, are included on your list. The Service concurs that the list you developed is accurate, and we are providing you a reference number to document our concurrence with your list (SP #1-4-98-SP-247).

At this time, staffing and funding constraints will preclude our direct involvement with your analysis of this project. As you know, Idaho Department of Fish and Game's Conservation Data Center is the repository for information about status and distribution of species of concern, including those listed under the Act. We encourage you to work with them to obtain the most current information about the species that may occur at the site. If you determine that a listed species may be affected by the project, Section 7 of the Act requires that you consult with the Service. In that event, we will be available for informal consultation.

Thank you for providing the Service with the opportunity to comment on the proposed project. Contact Alison Beck Haas of my staff in Boise (208) 378-5384 or Mike Donahoo in Pocatello (208) 233-8550 if you have questions.

Sincerely,

A handwritten signature in black ink that reads "Robert A. Russink". The signature is written in a cursive style with a large, prominent initial 'R'.

Supervisor, Snake River Basin Office

cc: FWS-CBE, Portland (Diggs)
FWS, Pocatello (Donahoo)



Department of Energy

Washington, DC 20585

July 28, 1998

Mr. George Stephens
Idaho Department of Fish and Game
Conservation Data Center
600 South Walnut
Boise, ID 83705

Dear Mr. Stephens:

The Department of Energy (DOE) published its Notice of Intent to prepare the *Surplus Plutonium Disposition Environmental Impact Statement* (SPD EIS) in the *Federal Register* (Vol. 92, No. 99) on May 22, 1997. This SPD EIS is tiered from the *Storage and Disposition of Weapons-Usable Fissile Materials Programmatic EIS* (DOE/EIS-0229), issued in December 1996, and the associated Record of Decision (62 FR 3014), issued on January 14, 1997. To summarize, the purpose of the proposed action is to reduce the threat of nuclear weapons proliferation worldwide in an environmentally safe and timely manner by conducting disposition of surplus plutonium in the United States, thus setting a nonproliferation example for other nations.

The SPD Draft EIS, a copy of which is attached for your review, examines twenty-four alternatives and analyzes the potential environmental impacts for the proposed siting, construction, and operation of three types of facilities: pit disassembly and conversion, mixed oxide (MOX) fuel fabrication, and plutonium conversion and immobilization. The Idaho National Engineering and Environmental Laboratory (INEEL) near Idaho Falls, Idaho is a candidate site for the pit disassembly and MOX facilities. Alternatives 7A, 7B, and 8 propose locating pit disassembly and conversion in the Fuel Processing Facility (FPF) and MOX fuel fabrication in new construction in the Idaho Nuclear Technology and Energy Center (INTEC) area. The candidate sites and alternatives are shown in Table 2-1 of the SPD Draft EIS. Please note that where practical, the modification of existing buildings is being considered.

Preliminary analyses suggest that overall impacts on ecological resources from constructing and operating the proposed surplus plutonium disposition facilities would be limited because the land area required (13 hectares [32 acres]) is relatively small in comparison to regionally available habitat; habitat disturbance would be minimized because construction would take place in previously disturbed or developed areas; and operational impacts would be minimized because facility releases of airborne and aqueous effluents would be controlled and permitted. Section 4.26.2.3 of the SPD Draft EIS presents the ecological resources analysis for INEEL.

Although sources indicate that no critical habitat for any threatened and endangered species exists near the proposed construction area, there may be Federal or State-classified special status species in the area surrounding INTEC. These species include bald eagle, black tern, burrowing owl, ferruginous hawk, loggerhead shrike, long-eared and small-footed myotis, northern goshawk,



Printed with soy ink on recycled paper

northern sagebrush lizard, peregrine falcon, pygmy rabbit, Townsend's western big-eared bat, trumpeter swan, and white-faced ibis. Noise disturbance is probably the most important impact affecting local wildlife populations.

As part of DOE's National Environmental Policy Act process, DOE encourages the Idaho Department of Fish and Game to identify any concerns or issues it believes should be addressed in the SPD EIS. To facilitate incorporation of your input into the SPD Final EIS, please provide a written response by September 16, 1998.

Please mail your response to:

Marcus Jones
SPD EIS Document Manager
U.S. Department of Energy
Office of Fissile Materials Disposition
1000 Independence Avenue, SW
Washington, DC 20585

If you have any questions, please contact me at (202) 586-0149.

Sincerely,

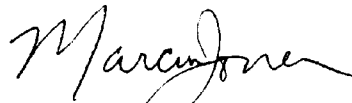

Marcus Jones
SPD EIS Document Manager

cc: Roger Twitchell, DOE
Tim Reynolds, ESRF



IDAHO CONSERVATION DATA CENTER



Idaho Department of Fish and Game • 600 South Walnut • P.O. Box 25 Boise, Idaho 83707 • (208) 334-3402 • FAX 334-2114

12 August 1998

Marcus Jones, SPD EIS Document Manager
Department of Energy
Washington, D. C. 20585

Dear Mr. Jones:

I am responding to your request for input relative to special status species associated with INEEL and construction at the Idaho Nuclear Technology and Energy Center (INTEC). Enclosed is a list of special status plants and animals known to occur at INEEL. These represent species for which the Conservation Data Center (CDC) has documentation of occurrence.

Within a 10-mile radius of INTEC, the only occurrences in the CDC database are ferruginous hawk nesting territories and Merriam's shrew capture sites. In the eastern part of Idaho, gray wolf is considered an experimental, nonessential population. With regard to the species listed in your letter, the Lower Snake River Basin office of the U. S. Fish and Wildlife Service does not consider northern sagebrush lizard to be a Species of Concern.

If you have questions regarding this response, please contact me.

Sincerely,

George Stephens
Fish and Game Data Coordinator



IDAHO CONSERVATION DATA CENTER



Idaho Department of Fish and Game • 600 South Walnut • P.O. Box 25, Boise, Idaho 83707 • (208) 334-3402 • FAX 334-2114

gstephen@idfg.state.id.us

<http://www.state.id.us/fishgame/cdchome.htm>

MEMORANDUM

TO: Kevin Folk
 FROM: George Stephens
 DATE: 12 February 1999
 RE: INTEC area at INEEL

I am responding to your phone call this morning. After reviewing the original request (28 Jul 1998, from Marcus Jones) and looking at my response (12 Aug 1998), I can provide an update to our phone conversation.

Jones' request was not clear. His letter refers to the INTEC "area," to multiple sites on INEEL, and to Idaho Fish and Game addressing any concerns it has with the EIS. With regard to special status species, I think my response to Jones' letter is in tune with his request. In the body of my (1998) letter, I addressed (1) the two known species occurrences in the INTEC "area" and (2) the known occurrences on the entirety of INEEL with regard to the multiple sites. If you check the species list accompanying my letter, you will note INEEL is indicated (at the top) of the list.

On the phone, I explained the basis for conducting a database search of a 10-mile radius around a project area. Primarily, it is to check whether a peregrine falcon eyrie or hawk site is known from the area. That 10-mile guideline came from the U. S. Fish and Wildlife Service for the CDC to use when developing a Sec. 7 (ESA) species list. Many other species don't have well-defined guidelines, and I simply included other known occurrences found within the 10-mile radius. Animals generally tend to move around and are often found over a larger area than where an individual was observed or trapped.

The pages accompanying this memorandum contain printed database records for the known occurrences in the INTEC area. In addition to these species, pygmy rabbit should be considered as a probable occurrence in any area of big sagebrush habitat. The printout contains a rare plant not addressed in the 1998 response. The CDC only recently began to track nonvascular plants; this plant occurrence had not been processed at the time of Jones' request.

If you have additional questions, please contact me.



Department of Energy

Washington, DC 20585

October 30, 1998

Mr. Virgil Franklin Sr.
Cheyenne-Arapaho Tribe of Oklahoma
P.O. Box 38
Concho OK 73022

Subject: Consultation for Surplus Plutonium Disposition Environmental Impact Analysis Process, Under Executive Memorandum Concerning Government-to-Government Relations with Native American Tribal Governments

Dear Mr. Franklin:

The purpose of this letter is to notify you that the United States Department of Energy (DOE) is in the process of conducting an Environmental Impact Analysis concerning the disposition of surplus plutonium.

With this letter we are soliciting specific concerns the Cheyenne-Arapaho Tribe of Oklahoma may have about the proposal. This consultation is in accordance with the Executive Memorandum (29 April 1994) entitled, "Government-to-Government Relations with Native American Tribal Governments", and DOE Order 1230.2. It also follows prior consultation initiated for compliance with the American Indian Religious Freedom Act (AIRFA) (PL 95-341) and the Native American Graves Protection and Repatriation Act (NAGPRA) (PL 101-601).

The *Surplus Plutonium Disposition Environmental Impact Statement* (SPD EIS) is tiered from the *Storage and Disposition of Weapons-Usable Fissile Materials Final Programmatic EIS* (DOE/EIS-0229), issued in December 1996, and the associated Record of Decision (62 FR 3014), issued on January 14, 1997. DOE is producing the SPD EIS in compliance with the National Environmental Policy Act (NEPA) and Council on Environmental Quality regulations implementing NEPA, DOE's NEPA Implementing Regulations (10 CFR 1021), and other applicable federal and state environmental legislation.

The purpose and need for the proposed action is to reduce the threat of nuclear weapons proliferation worldwide by disposing of surplus plutonium in the United States in an environmentally safe and timely manner. The SPD Draft EIS, a copy of which is attached for your review, examines the potential environmental impacts for 24 alternatives for the proposed siting, construction, and operation of three types of facilities: pit disassembly and conversion; mixed oxide (MOX) fuel fabrication; and plutonium conversion and immobilization.

Mr. Virgil Franklin Sr.
Cheyenne-Arapaho Tribe of Oklahoma
10/30/98
Page 2

If an alternative is selected that includes siting of surplus plutonium disposition facilities at the Pantex plant (e.g., Alternative 9A), a maximum of 16 hectares (39 acres) of land in or near Zone 4 would be impacted. Based on previous consultations, no traditional cultural properties have been identified in Zone 4 or immediately adjacent areas.

If you have any specific concerns about the SPD EIS proposal, we would like to hear from you. Please contact me with your concerns or questions at:

Marcus Jones
SPD EIS Document Manager
U.S. Department of Energy
Office of Fissile Materials Disposition
P.O. Box 23786
Washington, DC 20026-3786
(202) 586-0149.

You may also contact Vicki Battley, Pantex Environmental Protection Team Leader, at (806) 477-3189.

Sincerely,

Marcus Jones
SPD EIS Document Manager

cc: Vicki Battley, DOE – Amarillo Area Office
Brandt Petrasek, EM-20, DOE HQ

SPD EIS enclosure



Department of Energy
Washington, DC 20585

October 30, 1998

Mr. Billy Evans Horse
Kiowa Tribe of Oklahoma
P.O. Box 369
Carnegie OK 73015

Subject: Consultation for Surplus Plutonium Disposition Environmental Impact Analysis Process, Under Executive Memorandum Concerning Government-to-Government Relations with Native American Tribal Governments

Dear Mr. Evans Horse:

The purpose of this letter is to notify you that the United States Department of Energy (DOE) is in the process of conducting an Environmental Impact Analysis concerning the disposition of surplus plutonium.

With this letter we are soliciting specific concerns the Kiowa Tribe of Oklahoma may have about the proposal. This consultation is in accordance with the Executive Memorandum (29 April 1994) entitled, "Government-to-Government Relations with Native American Tribal Governments", and DOE Order 1230.2. It also follows prior consultation initiated for compliance with the American Indian Religious Freedom Act (AIRFA) (PL 95-341) and the Native American Graves Protection and Repatriation Act (NAGPRA) (PL 101-601).

The *Surplus Plutonium Disposition Environmental Impact Statement* (SPD EIS) is tiered from the *Storage and Disposition of Weapons-Usable Fissile Materials Final Programmatic EIS* (DOE/EIS-0229), issued in December 1996, and the associated Record of Decision (62 FR 3014), issued on January 14, 1997. DOE is producing the SPD EIS in compliance with the National Environmental Policy Act (NEPA) and Council on Environmental Quality regulations implementing NEPA, DOE's NEPA Implementing Regulations (10 CFR 1021), and other applicable federal and state environmental legislation.

The purpose and need for the proposed action is to reduce the threat of nuclear weapons proliferation worldwide by disposing of surplus plutonium in the United States in an environmentally safe and timely manner. The SPD Draft EIS, a copy of which is attached for your review, examines the potential environmental impacts for 24 alternatives for the proposed siting, construction, and operation of three types of facilities: pit disassembly and conversion; mixed oxide (MOX) fuel fabrication; and plutonium conversion and immobilization.

Mr. Billy Evans Horse
Kiowa Tribe of Oklahoma
10/30/98
Page 2

If an alternative is selected that includes siting of surplus plutonium disposition facilities at the Pantex plant (e.g., Alternative 9A), a maximum of 16 hectares (39 acres) of land in or near Zone 4 would be impacted. Based on previous consultations, no traditional cultural properties have been identified in Zone 4 or immediately adjacent areas.

If you have any specific concerns about the SPD EIS proposal, we would like to hear from you. Please contact me with your concerns or questions at:

Marcus Jones
SPD EIS Document Manager
U.S. Department of Energy
Office of Fissile Materials Disposition
P.O. Box 23786
Washington, DC 20026-3786
(202) 586-0149.

You may also contact Vicki Battley, Pantex Environmental Protection Team Leader, at (806) 477-3189.

Sincerely,

Marcus Jones
SPD EIS Document Manager

cc: Vicki Battley, DOE – Amarillo Area Office
Brandt Petrasek, EM-20, DOE HQ

SPD EIS enclosure



Department of Energy

Washington, DC 20585

October 30, 1998

Mr. D. J. Mowatt
Apache Tribe of Oklahoma
P.O. Box 1220
Anadarko OK

Subject: Consultation for Surplus Plutonium Disposition Environmental Impact Analysis Process, Under Executive Memorandum Concerning Government-to-Government Relations with Native American Tribal Governments

Dear Mr. Mowatt:

The purpose of this letter is to notify you that the United States Department of Energy (DOE) is in the process of conducting an Environmental Impact Analysis concerning the disposition of surplus plutonium.

With this letter we are soliciting specific concerns the Apache Tribe of Oklahoma may have about the proposal. This consultation is in accordance with the Executive Memorandum (29 April 1994) entitled, "Government-to-Government Relations with Native American Tribal Governments", and DOE Order 1230.2. It also follows prior consultation initiated for compliance with the American Indian Religious Freedom Act (AIRFA) (PL 95-341) and the Native American Graves Protection and Repatriation Act (NAGPRA) (PL 101-601).

The *Surplus Plutonium Disposition Environmental Impact Statement* (SPD EIS) is tiered from the *Storage and Disposition of Weapons-Usable Fissile Materials Final Programmatic EIS* (DOE/EIS-0229), issued in December 1996, and the associated Record of Decision (62 FR 3014), issued on January 14, 1997. DOE is producing the SPD EIS in compliance with the National Environmental Policy Act (NEPA) and Council on Environmental Quality regulations implementing NEPA, DOE's NEPA Implementing Regulations (10 CFR 1021), and other applicable federal and state environmental legislation.

The purpose and need for the proposed action is to reduce the threat of nuclear weapons proliferation worldwide by disposing of surplus plutonium in the United States in an environmentally safe and timely manner. The SPD Draft EIS, a copy of which is attached for your review, examines the potential environmental impacts for 24 alternatives for the proposed siting, construction, and operation of three types of facilities: pit disassembly and conversion; mixed oxide (MOX) fuel fabrication; and plutonium conversion and immobilization.

Mr. D. J. Mowatt
Apache Tribe of Oklahoma
10/30/98
Page 2

If an alternative is selected that includes siting of surplus plutonium disposition facilities at the Pantex plant (e.g., Alternative 9A), a maximum of 16 hectares (39 acres) of land in or near Zone 4 would be impacted. Based on previous consultations, no traditional cultural properties have been identified in Zone 4 or immediately adjacent areas.

If you have any specific concerns about the SPD EIS proposal, we would like to hear from you. Please contact me with your concerns or questions at:

Marcus Jones
SPD EIS Document Manager
U.S. Department of Energy
Office of Fissile Materials Disposition
P.O. Box 23786
Washington, DC 20026-3786
(202) 586-0149.

You may also contact Vicki Battley, Pantex Environmental Protection Team Leader, at (806) 477-3189.

Sincerely,

Marcus Jones
SPD EIS Document Manager

cc: Vicki Battley, DOE – Amarillo Area Office
Brandt Petrasek, EM-20, DOE HQ

SPD EIS enclosure

Appendix P
Environmental Synopsis

**ENVIRONMENTAL SYNOPSIS
OF INFORMATION PROVIDED IN RESPONSE TO
THE REQUEST FOR PROPOSALS FOR
MOX FUEL FABRICATION AND REACTOR IRRADIATION SERVICES**

April 1999

1.0 INTRODUCTION

In the aftermath of the Cold War, significant quantities of weapons-usable fissile materials (primarily plutonium and highly enriched uranium) have become surplus to national defense needs both in the United States and Russia. President Clinton announced, on September 27, 1993, the establishment of a framework for United States efforts to prevent the proliferation of weapons of mass destruction. As key elements of the President's policy, the United States will:

- X Seek to eliminate, where possible, accumulation of stockpiles of highly enriched uranium and plutonium,
- X Ensure that where these materials already exist, they are subject to the highest standards of safety, security, and international accountability, and
- X Initiate a comprehensive review of long-term options for plutonium disposition, taking into account technical, nonproliferation, environmental, budgetary, and economic considerations.

In January 1994, President Clinton and Russian President Yeltsin agreed that the proliferation of weapons of mass destruction and their delivery systems represent an acute threat to international security. They declared that both Nations would cooperate actively and closely with each other, and also with other interested nations, for the purpose of preventing and reducing this threat.

The Secretary of Energy and the Congress took action in October 1994 to create a permanent Office of Fissile Materials Disposition (MD) within the Department of Energy (DOE) to focus on the important national security objective of eliminating surplus weapons-usable fissile materials. As one of its major responsibilities, MD is tasked with determining how to disposition surplus weapons-usable plutonium. In January 1997, DOE issued a Record of Decision (ROD) for the *Storage and Disposition of Weapons-Usable Fissile Materials Final Programmatic Environmental Impact Statement (S&D PEIS)*¹. In that decision document, DOE decided to pursue a strategy that would allow for the possibility of both the immobilization of surplus plutonium and the use of surplus plutonium as mixed oxide (MOX) fuel in existing domestic, commercial reactors. In July, 1998, DOE issued the *Draft Surplus Plutonium Disposition Environmental Impact Statement (SPD Draft EIS)*² which analyzes sites for plutonium disposition activities and plutonium disposition technologies to support this strategy.

To support the timely undertaking of the surplus plutonium disposition program, DOE initiated a procurement action to contract for fuel fabrication and reactor irradiation services. On May 19, 1998, DOE issued a Request for Proposals (RFP) for these services (Solicitation Number DE-RP02-

¹ DOE/EIS-0229; December 1996

² DOE/EIS-0283D; July 1998

98CH10888). The services requested in this procurement process include design, licensing, construction, operation, and eventual decontamination and decommissioning of a MOX facility as well as irradiation of the MOX fuel in existing domestic, commercial reactors should the decision be made by DOE in the SPD EIS ROD to go forward with the MOX program.

In accordance with DOE's National Environmental Policy Act (NEPA) regulations (10 CFR 1021.216), DOE required offerors to submit reasonably available environmental data and analyses as a part of their proposals. DOE independently evaluated and verified the accuracy of the data provided by the offeror in the competitive range, and prepared and considered an Environmental Critique before the procurement selection was made.

As required by Section 216, the Environmental Critique included a discussion of the purpose of the procurement; the salient characteristics of the offeror's proposal; any licenses, permits or approvals needed to support the program; and an evaluation of the potential environmental impacts of the offer. In March 1999, after considering the Environmental Critique, DOE awarded a contract for MOX fuel fabrication and reactor irradiation services. Under this contract, MOX fuel would be fabricated at a DOE site to be selected in the SPD EIS ROD and then irradiated in six domestic commercial nuclear reactors at three commercial reactor sites. Additionally, under the contract only limited activities may be performed prior to issuance of the SPD EIS ROD. These activities include non-site-specific work primarily associated with the development of the initial conceptual design for the fuel fabrication facility, and plans (paper studies) for outreach, long lead-time procurements, regulatory management, facility quality assurance, safeguards, security, fuel qualifications, and deactivation. There would be no construction started on a MOX fuel fabrication facility until the SPD EIS ROD is issued. The MOX facility, if built, would be government-owned, licensed by the Nuclear Regulatory Commission (NRC), and located at one of four candidate DOE sites.

This Synopsis is based on the Environmental Critique and provides a publicly available assessment of the potential environmental impacts associated with the proposal based on an independent review of the representations and data contained in the proposal. The Synopsis serves as a record that DOE has considered the environmental factors and potential consequences of the reasonable alternatives analyzed during the selection process. The Synopsis will be filed with the U.S. Environmental Protection Agency and made publicly available. The Synopsis will also be incorporated into a Supplement to the SPD Draft EIS, which is to be issued in the near future.

2.0 ASSESSMENT METHODS

The analyses in this Synopsis (and in the Environmental Critique) were performed using information submitted by the offeror in the competitive range, independently developed information, publicly available information, and standard computer models and techniques.

In order to evaluate the reasonableness of the offeror's projected environmental impacts compared to those projected by DOE, the offeror's data for the MOX facility was compared to information in the SPD Draft EIS; for the use of MOX fuel in domestic commercial reactors, the offeror's data was compared to

information in the S&D PEIS.³

Data developed independently to support these analyses include the projection of populations around the proposed reactor sites⁴ and information related to the topography surrounding the proposed reactor sites for evaluating air dispersal patterns. Information was also provided by Oak Ridge National Laboratory (ORNL) on the expected ratio of radionuclide activities in MOX fuel compared to that in low enriched uranium (LEU) fuel for use in reactor accident analyses. Standard models for determining radiation doses from normal operations and accident scenarios, and air pollutant concentrations at the proposed disposition facility sites and reactors were run using data provided by the offeror. Reactor accident analyses assumed a 40 percent MOX core because this is a conservative estimate of the amount of MOX fuel that would be used in each of the reactors. The environmental analyses were prepared using the following computer models: GENII for estimating radiation doses to the public from normal operation of the MOX fuel fabrication facility and the proposed reactors; MACCS2 for design-basis and beyond-design-basis accident analyses at the proposed reactors; and ISC3 and SCREEN3 for estimated air pollutant concentrations as a result of normal MOX facility and reactor operations.

3.0 DESCRIPTION OF THE OFFER

The offeror has proposed to build a MOX facility on a DOE site⁵ with subsequent irradiation services being provided in six existing reactors at three commercial nuclear power plants in the Eastern United States.

The proposed MOX facility design, which is based on an existing MOX facility in France, will be modified to meet U.S. regulations. Under the proposed design, plutonium dioxide powder would be received from DOE's proposed pit disassembly and conversion facility. The plutonium dioxide would be aqueously processed (polished) to ensure that it meets the agreed-to fuel specification for MOX fuel. Following the polishing step, the plutonium in solution would then be converted back into plutonium dioxide. At that point, the process proposed by the offeror would be similar to that described in Chapter 2 of the SPD Draft EIS⁶. The plutonium dioxide would be mixed with uranium dioxide and formed into MOX fuel pellets.

³ Such information is also summarized in the SPD Draft EIS.

⁴ Population projections for the area encompassed in a 50-mile radius around the proposed reactor sites were projected to 2015 to approximate the mid-point of the irradiation services program. By 2015, the MOX program would be firmly established at all of the proposed reactor sites and would be expected to remain stable through the end of the program. Using 1990 census data as the base year and state-provided population increase factors for all counties included in this analysis, the population around the sites was projected for 2015. Baseline projections were needed for two of the reactor sites because the population information provided in the proposal was based on 1970 census data. Recent (i.e., 1990) census data were provided for the other proposed site and projected by the offeror to the years 2010 and 2020. From these data points, 2015 projections were interpolated.

⁵ This site would be selected in the SPD EIS ROD. As explained in the SPD Draft EIS, DOE's preference is to locate the MOX fuel fabrication plant at DOE's Savannah River site.

⁶ The SPD Draft EIS also included evaluation of an aqueous processing facility in Appendix N, that could be added to either the pit conversion or the MOX facility. Based on public comments received and information presented by the offeror subsequent to the release of the SPD Draft EIS, DOE is now considering whether to add the aqueous polishing process to the front end of the MOX facility. The environmental impacts associated with this option will be presented in Chapter 4 of the SPD Final EIS.

These pellets would be baked at high temperature, ground to exact dimensions, then loaded into fuel rods. The MOX fuel rods would then be bundled with standard LEU fuel rods to form MOX fuel assemblies. The MOX fuel assemblies would be shipped to the proposed reactor sites in DOE-provided safe, secure transport vehicles on a near just-in-time basis to minimize the amount of time the fresh MOX fuel would be stored at a reactor site prior to loading into the reactor.

Three sites, each with two operating pressurized light water reactors (PWRs), have been proposed for MOX fuel irradiation. The proposed sites are: the Catawba nuclear generation station near York, South Carolina; the McGuire nuclear generation station near Huntersville, North Carolina; and the North Anna nuclear generation station near Mineral, Virginia. All of these sites have been operating safely for a number of years. Table 1 provides some general information about each of the proposed plants.

Table 1. Reactor Plant Operating Information

Plant	Operator	Capacity (net MWe)	Date of First Operation (mo/yr)
Catawba No. 1	Duke Power Co.	1,129	01/85
Catawba No. 2	Duke Power Co.	1,129	05/86
McGuire No. 1	Duke Power Co.	1,129	07/81
McGuire No. 2	Duke Power Co.	1,129	05/83
North Anna No. 1	Virginia Power Co.	900	04/78
North Anna No. 2	Virginia Power Co.	887	08/80

Table 2 shows the results of the most recent Systematic Assessment of Licensee Performance performed by NRC for each of the proposed reactors. As can be seen in this table, all the proposed reactors have been operated and maintained in a safe manner.

Table 2. Systematic Assessment of Licensee Performance Results

	Catawba	McGuire	North Anna
Date of Latest SALP	06/97	04/97	02/97
Operations	Superior	Superior	Superior
Maintenance	Good	Good	Superior
Engineering	Superior	Good	Good
Plant Support	Superior	Superior	Superior

As proposed by the offeror, both MOX and LEU fuel assemblies would be loaded into the reactor. The MOX fuel assemblies are scheduled to remain in the core for two 18-month cycles and the LEU assemblies for either two or three cycles. After completing a normal (full) fuel cycle, the spent MOX fuel assemblies would be removed from the reactor in accordance with the plant's standard refueling procedures and placed in the plant's spent fuel pool for cooling along with other spent fuel. The offeror has stated that no changes are expected in the plant's spent fuel storage plans to accommodate the spent MOX fuel. Eventually, the fuel would be shipped to a potential geologic repository to be developed by DOE for permanent disposal of commercial spent fuel.

4.0 ENVIRONMENTAL IMPACTS

Human health risk, waste management, land use, infrastructure requirements, accidents, air quality, water quality, and socioeconomics have been evaluated in this Synopsis. Cultural, paleontological and ecological resources, and transportation requirements are not expected to be impacted other than as discussed in the SPD Draft EIS and were not evaluated in this Synopsis. Although four sites are being considered by DOE for the proposed MOX facility, this Environmental Synopsis focuses primarily on environmental impacts at DOE's Savannah River Site (SRS) for the potential MOX facility because, as stated in Section 1.6 of the SPD Draft EIS, it is DOE's preferred location for the MOX facility. However, this Synopsis also discusses non-radiological impacts at other potential MOX facility sites, where appropriate. Unless otherwise noted, impacts would likely be similar at other sites.

4.1 MOX Fuel Fabrication Facility

4.1.1 Human Health Risk

The annual radiological dose from normal operations to the general population residing within 50 miles of the proposed MOX facility at the preferred site, SRS, was calculated based on radiological emissions estimated by the offeror. The major contributor to this dose would be attributable to the offeror's estimated annual release of 0.25 mg of plutonium.⁷ In contrast to the "atmospheric release only" assumption presented in the SPD Draft EIS, the MOX facility data provided by the offeror includes both liquid and airborne releases because the proposed process includes some aqueous processing. Table 3 shows the projected radiological dose that would be received by the general population as a result of normal operations of the MOX facility proposed by the offeror.

The average individual living within 50 miles of the SRS site would be expected to receive an annual dose of 2.3×10^{-4} mrem/yr from normal operation of the MOX facility. The maximally exposed individual (MEI) would be expected to receive an annual dose of 3.7×10^{-3} mrem/yr from operation of the MOX facility at SRS. This dose is well below regulatory limits, which require doses resulting from DOE operations to be below 10 mrem/yr from airborne pathways, 4 mrem/yr from drinking water pathways, and 100 mrem/yr from all pathways combined. The additional dose to the general population would also be small in comparison with the average dose received from other SRS activities. For example, in 1997, the average individual living within 50 miles of SRS received a dose of 1.4×10^{-2} mrem/yr from site activities. (SPD Draft EIS, pg. 3-141)

⁷The isotopic distribution of the potential plutonium releases were modeled based on the isotopic distribution developed by Los Alamos National Laboratory for use in the SPD Draft EIS.

Table 3. Estimated Radiological Impacts on the Public from Operations of the MOX Facility at SRS

	Maximally Exposed Ind. (mrem/yr)	Latent Fatal Cancer Risk from 10 Year Operating Life	Est. Dose to Pop. within 50 mi. radius (person-rem/yr)	Latent Fatal Cancers from 10 Year Operating Life	Avg. Dose to Ind. within 50 mi. radius (mrem/yr)	Latent Fatal Cancer Risk from 10 Year Operating Life
Offeror	3.7×10^{-3}	1.9×10^{-8}	0.181	9.1×10^{-4}	2.3×10^{-4}	1.2×10^{-9}
SPD Draft EIS*	3.1×10^{-4}	1.6×10^{-9}	0.029	1.5×10^{-4}	3.7×10^{-5}	1.9×10^{-10}
SRS Base**	0.2	1.0×10^{-6}	8.6	4.3×10^{-2}	1.4×10^{-2}	7.0×10^{-8}

* Includes contributions from polishing process discussed in Appendix N in addition to those shown in Chapter 4.

** SPD Draft EIS pg. 3-141

Table 4 shows the potential radiological impacts on involved workers at the proposed MOX facility conservatively calculated from 1997 data from the offeror’s European operating facility. As shown in Table 4, the average radiation worker at the offeror’s proposed MOX facility would receive an annual dose of 65 mrem/yr from normal operations. The offeror has stated that in 1997 the maximum dose to an individual worker at the offeror’s MOX facility was 885 mrem, well below the DOE administrative control level of 2,000 mrem/yr and the Federal regulatory limit of 5,000 mrem/yr. The offeror also estimates that fewer radiation workers would be needed to operate the MOX facility than indicated in the SPD Draft EIS. The offeror estimates that approximately 330 radiation workers would be required, rather than the 410 estimated in the SPD Draft EIS.⁸

Table 4. Potential Radiological Impacts on Involved Workers from Operations of the MOX Facility

	No. of Radiation Workers	Average Worker Dose (mrem/yr)	Latent Fatal Cancer Risk from 10 Years of Operation	Total Dose to Workers (person-rem/yr)	Latent Fatal Cancers from 10 Years of Operations
Offeror	330	65	2.6×10^{-4}	22	0.088
SPD Draft EIS*	410	500	2.0×10^{-3}	205	0.82
SRS Base**	12,500	19	7.6×10^{-5}	237	0.95

* Includes contributions from polishing process discussed in Appendix N in addition to the doses shown in Chapter 4.

** SPD Draft EIS pg. 3-142.

4.1.2 Accidents

Design-basis and beyond-design-basis accidents were evaluated in the SPD Draft EIS for the MOX facility and the aqueous plutonium polishing process. Accidents evaluated for the MOX facility included a criticality, fires, and earthquakes. A spill, an uncontrolled reaction resulting in an explosion, a criticality, and an earthquake were evaluated for the plutonium polishing process. Any of these accidents could occur

⁸ Although it is estimated that about 385 personnel would be required to operate the facility, only about 330 of the 385 would be considered radiation workers.

in the proposed MOX facility since it would use similar processes.

Including the plutonium polishing process in the MOX facility as proposed by the offeror would make a criticality the bounding design-basis accident for the facility. As shown in Table 5, no major radiological impacts to the general population would be expected from design-basis accidents at the proposed MOX facility. The frequency of this accident, a criticality in solution, is estimated to be between 1 in 10,000 and 1 in 1,000,000 per year.

The bounding beyond-design-basis accident would be an earthquake of sufficient magnitude to collapse the MOX facility. An earthquake of this magnitude would be expected to result in major radiological impacts. However, an earthquake of this magnitude would also be expected to result in widespread damage across the site and throughout the surrounding area. The frequency of an earthquake of this magnitude is estimated to be between 1 in 100,000 and 1 in 10,000,000 per year. Table 5 shows the impact of this accident on SRS. At the other candidate sites, the estimated dose to the general population from this accident would range from $2.0H10^3$ to $5.7H10^4$ with the corresponding number of LCFs expected to range from 1.0 to 28 LCFs. The maximum dose to a person at the site boundary at the time of the accident would be expected to range from 16 to 25 rem with a corresponding risk of latent cancer fatality of $8.0H10^{-3}$ to $1.2H10^{-2}$. A noninvolved worker would be exposed to a dose in the range of $2.2H10^2$ to $6.4H10^2$ rem with a corresponding risk of latent cancer fatality of $8.8H10^{-2}$ to $2.3H10^{-1}$.

Table 5. Bounding Accidents for the Proposed MOX Facility

	Noninvolved Worker (rem)	Probability of Cancer Fatality per Accident	Estimated Dose at Site Boundary (rem)	Probability of Cancer Fatality per Accident	Estimated Dose to Pop. Within 50 mi. radius (person-rem)	Latent Cancer Fatalities per Accident
Criticality at SRS*	3.0×10^{-1}	1.2×10^{-4}	1.6×10^{-2}	8.0×10^{-6}	1.6×10^1	8.0×10^{-3}
Beyond-design-basis earthquake**	2.2×10^2	8.8×10^{-2}	8.9	4.5×10^{-3}	2.1×10^4	10.6

*SPD Draft EIS pg. N-15

**SPD Draft EIS pgs. K-50 and N-15

No major consequences for the maximally exposed involved worker would be expected from leaks, spills, and smaller fires. These accidents are such that involved workers would be able to evacuate immediately or would not be affected by the events. However, explosions could result in immediate injuries from flying debris, as well as the uptake of plutonium and uranium particulates through inhalation. If a criticality were to occur, workers within tens of meters could receive very high to fatal radiation exposures from the initial neutron burst. The dose would strongly depend on the magnitude of the criticality (number of fissions), the distance from the criticality, and the amount of shielding provided by the structures and equipment between the workers and the criticality. Earthquakes could also result in substantial consequences to workers, ranging from workers being killed by collapsing equipment and structures to high radiation exposures and uptakes of radionuclides. For all but the most severe accidents, immediate emergency response actions should reduce the magnitude of the consequences to workers near the accident.

4.1.3 Waste Management

The MOX facility would be expected to produce TRU waste, low-level radioactive waste (LLW), mixed LLW, hazardous waste and sanitary waste in the course of its normal operations. As shown in Table 6, the offeror’s estimated generation rates for radioactive wastes are consistent with those estimated in the SPD Draft EIS. None of these estimates is expected to impact the proposed sites in terms of their ability to handle these wastes. The ability to store, treat, and/or dispose of radioactive waste is limited at Pantex. If Pantex were chosen as the site for the MOX facility, the wastes would presumably be handled as discussed in the SPD Draft EIS. TRU waste would have to be stored in the MOX facility until it could be shipped to the Waste Isolation Pilot Plant (WIPP) for permanent disposal. Mixed LLW would be handled in the same manner as current mixed waste that is shipped offsite for treatment and disposal. LLW would be treated and stored onsite until shipped to the Nevada Test Site or a commercial facility for disposal.⁹

Table 6. Estimated Annual Waste Generation Rates

	TRU Waste	Mixed LLW	LLW	Hazardous Waste	Sanitary Waste
Offeror					
Liquid (l/yr)	500	0	300	1,200	11 million
Solid (m ³ /yr)	~67	3	94	0.1	150
SPD Draft EIS*					
Liquid (l/yr)	0.5	0.1	0.3	1,740	18 million
Solid (m ³ /yr)	~67	3	94	1.2	440
SRS Generation Rate**					
Liquid (l/yr)	na	na	na	Na	416 million
Solid (m ³ /yr)	431	1,135	10,043	74	6,670

na – not available

*Includes contributions from the polishing process discussed in Appendix N of the SPD Draft EIS, in addition to the wastes shown in Chapter 4.

**SPD Draft EIS pg. 3-130.

4.1.4 Land Use

It is estimated that a total of 6.2 hectares (15.3 acres) would be needed for the MOX facility. This estimate includes 1.0 hectares (2.5 acres) for the process building, 0.2 hectares (0.58 acres) for support facilities, and 5 hectares (12.4 acres) for parking and a security buffer. This is very close to the 6.0 hectares (14.9 acres) estimated in the SPD Draft EIS (pg. E-10). As indicated in the SPD Draft EIS, there is sufficient space available to accommodate the proposed MOX facility at any of the candidate sites.

⁹ DOE would ensure that any such disposal would be consistent with the RODs for the *Final Waste Management Programmatic Environmental Impact Statement for Managing Treatment, Storage, and Disposal of Radioactive and Hazardous Waste*, DOE/EIS-0200F, May 1997.

4.1.5 Infrastructure Requirements

The proposed MOX facility would use electricity, natural gas, water, and fuel oil. As shown in Table 7, the offeror’s proposed facility would use more of these materials than estimated in the SPD Draft EIS.

Table 7. Estimated MOX Facility Infrastructure Requirements

	Electricity (MWh/yr)	Natural Gas (m ³ /yr)	Water (10 ⁶ l/yr)	Fuel Oil (l/yr)
Offeror	30,000	1,070,000	68	63,000
SPD Draft EIS*	17,520	920,000	44	43,000
SRS F-Area Available Capacity**	482,700	na***	1,216	na****

*Includes contributions from the polishing process as discussed in Appendix N in addition to the infrastructure requirements shown in Chapter 4.

**SPD Draft EIS pg. 3-165.

***Heat in F-Area provided by steam.

****Fuel oil trucked in as needed and stored at MOX facility.

4.1.5 Air Quality

Operation of the proposed MOX facility would result in the release of a small amount of nonradiological air pollutants that would be expected to slightly increase the ambient air pollutant concentrations at the selected site. The majority of these pollutants would be associated with routine maintenance and testing runs of the facility’s emergency diesel generator and emissions from facility heating. Table 8 shows the estimated increases in ambient air pollutant concentrations for the proposed facility and the national standards for these pollutants. The projected emissions are a very small fraction of the national standards. Although some small radionuclide discharges are expected from the proposed MOX facility, these discharges are not expected to have a major impact on air quality. As explained in Section 4.1.1, these discharges would result in a very small dose to the general public.

Table 8. Estimated Nonradiological Ambient Air Pollutant Concentrations from the Proposed MOX Facility

	Carbon Monoxide 8 hour 1 hour	Nitrogen Dioxide Annual	PM ₁₀ Annual 24 hour	Sulfur Dioxide Annual 24 hour 3 hour
National Ambient Air Quality Standards ($\mu\text{g}/\text{m}^3$)	10,000 40,000	100	50 150	80 365 1,300
Offeror ($\mu\text{g}/\text{m}^3$)	0.123 0.371	0.011	0.001 0.011	0.039 0.531 1.39
SPD Draft EIS* ($\mu\text{g}/\text{m}^3$)	0.109 0.345	0.011	0.001 0.010	0.031 0.420 1.11
SRS Base** ($\mu\text{g}/\text{m}^3$)	64 279	9.3	4.14 56.4	15.1 219 962

*Includes contributions from the polishing process discussed in Appendix N in addition to the pollutant concentrations shown in Chapter 4.

**SPD Draft EIS pg. 4-6

4.1.6 Water Quality

Table 9 shows a comparison of water resources information described in the SPD Draft EIS to that provided by the offeror. Although the proposed water use is higher than that analyzed in the SPD Draft EIS, the amount of water needed is estimated to be from 0.9 to 6.0 percent of the site’s estimated annual water requirements. Therefore, the additional water use is not expected to have a major impact on water resources. Although some small radionuclide discharges are expected from the proposed MOX facility, these discharges are not expected to have a major impact on water quality. As explained in Section 4.1.1, these discharges would result in a very small dose to the general public.

Table 9. Comparison of Water Resources Information for the MOX Facility

	Water Use (10 ⁶ liters/yr)	Sanitary Wastewater Discharged (10 ⁶ liters/yr)	Radionuclide Emissions to Water (Ci)
SPD Draft EIS	44	18	0
Offeror	68	11	0.0025

4.1.7 Socioeconomics

The proposed MOX facility would employ about 385 workers, somewhat fewer than the 435 workers estimated in the SPD Draft EIS. An increase of 385 workers would not be expected to have a major impact on any of the candidate sites. At three of the four candidate sites (i.e., INEEL, Pantex, and SRS), the workforce is projected to be falling at the same time the proposed MOX facility would begin operations. The additional MOX facility workers would help mitigate the negative socioeconomic impacts

associated with such reductions. The SPD Draft EIS concluded that, at Hanford, although the increase in workforce requirements for proposed surplus plutonium disposition facilities (including MOX) would coincide with an increase in the site’s overall workforce (as a result of the planned tank waste remediation system), the projected changes would not have a major impact on the level of community services currently offered in the region of influence. (SPD Draft EIS pg. 4-37)

4.2 Proposed Reactor Sites

The offeror is proposing to use a partial MOX core (up to approximately 40 percent of the fuel in the core at equilibrium) in each of the proposed reactors. The S&D PEIS analyzed a full MOX core at a generic reactor site.

4.2.1 Human Health Risk

Risk to human health was assessed for the proposed reactor sites based on information provided by the offeror and compared to the generic reactor information in the S&D PEIS. The offeror stated that there would be no difference in dose to the general public from normal operations based on the use of MOX fuel versus LEU fuel in the proposed reactors. This is consistent with findings in the S&D PEIS that showed a very small range in the expected difference (-1.1×10^{-2} to 2×10^{-2} person-rem, S&D PEIS pg. 4-729). The doses shown in this section reflect the projected dose in the year 2015.

The annual radiological dose from normal operations to the general population residing within 50 miles of the proposed reactor sites was estimated based on radiological emissions estimated by the offeror. As shown in Table 10, the average individual living within 50 miles of one of the proposed reactor sites could expect to receive an annual dose of between 2.7×10^{-3} to 9.9×10^{-3} mrem/yr from normal operation of these reactors regardless of whether the reactors were using MOX fuel or LEU fuel.

Table 10. Estimated Dose to the General Population from Normal Operations of the Proposed Reactors in the Year 2015 (Partial MOX or LEU Core)

	Maximally Exposed Individual (mrem/yr)	Latent Fatal Cancer Risk	Est. Dose to Pop. within 50 mi. radius (person-rem/yr)	Annual Number of Latent Cancer Fatalities	Avg. Dose to Ind. within 50 mi. radius (mrem/yr)
Catawba ^a	0.73	3.7×10^{-7}	6.1	3.1×10^{-3}	2.7×10^{-3}
McGuire ^b	0.31	1.6×10^{-7}	10.7	5.4×10^{-3}	4.2×10^{-3}
North Anna ^c	0.37	1.9×10^{-7}	20.3	1.0×10^{-2}	9.9×10^{-3}
S&D PEIS (high)*	0.17	8.5×10^{-8}	2.0	1.0×10^{-3}	7.8×10^{-4}

*S&D PEIS pg. 4-729

^aThe population for the year 2015 is estimated to be 2,265,000.

^bThe population for the year 2015 is estimated to be 2,575,000.

^cThe population for the year 2015 is estimated to be 2,042,000.

The offeror also stated that the workers at the proposed reactor sites would be expected to receive about the same amount of radiation dose as a result of their job activities regardless of the plant’s decision to use

MOX fuel. As shown in Table 11, the average radiation worker at the proposed reactor sites could expect to receive an annual dose of between 46 and 123 mrem/yr from normal operations. This is lower than the worker dose range estimated in the S&D PEIS (281 to 543 mrem/yr). The offeror’s statement that the use of MOX fuel would not change the estimated worker dose is consistent with data presented in the S&D PEIS that showed an incremental increase in worker dose of less than 0.1 percent due to the use of MOX fuel. (S&D PEIS pg. 4-730)

Table 11. Estimated Dose to Workers from Normal Operations of the Proposed Reactors with MOX Fuel

	No. of Radiation Workers*	Total Dose to Workers (person-rem/year)	Annual Number of Latent Cancer Fatalities	Average Worker Dose (mrem/yr)	Annual Latent Fatal Cancer Risk
Catawba	3,400	265	0.11	78	3.1×10^{-5}
McGuire	4,000	492	0.20	123	4.9×10^{-5}
North Anna	2,240	103	0.041	46	1.8×10^{-5}
S&D PEIS (high)**	2,220	1,204	0.48	543	2.2×10^{-4}

*The number of radiation workers at the proposed reactor sites was estimated based on the total dose to workers given by the offeror divided by the average worker dose, also supplied by the offeror.

**S&D PEIS pg. 4-730; adjusted to reflect a two reactor site for comparison to the proposed reactor sites.

4.2.2 Accidents

Two design-basis accidents, a large break loss-of-coolant accident (LOCA) and a fuel handling accident (FHA), were evaluated for the Environmental Critique and are reflected in this Synopsis. These accidents were chosen because they are the limiting reactor and non-reactor design-basis accidents at the proposed facilities. As shown in Tables 12 through 14, only small increases in the estimated impacts would be expected from a LOCA at the proposed reactor sites due to the use of MOX fuel. In a FHA, the consequences (defined as latent cancer fatalities) would decrease as a result of using MOX fuel rather than LEU fuel. This is because the end-of-cycle krypton inventory is less in MOX fuel than in LEU fuel and krypton is one of the greatest contributors to radiation dose from a FHA.

Beyond-design-basis accidents, if they were to occur, would be expected to result in major impacts to workers, the surrounding communities, and the environment regardless of whether the reactor was using a LEU or a partial MOX core. As shown in Tables 15 through 17, the probability of a beyond-design-basis accident happening and the risk to an individual living within 50 miles of the proposed reactors is very low.

The largest estimated risk of a latent cancer fatality for the maximally exposed individual (MEI) at any of the proposed reactors is estimated to be 2.86×10^{-5} for a steam generator tube rupture at one of the North Anna reactors when using a partial MOX core. If this same accident were to happen at the reactor when it was using a LEU core, the estimated risk would be 2.46×10^{-5} . In either case, the risk of a latent cancer fatality is estimated to be less than 3 in 100,000 over the 16 year period the reactors would be using MOX fuel.

For beyond-design-basis accidents, the scenarios that lead to containment bypass or failure were evaluated because these are the accidents with the greatest potential consequences. The public and environmental consequences would be significantly less for accident scenarios that do not lead to containment bypass or failure. A steam generator tube rupture, early containment failure, late containment failure, and an interfacing systems loss-of-coolant accident (ISLOCA) were chosen as the representative set of beyond-design-basis accidents.

Commercial reactors, licensed by the NRC are required to complete Individual Plant Examinations (IPE) to assess plant vulnerabilities to severe accidents. An acceptable method of completing the IPEs is to perform a probabilistic risk assessment (PRA). A PRA analysis evaluates, in full detail (quantitatively), the consequences of all potential events caused by the operating disturbances (known as internal initiating events) within each plant. The PRA uses realistic criteria and assumptions in evaluating the accident progression and the systems required to mitigate each accident. The PRAs for the proposed reactors provided the required data to evaluate beyond-design-basis accidents.

As shown in Table 18, the difference in accident consequences for reactors using MOX fuel versus LEU fuel is generally very small. For beyond-design-basis accidents, the consequences would be expected to be slightly higher, with the largest increase associated with an ISLOCA. This is because the MOX fuel will release a higher actinide inventory in a severe accident. The impacts of an ISLOCA are estimated to be about 10 to 15 percent (an average of about 13 percent) greater to the general population living within 50 miles of the reactor operating with a partial MOX core instead of a LEU core. It should be noted that this accident has a very low estimated frequency of occurrence, an average of 1 in 3.2 million per year of reactor operation for the reactors being proposed.

Table 12. Design-Basis Accident Impacts for Catawba with LEU and Mixed Oxide Fuels

Accident Release Scenario	Accident Scenario Frequency (per year)	LEU or MOX Core	Noninvolved Worker			Maximally Exposed Offsite Individual			Population		
			Dose (rem)	Probability of Latent Cancer Fatality Given Dose to Noninvolved Worker ¹	Risk of Latent Cancer Fatality (over campaign) ²	Dose (rem)	Probability of Latent Cancer Fatality Given Dose at Site Boundary ¹	Risk of Latent Cancer Fatality (over campaign) ²	Dose (person-rem)	Number of Latent Cancer Fatalities in the Population within 80 km ³	Risk of Latent Cancer Fatalities (over campaign) ⁴
Loss-of-Coolant Accident	7.50x10 ⁻⁶	LEU	3.78	1.51x10 ⁻³	1.81x10 ⁻⁷	1.44	7.20x10 ⁻⁴	8.64x10 ⁻⁸	3.64x10 ⁺³	1.82	2.19x10 ⁻⁴
		MOX	3.85	1.54x10 ⁻³	1.86x10 ⁻⁷	1.48	7.40x10 ⁻⁴	8.88x10 ⁻⁸	3.75x10 ⁺³	1.88	2.26x10 ⁻⁴
Spent Fuel Handling Accident ⁵	1.00x10 ⁻⁴	LEU	0.275	1.10x10 ⁻⁴	1.78x10 ⁻⁷	0.138	6.90x10 ⁻⁵	1.10x10 ⁻⁷	1.12x10 ⁺²	5.61x10 ⁻²	8.98x10 ⁻⁵
		MOX	0.262	1.05x10 ⁻⁴	1.68x10 ⁻⁷	0.131	6.55x10 ⁻⁵	1.05x10 ⁻⁷	1.10x10 ⁺²	5.48x10 ⁻²	8.77x10 ⁻⁵

¹ Increased likelihood (probability) of cancer fatality to a hypothetical individual - a noninvolved worker at a distance of 640 meters or the maximally exposed offsite individual located at the site boundary (762 m) - if exposed to the indicated dose.

² Increased likelihood (probability) of cancer fatality over the estimated 16 year campaign (frequency weighted) to a hypothetical individual - a noninvolved worker at a distance of 640 meters or the maximally exposed offsite individual located at the site boundary (762 m).

³ Estimated number of cancer fatalities in the entire offsite population out to a distance of 80 kilometers (50 miles) if exposed to the indicated dose.

⁴ Estimated number of cancer fatalities over the estimated 16 year campaign (frequency weighted) in the entire offsite population out to a distance of 80 kilometers (50 miles).

⁵ Accident scenario frequency estimated in lieu of plant specific data.

Table 13. Design-Basis Accident Impacts for McGuire with LEU and Mixed Oxide Fuels

			Noninvolved Worker			Maximally Exposed Offsite Individual			Population		
Accident Release Scenario	Accident Scenario Frequency (per year)	LEU or MOX Core	Dose (rem)	Probability of Latent Cancer Fatality Given Dose to Noninvolved Worker ¹	Risk of Latent Cancer Fatality (over campaign) ²	Dose (rem)	Probability of Latent Cancer Fatality Given Dose at Site Boundary ¹	Risk of Latent Cancer Fatality (over campaign) ²	Dose (person-rem)	Number of Latent Cancer Fatalities in the Population within 80 km ³	Risk of Latent Cancer Fatalities (over campaign) ⁴
Loss-of-Coolant Accident	1.50x10 ⁻⁵	LEU	5.31	2.12x10 ⁻³	5.10x10 ⁻⁷	2.28	1.14x10 ⁻³	2.74x10 ⁻⁷	3.37x10 ⁺³	1.68	4.03x10 ⁻⁴
		MOX	5.46	2.18x10 ⁻³	5.25x10 ⁻⁷	2.34	1.17x10 ⁻³	2.82x10 ⁻⁷	3.47x10 ⁺³	1.73	4.16x10 ⁻⁴
Spent Fuel Handling Accident ⁵	1.00x10 ⁻⁴	LEU	0.392	1.57x10 ⁻⁴	2.51x10 ⁻⁷	0.212	1.06x10 ⁻⁴	1.70x10 ⁻⁷	99.1	4.96x10 ⁻²	7.94x10 ⁻⁵
		MOX	0.373	1.49x10 ⁻⁴	2.38x10 ⁻⁷	0.201	1.01x10 ⁻⁴	1.62x10 ⁻⁷	97.3	4.87x10 ⁻²	7.79x10 ⁻⁵

¹ Increased likelihood (probability) of cancer fatality to a hypothetical individual - a noninvolved worker at a distance of 640 meters or the maximally exposed offsite individual located at the site boundary (762 m) - if exposed to the indicated dose.

² Increased likelihood (probability) of cancer fatality over the estimated 16 year campaign (frequency weighted) to a hypothetical individual - a noninvolved worker at a distance of 640 meters or the maximally exposed offsite individual located at the site boundary (762 m).

³ Estimated number of cancer fatalities in the entire offsite population out to a distance of 80 kilometers (50 miles) if exposed to the indicated dose.

⁴ Estimated number of cancer fatalities over the estimated 16 year campaign (frequency weighted) in the entire offsite population out to a distance of 80 kilometers (50 miles).

⁵ Accident scenario frequency estimated in lieu of plant specific data.

Table 14. Design-Basis Accident Impacts for North Anna with LEU and Mixed Oxide Fuels

Accident Release Scenario	Accident Scenario Frequency (per year)	LEU or MOX Core	Noninvolved Worker			Maximally Exposed Offsite Individual			Population		
			Dose (rem)	Probability of Latent Cancer Fatality Given Dose to Noninvolved Worker ¹	Risk of Latent Cancer Fatality (over campaign) ²	Dose (rem)	Probability of Latent Cancer Fatality Given Dose at Site Boundary ¹	Risk of Latent Cancer Fatality (over campaign) ²	Dose (person-rem)	Number of Latent Cancer Fatalities in the Population within 80 km ³	Risk of Latent Cancer Fatalities (over campaign) ⁴
Loss-of-Coolant Accident	2.10x10 ⁻⁵	LEU	0.114	4.56x10 ⁻⁵	1.53x10 ⁻⁸	3.18x10 ⁻²	1.59x10 ⁻⁵	5.34x10 ⁻⁹	39.4	1.97x10 ⁻²	6.62x10 ⁻⁶
		MOX	0.115	4.60x10 ⁻⁵	1.55x10 ⁻⁸	3.20x10 ⁻²	1.60x10 ⁻⁵	5.38x10 ⁻⁹	40.3	2.02x10 ⁻²	6.78x10 ⁻⁶
Spent Fuel Handling Accident ⁵	1.00x10 ⁻⁴	LEU	0.261	1.04x10 ⁻⁴	1.66x10 ⁻⁷	9.54x10 ⁻²	4.77x10 ⁻⁵	7.63x10 ⁻⁸	29.4	1.47x10 ⁻²	2.35x10 ⁻⁵
		MOX	0.239	9.56x10 ⁻⁵	1.53x10 ⁻⁷	8.61x10 ⁻²	4.31x10 ⁻⁵	6.90x10 ⁻⁸	27.5	1.38x10 ⁻²	2.21x10 ⁻⁵

¹ Increased likelihood (probability) of cancer fatality to a hypothetical individual - a noninvolved worker at a distance of 640 meters or the maximally exposed offsite individual located at the site boundary (1349 m) - if exposed to the indicated dose.

² Increased likelihood (probability) of cancer fatality over the estimated 16 year campaign (frequency weighted) to a hypothetical individual - a noninvolved worker at a distance of 640 meters or the maximally exposed offsite individual located at the site boundary (1349 m).

³ Estimated number of cancer fatalities in the entire offsite population out to a distance of 80 kilometers (50 miles) if exposed to the indicated dose.

⁴ Estimated number of cancer fatalities over the estimated 16 year campaign (frequency weighted) in the entire offsite population out to a distance of 80 kilometers (50 miles).

⁵ Accident scenario frequency estimated in lieu of plant specific data.

Table 15. Beyond-Design-Basis Accident Impacts for Catawba with LEU and Mixed Oxide Fuels

Accident Release Scenario	Accident Scenario Frequency (per year)	LEU or MOX Core	Maximally Exposed Offsite Individual			Population		
			Dose (rem)	Probability of Latent Cancer Fatality Given Dose at Site Boundary ¹	Risk of Latent Cancer Fatality (over campaign) ²	Dose (person-rem)	Number of Latent Cancer Fatalities in the Population within 80 km ³	Risk of Latent Cancer Fatalities (over campaign) ⁴
Steam Generator Tube Rupture ⁵	6.31×10 ⁻¹⁰	LEU	3.46×10 ⁺²	0.346	3.49×10 ⁻⁹	5.71×10 ⁺⁶	2.86×10 ⁺³	2.88×10 ⁻⁵
		MOX	3.67×10 ⁺²	0.367	3.71×10 ⁻⁹	5.93×10 ⁺⁶	2.96×10 ⁺³	2.99×10 ⁻⁵
Early Containment Failure	3.42×10 ⁻⁸	LEU	5.97	2.99×10 ⁻³	1.63×10 ⁻⁹	7.70×10 ⁺⁵	3.85×10 ⁺²	2.11×10 ⁻⁴
		MOX	6.01	3.01×10 ⁻³	1.65×10 ⁻⁹	8.07×10 ⁺⁵	4.04×10 ⁺²	2.21×10 ⁻⁴
Late Containment Failure	1.21×10 ⁻⁵	LEU	3.25	1.63×10 ⁻³	3.15×10 ⁻⁷	3.93×10 ⁺⁵	1.96×10 ⁺²	3.79×10 ⁻²
		MOX	3.48	1.74×10 ⁻³	3.38×10 ⁻⁷	3.78×10 ⁺⁵	1.89×10 ⁺²	3.66×10 ⁻²
Interfacing System Loss of Cooling Accident	6.90×10 ⁻⁸	LEU	1.40×10 ⁺⁴	1	1.10×10 ⁻⁶	2.64×10 ⁺⁷	1.32×10 ⁺⁴	1.46×10 ⁻²
		MOX	1.60×10 ⁺⁴	1	1.10×10 ⁻⁶	2.96×10 ⁺⁷	1.48×10 ⁺⁴	1.63×10 ⁻²

¹ Increased likelihood (probability) of cancer fatality to the maximally exposed offsite individual located at the site boundary (762 m) - if exposed to the indicated dose.

² Increased likelihood (probability) of cancer fatality over the estimated 16 year campaign (frequency weighted) to a hypothetical individual - a noninvolved worker at a distance of 640 meters or the maximally exposed offsite individual located at the site boundary (762 m).

³ Estimated number of cancer fatalities in the entire offsite population out to a distance of 80 kilometers (50 miles) if exposed to the indicated dose.

⁴ Estimated number of cancer fatalities over the estimated 16 year campaign (frequency weighted) in the entire offsite population out to a distance of 80 kilometers (50 miles).

⁵ McGuire timing and release fractions were used to compare like scenarios.

Table 16. Beyond-Design-Basis Accident Impacts for McGuire with LEU and Mixed Oxide Fuels

Accident Release Scenario	Accident Scenario Frequency (per year)	LEU or MOX Core	Maximally Exposed Offsite Individual			Population		
			Dose (rem)	Probability of Latent Cancer Fatality Given Dose at Site Boundary ¹	Risk of Latent Cancer Fatality (over campaign) ²	Dose (person-rem)	Number of Latent Cancer Fatalities in the Population within 80 km ³	Risk of Latent Cancer Fatalities (over campaign) ⁴
Steam Generator Tube Rupture	5.81×10 ⁻⁹	LEU	6.10×10 ⁺²	0.610	5.66×10 ⁻⁸	5.08×10 ⁺⁶	2.54×10 ⁺³	2.37×10 ⁻⁴
		MOX	6.47×10 ⁺²	0.647	6.02×10 ⁻⁸	5.28×10 ⁺⁶	2.64×10 ⁺³	2.45×10 ⁻⁴
Early Containment Failure	9.89×10 ⁻⁸	LEU	12.2	6.10×10 ⁻³	9.65×10 ⁻⁹	7.90×10 ⁺⁵	3.95×10 ⁺²	6.26×10 ⁻⁴
		MOX	12.6	6.30×10 ⁻³	9.97×10 ⁻⁹	8.04×10 ⁺⁵	4.02×10 ⁺²	6.37×10 ⁻⁴
Late Containment Failure	7.21×10 ⁻⁶	LEU	2.18	1.09×10 ⁻³	1.26×10 ⁻⁷	3.04×10 ⁺⁵	1.52×10 ⁺²	1.76×10 ⁻²
		MOX	2.21	1.11×10 ⁻³	1.28×10 ⁻⁷	2.96×10 ⁺⁵	1.48×10 ⁺²	1.71×10 ⁻²
Interfacing System Loss of Cooling Accident	6.35×10 ⁻⁷	LEU	1.95×10 ⁺⁴	1	1.02×10 ⁻⁵	1.79×10 ⁺⁷	8.93×10 ⁺³	0.091
		MOX	2.19×10 ⁺⁴	1	1.02×10 ⁻⁵	1.97×10 ⁺⁷	9.85×10 ⁺³	0.10

¹ Increased likelihood (probability) of cancer fatality to the maximally exposed offsite individual located at the site boundary (762 m) - if exposed to the indicated dose.

² Increased likelihood (probability) of cancer fatality over the estimated 16 year campaign (frequency weighted) to a hypothetical individual - a noninvolved worker at a distance of 640 meters or the maximally exposed offsite individual located at the site boundary (762 m).

³ Estimated number of cancer fatalities in the entire offsite population out to a distance of 80 kilometers (50 miles) if exposed to the indicated dose.

⁴ Estimated number of cancer fatalities over the estimated 16 year campaign (frequency weighted) in the entire offsite population out to a distance of 80 kilometers (50 miles).

Table 17. Beyond-Design-Basis Accident Impacts for North Anna with LEU and Mixed Oxide Fuels

Accident Release Scenario	Accident Scenario Frequency (per year)	LEU or MOX Core	Maximally Exposed Offsite Individual			Population		
			Dose (rem)	Probability of Latent Cancer Fatality Given Dose at Site Boundary ¹	Risk of Latent Cancer Fatality (over campaign) ²	Dose (person-rem)	Number of Latent Cancer Fatalities in the Population within 80 km ³	Risk of Latent Cancer Fatalities (over campaign) ⁴
Steam Generator Tube Rupture ⁵	7.38×10 ⁻⁶	LEU	2.09×10 ⁺²	0.209	2.46×10 ⁻⁵	1.73×10 ⁺⁶	8.63×10 ⁺²	0.102
		MOX	2.43×10 ⁺²	0.243	2.86×10 ⁻⁵	1.84×10 ⁺⁶	9.20×10 ⁺²	0.109
Early Containment Failure ⁵	1.60×10 ⁻⁷	LEU	19.6	1.96×10 ⁻²	5.02×10 ⁻⁸	8.33×10 ⁺⁵	4.17×10 ⁺²	1.07×10 ⁻³
		MOX	21.6	2.16×10 ⁻²	5.54×10 ⁻⁸	8.42×10 ⁺⁵	4.21×10 ⁺²	1.08×10 ⁻³
Late Containment Failure ⁵	2.46×10 ⁻⁶	LEU	1.12	5.60×10 ⁻⁴	2.21×10 ⁻⁸	4.04×10 ⁺⁴	20.2	7.95×10 ⁻⁴
		MOX	1.15	5.75×10 ⁻⁴	2.26×10 ⁻⁸	4.43×10 ⁺⁴	22.1	8.70×10 ⁻⁴
Interfacing System Loss of Cooling Accident ⁵	2.40×10 ⁻⁷	LEU	1.00×10 ⁺⁴	1	3.84×10 ⁻⁶	4.68×10 ⁺⁶	2.34×10 ⁺³	8.99×10 ⁻³
		MOX	1.22×10 ⁺⁴	1	3.84×10 ⁻⁶	5.41×10 ⁺⁶	2.70×10 ⁺³	1.04×10 ⁻²

¹ Increased likelihood (probability) of cancer fatality to the maximally exposed offsite individual located at the site boundary (1349 m) - if exposed to the indicated dose.

² Increased likelihood (probability) of cancer fatality over the estimated 16 year campaign (frequency weighted) to a hypothetical individual - a noninvolved worker at a distance of 640 meters or the maximally exposed offsite individual located at the site boundary (1349 m).

³ Estimated number of cancer fatalities in the entire offsite population out to a distance of 80 kilometers (50 miles) if exposed to the indicated dose.

⁴ Estimated number of cancer fatalities over the estimated 16 year campaign (frequency weighted) in the entire offsite population out to a distance of 80 kilometers (50 miles).

⁵ McGuire release durations and warning times were used in lieu of site specific data.

Table 18. Ratio of Accident Impacts for Mixed Oxide Fueled and Uranium Fueled Reactors (Mixed Oxide Impacts/LEU Impacts)

Accident Scenario	Catawba		McGuire		North Anna		S&D PEIS	
	MEI	Population	MEI	Population	MEI	Population	MEI	Population
Design-Basis Accidents								
Loss-of-Coolant Accident	1.03	1.03	1.01	1.03	1.03	1.03	NA	NA
Fuel Handling Accident	0.95	0.98	0.90	0.94	0.95	0.98	NA	NA
Beyond-Design-Basis Accidents								
Steam Generator Tube Rupture	1.06	1.04	1.16	1.07	1.06	1.04	0.94	0.94
Early Containment Failure	1.01	1.05	1.10	1.01	1.03	1.02	0.96	0.97
Late Containment Failure	1.07	0.96	1.03	1.09	1.01	0.97	1.07	1.08
Interfacing System Loss of Cooling Accident	1.14	1.12	1.22	1.15	1.12	1.10	0.92	0.93

Key: MEI – Maximally Exposed Individual; NA – not available

Note: The number 1 represents the consequences equal to the accident occurring in the proposed reactors with an LEU core

Table 19 shows the number of prompt fatalities estimated from a postulated ISLOCA and a beyond-design-basis steam generator tube rupture. As shown in this table, the differences due to the use of MOX fuel rather than LEU are small. None of the other accidents evaluated in this Synopsis are expected to result in prompt fatalities.

Table 19. Estimated Prompt Fatalities from Beyond-Design-Basis Reactor Accidents

Reactor Site	LEU Core	MOX Core
Steam Generator Tube Rupture		
Catawba	1	1
McGuire	1	1
North Anna	0	0
Interfacing System Loss of Cooling Accident		
Catawba	815	843
McGuire	398	421
North Anna	54	60

4.2.3 Waste Management

The proposed reactors would be expected to continue to produce mixed LLW, LLW, hazardous waste, and nonhazardous waste as part of their normal operations. According to the offeror, the volume of waste generated is not expected to increase as a result of the reactors using MOX fuel. This is consistent with information presented in the S&D PEIS that stated the use of MOX fuel is not expected to increase the amount or change the content of the waste being generated. (S&D PEIS, pg. 4-734) Table 20 shows the annual waste volume that would be generated during operation of the proposed reactors.

Table 20. Estimated Waste Generation Rates

Reactor Site	Mixed LLW (m ³ /yr)	LLW (m ³ /yr)	Hazardous Waste (m ³ /yr)	Nonhazardous Waste Solid (m ³ /yr)
Catawba (per unit)	0.3	25	15	455
McGuire (per unit)	0.1	21	14	568
North Anna (per unit)	0.0	118	6	5,200
S&D PEIS*	na	178	na	na

na - not available.

*S&D PEIS pg. 4-734.

As shown in Table 20, the estimated LLW generation for each of the proposed reactors is less than the amount estimated in the S&D PEIS. None of these waste estimates are expected to impact the proposed reactor sites in terms of their ability to handle these wastes. The wastes would continue to be handled in the same manner as they are today with no change required due to the use of MOX fuel at the reactors.

4.2.4 Spent Fuel

As shown in Table 21, it is likely that some additional spent fuel would be generated by using a partial MOX core in the proposed reactors. The amount of additional spent nuclear fuel generated is estimated to range from approximately 2 to 16 percent of the total amount of spent fuel that would be generated by the proposed reactors during the time period MOX fuel would be used. The offeror intends to manage the spent MOX fuel the same as its spent LEU fuel, by storing it in the reactor’s spent fuel pool or in dry storage. According to the offeror, the amount of additional spent fuel is not expected to impact spent fuel management at the reactor sites.

Table 21. Total Additional Spent Fuel Assemblies Generated for the MOX Fuel Option

	Number of Spent Fuel Assemblies Generated with no MOX Fuel	Number of Additional Spent Fuel Assemblies with MOX Fuel	Percent Increase
<i>S&D PEIS (based on a shorter fuel cycle)</i>			
Typical PWR*	48/yr	32/yr	66.7%
<i>Offeror’s Reactors</i>			
Total Over MOX Campaign	3,732	199	5.3%

*S&D PEIS pg. 4-734

For the four units at Catawba and McGuire, all of the additional spent nuclear fuel assemblies would be generated during the transition cycles from LEU to MOX fuel. Additional assemblies help to maintain peaking below design and regulatory limits, and compensate for the greater end-of-cycle reactivity. Once equilibrium is reached in the partial MOX core, additional fuel assemblies would not be required.

Like Catawba and McGuire, the North Anna units are expected to require additional LEU assemblies during the first transition cores. However, additional assemblies will also be required during equilibrium cycles because the smaller North Anna cores (157 fuel assemblies compared to 193 each for the McGuire and Catawba units) are more prone to neutron leakage and provide less flexibility with respect to meeting power peaking limits.

As designs are finalized and optimized for MOX fuel it may be possible to reduce MOX fuel assembly peaking and thereby reduce the number of additional assemblies required (and spent fuel generated) at the proposed reactors. As it currently stands, the North Anna site could generate approximately 16 percent more spent fuel by using MOX fuel than if the plants continued to use LEU fuel. The total amount of additional spent fuel generated by all six proposed reactors is estimated to be approximately 92 metric tons heavy metal. However, such MOX spent fuel is included in the inventory for the potential Nuclear Waste Policy Act geologic repository being studied by DOE. DOE is in the process of completing an environmental impact statement for a geologic repository.

4.2.5 Land Use

The offeror has stated that the proposed reactor sites would not require any additional land to support the use of MOX fuel in their reactors. This statement is consistent with information presented in the S&D PEIS. (S&D PEIS, pg. 4-720)

4.2.6 Infrastructure Requirements

The offeror has stated that the proposed reactor sites would not require any additional infrastructure to support the use of MOX fuel in their reactors. This statement is consistent with information presented in the S&D PEIS. (S&D PEIS, pg. 4-721)

4.2.7 Air Quality

Continued operation of the proposed reactor sites would result in a small amount of nonradiological air pollutants being released to the atmosphere, mainly due to the requirement to periodically test emergency diesel generators. The estimated air pollutants resulting from operation of the proposed reactors would not be expected to increase due to the use of MOX fuel in these reactors. Table 22 shows the estimated air pollutant concentrations and the national standards for these pollutants at the proposed sites. The impact of radiological releases is included in Section 4.2.1.

Table 22. Nonradiological Ambient Air Pollutant Concentrations with or without MOX Fuel from the Continued Operation of the Proposed Reactors

	Carbon Monoxide 8 hour 1 hour	Nitrogen Dioxide Annual	PM ₁₀ Annual 24 hour	Sulfur Dioxide Annual 24 hour 3 hour
National Ambient Air Quality Standards (µg/m ³)	10,000 40,000	100	50 150	80 365 1,300
Catawba (µg/m ³)	978 1400	3.26	0.102 65.4	0.0418 26.9 60.4
McGuire (µg/m ³)	1060 1510	2.6	0.08 71.2	0.03 29.9 67.4
North Anna (µg/m ³)	416 594	0.01	0.004 15.4	0.02 63 142

4.2.8 Water Quality

The offeror stated that there would be no change in water usage or discharge of nonradiological pollutants resulting from use of MOX fuel in the proposed reactors. Each of the reactor sites discharges nonradiological wastewater in accordance with a National Pollutant Discharge Elimination System

(NPDES) Permit, or an analogous state-issued permit. Permitted outfalls discharge conventional and priority pollutants from the reactor and ancillary processes that are similar to discharges from most reactor sites. Discharge Monitoring Reports (DMRs) for North Anna (May 1994 through April 1998) and Catawba (calendar years 1995 through 1997) showed that for the most part, there were only occasional noncompliances with permit limitations, only one of which occurred at an outfall receiving reactor process discharges. (The offeror did not provide DMRs for McGuire.) During the period reviewed, Catawba experienced four noncompliances, two in 1995 and two in early 1996. North Anna has exceeded the chlorine limitation at its sewage treatment facility, but this would neither affect nor be affected by, the use of MOX fuel. The impact of radiological releases is included in Section 4.2.1.

4.2.9 Socioeconomics

The offeror has stated that the proposed reactor sites would not need to employ any additional workers to support the use of MOX fuel in their reactors so there would not be any expected socioeconomic impacts. This statement is consistent with information presented in the S&D PEIS which concluded that the use of MOX fuel could result in small increases in the worker population at the reactor sites (between 40 and 105), but that any increase would be filled from the area's existing workforce. Therefore, there would be little impact on the local economy and communities (S&D PEIS, pgs. 4-727).

5.0 REQUIRED PERMITS AND LICENSES

Both the MOX fabrication facility and the selected reactors will require permitting and licensing activities to support the proposed fabrication and use of MOX fuel. The MOX fabrication facility will be constructed and operated at an existing DOE-owned site, but will be licensed by the NRC. The selected reactors are all U.S. operating, commercial PWRs, licensed by the NRC. The MOX facility, in particular, has special licensing considerations apart from most facilities that are built and operated in the United States today. This section discusses the particular licensing and permitting requirements of both facilities.

Both DOE and NRC have their origins in the Atomic Energy Act (AEA). The AEA first established their predecessor agency, the Atomic Energy Commission (AEC) to promote and regulate the use of atomic energy in the United States. The AEC was subsequently split into two organizations that have since become DOE and NRC. DOE was authorized to manage defense-related nuclear activities, while NRC was given the responsibility of regulating civilian uses of nuclear materials. Both DOE and NRC publish their regulations in Title 10 of the *Code of Federal Regulations* (10 CFR), with NRC publishing in Parts 0–199, and DOE, Parts 200–1099. DOE supplements its regulations with a series of Orders, while NRC uses Regulatory Guides to further establish specific methods of implementation of its regulations. The proposed actions that are the subject of this Synopsis are unique in that DOE and NRC each have regulatory responsibility for certain parts of the activities.

The AEA authorizes DOE to establish standards to protect health or minimize dangers to life or property for activities under DOE's jurisdiction. Through a series of DOE orders and regulations, an extensive system of standards and requirements has been established to ensure safe operation of facilities. The DOE orders have been revised and reorganized to reduce duplication and eliminate obsolete provisions (though some older orders remain in effect during the transition). For DOE orders, the new organization is by Series and is generally intended to include all DOE policies, manuals, requirements documents, notices,

guides, and orders. For proposed actions involving fuel qualification, relevant DOE regulations include 10 CFR 820, Procedural Rules for DOE Nuclear Activities; 10 CFR 830, Nuclear Safety Management; 10 CFR.834, Radiation Protection of the Public and the Environment (Draft); 10 CFR 835, Occupational Radiation Protection; 10 CFR 1021, Compliance with the National Environmental Policy Act; and 10 CFR 1022, Compliance with Floodplains/Wetlands Environmental Review Requirements. DOE orders include those in new Series 400, which deals with Work Process; and within this Series, DOE Order 420.1 addresses Facility Safety; 425.1 addresses Startup and Restart of Nuclear Facilities; 452.1A addresses Nuclear Explosive and Weapons Surety Programs; 452.2A addresses the Safety of Nuclear Explosives Operations; 452.4 addresses the Security and Control of Nuclear Explosives; 460.1A addresses Packaging and Transportation Safety; 470.1 addresses the Safeguards and Security Program; and 474.1 addresses the Control and Accountability of Nuclear Materials. In addition, DOE (older number) Series 5400 addresses environmental, safety, and health programs for DOE operations. Not all of these DOE regulations and orders would apply to operation of the proposed MOX fuel fabrication facility, and most would not apply to use of the proposed reactors.

There are a number of Federal environmental statutes dealing with environmental protection, compliance, or consultation. In addition, certain environmental requirements have been delegated to state authorities for enforcement and implementation. Certain statutes and regulations require DOE to consult with Federal, State, and local agencies and federally recognized Native American groups. Most of these consultations are related to biotic resources, cultural resources, and Native American resources. Biotic resources consultations generally pertain to the potential for activities to disturb sensitive species or habitats. Cultural resources consultations relate to the potential for disruption of important cultural resources and archaeological sites. Finally, Native American consultations are concerned with the potential for disturbance of Native American sites and resources. DOE has conducted appropriate consultations at the candidate sites and will report the results of these consultations in the SPD Final EIS.

It is DOE policy to conduct its operations in an environmentally safe manner in compliance with all applicable statutes, regulations, and standards. Although this chapter does not address pending or future regulations, DOE recognizes that the regulatory environment is subject to change, and that the construction, operation, and decommissioning of any surplus plutonium disposition facility must be conducted in compliance with all applicable regulations and standards.

5.1 Regulatory Activities

It is likely that new or modified permits will be needed before the proposed surplus plutonium disposition facilities may be constructed or operated. Permits regulate many aspects of facility construction and operations, including the quality of construction, treatment and storage of hazardous waste, and discharges of effluents to the environment. These permits will be obtained from appropriate Federal, state, and local agencies. NRC issues operating licenses for major facilities such as commercial nuclear power reactors and fuel fabrication facilities, although the regulations under which these two facilities would be licensed are different.

5.1.1 The MOX Facility

The MOX facility would be licensed to operate by NRC under its regulations at 10 CFR 70, *Domestic Licensing of Special Nuclear Materials*. Because the facility would be located at a DOE site, however,

certain DOE requirements affecting site interfaces and infrastructure will also be applicable. In addition, as would be the case regardless of where the facility were built, Federal or state regulations implementing certain provisions of the Clean Water Act, Clean Air Act, and Resource Conservation and Recovery Act would be applicable. These regulations are implemented through permits. Evaluation would be required to determine whether MOX facility emissions and activities would necessitate modification of any of these permits. Analyses in the SPD Draft EIS have shown that there would be minimal impact from construction and operation of the MOX facility.

MOX facility design and operating parameters will be imposed by requirements of 10 CFR 70. Facility robustness, worker health and safety, and material and personnel security are all specified by 10 CFR 70. This regulation incorporates and refers the licensee to provisions of other NRC regulations such as those found at 10 CFR 20, *Radiation Protection Standards*. Safety and environmental analyses will be required to support the license application for the MOX facility.

Integral to the NEPA process is consideration of how the proposed action might affect biotic, cultural, and Native American resources, and the need for mitigation of any potential impacts. Required consultations with agencies and recognized Native American groups have been conducted.

5.1.2 Reactors

Nuclear power reactors undergo a lengthy licensing process under 10 CFR 50, *Domestic Licensing of Production and Utilization Facilities*, beginning before facility construction commences. This process includes preparation of safety analysis and environmental reports. The safety analysis report remains a living document that serves as the licensing basis for the plant, and is updated throughout the life of the plant. Public hearings before a licensing board are conducted prior to a license being issued. Once issued, operating licenses may be amended only with proper evaluation, review and approval as specified in 10 CFR 50.90. This prescriptive process requires demonstration that a proposed change does not involve an unreviewed environmental or safety question and provides for public notice and opportunity to comment prior to issuance of the license amendment. Minor license amendments can be processed fairly expeditiously, but more involved amendments can require multiple submittals before the NRC is assured that the proposed action will not reduce the margin of safety of the plant. All submittals, except portions that contain proprietary information, are available to the public.

The regulatory process for requesting reactor license amendments to use MOX fuel will be the same as for any 10 CFR 50 Operating License amendment request. The reactor licensee submitting an operating license amendment request in accordance with 10 CFR 50.90 initiates this process. Safety and environmental analyses commensurate with the level of potential impact are submitted in support, and as part, of the amendment request. NRC reviews the submitted information and denies or approves the request. The review process can involve submittal of additional information and face-to-face meetings between the licensee and NRC, and can result in modified license amendment requests. NRC provides notice in the *Federal Register* for certain steps in the process. The notice for the amendment request initially appears in the *Federal Register* with a Notice of Opportunity for Public Hearing. *Federal Register* notices are also required for the Proposed No Significant Hazards Determination, associated environmental documents, Consideration of Issuance of the License Amendment, and issuance of the final amendment. Certain of these notices allow for the opportunity to provide written comments, and for potentially affected parties to petition to intervene or request public hearings.

The six reactors proposed to use MOX fuel have been operating for a number of years. Revisions to each of their operating licenses will be required prior to MOX fuel being brought to the reactor sites and loaded into the reactors. The license amendment request will need to include a discussion of all potential impacts and changes in reactor operation that could be important to safety or the environment. This will include fresh and spent fuel handling, security and operational changes, as well as complete core load analysis and safety analyses, including potential changes to the severe accident analyses. Because the offeror has indicated that no new construction would be required to accommodate the use of MOX fuel, it is unlikely that any biotic, cultural or Native American resources would be impacted by the proposed action. The analyses performed for the Environmental Critique have demonstrated very little difference between the impacts from using a partial MOX core over a LEU core.

The need for modifications to site permits will be evaluated by the individual plants as part of their licensing activities. The offeror has indicated, and the analyses and reviews performed for the Environmental Critique, support the assertion, that there would be minimal or no change in effluents, emissions, and wastes (both radiological and nonradiological). Therefore, it is expected that few, if any, environmental permits or agreements will require modification for use of MOX fuel.

6.0 CONCLUSION

No major impacts to the environment surrounding the proposed MOX facility or reactor sites are expected to result from normal operation of these facilities. Environmental impacts from operation of the proposed reactors are not expected to change appreciably due to the use of MOX fuel. Impacts from construction and operation of the MOX facility are expected to be generally consistent with those presented in the SPD Draft EIS, and impacts at the reactor sites are expected to be generally consistent with those in the S&D PEIS.