

# Wildlife Water Catchment Construction in Nevada



## Technical Note 397



U.S. Department of the Interior • Bureau of Land Management  
September 1997–Revised September 2003

Cover photo of Desert Bighorn ewe and lamb at the Butte Guzzler east of Mina, Nevada, by Andy Stinson of Hawthorne, Nevada.

Chapter Two and Appendix A photos by William R. "Rick" Brigham, BLM Carson City District, Nevada.

---

Production services provided by:



National Science &  
Technology Center



*Bureau of Land Management*

Publishing Staff

Peter Doran (303-236-6547)

Janine Koselak: Layout and Design

Kathy Rohling: Editing

Lee Barkow, Director

National Science & Technology Center

P.O. Box 25047

Denver, Colorado 80225-0047

The Bureau of Land Management's National Science and Technology Center supports other BLM offices by providing a broad spectrum of services in areas such as physical, biological, and social science assessments; architecture and engineering support; library assistance; mapping science; photo imaging; geographic information systems applications; and publications support.

---

COPIES AVAILABLE FROM:

BLM National Business Center  
Printed Materials Distribution Service, BC-652  
P.O. Box 25047  
Denver, Colorado 80225-0047  
303-236-7637

TN 397

BLM/RS/ST-96/009+6500/REV03

This document is also available on the NSTC website at <http://www.blm.gov/nstc>



# Wildlife Water Catchment Construction in Nevada

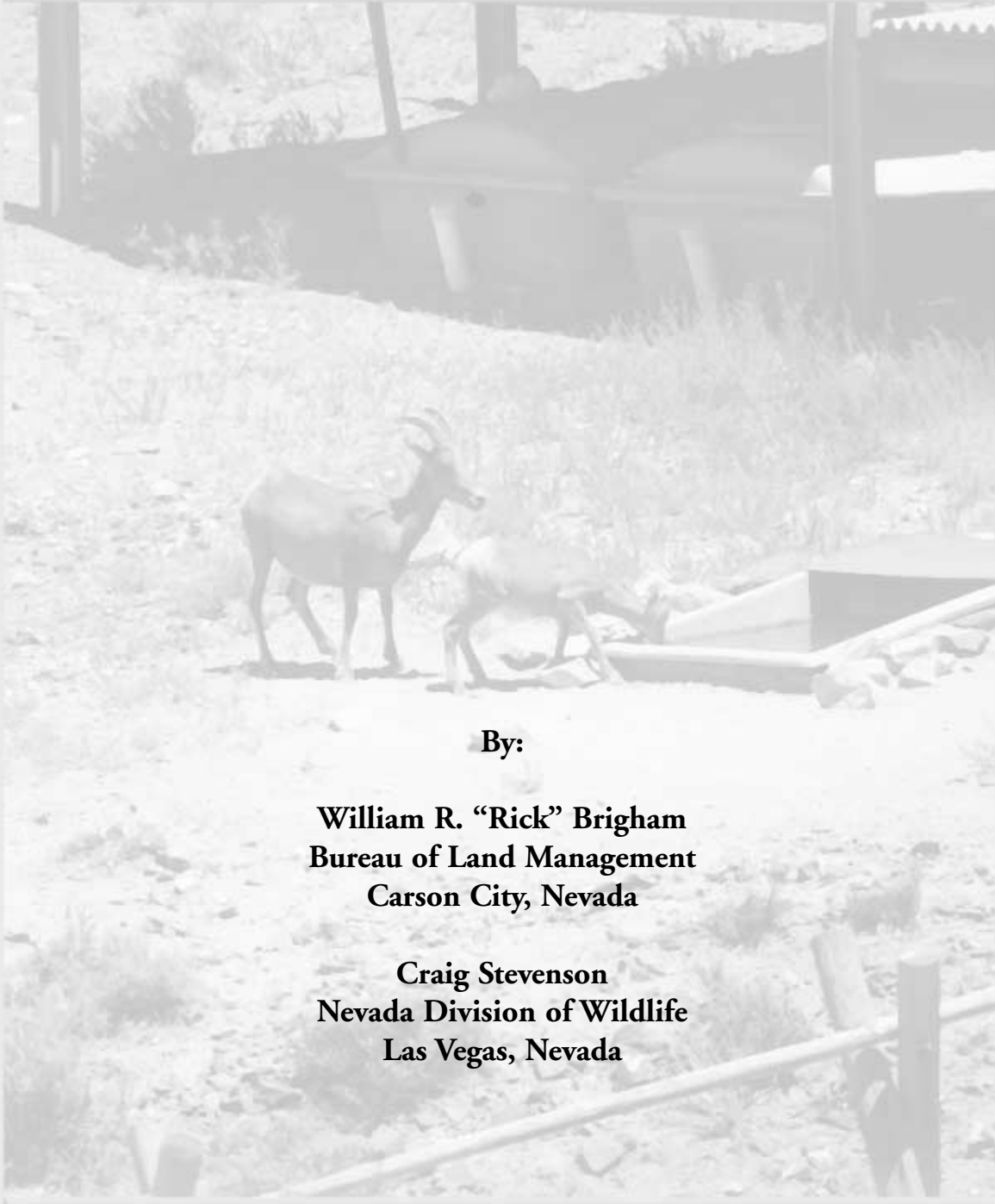

**By:**

**William R. “Rick” Brigham  
Bureau of Land Management  
Carson City, Nevada**

**Craig Stevenson  
Nevada Division of Wildlife  
Las Vegas, Nevada**

## Technical Note 397



U.S. Department of the Interior • Bureau of Land Management  
September 1997–Revised September 2003

---

**Suggested citation:**

Brigham, W.R. and C. Stevenson. 1997, Revised 2003. Wildlife Water Catchment Construction in Nevada. Technical Note 397. Bureau of Land Management, Denver, Colorado.  
BLM/RS/ST-96/0091-6500/REV03. 97 pp.

# Abstract

This technical note describes two artificial water catchment (guzzler) construction methods that are used in northern and southern Nevada. In northern Nevada, a standard guzzler unit is constructed, and a site is located in which to install it. In southern Nevada, the slickrock and artificial apron units are tailored to specific sites. Each of these methods includes detailed information on site selection,

site preparation, selection and transport of materials and equipment, and step-by-step construction information. The technical note should give prospective builders enough information to construct a guzzler on their own. The note also includes information on construction methods and materials that have proven to be less than successful, and a brief section on other water development methods.





# Acknowledgments

## September 1997 Version

The authors wish to thank the many interested and energetic volunteer groups for providing most of the labor and much of the funding for the water catchment projects and for the many ideas they have contributed—they have greatly enhanced the quality of the projects.

Both authors are indebted to Larry Johnson of the Reno Chapter of Nevada Bighorns Unlimited (NBU). Larry has been the prime mover in coordinating volunteers and funding.

Author Rick Brigham works closely with three local groups: the Reno and Fallon Chapters of NBU and the Hawthorne Sportsmen. A note of thanks to Ralph McClintock, who introduced Rick to the NBU organization back in 1987. This is when the big game guzzler program in the Carson City District really got off the ground. These partnerships evolved to the point that the two NBU groups funded and built most of the big game guzzlers in BLM's Carson City District. Without their support, the Carson City District would not have the water developments that now exist.

Author Craig Stevenson works closely with the Fraternity of the Desert Bighorn at Las Vegas, Nevada, and receives much of the funding for his program from the Reno Chapter of NBU.

We would be remiss if we failed to mention Ed Pribyl with the Fraternity of the Desert Bighorn and Royce "Woody" Wood, formerly with the Fraternity, and now a director for the Foundation for North American Wild Sheep. Ed has been the quiet strength of the Fraternity and Woody greatly improved the Fraternity's fundraising capabilities, placing helicopter use in our grasp so that we might place water catchments further from harm and more accessible to wildlife.

Thanks to Ray Boyd, now retired, for coordinating the production process for the original version of this technical note.

## September 2003 Revision Update

Thanks to Clint Bentley and his partner, Cindy Alexander, recent mainstays in the Fraternity of the Desert Bighorn. Clint has added his considerable contracting and construction knowledge and skills to the Fraternity's ongoing water development efforts.

Thanks also to Kathy Rohling, writer/editor, and Janine Koselak, Visual Information Specialist, both of BLM's National Science and Technology Center in Denver for the editing, layout, and final production of this revised publication.

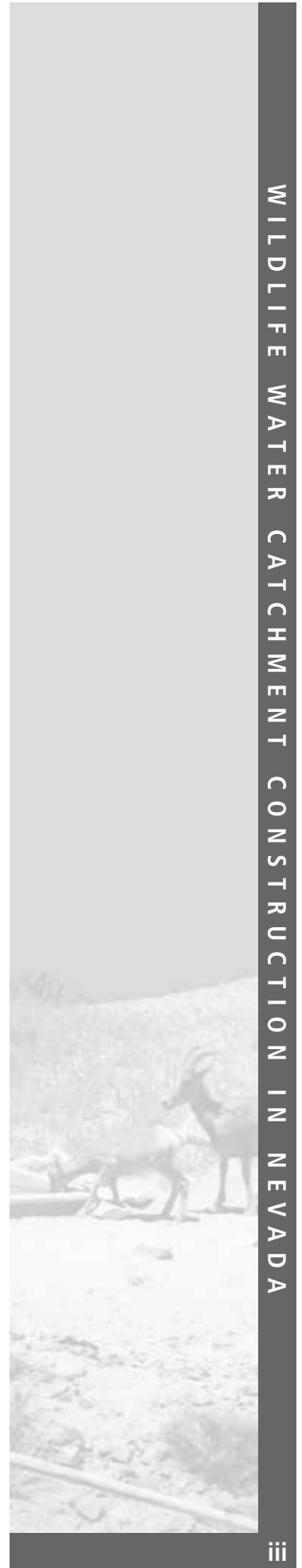





# A Note About the Authors

**Rick Brigham** has been a BLM wildlife biologist for 35 years. He has served in three districts in two states and has been building guzzlers since 1974.

**Craig Stevenson** is a wildlife biologist with the Nevada Division of Wildlife in Las Vegas, Nevada. He has been with the Division for 21 years and is the “water-development-for-wildlife expert” in southern Nevada.





# Table of Contents

Abstract .....	i
Acknowledgments .....	iii
A Note About the Authors .....	v
Chapter 1 - Introduction .....	1
Chapter 2 - Northern Nevada Water Catchment Guidelines .....	3
Small and Big Game Guzzlers .....	3
Site Selection .....	5
Small Game Guzzler .....	5
Big Game Guzzler .....	5
Site Preparation .....	6
Small Game Guzzler .....	6
Big Game Guzzler .....	6
Materials and Equipment Transport .....	6
Construction .....	7
Plumbing the Tanks .....	7
Setting the Tanks .....	10
Plumbing and Setting the Drinker .....	13
Apron Construction .....	15
Beams and Uprights .....	15
Sheeting .....	20
Gutter Construction .....	21
Fences .....	26
Buck and Rail Fence .....	26
Smooth Wire/4-5 Stand Barbed Wire Fence .....	26
Small Game Guzzler Fence .....	26
Loose Ends .....	29
Comments on Substitutions .....	29
Table 1 – Materials/Parts List for Small Game Guzzler .....	30
Table 2 – Materials/Parts List for Big Game Guzzler .....	31
Table 3 – Equipment/Tools Checklist for Guzzler and Fence Construction .....	35
Table 4 – Big Game Guzzler General Checklist .....	38
Specification drawing 1 – Water Storage Tank–Small Game Guzzler ..	40
Specification drawing 2 – Tank and Cover Corner Details .....	41
Specification drawing 3 – Tank Cover Details .....	42
Specification drawing 4 – Ramp Details .....	43
Specification drawing 5 – Water Storage Tank–Big Game Guzzler ...	44
Specification drawing 6 – Walk-Down Drinker .....	45

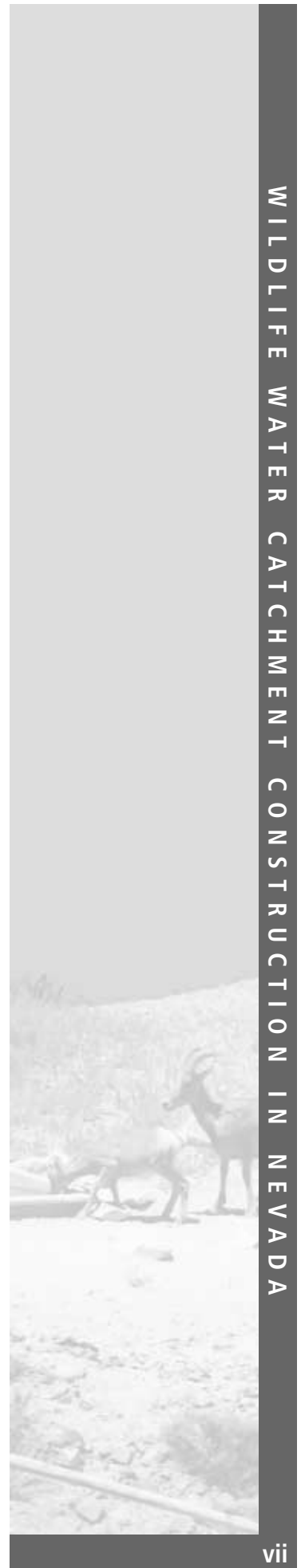

# Table of Contents (cont)

Chapter 3 - Southern Nevada Water Catchment Guidelines .....	47
Slickrock and Hypalon Guzzlers .....	47
Site Selection .....	47
Collection Surfaces .....	48
Slickrock .....	48
Tarp Aprons .....	50
Construction .....	51
General Comments .....	51
Slickrock Dam Construction .....	51
Hypalon Apron Construction .....	54
General Plumbing .....	57
Pipeline .....	61
Tank Location .....	61
Tank Pad .....	62
Tanks .....	63
Polytank Setup .....	67
Pipeline Inflow .....	67
Equalizers .....	69
Overflows .....	69
Manifold - Tanks to Drinker .....	72
Insulation .....	72
Float Box .....	72
Drinker .....	76
Fences .....	76
Table 1 – Sources for Water Development Materials .....	79
Table 2 – Polyethylene Tank Sizes .....	80
Chapter 4 - Aerial Transportation of Materials and Equipment .....	81
Helicopter Transport .....	81
Safety .....	81
Paperwork/Forms .....	82
Load Preparation .....	82
Staging .....	85
External Load Equipment/Sling Operations .....	86
Appendix A - Additional Water Catchment Devices .....	89
Appendix B - <i>Lasting Waters for Bighorn</i> by Robert S. Gray .....	95

# Chapter 1-Introduction

Nevada is the driest state in the United States. Usable water for humans, livestock, mining, or fish and wildlife is at a premium. Rainfall is as low as 4 inches per year in many areas and surface water is often nonexistent.

Water is one of the four essential habitat components for vertebrate wildlife species; the other three are food, cover and space. Where water is lacking, but other habitat essentials are available to benefit wildlife, water may be developed using artificial means, or a combination of artificial and natural means.

The purpose of this technical note is to describe artificial water catchment construction methods that are used in Nevada, including site selection, site preparation, and transport of materials and equipment. This technical note is not meant to be all inclusive, but should give the prospective “guzzler” builder enough information to get started. The technical note also includes information on construction methods and materials that have proven less than successful.

Nevada began a wildlife water development program in the 1950s. Big game water catchments were a novelty in the early years. The emphasis, initially, was on water catchments for small game bird species. One of the first bighorn (*Ovis canadensis spp.*) water catchments was constructed in June 1956 and was only recently “rediscovered” in southern Nevada.

Although there was a push for bighorn water catchments in the 1970s, it wasn't

until the early to mid-1980s that a program concentrating on bighorn sheep habitat evaluation and improvement was developed. The goal of the program was to establish viable bighorn populations in historic and otherwise suitable habitats throughout Nevada. More often, the program focused on mitigating the loss of natural water sources. The projects that were constructed to improve bighorn habitat ultimately proved more useful to all wildlife species than did the earlier small game units.

A term used for artificial water catchments for terrestrial wildlife species is “guzzler.” The term was originally coined in 1943 as “gallinaceous guzzler” by Ben Glading, who at the time was head of the California Department of Fish and Game (CDFG). Many parts of California lacked surface water for small game species, and the CDFG made a major effort over the next several decades to develop water for gallinaceous birds, especially California Quail (*Lophortyx californicus*), mourning doves (*Zenaidura macroura*), and the introduced chukar partridge (*Alectoris chukar*).

A guzzler consists of an apron for collecting precipitation, a tank to store it in, and access to the water by different sized wildlife species.

Materials used in guzzler construction have varied considerably in the past 40 years. In northern Nevada, where most soils and surface rock are comparatively porous, steel is preferred for the aprons. Fiberglass and cross-linked

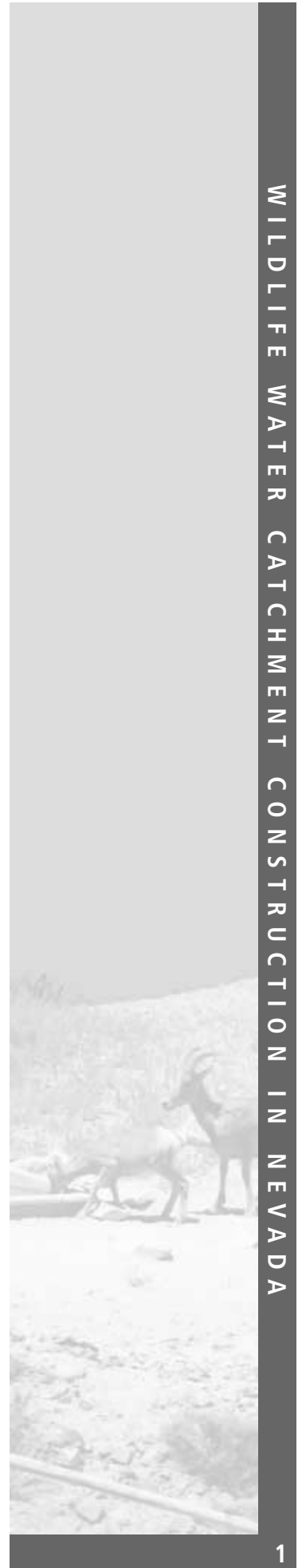

polyethylene are preferred for the storage tanks, PVC or plastic for the plumbing fittings, polypipe for the hose, and brass for the gate and float valves.

In southern Nevada, where soils and surface rock may be as impervious and concrete, natural aprons are used wherever possible. These are called “slickrock” aprons and they utilize natural features such as small gullies. Where slickrock is not available, hypalon fabric may be used. Polyethylene is used for the storage tanks, polypipe for the hose, steel for the pipe fittings, and brass for the valves.

A main consideration in building the guzzlers, whether in the northern or southern parts of Nevada, is to build them as simple and as strong as possible. This results in fewer problems and reduced maintenance costs.

Guzzlers are constructed in two basic sizes. The small guzzler attracts small game and nongame species such as quail, doves, chukars, rabbits (*Sylvilagus spp.*), and neotropical (migrating) birds. The large guzzler accommodates game such as antelope (*Antilocapra americana*), big horn sheep, and mule deer (*Odocoileus hemionus*).

In the information that follows, Chapter 2, *Northern Nevada Water Catchments Guidelines*, explains how water catchments are built by the Bureau of Land Management in northern Nevada, specifically by the Carson City District. This set of guidelines has been fine tuned over the past 14 years. Chapter 3, *Southern Nevada Water Catchment Guidelines*, contains infor-

mation on slickrock collection surfaces feeding storage tanks and drinkers. The information, originally published in an abbreviated form in 1988, has been updated to reflect the experience and expertise that has accrued since then. This chapter also contains information on artificial (hypalon) aprons placed at ground level.

In Chapters 2 and 3, the authors each describe a different construction method. In Chapter 2, author Rick Brigham constructs a fixed guzzler unit and then finds the appropriate setting in which to install it. In Chapter 3, author Craig Stevenson employs a flexible unit (in terms of materials) and tailors each unit to its selected site. Both approaches have been very effective.

Chapter 4, *Aerial Transportation of Materials and Equipment*, is based on the collective experience of both authors in the use of helicopters to transport materials and equipment to remote sites.

Appendix A, *Additional Water Catchment Devices*, discusses other types of natural and artificial water-catching and storing devices.

Appendix B, *Lasting Waters for Bighorn*, was originally presented to the 1974 Desert Bighorn Council by its late author, Robert S. Gray, who was president of the Arizona Desert Bighorn Sheep Society (ADBSS) at the time. Gray’s paper is reprinted here in its entirety with the permission of the ADBSS. It contains useful information on sealing rock for either collection or storage of water.

# Chapter 2-Northern Nevada Water Catchment Guidelines

## Small and Big Game Guzzlers

The BLM's Carson City District in northern Nevada currently has 126 BLM guzzlers, plus 102 more that were constructed by other agencies on the 5 million acres of public lands in the district. The guzzler designs used at Carson City have evolved over the last 27 years. The guzzlers are designed and built to last at least 30 years and to be virtually maintenance free. No slick-rock catchments have been constructed since opportunities for this design are very limited in this region. (See Chapter 3 for slick rock developments in southern Nevada)

A **small game guzzler** consists of a single 5-foot x 10-foot x 30-inch fiberglass storage tank of 800 gallon capacity, with a bolt-on lid that is open at one end, and a walk-down ramp to the water, overlain by a 16-foot x 16-foot almost horizontal steel roofing collection apron supported by a framework of steel "C" beams on steel uprights. Small game guzzlers have been constructed primarily for chukar and mourning dove. Two people can dig the hole for the tank and build the unit in two days or less if the hole is dug with a backhoe.

A **big game guzzler** consists of five of the same fiberglass storage tanks as those used for the small game guzzlers (or two of the Boss polypropylene tanks) set side by side in the ground, plumbed together underground, and overlain by four to six of the same collecting aprons used on small game guzzlers. The four to six aprons may also be combined into two side by side aprons. The roofs of the tanks, however, are solid; they are not open at one end.

The tanks are connected by underground plumbing to a separate, uncovered walk-down/ramped fiberglass drinker that is 36 inches x 72 inches x 30 inches deep. The water level in the drinker is controlled either by a float valve or by a self-leveling system.

The unit is protected by a fence varying in length from between 250 to 1,200 feet, comprised of either wood posts/buck and rail, or 4-5 strand barbed wire and smooth wire on steel posts and corners.

The big game guzzlers in the Carson City District have been constructed primarily for desert bighorn sheep, and secondarily for mule deer and antelope.

Small and big game guzzlers are produced in four phases: site selection; site preparation; materials and equipment transport; and construction.

### Specification Drawings

See specification drawings at the end of this chapter for the **small game guzzler**, specifically the water storage tank, roof ramp, and tank and cover corner detail. Also see Table 1 (end of chapter) for the small game guzzler materials/parts list.

See specification drawings at the end of this chapter for the **big game guzzler**, including the drinker, and for the small game roof, which is the same as the big game roof except both ends are closed. Also see Photos 1 and 2. See Table 2 for the big game guzzler materials/ parts list.





Photo 1. Northern guzzler details. Front aprons share three central uprights; rear apron shares uprights with one front apron. Gutter is in place and connected to tanks. Tops of tanks and sewer and drainpipe (S&D) protecting gate valves are visible.

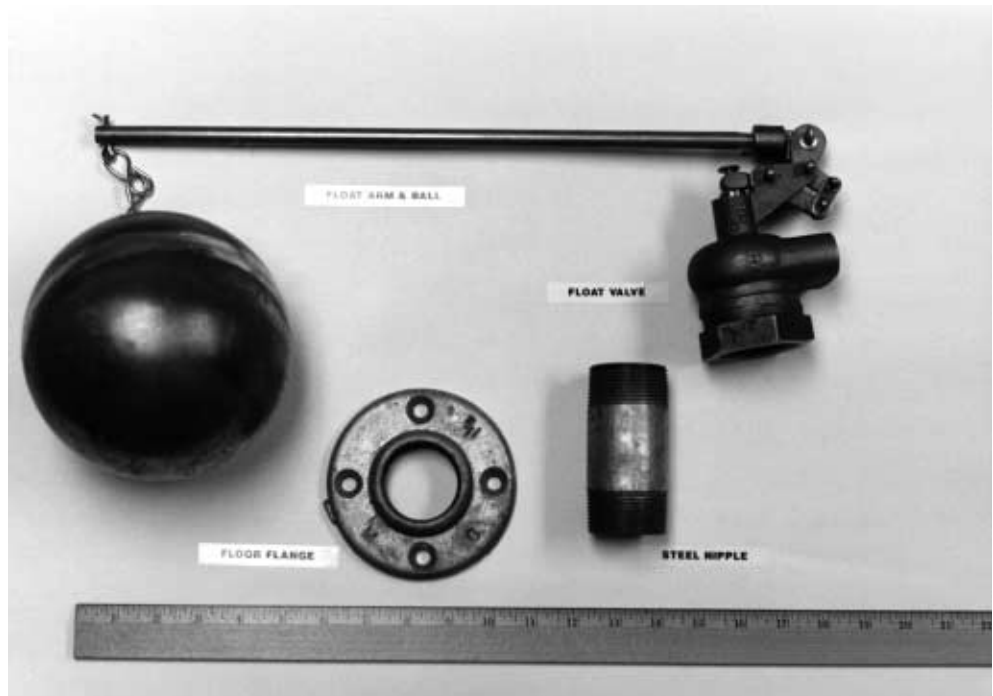

Photo 2. Brass float valve, arm and ball, with fittings. Two steel floor flanges are needed per assembly. All components are 1 1/2-inch in diameter. All flange bolts, nuts, and washers are stainless steel.



## Site Selection

### *Small Game Guzzler*

The site for the small game guzzler should be located where the species using it would normally expect to find water. It should be located in adequate habitat, such as canyons or draws in hilly areas with adequate escape cover (shrubs or rocks) close by for chukars, and the same or flat areas for mourning doves.

Many of the current small game guzzlers are located in wash bottoms, but on small benches so they won't wash away during thunderstorms. The intersections where several small canyons come together are also very good for chukars.

#### **The site should:**

- be as flat as possible for ease of construction.
- contain soft soil for ease in digging.
- be located away from outcrops and outcrop areas
- avoid depressions. If the tank is nearly empty and a thunderstorm or flood hits, it may float the tank out before it has a chance to fill.

Situate the tank opening so the sun doesn't shine into it and so that it faces away from the prevailing wind; both cut down on evaporation. If possible, have it face north. Keep in mind, however, that the tank opening will attract more birds, especially flying mourning doves, if it faces the wash, and if the apron is high enough above it that doves flying in the wash/canyon will see the water in the tank.

Another good location for small game guzzlers is in areas where small game predators are found. These animals hunt in good small game habitats.

### *Big Game Guzzler*

The site for the big game guzzler should be located where the species using it would normally expect to find water. It should be located in adequate habitat (except for water) for the primary species, which is usually in canyon bottoms/washes for desert bighorns and mule deer, and open flat/gently rolling areas for antelope. Make sure the catchment sits up out of the wash on a small bench so it will not be destroyed by high water during thunderstorms.

#### **The site should:**

- be as flat as possible for ease of construction.
- contain soft soil for ease in digging.
- avoid depressions. If the tanks are nearly empty and a thunderstorm or flood hits, it may float the tanks out before they have a chance to fill.

Leave room around the guzzler for a fence if livestock or feral horses or burros are in the area and constitute a threat to the water source. The fences are usually 240 to 300 feet in circumference for deer and bighorn, and a minimum of 300 feet in length on each of four sides for antelope. While the 300 x 300 foot fence has been used for antelope, they will also use the waters protected by the smaller, shorter fences, including buck and rail.

#### **Helpful Hint**

Read these instructions all the way through to familiarize yourself with the overall process before starting your guzzler. Some steps of the construction process are performed concurrently, which can save time and money.



**Helpful Hint**

Dig or blast the hole for the tanks as close as possible to the right size. If the hole is too small, you'll have to keep removing dirt; if the hole is too big, then a lot of backfilling will be necessary.

## Site Preparation

### *Small Game Guzzler*

For a small game guzzler, mark off the area for the tank. The hole size is 6 feet x 11 feet x 30 inches. It can be dug by hand, backhoe, or Bobcat. The bottom of the hole should be level so the tank is level. Use a 36-inch or longer level to ensure that the tank sets level in the hole. Backfill around the tank using fine material; large or sharp rocks will poke holes in the tank when the weight of the water pushes down. The tank should sit in the ground so that the entrance used by the birds is an inch or two above the surrounding dirt. Pave the area in front of the opening with flat rocks, if possible, to keep dirt from blowing into the tank. When finished, proceed to the *Apron Construction* section in this chapter.

### *Big Game Guzzler*

For a big game guzzler, mark off the area for the tanks. The hole size is 12-feet x 28-feet x 30-inches deep for five fiberglass tanks, or 18-feet x 19-feet x 24-inches for Boss tanks. It can be dug by hand, backhoe, or Bobcat; it can also be blasted. Blasting loosens the soil so the hole can be cleaned out easily. The big game guzzler tank holes in the Carson City District were blasted using commercially prepared Anfo (ammonium nitrate and fuel oil). It comes in very small pellet form in 50 pound bags (costs about \$10 a bag) or in 5-inch x 30-inch sausages. It usually requires three to four bags or sausages per site, depending upon rockiness.

The Carson City District uses a qualified blaster. The blasting crew consists

of approximately 4 to 10 agency people, including Explosive Ordnance Disposal (EOD) personnel from the local naval aircraft base. More personnel may be needed if blasting materials and digging equipment must be carried to the site. For safety reasons, the holes are blasted up to a month before construction takes place and before materials are delivered to the site.

## Materials and Equipment Transport

Materials and equipment can be transported to the site either by truck or helicopter. The fiberglass tanks have bolt-on lids so they can be removed and the tanks and lids nested for easier transport; this saves tremendous bulk. Smaller, lighter items can then be transported in them. Also, tanks of this size are easy to sling load with even a light helicopter. The Boss polypropylene tanks are 8 feet x 16 feet x 2 feet and weigh 800 pounds. A medium helicopter is safest for moving them. (See Chapter 4 for details on helicopter operations.) Carson City uses two trucks (2-ton flatbeds, 16- to 18-foot-long-beds with side rails) for big game units and one for small game units. The materials are usually transported between the time the hole is prepared and the construction crew arrives. Once the materials are unloaded at the site, unroll the black polypipe/ Driscopipe (See Table 2, *Materials/ Parts List for Big Game Guzzler and Fence*) so it has time to straighten in the sun. This will make it much easier to work with.



## Construction

On construction day, the crew should make sure the hold for the tanks is level on the bottom and free of rocks, which could gouge their way through fiberglass. Use a 3-foot level, flat shovels, one of the 18-foot “C” beams, plus McLeods (combination heavy-duty rake/hoes) and/or regular rakes to do this. A tripod-mounted engineering level and a stadia rod (standard items) help ensure that the hole and tanks are level. Make sure that the tanks are also level with each other.



Photo 3. Bottom of fiberglass tank showing bulkhead fastener and 90° MIP-barbed fittings in place.

If the hole is properly prepared prior to construction, it will take 15 to 20 persons 8 to 9 hours to complete the entire unit, including the fence. It will take less time if motorized earthmoving equipment, such as a Bobcat or backhoe, is available on construction day.

### *Plumbing the Tanks*

Make sure each fiberglass tank and lid combination is properly marked before removing the lid (lids must be off the tanks when installing plumbing fittings) so you won't have to redrill new bolt holes. (The polypropylene tanks do not require this.) Mark the end of the tank opposite the end where the manhole cover in the lid will be with a “P” for plumbing, prior to construction.

The plumbing is connected along the front ends of the tanks and the manhole

covers are at the rear. There is more room under the apron at the rear of the tanks than at the front, allowing future access into the tanks.

While most of the crew is cleaning and leveling the hole, have two to three people start plumbing the storage tanks (Photos 3, 4, and 5).

### Helpful Hint

To save time and to make the job easier:

1. Lay out the plumbing, tank, and apron tools and their associated equipment and parts on their own individual tarps.
2. Provide construction drawings
3. Prepare and pass out maps to the group leaders that outline directions into the site and to a well marked parking area.



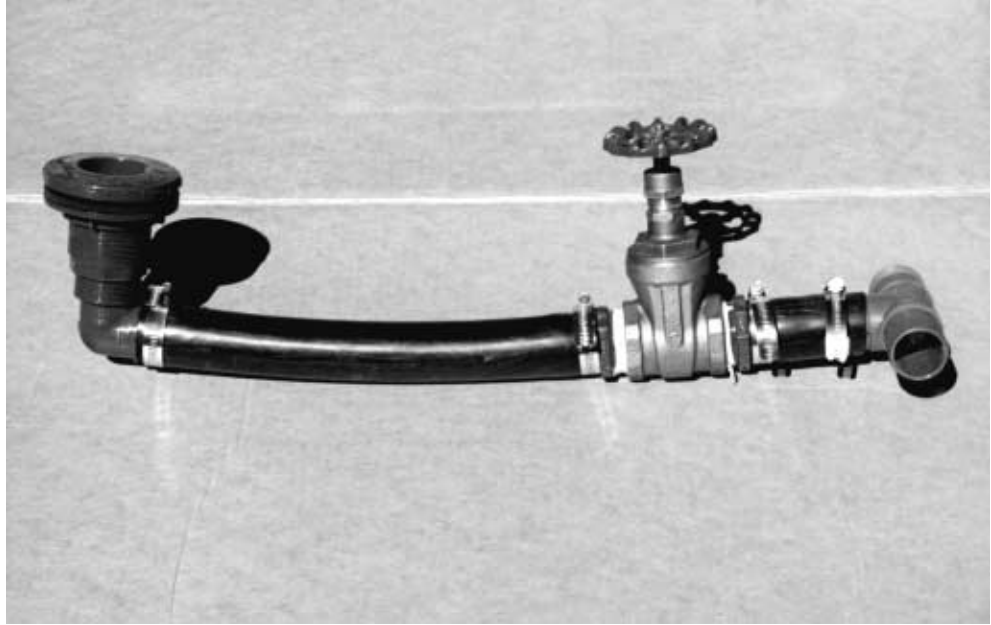

Photo 4. Tank plumbing assembly, left to right: bulkhead fastener, 90° MIP-plastic barbed adapter, polypipe with hose clamps, straight MIP-barbed adapter, brass gate valve, straight MIP-barbed adapter, polypipe with hose clamps, plastic tee.



Photo 5. Completed/installed plumbing unit for big game guzzler.

Prop the fiberglass tanks (without the lids bolted on) on their sides and cut a 2 3/8-inch hole in the bottom of each at the end marked “P.” The center of the hole (which is cut with the hole cutter) is 3 inches in from where the curved radius flattens out on the bottom of the tank and is centered between each side. Take the bulkhead fastener, put a bead of silicone caulking under the head of it and around the hole on the inside of the tank so the rubber gasket will have silicone on both sides when the fastener is tightened with the lock ring on the outside of the tank. The polypropylene tanks are heavy enough that they should be plumbed once in place.

Tighten the lock ring with a pipe wrench or channel-lock pliers. This takes two people, one on the outside and one on the inside of the tank. The lock ring should be tightened just to the point where the rubber gasket starts to bulge from under the flange of the bulkhead fastener. When initially tightened, the bulkhead fastener and tank plumbing unit can easily be rotated. Don't worry—the silicone caulking sets up firmly in about 24 hours.

Once the bulkhead fastener is tightened and the 90° MIP plastic-barbed adapter is screwed into it, make an assembly of the polypipe with hose clamps, straight MIP-barbed adapter, brass gate valve, the second straight MIP-barbed adapter, and polypipe with hose clamps and plastic “T” or “L.” Use the following dimensions for polypipe lengths: 12 inches between 90° MIP and the gate valve's straight MIP; a 4 inch connector between the gate valve MIP and the “T” or “L.” (See the specification drawings and photos also for the tank and plumbing unit sequence.)

Teflon tape and pipe dope are used to seal the threaded joints, such as the 90° MIP-to-bulkhead fitting and the MIP-to-gate-valve joints. Wind the tape in the same direction as you turn the fittings.

Be sure to put the hose clamps on each piece of polypipe before forcing the pipe onto fittings. Slip the end of the polypipe over the fitting and secure the joint with a stainless steel hose clamp. To tighten the hose clamps, use a 5/16-inch nut driver or a short-shank screw driver with proper bit.

Cover the opening of the “T” or “L” with duct tape so dirt won't get into the plumbing as it is lowered into the hole.

When you reach this point, right the tank so it is level. Make sure to prop up the plumbed end with one of the steel uprights lying on its edge. (Don't bust out the tank bottom by putting the weight of the tank and lid on the plumbing!)

Use a 36-inch piece of notched sewer and drain pipe (S&D) to protect the gate valve. The gate valve will be far enough from the 90° MIP when the assembly is connected that the 36-inch notched piece of 4-inch S&D pipe will be vertical when the tank is in the ground.

Note that the S&D caps will not fit over the enlarged end of the S&D pipe, so notch it and put the cap on the other end during installation. Also, instead of cutting out the tabs that are formed when the cuts are made for notches, bend the tabs out to 90° and tape the tabs to the fittings on either side of the gate valve using duct tape.

#### Helpful Hint

Once the polypipe is measured and cut, bevel the inside of the ends slightly with a knife and heat them gently with a hand-held propane torch. If you are buying a new torch, buy one with a built-in igniter to save hassle with matches or sparking devices. When it is raining or snowing and the torch is turned off between pipe heatings, matches or propane lighters do not work! The magnesium fire starters work best in this situation. Keep a roll of paper towels or mechanics' grease rags handy to help keep things dry.

#### Helpful Hint

The black polypipe is difficult to work with. When it is forced onto a MIP-barbed fitting (or “T” or “L”), it may not be perfectly straight. If you have any doubts about the quality of the joint once the hose clamp is tightened/retightened, run a bead of silicone caulking around the joint to seal it.

**Helpful Hint**

Make sure that the sprinkler key you will use to open/close the gate valves will fit the gate valve handle. Some of these round valve handles come with an aluminum disk on them; remove the disk before installation. Some gate valve handles may not fit in the 4-inch S&S pipe and may have to be cut down with a hacksaw, depending on the brand of valve.

Taping the tabs will prevent the S&D pipe from being inadvertently pulled out of the ground, thus burying the gate valve.

Once everything is attached and tightened down and you have reached the fifth fiberglass tank, go back and retighten all the hose clamps and the MIP fittings in the gate valves. Also retighten the hose clamps when you hook up the plumbing between the tanks and the drinker. This retightening is necessary because the polypipe expands when heated, then contracts as it cools.

Put one of the white, 4-inch PVC lids on the upper end of the S&D pipe, then tape it to the edge of the tank so it won't move around when the tank is picked up and lowered into the hole.

Bolt the lid onto the tank. When the lid is bolted back on, the tank unit is much stiffer, which will help when it is carried and lowered into the hole. Use either small Phillip's head screwdrivers or punches to align the lid holes with the tank holes; make sure you have at least three or four to speed up the process. Also, have extra 3 1/2-inch-long carriage bolts (5/16-inch) to replace any bolts that were damaged when the lids were removed.

Move each fiberglass tank with a minimum of four to six people. It helps to have two to three people move the tanks from the plumbing site and the others standing ready in the hole to receive them. This eliminates sloughing a lot of dirt back into the hole, which will have to be cleaned out again. The polypropylene tanks, which weigh 800 pounds, require 8 to 10 people to move easily.

## *Setting the Tanks*

The big game tanks are lined up in two pairs plus one leaving a 1-foot gap between pairs, so that all the fronts are in a straight line parallel with the trench (Figure 1).

Each tank, with plumbing attached, is lowered into the hole until the plumbing touches the ground. The tank is lifted up, a small trench is dug to accommodate the plumbing, and the tank is then lowered back into place. (The small trenches can also be dug beforehand.) Make sure that all tanks are level with each other so that no storage capacity will be lost.

Once the first tank is in the ground, dig a trench (if you haven't already) to accommodate the polypipe that will connect all the "T's" and "L's." Cut appropriate lengths (you measure them) of polypipe; if the polypipe is not straight, measure it on the inside of the curve or the piece will be too short. Remember to place the hose clamps loosely on these polypipe pieces beforehand so that you won't have to take them apart for installation.

When this is done and the tanks are connected to the drinker (see the next section, *Plumbing and Setting the Drinker*), backfill around the tanks being careful to use just dirt, sand, or small rocks. Carefully backfill around the plumbing and vertical sections of the S&D pipe. If the S&D pipe sticks out of the ground, cut it off so the handle of the sprinkler key doesn't have to fit inside the pipe when the valve is being operated.

On the big game units, two uprights need to be set in the gap between tank pairs (Figure 1) before backfilling.

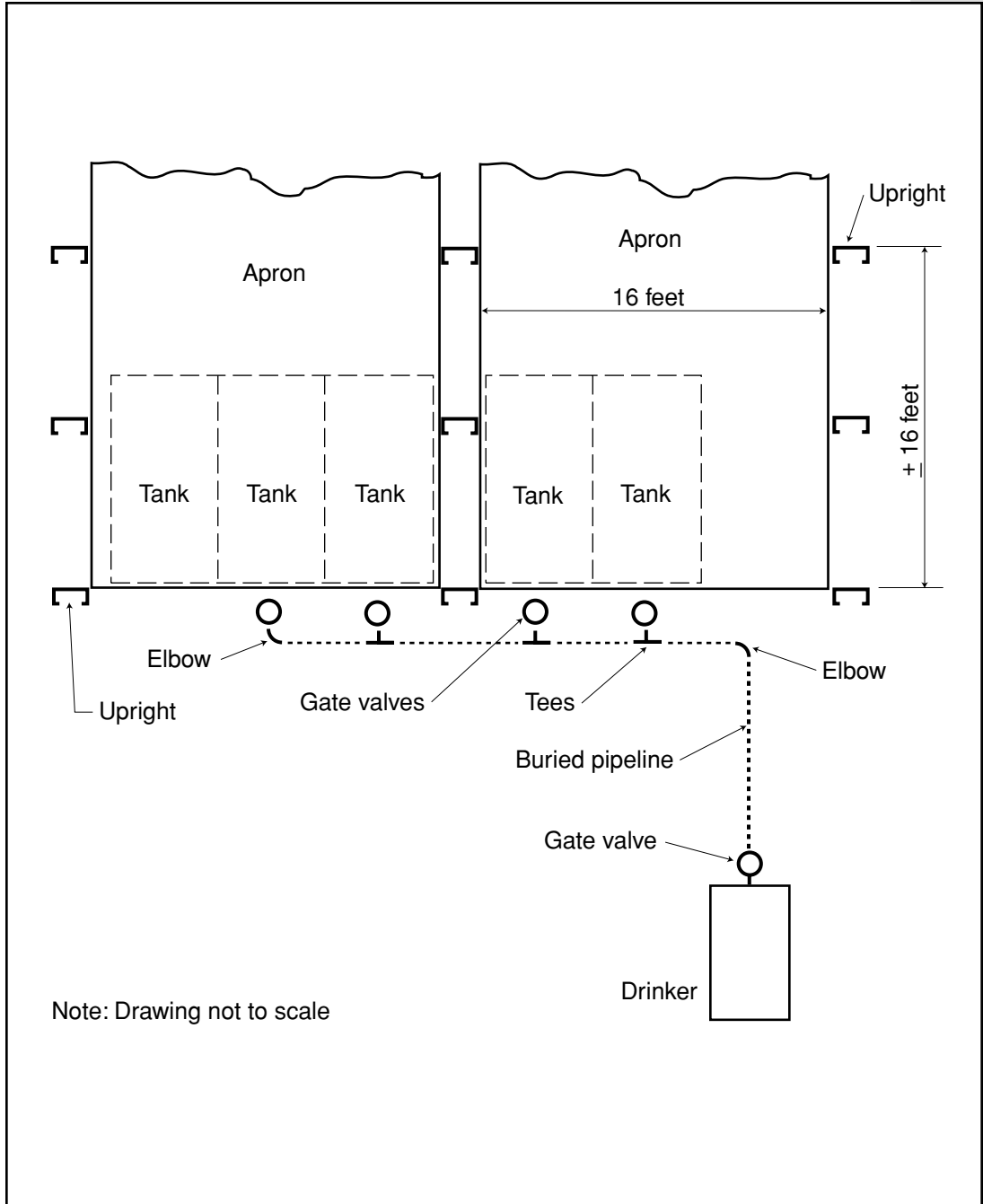

Figure 1. Carson City big game guzzler schematic. Schematic shows method that uses five fiberglass tanks. The alternate method uses two polypropylene (16' x 8' x 2') tanks.



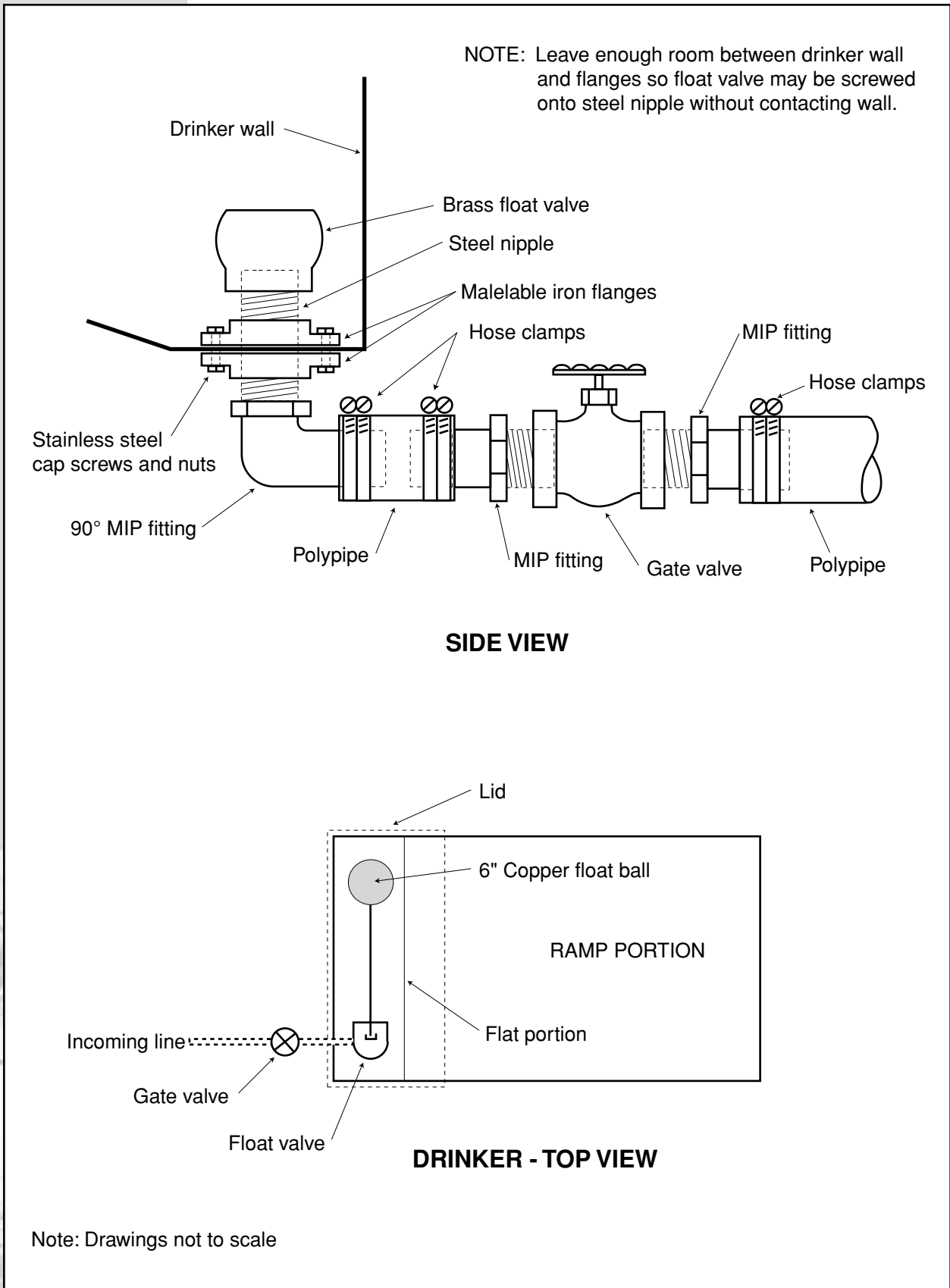

Figure 2. Float valve drinker details.



## *Plumbing and Setting the Drinker*

When using a float valve controlled system, situate the drinker downhill from the storage tanks far enough to have enough water pressure to operate the float valve. As a general rule, most drinkers are within 30 feet of the aprons.

When plumbing the drinker on a float valve system, situate the steel flanges at one end of the narrow flat bottom of the drinker so that when the entire unit is done, the float valve rod will be parallel and close to the drinker's vertical end (Figure 2 and Photo 2).

For self-leveling systems, which are preferred, all of the tanks and the drinker must be level with each other.

Strive, whenever possible, to use a self-leveling system, as it reduces maintenance problems and costs.

Go to each site prepared to build either way—self leveler or float-valve operated in case there is not enough room to fit the tanks and drinker on the same level.

Once the drinker is plumbed with either a float valve or a bulkhead fitting and gate valve, use a 36-inch notched piece of S&D pipe to protect the gate valve (same as with the tanks). The same comments about the total length of the S&D pipe, once installed, apply here.

For a float-valve setup, take the small sheet of steel (Table 2, Parts List) and

situate it over the deep end of the drinker to protect the float valve. Secure it to the drinker flange with TEK screws or nuts and bolts and washers. Anything that will protect the float from above will work; steel is preferred because it will last longer than plywood.

For self-leveling systems, build a riser made from one straight MIP fitting screwed into the flange end of the bulkhead fastener (Photos 6 and 7). The riser fits loosely into the bulkhead fitting; shim it with teflon tape so it fits snugly before inserting it. Cut a cross-shaped piece of stainless steel hardware cloth, fold it over the opening of the MIP fitting, and secure with a hose clamp. Use stainless steel mesh in preference to galvanized hardware cloth, if possible. The riser keeps mice and other small animals from getting into the plumbing system before water flows through it. It also keeps any blown-in dirt and debris from clogging the bulkhead fastener.

Once everything is hooked up, leave the gate valves **open** on the tanks and **closed** on the drinker until there is enough water in the tanks to adjust the float valve, or until there is enough water to support the wildlife adequately with the self-leveler (usually when tanks are one-half to two-thirds full). When adjusting the float valve, position the floatball so that, in operation, the top of the ball is 1 1/2 – 2 inches below the steel roof. If the unit freezes and the ball is forced upwards, it cannot be forced to the point where the valve arm will fail.

### **Strange Bedfellows**

Animals use drinkers apparently with little or no stress. Experiences in northern Nevada have shown that elevated aprons provide shade and tactical cover for predators. Black tailed jackrabbits (*Lepus californicus*) have been seen sharing shade with coyotes (*Canis latrans*) under small game guzzler aprons in the dead of summer. Bighorns have been seen shading up under big game aprons placed in steep country.





Photo 6. Guzzler for self-leveling systems.



Photo 7. Guzzler riser installed in drinker in self-leveling systems.

## Apron Construction

### Beams and Uprights

Familiarize yourself with Figures 3, 4, and 5 and Photo 8 for an overall view of how the beams and uprights fit together, and for aprons, sheeting, and upright details.

Each parts list (end of chapter) shows the number of C-beams required. An extra beam is added just in case any are bent or damaged. Some of the beams will be cut into shorter pieces and used as uprights. Uprights are made by cutting the 18-foot C-beams into three 6-foot lengths, and then welding two 8-inch pieces of 1 1/2-inch angle iron on each side of one end (Figure 5).

A **small game guzzler** requires a total of five C-beams: three horizontal beams to hold the apron, plus two more that will be cut up into 6-foot-tall uprights.

A **big game guzzler** requires the same number of C-beams per 16 foot x 16 foot apron except that the two front aprons will share one set of uprights (Figures 1 and 3, and Photo 8). And, depending on the site, the second pair of aprons may utilize the rear uprights of the front pair (Photo 1). So, for a big game guzzler with two 16-foot x 32-foot aprons, you will need 15 beams (10 support and 5 upright) plus one spare. For two 16-foot x 48-foot aprons, you will need 21 beams (14 support and 7 upright) plus one spare.

For **small game units**, take one of the 18-foot beams and lay its edge parallel to the opening of the tank mouth and about even with it. Mark holes to be dug for uprights at each end of the beam, get the beam out of the way, and dig the holes.

Note that on **big game units**, two uprights have already been placed between the pairs of fiberglass storage tanks.

For **big game units** it is essential that the plumbing crew hook up all tanks to each other as soon as they are in the ground, as the front upright between pairs of fiberglass tanks usually straddles the polypipe connector between tanks. This central front upright is the key corner of the first apron.

The back of the horizontal beam (the flat side) must face out so you can hang the gutter on it.

All of the uprights should have the open part of the C-beam facing toward the front (Figures 1 and 3).

It is important that the edges of the uprights be flush with the ends of the 18-foot beam, and that the uprights be vertical from both directions. Use post levels for this.

The uprights should be set with the angle iron feet at least 18 to 24 inches in the ground for stability.

The center uprights will each have two horizontal beams (for two aprons) attached; simply build one apron higher than the other for structural integrity (Photo 9).

When the uprights are in place and the C-beam ends are flush so that the holes can be drilled and the bolts installed, use the large C-clamps to secure the beam to the uprights. The beam must be level.

The bottom edge of the beam should be far enough above the tank covers to allow a person entry into the manhole

### Helpful Hint

If you have only one pair of large C-clamps, hold the uprights and beam together with a TEK screw until the hold drilling and bolting is completed. This allows use of the C-clamps for the next beam.



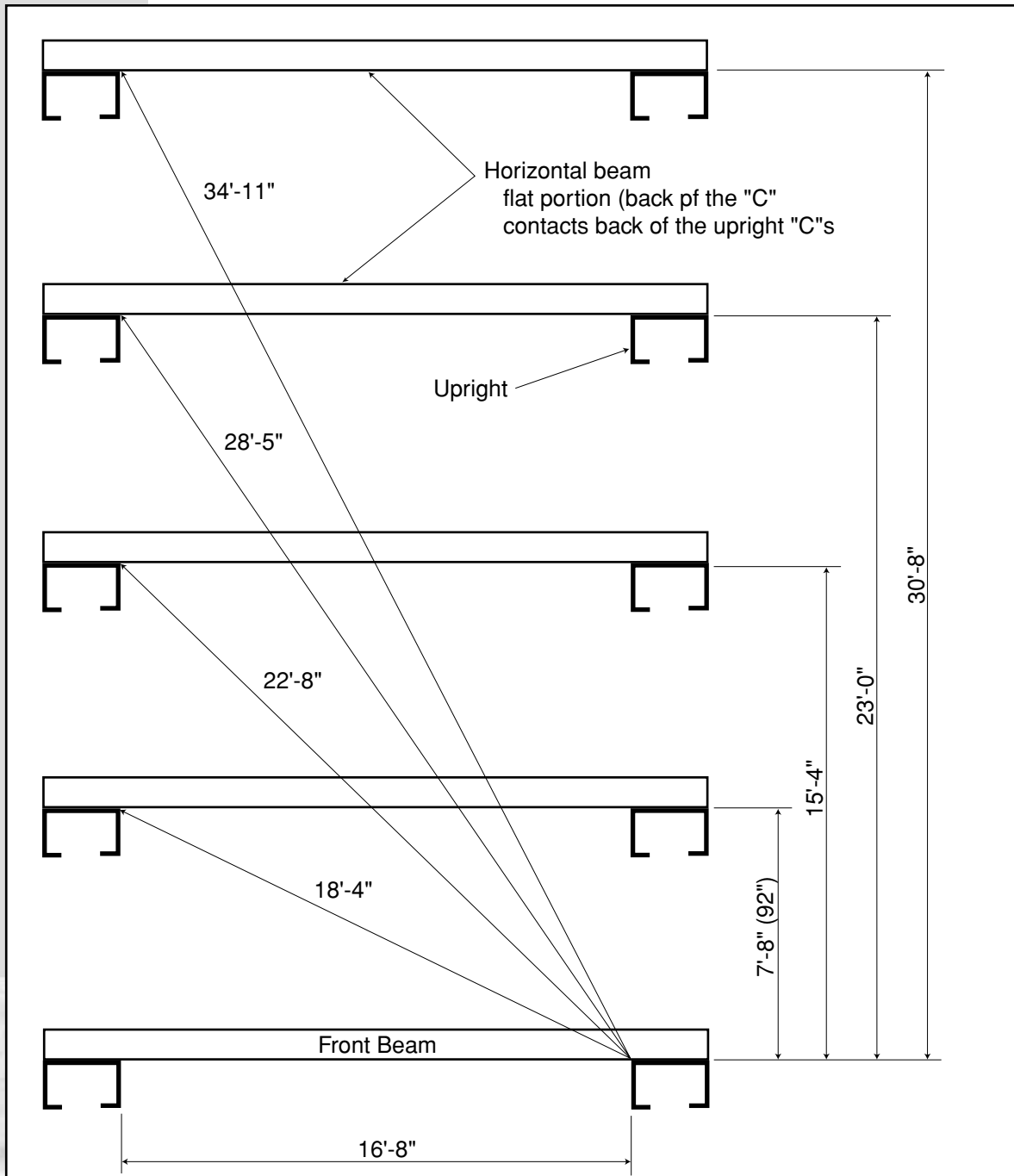

**TOP VIEW**

- Note: 1. All uprights face downhill toward the front edge of the apron.  
 2. All diagonal measurements are from the inside intersections of horizontal beams and upright corners.  
 3. 3 beams = 1 small or 1 big game apron; 5 beams = 1 big game apron. See text.

Note: Drawing not to scale.

Figure 3. Critical measurements for guzzler aprons. Note: These figures are for a 16-foot x 32-foot apron. If a longer apron (48 feet) is used, then key off the right rear upright using measurements for the first 3 beams shown in the drawing (front and 2).

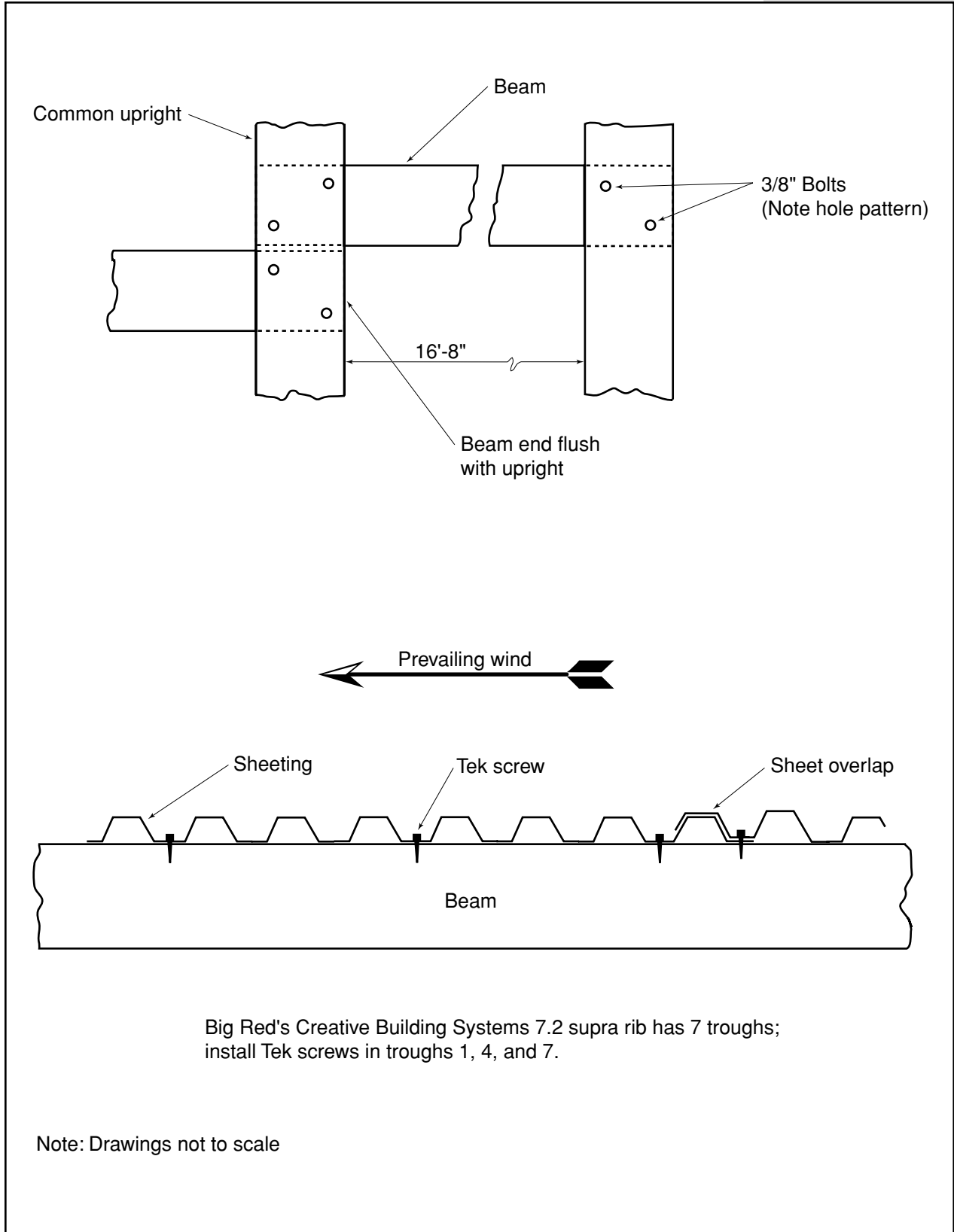

Figure 4. Apron and sheeting details.

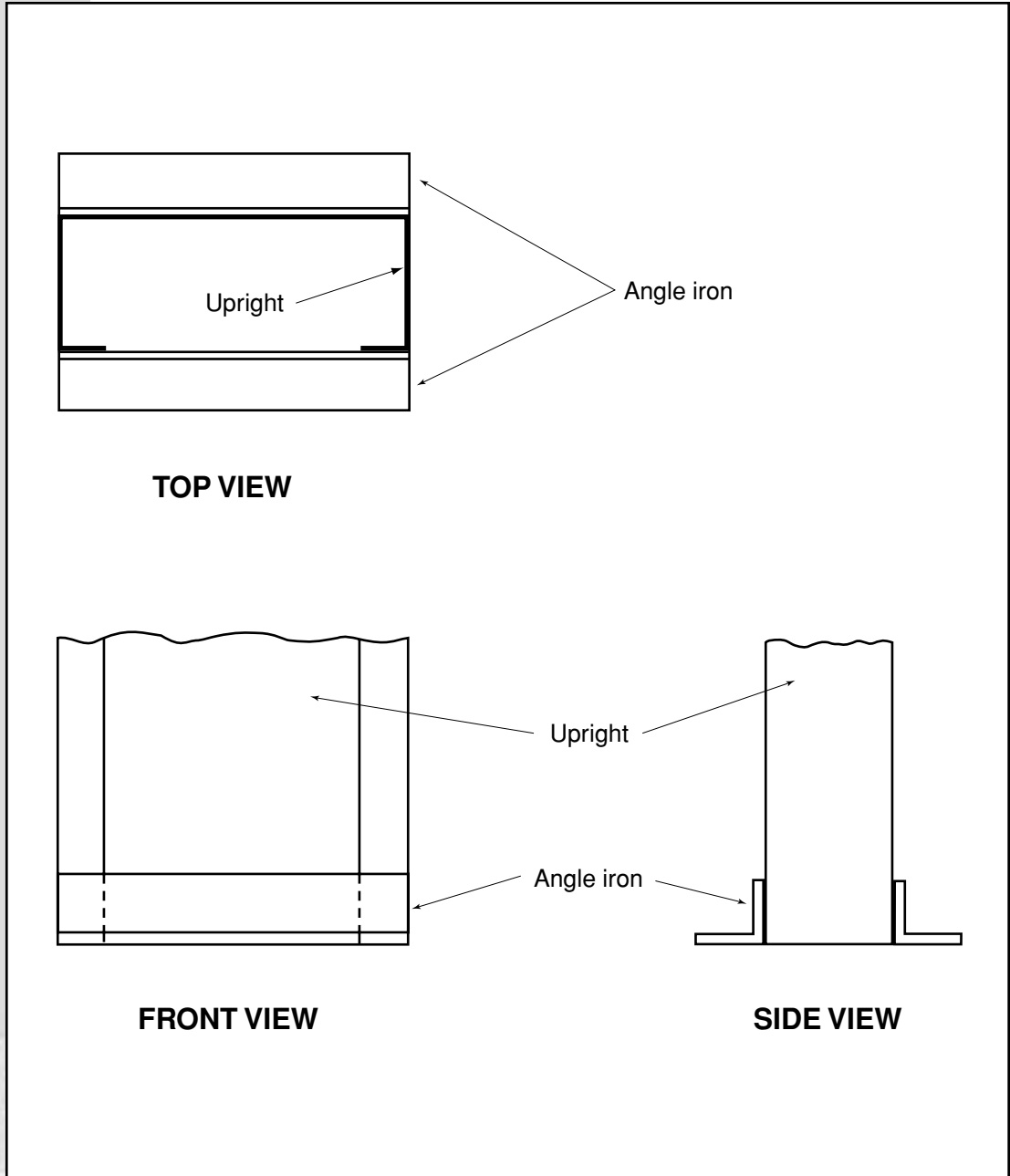

Figure 5. Upright details.



Photo 8. Guzzler showing 16-foot x 32-foot one-unit aprons; shared uprights between aprons; buried tanks, gutter hookups.

underneath the apron for repair and maintenance purposes. Also, this space is necessary to ensure that the lawn sprinkler keys can be easily inserted down into the S&D pipes.

Once you have reached this point - the front beam is level, its ends are flush with the uprights, it is off the ground enough so that the apron won't be hitting the top of the tank, and there is room for someone to get into the manhole under the middle beam, drill the 3/8-inch holes, two per joint. For strength and stability, the top hole should be close to the inside edge of the uprights and the bottom hole close to the outside edge of the upright/bottom edge of the beam (Figure 4). Use the 3/8-inch nut/washer/bolt assemblies; tighten with ratchet and sockets or wrenches.

If the site is right, then for **big game units** you'll have two 16-foot x 32 to 48 foot aprons, side by side, and you'll

need three 50-foot cloth tapes showing feet and inches, plus a 25-foot tape, steel or cloth, showing feet and inches to make all measurements shown in Figure 3 simultaneously. This process takes four people to hold and adjust the tapes, plus one or two more to mark where the holes for the uprights should be dug.

Squaring the apron is the single biggest problem we have had over the years. You cannot eyeball it! The most critical dimensions here are the diagonals. They must be the same from the left-front-inside corner to the right-rear-inside corner as from the right-front-inside corner to the left-rear-inside corner. Note from Figure 3 that the uprights are 92 inches apart on centers, front to back.

When the second set of uprights is true, hold the second 18-foot beam in place, clamp it, and make sure it is level (side to side) the same as the first

#### Helpful Hint

We usually run with two drills per two-man crew: one drill has a 1/4-inch bit and the other a 3/8-inch bit. Start the 3/8-inch holes with the 1/4-inch bit as hole cutting goes faster that way. The non-drilling person oils the bits during drilling to keep them cool and functioning. Variable speed electric drills do not have to be run at maximum speed—drill bits cut better if turned slower and oiled.

**Helpful Hint**

A field expedient if the apron supporters do not end up being square is to cut off the top of the upright.

**Helpful Hint**

Once the front beam for each apron is up and bolted, one or two people can work on gutters while the rest work on the sheeting.



Photo 9. Center uprights with horizontal beams attached, one above the other, resulting in left apron sitting higher.

beam, **BUT**—make sure it is a little higher than the first beam so that when water hits the apron, it will run downhill toward the gutter beam. Use about half a bubble plus on the 36-inch level to set the gradient. (When everything is in place, aprons should tilt about 12 inches in 16 feet—roughly a 6 percent grade. The water flows well, but not too fast to overshoot the gutter during a heavy downpour.)

Use another beam, which is not yet attached, as the straightedge between the front and second beams, and put the level on it. All beams should be in line with each other, both side-to-side and front-to-back, so the apron will be one plane and not have a hump or hollow in the center. Attach the rest of the beams to their prospective uprights the same as you did the first one.

You have now completed the framing for one of the four (or two long) aprons

for a **big game unit**. The second apron utilizes the right-hand uprights (as you face the guzzler) or the first apron as its left-hand uprights. The third and fourth aprons may be separate entirely, or if the site allows it, the rear uprights from either the first or second apron may be used as the front uprights for the third and fourth aprons.

We have, where the site allows it, made two long aprons – 16-foot x 32-foot (48 feet) which eliminates a third and fourth gutter assembly. Be very careful, however, as the long aprons must be barely tilted or much runoff will be lost during downpours as the rain overshoots the gutters. Use the 12 inches per 16 feet rule.

**Sheeting**

Strive to get sheeting of the pattern shown in the drawings and photos, with about the same number of peaks as valleys per sheet. Sheeting with few



humps and more flat area are structurally much weaker when snow loading is an issue, as it is in northern Nevada.

Start with the lower and middle beams, overlapping the sheets by one hump, side to side. Note the comment on the drawings about the prevailing wind (Figure 4).

The front edge of the sheeting should overhang the front beam face by about 1 inch (no more) so water drops right into the gutter and doesn't run down the face of the beam.

The front edge of the apron should be a straight line. If it is not, jiggle the sheets around until it is and the overhang still remains just an inch.

When the front edge of the sheets and the beam are 1 inch apart all the way across, and the sheeting is centered between the uprights, secure the sheeting to the **first beam only** with TEK screws (Figure 3). This will make it much easier to complete the apron, regardless of length.

Now, lay on the second set of sheeting, making sure that the downstream or lower edge comes right to the downstream angle of the middle beam's face and edge. Jiggle the sheets again if you have to.

If the beams and uprights are square, then the sheeting should go on with a little bit of room to spare, and no cutting of the sheeting will be required where it butts up against the uprights. Now it's time to mark where the rest of the TEK screws will go. Take the chalk line, center it on the top (horizontal) edge of each beam, snap it, and start installing the TEK screws.

Do the front edge first (if you haven't already), then the middle beam, then the third beam, and so on. When you get to the middle beams, you'll have to stand on them and the sheeting to put in the TEK screws. Stay centered on the beams—no more than a foot or so to each side of center as the sheeting is not very strong.

Use three TEK screws to attach each piece of sheeting to each beam (Figure 4). The rubber washed under the head of each TEK screw keeps water from flowing down the drill hole and through the beam. You'll need a 3/8-inch magnetic socket on the screw gun to install the #14 TEK screws.

One last (important) thing: bend the troughs of the front sheet down just a little using a Crescent wrench so the water will drop better into the gutter during light rainfall. If thunderstorms provide some of the water, use 1 1/2-inch x 1 1/2-inch aluminum flashing installed so the vertical side slows high flows and forces the water down into the gutter.

### *Gutter Construction*

For an overall view of gutter construction, examine Figure 6, Photos 10 and 11, and the Plastmo Vinyl Gutters sheet (Figure 7).

Galvanized gutter materials were used in earlier catchments, but the plastic Plastmo that is currently used snaps together and is as durable. (Two Plastmo gutters have lasted 19 years to date.)

Place the dropout (Figure 6 and Photo 11) so that it will be about 10 feet from one end of the apron and 5 feet from the other. Ten feet of gutter, plus

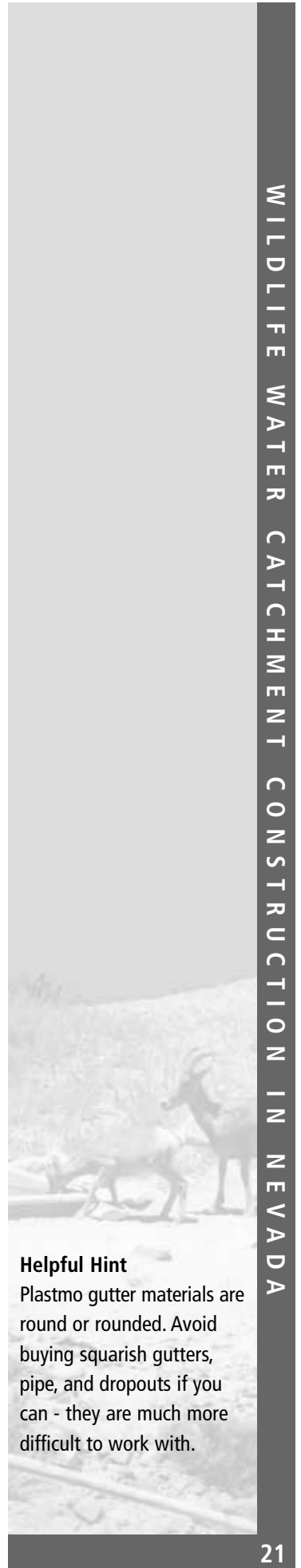

#### **Helpful Hint**

Plastmo gutter materials are round or rounded. Avoid buying squarish gutters, pipe, and dropouts if you can - they are much more difficult to work with.

5 feet of gutter, plus the dropout width equals about 16 feet, the width of the apron.

The dropout should be located down the face of the beam just far enough that water falling off the apron will run down both the 5- and 10-foot gutter pieces into it. You do not have to make it steep, just steep enough so water flows well to the dropout. One inch below the sheeting at the ends and 2 inches at the center drop are adequate.

Take a pencil or pen and draw a line on the beam face along the top edge of the gutter pieces and dropout, or mark points and use a chalk line. Hold brackets in place and mark their holds, as well as the dropout holes. Use a soft-pencil or felt-tip pen to mark the holes.

Use a 3/16-inch bit to drill holes in the beam for the #12 x 3/4-inch sheet metal screws for the gutter brackets. You can also use appropriately sized TEK screws. Use the 10/32 x 1-inch machine screw/washer/lock washer/nut combination for the dropout. When marking the holes for the dropout, make sure your pen goes all the way through and contacts the beam - sometimes the plastic is not broken through for these holes.

The neat thing about Plastmo is that once the brackets and dropout are attached, the gutter pieces snap into place. Make sure that there is adequate overlap of the gutter into the dropout to allow for expansion and contraction of the gutter material. Use PVC cement (or silicone caulking) when you snap on the end caps.

Once this is done, look at what you have to do to get water from the dropout down into the tank: use the 45° or 75° elbow and cut down pipe as needed.

For **big game** tanks, mark a hole for the downpipe where it will drain into a tank and cut it with either a 2 1/2-inch hole cutter or 1/4-inch drill, drilling holes all the way around and then knocking out the center.

Secure the dropout, elbow, pipe, and downpipe joints with a single TEK screw per joint.

Use a short piece of baling wire to hold the pipe against the corner of the mouth of the tank for **small game** tanks.

One last thing - cut a small rectangle of 1/4-inch hardware cloth (galvanized mesh) or preferably stainless steel mesh (better from a maintenance stand-point) to fit over the hole in the center drop, but under the lips of the gutter pieces on both types of units to keep debris (mostly bird droppings) from clogging the plumbing. See the suppliers list for stainless steel mesh.

Because of expansion and contraction from heat and cold, the gutter pieces will occasionally work themselves downhill so both pieces are actually touching over the drain hole. Either cut a triangular notch in both pieces, or hold them apart with a small spacer made from scrap.

When aprons are completed, remove the gutters and rinse the aprons off with the water in the cubitainers. This rinse removes most of the metal shav-

ings created during installation of TEK screws, which drill their own holes.

them with several steel fence posts and field fencing to keep large animals away from them.

The gutters are the weakest link in getting water into the tanks. Protect

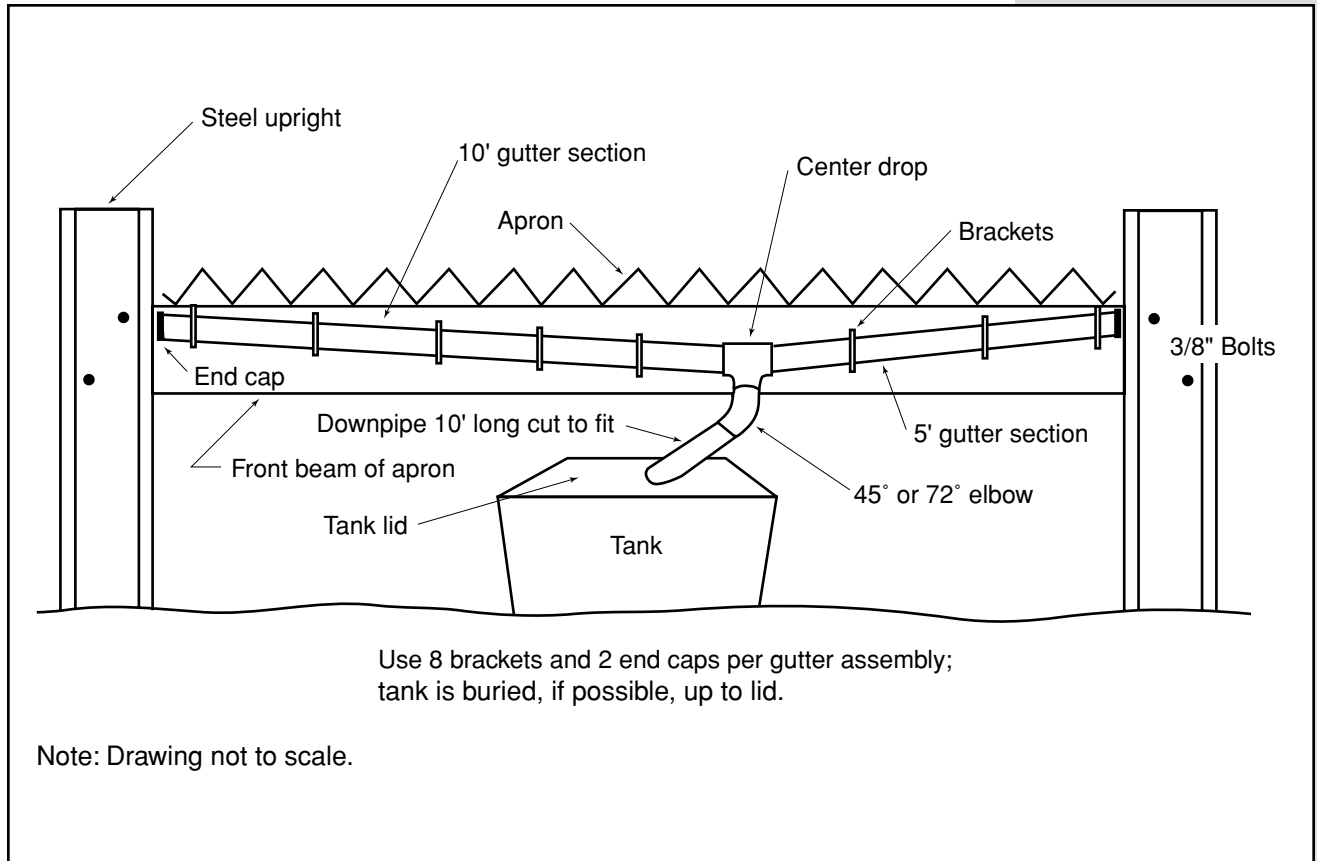

Figure 6. Carson City BLM game guzzler gutter details.



## Plastmo - Vinyl Gutters

Web Site: <http://www.plastmo.com/plangtr.html>

Carson City District uses the parts names/numbers that are circled. Use Charcoal Gray (item 4" x 2 1/2"; round, not angled stock) as it has proven to last longer in the sun.

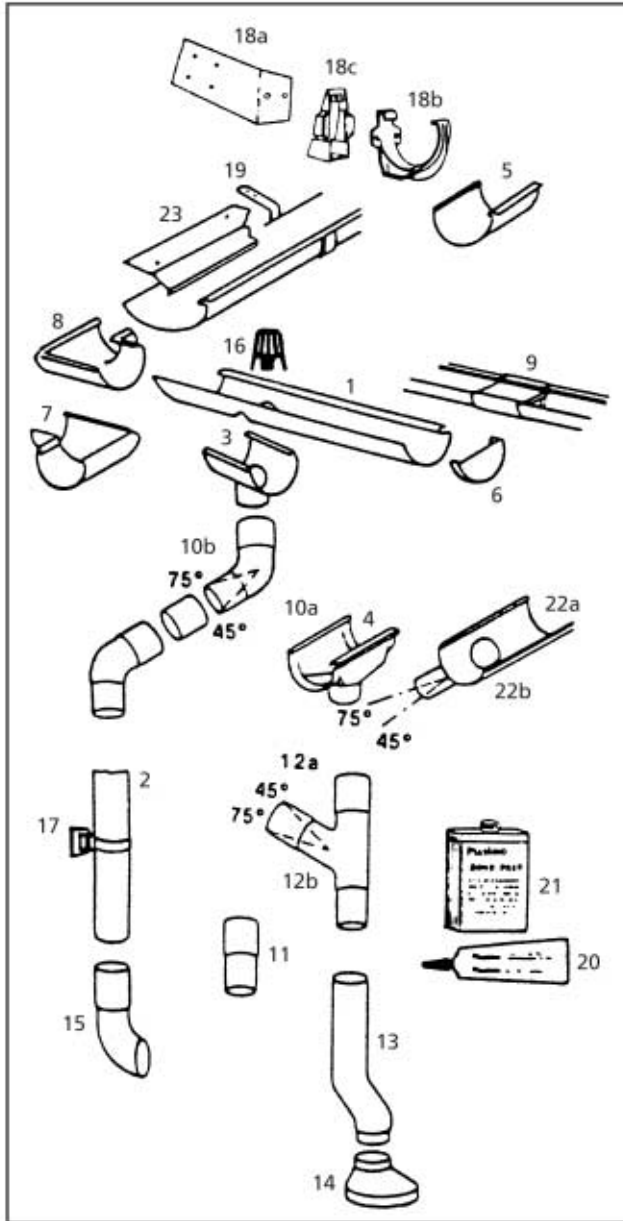

### Part Name - Number

- 1. Gutter 4" x 10' - P0140
- 2. Downpipe 10' - P1602
- 3. Center Drop
- 4. Expansion Center Drop - P1142
- 5. Joint Connector - P0240
- 6. End Cap - P0840
- 7. Corner, Outside
- 8. Corner, Inside
- 9. Expansion Joint Connector
- 10a. Elbow 45° - P1302
- 10b. Elbow 75° - P1202
- 11. Pipe Joint - P2002
- 12a. Junction 45°
- 12b. Junction 75°
- 13. Well Outlet
- 14. Well Cap
- 15. Shoe
- 16. Leaf Guard *Gray only*
- 17. Pipe Holder
- 18a. Rafter Adapter
- 18b. PVC Plastic Bracket - P0640
- 18c. Wedge
- 19. Long Hanger, galvanized only
- 20. Cement 5 fl. oz./142 ccm
- 21. Cleaning Fluid 8.9 oz./250 ccm
- 22a. Outlet 45°
- 22b. Outlet 75°
- 23. Driplet 6' 6"

Figure 7. Plastmo - Vinyl Gutters



Photo 10. Guzzler gutter parts, left to right: center drop; gutter bracket; pipe connector, 45° elbow; 75° elbow ("L").



Photo 11. Guzzler gutter details: center drop and PVC gutter brackets are installed; pieces of the snap-in gutter lie on apron.

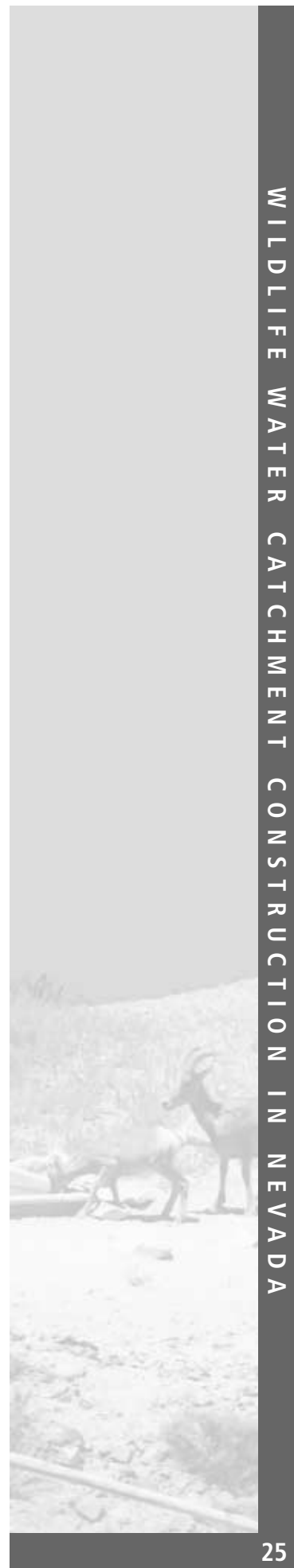

## Fences

Table 2, *Materials/Parts List for Big Game Guzzler and Fence*, includes parts for a buck and rail fence and for a 4-5 strand barbed and smooth wire fence.

### Buck and Rail Fence

We evolved to the buck and rail fence in the Carson City District because of the cattle and wild horses in the areas where we construct the big game units for desert bighorn sheep. Study Figure 8 and Photo 12 for construction details.

One advantage of the buck and rail fence is that no post holes have to be dug. A disadvantage is the sheer bulk of the wood posts and rails during transport and the fact that they weigh about 2 tons if you are using helicopter transport.

For this fence, staple the barbed wire just below the top rail to discourage horses from trying to lift this rail with their noses. (*This uses about 320 feet of the barbed wire, which is not included in the materials list.*) Also, be sure to nail the 4-foot-long 2-by-4s to the lower legs of the bucks so the bucks won't collapse.

### Smooth Wire/4-5 Strand Barbed Wire Fence

We have used standard BLM-spec antelope "Type B" fences to protect guzzlers in antelope areas where horses are not a problem and for some small game guzzlers. The fences around several antelope guzzlers are 300 feet on a side, so that a minimum of two acres was enclosed. Wires from ground level

up should measure 16-inch smooth, then 22-, 30-, and 42-inch barbed. We have found, however, that antelope will use the much smaller buck and rail fence and the same guzzlers where only the drinkers are protected with welded pipe fence.

In 1995, we used this same fence, only much shorter, to protect bighorn units where horses were not a problem. Wire spacing there (Photo 13) is 20-35-39-43 inches from the ground. The bottom wire is smooth and the rest are barbed.

While these fences are anchored entirely in the ground by standard 5 1/2-foot "T" posts, and each of these must be driven in by hand, the fences still go up much faster than the buck-and-rail types.

The smaller bulk of materials also makes transporting much easier. Note that we are using "EZ" panels for corners. These are easy to install and appear to do the job adequately.

### Small Game Guzzler Fence

Fencing is much simpler for small game guzzlers. Where these have to be protected from cows rubbing against the apron or uprights, we simply have stretched barbed wire around the uprights and anchored the wire to them. You can also use regular 3-post corners (Or EZ panels) in either a square or triangle configuration to protect the small game units.

When the job is complete, police the area for any litter and seed the area inside the fence with native grass, forb, and shrub species.



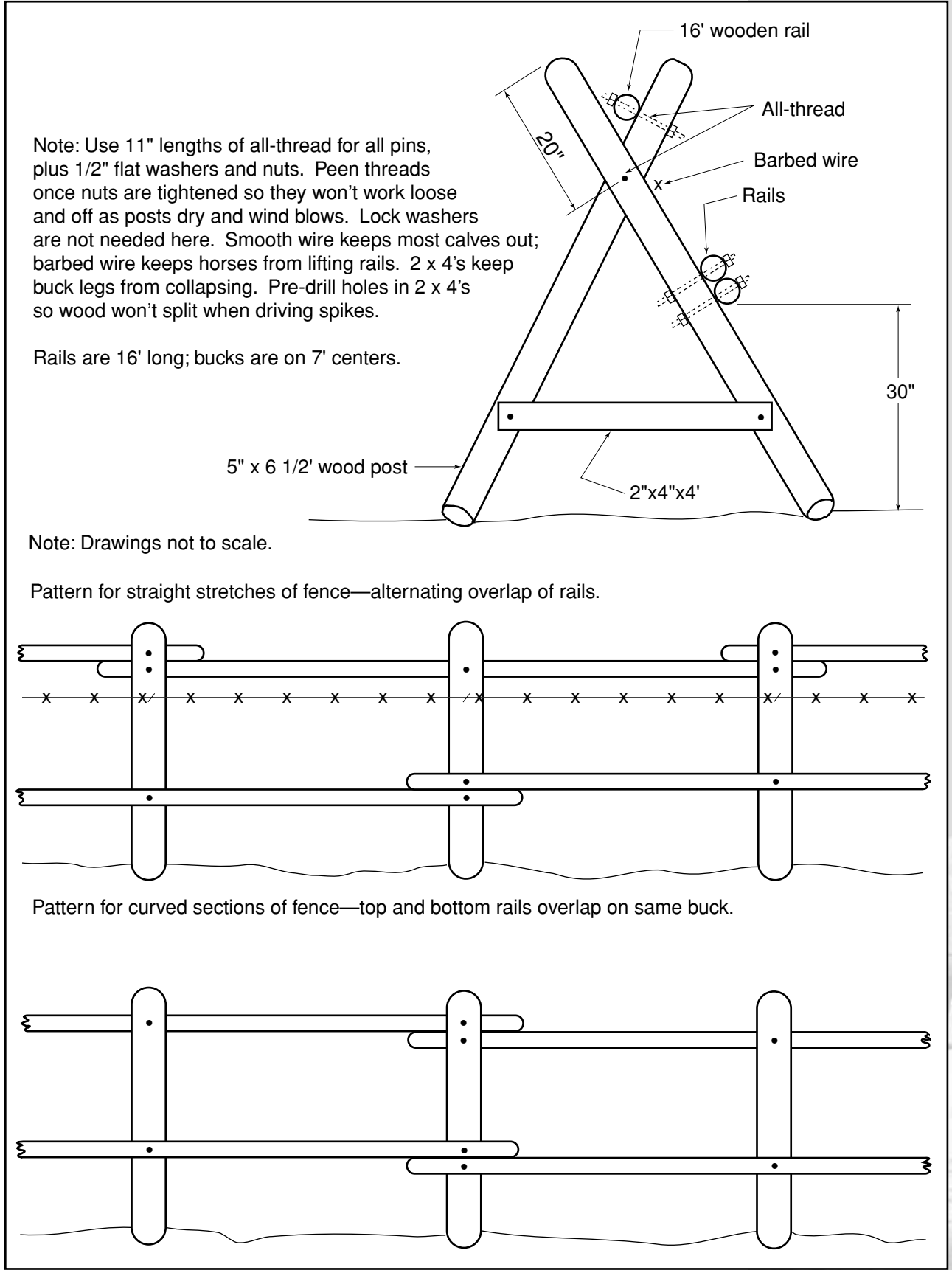

Figure 8. Carson City BLM big game guzzler fence details, buck-and-rail type.



Photo 12. Completed big game guzzler in northern Nevada, consisting of water collecting aprons, buried tanks, drinker surrounded by rocks, and buck-and-rail fence.



Photo 13. Barbed and smooth wire (bottom strand only) using steel "T" posts and "EZ" panel corners. Rocks (piled or wired on) strengthen the corner.



## Loose Ends

Go back to the **big game guzzler** after it rains or snows sufficiently. Open the gate valve for the drinker and adjust the float valve if there is one.

Some readers may question why we use so many different parts for plumbing instead of using PVC stiff pipe and fittings. Early use of PVC gave us nothing but grief, and we went with what we use now because individual parts are easily replaced. Another reason for the many small parts is that they are more easily carried into remote guzzler sites than PVC pipe, and many of the bighorn sheep units are well away from roads.

Every part that is used in construction of these guzzlers, large and small, is “off-the-shelf” and may be purchased or ordered from virtually anywhere. Even the tanks and steel have at least two suppliers each.

We are currently experimenting with one antelope guzzler using all PVC (underground). This is a site that we can drive to.

The parts for an additional fiberglass storage tank are as follows: one tank, one bulkhead fastener, one 90° MIP, one gate valve, one barbed “T” or “L,” five or six stainless steel hose clamps, two straight MIPs, one 36-inch piece of sewer and drain pipe, one 4-inch

PVC cap, and several feet of Teflon tape.

The parts needed for a stand-alone single 16 foot x 16 foot apron are listed in Table 1, except that a solid roof replaces the open-end roof and walk-down ramp.

## Comments on Substitutions

**DO NOT** let a salesman tell you that 26-gauge steel is equivalent to a 24-gauge steel. The difference in weight-bearing capacity is approximately 25 percent on the 8-foot lengths that are used.

You can order the big game tank lids just as they are shown in the construction drawings. Don't let people sell you lids that serve as catchment aprons themselves.

The manhole covers are held in place with 3 or 4 self-threading screws, not 8 or 10 nuts and bolts.

Plan adequate lead time when ordering parts, especially steel and fiberglass. Plan on six to eight week delivery times for these and shorter times for smaller parts. If anything has to go out for bid, **double** the time. The best bet is to order everything three months prior to construction.



**Table 1. Materials/parts list for small game guzzler (800 gallon capacity) (2002).**

Description	Unit Quantity	Cost	Total Cost*	Source
Tank, fiberglass, 5'x10'x 2 1/2' with bolt-on lid, open at one end, with manhole cover, plus walk-down (roughened) ramp	1 each	\$1,000.00	\$1,000.00	1, 2
"C" purlin (beam) steel, 8x3.5"x18" 14 gauge, plain ("black")	5 each	\$60.00	\$300.00	3
Roofdecking, steel, 24 gauge, 32"x8", tan, Source 3=7.2 supra rib	13 each	\$40.00	\$520.00	3
Plastmo raingutter 4"x10" (No.1) (Numbers are catalog numbers)	2 each	\$2.96	\$10.00	4
Plastmo downpipe, 2"x10" (No. 16)	1 each	\$5.87	\$5.87	4
Plastmo Expansion Center Drop (No. 11)	1 each	\$3.38	\$3.38	4
Plastmo end caps (No. 8)	2 each	\$1.13	\$2.26	4
Plastmo pipe joint (No. 2)	2 each	\$1.36	\$2.72	4
Plastmo elbow 75° (No. 12)	1 each	\$2.50	\$2.50	4
Plastmo PVC plastic bracket (No. 6)	8 each	\$1.56	\$12.48	4
1/4" mesh stainless steel cloth 1-3"x7" piece	1 each		\$1.50	5

\*Prices shown are representative for 2002. Tanks and steel purlins and roof decking are FOB the manufacturer.

**REFER TO DRAWINGS FOR TANK SPECIFICATIONS**

Sources are as follows:

- |  |  |  |
|--|--|--|
| <p>1. Fiber Erectors<br/>P.O. Box 1009<br/>Red Bluff, CA 96080<br/>(916) 527-1515<br/>FAX (916) 527-7755<br/>Ed Stricker</p> | <p>2. Fiberglass Structures Inc.<br/>119 South Washington Ave<br/>Laurel, MT 59044<br/>(406) 628-8208<br/>FAX (406) 628-2482<br/>www.fiberglass-structures.com</p>   | <p>3. Big Red's Creative Bldg. Systems<br/>P.O. Box 265<br/>Acampo, CA 95220<br/>(209) 368-5182<br/>FAX (209) 339-1929<br/>Cal Clark</p> |
| <p>4. Local plumbing suppliers or www.plastmo.com</p>  | <p>5. Howard Wire Cloth Co.<br/>28976 Hopkins St.<br/>Hayward, CA 94545<br/>(510) 887-8787<br/>1-800-969-3559<br/>FAX (510) 786-4167<br/>www.howardwirecloth.com</p> |  |

**Table 2. Materials/parts list for big game guzzler (4,000 gallon capacity) plus fence (2002)**

Description	Unit Quantity	Cost*	Total Cost*	Source
Tank, fiberglass, 5'x10' x 2 1/2'; with bolt-on lid & no plumbing, but with manhole cover <b>OR</b>	5 each	\$1,000	\$5,000	1, 2
Tank, Boss Polypropylene 16' x 8' x 2' Flat Root, 1 piece, 2,000 gallon cap	2 each	\$3,400	\$6,800	8
Drinker, fiberglass, 36" x 72" x 30"	1 each	\$225.00	\$225.00	2
"C" purlin (beam), steel, 8" x 3 1/2" x 18' 14 gauge, plain (15 beams + 20 uprights (minimum) + 1 spare)	23 each	\$63.36	\$1457.28	3
Roofdecking, steel, 24 gauge, 36" x 8" Source 3 = 7.2 supra-rib	74 each	\$36.32	\$2687.68	3
Angle iron, steel, 1 1/2" x 1 1/2" x 8 Buy in 10 ft. lengths, then cut	30 ft.	\$1.10	\$33.00	4
1 1/2" standard thread brass gate valve, Grinnell 3000 or equiv.	6 each	\$36.74	\$220.44	4
90° plastic 1 1/2" barbed L (1 1/2 insert x 1 1/2 insert Poly 90)	2 each	\$1.73	\$3.46	4
1 1/2" barbed T (1 1/2 insert Poly T)	4 each	\$2.65	\$10.60	4
1 1/2" plastic bulkhead fastener (1 1/2 PVC bulkhead)* for self-leveling system; 5 for float operated system	6 each*	\$8.99	\$53.94	4
1 1/2" MIP plastic barbed adapter (1 1/2 MIP x insert poly adapter) *10 for float operated system	13 each*	\$0.87	\$11.31	4
4" x 10' sewer & drain (S&D) pipe, non-perforated (solid)	2 each	\$4.05	\$8.10	4
4" S&D caps	6 each	\$0.66	\$3.96	4
1 1/2" Black polypipe, 100 ft. roll IPS 100 lbs. Pressure, potable water	1 each	\$127.77	\$127.77	4
1 1/2" stainless steel hose clamps	50 each	\$0.90	\$45.00	4
Teflon tape, 3/4" wide roll	2 each	\$2.50	\$5.00	4

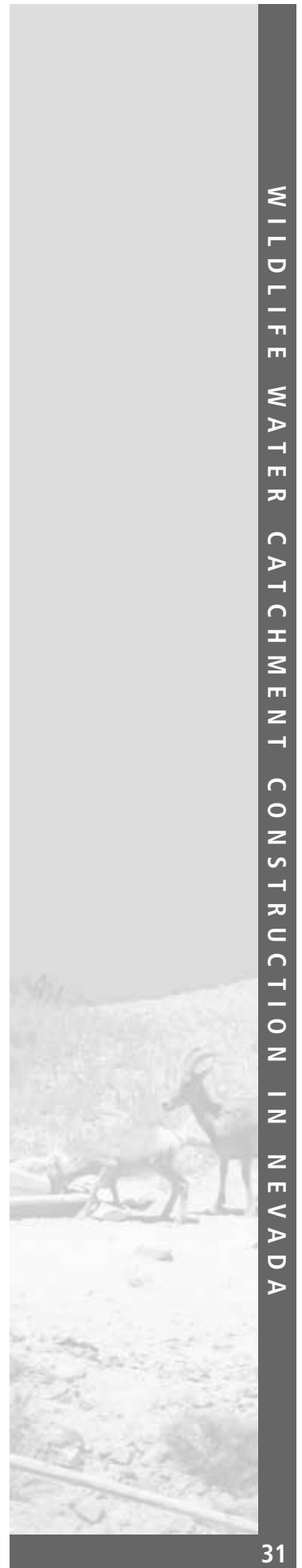

**Table 2 (cont)**

Description	Unit Quantity	Cost*	Total Cost*	Source
Sprinker Key, 24"	1 each	\$3.00	\$3.00	4
Silicone caulking, non-toxic (for aquariums) to fit regular caulking gun	1 tube (10 oz)	\$8.75	\$8.75	5
Plastmo raingutter 4" x 10' (No. 1)	8 each	\$2.96	\$23.68	4
Plastmo downpipe, 2" x 10' (No. 16)	4 each	\$5.87	\$23.28	4
Plastmo Expansion center drop (No. 11)	4 each	\$3.38	\$13.52	4
Plastmo end caps (No. 8)	8 each	\$1.13	\$9.04	4
Plastmo pipe joint (No. 2)	8 each	\$1.36	\$10.88	4
Plastmo elbow 75° (No. 12)	4 each	\$2.50	\$10.00	4
Plastmo PVC plastic bracket (No. 6)	34 each	\$1.56	\$53.04	4
TEK Screws, #14 x 1' sealer	300 each	\$160./M	\$48.00	4
Hex bolts, grade 2 plated steel, 3/8" x 1" x 16tpi	65 each	\$15.00/C	\$10.00	4
3/8" x 16 tpi nuts, plated steel	65 each	\$5.00/C	\$3.25	4
3/8" plated steel flat washers	130 each	\$0.05/C	\$6.50	4
3/8" plated steel lock washers	65 each	\$0.05	\$3.25	4
10/32 x 1" machine screw with fender washer, lock washer, & nut	8 units	\$1.00	\$9.00	4
No. 12 x 3/4" sheet metal screws	box of 100		\$9.00	4
1/4" mesh stainless steel cloth	1 square ft. (3, 3" x 7" pieces)		\$2.00	7
<b>Additional Parts Required For Float Operated System:</b>				
1 1/2" brass float valve with 18" rod, swivel and 6" copper float (no plastic)	1 each	\$85.00	\$85.00	4
1 1/2" standard thread steel floor flange, 4 hole pattern	2 each	\$5.00	\$10.00	4

Table 2 (cont)

Description	Unit Quantity	Cost*	Total Cost*	Source
1 1/2" x 3 1/2" steel nipple	1 each	\$1.75	\$1.75	4
5/16" x 18 x 1 1/2" stainless steel cap screw, + 5/16" and 18 stainless steel nut, + 5/16" s.s. lock washer, + 5/16" s.s. flat washer (10)	5 each		\$8.00	4
1/8" – 1/4" steel plate to protect	1 each	\$15.00	\$15.00	4
<b>Buck And Rail Fence Parts:</b>				
Treated wood post, 6 1/2' x 5-6"	92 each	\$5.00	\$552.00	4
Rail, wood, 16' x 3-4"	46 inch	\$7.50	\$345.00	4
Drive Screw fence nails	2 bundle (50 nails each)	\$6.00	\$12.00	4
2" x 4" x 4' wood	46 each	\$2.00	\$92.00	4
All-thread, steel, 1/2" x 11"	150 each	\$0.80/ft	\$110.00	4
All-thread, steel, 1/2" x 13"	50 each	\$0.80	\$44.00	4
Washer, flat, 1/2", plated steel	400 each	\$0.12	\$48.00	4
Nut, 1/2", plated steel to fit all thread	400 each	\$0.13	\$52.00	4
Fence staples	100 each	\$0.02	\$2.00	4
<b>All Steel Fence Parts:</b>				
Easy Fence panels/Grace Combinations	8 each	\$42.00	\$336.00	6
Steel "T" post (need 5-6/corner, plus any line posts)	24 each (X) each	\$2.75 \$2.75	\$66.00	4 4
Barbed wire roll (= 1,320 ft. long) 1-4 rolls	1-4 rolls	\$33.00	\$33.00 to \$132.00	4
Fence clips (package of 50)	1-3 packs	\$1.50	\$150 to \$4.50	4
Fens stays, 30"	each	\$0.30		4

\*Prices shown are representative for 2002. Tanks, steel purlins, and roofdecks are FOB the manufacturer.

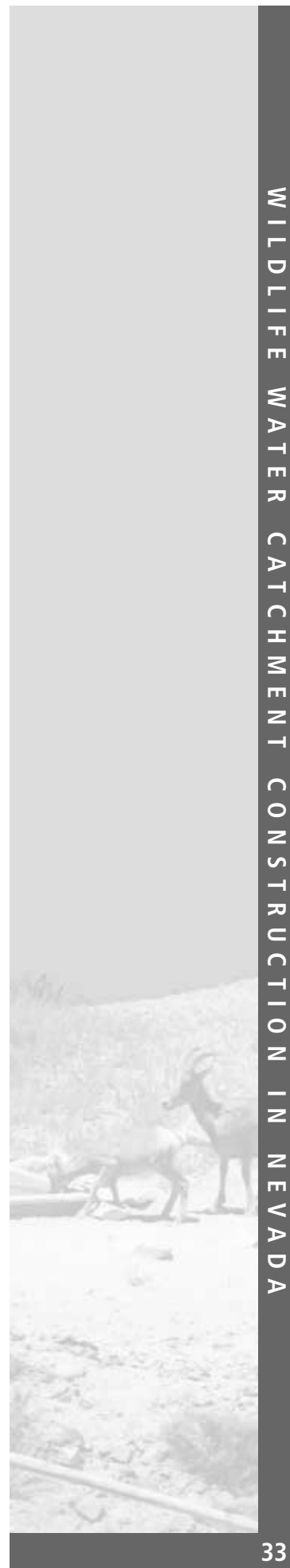

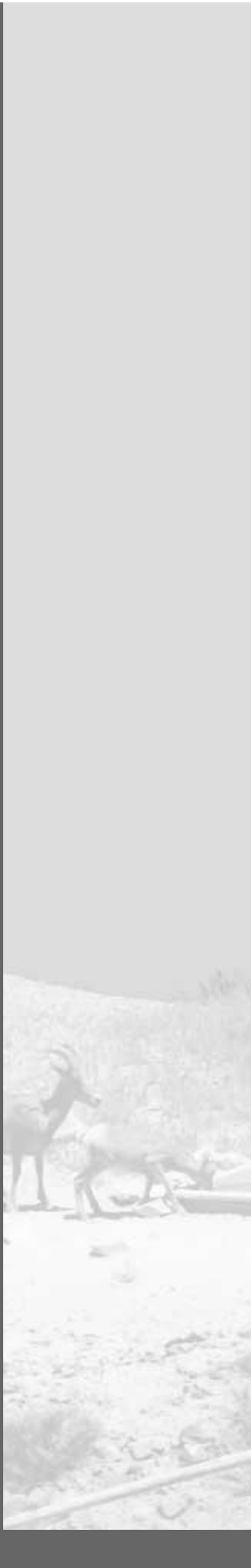

**Table 2 (cont)**

REFER TO DRAWINGS FOR TANK AND STEEL SPECIFICATIONS

- |  |  |  |
|--|--|--|
| <p>1. Fiber Erectors<br/>P.O. Box 1009<br/>Red Bluff, CA 96080<br/>(916) 527-1515<br/>FAX (916) 527-7755<br/>Ed Stricker</p>   | <p>2. Fiberglass Structures, Inc.<br/>119 South Washington Ave<br/>Laurel, MT 59044<br/>(406) 628-8208<br/>FAX (406) 628-2488<br/>www.fiberglass-structures.com</p>  | <p>3. Big Red's Creative Bldg. Systems<br/>P.O. Box 265<br/>Acampo, CA 95220<br/>(209) 368-5182<br/>FAX (209) 339-1929<br/>Cal Clark</p> |
| <p>4. Local plumbing, fastener, and fencing suppliers such as R Supply, Reno, NV.</p>  | <p>5. GE (General Electric)<br/>Caulking, #RTV108, form R.S. Hughes<br/>P.O. Box 292933<br/>Sacramento, CA 95827<br/>(916) 737-7484<br/>For nearest availability, call GE at 1-800-255-8886 and as for a technical rep</p> | <p>6. Easy Fence<br/>408 South 900 West<br/>Blackfoot, ID 83221<br/>(208) 782-1177<br/>www.easyfence.com</p>                             |
| <p>7. Howard Wire Cloth Co.<br/>28976 Hopkins St.<br/>Hayward, CA 94545<br/>(510) 887-8787<br/>FAX (510) 786-4167<br/>1-800-969-3559<br/>www.howardwirecloth.com</p> | <p>8. Boss Tanks<br/>P.O. Box 5689<br/>Elko, NV 89802<br/>(775) 738-2677<br/>FAX (775) 738-2367<br/>MOBILE (775) 777-5631<br/>www.bosstanks.com</p>  |  |

**Table 3. Equipment/tools checklist for guzzler and fence construction**

1. 2 portable generators (powerful enough to run 2, 1/2-inch drills each, simultaneously - ours are 18.5 amp, 2400 watt)
2. Backup generator
3. Extra gasoline (for generators and rock drill—4 gallons minimum)
4. Tarps (to put generators on when working to keep them out of the dirt—also to cover equipment or volunteers if it rains or snows or if everything sits at a site for several weeks between helicopter slinging and actual construction)
5. Small propane torch (preferably self-igniting with an extra gas bottle for heating polypipe)
6. 2 to 4, 1/2-inch variable speed (0-850 rpm) hand-held drills with reversing gear (We use 4 Milwaukee 0234-1 as they are professional quality and last longer than Black and Decker, etc. Not cheap, but worth it! You can also use 3/8-inch variable speed drills, Milwaukee 0-288-1)
7. 2 drill bits each of the following: 3/16-inch, 1/4-inch, 3/8-inch. (We usually buy 1 of each per job. The cobalt type is preferred because they last longest)
8. High speed (0-2500 rpm) screw gun (for installing TEK screws/apron to beam; we use a Milwaukee 6798-1 with 3/8-inch magnetic socket)
9. 1, 2 3/8-inch hole cutter (for bulkhead fasteners/fiberglass tanks; fits any electric drill)
10. 1, 2 1/2-inch hole cutter (for draining gutters into tanks via Plastmo pipe; make sure it is stout enough to cut through roof decking)
11. Rechargeable 9.6 volt or greater 3/8-inch cordless drill with 2 each 1/4-inch and 5/16-inch Apex heads (for plumbing and gutters)
12. 50-foot heavy duty extension cord - at least 1 per drill and screw gun. We use GFI (Ground Fault Interrupter) cords, which automatically break the circuit if the drills short out. Each of these will accommodate 2 drill/cord combinations.
13. Oilers for cooling the drill bits.
14. 1 quart of 10-30 weight oil (nothing thicker) for oilers
15. 2 pair, 4-inch channel lock pliers (for plumbing)
16. Hacksaw (for cutting Plastmo gutter and tubing; a 24 tooth/inch blade is adequate)
17. 6, 5-gallon cubitainers filled with water (for drinking and washing the apron - more if you wish)
18. Caulking gun (for silicone caulking)
19. Chalk line (for marking TEK screw locations on the apron and gutter locations on the front beam of each apron)

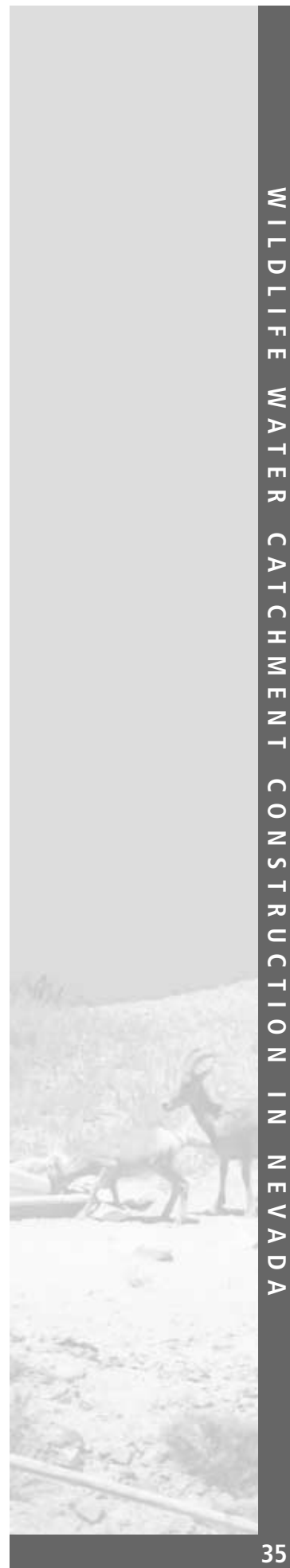

**Table 3. (cont)**

20. 1, 25-foot steel tape
21. 3, 50-foot cloth tapes
22. 3/8-inch drive ratchet with 2-inch extension and the following sockets: 3/4-inch deepset (for 1/2-inch fence nuts); 9/16-inch (for 3/8-inch stock for apron supports); 1/2 -inch (for 5/16-inch cap screws and nuts on drinker flanges when a float valve is used) (Get two of everything)
23. Open end/box combination wrenches in 9/16-inch, 3/4-inch and 7/16-inch (to complement ratchets and sockets)
24. Large C-clamps, 10-inch size, minimum of 2 but preferably 6 (for holding horizontal beams prior to drilling)
25. 36-inch level (for hole and apron)
26. 3 claw hammers
27. A center punch
28. 1 to 2 properly fitting screwdrivers (for machine screws and stainless steel hose clamps; check clamps - they may require a socket or nut driver instead)
29. 2, 5/16-inch nut drivers (better than screwdrivers for hose clamps)
30. 6 to 8 shovels (for digging)
31. 1 to 2 flat shovels (for hole leveling)
32. 1 to 2 Pulaskis (for brush clearing and trenching)
33. A pick for trenching
34. 1 to 2 McLeods (combination heavy-duty rake/hoes; for hole smoothing)
35. 1 rake (for hole smoothing)
36. A 4-foot piece of a 2 by 4 (for hole leveling)
37. 2-4 Pry bars/tampers (for upright; holes/rocks)
38. Vise grips/crescent wrench
39. Heavy gloves (for all personnel)
40. Plastic goggles (as needed)
41. 1, 20-man first aid kit



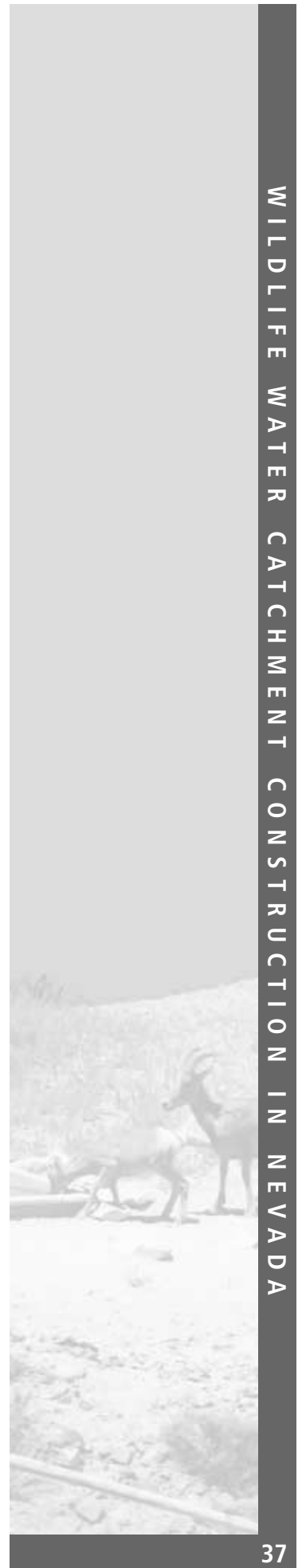

**Table 3. (cont)**

42. 24- or 30- inch lawn sprinkler tool (for opening and closing gate valves - leave this at the site tucked up into the backside of one of the front beams)
43. Tin snips (for cutting galvanized or steel hardware cloth)
44. Fiberglass repair kit including file (for repairing fiberglass tanks/drinker if necessary)
45. 2 to 3 pairs of fencing pliers
46. 2, 12-inch x 9/16-inch drill bits (for wood posts in wooden fences only)
47. 2 to 3 clam shell post hole diggers (for upland game guzzler fence posts and apron uprights)
48. Steel post drivers (for steel post and wire fences)
49. A bow saw for wooden fences
50. Cold chisel (to peen threads on all-thread after nuts are installed on wood fences)
51. Chisel (in case all-thread pieces are too short or the wood is too thick)
52. Post level (4-6)
53. Heavy twine and 4 steel rebar pins, 18-24-inches long for laying out storage tank hole and/or apron boundaries
54. 2 wide-tipped and 2 fine-tipped black felt tip pens for marking holes (for gutters)
55. 50 or so disposable drinking cups

**OPTIONAL EQUIPMENT:**

1. Gasoline-powered auger (for post holes, upright holes, blasting, etc)
2. Rock drill (Pionjar/Wacker - for drilling blasting holes and the trench for plumbing on big game guzzlers, if necessary; plus tough holes for uprights)
3. Backhoe (either rubber tired or tracked)
4. Bobcat earthmover with front-end loader and power auger (Both have been worth their weight in gold at tough digging sites)



**Table 4. Big game guzzler general checklist**

1. Job folder and checklist completed prior to construction
2. Notification: construction date(s) and maps to constituent groups, volunteers, and individuals, prepared/mailed/delivered
3. Signs; steel posts/post pounder/duct tape/yellow flagging/paper plates/wide felt-tip pens
4. Working drawings/spec sheets: three copies minimum to job site
5. Lists: parts/tools
6. Helicopter operation: OAS 23s/manifest pad/load calc pad/weight sheet/nets/sling/swivels/lead lines/duct tape/paracord/knives
7. Volunteers: clipboards/pens/forms - group, individual, under 18, Office of Workmen's Compensation (OWCP)
8. Liquids: cups/water/pop/Gatorade/ice/ice chests
9. Shade: tarps/paracord/tent stakes/trucks
10. Oil for oilers
11. Chalk in chalklines/fine felt-tip pens for marking gutter bracket holes
12. Rock drill: oil/gasoline/filters/spare spark plugs with tool
13. Generators: service timely/make sure they work/fuel
14. Backhoe: fuel/oil/hydraulic fluid
15. Parts and tools: count out/package/weigh (if helicopter operation)
16. Drill bits (buy one set per job): 3/16-, 1/4-, and 3/8-inch colbalt (two of each)
17. Fiberglass repair kit: full/replenished
18. First aid kit: full/replenished
19. Trucks: arrange for/load/drive to site (enough qualified drivers)/unload/cinch straps or chains
20. Four wood laths marked with wire spacing by species (antelope or bighorn) for fences.

**Table 4. (cont)**

21. Wire holder/axle for barbed and smooth wire spools
22. Carriage bolts: 5/16- x 3- or 3 1/2-inch with flat washers and nuts for tank lids
23. Sign for the project if someone paid to name it
24. BLM project marker
25. Seed: grass/forb/shrub
26. Make sure all job parts make it to the job site and that they are loaded on the trucks; have somebody else go through the parts list checking them off
27. Thank you letters as soon as possible after job completion
28. Finish job folder: write recap/as built drawings/final dollars spent/dollar value of effort from all entities



**WATER STORAGE TANK — SMALL GAME GUZZLER**  
 Carson City BLM District

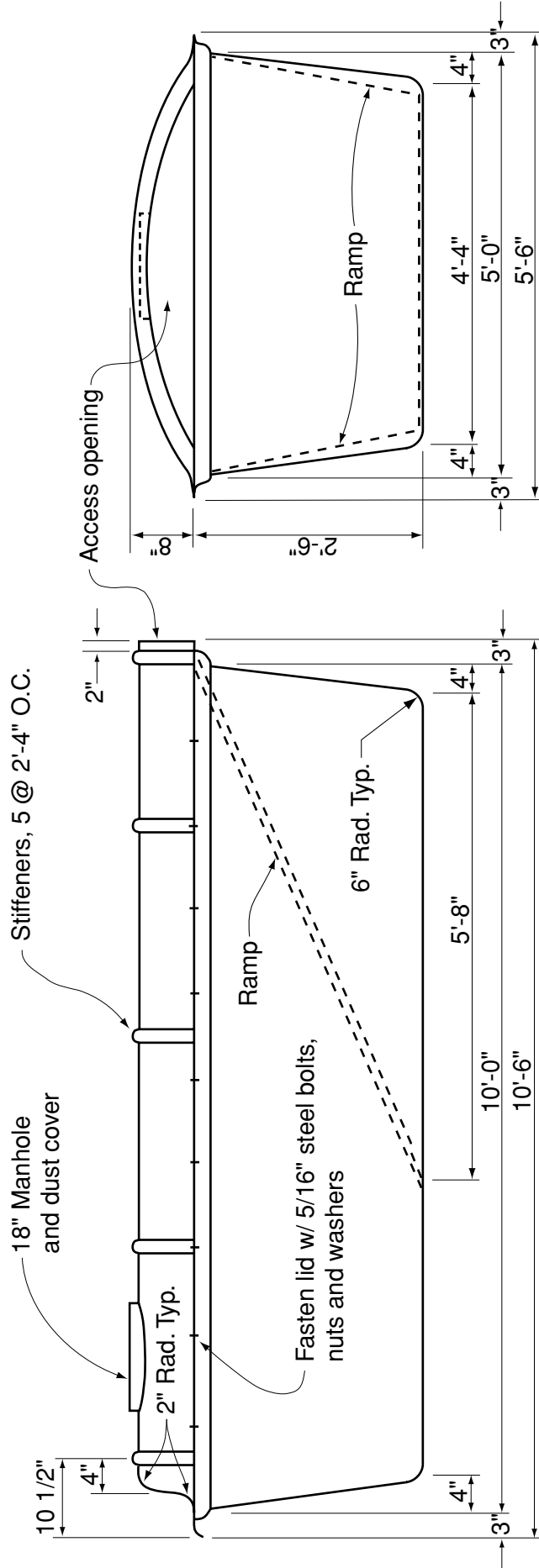

**SIDE VIEW**

**END VIEW**

- Note: 1) Fiberglass construction minimum 3/16" thickness  
 2) Approx. volume: 750 Gal. @ 2'-2" depth  
 3) All fiberglass parts constructed with Esopolyester Resin (non-toxic)  
 4) Color is Desert Tan  
 5) Drawing not to scale

Specification drawing 1.

# TANK AND COVER CORNER DETAILS

## SMALL GAME GUZZLERS

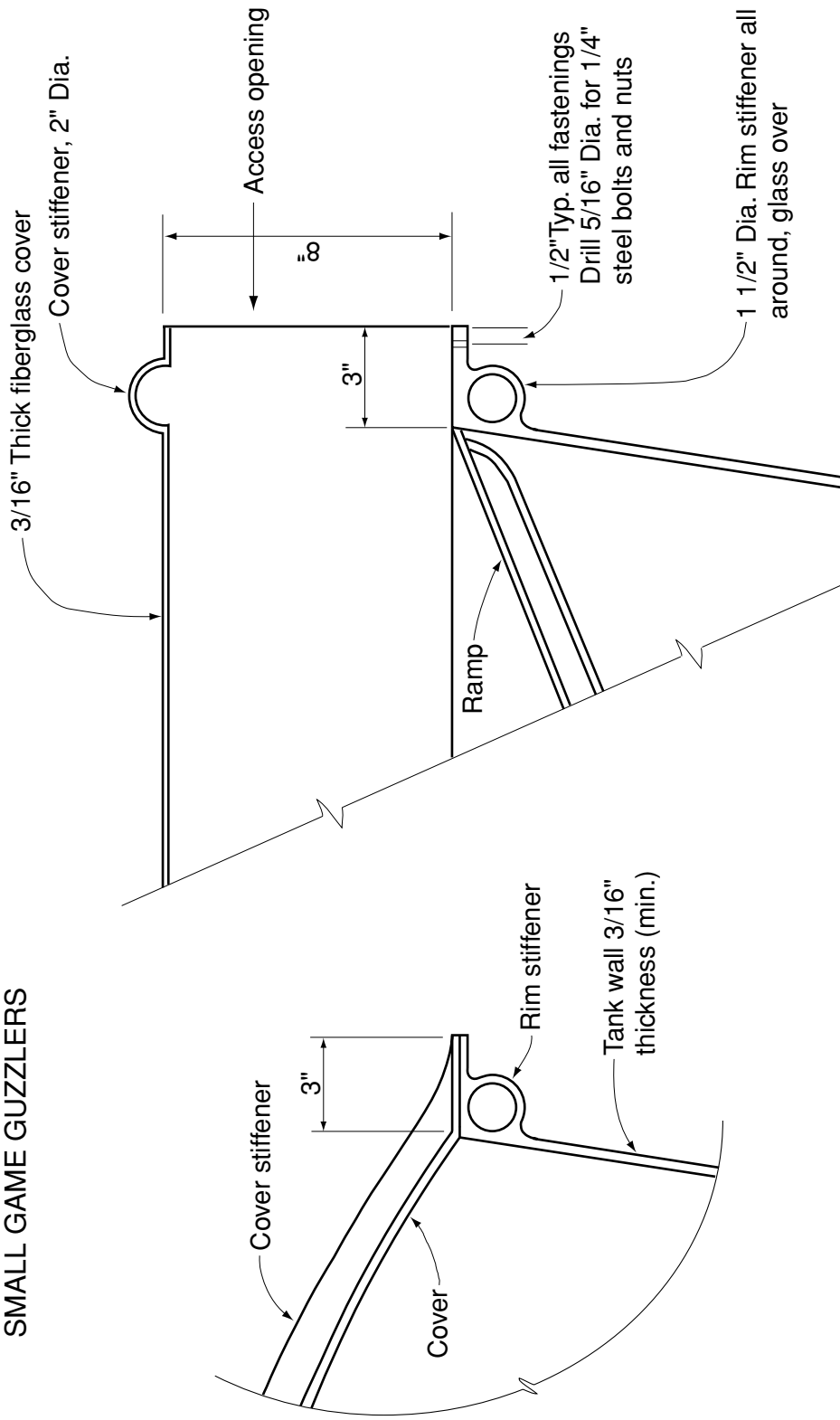

- Note: 1) Material around which the rim stiffener is formed shall be at the contractor's discretion.  
 2) Drawing not to scale

Specification drawing 2.

**TANK COVER DETAILS**

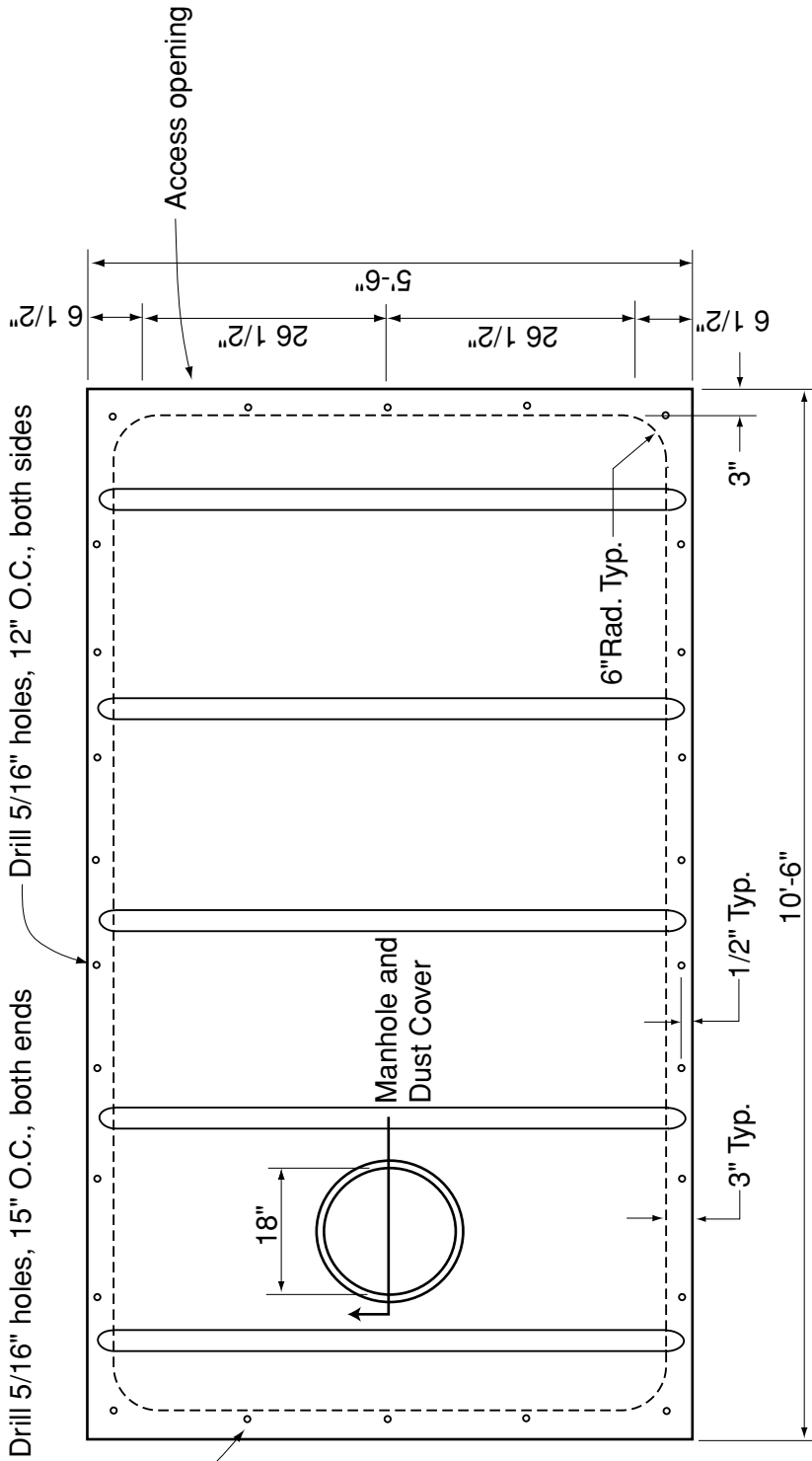

**TOP VIEW OF TANK  
SMALL GAME GUZZLER**

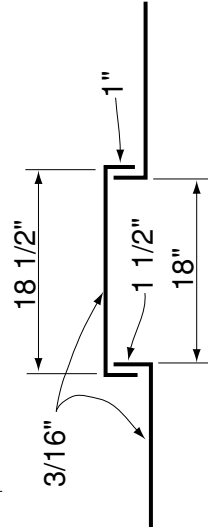

**MANHOLE COVER**

- Note: 1) Drill **tank and cover** to match  
 2) Drawing not to scale

Specification drawing 3.

**RAMP DETAILS**  
Carson City BLM District

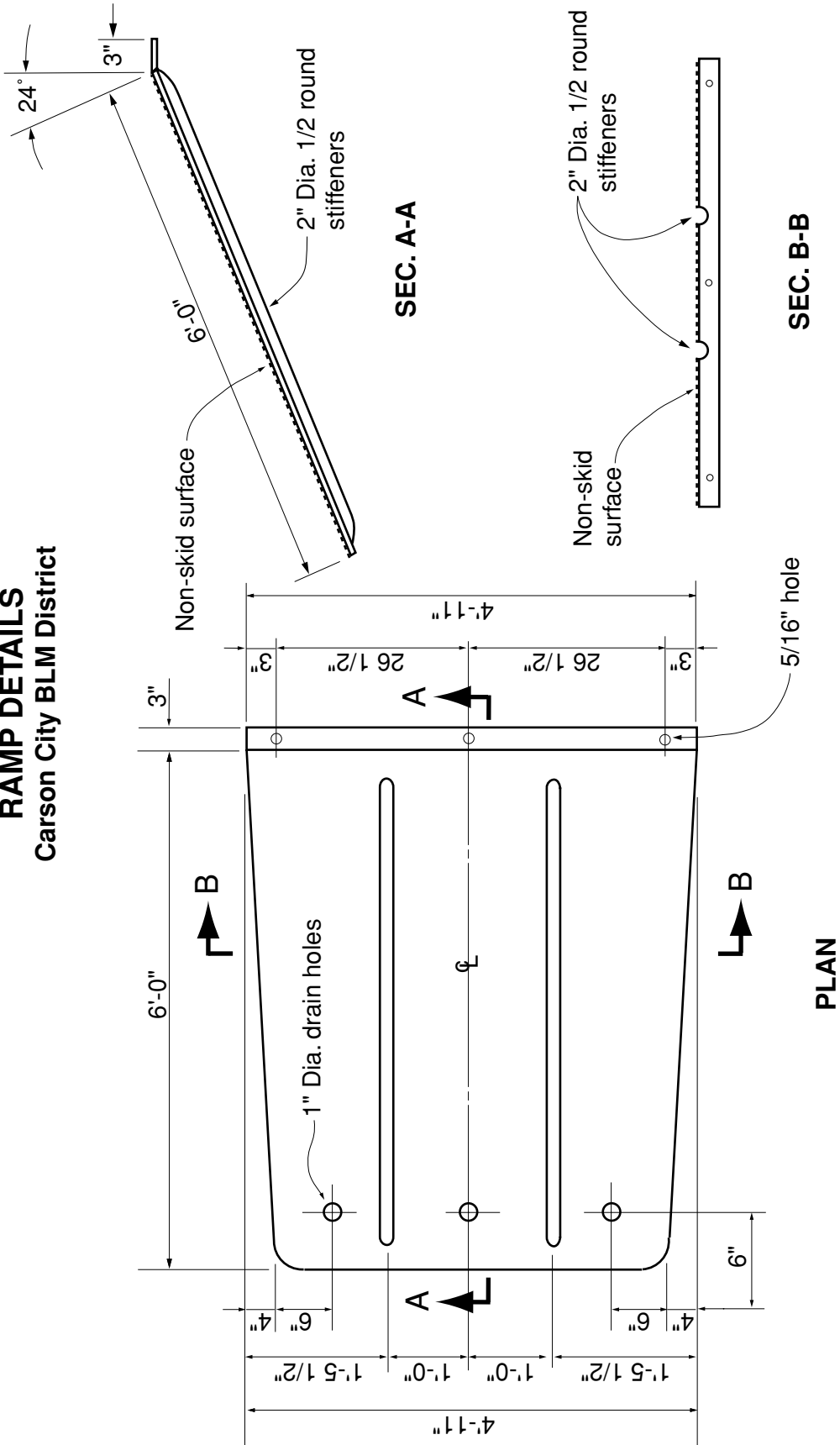

Note: 1) Plan dimensions of ramp are approximate only.  
Ramp to fit shell of tank snugly when in place.  
2) Drawing not to scale

Specification drawing 4.

## WATER STORAGE TANK — BIG GAME GUZZLER

Carson City BLM District

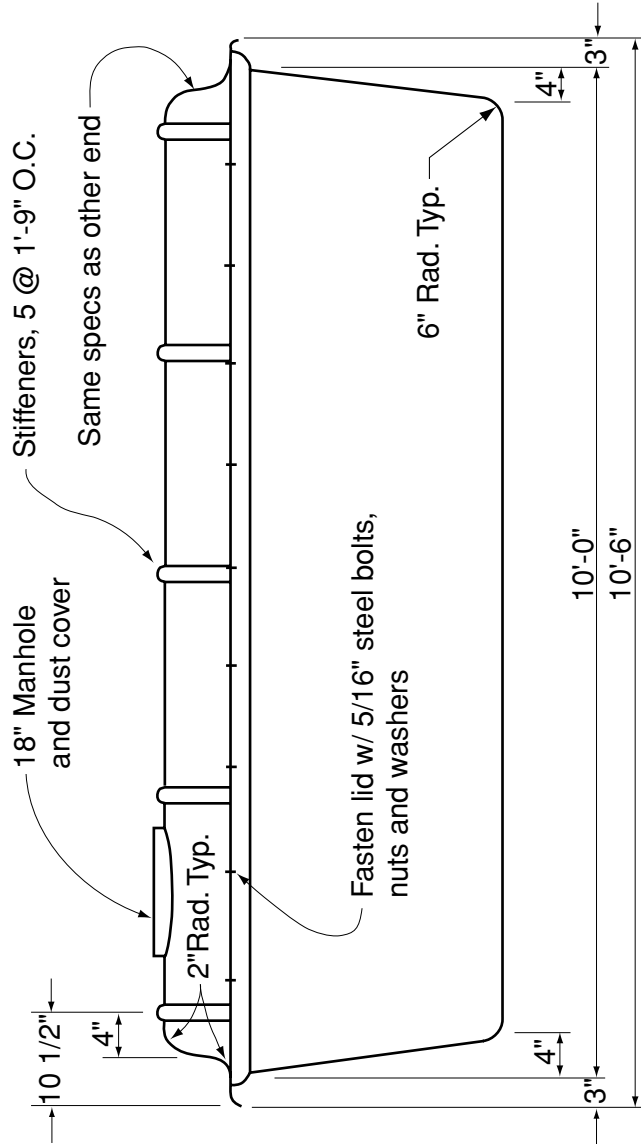

**SIDE VIEW**

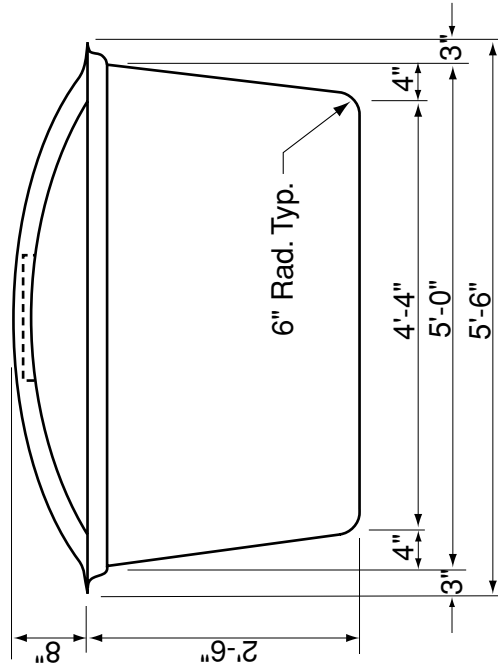

**END VIEW**

- Note: 1) Fiberglass construction minimum 3/16" thickness  
 2) Approx. volume: 750 Gal. @ 2'-2" depth  
 3) All fiberglass parts constructed with Esopolyester Resin (non-toxic)  
 4) Color is Desert Tan  
 5) Drawing not to scale



### WALK-DOWN DRINKER

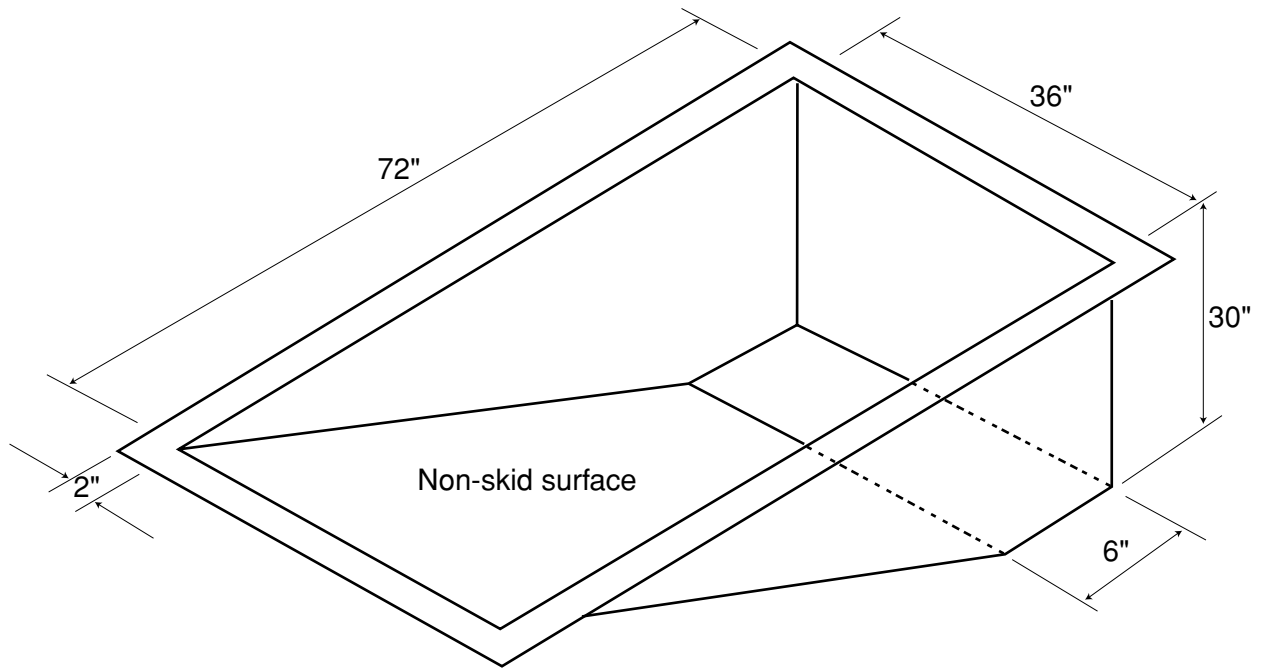

- Note: 1) Wall thickness is 3/16" to 1/4"  
2) Use esopolyester resin (non-toxic)  
3) Color is Desert Tan  
4) Drawing not to scale

Specification drawing 6.





# Chapter 3-Southern Nevada Water Catchment Guidelines

## Slickrock and Hypalon Guzzlers

The current emphasis in southern Nevada is on “slickrock” collection surfaces feeding storage tanks and drinkers, or artificial aprons (hypalon) placed at ground level (Also see Appendix A). A slickrock or hypalon unit consists of the apron (collection surface), which drains to a dam or sump (collection point), from which water is piped to tanks. The tanks store water for use at a float-valve operated or self-leveling drinker.

Flexibility in the design, materials used, and construction are a necessity. Too often, a certain type of water development is forced into an inappropriate location and fails. Projects should be adapted to each site. For example, we try to use slickrock when it is available, but sometimes other considerations determine the project location. After evaluating the slickrock surfaces in the area, it is sometimes determined that there are not any adequate slickrocks in the desired distribution. In such cases, an artificial collection surface or apron is utilized. This apron option can be a necessity when construction and maintenance efforts negate the use of a slickrock site.

This chapter covers site selection considerations, descriptions of the slickrock and hypalon collection surfaces, all aspects of the construction process, and observations throughout on the problems encountered during the planning and construction stages. Though the options and trade-offs involved in project site selection and construction may sometimes appear contradictory, the water development process is often a series of compromises to fit varying situations.

## Site Selection

Water catchments should be located in the best possible habitat for the target species. For example, desert bighorn sheep depend heavily upon their vision for protection; they prefer open water holes. Locating the drinker near brush or even too close to the tanks may provide cover for predators. Likewise, projects built in totally flat terrain negate the bighorn’s ability to use cliffs and ledges defensively. Placing a project in or adjacent to precipitous escape terrain enhances the attractiveness of the unit to bighorn. The special traits or behavioral quirks of each species should always be considered.

The seasonal distributions and use patterns of the different sexes are very

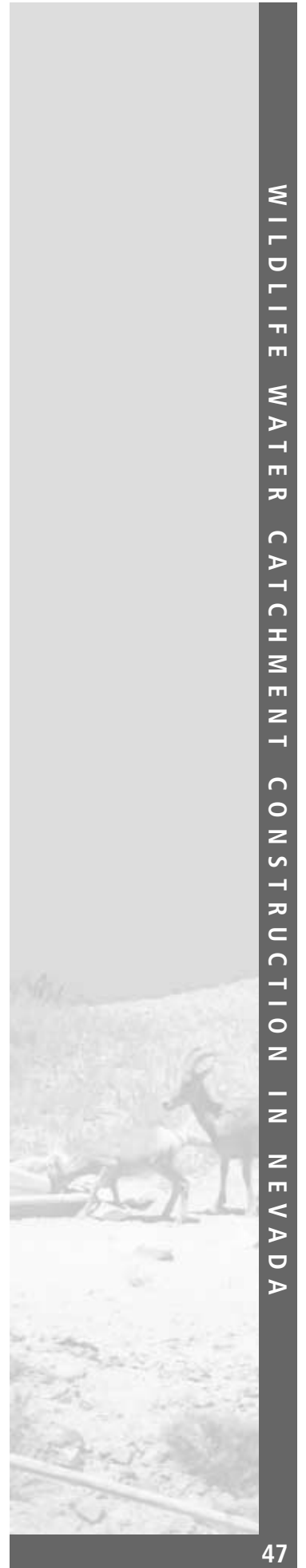

important. If water is placed in an area utilized exclusively by rams, do not expect to make a real impact on desert sheep in the area. The breeding season starts mid to late summer. During half the summer, the rams will not be in the habitat the ewes prefer. And, to expand the population, you have to key in on the ewes.

Total water needs are very important. Bighorns need 1 gallon of water per animal per day for each day of 100° F. Water catchments should be able to maintain at least 50 bighorns per unit, with additional storage for times of drought. Experience has shown that a storage capacity of 6,500 to 7,000 gallons per unit is usually adequate. Some of the earlier units ranged in capacity from between 3,200 to 50,000 gallons.

Spacing is very important. Bighorns seldom range more than 2 miles from water in mid-summer. In southern Nevada, units should be clustered in pairs or triads between 1 1/2 to 2 miles apart, with the clusters no more than 5 to 6 miles apart. The units should not be visible from existing roads, but can be placed close enough so that water can be pumped to them in case they dry out.

Anticipated use by all wildlife should be considered when selecting a site for the water development. Projects located at the range overlap between bighorns and deer habitat should take into account the higher water requirement of the deer.

## Collection Surfaces

### *Slickrock*

Slickrock is named for its bare-rock collection surface. This term most properly describes the vast, smooth sandstone canyons of Utah. Since sandstone formations are uncommon throughout much of Nevada, the harder limestone and volcanic rock formations are used for slickrock developments. You can usually find the larger surfaces in limestone and thus it is the commonly used surface. The right drainage in volcanic rock when available, however, can be superb. The surrounding soils can absorb water and release it slowly over several days.

Drainages are often scoured smooth by eons of sediment-laden runoff. Mountainside drainages are most often used. A sloping rock sheet can be exploited, but there is usually a problem finding a collection point (dam site).

When selecting slickrock, look for evidence of good flows down the drainage. Persistent cutting along the sides can be an indicator. Rock surfaces polished smooth by water, sand, and gravel can indicate a good drainage. However, many of these sites have resulted from eons of scouring and only collect adequate water during intense storms. Black streaking (algae) in the wash bottom indicates a surface that runs or sweeps water for long periods after rainfall. The ideal way to evaluate the potential of slickrock is to be at the site during or just after a rain.

Many of the rock surfaces are laced with cracks. This isn't always bad.



Where there is fracturing, drainage works best when the upper surfaces or slabs overlap the lower sections, much like roof shingles.

When cracks run lengthwise down the drainage, they can drain the flow, particularly behind the dam. At the Big Devil and Tungsten Projects, the angle of cracks slowed and drained the runoff. The fracturing of the rocks ran vertical or against the direction of flow. At every point, the water was slowed by a lip of rock; it dissipated into the cracks. The surface can be sealed, but costs are usually prohibitive if the entire slickrock needs sealing.

The surface slope is important on all slickrocks. Steep slopes get the water to the dam quicker. This may not be desired with a low dam as water will be lost over the dam. However, you will need a good slope to capture the light rains, which a flatter surface may absorb.

If the slope is around 30° or greater, the water gets to the dam quickly, moving over the cracks with less loss. This can be counted on only with moderate to heavy rains. The bulk of the Mojave rains are light and will be lost to the cracks.

Slickrock projects need as large a collection surface as possible. An entire mountainside drainage would work best in the right conditions. Yet, main washes are usually avoided. While they are subject to flooding (good), they often have high debris loads (bad). Debris can clog a dam and reduce the volume of short duration water storage. Main washes rarely have solid bottoms to construct a dam upon. For slickrocks, secondary washes are preferred.

Try to utilize slickrocks with a minimum of 15,000 square feet of surface area (about 1/3 acre). This collection surface should fill a 6,900 gallon project on 3/4 inches of rainfall.

Select the smallest, most efficient dam site possible. It is easier to work with single width 4-foot x 8-foot sheets of plywood and you save on costs (materials and helicopter time/sling loads).

When locating a site for the dam, consider the volume of water that can be stored behind the dam. Sudden thunderstorms are a great opportunity to collect water. Almost any dam will fill more quickly than the screened pipes can siphon off the water. At some point, you will lose water over the dam. Allow for storage capacity and you can collect several hundred to a thousand more gallons of water.

Development sites are generally selected in the middle to upper elevations. The further up the drainage the dam is placed, the less debris should gather in the runoff. So the need for vast collection areas must be weighed against the drainage's potential loads of trash. If the drainage carries much rock, sand, gravel and vegetative debris, you may have to occasionally shovel a lot of junk from behind the dam. As a counterpoint to creating storage capacity behind the dam, don't build the dam to hold any more debris than you want to clean out. Gabions (rock-filled wire baskets) can be built above the dam to hold up debris, but these are only effective if they are cleaned out regularly. Even clean rock surfaces with extensive debris (i.e., dirt, rocks, leaves), above the dam could be a problem. Animals using the project will create trailing, which could loosen debris.

#### Helpful Hint

Using the middle to upper elevations in bighorn habitat is usually sufficient to deter use by feral or domestic livestock.

Ideally, the slickrock should have a clean (bare rock) surface. Drainage with dirt and sand bottoms can absorb water and hide cracks that could drain water before it reaches the dam. Brushy vegetation usually requires extensive, deep root systems and may also indicate the presence of cracks in wash bottoms.

The biggest advantage of slickrock projects is the lower cost. Slickrock dam material costs are one tenth the cost of a hypalon apron. While the apron project requires fewer sling loads (2 to 10), factoring in helicopter expenses raises the cost of slickrock to slightly less than half that of hypalon. Personnel requirements are roughly the same for both projects.

Low maintenance, potentially huge collection surfaces, and apron replacement costs are important factors in selecting slickrock. Slickrock collection surfaces are natural. Dams are generally small. They are aesthetically the best alternative to natural water sources.

Slickrock surfaces are not as efficient in light rains as man-made aprons. The rock will absorb some water before it sheds the runoff. You can compensate by using much larger slickrock surfaces, collecting more during the substantial rains.

Small game slickrock projects should also be strongly considered. While it would be critical to protect the tops of the tanks from larger animals, the compactness and unobtrusiveness lends itself well to this application. Small, low elevation slickrocks seem to be more prevalent especially when you are looking for large surfaces in the upper elevations.

### *Tarp Aprons*

It is easier to find a good project site for a tarp apron than to locate a slickrock project. On a one-to-one basis, plasticized or rubberized tarps are much more efficient at water collection than natural surfaces.

Tarp aprons are usually conspicuous unless they are placed in a bowl or within a canyon. Their sharp outline is sometimes distracting. Sunlight reflection is a problem, especially in wilderness or wilderness study areas.

Aging processes also reduce the life of tarp aprons. Weakening occurs more rapidly around edges and damaged places in the material. More maintenance is required for tarps than slickrock or metal aprons, but repairs are often simple.

The preferred apron material in southern Nevada is hypalon. The material consists of rubberized mat layers reinforced by a nylon webbing. The more suitable thickness for our uses are the .45 mil and .60 mil.

Hypalon lays flat on the ground and is flexible. It can be cut and glued to fit around obstacles. Customizing the shape of the apron increases the time and effort; therefore it is rarely done.

The cost of a hypalon collection area is roughly twice the cost of a dam. While the hypalon is a more efficient surface, it is usually limited in size by cost and the availability of an adequate site and workforce.

The hypalon length and width can be varied according to need. It is often, but not always, available in various colors: black, white, tan, and gray.

Black is most readily available. Tan is most often utilized on desert sheep projects. Gray has been found to be the best overall color. The panels are reversible, providing a choice. You may be able to order specific color combinations (e.g., tan/black, tan/white, tan/gray).

Hypalon is heavy and can be difficult to move on site. A .45 mil. material weighs .29 pounds per square foot. A 75-1/2 foot x 42-foot section weighs 920 pounds. Practically, the apron must be ordered in two sections to stay within the maximum lifting capacity of the commonly used Bell Jet Ranger helicopter. Make sure when you order the apron to specify that the sections are to be boxed and bound separately to a wooden pallet for transport.

PHE liner, produced by Gundle, is another common apron material used in southern Nevada. It is often used by mining companies. It is both heavier and more rigid than hypalon. Sealing two pieces together requires a specialized machine, making PHE more difficult to install and repair.

## Construction

### *General Comments*

On every project, supply the crew with working diagrams; have them note anything that is altered, added, or deleted. You can use the diagrams to note any changes and then render finished or “as-built” drawings. Documenting this information will facilitate future repair and maintenance procedures.

Provide the construction crew with extra pipe, plumbing parts, and other materials. (See Table 1, *Sources for Water Development Materials*, at end of chapter). If you need three, 2-inch galvanized 90° elbows to build the project, add one or two more. A pipe might have a burr in the threads and it would be simpler to switch parts. Also, supply materials that might be needed to make adaptations or alterations; something always comes up. You can develop this supplemental list through experience and familiarity with the project site.

### *Slickrock Dam Construction*

Use 60-pound sacks of premix concrete on the dam and around the drinker. It's easier to move the 60-pound than the 90-pound Portland (Type I-II) and you don't have to find a supply of quality sand or gravel. Each sack produces half a cubic foot of concrete. Determine your needs by measuring the size of the dam. The average dam is 10 inches to 12 inches wide and 3 1/2 feet high. A 3 foot x 10 foot x 1 foot wide V-shaped or U-shaped dam usually requires 50 sacks. A 4 foot x 12 foot x 1 foot wide dam uses 70 sacks. Add about 5 to 10 bags to the total account for miscalculations and any bags broken during sling work.

You need slightly more than 1 gallon of water per sack of premix. The metal 55-gallon barrels we use weigh 440 pounds (within the lifting capability of the Jet Rangers.) You can weld special hoods for slinging or put it in a net, but looping a sling strap around the barrel works fine if it has ribs. Haul an extra barrel of water to the staging area for a backup. Remember to loosen the 2-inch plug on the barrel top before

### **Helpful Hint**

On the northern edges of the Mojave Desert and into the Great Basin, rabbits have caused a problem with hypalon aprons. The rodents chew on the edges or folds in the material, creating holes and tears. The holes can be easily patched with adhesive and hypalon scraps. In one case, the patches were pulled off by ravens. The rabbit problem was solved using chicken wire around the bottom of the unit's protective fence.

Two lessons were learned: The material needs to be pulled as tight as possible during installation allowing for expansion and contraction, and healthy rabbit/rodent populations may preclude the use of a hypalon in some situations.



**At the Jerry (Hughes) Project in the Muddy Mountains**, there was no room to set the mixer down near the dam. A sheet metal tube was made for the project. Cement was poured into a funnel, down the tube, and into the dam form.

**At the Patches Project in the Spotted Range**, the mixer could only be placed at the bottom of a dry falls, 35 feet below the dam. The crew formed a bucket brigade to get the cement to the dam. For safety, a rope was attached to each bucket and was hauled in by the dam crew. If someone lost their grip, the dam crew would keep it from falling on anyone below. The rope also allowed the dam crew to lower the buckets directly to the mixer.

using the 3/4-inch spigot. If you do not allow air to displace the draining water, the vacuum will slowly collapse the barrel.

We use a 1/3-yard electric mixer with a gas-powered engine. It is easily slung and can be moved over uneven ground by four people at the site by tying a 2 by 4 to either side. Sling the mixer to a spot near the dam. You can rarely pour from the mixer into the dam forms. Pour the cement into 5-gallon buckets, then pour into the forms. Set the water above the cement and mixer using a 50- or 100-foot garden hose to get water to the mixing site. Just in case, have an extra 5 to 10, 5-gallon buckets for hauling water, rocks, and sand.

Any dirt and brush at the dam site should be cleared to make sure the bottom is solid. Arizona uses a sealant to seal the dam and create tinajas (See Appendix B, *Lasting Waters for Bighorn* by Robert S. Gray).

One inch and 1/2-inch steel reinforcing bar (rebar) is installed in the rock in holes drilled with a roto-hammer. (The Milwaukee brand roto-hammer needs at least a 1200 watt generator). Rebar can be bought in lengths of up to 20 feet cut to your specifications. Rebar loads should be wrapped tightly when slung. Two equal length straps are wrapped around opposite ends of the longer lengths of rebar. Bundles of the shorter length rebar are tie-wired to the longer lengths near the ends. Place at least one sling strap over the smaller bundles to keep them in place.

Anchor the rebar in solid rock. One, 1-inch rebar is set horizontally, an inch from the top of the dam. Another

1-inch horizontal can be placed below that. One-inch uprights are spaced every 2 to 3 feet from the middle and 1/2-inch rebar is spaced every 12 inches. Order lengths accordingly, but if a few 1/2-inch pieces are slightly long, they can be bent to fit.

The dam is formed with plywood sheets, 1/2-or 5/8-inch x 4-feet x 8-feet (Figure 1). Five-ply is stronger than three-ply. The plywood is scribed along the bottom edge to fit the contour of the wash bottom. To do this, hold the plywood up to the top level of the dam. Using a tape measure, measure the height of the dam straight up from points along the bottom, 4 to 6 inches apart. For example, if the dam will be 3 feet high, the plywood is held 3 feet above the lowest point. Then the plywood is marked 3 feet straight above each point. A small chain saw or sabre saw is used to cut the plywood.

Cut two 2-inch slots in the plywood 5 to 12 inches apart and up 4 to 5 inches from the lowest point. Line the slots up on each form. These are for the galvanized pipe that runs through the dam. You can use a 2 3/8-inch hole saw to cut the holes for the pipe, but it makes stripping the forms very difficult. It is easier to cut slots and use plywood scraps and wood screws to block the slot below the pipes. When both plywood forms are cut, put them in place about a foot apart. Using a 3/8-inch x 12-inch drill bit, drill holes through both forms. The face of one plywood sheet needs six to eight evenly spaced holes. Try to locate holes so that the bit passes close to the upright rebar.

Insert the 1/4-inch x 14-inch allthread pieces. There should be a nut holding a 1/4-inch x 1 1/2 inch fender washed





against each of the interior faces. (Figure 2). A nut and fender washer on the outside holds the plywood 8 to 10 inches apart. A 4-foot x 8-foot dam would require six to eight allthread assemblies to separate the forms. Use tie wire to tie the allthread to the rebar.

The allthread assembly works well on small structures. If you are familiar with heavier construction techniques, using snap-ties and shoes is impractical because of the expense and weight. If you have to wait for the dam to set and then hike to the site to haul the shoes out, you'll only do it once (See Appendix B).

Insert the two 2-inch x 30-inch galvanized, male-threaded pipes through the

slots at the bottom. Attach the Johnson filtration screens to the upstream side of the pipes. Attach the PVC (Driscopipe) pipe to the downstream ends of the pipes with couplers and barb adapters. If you anticipate high debris loads, you might want to use a 90° elbow to angle the screen straight up. This screen should collect well enough as debris rises behind the dam.

When the screens are set, wire the pipes to the rebar in the dam. Make sure the screens themselves are not wedged against the rocks or each other. (You may need to remove them at some later date.) Put a small rock or wood under the screens to hold them off of the bottom.

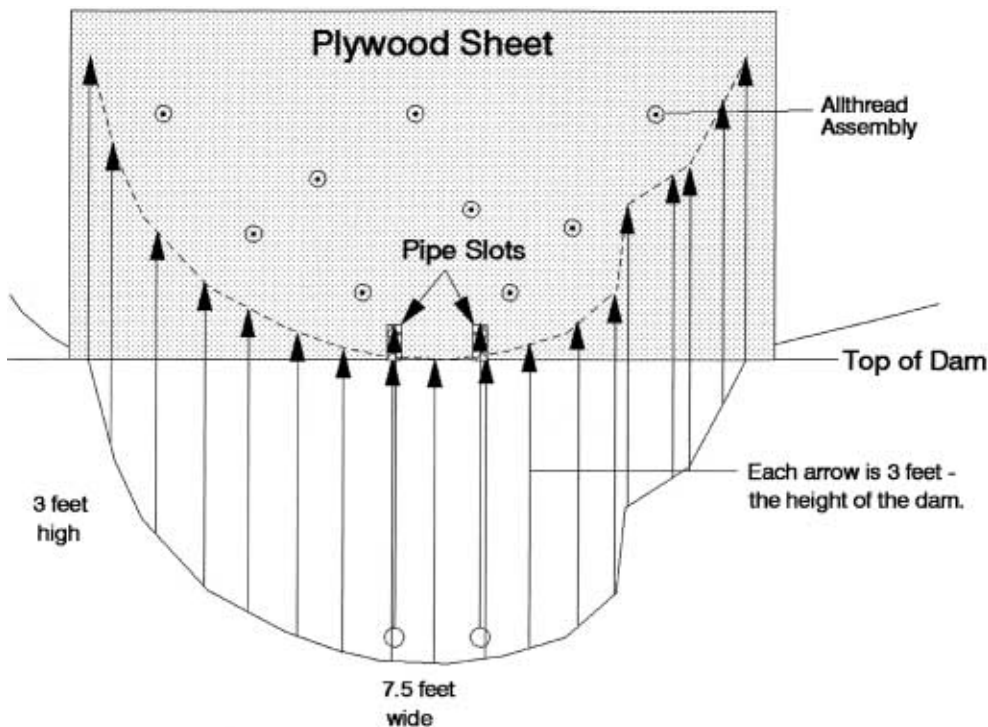

Figure 1. Dam design and materials.



**Helpful Hint**

Occasionally, the screens are set too high. In some cases, up to 100 gallons must collect behind the dam before it starts through the screens. You can take up space below the screens by filling in with rocks. This will displace some of the "wasted" water. Creative cement work is most helpful in correcting this problem.

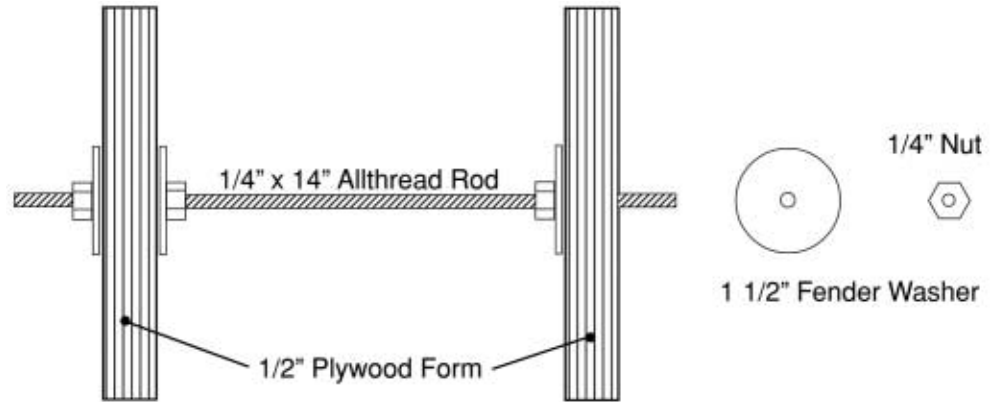

Figure 2. Allthread assembly.

Put rocks into the form to take up space and stretch the cement supply. Do not forget to mix in mortar dye to simulate the color of the surrounding rock. You can also inlay the face of the dam with rocks to make it blend in with the surroundings. Usually, the forms are tapped with a hammer to vibrate out air pockets that might leave weak spots. Do not pound the downstream side of the dam that you faced with rocks, or the rocks will sink back into the cement. Gather the cement bags off to the side or above the dam and weight the pile with rocks.

If you use excess cement to fill in behind the dam, protect the screens and don't let the cement wedge the screens in place. It is best to have the screens sit in a slight depression. Try to pour cement against the plywood or it will be hard to remove the form. You will need a wood chisel and hammer to break it loose. Surplus cement can also be used to create a curb which directs more runoff behind the dam.

To remove the forms, bring along a 7/16-inch combo wrench, crowbar, and vicegrips. Back the nuts on the outside of the forms off about a 1/4-inch. Clamp the vice grips onto the allthread and wiggle it up and down

until it breaks off next to the form. Pry the form away from the dam. Any allthread that sticks out should be hammered down. Save the 1/4-inch nuts and fender washers. You can use them many times over.

*Hypalon Apron Construction*

The aprons for the standard desert bighorn sheep projects (6,900 gallon storage capacity) are purchased in two sections for weight and handling considerations as noted earlier. Around the yard, you can load the pallets with a forklift or four strong people. In the field, the pallets can be unloaded from truck or trailer by one person with a digging bar. If you load the trailer right and have something to tie-off to, you can drive out from under the load. Even if this breaks the bands around the box, the sling straps will hold the load together when you sling it to the site.

The 37 3/4-foot x 40-foot panels do not translate to a 75 1/2-foot x 40-foot collection surface. The pieces are overlapped by 1 to 2 feet and the perimeter berms eat up more material. The finished product averages 65 feet x 35 feet or 2,275 square feet of effective surface (15 percent of the target surface area for a slickrock). This translates to 1,417.3 gallons of water per inch of

rain. An apron this size requires 4.86 inches of precipitation to fill a 6,900 gallon project.

Locate the apron on a relatively flat area. You need some slope, but the more the surface is tilted, the less horizontal exposure you have. There should be few rocks on the apron site itself, but you will need a supply of large rocks to place on the apron at the end of the installation. Rocks found on the apron site must be removed, broken, or covered with dirt to prevent them from puncturing the material.

Lay out the apron area so that the lowest point or corner is closest to the tanks. You can place the low point anywhere along the edge, but the corners are the most convenient. Clear a 60 foot x 30 foot area. Pull rocks and dirt downhill to create the lower berms or “V” where the water will be collected (Figure 3). The collection corner should be more rounded than the others. The low point and berms will take up more material to cover the low point and berms pulling in hypalon from the corner.

Form a well or basin at the collection point; the berm should be at least 2 feet above the lowest apron point. You will need some storage capacity for the intense showers. The greater the slope of the apron, the larger the well must be.

Pull out one apron section and lay it in place on the lower end, making sure that the well and berm are covered. Make any adjustments. Set the second section out with 12 to 18 inches of overlap, uphill over downhill.

With the downhill berms set and covered, the crew can now lay the uphill apron edges back and clear any more

brush, making low berms for the uphill sides. If your apron is on a hillside, you may want to cut drainage trenches to keep runoff from cutting your apron.

When projects are built in the winter, never sling the hypalon adhesive to the project site ahead of time. Cold adhesive is hard to work with. It is about the same as spreading cold tar. Keep it warm until it goes up to the project site and keep it as warm as possible until you need it. You can use a heat gun or blowdryer to warm the closed can. Never use a flame because of the flammable nature of the adhesive.

Always check the adhesive before the project, regardless of when the can arrived from the manufacturer. If the temperature is warm and the adhesive is still thick, the trichloroethylene (TCE) has evaporated. You can add TCE, which happens to be the hypalon solvent you use. Do not “water” the adhesive down too much; it has to stay where you brush it on and you don’t want it to take forever to dry. Be careful, TCE is classified as a hazardous chemical.

While the berms are being finished, start gluing the apron pieces together. Clean the surfaces to be glued with a rag and hypalon solvent. The solvent removes a protective film and yields a proper surface for bonding. Start in the middle of the seam and work outward. This helps keep the seam flat and even.

Work slow to get a good, sealed seam. Apply the adhesive in only 12- to 18-inch sections at a time (varies with temperature) or the adhesive will dry too fast. Apply the adhesive with a 4-inch paintbrush. Use a linoleum roller to press the pieces together and to work out any air pockets or bumps.

#### Bare #1

Despite 3 years of good rainfall, Bare #1 has not filled. The steep slope reduces the horizontal surface area. The slope also prevented a large well from being built. The intense storms overflow the well and much water is lost.



It can help to put a flat surface under the section you are working on; you can use the cardboard from the apron sections packaging.

After the seam is completed, pull the materials as tight as possible. Make sure it doesn't catch on a rock. Trench around the outside of the berms and lay the edges in the furrow. After the gluing and pipe fitting are finished, use rocks and dirt to bury the apron edges.

At the collection well, pull the apron back over the berm. Bring the two 2-inch polypipes through the berm at the lowest location. The pipe should

come through the material just above the lowest point of the apron or the Johnson filtration screens will stick up at odd angles. You could get them to lay flat with a 2-inch, 45° or 90° elbow. Try to keep at least one screen flat and straight. This allows for the greatest flow down the pipe and decreases the chance of any backup. Mark the apron material 2 to 4 inches above the lowest point and cut two circles or "Xs" in the apron material at least 1 foot apart. The spacing allows room for the hypalon pipe boots to be installed. Pull the pipes through the material and lay the apron over the berm.

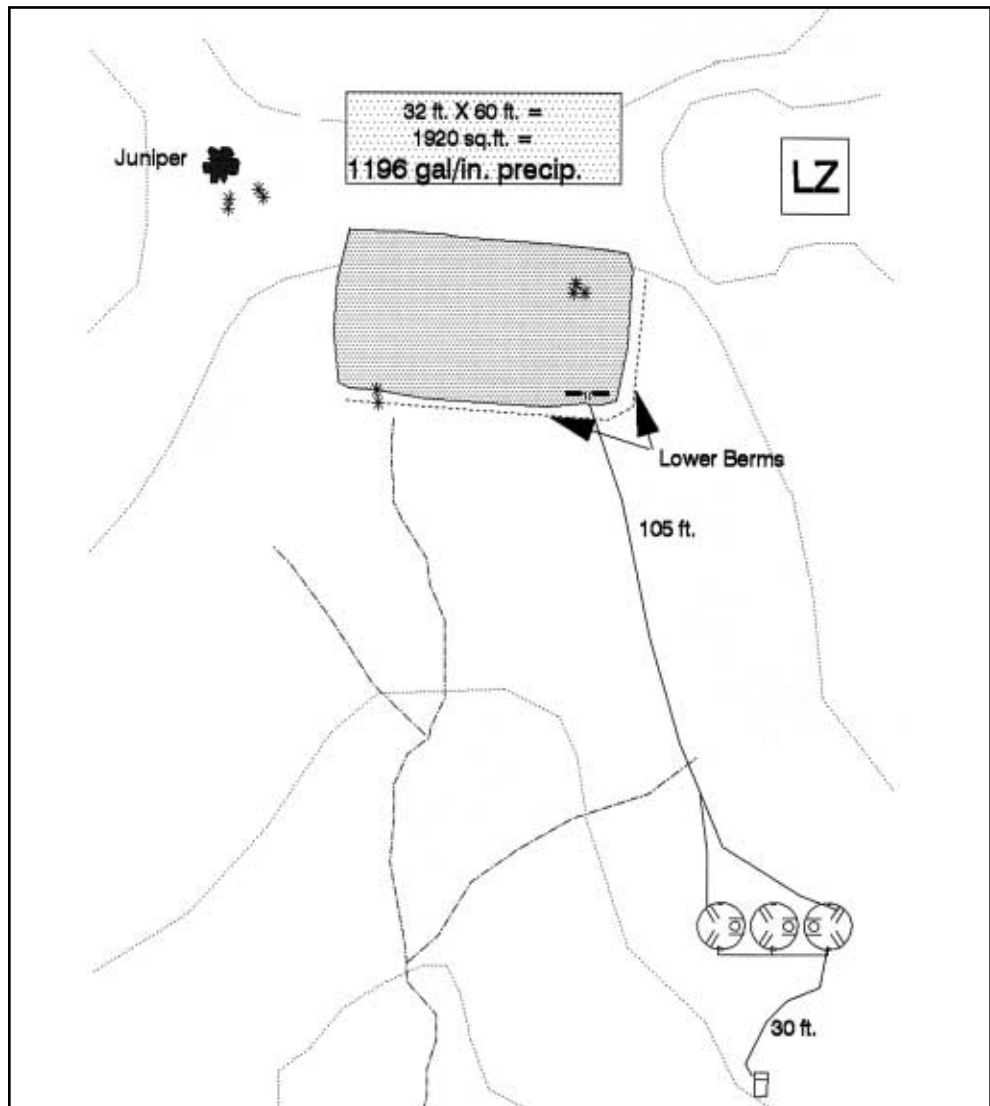

Figure 3. Badger apron water development; example of a hypalon apron setup.

A 2-inch, 90° hypalon pipe boot fits over each pipe like a sleeve with a square base that is glued to the apron. Slide the boot on, then attach the galvanized barb adapter and Johnson screens to the pipe. Use a tube of silicone caulk to form a plug or gasket around the pipe on both sides of the apron material. If the boot comes unglued or leaks, the plug will stop or retard water from steeping out here. Do not try to use silicone caulk as adhesive; it is not designed for this use. Glue the boot base to the apron and clamp the boot sleeve around the pipe with two #36 or #40 hose clamps. Be careful not to heat the pipe boot sleeve; it will melt.

Put rocks on the apron to keep the wind from pulling the apron and to break up the solid color. Try to cover the whole apron.

Some tarp-type aprons utilize a metal sump box to collect the water. These boxes have a number of problems; they become rusty and messy over time, the sump is hard to mate with the apron material, water is lost when the sump overfills, and there is a problem if the overflow erodes the berm. To help with this problem at Big Bertha, the Fraternity of the Desert Bighorn organization made a hypalon liner for the sump box. The box was also large enough to hold two filtration screens. Water quality is as important as quantity.

## *General Plumbing*

The need for standardization of plumbing must be emphasized or you can end up with some real repair nightmares. For example, a manifold that starts with a 1-inch tank adapter, goes to a 3/4-inch gate valve, then to a 1 1/4-inch drinker line, and finishes with a 1/2-inch float valve. If a project needs repairs you should not have to take an assortment of plumbing parts in various sizes up and down the mountain.

We use 1-inch and 2-inch parts (Figures 4 and 5). Our hose clamps have a slotted, #10 hex head. To maintain consistency, the insulation sheet metal screws also have a #10 hex head. A 5/16-inch nutdriver fits the #10 size.

At every pipe connection, we use teflon tape and a slow-dry pipe compound; both help ensure a better fit and seal. If you have to remove parts later, these will make it a much easier task as they inhibit rusting. We can even use it on the Johnson screen reducers. At the top of the plumbing system are the “Johnson” filtration screens. They are stainless steel well pick-up screens, and are designed to filter out sand and debris at the bottom of domestic water wells. The screens are designed to filter up to 30 gallons per minute.

The unit is 4 inches in diameter and 24 inches long with female threads on one end and a plate welded to the other. A 2- to 4-inch galvanized busing is used to reduce down to 2-inch pipe.

## **Helpful Hint**

Buy the highest quality, heavy duty plumbing you can afford. Use the minimum number of connections; every fitting is a weak point. Reduce the chances for failure by keeping the plumbing as simple and as strong as possible.



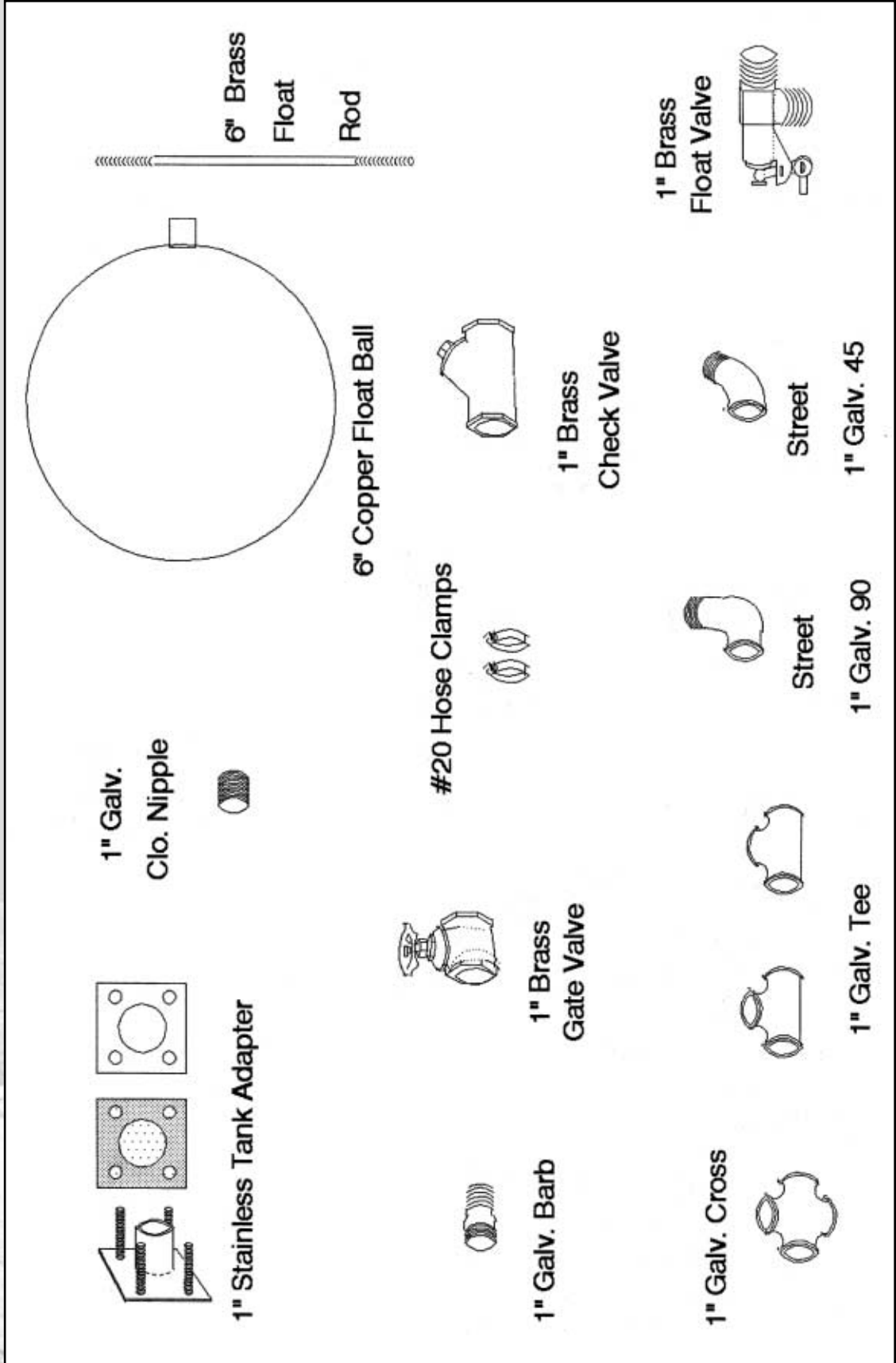

Figure 4. Water development, 1-inch plumbing.

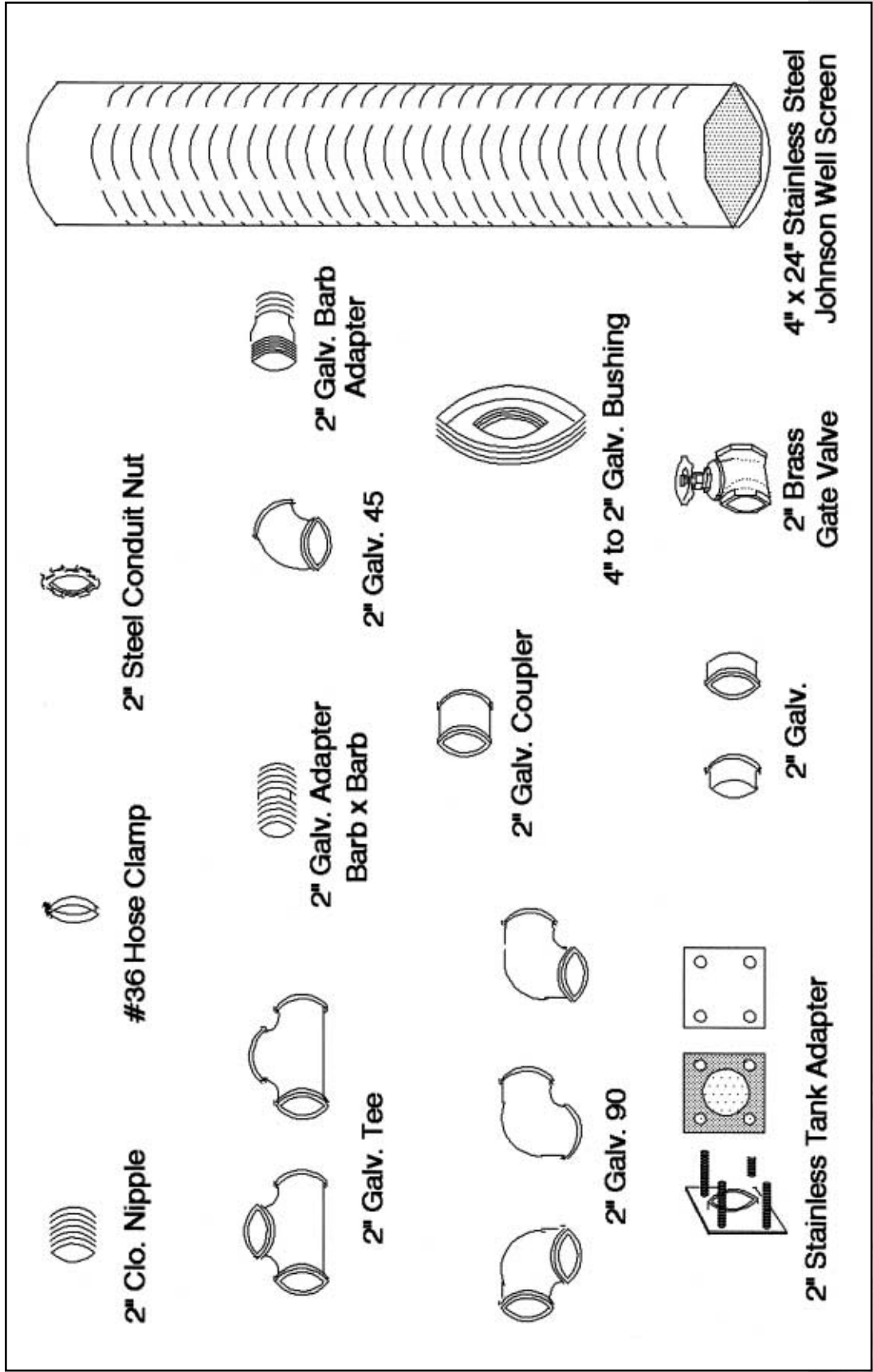

Figure 5. Water development, 2-inch plumbing.



### Troubleshooting

After watching one dam fill up during a sudden thunderstorm, it was surprising to find only a trickle going into the tanks. The suction had pulled vegetation tightly onto the screens, allowing little water through. After scraping the screens by hand, the 1,700 gallons behind the dam drained in 20 minutes.

There are hundreds of thin slots along the screen that allow water through and keep all but the finest silts out of the system. The slots are .05 mm in width.

The screens can be productive when fully covered with sand, rocks, and gravel; they are designed to be constantly immersed, as in a well shaft. However, the effectiveness of the screens is significantly reduced when vegetative debris is sucked onto the surface. This problem usually happens right after construction as the brush clearing creates a mess that is washed down in the first few rains. Always clean the screens during maintenance and remove any debris found behind the dam.

PVC was heavily used in the water developments at one time. But, PVC is made to be buried or protected in some other manner. In direct sunlight, PVC plastic oxidizes and deteriorates; it freezes and cracks easily after only a year of exposure. Even when buried, it cannot take the stress. PVC has been displaced by galvanized plumbing and stainless steel tank adapters. Whenever we get the chance, we upgrade.

Only the first few Nevada Division of Wildlife (NDOW) projects utilized solid galvanized manifolds, which carry water from the tanks to the drinker. Polypipe is now used on the 1- and 2-inch pipelines. The pipe is Drisco 8600 by Phillips Petroleum. It is made for exterior, industrial applications and is produced with a strong ultraviolet inhibitor. Drisco is available in various PSI ratings, but we usually use the 160 PSI in 1-inch pipes, and the 110 PSI in 2-inch pipes. The pipe is flexible

and expands and contracts depending upon the conditions. When using polypipe, always allow for some pipe movement. We do most of our construction in the winter and spring so the pipe is already contracted.

In northern parts of the state (other than the BLM Carson City District), there was a problem with polypipe because it popped off the fittings. Frozen water in the pipes was suspected of forcing the pipe off; it is more likely that the pipe was installed in the summer when it was fully expanded in the heat. When water did freeze in the system, the pipe contracted off of the fittings.

Part of the beauty of Driscopipe is its flexibility. It should be allowed to expand and contract. Even when buried, polypipe should be installed with a good amount of slack. The 2-inch pipelines can be run 450 feet from dam to tanks and can contract 1 to 3 feet along its length.

The polypipe is fitted on to galvanized plumbing by heating the pipe. A pipe welding machine can fuse pipe sections together, but it is not well adapted to remote construction. We use small propane torches to heat the pipe directly and slip it onto the fitting. When the clamps are in place, the pipe is heated again and the clamps are quickly tightened.

*Note: Phillips Petroleum has expressed some concern about heating with a direct flame. They are unsure as to whether a flame will harm the UV inhibitors. However, there has been no evidence of any problems with this technique.*





## *Pipeline*

The pipe from the dam to the tanks is usually 2-inch Driscopipe 8600; the 110 PSI rating is preferred. Higher PSI ratings mean thicker pipe walls and smaller inside diameters. Standards plumbing barbed adapters suit these well. Any tighter inside diameter (160 or 190 PSI) pipe can be almost impossible to slip on adapter plumbing. You have to use a file or rotary rasp to trim the interior. The heavy duty pipes are also just that, heavier.

In the winter, place the pipe in the sun to warm it up; it will roll out easier if it is warm. Use two to four people to roll the pipe out; don't uncoil it. It can cramp and will be very hard to straighten out. Cut the bands on the pipe roll before you get to them. If you over-rotate the roll, the weight of the pipe will crimp it. You may need to cut that point and insert a galvanized barb-x-barb adapter to keep it from restricting flow or being a weak point over time. Use two #36 hose clamps on each side of the barb. When necessary, use light heat to bend the pipe to fit it into crevasses or to go around corners.

Make as straight a run to the tanks as possible; but, when you lay the pipe during the summer, allow for contraction of the pipe in the winter. In other words, don't pull it too tight.

Long runs of pipe may be subject to vaporlocking especially if there is not much fall. Get advice from an engineer about venting long pipelines.

We recommend that there be at least 10 feet of drop between the bottom of the dam and the top of the tanks. Try for a quick drop of 5 feet after the pipe

leaves the dam; this creates a suction when there is sufficient water behind the dam and creates a good flow down the pipeline. It gets water to the tanks faster, which is important in a cloud-burst rain.

The pipeline should be painted and buried, if possible. Paint and cover the pipe with rocks where the ground is too rocky. Protecting any component of the project from exposure will extend the life of the project.

To keep the pipelines out of wash bottoms, the pipe is often hung along the wash walls with pipe clamps or pipe hanger. Try not to hold the pipe rigidly at any point (expansion and contraction again). The 5-inch pipe hangers are preferred because they allow the pipe to move and support both pipes; 2-inch pipe clamps hold things too rigidly.

Because of the weight of the pipe and the force of the water going through the pipe, there is a lot of jerking and twisting. Regular lead masonry anchors eventually loosen. Expansion anchors are better. Chemical anchors are better yet. A glass vial within a vial is placed in the hole. The anchor bolt is jammed in to break the vials and is twisted to mix the epoxy. The bolt is bonded to the rock.

There is a new epoxy "gun" which uses cartridges, more or less like a caulk gun; this appears to work better. It goes by the name Epcon and is marketed by Ramset/Red Head.

## *Tank Location*

There should be a minimum drop of 5 feet between the bottom of the apron/dam and the top of the tanks.



With aprons you are dealing with a smaller collection surface; there is less chance of hundreds of gallons of water running off. The apron is better at collecting small rainfalls, so you should make up what you might lose without strong suction.

Remember the need to camouflage the project. The tanks are the most obvious visual aspect. The tank locations is as important as using paint and vegetation to blend the tanks into the environment. Place the tanks in a swale (a low tract of land) or use large land forms to break the outlines of the tanks.

### *Tank Pad*

The location of the tanks above ground is limited only by the ability to improvise and use sound construction techniques. The tank pad should be constructed on the flattest area possible. For three polytanks, the minimum area to be covered should measure 9 feet x 26 feet, but 10 feet x 28 feet is better. Some separation between the tanks is mandatory. When the polytanks fill, the walls flex outward. The space also allows you to walk between the tanks; this makes inspections and maintenance easier.

If there is a concern that rocks or a rock shelf might stop construction, probe the ground prior to construction with a 3-foot piece of rebar and a hammer.

The tanks should rest, at a minimum, on two thirds solid ground and one third fill. If you can, try to set the tanks completely on solid ground and scatter the dirt you remove. Fill dirt will settle more under the weight of a full tank.

To start the pad construction, stack rocks along the front of the pad; pull dirt

to fill in between the rocks (Figure 6). Keep stacking and pulling dirt until you have a large enough level area. A 10-foot 2 by 4 and a carpenter's level are used to level the pad. There should be a 1-inch drop from front to back (fill to solid). As the fill settles, the tank will level out. Make sure the pad is level from side to side; if the tanks are not level, storage capacity is lost. Each inch a tank sits above the lowest tank results in a loss of 28 gallons.

Rake the surface to remove sharp rocks. Remember that a 2,300 gallon tank holds 9 tons of water. As the fill settles, that's a lot of weight pushing down on any sharp rocks.

When the pad is done, spread dry Portland (TYPE II) cement over the pad. This will reduce wearing or cutting when it is hardened by rainfall. Make sure the cement gets over and between the rocks on the face of the pad. The better the rocks stay in place, the longer the pad will last. The rain will harden the cement. You may want to cut a trench above the pad to divert water away from the pad.

On steep hillsides, stacking rocks may be insufficient to form a pad. In such cases, posts and fencing can be used to reinforce the pad front (Figure 7). Six foot T-posts are driven in at a slight angle, leaning back into the hill. Hog wire or chain link is stretched between the posts to hold the fill. Then build the pad as usual. If possible, cover the mesh with cement to keep the fill from washing out.

When the tanks must be placed on rock, it is necessary to build a retaining wall. Fill is put behind the wall and the tanks are placed on the fill. The

same techniques that are used to build the dam are used to make the retaining wall. An L-shaped wall 3 1/2 feet high and 20 feet in overall length takes 100 bags of cement.

Use rocks and sand to fill the void behind the wall. Overfill slightly to allow for settling. At the White Basin (Muddy #2) Project (Figure 8), a source of sand was not convenient. We used the helicopter and a simple dump bucket to haul 4 cubic yards

(60 five-gallon buckets) of material at six buckets per load.

### Tanks

What type of tanks should you use? Site selection will have a lot to do with that. In remote locations with shallow soils, tanks must remain above the ground. Most of the fiberglass tanks come in sections like slices of pie—four tank sections and four lid sections. They are broad and low.

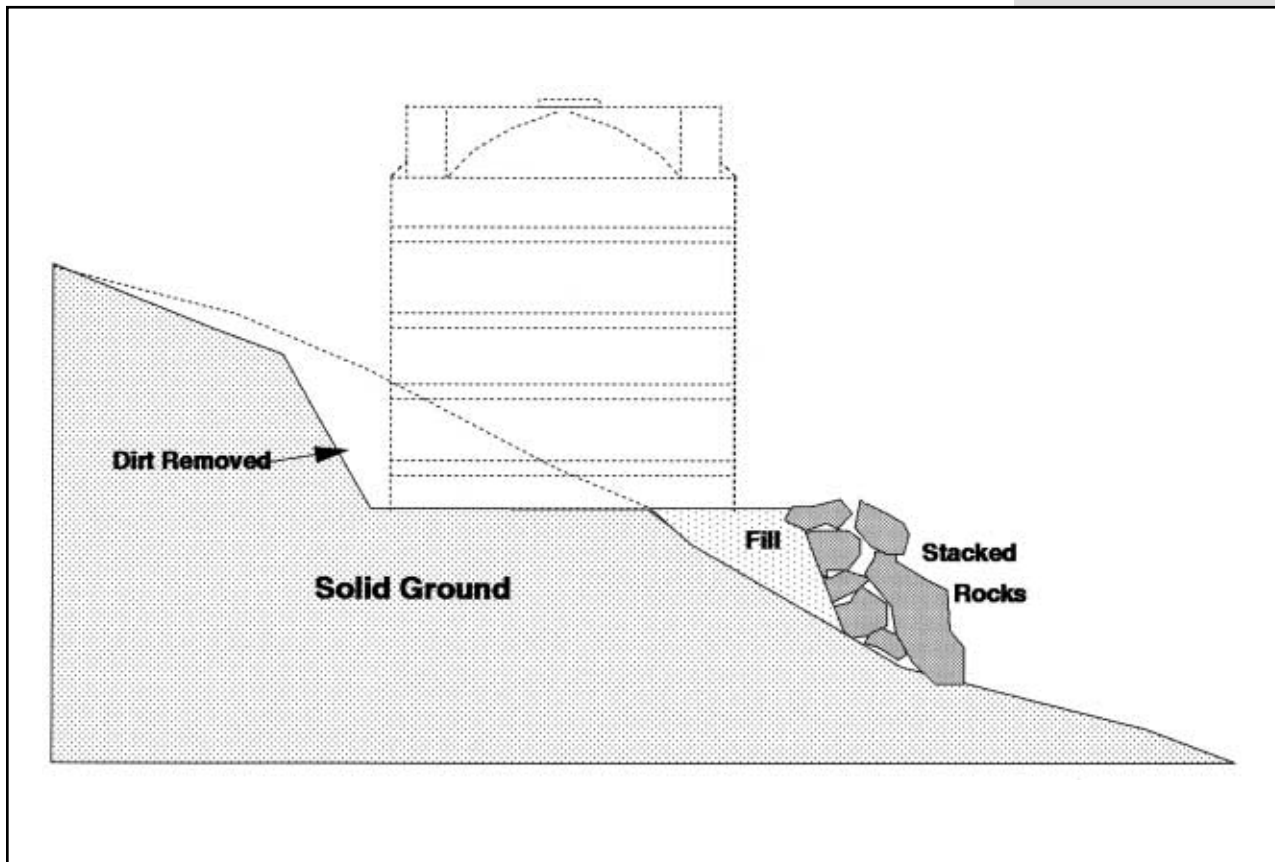
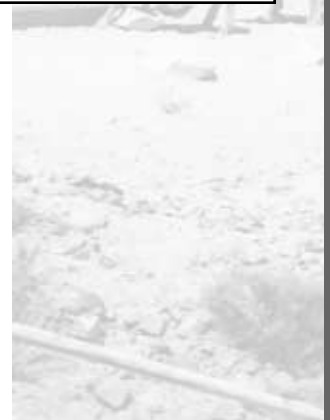
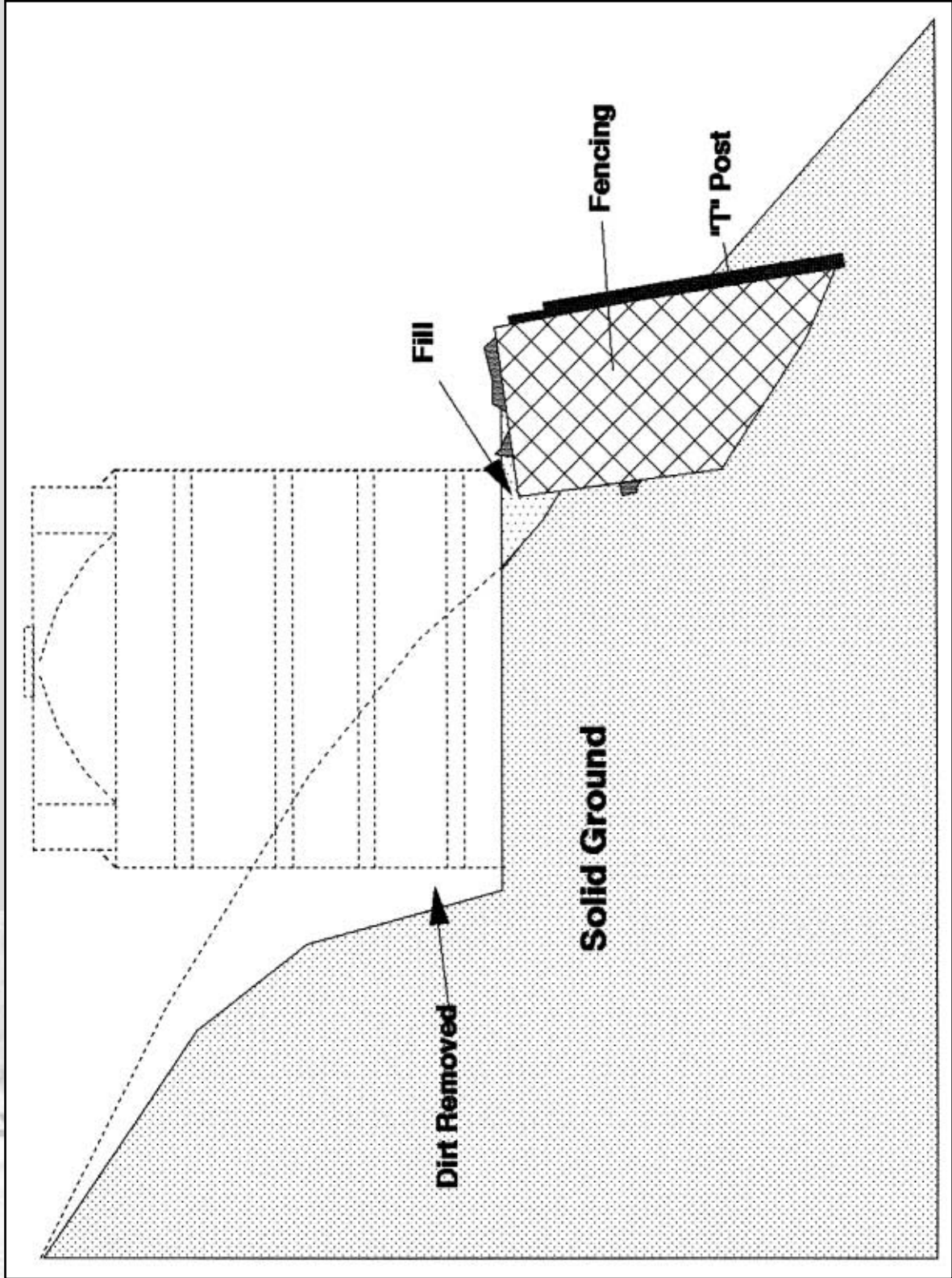
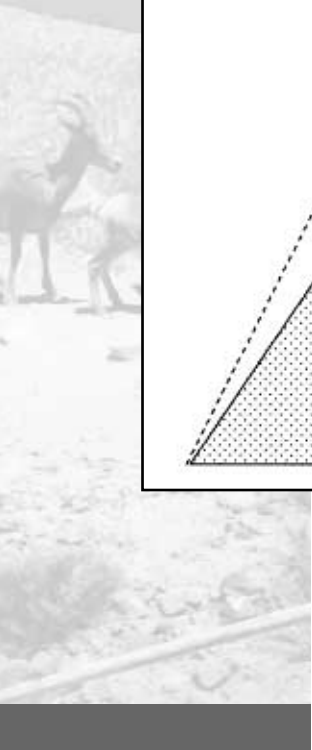

Figure 6. Tank pad profile.





Tank 7. Steep tank pad.

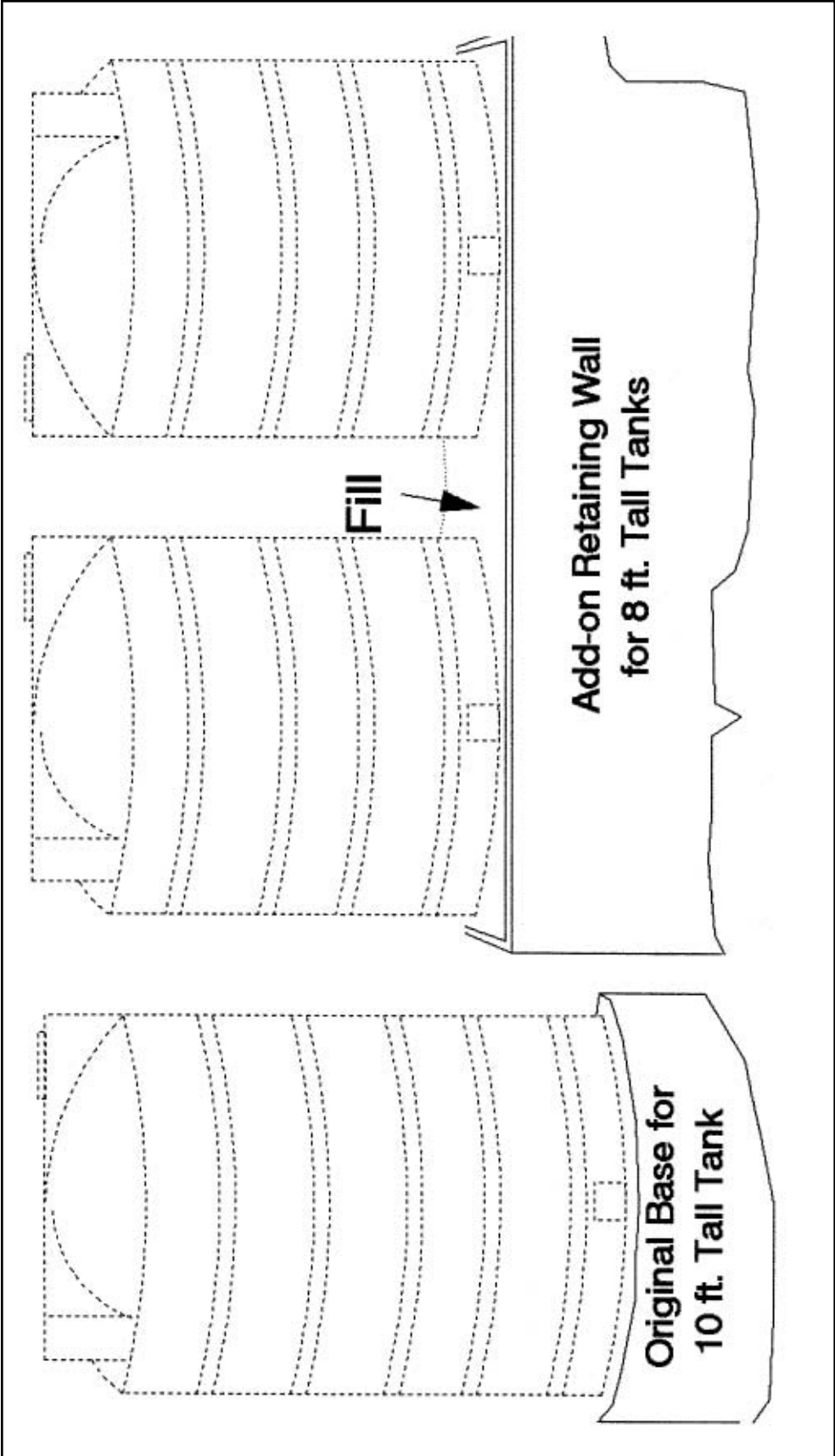

Figure 8. Muddy #2 tank pad.



**Helpful Hint**

Never store the polytanks on their sides without blocking them properly; a strong wind can send them rolling.



It is best to paint the tanks before the materials are hauled out. They will get scratched during construction, but you can touch them up. Also, install the tank adapters and mark the bottoms according to their setup location (North-Middle-South). The alignment is included in the working diagrams.

Two fiberglass tank types are the parabolic or saucer tanks and the rangeland style tank. The parabolic tanks are of 990-gallon capacity and are 16 feet across and 2.8 feet high in the center. The rangeland style tanks hold 2,100 gallons and are 16 feet across and 2.75 feet high. The bottom and side seams on the larger tanks total 37.5 linear feet. We have not been able to get a good seal on these and water rarely stays long in all but two of the eleven Nevada applications. In one Mojave Desert BLM project, the fiberglass began to deteriorate and water wept through the side walls. Yet fiberglass tanks can work well. The Utah Division of Wildlife Resources and BLM continue to use these tanks with success.

One project used a big 5,000 gallon corrugated metal cattle tank. The open top proved to be a problem in the Mojave heat at the Arrows #1 project. Evaporation was high, but wind action was even worse. The wind actually crested waves and sloshed the water over the sides. We built a lid for the tank to solve the problem.

Another problem was the 5,000 gallon designation. The tank would hold 5,000 gallons if it came with a bottom plate. Instead, the tank had to be sunk in concrete to form a bottom. As a result, the tank held only 3,810 gallons and was consistently drank dry until two 1,600 gallon polytanks were added.

We have primarily opted for the polyethylene tanks. The standard grade 2,300-gallon tanks are light at 450 pounds and flexible (See Table 2, *Polyethylene Tank Sizes*, at the end of this chapter). They can be handled roughly with few problems. One of the earlier models was dropped from a helicopter at 150 feet. The caved-in sides were pushed out and it has worked well for 10 years.

The polytanks are manufactured from two resins; cross-linked and linear-low. The cross-linked are molded cross-adhering resins, while the linear-low density resins do not bond as strongly. Most linear-low applications should not be placed in freezing areas; they are more suited to interior (warehouse) situations.

The standard grade crosslink tanks are for fluids of 12 1/2 pounds per gallon. The heavy-duty grade tanks are for fluids of 16 pounds per gallon. The latter cost more and exceed 500 pounds.

One advantage of these tanks is that small holes are easily repaired. Hot melt glue and a screw or bolt is all that is needed.

One problem with polytanks is they can't be buried. If they are even partially buried and the water level gets low, the dirt can cave in the tank wall. It is not ruined, but now it holds less water. This has occurred in northern areas where the tanks were buried to keep the plumbing below the freeze level.

The problem with burying tanks is getting enough storage capacity underground. Even in the best sheep habitat, it is virtually impossible to bury anything, much less a large tank. And, if

there is a good site in sheep habitat, you usually cannot get a backhoe to it.

If you do not completely bury the tank, you have to deal with animals walking on the top. The answer is to fence the tank area. Depending on the location, you might have to fence both tanks and the entire project to exclude livestock.

### *Polytank Set Up*

The standard tank setup faces the manholes in, toward the other tanks. Use ladders placed against the tanks to check water levels. Leave an aluminum ladder at each site for inspections.

Most holes are drilled with a 2 3/8-inch hole saw. A 2 1/2-inch hole saw will work, but is not as tight. You can use an adjustable fly-cutter bit, but if you standardize, you only need two hole sizes. The other size is a 1 5/8-inch hole saw for the tank adapter. A 3/8 inch drill bit is also needed for the tank adapter bolts.

The tank adapters are installed in the yard, which saves time and helps to ensure that they are all installed the same way. We have also abandoned the 1-inch PVC adapters for 1-inch stainless steel tank adapters (Figure 9). So far, these units have been problem free.

There are two types of tank adapters. One has a base plate with bolts that protrude through the tank wall and squeeze the tank wall between it and the outside plate with the 1-inch female threaded coupler. The adapter we prefer has the 1-inch female threaded coupler attached to the base (interior) plate. This unit has a single flat solid sealing face, while the first unit has two seals to make. The hole is plugged with a 1-inch plug to keep dirt and animals out prior to construction.

The only other hole drilled at the yard is the equalizer hole near the manhole on each tank for helicopter transport. We place the sling trap and tagline through this hole and the manhole. There have been few problems; just make sure that the strap does not bind on and crack the ring for the tank lid to screw into.

You could also drill holes for the overflows and attach the plumbing, but it is usually not that difficult to do it on site. The problem with doing it beforehand is that the plumbing could catch when it is rolled around or slung. Remember also, if you drill all your 2 3/8-inch holes in the yard, you do not allow for any fine tuning or unexpected circumstances. In the end, you may have to plug holes that do not suit the situations encountered.

In the yard, lay the polytanks on their sides to get in and out of them. They are easy to roll, but be careful in windy situations.

Be very careful when you work in a tank at a remote project alone or in the summer. The enclosed system gets very hot and very humid.

### *Pipeline Inflow*

Bring the inflow pipes into the tank as high as possible. The inflow pipe hole will remain unsealed, although the pipe will fit very snugly. If you place the hole too low, water will seep out and bring the tanks to that level. The BLM has two 1,600-gallon tanks in the Bird Spring Range at a horse water development that are effectively 800 gallon tanks. The inflows were drilled halfway up. The simple silicone sealer is moved by the contraction of the filter pipe.

#### **Helpful Hint**

Tie a 5-gallon bucket to a rope for anyone going into the tank. They can stand on the bucket to get out; the rope is then used to pull the bucket back out.



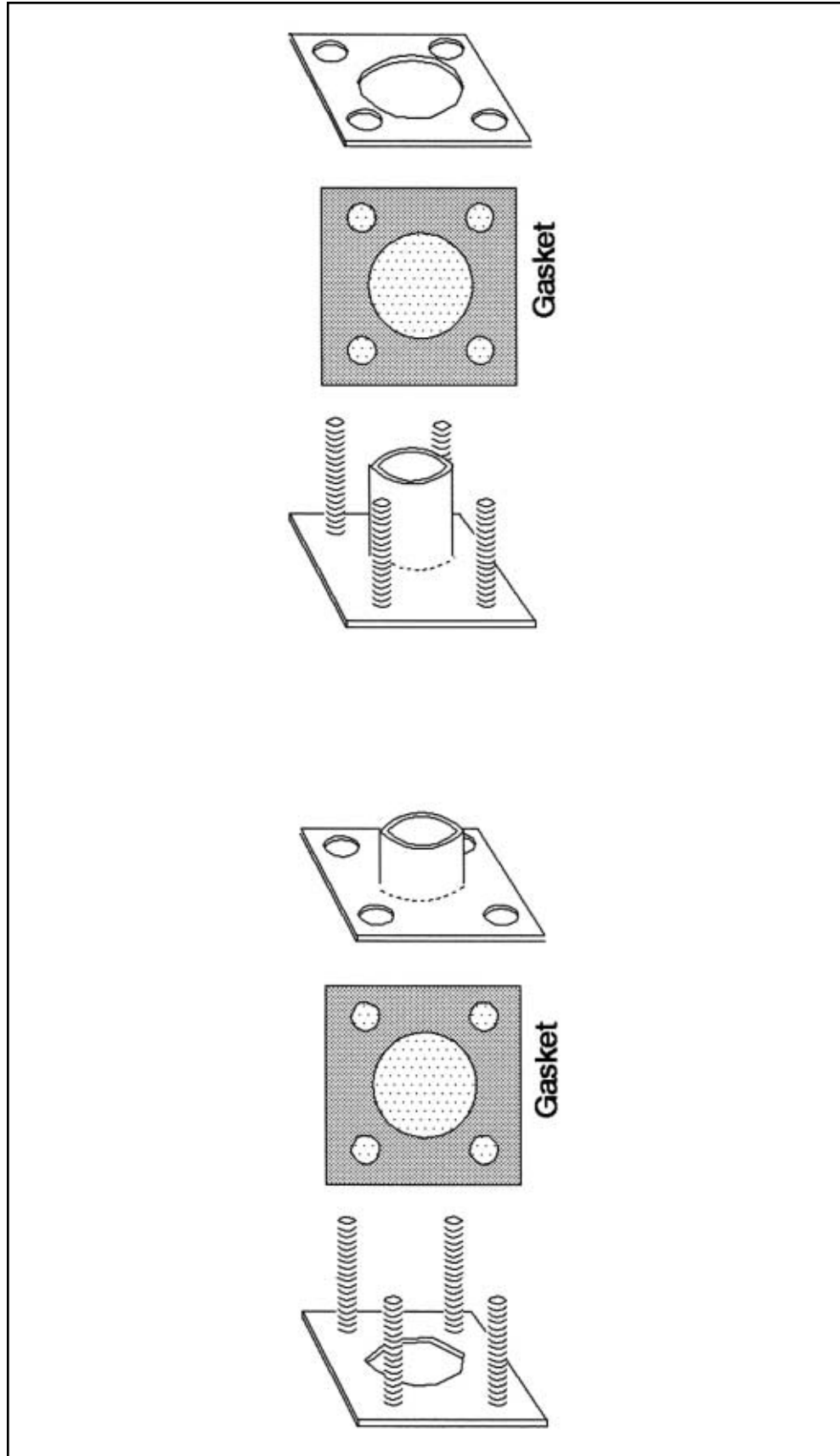
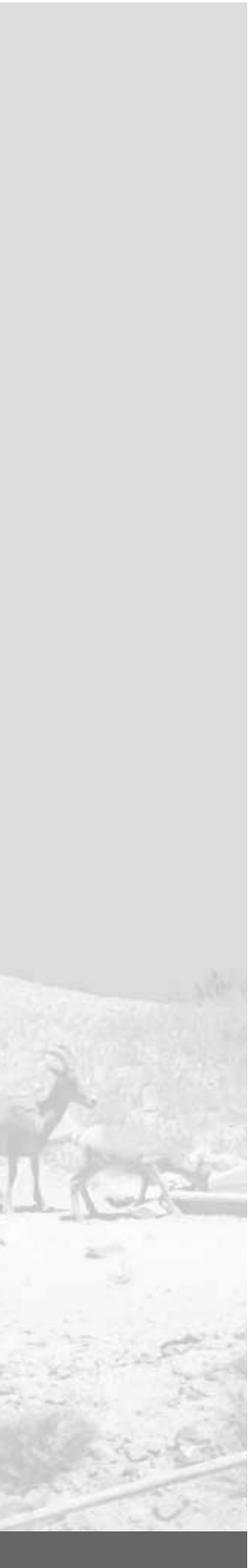

Figure 9. Stainless Steel tank adapters, 1-inch plumbing.



Shove 8 to 10 feet of the inflow pipe into the tank. The pipe will expand and contract, but it will eventually settle. If there is a possibility of the pipe pulling out, attach a #36 hose clamp onto the end of the pipe in the tank. If you used the 2 3/8-inch hole saw, the pipe will not pull out past this point.

The pipeline should not be attached too rigidly to the tank; flexing of the pipe with temperature changes will put undue stress on the tank wall.

One screen will always be lower than the other, so one pipeline will fill quicker than the other. This may be valuable to know. In light rains, this pipeline will take all the water. If the main tank is the only one on and you aren't going to be able to get to it to change tanks during the use period, you'll want all the recharge to go into that tank.

### *Equalizers*

Equalizers are pipe attachments that connect the tanks and allow excess water to flow from an almost full tank into another tank. Equalizers are a backup. When you have two pipelines in a three-tank setup, or when one pipeline fails, you need a backup fill method.

You can equalize between the tanks through the manifold plumbing. However, this plumbing is usually smaller and is not capable of equalizing quickly. When the water is flowing, you have to make every reasonable effort to collect it. Keeping all tanks on to equalize also reduces the ability to switch tanks on and off, maintaining a reserve water supply. The equalizers should be kept high. The tanks squat when full and pressure on the tank walls by the equalizers varies. This shifting causes many equalizers to leak at one tank or the other. Placing the

equalizers too low could easily reduce your storage capacity if they leak.

Do not put the equalizers all the way at the top of the tanks. Water will come into the tanks through the inflow pipe faster than it can equalize into another tank. There needs to be space above the equalizer before water flows out of the overflow.

Make sure that the equalizer pipes do not bow upward. Again, water will pour out of the overflows and be lost before it can go through the equalizers.

Seal the equalizers inside and outside with good silicone caulk. Also, use metal plumbing on the equalizers. PVC will deteriorate in the sun or crack under pressure. The more water you can store, the better off you are during dry times.

When using three or more tanks with two fill pipes, run the two inflow pipes into the outside tanks. When these tanks fill, they will equalize into the middle tank(s). Also, with the three-tank setups, put both overflow pipes on the middle tank. This way the controlled loss of water occurs when all the tanks are full. (Figures 10 and 11).

### *Overflows*

Why bother with overflowing plumbing? For control. Water from an overflowing tank can cut the tank pad or somewhere else that could cause damage. You can direct the overflow wherever you want. For conservation reasons, we try to put it back into the drainage we collect from. Paint and cover this pipe as you would the main pipelines.

Make sure your overflow pipes are not too short. Insects, lizards, and rodents can get into the tank through these conduits.



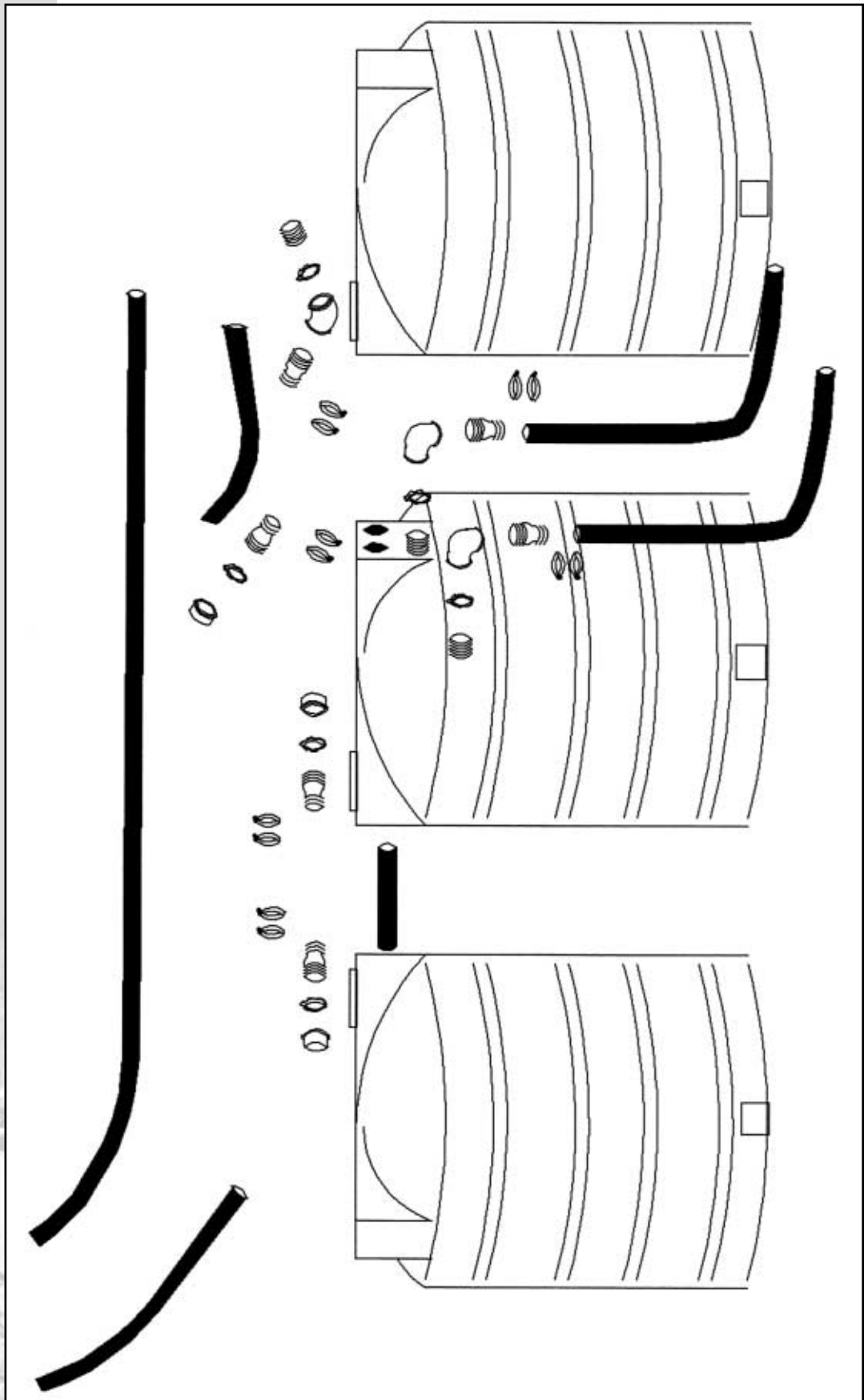

Figure 10. Inflow, equalizer, and overflow materials: standard 2-inch plumbing.

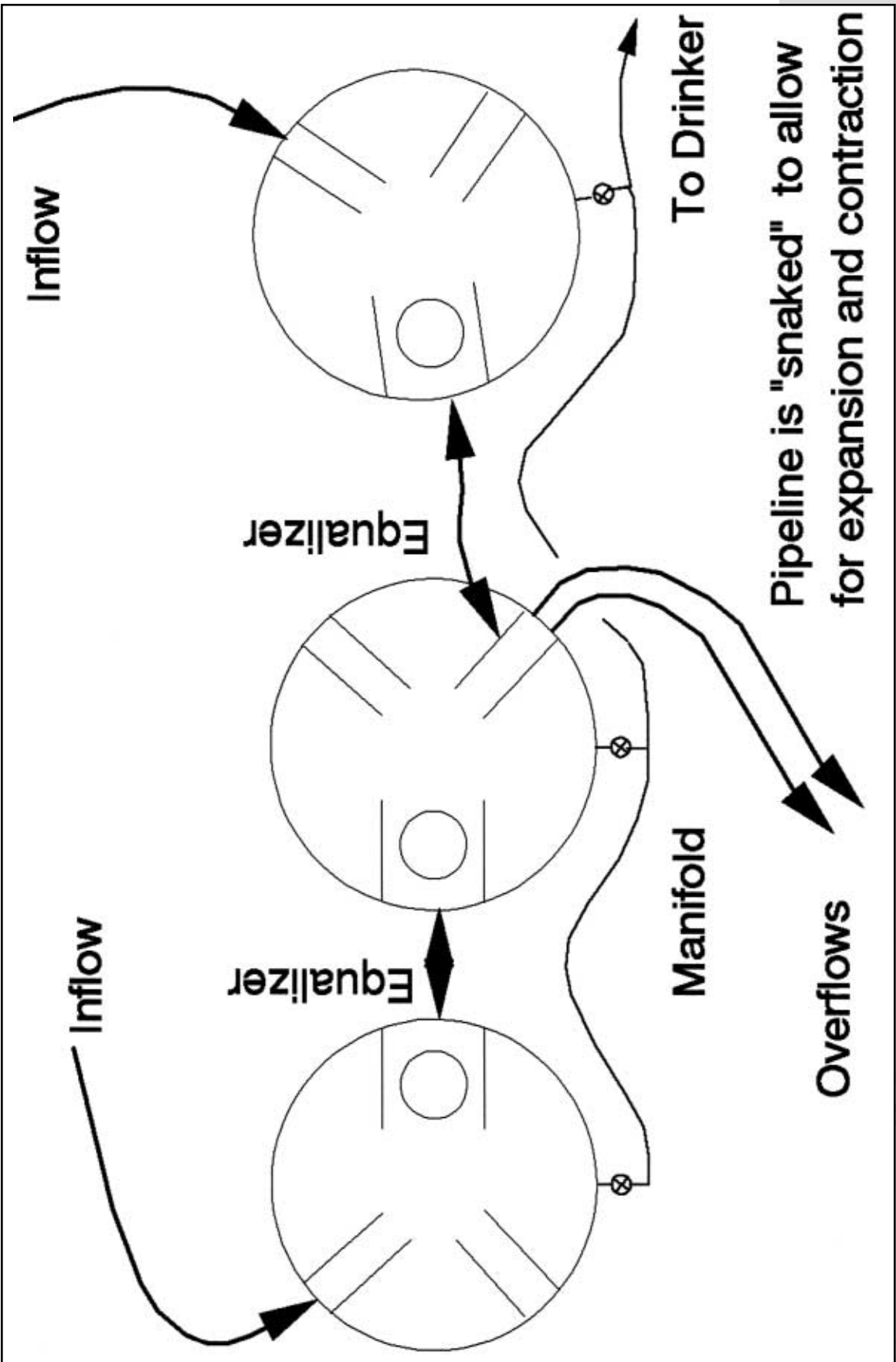

Figure 11. Water development tanks, overhead view.

**Helpful Hint**

Do not use the insulating foam that comes in a can. It deteriorates very rapidly.

*Manifold - Tanks to Drinker*

The manifold plumbing (Figure 12) is usually constructed of 1-inch parts. At this point, there is no great need for high flows and the 1-inch components cost less. Metal parts are preferred, but a galvanized metal manifold is a problem. Any additions or repairs are very difficult with all metal plumbing. You have to hacksaw the metal apart or disassemble the whole thing. To put it back together, you have to use a union and parts that are the exact length.

We keep the manifold above ground now to check for leaks and to allow the flexibility of the polypipe to be maximized. Besides, as the tank levels change and the tanks flex, having the manifold held rigidly in the ground can put undue stress on the tank and the plumbing.

The manifold should face to the south so it gets some sun in the winter. The tanks should add some reflective heat this way. At one higher elevation project (6,500 feet), 2-foot-tall, 4-inch-diameter black PVC "riser" pipes were installed over each gate valve. The tops are capped to keep animals out. The black pipe will absorb heat well and should supply adequate warmth to prevent freezing.

Check valves were once installed near the gate valve on every tank to prevent losses from leaks. It was thought that equal pressure would allow the valve to stay open, but a leak would create a pressure change, shutting the check valve and preventing the loss of all of a project's water. In practice, however, most leaks are small enough that the check valve never fully shuts off. They don't work in this setting. Additionally,

these brass units have been a weak point during freezing; they are the first parts to break.

*Insulation*

Insulation does not keep the plumbing warmer or colder; it moderates the temperature changes. Dirt is a good insulator. You can leave the pipe exposed, but if you want it to last as long as possible, cover it.

We use standard 1-inch x 1-inch pipe insulation that comes in 36-inch lengths. The insulation is wrapped in an aluminum sheath. The sheath is difficult to fit and you need tin snips. Attach the sheath sections with sheet metal screws (#10 x 1/2-inch screws are preferred). The #10 hex head is the same as the hose clamp hex heads. Insulation does little good if it is wet. The sheath is a start at protection, but try to seal the seams with silicone caulk.

*Float Box*

Ammo cans have been used for float boxes in the past and work poorly. The metal is too thin and rusts out easily. In some cases, the air-tight compartment acts as a vacuum and will not permit the water to flow to the drinker.

We currently use a one-piece unit that has the float box and drinker together (Figure 13), mainly because it decreases the plumbing connections. In colder climates, the float box/drinker is not a good option; the float box is less protected and is more likely to freeze. One shallow float box in the Mormon Mountains froze so hard that the ice locked around the float valve. As the ice block expanded upward, the float valve was ripped upward.

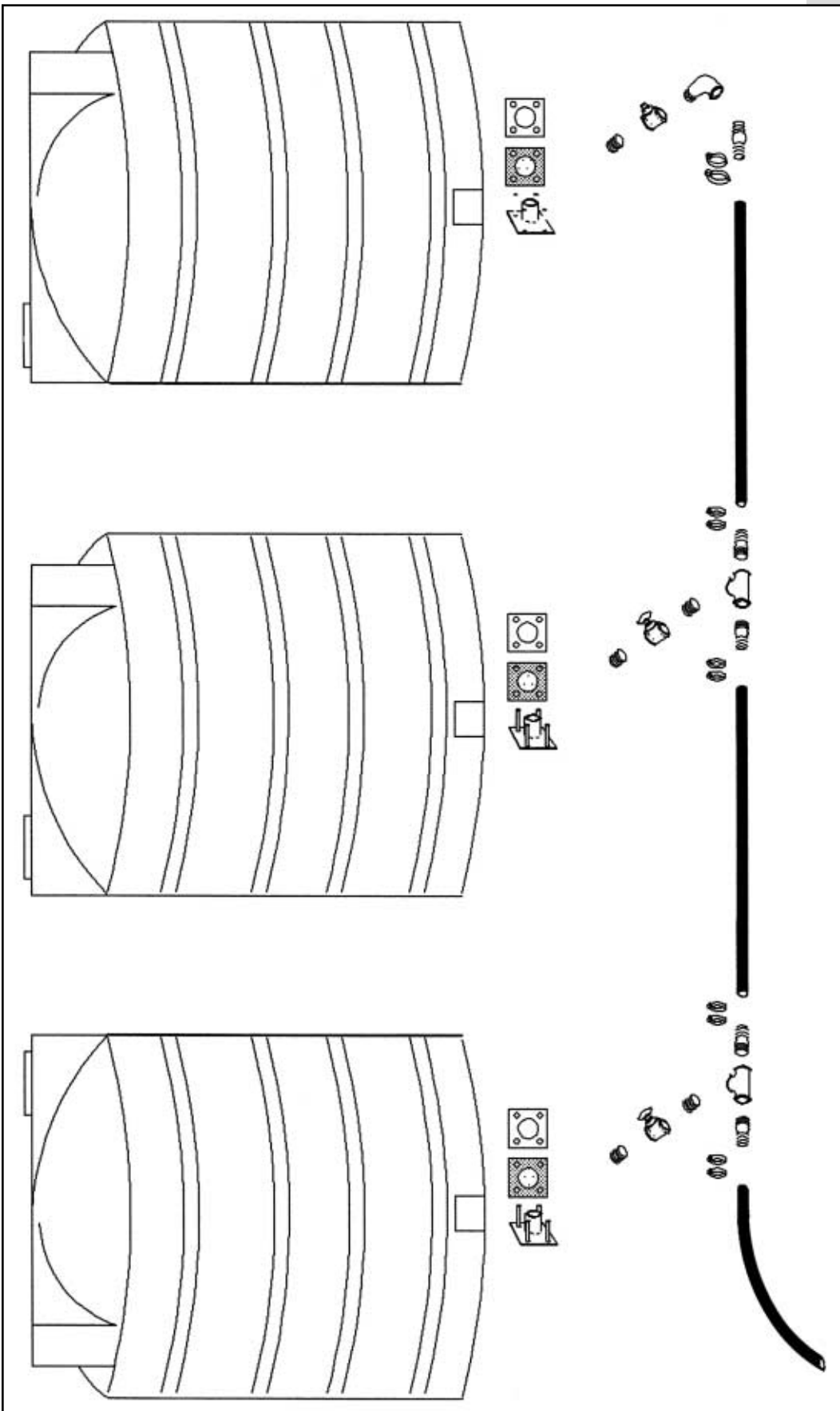

Figure 12. Standard manifold plumbing.

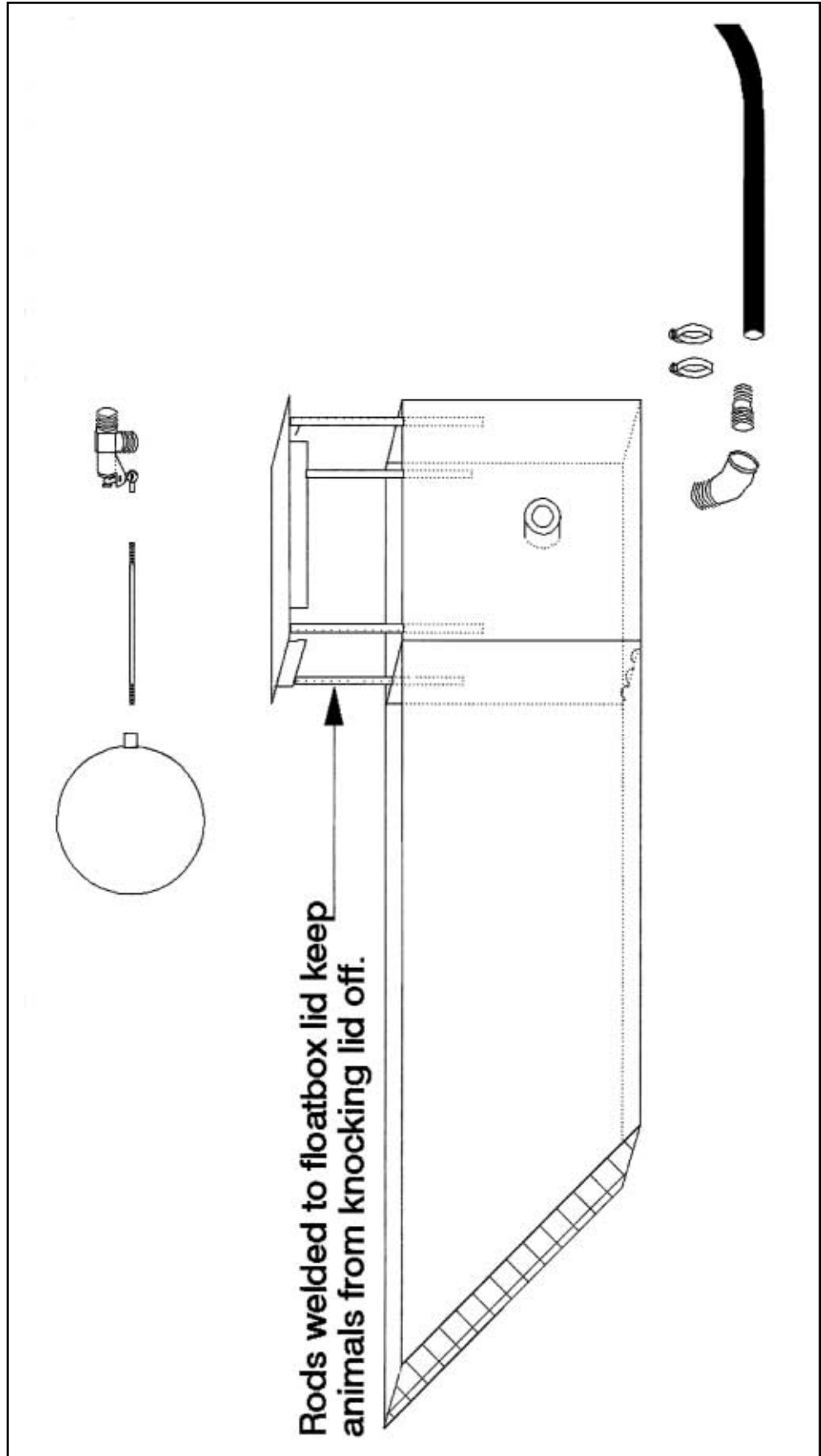
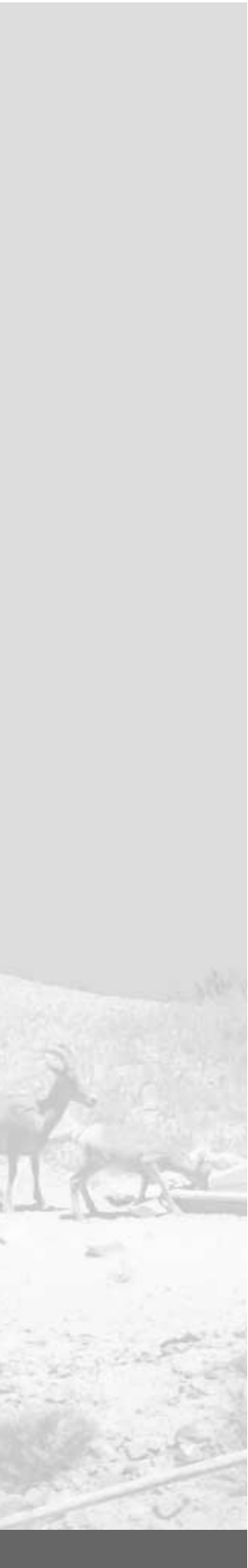

Figure 13. Floatbox/drinker unit.

One advantage to a separate floatbox and drinker is keeping the critical float valve away from the intensive animal use area. Inadvertent damage is possible as animals congregate. Several times when projects have dried up, sheep have pawed and banged the lid off the float box. In one case, the float ball was pinned down by the lid; if water had been collected later, it would have been lost immediately. Horses and cattle have also done this to some antelope developments.

The separate floatbox/drinker alternative also has problems. Since the box can be located anywhere in relation to the drinker, if its placement is not well documented, it can be difficult or even impossible to locate for repair and maintenance.

Sometimes the float box is buried several feet. Other times it is buried and covered with insulation. Both of these situations are difficult to inspect or repair.

The most critical part of the project is the float valve. We use 1-inch brass float valves. Since this part causes the most problems, projects that can do away with it are more desirable.

Keep the overflow pipe vertical at the tanks. If you slope the pipe, you could be making it a ramp for animals. A slight upturn of the overflow pipe along its length traps water and will inhibit unwanted intruders.

The float ball can be a problem. Originally, we used plastic or rubber float balls. These can last for many years in a domestic situation, but our float balls are subjected to extremes in temperatures; they crack and leak. We switched to a 4-inch copper float ball and had no problems until we tried to fill them with foam. It was insulating

foam and worked for several years. Then the foam began soaking up water and the float balls sank. Those were replaced with unaltered 6-inch copper float balls. The larger float balls dictate a lower drinker level, but they close the float valve with more force than the 4-inch units. When the drinker level is adjusted, the 1/4-inch x 6 1/2-inch brass float rod (one-piece drinker) is often "tweaked" up or down. A little bending is okay, but it can be broken. Use the longest rod possible; shorter rods reduce your ability to adjust the water level. Never use a substitute rod; it will corrode and bend, allowing the project to drain.

More water has been lost due to improper float adjustment than any single mechanical failure. Most often, the float is adjusted and the inspector walks away. If the valve is not closed, the slight drip may take hours to detect. With any adjustment, you must wait and watch for an hour before you leave.

Lay the float box lid sideways over the box. Pull the float ball up and make sure the ball cannot touch the lid. Try to leave a minimum gap of 1/2 inch between the ball and the lid. Overfill the drinker to check it.

Any mechanism is more likely to fail at the extremes of its functions. In the case of the float valve, this is fully up or fully down. Place a fist-sized rock under the float ball; the rock keeps the ball, and thus the float valve, from going all the way down. It reduces the chance that the valve will be stuck down, preventing the project from filling. There is not much you can do about the valve sticking in the up position; the larger float ball and the maximum length of float rod should help to keep this from happening.

**Plumbing in parts of western Canada** is simply buried 5 to 6 feet, with a covered culvert sunk to that level to allow access to valves. The temperature of the soil keeps the plumbing from freezing. A water drill is sometimes used to create a shaft below the plumbing, increasing the movement of heat from the earth.



### *Drinker*

Drinker location is vital. Do not put the drinker in a situation that gives an advantage to predators. Water sources are where desert bighorns are the most vulnerable, and predators depend on these places to focus on prey species. Desert sheep often watch the area of a water source for hours before they go in to drink. Then they drink and move away.

Animals are rough around a drinker. Sheep, for example, can wear ruts around a drinker, leaving it standing on a pedestal of dirt. Virtually every drinker has to have cement and rocks placed around it. Cement at least one animal body length away from the drinker. The best situation is to place the drinker on a sheet of rock, if possible.

Make sure you have a way to protect and cover the line coming in to the drinker. It should be buried, but the aluminum insulation sheath can protect the pipe as long as the animals can't move the pipe.

Do not cement too heavily over the inflow point for the drinker; you may need to make repairs or check for leaks at the point of attachment.

Where freezing is a big concern, the drinker should taper upward. Expanding ice will push upward. One suggestion is to provide a flexible cushion for the ice to push against in square drinkers or walk-in drinkers; bunched hypalon or a rubber material should work. Reflective heat can also be used to reduce ice by placing the drinker on the south face of a boulder.

Rocks are placed in all drinkers. Metal drinkers have abrupt corners, and unless

a rock is placed in the back, lizards and mice can and will swim into the corner and paddle until they drown. The rock provides a place to crawl out onto. It also displaces water and provides an irregular surface to heat up, increasing the melting of ice that forms.

Construction in the mid-1980s involved a separate float box and drinker. The float box was made of sheet metal. The drinkers were bowl-shaped and formed from cement. They function well, but several have leaked where the pipe comes in through the cement. The cement drinkers also seem to promote algae buildup more than sheet metal or plate steel drinkers.

### *Fences*

A post and wire fence on a Mormon Mountains Project was constructed to keep horses out. The standard BLM wildlife specification (16 feet 10 inches – 8 feet 6 inches) also kept sheep out. Deer would jump the fence, but sheep were not comfortable with this. The wires were bunched to form a 20-inch to 22-inch separation around the drinker area and sheep use increased dramatically.

Sheep fence specifications allow for animals to go under and through fences. The first wire or pole is 18 to 20 inches from the ground, the second is 6 to 8 inches above that, and the optional top wire or rail is about 42 inches above the ground (Figure 14).

There has been some experimentation with a single-rail fence in horse country. The rail is set at 36 to 38 inches. Horses cannot get under, nor are they inclined to go over. The problem comes when you add cattle or burros that will go under the rail.



Besides watching the rail spacings, make sure to allow room between the drinker and the fence so predators cannot trap startled animals against it. Most work to date recommends a minimum of 100 feet from the drinker for all fencing.

While it is best not to create an inhibitive barrier until wildlife has begun to use the project, once they do, they'll push a fence very hard to get back to

it. A solution is to install a fence with gates. The wildlife is accustomed to the fence, but when the livestock invade, gate panels will drop into place.

For bighorn sheep, you can incorporate cliffs or rock outcrops into the barrier. The sheep should more readily use the cliffs as "openings" in the fence, but livestock will still be deterred.

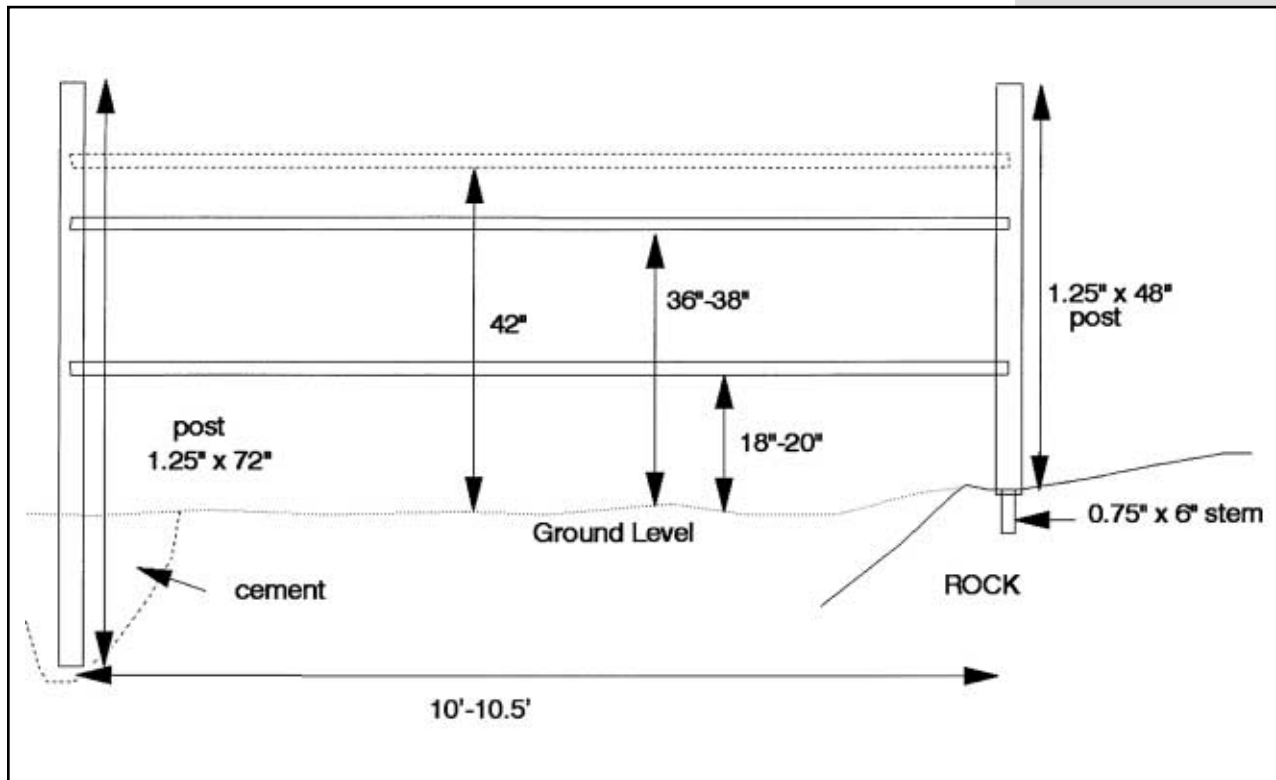

Figure 14. Fence spacings.



**Table 1. Sources for water development materials.**

<b>Polypipe</b>		
Driscopipe	Phillips Driscopipe, Inc PO Box 83-3866 2929 North Central Expressway Suite 100 Richardson, TX 75083	
	Maskell-Robbins, Inc 24113 56th Ave. W Mountlake, WA 98043-5503	(425) 775-8600
<b>Filtration Screens</b>		
Johnson Screens	Johnson Filtration Systems, Inc PO Box 64118 St. Paul, MN 55164-0118	(612) 636-3900 FAX (612) 638-3132
	The Water Well 410 South Orchard Suite #144 Boise, ID 83705	(208) 344-6690
<b>Polytanks and Tank Adapter Fittings</b>		
Rotational Molding	Rotational Molding 17038 South Figueroa Street Gardena, CA 90248	(310) 327 5401 FAX (310) 323-9567
	American Storage Tank Co. 11040 Hwy 41. Madera, CA 93638	(209) 439-5189
	Westec 195 W 3900 S. Salt Lake City, UT 84107	(801) 266-2545
Zorb Tanks	Poly Cal Plastics PO Box 80 French Camp, CA 95231	(209) 982-4904 FAX (209) 982-0455

Table 1. (cont)

**Fiberglass Tanks and Drinkers**

Desert Sun Fiberglass Systems, Ltd. 21412 N. 14th Avenue Phoenix, AZ 85027	(623) 869-0907 FAX (623) 869-9291
Fiberglass Structures, Inc 119 South Washington Avenue PO Box 206 Laurel, MT 59044	(406) 628-8208 FAX (406) 628-2480

**Cargo Nets and Straps**

International Cordage, Inc 1657 West 16th Long Beach, CA 90813	(310) 435-8916 (310) 437-0101 FAX (310) 435-2410
--	--

**Liner Aprons**

Hypalon	Water Saver Company, Inc PO Box 16456 Denver, CO 80216-0465	(303) 289-1818 FAX (303) 287-3136
	Environmental Liners, Inc 2009 N. Industrial Road Cortez, CO 81321	(303) 565-4221
PE Liners	Gundle Lining Systems, Inc 1340 East Richey Road Houston, TX 77073	(713) 443-8564
	Poly-America, Inc attn: Poly-Flex Div 2000 W Marshall Drive Grand Prairie, TX 75051	(972) 647-4374
	National Seal Company 600 N. First Bank Dr. Palatine, IL 60067	

**Miscellaneous**

Hand Tools	Bailey's PO Box 550 44650 Hwy. 101 Laytonville, CA 95454	(707) 984-6133 FAX (707) 984-8115
------------	---	--------------------------------------



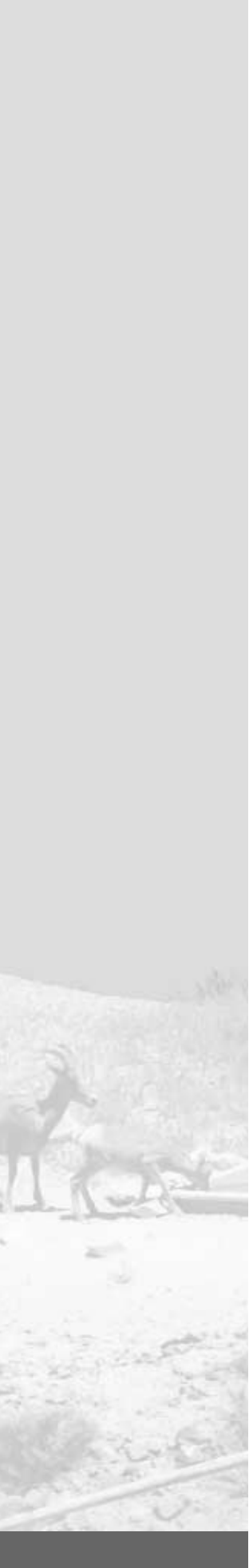

**Table 2. Polyethylene tank sizes.\***

Capacity (Gallons)	Diameter	Total Height	Weight (Lbs.)
30	1'11"	1'5"	18
500	4'0"	6'1"	133
1000	6'0"	5'4"	
1000	5'4"	5'9"	140
1600	7'6"	5'6"	
1600	7'8"	5'0"	282
2300	7'6"	7'7"	450
2500	7'10"	8'1"	485
3000	7'6"	9'10"	
3000	8'0"	8'6"	640
5000	9'11"	9'10"	1100
6500	9'10"	11'9"	
16400	4'0"	16'6"	4200

\* Figures from two manufacturers

# Chapter 4-Aerial Transportation of Materials and Equipment

## Helicopter Transport

Many guzzlers are located at sites that can be driven to, which simplifies logistics and makes the entire construction process easier. However, a significant number are located in remote sites, which necessitates the use of helicopters.

Helicopters are expensive and potentially very dangerous, but they have proven to be an essential part of guzzler construction. Eight of the 29 big game units in the Carson City District required the use of helicopters. These units were all located in desert bighorn sheep habitat.

The majority of the helicopters we use are small, either Bell Jet Rangers, Hughes 500 Cs or Ds, or Bell 47 (old MASH type) Soloy Conversions, powered by the same type of turbine engine as that used in the Jet ranger or Hughes 500. Personnel are usually all that is carried inside these helicopters, although never if there is anything on the hook.

Larger helicopters, such as the Bell 204/205/212 (Hueys), can accommodate items like the 18-foot steel beams

carried crosswise, with both ends of each beam sticking out from the helicopter several feet on each side.

Many things need to be considered when using helicopters, especially if you work for an agency within the U.S. Department of the Interior (USDI) or for the Forest Service (FS). These include safety; paperwork/forms; load preparation; staging; external load equipment; sling operations; and coordination between the helicopter pilot and the ground crew.

While the following information is not all-inclusive, it is based on many years of sling experience by both authors, not all of which was devoted to moving only guzzler materials or construction equipment.

### *Safety*

Personnel safety is first and foremost. Agency personnel, especially those employed by the Bureau of Land Management (BLM) or the FS, work under a set of no-nonsense rules that have evolved over the past 20 years, and have been developed and implemented by the Interior Department's Office of Aircraft Safety (OAS). In the last decade, several game and fish agencies have adopted all or part of these rules as well.

The reader is strongly urged to obtain a copy of the Department of the Interior's **Interagency Helicopter Operations Guide** (IHOG). It can be ordered from NIFC Supply. Ask for NFES 1885.



OAS rules require that all personnel working in, under, and close to helicopters (such as a sling operation) wear what is called “Personnel Protective Equipment” (PPE). PPE includes special fire-retardant clothing (Nomtex), either flight suites or pants/shirts; Nomex or leather gloves; and hard hat/goggles or flight helmet/goggles or visor. Wearing this equipment is mandatory for BLM employees. Personnel should also wear non-synthetic clothing such as cotton or wool under the PPE as this adds another layer of protection (it chars but does not melt.) The value of Nomex clothing is that it resists flash fires. PPE and non-synthetic clothing are the best protection against severe burns.

Proper training is also important. Many people who routinely hook loads under hovering helicopters have had no formal training; they learned “on the job.” While formal training may not be essential for non-Government personnel, it is required for Federal agency people. If you do not have the training necessary to do helicopter sling work, make an effort to get someone who is experienced to help you, such as helitack or qualified resource personnel.

### *Paperwork/Forms*

Before anything can be moved, two things are required:

1. The maximum allowable load in pounds for the helicopter, considering pressure, altitude, elevation, and temperature, must be determined.
2. The loads you assemble must not exceed the maximum allowable load, including the weight of the swivel/net/choker/sling.

Department of the Interior agencies use *Helicopter Load Calculation (OAS-67)* forms to figure the weight of the load. A sample of this form and the instructions for filling it out is shown in Figure 1. BLM regulations require that a “load calc” accompany the documentation sent to BLM so the aircraft owner can be paid. There is no need to do a load calc for every load. Instead, determine the allowable load using the highest elevation at which the helicopter will be working and the warmest temperature you anticipate. Keep in mind that the allowable load will increase as the helicopter burns off fuel during the operation.

### *Load Preparation*

Every item must be weighed, marked, and the weight recorded for future reference. We use duct tape and felt-tip pens to mark the items. Materials and equipment should be weighed before being sent to the work site to save time and effort during the sling operation itself. A spring-type Chatillon scale is used if an agency helitack crew does the weighing; otherwise a bathroom scale on a firm surface (even a small piece of plywood) is adequate.

Load placement inside the helicopter or on the hook is up to the pilot as he/she has charge of the actual transportation. Remember one basic concept - the pilot is in command. It is his/her call whether a load is safe to fly, how it is loaded, and whether the load must be jettisoned from the helicopter if it starts to swing erratically or out of control. That is why, for safety reasons, almost all of the materials and tools ferried into a remote site must be easy to jettison.

U.S. DEPARTMENT OF THE INTERIOR HELICOPTER LOAD CALCULATION		HELICOPTER MODEL _____ NO. _____
Pilot _____	Project _____	Date _____
1. Departure Base _____		Time _____
2. Destination Base _____		Pressure ALT Temperature _____
3. Helicopter Equipped Weight _____		Pressure ALT Temperature _____
4. Flight Crew Weight _____		
5. Fuel (Gals.           X           lbs.) _____		
6. Operating Weight _____		IGE           OGE
7. Computed Gross Weight _____		
8. Fixed Weight Reduction _____		
9. Adjusted Weight (7 Minus 8) _____		
10. Takeoff/Landing Limits (Handbook Limitation Section) _____		
11. Selected Weight (Lowest of 9 or 10 for Nonjettisonable) _____		
12. Operating Weight (Line 6) _____		
13. Allowable Payload _____		
14. Passengers and/or Cargo _____		
15. Actual Payload _____		
16. Actual Gross Weight (12 Plus 15) (Must Not Exceed Line 11) _____		
Pilot _____		Foreman _____
OAS-67 (02/81)		

### GENERAL INSTRUCTIONS

Complete a load calculation for all flights. For repetitive flights, one calculation is valid between like point of similar evaluations as long as loads do not exceed that authorized by the calculation for the initial flight, and weather conditions do not change.

### SPECIFIC INSTRUCTIONS

Pilot completes Items 1 through 13. Helicopter Foreman or Officer completes the balance of the form.

- 1 DEPARTURE BASE — Read altimeter when set to 29.92
- 2 DESTINATION BASE — Use MSL/Elevation.
- 3 HELICOPTER EQUIPPED WEIGHT — Empty weight of A/C + weight of accessories required for mission + weight of oil.
- 4 FLIGHT CREW WEIGHT — Weight of pilot (and any additional crew members) + their personal gear.
- 5 FUEL — AvgGas = 6.0 lbs./gal. Jet Fuel (JP) = 7 lbs./gal.
- 6 OPERATING WEIGHT = Add Items 3, 4 and 5.
- 7 COMPUTED GROSS WEIGHT — Obtain weight from A/C Hover-in-Ground-Effect (HIGE) Chart using External Load Chart if available. Sling load missions and adverse terrain or adverse weather, etc., flights will be computed from A/C Hover-Out-of-Ground Effect (HOGE) Charts.
- 8 WEIGHT REDUCTION — Enter applicable weight reduction for helicopter model as shown on Weight Reduction Chart.
- 9 ADJUSTED WEIGHT — 7-8.
- 10 TAKEOFF AND LANDING LIMITS — Enter applicable Takeoff and Landing Weight Limit as found in LIMITATIONS section of Handbook.
- 11 SELECTED WEIGHT — If line 9 is greater than line 10, line 9 may be used for JETTISONABLE loads. However, the lowest weight, line 9 or 10, will be used for NONJETTISONABLE loads.
- 12 OPERATING WEIGHT — Item 6.
- 13 ALLOWABLE LOAD — The maximum allowable weight (passenger and/or cargo) that can be carried for the mission.
- 14 PASSENGERS AND/OR CARGO — Enter passenger weights and/or type and weights of cargo. Manifest all passengers by name for each flight.
- 15 ACTUAL PAYLOAD — Total of all weights listed in Item 14.
- 16 ACTUAL GROSS WEIGHT — The total of weights in Item 12 and 15.

### WEIGHT REDUCTION CHART

MODEL	WEIGHT	MODEL	WEIGHT
AS-350D	130	206B III	130
SA-315B	180	206L-1	150
SA-316B	170	212	380
SA-318C	80	214B-1	380
SA-319B	210	UH-12F	90
47G-3B	90	UH-12 Soloy	100
47G-3B-1	90	FH-1100	100
47G-3B-2	90	H-500C	110
47G-3B-2	120	H-500D	120
204B	200	RO-105C	150
205A-1	260	W/250-C20	180
206B-1	100	W250-C20H	180
		S-55T	170

Figure 1. Form and instructions for determining helicopter's maximum allowable load.

The equipment used in the Carson City District for sling operations consists of swivels, nets, lead lines, and a special sling made of very heavy-duty nylon webbing. We can use a minimum of four units, each consisting of a swivel, a lead line (18 foot) and a net. If you have access to more units, the work will go faster, especially if the turnaround time for each load is short (e.g., less than 6 minutes). The quick turn around time is also why, before the helicopter lifts off with the first load, you should have at least four or more loads ready to go.

The nets, when stretched open on the ground, are 12 feet square and virtually everything except the tanks, tank lids, 10-foot gutter assemblies, and steel C-beams can be carried in them.

Strive to center everything in the net (paint the net center orange, if the paint won't negatively affect the material), and when the allowable weight is reached, pull the end/connecting rings pursing the net. Clip the lead line hook to both rings and add a swivel to the ring/loop of the lead line. Each net load is done this way unless the pilot prefers to fly without the lead line, which is his/her choice.

The swivel, rated at 3,000 pounds capacity, hooks directly to the hook on the helicopter. Be careful of the aluminum gates which fit into the openings on swivel hooks - these are fairly fragile and may be bent. Most can be straightened with vise-grip type pliers. If the gate is bent beyond repair, **DO NOT USE THE SWIVEL.**

For most loads, this is usually all the preparation that is necessary. However,

if you have many small boxes full of hand tools, drills, or light-weight items, the purse ropes of the net should be tied together with short pieces of paracord, or even duct taped. The boxes that house the hand tools, drill bits, oilers, fence parts, and other miscellaneous items should be tied together so they can't slip through the net mesh. The same applies to all hand tools such as shovels, pulaskis, and digging bars. We usually bind these together with duct tape. Obviously, people at both ends of the operation will have to have cutting tools of some sort (e.g., lockback folder, fixed blade sheath knife, or carton cutter).

The 18-foot steel beams, if slung, are rigged as follows. Take two of the lead lines and make them into chokers. Run the hooked end of the lead line under the beam ends and clip it back onto the cable. The first 2 feet from each end of the beams should be unsupported to allow the choker cable to slide easily under them. Connect the two lead line rings with a swivel and the load is ready.

The fiberglass tanks are lightweight and bulky and will become airfoils (out of control) unless they are rigged properly. We use the special sling mentioned earlier for the tanks and the lids, and on occasion as a choker for slinging the steel beams.

With a medium-sized helicopter, these tanks must be slung upside down; on smaller helicopters, they are slung right side up with the 10-foot gutter assembly pieces nested in them. The gutter pieces, including the white S&D pipe should be duct-taped together. We also put electric cords and cardboard boxes



containing parts in them, but no steel boxes or digging tools. If you don't have a sling, use a cargo net of at least 12 square feet.

For the polypropylene tanks, which weigh 800 pounds empty, a medium (Bell 205) helicopter is preferred; Hughes 500 E's or Bell 206 Long Rangers are marginal.

When using the sling, be very careful to make sure the sling loops are under the ends of the tanks far enough so that they won't slip off during transport. Once the tanks are in the sling and still on the ground, tie the opposite sides of the pursing cord of the sling together with paracord in such a way that they cannot move. When slinging tank lids with this sling, secure the sling loops near the lid ends with short pieces of paracord threaded through the drill holes on the lids and around the sling loop.

When slinging cubitainers full of water, **DO NOT** sling them with spare gas cans. If the load is not centered, things occasionally spill. **NEVER** put gasoline atop the water when you are slinging. Consider using small pallets for a stable platform when moving the water.

The total weight for a standard big time guzzler unit, with fiberglass tanks, plus steel fence for bighorn sheep is roughly 6,200 pounds. If polypropylene tanks are used, then add 500 pounds. If a 300-foot-long wood buck-and-rail fence is added, the total weight goes up another 4,000 pounds (subtract 640 pounds for the steel fence from the 6,200 pounds).

### *Staging*

The helispot should be as level as possible so the helicopter can land and refuel safely. It should be large enough so that the helicopter can land or hover and pick up a sling load. The more open the area is (i.e., fewer trees, rocks, and/or hills), the better the helispot will be as it will give the pilot better and safer maneuvering room for moving loads and for refueling. A good approach and departure route (always made into the wind) is necessary.

The actual landing pad for a small helicopter should be 15 feet x 15 feet, but a 75-foot diameter area is needed for safe operation. Specifications for a medium-sized helicopter pad are 20 feet x 20 feet and a 90-foot diameter area. The specifications for a heavy helicopter pad are 30 feet x 30 feet and a 110-foot diameter area. There should also be room at the helispot for the trucks to maneuver and off-load materials and equipment.

Equip both helispots (staging area and work site) with a 20-pound fire extinguisher and windsock or at least engineer's flagging tied to a pole or radio antennae. Also, stabilize the dust if you can with water or with foam from an agency fire truck.

Fueling the helicopter is also part of the process. Department of the Interior/OAS rules do not allow hot fueling (while the engine is running and the blades are turning) unless there is a helicopter-to-fuel-truck ground and a sealed fueling system. This is usually not present on small helicopters, but may be present on some medium and all large helicopters.

### **Safety Tip**

Make sure that roof decking/sheeting that is not already secured in a net as a load is well anchored as the rotor wash from the helicopter, even a small helicopter, will cause unweighted sheets to separate, float, and fly like 30-pound knife blades in every direction.



For safety purposes, stay at least 50 feet from refueling operations. If you must help with the fueling and are wearing Nomex PPE, be very careful NOT to get fuel on the PPE as it will negate its safety features.

Unless the helispot is small, and the helicopter cannot be refueled except right at the staging area, have the fueling done away from the staging area to allow load preparation to continue. Also, there should be no one inside the helicopter during refueling.

### *External Load Equipment/ Sling Operations*

The number of people needed to do a fast-paced sling operation is seven on the ground - four at the staging area and three at the work site. The extra person at the staging area is the loadmaster, who keeps track of loads and weights. Whoever has the most experience in this type of operation should be designated as helibase manager to properly coordinate that activity.

Before the first load is hauled, personnel unloading the nets and equipment at the work site must be ferried to it. This will require one or two trips if a Bell 47 sized helicopter is used. If receiving personnel have not been to the site, then the job supervisory will have to show the pilot where the site is, and one or more ground crew can ride at that time. Sometimes the helicopter arrives at the staging area ahead of the materials and equipment; that is also a good time for a recon flight.

A typical sling operation scenario would be as follows: the loadmaster, carrying a hand-held radio and, if possible, wearing a colored vest (to make

him/her stand out from the rest of the crew for easy identification by the pilot), stands 60 to 100 feet from the load. The task is to direct the pilot, not only during rigging the loads, but during flight as well.

The helicopter moves up, hovering over the load, and within reach of the hook up person, who has the swivel in hand. Once the swivel is forced onto the hook, the hook up person moves toward the loadmaster so the pilot can see both people, and the pilot lifts the load and proceeds to the destination. The hook-up person should stand so that he/she will not have to move around the load toward the loadmaster once it is hooked up.

The loadmaster indicates either by arm signals or by radio when the lead lines/sling are taut and when the load is clear of the ground. This is especially important when a long line - an electric hook at the end of a 50-foot-cable - is used. The hook-up person, to avoid bodily injury, must be very aware of the hook at all times, as it is very heavy and usually swinging like a pendulum. Never turn your back on a moving long-line hook.

Some helicopters develop static electricity and there may be a significant spark arching between the hook, swivel, and hook-up person. Swivels may be touched (grounded) against a helicopter skid before rigging the load. Usually this is not necessary on small helicopters, but the bigger the ship, the bigger the potential spark.

Before the first load lifts off, there must be a discussion between the pilot, the loadmaster, and the hook-up person to determine where everyone

should go in the event of a helicopter malfunction during hook up.

As noted above, the loadmaster directs load preparation. This person also keeps track of the number of loads and the weight of each. This is because a load manifest is required when the pay document is submitted. The loadmaster is also in radio communication with the pilot for flying conditions, return of empty nets/sling, etc.

When several loads have been ferried to the work site, the empty nets, lead lines, and swivels are rolled up and placed in one net. The net is then slung from the helicopter and released by the pilot at the staging area, where directed by the loadmaster. A single net or two nets should be rolled up and placed in the helicopter. They are too light by themselves if slung on the hook and can quickly become airfoils and create problems.

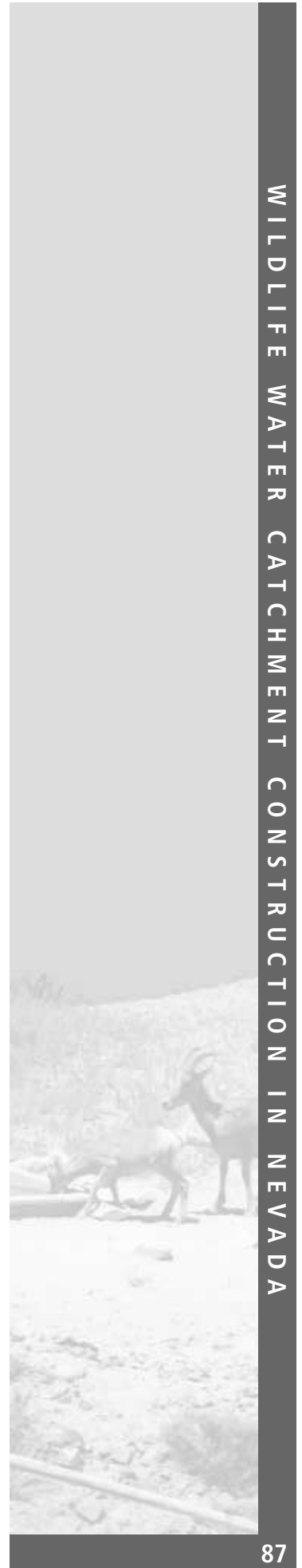



# APPENDIX A-

## Additional Water Catchment Devices

Other types of natural and artificial water-catching and storing devices include tinajas, inverted aprons, the Lesicka designs, saucer units, poured-in-place concrete tanks overlain by corrugated roofing aprons, and galvanized steel ring tanks supplied either by metal aprons (Chapter 2) or by the small dams used in slickrock development.

### Steel Ground-Hugging Aprons

The Fraternity of the Desert Bighorn group in Las Vegas has developed a steel ground-hugging collection apron that makes slopes up to 30 percent usable (Photos 1 and 2). The area must first be cleared of all rocks larger than fist-size. Then, 2-foot pieces of 5/8-inch steel rebar are driven into the ground in parallel rows, spaced 5 feet apart on the contour. Rebar spacing along the row depends on the width of the apron—a minimum of 2 and a maximum of 3 per purlin (C-beam) are used. Once the rebar is in place, steel purlins (13 foot for 39-foot wide aprons; 14 foot for 42-foot aprons; 15 foot for 45-foot aprons) are laid on the ground on the downhill side of the rebar and secured with U-bolts. Be sure the U-bolts have enough threaded portions so you don't need a lot of extra washers for spacers.

Purlins are simply butted up to each other with no overlap. Start with the first row of purlins, so gutter can be added while the remainder of the purlins are secured. Purlins come in various lengths up to 16 feet, are made of 16- or 18-gauge steel, and are 6 inches by 2 inches by 2 inches in cross-section.

Once the rows of purlins are completed, use a power hacksaw to cut off the tops of the rebar. While this is being done, secure the gutter to the first row of purlins. You'll need to cut a shallow trench for this, or make sure the first row of purlins is off the ground about 8 inches. The gutter was custom made, and in 10 foot pieces which were TEK-screwed together after being heavily caulked at the joint, and TEK-screwed to the first purlin.

The gutter is galvanized steel, approximately 12 inches across by 16 inches deep. Determine before construction whether the gutter should have drains at both ends. The ones used by the Fraternity have 2-inch threaded drains put in the ends (not bottoms) of the gutter. A 2-inch metal threaded/barbed MIP is then used to connect the polypipe leading to the storage tanks to the gutter. This size gutter will collect almost any amount of water coming off the apron during a cloudburst. The Fraternity used a Johnson screen





Photo 1. Rows of purlins in place.



Photo 2. Completed apron in background.

for each drain hole (there were 2 at one end) within the gutter, to trap any debris or sediment washing off the apron or surrounding area.

**Fraternity of the Desert Bighorn**  
P.O. Box 27494  
Las Vegas, NV 89126-1494  
Phone (702) 458-5858  
Email [info@desertbighorn.com](mailto:info@desertbighorn.com)

## Tinajas

Tinajas are natural tanks, water-scoured over time by high runoff in granite canyon and wash bottoms in the hot desert ranges found mostly in Arizona and California. These vary in size from a few inches deep, holding a few gallons of water, to 15 feet deep, holding hundreds of gallons of water after thunderstorms. The Arizona Desert Bighorn Sheep Society (ADBSS) based in Phoenix, Arizona, with help from the Arizona Game and Fish Department, has improved many dozens of these tinajas by enlarging and sealing them, and building shade structures over them.

Sealing the rock is an element critical to their success, and the ADBSS, through its experience and in a paper published by Robert S. Gray, one of its early presidents, has become expert at it. The paper, which was prepared and presented at the 1973 annual meeting of The Desert Bighorn Council, explains in step-by-step fashion the materials and methods needed to seal the tinajas. That paper is included in the Technical Note as Appendix B.

The same process is used for sealing concrete-and-rock dams, and natural or blasted stone cisterns, which are also a specialty for the ADBSS. The methods have well withstood the test of time.

### Arizona Desert Bighorn Sheep Society

P.O. Box Drawer 7545  
Phoenix, Arizona, 85011  
Phone (602) 912-5300

## Inverted Aprons/Umbrellas

Inverted aprons/umbrellas consist of a large (up to 10,000 gallons) circular, corrugated steel tank overlain by a circular apron of galvanized steel. This circular apron is usually much larger than the diameter of the tank. The apron serves as the roof of the tank. These have been used mainly in Arizona, New Mexico, and California by game and fish agencies, the BLM, and the Forest Service. Many have been in existence since the 1960s. Depending upon the size of the storage tank, the bottom of the tank may be poured concrete.

## Lesicka Design

The Lesicka Design is fairly recent and is used primarily in Southern California and Western Arizona. It collects thunderstorm water flowing under the surface in larger desert washes.

The perforated collection pipe is usually placed underground across a major wash or drainage that runs well. A small (low) dam may be constructed to retard the flow and protect the two or more 4-inch perforated polyethylene pipe or agricultural drain tiles that are used to collect the water. Surface water and debris pass over the system, but water seeping through the sand is continually drawn off. A solid bottom is not always necessary, but the system works best if that is a part of the unit.



The trenches for the collection pipe and drainpipe are cut with a backhoe. Six to 8-inch pipe is used for carrying water to the storage system to accommodate the very large, short-term flows that are the rule rather than the exception in that part of the world.

**Leon M. Lesicka**

4780 Highway 111  
Brawley, California, 92227  
Phone (619) 344-7073

## Second Lesicka Design

The Second Lesicka Design collects water from a natural apron, such as desert pavement, or from a small secondary wash draining two or more acres. The wash should be of coarse gravel, rocks, or hardpan. A low dam, usually 18-inches high or so, is sufficient. Water backing up behind it is drained through a screened 6-inch pipe to the holding tank and drinker. This is similar to the design used in southern Nevada (Chapter 3).

For both systems, Lesicka uses 10,000-gallon fiberglass fuel tanks for storage. The 8-foot tall by 30-foot long tanks are completely buried for protection. The walk-down drinker is made of fiberglass, and is 8-foot tall, 4-foot wide, and 16-foot long. It is self leveling with the tanks and is connected by flexible underground plumbing. The bottom of the drinker is made of concrete to provide durability.

**Leon M. Lesicka**

4780 Highway 111  
Brawley, California, 92227  
Phone (619) 344-7073

## Saucer Units

Saucer units (also referred to as desert discs, parabolic discs, or flying saucers), are a patented design marketed by Fiber Erectors of Red Bluff, California, which also makes a variety of other fiberglass products. They are circular, made of heavy fiberglass, and range in diameter from between 9 to 16 feet. Storage capacity ranges from between 200 to 2,200 gallons, depending upon configuration of the bottom (parabolic or flat). They are a bolt-together device and have up to 40 feet of seams. The roofs of these units also serve as their collecting aprons.

They have been tried throughout Nevada, California, and Utah, with varying success. The problems associated with them include lack of adequate collection surface and leakage. One of the big game units in the BLM's Carson City District had to be recaulked. The BLM's Ely and Las Vegas Districts installed seven of the large units and only one continues to function. The U.S. Fish and Wildlife Service has replaced one of its units. Members of the Society for the Conservation of Bighorn Sheep (southern California), in conjunction with the California Department of Fish and Game personnel, report that the one unit that does function worked after the seams had been resealed with fiberglass. On the other hand, the BLM Moab Utah District installed several of the large units over a several-year span and no maintenance problems have been identified.

Another problem identified with the larger units is that it takes several people to turn over the bottom, once its four quarters are caulked and bolted



together. The manufacturer says that the bottom may be stood on edge and allowed to flop, being cushioned by air as it approaches the ground. While this works fine on forest duff, most of Nevada and Southern California has too many rocks to chance breaking the unit by doing this.

#### **Fiber Erectors**

PO Box 1009  
Red Bluff, California 96080  
Phone (916) 527-1515

## Concrete Tanks/Drinkers

Concrete tanks/drinkers were used by the Arizona Game and Fish Department in the 1960s and 1970s. They consisted of a poured-in-place concrete tank, 2 to 3 feet deep, rectangular shaped, with a 2,500 gallon capacity. One feature was a walk-down drinker that was poured at the same time at one end of the unit. Water simply moved between the storage tank and the drinker through a hole cut in the wall. It was basically an early version of a self-leveling system. The apron consisted of steel corrugated roofing, 25 feet by 60 feet, which served as the roof of the storage tank. The apron sat almost level at ground level.

Many of these concrete tanks were filled via concrete collecting aprons. Many of the units, where deer use is heavy, are being revisited and improved. Up to three, 3,150 gallon

fiberglass storage tanks are buried nearby and provide water for a walk-in trough. These buried systems are being used in wilderness areas to reduce the need to haul water to the heavily used original tanks. The sites are completely landscaped and restored to their normal status, leaving virtually no trace of the construction work.

#### **Arizona Desert Bighorn Sheep Society**

PO Drawer 7545  
Phoenix, Arizona, 85011  
Phone (602) 912-5300

## Galvanized Steel Ring Tanks

Galvanized steel ring tanks, supplied either by aprons or slickrock catchments, are currently being built by the Arizona Game and Fish Department and the Arizona Desert Bighorn Sheep Society. These storage structures typically hold 15,000 gallons of water. Animals drink from a fiberglass trough, and the system is self-leveling. The tanks utilize a polyethylene floor, and Chemical Industrial Membrane (CIM) is used to seal the joints of the ring tank itself. A steel roof is constructed over the ring tank and essentially sealed to prevent evaporation.

#### **Arizona Desert Bighorn Sheep Society**

PO Box 7545  
Phoenix, Arizona, 85011  
Phone (602) 912-5300



## Final Notes

Here are some tips based on the authors' experience over the past 30 years in the intense sun and temperature extremes found in Nevada.

- DO NOT use wood structures to support aprons; they deteriorate quickly and burn readily in range fires.
- Storage bags made of butyl rubber deteriorate in sunlight and are subject to hoof damage by large wildlife, such as mule deer and desert bighorns if they get on top of the bags searching for the water.
- Fiberglass collecting aprons, tried in the mid-1970s in BLM's Carson City District, did not withstand the ultraviolet light from the sun and were also very easily vandalized.
- Collecting aprons made of rubber sheeting and asphalt both deteriorate quickly unless constantly maintained.



# Appendix B

## LASTING WATERS FOR BIGHORN

25

Robert S. Gray  
President, Arizona Desert Bighorn Sheep Society  
Phoenix, Arizona 85010

**Abstract.** The construction of water impoundment dams for desert bighorn has been simplified and made more effective with the use of calcium aluminate to accelerate cement setting, a bonding agent to bind rock to cement, and commercially available sealers. The techniques used in constructing a dam with such materials is described in detail.

One of the primary functions of the Arizona Desert Bighorn Sheep Society is to work with the Arizona Game and Fish Department in increasing the supply of water for desert bighorn sheep. Between 1971, when I first became involved with our society's cooperative water development efforts, and the present, we have learned to build larger water impoundments faster and with fewer problems. In 1971, for example, we were propping up 3-foot high dams to keep them from falling over until the cement set. In 1973, the Society was building dams 8 feet high and 10 feet long in 1 day, with no props.

As a plasterer who deals daily in cement products, my experience helped me to adapt waterproof materials to fit the needs of water developments used by bighorn. Thus, this paper describes the materials and detailed methods for successfully constructing a dam whereby "lasting waters" may be provided for desert bighorn.

### MATERIALS

Equipment and materials needed for constructing a water impoundment are listed in Table 1. Detailed construction procedures are given under Methods.

Table 1. Equipment and materials for construction a water impoundment dam.

Equipment	Materials
Standard broom	Cement (common or masonry)
Whisk broom	Hydrated lime
6" beaver brush	Screened sand
3-4" paint brush	Water
No. 3 or 4 coffee cans	Calcium aluminate
Mortar box	Acryl 60*
Mortar hoe	Thorseal*
No. 2 square-point shovel	Water Plug*
5 gal. cap. buckets	
Wheelbarrow	

\*Standard Dry Wall Products, Inc.  
411 Cecilia Way  
Los Altos, California 94022

### METHODS

Upon arriving at the selected site, a person will soon find out just how much thought and preparation has been given to properly preparing for the particular job. To insure success, I recommend the following:

1. Remove all rock overhangs, loose debris, trees, or brush from the construction area.
2. Clean the dam site down to bedrock to insure absolute bonding of the cement to the rock.

3. Drill holes and set the reinforcing rod ("rebar") in bedrock. Then, clean off all dust and debris again.

At this point you are ready to start the mortar mixing process; so all of the materials, equipment, and supplies should be arranged for an uninterrupted sequence of events.

4. Place 1 part cement and 3 to 5 parts sand (by volume) plus 1/10-part of hydrated lime in the mortar box. Dry mix until blended. Add water and mix the cement to the desired consistency. (Proportions are approximate and should be adjusted to local material conditions.)

5. Remove enough mortar to grout in the holes around the rebar. Add approximately 3 to 5% (about 1 to 2 cups full) of calcium aluminate (hereafter called Luminite) cement to the mortar. Mix the mortar rapidly and place it in rebar holes, working the mortar down in the holes so that the mortar completely fills the holes and encases the rebar. Luminite, when added to Portland cement mortars accelerates the setting time from hours to a matter of minutes, depending on the amount of Luminite used and the temperature. Cold weather (32 to 80°F) will lengthen the setting time of the mix, while hot weather (80°F+) will shorten the setting time. We can build dams and use Portland cement in other ways, because we have control of the setting time by the use of Luminite.

6. Fill a no. 3 coffee can with undiluted Acryl 60 and, with a 4" paint brush, liberally cover the bedrock, plus 6 inches on each side of the dam's base.

7. Immediately cover the Acryl 60, less the 6 inches on each side of the dam base, with the unaccelerated mortar from the mortar box. Then Acryl 60 is the bond between the bedrock and the mortar. You must keep the bonding area clean, because lack of bond is responsible for leakage in dams. Do not allow the Acryl 60 to dry out or change color. If this happens, then apply another coat of Acryl 60 and repeat the process.

8. Continue to mix the mortar as before. But now, after the final consistency is reached, add 1/2 to 1-1/2 pounds of Luminite cement to the mix and hoe into a proper blend and consistency. Experimentation on your part with the amount of Luminite to be added to the mortar will have to be by trial and error. If you use a mechanical mixer, do not add Luminite in the mixer, but dump the mortar into the mortar box or a wheelbarrow first.

9. Proceed with the laying of the single wall. You may prefer a double wall and a grouted core dam, using the rocks that have been accumulated from around the area. Care should be exercised to see that all dirt and mud is removed from the bedrock, so that a good mortar bond can be obtained. In hot weather (80°F+), wetting the rocks will help obtain a good mortar bond.

10. After the desired height is attained, clean off all excess mortar around the perimeter and 6 inches back from the dam. Using undiluted Acryl 60, liberally paint the entire perimeter plus 6 inches of the bedrock on the inside face. Immediately fill in voids around the perimeter with mortar and work your way across the inside face. Mortar will have to be hauled or thrown from the end of mason's trowel into voids. Attempt to fill in as many voids and envelope as many rocks as possible, including the underneath sides, so when you finish a fairly even plane will exist. This step again creates a water-tight seal around the perimeter of the dam and adds strength.

11. Using undiluted Acryl 60, start brushing the mortar as soon as it begins to stiffen. The Acryl 60 will act as a sealer to keep in moisture. The object of this process is to smooth out the leveling coat of mortar and, most important, to completely seal the perimeter and all protrusions of rocks in the dam. Lay on your back if you have to, but be sure you look underneath the protrusions for voids. Now complete the outside face and top in the same manner.

Another change in the application procedure is about to take place, as you are through with the Portland cement mortar process and will now start using the Thoroseal. Again it is time to rearrange materials and equipment for a smooth, fast operation.

12. Mix in a clean bucket 1 part Acryl 60 to 2 parts clean water. This will be the only liquid added to the Thoroseal mix. Do not use straight water.

DESERT BIGHORN COUNCIL 1994 TRANSACTIONS

13. Place Thoroseal in the mortar box and add 1 gallon of No. 30 silica sand or sand that has been screened through a regular screen door type screen, and add color, if desired. Add the water blended Acryl 60 to the mortar box and mix to the desired consistency. Caution should be used in the amount of liquid added, as the Thoroseal has an initial tendency to reject the liquid.

14. Again liberally apply undiluted Acryl 60 around the inside perimeter of the dam and 6 inches out on the bedrock. Immediately apply mixed Thoroseal from the mortar box or bucket over the Acryl 60 and across the face of the dam with either a whisk broom or a beaver brush. By holding your fingers behind the brush, you will have more control in the application procedure. As the Thoroseal loses its sheen or becomes firm, apply diluted Acryl 60 blend with a 4" brush to smooth out and seal all the perimeter, protrusions, and voids. This is the last of our 3 changes to provide a water-tight structure. Follow the same procedure on the face and top of the dam.

15. Keep tools and equipment as clean as possible after each batch of mortar is used. Scrape off the sides and bottom of the mortar box. This is especially good advice when using Luminite and Thoroseal. Both materials tend to set quickly as the thermometer rises. One application of Acryl 60 can destroy a good brush, unless you wash it in clean water every 2 to 4 hours, and at the end of the day leave it in a clean bucket of water.

16. Portland cement hardens with age and the first 7 days are the most crucial. Therefore, the height and water pressure of the storage area should be considered before filling or praying for rain.

Now you have an impoundment with water clear to the top, but along the south side of your dam something must have gone wrong, because there is a small leak. After that sinking feeling has caused a state of shock, another volunteer shows up. Her name is Mother Nature. Through the process known as "Efflorescence" she will seal up your leaks. Tom Geary of the Calaveras Cement Company explains efflorescence as,

"a deposit of mineral salts on the surface of concrete, plaster, or masonry that may be composed of varying mixtures of carbonates, sulphides, sulphates, chlorides, and other salts of calcium, sodium and related metals. The deposit may be soluble or insoluble in acid or water after it has formed.

The deposit occurs simply, the following way. The salts are dissolved in moisture with the mass of concrete, plaster or masonry. The water serves as a vehicle or carrying agent of the salt. As the water moves toward the surface of the slab or wall, the fluid carries the dissolved mineral salts to the surface. At the surface, the water evaporates into the air. The salt cannot vaporize under normal conditions and, thus, is deposited on the surface, sometimes as small crystals, almost powdery in appearance, and sometimes as a glazed area. Continued exposure of the deposit may result in alteration to form a more insoluble form. In addition, the physical form of efflorescence may vary from job to job.

Sometimes a chemical reaction that starts when water is introduced into the mix releases a compound that may migrate to the surface of the slab or wall, and combine with one of the ingredients of the air around us to form calcium carbonate."

Efflorescence may be objectionable to finished buildings downtown, but where dams for bighorn are built, we love it. Both our Black Bottom and Sand Tank pot holes sealed themselves up in less than a year.

Another product of the Thoro line is "Water Plus". Just mix it with water to a putty like consistency, hold it in your hand until it becomes warm, and stuff it in a hole. Hold the substance until it sets. It is that simple, and it really works.

Cisterns, caves, or blasted out water catchments can all be handled with Acryl 60 and Thoroseal in the same manner as described for dams. Clean out the loose rocks and debris, apply Acryl 60 with a brush or spray gun and follow with the Thoroseal process.

When rain falls and your catchment fills, a tingle goes up your spine, a sense of satisfaction creeps over you, and you smile to yourself and say, "Yep, she's holding water".

DESERT BIGHORN COUNCIL 1994 TRANSACTIONS



The mention of company names, trade names, or commercial products does not constitute endorsement or recommendation for use by the Federal Government.

