



US Army Corps
of Engineers
Hydrologic Engineering Center

Accuracy of Computed Water Surface Profiles

Prepared for **the** Federal Highway Administration

December 1986

REPORT DOCUMENTATION PAGE

Form Approved
OMB No. 0704-0188

1a. REPORT SECURITY CLASSIFICATION Unclassified		1 b. RESTRICTIVE MARKINGS	
2a. SECURITY CLASSIFICATION AUTHORITY		3. DISTRIBUTION / AVAILABILITY OF REPORT	
2b. DECLASSIFICATION / DOWNGRADING SCHEDULE			
4. PERFORMING ORGANIZATION REPORT NUMBER(S) Research Document No. 26		5. MONITORING ORGANIZATION REPORT NUMBER(S)	
6a. NAME OF PERFORMING ORGANIZATION US Army Corps of Engineers Hydrologic Engineering Center	6b. OFFICE SYMBOL (if applicable) CEWRC HEC	7a. NAME OF MONITORING ORGANIZATION	
6c. ADDRESS (City, State, and ZIP Code) 609 Second Street Davis, CA 95616		7b. ADDRESS (City, State, and ZIP Code)	
8a. NAME OF FUNDING /SPONSORING ORGANIZATION	8b. OFFICE SYMBOL (if applicable)	9. PROCUREMENT INSTRUMENT IDENTIFICATION NUMBER	
8c. ADDRESS (City, State, and ZIP Code)		10. SOURCE OF FUNDING NUMBERS	
		PROGRAM ELEMENT MO	PROJECT NO.
		TASK NO.	WORK UNIT ACCESSION NO.
11. TITLE (Include Security Classification) Accuracy of Computed Water Surface Profiles			
12. PERSONAL AUTHOR(S) Michael Burnham and Darryl W. Davis			
13a. TYPE OF REPORT Reserch Document	13b. TIME COVERED FROM _____ TO _____	14. DATE OF REPORT (Year, Month, Day) 1986 December	15. PAGE COUNT 198
16. SUPPLEMENTARY NOTATION'			
17. COSATICODES		18. SUBJECT TERMS (Continue on reverse if necessary and identify by block number)	
HELD	GROUP	SUB-GROUP	
19. ABSTRACT (Continue on reverse if necessary and identify by block number) Accuracy of Computed Water Surface Profiles documents an investigation of the effect of survey technology and accuracy and reilability of hydraulic roughness estimates on the accuracy of computed water surface profiles. The survey technologies studies include field surveys, aerial surveys, and topographic maps as data sources for stream cross-sectional geometry. A Monte Carlo simulation strategy was applied to develop an array of computed profile errors for the sruvey technologies and selected accuracies, and Manning's coeff iclent rei labili ty. Regression equations were derived for predicting profile errors as a function of survey technology, selected accuracy, Manning's roughness coefflcent, and stream hydraulic properties.			
20. DISTRIBUTION / AVAILABILITY OF ABSTRACT <input checked="" type="checkbox"/> UNCLASSIFIED/UNLIMITED <input type="checkbox"/> SAME AS RPT. <input type="checkbox"/> DTIC USERS		21. ABSTRACT SECURITY CLASSIFICATION Unclassified	
22a. NAME OF RESPONSIBLE INDIVIDUAL Darryl W. Davis		22b. TELEPHONE (Include Area Code) 916 756-1104	22c. OFFICE SYMBOL CEWRC-HEC

Accuracy of Computer Water Surface Profiles

December 1986

for the Federal Highway Administration

by

US **Army** Corps of Engineers
Hydrologic Engineering Center
609 Second **Street**
Davis, CA 95616-4687

(916) 756-1104

RD-26

ACCURACY **OF** COMPUTED WATER SURFACE PROFILES
- - - EXECUTIVE SUMMARY - - -

INTRODUCTION

Water surface profiles are computed for a variety of technical uses. Profiles are computed for flood insurance studies, flood hazard mitigation investigations, drainage **crossing** analysis, and other similar design needs. Tens of thousands **of** profile analyses are performed each year. The accuracy of the resulting computed profiles has profound implications. In the case of flood insurance studies, the computed profile is the determining factor of the acceptability of parcels of land for development. **For** flood control projects, the water surface elevation is important in planning and design of project features and in determining the economic feasibility of proposed solutions. **For** highway stream crossings, the computed profile can affect bridge design and is the mechanism for determining the effect of a bridge crossing on upstream water levels. The accuracy of computed profiles is thus of major interest to the water resources community. Similarly, with the large number **of** studies performed each year, the cost of acquiring essential data, such as cross-sectional geometry is significant. The relationship between mapping accuracy and resultant computed profile accuracy is therefore of major interest to engineers responsible for providing cost-effective technical analysis.

The water surface profile for the significant majority of streams can be computed using the step-profile (standard-step) method for steady flow. The method is based on solving the steady flow equations using a cross section to cross section, step by step procedure. Errors associated with computing water surface profiles with the step-profile method can be classified as technique applicability, computation, and data estimation errors (**McBean** 1984). The applicability of the technique is the responsibility of the professional engineer and much experience is available to assist in making an appropriate applicability decision. Computation **errors** include numerical round-off and numerical solution **errors**. The **former** is negligible using today's modern computers and the latter can be minimized by employing readily available mathematical solution techniques. Data estimation errors may result from incomplete or inaccurate data collection and inaccurate data estimation. The sources of data estimation errors are the accuracy of the stream geometry and the accuracy of the method used and data needed for the energy loss calculations. The accuracy in stream geometry as it affects accuracy of computed profiles is therefore of importance. The accuracy of energy loss calculations depends on the validity of the energy loss equation employed and the accuracy of the energy loss coefficients. The Manning equation is the most commonly used open channel flow equation and Manning's n-value is the coefficient measuring boundary friction.

This investigation focuses on determining the relationship between:

- * survey technology and accuracy employed for determining cross-sectional geometry,
- * degree of confidence in Manning's coefficient, and
- * the resulting accuracy of the computed water surface profile.

A second component of the study developed equations that may **be** used to estimate the upstream and downstream study limits needed for data collection and analysis to ensure that accurate profile analysis is performed in the vicinity of a highway stream crossing. The HEC-2 Water Surface Profiles computer program (Hydrologic Engineering Center 1982) is used **as** the computational tool to compute the profiles for the investigation.

INVESTIGATION STRATEGY

The strategy adopted for the investigation was to assemble an array of existing HEC-2 data sets and adjust the data sets in a carefully controlled manner and observe the error effects. The error effects are determined by comparing the profiles computed for the adjusted data sets with the profiles computed for the original data set. The data adjustment strategy is that of Monte Carlo simulation, which incorporates within its methodology the interaction among the several sources of error. Probability density functions are derived that define the error distributions for survey cross-sectional measurements and Manning's roughness coefficients. Error analyses are performed for conventional field surveys, and 2-, 5-, and 10-foot contour interval aerial spot elevation survey and topographic maps. Three levels of reliability of Manning's roughness coefficient are studied, varying from n-values selected through professional judgment to accurately calibrated n-values based on observed historical profiles.

Comparison of computed base condition profiles and Monte Carlo simulation profiles enables calculation of mean absolute and maximum absolute errors for each stream reach and error condition. Regression equations are derived for predicting profile error as a function of survey technology, selected accuracy, Manning's roughness coefficient and stream hydraulic properties. Regression equations are also developed for estimating the upstream and downstream distances from a highway stream crossing that are needed for data collection and water surface profile analysis. Profile calculation data are needed downstream to assure that any initial profile error does not impact on the profile at the crossing. Profile calculation data are needed upstream a distance equal to the estimated convergence location

of the profile resulting from stream crossing structure headloss.

Several important study bounds were adopted to ensure consistency in decisions involving data processing and analysis strategy, and to confine the investigation to a manageable set of issues. The study bounds are:

1. The discharge (flow rate) corresponding to the 1-percent chance flow is used and errors in discharge values are not considered,
2. The HEC-2 Water Surface Profiles computer program is used for all water surface profile computations. The program is applicable for natural stream geometry, one-dimensional, gradually varied, rigid boundary, steady flow conditions,
3. Only subcritical flow conditions are considered,
4. The incremental increase in error caused by local features such as bridges, culverts, dams, and radical bends are not considered.

Monte Carlo analysis provides a way to estimate the statistical properties of outputs (profile errors) of numerical models when one or more **of** inputs (surveyed cross section and Manning's coefficient errors) are random **variables**. The input variables used in a water surface profile calculation model differ from the true values because they are derived from measured data. Since the errors in these inputs are unknown, the evaluation of their effect on the profile **is** also unknown. A way to deal with this problem is to acknowledge that the inputs are samples drawn at random from a population of likely data sets. This approach allows probabilistic statements to be made regarding the relationship between input errors and output (profile) errors.

The adopted Monte Carlo simulation strategy is shown schematically in Figure 3.1. HEC-2 data sets obtained from Corps field **offices** are assembled in a data file for analysis (step 1 of Figure 3.1). The data sets are subsequently edited (step 2) to produce consistent data sets. This process eliminates all but the **1-** and 10-percent chance discharge values, removes all bridge data and non-surveyed cross sections, and edits all data sets to the same expansion and contraction loss coefficients. The data sets are subsequently evaluated to define appropriate reach lengths and to assure that all profiles are subcritical. **of** the 140 original data sets, 98 are retained for the profile accuracy analysis after editing.

The edited data sets are further modified to develop the base condition data sets. Interpolated cross sections are added to minimize numerical integration error (step 3). Comparison of profiles computed from the several commonly used friction loss approximation techniques of; average friction slope, average

conveyance, and geometric and harmonic mean friction slope shows significant differences, more than a foot, in reaches of many streams. A significant number of the original data sets underestimate the profiles as compared to those calculated with more accurate integration of the energy loss-distance function made possible by using closer-spaced cross sections. The cross sections are linearly interpolated at 500 foot spacings from the surveyed cross sections (step 3). These cross sections are not required for better definition of physical and hydraulic changes along the stream but only for increasing the number of computation steps. The original data sets adequately define the geometric variations.

The edited data sets with the interpolated cross sections become the base HEC-2 data sets (step 4) used to generate the base water surface profile (step 5). Figure 4.4 contains several charts that illustrate the range of stream characteristics represented by the adopted data sets. A base profile is calculated for each of the 98 data sets and subsequently compared with the profiles computed for the adjusted HEC-2 data sets.

The adjusted HEC-2 data sets are developed using the Monte Carlo simulation approach to randomly adjust survey **cross-sectional** coordinate points and Manning's coefficients for errors associated with these parameters. Analysis conditions are specified (step 6) and measurement error statistics are used to randomly adjust each coordinate point and Manning's coefficient in the data set (step 7). No adjustments are made for field surveys since they are considered to be without error. **Cross-sectional** adjustments are performed for aerial spot elevations and topographic maps for 2-, 5-, and 10-foot contour intervals. The probability density functions (PDF) of errors for these conditions are obtained from published mapping standards. Manning's coefficient analyses are performed for three levels of reliability of the estimates ranging from professional judgment based on field observations to precisely calibrated estimates.

The various combinations of survey and Manning's coefficient conditions result in 21 different error evaluation situations for each of the 98 edited data sets. The adjusted data sets (step 8) are then processed by HEC-2 to yield the error condition predicted water surface profiles (step 9). Each of the adjusted profiles is compared with the base condition profile (step 10) to determine the mean absolute reach error (average error over the stream reach) and absolute maximum reach error.

The profile computed for the adjusted HEC-2 data set for a specified survey and Manning's coefficient represents one of a Set of possible profiles based on the PDF's of the two error sources. It is therefore necessary to generate sufficient replicates of each condition analyzed to develop a reliable set of the error statistics of the mean absolute and maximum absolute reach errors. The resulting mean absolute reach error values and maximum absolute reach error values were subsequently used to

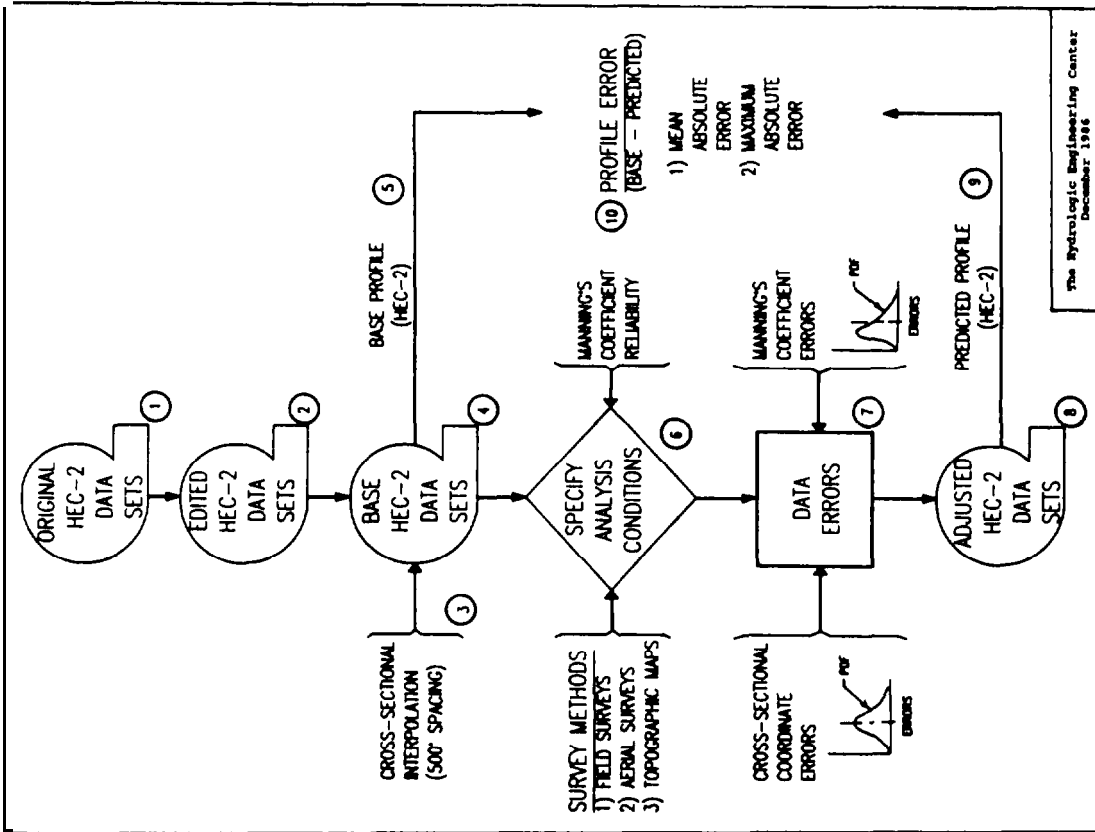

FIGURE 3.1 Profile Accuracy Analysis Strategy

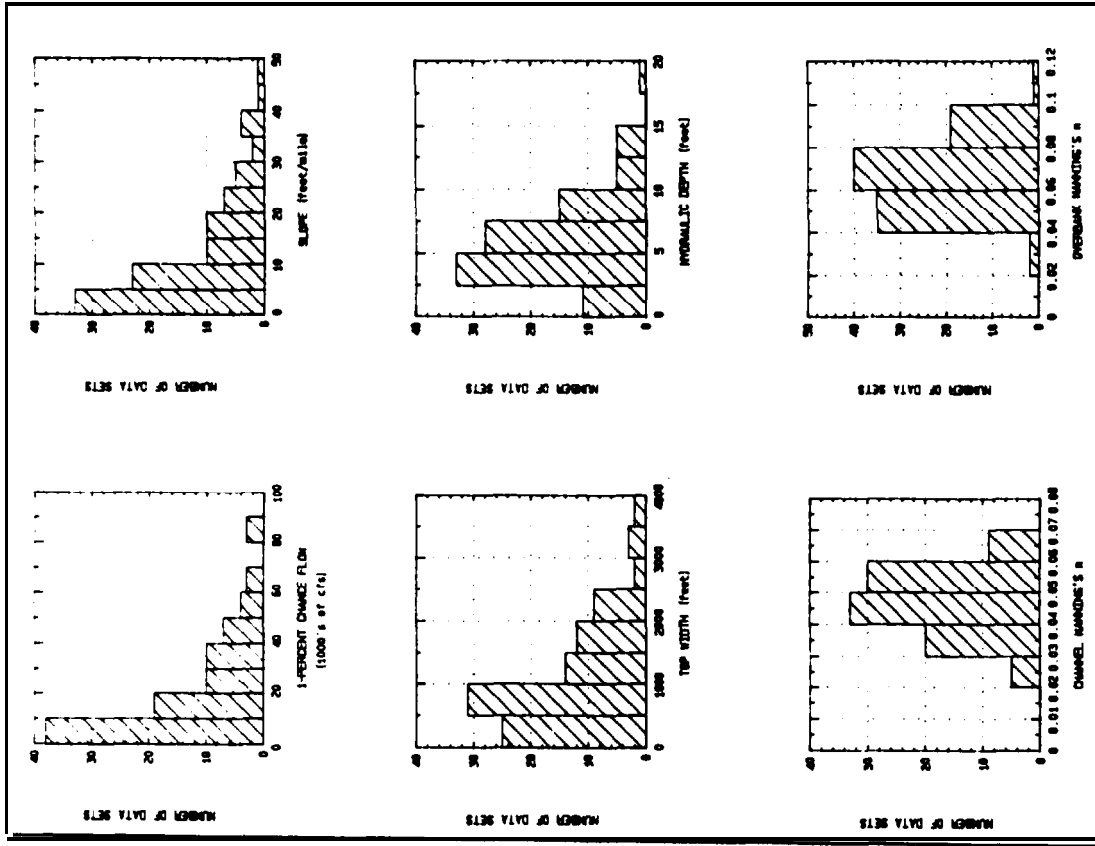

FIGURE 4.4 Stream Characteristics of Base Data Sets

derive regression equations for predicting water surface profile errors for specified survey accuracy and Manning's coefficient reliability conditions.

SURVEY METHODS AND ACCURACY

A stream cross section is a vertical section through the surface of the ground taken perpendicular to the flow. The cross section is defined by distance and elevation coordinates taken at changes in topography along the cross-sectional alignment.

The number of cross sections that are taken vary with study requirements and stream characteristics. Survey methods used to measure cross-sectional coordinates include field surveys performed with land surveying instruments, aerial spot elevations developed from aerial stereo models, topographic maps generated from aerial photography procedures, and hydrographic surveys that are needed when the size and depth of streams prevent measurement by other means. Measurement errors for these methods are a function of industry adopted accuracy standards, equipment, terrain, and land surface cover.

Aerial photogrammetry is an increasingly used technology for determining cross-sectional coordinate data. The data can be easily processed to the desired formats for direct computer application. Two distinct products are spot elevations along the alignment of the cross sections and topographic maps from which the cross sections are subsequently taken. Both techniques are derived from basic photogrammetry technology.

The accuracy of aerial technology for generating cross-sectional coordinate data are governed by mapping industry standards. Table 5.2 is a summary of relevant accuracy standards. Cross sections obtained from contours of topographic maps developed by photogrammetric methods are not as accurate as those generated from spot elevations. The elevation errors of aerial spot elevations and points on the topographic map are spatially uncorrelated and random (Hydrologic Engineering Center 1985). Therefore, measurement errors for adjacent cross-sectional coordinate points obtained from either procedure are not correlated.

The study was performed based on the following adopted survey accuracy statements.

1. Field surveys are considered to produce precise, exact replication of the base condition cross-sectional geometry with no errors. This represents the lower, no measurement error bound on the computed profile accuracy analysis,
2. Aerial spot elevation and topographic map cross-sectional measurement errors are based on the mapping industry accuracy standards shown in Table 5.2. Only

TABLE 5.2

Aerial Survey Procedures
Vertical (Elevation) Accuracy*

Aerial survey map accuracy **for** spot elevations and topographic maps is defined by the mapping industry standard. Standard Map Accuracy is described by the following criteria:

1. The plotted position of all coordinate grid ticks and monuments, except benchmarks, will be within 0.01 inch from their calculated positions.
2. At least 90 percent of all well-defined planimetric features shall be within 0.033 inch of their true positions, and all shall be within 0.066 inch of their true positions.
3. At least 90 percent of all contours shall be within **one-half** contour of true elevations, and all contours shall be within one contour interval of true elevation, except as follows:

For mapping at scales of **1" = 100'** or larger in areas where the ground is completely obscured by dense brush or timber, 90 percent of all contours shall be within one contour interval or one-half the average height of the ground cover, whichever is the greater, of true elevation. **All** contours shall be within two contour intervals or the average height of the groundcover, whichever is the greater, of true elevation. Contours in such areas shall be indicated by dashed lines.

Any contour which can be brought within the specified vertical tolerance by shifting its plotter position **.033** inch shall be accepted as correctly plotted.

At least 90 percent of all spot elevations shall be within one-fourth the specified contour interval of their true elevation, and all spot elevations shall be within one-half the contour interval of their true elevation, except that for 5-foot contours 90 percent shall be within 1.0 foot and all shall **be** within 2.0 **feet**.

*Source: Brochure from Cartwright Aerial Surveys Inc.,
Sacramento, California.

vertical (elevation) errors are analyzed. Errors in horizontal cross-sectional coordinates are not considered significant,

3. The accuracy of hydrographic surveys for channel cross sections is taken to be the same as that used for the **overbank** or floodplain portions of the cross sections,

4. The magnitude and frequency of errors due to human mistakes in measurements or calculations (blunders), are not readily definable and are not considered. Blunders are largely negated through normal verification of measurements with other sources of data.

The probability density function for the aerial survey spot elevations and topographic maps may be estimated from the values specified in Table 5.2. Table 5.3 is a tabulation of the standard deviations for the selected contour intervals for both aerial spot elevations and topographic maps.

TABLE 5.3
Standard Deviations
Aerial Spot Elevations and Topographic Maps
(feet)

<u>Contour Interval</u>	<u>Standard Deviation Aerial Spot Elevations</u>	<u>Standard Deviation Topographic Maps</u>
2	0.30	0.60
5	0.60	1.50
10	1.50	3.00

Adjusting cross-sectional coordinate values for the Monte Carlo simulation for aerial spot elevation surveys is performed as follows:

1. Determine the standard deviation for the contour interval being evaluated (Table **5.3**),
2. Calculate the standard normal deviate by first generating a uniform distribution of random numbers varying from 0 to 1. Transform the values to represent the normal (Gaussian) distribution,
3. Calculate the random error for the cross-sectional coordinate elevation using the generated standard normal deviate and the standard deviation for the survey method and accuracy standard for the specified contour interval,
4. Add the random error to the base coordinate point elevation value,

5. Repeat 2. through 4. for all coordinate points and cross sections in the HEC-2 data set.

A similar process is followed for adjusting cross-sectional coordinate values associated with reading points from topographic maps. The difference is the addition of steps to simulate being able to read the map only at contour lines. Figure 5.4 contains cross-sectional adjustment examples.

MANNING'S COEFFICIENT ERRORS

Accurate estimation of Manning's coefficients is hampered by lack of observable field attributes and spatial variation along the stream. Reliable estimates of Manning's coefficients are difficult even with use of documented procedures, field reconnaissance, and calibration methods (Chow 1959 and Federal Highway Administration 1984).

Statistical information on Manning's coefficient estimation errors is largely nonexistent. Therefore, an experiment is devised to obtain the error probability density functions required for the Monte Carlo simulation. Staff of the Hydrologic Engineering Center and participants in two training courses attended by experienced Corps of Engineers hydraulic engineers are asked to estimate the Manning's coefficient associated with the 1-percent chance flow for 10 widely different stream reaches. The participants are given a photograph and description of each stream and a method for estimating Manning's coefficients from Open Channel Hydraulics (Chow 1959). Study experience significantly influenced the estimates of some participants, while others rely primarily on comparisons of photographs and descriptions provided in reference materials.

The experiment, though approximate in nature, provides insight into the variations possible in estimating Manning's coefficient. A few **outliers** are deleted and histograms of the estimations constructed for each of the 10 reaches. **Figure 5.5** contains plots for five of the stream reaches illustrating the variability of the estimates. The log-normal distribution provides the best fit to the histogram data and is therefore adopted to represent the probability density function of errors associated with estimating Manning's coefficient. The mean of the estimates of each of the 10 histograms is taken as the true coefficient value.

Review of the histograms indicates a greater variance of estimates for higher Manning's coefficient values than for lower coefficient values. Estimates of Manning's coefficient for concrete channels, for example, have less variance than those for a densely vegetated stream as one would expect since the range of possibilities is larger. A simple linear regression analysis developed a relationship for the standard deviation of errors as

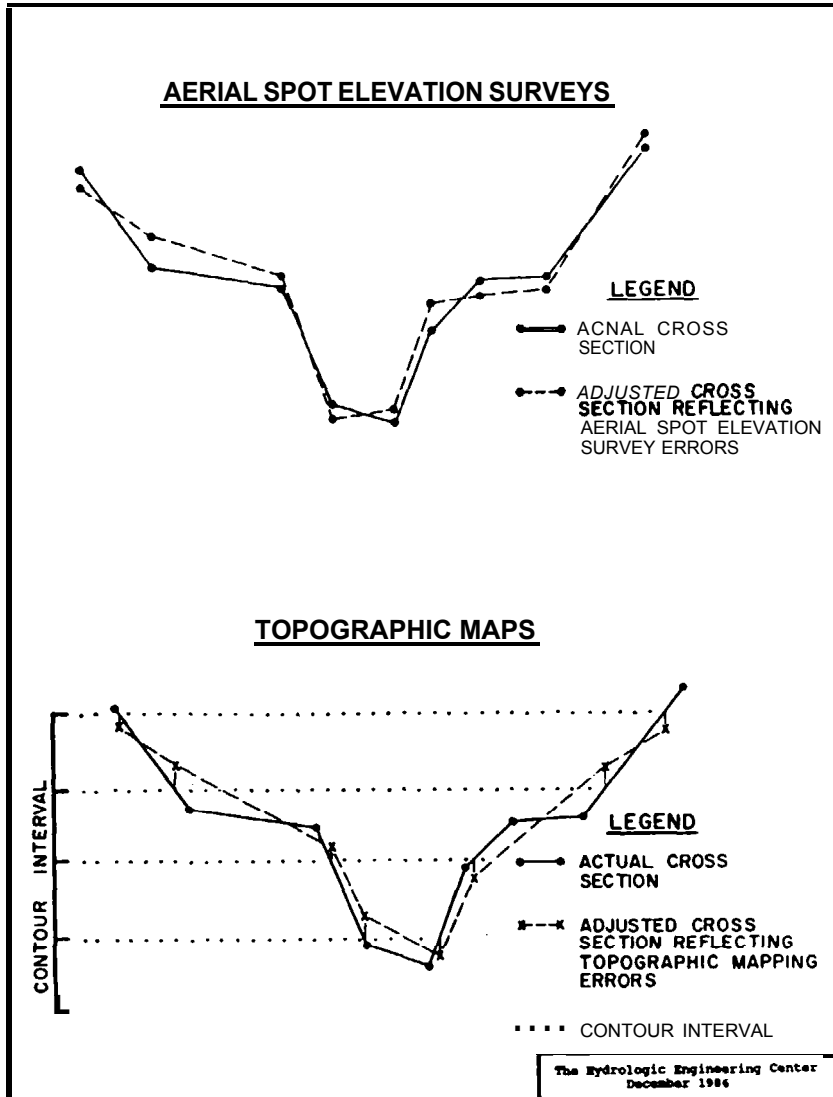

FIGURE 5.4 Cross Section Adjustment Examples

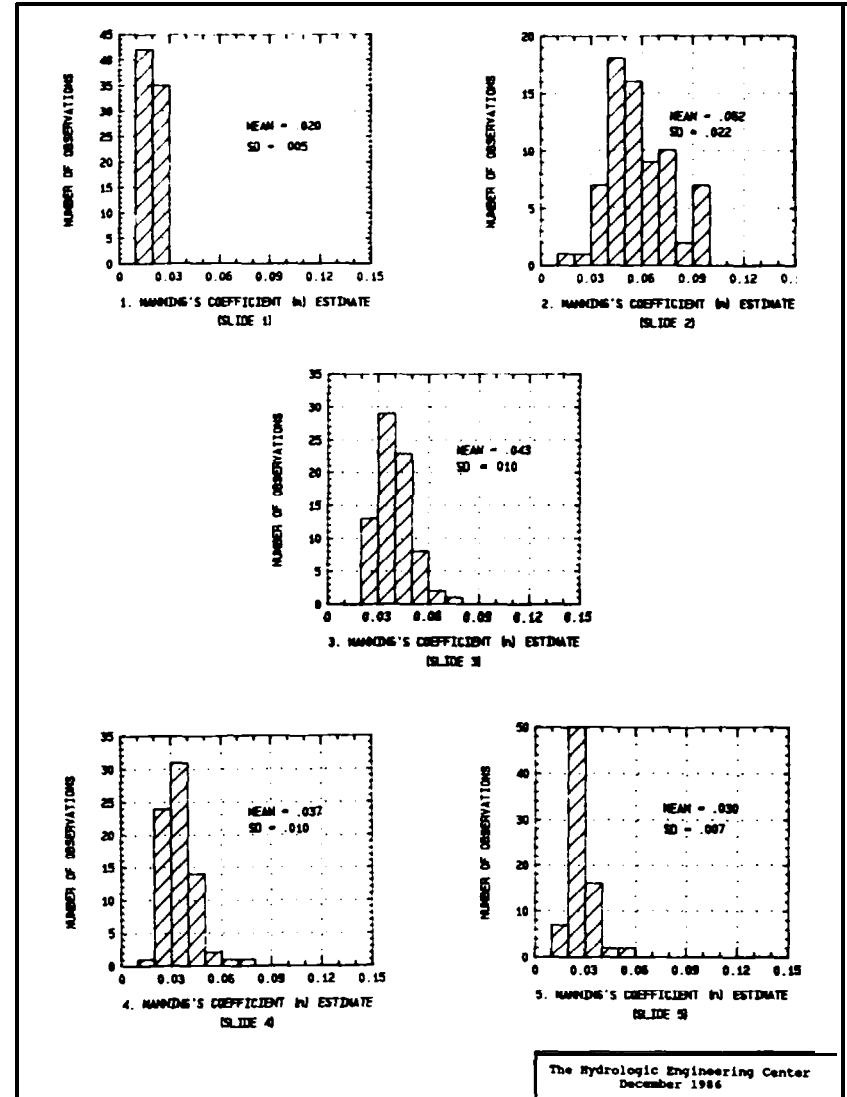

FIGURE 5.5 Manning's Coefficient Estimates

a function of the magnitude of the roughness coefficient.

The relationship represents an n-value estimate that would be representative of minimum effort based on professional judgment. It reflects estimates derived from photographs of a stream, a limited set of background and descriptive information, and made without interaction with other professionals. The other extreme is perfect knowledge of Manning's coefficient - no estimation error and no need for adjustment of the base coefficient values in the Monte Carlo simulation. This condition can be approached by skilled and **experienced** analysts using reliable calibration data. Most estimates used in practice for profile computations fall somewhere between these bounds.

A reliability coefficient (N_r) is postulated to enable numerical analysis of the error in Manning's n-value. N_r ranges from 0 to 1, where

$N_r = 0$, when the n-value is known exactly. This represents perfect confidence in the estimated value.

$N_r = .5$, when reasonable efforts are made to substantiate the estimate, but detailed, intensive calibration is not successful. Moderate confidence exists in the estimated value.

$N_r = 1.0$, when an approach similar to that tested in the experiment is used to estimate the coefficient. Modest confidence exists in estimated value.

The derived Manning's n-value error equation can be multiplied by the reliability coefficient to reflect the confidence of an n-value estimate. The procedure for randomly adjusting Manning's coefficient for the Monte Carlo simulation is:

1. The **overbank** and channel Manning's coefficients are retrieved from the base conditions **HEC-2** data files (they are contained on NC records),
2. The natural logarithms of the values are determined,
3. The reliability level (N_r) is selected and the associated Manning's coefficient standard deviation is computed,
4. A random normal standard deviate is generated. A single deviate is used to adjust the channel and **overbank** n-values simultaneously to simulate the likelihood of the estimates in practice to be consistently high or low at a specific location,
5. The adjusted Manning's coefficients are calculated by adding the product of the normal deviate and standard

deviation to the base condition n-value,

6. The adjusted Manning's coefficient is obtained by taking the antilog of the value calculated in 5. above,

7. Steps 1 through 6 are repeated for each set of Manning's coefficients in the data file (HEC-2 NC records).

COMPUTED PROFILE ERRORS

The specific error conditions analyzed are documented in Table 6.1. A total of 21 survey and Nr combination error conditions are analyzed for each of the 98 data sets. Processing these error conditions with the number of replicates needed to yield stable error statistics resulted in about 50,000 HEC-2 executions.

TABLE 6.1

Survey and Manning's Coefficient Error Conditions

Contour Interval (feet)	Reliability of Manning's Coefficient (Nr)		
	Field Surveys	Aerial spot Elevations	Topographic Maps
No Error	0, .5, 1.0	N.A.	N.A.
2	N.A.	0, .5, 1.0	0, .5, 1.0
5	N.A.	0, .5, 1.0	0, .5, 1.0
10	N.A.	0, .5, 1.0	0, .5, 1.0

Profile errors are computed as the absolute difference (in feet) between the base data set computed profiles and the adjusted data set computed profiles. The error calculations are made at the 500 foot interpolated **cross** section spacing. The reach mean absolute error is the sum of the absolute differences divided by the number of locations. The reach maximum absolute error is the largest absolute difference that occurs within the stream reach.

Cumulative frequency plots for the mean errors resulting from the Monte Carlo simulations for the 98 data sets were developed to display the range of errors generated in the analysis. Figures 6.2 and 6.3 present the frequency plots for both the mean absolute errors and maximum absolute errors at the extremes of Manning's coefficient reliability. Note that the errors are grouped in bands corresponding to the survey contour intervals. This indicates that the profile errors vary distinctly in magnitude with the 2-, **5-**, and 10-foot contour intervals. Note also that **as** Manning's n-value becomes less reliable, the

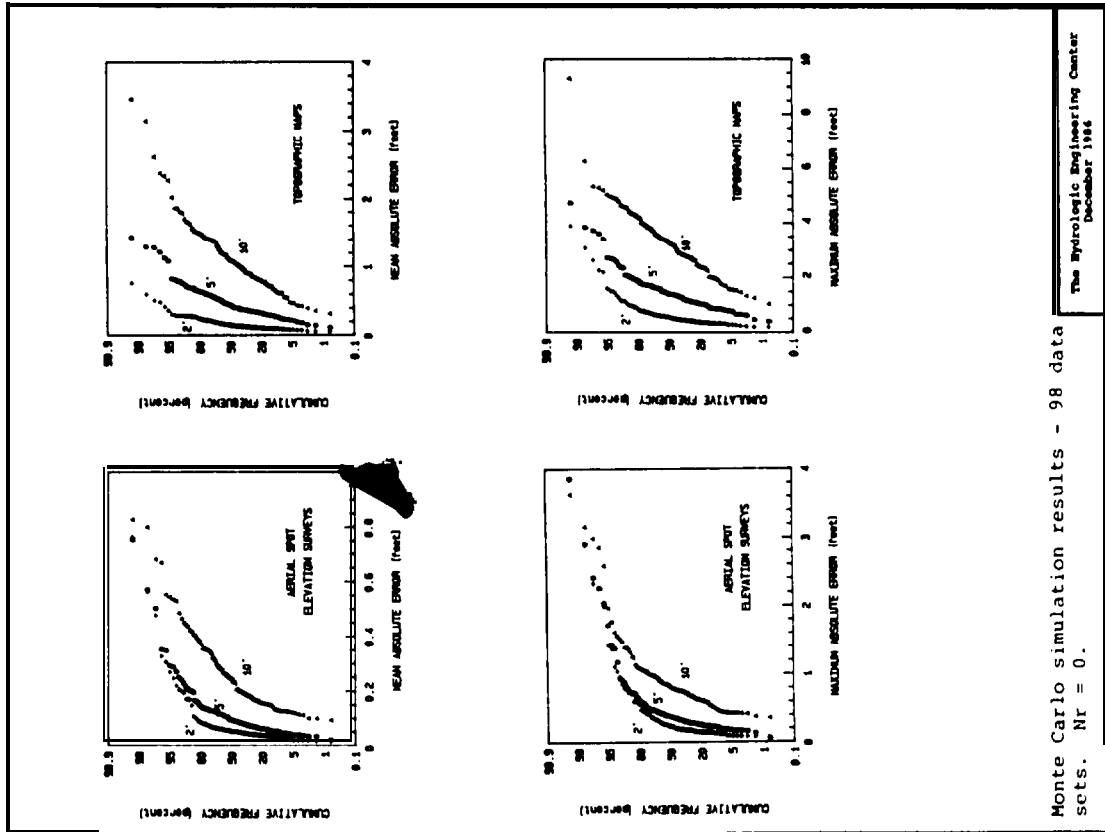

Monte Carlo simulation results - 98 data sets. $N_r = 0$.

FIGURE 6.2 Frequency of Profile Errors - High Reliability of Manning's Coefficient

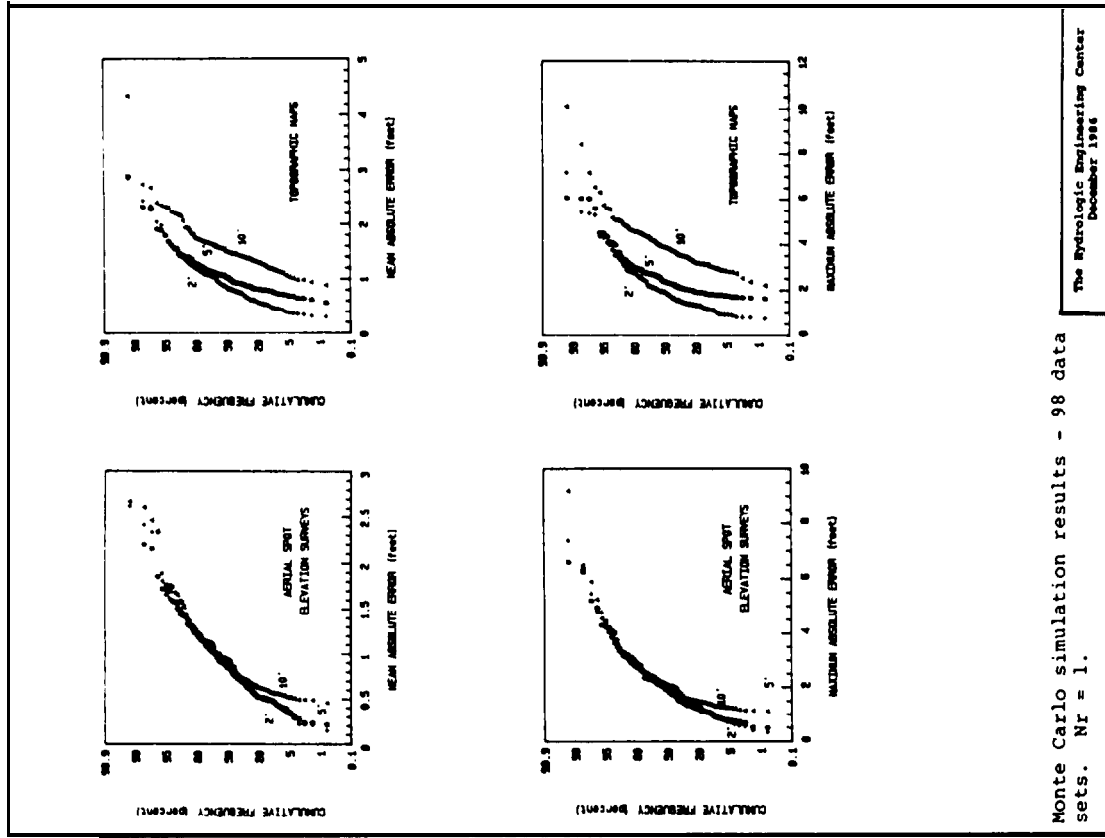

Monte Carlo simulation results - 98 data sets. $N_r = 1$.

FIGURE 6.3 Frequency of Profile Errors - Low Reliability of Manning's Coefficient

grouping into contour interval bands is less distinct.

Regression analyses are performed to develop equations for predicting the computed water surface profile error. The several hydraulic variables tested as explanatory variables include the 1-percent chance flow rate, Manning's coefficient, **cross-sectional** top width, hydraulic depth, and channel slope. Manning's coefficient, cross-sectional top width, and hydraulic depth are stream reach length weighted values. The dominant hydraulic variables are slope and hydraulic depth. A dimensionless term to account for joint variation in Manning's **n**-value confidence and contour interval is formulated for inclusion in the regression equation. Several combinations of dimensionless weighted coefficients are tested for this term and the best values selected.

The adopted regression equations derived for predicting computed profile errors for the three survey methods are tabulated below.

Field Surveys

$$E_{\text{mean}} = .076 * HD^{.60} * S^{.11} * (5 * N_r)^{.65} \quad (\text{Equation 6.3})$$

$$\text{and } E_{\text{max}} = 2.1 * (E_{\text{mean}})^{.8} \quad (\text{Equation 6.4})$$

where: E_{mean} = mean reach absolute profile error in feet,
 E_{max} = absolute reach maximum profile error in feet,
HD = reach mean hydraulic depth in feet,
S = reach average channel slope in feet per mile,
 N_r = reliability of estimation of Manning's coefficient on a scale of 0 to 1.0.

Aerial Spot Elevations

$$E_{\text{mean}} = .076 * HD^{.60} * S^{.11} * (5 * N_r + S_n)^{.65} \quad (\text{Equation 6.5})$$

$$\text{and } E_{\text{max}} = 2.1 * (E_{\text{mean}})^{.8} \quad (\text{Equation 6.6})$$

where: S_n = the standardized survey accuracy being analyzed - the contour interval 2-, 5-, ~~10~~-feet divided by 10; and other variables are as previously defined.

For the special case of Manning's coefficient being precisely known ($N_r = 0$),

$$E_{\text{mean}} = .0731 * S^{.49} * S_n^{.83} \quad (\text{Equation 6.7})$$

Topographic Maps

$$E_{\text{mean}} = .45 * HD^{.35} * S^{.13} * (N_r + S_n) \quad (\text{Equation 6.8})$$

and $E_{max} = 2.6*(E_{mean})^{.a}$ (Equation 6.9)

For the special case of Manning's coefficient being precisely known ($Nr = 0$),

$E_{mean} = .632*S^{.23}*S_n^{1.18}$ (Equation 6.10)

The goodness-of-fit of the regression equations can be expressed using the coefficient of determination and the standard error of regression. The coefficient of determination defines the proportion of the total variation of a dependent variable explained by the independent variables. For example, a value of 0.90 indicates that 90 percent of the variation is accounted for by the independent variables. The standard error of regression is the root-mean-square error. Table 6.2 summarizes the goodness-of-fit statistics for the adopted regression equations. Table 6.3 shows standard error values for selected profile accuracies.

The regression equations were adapted to nomographs to facilitate ease of use. Figures 6.5, and 6.7 are nomographs for aerial spot elevation survey and corresponding topographic map accuracies for Manning coefficient estimation reliabilities (Nr) of 0 and 1.0, respectively.

TABLE 6.2

Regression Analysis
Goodness-of-Fit Statistics

Statistic	Field and Aerial Spot Elevation Survey		Topographic Map	
	<u>Nr = 0</u>	<u>Nr > 0</u>	<u>Nr = 0</u>	<u>Nr > 0</u>
Coeff. of Deter- mination	.67	.68	.77	.64
Standard Error (Se) (log units, base 10)	.21	.17	.19	.20

TABLE 6.3

Profile Accuracy Prediction Reliability*
Aerial Spot Elevations Surveys

<u>Predicted Error (ft)</u>	<u>+1Se (ft)</u>	<u>-1Se (ft)</u>	<u>+2Se (ft)</u>	<u>-2Se (ft)</u>
.10	.15	.07	.21	.05
.30	.44	.20	.64	.14
.50	.73	.34	1.07	.23

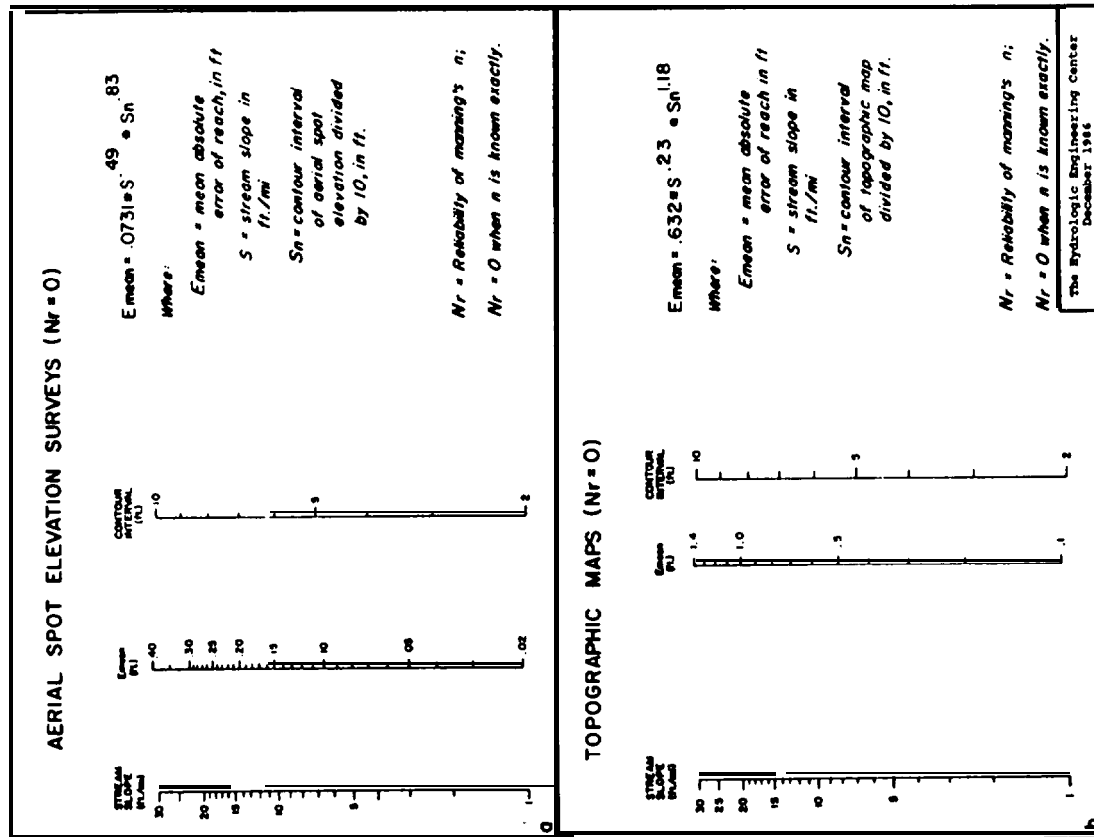

FIGURE 6.5 Profile Errors - High Reliability of Manning's Coefficients

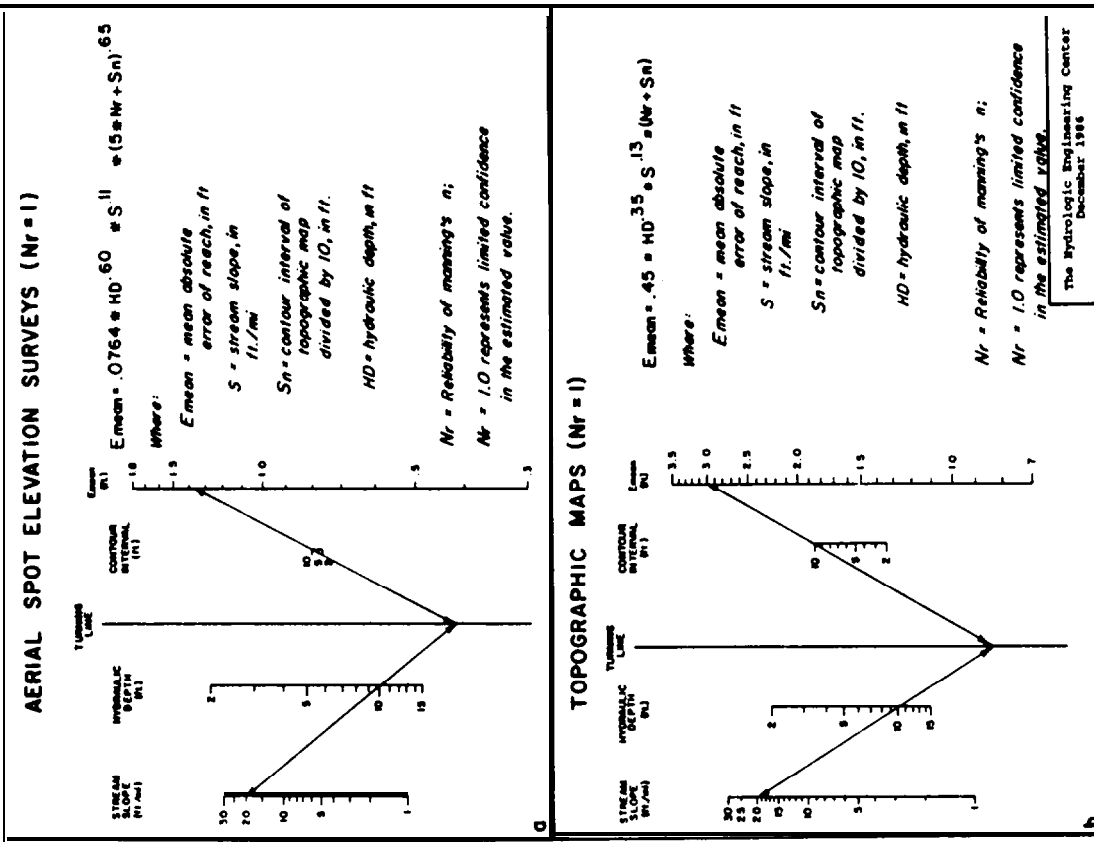

FIGURE 6.7 Profile Errors - Low Reliability of Manning's Coefficients

The Hydrologic Engineering Center
December 1986

TABLE 6.3 cntd
Topographic Maps

<u>Predicted Error (ft)</u>	<u>+1Se (ft)</u>	<u>-1Se (ft)</u>	<u>+2Se (ft)</u>	<u>-2Se (ft)</u>
.50	.79	.32	1.26	.20
1.00	1.58	.63	2.51	.40
1.50	2.38	.95	3.77	.60

* The values are the plus and minus limits.

SUMMARY OF PROFILE ERROR RESULTS

Profile errors resulting from use of commonly applied field survey methods of obtaining cross-sectional coordinate data are a function only of Manning's coefficient reliability. Computed profile error is relatively small even for rough estimates of Manning's coefficient. For example, for hydraulic depth of 5 feet and stream slope of 10 feet per mile, the predicted mean errors are 0, **.47**, and **.74** feet for reliability of Manning's n-value of 0, **.5**, and 1 respectively.

Profile errors resulting from use of aerial spot elevation surveys for obtaining cross-sectional coordinate data varies with the contour interval and reliability of Manning's n-value. For example, for hydraulic depth of 5 feet and stream slope of 10 feet per mile, the predicted mean errors for precisely known Manning's n-value is **.06**, **.13**, and **.22** feet for contour intervals of 2-, **5-**, and 10-feet respectively. Similarly, the predicted mean errors for low reliability of Manning's n-value (Nr = 1) are 0.75, 0.78, and 0.83 feet, respectively.

The relatively small profile error for the aerial spot elevation survey method is due to the high accuracy of aerial spot elevation surveys and the randomness of the measurement errors at the individual coordinate points. The latter results in compensating errors along the cross-sectional alignment. For the error prediction determined from the regression equations to be valid, eight or more cross-sectional coordinate points are needed to ensure that the randomness and thus compensatory error process has occurred.

Note also that the error in computed water surface profiles increase significantly with decreased reliability of Manning's coefficient. The profile errors resulting from less reliable estimates of Manning's coefficient are several times those resulting from survey measurement errors alone. Figure 6.7a readily shows the insignificant effect of survey contour intervals on the profile error when less reliable Manning's coefficients are used. For reliability of Manning's n-value of 1.0, the error in the computed water surface profiles will probably be **greater** than **.75** feet for stream reaches with

average slopes greater than 10 feet per mile regardless of the aerial spot survey contour interval.

There is significantly greater error for larger contour intervals for topographic maps than for aerial spot elevation surveys. Data from topographic maps are simply less accurate than data from spot elevation methods. Also, topographic map cross-sectional elevations can only be obtained at the contour intervals. For example, for the same values of hydraulic depth (5 feet), stream slope (10 feet per mile), and Manning's n-value reliability (0 and 1), respectively, the predicted mean errors are .16, 0.47, and 1.06 feet: and 1.28, 1.60, and 2.13 feet. Significant mean profile errors (greater than 2 feet) may be expected for analyses involving steep streams, large contour intervals, and unreliable estimates of Manning's coefficients.

TABLE 6.7
 SURVEY ACCURACY REQUIREMENTS¹
 FOR SPECIFIED PROFILE ACCURACIES
 (Hydraulic Depth is 5 Feet)

Stream Slope (ft./mi.)	Profile Accuracy E _{mean} (feet)	Manning's n-value Reliability - Nr = 0		Manning's n-value Reliability - Nr = 1	
		Aerial Survey Contour Interval	Topo Map Contour Interval	Aerial Survey Contour Interval	Topo Map Contour Interval
1	.1	10 foot	N.A.	N.A.	N.A.
1	.5	10 foot	5 foot	N.A.	N.A.
1	1.0	>10 foot	10 foot	10 foot	2 foot
1	1.5	>10 foot	10 foot	10 foot	5 foot
1	2.0	>10 foot	10 foot	>10 foot	10 foot
10	.1	2 foot	N.A.	N.A.	N.A.
10	.5	10 foot	5 foot	N.A.	N.A.
10	1.0	10 foot	5 foot	10 foot	N.A.
10	1.5	>10 foot	10 foot	10 foot	2 foot
10	2.0	>10 foot	10 foot	10 foot	5 foot
30	.1	2 foot	N.A.	N.A.	N.A.
30	.5	10 foot	2 foot	N.A.	N.A.
30	1.0	10 foot	5 foot	10 foot	N.A.
30	1.5	>10 foot	10 foot	10 foot	2 foot
30	2.0	>10 foot	10 foot	10 foot	5 foot

¹Denotes maximum survey contour interval to produce desired accuracy.
²E_{mean} is mean absolute reach error.

The error prediction equations may be used to determine the mapping required to achieve a desired computed profile accuracy. Table 6.7 is an example for selected stream slopes and N_r values of 0 and 1.0, and for a hydraulic depth of 5 feet. The table shows that a 10 foot contour interval for aerial spot elevations is sufficient except for mean profile errors of less than .1 feet for steep streams. Similar tables for other conditions may be developed from the nomographs or equations .

UPSTREAM AND DOWNSTREAM STUDY LIMITS

Establishment of the upstream and downstream study boundaries for profile calculations are required to define limits of data collection and subsequent analysis. Calculations must be initiated sufficiently far downstream to assure accurate results at the structure, and continued sufficiently upstream to accurately determine the impact of the structure on upstream water surface profiles. Underestimation of the upstream and downstream study lengths may produce less than desired accuracy of results and eventually require additional survey data at higher costs than could be obtained with initial surveys. On the other hand, significant over-estimation of the required study length can result in greater survey, data processing, and analysis costs than necessary.

The downstream study length is governed by the effect of errors in the starting water surface elevation on the computed water surface elevations at the structure (see Figure 7.1). When possible, the analysis should start at a location where there is either a known (historically recorded) water surface elevation or a downstream control where the profile passes through critical depth. Observed downstream high water marks are relatively common for calibration of models to historical events, but are unlikely to be available for evaluations of hypothetical events such as the 1-percent chance event. Alternative starting elevations are needed for stream conditions where high water marks and control locations are nonexistent or are too far downstream to be applicable. Two commonly applied starting criteria are critical depth and normal depth. The starting location should be far enough downstream so that the computed profile converges to the base (existing condition) profile prior to the bridge location.

The upstream study length is the distance to where the profile resulting from a structure-created **headloss** converges with the profile for the undisturbed condition. The magnitude of profile change and the upstream extent of the structure-induced disturbance are two of the primary criteria used to evaluate the impacts of modified or new structures.

Regression analyses were performed to develop prediction equations for determining study limits. HEC-2 base data sets were run for a variety of starting conditions and structure

headloss values. The results were then used in the regression analysis. The resulting equations and associated nomographs provide the capability for determining the extent of required survey and mapping and other hydraulic parameter data collection.

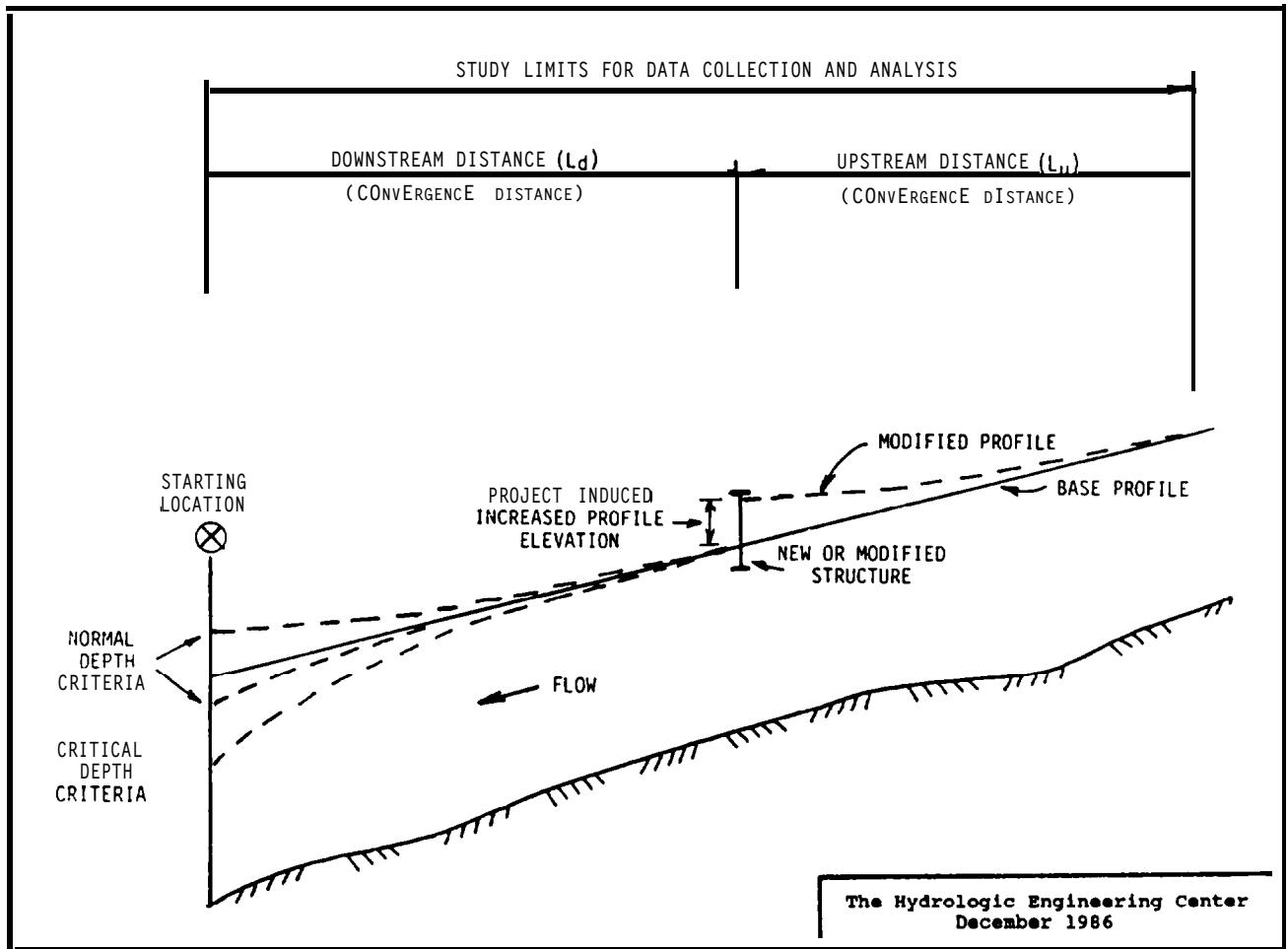

FIGURE 7.1 Profile Study Limits

The adopted regression equations are:

$$L_{dc} = 6600 \cdot HD / S \quad (\text{Equation 7.1})$$

$$L_{dn} = 8000 \cdot HD^{\cdot 8} / S \quad (\text{Equation 7.2})$$

$$L_u = 10,000 \cdot HD \cdot 6 \cdot HL_05 / S \quad (\text{Equation 7.3})$$

where: **L_{dc}** = downstream study length (along main channel) in feet for critical depth starting conditions,
L_{dn} = downstream study length (along main channel) in feet for normal depth starting conditions,
HD = average reach hydraulic depth (1-percent chance flow area divided by cross section top width) in feet,
S = average reach slope in feet per mile, and

HL = **headloss** ranging between **.5** and 5.0 feet at the channel crossing structure for the 1-percent chance flow.

The equations were converted to nomographs to present the results in a convenient form. Figures 7.4 and 7.5 are the nomographs for downstream normal depth starting conditions and upstream reach length, respectively.

The goodness-of-fit of the regression equations can be expressed using the coefficient of determination and the standard error of regression. The coefficients of determination for equations 7.1, 7.2, and 7.3 are **.89**, **.83**, and **.90** respectively. The standard errors of regression for the three equations are 0.26, 0.22, and 0.18 (in log units), respectively.

SUMMARY AND CONCLUSIONS

Aerial Survey and Topographic Map Accuracy. Stream **cross-sectional** geometry obtained from aerial surveys (aerial spot elevations and topographic maps) that conform to mapping industry standards are more accurate than is often recognized. **Cross-sectional** geometry obtained from the aerial spot elevation surveys is about twice as accurate as cross-sectional geometry obtained from topographic maps derived from aerial surveys for the same contour interval.

Profile Accuracy Prediction. The effect of aerial spot elevation survey or topographic mapping accuracy on the accuracy of computed water surface profiles can be predicted using the mapping industry accuracy standards, reliability of **Mannings's** coefficient, and stream hydraulic variables.

Manning's Coefficient Estimates. The reliability of the estimation of Manning's coefficient has a major impact on the accuracy of the computed water surface profile. Significant effort should be devoted to determining appropriate Manning's coefficients.

Additional Calculation Steps. Significant computational errors can result from using cross-sectional spacings that are often considered to be adequate. The errors are due to inaccurate integration of the energy loss-distance relationship that is the basis for profile computations. This error can be effectively eliminated by adding interpolated cross sections (more calculation steps) between surveyed sections.

Aerial Survey Procedures. Aerial spot elevation survey methods are generally more cost effective than field surveys when more than 15 survey cross sections are required. Use of aerial spot elevation survey technology permits additional coordinate points and cross sections to be obtained at small incremental cost. The coordinate points may be formatted for direct input to commonly used water surface profile computation computer programs.

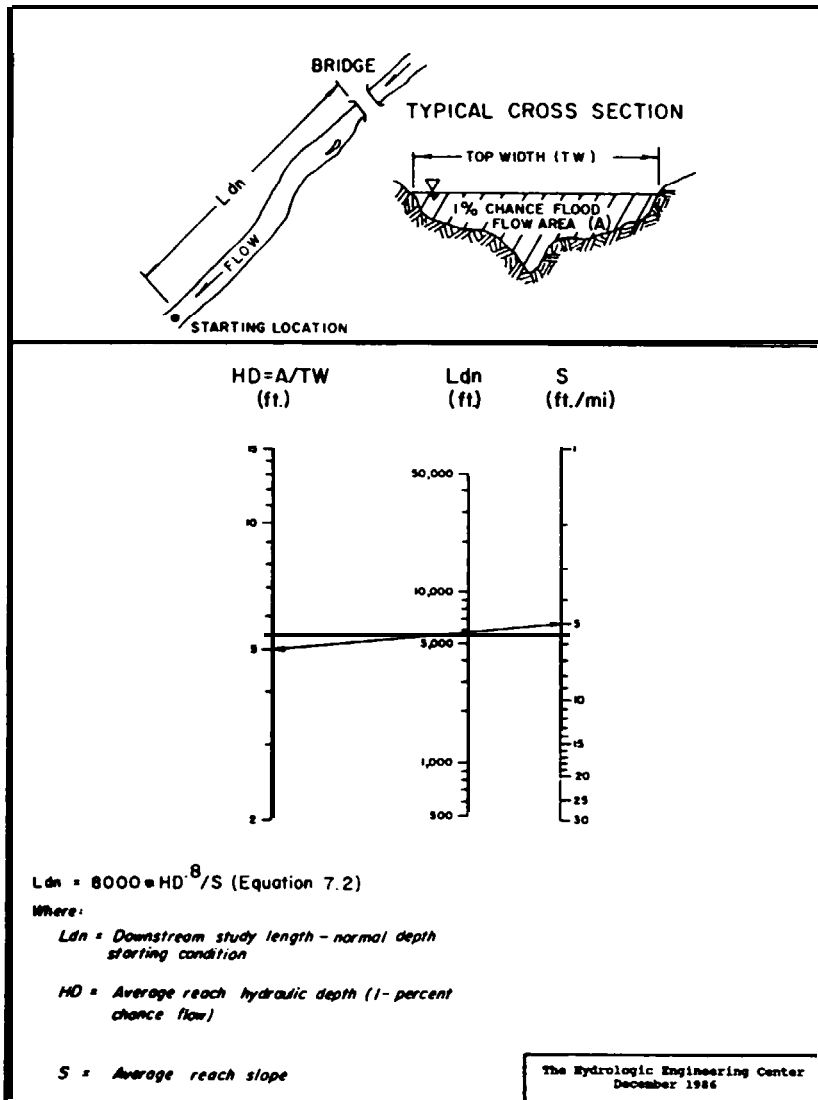

FIGURE 7.4 Downstream Reach Length Estimation - Normal Depth Criterion

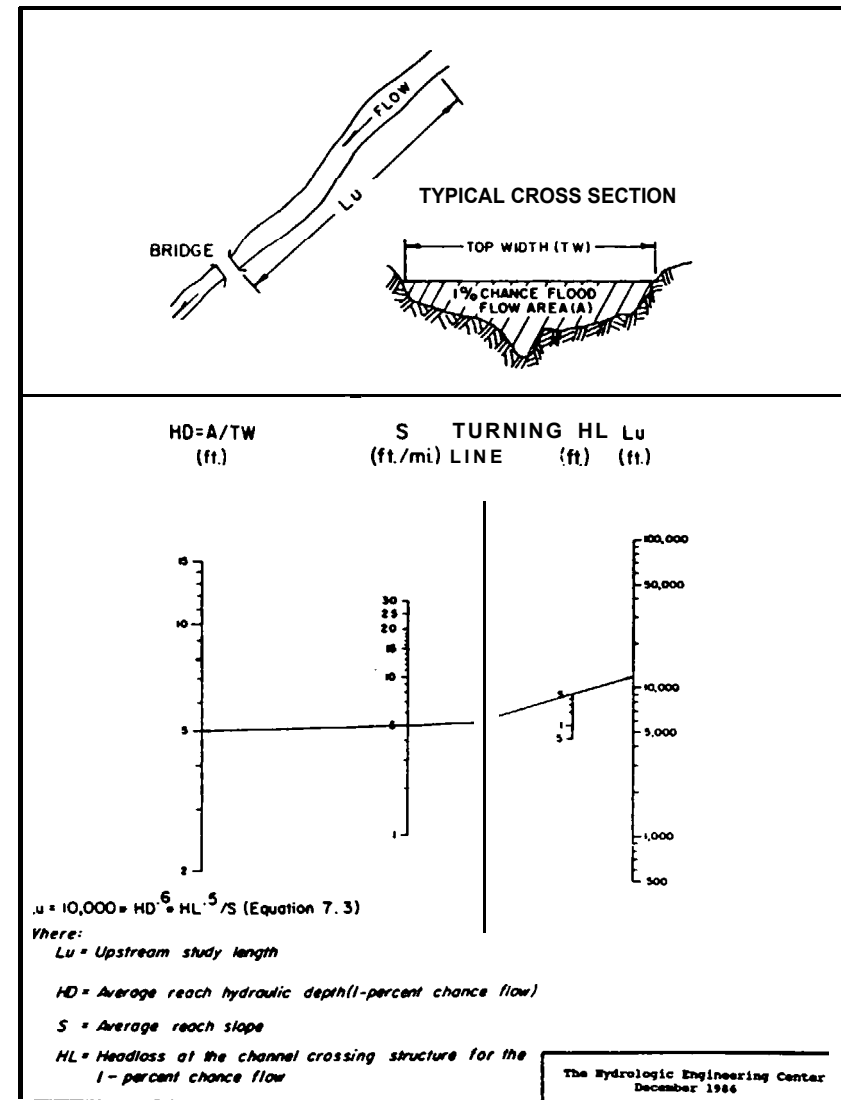

FIGURE 7.5 Upstream Reach Length Estimation

PREFACE

The Accuracy of Computed Water Surface Profiles study was performed by the Hydrologic Engineering Center (HEC), Water Resources Support Center, U.S. **Army** Corps of Engineers, Davis, California, **for** the Federal Highway Administration, Department of Transportation.

This document describes the results of an investigation of the effects of using survey **and** mapping technology for determining cross-sectional coordinate geometry and the reliability of Manning's roughness (n-value) coefficient on the accuracy of computed water surface profiles. The objective of the investigation is to develop a method for determining the needed survey and Manning's n-value accuracy in order to obtain a desired profile accuracy. **A** related aspect **of** the study was the development **of** a method for estimating upstream and downstream study limits needed for data collection for subsequent profile computations.

The research study was conducted by Michael **Burnham**, project manager, under the direction of Darryl Davis, Chief, Planning Division, the **HEC**. Robert Carl, also of the Planning Division, contributed significantly by developing the data processing strategy, and subsequent analysis of the over 50,000 computer program executions required for the study. **Alfredo** Montalvo provided valuable insights and assistance early in the study and John Peters offered excellent technical advice throughout. Keith Nelson and Barbara Bauer, University of California student interns, performed most of the data editing tasks. Ms. Bauer also performed the data processing associated with the statistical error analyses. Kimberly Powell and Beverly Porter typed the final report. Bill S. **Eichert** was Director **of** the HEC during the conduct of the study.

Several consultants provided valuable assistance in the study and warrant special acknowledgment. Dr. Dennis McLaughlin, Massachusetts Institute of Technology, formulated the basic Monte Carlo approach and assisted as a consultant throughout the investigation. John Buckley **of** Borcalli, Ensign, and Buckley Consulting Engineers, Sacramento, California, prepared the Commercial Survey Guidelines for Water Surface Profiles document which clarified survey techniques and defined survey accuracies and costs. This document is published separately. Don Johnson of Cartwright Aerial Surveys Inc., Sacramento, California, provided important insights into the technology of aerial photography and the associated accuracies and costs.

The guidance and suggestions offered by the contract manager, Roy Trent, Offices of Research, Development and Technology, and by Stan Davis, Chief of the Hydraulics Branch, Federal Highway Administration are greatly appreciated. Also, Mainard **Wacker** of State of Wyoming Department of Transportation provided helpful comments. The encouragement and efforts of these gentlemen made this project a satisfying and pleasurable undertaking.

TABLE OF CONTENTS

	<u>Page</u>
PREFACE	i
TABLE OF CONTENTS.	iii
CHAPTER 1: INTRODUCTION	1
1-1. Study Background and Purpose	1
1-2. Profile Computations	1
1-3. Error Analysis	2
1-4. Summary of Findings.	3
1-5. Report Organization	4
CHAPTER 2: WATER SURFACE PROFILE CALCULATION CONCEPTS.	7
2-1. General Overview	7
2-2. Open Channel Flow Concepts	7
2-2.1. Basic Concepts.	7
2-2.2. Steady, Uniform, and Non-uniform Flow	8
2-2.3. Flow Continuity	8
2-3. Energy Equation.	10
2-3.1. Derivation of Equations	10
2-3.2. Manning's Equation.	12
2-3.3. Expansion and Contraction Losses	12
2-4. Step-Profile Analysis	13
2-4.1. Analysis Concepts	13
2-4.2. Analysis Assumptions	13
2-4.3. Friction Loss	14
2-4.4. Cross-Sectional Location Criteria	17
2-4.5. Computational Procedure	17
2-5. Profile Analysis Errors	18
CHAPTER 3: PROFILE ACCURACY ANALYSIS STRATEGY	21
3-1. General Approach	21
3-2. Monte Carlo Simulation Concepts.	21
3-3. Methodology.	21
3-4. Data Management and Processing Overview.	24
3-4.1. General	24
3-4.2. Procedural Summary.	24
CHAPTER 4: ESTABLISHMENT OF BASE CONDITIONS	27
4-1. overview	27
4-2. Data Collection	27
4-3. Data Editing	27
4-4. Analysis Reach Determination	28
4-5. Friction Loss Criteria	30
4-5.1. Overview	30
4-5.2. Cross-Sectional Interpolation	30
4-6. Base Condition Data Sets	32

TABLE OF CONTENTS (continued)

	<u>Page</u>
CHAPTER 5: QUANTIFYING POTENTIAL ERRORS IN SURVEYS AND MANNING'S COEFFICIENT.	37
5-1. General Approach	37
5-2. Survey Methods and Accuracy	37
5-2.1. General	37
5-2.2. Field Surveys	37
5-2.3. Aerial Photogrammetry	40
5-2.4. Hydrographic Surveys	42
5-3. Survey Error Analysis	44
5-3.1. Survey Errors	44
5-3.2. Derivation of Error Probability Density Functions	45
5-3.3. Cross-Sectional Error Generation	45
5-3.4. Example Cross-Sectional Adjustment	46
5-4. Manning's Coefficient Errors	48
5-4.1. Overview	40
5-4.2. Derivation of PDF	48
5-4.3. Reliability of Estimates	50
5-4.4. Manning's Coefficient Adjustments	54
5-4.5. Summary.	55
CHAPTER 6: PROFILE ACCURACY ANALYSIS.	57
6-1. General	57
6-2. Error Calculation Procedure	57
6-3. Profile Replicates.	58
6-3.1. General	58
6-3.2. Replicate Approach	58
6-4. Regression Analyses	63
6-4.1. Regression Analysis Variables	63
6-4.2. Field Surveys.	64
6-4.3. Aerial Spot Elevations	64
6-4.4. Topographic Maps	65
6-5. Reliability of Results	65
6-6. Nomograph Adaptation.	67
6-7. Summary of Profile Error Results	67
6-7.1. Field Survey Results	67
6-7.2. Aerial Spot Elevation Results.	67
6-7.3. Topographic Map Results	71
6-7.4. Summary.	72
CHAPTER 7: DELINEATION OF STUDY BOUNDARIES FOR WATER SURFACE PROFILE ANALYSIS	77
7-1. General Concepts	77
7-2. Regression Analysis	79
7-2.1. General Procedures	79
7-2.2. Hydraulic Variables	79

TABLE OF CONTENTS (continued)

	<u>Page</u>
CHAPTER 7: DELINEATION OF STUDY BOUNDARIES FOR WATER	
SURFACE PROFILE ANALYSIS (continued)	
7-2.3. Downstream Reach Length	83
7-2.4. Upstream Reach Length	83
7-3. Reliability of Results	83
7-4. Nomograph Adaptation	85
CHAPTER 8: APPLICATION OF DERIVED PROCEDURES.	91
8-1. Application Overview.	91
8-2. Preliminary Assessments	91
8-2.1. General.	91
8-2.2. Study Detail Factors	91
8-2.3. Review of Previous Study Data.	92
8-2.4. Field Reconnaissance	92
8-3. Hydraulic Variable Estimation	93
8-3.1. Overview.	93
8-3.2. Cross-Sectional Layout	93
8-3.3. One-Percent Chance Flow.	93
8-3.4. Manning's Coefficient.	94
8-4. Delineation of Profile Analysis Limits.	94
8-5. Cost Effective Analyses of Survey Methods	95
APPENDICES:	
A. FLOODPLAIN REGULATORY POLICIES	103
B. EXAMPLE CROSS-SECTIONAL AND PROFILE REPLICATES	113
c. PROFILE ERROR SUMMARIES.	125
D. DATA MANAGEMENT PROCEDURES (BOUND SEPARATELY)	

TABLES

	<u>Page</u>
4.1 HEC-2 Data Editing Actions	29
4.2 Hydraulic Variables - Base Data Sets	33
5.1 Field Surveys Vertical (Elevation) Accuracy	41
5.2 Aerial Survey Procedures Vertical (Elevation)	
Accuracy	43
5.3 Standard Deviations of Spot Elevations and	
Topographic Maps	45
5.4 Manning's Coefficient Experiment Form	49
6.1 Survey and Manning's Coefficient Error Conditions	57

TABLES (continued)

	<u>Page</u>
6.2 Profile Accuracy Regression Analysis Goodness- of-Fit Statistics	66
6.3 Profile Accuracy Prediction Reliability	66
6.4 Field Survey Water Surface Profile Errors	71
6.5 Aerial Survey Method Effect on Water Surface Profile Accuracy	72
6.6 Topographic Map Effect on Water Surface Profile Accuracy	73
6.7 Survey Accuracy Requirements for Specified Profile Accuracies	74
7.1 Study Limit Analysis Summary	80
7.2 Study Length Regression Analysis Goodness-of-Fit Statistics	84
7.3 Study Length Adjustments for One Standard Error (Se) of Estimate.	84
8.1 Example Survey Cost Comparisons	98

FIGURES

	<u>Page</u>
2.1 Profile Transition Curves for Mild Slopes	9
2.2 Water Surface Profile Computation Diagram	11
2.3 Friction Slope Analysis Concepts	15
2.4 Energy Equation Integration Concepts'	16
3.1 Profile Accuracy Analysis Strategy.	22
3.2 Overview of Data Processing	25
4.1 Discharge-Slope Scatter Diagram	28
4.2 Profiles Using Alternative Friction Equations	31
4.3 Cross-Sectional Interpolation	32
4.4 Stream Characteristics of Base Data Sets.	35
5.1 Cross-Sectional Concepts.	38
5.2 Field Survey Concepts	39
5.3 Hydrographic Survey Concepts.	44
5.4 Cross Section Adjustment Examples	47
5.5 Manning's Coefficient Estimates	51
5.6 Manning's Coefficient vs. Standard Deviation	53
6.1 Profile Error Computation	59
6.2 Frequency of Profile Errors - High Reliability of Manning's Coefficients	60

FIGURES (continued)

	<u>Page</u>
6.3 Frequency of Profile Errors - Low Reliability of Manning's Coefficient ⁶	61
6.4 Replicate Profile Error Analysis	62
6.5 Profile Errors - High Reliability of Manning's Coefficients	68
6.6 Profile Errors - Moderate Reliability of Manning's Coefficients	69
6.7 Profile Errors - Low Reliability of Manning's Coefficients	70
7.1 Profile Study Limits	78
7.2 Study Distance Analysis Concepts	82
7.3 Downstream Reach Length Estimation - Critical Depth Criterion	86
7.4 Downstream Reach Length Estimation - Normal Depth Criterion	87
7.5 Upstream Reach Length Estimation	88
8.1 Survey Cost Estimate Example	97

CHAPTER 1

INTRODUCTION

1-1. Study Background and Purpose

Water surface profiles are computed for a variety of technical uses. Profiles are computed for flood insurance studies, flood hazard mitigation investigations, drainage crossing analyses, and other similar design needs. Tens of thousands of profile analyses are performed each year. The accuracy of the resulting computed profiles has profound implications. In the case of flood insurance studies, the computed profile is the determining factor of the acceptability of parcels of land for development. For flood control projects, the water surface elevation is important in planning and design of project features and for determining the economic feasibility of proposed solutions. For highway stream crossings, the computed profile can affect bridge design and is the mechanism for determining the effect of a bridge crossing on upstream water levels. The accuracy of computed profiles is thus of major interest to the water resources community. Similarly, with the large number of studies performed each year, the cost of acquiring essential data, such as cross-sectional geometry, is significant. The relationship between mapping **accuracy** and resultant computed profile accuracy is therefore of major interest to engineers responsible for providing cost-effective technical analysis.

The study has two separate components. The first component develops equations for predicting the effects of cross-sectional survey method and accuracy (field **surveys**, aerial spot elevation surveys, and topographic maps) and uncertainty in Manning's coefficient on the accuracy of the computed water surface profiles. The second component develops equations to estimate the upstream and downstream study limits needed for data collection and analysis to enable accurate profile analysis to be performed in the vicinity of a highway stream crossing.

1-2. Profile Computations

The water surface profile for the significant majority of streams can be computed using the step-profile (standard-step) method for steady flow. The method is based on solving the steady flow equations using a cross section to cross section, step by step procedure. Errors associated with computing water surface profiles with the step-profile method can be classified as basic theory, computation, or data estimation errors (**McBean** 1984). The applicability of the theory is the responsibility of the professional engineer. Computation **errors** include numerical round-off and numerical solution errors. The former is negligible

using today's modern computers and the latter can be minimized by employing readily available mathematical solution techniques. Data estimation errors may result from incomplete or inaccurate data collection and inaccurate data estimation. The sources of data estimation errors are the accuracy of the stream geometry and the accuracy of the method used and data needed for energy loss calculations. The accuracy in stream geometry as it affects accuracy of computed profiles is therefore of importance. The accuracy of energy loss calculations depends on the validity of the energy loss equation employed and the accuracy of the energy loss coefficients. The Manning equation is the most commonly used open channel flow equation and the coefficient measuring boundary friction is Manning's n-value.

This investigation focuses on determining the relationship between

- (1) survey technology and accuracy employed for determining cross-sectional geometry,
- (2) degree of confidence in Manning's coefficient, and
- (3) the resulting accuracy of the computed water surface profile.

A second component of the study develops equations that may be used to estimate the upstream and downstream study limits needed for data collection and analysis to ensure that accurate profile analysis is performed in the vicinity of a highway stream crossing. The HEC-2 Water Surface Profiles computer program (Hydrologic Engineering Center 1982) is the computational tool used to compute the profiles for the investigation.

1-3. Error Analysis

The strategy adopted for the investigation was to assemble an array of existing HEC-2 data sets, adjust the data sets in a carefully controlled manner and observe the error effects. The error effects may then be determined by comparing the profiles computed for the adjusted data sets with the profiles computed for the original data set. The data adjustment strategy is that of Monte Carlo simulation, which incorporates within its methodology, the interaction among the several sources of error. Probability density functions are derived that define the error distributions for survey cross-sectional measurements and Manning's roughness coefficients. Error analyses **are** performed for conventional field surveys, and 2-, **5-**, and 10-foot contour interval aerial spot elevation survey and topographic maps derived from aerial surveys. Three levels of reliability of Manning's roughness coefficient are studied, varying from n-values selected through professional judgement to accurately calibrated n-values based on observed historical profiles.

Comparison of computed base condition profiles and Monte Carlo simulation profiles enables calculation of mean absolute and maximum absolute errors for each stream reach and error condition. Regression equations are derived for predicting profile error as a function of survey technology, selected accuracy, Manning's roughness coefficient and stream hydraulic properties.

Regression equations are developed for estimating the upstream and downstream distances from a highway stream crossing that are needed for data collection and water surface profile analysis. Profile calculation data are needed downstream to assure that any initial profile error does not impact on the profile at the crossing. Profile calculation data are needed upstream a distance **equal** to the estimated convergence location of the profile resulting from stream crossing structure headloss.

The collection of HEC-2 input records from completed Corps of Engineers studies yielded 140 HEC-2 data sets. Of these, 98 were ultimately used in the analysis. Over 50,000 HEC-2 program executions were required to generate the profiles needed to analyze the stream data sets for all desired error conditions.

Several important study bounds were adopted to ensure consistency in decisions involving data processing and analysis strategy, and to confine the investigation to a manageable set of issues. The study bounds are listed below.

- (1) The discharge (flow rate) corresponding to the 1-percent chance flow is used and errors in discharge values are not considered.
- (2) The HEC-2 Water Surface Profiles computer program is used for all water surface profile computations. The program is applicable for natural stream geometry, **one-**dimensional, gradually varied, rigid boundary steady flow conditions.
- (3) Only subcritical flow conditions **are** evaluated.
- (4) The incremental error contributed by the impact of local features (bridges, culverts, dams, and radical bends in **streams**) are not considered.

1-4. Summary of Findings

The major findings of the research study are:

- (1) Aerial Survey and Topographic Map Accuracy. Stream cross-sectional geometry obtained from aerial surveys (aerial spot elevations and topographic maps) that conform to mapping industry standards are more accurate than is often recognized. Cross-sectional geometry obtained from aerial spot elevation surveys **is about**

twice as accurate as cross-sectional geometry obtained from topographic maps derived from aerial surveys for the same contour interval.

- (2) Profile Accuracy Prediction. The effect of aerial spot elevation survey or topographic mapping accuracy on the accuracy of **computed** water surface **profiles** can be predicted using the mapping industry accuracy standards, reliability of **Mannings's** coefficient, and stream hydraulic variables.
- (3) Manning's Coefficient Estimates. The reliability of the estimation of Manning's coefficient has a major impact on the accuracy of the computed water surface profile. Significant effort should be devoted to determining appropriate Manning's coefficients.
- (4) Additional Calculation Steps. Significant computational errors can result from using cross-sectional spacings that are often considered to be adequate. The errors are due to inaccurate integration of the energy **loss-distance** relationship that is the basis for profile computations. This error can be effectively eliminated by adding interpolated cross sections (more calculation steps) between surveyed sections.
- (5) Aerial Survey Procedures. Aerial spot elevation survey methods are generally more cost effective than field surveys when more than 15 survey cross sections are required. Use of aerial spot elevation survey technology permits additional coordinate points and cross sections to be obtained at small incremental cost. The coordinate points may be formatted for direct input to commonly used water surface profile **computation** computer programs.

1-5. Report Organization

The report includes an executive summary, preface, an introductory chapter, eight chapters that describe the study methodology and results, and several appendices. Chapter 2 describes selected aspects of open channel hydraulics and concepts of water surface profile computations. Chapter 3 provides a detailed description of the research strategy. Chapter 4 describes the stream profile data sets that were gathered, editing that was performed on the data sets, and documents the adopted base condition data sets. Chapter 5 describes the source and nature of errors in cross-sectional geometry and Manning's coefficient. Chapter 6 describes the error analysis and presents the results of this portion of the investigation. Chapter 7 describes the study limit analysis **for** estimating the upstream and downstream study limits. Chapter 8 summarizes and references a

suggested approach for locating and collecting data for water surface profile calculations. A brief example is presented.

The main report is supplemented by four Appendices and a separate report. Appendix A describes the Federal Insurance Administrations's regulatory policies applicable to water surface profile analyses for highway stream crossings. Appendix B illustrates adjustments to cross sections and profiles based on the Monte Carlo simulation technique. Appendix C provides a listing of the error analysis results. Appendix D, Data Management Procedures, bound separately, describes in detail the data management and processing applied throughout the analysis. Also, bound separately is Commercial Survey Guidelines for Water Surface Profiles which documents the survey technology appropriate for determining the natural stream geometry.

REFERENCES CITED

1. Hydrologic Engineering Center 1982 (reprint May 1985), HEC-2 Water Surface Profiles, User's Manual, U.S. Army Corps of Engineers.
2. **McBean**, Edward and Penel, Jacques 1984, "**Uncertainty** Analysis of Delineated **Floodplain**", Canadian Journal of Civil Engineering 71, 385-387.

CHAPTER 2

WATER **SURFACE** PROFILE CALCULATION CONCEPTS

2-1. General Overview

Computation **of** a water surface profile for a natural stream is a complex task. The present, generally accepted method of calculating the water surface profile is based on several important simplifying assumptions. The water surface profile for the significant majority of streams can be computed using the step-profile (standard-step) method **for steady** flow (U.S. **Army** Corps of Engineers 1959). The widely applied HEC-2 computer program is based on this method. The method is a finite difference solution of the differential form of the energy equation written between successive natural stream cross sections. The importance of the basis for the method of solving a differential equation using a numerical approximation approach will become apparent later in this report.

This chapter presents basic concepts of open channel hydraulics relevant to water surface profile calculations. Emphasis is on the uncertainties associated with applying the concepts when performing the calculations. The material is not intended as a complete treatise on the subject but is intended to highlight important concepts relevant to this study. More complete descriptions of open channel flow hydraulics may be found in several well recognized publications such as Open Channel Hydraulics (Chow **1959**), Open Channel **Flow**, (Henderson **1966**), Computation of Water-Surface Profiles in Open Channels (U.S. Geological Survey **1984**), Backwater Curves in River Channels (U.S. Army Corps of Engineers **1959**), and IHD Volume 6 Water Surface Profiles (The Hydrologic Engineering Center 1975).

2-2. Open Channel **Flow** Concepts

2-2.1. Basic Concepts. Flow in a natural river changes with time; the rate of change depends on the size **of** the stream, the season of the year, and many other factors. The flow pattern is typically three-dimensional with a single dimension adequate to describe the flow field. Many streams flow on alluvial beds resulting in a non-rigid flow boundary.

The step-profile method is applicable for steady, **one-**dimensional rigid boundary flow. The degree to which the careful application of the step-profile method can provide satisfactory results is an issue for debate. The step-profile method may be applied by experienced professionals in a way that minimizes the potential source of errors. The cross section is subdivided to permit approximation of the variation in velocity transverse to the direction of flow. The vertical velocity variation is usually

unimportant. Different flow lengths are specified for channel and **overbank** sections. The flow rate used for the profile computation is carefully selected to satisfy the steady flow approximation. For this investigation, it is assumed that the application of the step-profile method of analysis is appropriate and that it is being applied in an experienced, professional manner.

2-2.2. Steady, Uniform, and Non-uniform Flow. Velocity of a fluid in motion can change in both time and space. When the velocity is constant with respect to time, **the** flow is defined as being steady. When velocity at a location changes with time, the flow is defined as unsteady. A constant velocity (and thus constant depth) with respect to distance along a prismatic channel is described as uniform flow. Natural streams do not have prismatic channels but instead, the cross-sectional geometry varies along the stream. Non-uniform flow occurs when the velocity changes along a stream because the geometry or roughness changes. Flow is considered to be one-dimensional when all important aspects of the flow phenomena can be explained by single values of velocity and depth at each cross section throughout the profile. . . in effect one velocity and depth at each location on the stream.

Steady flow in a long stream with an approximately prismatic channel occurs at a constant depth, called normal depth. Since adjacent stream reaches will in practice have different roughnesses, geometric configurations, flows, or invert slopes, each reach can be thought **of** as having a different normal depth. The natural stream water surface profile therefore consists of a series of transitional curves, each converging toward normal depth from one reach to the next. Since the profile transitions for gradual changes in roughness, geometry, or flow are not likely to be abrupt, the pressure distribution in a vertical column of water will remain hydrostatic and thus the flow can be classified as gradually varied. **Figure 2.1** illustrates selected transitional profile curves that occur **for** streams with mild slopes.

2-2.3. Flow Continuity. Discharge is the product of the cross-sectional area of flow and the mean flow velocity. The discharge through a cross section is the sum of all the discharges through the component subareas **of** a cross section, or

$$Q = \sum_{i=0}^n Q_i = \sum_{i=0}^n (V_i \cdot A_i) = V \cdot A \quad \text{(Equation 2.1)}$$

where: V = the average velocity,
 A = the total area **of** the cross section,
 Q = discharge, and
 i = element **of** the cross section.
 n = number of cross section elements

A. STREAMBED SLOPE

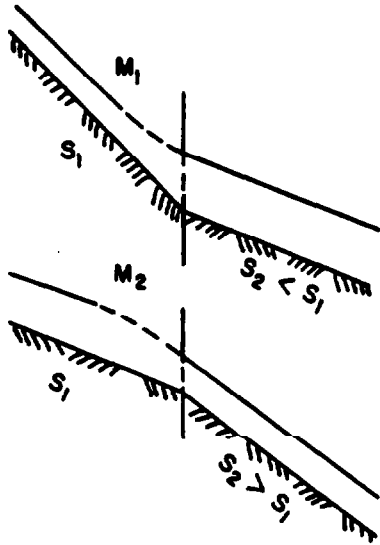

B. DISCHARGE

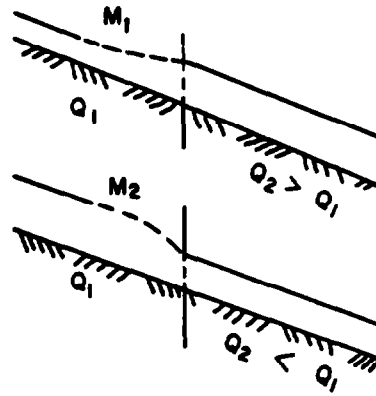

C. FLOW ROUGHNESS

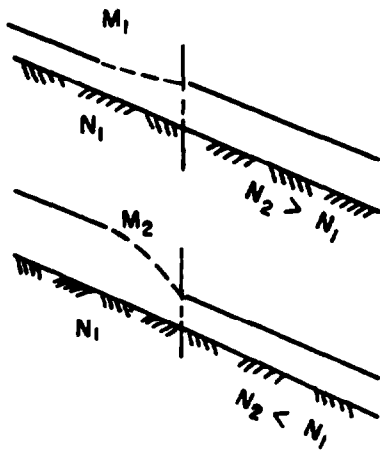

D. FLOW GEOMETRY

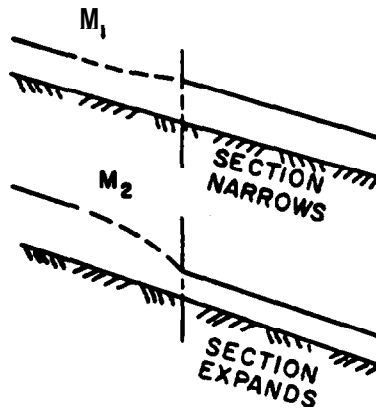

LEGEND

- M_1 - BACKWATER CURVE
- M_2 - DRAWDOWN CURVE
- ==== FLOW AT NORMAL DEPTH
- TRANSITION PROFILE

The Hydrologic Engineering Center
December 1966

FIGURE 2.1 Profile Transition Curves for Mild Slopes

Thus for reaches having constant discharge at successive cross sections, the equation of continuity results in the relationship

$$Q = v_1 * A_1 = v_2 * A_2 \quad (\text{Equation 2.2})$$

2-3. Energy Equation

2-3.1. Derivation of Equations. The equation for the principle of conservation of energy may be written between adjacent cross sections. Figure 2.2 is a definition sketch for the energy principle applied to a natural stream. The velocity head coefficient used to correct the one-dimensional equation calculations for the usual two-dimensional velocity field is omitted to simplify the presentation and discussion. HEC-2 and other water surface profile programs account for varied velocity across the section but it is not important to the discussion here. Other minor energy loss terms are left out as well. The resulting equation is

$$WS_2 + v_2^2/2g = WS_1 + v_1^2/2g + h_f \quad (\text{Equation 2.3})$$

(See Figure 2.2 for definition and illustration of terms)

The potential and kinetic energy terms in the above equation are **equal** to the water surface and velocity head terms, respectively. Inspection of **Figure 2.2** shows that the energy loss due to friction for the reach is a function of the rate **of energy loss** and the reach length. A simple approximation of this **loss is**

$$h_f = L * \bar{S}_f \quad (\text{Equation 2.4})$$

and by substitution,

$$h_f/L = ((WS_2 - WS_1) + (v_2^2 - v_1^2)/2g)/L = \bar{S}_f \quad (\text{Equation 2.5})$$

Written as a differential equation, the rate **of energy loss** at a point on a stream is

$$dh_f/dx = d(WS - v^2/2g)/dx = S_f \quad (\text{Equation 2.6})$$

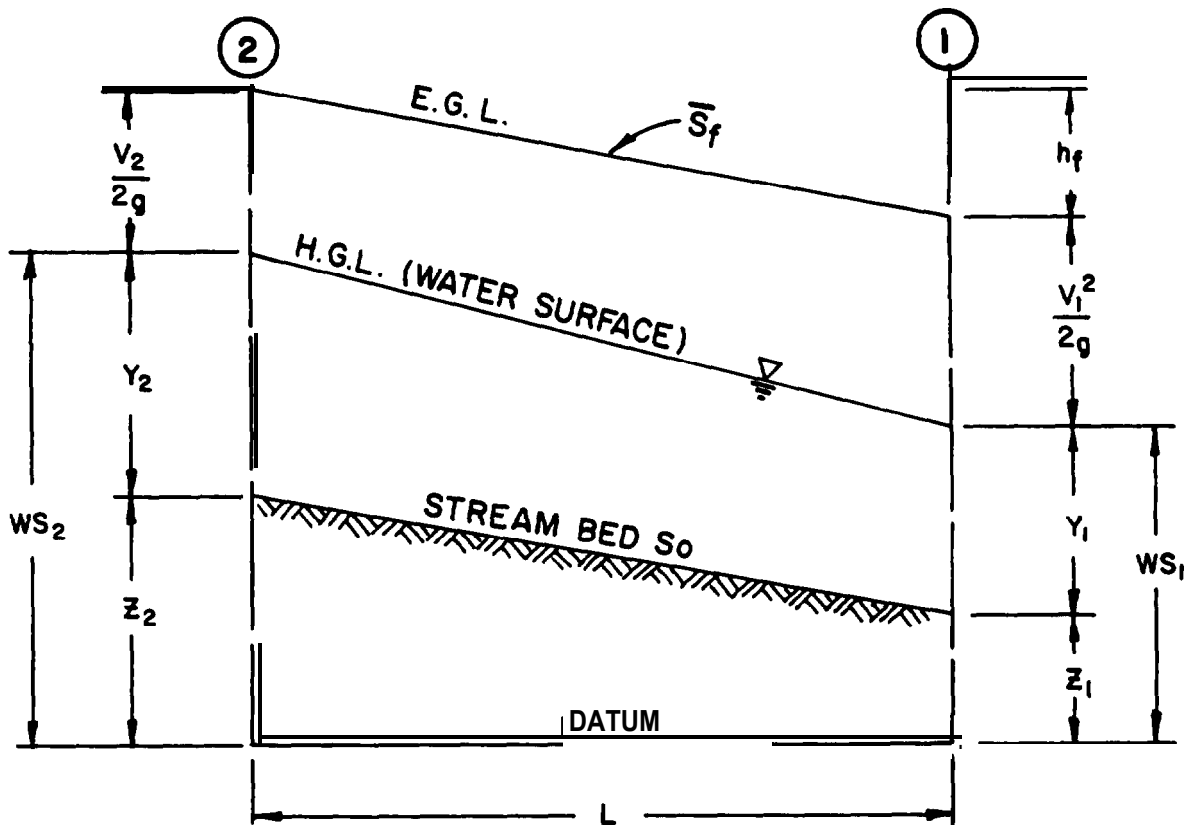

- Where:
- H.G.L. = hydraulic grade line
 - E.G.L. = energy grade line
 - Z = elevation of the streambed above the datum
 - Y = depth of flow in the channel
 - L = distance along the **streambed** between the cross sections
 - V = average velocity of flow area
 - g = acceleration due to gravity
 - \bar{S}_f = **average** slope of the energy **grade** line
 - S_0 = slope of the **streambed**
 - h_f = **headloss** due to friction
 - WS = water surface elevation above the datum
 - no. = cross-sectional number

The Hydrologic Engineering Center
December 1986

FIGURE 2.2 Water Surface Profile Computation Diagram

The total energy loss between two sections may be calculated by integration of Equation 2.6 as

$$h_f = \int_{x=0}^{x=L} S_f * dx \quad (\text{Equation 2.7})$$

where: L = the length of stream,
 dx = integration increment, and
 S_f = the rate of energy loss, sometimes referred to as friction slope, at any given location.

The other losses normally **accounted** for, such as expansion and contraction losses, **have** been omitted for clarity. These losses are described in Section 2-3.3. Equation 2.7 is the correct representation of energy loss whereas Equation 2.4 is a simple approximation. Note that friction slope is not constant throughout the reach.

2-3.2. Manning's Equation. The empirical Manning's equation commonly applied in water surface profile calculations defines the relationship between surface roughness, discharge, flow geometry, and rate of friction loss for a given stream location. It is

$$Q = 1.49 * A * R^{2/3} * S_f^{1/2} / n \quad (\text{Equation 2.8})$$

where: n = Manning's roughness coefficient,
 Q = discharge (cubic feet per second),
 A = flow area (square feet),
 R = hydraulic radius (feet), and
 S_f = friction slope (feet per foot).

Manning's equation in conjunction with the continuity equation (Equation 2.2) may **be used to** estimate the rate of energy loss due to boundary friction between successive **cross** sections. Rearranging Equation 2.8, the friction slope at a **cross** section may be estimated as

$$S_f = (n * Q / 1.49 * A * R^{2/3})^2 \quad (\text{Equation 2.9})$$

2-3.3. Expansion and Contraction Losses. An abrupt change in flow geometry from expansion or contraction of the channel and floodplain flow area results in a local energy loss from increased internal fluid friction and turbulence losses. These losses are approximated **by**

$$h_e = C * |(v_2^2 - v_1^2) / 2 * g| \quad (\text{Equation 2.10})$$

where: h_e = expansion or contraction energy loss, and
 C = expansion or contraction coefficient
and other parameters are as previously defined.

Separate but constant loss coefficients were adopted for expansion and contraction loss computations for the research study.

2-4. Step-Profile Analysis

2-4.1. Analysis Concepts. The water surface profile for the significant majority of streams can be computed using the **step-profile** method for steady flow (U.S. Army Corps of Engineers 1959). The method is based on solving the steady flow equations using a cross section to cross section, step by step procedure. The distance between cross sections is known and water surface elevations assumed and calculated in an iterative process. This is accomplished by successively performing an energy balance between consecutive cross sections until a stable condition is achieved and thus the water surface elevation known (Chow 1959 and Henderson 1966). It is a simple numerical integration solution of the differential energy equation written between adjacent cross sections.

2-4.2. Analysis Assumptions. The key assumptions for the **step-profile** analysis procedure are **listed** below.

- (1) The flow is steady.
- (2) Manning's equation is valid for computing the rate of energy loss due to boundary friction in a natural stream.
- (3) Manning's roughness coefficient roughness is valid for gradually varied flow and is constant for the reach.
- (4) The change in elevation of the streambed between cross sections is small.
- (5) The stream cross-sectional boundary is rigid.
- (6) Flow is one dimensional (vertical and lateral velocity variation in the flow direction is small).
- (7) The vertical pressure distribution is hydrostatic (flow is gradually varied).

2-4.3. Friction Loss. The energy loss due to boundary friction for a stream reach is the integral of the rate of energy loss over the reach length. Several simplified approximations of this energy loss have been **developed**. They all compute a representative rate of energy loss (average value) that can then be multiplied by the length to compute the loss. Reference Equation 2.4. The friction loss approximation methods include: simple **average**, harmonic mean, and geometric mean of the friction slopes of the ends of the reach, and the average of the conveyance at the reach ends (Hydrologic Engineering Center 1982). In equation form, they **are**

(1) Average Friction Slope Equation

$$\bar{s}_f = (s_{f1} + s_{f2})/2 \quad (\text{Equation 2.11})$$

(2) Average Conveyance Equation

$$\bar{s}_f = ((Q_1 + Q_2)/(K_1 + K_2))^2 \quad (\text{Equation 2.12})$$

(3) Geometric Mean Friction Slope Equation

$$\bar{s}_f = (s_{f1} * s_{f2})^{.5} \quad (\text{Equation 2.13})$$

(4) Harmonic Mean Friction Slope Equation

$$\bar{s}_f = (2 * s_{f1} * s_{f2}) / (s_{f1} + s_{f2}) \quad (\text{Equation 2.14})$$

If the reach lengths are short, all of the above equations provide essentially the same result in profile computations. As the reach length is extended, the resulting representative rate of friction loss is increasingly different and the most accurate approximation to use depends on the flow regime. Figure 2.3 illustrates this concept for the commonly occurring backwater (M1) and **drawdown** (M2) curves. It also shows that as the cross sections **are** placed closer together (dx becomes smaller), the representative friction slope approaches a constant value. Figure 2.4 shows the effect of adding more cross sections (more integration steps) over two reach lengths. The result is a better integration of the friction rate variation **over** the reach and therefore a more accurate calculation of the profile. This occurs even though the additional cross sections may only add computation steps and do not necessarily reflect changes in geometry.

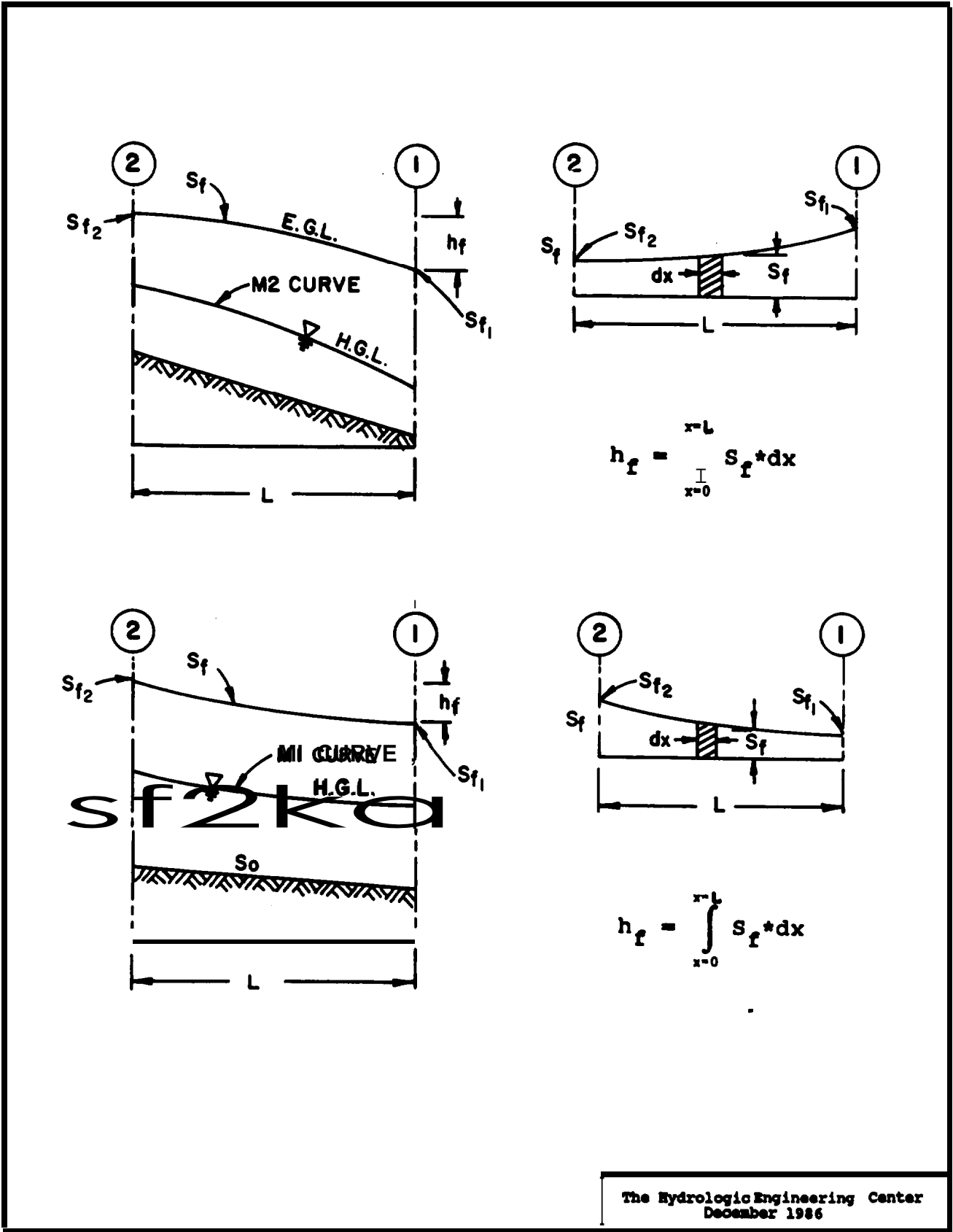

The Hydrologic Engineering Center
December 1986

FIGURE 2.3 Friction Slope Analysis Concepts

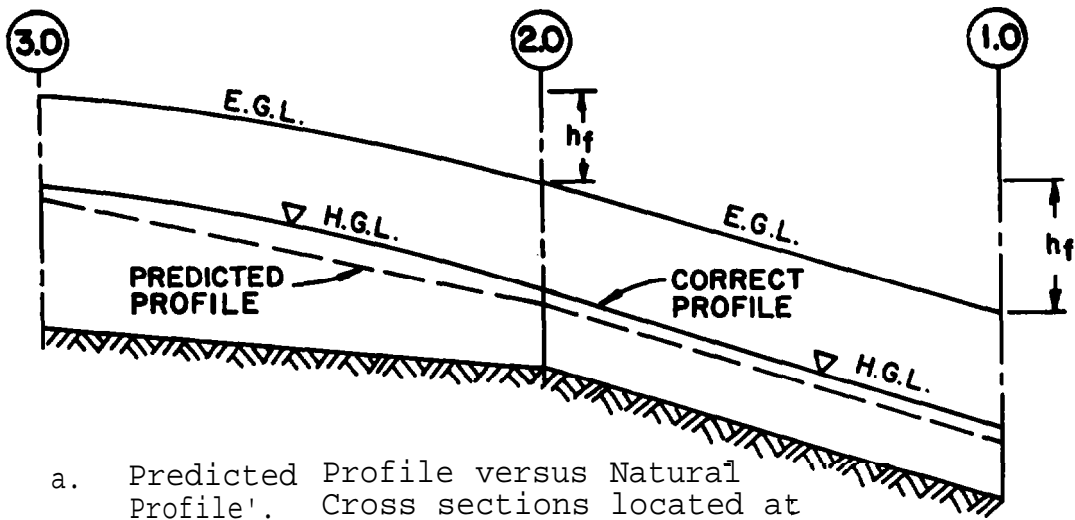

a. Predicted Profile versus Natural Profile'. Cross sections located at physical change to bed slope.

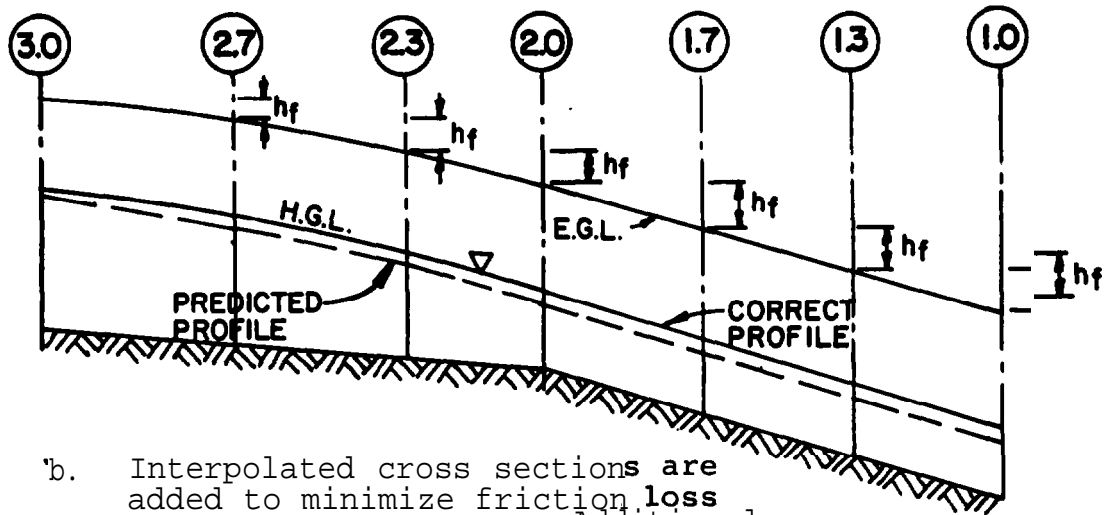

b. Interpolated cross sections are added to minimize friction loss approximation errors. Additional cross sections (calculation steps) provide a more accurate integration of the energy equation (Equation 2.7).

The Hydrologic Engineering Center
December 1986

FIGURE 2.4 Energy Equation Integration Concepts

The choice of the friction loss equation for this study is made insignificant because such short reach lengths are used that the values computed from **Equations** 2.11 to 2.14 are the same. Interpolated cross sections were inserted at 500 foot intervals in all data sets used in the study. The various friction loss equations then yield essentially the same results. The interpolation procedure is described in Section 4-5.

2-4.4. Cross-Sectional Location Criteria. Cross-sectional locations coincide with the calculation steps of the finite difference profile analysis process. The cross sections are typically located to ensure the assumptions stated in Section 2-4.2 are met. The appropriate cross-sectional location criteria may be determined from review of the parameters of Equations 2.6, 2.7, and 2.9. Cross sections are commonly located for physical and hydraulic reasons as summarized below. Numerous references detail procedures for cross-sectional layout including: HEC-2 Water Surface Profiles (Hydrologic Engineering Center 1982), Water Surface Profiles (Hydrologic Engineering Center 1975), and Computation of Water-Surface Profiles in Open Channels (U.S. Geological Survey 1984).

- (1) Cross sections should be located at distinct changes in stream bed slope.
- (2) Cross sections should be placed immediately upstream and downstream of locations where changes in discharge occur.
- (3) Cross sections should be located to accurately describe variations in geometry, including local abrupt expansions and contractions in flow geometry.
- (4) Cross sections should **be** located to accurately describe variations in channel and **overbank** resistance.
- (5) Cross sections are required at bends in the stream to ensure that channel and **overbank** reach lengths are correctly defined.
- (6) Interpolated cross sections may be required to provide sufficient computation points to accurately compute the energy loss.

2-4.5. Computational Procedure. The unknown water surface elevation at a **cross** section is determined by an iterative solution of Equation 2.5 where the water surface elevation of the adjacent cross section is known. The computational procedure is

- (1) **Assume a** water surface elevation at the target **cross section.**

- (2) Based on the assumed water surface elevation, determine the corresponding total conveyance and velocity **head**.
- (3) With values from step 2, compute the representative reach friction slope. Solve Equation 2.4 for headloss.
- (4) With values from steps 2 and 3, solve Equation 2.5 for **WS₂**.
- (5) Compare the computed value of **WS₂** with the values assumed in step 1. Steps 1 **through** 5 should be repeated until the values **agree** within the specified tolerance, **say .01** feet.
- (6) Repeat for next cross section location.

(Hydrologic Engineering Center 1982)

2-5. Profile Analysis Errors

The physical properties of topography, roughness, discharge, and slope, of a natural stream **are** highly variable and spatially and temporally heterogeneous. In addition, some conditions such as roughness continuously change throughout the year, while others such as floodplain and channel topography change more slowly unless altered by man or natural disasters. Although further information can always be extracted by finer examination, it is impractical, in fact impossible, to define the variability perfectly. Hydraulic variables affected by data limitations include: discharge, boundary roughness, and flow geometry. This investigation is focused on determining the relationship between the sources of error in basic data and resultant error in computed profile.

REFERENCES CITED

1. Chow, Ven Te 1959, Open Channel Hydraulics, McGraw-Hill Book Company, New York, New York.
2. Henderson, F.M. 1966, Open Channel Flow, The MacMillan Company, New York, New York.
3. Hydrologic Engineering Center 1982 (reprint May **1985**), HEC-2 Water Surface Profiles, Computer Program **User's** Manual, U.S. Army Corps of Engineers.
4. Hydrologic Engineering Center 1975, Water Surface Profiles, Volume 6, A United States Contribution to the International Hydrological Decade, U.S. Army Corps of Engineers.

5. **McBean**, Edward and **Penel**, Jacques 1984, "Uncertainty Analysis of Delineated **Floodplain**," Canadian Journal of Civil Engineering 71, 385-387.

6. U.S. Army Corps of Engineers 1959, Backwater Curve in River Channels, Engineering Manual 1110-2-1409.

7. U.S. Geological Survey 1984, Computation of Water-Surface Profiles in Open Channels, Book 3, Chapter A15, Department of Interior.

CHAPTER 3

PROFILE ACCURACY ANALYSIS STRATEGY

3-1. General Approach

The adopted analysis strategy was formulated to jointly evaluate the effects of errors in survey data and estimation of Manning's coefficient on errors in the computed water surface profile. The combined effect of these errors ranges from completely additive to completely compensative. This goal precluded formulating an analysis strategy based on application of conventional sensitivity analysis. The Monte Carlo simulation approach incorporates the interaction of error sources and was adopted for the study.

3-2. Monte Carlo Simulation Concepts

Monte Carlo analysis provides a way to estimate the statistical properties of outputs (**profile** errors) of numerical models when one or more of inputs (surveyed cross section and Manning's coefficient errors) are random variables. The input variables used in a water surface profile calculation model differ from the true values because they are derived from measured data. Since the errors in these inputs are unknown, the evaluation of their effect on the profile is also unknown. A way to deal with this problem is to acknowledge that the inputs are samples drawn at random from a population of likely data sets. This approach allows probabilistic statements to be made regarding the relationship between input errors and output (profile) errors.

Probability theory uses the probability density function (PDF) to describe the likelihood (probability) of obtaining a particular value from a parent population. **For** the Monte Carlo approach used herein, each survey method and companion accuracy standard, and Manning's coefficient must have a PDF defining its error distribution. The **PDF's** should be based on reliable experimental data to assure validity of the analysis.

3-3. Methodology

The adopted Monte Carlo simulation strategy is shown schematically in Figure 3.1. HEC-2 data sets obtained from Corps field offices are assembled in a data file **for** analysis (step 1 of **Figure** 3.1). The data sets are subsequently edited (step 2) to produce consistent data sets. This process eliminates all but the **1-** and 10-percent chance discharge values, **removes** all bridge data and non-surveyed cross sections, and edits all data

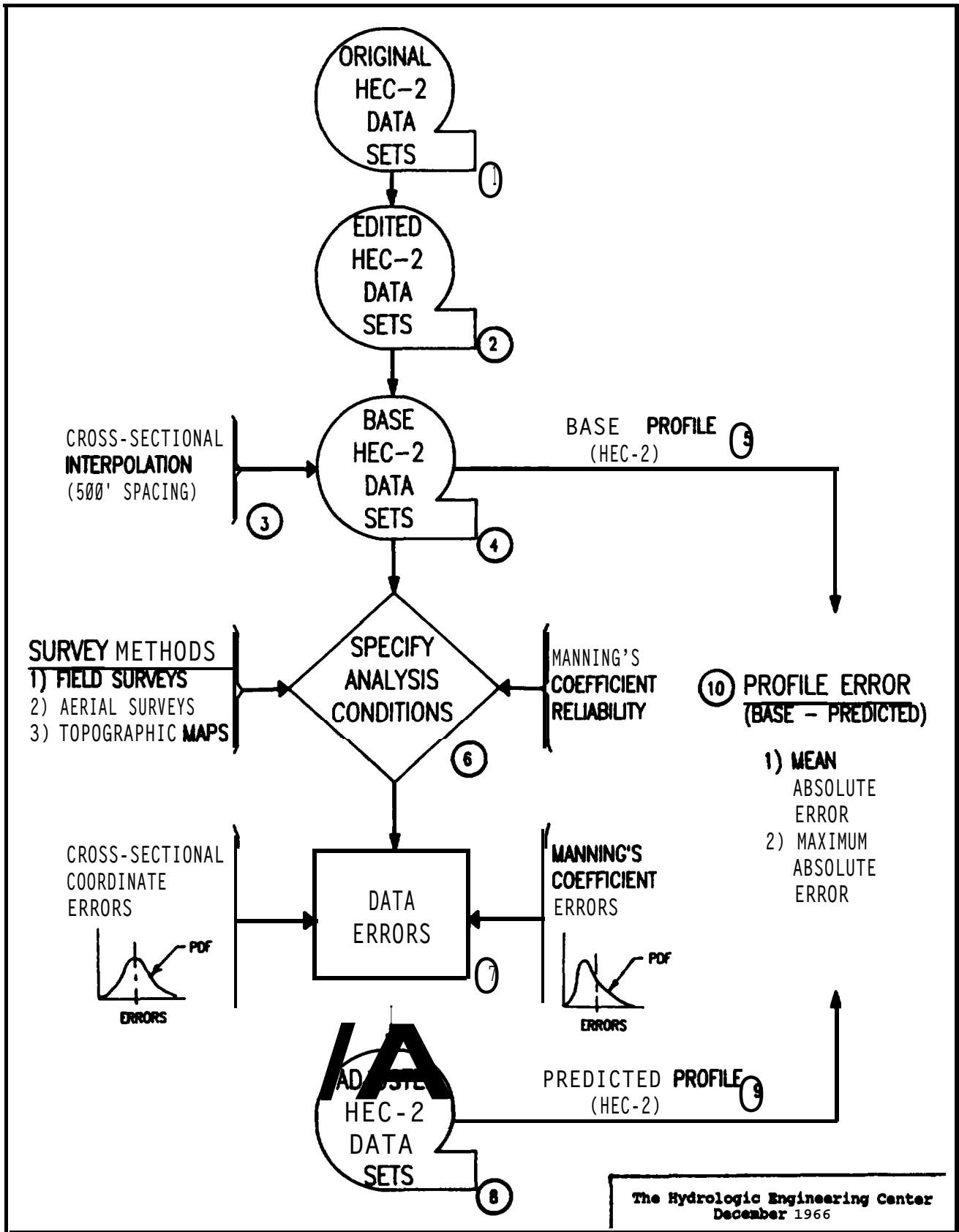

FIGURE 3.1 Profile Accuracy Analysis Strategy

sets to the same expansion and contraction coefficients. The data sets **are** subsequently evaluated to define appropriate reach lengths and to assure that all profiles are represented by subcritical flow conditions. **Of** the 140 original data sets, 98 are retained for the profile accuracy analysis after editing.

The edited data sets are further modified to develop the base condition data sets. Interpolated cross sections are added to eliminate the numerical integration error. The cross sections are linearly interpolated at 500 foot spacings from the surveyed cross sections (step 3). The edited data sets with the interpolated cross sections become the base HEC-2 data sets (step 4) used to generate the base water surface profile (step 5). **A** base profile is calculated for each **of** the 98 data sets and subsequently compared with the profiles computed for the adjusted HEC-2 data sets. Chapter 4 more completely describes the data editing and cross-sectional interpolations performed.

The adjusted HEC-2 data sets are developed using the Monte Carlo simulation approach to randomly adjust survey **cross-sectional** coordinate points and Manning's coefficients for errors associated with these parameters. Analysis conditions are specified (step 6) and measurement error statistics are used to randomly adjust each coordinate point and Manning's coefficient in the data set (step 7). No adjustments are made for field surveys since they were considered to be without error. Cross-sectional adjustments are **performed** for both aerial spot elevations and topographic maps for **2-, 5-,** and 10-foot contour intervals. The probability density functions (PDF) of errors for these conditions are obtained from published mapping standards (see Chapter 5). Manning's coefficient analyses are performed for three levels of reliability of the estimates ranging from professional judgement based on field observations to precisely calibrated estimates.

The various combinations of survey and Manning's coefficient conditions result in 21 different error evaluation situations for each of the 98 edited data sets. The adjusted data sets (step 8) are then processed by HEC-2 to yield the **error** condition predicted water surface profiles (step 9). Each of the adjusted profiles is compared with the base condition profile (step 10) to determine the mean absolute reach error (**average error over** the stream reach) and absolute maximum reach error.

The profile computed for the adjusted HEC-2 data set for a specified survey and Manning's coefficient represents one of a set of possible profiles based on the **PDF's** of the two error sources. It is therefore necessary to generate sufficient replicates of each condition analyzed to develop a reliable set of the error statistics of the mean absolute and maximum absolute reach errors. The resulting mean absolute reach error values and maximum absolute reach error values are subsequently used to derive regression equations for predicting water surface profile errors for specified survey accuracy and Manning's coefficient reliability conditions.

3-4. Data Management and Processing Overview

3-4.1. General. Data processing and management represented a major task for the study. Over 50,000 HEC-2 program executions were performed, necessitating the successful interfacing of several analysis and utility programs and data management systems. The processing used a mix of commercial software, standard HEC software, and newly developed software. An overview of study data processing and management is shown in Figure 3.2.

Data manipulation is performed by the newly developed utility programs SETUP (Hydrologic Engineering Center 1985) and COMPER (Appendix D). The water surface profiles are computed by the **HEC-2** program, and the regression analyses are performed with the Multiple Linear Regression program (Hydrologic Engineering Center 1970) and the STATGRAPHICS PC program (STSC, Inc. 1984). Interpolations of cross sections at the selected 500 foot spacing are performed by the INTSEC utility program (Hydrologic Engineering Center 1982). Data management and data storage software used include the HEC-DSS (Hydrologic Engineering Center 1985) and the INFO Data Base Management System (**Henco** Software Company 1981).

3-4.2 Procedural Summary. Edited HEC-2 data sets are retrieved by the multipurpose SETUP program which subsequently performs cross-sectional and Manning's coefficient adjustments, retrieves interpolated cross sections from the INTSEC program, generates JCL (job control language) and disk file names, and submits HEC-2 jobs. The HEC-2 program performs all water surface profile calculations. The results are stored in HEC-DSS.

Water surface profile errors (difference between the base and the computed profile resulting from the adjusted data set) are calculated by the COMPER program. Error results and associated hydraulic variables for each HEC-2 data set are stored in the INFO DBMS. INFO is a relational data base software system which allows multiple files to be related to each other through common variables. It also allows selective retrieval of data based on user-specified criteria, sorting of data, and generation of reports.

Equations for predicting errors in water surface profiles **are** derived by regression analyses. These are developed by regressing related error data and hydraulic variables using the Multiple Linear Regression Program (MLRP) and STATGRAPHICS software. The report generation capability of INFO is used to develop data in a format acceptable by the regression programs.

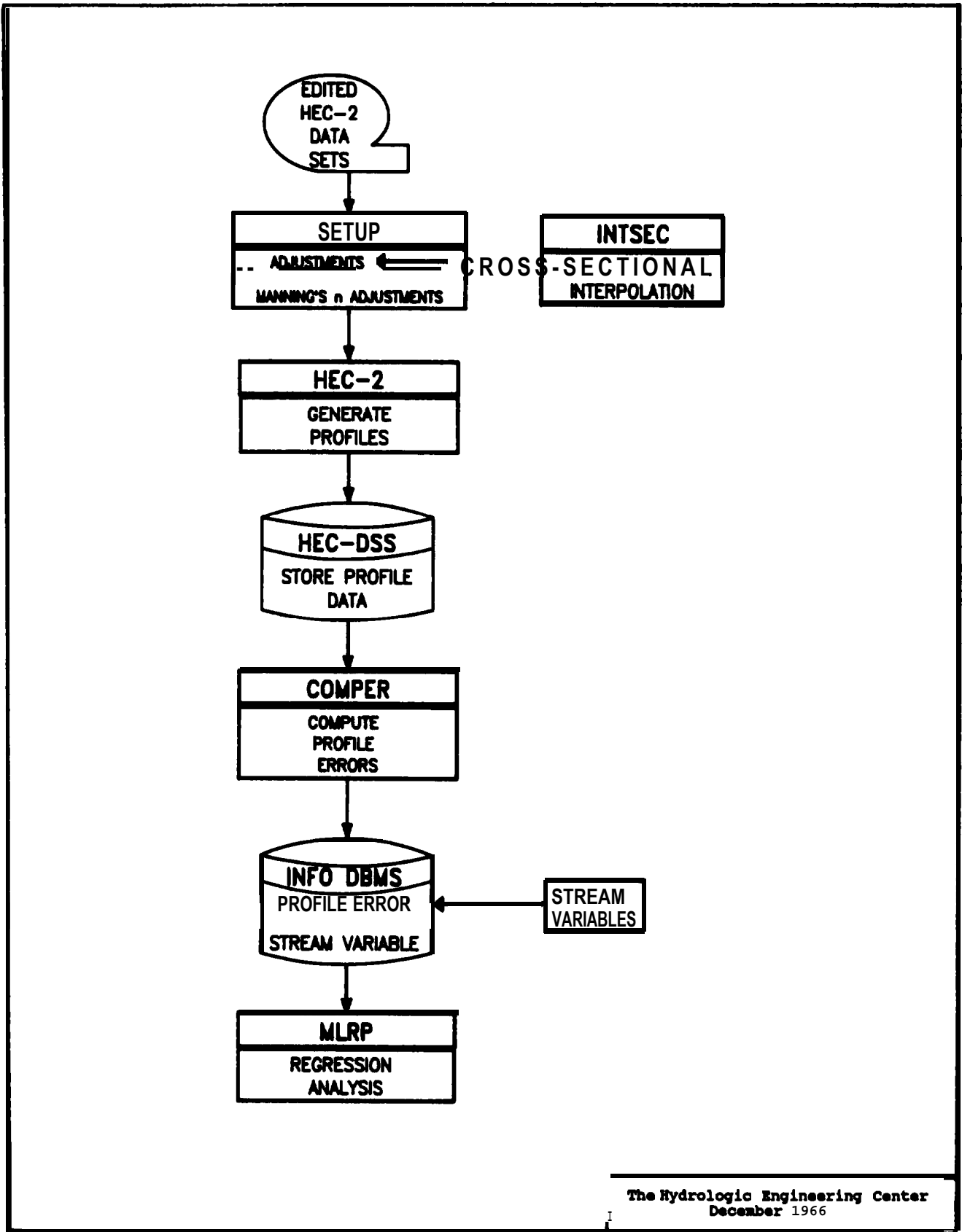

The Hydrologic Engineering Center
December 1966

FIGURE 3.2 Overview of Data Processing

The procedures were developed over an 8 month period and the final processing accomplished in about six weeks. Data management and processing is performed *on* the Harris 1000 minicomputer located at the Hydrologic Engineering Center. Much of the regression analysis is performed on an IBM PC/XT.

REFERENCES CITED

1. Benjamin, Jack R. and Cornell, **Allin C.** 1970, Probability, Statistics and Decision for Civil Engineers, McGraw-Hill Inc., New York, New York.
2. **Henco** Software Incorporated 1983, Info Data Base Management System, Info Study Guide Reference Manual, Version 8.4, **Henco** Software Inc., 120 Fifth Avenue, **Waltham**, MA.
3. Hydrologic Engineering Center 1985, HEC-DSS Users Guide and Utility Program Manuals (draft), U.S. **Army Corps of Engineers**.
4. Hydrologic Engineering Center 1974, HEC-2 Data Edit, Computer Program, undocumented, U.S. **Army Corps of Engineers**.
5. Hydrologic Engineering Center 1970, Multiple Linear Regression, Computer Program Users Manual, U.S. **Army Corps of Engineers**.
6. STSC Inc. 1984, Statgraphics, Microcomputer Software Users Manual, STSC, Inc. 2115 E. Jefferson St., Rockville, MD.

CHAPTER 4

ESTABLISHMENT **OF** BASE CONDITIONS

4-1. Overview

This chapter describes the data collection and editing activities performed to establish the base condition data sets. The data sets are HEC-2 input files for water surface profile analyses. This phase of the research also identifies the energy loss numerical integration errors described in Chapter 2, and develops the means for minimizing the effect on study results.

4-2. Data Collection

The collection of HEC-2 input files yielded **over** 140 data sets representing a wide variety of stream conditions. Of these, 98 are retained for use. The data sets were obtained from the following Corps **of** Engineers District offices: St. Louis, **Ft.** Worth, Jacksonville, Los Angeles, and Sacramento. The data collection criteria were based on acquisition of data sets that: (1) represent a diversity of streams, (2) contain cross-sectional data that are obtained from detailed surveys, (3) contained flow values for the 1-percent chance event, and (4) had been thoroughly tested and applied in planning, design, or flood insurance studies. Figure 4.1 is a discharge-slope scatter diagram that illustrates the wide range of streams represented by the data sets.

4-3. Data Editing

Data editing adjusted each **of** the HEC-2 input **data** sets to a consistent base. The process is described below.

- (1) Plot all cross sections.
- (2) Remove all bridge data and simplified cross sections obviously not obtained from detailed surveys.
- (3) Eliminate all but the **1-** and 10-percent chance flows. Maintain Manning's coefficient values as specified in the **data** sets. Convert all expansion and contraction coefficients to **.5** and 0, respectively, to be consistent with values recommended by the Federal Highway Administration. Table 4.1 tabulates the data editing actions taken for each **of** the **HEC-2** data records.
- (4) Verify the data using the HEC-2 Edit program (Hydrologic Engineering Center 1974) and make required corrections.

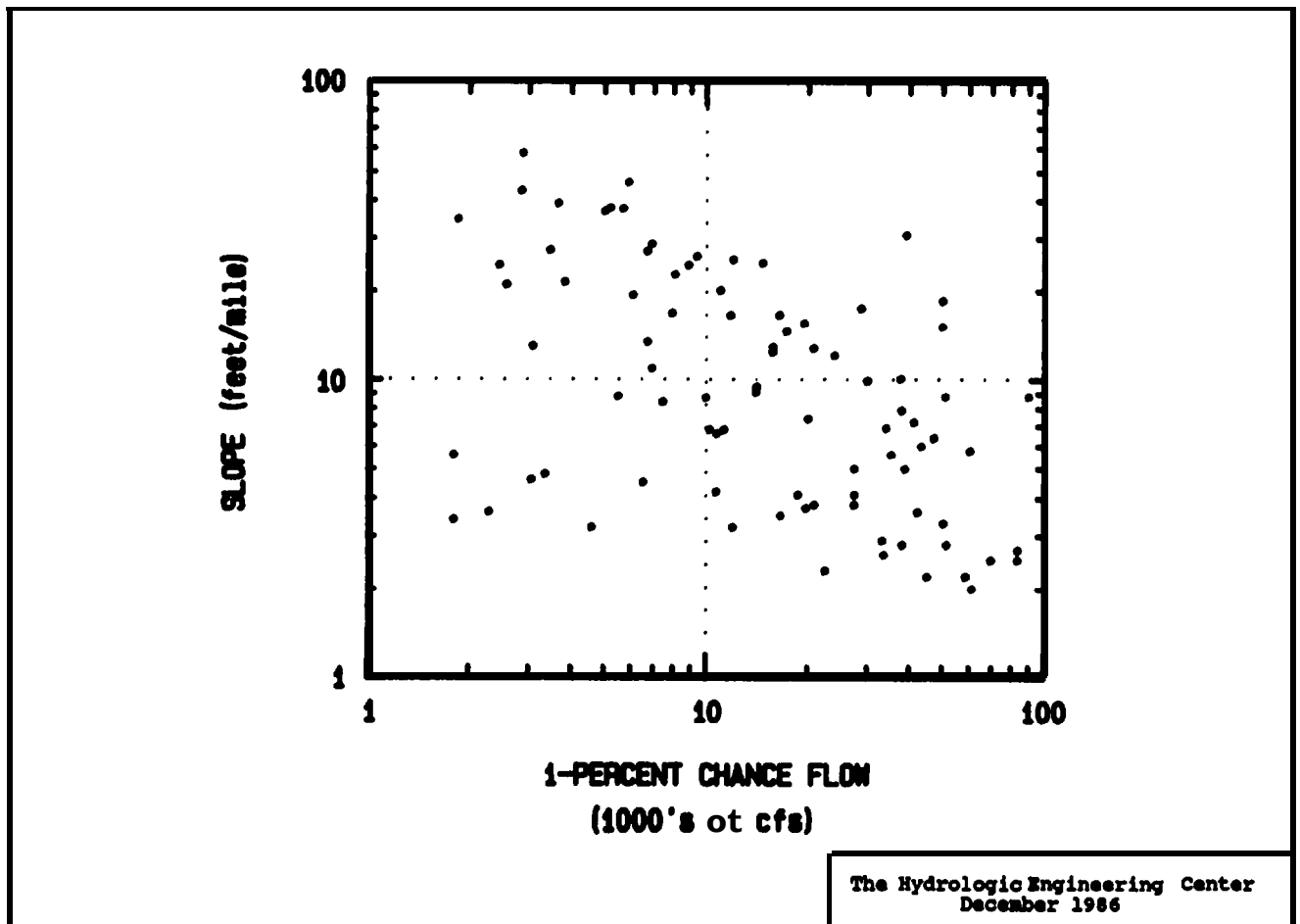

FIGURE 4.1 Discharge-Slope Scatter Diagram

4-4. Analysis Reach Determination

The editing resulted in a clean, consistent set of HEC-2 data files. Many data sets, however, were too long (stream reaches of 20 to 60 miles) and had significant variation in flow between the first and last cross section. The criteria applied to derive appropriate reach length data sets are described in subsequent paragraphs.

- (1) Reaches must have a reasonably constant water surface profile slope for the 1-percent chance event. The flow regime must be subcritical throughout the entire reach.
- (2) No reaches are included where lateral inflow for the 1-percent chance event exceeds 1b-percent of the total or where the difference in flow is more than **25-** percent between the first and last cross section.
- (3) Reach lengths must be sufficient to perform the desired analyses.

TABLE 4.1

HEC-2 Data Editing Actions

<u>Data Record</u>	<u>Analysis Purpose</u>	<u>Modifications of Data Records</u>
C	Comment Information	Always deleted
T1	First Title Record	Changed to STREAM NAME-FHWASTUDY
T2	Second Title Record	Changed to EDITED DATA
T3	Third Title Record	Changed to 1 or 10 % chance discharge
J1	Job Starting Conditions	INQ Changed to 2 (1 and 10 % chance discharge) or 1 (if only 1% chance discharge)
JR	Starting Rating Curve	Never encountered
JS	Starting Split Flow	Never encountered
J2	Multiple Profiles	Used to suppress unwanted output
J3	Summary Output Options	Always deleted
J4	Punch Card Option	Always deleted
J5	Print Control Option	Used to suppress unwanted output
J6	Friction Loss Option	Program default always used
IC	Ice Data	Never encountered
NC	Manning's Coefficient Expansion/Contraction	Manning's values not changed. Set CCHV = 0 and CEHV = 0.5
NH	Horizontal Manning's Coefficient	Values weighted to get overbank and channel n values for NC records
NV	Vertical Manning's Coefficient	Values weighted to get overbank and channel n values for NC records
QT	Discharge Table	Changed to 1 % and 10% chance discharge
ET	Bridge Encroachment Table	Always deleted, cross-sectional distance adjusted
SB	Special Bridge	Always deleted, cross-sectional distance adjusted
X1	Cross-Sectional Data	Unchanged/interpolated sections removed
RC	Rating Curve	Never encountered
CI	Channel Improvement	Never encountered
x2	Cross-Section Data	Always deleted
x3	Ineffective Flow Areas	Deleted in the vicinity of bridges
x4	Additional Ground Points	All points changed to CR record points, NUMST (X1 record) adjusted accordingly
X5	Profile Elevation Table	Always deleted
BT	Bridge Profiles	Always deleted, cross-sectional distances adjusted
CR	Ground Profile	Unmodified, unless as previously described
EJ	End-of-Job	Required
ER	End-of-Job	Required
SF, JC, TW WS, WC, TN NS, NG, TC CS, CR, EE AC	Miscellaneous Data Records	Group of data records never encountered

The Hydrologic Engineering Center
December 1986

- (4) Data sets are selected with sufficient variation in **stream** characteristics to assure independence.

4-5. Friction Loss Criteria

4-5.1. Overview. Comparisons of profiles computed from the several friction loss approximation techniques show significant differences, more than a foot in reaches of many streams. Figure 4.2 is an example of the difference in profiles calculated from various friction loss approximation methods. A significant number of the original data sets under-estimated the profiles as compared to those calculated with more accurate integration of the energy loss distance function using closer-spaced cross sections.

The difference **in** calculated profiles demonstrates the need for more calculation steps to accurately integrate the energy loss-rate distance relationship equation (Equation 2.7) as described in Section 2-4.3. Increasing the number of calculation steps is accomplished **by** interpolating intermediate cross sections. These cross sections are not required for better definition of physical and hydraulic changes along the stream but only for increasing the number of computation steps. The original data sets adequately defined the geometric variations.

4-5.2. Cross-Sectional Interpolation. The HEC computer program INTSEC (Hydrologic Engineering Center 1981) is used to add interpolated cross sections. The cross sections are inserted at a uniform 500 foot spacing for all data sets. This interval is adopted after testing several spacings for the range of stream types. The interval is judged to **be** adequate when nearly identical (within **.02** ft) profiles are obtained for all friction loss approximation techniques. Greater spacings of interpolated cross sections may be possible for very large streams but additional research is required to make definitive recommendations.

The INTSEC program interpolates between two adjacent cross sections which define the flood plain geometry at their respective locations. The program divides each cross section into: (1) left **overbank** segment, (2) left segment portion of channel, (3) right segment portion of channel, and (4) right **overbank** segment. The first and last point of each segment are tied to the first and last points of the corresponding segment of the other section. The interpolation is performed by developing a linear equation between each cross-sectional point and a corresponding location (based on percent distance of corresponding line segment) **of** the adjacent section. See Figure 4.3. Equations for x versus channel length and **for** y versus channel length are developed for each point. Points between the first and last points of the segment **are** located on the other section by the corresponding distance

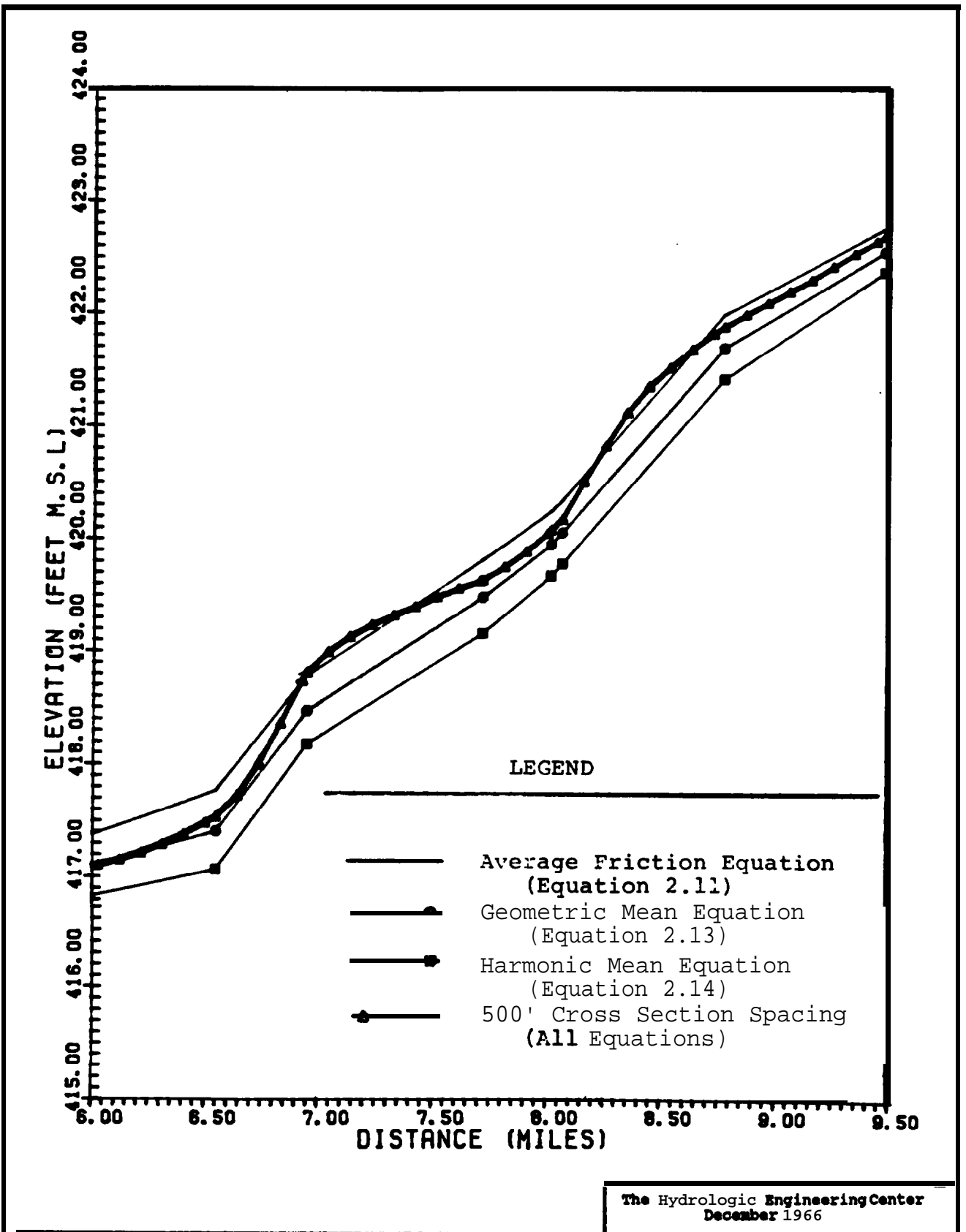

FIGURE 4.2 Profiles Using Alternative Friction Equations

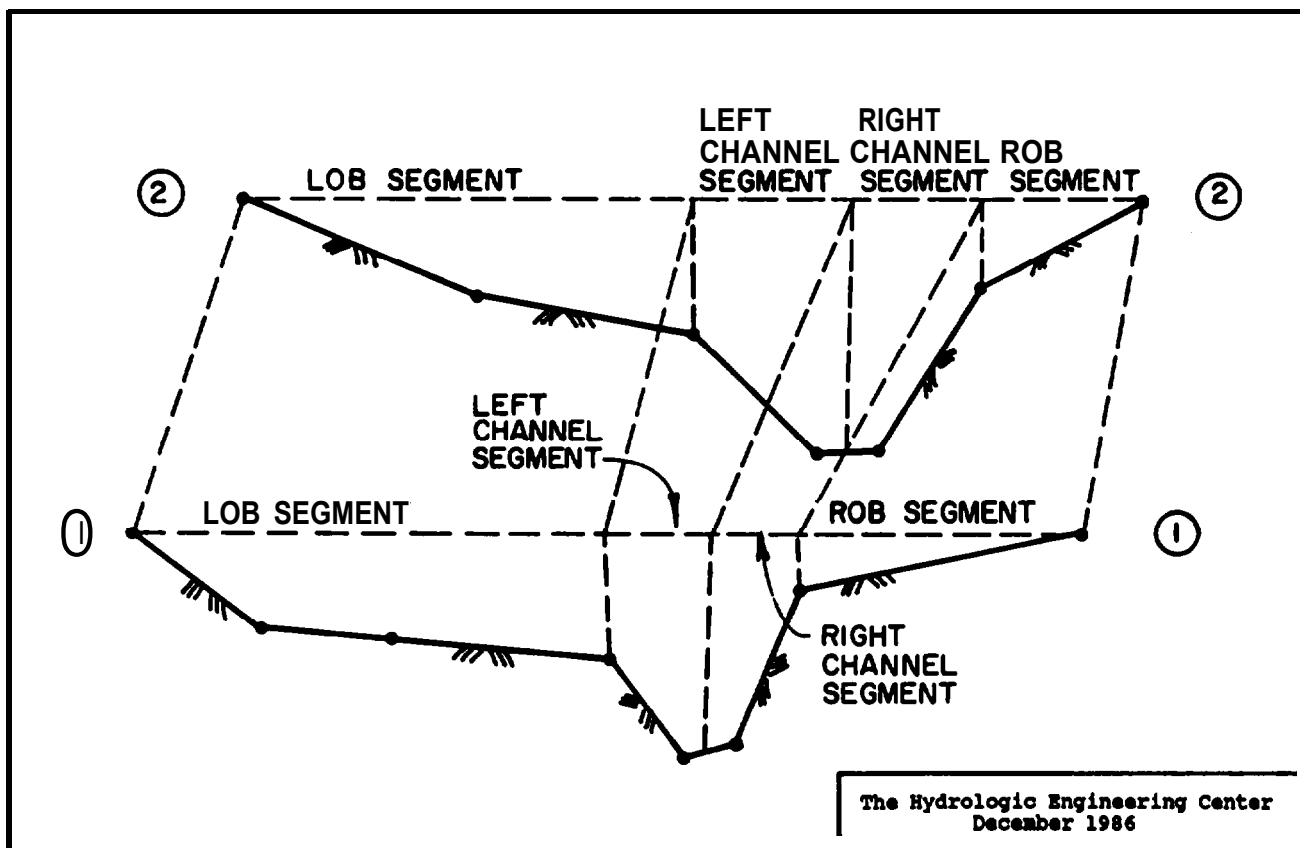

FIGURE 4.3 Cross-Sectional Interpolation

weighting of the sections. This process is repeated for all points and segments of each section. The result is an array of x and y coordinate points **equal** in number to the **sum** of the number of coordinate points in the two original section minus the five end points **of** each segment. The linear equations generate interpolated cross-sectional coordinates at user-specified intervals along the channel reach.

4-6. Base Condition Data Sets

The water surface profiles generated from HEC-2 profile computations for the edited data records for each stream reach that include the interpolated **cross** sections represent the base condition water surface profiles for the study. Table 4.2 lists stream characteristics and hydraulic variables for each of the **data sets**. Figure 4.4 contains several charts that illustrate the range of stream characteristics represented by the 98 adopted data sets used for the study.

TABLE 4.2

Hydraulic Variables - Base Data Sets
(Based on 1-Percent Chance **Flow**)

DATA FILE I.D.	REACH LENGTH (mi)	1% CHANCE FLOW (cfs)	REACH SLOPE (ft/mi)	MANNING'S n FOR REACH	TOP WIDTH (ft)	HYDRAULIC DEPTH (ft)	NO. OF SURVEYED SECTIONS
S01M1	3.6	10,700	4.2	0.050	1,840	3.1	16
S02M1	4.0	10,200	6.8	0.061	1,100	4.0	23
S03M1	3.2	6,500	4.5	0.074	1,850	3.4	9
S04M1	1.6	10,000	8.7	0.061	740	4.7	8
S05M1	4.2	5,500	8.8	0.056	500	3.7	12
S06M1	7.6	7,500	8.4	0.069	640	5.5	21
S07M1	11.3	2,300	3.6	0.059	1,000	2.0	56
S08M1	4.7	700	2.9	0.034	390	2.5	33
S09M1	2.7	900	6.3	0.042	740	1.0	16
S10M1	4.0	800	4.3	0.036	270	2.9	32
S11M1	2.4	1,800	3.4	0.039	690	2.2	22
S12M1	3.0	700	6.5	0.037	260	2.6	19
S13M1	1.6	700	3.6	0.044	720	0.9	10
S14M1	5.0	4,600	3.2	0.029	350	6.1	41
S15M1	6.6	3,400	4.8	0.037	860	2.3	42
S16M1	3.8	3,100	4.6	0.039	690	3.5	25
S17M1	5.1	1,800	5.6	0.039	970	1.2	30
S01M2	7.5	35,400	5.6	0.045	1,120	9.0	19
S02M2	1.7	14,000	9.1	0.053	870	4.9	8
S03M2	5.6	12,000	3.2	0.083	1,510	5.5	14
S04M2	9.9	16,600	3.5	0.045	1,090	6.4	35
S05M2	2.1	14,100	9.5	0.067	730	6.4	13
S06M2	9.4	20,900	3.8	0.051	1,980	5.6	42
S07M2	8.8	20,100	7.4	0.054	1,430	5.7	31
S08M2	8.7	42,300	3.6	0.071	3,250	6.0	6
S09M2	9.5	33,300	2.9	0.067	2,270	9.4	16
S10M2	9.5	19,800	3.7	0.051	2,120	4.0	35
S12M2	1.4	10,800	6.6	0.040	980	2.9	5
S13M2	9.9	33,600	2.6	0.086	3,660	7.5	19
S14M2	20.9	22,500	2.3	0.079	2,300	7.0	30
S16M2	10.8	18,700	4.1	0.077	1,650	6.4	11
S18M2	20.4	45,100	2.2	0.063	1,510	12.0	36
S22M2	21.0	58,500	2.2	0.060	1,490	15.0	22
S26M2	11.5	51,400	2.8	0.065	1,830	11.0	27
S29M2	9.5	27,400	3.8	0.061	1,200	8.0	18
S30M2	8.3	27,400	4.1	0.060	1,150	8.5	21
S31M2	4.0	27,400	5.0	0.063	1,220	8.0	7
S32M2	9.9	61,000	2.0	0.057	2,940	9.0	20
S33M2	10.0	69,500	2.5	0.045	1,280	13.0	17
S37M2	16.2	50,300	3.3	0.056	810	15.0	31
S41M2	10.1	30,800	5.0	0.057	820	12.0	22
S42M2	17.2	03,400	2.7	0.049	1,900	13.0	28
S44M2	21.7	83,400	2.5	0.045	1,760	12.0	40
S46M2	7.7	60,400	5.8	0.058	2,740	6.9	16
S47M2	6.4	43,400	6.0	0.072	1,820	8.1	14
S48M2	7.1	34,200	6.9	0.072	2,070	5.8	15
S49M2	3.4	30,000	9.9	0.067	1,530	5.7	8
S50M2	9.4	47,200	6.4	0.063	2,250	7.5	25
S51M2	4.3	41,200	7.2	0.069	2,040	8.2	18

TABLE 4.2 (Continued)

Hydraulic Variables - Base Data Sets
(Based on 1-Percent Chance Flow)

DATA FILE I.D.	REACH LENGTH (mi)	1% CHANCE FLOW (cfs)	REACH SMPE (ft/mi)	MANNING'S n FOR REACH	TOP WIDTH (ft)	HYDRAULIC DEPTH (ft)	NO. OF SURVEYED SECTIONS
S52M2	7.7	51,000	8.8	0.062	2,370	6.3	27
S53M2	3.2	37,900	7.9	0.066	2,060	6.1	11
S54M2	5.3	11,300	6.8	0.042	820	4.6	25
S55M2	6.9	90,000	8.8	0.032	3,050	5.3	54
S56M2	5.6	38,000	2.8	0.029	1,200	8.0	6
S01M3	7.1	161,000	3.5	0.043	3,260	9.4	17
S05M3	5.3	118,000	8.0	0.041	3,960	7.5	40
S01S1	5.2	6,900	10.9	0.052	740	3.3	14
S02S1	1.2	6,700	27.2	0.053	480	2.7	6
S03S1	3.9	3,100	13.0	0.052	220	3.4	12
S04S1	1.6	8,100	22.7	0.049	590	3.1	11
S05S1	2.6	5,000	36.9	0.053	340	3.0	18
S06S1	2.8	5,200	37.8	0.073	300	4.1	21
S07S1	3.3	6,700	13.4	0.057	760	2.9	12
S08S1	4.1	6,100	19.4	0.071	450	4.1	19
S09S1	1.4	5,700	37.6	0.061	110	7.3	6
S10S1	3.2	6,900	28.7	0.050	180	5.9	16
S11S1	2.3	7,900	16.9	0.065	670	3.9	10
S12S1	1.6	3,800	21.4	0.065	510	2.5	9
S13S1	1.6	5,900	46.4	0.072	170	6.1	42
S14S1	2.2	3,700	39.2	0.068	240	3.5	43
S15S1	3.6	3,500	27.4	0.064	330	3.6	81
S16S1	0.6	8,900	24.4	0.052	240	5.9	4
S17S1	1.9	2,900	43.4	0.051	200	3.9	8
S18S1	2.5	2,600	21.0	0.073	390	2.6	20
S19S1	1.5	2,900	57.8	0.062	100	4.6	33
S20S1	1.7	1,900	34.7	0.056	230	2.0	12
S21S1	1.4	2,500	24.4	0.051	340	2.1	14
S22S1	3.0	800	11.2	0.037	350	1.2	18
S23S1	1.6	9,400	26.1	0.034	860	2.2	9
S01S2	2.4	15,700	12.9	0.052	900	4.3	14
S02S2	1.2	11,800	16.6	0.053	820	3.5	8
S03S2	5.4	37,600	10.1	0.059	1,270	7.6	12
S04S2	10.1	19,500	15.6	0.062	630	8.0	74
S05S2	3.7	12,000	25.4	0.087	390	7.9	29
S06S2	4.2	16,500	16.6	0.055	570	5.1	8
S07S2	4.4	20,800	12.8	0.066	1,100	5.3	13
S08S2	4.6	24,000	12.1	0.057	820	6.5	16
S09S2	3.1	17,300	14.6	0.056	740	5.1	10
S10S2	3.5	15,700	12.4	0.058	800	4.7	30
S11S2	2.4	11,000	20.1	0.064	360	6.5	6
S12S2	3.6	28,800	17.5	0.070	2,020	3.7	19
S13S2	4.9	34,000	106.0	0.122	350	12.0	69
S17S2	4.5	50,000	18.6	0.040	1,440	6.0	48
81852	1.9	50,000	15.2	0.045	1,000	7.8	22
S19S2	4.6	39,000	30.8	0.039	1,990	3.8	26
S20S2	2.8	14,700	24.8	0.030	580	3.5	16
S01S3	10.7	270,000	15.4	0.031	710	20.0	9
80283	5.7	152,000	15.9	0.067	1,480	13.0	15

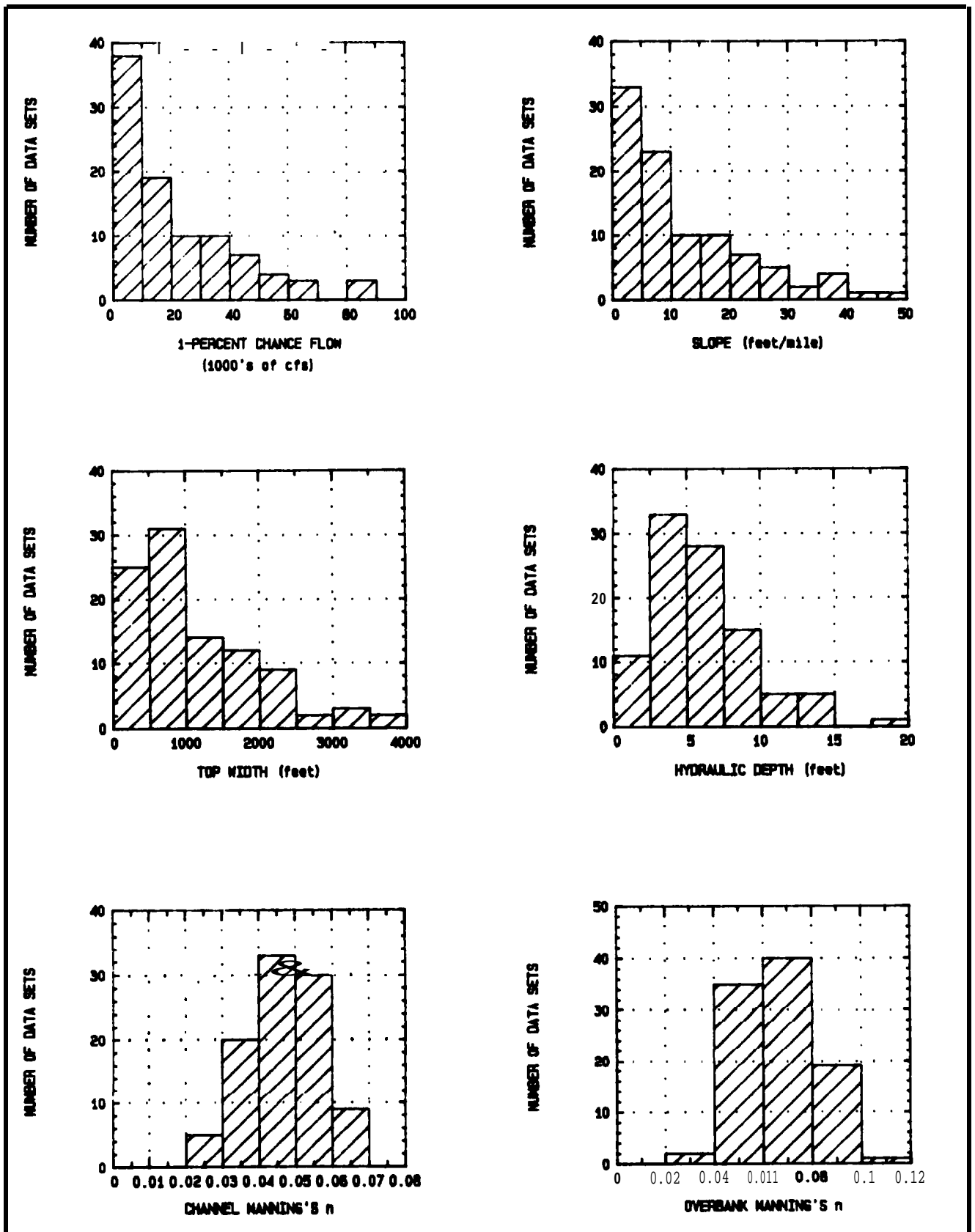

FIGURE 4.4 Stream Characteristics of Base Data Sets

REFERENCES CITED

1. Hydrologic Engineering Center 1982 (reprint May **1985**), HEC-2 Water Surface Profiles, Computer Program Users Manual, U.S. Army Corps of Engineers.
2. Hydrologic Engineering Center 1981, Cross-Section Interpolation (INTSEC), Computer Program, undocumented, U.S. Army Corps of Engineers.
3. Hydrologic Engineering Center 1974, HEC-2 Data Edit, Computer Program Users Manual, U.S. Army Corps of Engineers.

CHAPTER 5

QUANTIFYING POTENTIAL ERRORS IN SURVEYS AND MANNING'S COEFFICIENT

5-1. General Approach

This chapter describes the method used to adjust cross-sectional coordinate values and Manning's coefficients for survey measurement and Manning's coefficient estimation errors. Probability density functions (**PDFs**) are developed for the survey and Manning's coefficient errors. The application of the **PDF's** in the Monte Carlo simulation analysis is described in detail. A discussion of the survey methods and associated accuracy standards is also included.

5-2. Survey Methods and Accuracy

5-2.1. General. A stream cross section is a vertical section through the surface of the ground taken perpendicular to the stream flow (American Congress on Surveying and Mapping 1981). The cross section is defined by distance and elevation coordinates taken at changes in topography along a cross-sectional alignment. Figure 5.1 shows cross-sectional coordinate measurements representing the natural topography along a specified alignment.

The number of cross sections that are taken vary with study requirements and stream characteristics. Survey methods used to measure cross-sectional coordinates include: (1) field surveys performed with land surveying instruments, (2) aerial spot elevations developed from aerial stereo models, (3) topographic maps generated from aerial photogrammetry procedures, and (4) hydrographic surveys. Measurement errors for these methods are a function of industry adopted accuracy standards, equipment, terrain, and land surface cover.

5-2.2. Field Surveys. Field surveys are normally performed by 2-4 person crews. Methods relating to survey equipment include: (1) hand levels, (2) conventional levels, and (3) Electronic Distance Meters (**EDMs**). A baseline or survey control is performed prior to the survey. The baseline survey establishes temporary benchmarks and land surface coordinates near the cross-sectional locations, based on nearby permanent U.S. Geological Survey or local benchmarks. It also assists in defining distances between cross sections. Figure 5.2 shows the survey baseline concept.

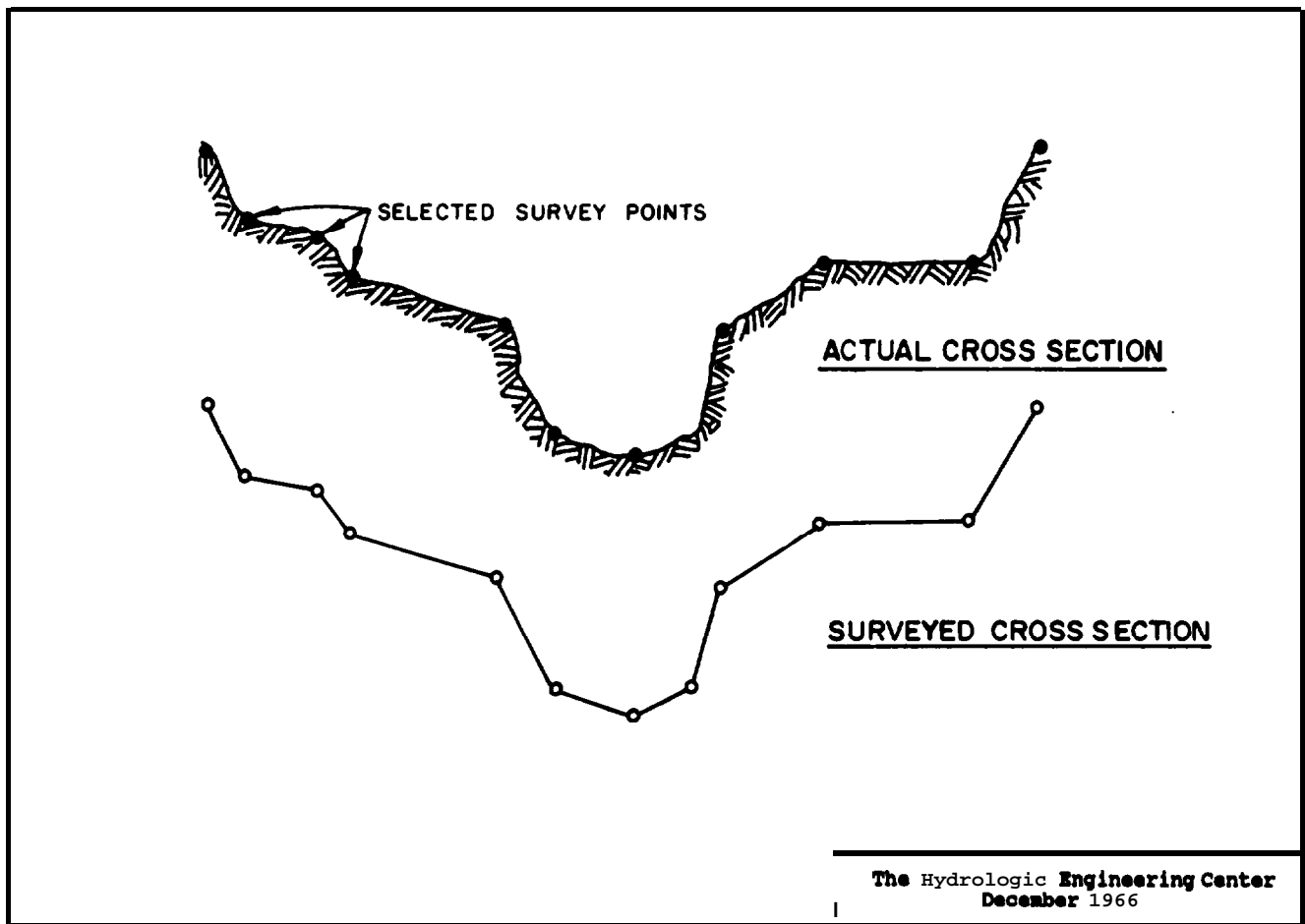

FIGURE 5.1 Cross-Sectional Concepts

- (1) Hand Levels. Cross-sectional coordinates may be estimated using a hand level and tape when distances are short and vertical accuracy is not critical. This is the least accurate method of field survey and is performed **by** one or two **persons**. **Hand** level surveys are applicable **for** preliminary surveys **and** for augmenting more detailed surveys.

- (2) Conventional Levels. The survey crew usually consists of an instrument man, **rodman**, and note keeper. Typical equipment includes a surveyor's level, **rod**, and tape. The level most commonly used **is** the tripod mounted automatic or self-leveling instrument. The survey accuracy depends on procedures used for distance measurements and **elevation** readings of the surveying rod. Distance is measured with steel or cloth tapes, stadia (estimation of distance from the survey rod graduations), and pacing. Elevation measurement accuracies typically range from precise (**.1** foot or less) to the nearest foot.

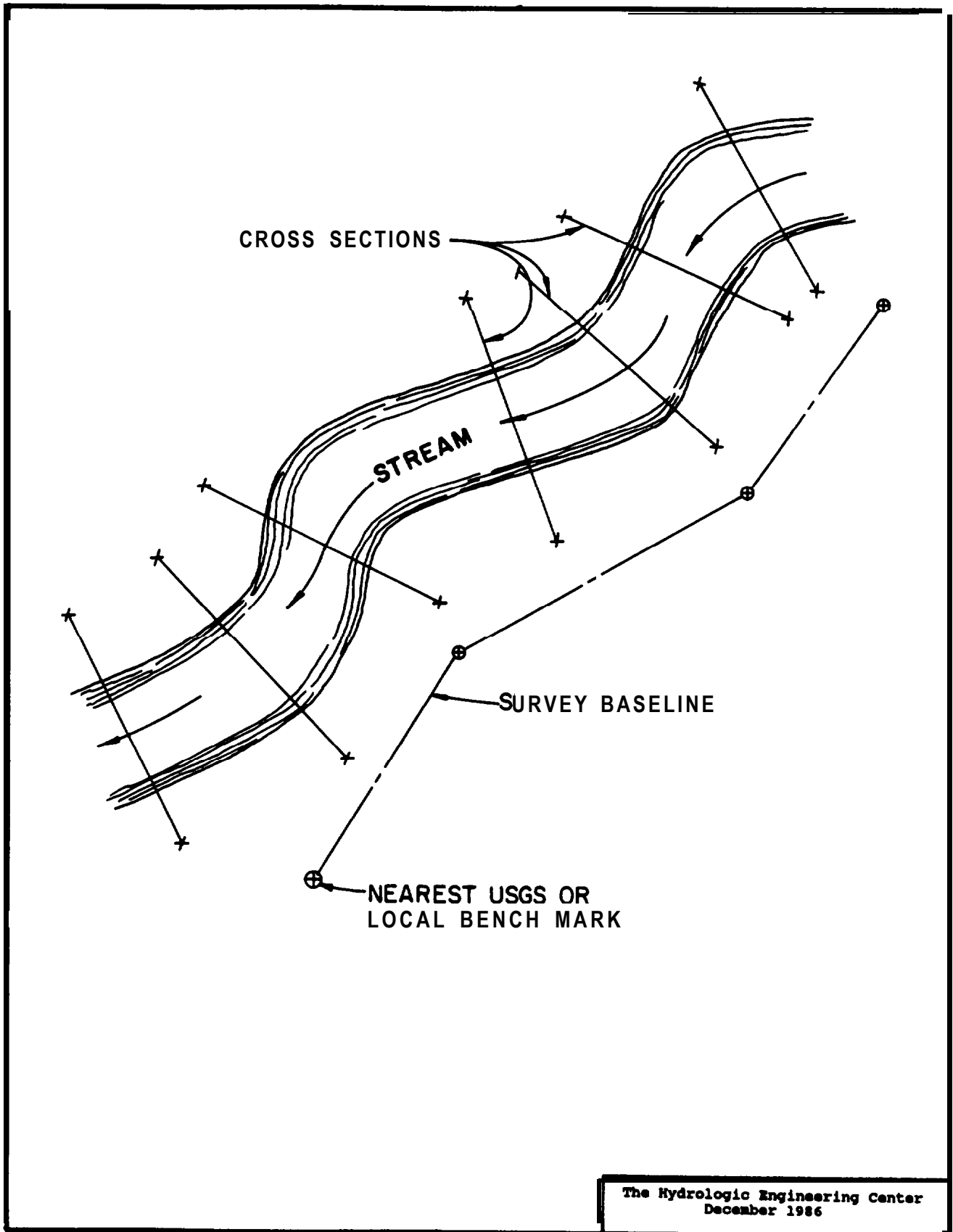

FIGURE 5.2 Field Survey Concepts

- (3) Electronic Distance Meters. Total station Electronic Distance Meters measure distances and calculate differences in vertical elevations by either comparing the phase differences between transmitted and returned electromagnetic waves or by computing the distance from the round-trip transit time of a pulsed signal (American Congress on Surveying and Mapping and the ASCE 1981). Total station **EDM's** determine horizontal distances and elevations of cross-sectional data points more rapidly than the conventional level procedures. A two-person survey **crew** often can efficiently perform the surveys. Many **EDM's** store survey cross-sectional data on a magnetic cassette tape. The data may be directly transferred to plotters for verification and formatted **for** input to water surface profile computer program analyses (Hydrologic Engineering Center 1985).

Table 5.1 is a list of survey methods, related equipment, and vertical elevation accuracies for the several field survey methods described.

5-2.3. Aerial Photogrammetry Aerial photogrammetry is an increasingly used technology for determining cross-sectional coordinate data. The data can be easily **processed** to the desired formats for direct computer application. Two distinct products are: (1) **spot** elevations along the alignment **of** the **cross** sections, and (2) topographic maps from which the **cross** sections are subsequently taken. Both techniques are derived **from** basic photogrammetry procedures. Achievable accuracies depend on the factors listed in the following paragraphs.

- (1) Preflight Planning. Preflight planning defines the aircraft flight elevation and overflight pattern needed to **cover** the study area. Coordination with field surveys are required to establish horizontal and vertical controls. The desired map and photograph scale, contour interval, and horizontal accuracy **determine** the flight elevation and ground control marker **sizes**. The width of the floodplain (cross-sectional lengths) **determines** the number of flights along the stream.
- (2) Horizontal and Vertical Control. Ground control points established by field survey crews provide horizontal and vertical control for the study area. The control points are tied to **a** national or local datum.
- (3) Flights. Flights should **be** timed to reduce shadows on the photographs. Aerial surveys are normally taken during the winter season for areas with heavy vegetation cover.

TABLE 5.1
Field Surveys
Vertical (Elevation) Accuracy

Equipment	Accuracy	Remarks
Hand Level	$\pm 0.2' @ 50'$	With support of level and careful sighting, can obtain $\pm 0.1' @ 50'$.
Stadia	$\pm 0.4' @ 500'$	Using double target intercept of rod can expect $\pm 0.2' @ 500'$ for land surface slopes less than 30 degrees .
Conventional Level Wye-Dumpy	$\pm 0.05' @ 800'$	Sights limited to 200' to 300' can produce readings to 0.01'. Depends upon the skill of the observer .
Automatic Level	$\pm 0.03' @ 800'$	Automatic level results similar, but faster in operation than conventional levels.
E.D.M. with Theo- olite or Total Station	$\pm 0.05' @ 500'$	Depends upon type of instrument and skill of operator.

Source: American Congress on Surveying and Mapping and the American Society of Civil Engineers, "Definitions of Surveying and Associated Terms," reprinted 1981.

- (4) Photogrammetric Processing. Photographic plates are produced from the flight negatives and used in a stereoplotter to obtain spot elevations or topographic maps. The stereoplotter is an analytical device which links a processing computer, data storage system, digital plotting table, and a printer for hard copy output. Cross-sectional data can then be easily developed, stored, and plotted. An advantage of the spot elevation method is that the coordinate data may be formatted for input to water surface profile computer programs (Hydrologic Engineering Center 1985, and **Moffitt and Mikhail** 1980).

The accuracy of aerial technology for generating **cross-sectional** coordinate data are governed by mapping industry standards. Table 5.2 is a summary of relevant accuracy standards. Cross sections obtained from contours of topographic maps developed by photogrammetric methods are not as accurate as those generated from spot elevations. The elevation errors of spot elevations and points on the topographic map are spatially uncorrelated and random (Hydrologic Engineering Center 1985). Therefore, measurement errors for adjacent cross-sectional coordinate points obtained from either procedure are not correlated.

5-2.4. Hydrographic Surveys. Hydrographic surveys determine cross-sectional geometry below the water surface. They are required when the size and depth of the stream prohibits use of other methods to estimate the channel dimensions. See Figure 5.3. All hydrographic survey methods require shore control for alignment and distance determination.

Channel cross sections for small streams may be obtained by a person wading the stream, using a cloth tape for distance and staff or rod readings from a level. An Electronics Distance Meter (**EDM**) may be used in place of the tape and level to record both distance and elevation readings. **For** larger streams requiring a boat, soundings may be obtained from lead-lines or recording sonar devices (Sound Navigation Ranging). Both methods use **EDM's** or other shore control instruments to position the boat on the cross-sectional alignment.

Hydrographic survey accuracy varies significantly depending on bottom surface, calmness of the water surface, and stream velocity. Staff or rod readings have similar accuracies as other field survey procedures. **For** calm water conditions with firm stream beds, the lead-lines survey method may be accurate within a foot, and sonar devices accurate within **.2** of a foot (Hydrologic Engineering Center 1985).

TABLE 5.2

Aerial **Survey** Procedures
Vertical (Elevation) Accuracy*

Aerial survey map accuracy for spot **elevations** and topographic maps is defined **by** the mapping industry standard. Standard Map Accuracy is described by the following criteria:

1. The plotted position of all coordinate **grid** ticks and monuments, except benchmarks, will be within 0.01 inch from their calculated positions.
2. **At least 90 percent of all well-defined planimetric** features shall be within 0.033 inch of their true positions, and all shall be within 0.066 inch of their true positions.
3. At least 90 percent of all contours shall be within **one-half** contour of true elevations, and all contours shall be within one contour interval of true elevation, except as follows:

For mapping at scales of **1" = 100'** or larger in areas where the **ground** is completely obscured by dense brush or timber, 90 percent of all contours shall be within one contour interval or one-half **the average** height of the **ground** cover, whichever is the greater, of true elevation. All contours shall be within two contour intervals or the average height of the groundcover, whichever is the greater, of true elevation. Contours in such areas shall be indicated by dashed lines.

Any contour which can be brought within the specified vertical tolerance by shifting its plotter position **.033** inch shall be accepted as correctly plotted.

At least 90 percent of all **spot** elevations shall be within one-fourth the specified contour interval of their true **elevation**, and all spot elevations shall be within one-half the contour interval of their true elevation, except that for b-foot contours 90 percent shall **be** within 1.0 foot and all shall be within 2.0 feet.

*Source: Brochure from Cartwright Aerial Surveys Inc.,
Sacramento, California.

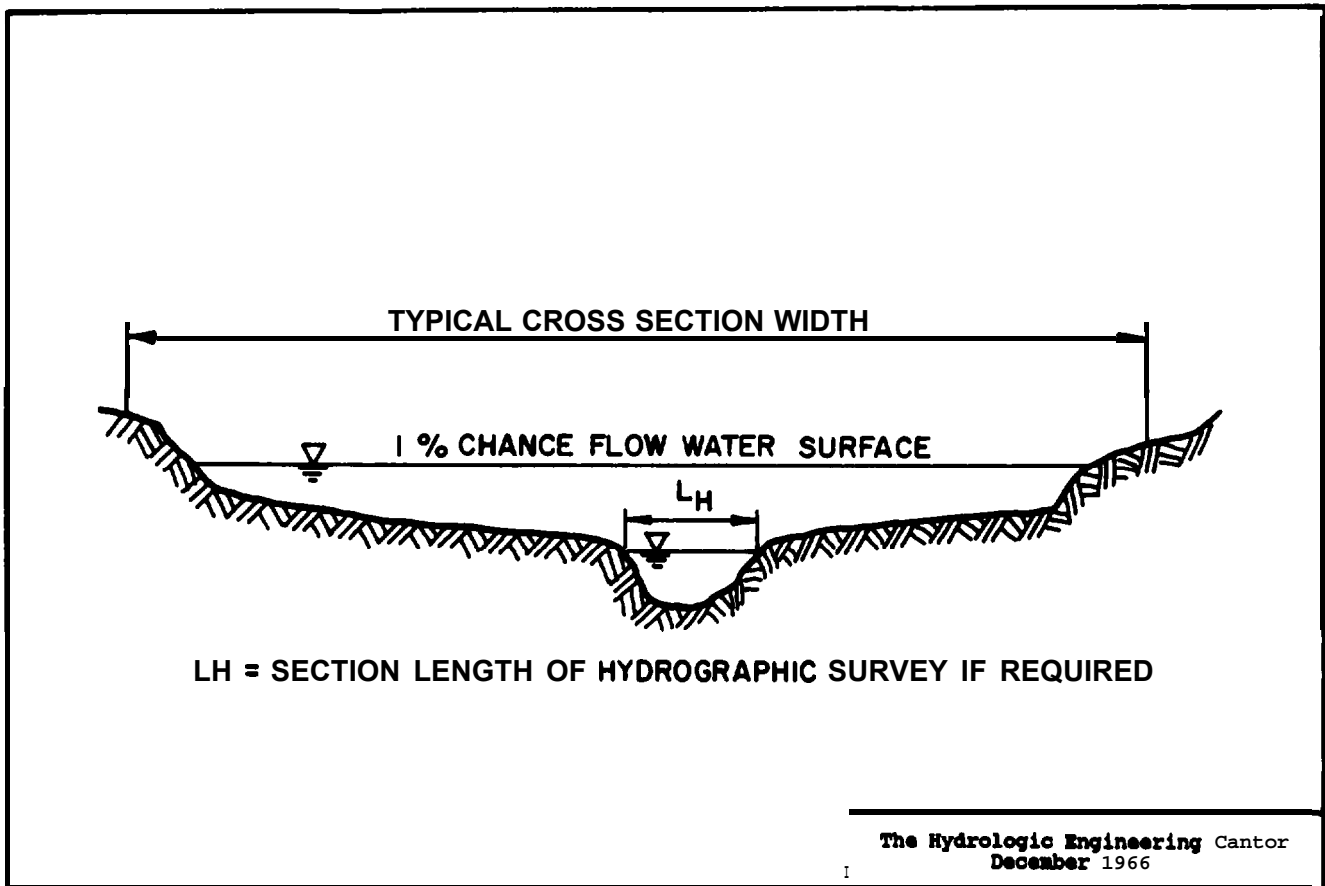

FIGURE 5.3 Hydrographic Survey Concepts

5-3. Survey Error Analysis

5-3.1. Survey Errors. The study was performed based on the following adopted **survey** accuracy statements.

- (1) **Field surveys** are considered to produce precise, exact replication of the **base condition** cross-sectional **geometry** with no errors. **This** represents the lower, no measurement error bound **on** the computed profile accuracy analysis.
- (2) Aerial spot elevation and topographic map **cross-sectional** measurement errors are based on the mapping industry accuracy standards shown in Table 5.2. Only vertical (elevation) errors are analyzed. Errors in horizontal cross-sectional coordinates are not considered significant.
- (3) The accuracy of hydrographic surveys **for** channel cross sections is taken to be the same as that used for the **overbank** or floodplain portions of the cross-sections. Therefore, hydrographic survey accuracy is not separately analyzed.

- (4) The magnitude and frequency of errors due to human mistakes in measurements or calculations (blunders), are not readily definable and are not considered. Blunders are largely negated through normal verification of measurements with other sources of data.

5-3.2. Derivation of Error Probability Density Functions.

The PDF for the aerial **survey** spot elevations and topographic maps may be estimated from the aerial mapping industry accuracy standards (Hydrologic Engineering Center 1984, and Funk 1959). The accuracy standards require that the errors be normally distributed. Since the **error** distribution is normal, the standard deviation of the errors associated with the specified accuracy of the contour interval may be estimated from the values specified in Table 5.2. Table 5.3 is a tabulation of the standard deviations for the selected contour intervals for both aerial spot elevations and topographic maps. The complete **PDF's** can be developed from the tabulated standard deviations and properties of the normal probability distribution. This resulting error distribution will be in most instances an upper bound on the survey errors that can be expected. The mapping industry is generally acknowledged as significantly exceeding these standards.

TABLE 5.3

Standard Deviations of
Aerial Spot Elevations and Topographic Maps
(feet)

<u>Contour Interval</u>	<u>Standard Deviation Aerial Spot Elevations</u>	<u>Standard Deviation Topographic Maps</u>
2	0.30	0.60
5	0.60	1.50
10	1.50	3.00

5-3.3. Cross-Sectional Error Generation. Adjusting **cross-sectional** coordinate values for the Monte Carlo simulation is performed as listed in **subsequent** paragraphs.

- (1) Determine the standard deviation (SD) for the contour interval being evaluated (Table 5.3).
- (2) Calculate the standard normal deviate (k) by first generating a uniform distribution of random numbers varying from 0 to 1. Transform the values to represent the normal (Gaussian) distribution. The process is discussed in Appendix D.

- (3) Calculate the random error for the cross-sectional coordinate elevation using the equation

$$\text{ERROR} = k \cdot \text{SD} \quad (\text{Equation 5.1})$$

where: ERROR = magnitude of elevation (in feet) error for **cross-sectional** coordinate point,
k = generated standard normal deviate, and
SD = standard deviation for survey method and accuracy standard for specified contour interval.

- (4) Add the random error to the base coordinate point elevation value.
- (5) Repeat (2) through (4) for all coordinate points and cross sections in the HEC-2 data set.

5-3.4. Example Cross-Sectional Adjustment. The cross-sectional coordinate points (including those of the interpolated **cross** sections) of the base data sets **are** adjusted to simulate survey and mapping measurement errors. The adjustment procedure varies with the survey or mapping method and accuracy (contour interval) under study. No adjustments to cross-sectional coordinate data are made for field survey methods. Only vertical or elevation errors are considered to have a significant impact on the computed water surface profile error. No horizontal measurement errors are considered. Also, measurement errors for adjacent cross-sectional coordinate points obtained from aerial spot elevations or topographic mapping methods are not correlated (See **5-2.3(4)**). The cross-sectional coordinate point adjustment procedures for aerial spot elevations and topographic mapping methods are shown on Figure 5.4 and are described in subsequent paragraphs.

- (1) The contour interval (**2-**, 5-, or 10-foot) of the aerial spot elevation survey method is specified.
- (2) The aerial spot elevations are assumed to be taken at the same locations as the coordinate points of the base cross section (see Figure 5.4 and Appendix B).
- (3) Each coordinate point is randomly adjusted in the vertical direction using the Monte Carlo **error** generation process described in Section 5-3.3 **for** the aerial spot elevation survey method.
- (4) The procedure is repeated for all cross sections of the data set.

AERIAL SPOT ELEVATION SURVEYS

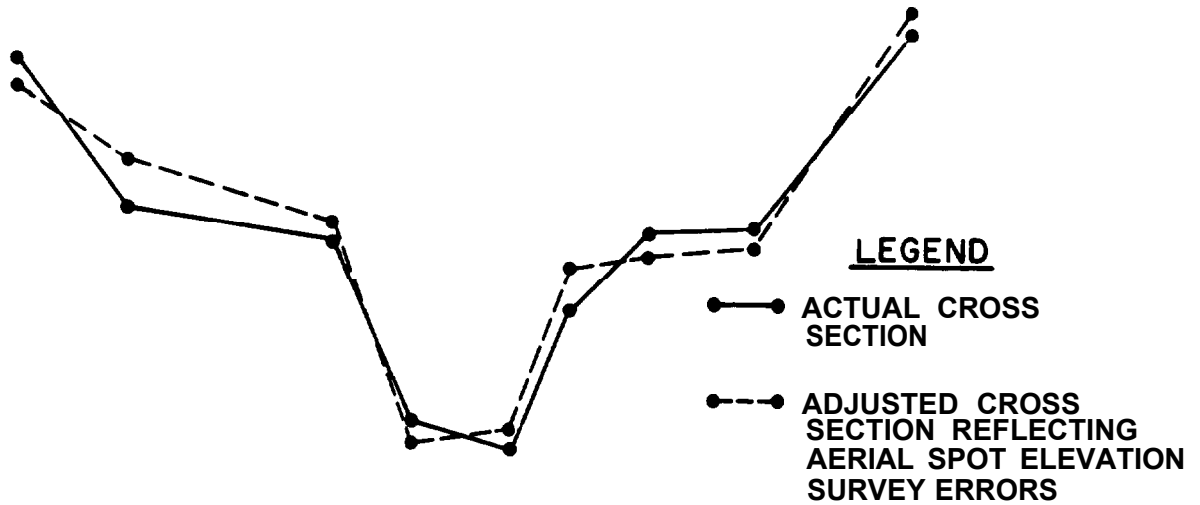

TOPOGRAPHIC MAPS

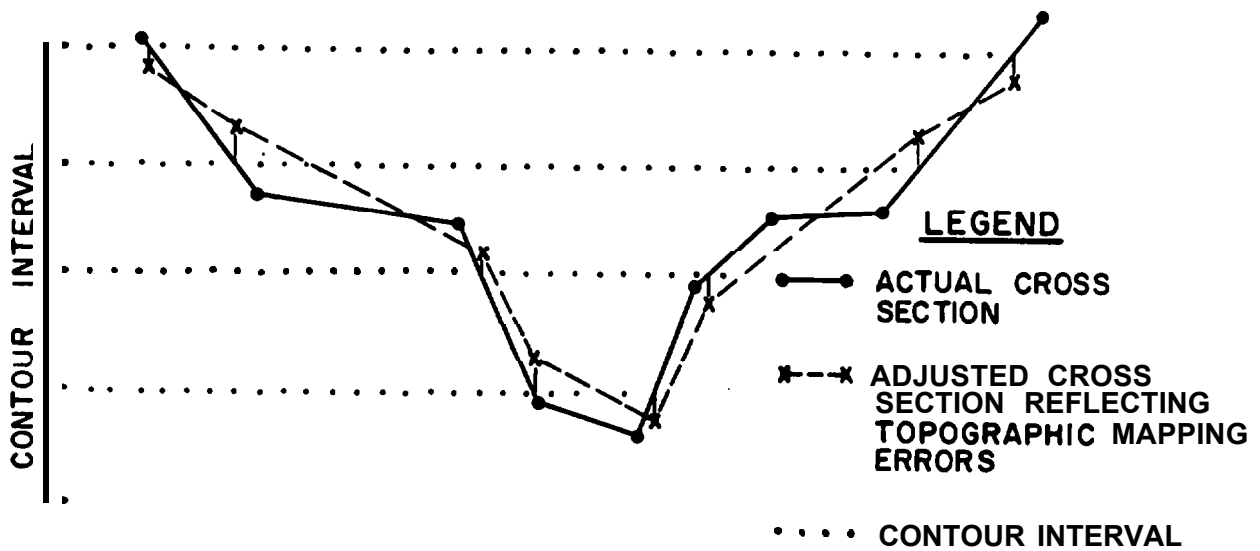

The Hydrologic Engineering Center
December 1966

FIGURE 5.4 Cross Section Adjustment Examples

The procedure used to simulate cross-sectional coordinate point errors associated with reading the points off of topographic maps is listed in the following paragraphs.

- (1) The topographic map contour interval (~~2-~~, ~~5-~~, or ~~10-~~ foot) to be analyzed is specified.
- (2) The base cross section invert coordinate point of the channel is taken as an initial invert coordinate point of the cross section to be adjusted.
- (3) The coordinate points defining the initial topographic map cross section are obtained by interpolating the coordinate points from the base cross section at even contour intervals (see Figure 5.4 and Appendix B).
- (4) Each coordinate point of the initial topographic cross section, including the invert coordinate, is randomly adjusted in the vertical direction using the Monte Carlo error generation procedure described in Section 5-3.3 for topographic map data.
- (5) The procedure is repeated for all cross sections of the data set.

5-4. Manning's Coefficient Errors

5-4.1. Overview. Accurate estimation of Manning's coefficients is hampered by lack of observable field attributes and spatial variation along the stream. The coefficients are often used as a means of calibrating a computer model to reproduce high water marks, thus accounting for a number of undefined effects. Therefore, calibration can result in distortion of the coefficient values. Reliable estimates of Manning's coefficients are difficult even with use of documented procedures, field reconnaissance, and calibration methods (Chow 1959 and Federal Highway Administration 1984).

5-4.2. Derivation of PDF. Statistical information on Manning's coefficient estimation errors is largely nonexistent. Therefore, an experiment is devised to obtain the error **PDFs** required for the Monte Carlo simulation. The HEC staff and participants in two HEC training courses involving experienced Corps of Engineers hydraulic engineers were asked to estimate the Manning's coefficient associated with the 1-percent chance flow for 10 widely different stream reaches. See Table 5.4. The participants are given a photograph and description of each stream and a method for estimating Manning's coefficients from Open Channel Hydraulics (Chow 1959). Table 5.4 is filled out by each participant in the experiment. Study experience

TABLE 5.4

MANNING 'S COEFFICIENT EXPERIMENT *FORM*

The purpose of this experiment is to estimate the Manning's n-values *of* the stream locations shown in the slides. The estimates should coincide with a 1-percent chance event. The estimates may be based on available materials. However, you are asked not to discuss them with others participating in the exercise.

Statistical results *of* the n-value estimates will be used to evaluate the **effects** of the reliability of n-values on computed water surface profile accuracy. No names will be used in this **exercise**.

SLIDE NO.	DESCRIPTION <i>OF</i> STREAM	N-VALUE ESTIMATE
1	A 60 square mile basin near Houston, Texas. The channel surface is a combination of concrete (lower flows) and grass (higher) flows). The concrete section is designed for a 10-percent chance event.	_____
2	Upper Gila River, New Mexico. A 30 square mile basin, channel 10 yards across .	_____
3	A 90 square mile Pennsylvania stream, channel 25 yards across.	_____
4	700 square mile southern Illinois stream, channel 30 yards across.	_____
5	20,000 square mile Ohio River, channel 250 yards across.	_____
6	7600 square mile Muskingham River, channel 250 yards across .	_____
7	4000 square mile Arkansas River, channel 85 yards across.	_____
8	1000 square mile southern Mississippi stream, channel 100 yards across .	_____
9	450 square mile Cache Creek, Ca. basin, channel 35 yards across.	_____
10	900 square mile Colorado stream, channel 50 yards across.	_____

significantly influences the estimates *of* some participants, while others rely primarily on comparisons of photographs and descriptions provided in *reference* materials.

The experiment, though approximate in nature, provides insight into the variations possible in estimating Manning's coefficient. Outliers are deleted, and histograms of the estimations constructed for each of the 10 reaches. **Figure 5.5** contains plots illustrating the variability of the estimates. Analysis of estimates using uniform, normal, and log-normal probability distributions of the histograms shows the log-normal distribution provides the best fit. The log-normal distribution is therefore adopted to represent the PDF of errors associated with estimating Manning's coefficient. The mean of the estimates of each of the 10 histograms is taken as the true coefficient value.

Review of the histograms shows a greater variance of estimates for higher Manning's coefficient values than for lower coefficient values. Estimates of Manning's coefficient for concrete channels, for example, have less variance than those for a densely vegetated stream. A simple linear regression is performed to determine the relationship of the magnitude *of* the coefficient with the standard deviation of errors in estimating the coefficient. A graph of this relationship **is** shown in **Figure 5.6**.

The equation derived to account for variation of the standard deviation with magnitude of Manning's coefficient for the log-normal PDF is

$$SD = n \sqrt{e^{(.582 + .10 \ln(n))^2} - 1} \quad (\text{Equation 5.2})$$

where: SD = standard deviation of Manning's n estimates, and

n = Manning's coefficient for roughness.

5-4.3. Reliability of Estimates. Equation 5.2 represents a coefficient estimate that would be characterized as a minimum effort based on professional judgement. It reflects estimates derived from photographs of a stream, a limited set of background and descriptive information, and made without interaction with other professionals. The other extreme is perfect knowledge of Manning's coefficient - no estimation error and no need for adjustment of the base coefficient values in the Monte Carlo simulation. This condition can be approached by skilled and experienced analysts using reliable calibration data. Most

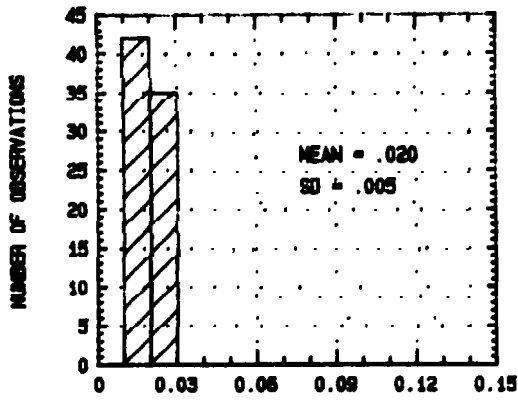

1. MANNING'S COEFFICIENT (n) ESTIMATE
(SLIDE 1)

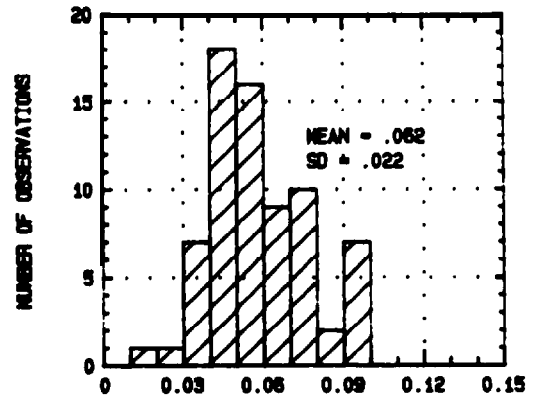

2. MANNING'S COEFFICIENT (n) ESTIMATE
(SLIDE 2)

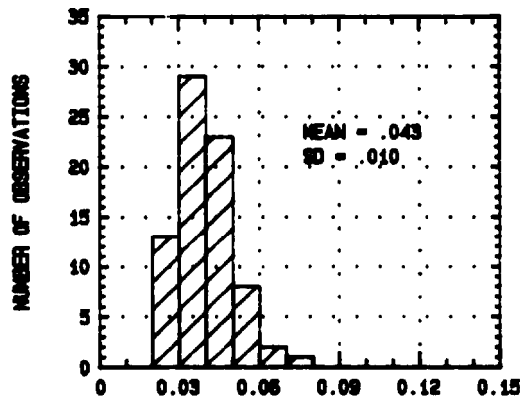

3. MANNING'S COEFFICIENT (n) ESTIMATE
(SLIDE 3)

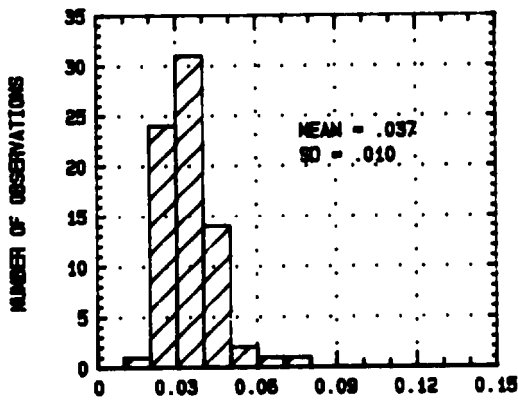

4. MANNING'S COEFFICIENT (n) ESTIMATE
(SLIDE 4)

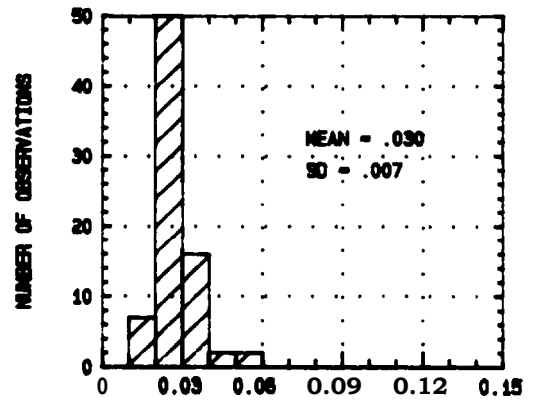

5. MANNING'S COEFFICIENT (n) ESTIMATE
(SLIDE 5)

Slide number corresponds to slide number on Table 5.4.

The Hydrologic Engineering Center
December 1966

FIGURE 5.5 Manning's Coefficient Estimates

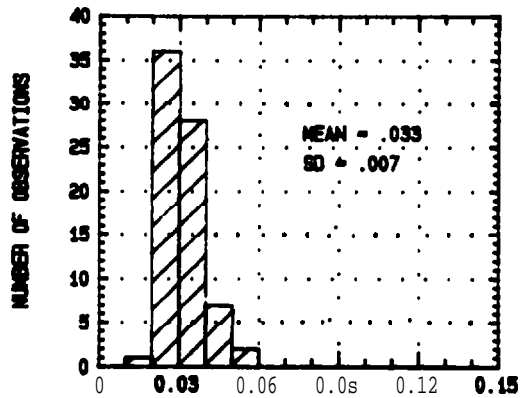

6. MANNING'S COEFFICIENT (n) ESTIMATE (SLIDE 6)

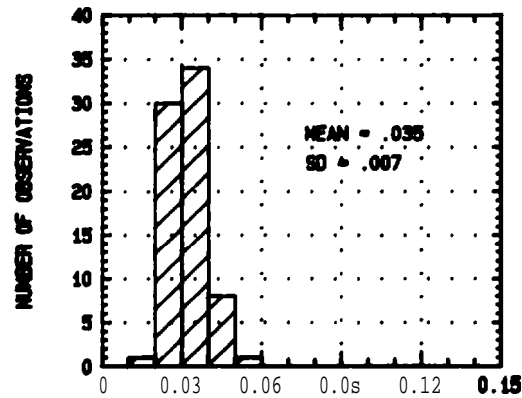

7. MANNING'S COEFFICIENT (n) ESTIMATE (SLIDE 7)

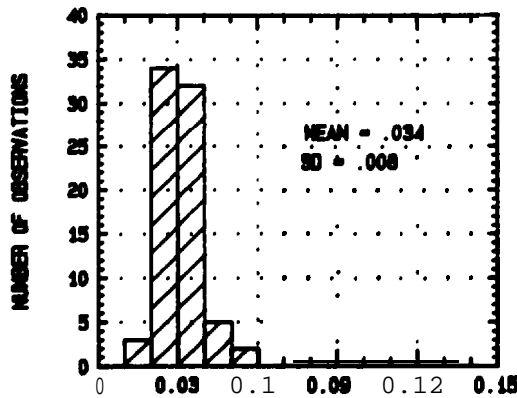

6. MANNING'S COEFFICIENT (n) ESTIMATE (SLIDE 8)

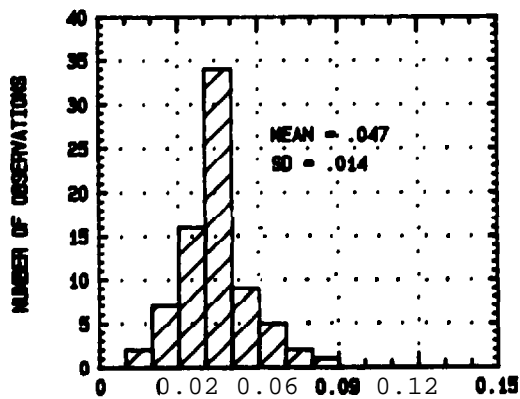

9. MANNING'S COEFFICIENT (n) ESTIMATE (SLIDE 9)

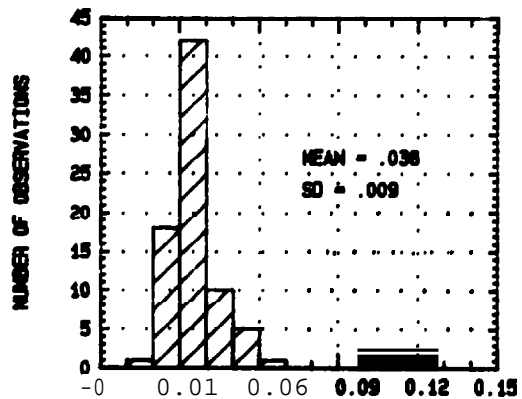

10. MANNING'S COEFFICIENT (n) ESTIMATE (SLIDE 10)

Slide number corresponds to slide number on Table 5.4.

The Hydrologic Engineering Cantor
December 1966

FIGURE 5.5 (continued) Manning's Coefficient Estimates

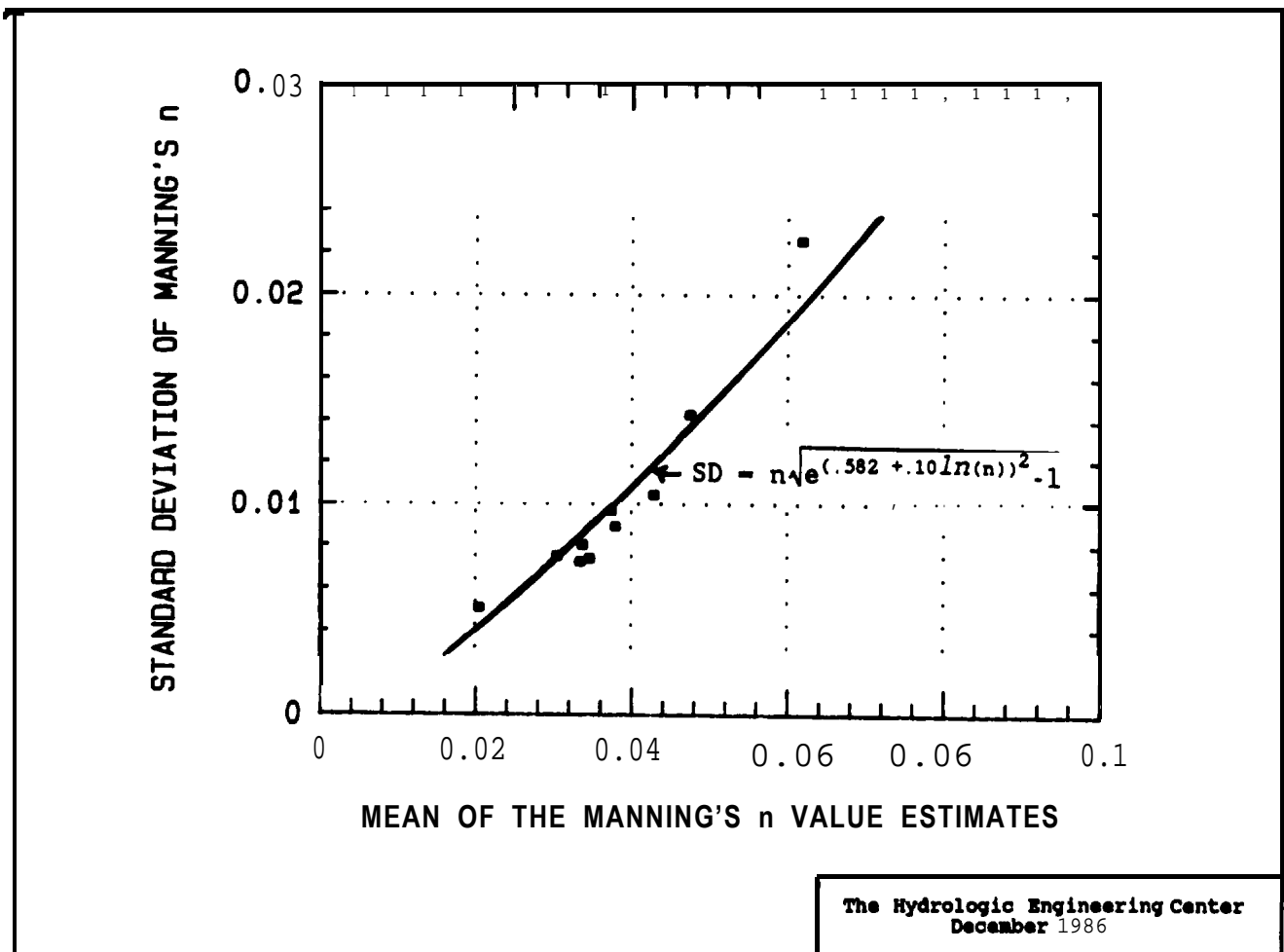

FIGURE 5.6 Manning's Coefficient vs. Standard Deviation

estimates used in practice for profile computations fall somewhere between these bounds.

A reliability coefficient (N_r) is postulated to enable considering the error in Manning's n -value in the simulations. N_r ranges from 0 to 1, where

- $N_r = 0$, when n -value is known exactly. This represents perfect confidence in the estimated value.
- $N_r = .5$, when reasonable **efforts** are made **to substantiate** the estimate, but detailed, intensive calibration is not successful. Moderate confidence exists in the estimated value.
- $N_r = 1.0$, when an approach similar to that tested in the experiment **is** used to estimate the coefficient. No detailed field investigations or calibration is applied. Modest confidence exists in estimated value.

A general form of Equation 5.2 incorporating the reliability concept may be written as

$$SD = Nr * (.582 + .10 * \ln(n)) \quad (\text{Equation 5.3})$$

5-4.4. Manning's Coefficient Adjustments. The procedure for randomly adjusting Manning's coefficient for the Monte Carlo simulation is listed below.

- (1) The **overbank** and channel Manning's coefficients are retrieved from the base conditions HEC-2 data files (they are contained on NC records).
- (2) The natural logarithms of the values are determined.
- (3) The reliability level (Nr) is selected and Equation 5.3 is used to obtain the Manning's coefficient standard deviation.
- (4) A random normal standard deviate (k) is generated as before (Section 5-3.3). A single deviate is used to adjust the channel and **overbank** n-values simultaneously to simulate the likelihood of the estimates in practice to be consistently high or low at a specific location. The magnitude of the adjustment, however, is a function of the individual **overbank** and channel values and the selected reliability level.
- (5) The adjusted coefficients are calculated from the equation

$$\ln(n)_{adj} = \ln(n) + k * SD \quad (\text{Equation 5.4})$$

where: $\ln(n)_{adj}$ = the natural logarithm of adjusted Manning's coefficient (n-value),
 $\ln(n)$ = the natural logarithm of the unadjusted or base condition Manning's coefficient (n-value) defined in step 2,
k = normal standard deviate as described in Section 5.3, and
SD = standard deviation of logarithms of the Manning's coefficient (n-value).

- (6) The adjusted Manning's coefficient is obtained by taking the antilog of the value calculated from Equation 5.4.
- (7) Steps 1 through 6 are repeated for each set of Manning's coefficients in the data file (HEC-2 NC record) .

5-4.5. Summary Error PDFs are developed to represent estimation errors for cross-sectional coordinates and for Manning's roughness coefficient. Strategies **are** formulated to enable generation of likely HEC-2 data sets representative of the error **PDF's**. Systematic application of the **strategies** for all error conditions for all data sets yields the requisite HEC-2 data sets that **are** then processed to compute the profiles reflecting the estimation errors. Data are thus now available for performing the computed profile error analysis.

REFERENCES CITED

1. American Congress on Surveying and Mapping and the American Society of Civil Engineers 1981, "**Definitions** of Survey and Associated Terms."
2. Barnes, H.H., Jr., 1967, Roughness Characteristics of Natural Channels, U.S. Geological Survey Water Supply 1849.
3. Chow, Ven Te, 1959, Open Channel Hydraulics, McGraw-Hill Book Company, New York, New York.
4. Federal Highway Administration 1984, Guide for Selecting Manning's Roughness Coefficients for Natural Channels and Flood Plains, Report No. FHWA-TS-84-204, U.S. Department of Transportation.
5. Funk L.L. 1958, "Photographic Map Accuracy" Highway Research Board Bulletin 189, presented at the 37th Annual Meeting of Land Acquisition and Economic Impact Studies Conference, January 6-10, 1958.
6. Hydrologic Engineering Center 1985, Commercial Survey Guidelines for Water Surface Profiles, prepared by Borcalli, Ensign, and Buckley Consulting Engineers, Sacramento, California, for the Hydrologic Engineering Center, U.S. Army Corps of Engineers.
7. Moffitt, Francis H. and **Mikhail**, Edward M. 1980, Photogrammetry, Harper and Row, Publishers, Inc., 10 East 53rd Street, New **York**, New York.

CHAPTER 6

PROFILE ACCURACY ANALYSIS

6-1. General

As described in Chapter 5, Monte Carlo simulation techniques are applied to generate random survey measurement errors and Manning's coefficient estimation **errors**. The BEC-2 data sets containing the **adjusted** cross sections **and** adjusted Manning's coefficients **are** processed with HEC-2 to produce computed profiles **for** the conditions analyzed. This chapter describes the computation **of** the profile errors for each combination of error conditions. Regression equations and nomographs **are** developed to predict profile errors given stream characteristics, survey method and accuracy, and Manning's coefficient estimation reliability (Nr).

6-2. Error Calculation Procedure

A total of 21 survey and Nr combination error conditions are analyzed for **each of** the data sets. Field surveys are taken as exact: thus, profile **errors for** this condition are a function only of Manning's coefficient reliability. Aerial spot elevations and topographic map accuracies are evaluated for **2-, 5-, and 10-** foot contour intervals **and** Nr values of 0, 0.5, and 1.0. The specific error conditions analyzed are documented in Table 6.1.

TABLE 6.1

Survey and Manning's
Coefficient Error Conditions

Contour Interval (feet)	Reliability of Manning's Coefficient (Nr)		
	Field Surveys	Aerial spot Elevations	Topographic Maps
No Error	0, .5, 1.0	N.A.	N.A.
2	N.A.	0, .5, 1.0	0, .5, 1.0
5	N.A.	0, .5, 1.0	0, .5, 1.0
10	N.A.	0, .5, 1.0	0, .5, 1.0

Profile errors are computed as the absolute difference (in feet) between the base data set computed profiles and the adjusted data set computed profiles. The error calculations are made at the 500 foot interpolated cross section spacing. The reach mean absolute error is the sum of the absolute differences divided by the number of locations. The reach maximum absolute error is the largest absolute difference that occurs within the stream reach. Figure 6.1 illustrates the error computations.

Cumulative frequency plots for the mean errors resulting from the Monte Carlo simulations for the 98 data sets were developed to display the range of errors generated in the analysis. Figures 6.2 and 6.3 present the frequency plots for both the mean absolute errors and maximum absolute errors at the extremes of Manning's coefficient reliability. Note **that** the errors are grouped in bands corresponding to the survey contour intervals. This indicates that the profile errors vary distinctly in magnitude with the 2-, 5-, and 10-foot contour intervals. Note also that as Manning's n-value becomes less reliable, the grouping into contour interval bands is less distinct.

6-3. Profile Replicates

6-3.1. General. The computed profile error for an **HEC-2** run represents but **one** possible error associated with each survey method and Manning's coefficient estimation reliability. The single result of a single reach error analysis does not necessarily permit development of stable error statistics of mean and variance for the error analysis condition. Therefore, a series of replicate analyses are performed for each of the combinations evaluated to provide a representative sample of errors. Each replicate yields an alternative error result. The mean reach maximum absolute and mean absolute errors for the common sets of replicates are averaged, respectively, to produce a stable and consistent error result for the error conditions evaluated. Figure 6.4 illustrates the replicate analysis performed.

A method is developed to determine the number of profile replicates needed to assure that the computed mean error is within specified limits with a stated probability. The replicate requirements may be described by example. Suppose a stream reach data set has 15 cross sections and 3 NC records defining the geometry and Manning's coefficients, respectively. How many replicates (adjusted data sets with Monte Carlo generated cross sections and Manning's coefficients) are required so that the true mean error for the stream (data set) lies between specified bounds, with a stated probability?

6-3.2. Replicate Approach. The statistical analysis concept used to determine the number of replicates required to provide stable results for a stream data set is called significance

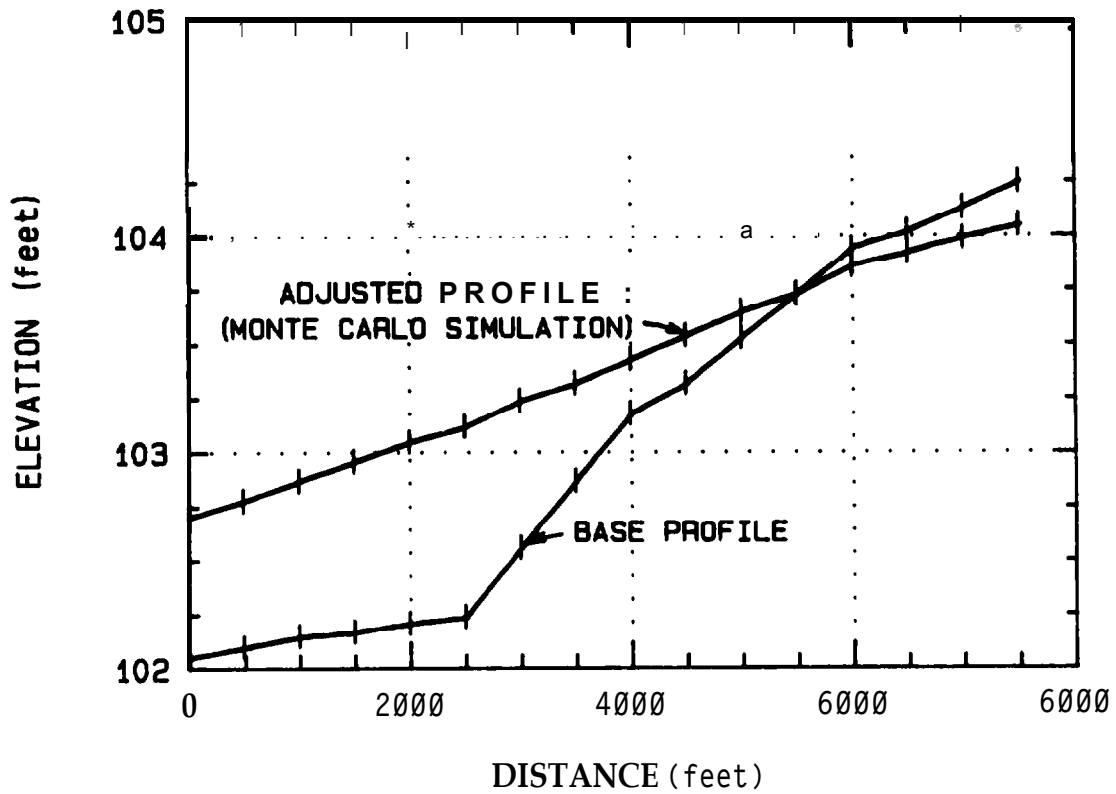

<u>DISTANCE</u> (ft.)	<u>BASE</u> <u>PROFILE</u> <u>ELEV.</u>	<u>ADJUSTED</u> <u>PROFILE</u> <u>ELEV</u>	<u>ERROR</u> (ft.)	<u>ABSOLUTE</u> <u>ERROR</u> (ft.)
500	102.10	102.78	+.68	.68
1000	102.15	102.87	+.72	.72
1500	102.17	102.96	+.79	.79
2000	102.21	103.05	+.84	.84
2500	102.24	103.12	+.88	.88
3000	102.56	103.24	+.68	.68
3500	102.87	103.32	+.45	.45
4000	103.18	103.43	+.25	.25
4500	103.32	103.54	+.22	.22
5000	103.53	103.65	+.12	.12
5500	103.73	103.73	.00	.00
6000	103.94	103.86	-.08	.08
6500	104.02	103.92	-.10	.10
7000	104.13	103.99	-.14	.14
7500	104.25	104.05	-.20	.20

sum 6.15 ft.

Reach Absolute Mean Error = $6.15/15 = .41$ feet
 Reach Absolute Maximum Error = **.88** feet

TheHydrologic Engineering Center
 December 1966

FIGURE 6.1 Profile Error Computation

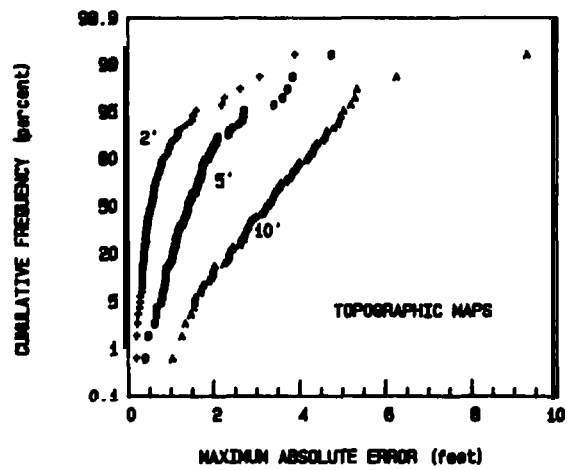
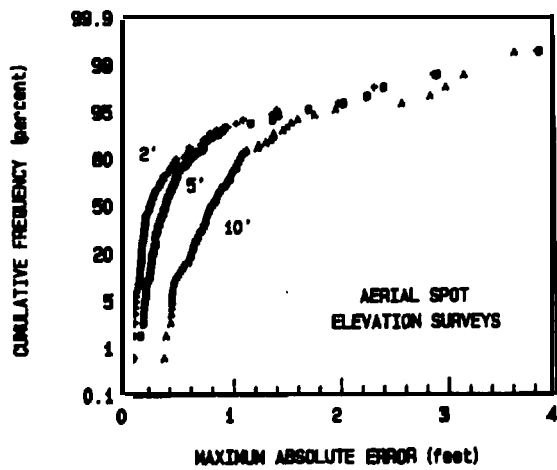
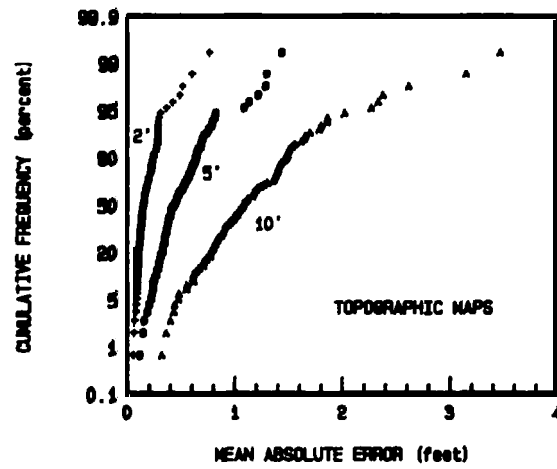
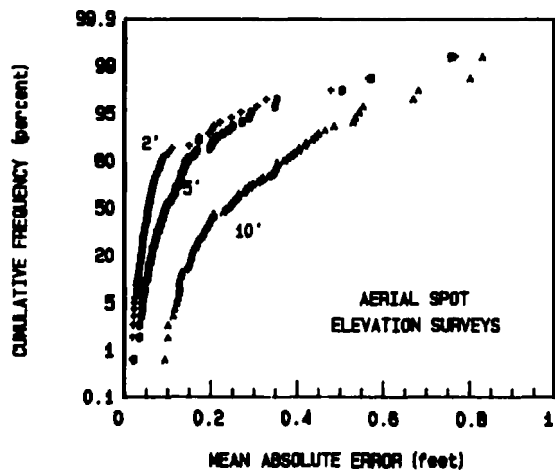

Monte Carlo simulation results - 98 data sets. Nr = 0.

The Hydrologic Engineering Center
December 1986

FIGURE 6.2 Frequency of Profile Errors - High Reliability of Manning's Coefficient

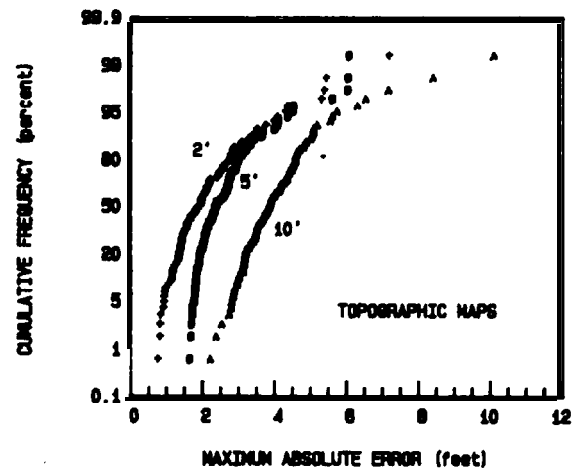
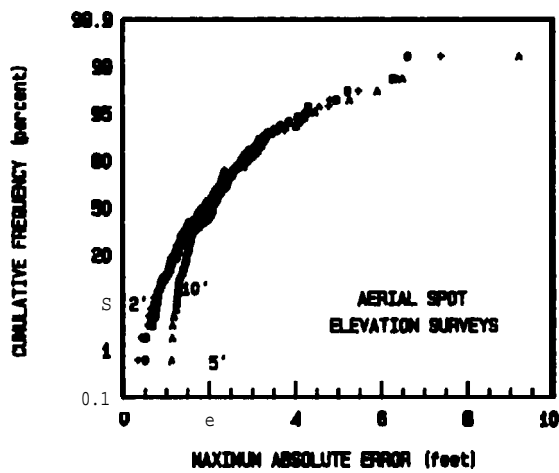
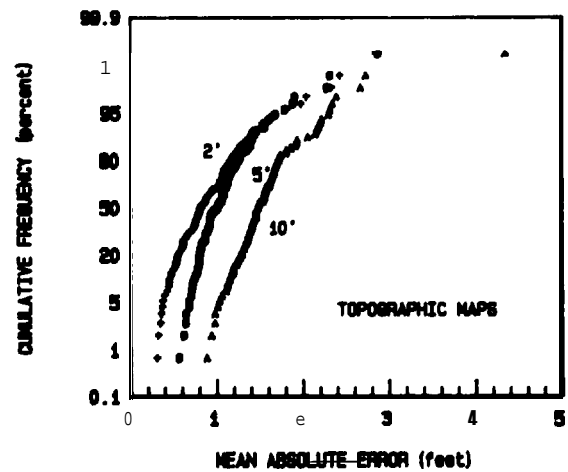
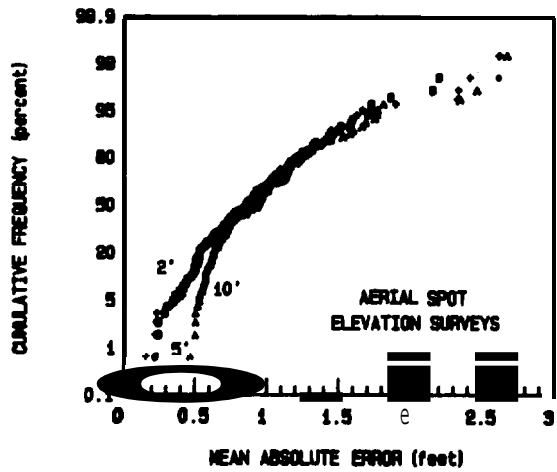

Monte Carlo simulation results - 98 data sets. Nr = 1.

The Hydrologic Engineering Center
December 1906

FIGURE 6.3 Frequency of Profile Errors - Low Reliability of Manning's Coefficient

REPLICATE 1

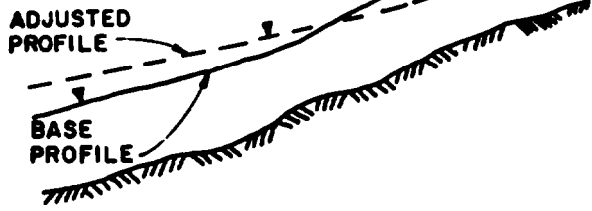

REACH
MEAN
ABSOLUTE
ERROR

REACH
MAXIMUM
ABSOLUTE
ERROR

E_1

E_{max1}

REPLICATE 2

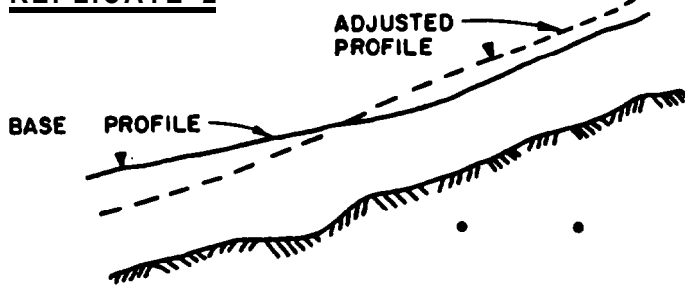

$\overline{E_2}$

E_{max_2}

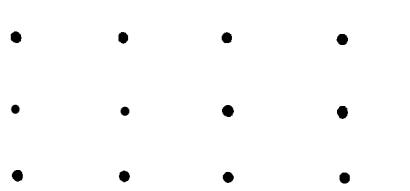

REPLICATE n

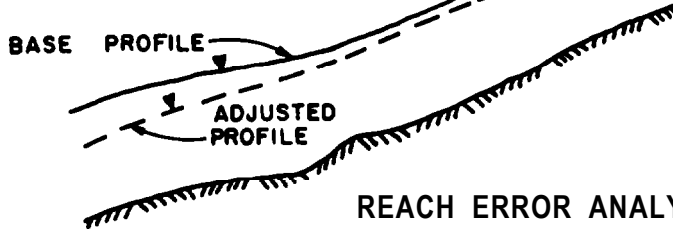

$\overline{E_n}$

E_{max_n}

REACH ERROR ANALYSIS

$\overline{\overline{E_{mean}}}$

$\overline{\overline{E_{max}}}$

E_{mean} = Sample Estimate of Mean Absolute Error

$$= \frac{\sum_{i=1}^n |E_i|}{n}$$

E_{max} = Sample Estimate of Maximum Absolute Error

$$= \frac{\sum_{i=1}^n |E_{max_i}|}{n}$$

The Hydrologic Engineering Center
December 1986

FIGURE 6.4 Replicate Profile Error Analysis

testing. To estimate the mean of a sample drawn randomly from a normally distributed population of unknown mean and standard deviation, a two-sided "t" test of hypothesis about the means is used. Error acceptances are specified, statistics computed, and the required sample size is estimated (Bowker and Lieberman 1965). The error tolerances chosen are: (1) the Monte Carlo simulation experiments will yield estimates of mean errors that are within 10-percent of the true error, with (2) a **5-percent** chance that the true mean error is within the 10-percent tolerance band but based on sample computed statistics, the decision criteria would conclude it is not, and (3) a 10-percent chance that the true mean error lies outside the tolerance band but based on sample computed statistics, the decision criteria would conclude that it is within.

The determination of the number of replicates necessary for each data set required an initial assumption of the ratio of the mean error to the variance of the errors. A value of .3 is initially assumed and later verified during the analysis. The number of NC records used to define the channel and **overbank** roughness values and the number of stream cross sections are considered independently. The governing condition determining the number of replicates needed is almost always the lack of sufficient NC records, meaning a shortage of independent samples for variations in Manning's coefficients.

The above tests the hypothesis that the true mean error falls within a stated acceptance band about the sample mean error, given selected levels of significance and the probability of the hypotheses being correct. The sample size is a by-product of the hypothesis testing. The significant assumptions are that the errors are randomly distributed in accordance with the normal probability density function and that the error statistics related to NC (Manning's coefficient) variance and cross-sectional (survey error) variance are independent.

Appendix D (bound separately) contains a tabulation of the number of replicates for each HEC-2 data set required to yield stable results. The required number of replicates varies from 3 to 60 for each of the 98 data sets.

6-4. Regression Analyses

6-4.1. Regression Analysis Variables. Regression analyses are performed to develop equations for predicting the computed water surface profile error. The general form of the error prediction equations adopted is

$$\log \text{Error} = C + a \cdot \log X + b \cdot \log Y + g \cdot \log(d \cdot S_n + e \cdot N_r) \quad (\text{Equation 6.1})$$

or

$$\text{Error} = C * X^a * Y^b * (d * S_n + e * N_r)^g \quad (\text{Equation 6.2})$$

where: C = regression constant,
a, b, g = power coefficients for variables X, Y, and
 (d * S_n + e * N_r),
 S_n = standardized contour interval (interval divided by
 10),
d, e = survey and Manning's dimensionless weight
 coefficients, respectively, and
 N_r = Manning's n-value estimate confidence.

The several hydraulic variables **tested** as explanatory variables include the 1-percent chance flow rate, Manning's coefficient, cross-sectional top width, hydraulic depth, and channel slope. Manning's coefficient, cross-sectional top width, and hydraulic depth are length weighted values. The dominant hydraulic variables are slope and hydraulic depth. Several combinations of dimensionless weight coefficients for the term (d * S_n + e * N_r) were tried for field and aerial spot elevations surveys and topographic maps. The selected values are those that provided the best regression fit. The complete set of error values for each stream data set, survey method and accuracy, and reliability of estimation of Manning's coefficient are provided in Appendix C.

6-4.2. Field Surveys. The adopted regression equations for field surveys are

$$E_{\text{mean}} = .076 * HD^{.60} * S^{.11} * (5 * N_r)^{.65} \quad (\text{Equation 6.3})$$

and $E_{\text{max}} = 2.1 (E_{\text{mean}})^{.8} \quad (\text{Equation 6.4})$

where: E_{mean} = mean reach absolute profile **error** in feet,
 E_{max} = absolute reach maximum profile error in feet,
 HD = reach mean hydraulic depth in feet,
 S = reach average channel slope in feet per mile,
 and
 N_r = reliability of estimation of Manning's
 coefficient on a scale of 0 to 1.0.

Equation 6.3 reflects only the error of estimating Manning's coefficient since there is no error for field surveys used to obtain cross-sectional coordinate data.

6-4.3. Aerial Spot Elevations. The regression equations to predict computed profile **errors** from aerial spot elevation survey measurement errors and Manning's coefficient estimation errors are

$$E_{\text{mean}} = .076 * HD^{.60} * S^{.11} * (5 * N_r + S_n)^{.65} \quad (\text{Equation 6.5})$$

and $E_{\text{max}} = 2.1 * (E_{\text{mean}})^{.8}$ (Equation 6.6)

where: S_n = the standardized survey accuracy being analyzed - the contour interval **2-, 5-, 10-feet** divided by **10**; and other variables are as previously defined.

For the special case of $N_r = 0$, when Manning's coefficient is precisely known, a tighter regression fit is given by the equation

$$E_{\text{mean}} = .0731 * S^{.49} * S_n^{.83} \quad (\text{Equation 6.7})$$

6-4.4. Topographic Maps. The regression equations to predict **profile errors** from topographic **map survey** measurement errors and Manning's coefficient estimation errors are

$$E_{\text{mean}} = .45 * HD^{.35} * S^{.13} * (N_r + S_n) \quad (\text{Equation 6.8})$$

and $E_{\text{max}} = 2.6 * (E_{\text{mean}})^{.8}$ (Equation 6.9)

For the special case when Manning's coefficient is precisely known ($N_r = 0$), the profile error can be found with greater accuracy with the equation

$$E_{\text{mean}} = .632 * S^{.23} * S_n^{1.18} \quad (\text{Equation 6.10})$$

6-5. Reliability of Results

The goodness-of-fit of the regression equations can be expressed using the coefficient of determination and the standard **error of regression**. The coefficient of determination defines the **proportion** of the total variation of a dependent variable explained by the independent variables. **For** example, a value of 0.90 indicates that 90 percent of the variation is accounted for by the independent variables. The standard error of regression is the root-mean-square error. Table 6.2 summarizes the **goodness-of-fit** statistics for the adopted regression equations. Table 6.3 shows standard error values for selected profile accuracies.

TABLE 6.2

Profile Accuracy* Regression Analysis
Goodness-of-Fit Statistics

<u>Statistic</u>	Field and Aerial Spot Elevation Survey		Topographic	
			M	a
	<u>Nr = 0</u>	<u>Nr > 0</u>	<u>Nr = 0</u>	<u>Nr > 0</u>
Coeff. of Deter- mination (R^2)	.67	.68	.77	.64
Standard Error (Log Units, Base 10)	.21	.17	.19	.20

* Mean reach absolute profile error analyses.

TABLE 6.3

Profile Accuracy Prediction Reliability*
(in feet)

Aerial Spot Elevations Surveys

<u>Predicted Error (ft)</u>	<u>+1Se (ft)</u>	<u>-1se (ft)</u>	<u>+2Se (ft)</u>	<u>-2Se (ft)</u>
.05	.07	.03	.11	.02
.10	.15	.07	.21	.05
.20	.29	.14	.43	.09
.30	.44	.20	.64	.14
.40	.59	.27	.86	.19
.50	.73	.34	1.07	.23

Topographic Maps

<u>Predicted Error (ft)</u>	<u>+1Se (ft)</u>	<u>-1Se (ft)</u>	<u>+2Se (ft)</u>	<u>-2Se (ft)</u>
.25	.40	.16	.63	.10
.50	.79	.32	1.26	.20
.75	1.19	.47	1.88	.30
1.00	1.58	.63	2.51	.40
1.25	1.98	.79	3.14	.50
1.50	2.38	.95	3.77	.60

* The values in the table are the plus and minus limits in feet for the stated standard error criterion.

6-6. Nomograph Adaptation

The regression equations are adapted to nomographs to facilitate ease of use. Figures 6.5, 6.6, and 6.7 are nomographs for aerial spot elevation survey and corresponding topographic map accuracies for Manning coefficient estimation reliabilities (N_r) of 0, **.5** and 1.0, respectively.

For example, suppose a stream has a hydraulic depth of 10 feet and a slope of 20 feet per mile. If 10-foot aerial spot elevation surveys are used and the Manning's coefficient is not well known ($N_r = 1$), what is the predicted mean error for the profile? Using Figure **6.5a**, draw a line through the given values of slope and hydraulic depth until it intersects with the turning line. This intersection point and the contour interval value are aligned to give the mean error, 1.35 feet. *For* 10-foot topographic maps, a 20 foot per mile slope and low Manning's coefficient reliability give a predicted profile error of nearly 3 feet.

6-7. Summary of Profile Error Results

6-7.1. Field Survey Results. The profile errors resulting from commonly applied field survey methods of obtaining **cross-sectional** coordinate data are a function only of Manning's coefficient reliability. Computed profile error is relatively small even for rough estimates of Manning's coefficient. Table 6.4 shows the range of mean profile errors expected for streams with hydraulic depths of 5 feet. The table is derived from Equation 6.3.

6-7.2. Aerial Spot Elevation Results. Errors for aerial spot elevation surveys for obtaining cross-sectional coordinate data varies with the contour interval and reliability of Manning's **n-value**. Table 6.5 tabulates errors for a stream hydraulic depth of 5 feet. Different errors would be predicted for other hydraulic depths. *For* the range of data analyzed (stream slopes varying from 1 to 30 feet per mile and contour intervals of 2 to 10 feet), the mean profile error is less than **.5** feet when Manning's n-value is exactly known. For flat stream reaches (slope of 1 foot per mile), the profile **error** is less than **.1** feet even if a 10 foot contour interval is used for the cross-sectional measurements.

The relatively small profile error for the aerial spot elevation survey method is due to the high accuracy of aerial spot elevation surveys and the randomness of the measurement errors at the individual coordinate points. The latter results in compensating errors along the cross-sectional alignment. *For* the error prediction determined from the regression equations to be valid, eight or more cross-sectional coordinate points are needed to ensure that the randomness and thus compensatory error process has occurred.

AERIAL SPOT ELEVATION SURVEYS (Nr = 0)

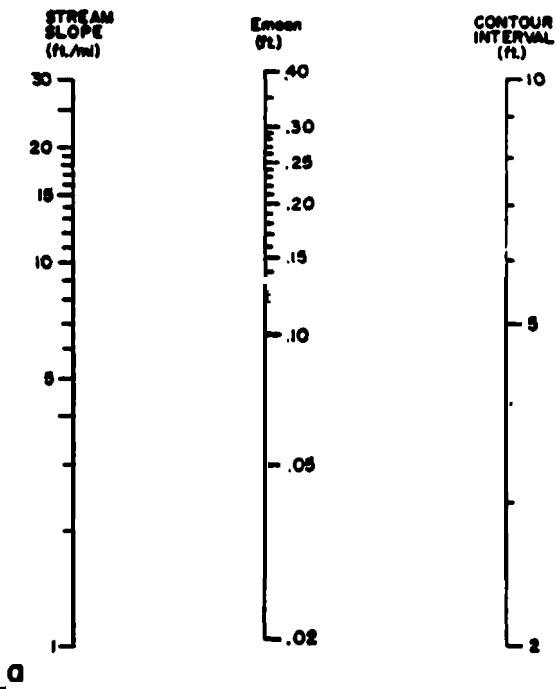

$$E_{mean} = .0731 * S^{.49} * S_n^{.83}$$

Where:

E_{mean} = mean absolute
• ww of reach, in ft

S = stream dope in
ft./mi

S_n = contour interval
of aerial spot
elevation divided
by 10, in ft.

N_r = Reliability of Manning's n ;
 $N_r = 0$ when n is known exactly.

TOPOGRAPHIC MAPS (Nr = 0)

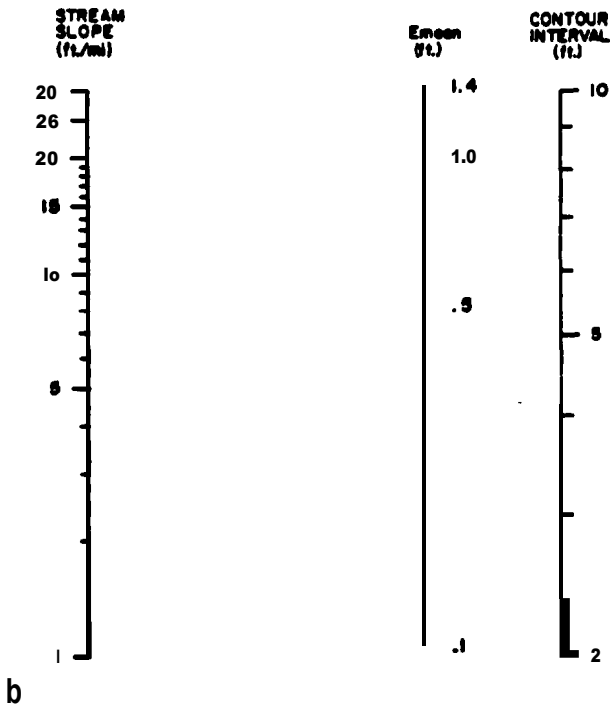

$$E_{mean} = .632 * S^{.23} * S_n^{1.18}$$

Where:

E_{mean} = mean absolute
• WW of reach in ft

S = stream slope in
ft./mi

S_n = contour interval
of topographic map
divided by 10, in ft.

N_r = Reliability of Manning's n ;
 $N_r = 0$ when n is known exactly.

The Hydrologic Engineering Center
December 1966

FIGURE 6.5 Profile Errors - High Reliability of Manning's Coefficients

AERIAL SPOT ELEVATION SURVEYS (Nr = .5)

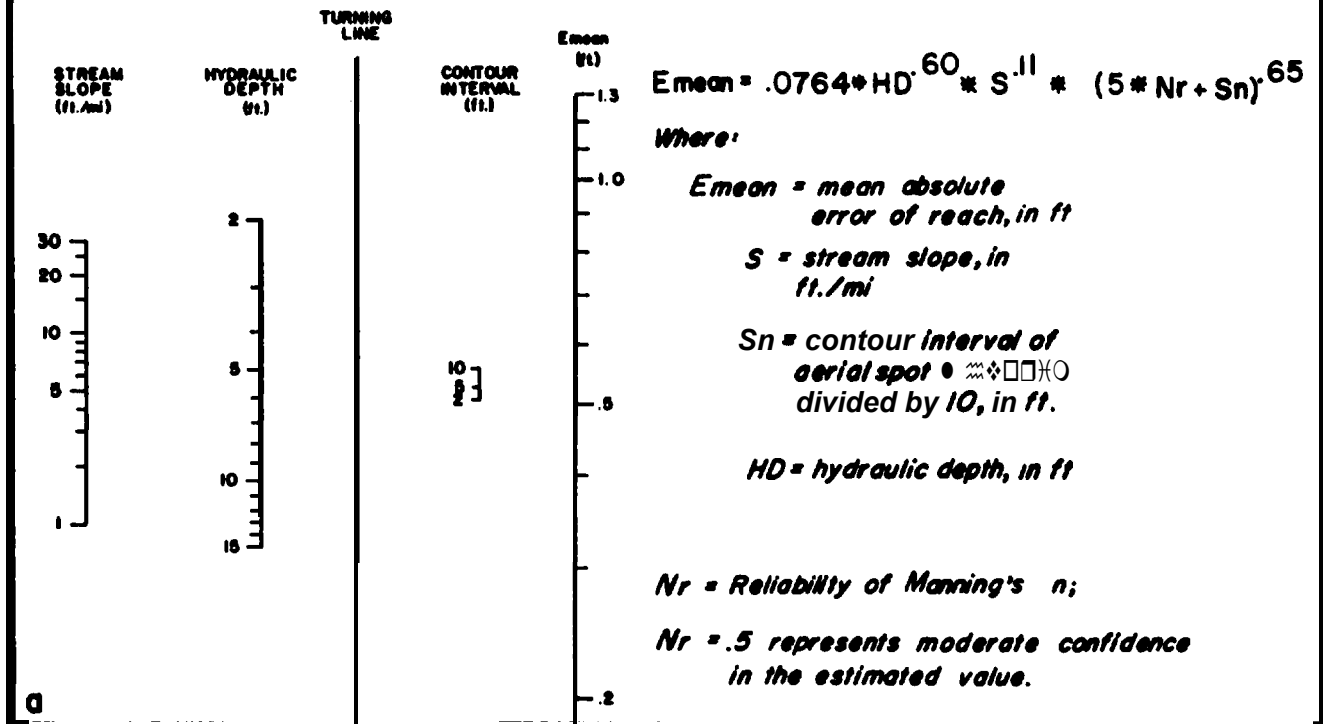

TOPOGRAPHIC MAPS (Nr = .5)

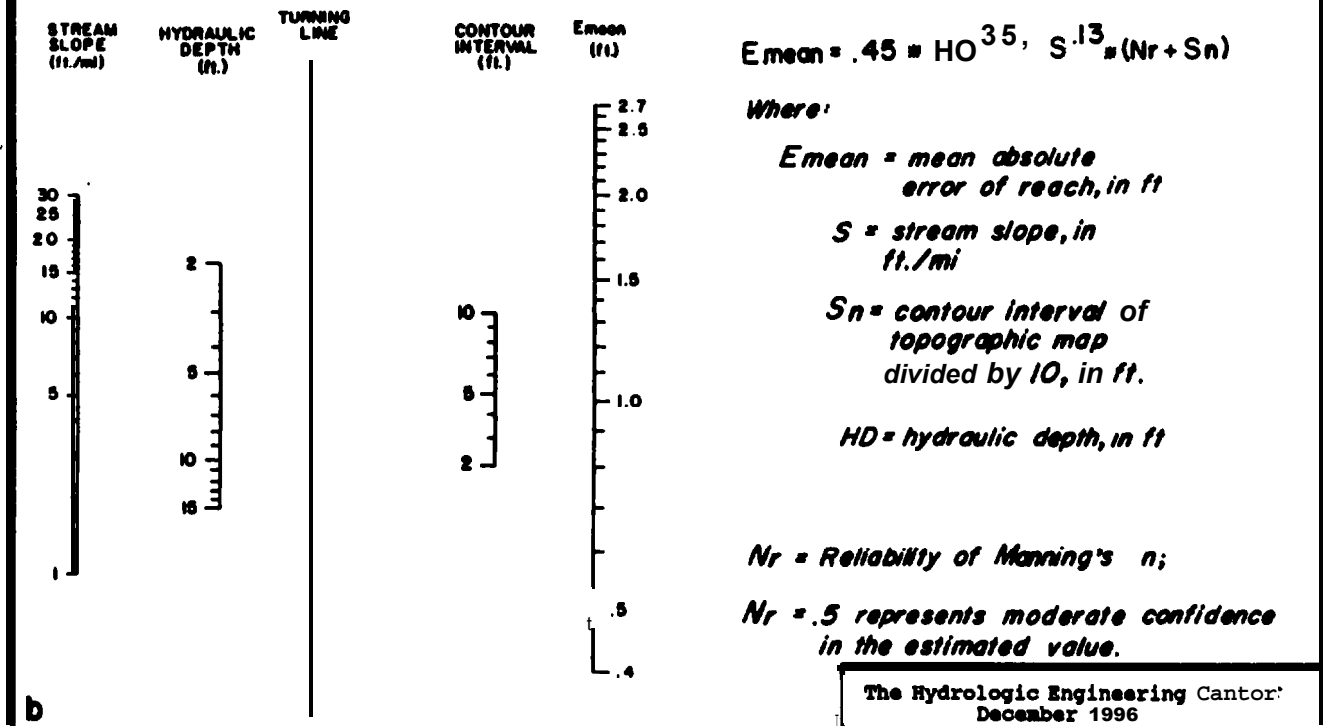

The Hydrologic Engineering Cantor:
December 1996

FIGURE 6.6 Profile Errors - Moderate Reliability of Manning's Coefficients

AERIAL SPOT ELEVATION SURVEYS (Nr = 1)

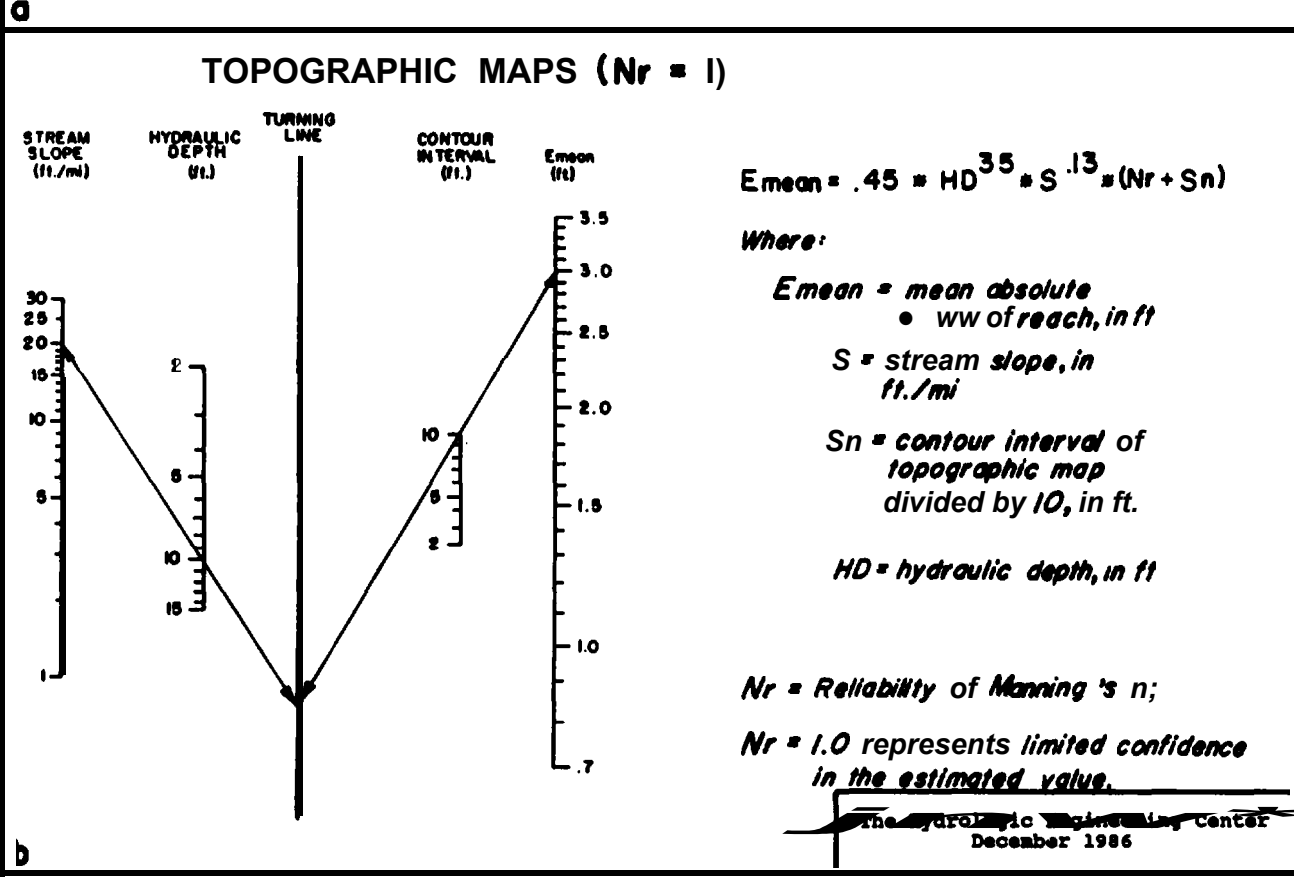
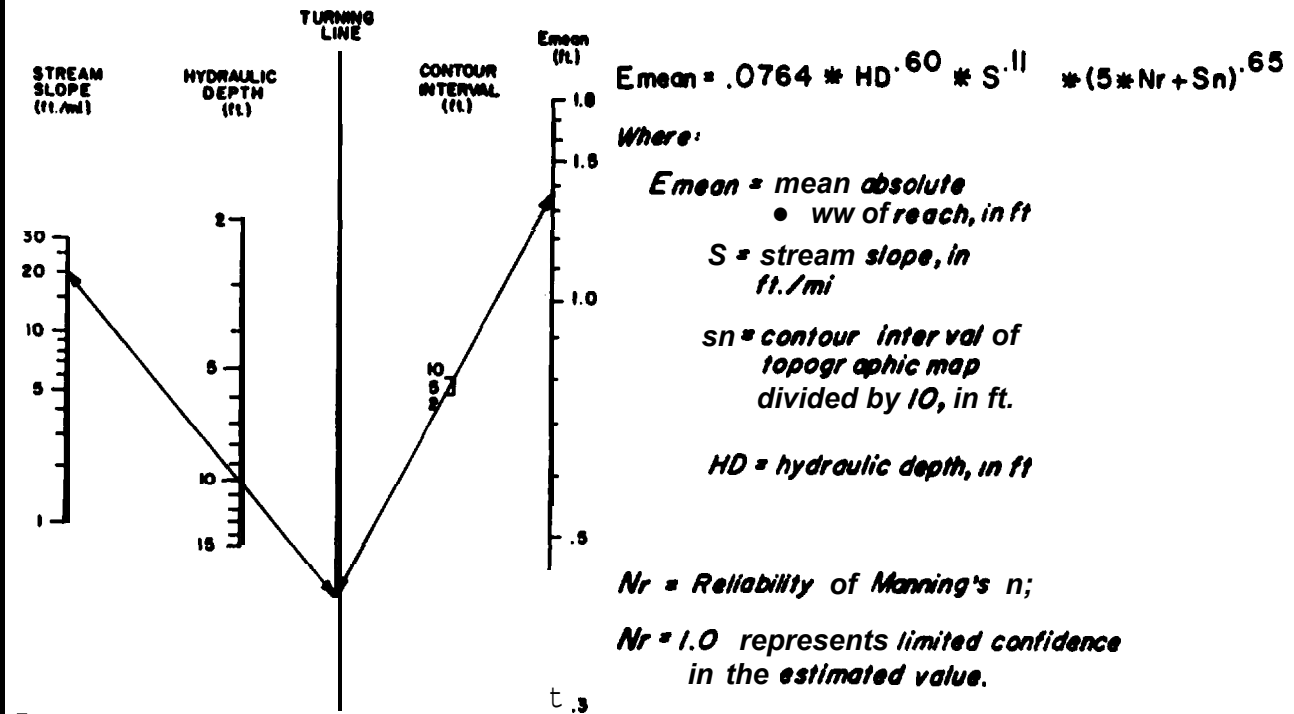

FIGURE 6.7 Profile Errors - Low Reliability of Manning's Coefficients

TABLE 6.4
Field Survey
Water Surface Profile Errors

Stream Slope (ft./mi.)	Manning's Coefficient Reliability (Nr)	Profile Error E _{mean} (ft.)
1	.0	.0
1	.5	.36
1	1.0	.57
10	.0	.0
10	.5	.47
10	1.0	.74
30	.0	.0
30	.5	.53
30	1.0	.a3

*E_{mean} = Mean absolute reach error for hydraulic depth of 5 feet.

Table 6.5 also shows that the error in computed water surface profiles increases significantly with **decreased** reliability of Manning's coefficient. The profile errors resulting from less reliable estimates of Manning's coefficient are several times those resulting from survey measurement error. The relative insignificance of the aerial spot elevation survey contour intervals on the profile error when less reliable Manning's coefficients are used can be seen in Table 6.5 and is graphically depicted in the nomographs of Figures 6.6a and 6.7a. For less reliable estimates of Manning's coefficients (Nr = 1.0), it is likely that the error in the computed water surface profiles will be greater than .75 feet for stream reaches with average slopes greater than 10 feet per mile regardless of the accuracy of the spot elevation contour interval.

6-7.3. Topographic Map Results. A summary of the profile error associated with using topographic maps for cross-sectional coordinate data is shown on Table 6.6. The table lists the estimated error for slopes ranging from 1 to 30 feet per mile and contour intervals of 2-, 5-, and 10-feet. There is significantly

TABLE 6.5

Aerial **Survey** Method Effect
On Water Surface Profile Accuracy

<u>Stream Slope (ft./mi.)</u>	<u>Contour Interval (feet)</u>	<u>E_{mean}* for Nr = 0 (feet)</u>	<u>E_{mean}* for Nr = 1 (feet)</u>
1	2	.02	.59
1	5	.04	.61
1	10	.07	.64
10	2	.06	.75
10	5	.13	.78
10	10	.22	.83
30	2	.10	.85
30	5	.22	.88
30	10	.39	.93

*E_{mean} = Reach mean absolute error where hydraulic depth is assumed to be 5 feet.

greater error for larger contour intervals **for** topographic maps than for aerial spot elevation surveys. Data from topographic maps are simply less accurate than data from aerial spot elevation methods. Also, topographic map cross-sectional elevations can only be obtained at the contour intervals. Because of the randomness of the error the compensating error phenomena may be an important issue for streams that have small **cross** section elevation variation compared to the map contour interval. If less than eight coordinate points **are** obtained from the map, the actual profile **error** will be larger than predicted by the nomographs and equations. Significant mean profile errors (greater than 2 feet) may be expected for analyses involving steep streams, large contour intervals, and unreliable estimates of Manning's coefficients.

6-7.4. Summary. Error in Manning's coefficient can have a significant **impact** on the profile accuracy. Less reliable estimates of Manning's coefficient generally produce profile errors several times those obtained when the values are exactly known. The contour interval **of** aerial spot elevation surveys is essentially unimportant unless the Manning's coefficients **are** reliably estimated. However, **if** topographic maps are used for cross-sectional geometry, both the contour interval and Manning's coefficient error have a significant bearing on the profile

error. The results show that reliable Manning's coefficient estimates are required for accurate water surface profile analyses. For detailed studies with significant survey costs, detailed calibration and verification studies are required to provide appropriate estimates of Manning's coefficients.

TABLE 6.6
Topographic *Map* Effect
On Water Surface Profile Accuracy

<u>Stream Slope (ft./mi.)</u>	<u>Contour Interval (feet)</u>	<u>E_{mean}* for Nr = 0 (feet)</u>	<u>E_{mean}* for Nr = 1 (feet)</u>
1	2	.09	.95
1	5	.28	1.19
1	10	.63	1.58
10	2	.16	1.28
10	5	.47	1.60
10	10	1.07	2.13
30	2	.21	1.48
30	5	.61	1.84
30	10	1.38	2.46

***E_{mean}** = Reach mean absolute *error* where hydraulic depth is assumed to be 5.0 feet.

The research results may be used in reverse by determining the mapping required to achieve a desired computed profile accuracy. Table 6.7 is an example of this type of application for selected stream slopes and Nr values of 0 and 1.0, and for a hydraulic depth of 5 feet. The table shows that a 10 foot contour interval for aerial spot elevations is sufficient except when mean profile errors of less than .1 feet are sought for relatively steep streams. Tables similar to Table 6.7 may be developed from the nomographs or equations for other stream and reliability conditions.

TABLE 6.7

SURVEY ACCURACY REQUIREMENTS¹
FOR SPECIFIED PROFILE ACCURACIES
 (Hydraulic Depth is 5 Feet)

Stream Slope (ft./mi.)	Profile Accuracy ² E _{mean} (feet)	Manning's n-value Reliability - Nr = 0		Manning's n-value Reliability - Nr = 1	
		Aerial Survey Contour Interval	Topo Map Contour Interval	Aerial Survey Contour Interval	Topo Map Contour Interval
1	.1	10 foot	N.A.	N.A.	N.A.
1	.5	10 foot	5 foot	N.A.	N.A.
1	1.0	>10 foot	10 foot	10 foot	2 foot
1	1.5	>10 foot	10 foot	10 foot	5 foot
1	2.0	>10 foot	10 foot	>10 foot	10 foot
10	.1	2 foot	N.A.	N.A.	N.A.
10	.5	10 foot	5 foot	N.A.	N.A.
10	1.0	10 foot	5 foot	10 foot	N.A.
10	1.5	>10 foot	10 foot	10 foot	2 foot
10	2.0	>10 foot	10 foot	10 foot	5 foot
30	.1	2 foot	N.A.	N.A.	N.A.
30	.5	10 foot	2 foot	N.A.	N.A.
30	1.0	10 foot	5 foot	10 foot	N.A.
30	1.5	>10 foot	10 foot	10 foot	2 foot
30	2.0	>10 foot	10 foot	10 foot	5 foot

¹Denotes maximum survey contour interval to produce desired accuracy.

²E_{mean} is mean absolute reach error.

The Hydrologic Engineering Center
December 1966

REFERENCE CITED

1. Bowker, Albert I-I. and Lieberman, Gerald J. 1964.
Engineering Statistics Prentice-Hall, Inc., Englewood Cliffs,
New Jersey.

CHAPTER 7

DELINEATION **OF** STUDY BOUNDARIES FOR WATER SURFACE PROFILE ANALYSIS

7-1. General Concepts

Establishment of the upstream and downstream study boundaries for the profile calculation is required to define limits of data collection and subsequent analysis. Calculations must be initiated sufficiently far downstream to assure accurate results at the structure, and continued a sufficient distance upstream to accurately determine the impact of the structure on upstream water surface profiles. Underestimation of the upstream and downstream study lengths may produce less than desired accuracy of results and eventually require additional survey data at higher costs than could be obtained with initial surveys. On the other hand, significant over-estimation of the required study length can result in greater survey, data processing, and analysis costs than necessary.

The downstream study length is governed by the impact of errors in the starting water surface elevation on the computed water surface elevations at the structure (see Figure 7.1). When possible, the analysis should start at a location where there is either known (historically recorded) water surface elevation or a downstream control (Chow 1959 and Henderson 1966) where the profile passes through critical depth. Observed downstream high water marks are relatively common for calibration of models to historical events, but are unlikely to be available for evaluations of hypothetical events such as the 1-percent chance event.

Alternative starting elevations are needed for stream conditions where high water marks and hydraulic control conditions are nonexistent or are too far downstream to be applicable. Two commonly applied starting criteria are critical depth and normal depth. The starting location should be far enough downstream so that the computed profile converges to the base (existing condition) profile prior to the bridge location.

The upstream study length is the distance where the profile resulting from a structure-created **headloss** converges with the profile for the undisturbed condition (see Figure 7.1). The magnitude of profile change due to bridge created **headloss** and the upstream extent of the structure-induced disturbance are two of the primary criteria used to evaluate the impacts of modified or new structures.

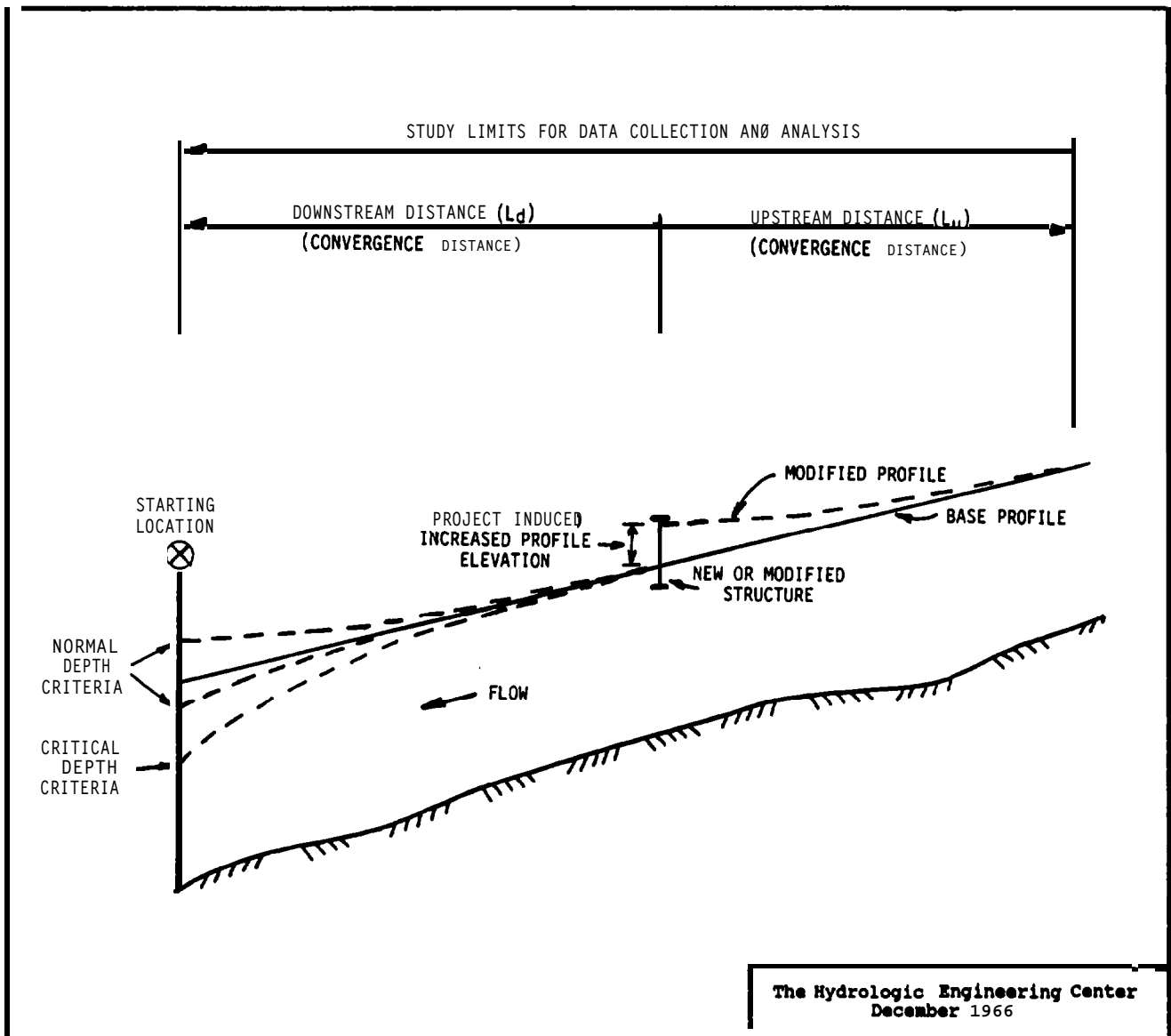

FIGURE 7.1 Profile Study Limits

Regression analyses to develop prediction equations for determining study limits are performed on data resulting from HEC-2 runs for the base data sets for a variety of starting conditions and structure **headloss** values. The resulting equations and associated nomographs provide the capability for determining the extent of required survey and mapping and other hydraulic parameter data collection.

7-2. Regression Analysis

7-2.1. General Procedures. Regression equations were developed for estimating the downstream study length for normal and critical depth downstream starting conditions and for the upstream study length for stream crossing **headloss** values ranging from 0.5 feet to 5.0 feet. The evaluations were performed using data for 80 of the original stream data sets. The analyses are based on the 1-percent chance events. Only actual surveyed cross sections are used in the analysis.

Streams selected for the regression analysis are those with adjacent downstream reaches of sufficient lengths to assure convergence of starting condition profiles before the location of interest, as depicted by reaches A and B in the example of Figure 7.2a. The water surface elevation of the converged profiles in Reach A is used as the starting water surface elevation for Reach B. This profile becomes the base profile through Reach B, and is subsequently used as the basis for comparison of downstream normal and critical depth starting conditions profiles and upstream headloss-induced profiles.

Downstream reach length analyses are performed by using the critical and normal depth starting condition options of HEC-2 (Figure 7.2b). Upstream distance determinations are performed by computing profiles for the 80 data sets and determining convergence distance for the designated structure-generated **headloss** value.

The modified and base condition profiles are considered converged when the profiles were within 0.1 ft. This tolerance criterion is consistent with similar criterion used by The National Flood Insurance Program (Federal Emergency Management Agency 1982).

7-2.2. Hydraulic Variables. The several hydraulic variables evaluated as explanatory variables in the regression analysis include the 1-percent chance discharge, Manning's coefficient, channel slope, cross-sectional top width, and hydraulic depth. Manning's coefficient, cross-sectional top width, and reach hydraulic depth are length weighted values. Table 7.1 lists the hydraulic parameters and profile convergence distances for the 80 data sets.

Several trials of different combinations of variables and data transforms were tested in the regression analyses. Channel slope and reach hydraulic depth are consistently dominant independent variables. The analysis for upstream reach length also included the channel crossing structure **headloss** value.

TABLE 7.1
Study Limit Analysis Summary

DATA FILE I.D.	HYDRAULIC VARIABLES OF REACH			DOWNSTREAM STUDY LIMIT (ft)			UPSTREAM STUDY LIMIT (ft)					
	AVERAGE REACH SLOPE (ft/ml)	AVERAGE CHANNEL FLOW (cfs)	MANNING'S n VALUE	REACH MEAN TOP WIDTH (ft)	REACH MEAN HYDRAULIC DEPTH (ft)	NORMAL DEPTH CRITERION (ft)	CRITICAL DEPTH CRITERION (ft)		CROSSING STRUCTURE HEADLOSS (ft)			
							.5	1.0	3.0	5.0		
S02F2	1.2	30,200	0.086	5810	15.5							
S03F2	1.0	33,800	0.061	3590	13.1			6.700	9,900			
S05F2	1.8	87,600	0.084	2640	10.9	19,300	27.700	9,800	14,100	48,800		
S08F2	1.3	90,000	0.027	700	19.0	10,600	51,800	16,200	26,900	62,300	87,000	
S01F3	1.6	120,000	0.050	3200	15.7	88,800	89,300	55.700				
S02F3	1.7	120,000	0.047	2500	14.8	28,800	47,200	20,200	21,900			
S03M1	4.5	7,300	0.071	1050	3.4	5,800	5.500	4,500	6,100	10,300	11,500	
S04M1	6.7	10,200	0.061	740	4.7	7,000	7.100	5,000	6,500	1,200		
S06M1	s.4	7,500	0.089	640	5.5	10,300	7.600	1,600	3,900	10,800	11,406	
S12M1	6.5	700	0.037	260	2.6	2,400	2.000	2,400	3,000	6,000	10,100	
S15M1	4.8	3,900	0.037	860	2.3	4,100	3.000	1,500	3,100	10,400	13,100	
S17M1	5.6	2,000	0.030	970	1.2	1,600	500	1,000	1,300	2,000	4,400	
S02M2	8.1	12,400	0.053	870	4.9	3,300	3.300	3,100	3,400	5,200	6,100	
S05M2	a.5	16,100	0.067	730	6.4	4,500	6,800	3,900	5,900	8,100	9,800	
S07M2	7.4	21,700	0.054	1430	5.7	800	800	1,400	2,600	6,800	0.500	
S09M2	2.9	32,200	0.067	2270	8.4	23,300	34,900	19,600	25,200	38,400	44,900	
S10M2	2.4	26,500	0.052	2710	4.6	7,900	6.700	7,000	9,100	14,200		
S11M2	4.4	16,300	0.050	1730	3.7	2,100	2.500	2,500	4,600	9,400	12,270	
S12M2	6.6	10,900	0.040	980	2.9	1,300	1.200	1,500	1,900	2,700	4,300	
S13M2	2.0	33,400	0.086	3666	7.5	40,400	40,400	20,000	37,400	42,900	44,900	
S14M2	2.2	22,000	0.082	2670	5.0	20,700	26.700	17,700	20,600	26,000	33,400	
S15M2	2.2	22,200	0.075	1910	a.2	25,400	24.630	13,900	21,200	32,000	37,200	
S16M2	b.1	22,900	0.077	1840	e s	16,900	19.200	13,900	19,000	224,200	25,300	
S17M2	4.5	14,500	0.078	1220	5.9	3,000	6.100	4,400	6,400	12,000	14,000	
S18M2	2.2	43,400	0.071	1480	12.8	35,000	44,700	20,900	30,600	43,800	50,100	
S20M2	2.0	46,000	0.076	1070	17.0	45,300	50.300	21,900	30,700	48,800		
S21M2	2.3	50,300	0.074	990	18.6	45,900	52.000	PO.100	30,560	51,500		
S22M2	2.2	50,200	0.060	1170	16.5			18,000	29,200			
S23M2	2.1	59,200	0.059	1610	13.1	14,000	47,600	16,100	28,800	50,800		
S24M2	2.2	57,100	0.050	1320	14.8	25,700	46.500	19,000	29,400	48,100		
S25M2	2.4	57,000	0.060	1550	13.1	10,200	41,700	17,200	31,400	43,800		
S26M2	2.5	52,000	0.066	1000	10.6	24,200	27,900	18,700	23,600	35,600	40,700	
S27M2	3.0	50,800	0.063	1600	10.8	8,700	21,160	10,300	17,400	29,400	32,000	
S28M2	2.0	33,600	0.061	1140	9.5			19,800				
S29M2	3.1	27,400	0.061	1200	8.0	16,200	17,200	11,700	13,600	19,700	23,800	
S30M2	4.1	27,400	0.060	1150	8.3	5,100	9,400	5,300	6,600	16,600	21,500	
S31M2	5.0	27,400	0.003	1220	8.0	a.000	7,900	5,100	7,200	12,800	17,000	
S32M2	2.0	81,000	0.057	2940	9.0	37,700	41,400	22,100	30,100	42,500	43,700	
S33M2	2.4	60,500	0.044	1550	10.6	23,200	23,700	15,900	19,100	27,600	33,600	
S34M2	2.8	88,500	0.048	1040	15.5	11,000	40,200	17,000	25,000	42,100		

The Hydrologic Engineering Center
December 1966

TABLE 7.1 (Continued)
Study Limit Analysis Summary

DATA FILE I.D.	HYDRAULIC VARIABLES OF REACH				DOWNSTREAM STUDY LIMIT (ft)			UPSTREAM STUDY LIMIT (ft)				
	AVERAGE REACH SLOPE (ft/mi)	AVERAGE 1% CHANCE FLOW (cfs)	MANNING'S n VALUE	REACH MEAN TOP WIDTH (ft)	REACH MEAN HYDRAULIC DEPTH (ft)	NORMAL DEPTH CRITERION (ft)	CRITICAL DEPTH CRITERION (ft)	CROSSING STRUCTURE HEADLOSS (ft)				
								.5	1	0	3.0	5.0
S35M2	2.6	63,000	0.046	1210	12.3	33,400	34,000	21,600	29,200	34,500	41,300	
S36M2	2.8	54,000	0.057	1130	13.3	37,200	38,500	22,200	27,700	41,100		
S37M2	3.0	50,300	0.055	750	14.3	24,800	30,300	14,400	20,600	30,100	36,000	
S38M2	3.0	50,300	0.058	910	15.5	36,000	33,500	16,200	22,700	33,900	38,300	
S39M2	3.0	43,400	0.055	760	13.5	33,500	35,600	18,000	23,500	36,000	37,700	
S40M2	4.3	40,300	0.057	720	13.4	23,200	29,700	12,300	17,900	26,900	36,400	
S41M2	5.0	40,000	0.057	820	11.0	23,200	23,600	18,000	20,700	26,300	30,900	
S42M2	2.9	83,400	0.052	2820	11.2	30,300	39,200	26,300	33,000	41,500	0.700	
S43M2	2.0	83,400	0.046	1890	13.7			29,300	37,000			
S44M2	2.3	es.400	0.047	2060	11.6	26,200	33,900	18,700	272.300	39,500	re.300	
S45M2	2.7	83,400	0.044	1500	12.6	13,700	25,500	13,400	20,800	30,500	33,700	
S47M2	6.0	40,800	0.072	1820	8.1	2,400	6,500	4,400	6,400	11,600	13,900	
S48M2	6.0	32,200	0.072	2070	5.8	3,800	4,300	3,000	4,600	8,000	9,700	
S49M2	9.9	28,100	0.067	1530	5.7	2,000	2,400	2,100	3,000	4,600	6,700	
S51M2	7.2	40,700	0.069	2040	8.2	4,200	4,800	3,800	4,900	7,600	9,100	
S53M2	7.0	36,700	0.066	2060	6.1	2,800	3,300	2,600	3,400	5,600	6,900	
S56M2	2.e	se.000	0.028	1200	8.0	22,800	21,300	1e.400	21.200			
S01S1	10.9	7,200	0.052	740	3.3	2,400	2,700	2,300	3,100	4,700	5,800	
S02S1	27.2	6,900	0.053	480	2.7	1,300	1,000	1,300	1,400	1,800	1,900	
S03S1	13.0	4,500	0.052	220	3.4	800	800	eeo	1,300	3,800	4,800	
S04S1	22.7	0.200	0.049	590	3.1	400	1,100	400	50"	1,100	1,400	
S05S1	3e.9	5,100	0.053	340	J 0	500	'00	400	500	800	2,100	
S06S1	37.e	6,200	0.073	300	4.1	1,200	1,200	1,100	1,300	2,100	2,500	
S09S1	37.6	4,600	0.061	110	7.3	800	700	700	800	1,300	1,400	
S12S1	21.4	3,100	0.065	510	2.5	700	800	800	800	1,800	2,600	
S14S1	39.2	3,000	0.066	240	3.5	500	500	400	500	900	1,300	
S17S1	43.4	1,800	0.051	200	3.9	1,200	1,000	1,000	1,300	1,900	2,300	
S22S1	11.2	800	0.037	350	1.2	1,000	900	900	,,100	2,200	3,000	
S23S1	28.1	10,300	0.034	800	2.2	800	1,200	500	500	1,300	1,700	
S01S2	12.9	17,300	0.052	900	4.3	2,300	2,300	1,100	1,400	2,800	3,300	
S02S2	18.6	15,300	0.053	820	3.4	1,200	1,300	2,100	2,400	2,900	,,700	
S03S2	10.1	37,600	0.059	1270	7.6	6,400	,,800	2,200	2,400	3,900	4,100	
S05S2	25.4	14,300	0.087	390	,,0	2,500	7,500	1,800	2,400	3,900	5,000	
S06S2	18.6	15,100	0.055	570	5.1	2,400	2,400	2,200	3,000	6,000	6,500	
S07S2	12.8	20,700	0.066	1100	5.3	6,600	6,700	4,500	6,900	8,800	9,900	
sons2	14.e	15,600	0.056	740	5.1	2,190	2,300	1,200	1,500	2,400	2,400	
S15S2	22.5	33,000	0.041	1900	3.0	200	800	400	400	1,000	1,600	
S16S2	22.5	24,000	0.052	1900	3.0	1,200	1,200	,,400	5,300	9,700	11,100	
S18S2	15.2	50,000	0.045	1000	,,8	2,300	2,900	2,100	3,000	4,200	4,600	
S01S3	15.4	274,000	0.031	710	19.9	1,300	1,300	1,400	1,500	1,500	1,900	

The Hydrologic Engineering Center
December 1986

a. Development of Base Profile

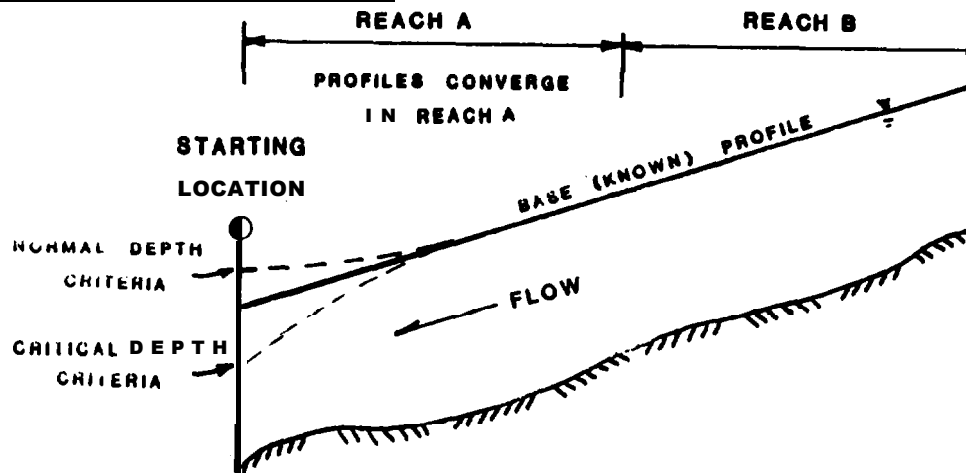

b. Downstream Reach Length Analysis

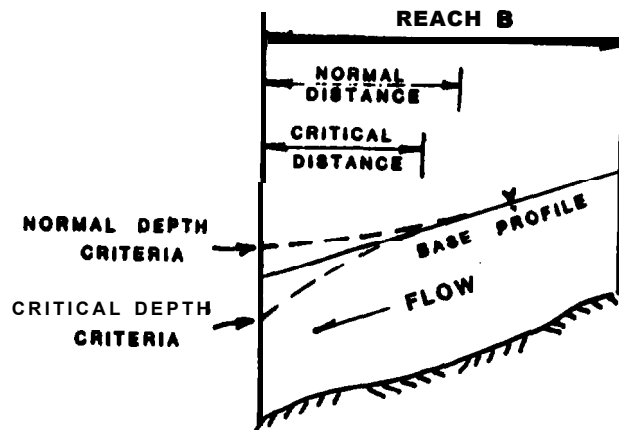

c. Upstream Reach Length Analysis

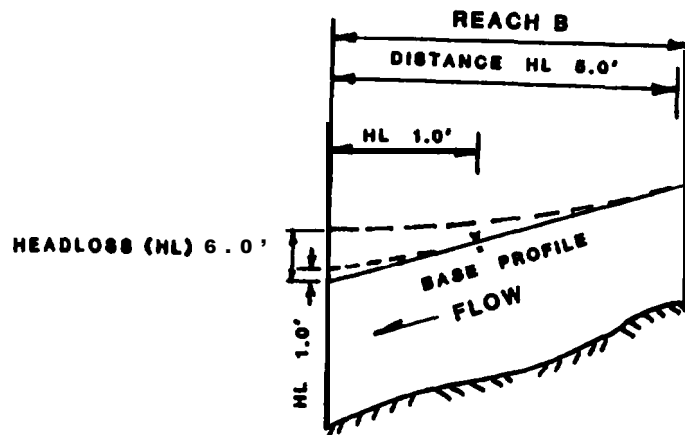

The Hydrologic Engineering Center
December 1986

FIGURE 7.2 Study Distance Analysis Concepts

7-2.3. Downstream Reach Length. The adopted regression equations for normal **and** critical depth starting conditions are:

$$L_{dc} = 6600 \cdot HD / S \quad (\text{Equation 7.1})$$

and,

$$L_{dn} = 8000 \cdot HD^8 / S \quad (\text{Equation 7.2})$$

where: L_{dc} = downstream study length (along main channel) in feet for critical depth starting conditions,
 L_{dn} = downstream study length (along main channel) in feet for normal depth starting conditions,
 HD = average reach hydraulic depth (1-percent chance flow area divided by cross section top width) in feet, and
 S = average reach slope in feet per mile.

7-2.4. Upstream Reach Length. The adopted equation for estimating the upstream reach **length** is

$$L_u = 10,000 \cdot HD^6 \cdot HL^5 / S \quad (\text{Equation 7.3})$$

where: L_u = the estimated upstream study length (along main channel) in feet required for convergence **of** the modified profile to within **.1** feet **of** the base profile,
 HD = average hydraulic depth (1-percent chance event flow area divided by the top width) in feet,
 S = average reach slope in feet per mile, and
 HL = **headloss** ranging between **.5** and **5.0** feet at the channel crossing structure **for** the 1-percent chance flow.

7-3. Reliability of Results

The goodness-of-fit of the regression equations can be expressed using the coefficient of determination and the standard error of regression. The coefficient of determination defines the proportion of the total variation of a dependent variable explained by the independent variables. **For** example, a coefficient of determination of **.90** indicates that 90 percent of the variation is accounted for by the independent **variables**.

The standard error **of** regression is the root-mean-square error. Tables 7.2 and 7.3 summarize the goodness-of-fit statistics of the adopted regression equations.

TABLE 7.2

Study Length Regression Analysis
Goodness-of-Fit Statistics

<u>Statistic</u>	<u>Downstream Study Length</u>		<u>Upstream Study Length</u>
	<u>Normal Depth Criterion</u>	<u>Critical Depth Criterion</u>	
Coeff. of Determination	.83	.89	.90
Standard Error (Log Units, Base 10)	.26	.22	.18

TABLE 7.3

Study Length Adjustments for
One Standard Error (Se) of Estimate
(in feet)

<u>Predicted Distance (ft)</u> (Eq. 7.1, 7.2 or 7.3)	<u>Downstream Study Length</u>		<u>Upstream Study Length</u>
	<u>Normal Depth Criterion</u>	<u>Critical Depth Criterion</u>	
	+1Se	+1Se	+1Se
1,000	1,800	1,700	1,500
5,000	9,000	8,000	8,000
10,000	18,000	17,000	15,000
15,000	28,000	25,000	23,000
20,000	37,000	34,000	30,000
25,000	46,000	42,000	38,000
30,000	55,000	50,000	45,000
35,000	65,000	59,000	53,000
40,000	73,000	66,000	61,000

The Hydrologic Engineering Center
December 1986

7-4. Nomograph Adaptation

The equations were converted to nomographs to present the results in a convenient form. The nomographs can be used to estimate study limits for data collection purposes. **For** example, if the average hydraulic depth and slope downstream of a bridge are **five** feet and five feet per mile, respectively, the downstream reach length for critical depth starting criterion can be estimated from **Figure 7.3**. The value **L_{dc} = 6,600** feet is read directly off the nomograph. Similarly, for normal depth criterion, a value for **L_{dn}** of about 5,800 feet is obtained from **Figure 7.4**.

The upstream study limits can be estimated in a similar manner using Figure 7.5. Again, **for** an average hydraulic depth of **five** feet, a slope of five feet **per** mile, and a structure-induced **headloss** of five feet, the estimated required upstream study distance L_u is 12,000 feet.

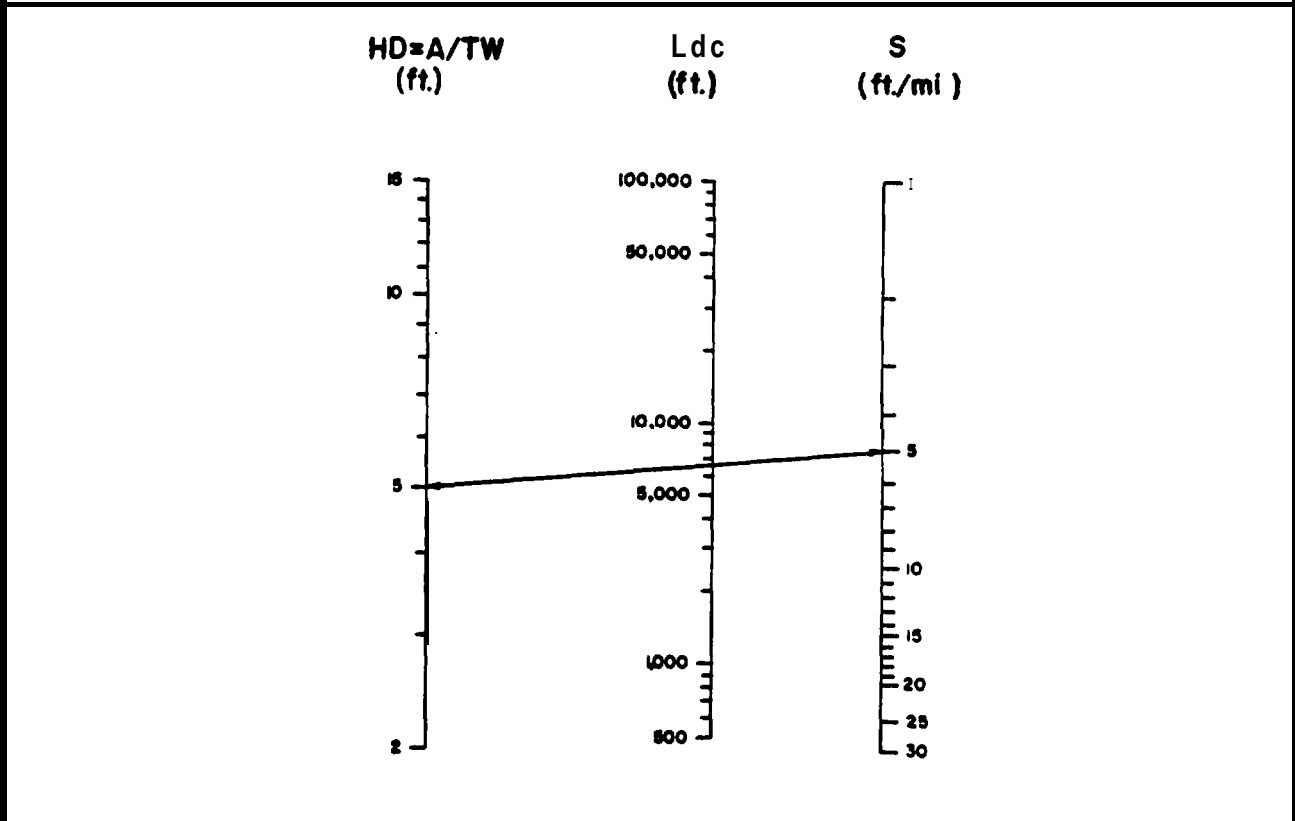
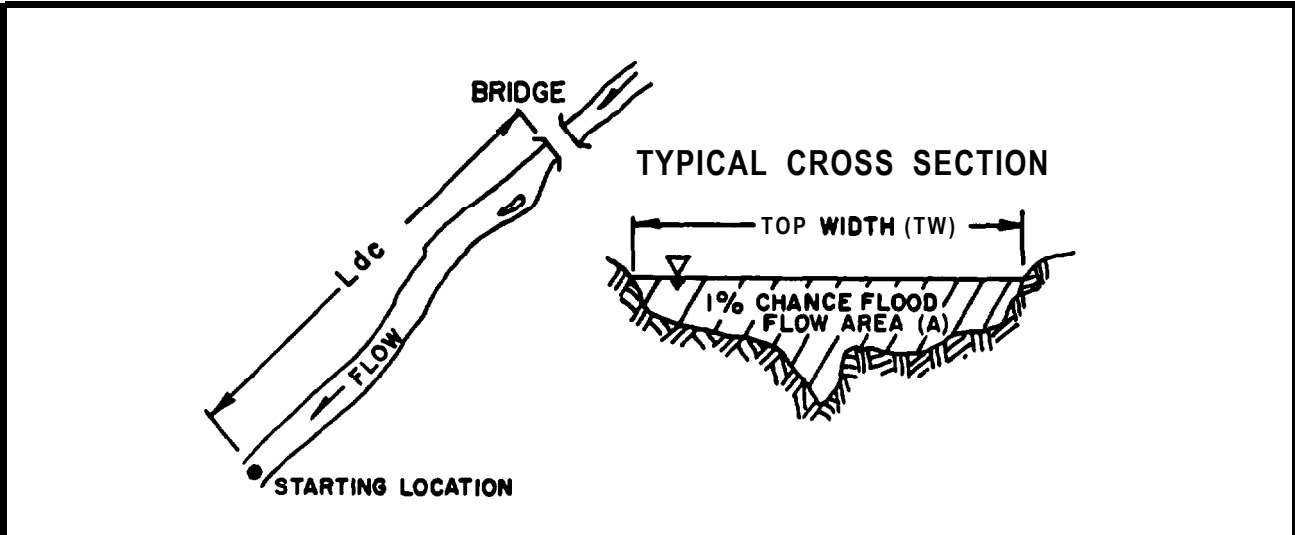

$L_{dc} = 6600 * HD/S$ (Equation 7. 1)

Where:

L_{dc} = Downstream study length - critical depth starting condition

HD = Average hydraulic depth (1 - percent chance flow)

S = Average reach slope

The Hydrologic Engineering Center
December 1986

FIGURE 7.3 Downstream Reach Length Estimation - Critical Depth Criterion

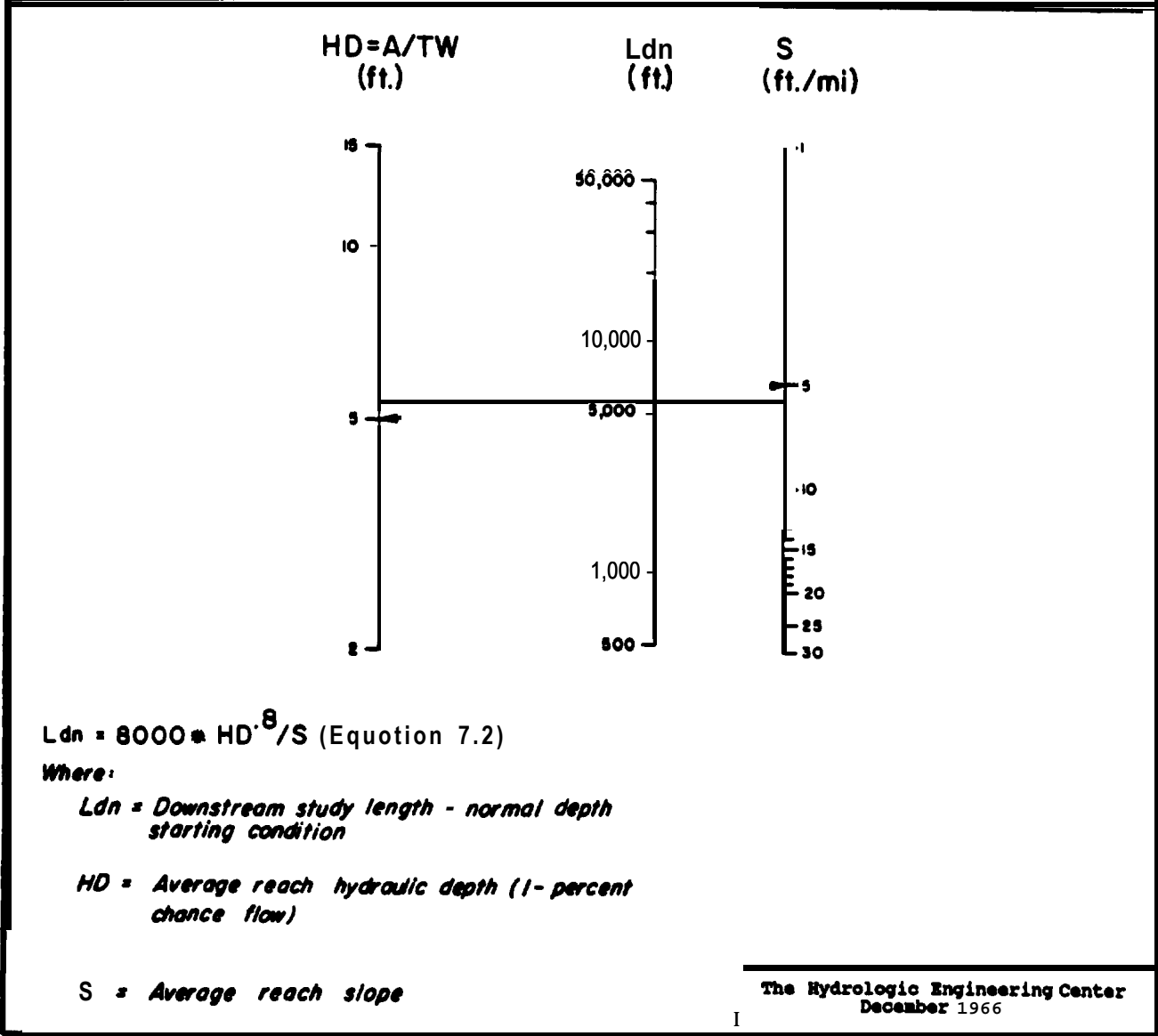
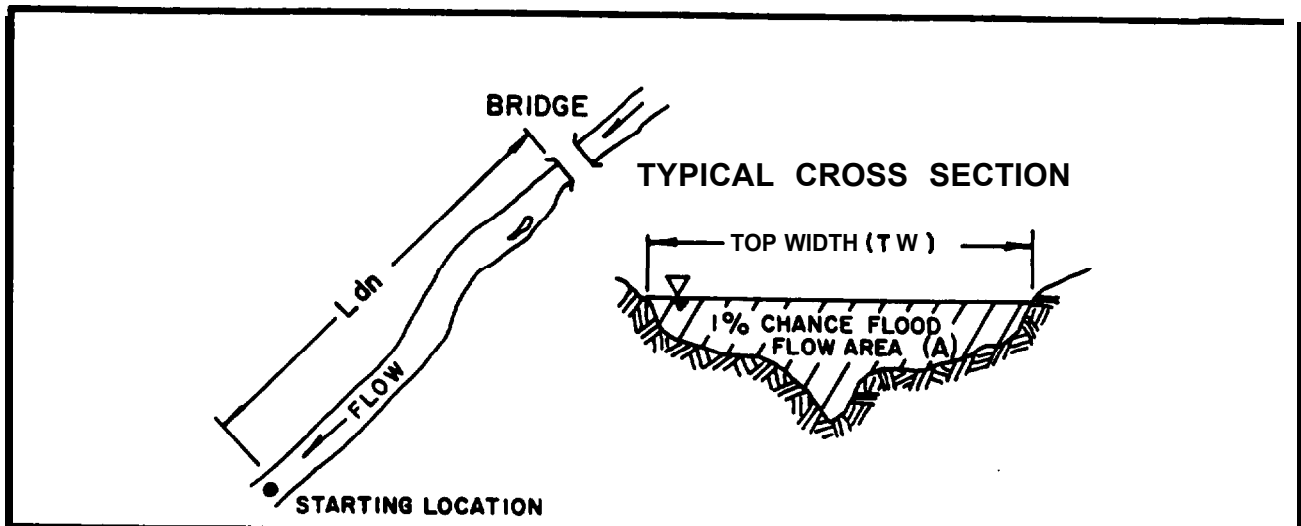
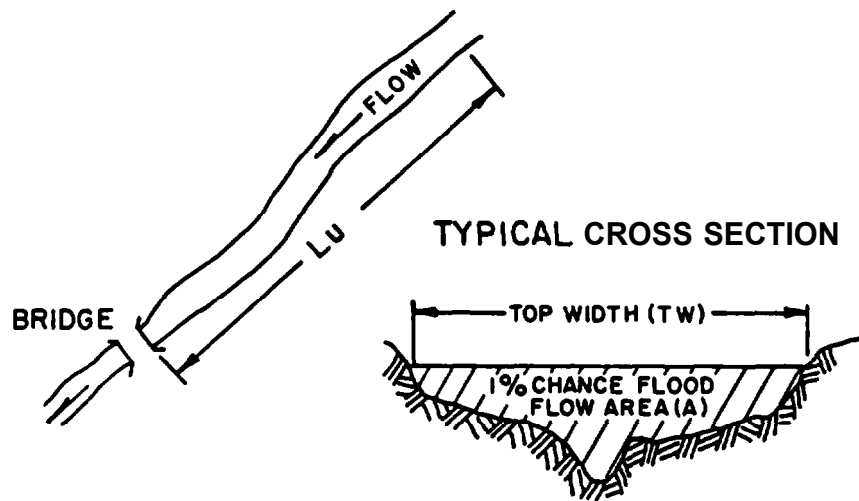
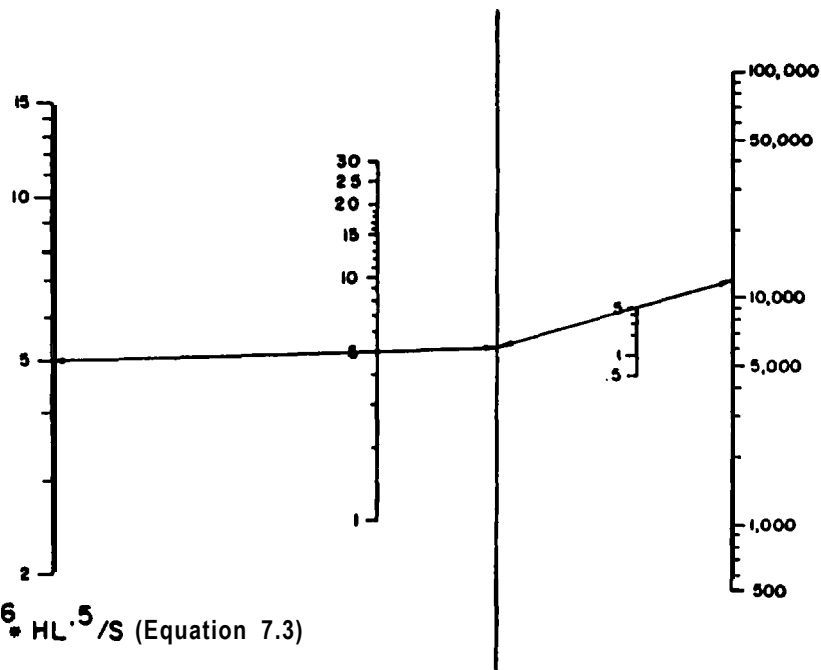

FIGURE 7.4 Downstream Reach Length Estimation - Normal Depth Criterion



$HD = A/TW$
(ft.)

S TURNING HL Lu
(ft./mi.) LINE (ft.) (ft.)



$$Lu = 10,000 * HD^{.6} * HL^{.5} / S \text{ (Equation 7.3)}$$

Where:

Lu = Upstream study length

HD = Average reach hydraulic depth (1-percent chance flow)

S = Average reach slope

HL = Headloss at the channel crossing structure for the 1-percent chance flow

The Hydrologic Engineering Center
December 1999

FIGURE 7.3 Upstream Reach Length Estimation

REFERENCES CITED

1. Chow, Ven Te. 1959, Open Channel Hydraulics, McGraw-Hill Book Company, New York, New York.
2. Federal Emergency Management Agency 1982, "**Coordination** on Highway Encroachments," Memorandum to FEMA Directors, 7 June 1982.
3. Federal Highway Administration 1961, Design Charts For **Open-Channel Flow**, Hydraulic Design Series No. 3, U.S. Department of Transportation.
4. Henderson, F.M. 1966, Open Channel **Flow**, The MacMillan Company, New York, New York.
5. Hydrologic Engineering Center 1982 (reprint May **1985**), Water Surface Profiles, Users Manual, U.S. **Army** Corps of Engineers Water Resources Support Center.

5. Hydrologic Engineering Center **1982a**, HEC-2 Water Surface Profiles, Users Manual, U.S. Army Corps of Engineers, Water Resources Support Center.
6. Hydrologic Engineering Center **1982b**, Hydrologic Analysis of Ungaged Watersheds Using HEC-1, Training Document No. 15, U.S. Army Corps of Engineers, Department of Defense.
7. Hydrologic Engineering Center 1980, "Adoption of Flood Flow Frequency Estimates at Ungaged Locations,*@ Training Document No. 11, U.S. Army Corps of Engineers.
8. U.S. Geological Survey 1984, Computation of Water-Surface Profiles in Open Channels, Department of Interior.
9. U.S. Geological Survey **1982**, Guidelines for Determining Flood Flow Frequency, Bulletin #17B, U.S. Department of the Interior.
10. U.S. Geological Survey 1967, Roughness Characteristics of Natural Channels, Water Supply Paper, Department of Interior.
11. U.S. Geological Survey 1984, Computation of Water-Surface Profiles in Open Channels, Book 3, Chapter **A15**, Department of Interior.
12. U.S. Geological Survey Undated **b**, Flood Characteristics of Urban Watersheds in the United States, Water Supply Paper 2207, Department of Interior.
13. U.S. Water Resources Council 1981, Estimating Peak Flow Frequencies for Natural Ungaged Watersheds, Hydrology Committee, U.S. Water.

study and methodologies. Professional experience, -judgment, and capabilities of the analyst also influence the level-of-detail.

a-2.3. Review of Previous Study Data. The availability of hydrologic studies and water surface profile analyses may significantly reduce the data collection, verification, and analysis effort. Federal (e.g. Corps of Engineers, Federal Emergency Management Agency (**FEMA**), U.S. Geological Survey, U.S. Soil Conservation Service), state, and local agencies should be contacted to determine the availability of **data** and information. Data may include: (1) the 1-percent chance discharge values, (2) Manning's roughness coefficients, (3) cross sections, (4) high water marks for historic events, and (5) topographic maps and aerial photographs of the study area. Aerial photogrammetry firms should be contacted for map availability.

The use of water surface profile computer programs and previously developed data may reduce the study effort and yield consistent results with respect to prior investigations. Determination of whether the study area is part of the National Flood Insurance flood plain regulatory program or under other state or local regulatory policies is required. If so, much of the analysis data should be available. Consistent procedures are required where regulatory policies exist.

a-2.4. Field Reconnaissance. A field reconnaissance of the study area should be made after the study purpose and **level-of-detail** are established, previous study data assembled, and preliminary cross-sectional locations determined. Field reconnaissance includes interviews of local agency personnel and residents, review of local documents, and visual inspection of the study area (Hydrologic Engineering Center 1980). Examples of information that may be obtained from a field reconnaissance are listed below.

- (1) Meteorological and physical data of the study area.
- (2) Historic high water marks and photographs for profile calibration studies.
- (3) General knowledge of flow paths, blockage by debris, and frequency of historic overtoppings of stream crossings and roads.
- (4) Design discharge of highway crossings and other physical works in the study area.
- (5) Information on authorized and anticipated future development that may impact on the design or regulatory water surface profile.
- (6) Verification of cross-sectional locations and determination of survey procedures.

- (7) **Estimation** of Manning's coefficient including documentation from **visual inspection**, aerial and ground photographs.
- (8) **Estimation** of geometry of one to five typical **cross sections** (with 8ay 8-10 coordinate points) and **Manning's** coefficient at key location throughout **the study** area. **Hand levels**, **topographic maps**, and other equipment and data may be used.

a-3. Hydraulic Variable Estimation

8-3.1. Overview. Information needed to perform water surface **profile analyses** includes: (1) **cross-sectional data**, (2) discharge, and (3) Manning's **roughness coefficients**. The data are used to derive data collection (**study**) **limits**. The data should be obtained from previous **study** data if **possible**. When not available, the data may be derived by analyses, **surveys**, and field reconnaissance. The value are subsequently adjusted (or calibrated) so that observed discharge-frequency relationships and high water mark are reproduced as accurately as possible.

8-3.2. Cross-Sectional Layout. **Cross-sectional** locations are the **calculation** location in the profile computation. The cross sections are located to ensure that the **basic** concept and principle of the **step-profile** procedure are met as described in Section 2-4. The **cross sections** should be **laid-out** on U.S. Geological Survey Quadrangle Topographic Map as described in Section 8-4. The location and alignment should be adjusted and verified during field **reconnaissance** of the study area as **necessary**.

a-3.3. One-Percent Chance Flow. The 1-percent chance flow rate may be estimated from streamflow data or by various **statistical** methods where records are **nonexistent**. For areas where 10 or more years of **stream flow records** are available the U.S. Geological Survey (1982) publication Guidelines for Determining Flood Flow Frequency procedure should be applied. **Procedures** for ungaged conditions vary **significantly** in detail and applicability for **estimating** the 1-percent chance flow. **Common procedures** include **simplified** equations, transfer from **similar gaged watersheds**, **regression equations**, and **rainfall-runoff analysis** methods. A principal reference describing the method is the U.S. Water Resources Council (1981), Estimating Peak Flow Frequencies for Natural Ungaged Watersheds. Other references for ungaged **watersheds** include the Adoption of Flood Flow Frequency Estimates at Ungaged Locations (Hydrologic Engineering Center 1980) and Hydrologic Analysis of Ungaged Watersheds Using HEC-1 (Hydrologic Engineering Center 198213).

8-3.4. Manning's Coefficient. The importance of using reliable **estimates** of Manning's roughness coefficients when computing water surface profiles is emphasized in Chapter 6. Estimation guidelines may be found in such references as Guide for Selecting Manning's Roughness Coefficients for Natural Channels and Flood Plains (Federal Highway Administration **1984**), Roughness Characteristics of Natural Channels (U.S. Geological Survey **1967**), and Open-Channel Hydraulics (Chow 1959).

Developing reliable Manning coefficient estimates for water surface profiles typically requires use of aerial photographs and field reconnaissance in conjunction with the above or similar references. Reach photographs and typical values also provide valuable aids. The initial **estimates** should be adjusted and calibrated to historic highwater marks. The calibration process should be performed for events in *the range* of the 1-percent chance event when possible.

8-4. Delineation of Profile Analysis Limits

Chapter 7 describes the analysis needed to estimate the upstream and downstream limits of the profile analysis. A strategy for determining the analysis limits is provided below.

- (1) Review available data (such as proposed crossing alternatives and maps) including those from previous studies (such as water surface profiles, highwater marks) to determine scope of investigation, expected maximum headloss, and channel obstructions.
- (2) Roughly estimate study limits on a map, such as a U.S. Geological Survey Quadrangle map, for the purpose of estimating reach hydraulic parameters.
- (3) Conduct preliminary field reconnaissance, determining two to five typical cross sections by visual observation, available maps and/or rough pacing, and hand levels for upstream and downstream reaches.
- (4) Estimate hydraulic depth of typical cross sections at the upstream and downstream study limits using (as available) applicable highwater marks, normal depth calculations of simplified cross sections, previous study data, charts and tables (Chow 1959 and Federal Highway Administration 1961) and judgment.
- (5) Estimate the channel slope from topographic maps, previous study data or from simple field surveys procedures such as hand levels.
- (6) Estimate the downstream study limit for critical or normal depth starting criteria, as preferred, from

Figures 7.3 or 7.4, respectively. NOTE: If a known starting elevation, such as a stream gage, **or** critical depth control point falls within the estimated study limits, **then** that location should be used to establish starting elevations for the profile calculations.

- (7) Estimate the hydraulic depth **associated** with a typical upstream reach cross section, the average reach slope, and the maximum induced **headloss** anticipated in the analysis of the new or modified bridge configurations from (1).
- (8) Estimate the upstream reach length using Figure 7.5. The upstream length may be adjusted (to **be** conservative) by adding distance based on the standard **error** using Table 7.3 if desired.
- (9) Once the upstream and downstream study reach lengths are determined, cross-sectional and other hydraulic parameter data collection needs can be defined and a data collection plan developed based on physical characteristics, costs and other factors.

8-5. Cost Effective Analyses of Survey Methods

The study results allow comparisons of survey accuracy requirements of field, aerial spot elevations, and topographic map methods **for** obtaining cross-sectional coordinate data. The comparisons **are** based on minimum survey accuracy (contour interval) requirements to meet specified profile accuracy levels. Table 6.7 is an example comparison for **aerial** spot elevations and topographic map methods. Cost estimates for the survey method may be developed and comparisons made to determine the cost effective method of obtaining the **surveyed** cross-sectional coordinate information.

A decision on survey method and accuracy should also consider other uses **for** the survey information, such as the use of topographic map data for cut-and-fill analyses. Since aerial spot elevations (characterized herein as significantly more accurate **than** topographic maps) and topographic maps **may** be derived from the same aerial photograph stereo models, both methods may be used for water surface profile analyses and other applications at a cost increment less than the combined individual costs. The need for field surveys of unique features, such as bridges, and hydrographic surveys below existing water surfaces are other considerations in selecting the survey method.

Regional cost curves and tables for field surveys, aerial spot elevations, and topographic maps may **be** used to expedite the the survey method selection process. **Figure 8.1** shows an example of total survey costs versus number of cross sections for the aerial and field survey methods. This example is based on a

2000 foot reach and a **2-foot** contour interval accuracy. The cost curves, developed for Northern California, show that field surveys are less costly than aerial spot elevations for a few sections (fewer than 10 cross sections). However, the aerial method becomes significantly less costly as the width of the floodplain and the number of cross sections increase. The example also shows that the total cost of the aerial spot elevation survey method increases only slightly with the increase in floodplain width and number of cross sections. Similar cost curves may be developed to include topographic mapping and hydrographic survey costs, additional contour intervals, and terrain and land cover.

The basic strategy for performing a cost comparison analysis of survey methods is listed below.

- (1) Adopt a target level of water surface profile accuracy.
- (2) Estimate *the* number of *required* surveyed cross sections for the limits of the study using guidelines described in Section 2-4.4 and other references such as Computation of Water Surface Profiles in Open Channels (U.S. Geological Survey 1984) and the HEC-2 Water Surface Profile user's manual (Hydrologic Engineering Center 1982a).
- (3) Determine the required minimum level of the survey accuracy based on the stream characteristics, target profile accuracy, and the reliability of Manning's coefficient estimates.
- (4) Review available survey data from previous studies and specific survey needs, such as bridge and hydrographic survey locations.
- (5) Review applicability of various survey methods considering access, land cover and other factors.
- (6) Estimate costs of the various survey methods and requirements.
- (7) Select the most cost effective survey method that meets the needs and requirements of the study. Table 8.1 provides a simplified example of a cost comparison analysis of selected survey procedures.

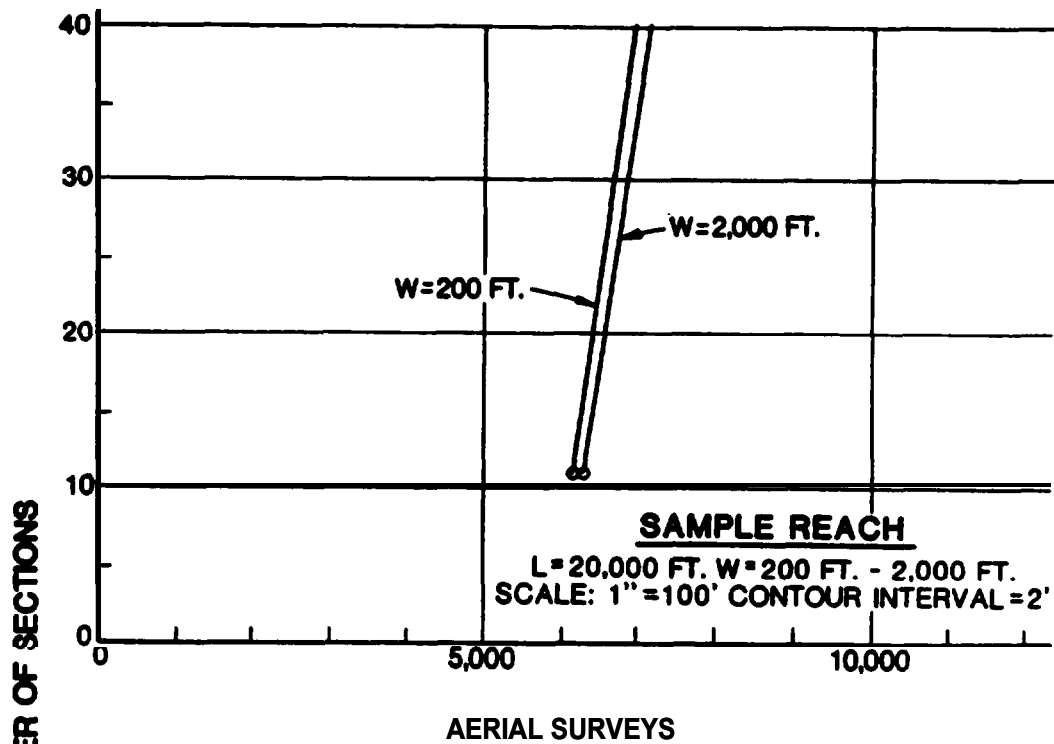

W = Length of cross section

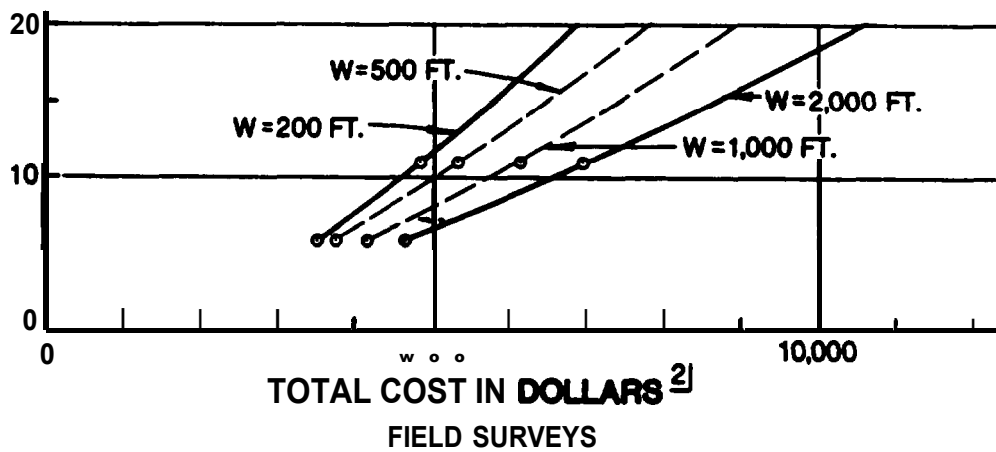

^{2]} JAN. 1, 1985 COSTS

FIELD AND AERIAL SURVEYS
COST INFORMATION - CROSS SECTIONS ONLY
FLAT. LIGHT-COVER CASE

(Hydrologic Engineering Center 1985)

The Hydrologic Engineering Center
 December 1986

FIGURE 8.1 Survey Cost Estimate Example

TABLE 8.1

Example **Survey*Cost**
Comparisons

<u>survey Method</u>	<u>Specified Profile Accuracy</u>	<u>No. of Cross Sections</u>	<u>Contour Interval Required</u>	<u>Estimate Survey** cost</u>
Field Surveys	1.0 feet	15	N.A.***	\$ 9,000
Aerial Surveys	1.0 feet	15	10 foot ***	5,500
Topographic Maps	1.0 feet	15	5 foot ***	15,500

* Example based on an average 2000 foot wide cross section, flat terrain with light cover. Average stream slope is 10 feet per mile. The reliability of estimation of Manning's coefficient is assumed to be precise ($NR = 0$) due to the availability of a long period-of-record of a nearby streamgage and historic high water mark for calibration. A hydraulic depth of 5 feet was assumed for the example.

** Cost values are for illustration purposes only.

***From Table 6.7.

REFERENCES CITED

1. Chow, Ven Te 1959, Open-Channel Hydraulics, McGraw-Hill Book Company, New York, New York.
2. Federal Highway Administration 1984, Guide for Selecting Manning's Roughness Coefficients for Natural Channels and Flood Plains, Report No. FHWA-TS-84-204, U.S. Department of Transportation.
3. Henderson, F.M. 1966, Open Channel Flow, The Macmillan Company, New York, New York.
4. Hydrologic Engineering Center 1985, Commercial Survey Guidelines for Water Surface Profiles, prepared by Borcalli, Ensign, and Buckley Consulting Engineers, Sacramento, California, for the Hydrologic Engineering Center, U.S. Army Corps of Engineers.

5. Hydrologic Engineering Center **1982a**, HEC-2 Water Surface Profiles, Users Manual, U.S. Army Corps of Engineers, Water Resources Support Center.
6. Hydrologic Engineering Center **1982b**, Hydrologic Analysis of Ungaged Watersheds Using HEC-1, Training Document No. 15, U.S. Army Corps of Engineers, Department of Defense.
7. Hydrologic Engineering Center 1980, "Adoption of Flood Flow Frequency Estimates at Ungaged Locations,*@ Training Document No. 11, U.S. Army Corps of Engineers.
8. U.S. Geological Survey 1984, Computation of Water-Surface Profiles in Open Channels, Department of Interior.
9. U.S. Geological Survey **1982**, Guidelines for Determining Flood Flow Frequency, Bulletin #17B, U.S. Department of the Interior.
10. U.S. Geological Survey 1967, Roughness Characteristics of Natural Channels, Water Supply Paper, Department of Interior.
11. U.S. Geological Survey 1984, Computation of Water-Surface Profiles in Open Channels, Book 3, Chapter **A15**, Department of Interior.
12. U.S. Geological Survey Undated **b**, Flood Characteristics of Urban Watersheds in the United States, Water Supply Paper 2207, Department of Interior.
13. U.S. Water Resources Council 1981, Estimating Peak Flow Frequencies for Natural Ungaged Watersheds, Hydrology Committee, U.S. Water.

APPENDIX A

APPENDIX A

FLOODPLAIN REGULATORY POLICIES

A-1. Overview and Purpose

This appendix describes general guidance and procedures for state highway agencies and others in coordinating modified or new proposed highway stream crossings with the Federal Emergency Management Agency (**FEMA**) and communities participating in the National **Flood** Insurance Program. It also provides conditions which must be met prior to **FEMA's** approval of changes in floodplains, floodways, or base flood elevations resulting from a proposed highway crossing. **The procedures** are generally applicable to other types of water surface profile analyses.

A-2. The National Flood Insurance Program

The National Flood Insurance Program (NFIP) is a major Federal floodplain management program. Its primary objectives are: (1) to provide flood insurance coverage; and (2) to promote wise floodplain policies that regulate future development to minimize the potential for flood damage. The NFIP was initiated **by** the National **Flood** Insurance **Act of** 1968. The NFIP **subsequently** became a significant Federal involvement in flood hazard mitigation with the passage of the Flood Disaster Protection **Act** of 1973.

In order to participate in the **Flood** Insurance Program (**FIA**), each community must: (1) identify the 1-percent chance flood event floodplain and floodway; (2) provide appropriate floodproofing **or** restrictions on new development or substantial improvement of old development in the floodplain; and (3) develop a local land use management program for its flood prone areas.

Each community is divided into flood hazard areas that reflect the regulatory **aspects** of the NFIP. The regulatory floodway **carries** the base flood (1-percent chance flow) without increasing the water surface elevation more than one foot at any point. The remainder of the floodplain between regulatory floodway and the 1-percent chance flood boundary is defined as the **flood** fringe.

Within the flood fringe, **new** development **or** substantial improvements, such **as** highway stream crossings, are allowed provided **that** all residential developments are elevated to above the base flood level and non-residential development are elevated or floodproofed **above** the base flood level. Development within the regulatory floodway is only allowed if there is no increase in flood elevation (Federal Highway Administration 1980).

A-3. Variations in Floodplain Regulations

The National Flood Insurance Program requires a number of criteria as the minimum standards for adoption of floodplain management regulations by local communities enrolling in the program. The NFIP emphasizes that these criteria and standards are minimum requirements. Direct state regulation of users is usually authorized only if local governments fail to adopt and administer regulations meeting minimum state standards. State floodway criteria are shown in Tablo 1 (Federal Highway Administration 1980 and Water Resources Council 1982).

A-4. Profile Analysis of NFIP Areas

A4-1. Overview and Background. The local community with land use jurisdiction, whether it is a city, county, or state, has the responsibility for enforcing National Flood Insurance Program regulations if that community is participating in the NFIP. Determination of the status of a community's participation in the NFIP and review of applicable NFIP maps and ordinances are essential initial first steps in conducting water surface profile analysis of modified or new highway stream crossings.

Where NFIP maps are available, their use is mandatory in determining if a highway **stream** crossing alternative will encroach on the base floodplain. Three types of maps are published: (1) a Flood Hazard Boundary Map; (2) a Flood Boundary and Floodway Map; and (3) a Flood Insurance Rate Map. A Flood Hazard Boundary Map is generally not based on a detailed hydraulic study, **and**, therefore, the floodplain boundaries are approximate. A Floodplain Boundary and Floodway Map is generally derived from a detailed hydraulic study and should provide reasonably accurate information. The hydraulic data are available through regional offices **of** the Federal Emergency Management Agency (FEMA). The hydraulic data are normally in the form of computer input data sets for calculating water surface profiles. The Flood Insurance Rate Map is usually developed at the same time as the water surface profile analysis model and has base flood elevations added (Federal Emergency Management Agency 1982).

The analysis of proposed new or altered highway stream crossings generally fall within three situations with regards to the NFIP regulations. These are: (1) detailed flood insurance studies have been performed and a regulatory floodway is in effect; (2) a community is participating in the regular program, but no regulatory floodway has been established; and (3) the community or area is not in **the** NFIP. Following paragraphs describe the analysis considerations and requirements of performing water surface profile analysis for **these** conditions (**Federal** Highway Administration 1985).

TABLE A-1

STATE FLOODWAY CRITERIA

Alabama	NFIP	Montana	NFIP
Alaska	NFIP	Nebraska	NFIP
Arizona	NFIP	Nevada	NFIP
Arkansas	NFIP	New Hampshire	NFIP
California	NFIP	New Jersey	MR (.2)
Colorado	MR	New Mexico	NFIP
Connecticut	NFIP	New York	NFIP
Delaware	NFIP	North Carolina	NFIP
Florida	NFIP	North Dakota	NFIP
Georgia	NFIP	Ohio	MR (.5)
Hawaii	NFIP	Oklahoma	NFIP
Idaho	NFIP	Oregon	NFIP
Illinois	MR (.1)	Pennsylvania	NFIP
Indiana	MR (.1)	Rhode Island	NFIP
Iowa	NFIP	South Carolina	NFIP
Kansas	NFIP	South Dakota	NFIP
Kentucky	NFIP	Tennessee	NFIP
Louisiana	NFIP	Texas	NFIP
Maine	NFIP	Utah	NFIP
Maryland	MR	Vermont	NFIP
Massachusetts	NFIP	Virginia	NFIP
Michigan	MR (.1)	Washington	NFIP
Minnesota	MR (.5)	West Virginia	NFIP
Mississippi	NFIP	Wisconsin	MR (.1)
Missouri	NFIP	Wyoming	MR (.1)

NFIP = State criteria are the same as the NFIP criteria

MR () = State criteria are *more* restrictive than the NFIP criteria. When appropriate, the allowable increase in the water surface elevation is indicated in feet.

(Federal Highway Administration 1980) **"Assessment** of the Impacts of the National Flood Insurance Program on Highways," Report No. **FHWA/RD-80/015.**

A4-2. NFIP-Regulatory Floodway in Effect. For communities where the NFIP regulations are in effect and regulatory floodway defined, the initial alternative analyzed should be a highway stream crossing with all components excluded from the floodway. The design, which essentially spans the floodway, must also limit the rise of the base flood (1-percent chance event profile) within the regulatory criteria (normally one foot). The alternative must be sufficiently detailed to show the associated impacts on the base flood and to provide a reasonable cost estimate.

Where it is not practical or cost-effective for the highway stream crossing to span the floodway, alternative designs that modify the floodway should be investigated. The project may normally be considered as being consistent with the regulatory standards if the hydraulic conditions can be improved so that no water surface elevation increase results for the proposed design. **For** floodway components, such as piers, which have a minor effect on the floodway water surface elevations, these modifications may be easily accomplished.

For alternatives where the highway stream crossing components encroach in the floodway and result in increased floodway profile elevations, more extensive modifications may be required. Often, the community will be willing to accept an alternative floodway configuration to accommodate a proposed crossing providing the NFIP limitations on increases in the base flood profile are not exceeded. This is best accomplished when the floodway is first established. However, where the community is willing to amend an established floodway to support this option, the floodway may be revised. Modifications analyzed to alter the floodway hydraulics to mitigate the increase in the revised conditions **profile** are listed below.

- (1) Increase the flow conveyance *area* upstream *and/or* downstream of the structure.
- (2) Modify the flow alignment through the structure.
- (3) Reduce the roughness to increase the efficiency of the base flood flow.
- (4) Increase the flow gradient in the vicinity of the structure.
- (5) Modify design of the piers and the **crossing** abutments to reduce losses through the structure.

(Federal Emergency Management Agency 1982).

The community has the ultimate responsibility for demonstrating that an alternative floodway configuration meets the NFIP requirements. However, this responsibility may be borne

by the agency proposing to **construct the** highway crossing. Floodway **revisions** must be based on the water surface profile data sets **used** to develop **the** affective floodway but updated to reflect existing encroachment **conditions**. This allow⁸ determination of the increase in the bare flood elevation caused by encroachment⁸ since the original floodway wa⁸ established.

The increase to the profile must be referenced to the existing condition⁸ profile developed when the floodway was first established. The base and modified conditions water surface profile analysis must extend far enough upstream and downstream to evaluate the impact of the **proposed highway stream** crossing. Downstream distances **must** be sufficient to mitigate starting condition⁸ profile error⁸ prior to **downstream** floodway revisions associated with the structure. Upstream **distances** must be sufficient so that the modified condition⁸ profile essentially converge⁸ to that of the base condition. The **distances** will vary depending on the magnitude of the floodway revision and the hydraulic characteristics of the stream. The research procedures derived and presented in Chapter 7 are applicable for defining upstream and **downstream** analysis **distances**. Chapter 8 describes an analysis strategy for the **distance** determinations.

If the water surface profile **analysis** input data representing the original regulatory condition⁸ is unavailable, a new data set should be **established** using the original cross-sectional topographic information, where **possible**, and the discharges contained in the Flood Insurance Study which establish the original floodway. The profile **analysis** should then be performed confining the effective flow area to the currently established floodway and calibrated to reproduce within 0.10 foot. The profile accuracy procedure⁸ developed and **presented** in Chapter 6 may be **used** to assist in this **analysis**. Modified floodway conditions are then evaluated using the above procedures.

The increase to the profile must be referenced to the existing conditions profile developed when the floodway was first established.

Data submitted to **FEMA** in support of a floodway revision request should include the item⁸ listed below.

- (1) Copy of current regulatory Flood Boundary Floodway Map, **showing existing** conditions, proposed highway crossing and revised floodway limits.
- (2) Copy of profile **analysis** (computer input and output results) of the existing and modified regulatory conditions 1-percent chance flood **event**. Any fill or development that has occurred in the existing flood fringe area must be incorporated into the modified conditions floodway model.

When it is clearly **shown** to be inappropriate to **design** a highway crossing to avoid encroachment on the floodway and where the floodway cannot be modified **such** that the **structure** could be excluded, **FEMA** will approve an alternate floodway with backwater in excess **of** the 1 foot maximum only when the following conditions have been met.

- (1) A location hydraulic study has been performed in accordance with Federal-aid Highway Program Manual (**FHPM**) 6-7-3-2 "Location and Hydraulic Design of Encroachments on **Floodplains**" (23 CFR 650, Subpart A) and **FHWA** finds the encroachment is the only practicable alternative.
- (2) The constructing agency has made appropriate arrangements with affected property owners and the community to obtain flooding easements or otherwise compensate them for future flood losses due to the effects of the structure.
- (3) The constructing agency has made appropriate arrangements to assure that the National Flood Insurance Program and Flood Insurance Fund do not incur any liability for additional future flood losses to existing structures which are insured under the Program and grandfathered in under the risk status existing prior to the construction of the structure.
- (4) Prior to initiating construction, the constructing agency provides **FEMA** with revised flood profiles, floodway and floodplain mapping, and background technical data necessary **for FEMA** to issue revised Flood Insurance Rate Maps and Flood Boundary and Floodway Maps for the affected area upon completion of the structure (Federal Emergency Management Agency 1982).

A4-3. NFIP-No Regulatory Floodway. **For** communities where a detailed flood insurance study has been performed but no regulatory floodway **designated**, the base-condition flood profile is the focus of the analysis. The highway stream crossing should be designed to allow no more than the regulatory criteria (1 foot) increase in the base profile established from the flood insurance study. Where it is not practical or cost effective to design the highway crossing and meet the regulatory criteria, the procedures **outlined** under Floodway Encroachment Where **Demonstrably** Appropriate should be followed in requesting a revision of the base regulatory profile.

A4-4. Highway Encroachment on Unregulated Floodplains. Design of **highway** stream crossings outside of the NFIP communities or identified flood hazard areas should be based on

sound engineering principles, economics, the flood hazard potential of the area, and other factors. The base or existing water surface profiles and revised profiles resulting from the bridge encroachment must be computed and compared. The upstream and downstream profile distances should be defined based on the procedures described in Section 7-2.

The profile analysis of the modified condition should normally be carried far enough upstream so that convergence with the base profile is within **.1** feet (Federal Emergency Management Agency 1982 and Federal Highway Administration 1985).

REFERENCES CITED

1. Federal Highway Administration 1980, @@Assessment of the Impacts of the National Flood Insurance Program on Highways," Report No. **FHWA/RD-801015**, Prepared by **Keifer and Associates, Inc.**, for the Federal Highway Administration, Department of Transportation.
2. Water Resources Council 1982, "Strengthening State Floodplain Management," Appendix A, Regulation of Flood Hazard Areas to Reduce Flood Losses, Volume 3.
3. Federal Emergency Management Agency **1982**, "**Coordination** on Highway Encroachments," Memorandum to Federal Emergency Management Regional Directors.
4. Federal Highway Administration 1985, "Federal Highway Involvement with Floodplains," Memorandum to the Hydrologic Engineering Center.

APPENDIX B

APPENDIX B

EXAMPLE CROSS-SECTIONAL AND PROFILE REPLICATES

This appendix presents examples of the Monte Carlo simulation adjustments to cross sections and samples of resulting computed water surface profiles from Monte Carlo adjusted cross sections. The cross-sectional adjustments simulate data measurement errors associated with **2-**, **5-**, and 10-foot contour intervals of aerial spot elevation surveys and topographic maps. The profiles are replicates generated from the adjusted cross sections and Manning's n-values for a selected HEC-2 data set. Although the discussion centers about the selected results of a particular stream and analysis conditions, the results *are* consistent with those derived from analysis of the 50,000 HEC-2 runs for the study.

Figures **B1** and **B2** *are* examples of **cross** section replicates for an HEC-2 base condition cross section for a 5-foot contour interval of aerial spot elevations and topographic mapping methods of obtaining cross-sectional coordinate data, respectively. Two replicates and the base cross section are shown to illustrate possible Monte Carlo adjustments to simulate aerial spot elevations and topographic mapping data measurement errors. **The** aerial spot elevation adjustments (**Figure B1**) are made at each of the base **cross** section coordinates. The topographic map adjustments (**B2**) are made at interpolated coordinate locations of the base cross section at 5-foot contour intervals. Comparisons of the aerial spot elevation results of **Figure B1** with the topographic map results of **Figure B2** clearly show the aerial procedure to produce the more accurate representation of the base condition cross section. This is due primarily to the difference in accuracy and to a lesser degree, the fewer coordinate points that result when using topographic maps.

Figures **B3** and **B4** show adjusted replicates for **2-**, and 10-foot **contour** interval of aerial spot elevation surveys and topographic mapping, respectively. The figures are included to illustrate the difference in impact of the contour interval of the two methods. The contour interval has significantly less effect on the aerial spot elevation method *for* obtaining cross section coordinate data than for topographic maps. The effect of fewer coordinate points and larger errors **associated** with a larger contour interval is illustrated in the 10-foot contour plot of the topographic map representation shown on **Figure B4**.

Figures **B5** through **B8** show the base profile and profile replicates computed for adjusted cross sections generated for **2-**, **5-**, 10-foot contour intervals of aerial spot elevations and topographic map methods, for two reliabilities of Manning's **n**-value estimates. Each adjusted profile represents one replicate of many possible for each survey method and associated accuracy (contour interval), and reliability of Manning's n-value.

Figures B5 and **B6** show the **base** and selected **2-, 5-, and 10-** foot aerial spot elevation cross **section** data replicate profiles for high (*Nr-0*) and low (*Nr-1*) reliabilities of estimating Manning's coefficient. **Comparison** of the profile plots of the two figures clearly show that the aerial spot elevation (**Figure B5**) produces relatively accurate results for the stream regardless of the contour interval, and that the reliability of estimating Manning's coefficient (**Figure B6**) can have a significant impact on the computed water surface profiles.

Figures B7 and **B8** show similar results for topographic maps to that of the aerial spot elevations. Figure B7 shows that the contour interval has a greater impact on the accuracy of the profiles resulting from geometry data developed from topographic map data than from those of aerial spot elevations of Figure B5. The effect of the reliability of Manning's n-value estimate can also be seen by comparing **Figures B7** and **B8**.

FIGURE B1 Example Cross-Sectional Adjustments: 5-Foot Contour
Aerial Spot Elevations

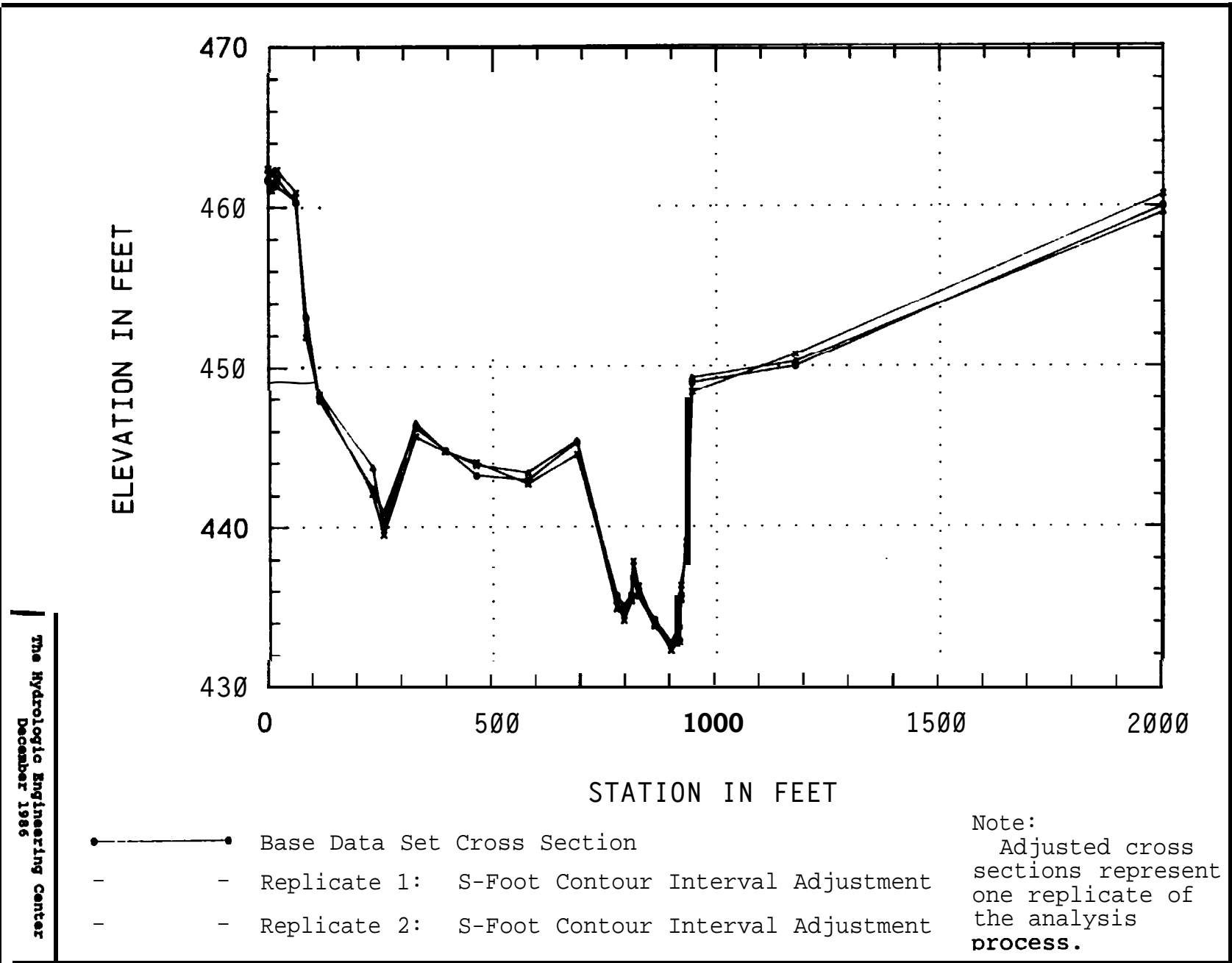

The Hydrologic Engineering Center
December 1986

Note:
Adjusted cross sections represent one replicate of the analysis process.

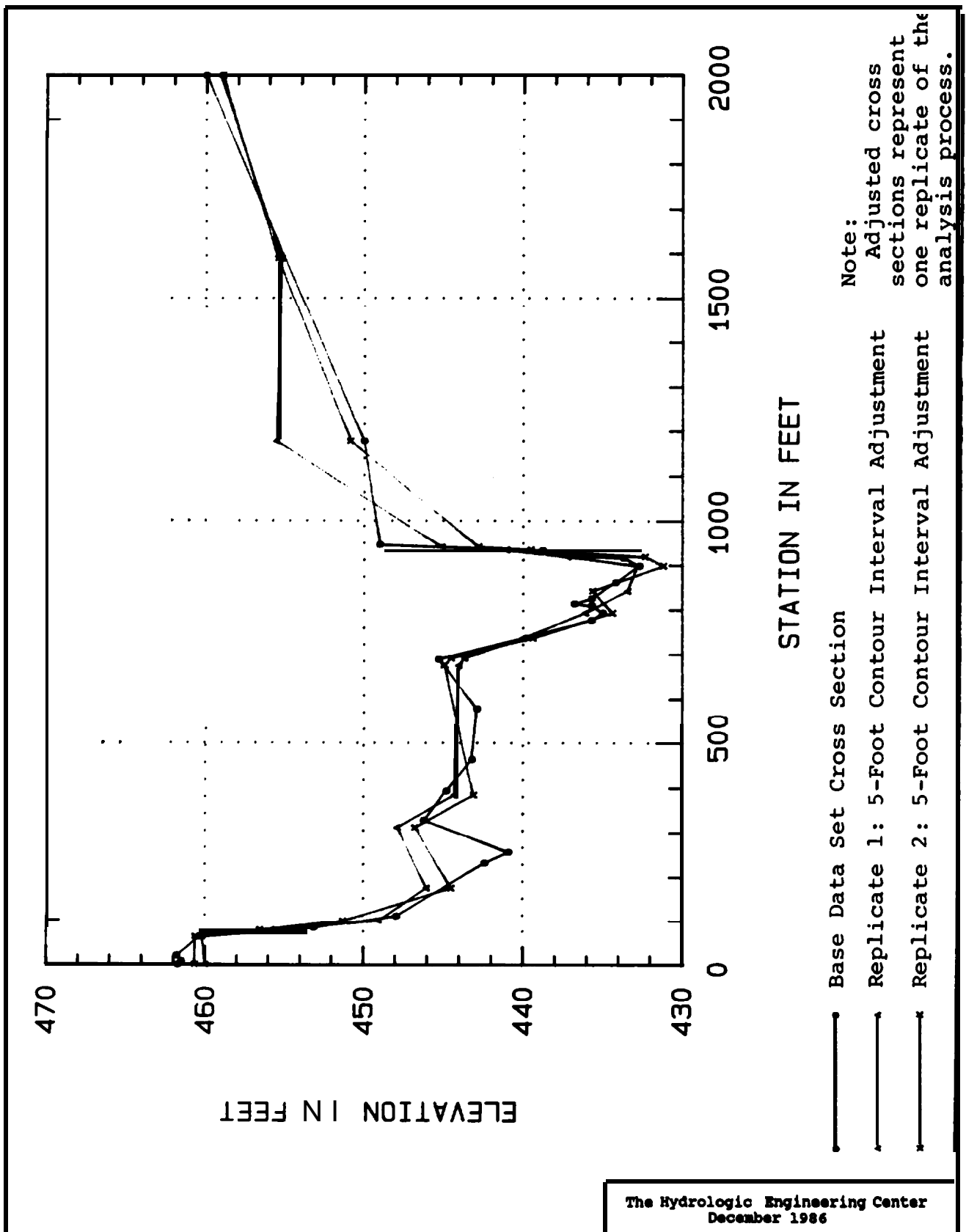

FIGURE B2 Example Cross-Sectional Adjustments: 5-Foot Contour Topographic Maps

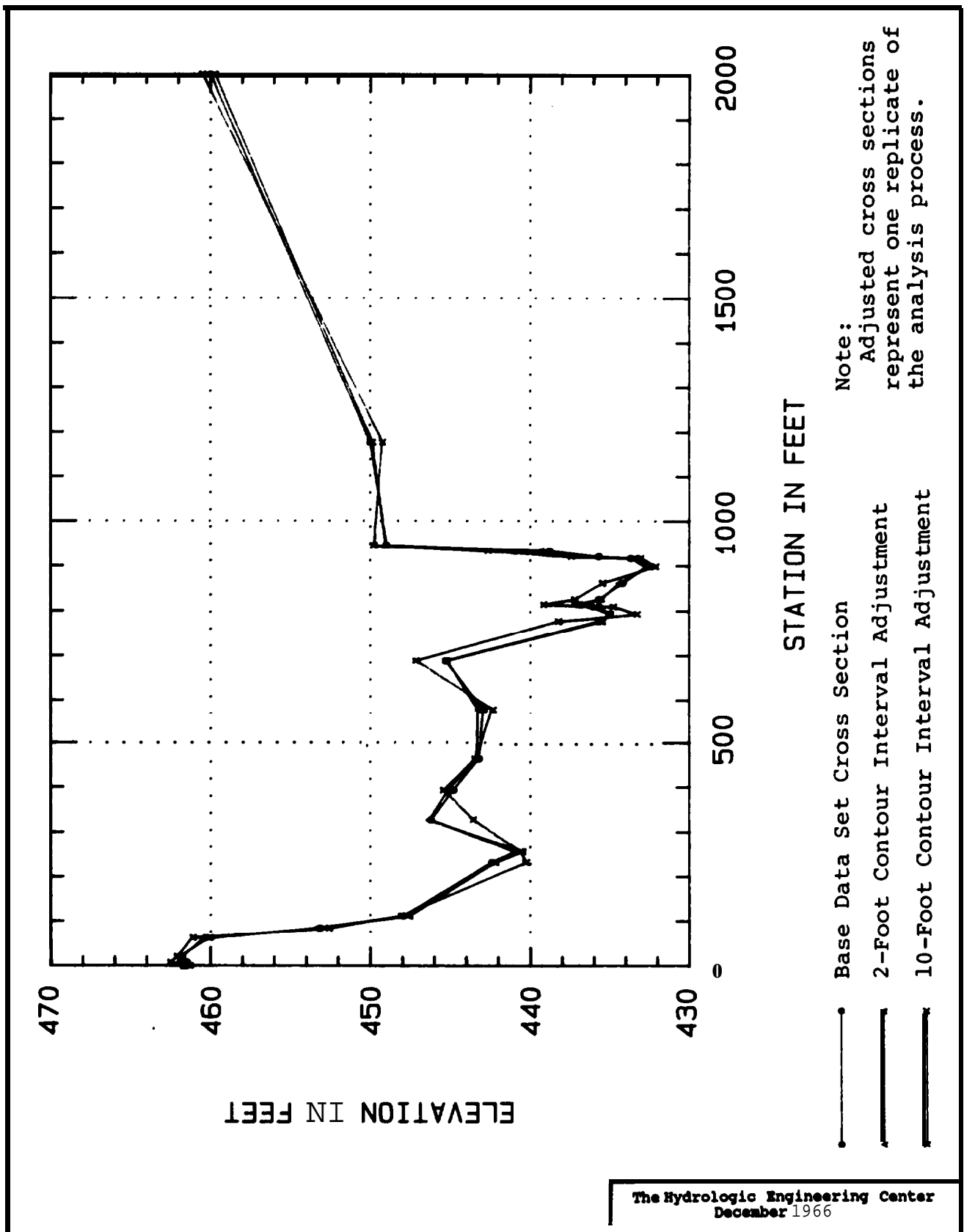

FIGURE B3 Example Cross-Sectional Adjustments: Aerial Spot Elevations

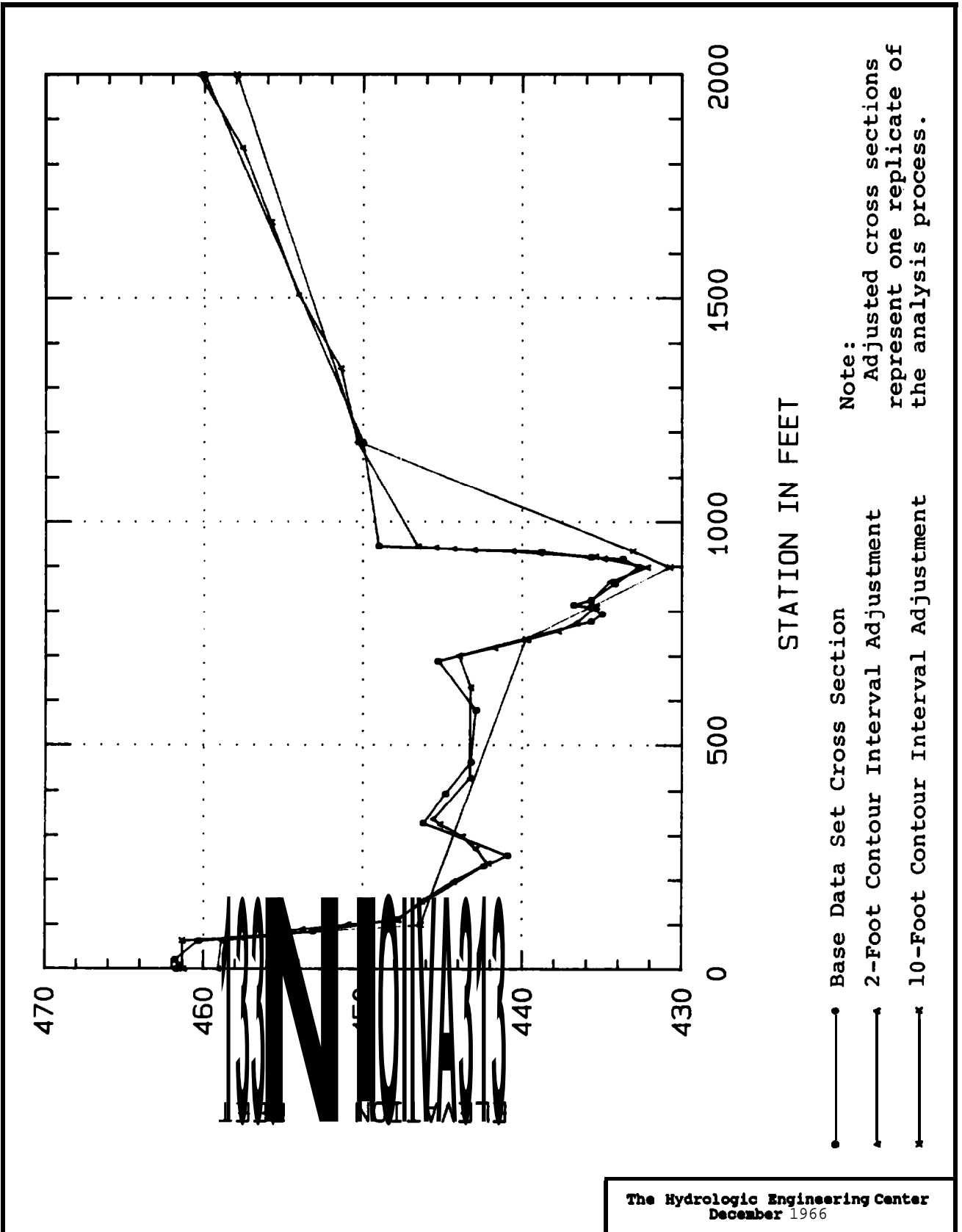

FIGURE B4 Example "cross-sectional" Adjustments: Topographic Maps

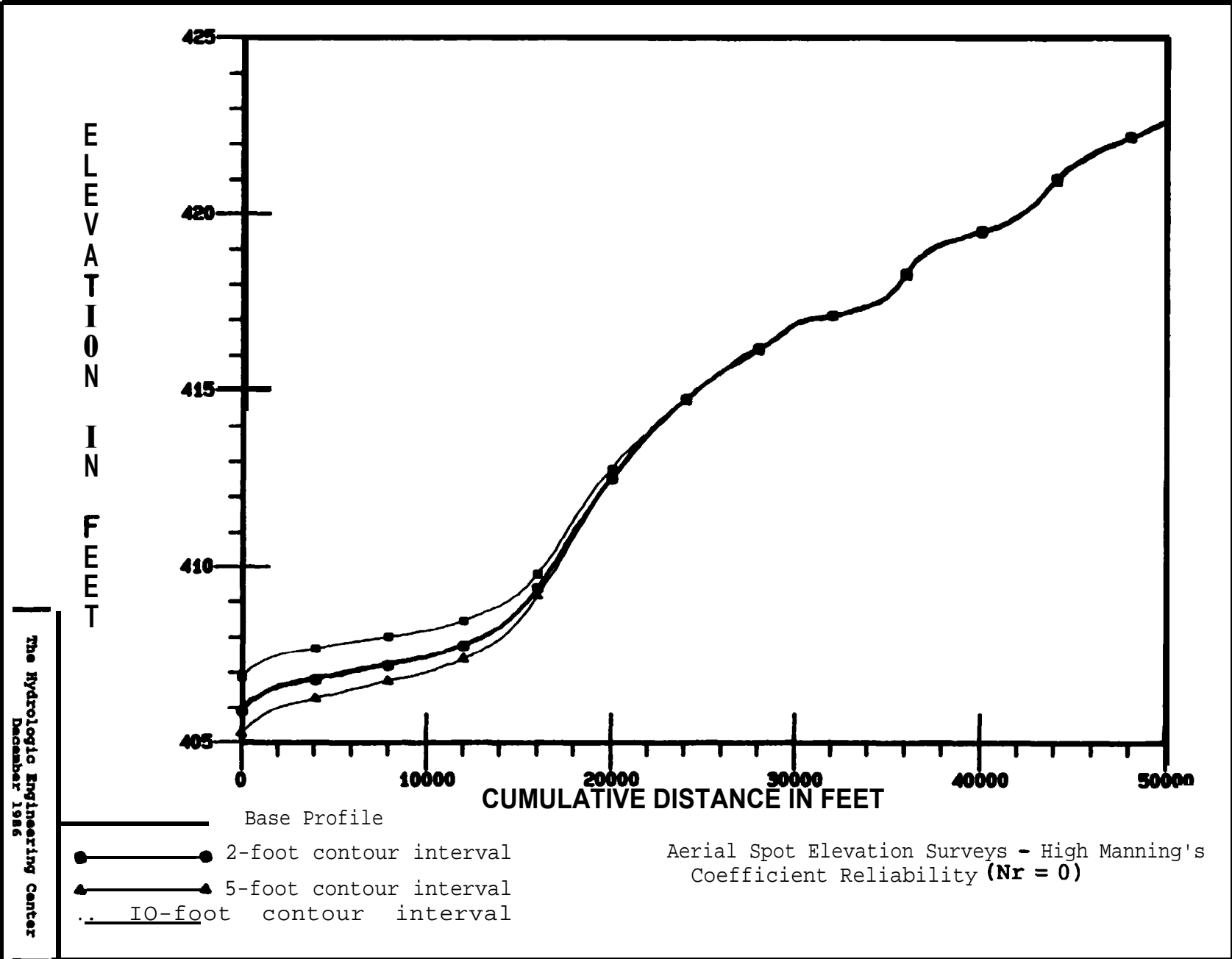

FIGURE B5 Example Profile Replicates - Aerial Spot Elevation Surveys ($Nr = 0$)

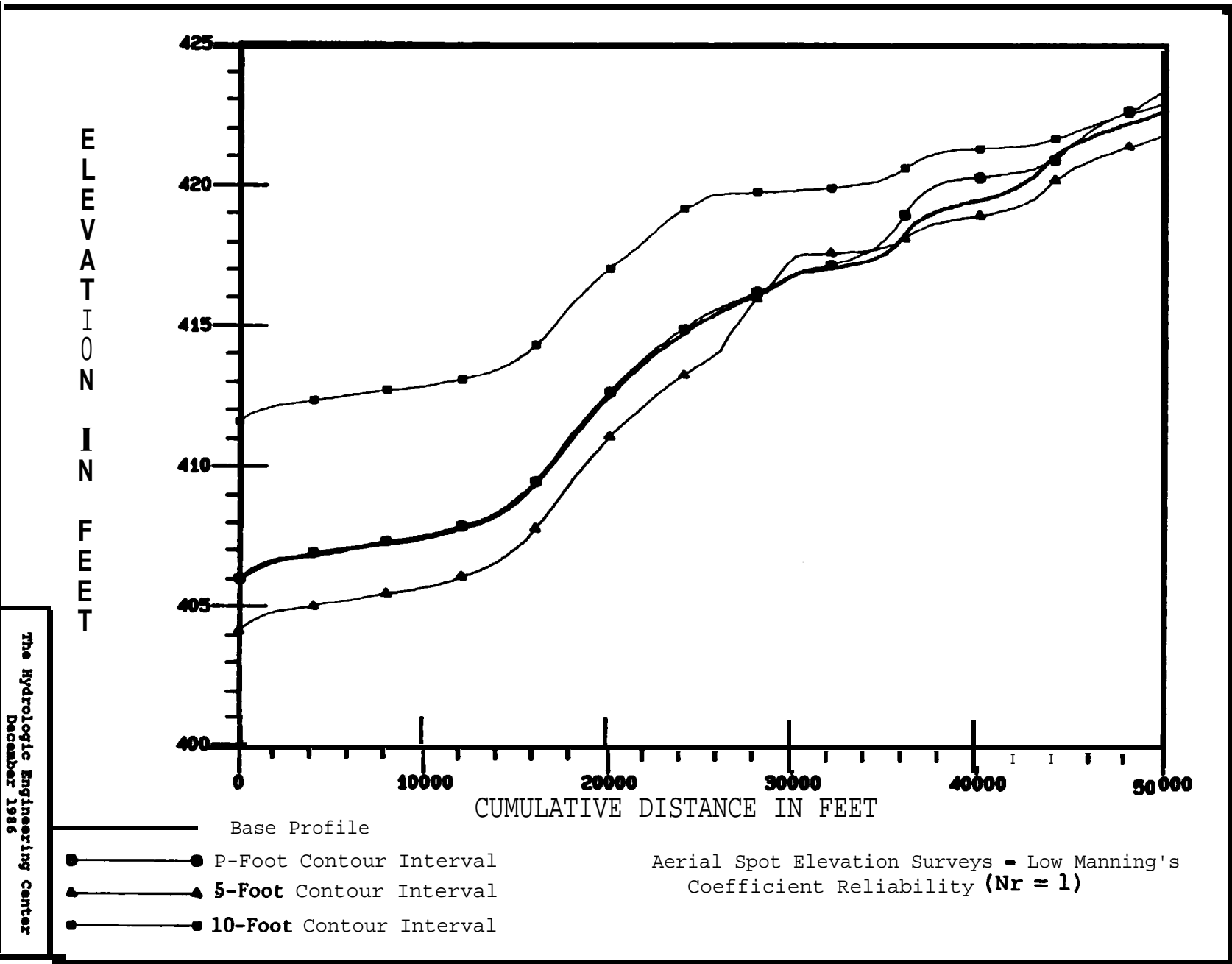

FIGURE B6 Example Profile Replicates - Aerial Spot Elevation Surveys (Nr = 1)

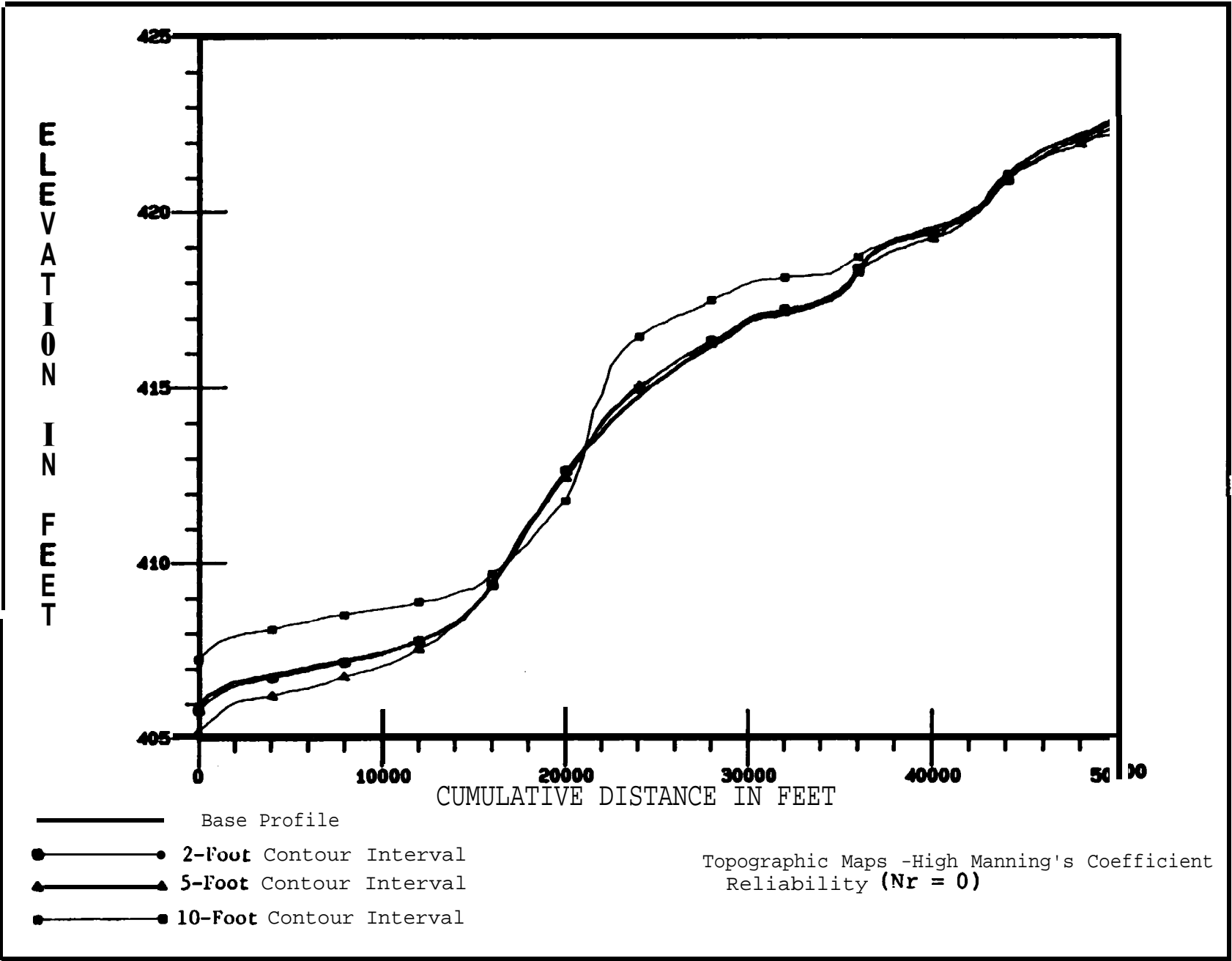

FIGURE B7 Example Profile Replicates - Topographic Map Surveys
($N_r = 0$)

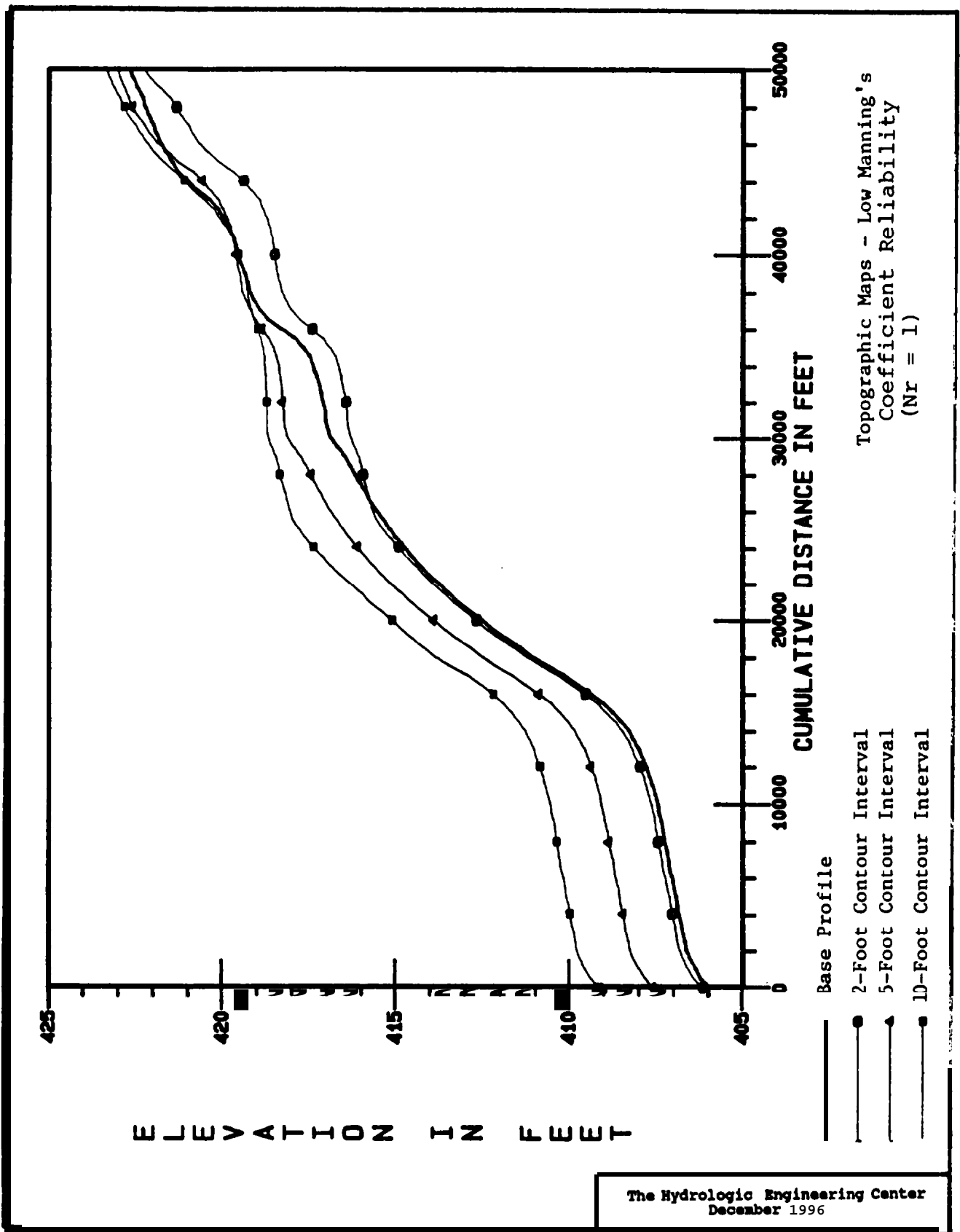

FIGURE B8 Example Profile Replicates - Topographic Map Surveys (Nr = 1)

APPENDIX C

PROFILE ERROR SUMMARIES

This appendix provides a complete listing of the hydraulic variable⁸ and error results for the 98 stream data sets. The listing includes 21 different profile analyses corresponding to each of the error condition⁸ analyzed for each of the 98 data sets. Page⁸ 127 through 154 list the profile error results for the aerial spot elevation survey method for defining cross-sectional coordinate data. Page⁸ 155 through 177 list the calculated errors for topographic map method of defining cross-sectional coordinate data.

Definition of Term⁸

Data Set I.D.	The data file label associated with an input HEC-2 data set
Average Q100 (cfs)	The average 1-percent chance flow rate in cubic feet per second for the analysis reach. The Q100 was determined by averaging the discharge value ⁸ of the first and last cross sections.
Average Slope (ft./mi.)	The average slope in feet per mile for the analysis reach. The slope is the difference in bed elevation between the first and last cross sections divided by the channel distance in miles.
Hydr Depth (ft)	The mean reach hydraulic depth in feet of the stream under analysis calculated as the flow area divided by the top width of the flow at the cross-sections. Weighted value ⁸ were calculated by cross section and by analysis reach.
Manning'8 n-value	The reach mean value of Manning's coefficient for stream roughness.
Survey Accuracy (ft)	Contour interval in feet used for various level ⁸ of surveys for defining cross-sectional coordinate data.
Nr	The reliability of the Manning's coefficient estimate where: 1.0 =

low reliability estimate: **.5 =**
~~moderate~~reliability estimate:
and 0 = known exactly,

Mean Absolute Error

The reach mean absolute profile error in **feet** of the analysis **reach** computed **by** summing the calculated profile error at 500 foot intervals and dividing by the total number of calculations points.

Maximum Absolute Error

The reach maximum absolute error **in feet.**

Profile Error Analysis **Summary**
Aerial Spot Elevation Survey
1-Percent Chance Flood Event

Data Set I.D.	Average Q100 (cfs)	Average Slope (ft/mi)	Hydr Depth (ft)	Manning's n Value	Survey Accuracy (ft)	Manning's Reliability Nr	Absolute Mean Error (ft)	Absolute Maximum Error (ft)
S12M1	700	6.5	2.61	0.037	2	0.0	0.061	0.190
S12M1	700	6.5	2.61	0.037	5	0.0	0.136	0.436
S12M1	700	6.5	2.61	0.037	10	0.0	0.434	1.053
S12M1	700	6.5	2.61	0.037	0	0.5	0.192	0.477
S12M1	700	6.5	2.61	0.037	2	0.5	0.252	0.657
S12M1	700	6.5	2.61	0.037	5	0.5	0.247	0.653
S12M1	700	6.5	2.61	0.037	10	0.5	0.540	1.234
S12M1	700	6.5	2.61	0.037	0	1.0	0.306	0.746
S12M1	700	6.5	2.61	0.037	2	1.0	0.497	1.094
S12M1	700	6.5	2.61	0.037	5	1.0	0.350	0.798
S12M1	700	6.5	2.61	0.037	10	1.0	0.490	1.275
S13M1	700	3.6	0.93	0.044	2	0.0	0.066	0.192
S13M1	700	3.6	0.93	0.044	5	0.0	0.124	0.302
S13M1	700	3.6	0.93	0.044	10	0.0	0.529	1.034
S13M1	700	3.6	0.93	0.044	0	0.5	0.095	0.236
S13M1	700	3.6	0.93	0.044	2	0.5	0.123	0.279
S13M1	700	3.6	0.93	0.044	5	0.5	0.148	0.373
S13M1	700	3.6	0.93	0.044	10	0.5	0.499	0.967
S13M1	700	3.6	0.93	0.044	0	1.0	0.169	0.393
S13M1	700	3.6	0.93	0.044	2	1.0	0.147	0.337
S13M1	700	3.6	0.93	0.044	5	1.0	0.215	0.509
S13M1	700	3.6	0.93	0.044	10	1.0	0.517	1.111
S10M1	800	4.3	2.92	0.036	2	0.0	0.050	0.173
S10M1	800	4.3	2.92	0.036	5	0.0	0.098	0.360
S10M1	800	4.3	2.92	0.036	10	0.0	0.344	0.849
S10M1	800	4.3	2.92	0.036	0	0.5	0.116	0.289
S10M1	800	4.3	2.92	0.036	2	0.5	0.282	0.613
S10M1	800	4.3	2.92	0.036	5	0.5	0.292	0.699
S10M1	800	4.3	2.92	0.036	10	0.5	0.375	0.964
S10M1	800	4.3	2.92	0.036	0	1.0	0.409	0.814
S10M1	800	4.3	2.92	0.036	2	1.0	0.413	0.858
S10M1	800	4.3	2.92	0.036	5	1.0	0.516	1.087
S10M1	800	4.3	2.92	0.036	10	1.0	0.540	1.130
S22S1	800	11.2	1.21	0.037	2	0.0	0.079	0.279
S22S1	800	11.2	1.21	0.037	5	0.0	0.159	0.515
S22S1	800	11.2	1.21	0.037	10	0.0	0.485	1.384
S22S1	800	11.2	1.21	0.037	0	0.5	0.092	0.245
S22S1	800	11.2	1.21	0.037	2	0.5	0.118	0.381
S22S1	800	11.2	1.21	0.037	5	0.5	0.189	0.594
S22S1	800	11.2	1.21	0.037	10	0.5	0.478	1.360

Profile Error Analysis Summary
Aerial Spot Elevation Survey
 1-Percent Chance Flood Event

Data Set I.D.	Average Q100 (cfs)	Average Slope (ft/mi)	Hydr Depth (ft)	Manning's n Value	Survey Accuracy (ft)	Manning's Reliability Nr	Absolute Mean Error (ft)	Absolute Maximum Error (ft)
S22S1	800	11.2	1.21	0.037	0	1.0	0.193	0.513
S22S1	800	11.2	1.21	0.037	2	1.0	0.211	0.591
S22S1	800	11.2	1.21	0.037	5	1.0	0.278	0.842
S22S1	800	11.2	1.21	0.037	10	1.0	0.503	1.464
S09M1	900	6.3	1.03	0.041	2	0.0	0.061	0.178
S09M1	900	6.3	1.03	0.041	5	0.0	0.137	0.395
S09M1	900	6.3	1.03	0.041	10	0.0	0.543	1.237
S09M1	900	6.3	1.03	0.041	0	0.5	0.098	0.152
S09M1	900	6.3	1.03	0.041	2	0.5	0.135	0.281
S09M1	900	6.3	1.03	0.041	5	0.5	0.173	0.441
S09M1	900	6.3	1.03	0.041	10	0.5	0.544	1.282
S09M1	900	6.3	1.03	0.041	0	1.0	0.214	0.334
S09M1	900	6.3	1.03	0.041	2	1.0	0.220	0.411
S09M1	900	6.3	1.03	0.041	5	1.0	0.235	0.517
S09M1	900	6.3	1.03	0.041	10	1.0	0.577	1.258
S11M1	1,800	3.4	2.16	0.039	2	0.0	0.051	0.225
S11M1	1,800	3.4	2.16	0.039	5	0.0	0.112	0.388
S11M1	1,800	3.4	2.16	0.039	10	0.0	0.404	0.940
S11M1	1,800	3.4	2.16	0.039	0	0.5	0.210	0.344
S11M1	1,800	3.4	2.16	0.039	2	0.5	0.223	0.427
S11M1	1,800	3.4	2.16	0.039	5	0.5	0.225	0.494
S11M1	1,800	3.4	2.16	0.039	10	0.5	0.468	1.016
S11M1	1,800	3.4	2.16	0.039	0	1.0	0.428	0.701
S11M1	1,800	3.4	2.16	0.039	2	1.0	0.485	0.831
S11M1	1,800	3.4	2.16	0.039	5	1.0	0.489	0.873
S11M1	1,800	3.4	2.16	0.039	10	1.0	0.614	1.246
S17M1	1,800	5.6	1.24	0.039	2	0.0	0.056	0.175
S17M1	1,800	5.6	1.24	0.039	5	0.0	0.116	0.338
S17M1	1,800	5.6	1.24	0.039	10	0.0	0.534	1.106
S17M1	1,800	5.6	1.24	0.039	0	0.5	0.128	0.547
S17M1	1,800	5.6	1.24	0.039	2	0.5	0.118	0.420
S17M1	1,800	5.6	1.24	0.039	5	0.5	0.165	0.545
S17M1	1,800	5.6	1.24	0.039	10	0.5	0.572	1.255
S17M1	1,800	5.6	1.24	0.039	0	1.0	0.200	0.731
S17M1	1,800	5.6	1.24	0.039	2	1.0	0.215	0.814
S17M1	1,800	5.6	1.24	0.039	5	1.0	0.234	0.794
S17M1	1,800	5.6	1.24	0.039	10	1.0	0.550	1.398
S20S1	1,850	34.7	2.01	0.056	2	0.0	0.306	2.326
S20S1	1,850	34.7	2.01	0.056	5	0.0	0.352	2.416

Profile Error Analysis Summary
Aerial Spot Elevation Survey
1-Percent Chance Flood Event

Data Set I.D.	Average Q100 (cfs)	Average Slope (ft/mi)	Hydr Depth (ft)	Manning's n Value	Survey Accuracy (ft)	Manning's Reliability Nr	Absolute Mean Error (ft)	Absolute Maximum Error (ft)
S20S1	1,850	34.7	2.01	0.056	10	0.0	0.552	2.990
S20S1	1,850	34.7	2.01	0.056	0	0.5	0.365	2.335
S20S1	1,850	34.7	2.01	0.056	2	0.5	0.363	2.348
S20S1	1,850	34.7	2.01	0.056	5	0.5	0.402	2.467
S20S1	1,850	34.7	2.01	0.056	10	0.5	0.599	2.901
S20S1	1,850	34.7	2.01	0.056	0	1.0	0.471	2.336
S20S1	1,850	34.7	2.01	0.056	2	1.0	0.492	2.206
S20S1	1,850	34.7	2.01	0.056	5	1.0	0.571	2.375
S20S1	1,850	34.7	2.01	0.056	10	1.0	0.619	2.793
S07M1	2,292	3.6	1.96	0.059	2	0.0	0.052	0.303
S07M1	2,292	3.6	1.96	0.059	5	0.0	0.083	0.322
S07M1	2,292	3.6	1.96	0.059	10	0.0	0.288	0.835
S07M1	2,292	3.6	1.96	0.059	0	0.5	0.226	0.605
S07M1	2,292	3.6	1.96	0.059	2	0.5	0.165	0.473
S07M1	2,292	3.6	1.96	0.059	5	0.5	0.210	0.691
S07M1	2,292	3.6	1.96	0.059	10	0.5	0.361	1.034
S07M1	2,292	3.6	1.96	0.059	0	1.0	0.449	1.196
S07M1	2,292	3.6	1.96	0.059	2	1.0	0.537	1.365
S07M1	2,292	3.6	1.96	0.059	5	1.0	0.433	1.130
S07M1	2,292	3.6	1.96	0.059	10	1.0	0.488	1.271
S21S1	2,450	24.4	2.12	0.051	2	0.0	0.085	0.259
S21S1	2,450	24.4	2.12	0.051	5	0.0	0.168	0.468
S21S1	2,450	24.4	2.12	0.051	10	0.0	0.386	1.034
S21S1	2,450	24.4	2.12	0.051	0	0.5	0.240	0.505
S21S1	2,450	24.4	2.12	0.051	2	0.5	0.199	0.417
S21S1	2,450	24.4	2.12	0.051	5	0.5	0.266	0.602
S21S1	2,450	24.4	2.12	0.051	10	0.5	0.444	1.176
S21S1	2,450	24.4	2.12	0.051	0	1.0	0.296	0.604
S21S1	2,450	24.4	2.12	0.051	2	1.0	0.404	0.723
S21S1	2,450	24.4	2.12	0.051	5	1.0	0.333	0.788
S21S1	2,450	24.4	2.12	0.051	10	1.0	0.557	1.312
S18S1	2,575	21.0	2.63	0.073	2	0.0	0.068	0.235
S18S1	2,575	21.0	2.63	0.073	5	0.0	0.124	0.356
S18S1	2,575	21.0	2.63	0.073	10	0.0	0.308	0.841
S18S1	2,575	21.0	2.63	0.073	0	0.5	0.257	0.502
S18S1	2,575	21.0	2.63	0.073	2	0.5	0.241	0.497
S18S1	2,575	21.0	2.63	0.073	5	0.5	0.245	0.586
S18S1	2,575	21.0	2.63	0.073	10	0.5	0.356	0.940
S18S1	2,575	21.0	2.63	0.073	0	1.0	0.539	0.970
S18S1	2,575	21.0	2.63	0.073	2	1.0	0.469	0.864

Profile Error Analysis Summary
Aerial Spot Elevation Survey
1-Percent Chance Flood Event

Data Set I.D.	Average Q100 (cfs)	Average Slope (ft/mi)	Hydr Depth (ft)	Manning's n Value	Survey Accuracy (ft)	Manning's Reliability Nr	Absolute Mean Error (ft)	Absolute Maximum Error (ft)
S18S1	2,575	21.0	2.63	0.073	5	1.0	0.492	1.001
S18S1	2,575	21.0	2.63	0.073	10	1.0	0.674	1.455
S17S1	2,850	43.4	3.92	0.051	2	0.0	0.172	0.858
S17S1	2,850	43.4	3.92	0.051	5	0.0	0.215	0.917
S17S1	2,850	43.4	3.92	0.051	10	0.0	0.441	1.385
S17S1	2,850	43.4	3.92	0.051	0	0.5	0.356	0.858
S17S1	2,850	43.4	3.92	0.051	2	0.5	0.346	0.894
S17S1	2,850	43.4	3.92	0.051	5	0.5	0.344	1.038
S17S1	2,850	43.4	3.92	0.051	10	0.5	0.533	1.431
S17S1	2,850	43.4	3.92	0.051	0	1.0	0.682	1.461
S17S1	2,850	43.4	3.92	0.051	2	1.0	0.616	1.333
S17S1	2,850	43.4	3.92	0.051	5	1.0	0.605	1.364
S17S1	2,850	43.4	3.92	0.051	10	1.0	0.714	1.555
S19S1	2,870	57.8	4.60	0.062	2	0.0	0.477	1.372
S19S1	2,870	57.8	4.60	0.062	5	0.0	0.503	1.376
S19S1	2,870	57.8	4.60	0.062	10	0.0	0.668	1.770
S19S1	2,870	57.8	4.60	0.062	0	0.5	0.613	1.777
S19S1	2,870	57.8	4.60	0.062	2	0.5	0.608	1.685
S19S1	2,870	57.8	4.60	0.062	5	0.5	0.601	1.647
S19S1	2,870	57.8	4.60	0.062	10	0.5	0.780	2.078
S19S1	2,870	57.8	4.60	0.062	0	1.0	0.838	2.065
S19S1	2,870	57.8	4.60	0.062	2	1.0	0.910	2.293
S19S1	2,870	57.8	4.60	0.062	5	1.0	0.836	2.263
S19S1	2,870	57.8	4.60	0.062	10	1.0	1.016	2.559
S16M1	3,050	4.6	3.48	0.039	2	0.0	0.053	0.144
S16M1	3,050	4.6	3.48	0.039	5	0.0	0.118	0.319
S16M1	3,050	4.6	3.48	0.039	10	0.0	0.345	0.807
S16M1	3,050	4.6	3.48	0.039	0	0.5	0.447	1.264
S16M1	3,050	4.6	3.48	0.039	2	0.5	0.343	0.978
S16M1	3,050	4.6	3.48	0.039	5	0.5	0.371	1.010
S16M1	3,050	4.6	3.48	0.039	10	0.5	0.461	1.140
S16M1	3,050	4.6	3.48	0.039	0	1.0	0.627	1.547
S16M1	3,050	4.6	3.48	0.039	2	1.0	0.861	2.058
S16M1	3,050	4.6	3.48	0.039	5	1.0	0.770	1.792
S16M1	3,050	4.6	3.48	0.039	10	1.0	0.770	2.169
S03S1	3,077	13.0	3.38	0.052	2	0.0	0.046	0.149
S03S1	3,077	13.0	3.38	0.052	5	0.0	0.095	0.298
S03S1	3,077	13.0	3.38	0.052	10	0.0	0.235	0.762
S03S1	3,077	13.0	3.38	0.052	0	0.5	0.406	0.553

Profile Error **Analysis** Summary
Aerial Spot Elevation Survey
1-Percent Chance Flood Event

Data Set I.D.	Average Q100 (cfs)	Average Slope (ft/mi)	Hydr Depth (ft)	Manning's n Value	Survey Accuracy (ft)	Manning's Reliability Nr	Absolute Mean Error (ft)	Absolute Maximum Error (ft)
S03S1	3,077	13.0	3.38	0.052	2	0.5	0.436	0.646
S03S1	3,077	13.0	3.38	0.052	5	0.5	0.336	0.600
S03S1	3,077	13.0	3.38	0.052	10	0.5	0.430	1.016
S03S1	3,077	13.0	3.38	0.052	0	1.0	0.646	0.894
S03S1	3,077	13.0	3.38	0.052	2	1.0	0.747	1.072
S03S1	3,077	13.0	3.38	0.052	5	1.0	0.686	1.044
S03S1	3,077	13.0	3.38	0.052	10	1.0	0.846	1.511
S15S1	3,458	27.4	3.63	0.064	2	0.0	0.221	0.959
S15S1	3,458	27.4	3.63	0.064	5	0.0	0.250	0.936
S15S1	3,458	27.4	3.63	0.064	10	0.0	0.403	1.310
S15S1	3,458	27.4	3.63	0.064	0	0.5	0.429	1.179
S15S1	3,458	27.4	3.63	0.064	2	0.5	0.460	1.370
S15S1	3,458	27.4	3.63	0.064	5	0.5	0.419	1.411
S15S1	3,458	27.4	3.63	0.064	10	0.5	0.573	1.692
S15S1	3,458	27.4	3.63	0.064	0	1.0	0.739	2.087
S15S1	3,458	27.4	3.63	0.064	2	1.0	0.768	2.085
S15S1	3,458	27.4	3.63	0.064	5	1.0	0.728	1.928
S15S1	3,458	27.4	3.63	0.064	10	1.0	0.854	2.087
S14S1	3,655	39.2	3.49	0.068	2	0.0	0.327	1.421
S14S1	3,655	39.2	3.49	0.068	5	0.0	0.348	1.434
S14S1	3,655	39.2	3.49	0.068	10	0.0	0.464	1.549
S14S1	3,655	39.2	3.49	0.068	0	0.5	0.519	1.575
S14S1	3,655	39.2	3.49	0.068	2	0.5	0.520	1.533
S14S1	3,655	39.2	3.49	0.068	5	0.5	0.479	1.452
S14S1	3,655	39.2	3.49	0.068	10	0.5	0.614	1.787
S14S1	3,655	39.2	3.49	0.068	0	1.0	0.859	1.962
S14S1	3,655	39.2	3.49	0.068	2	1.0	0.950	2.271
S14S1	3,655	39.2	3.49	0.068	5	1.0	0.854	1.955
S14S1	3,655	39.2	3.49	0.068	10	1.0	0.996	2.534
S12S1	3,825	21.4	2.53	0.065	2	0.0	0.056	0.148
S12S1	3,825	21.4	2.53	0.065	5	0.0	0.117	0.307
S12S1	3,825	21.4	2.53	0.065	10	0.0	0.296	0.851
S12S1	3,825	21.4	2.53	0.065	0	0.5	0.226	0.277
S12S1	3,825	21.4	2.53	0.065	2	0.5	0.224	0.361
S12S1	3,825	21.4	2.53	0.065	5	0.5	0.290	0.551
S12S1	3,825	21.4	2.53	0.065	10	0.5	0.387	0.977
S12S1	3,825	21.4	2.53	0.065	0	1.0	0.413	0.507
S12S1	3,825	21.4	2.53	0.065	2	1.0	0.409	0.571
S12S1	3,825	21.4	2.53	0.065	5	1.0	0.464	0.752
S12S1	3,825	21.4	2.53	0.065	10	1.0	0.707	1.370

Profile Error Analysis Summary
Aerial Spot Elevation Survey
1-Percent Chance Flood Event

Data Set I.D.	Average Q100 (cfs)	Average Slope (ft/mi)	Hydr Depth (ft)	Manning's n Value	Survey Accuracy (ft)	Manning's Reliability Nr	Absolute Mean Error (ft)	Absolute Maximum Error (ft)
							--s _e --	-----
S14M1	4,600	3.2	6.09	0.029	2	0.0	0.109	0.581
S14M1	4,600	3.2	6.09	0.029	5	0.0	0.146	0.734
S14M1	4,600	3.2	6.09	0.029	10	0.0	0.257	1.134
S14M1	4,600	3.2	6.09	0.029	0	0.5	0.274	0.870
S14M1	4,600	3.2	6.09	0.029	2	0.5	0.318	1.002
S14M1	4,600	3.2	6.09	0.029	5	0.5	0.271	0.876
S14M1	4,600	3.2	6.09	0.029	10	0.5	0.304	0.884
S14M1	4,600	3.2	6.09	0.029	0	1.0	0.435	1.080
S14M1	4,600	3.2	6.09	0.029	2	1.0	0.674	2.597
S14M1	4,600	3.2	6.09	0.029	5	1.0	0.502	1.521
S14M1	4,600	3.2	6.09	0.029	10	1.0	0.699	2.417
S05S1	5,010	36.9	3.00	0.053	2	0.0	0.171	0.604
S05S1	5,010	36.9	3.00	0.053	5	0.0	0.197	0.645
S05S1	5,010	36.9	3.00	0.053	10	0.0	0.340	0.993
S05S1	5,010	36.9	3.00	0.053	0	0.5	0.310	0.849
S05S1	5,010	36.9	3.00	0.053	2	0.5	0.349	0.978
S05S1	5,010	36.9	3.00	0.053	5	0.5	0.365	1.063
S05S1	5,010	36.9	3.00	0.053	10	0.5	0.400	1.369
S05S1	5,010	36.9	3.00	0.053	0	1.0	0.564	1.771
S05S1	5,010	36.9	3.00	0.053	2	1.0	0.569	1.637
S05S1	5,010	36.9	3.00	0.053	5	1.0	0.521	1.711
S05S1	5,010	36.9	3.00	0.053	10	1.0	0.606	1.757
S06S1	5,197	37.8	4.12	0.073	2	0.0	0.247	2.878
S06S1	5,197	37.8	4.12	0.073	5	0.0	0.272	2.915
S06S1	5,197	37.8	4.12	0.073	10	0.0	0.448	2.847
S06S1	5,197	37.8	4.12	0.073	0	0.5	0.590	2.893
S06S1	5,197	37.8	4.12	0.073	2	0.5	0.608	2.982
S06S1	5,197	37.8	4.12	0.073	5	0.5	0.564	3.004
S06S1	5,197	37.8	4.12	0.073	10	0.5	0.589	3.168
S06S1	5,197	37.8	4.12	0.073	0	1.0	0.989	3.079
S06S1	5,197	37.8	4.12	0.073	2	1.0	0.884	3.117
S06S1	5,197	37.8	4.12	0.073	5	1.0	0.841	2.915
S06S1	5,197	37.8	4.12	0.073	10	1.0	0.920	3.116
S05M1	5,493	8.8	3.74	0.056	2	0.0	0.036	0.115
S05M1	5,493	8.8	3.74	0.056	5	0.0	0.078	0.255
S05M1	5,493	8.8	3.74	0.056	10	0.0	0.190	0.589
S05M1	5,493	8.8	3.74	0.056	0	0.5	0.318	0.398
S05M1	5,493	8.8	3.74	0.056	2	0.5	0.320	0.450
S05M1	5,493	8.8	3.74	0.056	5	0.5	0.411	0.634
S05M1	5,493	8.8	3.74	0.056	10	0.5	0.411	0.895

Profile Error Analysis Summary
Aerial Spot Elevation Survey
1-Percent Chance Flood Event

Data Set I.D.	Average Q100 (cfs)	Average Slope (ft/mi)	Hydr Depth (ft)	Manning's n Value	Survey Accuracy (ft)	Manning's Reliability Nr	Absolute Mean Error (ft)	Absolute Maximum Error (ft)
S05M1	5,493	8.8	3.74	0.056	0	1.0	0.721	0.920
S05M1	5,493	8.8	3.74	0.056	2	1.0	0.832	1.088
S05M1	5,493	8.8	3.74	0.056	5	1.0	0.689	0.957
S05M1	5,493	8.8	3.74	0.056	10	1.0	0.651	1.136
S09S1	5,675	37.6	7.30	0.061	2	0.0	0.063	0.171
S09S1	5,675	37.6	7.30	0.061	5	0.0	0.132	0.360
S09S1	5,675	37.6	7.30	0.061	10	0.0	0.348	0.859
S09S1	5,675	37.6	7.30	0.061	0	0.5	0.754	1.240
S09S1	5,675	37.6	7.30	0.061	2	0.5	0.638	1.106
S09S1	5,675	37.6	7.30	0.061	5	0.5	0.730	1.270
S09S1	5,675	37.6	7.30	0.061	10	0.5	0.812	1.608
S09S1	5,675	37.6	7.30	0.061	0	1.0	1.352	2.158
S09S1	5,675	37.6	7.30	0.061	2	1.0	1.235	2.039
S09S1	5,675	37.6	7.30	0.061	5	1.0	1.106	1.858
S09S1	5,675	37.6	7.30	0.061	10	1.0	1.523	2.837
S13S1	5,880	46.4	6.07	0.072	2	0.0	0.764	3.842
S13S1	5,880	46.4	6.07	0.072	5	0.0	0.754	3.861
S13S1	5,880	46.4	6.07	0.072	10	0.0	0.828	3.630
S13S1	5,880	46.4	6.07	0.072	0	0.5	1.035	3.681
S13S1	5,880	46.4	6.07	0.072	2	0.5	1.076	4.092
S13S1	5,880	46.4	6.07	0.072	5	0.5	0.985	3.742
S13S1	5,880	46.4	6.07	0.072	10	0.5	1.139	4.133
S13S1	5,880	46.4	6.07	0.072	0	1.0	1.275	4.137
S13S1	5,880	46.4	6.07	0.072	2	1.0	1.417	4.137
S13S1	5,880	46.4	6.07	0.072	5	1.0	1.328	3.847
S13S1	5,880	46.4	6.07	0.072	10	1.0	1.590	4.218
S08S1	6,075	19.4	4.05	0.070	2	0.0	0.065	0.268
S08S1	6,075	19.4	4.05	0.070	5	0.0	0.129	0.420
S08S1	6,075	19.4	4.05	0.070	10	0.0	0.277	0.879
S08S1	6,075	19.4	4.05	0.070	0	0.5	0.457	0.995
S08S1	6,075	19.4	4.05	0.070	2	0.5	0.420	0.913
S08S1	6,075	19.4	4.05	0.070	5	0.5	0.477	1.111
S08S1	6,075	19.4	4.05	0.070	10	0.5	0.471	1.306
S08S1	6,075	19.4	4.05	0.070	0	1.0	0.855	1.960
S08S1	6,075	19.4	4.05	0.070	2	1.0	0.843	1.778
S08S1	6,075	19.4	4.05	0.070	5	1.0	0.892	2.083
S08S1	6,075	19.4	4.05	0.070	10	1.0	0.970	2.29s
S03M1	6,530	4.5	3.39	0.074	2	0.0	0.051	0.141
S03M1	6,530	4.5	3.39	0.074	5	0.0	0.09s	0.282

Profile Error **Analysis** Summary
Aerial Spot Elevation Survey
1-Percent Chance Flood Event

Data Set I.D.	Average Q100 (cfs)	Average Slope (ft/mi)	Hydr Depth (ft)	Manning's n Value	Survey Accuracy (ft)	Manning's Reliability Nr	Absolute Mean Error (ft)	Absolute Maximum Error (ft)
S03M1	6,530	4.5	3.39	0.074	10	0.0	0.260	0.812
S03M1	6,530	4.5	3.39	0.074	0	0.5	0.309	0.569
S03M1	6,530	4.5	3.39	0.074	2	0.5	0.268	0.509
S03M1	6,530	4.5	3.39	0.074	5	0.5	0.348	0.675
S03M1	6,530	4.5	3.39	0.074	10	0.5	0.432	1.060
S03M1	6,530	4.5	3.39	0.074	0	1.0	0.656	1.129
S03M1	6,530	4.5	3.39	0.074	2	1.0	0.661	1.206
S03M1	6,530	4.5	3.39	0.074	5	1.0	0.637	1.271
S03M1	6,530	4.5	3.39	0.074	10	1.0	0.648	1.292
S02S1	6,688	27.2	2.65	0.053	2	0.0	0.083	0.328
S02S1	6,608	27.2	2.65	0.053	5	0.0	0.136	0.412
S02S1	6,686	27.2	2.65	0.053	10	0.0	0.350	0.852
S02S1	6,688	27.2	2.65	0.053	0	0.5	0.313	0.727
S02S1	6,688	27.2	2.65	0.053	2	0.5	0.346	0.818
S02S1	6,688	27.2	2.65	0.053	5	0.5	0.384	0.823
S02S1	6,688	27.2	2.65	0.053	10	0.5	0.447	1.049
S02S1	6,688	27.2	2.65	0.053	0	1.0	0.627	1.495
S02S1	6,688	27.2	2.65	0.053	2	1.0	0.510	1.235
S02S1	6,688	27.2	2.65	0.053	5	1.0	0.554	1.396
S02S1	6,688	27.2	2.65	0.053	10	1.0	0.750	1.597
S07S1	6,700	13.4	2.89	0.057	2	0.0	0.045	0.169
S07S1	6,700	13.4	2.89	0.057	5	0.0	0.089	0.304
S07S1	6,700	13.4	2.89	0.057	10	0.0	0.243	0.778
S07S1	6,700	13.4	2.89	0.057	0	0.5	0.270	0.318
S07S1	6,700	13.4	2.89	0.057	2	0.5	0.270	0.419
S07S1	6,700	13.4	2.89	0.057	5	0.5	0.278	0.515
S07S1	6,700	13.4	2.89	0.057	10	0.5	0.393	1.007
S07S1	6,700	13.4	2.89	0.057	0	1.0	0.445	0.527
S07S1	6,700	13.4	2.89	0.057	2	1.0	0.481	0.647
S07S1	6,700	13.4	2.89	0.057	5	1.0	0.479	0.742
S07S1	6,700	13.4	2.89	0.057	10	1.0	0.614	1.290
S10S1	6,900	28.7	5.90	0.050	2	0.0	0.079	0.319
S10S1	6,900	28.7	5.90	0.050	5	0.0	0.141	0.441
S10S1	6,900	28.7	5.90	0.050	10	0.0	0.353	1.060
S10S1	6,900	28.7	5.90	0.050	0	0.5	0.471	1.132
S10S1	6,900	28.7	5.90	0.050	2	0.5	0.454	1.275
S10S1	6,900	28.7	5.90	0.050	5	0.5	0.501	1.264
S10S1	6,900	28.7	5.90	0.050	10	0.5	0.557	1.673
S10S1	6,900	28.7	5.90	0.050	0	1.0	0.919	2.368
S10S1	6,900	28.7	5.90	0.050	2	1.0	0.926	2.306

Profile Error Analyeis Summary
Aerial Spot Elevation Survey
1-Percent Chance Flood Event

Data Set I.D.	Average Q100 (cfs)	Average Slope (ft/mi)	Hydr Depth (ft)	Manning's n Value	Survey Accuracy (ft)	Manning's Reliability Nr	Absolute Mean Error (ft)	Absolute Maximum Error (ft)
S10S1	6,900	28.7	5.90	0.050	5	1.0	0.898	2.730
S10S1	6,900	28.7	5.90	0.050	10	1.0	1.004	2.387
S01S1	6,910	10.9	3.32	0.052	2	0.0	0.060	0.260
S01S1	6,910	10.9	3.32	0.052	5	0.0	0.108	0.513
S01S1	6,910	10.9	3.32	0.052	10	0.0	0.241	0.978
S01S1	6,910	10.9	3.32	0.052	0	0.5	0.306	0.894
S01S1	6,910	10.9	3.32	0.052	2	0.5	0.316	0.695
S01S1	6,910	10.9	3.32	0.052	5	0.5	0.251	0.894
S01S1	6,910	10.9	3.32	0.052	10	0.5	0.381	1.293
S01S1	6,910	10.9	3.32	0.052	0	1.0	0.733	1.717
S01S1	6,910	10.9	3.32	0.052	2	1.0	0.520	1.314
S01S1	6,910	10.9	3.32	0.052	5	1.0	0.511	1.326
S01S1	6,910	10.9	3.32	0.052	10	1.0	0.626	1.980
S06M1	7,450	8.4	5.49	0.069	2	0.0	0.054	0.210
S06M1	7,450	8.4	5.49	0.069	5	0.0	0.073	0.325
S06M1	7,450	8.4	5.49	0.069	10	0.0	0.148	0.429
S06M1	7,450	8.4	5.49	0.069	0	0.5	0.278	0.668
S06M1	7,450	8.4	5.49	0.069	2	0.5	0.417	1.002
S06M1	7,450	8.4	5.49	0.069	5	0.5	0.476	0.973
S06M1	7,450	8.4	5.49	0.069	10	0.5	0.357	0.887
S06M1	7,450	8.4	5.49	0.069	0	1.0	0.766	2.444
S06M1	7,450	8.4	5.49	0.069	2	1.0	0.626	1.484
S06M1	7,450	8.4	5.49	0.069	5	1.0	0.968	2.160
S06M1	7,450	8.4	5.49	0.069	10	1.0	0.456	1.434
S11S1	7,925	16.9	3.92	0.065	2	0.0	0.088	0.454
S11S1	7,925	16.9	3.92	0.065	5	0.0	0.128	0.498
S11S1	7,925	16.9	3.92	0.065	10	0.0	0.252	0.792
S11S1	7,925	16.9	3.92	0.065	0	0.5	0.359	0.726
S11S1	7,925	16.9	3.92	0.065	2	0.5	0.393	0.779
S11S1	7,925	16.9	3.92	0.065	5	0.5	0.395	0.899
S11S1	7,925	16.9	3.92	0.065	10	0.5	0.411	0.957
S11S1	7,925	16.9	3.92	0.065	0	1.0	0.716	1.400
S11S1	7,925	16.9	3.92	0.065	2	1.0	0.651	1.220
S11S1	7,925	16.9	3.92	0.065	5	1.0	0.742	1.445
S11S1	7,925	16.9	3.92	0.065	10	1.0	0.593	1.231
S04S1	8,070	22.7	3.10	0.049	2	0.0	0.076	0.270
S04S1	8,070	22.7	3.10	0.049	5	0.0	0.163	0.467
S04S1	8,070	22.7	3.10	0.049	10	0.0	0.353	0.978
S04S1	8,070	22.7	3.10	0.049	0	0.5	0.206	0.526

Profile Error Analysis Summary
Aerial Spot Elevation Survey
1-Percent Chance Flood Event

Data Set I.D.	Average Q100 (cfs)	Average Slope (ft/mi)	Hydr Depth (ft)	Manning's n Value	Survey Accuracy (ft)	Manning's Reliability Nr	Absolute Mean Error (ft)	Absolute Maximum Error (ft)
S04S1	8,070	22.7	3.10	0.049	2	0.5	0.265	0.615
S04S1	8,070	22.7	3.10	0.049	5	0.5	0.281	0.697
S04S1	8,070	22.7	3.10	0.049	10	0.5	0.492	1.286
S04S1	8,070	22.7	3.10	0.049	0	1.0	0.491	1.326
S04S1	8,070	22.7	3.10	0.049	2	1.0	0.399	0.931
S04S1	8,070	22.7	3.10	0.049	5	1.0	0.518	1.259
S04S1	8,070	22.7	3.10	0.049	10	1.0	0.596	1.530
S16S1	8,850	24.4	5.85	0.052	2	0.0	0.069	0.132
S16S1	8,850	24.4	5.85	0.052	5	0.0	0.130	0.246
S16S1	8,850	24.4	5.85	0.052	10	0.0	0.276	0.529
S16S1	8,850	24.4	5.85	0.052	0	0.5	0.412	0.749
S16S1	8,850	24.4	5.85	0.052	2	0.5	0.443	0.768
S16S1	8,850	24.4	5.85	0.052	5	0.5	0.474	0.743
S16S1	8,850	24.4	5.85	0.052	10	0.5	0.572	0.929
S16S1	8,850	24.4	5.85	0.052	0	1.0	0.987	1.488
S16S1	8,850	24.4	5.85	0.052	2	1.0	0.775	1.250
S16S1	8,850	24.4	5.85	0.052	5	1.0	1.004	1.466
S16S1	8,850	24.4	5.85	0.052	10	1.0	0.934	1.636
S23S1	9,355	26.1	2.21	0.034	2	0.0	0.080	0.242
S23S1	9,355	26.1	2.21	0.034	5	0.0	0.148	0.456
S23S1	9,355	26.1	2.21	0.034	10	0.0	0.378	0.932
S23S1	9,355	26.1	2.21	0.034	0	0.5	0.175	0.362
S23S1	9,355	26.1	2.21	0.034	2	0.5	0.185	0.406
S23S1	9,355	26.1	2.21	0.034	5	0.5	0.194	0.535
S23S1	9,355	26.1	2.21	0.034	10	0.5	0.378	1.033
S23S1	9,355	26.1	2.21	0.034	0	1.0	0.288	0.631
S23S1	9,355	26.1	2.21	0.034	2	1.0	0.357	0.712
S23S1	9,355	26.1	2.21	0.034	5	1.0	0.289	0.680
S23S1	9,355	26.1	2.21	0.034	10	1.0	0.490	1.165
S04M1	9,973	8.7	4.68	0.061	2	0.0	0.049	0.143
S04M1	9,973	8.7	4.68	0.061	5	0.0	0.090	0.240
S04M1	9,973	8.7	4.68	0.061	10	0.0	0.245	0.675
S04M1	9,973	8.7	4.68	0.061	0	0.5	0.462	0.497
S04M1	9,973	8.7	4.68	0.061	2	0.5	0.541	0.638
S04M1	9,973	8.7	4.68	0.061	5	0.5	0.604	0.799
S04M1	9,973	8.7	4.68	0.061	10	0.5	0.602	1.032
S04M1	9,973	8.7	4.68	0.061	0	1.0	1.024	1.112
S04M1	9,973	8.7	4.68	0.061	2	1.0	0.939	1.070
S04M1	9,973	a.7	4.68	0.061	5	1.0	1.309	1.525
S04M1	9,973	a.7	4.68	0.061	10	1.0	1.035	1.511

Profile Error Analysis Summary
Aerial Spot Elevation Survey
1-Percent Chance Flood Event

Data Set I.D.	Average Q100 (cfs)	Average Slope (ft/mi)	Hydr Depth (ft)	Manning's n Value	Survey Accuracy (ft)	Manning's Reliability Nr	Absolute Mean Error (ft)	Absolute Maximum Error (ft)
S02M1	10,243	6.8	3.96	0.061	2	0.0	0.059	0.467
S02M1	10,243	6.8	3.96	0.061	5	0.0	0.085	0.441
S02M1	10,243	6.8	3.96	0.061	10	0.0	0.167	0.761
S02M1	10,243	6.8	3.96	0.061	0	0.5	0.246	0.820
S02M1	10,243	6.8	3.96	0.061	2	0.5	0.285	0.856
S02M1	10,243	6.8	3.96	0.061	5	0.5	0.242	0.723
S02M1	10,243	6.8	3.96	0.061	10	0.5	0.412	0.973
S02M1	10,243	6.8	3.96	0.061	0	1.0	0.511	1.491
S02M1	10,243	6.8	3.96	0.061	2	1.0	0.443	1.802
S02M1	10,243	6.8	3.96	0.061	5	1.0	0.532	1.908
S02M1	10,243	6.8	3.96	0.061	10	1.0	0.562	1.520
S12M2	10,750	6.6	2.92	0.048	2	0.0	0.090	0.357
S12M2	10,750	6.6	2.92	0.048	5	0.0	0.129	0.402
S12M2	10,750	6.6	2.92	0.048	10	0.0	0.314	0.750
S12M2	10,750	6.6	2.92	0.048	0	0.5	0.359	0.721
S12M2	10,750	6.6	2.92	0.048	2	0.5	0.359	0.713
S12M2	10,750	6.6	2.92	0.048	5	0.5	0.320	0.687
S12M2	10,750	6.6	2.92	0.048	10	0.5	0.349	0.877
S12M2	10,750	6.6	2.92	0.048	0	1.0	0.526	0.917
S12M2	10,750	6.6	2.92	0.048	2	1.0	0.493	0.894
S12M2	10,750	6.6	2.92	0.048	5	1.0	0.674	1.224
S12M2	10,750	6.6	2.92	0.048	10	1.0	0.659	1.402
S11S2	11,000	20.1	6.49	0.063	2	0.0	0.064	0.555
S11S2	11,000	20.1	6.49	0.063	5	0.0	0.108	0.585
S11S2	11,000	20.1	6.49	0.063	10	0.0	0.249	0.976
S11S2	11,000	20.1	6.49	0.063	0	0.5	0.643	1.523
S11S2	11,000	20.1	6.49	0.063	2	0.5	0.575	1.416
S11S2	11,000	20.1	6.49	0.063	5	0.5	0.595	1.286
S11S2	11,000	20.1	6.49	0.063	10	0.5	0.622	1.640
S11S2	11,000	20.1	6.49	0.063	0	1.0	1.358	3.183
S11S2	11,000	20.1	6.49	0.063	2	1.0	1.210	2.344
S11S2	11,000	20.1	6.49	0.063	5	1.0	1.139	2.709
S11S2	11,000	20.1	6.49	0.063	10	1.0	1.063	2.190
S54M2	11,300	6.8	4.58	0.042	2	0.0	0.037	0.144
S54M2	11,300	6.8	4.58	0.042	5	0.0	0.072	0.282
S54M2	11,300	6.8	4.58	0.042	10	0.0	0.194	0.715
S54M2	11,300	6.8	4.58	0.042	0	0.5	0.463	0.938
S54M2	11,300	6.8	4.58	0.042	2	0.5	0.448	0.912
S54M2	11,300	6.8	4.58	0.042	5	0.5	0.457	0.965
S54M2	11,300	6.8	4.58	0.042	10	0.5	0.424	1.051

Profile Error Analysis Summary
Aerial Spot Elevation Survey
1-Percent Chance Flood Event

Data Set I.D.	Average Q100 (cfs)	Average Slope (ft/mi)	Hydr Depth (ft)	Manning's n Value	Survey Accuracy (ft)	Manning's Reliability Nr	Absolute Mean Error (ft)	Absolute Maximum Error (ft)
							S-m---	--S--W--
S54M2	11,300	6.8	4.58	0.042	0	1.0	0.783	1.551
S54M2	11,300	6.8	4.58	0.042	2	1.0	0.923	1.805
S54M2	11,300	6.8	4.58	0.042	5	1.0	0.608	1.281
S54M2	11,300	6.8	4.58	0.042	10	1.0	0.716	1.576
S02S2	11,790	16.6	3.53	0.053	2	0.0	0.057	0.157
S02S2	11,790	16.6	3.53	0.053	5	0.0	0.139	0.382
S02S2	11,790	16.6	3.53	0.053	10	0.0	0.420	1.081
S02S2	11,790	16.6	3.53	0.053	0	0.5	0.242	0.602
S02S2	11,790	16.6	3.53	0.053	2	0.5	0.293	0.731
S02S2	11,790	16.6	3.53	0.053	5	0.5	0.294	0.689
S02S2	11,790	16.6	3.53	0.053	10	0.5	0.445	1.067
S02S2	11,790	16.6	3.53	0.053	0	1.0	0.602	1.435
S02S2	11,790	16.6	3.53	0.053	2	1.0	0.640	1.594
S02S2	11,790	16.6	3.53	0.053	5	1.0	0.512	1.455
S02S2	11,790	16.6	3.53	0.053	10	1.0	0.736	1.873
S05S2	11,979	25.4	7.85	0.087	2	0.0	0.056	0.181
S05S2	11,979	25.4	7.85	0.087	5	0.0	0.114	0.375
S05S2	11,979	25.4	7.85	0.087	10	0.0	0.288	0.920
S05S2	11,979	25.4	7.85	0.087	0	0.5	0.698	0.942
S05S2	11,979	25.4	7.85	0.087	2	0.5	0.678	0.973
S05S2	11,979	25.4	7.85	0.087	5	0.5	0.895	1.332
S05S2	11,979	25.4	7.85	0.087	10	0.5	0.963	1.789
S05S2	11,979	25.4	7.85	0.087	0	1.0	1.537	2.084
S05S2	11,979	25.4	7.85	0.087	2	1.0	1.653	2.297
S05S2	11,979	25.4	7.85	0.087	5	1.0	1.852	2.566
S05S2	11,979	25.4	7.85	0.087	10	1.0	1.802	2.867
S03M2	11,985	3.2	5.53	0.083	2	0.0	0.032	0.125
S03M2	11,985	3.2	5.53	0.083	5	0.0	0.061	0.236
S03M2	11,985	3.2	5.53	0.083	10	0.0	0.175	0.707
S03M2	11,985	3.2	5.53	0.083	0	0.5	0.561	0.630
S03M2	11,985	3.2	5.53	0.083	2	0.5	0.508	0.606
S03M2	11,985	3.2	5.53	0.083	5	0.5	0.469	0.622
S03M2	11,985	3.2	5.53	0.083	10	0.5	0.508	0.963
S03M2	11,985	3.2	5.53	0.083	0	1.0	0.827	0.930
S03M2	11,985	3.2	5.53	0.083	2	1.0	1.096	1.248
S03M2	11,985	3.2	5.53	0.083	5	1.0	0.896	1.111
S03M2	11,985	3.2	5.53	0.083	10	1.0	1.008	1.467
S02M2	14,037	9.1	4.85	0.053	2	0.0	0.171	0.795
S02M2	14,037	9.1	4.85	0.053	5	0.0	0.201	0.812

Profile Error **Analysis** Summary
Aerial Spot Elevation Survey
1-Percent Chance Flood Event

Data set I.D.	Average Q100 (cfs)	Average Slope (ft/mi)	Hydr Depth (ft)	Manning's n Value	Survey Accuracy (ft)	Manning's Reliability Nr	Absolute Mean Error (ft)	Absolute Maximum Error (ft)
S02M2	14,037	9.1	4.85	0.053	10	0.0	0.333	0.986
S02M2	14,037	9.1	4.85	0.053	0	0.5	0.392	0.966
S02M2	14,037	9.1	4.85	0.053	2	0.5	0.361	0.914
S02M2	14,037	9.1	4.85	0.053	5	0.5	0.417	1.160
S02M2	14,037	9.1	4.85	0.053	10	0.5	0.383	0.941
S02M2	14,037	9.1	4.85	0.053	0	1.0	0.599	1.437
S02M2	14,037	9.1	4.85	0.053	2	1.0	0.592	1.422
S02M2	14,037	9.1	4.85	0.053	5	1.0	0.518	1.365
S02M2	14,037	9.1	4.85	0.053	10	1.0	0.602	1.591
S05M2	14,100	9.5	6.39	0.067	2	0.0	0.047	0.141
S05M2	14,100	9.5	6.39	0.067	5	0.0	0.107	0.380
S05M2	14,100	9.5	6.39	0.067	10	0.0	0.230	0.756
S05M2	14,100	9.5	6.39	0.067	0	0.5	0.764	0.942
S05M2	14,100	9.5	6.39	0.067	2	0.5	0.642	0.849
S05M2	14,100	9.5	6.39	0.067	5	0.5	0.667	0.929
S05M2	14,100	9.5	6.39	0.067	10	0.5	0.615	1.174
S05M2	14,100	9.5	6.39	0.067	0	1.0	1.300	1.521
S05M2	14,100	9.5	6.39	0.067	2	1.0	1.104	1.341
S05M2	14,100	9.5	6.39	0.067	5	1.0	1.119	1.507
S05M2	14,100	9.5	6.39	0.067	10	1.0	1.256	1.931
S20S2	14,665	24.8	3.46	0.030	2	0.0	0.104	0.355
S20S2	14,665	24.8	3.46	0.030	5	0.0	0.203	0.722
S20S2	14,665	24.8	3.46	0.030	10	0.0	0.417	1.510
S20S2	14,665	24.8	3.46	0.030	0	0.5	0.205	0.607
S20S2	14,665	24.8	3.46	0.030	2	0.5	0.246	0.688
S20S2	14,665	24.8	3.46	0.030	5	0.5	0.259	1.203
S20S2	14,665	24.8	3.46	0.030	10	0.5	0.421	1.458
S20S2	14,665	24.8	3.46	0.030	0	1.0	0.452	1.268
S20S2	14,665	24.8	3.46	0.030	2	1.0	0.450	1.314
S20S2	14,665	24.8	3.46	0.030	5	1.0	0.382	1.091
S20S2	14,665	24.8	3.46	0.030	10	1.0	0.563	1.748
S10S2	15,725	12.4	4.69	0.057	2	0.0	0.039	0.135
S10S2	15,725	12.4	4.69	0.057	5	0.0	0.081	0.278
S10S2	15,725	12.4	4.69	0.057	10	0.0	0.204	0.711
S10S2	15,725	12.4	4.69	0.057	0	0.5	0.354	0.587
S10S2	15,725	12.4	4.69	0.057	2	0.5	0.371	0.619
S10S2	15,725	12.4	4.69	0.057	5	0.5	0.398	0.722
S10S2	15,725	12.4	4.69	0.057	10	0.5	0.459	1.096
S10S2	15,725	12.4	4.69	0.057	0	1.0	0.848	1.338
S10S2	15,725	12.4	4.69	0.057	2	1.0	0.731	1.172

Profile Error Analysis Summary
Aerial Spot Elevation Survey
1-Percent Chance Flood Event

Data Set I.D.	Average Q100 (cfs)	Average Slope (ft/mi)	Hydr Depth (ft)	Manning's n Value	Survey Accuracy (ft)	Manning's Reliability Nr	Absolute Mean Error (ft)	Absolute Maximum Error (ft)
S10S2	15,725	12.1	4.69	0.057	5	1.0	0.709	1.231
S10S2	15,725	12.4	4.69	0.057	10	1.0	0.760	1.548
S01S2	15,745	12.9	4.32	0.052	2	0.0	0.101	0.413
S01S2	15,745	12.9	4.32	0.052	5	0.0	0.127	0.487
S01S2	15,745	12.9	4.32	0.052	10	0.0	0.228	0.749
S01S2	15,745	12.9	4.32	0.052	0	0.5	0.247	0.701
S01S2	15,745	12.9	4.32	0.052	2	0.5	0.292	0.939
S01S2	15,745	12.9	4.32	0.052	5	0.5	0.353	0.972
S01S2	15,745	12.9	4.32	0.052	10	0.5	0.437	1.179
S01S2	15,745	12.9	4.32	0.052	0	1.0	0.663	1.744
S01S2	15,745	12.9	4.32	0.052	2	1.0	0.664	1.941
S01S2	15,745	12.9	4.32	0.052	5	1.0	0.800	2.148
S01S2	15,745	12.9	4.32	0.052	10	1.0	0.675	2.104
S06S2	16,450	16.6	5.06	0.055	2	0.0	0.043	0.144
S06S2	16,450	16.6	5.06	0.055	5	0.0	0.089	0.295
S06S2	16,450	16.6	5.06	0.055	10	0.0	0.204	0.659
S06S2	16,450	16.6	5.06	0.055	0	0.5	0.621	0.719
S06S2	16,450	16.6	5.06	0.055	2	0.5	0.579	0.740
S06S2	16,450	16.6	5.06	0.055	5	0.5	0.562	0.814
S06S2	16,450	16.6	5.06	0.055	10	0.5	0.728	1.294
S06S2	16,450	16.6	5.06	0.055	0	1.0	1.209	1.412
S06S2	16,450	16.6	5.06	0.055	2	1.0	1.231	1.485
S06S2	16,450	16.6	5.06	0.055	5	1.0	1.127	1.487
S06S2	16,450	16.6	5.06	0.055	10	1.0	1.197	1.822
S04M2	16,595	3.5	6.38	0.045	2	0.0	0.061	0.437
S04M2	16,595	3.5	6.38	0.045	5	0.0	0.102	0.670
S04M2	16,595	3.5	6.38	0.045	10	0.0	0.263	1.611
S04M2	16,595	3.5	6.38	0.045	0	0.5	0.323	0.982
S04M2	16,595	3.5	6.38	0.045	2	0.5	0.306	0.940
S04M2	16,595	3.5	6.38	0.045	5	0.5	0.252	0.983
S04M2	16,595	3.5	6.38	0.045	10	0.5	0.498	1.441
S04M2	16,595	3.5	6.38	0.045	0	1.0	0.696	1.911
S04M2	16,595	3.5	6.38	0.045	2	1.0	0.537	2.232
S04M2	16,595	3.5	6.38	0.045	5	1.0	0.623	1.760
S04M2	16,595	3.5	6.38	0.045	10	1.0	0.721	2.113
S09S2	17,300	14.6	5.09	0.056	2	0.0	0.072	0.737
S09S2	17,300	14.6	5.09	0.056	5	0.0	0.090	0.733
S09S2	17,300	14.6	5.09	0.056	10	0.0	0.183	0.741
S09S2	17,300	14.6	5.09	0.056	0	0.5	0.521	1.378

Profile Error Analysis Summary
Aerial Spot Elevation Survey
1-Percent Chance Flood Event

Data set I.D.	Average Q100 (cfs)	Average Slope (ft/mi)	Hydr Depth (ft)	Manning's n Value	Survey Accuracy (ft)	Manning's Reliability Nr	Absolute Mean Error (ft)	Absolute Maximum Error (ft)
S09S2	17,300	14.6	5.09	0.056	2	0.5	0.326	1.074
S09S2	17,300	14.6	5.09	0.056	5	0.5	0.560	1.338
S09S2	17,300	14.6	5.09	0.056	10	0.5	0.523	1.494
S09S2	17,300	14.6	5.09	0.056	0	1.0	0.871	2.261
S09S2	17,300	14.6	5.09	0.056	2	1.0	1.024	2.157
S09S2	17,300	14.6	5.09	0.056	5	1.0	0.948	2.137
S09S2	17,300	14.6	5.09	0.056	10	1.0	0.845	2.064
S04S2	19,461	15.6	7.95	0.062	2	0.0	0.206	1.103
S04S2	19,461	15.6	7.95	0.062	5	0.0	0.228	1.177
S04S2	19,461	15.6	7.95	0.062	10	0.0	0.319	1.472
S04S2	19,461	15.6	7.95	0.062	0	0.5	0.729	2.358
S04S2	19,461	15.6	7.95	0.062	2	0.5	0.676	2.185
S04S2	19,461	15.6	7.95	0.062	5	0.5	0.718	2.276
S04S2	19,461	15.6	7.95	0.062	10	0.5	0.761	2.335
S04S2	19,461	15.6	7.95	0.062	0	1.0	1.489	4.739
S04S2	19,461	15.6	7.95	0.062	2	1.0	1.310	4.200
S04S2	19,461	15.6	7.95	0.062	5	1.0	1.312	4.291
S04S2	19,461	15.6	7.95	0.062	10	1.0	1.299	4.076
S07M2	20,050	7.4	5.74	0.054	2	0.0	0.043	0.182
S07M2	20,050	7.4	5.74	0.054	5	0.0	0.069	0.329
S07M2	20,050	7.4	5.74	0.054	10	0.0	0.170	0.890
S07M2	20,050	7.4	5.74	0.054	0	0.5	0.444	1.783
S07M2	20,050	7.4	5.74	0.054	2	0.5	0.389	1.325
S07M2	20,050	7.4	5.74	0.054	5	0.5	0.337	1.363
S07M2	20,050	7.4	5.74	0.054	10	0.5	0.303	1.112
S07M2	20,050	7.4	5.74	0.054	0	1.0	0.727	1.944
S07M2	20,050	7.4	5.74	0.054	2	1.0	0.658	2.104
S07M2	20,050	7.4	5.74	0.054	5	1.0	0.618	2.539
S07M2	20,050	7.4	5.74	0.054	10	1.0	0.649	2.172
S07S2	20,800	12.8	5.29	0.066	2	0.0	0.073	0.795
S07S2	20,800	12.8	5.29	0.066	5	0.0	0.092	0.771
S07S2	20,800	12.8	5.29	0.066	10	0.0	0.166	0.733
S07S2	20,800	12.8	5.29	0.066	0	0.5	0.502	1.112
S07S2	20,800	12.8	5.29	0.066	2	0.5	0.448	1.215
S07S2	20,800	12.8	5.29	0.066	5	0.5	0.576	1.208
S07S2	20,800	12.8	5.29	0.066	10	0.5	0.574	1.278
S07S2	20,800	12.8	5.29	0.066	0	1.0	1.047	1.915
S07S2	20,800	12.8	5.29	0.066	2	1.0	0.991	2.143
S07S2	20,800	12.8	5.29	0.066	5	1.0	1.236	2.319
S07S2	20,800	12.8	5.29	0.066	10	1.0	1.141	2.263

Profile Error Analysis Summary
Aerial Spot Elevation Survey
1-Percent Chance Flood Event

Data Set I.D.	Average Q100 (cfs)	Average Slope (ft/mi)	Hydr Depth (ft)	Manning's n Value	survey Accuracy (ft)	Manning's Reliability Nr	Absolute Mean Error (ft)	Absolute Maximum Error (ft)
S06M2	20,910	3.8	5.61	0.051	2	0.0	0.041	0.250
S06M2	20,910	3.8	5.61	0.051	5	0.0	0.083	0.471
S06M2	20,910	3.8	5.61	0.051	10	0.0	0.198	1.243
S06M2	20,910	3.8	5.61	0.051	0	0.5	0.259	0.690
S06M2	20,910	3.8	5.61	0.051	2	0.5	0.335	0.883
S06M2	20,910	3.8	5.61	0.051	5	0.5	0.238	0.786
S06M2	20,910	3.8	5.61	0.051	10	0.5	0.409	1.184
S06M2	20,910	3.8	5.61	0.051	0	1.0	0.511	1.219
S06M2	20,910	3.8	5.61	0.051	2	1.0	0.530	1.769
S06M2	20,910	3.8	5.61	0.051	5	1.0	0.425	1.278
S06M2	20,910	3.8	5.61	0.051	10	1.0	0.538	2.060
S16M2	21,188	4.1	6.63	0.077	2	0.0	0.027	0.128
S16M2	21,188	4.1	6.63	0.077	5	0.0	0.055	0.263
S16M2	21,188	4.1	6.63	0.077	10	0.0	0.132	0.628
S16M2	21,188	4.1	6.63	0.077	0	0.5	0.588	0.658
S16M2	21,188	4.1	6.63	0.077	2	0.5	0.496	0.592
S16M2	21,188	4.1	6.63	0.077	5	0.5	0.607	0.776
S16M2	21,188	4.1	6.63	0.077	10	0.5	0.498	0.947
S16M2	21,188	4.1	6.63	0.077	0	1.0	1.163	1.299
S16M2	21,188	4.1	6.63	0.077	2	1.0	0.980	1.114
S16M2	21,188	4.1	6.63	0.077	5	1.0	1.133	1.332
S16M2	21,188	4.1	6.63	0.077	10	1.0	1.081	1.502
S14M2	22,135	2.2	5.83	0.082	2	0.0	0.020	0.144
S14M2	22,135	2.2	5.83	0.082	5	0.0	0.039	0.176
S14M2	22,135	2.2	5.83	0.082	10	0.0	0.093	0.372
S14M2	22,135	2.2	5.83	0.082	0	0.5	0.513	1.187
S14M2	22,135	2.2	5.83	0.082	2	0.5	0.580	1.201
S14M2	22,135	2.2	5.83	0.082	5	0.5	0.450	1.160
S14M2	22,135	2.2	5.83	0.082	10	0.5	0.610	1.689
S14M2	22,135	2.2	5.83	0.082	0	1.0	1.179	2.374
S14M2	22,135	2.2	5.83	0.082	2	1.0	0.704	1.661
S14M2	22,135	2.2	5.83	0.082	5	1.0	0.829	2.252
S14M2	22,135	2.2	5.83	0.082	10	1.0	1.040	2.351
S08S2	24,000	12.1	6.48	0.057	2	0.0	0.041	0.153
S08S2	24,000	12.1	6.48	0.057	5	0.0	0.070	0.233
S08S2	24,000	12.1	6.48	0.057	10	0.0	0.153	0.506
S08S2	24,000	12.1	6.48	0.057	0	0.5	0.470	1.255
S08S2	24,000	12.1	6.48	0.057	2	0.5	0.413	1.329
S08S2	24,000	12.1	6.48	0.057	5	0.5	0.611	1.696
S08S2	24,000	12.1	6.48	0.057	10	0.5	0.531	1.417

Profile Error **Analysis** Summary
Aerial Spot Elevation Survey
1-Percent Chance Flood Event

Data Set I.D.	Average Q100 (cfs)	Average Slope (ft/mi)	Hydr Depth (ft)	Manning's n Value	Survey Accuracy (ft)	Manning ' s Reliability Nr	Absolute Mean Error (ft)	Absolute Maximum Error (ft)
S08S2	24,000	12.1	6.48	0.057	0	1.0	0.908	2.458
S08S2	24,000	12.1	6.48	0.057	2	1.0	1.244	3.224
S08S2	24,000	12.1	6.48	0.057	5	1.0	0.870	2.763
S08S2	24,000	12.1	6.48	0.057	10	1.0	0.918	2.462
S10M2	24,900	2.4	4.59	0.052	2	0.0	0.038	0.188
S10M2	24,900	2.4	4.59	0.052	5	0.0	0.066	0.244
S10M2	24,900	2.4	4.59	0.052	10	0.0	0.154	0.681
S10M2	24,900	2.4	4.59	0.052	0	0.5	0.243	0.669
S10M2	24,900	2.4	4.59	0.052	2	0.5	0.206	0.777
S10M2	24,900	2.4	4.59	0.052	5	0.5	0.298	0.764
S10M2	24,900	2.4	4.59	0.052	10	0.5	0.343	1.257
S10M2	24,900	2.4	4.59	0.052	0	1.0	0.463	1.232
S10M2	24,900	2.4	4.59	0.052	2	1.0	0.485	1.405
S10M2	24,900	2.4	4.59	0.052	5	1.0	0.721	1.921
S10M2	24,900	2.4	4.59	0.052	10	1.0	0.565	1.447
S29M2	27,444	3.8	8.03	0.061	2	0.0	0.021	0.087
S29M2	27,444	3.8	8.03	0.061	5	0.0	0.049	0.192
S29M2	27,444	3.8	8.03	0.061	10	0.0	0.127	0.422
82912	27,444	3.8	8.03	0.061	0	0.5	0.559	1.558
S29M2	27,444	3.8	8.03	0.061	2	0.5	0.541	1.416
S29M2	27,444	3.8	8.03	0.061	5	0.5	0.463	1.290
S29M2	27,444	3.8	8.03	0.061	10	0.5	0.626	1.740
S29M2	27,444	3.8	8.03	0.061	0	1.0	0.873	2.212
S29M2	27,444	3.8	8.03	0.061	2	1.0	1.222	3.218
S29M2	27,444	3.8	8.03	0.061	5	1.0	1.149	3.098
S29M2	27,444	3.8	8.03	0.061	10	1.0	0.956	2.249
S30M2	27,444	4.1	8.47	0.059	2	0.0	0.039	0.176
S30M2	27,444	4.1	8.47	0.059	5	0.0	0.047	0.195
S30M2	27,444	4.1	8.47	0.059	10	0.0	0.165	1.011
S30M2	27,444	4.1	8.47	0.059	0	0.5	0.414	1.048
S30M2	27,444	4.1	8.47	0.059	2	0.5	0.373	1.201
S30M2	27,444	4.1	8.47	0.059	5	0.5	0.707	1.776
S30M2	27,444	4.1	8.47	0.059	10	0.5	0.460	1.295
S30M2	27,444	4.1	8.47	0.059	0	1.0	1.034	3.076
S30M2	27,444	4.1	8.47	0.059	2	1.0	0.838	2.341
S30M2	27,444	4.1	8.47	0.059	5	1.0	0.757	2.541
S30M2	27,444	4.1	8.47	0.059	10	1.0	1.080	3.085
S31M2	27,444	5.0	7.95	0.063	2	0.0	0.037	0.228
S31M2	27,444	5.0	7.95	0.063	5	0.0	0.054	0.262

Profile Error Analysis Summary
Aerial Spot Elevation **Survey**
1-Percent Chance Flood Event

Data Set I.D.	Average Q100 (cfs)	Average Slope (ft/mi)	Hydr Depth (ft)	Manning's n Value	Survey Accuracy (ft)	Manning's Reliability Nr	Absolute Mean Error (ft)	Absolute Maximum Error (ft)
S31M2	27,444	5.0	7.95	0.063	10	0.0	0.179	0.608
S31M2	27,444	5.0	7.95	0.063	0	0.5	0.468	1.044
S31M2	27,444	5.0	7.95	0.063	2	0.5	0.436	0.960
S31M2	27,444	5.0	7.95	0.063	5	0.5	0.628	1.338
S31M2	27,444	5.0	7.95	0.063	10	0.5	0.502	1.277
S31M2	27,444	5.0	7.95	0.063	0	1.0	1.010	2.032
S31M2	27,444	5.0	7.95	0.063	2	1.0	0.934	2.006
S31M2	27,444	5.0	7.95	0.063	5	1.0	0.849	1.977
S31M2	27,444	5.0	7.95	0.063	10	1.0	1.005	2.195
S12S2	28,775	17.5	3.67	0.070	2	0.0	0.042	0.191
S12S2	28,775	17.5	3.67	0.070	5	0.0	0.062	0.246
S12S2	28,775	17.5	3.67	0.070	10	0.0	0.183	0.579
S12S2	28,775	17.5	3.67	0.070	0	0.5	0.327	0.853
S12S2	28,775	17.5	3.67	0.070	2	0.5	0.313	0.825
S12S2	28,775	17.5	3.67	0.070	5	0.5	0.411	1.132
S12S2	28,775	17.5	3.67	0.070	10	0.5	0.478	1.193
S12S2	28,775	17.5	3.67	0.070	0	1.0	0.922	2.261
S12S2	28,775	17.5	3.67	0.070	2	1.0	0.812	2.097
S12S2	28,775	17.5	3.67	0.070	5	1.0	0.716	1.699
S12S2	28,775	17.5	3.67	0.070	10	1.0	0.783	2.065
S12F2	29,100	0.8	10.20	0.126	2	0.0	0.015	0.034
S12F2	29,100	0.8	10.20	0.126	5	0.0	0.039	0.074
S12F2	29,100	0.8	10.20	0.126	10	0.0	0.136	0.230
S12F2	29,100	0.8	10.20	0.126	0	0.5	1.018	1.508
S12F2	29,100	0.8	10.20	0.126	2	0.5	0.988	1.714
S12F2	29,100	0.8	10.20	0.126	5	0.5	1.328	1.816
S12F2	29,100	0.8	10.20	0.126	10	0.5	1.064	1.772
S12F2	29,100	0.8	10.20	0.126	0	1.0	2.286	3.422
S12F2	29,100	0.8	10.20	0.126	2	1.0	2.558	3.678
S12F2	29,100	0.8	10.20	0.126	5	1.0	2.080	3.046
S12F2	29,100	0.8	10.20	0.126	10	1.0	2.632	3.923
S49M2	30,000	9.9	5.73	0.066	2	0.0	0.052	0.420
S49M2	30,000	9.9	5.73	0.066	5	0.0	0.071	0.420
S49M2	30,000	9.9	5.73	0.066	10	0.0	0.132	0.430
S49M2	30,000	9.9	5.73	0.066	0	0.5	0.540	0.985
S49M2	30,000	9.9	5.73	0.066	2	0.5	0.416	0.868
S49M2	30,000	9.9	5.73	0.066	5	0.5	0.509	0.922
S49M2	30,000	9.9	5.73	0.066	10	0.5	0.494	1.061
S49M2	30,000	9.9	5.73	0.066	0	1.0	0.789	1.698
S49M2	30,000	9.9	5.73	0.066	2	1.0	0.990	1.734

Profile Error Analysis Summary
Aerial Spot Elevation Survey
1-Percent Chance Flood Event

Data Set I.D.	Average Q100 (cfs)	Average Slope (ft/mi)	Hydr Depth (ft)	Manning's n Value	Survey Accuracy (ft)	Manning's Reliability Nr	Absolute Mean Error (ft)	Absolute Maximum Error (ft)
S49M2	30,000	9.9	5.73	0.066	5	1.0	0.912	1.736
S49M2	30,000	9.9	5.73	0.066	10	1.0	1.006	2.025
S09M2	33,250	2.9	9.41	0.067	2	0.0	0.040	0.121
S09M2	33,250	2.9	9.41	0.067	5	0.0	0.094	0.279
S09M2	33,250	2.9	9.41	0.067	10	0.0	0.185	0.608
S09M2	33,250	2.9	9.41	0.067	0	0.5	0.783	1.325
S09M2	33,250	2.9	9.41	0.067	2	0.5	0.803	1.448
S09M2	33,250	2.9	9.41	0.067	5	0.5	0.778	1.247
S09M2	33,250	2.9	9.41	0.067	10	0.5	0.530	1.174
S09M2	33,250	2.9	9.41	0.067	0	1.0	1.247	2.147
S09M2	33,250	2.9	9.41	0.067	2	1.0	1.099	1.995
S09M2	33,250	2.9	9.41	0.067	5	1.0	1.574	2.649
S09M2	33,250	2.9	9.41	0.067	10	1.0	1.744	2.807
S13M2	33,575	2.6	7.46	0.086	2	0.0	0.018	0.081
S13M2	33,575	2.6	7.46	0.086	5	0.0	0.035	0.166
S13M2	33,575	2.6	7.46	0.086	10	0.0	0.100	0.538
S13M2	33,575	2.6	7.46	0.086	0	0.5	0.485	0.911
S13M2	33,575	2.6	7.46	0.086	2	0.5	0.560	0.859
S13M2	33,575	2.6	7.46	0.086	5	0.5	0.615	0.902
S13M2	33,575	2.6	7.46	0.086	10	0.5	0.492	0.951
S13M2	33,575	2.6	7.46	0.086	0	1.0	1.221	1.977
S13M2	33,575	2.6	7.46	0.086	2	1.0	1.111	1.778
S13M2	33,575	2.6	7.46	0.086	5	1.0	1.435	2.107
S13M2	33,575	2.6	7.46	0.086	10	1.0	1.371	2.067
S13S2	34,000	106.0	11.98	0.122	2	0.0	0.564	2.263
S13S2	34,000	106.0	11.98	0.122	5	0.0	0.571	2.261
S13S2	34,000	106.0	11.98	0.122	10	0.0	0.680	2.583
S13S2	34,000	106.0	11.98	0.122	0	0.5	1.224	3.897
S13S2	34,000	106.0	11.98	0.122	2	0.5	1.393	3.705
S13S2	34,000	106.0	11.98	0.122	5	0.5	1.419	3.953
S13S2	34,000	106.0	11.98	0.122	10	0.5	1.303	3.683
S13S2	34,000	106.0	11.98	0.122	0	1.0	2.555	7.489
S13S2	34,000	106.0	11.98	0.122	2	1.0	2.618	7.378
S13S2	34,000	106.0	11.98	0.122	5	1.0	2.194	6.255
S13S2	34,000	106.0	11.98	0.122	10	1.0	2.458	9.194
S48M2	34,150	6.9	5.82	0.072	2	0.0	0.034	0.363
S48M2	34,150	6.9	5.82	0.072	5	0.0	0.047	0.354
S48M2	34,150	6.9	5.82	0.072	10	0.0	0.100	0.473
S48M2	34,150	6.9	5.82	0.072	0	0.5	0.383	0.972

Profile Error Analysis Summary
Aerial Spot Elevation Survey
1-Percent Chance Flood Event

Data Set I.D.	Average Q100 (cfs)	Average Slope (ft/mi)	Hydr Depth (ft)	Manning's n Value	Survey Accuracy (ft)	Manning's Reliability Nr	Absolute Mean Error (ft)	Absolute Maximum Error (ft)
S48M2	34,150	6.9	5.82	0.072	2	0.5	0.482	1.099
S48M2	34,150	6.9	5.82	0.072	5	0.5	0.509	1.158
S48M2	34,150	6.9	5.82	0.072	10	0.5	0.542	1.354
S48M2	34,150	6.9	5.82	0.072	0	1.0	0.816	1.946
S48M2	34,150	6.9	5.82	0.072	2	1.0	0.790	2.031
S48M2	34,150	6.9	5.82	0.072	5	1.0	0.990	2.215
S48M2	34,150	6.9	5.82	0.072	10	1.0	0.951	2.040
S01M2	35,350	5.6	9.04	0.045	2	0.0	0.050	0.329
S01M2	35,350	5.6	9.04	0.045	5	0.0	0.087	0.600
S01M2	35,350	5.6	9.04	0.045	10	0.0	0.151	0.885
S01M2	35,350	5.6	9.04	0.045	0	0.5	0.434	1.254
S01M2	35,350	5.6	9.04	0.045	2	0.5	0.546	1.063
S01M2	35,350	5.6	9.04	0.045	5	0.5	0.405	1.240
S01M2	35,350	5.6	9.04	0.045	10	0.5	0.623	1.471
S01M2	35,350	5.6	9.04	0.045	0	1.0	1.077	2.513
S01M2	35,350	5.6	9.04	0.045	2	1.0	1.095	2.339
S01M2	35,350	5.6	9.04	0.045	5	1.0	1.164	2.500
S01M2	35,350	5.6	9.04	0.045	10	1.0	0.998	2.239
S03S2	37,600	10.1	7.61	0.059	2	0.0	0.051	0.738
S03S2	37,600	10.1	7.61	0.059	5	0.0	0.074	0.740
S03S2	37,600	10.1	7.61	0.059	10	0.0	0.167	0.736
S03S2	37,600	10.1	7.61	0.059	0	0.5	0.621	1.263
S03S2	37,600	10.1	7.61	0.059	2	0.5	0.512	1.300
S03S2	37,600	10.1	7.61	0.059	5	0.5	0.429	1.287
S03S2	37,600	10.1	7.61	0.059	10	0.5	0.570	1.486
S03S2	37,600	10.1	7.61	0.059	0	1.0	0.877	2.287
S03S2	37,600	10.1	7.61	0.059	2	1.0	1.320	2.719
S03S2	37,600	10.1	7.61	0.059	5	1.0	1.308	2.615
S03S2	37,600	10.1	7.61	0.059	10	1.0	0.996	2.441
S53M2	37,850	7.9	6.14	0.066	2	0.0	0.021	0.066
S53M2	37,850	7.9	6.14	0.066	5	0.0	0.041	0.138
S53M2	37,850	7.9	6.14	0.066	10	0.0	0.120	0.353
S53M2	37,850	7.9	6.14	0.066	0	0.5	0.580	0.829
S53M2	37,850	7.9	6.14	0.066	2	0.5	0.545	0.781
S53M2	37,850	7.9	6.14	0.066	5	0.5	0.376	0.569
S53M2	37,850	7.9	6.14	0.066	10	0.5	0.481	0.816
S53M2	37,850	7.9	6.14	0.066	0	1.0	1.072	1.493
S53M2	37,850	7.9	6.14	0.066	2	1.0	0.901	1.340
S53M2	37,850	7.9	6.14	0.066	5	1.0	1.121	1.643
S53M2	37,850	7.9	6.14	0.066	10	1.0	0.885	1.383

Profile Error **Analysis** Summary
Aerial Spot Elevation Survey
1-Percent Chance Flood Event

Data Set I.D.	Average Q100 (cfs)	Average Slope (ft/mi)	Hydr Depth (ft)	Manning's n Value	Survey Accuracy (ft)	Manning's Reliability Nr	Absolute Mean Error (ft)	Absolute Maximum Error (ft)
S56M2	38,000	2.8	8.04	0.029	2	0.0	0.028	0.096
S56M2	38,000	2.8	8.04	0.029	5	0.0	0.064	0.210
S56M2	38,000	2.8	8.04	0.029	10	0.0	0.156	0.490
S56M2	38,000	2.8	8.04	0.029	0	0.5	0.493	0.591
S56M2	38,000	2.8	8.04	0.029	2	0.5	0.635	0.771
S56M2	38,000	2.8	8.04	0.029	5	0.5	0.465	0.607
S56M2	38,000	2.8	8.04	0.029	10	0.5	0.519	0.811
S56M2	38,000	2.8	8.04	0.029	0	1.0	1.111	1.326
S56M2	38,000	2.8	8.04	0.029	2	1.0	1.314	1.569
S56M2	38,000	2.8	8.04	0.029	5	1.0	0.916	1.136
S56M2	38,000	2.8	8.04	0.029	10	1.0	1.217	1.569
S41M2	38,800	5.0	11.79	0.057	2	0.0	0.047	0.424
S41M2	38,800	5.0	11.79	0.057	5	0.0	0.074	0.388
S41M2	38,800	5.0	11.79	0.057	10	0.0	0.158	0.750
S41M2	38,800	5.0	11.79	0.057	0	0.5	0.786	1.999
S41M2	38,800	5.0	11.79	0.057	2	0.5	0.805	1.692
S41M2	38,800	5.0	11.79	0.057	5	0.5	0.816	2.057
S41M2	38,800	5.0	11.79	0.057	10	0.5	0.864	2.025
S41M2	38,800	5.0	11.79	0.057	0	1.0	1.180	3.277
S41M2	38,800	5.0	11.79	0.057	2	1.0	1.888	4.006
S41M2	38,800	5.0	11.79	0.057	5	1.0	1.586	3.648
S41M2	38,800	5.0	11.79	0.057	10	1.0	1.757	4.015
S19S2	39,000	30.8	3.77	0.039	2	0.0	0.202	0.711
S19S2	39,000	30.8	3.77	0.039	5	0.0	0.241	0.877
S19S2	39,000	30.8	3.77	0.039	10	0.0	0.369	1.035
S19S2	39,000	30.8	3.77	0.039	0	0.5	0.269	0.887
S19S2	39,000	30.8	3.77	0.039	2	0.5	0.261	0.797
S19S2	39,000	30.8	3.77	0.039	5	0.5	0.319	1.019
S19S2	39,000	30.8	3.77	0.039	10	0.5	0.349	1.087
S19S2	39,000	30.8	3.77	0.039	0	1.0	0.437	1.546
S19S2	39,000	30.8	3.77	0.039	2	1.0	0.319	1.028
S19S2	39,000	30.8	3.77	0.039	5	1.0	0.403	1.346
S19S2	39,000	30.8	3.77	0.039	10	1.0	0.517	1.680
S51M2	41,200	7.2	8.24	0.069	2	0.0	0.027	0.088
S51M2	41,200	7.2	8.24	0.069	5	0.0	0.060	0.174
S51M2	41,200	7.2	a.24	0.069	10	0.0	0.149	0.443
S51M2	41,200	7.2	8.24	0.069	0	0.5	0.950	1.741
S51M2	41,200	7.2	a.24	0.069	2	0.5	0.722	1.266
S51M2	41,200	7.2	8.24	0.069	5	0.5	0.771	1.637
S51M2	41,200	7.2	8.24	0.069	10	0.5	1.020	1.832

Profile Error Analysis Summary
Aerial Spot Elevation Survey
1-Percent Chance Flood Event

Data Set I.D.	Average Q100 (cfs)	Average Slope (ft/mi)	Hydr Depth (ft)	Manning's n Value	Survey Accuracy (ft)	Manning's Reliability Nr	Absolute Mean Error (ft)	Absolute Maximum Error (ft)
S51M2	41,200	7.2	8.24	0.069	0	1.0	1.228	2.315
S51M2	41,200	7.2	8.24	0.069	2	1.0	1.616	2.936
S51M2	41,200	7.2	8.24	0.069	5	1.0	1.694	3.206
S51M2	41,200	7.2	8.24	0.069	10	1.0	1.679	3.067
S08M2	42,250	3.6	6.78	0.071	2	0.0	0.041	0.280
S08M2	42,250	3.6	6.78	0.071	5	0.0	0.080	0.556
S08M2	42,250	3.6	6.78	0.071	10	0.0	0.205	1.357
S08M2	42,250	3.6	6.78	0.071	0	0.5	0.647	0.842
S08M2	42,250	3.6	6.78	0.071	2	0.5	0.674	0.955
S08M2	42,250	3.6	6.78	0.071	5	0.5	0.676	1.123
S08M2	42,250	3.6	6.78	0.071	10	0.5	0.675	1.669
S08M2	42,250	3.6	6.78	0.071	0	1.0	1.193	1.583
S08M2	42,250	3.6	6.78	0.071	2	1.0	1.158	1.592
S08M2	42,250	3.6	6.78	0.071	5	1.0	1.183	1.726
S08M2	42,250	3.6	6.78	0.071	10	1.0	1.360	2.388
S47M2	43,350	6.0	8.11	0.072	2	0.0	0.042	0.174
S47M2	43,350	6.0	8.11	0.072	5	0.0	0.054	0.228
S47M2	43,350	6.0	8.11	0.072	10	0.0	0.122	0.628
S47M2	43,350	6.0	8.11	0.072	0	0.5	0.653	1.377
S47M2	43,350	6.0	8.11	0.072	2	0.5	0.709	1.526
S47M2	43,350	6.0	8.11	0.072	5	0.5	0.647	1.309
S47M2	43,350	6.0	8.11	0.072	10	0.5	0.898	1.780
S47M2	43,350	6.0	8.11	0.072	0	1.0	1.107	2.527
S47M2	43,350	6.0	8.11	0.072	2	1.0	1.262	3.052
S47M2	43,350	6.0	8.11	0.072	5	1.0	1.503	3.222
S47M2	43,350	6.0	8.11	0.072	10	1.0	1.276	2.786
S18M2	43,400	2.1	12.07	0.055	2	0.0	0.028	0.386
S18M2	43,400	2.1	12.07	0.055	5	0.0	0.035	0.372
S18M2	43,400	2.1	12.07	0.055	10	0.0	0.115	0.449
S18M2	43,400	2.1	12.07	0.055	0	0.5	0.550	1.500
S18M2	43,400	2.1	12.07	0.055	2	0.5	0.450	1.421
S18M2	43,400	2.1	12.07	0.055	5	0.5	0.929	2.018
S18M2	43,400	2.1	12.07	0.055	10	0.5	0.835	2.923
S18M2	43,400	2.1	12.07	0.055	0	1.0	0.903	3.318
S18M2	43,400	2.1	12.07	0.055	2	1.0	0.998	3.415
S18M2	43,400	2.1	12.07	0.055	5	1.0	1.179	3.357
S18M2	43,400	2.1	12.07	0.055	10	1.0	1.571	4.547
S50M2	47,225	6.4	7.46	0.063	2	0.0	0.034	0.476
S50M2	47,225	6.4	7.46	0.063	5	0.0	0.055	0.485

Profile Error Analysis Summary
Aerial Spot Elevation Survey
1-Percent Chance Flood Event

Data Set I.D.	Average Q100 (cfs)	Average Slope (ft/mi)	Hydr Depth (ft)	Manning's n Value	Survey Accuracy (ft)	Manning's Reliability Nr	Absolute Mean Error (ft)	Absolute Maximum Error (ft)
S50M2	47,225	6.4	7.46	0.063	10	0.0	0.128	0.608
S50M2	47,225	6.4	7.46	0.063	0	0.5	0.439	1.157
S50M2	47,225	6.4	7.46	0.063	2	0.5	0.600	1.465
S50M2	47,225	6.4	7.46	0.063	5	0.5	0.533	1.301
S50M2	47,225	6.4	7.46	0.063	10	0.5	0.596	1.572
S50M2	47,225	6.4	7.46	0.063	0	1.0	1.146	2.471
S50M2	47,225	6.4	7.46	0.063	2	1.0	1.436	3.120
S50M2	47,225	6.4	7.46	0.063	5	1.0	1.205	2.797
S50M2	47,225	6.4	7.46	0.063	10	1.0	1.144	2.551
S17S2	50,000	18.6	5.99	0.048	2	0.0	0.057	0.225
S17S2	50,000	18.6	5.99	0.048	5	0.0	0.117	0.488
S17S2	50,000	18.6	5.99	0.048	10	0.0	0.279	0.950
S17S2	50,000	18.6	5.99	0.048	0	0.5	0.381	0.912
S17S2	50,000	18.6	5.99	0.048	2	0.5	0.348	0.958
S17S2	50,000	18.6	5.99	0.048	5	0.5	0.466	1.296
S17S2	50,000	18.6	5.99	0.048	10	0.5	0.495	1.456
S17S2	50,000	18.6	5.99	0.048	0	1.0	0.738	1.721
S17S2	50,000	18.6	5.99	0.048	2	1.0	0.745	1.968
S17S2	50,000	18.6	5.99	0.048	5	1.0	0.914	2.303
S17S2	50,000	18.6	5.99	0.048	10	1.0	0.929	2.425
S18S2	50,000	15.2	7.81	0.045	2	0.0	0.195	0.596
S18S2	50,000	15.2	7.81	0.045	5	0.0	0.209	0.619
S18S2	50,000	15.2	7.81	0.045	10	0.0	0.262	0.778
S18S2	50,000	15.2	7.81	0.045	0	0.5	0.356	0.902
S18S2	50,000	15.2	7.81	0.045	2	0.5	0.495	1.285
S18S2	50,000	15.2	7.81	0.045	5	0.5	0.420	1.014
S18S2	50,000	15.2	7.81	0.045	10	0.5	0.546	1.315
S18S2	50,000	15.2	7.81	0.045	0	1.0	0.879	2.092
S18S2	50,000	15.2	7.81	0.045	2	1.0	1.028	2.285
S18S2	50,000	15.2	7.81	0.045	5	1.0	1.063	2.432
S18S2	50,000	15.2	7.81	0.045	10	1.0	0.948	2.416
S37M2	50,300	3.0	14.31	0.055	2	0.0	0.051	0.214
S37M2	50,300	3.0	14.31	0.055	5	0.0	0.056	0.259
S37M2	50,300	3.0	14.31	0.055	10	0.0	0.180	0.630
S37M2	50,300	3.0	14.31	0.055	0	0.5	0.815	2.598
S37M2	50,300	3.0	14.31	0.055	2	0.5	0.706	2.667
S37M2	50,300	3.0	14.31	0.055	5	0.5	0.601	1.991
S37M2	50,300	3.0	14.31	0.055	10	0.5	0.739	2.264
S37M2	50,300	3.0	14.31	0.055	0	1.0	1.578	4.663
S37M2	50,300	3.0	14.31	0.055	2	1.0	2.323	6.360

Profile Error Analysis Summary
Aerial Spot Elevation Survey
1-Percent Chance Flood Event

Data Set I.D.	Average Q100 (cfs)	Average Slope (ft/mi)	Hydr Depth (ft)	Manning's n Value	Survey Accuracy (ft)	Manning's Reliability Nr	Absolute Mean Error (ft)	Absolute Maximum Error (ft)
S37M2	50,300	3.0	14.31	0.055	5	1.0	1.450	3.568
S37M2	50,300	3.0	14.31	0.055	10	1.0	1.654	4.452
S52M2	50,950	8.8	6.31	0.062	2	0.0	0.066	0.601
S52M2	50,950	8.8	6.31	0.062	5	0.0	0.080	0.577
S52M2	50,950	8.8	6.31	0.062	10	0.0	0.156	1.075
S52M2	50,950	8.8	6.31	0.062	0	0.5	0.513	1.597
S52M2	50,950	8.8	6.31	0.062	2	0.5	0.490	1.561
S52M2	50,950	8.8	6.31	0.062	5	0.5	0.524	1.549
S52M2	50,950	8.8	6.31	0.062	10	0.5	0.395	1.389
S52M2	50,950	8.8	6.31	0.062	0	1.0	0.926	2.664
S52M2	50,950	8.8	6.31	0.062	2	1.0	1.065	2.630
S52M2	50,950	8.8	6.31	0.062	5	1.0	1.135	3.295
S52M2	50,950	8.8	6.31	0.062	10	1.0	1.120	2.883
S26M2	51,388	2.5	10.60	0.066	2	0.0	0.034	0.117
S26M2	51,388	2.5	10.60	0.066	5	0.0	0.064	0.234
S26M2	51,388	2.5	10.60	0.066	10	0.0	0.190	0.581
S26M2	51,388	2.5	10.60	0.066	0	0.5	0.476	1.462
S26M2	51,388	2.5	10.60	0.066	2	0.5	0.458	1.103
S26M2	51,388	2.5	10.60	0.066	5	0.5	0.550	1.714
S26M2	51,388	2.5	10.60	0.066	10	0.5	0.716	2.299
S26M2	51,388	2.5	10.60	0.066	0	1.0	1.258	3.876
S26M2	51,388	2.5	10.60	0.066	2	1.0	1.238	3.196
S26M2	51,388	2.5	10.60	0.066	5	1.0	1.231	2.893
S26M2	51,388	2.5	10.60	0.066	10	1.0	0.955	3.471
S22M2	59,225	2.2	16.52	0.060	2	0.0	0.021	0.078
S22M2	59,225	2.2	16.52	0.060	5	0.0	0.022	0.062
S22M2	59,225	2.2	16.52	0.060	10	0.0	0.142	0.428
S22M2	59,225	2.2	16.52	0.060	0	0.5	0.656	2.289
S22M2	59,225	2.2	16.52	0.060	2	0.5	0.790	2.014
S22M2	59,225	2.2	16.52	0.060	5	0.5	0.591	1.579
S22M2	59,225	2.2	16.52	0.060	10	0.5	0.957	2.170
S22M2	59,225	2.2	16.52	0.060	0	1.0	1.361	3.121
S22M2	59,225	2.2	16.52	0.060	2	1.0	1.581	4.794
S22M2	59,225	2.2	16.52	0.060	5	1.0	1.716	5.211
S22M2	59,225	2.2	16.52	0.060	10	1.0	2.608	6.487
S46M2	60,350	5.8	6.92	0.058	2	0.0	0.037	0.238
S46M2	60,350	5.8	6.92	0.058	5	0.0	0.064	0.276
S46M2	60,350	5.8	6.92	0.058	10	0.0	0.112	0.427
S46M2	60,350	5.8	6.92	0.058	0	0.5	0.472	1.171

Profile Error Analysis Summary
Aerial Spot Elevation Survey
1-Percent Chance Flood Event

Data Set I.D.	Average Q100 (cfs)	Average Slope (ft/mi)	Hydr Depth (ft)	Manning's n Value	Survey Accuracy (ft)	Manning's Reliability Nr	Absolute Mean Error (ft)	Absolute Maximum Error (ft)
S46M2	60,350	5.8	6.92	0.058	2	0.5	0.410	1.165
S46M2	60,350	5.8	6.92	0.058	5	0.5	0.325	1.139
S46M2	60,350	5.8	6.92	0.058	10	0.5	0.561	1.374
S46M2	60,350	5.8	6.92	0.058	0	1.0	0.962	2.495
S46M2	60,350	5.8	6.92	0.058	2	1.0	1.142	3.121
S46M2	60,350	5.8	6.92	0.058	5	1.0	0.763	2.071
S46M2	60,350	5.8	6.92	0.058	10	1.0	0.702	1.973
S33M2	69,520	2.4	10.62	0.044	2	0.0	0.017	0.083
S33M2	69,520	2.4	10.62	0.044	5	0.0	0.041	0.192
S33M2	69,520	2.4	10.62	0.044	10	0.0	0.126	0.416
S33M2	69,520	2.4	10.62	0.044	0	0.5	0.934	1.614
S33M2	69,520	2.4	10.62	0.044	2	0.5	0.953	1.779
S33M2	69,520	2.4	10.62	0.044	5	0.5	1.012	1.667
S33M2	69,520	2.4	10.62	0.044	10	0.5	0.794	1.445
S33M2	69,520	2.4	10.62	0.044	0	1.0	1.742	2.930
S33M2	69,520	2.4	10.62	0.044	2	1.0	1.554	2.867
S33M2	69,520	2.4	10.62	0.044	5	1.0	1.715	3.283
S33M2	69,520	2.4	10.62	0.044	10	1.0	1.762	2.950
S10F2	73,980	0.5	11.56	0.109	2	0.0	0.019	0.029
S10F2	73,980	0.5	11.56	0.109	5	0.0	0.052	0.075
S10F2	73,980	0.5	11.56	0.109	10	0.0	0.128	0.188
S10F2	73,980	0.5	11.56	0.109	0	0.5	1.561	2.121
S10F2	73,980	0.5	11.56	0.109	2	0.5	1.191	1.673
S10F2	73,980	0.5	11.56	0.109	5	0.5	1.285	1.995
S10F2	73,980	0.5	11.56	0.109	10	0.5	1.305	1.805
S10F2	73,980	0.5	11.56	0.109	0	1.0	3.128	4.107
S10F2	73,980	0.5	11.56	0.109	2	1.0	2.914	3.973
S10F2	73,980	0.5	11.56	0.109	5	1.0	2.852	3.807
S10F2	73,980	0.5	11.56	0.109	10	1.0	2.666	3.699
S42M2	83,400	2.9	11.22	0.052	2	0.0	0.039	0.319
S42M2	83,400	2.9	11.22	0.052	5	0.0	0.057	0.341
S42M2	83,400	2.9	11.22	0.052	10	0.0	0.127	0.680
S42M2	83,400	2.9	11.22	0.052	0	0.5	0.648	1.706
S42M2	83,400	2.9	11.22	0.052	2	0.5	0.652	1.733
S42M2	83,400	2.9	11.22	0.052	5	0.5	0.597	1.696
S42M2	83,400	2.9	11.22	0.052	10	0.5	0.615	1.576
S42M2	83,400	2.9	11.22	0.052	0	1.0	0.954	2.744
S42M2	83,400	2.9	11.22	0.052	2	1.0	1.421	3.760
S42M2	83,400	2.9	11.22	0.052	5	1.0	1.486	4.053
S42M2	83,400	2.9	11.22	0.052	10	1.0	1.271	3.427

Profile Error Analysis Summary
Aerial Spot Elevation Survey
1-Percent Chance Flood Event

Data Set I.D.	Average Q100 (cfs)	Average Slope (ft/mi)	Hydr Depth (ft)	Manning's n Value	Survey Accuracy (ft)	Manning's Reliability Nr	Absolute Mean Error (ft)	Absolute Maximum Error (ft)
S44M2	83,400	2.3	11.64	0.047	2	0.0	0.030	0.179
S44M2	83,400	2.3	11.64	0.047	5	0.0	0.043	0.187
S44M2	83,400	2.3	11.64	0.047	10	0.0	0.196	0.780
S44M2	83,400	2.3	11.64	0.047	0	0.5	0.513	1.355
S44M2	83,400	2.3	11.64	0.047	2	0.5	0.751	2.425
S44M2	83,400	2.3	11.64	0.047	5	0.5	0.536	1.767
S44M2	83,400	2.3	11.64	0.047	10	0.5	0.730	2.400
S44M2	83,400	2.3	11.64	0.047	0	1.0	1.409	3.949
S44M2	83,400	2.3	11.64	0.047	2	1.0	1.393	4.222
S44M2	83,400	2.3	11.64	0.047	5	1.0	1.437	4.288
S44M2	83,400	2.3	11.64	0.047	10	1.0	0.935	2.968
S55M2	90,000	8.8	5.29	0.032	2	0.0	0.023	0.091
S55M2	90,000	8.8	5.29	0.032	5	0.0	0.045	0.171
S55M2	90,000	8.8	5.29	0.032	10	0.0	0.125	0.436
S55M2	90,000	8.8	5.29	0.032	0	0.5	0.366	0.536
S55M2	90,000	8.8	5.29	0.032	2	0.5	0.326	0.499
S55M2	90,000	8.8	5.29	0.032	5	0.5	0.372	0.611
S55M2	90,000	8.8	5.29	0.032	10	0.5	0.348	0.737
S55M2	90,000	8.8	5.29	0.032	0	1.0	0.895	1.357
S55M2	90,000	8.8	5.29	0.032	2	1.0	0.693	1.058
S55M2	90,000	8.8	5.29	0.032	5	1.0	0.565	0.893
S55M2	90,000	8.8	5.29	0.032	10	1.0	0.724	1.222
S05M3	118,000	8.0	7.54	0.041	2	0.0	0.269	1.993
S05M3	118,000	8.0	7.54	0.041	5	0.0	0.289	2.043
S05M3	118,000	8.0	7.54	0.041	10	0.0	0.393	1.969
S05M3	118,000	8.0	7.54	0.041	0	0.5	0.510	2.044
S05M3	118,000	8.0	7.54	0.041	2	0.5	0.518	1.928
S05M3	118,000	8.0	7.54	0.041	5	0.5	0.569	2.058
S05M3	118,000	8.0	7.54	0.041	10	0.5	0.578	1.994
S05M3	118,000	8.0	7.54	0.041	0	1.0	0.812	2.329
S05M3	118,000	8.0	7.54	0.041	2	1.0	1.156	2.973
S05M3	118,000	8.0	7.54	0.041	5	1.0	0.680	2.055
S05M3	118,000	8.0	7.54	0.041	10	1.0	1.134	3.000
S02S3	152,000	15.9	13.13	0.067	2	0.0	0.032	0.137
S02S3	152,000	15.9	13.13	0.067	5	0.0	0.063	0.276
S02S3	152,000	15.9	13.13	0.067	10	0.0	0.155	0.656
S02S3	152,000	15.9	13.13	0.067	0	0.5	1.254	2.967
S02S3	152,000	15.9	13.13	0.067	2	0.5	1.294	2.671
S02S3	152,000	15.9	13.13	0.067	5	0.5	1.217	2.766
S02S3	152,000	15.9	13.13	0.067	10	0.5	1.024	2.210

Profile Error **Analysis Summary**
Aerial Spot Elevation Survey
 1-Percent Chance Flood Event

Data set I.D.	Average Q100 (cfs)	Average Slope (ft/mi)	Hydr Depth (ft)	Manning's n Value	survey Accuracy (ft)	Manning's Reliability Nr	Absolute Mean Error (ft)	Absolute Maximum Error (ft)
S02S3	152,000	15.9	13.13	0.067	0	1.0	2.633	5.415
S02S3	152,000	15.9	13.13	0.067	2	1.0	2.328	4.779
S02S3	152,000	15.9	13.13	0.067	5	1.0	3.050	6.608
S02S3	152,000	15.9	13.13	0.067	10	1.0	2.670	5.255
S04M3	158,000	6.6	22.31	0.057	2	0.0	0.030	0.078
S04M3	158,000	6.6	22.31	0.057	5	0.0	0.100	0.195
S04M3	158,000	6.6	22.31	0.057	10	0.0	0.446	0.653
S04M3	158,000	6.6	22.31	0.057	0	0.5	2.028	2.276
S04M3	158,000	6.6	22.31	0.057	2	0.5	2.219	2.495
S04M3	158,000	6.6	22.31	0.057	5	0.5	2.147	2.426
S04M3	158,000	6.6	22.31	0.057	10	0.5	2.575	2.982
S04M3	158,000	6.6	22.31	0.057	0	1.0	4.525	5.069
S04M3	158,000	6.6	22.31	0.057	2	1.0	4.114	4.657
S04M3	158,000	6.6	22.31	0.057	5	1.0	3.779	4.233
S04M3	158,000	6.6	22.31	0.057	10	1.0	3.875	4.470
S01M3	161,000	3.5	9.43	0.043	2	0.0	0.045	0.183
sow3	161,000	3.5	9.43	0.043	5	0.0	0.068	0.226
solM3	161,000	3.5	9.43	0.043	10	0.0	0.197	0.631
sow3	161,000	3.5	9.43	0.043	0	0.5	0.643	1.792
solM3	161,000	3.5	9.43	0.043	2	0.5	0.612	2.154
solM3	161,000	3.5	9.43	0.043	5	0.5	0.770	1.710
solM3	161,000	3.5	9.43	0.043	10	0.5	0.647	1.637
solM3	161,000	3.5	9.43	0.043	0	1.0	1.230	2.953
S01M3	161,000	3.5	9.43	0.043	2	1.0	1.589	3.220
S01M3	161,000	3.5	9.43	0.043	5	1.0	1.153	2.826
solM3	161,000	3.5	9.43	0.043	10	1.0	1.435	3.316
S01S3	270,300	15.4	19.86	0.031	2	0.0	0.149	1.039
S01S3	270,300	15.4	19.86	0.031	5	0.0	0.293	1.719
S01S3	270,300	15.4	19.86	0.031	10	0.0	0.800	3.159
S01S3	270,300	15.4	19.86	0.031	0	0.5	1.272	2.826
S01S3	270,300	15.4	19.86	0.031	2	0.5	1.361	3.033
S01S3	270,300	15.4	19.86	0.031	5	0.5	1.148	3.121
S01S3	270,300	15.4	19.86	0.031	10	0.5	1.239	3.618
S01S3	270,300	15.4	19.86	0.031	0	1.0	2.332	5.632
S01S3	270,300	15.4	19.86	0.031	2	1.0	2.408	5.460
S01S3	270,300	15.4	19.86	0.031	5	1.0	2.150	4.952
S01S3	270,300	15.4	19.86	0.031	10	1.0	2.343	5.900

Profile Error Analysis Summary
 Topographic Maps
 1-Percent Chance Flood Event

Data Set I.D.	Average Q100 (cfs)	Average Slope (ft/mi)	Hydr Depth (ft)	Manning's n Value	survey Contour Interval (ft)	Manning's Reliability Nr	Absolute Mean Error (ft)	Absolute Maximum Error (ft)
S12M1	700	6.5	2.61	0.037	2	0.0	0.281	0.935
S12M1	700	6.5	2.61	0.037	5	0.0	1.283	2.586
S12M1	700	6.5	2.61	0.037	10	0.0	3.144	6.268
S12M1	700	6.5	2.61	0.037	2	0.5	0.444	1.133
S12M1	700	6.5	2.61	0.037	5	0.5	1.366	2.650
S12M1	700	6.5	2.61	0.037	10	0.5	3.083	6.635
S12M1	700	6.5	2.61	0.037	2	1.0	0.464	1.148
S12M1	700	6.5	2.61	0.037	5	1.0	1.206	2.760
S12M1	700	6.5	2.61	0.037	10	1.0	2.672	5.725
S13M1	700	3.6	0.93	0.044	2	0.0	0.282	0.599
S13M1	700	3.6	0.93	0.044	5	0.0	1.131	1.929
S13M1	700	3.6	0.93	0.044	10	0.0	1.858	4.212
S13M1	700	3.6	0.93	0.044	2	0.5	0.290	0.639
S13M1	700	3.6	0.93	0.044	5	0.5	1.099	1.883
S13M1	700	3.6	0.93	0.044	10	0.5	2.240	5.167
S13M1	700	3.6	0.93	0.044	2	1.0	0.347	0.753
S13M1	700	3.6	0.93	0.044	5	1.0	1.085	1.804
S13M1	700	3.6	0.93	0.044	10	1.0	1.915	3.993
S10M1	800	4.3	2.92	0.036	2	0.0	0.145	0.510
S10M1	800	4.3	2.92	0.036	5	0.0	0.690	1.729
S10M1	800	4.3	2.92	0.036	10	0.0	2.267	4.624
S10M1	800	4.3	2.92	0.036	2	0.5	0.252	0.617
S10M1	800	4.3	2.92	0.036	5	0.5	0.744	1.843
S10M1	800	4.3	2.92	0.036	10	0.5	2.340	4.839
S10M1	800	4.3	2.92	0.036	2	1.0	0.450	1.047
S10M1	800	4.3	2.92	0.036	5	1.0	0.809	1.915
S10M1	800	4.3	2.92	0.036	10	1.0	2.144	4.506
S22S1	800	11.2	1.21	0.037	2	0.0	0.237	0.729
S22S1	800	11.2	1.21	0.037	5	0.0	0.757	2.074
S22S1	800	11.2	1.21	0.037	10	0.0	1.482	3.934
S22S1	800	11.2	1.21	0.037	2	0.5	0.251	0.719
S22S1	800	11.2	1.21	0.037	5	0.5	0.730	2.086
S22S1	800	11.2	1.21	0.037	10	0.5	1.453	4.022
S22S1	800	11.2	1.21	0.037	2	1.0	0.305	0.814
S22S1	800	11.2	1.21	0.037	5	1.0	0.705	2.039
S22S1	800	11.2	1.21	0.037	10	1.0	1.539	4.123
S09M1	900	6.3	1.03	0.041	2	0.0	0.285	0.781
S09M1	900	6.3	1.03	0.041	5	0.0	1.292	2.697
S09M1	900	6.3	1.03	0.041	10	0.0	2.329	4.913

Profile Error Analysis Summary
Topographic Maps
1-Percent Chance Flood Event

Data Set I.D.	Average Q100 (cfs)	Average Slope (ft/mi)	Hydr Depth (ft)	Manning's n Value	Survey Contour Interval (ft)	Manning's Reliability Nr	Absolute Mean Error (ft)	Absolute Maximum Error (ft)
S09M1	900	6.3	1.03	0.041	2	0.5	0.287	0.748
S09M1	900	6.3	1.03	0.041	5	0.5	1.274	2.655
S09M1	900	6.3	1.03	0.041	10	0.5	2.327	5.056
S09M1	900	6.3	1.03	0.041	2	1.0	0.374	0.832
S09M1	900	6.3	1.03	0.041	5	1.0	1.273	2.699
S09M1	900	6.3	1.03	0.041	10	1.0	2.297	4.871
S11M1	1,800	3.4	2.16	0.039	2	0.0	0.205	0.610
S11M1	1,800	3.4	2.16	0.039	5	0.0	0.634	1.442
S11M1	1,800	3.4	2.16	0.039	10	0.0	2.018	4.400
S11M1	1,800	3.4	2.16	0.039	2	0.5	0.311	0.726
S11M1	1,800	3.4	2.16	0.039	5	0.5	0.664	1.527
S11M1	1,800	3.4	2.16	0.039	10	0.5	2.000	4.350
S11M1	1,800	3.4	2.16	0.039	2	1.0	0.425	0.903
S11M1	1,800	3.4	2.16	0.039	5	1.0	0.712	1.686
S11M1	1,800	3.4	2.16	0.039	10	1.0	2.179	4.685
S17M1	1,800	5.6	1.24	0.039	2	0.0	0.193	0.616
S17M1	1,800	5.6	1.24	0.039	5	0.0	1.214	2.669
S17M1	1,800	5.6	1.24	0.039	10	0.0	2.613	5.205
S17M1	1,800	5.6	1.24	0.039	2	0.5	0.224	0.655
S17M1	1,800	5.6	1.24	0.039	5	0.5	1.228	2.693
S17M1	1,800	5.6	1.24	0.039	10	0.5	2.648	5.340
S17M1	1,800	5.6	1.24	0.039	2	1.0	0.320	0.942
S17M1	1,800	5.6	1.24	0.039	5	1.0	1.289	2.723
S17M1	1,800	5.6	1.24	0.039	10	1.0	2.733	5.171
S20S1	1,850	34.7	2.01	0.056	2	0.0	0.422	2.628
S20S1	1,850	34.7	2.01	0.056	5	0.0	1.085	3.621
S20S1	1,850	34.7	2.01	0.056	10	0.0	2.373	5.344
S20S1	1,850	34.7	2.01	0.056	2	0.5	0.449	2.393
S20S1	1,850	34.7	2.01	0.056	5	0.5	0.987	3.630
S20S1	1,850	34.7	2.01	0.056	10	0.5	1.981	5.140
S20S1	1,850	34.7	2.01	0.056	2	1.0	0.562	2.760
S20S1	1,850	34.7	2.01	0.056	5	1.0	1.103	3.209
S20S1	1,850	34.7	2.01	0.056	10	1.0	1.926	5.069
S07M1	2,292	3.6	1.96	0.059	2	0.0	0.192	0.671
S07M1	2,292	3.6	1.96	0.059	5	0.0	0.693	1.789
S07M1	2,292	3.6	1.96	0.059	10	0.0	1.533	3.814
S07M1	2,292	3.6	1.96	0.059	2	0.5	0.268	0.759
S07M1	2,292	3.6	1.96	0.059	5	0.5	0.720	2.231
S07M1	2,292	3.6	1.96	0.059	10	0.5	1.503	4.076

Profile Error Analysis Summary
 Topographic Maps
 1-Percent Chance Flood Event

Data Set I.D.	Average Q100 (cfs)	Average Slope (ft/mi)	Hydr Depth (ft)	Manning's n Value	Survey Contour Interval (ft)	Manning's Reliability Nr	Absolute Mean Error (ft)	Absolute Maximum Error (ft)
S07M1	2,292	3.6	1.96	0.059	2	1.0	0.369	1.170
S07M1	2,292	3.6	1.96	0.059	5	1.0	0.825	2.328
S07M1	2,292	3.6	1.96	0.059	10	1.0	1.484	4.149
S21S1	2,450	24.4	2.12	0.051	2	0.0	0.220	0.570
S21S1	2,450	24.4	2.12	0.051	5	0.0	0.784	1.882
S21S1	2,450	24.4	2.12	0.051	10	0.0	1.428	3.372
S21S1	2,450	24.4	2.12	0.051	2	0.5	0.295	0.774
S21S1	2,450	24.4	2.12	0.051	5	0.5	0.713	1.763
S21S1	2,450	24.4	2.12	0.051	10	0.5	1.630	3.691
S21S1	2,450	24.4	2.12	0.051	2	1.0	0.440	0.960
S21S1	2,450	24.4	2.12	0.051	5	1.0	0.814	2.002
S21S1	2,450	24.4	2.12	0.051	10	1.0	1.739	3.874
S18S1	2,575	21.0	2.63	0.073	2	0.0	0.209	0.582
S18S1	2,575	21.0	2.63	0.073	5	0.0	0.587	1.756
S18S1	2,575	21.0	2.63	0.073	10	0.0	1.377	3.537
S18S1	2,575	21.0	2.63	0.073	2	0.5	0.331	0.748
S18S1	2,575	21.0	2.63	0.073	5	0.5	0.641	2.020
S18S1	2,575	21.0	2.63	0.073	10	0.5	1.448	3.859
S18S1	2,575	21.0	2.63	0.073	2	1.0	0.600	1.260
S18S1	2,575	21.0	2.63	0.073	5	1.0	0.797	2.138
S18S1	2,575	21.0	2.63	0.073	10	1.0	1.611	4.260
S17S1	2,850	43.4	3.92	0.051	2	0.0	0.281	1.038
S17S1	2,850	43.4	3.92	0.051	5	0.0	0.619	1.593
S17S1	2,850	43.4	3.92	0.051	10	0.0	1.413	4.293
S17S1	2,850	43.4	3.92	0.051	2	0.5	0.477	1.220
S17S1	2,850	43.4	3.92	0.051	5	0.5	0.799	2.100
S17S1	2,850	43.4	3.92	0.051	10	0.5	1.466	4.045
S17S1	2,850	43.4	3.92	0.051	2	1.0	0.882	1.943
S17S1	2,850	43.4	3.92	0.051	5	1.0	0.971	2.259
S17S1	2,850	43.4	3.92	0.051	10	1.0	1.660	3.799
S19S1	2,870	57.8	4.60	0.062	2	0.0	0.513	1.491
S19S1	2,870	57.8	4.60	0.062	5	0.0	0.653	1.714
S19S1	2,870	57.8	4.60	0.062	10	0.0	1.060	2.808
S19S1	2,870	57.8	4.60	0.062	2	0.5	0.595	1.637
S19S1	2,870	57.8	4.60	0.062	5	0.5	0.776	1.917
S19S1	2,870	57.8	4.60	0.062	10	0.5	1.120	2.843
S19S1	2,870	57.8	4.60	0.062	2	1.0	0.795	2.079
S19S1	2,870	57.8	4.60	0.062	5	1.0	0.926	2.279
S19S1	2,870	57.8	4.60	0.062	10	1.0	1.270	3.145

Profile Error Analysis Summary
 Topographic Maps
 1-Percent Chance Flood Event

Data Set I.D.	Average Q100 (cfs)	Average Slope (ft/mi)	Hydr Depth (ft)	Manning's n Value	Survey Contour Interval (ft)	Manning's Reliability Nr	Absolute Mean Error (ft)	Absolute Maximum Error (ft)
S16M1	3,050	4.6	3.48	0.039	2	0.0	0.169	0.411
S16M1	3,050	4.6	3.48	0.039	5	0.0	0.740	1.716
S16M1	3,050	4.6	3.48	0.039	10	0.0	1.697	4.353
S16M1	3,050	4.6	3.48	0.039	2	0.5	0.344	0.800
S16M1	3,050	4.6	3.48	0.039	5	0.5	0.719	1.790
S16M1	3,050	4.6	3.48	0.039	10	0.5	1.903	4.562
S16M1	3,050	4.6	3.48	0.039	2	1.0	0.740	1.880
S16M1	3,050	4.6	3.48	0.039	5	1.0	1.014	2.165
S16M1	3,050	4.6	3.48	0.039	10	1.0	1.684	4.474
S03S1	3,077	13.0	3.38	0.052	2	0.0	0.140	0.455
S03S1	3,077	13.0	3.38	0.052	5	0.0	0.460	1.406
S03S1	3,077	13.0	3.38	0.052	10	0.0	1.350	3.487
S03S1	3,077	13.0	3.38	0.052	2	0.5	0.405	0.764
S03S1	3,077	13.0	3.38	0.052	5	0.5	0.634	1.630
S03S1	3,077	13.0	3.38	0.052	10	0.5	1.313	3.347
S03S1	3,077	13.0	3.38	0.052	2	1.0	0.735	1.170
S03S1	3,077	13.0	3.38	0.052	5	1.0	0.936	1.922
S03S1	3,077	13.0	3.38	0.052	10	1.0	1.414	3.325
S15S1	3,458	27.4	3.63	0.064	2	0.0	0.272	1.009
S15S1	3,458	27.4	3.63	0.064	5	0.0	0.598	2.432
S15S1	3,458	27.4	3.63	0.064	10	0.0	1.364	4.522
S15S1	3,458	27.4	3.63	0.064	2	0.5	0.426	1.232
S15S1	3,458	27.4	3.63	0.064	5	0.5	0.689	2.302
S15S1	3,458	27.4	3.63	0.064	10	0.5	1.360	4.488
S15S1	3,458	27.4	3.63	0.064	2	1.0	0.874	2.451
S15S1	3,458	27.4	3.63	0.064	5	1.0	0.921	2.978
S15S1	3,458	27.4	3.63	0.064	10	1.0	1.476	4.610
S14S1	3,655	39.2	3.49	0.068	2	0.0	0.3164	1.511
S14S1	3,655	39.2	3.49	0.068	5	0.0	0.595	1.885
S14S1	3,655	39.2	3.49	0.068	10	0.0	1.404	3.817
S14S1	3,655	39.2	3.49	0.068	2	0.5	0.546	1.750
S14S1	3,655	39.2	3.49	0.068	5	0.5	0.734	2.098
S14S1	3,655	39.2	3.49	0.068	10	0.5	1.522	3.994
S14S1	3,655	39.2	3.49	0.068	2	1.0	0.865	2.138
S14S1	3,655	39.2	3.49	0.068	5	1.0	1.065	2.743
S14S1	3,655	39.2	3.49	0.068	10	1.0	1.461	3.701
S12S1	3,825	21.4	2.53	0.065	2	0.0	0.183	0.478
S12S1	3,825	21.4	2.53	0.065	5	0.0	0.650	1.621
S12S1	3,825	21.4	2.53	0.065	10	0.0	1.618	4.302

Profile Error Analysis Summary
 Topographic Maps
 1-Percent Chance Flood Event

Data Set I.D.	Average Q100 (cfs)	Average Slope (ft/mi)	Hydr Depth (ft)	Manning's n Value	Survey Contour Interval (ft)	Manning's Reliability Nr	Absolute Mean Error (ft)	Absolute Maximum Error (ft)
S12S1	3,825	21.4	2.53	0.065	2	0.5	0.309	0.679
S12S1	3,825	21.4	2.53	0.065	5	0.5	0.719	1.696
S12S1	3,825	21.4	2.53	0.065	10	0.5	1.611	4.862
S12S1	3,825	21.4	2.53	0.065	2	1.0	0.448	0.811
S12S1	3,825	21.4	2.53	0.065	5	1.0	0.899	2.089
S12S1	3,825	21.4	2.53	0.065	10	1.0	1.670	4.516
S14M1	4,600	3.2	6.09	0.029	2	0.0	0.306	0.898
S14M1	4,600	3.2	6.09	0.029	5	0.0	0.567	1.489
S14M1	4,600	3.2	6.09	0.029	10	0.0	1.394	3.422
S14M1	4,600	3.2	6.09	0.029	2	0.5	0.289	0.764
S14M1	4,600	3.2	6.09	0.029	5	0.5	0.650	1.437
S14M1	4,600	3.2	6.09	0.029	10	0.5	1.303	3.337
S14M1	4,600	3.2	6.09	0.029	2	1.0	0.357	1.543
S14M1	4,600	3.2	6.09	0.029	5	1.0	0.743	1.904
S14M1	4,600	3.2	6.09	0.029	10	1.0	1.287	3.461
S05S1	5,010	36.9	3.00	0.053	2	0.0	0.288	0.830
S05S1	5,010	36.9	3.00	0.053	5	0.0	0.533	1.705
S05S1	5,010	36.9	3.00	0.053	10	0.0	1.239	4.589
S05S1	5,010	36.9	3.00	0.053	2	0.5	0.462	1.354
S05S1	5,010	36.9	3.00	0.053	5	0.5	0.633	2.011
S05S1	5,010	36.9	3.00	0.053	10	0.5	1.634	5.024
S05S1	5,010	36.9	3.00	0.053	2	1.0	0.579	1.489
S05S1	5,010	36.9	3.00	0.053	5	1.0	0.868	2.104
S05S1	5,010	36.9	3.00	0.053	10	1.0	1.551	6.295
S06S1	5,197	37.8	4.12	0.073	2	0.0	0.285	3.076
S06S1	5,197	37.8	4.12	0.073	5	0.0	0.554	3.415
S06S1	5,197	37.8	4.12	0.073	10	0.0	1.267	4.888
S06S1	5,197	37.8	4.12	0.073	2	0.5	0.549	3.033
S06S1	5,197	37.8	4.12	0.073	5	0.5	0.661	2.934
S06S1	5,197	37.8	4.12	0.073	10	0.5	1.263	4.660
S06S1	5,197	37.8	4.12	0.073	2	1.0	1.083	3.089
S06S1	5,197	37.8	4.12	0.073	5	1.0	0.917	3.646
S06S1	5,197	37.8	4.12	0.073	10	1.0	1.495	5.035
S05M1	5,493	8.8	3.74	0.056	2	0.0	0.161	0.732
S05M1	5,493	8.8	3.74	0.056	5	0.0	0.436	1.365
S05M1	5,493	8.8	3.74	0.056	10	0.0	1.070	2.936
S05M1	5,493	8.8	3.74	0.056	2	0.5	0.424	0.864
S05M1	5,493	8.8	3.74	0.056	5	0.5	0.559	1.537
S05M1	5,493	8.8	3.74	0.056	10	0.5	1.129	3.132

Profile Error Analysis Summary
 Topographic Maps
 1-Percent Chance Flood Event

Data Set I.D.	Average Q100 (cfs)	Average Slope (ft/mi)	Hydr Depth (ft)	Manning's n Value	Survey Contour Interval (ft)	Manning's Reliability Nr	Absolute Mean Error (ft)	Absolute Maximum Error (ft)
S05M1	5,493	8.8	3.74	0.056	2	1.0	0.816	1.337
S05M1	5,493	8.8	3.74	0.056	5	1.0	0.839	1.912
S05M1	5,493	8.8	3.74	0.056	10	1.0	1.191	3.195
S09S1	5,675	37.6	7.30	0.061	2	0.0	0.111	0.284
S09S1	5,675	37.6	7.30	0.061	5	0.0	0.361	0.877
S09S1	5,675	37.6	7.30	0.061	10	0.0	0.906	2.356
S09S1	5,675	37.6	7.30	0.061	2	0.5	0.556	0.974
S09S1	5,675	37.6	7.30	0.061	5	0.5	0.705	1.440
S09S1	5,675	37.6	7.30	0.061	10	0.5	1.037	2.611
S09S1	5,675	37.6	7.30	0.061	2	1.0	1.278	2.114
S09S1	5,675	37.6	7.30	0.061	5	1.0	1.348	2.514
S09S1	5,675	37.6	7.30	0.061	10	1.0	1.398	3.161
S13S1	5,880	46.4	6.07	0.072	2	0.0	0.761	3.899
S13S1	5,880	46.4	6.07	0.072	5	0.0	0.788	3.852
S13S1	5,880	46.4	6.07	0.072	10	0.0	1.174	4.301
S13S1	5,880	46.4	6.07	0.072	2	0.5	1.072	4.003
S13S1	5,880	46.4	6.07	0.072	5	0.5	1.123	4.051
S13S1	5,880	46.4	6.07	0.072	10	0.5	1.293	4.338
S13S1	5,880	46.4	6.07	0.072	2	1.0	1.522	4.298
S13S1	5,880	46.4	6.07	0.072	5	1.0	1.439	4.099
S13S1	5,880	46.4	6.07	0.072	10	1.0	1.617	4.277
S08S1	6,075	19.4	4.05	0.070	2	0.0	0.174	0.595
S08S1	6,075	19.4	4.05	0.070	5	0.0	0.451	1.450
S08S1	6,075	19.4	4.05	0.070	10	0.0	1.170	3.563
S08S1	6,075	19.4	4.05	0.070	2	0.5	0.446	1.097
S08S1	6,075	19.4	4.05	0.070	5	0.5	0.588	1.636
S08S1	6,075	19.4	4.05	0.070	10	0.5	1.159	3.225
S08S1	6,075	19.4	4.05	0.070	2	1.0	0.914	2.009
S08S1	6,075	19.4	4.05	0.070	5	1.0	0.920	2.394
S08S1	6,075	19.4	4.05	0.070	10	1.0	1.317	3.481
S03M1	6,530	4.5	3.39	0.074	2	0.0	0.133	0.366
S03M1	6,530	4.5	3.39	0.074	5	0.0	0.469	1.116
S03M1	6,530	4.5	3.39	0.074	10	0.0	1.644	3.379
S03M1	6,530	4.5	3.39	0.074	2	0.5	0.326	0.704
S03M1	6,530	4.5	3.39	0.074	5	0.5	0.506	1.165
S03M1	6,530	4.5	3.39	0.074	10	0.5	1.489	3.095
S03M1	6,530	4.5	3.39	0.074	2	1.0	0.747	1.382
S03M1	6,530	4.5	3.39	0.074	5	1.0	0.868	1.846
S03M1	6,530	4.5	3.39	0.074	10	1.0	1.723	3.672

Profile Error Analysis Summary
 Topographic Maps
 1-Percent Chance Flood Event

Data Set I.D.	Average Q100 (cfs)	Average Slope (ft/mi)	Hydr Depth (ft)	Manning's n Value	Survey Contour Interval (ft)	Manning's Reliability Nr	Absolute Mean Error (ft)	Absolute Maximum Error (ft)
S02S1	6,688	27.2	2.65	0.053	2	0.0	0.216	0.571
S02S1	6,688	27.2	2.65	0.053	5	0.0	0.574	1.292
S02S1	6,688	27.2	2.65	0.053	10	0.0	1.399	3.179
S02S1	6,688	27.2	2.65	0.053	2	0.5	0.335	0.802
S02S1	6,688	27.2	2.65	0.053	5	0.5	0.667	1.638
S02S1	6,688	27.2	2.65	0.053	10	0.5	1.399	2.975
S02S1	6,688	27.2	2.65	0.053	2	1.0	0.611	1.415
S02S1	6,688	27.2	2.65	0.053	5	1.0	0.798	1.905
S02S1	6,688	27.2	2.65	0.053	10	1.0	1.351	3.113
S07S1	6,700	13.4	2.89	0.057	2	0.0	0.150	0.455
S07S1	6,700	13.4	2.89	0.057	5	0.0	0.509	1.383
S07S1	6,700	13.4	2.89	0.057	10	0.0	1.473	3.675
S07S1	6,700	13.4	2.89	0.057	2	0.5	0.298	0.649
S07S1	6,700	13.4	2.89	0.057	5	0.5	0.585	1.525
S07S1	6,700	13.4	2.89	0.057	10	0.5	1.502	3.676
S07S1	6,700	13.4	2.89	0.057	2	1.0	0.537	0.921
S07S1	6,700	13.4	2.89	0.057	5	1.0	0.776	1.836
S07S1	6,700	13.4	2.89	0.057	10	1.0	1.556	3.904
SLOS1	6,900	28.7	5.90	0.050	2	0.0	0.129	0.497
SLOS1	6,900	28.7	5.90	0.050	5	0.0	0.387	1.163
SLOS1	6,900	28.7	5.90	0.050	10	0.0	1.160	3.476
SLOS1	6,900	28.7	5.90	0.050	2	0.5	0.505	1.187
SLOS1	6,900	28.7	5.90	0.050	5	0.5	0.595	1.570
SLOS1	6,900	28.7	5.90	0.050	10	0.5	1.125	3.143
SLOS1	6,900	28.7	5.90	0.050	2	1.0	1.106	2.557
SLOS1	6,900	28.7	5.90	0.050	5	1.0	1.143	2.930
SLOS1	6,900	28.7	5.90	0.050	10	1.0	1.452	3.895
SOLS1	6,910	10.9	3.32	0.052	2	0.0	0.150	0.640
SOLS1	6,910	10.9	3.32	0.052	5	0.0	0.481	1.797
SOLS1	6,910	10.9	3.32	0.052	10	0.0	1.163	3.959
SOLS1	6,910	10.9	3.32	0.052	2	0.5	0.286	0.760
SOLS1	6,910	10.9	3.32	0.052	5	0.5	0.487	1.694
SOLS1	6,910	10.9	3.32	0.052	10	0.5	1.318	3.896
SOLS1	6,910	10.9	3.32	0.052	2	1.0	0.611	1.650
SOLS1	6,910	10.9	3.32	0.052	5	1.0	0.723	1.963
SOLS1	6,910	10.9	3.32	0.052	10	1.0	1.346	4.018
S06M1	7,450	8.4	5.49	0.069	2	0.0	0.108	0.377
S06M1	7,450	8.4	5.49	0.069	5	0.0	0.294	1.421
S06M1	7,450	8.4	5.49	0.069	10	0.0	0.992	3.190

Profile Error Analysis Summary
 Topographic Maps
 1-Percent Chance Flood Event

Data Set I.D.	Average Q100 (cfs)	Average Slope (ft/mi)	Hydr Depth (ft)	Manning's n Value	Survey Contour Interval (ft)	Manning's Reliability Nr	Absolute Mean Error (ft)	Absolute Maximum Error (ft)
S06M1	7,450	8.4	5.49	0.069	2	0.5	0.305	0.878
S06M1	7,450	8.4	5.49	0.069	5	0.5	0.544	1.470
S06M1	7,450	8.4	5.49	0.069	10	0.5	1.135	3.404
S06M1	7,450	8.4	5.49	0.069	2	1.0	0.763	1.957
S06M1	7,450	8.4	5.49	0.069	5	1.0	0.642	1.825
S06M1	7,450	8.4	5.49	0.069	10	1.0	0.976	2.889
S11S1	7,925	16.9	3.92	0.065	2	0.0	0.227	0.780
S11S1	7,925	16.9	3.92	0.065	5	0.0	0.408	1.114
S11S1	7,925	16.9	3.92	0.065	10	0.0	1.375	4.584
S11S1	7,925	16.9	3.92	0.065	2	0.5	0.399	1.006
S11S1	7,925	16.9	3.92	0.065	5	0.5	0.567	1.354
S11S1	7,925	16.9	3.92	0.065	10	0.5	1.549	4.125
S11S1	7,925	16.9	3.92	0.065	2	1.0	0.790	1.656
S11S1	7,925	16.9	3.92	0.065	5	1.0	0.680	1.630
S11S1	7,925	16.9	3.92	0.065	10	1.0	1.566	4.476
S04S1	8,070	22.7	3.10	0.049	2	0.0	0.244	0.647
S04S1	8,070	22.7	3.10	0.049	5	0.0	0.641	1.605
S04S1	8,070	22.7	3.10	0.049	10	0.0	1.485	4.150
S04S1	8,070	22.7	3.10	0.049	2	0.5	0.339	0.788
S04S1	8,070	22.7	3.10	0.049	5	0.5	0.663	1.567
S04S1	8,070	22.7	3.10	0.049	10	0.5	1.434	3.645
S04S1	8,070	22.7	3.10	0.049	2	1.0	0.553	1.303
S04S1	8,070	22.7	3.10	0.049	5	1.0	0.798	1.753
S04S1	8,070	22.7	3.10	0.049	10	1.0	1.659	4.349
S16S1	8,850	24.4	5.85	0.052	2	0.0	0.098	0.201
S16S1	8,850	24.4	5.85	0.052	5	0.0	0.471	0.869
S16S1	8,850	24.4	5.85	0.052	10	0.0	0.792	1.336
S16S1	8,850	24.4	5.85	0.052	2	0.5	0.473	0.778
S16S1	8,850	24.4	5.85	0.052	5	0.5	0.634	1.081
S16S1	8,850	24.4	5.85	0.052	10	0.5	0.907	1.683
S16S1	8,850	24.4	5.85	0.052	2	1.0	0.929	1.449
S16S1	8,850	24.4	5.85	0.052	5	1.0	1.064	1.814
S16S1	8,850	24.4	5.85	0.052	10	1.0	1.189	2.196
S23S1	9,355	26.1	2.21	0.034	2	0.0	0.221	0.594
S23S1	9,355	26.1	2.21	0.034	5	0.0	0.569	1.597
S23S1	9,355	26.1	2.21	0.034	10	0.0	1.783	5.302
S23S1	9,355	26.1	2.21	0.034	2	0.5	0.268	0.714
S23S1	9,355	26.1	2.21	0.034	5	0.5	0.590	1.566
S23S1	9,355	26.1	2.21	0.034	10	0.5	1.921	5.062

Profile Error Analysis Summary
Topographic Maps
1-Percent Chance Flood Event

Data Set I.D.	Average Q100 (cfs)	Average Slope (ft/mi)	Hydr Depth (ft)	Manning's n Value	Survey Contour Interval (ft)	Manning's Reliability Nr	Absolute Mean Error (ft)	Absolute Maximum Error (ft)
S23S1	9,355	26.1	2.21	0.034	2	1.0	0.392	0.927
S23S1	9,355	26.1	2.21	0.034	5	1.0	0.686	1.710
S23S1	9,355	26.1	2.21	0.034	10	1.0	1.806	4.995
S04M1	9,973	8.7	4.68	0.061	2	0.0	0.134	0.418
S04M1	9,973	8.7	4.68	0.061	5	0.0	0.377	0.872
S04M1	9,973	8.7	4.68	0.061	10	0.0	1.298	2.750
S04M1	9,973	8.7	4.68	0.061	2	0.5	0.585	0.883
S04M1	9,973	8.7	4.68	0.061	5	0.5	0.584	1.209
S04M1	9,973	8.7	4.68	0.061	10	0.5	1.333	2.756
S04M1	9,973	8.7	4.68	0.061	2	1.0	1.074	1.383
S04M1	9,973	8.7	4.68	0.061	5	1.0	1.066	1.714
S04M1	9,973	8.7	4.68	0.061	10	1.0	1.808	3.571
S02M1	10,243	6.8	3.96	0.061	2	0.0	0.115	0.761
S02M1	10,243	6.8	3.96	0.061	5	0.0	0.374	1.294
S02M1	10,243	6.8	3.96	0.061	10	0.0	1.119	2.693
S02M1	10,243	6.8	3.96	0.061	2	0.5	0.289	0.802
S02M1	10,243	6.8	3.96	0.061	5	0.5	0.483	1.369
S02M1	10,243	6.8	3.96	0.061	10	0.5	1.089	2.704
S02M1	10,243	6.8	3.96	0.061	2	1.0	0.518	2.113
S02M1	10,243	6.8	3.96	0.061	5	1.0	0.563	2.079
S02M1	10,243	6.8	3.96	0.061	10	1.0	1.106	3.287
S12M2	10,750	6.6	2.92	0.048	2	0.0	0.187	0.423
S12M2	10,750	6.6	2.92	0.048	5	0.0	0.600	1.626
S12M2	10,750	6.6	2.92	0.048	10	0.0	1.858	4.002
S12M2	10,750	6.6	2.92	0.048	2	0.5	0.315	0.671
S12M2	10,750	6.6	2.92	0.048	5	0.5	0.601	1.432
S12M2	10,750	6.6	2.92	0.048	10	0.5	2.118	4.795
S12M2	10,750	6.6	2.92	0.048	2	1.0	0.604	1.135
S12M2	10,750	6.6	2.92	0.048	5	1.0	0.930	2.043
S12M2	10,750	6.6	2.92	0.048	10	1.0	2.198	4.562
S11S2	11,000	20.1	6.49	0.063	2	0.0	0.132	0.557
S11S2	11,000	20.1	6.49	0.063	5	0.0	0.407	1.336
S11S2	11,000	20.1	6.49	0.063	10	0.0	0.993	3.346
S11S2	11,000	20.1	6.49	0.063	2	0.5	0.496	1.316
S11S2	11,000	20.1	6.49	0.063	5	0.5	0.702	1.808
S11S2	11,000	20.1	6.49	0.063	10	0.5	1.243	3.766
S11S2	11,000	20.1	6.49	0.063	2	1.0	1.069	2.559
S11S2	11,000	20.1	6.49	0.063	5	1.0	1.263	2.686
S11S2	11,000	20.1	6.49	0.063	10	1.0	1.691	4.602

Profile Error Analysis Summary
Topographic Maps
1-Percent Chance Flood Event

Data Set I.D.	Average Q100 (cfs)	Average Slope (ft/mi)	Hydr Depth (ft)	Manning's n Value	Survey Contour Interval (ft)	Manning's Reliability Nr	Absolute Mean Error (ft)	Absolute Maximum Error (ft)
S54M2	11,300	6.8	4.58	0.042	2	0.0	0.128	0.572
S54M2	11,300	6.8	4.58	0.042	5	0.0	0.546	1.992
S54M2	11,300	6.8	4.58	0.042	10	0.0	0.962	2.793
S54M2	11,300	6.8	4.58	0.042	2	0.5	0.447	1.019
S54M2	11,300	6.8	4.58	0.042	5	0.5	0.750	2.214
S54M2	11,300	6.8	4.58	0.042	10	0.5	1.025	2.775
S54M2	11,300	6.8	4.58	0.042	2	1.0	0.724	1.563
S54M2	11,300	6.8	4.58	0.042	5	1.0	1.086	2.654
S54M2	11,300	6.8	4.58	0.042	10	1.0	1.119	2.999
S02S2	11,790	16.6	3.53	0.053	2	0.0	0.190	0.475
S02S2	11,790	16.6	3.53	0.053	5	0.0	0.513	1.404
S02S2	11,790	16.6	3.53	0.053	10	0.0	1.505	3.140
S02S2	11,790	16.6	3.53	0.053	2	0.5	0.395	0.965
S02S2	11,790	16.6	3.53	0.053	5	0.5	0.534	1.397
S02S2	11,790	16.6	3.53	0.053	10	0.5	1.356	3.346
S02S2	11,790	16.6	3.53	0.053	2	1.0	0.675	1.793
S02S2	11,790	16.6	3.53	0.053	5	1.0	0.619	1.792
S02S2	11,790	16.6	3.53	0.053	10	1.0	1.326	2.859
S05S2	11,979	25.4	7.85	0.087	2	0.0	0.097	0.328
S05S2	11,979	25.4	7.85	0.087	5	0.0	0.291	0.883
S05S2	11,979	25.4	7.85	0.087	10	0.0	0.773	2.432
S05S2	11,979	25.4	7.85	0.087	2	0.5	0.894	1.308
S05S2	11,979	25.4	7.85	0.087	5	0.5	0.845	1.658
S05S2	11,979	25.4	7.85	0.087	10	0.5	1.224	3.032
S05S2	11,979	25.4	7.85	0.087	2	1.0	1.535	2.170
S05S2	11,979	25.4	7.85	0.087	5	1.0	1.905	2.915
S05S2	11,979	25.4	7.85	0.087	10	1.0	1.861	3.838
S03M2	11,985	3.2	5.53	0.083	2	0.0	0.111	0.362
S03M2	11,985	3.2	5.53	0.083	5	0.0	0.350	1.350
S03M2	11,985	3.2	5.53	0.083	10	0.0	0.892	2.363
S03M2	11,985	3.2	5.53	0.083	2	0.5	0.484	0.718
S03M2	11,985	3.2	5.53	0.083	5	0.5	0.626	1.562
S03M2	11,985	3.2	5.53	0.083	10	0.5	1.042	2.608
S03M2	11,985	3.2	5.53	0.083	2	1.0	1.040	1.339
S03M2	11,985	3.2	5.53	0.083	5	1.0	1.086	1.887
S03M2	11,985	3.2	5.53	0.083	10	1.0	1.486	3.127
S02M2	14,037	9.1	4.85	0.053	2	0.0	0.294	0.973
S02M2	14,037	9.1	4.85	0.053	5	0.0	0.661	1.733
S02M2	14,037	9.1	4.85	0.053	10	0.0	1.358	2.836

Profile Error Analysis Summary
 Topographic Maps
 1-Percent Chance Flood Event

Data Set I.D.	Average Q100 (cfs)	Average Slope (ft/mi)	Hydr Depth (ft)	Manning's n Value	Survey Contour Interval (ft)	Manning's Reliability Nr	Absolute Mean Error (ft)	Absolute Maximum Error (ft)
S02M2	14,037	9.1	4.85	0.053	2	0.5	0.371	1.048
S02M2	14,037	9.1	4.85	0.053	5	0.5	0.719	1.672
S02M2	14,037	9.1	4.85	0.053	10	0.5	1.236	2.584
S02M2	14,037	9.1	4.85	0.053	2	1.0	0.546	1.407
S02M2	14,037	9.1	4.85	0.053	5	1.0	0.931	2.250
S02M2	14,037	9.1	4.85	0.053	10	1.0	1.230	2.522
S05M2	14,100	9.5	6.39	0.067	2	0.0	0.135	0.499
S05M2	14,100	9.5	6.39	0.067	5	0.0	0.335	1.039
S05M2	14,100	9.5	6.39	0.067	10	0.0	0.899	2.728
S05M2	14,100	9.5	6.39	0.067	2	0.5	0.732	1.065
S05M2	14,100	9.5	6.39	0.067	5	0.5	0.783	1.616
S05M2	14,100	9.5	6.39	0.067	10	0.5	1.023	2.808
S05M2	14,100	9.5	6.39	0.067	2	1.0	1.402	1.819
S05M2	14,100	9.5	6.39	0.067	5	1.0	1.396	2.181
S05M2	14,100	9.5	6.39	0.067	10	1.0	1.545	3.195
S20S2	14,665	24.8	3.46	0.030	2	0.0	0.265	1.265
S20S2	14,665	24.8	3.46	0.030	5	0.0	0.702	2.370
S20S2	14,665	24.8	3.46	0.030	10	0.0	1.556	4.956
S20S2	14,665	24.8	3.46	0.030	2	0.5	0.353	1.209
S20S2	14,665	24.8	3.46	0.030	5	0.5	0.698	2.212
S20S2	14,665	24.8	3.46	0.030	10	0.5	1.759	5.388
S20S2	14,665	24.8	3.46	0.030	2	1.0	0.499	1.573
S20S2	14,665	24.8	3.46	0.030	5	1.0	0.718	2.466
S20S2	14,665	24.8	3.46	0.030	10	1.0	1.561	5.069
S10S2	15,725	12.4	4.69	0.057	2	0.0	0.124	0.428
S10S2	15,725	12.4	4.69	0.057	5	0.0	0.448	1.407
S10S2	15,725	12.4	4.69	0.057	10	0.0	1.194	3.410
S10S2	15,725	12.4	4.69	0.057	2	0.5	0.508	1.006
S10S2	15,725	12.4	4.69	0.057	5	0.5	0.624	1.579
S10S2	15,725	12.4	4.69	0.057	10	0.5	1.244	3.408
S10S2	15,725	12.4	4.69	0.057	2	1.0	0.774	1.388
S10S2	15,725	12.4	4.69	0.057	5	1.0	0.922	1.929
S10S2	15,725	12.4	4.69	0.057	10	1.0	1.455	3.803
S01S2	15,745	12.9	4.32	0.052	2	0.0	0.157	0.526
S01S2	15,745	12.9	4.32	0.052	5	0.0	0.360	1.320
S01S2	15,745	12.9	4.32	0.052	10	0.0	1.078	2.877
S01S2	15,745	12.9	4.32	0.052	2	0.5	0.390	1.258
S01S2	15,745	12.9	4.32	0.052	5	0.5	0.582	1.668
S01S2	15,745	12.9	4.32	0.052	10	0.5	1.137	3.247

Profile Error Analysis Summary
 Topographic Maps
 1-Percent Chance Flood Event

Data Set I.D.	Average Q100 (cfs)	Average Slope (ft/mi)	Hydr Depth (ft)	Manning's n Value	Survey Contour Interval (ft)	Manning's Reliability Nr	Absolute Mean Error (ft)	Absolute Maximum Error (ft)
S01S2	15,745	12.9	4.32	0.052	2	1.0	0.608	1.345
S01S2	15,745	12.9	4.32	0.052	5	1.0	0.911	2.818
S01S2	15,745	12.9	4.32	0.052	10	1.0	0.974	2.726
S06S2	16,450	16.6	5.06	0.055	2	0.0	0.098	0.331
S06S2	16,450	16.6	5.06	0.055	5	0.0	0.312	1.024
S06S2	16,450	16.6	5.06	0.055	10	0.0	0.820	2.436
S06S2	16,450	16.6	5.06	0.055	2	0.5	0.659	0.967
S06S2	16,450	16.6	5.06	0.055	5	0.5	0.730	1.521
S06S2	16,450	16.6	5.06	0.055	10	0.5	0.973	2.774
S06S2	16,450	16.6	5.06	0.055	2	1.0	1.216	1.555
S06S2	16,450	16.6	5.06	0.055	5	1.0	1.244	2.109
S06S2	16,450	16.6	5.06	0.055	10	1.0	1.420	3.160
S04M2	16,595	3.5	6.38	0.045	2	0.0	0.122	1.377
S04M2	16,595	3.5	6.38	0.045	5	0.0	0.355	1.989
S04M2	16,595	3.5	6.38	0.045	10	0.0	1.021	3.911
S04M2	16,595	3.5	6.38	0.045	2	0.5	0.366	1.424
S04M2	16,595	3.5	6.38	0.045	5	0.5	0.516	2.652
S04M2	16,595	3.5	6.38	0.045	10	0.5	0.969	4.117
S04M2	16,595	3.5	6.38	0.045	2	1.0	0.660	2.402
S04M2	16,595	3.5	6.38	0.045	5	1.0	0.791	2.009
S04M2	16,595	3.5	6.38	0.045	10	1.0	1.457	4.806
S09S2	17,300	14.6	5.09	0.056	2	0.0	0.117	0.777
S09S2	17,300	14.6	5.09	0.056	5	0.0	0.305	1.128
S09S2	17,300	14.6	5.09	0.056	10	0.0	0.882	3.349
S09S2	17,300	14.6	5.09	0.056	2	0.5	0.474	1.526
S09S2	17,300	14.6	5.09	0.056	5	0.5	0.707	1.744
S09S2	17,300	14.6	5.09	0.056	10	0.5	1.037	3.431
S09S2	17,300	14.6	5.09	0.056	2	1.0	1.076	2.849
S09S2	17,300	14.6	5.09	0.056	5	1.0	0.826	2.342
S09S2	17,300	14.6	5.09	0.056	10	1.0	1.234	4.154
S04S2	19,461	15.6	7.95	0.062	2	0.0	0.219	1.152
S04S2	19,461	15.6	7.95	0.062	5	0.0	0.380	1.664
S04S2	19,461	15.6	7.95	0.062	10	0.0	0.770	2.740
S04S2	19,461	15.6	7.95	0.062	2	0.5	0.700	2.152
S04S2	19,461	15.6	7.95	0.062	5	0.5	0.824	2.655
S04S2	19,461	15.6	7.95	0.062	10	0.5	1.011	3.526
S04S2	19,461	15.6	7.95	0.062	2	1.0	1.401	3.984
S04S2	19,461	15.6	7.95	0.062	5	1.0	1.465	3.991
S04S2	19,461	15.6	7.95	0.062	10	1.0	1.618	4.804

Profile Error Analysis Summary
Topographic Maps
1-Percent Chance Flood Event

Data Set I.D.	Average Q100 (cfs)	Average Slope (ft/mi)	Hydr Depth (ft)	Manning's n Value	Survey Contour Interval (ft)	Manning's Reliability Nr	Absolute Mean Error (ft)	Absolute Maximum Error (ft)
S07M2	20,050	7.4	5.74	0.054	2	0.0	0.170	1.148
S07M2	20,050	7.4	5.74	0.054	5	0.0	0.428	1.748
S07M2	20,050	7.4	5.74	0.054	10	0.0	1.076	3.312
S07M2	20,050	7.4	5.74	0.054	2	0.5	0.319	1.188
S07M2	20,050	7.4	5.74	0.054	5	0.5	0.705	2.938
S07M2	20,050	7.4	5.74	0.054	10	0.5	1.093	3.922
S07M2	20,050	7.4	5.74	0.054	2	1.0	0.645	1.961
S07M2	20,050	7.4	5.74	0.054	5	1.0	0.796	2.590
S07M2	20,050	7.4	5.74	0.054	10	1.0	1.028	3.868
S07S2	20,800	12.8	5.29	0.066	2	0.0	0.161	0.801
S07S2	20,800	12.8	5.29	0.066	5	0.0	0.337	1.062
S07S2	20,800	12.8	5.29	0.066	10	0.0	0.824	2.341
S07S2	20,800	12.8	5.29	0.066	2	0.5	0.611	1.400
S07S2	20,800	12.8	5.29	0.066	5	0.5	0.623	1.520
S07S2	20,800	12.8	5.29	0.066	10	0.5	1.003	2.684
S07S2	20,800	12.8	5.29	0.066	2	1.0	0.755	1.664
S07S2	20,800	12.8	5.29	0.066	5	1.0	1.116	2.356
S07S2	20,800	12.8	5.29	0.066	10	1.0	1.256	3.123
S06M2	20,910	3.8	5.61	0.051	2	0.0	0.272	1.161
S06M2	20,910	3.8	5.61	0.051	5	0.0	0.820	2.718
S06M2	20,910	3.8	5.61	0.051	10	0.0	1.111	5.037
S06M2	20,910	3.8	5.61	0.051	2	0.5	0.377	0.999
S06M2	20,910	3.8	5.61	0.051	5	0.5	0.768	3.002
S06M2	20,910	3.8	5.61	0.051	10	0.5	0.951	2.673
S06M2	20,910	3.8	5.61	0.051	2	1.0	0.530	1.415
S06M2	20,910	3.8	5.61	0.051	5	1.0	0.996	2.730
S06M2	20,910	3.8	5.61	0.051	10	1.0	1.316	3.286
S16M2	21,188	4.1	6.63	0.077	2	0.0	0.094	0.326
S16M2	21,188	4.1	6.63	0.077	5	0.0	0.372	1.212
S16M2	21,188	4.1	6.63	0.077	10	0.0	0.870	3.156
S16M2	21,188	4.1	6.63	0.077	2	0.5	0.574	0.828
S16M2	21,188	4.1	6.63	0.077	5	0.5	0.603	1.475
S16M2	21,188	4.1	6.63	0.077	10	0.5	1.053	3.078
S16M2	21,188	4.1	6.63	0.077	2	1.0	1.040	1.331
S16M2	21,188	4.1	6.63	0.077	5	1.0	1.229	2.066
S16M2	21,188	4.1	6.63	0.077	10	1.0	1.608	3.614
S14M2	22,135	2.2	5.83	0.082	2	0.0	0.129	0.408
S14M2	22,135	2.2	5.83	0.082	5	0.0	0.348	1.493
S14M2	22,135	2.2	5.83	0.082	10	0.0	0.887	3.089

Profile Error Analysis Summary
 Topographic Maps
 1-Percent Chance Flood Event

Data Set I.D.	Average Q100 (cfs)	Average Slope (ft/mi)	Hydr Depth (ft)	Manning's n Value	Survey Contour Interval (ft)	Manning's Reliability Nr	Absolute Mean Error (ft)	Absolute Maximum Error (ft)
S14M2	22,135	2.2	5.83	0.082	2	0.5	0.461	1.196
S14M2	22,135	2.2	5.83	0.082	5	0.5	0.566	1.699
S14M2	22,135	2.2	5.83	0.082	10	0.5	1.010	3.163
S14M2	22,135	2.2	5.83	0.082	2	1.0	1.087	2.700
S14M2	22,135	2.2	5.83	0.082	5	1.0	1.128	3.004
S14M2	22,135	2.2	5.83	0.082	10	1.0	1.637	4.571
S08S2	24,000	12.1	6.48	0.057	2	0.0	0.104	0.370
S08S2	24,000	12.1	6.48	0.057	5	0.0	0.315	1.051
S08S2	24,000	12.1	6.48	0.057	10	0.0	0.614	1.754
S08S2	24,000	12.1	6.48	0.057	2	0.5	0.426	1.240
S08S2	24,000	12.1	6.48	0.057	5	0.5	0.687	2.126
S08S2	24,000	12.1	6.48	0.057	10	0.5	0.867	2.538
S08S2	24,000	12.1	6.48	0.057	2	1.0	0.852	2.197
S08S2	24,000	12.1	6.48	0.057	5	1.0	1.140	2.987
S08S2	24,000	12.1	6.48	0.057	10	1.0	1.130	3.197
S10M2	24,900	2.4	4.59	0.052	2	0.0	0.218	0.931
S10M2	24,900	2.4	4.59	0.052	5	0.0	0.455	1.660
S10M2	24,900	2.4	4.59	0.052	10	0.0	1.391	3.766
S10M2	24,900	2.4	4.59	0.052	2	0.5	0.310	0.988
S10M2	24,900	2.4	4.59	0.052	5	0.5	0.522	1.948
S10M2	24,900	2.4	4.59	0.052	10	0.5	1.288	4.245
S10M2	24,900	2.4	4.59	0.052	2	1.0	0.529	1.420
S10M2	24,900	2.4	4.59	0.052	5	1.0	0.776	2.033
S10M2	24,900	2.4	4.59	0.052	10	1.0	1.192	2.786
S29M2	27,444	3.8	8.03	0.061	2	0.0	0.063	0.200
S29M2	27,444	3.8	8.03	0.061	5	0.0	0.200	0.665
S29M2	27,444	3.8	8.03	0.061	10	0.0	0.548	1.536
S29M2	27,444	3.8	8.03	0.061	2	0.5	0.328	0.982
S29M2	27,444	3.8	8.03	0.061	5	0.5	0.672	1.753
S29M2	27,444	3.8	8.03	0.061	10	0.5	0.658	2.472
S29M2	27,444	3.8	8.03	0.061	2	1.0	0.806	1.942
S29M2	27,444	3.8	8.03	0.061	5	1.0	1.163	3.223
S29M2	27,444	3.8	8.03	0.061	10	1.0	0.877	2.364
S30M2	27,444	4.1	8.47	0.059	2	0.0	0.114	0.320
S30M2	27,444	4.1	8.47	0.059	5	0.0	0.227	1.031
S30M2	27,444	4.1	8.47	0.059	10	0.0	0.434	1.553
S30M2	27,444	4.1	8.47	0.059	2	0.5	0.457	1.348
S30M2	27,444	4.1	8.47	0.059	5	0.5	0.516	1.766
S30M2	27,444	4.1	8.47	0.059	10	0.5	0.726	2.845

Profile Error Analysis Summary
Topographic Maps
1-Percent Chance Flood Event

Data Set I.D.	Average Q100 (cfs)	Average Slope (ft/mi)	Hydr Depth (ft)	Manning's n Value	Survey Contour Interval (ft)	Manning's Reliability Nr	Absolute Mean Error (ft)	Absolute Maximum Error (ft)
S30M2	27,444	4.1	8.47	0.059	2	1.0	0.753	1.959
S30M2	27,444	4.1	8.47	0.059	5	1.0	0.819	2.167
S30M2	27,444	4.1	8.47	0.059	10	1.0	1.061	3.860
S31M2	27,444	5.0	7.95	0.063	2	0.0	0.093	0.316
S31M2	27,444	5.0	7.95	0.063	5	0.0	0.366	0.900
S31M2	27,444	5.0	7.95	0.063	10	0.0	0.612	1.566
S31M2	27,444	5.0	7.95	0.063	2	0.5	0.364	0.874
S31M2	27,444	5.0	7.95	0.063	5	0.5	0.758	1.372
S31M2	27,444	5.0	7.95	0.063	10	0.5	0.722	1.805
S31M2	27,444	5.0	7.95	0.063	2	1.0	0.816	2.027
S31M2	27,444	5.0	7.95	0.063	5	1.0	1.084	2.626
S31M2	27,444	5.0	7.95	0.063	10	1.0	1.368	2.802
S12S2	28,775	17.5	3.67	0.070	2	0.0	0.243	0.544
S12S2	28,775	17.5	3.67	0.070	5	0.0	0.688	2.352
S12S2	28,775	17.5	3.67	0.070	10	0.0	1.654	4.184
S12S2	28,775	17.5	3.67	0.070	2	0.5	0.522	1.334
S12S2	28,775	17.5	3.67	0.070	5	0.5	0.705	2.095
S12S2	28,775	17.5	3.67	0.070	10	0.5	1.546	3.774
S12S2	28,775	17.5	3.67	0.070	2	1.0	0.803	2.062
S12S2	28,775	17.5	3.67	0.070	5	1.0	0.869	2.620
S12S2	28,775	17.5	3.67	0.070	10	1.0	1.725	4.347
S12F2	29,100	0.8	10.20	0.126	2	0.0	0.059	0.087
S12F2	29,100	0.8	10.20	0.126	5	0.0	0.128	0.378
S12F2	29,100	0.8	10.20	0.126	10	0.0	0.305	1.090
S12F2	29,100	0.8	10.20	0.126	2	0.5	1.280	1.892
S12F2	29,100	0.8	10.20	0.126	5	0.5	1.244	1.996
S12F2	29,100	0.8	10.20	0.126	10	0.5	1.498	2.325
S12F2	29,100	0.8	10.20	0.126	2	1.0	2.351	3.465
S12F2	29,100	0.8	10.20	0.126	5	1.0	2.720	3.847
S12F2	29,100	0.8	10.20	0.126	10	1.0	2.312	3.808
S49M2	30,000	9.9	5.73	0.066	2	0.0	0.121	0.439
S49M2	30,000	9.9	5.73	0.066	5	0.0	0.345	1.082
S49M2	30,000	9.9	5.73	0.066	10	0.0	0.934	2.699
S49M2	30,000	9.9	5.73	0.066	2	0.5	0.369	0.883
S49M2	30,000	9.9	5.73	0.066	5	0.5	0.558	1.442
S49M2	30,000	9.9	5.73	0.066	10	0.5	1.108	2.912
S49M2	30,000	9.9	5.73	0.066	2	1.0	0.861	1.968
S49M2	30,000	9.9	5.73	0.066	5	1.0	1.121	2.337
S49M2	30,000	9.9	5.73	0.066	10	1.0	1.378	3.682

Profile Error Analysis Summary
 Topographic Maps
 1-Percent Chance Flood Event

Data Set I.D.	Average Q100 (cfs)	Average Slope (ft/mi)	Hydr Depth (ft)	Manning's n Value	Survey Contour Interval (ft)	Manning's Reliability Nr	Absolute Mean Error (ft)	Absolute Maximum Error (ft)
S09M2	33,250	2.9	9.41	0.067	2	0.0	0.128	0.377
S09M2	33,250	2.9	9.41	0.067	5	0.0	0.273	0.670
S09M2	33,250	2.9	9.41	0.067	10	0.0	0.843	1.965
S09M2	33,250	2.9	9.41	0.067	2	0.5	0.744	1.226
S09M2	33,250	2.9	9.41	0.067	5	0.5	0.745	1.371
S09M2	33,250	2.9	9.41	0.067	10	0.5	1.234	2.550
S09M2	33,250	2.9	9.41	0.067	2	1.0	1.811	2.768
S09M2	33,250	2.9	9.41	0.067	5	1.0	1.564	2.952
S09M2	33,250	2.9	9.41	0.067	10	1.0	2.341	3.771
S13M2	33,575	2.6	7.46	0.086	2	0.0	0.112	0.520
S13M2	33,575	2.6	7.46	0.086	5	0.0	0.487	1.516
S13M2	33,575	2.6	7.46	0.086	10	0.0	1.452	2.991
S13M2	33,575	2.6	7.46	0.086	2	0.5	0.709	1.239
S13M2	33,575	2.6	7.46	0.086	5	0.5	0.738	1.933
S13M2	33,575	2.6	7.46	0.086	10	0.5	1.460	3.035
S13M2	33,575	2.6	7.46	0.086	2	1.0	1.122	1.783
S13M2	33,575	2.6	7.46	0.086	5	1.0	1.066	2.378
S13M2	33,575	2.6	7.46	0.086	10	1.0	1.637	3.373
S13S2	34,000	106.0	11.98	0.122	2	0.0	0.599	2.256
S13S2	34,000	106.0	11.98	0.122	5	0.0	0.813	3.729
S13S2	34,000	106.0	11.98	0.122	10	0.0	1.206	4.784
S13S2	34,000	106.0	11.98	0.122	2	0.5	1.488	4.290
S13S2	34,000	106.0	11.98	0.122	5	0.5	1.289	4.051
S13S2	34,000	106.0	11.98	0.122	10	0.5	1.964	5.815
S13S2	34,000	106.0	11.98	0.122	2	1.0	2.432	7.178
S13S2	34,000	106.0	11.98	0.122	5	1.0	2.277	6.066
S13S2	34,000	106.0	11.98	0.122	10	1.0	2.390	a.395
S48M2	34,150	6.9	5.82	0.072	2	0.0	0.154	0.434
S48M2	34,150	6.9	5.82	0.072	5	0.0	0.408	1.388
S48M2	34,150	6.9	5.82	0.072	10	0.0	0.950	3.537
S48M2	34,150	6.9	5.82	0.072	2	0.5	0.525	1.242
S48M2	34,150	6.9	5.82	0.072	5	0.5	0.586	1.731
S48M2	34,150	6.9	5.82	0.072	10	0.5	1.111	4.155
S48M2	34,150	6.9	5.82	0.072	2	1.0	1.021	2.436
S48M2	34,150	6.9	5.82	0.072	5	1.0	1.144	2.780
S48M2	34,150	6.9	5.82	0.072	10	1.0	1.365	4.108
S01M2	35,350	5.6	9.04	0.045	2	0.0	0.117	0.602
S01M2	35,350	5.6	9.04	0.045	5	0.0	0.295	1.636
S01M2	35,350	5.6	9.04	0.045	10	0.0	0.616	3.272

Profile Error Analysis Summary
Topographic Maps
1-Percent Chance Flood Event

Data Set I.D.	Average Q100 (cfs)	Average Slope (ft/mi)	Hydr Depth (ft)	Manning's n Value	Survey Contour Interval (ft)	Manning's Reliability Nr	Absolute Mean Error (ft)	Absolute Maximum Error (ft)
S01M2	35,350	5.6	9.04	0.045	2	0.5	0.435	1.103
S01M2	35,350	5.6	9.04	0.045	5	0.5	0.508	1.857
solM2	35,350	5.6	9.04	0.045	10	0.5	0.856	3.364
S01M2	35,350	5.6	9.04	0.045	2	1.0	0.895	1.682
solM2	35,350	5.6	9.04	0.045	5	1.0	1.014	2.272
S01M2	35,350	5.6	9.04	0.045	10	1.0	1.154	3.738
S03S2	37,600	10.1	7.61	0.059	2	0.0	0.097	0.731
S03S2	37,600	10.1	7.61	0.059	5	0.0	0.378	1.077
S03S2	37,600	10.1	7.61	0.059	10	0.0	0.985	2.624
S03S2	37,600	10.1	7.61	0.059	2	0.5	0.566	1.504
S03S2	37,600	10.1	7.61	0.059	5	0.5	0.722	1.866
S03S2	37,600	10.1	7.61	0.059	10	0.5	1.235	3.104
S03S2	37,600	10.1	7.61	0.059	2	1.0	1.319	2.567
S03S2	37,600	10.1	7.61	0.059	5	1.0	1.422	3.116
S03S2	37,600	10.1	7.61	0.059	10	1.0	1.703	3.920
S53M2	37,850	7.9	6.14	0.066	2	0.0	0.108	0.346
S53M2	37,850	7.9	6.14	0.066	5	0.0	0.303	0.881
S53M2	37,850	7.9	6.14	0.066	10	0.0	1.099	2.853
S53M2	37,850	7.9	6.14	0.066	2	0.5	0.506	0.886
S53M2	37,850	7.9	6.14	0.066	5	0.5	0.634	1.362
S53M2	37,850	7.9	6.14	0.066	10	0.5	1.118	2.749
S53M2	37,850	7.9	6.14	0.066	2	1.0	1.149	1.563
S53M2	37,850	7.9	6.14	0.066	5	1.0	1.170	2.017
S53M2	37,850	7.9	6.14	0.066	10	1.0	1.537	3.507
S56M2	38,000	2.8	8.04	0.029	2	0.0	0.130	0.284
S56M2	38,000	2.8	8.04	0.029	5	0.0	0.711	1.311
S56M2	38,000	2.8	8.04	0.029	10	0.0	1.799	3.274
S56M2	38,000	2.8	8.04	0.029	2	0.5	0.525	0.746
S56M2	38,000	2.8	8.04	0.029	5	0.5	0.764	1.348
S56M2	38,000	2.8	8.04	0.029	10	0.5	1.859	3.349
S56M2	38,000	2.8	8.04	0.029	2	1.0	0.946	1.210
S56M2	38,000	2.8	8.04	0.029	5	1.0	1.030	1.676
S56M2	38,000	2.8	8.04	0.029	10	1.0	2.057	3.469
S41M2	38,800	5.0	11.79	0.057	2	0.0	0.077	0.477
S41M2	38,800	5.0	11.79	0.057	5	0.0	0.219	0.843
S41M2	38,800	5.0	11.79	0.057	10	0.0	0.735	1.875
S41M2	38,800	5.0	11.79	0.057	2	0.5	1.045	2.378
S41M2	38,800	5.0	11.79	0.057	5	0.5	0.760	1.890
S41M2	38,800	5.0	11.79	0.057	10	0.5	1.053	2.423

Profile Error Analysis Summary
 Topographic Maps
 1-Percent Chance Flood Event

Data Set I.D.	Average Q100 (cfs)	Average Slope (ft/mi)	Hydr Depth (ft)	Manning's n Value	Survey Contour Interval (ft)	Manning's Reliability Nr	Absolute Mean Error (ft)	Absolute Maximum Error (ft)
S41M2	38,800	5.0	11.79	0.057	2	1.0	1.653	3.751
S41M2	38,800	5.0	11.79	0.057	5	1.0	1.557	3.661
S41M2	38,800	5.0	11.79	0.057	10	1.0	1.934	4.343
S19S2	39,000	30.8	3.77	0.039	2	0.0	0.285	0.968
S19S2	39,000	30.8	3.77	0.039	5	0.0	0.634	1.742
S19S2	39,000	30.8	3.77	0.039	10	0.0	1.496	3.886
S19S2	39,000	30.8	3.77	0.039	2	0.5	0.338	1.042
S19S2	39,000	30.8	3.77	0.039	5	0.5	0.620	1.639
S19S2	39,000	30.8	3.77	0.039	10	0.5	1.424	3.645
S19S2	39,000	30.8	3.77	0.039	2	1.0	0.473	1.491
S19S2	39,000	30.8	3.77	0.039	5	1.0	0.644	1.822
S19S2	39,000	30.8	3.77	0.039	10	1.0	1.408	3.419
S51M2	41,200	7.2	8.24	0.069	2	0.0	0.096	0.341
S51M2	41,200	7.2	8.24	0.069	5	0.0	0.410	1.114
S51M2	41,200	7.2	8.24	0.069	10	0.0	0.803	2.293
S51M2	41,200	7.2	8.24	0.069	2	0.5	0.680	1.402
S51M2	41,200	7.2	8.24	0.069	5	0.5	0.891	1.847
S51M2	41,200	7.2	8.24	0.069	10	0.5	1.112	2.749
S51M2	41,200	7.2	8.24	0.069	2	1.0	1.423	2.877
S51M2	41,200	7.2	8.24	0.069	5	1.0	1.395	2.792
S51M2	41,200	7.2	8.24	0.069	10	1.0	1.456	3.524
S08M2	42,250	3.6	6.78	0.071	2	0.0	0.145	0.379
S08M2	42,250	3.6	6.78	0.071	5	0.0	0.522	1.941
S08M2	42,250	3.6	6.78	0.071	10	0.0	1.036	3.209
S08M2	42,250	3.6	6.78	0.071	2	0.5	0.704	1.033
S08M2	42,250	3.6	6.78	0.071	5	0.5	0.813	2.085
S08M2	42,250	3.6	6.78	0.071	10	0.5	1.148	3.297
S08M2	42,250	3.6	6.78	0.071	2	1.0	1.037	1.458
S08M2	42,250	3.6	6.78	0.071	5	1.0	1.408	2.685
S08M2	42,250	3.6	6.78	0.071	10	1.0	1.572	3.987
S47M2	43,350	6.0	8.11	0.072	2	0.0	0.098	0.330
S47M2	43,350	6.0	8.11	0.072	5	0.0	0.237	0.796
S47M2	43,350	6.0	8.11	0.072	10	0.0	0.547	1.706
S47M2	43,350	6.0	8.11	0.072	2	0.5	0.632	1.447
S47M2	43,350	6.0	8.11	0.072	5	0.5	0.679	1.862
S47M2	43,350	6.0	8.11	0.072	10	0.5	0.754	1.925
S47M2	43,350	6.0	8.11	0.072	2	1.0	1.169	2.828
S47M2	43,350	6.0	8.11	0.072	5	1.0	1.376	2.919
S47M2	43,350	6.0	8.11	0.072	10	1.0	1.568	3.640

Profile Error Analysis Summary
 Topographic Maps
 1-Percent Chance Flood Event

Data set I.D.	Average Q100 (cfs)	Average Slope (ft/mi)	Hydr Depth (ft)	Manning's n Value	Survey Contour Interval (ft)	Manning's Reliability Nr	Absolute Mean Error (ft)	Absolute Maximum Error (ft)
S18M2	43,400	2.1	12.07	0.055	2	0.0	0.081	0.452
S18M2	43,400	2.1	12.07	0.055	5	0.0	0.235	0.775
S18M2	43,400	2.1	12.07	0.055	10	0.0	0.397	1.034
S18M2	43,400	2.1	12.07	0.055	2	0.5	0.576	1.946
S18M2	43,400	2.1	12.07	0.055	5	0.5	0.419	1.467
S18M2	43,400	2.1	12.07	0.055	10	0.5	0.763	2.059
S18M2	43,400	2.1	12.07	0.055	2	1.0	1.019	3.074
S18M2	43,400	2.1	12.07	0.055	5	1.0	1.271	4.361
S18M2	43,400	2.1	12.07	0.055	10	1.0	1.677	4.406
S50M2	47,225	6.4	7.46	0.063	2	0.0	0.130	0.613
S50M2	47,225	6.4	7.46	0.063	5	0.0	0.335	1.405
S50M2	47,225	6.4	7.46	0.063	10	0.0	0.642	2.704
S50M2	47,225	6.4	7.46	0.063	2	0.5	0.636	1.489
S50M2	47,225	6.4	7.46	0.063	5	0.5	0.713	1.837
S50M2	47,225	6.4	7.46	0.063	10	0.5	0.864	2.958
S50M2	47,225	6.4	7.46	0.063	2	1.0	1.240	2.645
S50M2	47,225	6.4	7.46	0.063	5	1.0	1.028	2.725
S50M2	47,225	6.4	7.46	0.063	10	1.0	1.295	3.518
S17S2	50,000	18.6	5.99	0.048	2	0.0	0.171	0.644
S17S2	50,000	18.6	5.99	0.048	5	0.0	0.617	2.051
S17S2	50,000	18.6	5.99	0.048	10	0.0	1.043	3.782
S17S2	50,000	18.6	5.99	0.048	2	0.5	0.440	1.189
S17S2	50,000	18.6	5.99	0.048	5	0.5	0.668	2.070
S17S2	50,000	18.6	5.99	0.048	10	0.5	1.181	3.931
S17S2	50,000	18.6	5.99	0.048	2	1.0	0.636	1.813
S17S2	50,000	18.6	5.99	0.048	5	1.0	0.864	2.395
S17S2	50,000	18.6	5.99	0.048	10	1.0	1.459	4.391
S18S2	50,000	15.2	7.81	0.045	2	0.0	0.225	0.703
S18S2	50,000	15.2	7.81	0.045	5	0.0	0.399	1.160
S18S2	50,000	15.2	7.81	0.045	10	0.0	0.800	1.972
S18S2	50,000	15.2	7.81	0.045	2	0.5	0.430	0.987
S18S2	50,000	15.2	7.81	0.045	5	0.5	0.637	1.623
S18S2	50,000	15.2	7.81	0.045	10	0.5	1.127	2.938
S18S2	50,000	15.2	7.81	0.045	2	1.0	1.072	2.186
S18S2	50,000	15.2	7.81	0.045	5	1.0	0.811	1.785
S18S2	50,000	15.2	7.81	0.045	10	1.0	1.382	2.956
S37M2	50,300	3.0	14.31	0.055	2	0.0	0.088	0.447
S37M2	50,300	3.0	14.31	0.055	5	0.0	0.144	0.411
S37M2	50,300	3.0	14.31	0.055	10	0.0	0.356	1.258

Profile Error Analysis Summary
 Topographic Maps
 1-Percent Chance Flood Event

Data Set I.D.	Average Q100 (cfs)	Average Slope (ft/mi)	Hydr Depth (ft)	Manning's n Value	Survey Contour Interval (ft)	Manning's Reliability Nr	Absolute Mean Error (ft)	Absolute Maximum Error (ft)
S37M2	50,300	3.0	14.31	0.055	2	0.5	0.671	1.964
S37M2	50,300	3.0	14.31	0.055	5	0.5	0.844	2.269
S37M2	50,300	3.0	14.31	0.055	10	0.5	1.020	3.062
S37M2	50,300	3.0	14.31	0.055	2	1.0	1.347	4.075
S37M2	50,300	3.0	14.31	0.055	5	1.0	1.683	4.519
S37M2	50,300	3.0	14.31	0.055	10	1.0	2.313	6.524
S52M2	50,950	8.8	6.31	0.062	2	0.0	0.157	0.682
S52M2	50,950	8.8	6.31	0.062	5	0.0	0.403	1.195
S52M2	50,950	8.8	6.31	0.062	10	0.0	0.707	2.341
S52M2	50,950	8.8	6.31	0.062	2	0.5	0.387	1.176
S52M2	50,950	8.8	6.31	0.062	5	0.5	0.558	1.721
S52M2	50,950	8.8	6.31	0.062	10	0.5	0.981	3.060
S52M2	50,950	8.8	6.31	0.062	2	1.0	0.952	2.484
S52M2	50,950	8.8	6.31	0.062	5	1.0	0.902	2.575
S52M2	50,950	8.8	6.31	0.062	10	1.0	1.369	4.179
S26M2	51,388	2.5	10.60	0.066	2	0.0	0.085	0.405
S26M2	51,388	2.5	10.60	0.066	5	0.0	0.185	0.631
S26M2	51,388	2.5	10.60	0.066	10	0.0	0.315	1.681
S26M2	51,388	2.5	10.60	0.066	2	0.5	0.445	1.332
S26M2	51,388	2.5	10.60	0.066	5	0.5	0.743	1.714
S26M2	51,388	2.5	10.60	0.066	10	0.5	0.569	2.082
S26M2	51,388	2.5	10.60	0.066	2	1.0	1.268	3.517
S26M2	51,388	2.5	10.60	0.066	5	1.0	1.224	3.339
S26M2	51,388	2.5	10.60	0.066	10	1.0	1.008	3.021
S22M2	59,225	2.2	16.52	0.060	2	0.0	0.076	0.226
S22M2	59,225	2.2	16.52	0.060	5	0.0	0.114	0.471
S22M2	59,225	2.2	16.52	0.060	10	0.0	0.426	1.985
S22M2	59,225	2.2	16.52	0.060	2	0.5	0.695	1.682
S22M2	59,225	2.2	16.52	0.060	5	0.5	0.673	2.772
S22M2	59,225	2.2	16.52	0.060	10	0.5	0.797	2.544
S22M2	59,225	2.2	16.52	0.060	2	1.0	2.845	5.431
S22M2	59,225	2.2	16.52	0.060	5	1.0	1.885	5.602
S22M2	59,225	2.2	16.52	0.060	10	1.0	2.158	7.157
S46M2	60,350	5.8	6.92	0.058	2	0.0	0.142	0.452
S46M2	60,350	5.8	6.92	0.058	5	0.0	0.380	1.223
S46M2	60,350	5.8	6.92	0.058	10	0.0	0.705	2.239
S46M2	60,350	5.8	6.92	0.058	2	0.5	0.495	1.257
S46M2	60,350	5.8	6.92	0.058	5	0.5	0.668	1.900
S46M2	60,350	5.8	6.92	0.058	10	0.5	0.890	2.603

Profile Error Analysis Summary
 Topographic Maps
 1-Percent Chance Flood Event

Data Set I.D.	Average Q100 (cfs)	Average Slope (ft/mi)	Hydr Depth (ft)	Manning's n Value	Survey Contour Interval (ft)	Manning's Reliability Nr	Absolute Mean Error (ft)	Absolute Maximum Error (ft)
S46M2	60,350	5.8	6.92	0.058	2	1.0	0.783	2.186
S46M2	60,350	5.8	6.92	0.058	5	1.0	0.877	2.303
S46M2	60,350	5.8	6.92	0.058	10	1.0	1.157	2.954
S33M2	69,520	2.4	10.62	0.044	2	0.0	0.059	0.237
S33M2	69,520	2.4	10.62	0.044	5	0.0	0.245	0.984
S33M2	69,520	2.4	10.62	0.044	10	0.0	0.473	1.940
S33M2	69,520	2.4	10.62	0.044	2	0.5	0.907	1.704
S33M2	69,520	2.4	10.62	0.044	5	0.5	0.892	1.784
S33M2	69,520	2.4	10.62	0.044	10	0.5	1.010	2.641
S33M2	69,520	2.4	10.62	0.044	2	1.0	1.980	3.487
S33M2	69,520	2.4	10.62	0.044	5	1.0	1.793	3.326
S33M2	69,520	2.4	10.62	0.044	10	1.0	1.399	3.145
S10F2	73,980	0.5	11.56	0.109	2	0.0	0.051	0.083
S10F2	73,980	0.5	11.56	0.109	5	0.0	0.275	0.469
S10F2	73,980	0.5	11.56	0.109	10	0.0	1.018	1.892
S10F2	73,980	0.5	11.56	0.109	2	0.5	1.252	1.711
S10F2	73,980	0.5	11.56	0.109	5	0.5	1.529	2.041
S10F2	73,980	0.5	11.56	0.109	10	0.5	1.731	2.934
S10F2	73,980	0.5	11.56	0.109	2	1.0	2.756	3.804
S10F2	73,980	0.5	11.56	0.109	5	1.0	2.380	3.483
S10F2	73,980	0.5	11.56	0.109	10	1.0	3.211	4.659
S42M2	83,400	2.9	11.22	0.052	2	0.0	0.101	0.363
S42M2	83,400	2.9	11.22	0.052	5	0.0	0.153	0.817
S42M2	83,400	2.9	11.22	0.052	10	0.0	0.475	2.009
S42M2	83,400	2.9	11.22	0.052	2	0.5	0.469	1.316
S42M2	83,400	2.9	11.22	0.052	5	0.5	0.510	1.912
S42M2	83,400	2.9	11.22	0.052	10	0.5	0.684	1.817
S42M2	83,400	2.9	11.22	0.052	2	1.0	1.195	3.276
S42M2	83,400	2.9	11.22	0.052	5	1.0	1.181	3.434
S42M2	83,400	2.9	11.22	0.052	10	1.0	1.433	4.565
S44M2	83,400	2.3	11.64	0.047	2	0.0	0.052	0.263
S44M2	83,400	2.3	11.64	0.047	5	0.0	0.274	1.496
S44M2	83,400	2.3	11.64	0.047	10	0.0	0.839	3.690
S44M2	83,400	2.3	11.64	0.047	2	0.5	0.737	2.140
S44M2	83,400	2.3	11.64	0.047	5	0.5	0.785	2.898
S44M2	83,400	2.3	11.64	0.047	10	0.5	0.888	3.238
S44M2	83,400	2.3	11.64	0.047	2	1.0	1.603	4.352
S44M2	83,400	2.3	11.64	0.047	5	1.0	0.958	4.505
S44M2	83,400	2.3	11.64	0.047	10	1.0	1.651	5.592

Profile Error Analysis Summary
 Topographic Maps
 1-Percent Chance Flood Event

Data Set I.D.	Average Q100 (cfs)	Average Slope (ft/mi)	Hydr Depth (ft)	Manning's n Value	Survey Contour Interval (ft)	Manning's Reliability Nr	Absolute Mean Error (ft)	Absolute Maximum Error (ft)
S55M2	90,000	8.8	5.29	0.032	2	0.0	0.103	0.336
S55M2	90,000	8.8	5.29	0.032	5	0.0	0.332	1.170
S55M2	90,000	8.8	5.29	0.032	10	0.0	0.771	2.602
S55M2	90,000	8.8	5.29	0.032	2	0.5	0.339	0.664
S55M2	90,000	8.8	5.29	0.032	5	0.5	0.481	1.423
S55M2	90,000	8.8	5.29	0.032	10	0.5	0.831	2.775
S55M2	90,000	8.8	5.29	0.032	2	1.0	0.694	1.122
S55M2	90,000	8.8	5.29	0.032	5	1.0	0.754	1.776
S55M2	90,000	8.8	5.29	0.032	10	1.0	0.935	2.846
S05M3	118,000	8.0	7.54	0.041	2	0.0	0.285	1.606
S05M3	118,000	8.0	7.54	0.041	5	0.0	0.533	2.086
S05M3	118,000	8.0	7.54	0.041	10	0.0	1.023	2.812
S05M3	118,000	8.0	7.54	0.041	2	0.5	0.539	1.529
S05M3	118,000	8.0	7.54	0.041	5	0.5	0.777	2.263
S05M3	118,000	8.0	7.54	0.041	10	0.5	1.220	3.292
S05M3	118,000	8.0	7.54	0.041	2	1.0	1.185	2.792
S05M3	118,000	8.0	7.54	0.041	5	1.0	1.128	3.091
S05M3	118,000	8.0	7.54	0.041	10	1.0	1.424	3.442
S02S3	152,000	15.9	13.13	0.067	2	0.0	0.087	0.360
S02S3	152,000	15.9	13.13	0.067	5	0.0	0.259	1.185
S02S3	152,000	15.9	13.13	0.067	10	0.0	0.669	2.602
S02S3	152,000	15.9	13.13	0.067	2	0.5	1.031	2.701
S02S3	152,000	15.9	13.13	0.067	5	0.5	1.144	2.877
S02S3	152,000	15.9	13.13	0.067	10	0.5	1.470	4.141
S02S3	152,000	15.9	13.13	0.067	2	1.0	2.332	5.300
S02S3	152,000	15.9	13.13	0.067	5	1.0	2.880	6.034
S02S3	152,000	15.9	13.13	0.067	10	1.0	2.216	5.544
S04M3	158,000	6.6	22.31	0.057	2	0.0	0.062	0.240
S04M3	158,000	6.6	22.31	0.057	5	0.0	0.172	0.608
S04M3	158,000	6.6	22.31	0.057	10	0.0	0.369	1.400
S04M3	158,000	6.6	22.31	0.057	2	0.5	2.439	2.787
S04M3	158,000	6.6	22.31	0.057	5	0.5	2.004	2.570
S04M3	158,000	6.6	22.31	0.057	10	0.5	2.051	2.925
S04M3	158,000	6.6	22.31	0.057	2	1.0	4.167	4.767
S04M3	158,000	6.6	22.31	0.057	5	1.0	4.146	4.859
S04M3	158,000	6.6	22.31	0.057	10	1.0	4.467	5.584
S01M3	161,000	3.5	9.43	0.043	2	0.0	0.098	0.328
S01M3	161,000	3.5	9.43	0.043	5	0.0	0.352	0.943
S01M3	161,000	3.5	9.43	0.043	10	0.0	0.711	1.467

Profile Error Analysis Summary
 Topographic Maps
 1-Percent Chance Flood Event

Data Set I.D.	Average Q100 (cfs)	Average Slope (ft/mi)	Hydr Depth (ft)	Manning's n Value	Survey Contour Interval (ft)	Manning's Reliability Nr	Absolute Mean Error (ft)	Absolute Maximum Error (ft)
S01M3	161,000	3.5	9.43	0.043	2	0.5	0.828	1.893
S01M3	161,000	3.5	9.43	0.043	5	0.5	0.742	2.470
S01M3	161,000	3.5	9.43	0.043	10	0.5	1.232	3.415
S01M3	161,000	3.5	9.43	0.043	2	1.0	1.140	3.368
S01M3	161,000	3.5	9.43	0.043	5	1.0	1.615	4.075
S01M3	161,000	3.5	9.43	0.043	10	1.0	1.287	3.475
S01S3	270,300	15.4	19.86	0.031	2	0.0	0.487	2.198
S01S3	270,300	15.4	19.86	0.031	5	0.0	1.431	4.748
S01S3	270,300	15.4	19.86	0.031	10	0.0	3.462	9.300
S01S3	270,300	15.4	19.86	0.031	2	0.5	1.293	3.367
S01S3	270,300	15.4	19.86	0.031	5	0.5	1.748	5.024
S01S3	270,300	15.4	19.86	0.031	10	0.5	3.436	9.040
S01S3	270,300	15.4	19.86	0.031	2	1.0	2.044	5.372
S01S3	270,300	15.4	19.86	0.031	5	1.0	2.315	6.023
S01S3	270,300	15.4	19.86	0.031	10	1.0	4.342	10.084

