

SECTION A-A

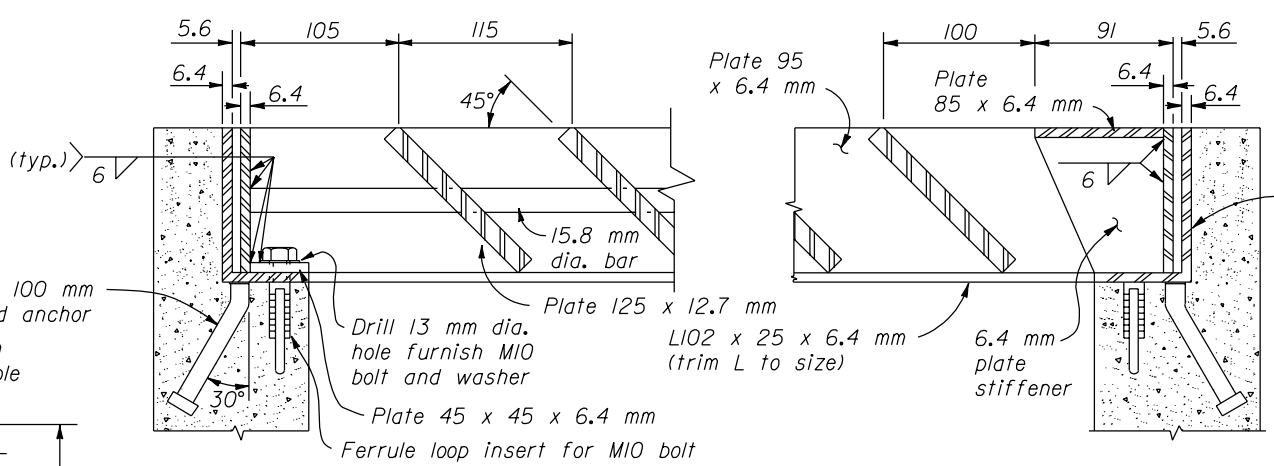

SECTION B-B

L102 x 64 x 6.4 mm (trim L to size)

- NOTE:**
- Dimensions not labeled are in millimeters.
 - STRUCTURAL STEEL: AASHTO M 183 (ASTM A 36M).
 - BOLTS & WASHERS: ASTM A 307, Galvanized.
 - THREADED CONCRETE ANCHORS: Ferrule loop inserts for M10 bolt or approved equal.
 - HEADED CONCRETE ANCHORS: Weld to frame with a full penetration butt weld.
 - WELDING: Weld in conformance with the Standard Specifications. Unless otherwise indicated seal weld all joints with a minimum size fillet weld, based on material thickness. Grind smooth all contact surfaces. FINISH: Galvanized after fabrication.
 - Estimated weight, frame and grate (756 x 756 mm) 97.5 kg. Increase or decrease weight by 12.7 kg for each 115 mm increment.
 - Furnish hardware in the metric sizes shown. Equivalent imperial sizes may be used when metric sizes are not available.

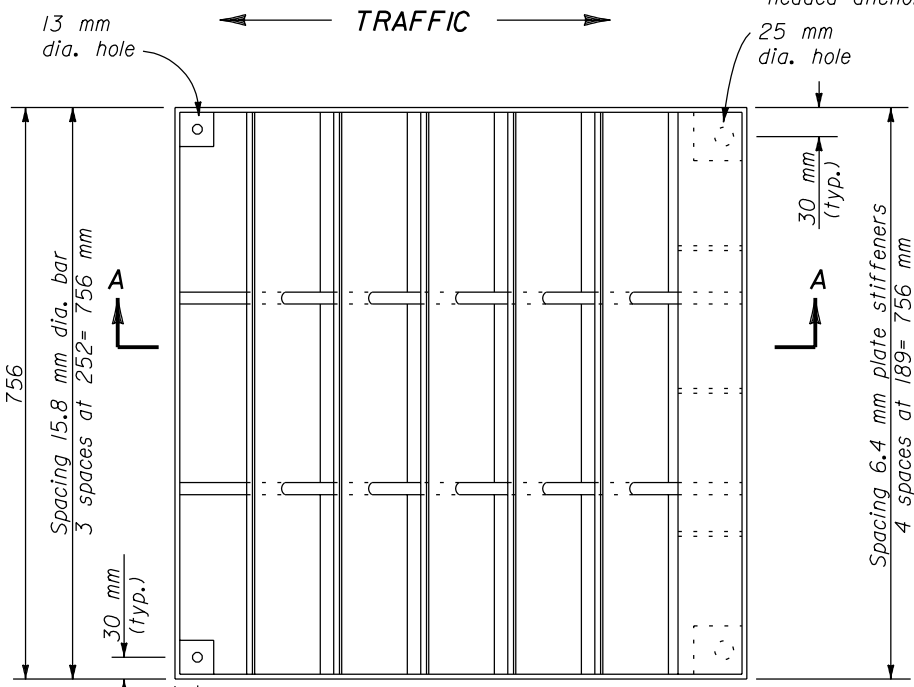

GRATE DETAILS

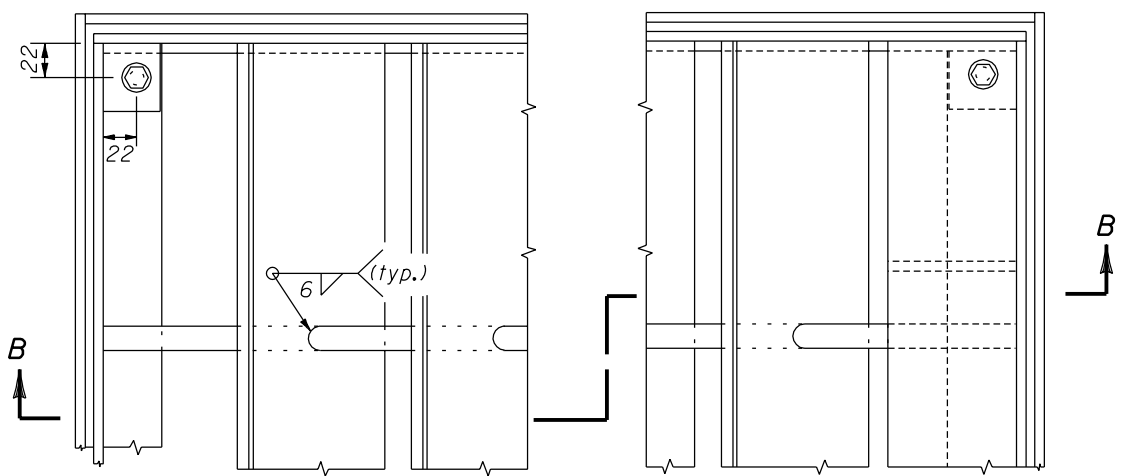

FRAME AND GRATE DETAILS

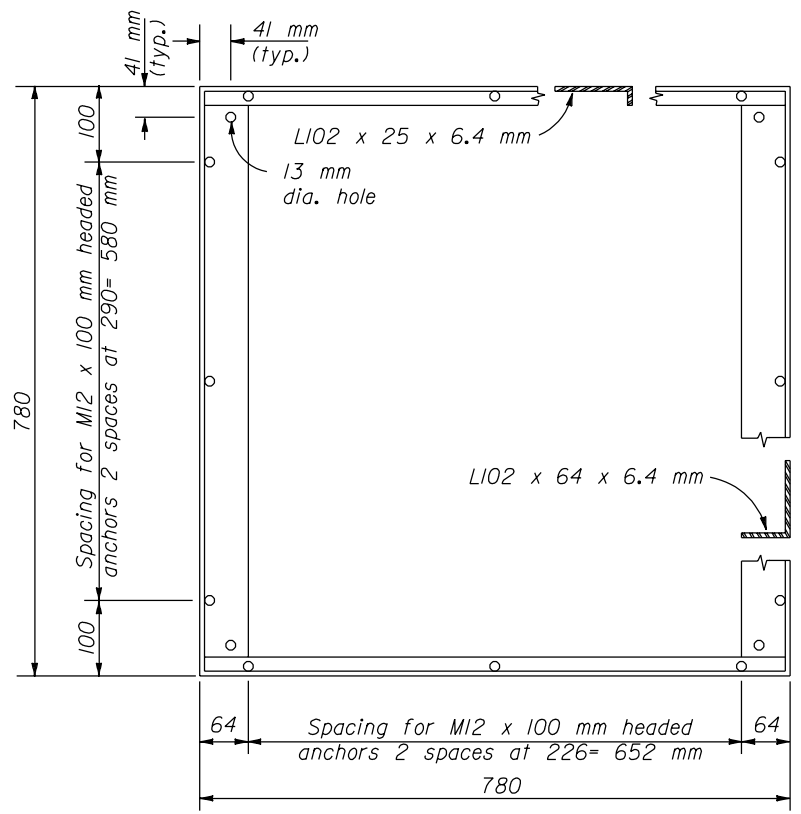

FRAME DETAIL

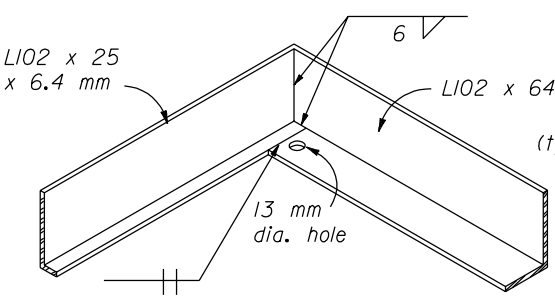

FRAME CORNER DETAIL

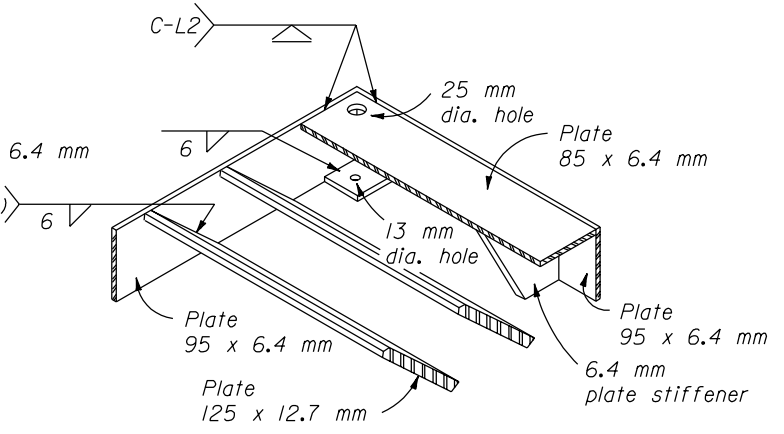

GRATE CORNER DETAIL

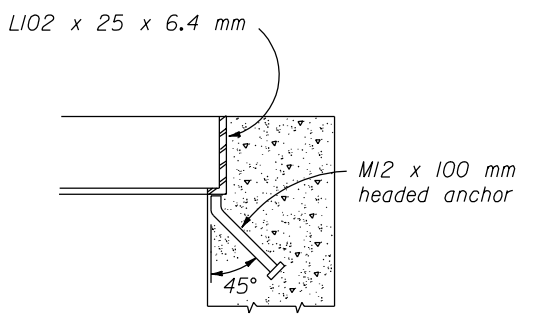

FRAME ANCHOR DETAIL

NO SCALE

U.S. DEPARTMENT OF TRANSPORTATION FEDERAL HIGHWAY ADMINISTRATION FEDERAL LANDS HIGHWAY	
METRIC STANDARD	
METAL FRAME AND GRATE TYPE A	
STANDARD APPROVED FOR USE 3/1996 REVISED: 8/1997	STANDARD M604-2

17 NOV 2000 f:\standrow\metric\m60402.dgn