

SCHMATIC OF VEHICLE LOOP DETECTORS

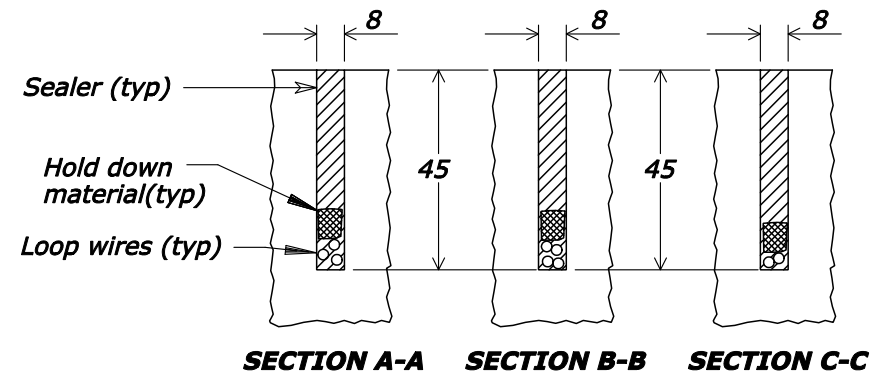

SECTIONS

Provide diagonal cuts such that slot is full depth at turn points

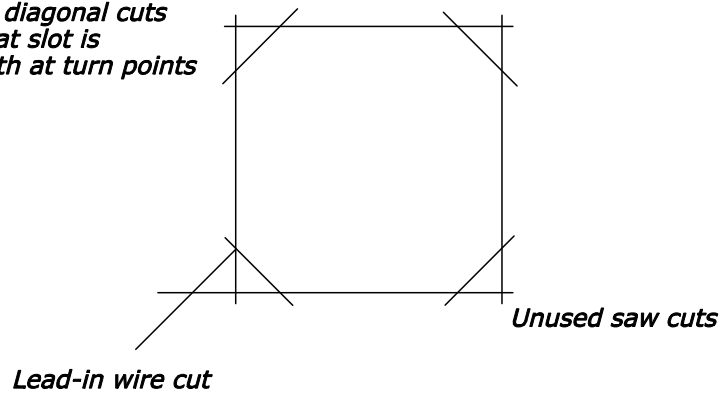

SAW CUT LAYOUT

NOTES:

1. Unless otherwise shown, dimensions are in millimeters.

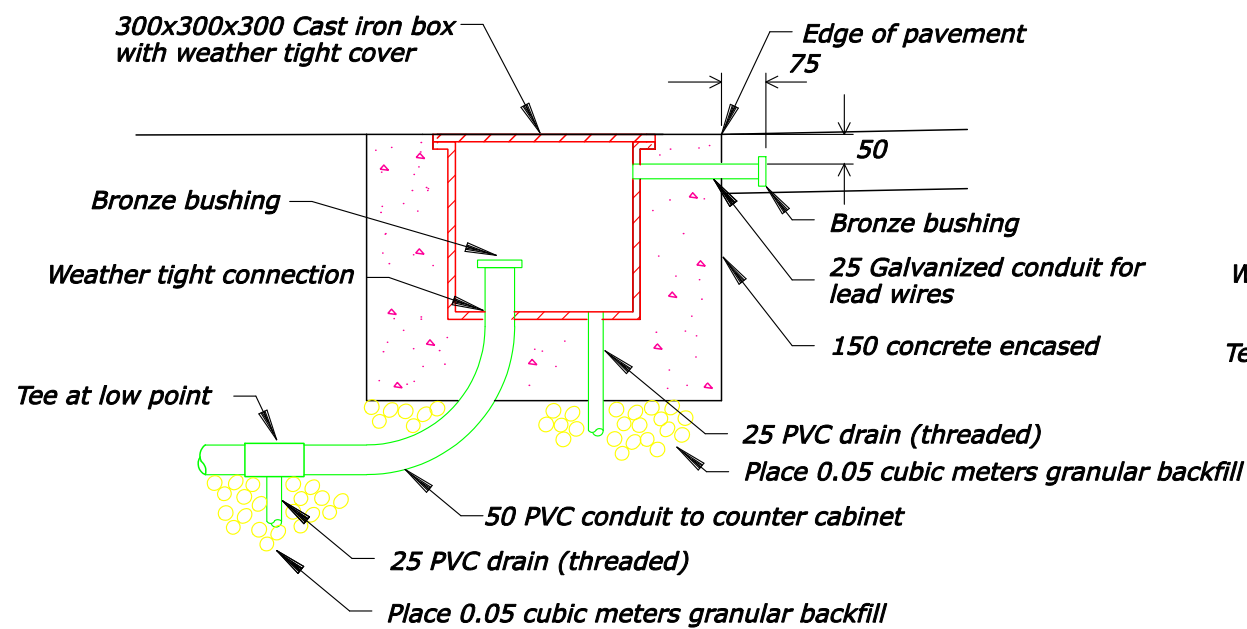

SPLICE BOX - WITHOUT CURB

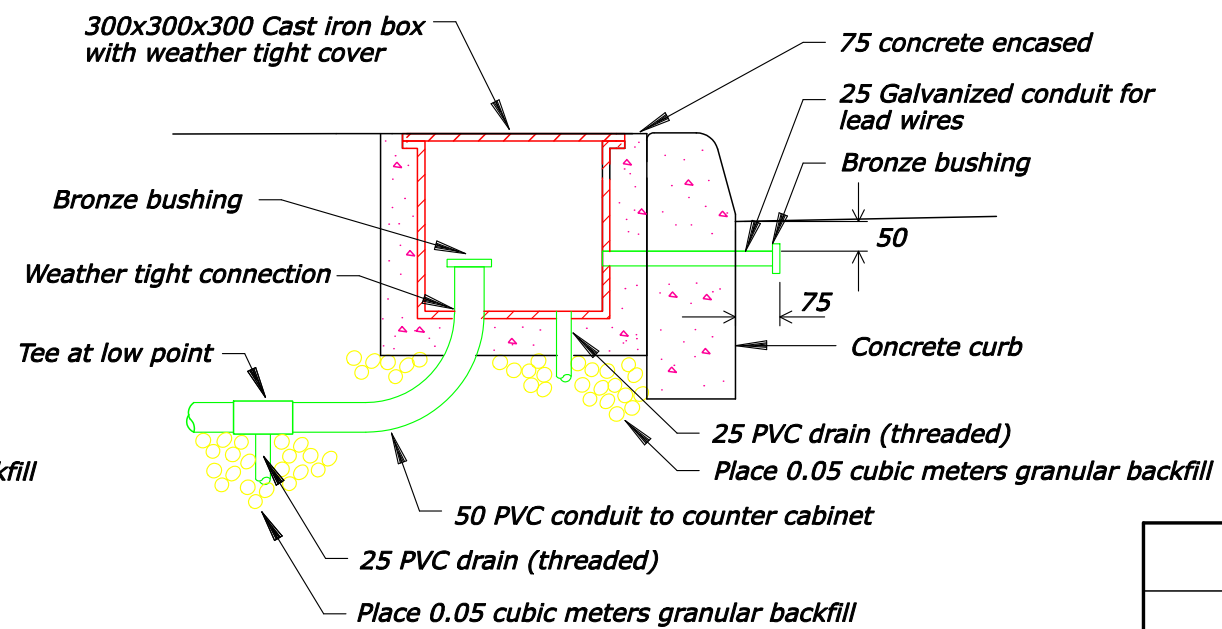

SPLICE BOX - WITH CURB

NO SCALE

U.S. DEPARTMENT OF TRANSPORTATION FEDERAL HIGHWAY ADMINISTRATION EASTERN FEDERAL LANDS HIGHWAY DIVISION	
METRIC DETAIL	
TRAFFIC DETECTION DEVICES	
DETAIL APPROVED FOR USE	DETAIL
REVISED: 07/07	EM636-01