

PLAN

END SECTION DIMENSIONS					
SPAN X RISE	A	B	C	L	E
23" X 14"	6"	2'-3"	3'-10"	6'-1"	2'-8"
30" X 19"	9"	2'-11"	3'-2"	6'-1"	3'-6"
38" X 24"	10"	3'-8"	2'-6"	6'-2"	4'-0"
42" X 27"	12"	4'-8"	1'-8"	6'-2"	5'-0"
45" X 29"	13"	4'-11"	3'-3"	8'-2"	5'-6"
53" X 34"	15"	5'-3"	2'-11"	8'-2"	6'-0"

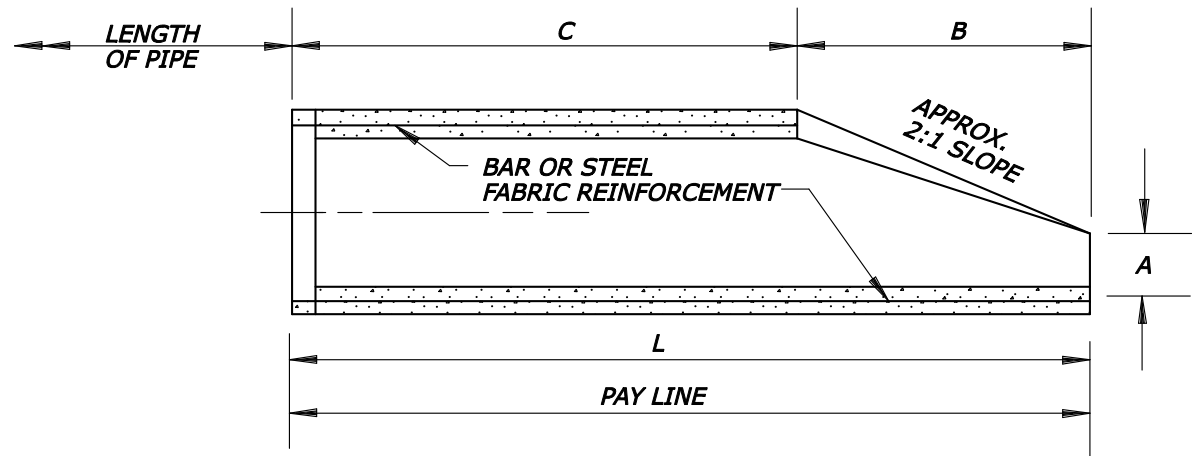

SECTION X-X

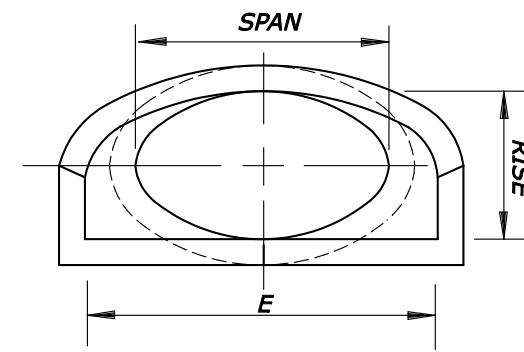

END VIEW

CONCRETE TO BE
4000 PSI MINIMUM

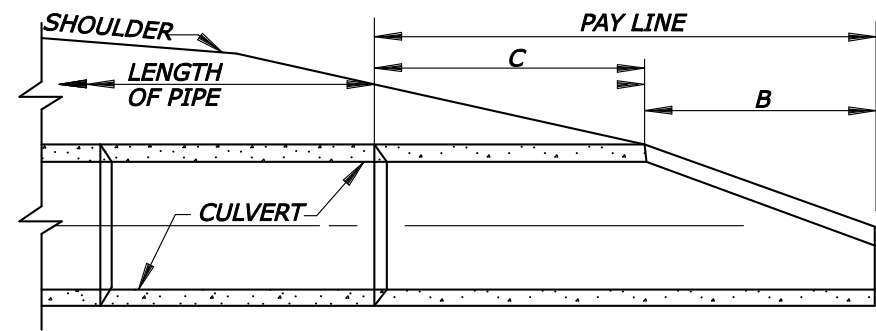

SLOPE DETAIL

NO SCALE

ADOPTED FROM:
VIRGINIA DEPARTMENT OF TRANSPORTATION
STANDARD PB-1, PAGE 107.02

U.S. DEPARTMENT OF TRANSPORTATION FEDERAL HIGHWAY ADMINISTRATION EASTERN FEDERAL LANDS HIGHWAY DIVISION	
METRIC DETAIL	
CONCRETE END SECTION FOR ELLIPTICAL PIPE	
DETAIL APPROVED FOR USE REVISED: 03/03 04/07	DETAIL EM602-10