

REG	STATE	PROJECT	SHEET NO.
SE	LA	RRP-LOP 10(2)	

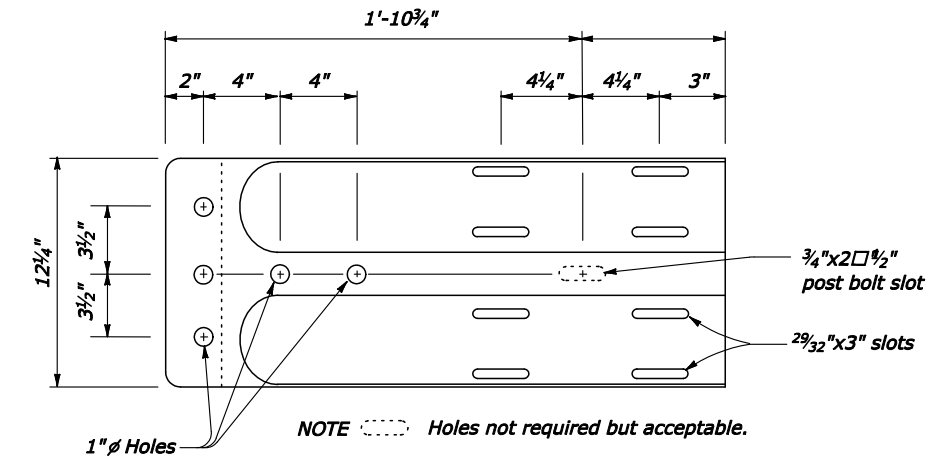

ELEVATION

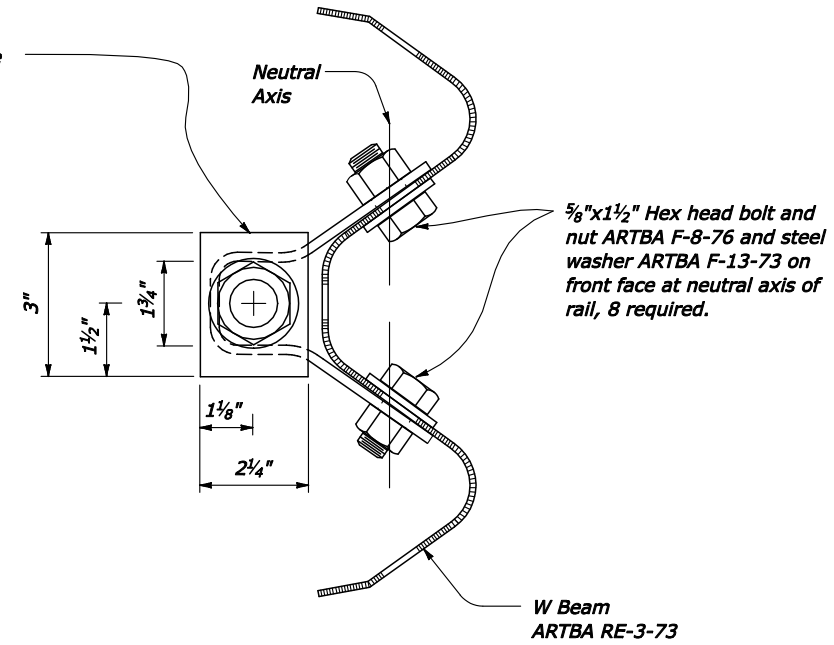
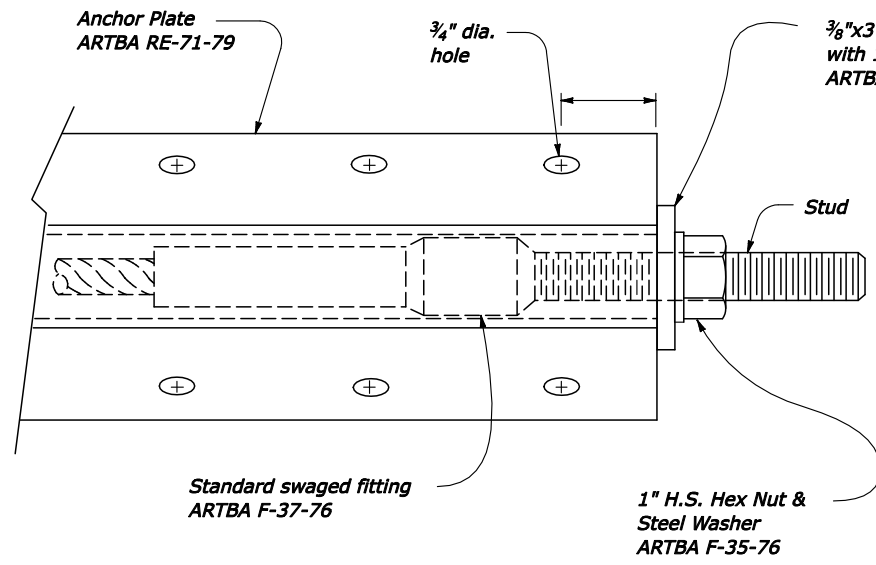
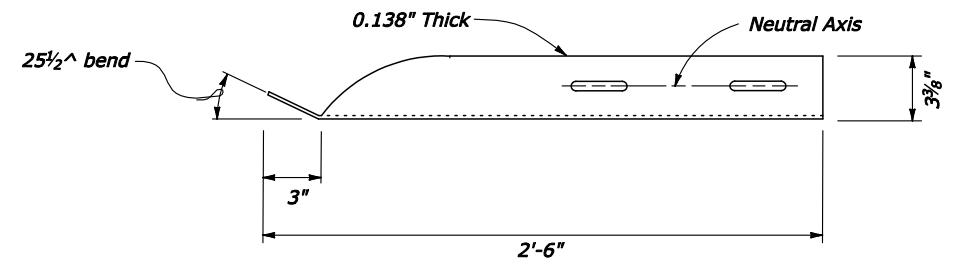

PLAN

**TERMINAL CONNECTOR
ARTBA RE-8-79**

**ANCHOR PLATE DETAILS FOR BCT AND MELT ANCHORAGE ASSEMBLY
ARTBA RE-71-79**

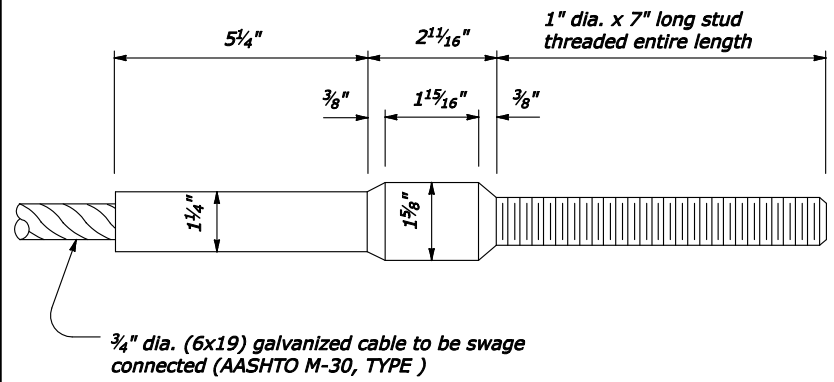

Standard swaged fitting and stud
**CABLE ASSEMBLY
ARTBA F-37-76**

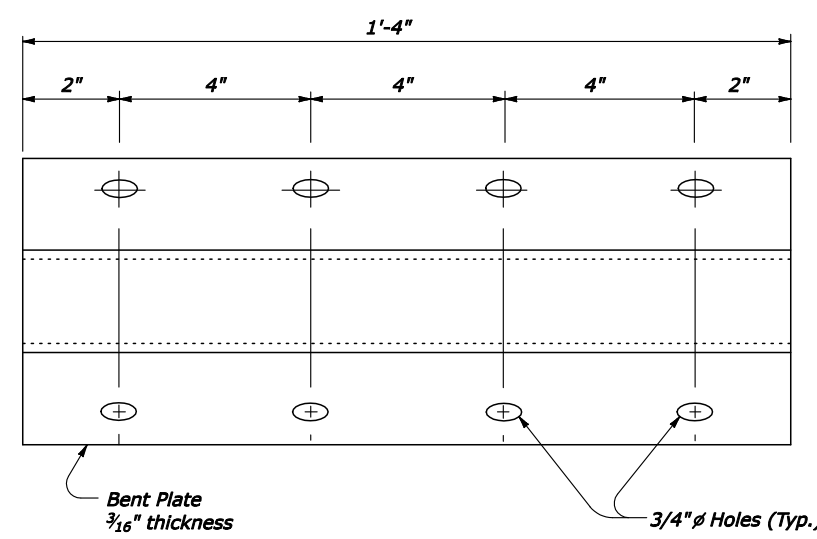

**ANCHOR PLATE
ARTBA RE-71-79**

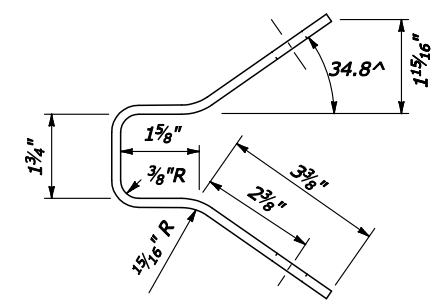

NO SCALE

U.S. DEPARTMENT OF TRANSPORTATION FEDERAL HIGHWAY ADMINISTRATION EASTERN FEDERAL LANDS HIGHWAY DIVISION	
U.S. CUSTOMARY DETAIL	
G4 W BEAM GUARDRAIL BCT AND MELT ANCHORAGE ASSEMBLY DETAILS	
DETAIL APPROVED FOR USE	DETAIL
REVISED:	E617-13

3:59:39 PM M:\Standard\FHLD_Standards & Details\SV0616713_detail.dgn
 9/19/2007