

SECTION B-B

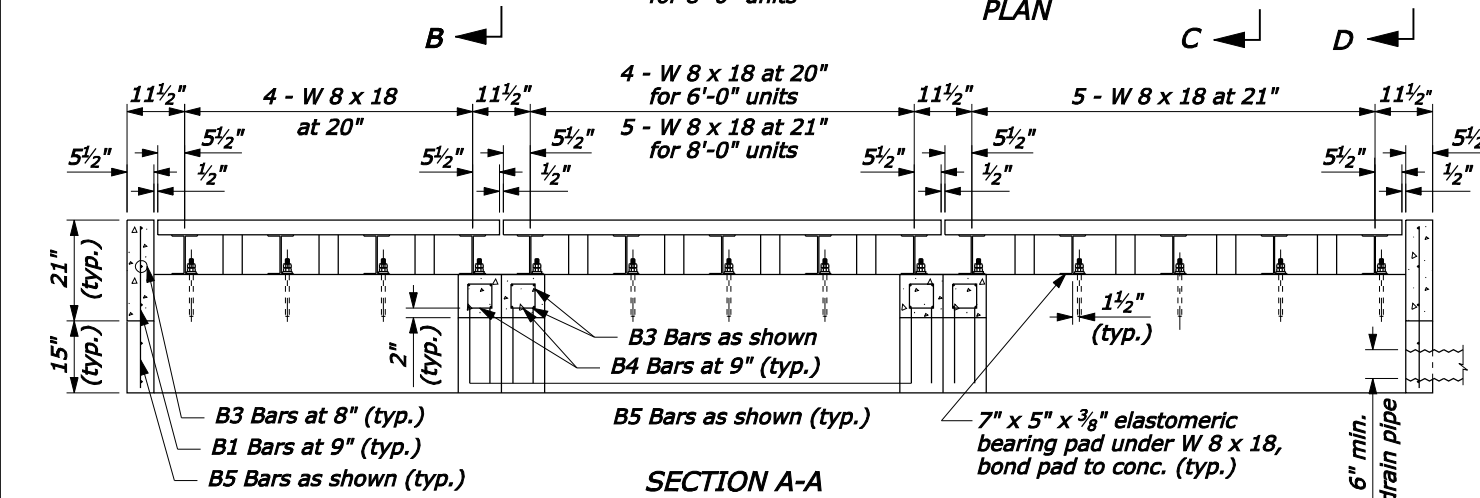

SECTION A-A

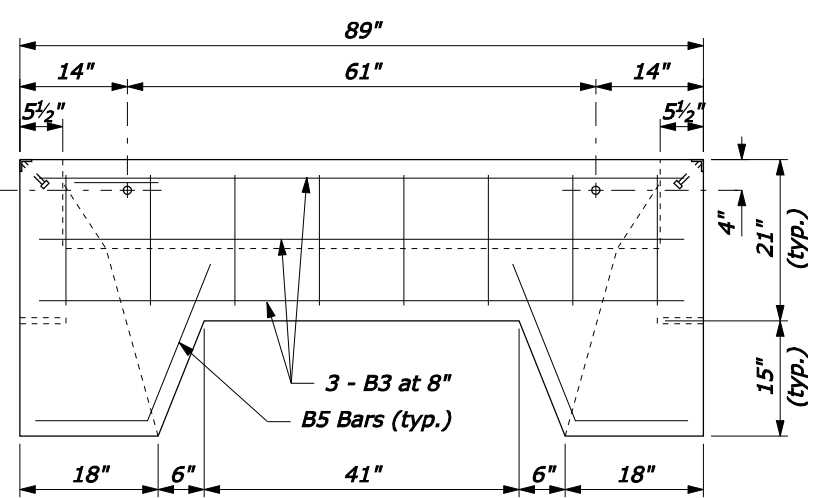

SECTION D-D

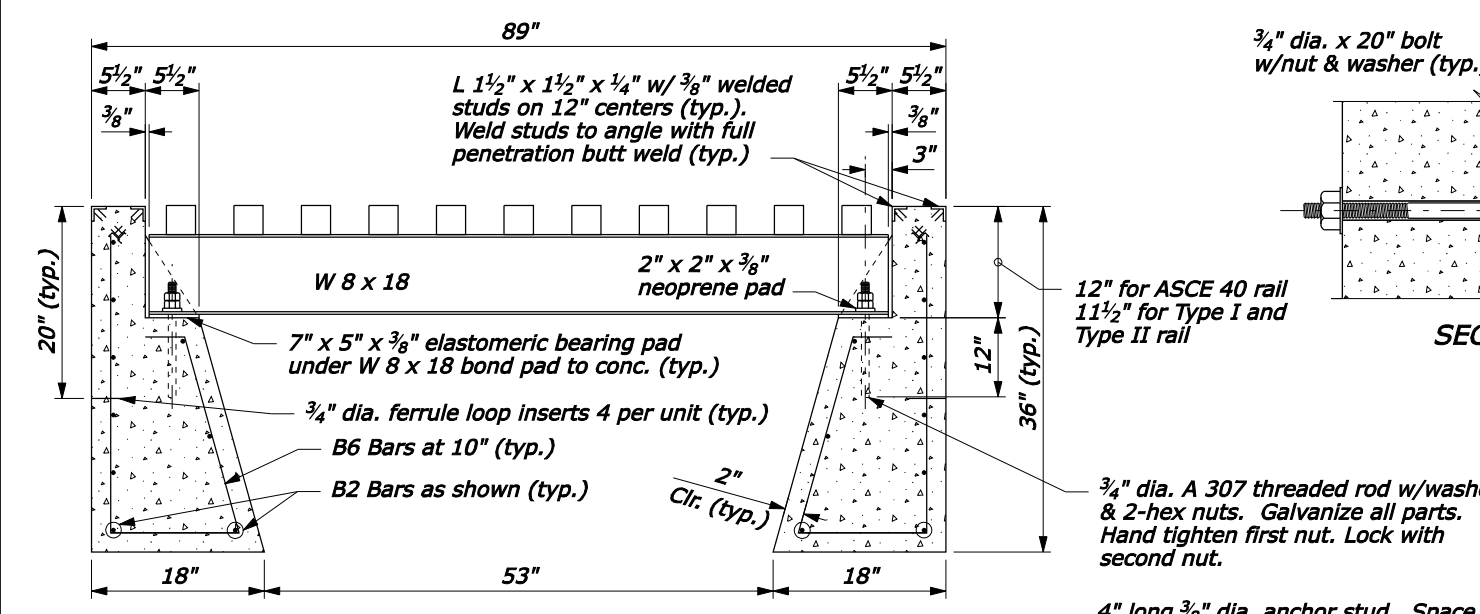

SECTION C-C

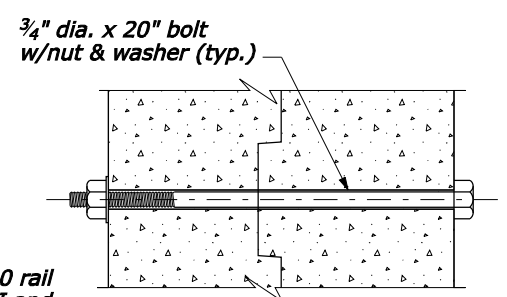

SECTION E-E

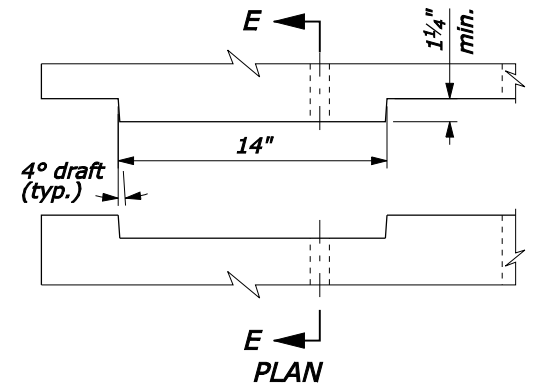

E PLAN

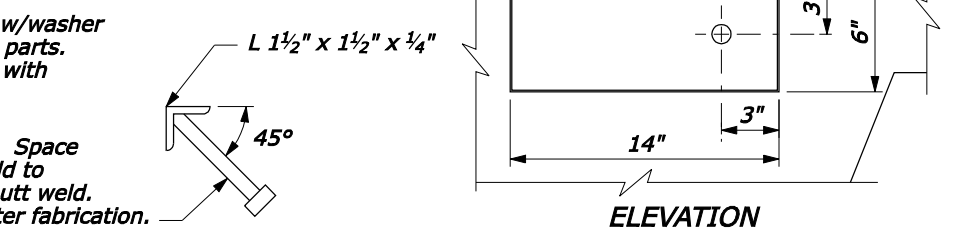

GUARD ANGLE DETAIL

ELEVATION KEY DETAIL NO SCALE

NOTE:

1. See Standard 619-1 for reinforcing steel size and grade.
2. See Standard 619-2 for cattle guard wing details. Fabricate end units to accommodate selected cattle guard wing.
3. Minimum soil bearing 4,000 lb/ft². Place units in fine aggregate bed 3 inch thick over hand leveled soil compacted to not less than 95 percent density.
4. Chamfer exposed concrete edges 3/4" unless otherwise shown. Give all concrete surfaces a Class 1 finish.
5. Approved alternate designs may be used.

PRECAST CATTLE GUARD REINFORCING STEEL AND CONCRETE					
UNIT	No. of BARS	BAR MARK	LENGTH	MASS LB	CONCRETE CU YD
6'-0" END	7	B3	85"	33.1	1.89
	10	B2	74"	41.2	
	8	B1	17"	7.6	
	6	B4	26"	8.7	
	18	B6	70"	70.1	
6'-0" INTERIOR	6	B5	36"	12.0	1.90
	8	B3	85"	37.9	
	10	B2	68"	37.9	
	12	B4	26"	17.4	
	18	B6	70"	70.1	
8'-0" INTERIOR	8	B5	36"	16.0	2.34
	8	B3	85"	37.9	
	10	B2	92"	51.2	
	12	B4	26"	17.4	
	20	B6	70"	77.9	
8'-0" END	8	B5	36"	16.0	2.32
	7	B3	85"	33.1	
	10	B2	98"	54.6	
	8	B1	17"	7.6	
	20	B6	70"	77.9	
6	B5	36"	12.0		

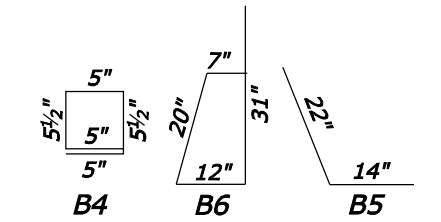

BAR BENDING DETAIL

U.S. DEPARTMENT OF TRANSPORTATION
FEDERAL HIGHWAY ADMINISTRATION
FEDERAL LANDS HIGHWAY

U.S. CUSTOMARY STANDARD

CATTLE GUARD PRECAST FOUNDATION

STANDARD APPROVED FOR USE 6/2005
REVISED:

STANDARD 619-3

06-Nov-2007 06:44 AM
P:\198.145.186.2\std. plan\std1903.dgn [US Customary]