

NOTE:

1. Use weathering steel for all structural steel and fastener hardware as specified.
2. Place terminal section on both approach and trailing ends of barrier installations. See Standards 617-61 and 617-62.
3. Use no more than 3 short guardrail posts in a row. A 25" diameter round anchor may be used instead of the square anchor shown. A reduced size is acceptable in solid rock.
4. In areas where the rail face is offset a minimum of 20 feet from the edge of travel lane, a maximum approach shoulder slope of 1V:6H may be used.

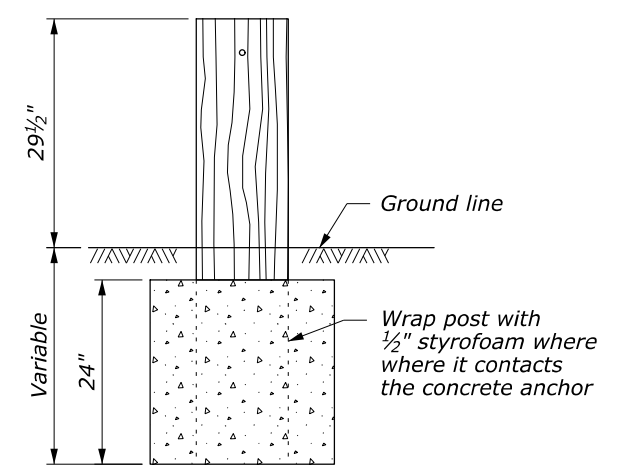

CONCRETE ANCHOR FOR SHORT GUARDRAIL POST
See Note 3

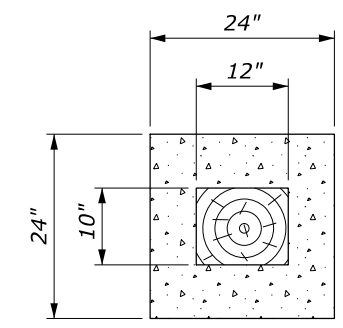
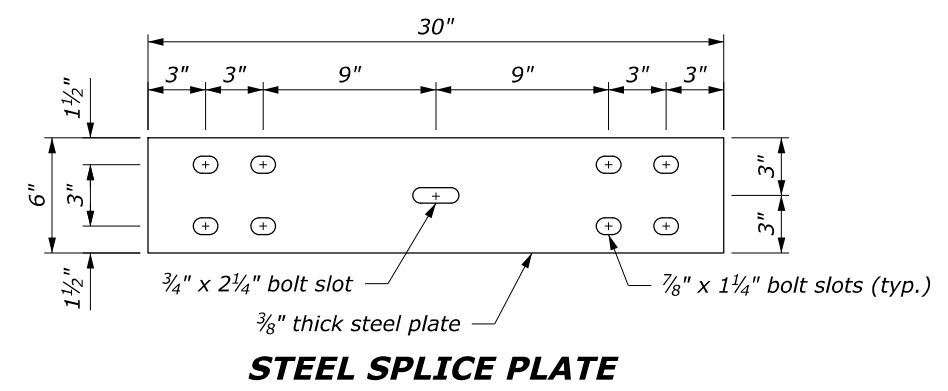
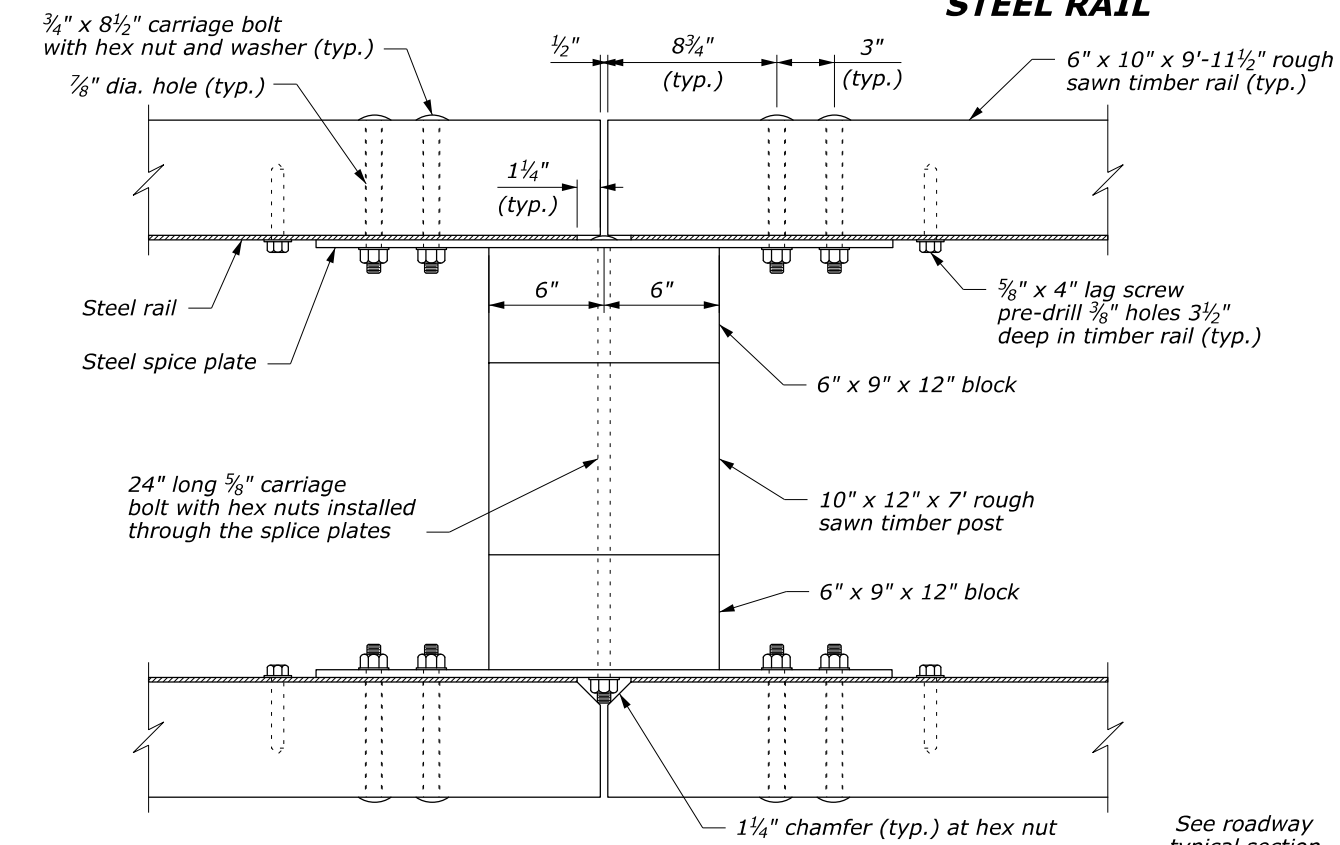
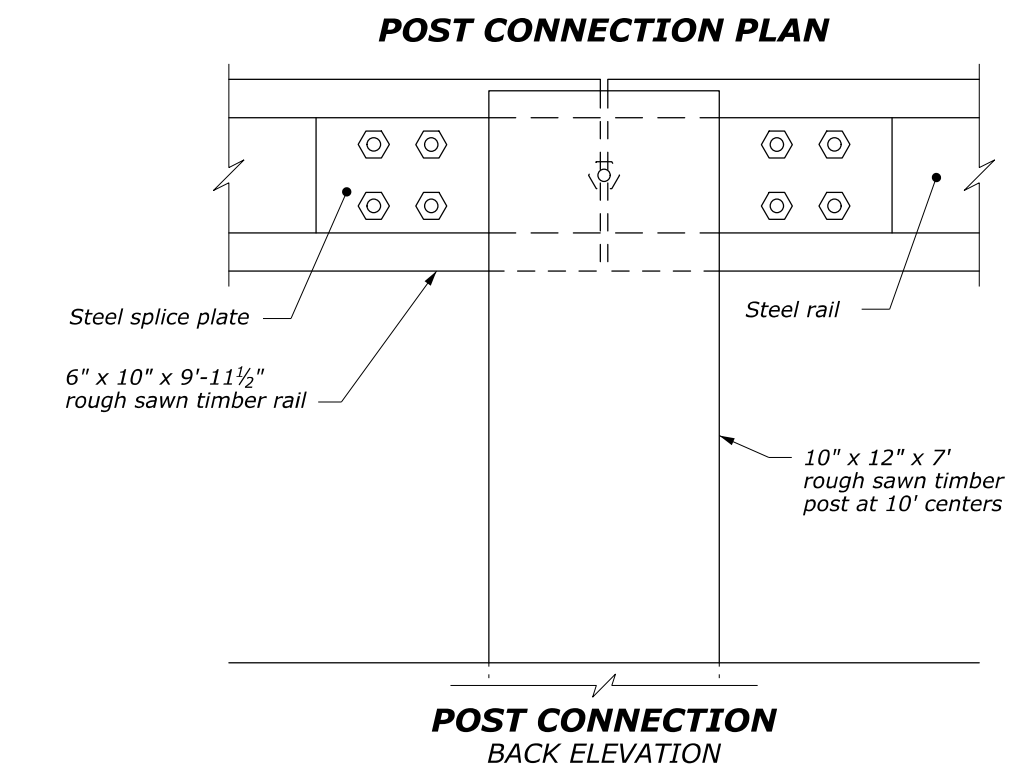

POST CONNECTION BACK ELEVATION

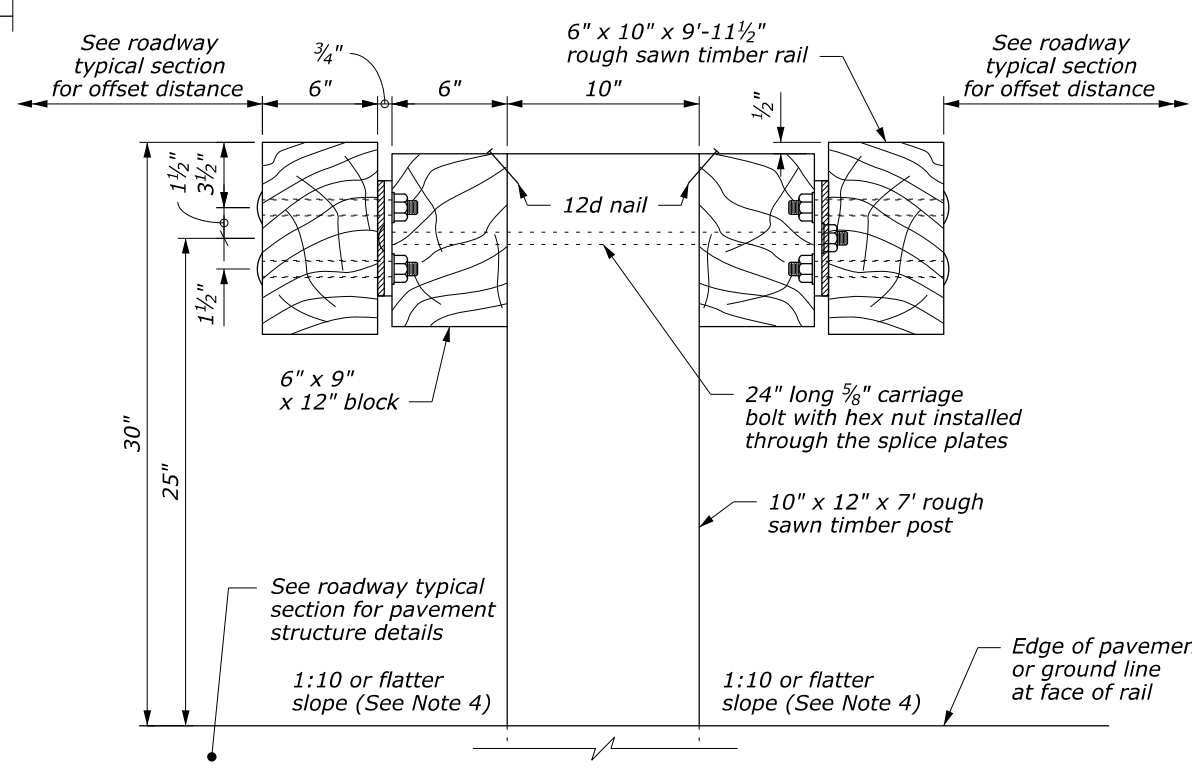

TYPICAL GUARDRAIL CROSS SECTION

NO SCALE

U.S. DEPARTMENT OF TRANSPORTATION FEDERAL HIGHWAY ADMINISTRATION FEDERAL LANDS HIGHWAY	
U.S. CUSTOMARY STANDARD STEEL-BACKED TIMBER GUARDRAIL MEDIAN, TYPE A	
STANDARD APPROVED FOR USE --/----	STANDARD
REVISED: DRAFT: 3/2010	617-70

H:\StanDraw\st61770.dgn [USC] 11 March 2010 11:17 AM

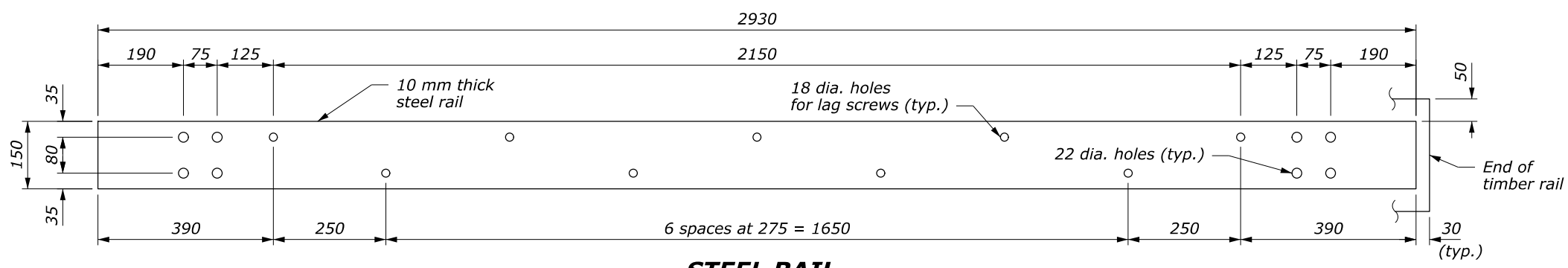

NOTE:

1. Use weathering steel for all structural steel and fastener hardware as specified.
2. Place terminal section on both approach and trailing ends of barrier installations. See Standards M617-61 and M617-62.
3. Use no more than 3 short guardrail posts in a row. A 625 mm diameter round anchor may be used instead of the square anchor shown. A reduced size is acceptable in solid rock.
4. In areas where the rail face is offset a minimum of 6 m from the edge of travel lane, a maximum approach shoulder slope of 1V:6H may be used.
5. Furnish hardware in the metric sizes shown. Equivalent US Customary sizes may be used when metric sizes are unavailable.
6. Dimensions without units are millimeters.

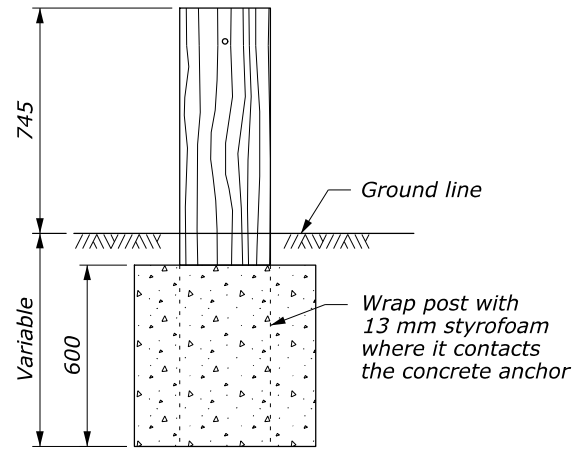
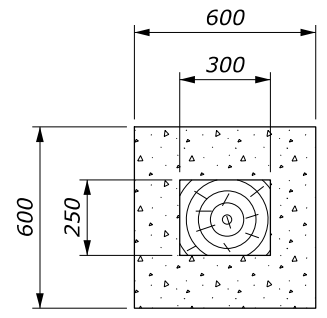
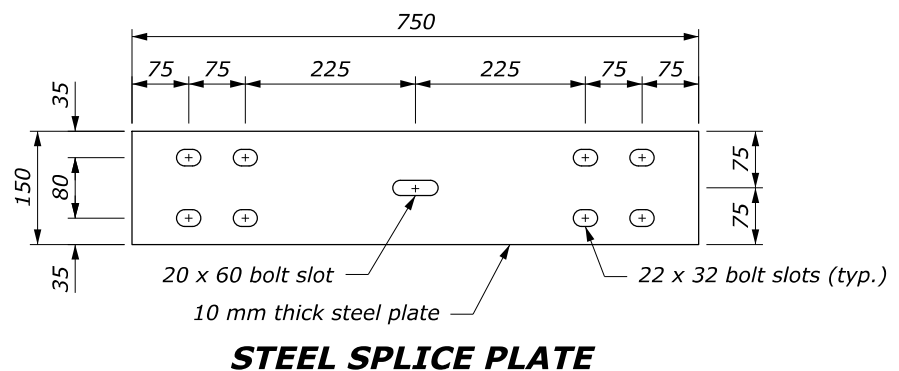
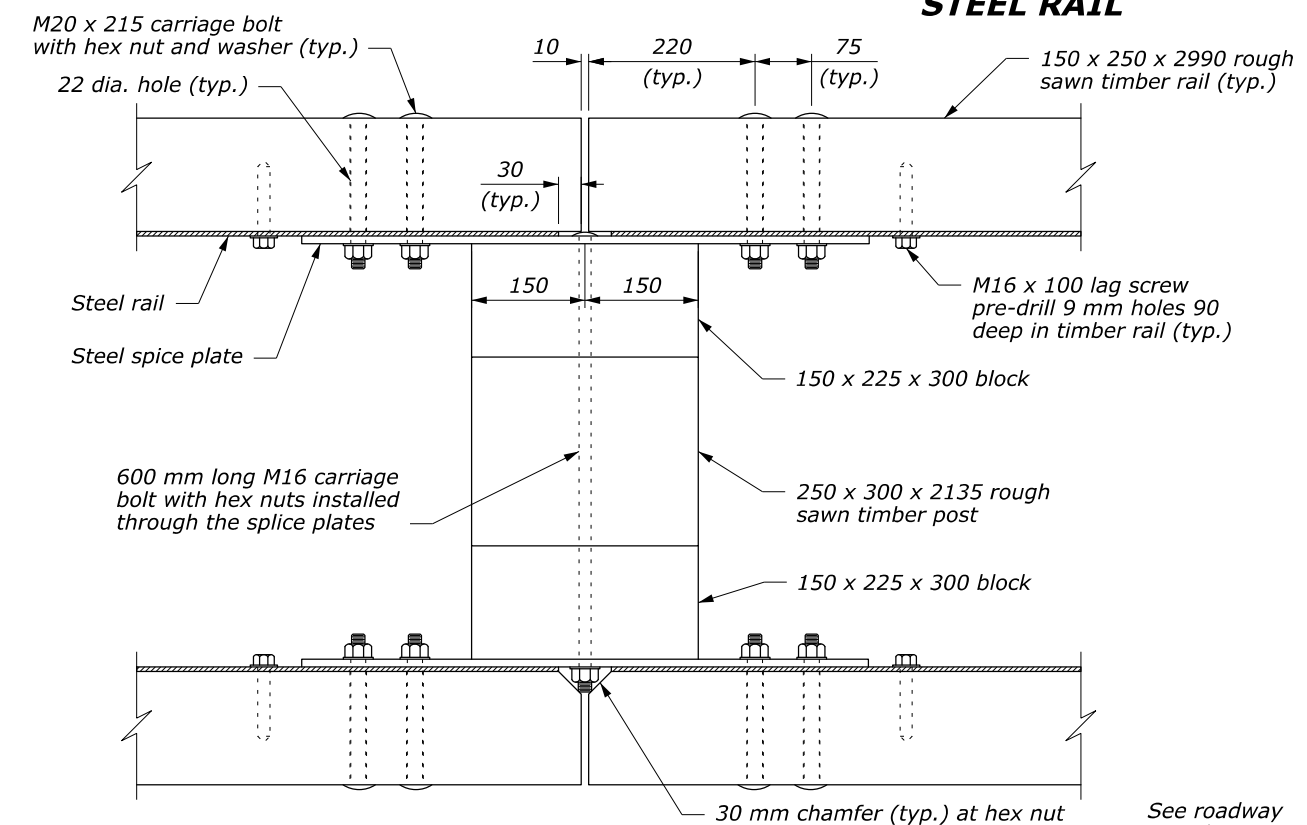

CONCRETE ANCHOR FOR SHORT GUARDRAIL POST
See Note 3

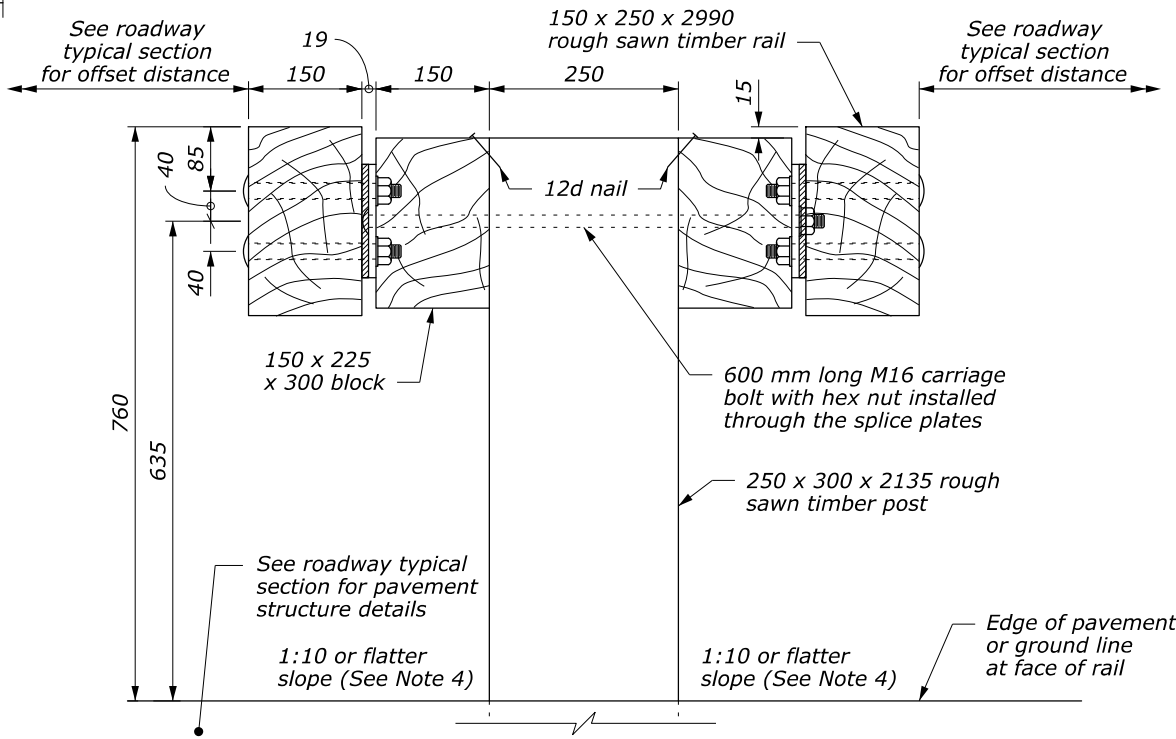
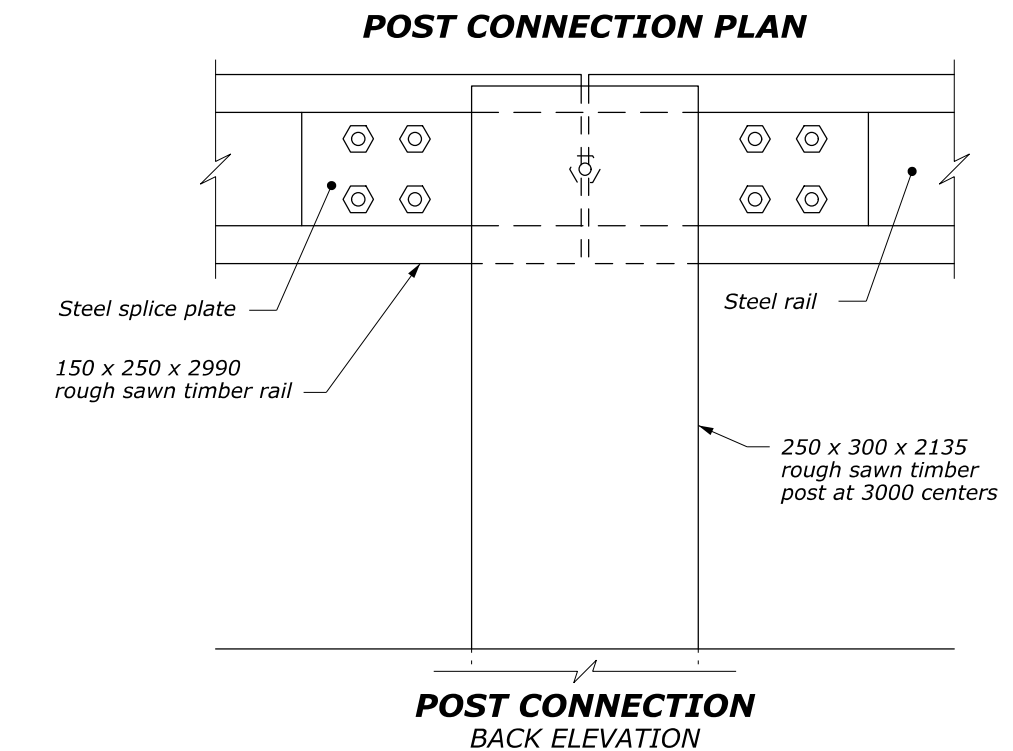

TYPICAL GUARDRAIL CROSS SECTION

NO SCALE

U.S. DEPARTMENT OF TRANSPORTATION FEDERAL HIGHWAY ADMINISTRATION FEDERAL LANDS HIGHWAY	
METRIC STANDARD	
STEEL-BACKED TIMBER GUARDRAIL MEDIAN, TYPE A	
STANDARD APPROVED FOR USE --/----	STANDARD
REVISED: DRAFT: 3/2010	M617-70

H:\StanDraw\st61770.dgn [Metric] 11 March 2010 11:27 AM

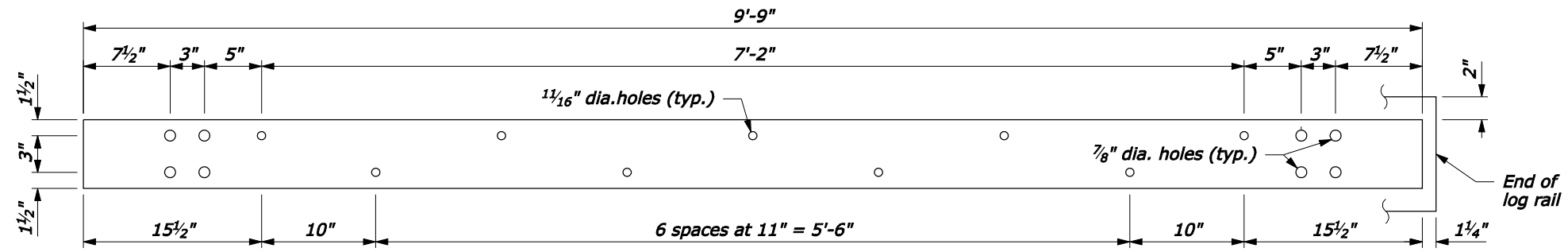

STEEL RAIL
6" x 3/8" x 9'-9"

NOTE:
1. For details of the wood block-out, post notch, and general notes for Steel-Backed Log Guardrail. See Standard 617-81.

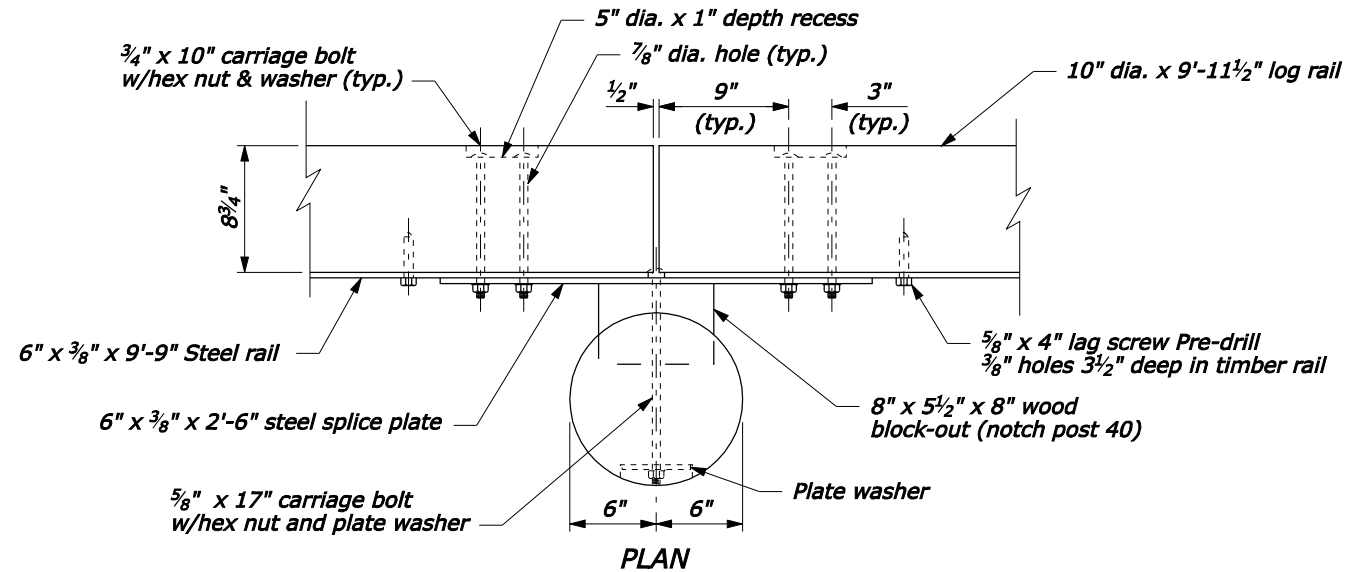

PLAN

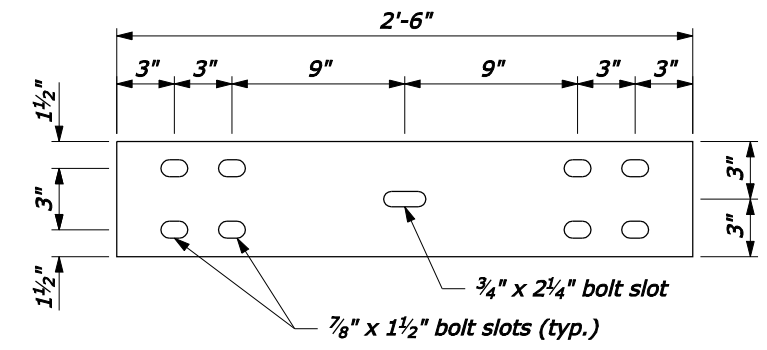

STEEL SPLICE PLATE
6" x 3/8" x 2'-6"

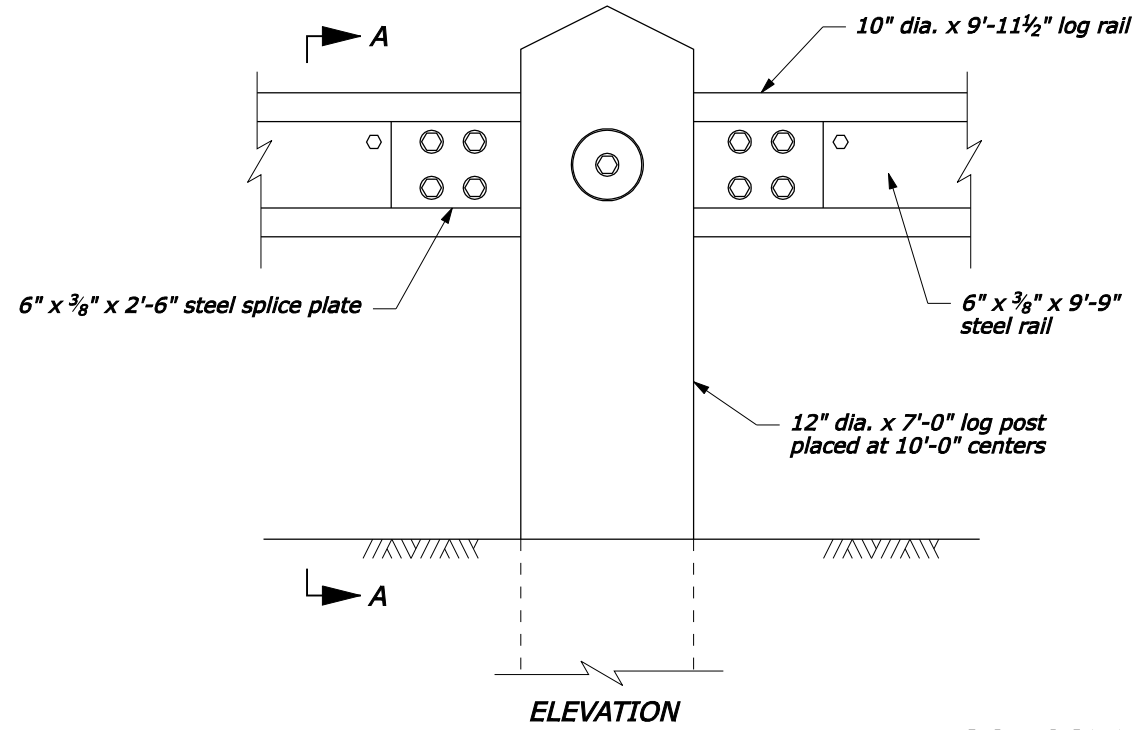

ELEVATION

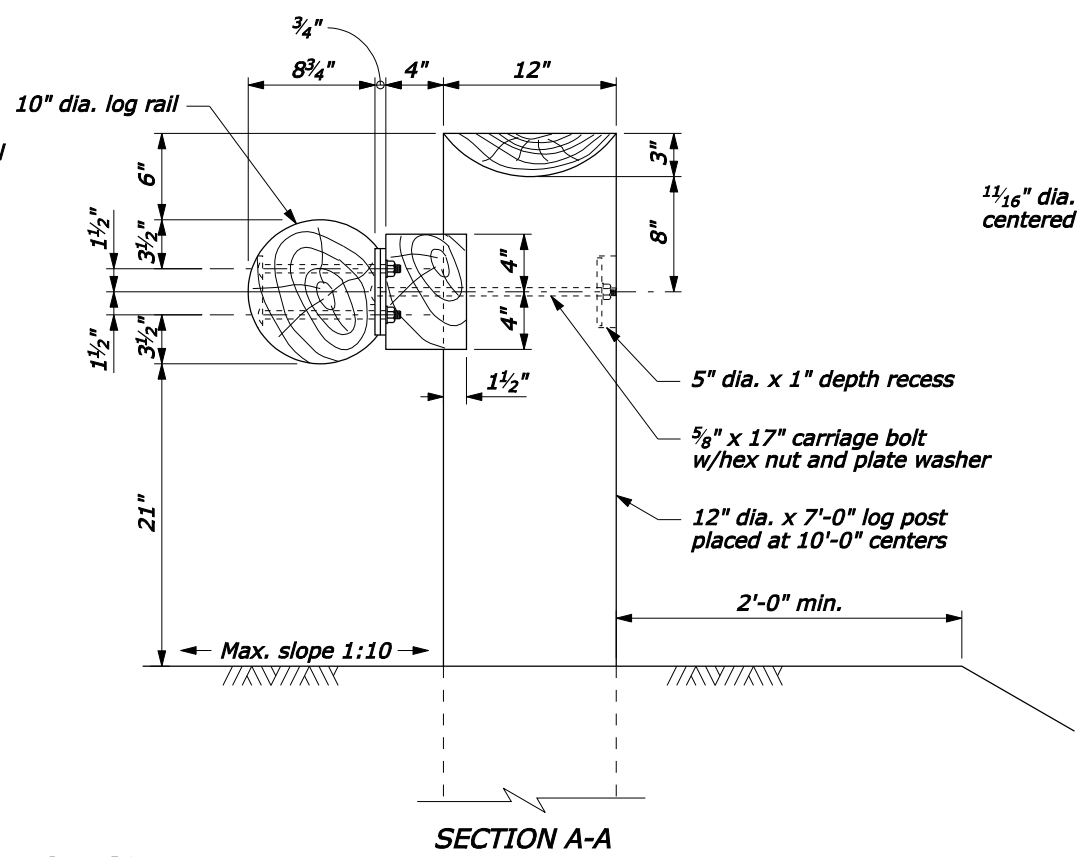

SECTION A-A

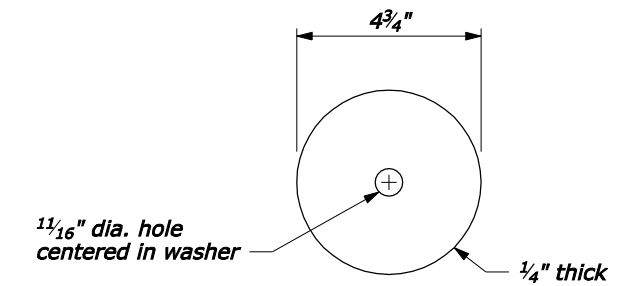
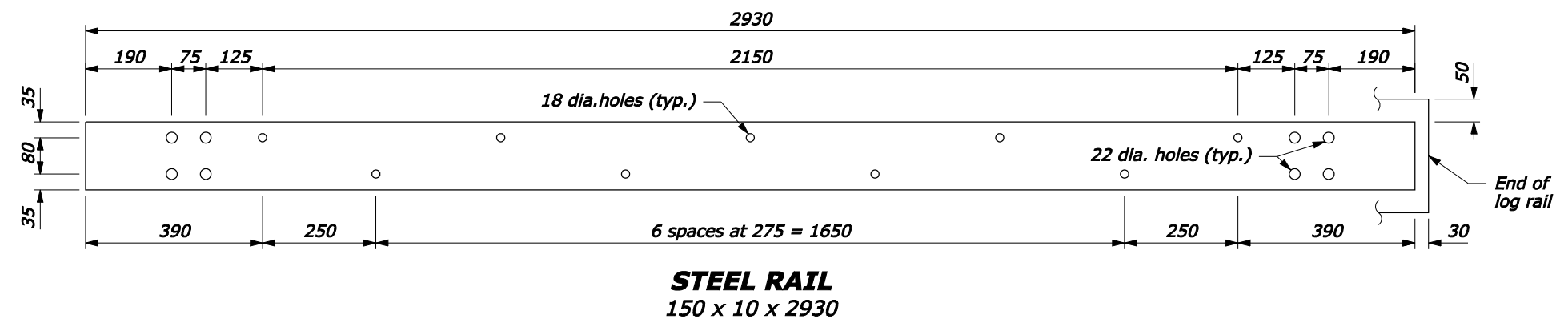

PLATE WASHER

NO SCALE

POST CONNECTION

U.S. DEPARTMENT OF TRANSPORTATION FEDERAL HIGHWAY ADMINISTRATION FEDERAL LANDS HIGHWAY	
U.S. CUSTOMARY STANDARD	
STEEL-BACKED LOG RAIL	
STANDARD APPROVED FOR USE 6/2005	STANDARD
REVISED:	617-80



- NOTE:**
1. For details of the wood block-out, post notch, and general notes for Steel-Backed Log Guardrail. See Standard M617-81.
 2. Furnish hardware in the metric sizes shown. Equivalent US Customary sizes may be used when metric sizes are not available.
 3. Dimensions without units are millimeters.

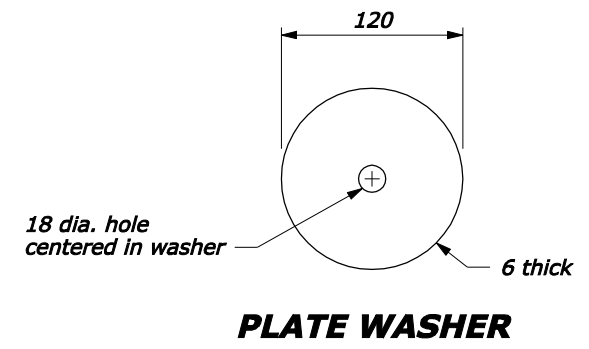
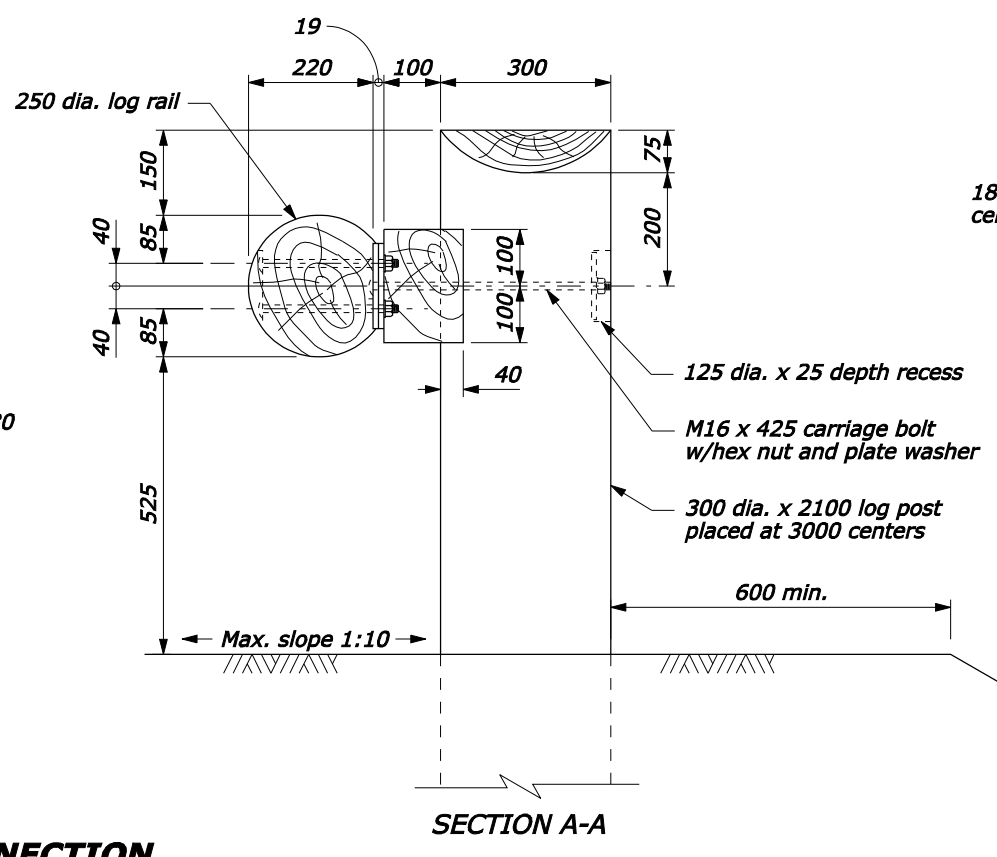
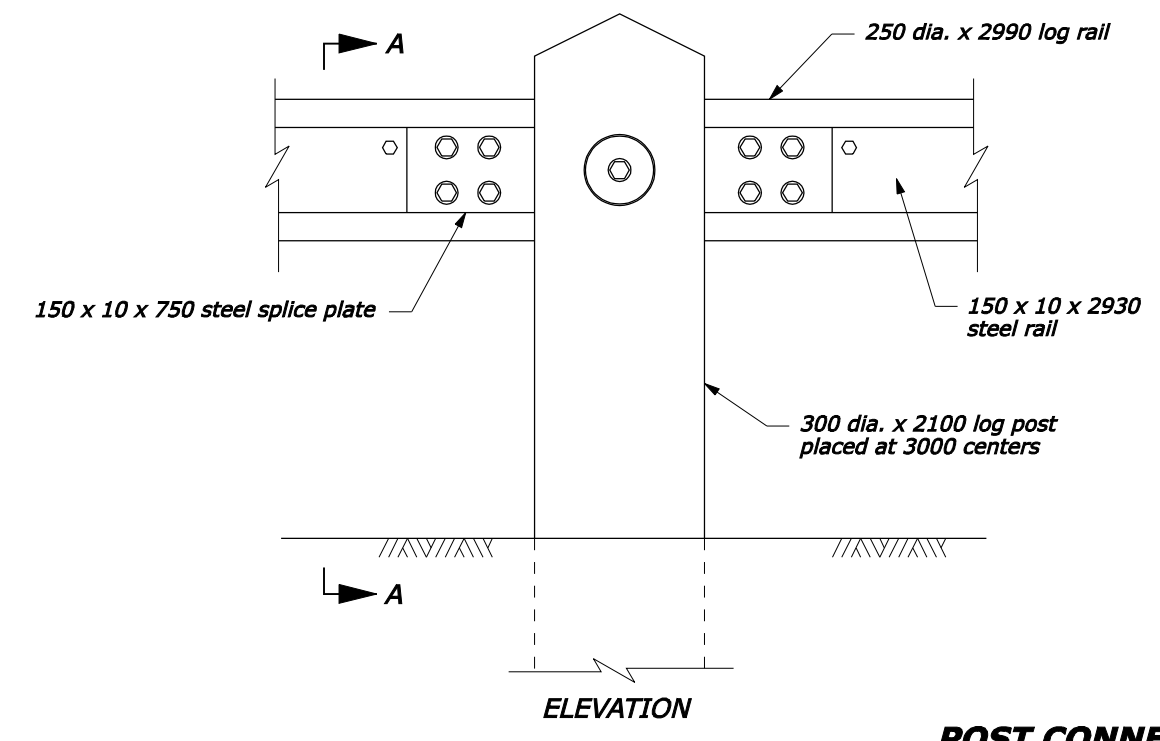
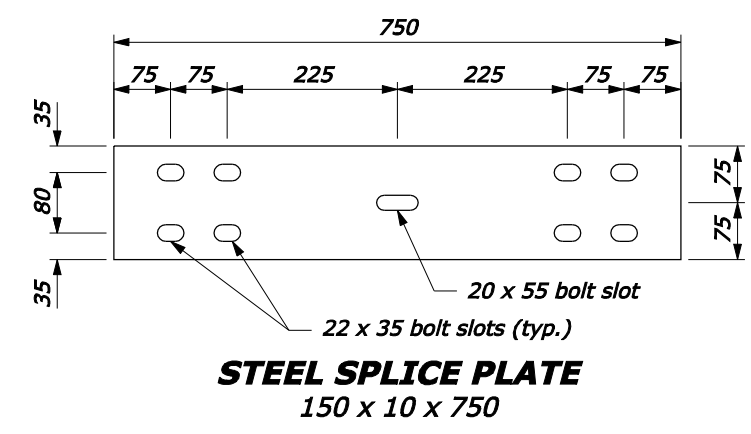
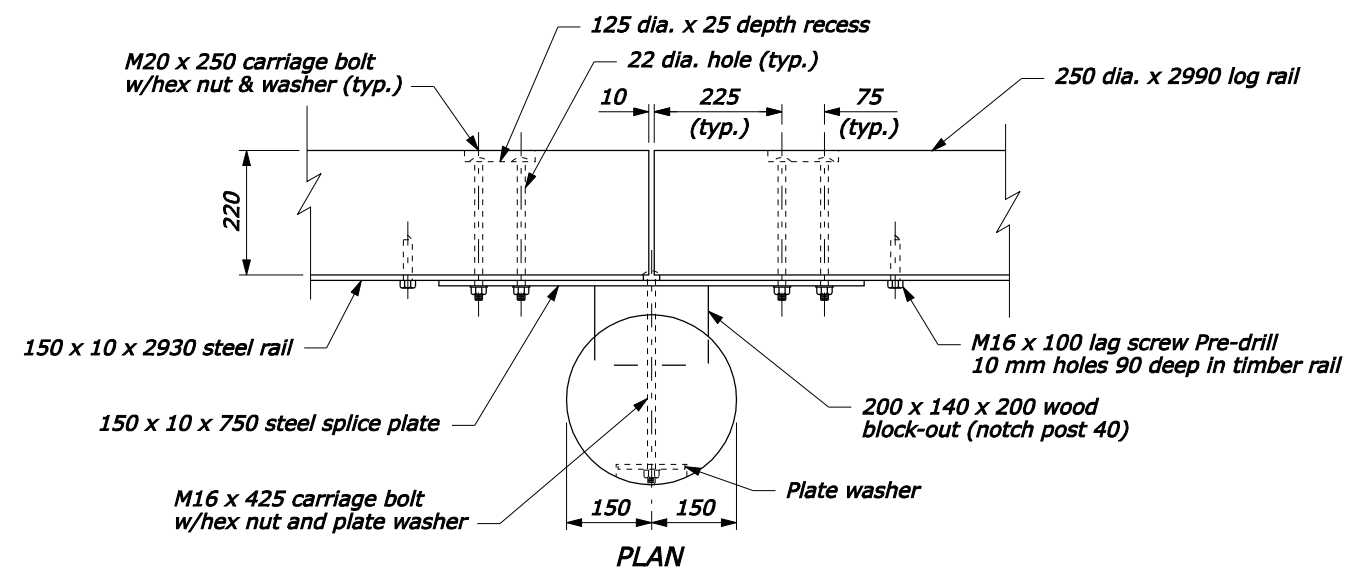

POST CONNECTION

NO SCALE

U.S. DEPARTMENT OF TRANSPORTATION FEDERAL HIGHWAY ADMINISTRATION FEDERAL LANDS HIGHWAY	
METRIC STANDARD	
STEEL-BACKED LOG RAIL	
STANDARD APPROVED FOR USE 3/1996	STANDARD
REVISED: 6/2005	M617-80

24-Sep-2007 07:25 AM F:\StandDraw\std61780.dgn [Metric]

NOTE:

1. Furnish post and rail elements of peeled, round timber and treat with water-borne preservative according to Section 710.08.
2. Install logs for rails butt to butt and tip to tip. A 2" maximum taper between the butt and tip ends of individual logs is permitted.
3. 20 foot logs are acceptable for rails provided the 2" maximum taper requirement is met and roadway curvature permits.
4. Make splices in rail elements at posts only.
5. Field cut log ends and dress as necessary to obtain tight fitting butt joints in full contact with each other at the log ends. Trim traffic exposed faces of log ends at the joints and elsewhere and dress as necessary to obtain a smooth surface with no protrusions.
6. Dress back face of log rail members to provide a flat surface wide enough to accommodate a 6" steel rail.
7. Apply an approved tinted brown color stain to all exposed surfaces of logs. Apply stain either as a part of or subsequent to preservative treatment.
8. Treat all field cuts and drill holes with two applications of the same preservative and stain as the rails and posts.
9. Furnish structural steel conforming to AASHTO M222 (ASTM A588).
10. Furnish corrosion resistant fastener hardware manufactured from steel conforming to AASHTO M164, Type 3 (ASTM A325, Type 3).
11. The nominal bolt length is 16". Bolt lengths will vary according to log size. Extra long threaded bolts may be used, provided they are field cut so that none of the shank protrudes beyond the back of the post.

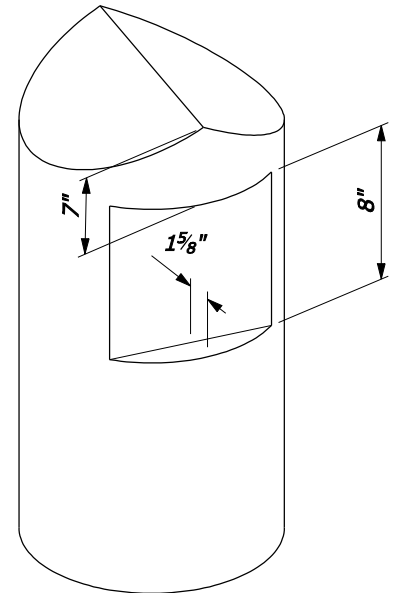

POST NOTCH FOR WOOD BLOCK-OUT

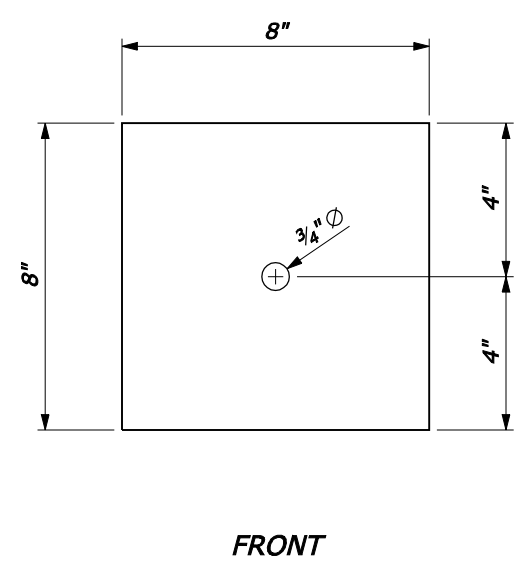
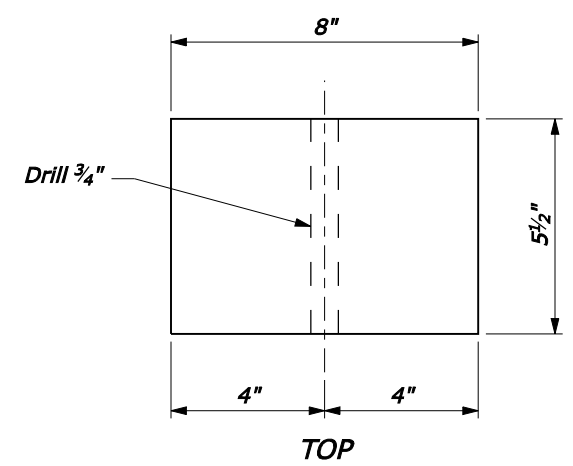

WOOD BLOCK-OUT
8" x 5 1/2" x 8"

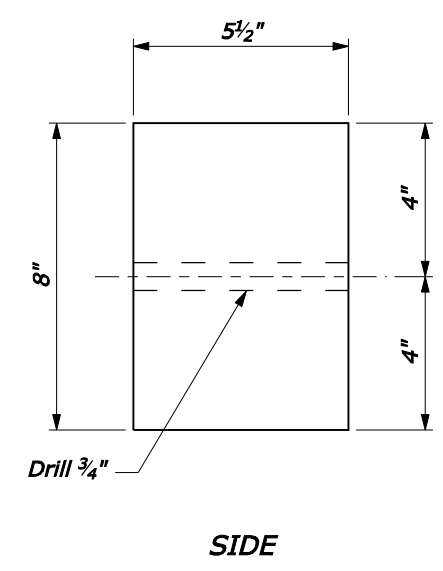

NO SCALE

U.S. DEPARTMENT OF TRANSPORTATION FEDERAL HIGHWAY ADMINISTRATION FEDERAL LANDS HIGHWAY	
U.S. CUSTOMARY STANDARD	
STEEL-BACKED LOG RAIL BLOCKOUT	
STANDARD APPROVED FOR USE 6/2005	STANDARD
REVISED: DRAFT: 5/2008	617-81

NOTE:

1. Furnish post and rail elements of peeled, round timber and treat with water-borne preservative according to Section 710.08.
2. Install logs for rails butt to butt and tip to tip. A 50 mm maximum taper between the butt and tip ends of individual logs is permitted.
3. 6 meter logs are acceptable for rails provided the 50 mm maximum taper requirement is met and roadway curvature permits.
4. Make splices in rail elements at posts only.
5. Field cut log ends and dress as necessary to obtain tight fitting butt joints in full contact with each other at the log ends. Trim traffic exposed faces of log ends at the joints and elsewhere and dress as necessary to obtain a smooth surface with no protrusions.
6. Dress back face of log rail members to provide a flat surface wide enough to accommodate a 150 mm steel rail.
7. Apply an approved tinted brown color stain to all exposed surfaces of logs. Apply stain either as a part of or subsequent to preservative treatment.
8. Treat all field cuts and drill holes with two applications of the same preservative and stain as the rails and posts.
9. Furnish structural steel conforming to AASHTO M222 (ASTM A588).
10. Furnish corrosion resistant fastener hardware manufactured from steel conforming to AASHTO M164, Type 3 (ASTM A325, Type 3).
11. The nominal bolt length is 400 mm. Bolt lengths will vary according to log size. Extra long threaded bolts may be used, provided they are field cut so that none of the shank protrudes beyond the back of the post.
12. Dimensions without units are millimeters.

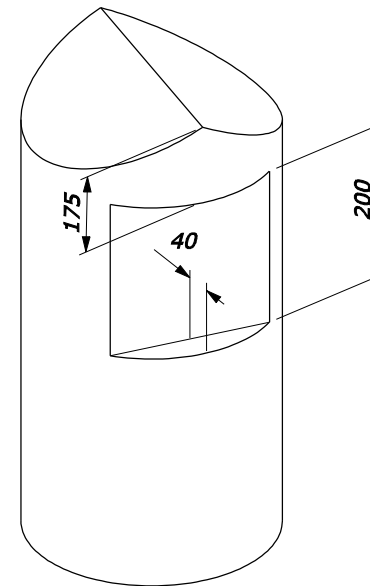

POST NOTCH FOR WOOD BLOCK-OUT

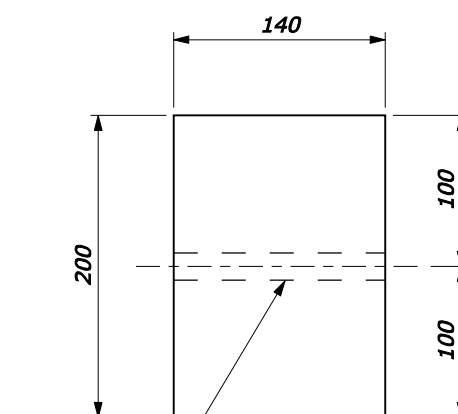
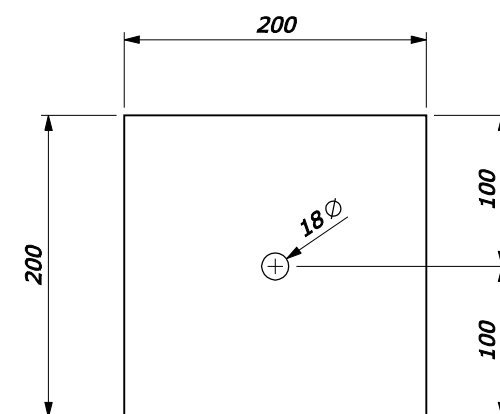
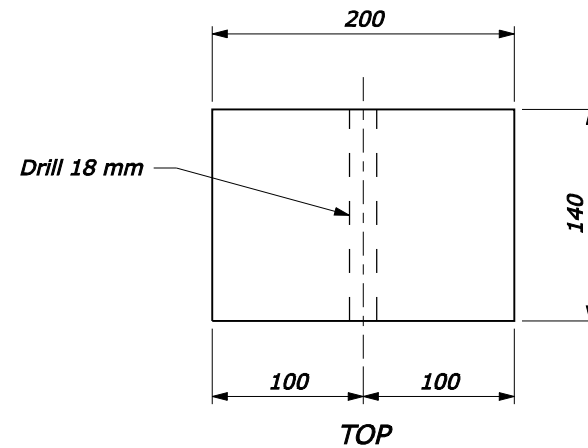

FRONT

SIDE

WOOD BLOCK-OUT
200 x 140 x 200

NO SCALE

U.S. DEPARTMENT OF TRANSPORTATION FEDERAL HIGHWAY ADMINISTRATION FEDERAL LANDS HIGHWAY	
METRIC STANDARD	
STEEL-BACKED LOG RAIL BLOCKOUT	
STANDARD APPROVED FOR USE 3/1996	STANDARD
REVISED: 6/2005 DRAFT: 5/2008	M617-81

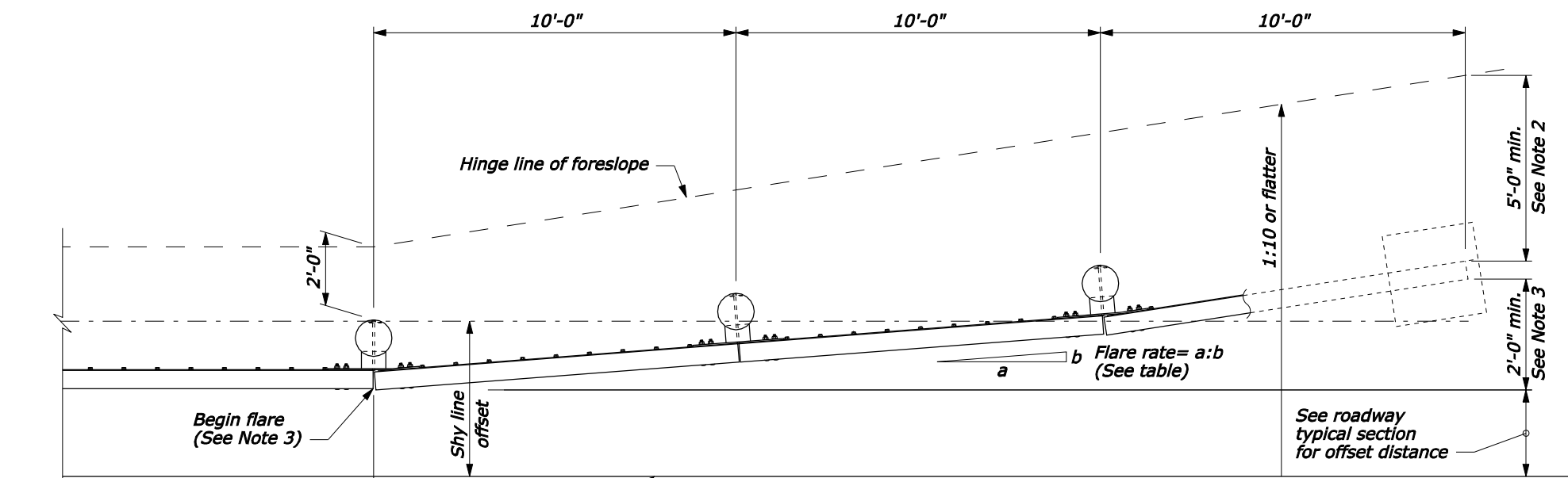

NOTE:

1. See Standard 617-80 and 617-81, Steel-Backed Log Rail, for timber, structural steel, and hardware details.
2. Extend the fill widening a minimum of 5 feet behind the guardrail, unless otherwise directed by the CO.
3. The guardrail flare shown in the plan view is the minimum length and rate required. As directed by the CO, flare the guardrail so that the terminal section is outside the clear zone. If the terminal section cannot be located outside the clear zone, it should be flared as far as practical from the road at the maximum rate indicated on the Guardrail Flare Rates table.

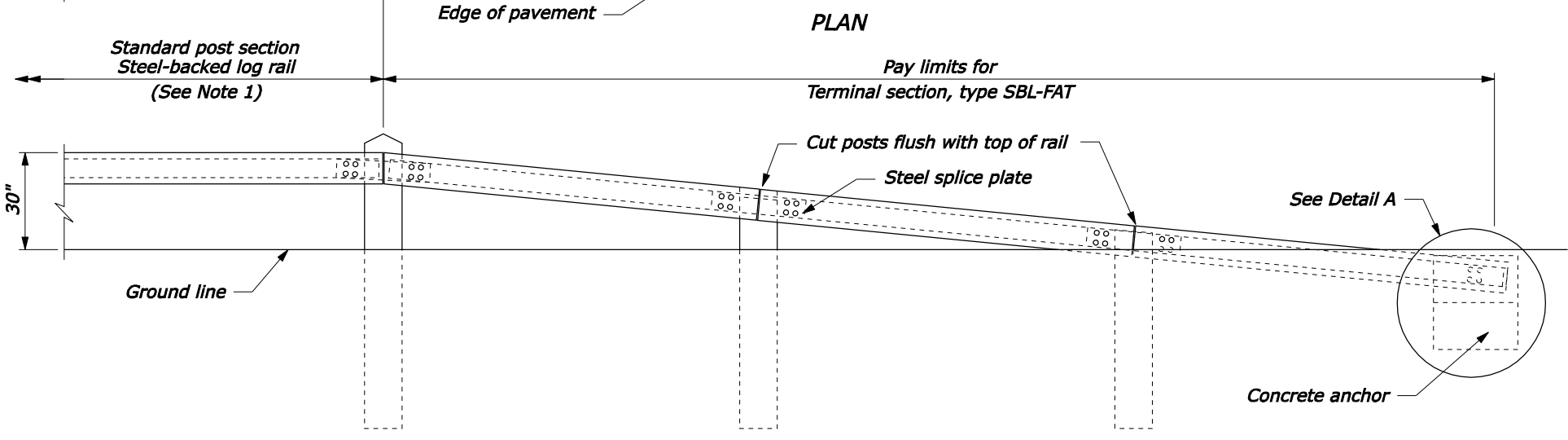

APPROACH & DEPARTURE FLARE WITH FLARED ANCHOR TERMINAL (FAT)

Design Speed (mph)	Shy line offset (ft)	Flare rate inside shy line (a:b)	Flare rate outside shy line (a:b)
60	8.0	26:1	14:1
50	6.5	21:1	11:1
40	5.0	16:1	8:1
40 or less	3.5	13:1	7:1

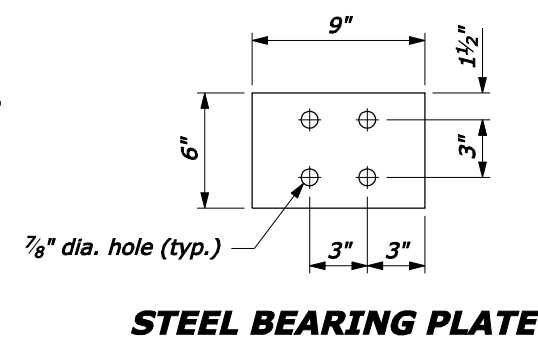
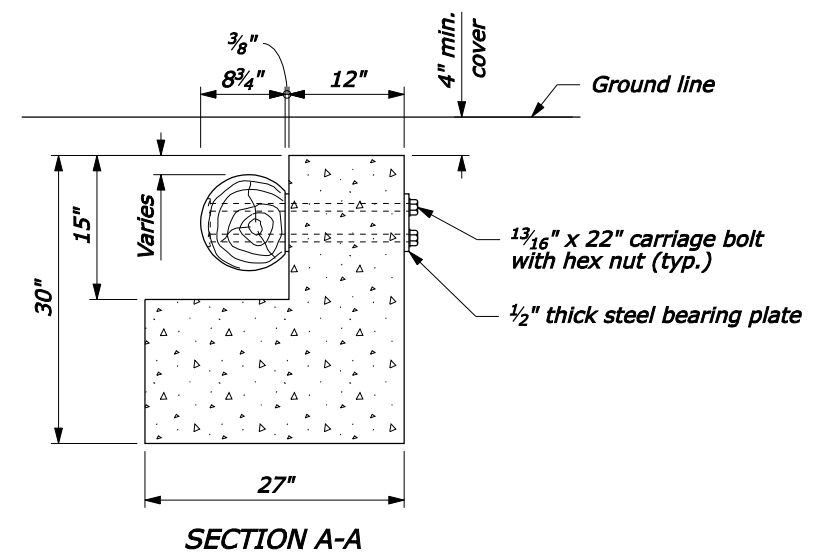
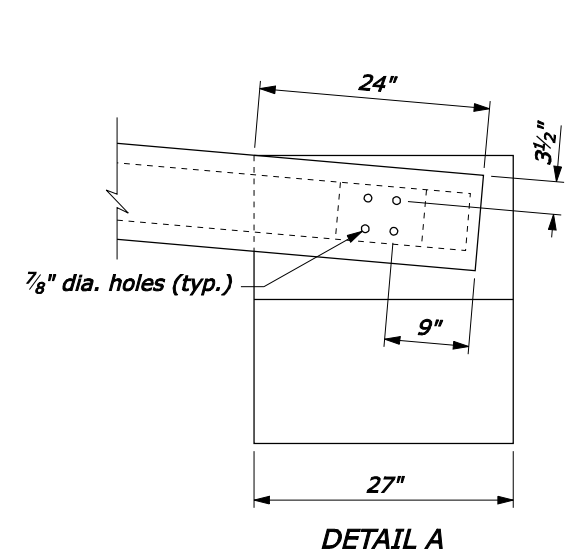

CONCRETE ANCHOR

STEEL BEARING PLATE

NO SCALE

U.S. DEPARTMENT OF TRANSPORTATION
 FEDERAL HIGHWAY ADMINISTRATION
 FEDERAL LANDS HIGHWAY

U.S. CUSTOMARY STANDARD

**STEEL-BACKED LOG RAIL
 TERMINAL SECTION,
 TYPE SBL-FAT**

STANDARD APPROVED FOR USE 6/2005	STANDARD
REVISED: DRAFT: 9/2007	617-82

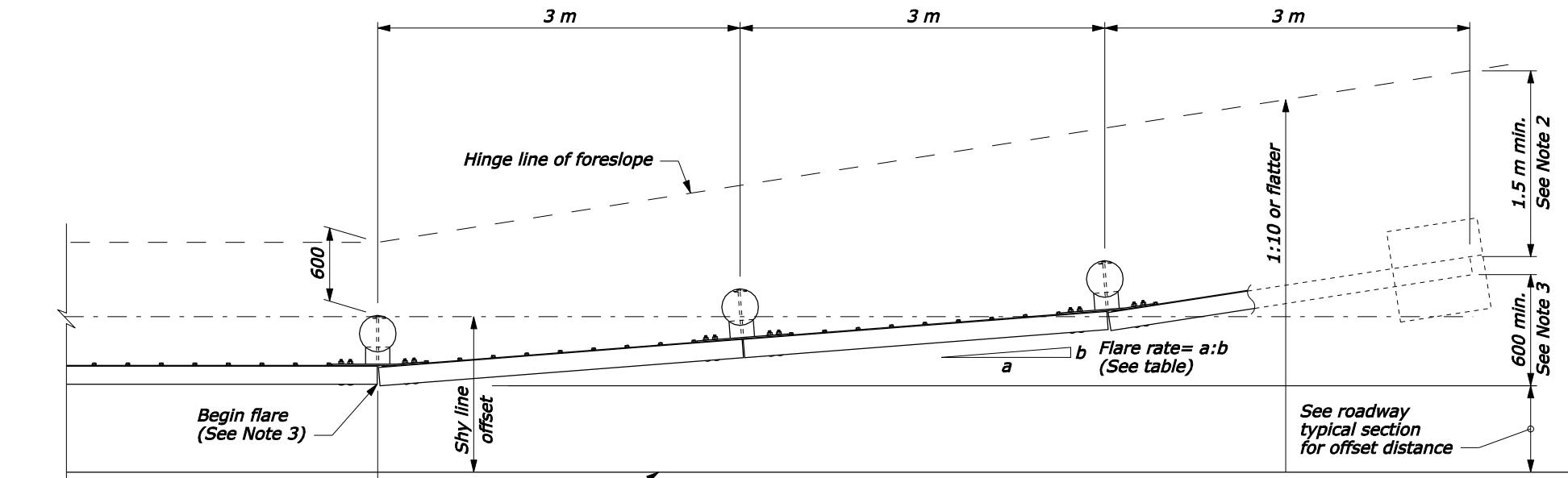

NOTE:

1. See Standard M617-80 and M617-81, Steel-Backed Log Rail, for timber, structural steel, and hardware details.
2. Extend the fill widening a minimum of 1.5 m behind the guardrail, unless otherwise directed by the CO.
3. The guardrail flare shown in the plan view is the minimum length and rate required. As directed by the CO, flare the guardrail so that the terminal section is outside the clear zone. If the terminal section cannot be located outside the clear zone, it should be flared as far as practical from the road at the maximum rate indicated on the Guardrail Flare Rates table.
4. Finish hardware in the metric sizes shown. Equivalent US Customary sizes may be used when metric sizes are not available.
5. Dimensions without units are millimeters.

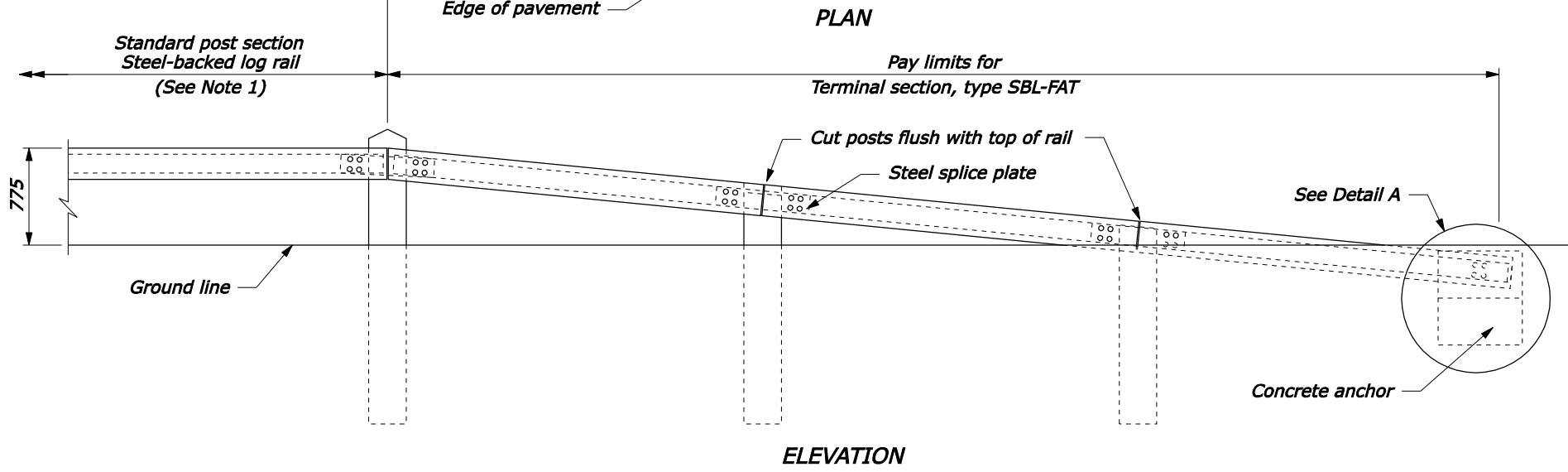

APPROACH & DEPARTURE FLARE WITH FLARED ANCHOR TERMINAL (FAT)

GUARDRAIL FLARE RATE TABLE			
Design Speed (km/h)	Shy line offset (m)	Flare rate inside shy line (a:b)	Flare rate outside shy line (a:b)
100	2.5	26:1	14:1
80	2.0	21:1	11:1
60	1.5	16:1	8:1
50 or less	1.0	13:1	7:1

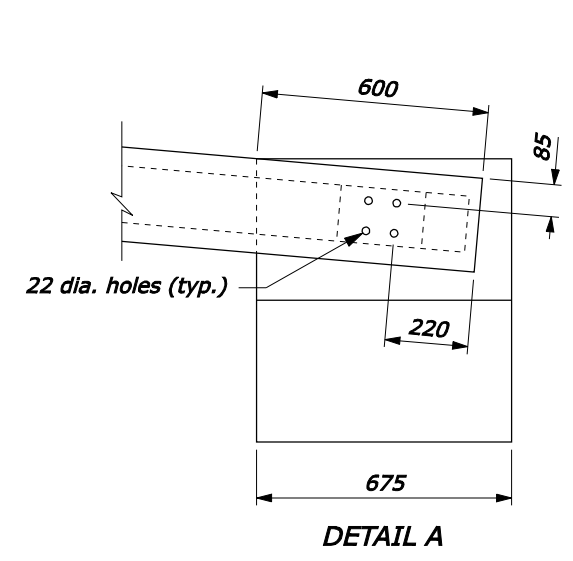

CONCRETE ANCHOR

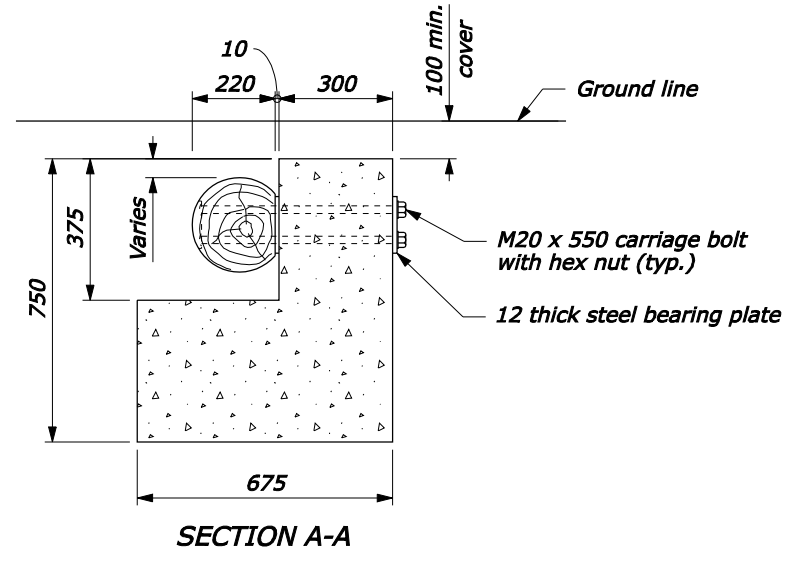

SECTION A-A

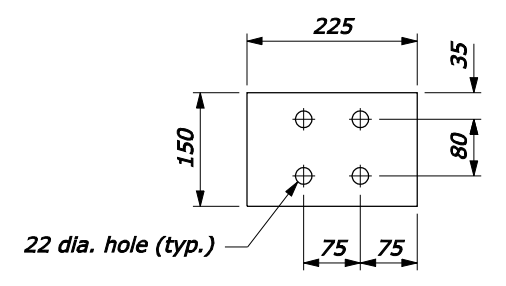

STEEL BEARING PLATE

NO SCALE

U.S. DEPARTMENT OF TRANSPORTATION
 FEDERAL HIGHWAY ADMINISTRATION
 FEDERAL LANDS HIGHWAY

METRIC STANDARD

**STEEL-BACKED LOG RAIL
 TERMINAL SECTION,
 TYPE SBL-FAT**

STANDARD APPROVED FOR USE 6/2005

REVISOR: 9/2007

STANDARD M617-82