

ALTERNATE 1

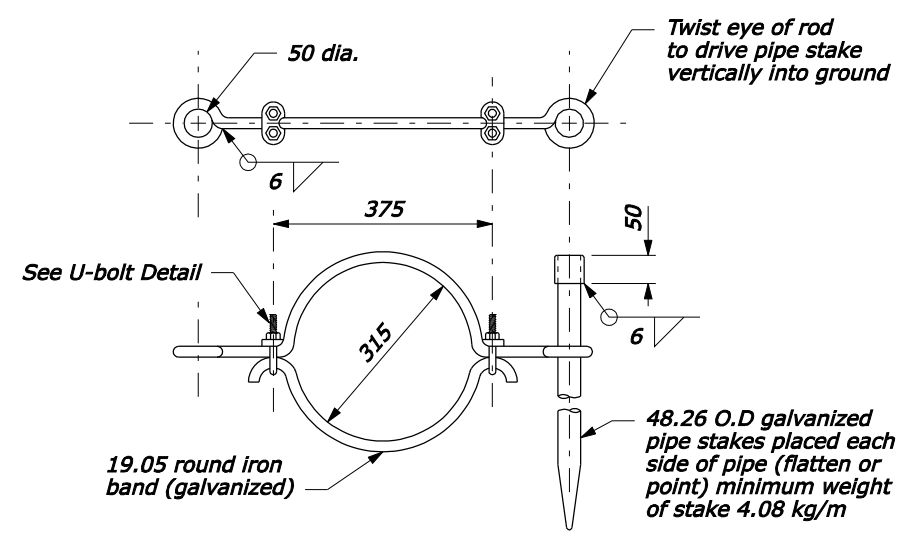

ALTERNATE 2

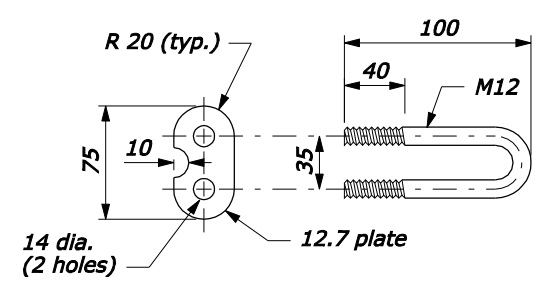

U-BOLT DETAIL

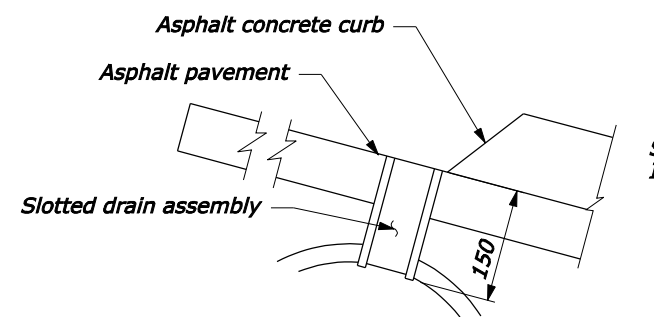

INSTALLATION DETAIL

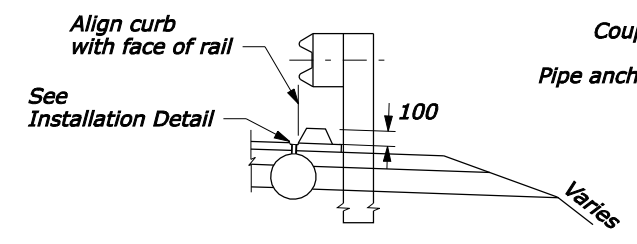

TYPICAL PLACEMENT AT GUARDRAIL

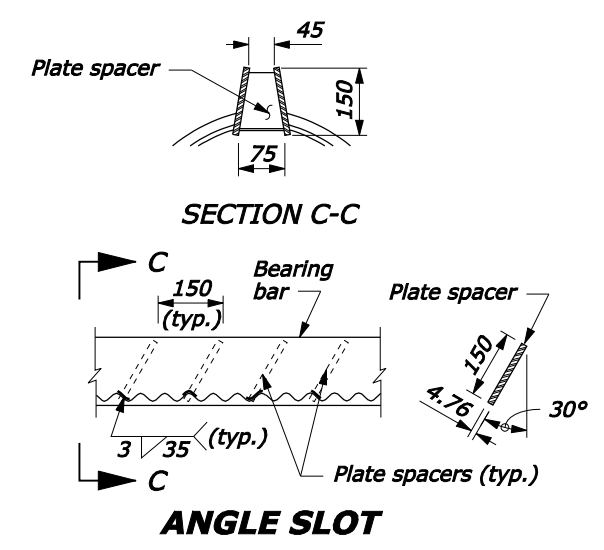
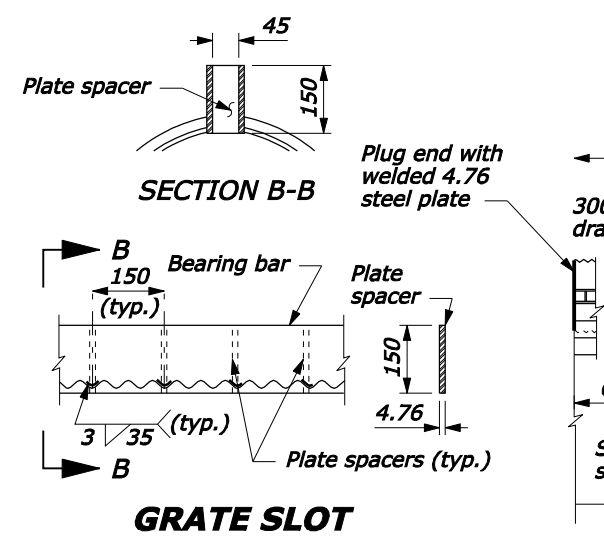

SLOTTED DRAIN ASSEMBLY

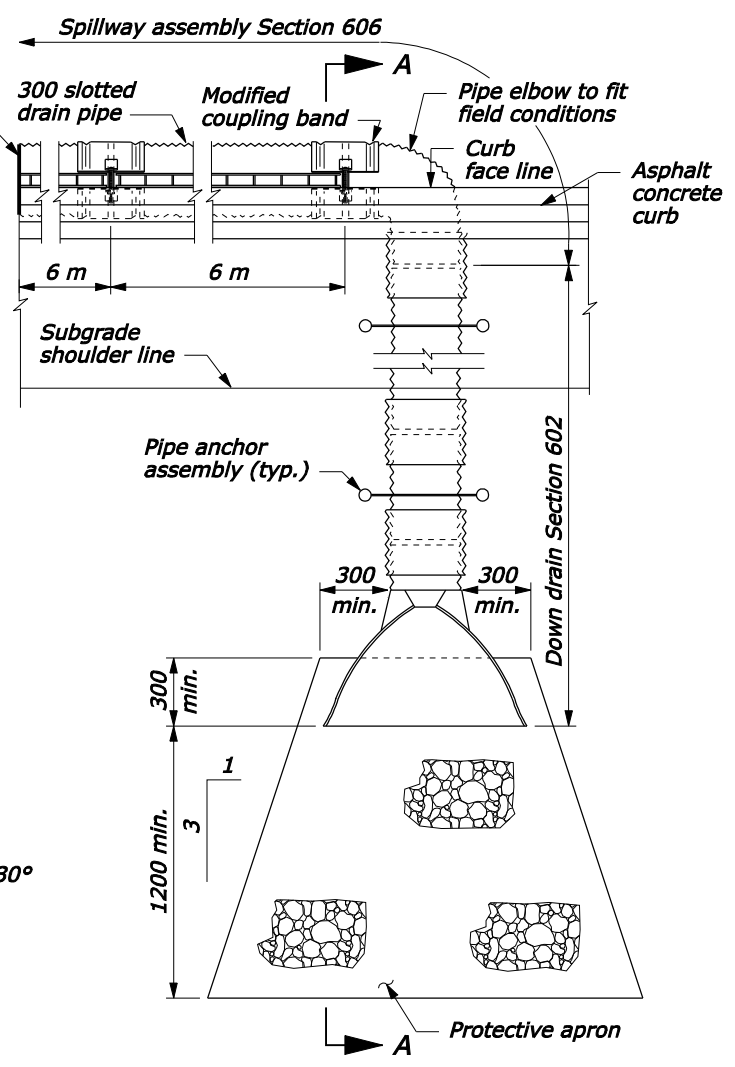

SECTION A-A

NOTE:

1. Fabricate slotted drain pipe, down drain pipe culvert, elbows, end section, and coupling bands from sheets 1.62 mm thickness.
2. Grate slot assembly and plate end plug conform to AASHTO M 183.
3. Galvanize grate slot assembly, plate end plug, and all hardware according to AASHTO M 111.
4. Approved alternate pipe anchor assemblies may be used.
5. Place Class 2 riprap conforming to Section 251 for protective apron.
6. Place pipe anchor assemblies approximately 6 meter intervals along down drain pipe culvert. Place a minimum of 2 anchors per down drain.
7. For installations at sag vertical curves, use a tee connection instead of an elbow and a minimum of two 6 meter slotted drain pipe sections.
8. Make all band connections watertight by placing gaskets or O-rings under the bands before tightening in accordance with Subsection 712.03.
9. Use either the grate slot or the angle slot slotted drain assembly.
10. Provide hardware in the metric sizes shown. Equivalent US Customary sizes may be used when metric sizes are not available.
11. Dimensions without units are millimeters.

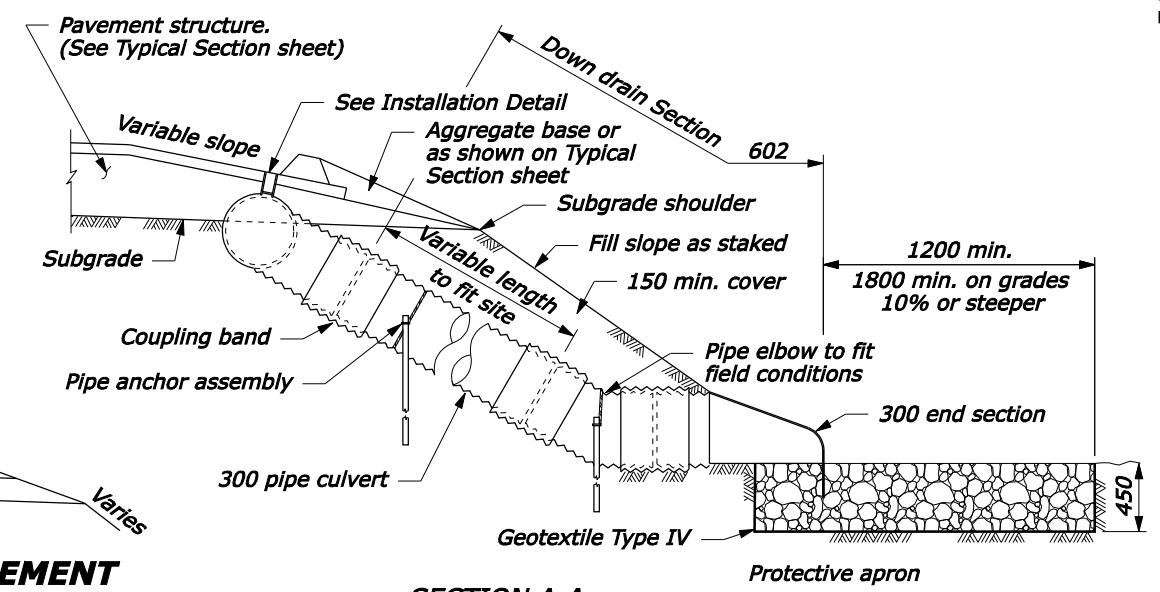
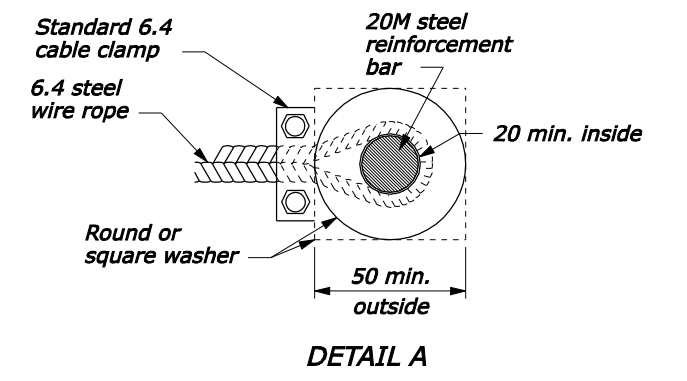

NO SCALE

U.S. DEPARTMENT OF TRANSPORTATION
FEDERAL HIGHWAY ADMINISTRATION
FEDERAL LANDS HIGHWAY
METRIC STANDARD

**SLOTTED DRAIN
SPILLWAY ASSEMBLY**

STANDARD APPROVED FOR USE 3/1996
REVISED: 6/2005

STANDARD
M606-1