

SLOPE DRAINS

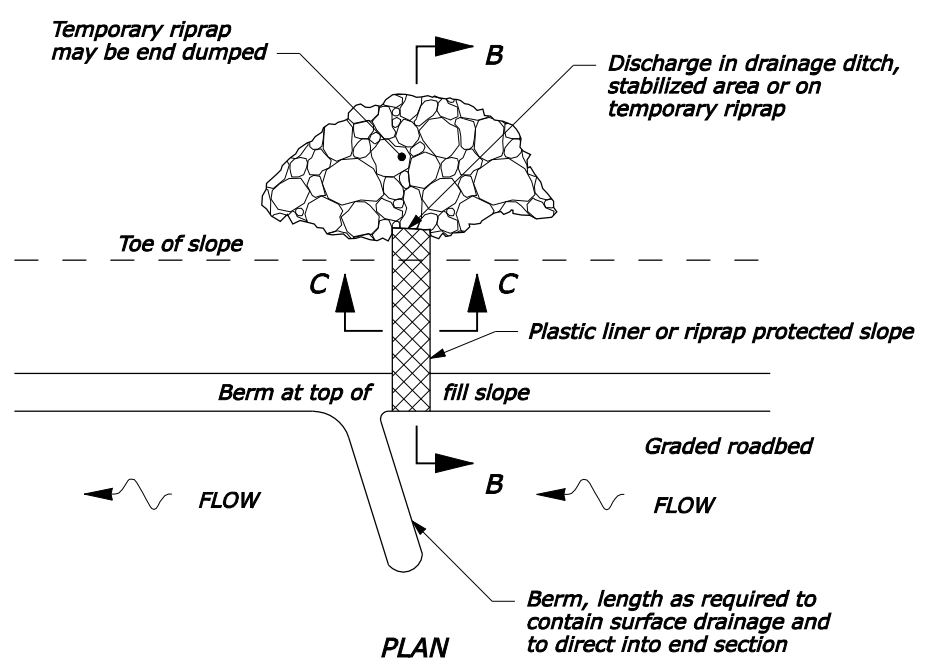

PLASTIC LINED WATERWAY

NOTE:

1. Use temporary slope drains (berms, drains, and riprap) as the embankment is constructed. Use spacings as shown on the Erosion Control Plans or as designated by the CO. Place all slope drains at the end of each work shift. Use slope drains until the slopes are permanently stabilized.
2. Construct temporary berms at the top of all erodible cut slopes as shown on the Erosion Control Plans or as designated by the CO. Use check dams to reduce the runoff velocity when existing grades are steep.
3. Do not use transverse or longitudinal joints in plastic liner. Plastic liner is not required for rock embankments.
4. Use toe-of-fill slope berms to divert offsite runoff away from disturbed areas.
5. Seed and mulch all cut slope berms and toe-of-fill berms immediately after berm construction.
6. Use Class 2 temporary riprap.
7. Dimensions without units are millimeters.

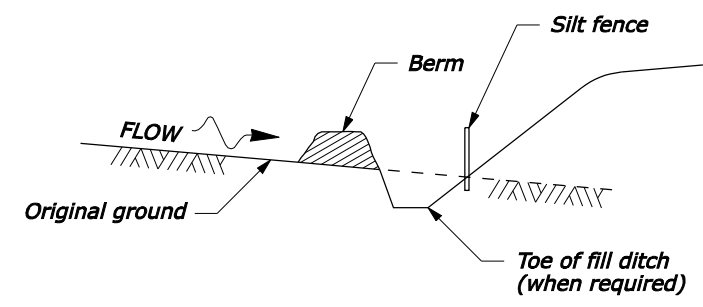
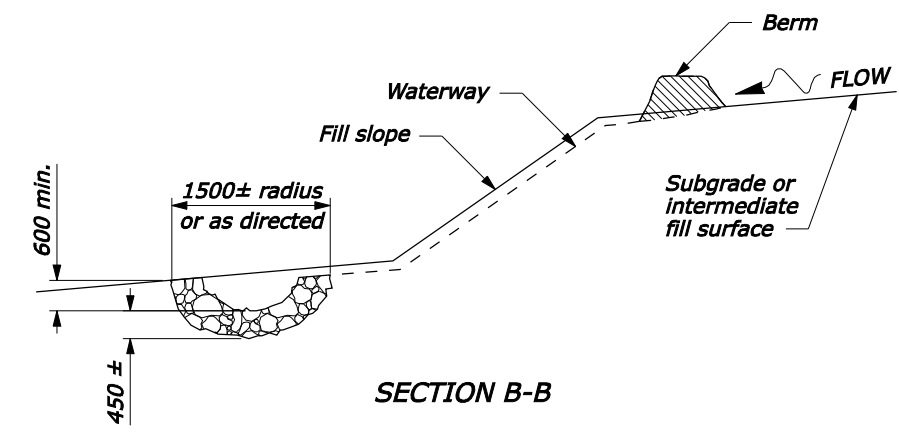
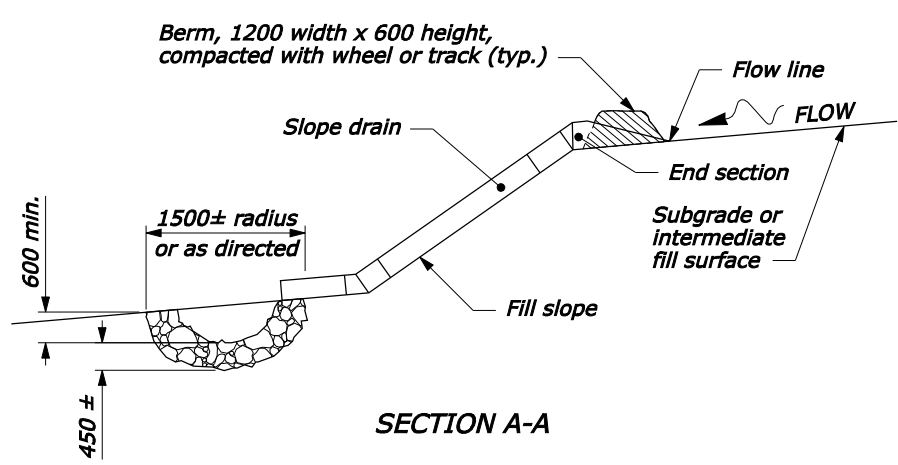

TOE-OF-FILL SLOPE BERM

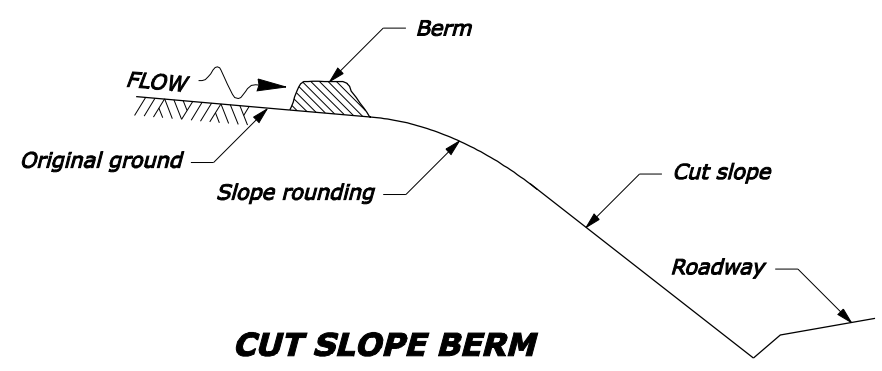

CUT SLOPE BERM

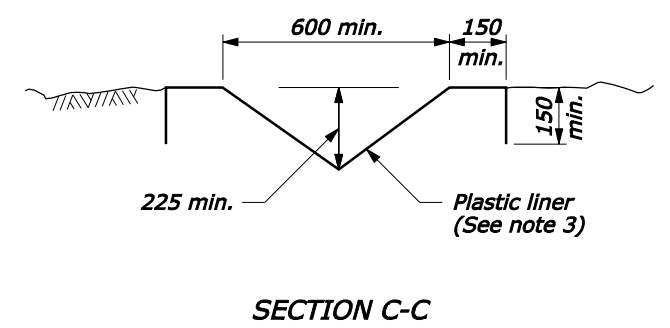

U.S. DEPARTMENT OF TRANSPORTATION
 FEDERAL HIGHWAY ADMINISTRATION
 FEDERAL LANDS HIGHWAY

METRIC STANDARD

**TEMPORARY EROSION CONTROL
 BERMS, SLOPE DRAINS,
 AND LINED WATERWAYS**

STANDARD APPROVED FOR USE 3/1996
 REVISED: 6/2005

STANDARD
 M157-7

NO SCALE

06-Oct-2005 08:32 AM F:\StandDraw\st15707.dgn [Metric]