

SILT FENCE DROP INLET PROTECTION (TYPE A)

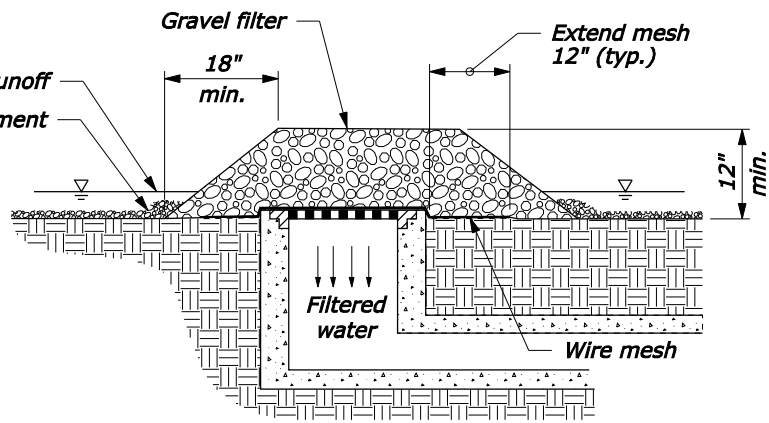

GRAVEL AND WIRE MESH DROP INLET PROTECTION (TYPE B)

- NOTE:**
1. For gravel filters use 2" - 3" diameter coarse aggregate.
 2. Use wire mesh with 1/2" x 1/2" openings.
 3. Use Type A inlet protection in sump locations only.
 4. Use Type B inlet protection only in sump locations where heavy concentrated flows are not expected. Do not use where ponding around the structure might cause inconvenience or damage.

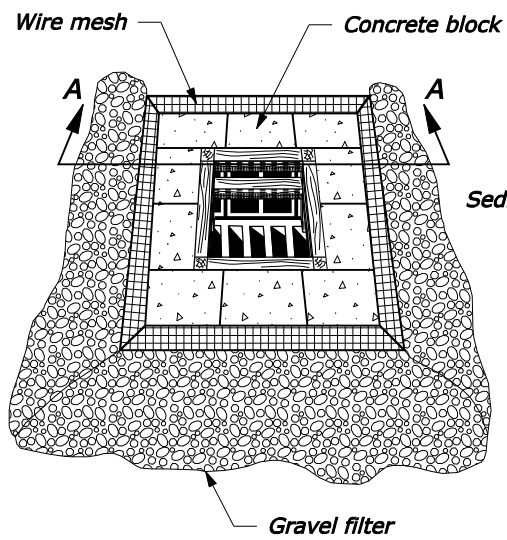

BLOCK AND GRAVEL DROP INLET PROTECTION (TYPE C)

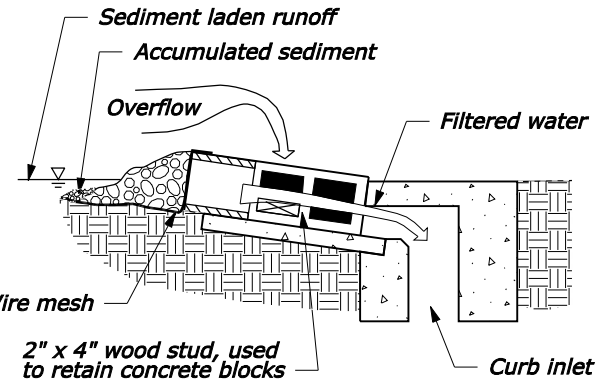
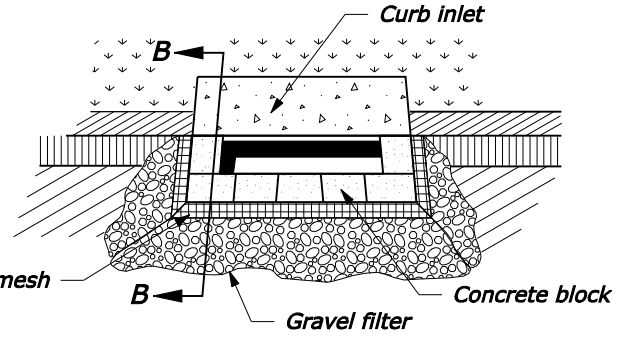
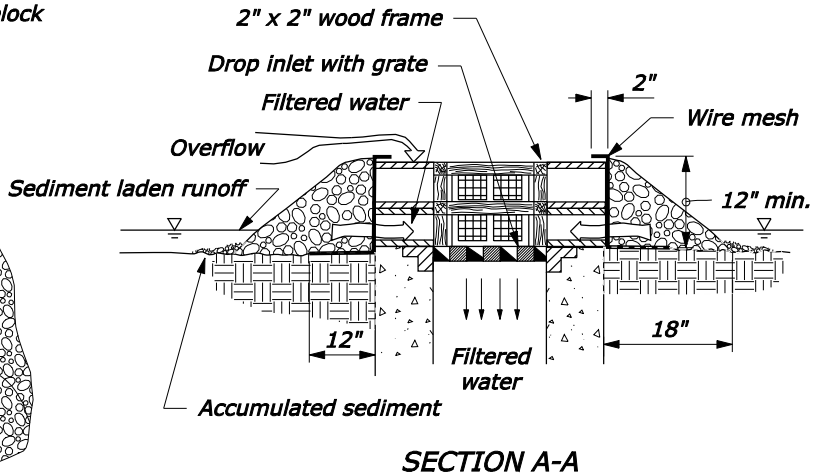

CURB INLET PROTECTION, BLOCK AND GRAVEL (TYPE D)

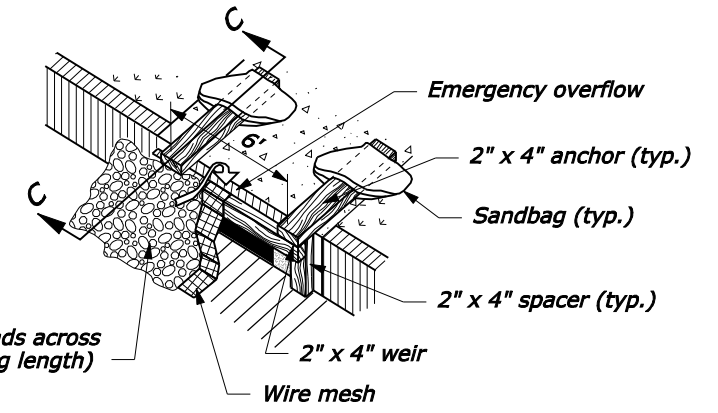

CURB INLET PROTECTION, WOODEN WEIR (TYPE E)

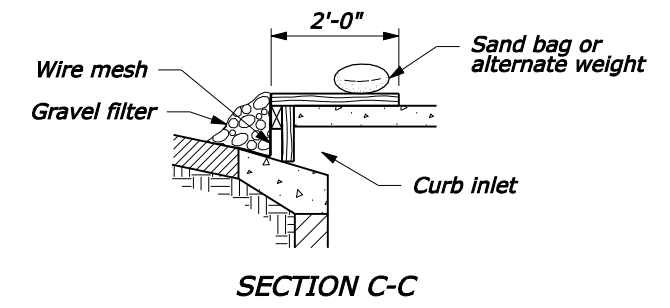

NO SCALE

U.S. DEPARTMENT OF TRANSPORTATION FEDERAL HIGHWAY ADMINISTRATION FEDERAL LANDS HIGHWAY	
U.S. CUSTOMARY STANDARD	
TEMPORARY INLET PROTECTION	
STANDARD APPROVED FOR USE 6/2005	STANDARD
REVISED:	157-2

06-Oct-2005 08:25 AM F:\StdDraw\std15702.dgn [US Customary]