

Energy Efficiency in Data Centers

**Climate Leaders Meeting
Boulder, CO. Dec. 2007**



Mukesh Khattar, Ph.D., PE

Oracle

Electricity Use in Data Centers

IT Equipment

- Servers
- Storage
- Networking

...critical and UPS backed up.

Support Equipment

- Cooling, Airflow
- UPS/power distribution losses
- Lighting, etc.

...any use other than IT equipment

Electricity Flow in Data Centers

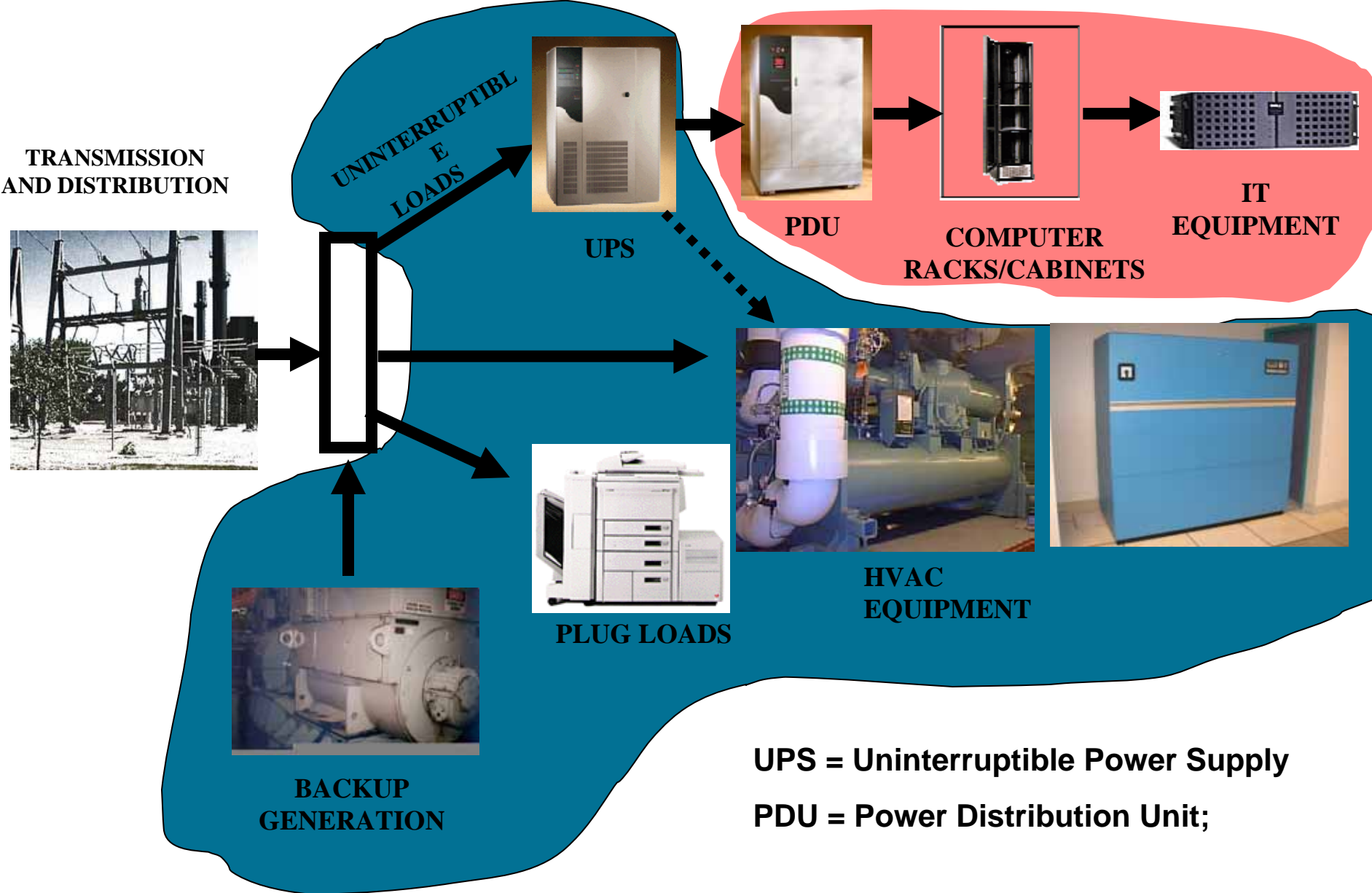

UPS = Uninterruptible Power Supply
PDU = Power Distribution Unit;

Oracle Benchmark Index

Benchmark to quantify data center operating energy performance

Criteria:

- Should be easy to measure in the field
- Should be easy to understand
- Should provide overall health of the data center energy performance
- Require minimal additional instrumentation/monitoring

Oracle Benchmark Index

OBI = Support Power for each unit of IT equipment power

Easy to obtain—

- IT power data available from the UPS output (UPSoutput)
- Total power input to data center available from utility power meter (DCPowerinput)
- Support power = UPSoutput – DCPowerinput

OBI = Support Power/UPSoutput

Energy Performance

- Data reported differently in the industry
- Differences in data centers: small to large
- Stand alone or part of the building

LBL study indicated a wide range of OBI, as high as 2.5

Industry experts consider an OBI of 1.0 as efficient

IT Equipment Energy Use

Significant developments

- Virtualization
- Power saving modes ...load variation

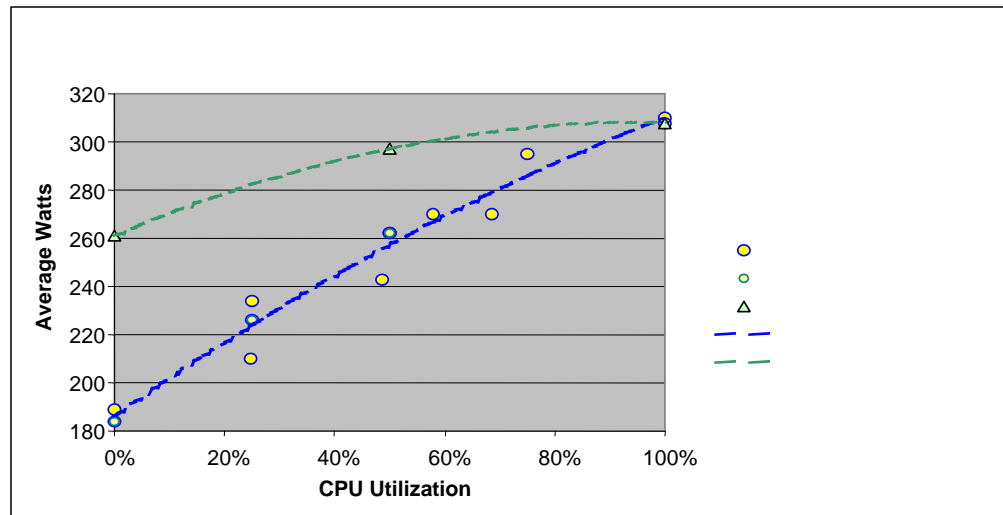

Support Equipment Energy Use

- Cooling, Airflow
- UPS/power distribution losses
- Lighting, etc.

...any use other than IT equipment

Cooling/heat Rejection Chain

Six degrees of separation

...independent, but interacting

- 1. Server fans, from server chips to room air**
- 2. CRAC, from room air to cooling coil chilled water**
- 3. Secondary pumps, from cooling coil chilled water to primary loop chilled water**
- 4. Primary pump, from loop chilled water to chiller**
- 5. Condenser water, from chiller to condenser water**
- 6. CT fans, from condenser water to outdoor air**

HVAC Energy Use

HVAC (as a % of total load)

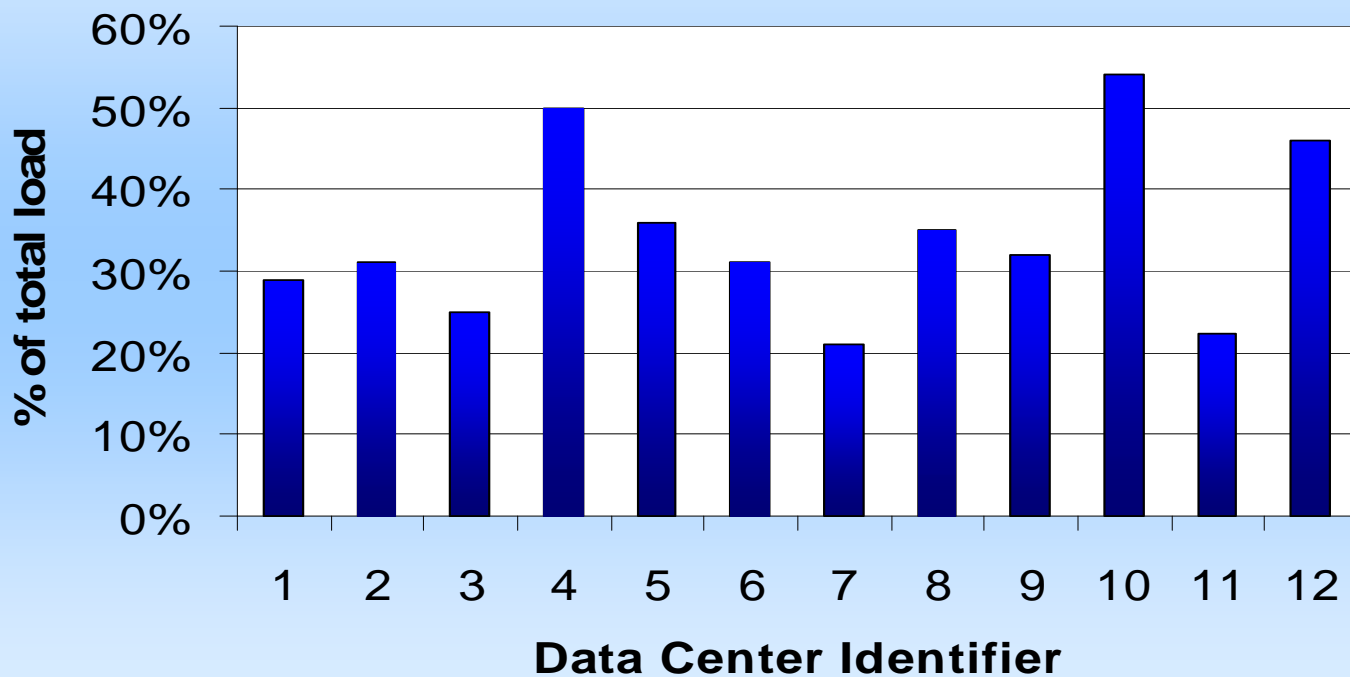

Source: LBL

Conventional Air Distribution

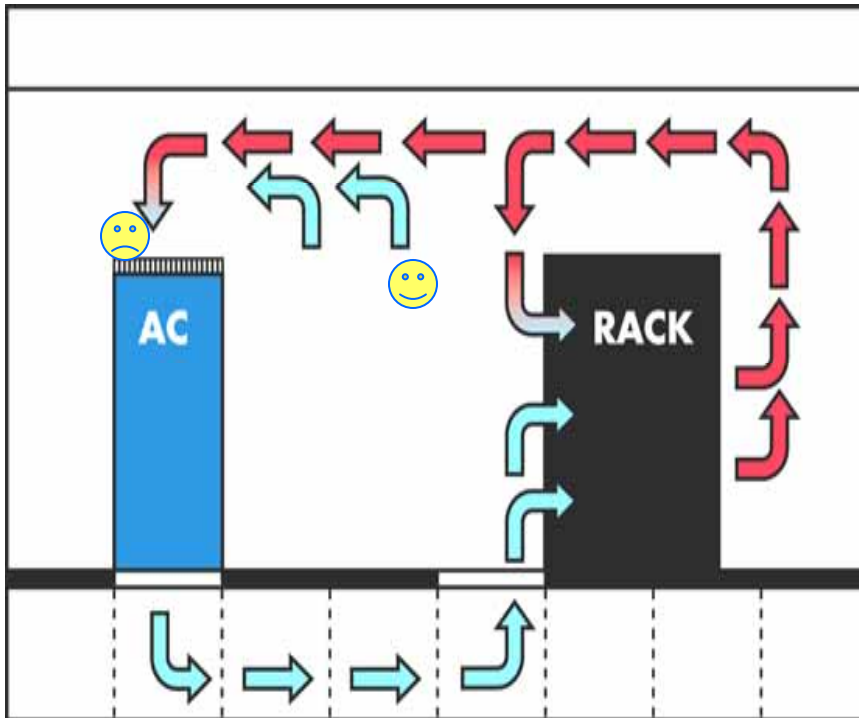

General approach:

Keep lowering the return air temperature set point 😞 to achieve acceptable temperature at inlet of the top level server 😊

Excess supply of air in typical hot/cold isle

Air flow > two times needed

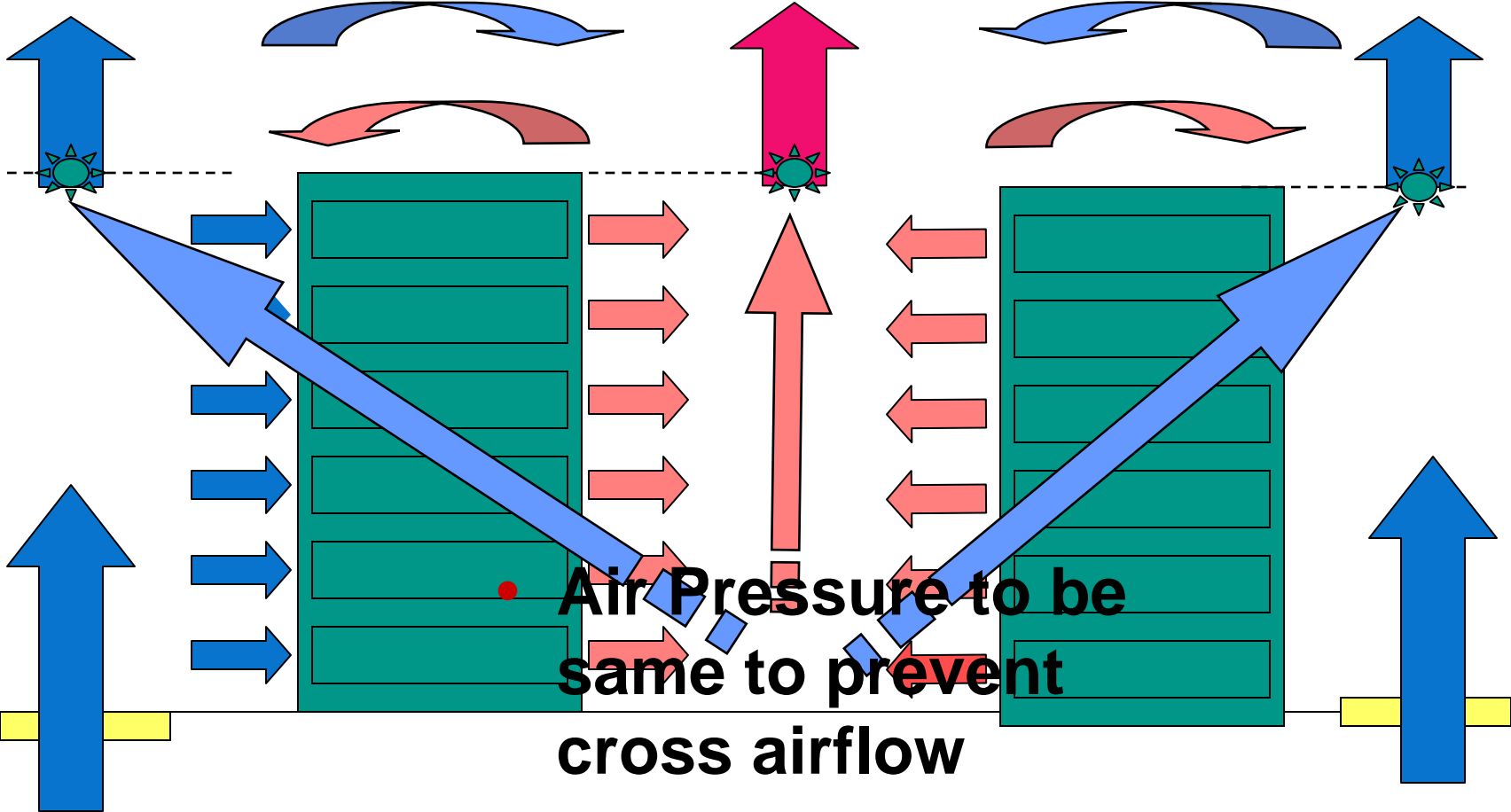

Excess airflow in data centers

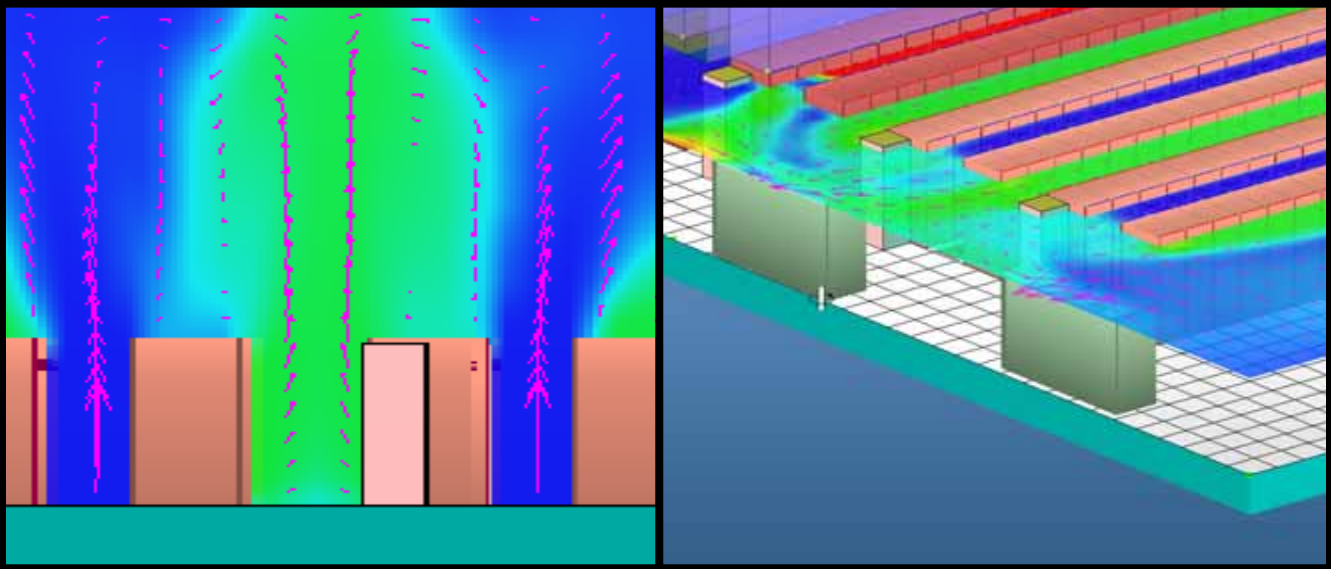

Preventing Hot/cold Isle Mixing

Create physical barriers between hot/cold air streams

- **Hot air/isle enclosure**
- **Cold air/isle enclosure**
- **Rack hot air exhaust to enclosed plenum**

Separation of hot/cold air

Applied at Austin site for expansion

- Eliminated excess air flow
- Permitted use of supply fan VFDs
- Supply air temperature raised to 68 F

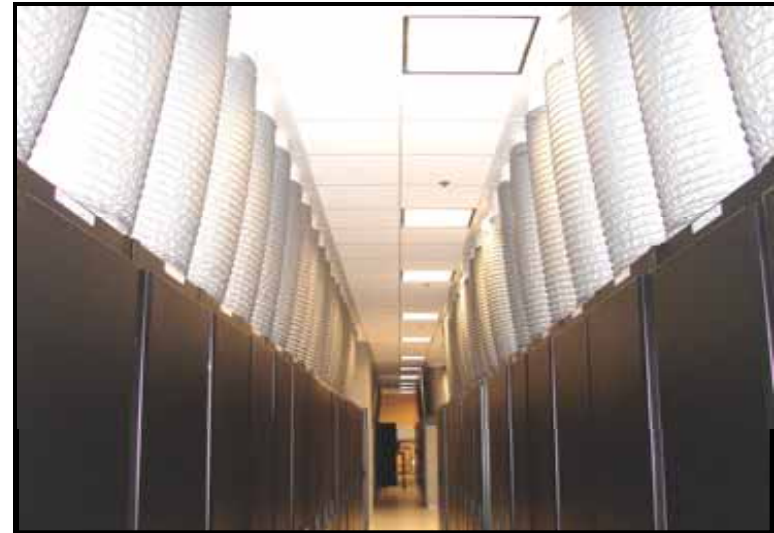
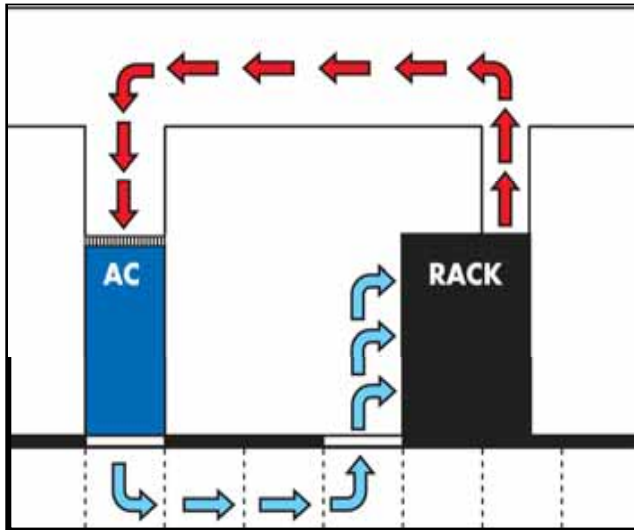

Cold/hot Isle Enclosure

...an example



Air Flow Measured Savings

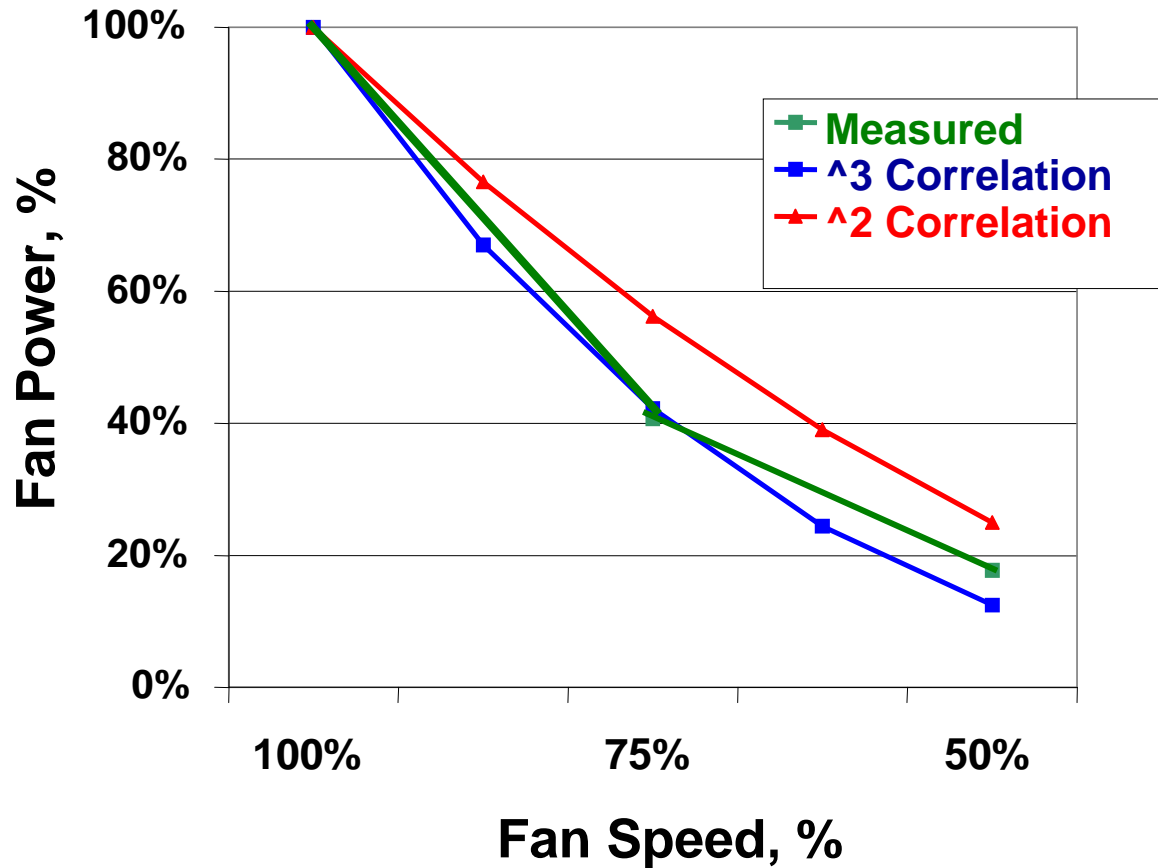

VFD Measured Economics

Estimated payback ~16 months

(based on 15% speed reduction— equal to redundancy— ~50% power reduction)

Actual payback <9 months

- due to time required to fill servers/rack in space
- VFD operating 55% speed even at full load, primarily due to separation of hot/cold air
- Obtained ~80% fan power savings

Arguments Against VFD

Beginning to Disappear...

- data center loads are constant and do not vary
...though change little from hour to hour, it does change over time
- not cost effective; it is not used in data centers
...15-20% redundancy; 15% flow reduction would payback ~16 months
- fan power is small portion of total load
...not really on annual basis
- how would you control VFD anyway?
...static pressure, rack outlet temperature
- VFD adoption rates beginning to increase
...CA utility started offering special rebates

Supply Air Temperature Raised

Absence of hot/cold air mixing allowed:

- Supply air temperature control
- Raising temperature to 68 F

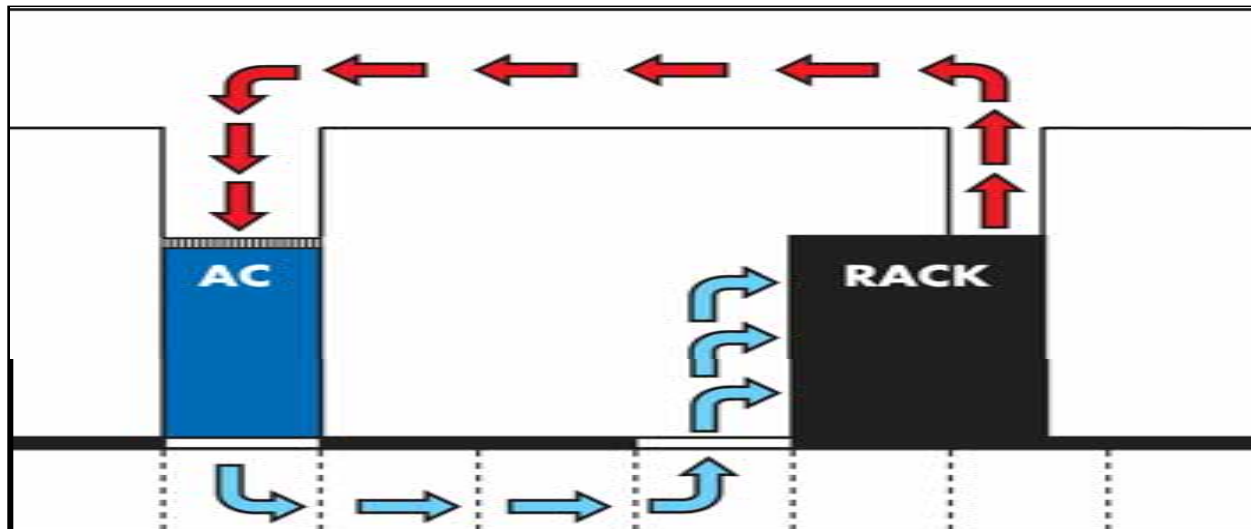

Can SA Temperature Control Be Applied in Conventional Hot/cold Isles?

How can we use it with existing infrastructure?



SA Temperature Control

Supply air temp increased to 66.2 F from 59.9 F under RA control

A 6.3 F temperature increase would allow:

- **Higher chilled water temp, say from 45 to 50 F**
- **Higher chiller efficiency**
- **Continued use of existing chillers, which are close to surging under high condensing temperatures**

Question:

Will optimized chillers be available for high temp, say 50-60 F, if SA temperature controls adopted?

Free Cooling/economizer

- Air side economizer
 - Can be used fully when ambient air below SA temperature set point
 - Large increase in number of available hours for each degree temperature set point increase (see slope of curve of cumulative hours vs. ambient temperature)
- Water side economizer
 - Available cooling increases as the chilled water SA temp increases
 - Large increase in number of available hours for each degree temperature set point increase

Free Cooling/economizer Potential

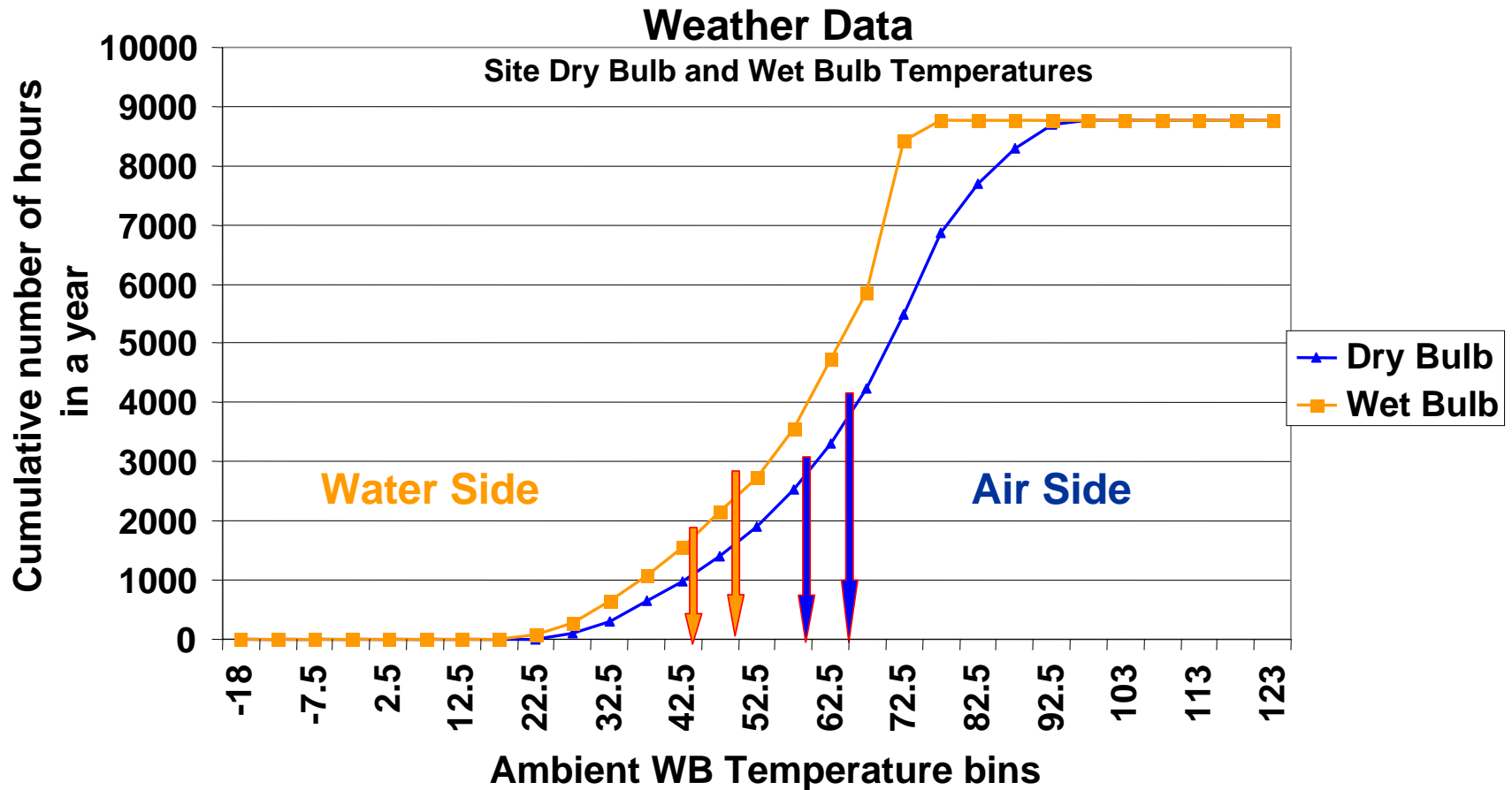

Economizer Potential: Water Side

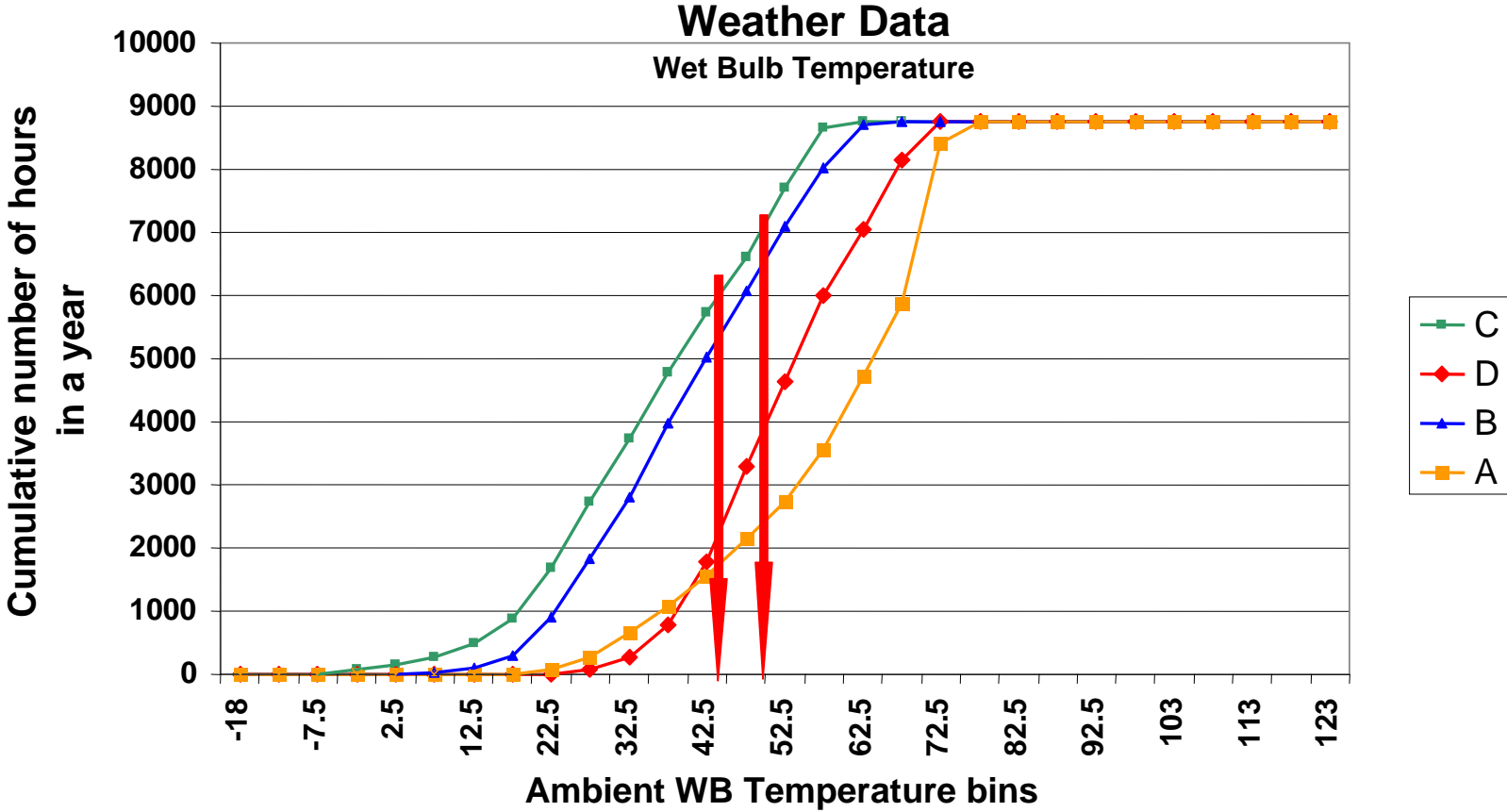

Economizer Potential: Air Side

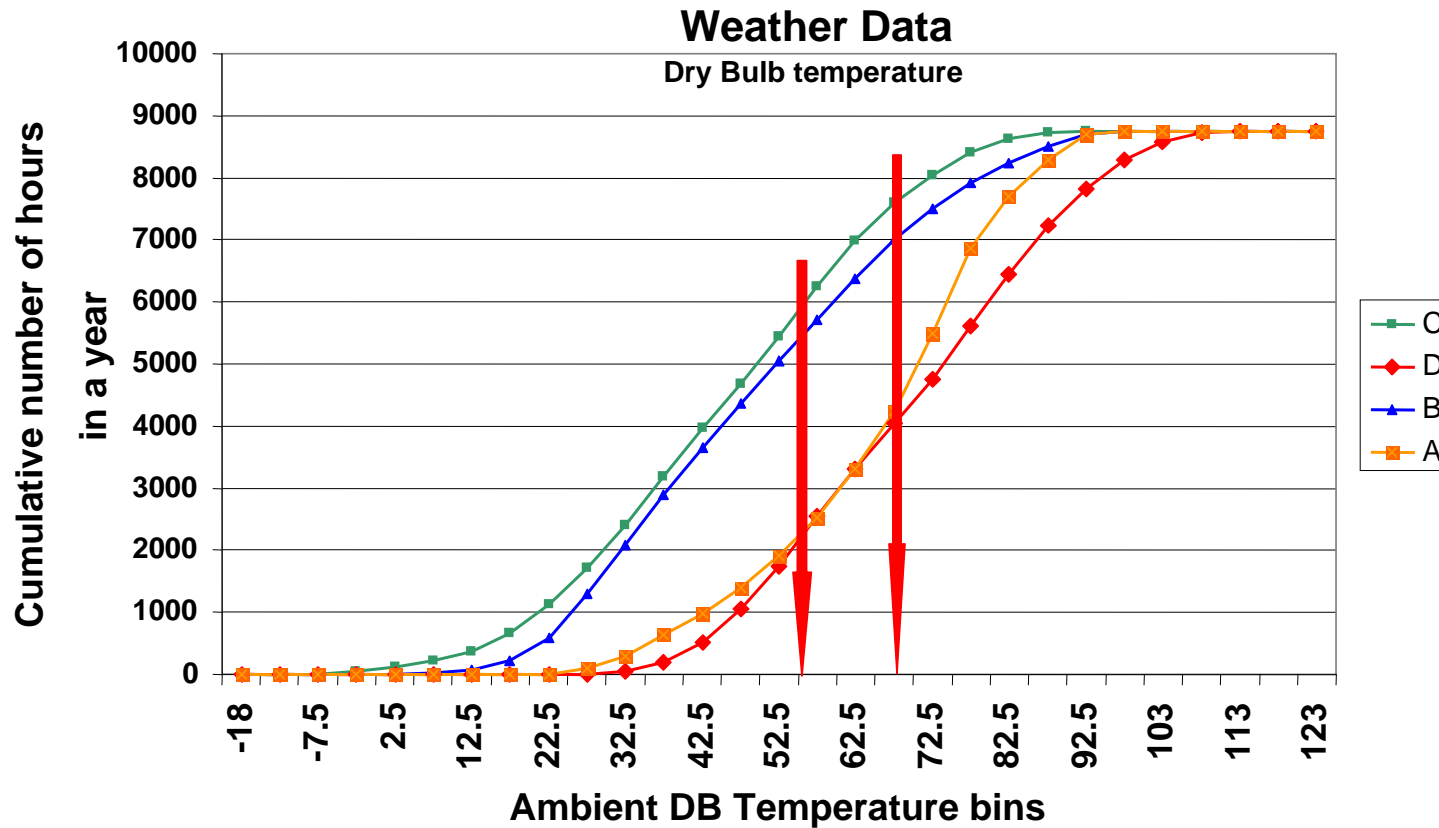

Oracle Data Centers Energy Performance

OBI has ranged from 1.2 to 0.8 in its many data centers.

However, for our Austin Data Center

OBI increased from 0.8 to 0.5 during expansion and upgrades

Significance of Benchmarking

	OBI: Support Power to IT Power Ratio				
	1 to 1	0.7 to 1	0.50 to 1	0.33 to 1	0.25 to 1
Available IT/Server Capacity, MW Load	5	5.9	6.7	7.5	8.0
Support Equipment Capacity, MW	5	4.1	3.33	2.5	2.0
Total Power, MW	10	10	10	10	10
Extra Server Capacity Available, kW, compared to support power ratio of 1 to 1	0	0.9	1.67	2.5	3
% Increase in IT/server capacity	0%	18%	33%	50%	60%

Energy Performance Goals

For the next data center:

Aspire to achieve an OBI of 0.33 kW/kW

Believe have the know how today.

Long term goal:

Working on design concepts with OBI of 0.25 kW/kW

The logo features a large, light gray 'Q' on the left and a large, light gray 'A' on the right. A red ampersand (&) is positioned in the center, overlapping both the 'Q' and the 'A'. The words 'QUESTIONS' and 'ANSWERS' are written in a black, sans-serif font across the middle of the logo, with 'QUESTIONS' on the top line and 'ANSWERS' on the bottom line.

QUESTIONS
ANSWERS