

METHOD 8151A

CHLORINATED HERBICIDES BY GC USING METHYLATION OR PENTAFLUOROBENZYLATION DERIVATIZATION

1.0 SCOPE AND APPLICATION

1.1 Method 8151 is a capillary gas chromatographic (GC) method for determining certain chlorinated acid herbicides and related compounds in aqueous, soil and waste matrices. Specifically, Method 8151 may be used to determine the following compounds:

Compound	CAS No. ^a
2,4-D	94-75-7
2,4-DB	94-82-6
2,4,5-TP (Silvex)	93-72-1
2,4,5-T	93-76-5
Dalapon	75-99-0
Dicamba	1918-00-9
Dichloroprop	120-36-5
Dinoseb	88-85-7
MCPA	94-74-6
MCPP	93-65-2
4-Nitrophenol	100-02-1
Pentachlorophenol	87-86-5

^a Chemical Abstract Service Registry Number

1.2 Because these compounds are produced and used in various forms (i.e., acid, salt, ester, etc.), Method 8151 describes a hydrolysis step that can be used to convert herbicide esters into the acid form prior to analysis. Herbicide esters generally have a half-life of less than one week in soil.

1.3 When Method 8151 is used to analyze unfamiliar samples, compound identifications should be supported by at least one additional qualitative technique. Sec. 8.4 provides gas chromatograph/mass spectrometer (GC/MS) criteria appropriate for the qualitative confirmation of compound identifications.

1.4 The estimated detection limits for each of the compounds in aqueous and soil matrices are listed in Table 1. The detection limits for a specific waste sample may differ from those listed, depending upon the nature of the interferences and the sample matrix.

1.5 The following compounds may also be determined using this method:

Compound	CAS No. ^a
Acifluorfen	50594-66-6
Bentazon	25057-89-0
Chloramben	133-90-4
DCPA diacid ^b	2136-79-0
3,5-Dichlorobenzoic acid	51-36-5
5-Hydroxydicamba	7600-50-2
Picloram	1918-02-1

^a Chemical Abstract Service Registry Number

^b DCPA monoacid and diacid metabolites included in method scope; DCPA diacid metabolite used for validation studies. DCPA is a dimethyl ester.

1.6 This method is restricted to use by or under the supervision of analysts experienced in the use of gas chromatography and skilled in the interpretation of gas chromatograms. Each analyst must demonstrate the ability to generate acceptable results with this method.

1.7 Only experienced analysts should be allowed to work with diazomethane due to the potential hazards associated with its use (explosive, carcinogenic).

2.0 SUMMARY OF METHOD

2.1 Method 8151 provides extraction, derivatization, and gas chromatographic conditions for the analysis of chlorinated acid herbicides in water, soil, and waste samples. An option for the hydrolysis of esters is also described.

2.2 Water samples are extracted with diethyl ether and then esterified with either diazomethane or pentafluorobenzyl bromide. The derivatives are determined by gas chromatography with an electron capture detector (GC/ECD). The results are reported as acid equivalents.

2.3 Soil and waste samples are extracted and esterified with either diazomethane or pentafluorobenzyl bromide. The derivatives are determined by gas chromatography with an electron capture detector (GC/ECD). The results are reported as acid equivalents.

2.4 If herbicide esters are to be determined using this method, hydrolysis conditions for the esters in water and soil extracts are described.

2.5 The sensitivity of Method 8151 depends on the level of interferences in addition to instrumental limitations. Table 1 lists the GC/ECD and GC/MS detection limits that can be obtained in aqueous and soil matrices in the absence of interferences. Detection limits for a typical waste sample should be higher.

3.0 INTERFERENCES

3.1 Refer to Method 8000.

3.2 Method interferences may be caused by contaminants in solvents, reagents, glassware, and other sample processing hardware that lead to discrete artifacts or elevated baselines in gas chromatograms. All these materials must be routinely demonstrated to be free from interferences under the conditions of the analysis, by analyzing reagent blanks.

3.2.1 Glassware must be scrupulously cleaned. Clean each piece of glassware as soon as possible after use by rinsing it with the last solvent used in it. This should be followed by detergent washing with hot water and rinses with tap water, then with organic-free reagent water. Glassware should be solvent-rinsed with acetone and pesticide-quality hexane. After rinsing and drying, glassware should be sealed and stored in a clean environment to prevent any accumulation of dust or other contaminants. Store glassware inverted or capped with aluminum foil. Immediately prior to use, glassware should be rinsed with the next solvent to be used.

3.2.2 The use of high purity reagents and solvents helps to minimize interference problems. Purification of solvents by distillation in all-glass systems may be required.

3.3 Matrix interferences may be caused by contaminants that are coextracted from the sample. The extent of matrix interferences will vary considerably from waste to waste, depending upon the nature and diversity of the waste being sampled.

3.4 Organic acids, especially chlorinated acids, cause the most direct interference with the determination by methylation. Phenols, including chlorophenols, may also interfere with this procedure. The determination using pentafluorobenzoylation is more sensitive, and more prone to interferences from the presence of organic acids or phenols than by methylation.

3.5 Alkaline hydrolysis and subsequent extraction of the basic solution removes many chlorinated hydrocarbons and phthalate esters that might otherwise interfere with the electron capture analysis. However, hydrolysis may result in the loss of dinoseb and the formation of aldol condensation products if any residual acetone remains from the extraction of solids.

3.6 The herbicides, being strong organic acids, react readily with alkaline substances and may be lost during analysis. Therefore, glassware must be acid-rinsed and then rinsed to constant pH with organic-free reagent water. Sodium sulfate must be acidified.

3.7 Sample extracts should be dry prior to methylation or else poor recoveries will be obtained.

4.0 APPARATUS AND MATERIALS

4.1 Gas chromatograph - Analytical system complete with gas chromatograph suitable for Grob-type injection using capillary columns, and all required accessories including detector, capillary analytical columns, recorder, gases, and syringes. A data system for measuring peak heights and/or peak areas is recommended.

4.2 GC columns

The analyst may choose either narrow-bore or wide-bore GC columns. Narrow-bore column 1a is useful for GC/MS confirmation of these analytes. When using an electron capture detector, analyses two columns are necessary to provide confirmation of identifications.

Although not specifically evaluated under the chromatographic conditions described in this procedure, the analyst may opt to configure the GC for simultaneous dual-column operation using commercially-available Y-adapters to connect both columns to a single injector port and employing a separate electron capture detector for each column.

4.2.1 Narrow-bore columns

4.1.2.1 Primary column 1 - 30 m x 0.25 mm, 5% phenyl/95% methyl silicone (DB-5, J&W Scientific, or equivalent), 0.25 μ m film thickness.

4.1.2.2 Primary column 1a (GC/MS) - 30 m x 0.32 mm, 5% phenyl/95% methyl silicone, (DB-5, J&W Scientific, or equivalent), 1 μ m film thickness.

4.1.2.3 Column 2 - 30 m x 0.25 mm, 35% phenyl methylpolysiloxane (DB-608, J&W Scientific or equivalent), a 0.25 μ m film thickness.

4.1.2.4 Confirmation column - 30 m x 0.25 mm, 14% cyanopropyl phenyl silicone, (DB-1701, J&W Scientific, or equivalent), 0.25 μ m film thickness.

4.2.2 Wide-bore columns

4.2.2.1 Primary Column - 30 m x 0.53 mm DB-608 (J&W Scientific or equivalent) with 0.83 μ m film thickness.

4.2.2.2 Confirmation Column - 30 m x 0.53 mm, 14% cyanopropyl phenyl silicone, (DB-1701, J&W Scientific, or equivalent), 1.0 μ m film thickness.

4.3 Electron capture detector (ECD).

4.4 Kuderna-Danish (K-D) apparatus.

4.4.1 Concentrator tube - 10-mL graduated (Kontes K-570050-1025 or equivalent). A ground-glass stopper is used to prevent evaporation of extracts.

4.4.2 Evaporation flask - 500-mL (Kontes K-570001-500 or equivalent). Attach to concentrator tube with springs, clamps, or equivalent.

4.4.3 Snyder column - Three-ball macro (Kontes K-503000-0121 or equivalent).

4.4.4 Snyder column - Two-ball micro (Kontes K-569001-0219 or equivalent).

4.4.5 Springs - 1/2 inch (Kontes K-662750 or equivalent).

NOTE: The following glassware is recommended for the purpose of solvent recovery during the concentration procedures requiring the use of Kuderna-Danish evaporative concentrators. Incorporation of this apparatus may be required

by State or local municipality regulations that govern air emissions of volatile organics. EPA recommends the incorporation of this type of reclamation system as a method to implement an emissions reduction program. Solvent recovery is a means to conform with waste minimization and pollution prevention initiatives.

4.4.6 Solvent vapor recovery system (Kontes K-545000-1006 or K-547300-0000, Ace Glass 6614-30, or equivalent).

4.5 Diazomethane generator - Refer to Sec. 7.5 to determine which method of diazomethane generation should be used for a particular generation.

4.5.1 Diazald kit - Recommended for the generation of diazomethane (Aldrich Chemical Co., Catalog No. 210,025-0, or equivalent).

4.5.2 As an alternative, assemble from two 20 mm x 150 mm test tubes, two Neoprene rubber stoppers, and a source of nitrogen. Use Neoprene rubber stoppers with holes drilled in them to accommodate glass delivery tubes. The exit tube must be drawn to a point to bubble diazomethane through the sample extract. The generator assembly is shown in Figure 1. The procedure for use of this type of generator is given in Sec. 7.5.

4.6 Beaker - 400-mL, thick-walled.

4.7 Funnel - 75 mm diameter.

4.8 Separatory funnel - 500-mL, with polytetrafluoroethylene (PTFE) stopcock.

4.9 Centrifuge bottle - 500-mL, Pyrex® 1260 or equivalent.

4.10 Erlenmeyer flasks - 250-mL and 500-mL, with a ground-glass joint at the neck.

4.11 Pipet - Pasteur, glass, disposable (140 mm x 5 mm ID).

4.12 Vials - 10-mL, glass, with PTFE-lined screw-caps.

4.13 Volumetric flasks, Class A - 10-mL to 1000-mL.

4.14 Filter paper - 15 cm diameter (Whatman No. 1 or equivalent).

4.15 Glass wool - Pyrex®, acid washed.

4.16 Boiling chips - Solvent-extracted with methylene chloride, approximately 10/40 mesh (silicon carbide or equivalent).

4.17 Water bath - Heated, with concentric ring cover, capable of temperature control ($\pm 2^{\circ}\text{C}$). The bath should be used in a hood.

4.18 Balance - Analytical, capable of accurately weighing to 0.0001 g.

4.19 Centrifuge.

4.20 Ultrasonic extraction system - A horn-type device equipped with a titanium tip, or a device that will give equivalent performance, should be used. The disrupter must have a minimum power wattage of 300 watts, with pulsing capability. A device designed to reduce the cavitation sound is recommended. Follow the manufacturer's instructions for preparing the disrupter for extraction of samples. Use a 3/4" horn for most samples.

4.21 Sonabox - Recommended with above disrupters for decreasing cavitation sound (Heat Systems - Ultrasonics, Inc., Model 432B or equivalent).

4.22 pH paper - wide range

4.23 Silica gel cleanup column (Bond Elut™ - Analytichem, Harbor City, CA or equivalent).

4.24 Microsyringe - 10- μ L.

4.25 Wrist shaker - Burrell Model 75 or equivalent.

4.26 Drying column - 400 mm x 20 mm ID Pyrex® chromatographic column with Pyrex® glass wool at bottom and a PTFE stopcock.

NOTE: Fritted glass discs are difficult to decontaminate after highly contaminated extracts have been passed through. Columns without frits may be purchased. Use a small pad of Pyrex® glass wool to retain the adsorbent. Prewash the glass wool pad with 50 mL of acetone followed by 50 mL of elution solvent prior to packing the column with adsorbent.

5.0 REAGENTS

5.1 Reagent grade inorganic chemicals shall be used in all tests. Unless otherwise indicated, it is intended that all reagents shall conform to the specifications of the Committee on Analytical Reagents of the American Chemical Society, where such specifications are available. Other grades may be used, provided it is first ascertained that the reagent is of sufficiently high purity to permit its use without lessening the accuracy of the determination.

5.2 Organic-free reagent water. All references to water in this method refer to organic-free water, as defined in Chapter One.

5.3 Sodium hydroxide solution (0.1 N), NaOH - Dissolve 4 g of NaOH in organic-free reagent water and dilute to 1.0 L.

5.4 Potassium hydroxide solution (37% aqueous solution (w/v)), KOH - Dissolve 37 g of potassium hydroxide pellets in organic-free reagent water and dilute to 100 mL.

5.5 Phosphate buffer (0.1 M), pH = 2.5 - Dissolve 12 g sodium phosphate (NaH_2PO_4) in organic-free reagent water and dilute to 1.0 L. Add phosphoric acid to adjust the pH to 2.5.

5.6 N-methyl-N-nitroso-p-toluenesulfonamide (Diazald) - High purity (Aldrich Chemical Co., or equivalent).

5.7 Silicic acid, H_2SiO_5 - 100-mesh powder, store at 130°C.

5.8 Potassium carbonate, K_2CO_3 .

5.9 2,3,4,5,6-Pentafluorobenzyl bromide (PFBBR), $C_6F_5CH_2Br$ - Pesticide quality or equivalent.

5.10 Sodium sulfate (granular, acidified, anhydrous), Na_2SO_4 - Purify by heating at 400°C for 4 hours in a shallow tray, or by precleaning the sodium sulfate with methylene chloride. If the sodium sulfate is precleaned with methylene chloride, a method blank must be analyzed, demonstrating that there is no interference from the sodium sulfate. Acidify by slurring 100 g sodium sulfate with enough diethyl ether to just cover the solid; then add 0.1 mL of concentrated sulfuric acid and mix thoroughly. Remove the ether under vacuum. Mix 1 g of the resulting solid with 5 mL of organic-free reagent water and measure the pH of the mixture. It must be below a pH of 4. Store the remaining solid at 130°C.

5.11 Solvents - All solvents should be pesticide quality or equivalent.

5.11.1 Methylene chloride, CH_2Cl_2 .

5.11.2 Acetone, CH_3COCH_3 .

5.11.3 Methanol, CH_3OH .

5.11.4 Toluene, $C_6H_5CH_3$.

5.11.5 Diethyl Ether, $C_2H_5OC_2H_5$. Must be free of peroxides as indicated by test strips (EM Quant, or equivalent). Procedures for removal of peroxides are provided with the test strips.

NOTE: Diethyl ether used for this procedure should be stabilized with BHT, not with ethanol, as when ethanol-stabilized ether is used, the methylation reaction may not proceed efficiently, leading to low recoveries of target analytes.

5.11.6 Isooctane, $(CH_3)_3CH_2CH(CH_3)_2$.

5.11.7 Hexane, C_6H_{14} .

5.11.8 Carbitol (diethylene glycol monoethyl ether), $C_2H_5OCH_2CH_2OCH_2CH_2O$ - optional, for producing alcohol-free diazomethane.

5.12 Stock standard solutions (1000 mg/L) - May be prepared from pure standard materials or purchased as certified solutions.

5.12.1 Prepare stock standard solutions by accurately weighing about 0.010 g of pure acid. Dissolve the material in pesticide quality acetone and dilute to volume in a 10-mL volumetric flask. Stocks prepared from pure methyl esters are dissolved in 10% acetone/isooctane (v/v). Larger volumes may be used at the convenience of the analyst. If compound purity is certified at 96% or greater, the weight may be used without correction to calculate the concentration of the stock standard.

5.12.2 Transfer the stock standard solutions to vials with PTFE-lined screw-caps. Store at 4°C, protected from light. Stock standard solutions should be checked frequently for signs of degradation or evaporation, especially immediately prior to preparing calibration standards from them.

5.12.3 Stock standard solutions of the derivatized acids must be replaced after 1 year, or sooner, if comparison with check standards indicates a problem. Stock standard solutions of the free acids degrade more quickly and should be replaced after two months, or sooner if comparison with check standards indicates a problem.

5.13 Internal Standard Spiking Solution (if internal standard calibration is used) - To use this approach, the analyst must select one or more internal standards that are similar in analytical behavior to the compounds of interest. The analyst must further demonstrate that the measurement of the internal standard is not affected by method or matrix interferences.

5.13.1 The compound 4,4'-dibromooctafluorobiphenyl (DBOB) has been shown to be an effective internal standard, but other compounds, such as 1,4-dichlorobenzene, may be used if there is a DBOB interference.

5.13.2 Prepare an internal standard spiking solution by accurately weighing approximately 0.0025 g of pure DBOB. Dissolve the DBOB in acetone and dilute to volume in a 10 mL volumetric flask. Transfer the internal standard spiking solution to a vial with a PTFE-lined screw-cap, and store at room temperature. Addition of 10 μ L of the internal standard spiking solution to 10 mL of sample extract results in a final internal standard concentration of 0.25 μ g/L. The solution should be replaced if there is a change in internal standard response greater than 20 percent of the original response recorded.

5.14 Calibration standards - Prepare a minimum of five different concentrations for each parameter of interest, through dilution of the stock standards with diethyl ether or hexane. One of the standards should be at a concentration near, but above, the method detection limit. The remaining standards should correspond to the expected range of concentrations found in real samples or should define the working range of the GC. Calibration solutions must be replaced after six months, or sooner if comparison with check standards indicates a problem.

5.14.1 Derivatize each calibration standard prepared from free acids in a 10-mL K-D concentrator tube, according to the procedures beginning at Sec. 7.5.

5.14.2 Add a known, constant, amount of one or more internal standards to each derivatized calibration standard, and dilute to volume with the solvent indicated in the derivative option used.

5.15 Surrogate standards - The analyst should monitor the performance of the extraction, cleanup (when used), and determinative step, and the effectiveness of the method in dealing with each sample matrix, by spiking each sample, standard, and blank with one or two herbicide surrogates (e.g., herbicides that are not expected to be present in the sample) recommended to encompass the range of the temperature program used in this method. Deuterated analogs of analytes should not be used as surrogates in gas chromatographic analysis due to coelution problems.

5.15.1 The recommended surrogate is 2,4-Dichlorophenylacetic acid (DCAA).

5.15.2 Prepare a surrogate spiking solution by accurately weighing approximately 0.001 g of pure DCAA. Dissolve the DCAA in acetone, and dilute to volume in a 10-mL volumetric flask. Transfer the surrogate spiking solution to a vial with a PTFE-lined screw-cap, and store at room temperature. Addition of 50 μ L of the surrogate spiking solution to 1 L of sample, prior to extraction, results in a final concentration in the extract of 0.5 mg/L.

5.16 pH Adjustment Solutions

5.16.1 Sodium hydroxide, NaOH, 6 N.

5.16.2 Sulfuric acid, H₂SO₄, 12 N.

6.0 SAMPLE COLLECTION, PRESERVATION, AND HANDLING

6.1 See the introductory material to this chapter, Organic Analytes, Sec. 4.1. One-Liter samples should be collected.

6.2 Extracts must be stored under refrigeration (4°C) and protected from light.

7.0 PROCEDURE

7.1 Extraction and hydrolysis of high concentration waste samples

7.1.1 Follow Method 3580, Waste Dilution, with the following exceptions:

7.1.1.1 Use diethyl ether as the dilution solvent.

7.1.1.2 Use acidified anhydrous sodium sulfate and acidified glass wool.

7.1.1.3 Spike the sample with surrogate(s) according to Sec. 5.15.

7.1.2 If the sample is to be analyzed for both herbicide esters and acids, then the sample extract must be hydrolyzed. In this case, transfer 1.0 mL (a smaller volume or a dilution may be required if herbicide concentrations are large) to a 250-mL Erlenmeyer flask with a ground-glass joint at the neck. Proceed to Sec. 7.2.3. If the analysis is for acid herbicides only, proceed to Sec. 7.5 for derivatization by diazomethane (if PFB derivatization is selected, reduce the volume of diethyl ether to 0.1 -0.5 mL as per Sec. 7.2 and then dilute to 4 mL with acetone).

7.2 Extraction and hydrolysis of soil, sediment, and other solid samples

Two extraction procedures are applicable to solid samples: ultrasonic extraction and shaker extraction. The same hydrolysis procedures (Sec. 7.2.3) apply to both types of extracts.

7.2.1 Ultrasonic extraction

7.2.1.1 Add 30 g (dry weight) of the well-mixed solid sample to a 400-mL thick-wall beaker. Adjust the pH to 2 with concentrated hydrochloric acid or acidify solids in the beaker with 85 mL of 0.1 M phosphate buffer (pH = 2.5) and thoroughly mix the contents with a glass stirring rod. Spike the sample with surrogate(s) (Sec. 5.15).

7.2.1.2 The ultrasonic extraction of solids must be optimized for each type of sample. In order for the ultrasonic extractor to efficiently extract solid samples, the sample must be free flowing when the solvent is added. Acidified anhydrous sodium sulfate should be added to clay type soils (normally 1:1), or any other solid that is not a free flowing sandy mixture, until a free flowing mixture is obtained.

7.2.1.3 Add 100 mL of methylene chloride/acetone (1:1 v/v) to the beaker. Perform ultrasonic extraction for 3 minutes, with output control knob set at 10 (full power) and with mode switch on Pulse (pulsing energy rather than continuous energy) and percent-duty cycle knob set at 50% (energy on 50% of time and off 50% of time). Allow the solids to settle. Transfer the organic layer into a 500-mL centrifuge bottle.

7.2.1.4 Ultrasonically extract the sample twice more using 100 mL of methylene chloride and the same ultrasonic conditions.

7.2.1.5 Combine the three organic extracts from the sample in the centrifuge bottle and centrifuge 10 minutes to settle the fine particles. Filter the combined extract through filter paper (Whatman #1, or equivalent) containing 7-10 g of acidified sodium sulfate into a 500-mL 24/40 Erlenmeyer flask. Add 10 g of acidified anhydrous sodium sulfate. Periodically, vigorously shake the extract and drying agent and allow the drying agent to remain in contact with the extract for a minimum of 2 hours. See NOTE in Sec. 7.3.6 that emphasizes the need for a dry extract prior to esterification.

7.2.1.6 Quantitatively transfer the contents of the flask to a 500-mL K-D flask with a 10-mL concentrator tube attached. Add boiling chips and attach the macro Snyder column. Evaporate the extract on the water bath to a volume of approximately 5 mL. Remove the flasks from the water bath and allow them to cool.

7.2.1.7 If hydrolysis or additional cleanup is not required and the sample is dry, proceed to Sec. 7.4.4. Otherwise, proceed to Sec. 7.2.3 for hydrolysis or Sec. 7.2.4 for cleanup.

7.2.2 Shaker extraction

7.2.2.1 Add 50 g (dry weight) of the well mixed, moist solid sample to a 500-mL wide-mouth Erlenmeyer flask. Adjust the pH to 2 with concentrated HCl and monitor the pH for 15 minutes with occasional stirring. If necessary, add additional HCl until the pH remains at 2. Spike the sample with surrogate(s) (Sec. 5.15).

7.2.2.2 Add 20 mL of acetone to the flask and mix the contents with the wrist shaker for 20 minutes. Add 80 mL diethyl ether to the same flask and shake again for 20 minutes. Decant the extract and measure the volume of solvent recovered.

7.2.2.3 Extract the sample twice more using 20 mL of acetone followed by 80 mL of diethyl ether. After addition of each solvent, the mixture should be shaken with the wrist shaker for 10 minutes and the acetone-ether extract decanted.

7.2.2.4 After the third extraction, the volume of extract recovered should be at least 75% of the volume of added solvent. If this is not the case, additional extractions may be necessary. Combine the extracts in a 2-L separatory funnel containing 250 mL of reagent water. If an emulsion forms, slowly add 5 g of acidified sodium sulfate (anhydrous) until the solvent-water mixture separates. A quantity of acidified sodium sulfate equal to the weight of the sample may be added, if necessary.

7.2.2.5 Check the pH of the extract. If it is not at or below pH 2, add more concentrated HCl until stabilized at the desired pH. Gently mix the contents of the separatory funnel for 1 minute and allow the layers to separate. Collect the aqueous phase in a clean beaker and the extract phase (top layer) in a 500-mL ground glass-

stoppered Erlenmeyer flask. Place the aqueous phase back into the separatory funnel and re-extract using 25 mL of diethyl ether. Allow the layers to separate and discard the aqueous layer. Combine the ether extracts in a 500-mL K-D flask.

7.2.2.6 If hydrolysis or additional cleanup is not required and the sample is dry, proceed to Sec. 7.4.4. Otherwise, proceed to Sec. 7.2.3 for hydrolysis or Sec. 7.2.4 for extract cleanup.

7.2.3 Hydrolysis of soil, sediment, or other solid sample extracts

Use this step only if herbicide esters in addition to herbicide acids are to be determined.

7.2.3.1 Add 5 mL of 37% aqueous potassium hydroxide and 30 mL of water to the extract. Add additional boiling chips to the K-D flask. Reflux the mixture on a water bath at 60 - 65°C until the hydrolysis step is completed (usually 1 - 2 hours). Remove the flasks from the water bath and cool to room temperature.

CAUTION: The presence of residual acetone will result in the formation of aldol condensation products which will cause GC interference.

7.2.3.2 Transfer the hydrolyzed aqueous solution to a 500-mL separatory funnel and extract the solution three times with 100-mL portions of methylene chloride. Discard the methylene chloride phase. At this point, the basic (aqueous) solution contains the herbicide salts.

7.2.3.3 Adjust the pH of the solution to <2 with cold (4°C) sulfuric acid (1:3) and extract once with 40 mL of diethyl ether and twice with 20-mL portions of ether. Combine the extracts and pour them through a pre-rinsed drying column containing 7 to 10 cm of acidified anhydrous sodium sulfate. Collect the dried extracts in a 500-mL Erlenmeyer flask (with a 24/40 joint) containing 10 g of acidified anhydrous sodium sulfate. Periodically, vigorously shake the extract and drying agent and allow the drying agent to remain in contact with the extract for a minimum of 2 hours. See NOTE in Sec. 7.3.6 that emphasizes the need for a dry extract prior to esterification. Quantitatively transfer the contents of the flask to a 500-mL Kuderna-Danish flask with a 10-mL concentrator tube attached when the extract is known to be dry.

7.2.3.4 Proceed to Sec. 7.4 for extract concentration. If additional cleanup is required, proceed to Sec. 7.2.4.

7.2.4 Cleanup of non-hydrolyzed herbicides

Use this step if additional cleanup of the non-hydrolyzed herbicides is required.

7.2.4.1 Partition the herbicides by extracting the methylene chloride from 7.2.1.7 (or diethyl ether from 7.2.3.4) three times with 15-mL portions of aqueous base prepared by carefully mixing 30 mL of reagent water into 15 mL of 37% aqueous potassium hydroxide. Discard the methylene chloride or ether phase. At this point the basic (aqueous) solution contains the herbicide salts.

7.2.4.2 Adjust the pH of the solution to <2 with cold (4°C) sulfuric acid (1:3) and extract once with 40 mL of diethyl ether and twice with 20-mL portions of ether. Combine the extracts and pour them through a pre-rinsed drying column containing 7-10 cm of

acidified anhydrous sodium sulfate. Collect the dried extracts in a 500-mL Erlenmeyer flask (with a 24/40 joint) containing 10 g of acidified anhydrous sodium sulfate. Periodically, vigorously shake the extract and drying agent and allow the drying agent to remain in contact with the extract for a minimum of 2 hours. See NOTE in Sec. 7.3.6 that emphasizes the need for a dry extract prior to esterification. Quantitatively transfer the contents of the flask to a 500-mL Kuderna-Danish flask with a 10-mL concentrator tube attached when the extract is known to be dry.

7.2.4.3 Proceed to Sec. 7.4 for extract concentration.

7.3 Preparation of aqueous samples

7.3.1 Using a graduated cylinder, transfer a 1-L sample aliquot to a 2-L separatory funnel. Spike the sample with surrogate compound(s) according to Sec. 5.15.

7.3.2 Add 250 g of NaCl to the sample, seal, and shake to dissolve the salt.

7.3.3 Use this step only if herbicide esters, in addition to herbicide acids, are to be determined

7.3.3.1 Add 17 mL of 6 N NaOH to the sample, seal, and shake. Check the pH of the sample with pH paper. If the sample does not have a pH greater than or equal to 12, adjust the pH by adding more 6 N NaOH. Let the sample sit at room temperature until the hydrolysis step is completed (usually 1 - 2 hours), shaking the separatory funnel and contents periodically.

7.3.3.2 Add 60 mL of methylene chloride to the sample bottle and rinse both the bottle and the graduated cylinder. Transfer the methylene chloride to the separatory funnel and extract the sample by vigorously shaking the funnel for 2 minutes, with periodic venting to release excess pressure. Allow the organic layer to separate from the water phase for a minimum of 10 minutes. If the emulsion interface between the layers is more than one-third the volume of the solvent layer, the analyst must employ mechanical techniques to complete the phase separation. The optimum technique depends upon the sample, but may include stirring, filtration through glass wool, centrifugation, or other physical methods. Discard the methylene chloride phase.

7.3.3.3 Add a second 60-mL volume of methylene chloride to the separatory funnel and repeat the extraction procedure a second time, discarding the methylene chloride layer. Perform a third extraction in the same manner.

7.3.4 Add 17 mL of cold (4°C) 12 N sulfuric acid to the sample (or hydrolyzed sample), seal, and shake to mix. Check the pH of the sample with pH paper. If the sample does not have a pH less than or equal to 2, adjust the pH by adding more acid.

7.3.5 Add 120 mL diethyl ether to the sample, seal, and extract the sample by vigorously shaking the funnel for 2 min with periodic venting to release excess pressure. Allow the organic layer to separate from the water phase for a minimum of 10 min. If the emulsion interface between layers is more than one third the volume of the solvent layer, the analyst must employ mechanical techniques to complete the phase separation. The optimum techniques to complete the phase separation depends upon the sample, but may include stirring, filtration through glass wool, centrifugation, or other physical methods. Remove the aqueous phase to a 2-L Erlenmeyer flask and collect the ether phase in a 500-mL Erlenmeyer

flask containing approximately 10 g of acidified anhydrous sodium sulfate. Periodically, vigorously shake the extract and drying agent.

7.3.6 Return the aqueous phase to the separatory funnel, add 60 mL of diethyl ether to the sample, and repeat the extraction procedure a second time, combining the extracts in the 500-mL Erlenmeyer flask. Perform a third extraction with 60 mL diethyl ether in the same manner. Allow the extract to remain in contact with the sodium sulfate for approximately 2 hours.

NOTE: The drying step is very critical to ensuring complete esterification. Any moisture remaining in the ether will result in low herbicide recoveries. The amount of sodium sulfate is adequate if some free flowing crystals are visible when swirling the flask. If all of the sodium sulfate solidifies in a cake, add a few additional grams of acidified sodium sulfate and again test by swirling. The 2 hour drying time is a minimum, however, the extracts may be held in contact with the sodium sulfate overnight.

7.3.7 Pour the dried extract through a funnel plugged with acid washed glass wool, and collect the extract in the K-D concentrator. Use a glass rod to crush any caked sodium sulfate during the transfer. Rinse the Erlenmeyer flask and funnel with 20 to 30 mL of diethyl ether to complete the quantitative transfer. Proceed to Sec. 7.4 for extract concentration.

7.4 Extract concentration

7.4.1 Add one or two clean boiling chips to the flask and attach a three-ball Snyder column. Prewet the Snyder column by adding about 1 mL of diethyl ether to the top of the column. Attach the solvent vapor recovery glassware (condenser and collection device) (Sec. 4.4.6) to the Snyder column of the K-D apparatus following manufacturer's instructions. Place the K-D apparatus on a hot water bath (15 - 20°C above the boiling point of the solvent) so that the concentrator tube is partially immersed in the hot water and the entire lower rounded surface of the flask is bathed with hot vapor. Adjust the vertical position of the apparatus and the water temperature, as required, to complete the concentration in 10 - 20 minutes. At the proper rate of distillation the balls of the column will actively chatter, but the chambers will not flood. When the apparent volume of liquid reaches 1 mL, remove the K-D apparatus from the water bath and allow it to drain and cool for at least 10 minutes.

7.4.2 Remove the Snyder column and rinse the flask and its lower joints into the concentrator tube with 1 - 2 mL of diethyl ether. The extract may be further concentrated by using either the micro Snyder column technique (Sec. 7.4.3) or nitrogen blowdown technique (Sec. 7.4.4).

7.4.3 Micro Snyder column technique

7.4.3.1 Add another one or two clean boiling chips to the concentrator tube and attach a two-ball micro Snyder column. Prewet the column by adding about 0.5 mL of diethyl ether to the top of the column. Place the K-D apparatus in a hot water bath so that the concentrator tube is partially immersed in the hot water. Adjust the vertical position of the apparatus and the water temperature, as required, to complete the concentration in 5-10 minutes. At the proper rate of distillation the balls of the column will actively chatter, but the chambers will not flood. When the apparent volume of liquid reaches 0.5 mL, remove the K-D apparatus from the water bath and allow it to drain and cool for at least 10 minutes. Remove the Snyder column, rinse the flask and its lower

joints with about 0.2 mL of diethyl ether and add to the concentrator tube. Proceed to Sec. 7.4.5.

7.4.4 Nitrogen blowdown

7.4.4.1 Place the concentrator tube in a warm water bath (approximately 35°C) and evaporate the solvent volume to the required level using a gentle stream of clean, dry nitrogen (filtered through a column of activated carbon).

CAUTION: Do not use plasticized tubing between the carbon trap and the sample.

7.4.4.2 The internal wall of the tube must be rinsed down several times with diethyl ether during the operation. During evaporation, the solvent level in the tube must be positioned to prevent water from condensing into the sample (i.e., the solvent level should be below the level of the water bath). Under normal operating conditions, the extract should not be allowed to become dry. Proceed to Sec. 7.4.5.

7.4.5 Dilute the extract with 1 mL of isooctane and 0.5 mL of methanol. Dilute to a final volume of 4 mL with diethyl ether. The sample is now ready for methylation with diazomethane. If PFB derivation is being performed, dilute to 4 mL with acetone.

7.5 Esterification - For diazomethane derivatization proceed with Sec. 7.5.1. For PFB derivatization proceed with Sec. 7.5.2.

7.5.1 Diazomethane derivatization - Two methods may be used for the generation of diazomethane: the bubbler method (see Figure 1), Sec. 7.5.1.1, and the Diazald kit method, Sec. 7.5.1.2.

CAUTION: Diazomethane is a carcinogen and can explode under certain conditions.

The bubbler method is suggested when small batches of samples (10 - 15) require esterification. The bubbler method works well with samples that have low concentrations of herbicides (e.g., aqueous samples) and is safer to use than the Diazald kit procedure. The Diazald kit method is good for large quantities of samples needing esterification. The Diazald kit method is more effective than the bubbler method for soils or samples that may contain high concentrations of herbicides (e.g., samples such as soils that may result in yellow extracts following hydrolysis may be difficult to handle by the bubbler method).

The diazomethane derivatization procedures described below will react efficiently with all of the chlorinated herbicides described in this method and should be used only by experienced analysts, due to the potential hazards associated with its use.

The following precautions should be taken:

- Use a safety screen.
- Use mechanical pipetting aides.
- Do not heat above 90°C - EXPLOSION may result.
- Avoid grinding surfaces, ground-glass joints, sleeve bearings, and glass stirrers - EXPLOSION may result.

Store away from alkali metals - EXPLOSION may result.
Solutions of diazomethane decompose rapidly in the presence of solid materials such as copper powder, calcium chloride, and boiling chips.

7.5.1.1 Bubbler method - Assemble the diazomethane bubbler (see Figure 1).

7.5.1.1.1 Add 5 mL of diethyl ether to the first test tube. Add 1 mL of diethyl ether, 1 mL of carbitol, 1.5 mL of 37% KOH, and 0.1 - 0.2 g of Diazald to the second test tube. Immediately place the exit tube into the concentrator tube containing the sample extract. Apply nitrogen flow (10 mL/min) to bubble diazomethane through the extract for 10 minutes or until the yellow color of diazomethane persists. The amount of Diazald used is sufficient for esterification of approximately three sample extracts. An additional 0.1 - 0.2 g of Diazald may be added (after the initial Diazald is consumed) to extend the generation of the diazomethane. There is sufficient KOH present in the original solution to perform a maximum of approximately 20 minutes of total esterification.

7.5.1.1.2 Remove the concentrator tube and seal it with a Neoprene or PTFE stopper. Store at room temperature in a hood for 20 minutes.

7.5.1.1.3 Destroy any unreacted diazomethane by adding 0.1 - 0.2 g of silicic acid to the concentrator tube. Allow to stand until the evolution of nitrogen gas has stopped. Adjust the sample volume to 10.0 mL with hexane. Stopper the concentrator tube or transfer 1 mL of sample to a GC vial, and store refrigerated if further processing will not be performed immediately. Analyze by gas chromatography.

7.5.1.1.4 Extracts should be stored at 4°C away from light. Preservation study results indicate that most analytes are stable for 28 days; however, it is recommended that the methylated extracts be analyzed immediately to minimize the trans-esterification and other potential reactions that may occur.

7.5.1.2 Diazald kit method - Instructions for preparing diazomethane are provided with the generator kit.

7.5.1.2.1 Add 2 mL of diazomethane solution and let the sample stand for 10 minutes with occasional swirling. The yellow color of diazomethane should be evident and should persist for this period.

7.5.1.2.2 Rinse the inside wall of the ampule with 700 µL of diethyl ether. Reduce the sample volume to approximately 2 mL to remove excess diazomethane by allowing the solvent to evaporate spontaneously at room temperature. Alternatively, 10 mg of silicic acid can be added to destroy the excess diazomethane.

7.5.1.2.3 Dilute the sample to 10.0 mL with hexane. Analyze by gas chromatography. It is recommended that the methylated extracts be analyzed immediately to minimize the trans-esterification and other potential reactions that may occur.

7.5.2 PFB derivatization

7.5.2.1 Add 30 μL of 10% K_2CO_3 and 200 μL of 3% PFBBr in acetone. Close the tube with a glass stopper and mix on a vortex mixer. Heat the tube at 60°C for 3 hours.

7.5.2.2 Evaporate the solution to 0.5 mL with a gentle stream of nitrogen. Add 2 mL of hexane and repeat evaporation just to dryness at ambient temperature.

7.5.2.3 Redissolve the residue in 2 mL of toluene:hexane (1:6) for column cleanup.

7.5.2.4 Top a silica column (Bond Elut™ or equivalent) with 0.5 cm of anhydrous sodium sulfate. Prewet the column with 5 mL hexane and let the solvent drain to the top of the adsorbent. Quantitatively transfer the reaction residue to the column with several rinsings of the toluene:hexane solution (total 2 - 3 mL).

7.5.2.5 Elute the column with sufficient toluene:hexane to collect 8 mL of eluent. Discard this fraction, which contains excess reagent.

7.5.2.6 Elute the column with toluene:hexane (9:1) to collect 8 mL of eluent containing PFB derivatives in a 10-mL volumetric flask. Dilute to 10 mL with hexane. Analyze by GC/ECD.

7.6 Gas chromatographic conditions (recommended)

7.6.1 Narrow-bore columns

Temperature program:	60°C to 300°C, at 4°C/min
Helium carrier flow:	30 cm/sec
Injection volume:	2 μL , splitless, 45 sec delay
Injector temperature:	250°C
Detector temperature:	320°C

7.6.2 Wide-bore columns

Temperature program:	0.5 minute at 150°C, 150°C to 270°C, at 5°C/min
Helium carrier flow:	7 mL/min
Injection volume:	1 μL
Injector temperature:	250°C
Detector temperature:	320°C

7.7 Calibration

The procedure for internal or external calibration may be used. Refer to Method 8000 for a description of each of these procedures. Use Table 1 for guidance on selecting the lowest point on the calibration curve.

7.8 Gas chromatographic analysis of samples

7.8.1 Refer to Method 8000. If the internal standard calibration technique is used, add 10 μL of internal standard to the sample prior to injection.

7.8.2 Follow Method 8000 for instructions on the analysis sequence, appropriate dilutions, establishing daily retention time windows, and identification criteria. Include a mid-concentration standard after each group of 10 samples in the analysis sequence.

7.8.3 An example of a chromatogram for a methylated chlorophenoxy herbicide is shown in Figure 2. Tables 2 and 3 present retention times for the target analytes after esterification, using the diazomethane derivatization procedure and the PFBBr derivatization procedure, respectively.

7.8.4 Record the sample volume injected and the resulting peak sizes (in area units or peak heights).

7.8.5 Using either the internal or external calibration procedure (Method 8000), determine the identity and quantity of each component peak in the sample chromatogram which corresponds to the compounds used for calibration purposes.

7.8.6 If calibration standards have been analyzed in the same manner as the samples (e.g., have undergone hydrolysis and esterification), then the calculation of concentration given in Method 8000 should be used. However, if calibration is performed using standards made from methyl ester compounds (compounds not esterified by application of this method), then the calculation of concentration must include a correction for the molecular weight of the methyl ester versus the acid herbicide.

7.8.7 If peak detection and identification are prevented due to interferences, further cleanup is required. Before using any cleanup procedure, the analyst must process a series of standards through the procedure to validate elution patterns and the absence of interferences from reagents.

7.9 GC/MS confirmation

7.9.1 GC/MS techniques should be judiciously employed to support qualitative identifications made with this method. Refer to Method 8270 for the appropriate GC/MS operating conditions and analysis procedures.

7.9.2 When available, chemical ionization mass spectra may be employed to aid the qualitative identification process.

7.9.3 Should these MS procedures fail to provide satisfactory results, additional steps may be taken before reanalysis. These steps may include the use of alternate GC columns or additional cleanup.

8.0 QUALITY CONTROL

8.1 Refer to Chapter One and Method 8000 for specific quality control (QC) procedures. Quality control procedures to ensure the proper operation of the various sample preparation and/or sample introduction techniques can be found in Method 3500. Each laboratory should maintain a

formal quality assurance program. The laboratory should also maintain records to document the quality of the data generated.

8.2 Quality control procedures necessary to evaluate the GC system operation are found in Method 8000, Sec. 7.0 and include evaluation of retention time windows, calibration verification and chromatographic analysis of samples.

8.3 Initial Demonstration of Proficiency - Each laboratory must demonstrate initial proficiency with each sample preparation and determinative method combination it utilizes, by generating data of acceptable accuracy and precision for target analytes in a clean matrix. The laboratory must also repeat the following operations whenever new staff are trained or significant changes in instrumentation are made. See Method 8000, Sec. 8.0 for information on how to accomplish this demonstration.

8.4 Sample Quality Control for Preparation and Analysis - The laboratory must also have procedures for documenting the effect of the matrix on method performance (precision, accuracy, and detection limit). At a minimum, this includes the analysis of QC samples including a method blank, matrix spike, a duplicate, and a laboratory control sample (LCS) in each analytical batch and the addition of surrogates to each field sample and QC sample.

8.4.1 Before processing any samples, the analyst should demonstrate, through the analysis of a method blank, that interferences from the analytical system, glassware, and reagents are under control. Each time a set of samples is analyzed or there is a change in reagents, a method blank should be analyzed as a safeguard against chronic laboratory contamination. The blanks should be carried through all stages of sample preparation and measurement.

8.4.2 Documenting the effect of the matrix should include the analysis of at least one matrix spike and one duplicate unspiked sample or one matrix spike/matrix spike duplicate pair. The decision on whether to prepare and analyze duplicate samples or a matrix spike/matrix spike duplicate must be based on a knowledge of the samples in the sample batch. If samples are expected to contain target analytes, then laboratories may use one matrix spike and a duplicate analysis of an unspiked field sample. If samples are not expected to contain target analytes, laboratories should use a matrix spike and matrix spike duplicate pair.

8.4.3 A Laboratory Control Sample (LCS) should be included with each analytical batch. The LCS consists of an aliquot of a clean (control) matrix similar to the sample matrix and of the same weight or volume. The LCS is spiked with the same analytes at the same concentrations as the matrix spike. When the results of the matrix spike analysis indicate a potential problem due to the sample matrix itself, the LCS results are used to verify that the laboratory can perform the analysis in a clean matrix.

8.4.4 See Method 8000, Sec. 8.0 for the details on carrying out sample quality control procedures for preparation and analysis.

8.5 Surrogate recoveries - The laboratory must evaluate surrogate recovery data from individual samples versus the surrogate control limits developed by the laboratory. See Method 8000, Sec. 8.0 for information on evaluating surrogate data and developing and updating surrogate limits.

8.6 It is recommended that the laboratory adopt additional quality assurance practices for use with this method. The specific practices that are most productive depend upon the needs of the

laboratory and the nature of the samples. Whenever possible, the laboratory should analyze standard reference materials and participate in relevant performance evaluation studies.

9.0 METHOD PERFORMANCE

9.1 In single laboratory studies using organic-free reagent water and clay/still bottom samples, the mean recoveries presented in Tables 4 and 5 were obtained for diazomethane derivatization. The standard deviations of the percent recoveries of these measurements are also in Tables 4 and 5.

9.2 Table 6 presents relative recoveries of the target analytes obtained using the PFBBr derivatization procedure with spiked water samples.

10.0 REFERENCES

1. Goerlitz, D.G., Lamar, W.L., "Determination of Phenoxy Acid Herbicides in Water by Electron Capture and Microcoulometric Gas Chromatography", U.S. Geol. Survey Water Supply Paper 1967, 1817-C.
2. Burke, J.A. "Gas Chromatography for Pesticide Residue Analysis: Some Practical Aspects", J. Assoc. Off. Anal. Chem. (JAOAC), 1965, 48, 1037.
3. "Extraction and Cleanup Procedures for the Determination of Phenoxy Acid Herbicides in Sediment", U.S. Environmental Protection Agency, EPA Toxicant and Analysis Center, Bay St. Louis, MS, 1972.
4. Shore, F.L., Amick, E.N., Pan, S.T., "Single Laboratory Validation of EPA Method 8151 for the Analysis of Chlorinated Herbicides in Hazardous Waste", U.S. Environmental Protection Agency, Environmental Monitoring Systems Laboratory, Office of Research and Development, Las Vegas, NV, 1985; EPA-60014-85-060.
5. Method 515.1, "Determination of Chlorinated Acids in Water by Gas Chromatography with an Electron Capture Detector", Revision 4.0, U.S. Environmental Protection Agency, Office of Research and Development, Environmental Monitoring Systems Laboratory, Cincinnati, OH.
6. Gurka, D.F., Shore, F.L., Pan, S.T., "Single Laboratory Validation of EPA Method 8150 for Determination of Chlorinated Herbicides in Hazardous Waste", JAOAC, 69, 970, 1986.

TABLE 1

ESTIMATED METHOD DETECTION LIMITS FOR
DIAZOMETHANE DERIVATIZATION

Compound	Aqueous Samples	Soil Samples	
	GC/ECD Estimated Detection Limit ^a (µg/L)	GC/ECD Estimated Detection Limit ^b (µg/kg)	GC/MS Estimated Identification Limit ^c (ng)
Acifluorfen	0.096	-	-
Bentazon	0.2	-	-
Chloramben	0.093	4.0	1.7
2,4-D	0.2	0.11	1.25
Dalapon	1.3	0.12	0.5
2,4-DB	0.8	-	-
DCPA diacid ^e	0.02	-	-
Dicamba	0.081	-	-
3,5-Dichlorobenzoic acid	0.061	0.38	0.65
Dichloroprop	0.26	-	-
Dinoseb	0.19	-	-
5-Hydroxydicamba	0.04	-	-
MCP	0.09 ^d	66	0.43
MCPA	0.056 ^d	43	0.3
4-Nitrophenol	0.13	0.34	0.44
Pentachlorophenol	0.076	0.16	1.3
Picloram	0.14	-	-
2,4,5-T	0.08	-	-
2,4,5-TP	0.075	0.28	4.5

^a EDL = estimated detection limit; defined as either the MDL, or a concentration of analyte in a sample yielding a peak in the final extract with signal-to-noise ratio of approximately 5, whichever value is higher.

^b Detection limits determined from standard solutions corrected back to 50-g samples, extracted and concentrated to 10 mL, with 5 µL injected. Chromatography using narrow-bore capillary column, 0.25 µm film, 5% phenyl/95% methyl silicone.

^c The minimum amount of analyte to give a Finnigan INCOS FIT value of 800 as the methyl derivative vs. the spectrum obtained from 50 ng of the respective free acid herbicide.

^d From Method 1658, "The Determination of Phenoxy-Acid Herbicides in Municipal and Industrial Wastewater", Methods for the Determination of Nonconventional Pesticides in Municipal and Industrial Wastewater, EPA-821-R-93-010-A, the USEPA Office of Water, Engineering and Analysis Division. MDLs were obtained with an electrolytic conductivity detector.

^e DCPA monoacid and diacid metabolites included in method scope; DCPA diacid metabolite used for validation studies. DCPA is a dimethyl ester.

TABLE 2

RETENTION TIMES (MINUTES) OF METHYL DERIVATIVES OF CHLORINATED HERBICIDES

Analyte	Narrow Bore Columns		Wide-bore Columns	
	Primary ^a Column	Confirmation ^a Column	Primary ^b Column	Confirmation ^b Column
Dalapon	3.4	4.7	-	-
3,5-Dichlorobenzoic acid	18.6	17.7	-	-
4-Nitrophenol	18.6	20.5	-	-
DCAA (surrogate)	22.0	14.9	-	-
Dicamba	22.1	22.6	4.39	4.39
Dichloroprop	25.0	25.6	5.15	5.46
2,4-D	25.5	27.0	5.85	6.05
DBOB (internal std.)	27.5	27.6	-	-
Pentachlorophenol	28.3	27.0	-	-
Chloramben	29.7	32.8	-	-
2,4,5-TP	29.7	29.5	6.97	7.37
5-Hydroxydicamba	30.0	30.7	-	-
2,4,5-T	30.5	30.9	7.92	8.20
2,4-DB	32.2	32.2	8.74	9.02
Dinoseb	32.4	34.1	-	-
Bentazon	33.3	34.6	-	-
Picloram	34.4	37.5	-	-
DCPA diacid ^c	35.8	37.8	-	-
Acifluorfen	41.5	42.8	-	-
MCPP	-	-	4.24	4.55
MCPA	-	-	4.74	4.94

- ^a Primary Column: 5% phenyl/95% methyl silicone
Confirmation Column: 14% cyanopropyl phenyl silicone
Temperature program: 60·C to 300·C, at 4·C/min
Helium carrier flow: 30 cm/sec
Injection volume: 2 µL, splitless, 45 sec delay
Injector temperature: 250·C
Detector temperature: 320·C
- ^b Primary Column: DB-608
Confirmatory Column: 14% cyanopropyl phenyl silicone
Temperature program: 0.5 minute at 150·C, 150·C to 270·C,
at 5·C/min
Helium carrier flow: 7 mL/min
Injection volume: 1 µL
- ^c DCPA monoacid and diacid metabolites included in method scope; DCPA diacid metabolite used for validation studies. DCPA is a dimethyl ester.

TABLE 3

RETENTION TIMES (MINUTES) OF PFB DERIVATIVES OF CHLORINATED HERBICIDES

Compound	Gas Chromatographic Column		
	Thin-film DB-5 ^a	SP-2250 ^b	Thick-film DB-5 ^c
Dalapon	10.41	12.94	13.54
MCPP	18.22	22.30	22.98
Dicamba	18.73	23.57	23.94
MCPA	18.88	23.95	24.18
Dichloroprop	19.10	24.10	24.70
2,4-D	19.84	26.33	26.20
Silvex	21.00	27.90	29.02
2,4,5-T	22.03	31.45	31.36
Dinoseb	22.11	28.93	31.57
2,4-DB	23.85	35.61	35.97

^a DB-5 capillary column, 0.25 µm film thickness, 0.25 mm ID x 30 m long. Column programmed: 70°C for 1 minute, program 10°C/min. to 240°C, hold for 17 minutes.

^b SP-2550 capillary column, 0.25 µm film thickness, 0.25 mm ID x 30 m long. Column programmed: 70°C for 1 minute, program 10°C/min. to 240°C, hold for 10 minutes.

^c DB-5 capillary column, 1.0 µm film thickness, 0.32 mm ID x 30 m long. Column programmed: 70°C for 1 minute, program 10°C/min. to 240°C, hold for 10 minutes.

TABLE 4

ACCURACY AND PRECISION FOR DIAZOMETHANE DERIVATIZATION
ORGANIC-FREE REAGENT WATER MATRIX

Compound	Spike Concentration (µg/L)	Mean ^a Percent Recovery	Standard Deviation of Percent Recovery
Acifluorfen	0.2	121	15.7
Bentazon	1	120	16.8
Chloramben	0.4	111	14.4
2,4-D	1	131	27.5
Dalapon	10	100	20.0
2,4-DB	4	87	13.1
DCPA diacid ^b	0.2	74	9.7
Dicamba	0.4	135	32.4
3,5-Dichlorobenzoic acid	0.6	102	16.3
Dichloroprop	2	107	20.3
Dinoseb	0.4	42	14.3
5-Hydroxydicamba	0.2	103	16.5
4-Nitrophenol	1	131	23.6
Pentachlorophenol	0.04	130	31.2
Picloram	0.6	91	15.5
2,4,5-TP	0.4	117	16.4
2,4,5-T	0.2	134	30.8

^a Mean percent recovery calculated from 7-8 determinations of spiked organic-free reagent water.

^b DCPA monoacid and diacid metabolites included in method scope; DCPA diacid metabolite used for validation studies. DCPA is a dimethyl ester.

TABLE 5
 ACCURACY AND PRECISION FOR DIAZOMETHANE DERIVATIZATION
 CLAY MATRIX

Compound	Mean Percent Recovery ^a	Linear Concentration Range ^b (ng/g)	Percent Relative Standard Deviation ^c (n=20)
Dicamba	95.7	0.52 - 104	7.5
MCPP	98.3	620 - 61,800	3.4
MCPA	96.9	620 - 61,200	5.3
Dichloroprop	97.3	1.5 - 3,000	5.0
2,4-D	84.3	1.2 - 2,440	5.3
2,4,5-TP	94.5	0.42 - 828	5.7
2,4,5-T	83.1	0.42 - 828	7.3
2,4-DB	90.7	4.0 - 8,060	7.6
Dinoseb	93.7	0.82 - 1,620	8.7

^a Mean percent recovery calculated from 10 determinations of spiked clay and clay/still bottom samples over the linear concentration range.

^b Linear concentration range was determined using standard solutions and corrected to 50 g solid samples.

^c Percent relative standard deviation was calculated using standard solutions, 10 samples high in the linear concentration range, and 10 samples low in the range.

TABLE 6
RELATIVE RECOVERIES OF PFB DERIVATIVES OF HERBICIDES^a

Compound	Standard Concentration mg/L	Percent Recoveries								Mean
		1	2	3	4	5	6	7	8	
MCPP	5.1	95.6	88.8	97.1	100	95.5	97.2	98.1	98.2	96.3
Dicamba	3.9	91.4	99.2	100	92.7	84.0	93.0	91.1	90.1	92.7
MCPA	10.1	89.6	79.7	87.0	100	89.5	84.9	92.3	98.6	90.2
Dichloroprop	6.0	88.4	80.3	89.5	100	85.2	87.9	84.5	90.5	88.3
2,4-D	9.8	55.6	90.3	100	65.9	58.3	61.6	60.8	67.6	70.0
Silvex	10.4	95.3	85.8	91.5	100	91.3	95.0	91.1	96.0	93.3
2,4,5-T	12.8	78.6	65.6	69.2	100	81.6	90.1	84.3	98.5	83.5
2,4-DB	20.1	99.8	96.3	100	88.4	97.1	92.4	91.6	91.6	95.0
Mean		86.8	85.7	91.8	93.4	85.3	89.0	87.1	91.4	

^aPercent recovery determinations made using eight spiked water samples.

FIGURE 1
DIAZOMETHANE GENERATOR

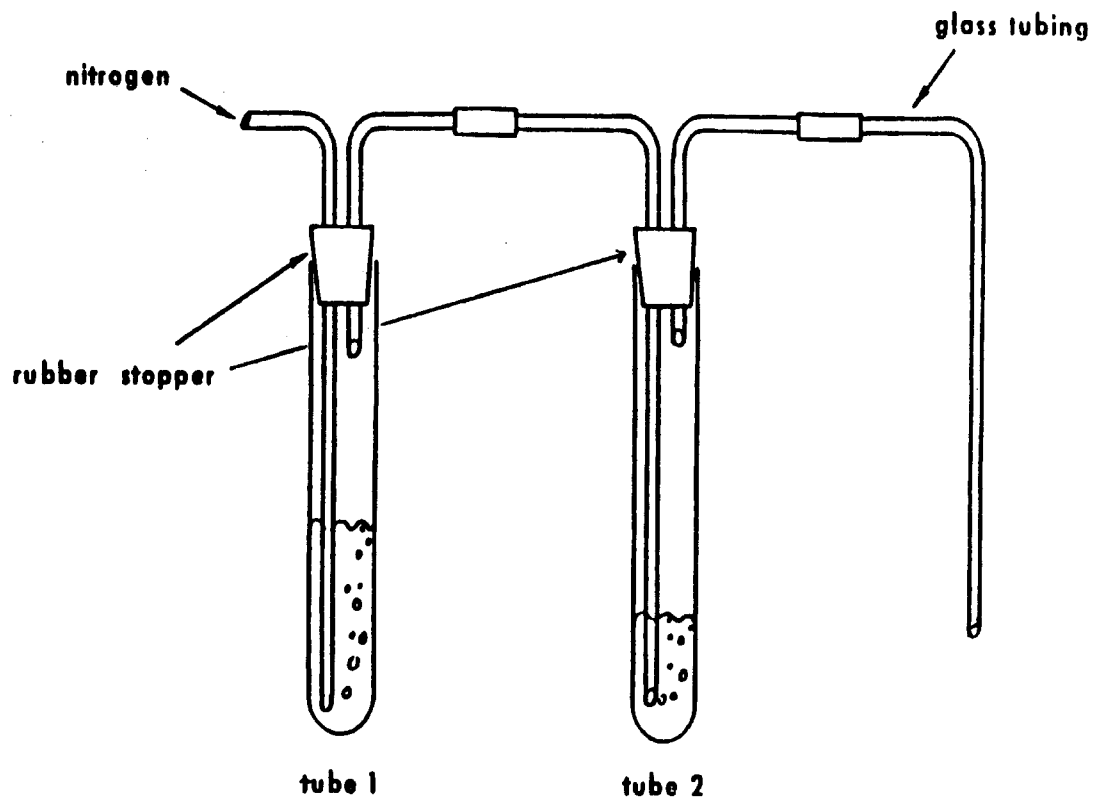
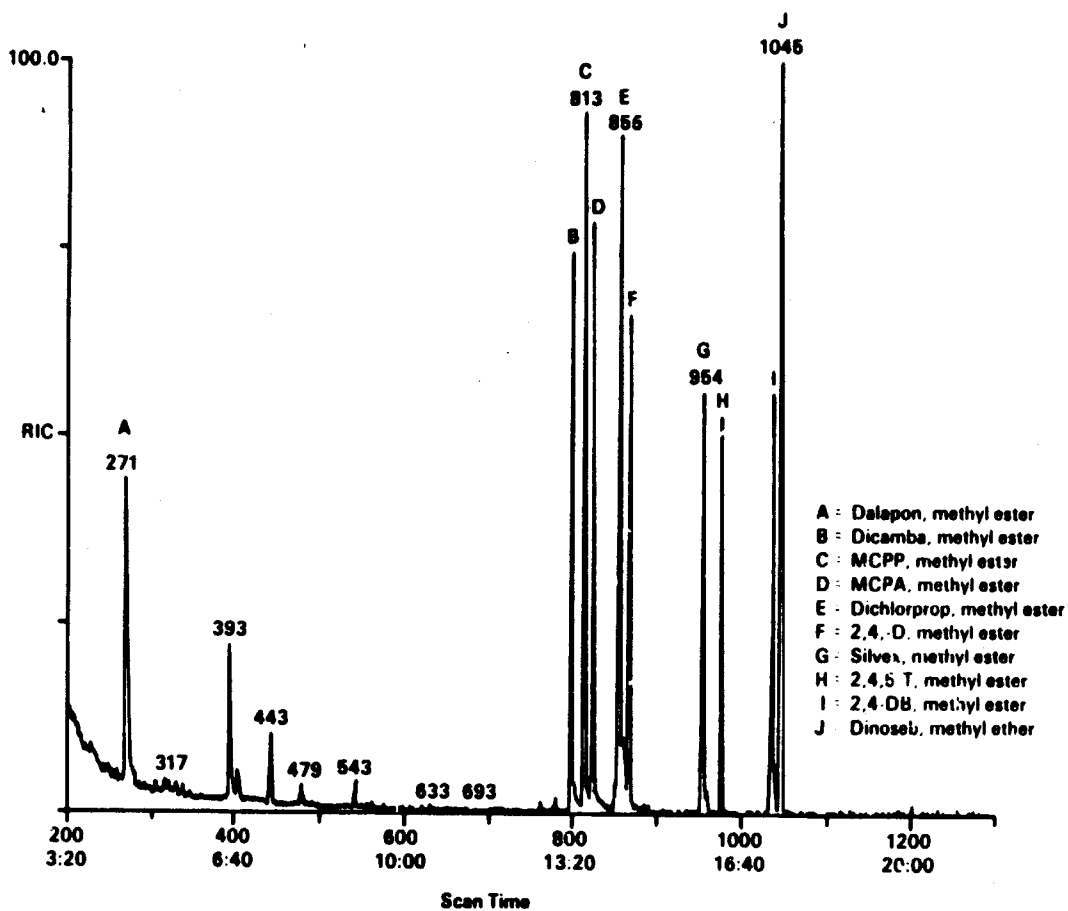

FIGURE 2
CHROMATOGRAM OF METHYL ESTERS OF CHLOROPHENOXYACIDS



METHOD 8151A

CHLORINATED HERBICIDES BY GC USING METHYLATION OR PENTAFLUOROBENZYLATION DERIVATIZATION

Extraction/Hydrolysis of Waste and Soil Samples

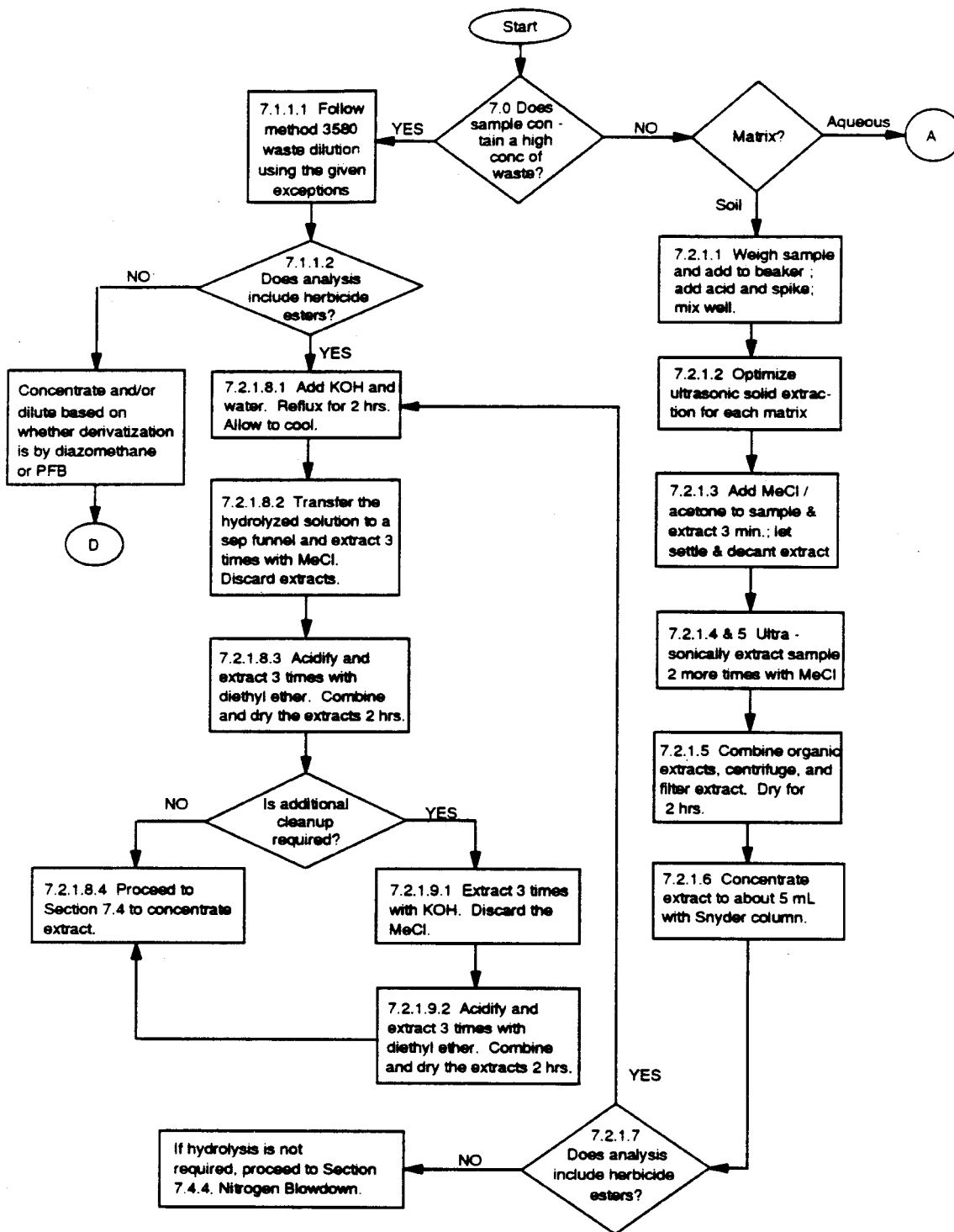

METHOD 8151A
(continued)

Extraction/Hydrolysis of Aqueous Samples and Extract Concentration

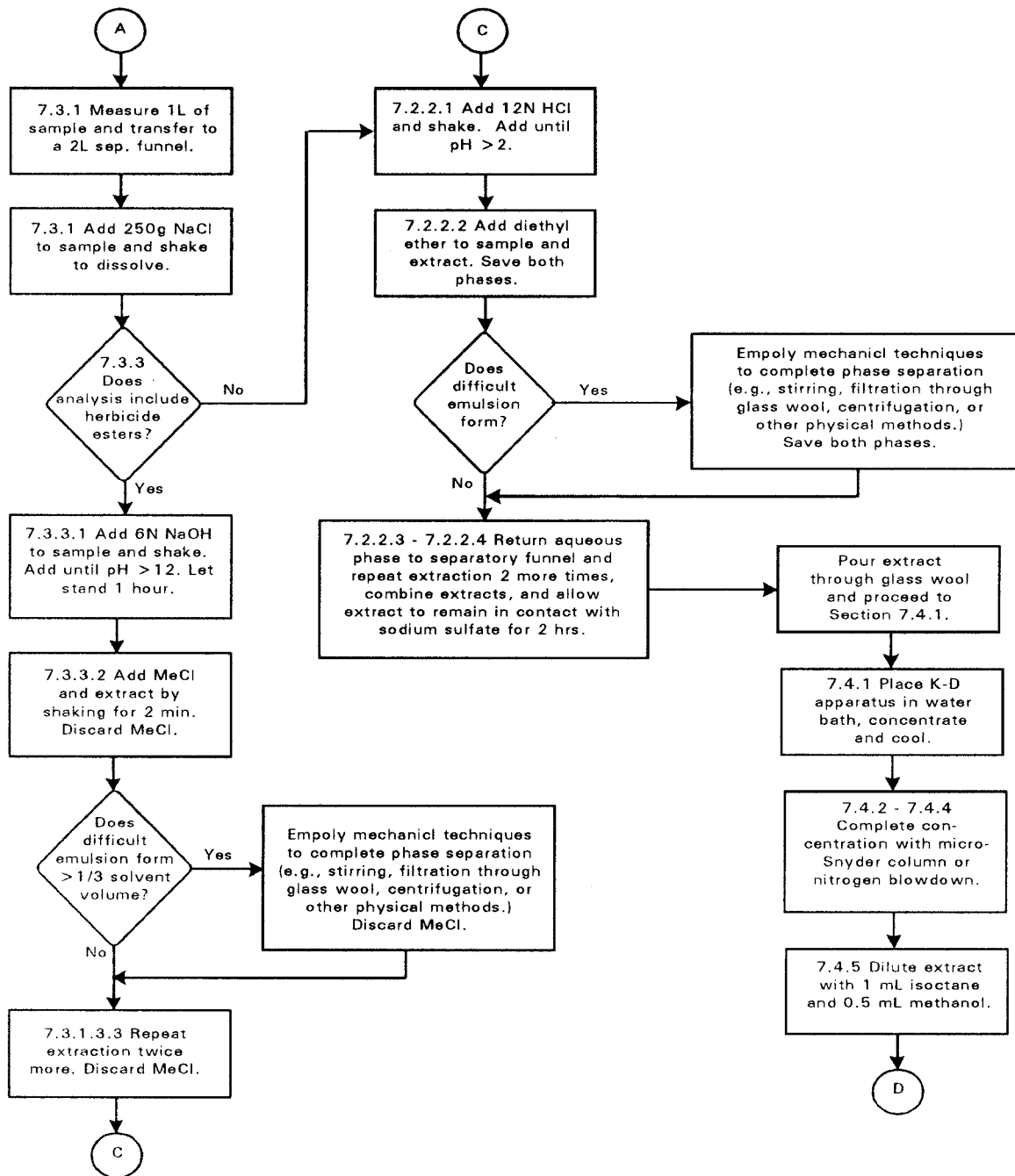

METHOD 8151A
(continued)

Extract Derivatization

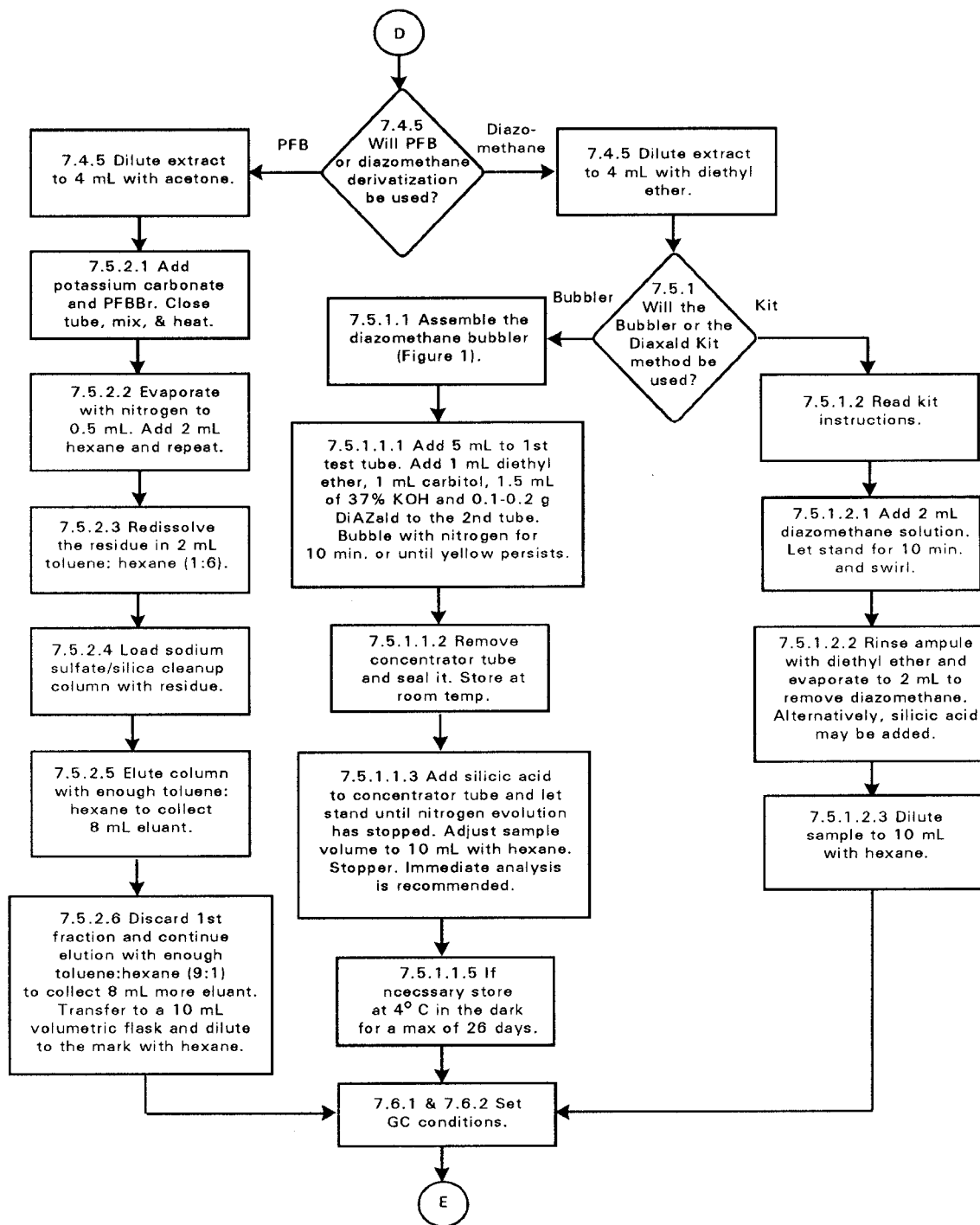

METHOD 8151A
(continued)

Analysis by Gas Chromatography

