

Mobile Source Observation Database (MSOD)

User Guide and Reference

Mobile Source Observation Database (MSOD)

User Guide and Reference

Assessment and Standards Division
Office of Transportation and Air Quality
U.S. Environmental Protection Agency



Table of Contents

I.	Overview	
a.	MSOD	1
b.	MSOD Input Structure	5
c.	Quality Control & Quality Assurance Procedures	5
d.	How to Request a CD-R/DVD Copy	7
II.	MSOD Top-Level Design Information	
a.	Overall Design	9
b.	Major Area Translation – Entity Flows	11
III.	Detailed MSOD Design Information	
a.	Entity – Relationship Diagrams	15
b.	Entity Definitions	32
c.	Entity and Field Attribute Definitions	36
IV.	Detailed Input Data Design Information	
a.	Entity – Relationship Diagrams	59
b.	Entity Definitions	76
c.	Entity and Field Attribute Definitions	79
V.	Translational Tables	
a.	Table Names Listing	100
b.	Entity Definitions	102
c.	Entity and Field Attribute Definitions	105

I. Overview

Background and Purpose

The Mobile Source Observation Database (MSOD) is a relational database being developed by the Assessment and Standards Division (ASD) of the United States Environmental Protection Agency (U.S. EPA or Agency) Office of Transportation and Air Quality (OTAQ, formerly the Office of Mobile Sources). The database supercedes a previous database that was called "Mobile Source Emission Factor Database." Currently, the database stores general purpose emission factor data collected since 1982 and other activity and emission test programs that was gathered by U.S. EPA and from other testing facilities that were designed for more specific purposes. The data contained in the database was not gathered on a purely "random" sample and for different research issues but the data is intended to be representative of in-use vehicle emissions in the United States.

Considerable knowledge of vehicle emission testing and of relational database design and query methods is required to make effective use of this database. It is not intended for the casual or novice user. The database has been designed and documented using entity-relationship data modeling methods.

The database includes a User Guide and Reference Manual in Adobe Acrobat (*.PDF) format. The database itself is implemented as an Oracle database containing a set of approximately 60 tables, supplemented by a larger number of small "translation" or "category" tables which define and explain the legal values for some of its individual data items. All tables will be exported upon request in standard database format (*.DBF) which is usable by a variety of software and users.

While ASD is interested in comments and questions regarding the database, it can afford to provide only very limited support beyond this Guide to external users. A copy of the MSOD User's Guide and Reference can be downloaded from this web site by returning to the parent of this page and making the appropriate selection. The Guide explains how to request a CD_ROM copy of the database.

EPA has made considerable effort to assure the validity of the data in this database through the development and use of quality assurance and control procedures. EPA is not responsible for the validity of conclusions reached by others using this data. New records are being added continuously to the data sample as they complete their review. EPA cannot guarantee that all current, relevant data has been included in the database. Because additions and changes are being made to the database on a continuous basis, it is recommended that those using it regularly may wish to request an updated copy every year or so.

a. Mobile Source Observation Database (MSOD)

Design Features

This new relational design enables storage of any observation of a mobile source, which can include emission tests (laboratory and in-use "field"), activity measurements, fuel, engine and vehicle characteristics. Observations are results that were derived from (laboratory or in-use "field") testing a mobile source. A "mobile source" is a term used to describe a wide variety of

vehicles, engines, and equipment that generate air pollution and that move, or can be moved, from place to place. Mobile Sources can be separated into two main categories: "On-Road" and "Non-Road." "On-Road" (also called "on-highway") sources include vehicles used on roads for transportation of passengers or freight. "Non-road" (also called "nonroad") sources include vehicles, engines, and equipment used for construction, agriculture, transportation, recreation, and many other purposes. These two broad categories, on-road and nonroad sources can be further segregated by size, weight, use, and/or horsepower. MSOD was designed with the following features:

- Design leads to client server-based database with an economy of tables and fields with most data stored in only one place.
- Low cost to implement and maintain database design
- Easy to adapt for new data types and design resides within EPA
- Modern database design allows for it to be portable and compatible with other modern tools.
- Designed for broad scope to contain both vehicle and engine data (laboratory or field testing including second-by-second data)
- Tables are easily linked together
- Easy to understand by using meaningful field names, documenting the legal values and definitions that are explained in the database
- Contains "Meta" data on who conducted the test, statements of work, etc
- Contains information on driving schedules, diurnal temperature evaporative test cycles, etc.
- Contains information about fuels on either a generic (batch) or specific fuel analysis.

What are Results?

Observing mobile sources (vehicles and engines) will give different kinds of results. A result can be grouped into specific areas called "entities" that contain "fields" or "attributes" with similar characteristics might be observed. Some different kinds of results or entities are listed below:

- Procurement
- Inspection
- Owner's Report
- Repair
- Tailpipe Emission Test
- Running Loss Emission Test
- Evaporative Emission Test
- In-Use or "Real World" Emission Test
- Engine Power MAP
- Engine Dynamometer Emission Test
- Tank Fuel Measurement
- Fuel Type Information
- Driving Schedules
- Etc.

Some of the result tables can be large and complex. These tables have been indexed to improve their performance. All result tables have had their fields either coded or categorized (fields that have translation tables) so that have their meaning or description are known.

What is the CAUSE Relationship between RESULT?

A “cause” relationship between certain “results” represents the fact that some “results” affect subsequent “results.” Currently this occurs only in the PROCURE and REPAIR type RESULT tables. The CAUSE is a foreign key (recursive relationship) back into RESULT table. It identifies the most immediately preceding RESULT instance (e.g. a PROCURE or REPAIR on this mobile source instance) that might affect the outcome of the present one. This feature allows for a query into the database to see if different procurements of the same mobile source have intervening repairs or previous testing conditions plus others that may not be comparable for some purpose. For example, you can use the CAUSE attribute to distinguish post-repair observations from pre-repair observations. A CAUSE = 0 means that there are no related results or “none.”

Mobile Source Observation Database

October 10, 2000,
Last Update March 7, 20

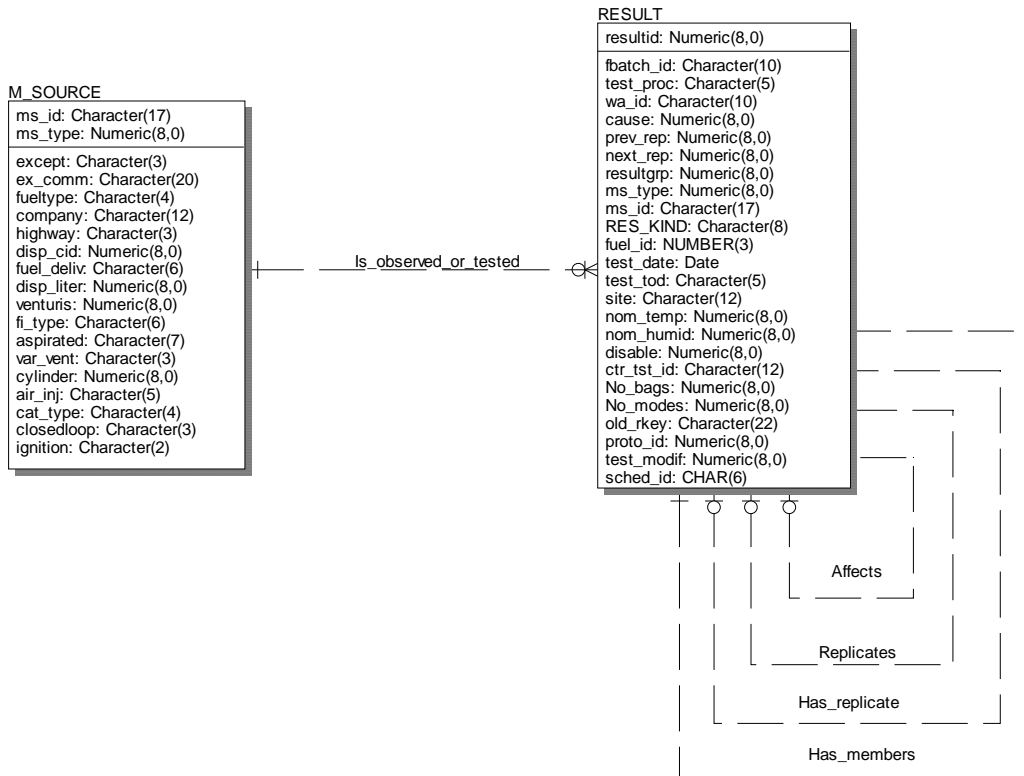

What is a “Replicate” RESULT?

A replicate RESULT represents a repeated observation of the same thing and is often performed to investigate the repeatability of measurements. Replicates are stored in the MSOD database and are found in the RESULT table under PREV_REP and NEXT_REP fields. These fields link RESULTS together in a forward chain (NEXT_REP) and backward (PREV_REP). The value “0” indicates the end of the PREV_REP and NEXT_REP chain. To eliminate multiple replicates from query outcomes, the user will need to specify that PREV_REP = 0 or NEXT_REP = 0 as a query selection criteria.

What is a “Composite” RESULT?

The MSOD database structure allows a group of RESULTS to be considered a RESULT in its own right and are called “Composite RESULTS” or “RESULT Group.” An example use of this feature is that the component portions of the Supplemental Federal Test Procedure (SFTP), which consists of multiple individual tests that are weighted together to give one Composite RESULT. The RESULTGRP field in the RESULT table indicates or joins the individual RESULTS to the Composite RESULT. A RESULTGRP = 0 indicates that the RESULT is not part of the Composite RESULT.

Understanding Translation Tables or Legal Value Lists for Categorized Fields

The database has been documented in a platform-independent fashion that allows for greater flexibility in its use on different database platforms and helps implement data quality by defining all legal values of all categorized fields. Every categorized field, which includes most character-type fields in the database, has a “translation table” not shown in the entity-relationship diagrams. These “translation tables” contain:

- The table name is the same as the name of the field, truncated if necessary to meet a eight-character limitation.
- The first column in the table is the same as name in field.
- The second column in the table is typically the field name number “Fieldname_N” which expresses the category as a number so that it can be used in statistical programs (e.g. SPSS or SAS).
- The third column in the table is typically the field name description “Fieldname_D” which defines the category value.

Representation of Missing or “Null” Data

The current version of MSOD was upgraded to take advantage of “true” NULL for each field in each table. Users should attach no meaning to data values that contain “Null.” The value simply means that the data for this field is not present in the record and can occur for many reasons.

What are MEASTYPEs?

The database design contains areas or tables that allow for the storage of data that are only gathered occasionally and are not considered of central importance. These MEASTYPEs are referred to as “Non-Core Measurements.” By permitting, MEASTYPEs in the database structure this allows for the following aspects: it avoids having to create additional columns for data items that are only occasionally needed and it makes it easy to extend the database design to accommodate new items. Tables that contain names like “xxxMEAS” and VEH_MISC are examples containing such data.

b. MSOD Input Structure

Lab and field data must be formatted in specified data entry tables before the data can be quality assured and loaded into MSOD. The conformity of the data to this format allows pre-programmed computer software to check the data for its conformity to MSOD data types and categories for attributes (fields), range checking of numeric data, and the assurance of parent child referential integrity. The input structures in general are relational data bases based on result kinds found in the database and reflect the entities and attributes associated with them in MSOD. Input data tables in general follow a naming convention that close to the table name reflect its result kind’s entities in MSOD, but ending with “_IN.” The tables are in a *.DBF database structure that allows for true NULLs. Most PC based database software (e.g. Microsoft Access, DBASE, Visual FoxPro and Lotus Approach) are capable of reading and writing to this format. All tables, fields, categories and attributes have legal naming convention and definitions including measurement units that are directly from the MSOD design. Section III gives the user a graphical picture plus table and field definitions on the most current input table designs. An electronic copy of the input structures can be requested, please see section I(e) below for further information.

c. Quality Control and Quality Assurance Procedures

OTAQ’s Data Acquisition and Management Team (DAMT) has designed two levels of data checking software available to interested parties: VALDATA and EFLOAD. The VALDATA is an application for checking input data received from either contractors, independent testing program operators or from internal EPA test programs and replaces two FoxPro 2.6 applications, QCSPECS.PRG and ORPHANID.PRG that were previously used for this purpose. The EFLOAD data checking software is an application for loading input test data sets into EPA’s MSOD Oracle database and replaces the current EF00Load and EF99Load programs. Its input are test data sets released by the Work Assignment Manager (WAM) after having been successfully processed by the VALDATA program. EFLOAD’s output are data sets that have been successfully loaded into the MSOD Oracle database.

VALDATA Software

All test data is required to be in the input table structure as outlined in section I(b) and section III before using either of these data checking software. The VALDATA software checking program is the first level of quality controlling and quality assuring the data. This program has been designed to be used independently of MSOD and therefore can be deployed

remotely. It is intended to be a data checking tool for principal investigators near or at the testing site. EPA's intent is that the data gathered in the field be checked immediately after the completion of a specific mobile source's emission testing or activity gathering activity. The goal is assure data quality before releasing the mobile source from the testing or sampling program. . If any issues are raised from VALDATA, or from other data checking software, the vehicle or equipment that the test was conducted on is still available for further inquiry or testing before it is put back into normal operation or service.

The VALDATA program checks the data structure and content of the input tables for conformity to the data set specifications, as they are defined by the structure of the INFILES and the content of QC_SPECS.DBF. QC_SPECS.DBF is a control table maintained by EPA for the purpose of testing the content of the input data. The QC_SPECS.DBF is a table used to determine the suitability of field level data within all of the individual input tables with some cross level checking of test and vehicle weights. Some examples of fixes to the input data tables that are normally found from data processed by VALDATA are: 1) work assignment (WA_ID) names misspelled; 2) fields requiring or not requiring "CAPITAL" letters; 3) fields containing incorrect NULL value indicator was used; 4) use of non-defined field names or 5) a data field may exceed an upper or lower bounds for table data (records). In some of these cases, it might require a change in the QC_SPEC.DBF by EPA to allow the test results in question to pass data table review. Some data inconsistencies may simply need to be accepted early on in the test program until enough results have been accumulated that an informed decision can be made resolving the inconsistency. All errors are written to an error log, XERRLOG.DBF, which is maintained in the user's Master Data directory. Input data satisfies all the format and context checks provided by the VALDATA program are "RELEASED" by the user and become eligible for loading into the EFLOAD program database for further processing and conversion for loading into the MSOD Oracle database. EPA also runs other data checking programs that include looking for and identifying "spikes" and "plateaus" or time alignment of emission and activity results.

EFLOAD Software

EFLOAD is an application for loading Visual FoxPro input test data sets into the MSOD Oracle database. It replaces the current EF00Load and EF99Load programs. Its input are Visual Fox Pro test data sets released by the Work Assignment Manager (WAM) or test program coordinator after having been successfully processed by the VALDATA program. EFLOAD's output are data sets successfully loaded into the MSOD Oracle database. EFLOAD rigorously tests the input data sets to ensure that the data structures, primary and foreign keys, and NULL constraints match those of the Oracle MSOD tables. This requires access to the MSOD Oracle database in order to perform this function and is limited to a few select authorized EPA personnel. In addition, it provides all the functionality of the past used EF00Load and EF99Load programs including orphan checking, elimination of internal and transactional duplicates, and construction of all relational links required by the current business rules within the Oracle database.

d. Further Information:

If you would like a copy of MSOD, have any questions or comments about the design, linking data fields, input structures, or quality control and quality assurance procedures, you can submit your questions or comments by e-mail or contact:

Carl Fulper
US Environmental Protection Agency
Office of Transportation and Air Quality
National Vehicle and Fuels Emission Laboratory
2000 Traverwood Drive
Ann Arbor, MI 48105
(734) 214-4400
fulper.carlr@epa.gov

II. MSOD Top-Level Design Information

- a. Overall Design
- b. General Entity-Relationships

II. MSOD Top-Level Design Information

a. Overall Design

II. MSOD Top-Level Design Information

b. General Entity Relationships

Mobile Source Observation Database

October 10, 2000,
Last Update March 7, 2002

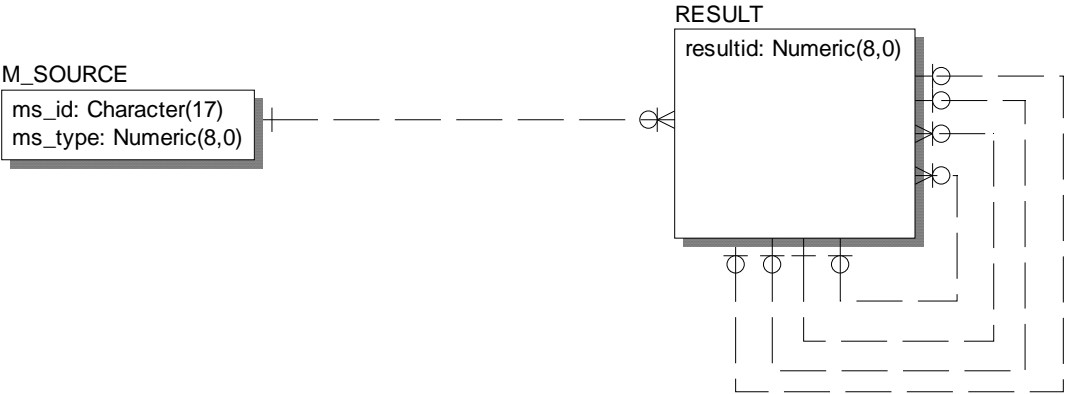

Mobile Source Observation Database

October 10, 2000,
Last Update March 7, 2001

M_SOURCE

```

ms_id: Character(17)
ms_type: Numeric(8,0)
except: Character(3)
ex_comm: Character(20)
fueltype: Character(4)
company: Character(12)
highway: Character(3)
disp_cid: Numeric(8,0)
disp_liter: Numeric(8,0)
fuel_deliv: Character(6)
venturis: Numeric(8,0)
fi_type: Character(6)
aspirated: Character(7)
var_vent: Character(3)
cylinder: Numeric(8,0)
air_inj: Character(5)
cat_type: Character(4)
closedloop: Character(3)
ignition: Character(2)
    
```

is_observed_modified_te

RESULT

```

resultid: Numeric(8,0)
fbatch_id: Character(10)
test_proc: Character(5)
wa_id: Character(10)
cause: Numeric(8,0)
prev_rep: Numeric(8,0)
next_rep: Numeric(8,0)
resultgrp: Numeric(8,0)
ms_type: Numeric(8,0)
ms_id: Character(17)
RES_KIND: Character(8)
fuel_id: NUMBER(3)
test_date: Date
test_tod: Character(5)
site: Character(12)
nom_temp: Numeric(8,0)
nom_humid: Numeric(8,0)
disable: Numeric(8,0)
ctr_tst_id: Character(12)
No_bags: Numeric(8,0)
No_modes: Numeric(8,0)
old_rkey: Character(22)
proto_id: Numeric(8,0)
test_modif: Numeric(8,0)
sched_id: CHAR(6)
    
```

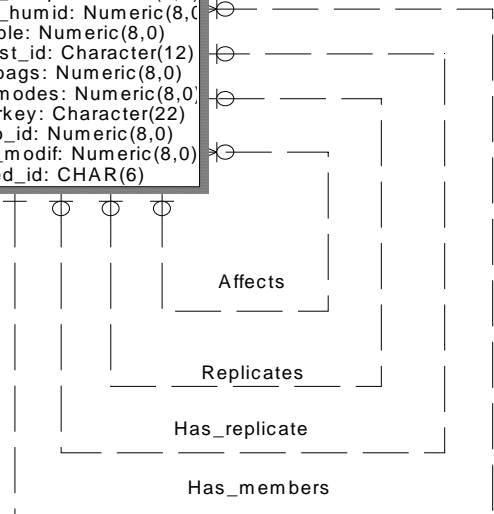

III. Detailed MSOD Design Information

- a. Entity (Table) - Relationship Diagrams**
- b. Entity (Table) and Attribute Definitions**
- c. Entity (Table) and Field Attribute Definitions**

III. Top-Level MSOD Design Information

a. Entity (Table)–Relationship Diagrams

RESULT STORAGE TABLES

VEHICLE

MSID: NUMBER(12) (FK)
MODEL_YR: NUMBER(4)
MODEL_NAME: VARCHAR2(20)
OVERDRIVE: CHAR(3)
CREEPER: CHAR(3)
LOCKUP: CHAR(3)
GVWR: NUMBER(6)
AC: CHAR(3)
CURBWEIGHT: NUMBER(6)
BLD_DATE: DATE
GCWR: NUMBER(6)
THCSTD: NUMBER(6,3)
NMHCSTD: NUMBER(6,3)
COSTD: NUMBER(6,3)
NOXSTD: NUMBER(6,3)
TANK_CAP: NUMBER(3)
CITY_FE: NUMBER(2)
THCESTD: NUMBER(6,3)
HWAY_FE: NUMBER(2)
PMSTD: NUMBER(6,3)
NMHCSTD: NUMBER(6,3)
EVAPSTD: NUMBER(6,3)
FUELTANKS: NUMBER(1)
AXLE_RATIO: NUMBER(5,2)
PURPOSE: VARCHAR2(100)
CERT_NOX: NUMBER(6,3)
CERT_PM: NUMBER(6,3)
TRAN_TYPE: CHAR(6)
STANDARDS: CHAR(6)
MODELSIZE: CHAR(10)
MAKE: VARCHAR2(12)
GEARS: CHAR(6)
DRV_TRN: CHAR(4)
CANISTER: CHAR(10)
ENGMOUNT: CHAR(10)
VEHCLASS: CHAR(6)
EVAP_FAM: VARCHAR2(12)
ENG_FAM: VARCHAR2(19)
SCC: VARCHAR2(14)
EGR: CHAR(3)
AXLE: NUMBER(2)
CERT_CO: NUMBER(6,3)
CERT_HC: NUMBER(6,3)
VIN8: VARCHAR2(8)
VIN_BODY: VARCHAR2(30)

WKASSIGN

WA_ID: CHAR(10)
WA_DESC: VARCHAR2(254)
EPA_CONTNO: VARCHAR2(11)
EPA_WANO: CHAR(4)
CONTRACTOR: VARCHAR2(20)
FISCALYR: NUMBER(4)
CONTACT: VARCHAR2(20)
SOW_FNAME: CHAR(8)
PHONE_NO: VARCHAR2(18)
WP_FNAME: CHAR(8)
ALTERNATE: VARCHAR2(20)
ABSTRACT: VARCHAR2(254)
NO_MSOURCE: NUMBER(4)
FRPT_FNAME: CHAR(8)
SPONSOR: VARCHAR2(20)
MIN_MOD_YR: NUMBER(4)
MAX_MOD_YR: NUMBER(4)
WA_STATUS: CHAR(10)
P_CRITERIA: VARCHAR2(11)
EMAIL: VARCHAR2(30)
FILEPATH: VARCHAR2(50)
RESTRICT: CHAR(1)

TASK

PROTO_ID: NUMBER(3)
CONTRACT: NUMBER(4)
PROGRAM: CHAR(4)
TASK_D: VARCHAR2(80)
P_CRITERIA: VARCHAR2(11)

M_SOURCE

MSID: NUMBER(12) (FK)
MS_TYPE: NUMBER(2)
EXCEPT: CHAR(3)
EX_COMM: VARCHAR2(20)
HIGHWAY: CHAR(3)
DISP_CID: NUMBER(4)
DISP_LITER: NUMBER(4,1)
VENTURIS: NUMBER(2)
VAR_VENT: CHAR(3)
CYLINDER: NUMBER(2)
CLOSEDLOOP: CHAR(3)
CAT_TYPE: CHAR(4)
AIR_INJ: CHAR(5)
FUEL_DELIV: CHAR(6)
IGNITION: CHAR(2)
FUELTYPE: CHAR(4)
FL_TYPE: CHAR(6)
COMPANY: VARCHAR2(12)
ASPIRATED: CHAR(7)

MS_IDNO

MSID: NUMBER(12)
MS_ID: VARCHAR2(17)
VIN: VARCHAR2(17)
ENGSERIALN: VARCHAR2(17)

RESULT

TEST_PROC: CHAR(5)
WA_ID: CHAR(10) (FK)
SCHED_ID: CHAR(6)
CAUSE: NUMBER(12) (FK)
RESULTGRP: NUMBER(12) (FK)
TEST_TOD: CHAR(5)
NOM_HUMID: NUMBER(3)
NO_MODES: NUMBER(2)
DISABLE: NUMERIC(3)
FUEL_ID: NUMERIC(3)
SITE: VARCHAR2(12)
PROTO_ID: NUMBER(3) (FK)
MSID: NUMBER(12) (FK)

ENGINE

MSID: NUMBER(12) (FK)
ENG_FAM: VARCHAR2(19)
ENGSERIES: VARCHAR2(20)
BLD_DATE: DATE
ENG_MOD_YR: NUMBER(4)
INJECTORS: NUMBER(1)
FI_PRESS: NUMBER(5)
RATE_SHAPE: CHAR(3)
MAXADVANCE: NUMBER(5,2)
MAXRETARD: NUMBER(5,2)
PARTTRAP: CHAR(3)
RATEDPOWER: NUMBER(7,1)
RATEDSPEED: NUMBER(5)
IDLE_RPM: NUMBER(5)
TECH_CONFG: VARCHAR2(50)
PUMP_TYPE: VARCHAR2(50)
ECS_DESCPT: VARCHAR2(50)
ELECT_CONT: VARCHAR2(100)
PEAKTORQUE: NUMBER(4)
PEAKSPEED: NUMBER(5)
PEAKFRATE: NUMBER(5,1)
RATEDFRATE: NUMBER(5,1)
AIRFUEL: CHAR(4)
COOLING: CHAR(7)
EGR_TYPE: CHAR(6)
ENG_CLASS: CHAR(7)
ENG_CYCLE: CHAR(1)
FI_METH: CHAR(4)
MFR_INTSPD: NUMBER(2)
CAMEFROM: NUMBER(12)

DYNOTEST STORAGE TABLES

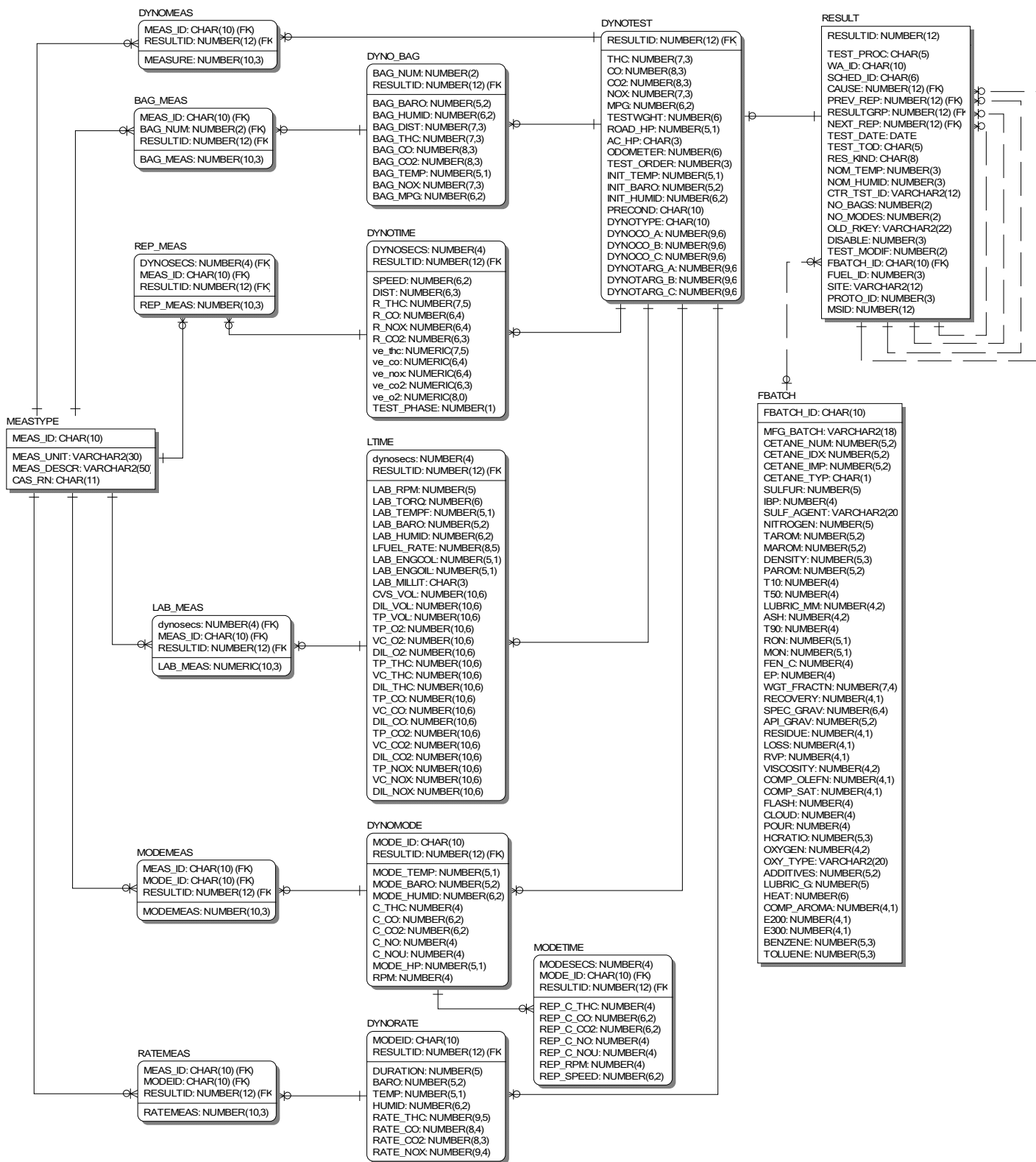

**EVAPTEST
STORAGE TABLES**

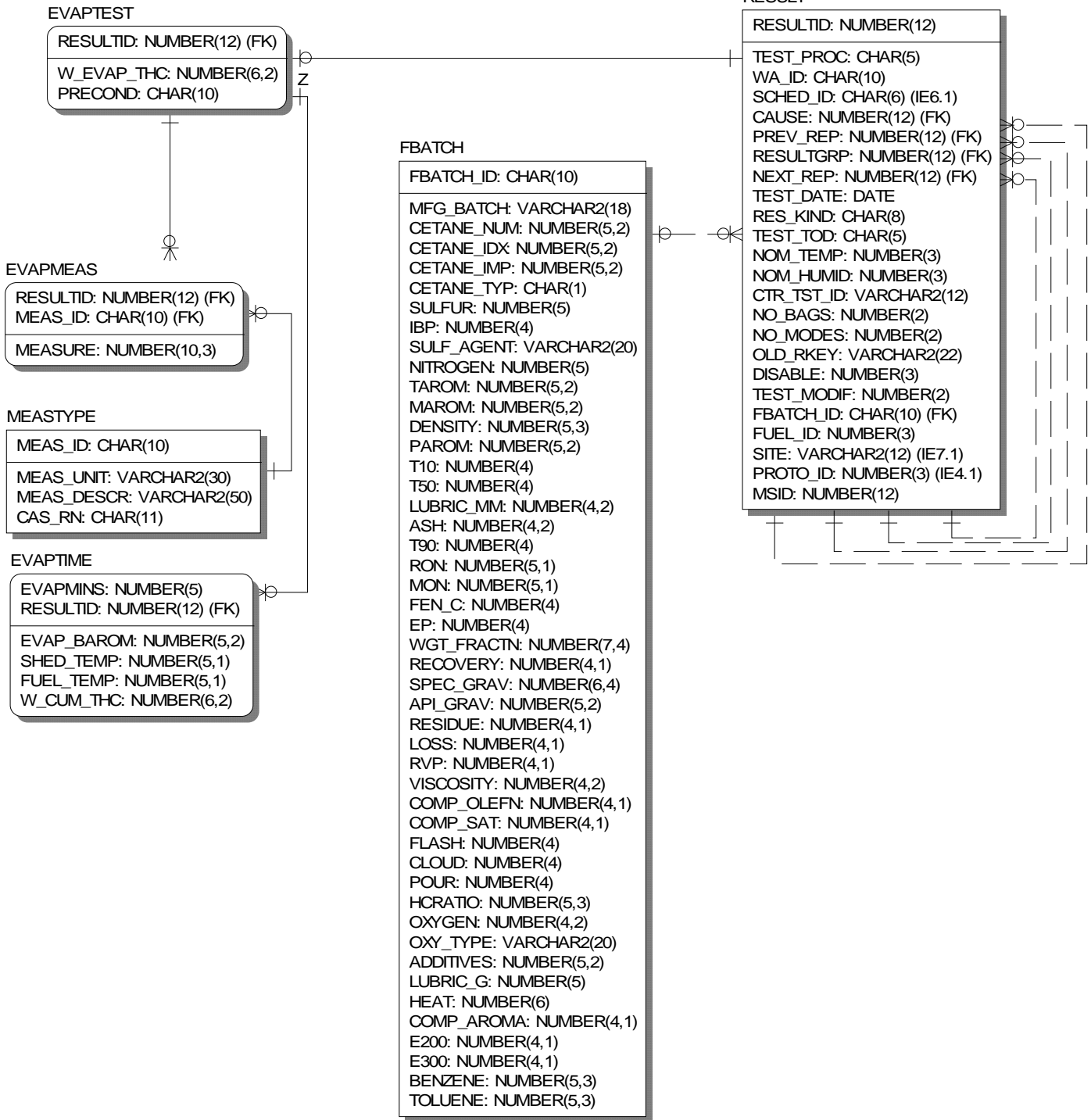

ENGTEST STORAGE TABLES

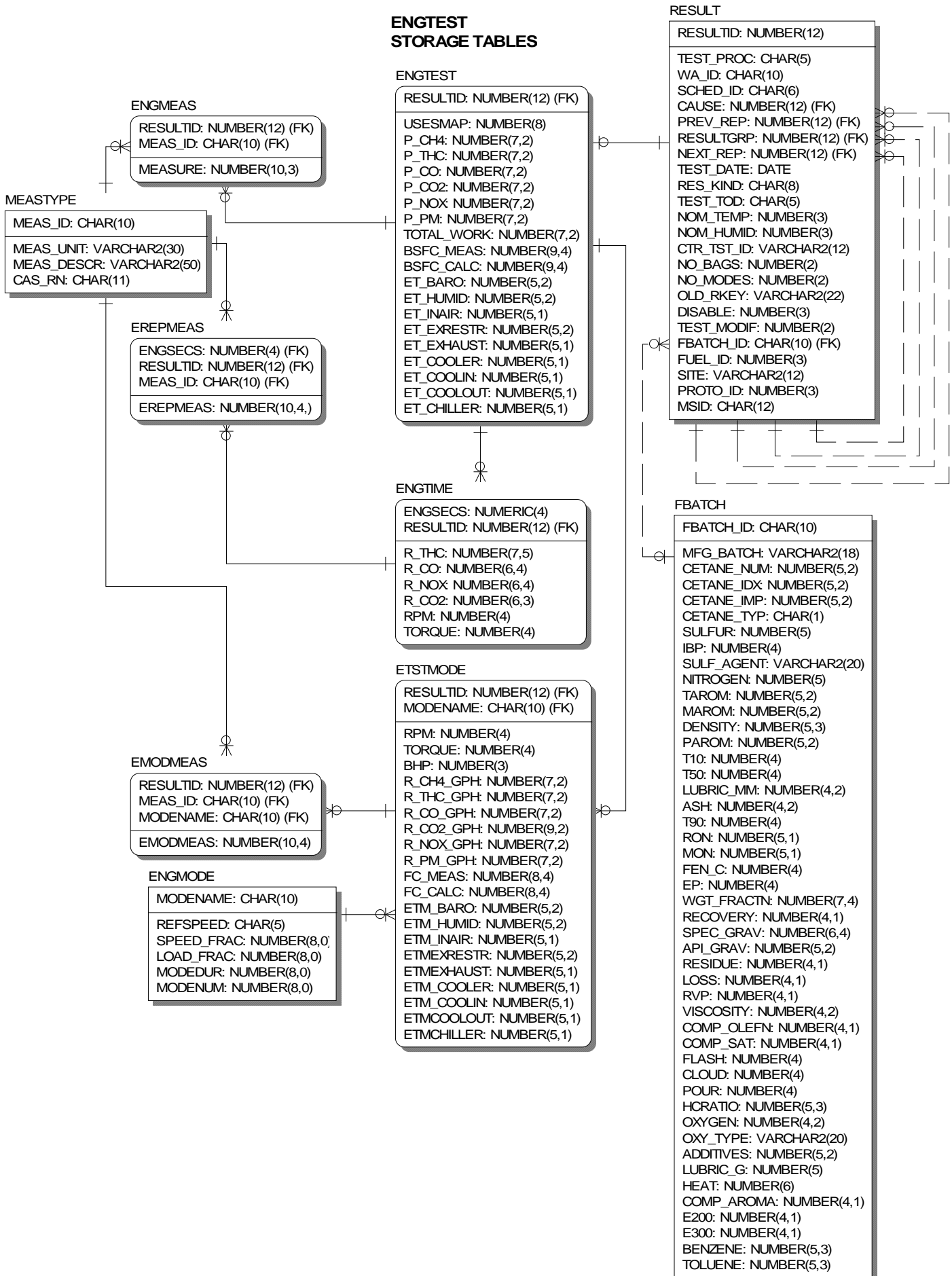

ENGINMAP STORAGE TABLES

ENGINMAP

RESULTID: NUMBER(12) (FK)
MSDRTPWR: NUMBER(5)
MSDRDTPED: NUMBER(5)
MAXTORQUE: NUMBER(4)
MSDTRQSPED: NUMBER(5)
GOV_SPEED: NUMBER(5)
EXRESTRICT: NUMBER(5,2)
BARO: NUMBER(5,2)
HUMIDITY: NUMBER(5,2)
INLET_AIR: NUMBER(5,1)
EXHAUST: NUMBER(5,1)
COOLER_OUT: NUMBER(5,1)
COOLANT_IN: NUMBER(5,1)
COOLANTOUT: NUMBER(5,1)
CHILLER: NUMBER(5,1)
MAPTYPE: CHAR(5)

MAPPOINT

MAP_RPM: NUMBER(5)
RESULTID: NUMBER(12) (FK)
MAP_TORQUE: NUMBER(4)

FBATCH

FBATCH_ID: CHAR(10)
MFG_BATCH: VARCHAR2(18)
CETANE_NUM: NUMBER(5,2)
CETANE_IDX: NUMBER(5,2)
CETANE_IMP: NUMBER(5,2)
CETANE_TYP: CHAR(1)
SULFUR: NUMBER(5)
IBP: NUMBER(4)
SULF_AGENT: VARCHAR2(20)
NITROGEN: NUMBER(5)
TAROM: NUMBER(5,2)
MAROM: NUMBER(5,2)
DENSITY: NUMBER(5,3)
PAROM: NUMBER(5,2)
T10: NUMBER(4)
T50: NUMBER(4)
LUBRIC_MM: NUMBER(4,2)
ASH: NUMBER(4,2)
T90: NUMBER(4)
RON: NUMBER(5,1)
MON: NUMBER(5,1)
FEN_C: NUMBER(4)
EP: NUMBER(4)
WGT_FRACTN: NUMBER(7,4)
RECOVERY: NUMBER(4,1)
SPEC_GRAV: NUMBER(6,4)
API_GRAV: NUMBER(5,2)
RESIDUE: NUMBER(4,1)
LOSS: NUMBER(4,1)
RVP: NUMBER(4,1)
VISCOSITY: NUMBER(4,2)
COMP_OLEFN: NUMBER(4,1)
COMP_SAT: NUMBER(4,1)
FLASH: NUMBER(4)
CLOUD: NUMBER(4)
POUR: NUMBER(4)
HCRATIO: NUMBER(5,3)
OXYGEN: NUMBER(4,2)
OXY_TYPE: VARCHAR2(20)
ADDITIVES: NUMBER(5,2)
LUBRIC_G: NUMBER(5)
HEAT: NUMBER(6)
COMP_AROMA: NUMBER(4,1)
E200: NUMBER(4,1)
E300: NUMBER(4,1)
BENZENE: NUMBER(5,3)
TOLUENE: NUMBER(5,3)

RESULT

RESULTID: NUMBER(12)
TEST_PROC: CHAR(5)
WA_ID: CHAR(10)
SCHED_ID: CHAR(6)
CAUSE: NUMBER(12) (FK)
PREV_REP: NUMBER(12) (FK)
RESULTGRP: NUMBER(12) (FK)
NEXT_REP: NUMBER(12) (FK)
FBATCH_ID: CHAR(10) (FK)
TEST_DATE: DATE
RES_KIND: CHAR(8)
TEST_TOD: CHAR(5)
NOM_TEMP: NUMBER(3)
NOM_HUMID: NUMBER(3)
CTR_TST_ID: VARCHAR2(12)
NO_BAGS: NUMBER(2)
NO_MODES: NUMBER(2)
OLD_RKEY: VARCHAR2(22)
DISABLE: NUMBER(3)
TEST_MODIF: NUMBER(2)
FUEL_ID: NUMBER(3)
SITE: VARCHAR2(12)
PROTO_ID: NUMBER(3)
MSID: NUMBER(12)

FUELCHEM STORAGE TABLES

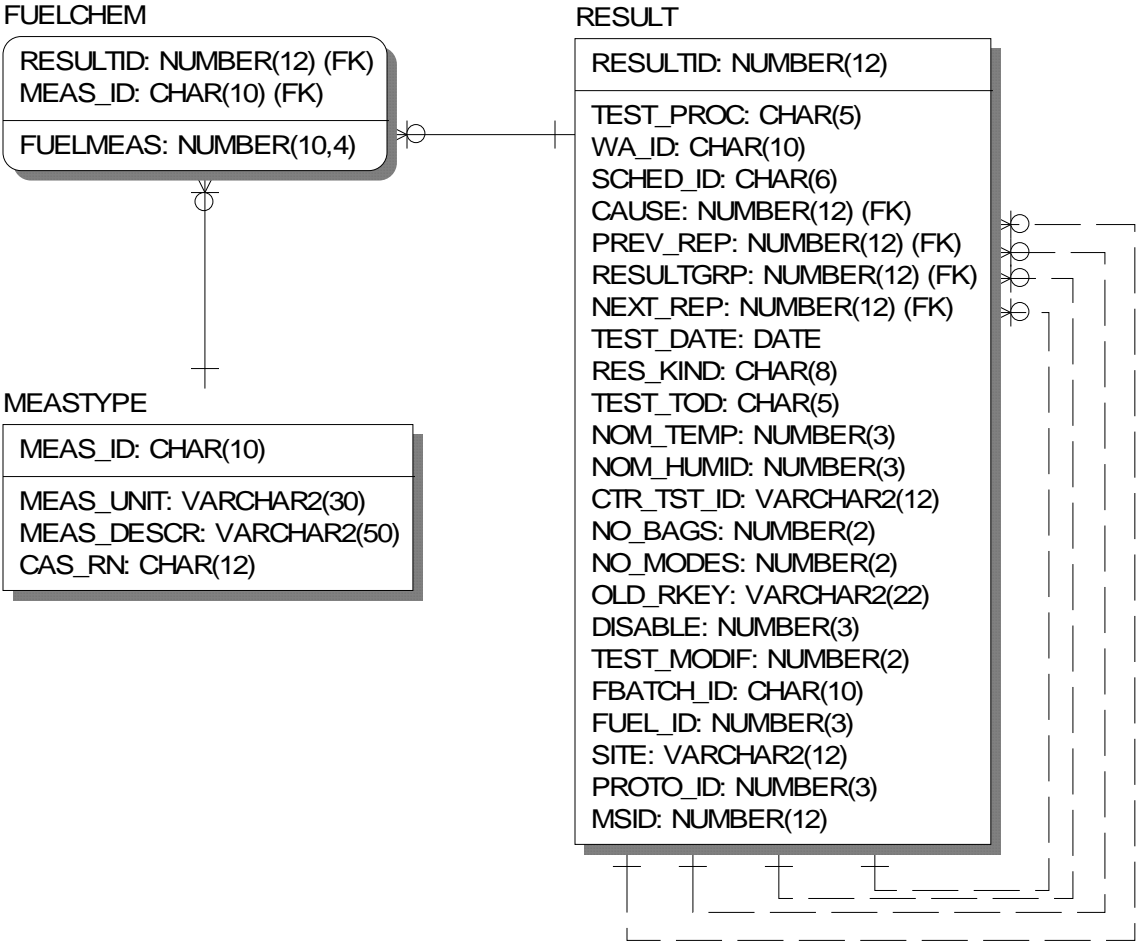

**INSPECT
STORAGE TABLES**

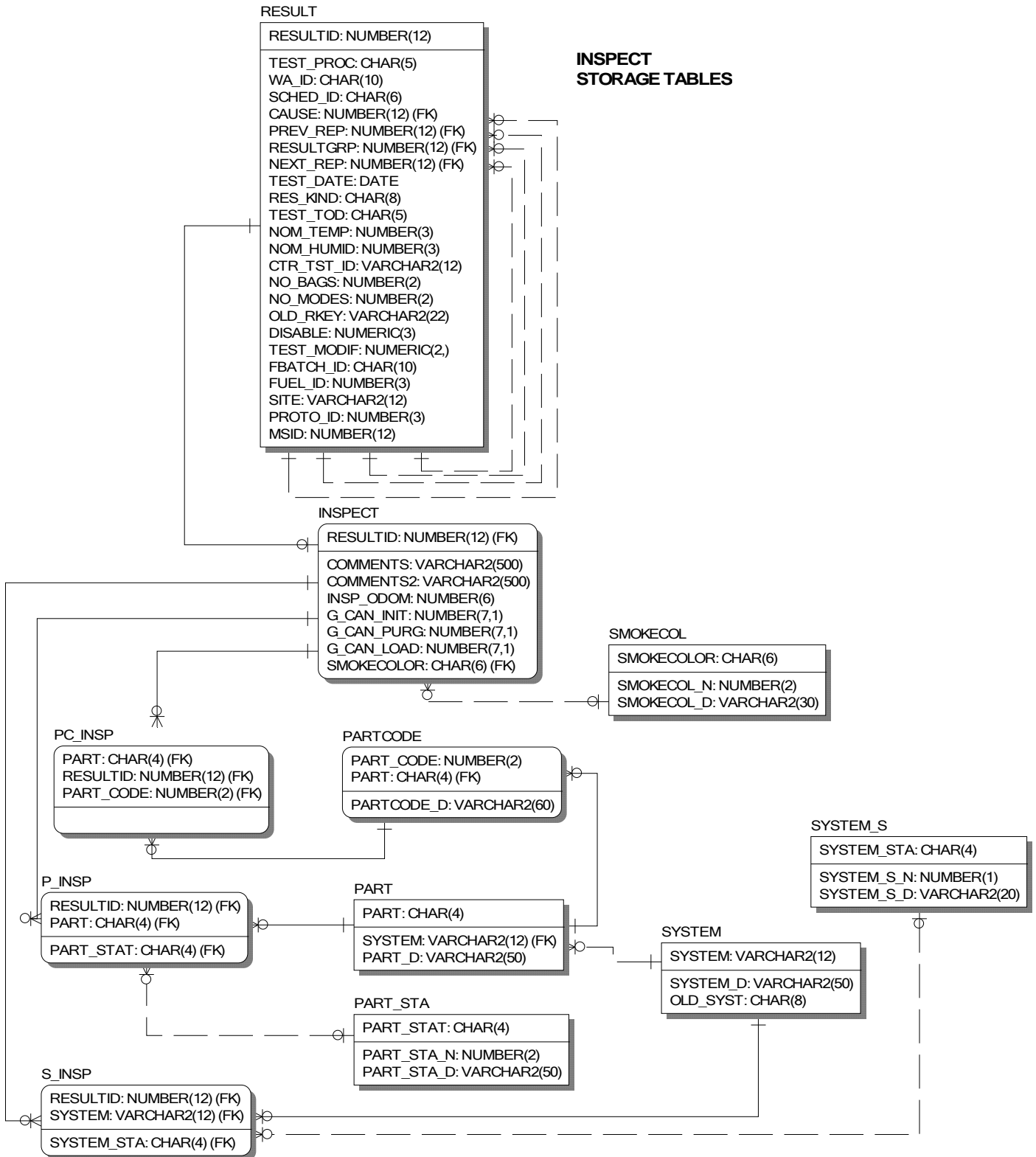

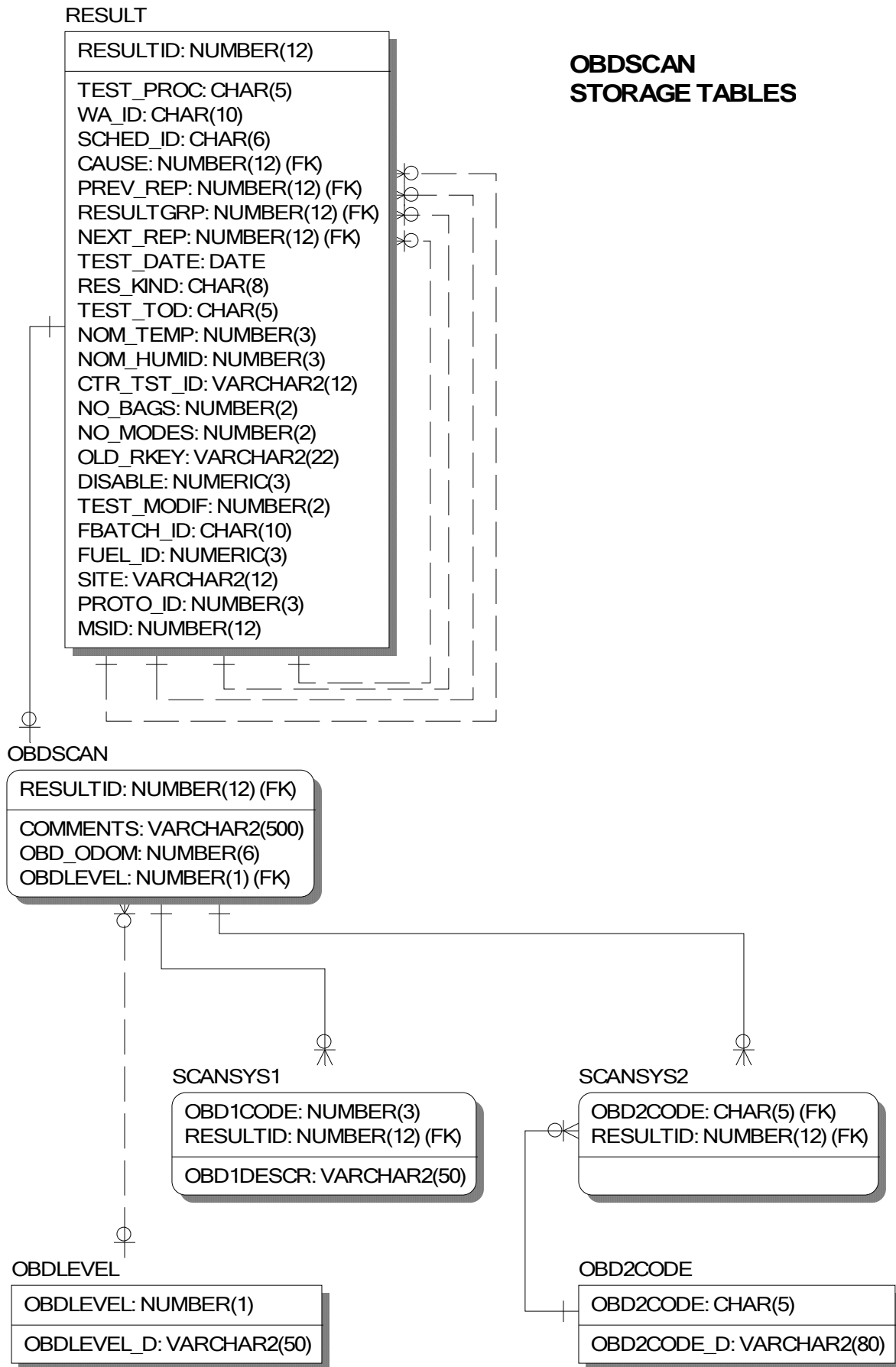

**OWNERQST
STORAGE TABLES**

RESULT

OWNERQST

RESULTID: NUMBER(12) (FK)
TRIPS: NUMBER(2)
CHECK_LITE: CHAR(3)
NEW_CAT: CHAR(4)
LAST_IM: DATE
ODOM_OK: CHAR(3)
TRUE_MILES: NUMBER(6)
MILES2LAB: NUMBER(4)
QUEST_ODOM: NUMBER(6)
SURVEY_MPG: NUMERIC(6,2)
MPG_DIST: NUMBER(5)
DRV_TYPE: VARCHAR2(14)
TRIP2LAB: CHAR(4)
IM_STATUS: CHAR(5)
LITEACTION: CHAR(6)
HOW_LONG: CHAR(2)

RESULTID: NUMBER(12)
TEST_PROC: CHAR(5)
WA_ID: CHAR(10)
SCHED_ID: CHAR(6)
CAUSE: NUMBER(12) (FK)
PREV_REP: NUMBER(12) (FK)
RESULTGRP: NUMBER(12) (FK)
NEXT_REP: NUMBER(12) (FK)
TEST_DATE: DATE
RES_KIND: CHAR(8)
TEST_TOD: CHAR(5)
NOM_TEMP: NUMBER(3)
NOM_HUMID: NUMBER(3)
CTR_TST_ID: VARCHAR2(12)
NO_BAGS: NUMBER(2)
NO_MODES: NUMBER(2)
OLD_RKEY: VARCHAR2(22)
DISABLE: NUMERIC(3)
TEST_MODIF: NUMBER(2)
FBATCH_ID: CHAR(10)
FUEL_ID: NUMERIC(3)
SITE: VARCHAR2(12)
PROTO_ID: NUMBER(3)
MSID: NUMBER(12)

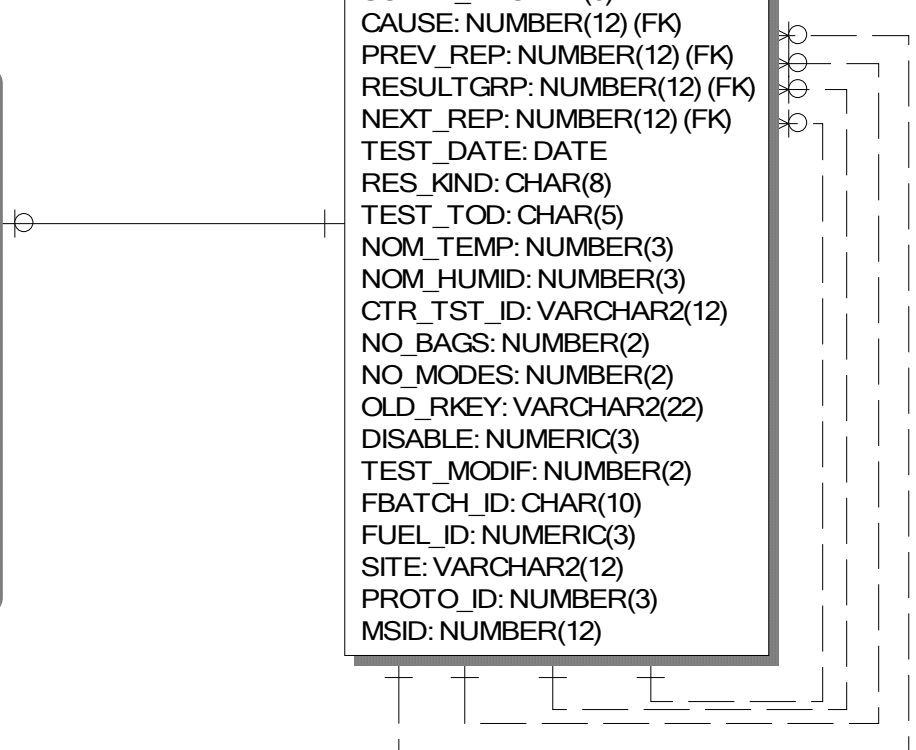

**RUNLOSS
STORAGE TABLES**

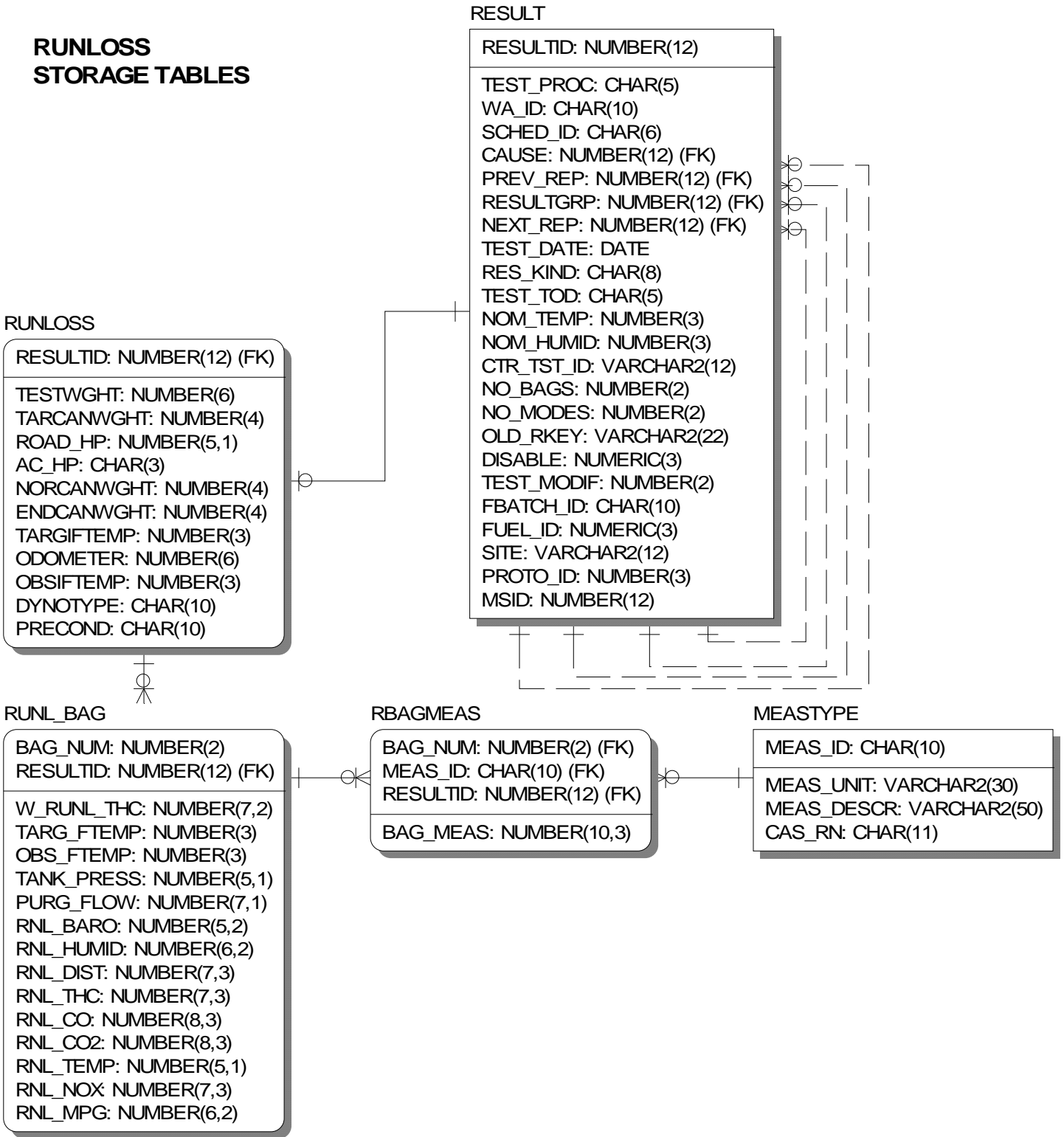

**PEMS/PAMS
ACTIVITY TRIP
STORAGE TABLES**

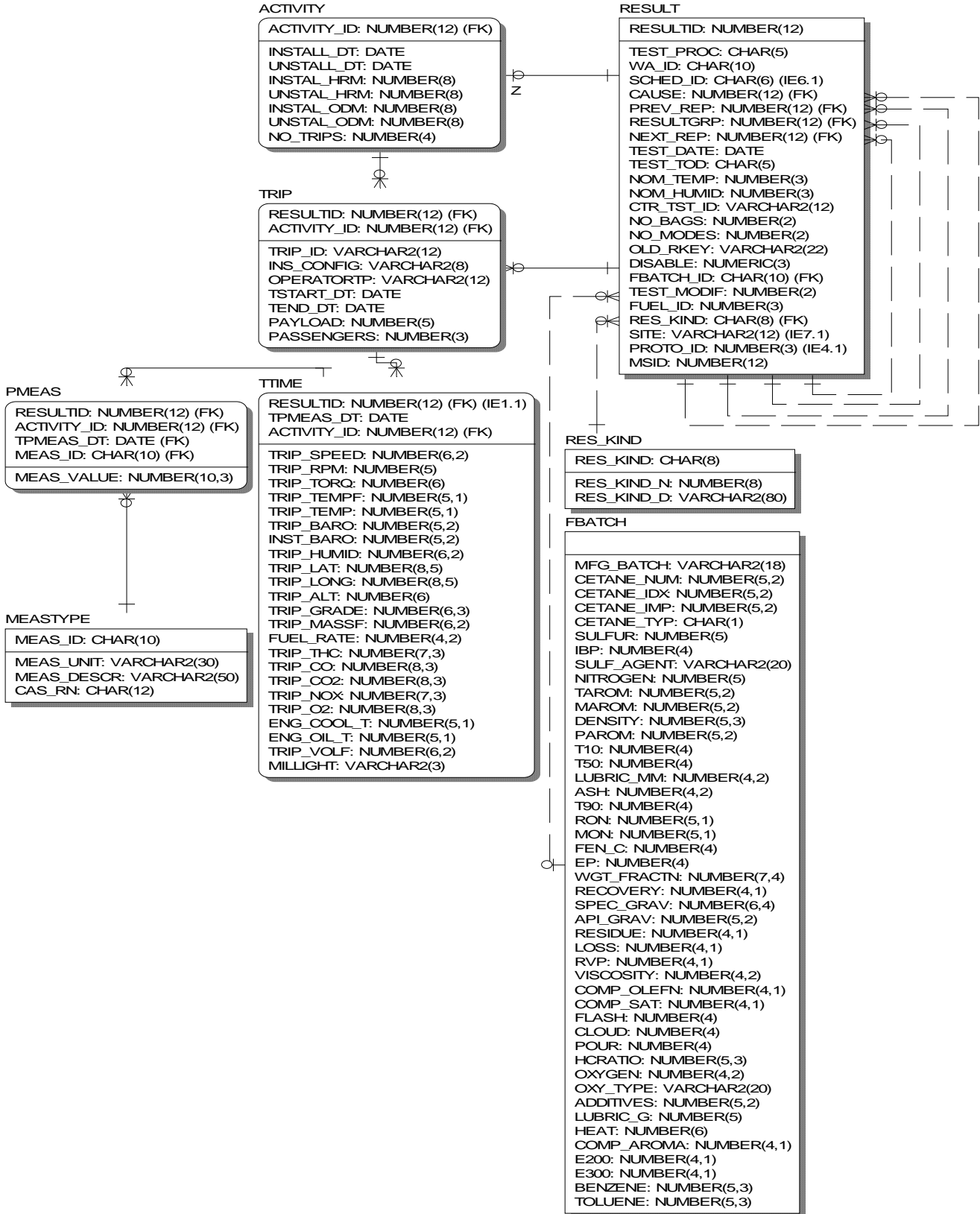

COMPOSIT STORAGE TABLES

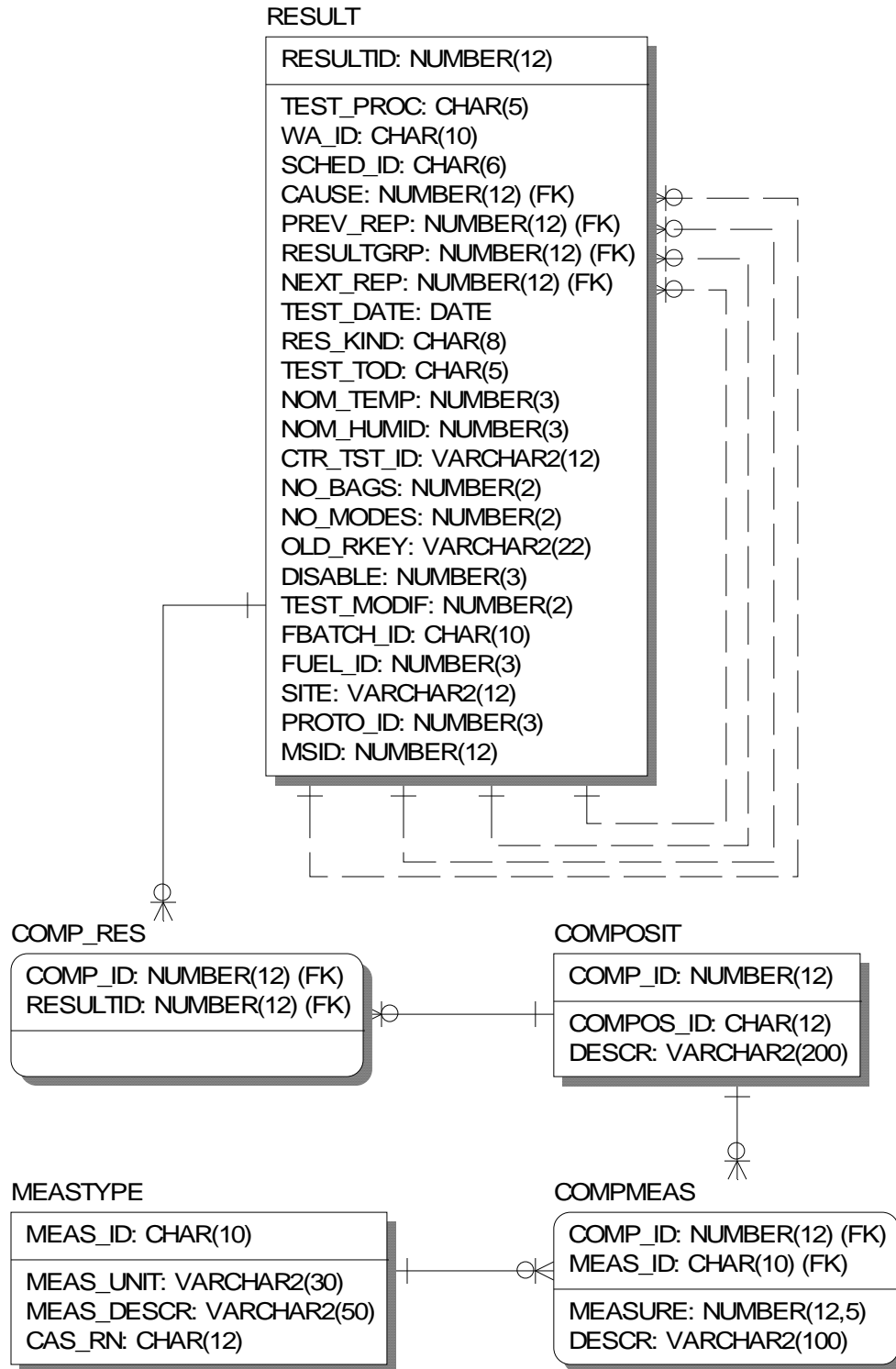

**PRESSTST
STORAGE TABLES**

RESULT

RESULTID: NUMBER(12)
TEST_PROC: CHAR(5)
WA_ID: CHAR(10)
SCHED_ID: CHAR(6)
CAUSE: NUMBER(12) (FK)
PREV_REP: NUMBER(12) (FK)
RESULTGRP: NUMBER(12) (FK)
NEXT_REP: NUMBER(12) (FK)
TEST_DATE: DATE
RES_KIND: CHAR(8)
TEST_TOD: CHAR(5)
NOM_TEMP: NUMBER(3)
NOM_HUMID: NUMBER(3)
CTR_TST_ID: VARCHAR2(12)
NO_BAGS: NUMBER(2)
NO_MODES: NUMBER(2)
OLD_RKEY: VARCHAR2(22)
DISABLE: NUMERIC(3)
TEST_MODIF: NUMBER(2)
FBATCH_ID: CHAR(10)
FUEL_ID: NUMERIC(3)
SITE: VARCHAR2(12)
PROTO_ID: NUMBER(3)
MSID: NUMBER(12)

MEASTYPE

MEAS_ID: CHAR(10)
MEAS_UNIT: VARCHAR2(30)
MEAS_DESCR: VARCHAR2(50)
CAS_RN: CHAR(11)

PRESMEAS

MEAS_ID: CHAR(10) (FK)
RESULTID: NUMBER(12) (FK)
MEASURE: NUMBER(10,3)

PRESSTST

RESULTID: NUMBER(12) (FK)
FUEL_CAP: CHAR(3)
CAPOKSTANT: CHAR(3)
FILLER_OK: CHAR(3)
CANHOSE_OK: CHAR(3)
CANIST_ACC: CHAR(3)
CANIST_CON: CHAR(3)
HOSE_OK: CHAR(3)
PRESS_INIT: NUMBER(5,1)
PRESS_1MIN: NUMBER(5,1)
PRESS_2MIN: NUMBER(5,1)
COMMENTS: VARCHAR2(500)
PRESS_ODOM: NUMBER(6)
PRESSTAT: VARCHAR2(15)

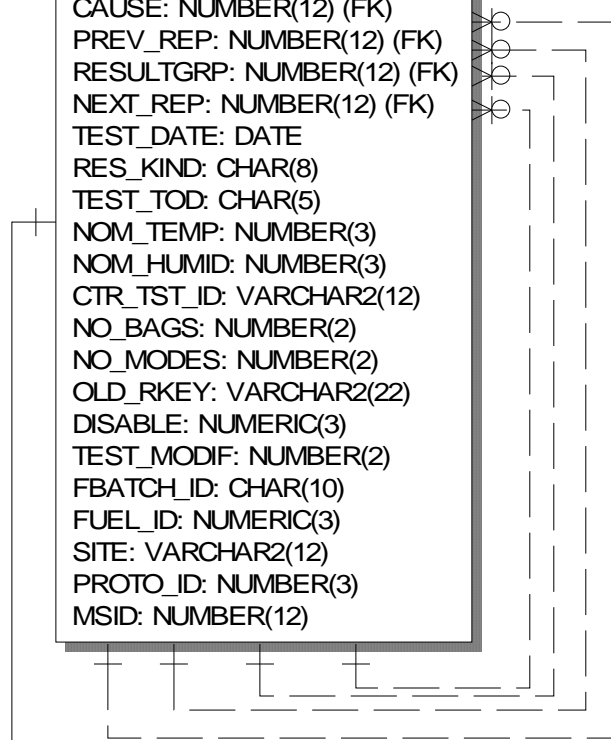

**PROCURE
STORAGE TABLES**

PROCURE

RESULTID: NUMBER(12) (FK)
VEH_NO: NUMBER(5)
VEH_LANE: NUMBER(5)
RECRUIT_NO: VARCHAR2(15)
FUEL_PB: NUMBER(6,3)
PLUMB_TEST: CHAR(4)
PROC_ODOM: NUMBER(6)
TANKNECK: CHAR(4)
REP_TIME: NUMBER(4)
ECMPTIME: NUMBER(4)
CONPART: NUMBER(4)
TVVYPART: NUMBER(4)
TIRESIZE: VARCHAR2(11)
TIRE_MFR: CHAR(10)
LF_PSI: NUMBER(2)
RF_PSI: NUMBER(2)
LR_PSI: NUMBER(2)
RR_PSI: NUMBER(2)
FPSI_SPEC: NUMBER(2)
RPSI_SPEC: NUMBER(2)
HOUR_METER: NUMBER(6)
CUTHC: NUMBER(5,2)
REBUILD_CT: NUMBER(2)
REBUILD_DT: DATE
CUTC0: NUMBER(6,2)
REBUILDWHY: VARCHAR2(30)
CUTNOX: NUMBER(5,2)
MODIFS: VARCHAR2(100)
OWNERSHIP: CHAR(7)
DEPOT: VARCHAR2(12)
CUTPOINTS: NUMBER(2)
FIXES: NUMBER(2)
IM240_PF: CHAR(4)
PROC METH: CHAR(10)
PRESSURE: CHAR(7)
PROC_MATCH: CHAR(7)
LF_WEAR: CHAR(7)
STATETEST: CHAR(8)
PURGE: CHAR(7)
RF_WEAR: VARCHAR2(7)
IM_STATION: NUMBER(3)
VIN_BODY: VARCHAR2(30)
VINDCODE: VARCHAR2(12)

MS_IDNO

MSID: NUMBER(12) (FK)
MS_ID: CHAR(17)
VIN: CHAR(17)
ENG SERIALN: CHAR(17)

M_SOURCE

MSID: NUMBER(12)
MS_TYPE: NUMBER(2)
EXCEPT: CHAR(3)
EX_COMM: VARCHAR2(20)
HIGHWAY: CHAR(3)
DISP_CID: NUMBER(4)
DISP_LITER: NUMBER(4,1)
VENTURIS: NUMBER(2)
VAR_VENT: CHAR(3)
CYLINDER: NUMBER(2)
CLOSEDLOOP: CHAR(3)
CAT_TYPE: CHAR(4)
AIR_INJ: CHAR(5)
FUEL_DELIV: CHAR(6)
IGNITION: CHAR(2)
FUELTYPE: CHAR(4)
FI_TYPE: CHAR(6)
COMPANY: VARCHAR2(12)
ASPIRATED: CHAR(7)

RESULT

RESULTID: NUMBER(12)
TEST_PROC: CHAR(18)
WA_ID: CHAR(18)
SCHED_ID: CHAR(6)
CAUSE: NUMBER(12) (FK)
MSID: NUMBER(12) (FK)
SITE: VARCHAR2(12)
PREV_REP: NUMBER(12) (FK)
RESULTGRP: NUMBER(12) (FK)
NEXT_REP: NUMBER(12) (FK)
TEST_DATE: DATE
RES_KIND: CHAR(18)
TEST_TOD: CHAR(5)
NOM_TEMP: NUMBER(3)
NOM_HUMID: NUMBER(3)
CTR_TST_ID: VARCHAR2(12)
NO_BAGS: NUMBER(2)
NO_MODES: NUMBER(2)
OLD_RKEY: VARCHAR2(22)
DISABLE: CHAR(18)
TEST_MODIF: CHAR(18)
FBATCH_ID: CHAR(18)
FUEL_ID: CHAR(18)
PROTO_ID: NUMBER(3)

VEHICLE

MSID: NUMBER(12) (FK)
EVAP_FAM: CHARACTER(12)
ENG_FAM: CHARACTER(19)
VEHCLASS: CHARACTER(5)
MODEL_YR: Numeric(8,0)
MAKE: CHARACTER(12)
MODEL_NAME: CHARACTER(20)
OVERDRIVE: CHARACTER(3)
TRAN_TYPE: CHARACTER(6)
CREEPER: CHARACTER(3)
LOCKUP: CHARACTER(3)
GEARS: CHARACTER(6)
GVWR: Numeric(8,0)
GCWR: Numeric(8,0)
CURBWEIGHT: Numeric(8,0)
AC: CHARACTER(3)
BLD_DATE: DATE
THCSTD: Numeric(8,0)
NMHCSTD: Numeric(8,0)
COSTD: Numeric(8,0)
NOXSTD: Numeric(8,0)
THCESTD: Numeric(8,0)
PMSTD: Numeric(8,0)
NMHCSTD: Numeric(8,0)
EVAPSTD: Numeric(8,0)
FUELTANKS: NUMBER(1)
TANK_CAP: Numeric(8,0)
CANISTER: CHARACTER(10)
EGR: CHARACTER(3)
CITY_FE: Numeric(8,0)
HWAY_FE: Numeric(8,0)
DRV_TRN: CHARACTER(4)
MODELSIZE: CHARACTER(10)
AXLE_RATIO: Numeric(8,0)
STANDARDS: CHARACTER(6)
ENGMOUNT: CHARACTER(10)
PURPOSE: CHARACTER(100)
SCC: CHARACTER(14)
CERT_NOX: NUMBER(6,3)
CERT_PM: NUMBER(6,3)
AXLE: Numeric(2)
CERT_CO: Numeric(6,3)
CERT_HC: Numeric(6,3)
VIN8: CHARACTER(8)
VIN_BODY: CHARACTER(30)

ENGINE

MSID: NUMBER(12) (FK)
ENG_FAM: VARCHAR2(19)
ENGSERIES: VARCHAR2(20)
BLD_DATE: DATE
ENG_MOD_YR: NUMBER(4)
INJECTORS: NUMBER(1)
FI_PRESS: NUMBER(5)
RATE_SHAPE: CHAR(3)
MAXADVANCE: NUMBER(5,2)
MAXRETARD: NUMBER(5,2)
PARTTRAP: CHAR(3)
RATEDPOWER: NUMBER(7,1)
RATEDSPEED: NUMBER(5)
IDLE_RPM: NUMBER(5)
TECH_CFG: VARCHAR2(50)
PUMP_TYPE: VARCHAR2(50)
ECS_DESCPT: VARCHAR2(50)
ELECT_CONT: VARCHAR2(100)
PEAKTORQUE: NUMBER(4)
PEAKSPEED: NUMBER(5)
PEAKFRATE: NUMBER(5,1)
RATEDFRATE: NUMBER(5,1)
AIRFUEL: CHAR(4)
COOLING: CHAR(7)
EGR_TYPE: CHAR(6)
ENG_CLASS: CHAR(7)
ENG_CYCLE: CHAR(1)
FI METH: CHAR(4)
MFR_INTSPD: NUMBER(2)
CAMEFROM: NUMBER(12)

**REPAIR
STORAGE TABLES**

REPAIR

RESULTID: NUMBER(12) (FK)
COMMENTS: VARCHAR2(500)
COMMENTS2: VARCHAR2(500)
REPAR_ODOM: NUMBER(6)
REPAR_HRM: CHAR(5)
SYST_REP: CHAR(7)
REP_TYPE: NUMBER(3)

RESULT

RESULTID: NUMBER(12)
TEST_PROC: CHAR(5)
WA_ID: CHAR(10)
SCHED_ID: CHAR(6)
CAUSE: NUMBER(12) (FK)
PREV_REP: NUMBER(12) (FK)
RESULTGRP: NUMBER(12) (FK)
NEXT_REP: NUMBER(12) (FK)
TEST_DATE: DATE
RES_KIND: CHAR(8)
TEST_TOD: CHAR(5)
NOM_TEMP: NUMBER(3)
NOM_HUMID: NUMBER(3)
CTR_TST_ID: VARCHAR2(12)
NO_BAGS: NUMBER(2)
NO_MODES: NUMBER(2)
OLD_RKEY: VARCHAR2(22)
DISABLE: NUMERIC(3)
TEST_MODIF: NUMBER(2)
FBATCH_ID: CHAR(10)
FUEL_ID: NUMERIC(3)
SITE: VARCHAR2(12)
PROTO_ID: NUMBER(3)
MSID: NUMBER(12)

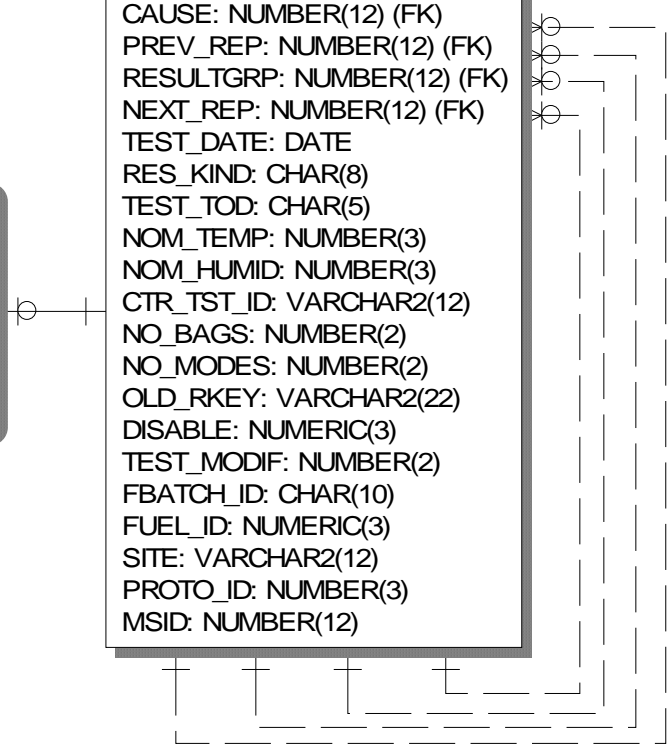

STANDARDS STORAGE TABLES

VEHICLE

MSID: NUMBER(12)
MODEL_YR: NUMBER(4)
MODEL_NAME: VARCHAR2(20)
OVERDRIVE: CHAR(3)
CREEPER: CHAR(3)
LOCKUP: CHAR(3)
GVWR: NUMBER(6)
AC: CHAR(3)
CURBWEIGHT: NUMBER(6)
BLD_DATE: DATE
GCWR: NUMBER(6)
THCSTD: NUMBER(6,3)
NMHCSTD: NUMERIC(6,3)
COSTD: NUMBER(6,3)
NOXSTD: NUMBER(6,3)
EVAP_FAM: VARCHAR2(12) (FK)
TANK_CAP: NUMBER(3)
CITY_FE: NUMBER(2)
THCESTD: NUMBER(6,3)
HWAY_FE: NUMBER(2)
PMSTD: NUMBER(6,3)
NMHCSTD: NUMBER(6,3)
EVAPSTD: NUMBER(6,3)
FUELTANKS: NUMBER(1)
AXLE_RATIO: NUMBER(5,2)
PURPOSE: VARCHAR2(100)
ENG_FAM: VARCHAR2(19) (FK)
CERT_NOX: NUMBER(6,3)
CERT_PM: NUMBER(6,3)
TRAN_TYPE: CHAR(6)
STANDARDS: CHAR(6)
MODELSIZE: CHAR(10)
MAKE: VARCHAR2(12)
GEARS: CHAR(6)
DRV_TRN: CHAR(4)
CANISTER: CHAR(10)
ENGMOUNT: CHAR(10)
VEHCLASS: CHAR(6)
SCC: VARCHAR2(14)
EGR: CHAR(3)
AXLE: NUMBER(2)
CERT_CO: NUMBER(6,3)
CERT_HC: NUMBER(6,3)
VIN8: VARCHAR2(8)
VIN_BODY: VARCHAR2(30)

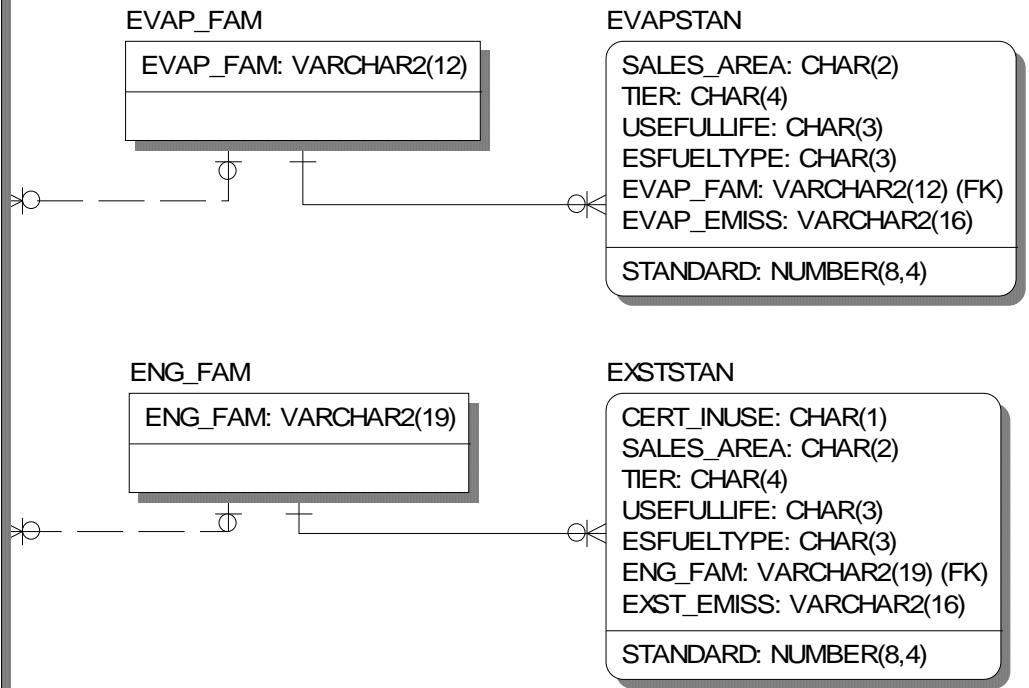

III. Top-Level MSOD Design Information

b. Entity (Table) Names and Definitions

Table Name	Table Definition
ACTIVITY	An activity covered by a PEMS/PAMS vehicle. This result subtype is identified in RESULT by RES_KIND = "ACTIVITY".
BAG_MEAS	Used to store a MEASTYPE measurement at the test bag level.
COMP_RES	A table that identifies the observations of mobile sources to a composite sample
COMPMEAS	Table stores the measurements of composited samples from more than one observation of one or more mobile sources
COMPOSIT	A look up table where the input unique identifier for a composite sample can be found for an MSOD generated unique identifier for a composite sample.
DYNO_BAG	One bag set of a DYNOTEST or RUNLOSS test. (A bag set usually results from two physical bags: one sample and one background, with the background measurements subtracted from the sample measurements to yield the bag set measurements). For DYNOTESTs having a single bag set the bag results are stored here, in addition to being the summary results for the test as a whole.
DYNOMEAS	Used to store a MEASTYPE measurement at the summary test level.
DYNOMODE	One "mode" of a possibly multimode DYNOTEST whose results are expressed in mass units. The set modes are defined at any point in time by the translation table for the MODE_ID attribute. Examples of a "mode" include IDLE, IDLE with engine running at 2500 rpm, etc.
DYNORATE	One "mode" of a possibly multimode DYNOTEST whose results are expressed in mass/time units. The set of possible modes is defined at any point in time by the translation table for the MODE_ID attribute. Examples of a "mode" include IDLE, IDLE with engine running at 2500 rpm, etc.
DYNOTEST	This result subtype stores the results of a vehicle chassis exhaust emission test, or in some cases a group of tests. This table stores information pertaining to the test, or test group as a whole. Note: The emission summary result fields in this entity are used only to summarize the results of bagged exhaust emission tests. This result subtype is identified in RESULT by RES_KIND = "DYNOTEST". The entity name DYNOTEST reflects the fact that a chassis dynamometer is used in most of these tests. The subtype includes exhaust emission tests for which a dynamometer could be used, but is not required, such as idle emission measurements. This subtype does not include "running loss" tests, which are performed on a chassis dynamometer, but which measure both exhaust and evaporative emissions.
DYNOTIME	A point in time during a DYNOTEST.
EMODMEAS	Used to store a MEASTYPE measurement at the engine test mode level.
ENG_FAM	Exhaust Engine Family. Represents an engine or group of engines with the same emission certificate and is the result of Federal Vehicle Emission Certification process.
ENGINE	An engine or motor used to power an M_SOURCE, exclusive of other components of the M_SOURCE such as its structural frame, wheels, etc. Additional Notes: 1. Since MS_TYPE = 2 for all instances of this entity the MS_TYPE field is not physically implemented in this table. 2. MS_ID will likely be the engine serial number for instances of this entity, though if some small engines do not bear unique serial numbers then another solution will have to be found for them. Sample Queries: To access ENGINE fields in conjunction with their RESULT information the following join condition would typically be used: WHERE RESULT.MS_TYPE = 2 AND RESULT.MS_ID = ENGINE.MS_ID
ENGINMAP	This result subtype stores an engine "MAP". Maximum available power or torque as a function of RPM. This result subtype is identified in RESULT by RES_KIND = "ENGINMAP".
ENGMEAS	Used to store a MEASTYPE measurement at the ENGTEST bag level.
ENGMODE	Steady-state mode used in engine testing on an engine dynamometer. Characterized by a speed, expressed as a percentage of one of several maximum speeds (rated, idle, or governed central speed, etc), and a load, expressed as a percentage of the mapped torque at that speed.
ENGTEST	This result subtype stores the results of an engine test performed on an engine dynamometer, exclusive of smoke opacity measurement. This subtype is identified by RES_KIND = "ENGTEST".
ENGTIME	A point in time within an ENGTEST.
EREPMEAS	A non-core measurement associated with a point in time in an engine test (i.e. an ENGTIME).
ETSTMODE	The results of one steady-state mode of an engine dynamometer test. (Only used to store steady-state results.)
EVAPMEAS	Used to store a MEASTYPE measurement at the EVAPTEST bag level.
EVAPTEST	This result subtype stores the results of an evaporative emission test. This table stores information pertaining to the test as a whole. This result subtype is identified in RESULT by RES_KIND = "EVAPTEST". This subtype does not include "running loss" tests, which are performed on a chassis dynamometer and which measures both exhaust and evaporative emissions.
EVAPTIME	One point in time during an evaporative emission test.
FBATCH	A particular batch of fuel that can be used to power mobile sources during emission tests. Unlike the FUEL table, which is a general kind of fuel, instances of this entity represent a physical batch of fuel that has measured properties.
FUELICHEM	This result subtype stores the results of an analysis of the fuel being used in the mobile source. This result subtype is identified in RESULT by RES_KIND = "FUELICHEM".
INSPECT	This result subtype is identified in RESULT by RES_KIND = "INSPECT". This result subtype is used to store the results of the emission component inspection often referred to as the M1 maintenance inspection, or just M1 maintenance. This top level subtype entity is used to store information about the inspection as a whole. This result subtype can also be used to store observational comments pertaining to a Mobile Source, even when no parts or systems are actually inspected.

Table Name	Table Definition
LAB_MEAS	Used to store a MEASTYPE measurement at the test mode level.
LTIME	LTIME is to store measurements used to calculate the mass per unit time measurements found in the input table TIME_IN during a lab test.
MAPPOINT	A single point within an engine map.
MEASTYPE	A type of numeric, "non-core", emission-related measurement. e.g. methane emissions in grams per mile, not usually performed. Note: This table does not store a result measurement, but information about a kind of measurement.
MODEMEAS	Used to store a MEASTYPE measurement at the test mode level.
MODETIME	A point in time within a DYNOMODE.
M_SOURCE	A physical object which can move, and which produces outdoor air pollution. Historically interest has been in passenger cars and trucks designed to be driven on roadways, and the internal combustion engines used to power such vehicles. Future data will pertain to other types of mobile sources such as off-road vehicles, boats, farm and construction equipment, etc., and the engines used to power such equipment. Additional Notes: 1. EPA and the principal air- pollution-regulating statutes make a fundamental distinction between mobile and stationary sources of air pollution such as factories and power plants. 2. This entity is broken down into subtype entities based on MS_TYPE. Fields common to all or most types of mobile sources will be stored in this table. Fields particular to certain types of mobile sources will be stored in subtype tables. Sample Queries: To access M_SOURCE fields in conjunction with their RESULT information the following join condition would typically be used: WHERE RESULT.MS_TYPE = M_SOURCE.MS_TYPE AND RESULT.MS_ID = M_SOURCE.MS_ID Example Instances: Passenger cars, trucks, busses, farm tractors, locomotives, ships, airplanes, portable generators, and power lawnmowers are all M_SOURCES. A trailer is not (does not produce air pollution). A gasoline service station is not (can not move). A transportation activity such as "shipping" is not (not an object). A class of mobile sources such as "LDTs" (light duty trucks), about which we might collect for example population, activity, or usage data, is likewise not an M_SOURCE.
MS_IDNO	This table is used to store legal engine serial numbers, VINs, and MSOD assigned identifier 'MSID'. The engine serial numbers and the VINs are considered to be confidential information This table permits authorized personnel access to this confidential information.
OBD2CODE	OBD2 scan code. Contains information about the code itself. e.g. its meaning.
OBDLEVEL	Table that represents a Type of on board diagnostic system. Level 1 systems are present on many older vehicles and produce 2 digit numeric codes particular to the vehicle manufacturer and model year. Level 2 system produce 5 character codes some of which have industry standardized significance.
OBDSCAN	This result subtype is used to store summary level information pertinent to a scan of a vehicle's on board diagnostic system. While both level 1 and level 2 on board diagnostic systems scans are supported by this data structure, data collected on level 1 systems prior to 1999 are stored as part of the vehicle inspection data. This result subtype is identified in RESULT by RES_KIND = "OBDSCAN". This table is used to store information pertaining to the scan as a whole.
OWNERQST	This result subtype stores information from the Owner's questionnaire, and, where collected, summary information from the fuel economy postcard survey. This result subtype is identified in RESULT by RES_KIND = "OWNERQST".
P_INSP	Emission component part inspection.
PART	Emission Component Part e.g. E101, etc. Other values represent the MIL light, OBD1, codes, etc.
PART_STA	Translation table that relates a key field to a more detailed description of the status of a part..
PARTCODE	Numeric value representing a status or failure of an emission component system part.
PC_INSP	Emission component part code inspection.
PMEAS	Used to store a MEASTYPE measurement for PEMS/PAMS devices on vehicles.
PRESMEAS	Used to store a MEASTYPE measurement at the PRESTEST bag level.
PRESSTST	This Result Subtype stores the outcome of an evaporative system pressure check. In cases where an attempt was made to perform a pressure check, but it could not be performed, the reason for this is stored. This result subtype is identified in RESULT by RES_KIND = "PRESSTST".
PROCURE	The obtaining of an M_SOURCE for testing. Usually a series of tests is performed during the M_SOURCE's stay at a test facility. This result subtype is identified in RESULT by RES_KIND = "PROCURE". Historically AMD's emission factor testing program can be considered to have always "procured" a vehicle or engine prior to testing it, but it is not a logical requirement of the database that a PROCURE instance exist for every RESULT if no information of this nature is collected, e.g. vehicles observed driving on the road would not have to be "procured".
RATEMEAS	Used to store a rate MEASTYPE measurement at the test mode level.
RBAGMEAS	Used to store a MEASTYPE measurement at the run-loss test bag level.
REPAIR	A repair is a procedure performed on a Mobile_Source intended to improve its performance, which is assumed to affect all subsequent RESULTS on that Mobile Source. This result subtype is identified in RESULT by RES_KIND = "REPAIR".
REP_MEAS	Used to store a MEASTYPE measurement at the test time point level.
RES_KIND	This table is used to aggregate RESULT instances into a few different subtypes.

Table Name	Table Definition
RESULT	Any observation, measurement, or modification to an M_SOURCE including... Information pertinent to the procurement of the M_SOURCE. An outcome of any test procedure performed on an M_SOURCE, such as an exhaust emissions test or an evaporative emissions test. Observations of the M_SOURCE, e.g. a questionnaire about the M_SOURCE submitted by the owner. Repairs or modifications made to the M_SOURCE which could effect future measurements. Additional Notes: This entity is broken down into an incomplete collection of dependent subtype entities based on its RES_KIND field. Additional result subtypes will be added as are needed.
RUNL_BAG	The evaporative emissions for a portion of a "running loss" test, identified by "bag number" within the test.
RUNLOSS	This result subtype stores the results of a vehicle chassis running loss emission test. Like DYNOTESTs, these are performed on a chassis dynamometer and exhaust emission measurements are taken. Unlike DYNOTESTs, however: 1. Evaporative running losses are measured during portions of the test. 2. An attempt is made to heat or cool the vehicle's fuel tank as necessary to simulate the temperature pattern it would experience in on-road driving. This result subtype is identified in RESULT by RES_KIND = "RUNLOSS". This table is used to store results which pertain to the test as a whole; no attempt is usually made to summarize the emission results, exhaust or evaporative, for the test as a whole.
SCANSYS1	Individual scan code resulting from a scan of a level 1 on board diagnostic system.
SCANSYS2	Individual scan code resulting from a scan of a level 2 on board diagnostic system.
S_INSP	Emission component system inspection.
SMOKECOL	Translation table that relates a key field to a more detailed description of the color of the tailpipe smoke.
SMOKETST	This result subtype stores the results of a smoke opacity test. This subtype is identified by RES_KIND = "SMOKETST".
STSTMODE	One mode of a smoke test procedure.
SYSTEM	Emission Component System e.g. "Induction", etc. "OBD", etc.
SYSTEM_S	Translation table that relates a key field to a more detailed description of the status of an emission component.
TASK	Work effort which produced the RESULT as classified historically. Usually corresponded to a contract task or analogous internal effort. Note: The WKASSIGN entity was intended to subsume this TASK entity. Until WKASSIGN is fully populated, however, this TASK entity will be used to store more sparse information which is available from the "old database" about the work efforts which produced the older RESULTS.
TRIP	A trip traveled by a PEMS/PAMS instrumented vehicle or non-road piece of equipment as defined by time period when the engine was turned on and then turned off. This result subtype is identified in RESULT by RES_KIND = "TRIP".
TTIME	Used to store second-by-second data recorded by a PEMS/PAMS device.
VEHICLE	A motor vehicle, inclusive of its engine and chassis, having a unique (within this entity) vehicle identification number (VIN). Additional Notes: 1. It may be necessary at some point to distinguish between light duty and heavy duty vehicles. If made such a distinction would probably be based on the vehicle certification regulations at CFR 40 Part 86 section 082-2. Most fundamentally if this distinction were made a light duty vehicle instance, if certified for compliance with air emission regulations, would be certified as an entire vehicle or "chassis", whereas a heavy duty vehicle instance would have its engine certified. 2. Since MS_TYPE = 1 for all instances of this entity the MS_TYPE field is not physically implemented in this table. 3. MS_ID is the Vehicle's Identification Number (VIN) for instances of this entity. Sample Queries: To access VEHICLE fields in conjunction with their RESULT information the following join condition would typically be used: WHERE RESULT.MS_TYPE = 1 AND RESULT.MS_ID = VEHICLE.MS_ID Example Instances: This entity includes motorcycles and off road vehicles.
WKASSIGN	A work assignment, whether contracted or performed in-house, which produces RESULTS. Often also referred to as a "test program". These efforts have often been performed by vehicle testing contractors under work assignment contracts. This entity represents a broader view of this fundamental construct.

III. Top-Level MSOD Design Information

c. Entity (Table) Attribute Definitions

"ACTIVITY" Table				
Name	Comment	Datatype	Null Option	Is PK
ACTIVITY_ID	Unique number sequentially assigned to each RESULT instance (including all RESULT subtype instances) as it is entered into this database. Number has no other significance.	NUMBER(12)	NOT NULL	Yes
INSTALL_DT	Data and time the unit, e.g., PEMS or PAMS, was installed onto the vehicle.	DATE	NOT NULL	No
UNSTALL_DT	Data and time the unit, e.g., PEMS or PAMS, was uninstalled from the vehicle.	DATE	NOT NULL	No
INSTAL_HRM	Hour meter reading at the time the unit, e.g., PEMS or PAMS, was installed.	NUMBER(8)	NOT NULL	No
UNSTAL_HRM	Hour meter reading at the time the unit, e.g., PEMS or PAMS, was uninstalled.	NUMBER(8)	NOT NULL	No
INSTAL_ODM	Odometer reading at the time the unit, e.g., PEMS or PAMS, was installed.	NUMBER(8)	NULL	No
UNSTAL_ODM	Odometer reading at the time the unit, e.g., PEMS or PAMS, was uninstalled.	NUMBER(8)	NULL	No
NO_TRIPS	Number of trips taken as defined by the period of time that an engine has been "key on" to "key off".	NUMBER(4)	NULL	No

"BAG_MEAS" Table				
Name	Comment	Datatype	Null Option	Is PK
MEAS_ID	Measurement type identification. Legal values defined by MEASTYPE table.	CHAR(10)	NOT NULL	Yes
BAG_NUM	Bag number.	NUMBER(2)	NOT NULL	Yes
RESULTID	Unique number sequentially assigned to each RESULT instance (including all RESULT subtype instances) as it is entered into this database. Number has no other significance.	NUMBER(12)	NOT NULL	Yes
BAG_MEAS	Bag-level measurement.	NUMBER(10,3)	NULL	No

"COMP_RES" Table				
Name	Comment	Datatype	Null Option	Is PK
COMP_ID	MSOD generated unique identifier for a composite measurement.	NUMBER(12)	NOT NULL	Yes
RESULTID	Unique number sequentially assigned to each RESULT instance (including all RESULT subtype instances) as it is entered into this database. Number has no other significance.	NUMBER(12)	NOT NULL	Yes

"COMPMEAS" Table				
Name	Comment	Datatype	Null Option	Is PK
COMP_ID	MSOD generated unique identifier for a composite measurement.	NUMBER(12)	NOT NULL	Yes
MEAS_ID	Measurement type identification. Legal values defined by MEASTYPE translation table.	CHAR(10)	NOT NULL	Yes
MEASURE	Measured value.	NUMBER(12,5)	NULL	No
DESCR	Description of the composite (not used).	VARCHAR2(100)	NULL	No

"COMPOSIT" Table				
Name	Comment	Datatype	Null Option	Is PK
COMP_ID	MSOD generated unique identifier for a composite measurement.	NUMBER(12)	NOT NULL	Yes
COMPOS_ID	Contractor generated unique identifier for a composite measurement.	CHAR(12)	NULL	No
DESCR	Description of the composite measurement (not used).	VARCHAR2(200)	NULL	No

"DYNO_BAG" Table				
Name	Comment	Datatype	Null Option	Is PK
BAG_NUM	Bag number.	NUMBER(2)	NOT NULL	Yes
RESULTID	Unique number sequentially assigned to each RESULT instance (including all RESULT subtype instances) as it is entered into this database. Number has no other significance.	NUMBER(12)	NOT NULL	Yes
BAG_BARO	Barometric pressure expressed in inches of mercury.	NUMBER(5,2)	NULL	No
BAG_HUMID	Humidity expressed in grains of water per pound of dry air.	NUMBER(6,2)	NULL	No
BAG_DIST	Distance traveled expressed in miles.	NUMBER(7,3)	NULL	No
BAG_THC	Total hydrocarbon emissions expressed in grams per mile.	NUMBER(7,3)	NULL	No
BAG_CO	Carbon monoxide emissions expressed in grams per mile.	NUMBER(8,3)	NULL	No
BAG_CO2	Carbon dioxide emissions expressed in grams per mile.	NUMBER(8,3)	NULL	No
BAG_TEMP	Temperature expressed in degrees Fahrenheit.	NUMBER(5,1)	NULL	No
BAG_NOX	Emissions of oxides of nitrogen expressed in grams per mile.	NUMBER(7,3)	NULL	No
BAG_MPG	Fuel economy expressed in miles per gallon.	NUMBER(6,2)	NULL	No

"DYNOMEAS" Table				
Name	Comment	Datatype	Null Option	Is PK
MEAS_ID	Measurement type identification. Legal values defined by MEASTYPE table.	CHAR(10)	NOT NULL	Yes
RESULTID	Unique number sequentially assigned to each RESULT instance (including all RESULT subtype instances) as it is entered into this database. Number has no other significance.	NUMBER(12)	NOT NULL	Yes
MEASURE	Test level measurement.	NUMBER(10,3)	NULL	No

"DYNOMODE" Table				
Name	Comment	Datatype	Null Option	Is PK
MODE_ID	The abbreviated name used to identify a type of "mode" emission test for a vehicle.	CHAR(10)	NOT NULL	Yes
RESULTID	Unique number sequentially assigned to each RESULT instance (including all RESULT subtype instances) as it is entered into this database. Number has no other significance.	NUMBER(12)	NOT NULL	Yes
MODE_TEMP	Measured ambient temperature during this test mode expressed in degrees Fahrenheit.	NUMBER(5,1)	NULL	No
MODE_BARO	Barometric pressure measured during test mode expressed in inches of mercury.	NUMBER(5,2)	NULL	No
MODE_HUMID	Humidity measured during test mode expressed in grains of water per pound of dry air.	NUMBER(6,2)	NULL	No
C_THC	Total hydrocarbon concentration expressed in parts per million.	NUMBER(4)	NULL	No
C_CO	Carbon monoxide concentration expressed in percent.	NUMBER(6,2)	NULL	No
C_CO2	Carbon dioxide concentration expressed in percent.	NUMBER(6,2)	NULL	No
C_NO	NO concentration expressed in parts per million, corrected for humidity via humidity correction factor.	NUMBER(4)	NULL	No
C_NOU	NO concentration expressed in parts per million, not corrected for humidity.	NUMBER(4)	NULL	No
MODE_HP	Load horsepower.	NUMBER(5,1)	NULL	No
RPM	Measured Engine RPM.	NUMBER(4)	NULL	No

"DYNORATE" Table				
Name	Comment	Datatype	Null Option	Is PK
MODEID	Mode identification. Legal values defined by MODE_ID translation table.	CHAR(10)	NOT NULL	Yes
RESULTID	Unique number sequentially assigned to each RESULT instance (including all RESULT subtype instances) as it is entered into this database. Number has no other significance.	NUMBER(12)	NOT NULL	Yes
DURATION	Length of test mode in seconds	NUMBER(5)	NULL	No
BARO	Barometric pressure during mode expressed in inches of mercury.	NUMBER(5,2)	NULL	No
TEMP	Ambient temperature during mode expressed in degrees Fahrenheit.	NUMBER(5,1)	NULL	No
HUMID	Absolute humidity expressed in grains of water per pound of dry air.	NUMBER(6,2)	NULL	No
RATE_THC	Total hydrocarbon emissions during mode expressed in grams per hour.	NUMBER(9,5)	NULL	No
RATE_CO	Total carbon monoxide emissions during mode expressed in grams per hour.	NUMBER(8,4)	NULL	No
RATE_CO2	Total carbon dioxide emissions during mode expressed in grams per hour.	NUMBER(8,3)	NULL	No
RATE_NOX	Total oxides of nitrogen emissions during mode expressed in grams per hour.	NUMBER(9,4)	NULL	No

"DYNOTEST" Table				
Name	Comment	Datatype	Null Option	Is PK
RESULTID	Unique number sequentially assigned to each RESULT instance (including all RESULT subtype instances) as it is entered into this database. Number has no other significance.	NUMBER(12)	NOT NULL	Yes
THC	Total hydrocarbon emissions expressed in grams per mile. (Composite bag result for the entire test)	NUMBER(7,3)	NULL	No
CO	Carbon monoxide emissions expressed in grams per mile. (Composite bag result for the entire test)	NUMBER(8,3)	NULL	No
CO2	Carbon dioxide emissions expressed in grams per mile. (Composite bag result for the entire test)	NUMBER(8,3)	NULL	No
NOX	Oxides of nitrogen emissions expressed in grams per mile. (Composite bag result for the entire test)	NUMBER(7,3)	NULL	No
MPG	Fuel economy expressed in miles per gallon. (Composite bag result for the entire test)	NUMBER(6,2)	NULL	No
TESTWGHT	Dynamometer inertia weight setting used for this test expressed in pounds.	NUMBER(6)	NULL	No
ROAD_HP	Dynamometer road load horsepower setting used for this test.	NUMBER(5,1)	NULL	No
AC_HP	Did dynamometer road load setting for this test include air conditioning load factor? YES, NO, or NUL.	CHAR(3)	NULL	No
ODOMETER	Approximate odometer reading of vehicle at beginning of test expressed in miles.	NUMBER(6)	NULL	No
TEST_ORDER	A specialized field used to date only for facility cycle testing. Indicates the numerical position of individual tests in a sequence of tests run. Value of zero represents NULL.	NUMBER(3)	NULL	No
INIT_TEMP	Initial test temperature in degrees F. For bag tests this will often have the null value of 0, since it is reported at the bag level.	NUMBER(5,1)	NULL	No
INIT_BARO	Barometric pressure measured at the beginning of the test. Expressed in inches of mercury. This will often have the null value of 0 since it was usually reported at the bag level.	NUMBER(5,2)	NULL	No

"DYNOTEST" Table				
Name	Comment	Datatype	Null Option	Is PK
INIT_HUMID	Absolute humidity measured at beginning of test expressed in grains of water per pound of dry air. Often assumes null value of zero in this table, since it is often reported at the bag level.	NUMBER(6,2)	NULL	No
PRECOND	Type of preconditioning performed on the vehicle prior to the test. Legal values defined by translation table PRECOND.DBF	CHAR(10)	NULL	No
DYNOTYPE	Type of dynamometer used. Valid values for this field are contained in the DYNOTYPE code translation table.	CHAR(10)	NULL	No
DYNOCO_A	The a term. Dynamometer road load power absorption "set" coefficient in pounds force.	NUMBER(9,6)	NULL	No
DYNOCO_B	The b term. Dynamometer road load power absorption "set" coefficient in (pounds force)/(miles per hour).	NUMBER(9,6)	NULL	No
DYNOCO_C	The c term. Dynamometer road load power absorption "set" coefficient in (pounds force)/(miles per hour) ^2.	NUMBER(9,6)	NULL	No
DYNOTARG_A	The a term. Dynamometer Target road load "target" coefficient in pounds force.	NUMBER(9,6)	NULL	No
DYNOTARG_B	The b term. Dynamometer Target road load "target" coefficient in (pounds force)/(miles per hour).	NUMBER(9,6)	NULL	No
DYNOTARG_C	The c term. Dynamometer Target road load "target" coefficient in (pounds force)/(miles per hour) ^2.	NUMBER(9,6)	NULL	No

"DYNOTIME" Table				
Name	Comment	Datatype	Null Option	Is PK
DYNOSECS	Time within dynamometer test, expressed in seconds, beginning of test has dynosecs = 0.	NUMBER(4)	NOT NULL	Yes
RESULTID	Unique number sequentially assigned to each RESULT instance (including all RESULT subtype instances) as it is entered into this database. Number has no other significance.	NUMBER(12)	NOT NULL	Yes
SPEED	Measured speed in miles per hour.	NUMBER(6,2)	NULL	No
DIST	Distance traveled in miles, cumulative from beginning of test phase.	NUMBER(6,3)	NULL	No
R_THC	Total hydrocarbon emissions measurement expressed in grams per second.	NUMBER(7,5)	NULL	No
R_CO	Carbon monoxide emissions measurement expressed in grams per second.	NUMBER(6,4)	NULL	No
R_NOX	Oxides of nitrogen emissions measurement expressed in grams per sec.	NUMBER(6,4)	NULL	No
R_CO2	Carbon dioxide emissions measurement expressed in grams per second.	NUMBER(6,3)	NULL	No
VE_THC	Engine-out total hydrocarbon emissions measurement expressed in grams per second.	NUMERIC(7,5)	NULL	No
VE_CO	Engine-out carbon monoxide emissions measurement expressed in grams per second.	NUMERIC(6,4)	NULL	No
VE_NOX	Engine-out oxides of nitrogen emissions measurement expressed in grams per second.	NUMERIC(6,4)	NULL	No
VE_CO2	Engine-out carbon dioxide emissions measurement expressed in grams per second.	NUMERIC(6,3)	NULL	No
VE_O2	Engine-out oxygen emissions measurement expressed in grams per second.	NUMERIC(8,0)	NULL	No
TEST_PHASE	Phase of the test to which this measurement belongs. This might be used for example to divide a repeated measurement test into time periods corresponding to bag samples, even though no bag samples were taken.	NUMBER(1)	NULL	No

"EMODMEAS" Table				
Name	Comment	Datatype	Null Option	Is PK
RESULTID	Unique number sequentially assigned to each RESULT instance (including all RESULT subtype instances) as it is entered into this database. Number has no other significance.	NUMBER(12)	NOT NULL	Yes
MEAS_ID	Measurement type identification. Legal values defined by MEASTYPE translation	CHAR(10)	NOT NULL	Yes
MODENAME	Name of engine test mode. Based on its reference speed, speed fraction, and load Fraction. Legal values defined by ENGMODE translation table.	CHAR(10)	NOT NULL	Yes
EMODMEAS	Engine test mode level measurement of this MEAS_ID	NUMBER(10,4)	NULL	No

"ENGINE" Table				
Name	Comment	Datatype	Null Option	Is PK
MSID	Mobile source identifier. For vehicles their VIN would be used. For engines, their serial number, probably in conjunction with their manufacturer code.	NUMBER(12)	NOT NULL	Yes
ENG_FAM	Engine family for emission certification purposes. A value of "NONE" indicates the engine does not belong to an engine family, which in turn means that it was not certified.	VARCHAR2(19)	NULL	No
ENGSERIES	Engine series or product line name.	VARCHAR2(20)	NULL	No
BLD_DATE	Approximate date engine was manufactured.	DATE	NULL	No
ENG_MOD_YR	Engine model year.	NUMBER(4)	NULL	No
INJECTORS	Number of injectors per cylinder.	NUMBER(1)	NULL	No
FI_PRESS	Fuel injection pressure. Expressed in kPa.	NUMBER(5)	NULL	No
RATE_SHAPE	Is rate shaping used? "YES", "NO", or "NUL"	CHAR(3)	NULL	No
MAXADVANCE	Maximum advance Expressed in degrees.	NUMBER(5,2)	NULL	No
MAXRETARD	Maximum retard. Expressed in degrees.	NUMBER(5,2)	NULL	No
PARTTRAP	Is particulate trap used? "YES", "NO", or "NUL".	CHAR(3)	NULL	No
RATEDPOWER	Rated horsepower of engine.	NUMBER(7,1)	NULL	No
RATEDSPEED	Rated rpm of engine.	NUMBER(5)	NULL	No
IDLE_RPM	Idle rpm as declared by the OEM.	NUMBER(5)	NULL	No
TECH_CONFG	Description of technical configuration. (Not categorized.)	VARCHAR2(50)	NULL	No
PUMP_TYPE	Type of fuel pump. (Not categorized.)	VARCHAR2(50)	NULL	No
ECS_DESCPT	Description of emission control system.	VARCHAR2(50)	NULL	No
ELECT_CONT	Description of electronic control.	VARCHAR2(100)	NULL	No
PEAKTORQUE	Peak torque in ft-lbs.	NUMBER(4)	NULL	No
PEAKSPEED	Peak torque speed in rpm.	NUMBER(5)	NULL	No
PEAKFRATE	Fuel rate @ peak torque in lbs/hr.	NUMBER(5,1)	NULL	No
RATEDFRATE	Fuel rate @ rated speed in lbs/hr.	NUMBER(5,1)	NULL	No
AIRFUEL	Air fuel mixture method. Values defined by AIRFUEL translation table	CHAR(4)	NULL	No
COOLING	Type of after cooling. Legal values defined by COOLING translation table.	CHAR(7)	NULL	No
EGR_TYPE	Type of exhaust gas recirculation (EGR). Values defined by EGR_TYPETranslation table.	CHAR(6)	NULL	No
ENG_CLASS	Intended engine service class. (In conjunction with engine type (SI or CI), and model year, this field allows determination of the emission standards to which many engines were certified; for small spark ignition engines, displacement class, which can be determined from displacement, may be used instead.) Legal values defined ENG_CLAS by translation table.	CHAR(7)	NULL	No
ENG_CYCLE	Engine cycle. Legal values defined by ENG_CYCL translation table.	CHAR(1)	NULL	No
FI_METH	Method of fuel injection. Legal values defined by FI_METH translation table.	CHAR(4)	NULL	No
MFR_INTSPD	Manufacturer specified intermediate speed as the percentage of maximum speed.	NUMBER(2)	NULL	No
CAMEFROM	Mobile source identifier. For vehicles their VIN would be used. For engines, their serial number, probably in conjunction with their manufacturer code.	NUMBER(12)	NULL	No

"ENGINMAP" Table				
Name	Comment	Datatype	Null Option	Is PK
RESULTID	Unique number sequentially assigned to each RESULT instance (including all RESULT subtype instances) as it is entered into this database. Number has no other significance.	NUMBER(12)	NOT NULL	Yes
MSDRTPWR	Measured rated horsepower.	NUMBER(5)	NULL	No
MSDRDSPED	Measured rated speed (rpm).	NUMBER(5)	NULL	No
MAXTORQUE	Measured peak torque. Expressed in foot pounds.	NUMBER(4)	NULL	No
MSDRQSPED	Measured torque speed. Expressed in rpm.	NUMBER(5)	NULL	No
GOV_SPEED	Governed central speed (rpm).	NUMBER(5)	NULL	No
EXRESTRICT	Exhaust restriction pressure. Expressed in inches of mercury.	NUMBER(5,2)	NULL	No
BARO	Barometric pressure. Expressed in inches of mercury.	NUMBER(5,2)	NULL	No
HUMIDITY	Absolute humidity. Expressed in grains of water per pound of dry air.	NUMBER(5,2)	NULL	No
INLET_AIR	Engine inlet air temperature. Expressed in degrees F.	NUMBER(5,1)	NULL	No
EXHAUST	Exhaust temperature, after emission controls. Expressed in degrees F.	NUMBER(5,1)	NULL	No
COOLER_OUT	Air temperature after intercooler. Expressed in degrees F.	NUMBER(5,1)	NULL	No
COOLANT_IN	Engine coolant input temperature. Expressed in degrees F.	NUMBER(5,1)	NULL	No
COOLANTOUT	Engine coolant output temperature. Expressed in degrees F.	NUMBER(5,1)	NULL	No
CHILLER	Chiller water temperature. Expressed in degrees F.	NUMBER(5,1)	NULL	No
MAPTYPE	Type of Engine Map. Legal values defined by MAPTYPE translation table.	CHAR(5)	NULL	No

"ENGMEAS" Table				
Name	Comment	Datatype	Null Option	Is PK
RESULTID	Unique number sequentially assigned to each RESULT instance (including all RESULT subtype instances) as it is entered into this database. Number has no other significance.	NUMBER(12)	NOT NULL	Yes
MEAS_ID	Measurement type identification. Legal values defined by MEASTYPE translation	CHAR(10)	NOT NULL	Yes
MEASURE	Bag-level measurement.	NUMBER(10,3)	NULL	No

"ENGMODE" Table				
Name	Comment	Datatype	Null Option	Is PK
MODENAME	Name of engine test mode. Based on its reference speed, speed fraction, and load fraction. Legal values defined by ENGMODE translation table.	CHAR(10)	NOT NULL	Yes
REFSPEED	Reference speed. Identifies which of several speeds the speed aspect of the mode is based on. Legal values defined by REFSPEED translation table.	CHAR(5)	NULL	No
SPEED_FRAC	Fraction of the reference speed at which this mode is run expressed as a percentage.	NUMBER(8,0)	NULL	No
LOAD_FRAC	Fraction of the mapped load at this engine speed at which this mode is run expressed as a percentage.	NUMBER(8,0)	NULL	No
MODEDUR	Minimum duration of the mode expressed in seconds.	NUMBER(8,0)	NULL	No
MODENUM	Mode number. Added for convenience, e.g. to facilitate exporting data to software, such as SAS which expects keys to be numeric. Should be considered an arbitrary number, but the first 28 modes are numbered as in SWRI work assignment 2-2.	NUMBER(8,0)	NULL	No

"ENGTEST" Table				
Name	Comment	Datatype	Null Option	Is PK
RESULTID	Unique number sequentially assigned to each RESULT instance (including all RESULT subtype instances) as it is entered into this database. Number has no other significance.	NUMBER(12)	NOT NULL	Yes
USESAP	Unique number sequentially assigned to each RESULT instance (including all RESULT subtype instances) as it is entered into this database. Number has no other significance.	NUMBER(8)	NULL	No
P_CH4	Methane emissions expressed in grams per bhp-hr.	NUMBER(7,2)	NULL	No
P_THC	Total HC emissions expressed in grams per bhp-hr.	NUMBER(7,2)	NULL	No
P_CO	CO emissions expressed in grams per bhp-hr.	NUMBER(7,2)	NULL	No
P_CO2	CO2 emissions expressed in grams per bhp-hr.	NUMBER(7,2)	NULL	No
P_NOX	NOx emissions expressed in grams per bhp-hr.	NUMBER(7,2)	NULL	No
P_PM	Total particulate emissions expressed in grams per bhp-hr.	NUMBER(7,2)	NULL	No
TOTAL_WORK	Total work performed in test expressed in bhp-hrs.	NUMBER(7,2)	NULL	No
BSFC_MEAS	Measured brake-specific fuel consumption expressed in lbs per bhp-hr.	NUMBER(9,4)	NULL	No
BSFC_CALC	Calculated brake-specific fuel consumption expressed in lbs per bhp-hr.	NUMBER(9,4)	NULL	No
ET_BARO	Average barometric pressure during test expressed in inches of Hg. Not meaningful for multi-mode steady-state tests.	NUMBER(5,2)	NULL	No
ET_HUMID	Average absolute humidity during test expressed in grains of water per pound of dry air. Not meaningful for multi-mode steady-state tests.	NUMBER(5,2)	NULL	No
ET_INAIR	Engine inlet air temperature expressed in degrees F. Not meaningful for multi-mode steady-state tests.	NUMBER(5,1)	NULL	No
ET_EXRESTR	Exhaust restriction pressure expressed in inches of mercury. Not meaningful for multi-mode steady-state tests.	NUMBER(5,2)	NULL	No
ET_EXHAUST	Exhaust temperature, after emission controls expressed in degrees F. Not meaningful for multi-mode steady-state tests.	NUMBER(5,1)	NULL	No
ET_COOLER	Air temperature after intercooler expressed in degrees F. Not meaningful for multi-mode steady-state tests.	NUMBER(5,1)	NULL	No
ET_COOLIN	Engine coolant input temperature expressed in degrees F. Not meaningful for multi-mode steady-state tests.	NUMBER(5,1)	NULL	No
ET_COOLOUT	Engine coolant output temperature expressed in degrees F. Not meaningful for multi-mode steady-state tests.	NUMBER(5,1)	NULL	No
ET_CHILLER	Chiller water temperature expressed in degrees F. Not meaningful for multi-mode steady-state tests.	NUMBER(5,1)	NULL	No

"ENGTIME" Table				
Name	Comment	Datatype	Null Option	Is PK
ENGSECS	Time within an engine dynamometer test, expressed in seconds, beginning of test has engsecs = 0.	NUMERIC(4)	NOT NULL	Yes
RESULTID	Unique number sequentially assigned to each RESULT instance (including all RESULT subtype instances) as it is entered into this database. Number has no other significance.	NUMBER(12)	NOT NULL	Yes
R_THC	Total hydrocarbon emissions measurement expressed in grams per second.	NUMBER(7,5)	NULL	No
R_CO	Carbon monoxide emissions measurement expressed in grams per second.	NUMBER(6,4)	NULL	No
R_NOX	Oxides of nitrogen emissions measurement expressed in grams per sec.	NUMBER(6,4)	NULL	No
R_CO2	Carbon dioxide emissions measurement expressed in grams per second.	NUMBER(6,3)	NULL	No
RPM	Measured engine rpm.	NUMBER(4)	NULL	No
TORQUE	Measured torque expressed in foot-pounds.	NUMBER(4)	NULL	No

"EREPMEAS" Table				
Name	Comment	Datatype	Null Option	Is PK
ENGSECS	Time within an engine dynamometer test, expressed in seconds, beginning of test has engsecs = 0.	NUMBER(4)	NOT NULL	Yes
RESULTID	Unique number sequentially assigned to each RESULT instance (including all RESULT subtype instances) as it is entered into this database. Number has no other significance.	NUMBER(12)	NOT NULL	Yes
MEAS_ID	Measurement type identification. Legal values defined by MEASTYPE translation	CHAR(10)	NOT NULL	Yes
EREPMEAS	Engine test time level measurement of this MEAS_ID	NUMBER(10,4)	NULL	No

"ETSTMODE" Table				
Name	Comment	Datatype	Null Option	Is PK
RESULTID	Unique number sequentially assigned to each RESULT instance (including all RESULT subtype instances) as it is entered into this database. Number has no other significance.	NUMBER(12)	NOT NULL	Yes
MODENAME	Name of engine test mode. Based on its reference speed, speed fraction, and load fraction. Legal values defined by ENGMODE translation table.	CHAR(10)	NOT NULL	Yes
RPM	Measured engine rpm.	NUMBER(4)	NULL	No
TORQUE	Measured torque expressed in foot-pounds.	NUMBER(4)	NULL	No
BHP	Brake horsepower.	NUMBER(3)	NULL	No
R_CH4_GPH	Methane emission rate expressed in grams per hour.	NUMBER(7,2)	NULL	No
R_THC_GPH	Total hydrocarbon emission rate expressed in grams per hour.	NUMBER(7,2)	NULL	No
R_CO_GPH	Carbon monoxide emission rate expressed in grams per hour.	NUMBER(7,2)	NULL	No
R_CO2_GPH	Carbon dioxide emission rate expressed in grams per hour.	NUMBER(9,2)	NULL	No
R_NOX_GPH	Oxides of nitrogen emission rate expressed in grams per hour.	NUMBER(7,2)	NULL	No
R_PM_GPH	Total particulate emission rate expressed in grams per hour.	NUMBER(7,2)	NULL	No
FC_MEAS	Measured fuel consumption expressed in kg. Per hour.	NUMBER(8,4)	NULL	No
FC_CALC	Calculated fuel consumption expressed in kg per hour.	NUMBER(8,4)	NULL	No
ETM_BARO	Average barometric pressure during engine test mode expressed in inches of Hg.	NUMBER(5,2)	NULL	No
ETM_HUMID	Average absolute humidity during engine test mode expressed in grains of water per pound of dry air.	NUMBER(5,2)	NULL	No
ETM_INAIR	Engine inlet air temperature expressed in degrees F.	NUMBER(5,1)	NULL	No
ETMEXRESTR	Exhaust restriction pressure expressed in inches of Hg.	NUMBER(5,2)	NULL	No
ETMEXHAUST	Exhaust temperature, after emission controls expressed in degrees F.	NUMBER(5,1)	NULL	No
ETM_COOLER	Air temperature after intercooler expressed in degrees F.	NUMBER(5,1)	NULL	No
ETM_COOLIN	Engine coolant input temperature expressed in degrees F.	NUMBER(5,1)	NULL	No
ETMCOOLOUT	Engine coolant output temperature expressed in degrees F	NUMBER(5,1)	NULL	No
ETMCHILLER	Chiller water temperature expressed in degrees F.	NUMBER(5,1)	NULL	No

"EVAPMEAS" Table				
Name	Comment	Datatype	Null Option	Is PK
RESULTID	Unique number sequentially assigned to each RESULT instance (including all RESULT subtype instances) as it is entered into this database. Number has no other significance.	NUMBER(12)	NOT NULL	Yes
MEAS_ID	Measurement type identification. Legal values defined by MEASTYPE translation	CHAR(10)	NOT NULL	Yes
MEASURE	Bag-level measurement.	NUMBER(10,3)	NULL	No

"EVAPTEST" Table				
Name	Comment	Datatype	Null Option	Is PK
RESULTID	Unique number sequentially assigned to each RESULT instance (including all RESULT subtype instances) as it is entered into this database. Number has no other significance.	NUMBER(12)	NOT NULL	Yes
W_EVAP_THC	Total hydrocarbon emissions of test. Expressed in grams.	NUMBER(6,2)	NULL	No
PRECOND	Type of preconditioning performed on the vehicle prior to the test. Legal values defined by PRECOND translation table.	CHAR(10)	NULL	No

"EVAPTIME" Table				
Name	Comment	Datatype	Null Option	Is PK
EVAPMINS	Time of measurement expressed in minutes after start of test.	NUMBER(5)	NOT NULL	Yes
RESULTID	Unique number sequentially assigned to each RESULT instance (including all RESULT subtype instances) as it is entered into this database. Number has no other significance.	NUMBER(12)	NOT NULL	Yes
EVAP_BAROM	Barometric pressure. Expressed in inches of Hg.	NUMBER(5,2)	NULL	No
SHED_TEMP	Temperature of SHED or air surrounding vehicle. Expressed in degrees F.	NUMBER(5,1)	NULL	No
FUEL_TEMP	Temperature of vehicle's fuel. Expressed in degrees F.	NUMBER(5,1)	NULL	No
W_CUM_THC	Cumulative hydrocarbon emissions, since start of test. Expressed in grams.	NUMBER(6,2)	NULL	No

"FBATCH" Table				
Name	Comment	Datatype	Null Option	Is PK
FBATCH_ID	Fuel batch identification.	CHAR(10)	NOT NULL	Yes
MFG_BATCH	Manufacturer's fuel batch identification	VARCHAR2(18)	NULL	No
CETANE_NUM	Cetane number of complete fuel.	NUMBER(5,2)	NULL	No
CETANE_IDX	Cetane index of complete fuel.	NUMBER(5,2)	NULL	No
CETANE_IMP	Amount of cetane improver added, expressed as percentage by volume	NUMBER(5,2)	NULL	No
CETANE_TYP	Type of cetane improver used, e.g. "N" for nitrate type or "P" for peroxide type. Exact set of legal values defined and described by translation table for this field.	CHAR(1)	NULL	No
SULFUR	Sulfur content, expressed in parts per million.	NUMBER(5)	NULL	No
IBP	Initial boiling point expressed in degrees F.	NUMBER(4)	NULL	No
SULF_AGENT	Name of any sulfur doping agent added to the fuel. Value of "NONE" indicates that all sulfur in the fuel was present naturally.	VARCHAR2(20)	NULL	No
NITROGEN	Nitrogen content, expressed in parts per million.	NUMBER(5)	NULL	No
TAROM	Total aromatics content of fuel, expressed as a percentage by volume. This is a measured value, as opposed as being calculated as the sum of the monoaromatics and polyaromatics fields.	NUMBER(5,2)	NULL	No
MAROM	Monoaromatics content of fuel expressed as a percentage by weight. This is a measured value, as opposed as being calculated as the difference of the total aromatics and polyaromatics fields.	NUMBER(5,2)	NULL	No
DENSITY	Measured density of the fuel, expressed in pounds per gallon.	NUMBER(5,3)	NULL	No
PAROM	Polyaromatics content of fuel, expressed as a percentage by weight. This is a measured value, as opposed as being calculated as the difference of the total aromatics and monoaromatics fields.	NUMBER(5,2)	NULL	No
T10	10% distillation boiling point expressed in degrees Fahrenheit.	NUMBER(4)	NULL	No
T50	50% distillation boiling point expressed in degrees Fahrenheit.	NUMBER(4)	NULL	No
LUBRIC_MM	Fuel lubricity expressed in millimeters of scar wear. As measured by ASTM D6079 or comparable method.	NUMBER(4,2)	NULL	No
ASH	Ash content of fuel expressed as a percentage.	NUMBER(4,2)	NULL	No
T90	90% distillation boiling point expressed in degrees Fahrenheit.	NUMBER(4)	NULL	No
RON	Research Octane Number conducted in accordance with ASTM D2699	NUMBER(5,1)	NULL	No
MON	Motor Octane Number conducted in accordance with ASTM D2700	NUMBER(5,1)	NULL	No
FEN_C	Fuel Economy Numerator/C Density conducted in accordance with ASTM E191 (g carbon/gal)	NUMBER(4)	NULL	No
EP	End point of distillation curve expressed in degrees Fahrenheit.	NUMBER(4)	NULL	No
WGT_FRACTN	Weight fraction carbon conducted in accordance with ASTM D3343	NUMBER(7,4)	NULL	No
RECOVERY	The amount of distillate recovered measured in volume percent.	NUMBER(4,1)	NULL	No
SPEC_GRAV	Specific gravity.	NUMBER(6,4)	NULL	No
API_GRAV	API gravity expressed in degrees API	NUMBER(5,2)	NULL	No
RESIDUE	The amount of residue matter remaining after distillate has been boiled off and is measured in volume percent.	NUMBER(4,1)	NULL	No
LOSS	The amount of loss measured in volume percent.	NUMBER(4,1)	NULL	No
RVP	The Reid Vapor Pressure of the fuel measured in pounds per square inch (psi) in accordance with ASTM D323 or D5191.	NUMBER(4,1)	NULL	No

"FBATCH" Table				
Name	Comment	Datatype	Null Option	Is PK
VISCOSITY	Viscosity expressed in centistokes.	NUMBER(4,2)	NULL	No
COMP_OLEFN	Olefin composition measured in volume percent of the fuel in accordance with ASTM D1319.	NUMBER(4,1)	NULL	No
COMP_SAT	Saturates Composition measured in volume percent of the fuel in accordance with ASTM D1319.	NUMBER(4,1)	NULL	No
FLASH	Flashpoint temperature expressed in degrees Fahrenheit.	NUMBER(4)	NULL	No
CLOUD	Cloudpoint temperature expressed in degrees Fahrenheit.	NUMBER(4)	NULL	No
POUR	Pourpoint temperature expressed in degrees Fahrenheit.	NUMBER(4)	NULL	No
HCRATIO	Ratio of hydrogen to carbon	NUMBER(5,3)	NULL	No
OXYGEN	Amount of oxygen in the fuel, expressed as a percentage by weight.	NUMBER(4,2)	NULL	No
OXY_TYPE	Type of oxygenate. "NONE" if no oxygenate was added to the base fuel. Values defined by translation table for this field.	VARCHAR2(20)	NULL	No
ADDITIVES	Total amount of additives, other than cetane improvers, in the fuel, expressed as a percentage by weight.	NUMBER(5,2)	NULL	No
LUBRIC_G	Fuel lubricity expressed in grams. As measured by ASTM D6078 or comparable method.	NUMBER(5)	NULL	No
HEAT	Net heating value of the fuel, expressed in btu/pound.	NUMBER(6)	NULL	No
COMP_AROMA		NUMBER(4,1)	NULL	No
E200	Percent fuel evaporated at 200 degrees f.	NUMBER(4,1)	NULL	No
E300	Percent fuel evaporated at 300 degrees f.	NUMBER(4,1)	NULL	No
BENZENE	Fuel Benzene in volume percent.	NUMBER(5,3)	NULL	No
TOLUENE	Fuel Toluene in volume percent.	NUMBER(5,3)	NULL	No

"FUELCHEM" Table				
Name	Comment	Datatype	Null Option	Is PK
RESULTID	Unique number sequentially assigned to each RESULT instance (including all RESULT subtype instances) as it is entered into this database. Number has no other significance.	NUMBER(12)	NOT NULL	Yes
MEAS_ID	Measurement type identification. Legal values defined by MEATYPE translation table	CHAR(10)	NOT NULL	Yes
FUELMEAS	Test level fuel measurement.	NUMBER(10,4)	NULL	No

"INSPECT" Table				
Name	Comment	Datatype	Null Option	Is PK
RESULTID	Unique number sequentially assigned to each RESULT instance (including all RESULT subtype instances) as it is entered into this database. Number has no other significance.	NUMBER(12)	NOT NULL	Yes
COMMENTS	Inspection comments, first portion.	VARCHAR2(500)	NULL	No
COMMENTS2	Inspection comments, second portion.	VARCHAR2(500)	NULL	No
INSP_ODOM	Approximate odometer reading, in miles, at time of mechanics M1 emission component inspection. Zero represents NULL. (This item not collected prior to FY98).	NUMBER(6)	NULL	No
G_CAN_INIT	Weight of evaporative emission canister as vehicle was received. Expressed in grams. If vehicle has multiple canisters weight entered is total of all canisters present. Zero if null.	NUMBER(7,1)	NULL	No
G_CAN_PURG	Weight of evaporative emission canister after canister purge. Expressed in grams. If vehicle has multiple canisters weight entered is total of all canisters present. Zero if null.	NUMBER(7,1)	NULL	No
G_CAN_LOAD	Weight of evaporative emission canister after full loading. Expressed in grams. If vehicle has multiple canisters weight entered is total of all canisters present. Zero if null.	NUMBER(7,1)	NULL	No
SMOKECOLOR	The abbreviated name used to identify the color of the tailpipe smoke.	CHAR(6)	NULL	No

"LAB_MEAS" Table				
Name	Comment	Datatype	Null Option	Is PK
DYNOSECS	Time within dynamometer test, expressed in seconds, beginning of test has dynosecs = 0.	NUMBER(4)	NOT NULL	Yes
MEAS_ID	Measurement type identification. Legal values defined by MEATYPE table.	CHAR(10)	NOT NULL	Yes
RESULTID	Unique number sequentially assigned to each RESULT instance (including all RESULT subtype instances) as it is entered into this database. Number has no other significance.	NUMBER(12)	NOT NULL	Yes
LAB_MEAS	Lab level measurement of this meas_id.	NUMERIC(10,3)	NULL	No

"LTIME" Table				
Name	Comment	Datatype	Null Option	Is PK
DYNOSECS	Time within dynamometer test, expressed in seconds, beginning of test has dynosecs = 0.	NUMBER(4)	NOT NULL	Yes
RESULTID	Unique number sequentially assigned to each RESULT instance (including all RESULT subtype instances) as it is entered into this database. Number has no other significance.	NUMBER(12)	NOT NULL	Yes
LAB_RPM	Engine's rpm for each second.	NUMBER(5)	NULL	No
LAB_TORQ	Engine's torque (calculated or measured) per second in ft-lbs.	NUMBER(6)	NULL	No
LAB_TEMPF	Ambient air temperature in degrees F per second.	NUMBER(5,1)	NULL	No
LAB_BARO	Ambient air's barometric pressure measured for each second in inches of mercury.	NUMBER(5,2)	NULL	No
LAB_HUMID	Absolute humidity measured each second expressed in grains of water per pound of dry air.	NUMBER(6,2)	NULL	No
LFUEL_RATE	Rate of fuel flow in lbs/sec.	NUMBER(8,5)	NULL	No
LAB_ENGCOL	Engine coolant temperature (degrees F).	NUMBER(5,1)	NULL	No
LAB_ENGOIL	Engine oil temperature (degrees F).	NUMBER(5,1)	NULL	No
LAB_MILLIT	Yes - if millight is on; No if off.	CHAR(3)	NULL	No
CVS_VOL	CVS flow in standard cubic feet per second.	NUMBER(10,6)	NULL	No
DIL_VOL	Dilution air in standard cubic feet per second.	NUMBER(10,6)	NULL	No
TP_VOL	Tailpipe volume in standard cubic feet per second.	NUMBER(10,6)	NULL	No
TP_O2	Oxygen in volume percent (%) as measured at the tailpipe.	NUMBER(10,6)	NULL	No
VC_O2	Engine-out oxygen emission measurements expressed in volume percent.	NUMBER(10,6)	NULL	No
DIL_O2	Oxygen in volume percent (%) as measured after mixed with dilution air.	NUMBER(10,6)	NULL	No
TP_THC	Total hydrocarbon in ppm by volume as measured at the tailpipe.	NUMBER(10,6)	NULL	No
VC_THC	Engine-out total hydrocarbon emissions expressed in ppm by volume.	NUMBER(10,6)	NULL	No
DIL_THC	Total hydrocarbon in ppm by volume as measured after mixed with dilution air.	NUMBER(10,6)	NULL	No
TP_CO	Carbon monoxide in ppm by volume as measured at the tailpipe.	NUMBER(10,6)	NULL	No
VC_CO	Engine-out carbon monoxide emissions measurements expressed in ppm by volume.	NUMBER(10,6)	NULL	No
DIL_CO	Carbon monoxide in ppm by volume as measured after mixed with dilution air.	NUMBER(10,6)	NULL	No
TP_CO2	Carbon dioxide in volume percent (%) as measured at the tailpipe.	NUMBER(10,6)	NULL	No
VC_CO2	Engine-out carbon dioxide emission measurements expressed in volume percent.	NUMBER(10,6)	NULL	No
DIL_CO2	Carbon dioxide in volume percent (%) as measured after mixed with dilution air.	NUMBER(10,6)	NULL	No
TP_NOX	Nitrogen oxides in ppm by volume as measured at the tailpipe.	NUMBER(10,6)	NULL	No
VC_NOX	Engine-out oxides of nitrogen emission measurements expressed in ppm by volume.	NUMBER(10,6)	NULL	No
DIL_NOX	Nitrogen oxides in ppm by volume as measured after mixed with dilution air.	NUMBER(10,6)	NULL	No

"MAPPOINT" Table				
Name	Comment	Datatype	Null Option	Is PK
MAP_RPM	Speed. Expressed in rpm.	NUMBER(5)	NOT NULL	Yes
RESULTID	Unique number sequentially assigned to each RESULT instance (including all RESULT subtype instances) as it is entered into this database. Number has no other significance.	NUMBER(12)	NOT NULL	Yes
MAP_TORQUE	Torque. Expressed in foot pounds	NUMBER(4)	NULL	No

"MEASTYPE" Table				
Name	Comment	Datatype	Null Option	Is PK
MEAS_ID	Measurement type identification. Legal values defined by MEASTYPE translation	CHAR(10)	NOT NULL	Yes
MEAS_UNIT	Engineering units applicable to this measurement type.	VARCHAR2(30)	NULL	No
MEAS_DESCR	Measurement description.	VARCHAR2(50)	NULL	No
CAS_RN	CAS Registry Numbers (CAS RN) are numbers that uniquely identify chemical substances that are assigned by the Chemical Abstract Service. These numbers have three parts and are arranged in the format: xxxx-yy-z where xxxx - varies between 2 and 6 digits, yy - is always 2 digits, and z - is always 1 digit. For example the Registry Number for ethylene glycol is I07-2I-I.	CHAR(12)	NULL	No

"MODEMEAS" Table				
Name	Comment	Datatype	Null Option	Is PK
MEAS_ID	Measurement type identification. Legal values defined by MEASTYPE table.	CHAR(10)	NOT NULL	Yes
MODE_ID	The abbreviated name used to identify a type of "mode" emission test for a vehicle.	CHAR(10)	NOT NULL	Yes
RESULTID	Unique number sequentially assigned to each RESULT instance (including all RESULT subtype instances) as it is entered into this database. Number has no other significance.	NUMBER(12)	NOT NULL	Yes
MODEMEAS	Mode level measurement of this MEAS_ID	NUMBER(10,3)	NULL	No

"MODETIME" Table				
Name	Comment	Datatype	Null Option	Is PK
MODESECS	Identifies point in time within a Mode of an chassis exhaust emissions test expressed in seconds.	NUMBER(4)	NOT NULL	Yes
MODE_ID	The abbreviated name used to identify a type of "mode" emission test for a vehicle.	CHAR(10)	NOT NULL	Yes
RESULTID	Unique number sequentially assigned to each RESULT instance (including all RESULT subtype instances) as it is entered into this database. Number has no other significance.	NUMBER(12)	NOT NULL	Yes
REP_C_THC	Second-by-second measurement of total hydrocarbon concentration expressed in parts per million.	NUMBER(4)	NULL	No
REP_C_CO	Second-by-second measurement of carbon monoxide concentration expressed as a percentage.	NUMBER(6,2)	NULL	No
REP_C_CO2	Second-by-second measurement of carbon dioxide concentration expressed as a percentage.	NUMBER(6,2)	NULL	No
REP_C_NO	Second-by-second measurement of nitric oxide (NO) concentration, corrected for humidity expressed in parts per million.	NUMBER(4)	NULL	No
REP_C_NOU	Second-by-second measurement of nitric oxide (NO) concentration, not corrected for humidity expressed in parts per million.	NUMBER(4)	NULL	No
REP_RPM	Second-by-second measurement of engine speed expressed in revolutions per minute.	NUMBER(4)	NULL	No
REP_SPEED	Measured speed expressed in miles per hour.	NUMBER(6,2)	NULL	No

"M_SOURCE" Table				
Name	Comment	Datatype	Null Option	Is PK
MSID	Mobile source identifier. For vehicles their VIN would be used. For engines, their serial number, probably in conjunction with their manufacturer code.	NUMBER(12)	NOT NULL	Yes
MS_TYPE	General kind of mobile source: 1 = Vehicle 2 = Engine.	NUMBER(2)	NOT NULL	No
EXCEPT	YES if something is exceptional about this mobile source that would make it an outlier for most analysis. (e.g. engine has been replaced, etc.)	CHAR(3)	NULL	No
EX_COMM	Used if except is true. Comment as to why vehicle is exceptional.	VARCHAR2(20)	NULL	No
HIGHWAY	Yes if mobile source is intended for highway use. No for non-road mobile sources.	CHAR(3)	NULL	No
DISP_CID	Nominal Engine displacement. Expressed in cubic inches.	NUMBER(4)	NULL	No
DISP_LITER	Nominal engine displacement. Expressed in liters.	NUMBER(4,1)	NULL	No
VENTURIS	Number of venturis. Not meaningful for fuel injected mobile sources.	NUMBER(2)	NULL	No
VAR_VENT	YES if size of carburetor venturis is designed to vary. Otherwise NO. (or NUL). Intend to convert to a logical type field when good tool is available.	CHAR(3)	NULL	No
CYLINDER	Number of cylinders or rotors.	NUMBER(2)	NULL	No
CLOSEDLOOP	"YES" indicates a "closed loop" configuration in which the exhaust sensing is used to help control the fuel combustion process. "No means this is not done on the vehicle.	CHAR(3)	NULL	No
CAT_TYPE	What type catalyst, if any, is present on the mobile source. Legal values defined by CAT_TYPE translation table.	CHAR(4)	NULL	No
AIR_INJ	Represents what method, if any, is used to introduce supplemental air into the	CHAR(5)	NULL	No

"M_SOURCE" Table				
Name	Comment	Datatype	Null Option	Is PK
	exhaust stream. Legal values defined by AIR_INJ translation table.			
FUEL_DELIV	Kind of fuel delivery system. Legal values defined by FUEL_DEL translation table.	CHAR(6)	NULL	No
IGNITION	Ignition type of engine in mobile source. Legal values defined by IGNITION translation table.	CHAR(2)	NULL	No
FUELTYPE	Type of fuel mobile source is designed to use. Legal values defined by FUELTYPE translation table.	CHAR(4)	NULL	No
FI_TYPE	Type of fuel injection. Legal values defined by FI_TYPE translation table.	CHAR(6)	NULL	No
COMPANY	Mobile source manufacturer. Is designed to align with the MFR_ fields in CFEIS. Has extended translation table in which COMPANY_N will contain the same numeric code as CFEIS for this manufacturer. Legal values defined by COMPANY translation table. NONROAD manufacturers will also be included in the COMPANY table.	VARCHAR2(12)	NULL	No
ASPIRATED	Indicates how engine is aspirated. Legal values defined by ASPIRATE translation table.	CHAR(7)	NULL	No

"MS_IDNO" Table				
Name	Comment	Datatype	Null Option	Is PK
MSID	Mobile source identifier. For vehicles their VIN would be used. For engines, their serial number, probably in conjunction with their manufacturer code.	NUMBER(12)	NOT NULL	Yes
MS_ID	Mobile source identifier. For vehicles their VIN would be used. For engines, their serial number, probably in conjunction with their manufacturer code.	CHAR(17)	NOT NULL	No
VIN	Vehicle identification number	CHAR(17)	NOT NULL	No
ENGSERIALN	Engine serial number	CHAR(17)	NOT NULL	No

"OBD2CODE" Table				
Name	Comment	Datatype	Null Option	Is PK
OBD2CODE	Character string code resulting from a scan of a level 2 on board diagnostic system.	CHAR(5)	NOT NULL	Yes
OBD2CODE_D	Meaning of a particular level 2 on board diagnostic code.	VARCHAR2(80)	NULL	No

"OBDLEVEL" Table				
Name	Comment	Datatype	Null Option	Is PK
OBDLEVEL	Type of on board diagnostic system. Level 1 systems are present on many older vehicles and produce 2 digit numeric codes particular to the vehicle manufacturer and model year. Level 2 system produce 5 character codes some of which have industry standardized significance.	NUMBER(1)	NOT NULL	Yes
OBDLEVEL_D	The detailed description on the onboard diagnostic system used in the vehicle.	VARCHAR2(50)	NULL	No

"OBDSCAN" Table				
Name	Comment	Datatype	Null Option	Is PK
RESULTID	Unique number sequentially assigned to each RESULT instance (including all RESULT subtype instances) as it is entered into this database. Number has no other significance.	NUMBER(12)	NOT NULL	Yes
COMMENTS	Comment associated with scan of vehicle's on board diagnostic system.	VARCHAR2(500)	NULL	No
OBD_ODOM	Approximate odometer reading, in miles, at time of OBD scan. Zero represents NULL value.	NUMBER(6)	NULL	No
OBDLEVEL	Type of on board diagnostic system. Level 1 systems are present on many older vehicles and produce 2 digit numeric codes particular to the vehicle manufacturer and model year. Level 2 system produce 5 character codes some of which have industry standardized significance.	NUMBER(1)	NULL	No

"OWNERQST" Table				
Name	Comment	Datatype	Null Option	Is PK
RESULTID	Unique number sequentially assigned to each RESULT instance (including all RESULT subtype instances) as it is entered into this database. Number has no other significance.	NUMBER(12)	NOT NULL	Yes
TRIPS	Response to question: "On a typical day, how many trips are made with this vehicle?"	NUMBER(2)	NULL	No
CHECK_LITE	Response to question: "Has the 'check engine' light or any other warning light ever comes on while you were driving your vehicle?" Responses are coded as "yes", "no", or "nul"	CHAR(3)	NULL	No
NEW_CAT	Response to question: "Has the catalytic converter ever been replaced on this vehicle?" Coded as YES, NO, NONE or NULL.	CHAR(4)	NULL	No

"OWNERQST" Table				
Name	Comment	Datatype	Null Option	Is PK
LAST_IM	Response to question: "Date of last city or state emissions inspection?" (99/99/99) if never inspected.	DATE	NULL	No
ODOM_OK	Response to question: "Does the odometer indicate the true number of miles on your vehicle?" Values coded as YES, NO, or NUL.	CHAR(3)	NULL	No
TRUE_MILES	Response to question: "If no, what are the true miles?" (0 indicates missing or that ODOM_OK = YES.)	NUMBER(6)	NULL	No
MILES2LAB	Response to question: "Approximate mileage to get here today?"	NUMBER(4)	NULL	No
QUEST_ODOM	Approximate odometer reading at time vehicle owner questionnaire was filled out. Zero if NULL. This item only began to be collected in FY98.	NUMBER(6)	NULL	No
SURVEY_MPG	Fuel economy calculated from the fuel economy postcard survey. Expressed in miles per gallon.	NUMERIC(6,2)	NULL	No
MPG_DIST	Distance, in miles, over which fuel economy was measured in the fuel economy postcard survey.	NUMBER(5)	NULL	No
DRV_TYPE	"Type of driving" as indicated on the fuel economy postcard survey. Characterized driving during a period of fuel purchases as to degree of city versus highway driving. Legal values defined by DRV_TYPE translation table.	VARCHAR2(14)	NULL	No
TRIP2LAB	Response to question: "How did you get here today?" Legal values defined by TRIP2LAB translation table.	CHAR(4)	NULL	No
IM_STATUS	Response to question: "Did your vehicle pass or fail the inspection?" Legal values defined by IM_STAT translation table.	CHAR(5)	NULL	No
LITEACTION	Response to question: "What did you do after the light came on?" Legal values defined by LITEACT translation table.	CHAR(6)	NULL	No
HOW_LONG	Response to question: "How long ago did you purchase the vehicle to be tested?" Legal values defined by HOW_LONG translation table.	CHAR(2)	NULL	No

"P_INSP" Table				
Name	Comment	Datatype	Null Option	Is PK
RESULTID	Unique number sequentially assigned to each RESULT instance (including all RESULT subtype instances) as it is entered into this database. Number has no other ignificance.	NUMBER(12)	NOT NULL	Yes
PART	Identification of emission component usually a field name from the emission component worksheet e.g. E101.	CHAR(4)	NOT NULL	Yes
PART_STAT	Status of this emission component part. Legal values defined by PART_STA translation table.	CHAR(4)	NULL	No

"PART" Table				
Name	Comment	Datatype	Null Option	Is PK
PART	Identification of emission component usually a field name from the emission component worksheet e.g. E101.	CHAR(4)	NOT NULL	Yes
SYSTEM	Identitfication of an emission component system.	VARCHAR2(12)	NOT NULL	No
PART_D	More full description of the emission component.	VARCHAR2(50)	NULL	No

"PART_STA" Table				
Name	Comment	Datatype	Null Option	Is PK
PART_STAT		CHAR(4)	NOT NULL	Yes
PART_STA_N		NUMBER(2)	NULL	No
PART_STA_D		VARCHAR2(50)	NULL	No

"PARTCODE" Table				
Name	Comment	Datatype	Null Option	Is PK
PART_CODE	Numeric code which can be used to describe the status of an emission component.	NUMBER(2)	NOT NULL	Yes
PART	Identification of emission component usually a field name from the emission component worksheet e.g. E101.	CHAR(4)	NOT NULL	Yes
PARTCODE_D	Full description of what the part_code means	VARCHAR2(60)	NULL	No

"PC_INSP" Table				
Name	Comment	Datatype	Null Option	Is PK
PART	Identification of emission component usually a field name from the emission component worksheet e.g. E101.	CHAR(4)	NOT NULL	Yes
RESULTID	Unique number sequentially assigned to each RESULT instance (including all RESULT subtype instances) as it is entered into this database. Number has no other significance.	NUMBER(12)	NOT NULL	Yes
PART_CODE	Numeric code which can be used to describe the status of an emission component.	NUMBER(2)	NOT NULL	Yes

"PMEAS" Table				
Name	Comment	Datatype	Null Option	Is PK
RESULTID	Unique number sequentially assigned to each RESULT instance (including all RESULT subtype instances) as it is entered into this database. Number has no other significance.	NUMBER(12)	NOT NULL	Yes
ACTIVITY_ID	Unique number sequentially assigned to each RESULT instance (including all RESULT subtype instances) as it is entered into this database. Number has no other significance.	NUMBER(12)	NOT NULL	Yes
TPMEAS_DT	The time and date of each TTIME record. Resolution to one second.	DATE	NOT NULL	Yes
MEAS_ID	Measurement type identification. Legal values defined by MEASTYPE translation.	CHAR(10)	NOT NULL	Yes
MEAS_VALUE	The measurement.	NUMBER(10,3)	NULL	No

"PRESMEAS" Table				
Name	Comment	Datatype	Null Option	Is PK
MEAS_ID	Measurement type identification. Legal values defined by MEASTYPE translation	CHAR(10)	NOT NULL	Yes
RESULTID	Unique number sequentially assigned to each RESULT instance (including all RESULT subtype instances) as it is entered into this database. Number has no other significance.	NUMBER(12)	NOT NULL	Yes
MEASURE	Bag-level measurement.	NUMBER(10,3)	NULL	No

"PRESSTST" Table				
Name	Comment	Datatype	Null Option	Is PK
RESULTID	Unique number sequentially assigned to each RESULT instance (including all RESULT subtype instances) as it is entered into this database. Number has no other significance.	NUMBER(12)	NOT NULL	Yes
FUEL_CAP	Fuel cap present? "YES", "NO", or "NUL".	CHAR(3)	NULL	No
CAPOKSTANT	Did gas cap pass the Stant test? "YES", "NO", or "NUL".	CHAR(3)	NULL	No
FILLER_OK	Did filler neck look ok? "YES", "NO", or "NUL".	CHAR(3)	NULL	No
CANHOSE_OK	Did canister and hose look ok? "YES", "NO", or "NUL".	CHAR(3)	NULL	No
CANIST_ACC	Was the canister accessible? "YES", "NO", or "NUL".	CHAR(3)	NULL	No
CANIST_CON	Was the canister connected to the fuel tank? "YES", "NO", or "NUL".	CHAR(3)	NULL	No
HOSE_OK	Were the canister hoses ok, in terms of not being frayed? "YES", "NO", or "NUL".	CHAR(3)	NULL	No
PRESS_INIT	Initial pressure reading. Expressed in inches of water.	NUMBER(5,1)	NULL	No
PRESS_1MIN	Pressure reading after one minute. Expressed in inches of water. Null value is 99.9.	NUMBER(5,1)	NULL	No
PRESS_2MIN	Pressure reading after two minutes. Expressed in inches of water. Null value is 99.9.	NUMBER(5,1)	NULL	No
COMMENTS	Comment.	VARCHAR2(500)	NULL	No
PRESS_ODOM	Approximate odometer reading at time of pressure test. Expressed in miles. Zero represents NULL value. (This information item was not collected prior to FY98.)	NUMBER(6)	NULL	No
PRESSTAT	The abbreviated name used to identify the result from a fuel tank pressure test.	VARCHAR2(15)	NULL	No

"PROCURE" Table				
Name	Comment	Datatype	Null Option	Is PK
RESULTID	Unique number sequentially assigned to each RESULT instance (including all RESULT subtype instances) as it is entered into this database. Number has no other significance..	NUMBER(12)	NOT NULL	Yes
VEH_NO	Vehicle number historically assigned sequentially by recruitment contractor.	NUMBER(5)	NULL	No
VEH_LANE	Number historically used to identify procurement of a vehicle from an I/M lane (as compared with VEH_NO which identified a physical vehicle.) Vehicles were recruited for a series of tests, typically a purge-pressure, IM240 and FTP.	NUMBER(5)	NULL	No
RECRUIT_NO	This field would be rarely used for analysis purposes. Vehicle recruitment number. Previously known as "Recall_Number" in some datasets this is the "vehicle recruitment control number" which can be used to link back to paper record recruitment information outside of this database such as the recruitment class.	VARCHAR2(15)	NULL	No

"PROCURE" Table				
Name	Comment	Datatype	Null Option	Is PK
	In historical data where "Recall Number was not available" this field will contain the 4 character "vehicle run number" assigned by the recruitment contractor, which was rarely used.			
FUEL_PB	Used to represent the lead content of fuel in vehicle tank as received. Expressed in grams per gallon.	NUMBER(6,3)	NULL	No
PLUMB_TEST	Whether or not lead was detected on the vehicle exhaust tailpipe with plumbtesmo paper. Values are "PASS", "FAIL", and "NULL"	CHAR(4)	NULL	No
PROC_ODOM	Approximate odometer reading at time of vehicle recruitment. Expressed in miles.	NUMBER(6)	NULL	No
TANKNECK	Whether the fuel tank inlet restrictor, if present, was damaged. Legal values defined by translation table. Values are "YES", "NO", "NA" or "NULL".	CHAR(4)	NULL	No
REP_TIME	Time required performing repairs on this vehicle. Expressed in minutes. If multiple repairs were performed this represents the total time required.	NUMBER(4)	NULL	No
ECMPTIME	Time required performing the emission components inspections on this vehicle. Expressed in minutes.	NUMBER(4)	NULL	No
CONPART	Cost of conventional parts in U.S. dollars. If multiple repairs were conducted this field represents the total cost of these parts.	NUMBER(4)	NULL	No
TWYPART	Cost of three way catalyst parts in U.S. dollars. If multiple repairs were conducted this field represents the total cost of these parts.	NUMBER(4)	NULL	No
TIRESIZE	Tire size. Expressed as a character string. There is no translation table for this field and data may not be well coded.	VARCHAR2(11)	NULL	No
TIRE_MFR	Tire manufacturer.	CHAR(10)	NULL	No
LF_PSI	Left front tire pressure. Expressed in pounds per square inch.	NUMBER(2)	NULL	No
RF_PSI	Right front tire pressure. Expressed in pounds per square inch.	NUMBER(2)	NULL	No
LR_PSI	Left rear tire pressure. Expressed in pounds per square inch.	NUMBER(2)	NULL	No
RR_PSI	Right rear tire pressure. Expressed in pounds per square inch.	NUMBER(2)	NULL	No
FPSI_SPEC	Front tire pressure specification. Expressed in pounds per square inch.	NUMBER(2)	NULL	No
RPSI_SPEC	Rear tire pressure specification. Expressed in pounds per square inch.	NUMBER(2)	NULL	No
HOUR_METER	Hours of operation (usually available only for off-road mobile sources). Null value is Zero.	NUMBER(6)	NULL	No
CUTHC	Recruitment "cut point" or threshold value for hydrocarbon emissions. Expressed in terms of grams/mile as measured by an IM240 test. Null value of this field is zero.	NUMBER(5,2)	NULL	No
REBUILD_CT	Number of times mobile source was rebuilt, generally applicable only to engines. Null value is 99.	NUMBER(2)	NULL	No
REBUILD_DT	Date of last rebuild.	DATE	NULL	No
CUTCO	Recruitment "cut point" or threshold value for carbon monoxide emissions. Expressed in terms of grams/mile as measured by an IM240 test. Null value of this field is zero.	NUMBER(6,2)	NULL	No
REBUILDWHY	Purpose or reason for last rebuild.	VARCHAR2(30)	NULL	No
CUTNOX	Recruitment "cut point" or threshold value for oxides of nitrogen emissions. Expressed in terms of grams/mile as measured by an IM240 test. Null value of this field is zero.	NUMBER(5,2)	NULL	No
MODIFS	Description of significant post-OEM additions or modifications.	VARCHAR2(100)	NULL	No
OWNERSHIP	The relationship between the user and the equipment.	CHAR(7)	NULL	No
DEPOT	Depot means site where vehicle is stored when not in use.	VARCHAR2(12)	NULL	No
CUTPOINTS	Information pertaining to the set of IM240 emission "cutpoint" values which governed this procurement. These emission "cutpoint" levels do not generally correspond to the emission standards to which the vehicle was certified. Legal values defined by CUTPOINT translation table.	NUMBER(2)	NULL	No
FIXES	Identifies minor corrections made to the mobile source to enable testing. These things, such as fixing post catalyst exhaust leaks or brakes would not be expected to affect emission results, but may affect lab test to I/m lane test comparability for those vehicles that were tested in I/m lane before being recruited to the test laboratory. This field was added to the database to accommodate historical data and is nul (0) for most records. Legal values defined by FIXES translation table.	NUMBER(2)	NULL	No
IM240_PF	Indicates whether a recruited vehicle passed or failed an EPA-conducted IM240 test. Legal values defined by IM240_PF translation table.	CHAR(4)	NULL	No
PROC METH	Procurement method. Legal values defined by PROC METH translation table.	CHAR(10)	NULL	No
PRESSURE	Results of evaporative system pressure check procedure. Legal values defined by PRESSURE translation table.	CHAR(7)	NULL	No
PROC_MATCH	Relationship between originally specified procurement criteria and vehicle actually recruited. Legal values defined by PROC_MAT translation table.	CHAR(7)	NULL	No
LF_WEAR	Left front tire wear description. Legal values defined by LF_WEAR translation table.	CHAR(7)	NULL	No
STATETEST	Indicates whether the vehicle recruited passed or failed a state IM test. Legal values defined by STATETES translation table.	CHAR(8)	NULL	No
PURGE	Contains results of evaporative system purge check procedure. Legal values defined by PURGE translation table	CHAR(7)	NULL	No
RF_WEAR	Right front tire wear description. Legal values defined by RF_WEAR translation table.	VARCHAR2(7)	NULL	No

"PROCURE" Table				
Name	Comment	Datatype	Null Option	Is PK
IM_STATION	IM program station id.	NUMBER(3)	NULL	No
VIN_BODY	Vehicle physical attributes as described by VIN decoding software for the procurement.	VARCHAR2(30)	NULL	No
VINDCODE	Version of VIN decoding software used for the procurement.	VARCHAR2(12)	NULL	No

"RATEMEAS" Table				
Name	Comment	Datatype	Null Option	Is PK
MEAS_ID	Measurement type identification. Legal values defined by MEASTYPE table.	CHAR(10)	NOT NULL	Yes
MODEID	Mode identification. Legal values defined by MODE_ID translation table.	CHAR(10)	NOT NULL	Yes
RESULTID	Unique number sequentially assigned to each RESULT instance (including all RESULT subtype instances) as it is entered into this database. Number has no other significance.	NUMBER(12)	NOT NULL	Yes
RATEMEAS	Mode level measurement of this MEAS_ID	NUMBER(10,3)	NULL	No

"RBAGMEAS" Table				
Name	Comment	Datatype	Null Option	Is PK
BAG_NUM	Bag number.	NUMBER(2)	NOT NULL	Yes
MEAS_ID	Measurement type identification. Legal values defined by MEASTYPE translation	CHAR(10)	NOT NULL	Yes
RESULTID	Unique number sequentially assigned to each RESULT instance (including all RESULT subtype instances) as it is entered into this database. Number has no other significance.	NUMBER(12)	NOT NULL	Yes
BAG_MEAS	Bag-level run-loss measurement.	NUMBER(10,3)	NULL	No

"REPAIR" Table				
Name	Comment	Datatype	Null Option	Is PK
RESULTID	Unique number sequentially assigned to each RESULT instance (including all RESULT subtype instances) as it is entered into this database. Number has no other significance.	NUMBER(12)	NOT NULL	Yes
COMMENTS	Repair description - first portion. 50 character field.	VARCHAR2(500)	NULL	No
COMMENTS2	Repair description - second portion. 50 character field.	VARCHAR2(500)	NULL	No
REPAR_ODOM	Approximate odometer reading at time repair was made. Expressed in miles. Zero represents NULL value. This information item was not collected prior to FY98.	NUMBER(6)	NULL	No
REPAR_HRM	Approximate hour meter reading at time repair was made. Expressed in hours. Zero represents NULL value. This information item was not collected prior to FY2001.	CHAR(5)	NULL	No
SYST_REP	System(s) affected by the repair. Legal values defined by SYST_REP translation table	CHAR(7)	NULL	No
REP_TYPE	Type of repair performed. Legal values defined by REP_TYPE translation table.	NUMBER(3)	NULL	No

"REP_MEAS" Table				
Name	Comment	Datatype	Null Option	Is PK
DYNOSECS	Time within dynamometer test, expressed in seconds, beginning of test has dynosecs = 0.	NUMBER(4)	NOT NULL	Yes
MEAS_ID	Measurement type identification. Legal values defined by MEASTYPE table.	CHAR(10)	NOT NULL	Yes
RESULTID	Unique number sequentially assigned to each RESULT instance (including all RESULT subtype instances) as it is entered into this database. Number has no other significance.	NUMBER(12)	NOT NULL	Yes
REP_MEAS	Repeated measurement.	NUMBER(10,3)	NULL	No

"RES_KIND" Table				
Name	Comment	Datatype	Null Option	Is PK
RES_KIND	The abbreviated name used to identify which subtype this result belongs to. Overall intent is to aggregate RESULT instances into few different subtypes as practical.	CHAR(8)	NOT NULL	Yes
RES_KIND_N	The numeric ID used to identify which subtype this result belongs to.	NUMBER(8)	NULL	No
RES_KIND_D	The detailed description on the meaning of each RES_KIND.	VARCHAR2(80)	NULL	No

"RESULT" Table				
Name	Comment	Datatype	Null Option	Is PK
RESULTID	Unique number sequentially assigned to each RESULT instance (including all RESULT subtype instances) as it is entered into this database. Number has no other significance.	NUMBER(12)	NOT NULL	Yes
TEST_PROC	Identifies the specific test procedure used. A more detailed classification than RES_KIND. Based largely upon values of TEST_TYPE in earlier design. Conceptually distinct from the driving or operational schedule used.	CHAR(5)	NULL	No
WA_ID	Work Assignment name which is equivalent to EPA's test program name.	CHAR(10)	NULL	No
SCHED_ID	Schedule identification.	CHAR(6)	NULL	No
CAUSE	A foreign key back into RESULT. Identifies the most immediately preceding RESULT instance (e.g. a PROCURE or REPAIR on this mobile source instance) affecting the outcome of this one. A departure from the relational model.	NUMBER(12)	NOT NULL	No
PREV_REP	A foreign key back into RESULT. Identifies any most immediately preceding RESULT instance for which this RESULT is a replicate (repeat). A departure from the relational model.	NUMBER(12)	NOT NULL	No
RESULTGRP	May be used to relate a RESULT to another RESULT of which it considered a part. This relationship was originally established to relate the FTP, US06 and SC03 portions of the SFTP to the SFTP summary calculations (All four being considered DYNOTESTs.) The SFTP is considered the Result Group and the FTP, US06 and SC03 are considered to belong to this Result Group. A value of zero is used to indicate that a particular RESULT is not part of a higher level group.	NUMBER(12)	NOT NULL	No
NEXT_REP	A foreign key back into RESULT. Identifies any most immediately following RESULT instance which is a replicate (repeat) of this one. A departure from the relational model.	NUMBER(12)	NOT NULL	No
FBATCH_ID	Fuel batch identification.	CHAR(10)	NULL	No
TEST_DATE	Result date.	DATE	NOT NULL	No
TEST_TOD	Time of day of the start of the result. Stored as a 5 character string HH:MM.	CHAR(5)	NOT NULL	No
RES_KIND	RESULT kind. Used to identify which subtype this result belongs to. Overall intent is to aggregate RESULT instances into as few different subtypes as practical. E.g. all vehicle dynamometer tests may be one subtype, all SHED tests another legal value.	CHAR(8)	NOT NULL	No
NOM_TEMP	Nominal temperature at which test was to be conducted. Expressed in degrees Fahrenheit.	NUMBER(3)	NULL	No
NOM_HUMID	Nominal absolute humidity at which test was to be conducted. Expressed in grains of water per pound of dry air.	NUMBER(3)	NULL	No
CTR_TST_ID	Identification number assigned to the RESULT by a test contractor. (Hopefully uniquely identifies RESULT instances within a given wa_id.) Not used for analytical purposes. But could help locate contractor's records pertinent to this RESULT.	VARCHAR2(12)	NULL	No
NO_BAGS	Number of bags involved in this RESULT. Data for individual bags is stored in the BAG_DATA table.	NUMBER(2)	NULL	No
NO_MODES	Number of test modes involved in this result. Data for individual chassis test modes is stored in the DYNOMODE table. Data for individual engine dynamometer test modes is stored in the ETSTMODE table.	NUMBER(2)	NULL	No
OLD_RKEY	Old result key in previous database. This field is intended for data administrator use only. It contains sufficient information to uniquely locate a result-type record in the old database as follows: Site code - 3 columns Program - 4 columns Contract 4 columns(upper 2 columns sometimes used for other special key info. ex. nom-speed in STSTEP98) veh_no - 5 columns test_seq_ 3 columns test_type (test procedure) - 2 columns lane/lab - 1 column	VARCHAR2(22)	NULL	No
DISABLE	Indication of any special conditions or "disablements" performed on the mobile source for particular tests. A value of zero indicates that no special condition or disablement to the vehicle was performed. Positive values indicate a particular disablement or set of disablements. Legal values defined by DISABLE translation table.	NUMERIC(3)	NULL	No
TEST_MODIF	Identifies any minor deviation from normal test procedure indicated by "test_proc". Legal values defined by TEST_MOD translation table.	NUMBER(2)	NULL	No
FUEL_ID	Numeric code uniquely identifying the general type of fuel used. Sometimes referred to as the "gross fuel type".	NUMBER(3)	NULL	No
SITE	Location where test was conducted. Legal values defined by SITE translation table.	VARCHAR2(12)	NOT NULL	No
PROTO_ID	Task number. Field has this name because thought at one point was to call these "protocols".	NUMBER(3)	NULL	No

"RESULT" Table				
Name	Comment	Datatype	Null Option	Is PK
MSID	Mobile source identifier. For vehicles their VIN would be used. For engines, their serial number, probably in conjunction with their manufacturer code.	NUMBER(12)	NOT NULL	No

"RUNL_BAG" Table				
Name	Comment	Datatype	Null Option	Is PK
BAG_NUM	Bag number.	NUMBER(2)	NOT NULL	Yes
RESULTID	Unique number sequentially assigned to each RESULT instance (including all RESULT subtype instances) as it is entered into this database. Number has no other significance.	NUMBER(12)	NOT NULL	Yes
W_RUNL_THC	Total hydrocarbon evaporative emissions, (for this portion of the test) expressed in grams. Often termed "running loss" emissions.	NUMBER(7,2)	NULL	No
TARG_FTEMP	Target fuel tank temperature expressed in degrees Fahrenheit.	NUMBER(3)	NULL	No
OBS_FTEMP	Observed fuel tank temperature expressed in degrees Fahrenheit.	NUMBER(3)	NULL	No
TANK_PRESS	Fuel tank pressure expressed in pounds per square inch.	NUMBER(5,1)	NULL	No
PURG_FLOW	Purge air flow volume during this portion of the test expressed in liters.	NUMBER(7,1)	NULL	No
RNL_BARO	Barometric pressure expressed in inches of mercury.	NUMBER(5,2)	NULL	No
RNL_HUMID	Humidity expressed in grains of water per pound of dry air.	NUMBER(6,2)	NULL	No
RNL_DIST	Distance traveled expressed in miles.	NUMBER(7,3)	NULL	No
RNL_THC	Total hydrocarbon emissions expressed in grams per mile.	NUMBER(7,3)	NULL	No
RNL_CO	Carbon monoxide emissions expressed in grams per mile.	NUMBER(8,3)	NULL	No
RNL_CO2	Carbon dioxide emissions expressed in grams per mile.	NUMBER(8,3)	NULL	No
RNL_TEMP	Temperature expressed in degrees Fahrenheit	NUMBER(5,1)	NULL	No
RNL_NOX	Emissions of oxides of nitrogen expressed in grams per mile.	NUMBER(7,3)	NULL	No
RNL_MPG	Fuel economy expressed in miles per gallon.	NUMBER(6,2)	NULL	No

"RUNLOSS" Table				
Name	Comment	Datatype	Null Option	Is PK
RESULTID	Unique number sequentially assigned to each RESULT instance (including all RESULT subtype instances) as it is entered into this database. Number has no other significance.	NUMBER(12)	NOT NULL	Yes
TESTWGHT	Dynamometer inertia weight setting used for this test expressed in pounds.	NUMBER(6)	NULL	No
TARCANWGHT	Target canister weight expressed in grams	NUMBER(4)	NULL	No
ROAD_HP	Dynamometer road load horsepower setting used for this test.	NUMBER(5,1)	NULL	No
AC_HP	Did dynamometer road load setting for this test include air conditioning load factor? YES, NO, or NUL.	CHAR(3)	NULL	No
NORCANWGHT	Normalized canister weight expressed in grams	NUMBER(4)	NULL	No
ENDCANWGHT	Observed canister weight at end of test expressed in grams.	NUMBER(4)	NULL	No
TARGIFTEMP	Target initial fuel tank temperature expressed in degrees Fahrenheit.	NUMBER(3)	NULL	No
ODOMETER	Approximate odometer reading of vehicle at beginning of test expressed in miles.	NUMBER(6)	NULL	No
OBSIFTEMP	Observed initial fuel tank temperature expressed in degrees Fahrenheit.	NUMBER(3)	NULL	No
DYNOTYPE	Type of dynamometer used. Legal values defined by DYNOTYPE translation table.	CHAR(10)	NULL	No
PRECOND	Type of preconditioning performed on the vehicle prior to the test. Legal values defined by PRECOND translation table.	CHAR(10)	NULL	No

"SCANSYS1" Table				
Name	Comment	Datatype	Null Option	Is PK
OBD1CODE	Numeric code resulting from a scan of level 1 on board diagnostic system.	NUMBER(3)	NOT NULL	Yes
RESULTID	Unique number sequentially assigned to each RESULT instance (including all RESULT subtype instances) as it is entered into this database. Number has no other significance.	NUMBER(12)	NOT NULL	Yes
OBD1DESCR	Narrative explaining significance of individual code resulting from scan of a level 1 on board diagnostic system.	VARCHAR2(50)	NULL	No

"SCANSYS2" Table				
Name	Comment	Datatype	Null Option	Is PK
OBD2CODE	Character string code resulting from a scan of a level 2 on board diagnostic system.	CHAR(5)	NOT NULL	Yes
RESULTID	Unique number sequentially assigned to each RESULT instance (including all RESULT subtype instances) as it is entered into this database. Number has no other significance.	NUMBER(12)	NOT NULL	Yes

"S_INSP" Table				
Name	Comment	Datatype	Null Option	Is PK
RESULTID	Unique number sequentially assigned to each RESULT instance (including all RESULT subtype instances) as it is entered into this database. Number has no other significance.	NUMBER(12)	NOT NULL	Yes
SYSTEM	Identification of an emission component system.	VARCHAR2(12)	NOT NULL	Yes
SYSTEM_STA	Identifies if the status of the emission component system (e.g. passed or failed).	CHAR(4)	NULL	No

"SMOKECOL" Table				
Name	Comment	Datatype	Null Option	Is PK
SMOKECOLOR	The abbreviated name used to identify the color of the tailpipe smoke.	CHAR(6)	NOT NULL	Yes
SMOKECOL_N	The numeric ID used to identify the color of the tailpipe smoke.	NUMBER(2)	NULL	No
SMOKECOL_D	The detailed description of the SMOKECOLOR.	VARCHAR2(30)	NULL	No

"SMOKETST" Table				
Name	Comment	Datatype	Null Option	Is PK
RESULTID	Unique number sequentially assigned to each RESULT instance (including all RESULT subtype instances) as it is entered into this database. Number has no other significance.	NUMBER(12)	NOT NULL	Yes
SMOKE_SUM	Single number representing the overall result of the smoke test, in units of percent opacity. For smoke test procedures which do not have such a summary result this field will be null.	NUMBER(5,2)	NULL	No

"STSTMODE" Table				
Name	Comment	Datatype	Null Option	Is PK
SMOKEMODE	Name of the smoke test mode. Legal values defined by translation table.	CHAR(10)	NOT NULL	Yes
RESULTID	Unique number sequentially assigned to each RESULT instance (including all RESULT subtype instances) as it is entered into this database. Number has no other significance.	NUMBER(12)	NOT NULL	Yes
SMOKE_OPAC	Percent smoke opacity measured during one mode of a smoke test.	NUMBER(5,2)	NULL	No

"SYSTEM" Table				
Name	Comment	Datatype	Null Option	Is PK
SYSTEM	Identification of an emission component system.	VARCHAR2(12)	NOT NULL	Yes
SYSTEM_D	More lengthy description of the emission component system.	VARCHAR2(50)	NULL	No
OLD_SYST	Name of field describing this emission component "system" in the old database.	CHAR(8)	NULL	No

"SYSTEM_S" Table				
Name	Comment	Datatype	Null Option	Is PK
SYSTEM_STA	Identifies if the status of the emission component system (e.g. passed or failed).	CHAR(4)	NOT NULL	Yes
SYSTEM_S_N	Identifies if the status of the emission component system (e.g. passed or failed).	NUMBER(1)	NULL	No
SYSTEM_S_D	The detailed description of SYSTEM_STA field.	VARCHAR2(20)	NULL	No

"TASK" Table				
Name	Comment	Datatype	Null Option	Is PK
PROTO_ID	Task number. Field has this name because thought at one point was to call these "protocols".	NUMBER(3)	NOT NULL	Yes
CONTRACT	A number intended to identify the contract, as historically classified, to which a Task belongs.	NUMBER(4)	NOT NULL	No
PROGRAM	Test program, as historically classified, to which the Task belonged. This data element formed the "SUFFIX" portion of table names in an older, non-relational, implementation of this database.	CHAR(4)	NOT NULL	No
TASK_D	Brief task title or description.	VARCHAR2(80)	NOT NULL	No
P_CRITERIA	The abbreviated name used to describe additional vehicle-condition-specific criteria that was or was not done. Procurement criteria. A categorical attribute with two valid entries: GENERAL or CONDITIONAL. GENERAL pertains to projects where vehicles were accepted for testing without additional, vehicle-condition-specific criteria. For example, a task might intend to recruit 1997 model year light-duty trucks with less than 6,000 pounds gross vehicle weight. If the first truck meeting these criteria and willing to be tested is accepted for testing, then the procurement would be considered GENERAL. (Rejecting vehicles for testing safety reasons is not considered as additional criteria.) Most EPA test data is usually not procured in a purely random manner. Vehicle class criteria (i.e., model year) is commonly used as a criteria to limit the scope of the procurement and maximize the data sample in the areas of interest. This	VARCHAR2(11)	NULL	No

"TASK" Table				
Name	Comment	Datatype	Null Option	Is PK
	"nonrandom" procurement is normally not a problem as long as the analysis of the data is stratified by the vehicle class criteria. CONDITIONAL refers to tasks which included additional, vehicle-condition specific criteria in addition to any vehicle class criteria. The additional criteria is based on the condition of the vehicle (i.e., mileage, emission level, vehicle owner, etc.) and not the vehicle as manufactured (i.e., fuel injection, catalyst type, model year, etc.). Users should refer to the text of the work assignment which recruited the vehicle to determine the precise conditions used for recruitment.			

"TRIP" Table				
Name	Comment	Datatype	Null Option	Is PK
RESULTID	Unique number sequentially assigned to each RESULT instance (including all RESULT subtype instances) as it is entered into this database. Number has no other significance.	NUMBER(12)	NOT NULL	Yes
ACTIVITY_ID	Unique number sequentially assigned to each RESULT instance (including all RESULT subtype instances) as it is entered into this database. Number has no other significance...	NUMBER(12)	NOT NULL	Yes
TRIP_ID	ID that identifies a trip of an activity.	VARCHAR2(12)	NOT NULL	No
INS_CONFIG	Instrumentation Configuration.	VARCHAR2(8)	NULL	No
OPERATORTP	Type of operator that is using the vehicle. (Owner, Experienced Operator, etc.)	VARCHAR2(12)	NULL	No
TSTART_DT	Date and time at the start of each trip.	DATE	NULL	No
TEND_DT	Date and time at the end of each trip.	DATE	NULL	No
PAYLOAD	Total weight of passengers in the vehicle in pounds.	NUMBER(5)	NULL	No
PASSENGERS	Number of passengers in the vehicle.	NUMBER(3)	NULL	No

"TTIME" Table				
Name	Comment	Datatype	Null Option	Is PK
RESULTID	Unique number sequentially assigned to each RESULT instance (including all RESULT subtype instances) as it is entered into this database. Number has no other significance.	NUMBER(12)	NOT NULL	Yes
TPMEAS_DT	The time of each TTIME record. Second count for each trip.	DATE	NOT NULL	Yes
ACTIVITY_ID	Unique number sequentially assigned to each RESULT instance (including all RESULT subtype instances) as it is entered into this database. Number has no other significance.	NUMBER(12)	NOT NULL	Yes
TRIP_SPEED	Vehicle speed (miles per hour) for each second.	NUMBER(6,2)	NULL	No
TRIP_RPM	Engine's rpm for each second.	NUMBER(5)	NULL	No
TRIP_TORQ	Engine's torque (calculated or measured) per second in ft-lbs.	NUMBER(6)	NULL	No
TRIP_TEMP	Ambient air temperature in degrees F per second.	NUMBER(5,1)	NULL	No
TRIP_TEMP	Ambient air temperature in degrees C per second.	NUMBER(5,1)	NULL	No
TRIP_BARO	Ambient air's barometric pressure measured for each second in inches of mercury.	NUMBER(5,2)	NULL	No
INST_BARO	Ambient air's barometric pressure measured for each second in kPa.	NUMBER(5,2)	NULL	No
TRIP_HUMID	Absolute humidity measured each second expressed in grains of water per pound of dry air.	NUMBER(6,2)	NULL	No
TRIP_LAT	Latitude of the vehicle measured for each second.	NUMBER(8,5)	NULL	No
TRIP_LONG	Longitude of the vehicle measured for each second.	NUMBER(8,5)	NULL	No
TRIP_ALT	Altitude of the vehicle measured for each second.	NUMBER(6)	NULL	No
TRIP_GRADE	Grade measured for each second.	NUMBER(6,3)	NULL	No
TRIP_MASSF	Gas in cubic feet per second.	NUMBER(6,2)	NULL	No
FUEL_RATE	Fuel rate in lbs/sec	NUMBER(4,2)	NULL	No
TRIP_THC	Total Hydrocarbon in grams/sec.	NUMBER(7,3)	NULL	No
TRIP_CO	Carbon Monoxide in grams/sec.	NUMBER(8,3)	NULL	No
TRIP_CO2	Carbon Dioxide in grams/sec.	NUMBER(8,3)	NULL	No
TRIP_NOX	Nitrogen Oxides in grams/sec.	NUMBER(7,3)	NULL	No
TRIP_O2	Oxygen in grams/sec.	NUMBER(8,3)	NULL	No
ENG_COOL_T	Engine coolant temperature (degrees F).	NUMBER(5,1)	NULL	No
ENG_OIL_T	Engine oil temperature (degrees F).	NUMBER(5,1)	NULL	No
TRIP_VOLF	Volume of mass flow in cubic feet per minute (SCFM) STP (Standard Temperature Pressure).	NUMBER(6,2)	NULL	No
MILLIGHT	Indicating millight is on or off.	VARCHAR2(3)	NULL	No

"VEHICLE" Table				
Name	Comment	Datatype	Null Option	Is PK
MSID	Mobile source identifier. For vehicles their VIN would be used. For engines, their serial number, probably in conjunction with their manufacturer code.	NUMBER(12)	NOT NULL	Yes
EVAP_FAM	EPA standardized evaporative family name as defined in CFR40 Part 86	CHARACTER(12)	NULL	No
ENG_FAM	Exhaust emission certification family to which this vehicle belongs.	CHARACTER(19)	NULL	No
VEHCLASS	Vehicle class. Legal values defined by VEHCLASS translation table.	CHARACTER(5)	NULL	No
MODEL_YR	Model year.	Numeric(8,0)	NULL	No
MAKE	Vehicle makes e.g. Buick, as distinct from vehicle manufacturer, GM. Legal values defined by MAKE translation table.	CHARACTER(12)	NULL	No
MODEL_NAME	Model name.	CHARACTER(20)	NULL	No
OVERDRIVE	Indicates whether vehicle has overdrive gear.	CHARACTER(3)	NULL	No
TRAN_TYPE	Transmission type. Legal values defined by TTRNTRAN translation table.	CHARACTER(6)	NULL	No
CREEPER	Indicates whether vehicle has creeper gear.	CHARACTER(3)	NULL	No
LOCKUP	Indicates whether vehicle has lockup transmission.	CHARACTER(3)	NULL	No
GEARS	Number of forward gears in vehicle transmission. Legal values defined by GEARS translation table.	CHARACTER(6)	NULL	No
GVWR	Gross vehicle weight rating in pounds. The value specified by the manufacturer as the loaded weight of a single vehicle.	Numeric(8,0)	NULL	No
GCWR	The weight rating, expressed in pounds, specified by the vehicle manufacturer as the loaded weight of a combination (articulated) vehicle. In the absence of a value specified by the manufacturer, GCVR will be determined by adding the GVWR of the power unit and the total weight of the towed unit and any load thereon.	Numeric(8,0)	NULL	No
CURBWEIGHT	Curb weight in pounds. For on-road vehicles this has a precise definition. For other mobile sources, e.g. non-road vehicles, the unadjusted actual weight of the mobile source is used.	Numeric(8,0)	NULL	No
AC	Is vehicle equipped with air conditioning? YES, NO, or NUL Intend to change to logical type field when good tool is available.	CHARACTER(3)	NULL	No
BLD_DATE	Approximate date the vehicle was manufactured. Usually collected to nearest month only with day set to 15.	DATE	NULL	No
THCSTD	Total hydrocarbon standard level to which vehicle was certified. Expressed in grams per mile.	Numeric(8,0)	NULL	No
NMHCSTD	Non methane hydrocarbon standard level to which vehicle was certified. Expressed in grams per mile.	Numeric(8,0)	NULL	No
COSTD	Carbon monoxide standard level to which vehicle was certified. Expressed in grams per mile.	Numeric(8,0)	NULL	No
NOXSTD	Oxides of nitrogen standard level to which vehicle was certified. Expressed in grams per mile.	Numeric(8,0)	NULL	No
THCESTD	Total hydrocarbon equivalent standard to which vehicle was certified. Expressed in grams per mile.	Numeric(8,0)	NULL	No
PMSTD	Particulate matter standard to which vehicle was certified. Expressed in grams per mile.	Numeric(8,0)	NULL	No
NMHCESD	Non-methane hydrocarbon equivalent standard to which vehicle was certified. Expressed in grams per mile.	Numeric(8,0)	NULL	No
EVAPSTD	Evaporative emissions standard to which vehicle was certified. Expressed in grams per mile.	Numeric(8,0)	NULL	No
FUELTANKS	Number of fuel tanks on vehicle.	NUMBER(1)	NULL	No
TANK_CAP	Total fuel tank capacity to nearest gallon. (Includes all tanks.)	Numeric(8,0)	NULL	No
CANISTER	Type of canister on vehicle. Legal values defined by CANISTER translation table.	CHARACTER(10)	NULL	No
EGR	Does vehicle have exhaust gas recirculation? YES, NO, or NUL.	CHARACTER(3)	NULL	No
CITY_FE	Represents the city fuel economy rating in miles per gallon from the fuel economy guide.	Numeric(8,0)	NULL	No
HWAY_FE	Represents the highway fuel economy rating in miles per gallon from the fuel economy guide.	Numeric(8,0)	NULL	No
DRV_TRN	Represents drive train. Legal values defined by DRV_TRN translation table.	CHARACTER(4)	NULL	No
MODELSIZE	Represents the EPA Fuel Economy Guide model size category for the vehicle. Legal values defined by MODELSIZ translation table..	CHARACTER(10)	NULL	No
AXLE_RATIO	Axle ratio.	Numeric(8,0)	NULL	No
STANDARDS	Identifies set of emission standards applicable to this vehicle. This field is collected only for older data where there were only a few different standards in existence. Field is not adequate to characterize emission standards applicable to later model year vehicles. Legal values defined by STANDARDS translation table.	CHARACTER(6)	NULL	No
ENGMOUNT	Orientation of engine as mounted in the vehicle. Legal values defined by ENGMOUNT translation table.	CHARACTER(10)	NULL	No
PURPOSE	Purpose or use of the mobile source. Addition of this field was motivated by the need to describe the function of non-road vehicles and equipment and will likely be blank for other mobile sources.	CHARACTER(10 0)	NULL	No
SCC	Source classification code.	CHARACTER(14)	NULL	No

"VEHICLE" Table				
Name	Comment	Datatype	Null Option	Is PK
CERT_NOX	Oxides of nitrogen emission level at which vehicle was certified. Expressed in grams per mile.	NUMBER(6,3)	NULL	No
CERT_PM	Particulate matter emission level at which vehicle was certified. Expressed in grams per mile.	NUMBER(6,3)	NULL	No
AXLE	The number of axles the vehicle has.	Numeric(2)	NULL	No
CERT_CO	Carbon Monoxide emission level at which the heavy duty vehicle or engine was certified. Expressed in grams per mile.	Numeric(6,3)	NULL	No
CERT_HC	Hydrocarbon emission level at which vehicle was certified. Expressed in grams per mile.	Numeric(6,3)	NULL	No
VIN8	The first eight characters of vehicle Identification Number (VIN).	CHARACTER(8)	NULL	No
VIN_BODY	Vehicle physical attributes as described by VIN decoding software for the first procurement of the vehicle into MSOD.	CHARACTER(30)	NULL	No

"WKASSIGN" Table				
Name	Comment	Datatype	Null Option	Is PK
WA_ID	Work Assignment name which is equivalent to EPA's test program name.	CHAR(10)	NOT NULL	Yes
WA_DESC	Longer, descriptive name of the work assignment.	VARCHAR2(254)	NULL	No
EPA_CONTNO	EPA Contract Number of the contract to which the work assignment belongs.	VARCHAR2(11)	NULL	No
EPA_WANO	Work assignment number, as it appears in EPA contracts function. e.g. "2_05"	CHAR(4)	NULL	No
CONTRACTOR	Name of contractor.	VARCHAR2(20)	NULL	No
FISCALYR	Fiscal Year of work assignment.	NUMBER(4)	NULL	No
CONTACT	Contract person, often initially the work assignment manager or WAM, responsible for the work assignment and who can be contacted for additional information about it.	VARCHAR2(20)	NULL	No
SOW_FNAME	Name of file containing the SOW for this work assignment. Additional filing conventions at any point in time would be combined with this information to find the actual document. The SOW is not as likely to be updated as the project progresses as the work plan and the work assignment report.	CHAR(8)	NULL	No
PHONE_NO	Telephone number of contact person for this work assignment.	VARCHAR2(18)	NULL	No
WP_FNAME	Name of file containing the contractor's approved work plan for this work assignment. Filing conventions in effect at a given point in time, in combination with this file name, would allow one to find the document.	CHAR(8)	NULL	No
ALTERNATE	Alternate EPA contract person, initially the alternate work assignment manager, responsible for the work assignment and who can be contacted for additional information about it.	VARCHAR2(20)	NULL	No
ABSTRACT	Short description of this work effort.	VARCHAR2(254)	NULL	No
NO_MSOURCE	Number of mobile sources the work assignment is intended to procure or test.	NUMBER(4)	NULL	No
FRPT_FNAME	Name of file containing contractor's final report.	CHAR(8)	NULL	No
SPONSOR	Organization principally responsible for funding and defining the work assignment.	VARCHAR2(20)	NULL	No
MIN_MOD_YR	Earliest model year of mobile sources involved in the work assignment.	NUMBER(4)	NULL	No
MAX_MOD_YR	Latest model year of mobile sources involved in the work assignment.	NUMBER(4)	NULL	No
WA_STATUS	Status of work assignment. e.g. COMPLETE, UNDERWAY, or PLANNED. Legal values defined by translation table.	CHAR(10)	NULL	No
P_CRITERIA	Procurement criteria. A categorical attribute with two valid entries: GENERAL or CONDITIONAL. GENERAL pertains to projects where vehicles were accepted for testing without additional, vehicle-condition-specific criteria. For example, a task might intend to recruit 1997 model year light-duty trucks with less than 6,000 pounds gross vehicle weight. If the first truck meeting these criteria and willing to be tested is accepted for testing, then the procurement would be considered GENERAL. (Rejecting vehicles for testing safety reasons is not considered as an additional criteria.) Most EPA test data is usually not procured in a purely random manner. Vehicle class criteria (i.e., model year) is commonly used as a criteria to limit the scope of the procurement and maximize the data sample in the areas of interest. This "nonrandom" procurement is normally not a problem as long as the analysis of the data is stratified by the vehicle class criteria. CONDITIONAL refers to tasks which included additional, vehicle-condition-specific criteria in addition to any vehicle class criteria. The additional criteria is based on the condition of the vehicle (i.e., mileage, emission level, vehicle owner, etc.) and not the vehicle as manufactured (i.e., fuel injection, catalyst type, model year, etc.). Users should refer to the text of the work assignment which recruited the vehicle to determine the precise conditions used for recruitment.	VARCHAR2(11)	NULL	No
EMAIL	Email address.	VARCHAR2(30)	NULL	No
FILEPATH	EPA network drive and directory where electronic documents can be found.	VARCHAR2(50)	NULL	No
RESTRICT	Indicates if a particular work assignment's data is available to the public.	CHAR(1)	NULL	No

IV. Detailed Input Data Design Information

- a. Input Entity - Relationship Diagrams**
- b. Input Entity and Field Attribute Definitions**

IV. Detailed Input Data Design Information

a. Input Entity - Relationship Diagrams

PEMS/PAMS ACTIVITY/TRIP INPUT TABLES

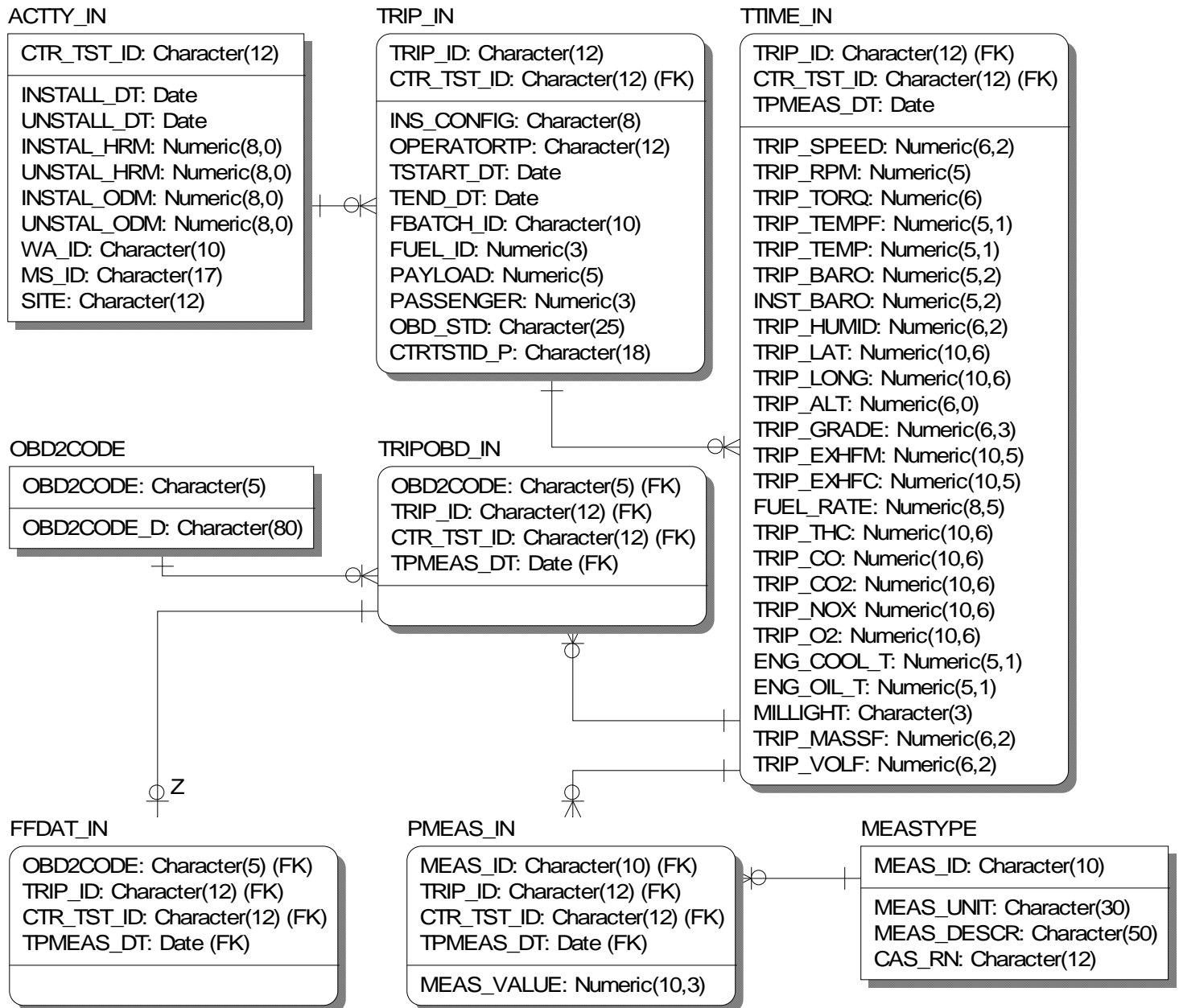

**DYNOB_IN
INPUT TABLES**

DYNOB_IN

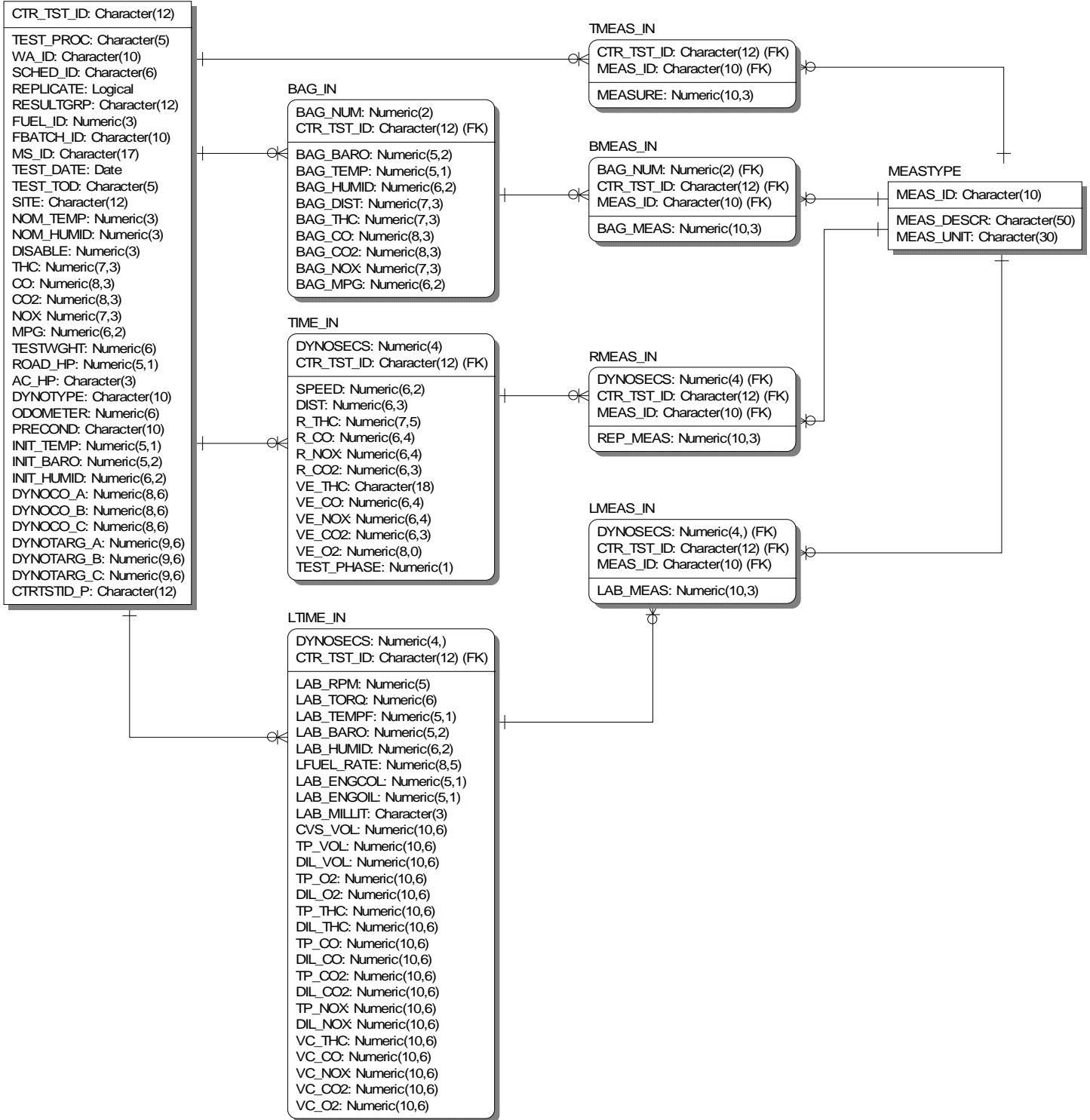

DYNOM_IN INPUT TABLES

DYNOM_IN

CTR_TST_ID: Character(12)
TEST_PROC: Character(5)
WA_ID: Character(10)
SCHED_ID: Character(6)
REPLICATE: Character(1)
FUEL_ID: Numeric(3)
FBATCH_ID: Character(10)
MS_ID: Character(17)
TEST_DATE: Date
TEST_TOD: Character(5)
SITE: Character(12)
NON_TEMP: Numeric(3)
NOM_HUMID: Numeric(3)
DISABLE: Numeric(3)
THC: Numeric(7,3)
CO: Numeric(8,3)
CO2: Numeric(8,3)
NOX: Numeric(7,3)
MPG: Numeric(6)
TESTWGHT: Numeric(6)
ROAD_HP: Numeric(5,1)
AC_HP: Character(3)
DYNOTYPE: Character(10)
ODOMETER: Numeric(6)
PRECOND: Character(10)
INIT_TEMP: Numeric(5,1)
INIT_BARO: Numeric(5,2)
INIT_HUMID: Numeric(6,2)
FBATCH_ID__1067: Character(10)

TMEAS_IN

CTR_TST_ID: Character(12) (FK)
MEAS_ID: Character(10) (FK)
MEASURE: Numeric(10,3)

MODE_IN

MODE_ID: Character(10)
CTR_TST_ID: Character(12) (FK)
MODE_TEMP: Numeric(5,1)
MODE_BARO: Numeric(5,2)
MODE_HUMID: Numeric(6,2)
C_THC: Numeric(4)
C_CO: Numeric(6,2)
C_CO2: Numeric(6,2)
C_NO: Numeric(4)
C_NOU: Numeric(4)
MODE_HP: Numeric(5,1)
RPM: Numeric(4)

MEASTYPE

MEAS_ID: Character(10)
MEAS_UNIT: Character(30)
MEAS_DESCR: Character(50)
CAS_RN: Character(12)

MMEAS_IN

MODE_ID: Character(10) (FK)
CTR_TST_ID: Character(12) (FK)
MEAS_ID: Character(10) (FK)
MODEMEAS: Numeric(10,3)

MTIME_IN

MODESECS: Numeric(4)
CTR_TST_ID: Character(12) (FK)
REP_C_THC: Numeric(4)
REP_C_CO: Numeric(6,2)
REP_C_CO2: Numeric(6,2)
REP_C_NO: Numeric(4)
REP_C_NOU: Numeric(4)
REP_RPM: Numeric(4)
REP_SPEED: Numeric(6,2)

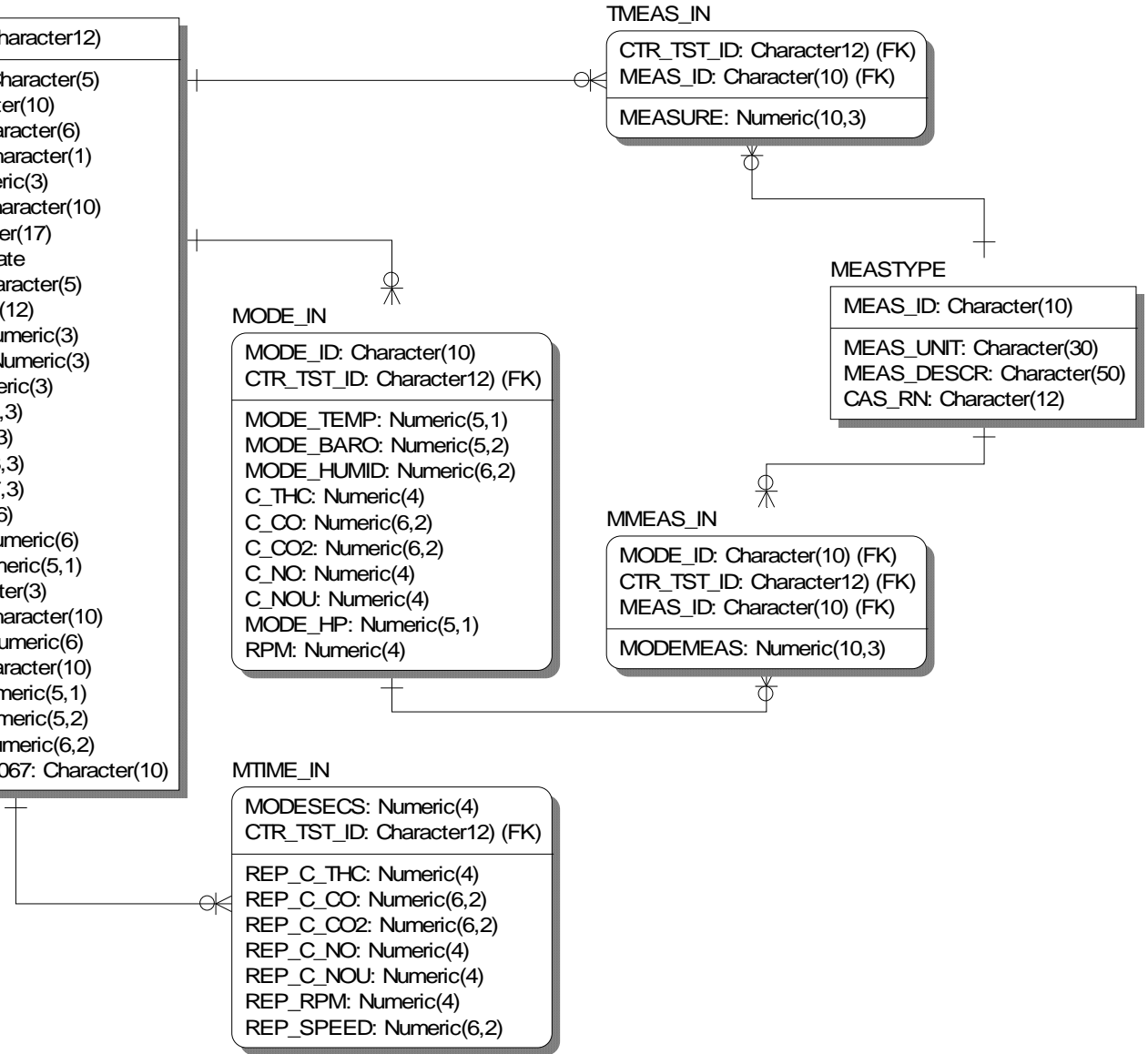

DYNOR_IN INPUT TABLES

DYNOR_IN

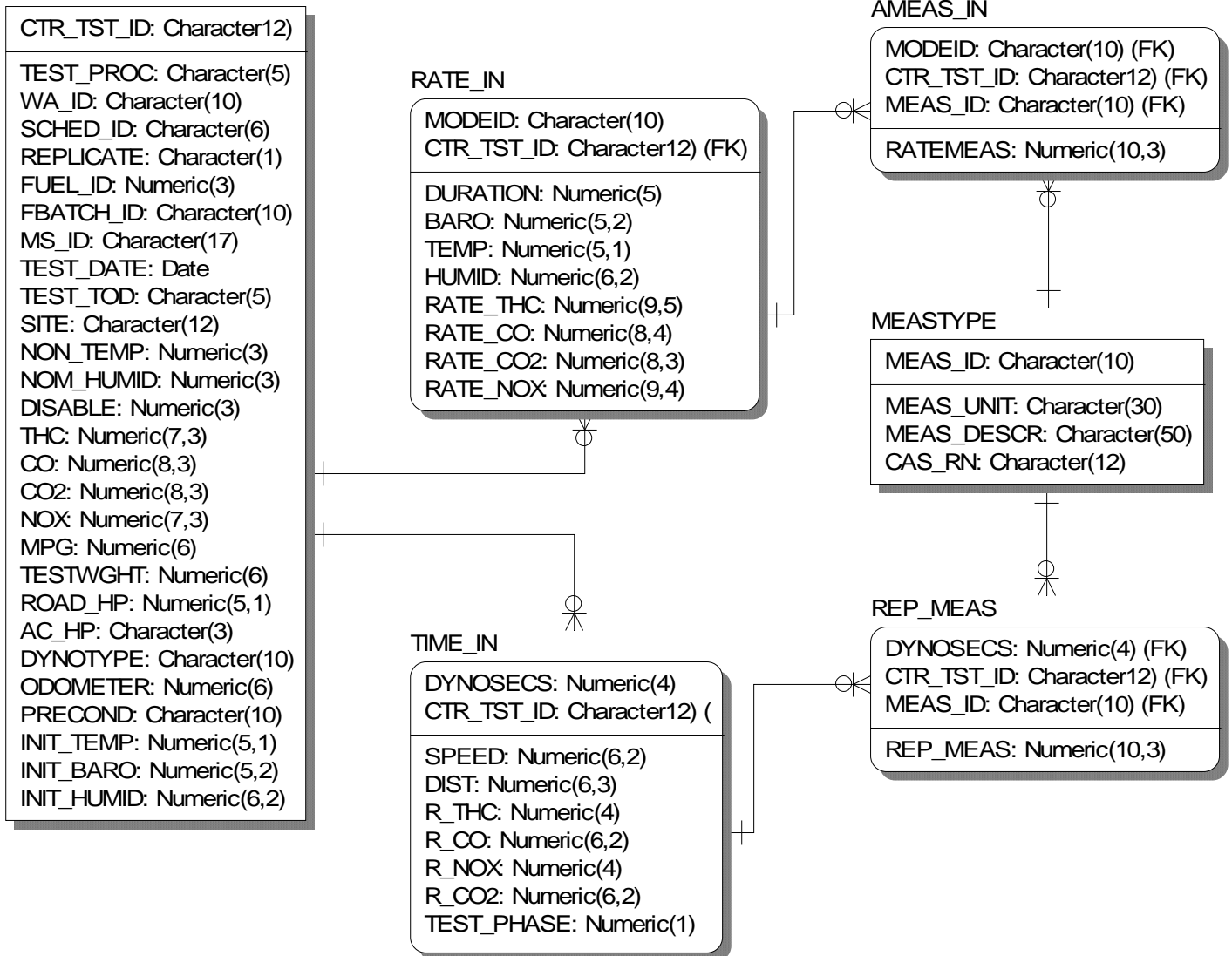

EMAP_IN INPUT TABLES

RESLT_IN

CTR_TST_ID: Character(12)
FBATCH_ID: Character(10)
TEST_PROC: Character(5)
WA_ID: Character(10)
SCHED_ID: Character(6)
REPLICATE: Character(1)
RESULTGRP: Character(12)
MS_TYPE: Numeric(2)
MS_ID: Character(17)
RES_KIND: Character(8)
FUEL_ID: Numeric(3)
TEST_DATE: Date
TEST_TOD: Character(5)
SITE: Character(12)
NOM_TEMP: Numeric(3)
NOM_HUMID: Numeric(3)
DISABLE: Numeric(3)
NO_MODES: Numeric(2)
TEST_MODIF: Numeric(2)

EMAP_IN

CTR_TST_ID: Character(12) (FK)
MAPTYPE: Character(5)
MSDRTDPWR: Numeric(5)
MSDRTDSPED: Numeric(5)
MAXTORQUE: Numeric(4)
MSDTRQSPED: Numeric(5)
GOV_SPEED: Numeric(5)
EXRESTRICT: Numeric(5,2)
BARO: Numeric(5,2)
HUMIDITY: Numeric(5,2)
INLET_AIR: Numeric(5,1)
EXHAUST: Numeric(5,1)
COOLER_OUT: Numeric(5,1)
COOLANT_IN: Numeric(5,1)
COOLANT_OUT: Numeric(5,1)
CHILLER: Numeric(5,1)

MAPPT_IN

CTR_TST_ID: Character(12) (FK)
MAP_RPM: Numeric(5)
MAP_TORQUE: Numeric(4)

**EQUIP_IN
INPUT TABLE**

EQUIP_IN

CTR_TST_ID: Character(12)
WA_ID: Character(10)
TEST_DATE: Date
TEST_TOD: Character(5)
SITE: Character(12)
VEH_MS_ID: Character(17)
ENG_MS_ID: Character(17)
VEHCLASS: Character(5)
EXCEPT: Character(3)
EX_COMM: Character(20)
FUELTYPE: Character(4)
VEHCOMPANY: Character(12)
ENGCOMPANY: Character(12)
HIGHWAY: Character(3)
PURPOSE: Character(100)
SCC: Character(14)
MODEL_NAME: Character(20)
MODEL_YR: Numeric(4)
MAKE: Character(12)
V_BLD_DATE: Date
DISP_CID: Numeric(4)
DISP_LITER: Numeric(4,1)
FUEL_DELIV: Character(6)
FL_TYPE: Character(6)
ASPIRATED: Character(7)
CYLINDER: Numeric(2)
INJECTORS: Numeric(1)
CAT_TYPE: Character(4)
AIR_INJ: Character(5)
CLOSEDLOOP: Character(3)
IGNITION: Character(2)
ENG_FAM: Character(19)
EVAP_FAM: Character(12)
OVERDRIVE: Character(3)
CREEPER: Character(3)
LOCKUP: Character(3)
GEARS: Character(6)
CURBWEIGHT: Numeric(6)
AC: Character(3)
CANISTER: Character(10)
EGR: Character(3)
FUELTANKS: Numeric(1)
TANK_CAP: Numeric(3)
EGR_TYPE: Character(6)
DRV_TRN: Character(4)
ENGSERIES: Character(20)
ENG_CLASS: Character(7)
E_BLD_DATE: Date
ENG_MOD_YR: Numeric(4)
COOLING: Character(7)
FL_METH: Character(4)
FL_PRESS: Numeric(6)
PARTTRAP: Character(3)
ENG_CYCLE: Character(1)
RATEDPOWER: Numeric(7,1)
RATEDSPEED: Numeric(5)
IDLE_RPM: Numeric(5)
TECH_CONFIG: Character(50)
ECS_DESCPT: Character(50)
ELECT_CONT: Character(100)
PROC METH: Character(10)
PROC_ODOM: Numeric(6)
HOUR_METER: Numeric(6)
REBUILD_CT: Numeric(2)
REBUILD_DT: Date
REBUILDWHY: Character(30)
MODIFS: Character(100)
TRAN_TYPE: Character(6)
GVWR: Numeric(6)
GCWR: Numeric(6)
COMMENTS: Character(254)
OWNERSHIP: Character(7)
DEPOT: Character(12)
PEAKTORQUE: Numeric(4)
PEAKSPEED: Numeric(5)
PEAKFRATE: Numeric(5,1)
RATEDFRATE: Numeric(5,1)
CERT_NOX: Numeric(6,3)
CERT_PM: Numeric(6,3)
AXLE: Numeric(2)
CERT_CO: Numeric(6,3)
CERT_HC: Numeric(6,3)
VIN8: Character(8)
VIN_BODY: Character(30)
THCSTD: Numeric(6,3)
COSTD: Numeric(6,3)
NOXSTD: Numeric(6,3)
PMSTD: Numeric(6,3)
VEH_LANE: Numeric(5)
STATETEST: Character(8)
CUTHC: Numeric(5,2)
CUTCO: Numeric(6,2)
CUTNOX: Numeric(5,2)
CUTPOINTS: Numeric(2)
IM_STATION: Numeric(3)
VINDCODE: Character(12)
CAT_AGE: Numeric(6)

RESLT_IN

CTR_TST_ID: Character(12)
FBATCH_ID: Character(10)
TEST_PROC: Character(5)
WA_ID: Character(10)
SCHED_ID: Character(6)
REPLICATE: Character(1)
RESULTGRP: Character(12)
MS_TYPE: Numeric(2)
MS_ID: Character(17)
RES_KIND: Character(8)
FUEL_ID: Numeric(3)
TEST_DATE: Date
TEST_TOD: Character(5)
SITE: Character(12)
NOM_TEMP: Numeric(3)
NOM_HUMID: Numeric(3)
DISABLE: Numeric(3)
NO_MODES: Numeric(2)
TEST_MODIF: Numeric(2)

ETEST_IN
INPUT TABLES

ETEST_IN

CTR_TST_ID: Character(12) (FK)
USESMAP: Character(12)
P_CH4: Numeric(7,2)
P_THC: Numeric(7,2)
P_CO: Numeric(7,2)
P_CO2: Numeric(7,2)
P_NOX: Numeric(7,2)
P_PM: Numeric(7,2)
TOTAL_WORK: Numeric(7,2)
BSFC_MEAS: Numeric(9,4)
BSFC_CALC: Numeric(9,4)
ET_BARO: Numeric(5,2)
ET_HUMID: Numeric(5,2)
ET_INAIR: Numeric(5,1)
ET_EXRESTR: Numeric(5,2)
ET_EXHAUST: Numeric(5,1)
ET_COOLER: Numeric(5,1)
ET_COOLIN: Numeric(5,1)
ET_COOLOUT: Numeric(5,1)
ET_CHILLER: Numeric(5,1)
ET_COOLER_332: Numeric
ET_COOLIN_335: Numeric

ENGT_IN

ENGSECS: Numeric(4)
R_CO: Numeric(6,4)
R_CO2: Numeric(6,3)

TMEAS_IN

MEAS_ID: Character(10) (FK)
CTR_TST_ID: Character(12) (FK)
MEASURE: Numeric(10,3)

EREPM_IN

ENGSECS: Numeric(4) (FK)
MEAS_ID: Character(10) (FK)
EREPMSEAS: Numeric(10)

MEASTYPE

MEAS_ID: Character(10)
MEAS_UNIT: Character(30)
MEAS_DESCR: Character(50)
CAS_RN: Character(12)

EMODE_IN

MODENAME: Character(10)
CTR_TST_ID: Character(12) (FK)
RPM: Numeric(4)
TORQUE: Numeric(4)
BHP: Numeric(3)
R_CH4_GPH: Numeric(7,2)
R_THC_GPH: Numeric(7,2)
R_CO_GPH: Numeric(7,2)
R_CO2_GPH: Numeric(9,2)
R_NOX_: Numeric(7,2)
R_PM_GPH: Numeric(7,2)
FC_MEAS: Numeric(8,4)
FC_CALC: Numeric(8,4)
ETM_BARO: Numeric(5,2)
ETM_HUMID: Numeric(5,2)
ETM_INAIR: Numeric(5,1)
ETMEXRESTR: Numeric(5,2)
ETMEXHAUST: Numeric(5,1)
ETM_COOLER: Numeric(5,1)
ETM_COOLIN: Numeric(5,1)
ETMCOOLOUT: Numeric(5,1)
ETMCHILLER: Numeric(5,1)

EMODM_IN

MODENAME: Character(10) (FK)
MEAS_ID: Character(10) (FK)
CTR_TST_ID: Character(12) (FK)
EMODMEAS: Numeric(10)

EVAP_IN INPUT TABLES

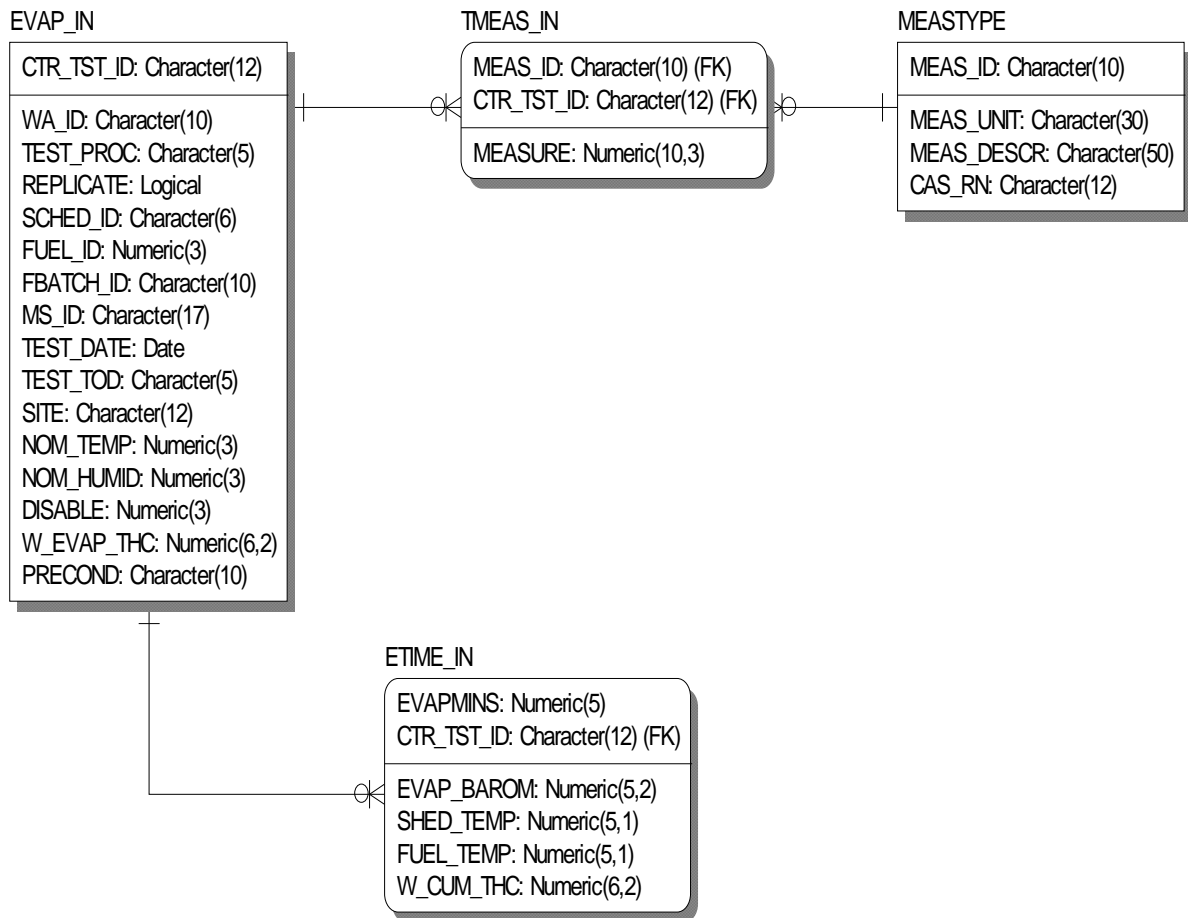

FBAT_IN

FBATCH_ID: Character(10)
MEAS_ID: Character(10)
CETANE_NUM: Numeric(5,2)
CETANE_IDX: Numeric(5,2)
CETANE_IMP: Numeric(5,2)
CETANE_TYP: Character(1)
SULFUR: Numeric(5)
MFG_BATCH: Character(18)
SULF_AGENT: Character(20)
NITROGEN: Numeric(5)
TAROM: Numeric(5,2)
MAROM: Numeric(5,2)
PAROM: Numeric(5,2)
IBP: Numeric(4)
T10: Numeric(4)
T50: Numeric(4)
T90: Numeric(4)
EP: Numeric(4)
SPEC_GRAV: Numeric(6,4)
API_GRAV: Numeric(5,2)
DENSITY: Numeric(5,3)
VISCOSITY: Numeric(4,2)
FLASH: Numeric(4)
CLOUD: Numeric(4)
POUR: Numeric(4)
HCRATIO: Numeric(5,3)
OXYGEN: Numeric(4,2)
OXY_TYPE: Character(20)
ADDITIVES: Numeric(5,2)
LUBRIC_G: Numeric(5,0)
LUBRIC_MM: Numeric(4,2)
HEAT: Numeric(6)
ASH: Numeric(4,2)
RON: Numeric(5,1)
MON: Numeric(5,1)
FEN_C: Numeric(4,0)
WGT_FRACTN: Numeric(7,4)
RECOVERY: Numeric(4,1)
RESIDUE: Numeric(4,1)
LOSS: Numeric(4,1)
RVP: Numeric(4,1)
COMP_OLEFN: Numeric(4,1)
COMP_SAT: Numeric(4,1)
WA_ID: Character(10)
RES_KIND: Character(8)
FUEL_ID: Numeric(3)
COMP_AROMA: Numeric(4,1)
E200: Numeric(5,1)
E300: Numeric(5,1)
TOLUENE: Numeric(6,3)
BENZENE: Numeric(6,3)

**FBAT_IN
INPUT TABLES**

MEASTYPE

MEAS_ID: Character(10)
MEAS_UNIT: Character(30)
MEAS_DESCR: Character(50)
CAS_RN: Character(12)



FUEL_IN INPUT TABLES

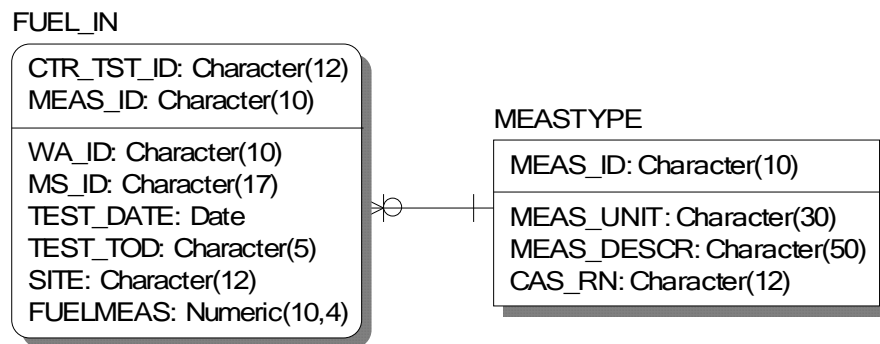

INSP_IN INPUT TABLES

INSP_IN

CTR_TST_ID: Character(12)
WA_ID: Character(10)
MS_ID: Character(17)
SITE: Character(12)
TEST_DATE: Date
TEST_TOD: Character(5)
COMMENTS: Character(254)
COMMENTS2: Character(254)
INSP_ODOM: Numeric(6)
G_CAN_INIT: Numeric(7,1)
G_CAN_PURG: Numeric(7,1)
G_CAN_LOAD: Numeric(7,1)
SMOKECOLOR: Character(6)



PART_IN

PART: Character(4)
PART_CODE: Numeric(2)
CTR_TST_ID: Character(12)

OBD_IN INPUT TABLES

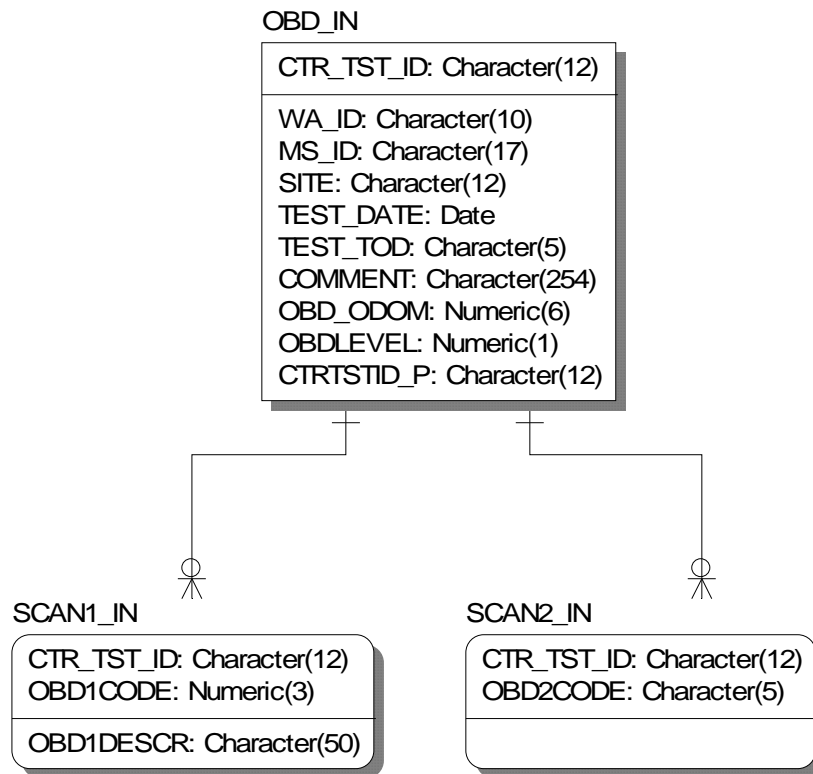

PRESS_IN INPUT TABLE

PRESS_IN

CTR_TST_ID: Character(12)

WA_ID: Character(10)

TEST_PROC: Character(5)

MS_ID: Character(17)

REPLICATE: Logical

TEST_DATE: Date

TEST_TOD: Character(5)

SITE: Character(12)

CAPOKSTANT: Character(3)

PRESS_INIT: Numeric(4,1)

PRESS_2MIN: Numeric(4,1)

PRESS_ODOM: Numeric(6)

REPAR_IN INPUT TABLE

REPAR_IN

MS_ID: Character(17) TEST_DATE: Date TEST_TOD: Character(5)

WA_ID: Character(10) SITE: Character(12) CTR_TST_ID: Character(12) REP_TYPE: Numeric(3) REPAR_HRM: Character(5) COMMENTS: Character(254) COMMENTS2: Character(254) REPAR_ODOM: Numeric(6)
--

RUNL_IN INPUT TABLES

RUNL_IN

CTR_TST_ID: Character(12)
TEST_PROC: Character(5)
WA_ID: Character(10)
SCHED_ID: Character(6)
REPLICATE: Logical
FUEL_ID: Numeric(3)
FBATCH_ID: Character(10)
MS_ID: Character(17)
TEST_DATE: Date
TEST_TOD: Character(5)
SITE: Character(12)
NOM_TEMP: Numeric(3)
NOM_HUMID: Numeric(3)
DISABLE: Numeric(3)
TESTWGHT: Numeric(6)
ROAD_HP: Numeric(5,1)
AC_HP: Character(3)
DYNOTYPE: Character(10)
ODOMETER: Numeric(6)
PRECOND: Character(10)
TARCANWGHT: Numeric(4)
NORCANWGHT: Numeric(4)
ENDCANWGHT: Numeric(4)
TARGIFTEMP: Numeric(3)
OBSIFTEMP: Numeric(3)

RUNLB_IN

CTR_TST_ID: Character(12) (FK)
BAG_NUM: Numeric(2)
BAG_BARO: Numeric(5,2)
BAG_TEMP: Numeric(5,1)
BAG_HUMID: Numeric(6,2)
BAG_DIST: Numeric(7,3)
BAG_THC: Numeric(7,3)
BAG_CO: Numeric(8,3)
BAG_CO2: Numeric(8,3)
BAG_NOX: Numeric(7,3)
BAG_MPG: Numeric(6,2)
W_RUNL_THC: Numeric(7,2)
TARG_FTEMP: Numeric(3)
OBS_FTEMP: Numeric(3)
TANK_PRESS: Numeric(5,1)
PURG_FLOW: Numeric(7,1)



SMOKE_IN INPUT TABLES

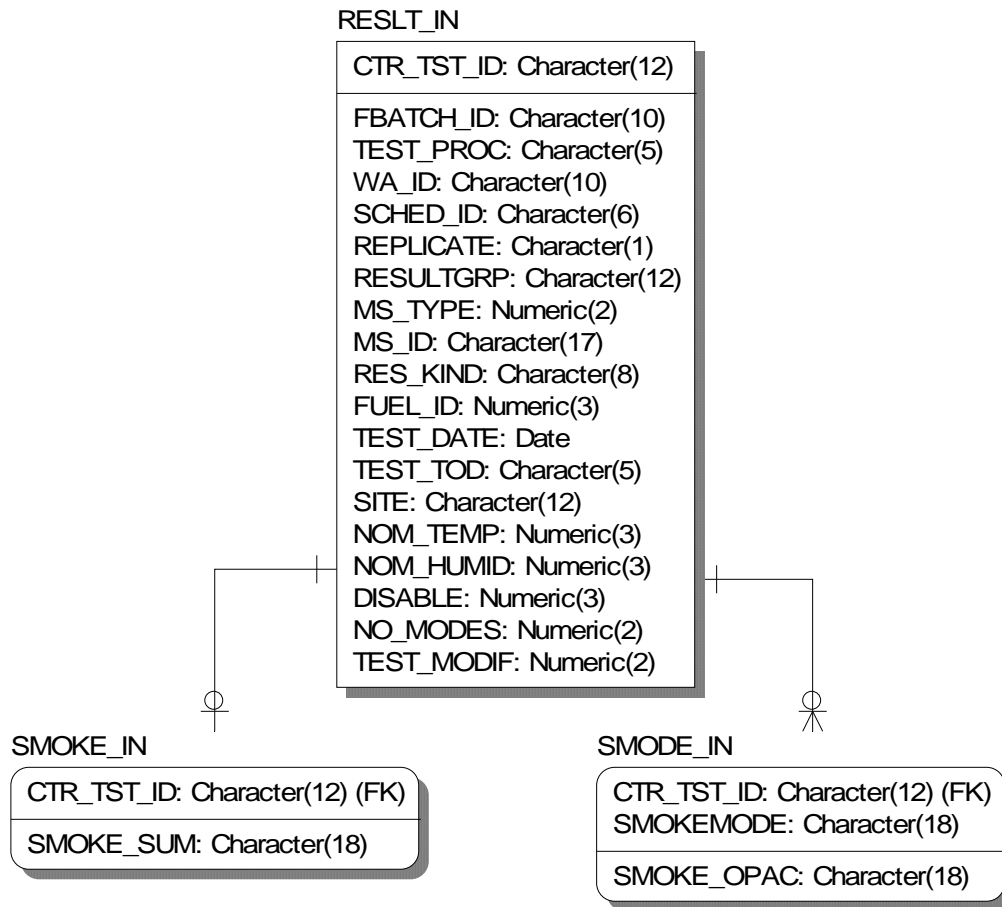

IV. Detailed Input Data Design Information

b. Entity (Tables) Names and Definitions

Table	
Name	Comment
ACTTY_IN	An activity is a collection of trips traveled by an PEMS/PAMS instrumented highway or non-road vehicle. This result subtype is identified in RESULT by RES_KIND = "ACTIVITY".
AMEAS_IN	Used to store a MEASTYPE measurement for a chassis dynamometer test where the emissions values are expressed as mass per unit time.
BAG_IN	One bag set of a DYNOTEST. (A bag set usually results from two physical bags: one sample and one background, with the background measurements subtracted from the sample measurements to yield the bag set measurements). Single bag set test results are stored here, as well as at the summary test level. Many DYNOTESTs involving bagged emission measurements utilize multiple bag sets.
BMEAS_IN	Used to store a MEASTYPE measurement at the test bag level.
DYNOB_IN	This input table stores the results of a vehicle chassis exhaust emission test whose results are expressed in grams per mile. This test is eventually stored as entity DYNOTEST. This input table stores information pertaining to the test as a whole. Note: The emission summary result fields in this entity are used only to summarize the results of bagged exhaust emission tests.
DYNOM_IN	Used to store test level information for a chassis dynamometer test reporting emissions in terms of one or multiple modes.
DYNOR_IN	Used to store test level information for a chassis dynamometer test where the emissions values are expressed as mass per unit time.
EMAP_IN	This result subtype stores an engine "MAP". Maximum available power or torque as a function of RPM. This result subtype is identified in RESULT by RES_KIND = "ENGINMAP".
EMODE_IN	The results of one steady-state mode of an engine dynamometer test. (Only used to store steady-state results.)
EMODM_IN	Used to store a MEASTYPE measurement at the engine test mode level.
ENGT_IN	A point in time within an ENGTEST.
EQUIP_IN	This Input Table Represents Procurement of both Equipment and Engine
EREPM_IN	A non-core measurement associated with a point in time in an engine test (i.e. an ENGTIME).
ETEST_IN	This result subtype stores the results of an engine test performed on an engine dynamometer, exclusive of smoke opacity measurement. This subtype is identified by RES_KIND = "ENGTEST".
ETIME_IN	One point in time during an evaporative emission test.
EVAP_IN	This entity stores the results of an evaporative emission test. This table stores information pertaining to the test as a whole.
FBAT_IN	A particular batch of fuel that can be used to power mobile sources during emission tests. Unlike a FUEL, which is a general kind of fuel, instances of this entity represent a physical batch of fuel that has measured properties.
FUEL_IN	This result subtype stores the results of an analysis of the fuel being used in the mobile source.
INSP_IN	This input entity is used to store the results of the emission component inspection often referred to as the M1 maintenance inspection, or just M1 maintenance. This top level entity is used to store information about the inspection as a whole.
LMEAS_IN	Used to store a meastype measurement at the lab level.
LTIME_IN	LTIME_IN is to store measurements used to calculate the mass per unit time measurements found in the input table TIME_IN during a lab test.
MAPPT_IN	A single point within an engine map.
MEASTYPE	A type of numeric, "non-core", emission-related measurement. e.g. methane emissions in grams per mile, not usually performed.
MMEAS_IN	Used to store a MEASTYPE measurement at the mode level.
MODE_IN	Used to store mode level emissions information for a modal chassis dynamometer test.
MTIME_IN	Used to store a MEASTYPE measurement at the second by second by level for a modal chassis dynamometer test.
OBD_IN	This input entity is used to store summary level information pertinent to a scan of a vehicle's on board diagnostic system. Both level 1 and level 2 on board diagnostic systems scans are supported by this data structure. This table is used to store information pertaining to the scan as a whole.
OBD2CODE	OBD2 scan code. Contains information about the code itself. e.g. it's meaning.
PART_IN	Emission component part code inspection.
PMEAS_IN	Used to store a MEASTYPE measurement at the second by second or point in time level.
PRESS_IN	This Result Subtype stores the result of an evaporative system pressure check.
RATE_IN	Used to store mode level information for a chassis dynamometer test where the emissions values are expressed as mass per unit time.
REPAR_IN	The type of repair performed on a vehicle.
REP_MEAS	Used to store a MEASTYPE measurement at the test time point level.
RESLT_IN	Any observation, measurement, or modification to an M_SOURCE including... Information pertinent to the procurement of the M_SOURCE. An outcome of any test procedure performed on an M_SOURCE, such as an exhaust emissions test or an evaporative emissions test.
RMEAS_IN	Used to store a MEASTYPE measurement at the test time point level.
RUNL_IN	The results of a vehicle chassis running loss emission test, eventually stored as entity RUNLOSS. This table stores information pertaining to the test as a whole.
RUNLB_IN	A portion of a "running loss" test, identified by "bag number" within the test.
SCAN1_IN	Individual scan code resulting from a scan of a level 1 on board diagnostic system.
SCAN2_IN	Individual scan code resulting from a scan of a level 2 on board diagnostic system.
SMODE_IN	One mode of a smoke test procedure.
SMOKE_IN	This result subtype stores the results of a smoke opacity test. This subtype is identified by RES_KIND= "SMOKETST"

Table	
Name	Comment
TMEAS_IN	Used to store a MEASTYPE measurement at the summary test level.
TRIP_IN	A trip traveled by an PEMS/PAM vehicle. This result subtype is identified in RESULT by RES_KIND = "TRIP". This result subtype is similar to a ROADTEST. The primary purpose of a ROADTEST is to measure exhaust emissions. The purpose of a ROADTRIP is to measure other aspects of the vehicle's usage or activity.
TRIPOBD_IN	One or more OBD code(s) occurring at a second by second or point in time during a trip.
TIME_IN	A point in time during a DYNOTEST.
TMEAS_IN	Used to store a MEASTYPE measurement at the summary test level.
TTIME_IN	Table to store second by second or point in time data during a trip.

IV. Detailed Input Data Design Information

c. Input Entity and Field Attribute Definitions

"ACTTY_IN" Table				
Name	Comment	Datatype	Null Option	Is PK
CTR_TST_ID	Identification number assigned to the RESULT by a test contractor. (Hopefully uniquely identifies RESULT instances within a given contractor.) The RES_KIND of the RESULT record ="ACTIVITY". Note that a ctr_tst_id can have only one activity and vice versa. Not used for analytical purposes. But could help locate contractor's records pertinent to this RESULT.	Character(12)	NOT NULL	Yes
INSTALL_DT	Data and time the unit, e.g., PEMS or PAMS, was installed onto the vehicle.	Date	NOT NULL	No
UNSTALL_DT	Data and time the unit, e.g., PEMS or PAMS, was uninstalled from the vehicle.	Date	NOT NULL	No
INSTAL_HRM	Hour meter reading at the time the unit, e.g., PEMS or PAMS, was installed.	Numeric(8,0)	NOT NULL	No
UNSTAL_HRM	Hour meter reading at the time the unit, e.g., PEMS or PAMS, was uninstalled.	Numeric(8,0)	NOT NULL	No
INSTAL_ODM	Odometer reading at the time the unit, e.g., PEMS or PAMS, was installed.	Numeric(8,0)	NULL	No
UNSTAL_ODM	Odometer reading at the time the unit, e.g., PEMS or PAMS, was uninstalled.	Numeric(8,0)	NULL	No
WA_ID	Work Assignment name which is equivalent to EPA's test program name.	Character(10)	NULL	No
MS_ID	Mobile source identifier. For vehicles their VIN would be used. For engines, their serial number, probably in conjunction with their manufacturer code.	Character(17)	NOT NULL	No
SITE	Location where test was conducted. Legal values defined by SITE translation table.	Character(12)	NOT NULL	No

"AMEAS_IN" Table				
Name	Comment	Datatype	Null Option	Is PK
MODEID	Tag used to identify a particular test mode. Values are defined in MODE_ID translation table.	Character(10)	NOT NULL	Yes
CTR_TST_ID	Identification number assigned to the RESULT by a test contractor. (Hopefully uniquely identifies RESULT instances within a given contractor.) Not used for analytical purposes. But could help locate contractor's records pertinent to this RESULT.	Character(12)	NOT NULL	Yes
MEAS_ID	Measurement type identification. Legal values defined by MEASTYPE translation table	Character(10)	NOT NULL	Yes
RATEMEAS	Used to store a rate MEASTYPE measurement at the test mode level.	Numeric(10,3)	NULL	No

"BAG_IN" Table				
Name	Comment	Datatype	Null Option	Is PK
BAG_NUM	Bag number.	Numeric(2)	NOT NULL	Yes
CTR_TST_ID	Identification number assigned to the RESULT by a test contractor. (Hopefully uniquely identifies RESULT instances within a given contractor.) Not used for analytical purposes. But could help locate contractor's records pertinent to this RESULT.	Character(12)	NOT NULL	Yes
BAG_BARO	Barometric pressure expressed in inches of mercury	Numeric(5,2)	NULL	No
BAG_TEMP	Temperature expressed in degrees Fahrenheit	Numeric(5,1)	NULL	No
BAG_HUMID	Humidity expressed in grains of water per pound of dry air.	Numeric(6,2)	NULL	No
BAG_DIST	Distance travelled expressed in miles.	Numeric(7,3)	NULL	No
BAG_THC	Total hydrocarbon emissions expressed in grams per mile.	Numeric(7,3)	NULL	No
BAG_CO	Carbon monoxide emissions expressed in grams per mile.	Numeric(8,3)	NULL	No
BAG_CO2	Carbon dioxide emissions expressed in grams per mile.	Numeric(8,3)	NULL	No
BAG_NOX	Emissions of oxides of nitrogen expressed in grams per mile.	Numeric(7,3)	NULL	No
BAG_MPG	Fuel economy expressed in miles per gallon.	Numeric(6,2)	NULL	No

"BMEAS_IN" Table				
Name	Comment	Datatype	Null Option	Is PK
BAG_NUM	Bag number.	Numeric(2)	NOT NULL	Yes
CTR_TST_ID	Identification number assigned to the RESULT by a test contractor. (Hopefully uniquely identifies RESULT instances within a given contractor.) Not used for analytical purposes. But could help locate contractor's records pertinent to this RESULT.	Character(12)	NOT NULL	Yes
MEAS_ID	Measurement type identification	Character(10)	NOT NULL	Yes
BAG_MEAS	Bag-level measurement.	Numeric(10,3)	NULL	No

"DYNOB_IN" Table				
Name	Comment	Datatype	Null Option	Is PK
CTR_TST_ID	Identification number assigned to the RESULT by a test contractor. (Hopefully uniquely identifies RESULT instances within a given contractor.) Not used for analytical purposes. But could help locate contractor's records pertinent to this RESULT.	Character(12)	NOT NULL	Yes
TEST_PROC	Identifies the specific test procedure used. A more detailed classification than RES_KIND. Based largely upon values of TEST_TYPE in earlier design. This is conceptually distinct from the driving or operational schedule used.	Character(5)	NOT NULL	No
WA_ID	Work Assignment name which is equivalent to EPA's test program name.	Character(10)	NOT NULL	No
SCHED_ID	Schedule identification.	Character(6)	NOT NULL	No
REPLICATE	TRUE if test is a replicate of one already entered. Otherwise FALSE.	Logical	NULL	No
RESULTGRP	Contains the ctr_tst_id of any test, e.g. an SFTP test, of which this test is a component part. A blank value indicates that this test is not part of a higher-level test group.	Character(12)	NULL	No
FUEL_ID	Numeric code uniquely identifying the general type of fuel used. (Sometimes referred to as the "gross fuel type")	Numeric(3)	NOT NULL	No
F BATCH_ID	Fuel batch identification.	Character(10)	NULL	No
MS_ID	Mobile source identifier. For vehicles their VIN would be used. For engines, their serial number, probably in conjunction with their manufacturer code.	Character(17)	NOT NULL	No
TEST_DATE	Test date	Date	NOT NULL	No
TEST_TOD	Time of day of the start of the test. Stored as a 5 character string HH:MM.	Character(5)	NOT NULL	No
SITE	Location where test was conducted.	Character(12)	NOT NULL	No
NOM_TEMP	Nominal temperature at which test was to be conducted expressed in degrees Fahrenheit.	Numeric(3)	NULL	No
NOM_HUMID	Nominal absolute humidity at which test was to be conducted expressed in grains of water per pound of dry air.	Numeric(3)	NULL	No
DISABLE	Indication of any special conditions or "disablements" performed on the mobile source for particular tests. A value of zero indicates that no special condition or disablement to the vehicle was performed. Positive values indicate a particular disablement or set of disablements as defined in the translation table for this field. e.g. 1 = gas cap removed, 2 = evap canister removed, 3 = both gas cap and canister removed, etc.	Numeric(3)	NULL	No
THC	Total hydrocarbon emissions expressed in grams/mile. (Composite bag result for the entire test)	Numeric(7,3)	NULL	No
CO	Carbon monoxide emissions expressed in grams/mile. (Composite bag result for the entire test)	Numeric(8,3)	NULL	No
CO2	Carbon dioxide emissions expressed in grams/mile. (Composite bag result for the entire test)	Numeric(8,3)	NULL	No
NOX	Oxides of nitrogen emissions expressed in grams/mile. (Composite bag result for the entire test)	Numeric(7,3)	NULL	No
MPG	Fuel economy expressed in miles/gallon. (Composite bag result for the entire test)	Numeric(6,2)	NULL	No
TESTWGHT	Dynamometer inertia weight setting used for this test. Expressed in pounds.	Numeric(6)	NULL	No
ROAD_HP	Dynamometer road load horsepower setting used for this test.	Numeric(5,1)	NULL	No
AC_HP	Did dynamometer road load setting for this test include air conditioning load factor? (YES, NO, or NUL)	Character(3)	NULL	No
DYNOTYPE	Type of used. Valid values for this field are contained in the DYNOTYPE code translation table.	Character(10)	NULL	No
ODOMETER	Odometer reading of vehicle at beginning of test. (Expressed in miles)	Numeric(6)	NULL	No
PRECOND	Type of preconditioning performed on the vehicle prior to the test. Legal values defined by translation table PRECOND.DBF	Character(10)	NULL	No
INIT_TEMP	Initial test temperature in degrees F. For bag tests this will often have the null value of 0, since it is reported at the bag level.	Numeric(5,1)	NULL	No
INIT_BARO	Barometric pressure measured at the beginning of the test expressed in inches of mercury. This will often have the null value of 0 since it was usually reported at the bag level.	Numeric(5,2)	NULL	No
INIT_HUMID	Absolute humidity measured at beginning of test expressed in grains of water per pound of dry air. Often assumes null value of zero in this table, since it is often reported at the bag level.	Numeric(6,2)	NULL	No
DYNOCO_A	The "a" term. Dynamometer road load power absorption coefficient in pounds force.	Numeric(8,6)	NULL	No
DYNOCO_B	The "b" term. Dynamometer road load power absorption coefficient in (pounds force)/(miles per hour).	Numeric(8,6)	NULL	No
DYNOCO_C	The "c" term. Dynamometer road load power absorption coefficient in (pounds force)/(miles per hour)^2.	Numeric(8,6)	NULL	No
DYNOTARG_A	The "a" term. Dynamometer Target road load "target" coefficient in pounds force.	Numeric(9,6)	NULL	No
DYNOTARG_B	The "b" term. Dynamometer Target road load "target" coefficient in (pounds force)/(miles per hour).	Numeric(9,6)	NULL	No
DYNOTARG_C	The "c" term. Dynamometer Target road load "target" coefficient in (pounds force)/(miles per hour)^2.	Numeric(9,6)	NULL	No

"DYNOB_IN" Table				
Name	Comment	Datatype	Null Option	Is PK
CTRSTID_P	This will equal the ctr_tst_id field from EQUIP_IN, added to provide a link between tables.	Character(12)	NULL	No

"DYNOR_IN" Table				
Name	Comment	Datatype	Null Option	Is PK
CTR_TST_ID	Identification number assigned to the RESULT by a test contractor. (Hopefully uniquely identifies RESULT instances within a given contractor.) Not used for analytical purposes. But could help locate contractor's records pertinent to this RESULT.	Character(12)	NOT NULL	Yes
TEST_PROC	Identifies the specific test procedure used. A more detailed classification than RES_KIND. Based largely upon values of TEST_TYPE in earlier design. Conceptually distinct from the driving or operational schedule used.	Character(5)	NOT NULL	No
WA_ID	Work Assignment name which is equivalent to EPA's test program name.	Character(10)	NOT NULL	No
SCHED_ID	Schedule identification.	Character(6)	NULL	No
REPLICATE	TRUE if test is a replicate of one already entered. Otherwise FALSE.	Character(1)	NOT NULL	No
FUEL_ID	Numeric code uniquely identifying the general type of fuel used. (Sometimes referred to as the "gross fuel type")	Numeric(3)	NOT NULL	No
FBATCH_ID	Fuel batch identification.	Character(10)	NULL	No
MS_ID	Mobile source identifier. For vehicles their VIN would be used. For engines, their serial number, probably in conjunction with their manufacturer code.	Character(17)	NOT NULL	No
TEST_DATE	Test date. MM/DD/YYYY	Date	NOT NULL	No
TEST_TOD	Time of day of the start of the test. Stored as a 5 character string HH:MM.	Character(5)	NOT NULL	No
SITE	Location where test was conducted. Legal values defined by SITE translation table.	Character(12)	NOT NULL	No
NON_TEMP	Nominal temperature at which test was to be conducted expressed in degrees Fahrenheit.	Numeric(3)	NULL	No
NOM_HUMID	Nominal absolute humidity at which test was to be conducted expressed in grains of water per pound of dry air.	Numeric(3)	NULL	No
DISABLE	Indication of any special conditions or "disablements" performed on the mobile source for particular tests. A value of zero indicates that no special condition or disablement to the vehicle was performed. Positive values indicate a particular disablement or set of disablements. Legal values defined by DISABLE translation table.	Numeric(3)	NOT NULL	No
THC	Total hydrocarbon emissions expressed in grams/mile. (Composite bag result for the entire test)	Numeric(7,3)	NULL	No
CO	Carbon monoxide emissions expressed in grams/mile. (Composite bag result for the entire test)	Numeric(8,3)	NULL	No
CO2	Carbon dioxide emissions expressed in grams/mile. (Composite bag result for the entire test)	Numeric(8,3)	NULL	No
NOX	Oxides of nitrogen emissions expressed in grams/mile. (Composite bag result for the entire test)	Numeric(7,3)	NULL	No
MPG	Fuel economy expressed in miles/gallon. (Composite bag result for the entire test)	Numeric(6)	NOT NULL	No
TESTWGHT	Dynamometer inertia weight setting used for this test. Expressed in pounds.	Numeric(6)	NOT NULL	No
ROAD_HP	Dynamometer road load horsepower setting used for this test.	Numeric(5,1)	NULL	No
AC_HP	Did dynamometer road load setting for this test include air conditioning load factor? (YES, NO, or NUL)	Character(3)	NULL	No
DYNOTYPE	Type of dynamometer used. Valid values for this field, are contained in the DYNOTYPE code translation table.	Character(10)	NULL	No
ODOMETER	Odometer reading of vehicle at beginning of test. (Expressed in miles)	Numeric(6)	NOT NULL	No
PRECOND	Type of preconditioning performed on the vehicle prior to the test. Legal values defined by PRECOND translation table.	Character(10)	NULL	No
INIT_TEMP	Initial test temperature in degrees F. For bag tests this will often have the null value of 0, since it is reported at the bag level.	Numeric(5,1)	NULL	No
INIT_BARO	Barometric pressure measured at the beginning of the test expressed in inches of mercury. This will often have the null value of 0 since it was usually reported at the bag level	Numeric(5,2)	NULL	No
INIT_HUMID	Absolute humidity measured at beginning of test expressed in grains of water per pound of dry air. Often assumes null value of zero in this table, since it is often reported at the bag level.	Numeric(6,2)	NULL	No

"EMAP_IN" Table				
Name	Comment	Datatype	Null Option	Is PK
CTR_TST_ID	Identification number assigned to the RESULT by a test contractor. (Hopefully uniquely identifies RESULT instances within a given contractor.) The RES_KIND of the RESULT record ="ACTIVITY". Note that a ctr_tst_id can have only one activity and vice versa. Not used for analytical purposes. But could help locate contractor's records pertinent to this RESULT.	Character(12)	NOT NULL	Yes
MAPTYPE	Type of Engine Map. Legal values defined by MAPTYPE translation table.	Character(5)	NULL	No
MSDRTPWR	Measured rated horsepower.	Numeric(5)	NULL	No
MSDRDTPED	Measured rated speed (rpm).	Numeric(5)	NULL	No
MAXTORQUE	Measured peak torque expressed in foot pounds.	Numeric(4)	NULL	No
MSDRQSPED	Measured torque speed expressed in rpm.	Numeric(5)	NULL	No
GOV_SPEED	Governed central speed (rpm).	Numeric(5)	NULL	No
EXRESTRICT	Exhaust restriction pressure expressed in inches of mercury.	Numeric(5,2)	NULL	No
BARO	Barometric pressure expressed in inches of mercury.	Numeric(5,2)	NULL	No
HUMIDITY	Absolute humidity expressed in grains of water per pound of dry air.	Numeric(5,2)	NULL	No
INLET_AIR	Engine inlet air temperature expressed in degrees F.	Numeric(5,1)	NULL	No
EXHAUST	Exhaust temperature, after emission controls expressed in degrees F.	Numeric(5,1)	NULL	No
COOLER_OUT	Air temperature after intercooler expressed in degrees F.	Numeric(5,1)	NULL	No
COOLANT_IN	Engine coolant input temperature expressed in degrees F.	Numeric(5,1)	NULL	No
COOLANT_OUT	Engine coolant output temperature expressed in degrees F.	Numeric(5,1)	NULL	No
CHILLER	Chiller water temperature expressed in degrees F.	Numeric(5,1)	NULL	No

"EMODE_IN" Table				
Name	Comment	Datatype	Null Option	Is PK
MODENAME	Name of engine test mode. Based on its reference speed, speed fraction, and load fraction. Legal values defined by ENGMODE translation table	Character(10)	NOT NULL	Yes
CTR_TST_ID	Identification number assigned to the RESULT by a test contractor. (Hopefully uniquely identifies RESULT instances within a given contractor.) The RES_KIND of the RESULT record ="ACTIVITY". Note that a ctr_tst_id can have only one activity and vice versa. Not used for analytical purposes. But could help locate contractor's records pertinent to this RESULT.	Character(12)	NOT NULL	Yes
RPM	Measured engine rpm.	Numeric(4)	NULL	No
TORQUE	Measured torque expressed in foot-pounds.	Numeric(4)	NULL	No
BHP	Brake horsepower.	Numeric(3)	NULL	No
R_CH4_GPH	Methane emission rate expressed in grams per hour.	Numeric(7,2)	NULL	No
R_THC_GPH	Total hydrocarbon emission rate expressed in grams per hour.	Numeric(7,2)	NULL	No
R_CO_GPH	Carbon monoxide emission rate expressed in grams per hour.	Numeric(7,2)	NULL	No
R_CO2_GPH	Carbon dioxide emission rate expressed in grams per hour.	Numeric(9,2)	NULL	No
R_NOX_GPH	Oxides of nitrogen emission rate expressed in grams per hour.	Numeric(7,2)	NULL	No
R_PM_GPH	Total particulate emission rate expressed in grams per hour.	Numeric(7,2)	NULL	No
FC_MEAS	Measured fuel consumption expressed in kg. per hour.	Numeric(8,4)	NULL	No
FC_CALC	Calculated fuel consumption expressed in kg per hour.	Numeric(8,4)	NULL	No
ETM_BARO	Average barometric pressure during engine test mode expressed in inches of Hg.	Numeric(5,2)	NULL	No
ETM_HUMID	Average absolute humidity during engine test mode expressed in grains of water per pound of dry air.	Numeric(5,2)	NULL	No
ETM_INAIR	Engine inlet air temperature expressed in degrees F.	Numeric(5,1)	NULL	No
ETMEXRESTR	Exhaust restriction pressure expressed in inches of Hg.	Numeric(5,2)	NULL	No
ETMEXHAUST	Exhaust temperature, after emission controls expressed in degrees F.	Numeric(5,1)	NULL	No
ETM_COOLER	Air temperature after intercooler expressed in degrees F.	Numeric(5,1)	NULL	No
ETM_COOLIN	Engine coolant input temperature expressed in degrees F	Numeric(5,1)	NULL	No
ETMCOOLOUT	Engine coolant output temperature expressed in degrees F.	Numeric(5,1)	NULL	No
ETMCHILLER	Chiller water temperature expressed in degrees F.	Numeric(5,1)	NULL	No

"EMODM_IN" Table				
Name	Comment	Datatype	Null Option	Is PK
MODENAME	Name of engine test mode. Based on its reference speed, speed fraction, and load fraction. Legal values defined by ENGMODE translation table	Character(10)	NOT NULL	Yes
MEAS_ID	Measurement type identification. Legal values defined by MEASTYPE translation table	Character(10)	NOT NULL	Yes
CTR_TST_ID	Identification number assigned to the RESULT by a test contractor. (Hopefully uniquely identifies RESULT instances within a given contractor.) The RES_KIND of the RESULT record ="ACTIVITY". Note that a ctr_tst_id can have only one activity and vice versa. Not used for analytical purposes. But could help locate contractor's records pertinent to this RESULT.	Character(12)	NOT NULL	Yes
EMODMEAS	Engine test mode level measurement of this MEAS_ID.	Numeric(10)	NULL	No

"ENGT_IN" Table				
Name	Comment	Datatype	Null Option	Is PK
ENGSECS	Time within an engine dynamometer test, expressed in seconds, beginning of test has engsecs = 0.	Numeric(4)	NOT NULL	Yes
CTR_TST_ID	Identification number assigned to the RESULT by a test contractor. (Hopefully uniquely identifies RESULT instances within a given contractor.) The RES_KIND of the RESULT record ="ACTIVITY". Note that a ctr_tst_id can have only one activity and vice versa. Not used for analytical purposes. But could help locate contractor's records pertinent to this RESULT.	Character(12)	NOT NULL	Yes
R_THC	Total hydrocarbon emissions measurement expressed in grams per second.	Numeric(7,5)	NULL	No
R_CO	Carbon monoxide emissions measurement expressed in grams per second.	Numeric(6,4)	NULL	No
R_NOX	Oxides of nitrogen emissions measurement expressed in grams per sec	Numeric(6,4)	NULL	No
R_CO2	Carbon dioxide emissions measurement expressed in grams per second.	Numeric(6,3)	NULL	No
RPM	Measured engine rpm.	Numeric(4)	NULL	No
TORQUE	Measured torque expressed in foot-pounds.	Numeric(4)	NULL	No

"ETIME_IN" Table				
Name	Comment	Datatype	Null Option	Is PK
EVAPMINS	Time of measurement, expressed in minutes after start of test.	Numeric(5)	NOT NULL	Yes
CTR_TST_ID	Identification number assigned to the RESULT by a test contractor. (Hopefully uniquely identifies RESULT instances within a given contractor.) Not used for analytical purposes. But could help locate contractor's records pertinent to this RESULT.	Character(12)	NOT NULL	Yes
EVAP_BAROM	Barometric pressure expressed in inches of mercury.	Numeric(5,2)	NULL	No
SHED_TEMP	Temperature of SHED or air surrounding vehicle in degrees F.	Numeric(5,1)	NULL	No
FUEL_TEMP	Temperature of vehicle's fuel expressed in degrees F.	Numeric(5,1)	NULL	No
W_CUM_THC	Cumulative hydrocarbon emissions, since start of test expressed in grams.	Numeric(6,2)	NULL	No

"EQUIP_IN" Table				
Name	Comment	Datatype	Null Option	Is PK
CTR_TST_ID	Identification number assigned to the equipment procurement by a test contractor. (Hopefully uniquely identifies all RESULT instances within a given contractor.) .Not used for analytical purposes. But could help locate contractor's records pertinent to this RESULT.	Character(12)	NOT NULL	Yes
WA_ID	Work Assignment name which is equivalent to EPA's test program name.	Character(10)	NULL	No
TEST_DATE	Date the equipment was procured.	Date	NOT NULL	No
TEST_TOD	Time of day the equipment was procured. Stored as a 5 character string HH:MM.	Character(5)	NOT NULL	No
SITE	Location where test was conducted. Legal values defined by SITE translation table.	Character(12)	NOT NULL	No
VEH_MS_ID	Mobile source identifier. For equipment this would be the serial number which best identifies the equipment as a whole, for a highway vehicle this would be the VIN.	Character(17)	NOT NULL	No
ENG_MS_ID	Serial number of the engine if available otherwise there must be a unique identifier applied like the VIN entered backwards.	Character(17)	NULL	No
VEHCLASS	Unique identifier for the fuel used for a test vehicle class. Legal values found in translation table.	Character(5)	NULL	No
EXCEPT	YES if something is exceptional about this mobile source that would make it an outlier for most analysis. (e.g. engine has been replaced, etc.).	Character(3)	NULL	No
EX_COMM	Used if except is true. Comment as to why vehicle is exceptional.	Character(20)	NULL	No
FUELTYPE	Type of fuel mobile source is designed to use. 'GAS ', "DIES", etc..	Character(4)	NULL	No
VEHCOMPANY	Vehicle manufacturer. Is designed to align with the MFR_ fields in CFEIS. Has extended translation table in which COMPANY_N will contain the same numeric code as CFEIS for this manufacturer.	Character(12)	NULL	No
ENGCOMPANY	Engine manufacturer. Is designed to align with the MFR_ fields in CFEIS. Has extended translation table in which COMPANY_N will contain the same numeric code as CFEIS for this manufacturer.	Character(12)	NULL	No
HIGHWAY	Yes if mobile source is intended for highway use. No for non-road mobile sources.	Character(3)	NULL	No
PURPOSE	Purpose or use of the mobile source. (Addition of this field was motivated by the need to describe the function of non-road vehicles and equipment and will likely be blank for other mobile sources.)	Character(100)	NULL	No
SCC	Source classification code.	Character(14)	NULL	No
MODEL_NAME	Model name.	Character(20)	NULL	No
MODEL_YR	Model year.	Numeric(4)	NULL	No
MAKE	Vehicle make e.g. Buick, as distinct from vehicle manufacturer, GM. Legal values defined by MAKE translation table.	Character(12)	NULL	No
V_BLD_DATE	Approximate date the vehicle was manufactured. Usually collected to nearest month only with day set to 15.	Date	NULL	No
DISP_CID	Nominal Engine displacement, expressed in cubic inches.	Numeric(4)	NULL	No

"EQUIP_IN" Table				
Name	Comment	Datatype	Null Option	Is PK
DISP_LITER	Nominal engine displacement, expressed in liters.	Numeric(4,1)	NULL	No
FUEL_DELIV	Kind of fuel delivery system. Legal values defined by FUEL_DEL translation table.	Character(6)	NULL	No
FI_TYPE	Type of fuel injection PFI (port fuel injection) TBI (throttle body injection) DIRECT (direct fuel injection e.g. as for most diesel engines.)	Character(6)	NULL	No
ASPIRATED	Indicates how engine is aspirated. CHARGED if turbocharged or supercharged. NATURAL if not	Character(7)	NULL	No
CYLINDER	Number of cylinders or rotors.	Numeric(2)	NULL	No
INJECTORS	Number of injectors per cylinder.	Numeric(1)	NULL	No
CAT_TYPE	What type catalyst, if any, is present on the mobile source. Values are: 3WAY Three-way catalyst OX3W Oxidation plus three-way catalyst OXID Oxidation Catalyst NONE No catalyst NULL Unknown	Character(4)	NULL	No
AIR_INJ	Represents what method, if any, is used to introduce supplemental air into the exhaust stream. Legal values defined by AIR_INJ translation table.	Character(5)	NULL	No
CLOSEDLOOP	"YES" indicates a "closed loop" configuration in which the exhaust sensing is used to help control the fuel combustion process. "No means this is not done on the vehicle.	Character(3)	NULL	No
IGNITION	Ignition type of engine in mobile source. Legal values defined by IGNITION translation table.	Character(2)	NULL	No
ENG_FAM	Exhaust emission certification family to which the engine in this equipment belongs.	Character(19)	NULL	No
EVAP_FAM	EPA standardized evaporative family name as defined in CFR40 Part 86	Character(12)	NULL	No
OVERDRIVE	Indicates whether vehicle has overdrive gear.	Character(3)	NULL	No
CREEPER	Indicates whether vehicle has creeper gear.	Character(3)	NULL	No
LOCKUP	Indicates whether vehicle has lockup transmission.	Character(3)	NULL	No
GEARS	Number of forward gears in vehicle transmission. Legal values defined by GEARS translation table.	Character(6)	NULL	No
CURBWEIGHT	Curb weight in pounds. For on-road vehicles this has a precise definition. For other mobile sources, e.g. non-road vehicles, the unadjusted actual weight of the mobile source is used.	Numeric(6)	NULL	No
AC	Is vehicle equipped with air conditioning? YES, NO, or NUL Intend to change to logical type field when good tool is available.	Character(3)	NULL	No
CANISTER	Type of canister on vehicle. Legal values defined by CANISTER translation table.	Character(10)	NULL	No
EGR	Does vehicle have exhaust gas recirculation? YES, NO, or NUL.	Character(3)	NULL	No
FUELTANKS	Number of fuel tanks on vehicle	Numeric(1)	NULL	No
TANK_CAP	Total fuel tank capacity to nearest gallon. (Includes all tanks.)	Numeric(3)	NULL	No
EGR_TYPE	Type of exhaust gas recirculation (EGR). (Legal values defined by translation table.)	Character(6)	NULL	No
DRV_TRN	Represents drive train with the following values (domain); FWD (front wheel drive), RWD (rear wheel drive), 4WDO (optional 4 wheel drive), and 4FWD (full-time 4 wheel drive)	Character(4)	NULL	No
ENGSERIES	Engine series or product line name.	Character(20)	NULL	No
ENG_CLASS	Intended engine service class. (In conjunction with engine type (SI or CI), and model year, this field allows determination of the emission standards to which many engines were certified; for small spark ignition engines, displacement class, which can be determined from displacement, may be used instead.) Legal values to be defined by translation table.	Character(7)	NULL	No
E_BLD_DATE	Approximate date engine was manufactured.	Date	NULL	No
ENG_MOD_YR	Engine model year.	Numeric(4)	NULL	No
COOLING	Type of after cooling. (Legal values defined by translation table.)	Character(7)	NULL	No
FI_METH	Method of fuel injection. (Legal values defined by translation table.)	Character(4)	NULL	No
FI_PRESS	Fuel injection pressure expressed in kPa.	Numeric(6)	NULL	No
PARTTRAP	Is particulate trap used? "YES", "NO", or "NUL".	Character(3)	NULL	No
ENG_CYCLE	Engine cycle, 2 = 2-stroke, 4 = 4-stroke. 0 = Unknown.	Character(1)	NULL	No
RATEDPOWER	Rated horsepower of engine.	Numeric(7,1)	NULL	No
RATEDSPEED	Rated rpm of engine.	Numeric(5)	NULL	No
IDLE_RPM	Idle rpm as declared by the OEM.	Numeric(5)	NULL	No
TECH_CONFG	Description of technical configuration. (Not categorized.)	Character(50)	NULL	No
ECS_DESCPT	Description of emission control system.	Character(50)	NULL	No
ELECT_CONT	Description of electronic control.	Character(100)	NULL	No
PROC METH	Procurement method. (Legal values defined by translation table.)	Character(10)	NULL	No
PROC_ODOM	Approximate odometer reading in miles at time of vehicle recruitment.	Numeric(6)	NULL	No
HOURL_METER	Hours of operation (usually available only for off-road mobile sources).	Numeric(6)	NULL	No
REBUILD_CT	Number of times mobile source was rebuilt, generally applicable only to engines.	Numeric(2)	NULL	No
REBUILD_DT	Date of last rebuild.	Date	NULL	No

"EQUIP_IN" Table				
Name	Comment	Datatype	Null Option	Is PK
REBUILDWHY	Purpose or reason for last rebuild.	Character(30)	NULL	No
MODIFS	Description of significant post-OEM additions or modifications.	Character(100)	NULL	No
TRAN_TYPE	Transmission type. Legal values defined by TTRNTRAN translation table.	Character(6)	NULL	No
GVWR	Gross vehicle weight rating in pounds. The value specified by the manufacturer as the loaded weight of a single vehicle.	Numeric(6)	NULL	No
GCWR	The weight rating expressed in pounds, specified by the vehicle manufacturer as the loaded weight of a combination (articulated) vehicle. In the absence of a value specified by the manufacturer, GCVR will be determined by adding the GVWR of the power unit and the total weight of the towed unit and any load thereon.	Numeric(6)	NULL	No
COMMENTS	Field used for comments from the data supplier, this field not loaded into database.	Character(254)	NULL	No
OWNERSHIP	The relationship between the user and the equipment.	Character(7)	NULL	No
DEPOT	Depot means site where vehicle is stored when not in use.	Character(12)	NULL	No
PEAKTORQUE	Peak torque in ft-lbs.	Numeric(4)	NULL	No
PEAKSPEED	Peak torque speed in rpm.	Numeric(5)	NULL	No
PEAKFRATE	Fuel rate @ peak torque in lbs/hr.	Numeric(5,1)	NULL	No
RATEDFRATE	Fuel rate @ rated speed in lbs/hr.	Numeric(5,1)	NULL	No
CERT_NOX	Oxides of nitrogen emission level at which vehicle was certified expressed in grams per mile.	Numeric(6,3)	NULL	No
CERT_PM	Particulate matter emission level at which vehicle was certified expressed in grams per mile.	Numeric(6,3)	NULL	No
AXLE	The number of axles the vehicle has.	Numeric(2)	NULL	No
CERT_CO	Carbon Monoxide emission level at which the heavy duty vehicle or engine was certified expressed in grams per mile.	Numeric(6,3)	NULL	No
CERT_HC	Hydrocarbon emission level at which vehicle was certified. Expressed in grams per mile.	Numeric(6,3)	NULL	No
VIN8	The first eight characters of vehicle Identification Number (VIN).	Character(8)	NULL	No
VIN_BODY	Vehicle physical attributes as described by VIN decoding software for the first procurement of the vehicle into MSOD.	Character(30)	NULL	No
THCSTD	Total hydrocarbon standard level to which vehicle was certified expressed in grams per mile.	Numeric(6,3)	NULL	No
COSTD	Carbon monoxide standard level to which vehicle was certified expressed in grams per mile.	Numeric(6,3)	NULL	No
NOXSTD	Oxides of nitrogen standard level to which vehicle was certified expressed in grams per mile.	Numeric(6,3)	NULL	No
PMSTD	Particulate matter standard to which vehicle was certified expressed in grams per mile.	Numeric(6,3)	NULL	No
VEH_LANE	Number historically used to identify procurement of a vehicle from an I/M lane (as compared with VEH_NO which identified a physical vehicle.) Vehicles were recruited for a series of tests, typically a purge-pressure, IM240 and FTP.	Numeric(5)	NULL	No
STATETEST	Indicates whether the vehicle recruited passed or failed a state IM test. Legal values defined by STATETES translation table.	Character(8)	NULL	No
CUTHC	Recruitment "cut point" or threshold value for hydrocarbon emissions expressed in terms of grams/mile as measured by an IM240 test. Null value of this field is zero.	Numeric(5,2)	NULL	No
CUTCO	Recruitment "cut point" or threshold value for carbon monoxide emissions expressed in terms of grams/mile as measured by an IM240 test. Null value of this field is zero.	Numeric(6,2)	NULL	No
CUTNOX	Recruitment "cut point" or threshold value for oxides of nitrogen emissions expressed in terms of grams/mile as measured by an IM240 test. Null value of this field is zero.	Numeric(5,2)	NULL	No
CUTPOINTS	Information pertaining to the set of IM240 emission "cutpoint" values which governed this procurement. These emission cutpoint levels do not generally correspond to the emission standards to which the vehicle was certified. Legal values defined by CUTPOINT translation table.	Numeric(2)	NULL	No
IM_STATION	IM program station id.	Numeric(3)	NULL	No
VINDCODE	Version of VIN decoding software used for the procurement.	Character(12)	NULL	No
CAT_AGE	Age of catalyst if artificially aged.	Numeric(6)	NULL	No

"EREPM_IN" Table				
Name	Comment	Datatype	Null Option	Is PK
ENGSECS	Time within an engine dynamometer test, expressed in seconds, beginning of test has engsecs = 0.	Numeric(4)	NOT NULL	Yes
MEAS_ID	Measurement type identification. Legal values defined by MEASTYPE translation table	Character(10)	NOT NULL	Yes
CTR_TST_ID	Identification number assigned to the RESULT by a test contractor. (Hopefully uniquely identifies RESULT instances within a given contractor.) The RES_KIND of the RESULT record ="ACTIVITY". Note that a ctr_tst_id can have only one activity and vice versa. Not used for analytical purposes. But could help locate contractor's records pertinent to this RESULT.	Character(12)	NOT NULL	Yes
EREPM_EAS	Engine test time level measurement of this MEAS_ID	Numeric(10)	NULL	No

"EATEST_IN" Table				
Name	Comment	Datatype	Null Option	Is PK
CTR_TST_ID	Identification number assigned to the RESULT by a test contractor. (Hopefully uniquely identifies RESULT instances within a given contractor.) The RES_KIND of the RESULT record ="ACTIVITY". Note that a ctr_tst_id can have only one activity and vice versa. Not used for analytical purposes. But could help locate contractor's records pertinent to this RESULT.	Character(12)	NOT NULL	Yes
USESMAP	CTR_TST_ID of engine map result associated with this engine test. Blank value indicates that no engine map in the database is associated with this engine test.	Character(12)	NOT NULL	No
P_CH4	Methane emissions expressed in grams per bhp-hr.	Numeric(7,2)	NULL	No
P_THC	Total HC emissions expressed in grams per bhp-hr.	Numeric(7,2)	NULL	No
P_CO	CO emissions expressed in grams per bhp-hr.	Numeric(7,2)	NULL	No
P_CO2	CO2 emissions expressed in grams per bhp-hr.	Numeric(7,2)	NULL	No
P_NOX	NOx emissions expressed in grams per bhp-hr.	Numeric(7,2)	NULL	No
P_PM	Total particulate emissions expressed in grams per bhp-hr.	Numeric(7,2)	NULL	No
TOTAL_WORK	Total work performed in test expressed in bhp-hrs.	Numeric(7,2)	NULL	No
BSFC_MEAS	Measured brake-specific fuel consumption expressed in grams per bhp-hr.	Numeric(9,4)	NULL	No
BSFC_CALC	Calculated brake-specific fuel consumption expressed in grams per bhp-hr.	Numeric(9,4)	NULL	No
ET_BARO	Average barometric pressure during test expressed in inches of Hg. Not meaningful for multi-mode steady-state tests.	Numeric(5,2)	NULL	No
ET_HUMID	Average absolute humidity during test expressed in grains of water per pound of dry air. Not meaningful for multi-mode steady-state tests.	Numeric(5,2)	NULL	No
ET_INAIR	Engine inlet air temperature expressed in degrees F. Not meaningful for multi-mode steady-state tests.	Numeric(5,1)	NULL	No
ET_EXRESTR	Exhaust restriction pressure expressed in inches of mercury. Not meaningful for multi-mode steady-state tests.	Numeric(5,2)	NULL	No
ET_EXHAUST	Exhaust temperature, after emission controls expressed in degrees F. Not meaningful for multi-mode steady-state tests.	Numeric(5,1)	NULL	No
ET_COOLER	Air temperature after intercooler expressed in degrees F. Not meaningful for multimode steady-state tests.	Numeric(5,1)	NULL	No
ET_COOLIN	Engine coolant input temperature expressed in degrees F. Not meaningful for multimode steady-state tests.	Numeric(5,1)	NULL	No
ET_COOLOUT	Engine coolant output temperature expressed in degrees F. Not meaningful for multi-mode steady-state tests.	Numeric(5,1)	NULL	No
ET_CHILLER	Chiller water temperature expressed in degrees F. Not meaningful for multi-mode steady-state tests.	Numeric(5,1)	NULL	No

"EVAP_IN" Table				
Name	Comment	Datatype	Null Option	Is PK
CTR_TST_ID	Identification number assigned to the RESULT by a test contractor. (Hopefully uniquely identifies RESULT instances within a given contractor.) Not used for analytical purposes. But could help locate contractor's records pertinent to this RESULT.	Character(12)	NOT NULL	Yes
WA_ID	Work Assignment name which is equivalent to EPA's test program name.	Character(10)	NOT NULL	No
TEST_PROC	Identifies the specific test procedure used. A more detailed classification than RES_KIND. Based largely upon values of TEST_TYPE in earlier design. Conceptually distinct from the driving or operational schedule used.	Character(5)	NOT NULL	No
REPLICATE	TRUE if this test replicates a previous one, otherwise FALSE.	Logical	NULL	No
SCHED_ID	Schedule identification.	Character(6)	NOT NULL	No
FUEL_ID	Numeric code uniquely identifying the general type of fuel used. (Sometimes referred to as the "gross fuel type")	Numeric(3)	NOT NULL	No
FBATCH_ID	Fuel batch identification.	Character(10)	NULL	No
MS_ID	Mobile source identifier. For vehicles their VIN would be used. For engines, their serial number, probably in conjunction with their manufacturer code.	Character(17)	NOT NULL	No
TEST_DATE	Result date.	Date	NOT NULL	No
TEST_TOD	Time of day of the start of the result. Stored as a 5 character string HH:MM.	Character(5)	NOT NULL	No
SITE	Location where test was conducted.	Character(12)	NOT NULL	No
NOM_TEMP	Nominal temperature at which test was to be conducted expressed in degrees Fahrenheit.	Numeric(3)	NULL	No
NOM_HUMID	Nominal absolute humidity at which test was to be conducted expressed in grains of water per pound of dry air.	Numeric(3)	NULL	No
DISABLE	Indication of any special conditions or "disablements" performed on the mobile source for particular tests. A value of zero indicates that no special condition or disablement to the vehicle was performed. Positive values indicate a particular disablement or set of disablements as defined in the translation table for this field. e.g. 1 = gas cap removed, 2 = evap canister removed, 3 = both gas cap and canister removed, etc.	Numeric(3)	NULL	No
W_EVAP_THC	Total hydrocarbon emissions of test expressed in grams.	Numeric(6,2)	NULL	No
PRECOND	Type of preconditioning. Values defined by PRECOND translation table. Same field appears in DYNOTEST.	Character(10)	NULL	No

"FBAT_IN" Table				
Name	Comment	Datatype	Null Option	Is PK
FBATCH_ID	Fuel batch identification.	Character(10)	NOT NULL	Yes
MEAS_ID	Measurement type identification. Legal values defined by MEASTYPE translation table	Character(10)	NOT NULL	Yes
CETANE_NUM	Cetane number of complete fuel.	Numeric(5,2)	NULL	No
CETANE_IDX	Cetane index of complete fuel.	Numeric(5,2)	NULL	No
CETANE_IMP	Amount of cetane improver added expressed as percentage by volume	Numeric(5,2)	NULL	No
CETANE_TYP	Type of cetane improver used, e.g. "N" for nitrate type or "P" for peroxide type. Exact set of legal values defined and described by translation table for this field.	Character(1)	NULL	No
SULFUR	Sulfur content expressed in parts per million.	Numeric(5)	NULL	No
MFG_BATCH	Manufacturer's fuel batch identification.	Character(18)	NULL	No
SULF_AGENT	Name of any sulfur doping agent added to the fuel. Value of "NONE" indicates that all sulfur in the fuel was present naturally.	Character(20)	NULL	No
NITROGEN	Nitrogen content expressed in parts per million.	Numeric(5)	NULL	No
TAROM	Total aromatics content of fuel expressed as a percentage by volume. This is a measured value, as opposed as being calculated as the sum of the monoaromatics and polyaromatics fields.	Numeric(5,2)	NULL	No
MAROM	Monoaromatics content of fuel expressed as a percentage by volume. This is a measured value, as opposed as being calculated as the difference of the total aromatics and polyaromatics fields.	Numeric(5,2)	NULL	No
PAROM	Polyaromatics content of fuel expressed as a percentage by volume. This is a measured value, as opposed as being calculated as the difference of the total aromatics and monoaromatics fields.	Numeric(5,2)	NULL	No
IBP	Initial boiling point expressed in degrees F.	Numeric(4)	NULL	No
T10	10% distillation boiling point expressed in degrees Fahrenheit.	Numeric(4)	NULL	No
T50	50% distillation boiling point expressed in degrees Fahrenheit.	Numeric(4)	NULL	No
T90	90% distillation boiling point expressed in degrees Fahrenheit.	Numeric(4)	NULL	No
EP	End point of distillation curve expressed in degrees Fahrenheit.	Numeric(4)	NULL	No
SPEC_GRAV	Specific gravity.	Numeric(6,4)	NULL	No
API_GRAV	API gravity expressed in degrees API.	Numeric(5,2)	NULL	No
DENSITY	Measured density of the fuel expressed in pounds per gallon.	Numeric(5,3)	NULL	No
VISCOSITY	Viscosity expressed in centistokes.	Numeric(4,2)	NULL	No
FLASH	Flashpoint temperature expressed in degrees Fahrenheit.	Numeric(4)	NULL	No
CLOUD	Cloudpoint temperature expressed in degrees Fahrenheit.	Numeric(4)	NULL	No
POUR	Pourpoint temperature expressed in degrees Fahrenheit.	Numeric(4)	NULL	No
HCRATIO	Ratio of hydrogen to carbon	Numeric(5,3)	NULL	No
OXYGEN	Amount of oxygen in the fuel expressed as a percentage by weight.	Numeric(4,2)	NULL	No
OXY_TYPE	Type of oxygenate. "NONE" if no oxygenate was added to the base fuel. Values defined by translation table for this field.	Character(20)	NULL	No
ADDITIVES	Total amount of additives, other than cetane improvers, in the fuel, expressed as a percentage by weight.	Numeric(5,2)	NULL	No
LUBRIC_G	Fuel lubricity expressed in grams. As measured by ASTM D6078 or comparable method.	Numeric(5,0)	NULL	No
LUBRIC_MM	Fuel lubricity expressed in millimeters of scar wear. As measured by ASTM D6079 or comparable method.	Numeric(4,2)	NULL	No
HEAT	Net heating value of the fuel expressed in btu/pound.	Numeric(6)	NULL	No
ASH	Ash content of fuel expressed as a percentage.	Numeric(4,2)	NULL	No
RON	Research Octane Number conducted in accordance with ASTM D2699	Numeric(5,1)	NULL	No
MON	Motor Octane Number conducted in accordance with ASTM D2700	Numeric(5,1)	NULL	No
FEN_C	Fuel Economy Numerator/C Density conducted in accordance with ASTM E191 (g carbon/gal)	Numeric(4,0)	NULL	No
WGT_FRACTN	Weight fraction carbon conducted in accordance with ASTM D3343	Numeric(7,4)	NULL	No
RECOVERY	The amount of distillate recovered measured in volume percent.	Numeric(4,1)	NULL	No
RESIDUE	The amount of residue matter remaining after distillate has been boiled off and is measured in volume percent.	Numeric(4,1)	NULL	No
LOSS	The amount of loss measured in volume percent.	Numeric(4,1)	NULL	No
RVP	The Reid Vapor Pressure of the fuel measured in pounds per square inch (psi) in accordance with ASTM D323 or D5191.	Numeric(4,1)	NULL	No
COMP_OLEFN	Olefin composition measured in volume percent of the fuel in accordance with ASTM D1319.	Numeric(4,1)	NULL	No
COMP_SAT	Saturates Composition measured in volume percent of the fuel in accordance with ASTM D1319.	Numeric(4,1)	NULL	No
WA_ID	Work Assignment name which is equivalent to EPA's test program name.	Character(10)	NULL	No
RES_KIND	RESULT kind. Used to identify which subtype this result belongs to. Overall intent is to aggregate RESULT instances into as few different subtypes as practical. E.g. all vehicle dynamometer tests may be one subtype, all SHED tests another. Legal values defined by RES_KIND translation table.	Character(8)	NULL	No

"FBAT_IN" Table				
Name	Comment	Datatype	Null Option	Is PK
FUEL_ID	Numeric code uniquely identifying the general type of fuel used. Sometimes referred to as the "gross fuel type".	Numeric(3)	NULL	No
COMP_AROMA	Volume % Aromatics in fuel by ASTM D1319.	Numeric(4,1)	NULL	No
E200	Percent fuel evaporated at 200 degrees Fahrenheit.	Numeric(5,1)	NULL	No
E300	Percent fuel evaporated at 300 degrees Fahrenheit.	Numeric(5,1)	NULL	No
TOLUENE	Fuel Toluene in volume percent.	Numeric(6,3)	NULL	No
BENZENE	Fuel Benzene in volume percent.	Numeric(6,3)	NULL	No

"FFDAT_IN" Table				
Name	Comment	Datatype	Null Option	Is PK
OBD2CODE	Character string code resulting from a scan of a level 2 on board diagnostic system.	Character(5)	NOT NULL	Yes
TRIP_ID	Identifier assigned to each TRIP instance.	Character(12)	NOT NULL	Yes
CTR_TST_ID	Identification number assigned to the RESULT by a test contractor. (Hopefully uniquely identifies RESULT instances within a given contractor.) The RES_KIND of the RESULT record ="ACTIVITY". Note that a ctr_tst_id can have only one activity and vice versa. Not used for analytical purposes. But could help locate contractor's records pertinent to this RESULT.	Character(12)	NOT NULL	Yes
TPMEAS_DT	Time within trip, expressed in seconds, beginning of test equals dynosecs = 0, first measurement is usually at dynosecs = 1.	Date	NOT NULL	Yes

"FUEL_IN" Table				
Name	Comment	Datatype	Null Option	Is PK
CTR_TST_ID	Identification number assigned to the RESULT by a test contractor. (Hopefully uniquely identifies RESULT instances within a given contractor.) In this case, functions as a sample_id for the fuel of the mobile source. Not used for analytical purposes. But could help locate contractor's records pertinent to this RESULT.	Character(12)	NOT NULL	Yes
MEAS_ID	Measurement type identification.	Character(10)	NOT NULL	Yes
WA_ID	Work Assignment name which is equivalent to EPA's test program name.	Character(10)	NOT NULL	No
MS_ID	Mobile source identifier. For vehicles their VIN would be used. For engines, their serial number, probably in conjunction with their manufacturer code.	Character(17)	NOT NULL	No
TEST_DATE	Result date.	Date	NOT NULL	No
TEST_TOD	Time of day of the start of the result. Stored as a 5 character string HH:MM.	Character(5)	NOT NULL	No
SITE	Location where test was conducted.	Character(12)	NOT NULL	No
FUELMEAS	Test level fuel measurement.	Numeric(10,4)	NULL	No

"INSP_IN" Table				
Name	Comment	Datatype	Null Option	Is PK
CTR_TST_ID	Identification number assigned to the RESULT by a test contractor. (Hopefully uniquely identifies RESULT instances within a given contractor.) Not used for analytical purposes. But could help locate contractor's records pertinent to this RESULT.	Character(12)	NOT NULL	Yes
WA_ID	Work Assignment name which is equivalent to EPA's test program name.	Character(10)	NOT NULL	No
MS_ID	Mobile source identifier. For vehicles their VIN would be used. For engines, their serial number, probably in conjunction with their manufacturer code.	Character(17)	NOT NULL	No
SITE	Location where test was conducted.	Character(12)	NOT NULL	No
TEST_DATE	Date of the inspection.	Date	NOT NULL	No
TEST_TOD	Time of day of the beginning of the inspection. Expressed as a 5 character string HH:MM.	Character(5)	NOT NULL	No
COMMENTS	Inspection comments, first portion.	Character(254)	NULL	No
COMMENTS2	Inspection comments, second portion.	Character(254)	NULL	No
INSP_ODOM	Approximate odometer reading, in miles, at time of mechanics M1 emission component inspection. 0 represents NULL. (This item not collected prior to FY98).	Numeric(6)	NULL	No
G_CAN_INIT	Weight of evaporative emission canister as vehicle was received expressed in grams. If vehicle has multiple canisters weight entered is total of all canisters present. Zero if null.	Numeric(7,1)	NULL	No
G_CAN_PURG	Weight of evaporative emission canister after canister purge expressed in grams. If vehicle has multiple canisters weight entered is total of all canisters present. Zero if null.	Numeric(7,1)	NULL	No
G_CAN_LOAD	Weight of evaporative emission canister after full loading expressed in grams. If vehicle has multiple canisters weight entered is total of all canisters present. Zero if null.	Numeric(7,1)	NULL	No
SMOKECOLOR	Result of visual observation of smoke emission. Whether and what color smoke was observed. Legal values defined by translation table.	Character(6)	NULL	No

"LMEAS_IN" Table				
Name	Comment	Datatype	Null Option	Is PK
DYNOSECS	Time within test, expressed in seconds, beginning of test equals dynosecs = 0, first measurement is usually at dynosecs = 1.	Numeric(4,)	NOT NULL	Yes
CTR_TST_ID	Identification number assigned to the RESULT by a test contractor. (Hopefully uniquely identifies RESULT instances within a given contractor.) Not used for analytical purposes. But could help locate contractor's records pertinent to this RESULT.	Character(12)	NOT NULL	Yes
MEAS_ID	Measurement type identification	Character(10)	NOT NULL	Yes
LAB_MEAS	Lab level measurement of this meas_id.	Numeric(10,3)	NULL	No

"LTIME_IN" Table				
Name	Comment	Datatype	Null Option	Is PK
DYNOSECS	Time within test, expressed in seconds, beginning of test equals dynosecs = 0, first measurement is usually at dynosecs = 1.	Numeric(4,)	NOT NULL	Yes
CTR_TST_ID	Identification number assigned to the RESULT by a test contractor. (Hopefully uniquely identifies RESULT instances within a given contractor.) Not used for analytical purposes. But could help locate contractor's records pertinent to this RESULT.	Character(12)	NOT NULL	Yes
LAB_RPM	Engine's rpm for each second.	Numeric(5)	NULL	No
LAB_TORQ	Engine's torque (calculated or measured) per second in ft-lbs.	Numeric(6)	NULL	No
LAB_TEMPF	Ambient air temperature in degrees F per second.	Numeric(5,1)	NULL	No
LAB_BARO	Ambient air's barometric pressure measured for each second in inches of mercury.	Numeric(5,2)	NULL	No
LAB_HUMID	Absolute humidity measured each second expressed in grains of water per pound of dry air.	Numeric(6,2)	NULL	No
LFUEL_RATE	Fuel rate expressed in lbs/sec.	Numeric(8,5)	NULL	No
LAB_ENGCOL	Engine coolant temperature (degrees F).	Numeric(5,1)	NULL	No
LAB_ENGOIL	Engine oil temperature (degrees F).	Numeric(5,1)	NULL	No
LAB_MILLIT	Yes - if millight is on; No if off.	Character(3)	NULL	No
CVS_VOL	CVS flow in standard cubic feet per second.	Numeric(10,6)	NULL	No
TP_VOL	Tailpipe volume in standard cubic feet per second.	Numeric(10,6)	NULL	No
DIL_VOL	Dilution air in standard cubic feet per second.	Numeric(10,6)	NULL	No
TP_O2	Oxygen in volume percent (%) as measured at the tailpipe.	Numeric(10,6)	NULL	No
DIL_O2	Oxygen in volume percent (%) as measured after mixed with dilution air.	Numeric(10,6)	NULL	No
TP_THC	Total hydrocarbon in ppm by volume as measured at the tailpipe.	Numeric(10,6)	NULL	No
DIL_THC	Total hydrocarbon in ppm by volume as measured after mixed with dilution air.	Numeric(10,6)	NULL	No
TP_CO	Carbon monoxide in ppm by volume as measured at the tailpipe.	Numeric(10,6)	NULL	No
DIL_CO	Carbon monoxide in ppm by volume as measured after mixed with dilution air.	Numeric(10,6)	NULL	No
TP_CO2	Carbon dioxide in volume percent (%) as measured at the tailpipe.	Numeric(10,6)	NULL	No
DIL_CO2	Carbon dioxide in volume percent (%) as measured after mixed with dilution air.	Numeric(10,6)	NULL	No
TP_NOX	Nitrogen oxides in ppm by volume as measured at the tailpipe.	Numeric(10,6)	NULL	No
DIL_NOX	Nitrogen oxides in ppm by volume as measured after mixed with dilution air.	Numeric(10,6)	NULL	No
VC_THC	Engine-out total hydrocarbon emission measurements expressed in ppm by volume.	Numeric(10,6)	NULL	No
VC_CO	Engine-out carbon monoxide emission measurements expressed in ppm by volume.	Numeric(10,6)	NULL	No
VC_NOX	Engine-out oxides of nitrogen emission measurements expressed in ppm by volume.	Numeric(10,6)	NULL	No
VC_CO2	Engine-out carbon dioxide emission measurements expressed in volume percent.	Numeric(10,6)	NULL	No
VC_O2	Engine-out oxygen emission measurements expressed in volume percent.	Numeric(10,6)	NULL	No

"MAPPT_IN" Table				
Name	Comment	Datatype	Null Option	Is PK
CTR_TST_ID	Identification number assigned to the RESULT by a test contractor. (Hopefully uniquely identifies RESULT instances within a given contractor.) The RES_KIND of the RESULT record ="ACTIVITY". Note that a ctr_tst_id can have only one activity and vice versa. Not used for analytical purposes. But could help locate contractor's records pertinent to this RESULT.	Character(12)	NOT NULL	Yes
MAP_RPM	Identification number assigned to the RESULT by a test contractor. (Hopefully uniquely identifies RESULT instances within a given contractor.) Not used for analytical purposes. But could help locate contractor's records pertinent to this RESULT.	Numeric(5)	NOT NULL	Yes
MAP_TORQUE	Torque expressed in foot pounds.	Numeric(4)	NULL	No

"MMEAS_IN" Table				
Name	Comment	Datatype	Null Option	Is PK
MODE_ID	Mode identification. Legal values defined by MODE_ID translation table.	Character(10)	NOT NULL	Yes
CTR_TST_ID	Identification number assigned to the RESULT by a test contractor. (Hopefully uniquely identifies RESULT instances within a given contractor.) Not used for analytical purposes. But could help locate contractor's records pertinent to this RESULT.	Character(12)	NOT NULL	Yes
MEAS_ID	Measurement type identification. Legal values defined by MEASTYPE translation table	Character(10)	NOT NULL	Yes
MODEMEAS	Used to store a MEASTYPE measurement at the test mode level.	Numeric(10,3)	NULL	No

"MEASTYPE" Table				
Name	Comment	Datatype	Null Option	Is PK
MEAS_ID	Measurement type identification. Legal values defined by MEASTYPE translation table	Character(10)	NOT NULL	Yes
MEAS_UNIT	Engineering units applicable to this measurement type.	Character(30)	NULL	No
MEAS_DESCR	Measurement description.	Character(50)	NULL	No
CAS_RN	CAS Registry Numbers (CAS RN) are numbers that uniquely identify chemical substances that are assigned by the Chemical Abstract Service. These numbers have three parts and are arranged in the format: xxxx-yy-z where xxxx - varies between 2 and 6 digits, yy - is always 2 digits, and z - is always 1 digit. For example the Registry Number for ethylene glycol is I07-2I-I.	Character(12)	NULL	No

"MODE_IN" Table				
Name	Comment	Datatype	Null Option	Is PK
MODE_ID	Mode identification. Legal values defined by MODE_ID translation table.	Character(10)	NOT NULL	Yes
CTR_TST_ID	Identification number assigned to the RESULT by a test contractor. (Hopefully uniquely identifies RESULT instances within a given contractor.) Not used for analytical purposes. But could help locate contractor's records pertinent to this RESULT.	Character(12)	NOT NULL	Yes
MODE_TEMP	Measured ambient temperature during this test mode expressed in degrees Fahrenheit.	Numeric(5,1)	NULL	No
MODE_BARO	Barometric pressure measured during test mode expressed in inches of mercury.	Numeric(5,2)	NULL	No
MODE_HUMID	Humidity measured during test mode expressed in grains of water per pound of dry air.	Numeric(6,2)	NULL	No
C_THC	Total hydrocarbon concentration expressed in parts per million.	Numeric(4)	NULL	No
C_CO	Carbon monoxide concentration expressed in percent.	Numeric(6,2)	NULL	No
C_CO2	Carbon dioxide concentration expressed in percent.	Numeric(6,2)	NULL	No
C_NO	NO concentration expressed in parts per million. Corrected for humidity via humidity correction factor.	Numeric(4)	NULL	No
C_NOU	NO concentration expressed in parts per million. Not corrected for humidity.	Numeric(4)	NULL	No
MODE_HP	Load horsepower.	Numeric(5,1)	NULL	No
RPM	Measured Engine RPM.	Numeric(4)	NULL	No

"MTIME_IN" Table				
Name	Comment	Datatype	Null Option	Is PK
MODESECS	Identifies point in time within a Mode of an chassis exhaust emissions test. Expressed in seconds.	Numeric(4)	NULL	Yes
CTR_TST_ID	Identification number assigned to the RESULT by a test contractor. (Hopefully uniquely identifies RESULT instances within a given contractor.) Not used for analytical purposes. But could help locate contractor's records pertinent to this RESULT.	Character(12)	NOT NULL	Yes
REP_C_THC	Second-by-second measurement of total hydrocarbon concentration expressed in parts per million.	Numeric(4)	NULL	No
REP_C_CO	Second-by-second measurement of carbon monoxide concentration expressed as a percentage.	Numeric(6,2)	NULL	No
REP_C_CO2	Second-by-second measurement of carbon dioxide concentration expressed as a percentage.	Numeric(6,2)	NULL	No
REP_C_NO	Second-by-second measurement of nitric oxide (NO) concentration, corrected for humidity expressed in parts per million.	Numeric(4)	NULL	No
REP_C_NOU	Second-by-second measurement of nitric oxide (NO) concentration, not corrected for humidity expressed in parts per million.	Numeric(4)	NULL	No
REP_RPM	Second-by-second measurement of engine speed expressed in revolutions per Minute (rpm).	Numeric(4)	NULL	No
REP_SPEED	Measured speed expressed in miles per hour.	Numeric(6,2)	NULL	No

"OBD_IN" Table				
Name	Comment	Datatype	Null Option	Is PK
CTR_TST_ID	Identification number assigned to the RESULT by a test contractor. (Hopefully uniquely identifies RESULT instances within a given contractor.) Not used for analytical purposes. But could help locate contractor's records pertinent to this RESULT.	Character(12)	NOT NULL	Yes
WA_ID	Work Assignment name which is equivalent to EPA's test program name.	Character(10)	NOT NULL	No
MS_ID	Mobile source identifier. For vehicles their VIN would be used. For engines, their serial number, probably in conjunction with their manufacturer code.	Character(17)	NOT NULL	No
SITE	Location where test was conducted.	Character(12)	NOT NULL	No
TEST_DATE	Result date.	Date	NOT NULL	No
TEST_TOD	Time of day of the start of the result. Stored as a 5 character string HH:MM.	Character(5)	NOT NULL	No
COMMENT	Comment associated with scan of a vehicle's on-board diagnostic (OBD) system.	Character(254)	NULL	No
OBD_ODOM	Approximate odometer reading, in miles, at time of OBD scan. 0 represents NULL value.	Numeric(6)	NULL	No
OBDLEVEL	Type of on board diagnostic system. Level 1 system are present on many older vehicles and produce 2 digit numeric codes particular to the vehicle manufacturer and model year. Level 2 system produce 5 character codes some of which have industry standardized significance. The legal values of this field are defined by its translation table.	Numeric(1)	NULL	No
CTRSTID_P	This will equal the ctr_tst_id field from EQUIP_IN, added to provide a link between tables.	Character(12)	NULL	No

"OBD2CODE" Table				
Name	Comment	Datatype	Null Option	Is PK
OBD2CODE	Character string code resulting from a scan of a level 2 on board diagnostic system.	Character(5)	NOT NULL	Yes
OBD2CODE_D	Meaning of a particular level 2 on board diagnostic code.	Character(80)	NULL	No

"PART_IN" Table				
Name	Comment	Datatype	Null Option	Is PK
PART	Identification of emission component usually a field name from the emission component worksheet e.g. E101.	Character(4)	NOT NULL	Yes
PART_CODE	Numeric code which can be used to describe the status of an emission component.	Numeric(2)	NOT NULL	Yes
CTR_TST_ID	Identification number assigned to the RESULT by a test contractor. (Hopefully uniquely identifies RESULT instances within a given contractor.) Not used for analytical purposes. But could help locate contractor's records pertinent to this RESULT.	Character(12)	NOT NULL	Yes

"PMEAS_IN" Table				
Name	Comment	Datatype	Null Option	Is PK
MEAS_ID	Measurement type identification. Legal values defined by MEASTYPE translation table	Character(10)	NOT NULL	Yes
TRIP_ID	Identifier assigned to each TRIP instance.	Character(12)	NOT NULL	Yes
CTR_TST_ID	Identification number assigned to the RESULT by a test contractor. (Hopefully uniquely identifies RESULT instances within a given contractor.) The RES_KIND of the RESULT record ="ACTIVITY". Note that a ctr_tst_id can have only one activity and vice versa. Not used for analytical purposes. But could help locate contractor's records pertinent to this RESULT.	Character(12)	NOT NULL	Yes
TPMEAS_DT	Time within trip, expressed in seconds, beginning of test equals dynosecs = 0, first measurement is usually at dynosecs = 1.	Date	NOT NULL	Yes
MEAS_VALUE	The measurement.	Numeric(10,3)	NULL	No

"PRESS_IN" Table				
Name	Comment	Datatype	Null Option	Is PK
CTR_TST_ID	Identification number assigned to the RESULT by a test contractor. (Hopefully uniquely identifies RESULT instances within a given contractor.) Not used for analytical purposes. But could help locate contractor's records pertinent to this RESULT.	Character(12)	NOT NULL	Yes
WA_ID	Work Assignment name which is equivalent to EPA's test program name.	Character(10)	NOT NULL	No
TEST_PROC	Identifies the specific test procedure used.	Character(5)	NOT NULL	No
MS_ID	Mobile source identifier. For vehicles their VIN would be used. For engines, their serial number, probably in conjunction with their manufacturer code.	Character(17)	NOT NULL	No
REPLICATE	TRUE if this test replicates one done earlier, FALSE otherwise.	Logical	NOT NULL	No
TEST_DATE	Result date.	Date	NOT NULL	No
TEST_TOD	Time of day of the start of the result. Stored as a 5 character string HH:MM.	Character(5)	NOT NULL	No
SITE	Location where test was conducted.	Character(12)	NOT NULL	No
CAPOKSTANT	Did gas cap pass the Stant test? ("YES", "NO", or "NUL")	Character(3)	NULL	No
PRESS_INIT	Initial pressure reading (expressed in inches of water).	Numeric(4,1)	NULL	No
PRESS_2MIN	Pressure reading after two minutes (expressed in inches of water). Null value is 99.9.	Numeric(4,1)	NULL	No
PRESS_ODOM	Approximate odometer reading, in miles, at time of pressure test. 0 represents NULL value. (This information item was not collected prior to FY98.)	Numeric(6)	NULL	No

"RATE_IN" Table				
Name	Comment	Datatype	Null Option	Is PK
MODEID	Tag used to identify a particular test mode. Values are defined in MODE_ID translation table.	Character(10)	NOT NULL	Yes
CTR_TST_ID	Identification number assigned to the RESULT by a test contractor. (Hopefully uniquely identifies RESULT instances within a given contractor.) Not used for analytical purposes. But could help locate contractor's records pertinent to this RESULT.	Character(12)	NOT NULL	Yes
DURATION	Length of test mode in seconds.	Numeric(5)	NULL	No
BARO	Barometric pressure expressed in inches of mercury.	Numeric(5,2)	NULL	No
TEMP	Ambient temperature during mode expressed in degrees Fahrenheit.	Numeric(5,1)	NULL	No
HUMID	Absolute humidity expressed in grains of water per pound of dry air.	Numeric(6,2)	NULL	No
RATE_THC	Total hydrocarbon concentration expressed in parts per million.	Numeric(9,5)	NULL	No
RATE_CO	Carbon monoxide concentration expressed in percent.	Numeric(8,4)	NULL	No
RATE_CO2	Carbon dioxide concentration expressed in percent.	Numeric(8,3)	NULL	No
RATE_NOX	NO concentration expressed in parts per million. Corrected for humidity via humidity correction factor.	Numeric(9,4)	NULL	No

"REPAR_IN" Table				
Name	Comment	Datatype	Null Option	Is PK
MS_ID	Mobile source identifier. For vehicles their VIN would be used. For engines, their serial number, probably in conjunction with their manufacturer code.	Character(17)	NOT NULL	Yes
TEST_DATE	Repair date.	Date	NOT NULL	Yes
TEST_TOD	Time of day of the start of the repair. Stored as a 5 character string HH:MM.	Character(5)	NOT NULL	Yes
WA_ID	Work Assignment name which is equivalent to EPA's test program name.	Character(10)	NOT NULL	No
SITE	Location where test was conducted.	Character(12)	NOT NULL	No
CTR_TST_ID	Identification number assigned to the RESULT by a test contractor. (Hopefully uniquely identifies RESULT instances within a given contractor.) Not used for analytical purposes. But could help locate contractor's records pertinent to this RESULT.	Character(12)	NULL	No
REP_TYPE	Type of repair performed. Valid repair type codes and their descriptions can be found in the REP_TYPE translation table.	Numeric(3)	NULL	No
REPAR_HRM	Approximate hour meter reading at time repair was made expressed in hours. Zero represents NULL value. This information item was not collected prior to FY2001.	Character(5)	NULL	No
COMMENTS	Repair description - first portion.	Character(254)	NULL	No
COMMENTS2	Repair description - second portion.	Character(254)	NULL	No
REPAR_ODOM	Odometer reading, in miles, at time repair was made. 0 represents NULL value.	Numeric(6)	NULL	No

"REP_MEAS" Table				
Name	Comment	Datatype	Null Option	Is PK
DYNOSECS	Identifies point in time within a Mode of a chassis exhaust emissions test. Expressed in seconds.	Numeric(4)	NOT NULL	Yes
CTR_TST_ID	Identification number assigned to the RESULT by a test contractor. (Hopefully uniquely identifies RESULT instances within a given contractor.) Not used for analytical purposes. But could help locate contractor's records pertinent to this RESULT.	Character(12)	NOT NULL	Yes
MEAS_ID	Measurement type identification. Legal values defined by MEASTYPE translation table	Character(10)	NOT NULL	Yes
REP_MEAS	Repeated measurement.	Numeric(10,3)	NULL	No

"RESLT_IN" Table				
Name	Comment	Datatype	Null Option	Is PK
CTR_TST_ID	Identification number assigned to the RESULT by a test contractor. (Hopefully uniquely identifies RESULT instances within a given contractor.) The RES_KIND of the RESULT record = "ACTIVITY". Note that a ctr_tst_id can have only one activity and vice versa. Not used for analytical purposes. But could help locate contractor's records pertinent to this RESULT.	Character(12)	NOT NULL	Yes
FBATCH_ID	Fuel batch identification.	Character(10)	NOT NULL	No
TEST_PROC	Identifies the specific test procedure used. A more detailed classification than RES_KIND. Based largely upon values of TEST_TYPE in earlier design. Conceptually distinct from the driving or operational schedule used.	Character(5)	NULL	No
WA_ID	Work Assignment name which is equivalent to EPA's test program name.	Character(10)	NOT NULL	No
SCHED_ID	Schedule identification.	Character(6)	NULL	No
REPLICATE	TRUE is this test is a replicate of one already entered, otherwise false.	Character(1)	NOT NULL	No
RESULTGRP	Contains the ctr_tst_id of any test, of which this is a component part. A blank value indicates that this test is not part of a higher-level test group.	Character(12)	NOT NULL	No
MS_TYPE	General kind of mobile source: 1 = Vehicle 2 = Engine.	Numeric(2)	NOT NULL	No
MS_ID	Mobile source identifier. For vehicles their VIN would be used. For engines, their serial number, probably in conjunction with their manufacturer code.	Character(17)	NOT NULL	No
RES_KIND	RESULT kind. Used to identify which subtype this result belongs to. Overall intent is to aggregate RESULT instances into as few different subtypes as practical, e.g. all vehicle dynamometer tests may be one subtype, all SHED tests another. Legal values defined by RES_KIND translation table	Character(8)	NOT NULL	No
FUEL_ID	Numeric code uniquely identifying the general type of fuel used. Sometimes referred to as the "gross fuel type".	Numeric(3)	NULL	No
TEST_DATE	Result date.	Date	NOT NULL	No
TEST_TOD	Time of day of the start of the result. Stored as a 5 character string HH:MM.	Character(5)	NOT NULL	No
SITE	Location where test was conducted. Legal values defined by SITE translation table.	Character(12)	NOT NULL	No
NOM_TEMP	Nominal temperature at which test was to be conducted expressed in degrees Fahrenheit.	Numeric(3)	NULL	No
NOM_HUMID	Nominal absolute humidity at which test was to be conducted expressed in grains of water per pound of dry air.	Numeric(3)	NULL	No
DISABLE	Indication of any special conditions or "disablements" performed on the mobile source for particular tests. A value of zero indicates that no special condition or disablement to the vehicle was performed. Positive values indicate a particular disablement or set of disablements. Legal values defined by DISABLE translation table.	Numeric(3)	NOT NULL	No
NO_MODES	Number of test modes involved in this result. Data for individual chassis test modes is stored in the DYNOMODE table; data for individual engine dynamometer test modes is stored in the ETSTMODE table.	Numeric(2)	NOT NULL	No
TEST_MODIF	Identifies any minor deviation from normal test procedure indicated by "test_proc". Legal values defined by TEST_MOD translation table.	Numeric(2)	NULL	No

"RUNL_IN" Table				
Name	Comment	Datatype	Null Option	Is PK
CTR_TST_ID	Identification number assigned to the RESULT by a test contractor. (Hopefully uniquely identifies RESULT instances within a given contractor.) Not used for analytical purposes. But could help locate contractor's records pertinent to this RESULT.	Character(12)	NOT NULL	Yes
TEST_PROC	Identifies the specific test procedure used. Conceptually distinct from the driving or operational schedule used.	Character(5)	NOT NULL	No
WA_ID	Work Assignment name which is equivalent to EPA's test program name.	Character(10)	NOT NULL	No
SCHED_ID	Schedule identification.	Character(6)	NOT NULL	No
REPLICATE	TRUE if test is a replicate of one already entered. Otherwise FALSE.	Logical	NOT NULL	No
FUEL_ID	Numeric code uniquely identifying the general type of fuel used. (Sometimes referred to as the "gross fuel type")	Numeric(3)	NOT NULL	No
FBATCH_ID	Fuel batch identification.	Character(10)	NULL	No
MS_ID	Mobile source identifier. For vehicles their VIN would be used.	Character(17)	NOT NULL	No
TEST_DATE	Test date.	Date	NOT NULL	No
TEST_TOD	Time of day of the start of the test. Stored as a 5 character string HH:MM.	Character(5)	NOT NULL	No
SITE	Location where test was conducted.	Character(12)	NOT NULL	No
NOM_TEMP	Nominal temperature at which test was to be conducted. Expressed in degrees Fahrenheit.	Numeric(3)	NULL	No
NOM_HUMID	Nominal absolute humidity at which test was to be conducted expressed in grains of water per pound of dry air.	Numeric(3)	NULL	No
DISABLE	Indication of any special conditions or "disablements" performed on the mobile source for particular tests. A value of zero indicates that no special condition or disablement to the vehicle was performed. Positive values indicate a particular disablement or set of disablements as defined in the translation table for this field. e.g. 1 = gas cap removed, 2 = evap canister removed, 3 = both gas cap and canister removed, etc.	Numeric(3)	NULL	No
TESTWGHT	Dynamometer inertia weight setting used for this test expressed in pounds.	Numeric(6)	NULL	No
ROAD_HP	Dynamometer road load horsepower setting used for this test.	Numeric(5,1)	NULL	No
AC_HP	Did dynamometer road load setting for this test include air conditioning load factor? (YES, NO, or NUL)	Character(3)	NULL	No
DYNOTYPE	Type of dynamometer used. Valid values for this field, are contained in the DYNOTYPE code translation table.	Character(10)	NULL	No
ODOMETER	Odometer reading of vehicle at beginning of test. (Expressed in miles)	Numeric(6)	NULL	No
PRECOND	Type of preconditioning performed on the vehicle prior to the test. Legal values defined by translation table PRECOND.DBF.	Character(10)	NULL	No
TARCANWGHT	Target canister weight expressed in grams	Numeric(4)	NULL	No
NORCANWGHT	Normalized canister weight expressed in grams	Numeric(4)	NULL	No
ENDCANWGHT	Observed canister weight at end of test expressed in grams.	Numeric(4)	NULL	No
TARGIFTEMP	Target initial fuel tank temperature expressed in degrees Fahrenheit.	Numeric(3)	NULL	No
OBSIFTEMP	Observed initial fuel tank temperature expressed in degrees Fahrenheit.	Numeric(3)	NULL	No

"RUNLB_IN" Table				
Name	Comment	Datatype	Null Option	Is PK
CTR_TST_ID	Identification number assigned to the RESULT by a test contractor. (Hopefully uniquely identifies RESULT instances within a given contractor.) Not used for analytical purposes. But could help locate contractor's records pertinent to this RESULT.	Character(12)	NOT NULL	Yes
BAG_NUM	Bag number.	Numeric(2)	NOT NULL	Yes
BAG_BARO	Barometric pressure expressed in inches of mercury.	Numeric(5,2)	NULL	No
BAG_TEMP	Temperature expressed in degrees Fahrenheit.	Numeric(5,1)	NULL	No
BAG_HUMID	Humidity expressed in grains of water per pound of dry air.	Numeric(6,2)	NULL	No
BAG_DIST	Distance travelled expressed in miles.	Numeric(7,3)	NULL	No
BAG_THC	Total hydrocarbon exhaust emissions expressed in grams per mile.	Numeric(7,3)	NULL	No
BAG_CO	Carbon monoxide emissions expressed in grams per mile.	Numeric(8,3)	NULL	No
BAG_CO2	Carbon dioxide emissions expressed in grams per mile.	Numeric(8,3)	NULL	No
BAG_NOX	Emissions of oxides of nitrogen expressed in grams per mile.	Numeric(7,3)	NULL	No
BAG_MPG	Fuel economy expressed in miles per gallon.	Numeric(6,2)	NULL	No
W_RUNL_THC	Total hydrocarbon evaporative emissions, (for this portion of the test) expressed in grams. Often termed "running loss" emissions.	Numeric(7,2)	NULL	No
TARG_FTEMP	Target fuel tank temperature expressed in degrees Fahrenheit.	Numeric(3)	NULL	No
OBS_FTEMP	Observed fuel tank temperature expressed in degrees Fahrenheit.	Numeric(3)	NULL	No
TANK_PRESS	Fuel tank pressure expressed in pounds per square inch.	Numeric(5,1)	NULL	No
PURG_FLOW	Purge air flow volume during this portion of the test, expressed in liters.	Numeric(7,1)	NULL	No

"SCAN1_IN" Table				
Name	Comment	Datatype	Null Option	Is PK
CTR_TST_ID	Identification number assigned to the RESULT by a test contractor. (Hopefully uniquely identifies RESULT instances within a given contractor.) Not used for analytical purposes. But could help locate contractor's records pertinent to this RESULT.	Character(12)	NOT NULL	Yes
OBD1CODE	Numeric code resulting from a scan of level 1 on board diagnostic system.	Numeric(3)	NOT NULL	Yes
OBD1DESCR	Narrative explaining significance of individual code resulting from scan of a level 1 on board diagnostic system.	Character(50)	NULL	No

"SCAN2_IN" Table				
Name	Comment	Datatype	Null Option	Is PK
CTR_TST_ID	Identification number assigned to the RESULT by a test contractor. (Hopefully uniquely identifies RESULT instances within a given contractor.) Not used for analytical purposes. But could help locate contractor's records pertinent to this RESULT.	Character(12)	NOT NULL	Yes
OBD2CODE	Character string code resulting from a scan of a level 2 on board diagnostic system.	Character(5)	NOT NULL	Yes

"SMODE_IN" Table				
Name	Comment	Datatype	Null Option	Is PK
CTR_TST_ID	Identification number assigned to the RESULT by a test contractor. (Hopefully uniquely identifies RESULT instances within a given contractor.) The RES_KIND of the RESULT record ="ACTIVITY". Note that a ctr_tst_id can have only one activity and vice versa. Not used for analytical purposes. But could help locate contractor's records pertinent to this RESULT.	Character(12)	NOT NULL	Yes
SMOKEMODE	Name of the smoke test mode. Legal values defined by translation table.	Character(18)	NULL	Yes
SMOKE_OPAC	Percent smoke opacity measured during one mode of a smoke test.	Character(18)	NULL	No

"SMOKE_IN" Table				
Name	Comment	Datatype	Null Option	Is PK
CTR_TST_ID	Identification number assigned to the RESULT by a test contractor. (Hopefully uniquely identifies RESULT instances within a given contractor.) The RES_KIND of the RESULT record ="ACTIVITY". Note that a ctr_tst_id can have only one activity and vice versa. Not used for analytical purposes. But could help locate contractor's records pertinent to this RESULT.	Character(12)	NOT NULL	Yes
SMOKE_SUM	Single number representing the overall result of the smoke test, in units of percent opacity. For smoke test procedures that do not have such a summary result this field will be null.	Character(18)	NULL	No

"TIME_IN" Table				
Name	Comment	Datatype	Null Option	Is PK
DYNOSECS	Identifies point in time within a Mode of an chassis exhaust emissions test. Expressed in seconds.	Numeric(4)	NULL	Yes
CTR_TST_ID	Identification number assigned to the RESULT by a test contractor. (Hopefully uniquely identifies RESULT instances within a given contractor.) Not used for analytical purposes. But could help locate contractor's records pertinent to this RESULT.	Character(12)	NOT NULL	Yes
SPEED	Measured speed in miles per hour.	Numeric(6,2)	NULL	No
DIST	Distance traveled in miles, cumulative from beginning of test phase.	Numeric(6,3)	NULL	No
R_THC	Second-by-second measurement of total hydrocarbon concentration expressed in parts per million (ppm).	Numeric(4)	NULL	No
R_CO	Second-by-second measurement of carbon monoxide concentration expressed as a percentage (%).	Numeric(6,2)	NULL	No
R_NOX	Second-by-second measurement of nitric oxide (NO) concentration corrected for humidity expressed in parts per million (ppm).	Numeric(4)	NULL	No
R_CO2	Second-by-second measurement of carbon dioxide concentration expressed as a percentage	Numeric(6,2)	NULL	No
TEST_PHASE	Phase of the test to which this measurement belongs. This might be used for example to divide a repeated measurement test into time periods corresponding to bag samples, even though no bag samples were taken.	Numeric(1)	NULL	No

"TMEAS_IN" Table				
Name	Comment	Datatype	Null Option	Is PK
CTR_TST_ID	Identification number assigned to the RESULT by a test contractor. (Hopefully uniquely identifies RESULT instances within a given contractor.) Not used for analytical purposes. But could help locate contractor's records pertinent to this RESULT.	Character(12)	NOT NULL	Yes
MEAS_ID	Measurement type identification. Legal values defined by MEASTYPE translation table	Character(10)	NOT NULL	Yes
MEASURE	test level measurement	Numeric(10,3)	NULL	No

"TRIP_IN" Table				
Name	Comment	Datatype	Null Option	Is PK
TRIP_ID	Identifier assigned to each TRIP instance.	Character(12)	NOT NULL	Yes
CTR_TST_ID	Identification number assigned to the RESULT by a test contractor. (Hopefully uniquely identifies RESULT instances within a given contractor.) The RES_KIND of the RESULT record ="ACTIVITY". Note that a ctr_tst_id can have only one activity and vice versa. Not used for analytical purposes. But could help locate contractor's records pertinent to this RESULT.	Character(12)	NOT NULL	Yes
INS_CONFIG	Instrumentation Configuration.	Character(8)	NULL	No
OPERATORPTP	Type of operator that is using the vehicle. (Owner, Experienced Operator, etc.)	Character(12)	NULL	No
TSTART_DT	Date and time at the start of each trip.	Date	NOT NULL	No
TEND_DT	Date and time at the end of each trip.	Date	NOT NULL	No
F BATCH_ID	Fuel batch identification.	Character(10)	NULL	No
FUEL_ID	Numeric code uniquely identifying the general type of fuel used. Sometimes referred to as the "gross fuel type".	Numeric(3)	NULL	No
PAYLOAD	Total weight of passengers in the vehicle in pounds.	Numeric(5)	NULL	No
PASSENGER	Number of passengers in the vehicle.	Numeric(3)	NULL	No
OBD_STD	Communications protocol used. Values defined in translation table OBD_STD.	Character(25)	NULL	No
CTRTRSTD_P	This will equal the ctr_tst_id field from EQUIP_IN, added to provide a link between tables.	Character(18)	NULL	No

"TRIPOBD_IN" Table				
Name	Comment	Datatype	Null Option	Is PK
OBD2CODE	Character string code resulting from a scan of a level 2 on board diagnostic system.	Character(5)	NOT NULL	Yes
TRIP_ID	Identifier assigned to each TRIP instance.	Character(12)	NOT NULL	Yes
CTR_TST_ID	Identification number assigned to the RESULT by a test contractor. (Hopefully uniquely identifies RESULT instances within a given contractor.) The RES_KIND of the RESULT record ="ACTIVITY". Note that a ctr_tst_id can have only one activity and vice versa. Not used for analytical purposes. But could help locate contractor's records pertinent to this RESULT.	Character(12)	NOT NULL	Yes
TPMEAS_DT	Time within trip, expressed in seconds, beginning of test equals dynosecs = 0, first measurement is usually at dynosecs = 1.	Date	NOT NULL	Yes

"TIME_IN" Table				
Name	Comment	Datatype	Null Option	Is PK
TRIP_ID	Identifier assigned to each TRIP instance.	Character(12)	NOT NULL	Yes
CTR_TST_ID	Identification number assigned to the RESULT by a test contractor. (Hopefully uniquely identifies RESULT instances within a given contractor.) The RES_KIND of the RESULT record ="ACTIVITY". Note that a ctr_tst_id can have only one activity and vice versa. Not used for analytical purposes. But could help locate contractor's records pertinent to this RESULT.	Character(12)	NOT NULL	Yes
TPMEAS_DT	Time within trip, expressed in seconds, beginning of test equals dynosecs = 0, first measurement is usually at dynosecs = 1.	Date	NOT NULL	Yes
TRIP_SPEED	Vehicle speed (miles per hour) for each second.	Numeric(6,2)	NULL	No
TRIP_RPM	Engine's rpm for each second.	Numeric(5)	NULL	No
TRIP_TORQ	Engine's torque (calculated or measured) per second in ft-lbs.	Numeric(6)	NULL	No
TRIP_TEMP F	Ambient air temperature in degrees F per second.	Numeric(5,1)	NULL	No
TRIP_TEMP C	Ambient air temperature in degrees C per second.	Numeric(5,1)	NULL	No
TRIP_BARO	Ambient air's barometric pressure measured for each second in inches of mercury.	Numeric(5,2)	NULL	No
INST_BARO	Ambient air's barometric pressure measured for each second in kPa.	Numeric(5,2)	NULL	No
TRIP_HUMID	Absolute humidity measured each second expressed in grains of water per pound of dry air.	Numeric(6,2)	NULL	No
TRIP_LAT	Latitude of the vehicle measured for each second.	Numeric(10,6)	NULL	No
TRIP_LONG	Longitude of the vehicle measured for each second.	Numeric(10,6)	NULL	No
TRIP_ALT	Altitude of the vehicle measured for each second.	Numeric(6,0)	NULL	No
TRIP_GRADE	Grade measured for each second expressed in %.	Numeric(6,3)	NULL	No
TRIP_EXHFM	Measured exhaust gas flow rate in cubic feet per minute (SCFM).	Numeric(10,5)	NULL	No

"TTIME_IN" Table				
Name	Comment	Datatype	Null Option	Is PK
TRIP_EXHFC	Calculated exhaust gas flow rate in cubic feet per minute (SCFM).	Numeric(10,5)	NULL	No
FUEL_RATE	Fuel rate in lbs/sec.	Numeric(8,5)	NULL	No
TRIP_THC	Total Hydrocarbon in grams/sec.	Numeric(10,6)	NULL	No
TRIP_CO	Carbon Monoxide in grams/sec.	Numeric(10,6)	NULL	No
TRIP_CO2	Carbon Dioxide in grams/sec.	Numeric(10,6)	NULL	No
TRIP_NOX	Nitrogen Oxides in grams/sec.	Numeric(10,6)	NULL	No
TRIP_O2	Oxygen in grams/sec.	Numeric(10,6)	NULL	No
ENG_COOL_T	Engine coolant temperature (degrees F).	Numeric(5,1)	NULL	No
ENG_OIL_T	Engine oil temperature (degrees F).	Numeric(5,1)	NULL	No
MILLIGHT	"Millight" on/off.	Character(3)	NULL	No
TRIP_MASSF	Grams of exhaust per second	Numeric(6,2)	NULL	No
TRIP_VOLF	Standard cubic feet per minute of exhaust	Numeric(6,2)	NULL	No

V. Translational Tables

- a. Table Names Listing**
- b. Entity Definitions**
- c. Entity and Field Attribute Definitions**

V. Translational Tables

a. Table Names Listing

TRANSLATION TABLES

AIR_INJ

FUEL_DEL

OXY_TYPE

STANDARD

AIRFUEL

FUEL

PLAN_TABLE

STATETES

ASPIRATE

FUELTYPE

PRECOND

SYST_REP

CARBFUEL

GEARS

PRESSTAT

SYSTEM_S

CANISTER

HOW_LONG

PRESSURE

SYSTEM

CAT_TYPE

IGNITION

PROC_MAT

TASK

CETANE_T

IM240_PF

PROC METH

TEST_MOD

COOLING

IM_STAT

PURGE

TEST_PRO

COMPANY

INSTRSYS

QUEST_WA

TRAN_TYP

CUTPOINT

INTEREST

QUESTION

TRIP2LAB

DISABLE

KEYWORD

REFSPEED

TTRNTRAN

DRV_TRN

MAKE

RF_WEAR

VEH_MISC

DRV_TYPE

LF_WEAR

RES_KIND

VEH_STAT

EGR_TYPE

MAPTYPE

REP_TYPE

VEHCLASS

ENG_CLAS

MEASTYPE

ROUTE

VIN_BODY

ENG_CYCL

MODELSIZ

SCHED_TY

WA_STAT

ENGMOUNT

MODE_ID

SCC

FI_METH

NOM_SOAK

SITE

FI_TYPE

OBDLEVEL

SMOKECOL

FIXES

OWNERSHP

SMOKEMOD

V. Translational Tables

b. Entity Definitions

Table	
Name	Comment
AIR_INJ	Translation table that relates a key field to the type of air injection system.
AIRFUEL	Translation table that relates a key field to the air/fuel mixture at time of combustion.
ASPIRATE	Translation table that relates a key field to the type of aspiration.
CANISTER	Translation table that relates a key field to the type of canister that is on the object being tested.
CARBFUEL	This table gives legal combinations for fuel delivery configurations.
CAT_TYPE	Translation table that relates a key field to the type of catalyst that is on the object being tested.
CETANE_T	Translation table that relates a key field to the type of Cetane source.
COMPANY	Translation table that relates a key field (company_n) to company name and manufacturer's number.
COOLING	Translation table that relates a key field to the type of cooling.
CUTPOINT	Translation table that relates a key field to values for HC,CO and NOX.
DISABLE	This translation table relates a numeric id to a more detailed description of the disablement.
DRV_TRN	Translation table that relates a key field to the type drive wheel configuration.
DRV_TYPE	Translation table that relates a key field to where the vehicle is driven.
EGR_TYPE	Translation table that relates a key field to the type of exhaust gas recirculation that is used.
ENG_CLAS	Translation table that relates a key field to the horsepower classification of the object being tested.
ENG_CYCL	Translation table that relates a key field to the stroke classification of the engine.
ENGMOUNT	Translation table that relates a key field to the orientation of the engine.
FI_METH	Translation table that relates a key field to the method of fuel injection.
FI_TYPE	Translation table that relates a key field to a fuel injection technology.
FIXES	Translation table that relates a key field to repairs made on the object.
FUEL	Translation table that relates a key field to characteristics of the fuel.
FUEL_DEL	Translation table that relates a key field to the method of fuel delivery.
FUELTYPE	Translation table that relates a key field to the type of fuel used in the test.
GEARS	Translation table that relates a key field to a description of the gear configuration on the vehicle.
HOW_LONG	Translation table that relates a key field to the length of time of vehicle ownership.
IGNITION	Translation table that relates a key field to the type of ignition.
IM_STAT	Translation table that relates a key field to the status of the vehicle in regards to the IM240 test.
IM240_PF	Translation table that relates a key field to the pass or fail of the IM240 test.
INSTRSYS	Translation table that relates a key field to the type of test analyzer used.
INTEREST	Translation table that relates a key field to a work assignment id.
KEYWORD	Translation table that relates a key field to an abbreviated key word description of the test.
LF_WEAR	Translation table that relates a key field to the wear pattern of the left front tire.
MAKE	Translation table that relates a key field to a description of the make of the vehicle.
MAPTYPE	Translation table that relates a key field to the maximum available power under different operating patterns.
MEASTYPE	Translation table that relates a unit of measure field to what is being measured.
MODE_ID	Translation table that relates a key field to a description of test mode.
MODELSIZ	Translation table that relates a key field to a description of the size of the vehicle being tested.
NOM_SOAK	Translation table that relates a key field to a description of the type of soak to which the test vehicle was subjected.
OBDLEVEL	Translation table that relates a key field to the type of OBD technology.
OWNERSHP	Translation table that relates a key field to a class of ownership of the test object.
OXY_TYPE	Translation table that relates a key field to the type of oxygenate used in the test.
PLAN_TABLE	we have nothing on this table.
PRECOND	Translation table that relates a key field to the type of preconditioning to which the test object was subjected.
PRESSTAT	Translation table that relates a key field to status of if the pressure check was performed.
PRESSURE	Translation table that relates a key field to the status of the result of the pressure test.
PROC_MAT	Translation table that relates a key field to how good a match was attained in the procurement of the vehicle.
PROC METH	Translation table that relates a key field to how the vehicle was procured.
PURGE	Translation table that relates a key field to the status of the results of the purge test.

Table	
Name	Comment
QUEST_WA	Relates work assignment id to questions of vehicle owner. This table is empty.
QUESTION	empty table
REFSPEED	Translation table that relates a key field to a description of the referenced speed and who specified it.
REP_TYPE	Translation table that relates a key field to the type of repair.
RES_KIND	Translation table that relates a key field to the result kind to which the test results are classified.
RF_WEAR	Translation table that relates a key field to the wear pattern on the right front tire.
ROUTE	Translation table that relates a key field to a description of the driving route involved in the test.
SCC	Translation table that relates a key field to a potential source of pollution.
SCHED_TY	This table associates a "SCHED_TYPE" number with a system of units of measure.
SITE	Translation table that relates a key field to a testing location.
SMOKECOL	Translation table that relates a key field to a color classification of exhaust smoke.
SMOKEMOD	Translation table that relates a key field to the mode of operation during a smoke test.
STANDARD	Translation table that relates a key field to pollution standards by location.
STATETES	Translation table that relates a key field to the status of test results.
SYST_REP	Translation table that relates a key field to the system that was tested.
SYSTEM	Translation table that relates a key field to a description of the system involved.
SYSTEM_S	Translation table that relates a key field to the status of the results of the test.
TASK	Translation table that relates a key field to a description of the testing program.
TEST_MOD	This translation table relates a test "modif" number with a detailed description of that modification.
TEST_PRO	Translation table that relates a key field to a testing procedure.
TRAN_TYP	Translation table that relates a key field to a type of transmission.
TRIP2LAB	Translation table that relates a key field to the type of street used during the trip to the lab.
TTRNTRAN	This table contains legal values for transmission related components.
VEH_MISC	This table is empty.
VEH_STAT	Translation table that relates a key field to the status of the temperature of the vehicle and components during a test.
VEHCLASS	Translation table that relates a key field to the general classification of the object being tested.
VIN_BODY	A listing of the abbreviated name used to identify the different types of vehicle body styles.
WA_STAT	Translation table that relates a key field to the status of a work project.

1

V. Translational Tables

c. Entity (Table) and Field Attribute Definitions

FUEL TABLE

DATE: 11/19/2007

PAGE: 1

FUEL_ID	FUELNAME	OXYGENATE	WTOXYGEN	RVP	SULFERLOW	SULFERHIGH
	(Whatever came with vehicle)		0	0	0	0
			0	6.3	0	1000
			0	6.7	0	0
				6.9	0	0
0	Tank		0	9	0	1000
1	Low RVP Test Gasoline		0	0	800	1200
2	Low RVP Test Gasoline	MTBE	2	7	0	40
3	Low RVP Test Gasoline		0	0	0	500
6	Unleaded Test Gasoline (96 RON)		0	11.7	0	0
9	(CFR 86.113-91(a)) (8.8 RVP) Diesel Fuel	ethanol	3.4	8.8	0	0
10	California Phase II Gasoline		0	10.5	0	0
11	California Diesel		0	7.7	0	0
16	Unleaded Test Gasoline (11.7 RVP)					
18	Gasohol		3.4	8.7	0	0
22	Unleaded Test Gasoline (10.5 RVP) 10% ethanol splash-blended into					
30	Non-Oxygenated Baseline Fuel - 7.7.		3.4	7.7	0	0
31	Oxygenated Baseline Fuel, 8.7 RVP, ethanol	MTBE	0	7.7	0	0
			0	8.8	304	354
		MTBE	2	7	130	140
32	Gasohol (10% ethanol), RVP = 7.7 ethanol	MTBE	3	9	0	0
33	Gasoline with MTBE, RVP = 7.7	MTBE	0	9	0	0
43	Clean Air Act Baseline Gasoline	MTBE	2.3	8.8	0	0
44	Federal Phase II Gasoline					
45	Oxygenated Test Gasoline					
46	Oxygenated Test Gasoline					
48	Phase I Low Sulfur Gasoline					

FUEL TABLE

DATE: 11/19/2007

PAGE: 2

FUEL_ID	FUELNAME	OXYGENATE	WTOXYGEN	RVP	SULFERLOW	SULFERHIGH
		MTBE	2	8		0
	(9.0 RVP)	ethanol	0	8.7	0	0
			0	9	0	0
			0	9	0 11	11
49	Phase I Gasoline					
50	Low T-90 Unleaded Gasoline		3.4	9	50	80
51	Gasohol					
55	Unleaded Test Gasoline (96 RON) 11		0	9	140	160
60	Unleaded Test Gasoline (96 RON)		0	9	330	
61	Unleaded Test Gasoline (96 RON)		0	9	620	370 680
62	Unleaded SULFUR Gasoline (96 RON)		2.6	9.1	0	0
63	Unleaded SULFUR Gasoline (96 RON)	MeOH, TBA MeOH, EtOH	2.7	8.8	0	0
64	Unleaded SULFUR		0	7	0	0
65	Oxynol		0	11	0	0
66	Unleaded Test Gasoline (7.0 RVP)		0	9.2	0	0
67	Unleaded Test Gasoline (11.0 RVP)		0	14.6	0	0
69	Commercial Fuel Used by Southwest		0	10.4		0
70	High-RVP Gasoline		0	9	0	0
71	Special gasoline, with T40 point =				0	
72	Special gasoline, with T40 point =					

|160 deg F

FUEL TABLE

DATE: 11/19/2007

PAGE: 3

FUEL_ID	FUELNAME	OXYGENATE	WTOXYGEN	RVP	SULFERLOW	SULFERHIGH
		ethanol	3.4	11.8	0	0
		MTBE		12.2	0	0
			0	10	0	0
73	Gasohol (11.8 RVP)	ethanol	0 3.4	9.8	0	0
74	Special gasoline (with MTBE, 12.2	MTBE	0	9.5	0	0
	r)		0	0	500	5000
75	Special gasoline (10 RVP		0	8.7	0	0
76	Gasohol (9.8 RVP)		0	8	0	0
77	Oxygenated Test Gasoline		0	8.7	0	0
79	Non-Road Grade Diesel (high sulfu		0		0	0
80	Base formula fuel		0	8.7	0	0
81	Low RVP Fuel					
82	Low Sulfur Fuel	ethanol	0	8 8.1	0	0
83	Low Sulfur, Low RVP, Low T90 Fuel	MTBE	0	8.1	0	0
84	Baseline Fuel, 32% aromatics, 1.5%	MTBE	0	8.1	0	0
		MTBE	0	8.1	0	0
85	Formula Fuel with Ethanol	MTBE	0	8.1	0	0
86	Formula Fuel with MTBE					
87	High T50 Fuel with MTBE	MTBE	0	8.1		0
88	High T90 Fuel with MTBE					
89	MTBE, Heavy Ends, Predominately					
		MTBE	0	8.1	0 0	0
90	Arctic High T90, Cutting out 2% max), Low	MTBE	0	8.1	0	65
	Heaviest 10%, float olefin and					
91	Arctic Low Olefins (2% max)					
92	MTBE, Low Olefins, (

FUEL TABLE

DATE: 11/19/2007

PAGE: 4

FUEL_ID	FUELNAME	OXYGENATE	WTOXYGEN	RVP	SULFERLOW	SULFERHIGH
		MTBE	0	7	0	0
	7%, Aromatics		0	7	0	50
93	Low RVP MTBE, Low Olefins, Low Sulfur	MTBE	0	7	0	0
94	Calif. Phase II, low RVP and 40 CFR86.1313-94(b)(2) Type 2		0	0	300	500
95	Low RVP from ARCO MTBE, Low Olefins, (EM-2866-F)	PPM	0	0	0	10
96	Diesel, from Howell 40 CFR86.1313-94(b)(2) Type 2		0	0	2200	2600
97	ULTRA LOW DIESEL (0.040WT% SULFUR) 40 D		0	0	400	400
98	Diesel		0	0	100	200
99	Diesel with extra sulfur		0	0	0	0
109	AATA In-use Diesel (Tosca_12556:150 CFR86.1313-94(b)(2) Type 2-		0	0	0	0
110	Butane (ppm Sulfur)		0	0	0	0
111	Compressed Natural Gas		0	0	0	0
112	Propane		0	0	0	0
113	Diesel - Butane		0	0	0	0
114	Diesel - Natural Gas		0	0	0	0
115	Diesel - Propane		0	0	0	0

FUEL TABLE

DATE: 11/19/2007

PAGE: 5

FUEL_ID	FUELNAME	OXYGENATE	WTOXYGEN	RVP	SULFERLOW	SULFERHIGH
			0	0	0	0
			0	0	0	0
			0	0	0	0
			0	0	0	0
116	Gasoline - Electric		0	0	0	0
117	Gasoline - Natural Gas		0	0	0	0
118	Gasoline - Propane		0	0	0	0
119	Multi-fuels		14.7	0	0	0
120	Natural Gas		0	0	0	0
121	Propane - Natural Gas		0	0	0	0
122	Compressed Natural Gas		21.3	0	0	0
123	85% Ethanol, 15% Gasoline		2	0	0	0
124	Liquid Natural Gas		2	0	0	0
125	Liquid Propane Gas		2	0	0	0
126	85% Methanol, 15% Gasoline		2	0	0	0
127	California Phase I Summertime		2	0	0	0
			2	0	0	0
129	Federal RFG with 100 ppm Sulfur		2	0	0	0
130	Federal RFG with 150 ppm Sulfur		2	0	0	0
131	Federal RFG with 330 ppm Sulfur		2	0	0	0
132	Federal RFG with 600 ppm Sulfur		2	0	0	0
133	California Phase 2 RFG with 40 ppm Sulfur		17.4	0	0	0
			0	0	0	0
134	California Phase 2 RFG with 150 ppm Sulfur					
135	Alcohol Sulfur					
136	New York Standard Diesel Fuel #1					
	(7 OF 7 COLUMNS)					
	with 300 ppm Sulfur					

FUEL TABLE

DATE: 11/19/2007

PAGE: 6

FUEL_ID	FUELNAME	OXYGENATE	WTOXYGEN	RVP	SULFERLOW	SULFERHIGH
			0	0	0	0
			0	0	0	0
			0	0	0	0
137	Ultra Low Sulfur Diesel <30 ppm					
138	Gasoline with 30 ppmw sulfur					
139	Gasoline with 330 ppmw sulfur					
140	CARB - CALIFORNIA AIR RESOURCES					
141	CECD1 - LOW SULFUR DIESEL					
142	BOARD DIESEL CNG - COMPRESSED NATURAL GAS					
143	D1 - DIESEL 1					
144	D2 - DIESEL 2					
145	ECD - LOW SULFUR DIESEL					
146	FT - FISCHER TROPSCH SYNTHETIC					
147	LNG - LIQUID NATURAL GAS					
148	DIESEL MG - MOSSGAS IS A FISCHER TROPSCH					
149	MG50D250 - FISCHER TROPSCH AND SYNTHETIC DIESEL					
150	ULSD1 - ULTRA LOW SULFUR DIESEL 1. BIO-DIESEL BLEND		0	8.7	0	0
151	100% ETHANOL		0	8.7	0	0
152	BELOW 10 PPM SULFUR 100% METHANOL		0	8.9	0	0
300	A1 - AQIRP fuel					
301	B - AQIRP fuel					
302	B27 - AQIRP fuel					

FUEL TABLE

DATE: 11/19/2007

PAGE: 7

FUEL_ID	FUELNAME	OXYGENATE	WTOXYGEN	RVP	SULFERLOW	SULFERHIGH
		MTBE	0	8.7	0	0
			0	8.5	0	0
		MTBE	0	8.7	0	0
			0	8.8	0	0
303	C - AQIRP fuel		0	8.8	0	0
304	D - AQIRP fuel	MTBE	0	8.5	0	0
305	E - AQIRP fuel		0	8.9	0	0
306	F - AQIRP fuel	MTBE	0	8.6	0	0
307	G - AQIRP fuel			8.8	0	0
308	H - AQIRP fuel		0	8.5	0	0
309	I - AQIRP fuel		0	8.7	0	0
310	J - AQIRP fuel	MTBE	0	8	0	0
311	K - AQIRP fuel	MTBE	0	8.8	0	0
312	L - AQIRP fuel	MTBE	0	8.8	0	0
313	M - AQIRP fuel	ETBE	0	8.8	0	0
314	MM - AQIRP fuel	MTBE	0	8.6	0	0
315	N - AQIRP fuel		0	8.5	0	0
316	N2 - AQIRP fuel		0		0	0
317	NN - AQIRP fuel	MTBE	0	8.8	0	0
318	O - AQIRP fuel		0	8	0	0
319	P - AQIRP fuel	ETOH	0	9.3	0	0
320	Q - AQIRP fuel	ETOH	0	9.6	0	0
321	R - AQIRP fuel		0	7.8	0	0
322	S - AQIRP fuel	ETOH	0	9	0	0
323	T - AQIRP fuel					
324	U - AQIRP fuel					
325	V - AQIRP fuel					
326	W - AQIRP fuel					
327	X - AQIRP fuel					
328	Y - AQIRP fuel					
329	Z - AQIRP fuel					

FUEL TABLE

DATE: 11/19/2007

8

FUEL_ID	FUELNAME	OXYGENATE	WTOXYGEN	RVP	SULFERLOW	SULFERHIGH
			0	9.6	PAGE: 0	0
			0	8.8	0	0
		MEOH	0	8.8	0	0
		MEOH	0	12	0	0
327	X - AQIRP fuel	MTBE	0	8.7	0	0
328	Y2 - AQIRP fuel	MTBE	0	8.7	0	0
329	Z - AQIRP fuel	MTBE	0	8.9	0	0
330	ZZ - AQIRP fuel	MTBE	0	9	0	0
331	10A - AQIRP fuel	MTBE	0	8.6	0	0
332	11A - AQIRP fuel	ETOH	0	8.5	0	0
333	12A - AQIRP fuel	MTBE	0	8.6	0	0
334	13A - AQIRP fuel	MTBE	0	8.7	0	0
335	14A - AQIRP fuel	MTBE	0	8.5	0	0
336	15A - AQIRP fuel	MTBE	0	8.7	0	0
337	16A - AQIRP fuel	MTBE	0	8.7	0	0
338	17A - AQIRP fuel	MTBE	0	6.9	0	0
339	18A - AQIRP fuel	MTBE	0	6.8	0	0
340	A2 - AQIRP fuel	MTBE	0	6.8	0	0
341	C1 - AQIRP fuel	MTBE	0	6.9	0	0
342	C3 - AQIRP fuel	MTBE	0	6.8	0	0
343	C35 - AQIRP fuel	MTBE	0	6.8	0	0
344	C4 - AQIRP fuel	MTBE	0	6.7	0	0
345	C46 - AQIRP fuel	MTBE	0	6.7	0	0
346	C5 - AQIRP fuel	MTBE	0	6.9	0	0
347	C6 - AQIRP fuel	MTBE	0	6.9	0	0
348	C7 - AQIRP fuel	MTBE	0	6.9	0	0
349	C8 - AQIRP fuel	MTBE	0	6.9	0	0
350	CG1ACEL50NSP fuel	MTBE	0	6.9	0	0

FUEL TABLE

DATE: 11/19/2007

PAGE: 9

FUEL_ID	FUELNAME	OXYGENATE	WTOXYGEN	RVP	SULFERLOW	SULFERHIGH
			0		0	0
			0		0	0
			0		0	0
			0		0	0
351	CG1B - AQIRP fuel		0		0	0
352	CG1C - AQIRP fuel		0		0	0
353	CG2A - AQIRP fuel		0		0	0
354	CG2B - AQIRP fuel		0		0	0
355	CG2C - AQIRP fuel		0		0	0
356	CG2D - AQIRP fuel		0		0	0
357	CG3A - AQIRP fuel		0		0	0
358	CG3B - AQIRP fuel		0		0	0
359	CG3C - AQIRP fuel		0		0	0
360	CG4A - AQIRP fuel		0		0	0
361	CG4B - AQIRP fuel	MTBE	0	6.7	0	0
362	CG4C - AQIRP fuel	MTBE	0	6.6	0	0
362	CG4C - AQIRP fuel	ETOH	0	6.5		0
363	CG4D - AQIRP fuel	ETOH	0	6.9	0	0
364	CR1 - AQIRP fuel	MTBE	0	8.7	0	0
365	CR2 - AQIRP fuel	MTBE	0	8.7	0	0
366	E85A - AQIRP fuel	MTBE	0	8.7	0	0
367	E85D - AQIRP fuel	MTBE	0	8.6	0	0
368	R1A - AQIRP fuel	MTBE	0	8.5	0	0
369	R1B - AQIRP fuel	MTBE	0	8.5	0	0
370	R2A - AQIRP fuel	MTBE	0	8.5	0	0
371	R2B - AQIRP fuel	MTBE	0	8.5	0	0
372	R3A - AQIRP fuel	MTBE	0	8.5	0	0
373	R3B - AQIRP fuel	MTBE	0	8.5	0	0
374	R4A (COMMON) fuel	MTBE	0	8.4	0	0

FUEL TABLE

DATE: 11/19/2007

10

FUEL_ID	FUELNAME		WTOXYGEN	RVP	SULFERLOW	SULFERHIGH
		MTBE	0	8.6	0	0
		MTBE	0	8.6	0	0
		MTBE	0	8.6	0	0
		OXYGENATE MTBE	0	8.7	0	0
375	R4B - AQIRP fuel	MTBE	0	9	0	0
376	R5A - AQIRP fuel	MTBE	0		0	0
377	R5B - AQIRP fuel	MTBE	0	8.8	0	0
378	R6A - AQIRP fuel	MTBE	0	8.5	0	0
379	R6B - AQIRP fuel	MTBE	0	8.9	0	0
380	R7A - AQIRP fuel	MTBE	0	8.9	0	0
381	R7B - AQIRP fuel	MTBE	PAGE	9.3	0	0
382	R8A - AQIRP fuel	MTBE	0	9.3	0	0
383	R8B - AQIRP fuel	MTBE	0	9.3	0	0
384	R9A - AQIRP fuel		0		0	0
385	S0 - AQIRP fuel	MTBE	0	8.9		0
386	S1 - AQIRP fuel	MTBE	0	8.9	0	0
387	S2 - AQIRP fuel	MTBE	0	8.9	0	0
388	Y3 - AQIRP fuel	MTBE	0	8.9	0	0
389	Y4 - AQIRP fuel		0	8.9	0	0
390	Y5 - AQIRP fuel		0	8.9	0	0
391	Y6 - AQIRP fuel	TAME	0	8.8	0	0
392	Y7 - AQIRP fuel	MTBE	0	9.1	0	0
393	Y8 - AQIRP fuel	MEOH	0	7.7	0	0
394	YA - AQIRP fuel	MTBE/MEOH	0	7.1	0	0
395	YM - AQIRP fuel	MTBE/MEOH	0	9.6	0	0
396	Z1 - AQIRP fuel	MTBE				0
397	ZC2 - AQIRP fuel					0
398	ZCC (AQIRP) fuel					0

FUEL TABLE

DATE: 11/19/2007

PAGE: 11

FUEL_ID	FUELNAME	OXYGENATE	WTOXYGEN	RVP	SULFERLOW	SULFERHIGH
		NONE	0	0	0	10
		NONE	0	0	0	10
399	SwRI Alkylate Base Fuel for	NONE	0	0	0	10
400	5% Benzene 95% SwRI Alkylate Base Cyclohexane Testing	NONE	0	0	0	10
401	5% Cyclohexane 95% SwRI Alkylate Fuel for Cyclohexane Testing		0	7.7	16	21
402	30% Cyclohexane 95% SwRI Alkylate Base Fuel for Cyclohexane Testing	ETHANOL	2.1	7.8	16	21
		ETHANOL	3.8	7.7	16	21
			0	7.7	16	21
403	CRC E 67 FUEL A Base Fuel for Cyclohexane Testing	ETHANOL	3.8	7.8	16	21
404	CRC E 67 FUEL B		0	7.6	16	21
405	CRC E 67 FUEL C					
406	CRC E 67 FUEL D	ETHANOL	3.8	7.8	16	21
407	CRC E 67 FUEL E			7.9	16	21
408	CRC E 67 FUEL F	ETHANOL	2.2	7.7	16	21
409	CRC E 67 FUEL G		0	7.6	16	21
410	CRC E 67 FUEL H		0	7.7	16	21
411	CRC E 67 FUEL I	ETHANOL	3.8	7.7	16	21
415	BASER-AA TIER A. BASE - a fuel with	.NULL.	0	6.9	0	0
412	CRC E 67 FUEL J					
413	CRC E 67 FUEL K	ETHANOL				
414	CRC E 67 FUEL L	.NULL.	0	9.1	0	0

416|BASER-AA TIER A. a fuel with low
low RVP low benzene and low sulfur;
(7 OF 7 COLUMNS)

|benzene and low sulfur (Base + RVP)|

FUEL TABLE

DATE: 11/19/2007

12

FUEL_ID	FUELNAME	OXYGENATE	WTOXYGEN	RVP	SULFERLOW	SULFERHIGH
		.NULL.	0	9	0	0
		.NULL.	0	9.1	0	0
417	BASERB-AA_TIER_A.a fuel with low					
		.NULL.	0	7	0	0
418	BASERBS-AA_TIER_A.the reference sulfur (Base + RVP + benzene)					
		None	0	8.4	9	11
419	CARFG-AA_TIER_A. a California sulfur)	ETHANOL	3.4	7	13	15
END DATA FOR FUEL TABLE						
420	NERL_1 Test Fuel					
421	NERL_2 Test Fuel					

PAGE:

(7 OF 7 COLUMNS)

MEASTYPE TABLE
(4 OF 4 COLUMNS)

DATE: 11/21/2007

PAGE: 1

<u>MEAS_ID</u>	<u>MEAS_DESCR</u>	<u>MEAS_UNIT</u>	<u>CAS_RN</u>
ABIE814	8,14-abietenic acid	Micrograms/Mile	
ABIET8	8-abietic acid	Micrograms/Mile	
AC_LOAD	AC Compressor Load	Watts	
AC_ON_OFF	0 means compressor off, 1 means compressor on	None	
AIRFUELR	Air to fuel ratio	Milligrams/Mile	
API_GRAVIT	Degrees API	Degrees API	
AROMATICCS	Aromatic Content	%volume	
ATMNAP	A-trimethylnaphthalene	Micrograms/Mile	
A_DMPH	A-dimethylphenanthrene	Micrograms/Mile	
A_MFLU	A-methylfluorene	Micrograms/Mile	
As_ICP	Arsenic by ICP/MS	Milligrams/Mile	
B&J&K_PAHS	total of benzo(b+j+k)fluroanthene emissions	Micrograms/mile	
BBJKFL	Benzo(b+j+k)fluoranthene	Micrograms/Mile	
BC_<02.5u	Black Carbon less than 2.5 microns	Milligrams/Mile	
BEABYL	1Butene+iButylene	Milligrams/Mile	
BENZENE	Benzene Content	%volume	
BHPH	Work performed	Brake horsepower-hour	
BMPYFL	B-MePy/MeFl	Micrograms/Mile	
BTMNAP	B-trimethylnaphthalene	Micrograms/Mile	
B_DMPH	B-dimethylphenanthrene	Micrograms/Mile	
B_MFLU	B-methylfluorene	Micrograms/Mile	
BabsInst	Instantaneous Babs Concentration	micrograms/cubic meter	
C000050000	Formaldehyde	Milligrams/Mile	
C000050328	Benzo(a)pyrene emissions	Micrograms/Mile	
C000053703	Dibenz(a,h)anthracene	Micrograms/Mile	
C000056553	Benz(a)anthracene emissions	Micrograms/Mile	
C000057103	palmitic acid (c16)	Micrograms/Mile	
C000057114	stearic acid (c18)	Micrograms/Mile	
C000057874	ergosterol	Micrograms/Mile	
C000057885	cholesterol	Micrograms/Mile	

MEASTYPE TABLE
(4 OF 4 COLUMNS)

DATE: 11/21/2007

PAGE: 2

<u>MEAS_ID</u>	<u>MEAS_DESCR</u>	<u>MEAS_UNIT</u>	<u>CAS_RN</u>
C000061018	2,4-dimethylbenzoic acid	Micrograms/Mile	
C000064175	Ethyl Alcohol	Milligrams/mile	
C000064186	Formic Acid	Milligrams/mile	
C000065850	benzoic acid	Micrograms/Mile	
C00006625	Hexanaldehyde	Milligrams/Mile	
C000066251	hexanal	Milligrams/Mile	
C000067561	methanol emissions	Milligrams/mile	
C000067630	2-PROPANOL	Milligrams/Mile	67-63-0
C000067641	acetone emissions	Milligrams/Mile	
C000069727	salcylic acid	Micrograms/Mile	
C000071432	benzene emissions	Milligrams/mile	
C000074828	Methane Emissions	Milligrams/mile	
C000074840	ethane	Milligrams/mile	
C000074851	ethylene	Milligrams/mile	
C00007486	Ethyne	Milligrams/Mile	
C000074862	Ethyne	Milligrams/Mile	
C000074908	Hydrogen Cyanide	Milligrams/Mile	
C00007498	Propane	Milligrams/Mile	
C000074986	propene	Milligrams/Mile	
C00007499	Propyne	Milligrams/Mile	
C000074997	Propyne	Milligrams/Mile	
C000075070	Acetaldehyde	Milligrams/Mile	
C000075194	Cyclopropane	Milligrams/mile	
C000075285	Isobutane	Milligrams/mile	
C000075730	Tetrafluoromethene, Carbon Tetrafluoride	Milligrams/mile	
C00007583	2,2-DM-Butane	Milligrams/Mile	
C000075832	22DiMeButane	Milligrams/Mile	
C00007878	2M-Buane	Milligrams/Mile	
C000078784	isopentane	Milligrams/Mile	
C00007879	2M-1,3-Butadiene	Milligrams/Mile	
C000078795	2M-1,3-Butadiene	Milligrams/Mile	
C000078808	2-METHYL-1-BUTEN-3-YNE	Milligrams/Mile	78-80-8
C000078853	methacrolein emissions	Milligrams/Mile	
C000078933	2-butanone emissions	Milligrams/Mile	
C00007929	2,3-DM-Butane	Milligrams/Mile	
C000079298	23DiMeButane	Milligrams/Mile	
C000079549	levopimaric acid	Micrograms/Mile	
C000080568	alpha-pinene	Milligrams/Mile	
C000080977	cholestanol	Micrograms/Mile	
C000082053	Benzanthrone	Micrograms/Mile	

MEASTYPE TABLE
(4 OF 4 COLUMNS)

DATE: 11/21/2007

PAGE: 3

<u>MEAS_ID</u>	<u>MEAS_DESCR</u>	<u>MEAS_UNIT</u>	<u>CAS_RN</u>
C000082860	Acenaphthenequinone	Micrograms/Mile	
C000083329	acenaphthene emissions	Micrograms/Mile	
C000083465	sitosterol	Micrograms/Mile	
C000083487	stigmasterol	Micrograms/Mile	
C000084651	Anthraquinone	Micrograms/Mile	
C000085018	phenanthrene emissions	Micrograms/Mile	
C000086000	2-nitrobiphenyl	Micrograms/Mile	
C000086577	1-nitronaphthalene	Micrograms/Mile	
C000086737	Fluorene	Micrograms/Mile	
C000088993	phthalic acid	Micrograms/Mile	
C000090051	guaiacol	Micrograms/Mile	
C000090120	1-methylnaphthalene	Micrograms/Mile	
C000090448	Anthrone	Micrograms/Mile	
C000090471	Xanthone	Micrograms/Mile	
C000091101	syringol	Micrograms/Mile	
C000091203	naphthalene emissions	Micrograms/mile	
C000091521	2,4-dimethoxybenzoic acid	Micrograms/Mile	
C000091576	2-methylnaphthalene	Micrograms/Mile	
C000092524	Biphenyl	Micrograms/Mile	
C000092933	4-nitrobiphenyl	Micrograms/Mile	
C000093072	3,4-dimethoxybenzoic acid	Micrograms/Mile	
C000093516	4-me-guaiacol	Micrograms/Mile	
C000095476	o-xylene emissions	Milligams/mile	
C000095636	124TriMeBenzene	Milligrams/Mile	
C00009593	1,2,4,5-TetMBenzene	Milligrams/Mile	
C000095932	1245tetraMeBenzene	Milligrams/Mile	
C00009614	3M-Pentane	Milligrams/Mile	
C000096140	3-MePentane	Milligrams/Mile	
C00009637	M-Cyclopentane	Milligrams/Mile	
C000096377	MeCyPentane	Milligrams/Mile	

MEASTYPE TABLE
(4 OF 4 COLUMNS)

DATE: 11/21/2007

PAGE: 4

MEAS_ID	MEAS_DESCR	MEAS_UNIT	CAS_RN
C000097530	4-allyl-guaiacol (eugenol)	Micrograms/Mile	
C000097541	isoeugenol	Micrograms/Mile	
C00009819	tert-1B-3,5-DM-Benz	Milligrams/Mile	
C000098191	tert-1B-3,5-DM-Benz	Milligrams/Mile	
C00009882	I-PropBenzene	Milligrams/Mile	
C000098828	iPropBenzene	Milligrams/Mile	
C000099047	m-toluic	Micrograms/Mile	
C00009987	1M-4-I-PropBenzene	Milligrams/Mile	
C000099876	4-isopropyltoluene	Milligrams/Mile	
C000099945	p-toluic	Micrograms/Mile	
C00010001	Uncalibrated peaks to CBM Olefins	Milligrams/Mile	
C00010002	Uncalibrated peaks to CBM Paraffins	Milligrams/Mile	
C00010003	Uncalibrated peaks to CBM Toluene	Milligrams/Mile	
C00010004	Uncalibrated peaks to CBM Xylene	Milligrams/Mile	
C00010006	Uncalibrated peaks to CBM Aldehydes	Milligrams/Mile	
C00010012	Uncalibrated peaks to CBM Non Reactive	Milligrams/Mile	
C000100414	ethylbenzene emissions	Milligrams/mile	
C000100425	styrene emissions	Milligrams/mile	
C000100527	benzaldehyde emissions	Milligrams/Mile	
C00010365	n-PropBenzene	Milligrams/Mile	
C000103651	nPropBenzene	Milligrams/Mile	
C000103822	phenylacetic acid	Micrograms/Mile	
C00010451	n-ButBenzene	Milligrams/Mile	
C000104518	n-ButBenzene	Milligrams/Mile	
C00010487	p-Tolualdehyde	Milligrams/Mile	
C00010505	1,4-DE-Benzene	Milligrams/Mile	
C000105055	1,4-diethylbenzene	Milligrams/Mile	
C000106423	p-xylene	Milligrams/Mile	00106-42-3
C00010697	Butane	Milligrams/Mile	
C000106978	n-Butane	Milligrams/Mile	
C00010698	1-Butene	Milligrams/Mile	
C000106989	1-Butene	Milligrams/Mile	
C000106990	1,3-butadiene emissions	Milligrams/mile	
C00010700	1-Butyne	Milligrams/Mile	
C000107006	1-butyne	Milligrams/Mile	00107-00-6
C000107028	2-propenal (Acrolein) emissions	Milligrams/Mile	

MEASTYPE TABLE
(4 OF 4 COLUMNS)

DATE: 11/21/2007

PAGE: 5

MEAS_ID	MEAS_DESCR	MEAS_UNIT	CAS_RN
C000107222	glyoxal	Milligrams/Mile	
C00010739	2,4,4-TM-1-Pentene	Milligrams/Mile	
C000107391	244TMe-1-Pentene	Milligrams/Mile	
C00010740	2,4,4-TM-2-Pentene	Milligrams/Mile	
C000107404	2,4,4-TM-2-Pentene	Milligrams/Mile	
C00010783	2M-Pentane	Milligrams/Mile	
C000107835	2-MePentane	Milligrams/Mile	
C00010808	2,4-DM-Pentane	Milligrams/Mile	
C000108087	2,4-DiMePentane	Milligrams/Mile	
C000108383	M-xylene	Milligrams/mile	
C00010867	1,3,5-TM-Benzene	Milligrams/Mile	
C000108678	135TriMeBenzene	Milligrams/Mile	
C00010887	M-Cyclohexane	Milligrams/Mile	
C000108872	MeCyHexane	Milligrams/Mile	
C000108883	toluene emissions	Milligrams/mile	
C00010966	Pentane	Milligrams/Mile	
C000109660	n-Pentane	Milligrams/Mile	
C00010967	1-Pentene	Milligrams/Mile	
C000109671	1-Pentene	Milligrams/Mile	
C000110156	succinic acid (d-c4)	Micrograms/Mile	
C000110167	maleic acid	Micrograms/Mile	
C000110543	n-hexane emissions	Milligrams/mile	
C00011062	Pentanaldehyde	Milligrams/Mile	
C000110623	valeraldehyde	Milligrams/Mile	
C00011082	Cyclohexane	Milligrams/Mile	
C000110827	CycloHexane	Milligrams/Mile	
C00011083	Cyclohexene	Milligrams/Mile	
C000110838	Cyclohexene	Milligrams/Mile	
C000110941	glutaric acid (d-c5)	Micrograms/Mile	
C000111148	heptanoic acid (c7)	Micrograms/Mile	
C000111160	heptanedioic (pimelic) acid (d-c7)	Micrograms/Mile	
C000111206	sebacic acid (d-c10)	Micrograms/Mile	
C000111659	Octane	Milligrams/mile	
C00011166	1-Octene	Milligrams/Mile	
C000111660	Octene-1	Milligrams/Mile	

MEASTYPE TABLE
(4 OF 4 COLUMNS)

DATE: 11/21/2007

PAGE: 6

MEAS_ID	MEAS_DESCR	MEAS_UNIT	CAS_RN
C000111671	2-OCTENE	Milligrams/Mile	111-67-1
C00011184	Nonane	Milligrams/Mile	
C000111842	n-Nonane	Milligrams/Mile	
C000112050	nonanoic acid (c9)	Micrograms/Mile	
C00011240	Dodecane	Milligrams/Mile	
C000112403	Dodecane	Micrograms/Mile	
C000112798	elaidic acid	Micrograms/Mile	
C000112801	oleic acid	Micrograms/Mile	
C000112856	DOCOSANOIC ACID (C22)	MICROGRAMS/MILE	
C000112958	Eicosane	Micrograms/Mile	
C00011507	Propene	Milligrams/Mile	
C000115071	propene	Milligrams/Mile	
C00011511	2M-Propene	Milligrams/Mile	
C000115117	2M-Propene	Milligrams/Mile	
C000118901	o-toluic	Micrograms/Mile	
C000120127	anthracene emissions	Micrograms/Mile	
C000121335	4-formyl-guaiacol (vanillin)	Micrograms/Mile	
C000121346	vanillic acid	Micrograms/Mile	
C000121915	isophthalic acid	Micrograms/Mile	
C000123386	propionaldehyde emissions	Milligrams/Mile	
C00012372	n-Butyraldehyde	Milligrams/Mile	
C000123728	n-butyraldehyde	Milligrams/Mile	
C00012373	Crotonaldehyde	Milligrams/Mile	
C000123999	azelaic acid (d-c9)	Micrograms/Mile	
C000124072	octanoic acid (c8)	Micrograms/Mile	
C00012411	1-Nonene	Milligrams/Mile	
C000124118	Nonene-1	Milligrams/Mile	
C000124130	Octanal	Milligrams/Mile	
C00012418	Decane	Milligrams/Mile	
C000124185	n-Decane	Milligrams/Mile	
C000124196	Nonanal	Milligrams/Mile	
C000127275	pimaric acid	Micrograms/Mile	
C000127913	beta-pinene	Milligrams/Mile	

MEASTYPE TABLE
(4 OF 4 COLUMNS)

DATE: 11/21/2007

PAGE: 7

MEAS_ID	MEAS_DESCR	MEAS_UNIT	CAS_RN
C000129000	pyrene emissions	Micrograms/Mile	
C000132649	Dibenzofuran	Micrograms/Mile	
C000132650	Dibenzothiophene	Micrograms/Mile	
C000134963	syringaldehyde	Micrograms/Mile	
C00013501	1,2-DE-Benzene	Milligrams/Mile	
C000135013	1,2-diethylbenzene	Milligrams/Mile	
C00013598	s-ButBenzene	Milligrams/Mile	
C000135988	sButBenzene	Milligrams/Mile	
C000138863	Limonene	Milligrams/Mile	
C000141822	me-malonic (d-c3)	Micrograms/Mile	
C00014193	1,3-DE-Benzene	Milligrams/Mile	
C000141935	1,3-diethylbenzene	Milligrams/Mile	
C00014229	Cyclopentene	Milligrams/Mile	
C000142290	CycloPentene	Milligrams/Mile	
C00014282	Heptane	Milligrams/Mile	
C000142825	n-Heptane	Milligrams/Mile	
C000143077	dodecanoic (lauric) acid (c12)	Micrograms/Mile	
C000189640	Dibenzo(a,h)pyrene	Micrograms/Mile	
C000191071	Coronene	Micrograms/Mile	
C000191242	Benzo[ghi]perylene emissions	Micrograms/Mile	
C000191264	Anthanthrene	Micrograms/Mile	
C000192654	Dibenzo(a,e)pyrene	Micrograms/Mile	
C000192972	BeP	Micrograms/Mile	
C000193395	Indeno(1,2,3-c,d)pyrene	Micrograms/Mile	
C000195197	Benzo(c)phenanthrene	Micrograms/Mile	
C000198550	Perylene	Micrograms/Mile	
C000203123	Benzo(ghi)fluoranthene	Micrograms/Mile	
C000203338	Benzo(a)fluoranthene	Micrograms/Mile	
C000205492	Benzo(b)fluoranthene emissions	Micrograms/Mile	
C000205970	Dibenzo(b,k)fluoranthene	Micrograms/Mile	
C000206440	fluoranthene	Micrograms/Mile	
C000207089	Benzo(k)fluoranthene emissions	Micrograms/Mile	

MEASTYPE TABLE
(4 OF 4 COLUMNS)

DATE: 11/21/2007

PAGE: 8

MEAS_ID	MEAS_DESCR	MEAS_UNIT	CAS_RN
C000208968	acenaphthylene emissions	Micrograms/Mile	
C000213467	Picene	Micrograms/Mile	
C000214175	Benzo(b)chrysene	Micrograms/Mile	
C000215587	Dibenzo(ah+ac)anthracene	Micrograms/Mile	
C000217594	Triphenylene	Micrograms/Mile	
C000218019	Chrysene emissions	Micrograms/Mile	
C000224419	Dibenzo(a,j)anthracene	Micrograms/Mile	
C00028792	Cyclopentane	Milligrams/Mile	
C000287923	CycloPentane	Milligrams/Mile	
C000306081	homovanillic acid	Micrograms/Mile	
C000334485	decanoic acid (c10)	Micrograms/Mile	
C000373499	palmitoleic acid	Micrograms/Mile	
C000460128	1,3-butadiyne	Milligrams/mile	00460-12-8
C00046349	Propadiene	Milligrams/Mile	
C000463490	Propadiene	Milligrams/Mile	
C00046382	2,2-DM-Propane	Milligrams/Mile	
C000463821	2,2-DM-Propane	Milligrams/Mile	
C00046406	2,2,3-TM-Butane	Milligrams/Mile	
C000464062	223TriMeButane	Milligrams/Mile	
C000471625	17á(H),21á(H)-Hopane	Micrograms/Mile	
C000471749	sandaracopimaric acid	Micrograms/Mile	
C000473723	cis-pinonic acid	Micrograms/Mile	
C000483658	Retene	Micrograms/Mile	
C000483874	1,7-dimethylphenanthrene	Micrograms/Mile	
C000486259	9-fluorenone	Micrograms/Mile	
C00048823	1,2,3,4-TetMBenzene	Milligrams/Mile	
C000488233	1234tetraMeBenzene	Milligrams/Mile	
C00049611	Indan	Milligrams/Mile	
C000496117	Indan	Milligrams/Mile	
C000498022	acetovanillone	Micrograms/Mile	
C000498077	levoglucosan	Micrograms/Mile	
C00050317	2-Butyne	Milligrams/Mile	
C000503173	2-butyne	Milligrams/Mile	00503-17-3

MEASTYPE TABLE
(4 OF 4 COLUMNS)

DATE: 11/21/2007

PAGE: 9

MEAS_ID	MEAS_DESCR	MEAS_UNIT	CAS_RN
C000505486	suberic acid (d-c8)	Micrograms/Mile	
C000505522	1,11-undecanedicarboxylic acid (d-c13)	Micrograms/Mile	
C000505544	hexanedioic (adipic) acid (d-c6)	Micrograms/Mile	
C000506127	heptadecanoic acid (c17)	Micrograms/Mile	
C000506309	eicosanoic acid (c20)	Micrograms/Mile	
C00051335	2M-2-Butene	Milligrams/Mile	
C000513359	2-Me-2-Butene	Milligrams/Mile	
C000514103	abietic acid	Micrograms/Mile	
C000526738	123TriMeBenzene	Milligrams/Mile	
C00052753	1,2,3,5-TetMBenzene	Milligrams/Mile	
C000527537	1235tetraMeBenzene	Milligrams/Mile	
C00052784	1M-2-I-PropBenzene	Milligrams/Mile	
C000527844	2-ipropyltoluene	Milligrams/Mile	
C000529204	O-TOLUALDEHYDE	Milligrams/Mile	529-20-4
C000530574	syringic acid	Micrograms/Mile	
C00053577	1M-3-I-PropBenzene	Milligrams/Mile	
C000535773	3-ipropyltoluene	Milligrams/Mile	
C00053868	n-PentBenzene	Milligrams/Mile	
C000538681	n-PentBenzene	Milligrams/Mile	
C00053893	I-ButylBenzene	Milligrams/Mile	
C000538932	iButBenzene	Milligrams/Mile	
C000540841	2,2,4-timethylpentane emissions	Milligrams/mile	
C00054292	Cyclopentadiene	Milligrams/Mile	
C000544638	myristic acid (c14)	Micrograms/Mile	
C000544649	myristoleic acid	Micrograms/Mile	
C000544763	Hexadecane	Micrograms/Mile	
C000544854	Dotriacontane	Micrograms/Mile	
C000548390	Perinaphthenone	Micrograms/Mile	
C000557595	tetracosanoic acid (c24)	Micrograms/Mile	
C00055837	3,3-DM-1-Butene	Milligrams/Mile	
C000558372	3,3-DM-1-Butane -spe	Milligrams/Mile	
C00056021	2,3,3-TM-Pentane	Milligrams/Mile	
C000560214	2,3,3-TM-Pentane	Milligrams/Mile	

MEASTYPE TABLE
(4 OF 4 COLUMNS)

DATE: 11/21/2007

PAGE: 10

MEAS_ID	MEAS_DESCR	MEAS_UNIT	CAS_RN
C00056249	3,3-DM-Pentane	Milligrams/Mile	
C000562492	3,3-DM-Pentane	Milligrams/Mile	
C00056316	3,3-DM-Hexane	Milligrams/Mile	
C000563166	3,3-DM-Hexane	Milligrams/Mile	
C00056345	3M-1-Butene	Milligrams/Mile	
C000563451	3-Me-1-Butene	Milligrams/Mile	
C00056346	2M-1-Butene	Milligrams/Mile	
C000563462	2-Me-1-Butene	Milligrams/Mile	
C000563780	2,3-dimethyl-1-butene	Milligrams/Mile	00563-78-0
C000563791	2,3-DIMETHYL-2-BUTENE	Milligrams/Mile	563-79-1
C000564023	2,2,3-TRIMETHYL-PENTANE	Milligrams/Mile	
C00056559	2,3-DM-Pentane	Milligrams/Mile	
C000565593	23DiMePentane	Milligrams/Mile	
C00056575	2,3,4-TM-Pentane	Milligrams/Mile	
C000565753	234TrMePentane	Milligrams/Mile	
C000573988	1,2-dimethylnaphthalene	Micrograms/Mile	
C00057673	1,2,3-TM-Benzene	Milligrams/Mile	
C000581895	2-nitronaphthalene	Micrograms/Mile	
C000583482	3,4-DIMETHYLHEXANE	Milligrams/Mile	
C00058494	2,3-DM-Hexane	Milligrams/Mile	
C000584941	23DiMeHexane	Milligrams/Mile	
C00058934	3M-Hexane	Milligrams/Mile	
C000589344	3MeHexane	Milligrams/Mile	
C00058943	2,4-DM-Hexane	Milligrams/Mile	
C000589435	24DiMeHexane	Milligrams/Mile	
C00058953	4M-Heptane	Milligrams/Mile	
C000589537	4MeHeptane	Milligrams/Mile	
C00058981	3M-Heptane	Milligrams/Mile	
C000589811	3MeHeptane	Milligrams/Mile	
C00059018	c-2-Butene	Milligrams/Mile	
C000590181	c-2-Butene	Milligrams/Mile	
C000590192	1,2-butadiene	Milligrams/mile	00590-19-2
C00059035	2,2-DM-Pentane	Milligrams/Mile	
C000590352	2,2-dimethylpentane	Milligrams/mile	00590-35-2
C000590669	11DMeCyHexane	Milligrams/Mile	
C00059073	2,2-DM-Hexane	Milligrams/Mile	
C000590738	2,2-DM-Hexane	Milligrams/Mile	
C000590863	ISOVALERALDEHYDE	Milligrams/Mile	590-86-3
C000591219	1,3-DIMETHYLCYCLOHEXANE	Milligrams/Mile	591-21-9
C000591479	4-METHYLCYCLOHEXENE	Milligrams/Mile	591-47-9

MEASTYPE TABLE
(4 OF 4 COLUMNS)

DATE: 11/21/2007

PAGE: 11

MEAS_ID	MEAS_DESCR	MEAS_UNIT	CAS_RN
C000591480	3-METHYLCYCLOHEXENE	Milligrams/Mile	591-48-0
C00059176	2M-Hexane	Milligrams/Mile	
C000591764	2MeHexane	Milligrams/Mile	
C000591935	1,4-PENTADIENE	Milligrams/Mile	591-93-5
C00059213	2,5-DM-Hexane	Milligrams/Mile	
C000592132	25DiMeHexane	Milligrams/Mile	
C00059227	2M-Heptane	Milligrams/Mile	
C000592278	2MeHeptane	Milligrams/Mile	
C00059241	1-Hexene	Milligrams/Mile	
C000592416	1-Hexene	Milligrams/Mile	
C00059276	1-Heptene	Milligrams/Mile	
C000592767	1-Heptene	Milligrams/Mile	
C000593453	Octadecane	Micrograms/Mile	
C000593497	Heptacosane	Micrograms/Mile	
C000602380	1,8-dinitronaphthalene	Micrograms/Mile	
C000602608	9-nitroanthracene	Micrograms/Mile	
C000602879	5-nitroacenaphthene	Micrograms/Mile	
C000603792	2,3- and 3,5- dimethylbenzoic acid	Micrograms/Mile	
C000605710	1,5-dinitronaphthalene	Micrograms/Mile	
C000606371	1,3-dinitronaphthalene	Micrograms/Mile	
C000607578	2-nitrofluorene	Micrograms/Mile	
C000610720	2,5-dimethylbenzoic acid	Micrograms/Mile	
C00061114	1E-2M-Benzene	Milligrams/Mile	
C000611143	oEtToluene	Milligrams/Mile	
C000611154	O-METHYLSTYRENE	Milligrams/Mile	611-15-4
C000613127	2-methylanthracene	Micrograms/Mile	
C00061612	3M-t-2-Pentene	Milligrams/Mile	
C000616126	t-3-Me-2-Pentene	Milligrams/Mile	
C00061778	3E-Pentane	Milligrams/Mile	
C000617787	3EtPentane	Milligrams/Mile	
C000619045	3,4-dimethylbenzoic acid	Micrograms/Mile	
C000619998	3-ETHYLHEXANE	Milligrams/Mile	
C00062014	1M-3E-Benzene	Milligrams/Mile	

MEASTYPE TABLE
(4 OF 4 COLUMNS)

DATE: 11/21/2007

PAGE: 12

MEAS_ID	MEAS_DESCR	MEAS_UNIT	CAS_RN
C000620144	mEtToluene	Milligrams/Mile	
C000620235	m-tolualdehyde	Milligrams/mile	00620-23-5
C00062296	1M-4E-Benzene	Milligrams/Mile	
C000622968	pEtToluene	Milligrams/Mile	
C00062464	t-2-Butene	Milligrams/Mile	
C000624646	t-2-Butene	Milligrams/Mile	
C00062527	2M-2-Pentene	Milligrams/Mile	
C000625274	2-Me-2-Pentene	Milligrams/Mile	
C000625650	2,4-dimethyl-2-pentene	Milligrams/Mile	00625-65-0
C000626517	3-methylglutaric acid (d-c5)	Micrograms/Mile	
C00062720	c-2-Pentene	Milligrams/Mile	
C000627203	c-2-Pentene	Milligrams/Mile	
C000629505	Tridecane	Micrograms/Mile	
C000629594	Tetradecane	Micrograms/Mile	
C000629629	Pentadecane	Micrograms/Mile	
C000629787	Heptadecane	Micrograms/Mile	
C000629925	Nonadecane	Micrograms/Mile	
C000629947	Heneicosane	Micrograms/Mile	
C000629970	Docosane	Micrograms/Mile	
C000629992	Pentacosane	Micrograms/Mile	
C000630013	Hexacosane	Micrograms/Mile	
C000630024	Octacosane	Micrograms/Mile	
C000630035	Nonacosane	Micrograms/Mile	
C000630046	Hentriacontane	Micrograms/Mile	
C000630057	Tritriacontane	Micrograms/Mile	
C000630068	Hexatriacontane	Micrograms/Mile	
C000630079	Pentatriacontane	Micrograms/Mile	
C000632462	2,6-dimethylbenzoic acid	Micrograms/Mile	
C00063792	ETBE	Milligrams/Mile	
C000637923	ETBE	Milligrams/Mile	
C00063804	c-1,3-DM-CycHexane	Milligrams/Mile	

MEASTYPE TABLE
(4 OF 4 COLUMNS)

DATE: 11/21/2007

PAGE: 13

MEAS_ID	MEAS_DESCR	MEAS_UNIT	CAS_RN
C000638040	c-1,3-DM-CycHexane	Milligrams/Mile	
C000638368	Phytane	Micrograms/Mile	
C000638539	tridecanoic acid (c13)	Micrograms/Mile	
C000638675	Tricosane	Micrograms/Mile	
C000638686	Triacontane	Micrograms/Mile	
C000642319	9-Anthraaldehyde	Micrograms/Mile	
C000643583	2-Methylbiphenyl	Micrograms/Mile	
C000643936	3-Methylbiphenyl	Micrograms/Mile	
C000644086	4-Methylbiphenyl	Micrograms/Mile	
C00064604	t-2-Pentene	Milligrams/Mile	
C000646048	t-2-Pentene	Milligrams/Mile	
C000646300	nonadecanoic acid (c19)	Micrograms/Mile	
C000646311	Tetracosane	Micrograms/Mile	
C00067476	4M-t-2-Pentene	Milligrams/Mile	
C000674760	4M-t-2-Pentene	Milligrams/Mile	
C000689974	1-buten-3-yne	Milligrams/mile	00689-97-4
C00069137	4M-1-Pentene	Milligrams/Mile	
C000691372	4M-1-Pentene	Milligrams/Mile	
C00069138	4M-c-2-Pentene	Milligrams/Mile	
C000691383	4M-c-2-Pentene	Milligrams/Mile	
C000692240	2-methyl-trans-3-hexene	Milligrams/mile	00692-24-0
C000693232	dodecanedioic acid (d-c12)	Micrograms/Mile	
C00069389	1M-Cyclopentene	Milligrams/Mile	
C000693890	1M-Cyclopentene	Milligrams/Mile	
C000694359	3-ETHYL CYCLOPENTENE	Milligrams/Mile	694-35-9
C000696297	iPropCyHexane	Milligrams/Mile	
C00076020	3M-1-Pentene	Milligrams/Mile	
C000760203	3M-1-Pentene	Milligrams/Mile	
C000760214	2-ETHYL-1-BUTENE	Milligrams/Mile	760-21-4
C00076329	2M-1-Pentene	Milligrams/Mile	
C000763291	2-Me-1-Pentene	Milligrams/Mile	
C000767599	1-METHYL-1H-INDENE	Milligrams/Mile	767-59-9
C000779022	9-methylanthracene	Micrograms/Mile	
C00081679	3E-c-2-Pentene	Milligrams/Mile	
C000816795	3E-c-2-Pentene	Milligrams/Mile	
C000821385	1,12-dodecanedicarboxylic acid (d-c14)	Micrograms/Mile	
C00082250	t-1,2-DM-CycloPentane	Milligrams/Mile	

MEASTYPE TABLE
(4 OF 4 COLUMNS)

DATE: 11/21/2007

PAGE: 14

MEAS_ID	MEAS_DESCR	MEAS_UNIT	CAS_RN
C000822504	t-1,2-DM-CycloPentane	Milligrams/Mile	
C000824226	4-methylindan	Milligrams/Mile	00824-22-6
C000824635	2-methylindan	Milligrams/Mile	00824-63-5
C000832699	1-methylphenanthrene	Micrograms/Mile	
C000832713	3-methylphenanthrene	Micrograms/Mile	
C000871830	2-methylnonane	Milligrams/Mile	00871-83-0
C000874351	5-methylindan	Milligrams/Mile	00874-35-1
C00087441	1,3-DM-4-E-Benzene	Milligrams/Mile	
C000874419	1,3-DM-4-E-Benzene	Milligrams/Mile	
C000883205	9-methylphenanthrene	Micrograms/Mile	
C000892217	3-nitrofluoranthene emissions	Micrograms/Mile	
C000922281	3,4-DIMETHYLHEPTANE	Milligrams/Mile	922-28-1
C000922623	c-3-Me-2-Pentene	Milligrams/Mile	
C00092682	3,5-DM-Heptane	Milligrams/Mile	
C000926829	3,5-DM-Heptane	Milligrams/Mile	
C00093398	1,2-DM-3-E-Benzene	Milligrams/Mile	
C000933982	1,2-DM-3-E-Benzene	Milligrams/Mile	
C000934747	1,3-dimethyl-5-ethylbenzene	Milligrams/mile	00934-74-7
C00093480	1,2-DM-4-E-Benzene	Milligrams/Mile	
C000934805	1,2-DM-4-E-Benzene	Milligrams/Mile	
C000954461	9-nitrophenanthrene	Micrograms/Mile	
C0009563	1,2,4-TM-Benzene	Milligrams/Mile	
C00099262	3M-c-2	Milligrams/Mile	
C00099405		Milligrams/Mile	
C001002842	pentadecanoic acid (c15)	Micrograms/Mile	
C00106953	2,3,5-TM-Hexane	Milligrams/Mile	
C001069530	2,3,5-TM-Hexane	Milligrams/Mile	
C001072055	2,6-DIMETHYLHEPTANE	Milligrams/Mile	
C00107417	1M-2-n-PropBenzene	Milligrams/Mile	
C001074175	1M-2-n-PropBenzene	Milligrams/Mile	
C00107443	1M-3-n-PropBenzene	Milligrams/Mile	
C001074437	1M-3-n-PropBenzene	Milligrams/Mile	
C00107455	1M-4-n-PropBenzene	Milligrams/Mile	
C001074551	1M-4-n-PropBenzene	Milligrams/Mile	
C001074926	1-(1,1-dimethylethyl)-2-methyl benzene	Milligrams/Mile	01074-92-6
C00112021	Undecane	Milligrams/Mile	
C001120214	Undecane	Micrograms/Mile	
C00112062	3M-Cyclopentene	Milligrams/Mile	
C001120623	3-methylcyclopentene	Milligrams/mile	01120-62-3
C001132214	3,5-dimethoxybenzoic acid	Micrograms/Mile	
C001176449	17á(H), 21a(H)-hopane	Micrograms/Mile	
C001192183	1-CIS-2-DIMETHYLCYCLOPENTANE	Milligrams/Mile	1192-18-3
C001334787	tolualdehyde	Milligrams/Mile	

MEASTYPE TABLE
(4 OF 4 COLUMNS)

DATE: 11/21/2007

PAGE: 15

MEAS_ID	MEAS_DESCR	MEAS_UNIT	CAS_RN
C001466768	2,6-dimethoxybenzoic acid	Micrograms/Mile	
C001521386	2,3-dimethoxybenzoic acid	Micrograms/Mile	
C001574410	CIS-1,3-PENTADIENE	Milligrams/Mile	1574-41-0
C001576676	3,6-dimethylphenanthrene	Micrograms/Mile	
C001595115	1-methyl-2-n-butylbenzene	Milligrams/Mile	01595-11-5
C001634044	2-methoxy-2-methylpropane (MTBE) emissions	Milligrams/mile	
C001638262	1,1-DIMETHYLCYCLOPENTANE	Milligrams/Mile	1638-26-2
C00164089	E-Cyclopentane	Milligrams/Mile	
C001640897	E-Cyclopentane	Milligrams/Mile	
C00167891	E-CycHexane	Milligrams/Mile	
C001678917	E-CycHexane	Milligrams/Mile	
C001688348	1-TRANS-2-CIS-4-TRIMETHYLCYCLO PENTANE	Milligrams/Mile	
C001730376	1-methylfluorene	Micrograms/Mile	
C001740198	dehydroabietic acid	Micrograms/Mile	
C00175888	1,4-DM-2-E-Benzene	Milligrams/Mile	
C001758889	1,4-DM-2-E-Benzene	Milligrams/Mile	
C001759586	TRANS-1,3-DIMETHYLCYCLOPENTANE	Milligrams/Mile	
C001759815	4-METHYLCYCLOPENTENE	Milligrams/Mile	1759-81-5
C001795159	Octylcyclohexane	Micrograms/Mile	
C001795160	Decylcyclohexane	Micrograms/Mile	
C001795171	Dodecylcyclohexane	Micrograms/Mile	
C001795182	Tetradecylcyclohexane	Micrograms/Mile	
C001839630	1,3,5-trimethylcyclohexane	Milligrams/Mile	01839-63-0
C001852046	undecanedioic acid (d-c11)	Micrograms/Mile	
C001945535	palustric acid	Micrograms/Mile	
C002004708	trans-1,3-pentadiene	Milligrams/mile	02004-70-8
C002023568	Palladium	Milligrams/Mile	
C002023695	Potassium	Milligrams/Mile	
C002040951	N-BUTYLCYCLOPENTANE	Milligrams/Mile	2040-95-1
C002040962	N-PROPYLCYCLOPENTANE	Milligrams/Mile	2040-96-2
C002051301	26DiMeOctane	Milligrams/Mile	
C002091956	2,2,5-trimethylheptane	Milligrams/Mile	02091-95-6
C002113588	3-nitrobiphenyl	Micrograms/Mile	
C002131411	1,4,5-trimethylnaphthalene	Micrograms/Mile	

MEASTYPE TABLE
(4 OF 4 COLUMNS)

DATE: 11/21/2007

PAGE: 16

MEAS_ID	MEAS_DESCR	MEAS_UNIT	CAS_RN
C002146385	1-ETHYLCYCLOPENTENE	Milligrams/Mile	2146-38-5
C002198234	4-NONENE	Milligrams/Mile	2198-23-4
C00220701	1c-2-DM-CycloHexane	Milligrams/Mile	
C002207014	cis-1,2-dimethylcyclohexane	Milligrams/Mile	02207-01-4
C00220703	t-1,3-DM-CycHexane	Milligrams/Mile	
C002207036	t-1,3-DM-CycHexane	Milligrams/Mile	
C00220704	t-1,4-DM-CycHexane	Milligrams/Mile	
C002207047	t-1,4-DM-CycHexane	Milligrams/Mile	
C00221323	2,4-DM-Heptane	Milligrams/Mile	
C002213232	24DiMeHeptane	Milligrams/Mile	
C002213323	2,4-dimethyl-1-pentene	Milligrams/mile	02213-32-3
C002216300	2,5-DIMETHYLHEPTANE	Milligrams/Mile	
C00221633	3M-Octane	Milligrams/Mile	
C002216333	3MeOctane	Milligrams/Mile	
C00221634	4M-Octane	Milligrams/Mile	
C002216344	4M-Octane	Milligrams/Mile	
C002216388	2-NONENE	Milligrams/Mile	2216-38-8
C002245387	2,3,5+I-trimethylnaphthalene	Micrograms/Mile	
C002363715	heneicosanoic acid (c21)	Micrograms/Mile	
C002381217	1-methylpyrene	Micrograms/Mile	
C002433967	TRICOSANOIC ACID (c23)	MICROGRAMS/MILE	
C002498660	Benz(a)anthracene-7,12-dione	Micrograms/Mile	
C002531842	2-methylphenanthrene	Micrograms/Mile	
C00253258	c-1,3-DM-CycloPentane	Milligrams/Mile	
C002532583	cis-1,3-dimethylcyclopentane	Milligrams/mile	02532-58-3
C002541697	7-methylbenz(a)anthracene	Micrograms/Mile	
C002613652	trans-1-methyl-3-ethylcyclopentane	Milligrams/mile	02613-65-2
C002613663	CIS-1-ETHYL-3-METHYLCYCLOPENTANE	Milligrams/Mile	2613-66-3
C002724585	isostearic acid	Micrograms/Mile	
C00273819	2M-2-Hexene	Milligrams/Mile	
C002738194	2M-2-Hexene	Milligrams/Mile	
C002785899	4-ethyl-guaiacol	Micrograms/Mile	
C002785980	2,5-dimethoxybenzoic acid	Micrograms/Mile	
C002815589	1,2,4-trimethylcyclopentane	Milligrams/Mile	02815-58-9
C00287004	1,3-DM-2-E-Benzene	Milligrams/Mile	
C002870044	1,3-dimethyl-2-ethylbenzene	Milligrams/mile	02870-04-4
C002883025	Nonylcyclohexane	Micrograms/Mile	
C003058013	3-methyladipic acid (d-c6)	Micrograms/Mile	

MEASTYPE TABLE
(4 OF 4 COLUMNS)

DATE: 11/21/2007

PAGE: 17

MEAS_ID	MEAS_DESCR	MEAS_UNIT	CAS_RN
C00307471	2,3-DM-Heptane	Milligrams/Mile	
C003074713	2,3-DM-Heptane	Milligrams/Mile	
C00322161	2M-Octane	Milligrams/Mile	
C003221612	2MeOctane	Milligrams/Mile	
C003331462	9,10-dihydrobenzo(a)pyrene-7(8H)-one	Micrograms/Mile	
C003351313	3-methylchrysene	Micrograms/Mile	
C003353126	4-methylpyrene	Micrograms/Mile	
C00340461	3M-1-Hexene	Milligrams/Mile	
C003404613	3-methyl-1-hexene	Milligrams/Mile	03404-61-3
C00352294	2,2,5-TM-Hexane	Milligrams/Mile	
C003522949	225TMHexane	Milligrams/Mile	
C003683225	4-methyl-trans-2-hexene	Milligrams/mile	03683-22-5
C003742389	4-ETHYL CYCLOPENTENE	Milligrams/Mile	3742-38-9
C003769231	4MeHexene	Milligrams/Mile	
C003875512	ISOPROPYLCYCLOPENTANE	Milligrams/Mile	3875-51-2
C003891983	Farnesane	Micrograms/Mile	
C003892000	Norpristane	Micrograms/Mile	
C00389936	3M-t-3-Hexene	Milligrams/Mile	
C003899363	3-methyl-trans-3-hexene	Milligrams/mile	03899-36-3
C003913857	trans-2-decenoic acid	Micrograms/Mile	
C00396885	2M-ButylBenzene	Milligrams/Mile	
C004032864	33DiMeHeptane	Milligrams/Mile	
C00403294	2,4-DM-Octane	Milligrams/Mile	
C004032944	2,4-DM-Octane	Milligrams/Mile	
C00405045	t-2-Hexene	Milligrams/Mile	
C004050457	t-2-Hexene	Milligrams/Mile	
C004110445	3,3-dimethyloctane	Milligrams/Mile	04110-44-5
C004170303	crotonaldehyde	Milligrams/Mile	
C004259001	1,1,2-TRIMETHYLCYCLOPENTANE	Milligrams/Mile	4259-00-1
C004443554	Eicosylcyclohexane	Micrograms/Mile	
C004445061	Octadecylcyclohexane	Micrograms/Mile	
C004516692	1,1,3-TRIMETHYLCYCLOPENTANE	Milligrams/Mile	
C004914890	CIS-3-METHYL-3-HEXENE	Milligrams/Mile	4914-89-0
C00516104	1M-4-I-ButBenzene	Milligrams/Mile	
C005522430	1-nitropyrene emissions	Micrograms/Mile	
C005617414	Heptylcyclohexane	Micrograms/Mile	
C005673369	dihydroisopimaric acid	Micrograms/Mile	

MEASTYPE TABLE
(4 OF 4 COLUMNS)

DATE: 11/21/2007

PAGE: 18

MEAS_ID	MEAS_DESCR	MEAS_UNIT	CAS_RN
C005779942	DIMETHYLBENZALDEHYDE	Milligrams/Mile	
C005835267	isopimaric acid	Micrograms/Mile	
C006006333	Tridecylcyclohexane	Micrograms/Mile	
C006006957	Pentadecylcyclohexane	Micrograms/Mile	
C006236880	1-methyl-4-ethylcyclohexane	Milligrams/Mile	06236-88-0
C006402364	traumatic acid	Micrograms/Mile	
C00644392	c-2-Heptene	Milligrams/Mile	
C006443921	c-2-Heptene	Milligrams/Mile	
C006638057	4-methyl-syringol	Micrograms/Mile	
C006812380	Hexadecylcyclohexane	Micrograms/Mile	
C006864535	Norfarnesane	Micrograms/Mile	
C007094271	1,1,4-TRIMETHYLCYCLOHEXANE	Milligrams/Mile	7094-27-1
C007146603	2,3-dimethyloctane	Milligrams/Mile	07146-60-3
C007194845	Heptatriacontane	Micrograms/Mile	
C007194856	Octatriacontane	Micrograms/Mile	
C007194867	Nonatriacontane	Micrograms/Mile	
C00738578	3,4-DM-1-Pentene	Milligrams/Mile	
C007385786	3,4-DM-1-Pentene	Milligrams/Mile	
C007385822	TRANS-5-METHYL-2-HEXENE	Milligrams/Mile	7385-82-2
C007429905	Aluminum	Milligrams/Mile	
C007439896	Iron	Milligrams/Mile	
C007439910	Lanthanum	Milligrams/Mile	
C007439921	Lead	Milligrams/Mile	
C007439954	Magnesium	Milligrams/Mile	
C007439965	Manganese	Milligrams/Mile	
C007439976	Mercury	Milligrams/Mile	
C007439987	Molybdenum	Milligrams/Mile	
C007440020	Nickel	Milligrams/Mile	
C007440177	Rubidium	Milligrams/Mile	
C007440213	Silicon	Milligrams/Mile	
C007440224	Silver	Milligrams/Mile	

MEASTYPE TABLE
(4 OF 4 COLUMNS)

DATE: 11/21/2007

PAGE: 19

MEAS_ID	MEAS_DESCR	MEAS_UNIT	CAS_RN
C007440235	Sodium	Milligrams/Mile	
C007440246	Strontium	Milligrams/Mile	
C007440280	Thallium	Milligrams/Mile	
C007440315	Tin	Milligrams/Mile	
C007440326	Titanium	Milligrams/Mile	
C007440360	Antimony	Milligrams/Mile	
C007440382	Arsenic	Milligrams/Mile	
C007440393	Barium	Milligrams/Mile	
C007440439	Cadmium	Milligrams/Mile	
C007440473	Chromium	Milligrams/Mile	
C007440484	Cobalt	Milligrams/Mile	
C007440508	Copper	Milligrams/Mile	
C007440553	Gallium	Milligrams/Mile	
C007440575	Gold	Milligrams/Mile	
C007440611	Uranium	Milligrams/Mile	
C007440622	Vanadium	Milligrams/Mile	
C007440655	Yttrium	Milligrams/Mile	
C007440666	Zinc	Milligrams/Mile	
C007440677	Zirconium	Milligrams/Mile	
C007440702	Calcium	Milligrams/Mile	
C007440746	Indium	Milligrams/Mile	
C007446095	Sulfur Dioxide	Milligrams/mile	
C007496028	6-nitrochrysene emissions	Micrograms/Mile	
C007525624	M-ETHYLSTYRENE	Milligrams/Mile	7525-62-4
C007564638	O-ETHYLSTYRENE	Milligrams/Mile	7564-63-8
C007572294	DICHLOROACETYLENE	Milligrams/Mile	
C00764204	c-2-Octene	Milligrams/Mile	
C007642048	c-2-Octene	Milligrams/Mile	
C00764209	c-3-Hexene	Milligrams/Mile	
C007642093	c-3-Hexene	Milligrams/Mile	
C007664417	Ammonia	Milligrams/Mile	

MEASTYPE TABLE
(4 OF 4 COLUMNS)

DATE: 11/21/2007

PAGE: 20

MEAS_ID	MEAS_DESCR	MEAS_UNIT	CAS_RN
C00768821	c-2-Hexene	Milligrams/Mile	
C007688213	c-2-Hexene	Milligrams/Mile	
C007697372	Nitric Acid	Milligrams/mile	
C007704349	Sulfur	Milligrams/Mile	
C007723140	Phosphorous	Milligrams/Mile	
C007726956	Bromine	Milligrams/Mile	
C007782492	Selenium	Milligrams/Mile	
C007782505	Chlorine	Milligrams/Mile	
C010102319	Nitrogen Monoxide	Milligrams/Mile	
C010102440	Nitrogen Dioxide	Milligrams/Mile	
C010574364	3-methyl-cis-2-hexene	Milligrams/Mile	10574-36-4
C01057437	2,3-DM-2-Pentene	Milligrams/Mile	
C010574375	2,3-DM-2-Pentene	Milligrams/Mile	
C01072055	2,6-DIMETHYLHEPTANE	Milligrams/Mile	
C013177292	2-nitrofluoranthene	Micrograms/Mile	
C01326952	t-3-Hexene	Milligrams/Mile	
C013269528	t-3-Hexene	Milligrams/Mile	
C01338942	t-2-Octene	Milligrams/Mile	
C013389429	t-2-Octene	Milligrams/Mile	
C013849962	17a(H), 21a(H)-Hopane	Micrograms/Mile	
C014167590	Tetratriacontane	Micrograms/Mile	
C01468613	t-2-Heptene	Milligrams/Mile	
C014686136	t-2-Heptene	Milligrams/Mile	
C01468614	t-3-Heptene	Milligrams/Mile	
C014686147	t-3-Heptene	Milligrams/Mile	
C014720742	2,2,4-trimethylheptane	Milligrams/Mile	14720-74-2
C01485023	t-4-Octene	Milligrams/Mile	
C014850238	t-4-Octene	Milligrams/Mile	
C01586987	2,2-DM-Octane	Milligrams/Mile	
C015869871	2,2-DM-Octane	Milligrams/Mile	
C015869893	2,5-dimethyloctane	Milligrams/Mile	15869-89-3
C01589040	1c,2t,3-TM-CycPentane	Milligrams/Mile	
C015890401	(1a,2a,3b)-1,2,3-trimethylcyclopentane	Milligrams/mile	15890-40-1
C016021208	1-ethyl-2-n-propylbenzene	Milligrams/Mile	16021-20-8
C016491159	1,5-DIMETHYLCYCLOPENTENE	Milligrams/Mile	16491-15-9
C016747265	2,2,4-trimethylhexane	Milligrams/Mile	16747-26-5
C016747301	2,4,4-trimethylhexane	Milligrams/Mile	16747-30-1
C016747505	cis-1-methyl-3-ethylcyclopentane	Milligrams/Mile	16747-50-5
C017057919	2,4,5-trimethylnaphthalene	Micrograms/Mile	
C017057931	1-ethyl-2-methylnaphthalene	Micrograms/Mile	

MEASTYPE TABLE
(4 OF 4 COLUMNS)

DATE: 11/21/2007

PAGE: 21

MEAS_ID	MEAS_DESCR	MEAS_UNIT	CAS_RN
C017171721	1,3-di-n-propylbenzene	Milligrams/Mile	17171-72-1
C01759586	TRANS-1,3-DIMETHYLCYCLOPENTANE	Milligrams/Mile	
C018069175	2-methylglutaric (d-c5)	Micrograms/Mile	
C018684554	7-oxodehydroabietic acid	Micrograms/Mile	
C019781738	Heptadecylcyclohexane	Micrograms/Mile	
C020268513	7-nitrobenzo(a)anthracene	Micrograms/Mile	
C020697034	M-METHYLSTYRENE	Milligrams/Mile	20697-03-4
C022349037	Nonadecylcyclohexane	Micrograms/Mile	
C025607163	2-ethyl-1-methylnaphthalene	Micrograms/Mile	
C025889605	1-MeFl+C-MeFl/Py	Micrograms/Mile	
C026232984	4,4-DIMETHYL-2-PENTENE	Milligrams/Mile	26232-98-4
C026718821	Heneicosylcyclohexane	Micrograms/Mile	
C02713821	tert-1B-2M-Benzene	Milligrams/Mile	
C027208373	Cyclopenta(c,d)pyrene	Micrograms/Mile	
C028729546	2-propylToluene	Milligrams/Mile	
C053584604	17a(H), 21a(H)-30-Norhopane	Micrograms/Mile	
C054105667	Undecylcyclohexane	Micrograms/Mile	
C060305228	22R-17a(H), 21a(H)-30-Homohopane	Micrograms/Mile	
C060305239	22S-17a(H), 21a(H)-30-Homohopane	Micrograms/Mile	
C061523340	Benzonaphthothiophene	Micrograms/Mile	
C063041770	7-methylbenzo(a)pyrene	Micrograms/Mile	
C063041907	6-nitrobenz[a]pyrene	Micrograms/Mile	
C082064151	4-nitrophenanthrene	Micrograms/Mile	
C16747505	CIS-1-METHYL-3-ETHYLCYCLOPENTANE	Milligrams/Mile	
C2CMPD	C2 compounds	Milligrams/Mile	
CAT_WARMUP	Catalyst Warmup (0/1, No/Yes)	Milligrams/Mile	
CETINDEX	Cetane Index		
CETNUM	Cetane number		
CHOKEMEAS	Choke notch setting observed	Notches lean (-), On index (0)	
CHOKESPEC	Choke notch setting specified	Notches lean (-), On index (0)	

MEASTYPE TABLE
(4 OF 4 COLUMNS)

DATE: 11/21/2007

PAGE: 22

MEAS_ID	MEAS_DESCR	MEAS_UNIT	CAS_RN
CHRY56M	5+6-methylchrysene	Micrograms/Mile	
CLOUDPOINT	Cloudpoint	deg. F	
CMPYFL	C-MePy/MeFl	Micrograms/Mile	
CTMNAP	C-trimethylnaphthalene	Micrograms/Mile	
CUNIDENTC5	UNIDENTIFIED C5 OLEFINS	Milligrams/Mile	
CUNIDENTC6	UNIDENTIFIED C6 OLEFINS	Milligrams/Mile	
CUNIDENTC7	UNIDENTIFIED C7	Milligrams/Mile	
CUNIDENTC8	UNIDENTIFIED C8	Milligrams/Mile	
CUNIDENTC9	UNIDENTIFIED C9-C12+	Milligrams/Mile	
C_C5H6	C5H6	Milligrams/mile	
C_C6H8	C6H8	Milligrams/mile	
C_DMPH	C-dimethylphenanthrene	Micrograms/Mile	
C_O2	Oxygen concentration	Percent	
C_OMHCE	OMHCE	Milligrams/Mile	
Cr_ICP	Chromium by ICP/MS	Milligrams/Mile	
Cu_ICP	Copper by ICP/MS	Milligrams/Mile	
D14523	1,4+1,5+2,3-dimethylnaphth	Micrograms/Mile	
DENSITY	Density @ 60 deg F	g/cm-03 @ 60 deg F	
DM1367	1,3+1,6+1,7dimethylnaphth	Micrograms/Mile	
DMN267	2,6+2,7-dimethylnaphthalene	Micrograms/Mile	
DMPYFL	D-MePy/MeFl	Micrograms/Mile	
DRI_E1	Elemental Carbon Fraction 1 (E3)	Milligrams/Mile	
DRI_E2	Elemental Carbon Fraction 2 (E3)	Milligrams/Mile	
DRI_E3	Elemental Carbon Fraction 3 (E3)	Milligrams/Mile	
DRI_EC	Elemental Carbon (DRI)	Milligrams/Mile	
DRI_O1	Organic Carbon Fraction 1 (DRI)	Milligrams/Mile	
DRI_O2	Organic Carbon Fraction 2 (DRI)	Milligrams/Mile	
DRI_O3	Organic Carbon Fraction 3 (DRI)	Milligrams/Mile	
DRI_O4	Organic Carbon Fraction 4 (DRI)	Milligrams/Mile	
DRI_OC	Organic Carbon (DRI)	Milligrams/Mile	
DRI_OP	Pyrolyzed Organic Carbon (OP)	Milligrams/Mile	
DRI_TC	Total Carbon (DRI)	Milligrams/Mile	

MEASTYPE TABLE
(4 OF 4 COLUMNS)

DATE: 11/21/2007

PAGE: 23

MEAS_ID	MEAS_DESCR	MEAS_UNIT	CAS_RN
DRInst	Instantaneous DataRAM Concentration	micrograms/cubic meter	
DTInst	Instantaneous DustTrak Concentration	micrograms/cubic meter	
DURATION	Duration of Test	Seconds	
D_DMPH	D-dimethylphenanthrene	Micrograms/Mile	
E000006625	Hexanaldehyde	mg/hp-hr	
E000010487	p-Tolualdehyde	mg/hp-hr	
E000010698	1-BUTENE	mg/hp-hr	
E000010700	1-BUTYNE	mg/hp-hr	
E000010967	1-PENTENE	mg/hp-hr	
E000011082	CYCLOHEXANE	mg/hp-hr	
E000011166	1-OCTENE	mg/hp-hr	
E000012373	Crotonaldehyde	mg/hp-hr	
E000014229	CYCLOPENTENE	mg/hp-hr	
E000028792	CYCLOPENTANE	mg/hp-hr	
E000046349	PROPADIENE	mg/hp-hr	
E000050000	Formaldehyde	mg/hp-hr	
E000054292	CYCLOPENTADIENE	mg/hp-hr	
E000059241	1-HEXENE	mg/hp-hr	
E000064175	ETHANOL	mg/hp-hr	
E000067561	METHANOL	mg/hp-hr	
E000067630	2-PROPANOL	mg/hp-hr	
E000067641	Acetone	mg/hp-hr	
E000071238	N-PROPANOL	mg/hp-hr	
E000071363	N-BUTANOL	mg/hp-hr	
E000071432	benzene emissions	Milligams/bhp-hr	
E000074828	METHANE	mg/hp-hr	
E000074840	ETHANE	mg/hp-hr	
E000074851	ETHYLENE	mg/hp-hr	
E000074862	ACETYLENE	mg/hp-hr	
E000074997	METHYLACETYLENE	mg/hp-hr	
E000075070	Acetaldehyde	mg/hp-hr	
E000075285	ISO-BUTANE	mg/hp-hr	
E000075650	TBA	mg/hp-hr	
E000075832	2,2-DIMETHYLBUTANE	mg/hp-hr	
E000078784	ISO-PENTANE	mg/hp-hr	
E000078795	ISOPRENE	mg/hp-hr	
E000078808	2-METHYL-1-BUTEN-3-YNE	mg/hp-hr	
E000078853	Methacrolein	mg/hp-hr	
E000078922	SEC-BUTANOL	mg/hp-hr	
E000078933	2-Butanone	mg/hp-hr	
E000079298	2,3-DIMETHYLBUTANE	mg/hp-hr	
E000091203	NAPHTHALENE	mg/hp-hr	
E000091576	2-METHYLNAPHTHALENE	mg/hp-hr	
E000095476	O-XYLENE	mg/hp-hr	
E000095636	1,2,4-TRIMETHYLBENZENE	mg/hp-hr	
E000095932	1,2,4,5-TETRAMETHYLBENZENE	mg/hp-hr	
E000096140	3-METHYLPENTANE	mg/hp-hr	
E000096377	METHYLCYCLOPENTANE	mg/hp-hr	
E000098828	ISOPROPYLBENZENE	mg/hp-hr	
E000100414	ETHYLBENZENE	mg/hp-hr	

MEASTYPE TABLE
(4 OF 4 COLUMNS)

DATE: 11/21/2007

PAGE: 24

MEAS_ID	MEAS_DESCR	MEAS_UNIT	CAS_RN
E000100527	Benzaldehyde	mg/hp-hr	
E000103651	N-PROPYLBENZENE	mg/hp-hr	
E000106978	N-BUTANE	mg/hp-hr	
E000106990	1,3-BUTADIENE	mg/hp-hr	
E000107028	Acrolein	mg/hp-hr	
E000107835	2-METHYLPENTANE	mg/hp-hr	
E000108087	2,4-DIMETHYLPENTANE	mg/hp-hr	
E000108678	1,3,5-TRIMETHYLBENZENE	mg/hp-hr	
E000108872	METYHLCYCLOHEXANE	mg/hp-hr	
E000108883	TOLUENE	mg/hp-hr	
E000109660	N-PENTANE	mg/hp-hr	
E000110543	N-HEXANE	mg/hp-hr	
E000110623	Valeraldehyde	mg/hp-hr	
E000111659	N-OCTANE	mg/hp-hr	
E000111671	2-OCTENE	mg/hp-hr	
E000111842	N-NONANE	mg/hp-hr	
E000112403	n-DODECANE	mg/hp-hr	
E000115071	PROPYLENE	mg/hp-hr	
E000115117	ISO-BUTYLENE	mg/hp-hr	
E000123386	Propionaldehyde	mg/hp-hr	
E000123728	Butyraldehyde	mg/hp-hr	
E000124185	N-DECANE	mg/hp-hr	
E000135013	1,2-DIETHYLBENZENE	mg/hp-hr	
E000135988	1-METHYLPROPYLBENZENE	mg/hp-hr	
E000141935	1,3-DIETHYLBENZENE	mg/hp-hr	
E000142825	N-HEPTANE	mg/hp-hr	
E000460128	1,3-BUTADIENE	mg/hp-hr	
E000496117	2,3-DIHYDROINDENE (INDAN)	mg/hp-hr	
E000513359	2-METHYL-2-BUTENE	mg/hp-hr	
E000526738	1,2,3-TRIMETHYLBENZENE	mg/hp-hr	
E000527537	1,2,3,5-TETRAMETHYLBENZENE	mg/hp-hr	
E000529204	o-Tolualdehyde	mg/hp-hr	
E000538932	2-METHYLPROPYLBENZENE	mg/hp-hr	
E000540841	ISO-OCTANE	mg/hp-hr	
E000558372	3,3-DIMETHYL-1-BUTENE	mg/hp-hr	
E000563451	3-METHYL-1-BUTENE	mg/hp-hr	
E000563462	2-METHYL-1-BUTENE	mg/hp-hr	
E000565593	2,3-DIMETHYLPENTANE	mg/hp-hr	
E000565753	2,3,4-TRIMETHYLPENTANE	mg/hp-hr	
E000584941	2,3-DIMETHYLHEXANE	mg/hp-hr	
E000589344	3-METHYLHEXANE	mg/hp-hr	
E000589435	2,4-DIMETHYLHEXANE	mg/hp-hr	
E000589537	4-METHYLHEPTANE	mg/hp-hr	
E000589811	3-METHYLHEPTANE	mg/hp-hr	
E000590181	CIS-2-BUTENE	mg/hp-hr	
E000590863	Isovaleraldehyde	mg/hp-hr	
E000591764	2-METHYLHEXANE	mg/hp-hr	
E000592132	2,5-DIMETHYLHEXANE	mg/hp-hr	
E000592278	2-METHYLHEPTANE	mg/hp-hr	
E000611143	1-METHYL-2-ETHYLBENZENE	mg/hp-hr	
E000611154	o-METHYLSTYRENE	mg/hp-hr	
E000616126	TRANS-3-METHYL-2-PENTENE	mg/hp-hr	
E000620144	1-METHYL-3-ETHYLBENZENE	mg/hp-hr	

MEASTYPE TABLE
(4 OF 4 COLUMNS)

DATE: 11/21/2007

PAGE: 25

MEAS_ID	MEAS_DESCR	MEAS_UNIT	CAS_RN
E000620235	m-Tolualdehyde	mg/hp-hr	
E000622968	1-METHYL-4-ETHYLBENZENE	mg/hp-hr	
E000624646	TRANS-2-BUTENE	mg/hp-hr	
E000627203	CIS-2-PENTENE	mg/hp-hr	
E000646048	TRANS-2-PENTENE	mg/hp-hr	
E000674760	4-METHYL-TRANS-2-PENTENE	mg/hp-hr	
E000689974	1-BUTEN-3-YNE	mg/hp-hr	
E000691383	4-METHYL-CIS-2-PENTENE	mg/hp-hr	
E000693890	1-METHYLCYCLOPENTENE	mg/hp-hr	
E000760203	3-METHYL-1-PENTENE	mg/hp-hr	
E000763291	2-METHYL-1-PENTENE	mg/hp-hr	
E000767599	1-METHYL-1H-INDENE	mg/hp-hr	
E000816795	3-ETHYL-2-PENTENE	mg/hp-hr	
E000874419	1,3-DIMETHYL-4-ETHYLBENZENE	mg/hp-hr	
E000922281	3,4-DIMETHYLHEPTANE	mg/hp-hr	
E000922623	CIS-3-METHYL-2-PENTENE	mg/hp-hr	
E000933982	1,2-DIMETHYL-3-ETHYLBENZENE	mg/hp-hr	
E000934805	1,2-DIMETHYL-4-ETHYLBENZENE	mg/hp-hr	
E001069530	2,3,5-TRIMETHYLHEXANE	mg/hp-hr	
E001072055	2,6-DIMETHYLHEPTANE	mg/hp-hr	
E001074175	1-METHYL-2-n-PROPYLBENZENE	mg/hp-hr	
E001074437	1-METHYL-3-n-PROPYLBENZENE	mg/hp-hr	
E001120214	n-UNDECANE	mg/hp-hr	
E001574410	CIS-1,3-PENTADIENE	mg/hp-hr	
E001638262	1,1-DIMETHYLCYCLOPENTANE	mg/hp-hr	
E001758889	1,4-DIMETHYL-2-ETHYLBENZENE	mg/hp-hr	
E001759586	TRANS-1,3-DIMETHYLCYCLOPENTANE	mg/hp-hr	
E001759815	4-METHYLCYCLOPENTENE	mg/hp-hr	
E002004708	TRANS-1,3-PENTADIENE	mg/hp-hr	
E002040951	n-BUTYLCYCLOPENTANE	mg/hp-hr	
E002040962	n-PROPYLCYCLOPENTANE	mg/hp-hr	
E002146385	1-ETHYLCYCLOPENTENE	mg/hp-hr	
E002207047	TRANS-1,4-DIMETHYLCYCLOHEXANE	mg/hp-hr	
E002213232	2,4-DIMETHYLHEPTANE	mg/hp-hr	
E002213323	2,4-DIMETHYL-1-PENTENE	mg/hp-hr	
E002216300	2,5-DIMETHYLHEPTANE	mg/hp-hr	
E002216333	3-METHYLOCTANE	mg/hp-hr	
E002532583	CIS-1,3-DIMETHYLCYCLOPENTANE	mg/hp-hr	
E002613663	CIS-1-ETHYL-3-METHYLCYCLOPENTA NE	mg/hp-hr	
E002870044	1,3-DIMETHYL-2-ETHYLBENZENE	mg/hp-hr	
E003074713	2,3-DIMETHYLHEPTANE	mg/hp-hr	
E003522949	2,2,5-TRIMETHYLHEXANE	mg/hp-hr	
E003742389	4-ETHYL CYCLOPENTENE	mg/hp-hr	
E003875512	ISOPROPYLCYCLOPENTANE	mg/hp-hr	
E004050457	TRANS-2-HEXENE	mg/hp-hr	
E004259001	1,1,2-TRIMETHYLCYCLOPENTANE	mg/hp-hr	
E004914890	CIS-3-METHYL-3-HEXENE	mg/hp-hr	
E005779942	2 5-DMbenzaldehyde	mg/hp-hr	
E007094271	1,1,4-TRIMETHYLCYCLOHEXANE	mg/hp-hr	
E007385822	TRANS-5-METHYL-2-HEXENE	mg/hp-hr	
E007642093	CIS-3-HEXENE	mg/hp-hr	
E007664417	Ammonia	Grams	

MEASTYPE TABLE
(4 OF 4 COLUMNS)

DATE: 11/21/2007

PAGE: 26

MEAS_ID	MEAS_DESCR	MEAS_UNIT	CAS_RN
E007688213	CIS-2-HEXENE	mg/hp-hr	
E014686136	TRANS-2-HEPTENE	mg/hp-hr	
E014686147	TRANS-3-HEPTENE	mg/hp-hr	
E015890401	C,T,C-1,2,3-TRIMETHYLCYCLOPENTANE	mg/hp-hr	
E016491159	1,5-DIMETHYLCYCLOPENTENE	mg/hp-hr	
E026232984	4,4-DIMETHYL-2-PENTENE	mg/hp-hr	
ENAP12	1+2ethylnaphthalene	Micrograms/Mile	
ENGRPM	Engine rpm	rpm	
ETMNAP	E-trimethylnaphthalene	Micrograms/Mile	
EXH_TEMP	Vehicle Exhaust Temperature	Degrees F	
E_C12H16	C12H16	mg/hp-hr	
E_C12H26	C12H26	mg/hp-hr	
E_C5H6	C5H6	mg/hp-hr	
E_C5H8	C5H8	mg/hp-hr	
E_C6H10	C6H10	mg/hp-hr	
E_C6H8	C6H8	mg/hp-hr	
E_C7H12	C7H12	mg/hp-hr	
E_DMPH	E-dimethylphenanthrene	Micrograms/Mile	
E_M&P-XYLE	M&P-XYLENE	mg/hp-hr	
E_PM2.5	PM2.5	mg/hp-hr	
E_TOLUAL	Tolual	mg/hp-hr	
FINLCANWGT	Final weight of vehicle's evaporative canister	grams	
FLASHPOINT	Flashpoint	deg. F	
FTMNAP	F-trimethylnaphthalene	Micrograms/Mile	
FUELTMPL	Fuel Temperature left side	deg. F	
FUELTMPR	Fuel Temperature right side	deg. F	
FUEL_RATE	Fuel use from ECU	cc	
H2O	Water	Milligrams/mile	
HEPTDPRIS	Heptadecane_Pristane	Micrograms/Mile	
HOP1314	18a(H),21a(H)-22,29,30-Trisnorhopane & 17a(H),18a(H),21a(H)-22,29,30-Trisnorhopane	Micrograms/Mile	
HOP15	17a(H),21a(H)-22,29,30-Trisnorhopane	Micrograms/Mile	
HOP24	22S-17a(H),21a(H)-30,31-Bishomohopane	Micrograms/Mile	
HOP25	22R-17a(H),21a(H)-30,31-Bishomohopane	Micrograms/Mile	
HOP26	22S-17a(H),21a(H)-30,31,32-Trihomohopane	Micrograms/Mile	
HOP27	22R-17a(H),21a(H)-30,31,32-Trihomohopane	Micrograms/Mile	
Hg_ICP	Mercury by ICP/MS	Milligrams/Mile	
INITCANWGT	Initial weight of vehicle's evaporative canister	grams	
INTAKE_MFP	Intake manifold pressure	Inches of Mercury	

MEASTYPE TABLE
(4 OF 4 COLUMNS)

DATE: 11/21/2007

PAGE: 27

MEAS_ID	MEAS_DESCR	MEAS_UNIT	CAS_RN
JTMNAP	J-trimethylnaphthalene	Micrograms/Mile	
LOAD	engine load from ECU	percent	
LOAD_DL	Engine Load from Data Logger	percent	
M&P-XYLENE	m&p-xylene emissions	Milligams/mile	
M000050000	Formaldehyde	grams per hour	
M000067641	Acetone	grams per hour	
M000071432	benzene emissions	Milligams/hr	
M000075070	Acetaldehyde	grams per hour	
M000100527	Benzaldehyde	grams per hour	
M000110623	Valeraldehyde	grams per hour	
MEOHTOG	Methanol TOG	grams/mile	
MESUCAC	me-succinic acid (d-c4)	Micrograms/Mile	
METHANE	Methane (CH4) Emissions	Grams/Mile	
MP_XYL	m/p-xylene	Milligrams/Mile	
M_13FL	1+3-methylfluoranthene	Micrograms/Mile	
M_TOLUAL	Tolual	grams per hour	
Mn_ICP	MANGANESE by ICP/MS	MILLIGRAMS/MILE	
N2O	Nitrous Oxide (N2O) Emissions	Grams/Mile	
NMHC	Non Methane Hydrocarbons	grams/mile	
NMOG	Non-methane organic gases	grams/mile	
NO	Nitrogen oxide	grams/mile	
NO2	Nitrogen dioxide	grams/mile	
NO3	Nitrate ion	Milligrams/Mile	
NOHC	Non-oxygenated HC	grams/mile	
NOXU	Oxides of Nitrogen, Uncorrected for Humidity	Grams/Mile	
OILTMP	Oil temperature	deg. F	
OLEFIN	Olefin Content	%volume	
OMHCE	Organic matter HC equiv	grams/mile	
OXYGENATE	Oxygenate Content	%volume	
PIM815	8,15-pimaradien-18-oic acid	Micrograms/Mile	
PM10_SEC	Particulate Matter	ug/second	
PMConcInst	Instantaneous QCM Concentration	micrograms/cubic meter	
PMEC_DRI	Elemental Carbon by Thermal Reflectance (DRI)	Milligrams/Mile	
PMHC_DRI	Organic Carbon by Thermal Reflectance (DRI)	Milligrams/Mile	
PMHC_SAE	Organic fraction of particulate matter SAE 872136	Milligrams/Mile	
PMIO_SAE	Inorganic fraction of particulate matter SAE 872136	Milligrams/Mile	
PMMassInst	Instantaneous QCM Mass	micrograms	
PMSO_SAE	Dry Sulfate ion fraction of particulate SAE872136	Milligrams/Mile	

MEASTYPE TABLE
(4 OF 4 COLUMNS)

DATE: 11/21/2007

PAGE: 28

MEAS_ID	MEAS_DESCR	MEAS_UNIT	CAS_RN
PMT_CFR110	Total particulate matter per CFR86.110-94	Milligrams/Mile	
PM_<02.5u	Particulate less than 2.5 microns in diameter	Milligrams/Mile	
PM_<02.5uD	PM 2.5 by Dustrak	Milligrams/Mile	
PM_<02.5uN	PM 2.5 by Nephelometer	Milligrams/Mile	
PM_<02.5uQ	PM 2.5 by QCM	Milligrams/Mile	
PM_<10.0u	Particulate less than 10.0 microns in diameter	Milligrams/Mile	
PM_AG	Silver in Particulate	Milligrams/Mile	
PM_AL	Aluminum in Particulate	Milligrams/Mile	
PM_AU	Gold in Particulate	Milligrams/Mile	
PM_BA	Barium in Particulate	Milligrams/Mile	
PM_BR	Bromine in Particulate	Milligrams/Mile	
PM_CA	Calcium in Particulate	Milligrams/Mile	
PM_CD	Cadmium in Particulate	Milligrams/Mile	
PM_CL	Chlorine in Particulate	Milligrams/Mile	
PM_CU	Copper in Particulate	Milligrams/Mile	
PM_FE	Iron in Particulate	Milligrams/Mile	
PM_GA	Gallium in Particulate	Milligrams/Mile	
PM_HG	Mercury in Particulate	Milligrams/Mile	
PM_K	Potassium in Particulate	Milligrams/Mile	
PM_LA	Lanthanum in Particulate	Milligrams/Mile	
PM_MG	Magnesium in Particulate	Milligrams/Mile	
PM_MN	Manganese in Particulate	Milligrams/Mile	
PM_MO	Molybdenum in Particulate	Milligrams/Mile	
PM_NA	Sodium in Particulate	Milligrams/Mile	
PM_NI	Nickel in Particulate	Milligrams/Mile	
PM_NITRATE	Nitrates in Particulate	Milligrams/Mile	
PM_P	Phosphorus in Particulate	Milligrams/Mile	
PM_PB	Lead in Particulate	Milligrams/Mile	
PM_PD	Palladium in Particulate	Milligrams/Mile	
PM_S	Sulfur in Particulate	Milligrams/Mile	
PM_SB	Antimony in Particulate	Milligrams/Mile	
PM_SI	Silicon in Particulate	Milligrams/Mile	
PM_SN	Tin in Particulate	Milligrams/Mile	
PM_SR	Strontium in Particulate	Milligrams/Mile	
PM_TI	Titanium in Particulate	Milligrams/Mile	
PM_Y	Yttrium in Particulate	Milligrams/Mile	
PM_ZN	Zinc in Particulate	Milligrams/Mile	
PM_ZR	Zirconium in Particulate	Milligrams/Mile	
PPM_SULFUR	Sulfur in Fuel by ASTM D 2622	Parts Per Million	
PSIA_RVP	Vapor Pressure by Appendix E Method 3	PSIA	
PURGE_RATE	Rate of airflow to evaporative emissions canister	Liters/Minute	
PURGE_STAT	1= PERFORMED; 2= INNACCESSIBLE; 3= EQUIPMENT DOWN	CATEGORIZED	
PURGE_VOL	Volume of air going to	Liters	

MEASTYPE TABLE
(4 OF 4 COLUMNS)

DATE: 11/21/2007

PAGE: 29

MEAS_ID	MEAS_DESCR	MEAS_UNIT	CAS_RN
	evaporative canister		
P_PMHC_SAE	Organic fraction of particulate matter SAE 872136	Milligrams/BHP	
P_PMIO_SAE	Inorganic fraction of particulate matter SAE 872136	Milligrams/BHP	
P_PMSO_SAE	Dry Sulfate ion fraction of particulate SAE 872136	Milligrams/BHP	
Pb_ICP	Lead by ICP/MS	Milligrams/Mile	
RAD_DL	Coolant Temperature from Data Logger	deg. F	
RPMSPEC	Engine idle speed specification	Revolutions per minute	
RPM_DL	Engine Speed from Data Logger	rpm	
RPM_TR	Target RPM	rpm	
R_METHANE	Methane Emission Rate	Grams/Hour	
R_N2O	Nitrous oxide emissions rate	grams	
SATURATES	Saturated Hydrocarbon Content	%volume	
SO4	Sulfate ion	Milligrams/Mile	
SOAK_MINS	Soak time, (time since engine turned off)	MINUTES	
SPECIFIC_G	Specific Gravity @ 60 Degrees	Specific Gravity	
SPEC_REC	Calculated Reactive VOCs using ARB Methodology	milligrams/mile	
SPEED_DL	Vehicle Speed from Data Logger	mph	
STATION	I/M INSPECTION STATION	INTEGER	
STER42	C27-20S5a(H),14a(H)-cholestane	Micrograms/Mile	
STER43	C27-20R5a(H),14a(H)-cholestane	Micrograms/Mile	
STER44	C27-20S5a(H),14a(H),17a(H)-cho lestane	Micrograms/Mile	
STER45_40	ster45+40(cholestane)	Micrograms/Mile	
STER46	C28-20S5a(H),14a(H),17a(H)-erg ostane	Micrograms/Mile	
STER47	C28-20R5a(H),14a(H),17a(H)-erg ostane	Micrograms/Mile	
STER48	C28-20S5a(H),14a(H),17a(H)-erg ostane	Micrograms/Mile	
STER49	C28-20R5a(H),14a(H),17a(H)-erg ostane	Micrograms/Mile	
STER50	C29-20S5a(H),14a(H),17a(H)-sti gmastane	Micrograms/Mile	
STER51	C29-20R5a(H),14a(H),17a(H)-sti gmastane	Micrograms/Mile	
STER52	C29-20S5a(H),14a(H),17a(H)-sti gmastane	Micrograms/Mile	
STER53	C29-20R5a(H),14a(H),17a(H)-sti gmastane	Micrograms/Mile	
T10	Temperature -- 10% Recovery	deg. F	
T50	Temperature -- 50% Recovery	deg. F	

MEASTYPE TABLE
(4 OF 4 COLUMNS)

DATE: 11/21/2007

PAGE: 30

MEAS_ID	MEAS_DESCR	MEAS_UNIT	CAS_RN
T90	Temperature -- 90% Recovery	deg. F	
T95	Temperature -- 95% Recovery	deg. F	
TANK_LEVEL	Fuel tank fill level (100=FULL)	Percent	
THROTTLE	Throttle Position	Percent	
TIME_TOT	Total Time	Seconds	
TIMING	Initial Engine Timing (with Vacuum Disconnected)	Degrees before (+) or after (-)	
TIMING2	Initial Engine Timing (with Vacuum Connected)	Degrees before (+) or after (-)	
TIMINGSPEC	Initial timing specification	Degrees before (+) or after (-)	
TOTSPECIES	Total species mass	grams/mile	
TRANS_GEAR	gear that transmission is in -1,0,1, 2, 3,4,5, +	None	
TRQ_TR	Target Throttle	ft/lb	
TR_SPEED	Target Speed	mph	
T_EP	Temperature -- End Point --100% Recovery	deg. F	
T_IBP	Temperature -- Initial Boiling Point --0% Recovery	deg. F	
VAPORTMP	Vapor temperature in fuel tank	deg. F	
VISCOSITY	Viscosity at 40 Degrees C	Centistokes	
V_ETHANOL	Ethanol by OFID	Volume Percent	
V_MTBE	MTBE by OFID	Volume Percent	
V_TAME	TAME by OFID	Volume Percent	
WT%_O2	Weight Percent Oxygen	Weight Percent	
Zn_ICP	Zinc by ICP/MS	Milligrams/Mile	

END OF DATA FOR MEASTYPE TABLE

WKASSIGN TABLE

(2 OF 22 COLUMNS)

DATE: 11/21/2007

WA_ID

WA_DESC

78TO81LDVS

A Study of Emissions from Light Duty Vehicles in San Antonio, Texas EPA Contract

98N2OA

Nitrous Oxide (N2O) Study on Tier 1 LDVs, LDTs, and LEVs (LDVs) at various mileages.

AAMA_A

AAMA In-use Vehicle FTP Test Data

AA_TIER2_A

Fuel effects testing on LEV and Tier 2 vehicles

AC_ACTIV_A

Study of In-Use Air-Conditioner Operation in Phoenix, Arizona, 20 LD highway vehicles recruited, instrumented to measure speed and air conditioning operation, operated 2 weeks by owners, temp/humid noted at beginning of trip

AFTER_MRK

Testing for effectiveness of new aftermarket Catalysts (Task 50)

AZ_IM_0201

Arizona Inspection and Maintenance (I/M) program entitled "Car Care." Total data from January 1, 2002 to June 30, 2002. Split into two datasets.

BC_IM_0101

British Columbia Inspection and Maintenance (I/M) program entitled AIRCARE. Total Data from January 1, 2001 to June 3, 2002. YYMM will be the year and month contained in that set of files.

BC_IM_0102

British Columbia Inspection and Maintenance (I/M) program entitled AIRCARE. Data from February 1, 2001 to February 28, 2001.

BC_IM_0103

British Columbia Inspection and Maintenance (I/M) program entitled AIRCARE. Data from March 1, 2001 to March 31, 2001.

BC_IM_0104

British Columbia Inspection and Maintenance (I/M) program entitled AIRCARE. Data from April 1, 2001 to April 30, 2001.

BC_IM_0105

British Columbia Inspection and Maintenance (I/M) program entitled AIRCARE. Data from May 1, 2001 to May 31, 2001.

BC_IM_0106

British Columbia Inspection and Maintenance (I/M) program entitled AIRCARE. Data from June 1, 2001 to June 30, 2001.

BC_IM_0107

British Columbia Inspection and Maintenance (I/M) program entitled AIRCARE. Data from July 1, 2001 to July 31, 2001.

BC_IM_0108

British Columbia Inspection and Maintenance (I/M) program entitled AIRCARE. Data from August 1, 2001 to August 31, 2001.

BC_IM_0109

British Columbia Inspection and Maintenance (I/M) program entitled AIRCARE. Data from September 1, 2001 to September 30, 2001.

BC_IM_0110

British Columbia Inspection and Maintenance (I/M) program entitled AIRCARE. Data from October 1, 2001 to October 31, 2001.

WKASSIGN TABLE

(2 OF 22 COLUMNS)

DATE: 11/21/2007

WA_ID

WA_DESC

BC_IM_0111

British Columbia Inspection and Maintenance (I/M) program entitled AIRCARE. Data from November 1, 2001 to November 30, 2001.

BC_IM_0112

British Columbia Inspection and Maintenance (I/M) program entitled AIRCARE. Data from December 1, 2001 to December 31, 2001.

BC_IM_0201

British Columbia Inspection and Maintenance (I/M) program entitled AIRCARE. Data from January 1, 2002 to January 31, 2002.

BC_IM_0202

British Columbia Inspection and Maintenance (I/M) program entitled AIRCARE. Data from February 1, 2002 to February 28, 2002.

BC_IM_0203

British Columbia Inspection and Maintenance (I/M) program entitled AIRCARE. Data from March 1, 2002 to March 31, 2002.

BC_IM_0204

British Columbia Inspection and Maintenance (I/M) program entitled AIRCARE. Data from April 1, 2002 to April 30, 2002.

BC_IM_0205

British Columbia Inspection and Maintenance (I/M) program entitled AIRCARE. Data from May 1, 2002 to May 31, 2002.

BC_IM_0206

British Columbia Inspection and Maintenance (I/M) program entitled AIRCARE. Data from June 1, 2002 to June 30, 2002.

CARB_N2O

California Air Resources Board (CARB) 16th Vehicle Surveillance Program with N2O bag data.

CARB_TOXIC

ARB Surveillance Emission that includes Air Toxic Compounds CARB_UCC96 California Air Resources Board (CARB) development of Unified Correction Cycles (UCC) in 1996

CDHOT_PM_A

Determining the Relationship of Opacity and Exhaust Emissions (Including Total PM) in In-use Gasoline Powered Vehicles during an IM240

CECERT_HDD

University of California Riverside College of Engineering Center for Environmental Research and Technology (CE-CERT) Heavy-duty Diesel Truck Study

CECERT_NH3

University of California Riverside College of Engineering Center for Environmental Research and Technology (CE-CERT) Emissions of Ammonia for Light -duty vehicles

CE_CERT_A

Correlation of Diesel Truck In-Use Emission Test Program (Correlation within LHDDT_A)

CE_CERT_B

Investigation of Exhaust Emissions from LHDVs (Diesel & Gasoline) as a Function of Payload

CO_IM_9901

Colorado Inspection and Maintenance (I/M) program entitled Air Care. Total data from January 1, 1999 to September 2002. YYMM will be the year and month contained in that set of files

WKASSIGN TABLE

(2 OF 22 COLUMNS)

DATE: 11/21/2007

WA_ID

WA_DESC

CRCE_24_1C

Measurement of Exhaust Particulate Matter Emissions from In-Use (smoking vehicles) Light Duty Motor Vehicles in the Denver, Colorado Area

CRCE_24_1G

Measurement of Exhaust Particulate Matter Emissions from In-Use Light Duty Motor Vehicles in the Denver, Colorado Area

CRCE_24_2C

Measurement of Primary Particulate Matter Emissions from Light-Duty (high emitters) Motor Vehicles in South Coast Air Quality Management District

CRCE_24_2G

Measurement of Primary Particulate Matter Emissions from Light-Duty Motor Vehicles in South Coast Air Quality Management District

CRCE_24_3C

Measurement of Primary Particulate Matter Emissions from Light-Duty (smoking vehicles) Motor Vehicles in San Antonio, Texas

CRCE_24_3G

Measurement of Primary Particulate Matter Emissions from Light-Duty Motor Vehicles in San Antonio, Texas

CRC_AQIRP

Coordinating Research Council (CRC) Auto/Oil Air Quality Improvement Research Program (early 1990's).

CRC_E55_59

Coordinating Research Council (CRC) study in 2002 on Heavy-duty Vehicle Chassis Dynamometer Testing for Emissions Inventory.

CRC_E_54

Central Carolina Vehicle Particulate Emission Study

CRC_S_LDVI

Coordinating Research Council (CRC) study in 1997 to determine the effects of sulfur levels in fuel on vehicles.

CYCLES_A

Determining Basic Exhaust Emission Rates for Light Duty Cars and Trucks using Multiple Drive Schedules and with the Air Conditioning On & Off

CYCLO_A

Southwest Research Institute conducted emission test program to evaluate the effects of benzene fuel control by its hydrogenation to cyclohexane

CYCLO_E

Southwest Research Institute conducted emission test program to evaluate the effects of benzene fuel control by its hydrogenation to cyclohexane

DIUR6_0_05

The purpose of work assignment 0-5 was to provide EPA with measurements of emission levels from older in-use vehicles using a new test procedure.

DRF055_2-4

The objective of this work assignment was to continue EPA's evaluation of the diagnostic and repair flowchart which was begun in WA 1-7 and WA 1-8.

ETC_N2O

Environment Canada's study on the Effects of Aged Catalysts and Cold Ambient Temperatures on Nitrous Oxide Emissions.

WKASSIGN TABLE

(2 OF 22 COLUMNS)

DATE: 11/21/2007

WA_ID

WA_DESC

EVAP_A

4 LDTs/1 LHDT with evaporative emission tests at 3 different temperature ranges and two different fuels (6.3 and 9.0) including FTPs. Gas cap on/off testing as included.

GRANT97_NY

NewYork/DEC-Characterization and Control of HD Diesel Vehicle Emissions in the New York Metropolitan Area

GRANT98_CO

Determining the Emissions Benefits and Costs of a Smoke Opacity Based I/M Program for HDDVs.

GRANT99_NR

NESCAUM-Methods for Estimating Construction Equipment Activity at the Local Level

HD_PM_FAIL

Investigation of Exhaust Emissions on Induced PM Failures on One Diesel Engine (Deterioration Testing)

HIMILE_A

High Mileage-Vehicle Emissions from Late-Model-Fuel Injected Vehicles

IM+HAMMOND

Operation of an Enhanced I/M Lane in Indiana

IM+SBEND

Laboratory Testing of IM-Lane Recruited Vehicles in Indiana

IM0046_2-2

The Effects of Improved I/M Short Tests and Criteria

IM_VARIABL

I/M Test Variability (Task 45)

KC_PM1

Kansas City random sample emission test program, primary goal is improved PM emission factors

KC_PM1.5

Kansas City targeted sample emission test program, primary goal is Fuel Economy data

KC_PM2

Kansas City random sample emission test program, primary goal is improved PM emission factors

LDV_A

25 gasoline LDV/LDTs MY1991 and later exhaust emission tests using FTP and ASM cycles

LDV_AC_A

Determining Basic Exhaust Emission Rates for Light Duty Cars and Trucks using Multiple Drive Schedules

LDV_AC_B

Correlation between EPA and GM's Rochester, NY test facility for Air Conditioning testing in a environmental chamber with solar loading.

WKASSIGN TABLE

(2 OF 22 COLUMNS)

DATE: 11/21/2007

WA_ID

WA_DESC

LDV_EVAPB

Determining Basic Evaporative Emission Rates for Light Duty Vehicle at 2 Different Temperature Schedules and 3 Different Fuels on the 48 Hour Diurnal

LDV_T1SA

Tier 1 Light Duty Vehicle (LDV) Exhaust Emission and Sulfur-Doped Fuel Study

LHDDT_A

Investigation on diesel LHDT exhaust emissions on various cycles, payloads including measuring for toxics, PMs and unregulated pollutants.

LHDDT_B

Investigation on diesel LHDT exhaust emissions over different driving cycles (including SFTP and starts), fuels, and payloads

LHDT_A

Investigation of gasoline 10 LHDTs on 8 driving cycles at different loads, start emissions, IMs, FTPs and different fuel sulfur levels

LHDT_B

Investigation on gasoline LHDT exhaust emission on various driving cycles, payloads, and fuels (sulfur)

LHDT_C

Determining Basic Exhaust Emission Rates for Light Heavy Duty Trucks using Multiple Drive Schedules and Payloads

LHDT_EVAP

LHDTs with evaporative emission tests at 3 different temperature ranges and two different fuels (6.3 and 9.0) including FTPs. Gas cap on/off followed.

LHDT_EVAPB

Determining Basic Evaporative Emission Rates for Light-Heavy Duty Trucks at 2 Different Temperature Schedules and 3 Different Fuels on the 48 Hour Diurnal

LHDT_LDT

Inventory Cycles/LA92 Exhaust Emissions Data Collection and Amendment #1 Sulfur Fuel Testing

LOTUS_A

Engine testing of nine lawn mower engines

MSAT_A

VOC/PM Cold Temperature characterization, interior climate control, and fuel economy impact for a program to characterize exhaust emissions of light-duty gasoline-powered vehicles operating at low temperatures (20 and 0 degrees F)

NCHRP

University of California Riverside College of Engineering Center for Environmental Research and Technology (CE_CERT) NCHRP 25-11 Comprehensive Modal Emissions Model and Vehicle Emissions Database, Version 2.02

NCSU_TRAF

North Carolina State University conducted an experiment to determine the emission savings that could be achieved through better traffic management.

NEW_TEC_DC

Inspection and Maintenance of New Technology Vehicles in Washington, DC (Task 19)

NEW_TEC_MD

Inspection and Maintenance of New Technology Vehicles in Maryland (Task22)

WKASSIGN TABLE

(2 OF 22 COLUMNS)

DATE: 11/21/2007

WA_ID

WA_DESC

NONROAD_1

Emission Factors for Compression-Ignition Nonroad Engines Operated on #2 Highway and Nonroad Diesel Fuel

NONROAD_2

Constructing an Excavator Transient Emission Duty Cycle

NONROAD_3

EPCD's 9 NR diesel engine emission program on Cert fuel, nonroad diesel, and CA diesel over 40-mode S-S & 6 transient cycles; includes mini-dilution PM, smoke tests, after-treatment and non-regulates. Re-do of JD6101 excavator for emission deterioration

NRMRL_LEV

Characterization of Emissions from Low Emission Vehicles (LEV)

NYIPA

The New York State Instrumentation/Protocol Assessment Study which compares the standard IM240 test procedure and instrumentation with the New York Transient Emissions Short Test (NYTEST). This is NOT the New York I/M program test data

NYIPA2002

Second Iteration of the New York State Instrumentation/Protocol Assessment Study which compares the standard IM240 test procedure and instrumentation with the New York Transient Emissions Short Test (NYTEST). This is NOT the New York I/M program test data.

OBD_A

Determining the Effectiveness of Onboard Diagnostic Systems in Identifying Vehicles that Fail the FTP

OBD_TYPE_I

Comparison of On-Board I Diagnostics to Tailpipe I/M (Task 51)

OEM_2100

An Investigation of OEM 2100's Capabilities to Accurately Measure Emissions of Late-Model Gasoline Vehicles

PRE75_PM

Heavy Duty Diesel Truck In-Use Emission Test Program for Model Years 1975 and Older

RL0041_0-2

Fuel, Cycle, and Temperature Effect on Running Losses

RL0041_0-3

Fuel, Cycle, Temperature, and A/C Effect on Running Losses

RL0041_0-5

Fuel, Cycle, and Temperature Effect on Running Losses

RL0041_1-1

Fuel, Cycle, Temperature and Evaporative Restorative Maintenance Effect on Running Losses

RL0041_1-3

Fuel, Cycle, Temperature and Evaporative Restorative Maintenance Effect on Running Losses

RL0041_1-5

Fuel, Cycle, Temperature and Evaporative RM Effect on Running Losses

WKASSIGN TABLE

(2 OF 22 COLUMNS)

DATE: 11/21/2007

WA_ID

WA_DESC

RLPP6_0_12

The purpose of this work assignment was to provide updated information on evaporative emissions from in-use light-duty cars and trucks. A secondary purpose was to evaluate the effectiveness of purge/pressure testing.

RLPP6_0_3

To test late model light-duty vehicles for running loss evaporative emissions. Secondary purpose was to evaluate the effectiveness of purge and pressure testing in identifying evaporative emission failures at a State I/M facility.

ROVER_A

Determining the Viability of Gathering with ROVER Exhaust and Vehicle Information for Diesel and Gasoline Powered Light-Heavy Duty Trucks

RSD_EVAL_A

Preliminary Evaluation of Siting Effects on Remote I/M Test Results

RTEE55_2_9

39 randomly selected vehicles testing new (1993) test procedure for diurnal emissions.

RUNLOSS_Y

Continued efforts towards fuel, cycle, temperature and remedial maintenance effect on running loss emissions.

RUNLOSS_Z

Continued efforts towards fuel, cycle, temperature and remedial maintenance effect on running loss emissions.

RWHS_01

Real World Hot Soak Testing - First Work Assignment

RWHS_02

LDVs--Emission Factor Evaporative Determination with Purge/Pressure

RWHS_03

LDTs--Emission Factor Evaporative Determination with Purge/Pressure

SHOOT_OUTA

On-Road Emission Test Data from 15 Light-Duty Vehicles and 15 Heavy Duty Diesel Trucks for On-Board Emission Data Analysis and Collection for the New Generation Model

SMALL_SI_A

Engine testing of 23 hand held nonroad SI engines over two conventional gasolines (one with ethanol and one without).

SULEV_A

Southwest Research Institute conducted a program for the U.S. Environmental Protection Agency (EPA) to evaluate exhaust emissions from 3 Super Low Emission Vehicles (SULEVs) that were already being tested at SwRI under a non-EPA funded test program.

TIER_1

Determining Basic Exhaust Emission Rates for Tier 1 Light Duty Cars using Multiple Drive Schedules

TIER_1_B

Investigation on gasoline vehicles/trucks/SUVs over different driving cycles including SFTP

TRR055_2-2

Procure vehicles for testing, repair, retesting based on enhanced I/M 240 lane test.

WKASSIGN TABLE
(2 OF 22 COLUMNS)

DATE: 11/21/2007

WA_ID

WA_DESC

RR055_2-8

The purpose of this work assignment was to procure a random selection of vehicles for FTP testing, repair and retesting.

TRUCK_DF00

Determining Deterioration Factors of Previously Tested Light Duty Vehicles, Light Duty Trucks, and Light-Heavy Duty Trucks

TXDOT_UT

Texas Department of Transportation and the University of Texas study in 2002-03 on the use of new fuels in heavy-duty diesel vehicles

WAIVER_VEH

Incremental Emission Benefits of Repairing I/M Waiver Cars (Task 43)

WVU_1

West Virginia University testing of heavy duty vehicles using their portable dynamometer.

WVU_2

West Virginia University testing of heavy duty vehicles using their portable dynamometer.

WVU_3

West Virginia University testing of heavy duty vehicles using their portable dynamometer.

WVU_4

West Virginia University testing of heavy duty vehicles using their portable dynamometer. (4th dataset received)

END OF DATA FOR WKASSIGN TABLE

FUEL TABLE

DATE: 11/19/2007

1

FUEL_ID	FUELNAME	OXYGENATE	WTOXYGEN	RVP	SULFERLOW	SULFERHIGH
	(Whatever came with vehicle)		0	0	0	0
			0	6.3	0	1000
			0	6.7	0	0
			0		0	0
0	Tank		0	6.9	9	1000
1	Low RVP Test Gasoline		0	0	800	1200
2	Low RVP Test Gasoline	MTBE	2	7	0	40
3	Low RVP Test Gasoline		0	0	0	500
6	Unleaded Test Gasoline (96 RON)		0	11.7	0	0
9	(CFR 86.113-91(a)) (8.8 RVP) Diesel Fuel	ethanol	3.4	8.8	0	0
10	California Phase II Gasoline		0	10.5	0	0
11	California Diesel		0	7.7		0
16	Unleaded Test Gasoline (11.7 RVP)					
18	Gasohol		3.4	8.7	0	0
22	Unleaded 10% ethanol splash blended into Test Gasoline (10.5 RVP)				0	
30	Non-Oxygenated Baseline Fuel - 7.7.					
			3.4	7.7	0	0
31	Oxygenated Baseline Fuel, 8.7 RVP, ethanol	MTBE	0	7.7	0	0
			0	8.8	304	354
		MTBE	2	7	130	140
32	Gasohol 10(10 % ethanol) , RVP = 7.7 ethanol	MTBE	3	9		0
33	Gasoline with MTBE, RVP = 7.7	MTBE	0	9	0	0
43	Clean Air Act Baseline Gasoline	MTBE		8.8	0	0
44	Federal Phase II Gasoline					
45	Oxygenated Test Gasoline					
46	Oxygenated Test Gasoline					
48	Phase I Low Sulfur Gasoline					

2.3 |

FUEL TABLE

DATE: 11/19/2007

PAGE: 2

FUEL_ID	FUELNAME	OXYGENATE	WTOXYGEN	RVP	SULFERLOW	SULFERHIGH
		MTBE	2	8	0	
	(9.0 RVP)	ethanol	3.4	9	0	0
49	Phase I Gasoline		0	9	11	11
50	Low T-90 Unleaded Gasoline		0	9	50	80
51	Gasohol					0
55	Unleaded Test Gasoline (96 RON) 11		0	9	140	160
	(7 OF 7 COLUMNS)					
60	Unleaded Test Gasoline (96 RON)		0	9	330	370
50	Unleaded Test Gasoline (96 RON)		0	9	620	680
24	Unleaded MTBE SULFUR Gasoline (96 RON)	MeOH, EtOH	2.6	9.1	0	0
		MeOH, TBA	2.7	8.8	0	0
33	Unleaded MTBE SULFUR Gasoline (96 RON)		0	7	0	0
			0	11	0	0
42	Unleaded MTBE SULFUR Gasoline (96 RON)		0	9.2	0	0
65	Oxynol					
66	Unleaded Test Gasoline (7.0 RVP)		0	14.6	0	0
67	Unleaded Test Gasoline (11.0 RVP)		0	10.4	0	0
69	Commercial Fuel Used by Southwest					
				9	0	0
70	High-RVP Gasoline					
71	Special gasoline, with T40 point =		0			
72	Special gasoline, with T40 point =					
	160 deg F					

FUEL TABLE

DATE: 11/19/2007

PAGE: 3

FUEL_ID FUELNAME	OXYGENATE	WTOXYGEN	RVP	SULFERLOW	SULFERHIGH
	ethanol	3.4	11.8	0	0
	MTBE	0		0	0
		0	12.2 10	0	0
73 Gasohol (11.8 RVP)	ethanol	3.4	9.8	0	0
74 Special gasoline (with MTBE, 12.2 RVP)	MTBE	0	9.5	0	0
		0	0	500	5000
75 Special gasoline (10 RVP)		0	8.7	0	0
76 Gasohol (9.8 RVP)		0	8	0	0
77 Oxygenated Test Gasoline		0	8.7	0	0
79 Non-Road Grade Diesel (high sulfur)		0	8		0
80 Base formula fuel		0	8.7	0	0
81 Low RVP Fuel					
82 Low Sulfur Fuel	ethanol	0	8.1	0	0
83 Low Sulfur, Low RVP, Low T90 Fuel	MTBE	0	8.1	0	0
84 Baseline Fuel, 32% aromatics, 1.5% MTBE	MTBE	0	8.1	0	0
	MTBE	0	8.1	0	0
85 Formula Fuel with Ethanol	MTBE	0	8.1	0	0
86 Formula Fuel with					
87 High T50 Fuel with MTBE	MTBE	0	8.1	0	
88 High T90 Fuel with MTBE					
89 MTBE, Heavy Ends, Predominately					
	MTBE	0	8.1	0	0
90 MTBE High T90, Cutting out Low	MTBE	0	8.1	0	0 65
91 MTBE Low Olefins (2% max)					
92 MTBE Low Olefins, (2% max),					

FUEL TABLE

DATE: 11/19/2007

PAGE: 4

FUEL_ID	FUELNAME	OXYGENATE	WTOXYGEN	RVP	SULFERLOW	SULFERHIGH
		MTBE	0	7	0	0
	7%, Aromatics		0	7	0	50
93	Low RVP MTBE, Low Olefins, Low Sulfur	MTBE	0	7	0	0
94	Calif. Phase II, low RVP and 40 CFR86.1313-94(b)(2) Type 2		0	0	300	500
95	Low RVP from ARCO MTBE, Low Olefins, (EM-2866-F)	MTBE	0	0	0	10
96	Diesel, from Howell 40 CFR86.1313-94(b)(2) Type 2-D, spiked with extra sulfur		0	0	2200	2600
97	ULTRA LOW DIESEL (TYPE 2; Sulfur) 40 D		0	0	400	400
98	Diesel		0	0	100	200
99	Diesel		0	0	0	0
109	AATA In-use Diesel (Tosca_12556:150 CFR86.1313-94(b)(2) Type 2-		0	0	0	0
110	Butane (ppm Sulfur)		0	0	0	0
111	Compressed Natural Gas		0	0	0	0
112	Propane		0	0	0	0
113	Diesel - Butane		0	0	0	0
114	Diesel - Natural Gas		0	0	0	0
115	Diesel - Propane		0	0	0	0

FUEL TABLE

DATE: 11/19/2007

PAGE: 5

FUEL_ID	FUELNAME	OXYGENATE	WTOXYGEN	RVP	SULFERLOW	SULFERHIGH
			0	0	0	0
			0	0	0	0
			0	0	0	0
			0	0	0	0
116	Gasoline - Electric		0	0	0	0
117	Gasoline - Natural Gas		0	0	0	0
118	Gasoline - Propane		0	0	0	0
119	Multi-fuels		14.7	0	0	0
120	Natural Gas		0	0	0	0
121	Propane - Natural Gas		0	0	0	0
122	Compressed Natural Gas		21.3	0	0	0
123	85% Ethanol, 15% Gasoline		2	0	0	0
124	Liquid Natural Gas	ur	2	0	0	0
125	Liquid Propane Gas		2	0	0	0
126	85% Methanol, 15% Gasoline		2	0	0	0
127	California Phase I Summertime		2	0	0	0
128	Federal RFG with 40 ppm Sulf		2	0	0	0
129	Federal RFG with 100 ppm Sulfur		2	0	0	0
130	Federal RFG with 150 ppm Sulfur		2	0	0	0
131	Federal RFG with 330 ppm Sulfur		2	0	0	0
132	Federal RFG with 600 ppm Sulfur		2	0	0	0
133	California Phase 2 RFG with 40 ppm		17.4	0	0	0
			0	0	0	0
134	California Phase 2 RFG with 150 ppm					
	Sulfur					
135	Alcohol					
136	New York Standard Diesel Fuel #1					
	(7 OF 7 COLUMNS)					
	with 300 ppm Sulf					

FUEL TABLE

DATE: 11/19/2007

PAGE: 6

FUEL_ID	FUELNAME	OXYGENATE	WTOXYGEN	RVP	SULFERLOW	SULFERHIGH
				0	0	0
	w sulfur		0	0	0	0
137	Ultra Low Sulfur Diesel <30 ppm		0			
138	Gasoline with 30 ppmw sulfur					
139	Gasoline with 330 ppm					
140	CARB - CALIFORNIA AIR RESOURCES					
141	CECD1 - LOW SULFUR DIESEL					
142	BOARD DIESEL CNG - COMPRESSED NATURAL GAS					
143	D1 - DIESEL 1					
144	D2 - DIESEL 2					
145	ECD - LOW SULFUR DIESEL					
146	FT - FISCHER TROPSCH SYNTHETIC					
147	LNG - LIQUID NATURAL GAS					
148	DIESEL MG - MOSSGAS IS A FISCHER TROPSCH					
149	MG50D250 - FISCHER TROPSCH AND SYNTHETIC DIESEL					
150	ULSD1 - ULTRA LOW SULFUR DIESEL 1. BIO-DIESEL BLEND		0	8.7	0	0
151	100% ETHANOL		0	8.7	0	0
152	BELOW 10 PPM SULFUR 100% METHANOL		0	8.9	0	0
300	A1 - AQIRP fuel					
301	B - AQIRP fuel					
302	B27 - AQIRP fuel					

FUEL TABLE

DATE: 11/19/2007

PAGE: 7

FUEL_ID	FUELNAME	OXYGENATE	WTOXYGEN	RVP	SULFERLOW	SULFERHIGH
		MTBE	0	8.7	0	0
			0	8.5	0	0
		MTBE	0	8.7	0	0
			0	8.8	0	0
303	C - AQIRP fuel		0	8.8	0	0
304	D - AQIRP fuel	MTBE	0	8.5	0	0
305	E - AQIRP fuel		0	8.9	0	0
306	F - AQIRP fuel	MTBE	0	8.6	0	0
307	G - AQIRP fuel		0		0	0
308	H - AQIRP fuel		0	8.8	0	0
309	I - AQIRP fuel	MTBE	0	8.7	0	0
310	J - AQIRP fuel	MTBE	0	8	0	0
311	K - AQIRP fuel	MTBE	0	8.8	0	0
312	L - AQIRP fuel	MTBE	0	8.8	0	0
313	M - AQIRP fuel	ETBE	0	8.8	0	0
314	MM - AQIRP fuel	MTBE	0	8.6	0	0
315	N - AQIRP fuel		0	8.5	0	0
316	N2 - AQIRP fuel		0	8.6		0
317	NN - AQIRP fuel	MTBE	0	8.4	0	0
318	O - AQIRP fuel			8	0	0
319	P - AQIRP fuel	ETOH	0	9.3	0	0
320	Q - AQIRP fuel		0	9.6	0	0
321	R - AQIRP fuel		0	7.8	0	0
322	S - AQIRP fuel	ETOH	0	9	0	0
323	T - AQIRP fuel					
324	U - AQIRP fuel					
325	V - AQIRP fuel					
326	W - AQIRP fuel					

ETOH

FUEL TABLE

DATE: 11/19/2007

PAGE: 8

FUEL_ID	FUELNAME	OXYGENATE	WTOXYGEN	RVP	SULFERLOW	SULFERHIGH
			0	9.6	0	0
			0	8.8	0	0
		ETOH	0	8.8	0	0
		ETOH	0	12	0	0
327	X - AQIRP fuel	MTBE	0	8.7	0	0
328	Y2 - AQIRP fuel	MTBE	0	8.7	0	0
329	Z - AQIRP fuel	MTBE	0	8.9	0	0
330	ZZ - AQIRP fuel	MTBE	0	9	0	0
331	10A - AQIRP fuel	MTBE	0	8.6	0	0
332	11A - AQIRP fuel	MTBE	0	8.5	0	0
333	12A - AQIRP fuel	MTBE	0	8.6	0	0
334	13A - AQIRP fuel	MTBE	0	8.7	0	0
335	14A - AQIRP fuel	MTBE	0	8.5	0	0
336	15A - AQIRP fuel		0	8.7	0	0
337	16A - AQIRP fuel		0	6.9	0	0
338	17A - AQIRP fuel	MTBE	0	6.8	0	0
339	18A - AQIRP fuel	MTBE	0	6.8	0	0
340	A2 - AQIRP fuel	MTBE	0	6.9	0	0
341	C1 - AQIRP fuel	MTBE	0	6.8	0	0
342	C3 - AQIRP fuel	MTBE	0	6.8	0	0
343	C35 - AQIRP fuel		0	6.8	0	0
344	C4 - AQIRP fuel	MTBE	0	6.7	0	0
345	C46 - AQIRP fuel	MTBE	0	6.7	0	0
346	C5 - AQIRP fuel		0	6.9	0	0
347	C6 - AQIRP fuel		0		0	0
348	C7 - AQIRP fuel	MTBE				
349	C8 - AQIRP fuel					
350	CG1ACEL50NSP fuel					

FUEL TABLE

DATE: 11/19/2007

PAGE: 9

FUEL_ID	FUELNAME	OXYGENATE	WTOXYGEN	RVP	SULFERLOW	SULFERHIGH
			0		0	0
			0		0	0
			0		0	0
			0		0	0
351	CG1B - AQIRP fuel		0		0	0
352	CG1C - AQIRP fuel		0		0	0
353	CG2A - AQIRP fuel		0		0	0
354	CG2B - AQIRP fuel		0		0	0
355	CG2C - AQIRP fuel		0		0	0
356	CG2D - AQIRP fuel		0		0	0
357	CG3A - AQIRP fuel		0		0	0
358	CG3B - AQIRP fuel		0		0	0
359	CG3C - AQIRP fuel		0		0	0
360	CG4A - AQIRP fuel		0		0	0
361	CG4B - AQIRP fuel	MTBE	0	6.7	0	0
362	CG4C - AQIRP fuel	MTBE	0	6.6	0	0
363	CG4D - AQIRP fuel	ETOH	0	6.5	0	0
		ETOH	0	6.9	0	0
364	CR1 - AQIRP fuel	MTBE	0	8.7	0	0
365	CR2 - AQIRP fuel	MTBE	0	8.7	0	0
366	E85A - AQIRP fuel		0	8.6	0	0
367	E85D - AQIRP fuel		0	8.6	0	0
		MTBE	0	8.5	0	0
368	R1A - AQIRP fuel	MTBE	0	8.5	0	0
369	R1B - AQIRP fuel	MTBE	0	8.5	0	0
370	R2A - AQIRP fuel	MTBE	0	8.5	0	0
371	R2B - AQIRP fuel	MTBE	0	8.4	0	0
372	R3A - AQIRP fuel					
373	R3B - AQIRP fuel					
374	R4A (COMMON) fuel					

FUEL TABLE

DATE: 11/19/2007

10

FUEL_ID	FUELNAME	OXYGENATE	WTOXYGEN	RVP	SULFERLOW	SULFERHIGH
		MTBE	0	8.6	0	0
		MTBE	0	8.6	0	0
		MTBE	0	8.6	0	0
		MTBE	0	8.7	0	0
375	R4B - AQIRP fuel	MTBE	0	PAGE	0	0
376	R5A - AQIRP fuel	MTBE	0	8.8		0
377	R5B - AQIRP fuel	MTBE	0	8.7		0
378	R6A - AQIRP fuel	MTBE	0	8.5	0	0
379	R6B - AQIRP fuel	MTBE	0	8.9	0	0
380	R7A - AQIRP fuel		0	8.9		0
381	R7B - AQIRP fuel	MTBE	0	9.3	0	0
382	R8A - AQIRP fuel	MTBE	0	9.3	0	0
383	R8B - AQIRP fuel	MTBE	0	9.3	0	0
384	R9A - AQIRP fuel		0		0	0
385	S0 - AQIRP fuel	MTBE	0	8.9	0	0
386	S1 - AQIRP fuel	MTBE	0	8.9	0	0
387	S2 - AQIRP fuel	MTBE	0	8.9	0	0
388	Y3 - AQIRP fuel	MTBE	0	8.9	0	0
389	Y4 - AQIRP fuel	MTBE	0	8.9	0	0
390	Y5 - AQIRP fuel	MTBE	0	8.9	0	0
391	Y6 - AQIRP fuel	MTBE	0	8.8	0	0
392	Y7 - AQIRP fuel	MTBE	0	9.1	0	0
393	Y8 - AQIRP fuel	MEOH	0	7.7	0	0
394	YA - AQIRP fuel	MTBE/MEOH	0	7.1	0	0
395	YM - AQIRP fuel	MTBE/MEOH	0	9.6	0	0
396	Z1 - AQIRP fuel					
397	ZC2 - AQIRP fuel					
398	ZCC (AQIRP) fuel					

FUEL TABLE

DATE: 11/19/2007

PAGE: 11

FUEL_ID	FUELNAME	OXYGENATE	WTOXYGEN	RVP	SULFERLOW	SULFERHIGH
		NONE	0	0	0	10
		NONE	0	0	0	10
399	SwRI Alkylate Base Fuel for	NONE	0	0	0	10
400	5% Benzene 95% SwRI Alkylate Base Cyclohexane Testing	NONE		0	0	10
401	5% Cyclohexane 95% SwRI Alkylate Fuel for Cyclohexane Testing		0	7.7	16	21
402	30% Cyclohexane 95% SwRI Alkylate Base Fuel for Cyclohexane Testing	ETHANOL	2.1	7.8	16	21
		ETHANOL	3.8	7.7	16	21
			0	7.7	16	21
403	CRC E 67 FUEL A Base Fuel for Cyclohexane Testing	ETHANOL	3.8	7.8	16	21
404	CRC E 67 FUEL B		0	7.6	16	21
405	CRC E 67 FUEL C					
406	CRC E 67 FUEL D	ETHANOL	3.8	7.8	16	21
407	CRC E 67 FUEL E		0		16	21
408	CRC E 67 FUEL F	ETHANOL	2.2	7.9	16	21
409	CRC E 67 FUEL G	ETHANOL	2.2	7.6	16	21
410	CRC E 67 FUEL H		0	7.7	16	21
411	CRC E 67 FUEL I	ETHANOL	3.8	7.7	16	21
415	BASER-AA TIER A. BASE - a fuel with	.NULL.	0	6.9	0	0
412	CRC E 67 FUEL J					
413	CRC E 67 FUEL K	.NULL.	0	9.1	0	0
414	CRC E 67 FUEL L					

416|BASER-AA TIER A. a fuel with low
low RVP low benzene and low sulfur;
(7 OF 7 COLUMNS)

|benzene and low sulfur (Base + RVP)|

FUEL TABLE

DATE: 11/19/2007

12

FUEL_ID	FUELNAME	WTOXYGEN	RVP	SULFERLOW	SULFERHIGH
	.NULL.	0	9	0	0
	.NULL.	0	9.1	0	0
417	BASERB-AA_TIER_A.a fuel with low				
	.NULL.	0	7	0	0
418	BASERBS-AA_TIER_A.the reference sulfur (Base + RVP + benzene) OXYGENATE				
	fuel (Base + RVP + benzene +	None	8.4	9	11
419	CARFG-AA_TIER_A. a California sulfur)	ETHANOL	7	13	15
END DATA FOR FUEL TABLE					
420	NERL_1 Test Fuel				
421	NERL_2 Test Fuel				

PAGE:

(7 OF 7 COLUMNS)

TEST PRO TABLE
(6 OF 6 COLUMNS)

DATE: 11/21/2007

PAGE: 1

TEST_	TEST_PRO_D	TEST_PRO_N	HC_METHOD	H	NOM_SO
24RTD	24 Hour Real Time Diurnal	107	FID (PROPANE EQUIV.)	N	
28MOD	28 mode, steady state engine dyno test as def. by Contract 68-65-0077, Task 2-2	195	HFID (PROPANE EQUIV)	N	
2SOAK	2 Hour Hot Soak Evap Test	102	FID (PROPANE EQUIV.)	N	
33RTD	33 Hour Real Time Diurnal	109	FID (PROPANE EQUIV.)	N	
38RTD	38 Hour Real Time Diurnal	118	FID (PROPANE EQUIV.)	N	
3REST	3 Hour Resting Loss Evap Emissions Test (Follows 1 Hour Hot Soak)	64	FID (PROPANE EQUIV.)	N	
40MOD	40 mode, steady state engine dyno test. (1 idle, 3 E3 marine, 36 load matrix)	193	HFID (PROPANE EQUIV)	N	
48RTD	48 Hour Real Time Diurnal	103	FID (PROPANE EQUIV.)	N	
4HD	Four Hour Diurnal Test	67	FID (PROPANE EQUIV.)	N	
4MID	Four Mode Idle Test (Idle, Idle @2500, Idle again, Idle in Drive	10	NDIR (HEXANE EQUIV.)	N	
505HR	First bag of FTP - engine on	97	FID (PROPANE EQUIV.)	N	
505HS	Hot Start 505	62	FID (PROPANE EQUIV.)	Y	VARIES
50MPH	50 MPH Cruise Mode Test	8	NDIR (HEXANE EQUIV.)	N	
5MILE	Chassis dynamometer test using WVU 5 Mile Route, (Routinized form of WVU 5 Peak)	204	FID (PROPANE EQUIV.)	N	
72RTD	72 Hour Real Time Diurnal	110	FID (PROPANE EQUIV.)	N	
85A	CFR 90 Table 2 Appendix F Subpart	217	FID (PROPANE E	N	
8M_C1	8 mode, steady state engine certification test as defined in CFR	194	HFID (PROPANE EQUIV)	N	
AC508	Airconditioning Cycle from CRC E_55	25	FID (PROPANE EQUIV.)	N	
ACSUR	Air conditioning activity survey as performed in WA_ID = 'AC_ACTIV_A'	184	NOT APPLICABLE	N	
ARBL5	ARB Low Speed Test	221	FID (PROPANE EQUIV.)	Y	
ASM	Acceleration Simulation Mode Test Procedure	98	NDIR (HEXANE EQUIV.)	N	

TEST PRO TABLE
(6 OF 6 COLUMNS)

DATE: 11/21/2007

PAGE: 2

TEST_	TEST_PRO_D	TEST_PRO_N	HC_METHOD	H	NOM_SO
ASMTK	ASM Performed On LHDTs With Emissions Averaged On Last 10 Seconds Of Each Mode	113	NDIR (HEXANE EQUIV.)	N	
ATD	Ambient temp diurnal evap test , shed temp const. , vehicle begins 24 deg cooler	66	FID (PROPANE EQUIV.)	N	
BGDR	Bag Idle-in-Drive Test	23	FID (PROPANE EQUIV.)	N	
BGID	Bag Idle Test	7	FID (PROPANE EQUIV.)	N	
BL_1A	1 Hour Breathing Loss Evap Test - Gas Cap Left On	6	FID (PROPANE EQUIV.)	N	
BL_1B	1 Hour Breathing Loss Evap Test - Canister As Recd	106	FID (PROPANE EQUIV.)	N	
C226	Colorado Dept. of Health 226 Second Test	24	FID (PROPANE EQUIV.)	N	
C226B	Colorado Dept of Health 226 Second Test - Restricted Range of Test Weight Values	58	FID (PROPANE EQUIV.)	N	
C2M10	Small Engine Test 10 minutes long, 90% open throttle, fixed load, 10 % Idle	220	FID (PROPANE EQUIV.)	N	
C2M6	Small Engine Test 6 minutes long, 90% open throttle, fixed load, 10 % Idle	219	FID (PROPANE EQUIV.)	N	
CARBC	Creep portion of CARB HHDDT cycle	21	FID (PROPANE EQUIV.)	N	
CARBI	Idle portion of CARB HHDDT cycle	19	FID (PROPANE EQUIV.)	N	
CARBR	Cruise portion of CARB HHDDT cycle	18	FID (PROPANE EQUIV.)	N	
CARBT	Transient portion of CARB HHDDT cycle	16	FID (PROPANE EQUIV.)	N	
CASPD	California Speed Correction Cycle Test (any of 10 driving schedules)	70	FID (PROPANE EQUIV.)	N	
CBD	Chassis dynamometer test using the WVU Truck Central Business District Cycle	205	FID (PROPANE EQUIV.)	N	
COLD	Vehicle test cycle used by CARB	209	FID (PROPANE EQUIV.)	N	
CRLOS	Vehicle Certification Running Loss Emissions Test	188	FID (PROPANE EQUIV.)	N	

TEST PRO TABLE
(6 OF 6 COLUMNS)

DATE: 11/21/2007

PAGE: 3

TEST_	TEST_PRO_D	TEST_PRO_N	HC_METHOD	H	NOM_SO
----	-----	-----	-----	-	-----
DROVE	Vehicle with on-board exhaust instruments, driven on chassis dynamometer	185	NDIR (HEXANE EQUIV.)	N	
DRT	TEST D ROUTE	15	FID (PROPANE EQUIV.)	N	
EC	CARB VERSION OF FTP	14	FID (PROPANE EQUIV.)	Y	720/10
EPA74	Federal Test Procedure - 1974	215	FID (PROPANE EQUIV.)	Y	720/10
FACIL	Roadway Facility Cycle Test	100	FID (PROPANE EQUIV.)	N	
FLA4	Facilty cycle LA4	63	FID (PROPANE EQUIV.)	N	
FTP	Federal Test Procedure	5	FID (PROPANE EQUIV.)	Y	720/10
FTP4S	FTP with 4th bag & only sec. by sec. data. Bag emissions estimated from sbs data	26	FID (PROPANE EQUIV.)	Y	720/10
FTPCC	FTP with second by second engine out data	27	FID (PROPANE EQUIV.)	Y	720/10
FTPFS	Cold start testing,first 123 seconds captured in bag1,FTP weighing of bags2-4	218	FID (PROPANE EQUIV.)	Y	720/10
FTPSS	FTP with only second by second data. Bag emissions estimated from sbs data	211	FID (PROPANE EQUIV.)	Y	720/10
GRADA	Telescoping Boom Excavator Cycle developed by ERG	28	FID (PROPANE EQUIV.)	N	
HDTHS	Heavy Duty Vehicle Transient Chassis Procedure with hot start	207	FID (PROPANE EQUIV.)	Y	
HD_DR	Heavy Duty Diesel Transient Test with driving schedule 'routinized'	206	FID (PROPANE EQUIV.)	N	
HD_DT	Heavy Duty Diesel Chassis Dynamometer Transient Test	189	HFID (PROPANE EQUIV)	N	
HFET	Highway Fuel Economy Test	9	FID (PROPANE EQUIV.)	N	
HSLA4	Hot Start LA4, LA4 is first two bags of FTP	105	FID (PROPANE EQUIV.)	Y	VARIABLES
HSOAK	1 Hour Hot Soak Evap Test	68	FID (PROPANE EQUIV.)	N	
IDLEI	Mechanic's Idle Inspection - usually prior to FTP	3	NDIR (HEXANE EQUIV.)	N	
IM147	IM147 Test Data	37	FID (PROPANE EQUIV.)	N	
IM14F	Fast Pass for IM147 test	214	FID (PROPANE EQUIV.)	N	

TEST PRO TABLE
(6 OF 6 COLUMNS)

DATE: 11/21/2007

PAGE: 4

TEST_	TEST_PRO_D	TEST_PRO_N	HC_METHOD	H	NOM_SO
IM24	IM240 Test Data	52	FID (PROPANE EQUIV.)	N	
IM24B	IM240 Test - Restricted Range of Test Weight Values	56	FID (PROPANE EQUIV.)	N	
IM24F	Fast Pass for IM240 test	212	FID (PROPANE EQUIV.)	N	
IM2LO	Official State I/M 2 Mode Loaded Emissions Test (30mph plus idle)	114	NDIR (HEXANE EQUIV.)	N	
IM2MO	Official State I/M 2 Mode Idle Emissions Test (Idle@2500 plus Idle)	112	NDIR (HEXANE EQUIV.)	N	
IM387	IM387 Test Results (3 bag IM240)	65	FID (PROPANE EQUIV.)	N	
IMIDL	Official State I/M Idle Emissions Test	111	NDIR (HEXANE EQUIV.)	N	
IRTD	Interrupted 24 hour real time diurnal	104	FID (PROPANE EQUIV.)	N	
IUS06	Incomplete US06	216	FID (PROPANE EQUIV.)	N	
KERN	KERN CYCLE	13	FID (PROPANE EQUIV.)	N	
L2M	Loaded 2 mode test, idle and 30mph.	11	NDIR (HEXANE EQUIV.)	N	
LA92	Unified Cycle (CARB)	12	FID (PROPANE EQUIV.)	N	
LA92C	Three Phase Cold Start CARB Unified Cycle CARB test level emission calculations	200	FID (PROPANE EQUIV.)	Y	720/10
LA9HR	California unified cycle test , conducted as a 1 bag test , without start	93	FID (PROPANE EQUIV.)	N	
LOADE	Wheeled Loader Cycle developed by ERG	29	FID (PROPANE EQUIV.)	N	720/10
M057	ARB Modal Test	222	FID (PROPANE EQUIV.)	N	
M058	ARB Modal Test	223	FID (PROPANE EQUIV.)	Y	
M059	ARB Modal Test	224	FID (PROPANE EQUIV.)	Y	
M060	ARB Modal Test	225	FID (PROPANE EQUIV.)	N	
M061	ARB Modal Test	226	FID (PROPANE EQUIV.)	N	
M062	ARB Modal Test	227	FID (PROPANE EQUIV.)	Y	
M063	ARB Modal Test	228	FID (PROPANE EQUIV.)	N	
M088	ARB Modal Test	229	FID (PROPANE EQUIV.)	N	
M091	ARB Modal Test	230	FID (PROPANE EQUIV.)	N	
M093	ARB Modal Test	231	FID (PROPANE EQUIV.)	N	
M094	ARB Modal Test	232	FID (PROPANE EQUIV.)	N	
M095	ARB Modal Test	233	FID (PROPANE EQUIV.)	N	
M096	ARB Modal Test	234	FID (PROPANE EQUIV.)	N	

TEST PRO TABLE
(6 OF 6 COLUMNS)

DATE: 11/21/2007

PAGE: 5

TEST_	TEST_PRO_D	TEST_PRO_N	HC_METHOD	H	NOM_SO
M097	ARB Modal Test	235	FID (PROPANE EQUIV.)	N	
M101	ARB Modal Test	236	FID (PROPANE EQUIV.)	N	
M102	ARB Modal Test	237	FID (PROPANE EQUIV.)	Y	
M103	ARB Modal Test	238	FID (PROPANE EQUIV.)	Y	
MEC	Modal Emission Cycle test of the EC	210	FID (PROPANE EQUIV.)	Y	
MHFET	Running loss evap/exhaust emission test, based on repeated runs of HFET Schedule	51	FID (PROPANE EQUIV.)	N	
MLA4	Running loss evap/exhaust emission test, based on repeated runs of LA4 Schedule	46	FID (PROPANE EQUIV.)	N	
MNYCC	Running loss evap/exhaust emission test, based on repeated runs of NYCC Schedule	50	FID (PROPANE EQUIV.)	N	
MUC	Modal Unified Cycle (CARB-LA92)	1	FID (PROPANE EQUIV.)	Y	720/10
NONR1	Engine dyno transient test as defined by Contract 68-65-0077; orig. Task 2-2	197	HFID (PROPANE EQUIV)	N	
NONR2	Engine dyno transient test as defined by Contract 68-65-0077; amended Task 2-2	196	HFID (PROPANE EQUIV)	N	
NYBUS	New York Bus Cycle	2	FID (PROPANE EQUIV.)	N	
NYCC	New York City Cycle Test	22	FID (PROPANE EQUIV.)	N	
PRESC	Evap system pressure check - Done at fuel cap.	198	NOT APPLICABLE	N	
PREST	Evap System Pressure Check - Done at fuel tank.	199	NOT APPLICABLE	N	
RROVE	Vehicle with on-board exhaust instruments, driven on road route	187	NDIR (HEXANE EQUIV.)	Y	VARIABLES
RSID	Restart Idle Test Data (as defined by 40 CFR 85-2210)	17	NDIR (HEXANE EQUIV.)	N	
SADT	Single Axle Dump Truck Cycle developed by ERG	30	FID (PROPANE EQUIV.)	N	
SC03	SC03 Air Conditioning Simulation as specified in 40 CFR 86.160-00 thru 161-00	200	FID (PROPANE EQUIV.)	Y	10
SC03A	SC03 AC1 Air Conditioning Simulation as specified in 40 CFR 86.160-00 to 162-00	201	FID (PROPANE EQUIV.)	Y	10
SC03B	SC03 AC2 Air Conditioning Simulation as specified in 40 CFR 86.160-00 to 162-00	202	FID (PROPANE EQUIV.)	Y	10

TEST PRO TABLE
(6 OF 6 COLUMNS)

DATE: 11/21/2007

PAGE: 6

TEST_	TEST_PRO_D	TEST_PRO_N	HC_METHOD	H	NOM_SO
SFTP	Calculation (only) of composite SFTP emissions as specified in 40 CFR 86.164	203	FID (PROPANE EQUIV.)	N	
SIACC	Snap-Idle Acceleration test procedure as def by SAE J-1667	192	NOT APPLICABLE	N	
SMELR	European Loaded Response Smoke Test Amending Directive 88/77/EEC 12/3/1988	208	NOT APPLICABLE	N	
SMOKI	opacity smoke test procedure as def by ISO 8178-9	191	NOT APPLICABLE	N	
SPEED	EPA Speed Correction Cycle Test (Any of Several, e.g. LSP1-3 or SC12, SC36)	20	FID (PROPANE EQUIV.)	N	
SROVE	Vehicle with on-board exhaust instruments, driven on schedule-like road route	186	NDIR (HEXANE EQUIV.)	Y	VARIES
ST01	Engine Start cycle test	96	FID (PROPANE EQUIV.)	Y	720
ST0HR	Hot Running ST01	34	FID (PROPANE EQUIV.)	N	
ST0HS	Hot start ST01	33	FID (PROPANE EQUIV.)	Y	VARIES
STEAD	Steady State Driving	108	FID (PROPANE EQUIV.)	N	
SWEEP		32	FID (PROPANE EQUIV.)	N	
TADT	Tandem Axle Dump Truck Cycle developed by ERG	35	FID (PROPANE EQUIV.)	N	
TWOSP	Two Speed Idle Test	101	NDIR (HEXANE EQUIV.)	N	
UCC	Unified Corrections Cycle Test created by California Air Resources Board	213	FID (PROPANE EQUIV.)	N	
UFTP	Uncut Federal Test Procedure	53	FID (PROPANE EQUIV.)	Y	720/10
US06	High Speed 4th Bag of FTP	81	FID (PROPANE EQUIV.)	N	
USMOK	U.S. Smoke Cycle Test, as def by 40 CFR 86.884, Subpart I	190	NOT APPLICABLE	N	
XIM24	IM240 Test - No Exhaust Measurements Taken	152	NOT APPLICABLE	N	
XRSID	Restart Idle Test - No Exhaust Measurements Taken	117	NOT APPLICABLE	N	
XSI	Extended special idle test; Involves 24 steps; Data stored at MODETIME level.	31	NDIR (HEXANE EQUIV.)	Y	15

TEST_PRO TABLE
(6 OF 6 COLUMNS)

DATE: 11/21/2007

PAGE: 7

TEST_	TEST_PRO_D	TEST_PRO_N	HC_METHOD	H	NOM_SO
----	-----	-----	-----	-	-----
YARD		36	FID (PROPANE EQUIV.)	N	

END OF DATA FOR TEST_PRO TABLE

SCHEDULE TABLE
(4 OF 4 COLUMNS)

DATE: 11/21/2007

PAGE: 1

SCHED_ID	SCHED_D	SCHED_LEN	SCHED_N
14C	Modified CBD	569	128
14R	Modified and routized CBD	569	129
2-5MIL	The 5MILE heavy duty drive cycle performed twice.	1798	99
20_40	drive first half at 20 miles per hour, second half at 40 mph steady state driving	0	91
20_MPH	20 mile per hour steady state driving	0	89
2CBD	Double Central Business District (CBD)	1201	187
2CSHVR	The CSHVR drive cycle performed twice.	3358	100
2TESTD	DOUBLE TEST D WITH WARMUP (TEST_D2W)	2197	157
30_MPH	30 mile per hour steady state driving	0	90
3CBD	Triple Central Business District	1799	127
3IM240	triple nspection/maintenance 240(29.38mph)	717	96
40_MPH	40 mile per hour steady state driving	0	49
45_MPH	45 mile per hour steady state driving	0	50
50_MPH	50 mile per hour steady state driving	0	51
55_MPH	55 mile per hour steady state driving	0	52
5MILE	Heavy Duty vehicle drive cycle over 5 miles.	898	101
5PEAK	West Virginia 5 Peak Route	820	93
60_MPH	60 mile per hour steady state driving	0	53

SCHEDULE TABLE
(4 OF 4 COLUMNS)

DATE: 11/21/2007

PAGE: 2

SCHED_ID	SCHED_D	SCHED_LEN	SCHED_N
65_MPH	65 mile per hour steady state driving	0	54
75_MPH	75 mile per hour steady state driving	0	56
80_MPH	80 mile per hour steady state driving	0	57
85_MPH	85 mile per hour steady state driving	0	58
95_MPH	95 mile per hour steady state driving	0	60
AC5080		0	161
AGRIC	agricultural tractor cycle	629	62
ALT1		1721	130
ALT2		1589	131
ARB02	ARB weighted aggressive driving(non-FTP) cycle	1639	1
ARBL5	Low Speed Test Cycle	513	189
ART	WVU ART	290	175
ART-AB	level of service A & B arterial/collector simulation inventory cycle(24.8mph)	736	2
ART-CD	level of service C & D arterial/collector simulator inventory cycle(19.2mph)	628	3
ART-EF	level of service E & F arterial/collector simulation inventory cycle(11.6mph)	503	4
BAKHO	backhoe-loader cycle	515	63
CAART1	california arterial1(14.35mph)	907	5
CAART2	california arterial2(24.05mph)	931	6
CAART3	california arterial3(34.22mph)	944	7
CACYC1	california freeway speed correction1(60.09mph)	468	8

SCHEDULE TABLE
(4 OF 4 COLUMNS)

DATE: 11/21/2007

PAGE: 3

SCHED_ID	SCHED_D	SCHED_LEN	SCHED_N
CACYC2	california freeway speed correction2(53.37mph)	607	9
CACYC3	california freeway speed correction3(40.89mph)	907	10
CACYC4	california freeway speed correction4(31.35mph)	909	11
CACYC5	california freeway speed correction5(23.92mph)	909	12
CACYC6	california freeway speed correction6(16.50mph)	919	13
CACYC7	california freeway speed correction7(9.11mph)	581	14
CARB-C	Creep portion of CARB HHDDT cycle	272	163
CARB-I	Idle portion of CARB HHDDT cycle	0	162
CARB-R	Cruise portion of CARB HHDDT cycle	2082	165
CARB-T	Transient protion of CARB HHDDTT cycle	687	164
CARBCL	Extended version of the CARB-C schedule	1032	186
CBD	Central Business District	568	95
CBD-RT	Routized CBD	599	179
CDH226	colorado department of health(22.32mph)	225	15
CITY		1430	132
CRAWL	crawler tractor cycle	744	64
CSCYC		1678	133
CSHVR	Heavy Duty vehicle drive cycle.	1678	102
CY106	shed temperature pattern - nominally constant at 106 degrees F.	0	69
CY6084	real time diurnal temperature pattern - range 60 to 84 degrees Fahrenheit	259200	16

SCHEDULE TABLE
(4 OF 4 COLUMNS)

DATE: 11/21/2007

PAGE: 4

SCHED_ID	SCHED_D	SCHED_LEN	SCHED_N
CY7296	real time diurnal temperature pattern - range 72 to 96 degrees Fahrenheit	259200	17
CY8210	real time diurnal temperature pattern - range 82 to 106 degrees Fahrenheit	259200	18
CY84	shed temperature pattern - nominally constant at 84 degrees F.	0	67
CY96	shed temperature pattern - nominally constant at 96 degrees F.	0	68
DIURB2	temperature rise for 1 hour diurnal evap emission test at elevated temperature 72- 96	3600	65
DIURB3	temperature rise for 1 hour diurnal evap emission test at elevated temperature 82-106	3600	66
DIURBL	standard temperature rise for 1 hour diurnal (or breathing loss) evaporative emission test	3600	19
DRT	TEST D ROUTE	1098	149
EC		0	159
F505	bag 1 of federal test procedure(25.55mph)	505	20
FIGE	European Transient Cycle	1800	134
FTP	federal test procedure(19.53mph), also referred to as the UDDP schedule	1877	21
FTPR5	FTP APPENDED WITH REP05 SCHEDULE	3277	178
FWY-AC	level of service A through C(free flow) freeway simulation inventory cycle(59.7mph)	515	22
FWY-D	level of service D freeway simulation inventory cycle(52.9mph)	405	23
FWY-E	level of service E freeway simulation inventory cycle(30.5mph)	455	24
FWY-F	level of service F freeway simulation inventory cycle(18.6mph)	441	25
FWY-G	level of service G freewat simulation inventory cycle(13.1mph)	389	26

SCHEDULE TABLE
(4 OF 4 COLUMNS)

DATE: 11/21/2007

PAGE: 5

SCHED_ID	SCHED_D	SCHED_LEN	SCHED_N
FWY-HI	high-speed freeway cycle(63.18mph)	609	27
GRADA	Telescoping Boom Excavator Cycle developed by ERG	1399	182
HCBD	One half of a normal Central Business District schedule (CBD)	287	185
HIWAY	WVU Hiway Driving Cycle	1648	135
HR_UC	No Start Bag 1 UC Modal Test	301	190
HVDUTY		0	139
HWFET	highway fuel economy test(48.14mph) -control cycle	764	28
IM240	inspection/maintenance 240(29.38mph)	239	29
IM386	inspection/maintenance 386(31.31mph)	385	30
KERN	KERN CYCLE	1900	146
LA4	Bags 1 and 2 of the FTP, also referred to as the UDDP schedule	1372	31
LA92	california unified cycle(areawide driving simulation inventory cycle	1435	32
LOADE	Wheeled Loader Cycle developed by ERG	918	183
LOCAL	urban local facility driving simulation inventory cycle(12.9mph)	524	33
LSP1	low speed 1(2.51mph)	601	34
LSP2	low speed 2(3.54mph)	718	35
LSP3	low speed 3(4.11mph)	555	36
MEC	Enhanced Cold CVS II Test	1879	166
MEC5	Modal Emission Cycle (MEC) version 5 Created by CE-CERT for the development of the NCHRP.	1920	105

SCHEDULE TABLE
(4 OF 4 COLUMNS)

DATE: 11/21/2007

PAGE: 6

SCHED_ID	SCHED_D	SCHED_LEN	SCHED_N
MEC6	Modal Emission Cycle (MEC) version 6 Created by CE-CERT for the development of the NCHRP.	1919	106
MEC7	Modal Emission Cycle (MEC) version 7 Created by CE-CERT for the development of the NCHRP.	1980	107
MUC	UNIFIED CYCLE	1879	160
NONFRW	areawide non-freeway cycle(19.35mph)	1347	37
NYBUS		600	140
NYCC	(new york city cycle(7.04mph)	602	38
NYCCT	New York Composite Cycle (NY-Comp)	1029	180
NYGT2	DOUBLE LENGTH NEW YORK GARBAGE TRUCK CYCLE	1240	158
NYGTC	New York Garbage Truck cycle	620	188
NYGTC3	New York Garbage Truck Cycle run 3 times	1861	141
NYTRK	NEW YORK TRUCK CYCLE	1015	150
OCRTC	Orange County Refuse Truck Cycle	1141	176
OCRTC2	OCRTC run 2 times	2323	181
PCC10	PCC10 with dilute modal and bag fill	323	196
PCC55	PCC55 with dilute modal and bag fill	1934	197
PCC65	PCC65 with dilute modal and bag fill	3508	198
RAMP	freeway ramp simulation inventory cycle(34.58mph)	265	39
REM01	EPA weighted 'FTP-like' cycle	1493	40
REP05	EPA weighted aggressive driving(non-FTP) cycle	1399	41
RT22	ROUTE 22	1887	153

SCHEDULE TABLE
(4 OF 4 COLUMNS)

DATE: 11/21/2007

PAGE: 7

SCHED_ID	SCHED_D	SCHED_LEN	SCHED_N
RT77	ROUTE 77	858	152
RTLHSP	RUBBER TIRE LOADER HIGH SPEED TRANSIENT DUTY SCHEDULE	1198	79
RTLHTQ	RUBBER TIRE LOADER HIGH TORQUE TRANSIENT DUTY SCHEDULE	1198	81
RTL_T1	RUBBER TIRE LOADER TYPICAL 1 DUTY SCHEDULE	1198	80
RTL_T2	RUBBER TIRE LOADER TYPICAL 2 DUTY SCHEDULE	1198	82
SADT	Single Axle Dump Truck Cycle developed by ERG	1295	173
SC03	SFTP air conditioning compliance cycle(EPA and ARB)	595	42
SCC12	speed correction cycle12(11.67mph)	360	43
SCC36	speed correction cycle36(36.47mph)	978	44
SMEC6	Special Modal Emission Cycle (MEC) ver 6 Created by CE-CERT for the development of NCHRP	1454	168
SMEC7	Special Modal Emission Cycle (MEC) ver 7 Created by CE-CERT for the development of NCHRP	1569	169
SSLHSP	SKID STEER LOADER HIGH SPEED TRANSIENT SCHEDULE	1198	83
SSLHTQ	SKID STEER LOADER HIGH TORQUE TRANSIENT DUTY SCHEDULE	1198	85
SSL_T1	SKID STEER LOADER TYPICAL 1 DUTY SCHEDULE	1198	84
SSL_T2	SKID STEER LOADER TYPICAL 2 DUTY SCHEDULE	1198	86
ST01	EPA start cycle - first 1.4 miles of SC03	263	45
SWEEP3		1638	142
TADT	Double Axle Dump Truck Cycle developed by ERG	1512	174

SCHEDULE TABLE
(4 OF 4 COLUMNS)

DATE: 11/21/2007

PAGE: 8

SCHED_ID	SCHED_D	SCHED_LEN	SCHED_N
TCDC		1638	136
TEST_D		1099	137
UCC10	UCC10	387	193
UCC15	UCC15 - Created by CARB	421	113
UCC20	UCC20 - Created by CARB	835	114
UCC25	UCC25 - Created by CARB	853	115
UCC30	UCC30 - Created by CARB	983	116
UCC35	UCC35 - Created by CARB	1350	117
UCC40	UCC40 - Created by CARB	1333	118
UCC45	UCC45 - Created by CARB	1303	119
UCC5	UCC5	210	192
UCC50	UCC50 - Created by CARB	2191	121
UCC55	UCC 55MPH MODAL	2317	194
UCC60	UCC 60MPH MODAL	2810	195
UDDSF2	EPA ENGINE DYNAMOMETER SCHEDULE FOR HEAVY DUTY DIESEL ENGINES.	1195	94
UDDS_D	URBAN DYNAMOMETER DRIVING SCHEDULE FOR HEAVY DUTY VEHICLES	1060	88
UDDS_W	WVU Truncated version of the UDD_S	1039	184
UNCFTP	uncut federal test procedure(21.25mph)	1874	46
UNIF01	EPA unified cycle	1929	47
US06	SFTP aggressive driving compliance cycle(EPA and ARB)	600	48
US06x2	US06x2 test	1202	191
VFAC	VIKING FREIGHT ADHOC CYCLE (VIKING_W)	1887	156
WELHSP	ARC WELDER HIGH SPEED TRANSIENT DUTY SCHEDULE	1198	75

SCHEDULE TABLE
(4 OF 4 COLUMNS)

DATE: 11/21/2007

PAGE: 9

SCHED_ID	SCHED_D	SCHED_LEN	SCHED_N
WELHTQ	ARC WELDER HIGH TORQUE TRANSIENT DUTY SCHEDULE	1198	77
WEL_T1	ARC WELDER TYPICAL 1 DUTY SCHEDULE	1198	76
WEL_T2	ARC WELDER TYPICAL 2 DUTY SCHEDULE	1198	78
WHM	WVU WHM Driving Cycle	1298	143
WVUCBD	West Virginia University Central Business District	850	92
X_CAV	EXCAVATOR SCHEDULE	1198	87
YARD	WVU Yard Driving Cycle	1169	144

END DATA FOR SCHEDULE TABLE

RES_KIND TABLE

(3 OF 3 COLUMNS)

DATE: 11/19/2007

PAGE: 1

RES_KIND	RES_KIND_D	RES_KIND_N
ACTIVITY	A collection of zero to many trips of a vehicle instrumented with PEMS/PAMS.	16
DYNOTEST	Chassis Dyno, (or Idle) Exhaust Emission Test	5
ENGINMAP	Engine Maximum Available Power (MAP) Determination	10
ENGTEST	Engine test on engine dynamometer	11
EVAPTEST	Evaporative Emission Test, e.g. done with SHED	6
FUELCHEM	Fuel Analysis	9
INSPECT	Emission Component Inspection	2
OBDSKAN	On-board Diagnostic Code Scan	3
OWNERQST	Vehicle Owner Questionnaire, Short Form	8
PRESSTST	Evaporative System Pressure Check	7
PROCURE	Mobile Source Procurement	1
REPAIR	Repair (lasting improvement)	4
ROADTEST	On Board Instrumented Exhaust Emission Test	14
ROADTRIP	Road trip travelled by an on-road vehicle	15
RUNLOSS	Running loss evaporative and exhaust emission test	13
SMOKETST	Smoke test	12
TRIP	Vehicle activity bounded by an intentional engine on and engine off event.	17

END OF DATA FOR RES_KIND TABLE

MODE_ID TABLE
(3 OF 3 COLUMNS)

DATE: 11/21/2007

PAGE: 1

MODE_ID	MODE_ID_D	MODE_ID_N
30MPH	Steady speed driving at 30 miles per hour	8
30MPH__X23	Loaded (7.0 HP) cruise at 28-32 mph; following 1 min of idle; step 23 of TEST_PROC = 'XSI'	33
50MPH	Steady speed driving at 50 miles per hour	7
ASM_2525	ASM Test Procedure - 25% Load at 25 mph.	2
ASM_5015	ASM Test Procedure - 50% Load at 15 mph.	1
IDLE	Idle in Neutral	3
IDLE_2500	Unloaded idle at 2500 rpm	5
IDLE_25X04	Unloaded idle at 2500 rpm; following 15 minute soak; step 4 of TEST_PROC = 'XSI'	14
IDLE_25X08	Unloaded idle at 2500 rpm; following 30 secs of idle; step 8 of TEST_PROC = 'XSI'	18
IDLE_25X11	Unloaded idle at 2500 rpm; following engine restart; step 11 of TEST_PROC = 'XSI'	21
IDLE_25X14	Unloaded idle at 2500 rpm; following 30 mins of idle; step 14 of TEST_PROC = 'XSI'	24
IDLE_25X17	Unloaded idle at 2500 rpm; following engine restart; step 17 of TEST_PROC = 'XSI'	27
IDLE_25X19	Unloaded idle at 2500 rpm; following 60 secs of idle; step 19 of TEST_PROC = 'XSI'	29
IDLE_25X21	Unloaded idle at 2500 rpm; previous step varies; step 21 of TEST_PROC = 'XSI'	31
IDLE_AGAIN	Repeated Idle in Neutral, Needed for 4 Mode Tests	6
IDLE_DRIVE	Idle in Drive, Assumes Automatic Transmission	4
IDLE__X05	Idle in Neutral; following 30 secs of idle at 2500 rpm; step 5 of TEST_PROC = 'XSI'	15
IDLE__X07	Idle in Neutral; following 505 cycle; step 7 of TEST_PROC = 'XSI'	17
IDLE__X09	Idle in Neutral; following 30 secs of idle at 2500 rpm; step 9 of TEST_PROC = 'XSI'	19
IDLE__X12	Idle in Neutral; following 30 secs of idle at 2500 rpm; steps 12 -13 of TEST_PROC = 'XSI'	22

MODE_ID TABLE
(3 OF 3 COLUMNS)

DATE: 11/21/2007

PAGE: 2

<u>MODE_ID</u>	<u>MODE_ID_D</u>	<u>MODE_ID_N</u>
IDLE__X15	Idle in Neutral; following 30 secs of idle at 2500 rpm; step 15 of TEST_PROC = 'XSI'	25
IDLE__X18	Idle in Neutral; following 30 secs of idle at 2500 rpm; step 18 of TEST_PROC = 'XSI'	28
IDLE__X22	Idle in Neutral; following 30 secs of idle at 2500 rpm; step 22 of TEST_PROC = 'XSI'	32
IDLE__X24	Idle in Neutral; following 30 secs of 30mph cruise; step 24 of TEST_PROC = 'XSI'	34

END OF DATA FOR MODE_ID TABLE

