

REG	STATE	PROJECT	SHEET NO.	TOTAL SHEETS

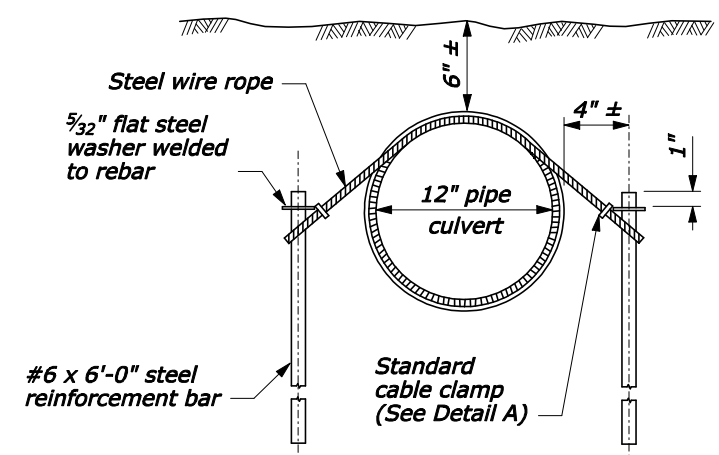

PIPE ANCHOR ASSEMBLY ALTERNATE 1

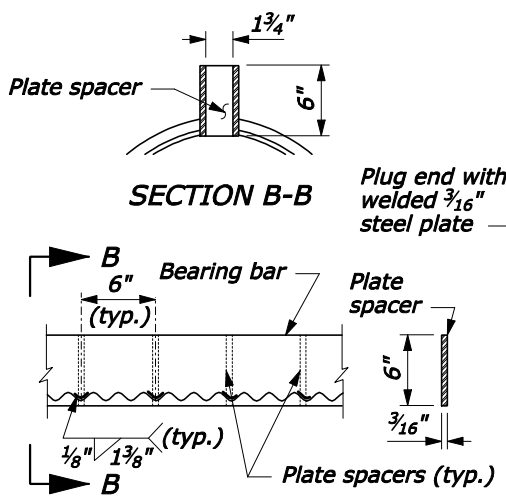

GRATE SLOT

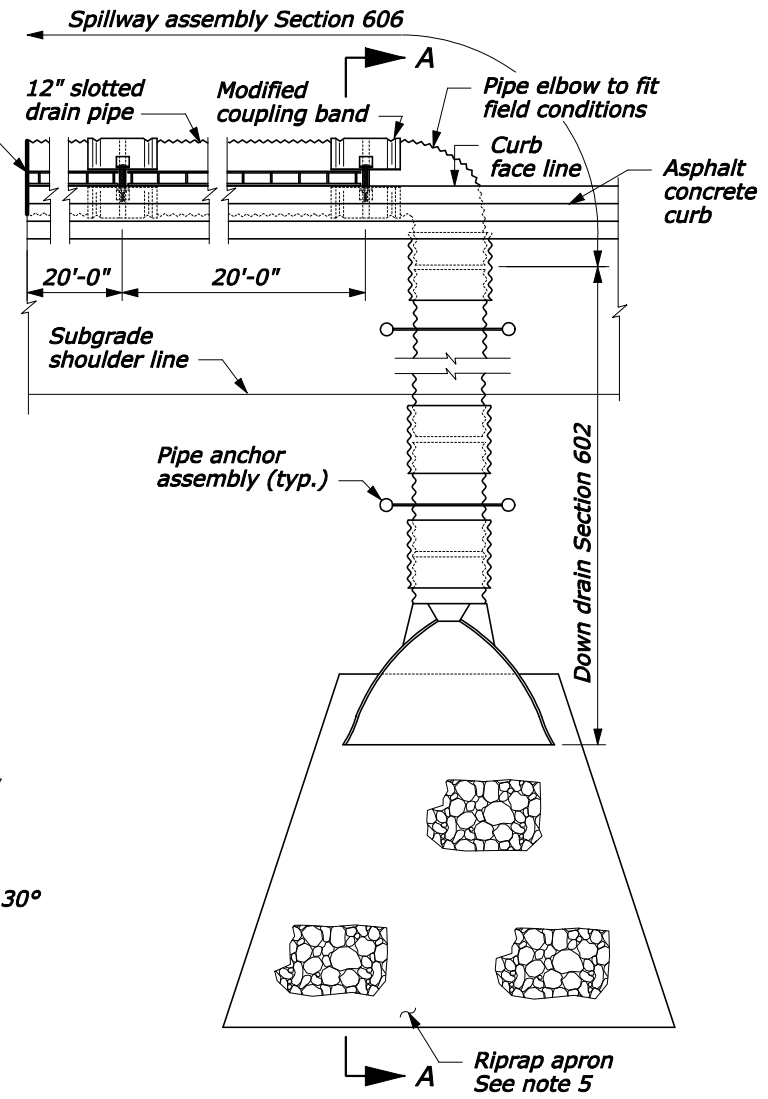

SLOTTED DRAIN ASSEMBLY

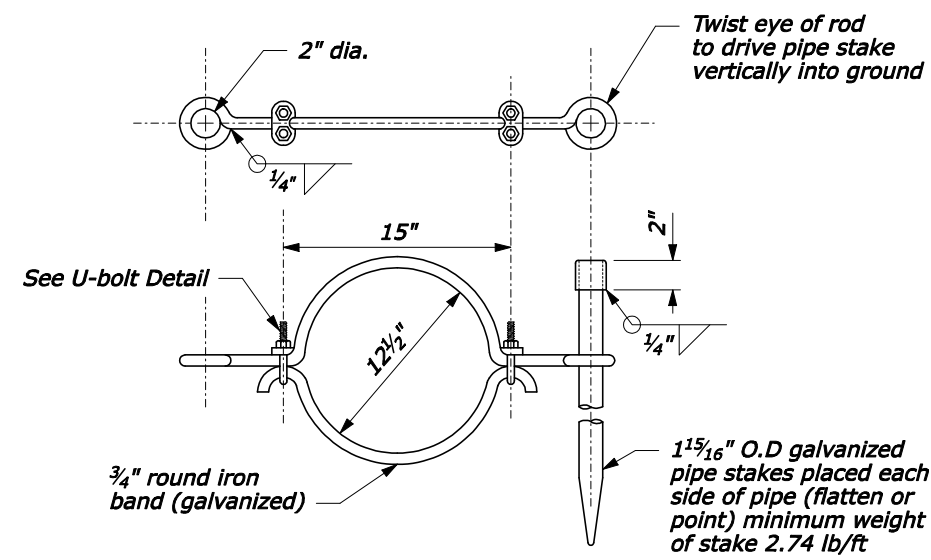

PIPE ANCHOR ASSEMBLY ALTERNATE 2

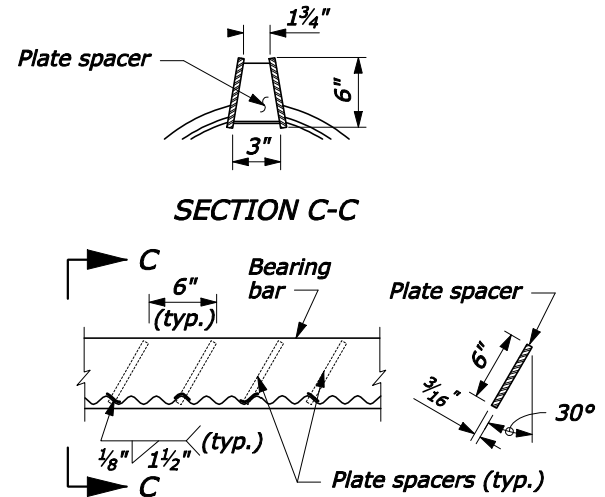

ANGLE SLOT

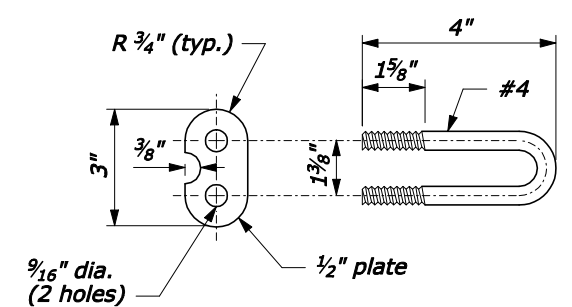

U-BOLT DETAIL

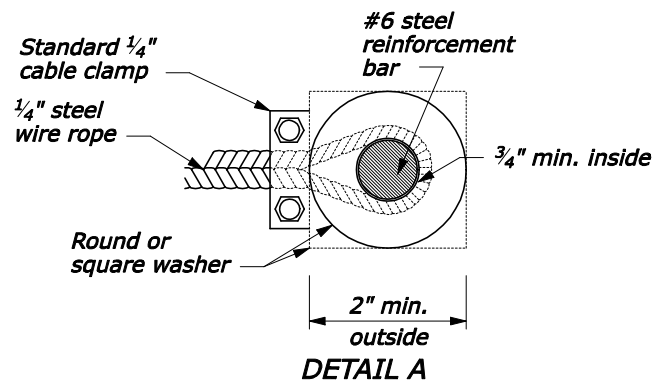

DETAIL A

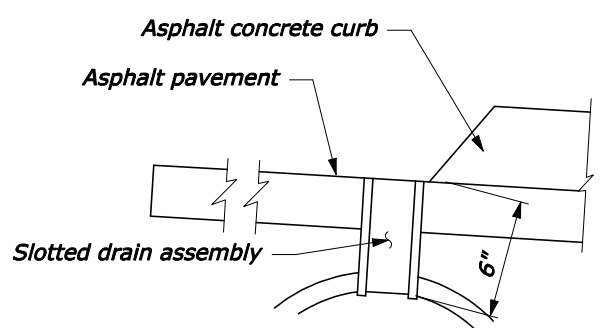

INSTALLATION DETAIL

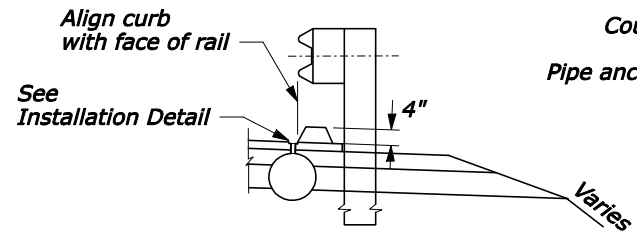

TYPICAL PLACEMENT AT GUARDRAIL

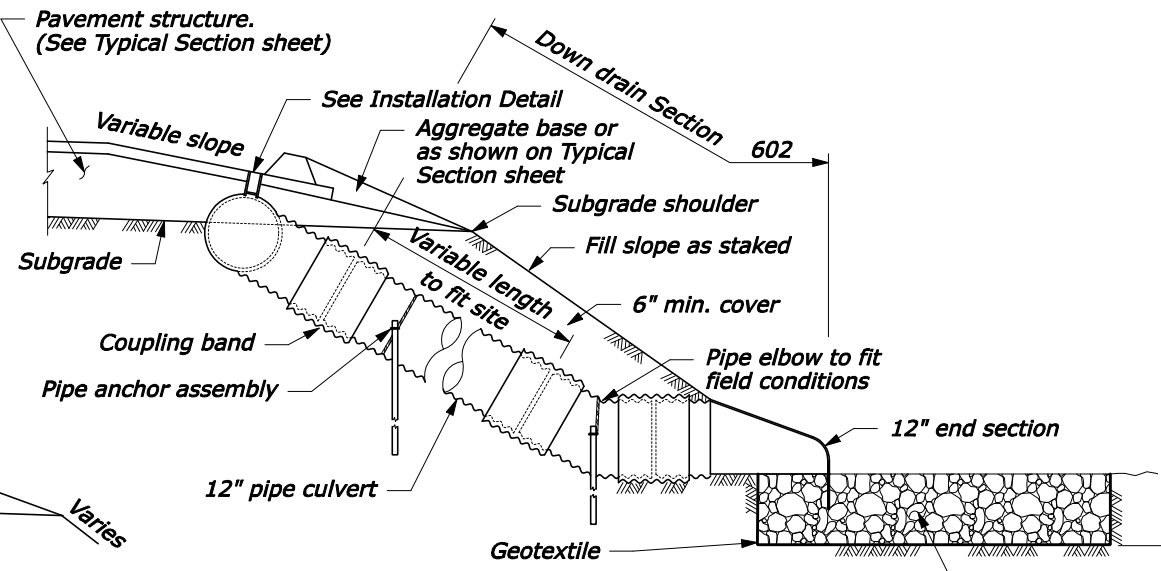

SECTION A-A

NO SCALE

- NOTE:**
1. Fabricate slotted drain pipe, down drain pipe culvert, elbows, end section, and coupling bands from sheets 1/16" thickness.
 2. Grate slot assembly and plate end plug conform to AASHTO M 183.
 3. Galvanize grate slot assembly, plate end plug, and all hardware according to AASHTO M 111.
 4. Approved alternate pipe anchor assemblies may be used.
 5. See Detail C251-50 for riprap apron.
 6. Place pipe anchor assemblies at approximately 20' (min.) intervals along down drain pipe culvert. Place a minimum of 2 anchors per down drain.
 7. For installations at sag vertical curves, use a tee connection instead of an elbow and a minimum of two 20' slotted drain pipe sections.
 8. Make all band connections watertight by placing gaskets or O-rings under the bands before tightening in accordance with Subsection 712.03.
 9. Use either the grate slot or the angle slot slotted drain assembly.

U.S. DEPARTMENT OF TRANSPORTATION
FEDERAL HIGHWAY ADMINISTRATION
CENTRAL FEDERAL LANDS HIGHWAY DIVISION

U.S. CUSTOMARY DETAIL

SLOTTED DRAIN SPILLWAY ASSEMBLY

DETAIL APPROVED FOR USE 03/2009

REVISIONS:

DETAIL C606-51

3/20/2009 12:39:29 PM N:\CFL-DPTT\Details Team\for_website\March09\C606-51.dgn



NOTES TO THE DESIGNER

Last Updated: March 2009

General Information

1. **Converted from an FLH Standard.** This drawing was originally an FLH Standard drawing that was modified to accommodate the new riprap SCR.
2. **Riprap classes.** Use this drawing only with NCHRP classifications (See the Section 251 SCRs on the LOS). Use [FLH Standard drawing 606-1](#) with FP-03 classifications.

Applicable SCRs

1. Section 251:
http://www.cflhd.gov/design/_documents/construction/scr_03/S251-03E.doc
2. Section 602:
http://www.cflhd.gov/design/_documents/construction/scr_03/S602-03E.doc
3. Section 705:
http://www.cflhd.gov/design/_documents/construction/scr_03/S705-03E.doc

Typical Pay Items Used

- 25101-2000 Placed riprap, class 2 and/or
- 25101-3000 Placed riprap, class 3 and/or
- 25101-4000 Placed riprap, class 4

- 60201-0400 12-inch pipe culvert
- 60210-0400 End section for 12-inch pipe culvert
- 60601-0000 Spillway assembly
- 60602-0300 Pipe anchor assembly, 12-inch

- Other project specific items, including curb, guardrail, and surfacing
- Geotextile quantity is shown for information only

Updates

March 2009

- Converted from an FLH Standard
- Deleted specific details at riprap aprons – refer to CFL Detail 251-50
- Minor drafting edits