

REG	STATE	PROJECT	SHEET NO.	TOTAL SHEETS

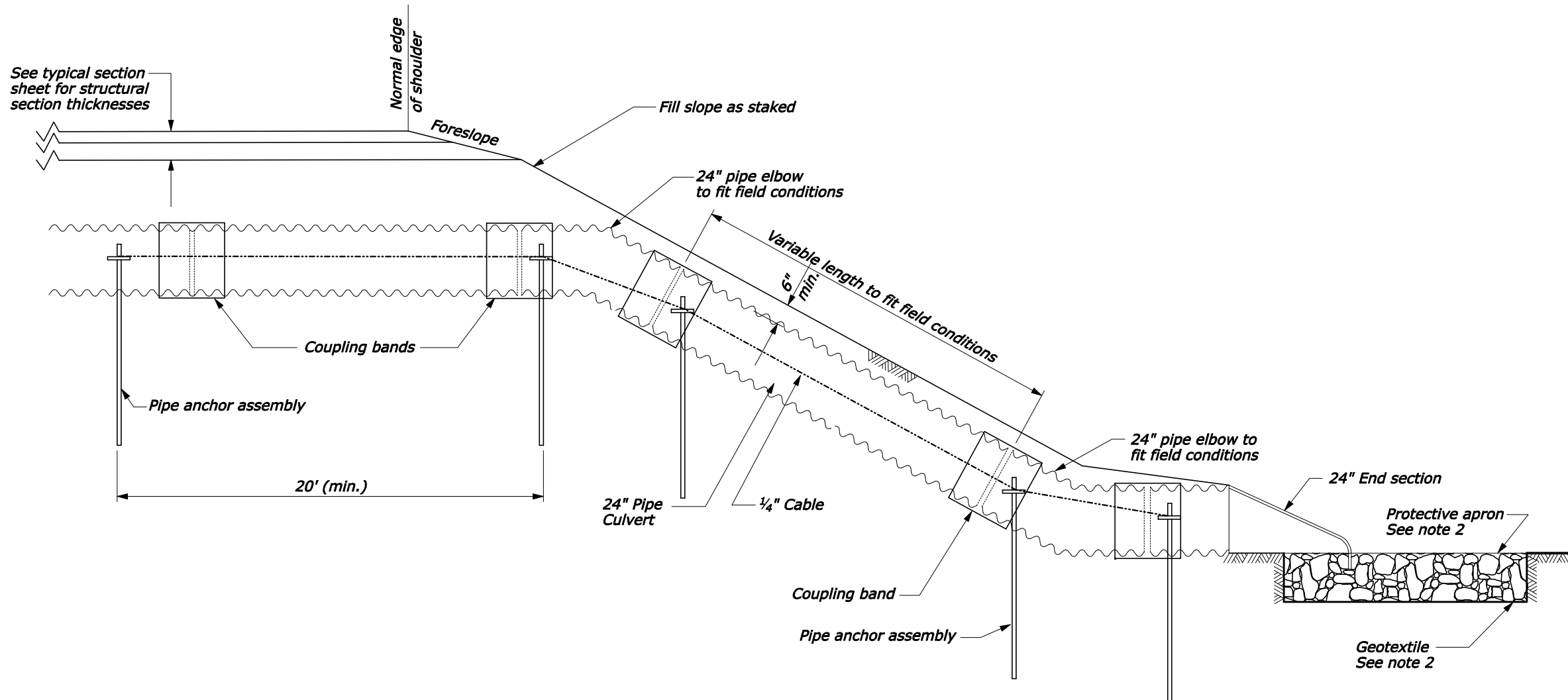

- NOTE:**
1. Furnish metal pipe culvert, elbows, and coupling bands according to Section 602.
  2. Furnish riprap and geotextile for protective apron according to Section 251 and Detail C251-50.
  3. Furnish hardware galvanized according to AASHTO M111.
  4. Place pipe anchor assemblies at approximately 20' (min.) intervals along rundown portion of drain pipe.
  5. Other suitable pipe anchor assemblies may be used upon approval in writing by the CO.
  6. The use of the hugger band is restricted to welded spiral pipe with annular end corrugations or riveted annularly corrugated pipe.
  7. Metal pipe shown is typical. Steel, aluminum, and concrete pipes as indicated on the drainage summary sheet, may be used.
  8. Join concrete pipe in accordance with section 602 or other methods approved by the CO.
  9. Use alternate A anchor assembly only with annular corrugations. May be placed on annular or preformed end HCSP coupling band if securely fastened on downstream side of joint. Alternate B anchor assembly to be fastened to pipe sections and not to band coupler used to join sections.
  10. Use gaskets on all joints along the rundown portion of drain pipe.
  11. Pipe anchor assemblies will be paid for under Section 606.

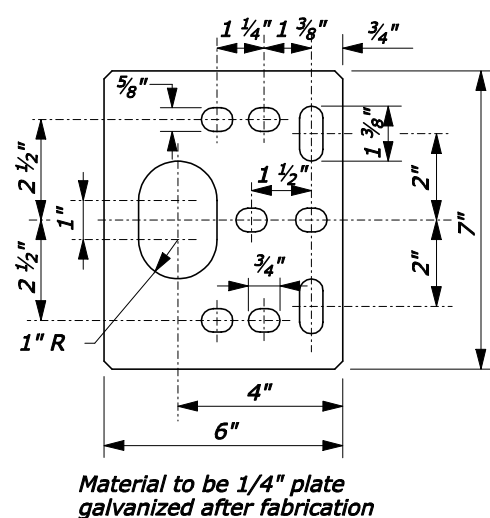
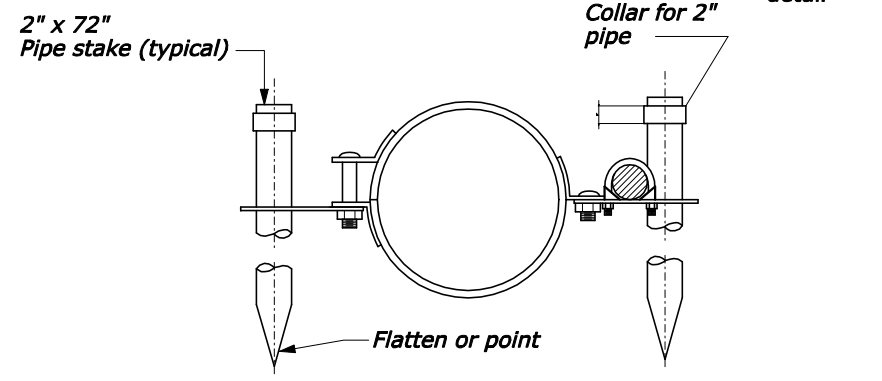
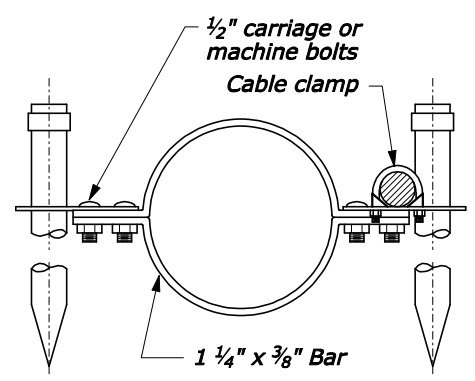
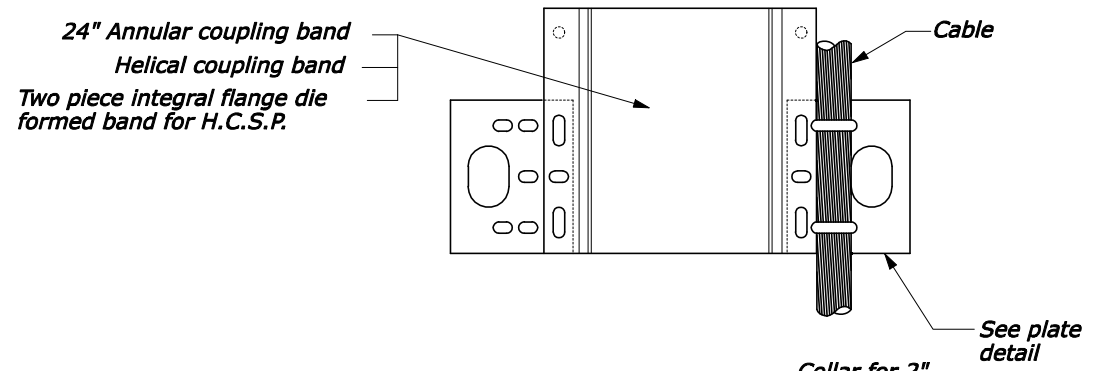
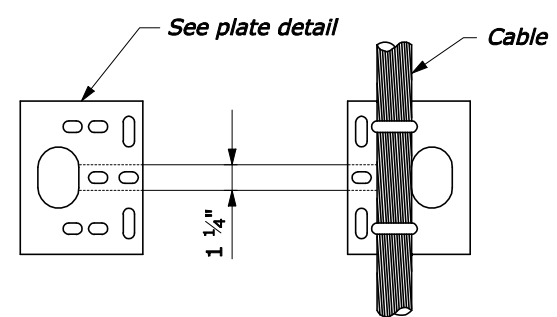

**PIPE ANCHOR ASSEMBLY DETAILS**

PLATE DETAIL NO SCALE

U.S. DEPARTMENT OF TRANSPORTATION  
 FEDERAL HIGHWAY ADMINISTRATION  
 CENTRAL FEDERAL LANDS HIGHWAY DIVISION

U.S. CUSTOMARY DETAIL

**24" BURIED RUN DOWN AND PIPE ANCHOR ASSEMBLY**

DETAIL APPROVED FOR USE 07/2004  
 REVISIONS: 08/2006 03/2009

DETAIL C602-51

3/20/2009 12:37:51 PM N:\CFL-DPTT\Details Team\for\_website\March09\C602-51.dgn

## NOTES TO THE DESIGNER

Last Updated: March 2009

---

### General Information

1. **Riprap classes.** Use these drawings with either the FP-03 riprap classifications or the NCHRP classifications (See the Section 251 SCRs on the LOS).

---

### Applicable SCRs

1. Section 251:  
[http://www.cflhd.gov/design/\\_documents/construction/scr\\_03/S251-03E.doc](http://www.cflhd.gov/design/_documents/construction/scr_03/S251-03E.doc)
2. Section 602:  
[http://www.cflhd.gov/design/\\_documents/construction/scr\\_03/S602-03E.doc](http://www.cflhd.gov/design/_documents/construction/scr_03/S602-03E.doc)
3. Section 705:  
[http://www.cflhd.gov/design/\\_documents/construction/scr\\_03/S705-03E.doc](http://www.cflhd.gov/design/_documents/construction/scr_03/S705-03E.doc)

---

### Typical Pay Items Used

- 25101-2000 Placed riprap, class 2 and/or
- 25101-3000 Placed riprap, class 3 and/or
- 25101-4000 Placed riprap, class 4
  
- 60201-0800 24-inch pipe culvert
- 60210-0800 End section for 24-inch pipe culvert
- 60212-0800 Elbow, 24-inch
- 60602-0700 Pipe anchor assembly, 24-inch
  
- Geotextile quantity is shown for information only

---

### Updates

October 16, 2000

- Updated border to FLH Standard

February 28, 2005

- Updated to MicroStation V8

March 2009

- Revised Note 2 to refer to 251 detail for riprap apron
- Minor drafting edits