

PLAN
CATCH BASIN LAYOUT AT BRIDGE ENDS

- NOTE:**
1. **CONCRETE:** Chamfer exposed edges 20 mm unless otherwise shown. Give all concrete surfaces a Class 1 finish.
 2. The minimum concrete cover to the face of any bar is 50 mm unless otherwise shown.
 3. See Standard M604-2 for Type A Frame and Grate and Standard M604-3 for Type B Frame and Grate.
 4. Make all coupling band connections watertight by placing 5 mm bead of approved caulking under each half of the bands before tightening.
 5. Fabricate tapered portion of slip-joint from either flat or corrugated sheets.
 6. See Detail CM251-50 for protective apron details.
 7. Dimensions without units are millimeters.

DESCRIPTION	FRAME AND GRATE	
	TYPE A	TYPE B
Reinforcing Steel	32 kg	32 kg
Structural Steel	98 kg	108 kg
Concrete	0.6 m ³	0.6 m ³

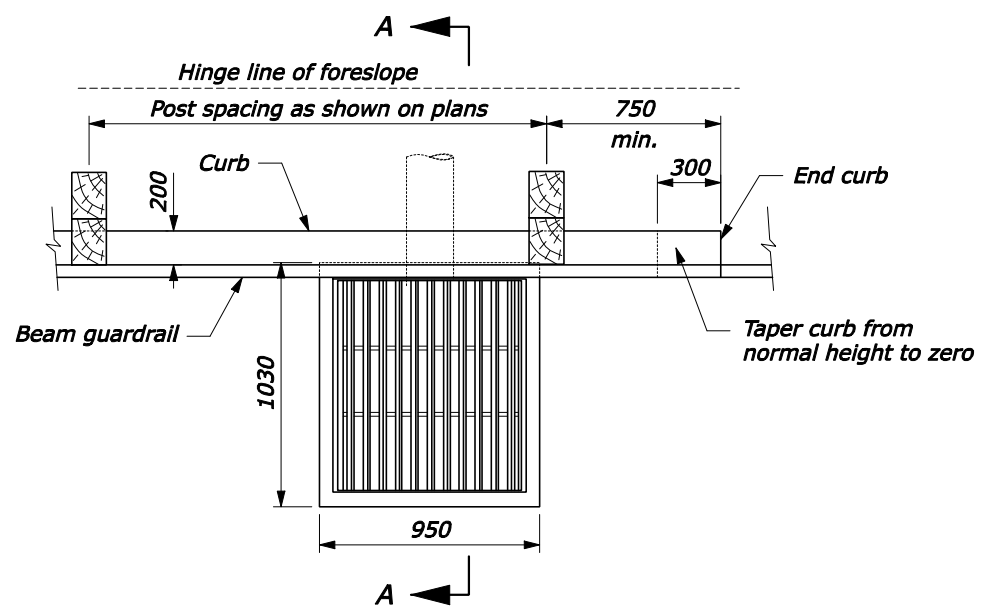

CATCH BASIN LAYOUT

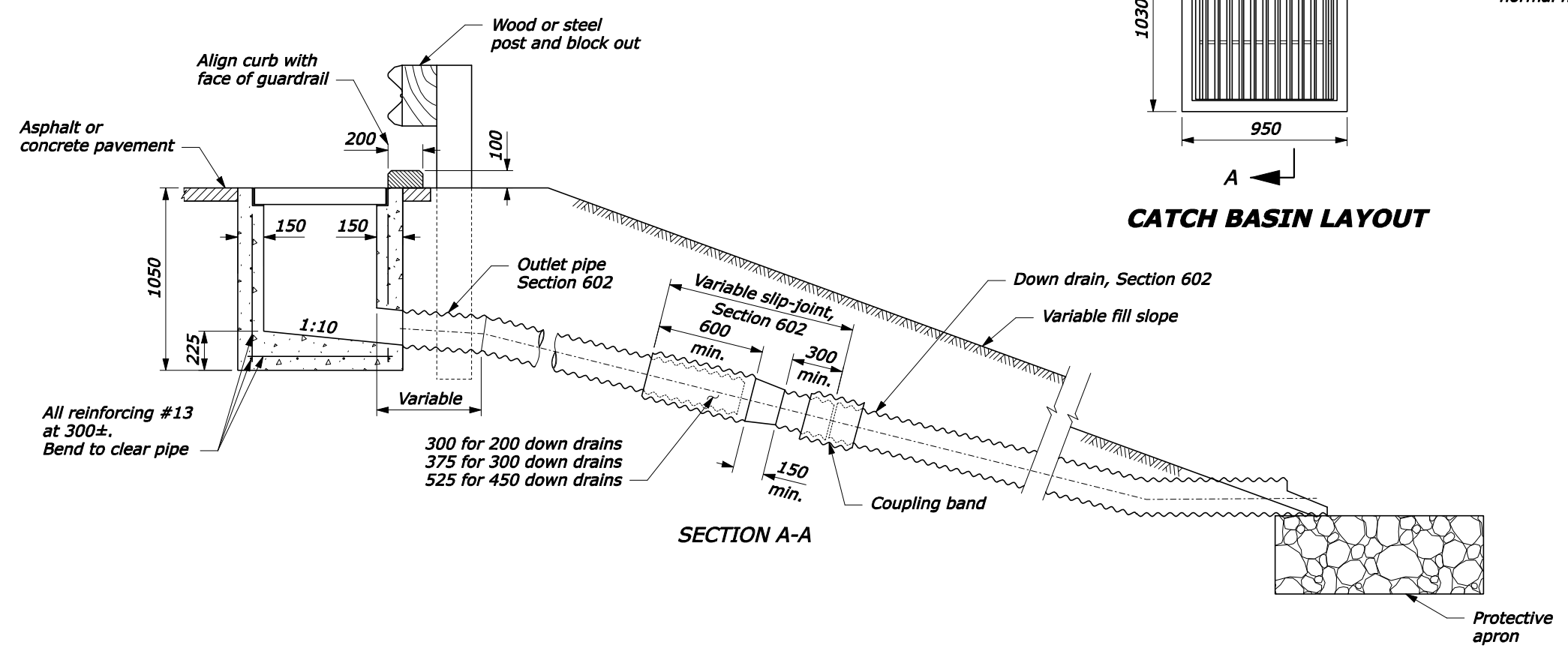

SECTION A-A

U.S. DEPARTMENT OF TRANSPORTATION
FEDERAL HIGHWAY ADMINISTRATION
CENTRAL FEDERAL LANDS HIGHWAY DIVISION

METRIC DETAIL

**CATCH BASIN
TYPE 2
WITH DOWN DRAIN**

DETAIL APPROVED FOR USE 03/2009

REVISID: _____

DETAIL
CM604-50

3/20/2009 12:38:50 PM N:\CFL-DPT\Details Team\for_website\March09\CM604-50.dgn

NOTES TO THE DESIGNER

Last Updated: March 2009

General Information

1. **Converted from an FLH Standard.** This drawing was originally an FLH Standard drawing that was modified to accommodate the new riprap SCR.
2. **Riprap classes.** Use this drawing only with NCHRP classifications (See the Section 251 SCRs on the LOS). Use [FLH Standard drawing 604-4](#) with FP-03 classifications.

Applicable SCRs

1. Section 251:
http://www.cflhd.gov/design/ documents/construction/scr_03/S251-03M.doc
2. Section 705:
http://www.cflhd.gov/design/ documents/construction/scr_03/S705-03M.doc

Typical Pay Items Used

- 25101-2000 Placed riprap, class 2 and/or
- 25101-3000 Placed riprap, class 3 and/or
- 25101-4000 Placed riprap, class 4

- 60201-0300 200mm pipe culvert or
- 60204-0400 300mm pipe culvert or
- 60201-0600 450mm pipe culvert

- 60404-2000 Catch basin, type 2

- 60409-0100 Metal frame and grate type A or
- 60409-0200 Metal frame and grate type B

- Other project-specific items, including curb, guardrail, and pavement surfacing
- Geotextile quantity is shown for information only

Updates

March 2009

- Converted from an FLH Standard
- Deleted protective apron detail – refers to CFL Detail 251-50 for riprap apron details.