

SECTION A-A SECTION B-B

**PROTECTIVE APRON AT CULVERT OUTLET WITHOUT DITCH**

<b>OUTLET WITHOUT DITCH PROTECTIVE APRON DIMENSIONS AND ESTIMATED QUANTITIES</b>						
	CULVERT SIZE D (mm)	RIPRAP CLASS	LENGTH OF APRON L (m)	DEPTH OF APRON H (m)	ESTIMATED RIPRAP QUANTITY (m3)	ESTIMATED GEOTEXTILE QUANTITY (m2)
WITH END SECTION	300	2	1.5	0.5	1.1	6
	450	2	2.1	0.5	2.2	9
	600	2	2.7	0.5	3.7	13
	750	3	4.1	0.6	8.8	25
	900	3	4.8	0.6	12.4	32
	1050	4	6.6	0.8	28.3	56
WITHOUT END SECTION	300	2	2.5	0.5	2.2	9
	450	2	3.1	0.5	3.7	14
	600	2	3.7	0.5	5.7	19
	750	3	5.1	0.6	12.0	31
	900	3	5.8	0.6	16.2	40
	1050	4	7.6	0.8	34.6	66
1200	4	8.5	0.8	43.8	80	

- NOTE:**
1. Use for aprons serving culverts with slopes of less than 10%.
  2. Furnish geotextile conforming to Subsection 714.01(a).
  3. Excavation for placement of riprap will not be measured for payment.

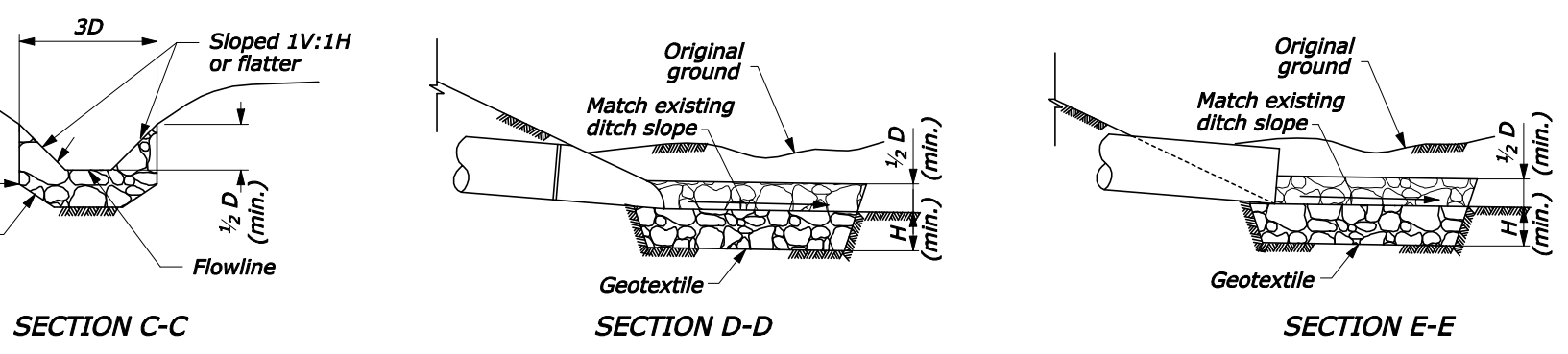
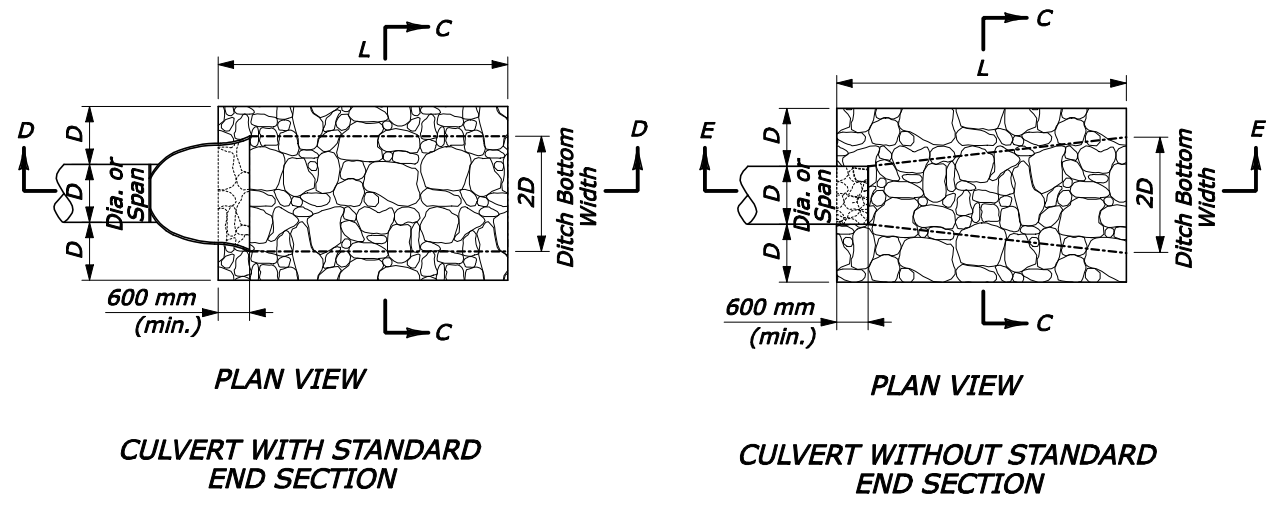

**PROTECTIVE APRON AT CULVERT OUTLET WITH DITCH**

<b>OUTLET WITH DITCH PROTECTIVE APRON DIMENSIONS AND ESTIMATED QUANTITIES</b>						
	CULVERT SIZE D (mm)	RIPRAP CLASS	LENGTH OF APRON L (m)	DEPTH OF APRON H (m)	ESTIMATED RIPRAP QUANTITY (m3)	ESTIMATED GEOTEXTILE QUANTITY (m2)
WITH END SECTION	300	2	1.5	0.5	0.7	4
	450	2	2.1	0.5	1.5	7
	600	2	2.7	0.5	2.5	10
	750	3	4.1	0.6	5.5	17
	900	3	4.8	0.6	7.8	22
	1050	4	6.6	0.8	16.7	37
WITHOUT END SECTION	300	2	2.5	0.5	1.2	6
	450	2	3.1	0.5	2.9	9
	600	2	3.7	0.5	4.7	13
	750	3	5.1	0.6	6.9	21
	900	3	5.8	0.6	9.4	26
	1050	4	7.6	0.8	19.2	42
1200	4	8.5	0.8	24.5	50	

U.S. DEPARTMENT OF TRANSPORTATION  
FEDERAL HIGHWAY ADMINISTRATION  
CENTRAL FEDERAL LANDS HIGHWAY DIVISION

METRIC DETAIL

**PLACED RIPRAP AT CULVERT OUTLETS**

NO SCALE

DETAIL APPROVED FOR USE 07/2004  
REVISOR: 08/2006 03/2009

DETAIL  
CM251-50

3/20/2009 12:33:50 PM N:\CFL-DPT\Details Team\for\_website\March09\CM251-50.dgn



## NOTES TO THE DESIGNER

Last Updated: March 2009

---

### General Information

1. **Maximum slope.** Riprap aprons shown in this drawing can be used for culvert outlets with slopes up to 10%. For steeper applications, use alternate protective aprons, such as revet mattresses.
2. **Riprap classes.** Use these drawings with either the FP-03 riprap classifications or the NCHRP classifications (See the Section 251 SCRs on the LOS).

---

### Applicable SCRs

1. Section 251:  
[http://www.cflhd.gov/design/\\_documents/construction/scr\\_03/S251-03M.doc](http://www.cflhd.gov/design/_documents/construction/scr_03/S251-03M.doc)
2. Section 602:  
[http://www.cflhd.gov/design/\\_documents/construction/scr\\_03/S602-03M.doc](http://www.cflhd.gov/design/_documents/construction/scr_03/S602-03M.doc)
3. Section 705:  
[http://www.cflhd.gov/design/\\_documents/construction/scr\\_03/S705-03M.doc](http://www.cflhd.gov/design/_documents/construction/scr_03/S705-03M.doc)

---

### Typical Pay Items Used

- 25101-2000 Placed riprap, class 2 and/or
- 25101-3000 Placed riprap, class 3 and/or
- 25101-4000 Placed riprap, class 4
  
- 60201-0700 [300mm to 1200mm] pipe culvert
- 60210-0700 End section for [300mm to 1200mm] pipe culvert
- Geotextile quantity is shown for information only

---

### Updates

October 16, 2000

- Updated border to FLH Standard

February 2, 2005

- Updated to MicroStation V8

March 2009

- Added drawings of aprons in ditches
- Added quantity tables
- Moved riprap rundown at culvert inlet to template drawing