

Experiment Design Requirements and Guidelines for Microgravity Research

Aircraft Operations Division

December 2010



National Aeronautics and
Space Administration

Lyndon B. Johnson Space Center
Houston, Texas 77058

Aircraft Operations Division Experiment Design Requirements and Guidelines for Microgravity Research	Doc. No.: AOD 33897	Doc. Version: Rev D
	Date: December 2010	Page 2 of 28

APPROVAL AUTHORITY

Original Signed By

Dominic L. Del Rosso
Lead, Reduced Gravity Program

Aircraft Operations Division Experiment Design Requirements and Guidelines for Microgravity Research	Doc. No.: AOD 33897	Doc. Version: Rev D
	Date: December 2010	Page 3 of 28

CHANGE RECORD/LIST OF EFFECTIVE PAGES

Doc. Version	Date	Process Owner/Ext.	Description
Basic	May 2002	John S. Yaniec/49211 Dominic Del Rosso/49113	Initial Release.
Basic PCN 1	Feb 2003	John S. Yaniec/49211 Dominic Del Rosso/49113	Incorporate changes to Structural, Cargo Strap, and Pressure Systems.
Rev A	Feb 2005	John S. Yaniec/49211 Dominic Del Rosso/49113	Major Revision.
Rev B	Aug 2005	John S. Yaniec/49211 Dominic Del Rosso/49113	Major Revision.
Rev C	Nov 2007	Dominic Del Rosso/49113	Major Revision.
Rev C PCN 1	Nov 2008	Dominic Del Rosso/49113	Replace reference to JPG-1700.1I with JPR-1700.1.
Rev D	Dec 2010	Dominic Del Rosso/49113	Document updated in support of 2011 Microgravity research flights.

Page No.	Doc. Version	Page No.	Doc. Version
Cover	Rev D		
2 thru 28	Rev D		

Verify that this is the correct version before use.

Aircraft Operations Division Experiment Design Requirements and Guidelines for Microgravity Research	Doc. No.: AOD 33897	Doc. Version: Rev D
	Date: December 2010	Page 4 of 28

TABLE OF CONTENTS

APPROVAL AUTHORITY.....2

CHANGE RECORD/LIST OF EFFECTIVE PAGES.....3

TABLE OF CONTENTS4

LIST OF FIGURES5

LIST OF TABLES5

1.0 INTRODUCTION.....6

1.1 Purpose.....6

1.2 Scope.....6

1.3 References6

1.4 Acronyms and Abbreviations6

2.0 TEST EQUIPMENT DESIGN REQUIREMENTS7

2.1 Test Equipment Structural Design Requirements.....8

2.1.1 Takeoff/Landing8

2.1.2 In-Flight Loads..... 11

2.2 Aircraft Loading12

2.3 Pressure/Vacuum System Requirements13

2.3.1 Classification Requirements13

2.3.2 Pressure System Design Requirements.....14

2.3.3 Pressure System Test and Inspection Requirements.....18

2.4 Electrical19

2.5 Free-Float.....22

2.6 Overboard Vent22

2.7 Laser.....22

2.7.1 Class Designation.....22

2.7.2 Protective Housings23

2.7.3 Equipment Labels23

2.7.4 Viewing Portals and Collecting Optics.....23

2.8 Emergency Procedures23

2.9 Hazardous Materials24

2.10 Tools24

2.11 Containment of Loose Parts and Equipment (Ground and Flight Ops)25

2.12 Liquid Containment.....25

2.13 Electromagnetic Interference/Radio Frequency Interference Checks (RFI).....26

2.14 Cleaning Equipment for Zero-G Flight26

2.15 Touch Temperature for Research Hardware.....26

2.16 Noise Levels26

2.17 Miscellaneous Guidelines26

2.17.1 Recommendations.....27

INDEX.....28

Aircraft Operations Division Experiment Design Requirements and Guidelines for Microgravity Research	Doc. No.: AOD 33897	Doc. Version: Rev D
	Date: December 2010	Page 5 of 28

LIST OF FIGURES

Figure 1. Cargo Strap (for Reference Only) 10
Figure 2. Floor Attachment Assembly Installed Dimension (representative of NASA C-9B) .. 11
Figure 3. Take-off and Landing Escape Path Example 13
Figure 4. Example of Free-Float Experiment 21

LIST OF TABLES

Table 1. Floor Attachment Hardware (for Reference Only)..... 9
Table 2. Minimum Wire Gauges (for Reference Only)..... 21

Aircraft Operations Division Experiment Design Requirements and Guidelines for Microgravity Research	Doc. No.: AOD 33897	Doc. Version: Rev D
	Date: December 2010	Page 6 of 28

1.0 INTRODUCTION

The Reduced Gravity Program, operated by the National Aeronautics and Space Administration (NASA), Lyndon B. Johnson Space Center (JSC) in Houston, Texas, provides a “weightless” environment, similar to the environment of space flight.

1.1 Purpose

The purpose of this Design Requirements document is to provide a guideline for existing and potential users of the JSC Reduced Gravity Program. This document outlines equipment design requirements and details user requirements and guidelines.

1.2 Scope

This document applies to all users and potential users of the JSC Reduced Gravity Program. Requirements in applicable documents supersede the Experiment Design Review Guide (EDRG).

1.3 References

[A2.4: 2007, Standard Symbols for Welding, Brazing, and Nondestructive Examination](#)

[ANSI Z136.1, American National Standard Institute for Safe Use of Lasers](#)

[AOD 33912, Interface Control Document NASA 932 C-9B](#)

[Interface Control Document, Boeing 727-200](#)

[Code of Federal Regulations \(CFR\) Title 49 Transportation](#)

[JPR-1700.1, JSC Safety and Health Handbook](#)

[JPR-1710.13, Design, Inspection, and Certification of Pressure Vessels and Pressurized Systems](#)

[National Fire Protection Association \(NFPA\) 70, National Electrical Code](#)

[Society of Automotive Engineers \(SAE\) AS50881, Wiring Aerospace Vehicle](#)

1.4 Acronyms and Abbreviations

AN	Army/Navy
ANSI	American National Standards Institute
ASME	American Society of Mechanical Engineers
CFR	Code of Federal Regulations
DIA	Diameter
DOT	Department of Transportation

Verify that this is the correct version before use.

Aircraft Operations Division Experiment Design Requirements and Guidelines for Microgravity Research	Doc. No.: AOD 33897	Doc. Version: Rev D
	Date: December 2010	Page 7 of 28

EDRG	Experiment Design Review Guide
EMC	Electromagnetic Compatibility
EMI	Electromagnetic Interference
FS	Factor of Safety
GFI	Ground Fault Interrupter
JSC	Johnson Space Center
MAWP	Maximum Allowable Working Pressure
MSDS	Material Safety Data Sheet
NASA	National Aeronautics and Space Administration
NEMA	National Electrical Manufacturers Association
NFPA	National Fire Protection Association
OCCP	Operation and Configuration Control Plan
OSHA	Occupational Safety and Health Administration
psig	Pounds per Square Inch Gauge
PSMO	Pressure Systems Manager's Office
RFI	Radio Frequency Interference
RGO	Reduced Gravity Office
SR&QA	Safety, Reliability, and Quality Assurance
SAE	Society of Automotive Engineers
TRR	Test Readiness Review
UPS	Uninterruptible Power Supply
VAC	Volts Alternating Current

2.0 TEST EQUIPMENT DESIGN REQUIREMENTS

The following provides a detailed description of test equipment design requirements and guidelines that must be met for flight on NASA's Reduced Gravity aircraft.

Be sure to retain all documentation throughout the design process so that it may be presented later in the flight approval process.

Verify that this is the correct version before use.

Aircraft Operations Division Experiment Design Requirements and Guidelines for Microgravity Research	Doc. No.: AOD 33897	Doc. Version: Rev D
	Date: December 2010	Page 8 of 28

2.1 Test Equipment Structural Design Requirements

Structural integrity of all equipment flown aboard NASA's Reduced Gravity aircraft must be verified [via accepted method(s), analysis, test, demonstration, similarity, etc.] and documented accordingly.

Factors of Safety (FS) of 2.0 or greater shall be applied to all structural or fracture critical elements. The Reduced Gravity Office (RGO) encourages designers to use FS greater than 2.0 whenever practical.

NOTE

Attention to quality of workmanship and materials is critical. Exceptions to the above (e.g., Flight Hardware) will be considered on a case-by-case basis and only with proper documentation.

2.1.1 Takeoff/Landing

Takeoff and landing configurations of all equipment must be verified to withstand the "hard landing loads" described herein. It is the expressed intent of this verification that any item, component, or subassembly (or enclosures specifically designed to retain said items), with the potential to detach and become a hazard to the researchers, crewmembers, and/or aircraft, not yield.

Reduced Gravity test/research equipment must comply with the following structural design requirements and have the necessary documentation.

1. G-Load Specifications

- a. All test equipment (i.e., fasteners, individual components, frames, and full assemblies, or enclosures around said items) must be designed to withstand the following g-loads in takeoff and landing configurations.
 - Forward 9-g's
 - Aft 3-g's
 - Down 6-g's
 - Lateral 2-g's
 - Up 2-g's
- b. Structures are to be verified using accepted practices (i.e., Free Body Diagrams) with load vectors applied at accurate centers of gravity. Material yield strengths are to be used as the maximum allowable throughout all design calculations.

2. Floor Attachment Hardware

- a. The RGO will provide all of the hardware required for fastening the test equipment to the floor of the aircraft. [Table 1](#) details the RGO-provided hardware to be utilized with test equipment.

Verify that this is the correct version before use.

Table 1. Floor Attachment Hardware (for Reference Only)

Floor Hardware Description	Hardware Dimensions	Yield Tensile Strength	Single Shear Strength
AN-6 Steel Bolts	3/8-inch DIA – Lengths Vary	5,000 lbs	5,000 lbs
2.0-inch Wide Cargo Strap	Lengths Vary	5,000 lbs	N/A
1.5-inch Wide Cargo Strap	Lengths Vary	1,000 lbs	N/A
1.0-inch Wide Cargo Strap	Lengths Vary	400 lbs	N/A
Cargo Rings	ANCRA 40149-16	Based on the deck fitting	Based on deck fitting

- b. Steel fittings, with aluminum spacers, are used to attach hardware to the aircraft deck using AN-6 bolts. These fittings integrate with the aircraft deck differently for each aircraft and are used to transfer the loads to the aircraft deck.

NOTE

Due to the difference in the mounting technique between aircraft, refer to [AOD 33912, Interface Control Document NASA 932 C-9B](#) or [Interface Control Document Boeing 727-200](#), as applicable, for the load limits.

These fittings are not intended to be used when straps or chains are the primary restraint. Each fitting can be loaded to 200 lbs static, 1-g, weight across its 1.5-inch diameter face. Load capacity for each fitting is determined by the seat track capacity and shall not exceed 3,750 lbs per fitting.

NOTE

This is the limiting case for all restraints.

Similar fittings are used for straps and chains and the load limit is the same 3,750 lbs. See [Figure 2](#).

- c. Test equipment fastened to the floor using bolts must possess a frame, or base-plate or fixture that matches the floor attachment grid in the aircraft test cabin. Floor attachment holes in the experiment base plate must be centered on a 20-inch ± 0.05-inch square pattern with holes drilled using a recommended clearance hole. Refer to [AOD 33912](#) or [Interface Control Document, Boeing 727-200](#).
- d. Cargo straps may be used to tie down equipment to the test cabin floor. Straps are provided by the RGO (refer to [AOD 33912](#) or [Interface Control Document, Boeing 727-200](#) for tensile strength limits of cargo straps). When using cargo straps, it is essential to design load-bearing beams and/or handles with sufficient load capacities to withstand g-load specifications and not exceed working limit of straps in specific configuration. See [Figure 1](#) for a typical cargo strap attachment schematic.

An anchoring plan must accompany all strap-secured hardware. This plan must include, but is not limited to: type, number, expected load, and allowable angle of cargo straps as well as anchor points and direction, hard-points, and load capacity.

- e. Test equipment resting on the floor padding instead of spacers (typically the case when cargo straps are used) must not exceed the allowable floor loading of 200 lbs/ft² (this is for the in-flight load case, not ground loading) without proper floor shoring. The RGO will implement any floor shoring required and must be coordinated in advance.
- f. If test equipment is over 10 feet in length (length being along the forward/aft axis of the fuselage), the structure of the test equipment must allow for fuselage bending without increased stress in the aircraft frame. For questions or concerns, contact the RGO (refer to [AOD 33912](#) for office contact information).

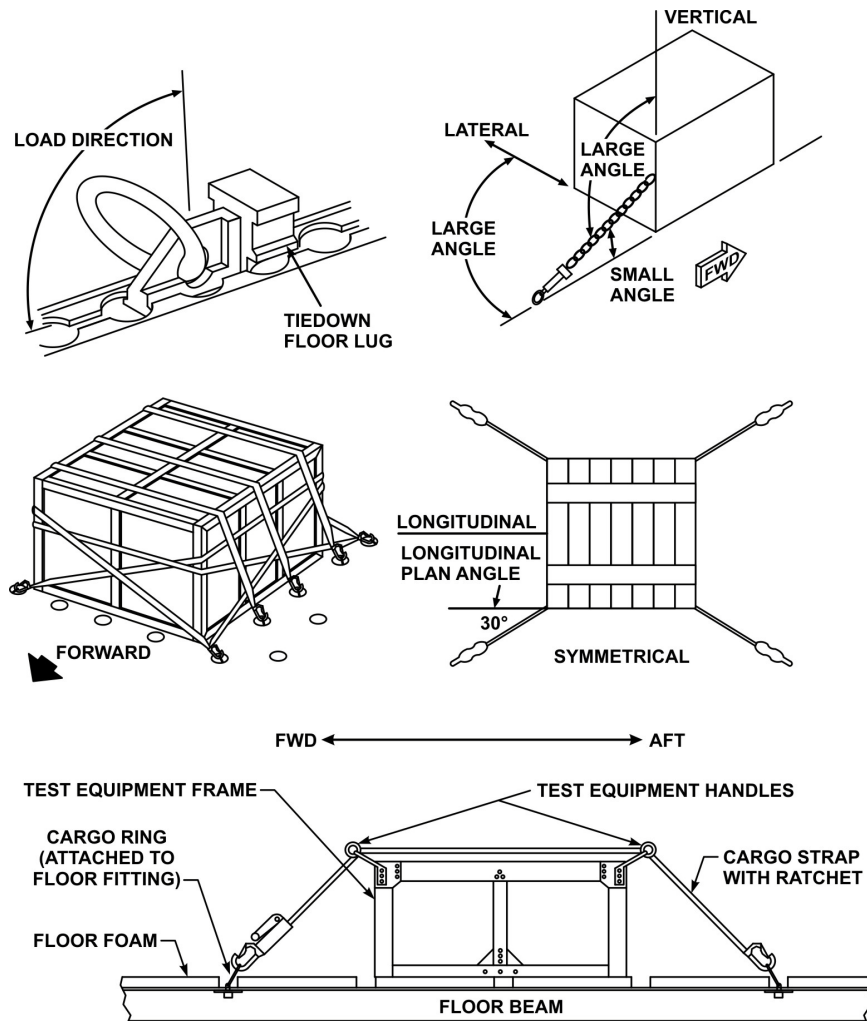

C9-571

Figure 1. Cargo Strap (for Reference Only)

Verify that this is the correct version before use.

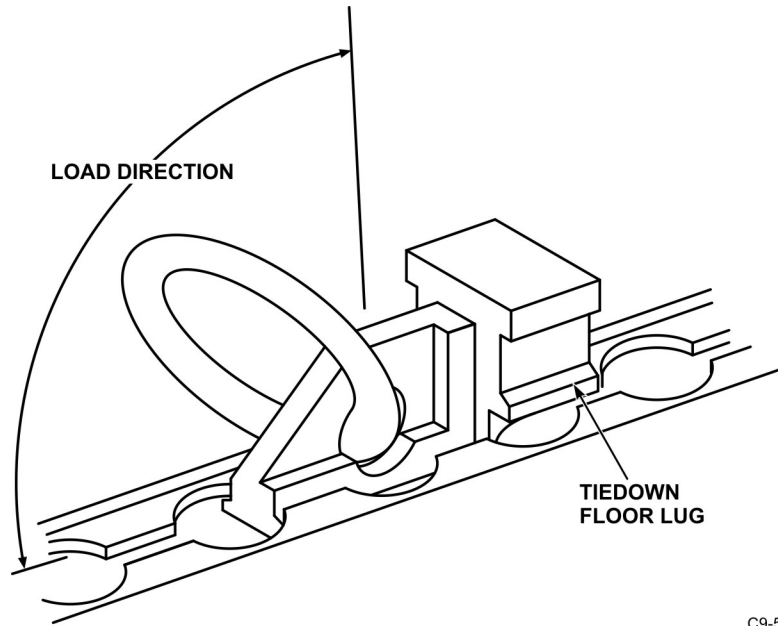

C9-577

**Figure 2. Floor Attachment Assembly Installed Dimension
(representative of NASA C-9B)**

2.1.2 In-Flight Loads

Experimental equipment should consider in-flight load cases in design. Depending upon the test configuration (e.g., free-floating, anchored), certain load cases should be considered for safety of flight as well as mission success. During the parabolic phase of flight, the equipment can experience g-load transitions from 0-g up to 2-g's.

2.1.2.1 Free-Floating Equipment

1. Handling aids should be able to withstand two times the weight of the equipment without damage.
2. Equipment (or protective cage) should withstand a drop of 4 feet at .75-g without damage.
3. Umbilical on free-floating equipment shall be strain-relieved to two times the equipment weight, and any energy in the umbilical adequately isolated from personnel [e.g., electricity, Ground Fault Interrupter (GFI), pressure, chemical].

2.1.2.2 Deployed During Reduced Gravity

1. Structures deployed during the reduced gravity portion of flight should consider nominal and unplanned load cases.
2. Nominally, fluctuations in g loads will vary between +0.1 and -0.1-g.
3. Occasionally, aborting the maneuver will result in loads reaching the nominal pull out condition within 5 seconds.

Aircraft Operations Division Experiment Design Requirements and Guidelines for Microgravity Research	Doc. No.: AOD 33897	Doc. Version: Rev D
	Date: December 2010	Page 12 of 28

2.1.2.3 Anchored

Anchored equipment may be subjected to inadvertent contact loads. These loads can exceed ‘hard landing case’ loads locally.

Equipment design should use the case of 180 pound mass impacting the structure at 2 feet per second, as worse case.

Additionally, inadvertent contact such as ‘kick loads’ may impart up to 125 pounds over a 2-inch radius.

2.2 Aircraft Loading

Hardware proposed for flight on NASA’s Reduced Gravity aircraft must take into consideration provisions for safe and efficient aircraft loading operations. Researcher hardware and proposed ground loading operations must comply with the following requirements:

1. All hardware must be designed to fit through the cargo door and into the test cabin with enough clearance to avoid the risk of damaging the aircraft structure. Installed, a 2-inch dynamic envelope must be maintained around fixed hardware.
2. A forklift is available at Ellington Field for lifting hardware up to the cargo door. This is typically done through utilization of the bare forks, fork extenders, or a lifting pallet.
3. Handles and/or lifting bars must be implemented in the hardware design if the proposed loading method involves human manipulation. There must be enough handles available so that any one person carrying the hardware does not lift more than 50 pounds.
4. For heavier assemblies, pneumatic casters, 6 inches in diameter or more, are recommended for hardware loading operations both on the ground and in the aircraft test cabin. Caster loads must not exceed 350 pounds/wheel. Casters may be removed from the hardware and taken off of the aircraft before flight.
5. Hardware base plates with an aircraft floor footprint greater than 1.5 ft² must not exceed 1,600 lbs/ft² of floor loading during ground loading operations.
6. Hardware base plates with an aircraft floor footprint of less than 1.5 ft² must not exceed 350 lbs/wheel.
7. If allowable floor load must be exceeded, proper floor shoring procedures must be integrated with ground loading operations. All shoring procedures must be designed and implemented through the RGO.
8. All experiment hardware shall be designed to allow for a clear escape path along either one side or the other for take-off and landing (may be reconfigured in flight, if required). See [Figure 3](#) as a visual example.

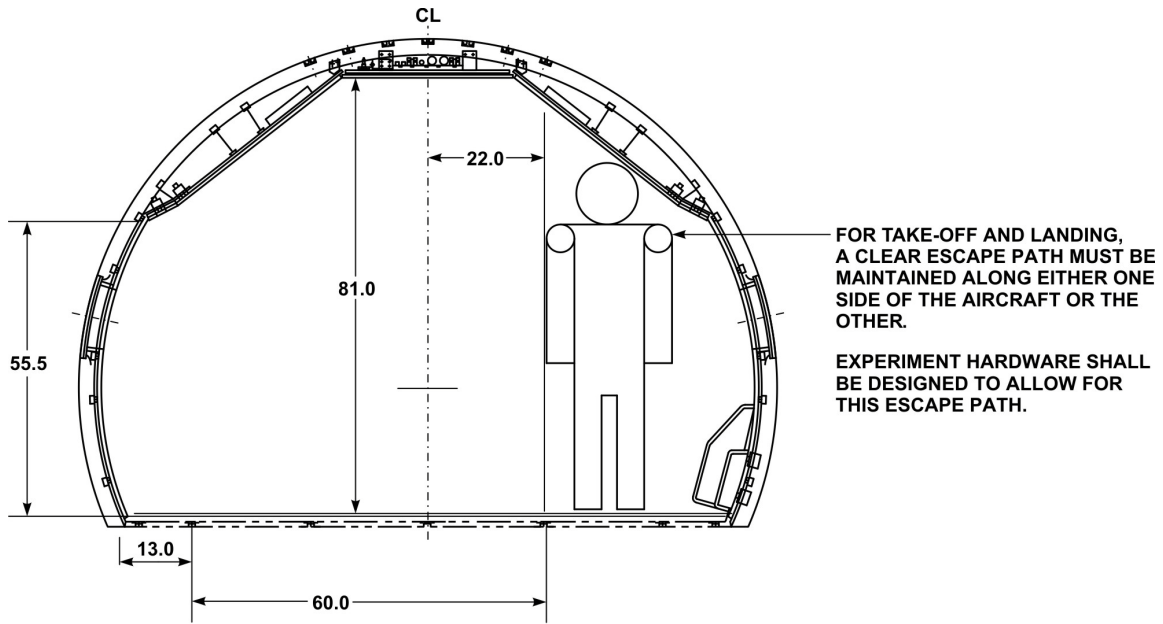

VIEW LOOKING FORWARD
C-9B INTERIOR CROSS SECTION

C9-569

Figure 3. Take-off and Landing Escape Path Example

2.3 Pressure/Vacuum System Requirements

All pressure/vacuum systems proposed for flight and/or ground use must comply with the [JPR-1710.13, Design, Inspection, and Certification of Pressure Vessels and Pressurized Systems](#).

NOTE

Pressure system is defined as “equipment used, in-flight or on the ground, to contain gas and/or liquid above or below ambient pressure.”

2.3.1 Classification Requirements

All pressure systems proposed for flight and/or ground support must fall into one of the five categories listed below. Review the category descriptions to determine which category best describes the experiment's pressure system.

Category A

1. **Level 1:** These pressure systems conform to consensus codes and standards as outlined by the [American Society of Mechanical Engineers \(ASME\)](#), [Department of Transportation \(DOT\)](#), [ANSI Z136.1](#), [American National Standard Institute for Safe Use of Lasers](#), etc., and may or may not have a code stamp. Non-stamped pressure systems are termed “code equivalent.” Pressure systems are automatically categorized as a Category A system if pressures of 150 pounds per square inch gauge (psig) or greater exist in the system, and/or the system contains a toxic, corrosive, explosive, and/or flammable fluid.

Aircraft Operations Division Experiment Design Requirements and Guidelines for Microgravity Research	Doc. No.: AOD 33897	Doc. Version: Rev D
	Date: December 2010	Page 14 of 28

2. **Level 2:** These pressure systems, because of pressure requirements, fabrication techniques, or material selection, do not fall within the scope of the applicable codes and standards, yet are designed in accordance with code formulas, documented stress values, and code safety factors. Pressure systems are automatically categorized as a Category A system if pressures of 150 psig or greater exist in the system, and/or the system contains a toxic, corrosive, explosive, and/or flammable fluid.

Category B

Category B pressure systems are defined as Flight or Flight-Like Experimental Pressure Vessels/Systems. Typically, these types of systems have one or more components that are not directly compliant with ASME Codes or other equivalent pressure codes, and are therefore not classified as Category A systems.

The majority of the experimental hardware expected to be flown aboard the NASA's Reduced Gravity Program is expected to be Category B.

Category C

Category C pressure systems have a combination of pressure contained volume and service fluid such that the maximum potential energy, if released, would not cause serious injury to personnel or significant damage to facilities.

Category D

Category D pressure systems are isolated, protected, contained, or restrained in such a manner that the maximum catastrophic failure would not be harmful to personnel, facilities, or equipment.

Category E

Category E pressure systems are inherently low in energy or possess a national record of operation without serious incident examples include:

1. Water systems (150 psig or less and at 110°F or less)
2. Commercially manufactured heating, ventilation, and air conditioning systems used expressly for their intended purpose
3. Commercially manufactured refrigerators and freezers used expressly for their intended purpose

2.3.2 Pressure System Design Requirements

All pressure systems proposed for flight and/or ground support must comply with the following design requirements. Be aware that the aircraft is pressurized at roughly 5,000 to 8,000 feet pressure altitude during nominal flight. Design calculations for flight hardware should assume the worst-case scenario (i.e., rapid cabin decompression at the peak flight altitude) and allow factors of safety to be sufficient if the cabin pressure rapidly falls to 36,000 feet pressure altitude. Please note that experimental

Aircraft Operations Division Experiment Design Requirements and Guidelines for Microgravity Research	Doc. No.: AOD 33897	Doc. Version: Rev D
	Date: December 2010	Page 15 of 28

hardware requiring deviation from accepted standards for mission-specific purposes will be classified as Category B.

2.3.2.1 Operation and Configuration Control Plan Requests

An Operation and Configuration Control Plan (OCCP) is a written assessment stating that flight or flight-like experimental pressure vessels/systems are safe for pressurization on JSC property. These unique pressure systems are referred to as Category B systems in [JPR 1710.13](#). Flight and flight-like pressure systems typically have one or more components that are not directly compliant with ASME Codes or other equivalent pressure codes, and therefore are not classified as Category A systems. Safety assessment of all JSC Category B systems is the responsibility of the [Materials and Process Technology Branch](#). Safety assessment of all other JSC pressure systems is the responsibility of the Pressure Systems Manager's Office (PSMO) within the Safety, Reliability, and Quality Assurance (SR&QA) organization.

An OCCP is required anytime a Category B system will be pressurized on JSC property. Pressurizations may include proof pressure tests, leak tests, functionality tests, charging processes, etc. OCCPs typically apply only to the actual flight or flight-like system. Therefore, the safety of any facility pressure system or ground support equipment to be mated to the Category B system shall be assessed by the PSMO.

Data and description should be submitted to the Materials and Process Technology Branch at least 4 weeks prior to flight. A guideline questionnaire is available at [Suggested Data for Operational and Configuration Control Plan Requests](#).

Category A Design Requirements

A Maximum Allowable Working Pressure (MAWP) must be designated for all pressure systems. Systems must be designed so that they never exceed this pressure under normal operating procedures. The system MAWP should not exceed the manufacturer specified MAWP of any individual component or line.

All hardware must be designed to satisfy a factor of safety of no less than 4.0 when MAWP is compared to material ultimate strengths, and no less than 2.0 when MAWP is compared to material yield strengths. All design calculations must be documented. Lower factors of safety may be used only with the approval of the JSC pressure system. See the example equation below:

$$\text{Factor of Safety} = \frac{\sigma_{ultimate}(psi)}{\sigma_{MAWP}(psi)} \geq 4$$

All mobile/portable pressure and vacuum vessels that are used on the aircraft and at Ellington Field shall be designed to address the requirements of [CFR Title 49 Transportation](#) or Section VIII of the [ASME Boiler and Pressure Vessel Code](#). Any mobile/portable pressure vessels that are to leave JSC property shall be designed according to the requirements stated in [CFR Title 49 Transportation](#).

Aircraft Operations Division Experiment Design Requirements and Guidelines for Microgravity Research	Doc. No.: AOD 33897	Doc. Version: Rev D
	Date: December 2010	Page 16 of 28

At a minimum, all pressure systems must be designed for the most severe condition of coincident pressure and temperature expected in operation. MAWP values should not be below this pressure. Also consider the following in determining a pressure system design:

1. Weight of the pressure system
2. Static reactions from weight of attached equipment
3. Cyclic and dynamic reactions caused by pressure or thermal variations, flow-induced vibrations, or attached equipment and mechanical loadings
4. Impact reactions such as those due to fluid shock
5. Temperature gradients and thermal expansion

Use materials that possess properly documented physical properties (i.e., strength, corrosion resistance, thermal expansion coefficients) by industry standard sources (i.e., Military Handbook-5: Metallic Materials and Elements for Aerospace Vehicle Structures). Consider the properties of a material carefully before utilizing it in a pressure system design.

The temperature used in the design of the pressure system shall not be less than the mean metal temperature (through the thickness) expected under operating conditions.

All Category A pressure systems shall be equipped with properly sized pressure relief devices. They shall be set to function at a maximum of 10 percent above the MAWP to prevent over-pressurization and possible catastrophic explosion due to component failure (e.g., failed regulator, runaway heater), ambient temperature influences, rapid cabin depressurization/over-pressurization, and/or external sources of heat (i.e., fire). These devices shall be:

1. Sized to prevent pressure from rising more than 10 percent above MAWP.
2. Properly calibrated to certify settings and function.
3. Selected on the basis of their intended service.
4. Installed on the pressure system in such a way that they are readily accessible for inspection.

All welds in a pressure system must be designed in accordance with the [ASME Document B31](#) and/or the [ASME Boiler and Pressure Vessel Code](#), as applicable. Complete drawings of the welded assembly shall be generated using weld symbols that meet the requirements of the American Welding Society [Document A2.4: 2007, Standard Symbols for Welding, Brazing, and Nondestructive Examination](#).

All piping systems must have adequate structural support to prevent the development of excessive piping stresses, leakage at joints, excessive loads on connected equipment, and resonance due to flow.

Aircraft Operations Division Experiment Design Requirements and Guidelines for Microgravity Research	Doc. No.: AOD 33897	Doc. Version: Rev D
	Date: December 2010	Page 17 of 28

Gauges shall be sized to indicate a minimum of 150 percent to a maximum of 200 percent of the pressure system's MAWP for all pressure gauges incorporating a mechanical, dial indicating, bourdon tube, bellows, or diaphragm type mechanism. Gauges must have a pressure relief mechanism internal to the gauge and must be properly calibrated before use.

Category B Design Requirements

Category B pressure systems requirements are generally user defined by mission parameters. These requirements are concurred with or amended, and a safety evaluation is performed by the Materials and Process Technology Branch.

The design requirements approval process is specifically defined as safe for intended operation and is documented in an OCCP. The OCCP is generated by the Materials and Process Technology Branch from user-supplied data via [Suggested Data for Operational and Configuration Control Plan Requests](#).

It is highly recommended to contact and involve the Materials and Process Technology Branch as early as possible in the design phase of the experiment.

Category C Design Requirements

Category C pressure systems are to be designed using good engineering practices. A MAWP must be designated for all Category C pressure systems. Systems should be designed to never exceed this pressure under normal operating procedures. The system MAWP should not exceed the manufacturer-specified MAWP of any individual component or line. Professionally calibrated pressure relief valves and gauges are required on all Category C pressure systems. All hardware must be designed to satisfy a safety factor of no less than 4.0 when MAWP is compared to material ultimate strengths, and no less than 2.0 when MAWP is compared to material yield strengths. All design calculations must be documented. Lower safety factors may be used only with the approval the JSC Pressure System. See the example equation below:

$$\text{Pressure Vessel Factor of Safety} = \frac{\sigma_{ultimate}(psi)}{\sigma_{MAWP}(psi)} \geq 4$$

Category D Design Requirements

Category D pressure systems are to be designed using good engineering practices. A MAWP must be designated for all Category D pressure systems. Systems should be designed to never exceed this pressure under normal operating procedures. The system MAWP should not exceed the manufacturer specified MAWP of any individual component or line. They shall be isolated, protected, constrained, or restrained in such a manner so that catastrophic failure would not be harmful to personnel, facilities, or equipment. Professionally calibrated pressure relief valves and gauges are required on all Category D pressure systems. Category D pressure system housings must be designed to satisfy a safety factor of no less than 4 in the event of being exposed to 1.25 times the MAWP of the system it is containing. Housing design calculations must be documented. See the example equation below:

Verify that this is the correct version before use.

Aircraft Operations Division Experiment Design Requirements and Guidelines for Microgravity Research	Doc. No.: AOD 33897	Doc. Version: Rev D
	Date: December 2010	Page 18 of 28

$$\text{Housing Factor of Safety} = \frac{\sigma_{ultimate}(psi)}{1.25\sigma_{MAWP}(psi)} \geq 4$$

Category E Design Requirements

Category E pressure systems shall be designed and installed using industry accepted engineering and fabrication practices.

2.3.3 Pressure System Test and Inspection Requirements

All pressure systems must comply with the test and inspection criteria listed below. Understand that all pressure systems (gauge calibration tags, relief valve tags, etc.) will be inspected and expected to operate at the Test Readiness Review (TRR). All pressure system documents should be readily available at the TRR. All pressure systems, regardless of classification, past flight history, and configuration, must be tested and inspected in their current configuration before each visit to Ellington Field. [ASME](#), [ANSI](#), and [DOT](#) components do not require testing if their certification tag is visible and current.

Category A Test and Inspection Requirements

Pressure systems must be proof pressure tested by qualified pressure systems specialists (i.e., certified technician, professional mechanical engineer). This can be accomplished through hydrostatic tests (i.e., pressurized system using water) up to 150 percent MAWP, or pneumostatic tests (i.e., pressurized system using gas) up to 125 percent MAWP. Hydrostatic testing is the preferred method. Proof pressure testing can be performed on the entire pressure system assembly or on each individual component, piping included. Document the inspection by including a brief test description, test date, technician/engineer involved (with signature), test procedure, and results. Remember to tag all equipment that has been calibrated and/or inspected with pertinent test information such as calibration dates, type of test (hydrostatic, pneumostatic), relief valve setting, etc. Professionally tagged [ASME](#), [DOT](#), and/or [ANSI](#) pressure vessels need not be pressure tested.

All relief valves must be initially tested and tagged by qualified pressure system specialists (i.e., certified technician, professional engineer) to verify relief valves have been tested and set to operate at proper pressure levels. Relief valves built into control devices (i.e., regulator relief valves) do not require certification when the control device and associated piping is adequately protected from over-pressurization by design of other relief devices. All gauges must be properly calibrated and tagged with pertinent inspection information by qualified pressure system specialists (i.e., certified technicians, professional engineers). A technical inspection and system operation test will be performed on all Category A pressure/vacuum systems at the TRR. All pressure/vacuum system documents should be readily available at the TRR. Have all gauges and pressure relief valves calibrated, tested, and tagged before arriving at the TRR to expedite the certification process.

Aircraft Operations Division Experiment Design Requirements and Guidelines for Microgravity Research	Doc. No.: AOD 33897	Doc. Version: Rev D
	Date: December 2010	Page 19 of 28

Category B Test and Inspection Requirements

Category B pressure systems do not fall within the scope of this document, and do not apply to Reduced Gravity research equipment.

Category C Test and Inspection Requirements

All Category C pressure/vacuum systems must meet the same Test and Inspection Requirements as Category A pressure systems (see Category A Test and Inspection Requirements).

Category D Test and Inspection Requirements

A technical inspection and system operation test will be performed on all Category D pressure/vacuum systems at the TRR. All pressure/vacuum system documents, housing design calculations, and component calibration tags should be readily available at the TRR.

Category E Test and Inspection Requirements

A technical inspection and system operation test will be performed on all Category E pressure/vacuum systems at the TRR. All pressure system documents should be readily available at the TRR.

2.4 Electrical

All electrical wiring and interconnect cabling must be fabricated and installed in accordance with the current versions of the [JPR-1700.1, JSC Safety and Health Handbook](#) and the [NFPA 70 National Electrical Code](#).

Each experiment must have emergency shutdown capabilities. The preferred shutdown method is a single “kill switch” in an easily accessible location. If an experiment requires multiple “kill switches,” they should be co-located in one area of the experiment. This “kill switch” must de-energize all components in a system to a safe state, including hardware powered by auxiliary sources or an Uninterruptible Power Supply (UPS). Researchers should be prepared to demonstrate their experiment’s emergency shutdown capability at the TRR.

In the event of electrical power loss (expected or unexpected), all experiments must fail to a safe configuration. There will be a brief interruption of electrical power during engine startup and momentary interruptions of electrical power may occur during flight. Although infrequent, brief power interruptions may disrupt certain sensitive instruments. Test equipment should incorporate protection devices (such as a UPS) to prevent data loss.

All electrical experiments must meet requirements for Electromagnetic Compatibility (EMC) and susceptibility that preclude interference with an aircraft.

Experiments that require aircraft power must provide an electrical cable to reach a power distribution panel. This cable will be referred to as a “power cord” for the remainder of this document. All power cords should be 20 feet in length and have a

Aircraft Operations Division Experiment Design Requirements and Guidelines Microgravity Research	Doc. No.: AOD 33897	Doc. Version: Rev D
	Date: December 2010	Page 20 of 28

descriptive tag secured to the end. The tag will clearly list the voltage and maximum current required (not maximum current available) from the aircraft outlet. Appropriately rated extension cords may be used as power cords.

Typically, an experiment platform will include a power-strip device to eliminate multiple power cords from the platform. When a power-strip is used, the combined current of all devices shall not exceed the capacity of the aircraft source outlet nor the power strip. Multiple power cords may be used on an experiment when load balancing is desired.

All experiment wiring, including power cords, must be adequately restrained and clamped. Normal aircraft vibration, high humidity, handling, and higher than one-g loads should be considered in connector and wiring selection. All exposed power leads and electrical contacts must be covered to protect personnel as well as the equipment itself. Electrical insulation should be protected against abrasion and chaffing which could expose bare contacts. Experiments must be adequately grounded to prevent electrical shock.

Each subsystem of an experiment's electrical system should be labeled. Each cable, connection and component should have a unique identifier that is clearly visible. High-voltage devices must be marked with warning labels.

In addition to existing aircraft circuit protection, each experiment must be self-protected with an incorporated circuit breaker or other current-limiting device. Though not yet required, it is strongly recommended that each electrical component have a dedicated current-limiting device as well. The limiting value of each device should be carefully chosen with the maximum current of the protected components in mind. As a minimum, 115 Volts Alternating Current (VAC) systems should be protected with an appropriately rated surge protector.

When selecting circuit breaker values, the sum of the *maximum* device currents cannot exceed the rated current of the power source (or circuit breaker value). Ideally, each circuit should be designed so that the total *nominal* current of all devices does not exceed 80 percent of the rated supply current. Experimenters must use wire sizes and circuit breakers in accordance with [Table 2](#).

All batteries used must be of the dry cell or gel-cell type. Liquid electrolyte batteries are not allowed on the aircraft.

Sizing of electrical wiring is critical. All experiment cables, including power cords, must be of the appropriate size (or gauge) for the intended current draw across the wire. The NASA RGO requires all experiments to comply with the wire sizing guidelines of [MIL-PRF-6106L](#) and [Society of Automotive Engineers \(SAE\) AS50881, Wiring Aerospace Vehicle](#) (which replaced MIL-W-5088L). A summary of those guidelines is provided in [Table 2](#).

Table 2. Minimum Wire Gauges (for Reference Only)

Maximum Current	Minimum Wire Gauge
5 A	18
10 A	16
15 A	14
20 A	12
25 A	10
30 A	8
50 A	4

The insulation of each wire must clearly show a manufacturer-printed wire gauge label. All wires should be made of copper and have a wire temperature rating of at least 60°C. Higher rated wire such as 105°C is strongly encouraged.

The minimum wire size guidelines have been created using mathematical formulas from [SAE document AS50881](#) (which replaced MIL-W-5088L). The calculations assume the worst-case (most conservative) operating conditions for electrical wire with a temperature rating of 60°C. Experimenters are encouraged to use wire with greater temperature ratings; however, the maximum current ratings from [Table 2](#) must be followed.

Electrical Connectors

Refer to [AOD 33912](#) or [Interface Control Document, Boeing 727-200](#), as applicable, for the correct type of electrical connectors.



Figure 4. Example of Free-Float Experiment

Verify that this is the correct version before use.

Aircraft Operations Division Experiment Design Requirements and Guidelines Microgravity Research	Doc. No.: AOD 33897	Doc. Version: Rev D
	Date: December 2010	Page 22 of 28

2.5 Free-Float

The test package can be allowed to free-float inside the cabin to prevent contact with the walls, ceiling, or floor of the aircraft, if required. The maximum allowable free-float package weight is 400 pounds.

If an umbilical is used between the floating package and tied-down support equipment, it must be at least 20 feet long to allow the floating package to freely drift.

Handles, the length of the longitudinal axis of the package in its floating configuration, should be mounted using 1-inch tubing near the top and bottom of the package.

Provisions to support take off/landing loads must be provided. Provisions for securing the experiment during zero-g (contingency) should be provided.

2.6 Overboard Vent

The overboard vent system is a passive system driven by the pressure differential between the cabin pressure and outside air pressure. Where no pressure differential exists, no flow will occur (i.e., ground level to 8,000 feet). It is required that the chemical composition and quantity of the vented gas be entirely known and completely understood by the experimenter and documented. It is the responsibility of the experimenter to inform the RGO concerning all possible hazards associated with the vent gas, including (but not limited to) the possibility of freeze-up, blockage, ignition, corrosion, and chemical reaction with other agents that could be introduced by another experiment.

A complete study of the volumetric flow rates through the overboard vent system has been conducted for the NASA C-9B and a copy is available through the RGO. Refer to [AOD 33912](#) or [Interface Control Document, Boeing 727-200](#) for the cabin volume and exchange rate for each aircraft.

2.7 Laser

The following requirements are to be used as guidelines for the use of all classes of lasers proposed for flight on the C-9B. The JSC Radiation Safety Committee has adopted the latest revision of [ANSI Z136.1](#) as the guide for approving lasers and/or laser systems proposed for use in facilities and aircraft under the administrative control of JSC.

2.7.1 Class Designation

All lasers or laser systems must be categorized in a class according to the class definitions listed below. It is recommended that the minimum class laser be used that will accomplish the payload objective. Class definitions are as follows:

Aircraft Operations Division Experiment Design Requirements and Guidelines Microgravity Research	Doc. No.: AOD 33897	Doc. Version: Rev D
	Date: December 2010	Page 23 of 28

1. **Class 1:** Lasers or laser systems that do not, under normal operating conditions, pose any hazard whatsoever.
2. **Class 2:** Low-power visible lasers or laser systems which, because of the normal human aversion response (i.e., blinking, eye movement), do not normally present a hazard, but may present some potential for hazard if viewed directly for extended periods of time.
3. **Class 2a:** Low-power visible lasers or laser systems that are not intended for prolonged viewing and under normal operating conditions will not produce a hazard if the beam is viewed directly for periods not exceeding 1,000 seconds.
4. **Class 3a:** Lasers or laser systems having CAUTION labels that normally would not injure the eye if viewed for only momentary periods (within the aversion period) with the unaided eye, but may present greater hazard if viewed using collecting optics. Lasers that have DANGER labels and are capable of exceeding permissible exposure levels for the eye in 0.25s should also be considered as a part of this class.
5. **Class 3b:** Lasers or laser systems that can produce a hazard if viewed directly. This includes intra-beam viewing of specular reflections.
6. **Class 4:** Lasers or laser systems that produce a hazard not only from direct or specular reflections, but can also produce hazardous diffuse reflections. Such lasers may also induce skin hazards as well as fire hazards.

2.7.2 Protective Housings

A suitable, protective housing shall be provided for all classes of lasers or laser systems. These housings or enclosures shall have interlock switches to prevent operation of the laser when the housing or enclosure is removed.

2.7.3 Equipment Labels

All lasers or laser systems shall have appropriate warning labels with an appropriate cautionary statement. The label shall be affixed to a conspicuous place on the laser housing or control panel. Such labels should be placed on both the housing and control panel if separated by more than 3 feet or by abrupt change in normal viewing direction.

2.7.4 Viewing Portals and Collecting Optics

Viewing portals and collecting optics (lenses, telescopes, microscopes, etc.), intended for viewing use on all lasers, must incorporate a means (interlocks, filters, attenuators, etc.) of maintaining a level of laser radiation at or below the Maximum Permissible Exposure limit at all times.

2.8 Emergency Procedures

Emergency procedures for experiments must be meticulously derived and easy to accomplish. Researchers must fully comprehend their experiment/hardware, and be

Aircraft Operations Division Experiment Design Requirements and Guidelines Microgravity Research	Doc. No.: AOD 33897	Doc. Version: Rev D
	Date: December 2010	Page 24 of 28

ready at all times to initiate these procedures without delay. All equipment must be designed so that in the event of test cabin power loss, rapid cabin depressurization, fluid leaks, fire, etc., there will be no chance of inducing another hazardous situation.

Emergency procedures must be placarded on equipment, using easy to understand instructions placed at a highly visible location.

In the event of a researcher becoming incapacitated, a NASA Reduced Gravity Test Director should be able to safely and efficiently initiate emergency procedures to fail-safe an experiment. A single action “kill switch” is the preferred means of securing research equipment in the event of an emergency.

2.9 Hazardous Materials

If such materials are required for a test, proper containment must be provided.

NOTE

Early contact with the RGO and the JSC Safety and Test Operations Division for discussions on proper use and containment of proposed hazardous materials may prevent delays in getting approval for the use of such materials. If such materials are necessary, provisions for dumping and purging in flight may be required.

A current Material Safety Data Sheet (MSDS) must be supplied for each hazardous material.

For hazard material release calculation, the cabin volume is 4,700 cubic feet. The cabin air exchange rate is one cabin volume every 3.5 minutes.

NOTE

Please address local concentration of potential released agents, as well as total aircraft volume.

2.10 Tools

A strict Tool Control Program is enforced at the Reduced Gravity Office. The RGO provides two general tool boxes for researcher use. The tools from these two tool boxes are the **ONLY** tools allowed on the aircraft.

NOTE

These tool boxes are inventoried every morning, before flight, and evening. Any tool missing from either of the tool boxes will result in a Missing Tool Report, which will result in the grounding of the NASA Reduced Gravity Aircraft until the tool is found.

Researchers are discouraged from bringing their own tools. If a researcher has special tools required for his/her experiment, those tools will be marked in such a way to identify the researcher and will have a complete inventory. This inventory will be

Verify that this is the correct version before use.

Aircraft Operations Division Experiment Design Requirements and Guidelines Microgravity Research	Doc. No.: AOD 33897	Doc. Version: Rev D
	Date: December 2010	Page 25 of 28

provided to the NASA Test Director. Tools required during flight operations will be signed out of the RGO tool box indicating that the tool is on the aircraft for the flight.

If the researcher is using special tools that he/she has brought with them during flight operations, those tools will have an inventory for each day of flight.

Those tools exposed on research hardware will be tethered to the equipment. A Test Director must approve changes to the tool list prior to flight.

2.11 Containment of Loose Parts and Equipment (Ground and Flight Ops)

All loose parts and equipment will be maintained in a proper container (such as a tool bag or box) during flight and on ground. These items must be marked to indicate their owner.

Each container will have an inventory sheet listing all items and shall be included during the TRR briefing for approval. Any loose item that cannot be contained during flight will be tethered.

NOTE

If any loose item is lost during flight, a Test Director must be notified immediately so that the experiment can be put into a safe mode and a search begun to locate the missing item.

2.12 Liquid Containment

Liquids approved for flight on NASA's Reduced Gravity Aircraft must be contained in a system that is structurally sound to withstand g-loads specified in [Section 2.1](#), and inadvertent contact loads.

An MSDS form must be submitted in the Test Equipment Data Package for all fluids other than water. Avoid the use of toxic, corrosive, and explosive fluids.

NOTE

Secondary and tertiary containment must be sufficient to contain total system volume. Secondary and tertiary levels may not be considered for nominal operational containment.

Hardware used to contain liquid must be designed with suitable provisions for fluid control to ensure a leak-free system during nominal ground and flight operations. In the event of aircraft power loss, all hardware must fail to a mode allowing for sound fluid containment.

Non-hazardous liquids, in free volume greater than 6 oz., should be double contained. Hazardous liquids must be triply contained.

Aircraft Operations Division Experiment Design Requirements and Guidelines Microgravity Research	Doc. No.: AOD 33897	Doc. Version: Rev D
	Date: December 2010	Page 26 of 28

2.13 Electromagnetic Interference/Radio Frequency Interference Checks (RFI)

All electrical experiments should meet requirements for EMC and susceptibility relating to interfering with other experiments or aircraft instrumentation systems.

NOTE

This may occur during flight operations. Experiments may also be powered down to help troubleshoot an Electromagnetic Interference (EMI) problem.

2.14 Cleaning Equipment for Zero-G Flight

Shavings, splinters, dirt, and dust pose very different problems in a zero-g environment than they do in a one-g environment. Small particles will become airborne in zero-g and pose a health hazard (e.g., for eyes, ingestion, inhalation).

All experimental hardware must be thoroughly cleaned prior to its loading on NASA's Reduced Gravity Aircraft. Hardware should be vacuumed, and/or blown out, removing material shavings created during the hardware assembly phase in all attitudes and orientations.

Equipment repairs performed onboard the aircraft (i.e., drilling, sanding, filing, or any other operation that may produce shavings or splinters) must be approved by a Test Director.

A Test Director will inspect the research hardware upon completion.

2.15 Touch Temperature for Research Hardware

Research hardware that contains heat producing devices shall maintain an inadvertent touch temperature of no greater than 122°F (50°C) on any potentially exposed surface or item. Continuous contact must not exceed 113°F.

2.16 Noise Levels

Refer to [AOD 33912](#) or [Interface Control Document, Boeing 727-200](#), as needed.

2.17 Miscellaneous Guidelines

The Reduced Gravity flight environment is one of the most unique flying experiences in the world. It is very difficult to describe the physical, zero-g sensation and even more difficult to model the operation of equipment during various g-phases of a parabola through tests on the ground. As a result of experiencing thousands of parabolas, Reduced Gravity flight crew members have formulated the following guidelines to help make research on NASA's Reduced Gravity aircraft effective, enjoyable, and most importantly, safe.

1. Pad all hard and sharp edges that could conceivably be accessed by nominal or inadvertent operations.

Aircraft Operations Division Experiment Design Requirements and Guidelines Microgravity Research	Doc. No.: AOD 33897	Doc. Version: Rev D
	Date: December 2010	Page 27 of 28

2. If the use of sharp objects is absolutely necessary, meticulous containment is required.
3. Any fragile items, glass, cathode ray tubes, gauges, windows, or any other object that is susceptible to shattering, must be entirely contained and unexposed to the test cabin.
4. Oil lubricated pumps are not allowed on NASA's Reduced Gravity Aircraft.
5. Duct tape used to attach miscellaneous articles (e.g., wire bundles, clip boards) to any part of the aircraft must be provided by the RGO.
6. Hook and loop fasteners (Velcro[®]) may be used to temporarily mount small equipment items (e.g., clipboards, keyboards) to the aircraft and/or hardware frame during the parabola phase of the flight.

NOTE

The adhesive side of a Velcro[®] strip must not be directly attached to any part of the aircraft.

7. Have contingency procedures ready for the operation and/or orderly shut down of equipment in the event of one or more researchers becoming incapacitated due to motion sickness.
8. Strategically locate experiment operators around the perimeter of an experiment. Do not over-crowd one specific area.
9. Keep controls and emergency shut down switches, valves, etc. in one localized area.
10. Foot straps may be provided by the RGO to help lightly anchor personnel to the floor of the aircraft test cabin upon request.
11. Inventory and provide proper containment for all articles (e.g., tools, cameras, disks) taken aboard the aircraft. This inventory list must be submitted to a Test Director before and after every flight.
12. NASA's Reduced Gravity Program Test Directors will be directly involved with any free-floating of an experiment.
13. Personal camcorders and cameras are generally allowed on the aircraft, but must be noted on the inventory list provided to the Test Director.

2.17.1 Recommendations

Ambient noise levels aboard the aircraft exceed Occupational Safety and Health Administration (OSHA) exposure limits if it is assumed that a typical Reduced Gravity flight lasts for more than one hour. To avoid permanent hearing loss for fliers, it is recommended that hearing protection devices be used. This is especially important for individuals making frequent flights aboard the aircraft.

Verify that this is the correct version before use.

Aircraft Operations Division Experiment Design Requirements and Guidelines Microgravity Research	Doc. No.: AOD 33897	Doc. Version: Rev D
	Date: December 2010	Page 28 of 28

INDEX

aircraft floor footprint, 12
Aircraft Loading, 12
C-9B, 22
Cargo strap, 10
Category A Design Requirements. *See*
Pressure System Design Requirements
Category A Test and Inspection
Requirements, 18
Category B Design Requirements. *See*
Pressure System Design Requirements
Category B Test and Inspection
Requirements, 19
Category C Design Requirements. *See*
Pressure System Design Requirements
Category C Test and Inspection
Requirements, 19
Category D Design Requirements. *See*
Pressure System Design Requirements
Category D Test and Inspection
Requirements, 19
Category E Design Requirements. *See*
Pressure System Design Requirements
Category E Test and Inspection
Requirements, 19
Class Designation. *See* Lasers
Classification Requirements, 13
Cleaning Equipment for Zero-G Flight, 26
Containment of Loose Parts and Equipment,
25
contingency procedures, 27
Electrical, 19, 20
electrical power during engine, 19
electrical power loss, 19
Ellington Field, 12, 15, 18
Emergency Procedures, 23
EMI/RFI Checks, 25
Equipment Labels. *See* Lasers
Escape Path, 13
Floor Attachment Hardware, 8, 9
Foot straps, 27
forklift, 12
Free Body Diagrams, 8
Free-Float, 22
glass, 27
G-Load Specifications, 8
Hazardous Materials, 24
JSC Safety and Health Handbook, 19
Laser, 22
Material yield strengths, 8
Miscellaneous Guidelines, 26
Oil lubricated pumps, 27
Overboard Vent, 22
Pad all hard and sharp edges, 26
Personal camcorders and cameras, 27
Pressure System Design Requirements, 14
Pressure System Test and Inspection
Requirements, 18
Pressure/Vacuum System Requirements, 13
Protective Housings. *See* Lasers
Reduced Gravity Office, 7, 8, 20, 22, 24, 27
Test Design Requirements, 7
Test Equipment Data Package, 25
Test Equipment Structural Design
Requirements, 8
Test Readiness Review, 18, 19
Touch Temperature for Research Hardware,
26
User Tools, 24
Velcro, 27
Viewing Portals and Collecting Optics. *See*
Lasers
volumetric flow rates, 22