

U.S. Department of Energy Office of Energy Efficiency and Renewable Energy  
**Wind and Hydropower Technologies Program**

**2008**  
**Merit Review Report**

---

June 17-18, 2008

Omni Interlocken Resort  
Broomfield, Colorado

---

Report prepared by:

**SENTECH, Inc.**



**U.S. Department of Energy**  
**Energy Efficiency**  
**and Renewable Energy**

Office of Wind and  
Hydropower Technologies  
Wind Energy Program

**2008 Merit Review Report  
June 2008**

U.S. Department of Energy  
Office of Energy Efficiency and Renewable Energy  
Office of Wind and Hydropower Technologies  
Wind Energy Program  
2008 Merit Review Report  
June 2008



---

**Carl J. Weinberg  
Chair**

**2008 Wind Energy Program  
Merit Review Panel**

The undersigned acknowledge receipt of the report and thank the panel for their input.



---

**Lisa Barnett  
Merit Review Leader  
U.S. DOE Wind Energy Program**

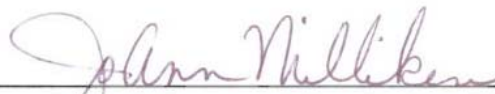

---

**JoAnn Milliken  
Acting Program Manager  
U.S. DOE Wind Energy Program**

# Table of Contents

<b>SUMMARY .....</b>	<b>1</b>
<b>MERIT REVIEW MEETING PROCESS.....</b>	<b>2</b>
<b>AGENDA.....</b>	<b>5</b>
<b>WIND PROGRAM MERIT REVIEW PANEL KEY FINDINGS .....</b>	<b>7</b>
<b>WIND PROGRAM MERIT REVIEW PROJECT EVALUATIONS.....</b>	<b>9</b>
<b>WIND PROGRAM OVERVIEW .....</b>	<b>9</b>
<b>TECHNOLOGY VIABILITY ACTIVITIES .....</b>	<b>10</b>
<b>LARGE TURBINE RELIABILITY &amp; PERFORMANCE SESSION .....</b>	<b>11</b>
<b>LARGE TURBINE TECHNOLOGY DEVELOPMENT COOPERATIVE RESEARCH AND DEVELOPMENT</b>	
<b>AGREEMENTS (CRADAs) SESSION.....</b>	<b>17</b>
<b>ADVANCED DISTRIBUTED WIND TURBINES –NREL .....</b>	<b>21</b>
<b>ADVANCED CONCEPTS, ANALYSIS, DESIGN TOOLS SESSION – NREL SESSION .....</b>	<b>25</b>
<b>ADVANCED CONCEPTS, ANALYSIS, DESIGN TOOLS – SANDIA NATIONAL LABORATORIES (SNL)</b>	
<b>SESSION .....</b>	<b>32</b>
<b>INDUSTRY TESTING SUPPORT.....</b>	<b>39</b>
<b>SUMMARY OF MERIT REVIEW PANEL SUGGESTIONS AND PROGRAM RESPONSES .....</b>	<b>43</b>
<b>APPENDICES .....</b>	<b>44</b>
<b>APPENDIX A: MEETING ATTENDEE LIST .....</b>	<b>45</b>
<b>APPENDIX B: SUMMARY OF MERIT REVIEW PANEL EVALUATION SCORES .....</b>	<b>47</b>

## Summary

Objective review and advice from peers—merit review—provides Department of Energy (DOE) managers, staff, and researchers with a powerful and effective tool for enhancing the management, relevance, effectiveness, and productivity of all research, development, demonstration, deployment, and supporting business management programs. A merit review is defined as:

*A rigorous, formal, and documented evaluation process using objective criteria and qualified and independent reviewers to make a judgment of the technical/scientific/business merit, the actual or anticipated results, and the productivity and management effectiveness of programs and/or projects.*

The DOE Wind Program Merit Review was conducted June 17-18, 2008, at the Omni Interlocken Resort in Broomfield, Colorado. Presentations were given on specific technical projects within the Technology Viability program area that were planned, underway, or recently completed. This program area is managed as three separate activities: large wind technology, distributed wind technology, and supporting research and testing. The findings of the Merit Review are considered by Wind Program managers, staff, and researchers in setting priorities, conducting operations, and improving projects.

The following document represents the Merit Review Panel's observations and findings, the response from the Wind Program to these findings, and supporting meeting materials, including an agenda and a list of participants. In accordance with the Office of Energy Efficiency and Renewable Energy (EERE) Peer Review Guide, Section 6.1, reviewers provided both quantitative and narrative evaluations of the materials and projects presented at the Merit Review meeting. The comments herein are the most direct reflection of reviewers' written evaluations and have been included verbatim when possible.

# Merit Review Meeting Process

The U.S. Department of Energy (DOE) Wind and Hydropower Program’s strategic planning framework consists of two elements (Figure 1). The first element is an ongoing technical assessment activity that monitors the status of wind technology progress in achieving program cost goals, evaluates that status within the context of marketplace needs, and identifies technological pathways that will lead to successful competition in the marketplace. The second element is the formal Merit Review process that the Program uses to benefit from the guidance of industry and the research community and to provide an outside view of the Program. As shown in Figure 1, technical assessment and merit review provide inputs that the program management team considers in making decisions about strategic program directions and funding priorities.

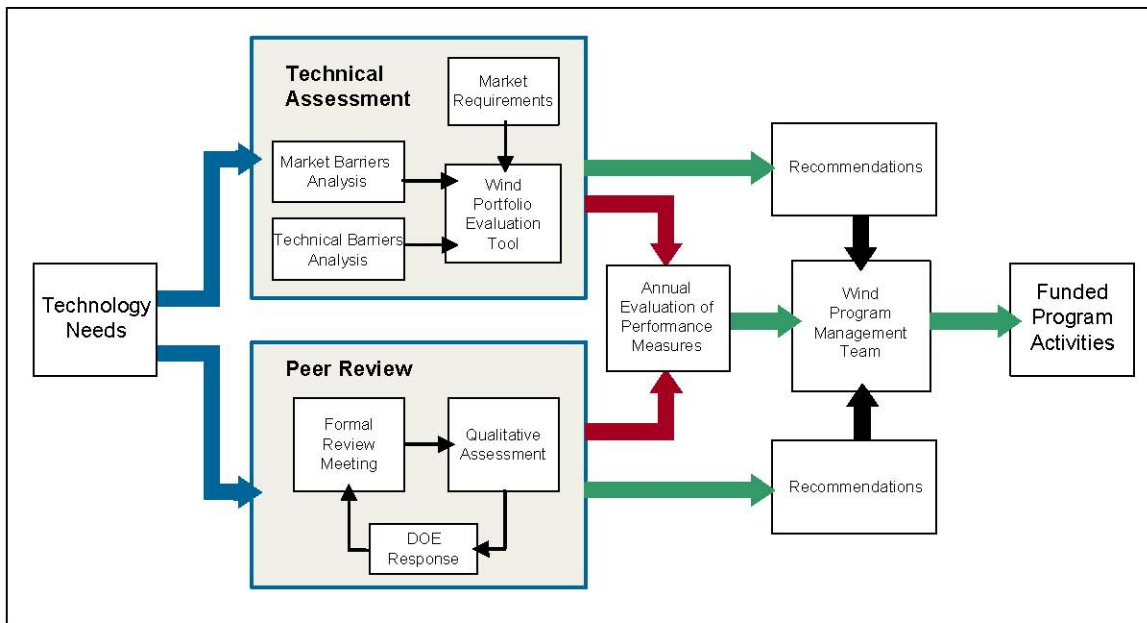

**Figure 1. Strategic Planning Framework.**

The Merit Review is designed to provide feedback to Wind Program management on the R&D areas chosen for review. Merit Reviews are conducted in compliance with EERE guidance. The results of the Review are considered when the program management team evaluates potential adjustments to Program direction.

The DOE Wind Energy Program Merit Review was held on June 17-18, 2008, at the Omni Interlocken Resort in Broomfield, CO. The Review focused on specific technical projects within the Technology Viability program area. The Review Panel was composed of experts in the wind energy field. None of the committee members are affiliated with the DOE Wind Energy Program. The Panel included:

Name	Affiliation
Carl Weinberg (Chair)	Weinberg Associates
John Mankins	Artemis Innovation Management Solutions, LLC
Stephen Connors	Massachusetts Institute of Technology
Ken Karas	Former CEO, Enron Wind Corp.; Former CEO, Zond Corp.
Mike Kelly	Sustainable Energy Advocate
Dale Osborn	Transmission Technical Manager, MISO
Joseph Slamm*	Partner, Hudson Capital Management (NJ), L.P.

\*New Merit Review Panelist in 2008

Reviewers received briefing materials prior to attending the meeting to aid in the program review process. This information included an agenda, the *2007 Wind Program Peer Review Report*, the Wind Program’s *Multi-Year Program Plan 2007-2011*, the *2008 Wind Program Strategic Planning Meeting Report*, and the *20% Wind Energy by 2030* report. Reviewers also received copies of the review evaluation forms and guidelines as provided in the EERE Peer Review Guide. Reviewers were also provided with an outline of the Wind Program’s mission and goals.

The Merit Review meeting took place over two days. The first day focused on Large Turbines, Advanced Distributed Wind Turbines, and Advanced Concepts, Analysis, and Design Tools program activities. The second day covered Advanced Concepts, Analysis, and Design Tools and Industry Testing Support program activities. Reviewers completed their evaluations in a separate location and provided an initial summary of their findings to members of the Wind Program at the conclusion of the Merit Review meeting.

In accordance with EERE Peer Review Guide, Section 6.1, the Merit Review Panel chose to submit both quantitative (i.e., numerical scores) and qualitative (i.e., narrative accounts) evaluations as part of their review of the materials and projects presented. The comments herein are the most direct reflection of their written evaluations, and where possible have been included verbatim. The Panel was asked to rate the projects in the following categories:

1. **Effectiveness** (considering the elements of quality, productivity, and accomplishments)
2. **Relevance** (to mission, goals, strategy, and technical and/or market barriers)
3. **Overall Impression** (considering all measures, inputs and outputs, and program management)

Numerical scores were based on a ten-point scale, with qualitative descriptors given for the numerical scoring index (i.e., a score of 1-2 corresponded to a “Seriously Deficient” rating, 4-6 corresponded to an “Average” rating, and 9-10 corresponded to an “Outstanding” rating). Furthermore, the Panel was asked to rate the projects with respect to the Wind Program’s Mission and Goals, as shown on the following page.

### **Program Mission and Goals**

**Mission:** To lead the nation's efforts to improve wind energy technology through public/private partnerships that enhance domestic economic benefit from wind power development and coordinate with stakeholders on activities that address barriers to wind energy use.

**Program Strategic Goal:** Collaborate with federal, state, industry, and stakeholder organizations and lead wind energy technology R&D and application efforts to support achieving the 20% wind vision for the Nation's electricity by 2030.

### **Program Performance Goals:**

- By 2012, reduce the cost of electricity from large wind systems in Class 4 winds to 3.6 cents/kWh for land-based systems (from a baseline of 5.5 cents/kWh in 2002).
- By 2014, reduce the cost of electricity from large wind systems in Class 6 winds to 7 cents/kWh for shallow water (depths up to 30 meters) offshore systems (from a baseline of 9.5 cents/kWh in 2005).
- By 2016, reduce the cost of electricity from large wind systems in Class 6 winds to 7 cents/kWh for transitional (depths up to 60 meters) offshore systems (from a baseline of 12.0 cents/kWh in FY2006).
- By 2008, reduce the cost of electricity from distributed wind systems to 10-15 cents/kWh in 2008 in Class 3 wind resources (from a baseline of 17-22 cents/kWh in 2002).
- By 2012, complete program activities addressing electric power market rules, interconnection impacts, operating strategies, and system planning needed for wind energy to compete without disadvantage to serve the Nation's energy needs.
- By 2010, at least 30 states with wind momentum needed to ensure wind's continued growth.

# Agenda

## Wind & Hydropower Technologies Program Merit Review Meeting June 17-18, 2008 • Broomfield, CO

### Tuesday, June 17, 2008

---

- 7:30 am **Registration & Continental Breakfast**
- 8:30 **Welcome & Introductions** Drew Ronneberg/Bobi Garrett/Jose Zayas
- 8:45 **WHTP Program Overview** Drew Ronneberg
- 9:00 **20% Wind Report Review** Ed DeMeo
- 9:40 **BREAK**

#### TECHNOLOGY VIABILITY

- 9:55 **Technology Viability Overview** Steve Lindenberg
- 10:10 **Large Turbine Reliability & Performance** Sandy Butterfield/Paul Veers
- Gearbox Collaborative; Certification & Standards (NREL) Sandy Butterfield
  - Reliability Collaboration & System Analysis; Certification & Standards (SNL) Roger Hill/Paul Veers
- 11:30 **Large Turbine Technology Development CRADAs** Dave Simms
- NWTC Utility Scale Turbines Lee Jay Fingersh
  - NWTC Technology Development Partnerships Ian Baring- Gould
  - SNL Technology Development Partnerships Jose Zayas
- 12:30 pm **Working Lunch- Wind Powering America** Phil Dougherty
- 1:45 **Advanced Distributed Wind Turbines (NREL)** Trudy Forsyth
- Independent Testing & Certification Hal Link
  - Small Wind Technical Support & Collaboration Trudy Forsyth
- 2:45 **BREAK (15 min)**
- 3:00 **Advanced Concepts, Analysis, Design Tools (NREL)** Mike Robinson
- Turbulence Characterization & Performance Impacts Neil Kelley
  - Mesoscale Modeling Initiative Scott Schreck
  - Aerodynamics, Aeroacoustics, Array Effects Patrick Moriarty
  - Adaptive Controls Alan Wright
  - Design tools and codes (Risoe MOU) Jason Jonkman
- 5:00 **Adjourn**



## Wednesday, June 18, 2008

---

7:30 am **Registration & Continental Breakfast**

### TECHNOLOGY VIABILITY

8:30 **Adv Concepts, Analysis, Design Tools (SNL)** Jose Zayas

- Materials & Manufacturing Tom Ashwill
- Advanced Manufacturing Initiative Daniel Laird
- Design Tools & System Modeling Daniel Laird
- Aerodynamic Tools & Aeroacoustics Dale Berg
- Innovative Concepts Dale Berg

10:30 **BREAK (15 min)**

10:45 **Industry Testing Support** Dave Simms

- LBTF CRADAs Jason Cotrell
- NREL Test Facilities Dave Simms
- Sandia & U.S.DA Test Facilities Paul Veers

11:45 **Review Panel Questions and/or Discussions**

12:00 – 12:15pm **Closing Remarks** Drew Ronneberg

---

1:15 -4:15pm **Merit Review Panel**

CLOSED ROOM MEETING

# Wind Program Merit Review Panel Key Findings

## Summary

Given the recent release of the *20% Wind Energy by 2030* report, this is a critical time for the Wind and Hydropower Technologies Program. The rapid expansion of the wind industry last year give the Program the opportunity to refocus its efforts around the vision set forth in the *20% Wind Energy by 2030* report. To achieve that vision, the Program needs increased funding support and timely allocation of those funds in order to become the necessary asset for the expanding industry and to play a major role in America's energy future. The Program needs to define what it can do over the next four to eight years in order to expand its current budget.

## Findings

1. The Technology Viability projects being pursued by the Wind Program are highly relevant to the goals of the United States regarding the utilization of wind power as an important part of the country's energy strategy. These projects are well managed and represent a body of excellent work that is being performed on a minimal budget.
2. The Program is commended for beginning to organize collaborative research and development (R&D) efforts around the major fundamental issues of turbulence and mesoscale modeling.
3. Many of the research projects presented this year are in the early stages of R&D, and it was therefore difficult to appreciate their full capability and visualize how they mesh with other parts of the Program.
4. In some instances the panel had a difficult time differentiating between presentations due to a perceived degree of project overlap. As an example, presentations on "Aerodynamics, Aeroacoustics, Array Effects," "Adaptive Controls," and "Aerodynamic Tools and Aeroacoustics" seemed to have substantial overlap and could have been combined into one presentation.
5. The Program needs increased funding support and staff to maximize benefits at the Program level and with key partners. The overall lack of funding has hampered the ability of Program staff to implement projects effectively and slowed project progress.
6. Additional funding needs to be allocated for the development of skilled personnel at the National Laboratories in order to support the Program's Technology Viability activities.
  - a. There is a need for a "National Wind Testing Facilities Plan" that addresses how resources such as NREL personnel (training and staffing) and specific laboratory testing capabilities will be shared between NREL and the new blade test facilities.
  - b. National laboratory interaction with undergraduate and graduate school students regarding wind energy issues is appreciated and should be continued. Universities are faced with limited budgets to draw professors and students into their research programs.

7. The distributed wind projects are worthwhile and legacy projects need to be completed. At the completion of those projects, the Program may want to reevaluate the appropriate level of funding for this portion of the Program considering the greatly expanded budget envisioned by the Review Panel. Distributed wind projects may not necessitate 10% of the Technology Viability program area's portion of the Wind Program budget.
8. Some aspects of the offshore wind R&D objectives should be restored. Some component of Program investment should address this important resource. While following European development is important, some R&D on structural foundations and platforms at the least is warranted.
9. The Wind Program historically reviews half of its Program each year, alternating between the Technology Viability and Technology Application/Systems Integration portions of the Program. However, given the rapidly changing and expanding industry and shifts in the Program's focus, the entire suite of projects should be reviewed on an annual basis.
10. The utility industry and manufacturers need to be more engaged and have greater participation with the DOE Wind Program and National Laboratory projects. Another round of Wind Partnerships for Advanced Component Technology (WindPact) is needed to increase interest from and participation by industry and manufacturers.
11. AWEA should be represented during the Merit Review process. It would be useful to hear an AWEA representative present the recommendations of the AWEA R&D Committee.

# Wind Program Merit Review Project Evaluations

## Wind Program Overview

The Wind Program is organized around two program areas: Technology Application and Technology Viability. The Technology Application program area consists of Technology Acceptance activities, including Wind Powering America, wind siting work, and environmental impact efforts, and Renewable Systems Interconnection projects, including wind resource assessments, interconnection and operation activities, and transmission efforts. The Technology Viability program area consists of Low Wind Speed Technology (also called Large Wind Technology) activities, Distributed Wind Technology activities, and Supporting Research and Testing activities. Reviews of these program areas are held every second year, such that every year either the Technology Application or the Technology Viability program area is reviewed; however, in the future, the Wind Program plans to review all program areas each year.

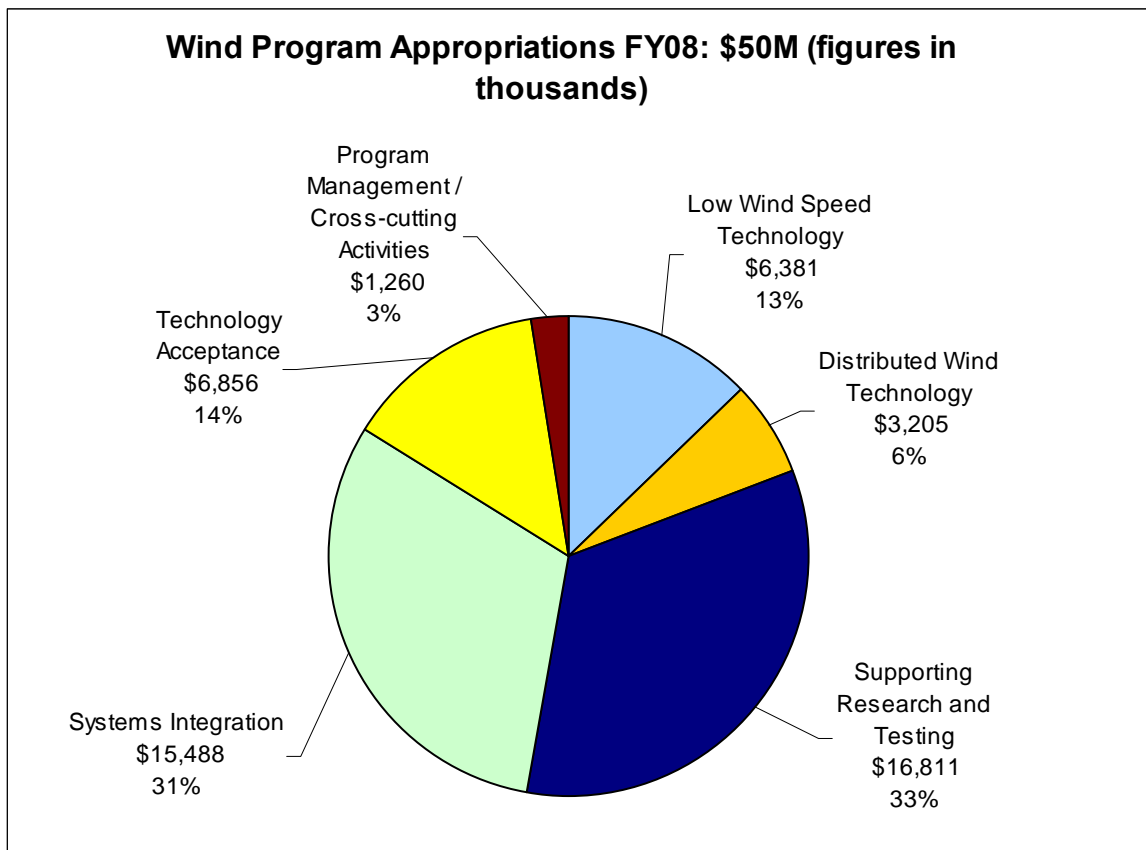

Figure 2. Wind Program Budget FY 2008

Figure 1 shows the Wind Program's program appropriation for FY 2008 (source is the Consolidated Appropriations Act of 2008 / Public Law 110-161). Program appropriations for Technology Viability activities (Low Wind Speed Technology, Distributed Wind Technology, and Supporting Research and Testing) total \$26.4 million. Cross-cutting activities include SBIR/STTR, Annual Merit Review, etc.

## Technology Viability Activities

Technology Viability activities are geared towards reducing the cost of large and small wind energy systems. Technology Viability is managed as three separate activities: Large Wind Technology, Advanced Distributed Wind Technology, and Supporting Research and Testing. The three Technology Viability activities are closely interrelated. Progress made in Supporting Research and Testing results in reductions in the cost of energy, and thus contributes directly to the cost goals for low wind speed technology and distributed wind technology. The 2008 Merit Review evaluated Technology Viability activities at NREL and SNL with a total budget of \$19.5 million.

Technology Viability activities are guided by Programmatic Performance Goals and the Advanced Energy Initiative.

### **Programmatic Performance Goals:**

- Reduce the cost of electricity from distributed wind systems to 10-15 cents/kWh in 2008 in Class 3 wind resources (from a baseline of 17-22 cents/kWh in 2002) by 2008;
- Reduce the cost of electricity from large wind systems in Class 4 winds to 3.6 cents/kWh for land-based systems (from a baseline of 5.5 cents/kWh in 2002) by 2012;
- Reduce the cost of electricity from large wind systems in Class 6 winds to 7 cents/kWh for shallow water (depths up to 30 meters) offshore systems (from a baseline of 9.5 cents/kWh in 2005) by 2014;
- Reduce the cost of electricity from large wind systems in Class 6 winds to 7 cents/kWh for transitional (depths up to 60 meters) offshore systems (from a baseline of 12.0 cents/kWh in FY 2006) for 2016.

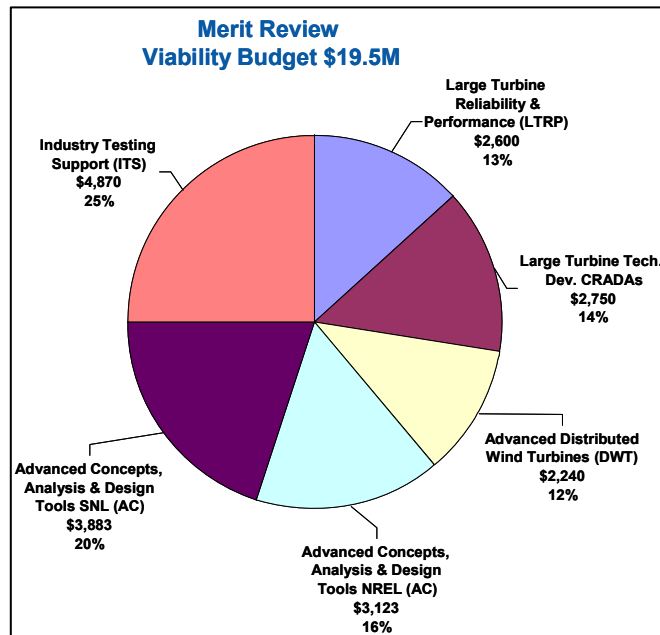

Figure 3. FY08 Technology Viability Budget

**Advanced Energy Initiative** –President Bush’s 2006 State of the Union Address included an Advanced Energy Initiative designed to reduce energy imports and fund alternative energy technologies. The Advanced Energy Initiative identifies wind energy as a part of that strategy: “areas with good wind resources have the potential to supply up to 20% of the electricity consumption of the United States.”

## **Large Turbine Reliability & Performance Session**

### Session Overview

The role of the DOE Wind Reliability and Performance Program is to create a national strategy that (1) identifies systemic issues, (2) facilitates root cause analyses, (3) targets resources of DOE and other institutions, and (4) maximizes the value of the national infrastructure investment. In order to fulfill this role and to systematically address wind plant reliability, Large Turbine Reliability and Performance (LTRP) activities focus on the following three areas: issue identification, issue resolution, and requirements. Greater emphasis is currently being placed on Reliability Collaboration & Systems Analysis, the Gearbox Collaborative, and Large Turbine Technology Development Cooperative Research and Development Agreement (CRADA) opportunities.

The goal of a national reliability program, from the perspective of the *20% Wind Energy by 2030* scenario, is to improve the wind industry as a whole:

- Expand the number of manufacturers, sizes, and types of turbines
- Address complex data issues
- Provide a baseline for requirements and strategic investment.

The budget currently supports \$2.6 million dollars in Large Turbine Reliability & Performance projects, or 13% of the total budget for Technology Viability activities. Table 1 represents a more detailed itemization of the current budget for LTRP.

<b>Current Budget for LTRP Activities</b>	
<b>Project</b>	<b>Funding</b>
Drive Train and Gearbox Collaborative	\$1.33M
Certification and Standards	\$200K
Reliability Collaboration and Systems Analysis	\$900K
Certification and Standards	\$170K

**Table 1. Budget Breakdown for LTRP Activities.**

High wind turbine reliability is an issue of national importance. The reliability and performance of the resource is a public expectation, critical for integrated grid operations and required for long-term economic sustainability. Under the *20% Wind Energy by 2030* scenario, wind is a national energy security resource that provides the nation with clean, sustainable, and domestic energy. Every \$.01/kWh reduction in operating costs will result in \$12 billion/year in electricity cost savings for the U.S. at 20% wind energy penetration levels. LTRP activities are essential to attaining those operating and electricity cost savings.

### Gearbox Reliability Collaborative (Sandy Butterfield, National Renewable Energy Laboratory)

The National Renewable Energy Laboratory (NREL) is addressing gearbox reliability as a major part of its research agenda and has formed a collaborative with a wide range of stakeholders, including researchers, consultants, bearing manufacturers, gearbox manufacturers, wind turbine manufacturers, and wind turbine owners/operators. The Gearbox Reliability Collaborative (GRC) addresses major gearbox issues and shares the common goal of increasing the overall reliability of wind turbines. The approach includes

three major technical efforts: field testing, dynamometer testing, and drivetrain analysis. The current budget for this collaborative is \$2.4 million. However, \$700K of the current budget was carried over from last year.

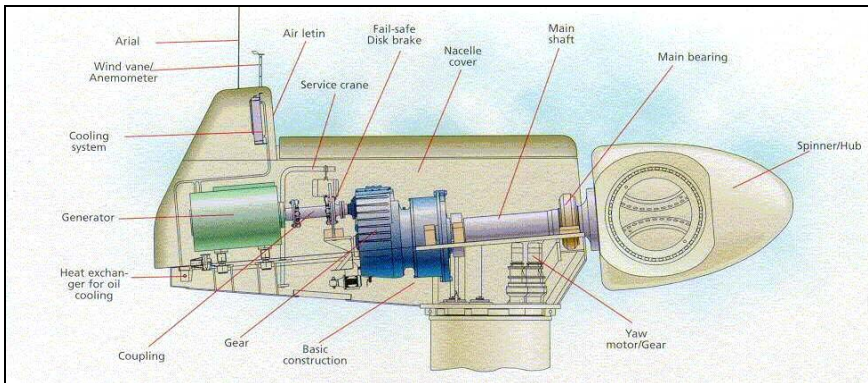

**Figure 4. Typical Wind Turbine Architecture**

Gearbox Reliability Collaborative objectives:

- Isolate sources of failures and suggest solutions
- Verify dynamometer testing to assess gearbox/drivetrain problems and solutions
- Understand how gearbox loads translate to bearing response, stress, slip, and other problems
- Improve load case matrix
- Evaluate design process
- Verify analytical tools

**Merit Review Panel Scores:**

Scoring Category	Average	Range
<b>1) Effectiveness</b>	8.3	7-9
<b>2) Relevance</b>	9.6	9-10
<b>3) Overall Impression</b>	8.7	7-9

**Merit Review Panel Comments:** Gearbox reliability poses a significant problem to the industry. The Gearbox Reliability Collaborative is needed to bring together the various portions of the gearbox design process and to share information needed to address the problems facing the industry.

There are several variables impacting the reliability issue for both U.S. and European operators and manufactures, including operating environment, bearings, and lubrication, and there is therefore no single solution to the problem. To address these issues, additional interaction is needed between worldwide experts in gears, bearings, and lubrication.

The panel feels that NREL, like General Electric, should be failing gearboxes in dynamometer tests. The panel noted that all of the gearbox models in the new fleet of MW-scale turbines have failed within a five year period, which is far below the 20-year life expectancy of a gearbox. Although a majority of the bearing failures are in the planetary stage, significant failures have also been observed in the high speed shaft bearings. The failing machines are run “hot,” or at approximately 50% capacity factor (or greater). Additionally, the panel suggests that NREL investigate the impacts that electrical currents

passing through gearboxes may have on bearings.

The GRC’s approach is to obtain detailed measurements via dynamometer and field testing analysis from multiple experts. There is huge fleet of machines currently operating in the U.S., and most of them are out of warranty. Therefore, some of the sensitivities to sharing information and data collected by dissecting and examining these failed gearboxes are reduced.

The panel feels the GRC is well organized, well staffed, well supported by industry, and presents an impressive solution to the sensitivities of collaborative partnerships. The GRC is an important element in the effort to address successfully the problems that gearbox reliability presents to the industry.

Certifications & Standards (Sandy Butterfield – NREL)

The goals of the NREL certifications and standards activities include supporting the development of international consensus standards (typically IEC TC88), facilitating the functionality of international certification, providing certification testing services, and supporting industry through an initial certification process. The current budget for certification and standards activities is \$200,000.

To achieve the previously stated goals of the project, NREL is participating in international standards committees, developing industry consensus, researching and developing analysis/test methods, and publishing reports. Standardized testing procedures, design requirements, design classes, definition of external conditions, and certification steps have been developed. Increased communication and interaction is ongoing with the international community. Current problems facing the project include conflicts with pre-existing U.S. national standards, lack of an effective feedback loop between end users and the certification process, and difficulties achieving balanced stakeholder participation and confidence.

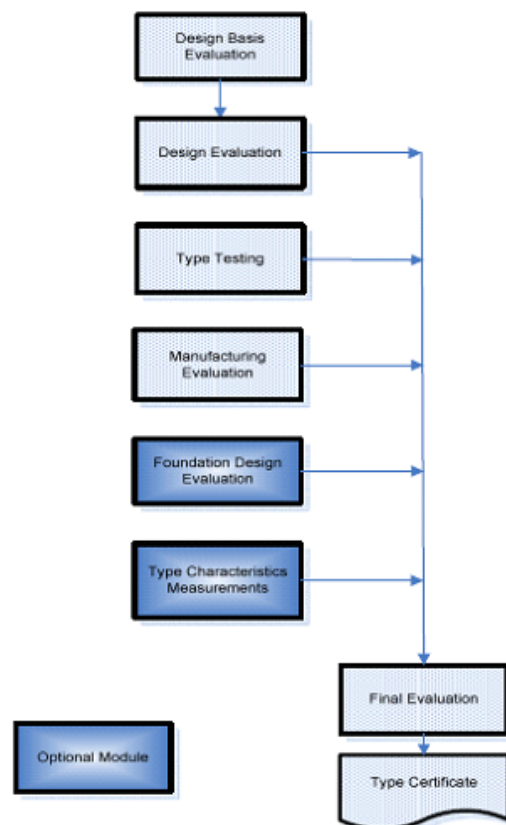

Figure 5. Modules for Type Certification

**Merit Review Panel Scores:**

Scoring Category	Average	Range
1) Effectiveness	8.7	8-10
2) Relevance	9.4	8-10
3) Overall Impression	8.7	8-10

**Merit Review Panel Comments:** The program is effective in implementing standards that increase the overall performance of wind turbines. Confidence in wind technology has improved greatly with the entrance of larger manufacturers guided by national and



international standards. This effort is well executed and essential to improving the reliability and performance of wind technologies. Several nations are involved in developing international standards, including several Asian and European countries. Nevertheless, there is still a long way to go to attain a mutual recognition agreement.

There are a number of successes noted in these activities, particularly in blade and gear certification. However, there are still failures, predominantly related to bearings. The consensus is that bearing failures are a design process failure and therefore a failure of standards.

Cross-border certification is essential for securing capital, and it provides U.S. manufacturers with “tax equity” options. The industry needs more turbine capacity in order to control costs. From a U.S. manufacturing perspective, the Certification & Standards work is especially important.

The panel compliments DOE and NREL on this work and hopes that these activities receive sufficient support in order to serve a critical, central need, and to help achieve commensurate attention within the industry.

#### Reliability Collaboration & System Analysis (Roger Hill – Sandia National Laboratories)

This project, managed by Sandia National Laboratories (SNL), intends to establish industry benchmarks for reliability performance, identify failure trends, and document industry reliability improvements over time. The project also aims to improve system performance through better resource management practices, and targets efforts to address important component reliability problems. The current budget was increased to \$900,000 in FY 2008.

SNL is collecting data on plant operations, plant development, turbines, materials, and component and subcomponent functionality to include in a National Reliability Database. The collaboration currently has four data partners, who together represent more than 570 MW of wind power production. However, data has only been captured from one of the partners. The top four turbine manufactures are also represented, accounting for 89% of the sales in 2007.

Future plans of this collaboration:

- Increase the number of data partners
- Involve NREL in select nondisclosure agreements (NDAs)
- Increase data handling capabilities/efficiency
- Increase analysis production capabilities/efficiency
- Increase industry interaction
- Use partners to program advantage
- Identify and pursue discrete opportunities
- Consider handover to industry institutions, such as the American Wind Energy Association, as the market matures

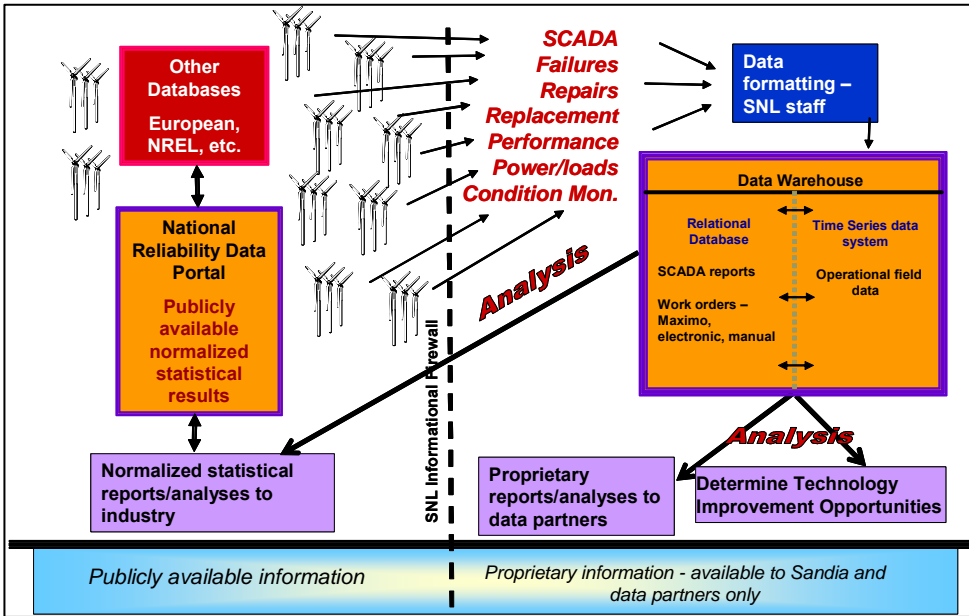

Figure 6. Diagram of a National Reliability Database

**Merit Review Panel Scores:**

Scoring Category	Average	Range
1) Effectiveness	6.8	4-8
2) Relevance	8.7	8-10
3) Overall Impression	7.7	6-9

**Merit Review Panel Comments:** Robust international standards and certification procedures are critical to the industry, and the Panel found it satisfying to see them extended from equipment to wind projects. Long-term participation by DOE, including the delivery of test results, is crucial to the success of this SNL project.

A major part of the effort for this project focuses on the creation of a National Reliability Database, in support of the concept of data-driven analysis to improve reliability. The panel was somewhat surprised at the reluctance of the industry to provide data regarding plant operations, plant development, turbines, components, and subcomponents and materials. Currently, only 3% of the industry is participating in the analyses. An effort needs to be made to increase industry participation in order to obtain valuable data, especially since these efforts have an impact on capital formation. Maintaining anonymity is vital for obtaining this data.

The objectives for this effort were clearly stated during the presentation. However, the connections between the objectives and the various parts of the program were a little unclear to the Panel. Also, a more detailed description of the link between the database development process and the identification of technology investment opportunities would have been helpful.

The panel recommends correlating the electric system data with the operator data to create quality assurance within the statistical database. From the viewpoint of a regional transmission organization or utility system, the aggregated data will be more valuable than the component-specific data that a manufacturer or operator would provide. The panel feels that this project is well organized and has developed a high-quality

conceptual design. The panel recommends utilizing the North American Electric Reliability Council to assist this effort. Since the database results have not yet been produced, the effectiveness of this project cannot yet be judged.

Certifications and Standards (Paul Veers, SNL)

This project focuses on improving the reliability of certification standards and enabling realistic risk assessments for individual site conditions. Current standards activities emphasize working in conjunction with International Electrotechnical Commission (IEC) standards committees to implement adequate, workable criteria. Current risk activities focus on generating risk assessments (hazard framework) that tie individual sites to conditions that may be outside the standard criteria. Interaction with NREL (certification lead), the University of Texas, and Texas Tech University are critical to project success. The current budget for the SNL certifications and standards activities is \$170,000.

A central goal of this project is to support the development of standards for design loads by utilizing extrapolations from fifty year extremes. This project aims to help industry better match turbine capabilities to site requirements, thus reducing overall operations and maintenance (O&M) costs.

Future work will focus on publishing a special issue of the journal *Wind Energy* devoted to design loads, publishing a white paper on earthquake risk, developing a template for site risk assessment based on atmospheric conditions, and determining which atmospheric characteristics are needed to calculate site risk-assessment.

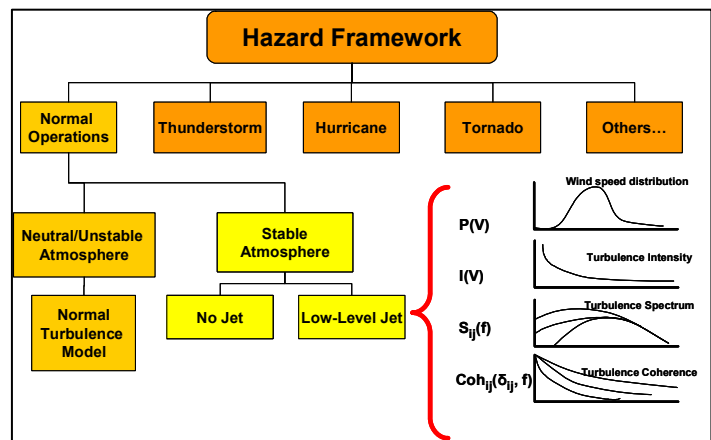

Figure 7. Hazard Framework

**Merit Review Panel Scores:**

Scoring Category	Average	Range
1) Effectiveness	7.8	7-9
2) Relevance	8.3	6-10
3) Overall Impression	8.0	7-9

**Merit Review Panel Comments:** The panel feels that this project provides an appropriate response to the problem of addressing potential extra-standard risks. The presentation clearly defined the goals of the effort, namely a focus on tying standards to risk assessment and actual individual site conditions. However, because this is a new project, the panel had some difficulty evaluating the project.

The panel sees a significant need to identify extremes that are beyond the scope of normal operations (e.g., tornadoes) and to distinguish between equipment performance expectations and the level of insurance required to effectively protect an investment. Even though it is too early to determine the effectiveness of this project, the panel feels the current approach to the problem is excellent.

## Large Turbine Technology Development Cooperative Research and Development Agreements (CRADAs) Session

### Session Overview

The Program, through the National Renewable Energy Laboratory (NREL) and Sandia National Laboratories (SNL), previously used cost-shared development subcontracts to support new wind system components and full system prototypes. These subcontracts were terminated in FY 2006 and FY 2007 at the direction of the DOE.

Recently, Cooperative Research and Development Agreements (CRADAs) have become the predominant mechanism for partnering National Laboratories with industry, universities, state entities, and international organizations. CRADAs have been implemented to leverage laboratory technical capabilities at the request of industry, without providing monetary support to an industry that is perceived not to need it.



There are many CRADA types and options, including shared resources, funds-in shared, and funds-in-work-for-others (fully funded by partners). No funding is paid to partners under the current CRADA mechanism, and partner selection can be a competitive process. The CRADA process is initiated by a pre-solicitation notice which is released to discover the level of industry interest. Responses are submitted and reviewed in order to develop a CRADA opportunity. A CRADA opportunity announcement is made, industry responses are submitted and reviewed, and partnership recommendations are submitted to DOE for approval.

The current budget for Large Turbine Technology Development CRADAs is \$2.75 million, or 14% of the budget for Technology Viability activities. Table 2 represents a more detailed itemization of the current budget for Large Turbine Technology Development CRADAs activities.

Current Budget for Large Turbine CRADA Activities	
Project	Funding
NWTC Utility Scale Turbine	\$1M
NREL Technology Development Partnerships	\$1.5M
SNL Technology Development Partnerships	\$250K

**Table 2. Budget for Large Turbine Technology Development CRADAs activities.**

CRADAs make laboratory expertise and testing facilities available to assist in improving the reliability and performance of utility-scale wind energy technology. They also provide technical support to the industry as needed. CRADAs are flexible and present fewer restrictions than cost-shared development subcontracts.

National Wind Technology Center Utility Scale Turbine CRADA (Lee Jay Fingersh – NREL)

The objective of this CRADA is to install and test a Siemens 2.3MW 101m-diameter turbine at the National Wind Technology Center (NWTC). CRADA details are still under negotiation, and the Agreement has yet to be signed. The turbine will be available at the end of calendar year 2008, and current installation is planned for the spring of 2009. The FY08 budget for this project is \$1 million.

A new design approach that uses computational fluid dynamics will be employed to develop a new rotor. As part of this work, the performance loads and reliability of the new design will be validated. The initial goals are to sign the CRADA, construct the infrastructure, and install and commission the turbine.



Figure 8. Siemens 2.3MW 101m Turbine

The turbine is expected to remain at the NWTC for the next three years (at a minimum). Siemens is planning to move the data systems developed on this turbine to two or more turbines at a customer site for more aerodynamics testing in other environments. The facility will become a training environment for Siemens engineers. Controls research may also be performed on this turbine in collaboration with NWTC staff.

**Merit Review Panel Scores:**

Scoring Category	Average	Range
1) Effectiveness	8.0	7-9
2) Relevance	7.0	5-9
3) Overall Impression	7.2	5-9

**Merit Review Panel Comments:** This CRADA represents a new program effort that was established over the past year to advance the understanding of aerodynamics & loads. This effort seeks to increase the wind turbine swept area without increasing the equipment loads. The panel feels that this CRADA is a potentially effective step in reducing the cost of energy and is an appropriate use of public R&D funds.

The presentation itself contained a straightforward statement of the objectives of Siemens, but it was unclear concerning the overall goals of the effort and their connection to the goals of the overall wind program. The panel feels that there is no self-evident linkage of the project to the *20% Wind Energy by 2030* scenario, even though this project was only initiated in May 2008.

At this time, it is not clear what information and data will be made available to the public. The NWTC is insisting that as much data as possible be made available; however, Siemens will most likely object to publishing details of the rotor design.

This project looks like a good start to the call for increased use of CRADAs. The balance of both public and private benefits is being addressed. The broader issues of how to do more proprietary contract work, increase lab expertise, and remain a long-term strategic

resource for the industry were only briefly touched upon (and appropriately so); these issues should be revisited as these types of projects grow in size and number.

NWTC Technology Development Partnerships – NREL, SNL, and Industry Partners  
(Ian Baring-Gould – NREL)

The basic premise of the NWTC technology development partnerships is to make program staff and testing facilities available to assist in the reliability and performance improvement of utility-scale wind energy technology. The goal of this project is to develop improved designs or approaches that lower costs, improve performance, and complete tests successfully, thereby allowing manufacturers to improve the reliability and performance of their components. The current budget for this effort, including NREL and SNL, is \$1.75 million.

This project faces two barriers to success: facility limitations, such as overall capacity and throughput, and the trials of the contracting and project approval process.

The two main branches of technology development partnerships activities are 1) cooperative equipment testing based on Program commitments of funds in CRADA opportunities, and 2) competitive utility-scale wind energy R&D CRADA partnerships.



Figure 9. Fatigue testing at the A-60 Test

Future plans are to complete the legacy activities by the end of FY 2008, initiate program work on the CRADA proposals approved by DOE, and prepare annual calls for additional CRADA proposals as funding and program support dictate. Additionally, the project potentially aims to expand its scope beyond components and to complete DOE-directed projects as required.

**Merit Review Panel Scores:**

Scoring Category	Average	Range
1) Effectiveness	7.8	7-9
2) Relevance	7.3	6-9
3) Overall Impression	7.7	7-9

**Merit Review Panel Comments:** This project represents an innovative method for using laboratory resources to solve practical problems and meet goals. The activity is a collection of various newer and legacy activities, and the individual legacy tasks are evidently of high quality.

The panel feels that the statement of the goals and objectives of these technology development partnerships is somewhat diffuse. The panel would have preferred a discussion regarding a self-evident linkage of the prospective activities to the *20% Wind Energy by 2030* scenario, particularly since this project only commenced in May 2008. For example, the 20% Wind scenario was not defined or even included in the CRADA proposal review criteria.

Additional synthesis on how these testing projects for external products fit into the overall

strategy of long-term expertise and technological innovation goals for the DOE Program would be helpful. Obtaining a clear and detailed industry data set is important to the future success of these activities.

## Advanced Distributed Wind Turbines –NREL

### Session Overview

The objectives of the Advanced Distributed Wind Turbines (DWT) effort are to stabilize the market through independent testing, support regional test centers and standards development, and expand the number of distributed wind turbine systems installed in the U.S. This effort increases the visibility and installed capacity of distributed wind. It also pre-conditions the market to be pro-wind and provides a rural corollary to urban photovoltaic systems (PV). Additionally, the DWT effort strives to develop a U.S. industry that dominates the world market. The most significant challenge to this project is supplying high-quality, reliable smaller turbines to the marketplace.

The budget for the Advanced Distributed Wind Turbines work is \$2.24 million, or 12% of total budget for Technology Viability activities. Table 3 represents a more detailed itemization of the current budget for Advanced DWT activities.

Current Budget for Advanced DWT Activities	
Project	Funding
DWT Independent Testing & Certification	\$1.74M
Small Wind Technical Support & Collaboration	\$550K

**Table 3. Itemized Budget for Advanced DWT activities.**

Increased funding is required in order to address the testing of over 70 turbine models that are currently in the testing queue. Increased funding would also support the construction of a structure needed to test roof-mounted and building-integrated distributed wind turbines.

Future plans include continuing with the second round of independent testing, developing partnerships with new and existing small wind test centers (regional test centers), and evaluating market assessment results from ICF International to determine the appropriate role for DOE/NREL regarding mid-size wind turbines and distributed wind turbines.

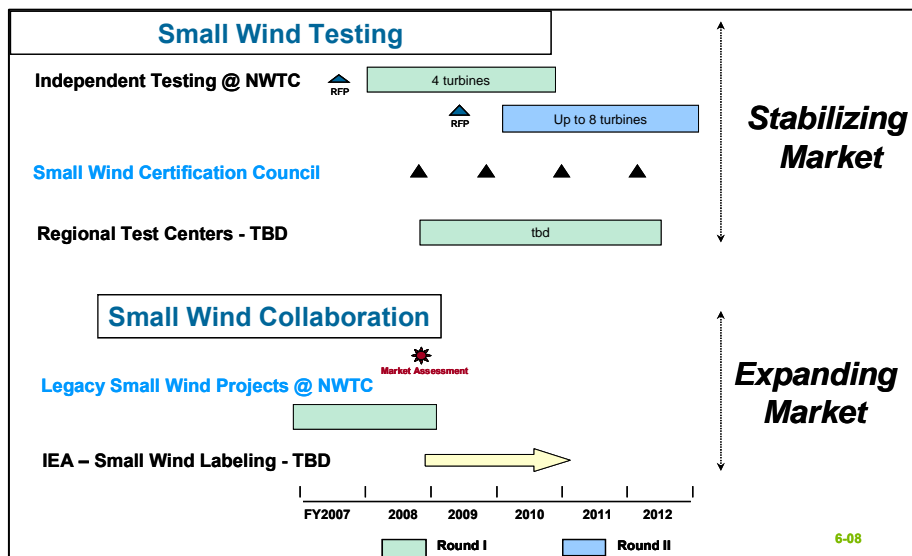

**Figure 10. Approach – Distributed Wind Plan**



### Independent Testing & Certification (Hal Link, National Renewable Energy Laboratory)

The objectives of the independent testing and certification work at NREL are to stabilize the U.S. small wind turbine market, expand the number of distributed wind turbines in the U.S., and increase the public acceptance of wind turbine technology. The budget for the independent testing and certification work at NREL is \$1.74 million.

This effort is currently addressing problems facing the industry, such as the number of poor products that have inundated the small wind turbine market, the quality and quantity of information available regarding manufacturers' claims, and the fact that public support for all wind technology is weakened by poor product quality.

By providing unbiased, quality test results, consumers can make better-informed decisions about purchasing distributed wind products. Additionally, as increased numbers of more reliable and better-performing turbines are sold, public support for all wind turbines will increase.

#### Project approach:

- Develop NREL testing capabilities by
  - developing quality system, trained staff, test equipment, and facilities,
  - achieving recognition as a qualified test center by attaining accreditation through A2LA, and
  - building test site infrastructure at the NWTC;
- Conduct first rounds of independent testing
- Publish test results
- Conduct additional rounds of independent testing at the NWTC
- Expand testing capabilities through development of regional test centers



**Figure 11. Infrastructure Upgrades for Small Turbine Independent Testing**

Four turbines have been selected for the first round of testing. Standard protocols from the International Electrotechnical Commission (IEC) and the American Wind Energy Association (AWEA) will be utilized during the first round of testing.

The DOE is planning a second round of independent testing of other small turbine models beginning in 2010. The second-round solicitation is planned for release in the second quarter of FY 2009. DOE/NREL will assist other North American organizations in developing regional test centers for testing distributed wind turbines in compliance with AWEA standards.

**Merit Review Panel Scores:**

Scoring Category	Average	Range
1) Effectiveness	7.1	5-9
2) Relevance	7.0	4-9
3) Overall Impression	7.1	5-9

**Merit Review Panel Comments:** Given the number and poor quality of some of the systems currently in the marketplace, benchmarking, creation of standards, and serving as a model for other test centers seem to form an excellent strategy. The technical accomplishments of this effort appear quite solid and correlate well with testing CRADAs for large wind turbines.

The Panel feels that the three objectives stated in the presentation (stabilizing the U.S. small wind turbine market, expanding the number of distributed wind turbines in the U.S., and increasing the public acceptance of wind turbine technology) are somewhat independent of one another. Additionally, it was unclear to the Panel how this project is being linked to the efforts toward achieving the *20% Wind Energy by 2030* scenario. The challenges arising from the range of environments in which distributed wind systems operate should be addressed in a manner similar to the operating environment challenges for utility-scale wind turbines. The Panel would also like to see increased dissemination of knowledge and results, especially to competitive sellers/installers of distributed wind systems.

The Panel feels the testing and evaluation of distributed wind turbines is essential in order to weed out a number of inferior products currently on the market. Certification of distributed wind turbines is necessary to protect consumers from inferior products and consequently to protect the reputation of wind energy of all sizes in the U.S.

Small Wind Technical Support & Collaboration (Trudy Forsyth – NREL)

This project fosters collaborations between industry, government agencies, and state and local governments; collaborations include the Small Wind Certification Council (SWCC) and NWTC industry partnerships with Endurance Wind Power, with Southwest Windpower, with Northern Power Systems, and with Forest City, Hawaii. The current budget for this project is \$550,000.

The collaboration with the Small Wind Certification Council (SWCC) is designed to certify that distributed wind turbines meet the requirements of the AWEA standard. Additionally, it is designed to verify and certify test results to the AWEA standard for the North American market.

The SWCC will work with the small wind industry, governments, and other stakeholders to develop and implement quality certification programs for distributed wind turbines. Certification is expected to commence in the latter part of 2008.

The NWTC collaboration with Endurance Wind Power will focus on the IEC-compliant testing of an S-250 wind turbine in order to obtain data regarding power performance, aeroacoustics, safety and function, and durability. The Southwest Windpower collaboration with the NWTC will test Skystream 3.7 wind turbines by developing and refining control software and obtaining data needed for certification to the IEC standard. The third NWTC industry collaboration with Northern Power Systems will develop a



Figure 12. Skystream 3.7 wind turbines

prototype NW100 wind turbine.

The DOE is collaborating with Forest City, Hawaii, to explore the potential for distributed wind systems as part of the larger Hawaii Clean Energy Initiative. NREL/NWTC is providing technical assistance to Forest City on distributed wind applications.

The current budget for the small wind technical support and collaboration work is \$550,000.

**Merit Review Panel Scores:**

Scoring Category	Average	Range
1) Effectiveness	7.0	6-8
2) Relevance	7.0	5-9
3) Overall Impression	7.3	5-9

**Merit Review Panel Comments:** The Panel feels that the certification work and the testing of generators represents a good use of public funds and a necessary function for improving the reliability of distributed wind systems, especially in light of identified quality issues.

The additional testing sites should provide a big boost to the small, distributed wind technology industry. The Panel also feels that the introduction of wind energy into schools is an excellent program.

According to the Panel, the presentation provided a quick summary of several activities, but it failed to provide a clear statement of the goals of the different areas of this effort or a correlation between those goals. The Panel feels that the collaborations with the SWCC, the NWTC, and industry are appropriate, but they question the value of the single turbine project in Forest City, Hawaii. The Panel would also like to see some measure or quantification of the impact that this effort will have on the growth of the wind industry in the U.S.

This collaboration effort answers some of the knowledge dissemination questions and addresses the need to build experiences and to conduct training regionally and locally. Efforts are in the early stages, and the Panel is looking forward to seeing how these efforts come together to produce the definitive resource for the distributed wind industry.

## **Advanced Concepts, Analysis, Design Tools Session – NREL Session**

### Session Overview

NREL researchers are investigating ways to mitigate system fatigue by gaining better control of the ways in which components interact and move. NREL conducts systems and controls research to increase energy capture and reduce structural loading at minimal cost. Conventional turbine component controls such as blade pitching, potential new components such as twist-coupled blades, and advanced devices such as micro-tabs are being examined. Researchers are also developing innovative hub control strategies to mitigate unwanted aerodynamic loads at the rotor hub and are investigating ways to improve design codes.

The role of the Advanced Concepts, Analysis, Design Tools activities is changing within the Program. Emphasis is shifting away from R&D and towards support for deployed systems. The shift results in broader recognition of systems issues and broader application of modeling tools in a larger systems context. Controls are an area of immediate focus, particularly given the need to optimize adaptive performance based on wind direction, speed, and location of the turbine within an array.

The total budget for the Advanced Concepts, Analysis and Design Tools work at the National Renewable Energy Laboratory (NREL) is \$3.123 million, or 16% of the Technology Viability budget. Table 4 below represents an itemized budget for the NREL Advanced Concepts, Analysis and Design Tools activities:

<b>Current Budget for NREL Advanced Concepts, Analysis, and Design Tools Activities</b>	
<b>Project</b>	<b>Funding</b>
Turbulence Characterization & Performance Impacts	\$1.05M
Advanced Rotor Technology Development <ul style="list-style-type: none"><li>- Mesoscale Modeling Initiative</li><li>- Aerodynamics, Aeroacoustics, Array Effects</li><li>- Adaptive Controls</li></ul>	\$1.4M
Design Tools and Codes	\$673K

**Table 4. Itemized Budget for NREL Advanced Concepts, Analysis and Design Tools Activities.**

### Turbulence Characterization & Performance Impacts (Neil Kelley, NREL)

The overall objective of this project is to apply modern, state-of-the-art observational and numerical simulation and predictive technologies to improve the assessment and prediction of the spatial distribution of the wind resource and the efficiency and reliability of wind farm operations. The current budget for the Turbulence Characterization and Performance Impacts work at NREL is \$1.05 million.

Prior to 2001, research focused on smaller wind turbines. Research in this area, active since 1989, has:

- Produced the first detailed measurements of the turbulence environment within a very large wind farm (1989)

- Resulted in some of the earliest detailed studies of the dynamics of turbulence interaction with a wind turbine (1990)
- Established the roll of atmospheric boundary layer dynamics on structural loads in wind turbines ranging from 65 kW to 600 kW turbines
- Received the DOE Wind Energy Program Outstanding Achievement Award (2003)

The focus of this project has shifted from distributed wind turbines to large wind turbines (1 MW and greater). The large wind turbine research effort recognized the potential impacts of the presence of low-level jets on the performance of large wind turbines operating in the Great Plains, and it developed the TurbSim inflow turbulence simulation code now used extensively throughout the world. This research effort has also received the DOE Wind Energy Program Outstanding Achievement Award.

As a result of the refocusing of the research, four project sub-elements have been established, each tied to a particular aspect of the overall project objective. The four sub-elements are 1) inflow simulation and turbine response, 2) remote sensing of wind resources' turbulence characteristics, 3) array performance and mesoscale effects, and 4) real-time, LIDAR/SODAR-based inflow characterization for turbine loads control. Figure 13 represents the percentage of funding allocated to the four project sub-elements.

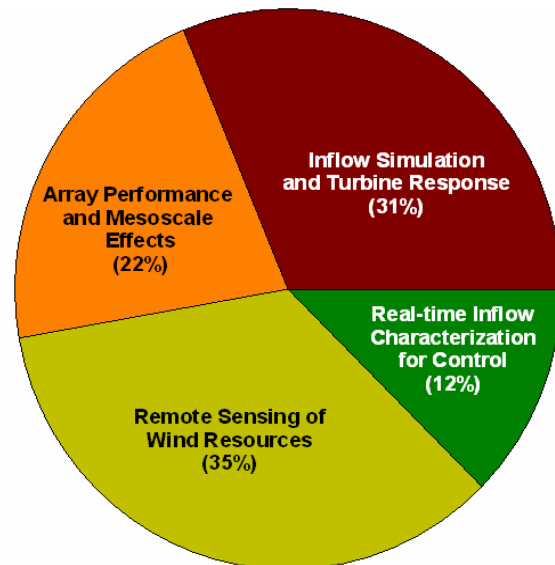

Figure 13. Percent of funding for Project Sub-elements

**Merit Review Panel Scores:**

Scoring Category	Average	Range
1) Effectiveness	7.0	6-9
2) Relevance	8.9	8-10
3) Overall Impression	7.9	7-9

**Merit Review Panel Comments:** The Panel feels that this work is essential and highly relevant to understanding turbine loading, reliability, and performance; it is also consistent with cost of energy (COE) reduction goals. The objective of this effort is very clearly stated and has a well-conceived linkage to the pressing issues of the *20% Wind Energy by 2030* scenario. The effort appears to be well-structured with logical and appropriate sub-elements. The four project sub-elements provide clear linkages from the models to measurements, design features, and challenges.

The presentation itself lacked an exciting and engaging discussion of the research. This project, as well as others, should think about visualization techniques in order to convey the value of these rich data sets. Utilities would be very interested in the wind forecasting research if the results were reliable. Education on applications would have to be provided in order for owners and operators to justify their budgets for the equipment. Most members of the utility industry do not have a background in SODAR or LIDAR.

The Panel finds it somewhat surprising that the turbulence topic has not merited a substantial research effort over the last twenty years. Therefore, it would be advantageous for the Program to give the issue some time and effort.

Mesoscale Modeling Initiative (Scott Schreck – NREL)

The Mesoscale Modeling Initiative was recently established to address problems associated with shortfalls in energy capture, excessive fatigue loads, and elevated cost of energy. In the winter of 2007, a Wind Resource Characterization Workshop was held to discuss reducing production shortfalls, attenuating fatigue loads, making accurate and reliable predictions, and understanding the fluid dynamics problem. The central topics of the workshop were turbine dynamics, micro-siting and array effects, mesoscale processes, and climate effects.

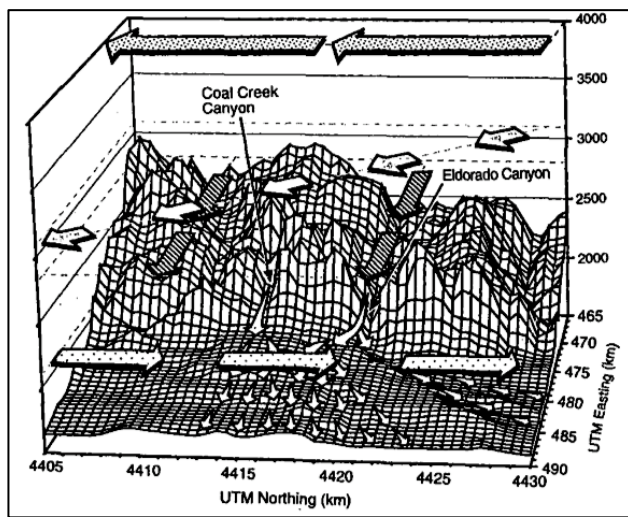

This initiative represents collaboration between the DOE Office of Energy Efficiency and Renewable Energy and the Office of Science. This initiative is a new program activity and is not yet a part of the current investment portfolio.

Future plans of the Mesoscale Modeling Initiative are to continue collaborating with the DOE Office of Science, to assemble and launch the initiative, and to adjust the budget to reflect the scale of the problem and the potential benefits of a solution.

Figure 14. Mesoscale modeling of airflow over complex terrain

**Merit Review Panel Scores:**

Scoring Category	Average	Range
1) Effectiveness	7.8	6-8
2) Relevance	8.9	8-10
3) Overall Impression	8.3	7-9

**Merit Review Panel Comments:** This is an entirely new initiative. The problem statement reflects the overall challenges facing the wind industry, including shortfalls in energy capture, excessive fatigue loads, and elevated COE. These problems are difficult to address but are worth the effort in order to prevent errors that may harm the financial future of wind generation due to poor performance on a large scale. The Panel feels a significant investment should be made to solve those problems.

The Wind Resource Characterization Workshop appears to have been well framed and implemented. However, there is a need for better definition of the rationale and the details for each topic area. Additionally, the Panel recommends that the climate effects efforts focus on misinformation in media.

The Panel feels that this initiative is a great topic that deserves public funding. According to the Panel, this initiative should be supported by boosting the team size, level of effort,

and industry participation. Once up to speed, the analytic platform will have an extremely broad and valuable application. A “super model,” or well-integrated suite, is far away. However, aggregating the inputs and making them widely available, as the individual models of differing scale and scope are linked together, will still be of great value to the industry.

Aerodynamics, Aeroacoustics, Array Effects (Patrick Moriarty – NREL)

This project is organized into three main focus areas: Aerodynamics, Aeroacoustics, and Array Effects. The budget for this project is included in the \$1.4 million allocated towards Advanced Rotor Technology Development.

The goal of the Aerodynamics activities is to improve the understanding of blade aerodynamics. The project intends to create more efficient blade designs that will improve energy capture. Areas of reliability are also being addressed, with a goal of better understanding load productions. Reducing the uncertainty of the model is the criterion for success in this work. The challenges facing this project are addressing the need to use more sophisticated computational fluid dynamics (CFD) models and obtaining reliable data.

The goal of the Aeroacoustics work is to reduce wind turbine noise. The projected performance impacts are a 15% increase in tip speed, a 5-7% COE reduction, and a 3 decibel (dB) decrease in sound emission. The criterion for success for this area of the project is a 3dB reduction in turbine noise. Data issues present the biggest challenge to the Aeroacoustics work.



**Figure 15. Acoustic array measurement of GE turbine (Oerlemans 2005)**

The goal of the Array Effects activities is to improve the understanding of wind turbine interactions within wind farms and of wind farm interactions with the atmosphere. The projected performance impacts from this work are the development of a 400MW wind farm with a COE of \$0.05/kWh, a 10% underproduction (common), and a lifetime cost of \$130 million. Reducing the uncertainty of the model is the criterion for success in this work. Some challenges facing Array Effects activities include the expense of large-scale experiments, the inaccuracy of current models, the lack of sophisticated computational fluid dynamics models, and the dearth of sufficiently reliable data.

Aerodynamics, Aeroacoustics, and Array Effects are synergistic. Future activities will focus on utilizing higher-fidelity computational fluid dynamics models, validating additional data, and increasing industry demand. Additional resources - including increased funding levels - are required in order to satisfy and increase future demand.

**Merit Review Panel Scores:**

Scoring Category	Average	Range
1) Effectiveness	7.6	7-9
2) Relevance	8.6	7-10
3) Overall Impression	7.9	7-9

**Merit Review Panel Comments:** It is clear that continued advanced work on aerodynamics of blades and turbines, including their interactions within wind farms, is a key research area for the Program to address. The increases in efficiency and relative impact on economic operation are important to the wind industry. The complexity of the problem and the cost of research will probably limit results unless more industry funding is contributed to the research efforts.

The presentation provided an effective statement of the goals and objectives of each of the three program activities. The presentation also showed the relationship of those areas to the major challenges facing the wind industry. It provided a clear statement of the impact that increased tip speed coupled with decreased noise can have on the COE for wind. This is an area of apparent importance to the goals of the Program as well as to industry. However, the problems are being addressed with insufficient resources and funding.

While this presentation was exceptional and had some good information pertaining to partnerships with industry and other National Laboratories, the Panel felt it lacked an exploratory punch. The Panel would like to see this effort, along with the SNL sister effort, place more emphasis in “high risk/high reward” design and analytic goals.

Adaptive Controls (Alan Wright – NREL)

The goals and objectives of the Adaptive Control project at NREL are to 1) develop advanced control strategies to mitigate loads and limit deflections on large commercial wind turbine structures, 2) develop control design and modeling tools for industry, and 3) apply controls to commercial machines. This project is important to the Program’s efforts to improve turbine reliability and reduce the COE of wind. The budget for this project is included in the \$1.4 million allocated towards Advanced Rotor Technology Development.

The University of Colorado, The Colorado School of Mines, and NREL are collaborating to develop and evaluate combined feedforward and feedback controls for turbulence-induced fatigue load mitigation. Feedforward controllers will be based on Doppler LIDAR measurements of turbulence statistics. The goal is to demonstrate that new controls lead to significantly less turbine loading. A future goal of this collaborative is to demonstrate advanced control performance through field testing on the 3-bladed Controls Advanced Research Turbine (CART3).

NREL is also collaborating with the University of Auckland (New Zealand), the University of Wyoming, and the UPWIND Project (pending further discussions) on issues of adaptive controls.

Future activities of the Adaptive Controls work at NREL are to continue advanced controls development and testing,

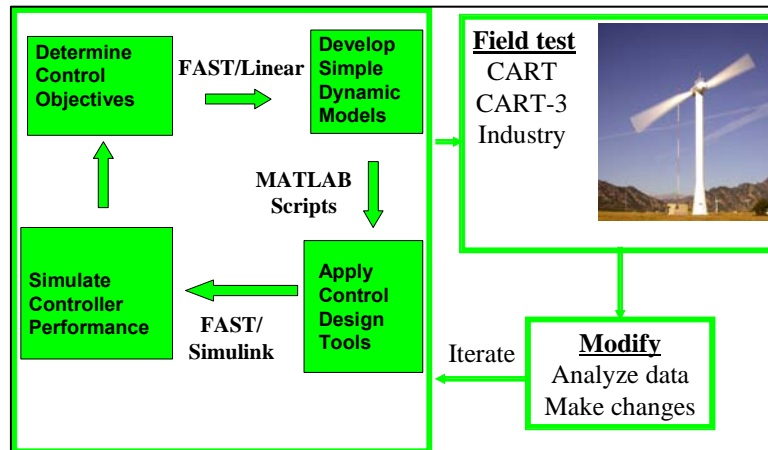

Figure 16. Control Design Process



to develop and test advanced independent blade pitch control with a look-ahead sensor, and to develop new field testing capabilities on a large flexible turbine through partnerships with industry.

**Merit Review Panel Scores:**

Scoring Category	Average	Range
1) Effectiveness	8.2	7-9
2) Relevance	8.7	8-9
3) Overall Impression	8.1	7-9

**Merit Review Panel Comments:** The efforts of this project focus on developing new control approaches to mitigate loads and deflections and to enhance energy capture. These control approaches will then be deployed in commercial turbines. Typical commercial turbine controls are very simple and are currently working quite well. However, the hope is to reduce loads and deflections, particularly in the context of the system-level turbulence and wind turbine arrays.

The presentation clearly states the goals and objectives of the effort and links them to the overall issues being addressed by the Program, especially the COE and fatigue loading. The research activities appear to have some potential promise for improvements. Many of the other R&D areas are examining turbine array level issues, but this project does not. However, the presenter agrees with the Panel that this is an area for future R&D. The Panel feels that some attention to controls at the turbine array level would seem to make sense given the emphasis on other technology elements.

Another important area of the adaptive controls research focuses on reducing turbine stress while maximizing energy capture. The Panel feels that a broader collaboration between NREL, SNL, and industry regarding what “best practices” are being conducted to explore more radical design and control concepts (including inflow sensing and advance warning) should be part of a robust strategy for future research and development.

A promising area of research associated with this project is independent blade pitch control. This is multi-objective control; enhancements to this control system can improve the blades’ energy capture and should be an important focus of future R&D efforts.

Design Tools and Codes (Jason Jonkman – NREL)

The objective of this project is to develop advanced design tools & codes to support the wind industry with state-of-the-art analysis capability. Codes provide a practical way of transferring wind energy research to the industry. Improved codes are needed to achieve COE goals and reliability objectives. The project supports industry by providing a website and technical support, soliciting user requirements, and facilitating various workshops. The current budget for this project is \$673,000.

The challenges facing the Design Tools and Codes project include limited funding and staff to support new users and add requested features and difficulties acquiring approval for

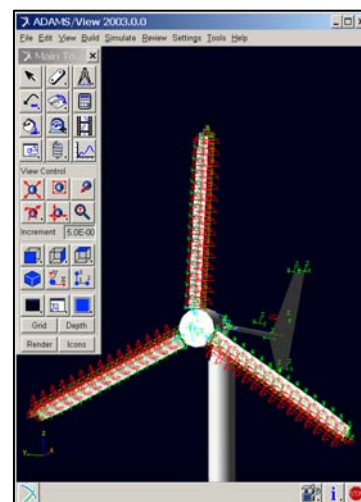

Figure 17. ADAMS Model Created by FAST

foreign travel.

Current and future work is aimed at improving code accuracy and supporting the analysis of the next generation of turbines.

**Merit Review Panel Scores:**

<b>Scoring Category</b>	<b>Average</b>	<b>Range</b>
<b>1) Effectiveness</b>	8.5	7-9
<b>2) Relevance</b>	8.6	7-10
<b>3) Overall Impression</b>	8.7	7-9

**Merit Review Panel Comments:** The DOE’s development, dissemination, and support for integrated design codes are exceptionally advanced for both industry and scientific communities, especially where they help refine design standards. Industry and academic use of the codes, both in the U.S. and abroad, also seems very valuable. Overall, the Panel feels that the technology transfer capability and extent of the codes is impressive and that this project represents an appropriate use of public funds.

The Panel recommends establishing high-level technical objectives that are stated clearly and used to guide and explain specific aspects of the effort. The Panel would also like to see a more detailed strategic vision regarding manpower and partnerships as well as the cost per full-time employee (FTE) within each activity. The economic impact of being able to obtain many person-years of industry-vetted code would benefit manufacturers greatly.

Codes and their continuous incorporation of design developments are essential to improving the COE of wind. Publicly funded development of this effort is valuable because it assures open-source coding and provides access to academia and industry. Opportunities for industry contribution to funding may be appropriate.

**Advanced Concepts, Analysis, Design Tools – Sandia National Laboratories (SNL) Session**

Session Overview

SNL conducts applied wind energy research designed to increase the viability of wind technology by improving wind turbine performance and reliability and reducing the COE. By partnering with both universities and industry, SNL focuses on advancing the state of knowledge in the areas of materials, structurally efficient airfoil designs, active-flow aerodynamic control, and sensors. Researchers at SNL are currently investigating integrated blade designs where airfoil choice, blade platform, materials, manufacturing process, and embedded controls are all considered from a systems perspective. By collaborating with operators, developers, and manufacturers, SNL evaluates known reliability problems and develops tools and methods to anticipate and investigate future reliability issues. This work is a joint effort with NREL under the sponsorship of DOE.

The overall goals of the advanced concepts, analysis, and design tools work at SNL are to develop and implement innovations that address system loads, increase turbine efficiency, and increase energy capture. This work focuses on bringing new concepts forward to maturity for industry application.

These Advanced Concepts, Analysis, and Design Tools activities are divided into five areas:

- Materials and Manufacturing
- Advanced Manufacturing Initiative
- Design Tools & System Modeling
- Aerodynamic Tools & Aeroacoustics
- Innovative Concepts

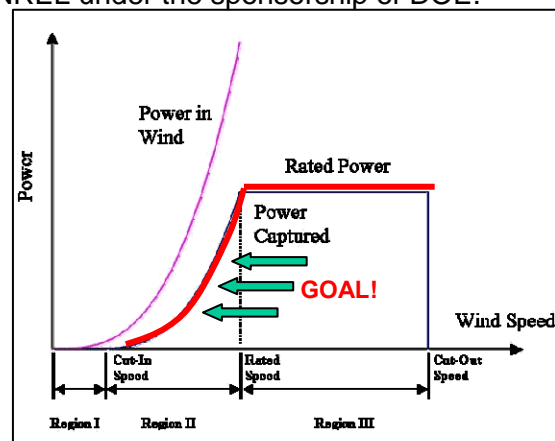

Figure 18. Wind Turbine Power Curve

The total budget for the Advanced Concepts, Analysis, and Design Tools activities at SNL is \$3.883 million. Table 5 below represents an itemized budget for these activities.

<b>Current Budget for SNL Advanced Concepts, Analysis, and Design Tools Activities</b>	
<b>Project</b>	<b>Funding</b>
Innovative Concepts	\$1.3M
Advanced Manufacturing Initiative	\$800K
Design Tools & System Modeling	\$665K
Materials & Manufacturing	\$650K
Aerodynamic Tools & Aeroacoustics	\$470K

**Table 5. Budget Breakdown for SNL Advanced Concepts, Analysis, and Design Tools Activities.**

Materials & Manufacturing (Tom Ashwill – SNL)

The goal of this task is to provide innovations in materials manufacturing that reduce the rate of weight growth occurring in larger blades as blade size increases, support existing technology through material characterizations and process improvements, and develop optimized sensors to enhance blade fatigue life, reliability, and load. The current budget for the Materials and Manufacturing activities at SNL is \$650,000.

This project uses industrial contracts to facilitate improvements in blade manufacturing. The areas of primary interest are manufacturing processes, advanced blade and sensor design, and overall quality enhancement. Current contract-supported work is demonstrating the advantages of using advanced materials (carbon and carbon/glass hybrids) and is exploring Resin Transfer Molding (RTM) and Vacuum-Assisted RTM

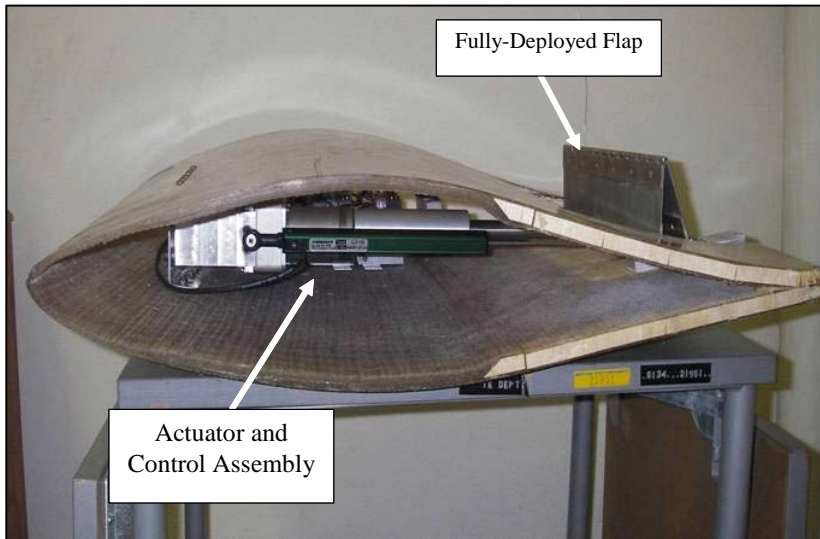

**Figure 19. Demonstration Hardware Integrated into 7.5m Wind Turbine Blade**

(VARTM) as manufacturing processes for utility-grade blades. This work also includes designing and fabricating advanced blades that incorporate innovations such as carbon/e-glass hybrid materials and aeroelastic tailoring as well as fabricating substructures and small blades to validate process developments and design modeling tools.

Future plans for the materials and

manufacturing work at SNL include:

- Continue advancements in manufacturing, materials, and sensor research
- Design, fabricate and test “Sensor Blade 2” to include sensors that measure inflow and angle-of-attack and provide structural health monitoring
- Combine sensing techniques and new control strategies with active load control into prototype substructures
- Support the new DOE/Turbine Manufacturers MOU by making advances in design, automation, and fabrication to reduce product variability and premature failure while increasing the domestic manufacturing base
- Publish a paper on blade coatings
- Develop conceptual composite blade joint designs
- Better understand lightning issues and reduce their effects on blades and turbine systems

**Merit Review Panel Scores:**

Scoring Category	Average	Range
1) Effectiveness	8.4	7-9
2) Relevance	8.7	7-10
3) Overall Impression	8.3	7-9

**Merit Review Panel Comments:** The Panel feels that this effort, especially with respect to blade design and performance, is of vital importance. Materials and manufacturing are areas in which government support for innovative concepts can have a large impact. The Panel believes that this project represents a worthwhile investment of public funds and is vital for improving reliability and reducing COE. The effort has been very productive to date with a modest budget of only \$650,000 (about 1.5 FTE), which the Panel feels should be increased.

The presentation itself provided a good, clear statement of project objectives and approach, and it included a useful discussion of the ongoing efforts of the effort's individual sub-tasks. However, the work breakdown structure of the project should be stated more clearly, with each sub-task identified as part of the approach and then described individually with its contribution to the project's overall objectives.

This effort seems to be extremely effective. The Panel is interested to see how this group can springboard off the May 2008 workshop, via the aforementioned MOU, to build a strong industry alliance in which SNL conducts innovative research that companies cannot, while still maintaining good relationships with companies so that innovations can be commercialized quickly.

#### Advanced Manufacturing Initiative (Daniel Laird – SNL)

The objective of this initiative is to expand U.S.-based manufacturing and domestic suppliers to the wind industry. The Advanced Manufacturing Initiative (AMI) enables the *20% Wind Energy by 2030* scenario through close collaboration with industry. The criteria for success for this initiative differ for each individual project but are based on U.S. manufacturing competitiveness. This is a new project with activity scheduled to commence in August of 2008.

The initiative focuses on components with cost structures that favor U.S. manufacturing:

- Components with high transportation costs
- Components that are difficult/expensive to inventory
- Components that minimize turbine downtime for replacement parts (blades, gearboxes, generators, and towers)

The first project of this initiative highlights blades because they are labor intensive, incorporate high transportation costs, and comprise 20% of the turbine cost yet are responsible for 100% of its energy capture. Incremental improvements in blades yield large system benefits, and blades exhibit large component-to-component variability.

The Advanced Manufacturing Initiative is a three-party collaboration between the U.S. DOE/SNL, TPI Composites, and Iowa State University/Iowa Power Fund. The budget for this initiative is \$800,000, with \$100,000 for in-house efforts and \$700,000 for cost-share efforts.

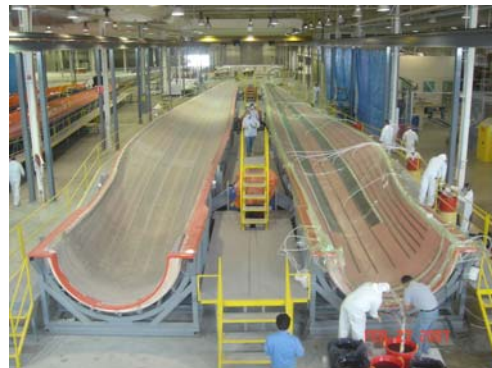

**Figure 20. Advanced Manufacturing Initiative - Blades**

**Merit Review Panel Scores:**

Scoring Category	Average	Range
1) Effectiveness	7.3	6-8
2) Relevance	8.5	7-10
3) Overall Impression	6.8	6-8

**Merit Review Panel Comments:** The Advanced Manufacturing Initiative is currently in the early phase of development, with activities scheduled to begin in August of 2008. The presentation provided a good discussion of the objectives of the project, including the key metric for success, namely improving the productivity of U.S. manufacturing. The information presented on the initiative would benefit from some additional information concerning the actual approaches being pursued in order to achieve the goal of 35% productivity improvement in blade manufacturing.

The initiative brings to light an interesting concept, but there are some current problems that are evident to the Panel, including receiving funding from the Iowa Power Fund for the blades project. Additionally, the Panel feels that the initiative lacks a detailed plan or roadmap for moving forward. SNL is currently putting together a roadmap with industry. However, they have not prepared a detailed plan for developing the AMI as a new project.

The panel would like to see broader industry collaboration. Better coordination is needed with states that have better manufacturing growth potential as indicated by the *20% Wind Energy by 2030* scenario. Michigan is one example of a state interested in manufacturing jobs that has a state office willing to assist in those efforts. Increased interaction with the Midwest Governors Association presents a good opportunity to expand the project. Presenting at the National Wind Coordinating Committee and Midwestern state wind meetings may also provide an avenue for promoting this initiative.

Design Tools & System Modeling (Daniel Laird – SNL)

The objectives of this project are to develop computational tools that enable technological advancements for industry and research institutions and to perform system modeling to support various Program research goals. Cost reductions critical to the Program’s *20% Wind Energy by 2030* scenario can only be achieved through improved design tools. The FY 2008 budget for the design tools and system modeling activities is \$665,000, of which \$420,000 is allocated for in-house efforts and \$245,000 towards contracts.

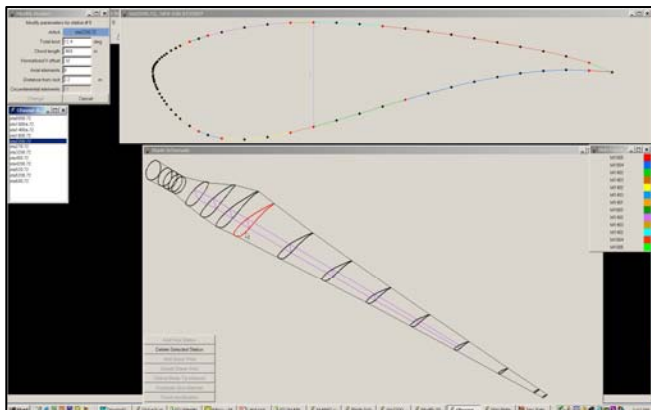

These analytical capabilities may be used to guide the design of new blades as well as validate/improve the design of existing blades. The validity of these tools is being demonstrated through a university collaboration that is developing a comprehensive validation program including design, analysis, fabrication, and testing.

**Figure 21. NuMAD - Structural Flexibility/Expandability Analysis**

The criterion for success is to design tools utilized by industry, academia, and research labs. The success of these research activities will inherently depend on system modeling. One challenge facing this project is adapting tools to the changing requirements of industry.

Future plans for the Design Tools effort are to complete the NuMAD upgrade/documentation and to continue the integration of design tools. Future system modeling activities will focus on continued support for internal research efforts pertaining to innovative blades, smart rotor development, and flutter.

**Merit Review Panel Scores:**

Scoring Category	Average	Range
1) Effectiveness	7.6	7-8
2) Relevance	8.0	7-9
3) Overall Impression	7.6	6-8

**Merit Review Panel Comments:** The Panel feels this is another great topic that links innovative fundamental design to the practical science of structural design and manufacturing. It is understandable that corporate intellectual property issues may arise when looking at specific aspects of the integrated design process. This is an area where interaction with industry, either formal or informal, should occur at a much higher level. One idea suggested by the Panel would be to have a much bigger “open door/open house” strategy, presenting members of the industry with opportunities to be included in this process. Two questions raised by the panel are 1) who at the labs and in academia will be learning how to use these tools, and 2) who will be hiring the people once they know how to use the tools?

The presentation provided a clear statement of the objectives of the project, but it would benefit from a more in-depth description of how top-level objectives connect to lower-level sub-tasks or individual projects. Additionally, the Panel feels that further coordination between SNL and NREL activities would be constructive and beneficial to future project success.

Aerodynamic Tools & Aeroacoustics (Dale Berg – SNL)

The objective of this effort is to create wind turbine blades that have better overall aerodynamic performance, less load transfer to the full system, and reduced noise effects through the use of improved aerodynamic and aeroacoustic modeling. This will enable industry to predict more accurately performance and loads, develop the ability to accurately predict noise generation, increase tip speed and decrease torque and cost, as well as, address industry concerns about the flatback concept.

The current budget for the aerodynamic tools and aeroacoustics work at SNL is \$470,000, with \$400,000 allotted for in-house efforts and \$70,000 for contracts.

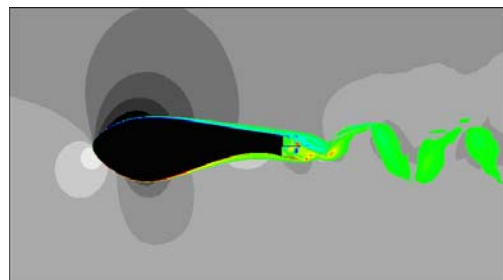

Figure 22. Flatback airfoil with splitter plate

Future plans of this work:

- Test additional flatback trailing edge treatments at Virginia Polytechnic Institute (VPI)
- Complete data reduction and publish VPI test results
- Continue funding the Pennsylvania State University to develop acoustic wind turbine production and propagation code
- Develop a plan to better utilize computational fluid dynamics tools in wind turbine performance and loads calculations
- Continue funding the University of California - Davis to investigate flow in the hub region of rotor

**Merit Review Panel Scores:**

Scoring Category	Average	Range
1) Effectiveness	8.2	7-9
2) Relevance	8.7	7-10
3) Overall Impression	8.0	6-9

**Merit Review Panel Comments:** Panel members recall being very impressed by the WindPACT flat-back airfoil research of two years ago, and they are pleased to see it move forward, although at a somewhat slow pace. The presentation highlighted the benchmarking of wind tunnel test simulations, which is essential to these efforts. As with most of these efforts, the budget and number of full-time employees are far lower than warranted, especially considering the potential impact of this work. The Panel feels that the low funding levels contribute to low industry interaction and university participation.

The presentation itself provided a clear statement of objectives for this project. However, it could be improved by including some technical content, as well as the programmatic statement regarding blade improvement. A more detailed explanation of the linkages between specific sub-tasks and the overall objective of the project would be useful. The excellent presentation of recent technical results vis-à-vis the integration of modeling and test results for the flat-back blade provided a good illustration of the effectiveness of the work.

The aerodynamic tools and aeroacoustics work at SNL applies research to new designs with a very quick market acceptance. This project is a good link from the laboratory to industry and illustrates exceptional value from the results of the research.

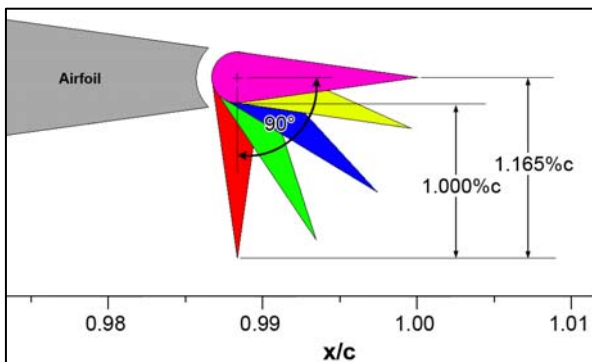

**Figure 23. Micro-flap concept**



Innovative Concepts (Dale Berg – SNL)

The goal of this project is to create wind turbine blades that can capture additional energy with no increase in fatigue loads through the use of active aerodynamic load control devices. This project will benefit industry by designing lighter and longer blades and will reduce the COE for wind. The current budget for this activity is \$1.3 million, with \$1.2 million allocated towards in-house efforts and \$100,000 towards contracts.

Future activities related to the Innovative Concepts effort will focus on complete COE analysis, developing an active aero control algorithm for wind tunnel testing, and performing a University of California - Davis wind tunnel test of active aero blades. Additional future activities include developing an active aero control algorithm for small rotors, developing prototype device actuators, performing a small-scale field test of an active aero rotor, and performing an intermediate-scale field test of an active aero rotor.

**Merit Review Panel Scores:**

<b>Scoring Category</b>	<b>Average</b>	<b>Range</b>
<b>1) Effectiveness</b>	7.5	7-8
<b>2) Relevance</b>	8.5	7-9
<b>3) Overall Impression</b>	7.8	7-9

**Merit Review Panel Comments:** The Panel feels that this research effort - exploring potential loads management - is worthwhile to the success of new technology adoption by the industry. The active aerodynamic controls present a potential way to achieve the stated goals of lighter blades, longer blades, and lower costs of energy. The interactions between these ideas and the adaptive controls and turbulence-related research should have been discussed in more detail. Panel members suspect that the large funding level for this project is inconsistent with the level of effort, especially relative to the funding levels of other Program R&D areas.

The presentation had several strengths and several weaknesses. For example, the statement of industry impacts could have been better framed. The statement of the objective was based solely on blades and excluded the overall wind system. Additionally, statements of the overall technical approach to this project and a clear statement of project outcomes were needed.

Given the radical nature of some of these concepts, the Panel prefers to see evidence of discussion with the National Aeronautical Space Administration (NASA) regarding their radical design concepts on materials and controls.

Load management activities are tremendously important to the Program, and this effort appears quite promising. However, goals and objectives need to be stated more strategically and in clearer, systems-level terms. The Panel also recommends that SNL develop a strategy for increasing industry interaction and participation.

## Industry Testing Support

### Session Overview

The industry testing and support activities at NREL and SNL are driven by industry needs. These efforts focus on supporting U.S. deployment goals, and they provide capabilities that industry cannot: investment in the development of new testing methodologies and procedures; independent, industry-wide, longer-term perspective; and consideration of input from a broad range of stakeholder groups. This Program area provides vital resources, both capital and staff, necessary to support evolving industry requirements. Additionally, these activities provide technical credibility, including leadership, to address industry-wide issues.

A comprehensive strategy to meet testing needs specific to wind energy technology includes building on already developed capabilities, such as specialized testing expertise, methodologies, equipment, and facilities; responding to operational needs by establishing quality and safety systems; and anticipating industry requirements in advance by innovating to support future needs.

The industry and testing support activities provide unbiased, third-party evaluations, which lead to improved acceptance of wind energy technology. These activities also support the transfer of successes, an innovative focus, and growing market needs.

The total budget for the industry testing and support activities at NREL and SNL is currently \$4.870 million. Table 6 below represents an itemized budget for individual activities.

<b>Current Budget for Industry Testing and Support Activities at NREL and SNL</b>	
<b>Project</b>	<b>Funding</b>
Large Blade Test Facilities CRADAs	\$2.81M
NREL Test Facilities	\$1.4M
Sandia and U.S.DA Test Facilities	\$660K

**Table 6. Budget Breakdown for Industry Testing and Support.**

### Large Blade Testing Facility (LBTF) CRADAs (Jason Cotrell – NREL)

The strategic objective of the LBTF CRADA is to expediently provide industry with needed commercial large blade testing capabilities with minimal queue and testing times at a



**Figure 24. Artist's depiction of Texas-NREL blade testing facility**

reasonable cost. Blade testing is essential to efforts for reducing risk, improving reliability, reducing blade costs, and meeting investor and certification requirements. Test method development is also a critical component to making testing methods faster, cheaper, and more accurate.

In 2006, NREL issued a solicitation for a LBTF CRADA opportunity for a public/private partnership to build a new blade test facility that met the following requirements: 1) 70+ meter blade test capacity; 2) two or more test stands; 3) located near a water port for easy transportation access; and 4) operating expenses recovered through user fees. In 2007, the University of Houston and the Massachusetts Technology Collaborative were selected as partners. Massachusetts provides access to East Coast manufacturers and offshore wind resources, while Texas provides access to primary shipping routes used by manufacturers and extensive land and offshore wind resources.

Future activities of the LBTF CRADA will emphasize the validation of existing testing methodologies to confirm that they are representative of field operating conditions, as well as collaborative research testing. The current budget for this effort is \$2.81 million.

**Merit Review Panel Scores:**

Scoring Category	Average	Range
1) Effectiveness	7.4	5-9
2) Relevance	8.8	7-10
3) Overall Impression	7.7	5-9

**Merit Review Panel Comments:** This was a lengthy, programmatic presentation of an activity that is moving the industry forward and developing next-generation testing capabilities. The Panel feels that this effort is a prudent use of public funds and is well aligned with the Program goals. The Panel did question the need for duplicate test facilities, and it wondered if DOE support of universities and national laboratories to create test facilities makes the most sense.

While somewhat administrative for the Panel’s taste, the presentation did bring up the very important staffing and expertise challenges facing NREL in order to assist with these project goals. These challenges, along with the status, timing, and need to perform innovative testing, should have been a major component of the presentation. The presentation did provide a clear statement of the objectives of the project. However, the presentation would have benefited from couching the project investment in terms of longer-term goals like the *20% Wind Energy by 2030* scenario, lowered costs, and improved product lifetime.

This endeavor has received a lot of industry participation. Companies want to be able to access the testing facility quickly to test their blades. There are challenges for NREL in supporting the LBTFs, including the development and testing of customer equipment in time as well as hiring and training new staff for the facilities. Further test method development is essential to achieve the goals of creating testing methods that are more accurate, efficient, and cost-effective. This effort, including research and testing, needs to be undertaken collaboratively with other National Laboratories.

NREL Test Facilities (Dave Simms – NREL)

The objective of this project is to provide specialized expertise, capabilities, equipment, and testing facilities specific to wind energy technology; full-scale field testing under diverse and extreme conditions; accredited testing to IEC standards; capabilities that industry cannot do themselves; and technical credibility. The current budget for this effort is \$1.4 million.



**Figure 25. Dynamometer testing**

Testing partnerships with manufacturers, developers, operators, and researchers helps minimize the risk of design and manufacturing flaws. These partnerships target reliability and performance issues, validate tools, tune models, evolve codes, and support new technology development.

One challenge or barrier to the success of this project is that rapid industry growth is currently outstripping National Wind

Technology Center (NWTC) test capabilities, particularly in regard to blades and drivetrains. Additional challenges or barriers to success are balancing the use of limited resources and prioritizing demands for limited available support.

Future plans of the NREL Test Facilities are to support:

- CRADAs for new large blade test facilities in Massachusetts and Texas, National Wind Technology Center utility-scale turbines, and remote partner test sites
- Innovate testing capabilities
- Large dynamometer testing
- The National Wind Energy Center

**Merit Review Panel Scores:**

Scoring Category	Average	Range
1) Effectiveness	8.7	7-10
2) Relevance	9.5	9-10
3) Overall Impression	8.8	7-10

**Merit Review Panel Comments:** This project is an essential investment needed to advance wind technology and to reduce the cost of energy. The Panel feels that this project is truly a foundation of the DOE Wind Program. The NREL test facilities effort involves a terrific breadth of technical expertise and specific capabilities for various types of testing.

The presentation itself provided a clear statement of the objectives of this project. Overall, the presentation could have been improved upon by better correlating the analytical/blade research and development efforts with the capabilities of the test facilities.

Testing is a required, specialized function that requires that NREL remain independent. Trying to support three challenges (current testing, new facilities in Massachusetts and Texas, and research and development efforts into new test methods) is very taxing on NREL. Given the existing resource and funding levels, the Panel feels that it will be difficult to achieve success in all of the project areas.

## System Performance and Blade Testing (Paul Veers – SNL)

The objectives of the SNL and the U.S. Department of Agriculture (USDA) system performance and blade testing program are to determine whether innovative blades have met their objectives in lab and field environments and to validate modeling tools. The program utilizes a three-step approach to achieve success. Those three steps are 1) developing the model tools, 2) using tools for innovative designs, and 3) testing the designs. The current budget for this effort is \$660,000, with \$450,000 allocated to SNL and \$210,000 allocated directly to the USDA.



Figure 26: Blade testing

This effort will provide industry with the results of the advanced blade concepts work, data for validation of blade and full system modeling codes, and development of next-generation blade designs and controls.

Future plans for the SNL and USDA testing facilities are to evaluate the advanced blades, to validate the modeling tool, and to support smart rotor development efforts.

### Merit Review Panel Scores:

Scoring Category	Average	Range
1) Effectiveness	8.8	8-10
2) Relevance	9.3	9-10
3) Overall Impression	9.2	9-10

**Merit Review Panel Comments:** The Panel feels strongly that having a testing facility with these capabilities in this country is essential to achieving the goals of the Wind Program. Leveraging non-wind aerodynamics research represents good management and demonstrates a worthy use of public funds. The presentation gave a very good review of how SNL links their modeling and design to testing (including schedule), and also covered the field testing of innovative blade designs and an overview of the West Texas USDA test facility.

The presentation provided a clear statement of the objectives of the project and a detailed summary of the approach being utilized to accomplish those objectives. The expected industry impact of this effort was well stated in the presentation. This work, particularly in verifying modeled blade performance under various loads, draws on the unique capabilities of SNL derived from past work for the nuclear weapons program.

Overall, the panel feels that this effort is critical to the success of the industry and illustrates an excellent use of public funds. The panel cannot stress enough how important it is to test, verify, modify, and better understand computational tools.

## Summary of Merit Review Panel Suggestions and Program Responses

As the Merit Review Panel points out, this is a critical time for the Department of Energy (DOE) Wind Program given the vision set forth in the *20% Wind Energy by 2030* report. To determine the path forward, the Department recently held two workshops in Washington, DC to identify the research, development, demonstration, and market transformation priorities necessary to achieve that vision. The first workshop, held on August 27-28, focused on the manufacturing activities needed to enable the wind industry to reach 300 GW of installed capacity by 2030. The workshop, which included over 80 participants from industry, government, and national laboratories, focused on advances in design, process automation, and fabrication techniques to reduce product variability and premature failure while increasing the domestic manufacturing base. The workshop also covered transportation and logistics, materials, policy issues, and workforce requirements. The second workshop, held on October 6-7, identified the most significant barriers to deployment of wind energy and the strategies to overcome them, as well as strategies to build a sustainable industry with broad stakeholder involvement. Over 150 participants focused on six major topics: land-based large wind turbine technologies, distributed wind technologies, grid system interconnection, environmental risks and siting strategies, market development and public policies, and offshore wind technologies and siting strategies.

The Program will incorporate the results of these workshops into a *National Wind Energy Roadmap*, an action plan that will drive the Wind Program's decisions regarding activities to be supported by DOE in the near-, mid- and long-term. These activities will be selected through competitive solicitations, the first of which will be issued in December 2008 or January 2009. Beginning in May or June of 2009, the Program will hold an annual merit review of its entire portfolio, evaluating existing projects on the basis of their contribution toward boosting U.S. wind power generation capacity to 300 gigawatts by 2030.

We thank the Merit Review Panel for their contribution to the Wind Program, and we look forward to partnering with industry, universities, national laboratories, Federal agencies and other stakeholders, to enable wind to play a major role in America's energy future.

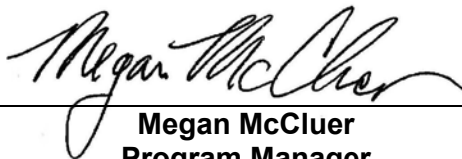

---

**Megan McCluer**  
**Program Manager**  
**U.S. DOE Wind Energy Program**

# **APPENDICES**

**Appendix A. Meeting Attendee List**

**Appendix B. Summary of Merit Review Panel Evaluation Scores**

**Appendix A: Meeting Attendee List**  
**2008 DOE Wind & Hydropower Program Merit review Meeting**  
**June 17-18, 2008**  
**Omni Interlocken Resort**  
**Golden, Colorado**

<b>Contact</b>	<b>Organization</b>	<b>E-mail</b>
Peter Ashley	U.S. Department of Energy	peter.ashley@hq.doe.gov
Tom Ashwill	Sandia National Laboratories	tdashwi@sandia.gov
Ian Baring-Gould	National Wind Technology Center	ian_baring-gould@nrel.gov
Lisa Barnett	U.S. Department of Energy	Lisa.Barnett@ee.doe.gov
Keith Bennett	U.S. Dept of Energy, Golden Field Office	keith.bennett@go.doe.gov
Dale Berg	Sandia National Laboratories	deberg@sandia.gov
Stacey Burge	National Renewable Energy Laboratory	stacey_burge@nrel.gov
Sandy Butterfield	National Renewable Energy Laboratory	sandy_butterfield@nrel.gov
Craig Christenson	Clipper Windpower, Inc.	cchristenson@clipperwind.com
Charlton Clark	Sentech Inc.	cclark@sentech.org
Stephen Connors	Massachusetts Institute of Technology	connorsr@mit.edu
Jason Cotrell	National Renewable Energy Laboratory	jason_cotrell@nrel.gov
Edgar DeMeo	Renewable Energy Consulting Services, Inc.	edemeo@earthlink.net
Phil Dougherty	U.S. Department of Energy	phil.dougherty@ee.doe.gov
Edward Eugeni	Sentech, Inc.	eeugeni@sentech.org
Lee Jay Fingersh	National Renewable Energy Laboratory	lee_fingersh@nrel.gov
Trudy Forsyth	National Renewable Energy Laboratory	trudy_forsyth@nrel.gov
Curtis Framel	U.S. Department of Energy	curtis.framel@go.doe.gov
Bobi Garrett	National Renewable Energy Laboratory	Bobi_garrett@nrel.gov
Peter Goldman	PRG Consulting	prgconsulting@comcast.net
Dan Hamai	Western Area Power Administration	ahamai@wapa.gov
Maureen Hand	National Renewable Energy Laboratory	maureen_hand@nrel.gov
Roger Hill	Sandia National Laboratories	rrhill@sandia.gov
Jason Jonkman	National Renewable Energy Laboratory/NWTC	jason_jonkman@nrel.gov
Kenneth Karas	Former CEO, Enron Wind Corp; and Zond Corp.	kenkaras@lightspeed.net
Mike Kelly	Horizon Wind Energy	mike.kelly@horizonwind.com
Daniel Laird	Sandia National Laboratories	dllaird@sandia.gov
Scott Lambert	National Renewable Energy Laboratory	scott_lambert@nrel.gov
Debra Lew	National Renewable Energy Laboratory	debra_lew@nrel.gov
Dennis Lin	U.S. Department of Energy	dennis.lin@ee.doe.gov
Steve Lindenberg	U.S. Department of Energy	steve.lindenberg@ee.doe.gov
Hal Link	National Renewable Energy Laboratory	hal_link@nrel.gov
John Mankins	Artemis Innovation	john.c.mankins@artemisinnovation
James McVeigh, Jr.	Sentech, Inc	jmcveigh@sentech.org
JoAnn Milliken	U.S. Department of Energy	joann.milliken@ee.doe.gov
Dale Osborn	Midwest Independent Systems Operator	dosborn@midwestiso.org
Andy Paliszewski	Siemens	andy.paliszewski@siemens.com
Al Pless	U.S. Department of Energy	alp@sepa.doe.gov
Roberts Poore	Global Energy Concepts	rpoore@globalenergyconcepts.com
Tim Ramsey	Navarro, U.S. Department of Energy	tim.ramsey@go.doe.gov
Mike Robinson	National Renewable Energy Laboratory	mike_robinson@nrel.gov



<b>Contact</b>	<b>Organization</b>	<b>E-mail</b>
Drew Ronneberg	U.S. Department of Energy	drew.ronneberg@ee.doe.gov
Scott Schreck	National Renewable Energy Laboratory	scott_schreck@nrel.gov
Bary Seifert	Idaho National Laboratory	gary.seifert@inl.gov
Dave Simms	National Renewable Energy Laboratory	david_simms@nrel.gov
Joe Slamm	Hudson Capital Management	joseph.slamm@hudsoncep.com
James Smith	Utility Wind Integration Group	jcharlessmith@comcast.net
Brian Smith	National Renewable Energy Laboratory	brian_smith@nrel.gov
Brennan Smith	Oak Ridge National Laboratory	smithbt@ornl.gov
Suzanne Tegen	National Renewable Energy Laboratory	suzanne_tegen@nrel.gov
Robert Thresher	National Renewable Energy Laboratory	robert_thresher@nrel.gov
Paul Veers	Sandia National Laboratories	psveers@sandia.gov
Carl Weinberg	Weinberg Associates	poppacarl@aol.com
Mary Wheeler	National Renewable Energy Laboratory	Mary_Wheeler@nrel.gov
Robert Whitson	Sentech, Inc.	rwhitson@sentech.org
Jose Zayas	Sandia National Laboratories	jrzasayas@sandia.gov

## Appendix B: Summary of Merit Review Panel Evaluation Scores

### Merit reviewer Project/Program Evaluation Form Scores

<b>Numerical Scoring Index</b>	1	2	3	4	5	6	7	8	9	10	
<b>Qualitative Descriptors</b>	Seriously Deficient			Average				Outstanding			

<b>Scoring Category \ Projects</b>	Gearbox Collaborative	Certification & Standards (NREL)	Reliability Collaboration & System Analysis	Certification and Standards (SNL)	NWTC Utility Scale Turbines	NWTC and SNL Technology Development Partnerships	Independent Testing & Certifications	Small Wind Technical Support & Collaboration	Turbulence Characterization & Performance Impacts	Mesoscale Modeling Initiative
<b>1) Effectiveness</b> (consider the elements of quality, productivity, and accomplishments)	8.3	8.7	6.8	7.8	8.0	7.8	7.1	7.0	7.0	7.8
<b>2) Relevance</b> (to mission, goals, strategy, and technical and/or market barriers)	9.6	9.4	8.7	8.3	7.0	7.3	7.0	7.3	8.9	8.9
<b>3) Overall Impression</b> (consider all measures, inputs and outputs, and program management)	8.7	8.7	7.7	8.0	7.2	7.7	7.1	7.3	7.9	8.3
<b>Average Category Score</b>	8.9	9.0	7.7	8.0	7.4	7.6	7.1	7.2	7.9	8.3

**Merit reviewer Project/Program Evaluation Form Scores**

<b>Scoring Category \ Projects</b>	Aerodynamics, Aeroacoustic, Array Effects	Adaptive Controls	Design Tools and Codes (Riseo MOU)	Materials and Manufacturing	Advanced Manufacturing Initiative	Design Tools and System Modeling	Aerodynamic Tools & Aeroacoustics	Innovative Concepts	LBTF CRADAs	NREL Test Facilities	Sandia & U.S.D.A. Test Facilities
<b>1) Effectiveness</b> (consider the elements of quality, productivity, and accomplishments)	7.6	8.2	8.5	8.4	7.3	7.6	8.2	7.5	7.4	8.7	8.8
<b>2) Relevance</b> (to mission, goals, strategy, and technical and/or market barriers)	8.6	8.7	8.6	8.7	8.5	8.0	8.7	8.5	8.8	9.5	9.3
<b>3) Overall Impression</b> (consider all measures, inputs and outputs, and program management)	7.9	8.1	8.7	8.3	6.8	7.6	8.0	7.8	7.7	8.8	9.2
<b>Average Category Score</b>	8.0	8.3	8.6	8.5	7.5	7.7	8.3	7.9	8.0	9.0	9.1