

PLANS FOR
LAKE PONTCHARTRAIN, LOUISIANA AND VICINITY
HURRICANE PROTECTION
HIGH LEVEL PLAN
ORLEANS PARISH - JEFFERSON PARISH

FRONTING PROTECTION FOR
PUMPING STATION NO. 6 AT
17th STREET OUTFALL CANAL

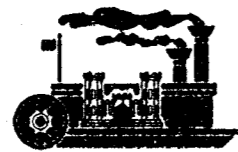

US Army Corps
of Engineers
New Orleans District
1997

DRAWINGS IN THIS FOLIO
HAVE BEEN REDUCED ONE
HALF THE ORIGINAL SCALE

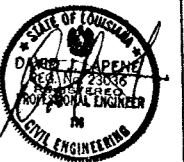

Safety is a Part of Your Contract

INDEX TO DRAWINGS

DWG	TITLE	DWG	TITLE
INDEX		MISCELLANEOUS DRAWINGS	
1-1	INDEX TO DRAWINGS	7-1	WALKWAY PLAN AND ELEVATIONS
MAPS, PLANS AND TYPICAL SECTIONS		7-2	WALKWAY AND HANDRAIL DETAILS
2-1	VICINITY MAP AND EXISTING SITE PLAN	7-3	GATE HOIST SUPPORT BEAM DETAILS
2-2	RIGHT-OF-WAY PLAN	7-4	GATE HOIST ANCHOR BOLT DETAILS
2-3	DEMOLITION PLAN	7-5	GRATING PLAN AND DETAILS
2-4	SITE PLAN	7-6	CATCH BASIN DETAILS
2-5	SLUICE GATE STRUCTURE LAYOUT @ EAST PUMPS	7-7	MISCELLANEOUS DETAILS
2-6	SLUICE GATE STRUCTURE LAYOUT @ WEST PUMPS	7-8	BULKHEAD SLOTS DETAILS
2-7	SLUICE GATE CROSS SECTIONS	7-9	BULKHEAD SEAL BEAM DETAILS
EARTHWORK - COFFERDAM, EXCAVATIONS AND CROSS SECTIONS		7-10	TYPICAL ROADWAY RESTORATION, GATE AND FENCE DETAILS
3-1	COFFERDAM PLAN	MECHANICAL	
3-2	ENLARGED COFFERDAM PLAN AND ELEVATION @ EAST MONOLITH	8-1	SLUICE GATE DETAILS
3-3	ENLARGED COFFERDAM PLAN AND ELEVATION @ WEST MONOLITH	8-2	BULKHEADS EAST MONOLITH
3-4	COFFERDAM DETAILS	8-3	BULKHEADS EAST MONOLITH
3-5	COFFERDAM @ WEST MONOLITH I	8-4	BULKHEADS EAST MONOLITH
3-6	EXCAVATION ELEVATIONS @ EAST MONOLITHS	8-5	BULKHEADS EAST MONOLITH
3-7	EXCAVATION ELEVATIONS @ WEST MONOLITHS	8-6	BULKHEADS WEST MONOLITH
3-8	EXCAVATION SECTIONS	8-7	BULKHEADS - EAST & WEST MONOLITH; MISCELLANEOUS DETAILS
3-9	CROSS SECTIONS	ELECTRICAL	
3-10	EXISTING I-WALL, RETAINING WALL, AND T-WALL SECTIONS	9-1	SYMBOL LEGEND, FIXTURE SCHEDULE, GENERAL NOTES
SOIL BORINGS		9-2	PARTIAL STATION ELECTRICAL PLAN
4-1	SOIL BORING PLAN	9-3	ELECTRICAL SITE PLAN
4-2	GEOLOGICAL PROFILE	9-4	COFFERDAM ELECTRICAL PLAN
4-3	SOIL BORING LEGEND AND NOTES COE AND EUSTIS	9-5	ENLARGED EAST SLUICE GATE PLAN AND SECTION
PILE FOUNDATIONS AND SHEET PILING		9-6	ENLARGED WEST SLUICE GATE PLAN AND SECTION
5-1	OVERALL PILE PLAN	9-7	TYPICAL ENLARGED COFFERDAM ELECTRICAL PLAN & ELEVATION
5-2	PILE LAYOUT	9-8	ELECTRICAL DETAILS
5-3	STEEL H-PILE DETAILS	9-9	PARTIAL ELECTRICAL ONE LINE DIAGRAM
5-4	COMPRESSION PILE TEST FRAME	9-10	CONTROL CONSOLE NO. 12 (N.O.S.&W.B. DWG.)
5-5	TENSION PILE TEST FRAME		
5-6	EAST MONOLITH SHEET PILE PLAN & DETAILS		
5-7	WEST MONOLITH I SHEET PILE PLAN & MISC. DETAILS		
STRUCTURAL CONCRETE			
6-1	GENERAL NOTES		
6-2	OVERALL STRUCTURAL PLAN		
6-3	CROSS SECTIONS @ EAST MONOLITH		
6-4	EAST MONOLITH BASE SLAB PLAN		
6-5	EAST MONOLITH BASE SLAB REINFORCEMENT		
6-6	EAST MONOLITH INTERMEDIATE PLAN		
6-7	EAST MONOLITH TOP PLAN		
6-8	EAST MONOLITH DETAILS		
6-9	EAST MONOLITH DETAILS		
6-10	EAST MONOLITH DETAILS		
6-11	CROSS SECTIONS @ WEST MONOLITHS		
6-12	STRUCTURAL PLANS @ WEST MONOLITHS		
6-13	WEST MONOLITHS BASE SLAB REINFORCEMENT		
6-14	WEST MONOLITH DETAILS		
6-15	WEST MONOLITH DETAILS		
6-16	I-WALL AND RETAINING WALL DETAILS		
6-17	JOINT DETAILS EAST MONOLITH		
6-18	JOINT DETAILS WEST MONOLITH		

ABBREVIATIONS

ALT. SP.	=	ALTERNATE SPACING
AZ	=	AZIMUTH
B/L	=	BASELINE
BF	=	BOTTOM FACE
BL	=	BOTTOM LAYER
C	=	CENTER
CB	=	CATCH BASIN
C.I.	=	CAST IRON
CJ	=	CONSTRUCTION JOINT
CL	=	CLEAR COVER
C/L OR C	=	CENTER LINE
C.R.S.	=	CORROSION RESISTANT STEEL
Ø	=	DIAMETER
D	=	DRAIN
D.I.	=	DROP INLET
D.P.	=	DRAIN PIPE
D/S	=	DOWN STREAM
D.V.	=	DRAIN VALVE
D.V. MH.	=	DRAIN VALVE MANHOLE
E	=	ELECTRICAL
EF	=	EACH FACE
EL.	=	ELEVATION
ES	=	EQUALLY SPACED
F.H.	=	FIRE HYDRANT
FF	=	FAR FACE
G	=	GAS
H.S.	=	HIGH STRENGTH
LP	=	LIGHT POLE
LS	=	LIGHT STANDARD
MH	=	MANHOLE
NF	=	NEAR FACE
O.C.	=	ON CENTER
OPT.	=	OPTIONAL
P	=	POWER
P.C.	=	POINT OF CURVATURE
P.T.	=	POINT OF TANGENCY
S	=	SEWER
SB/L	=	SUBBASELINE
S.C.O.	=	SEWER CLEANOUT
STD. HK.	=	STANDARD HOOK
STA.	=	STATION
T	=	TELEPHONE
TD	=	TRENCH DRAIN
TF	=	TOP FACE
TEL.M.H.	=	TELEPHONE MANHOLE
TL	=	TOP LAYER
TP	=	TEST PILE
U/S	=	UP STREAM
W	=	WATER
W/L	=	WALL LINE
W.M.	=	WATER METER
W.V.	=	WATER VALVE

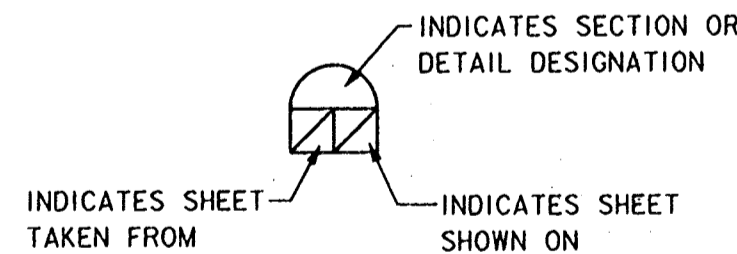

NOTE:
THIS PROJECT WAS DESIGNED BY THE FIRM OF URS CONSULTANTS, INC. FOR THE NEW ORLEANS DISTRICT OF U.S. ARMY CORPS OF ENGINEERS. THE INITIALS OR SIGNATURES & REGISTRATIONS DESIGNATIONS OF GOVERNMENT EMPLOYEES APPEARING ON THESE PROJECT DOCUMENTS ARE WITHIN THE SCOPE OF THEIR EMPLOYMENT AS REQUIRED BY ER 1110-1-8152.



SYMBOL	DESCRIPTION	DATE	APPROVED
REVISIONS			
U.S. ARMY ENGINEER DISTRICT, NEW ORLEANS CORPS OF ENGINEERS NEW ORLEANS, LOUISIANA			
URS CONSULTANTS, INC. LAKE PONTCHARTRAIN, LA. AND VICINITY HURRICANE PROTECTION HIGH LEVEL PLAN FRONTING PROTECTION AT PUMP STATION #8 ORLEANS PARISH - JEFFERSON PARISH 17th STREET OUTFALL CANAL (METAIRIE RELIEF)			
INDEX TO DRAWINGS			
DESIGNED BY: S.C.B.	SOLICITATION NO. DACW29-98-B-0112	CADD FILE: P58-1-01.DWG	
DRAWN BY: B.N.M.	APPROVED BY: [Signature]	PLOT DATE: SEPT. 1997	PLOT SCALE: 1
CHECKED BY: M.D.P.	DATE: SEPT. 1997	FILE NO. H-4-44654	
DATE: SEPT. 1997	APPROVED BY: [Signature]	DWG. 1-1 OF 1-1	



Safety is a Part of Your Contract

TABULATION OF BENCH MARK

BENCH MARKS	ELEV.	DETAIL DESCRIPTION
(TBM) P.S.NO. 6	14.32 NGVD 1983 EP.	AT METAIRIE, ABOUT 0.5 MILES NORTH OF THE INTERSECTION OF METAIRIE ROAD AND ORPHEUM AVENUE AT PUMP STATION NO. 6 ON THE FLOODWALL OVER THE CENTER TUBE OF THE WESTERN MOST DISCHARGE TUBES IS SET ON AN ALUMINUM HUB LOCATED APPROXIMATELY 175' N.E. OF THE N.W. CORNER OF THE PUMP STATION BUILDING AND 80' EAST OF THE INTERSECTION OF THE CURVED FLOODWALL AND DISCHARGE TUBE FLOODWALL.

LEGEND

- OVERHEAD POWER LINE
- FENCE

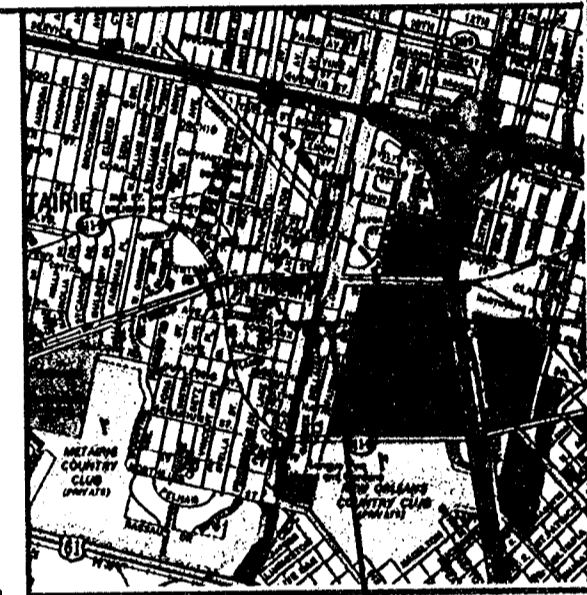
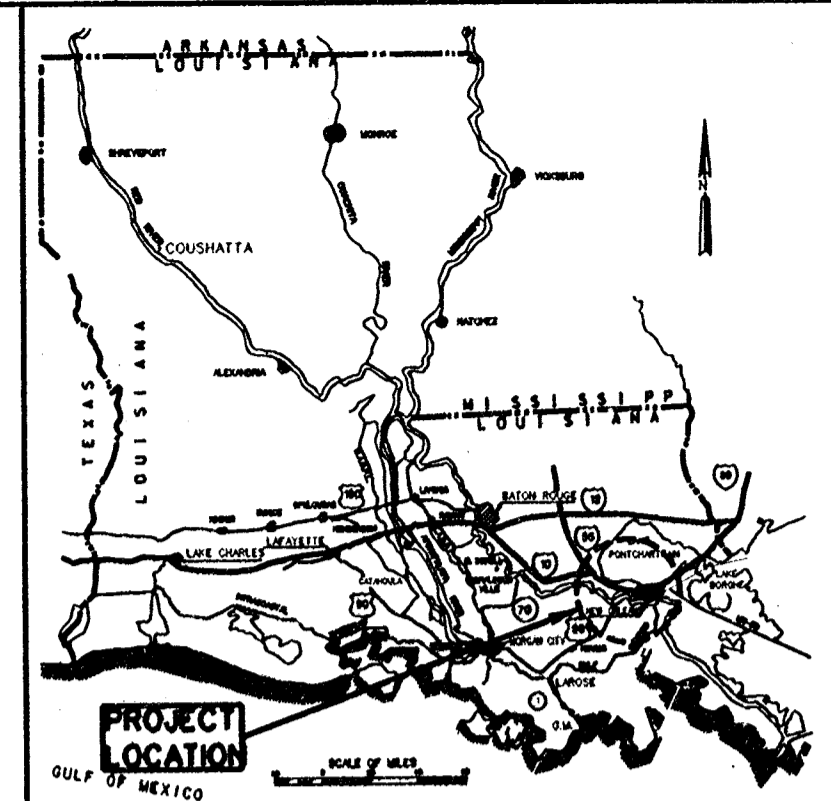
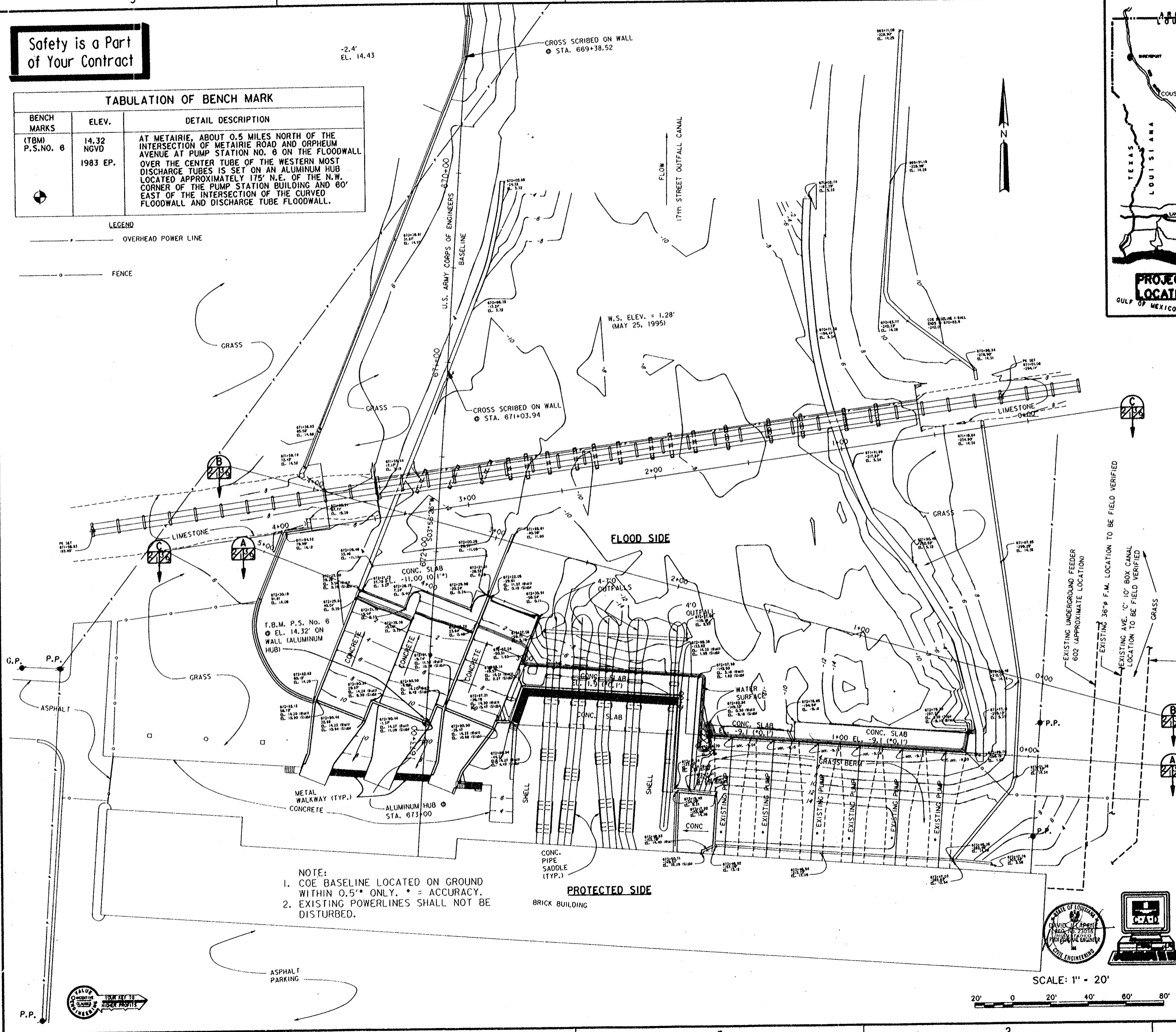

VICINITY MAP
N.T.S.

NOTE:
1. COE BASELINE LOCATED ON GROUND WITHIN 0.5' ONLY. * = ACCURACY.
2. EXISTING POWERLINES SHALL NOT BE DISTURBED.



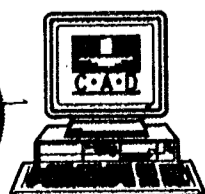
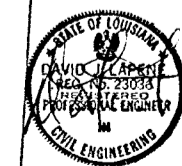

SYMBOL	DESCRIPTION	DATE	APPROVED
REVISIONS			
U.S. ARMY ENGINEER DISTRICT, NEW ORLEANS CORPS OF ENGINEERS NEW ORLEANS, LOUISIANA			
URS CONSULTANTS, INC. LAKE PONTCHARTRAIN, LA. AND VICINITY HURRICANE PROTECTION HIGH LEVEL PLAN FRONTING PROTECTION AT PUMP STATION #6 ORLEANS PARISH - JEFFERSON PARISH 17TH STREET OUTFALL CANAL (METAIRIE RELIEF)			
VICINITY MAP AND EXISTING SITE PLAN			
DESIGNED BY: S.C.B.	DATE: SEPT. 1997	PLOT SCALE: 20	PLOT DATE: SEPT. 1997
DRAWN BY: B.D.	CADD FILE: P58-2-01.DGN	FILE NO. H-4-44654	
CHECKED BY: M.O.P.	SUBMITTED BY: DACW29-98-B-0112	DESIGN ENGINEER	DWG. 2-1 OF 2-7

SCALE: 1" = 20'

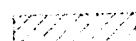

**Safety is a Part
of Your Contract**

LEGEND

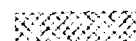
-  LIMITS OF CONSTRUCTION
-  CONSTRUCTION STAGING AREAS
-  PERMANENT EASEMENT FROM RAILROAD
-  TEMPORARY EASEMENT FROM RAILROAD
-  TEMPORARY EASEMENT

GENERAL NOTES:

1. AZIMUTHS ARE MEASURED FROM NORTH.
2. THE CONTRACTOR SHALL COORDINATE WITH "NORFOLK SOUTHERN RAILROAD (R/R)" WHILE WORKING OR ACCESSING IN THE TEMPORARY EASEMENT AREAS WITHIN THE R/R'S RIGHT OF WAY, THROUGH THE CONTRACTING OFFICER.

NOTE:
CROSS SCRIBED ON WALL
@ STA. 869+38.52

SEWERAGE AND WATER BOARD
OF NEW ORLEANS

CROSS SCRIBED ON WALL
@ STA. 871+03.94

STA. 871+61.38 @
E RAILROAD BRIDGE

STA. 871+75.46

S87°50'11"E - 242.71'
AZ92°03'49"

STA. 673+00

STA. 674+95.31

STA. 674+56.91

STA. 678+01.76

STA. 678+01.91

STA. 674+56.91

STA. 674+56.91

STA. 674+56.91

STA. 674+56.91

STA. 674+56.91

STA. 674+56.91

STA. 674+56.91

STA. 674+56.91

STA. 674+56.91

STA. 674+56.91

STA. 674+56.91

NOTE:
CONTRACTOR SHALL NOT DISTURB CATCH BASINS.
ADDITIONALLY, HE SHALL PLACE AND MAINTAIN HAY
BALES AT TOP STRUCTURES DURING CONSTRUCTION
TO PREVENT DEBRIS FROM ENTERING THESE BASINS.

SCALE: 1" = 20'

20' 0 20' 40' 60' 80'

ITEM	DESCRIPTION	OWNER	DISPOSITION
P1.	OVERHEAD POWER LINE 80'(1) HIGH (VERIFY)	N.O.P.S.I.	NOT TO BE DISTURBED
P2.	OVERHEAD POWER LINE 30'(1) HIGH (VERIFY)	N.O.P.S.I.	NOT TO BE DISTURBED
P3.	UNDERGROUND FEEDER	N.O.P.S.I.	NOT TO BE DISTURBED
U1.	BOX CANAL	N.O.S.&W.B.	NOT TO BE DISTURBED
D2.	30" FORCE MAIN	N.O.S.&W.B.	NOT TO BE DISTURBED
D3.	30" FORCE MAIN	N.O.S.&W.B.	NOT TO BE DISTURBED
D4.	CATCH BASIN	N.O.S.&W.B.	NOT TO BE DISTURBED
F1.	CHAIN LINK FENCE	N.O.S.&W.B.	TO BE REMOVED & REPLACED IN-KIND AS REQ'D. FOR CONSTR. SEE DWG. 7-10 FOR REPLACEMENT DETAILS.
P.P.	POWER POLE	N.O.S.&W.B.	NOT TO BE DISTURBED
G.P.	GUIDE POLE	N.O.S.&W.B.	NOT TO BE DISTURBED

CHAIN LINK FENCING AND GATES.
CONTRACTOR SHALL REMOVE AND
REPLACE IN-KIND AS REQUIRED FOR
CONSTRUCTION; (TYP.) SEE DWG. 7-10
FOR REPLACEMENT DETAILS

CONSTRUCTION TRAILER
AND PARKING (145'x20')

U.S. ARMY ENGINEER DISTRICT, NEW ORLEANS
CORPS OF ENGINEERS
NEW ORLEANS, LOUISIANA

URS CONSULTANTS, INC.

LAKE POITCHARTRAIN, LA. AND VICINITY FLOOD PROTECTION
HIGH LEVEL PLAN

**FRONTING PROTECTION
AT PUMP STATION #6
ORLEANS PARISH - JEFFERSON PARISH
(7TH STREET OUTFALL CANAL
(DETAINIE RELIEF))**

**RIGHT OF WAY
PLAN**

DESIGNED BY: M.O.P.	DATE: SEPT. 1997	PLOT SCALE: 20	PLOT DATE: SEPT. 1997
DRAWN BY: L.A.O.	CHECKED BY: M.O.P.	PROJECT NO.: DACW29-98-B-0112	FILE NO.: H-4-44854
DATE: 09/12/97	SCALE: 1"=20'	DWG. 2-2 OF 2-7	

Safety is a Part of Your Contract

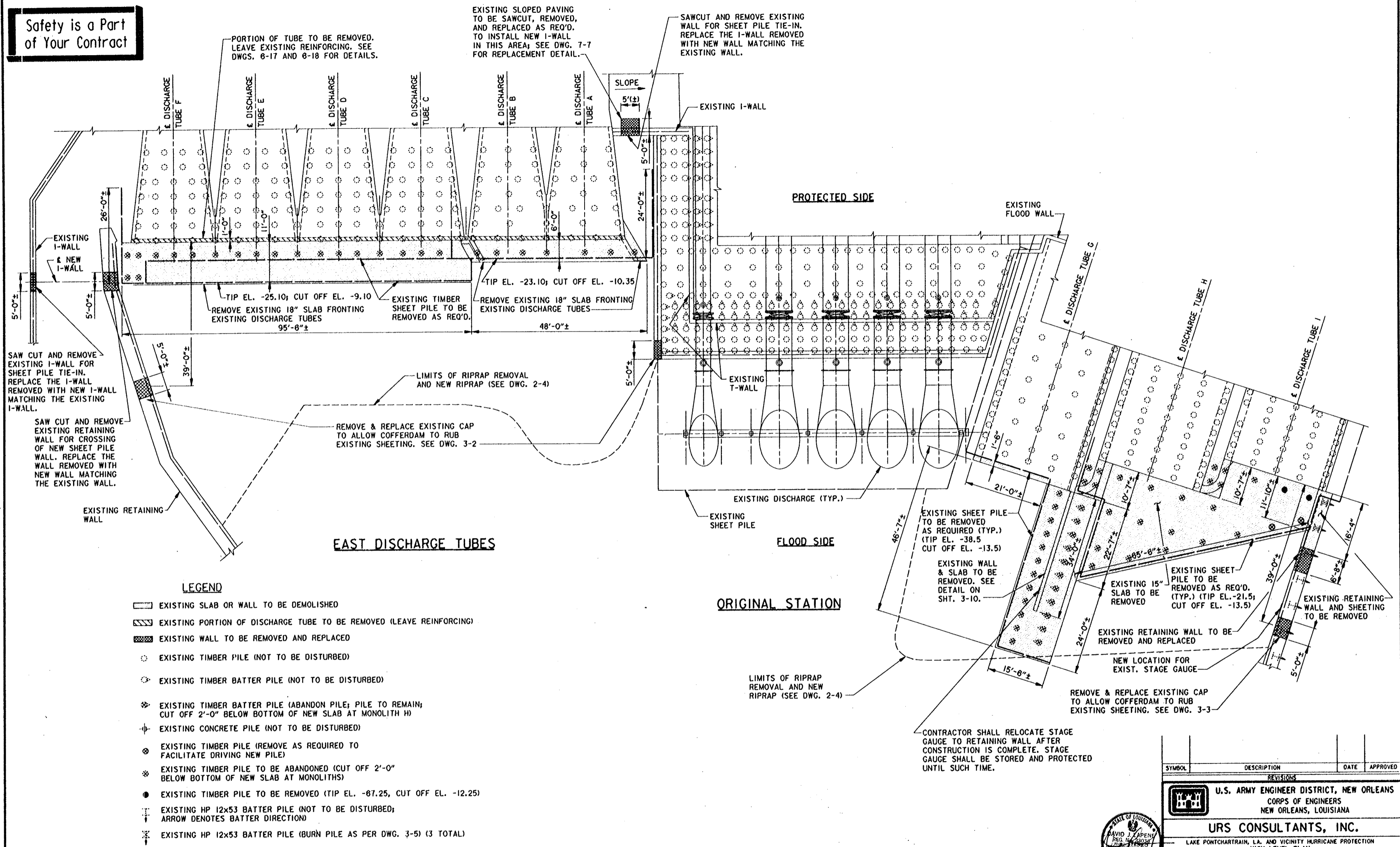

LEGEND

- EXISTING SLAB OR WALL TO BE DEMOLISHED
- EXISTING PORTION OF DISCHARGE TUBE TO BE REMOVED (LEAVE REINFORCING)
- EXISTING WALL TO BE REMOVED AND REPLACED
- EXISTING TIMBER PILE (NOT TO BE DISTURBED)
- EXISTING TIMBER BATTER PILE (NOT TO BE DISTURBED)
- EXISTING TIMBER BATTER PILE (ABANDON PILE; PILE TO REMAIN; CUT OFF 2'-0" BELOW BOTTOM OF NEW SLAB AT MONOLITH H)
- EXISTING CONCRETE PILE (NOT TO BE DISTURBED)
- EXISTING TIMBER PILE (REMOVE AS REQUIRED TO FACILITATE DRIVING NEW PILE)
- EXISTING TIMBER PILE TO BE ABANDONED (CUT OFF 2'-0" BELOW BOTTOM OF NEW SLAB AT MONOLITHS)
- EXISTING TIMBER PILE TO BE REMOVED (TIP EL. -67.25, CUT OFF EL. -12.25)
- EXISTING HP 12x53 BATTER PILE (NOT TO BE DISTURBED; ARROW DENOTES BATTER DIRECTION)
- EXISTING HP 12x53 BATTER PILE (BURN PILE AS PER DWG. 3-5) (3 TOTAL)

NOTE:
SEE DWG. 3-10 FOR DETAILS ON WALLS
BEING REMOVED OR REMOVED AND REPLACED.

ORIGINAL STATION

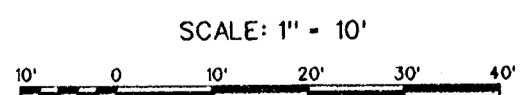

SYMBOL	DESCRIPTION	DATE	APPROVED
REVISIONS			
U.S. ARMY ENGINEER DISTRICT, NEW ORLEANS CORPS OF ENGINEERS NEW ORLEANS, LOUISIANA			
URS CONSULTANTS, INC. LAKE PONTCHARTRAIN, LA. AND VICINITY HURRICANE PROTECTION HIGH LEVEL PLAN FRONTING PROTECTION AT PUMP STATION #8 ORLEANS PARISH - JEFFERSON PARISH 17th STREET OUTFALL CANAL (FAIRIE RELIEF)			
DEMOLITION PLAN			
DESIGNED BY: S.C.B.	DATE: SEPT. 1997	PLOT SCALE: 10	PLOT DATE: SEPT. 1997
DRAWN BY: K.L.L.	CADD FILE: P8-2-03.DWG	FILE NO. H-4-4654	
CHECKED BY: D.J.L.	SUBMITTED BY: DACW29-98-B-0112	DWG. 2-3 OF 2-7	

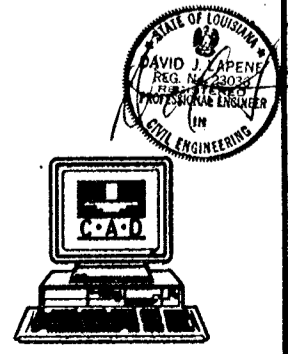

Safety is a Part of Your Contract

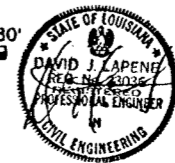
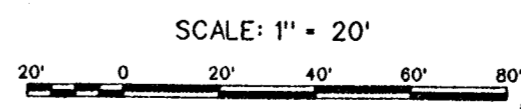
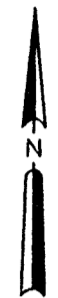
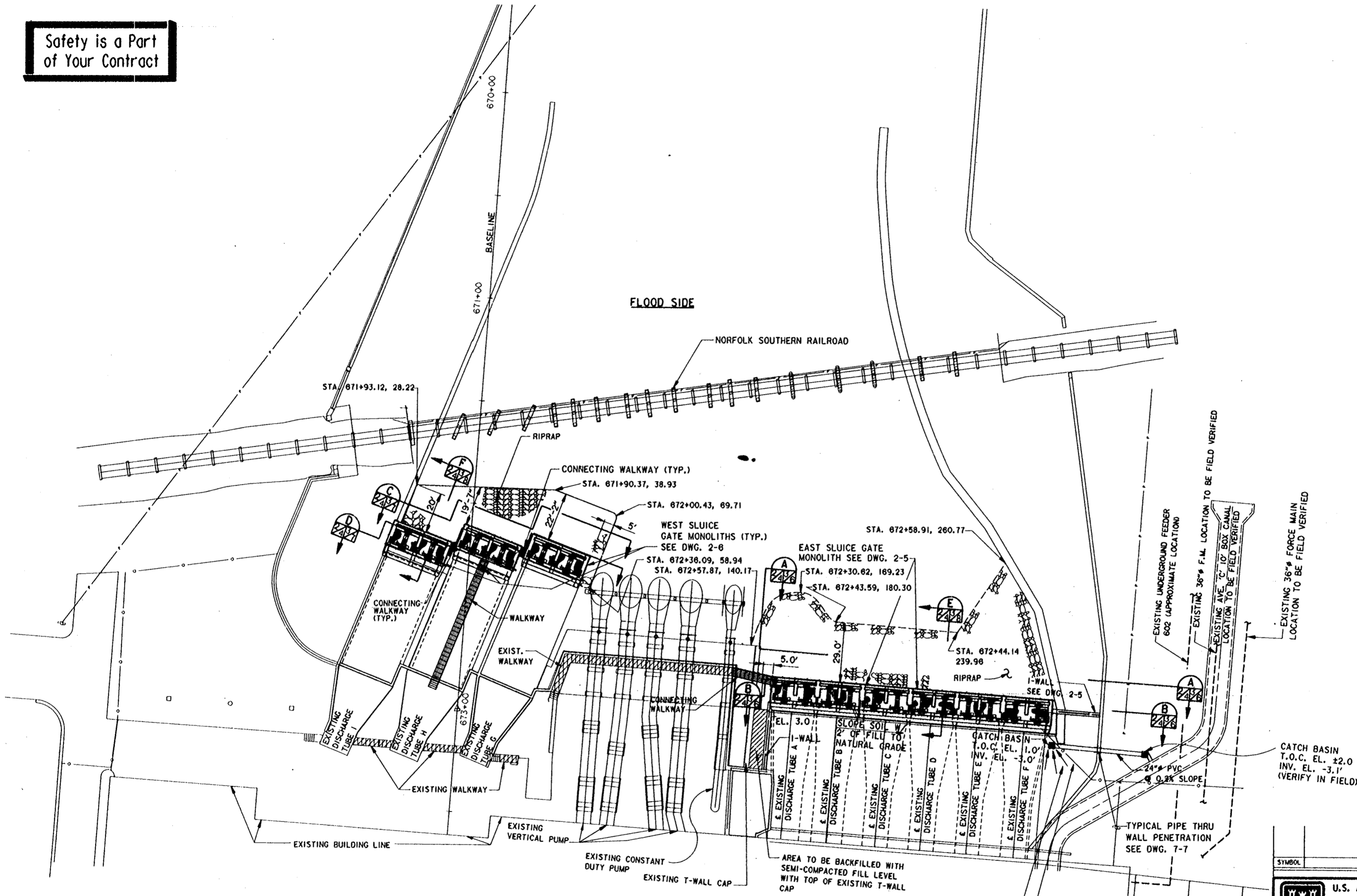

SYMBOL	DESCRIPTION	DATE	APPROVED
REVISIONS			
U.S. ARMY ENGINEER DISTRICT, NEW ORLEANS CORPS OF ENGINEERS NEW ORLEANS, LOUISIANA			
URS CONSULTANTS, INC. LAKE PONTCHARTRAIN, LA. AND VICINITY HURRICANE PROTECTION HIGH LEVEL PLAN FRONTING PROTECTION AT PUMP STATION #6 ORLEANS PARISH - JEFFERSON PARISH 17th STREET OUTFALL CANAL (METAIRIE RELIEF)			
SITE PLAN			
DESIGNED BY: S.C.B.	DATE: SEPT. 1997	PLOT SCALE: 20	PLOT DATE: SEPT. 1997
DRAWN BY: L.A.O.	CADD FILE: P58-2-04.DGN	FILE NO. H-4-44654	
CHECKED BY: M.D.P.	SOLICITATION NO. DACW29-98-B-0112	DWG. 2-4 OF 2-7	
SUBMITTED BY: _____ DESIGN ENGINEER			



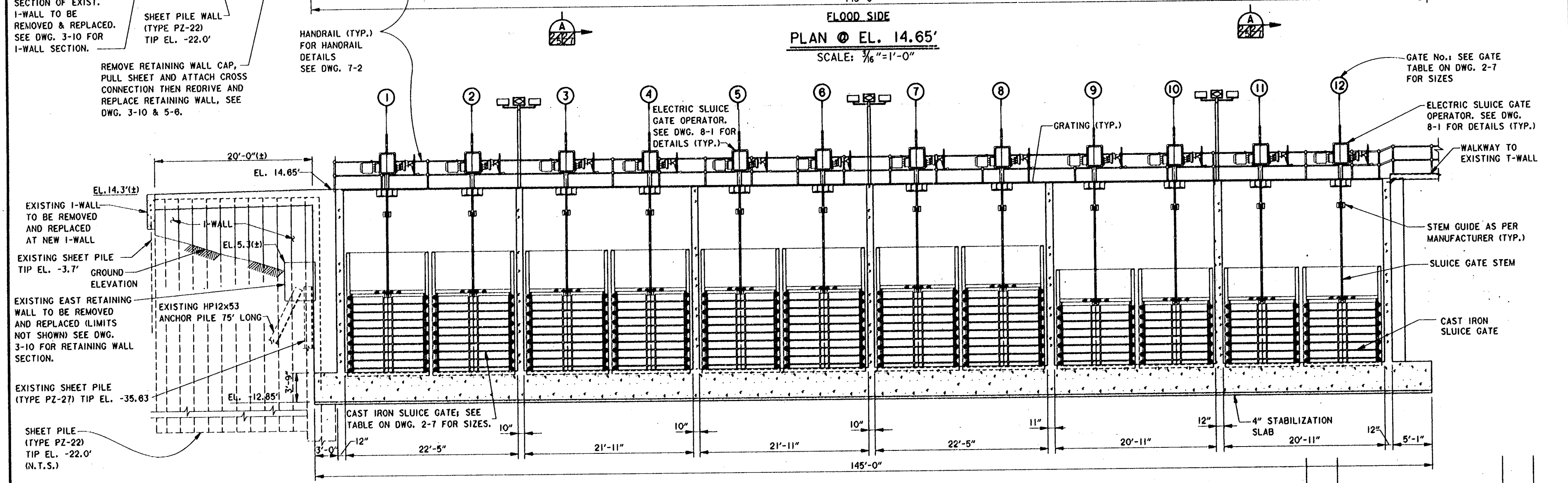
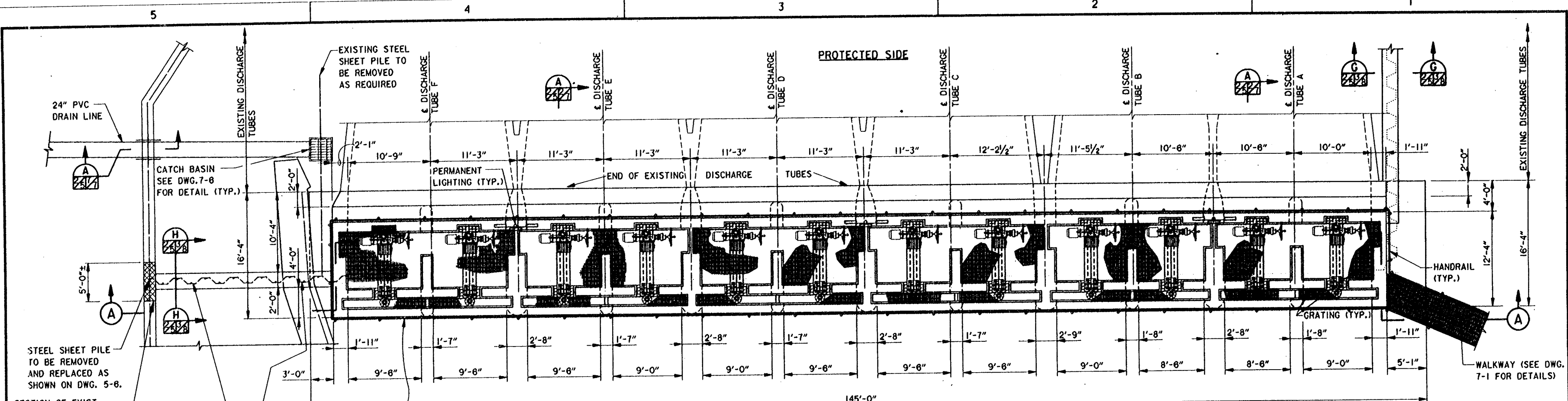

NOTE:
 THE FOLLOWING ITEMS ARE TO BE PAINTED IN ACCORDANCE WITH THE SPECIFICATIONS.
 A) SHEET PILING FROM CUT-OFF ELEVATION TO EL. (-)12.00.
 B) ALL EXPOSED METAL SURFACES EXCEPT TEMPORARY COFFERDAM WHICH ARE NOT ALUMINUM OR GALVANIZED.
 C) ALL MOTORS AND MECHANICAL EQUIPMENT INCLUDING SLUICE GATES & BUTTERFLY VALVES WHICH ARE NOT COATED BY THE MANUFACTURER.
 D) ALL DAMAGED SURFACES.
 E) ALL EXTERIOR SURFACES OF CONCRETE WALLS AND TOP OF TOP SLAB AT ALL SLUICE GATE MONOLITHS.

REVISIONS

SYMBOL	DESCRIPTION	DATE	APPROVED
	REVISIONS		
	U.S. ARMY ENGINEER DISTRICT, NEW ORLEANS CORPS OF ENGINEERS NEW ORLEANS, LOUISIANA		
	URS CONSULTANTS, INC. LAKE PONTCHARTRAIN, LA. AND VICINITY HURRICANE PROTECTION HIGH LEVEL PLAN FRONTING PROTECTION AT PUMP STATION #8 ORLEANS PARISH - JEFFERSON PARISH 17TH STREET OUTFALL CANAL (METAIRIE RELIEF)		
	SLUICE GATE STRUCTURE LAYOUT & EAST PUMPS		
DESIGNED BY: S.C.B.	DATE: SEPT. 1997	PLOT SCALE: 5.333	PLOT DATE: SEPT. 1997
DRAWN BY: K.L.L.	CADD FILE: P58-2-08.DGN	FILE NO. H-4-44654	
CHECKED BY: D.J.L.	SOLICITATION NO. DACW29-98-B-0112	DWG. 2-5	OF 2-7
SUBMITTED BY:	DESIGN ENGINEER		

SCALE: 3/16" = 1'-0"

Safety is a Part of Your Contract

Safety is a Part of Your Contract

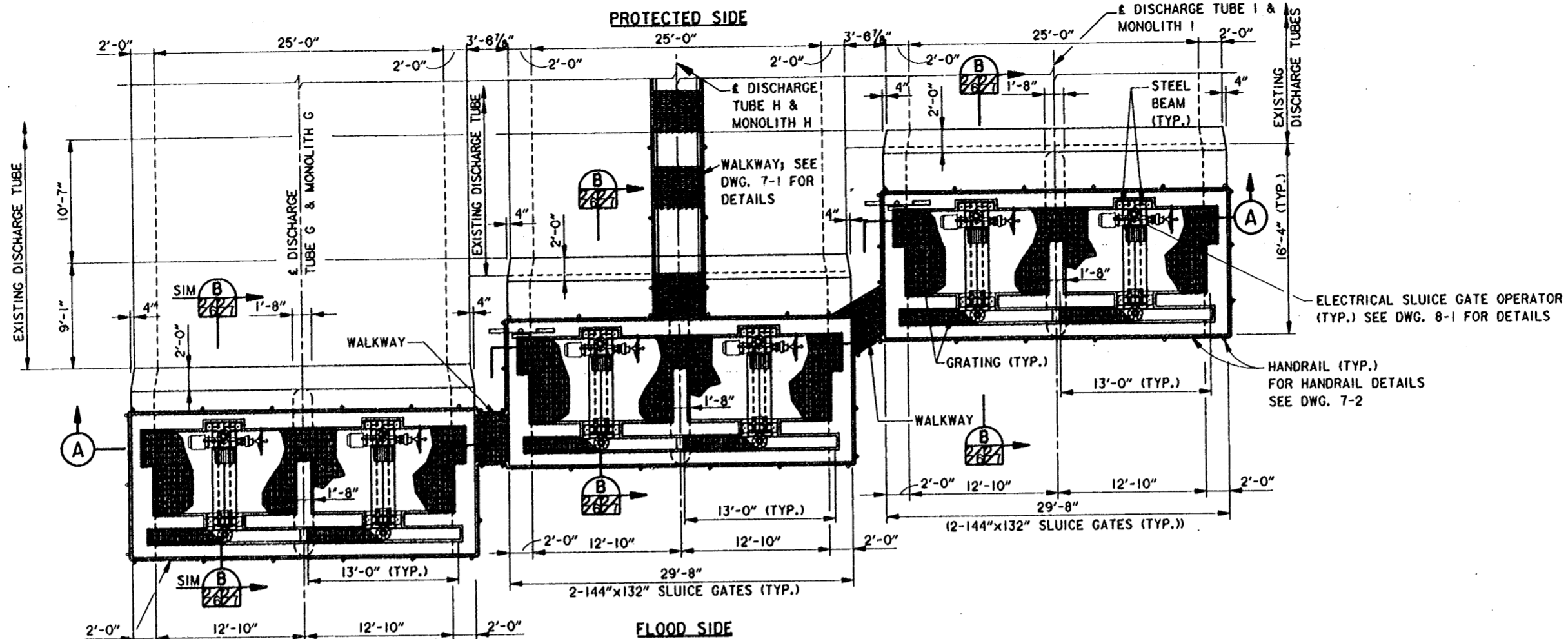

PLAN @ EL. 16.00'

SCALE: 3/16" = 1'-0"

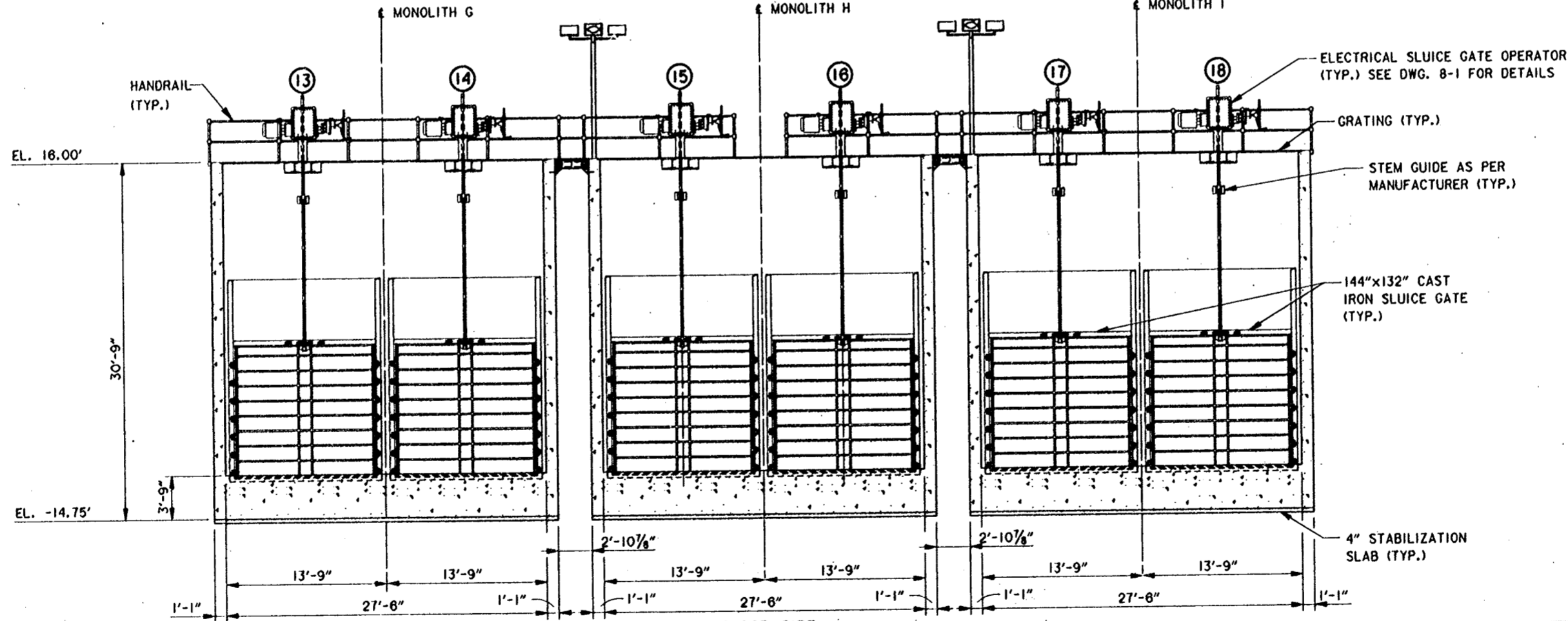

FLOOD SIDE SECTION A

SCALE: 3/16" = 1'-0"

- NOTE:
- A) SHEET PILING FROM CUT-OFF ELEVATION TO EL. (-)12.00.
 - B) ALL EXPOSED METAL SURFACES EXCEPT TEMPORARY COFFERDAM WHICH ARE NOT ALUMINUM OR GALVANIZED.
 - C) ALL MOTORS AND MECHANICAL EQUIPMENT INCLUDING SLUICE GATES & BUTTERFLY VALVES WHICH ARE NOT COATED BY THE MANUFACTURER.
 - D) ALL DAMAGED SURFACES.
 - E) ALL EXTERIOR SURFACES OF CONCRETE WALLS AND TOP OF TOP SLAB AT ALL SLUICE GATE MONOLITHS.

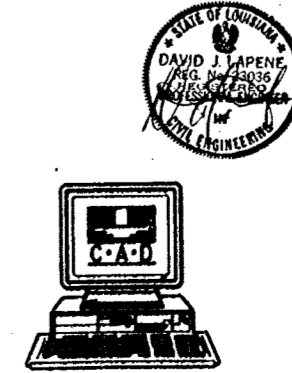
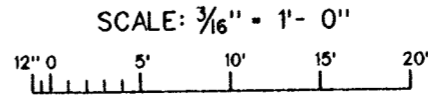

SYMBOL	DESCRIPTION	DATE	APPROVED
REVISIONS			
U.S. ARMY ENGINEER DISTRICT, NEW ORLEANS CORPS OF ENGINEERS NEW ORLEANS, LOUISIANA			
URS CONSULTANTS, INC. LAKE PONTCHARTRAIN, LA. AND VICINITY HURRICANE PROTECTION HIGH LEVEL PLAN FRONTING PROTECTION AT PUMP STATION #8 ORLEANS PARISH - JEFFERSON PARISH 17th STREET OUTFALL CANAL (METAIRIE RELIEF)			
SLUICE GATE STRUCTURE LAYOUT @ WEST PUMPS			
DESIGNED BY: S.C.B.	DATE: SEPT. 1997	PLOT SCALE: 5.333	PLOT DATE: SEPT. 1997
DRAWN BY: K.L.L.	CADD FILE: P56-2-08.DGN	FILE NO. H-4-44654	
CHECKED BY: D.J.L.	SOLICITATION NO. DACW29-98-B-0112	DWG. 2-6	OF 2-7
SUBMITTED BY:	DESIGN ENGINEER		



Safety is a Part of Your Contract

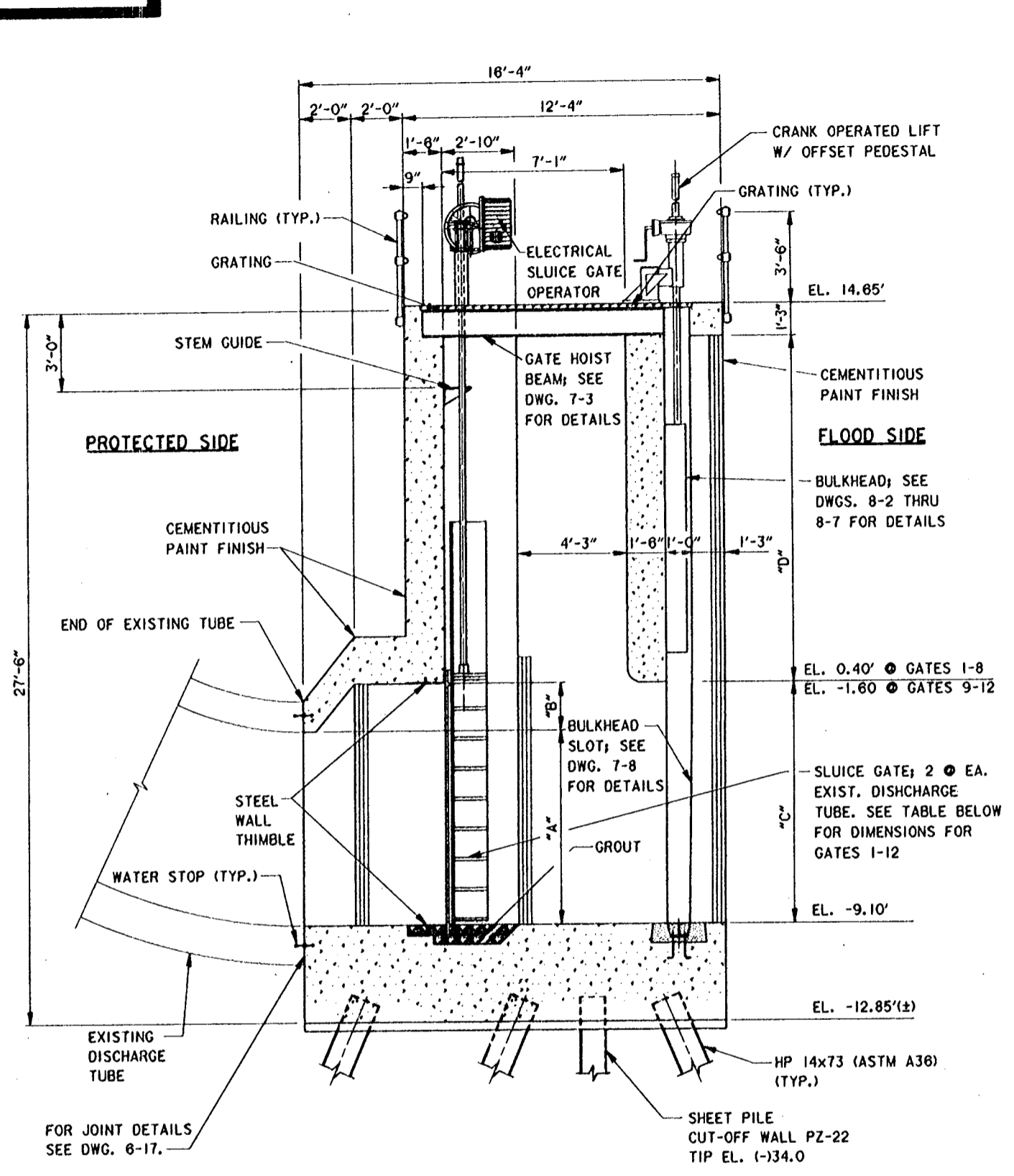

EAST MONOLITH
SECTION **A**
SCALE: 3/8" = 1'-0"

GATE	GATE TABLE				WIDTH OF NEW TUBE
	HEIGHT OF EXISTING TUBE "A"	HEIGHT EXTENSION "B"	HEIGHT OF NEW TUBE "C"	HEIGHT OF WALL "D"	
1-3, 8-8	7'-6"	2'-0"	9'-6"	13'-0"	9'-6"
4, 5	7'-6"	2'-0"	9'-6"	13'-0"	9'-0"
9, 12	8'-0"	1'-6"	7'-6"	15'-0"	9'-0"
10, 11	8'-0"	1'-6"	7'-6"	15'-0"	8'-6"

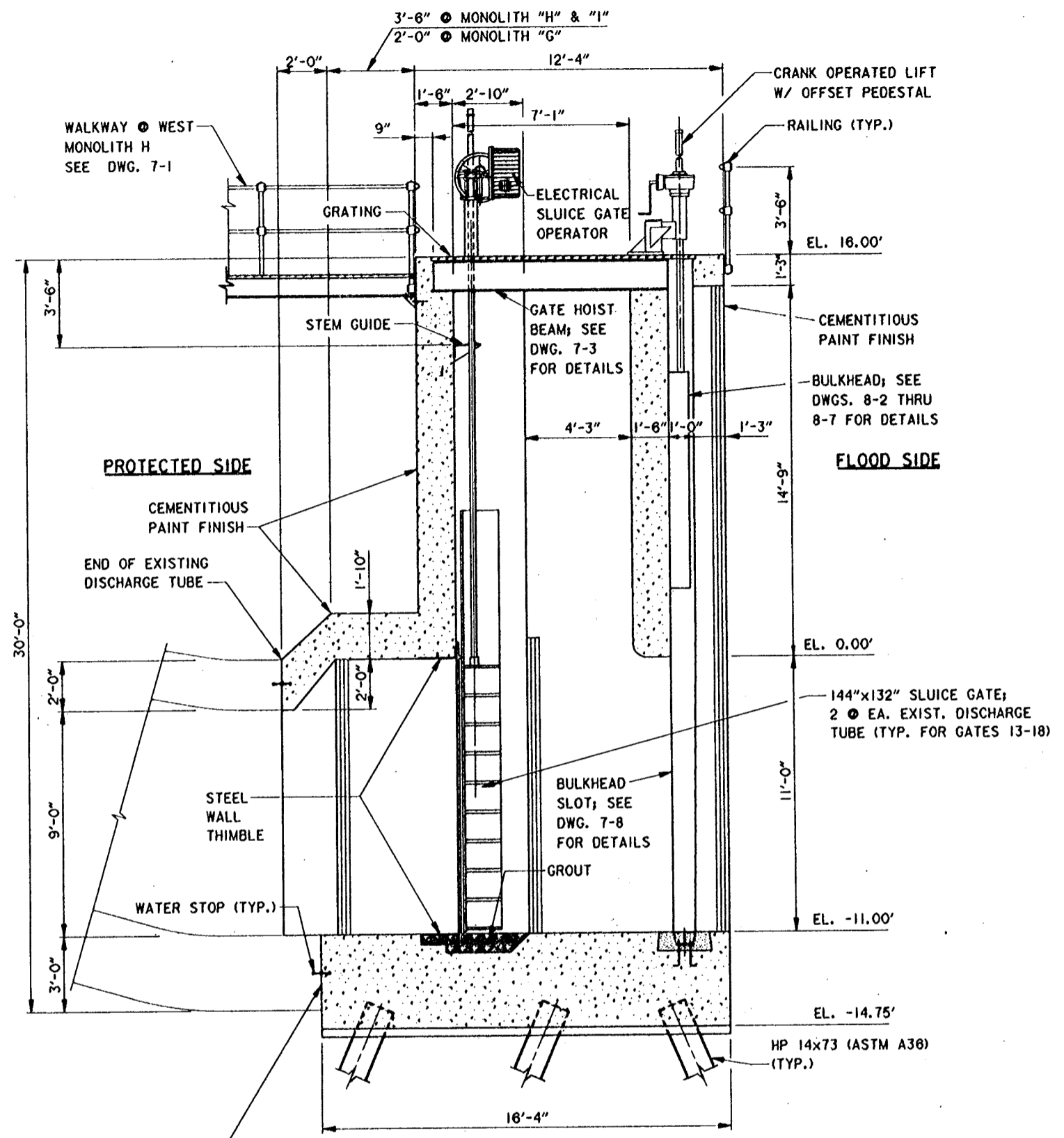

WEST MONOLITHS
SECTION **B**
SCALE: 3/8" = 1'-0"

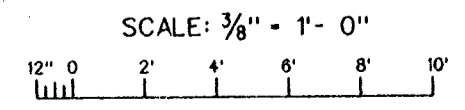

SYMBOL	DESCRIPTION	DATE	APPROVED
REVISIONS			
U.S. ARMY ENGINEER DISTRICT, NEW ORLEANS CORPS OF ENGINEERS NEW ORLEANS, LOUISIANA			
URS CONSULTANTS, INC. LAKE PONTCHARTRAIN, LA. AND VICINITY HURRICANE PROTECTION HIGH LEVEL PLAN FRONTING PROTECTION AT PUMP STATION #6 ORLEANS PARISH - JEFFERSON PARISH 17th STREET OUTFALL CANAL (JEFFAIRIE RELIEF)			
PROPOSED SLUICE GATE CROSS SECTIONS			
DESIGNED BY: S.C.B.	DATE: SEPT. 1997	PLOT SCALE: 2.67	PLOT DATE: SEPT. 1997
DRAWN BY: B.M.M.	CADD FILE: P56-2-07.DGN	FILE NO. H-4-44654	
CHECKED BY: D.J.L.	SOLICITATION NO. DACW29-98-B-0112	DWG. 2-7	OF 2-7
SUBMITTED BY:	DESIGN ENGINEER		

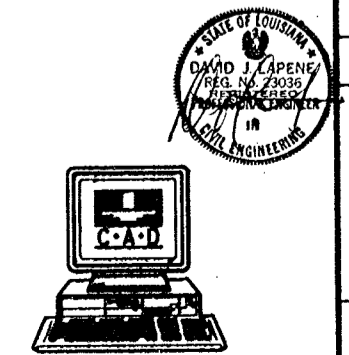

Safety is a Part
of Your Contract

NOTES:

1. AT NO TIME DURING CONSTRUCTION SHALL MORE THAN ONE (1) PUMP BE OUT OF SERVICE DUE TO CONSTRUCTION OPERATION ACTIVITIES.
2. THE CONTRACTOR SHALL COORDINATE ALL WORK WITHIN 10' FROM THE EDGE OF THE RAILROAD TRACK WITH THE NORFOLK SOUTHERN RAILROAD AND PROVIDE ALL INSURANCES, PERSONNEL, AND ITEMS REQUIRED DURING THE COURSE OF CONSTRUCTION.

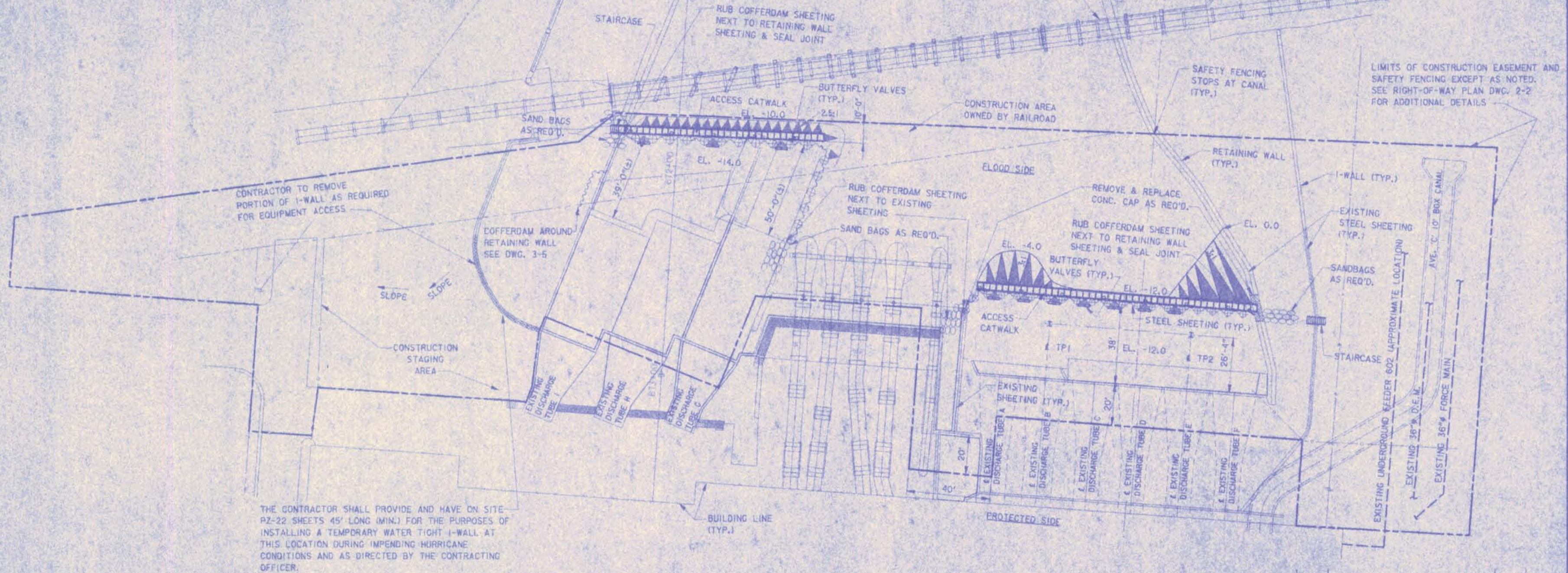

CONTRACTOR TO REMOVE PORTION OF I-WALL AS REQUIRED FOR EQUIPMENT ACCESS

COFFERDAM AROUND RETAINING WALL SEE DWG. 3-5

THE CONTRACTOR SHALL PROVIDE AND HAVE ON SITE PZ-22 SHEETS 45' LONG (MIN.) FOR THE PURPOSES OF INSTALLING A TEMPORARY WATER TIGHT I-WALL AT THIS LOCATION DURING IMPENDING HURRICANE CONDITIONS AND AS DIRECTED BY THE CONTRACTING OFFICER.

LIMITS OF CONSTRUCTION EASEMENT AND SAFETY FENCING EXCEPT AS NOTED. SEE RIGHT-OF-WAY PLAN DWG. 2-2 FOR ADDITIONAL DETAILS

SCALE: 1" = 20'



SYMBOL	DESCRIPTION	DATE	APPROVED
REVISIONS			
 U.S. ARMY ENGINEER DISTRICT, NEW ORLEANS CORPS OF ENGINEERS NEW ORLEANS, LOUISIANA			
URS CONSULTANTS, INC. <small>LIKE PONTCHARTRAIN, LA. AND VICINITY HURRICANE PROTECTION HIGH LEVEL PLAN</small> FRONTING PROTECTION AT PUMP STATION #6 ORLEANS PARISH - JEFFERSON PARISH (7TH STREET OUTFALL CANAL METAIRIE RELIEF)			
COFFERDAM PLAN			
DESIGNED BY: M.D.P.	DATE: SEPT., 1997	PLOT SCALE: 20	PLOT DATE: SEPT., 1997
DRAWN BY: L.A.O.	CHECKED BY: M.D.P.	CADD FILE NO: 9803-01209	FILE NO: H-4-44654
SUBMITTED BY:	SOLICITATION NO. DACW29-98-B-0112	DWG. 3-1 OF 3-10	

Safety is a Part of Your Contract

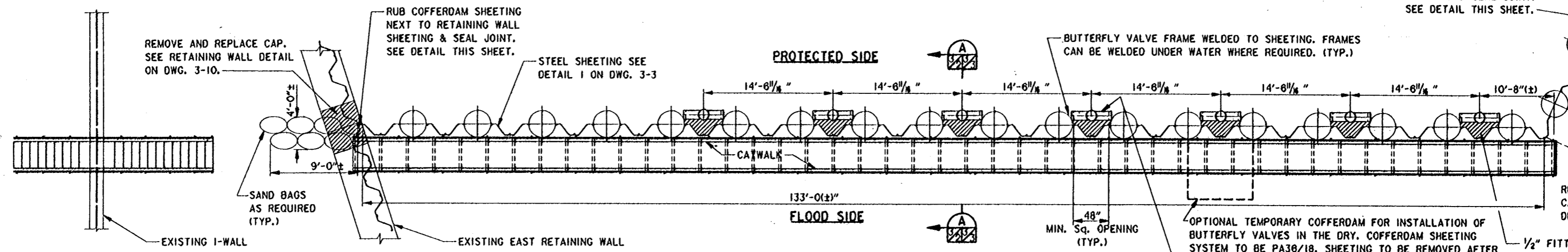

PLAN OF EAST MONOLITH COFFERDAM
SCALE: 3/16" = 1'-0"

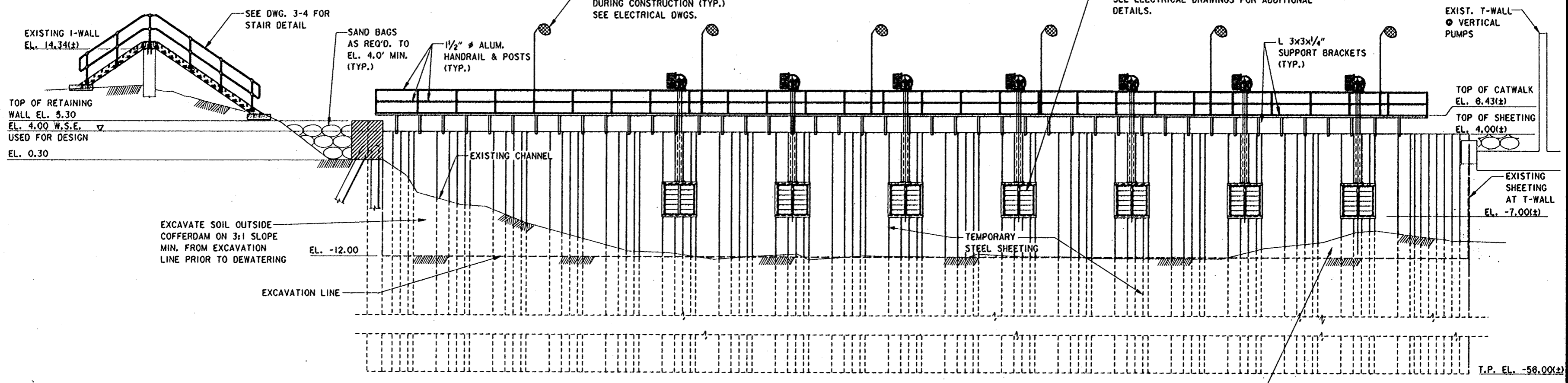

ELEVATION OF EAST MONOLITH COFFERDAM (FLOOD SIDE)
SCALE: 3/16" = 1'-0"

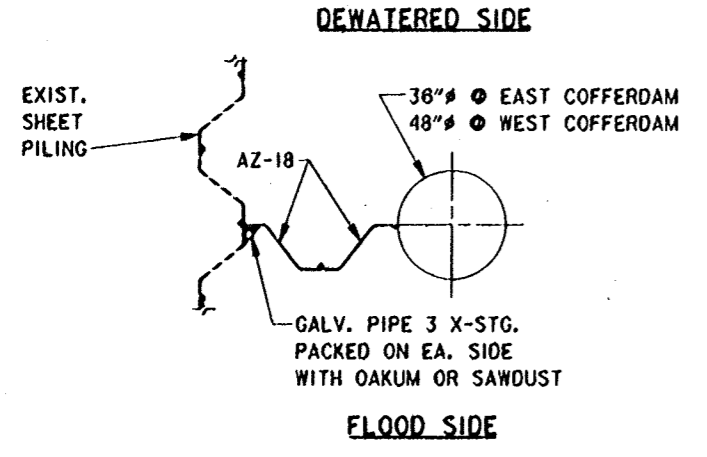

NEW TO EXISTING SHEET PILE RUB DETAIL
SCALE: 3/8" = 1'-0"

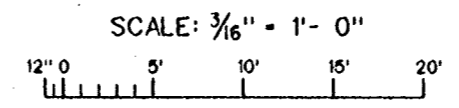

SYMBOL	DESCRIPTION	DATE	APPROVED
REVISIONS			
U.S. ARMY ENGINEER DISTRICT, NEW ORLEANS CORPS OF ENGINEERS NEW ORLEANS, LOUISIANA			
URS CONSULTANTS, INC. LAKE PONTCHARTRAIN, L.A. AND VICINITY HURRICANE PROTECTION HIGH LEVEL PLAN FRONTING PROTECTION AT PUMP STATION #6 ORLEANS PARISH - JEFFERSON PARISH 17TH STREET OUTFALL CANAL (GRETAIRE RELIEF)			
ENLARGED COFFERDAM PLAN AND ELEVATION OF EAST MONOLITH			
DESIGNED BY: M.O.P.	DATE: SEPT. 1997	PLOT SCALE: 5.33	PLOT DATE: SEPT. 1997
DRAWN BY: L.A.O.	CADD FILE: P58-3-02.DGN	FILE NO. H-4-44654	
CHECKED BY: M.O.P.	SOLICITATION NO. DACW29-98-8-0112	DWG. 3-2	OF 3-10
SUBMITTED BY:			

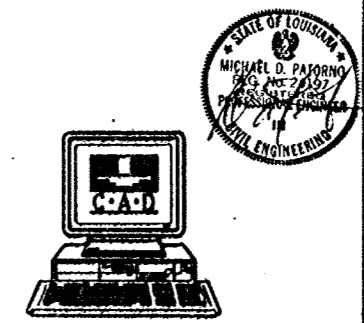

**Safety is a Part
of Your Contract**

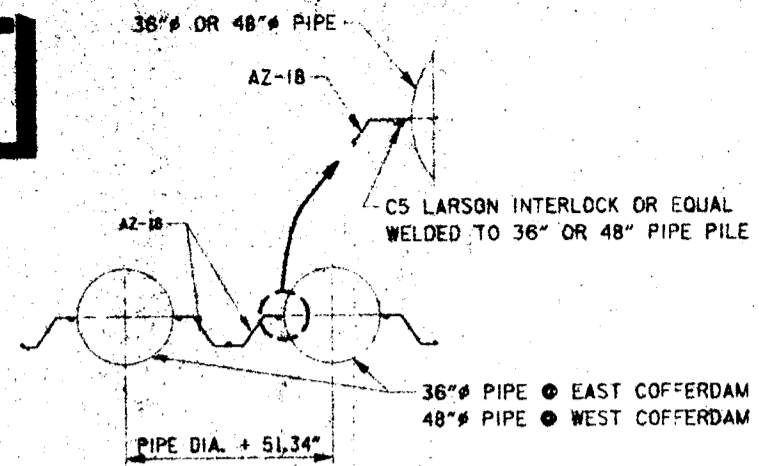

DETAIL 1
TYPICAL PLAN OF PA36/18, PA48/18
SCALE: 1/4" = 1'-0"

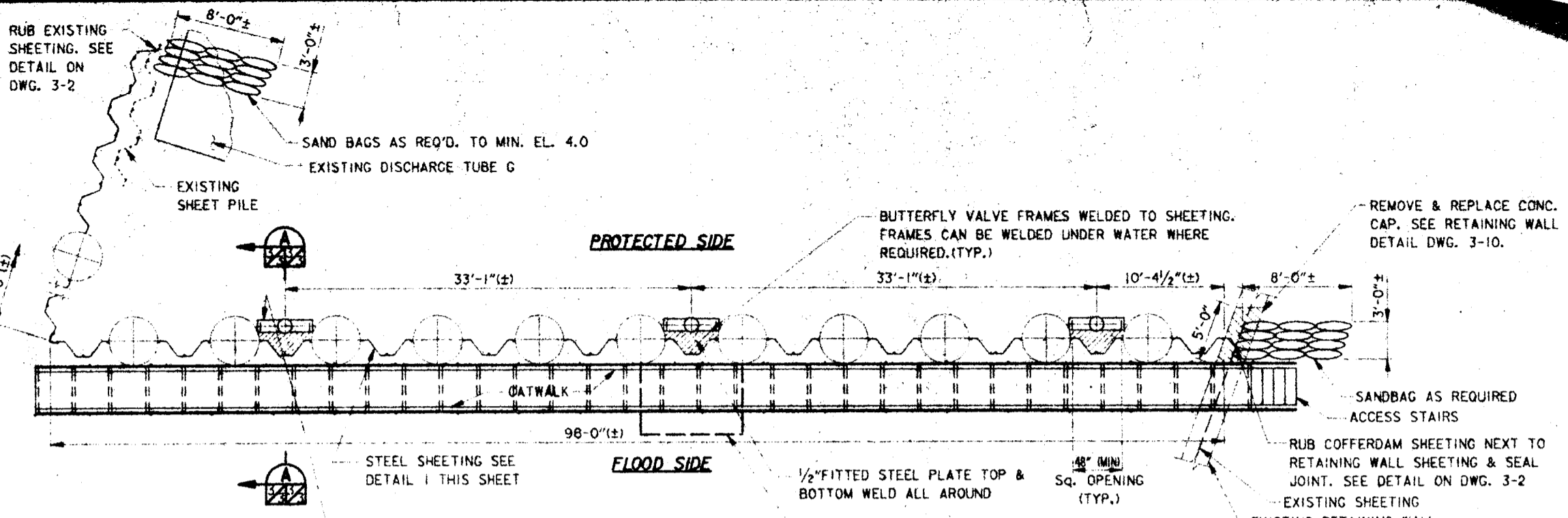

PLAN OF WEST MONOLITHS COFFERDAM
SCALE: 3/16" = 1'-0"

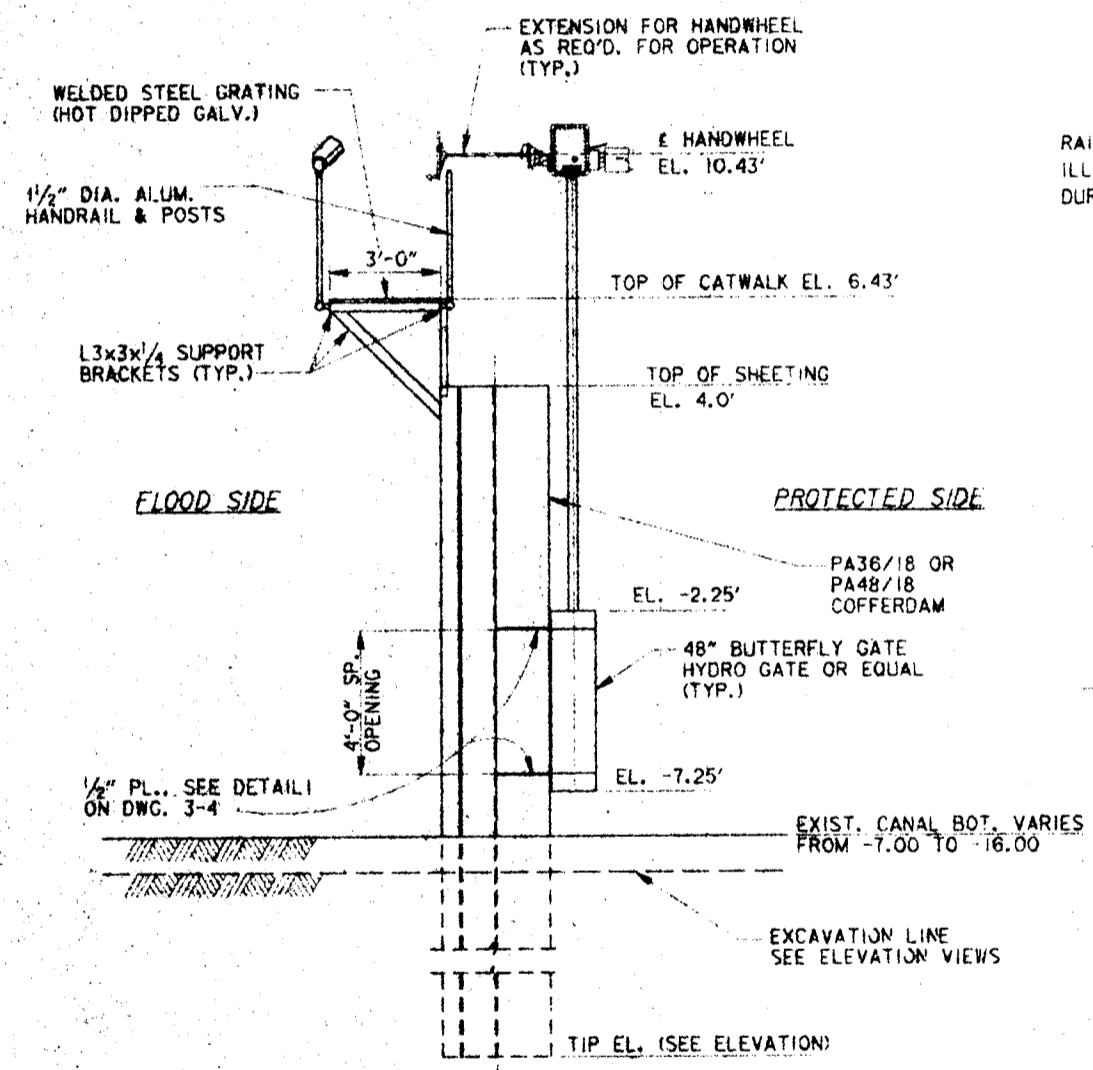

SECTION A-A
ELEVATION OF WEST MONOLITHS COFFERDAM (FLOOD SIDE)
SCALE: 3/16" = 1'-0"

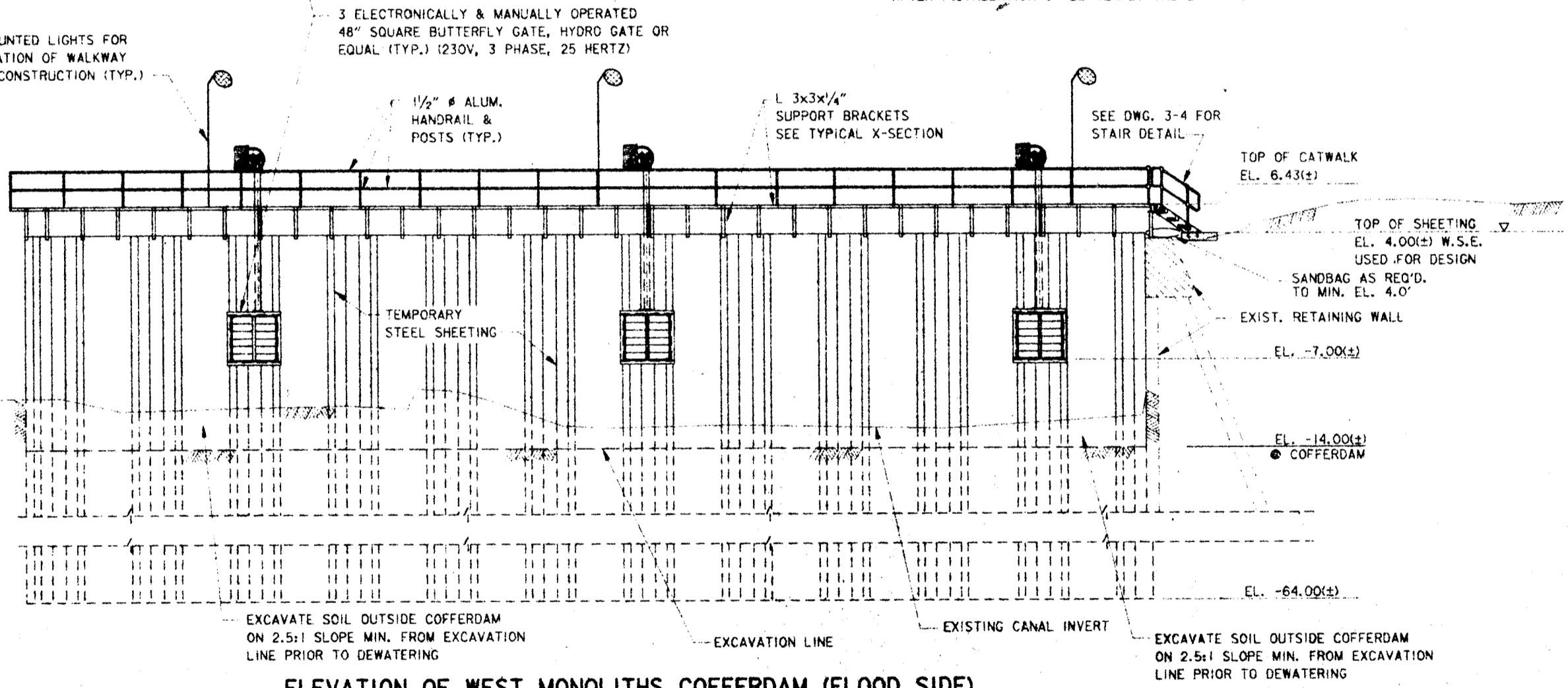

ELEVATION OF WEST MONOLITHS COFFERDAM (FLOOD SIDE)
SCALE: 3/16" = 1'-0"

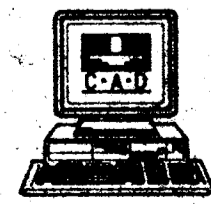
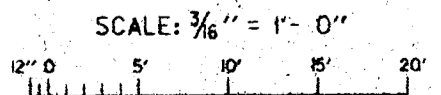

SYMBOL	DESCRIPTION	DATE	APPROVED
REVISIONS			
U.S. ARMY ENGINEER DISTRICT, NEW ORLEANS CORPS OF ENGINEERS NEW ORLEANS, LOUISIANA			
URS CONSULTANTS, INC. LAKE PONTCHARTRAIN, LA. AND VICINITY HURRICANE PROTECTION HIGH LEVEL PLAN FRONTING PROTECTION AT PUMP STATION #6 ORLEANS PARISH - JEFFERSON PARISH (7TH STREET OUTFALL CANAL METAIRIE RELIEF)			
ENLARGED COFFERDAM PLAN AND ELEVATION @ WEST MONOLITH			
DESIGNED BY: M.B.P.	DATE: SEPT. 1997	PLOT SCALE: 5.333	PLOT DATE: SEPT. 1997
DRAWN BY: K.L.L.	CADD FILE: P2-7-0100	FILE NO. H-4-44654	
CHECKED BY: M.Q.P.	SOLICITATION NO. DACW29-98-B-0112	DWG. 3-3	OF 3-10
SUBMITTED BY:			



Safety is a Part of Your Contract

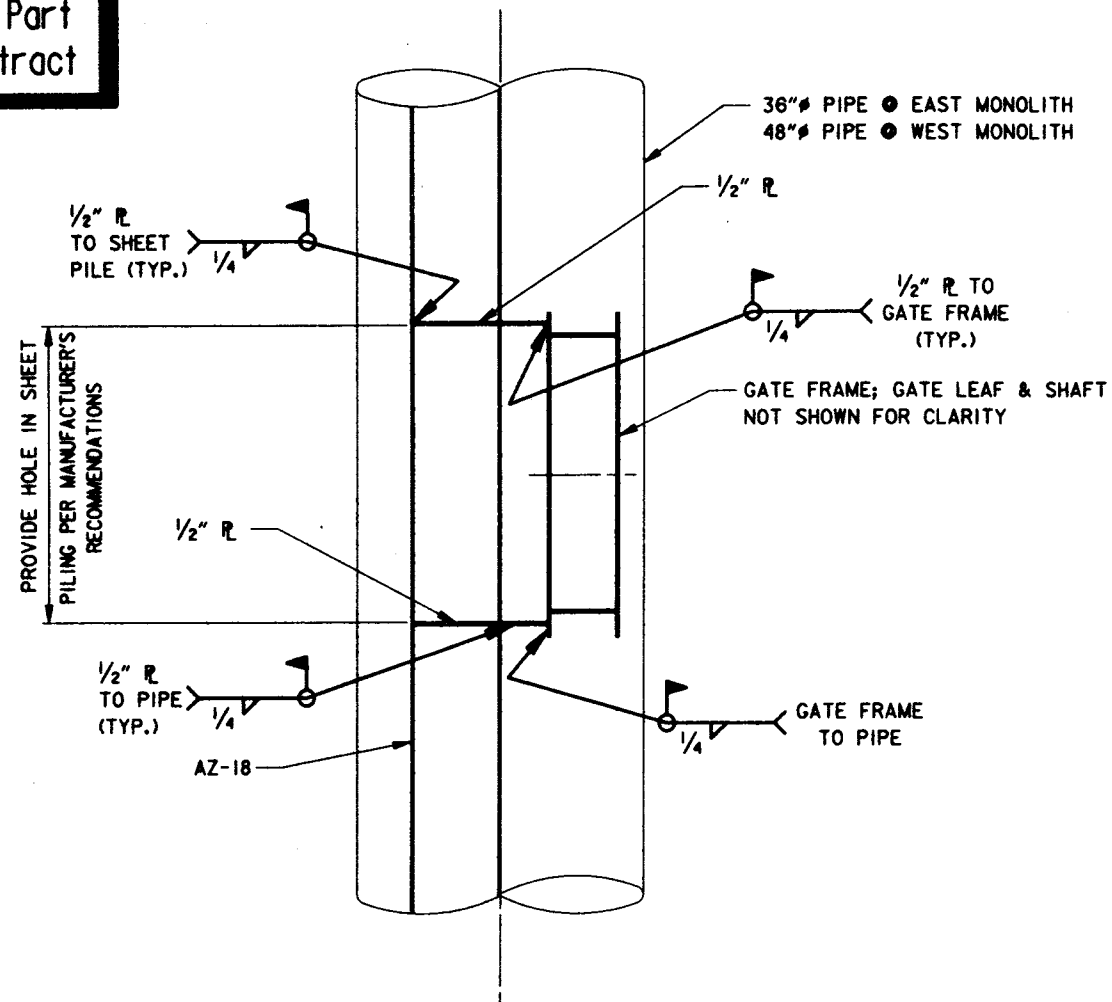

DETAIL ①
SCALE: 3/4" = 1'-0"

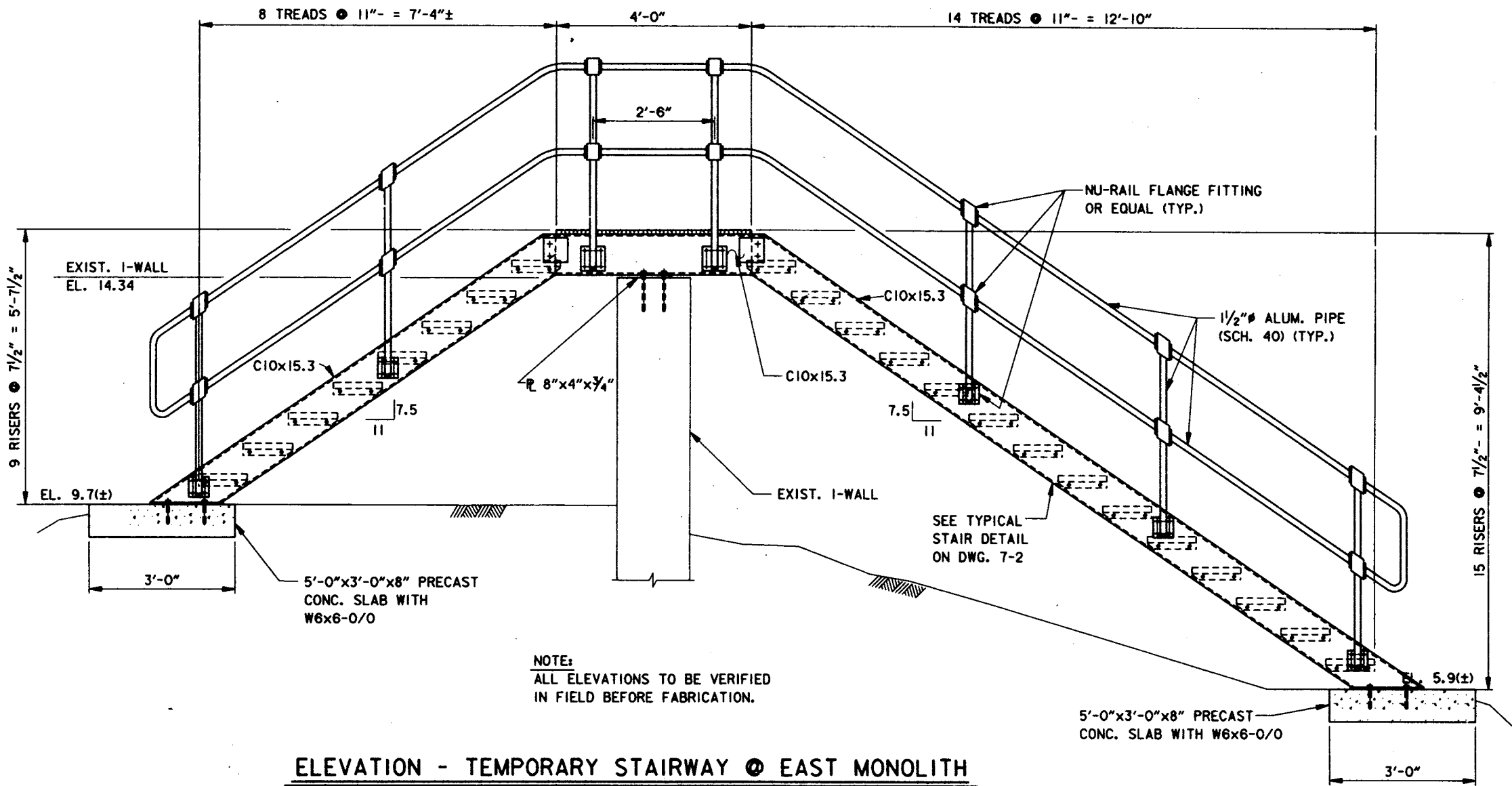

ELEVATION - TEMPORARY STAIRWAY @ EAST MONOLITH
SCALE: 3/4" = 1'-0"

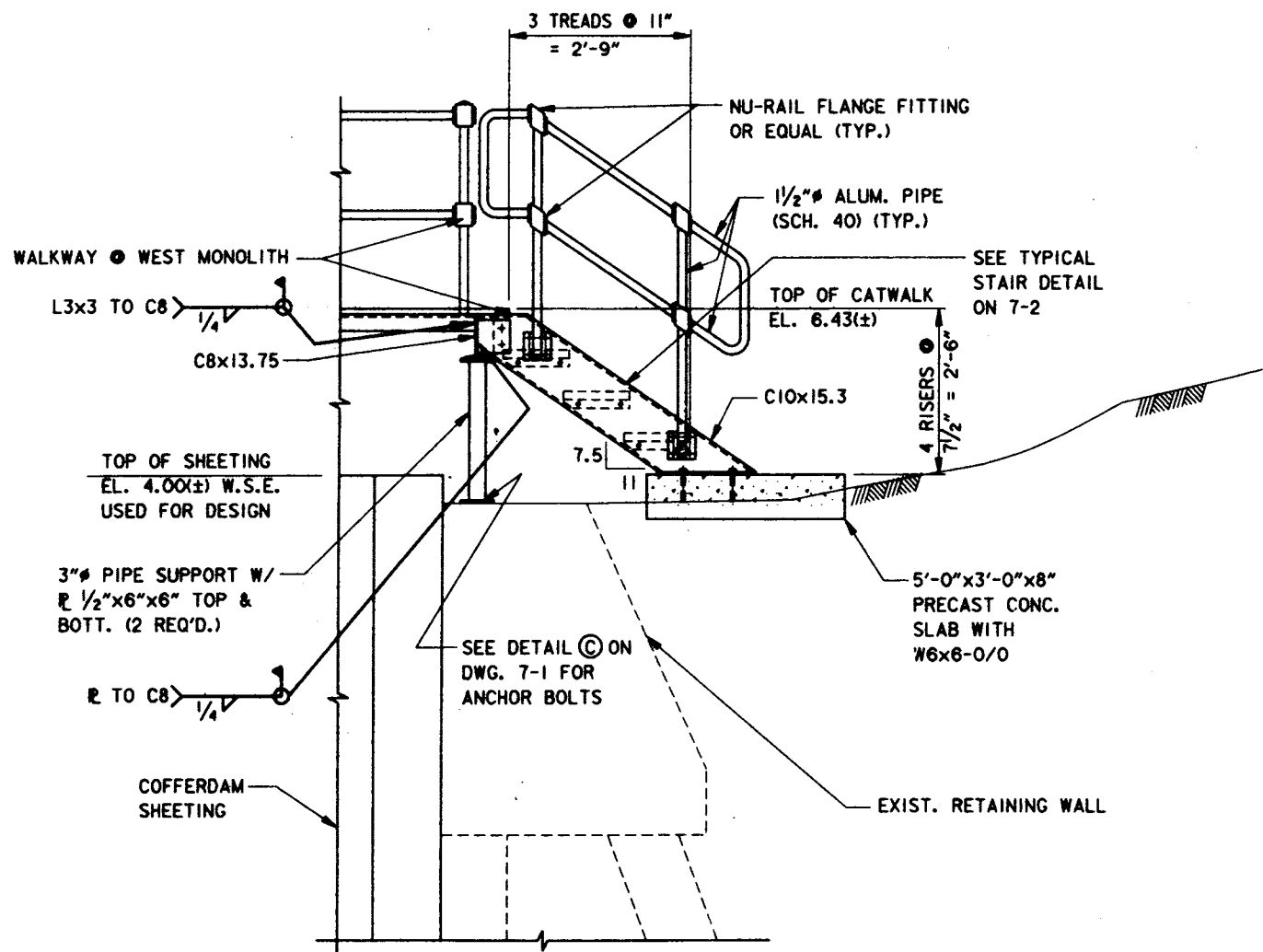

ELEVATION - TEMPORARY STAIRWAY @ WEST MONOLITH
SCALE: 3/4" = 1'-0"

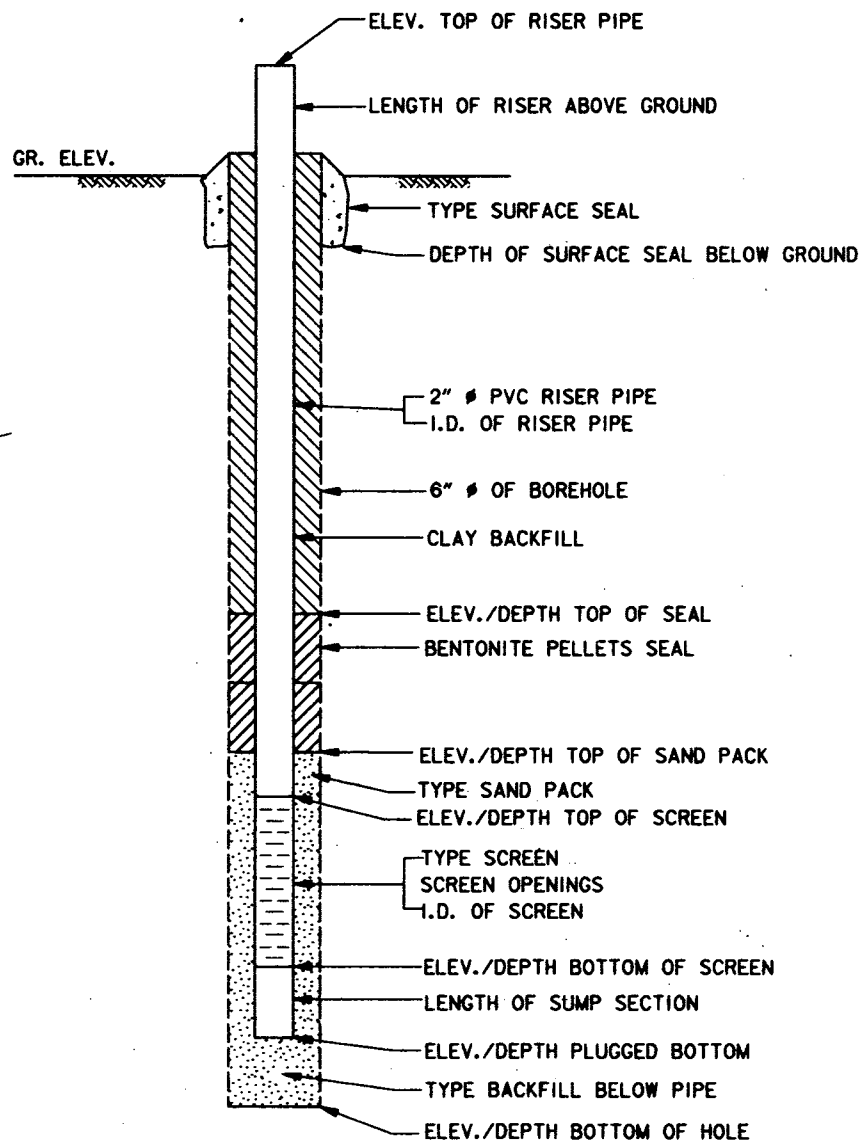

TYPICAL PIEZOMETER DETAIL
SCALE: NONE

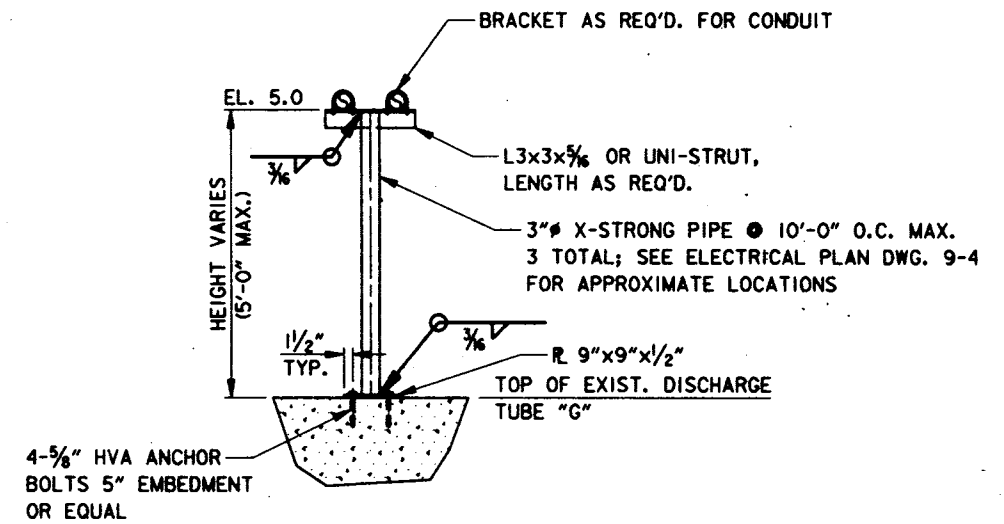

CONDUIT SUPPORT @ WEST MONOLITH
SCALE: 3/4" = 1'-0"

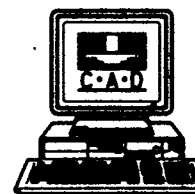
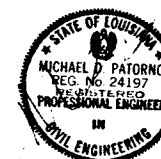

SYMBOL	DESCRIPTION	DATE	APPROVED
REVISIONS			
U.S. ARMY ENGINEER DISTRICT, NEW ORLEANS CORPS OF ENGINEERS NEW ORLEANS, LOUISIANA			
URS CONSULTANTS, INC.			
LAKE PONTCHARTRAIN, LA. AND VICINITY HURRICANE PROTECTION HIGH LEVEL PLAN FRONTING PROTECTION AT PUMP STATION #6 ORLEANS PARISH - JEFFERSON PARISH 17th STREET OUTFALL CANAL (METAIRIE RELIEF)			
COFFERDAM DETAILS			
DESIGNED BY: M.D.P.	DATE: SEPT. 1997	PLOT SCALE: 5.333	PLOT DATE: SEPT. 1997
DRAWN BY: K.L.L.	CADD FILE: P58-3-04.DGN	FILE NO. H-4-44654	
CHECKED BY: M.D.P.	SOLICITATION NO. DACW29-98-B-0112	DWG. 3-4	OF 3-10
SUBMITTED BY:	DESIGN ENGINEER		

**Safety is a Part
of Your Contract**

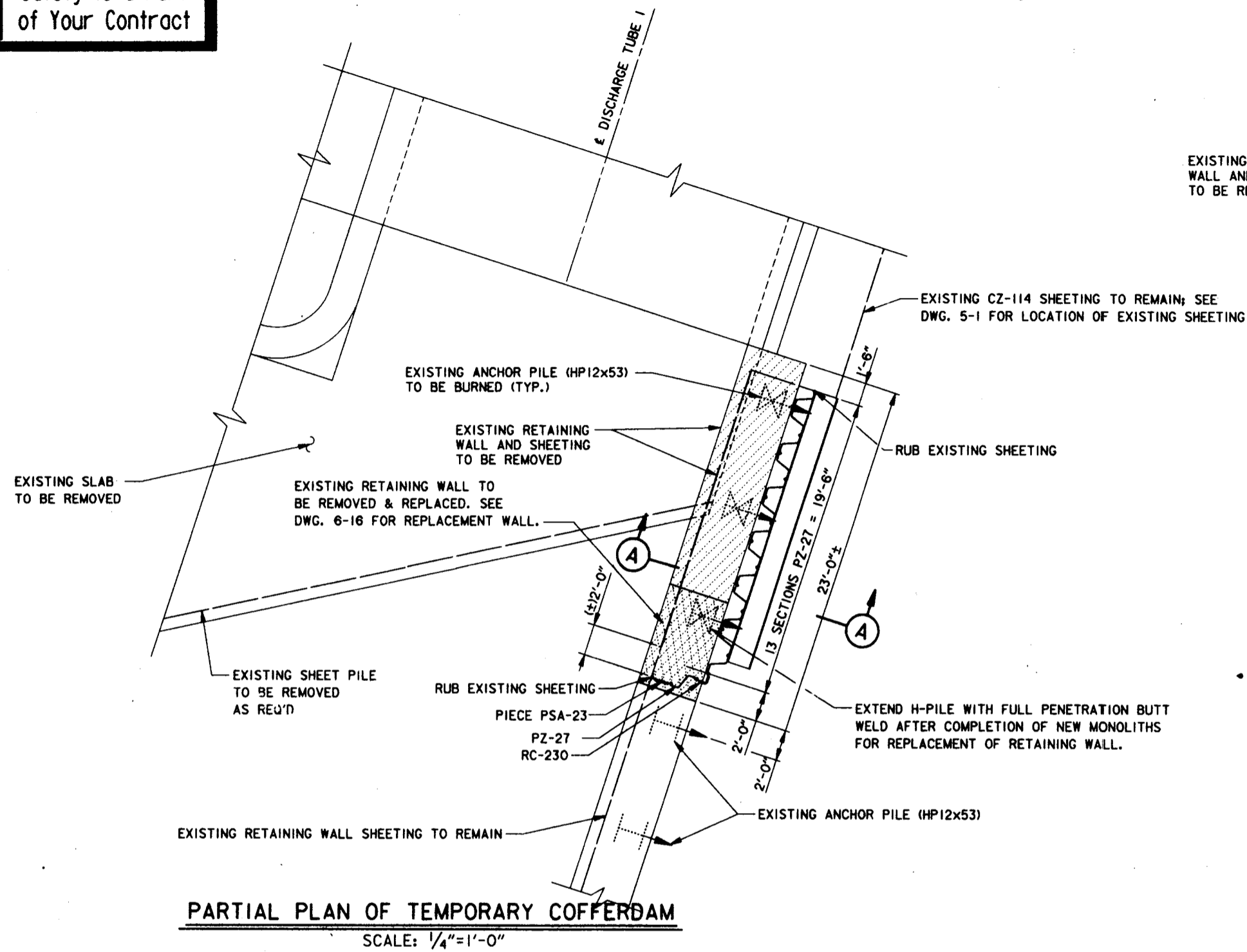

PARTIAL PLAN OF TEMPORARY COFFERDAM
SCALE: 1/4" = 1'-0"

CONSTRUCTION SEQUENCE

1. EXCAVATE TO EL. -10.0 AS SHOWN.
2. REMOVE CONCRETE CAP FROM EXISTING RETAINING WALL AS SHOWN.
3. BURN EXISTING ANCHOR PILE (HP12x53) AS SHOWN.
4. WELD R 3/4" TO EXISTING ANCHOR PILE (HP12x53) AS SHOWN.
5. WELD WALE (W18x86) TO R 3/4" AS SHOWN.
6. DRIVE SHEETING (PZ-27x40'-0") AS SHOWN.
7. WELD SHEETING (PZ-27) TO WALE (W18x86) AS SHOWN.
8. REMOVE SHEETING FROM EXISTING RETAINING WALL AS SHOWN.
9. BACKFILL EXCAVATED AREA.
10. REMOVE TEMPORARY SHEETING (IF USED).
11. BEGIN CONSTRUCTION OF WEST MONOLITHS.
12. AFTER COMPLETION OF WEST MONOLITHS, EXCAVATE AND REMOVE TEMPORARY COFFERDAM.
13. EXTEND NORTHMOST CUT H-PILE TO EXISTING CONDITION FOR REPLACEMENT OF RETAINING WALL.
14. REBUILD RETAINING WALL (SEE DWG. 6-16) AND BACKFILL.

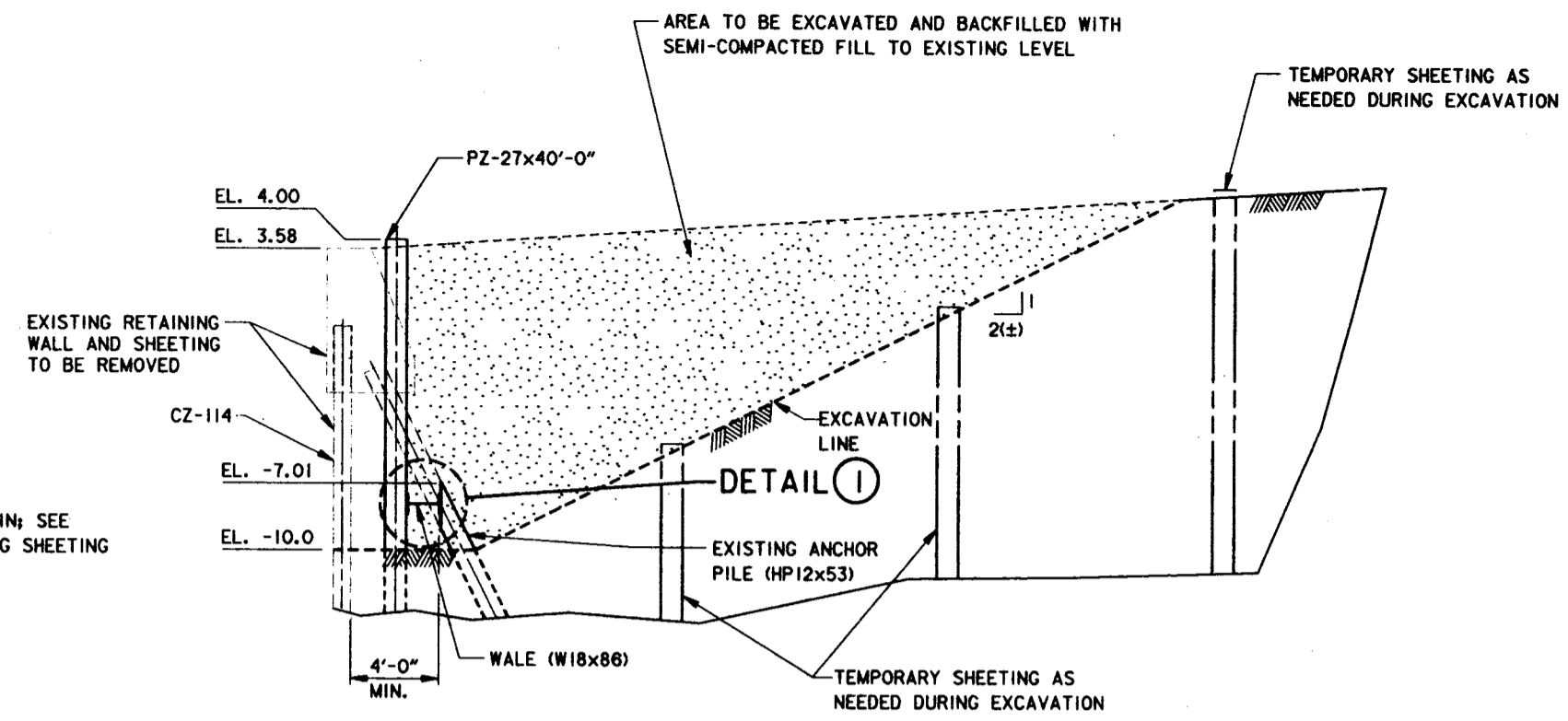

SECTION A
SCALE: 1/4" = 1'-0"

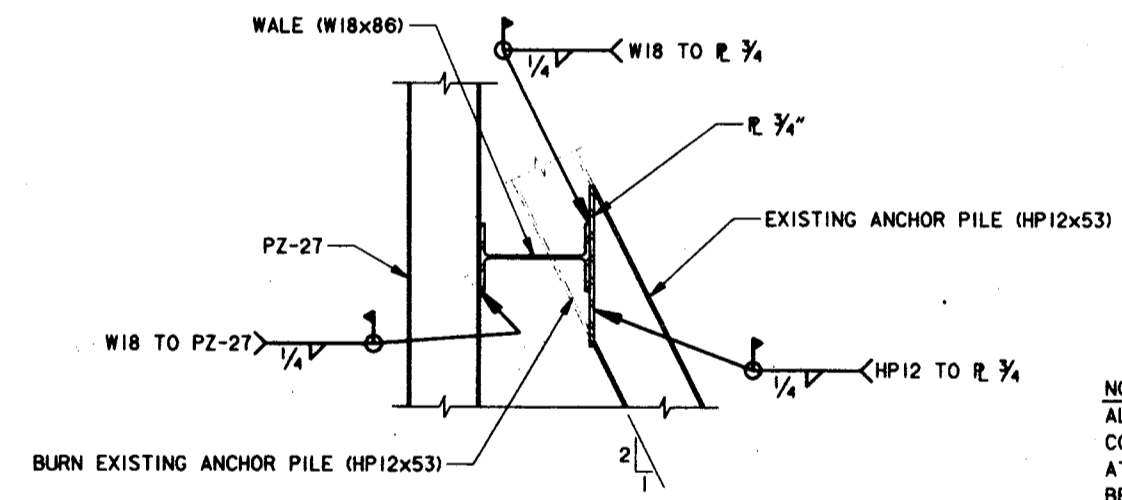

DETAIL 1
SCALE: 3/4" = 1'-0"

NOTE:
ALL OF THE ITEMS REQ'D. TO CONSTRUCT THE COFFERDAM AT WEST MONOLITH 1 SHALL BE PAID FOR UNDER COFFERDAM (WEST MONOLITH).

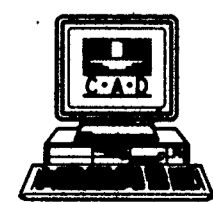
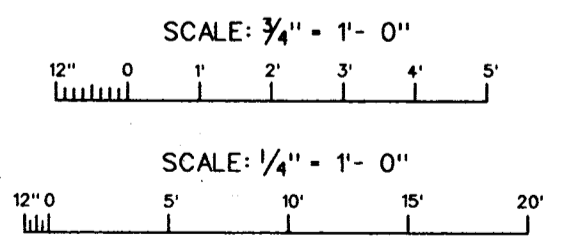

SYMBOL	DESCRIPTION	DATE	APPROVED
REVISIONS			
U.S. ARMY ENGINEER DISTRICT, NEW ORLEANS CORPS OF ENGINEERS NEW ORLEANS, LOUISIANA			
URS CONSULTANTS, INC.			
LAKE PONTCHARTRAIN, LA. AND VICINITY HURRICANE PROTECTION HIGH LEVEL PLAN			
FRONTING PROTECTION AT PUMP STATION #6 ORLEANS PARISH - JEFFERSON PARISH 17th STREET OUTFALL CANAL (METAIRIE RELIEF)			
COFFERDAM #1 WEST MONOLITH 1			
DESIGNED BY: L.A.K.	DATE: SEPT. 1997	PLOT SCALE: 4	PLOT DATE: SEPT. 1997
DRAWN BY: K.L.L.	CADD FILE: P99-3-06.DGN	FILE NO. H-4-44654	
CHECKED BY: D.J.L.	SOLICITATION NO. DACW29-98-B-0112	DWG. 3-5	OF 3-10
DESIGN ENGINEER			



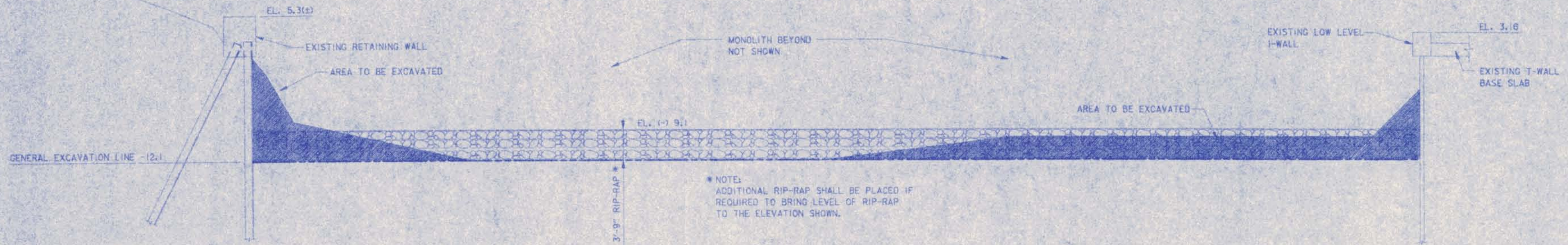

SECTION A
SCALE: 3/16" = 1'-0"

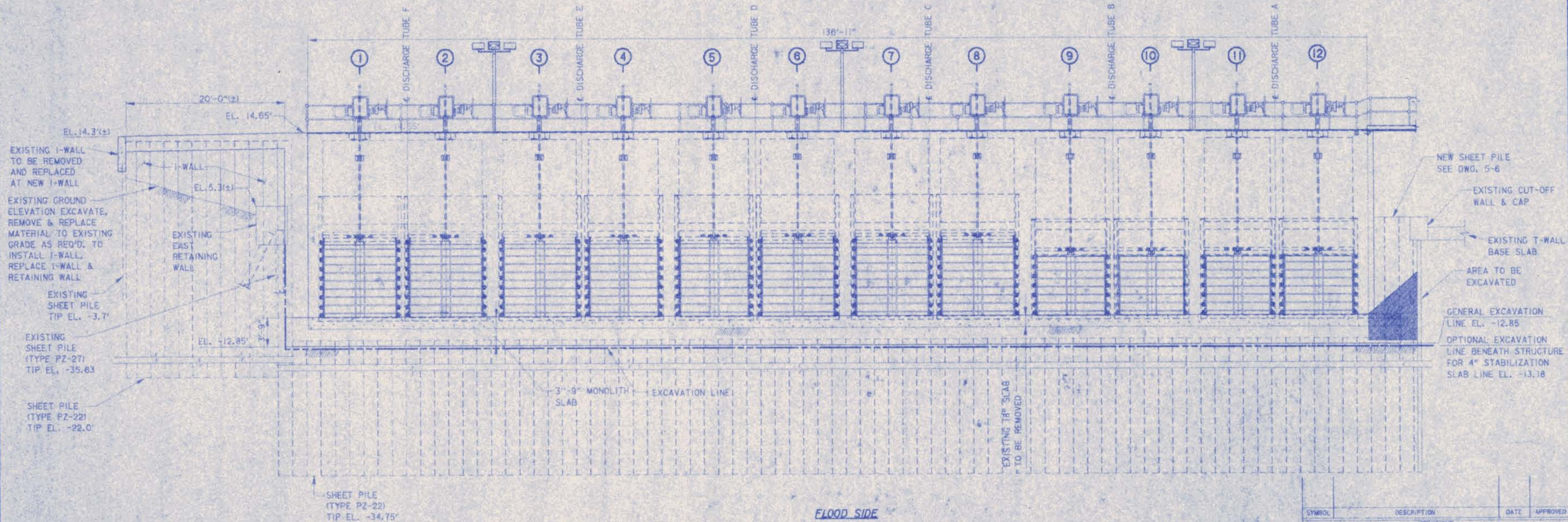

SECTION B
SCALE: 3/16" = 1'-0"

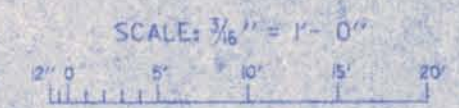

SYMBOL	DESCRIPTION	DATE	APPROVED
REVISIONS			
U.S. ARMY ENGINEER DISTRICT, NEW ORLEANS CORPS OF ENGINEERS NEW ORLEANS, LOUISIANA			
URS CONSULTANTS, INC. <small>LAKE PONTCHARTRAIN, LA. AND VICINITY HURRICANE PROTECTION HIGH LEVEL PLAN</small>			
FRONTING PROTECTION AT PUMP STATION #6 ORLEANS PARISH - JEFFERSON PARISH 17TH STREET OUTFALL CANAL (METAIRIE RELIEF)			
EXCAVATION ELEVATIONS ① EAST MONOLITH			
DESIGNED BY: S.C.B.	DATE: SEPT. 1997	PLOT SCALE: 5.333	PLOT DATE: SEPT. 1997
DRAWN BY: K.L.L.	CADD FILE: P58-3-ORL.DWG	FILE NO. H-4-44654	
CHECKED BY: M.D.P.	SOLIDIFICATION NO. DACW29-98-B-0112	DWG. 3-6	OF 3-10
SUBMITTED BY:	DESIGN ENGINEER		

NOTE:
STOP BULKHEADS NOT SHOWN

Safety is a Part of Your Contract

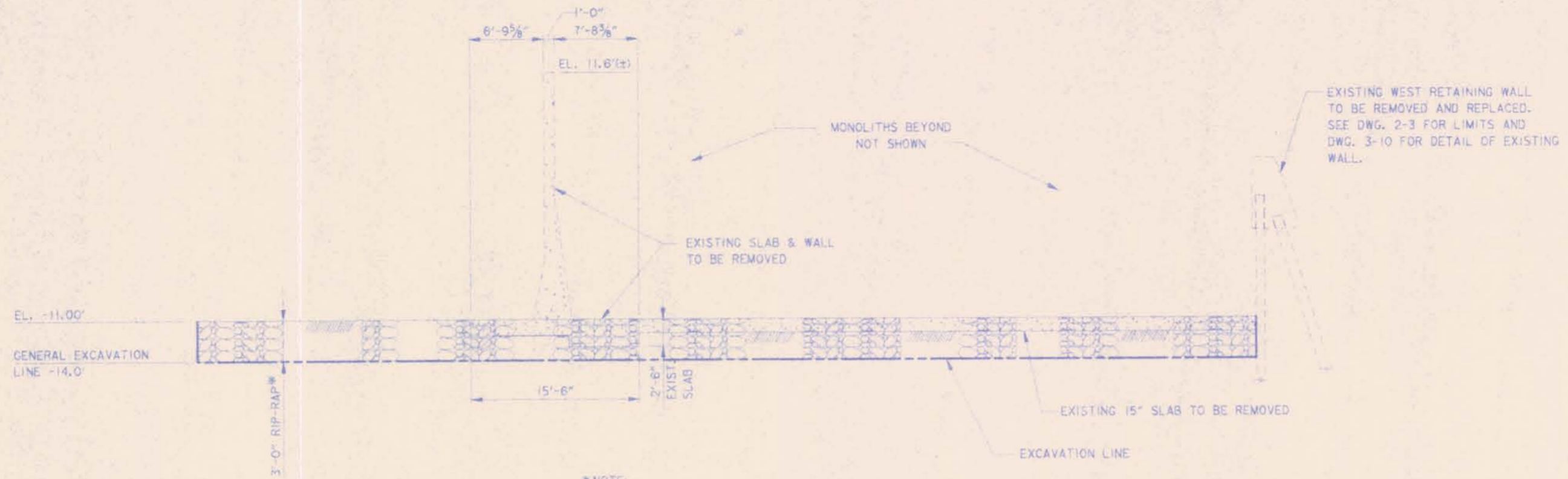

*NOTE:
ADDITIONAL STONE (RIP-RAP) SHALL BE PLACED IF REQUIRED
TO BRING LEVEL OF RIP-RAP TO THE ELEVATION SHOWN.

SECTION C
SCALE: 3/16" = 1'-0"

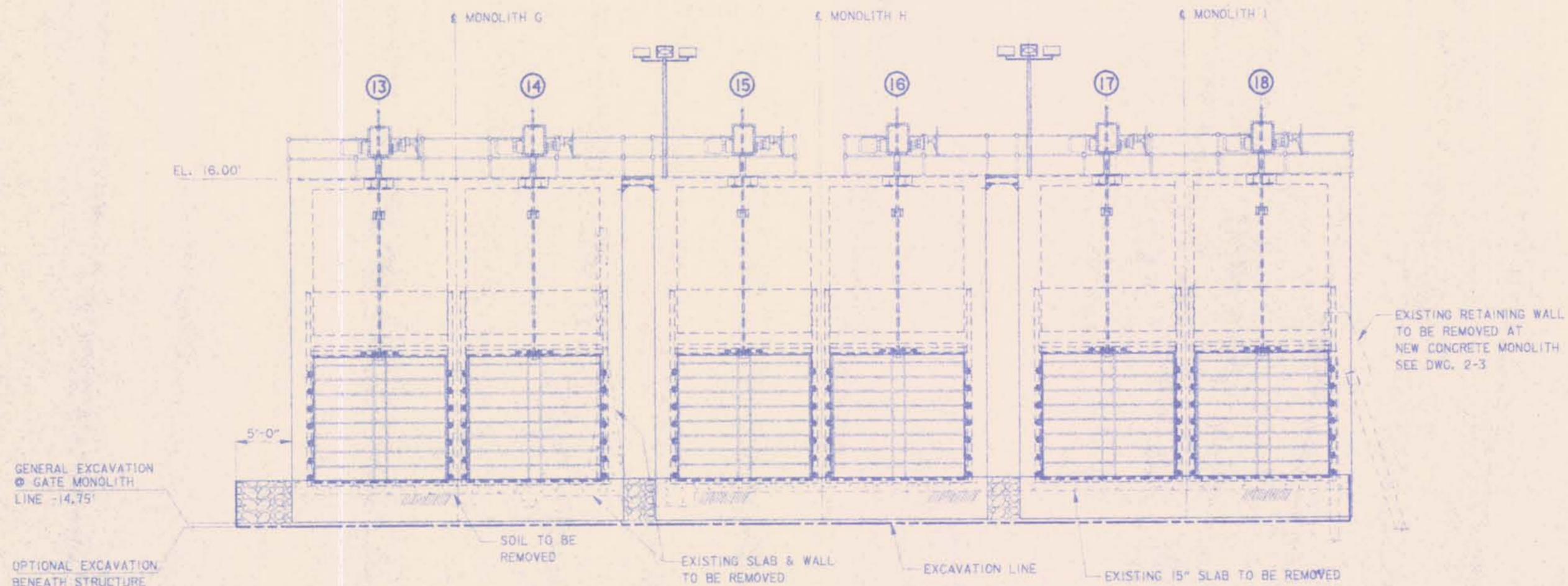

FLOOD SIDE

SECTION D
SCALE: 3/16" = 1'-0"

NOTE:
STOP BULKHEADS NOT SHOWN

SCALE: 3/16" = 1'-0"

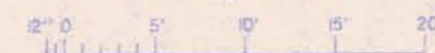

GENERAL EXCAVATION
GATE MONOLITH
LINE -14.75'

OPTIONAL EXCAVATION
BENEATH STRUCTURE
FOR 4" STABILIZATION
SLAB EL. -15.08

SYMBOL	DESCRIPTION	DATE	APPROVED
REVISIONS			
 U.S. ARMY ENGINEER DISTRICT, NEW ORLEANS CORPS OF ENGINEERS NEW ORLEANS, LOUISIANA			
URS CONSULTANTS, INC. LAKE FORTCHARTRAIN, LA. AND VICINITY HURRICANE PROTECTION HIGH LEVEL PLAN FRONTING PROTECTION AT PUMP STATION #6 ORLEANS PARISH - JEFFERSON PARISH (7th STREET OUTFALL CANAL METAIRIE RELIEF)			
EXCAVATION ELEVATIONS WEST MONOLITH			
DESIGNED BY: S.C.B.	DATE: SEPT. 1997	PLOT SCALE: 5.333	PLOT DATE: SEPT. 1997
DRAWN BY: K.L.L.	CHECKED BY: M.D.P.	CADD FILE: P58-3-07.DGN	FILE NO. H-4-44654
SUBMITTED BY:	SOL. CITATION NO. DACW29-98-B-0112	DWG 3-7 OF 3-10	
DESIGN ENGINEER			



**Safety is a Part
of Your Contract**

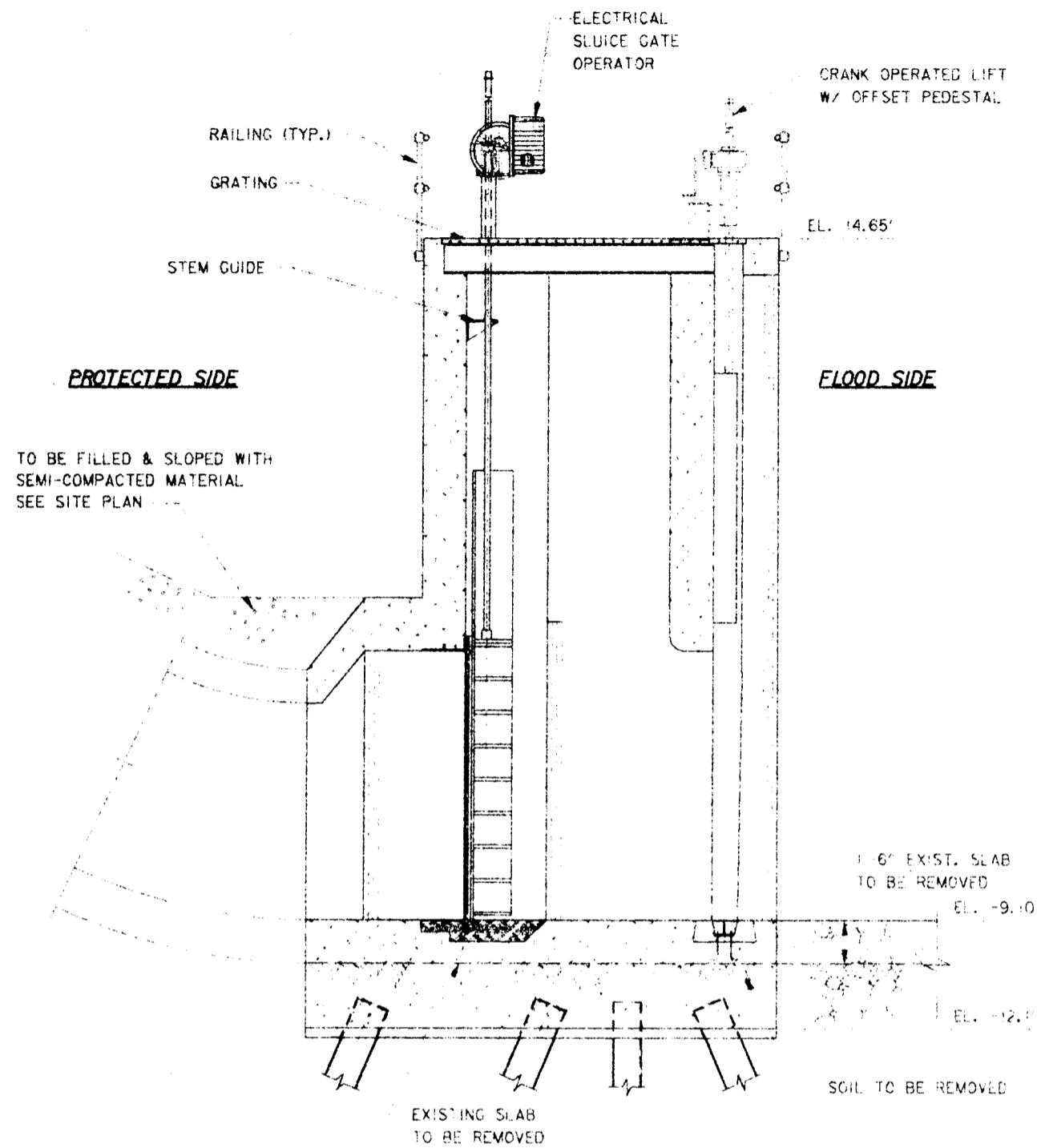

EAST MONOLITH

SECTION E
SCALE: 3/8" = 1'-0"

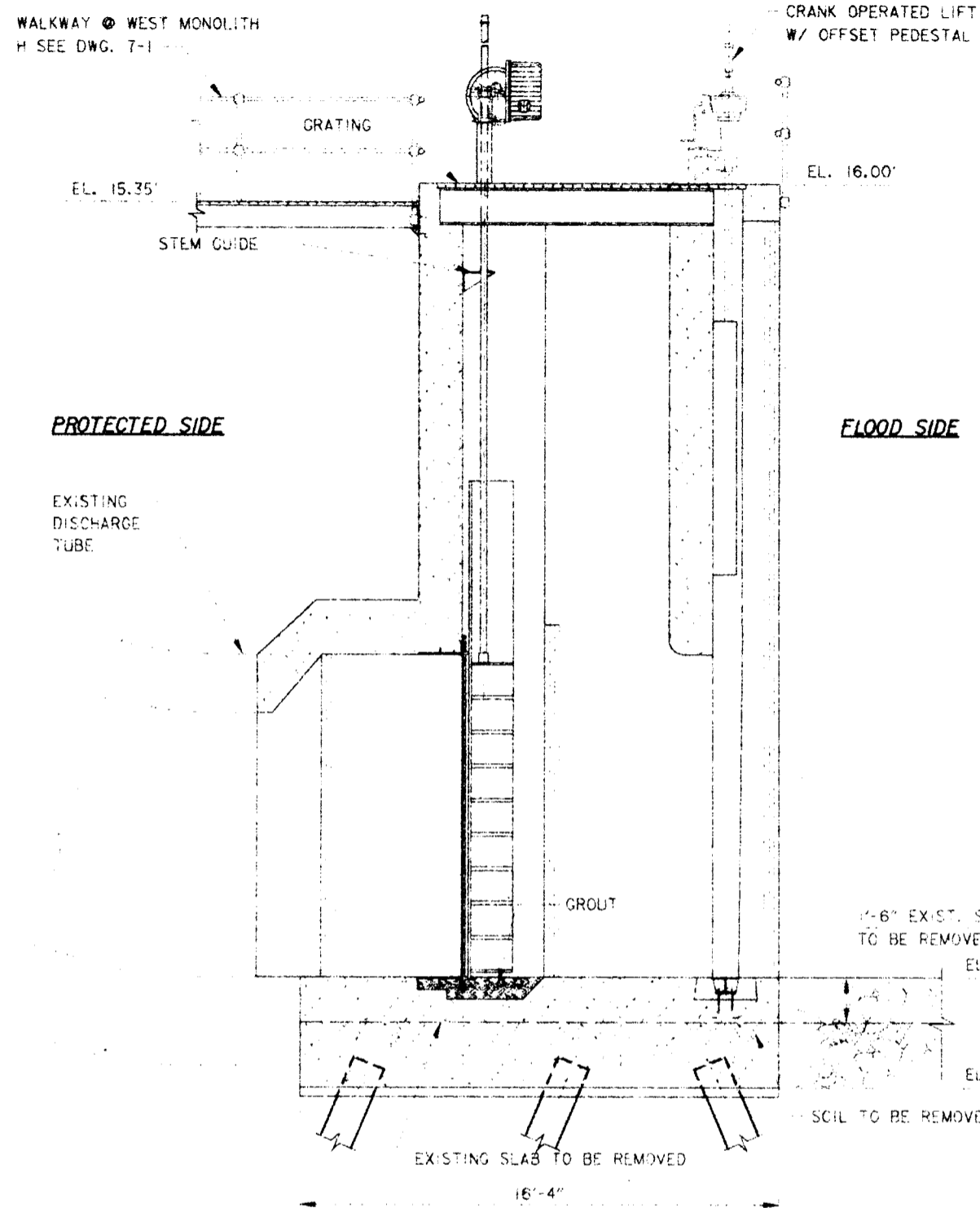

WEST MONOLITH

SECTION F
SCALE: 3/8" = 1'-0"

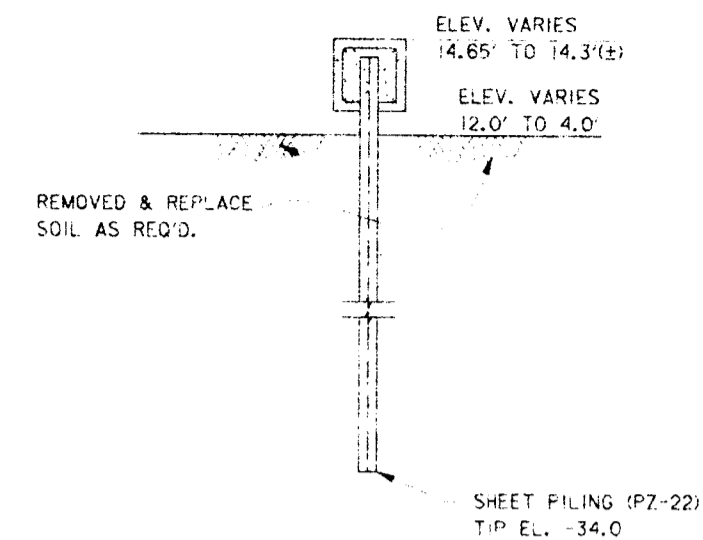

SECTION G I-WALL
SCALE: 3/8" = 1'-0"

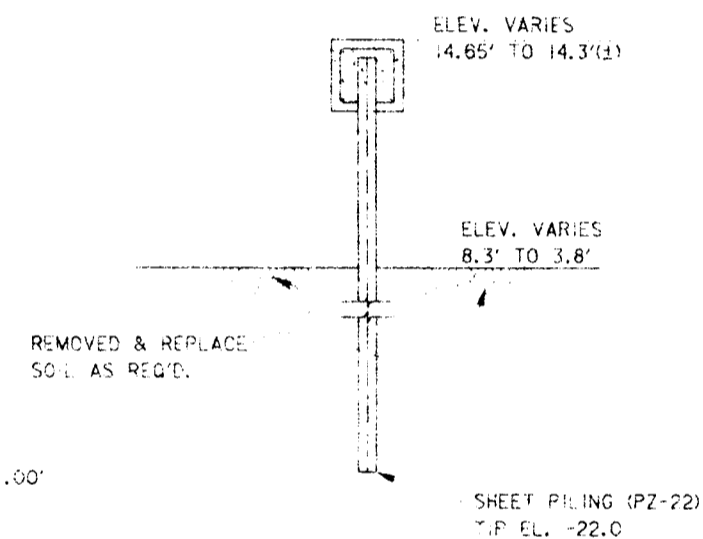

SECTION H I-WALL
SCALE: 3/8" = 1'-0"

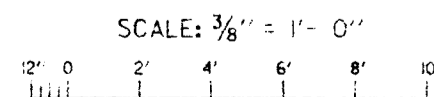

SYMBOL	DESCRIPTION	DATE	APPROVED
REVISIONS			
 U.S. ARMY ENGINEER DISTRICT, NEW ORLEANS CORPS OF ENGINEERS NEW ORLEANS, LOUISIANA			
URS CONSULTANTS, INC. LAKE PONCHARTRAIN, LA. AND VICINITY HURRICANE PROTECTION HIGH LEVEL PLAN FRONTING PROTECTION AT PUMP STATION #6 ORLEANS PARISH - JEFFERSON PARISH 17TH STREET OUTFALL CANAL (METAIRIE RELIEF)			
EXCAVATION SECTIONS			
DESIGNED BY: S.C.B.	DATE: SEPT. 1997	PLOT SCALE: 2.007	PLOT DATE: SEPT. 1997
DRAWN BY: K.L.L.	CHECKED BY: M.D.P.	GADD FILE: PSB-3-OLDGN	FILE NO: H-4-44654
SUBMITTED BY:	SOLICITATION NO. DACW29-98-B-0112	DWG. 3-8 OF 3-10	



Safety is a Part of Your Contract

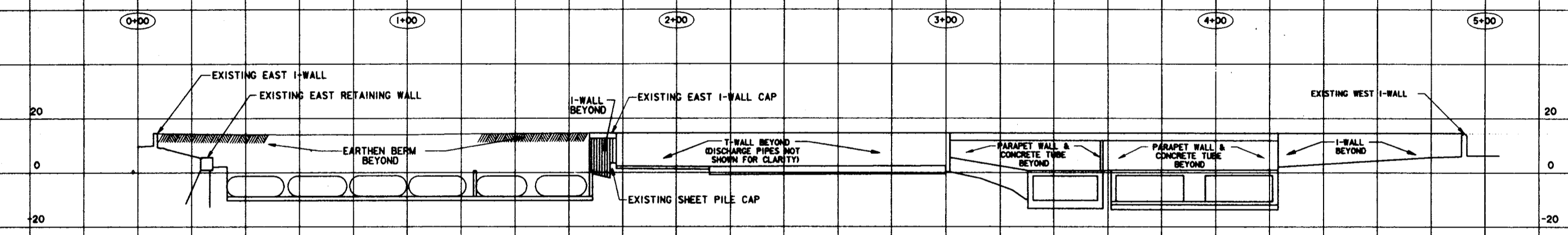

PROFILE @ DISCHARGE FLOOD SIDE

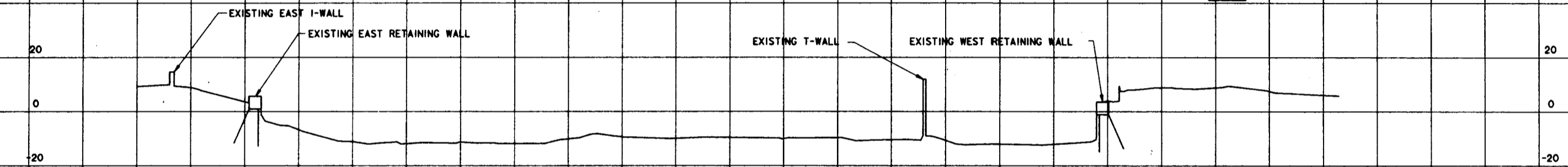

SECTION @ FLOOD SIDE

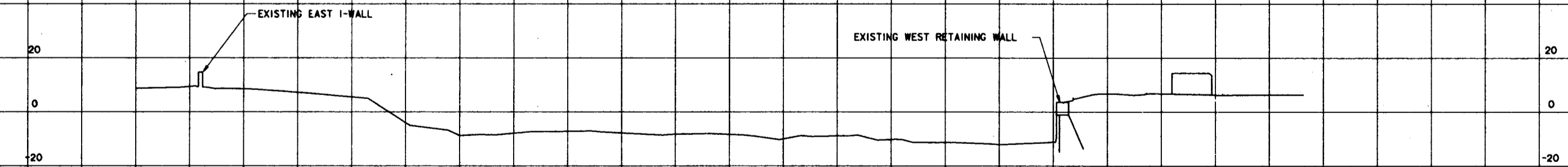

SECTION @ FLOOD SIDE

ELEVATION IN FEET, N.G.V.D.

ELEVATION IN FEET, N.G.V.D.

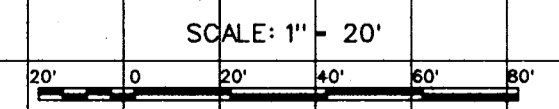

SYMBOL	DESCRIPTION	DATE	APPROVED
REVISIONS			
U.S. ARMY ENGINEER DISTRICT, NEW ORLEANS CORPS OF ENGINEERS NEW ORLEANS, LOUISIANA			
URS CONSULTANTS, INC. LAKE PONTCHARTRAIN, LA. AND VICINITY HURRICANE PROTECTION HIGH LEVEL PLAN FRONTING PROTECTION AT PUMP STATION #6 ORLEANS PARISH - JEFFERSON PARISH 17th STREET OUTFALL CANAL (METAIRIE RELIEF)			
CROSS SECTIONS			
DESIGNED BY: S.C.B.	DATE: SEPT. 1997	PLOT SCALE: 20	PLOT DATE: SEPT. 1997
DRAWN BY: K.L.L.	CADD FILE: P58-3-09.DGN	FILE NO. H-4-44654	
CHECKED BY: M.D.P.	SOLICITATION NO. DACW29-98-B-0112	DWG. 3-9 OF 3-10	
SUBMITTED BY:	DESIGN ENGINEER		

Safety is a Part of Your Contract

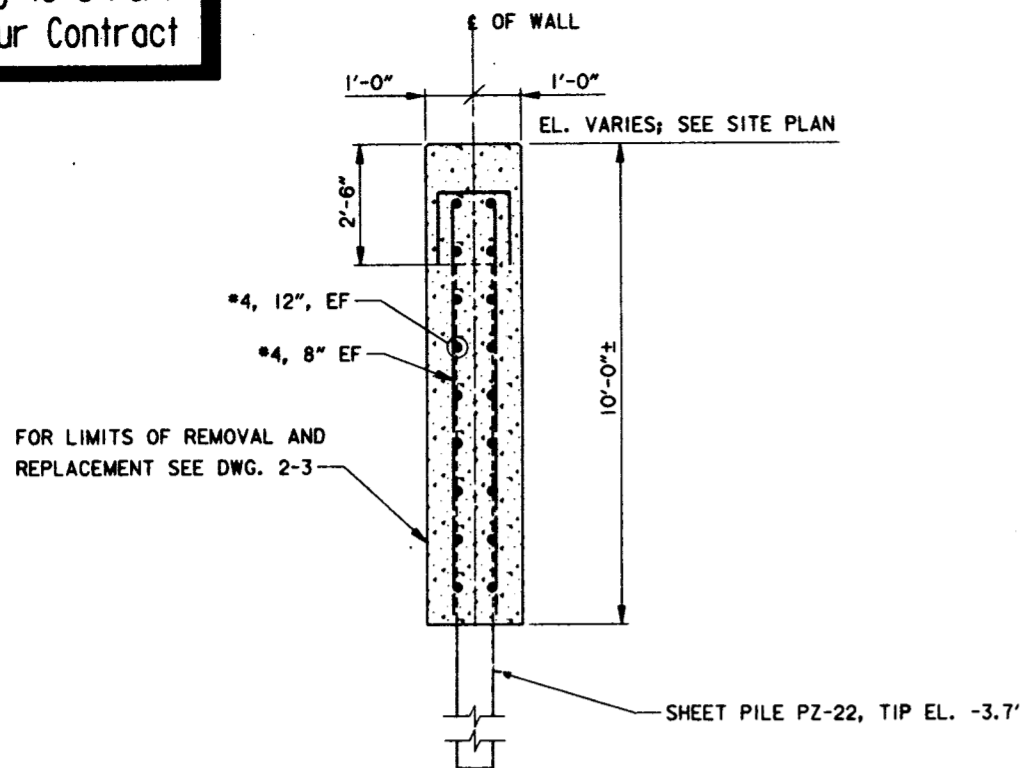

EXISTING EAST I-WALL

SCALE: 1/2" = 1'-0"

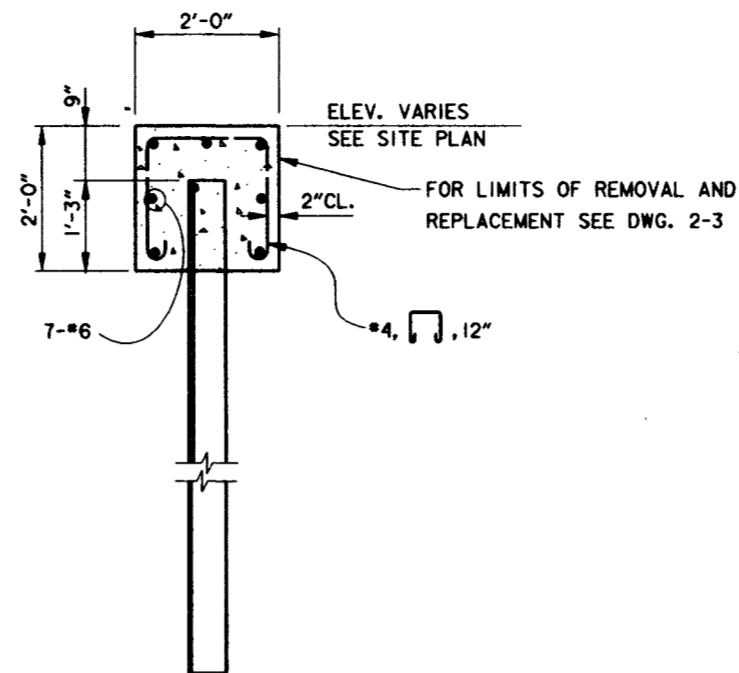

EXISTING EAST I-WALL CAP (SIMILAR)

SCALE: 3/4" = 1'-0"

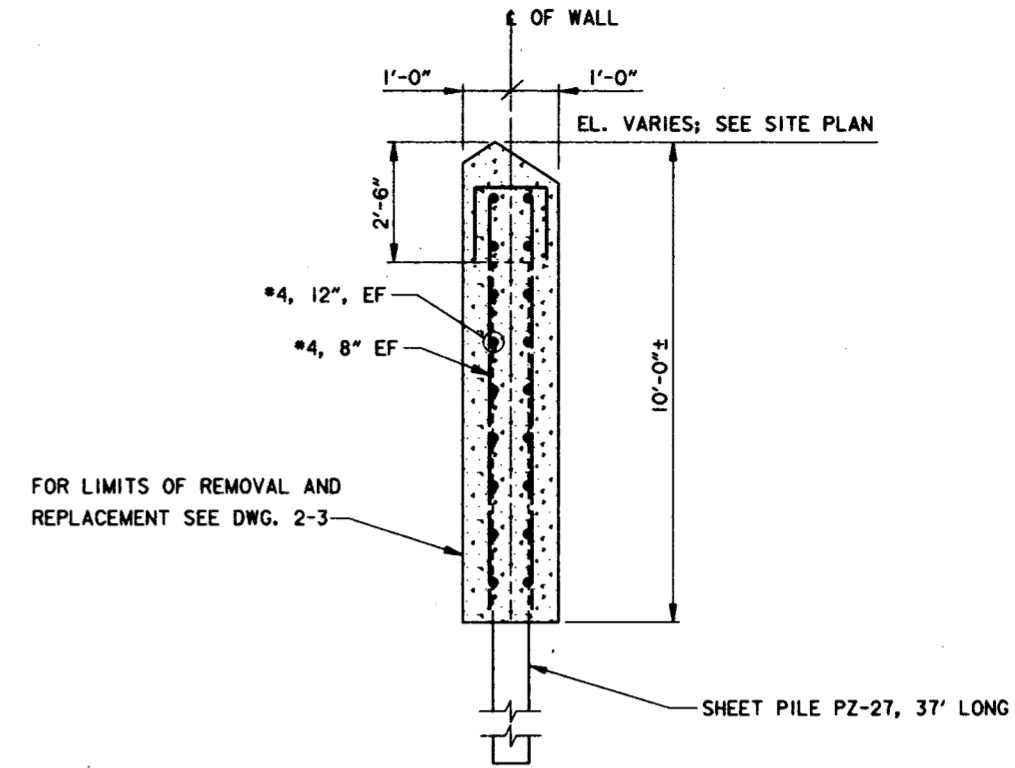

EXISTING WEST I-WALL

SCALE: 1/2" = 1'-0"

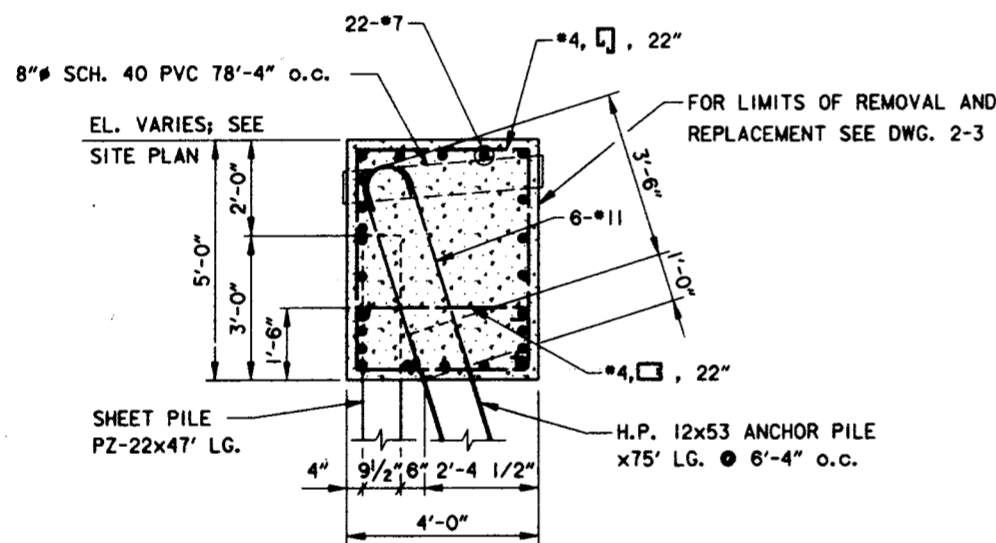

EXISTING EAST RETAINING WALL

SCALE: 1/2" = 1'-0"

NOTE:
SEE DRAWING 3-9 FOR
LOCATION OF WALLS

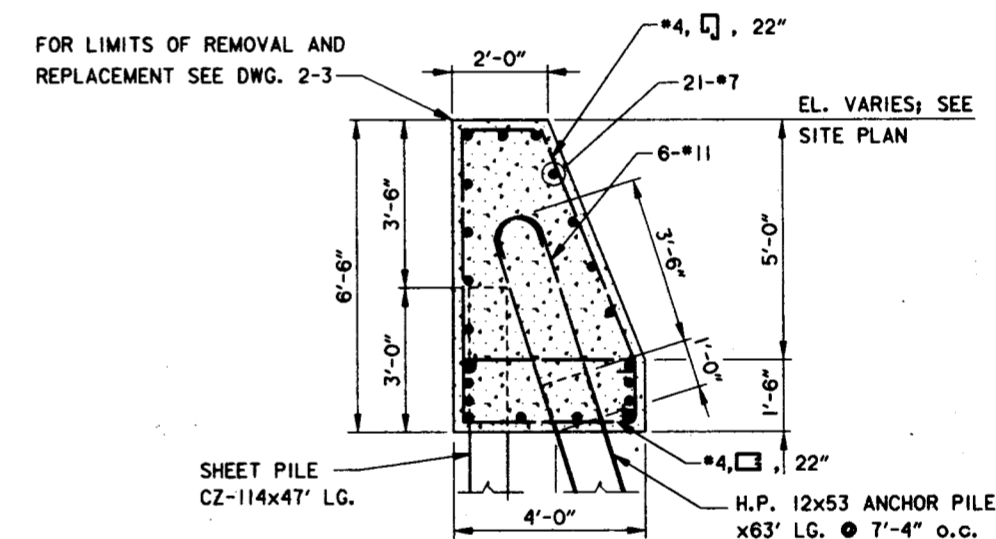

EXISTING WEST RETAINING WALL

SCALE: 1/2" = 1'-0"

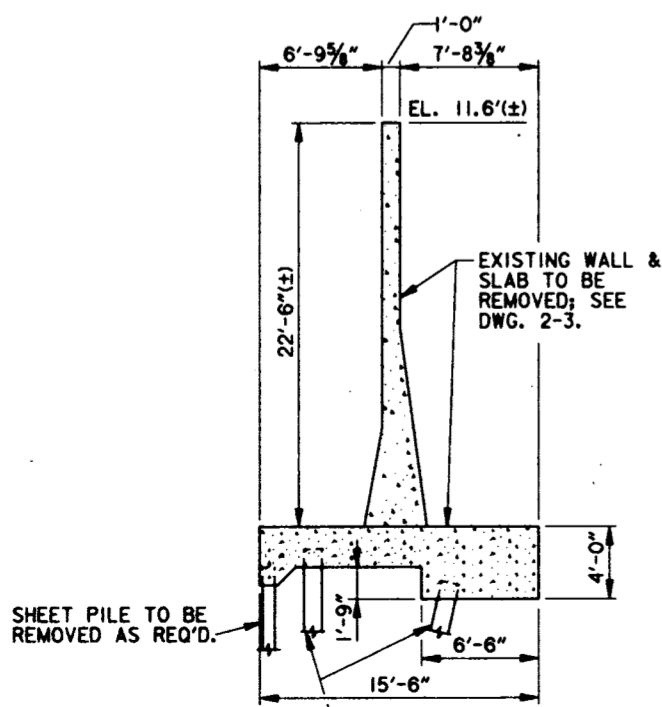

EXISTING T-WALL

SCALE: 3/16" = 1'-0"

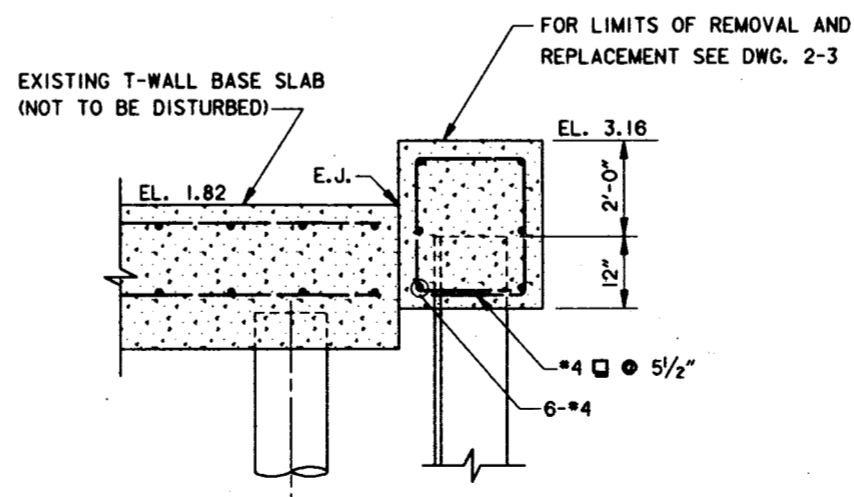

EXISTING SHEET PILE CAP @ T-WALL

SCALE: 3/4" = 1'-0"



SYMBOL	DESCRIPTION	DATE	APPROVED
REVISIONS			
U.S. ARMY ENGINEER DISTRICT, NEW ORLEANS CORPS OF ENGINEERS NEW ORLEANS, LOUISIANA			
URS CONSULTANTS, INC. LAKE PONTCHARTRAIN, LA. AND VICINITY HURRICANE PROTECTION HIGH LEVEL PLAN FRONTING PROTECTION AT PUMP STATION #6 ORLEANS PARISH - JEFFERSON PARISH 17th STREET OUTFALL CANAL (METAIRIE RELIEF)			
DESIGNED BY: S.C.B.	DATE: SEPT. 1997	PLOT SCALE: 2	PLOT DATE: SEPT. 1997
DRAWN BY: K.L.L.	CADD FILE: P58-3-10.DGN	FILE NO.	H-4-44654
CHECKED BY: M.D.P.	SOLICITATION NO.	DWG3-10	OF 3-10
SUBMITTED BY:	DACW29-98-B-0112	DWG3-10	OF 3-10
DESIGN ENGINEER			

Safety is a Part
of Your Contract

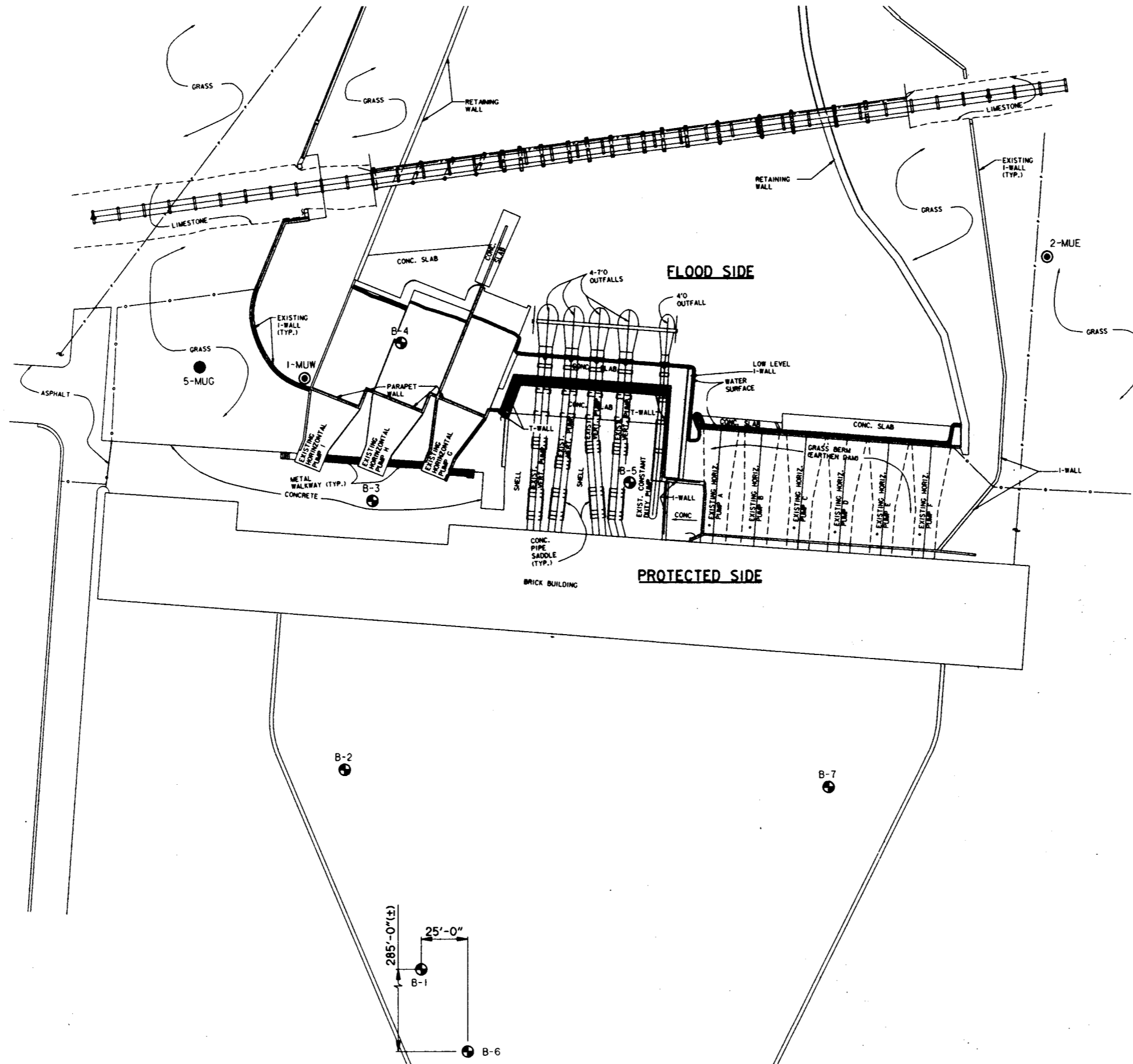

LEGEND

- DENOTES EUSTIS BORINGS DRILLED 16-19 AUGUST & 14-19 OCTOBER 1982
- ⊖ DENOTES COE BORINGS DRILLED JANUARY 1971
- DENOTES COE BORING DRILLED MAY 13, 1996

SCALE: 1" = 30'

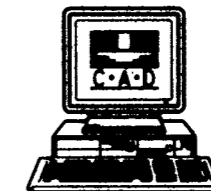
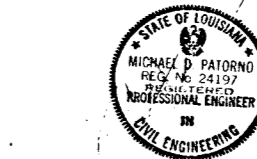

SYMBOL	DESCRIPTION	DATE	APPROVED
REVISIONS			
 U.S. ARMY ENGINEER DISTRICT, NEW ORLEANS CORPS OF ENGINEERS NEW ORLEANS, LOUISIANA			
URS CONSULTANTS, INC. LAKE PONTCHARTRAIN, LA. AND VICINITY HURRICANE PROTECTION HIGH LEVEL PLAN FRONTING PROTECTION AT PUMP STATION #6 ORLEANS PARISH - JEFFERSON PARISH 17th STREET OUTFALL CANAL (METRIE RELIEF)			
SOIL BORING PLAN			
DESIGNED BY: S.C.B.	DATE: SEPT. 1997	PLOT SCALE: 30	PLOT DATE: SEPT. 1997
DRAWN BY: K.L.L.	CHECKED BY: M.D.P.	CADD FILE: P58-4-01.DGN	FILE NO. H-4-44654
SUBMITTED BY:	SOLICITATION NO. DACW29-98-B-0112	DWC. 4-1 OF 4-3	
DESIGN ENGINEER			



UNIFIED SOIL CLASSIFICATION (COE BORINGS)

MAJOR DIVISION	TYPE	LETTER SYMBOL	SYM BOL	TYPICAL NAMES	
COARSE - GRAINED SOILS More than half of material is larger than No. 200 sieve size.	GRAVELS	CLEAN GRAVEL Little or no fines	GW	GRAVEL, Well Graded, gravel-sand mixtures, little or no fines	
		GRAVEL Poorly Graded, gravel-sand mixtures, little or no fines	GP	GRAVEL, Poorly Graded, gravel-sand mixtures, little or no fines	
	SANDS WITH FINES Cooperatively graded, 10% or more fines	SILTY GRAVEL, gravel-sand-silt mixtures	GM	SILTY GRAVEL, gravel-sand-silt mixtures	
		CLAYEY GRAVEL, gravel-sand-clay mixtures	GC	CLAYEY GRAVEL, gravel-sand-clay mixtures	
	SANDS More than half of material is larger than No. 200 sieve size.	CLEAN SAND Little or no fines	SW	SAND, Well-Graded, gravelly sands	
		SAND Poorly-Graded, gravelly sands	SP	SAND, Poorly-Graded, gravelly sands	
		SANDS WITH FINES Cooperatively graded, 10% or more fines	SM	SILTY SAND, sand-silt mixtures	
		CLAYEY SAND, sand-clay mixtures	SC	CLAYEY SAND, sand-clay mixtures	
	FINE - GRAINED SOILS More than half the material is smaller than No. 200 sieve size.	SILTS AND CLAYS Liquid Limit < 50	SILT & very fine sand, silty or clayey fine sand or clayey silt with slight plasticity	ML	SILT & very fine sand, silty or clayey fine sand or clayey silt with slight plasticity
			LEAN CLAY, Sandy Clay, Silty Clay, of low to medium plasticity	CL	LEAN CLAY, Sandy Clay, Silty Clay, of low to medium plasticity
SILTS AND CLAYS Liquid Limit > 50		ORGANIC SILTS, and organic silty clays of low plasticity	OL	ORGANIC SILTS, and organic silty clays of low plasticity	
		SILT, fine sandy or silty soil with high plasticity	MH	SILT, fine sandy or silty soil with high plasticity	
		FAT CLAY, inorganic clay of high plasticity	CH	FAT CLAY, inorganic clay of high plasticity	
ORGANIC CLAYS of medium to high plasticity, organic silts	OH	ORGANIC CLAYS of medium to high plasticity, organic silts			
HIGHLY ORGANIC SOILS		Pt	PEAT, and other highly organic soil		
WOOD		Wd	WOOD		
SHELLS		SI	SHELLS		
NO SAMPLE		NS	No Sample Retrieved		

NOTE: Soils possessing characteristics of two groups are designated by combinations of group symbols.

DESCRIPTIVE SYMBOLS (COE BORINGS)

COLOR		CONSISTENCY FOR COHESIVE SOILS			MODIFICATIONS	
COLOR	SYMBOL	CONSISTENCY	COHESION IN LBS./SQ.FT. FROM UNCONFINED COMPRESSION TEST	SYMBOL	MODIFICATION	SYMBOL
TAN	T	VERY SOFT	< 250	vSo	Traces	Tr
YELLOW	Y				Fine	F
RED	R				Medium	M
BLACK	BK				Coarse	C
GRAY	Gr				Concretions	cc
LIGHT GRAY	lGr	SOFT	250-500	So	Rootlets	rt
DARK GRAY	dGr				Lignite fragments	lg
BROWN	Br	MEDIUM	500-1000	M	Shale fragments	sh
LIGHT BROWN	lBr				Sandstone fragments	eds
DARK BROWN	dBr	STIFF	1000-2000	St	Shell fragments	sif
BROWNISH-GRAY	brGr				Organic matter	o
GRAYISH-BROWN	gyBr	VERY STIFF	2000-4000	vSt	Clay strata or lenses	CS
GREENISH-GRAY	gnGr				Silt strata or lenses	SIS
GRAYISH-GREEN	gyGn	HARD	> 4000	H	Sand strata or lenses	SS
GREEN	Gn				Sandy	S
BLUE	Bl				Gravelly	G
BLUE-GREEN	BlGn				Boulders	B
WHITE	Wh				Slickensides	SL
MOTTLED	Mot				Wood	Wd
					Oxidized	Ox

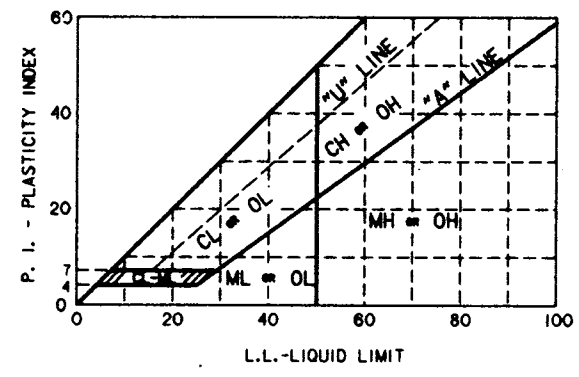

PLASTICITY CHART
For classification of fine-grained soils in accordance with ASTM D 2487

TYPICAL NOTES FOR C.O.E. BORINGS:

- While the borings are representative of subsurface conditions at their respective locations and for their respective vertical reaches, local variations characteristic of the subsurface materials of the region are anticipated and, if encountered, such variations will not be considered as differing materially within the purview of the contract clause entitled "Differing Site Conditions".
- Ground-water elevations shown on the boring logs represent ground-water surfaces encountered in such borings on the dates shown. Absence of water surface data on certain borings indicates that no ground-water data are available from the boring but does not necessarily mean that ground-water will not be encountered at the locations or within the vertical reaches of such borings.
- Consistency of cohesive soils shown on the boring logs is based on driller's log and visual examination and is approximate, except within those vertical reaches of the borings where shear strengths from unconfined compression tests are shown.
- Unless otherwise noted:
 - Undisturbed borings, indicated by the letter "U", are taken with a 5" I.D. Piston Type Sampler.
 - General type borings are taken with a 1 7/8" I.D. Tube Sampler and/or a 1 3/8" I.D. Split Spoon Sampler.

LEGEND AND NOTES FOR EUSTIS BORINGS

PP	POCKET PENETROMETER RESISTANCE IN TONS PER SQUARE FOOT
TV	TORVANE SHEAR STRENGTH IN TONS PER SQUARE FOOT
SPT	STANDARD PENETRATION TEST. TEST NUMBER OF BLOWS OF A 140-LB. HAMMER DROPPED 30 INCHES REQUIRED TO DRIVE 2-IN O.D., 1.4-IN I.D. SAMPLER A DISTANCE OF ONE FOOT INTO THE SOIL, AFTER FIRST SEATING IT 6 INCHES
SPLR	TYPE OF SAMPLING <input type="checkbox"/> SHELBY <input type="checkbox"/> SPT <input type="checkbox"/> AUGER <input type="checkbox"/> NO SAMPLE
SYMBOL	CLAY <input type="checkbox"/> SILT <input type="checkbox"/> SAND <input type="checkbox"/> HUMUS <input type="checkbox"/>
DENSITY	UNIT WEIGHT IN POUNDS PER CUBIC FOOT
USC	UNIFIED SOIL CLASSIFICATION
TYPE	UC UNCONFINED COMPRESSION SHEAR OB UNCONSOLIDATED UNDRAINED TRIAXIAL COMPRESSION SHEAR ON ONE SPECIMEN CONFINED AT THE APPROXIMATE OVERBURDEN PRESSURE UU UNCONSOLIDATED UNDRAINED TRIAXIAL COMPRESSION SHEAR CU CONSOLIDATED UNDRAINED TRIAXIAL COMPRESSION SHEAR DS DIRECT SHEAR CON CONSOLIDATION PD PARTICLE SIZE DISTRIBUTION K COEFFICIENT OF PERMEABILITY IN CENTIMETERS PER SECOND SP SWELLING PRESSURE IN POUNDS PER SQUARE FOOT
φ	ANGLE OF INTERNAL FRICTION IN DEGREES
c	COHESION IN POUNDS PER SQUARE FOOT

OTHER LABORATORY TEST RESULTS REPORTED ON SEPARATE FIGURE

GROUND WATER MEASUREMENTS INITIAL FINAL

GENERAL NOTES:

- AT THE TIME THE BORINGS WERE MADE, GROUND WATER LEVELS WERE MEASURED BELOW EXISTING GROUND SURFACE. THESE OBSERVATIONS ARE SHOWN ON THE BORING LOGS. HOWEVER, GROUND WATER LEVELS MAY VARY DUE TO SEASONAL AND OTHER FACTORS. IF IMPORTANT TO CONSTRUCTION, THE DEPTH TO GROUND WATER SHOULD BE DETERMINED BY THOSE PERSONS RESPONSIBLE FOR CONSTRUCTION, IMMEDIATELY PRIOR TO BEGINNING WORK.
- WHILE THE INDIVIDUAL LOGS OF BORINGS ARE CONSIDERED TO BE REPRESENTATIVE OF SUBSURFACE CONDITIONS AT THEIR RESPECTIVE LOCATIONS ON THE DATES SHOWN, IT IS NOT WARRANTED THAT THEY ARE REPRESENTATIVE OF SUBSURFACE CONDITIONS AT OTHER LOCATIONS AND TIMES.

NOTES FOR C.O.E. BORINGS:

FIGURES TO LEFT OF BORING UNDER COLUMN " W OR D ₁₀ "
Are natural water contents in percent dry weight
When underlined denotes D ₁₀ size in mm*
FIGURES TO LEFT OF BORING UNDER COLUMNS " LL " AND " PL "
Are liquid and plastic limits, respectively
SYMBOLS TO LEFT OF BORING
<input type="checkbox"/> Ground-water surface and date observed
<input type="checkbox"/> Denotes location of consolidation test**
<input type="checkbox"/> Denotes location of consolidated-drained direct shear test**
<input type="checkbox"/> Denotes location of consolidated-undrained triaxial compression test**
<input type="checkbox"/> Denotes location of unconsolidated-undrained triaxial compression test**
<input type="checkbox"/> Denotes location of sample subjected to consolidation test and each of the above three types of shear test**
FW Denotes free water encountered in boring or sample

FIGURES TO RIGHT OF BORING

Are values of cohesion in lbs./sq.ft. from unconfined compression tests
In parenthesis are driving resistances in blows per foot determined with a standard split spoon sampler (1 3/8" I.D., 2" O.D.) and a 140 lb. driving hammer with a 30" drop
Where underlined with a solid line denotes laboratory permeability in centimeters per second of undisturbed sample
Where underlined with a dashed line denotes laboratory permeability in centimeters per second of sample remoulded to the estimated natural void ratio
*The D ₁₀ size of a soil is the grain diameter in millimeters of which 10% of the soil is finer, and 90% coarser than D ₁₀ .
**Results of these tests are available for inspection in the U.S. Army Engineer District Office, if these symbols appear beside the boring logs on the drawings.

Safety is a Part of Your Contract

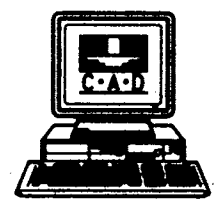

SYMBOL	DESCRIPTION	DATE	APPROVED
REVISIONS			
U.S. ARMY ENGINEER DISTRICT, NEW ORLEANS CORPS OF ENGINEERS NEW ORLEANS, LOUISIANA			
URS CONSULTANTS, INC. LAKE PONTCHARTRAIN, LA. AND VICINITY HURRICANE PROTECTION HIGH LEVEL PLAN FRONTING PROTECTION AT PUMP STATION #6 ORLEANS PARISH - JEFFERSON PARISH 17th STREET OUTFALL CANAL (METairie RELIEF)			
SOIL BORING LEGEND AND NOTES COE AND EUSTIS			
DESIGNED BY: S.C.B.	DATE: SEPT. 1997	PLOT SCALE: 10	PLOT DATE: SEPT. 1997
DRAWN BY: K.L.L.	CAD FILE: P88-4-02.DWG	FILE NO. H-4-44654	
CHECKED BY: M.D.P.	SOLICITATION NO. DACW29-98-B-0112	DWG. 4-3	OF 4-3
SUBMITTED BY:			

Safety is a Part of Your Contract

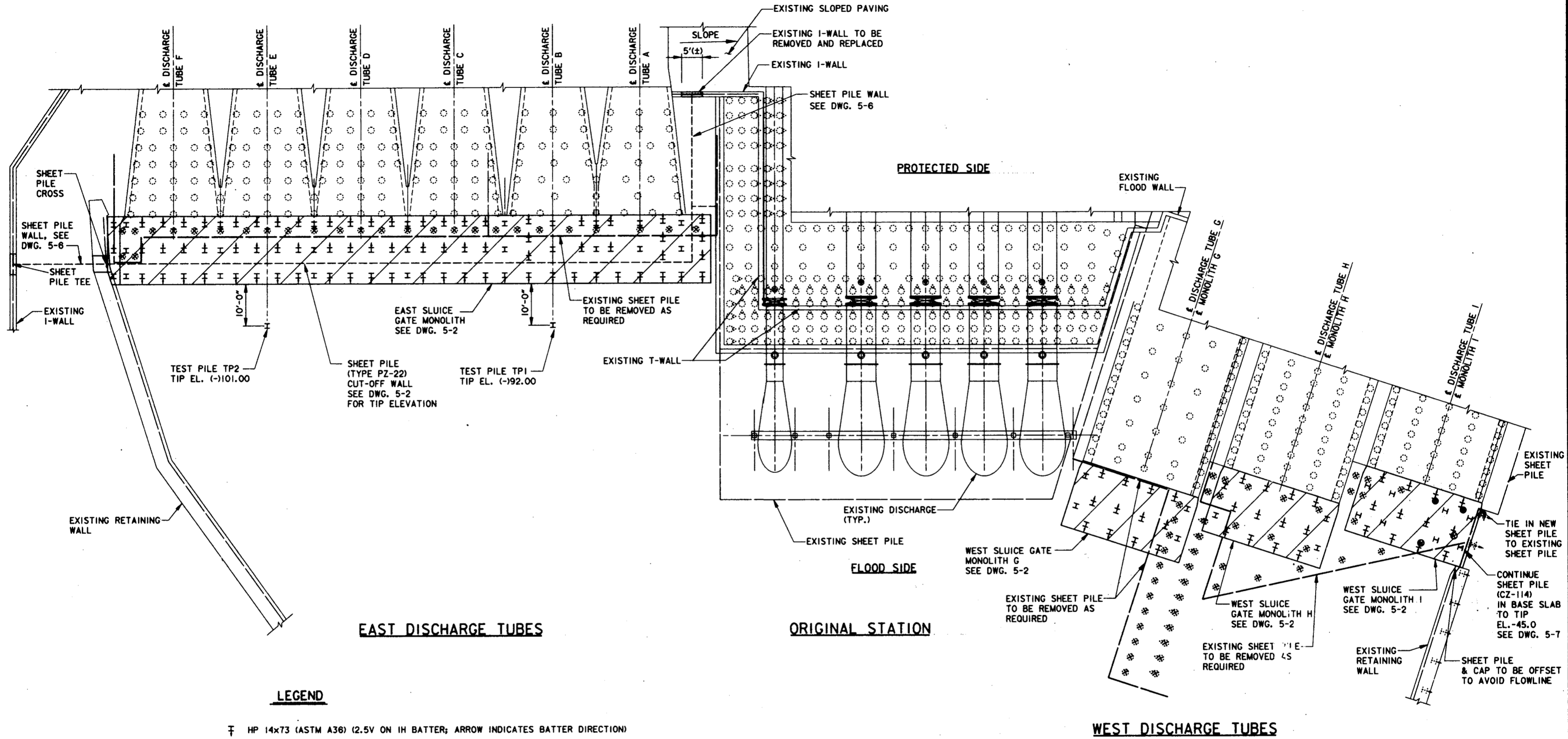

LEGEND

- ⌈ HP 14x73 (ASTM A36) (2.5V ON IH BATTER; ARROW INDICATES BATTER DIRECTION)
- ⌋ HP 14x73 (ASTM A36) (VERTICAL)
- EXISTING TIMBER PILE (NOT TO BE DISTURBED)
- ⊙ EXISTING TIMBER BATTER PILE (NOT TO BE DISTURBED)
- ⊕ EXISTING TIMBER BATTER PILE (ABANDON PILE; PILE TO REMAIN; CUT OFF 2'-0" BELOW BOTTOM OF NEW SLAB AT MONOLITH H)
- ⊕ EXISTING CONCRETE PILE (NOT TO BE DISTURBED)
- ⊙ EXISTING TIMBER PILE (REMOVE AS REQUIRED TO FACILITATE DRIVING NEW PILE)
- ⊕ EXISTING TIMBER PILE TO BE ABANDONED (CUT OFF 2'-0" BELOW BOTTOM OF NEW SLAB AT MONOLITHS)
- EXISTING TIMBER PILE (TO BE REMOVED)
- ⌈ EXISTING HP 12x53 BATTER PILE (NOT TO BE DISTURBED; ARROW DENOTES BATTER DIRECTION)
- ⌋ EXISTING HP 12x53 BATTER PILE (BURN PILE AS PER DWG. 3-5) (3 TOTAL)

▨ NEW WORK

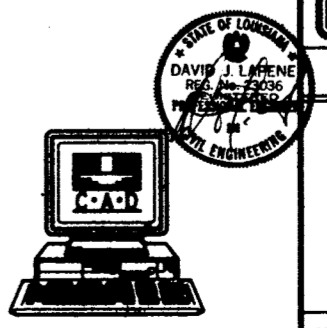
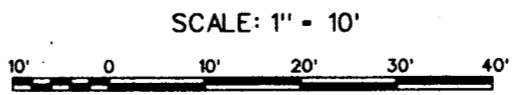

SYMBOL	DESCRIPTION	DATE	APPROVED
REVISIONS			
 U.S. ARMY ENGINEER DISTRICT, NEW ORLEANS CORPS OF ENGINEERS NEW ORLEANS, LOUISIANA			
URS CONSULTANTS, INC. LAKE PONCHARTRAIN, LA. AND VICINITY HURRICANE PROTECTION HIGH LEVEL PLAN			
FRONTING PROTECTION AT PUMP STATION #6 ORLEANS PARISH - JEFFERSON PARISH 17th STREET OUTFALL CANAL (METAIRIE RELIEF)			
OVERALL PILE PLAN			
DESIGNED BY: S.C.B.	DATE: SEPT. 1997	PLOT SCALE: 10	PLOT DATE: SEPT. 1997
DRAWN BY: K.L.L.	CADD FILE: P98-8-01.00H	FILE NO. H-4-4654	
CHECKED BY: D.J.L.	SOLICITATION NO. DACW29-98-B-0112	DWG. 5-1 OF 5-7	
SUBMITTED BY: _____			



Safety is a Part of Your Contract

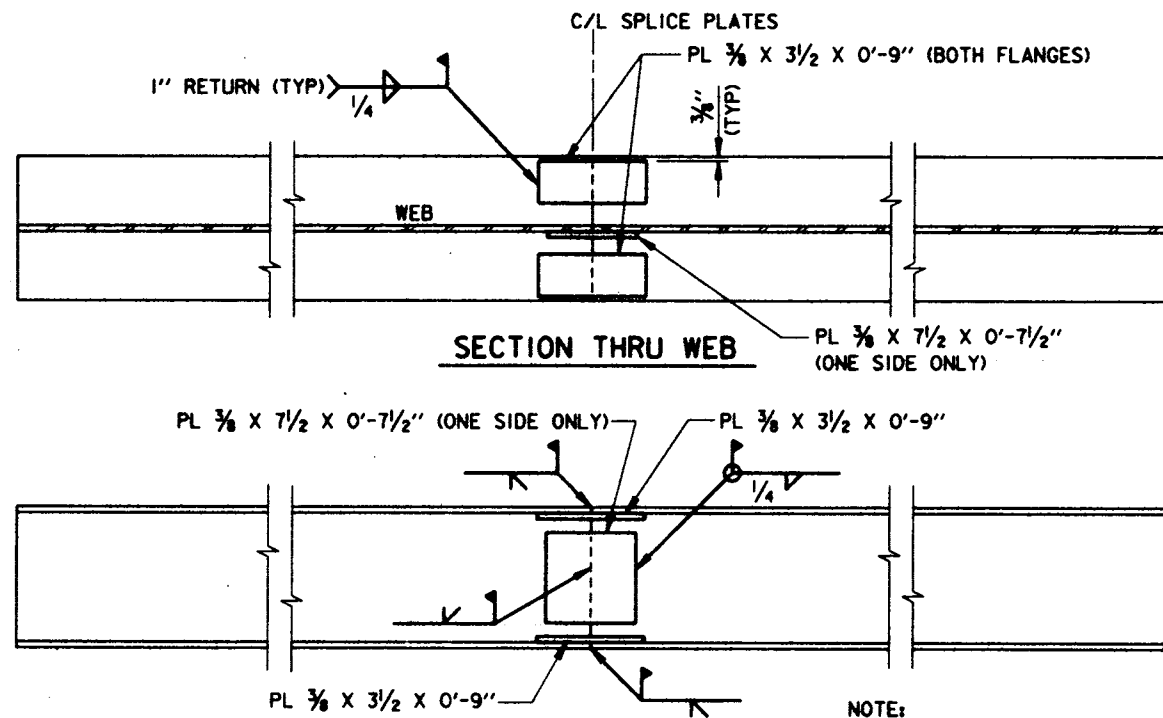

NOTE:
 1. GROOVE WELDS SHALL BE GROUND SMOOTH FOR FLUSH FIT OF OVERLAPPING SPLICE PLATES AS REQUIRED.
 2. H-PILE SPLICE SHALL BE LOCATED AT MIDSPAN OF PILE.

SCALE: 1 1/2" = 1'-0"

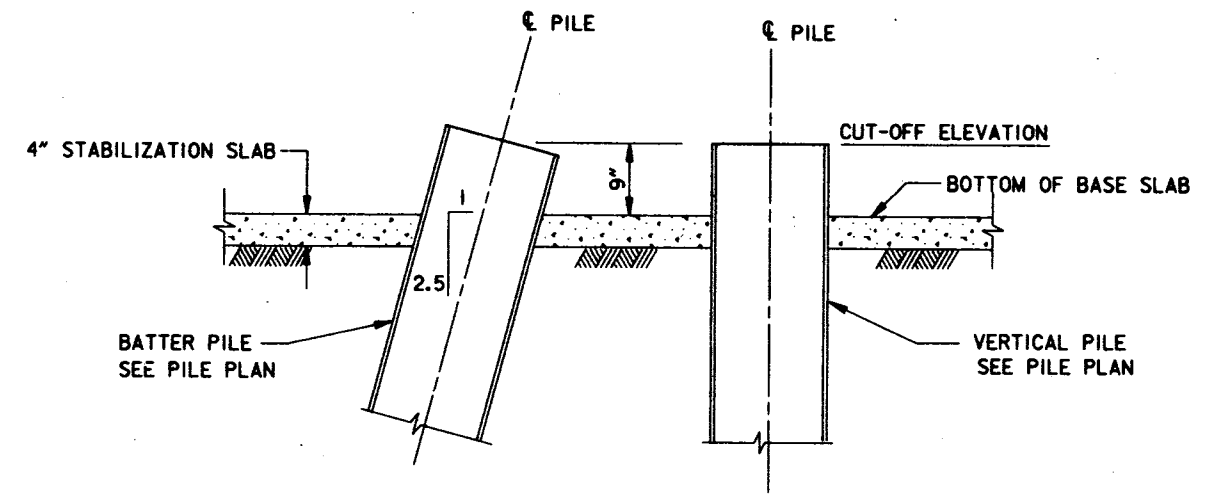

NOTES:
 1. FOR PILE CUT-OFF & TIP ELEVATIONS, SEE PILE SCHEDULE BELOW.
 2. PILE CUT-OFF DIMENSIONS ARE MEASURED PERPENDICULAR TO BOTTOM OF BASE SLAB.

PILE CUT-OFF DETAIL
 SCALE: 1" = 1'-0"

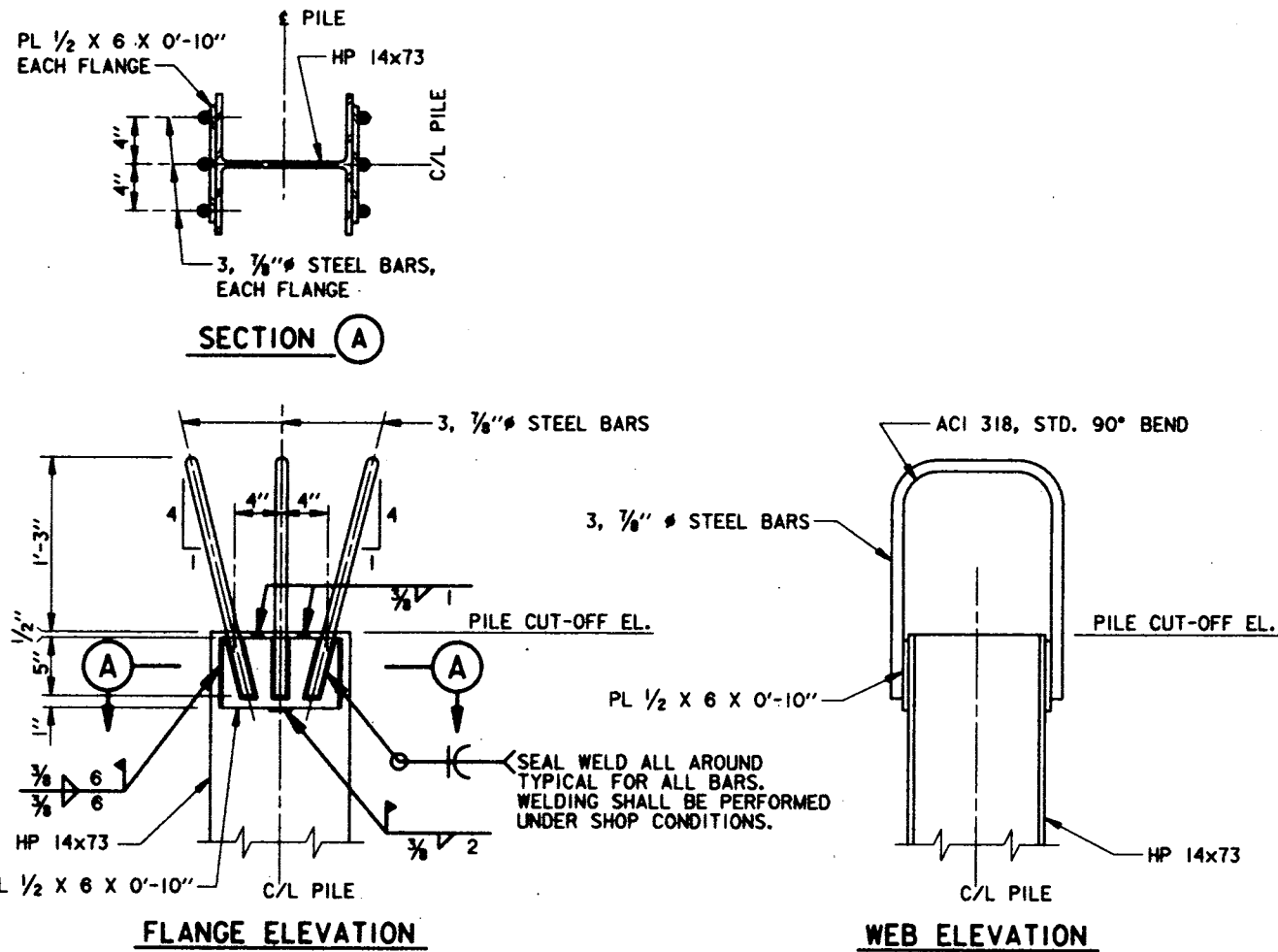

TENSION PILE CONNECTION DETAIL
 SCALE: 1 1/2" = 1'-0"

SERVICE PILE SCHEDULE				
MONOLITH	PILE NOS.	BATTER	CUT-OFF EL.	TIP EL.
EAST MONOLITH	E1, E3-E6, E8-E11, E13-E16, E18-E21, E23, E25, E27, E29, E31-E35	IHon2.5V	-12.10	-101.00
	E37-E40, E42-E45, E47-E50			
	E52-E55, E58, E60, E63-E65			
	E68-E71, E73-E76, E78-E81			
	E83-E96			
	E2, E7, E12, E17, E22, E24	VERTICAL	-12.10	-101.00
	E26, E28, E30, E36, E41			
	E46, E51, E56, E57, E59, E61			
	E62, E66, E67, E72, E77, E82			
WEST MONOLITH "G"	G1-G12	IHon2.5V	-14.00	-101.00
	G13-G16	VERTICAL	-14.00	-101.00
WEST MONOLITH "H"	H1-H12	IHon2.5V	-14.00	-101.00
	H13-H16	VERTICAL	-14.00	-101.00
WEST MONOLITH "I"	I1-I12	IHon2.5V	-14.00	-101.00
	I13-I20	VERTICAL	-14.00	-101.00
TEST PILE	TP1	VERTICAL	AS REQ'D. TO PERFORM TEST	-92.00
TEST PILE	TP2	VERTICAL	AS REQ'D. TO PERFORM TEST	-101.00

TENSION PILE SCHEDULE	
MONOLITH	PILE NOS.
EAST MONOLITH	E1, E3-E6, E8-E11, E13-E16, E18-E21, E23, E25, E27, E29, E31
	E68-E71, E73-E76
	E78-E81, E83-E96
WEST MONOLITH "G"	G1-G4, G15, G16
WEST MONOLITH "H"	H1-H4, H15, H16
WEST MONOLITH "I"	I1-I4, I17-I20

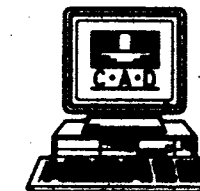
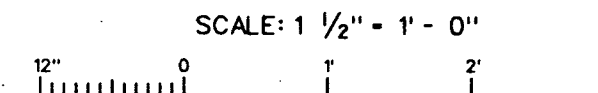
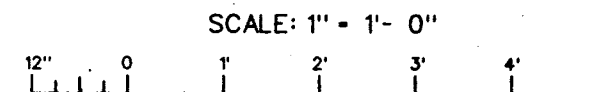

SYMBOL	DESCRIPTION	DATE	APPROVED

REVISIONS

U.S. ARMY ENGINEER DISTRICT, NEW ORLEANS
 CORPS OF ENGINEERS
 NEW ORLEANS, LOUISIANA

URS CONSULTANTS, INC.
 LAKE PONTCHARTRAIN, LA. AND VICINITY HURRICANE PROTECTION
 HIGH LEVEL PLAN

FRONTING PROTECTION
 AT PUMP STATION #8
 ORLEANS PARISH - JEFFERSON PARISH
 17th STREET OUTFALL CANAL
 METAIRIE RELIEF

STEEL H-PILE
 DETAILS

DESIGNED BY: S.C.B.	DATE: SEPT. 1997	PLOT SCALE: 1	PLOT DATE: SEPT. 1997
DRAWN BY: K.L.L.	CADD FILE: P98-9-02.000	FILE NO. H-4-44654	
CHECKED BY: D.J.L.	SUBMITTED BY:	SOLICITATION NO. DACW29-98-B-0112	DWG. 5-3 OF 5-7

Safety is a Part of Your Contract

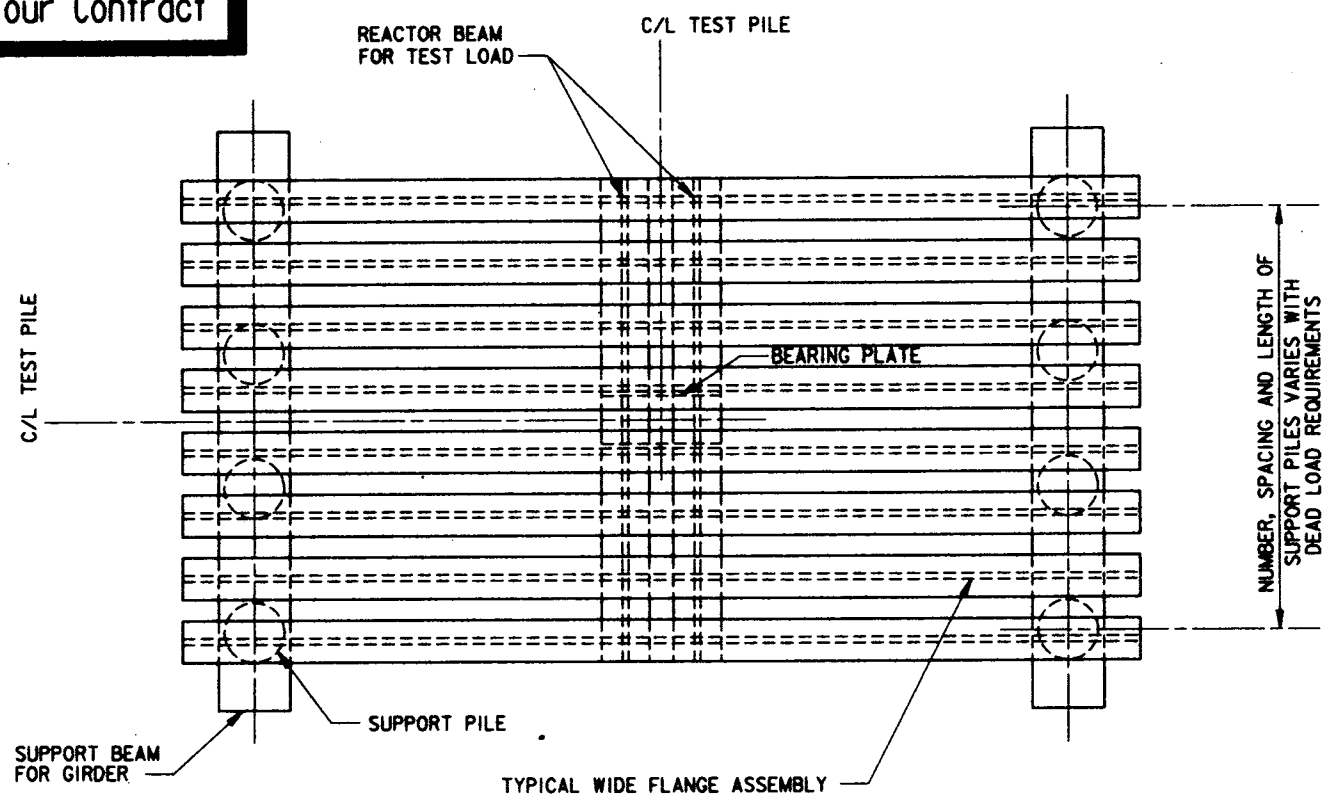

PLAN

LOADING FRAME NOTES:

1. LOADING FRAME SHOWN WITHOUT DEAD LOAD.
2. CONTRACTOR TO PROVIDE PILE LAYOUT FOR EACH PARTICULAR DEAD LOAD TEST.
3. SECURE DEAD WEIGHT LOAD TO LOADING FRAME WITH CHAINS AND BINDERS.

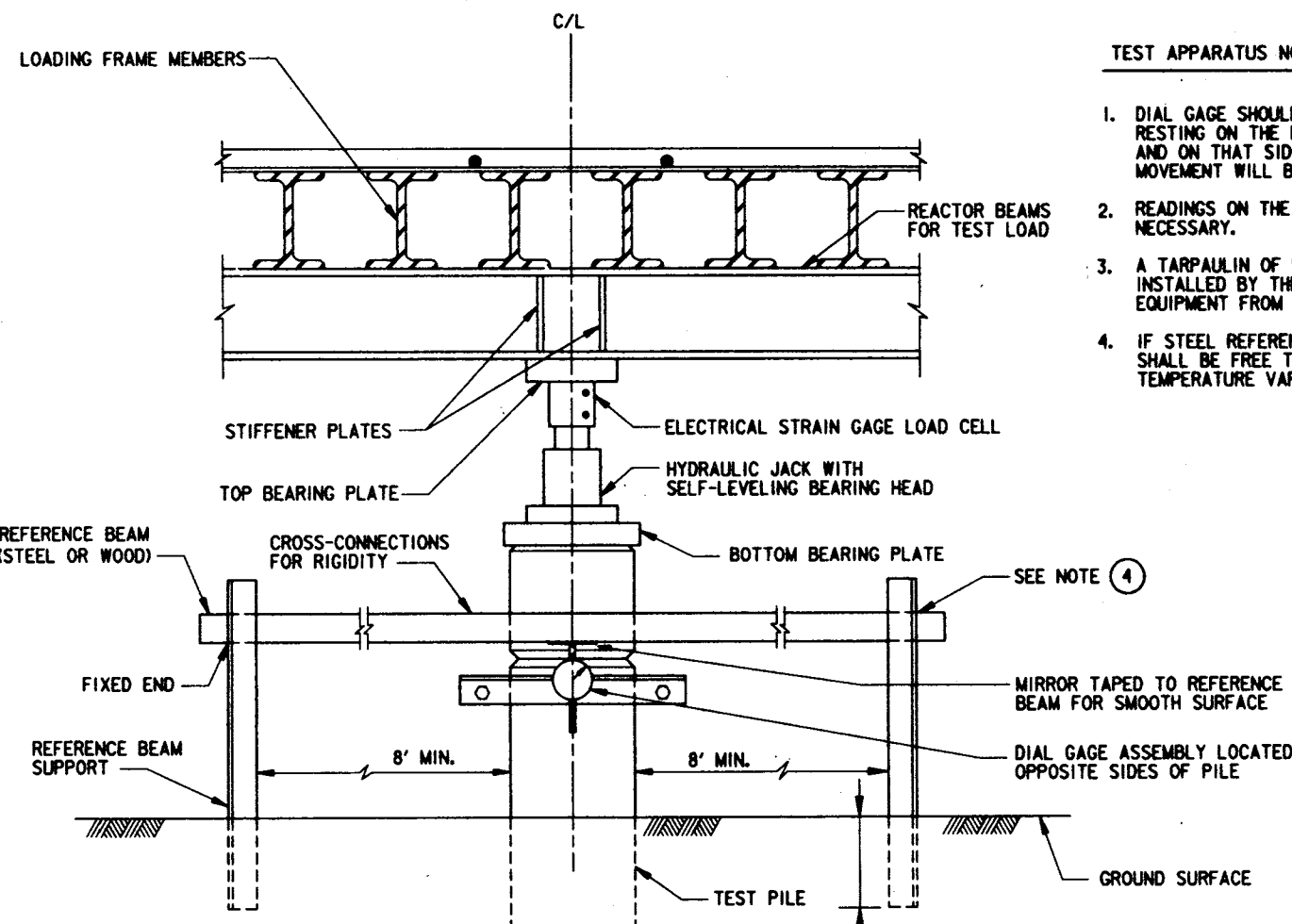

SECTION (B)

TEST APPARATUS

SCALE: 1" = 1'- 0"

TEST APPARATUS NOTES:

1. DIAL GAGE SHOULD BE ATTACHED TO THE PILE WITH THE STEM RESTING ON THE REFERENCE BEAM IN THE COMPRESSED POSITION AND ON THAT SIDE OF THE REFERENCE BEAM WHERE THE MOVEMENT WILL BE AWAY FROM THE BEAM.
2. READINGS ON THE OPPOSITE SIDES OF THE PILE ARE NECESSARY.
3. A TARPULIN OF MINIMUM DIMENSION 12' X 12' SHALL BE INSTALLED BY THE CONTRACTOR TO PROTECT THE MEASURING EQUIPMENT FROM THE DIRECT EFFECTS OF THE WEATHER.
4. IF STEEL REFERENCE BEAMS ARE USED, ONE END OF EACH BEAM SHALL BE FREE TO MOVE AS THE LENGTH OF BEAMS CHANGE WITH TEMPERATURE VARIATIONS.

NOTES:

THE CONTRACTOR HAS THE OPTION OF USING REACTION PILES IN LIEU OF THE LOADING FRAME. (SEE SPECIFICATIONS)

DESIGN OF THE LOADING FRAME, TEST APPARATUS AND REACTION PILE SET-UP, IS THE RESPONSIBILITY OF THE CONTRACTOR AND MUST BE SUBMITTED FOR APPROVAL BY THE CONTRACTING OFFICER.

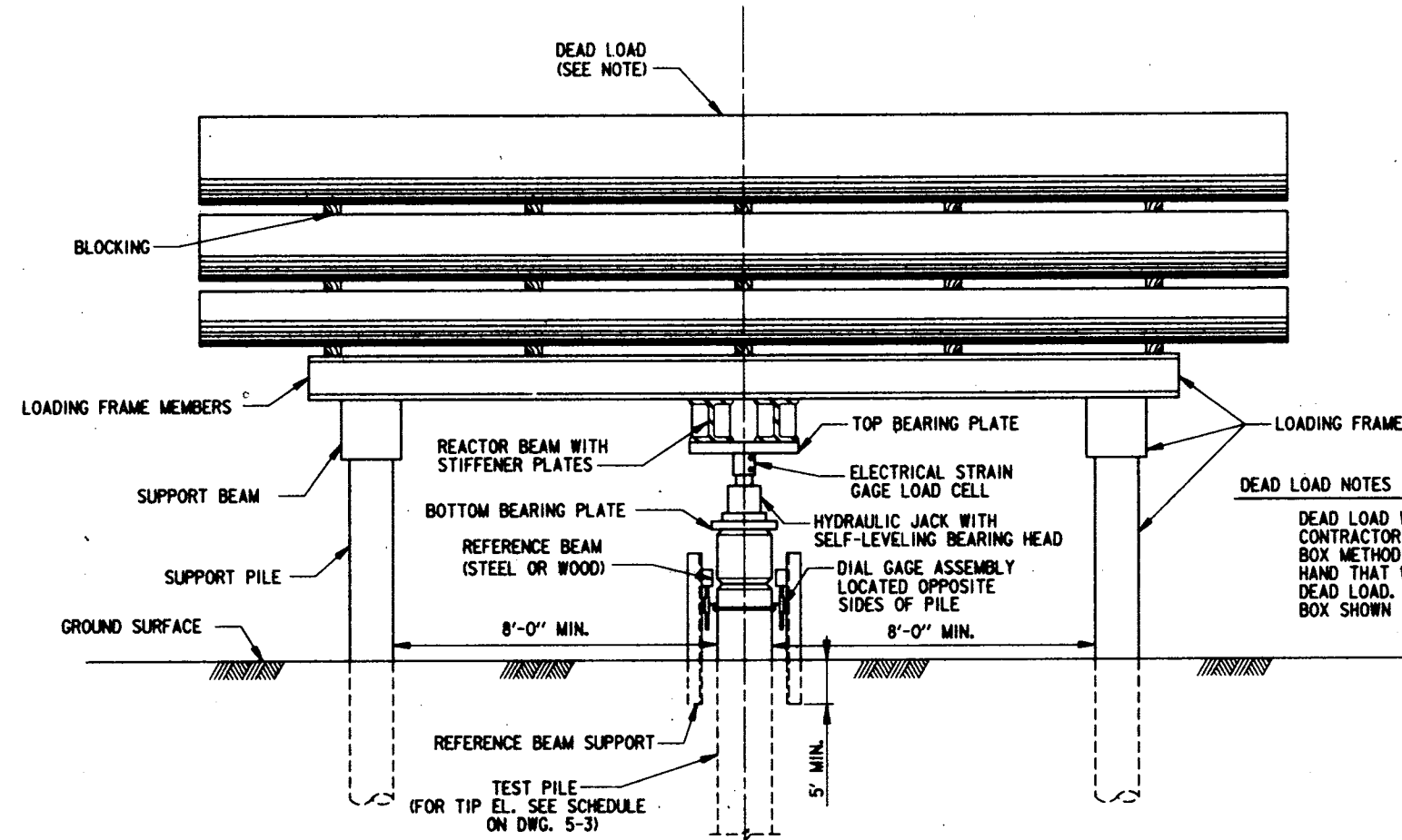

ELEVATION
LOADING FRAME

SCALE: 1/2" = 1'- 0"

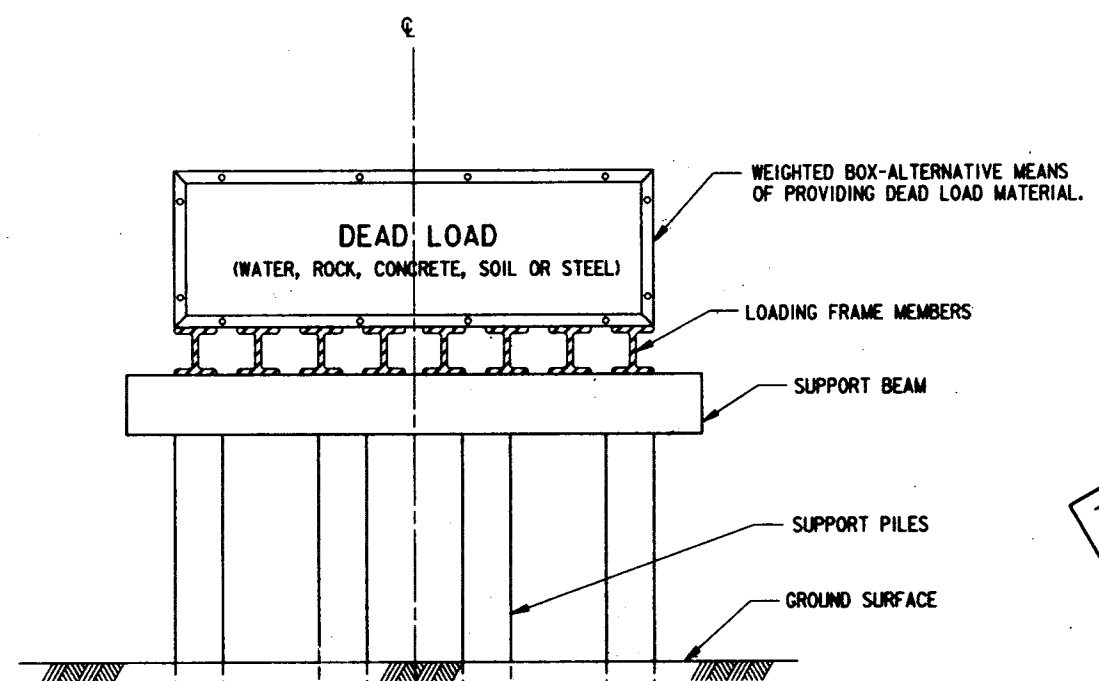

SECTION (A)

SCALE: 1/2" = 1'- 0"

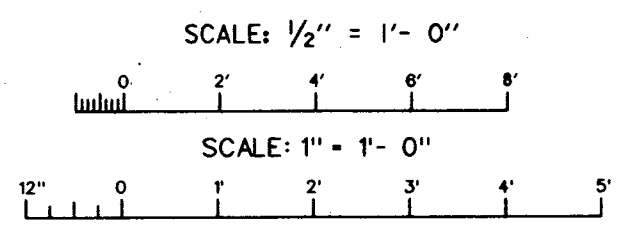

THIS DRAWING IS FOR ILLUSTRATION PURPOSES ONLY

SYMBOL	DESCRIPTION	DATE	APPROVED
REVISIONS			
U.S. ARMY ENGINEER DISTRICT, NEW ORLEANS CORPS OF ENGINEERS NEW ORLEANS, LOUISIANA			
URS CONSULTANTS, INC. LAKE PONTCHARTRAIN, LA. AND VICINITY HURRICANE PROTECTION HIGH LEVEL PLAN FRONTING PROTECTION AT PUMP STATION #8 ORLEANS PARISH - JEFFERSON PARISH 17th STREET OUTFALL CANAL (METAIRIE RELIEF)			
COMPRESSION PILE TEST FRAME			
DESIGNED BY: S.C.B.	DATE: SEPT. 1997	PLOT SCALE: 2.667	PLOT DATE: SEPT. 1997
DRAWN BY: B.M.D.	CHECKED BY: D.J.L.	CARD FILE: PSB-4-400	FILE NO: H-4-44654
SUBMITTED BY:	SOLICITATION NO: DACW29-98-B-0112	DWG. 5-4 of 5-7	



**Safety is a Part
of Your Contract**

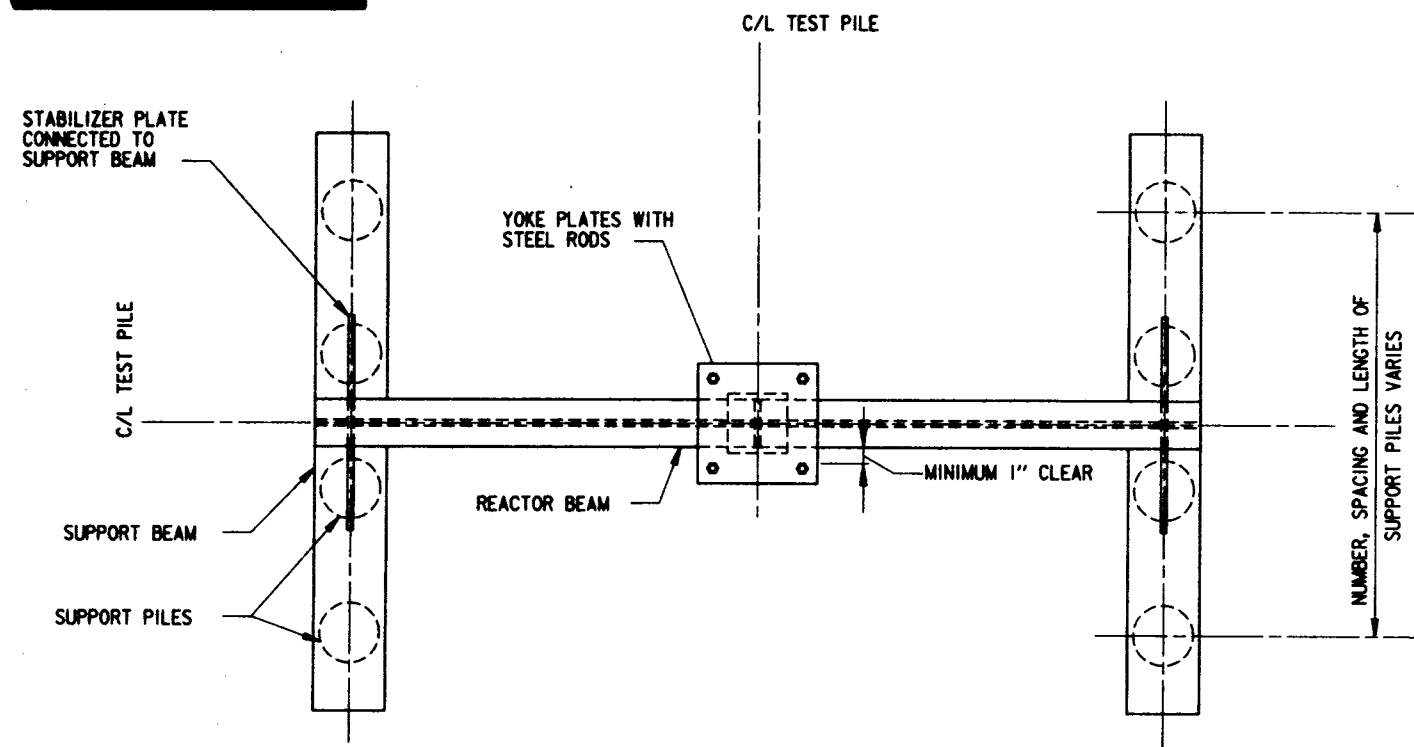

PLAN

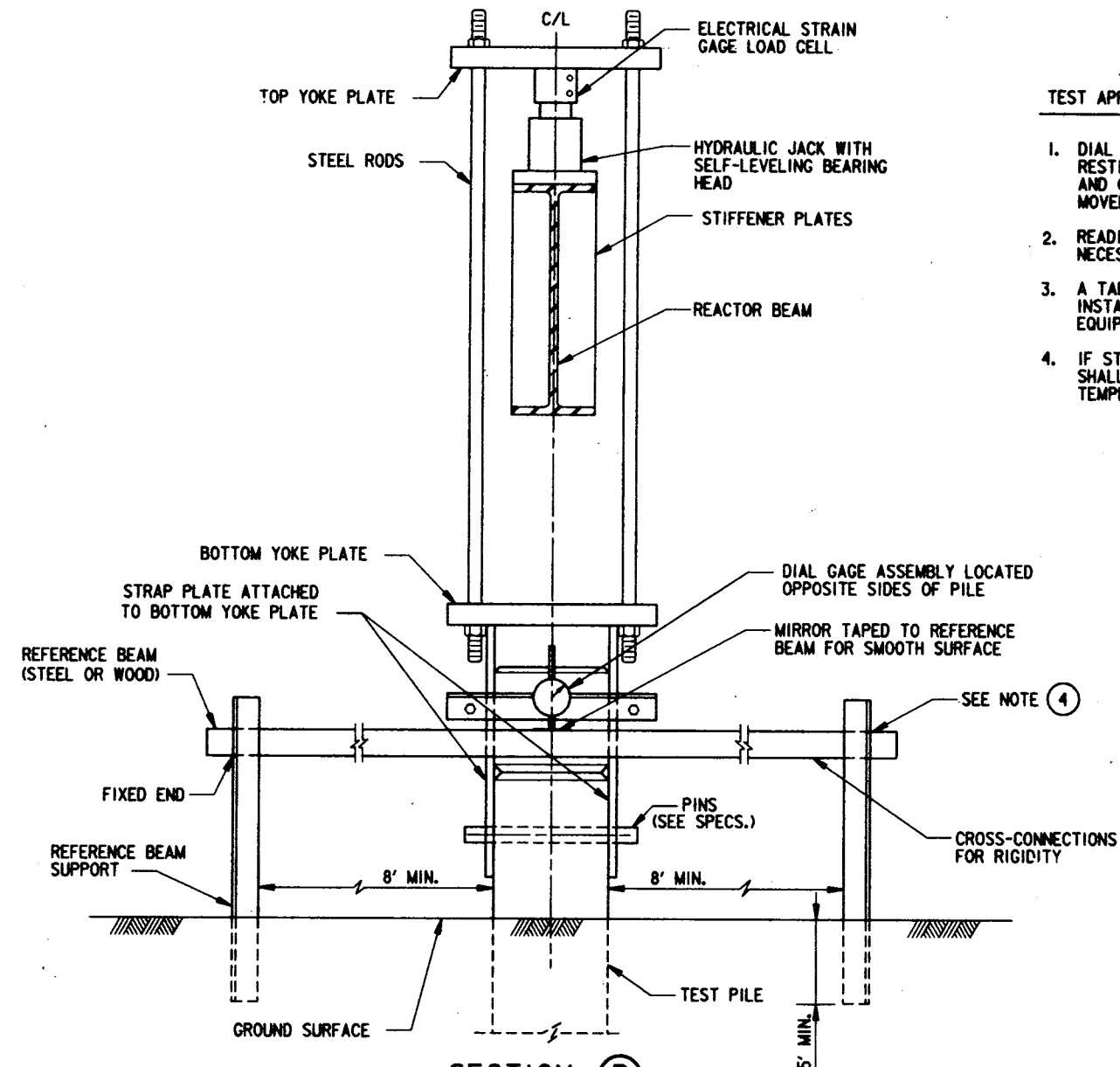

**SECTION B
TEST APPARATUS**

SCALE: 1" = 1'- 0"

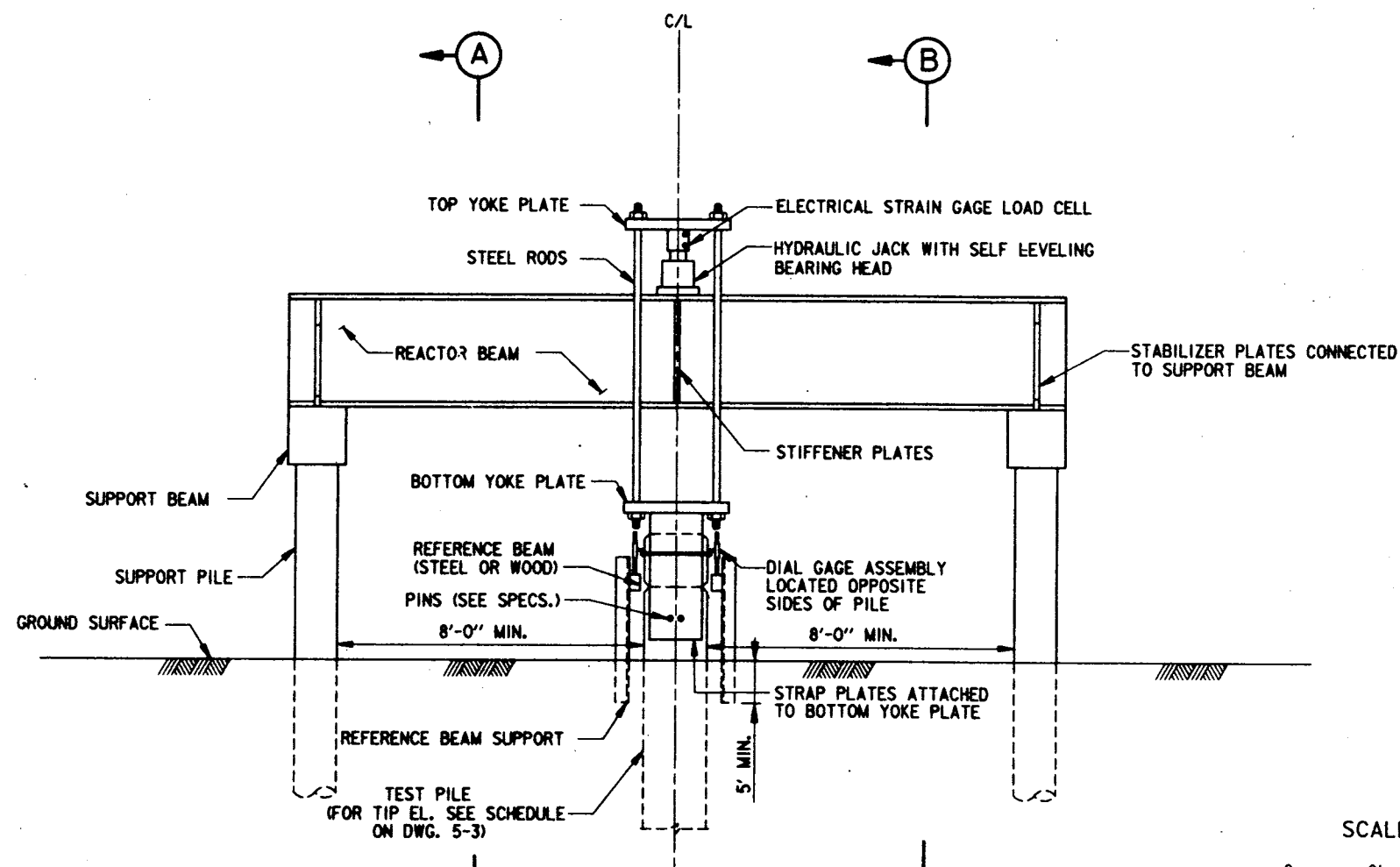

**ELEVATION
LOADING FRAME**

SCALE: 1/2" = 1'- 0"

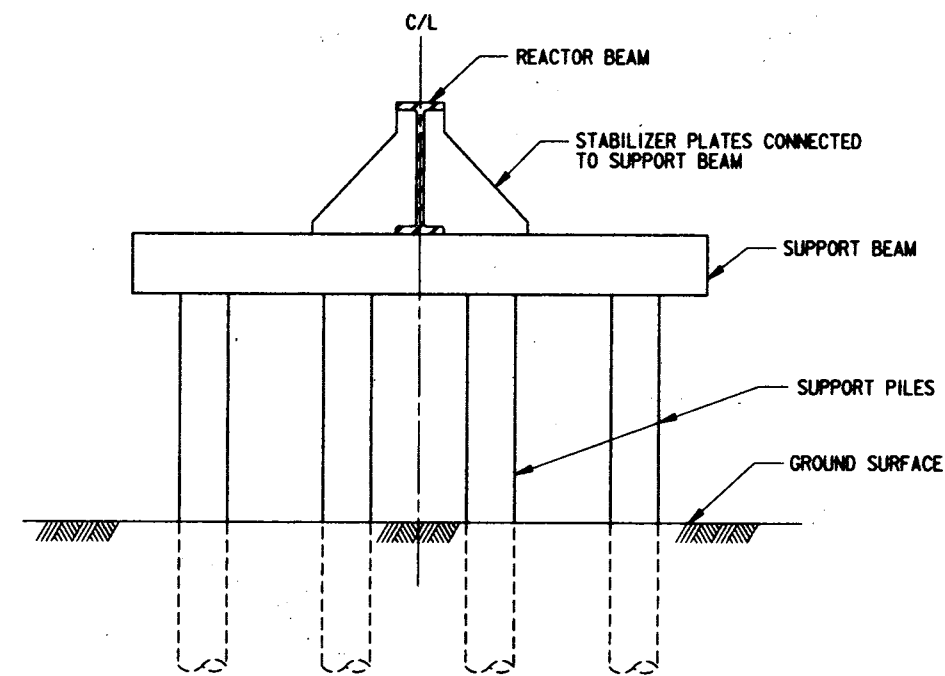

SECTION A

SCALE: 1/2" = 1'- 0"

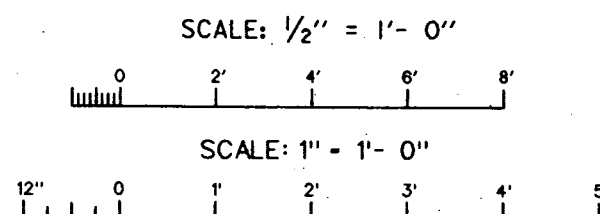

TEST APPARATUS NOTES:

1. DIAL GAGE SHOULD BE ATTACHED TO THE PILE WITH THE STEM RESTING ON THE REFERENCE BEAM IN THE COMPRESSED POSITION AND ON THAT SIDE OF THE REFERENCE BEAM WHERE THE MOVEMENT WILL BE AWAY FROM THE BEAM.
2. READINGS ON THE OPPOSITE SIDES OF THE PILE ARE NECESSARY.
3. A TARPULIN OF MINIMUM DIMENSION 12' X 12' SHALL BE INSTALLED BY THE CONTRACTOR TO PROTECT THE MEASURING EQUIPMENT FROM THE DIRECT EFFECTS OF THE WEATHER.
4. IF STEEL REFERENCE BEAMS ARE USED, ONE END OF EACH BEAM SHALL BE FREE TO MOVE AS THE LENGTH OF BEAMS CHANGE WITH TEMPERATURE VARIATIONS.

THIS DRAWING IS FOR ILLUSTRATION
PURPOSES ONLY

DESIGN OF THE LOADING FRAME AND TEST APPARATUS IS THE RESPONSIBILITY OF THE CONTRACTOR AND MUST BE SUBMITTED FOR APPROVAL.

SYMBOL	DESCRIPTION	DATE	APPROVED
REVISIONS			
U.S. ARMY ENGINEER DISTRICT, NEW ORLEANS CORPS OF ENGINEERS NEW ORLEANS, LOUISIANA			
URS CONSULTANTS, INC. LAKE PONTCHARTRAIN, LA. AND VICINITY HURRICANE PROTECTION HIGH LEVEL PLAN FRONTING PROTECTION AT PUMP STATION #6 ORLEANS PARISH - JEFFERSON PARISH 17th STREET OUTFALL CANAL (METAIRIE RELIEF)			
TENSION PILE TEST FRAME			
DESIGNED BY: S.C.B.	DATE: SEPT. 1997	PLOT SCALE: 2.007	PLOT DATE: SEPT. 1997
DRAWN BY: B.M.D.	CADD FILE: P50-9-8.DGN	FILE NO. H-4-44654	
CHECKED BY: D.J.L.	SOLICITATION NO. DACW29-98-B-0112	DWG. 5-5 OF 5-7	
SUBMITTED BY:			

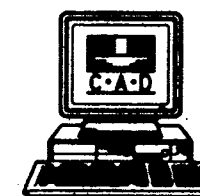

Safety is a Part of Your Contract

NOTE: COAL-TAR EPOXY COAT SHEET PILING FROM CUT-OFF EL. TO EL. (-)12.00 EXCEPT WHERE CONCRETE ENCASED. SEE SPECIFICATIONS.

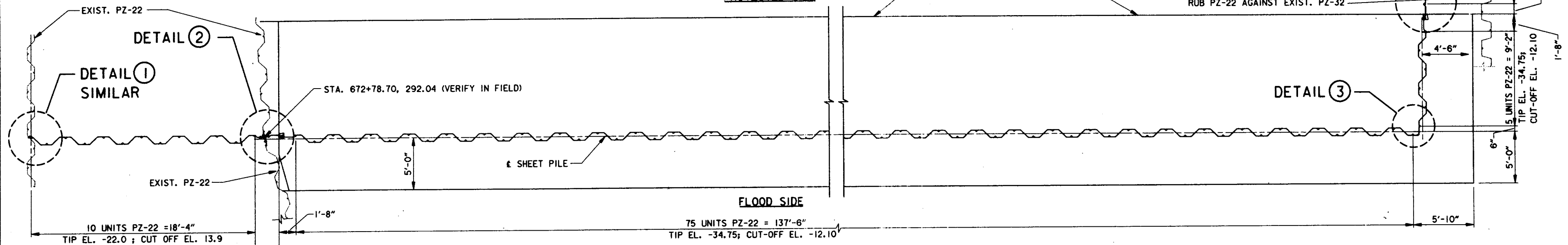
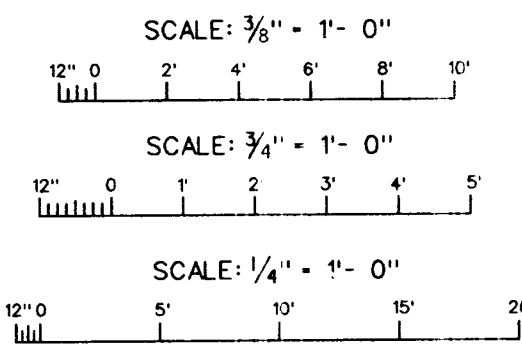

PLAN @ EAST MONOLITH SCALE: 1/4"=1'-0"

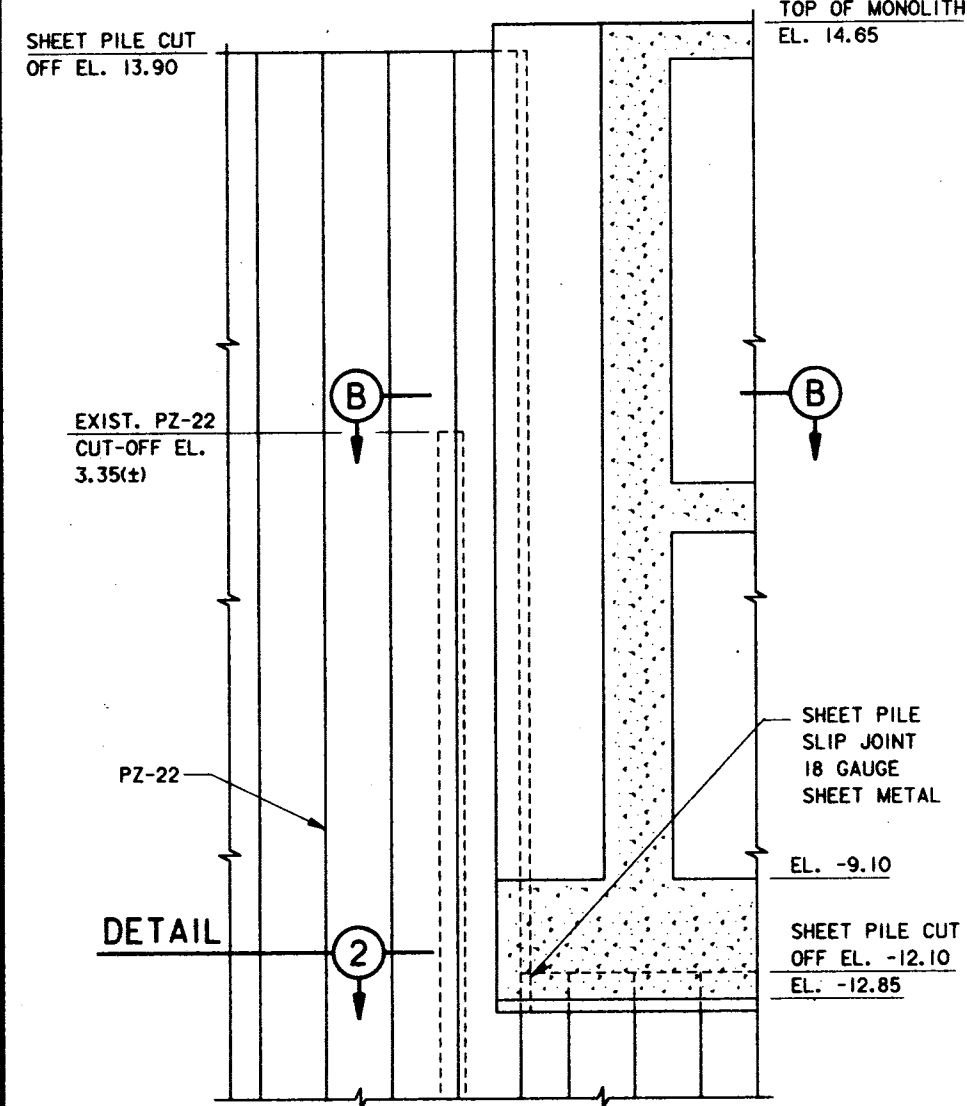

ELEVATION @ SHEET PILE TRANSITION (A) SCALE: 3/8"=1'-0"

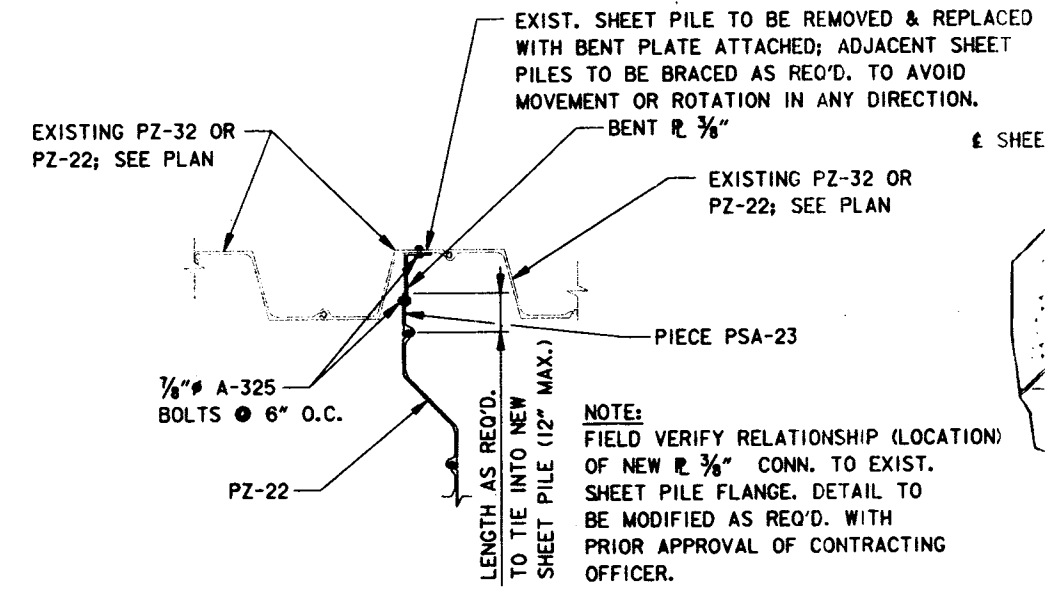

DETAIL 1 SCALE: 3/4"=1'-0"

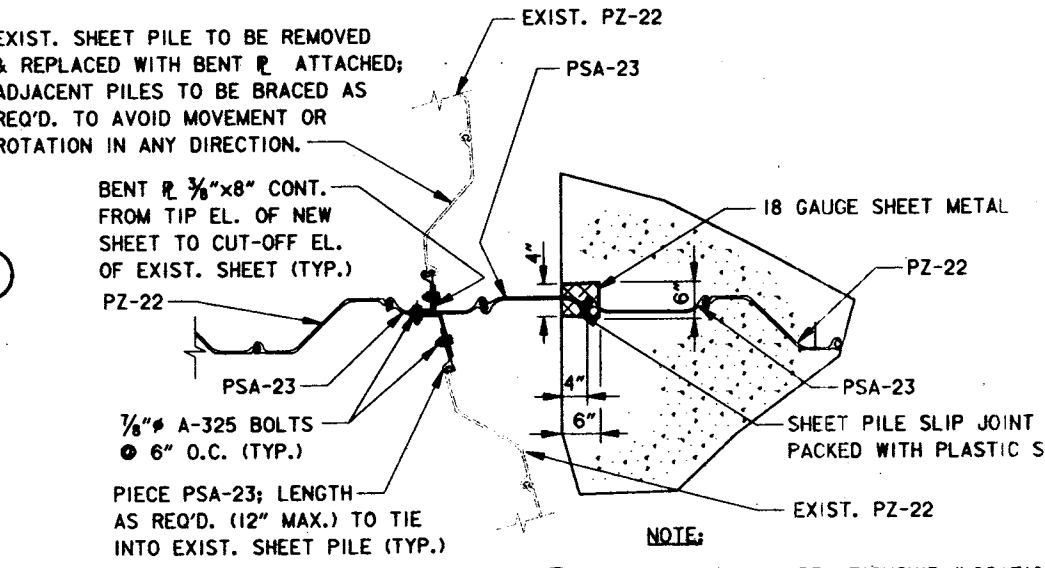

DETAIL 2 SCALE: 3/4"=1'-0"

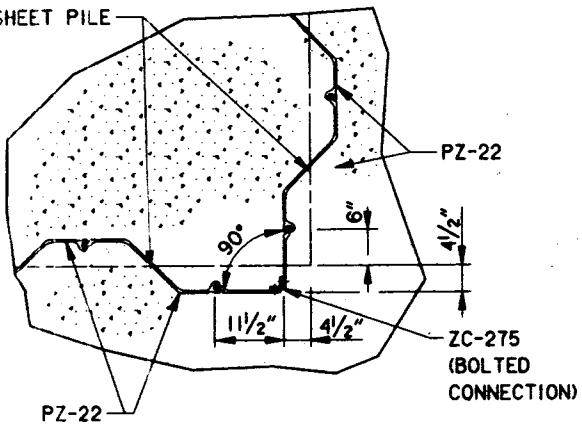

DETAIL 3 SCALE: 3/4"=1'-0"

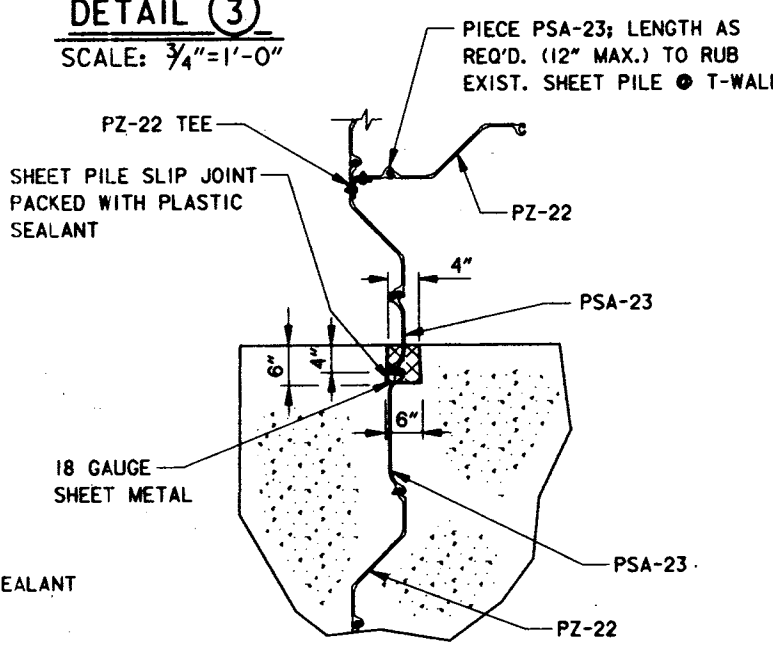

DETAIL 4 SCALE: 3/4"=1'-0"

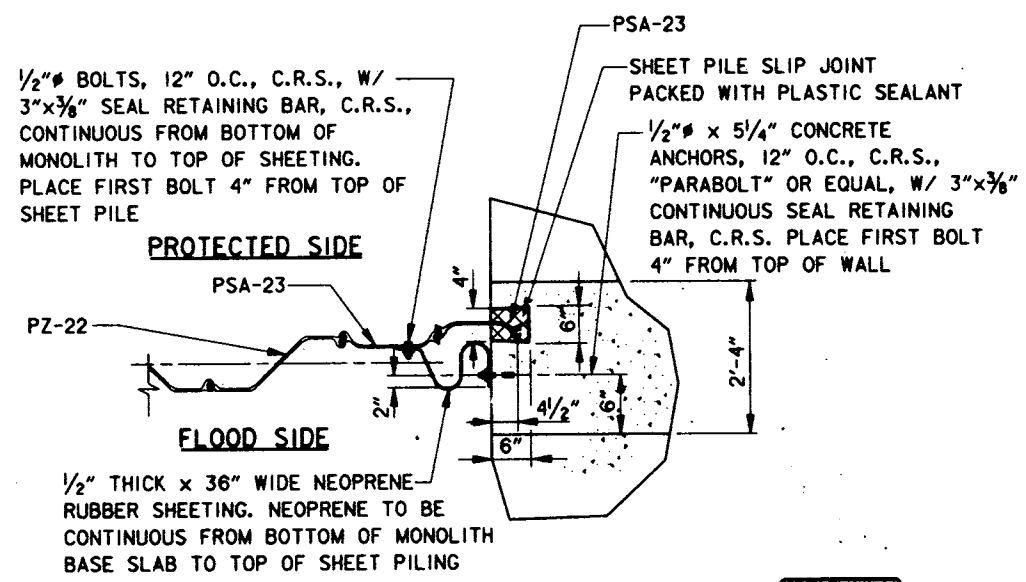

SECTION (B) SCALE: 3/4"=1'-0"

Table with columns: SYMBOL, DESCRIPTION, DATE, APPROVED. Includes project information for URS CONSULTANTS, INC. and a revision table.

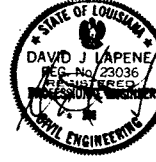

Safety is a Part of Your Contract

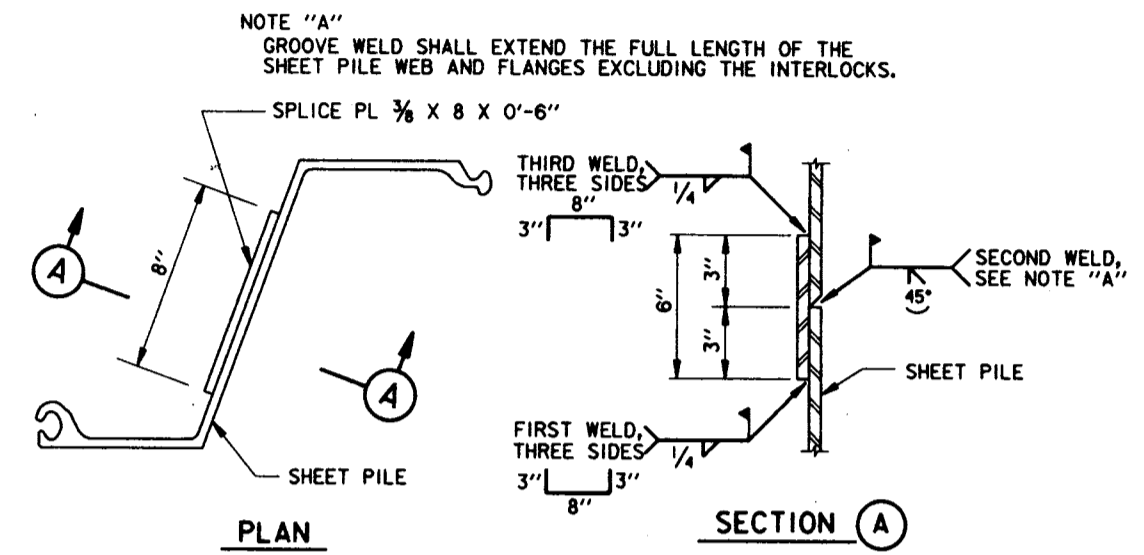
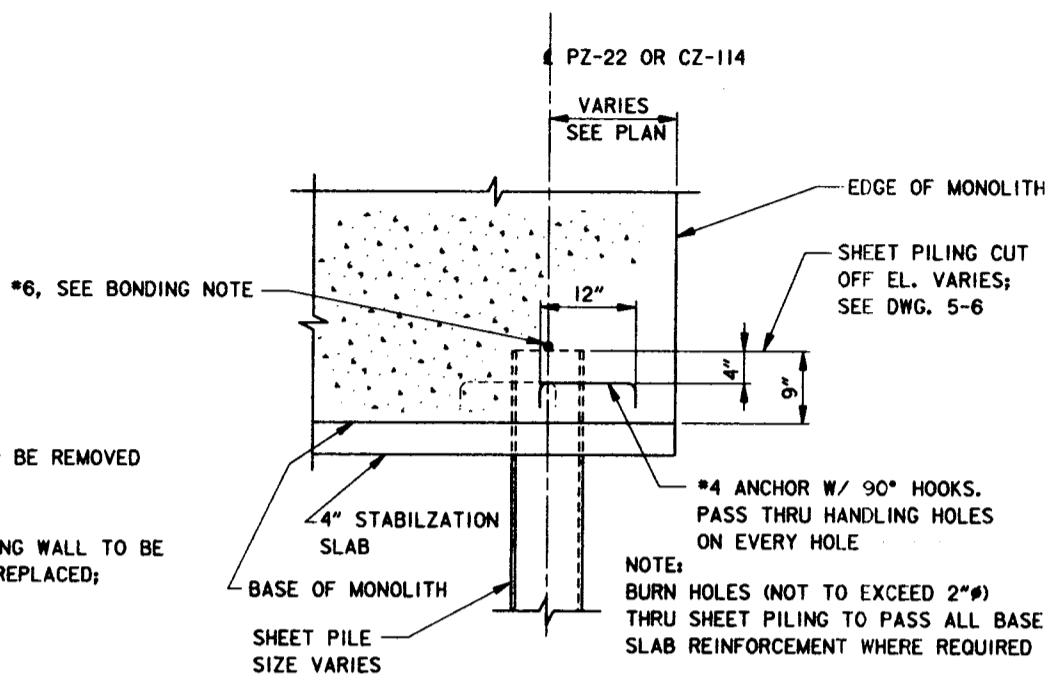
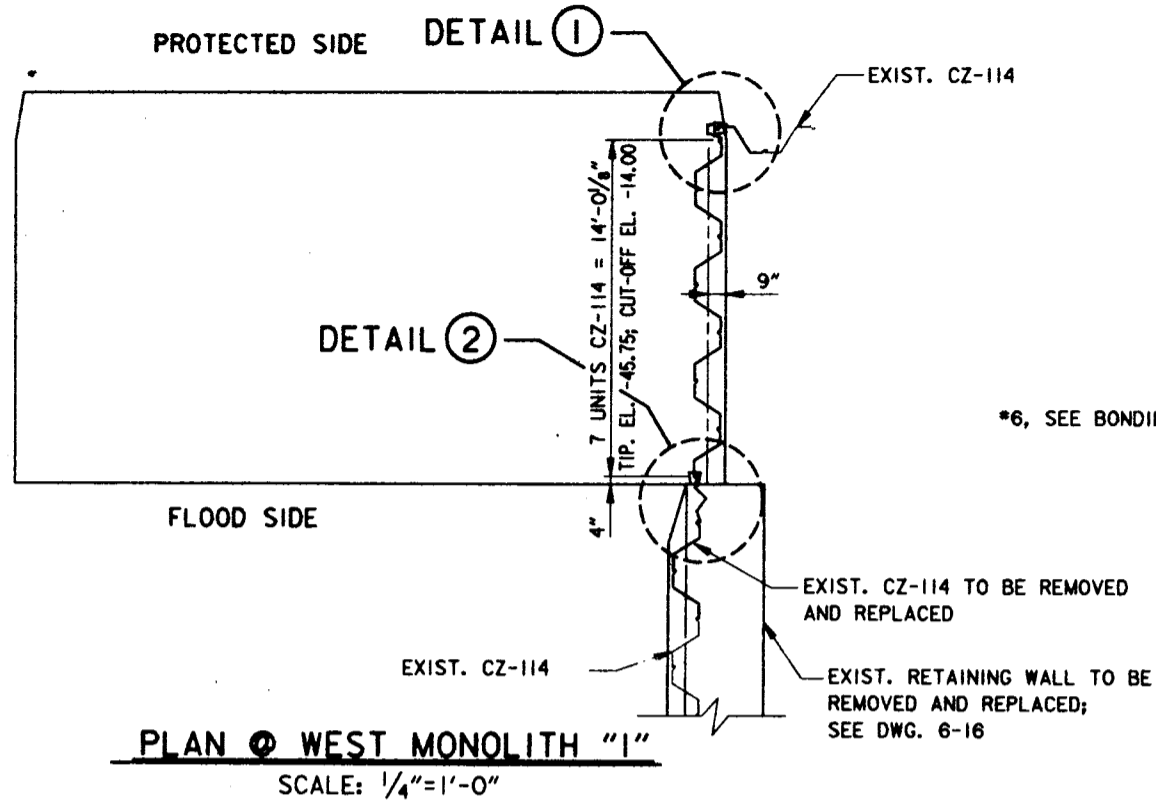

TYPICAL SHEET PILE ANCHORAGE DETAIL
SCALE: 1"=1'-0"

SHEET PILE SPLICE DETAIL
SCALE: 3"=1'-0"

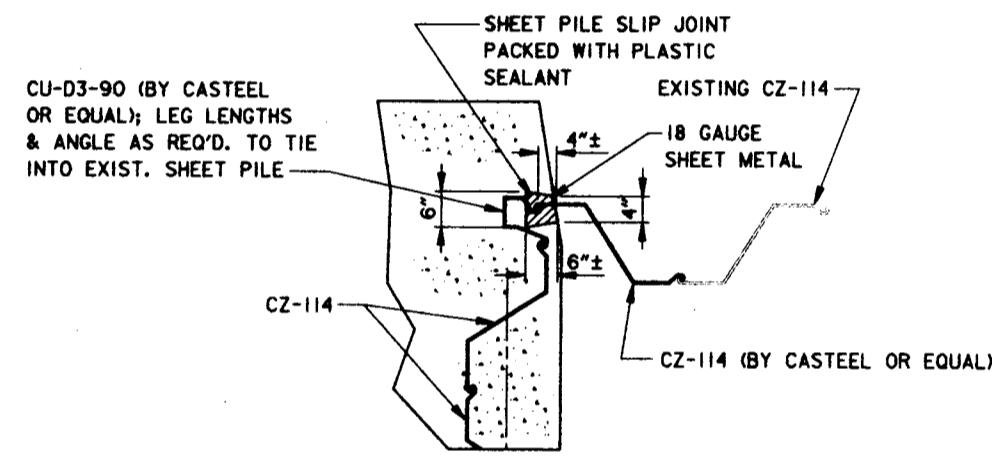

- BONDING NOTES:**
- #6 REINFORCING BAR TO BE WELDED TO THE TOP OF EACH EMBEDDED STEEL SHEET PILE. #6 REINFORCING BAR SHALL NOT EXTEND ACROSS THE MONOLITH JOINT. INSTALL BOND CABLE AT TRANSITIONS FROM MONOLITH TO SHEET PILE.
 - WELDED CONNECTIONS SHALL BE COATED WITH SPLICING EPOXY TO OBTAIN MOISTURE PROOF JOINT. SEE SPECIFICATIONS.
 - SPLICING OF #6 REINFORCING BAR WILL NOT BE ALLOWED.

- SHEET PILE NOTES**
- HOLES CUT IN STEEL SHEET PILING FOR PASSING REINFORCING BARS SHALL NOT EXCEED 2"Ø. WHERE HOLES FALL WITHIN THE WEB OF THE STEEL SHEET PILE, THE HOLE SHALL BE SLOTTED 4" HORIZONTALLY TO ACCOMMODATE PASSING THE REINFORCING BARS.
 - ANY SUBSTITUTIONS SHALL BE SUBMITTED TO THE CONTRACTING OFFICER REPRESENTATIVE FOR APPROVAL.
 - STEEL SHEET PILE SURFACE PREPARATION AND PAINTING SHALL BE IN ACCORDANCE WITH SECTION 09940 OF THE SPECIFICATIONS.

DETAIL 1
SCALE: 3/4"=1'-0"

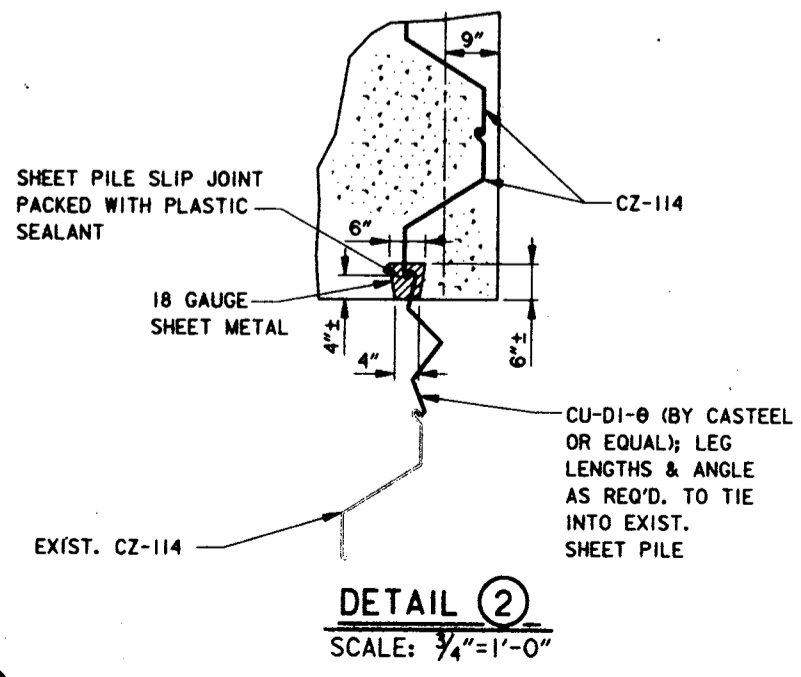

DETAIL 2
SCALE: 3/4"=1'-0"

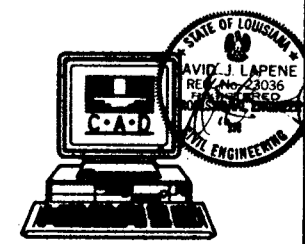
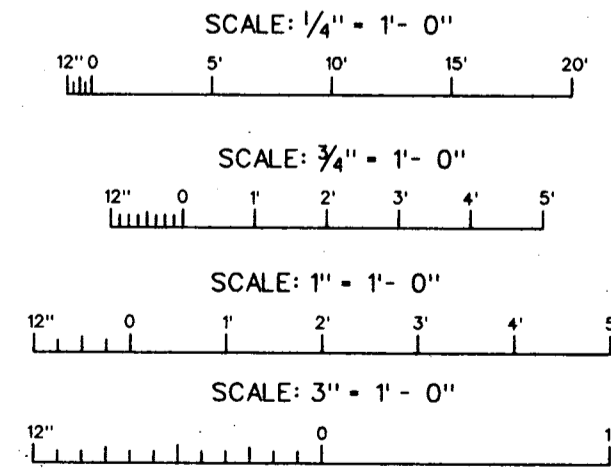

SYMBOL	DESCRIPTION	DATE	APPROVED
REVISIONS			
URS CONSULTANTS, INC. LAKE PONTCHARTRAIN, LA. AND VICINITY HURRICANE PROTECTION HIGH LEVEL PLAN FRONTING PROTECTION AT PUMP STATION #6 ORLEANS PARISH - JEFFERSON PARISH 17th STREET OUTFALL CANAL (METAIRIE RELIEF)			
WEST MONOLITH I SHEET PILE PLAN & MISC. DETAILS			
DESIGNED BY: S.C.B.	DATE: SEPT. 1997	PLOT SCALE: 4	PLOT DATE: SEPT. 1997
DRAWN BY: K.L.L.	CADD FILE: P98-8-07.dwg	FILE NO. H-4-44654	
CHECKED BY: D.J.L.	SOLICITATION NO. DACW29-98-B-0112	DESIGN ENGINEER	DWG. 5-7 OF 5-7



Safety is a Part
of Your Contract

GENERAL NOTES:

1. AZIMUTHS SHOWN ARE MEASURED CLOCKWISE FROM THE NORTH.
2. ELEVATIONS ARE IN FEET AND REFER TO NATIONAL GEODETIC VERTICAL DATUM (N.G.V.D.).
3. DIMENSIONS AND/OR ELEVATIONS MARKED THUS (±) ARE APPROXIMATE. CONTRACTOR SHALL VERIFY ACTUAL DIMENSIONS IN THE FIELD.
4. DIMENSIONS AND/OR ELEVATIONS MARKED THUS (N.T.S.) ARE NOT SHOWN TO SCALE.
5. DRAWINGS ARE GENERALLY TO SCALE, BUT SHOULD NOT BE SCALED. N.T.S. IS SHOWN ONLY WHERE DRAWING IS OBVIOUSLY OUT OF SCALE.
6. BENCH MARKS AND BASE LINES HAVE BEEN ESTABLISHED AT THE SITE BY THE GOVERNMENT
7. CONTRACTOR SHALL VERIFY ALL DIMENSIONS PRIOR TO ORDERING MATERIAL, COMMENCEMENT OF CONSTRUCTION, AND PREPARATION OF SHOP DRAWINGS. CONTRACTING OFFICER SHALL BE PROMPTLY NOTIFIED OF ALL DISCREPANCIES.
8. NO CONSTRUCTION SHALL COMMENCE OUTSIDE THE LIMITS OF CONSTRUCTION SHOWN WITH THE EXCEPTION OF ELECTRICAL WORK AND EQUIPMENT MOBILIZATION AT LOCATION AND TIMES COORDINATED WITH THE C.O.R.
9. CONTRACTOR SHALL VERIFY THE LOCATIONS OF ALL UTILITIES PRIOR TO THE COMMENCEMENT OF CONSTRUCTION. THE UTILITY LOCATIONS SHOWN ARE APPROXIMATE AND LOCATED IN THE FIELD WHERE SURFACE FEATURES ALLOW SUCH AND/OR SHOWN AT THE LOCATION UTILITY OWNERS DEPICT THEM ON THE UTILITY OWNERS PROVIDED DRAWINGS.
10. CONTRACTOR SHALL VERIFY THE LOCATIONS OF EXISTING SHEET PILING. LOCATIONS SHOWN ARE APPROXIMATE.

STEEL NOTES:

1. ALL STRUCTURAL STEEL SHALL BE ASTM A36, UNLESS OTHERWISE NOTED. ALL STRUCTURAL STEEL NOTED AS S.S. SHALL BE A-304 STAINLESS STEEL.
2. TO PREVENT CORROSION BY MOISTURE BETWEEN STEEL SURFACES IN CONTACT, ALL SUCH CONTACTS SHALL BE SEALED WATERTIGHT BY RUNNING A CONTINUOUS 1/4" FILLET WELD ALONG ALL EDGES OF THE CONTACT, UNLESS OTHERWISE NOTED.
3. ALL WELDING SHALL BE ELECTRIC WELDING. WORKMANSHIP AND TECHNIQUE, WHERE APPLICABLE, SHALL CONFORM TO THE AMERICAN WELDING SOCIETY (SEE SPECS.) STRUCTURAL WELDING CODE.
4. WELDING SYMBOLS SHOWN ARE THOSE ADOPTED BY THE AMERICAN WELDING SOCIETY AND INDICATE ONLY SIZE AND TYPE OF WELDS REQUIRED. DETAILED INFORMATION SHALL BE SHOWN ON THE SHOP DRAWINGS AND SUBMITTED BY THE CONTRACTOR FOR APPROVAL.
5. DIMENSIONS SHOWN OR CALLED FOR ARE THE FINAL DIMENSIONS; ALLOWANCES MUST BE MADE FOR MACHINING.
6. ITEMS MARKED C.R.S. SHALL BE CORROSION RESISTANT STEEL (STAINLESS STEEL), SEE SPECIFICATIONS.
7. ALL STRUCTURAL STEEL (EXCEPT STAINLESS STEEL) SHALL BE HOT-DIPPED GALVANIZED AFTER FABRICATION.
8. CORNERS OF ALL CAP PLATES TO HAVE 1/2" RADIUS.
9. ALL BOLTED CONNECTIONS TO USE ASTM A-325 BOLTS, HOT DIPPED GALV., UNLESS NOTED OTHERWISE.
10. STRUCTURAL STEEL FABRICATION AND ERECTION SHALL CONFORM TO THE LATEST EDITION OF THE A.I.S.C. MANUAL OF STEEL CONSTRUCTION UNLESS NOTED OTHERWISE.

CONCRETE NOTES:

1. CONCRETE SHALL HAVE A MINIMUM COMPRESSIVE STRENGTH (F_c) OF 4000 PSI AT 28 DAYS, 90 DAYS IF POZZOLAN IS USED, UNLESS OTHERWISE NOTED.
2. STABILIZATION SLAB CONCRETE SHALL HAVE A MINIMUM COMPRESSIVE STRENGTH (F_c) OF 2500 PSI AT 28 DAYS, 90 DAYS IF POZZOLAN IS USED.
3. REINFORCING STEEL SHALL HAVE A MINIMUM YIELD STRENGTH (F_y) OF 60,000 PSI.
4. CONSTRUCTION JOINTS SHALL BE PROVIDED WHERE SHOWN. WHERE NOT SHOWN, CONSTRUCTION JOINTS SHALL BE PLACED AT NEW LOCATIONS LEAST LIKELY TO IMPAIR THE INTEGRITY OF THE CONCRETE STRUCTURE. CONSTRUCTION JOINT LOCATIONS SHALL BE APPROVED BY THE CONTRACTING OFFICER.
5. UNLESS OTHERWISE NOTED, PROVIDE 3/4" CHAMFER AT ALL EXPOSED JOINTS, EDGES, EXTERNAL CORNERS, AND VERTICAL EXPANSION JOINTS.
6. ALL PRIMARY REINFORCEMENT SHALL HAVE A MINIMUM COVER OF 3" UNLESS OTHERWISE NOTED. THE COVER FOR SECONDARY REINFORCEMENT MAY BE REDUCED FROM THE ABOVE BY THE DIAMETER OF THE BAR.
7. ALL BENDS OF REINFORCEMENT AND ALL BAR SPACERS AND SUPPORTS SHALL BE IN ACCORDANCE WITH THE LATEST EDITION OF THE AMERICAN CONCRETE INSTITUTE DETAILING MANUAL, SP-66.
8. REINFORCING BAR DESIGNATION NUMBERS CONFORM TO THE NUMBERING SYSTEM OF THE CONCRETE REINFORCING STEEL INSTITUTE.
9. REINFORCING BARS SHALL BE CONTINUOUS AT ALL CORNERS UNLESS OTHERWISE NOTED.
10. REINFORCEMENT, WHERE NECESSARY TO AVOID OPENINGS, PIPES, EMBEDDED ITEMS AND OTHER OBSTRUCTIONS, SHALL BE BENT OR SHIFTED AS DIRECTED BY THE CONTRACTING OFFICER.
11. THE EMBEDMENT AND SPLICE TABLE SHALL BE USED IN DETERMINING LAP SPLICES AND EMBEDMENT LENGTHS WHERE LENGTHS ARE NOT OTHERWISE INDICATED. SPLICE LENGTHS SHALL BE BASED ON THE SMALLER BAR BEING LAPPED. THE CONTRACTOR WILL BE ALLOWED TO MAKE SPLICES IN ADDITION TO THOSE INDICATED IN THE DRAWINGS, WHERE ESSENTIAL TO CONSTRUCTIBILITY, SUBJECT TO APPROVAL BY THE CONTRACTING OFFICER. SPLICE WILL BE AT THE CONTRACTOR'S EXPENSE.
12. ALL EXTERIOR FORMED SURFACES NOT COVERED BY BACKFILL SHALL BE CLASS "A" FINISH AND SURFACES COVERED BY BACKFILL SHALL BE CLASS "D" FINISH, UNLESS OTHERWISE NOTED.

BAR SIZE	BASIC TABLE				ALTERNATE TABLE			
	MINIMUM EMBEDMENT LENGTH, INCHES		MINIMUM LAP LENGTH INCHES		MINIMUM EMBEDMENT LENGTH, INCHES		MINIMUM LAP LENGTH INCHES	
	TOP	OTHER	TOP	OTHER	TOP	OTHER	TOP	OTHER
3	16	12	21	16	16	12	21	16
4	21	16	28	21	21	16	28	21
5	27	21	35	27	27	21	35	27
6	32	25	42	32	32	25	42	32
7	37	29	49	37	37	29	49	37
8	45	35	59	45	43	33	56	43
9	57	44	74	57	48	37	63	48
10	72	56	94	72	58	45	75	58
11	89	68	116	89	71	55	92	71

NOTES:

1. USE THE BASIC TABLE IF ALL OF THE FOLLOWING CONDITIONS ARE MET:
 - A) CENTER TO CENTER BAR SPACING LATERALLY IS AT LEAST 4 BAR DIAMETERS
 - B) CONCRETE COVER IS AT LEAST 2 BAR DIAMETERS, AND
 - C) EDGE DISTANCE TO THE FIRST BAR IN A LAYER IS AT LEAST 2 BAR DIAMETERS.
2. THE ALTERNATE TABLE MAY BE USED IF ALL OF THE FOLLOWING CONDITIONS ARE MET:
 - A) CENTER TO CENTER BAR SPACING LATERALLY IS AT LEAST 6 BAR DIAMETERS
 - B) CONCRETE COVER IS AT LEAST 2 BAR DIAMETERS, AND
 - C) EDGE DISTANCE TO THE FIRST BAR IN A LAYER IS AT LEAST 2.5 BAR DIAMETERS.
3. IF CONCRETE COVER OR EDGE DISTANCE IS LESS THAN 2 BAR DIAMETERS OR THE CENTER TO CENTER BAR SPACING LATERALLY IS LESS THAN 4 DIAMETERS, SEE ACI 318 FOR APPROPRIATE GUIDANCE.
4. TOP BARS ARE HORIZONTAL BARS AND BARS INCLINED LESS THAN 45 DEGREES WITH RESPECT TO A HORIZONTAL PLANE WHICH ARE PLACED SUCH THAT MORE THAN 12 INCHES OF CONCRETE IS CAST IN THE MEMBER BELOW THE BAR.

ABBREVIATIONS

- ALUM. = ALUMINUM
- ALT. SP. = ALTERNATE SPACING
- AZ = AZIMUTH
- B/L = BASELINE
- BF = BOTTOM FACE
- BL = BOTTOM LAYER
- C = CENTER
- CB = CATCH BASIN
- C.I. = CAST IRON
- CJ = CONSTRUCTION JOINT
- CL = CLEAR COVER
- C/L OR ☉ = CENTER LINE
- C.R.S. = CORROSION RESISTANT STEEL
- Ø = DIAMETER
- D = DRAIN
- D.I. = DROP INLET
- D.P. = DRAIN PIPE
- D/S = DOWN STREAM
- D.V. = DRAIN VALVE
- D.V. MH. = DRAIN VALVE MANHOLE
- E = ELECTRICAL
- EF = EACH FACE
- E.J. = EXPANSION JOINT
- EL. = ELEVATION
- ES = EQUALLY SPACED
- F.H. = FIRE HYDRANT
- FF = FAR FACE
- G = GAS
- H.S. = HIGH STRENGTH
- LP = LIGHT POLE
- LS = LIGHT STANDARD
- MH = MANHOLE
- NF = NEAR FACE
- O.C. = ON CENTER
- OPT. = OPTIONAL
- P = POWER
- P.C. = POINT OF CURVATURE
- PL. = PLATE
- R = RADIUS
- P.T. = POINT OF TANGENCY
- R/R = RIGHT OF WAY
- S = SEWER
- SB/L = SUBBASELINE
- S.C.O. = SEWER CLEANOUT
- STD. HK. = STANDARD HOOK
- S.S. = STAINLESS STEEL
- STA. = STATION
- T = TELEPHONE
- TD = TRENCH DRAIN
- TF = TOP FACE
- TEL.M.H. = TELEPHONE MANHOLE
- TL = TOP LAYER
- TP = TEST PILE
- U/S = UP STREAM
- W = WATER
- W/L = WALL LINE
- W.M. = WATER METER
- W.V. = WATER VALVE
- W.S.E. = WATER SURFACE ELEVATION

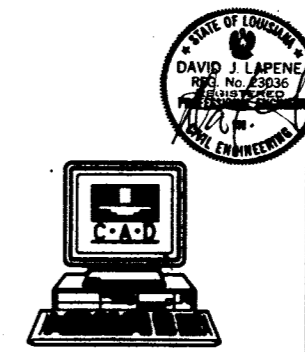

SYMBOL	DESCRIPTION	DATE	APPROVED
REVISIONS			
 U.S. ARMY ENGINEER DISTRICT, NEW ORLEANS CORPS OF ENGINEERS NEW ORLEANS, LOUISIANA			
URS CONSULTANTS, INC. LAKE PONTCHARTRAIN, LA. AND VICINITY HURRICANE PROTECTION HIGH LEVEL PLAN FRONTING PROTECTION AT PUMP STATION #6 ORLEANS PARISH - JEFFERSON PARISH 17th STREET OUTFALL CANAL (METAIRIE RELIEF)			
GENERAL NOTES			
DESIGNED BY: S.C.B.	DATE: SEPT. 1997	PLOT SCALE: .06333	PLOT DATE: SEPT. 1997
DRAWN BY: T.R.E.	CADD FILE: P30-0-01.DGN	FILE NO. H-4-44654	
CHECKED BY: D.J.L.	SOLICITATION NO. DACW29-98-B-0112	DESIGN ENGINEER	DWG. 6-1 of 6-18

Safety is a Part of Your Contract

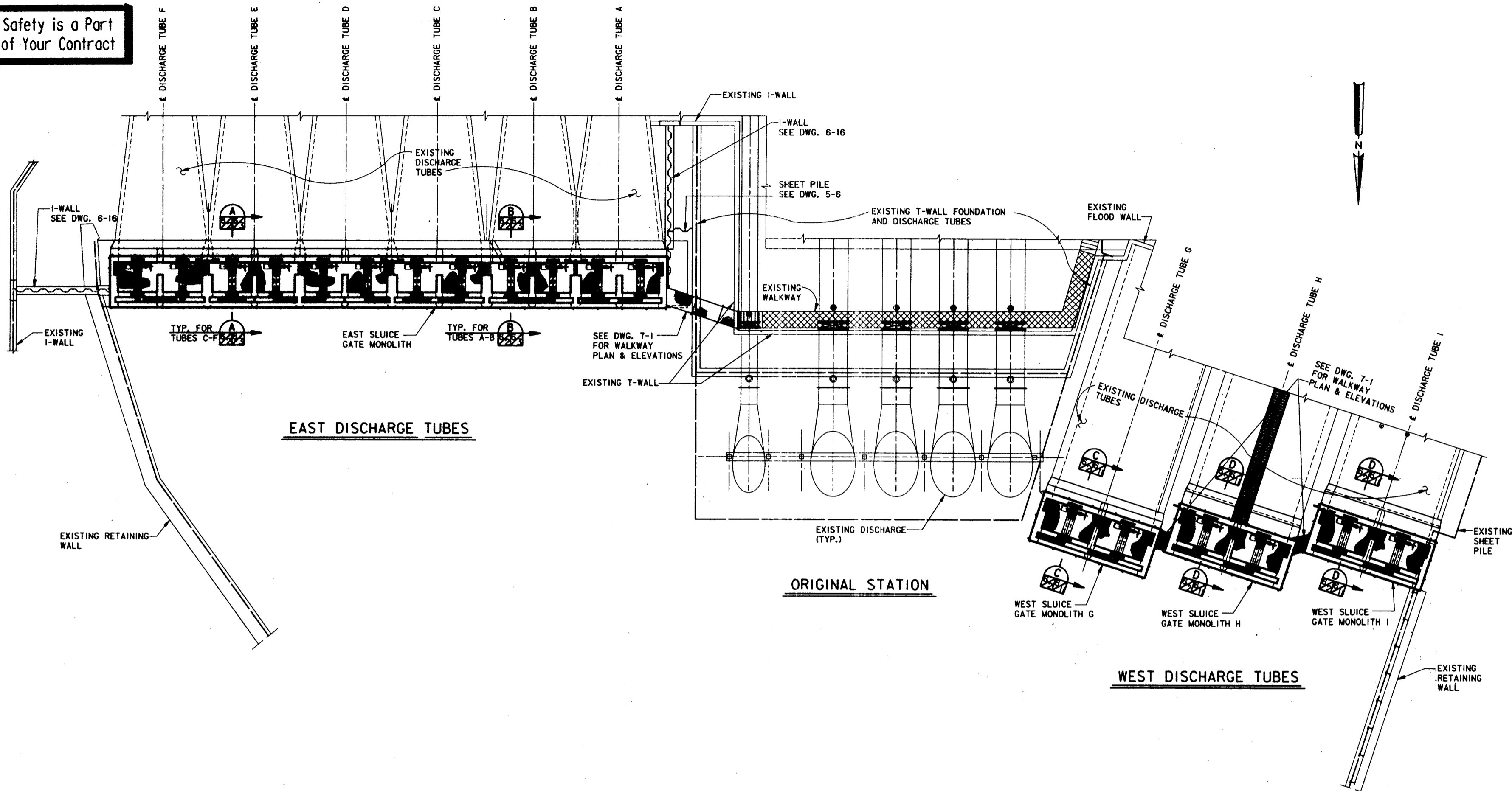

SCALE: 1" = 10'



SYMBOL	DESCRIPTION	DATE	APPROVED
REVISIONS			
U.S. ARMY ENGINEER DISTRICT, NEW ORLEANS CORPS OF ENGINEERS NEW ORLEANS, LOUISIANA			
URS CONSULTANTS, INC. LAKE PONTCHARTRAIN, L.A. AND VICINITY HURRICANE PROTECTION HIGH LEVEL PLAN FRONTING PROTECTION AT PUMP STATION #6 ORLEANS PARISH - JEFFERSON PARISH 17th STREET OUTFALL CANAL (METAIRIE RELIEF) OVERALL STRUCTURAL PLAN			
DESIGNED BY: S.C.B.	DATE: SEPT. 1997	PLOT SCALE: 10	PLOT DATE: SEPT. 1997
DRAWN BY: K.L.L.	CHECKED BY: D.J.L.	CADD FILE: P58-0-08.DGN	FILE NO. H-4-44654
SUBMITTED BY:	SOLICITATION NO. DACW29-98-B-0112	DWG. 6-2 OF 6-18	

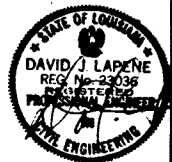

Safety is a Part of Your Contract

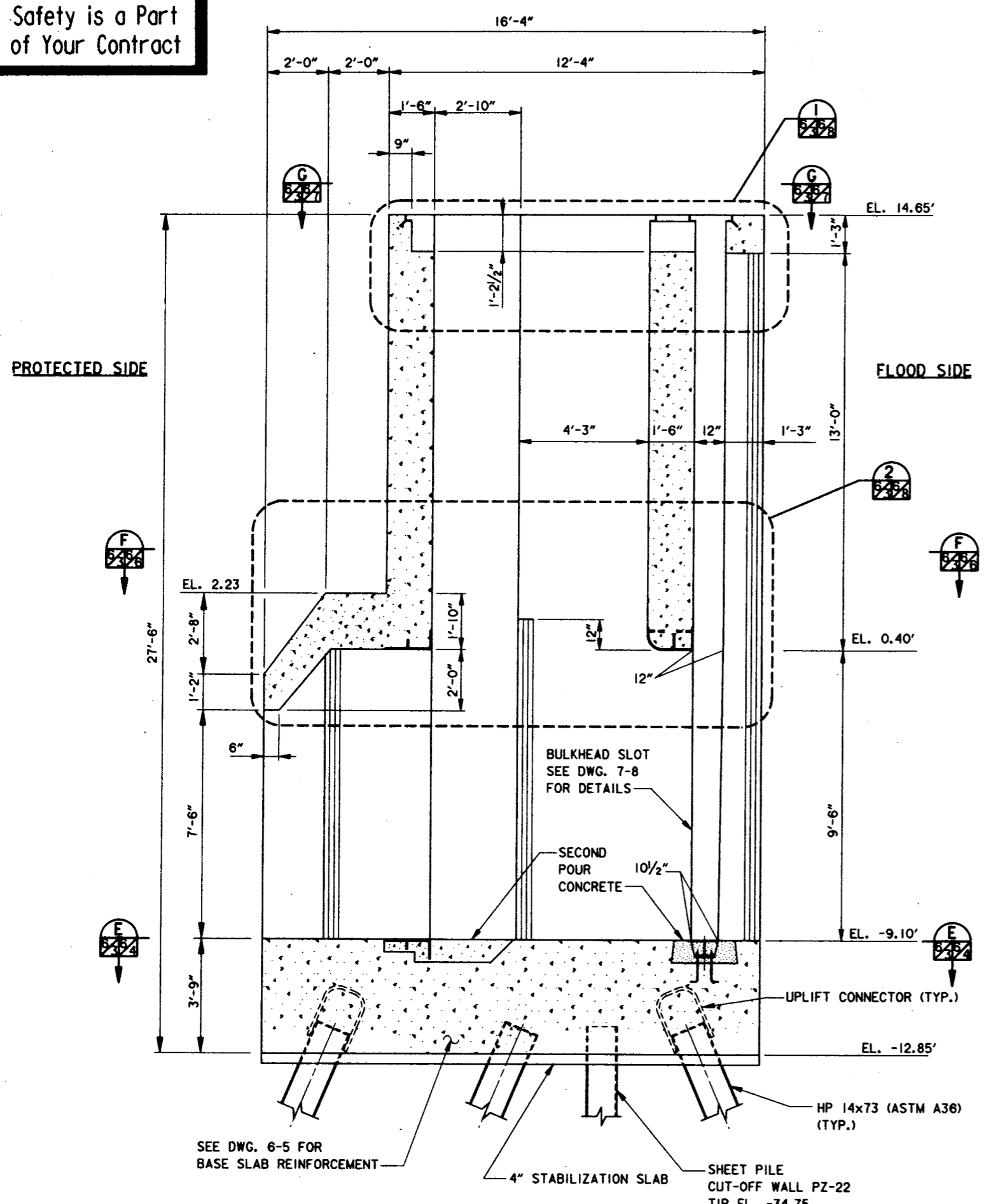

DISCHARGE TUBES C-F
SECTION A
 SCALE: 1/2" = 1'-0"

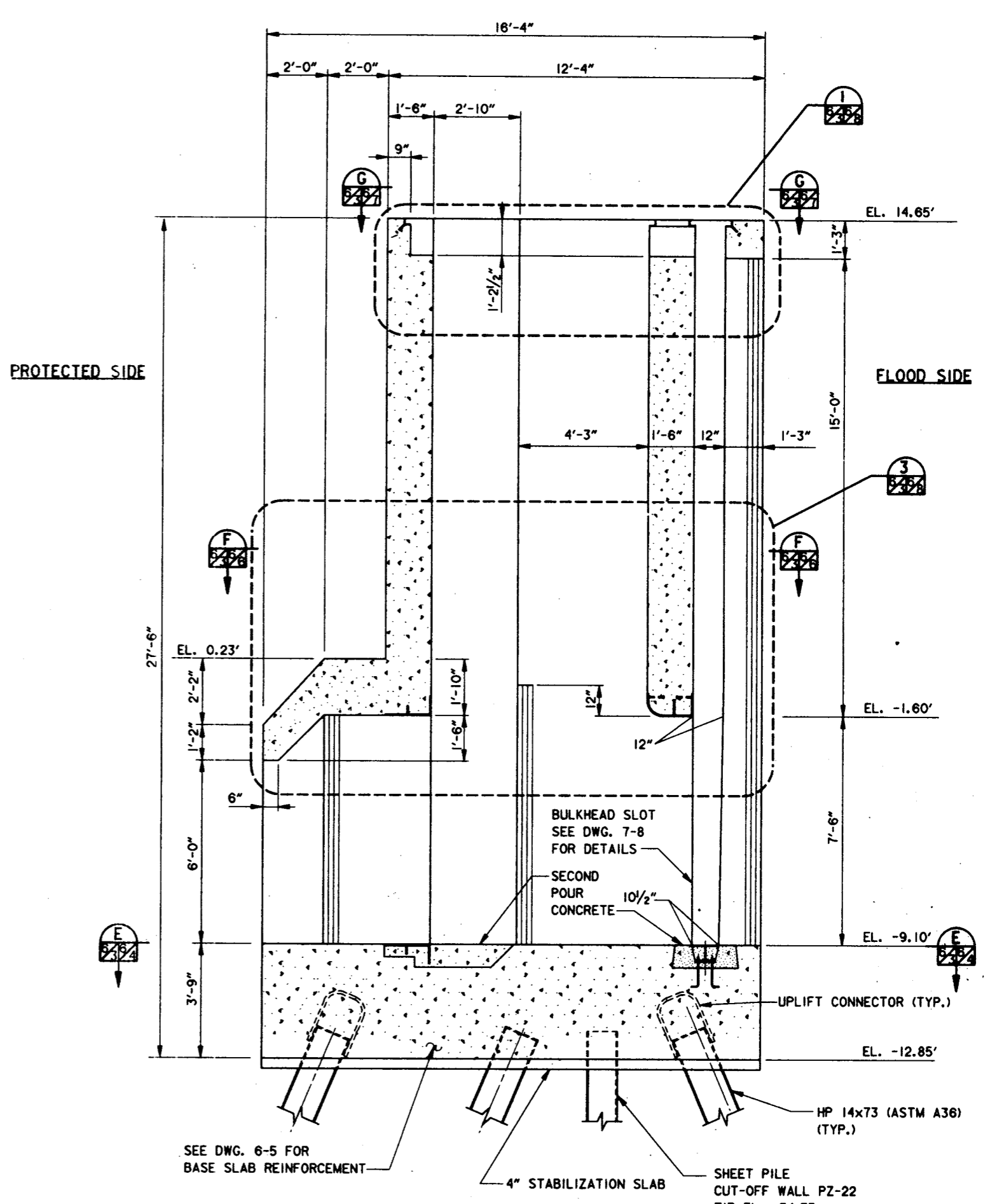

DISCHARGE TUBES A & B
SECTION B
 SCALE: 1/2" = 1'-0"

NOTE:
 FOR JOINT DETAILS BETWEEN EXISTING
 DISCHARGE TUBES AND SLUICE GATE
 MONOLITHS SEE DWG. 6-17.

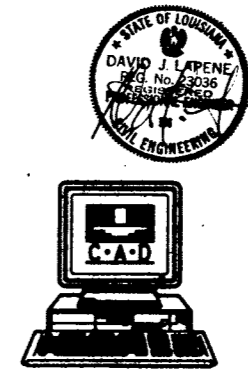
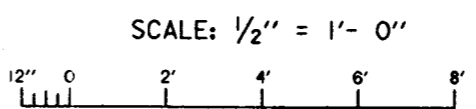

SYMBOL	DESCRIPTION	DATE	APPROVED
REVISIONS			
U.S. ARMY ENGINEER DISTRICT, NEW ORLEANS CORPS OF ENGINEERS NEW ORLEANS, LOUISIANA URS CONSULTANTS, INC. LAKE PONTCHARTRAIN, LA. AND VICINITY HURRICANE PROTECTION HIGH LEVEL PLAN FRONTING PROTECTION AT PUMP STATION #6 ORLEANS PARISH - JEFFERSON PARISH 17TH STREET OUTFALL CANAL (METAIRIE RELIEF) CROSS SECTIONS EAST MONOLITH			
DESIGNED BY: S.C.B.	DATE: SEPT. 1997	PLOT SCALE: 2	PLOT DATE: SEPT. 1997
DRAWN BY: K.L.L.	CHECKED BY: D.J.L.	CARD FILE: P90-9-03.00H	FILE NO. H-4-4654
SUBMITTED BY:	SOLIDIFICATION NO. DACW29-98-B-0112	DWG. 6-3	OF 6-18



Safety is a Part of Your Contract

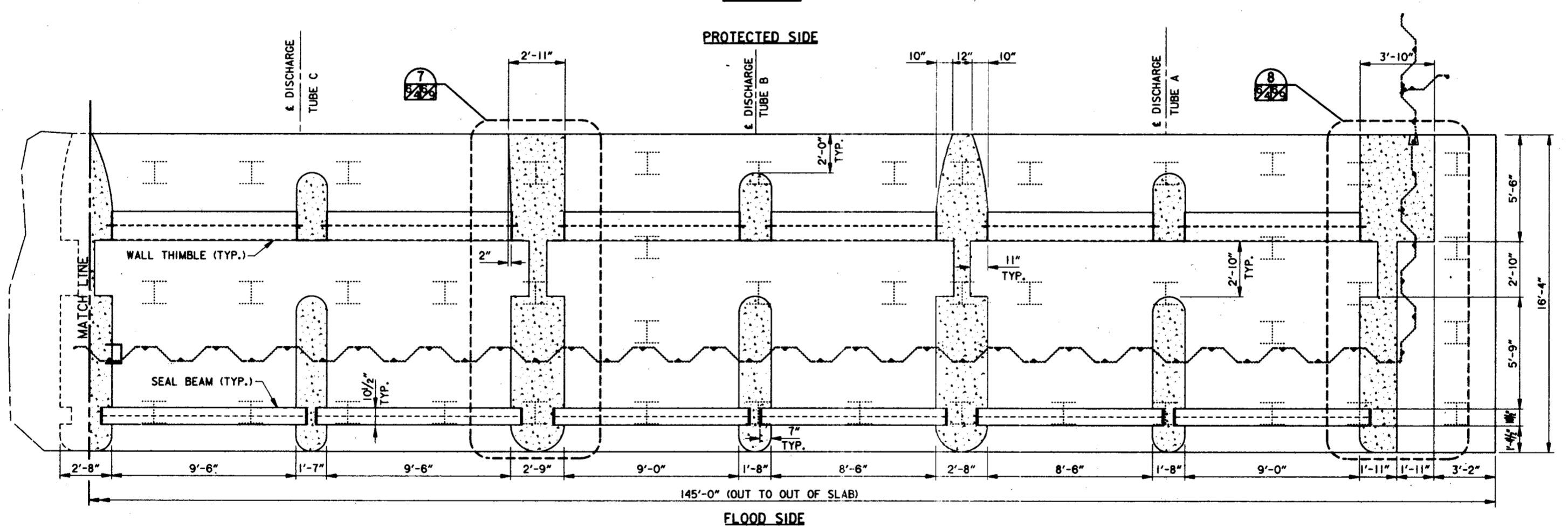
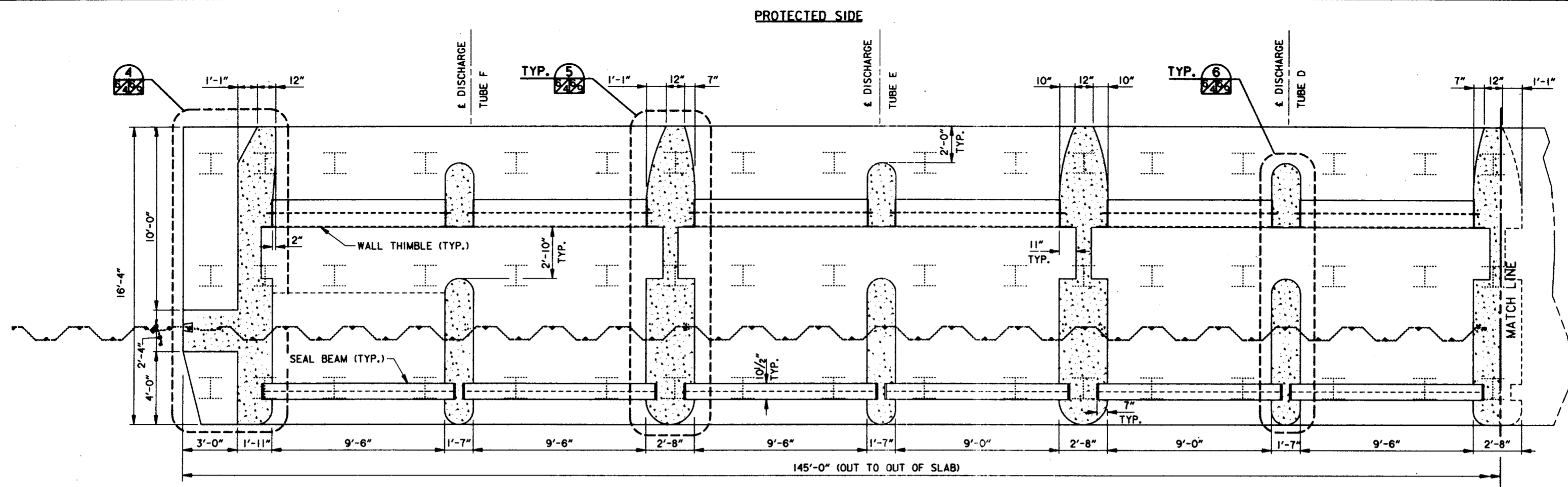

PLAN @ EL. -9.10' E
 SCALE: 3/8" = 1'-0"

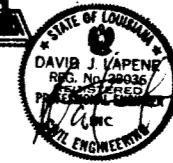
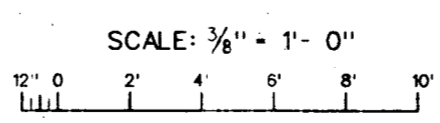

SYMBOL	DESCRIPTION	DATE	APPROVED
REVISIONS			
U.S. ARMY ENGINEER DISTRICT, NEW ORLEANS CORPS OF ENGINEERS NEW ORLEANS, LOUISIANA			
URS CONSULTANTS, INC. LAKE PONTCHARTRAIN, LA. AND VICINITY HURRICANE PROTECTION HIGH LEVEL PLAN FRONTING PROTECTION AT PUMP STATION #6 ORLEANS PARISH - JEFFERSON PARISH 17th STREET OUTFALL CANAL (JEFFERSON RELIEF) EAST MONOLITH BASE SLAB PLAN			
DESIGNED BY: S.C.B.	DATE: SEPT. 1997	PLOT SCALE: 2.667	PLOT DATE: SEPT. 1997
DRAWN BY: T.R.E.	CADD FILE: P50-0-0400N	FILE NO. H-4-44654	
CHECKED BY: D.J.L.	SOLICITATION NO. DACW29-98-B-0112	DWG. 6-4 OF 6-18	
SUBMITTED BY:			

Safety is a Part of Your Contract

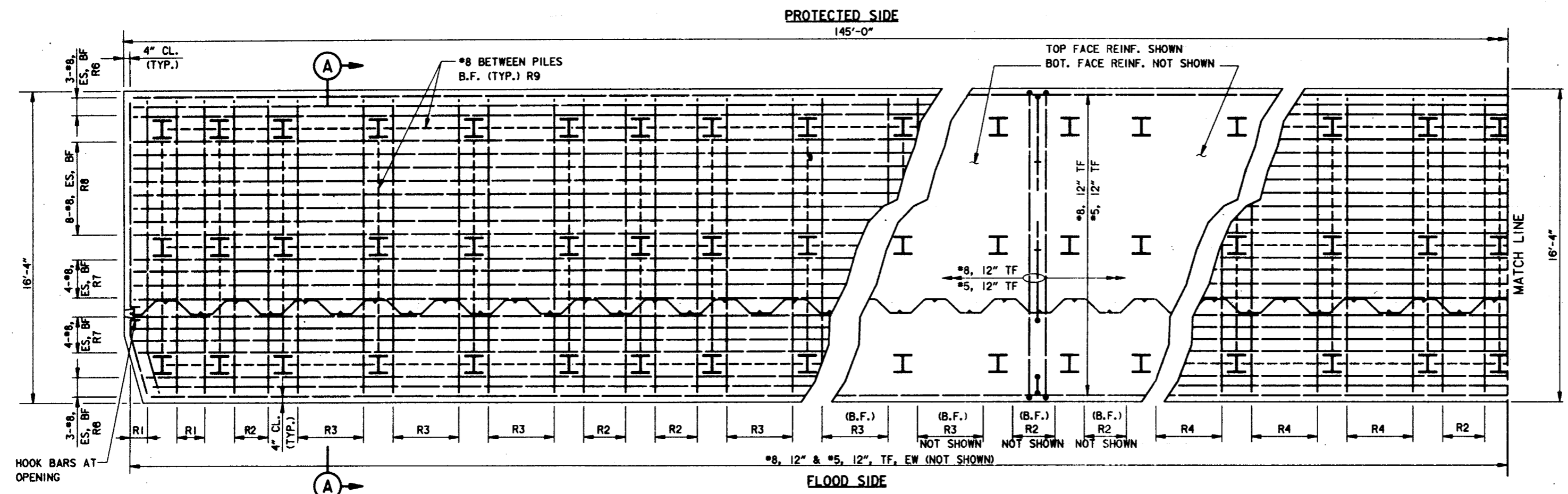

BOTTOM FACE REINFORCING SCHEDULE

CALLOUT	REINFORCING	S H O R T D I R.	L O N G D I R.
R1	3-#8, ES, BF		
R2	4-#8, ES, BF		
R3	5-#8, ES, BF		
R4	6-#8, ES, BF		
R5	7-#8, ES, BF		
R6	3-#8, ES, BF		
R7	4-#8, ES, BF		
R8	8-#8, ES, BF		
R9	#8 BF BTWN. PILES (LONG & SHORT DIR.)		

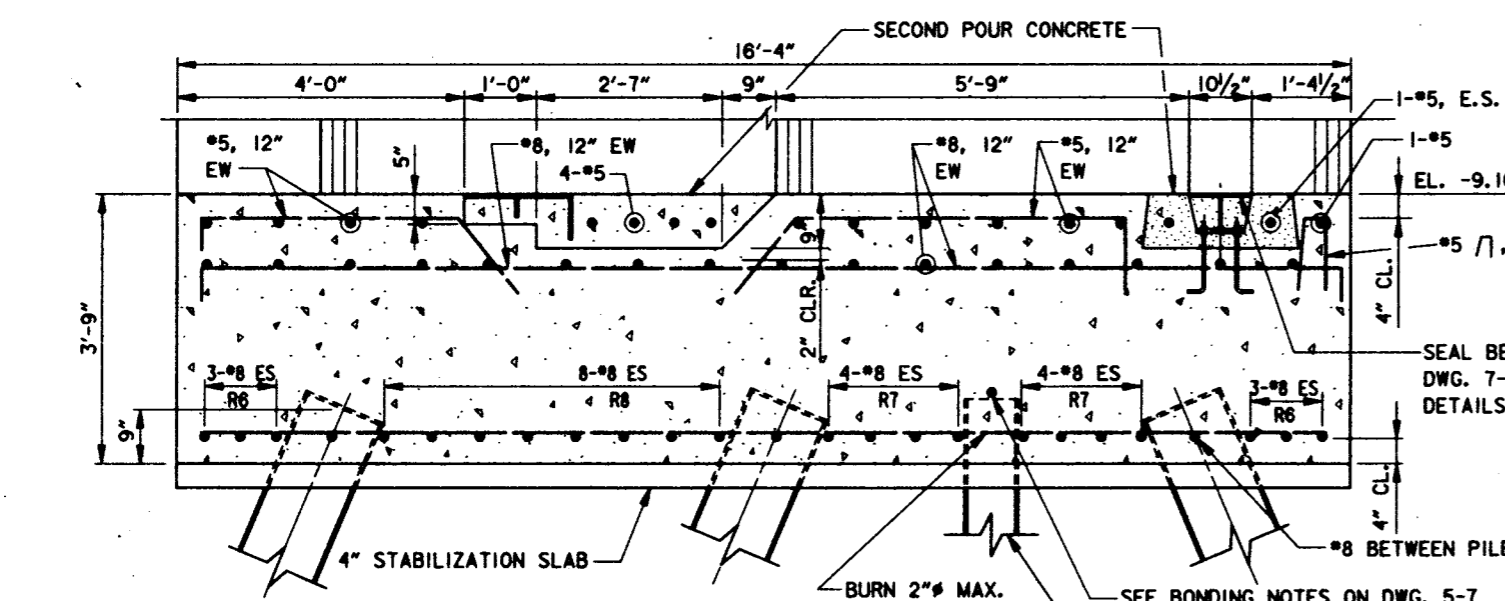
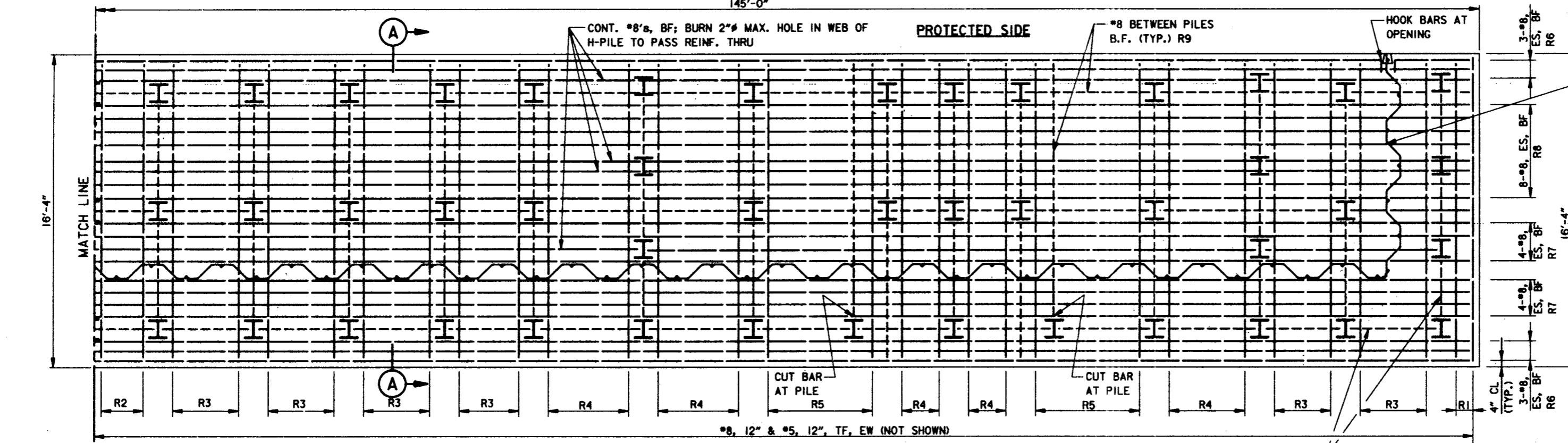

EAST MONOLITH BASE SLAB PLAN
SCALE: 3/8" = 1'-0"

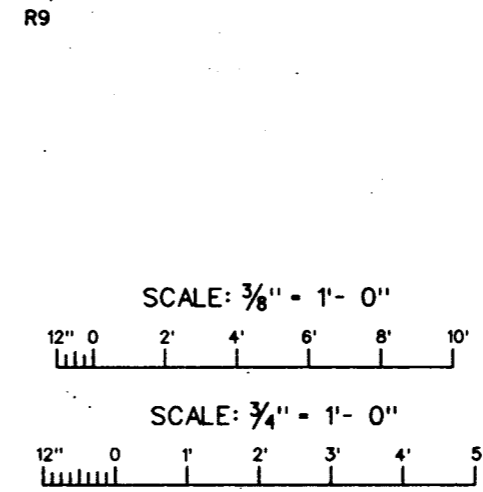

NOTE:
FOR REINFORCING CALLOUTS R1-R9
SEE REINFORCING SCHEDULE FOR
DESIGNATION OF REINFORCING. IN
SHORT DIRECTION ALL BARS NOT
SHOWN FOR CLARITY.

EAST MONOLITH SECTION (A)
SCALE: 3/4" = 1'-0"



SYMBOL	DESCRIPTION	DATE	APPROVED
 U.S. ARMY ENGINEER DISTRICT, NEW ORLEANS CORPS OF ENGINEERS NEW ORLEANS, LOUISIANA URS CONSULTANTS, INC. LAKE PONTCHARTRAIN, LA. AND VICINITY HURRICANE PROTECTION HIGH LEVEL PLAN FRONTING PROTECTION AT PUMP STATION #8 ORLEANS PARISH - JEFFERSON PARISH 17th STREET OUTFALL CANAL (METAIRIE RELIEF) EAST MONOLITH BASE SLAB REINFORCEMENT			
DESIGNED BY: S.C.B.	DATE: SEPT. 1997	PLOT SCALE: 2.007	PLOT DATE: SEPT. 1997
DRAWN BY: K.L.L.	CHECKED BY: D.J.L.	FILE NO. H-4-44654	
SUBMITTED BY:	SOLICITATION NO. DACW29-98-B-0112	DWG. 6-5	08-18

Safety is a Part of Your Contract

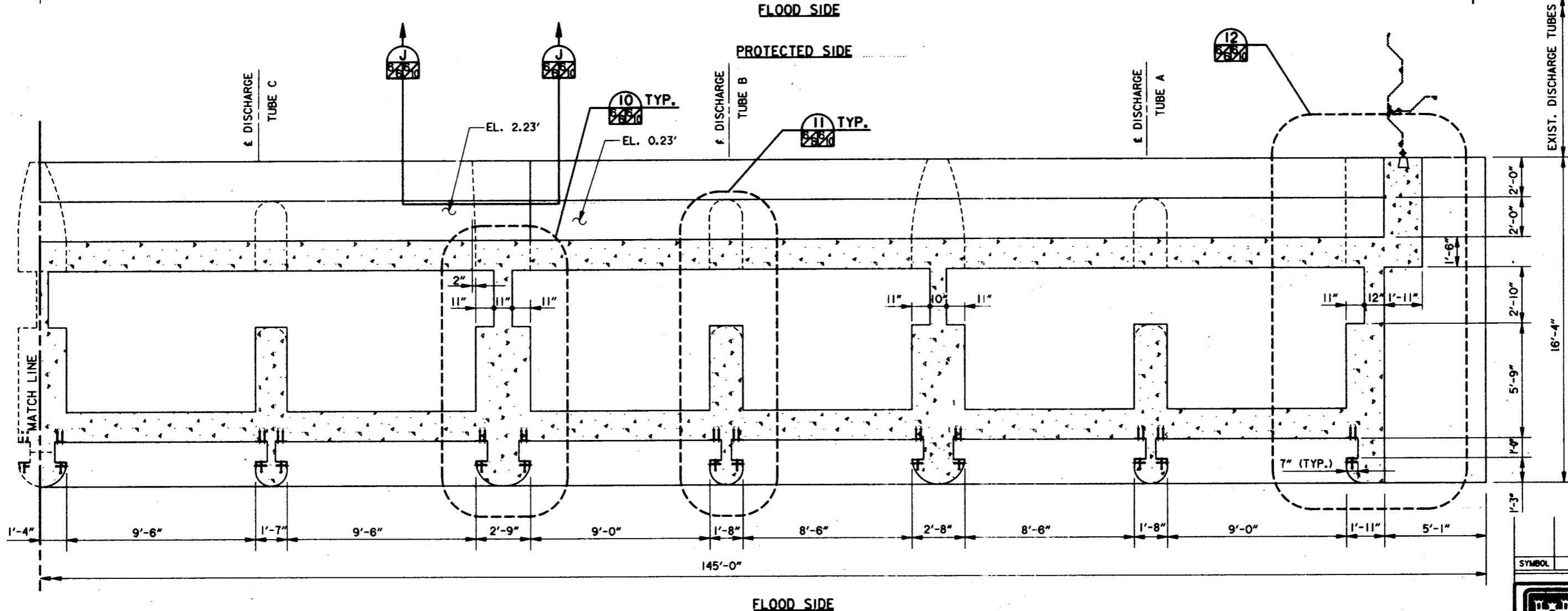
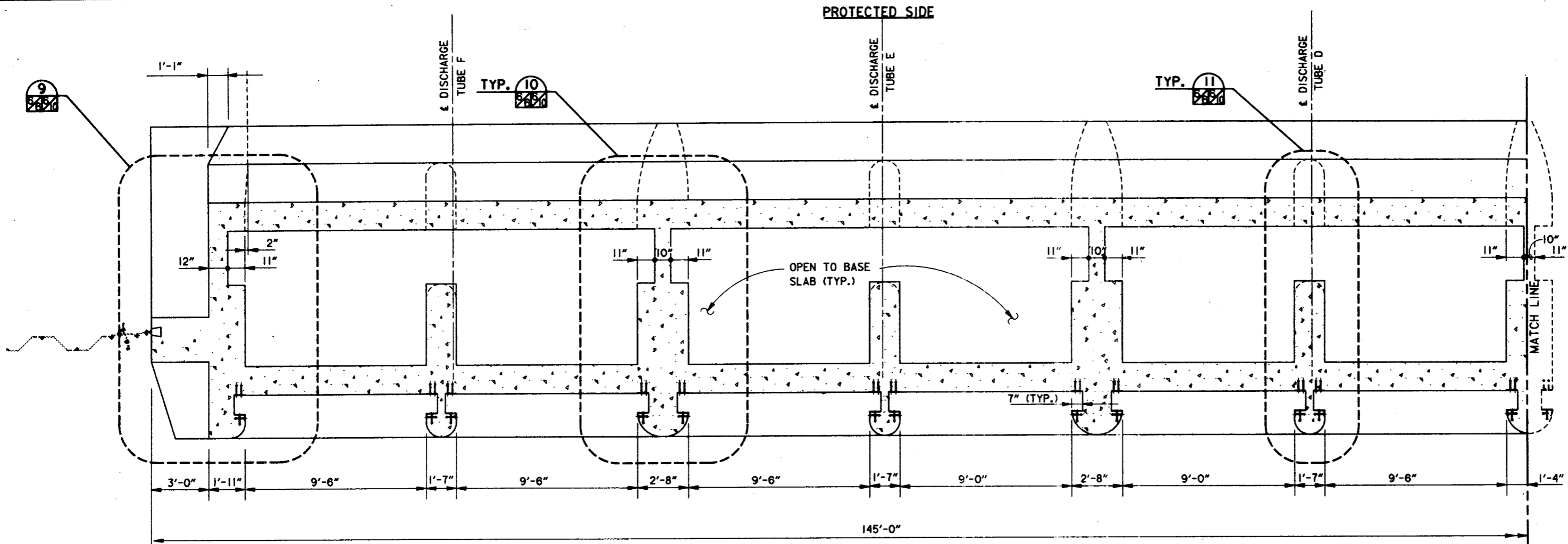

PLAN @ EL. 2.23'

SCALE: 3/8" = 1'-0"

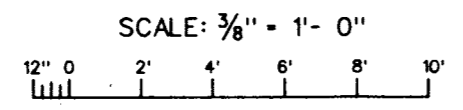

SYMBOL	DESCRIPTION	DATE	APPROVED
REVISIONS			
U.S. ARMY ENGINEER DISTRICT, NEW ORLEANS CORPS OF ENGINEERS NEW ORLEANS, LOUISIANA			
URS CONSULTANTS, INC. LAKE PONTCHARTRAIN, LA. AND VICINITY HURRICANE PROTECTION HIGH LEVEL PLAN FRONTING PROTECTION AT PUMP STATION #8 ORLEANS PARISH - JEFFERSON PARISH 17TH STREET OUTFALL CANAL (METAIRIE RELIEF) EAST MONOLITH INTERMEDIATE PLAN			
DESIGNED BY: S.C.B.	DATE: SEPT. 1997	PLOT SCALE: 2.007	PLOT DATE: SEPT. 1997
DRAWN BY: K.L.L.	CADD FILE: P20-9-00.DWG	FILE NO. H-4-44654	
CHECKED BY: D.J.L.	SUBMITTED BY: DACW29-98-B-0112	DWG. 6-6 OF 6-18	

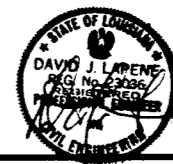
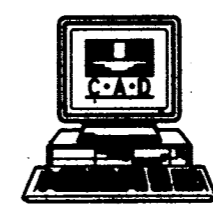

Safety is a Part of Your Contract

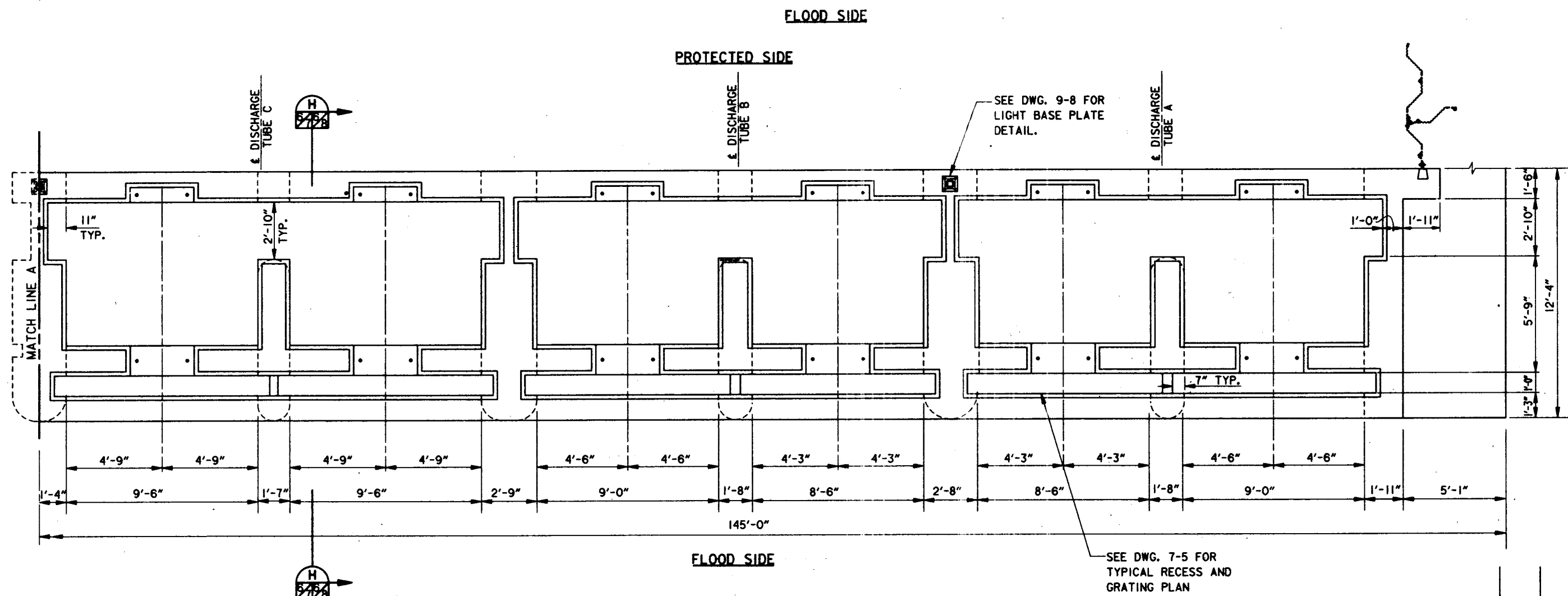
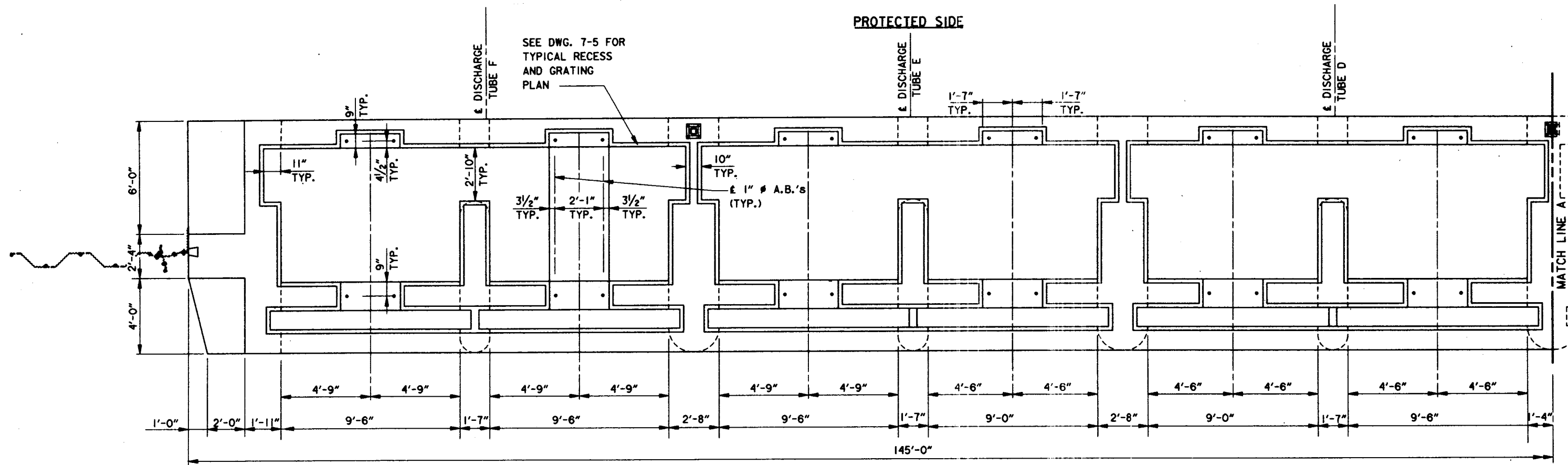

PLAN @ EL. 14.65'
SCALE: 3/8" = 1'-0"

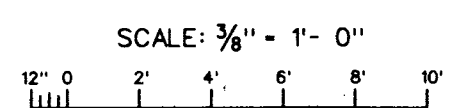

SYMBOL	DESCRIPTION	DATE	APPROVED
REVISIONS			
U.S. ARMY ENGINEER DISTRICT, NEW ORLEANS CORPS OF ENGINEERS NEW ORLEANS, LOUISIANA			
URS CONSULTANTS, INC. LAKE PONTCHARTRAIN, LA. AND VICINITY HURRICANE PROTECTION HIGH LEVEL PLAN FRONTING PROTECTION AT PUMP STATION #8 ORLEANS PARISH - JEFFERSON PARISH 17th STREET OUTFALL CANAL (METAIRIE RELIEF) EAST MONOLITH TOP PLAN			
DESIGNED BY: S.C.B.	DATE: SEPT. 1997	PLOT SCALE: 2.667	PLOT DATE: SEPT. 1997
DRAWN BY: K.L.L.	CADD FILE: P28-8-07.DWG	FILE NO. H-4-44654	
CHECKED BY: D.A.L.	SOLICITATION NO. DACW29-98-B-0112	DWG. 6-7 OF 6-18	

Safety is a Part of Your Contract

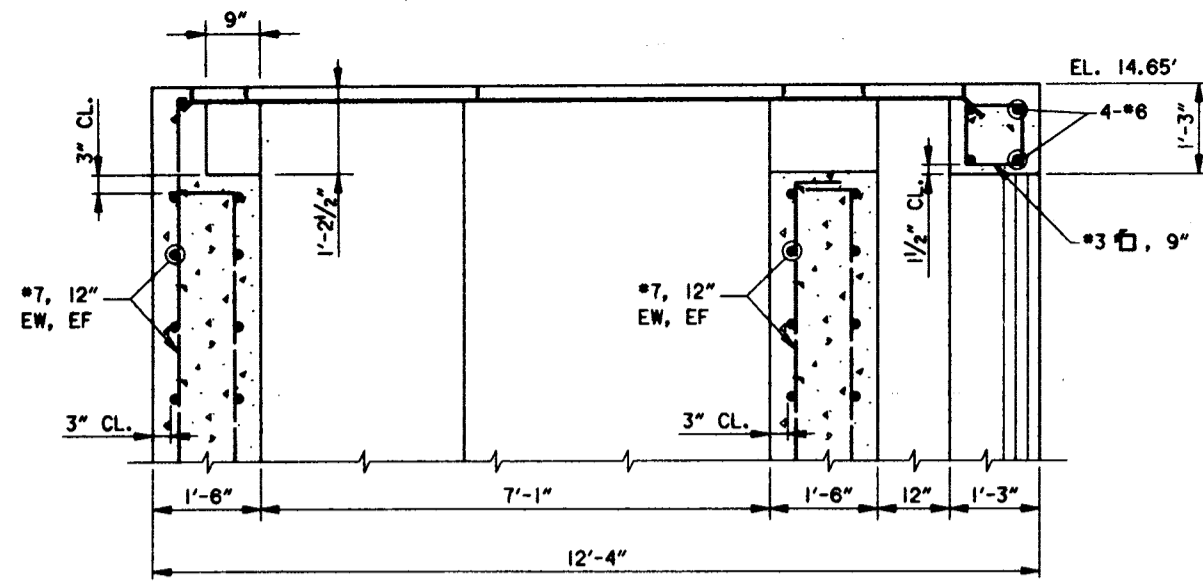

DETAIL 1
SCALE: 3/4" = 1'-0"

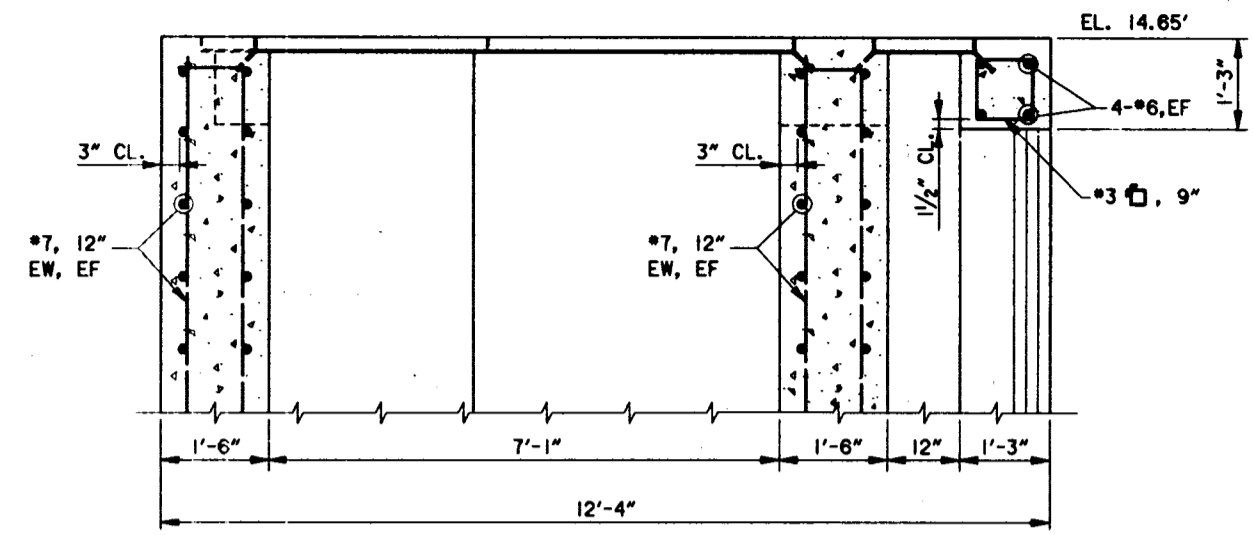

SECTION H
SCALE: 3/4" = 1'-0"

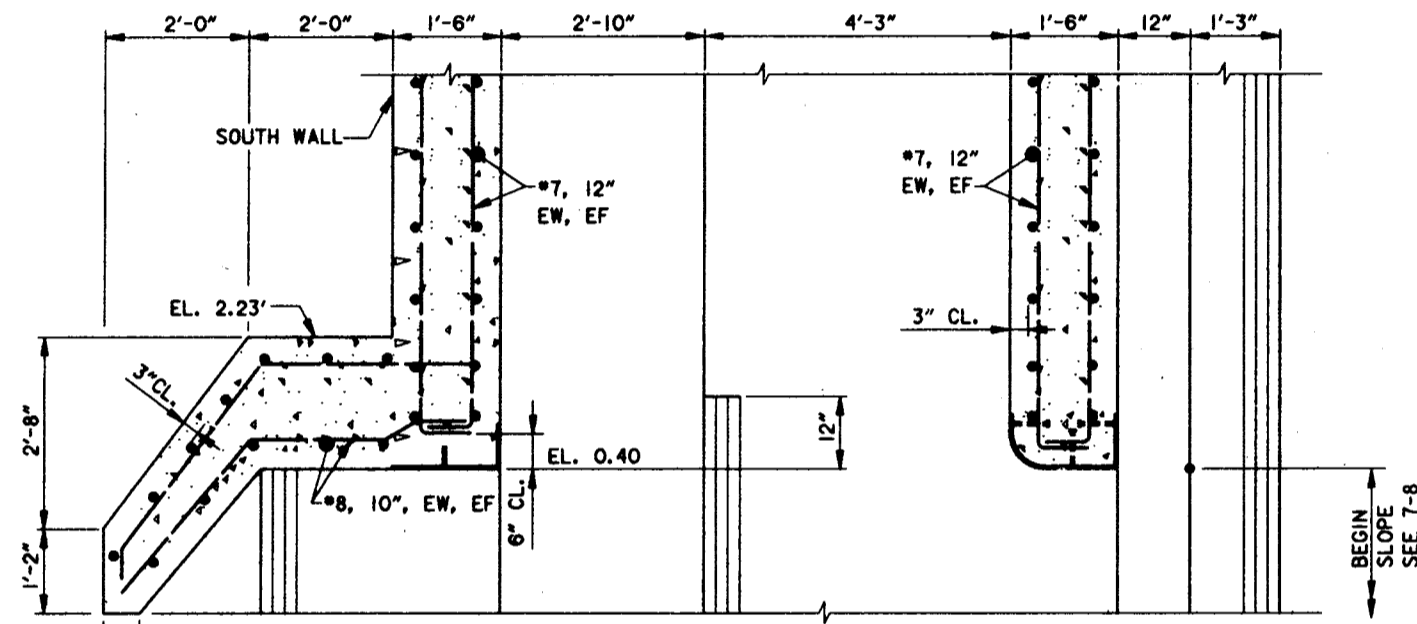

DETAIL 2
SCALE: 3/4" = 1'-0"

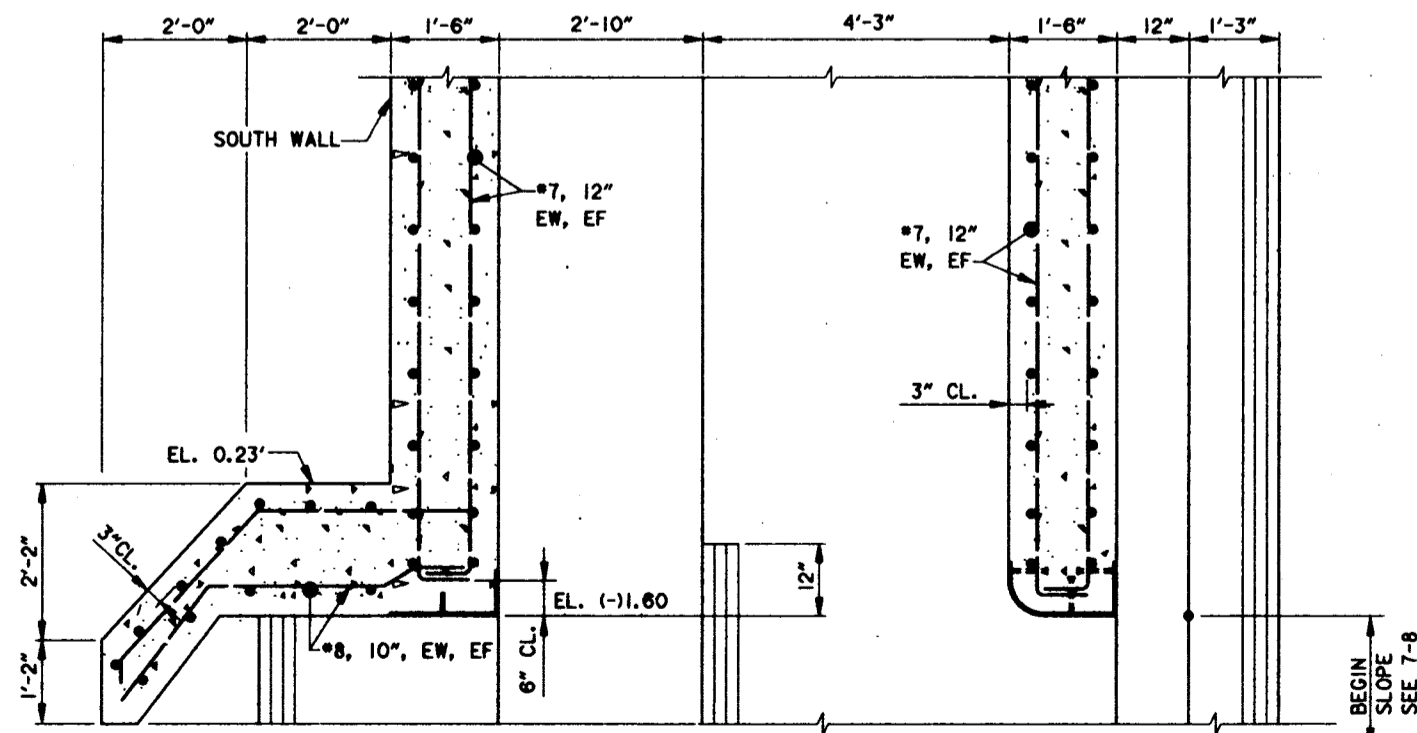

DETAIL 3
SCALE: 3/4" = 1'-0"



SCALE: 3/4" = 1'-0"
12" 0 1' 2' 3' 4' 5'

SYMBOL	DESCRIPTION	DATE	APPROVED
REVISIONS			
U.S. ARMY ENGINEER DISTRICT, NEW ORLEANS CORPS OF ENGINEERS NEW ORLEANS, LOUISIANA			
URS CONSULTANTS, INC.			
LAKE PONTCHARTRAIN, LA. AND VICINITY HURRICANE PROTECTION HIGH LEVEL PLAN			
FRONTING PROTECTION AT PUMP STATION #6 ORLEANS PARISH - JEFFERSON PARISH 17TH STREET OUTFALL CANAL (DETARRE RELIEF)			
EAST MONOLITH DETAILS			
DESIGNED BY: M.F.L.	DATE: SEPT. 1997	PLOT SCALE: 1.33	PLOT DATE: SEPT. 1997
DRAWN BY: T.R.E.	CHECKED BY: D.J.L.	FILE NO. H-4-44654	
SOLICITATION NO. DACW29-98-B-0112		DWG. 6-8 OF 6-18	

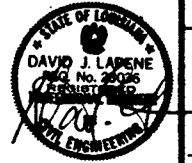

Safety is a Part of Your Contract

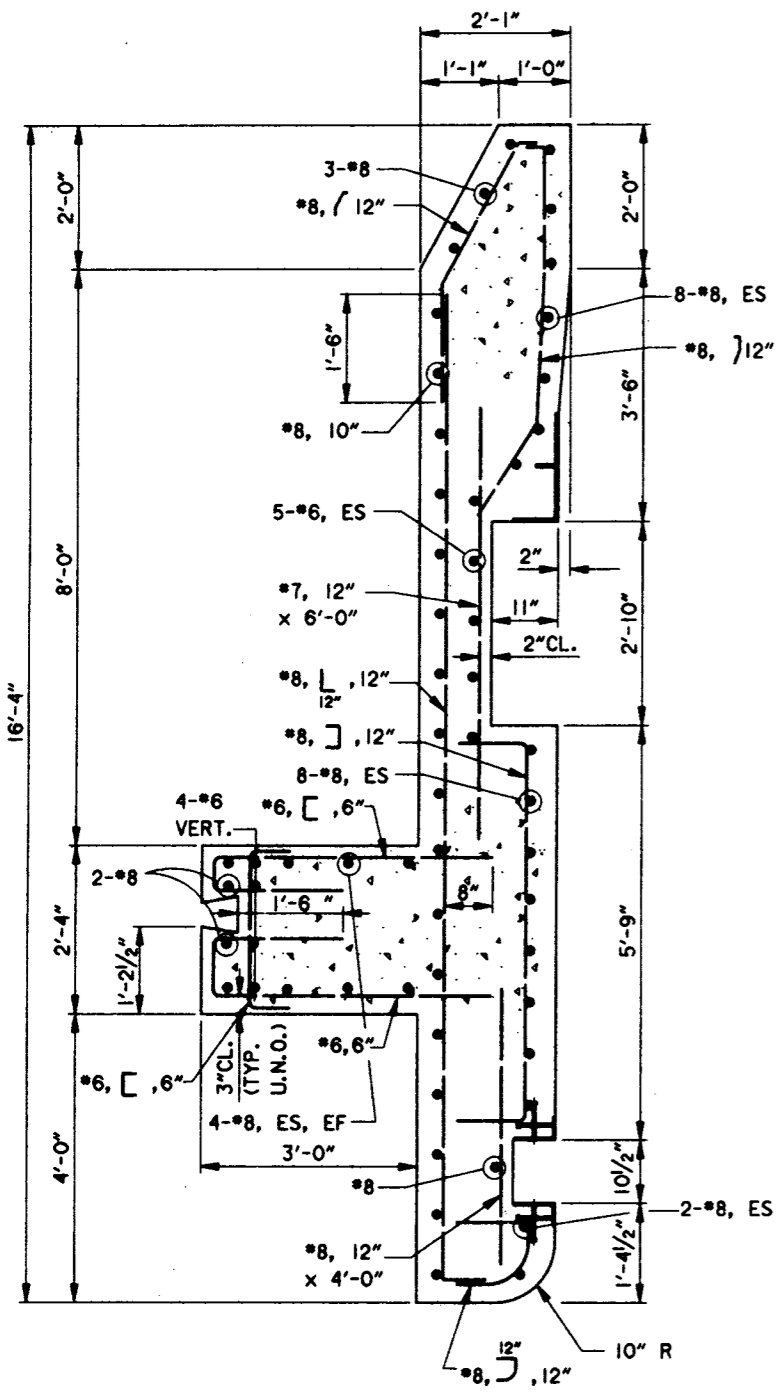

DETAIL 4
SCALE: 3/4" = 1'-0"

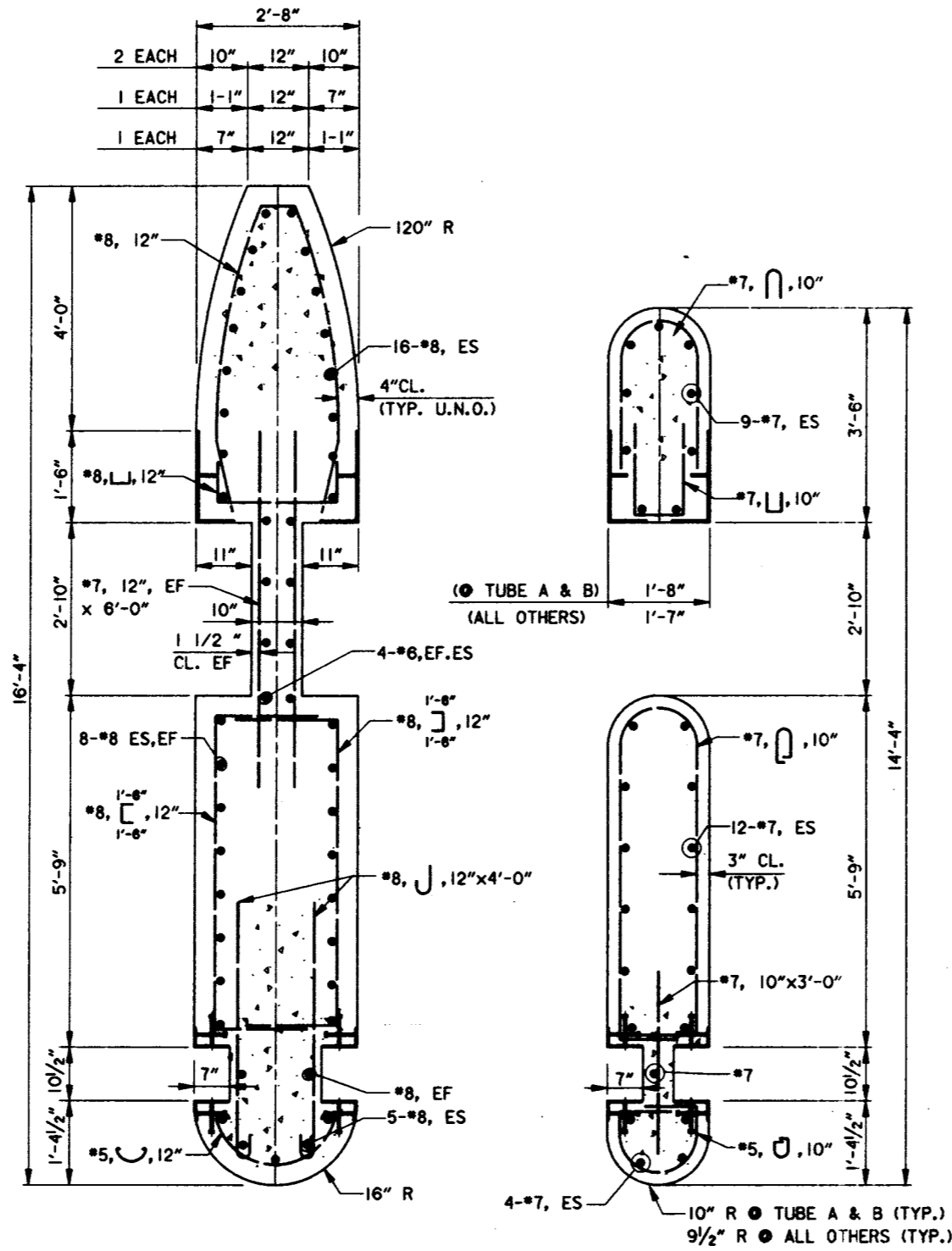

DETAIL 5
SCALE: 3/4" = 1'-0"

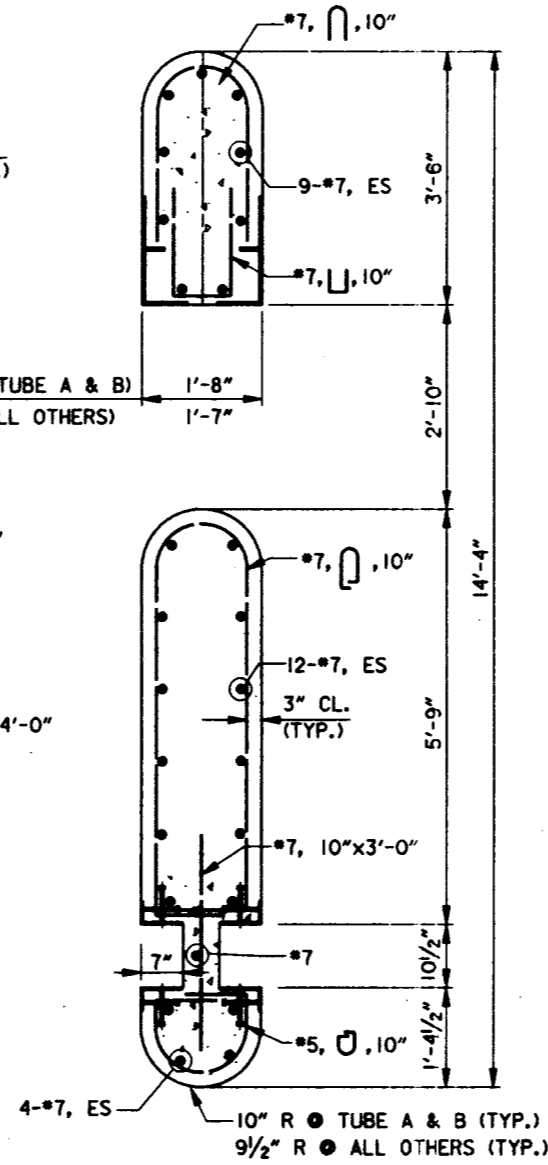

DETAIL 6
SCALE: 3/4" = 1'-0"

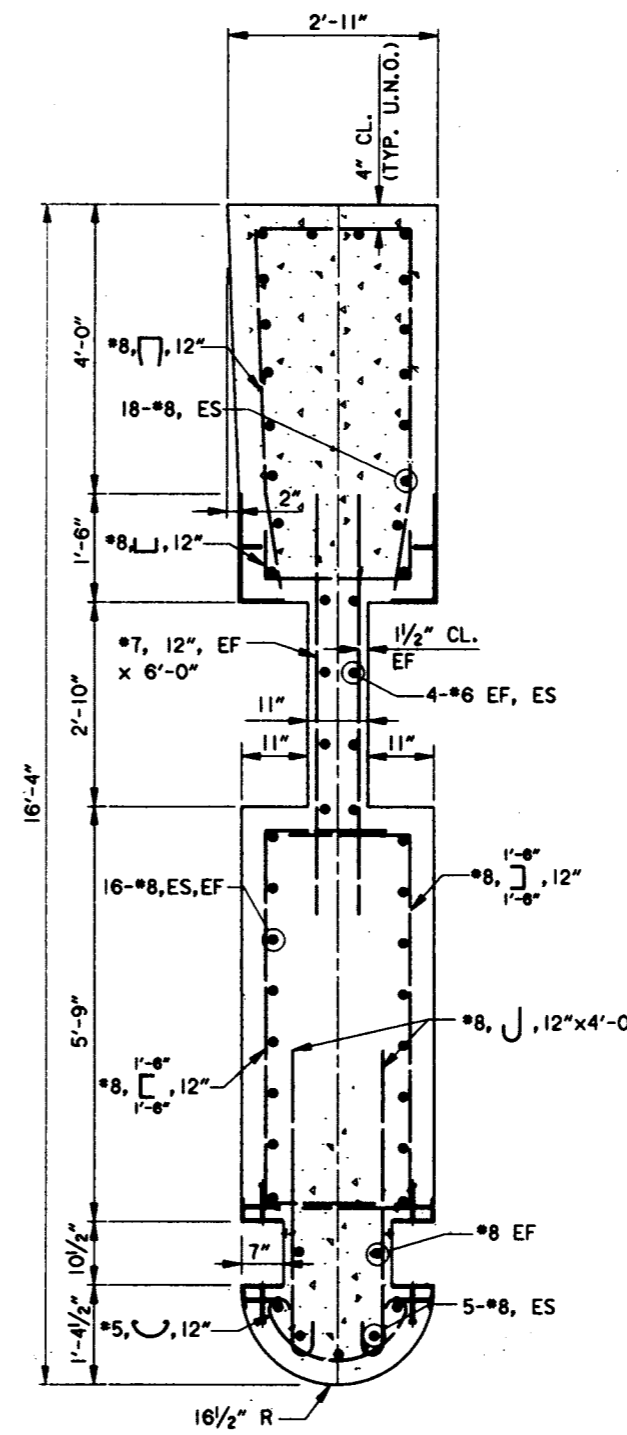

DETAIL 7
SCALE: 3/4" = 1'-0"

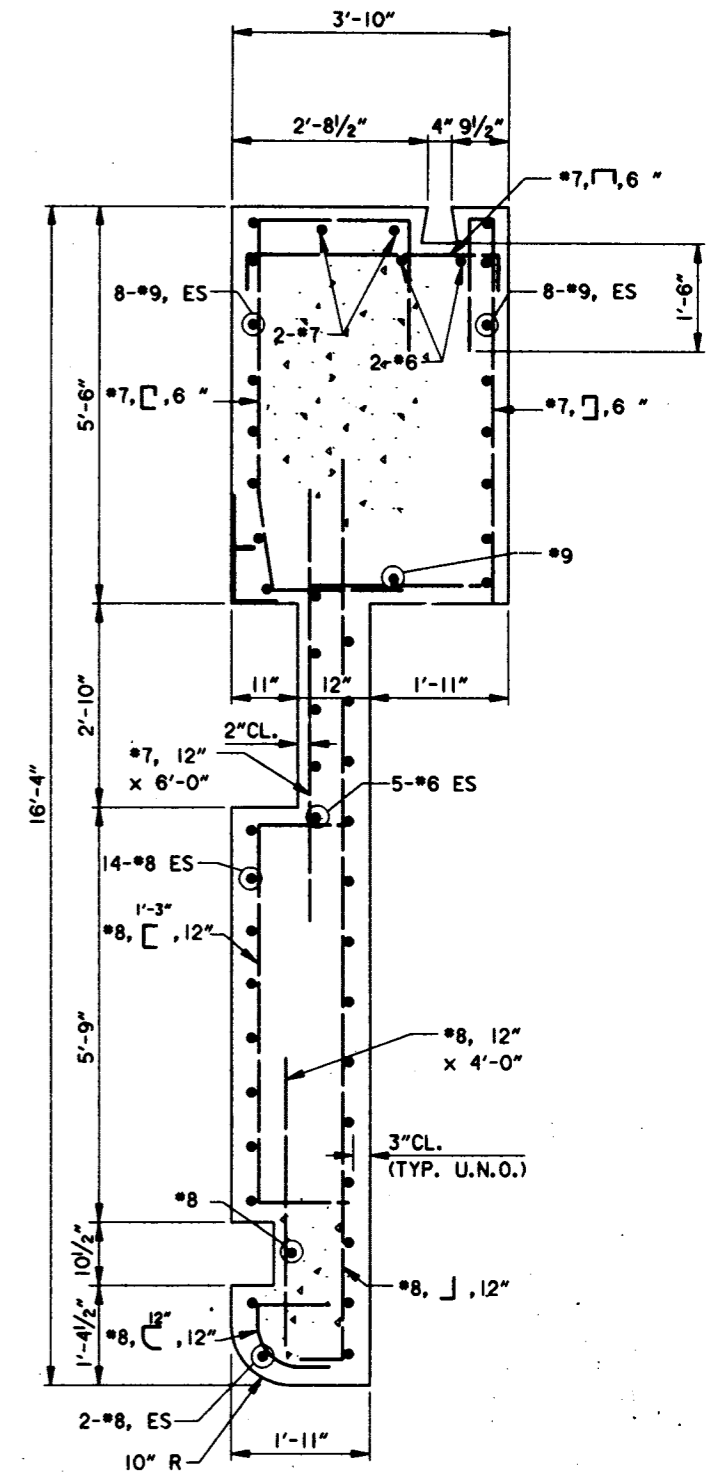

DETAIL 8
SCALE: 3/4" = 1'-0"

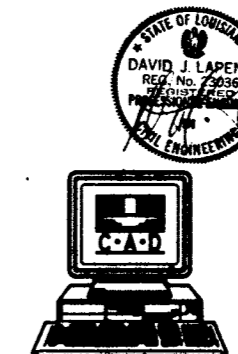
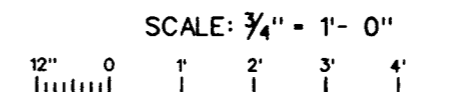

SYMBOL	DESCRIPTION	DATE	APPROVED
REVISIONS			
 U.S. ARMY ENGINEER DISTRICT, NEW ORLEANS CORPS OF ENGINEERS NEW ORLEANS, LOUISIANA			
URS CONSULTANTS, INC. LAKE PONTCHARTRAIN, LA. AND VICINITY HURRICANE PROTECTION HIGH LEVEL PLAN FRONTING PROTECTION AT PUMP STATION #8 ORLEANS PARISH - JEFFERSON PARISH 17th STREET OUTFALL CANAL (METAIRIE RELIEF)			
EAST MONOLITH DETAILS			
DESIGNED BY: M.F.L.	DATE: SEPT. 1997	PLOT SCALE: 1.33	PLOT DATE: SEPT. 1997
DRAWN BY: T.R.E.	CADD FILE: P88-0-OLDON	FILE NO. H-4-44654	
CHECKED BY: D.J.L.	SOLICITATION NO. DACW29-98-B-0112	DWG. 6-9 OF 6-18	
SUBMITTED BY:			

Safety is a Part of Your Contract

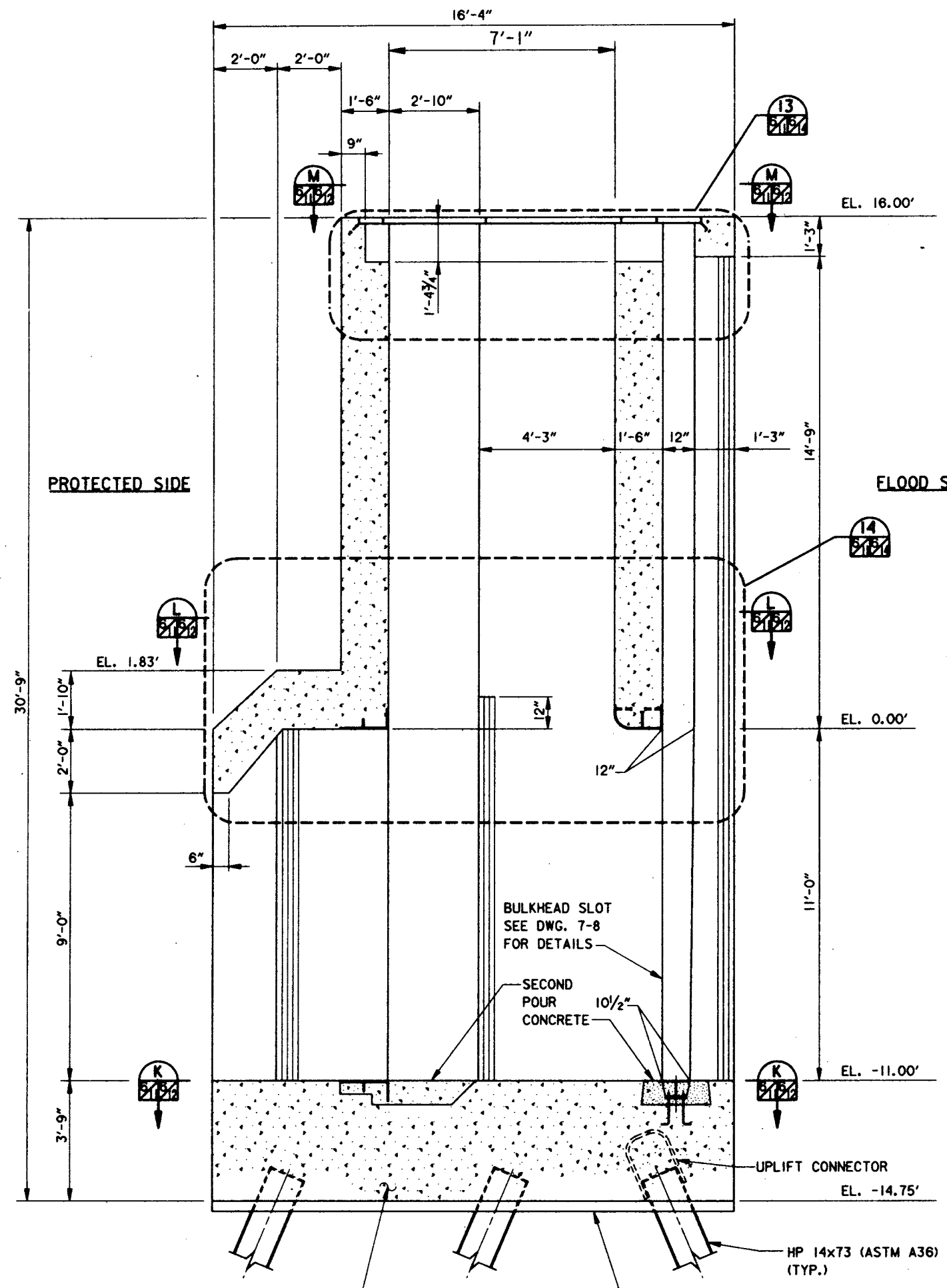

SEE DWG. 6-13 FOR
BASE SLAB REINFORCEMENT

MONOLITH G

SECTION C

SCALE: 1/2" = 1'-0"

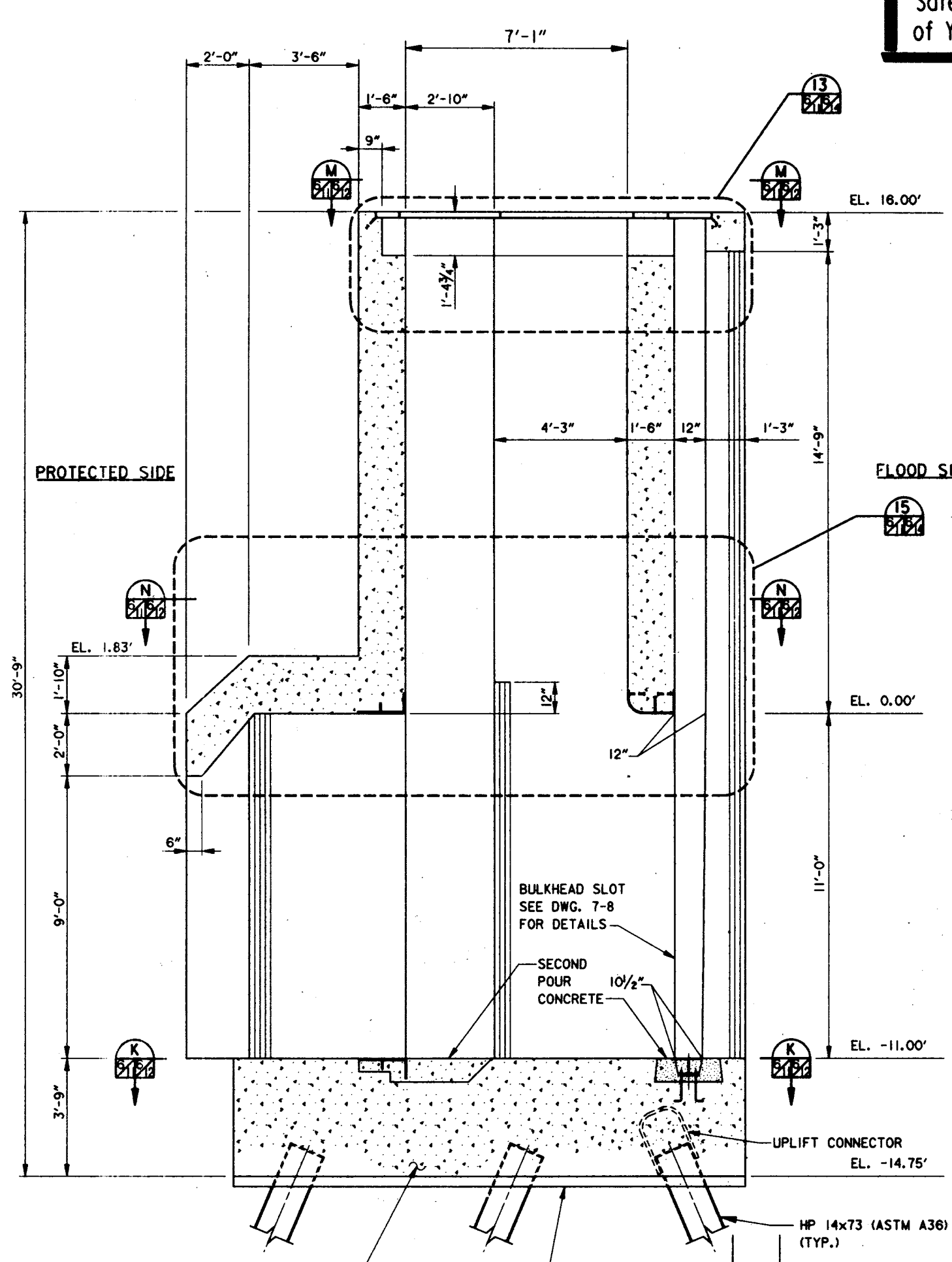

SEE DWG. 6-13 FOR
BASE SLAB REINFORCEMENT

MONOLITHS H & I

SECTION D

SCALE: 1/2" = 1'-0"

NOTE:
FOR JOINT DETAILS BETWEEN EXISTING DISCHARGE
TUBES AND SLUICE GATE MONOLITHS SEE DWG. 6-18.

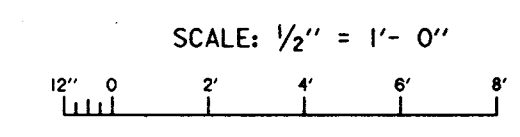

SYMBOL	DESCRIPTION	DATE	APPROVED
REVISIONS			
U.S. ARMY ENGINEER DISTRICT, NEW ORLEANS CORPS OF ENGINEERS NEW ORLEANS, LOUISIANA			
URS CONSULTANTS, INC.			
LAKE PONCHARTRAIN, LA. AND VICINITY HURRICANE PROTECTION HIGH LEVEL PLAN			
FRONTING PROTECTION AT PUMP STATION #8 ORLEANS PARISH - JEFFERSON PARISH 17TH STREET OUTFALL CANAL (METAIRIE RELIEF)			
CROSS SECTIONS WEST MONOLITHS			
DESIGNED BY: S.C.B.	DATE: SEPT. 1997	PLOT SCALE: 2	PLOT DATE: SEPT. 1997
DRAWN BY: K.L.L.	CADD FILE: P98-0-1100	FILE NO. H-4-44654	
CHECKED BY: D.J.L.	SUBMITTED BY: DACW29-98-B-0112	DWG. 6-11 OF 6-18	

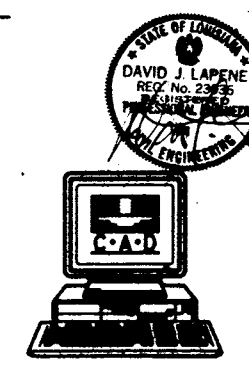

Safety is a Part of Your Contract

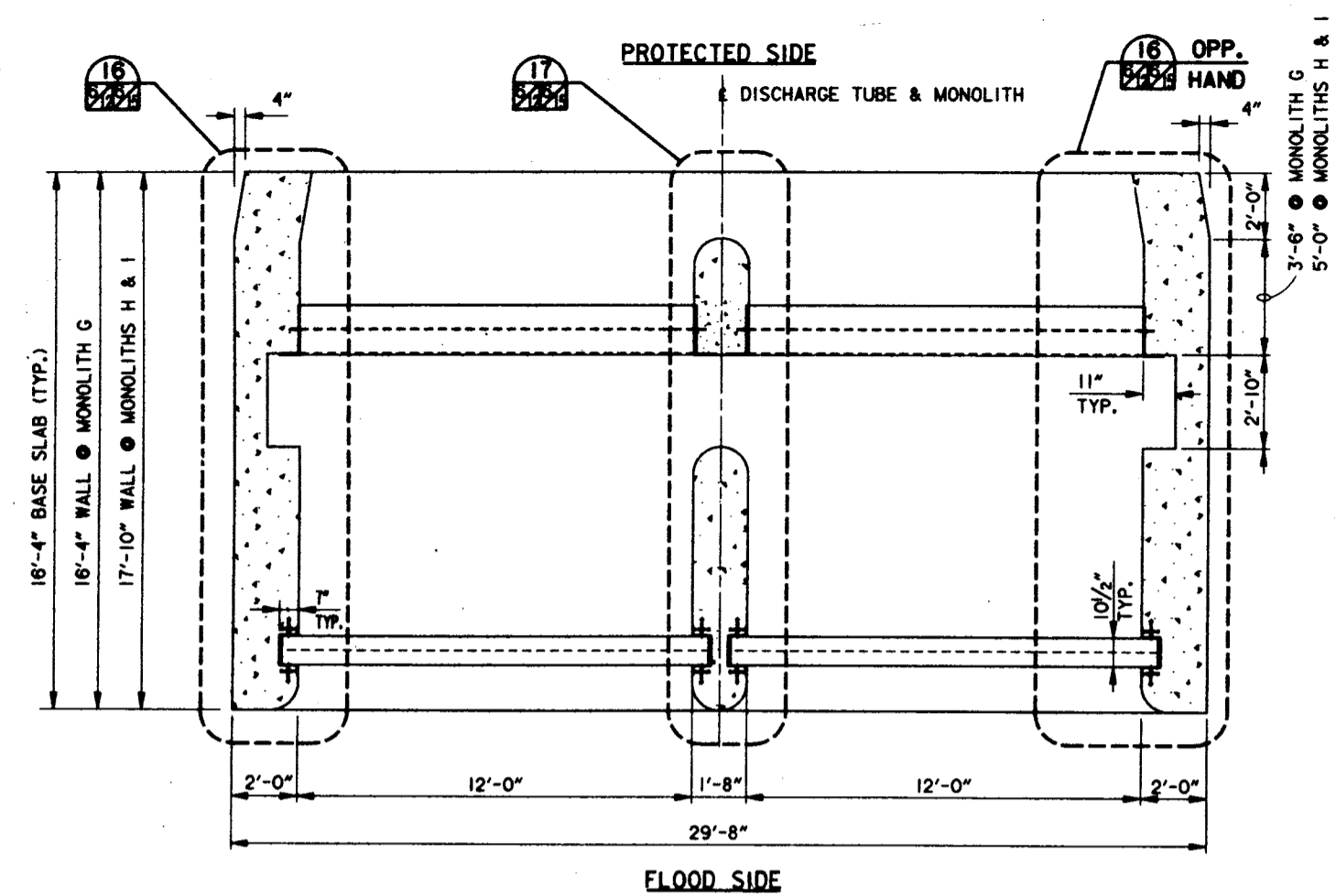

MONOLITHS G, H, & I
 PLAN @ ELEVATION -11.00'
 SCALE: 3/8"=1'-0" K

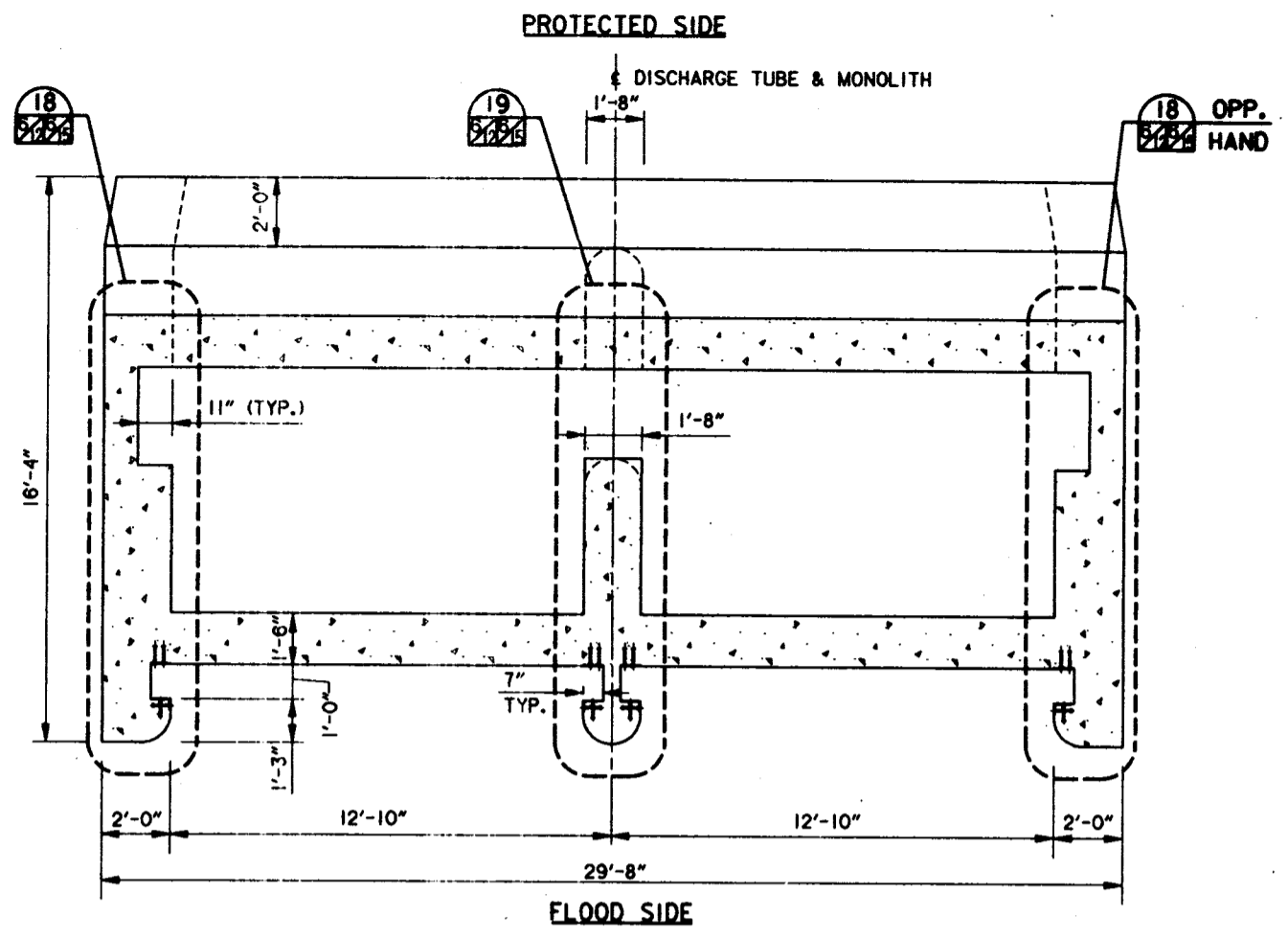

MONOLITH G
 PLAN @ ELEVATION 1.83'
 SCALE: 3/8"=1'-0" L

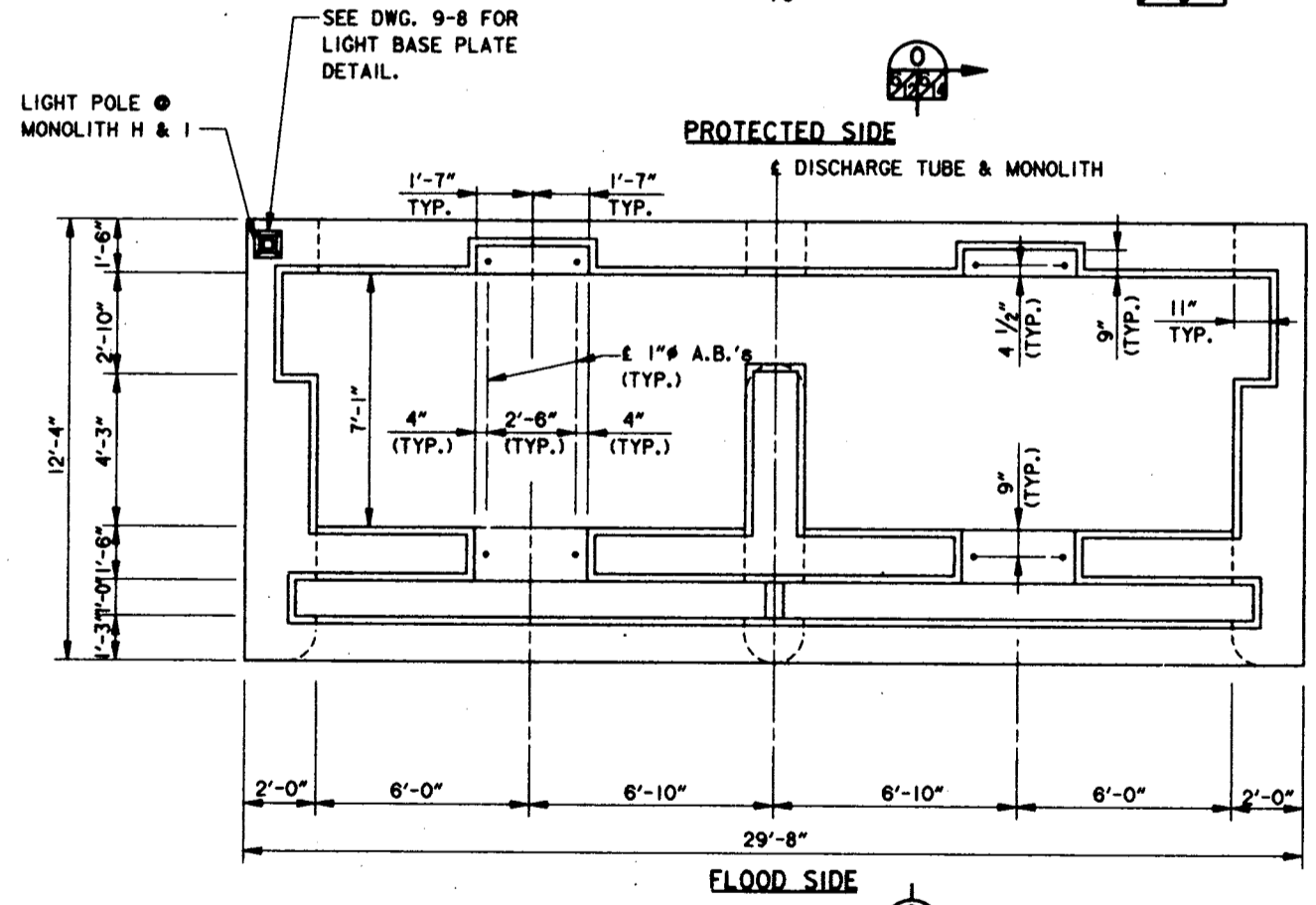

MONOLITHS G, H, & I
 PLAN @ ELEVATION 16.00
 SCALE: 3/8"=1'-0" M

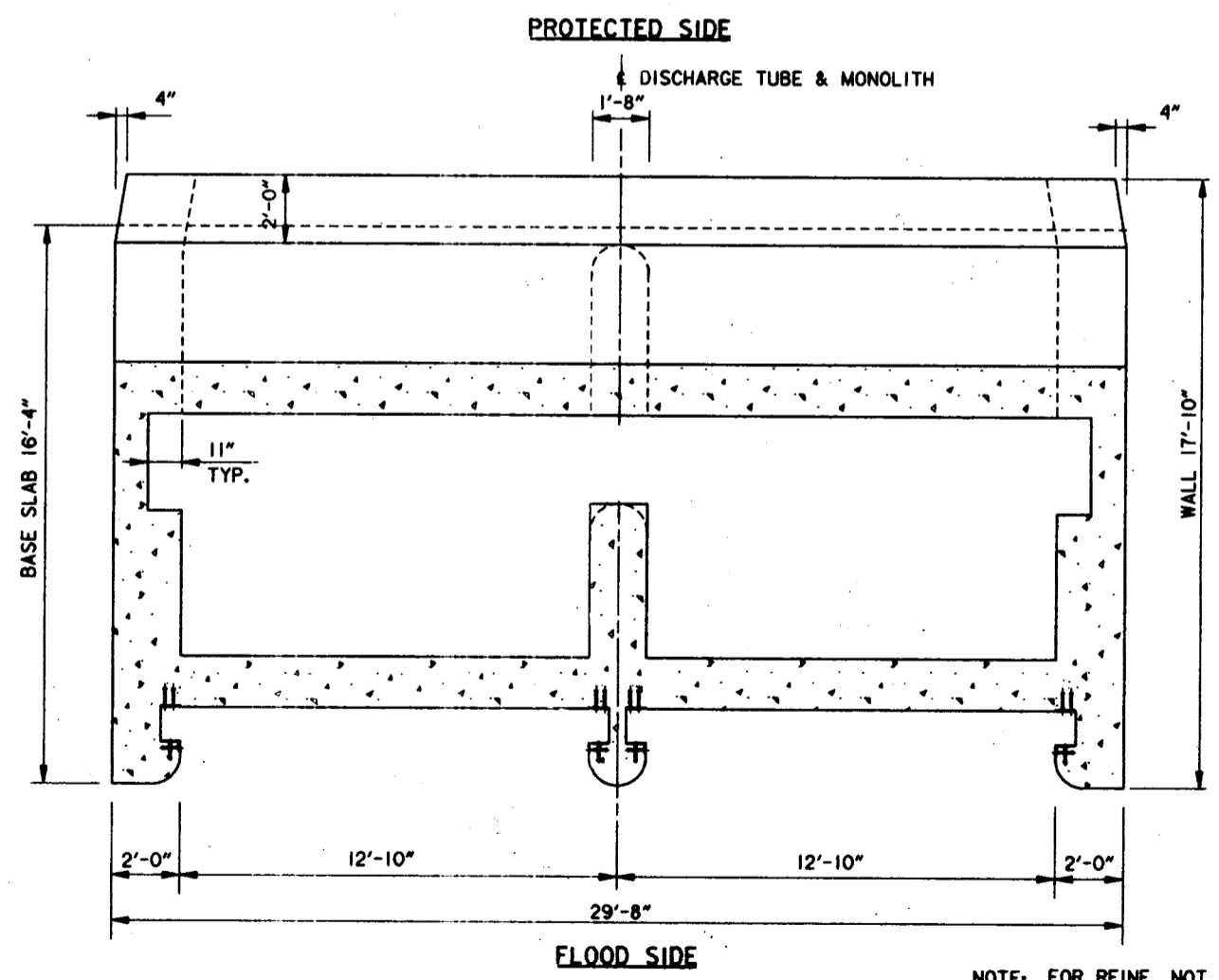

MONOLITH H & I
 PLAN @ ELEVATION 1.83'
 SCALE: 3/8"=1'-0" N

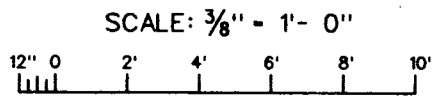

SYMBOL	DESCRIPTION	DATE	APPROVED
REVISIONS			
U.S. ARMY ENGINEER DISTRICT, NEW ORLEANS CORPS OF ENGINEERS NEW ORLEANS, LOUISIANA			
URS CONSULTANTS, INC. LAKE PONCHARTRAIN, LA. AND VICINITY HURRICANE PROTECTION HIGH LEVEL PLAN FRONTING PROTECTION AT PUMP STATION #6 ORLEANS PARISH - JEFFERSON PARISH 17th STREET OUTFALL CANAL (METAIRIE RELIEF)			
STRUCTURAL PLANS WEST MONOLITHS			
DESIGNED BY: S.C.B.	DATE: SEPT. 1997	PLOT SCALE: 2.007	PLOT DATE: SEPT. 1997
DRAWN BY: T.R.E.	CHECKED BY: D.J.L.	FILE NO. H-4-44654	
SUBMITTED BY:	SOLICITATION NO. DACW29-98-B-0112	DWG. 6-12 OF 6-18	



Safety is a Part of Your Contract

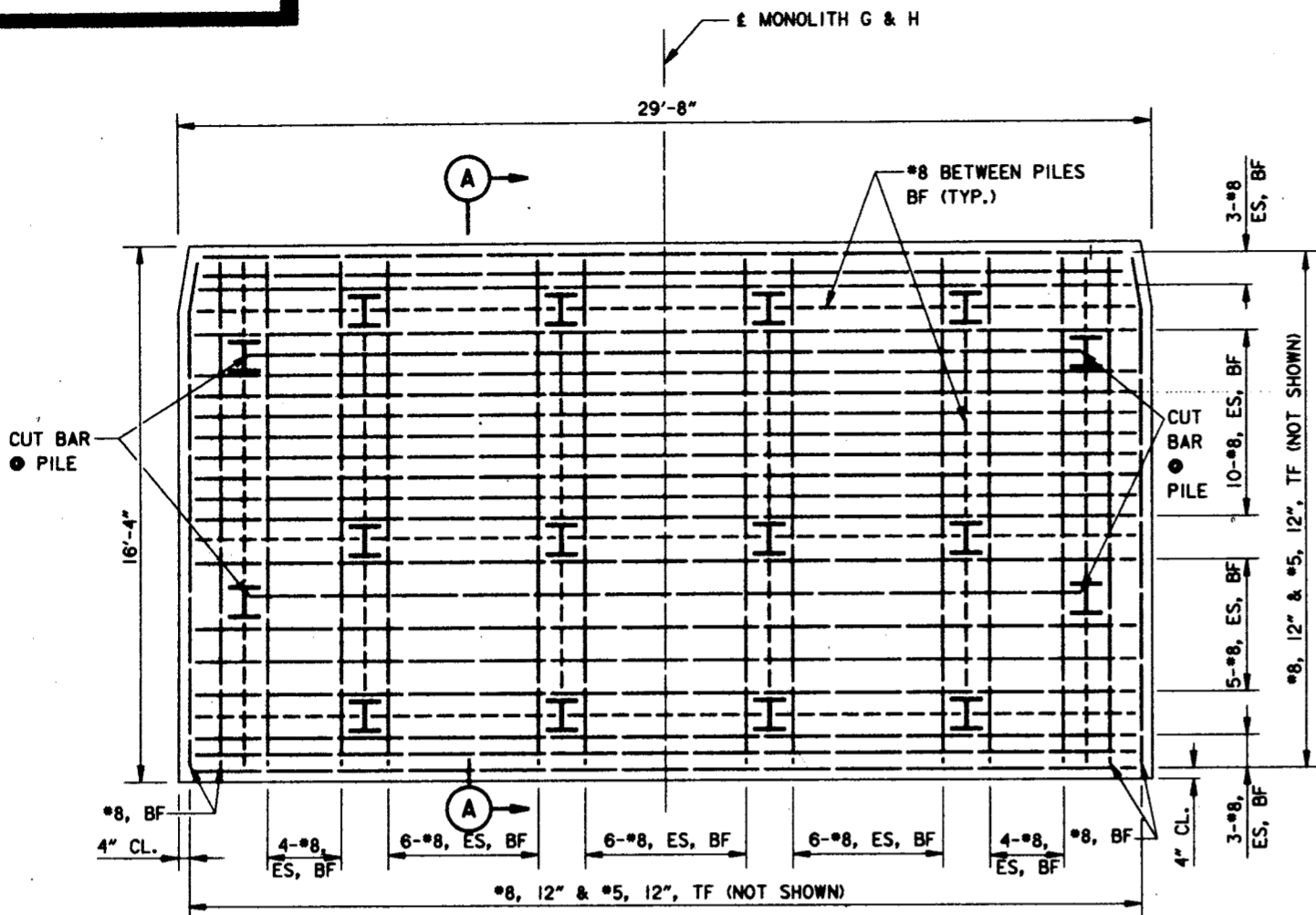

WEST MONOLITH G & H
BASE SLAB PLAN
SCALE: 3/8" = 1'-0"

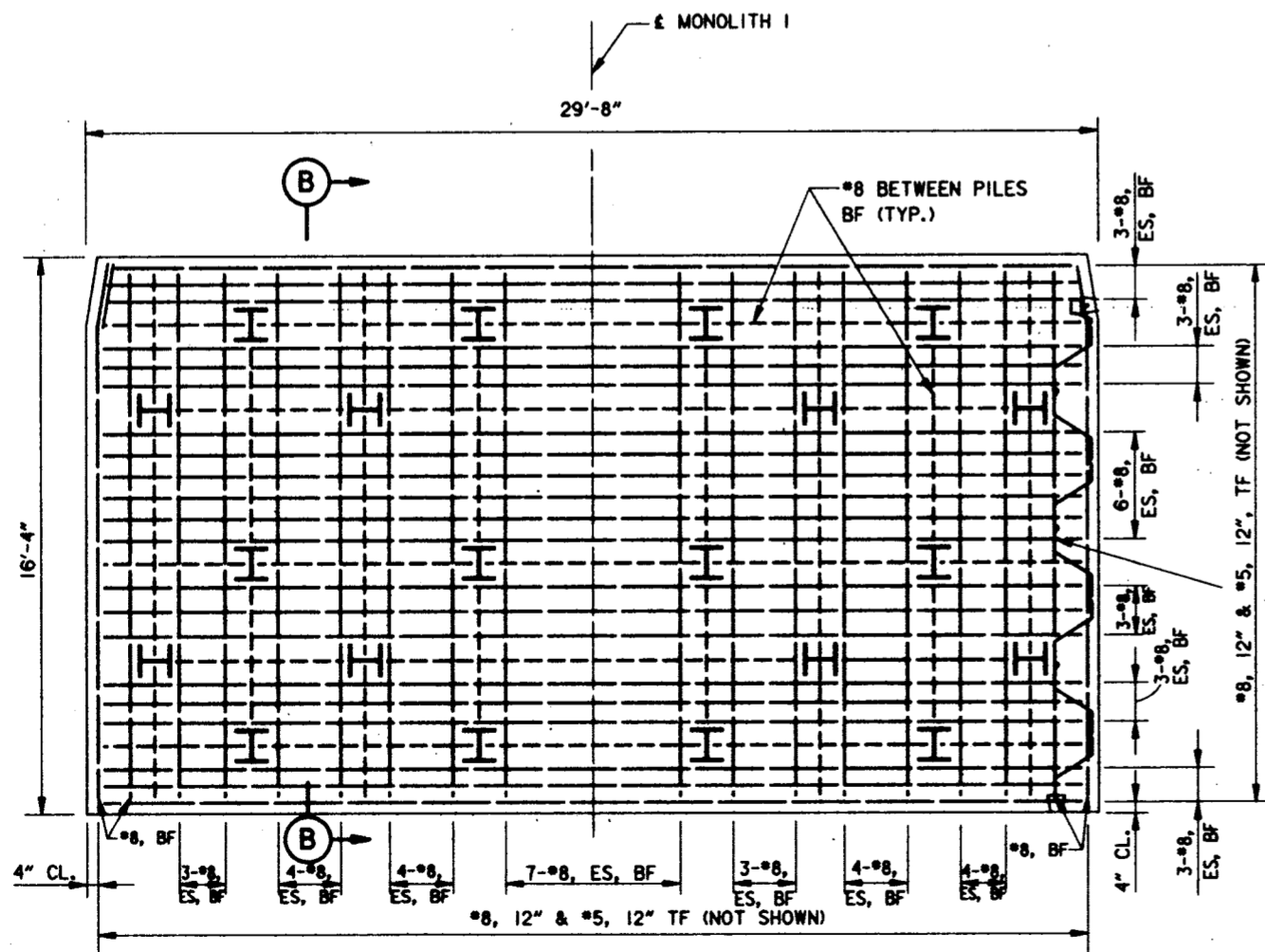

WEST MONOLITH I
BASE SLAB PLAN
SCALE: 3/8" = 1'-0"

BURN 2" MAX HOLE IN SHEET PILE TO PASS REINFORCING THRU AVOIDING INTERLOCKS (TYP.)

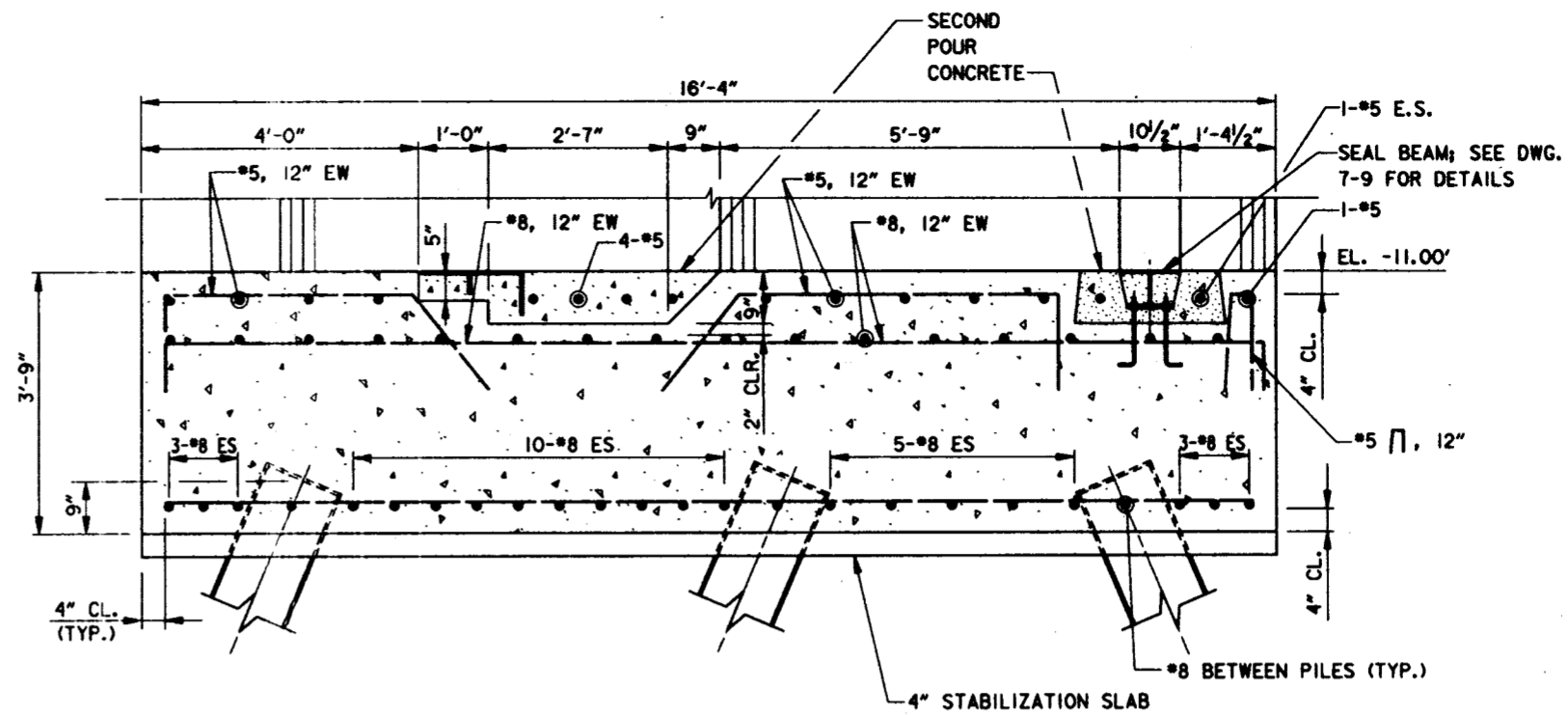

WEST MONOLITH G & H
SECTION (A)
SCALE: 3/4" = 1'-0"

NOTE:
UPLIFT CONNECTORS NOT SHOWN FOR CLARITY. SEE DWG. 5-3 FOR LOCATIONS.

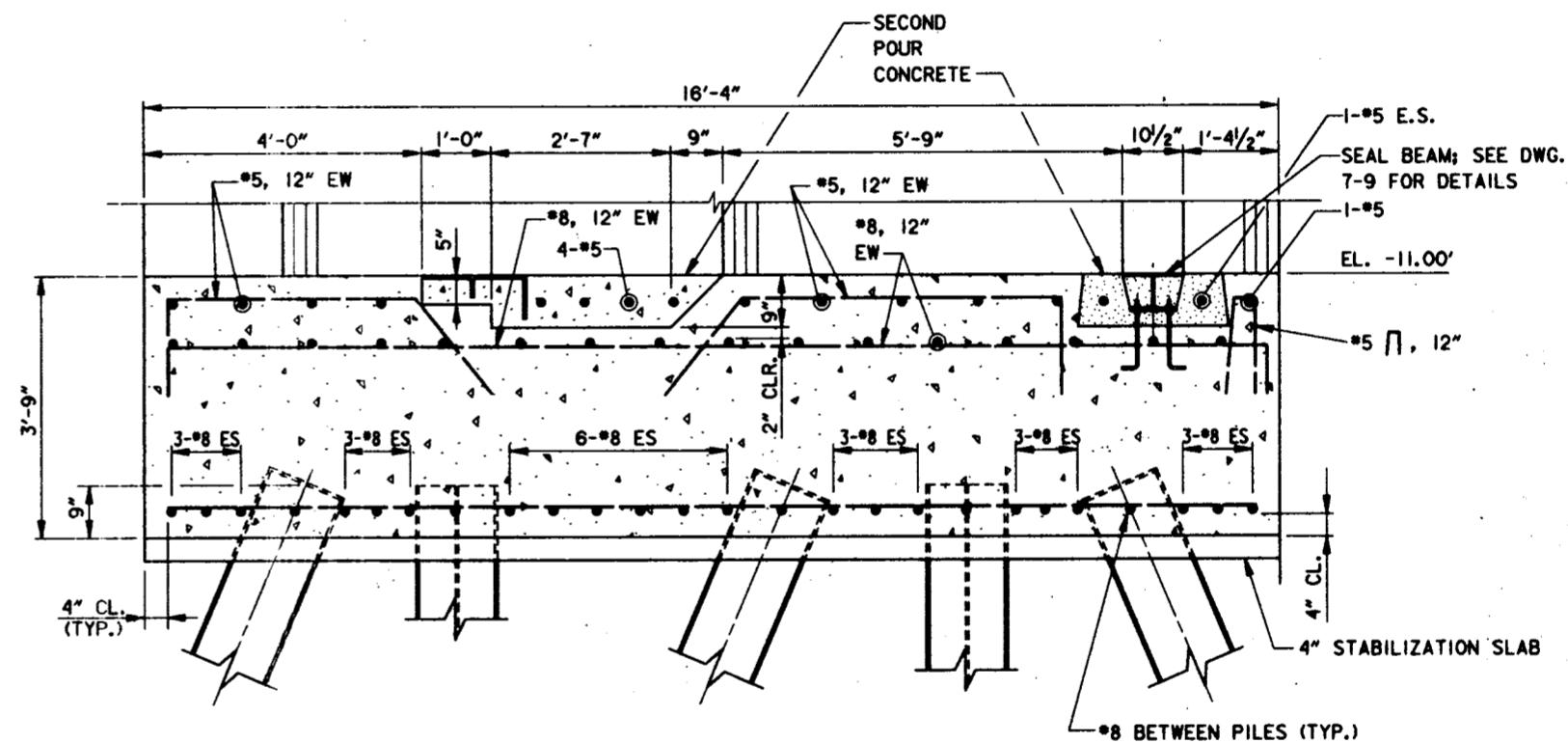

WEST MONOLITH I
SECTION (B)
SCALE: 3/4" = 1'-0"

NOTE:
UPLIFT CONNECTORS NOT SHOWN FOR CLARITY. SEE DWG. 5-3 FOR LOCATIONS.

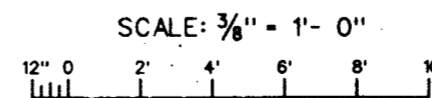
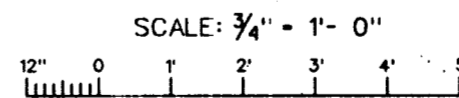

SYMBOL	DESCRIPTION	DATE	APPROVED
REVISIONS			
U.S. ARMY ENGINEER DISTRICT, NEW ORLEANS CORPS OF ENGINEERS NEW ORLEANS, LOUISIANA			
URS CONSULTANTS, INC. LAKE PONTCHARTRAIN, LA. AND VICINITY HURRICANE PROTECTION HIGH LEVEL PLAN			
FRONTING PROTECTION AT PUMP STATION #6 ORLEANS PARISH - JEFFERSON PARISH 17th STREET OUTFALL CANAL (METAIRIE RELIEF)			
WEST MONOLITHS BASE SLAB REINFORCEMENT			
DESIGNED BY: S.C.B.	DATE: SEPT. 1997	PLOT SCALE: 2.007	PLOT DATE: SEPT. 1997
DRAWN BY: B.M.D.	CHECKED BY: D.J.L.	FILE NO. H-4-44654	
SUBMITTED BY:	SOLICITATION NO. DACW29-98-B-0112	DWG. 6-13 of 6-18	

Safety is a Part of Your Contract

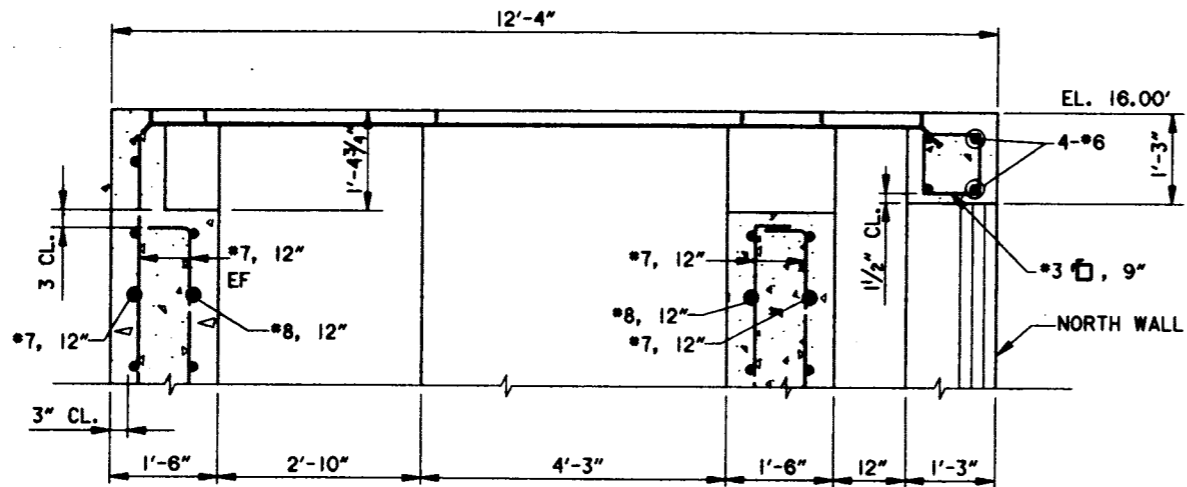

DETAIL 13
SCALE: 3/4" = 1'-0"

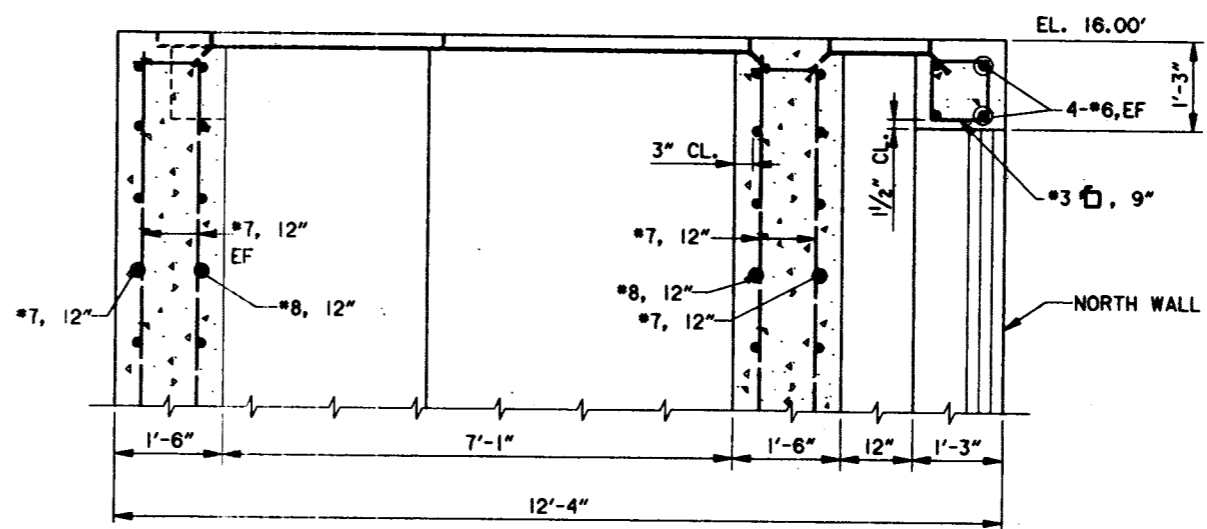

SECTION 0
SCALE: 3/4" = 1'-0"

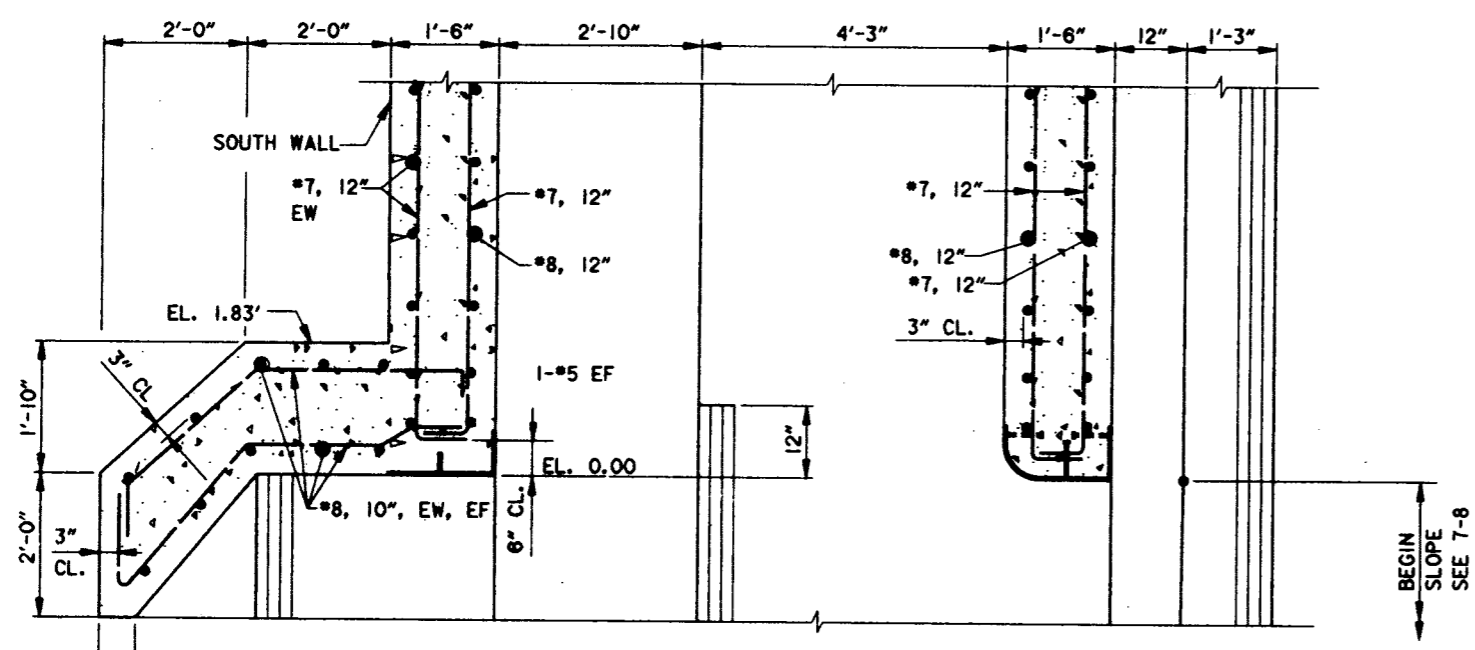

DETAIL 14
SCALE: 3/4" = 1'-0"

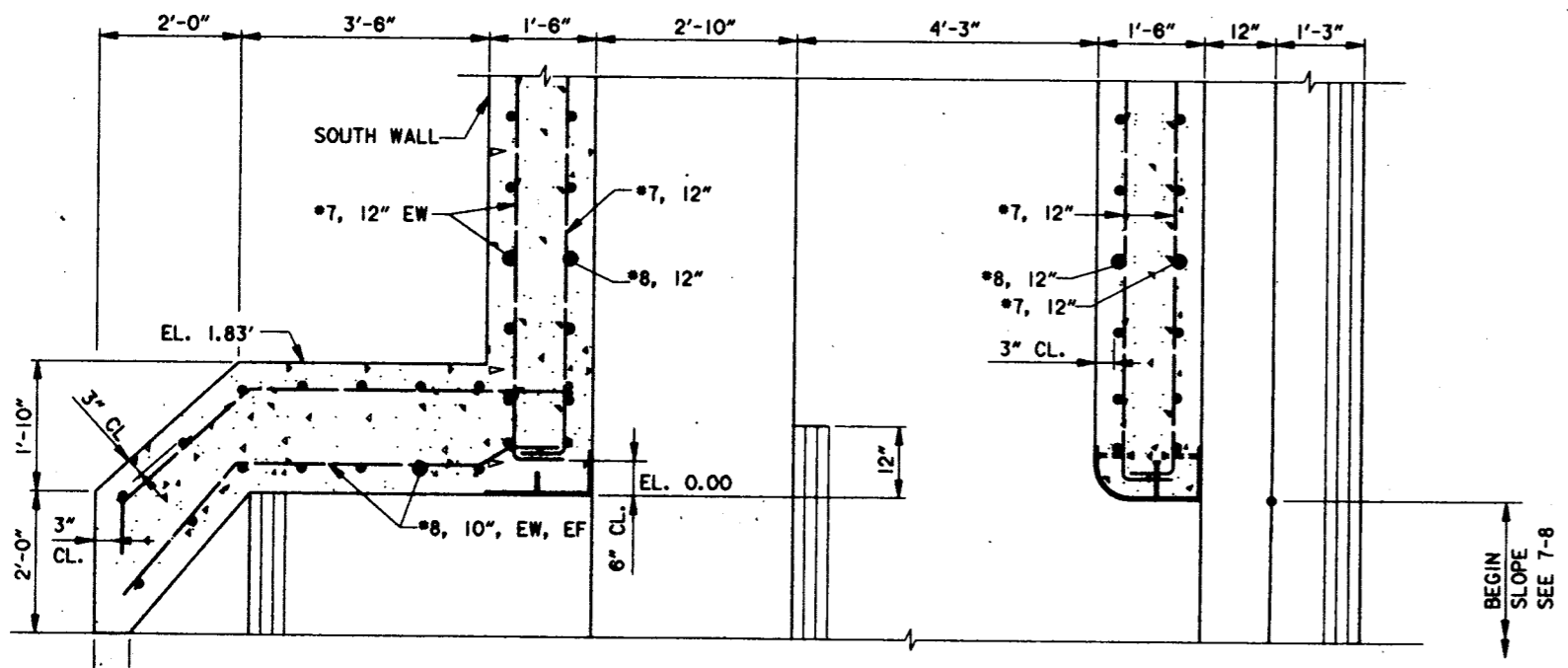

DETAIL 15
SCALE: 3/4" = 1'-0"

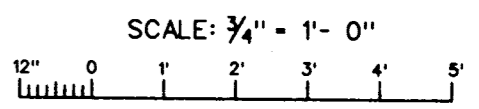

SYMBOL	DESCRIPTION	DATE	APPROVED
REVISIONS			
U.S. ARMY ENGINEER DISTRICT, NEW ORLEANS CORPS OF ENGINEERS NEW ORLEANS, LOUISIANA			
URS CONSULTANTS, INC. LAKE PONTCHARTRAIN, LA. AND VICINITY HURRICANE PROTECTION HIGH LEVEL PLAN FRONTING PROTECTION AT PUMP STATION #6 ORLEANS PARISH - JEFFERSON PARISH 17th STREET OUTFALL CANAL (METAIRIE RELIEF)			
WEST MONOLITH DETAILS			
DESIGNED BY: M.F.L.	DATE: SEPT. 1997	PLOT SCALE: 1,333	PLOT DATE: SEPT. 1997
DRAWN BY: T.R.E.	CHECKED BY: D.J.L.	FILE NO. H-4-44654	
SUBMITTED BY:	SOLICITATION NO. DACW29-98-B-0112	DWG. 6-14068-18	

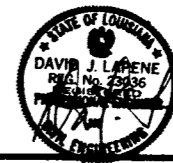

Safety is a Part
of Your Contract

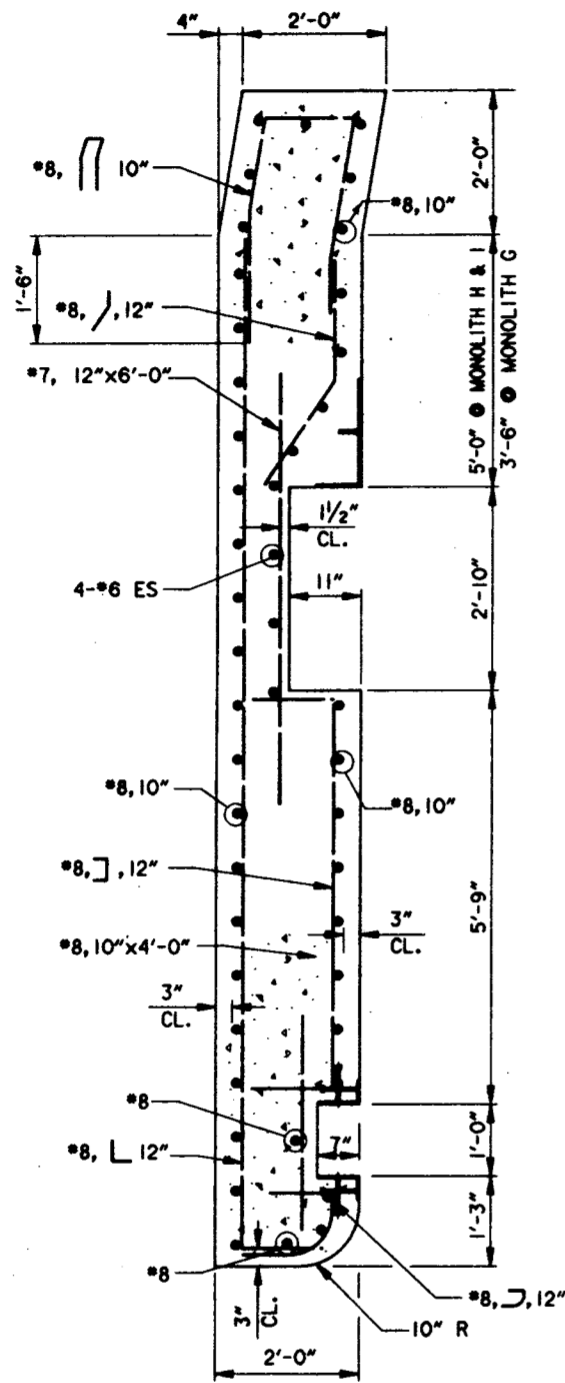

SECTION 16
SCALE: 3/4" = 1'-0"

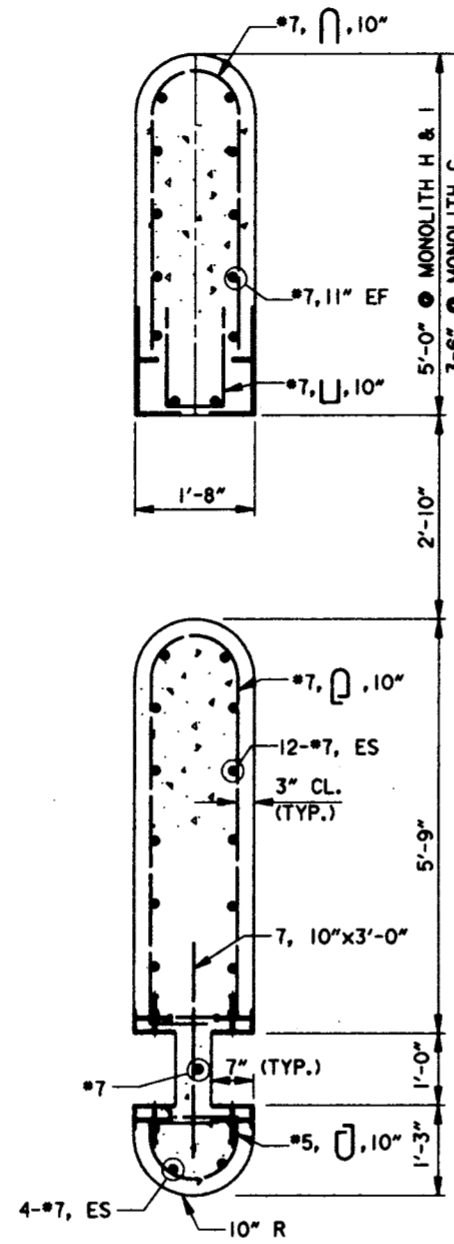

SECTION 17
SCALE: 3/4" = 1'-0"

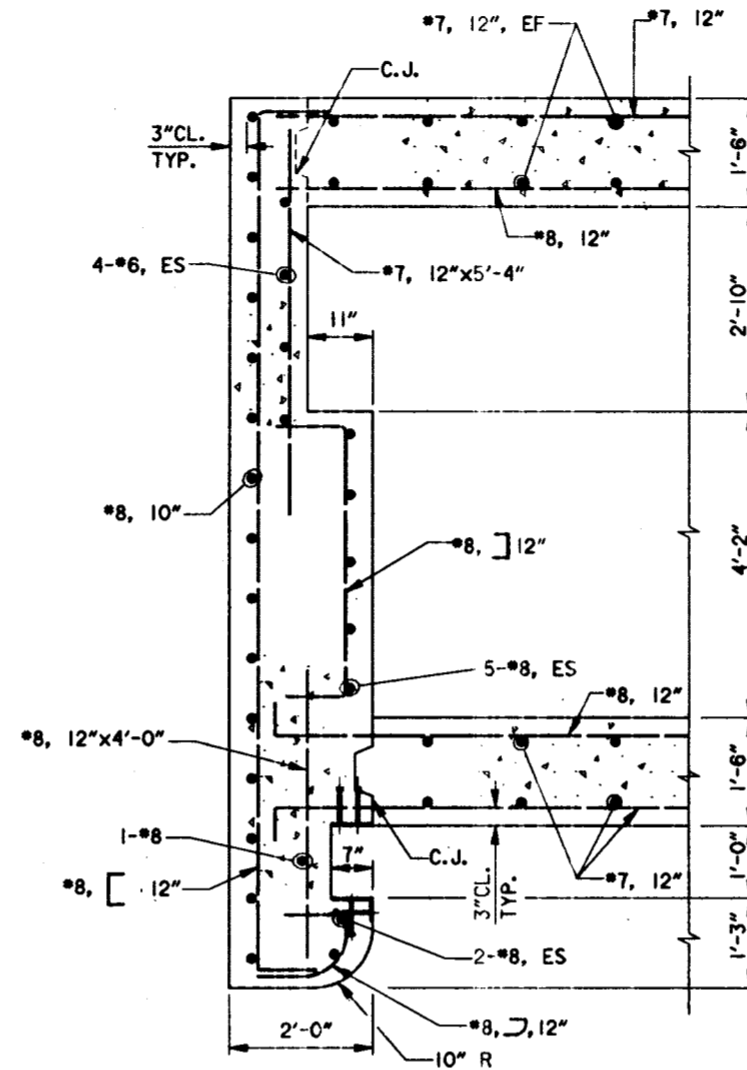

DETAIL 18
SCALE: 3/4" = 1'-0"

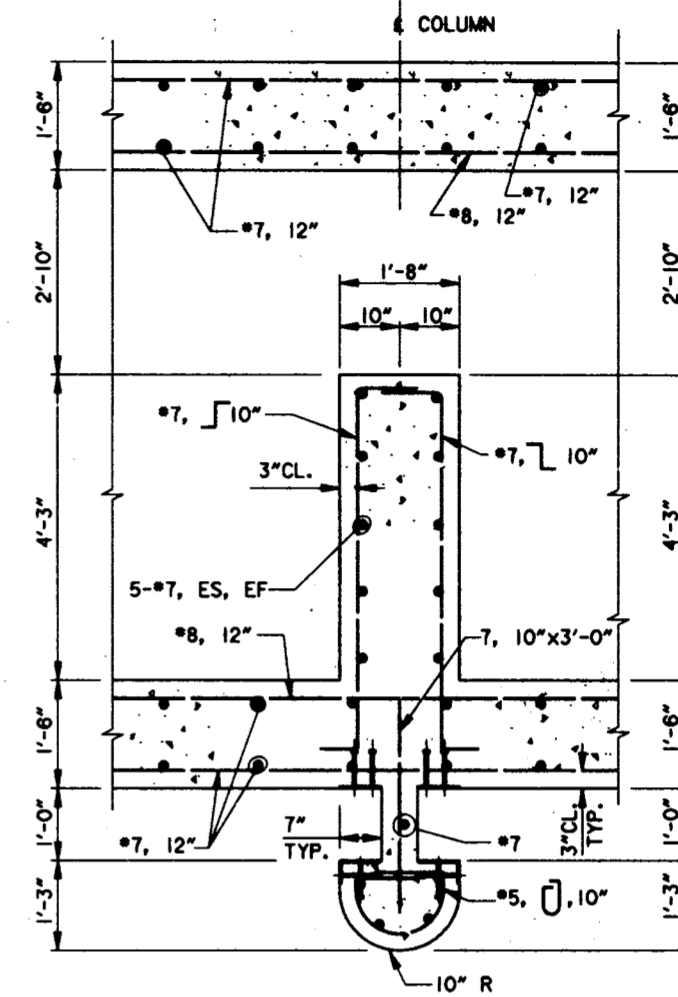

DETAIL 19
SCALE: 3/4" = 1'-0"

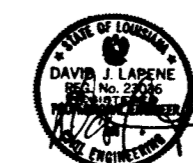
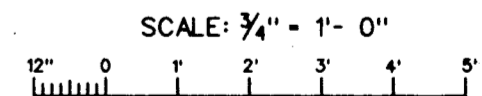

SYMBOL	DESCRIPTION	DATE	APPROVED
REVISIONS			
 U.S. ARMY ENGINEER DISTRICT, NEW ORLEANS CORPS OF ENGINEERS NEW ORLEANS, LOUISIANA			
URS CONSULTANTS, INC. LAKE PONTCHARTRAIN, LA. AND VICINITY HURRICANE PROTECTION HIGH LEVEL PLAN FRONTING PROTECTION AT PUMP STATION #8 ORLEANS PARISH - JEFFERSON PARISH 17TH STREET OUTFALL CANAL (DETAINIE RELIEF)			
WEST MONOLITH DETAILS			
DESIGNED BY: M.F.L.	DATE: SEPT. 1997	PLOT SCALE: 1.333	PLOT DATE: SEPT. 1997
DRAWN BY: T.R.E.	CADD FILE: P80-0-N.001	FILE NO. H-4-44654	
CHECKED BY: D.J.L.	SOLICITATION NO. DACW29-98-B-0112	DWG. 6-15 OF 6-18	

Safety is a Part of Your Contract

SAW CUT EXIST. SHEET PILE CAP & SLAB @ TIE-IN AND REMOVE CONCRETE AS REQ'D. TO PULL SHEET PILE, SEE DEMOLITION PLAN DWG. 2-3; CUT & BEND I-WALL REINF. AT TIE-IN LOCATION; BRACE ADJACENT SHEETS, PULL REQ'D. SHEET AND ATTACH BENT PLATE SEE DWG. 5-6; BENT REINF. BACK & SPLICE #6 BARS @ EA. CUT BAR, REPLACE CONCRETE.

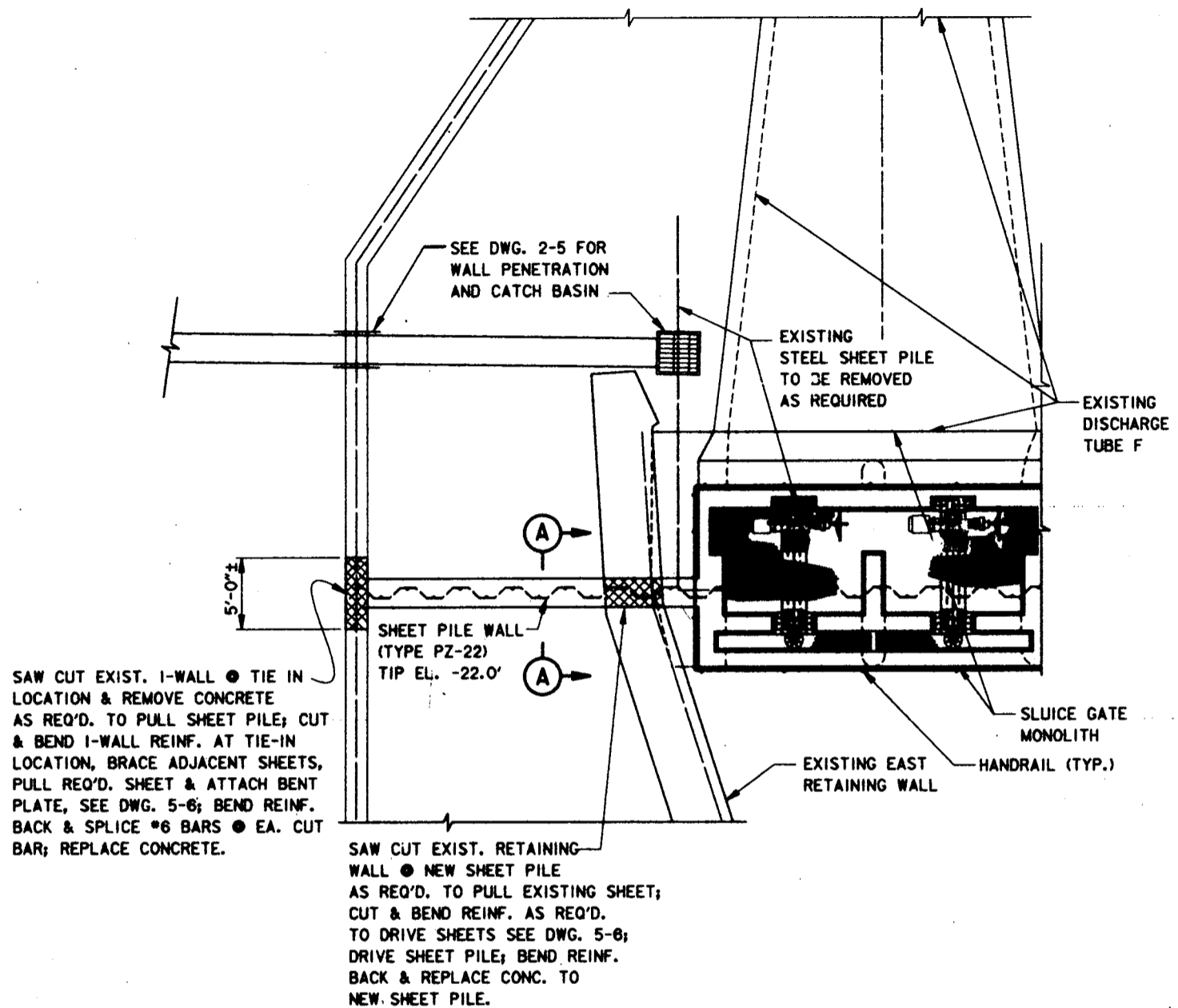

PART PLAN OF I-WALL EAST OF EAST MONOLITH

SCALE: 3/16" = 1'-0"

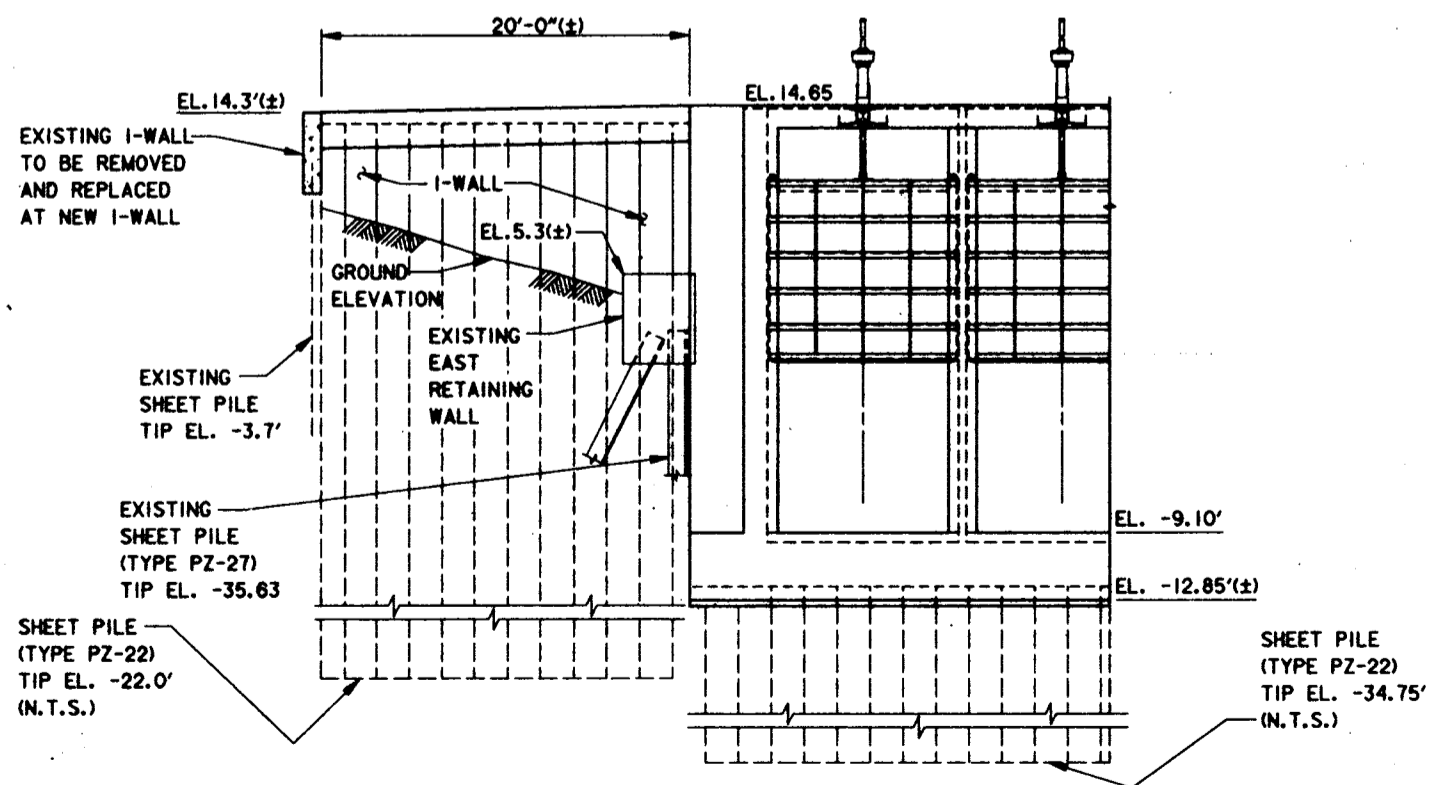

PART FLOOD SIDE ELEVATION EAST OF EAST MONOLITH

SCALE: 3/16" = 1'-0"

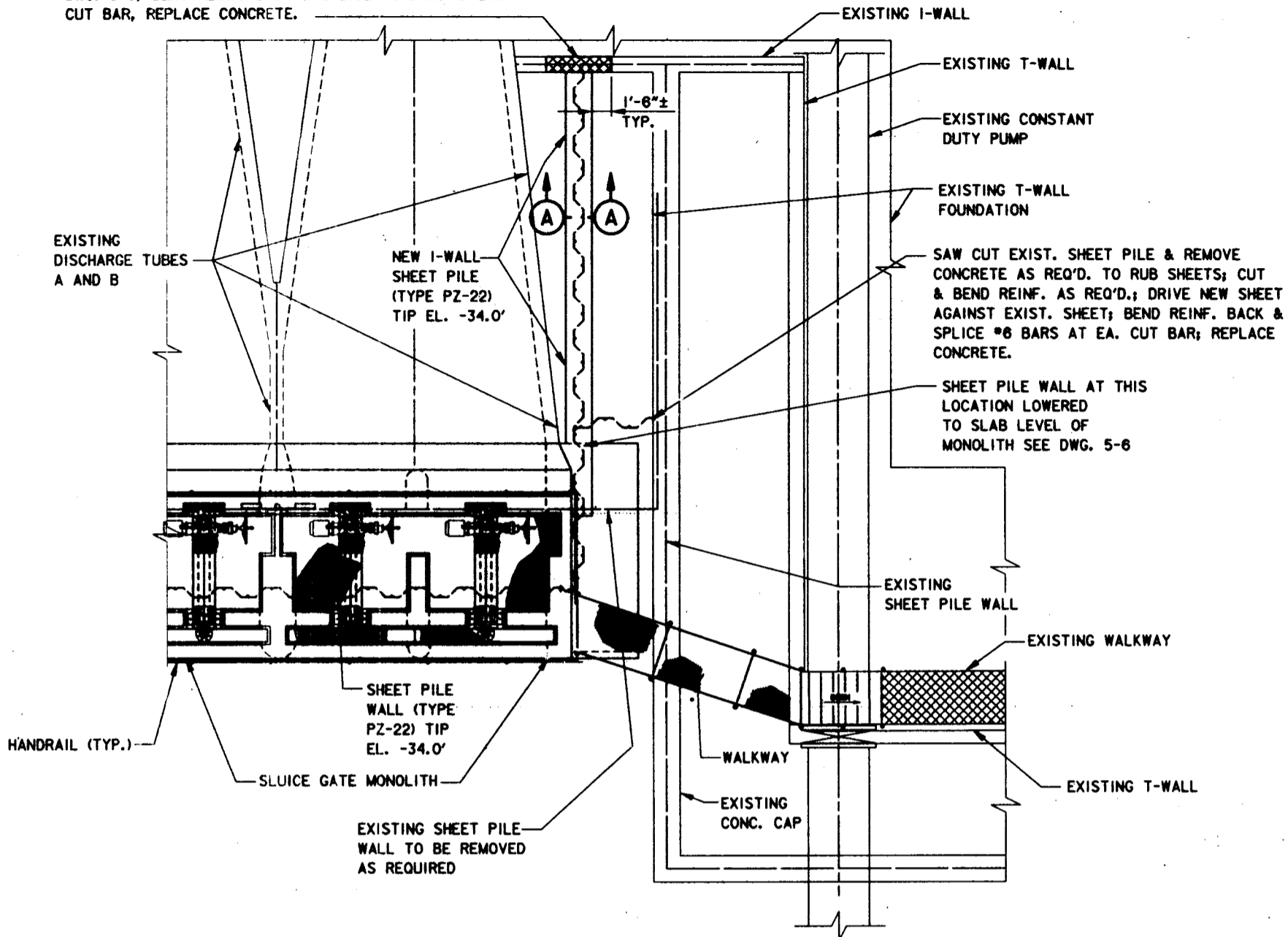

PART PLAN OF I-WALL WEST OF EAST MONOLITH

SCALE: 3/16" = 1'-0"

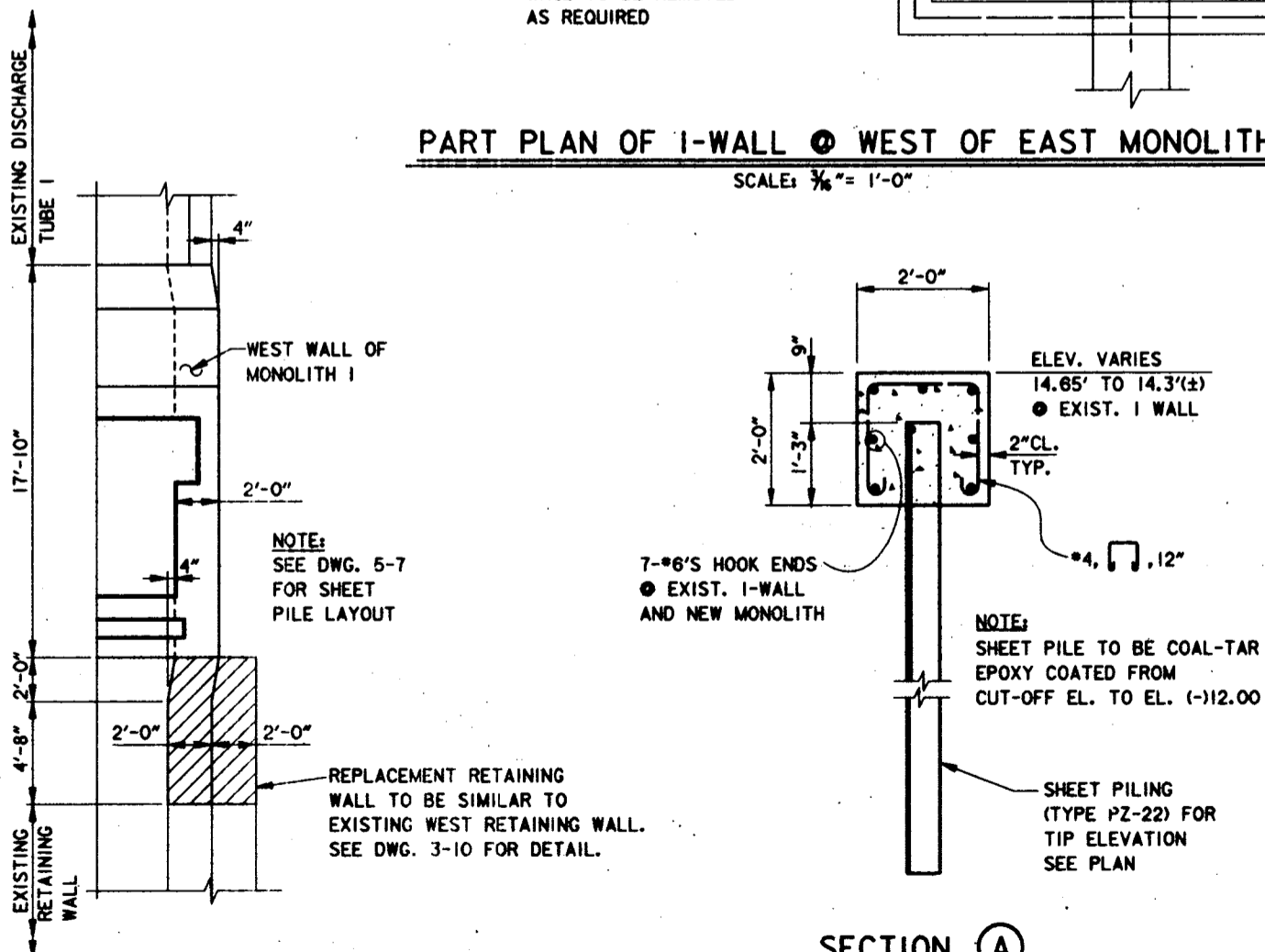

SECTION A I-WALL

SCALE: 3/4" = 1'-0"

PLAN WEST RETAINING WALL

SCALE: 1/4" = 1'-0"

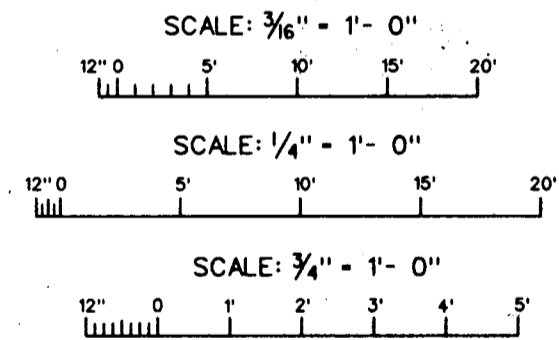

SYMBOL	DESCRIPTION	DATE	APPROVED
REVISIONS			
U.S. ARMY ENGINEER DISTRICT, NEW ORLEANS CORPS OF ENGINEERS NEW ORLEANS, LOUISIANA			
URS CONSULTANTS, INC.			
LAKE PONCHARTRAIN, LA. AND VICINITY HURRICANE PROTECTION HIGH LEVEL PLAN			
FRONTING PROTECTION AT PUMP STATION #6 ORLEANS PARISH - JEFFERSON PARISH 17th STREET OUTFALL CANAL RETAINING WALL			
I-WALLS & RETAINING WALL DETAILS			
DESIGNED BY: S.C.B.	DATE: SEPT. 1997	PLOT SCALE: 5,333	PLOT DATE: SEPT. 1997
DRAWN BY: K.L.L.	CHECKED BY: D.J.L.	FILE NO. H-4-44654	
REVISIONS BY:	SOLICITATION NO. DACW29-98-B-0112	DWG. 6-16 OF 6-18	



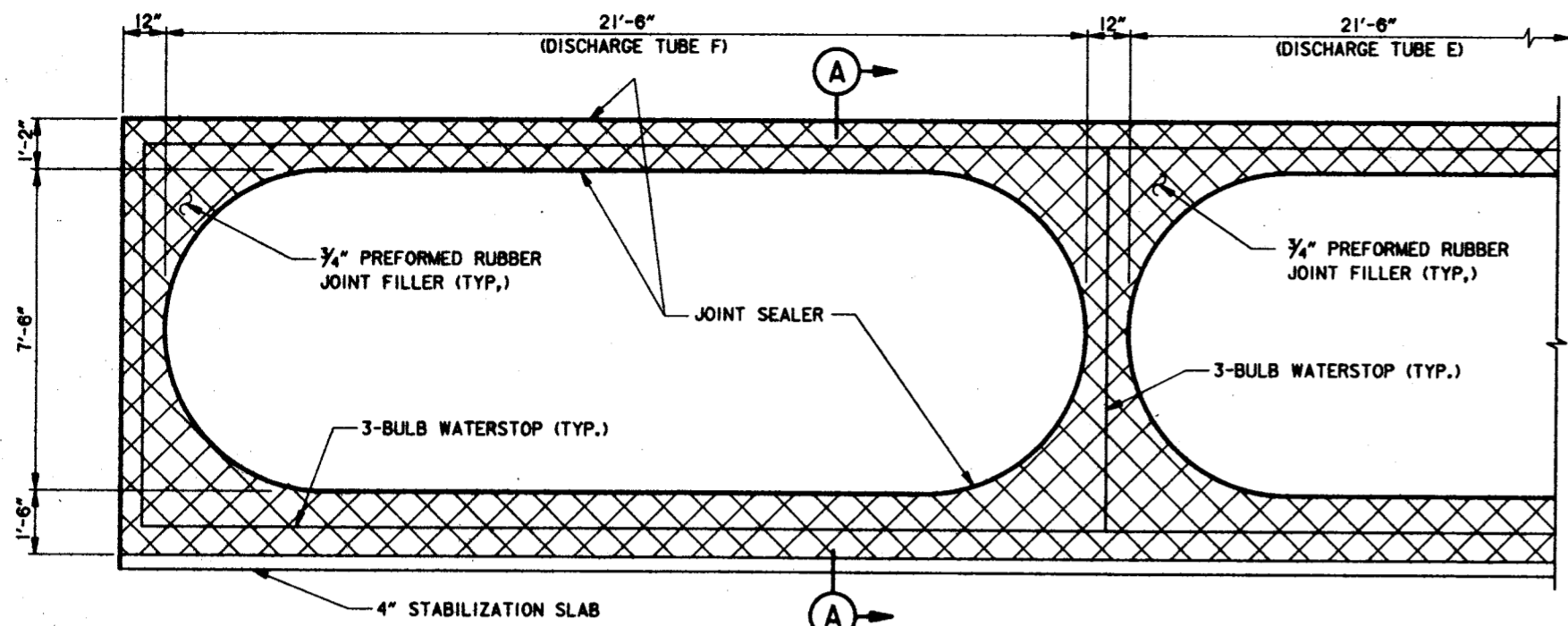

**JOINT BETWEEN EXIST. DISCHARGE TUBES "C", "D", "E", & "F"
AND NEW EAST MONOLITH**
SCALE: 1/2"=1'-0"

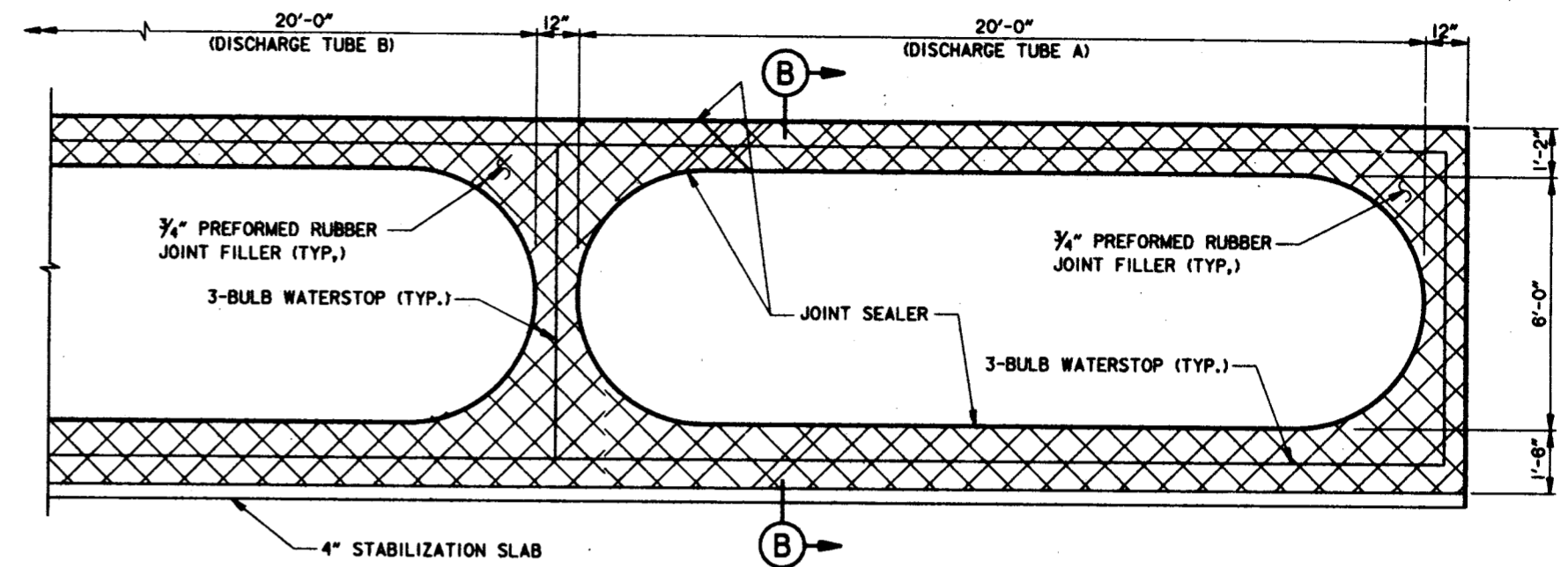

**JOINT BETWEEN EXIST. DISCHARGE TUBES "A" & "B"
AND NEW EAST MONOLITH**
SCALE: 1/2"=1'-0"

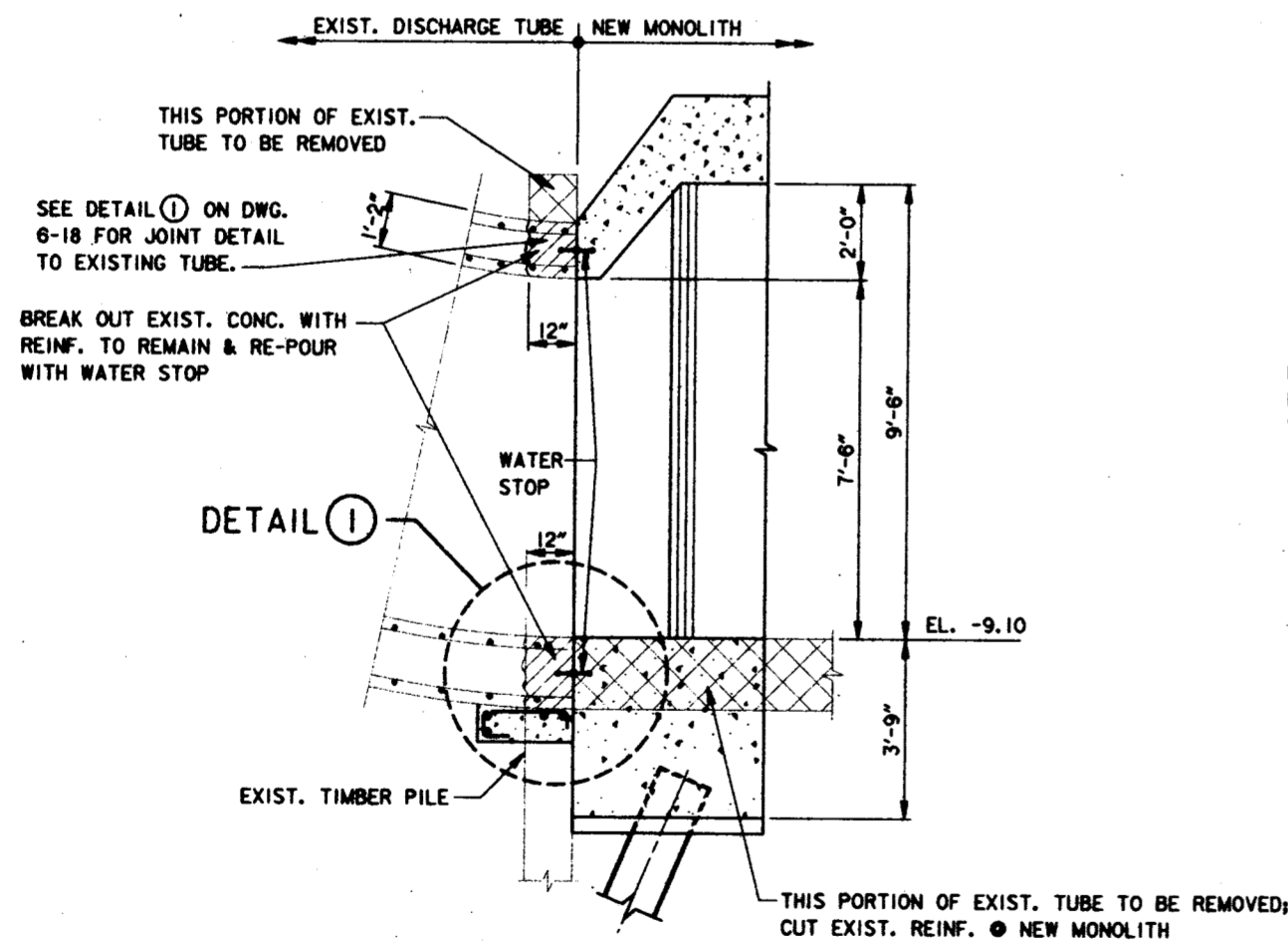

DISCHARGE TUBES "C"- "F"
SECTION (A)
SCALE: 1/2"=1'-0"

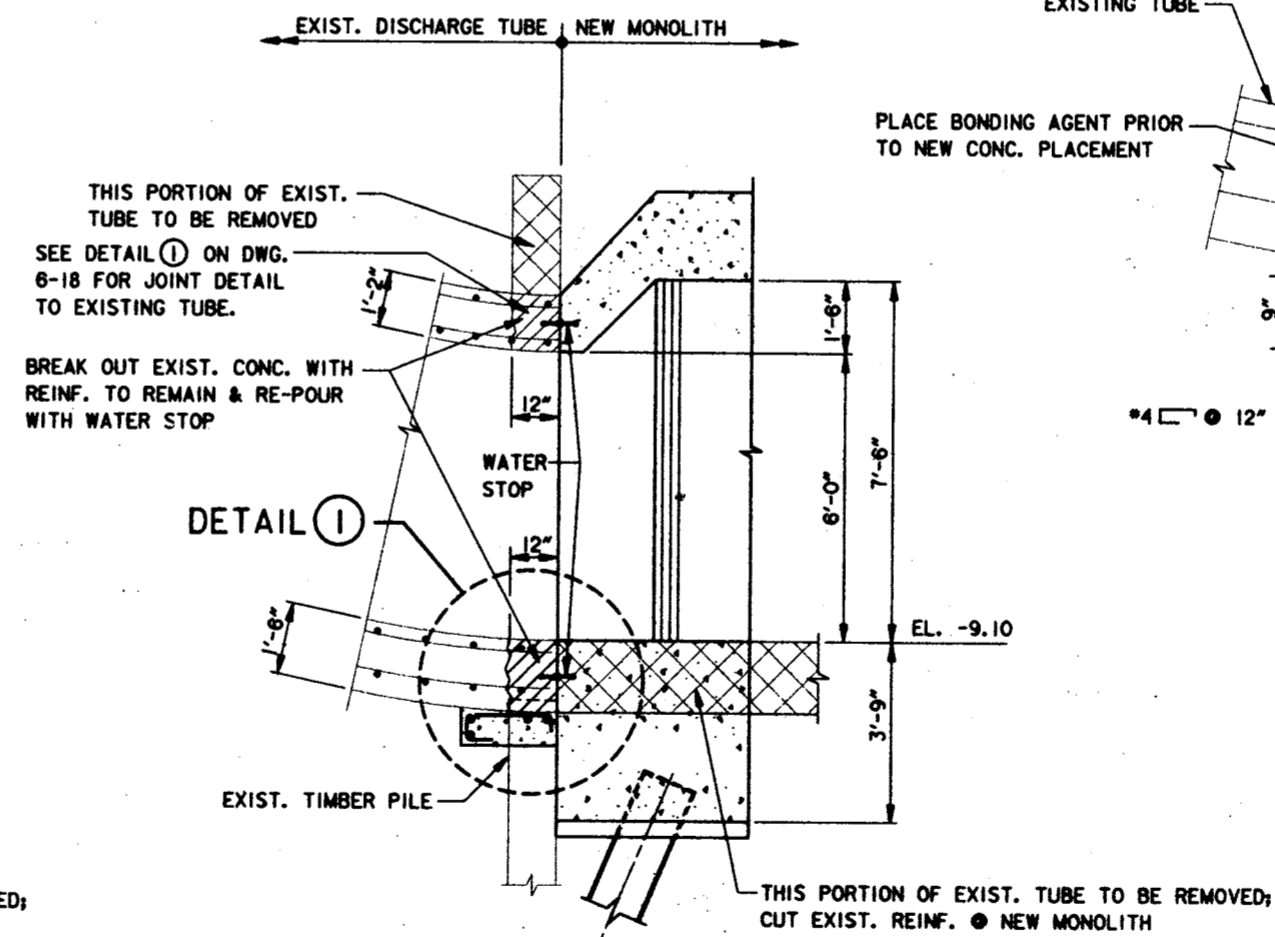

DISCHARGE TUBES "A" & "B"
SECTION (B)
SCALE: 1/2"=1'-0"

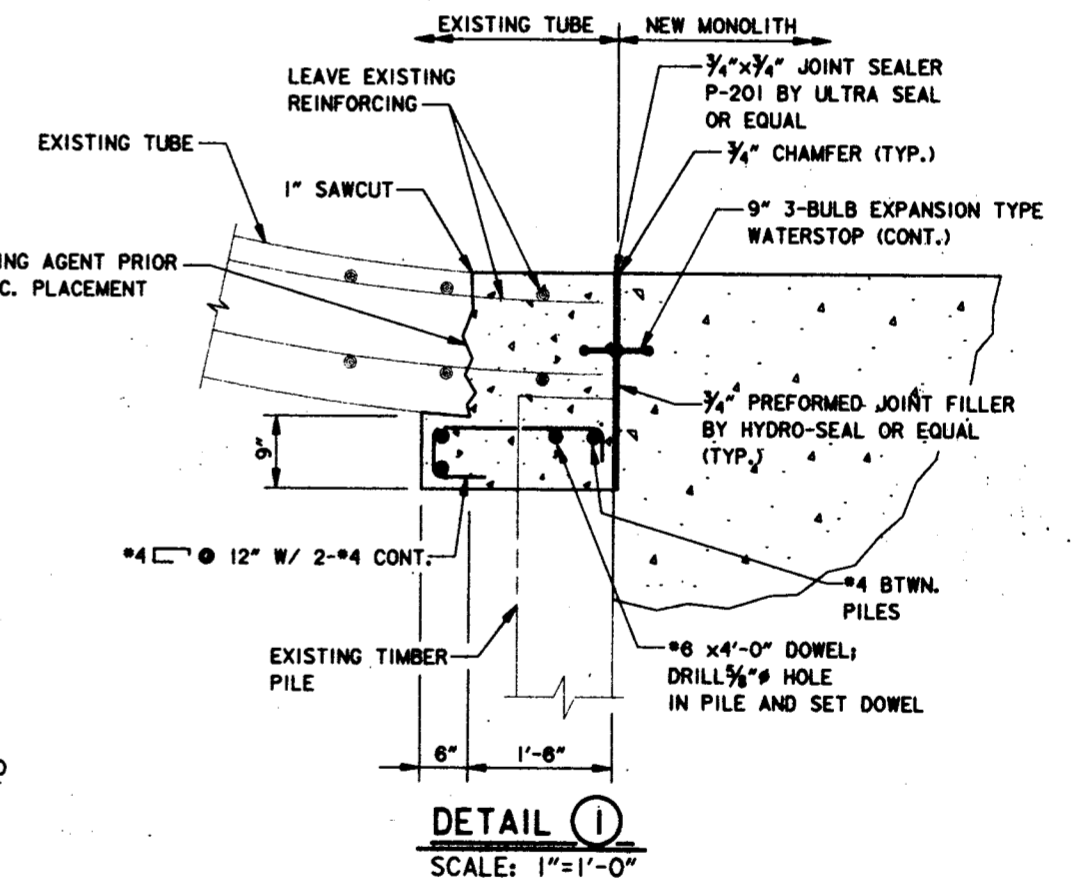

DETAIL 1
SCALE: 1"=1'-0"

SYMBOL	DESCRIPTION	DATE	APPROVED
REVISORS			
 U.S. ARMY ENGINEER DISTRICT, NEW ORLEANS CORPS OF ENGINEERS NEW ORLEANS, LOUISIANA			
URS CONSULTANTS, INC. LAKE PONCHARTRAIN, LA. AND VICINITY HURRICANE PROTECTION HIGH LEVEL PLAN FRONTING PROTECTION AT PUMP STATION #6 ORLEANS PARISH - JEFFERSON PARISH 17th STREET OUTFALL CANAL METAIRIE RELIEF			
JOINT DETAILS			
EAST MONOLITH			
DESIGNED BY: S.C.B.	DATE: SEPT. 1997	PLOT SCALE: 2	PLOT DATE: SEPT. 1997
DRAWN BY: K.L.L.	CHECKED BY: D.J.L.	CADD FILE: PDP-9-17.DWG	FILE NO. H-4-44654
SUBMITTED BY:	SOLICITATION NO. DACW29-98-B-0112	DWG. 6-17 OF 6-18	



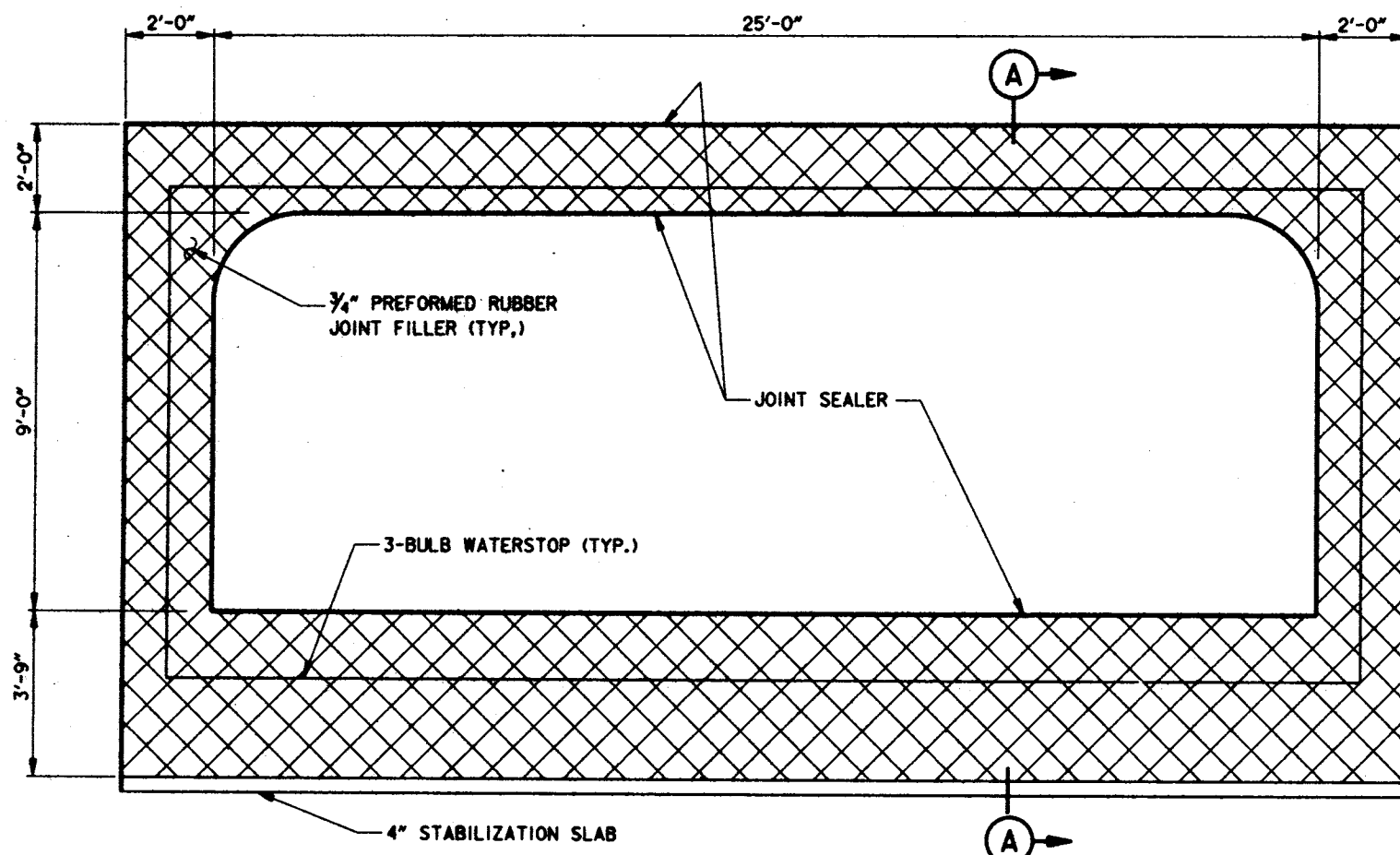

JOINT BETWEEN EXIST. DISCHARGE TUBES "G", "H", & "I" AND NEW WEST MONOLITH

SCALE: 1/2"=1'-0"

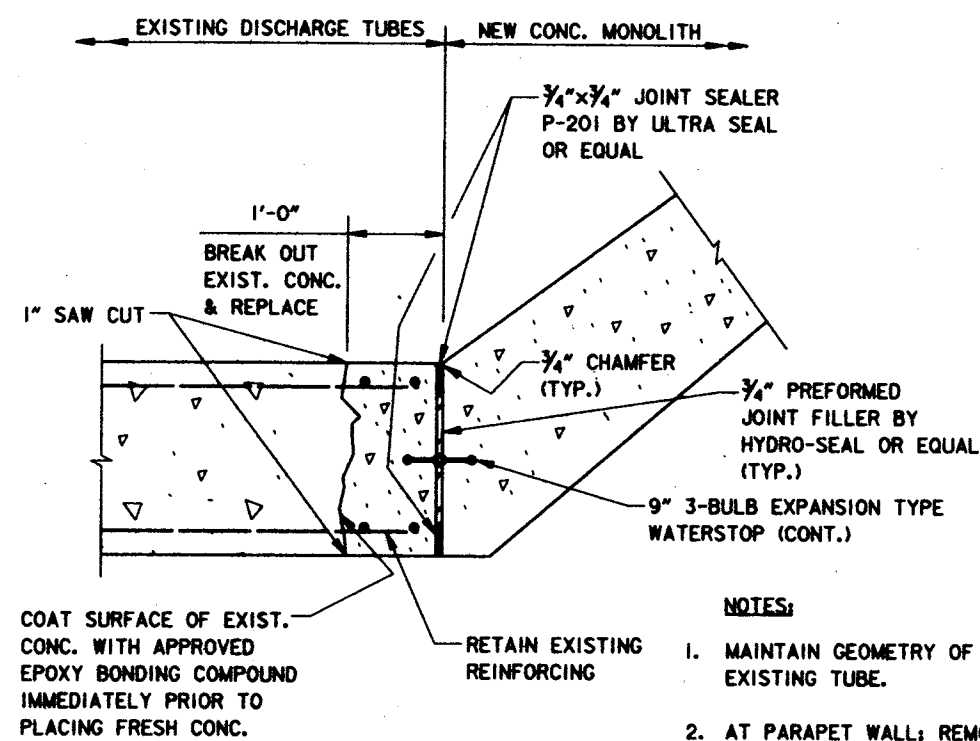

DETAIL ① EXISTING TUBE TO NEW MONOLITH

SCALE: N.T.S.

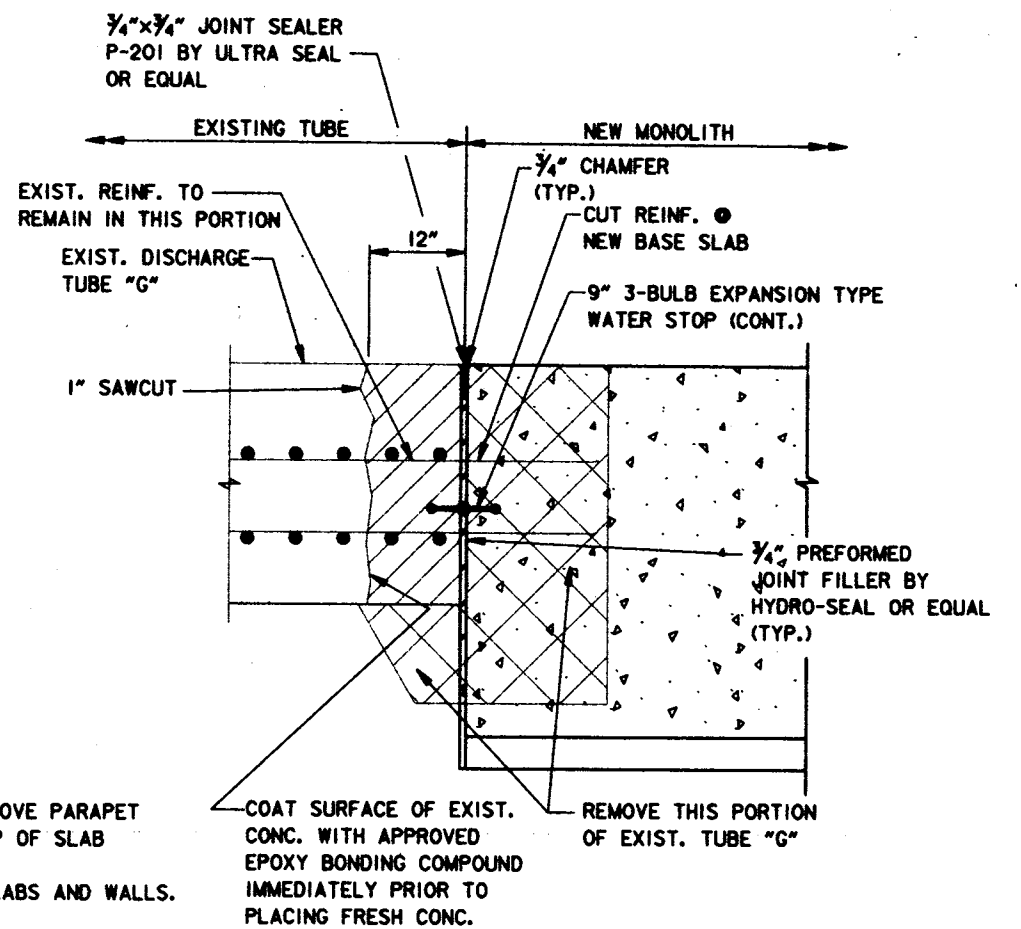

DETAIL ② EXISTING TUBE TO NEW MONOLITH

SCALE: N.T.S.

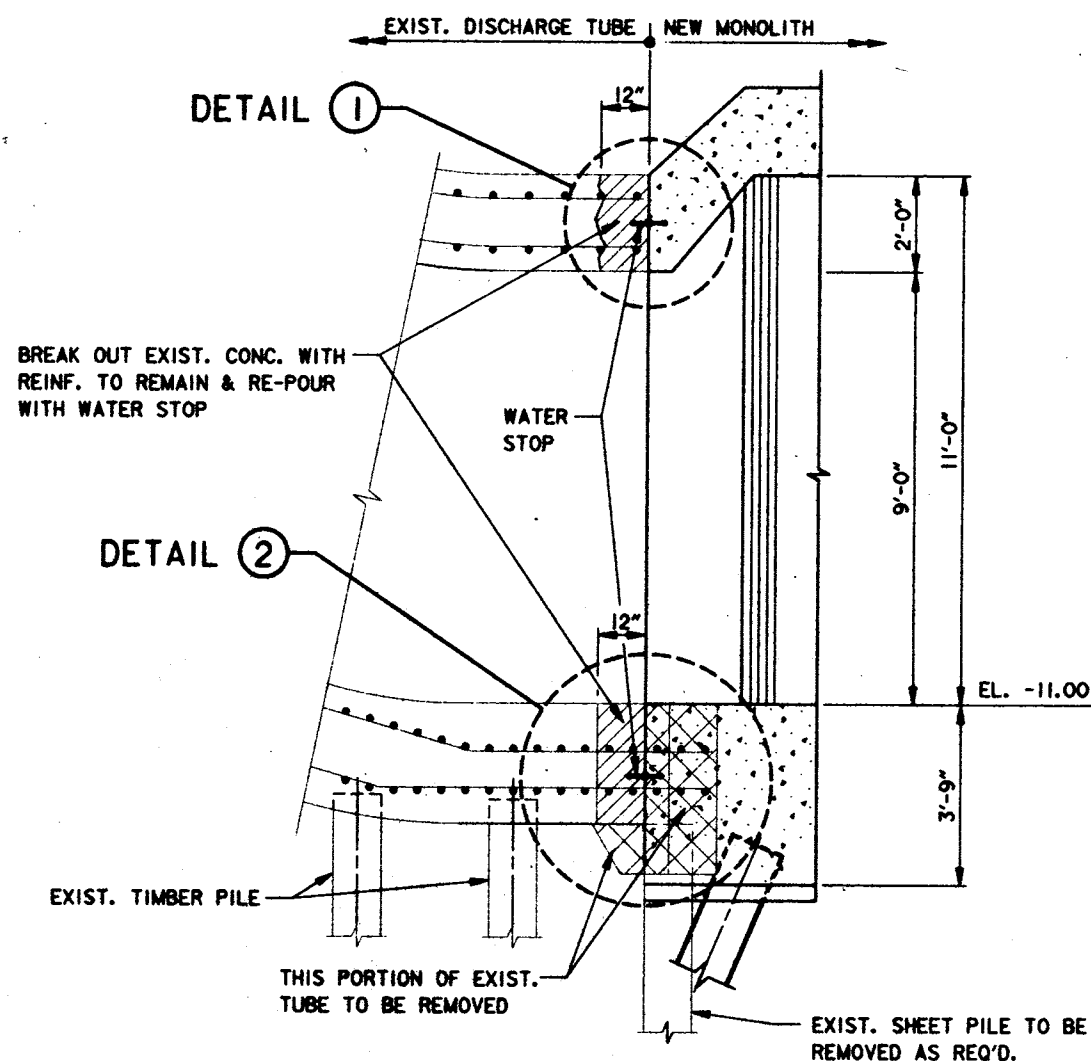

DISCHARGE TUBE "G"

SECTION (A)
SCALE: 1/2"=1'-0"

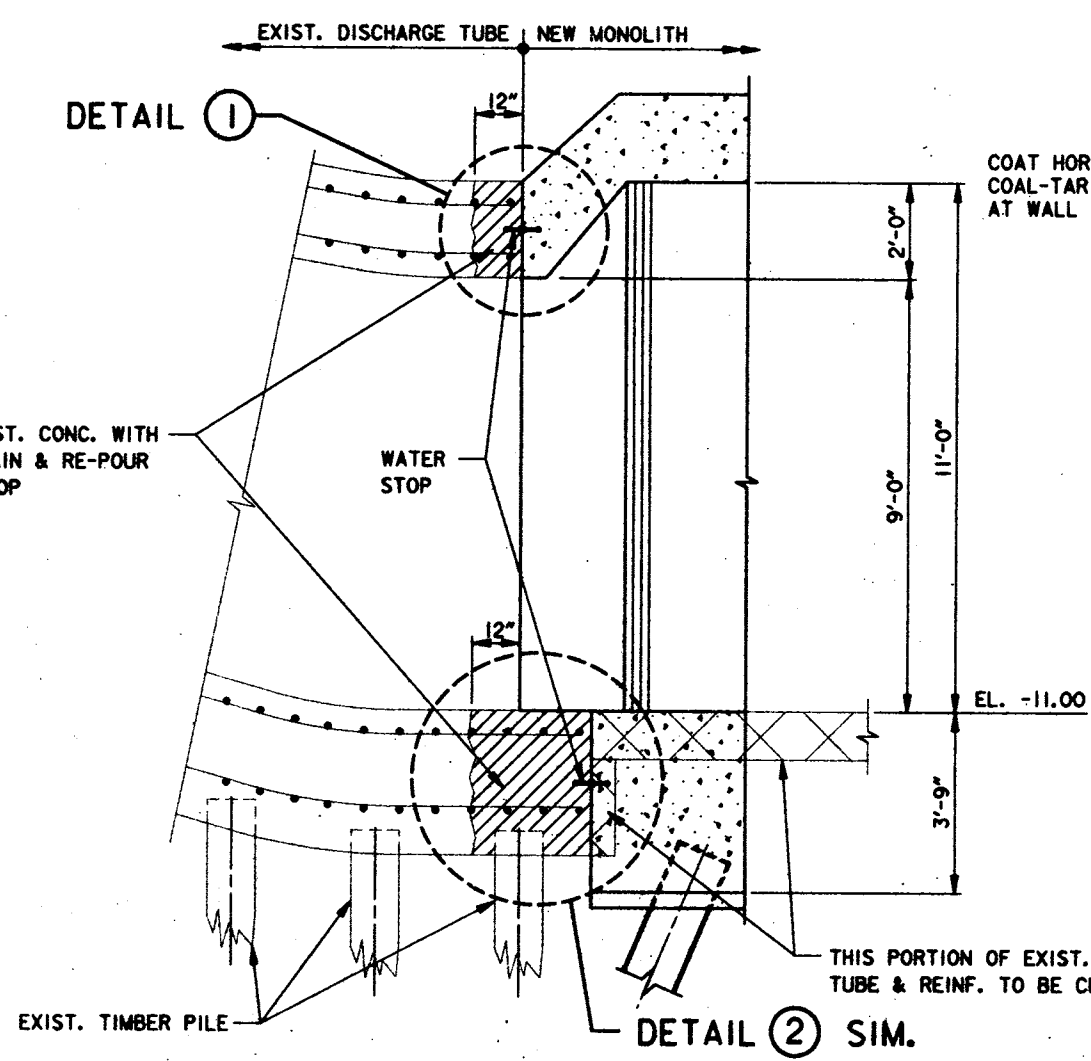

DISCHARGE TUBES "H" & "I"

SECTION (A)
SCALE: 1/2"=1'-0"

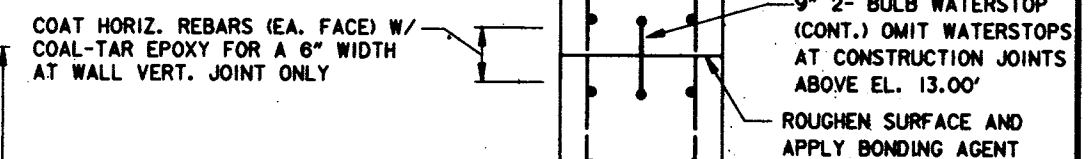

TYPICAL - CONSTRUCTION JOINT DETAIL

SCALE: N.T.S.

SYMBOL	DESCRIPTION	DATE	APPROVED
REVISIONS			
U.S. ARMY ENGINEER DISTRICT, NEW ORLEANS CORPS OF ENGINEERS NEW ORLEANS, LOUISIANA			
URS CONSULTANTS, INC.			
LAKE PONTCHARTRAIN, LA. AND VICINITY HIGH LEVEL PLAN FRONTING PROTECTION AT PUMP STATION #6 ORLEANS PARISH - JEFFERSON PARISH 17th STREET OUTFALL CANAL (METARRIE RELIEF)			
JOINT DETAILS WEST MONOLITH			
DESIGNED BY: S.C.B.	DATE: SEPT. 1997	PLOT SCALE: 2	PLOT DATE: SEPT. 1997
DRAWN BY: K.L.L.	CHECKED BY: D.J.L.	CADD FILE: POP-9-10.000	FILE NO. H-4-44654
SUBMITTED BY:	SOLICITATION NO. DACW29-98-B-0112	DWG. 6-18 OF 6-18	

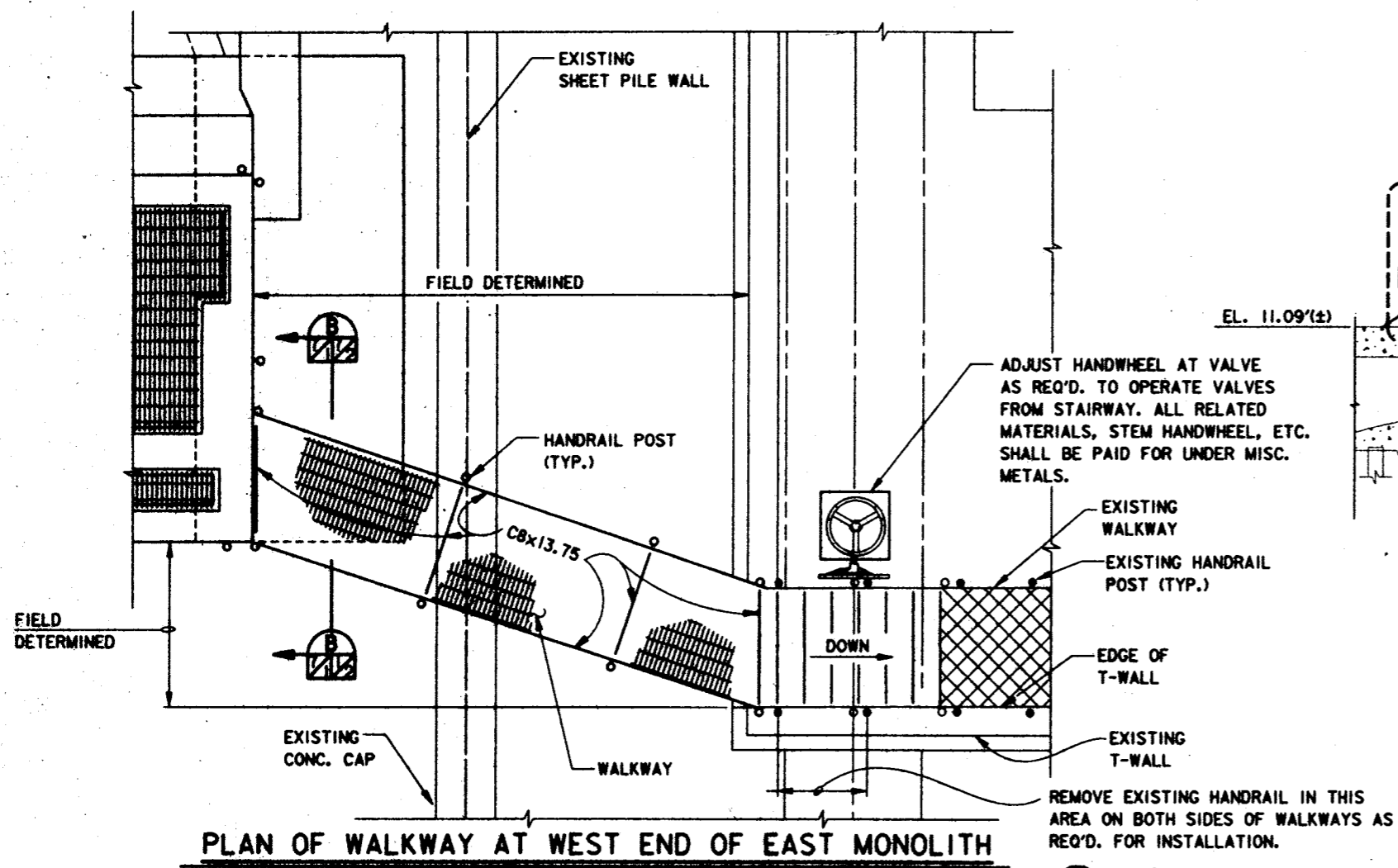

PLAN OF WALKWAY AT WEST END OF EAST MONOLITH
SCALE: 3/8" = 1'-0"

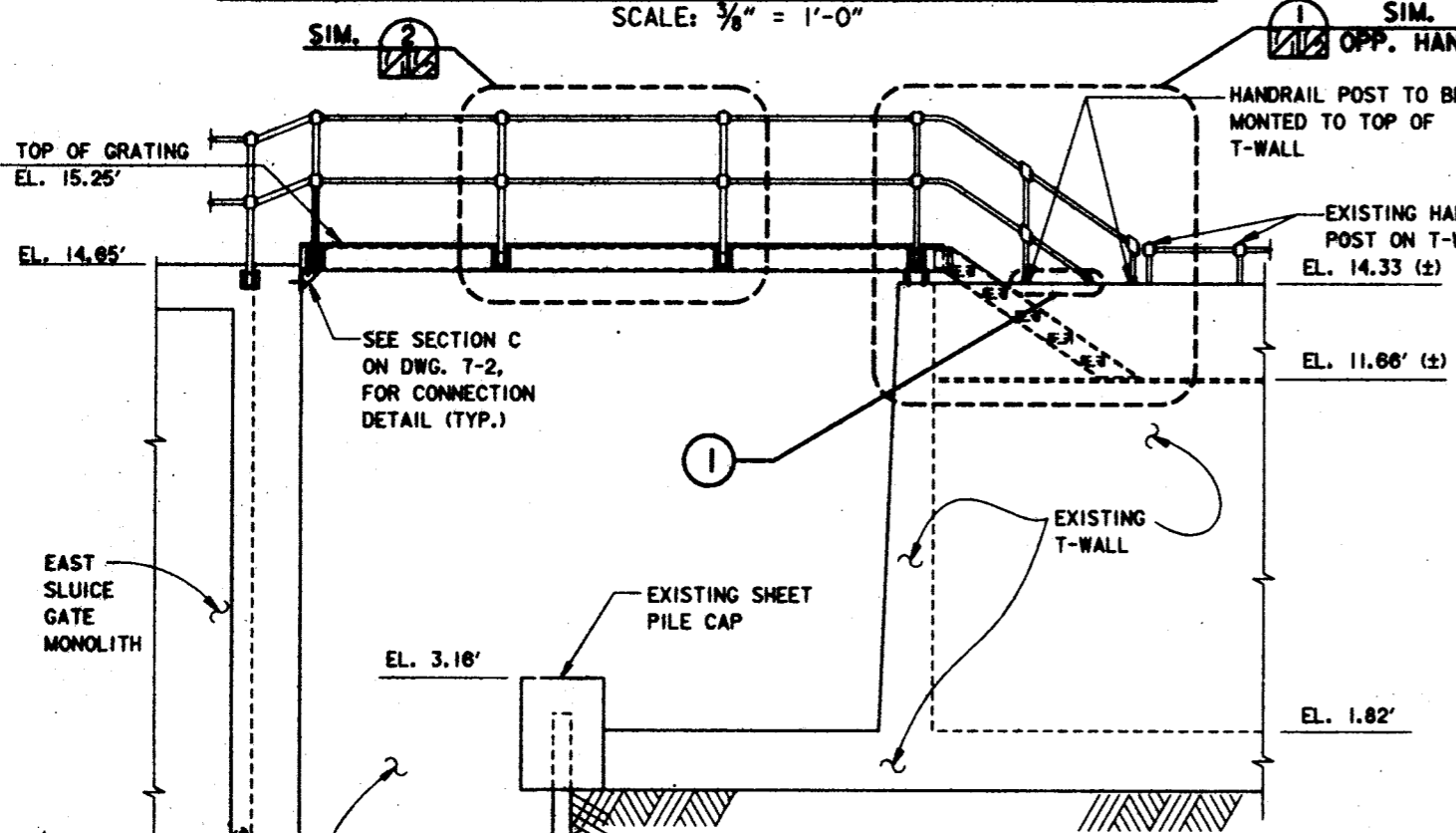

ELEVATION OF WALKWAY AT WEST END OF EAST MONOLITH
SCALE: 3/8" = 1'-0"

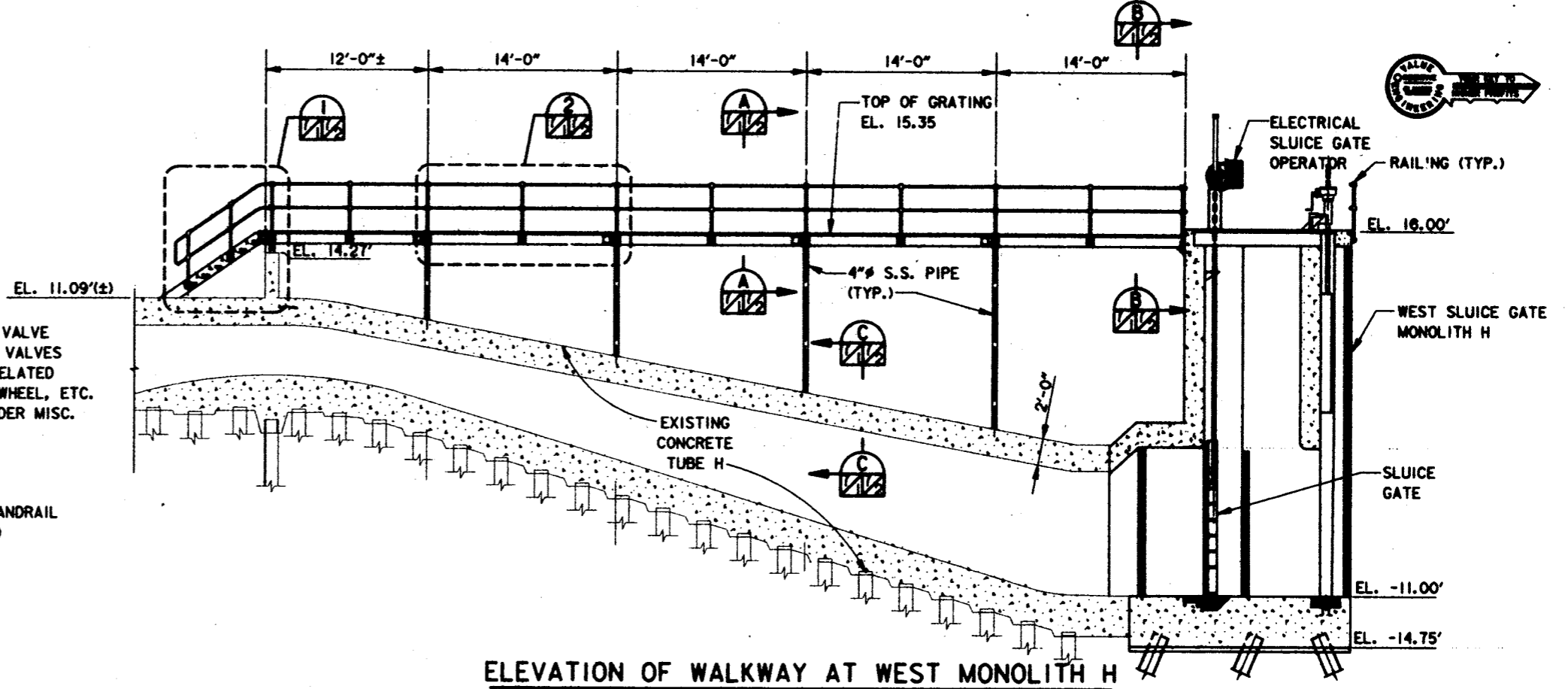
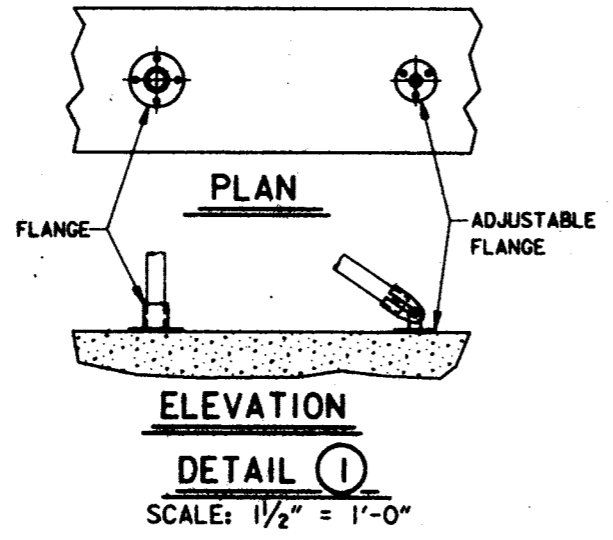

ELEVATION OF WALKWAY AT WEST MONOLITH H
SCALE: 3/8" = 1'-0"

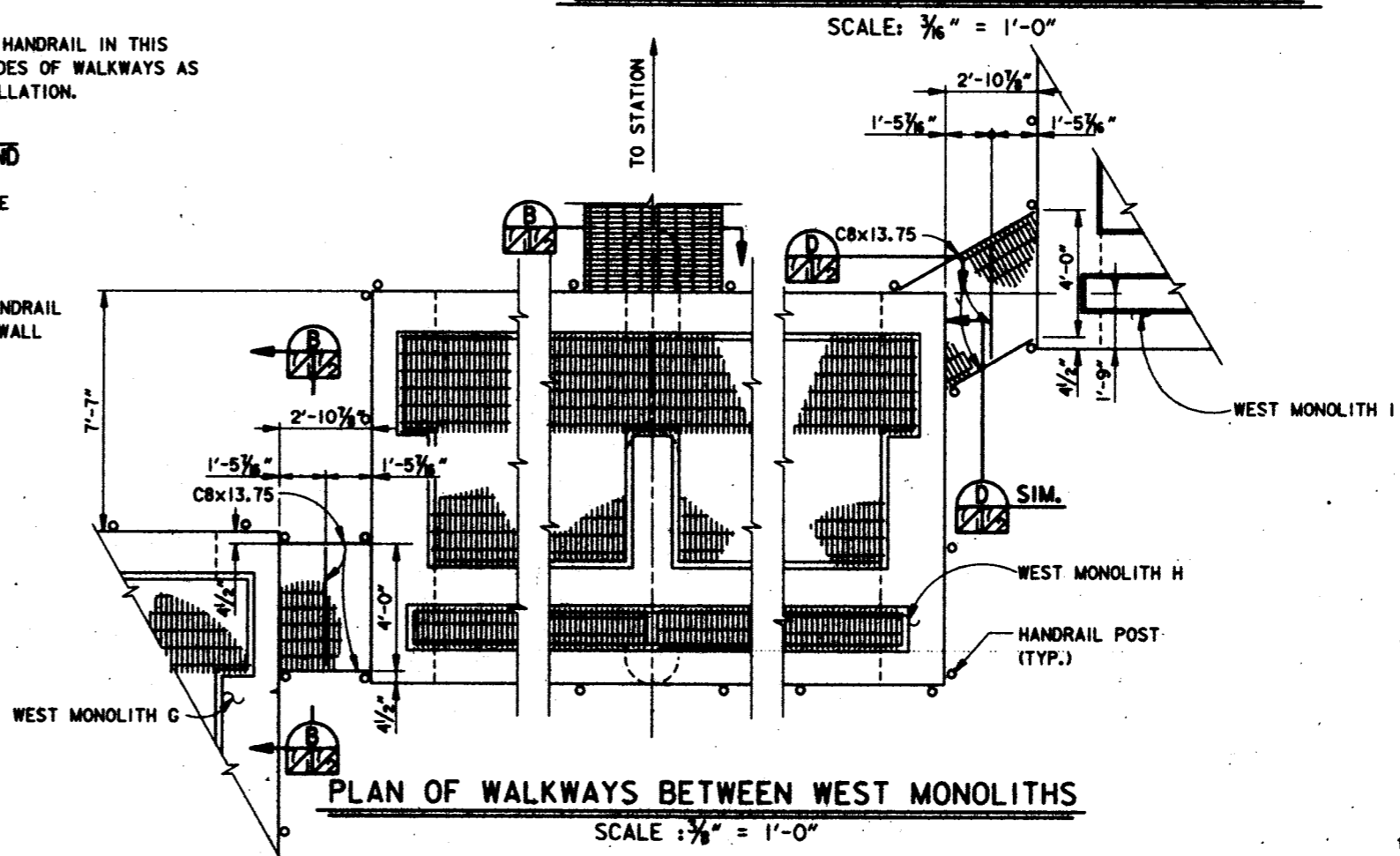

PLAN OF WALKWAYS BETWEEN WEST MONOLITHS
SCALE: 3/8" = 1'-0"

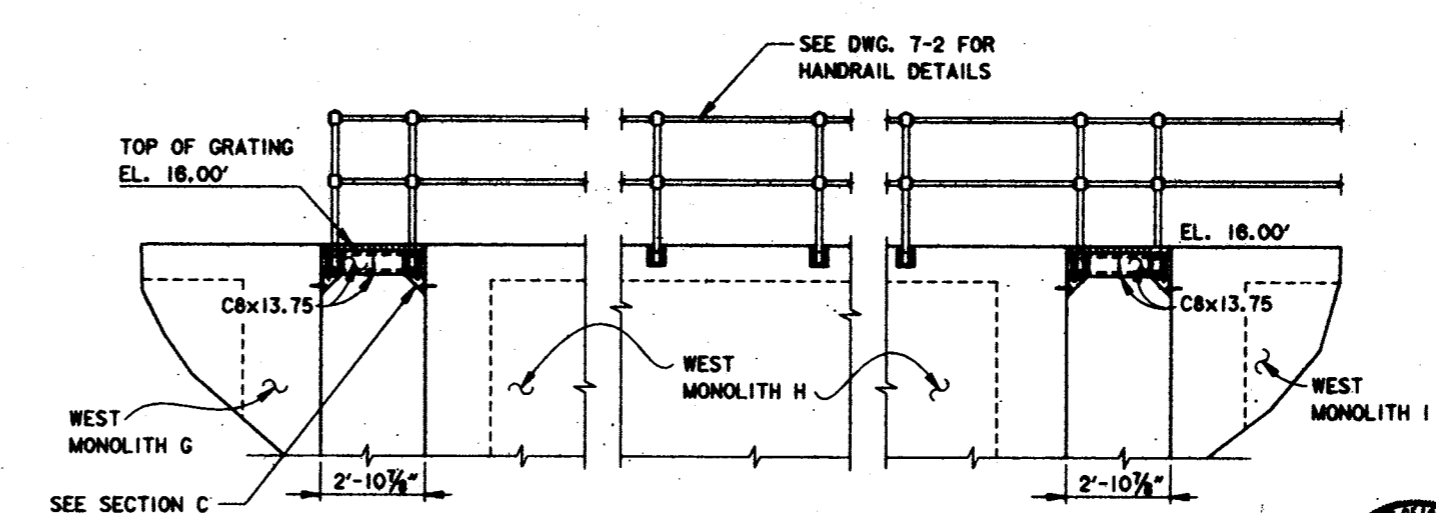

ELEVATION AT WEST MONOLITH WALKWAYS
SCALE: 3/8" = 1'-0"

Safety is a Part of Your Contract

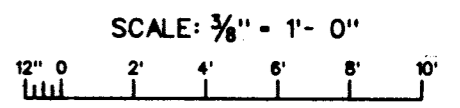

SYMBOL	DESCRIPTION	DATE	APPROVED
REVISIONS U.S. ARMY ENGINEER DISTRICT, NEW ORLEANS CORPS OF ENGINEERS NEW ORLEANS, LOUISIANA URS CONSULTANTS, INC. LAKE PONTCHARTRAIN, LA. AND VICINITY HURRICANE PROTECTION HIGH LEVEL PLAN FRONTING PROTECTION AT PUMP STATION #8 ORLEANS PARISH - JEFFERSON PARISH 17th STREET OUTFALL CANAL RETAINMENT RELIEF WALKWAY PLAN AND ELEVATIONS			
DESIGNED BY: S.C.B.	DATE: SEPT. 1997	PLOT SCALE: 2.00000	PLOT DATE: SEPT. 1997
DRAWN BY: T.R.E.	CHECKED BY: D.J.L.	FILE NO. H-4-44654	
SUBMITTED BY:	SOLICITATION NO. DACW29-98-B-0112	DWG. 7-1 of 7-10	

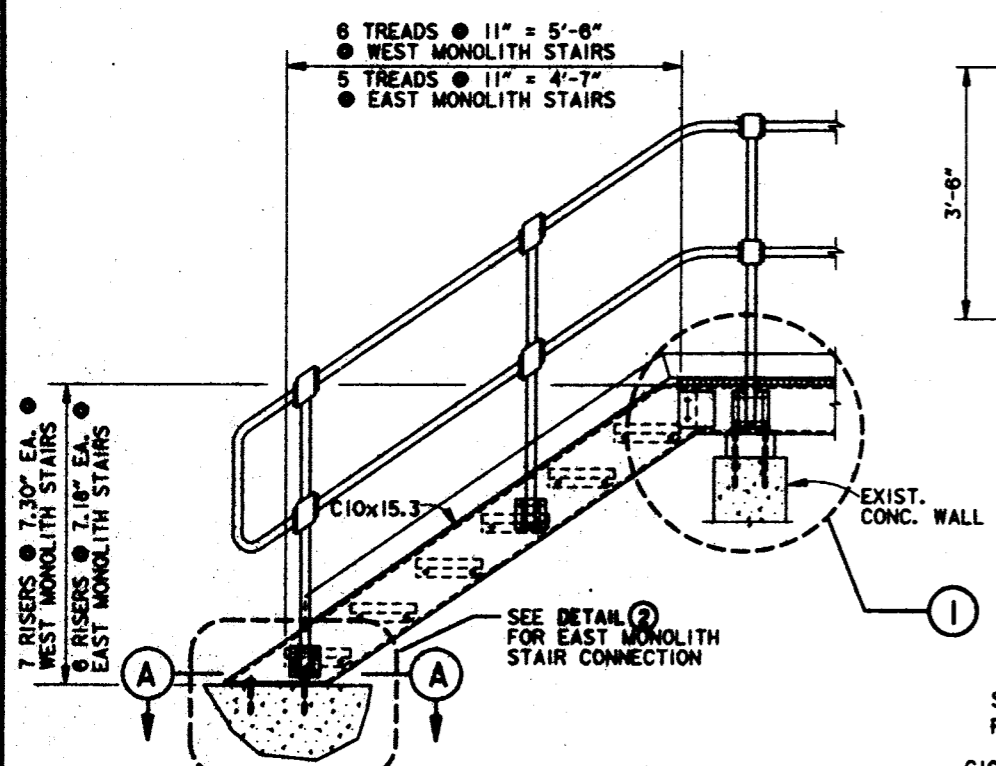

TYPICAL STAIR DETAIL
SCALE: 3/4" = 1'-0"

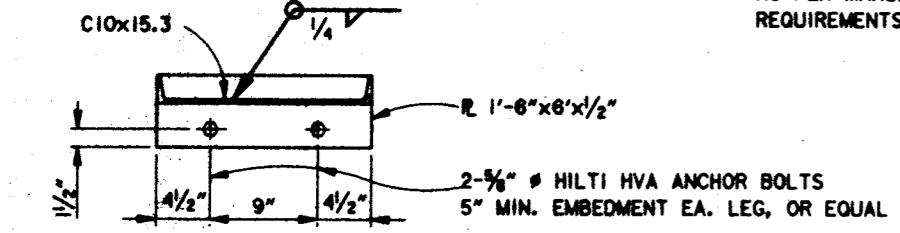

SECTION A
SCALE: 1/2" = 1'-0"

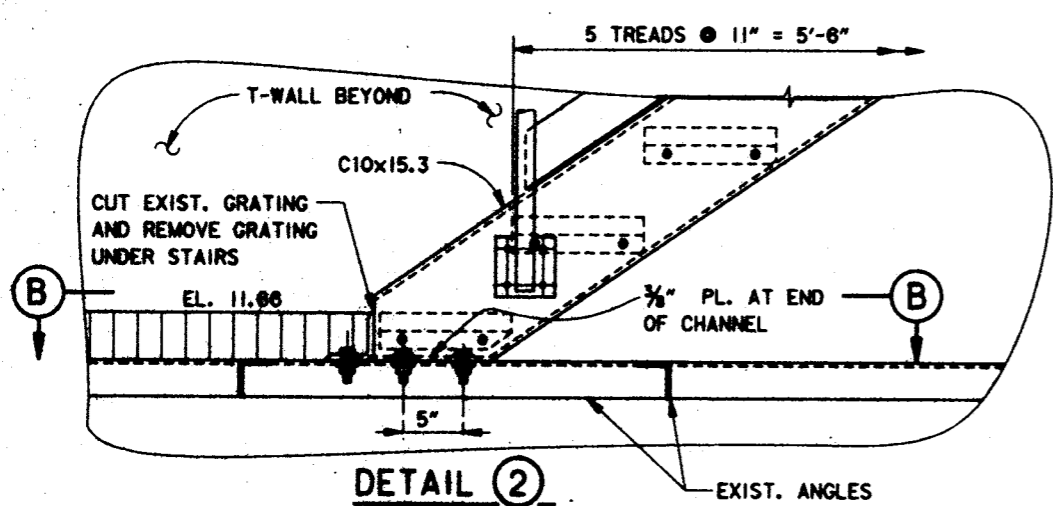

DETAIL 2
SCALE: 1/2" = 1'-0"

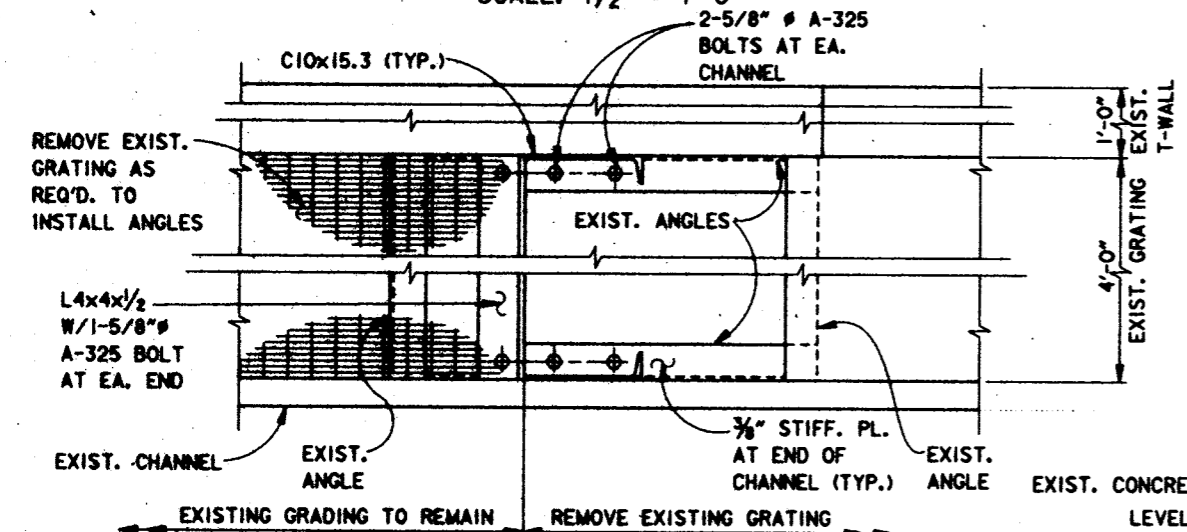

SECTION B
SCALE: 1/2" = 1'-0"

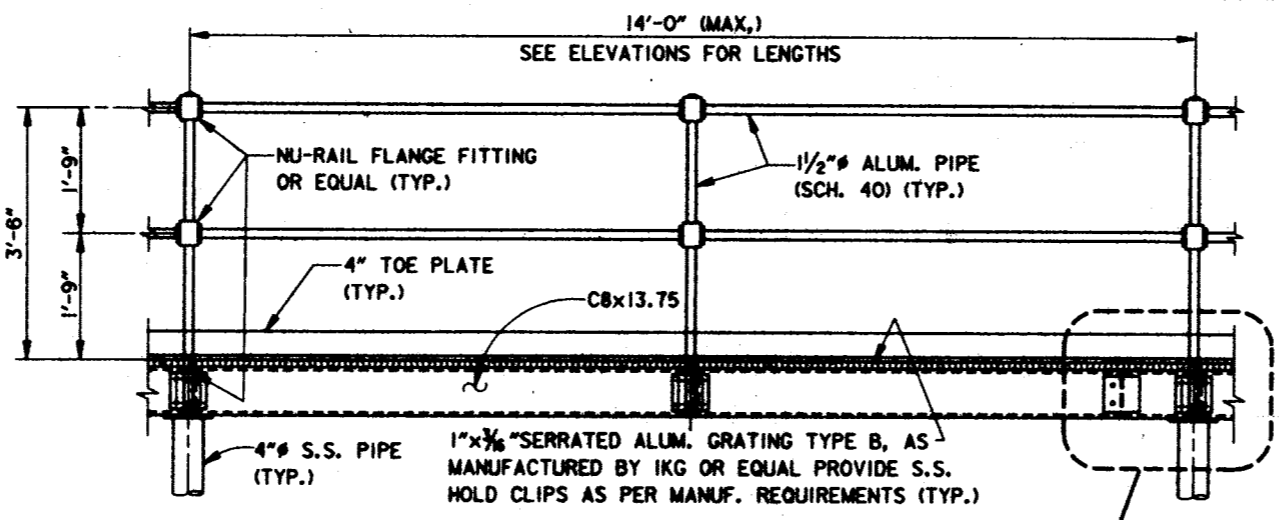

TYPICAL WALKWAY DETAIL
SCALE: 3/4" = 1'-0"

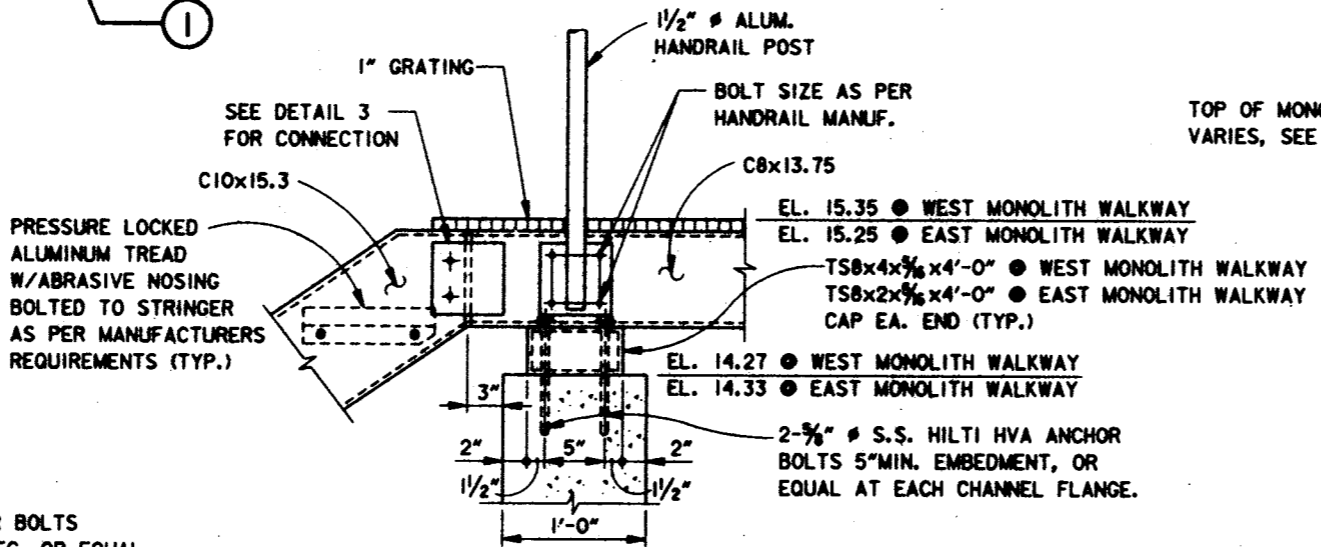

DETAIL 1
SCALE: 1/2" = 1'-0"

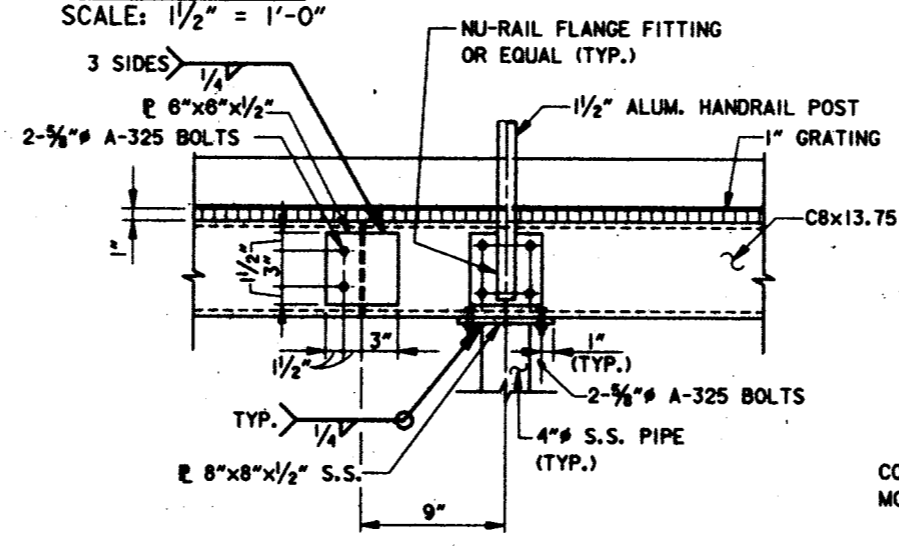

DETAIL 3
SCALE: 1/2" = 1'-0"

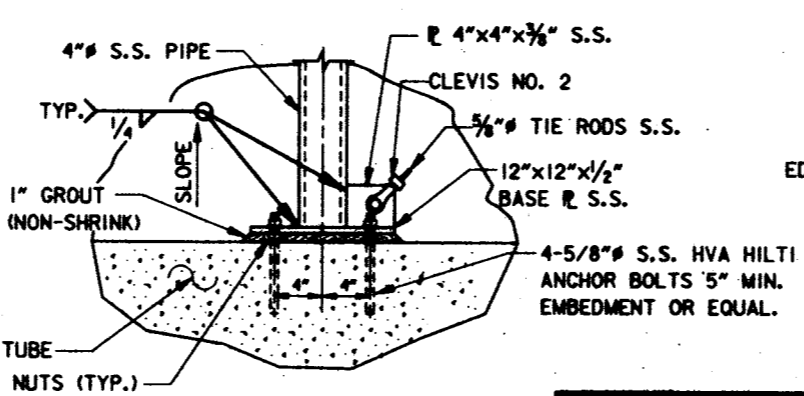

DETAIL C
SCALE: 1/2" = 1'-0"

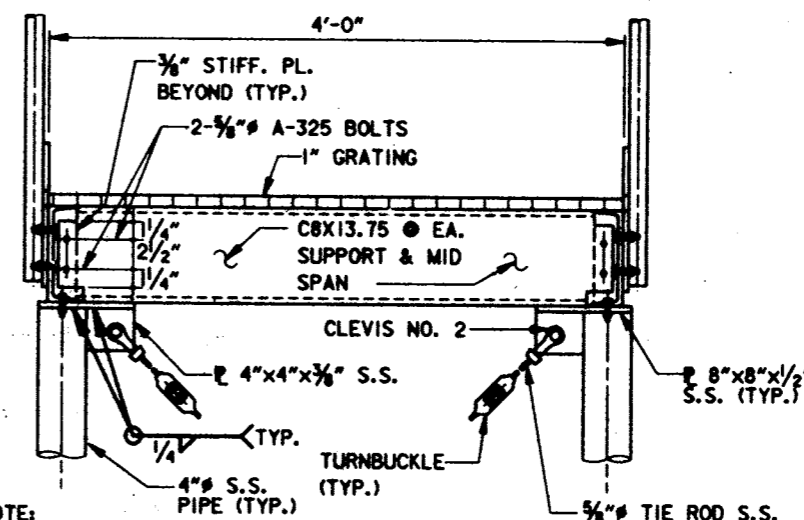

SECTION C
SCALE: 1/2" = 1'-0"

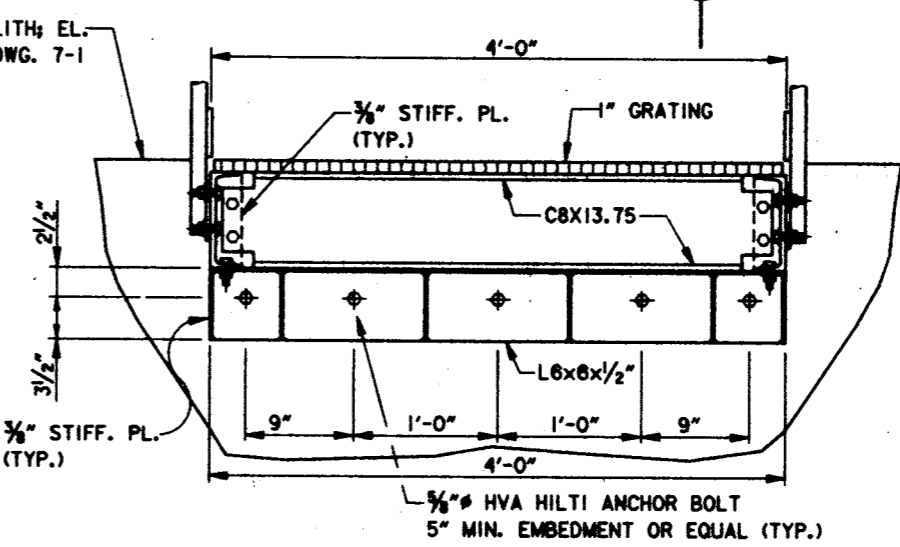

SECTION B
SCALE: 1/2" = 1'-0"

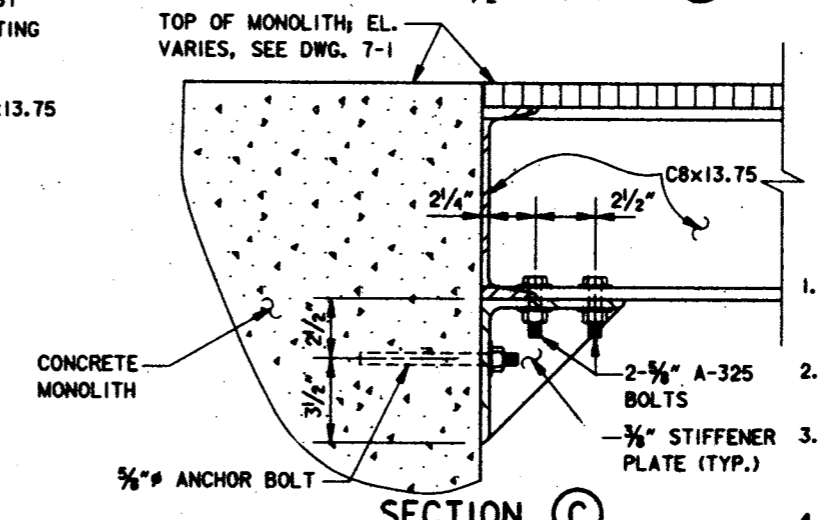

SECTION A
SCALE: 3" = 1'-0"

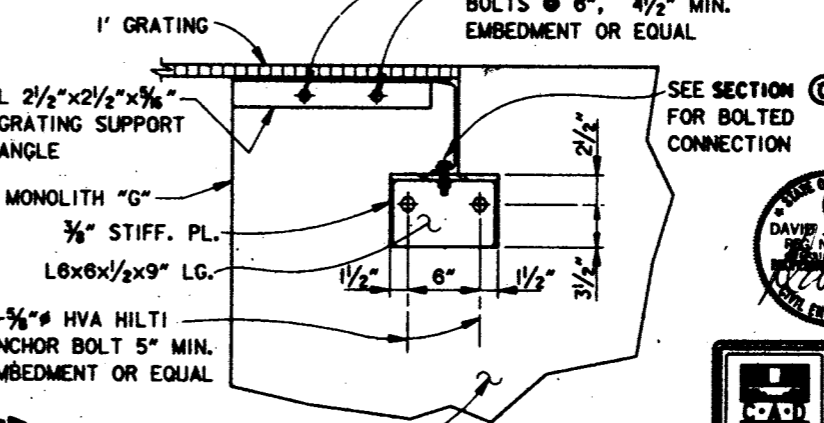

SECTION D
SCALE: 1/2" = 1'-0"

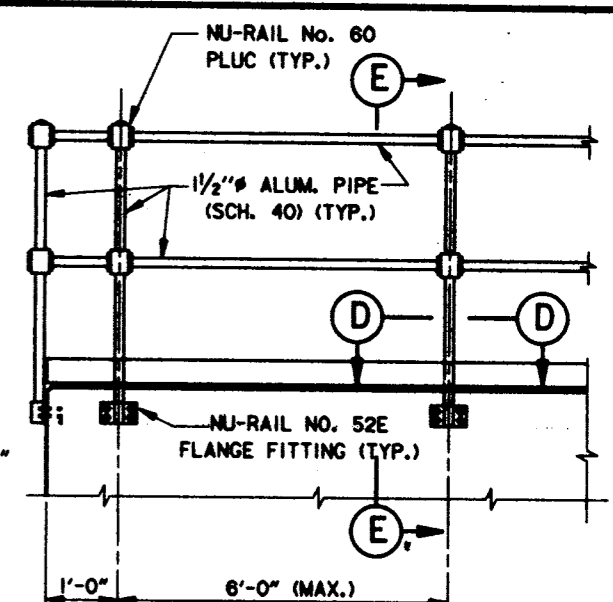

TYPICAL HANDRAIL ELEVATION
SCALE: 3/4" = 1'-0"

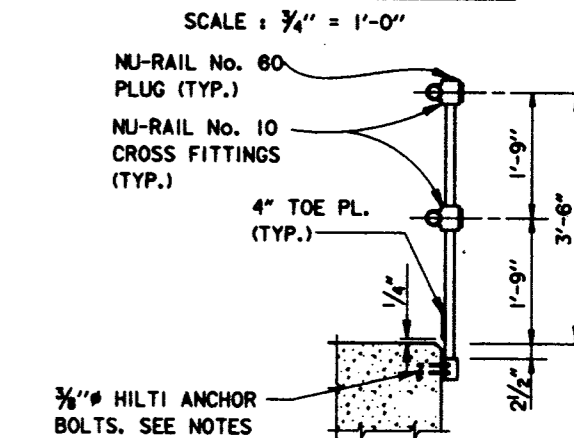

SECTION E
SCALE: 3/4" = 1'-0"

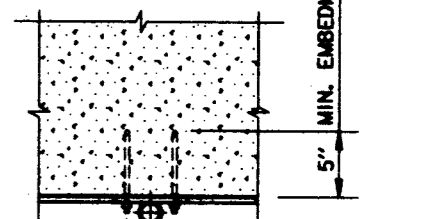

SECTION D
SCALE: 1/2" = 1'-0"

HANDRAIL NOTES

1. ALL GUARDRAIL FITTINGS SHALL BE ALUMINUM NU-RAIL SLIP-ON OFFSET FITTINGS AS MFD. BY THE HOLLAENDER MFG. CO., CINCINNATI, OHIO OR EQUAL.
2. ALL GUARDRAIL PIPE SHALL BE 1/2" ALUMINUM PIPE (SCH.40). ALUMINUM SHALL BE ALLOY 6061-T6.
3. WHERE ALUMINUM IS EXPOSED TO CONCRETE, USE 2 COATS OF BITUMINOUS PAINT OR A COAT OF ZINC-CHROMATE PRIMER AND A COAT OF ALUM. PAINT.
4. FOR HANDRAIL LAYOUT AT MONOLITHS, SEE DWG. 2-5 THRU 2-7.
5. ANCHOR BOLTS FOR HANDRAILS @ MONOLITHS SHALL BE HILTI SUPER KWIK BOLTS, (CRS) 3/8" WITH 5" MIN. EMBEDMENT OR EQUAL.

SYMBOL	DESCRIPTION	DATE	APPROVED
REVISIONS			
U.S. ARMY ENGINEER DISTRICT, NEW ORLEANS CORPS OF ENGINEERS NEW ORLEANS, LOUISIANA			
URS CONSULTANTS, INC. LAKE PONTCHARTRAIN, LA. AND VICINITY HURRICANE PROTECTION HIGH LEVEL PLAN			
FRONTING PROTECTION AT PUMP STATION #8 ORLEANS PARISH - JEFFERSON PARISH 17TH STREET OUTFALL CANAL (METairie RELIEF)			
WALKWAY AND HANDRAIL DETAILS			
DESIGNED BY: S.C.B.	DATE: SEPT. 1997	PLOT SCALE: 1.33	PLOT DATE: SEPT. 1997
DRAWN BY: T.R.E.	CAD FILE: P02-7-GRAN	FILE NO. H-4-44654	
CHECKED BY: D.J.L.	SOLICITATION NO. DACW29-98-B-0112	DWG. 7-2	07-10
SUBMITTED BY:			

Safety is a Part of Your Contract

Safety is a Part of Your Contract

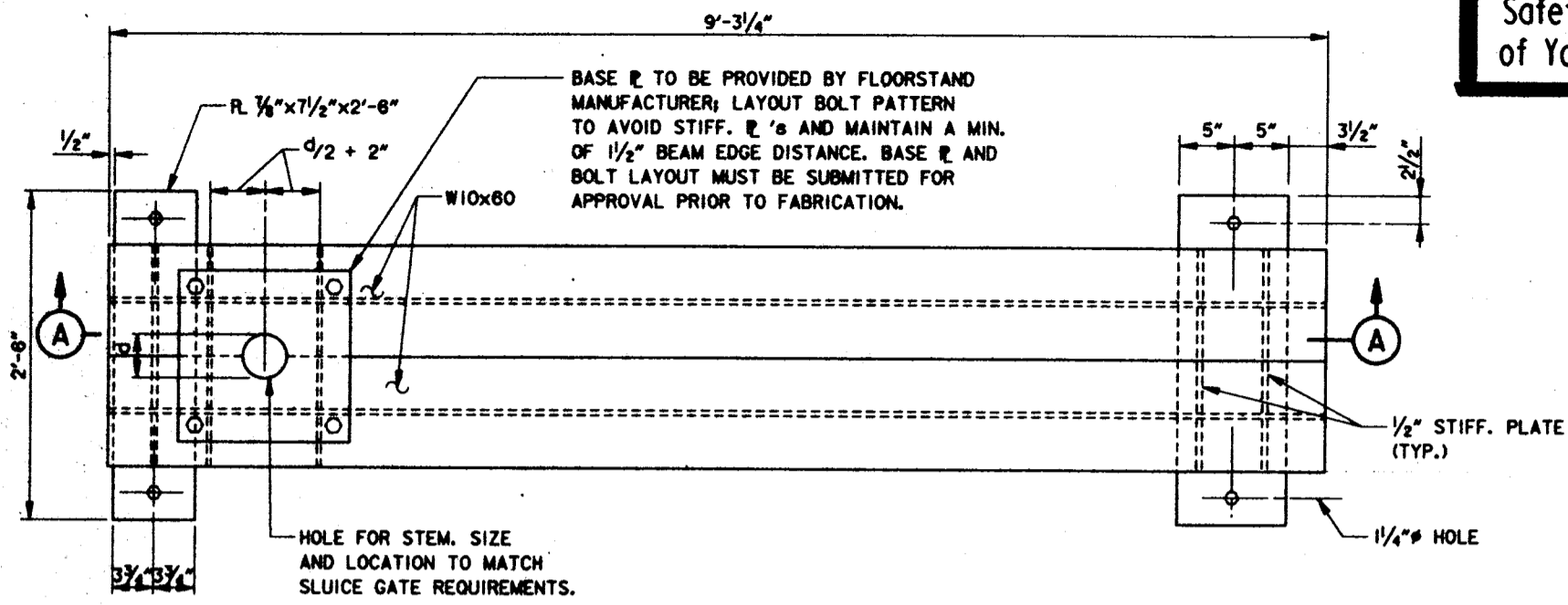

PLAN
SCALE: 1/2" = 1'-0"

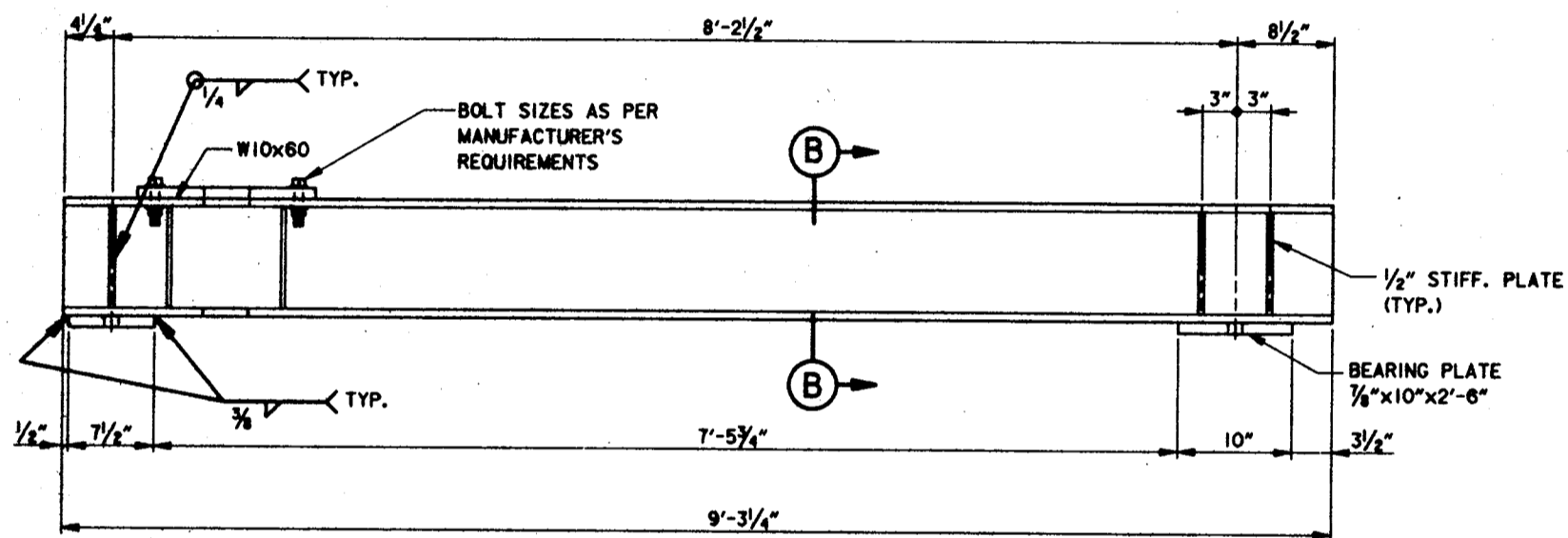

SECTION (A)
SCALE: 1/2" = 1'-0"
GATE HOIST SUPPORT BEAM
(EAST MONOLITH)

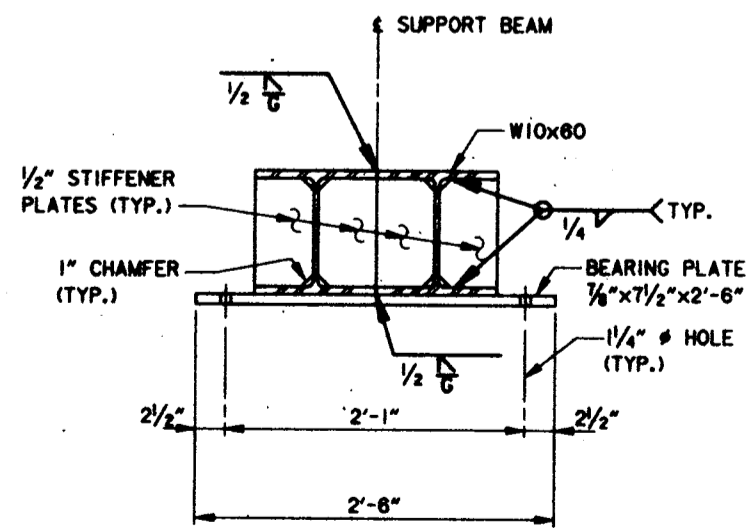

SECTION (B)
SCALE: 1/2" = 1'-0"
APPLICABLE AT EAST MONOLITH

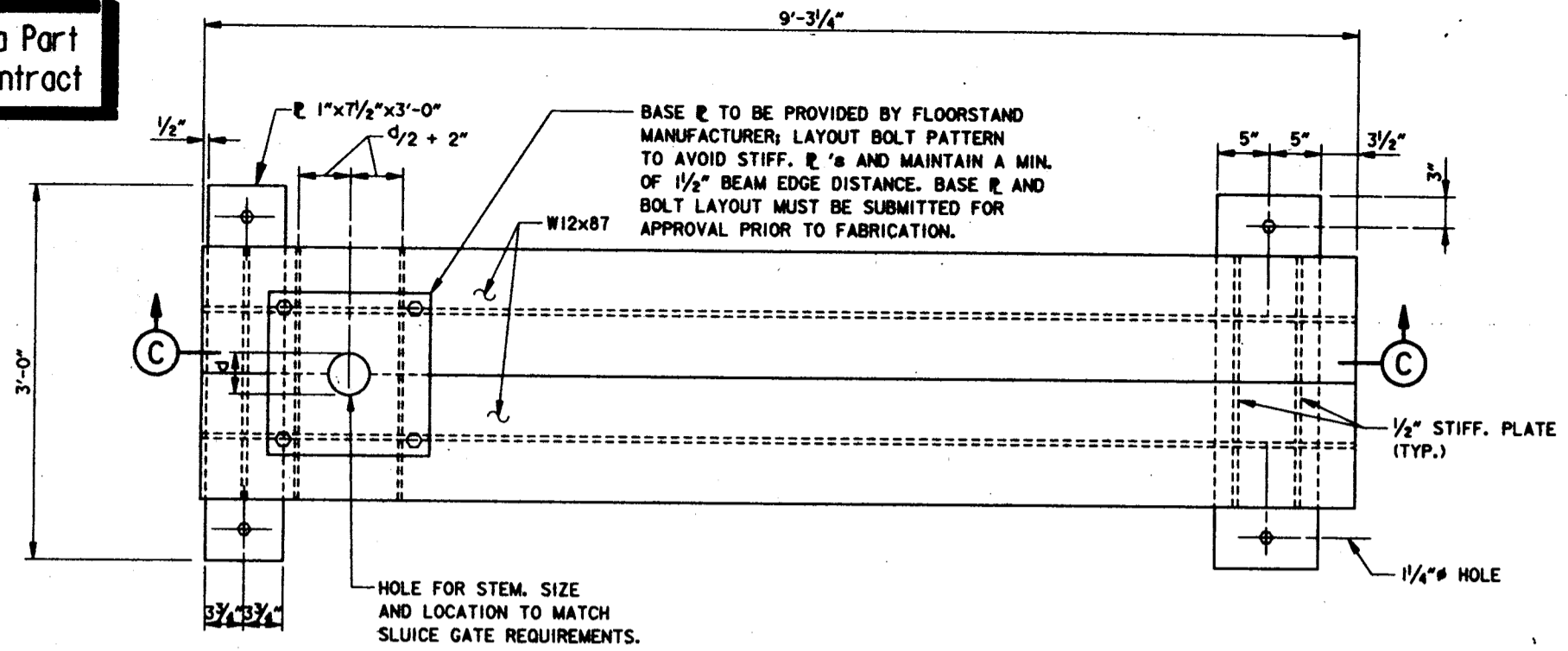

PLAN
SCALE: 1/2" = 1'-0"

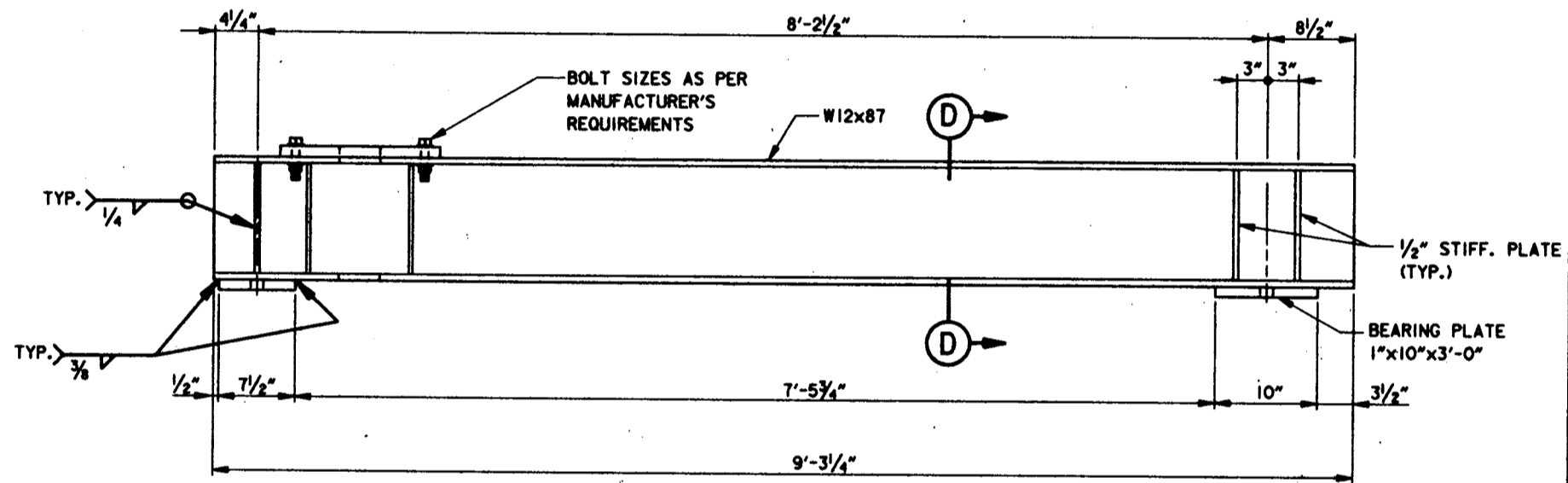

SECTION (C)
SCALE: 1/2" = 1'-0"
GATE HOIST SUPPORT BEAM
(WEST MONOLITH)

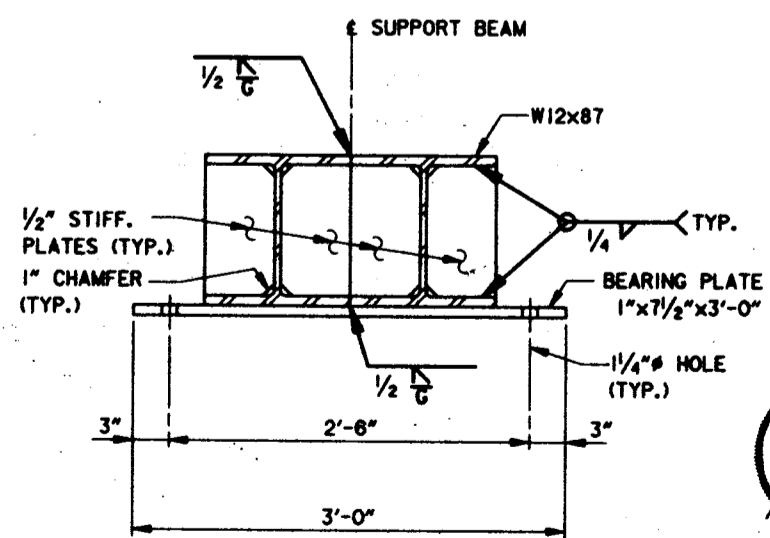

SECTION (D)
SCALE: 1/2" = 1'-0"
APPLICABLE AT WEST MONOLITHS

SUPPORT BEAM NOTES:

- SUPPORT BEAM ASSEMBLY TO BE HOT DIPPED GALVANIZED AFTER FABRICATION BUT PRIOR TO INSTALLATION OF FLOORSTAND.
- DISTANCE TO R CYLINDER TO BE DETERMINED BY SLUICE GATE MANUFACTURER.

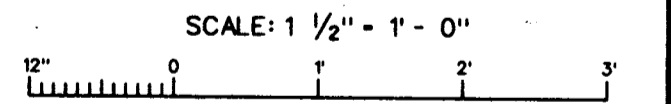

SYMBOL	DESCRIPTION	DATE	APPROVED
	U.S. ARMY ENGINEER DISTRICT, NEW ORLEANS CORPS OF ENGINEERS NEW ORLEANS, LOUISIANA		
	URS CONSULTANTS, INC. LAKE PONTCHARTRAIN, LA. AND VICINITY HURRICANE PROTECTION HIGH LEVEL PLAN FRONTING PROTECTION AT PUMP STATION #6 ORLEANS PARISH - JEFFERSON PARISH 17th STREET OUTFALL CANAL (METAIRE RELIEF)		
DESIGNED BY: M.F.L.	DATE: SEPT. 1997	PLOT SCALE: .0007	PLOT DATE: SEPT. 1997
DRAWN BY: T.R.E.	CAD FILE: P90-7-05.DWG	FILE NO. H-4-44654	
CHECKED BY: D.J.L.	SOLICITATION NO. DACW29-98-B-0112	DWG. 7-3 OF 7-10	

Safety is a Part of Your Contract

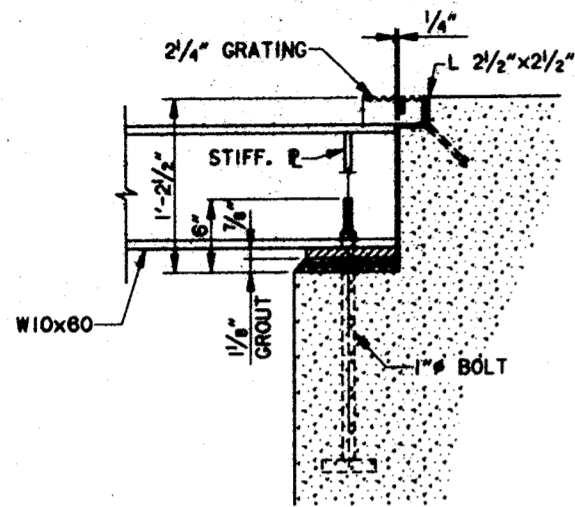

EAST MONOLITH

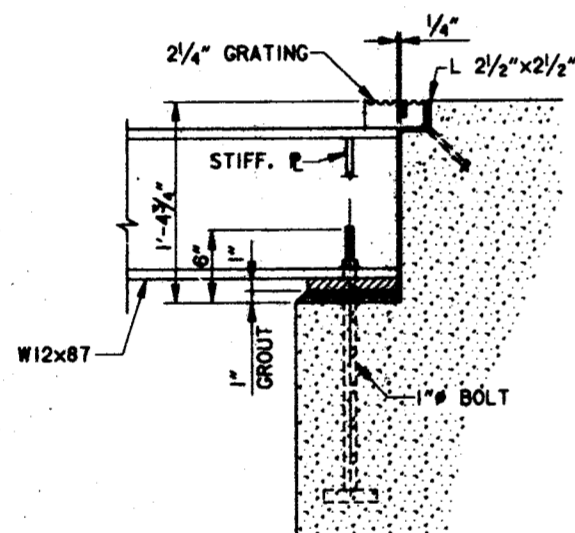

WEST MONOLITH

TYPICAL ANCHOR BOLT BEDDING DETAILS

SCALE: 1/2" = 1'-0"

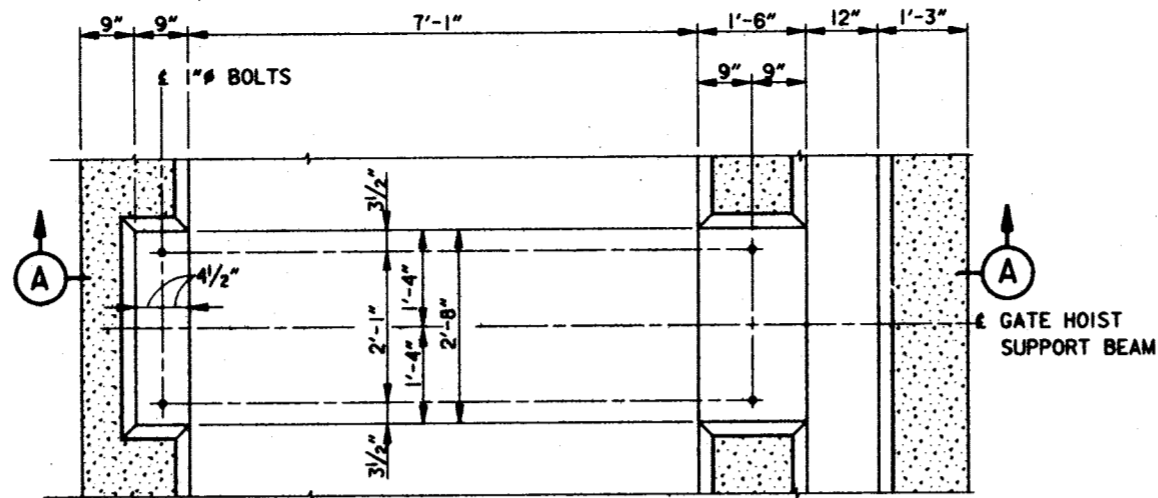

TYPICAL PLAN EAST MONOLITH

SCALE: 3/4" = 1'-0"

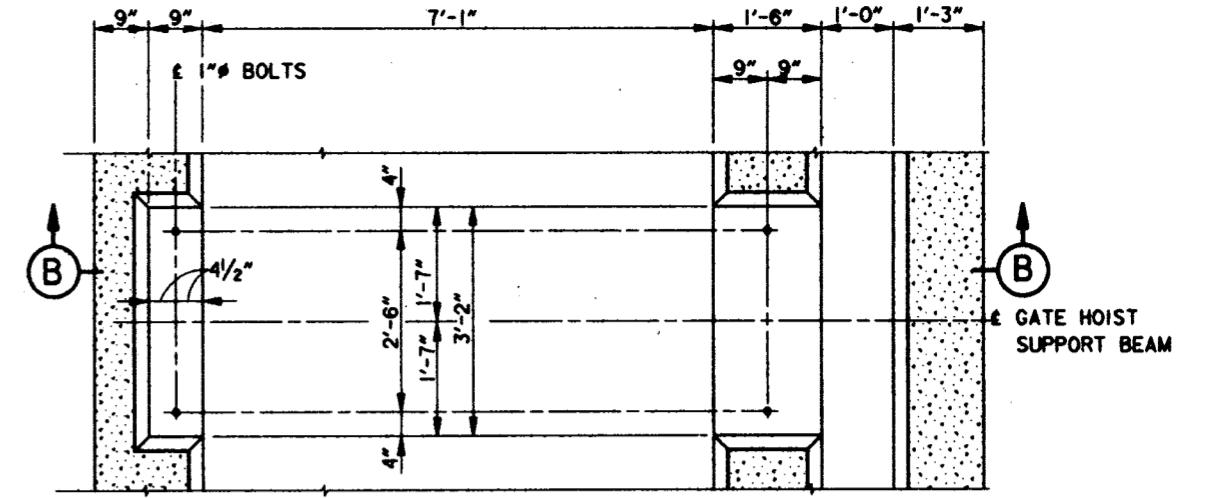

TYPICAL PLAN WEST MONOLITH

SCALE: 3/4" = 1'-0"

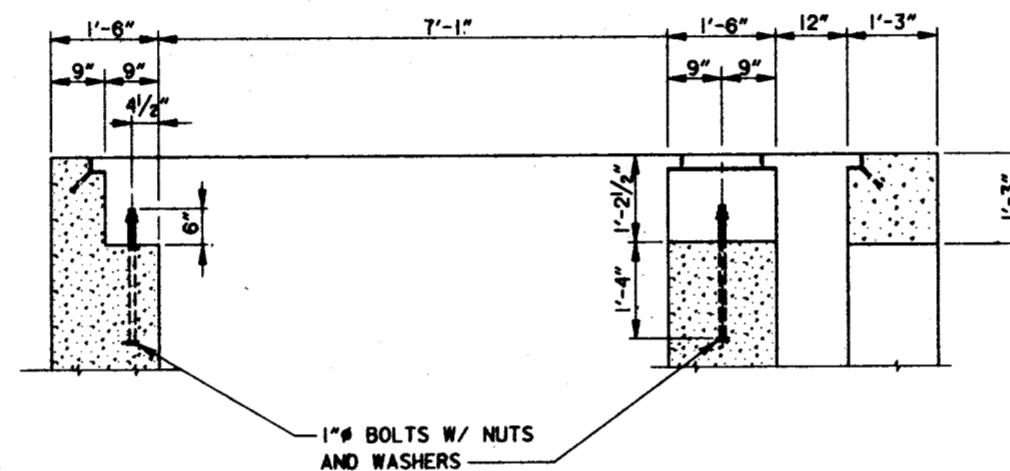

SECTION A

SCALE: 3/4" = 1'-0"

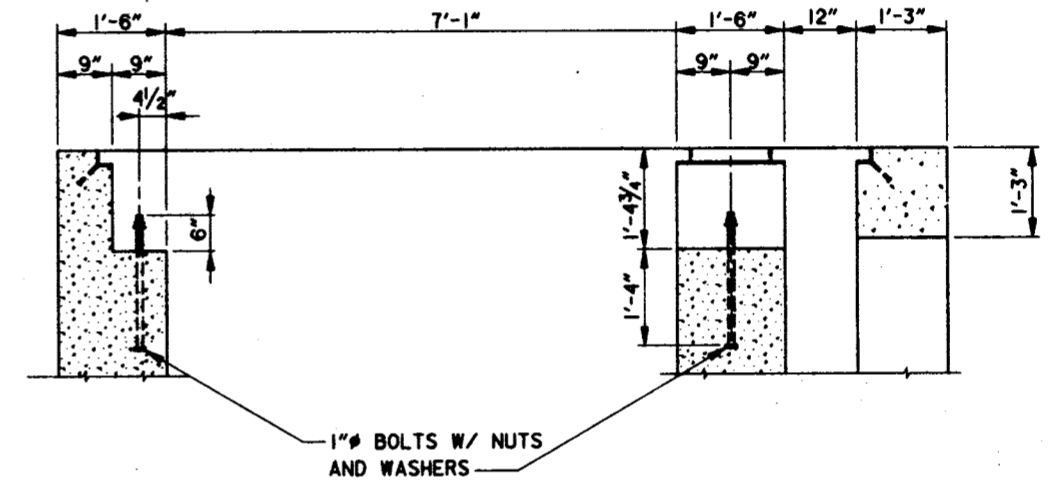

SECTION B

SCALE: 3/4" = 1'-0"

SCALE: 3/4" = 1'-0"

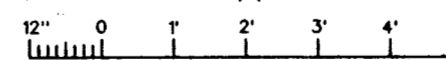

SCALE: 1 1/2" = 1'-0"

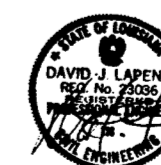
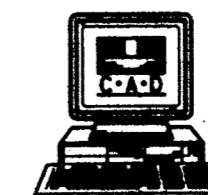
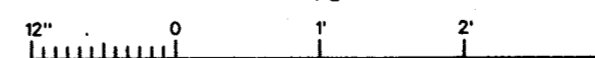

SYMBOL	DESCRIPTION	DATE	APPROVED
REVISIONS			
U.S. ARMY ENGINEER DISTRICT, NEW ORLEANS CORPS OF ENGINEERS NEW ORLEANS, LOUISIANA			
URS CONSULTANTS, INC.			
LAKE PONTCHARTRAIN, LA. AND VICINITY HURRICANE PROTECTION HIGH LEVEL PLAN			
FRONTING PROTECTION AT PUMP STATION #6 ORLEANS PARISH - JEFFERSON PARISH (17th STREET OUTFALL CANAL METAIRIE RELIEF)			
GATE HOIST ANCHOR BOLT DETAILS			
DESIGNED BY: M.F.L.	DATE: SEPT. 1997	PLOT SCALE: .6667	PLOT DATE: SEPT. 1997
DRAWN BY: B.M.M.	CAD FILE: P99-7-04.DGN	FILE NO. H-4-44654	
CHECKED BY: D.J.L.	SOLICITATION NO. DACW29-98-B-0112	DWG. 7-4 OF 7-10	
SUBMITTED BY:			



Safety is a Part of Your Contract

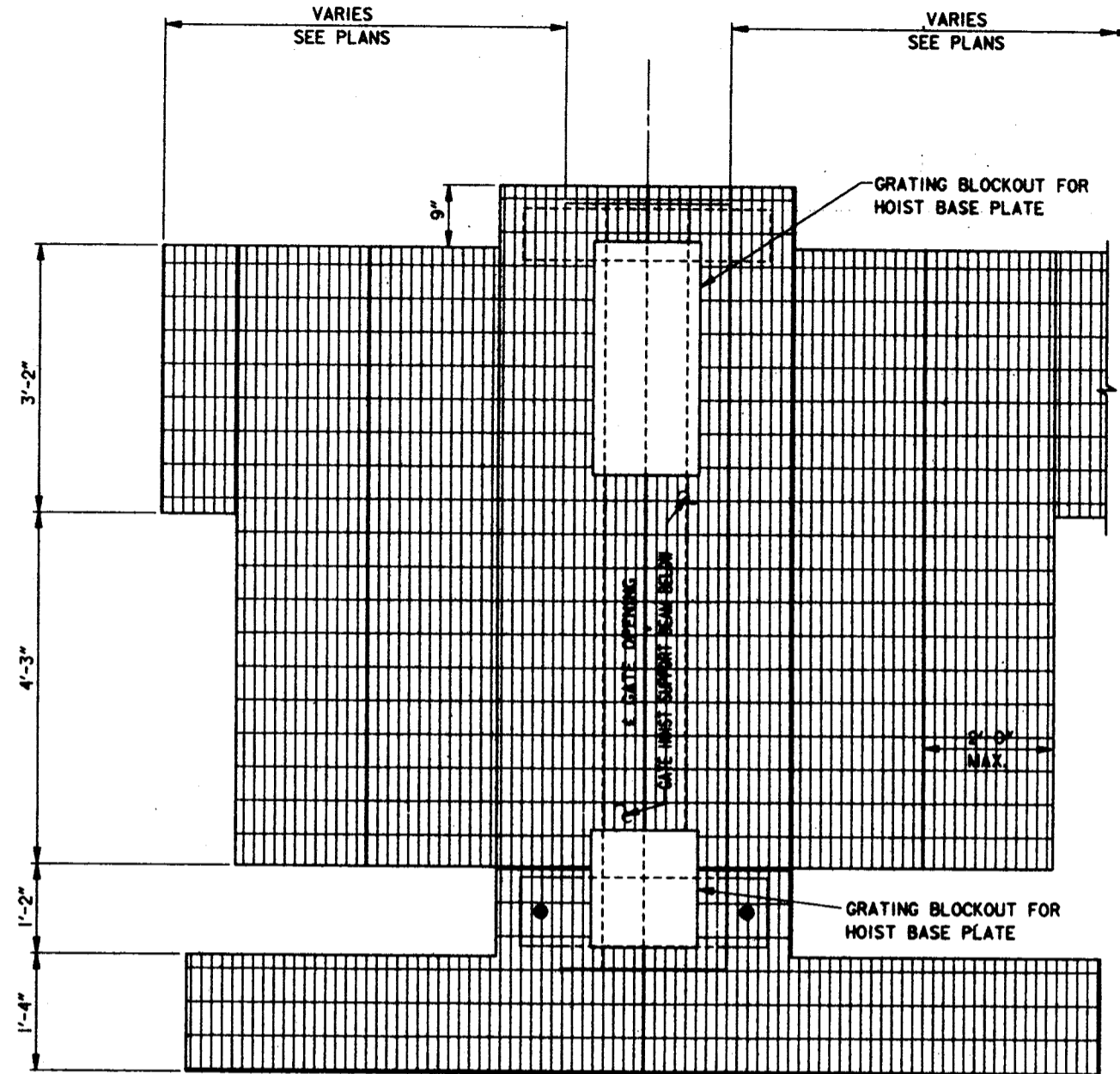
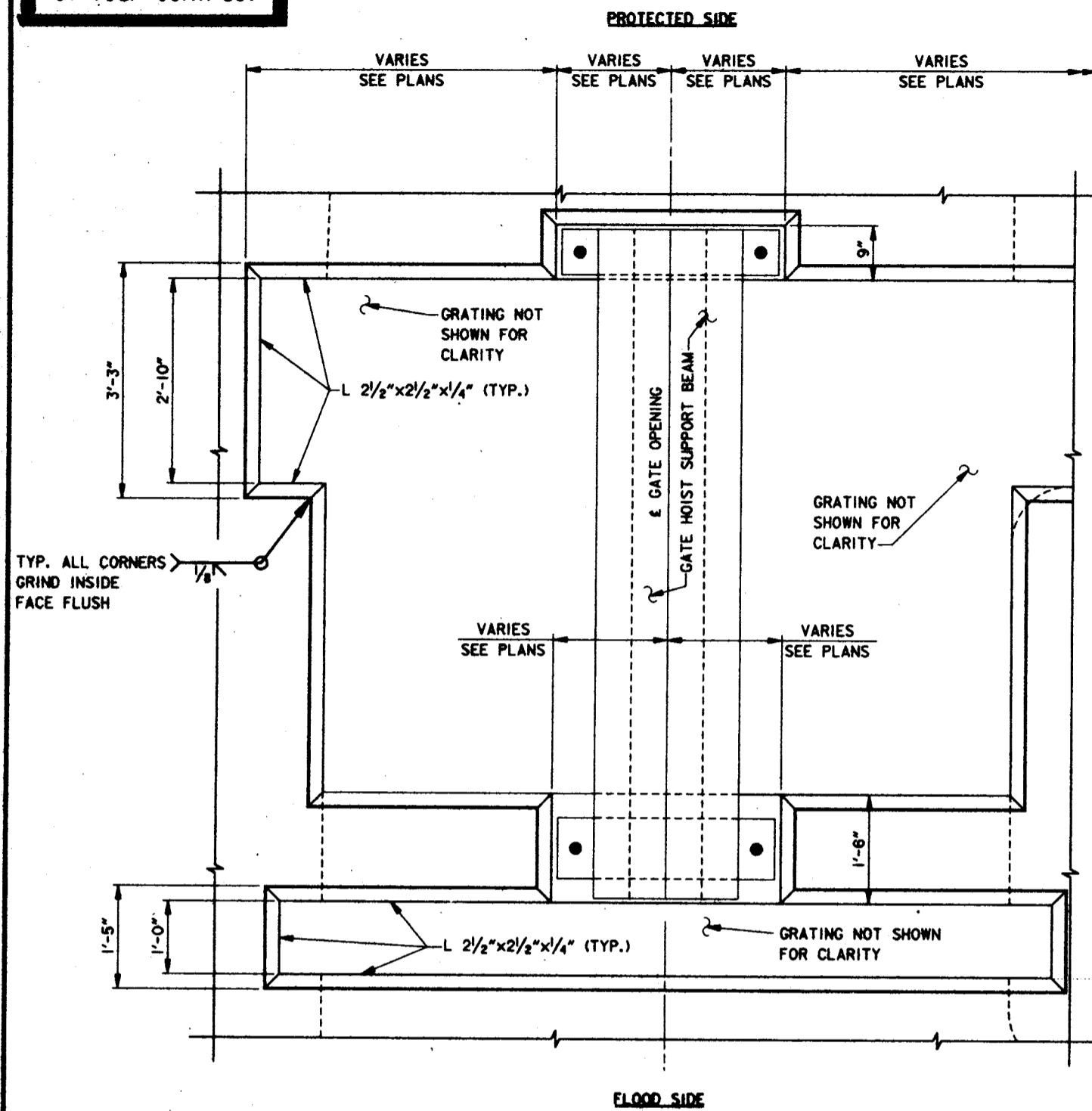

TYPICAL GRATING PLAN - TOP SLAB
SCALE: 1" = 1'-0"

TYPICAL GRATING RECESS PLAN - TOP SLAB
SCALE: 1" = 1'-0"

NOTE:
FOR DIMENSIONS NOT SHOWN SEE STRUCTURAL DWGS.

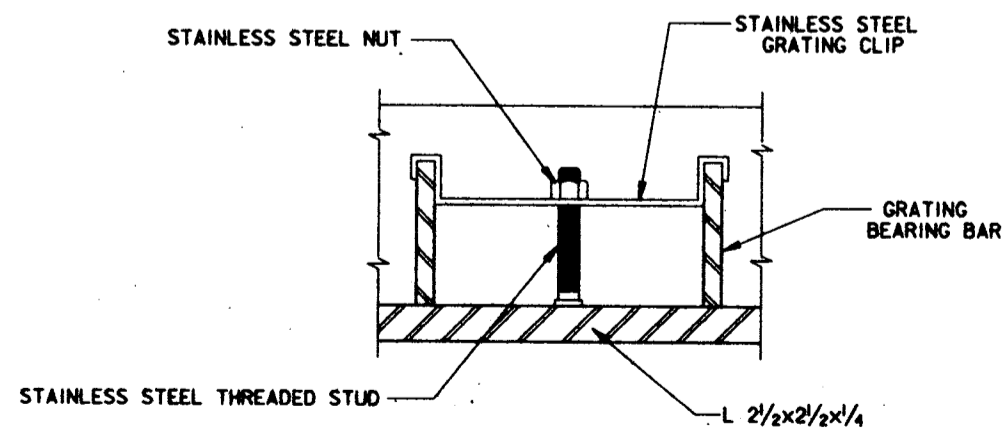

TYPICAL GRATING CLIP DETAIL
N.T.S.

NOTE:
PROVIDE STAINLESS STEEL GRATING CLIPS AS PER MANUFACTURERS REQUIREMENTS.

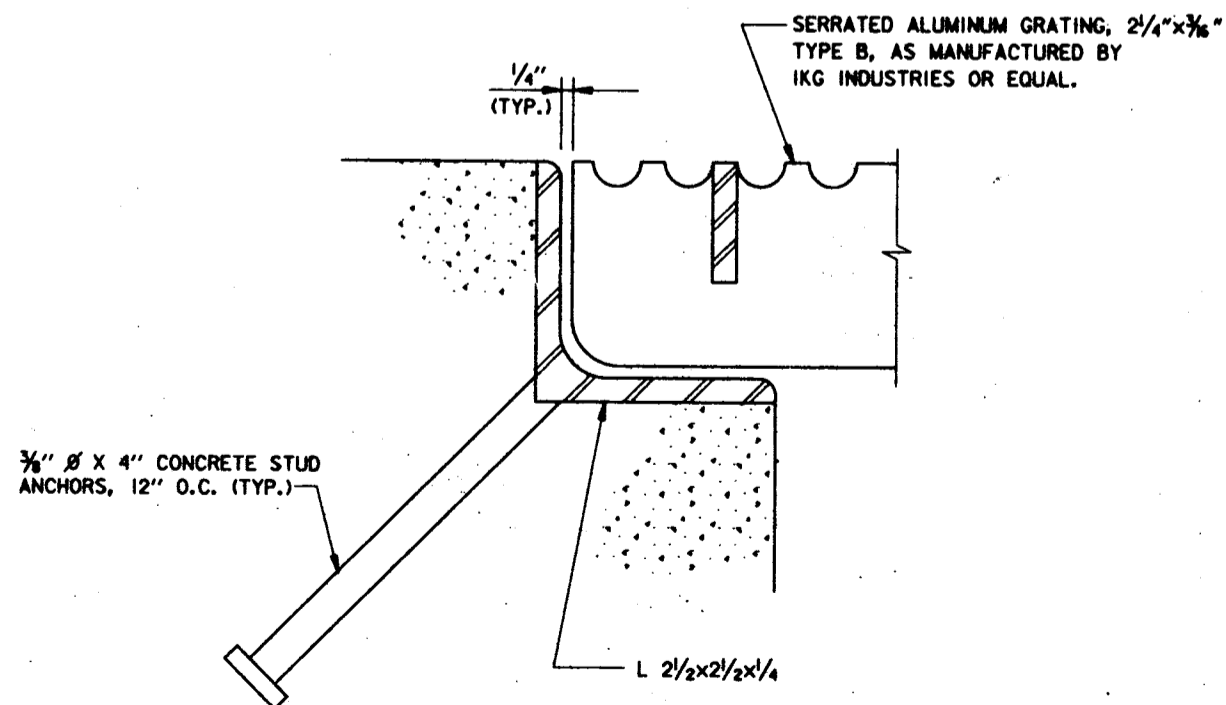

TYPICAL SUPPORT ANGLE ANCHORAGE
SCALE: NONE

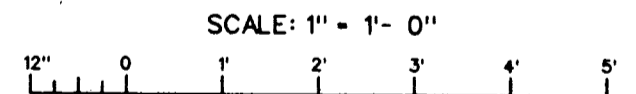

SYMBOL	DESCRIPTION	DATE	APPROVED
REVISIONS			
 U.S. ARMY ENGINEER DISTRICT, NEW ORLEANS CORPS OF ENGINEERS NEW ORLEANS, LOUISIANA			
URS CONSULTANTS, INC. LAKE PONCHARTRAIL, LA. AND VICINITY HURRICANE PROTECTION HIGH LEVEL PLAN FRONTING PROTECTION AT PUMP STATION #8 ORLEANS PARISH - JEFFERSON PARISH 17th STREET OUTFALL CANAL (METAIRIE RELIEF)			
GRATING PLAN AND DETAILS			
DESIGNED BY: S.C.B.	DATE: SEPT. 1997	PLOT SCALE: 1	PLOT DATE: SEPT. 1997
DRAWN BY: B.M.M.	CADD FILE: P50-1-05.DGN	FILE NO. H-4-44654	
CHECKED BY: M.D.P.	SOLICITATION NO. DACW29-98-B-0112	DWG. 7-5	07-10

Safety is a Part of Your Contract

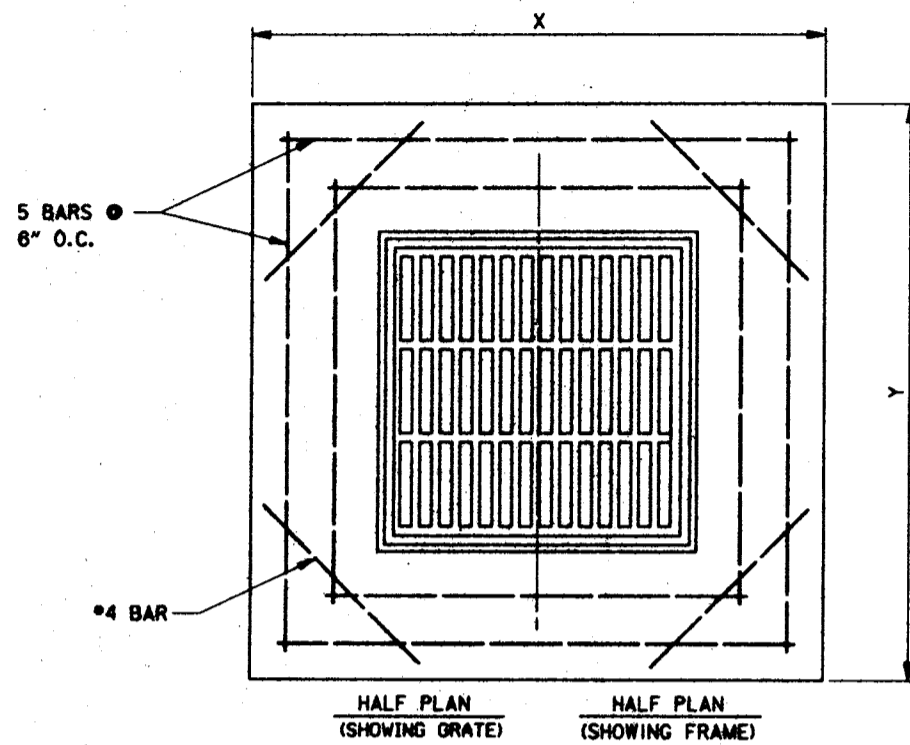

PLAN VIEW

DIMENSIONS

PIPE DIAMETER	X & Y
24" - 48"	6'-10"

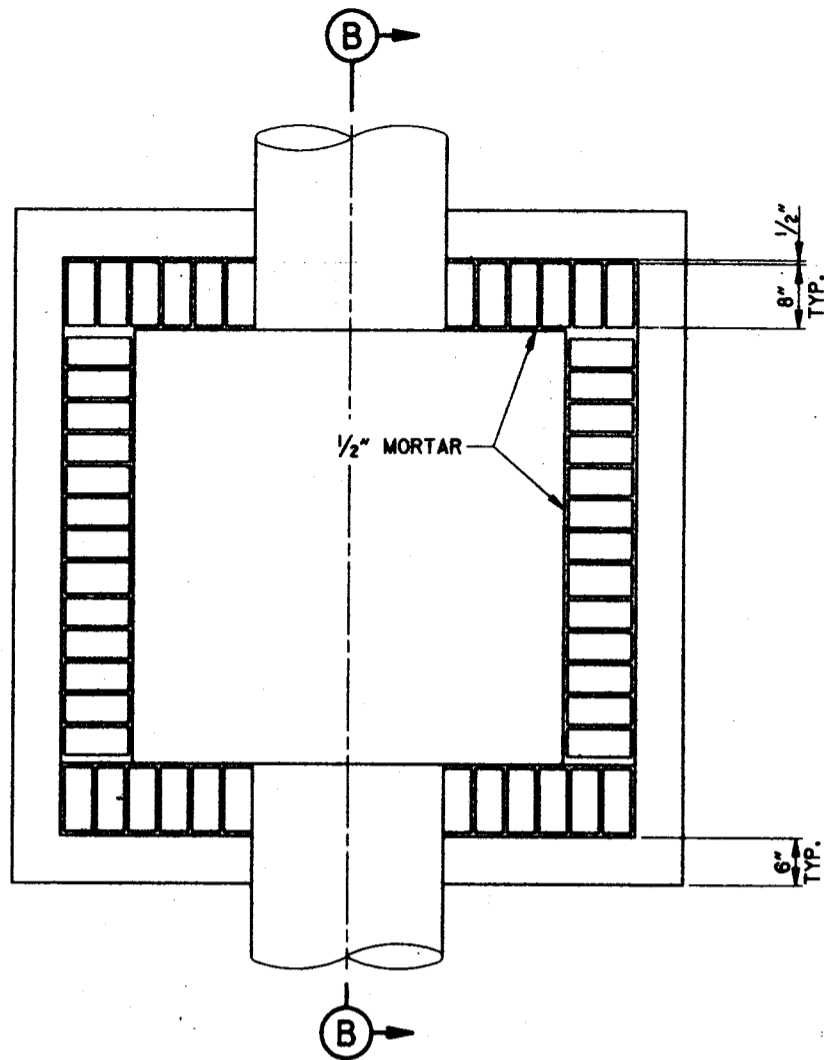

PLAN - SECTION C-C

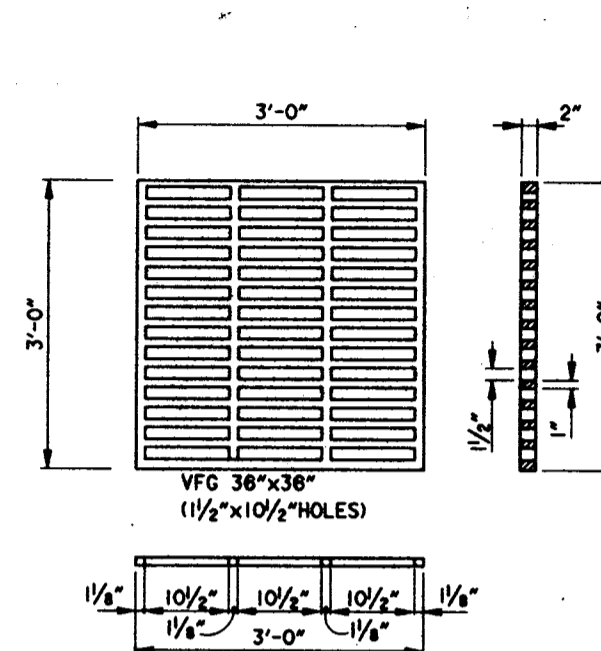

NOTE:
GRAY IRON CASTING SHALL CONFORM TO ASTM DESIGNATION A48, CLASS 30.

DETAIL OF GRATE

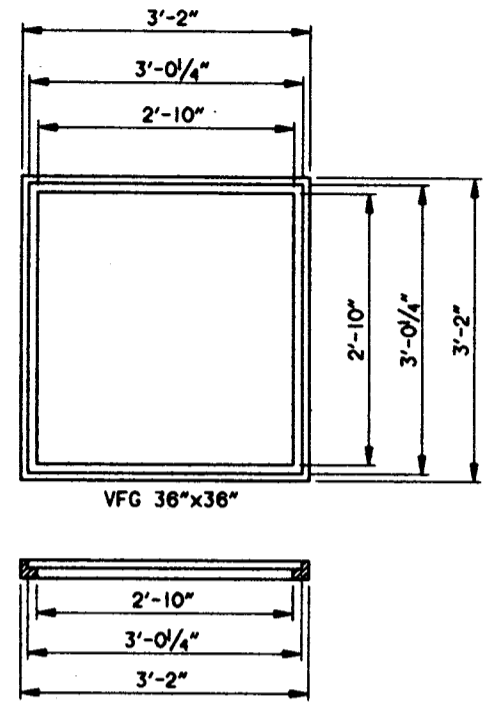

DETAIL OF FRAME

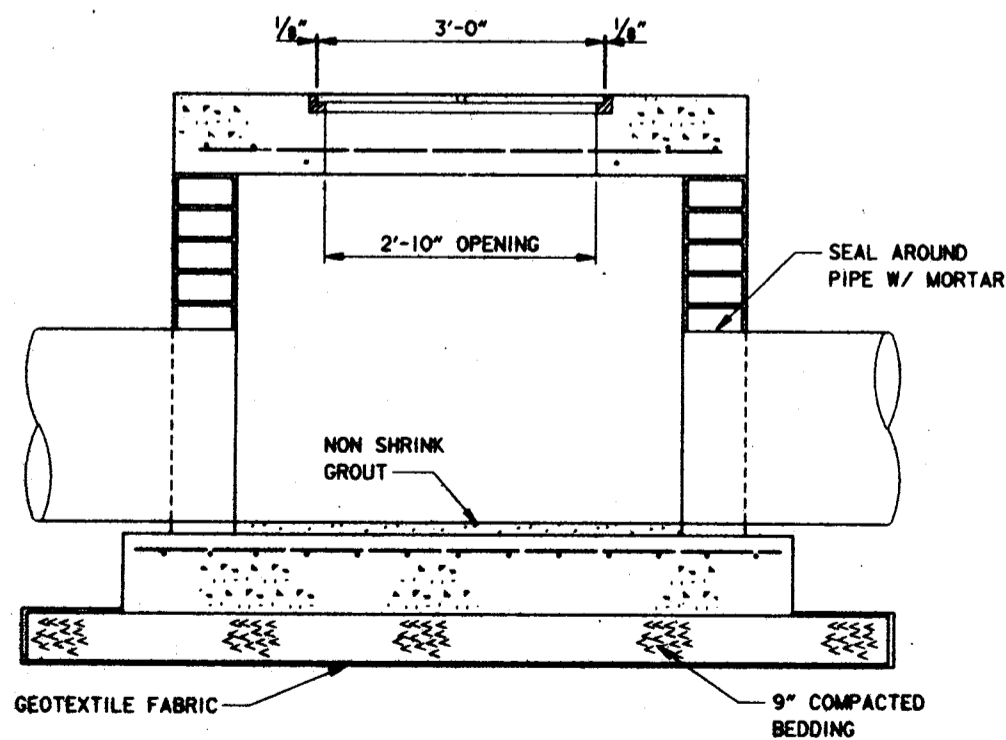

ELEVATION - SECTION B-B

TOP ELEVATION TO BE VERIFIED IN FIELD BY CONTRACTING OFFICER

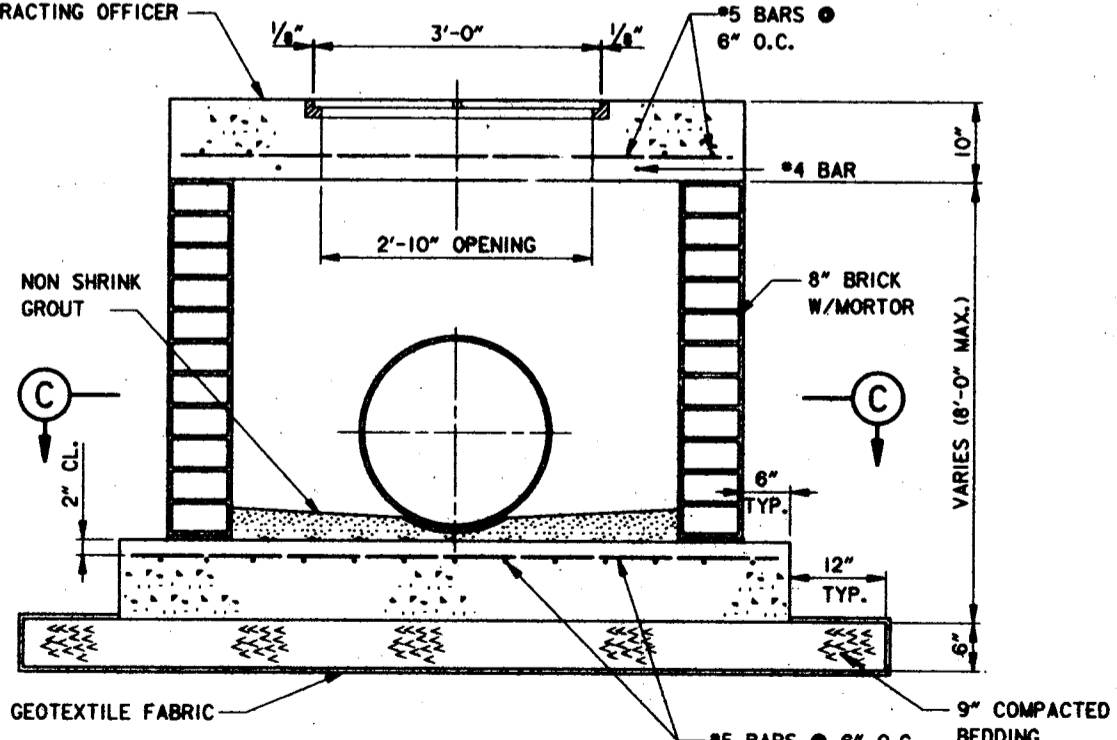

ELEVATION

TYPE II DRAIN MANHOLE
SCALE: 1"=1'-0"

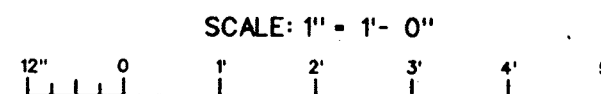

SCALE: 1" = 1'-0"

SYMBOL	DESCRIPTION	DATE	APPROVED
	REVISION		
 URS CONSULTANTS, INC. LAKE PONTCHARTRAIN, LA. AND VICINITY HURRICANE PROTECTION HIGH LEVEL PLAN FRONTING PROTECTION AT PUMP STATION #6 ORLEANS PARISH - JEFFERSON PARISH 17th STREET OUTFALL CANAL (METAIRIE RELIEF) CATCH BASIN DETAILS			
DESIGNED BY: S.P.C.	DATE: SEPT. 1997	PLOT SCALE: 1	PLOT DATE: SEPT. 1997
DRAWN BY: K.L.L.	CAD FILE: P90-7-08.BDD	FILE NO.	H-4-44654
CHECKED BY: M.D.P.	SOLICITATION NO. DACW29-98-B-0112	DWG. 7-6	07-10
REMITTED BY:			

Safety is a Part of Your Contract

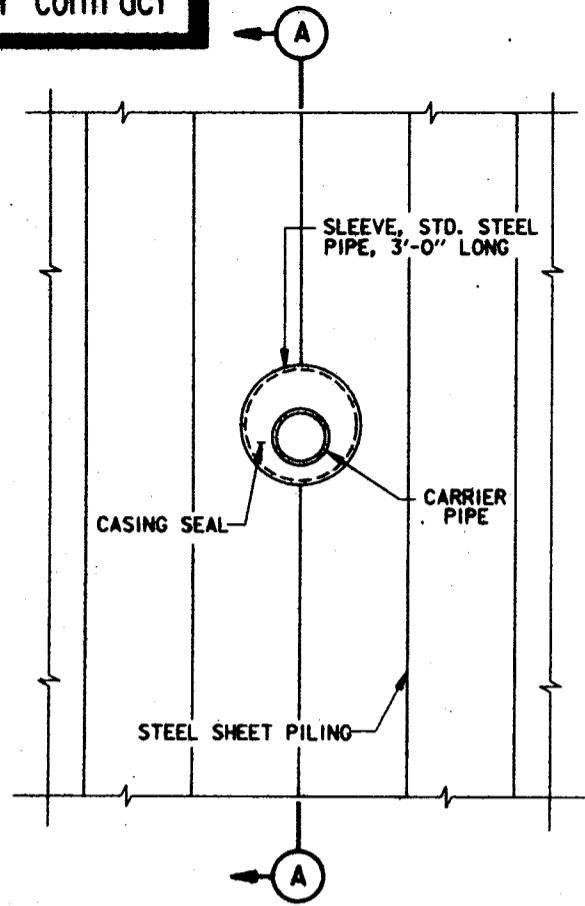

ELEVATION
SCALE: 3/4" = 1'-0"

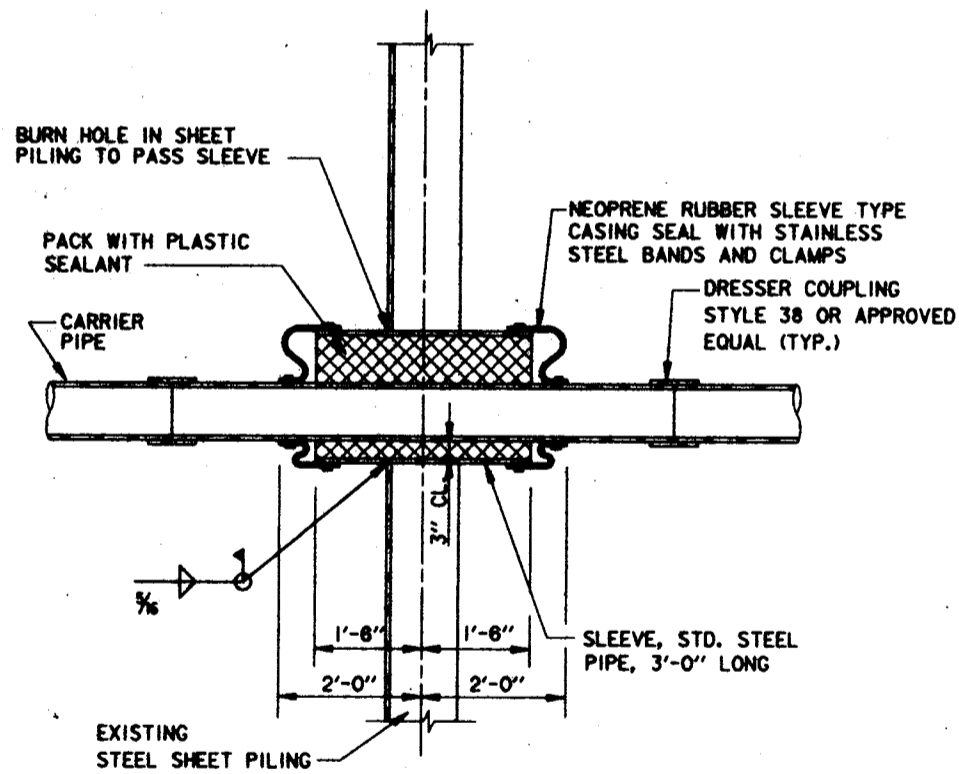

SECTION A-A
DRAINAGE PIPE THRU EXISTING I-WALL
SCALE: 3/4" = 1'-0"

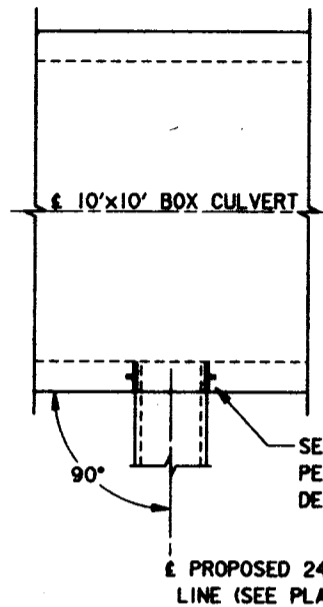

PLAN - DRAIN CONNECTION TO BOX CULVERT
SCALE: 3/4" = 1'-0"

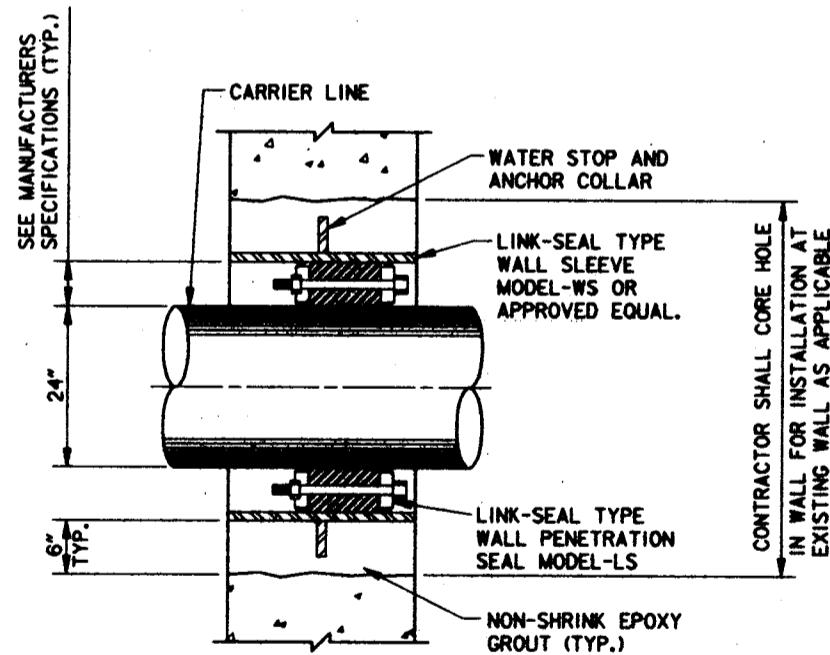

DETAIL
PIPE THRU WALL PENETRATION ASSEMBLY
SCALE: 3/4" = 1'-0"

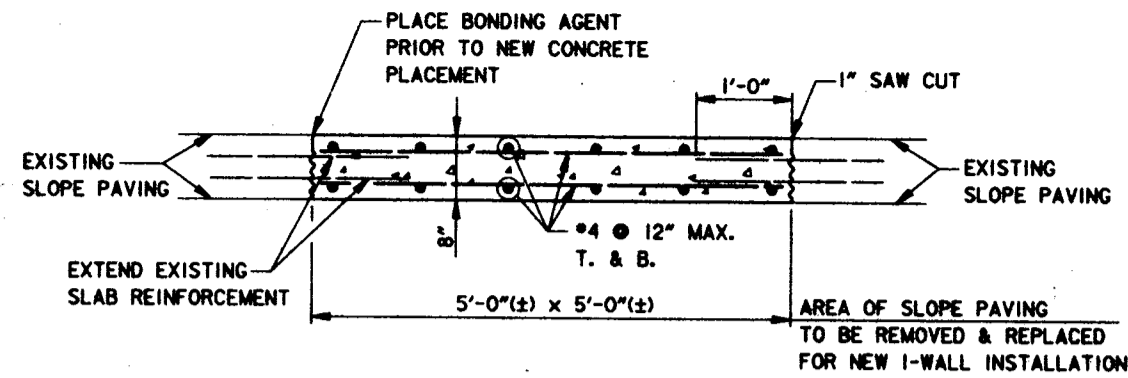

SLOPE PAVING REPLACEMENT DETAIL
SCALE: 3/4" = 1'-0"

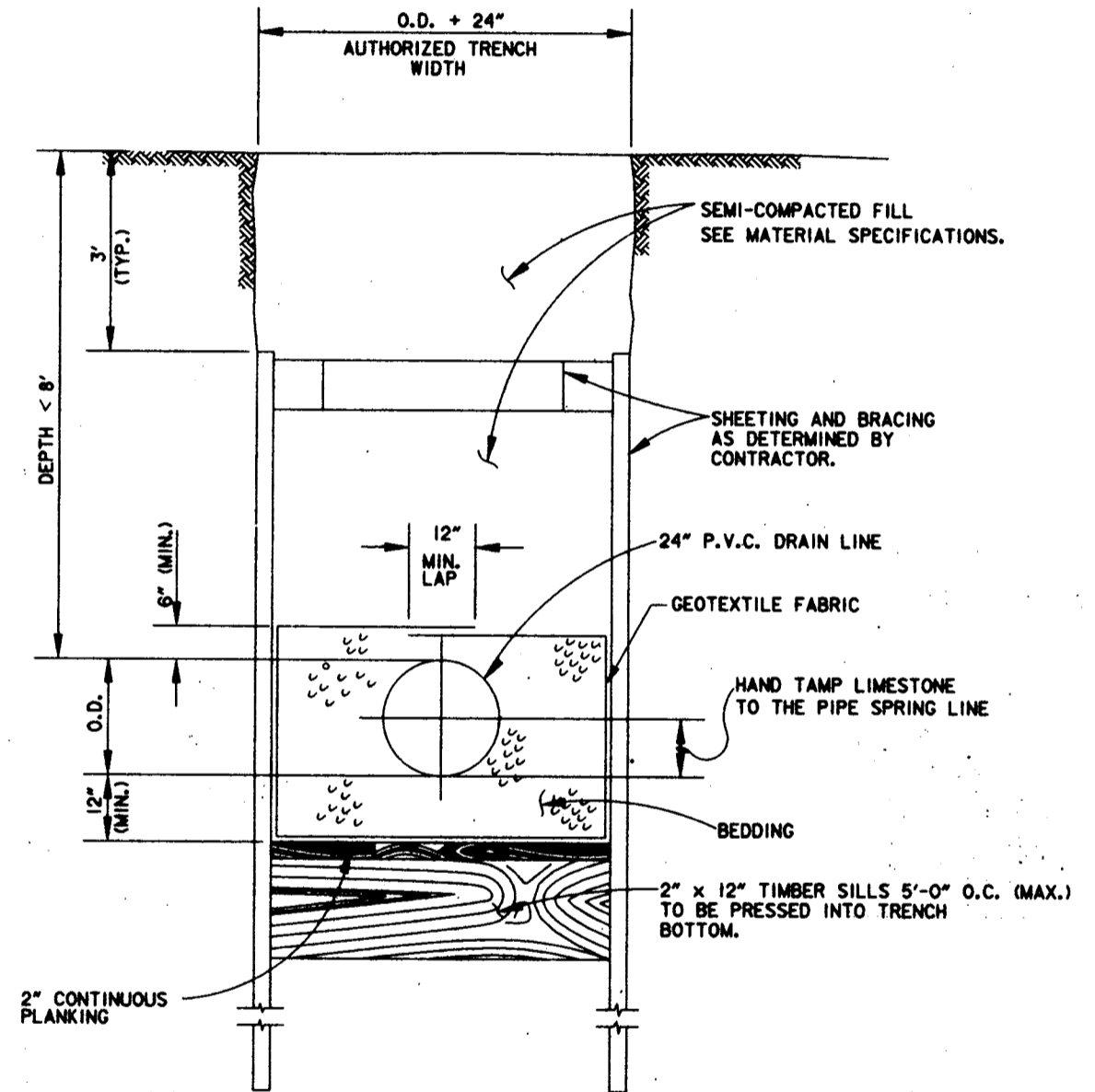

DRAINAGE PIPE BEDDING DETAIL
SCALE: N.T.S.

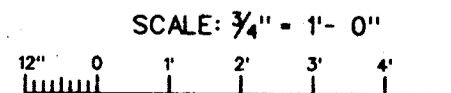

SYMBOL	DESCRIPTION	DATE	APPROVED
REVISIONS			
U.S. ARMY ENGINEER DISTRICT, NEW ORLEANS CORPS OF ENGINEERS NEW ORLEANS, LOUISIANA			
URS CONSULTANTS, INC.			
LAKE PONTCHARTRAIN, LA. AND VICINITY HURRICANE PROTECTION HIGH LEVEL PLAN FRONTING PROTECTION AT PUMP STATION #6 ORLEANS PARISH - JEFFERSON PARISH 17th STREET OUTFALL CANAL (METABIE RELIEF)			
MISCELLANEOUS DETAILS			
DESIGNED BY: S.C.B.	DATE: SEPT. 1997	PLOT SCALE: 1,333	PLOT DATE: SEPT. 1997
DRAWN BY: B.M.M.	CADD FILE: P90-1-07.DWG	FILE NO. H-4-44654	
CHECKED BY: D.L.L.	SOLICITATION NO. DACW29-98-B-0112	DWG. 7-7	07-10
SUBMITTED BY:			

Safety is a Part of Your Contract

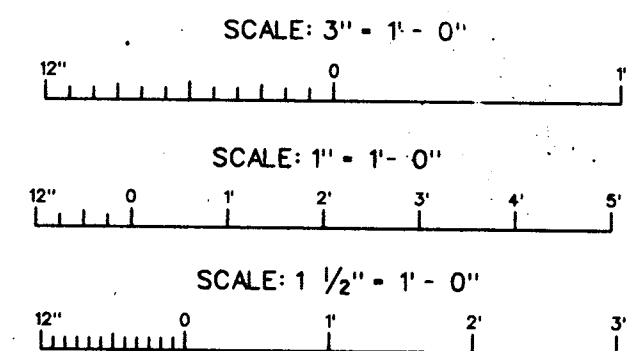
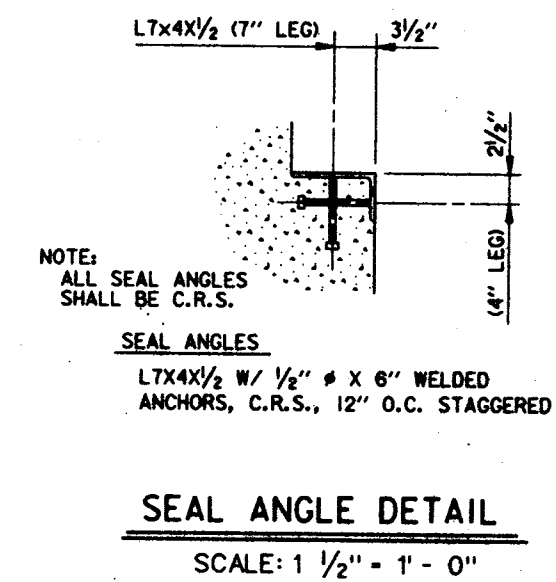
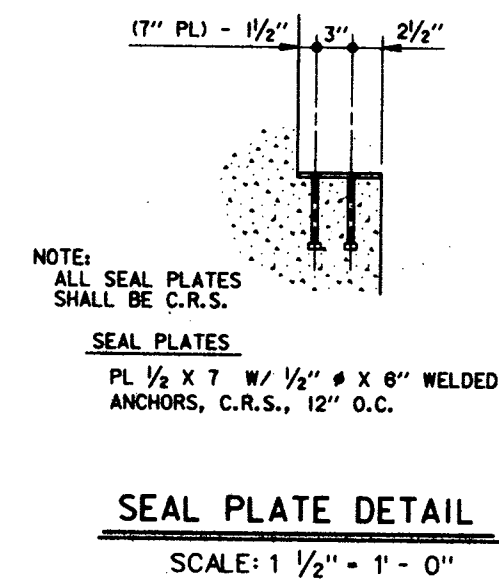
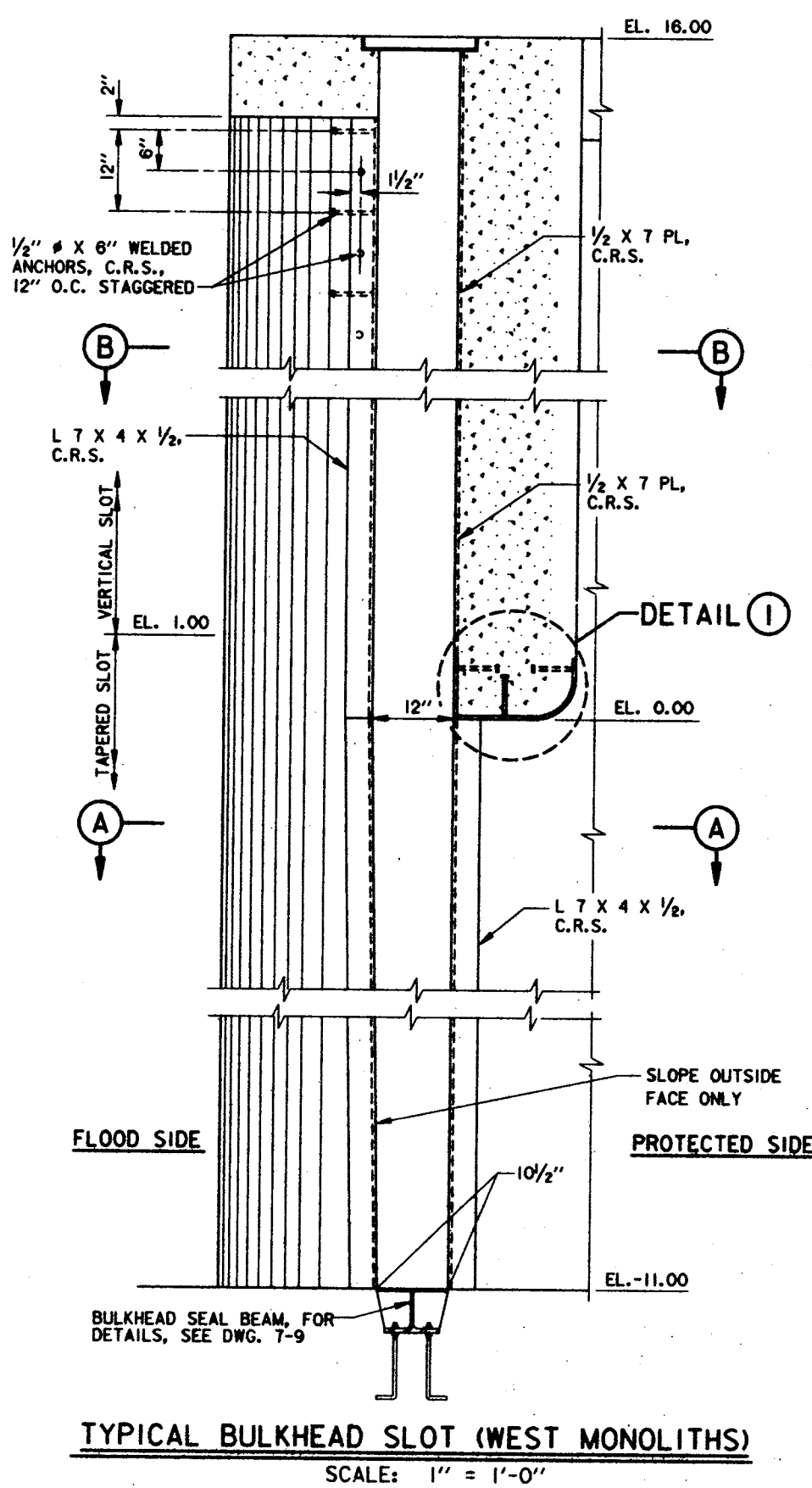
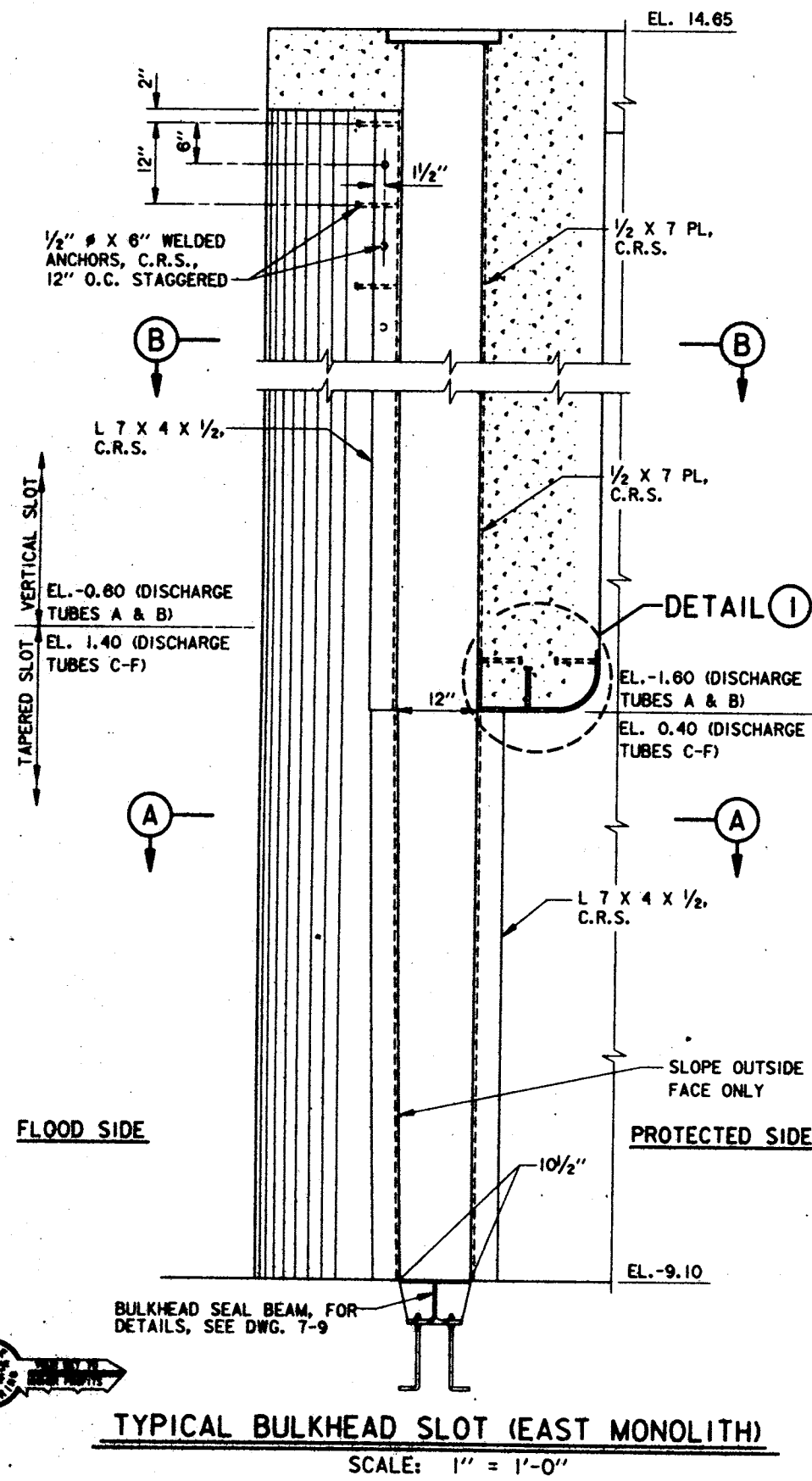
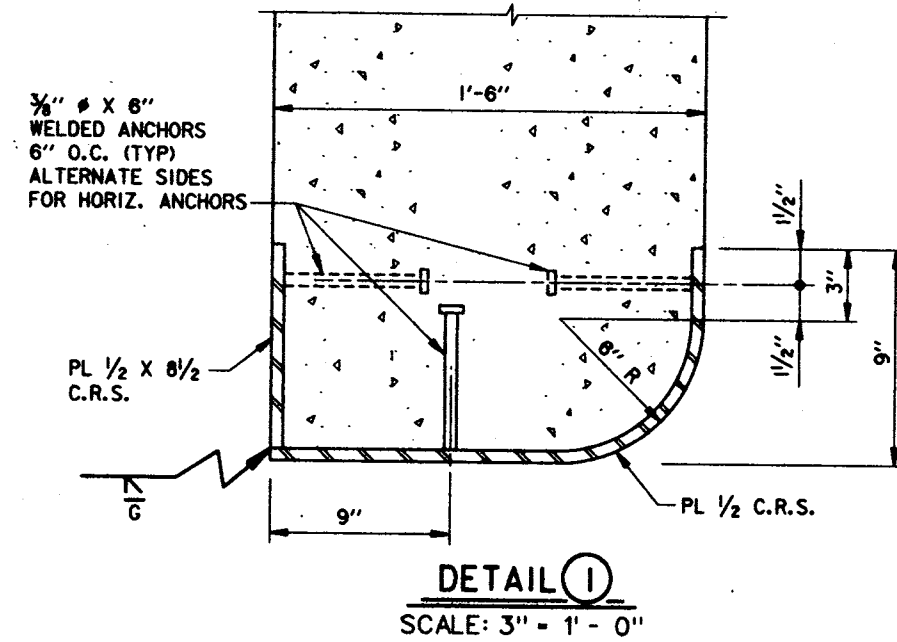
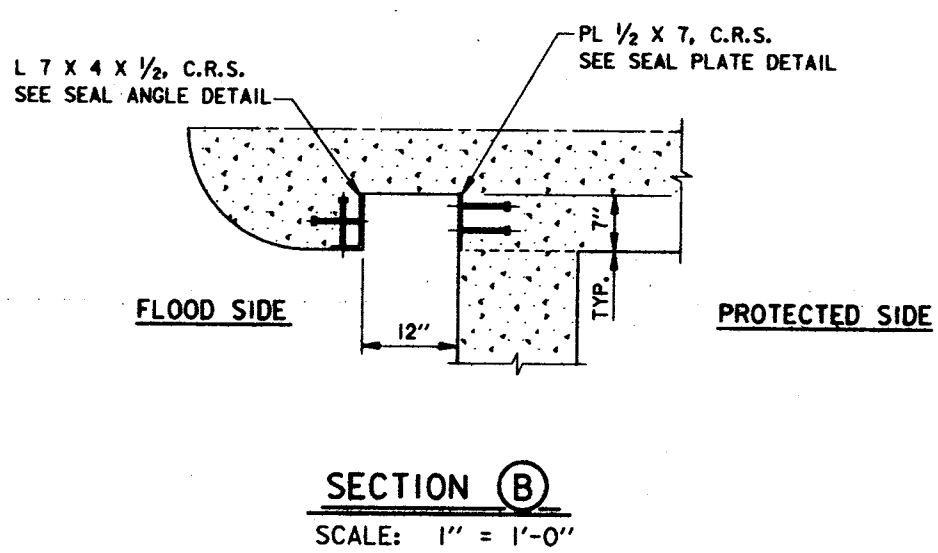
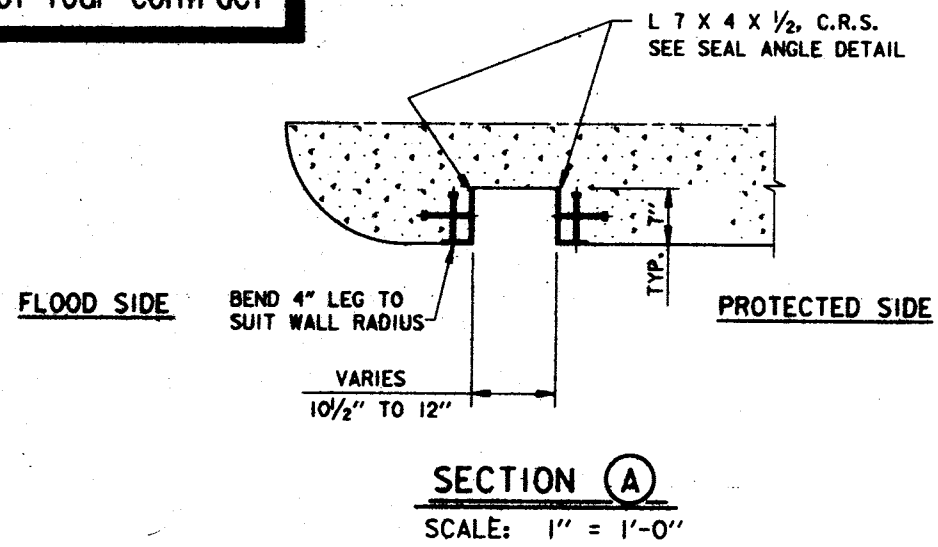

SYMBOL	DESCRIPTION	DATE	APPROVED
REVISIONS			
U.S. ARMY ENGINEER DISTRICT, NEW ORLEANS CORPS OF ENGINEERS NEW ORLEANS, LOUISIANA			
URS CONSULTANTS, INC.			
LAKE PONCHARTRAIN, LA. AND VICINITY HURRICANE PROTECTION HIGH LEVEL PLAN			
FRONTING PROTECTION AT PUMP STATION #8 ORLEANS PARISH - JEFFERSON PARISH 17th STREET OUTFALL CANAL (DELAIRE RELIEF)			
BULKHEAD SLOTS DETAILS			
DESIGNED BY: S.C.B.	DATE: SEPT. 1997	PLOT SCALE: 1	PLOT DATE: SEPT. 1997
DRAWN BY: K.L.L.	CADD FILE: P99-7-08.000	FILE NO. H-4-44654	
CHECKED BY: M.F.L.	SOLICITATION NO. DACW29-98-B-0112	DWG. 7-8	07-10
SUBMITTED BY: _____			

Safety is a Part of Your Contract

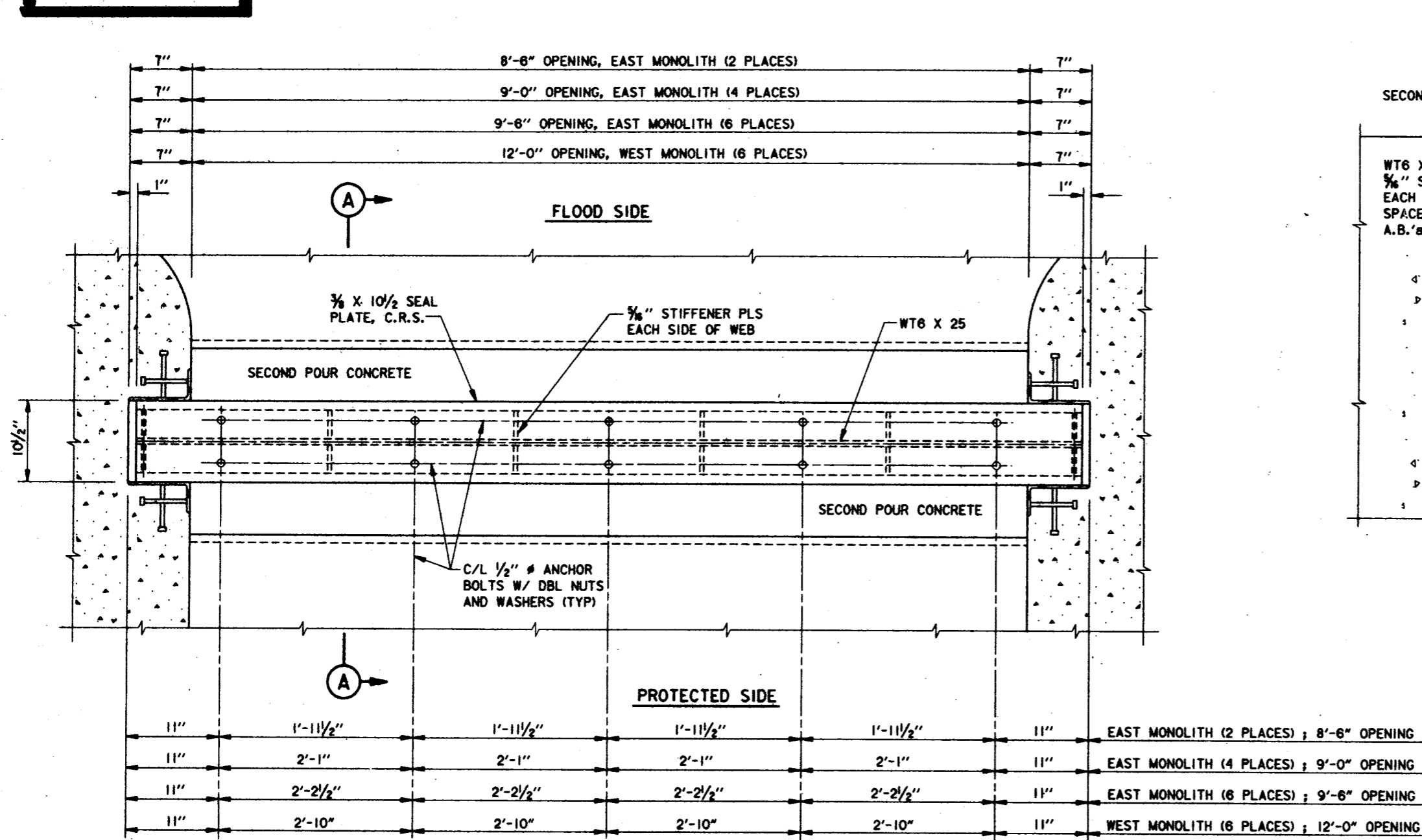

PLAN
BULKHEAD SEAL BEAM (EAST & WEST MONOLITHS)
SCALE: 1 1/2" = 1' - 0"

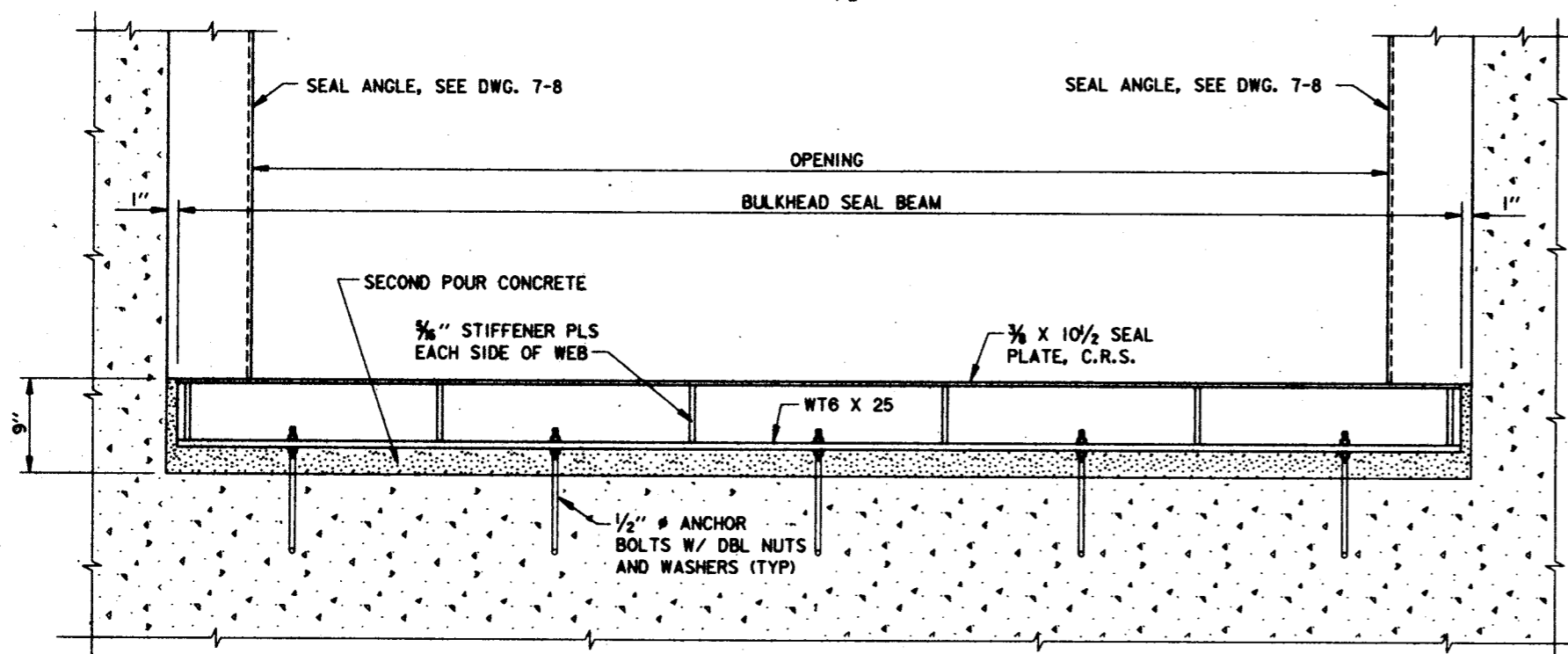

PROTECTED SIDE ELEVATION
BULKHEAD SEAL BEAM RECESS (EAST & WEST MONOLITHS)
SCALE: 1 1/2" = 1' - 0"

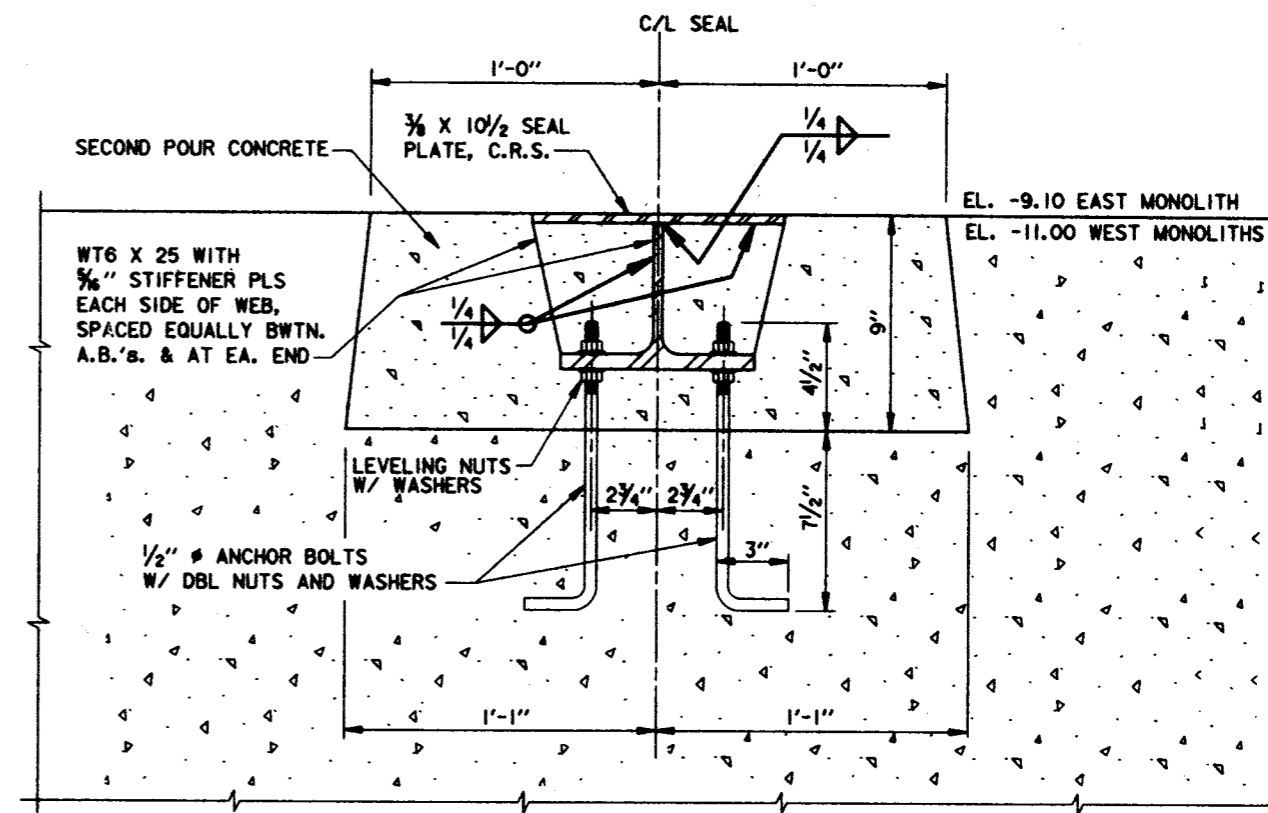

SECTION A
BULKHEAD SEAL BEAM DETAIL
SCALE: 3" = 1' - 0"

NOTE
FOR BULKHEAD SLOT DETAILS, SEE DWG. 7-8.

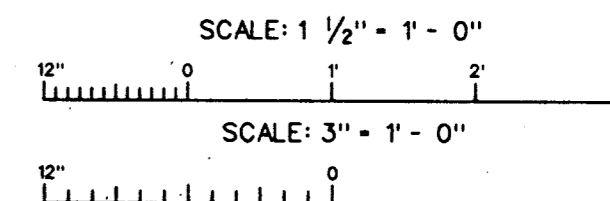

SYMBOL	DESCRIPTION	DATE	APPROVED
REVISIONS			
U.S. ARMY ENGINEER DISTRICT, NEW ORLEANS CORPS OF ENGINEERS NEW ORLEANS, LOUISIANA			
URS CONSULTANTS, INC. LAKE PONTCHARTRAIN, LA. AND VICINITY HURRICANE PROTECTION HIGH LEVEL PLAN FRONTING PROTECTION AT PUMP STATION #6 ORLEANS PARISH - JEFFERSON PARISH 17th STREET OUTFALL CANAL (METABIE RELIEF)			
BULKHEAD SEAL BEAM DETAILS			
DESIGNED BY: S.C.B.	DATE: SEPT. 1997	PLOT SCALE: 1	PLOT DATE: SEPT. 1997
DRAWN BY: K.L.L.	CHECKED BY: M.F.L.	CADD FILE: P99-7-05.BIN	FILE NO. H-4-44654
SUBMITTED BY:	SOLICITATION NO. DACW29-98-B-0112	DWG. 7-9 OF 10	

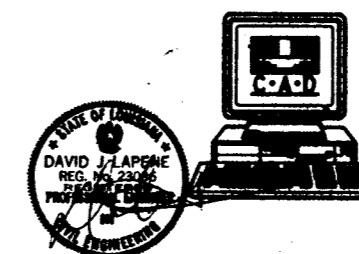

**Safety is a Part
of Your Contract**

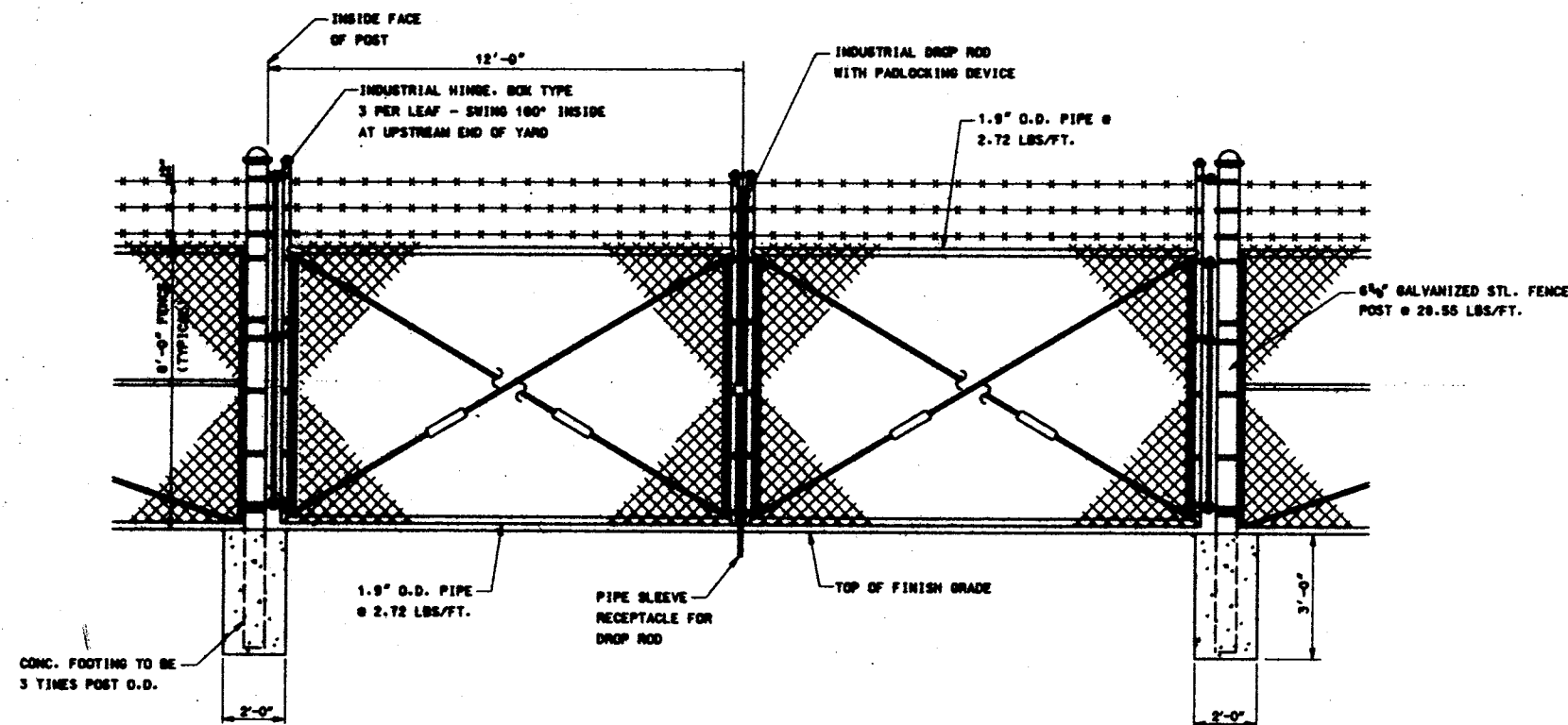

DOUBLE SWING GATE DETAILS
N.T.S.

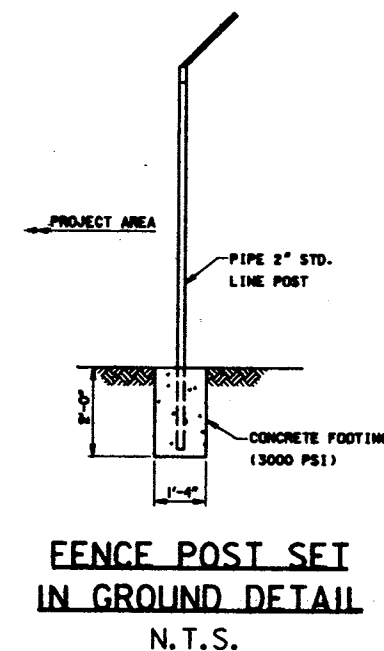

**FENCE POST SET
IN GROUND DETAIL**
N.T.S.

- NOTE:**
- DAMAGE TO PAVEMENT CAUSED BY CONTRACTORS OPERATIONS SHALL BE REMOVED AND REPLACED BY THE CONTRACTOR. PAYMENT FOR PAVEMENT RESTORATION SHALL BE MADE BY THE SQUARE YARD.
 - IF PAVEMENT DAMAGE IS LESS THAN 2' FROM EDGE OF PAVEMENT, CUT TO THE EDGE OF PAVEMENT. REMOVE ALL PAVEMENT FROM WITHIN THE STRIPS AND INCLUDE IN THE PAY WIDTH.
 - CONTRACTOR SHALL BACKFILL WITH BASE MATERIAL AND 4" OF ASPHALT BINDER COURSE TO EXISTING GRADE AND MAINTAIN AREA AS A RIDING SURFACE FOR A MINIMUM OF ONE MONTH OR AS DIRECTED BY THE CONTRACTING OFFICER. ASPHALT BINDER MATERIAL SHALL BE REMOVED FROM TRENCH AND EXPOSED SURFACE MECHANICALLY COMPACTED TO REQUIRED COMPACTION PRIOR TO PERMANENT ASPHALT PLACEMENT.
 - WEARING COURSE MIX MAY BE USED AS A BINDER BUT NOT VISE-VERSA.
 - SAW CUTTING USING A CONCRETE CUTTING TYPE SAW TO MAKE A TRUE STRAIGHT LINE TO A MINIMUM DEPTH OF ONE (1) INCH SHALL BE REQUIRED ALONG THE ENTIRE LIMITS OF THE AFFECTED AREA OF REMOVAL UNLESS OTHER METHODS ARE APPROVED BY CONTRACTING OFFICER.
 - JOB MIX FORMULA (PER LA. D.D.T.O. STANDARDS)
 - ALL CONSTRUCTION MATERIALS, PROCEDURES, TESTING FINISHING, ETC. SHALL CONFORM TO THE LOUISIANA STANDARD SPECIFICATIONS FOR ROADS AND BRIDGES (DOTD) LATEST EDITION. DEVIATIONS FROM THESE SPECIFICATIONS SHALL HAVE TO BE APPROVED BY THE CONTRACTING OFFICER.

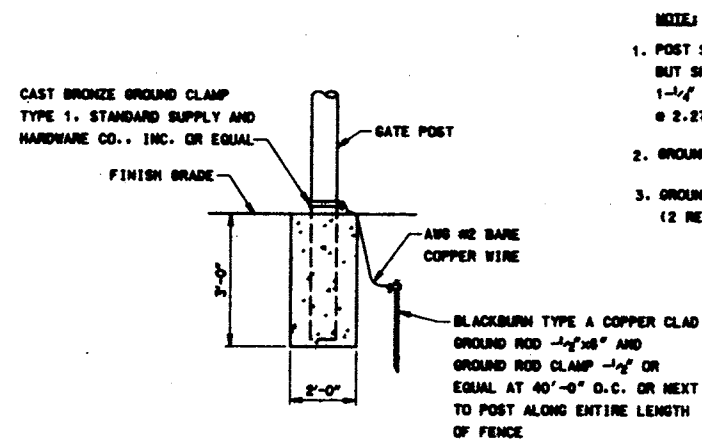

GROUND LINE POST DETAIL
N.T.S.

- NOTE:**
- POST SPACING SHALL BE EQUIDISTANT BUT SHOULD NOT EXCEED 10'-0" O.C. 1-1/2" STD. PIPE IS 1.66" O.D. @ 2.27 LBS/FT.. EXCEPT AS NOTED.
 - GROUND LINE POST EVERY 40' (MAX.)
 - GROUND ALL END GATE POST. (2 REQUIRED AT EACH DOUBLE GATE)

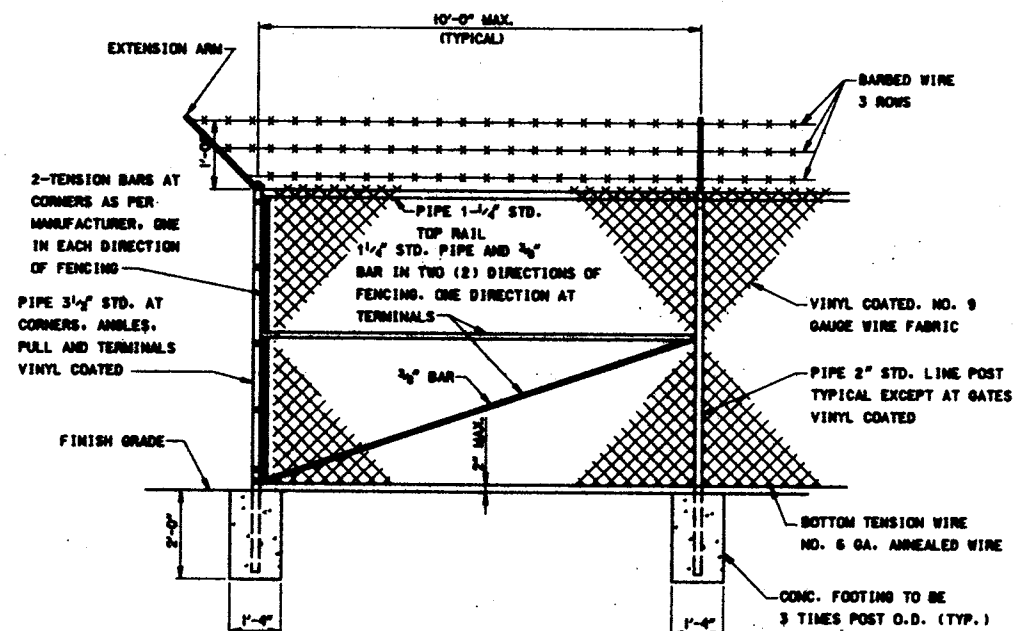

**TYPICAL FENCE DETAILS
CORNER AND LINE POST**
N.T.S.

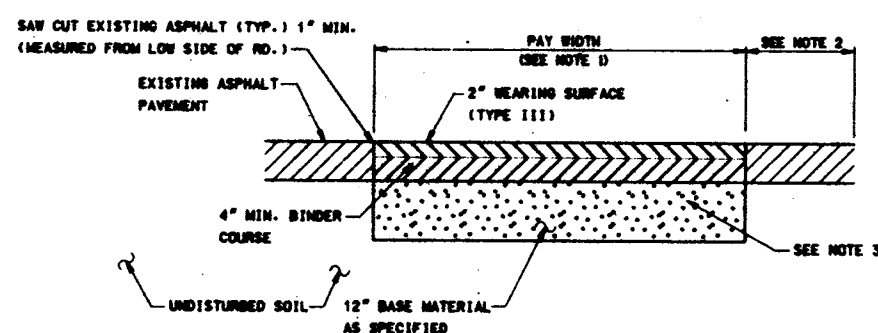

ASPHALT REPLACEMENT DETAIL
N.T.S.

SYMBOL	DESCRIPTION	DATE	APPROVED
REVISIONS			
 U.S. ARMY ENGINEER DISTRICT, NEW ORLEANS CORPS OF ENGINEERS NEW ORLEANS, LOUISIANA			
URS CONSULTANTS, INC. LAKE PONCHARTRAIN, LA. AND VICINITY HURRICANE PROTECTION HIGH LEVEL PLAN FRONTING PROTECTION AT PUMP STATION #8 ORLEANS PARISH - JEFFERSON PARISH 17th STREET OUTFALL CANAL (METAIRIE RELIEF)			
TYPICAL ROADWAY RESTORATION, GATE AND FENCE DETAILS			
DESIGNED BY: M.P.H.	DATE: SEPT. 1997	PLOT SCALE: 1	PLOT DATE: SEPT. 1997
DRAWN BY: S.M.M.	CAD FILE: P10-7-10.DWG		FILE NO. H-4-44654
CHECKED BY: M.D.P.	SOLICITATION NO. DACW29-98-B-0112		DWG-7-10 07-10



Safety is a Part
of Your Contract

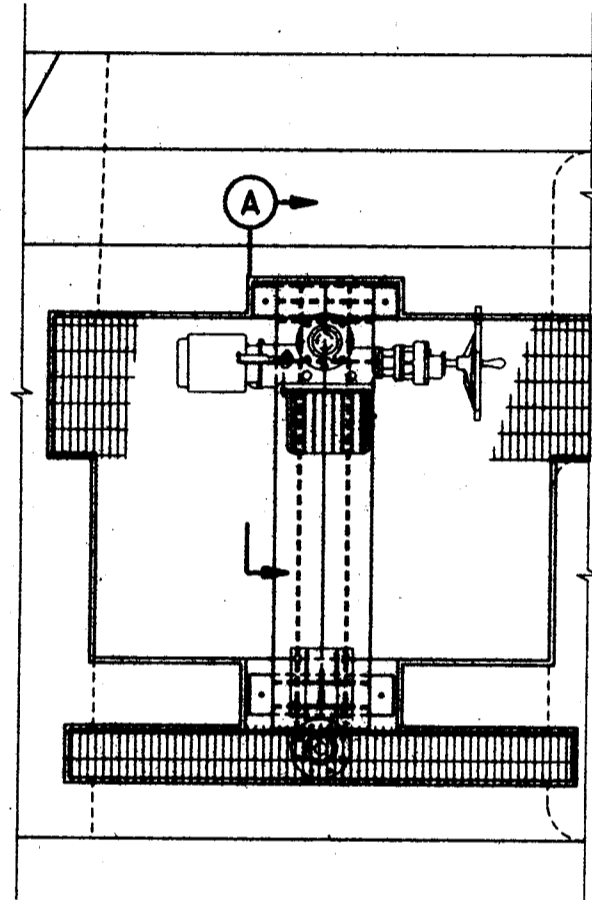

PLAN - SLUICE GATE
SCALE: 1/2" = 1'-0"

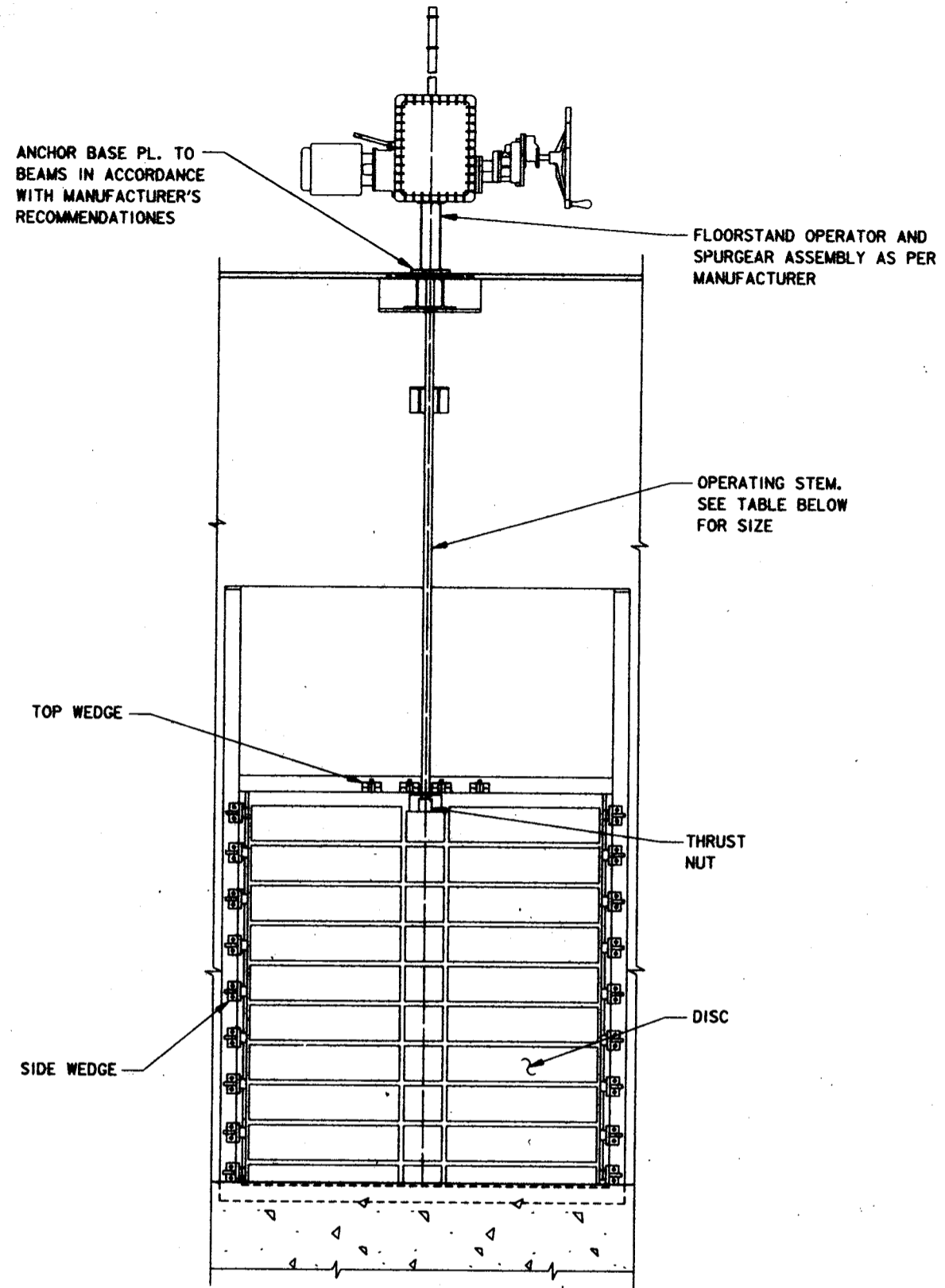

ELEVATION - SLUICE GATE
SCALE: 1/2" = 1'-0"

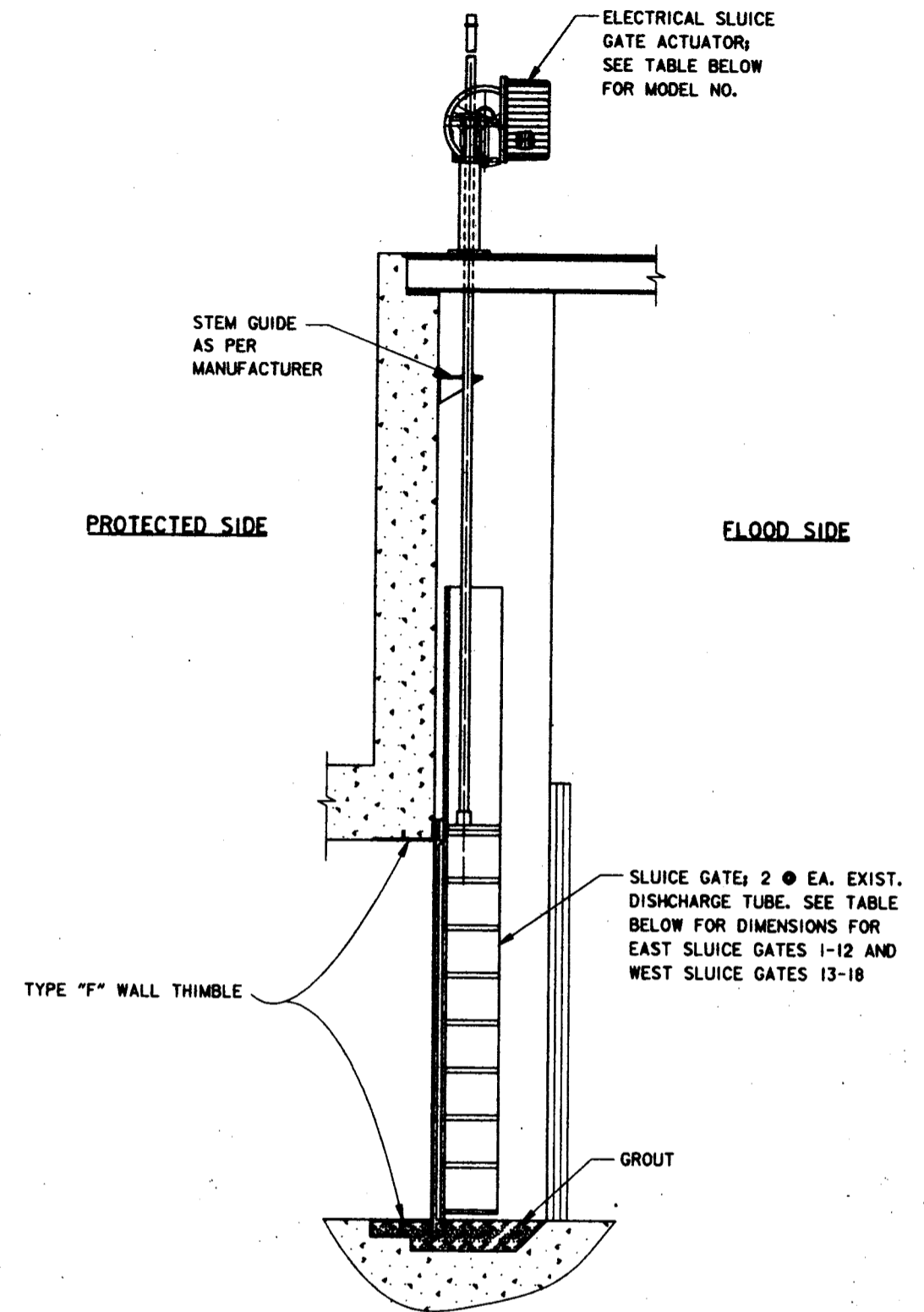

SECTION A
SCALE: 1/2" = 1'-0"

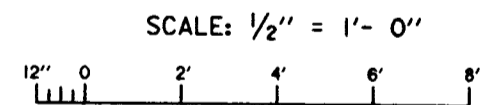

SLUICE GATE TABLE								
GATE NO.	GATE SIZE	STEM * SIZE	THREADS * PER INCH	LIMITORQUE * ACTUATOR MODEL NO.	HORSEPOWER*	RUNNING * TORQUE	MAXIMUM LOCKED * ROTOR TORQUE	MAXIMUM LOCKED ** ROTOR THRUST
1-3,6-8	114"x114"	4"	2	L-120/420/100	10	899' *	4249' *	111,816' *
4,5	108"x114"	4"	2	L-120/420/100	10	867' *	4249' *	111,816' *
9,12	108"x90"	3.5"	2	L-120/190/60	6	625' *	2980' *	87,648' *
10,11	102"x90"	3"	2.5	L-120/190/60	6	502' *	2980' *	102,759' *
13-18	144"x132"	4.5"	2	L-120-420/150	15	1551' *	8610' *	205,000' *

* VALUES SHOWN ARE AS PER RODNEY HUNT OR LIMITORQUE.
** MAXIMUM ALLOWABLE SERVICE LOAD ON MONOLITH.

SYMBOL	DESCRIPTION	DATE	APPROVED
REVISIONS U.S. ARMY ENGINEER DISTRICT, NEW ORLEANS CORPS OF ENGINEERS NEW ORLEANS, LOUISIANA URS CONSULTANTS, INC. LAKE PONTCHARTRAIN, LA. AND VICINITY HURRICANE PROTECTION HIGH LEVEL PLAN FRONTING PROTECTION AT PUMP STATION #6 ORLEANS PARISH - JEFFERSON PARISH 17th STREET OUTFALL CANAL (METAIRIE RELIEF)			
SLUICE GATE DETAILS			
DESIGNED BY: S.P.C.	DATE: SEPT. 1997	PLOT SCALE: 2	PLOT DATE: SEPT. 1997
DRAWN BY: B.M.M.	CADD FILE: P90-0-01-20H	FILE NO. H-4-44654	
CHECKED BY: D.J.L.	SOLICITATION NO. DACW29-98-B-0112	DWG. 8-1 OF 8-7	

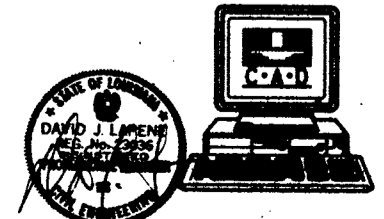

Safety is a Part of Your Contract

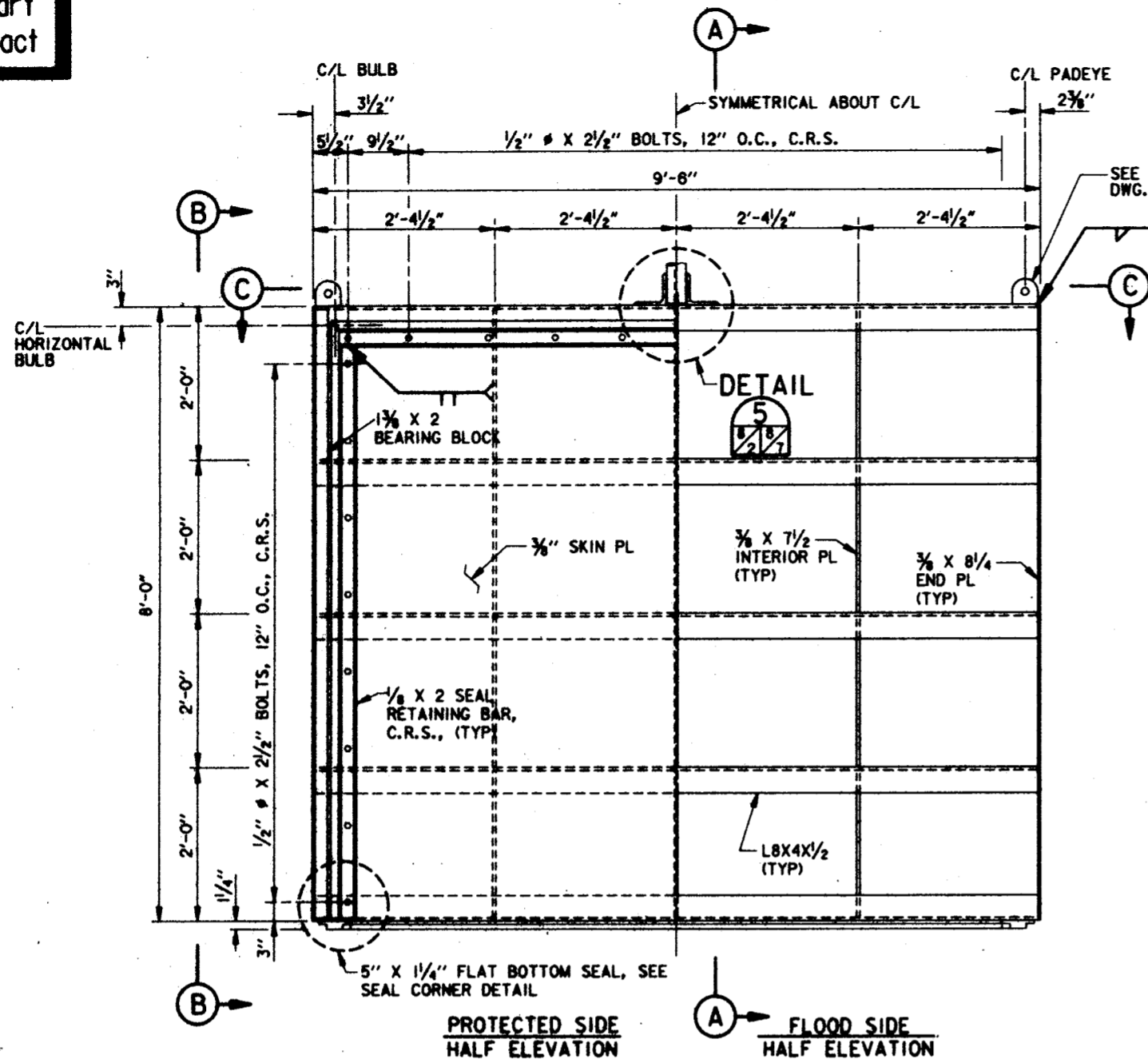

BULKHEAD ELEVATION
SCALE: 1" = 1'-0"
(ONE REQ'D. ● TUBE "A"; ONE REQ'D. ● TUBE "B")

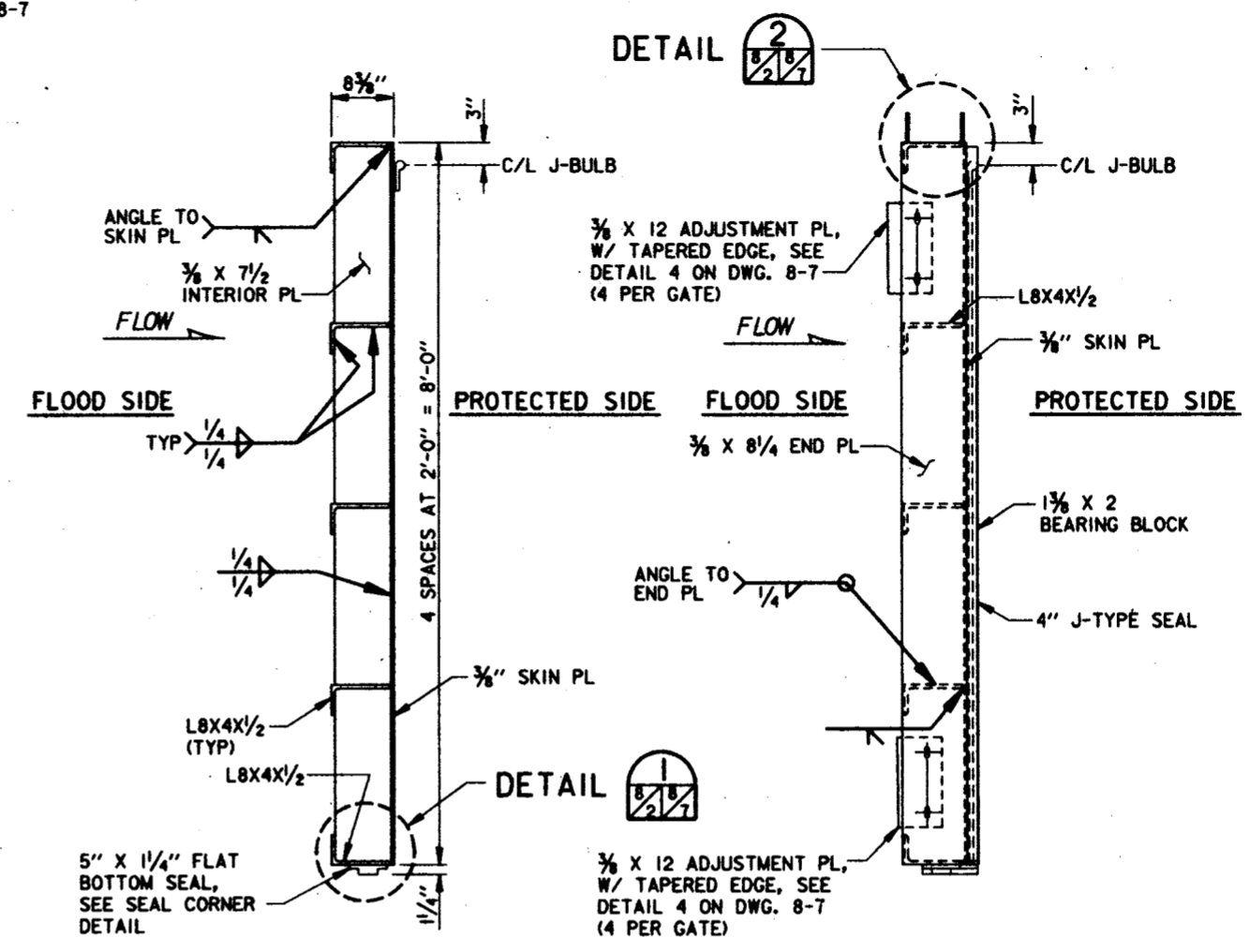

SECTION A SCALE: 1" = 1'-0"
SECTION B SCALE: 1" = 1'-0"

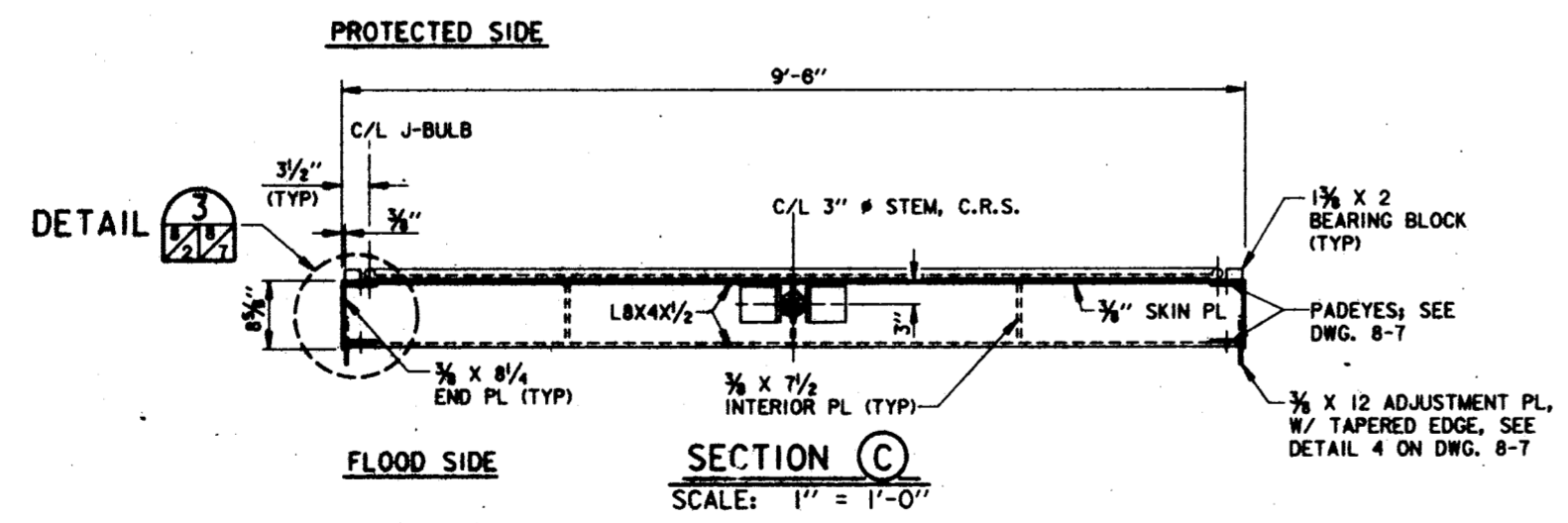

SECTION C
SCALE: 1" = 1'-0"

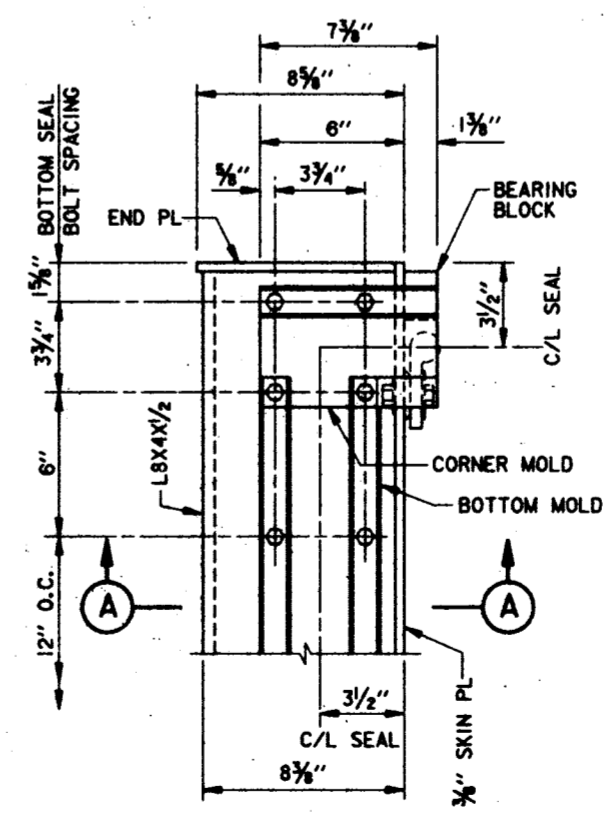

BOTTOM VIEW SEAL CORNER DETAIL
SCALE: 3" = 1'-0"

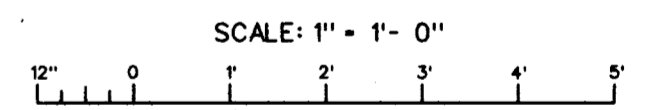

NOTE:
ALL MATERIAL FOR BULKHEADS TO BE ALUMINUM, UNLESS OTHERWISE NOTED.

SYMBOL	DESCRIPTION	DATE	APPROVED
REVISIONS			
U.S. ARMY ENGINEER DISTRICT, NEW ORLEANS CORPS OF ENGINEERS NEW ORLEANS, LOUISIANA URS CONSULTANTS, INC. LAKE PONCHARTRAIN, LA. AND VICINITY HURRICANE PROTECTION HIGH LEVEL PLAN FRONTING PROTECTION AT PUMP STATION #6 ORLEANS PARISH - JEFFERSON PARISH 17th STREET OUTFALL CANAL (BEFORE RELET)			
DESIGNED BY: M.F.L.	DATE: SEPT. 1997	PLOT SCALE: 12	PLOT DATE: SEPT. 1997
DRAWN BY: K.L.L.	CARD FILE: P99-0-0200	FILE NO. H-4-44654	
CHECKED BY: D.J.L.	SOLICITATION NO. DACW29-98-B-0112	DWG. 8-2 OF 8-7	

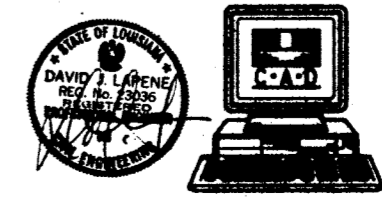

Safety is a Part of Your Contract

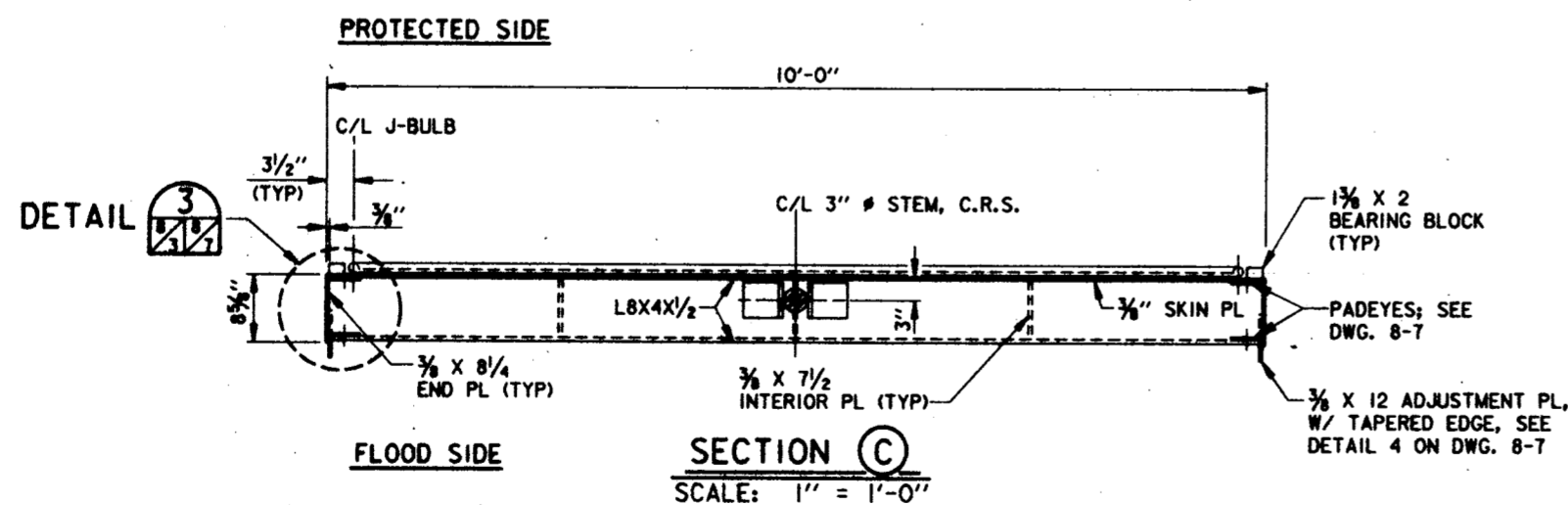
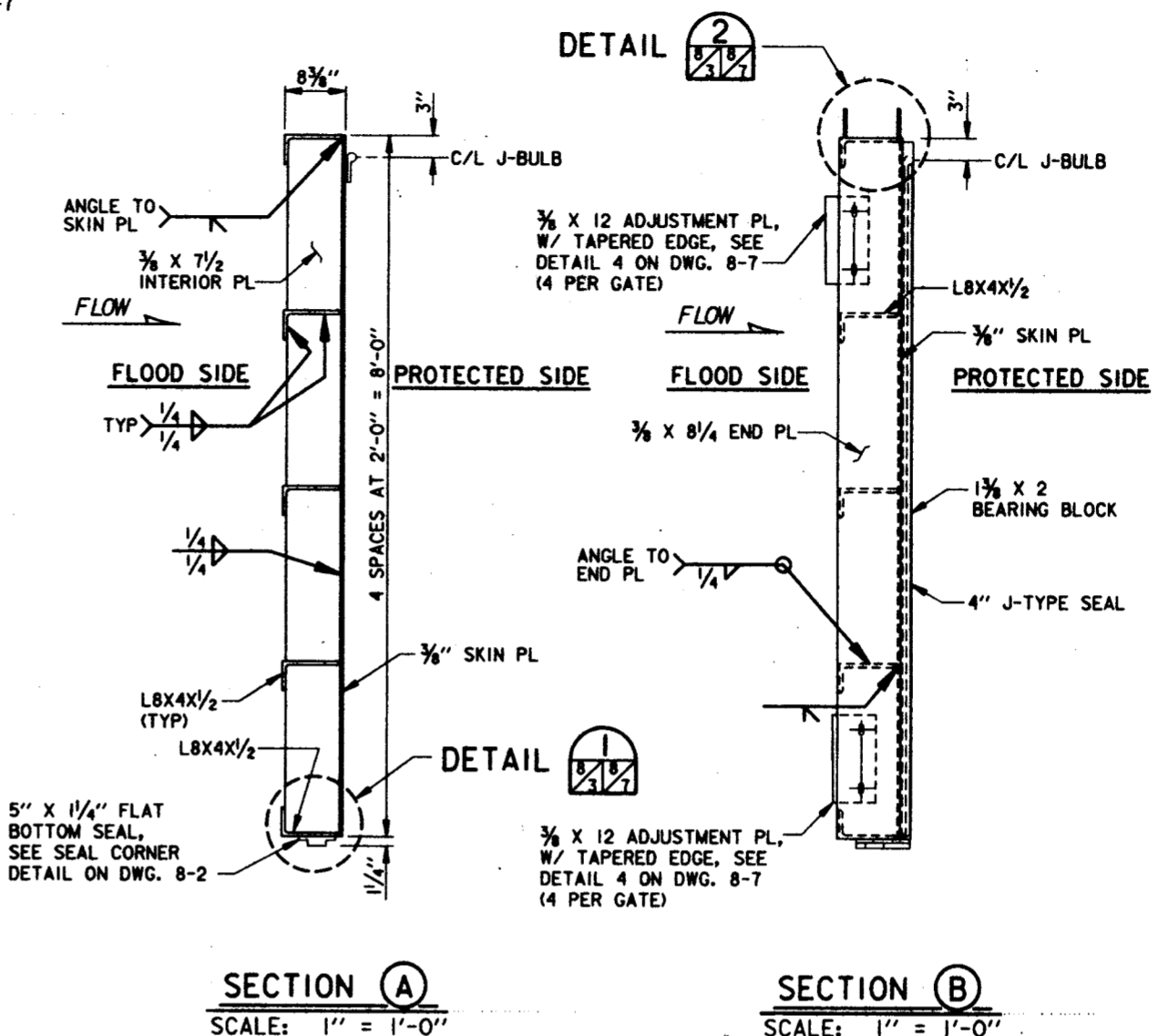
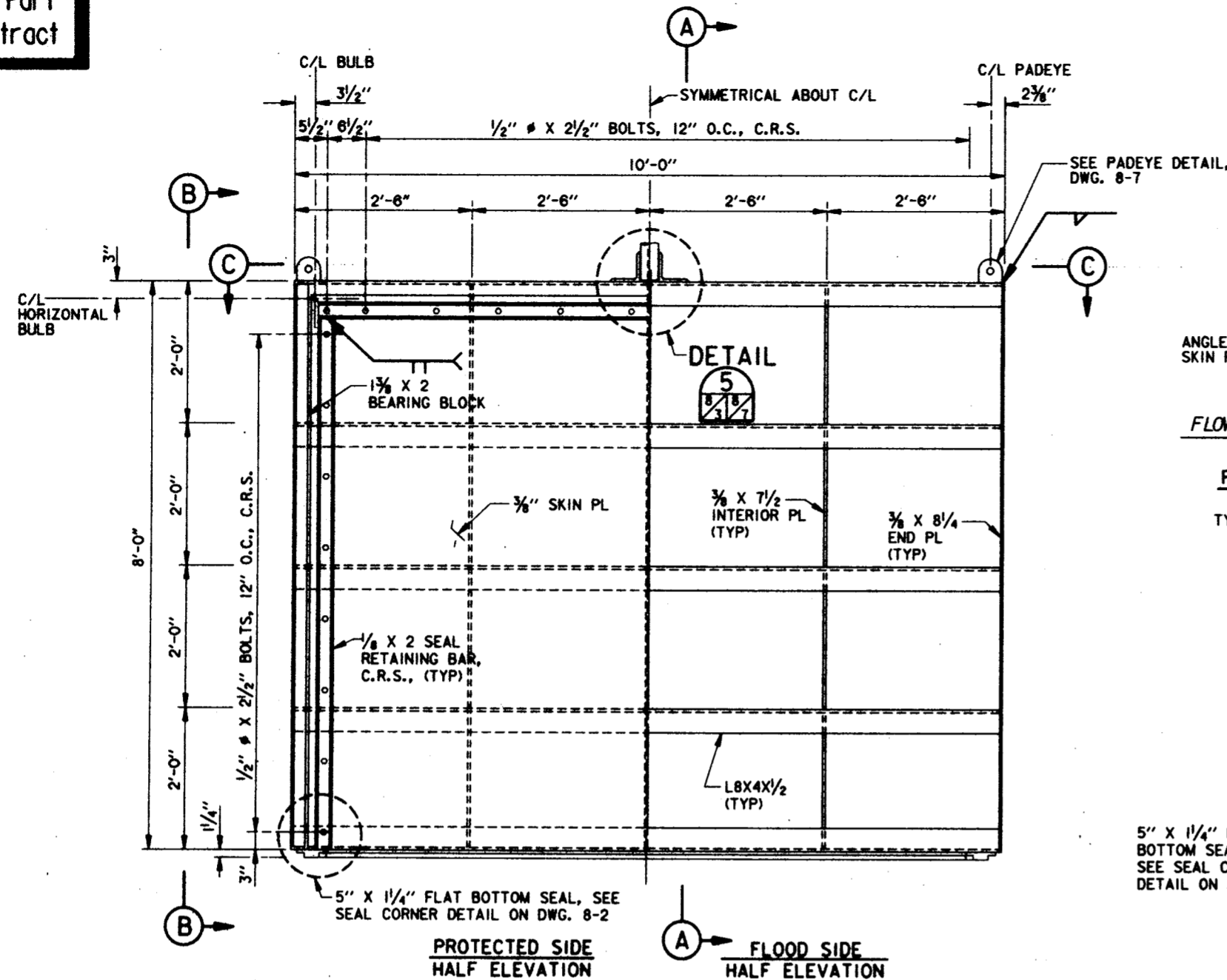

NOTE:
ALL MATERIAL FOR BULKHEADS TO BE ALUMINUM, UNLESS OTHERWISE NOTED.

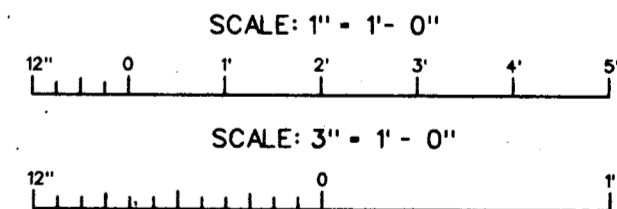

SYMBOL	DESCRIPTION	DATE	APPROVED
REVISIONS			
U.S. ARMY ENGINEER DISTRICT, NEW ORLEANS CORPS OF ENGINEERS NEW ORLEANS, LOUISIANA			
URS CONSULTANTS, INC. LAKE PONTCHARTRAIN, LA. AND VICINITY HURRICANE PROTECTION HIGH LEVEL PLAN FRONTING PROTECTION AT PUMP STATION #6 ORLEANS PARISH - JEFFERSON PARISH 17th STREET OUTFALL CANAL (METAIRIE BELLEVUE)			
BULKHEADS			
EAST MONOLITH			
DESIGNED BY: M.F.L.	DATE: SEPT. 1997	PLOT SCALE: 12	PLOT DATE: SEPT. 1997
DRAWN BY: K.L.L.	CADD FILE: P29-0-08.DWG	FILE NO. H-4-44654	
CHECKED BY: D.J.L.	SOLICITATION NO. DACW29-98-B-0112	DWG. 8-3 OF 8-7	
SUBMITTED BY:			

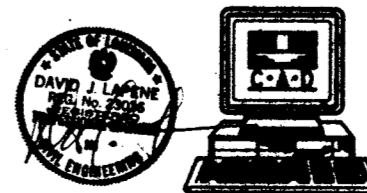

Safety is a Part of Your Contract

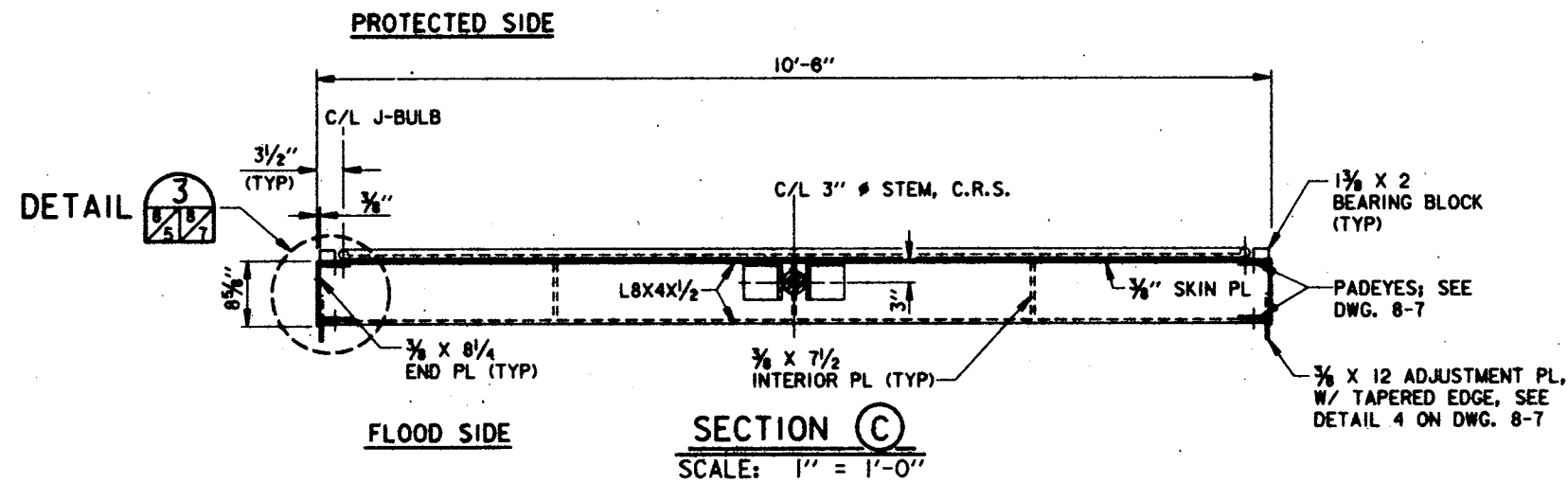
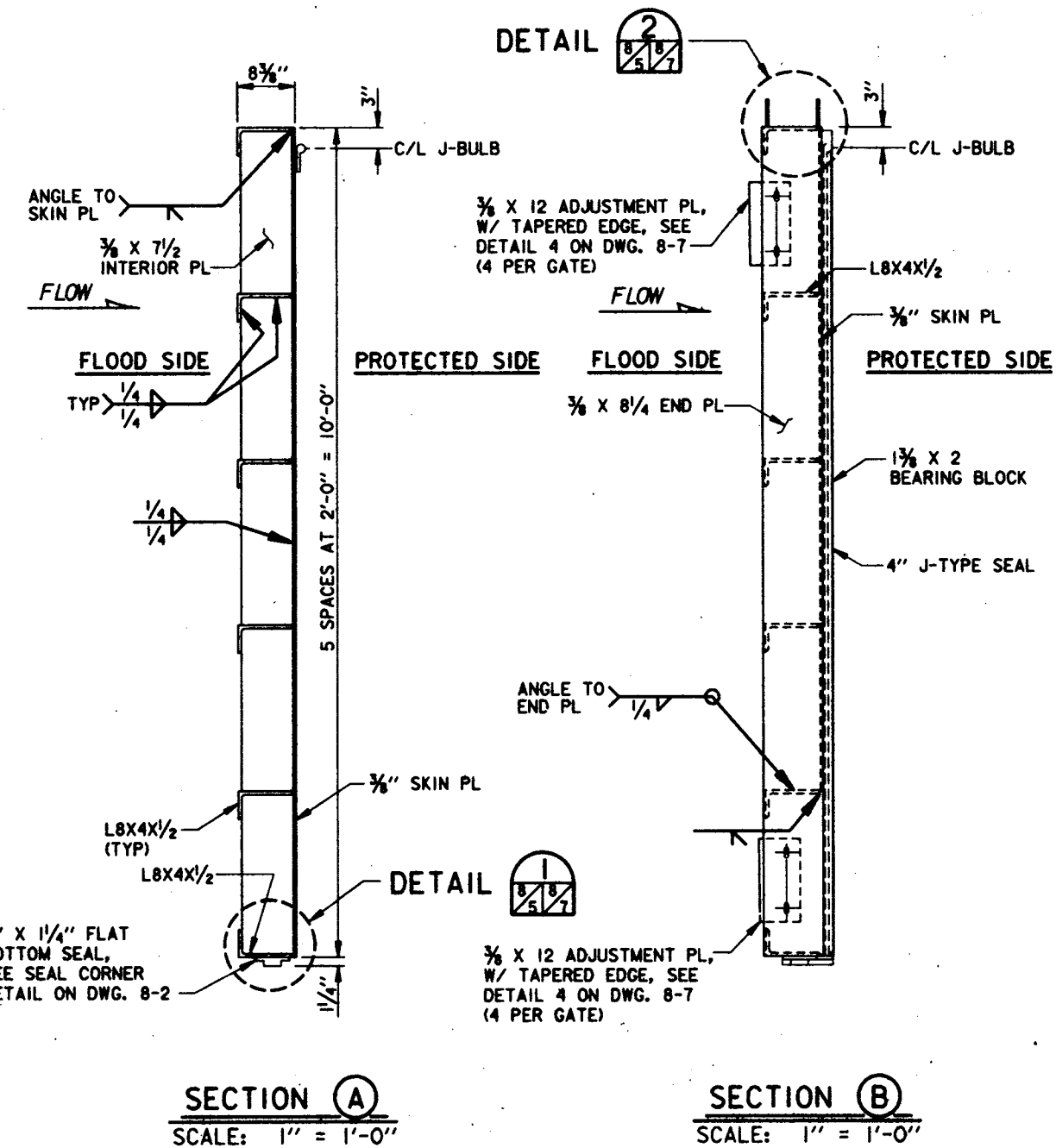
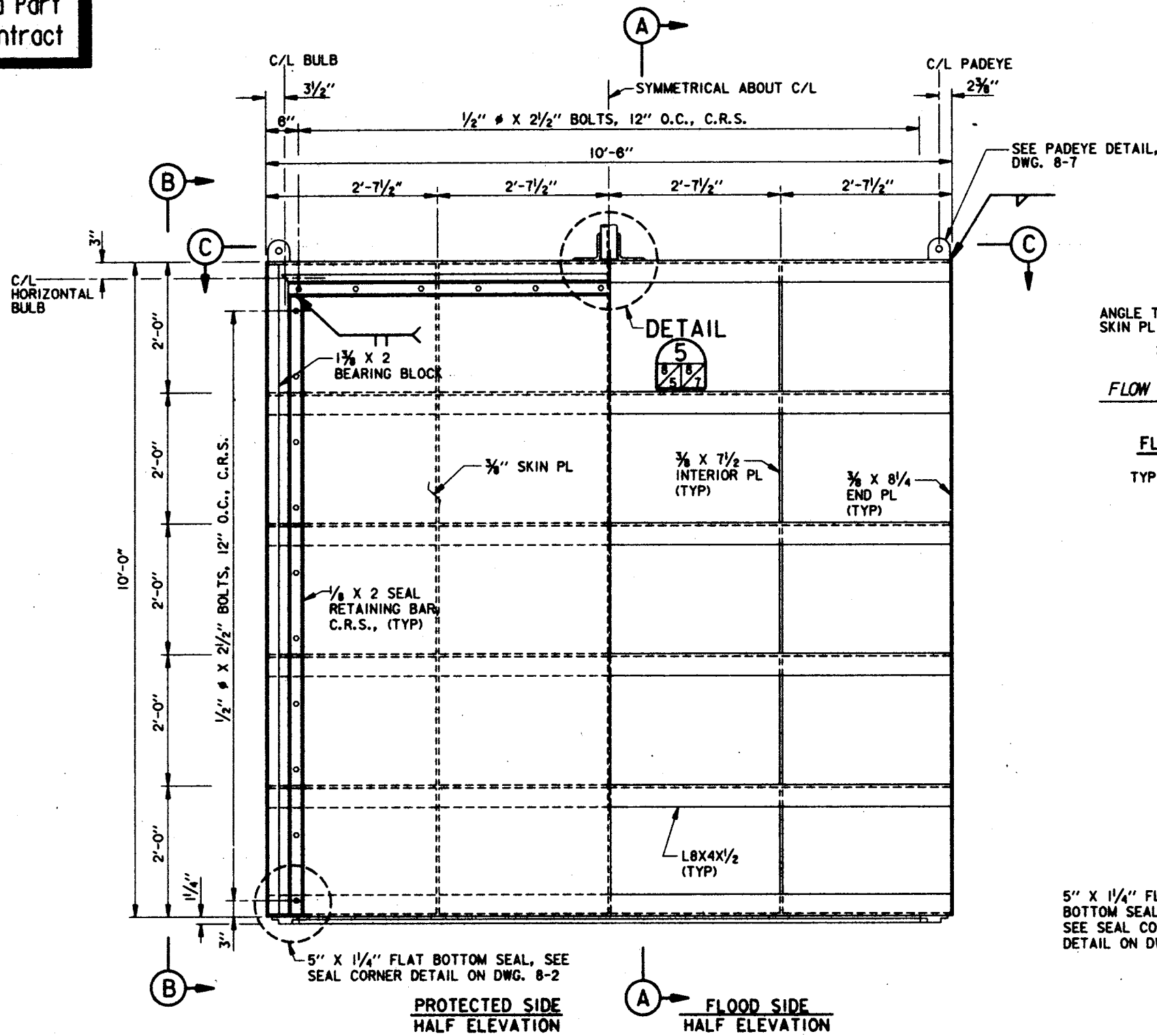

NOTE:
ALL MATERIAL FOR BULKHEADS TO BE ALUMINUM, UNLESS OTHERWISE NOTED.

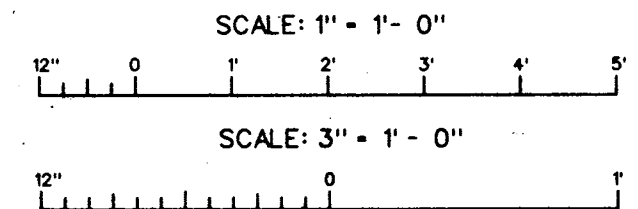

SYMBOL	DESCRIPTION	DATE	APPROVED
REVISIONS			
U.S. ARMY ENGINEER DISTRICT, NEW ORLEANS CORPS OF ENGINEERS NEW ORLEANS, LOUISIANA			
URS CONSULTANTS, INC.			
LAKE PONTCHARTRAIN, LA. AND VICINITY HURRICANE PROTECTION HIGH LEVEL PLAN FRONTING PROTECTION AT PUMP STATION #8 ORLEANS PARISH - JEFFERSON PARISH 17th STREET OUTFALL CANAL (BETAIRIE BELIEF)			
BULKHEADS EAST MONOLITH			
DESIGNED BY: M.F.L.	DATE: SEPT. 1997	PLOT SCALE: 12	PLOT DATE: SEPT. 1997
DRAWN BY: K.L.L.	CHECKED BY: D.J.L.	CAD FILE: P10-0-0100	FILE NO. H-4-44654
SUBMITTED BY:	SOLICITATION NO. DACW29-98-B-0112	DWG. 8-5 OF 8-7	

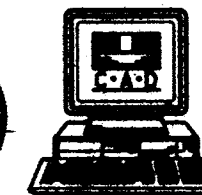
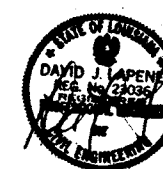

Safety is a Part of Your Contract

C/L 1" X 1/2" SLOTTED HOLE FOR 3/8" X 3" BOLT, C.R.S., (THREADS EXCLUDED FROM SHEAR PLANE)

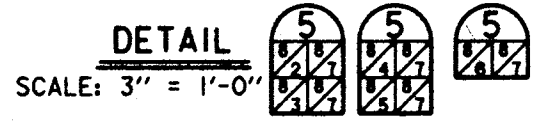
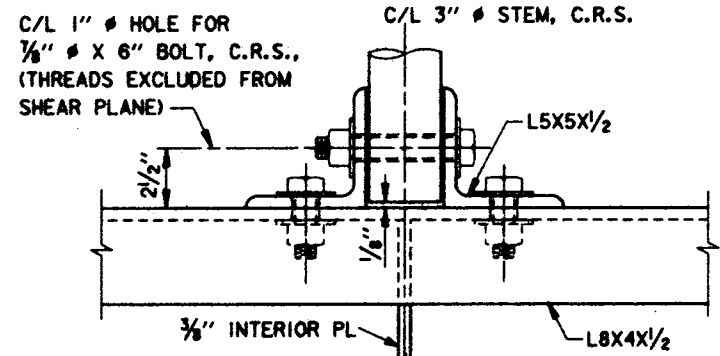
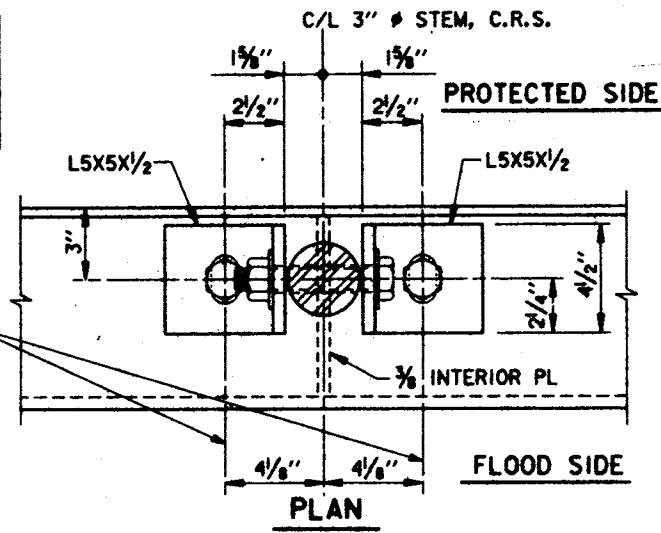
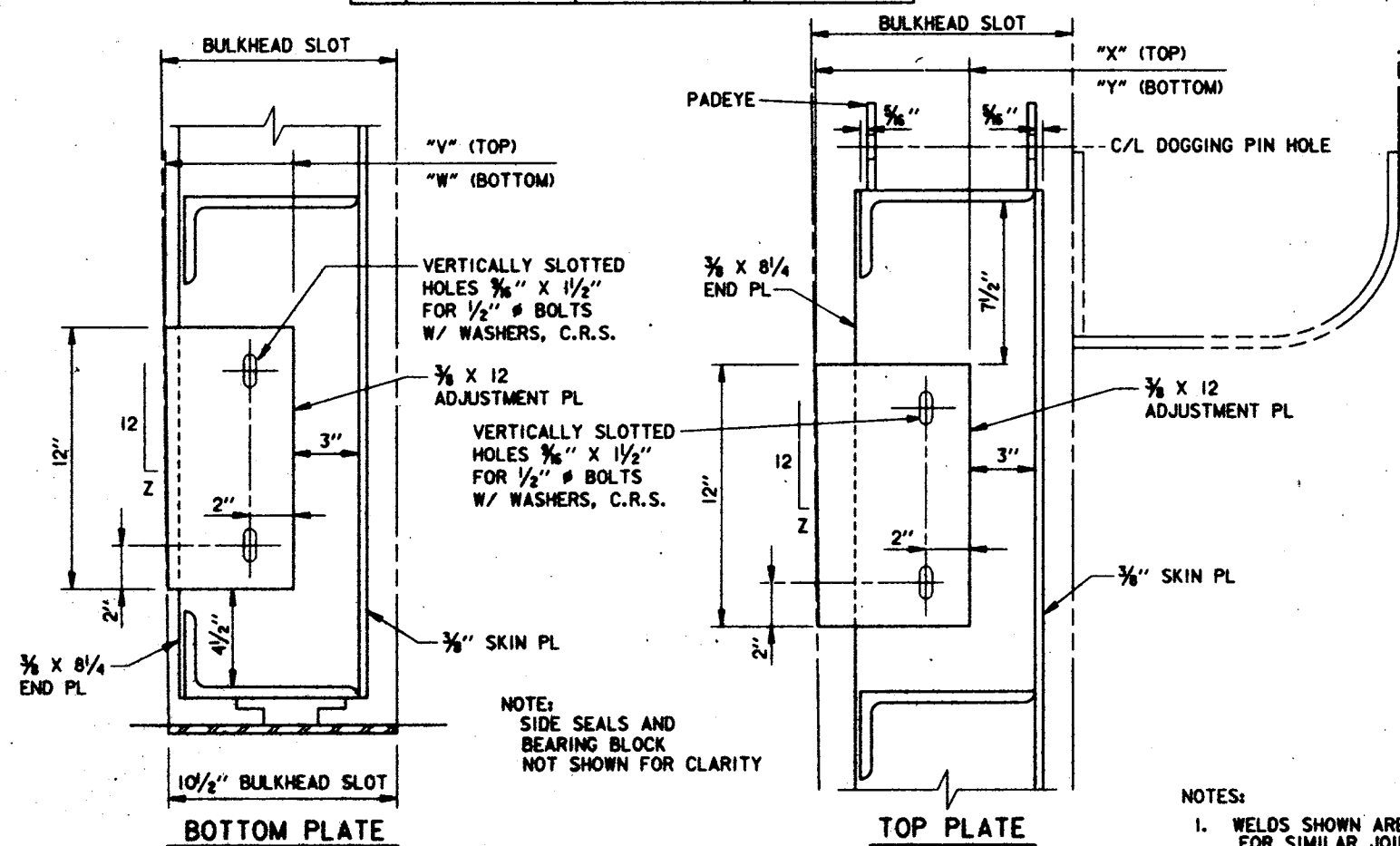
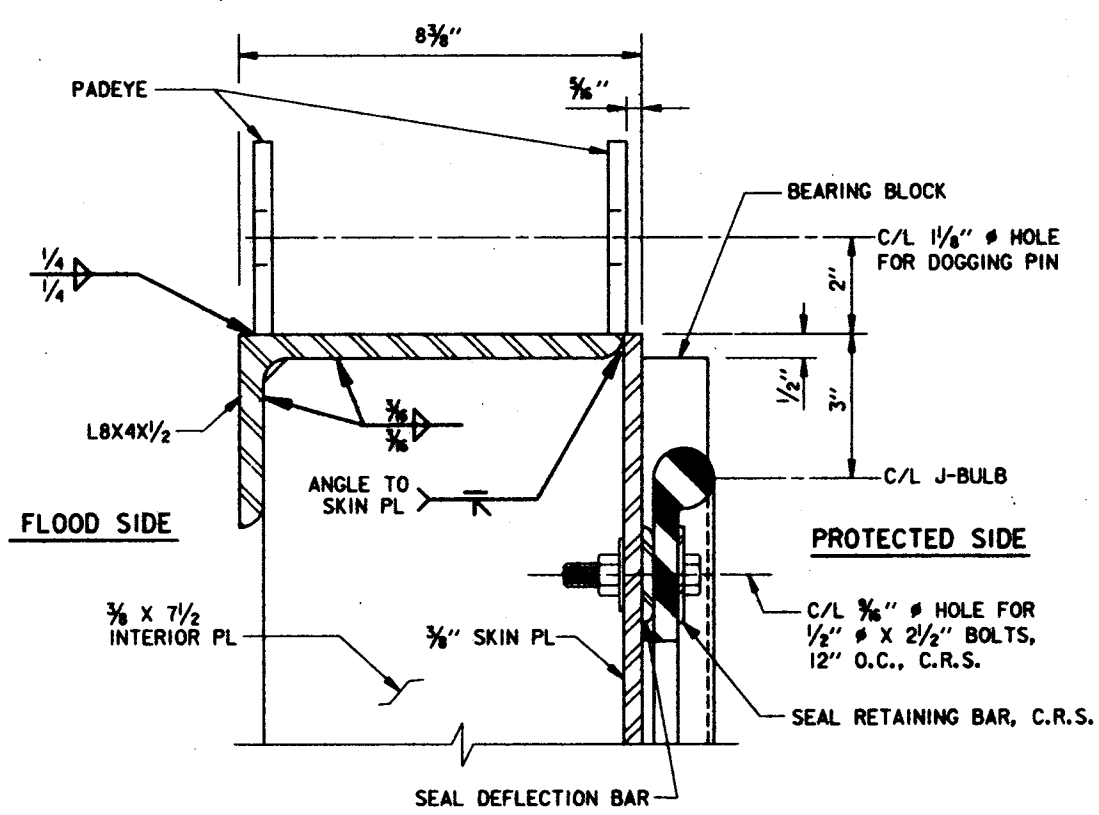

TABLE - ADJUSTMENT PLATE DIMENSIONS

	EAST MONOLITH GATES A & B	EAST MONOLITH GATES C - F	WEST MONOLITH GATES G - I
"V"	6.143"	6.094"	6.065"
"W"	5.967"	5.951"	5.940"
"X"	7.188"	7.224"	7.242"
"Y"	7.011"	7.081"	7.117"
"Z"	0.177"	0.143"	0.125"



ADJUSTMENT PLATE DETAIL
SCALE: 3" = 1'-0"



DETAIL
SCALE: 6" = 1'-0"

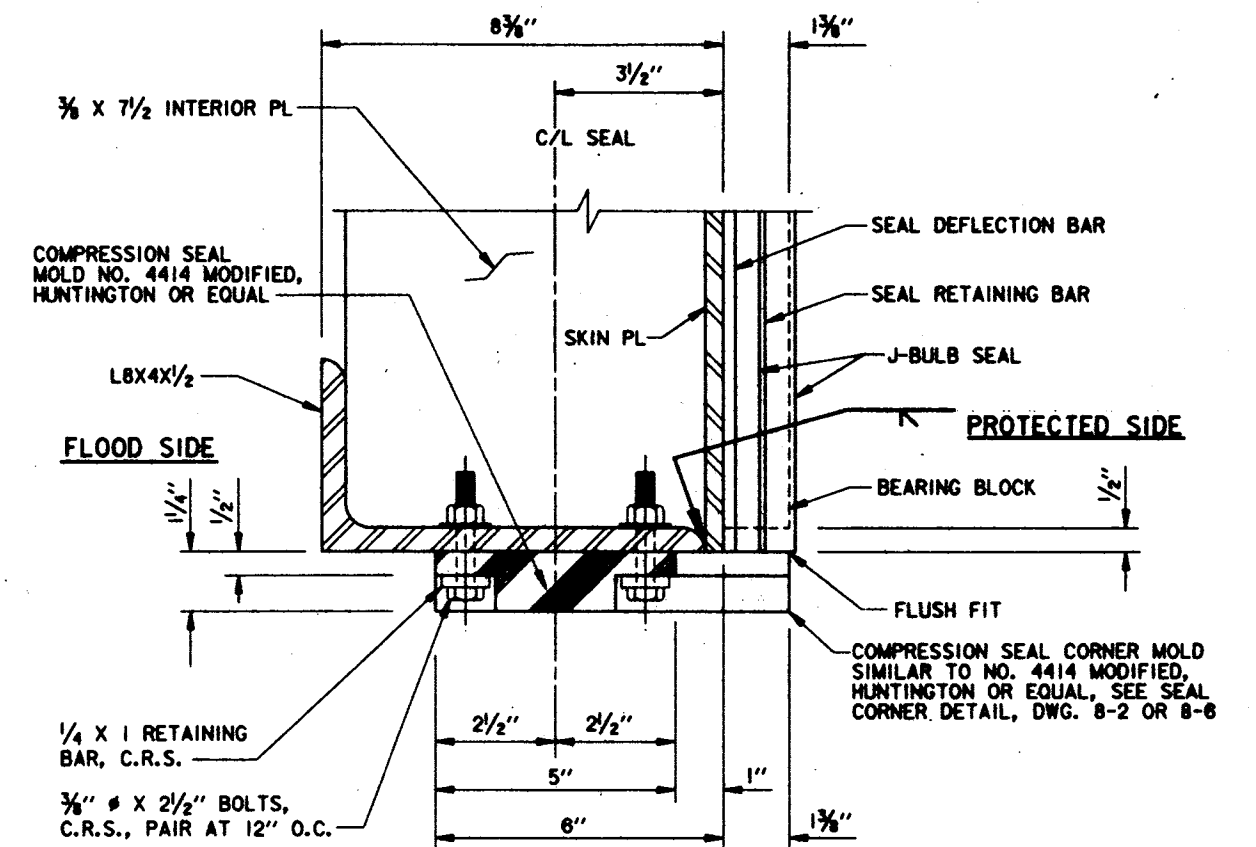
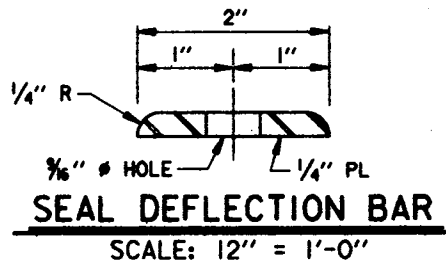
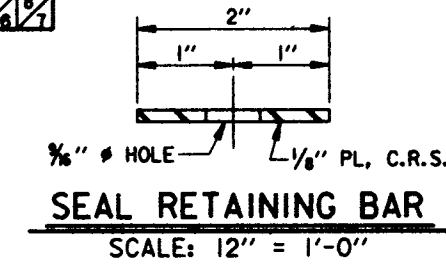

DETAIL
SCALE: 6" = 1'-0"

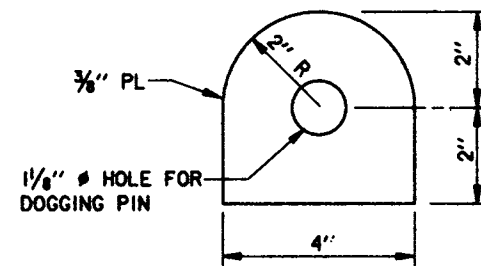

PADEYE DETAIL
SCALE: 6" = 1'-0"

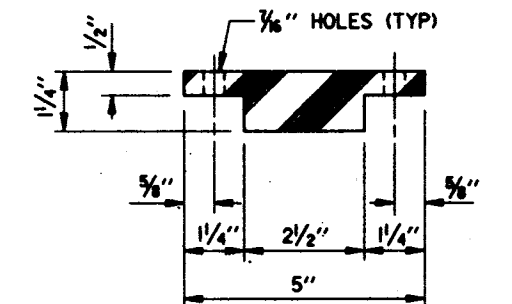

MOLD NO. 4414 MODIFIED
SCALE: 6" = 1'-0"

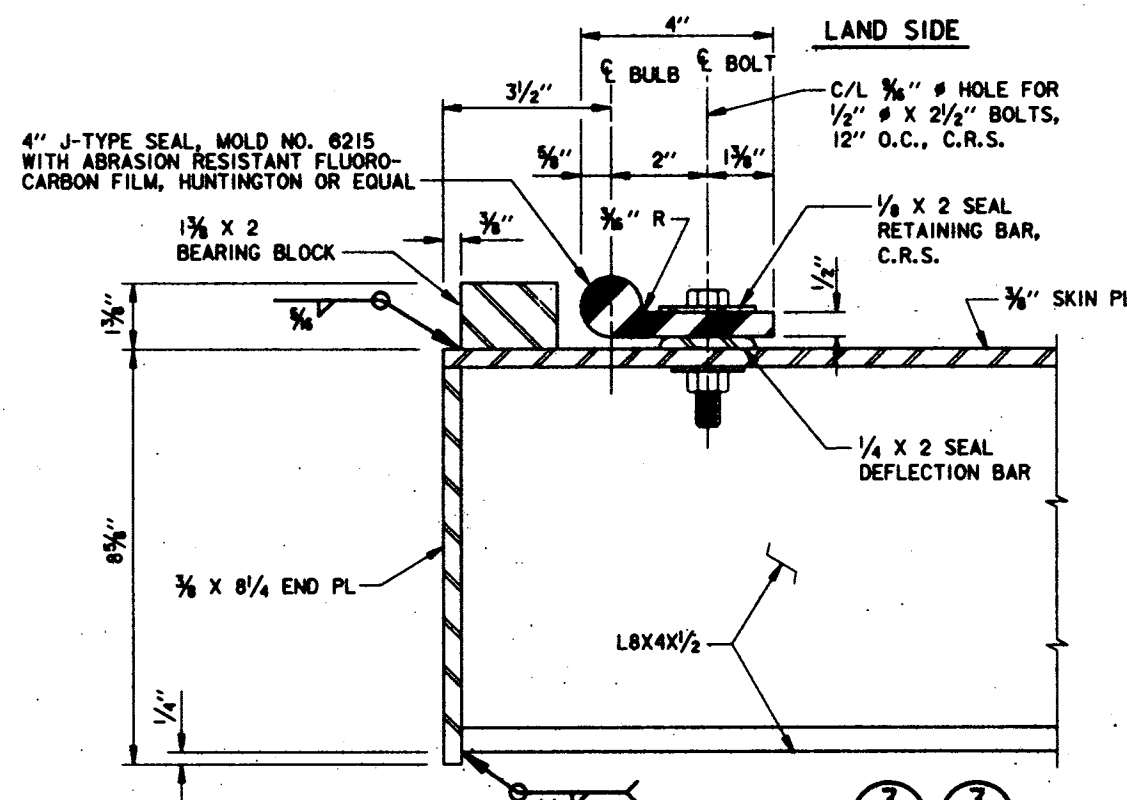

DETAIL
SCALE: 6" = 1'-0"

- NOTES:
1. WELDS SHOWN ARE TYPICAL FOR SIMILAR JOINTS.
 2. ALL MATERIAL FOR BULKHEADS SHALL BE ALUMINIUM, UNLESS OTHERWISE NOTED.

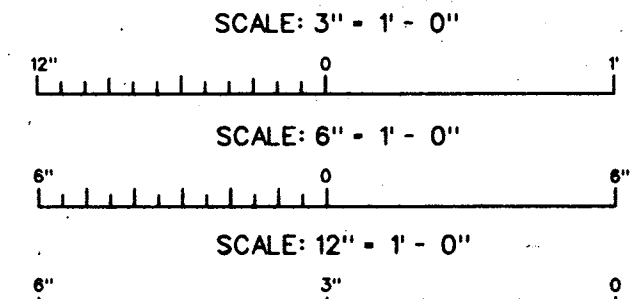

SYMBOL	DESCRIPTION	DATE	APPROVED
REVISIONS			
U.S. ARMY ENGINEER DISTRICT, NEW ORLEANS CORPS OF ENGINEERS NEW ORLEANS, LOUISIANA			
URS CONSULTANTS, INC. LAKE PONTCHARTRAIN, LA. AND VICINITY HURRICANE PROTECTION HIGH LEVEL PLAN FRONTING PROTECTION AT PUMP STATION #8 ORLEANS PARISH - JEFFERSON PARISH 17th STREET OUTFALL CANAL (METABIE RELIEF)			
BULKHEADS - EAST & WEST MONOLITH ; MISCELLANEOUS DETAILS			
DESIGNED BY: M.F.L.	DATE: PLOT SCALE:	PLOT DATE:	
DRAWN BY: K.L.L.	SEPT. 12	SEPT. 1997	
CHECKED BY: D.J.L.	FILE NO. H-4-44654		
SUBMITTED BY:	SOLICITATION NO. DACW29-98-B-0112	DWG. 8-7 OF 8-7	

Safety is a Part of Your Contract

FIXTURE SCHEDULE

- F1 INCANDESCENT VAPORTITE, CAST ALUMINUM FIXTURE BODY, CLEAR TEMPERED GLASS GLOBE, CAST ALUMINUM GUARD, STANCHION MOUNT, UL WET LOCATION LISTED, 120 VOLT LAMP-150 WATT A-21
HUBBELL CAT * VS-150
- F2 HID FLOODLIGHT, HORIZONTAL LAMP, 7x6 NEMA BEAM DISTRIBUTION, HIGH POWER FACTOR BALLAST, HUBBELL CAT. * 4024HD SLIPFITTER FITTING, QUAD TAP 120/208/240/277 VOLTAGE, LAMP-MS400/HOR
HUBBELL CAT* MHS-400H-268

SYMBOL		DESCRIPTION	SYMBOL		DESCRIPTION
CEILING	WALL		CEILING	WALL	
		FLUORESCENT LIGHT FIXTURE. LETTER DENOTES FIXTURE TYPE. SEE FIXTURE SCHEDULE.			FUSE.
		FLUORESCENT LIGHT FIXTURE ON EMERGENCY CIRCUIT			NORMALLY OPEN CONTACT.
		HID OR INCANDESCENT LIGHT FIXTURE. SEE FIXTURE SCHEDULE.			NORMALLY CLOSED CONTACT
		SINGLE-POLE TOGGLE SWITCH.			JUNCTION BOX WITH FIXTURE WHIP
		TOGGLE SWITCH WITH PILOT LIGHT.			JUNCTION BOX
		DUPLEX OUTLET, 15 AMP, 125V., NEMA 5-15R.			EXTEND EXISTING CONDUIT WITH NEW CONDUIT
		DUPLEX OUTLET WITH WEATHERPROOF COVER.			WIRING (IN CONDUIT) CONCEALED UNDER FLOOR SLAB OR UNDERGROUND
		GROUND FAULT CIRCUIT INTERRUPTER DUPLEX OUTLET.			WIRING (IN CONDUIT) CONCEALED IN CEILING OR WALL
		QUADRAPLEX (2-15A., 125-VOLT, NEMA 5-15R MOUNTED IN ONE BOX.)			WIRING (IN CONDUIT) RUN EXPOSED
		GROUND CONNECTION.			EXISTING
		BRANCH CIRCUIT PANELBOARD.			EXISTING TO BE REMOVED
		DISTRIBUTION PANELBOARD.			WIRING (IN CONDUIT) RUN UNDER GROUND
		MANUAL MOTOR STARTING SWITCH.			CIRCUIT TURNED UP
		DISCONNECT SWITCH. FUSED UNLESS OTHERWISE NOTED.			CIRCUIT TURNED DOWN
		MAGNETIC MOTOR STARTER. (SUPPLIED UNDER DIVISION 15000)			OUTDOOR AERIAL CONDUCTORS
		COMBINATION STARTER/DISCONNECT SWITCH FUSED UNLESS OTHERWISE NOTED		A	AMP
		TERMINAL CABINET		V	VOLT
		HANDHOLE		W	WIRE
		LADDER CABLE TRAY		P	POLE
		PULLBOX OR TROUGH		C	CONDUIT
		MOTOR, SINGLE-PHASE, NUMERAL DENOTES HORSEPOWER.		GD	GROUND
		MOTOR, THREE PHASE. NUMERAL DENOTES HORSEPOWER.		C/B	CIRCUIT BREAKER
		CIRCUIT BREAKER DEVICE		AC	AIR CONDITION
		SWITCH DEVICE.		AFF	ABOVE FINISHED FLOOR
				WH	WATER HEATER
				GF1	GROUND FAULT INTERRUPTER
				◇	NOTE REFERENCE
					HOMERUN TO PANELBOARD WITH NOMENCLATURE (LETTERS), CIRCUIT NUMBERS (NUMBERS), NUMBER OF PHASE AND NEUTRAL CONDUCTORS WHEN MORE THAN TWO (HASH MARKS), OPPOSITE SLANT DENOTES GROUND, NUMBER OF CIRCUITS (NUMBER OF ARROWS).

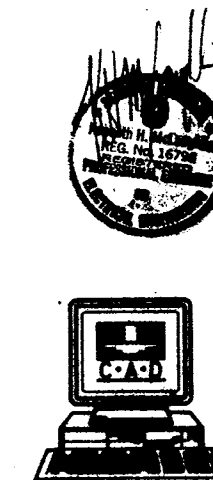

SYMBOL	DESCRIPTION	DATE	APPROVED
REVISIONS			
U.S. ARMY ENGINEER DISTRICT, NEW ORLEANS CORPS OF ENGINEERS NEW ORLEANS, LOUISIANA			
IMC CONSULTING ENGINEERS LAKE PONTCHARTRAIN, LA. AND VICINITY HURRICANE PROTECTION HIGH LEVEL PLAN FRONTING PROTECTION AT PUMP STATION #8 ORLEANS PARISH - JEFFERSON PARISH 17th STREET OUTFALL CANAL (METAIRIE RELIEF)			
SYMBOL LEGEND, FIXTURE SCHEDULE, GENERAL NOTES			
DESIGNED BY: R.E.H.	DATE: SEPT. 1997	PLOT SCALE: 4	PLOT DATE: SEPT. 1997
DRAWN BY: B.D.	CADD FILE: P80-9-01.B01	FILE NO. H-4-44654	
CHECKED BY: R.E.H.	SOLICITATION NO. DACW29-88-B-0112	DWG. 9-1	OF 9-10
SUBMITTED BY:			

Safety is a Part
of Your Contract

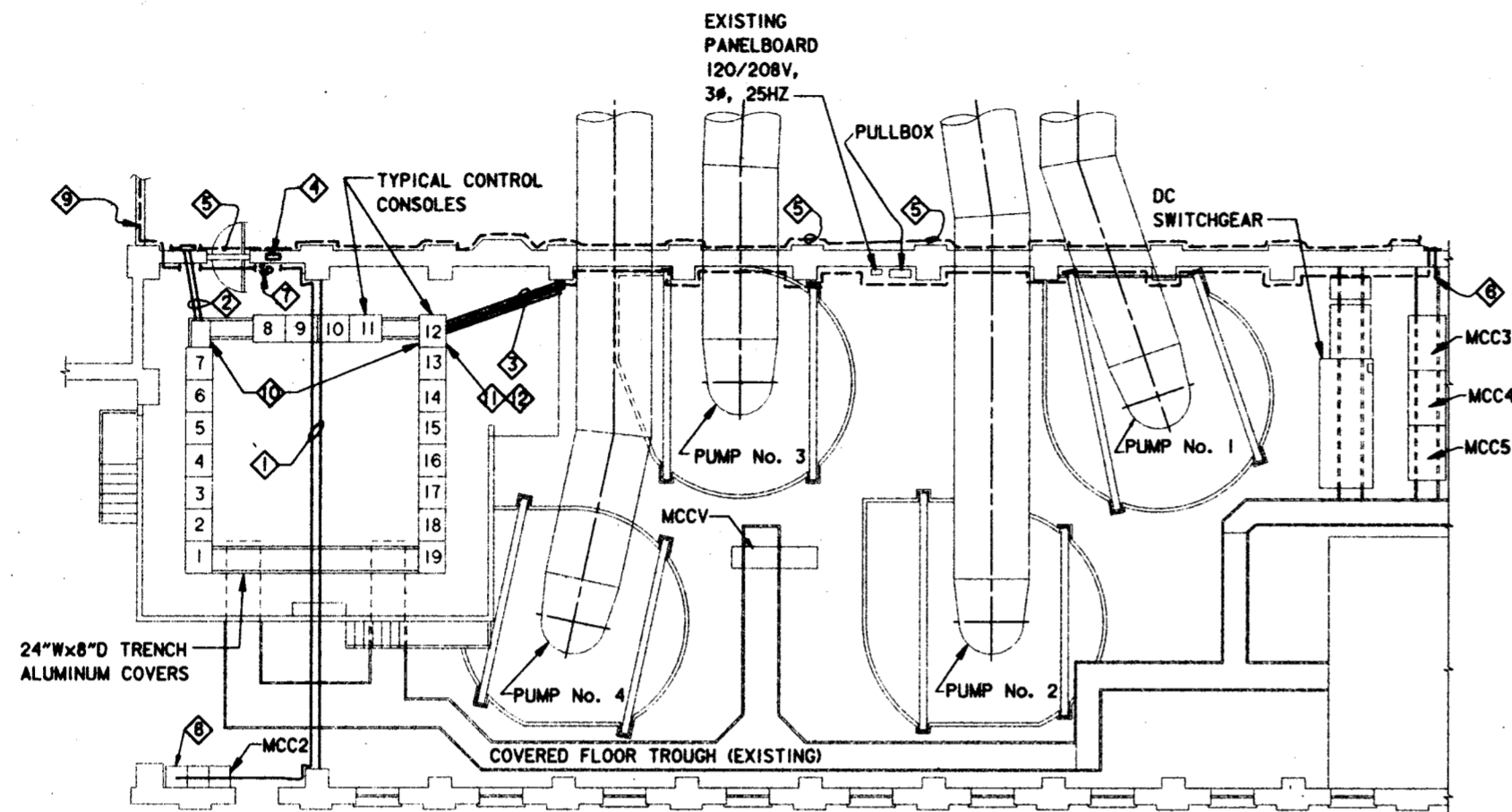

**PARTIAL STATION FLOOR PLAN
CONTROL ROOM AND VERTICAL PUMP**
SCALE 1/8" = 1'-0"

SPECIFIC NOTES

- ① FROM MCC2 ROUTE POWER FEEDER FOR GATE MOTORS UP EXTERIOR WALL AND OVER TO WHERE STRUCTURAL BEAM CROSSES STATION. CONDUIT SHALL ATTACH TO EXISTING BEAM AND CROSS STATION OVER CONTROL ROOM AND PENETRATE EXTERIOR WALL. ONCE OUTSIDE THE BUILDING CONDUIT SHALL BE ROUTED TO SLUICE GATES ON EXISTING OVERHEAD BEAM. SEE SHEET 9-3 FOR EXTERIOR CONDUIT ROUTING.
- ② ROUTE TWO 1/2" CONTROL CONDUITS UNDER RAISED CONTROL ROOM FROM FLOOR DUCT SYSTEM TO NEW JUNCTION BOX MOUNTED ON EXTERIOR WALL. FROM JUNCTION BOX ROUTE CONDUITS UP EXTERIOR WALL AND THEN OUT TO GATES ON EXISTING BEAM. SEE SHEET 9-3 FOR EXTERIOR CONDUIT ROUTING.
- ③ ROUTE FOUR 1/2" CONTROL CONDUITS UNDER RAISED CONTROL ROOM FLOOR FROM FLOOR DUCT SYSTEM TO EXTERIOR WALL OUTSIDE OF CONTROL ROOM. ROUTE UP WALL TO RAFTERS AND THEN ROUTE CONDUITS INSIDE BUILDING ALONG EXTERIOR WALL. TWO CONDUITS SHALL BE ROUTED TO EXISTING PULLBOX AND THE OTHER FOUR SHALL BE ROUTED TO NEAR MCC3 AND THEN PENETRATE EXTERIOR WALL AND THEN OUT TO SLUICE GATES (SEE SHEET 9-3 FOR EXTERIOR CONDUIT ROUTE.)
- ④ RECESS MOUNT NEW LIGHTING CONTACTOR ABOVE EXISTING PANELBOARD "LB" NEAR CONTROL ROOM. (SEE EXTERIOR LIGHTING CONTROL DIAGRAM SHEET 9-8)
- ⑤ FROM NEW LIGHTING CONTACTOR PENETRATE EXTERIOR WALL WITH A 3/4" CONDUIT AND ROUTE OUT TO EAST AND WEST MONOLITH.
- ⑥ FROM FLOOR TROUGH ROUTE 1/2" CONDUIT UP ALONG EXTERIOR WALL AND THEN PENETRATE WALL AND ROUTE CONDUITS OUT TO GATE MOTORS. SEE SHEET 9-3 FOR EXTERIOR CONDUIT ROUTING.
- ⑦ SWITCH FOR EXTERIOR LIGHTS (SEE EXTERIOR LIGHTING CONTROL DIAGRAM SHEET 9-8). SWITCH SHALL BE A LIGHTED TOGGLE SWITCH HUBBELL CAT. #1221-PL. SET SWITCH IN FLUSH BOX IN WALL WITH STAINLESS STEEL COVER. AFFIX ENGRAVED PHENOLIC NAMEPLATE READING "MONOLITH LIGHTS".
- ⑧ REPLACE EXISTING 30 AMP BUCKET SECTION WITH NEW 100 AMP BUCKET SECTION FOR NEW FEEDER FOR GATE MOTORS.
- ⑨ SEE SHEET 9-3 FOR CONTINUATION OF CONDUIT ROUTE.
- ⑩ IN ORDER TO ACCESS FLOOR DUCT SYSTEM THE CONTRACTOR MUST CORE DRILL CONCRETE CONTROL ROOM FLOOR. IN ORDER TO CORE DRILL CONTROL ROOM FLOOR, CONTROL PANEL #12 MUST BE TEMPORARILY REMOVED. DUST CONTROL IS A PRIORITY. CONTRACTOR SHALL CREATE A TENT OVER AREA TO BE CORE DRILLED AND THEN VACUUM THE AREA BEFORE REMOVING TENT. ALL CONSOLES, SWITCHES, AND DEVICES SHALL BE CLEANED OF ALL CONCRETE DUST.
- ⑪ INSTALL NEW SELECTOR SWITCHES AND PILOT LIGHTS IN EXISTING CONTROL CONSOLE #12. SEE DRAWING 9-10 FOR INFORMATION.
- ⑫ EXISTING CONTROL CONSOLE SHALL BE REFINISHED AFTER KNOCKOUTS FOR 18 VALVE CONTROL STATIONS HAVE BEEN MADE. SEE PAINT SPECIFICATION SECTION 09940 PARAGRAPH 14.

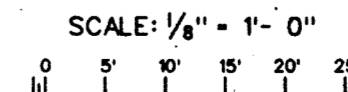

SYMBOL	DESCRIPTION	DATE	APPROVED
REVISIONS			
U.S. ARMY ENGINEER DISTRICT, NEW ORLEANS CORPS OF ENGINEERS NEW ORLEANS, LOUISIANA			
IMC CONSULTING ENGINEERS			
LAKE PONTCHARTRAIN, LA. AND VICINITY HURRICANE PROTECTION HIGH LEVEL PLAN FRONTING PROTECTION AT PUMP STATION #8 ORLEANS PARISH - JEFFERSON PARISH 17th STREET OUTFALL CANAL (METAIRIE RELIEF)			
PARTIAL STATION ELECTRICAL PLAN			
DESIGNED BY: R.E.N.	DATE: SEPT. 1997	PLOT SCALE: 4	PLOT DATE: SEPT. 1997
DRAWN BY: K.L.L.	CADD FILE: P98-0-01.DWG		FILE NO. H-4-44654
CHECKED BY: R.E.N.			
SUBMITTED BY:	SOLICITATION NO. DACW29-98-B-0112		DWG. 9-2 OF 9-10

**Safety is a Part
of Your Contract**

SPECIFIC NOTES:

- ① STUB 1/2" POWER CONDUIT INTO BUILDING AND ROUTE TO MCC #4. SEE SHEET 9-2 FOR CONTINUATION OF CONDUIT ROUTE. ALSO SEE ONE LINE DIAGRAM FOR POWER FEEDER SIZE.
- ② ROUTE ONE 1/2" POWER CONDUIT FOR SLUICE GATE MOTORS AND ROUTE THREE 1/2" CONTROL CONDUITS AND ONE 3/4" LIGHTING CONDUIT ALONG EXISTING WALL TO PULL BOX. AT PULL BOX POWER CONDUCTORS FOR GATE MOTOR AND LIGHTS SHALL BE SPLICED.
- ③ FROM PULL BOX ROUTE ONE 1/2" POWER CONDUIT FOR GATE MOTORS, THREE 1/2" CONTROL CONDUITS AND ONE 3/4" LIGHTING CONDUIT UP AND OVER EXISTING WALL AND THEN ALONG NEW PROPOSED I WALL TO EAST MONOLITH. AT EAST MONOLITH 3/4" LIGHTING CONDUIT SHALL BE RUN IN CONCRETE SLAB ON TOP OF MONOLITH TO NEW LIGHT POLES.
- ④ FROM PULL BOX ROUTE ONE 1/2" POWER CONDUIT FOR BUTTERFLY VALVE MOTORS AND ONE 3/4" CONDUIT FOR LIGHTS ALONG EXISTING T-WALL. THEN ROUTE CONDUITS UP AND OVER EXISTING T-WALL AND THEN DOWN TO EXISTING SHEETING. ROUTE ALONG TOP OF SHEETING TO COFFERDAM. SEE SHEET 9-4 FOR CONTINUATION OF CONDUIT ROUTING. THESE CONDUITS SHALL BE REMOVED ONCE THE COFFERDAM IS REMOVED.
- ⑤ ROUTE ONE 1/2" POWER CONDUIT FOR GATE MOTORS AND THREE 1/2" CONTROL CONDUITS, ALONG SIDE OF EAST MONOLITH. (SEE SECTION I ON SHEET 9-5) THERE IS ONE CONTROL CONDUIT FOR EVERY THREE GATES.

- ⑥ ROUTE ONE 1/2" POWER CONDUIT FOR GATE MOTORS AND TWO CONTROL CONDUITS ALONG SIDE OF EAST MONOLITH. CONDUITS SHALL BE SUPPORTED BY UNISTRUT SUPPORT RACK. (SEE SECTION I, SHEET 9-5)
- ⑦ ROUTE ONE 1/2" POWER CONDUIT FOR GATE MOTORS ONE CONTROL CONDUIT ALONG SIDE OF EAST MONOLITH.
- ⑧ NOT USED
- ⑨ FROM BUILDING ROUTE ONE 1/2" POWER CONDUIT FOR GATE MOTORS, TWO CONTROL CONDUITS, AND ONE LIGHTING CONDUIT ON TOP OF OVERHEAD BEAM TO SUPPORT BEAM. THEN ROUTE CONDUITS DOWN SUPPORT BEAM AND THEN UNDER STAIR TO EXISTING I-WALL. THEN ROUTE CONDUITS ALONG I-WALL TO NEW JUNCTION BOX. AT NEW JUNCTION BOX POWER CONDUCTORS FOR GATE MOTORS AND LIGHTS SHALL BE SPLICED.
- ⑩ FROM NEW JUNCTION BOX ROUTE ONE 1/2" POWER CONDUIT FOR SLUICE GATE MOTORS, TWO 1/2" CONTROL CONDUITS AND ONE 3/4" LIGHTING CONDUIT UP AND OVER I-WALL TO NEW WALKWAY. THEN ROUTE CONDUITS ON SIDE OF WALKWAY ON ALUMINUM UNISTRUT SUPPORT OUT TO WEST MONOLITH. THE UNISTRUT SHALL BE ISOLATED FROM THE CONCRETE BY 1/4" NEOPRENE RUBBER.
- ⑪ ALUMINUM UNISTRUT CHANNEL WELDED TO BOTTOM OF WALKWAY TO BE USED FOR CONDUIT SUPPORT.
- ⑫ AT PULLBOX SPLICE POWER CONDUCTORS FOR GATE POWER AND FOR LIGHTS AND THEN ROUTE ONE 1/2" CONDUIT FOR GATE POWER, ONE 1/2" CONDUIT FOR CONTROL AND ONE 3/4" FOR LIGHTING BOTH EAST AND WEST TO ENDS OF WEST MONOLITH.

- ⑬ FROM NEW JUNCTION ROUTE ONE 1/2" CONDUIT FOR BUTTERFLY GATE MOTORS AND ONE 3/4" CONDUIT FOR LIGHTS OUT TO COFFERDAM. SEE SHEET 9-4 FOR CONTINUATION OF CONDUIT ROUTE. THESE CONDUITS SHALL BE REMOVED ONCE THE COFFERDAM IS REMOVED.
- ⑭ STUB 4-1/2" CONDUITS INTO BUILDING AND ROUTE BACK TO CONTROL PANEL #12 IN CONTROL ROOM. SEE SHEET 9-2 FOR CONTINUATION OF CONDUIT ROUTE.
- ⑮ STUB ONE 3/4" CONDUIT INTO BUILDING AND ROUTE BACK TO PANEL "LB". SEE SHEET 9-2 FOR CONTINUATION OF CONDUIT ROUTE.
- ⑯ CONTRACTOR SHALL BE RESPONSIBLE FOR RELOCATING OVERHEAD FEEDER IF IT INTERFERES WITH CONSTRUCTION.
- ⑰ APPROXIMATE LOCATION OF EXISTING UNDERGROUND FEEDER.
- ⑱ FOR SIZE OF PULLBOXES ON MONOLITH SEE DWG. 9-5 OR 9-6.

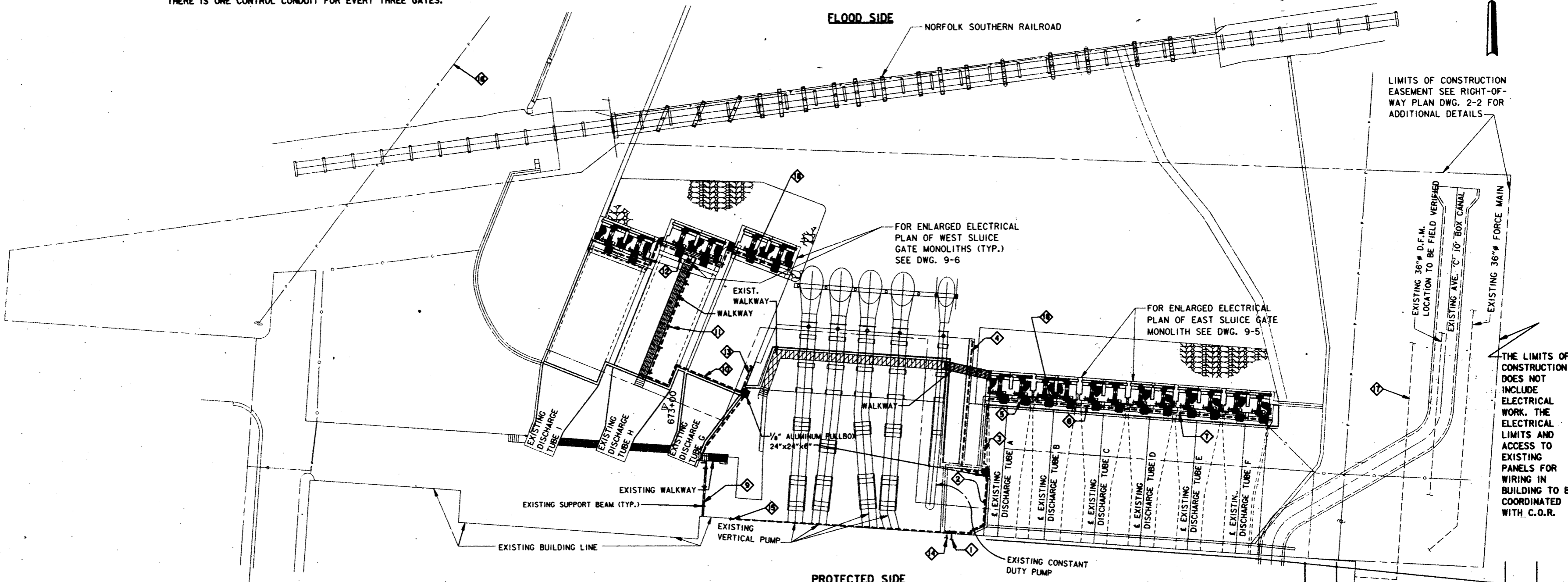

LIMITS OF CONSTRUCTION EASEMENT SEE RIGHT-OF-WAY PLAN DWG. 2-2 FOR ADDITIONAL DETAILS

THE LIMITS OF CONSTRUCTION DOES NOT INCLUDE ELECTRICAL WORK. THE ELECTRICAL LIMITS AND ACCESS TO EXISTING PANELS FOR WIRING IN BUILDING TO BE COORDINATED WITH C.O.R.

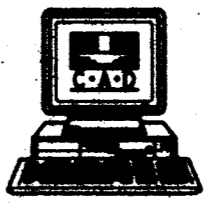
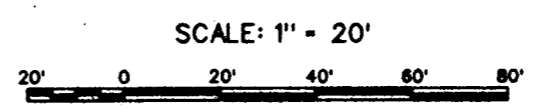

SYMBOL	DESCRIPTION	DATE	APPROVED
REVISIONS			
 U.S. ARMY ENGINEER DISTRICT, NEW ORLEANS CORPS OF ENGINEERS NEW ORLEANS, LOUISIANA			
IMC CONSULTING ENGINEERS LAKE PONCHARTRAIN, LA. AND VICINITY HURRICANE PROTECTION HIGH LEVEL PLAN FRONTING PROTECTION AT PUMP STATION #8 ORLEANS PARISH - JEFFERSON PARISH 17th STREET OUTFALL CANAL (METAIRIE RELIEF)			
ELECTRICAL SITE PLAN			
DESIGNED BY: R.E.H.	DATE: SEPT. 1997	PLOT SCALE: 20	PLOT DATE: SEPT. 1997
DRAWN BY: L.A.O.	CADD FILE: 98-0112	FILE NO. H-4-44654	
CHECKED BY: R.E.H.	SOLICITATION NO. DACW29-98-B-0112	DWG. 9-3	09-10
SUBMITTED BY:			



Safety is a Part
of Your Contract

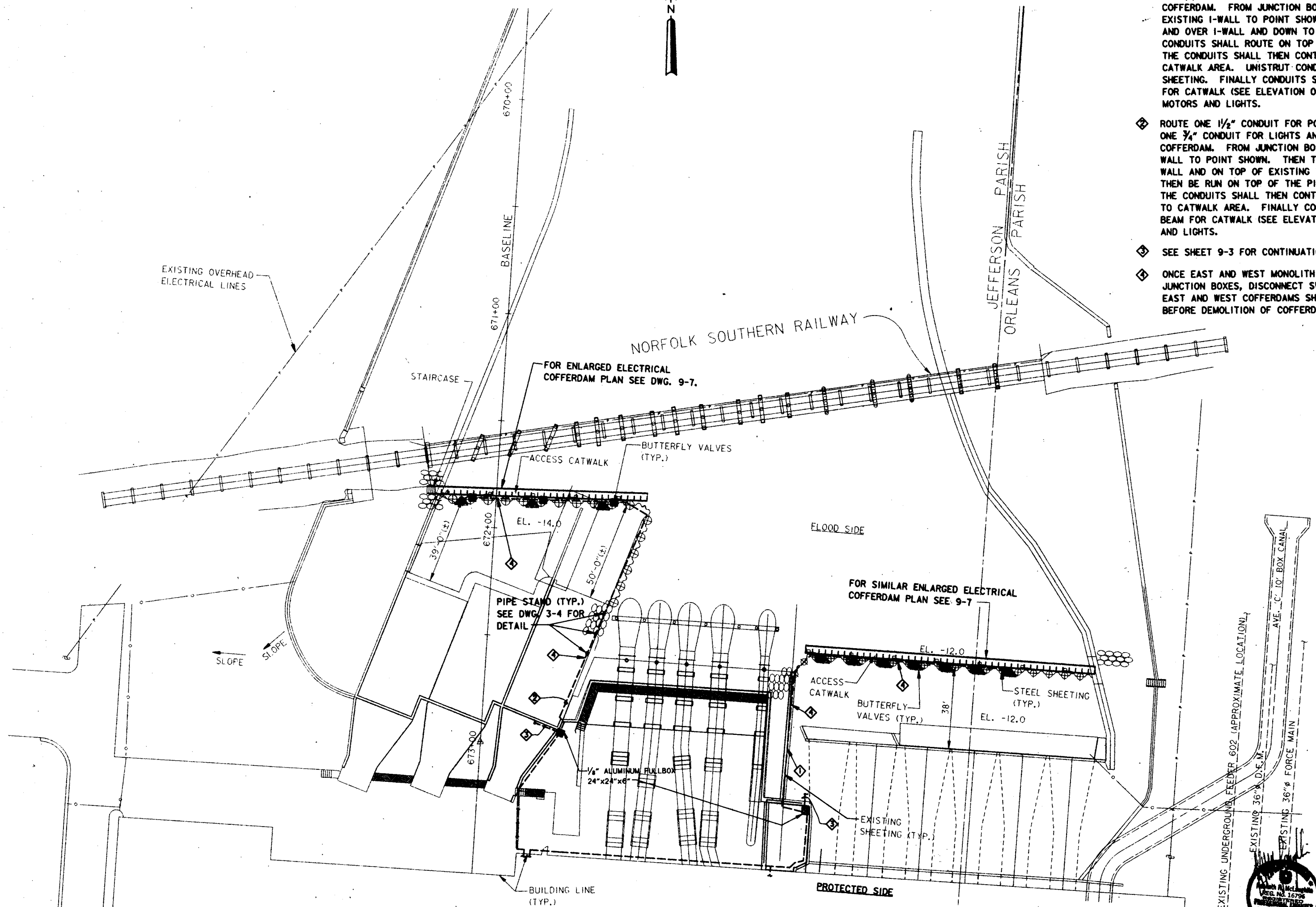
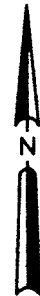

- ◆ ROUTE ONE 1/2" CONDUIT FOR POWER FOR BUTTERFLY GATE VALVE MOTORS AND ONE 3/4" CONDUIT FOR LIGHTS AND RECEPTACLES FROM JUNCTION BOX OUT TO COFFERDAM. FROM JUNCTION BOX CONDUITS SHALL BE ROUTED ALONG EXISTING I-WALL TO POINT SHOWN. THEN THE CONDUITS SHALL BE ROUTED UP AND OVER I-WALL AND DOWN TO EXISTING CONCRETE CAPPED STEEL SHEETING. CONDUITS SHALL ROUTE ON TOP OF EXISTING SHEETING TO THE END. THE CONDUITS SHALL THEN CONTINUE ON TOP OF NEW SHEETING TO CATWALK AREA. UNISTRUT CONDUIT SUPPORTS SHALL BE WELDED ON TOP OF SHEETING. FINALLY CONDUITS SHALL BE ROUTED ALONG SIDE OF SUPPORT BEAM FOR CATWALK (SEE ELEVATION OF COFFERDAM SHEET 9-5) TO VALVE MOTORS AND LIGHTS.
- ◆ ROUTE ONE 1/2" CONDUIT FOR POWER FOR BUTTERFLY GATE VALVE MOTORS AND ONE 3/4" CONDUIT FOR LIGHTS AND RECEPTACLES FROM JUNCTION BOX OUT TO COFFERDAM. FROM JUNCTION BOX CONDUITS SHALL BE ROUTED ALONG EXISTING WALL TO POINT SHOWN. THEN THE CONDUITS SHALL BE ROUTED UP AND OVER WALL AND ON TOP OF EXISTING TUBE TO THE PIPE STAND. THE CONDUIT SHOULD THEN BE RUN ON TOP OF THE PIPE STAND TO THE COFFERDAM SHEETING. THE CONDUITS SHALL THEN CONTINUE ON TOP OF NEW COFFERDAM SHEETING TO CATWALK AREA. FINALLY CONDUITS SHALL BE ROUTED ALONG SIDE OF SUPPORT BEAM FOR CATWALK (SEE ELEVATION OF COFFERDAM SHEET 9-6) TO VALVE MOTORS AND LIGHTS.
- ◆ SEE SHEET 9-3 FOR CONTINUATION OUT TO SLUICE GATES.
- ◆ ONCE EAST AND WEST MONOLITH ARE COMPLETED ALL ELECTRICAL WORK (CONDUITS, JUNCTION BOXES, DISCONNECT SWITCHES, LIGHTS, AND RECEPTACLES) ASSOCIATED WITH EAST AND WEST COFFERDAMS SHALL BE REMOVED. REMOVE ALL ELECTRICAL EQUIPMENT BEFORE DEMOLITION OF COFFERDAM BEGINS.

SLOPE

FLOOD SIDE

FOR SIMILAR ENLARGED ELECTRICAL COFFERDAM PLAN SEE: 9-7

PROTECTED SIDE

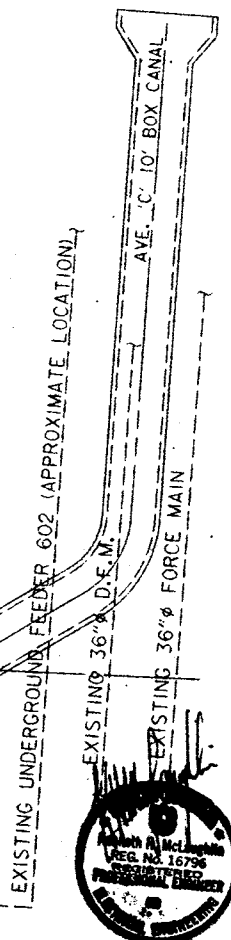

SCALE: 1" = 20'

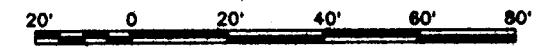

SYMBOL	DESCRIPTION	DATE	APPROVED
U.S. ARMY ENGINEER DISTRICT, NEW ORLEANS CORPS OF ENGINEERS NEW ORLEANS, LOUISIANA			
IMC CONSULTING ENGINEERS LAKE PONTCHARTRAIN, LA. AND VICINITY HURRICANE PROTECTION HIGH LEVEL PLAN FRONTING PROTECTION AT PUMP STATION #8 ORLEANS PARISH - JEFFERSON PARISH 17th STREET OUTFALL CANAL METAIRIE RELIEF			
COFFERDAM ELECTRICAL PLAN			
DESIGNED BY: R.E.N.	DATE: SEPT. 1997	PLOT SCALE: 20	PLOT DATE: SEPT. 1997
DRAWN BY: L.A.O.	CHECKED BY: R.E.N.	CAD FILE: 98-0-04-01	FILE NO. H-4-44654
SUBMITTED BY:	SOLICITATION NO. DACW29-98-B-0112	DWG. 9-4	OP-10

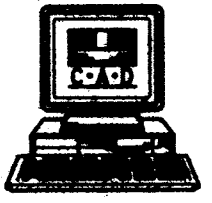

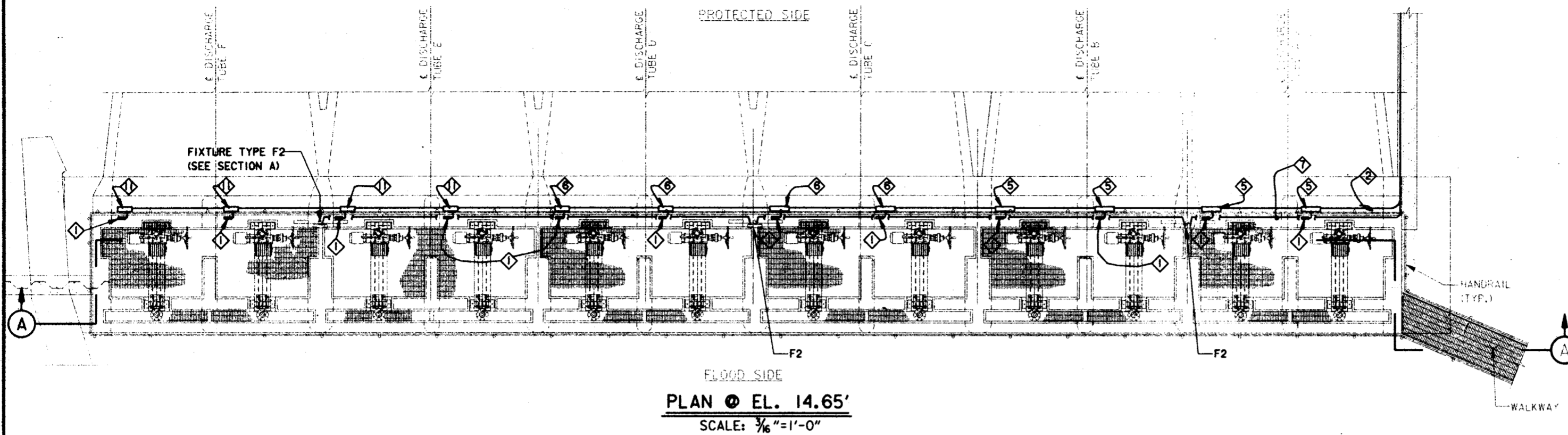

- SPECIFIC NOTES**
- 1 30 AMP FUSED SWITCH NEMA 4x, STAINLESS STEEL MOUNTED ON UNISTRUT CHANNEL. (TYPICAL FOR ALL EAST GATE MOTORS).
 - 2 POWER AND CONTROL CONDUITS ROUTED EXPOSED ALONG PROTECTED SIDE OF MONOLITH.
 - 3 WELD ALUMINUM UNISTRUT TO HANDRAIL
 - 4 ROUTE 3-#12, 1-#12 GD IN 3/4" LIQUIDTIGHT FLEXIBLE CONNECTION BETWEEN FUSED SWITCH AND GATE CONTROLLER.
 - 5 1/8" ALUMINUM PULLBOX 24"x24"x6"
 - 6 1/8" ALUMINUM PULLBOX 18"x18"x6"
 - 7 3/4" CONDUIT FOR LIGHTS AND RECEPTACLES ROUTED IN CONCRETE SLAB TO LIGHT POLES. SEE TYPICAL LIGHT POLE DETAIL SHEET 9-8.
 - 8 NOTE TWO FIXTURES SHALL BE AIMED SOUTH (TOWARD THE STATION) AND ONE FIXTURE SHALL BE AIMED NORTH. (SEE SHEET 9-1 FOR FIXTURE SCHEDULE.)
 - 9 THESE LIGHT FIXTURES SHALL BE FED BY EXISTING 20 AMP, 2 POLE C/B IN PANEL LB CIRCUIT 3. (SEE EXTERIOR LIGHT CONTROL DIAGRAM SHEET 9-8).
 - 10 THESE LIGHT FIXTURES SHALL BE FED BY EXISTING 20 AMP, 2 POLE C/B IN PANEL LB CIRCUIT 5. (SEE EXTERIOR LIGHT CONTROL DIAGRAM SHEET 9-8).
 - 11 1/8" ALUMINUM PULLBOX 12"x12"x6"
 - 12 ROUTE 9/C CONTROL CABLE IN 3/4" CONDUIT FROM PULLBOX TO GATE OPERATOR.
 - 13 ROUTE 3-#12, 1-#12 GD, IN 3/4" CONDUIT FROM PULLBOX TO DISCONNECT SWITCH.
 - 14 REPLACE EXISTING 30 AMP, 2 POLE C/B IN PANEL LB CKT. 7 WITH NEW 20 AMP, 2 POLE CLB. THESE LIGHT FIXTURES SHALL BE FED BY NEW 20 AMP C/B (SEE EXTERIOR LIGHTING CONTROL DIAGRAM SHEET 9-8).

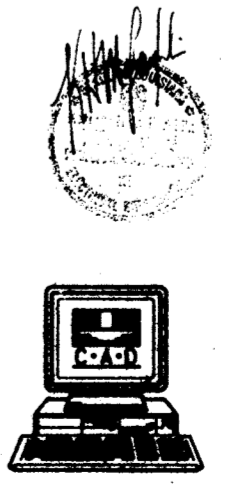
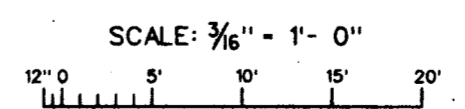
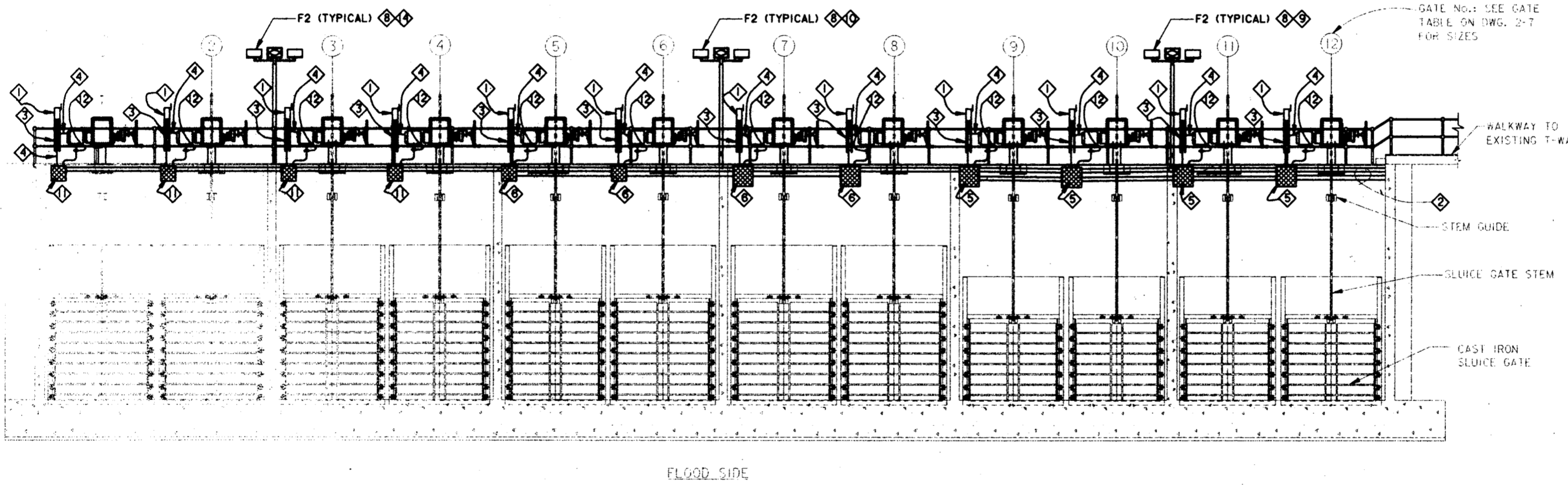

Safety is a Part of Your Contract

SYMBOL	DESCRIPTION	DATE	APPROVED
REVISIONS			
U.S. ARMY ENGINEER DISTRICT, NEW ORLEANS CORPS OF ENGINEERS NEW ORLEANS, LOUISIANA			
IMC CONSULTING ENGINEERS LAKE PONCHARTRAIN, LA. AND VICINITY HURRICANE PROTECTION HIGH LEVEL PLAN FRONTING PROTECTION AT PUMP STATION #6 ORLEANS PARISH - JEFFERSON PARISH 17th STREET OUTFALL CANAL (DETAINÉ RELIEF)			
ENLARGED EAST SLUICE GATE PLAN AND SECTION			
DESIGNED BY: R.E.N.	DATE: SEPT. 1997	PLOT SCALE: 5.333	PLOT DATE: SEPT. 1997
DRAWN BY: K.L.L.	CADD FILE: PSD-9-02.DWG	FILE NO. H-4-44654	
CHECKED BY: R.E.N.	SOLICITATION NO. DACW29-98-B-0112	DWG. 9-5	OF 9-10
SUBMITTED BY:			



Safety is a Part of Your Contract

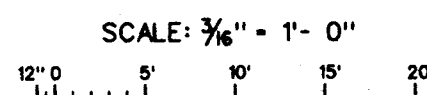
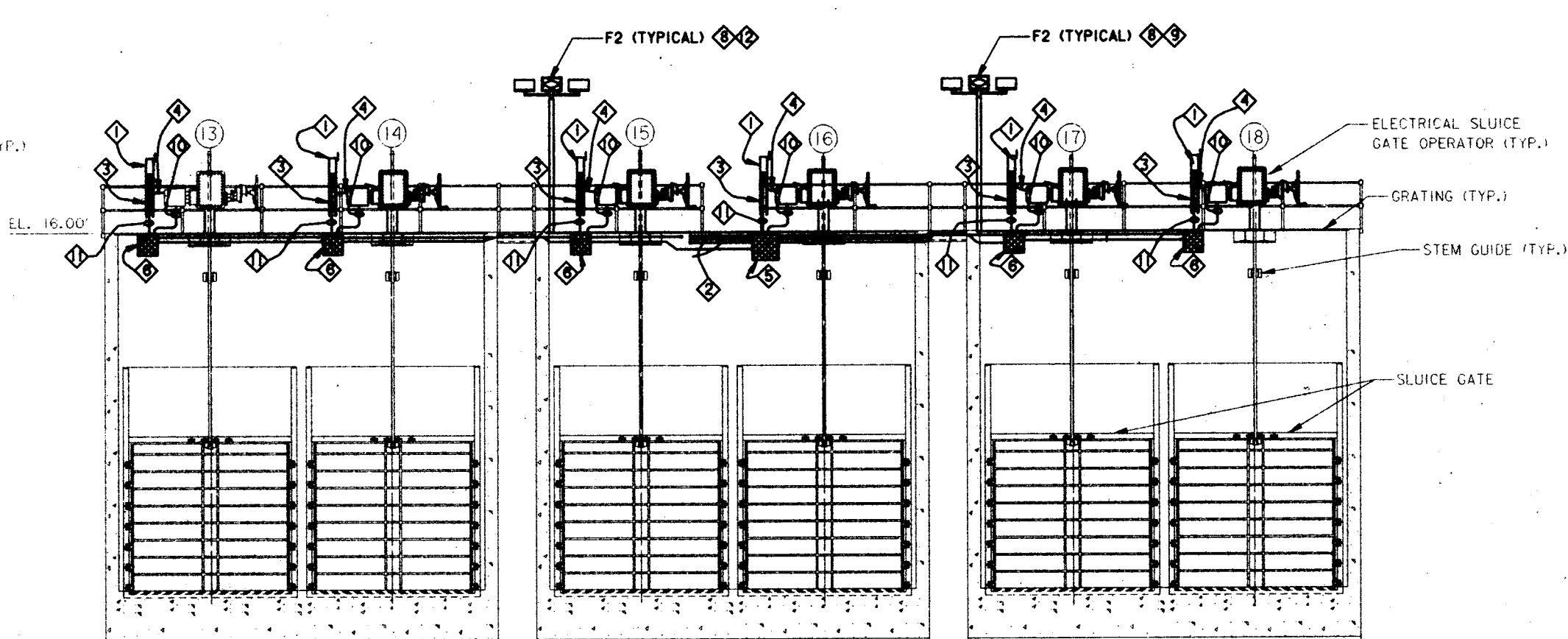
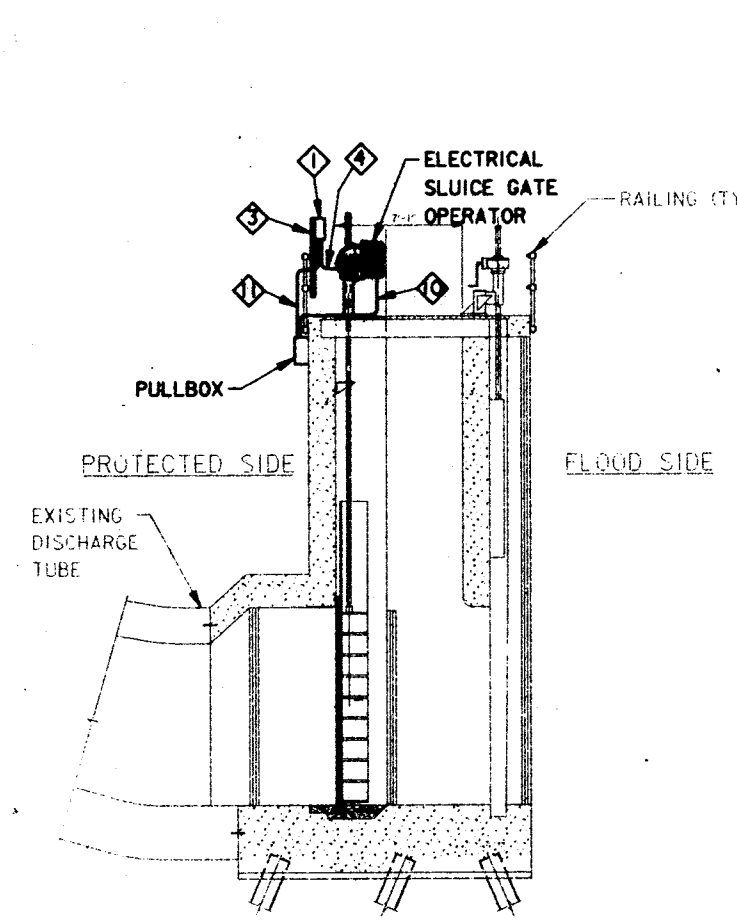
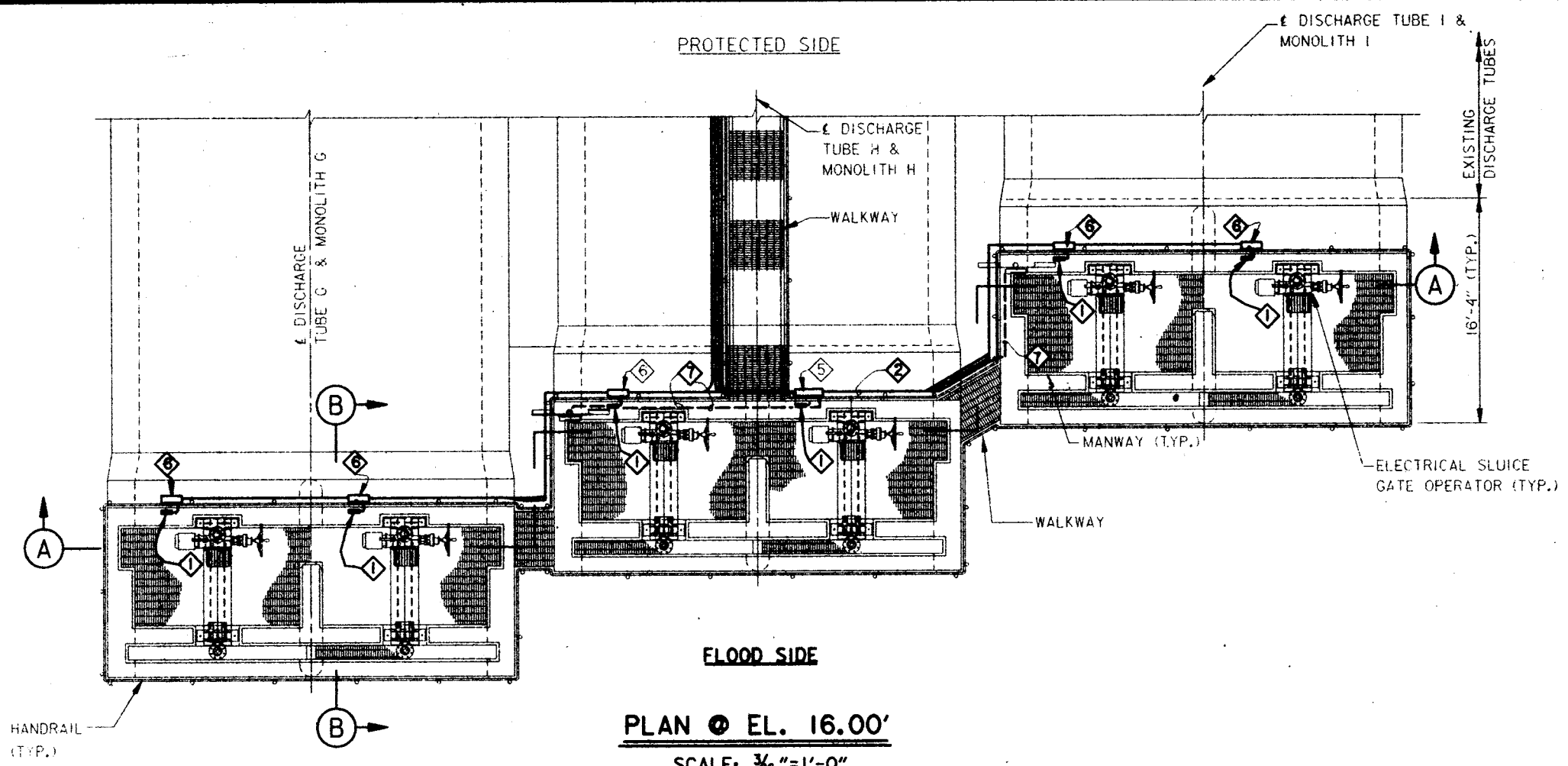

- SPECIFIC NOTES**
- 1 30 AMP FUSED SWITCH NEMA 4X, STAINLESS STEEL MOUNTED ON UNISTRUT CHANNEL. (TYPICAL FOR ALL WEST GATE MOTORS).
 - 2 ROUTE POWER, LIGHTING, AND CONTROL CONDUITS EXPOSED ALONG PROTECTIVE SIDE OF MONOLITH.
 - 3 WELD ALUMINUM UNISTRUT TO HANDRAIL.
 - 4 ROUTE 3-#10, 1-#10 GD. IN 3/4" LIQUIDTIGHT FLEXIBLE CONNECTION BETWEEN FUSED SWITCH AND GATE CONTROLLER ON WEST SIDE SLUICE GATES. (USE 3-#12, 1-#12 GD. ON EAST SLUICE GATES).
 - 5 1/8" ALUMINUM PULLBOX 24"x24"x6"
 - 6 1/8" ALUMINUM PULLBOX 12"x12"x6"
 - 7 ROUTE 3/4" LIGHTING CONDUIT IN CONCRETE SLAB OF MONOLITH TO LIGHT POLE. (SEE LIGHT POLE DETAIL SHEET 9-8).
 - 8 NOTE TWO FIXTURES SHALL BE AIMED SOUTH (TOWARD THE STATION) AND ONE FIXTURE AIMED NORTH. SEE SHEET 9-1 FOR FIXTURE SCHEDULE.
 - 9 THESE LIGHT FIXTURES SHALL BE FED BY EXISTING 20 AMP, 2 POLE, C/B IN PANEL LB CIRCUIT 6. (SEE EXTERIOR LIGHTING CONTROL DIAGRAM SHEET 9-8).
 - 10 ROUTE 9/C CONTROL CABLE IN 3/4" CONDUIT FROM PULLBOX TO GATE OPERATOR.
 - 11 ROUTE 3-#10, 1-#10 GD. IN 3/4" CONDUIT FROM PULLBOX TO DISCONNECT SWITCH ON WEST SIDE SLUICE GATES. (USE 3-#12, 1-#12 GD. ON EAST SLUICE GATES.)
 - 12 THESE LIGHT FIXTURES SHALL BE FED BY EXISTING 20 AMP, 2 POLE C/B. IN PANEL LB CIRCUIT 8. (SEE EXTERIOR LIGHTING CONTROL DIAGRAM SHEET 9-8).

SYMBOL	DESCRIPTION	DATE	APPROVED
REVISIONS			
U.S. ARMY ENGINEER DISTRICT, NEW ORLEANS CORPS OF ENGINEERS NEW ORLEANS, LOUISIANA			
IMC CONSULTING ENGINEERS			
LAKE PONCHARTRAIN, LA. AND VICINITY HURRICANE PROTECTION HIGH LEVEL PLAN FRONTING PROTECTION AT PUMP STATION #8 ORLEANS PARISH - JEFFERSON PARISH 17TH STREET OUTFALL CANAL (JEFFERSON WELLS)			
ENLARGED WEST SLUICE GATE PLAN AND SECTION			
DESIGNED BY: R.E.N.	DATE: SEPT. 1997	PLOT SCALE: 5.333	PLOT DATE: SEPT. 1997
DRAWN BY: K.L.L.	CHECKED BY: R.E.N.	CADD FILE: P08-9-OLDEN	FILE NO. H-4-44654
SUBMITTED BY:	SOLICITATION NO. DACW29-98-B-0112	DWG. 9-6 OF 9-10	

**Safety is a Part
of Your Contract**

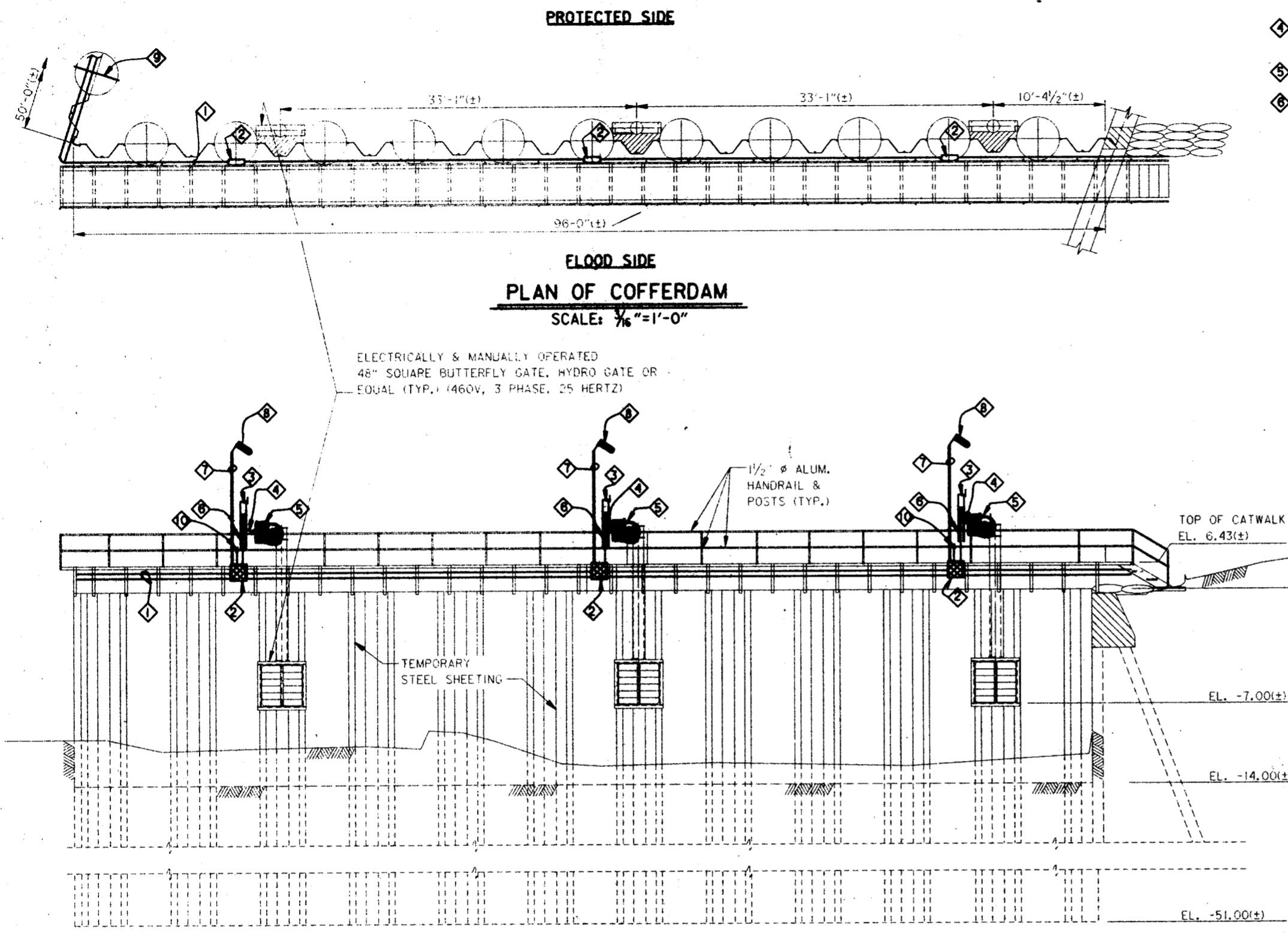

PLAN OF COFFERDAM
SCALE: 3/8" = 1'-0"

ELECTRICALLY & MANUALLY OPERATED
48" SQUARE BUTTERFLY GATE, HYDRO GATE OR
EQUAL (TYP.) (460V, 3 PHASE, 25 HERTZ)

TYPICAL ELEVATION OF COFFERDAM (FLOOD SIDE)
SCALE: 3/8" = 1'-0"

SPECIFIC NOTES

- ① ROUTE ONE 1/2" CONDUIT FOR POWER FOR GATE MOTORS AND ONE 3/4" CONDUIT FOR LIGHTING AND RECEPTACLES EXPOSED ALONG PROTECTIVE SIDE OF COFFERDAM.
- ② 12"x12"x8", 1/8" ALUMINUM JUNCTION BOX USED TO TAP POWER FEEDER CONDUCTORS.
- ③ 30 AMP, 3 POLE, 480V, NEMA 4X, STAINLESS STEEL FUSED SWITCH MOUNTED TO UNISTRUT SUPPORTS FOR GATE MOTOR.
- ④ ROUTE 3-#12, 1-#12 GD. IN 3/4" FLEXIBLE LIQUIDTIGHT CONDUIT BETWEEN FUSED SWITCH AND GATE MOTOR CONTROLLER.
- ⑤ BUTTERFLY GATE MOTOR CONTROLLER.
- ⑥ UNISTRUT SUPPORTS ATTACHED TO HANDRAIL.
- ⑦ 1/2" CONDUIT ATTACHED TO UPPER AND LOWER HANDRAIL USED TO SUPPORT 1/4" STANCHION MOUNT LIGHT FIXTURE.
- ⑧ LIGHT FIXTURE TYPE F1 SEE FIXTURE SCHEDULE SHEET 9-1 FOR MORE INFORMATION.
- ⑨ UNISTRUT SUPPORT WELDED TO TOP OF PIPE SHEETING TO SUPPORT CONDUITS.
- ⑩ GF1 WEATHER PROOF DUPLEX OUTLET IN CAST ALUMINUM WEATHER PROOF BOX INSTALLED AT EVERY OTHER BUTTERFLY GATE. (TWO RECEPTACLES ON WEST SIDE ON CIRCUIT LB: 14, AND THREE RECEPTACLE, ON EAST SIDE ON CIRCUIT LB: 12)

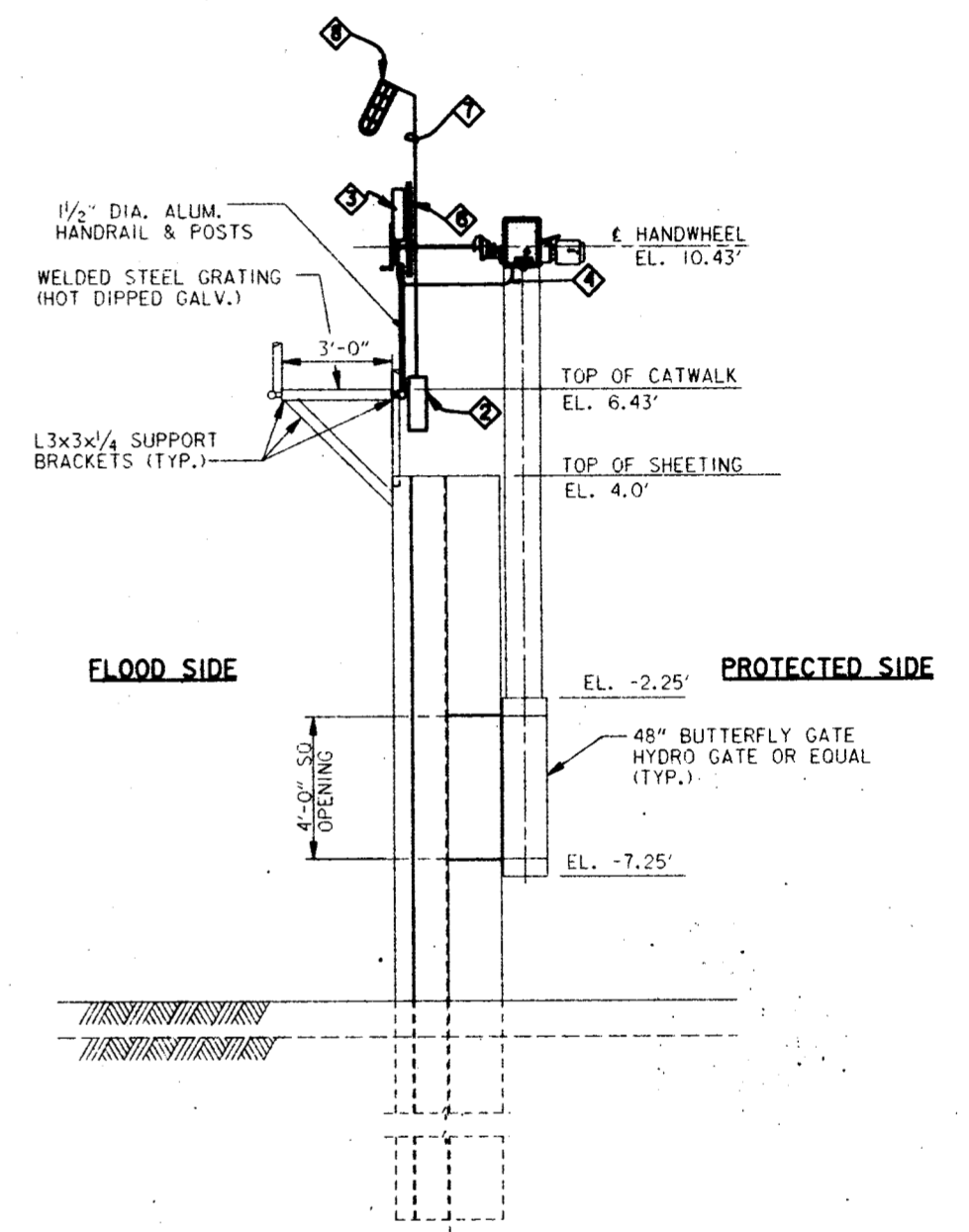

TYPICAL CROSS SECTION - COFFERDAM
SCALE: 3/8" = 1'-0"

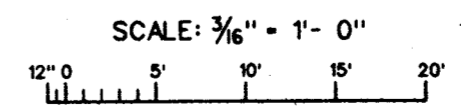

SYMBOL	DESCRIPTION	DATE	APPROVED
REVISIONS			
U.S. ARMY ENGINEER DISTRICT, NEW ORLEANS CORPS OF ENGINEERS NEW ORLEANS, LOUISIANA			
IMC CONSULTING ENGINEERS			
LAKE PONTCHARTRAIN, L.A. AND VICINITY HURRICANE PROTECTION HIGH LEVEL PLAN FRONTING PROTECTION AT PUMP STATION #6 ORLEANS PARISH - JEFFERSON PARISH 17th STREET OUTFALL CANAL (METAIRIE RELIEF)			
TYPICAL ENLARGED COFFERDAM ELECTRICAL PLAN AND ELEVATION			
DESIGNED BY: R.E.N.	DATE: SEPT. 1997	PLOT SCALE: 5.333	PLOT DATE: SEPT. 1997
DRAWN BY: K.L.L.	CARD FILE# P28-9-07.000		FILE NO: H-4-44654
CHECKED BY: R.E.N.			
SUBMITTED BY:	SOLICITATION NO: DACW29-98-B-0112		DWG. 9-7 OF 9-10

**Safety is a Part
of Your Contract**

CONTACTOR 12 POLE, 208 VOLT, 20A
ELECTRICALLY HELD RECESSED MOUNTED
NEMA 1 ENCLOSURE, MOUNT ABOVE PANEL "LB"

SIZE FUSE BASED ON MANUFACTURER'S
RECOMMENDATION. FUSE SIZE TO
PROTECT COIL.

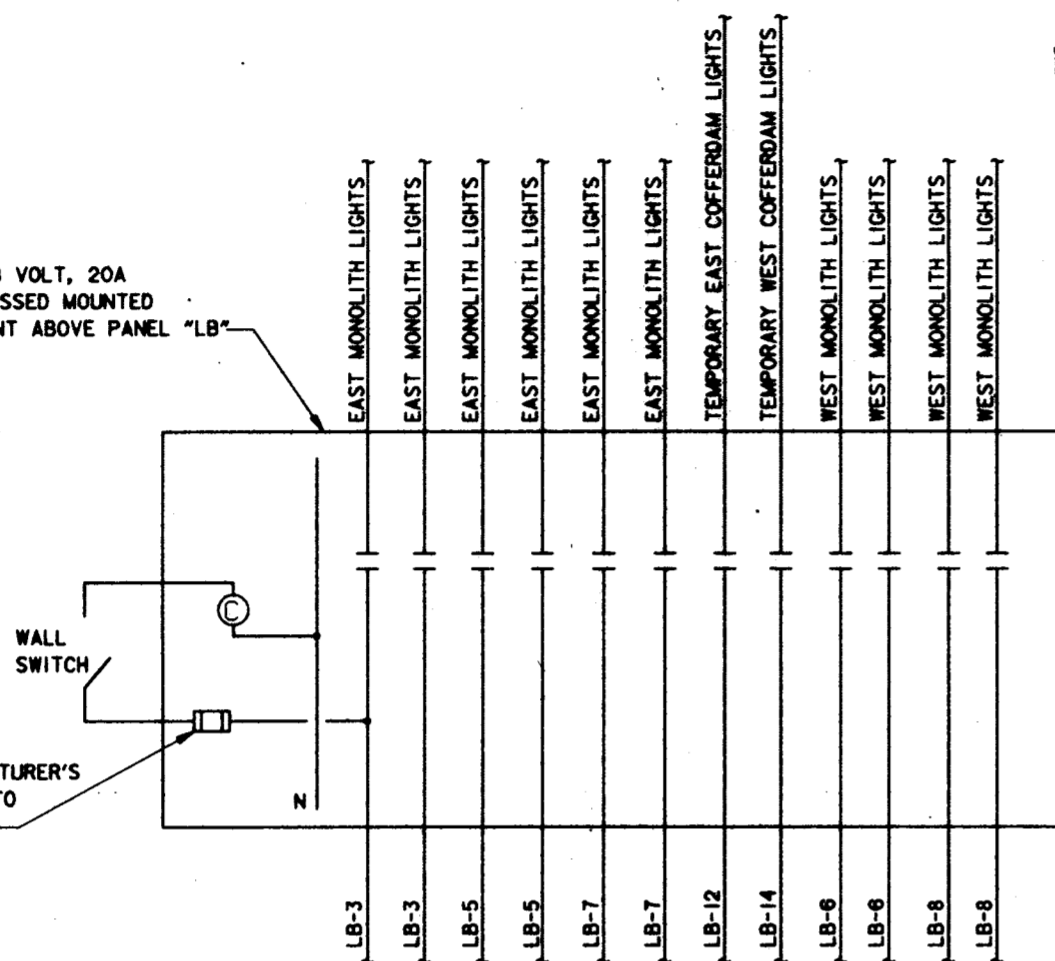

EXTERIOR LIGHTS

① LIGHTING CONTROLS
N.T.S.

20' SQUARE STEEL HINGED POLE. HOT DIPPED GALVANIZED FINISH, 2 3/8" x 5" LONG TENON TOP HUBBELL CAT #SHP-4201-PO OR EQUAL. ALSO INCLUDE GFI WEATHERPROOF RECEPTACLE HUBBELL CAT #M18 AND LOWERING CHAINS WITH HOOK HUBBELL CAT #THC-24 AND GROUNDING LUG.

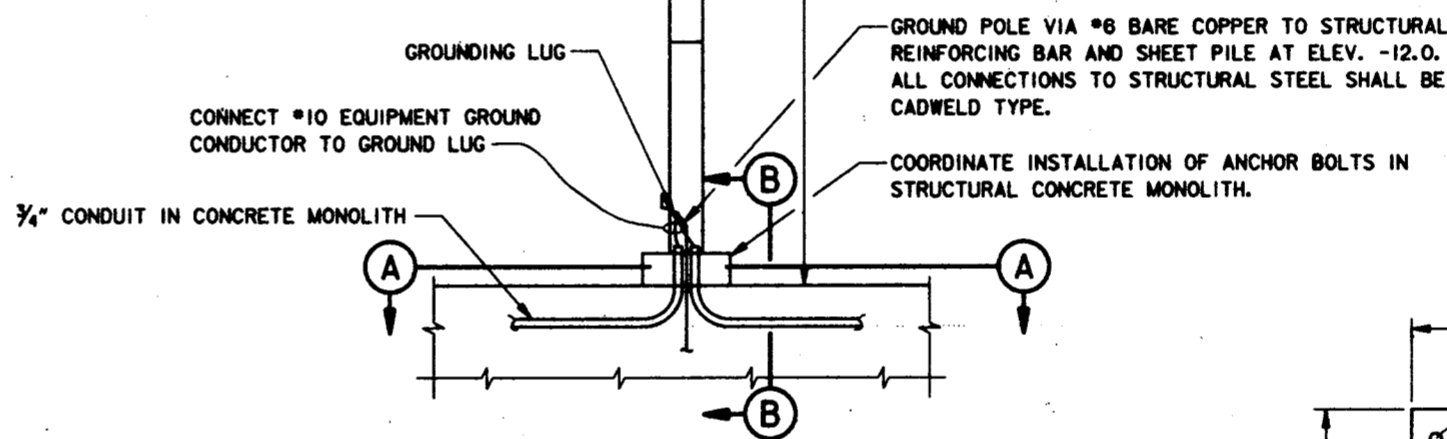

② FLOOD GATE LIGHTING POLE
N.T.S.

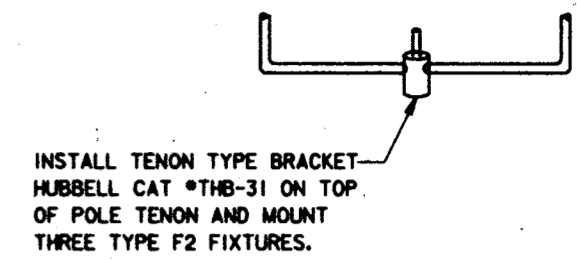

INSTALL TENON TYPE BRACKET HUBBELL CAT #THB-31 ON TOP OF POLE TENON AND MOUNT THREE TYPE F2 FIXTURES.

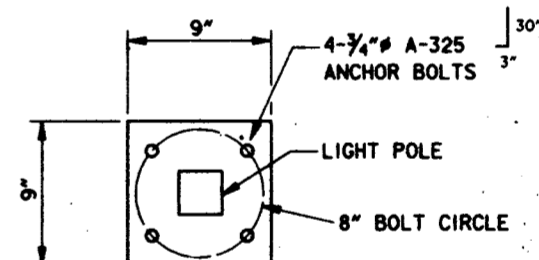

SECTION A
N.T.S.

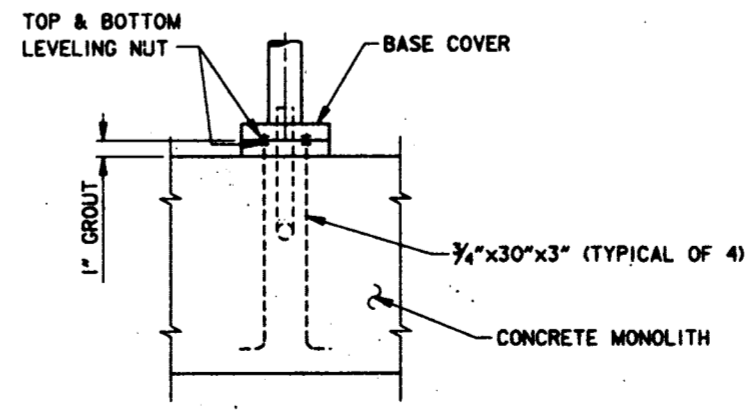

SECTION B
N.T.S.

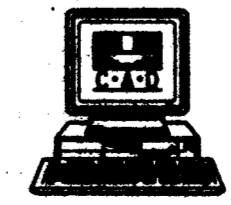

SYMBOL	DESCRIPTION	DATE	APPROVED
REVISIONS			
U.S. ARMY ENGINEER DISTRICT, NEW ORLEANS CORPS OF ENGINEERS NEW ORLEANS, LOUISIANA			
IMC CONSULTING ENGINEERS			
LAKE PONTCHARTRAIN, LA. AND VICINITY HURRICANE PROTECTION HIGH LEVEL PLAN FRONTING PROTECTION AT PUMP STATION #8 ORLEANS PARISH - JEFFERSON PARISH 171H STREET OUTFALL CANAL (METAIRIE RELIEF)			
ELECTRICAL DETAILS			
DESIGNED BY: R.E.N.	DATE: SEPT. 1997	PLOT SCALE: 4	PLOT DATE: SEPT. 1997
DRAWN BY: S.B.	CHECKED BY: R.E.N.	CADD FILE: P29-9-01.DWG	FILE NO. H-4-44654
SUBMITTED BY:	SOLICITATION NO. DACW29-98-B-0112	DWG. 9-8 OF 9-10	



Safety is a Part of Your Contract

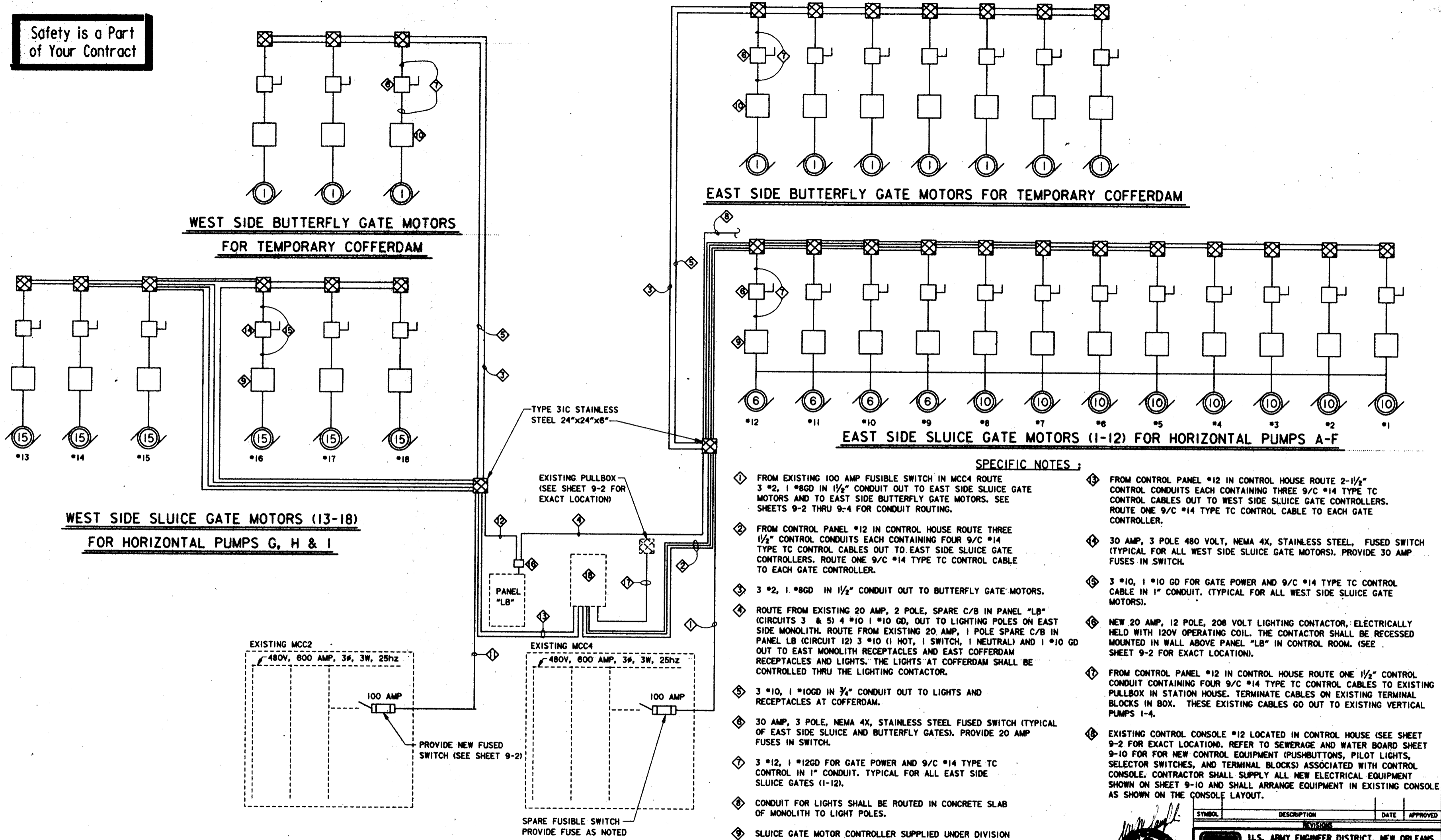

PARTIAL ELECTRICAL ONE LINE DIAGRAM

EAST SIDE BUTTERFLY GATE MOTORS FOR TEMPORARY COFFERDAM

EAST SIDE SLUICE GATE MOTORS (1-12) FOR HORIZONTAL PUMPS A-F

SPECIFIC NOTES :

- 1 FROM EXISTING 100 AMP FUSIBLE SWITCH IN MCC4 ROUTE 3 #2, 1 #8GD IN 1/2" CONDUIT OUT TO EAST SIDE SLUICE GATE MOTORS AND TO EAST SIDE BUTTERFLY GATE MOTORS. SEE SHEETS 9-2 THRU 9-4 FOR CONDUIT ROUTING.
- 2 FROM CONTROL PANEL #12 IN CONTROL HOUSE ROUTE THREE 1/2" CONTROL CONDUITS EACH CONTAINING FOUR 9/C #14 TYPE TC CONTROL CABLES OUT TO EAST SIDE SLUICE GATE CONTROLLERS. ROUTE ONE 9/C #14 TYPE TC CONTROL CABLE TO EACH GATE CONTROLLER.
- 3 3 #2, 1 #8GD IN 1/2" CONDUIT OUT TO BUTTERFLY GATE MOTORS.
- 4 ROUTE FROM EXISTING 20 AMP, 2 POLE, SPARE C/B IN PANEL "LB" (CIRCUITS 3 & 5) 4 #10 1 #10 GD, OUT TO LIGHTING POLES ON EAST SIDE MONOLITH. ROUTE FROM EXISTING 20 AMP, 1 POLE SPARE C/B IN PANEL LB (CIRCUIT 12) 3 #10 (1 HOT, 1 SWITCH, 1 NEUTRAL) AND 1 #10 GD OUT TO EAST MONOLITH RECEPTACLES AND EAST COFFERDAM RECEPTACLES AND LIGHTS. THE LIGHTS AT COFFERDAM SHALL BE CONTROLLED THRU THE LIGHTING CONTACTOR.
- 5 3 #10, 1 #10GD IN 3/4" CONDUIT OUT TO LIGHTS AND RECEPTACLES AT COFFERDAM.
- 6 30 AMP, 3 POLE, NEMA 4X, STAINLESS STEEL FUSED SWITCH (TYPICAL OF EAST SIDE SLUICE AND BUTTERFLY GATES). PROVIDE 20 AMP FUSES IN SWITCH.
- 7 3 #12, 1 #12GD FOR GATE POWER AND 9/C #14 TYPE TC CONTROL IN 1" CONDUIT. TYPICAL FOR ALL EAST SIDE SLUICE GATES (1-12).
- 8 CONDUIT FOR LIGHTS SHALL BE ROUTED IN CONCRETE SLAB OF MONOLITH TO LIGHT POLES.
- 9 SLUICE GATE MOTOR CONTROLLER SUPPLIED UNDER DIVISION 11285 (TYPICAL FOR ALL SLUICE GATES 1-18).
- 10 BUTTERFLY GATE MOTOR CONTROLLER SUPPLIED UNDER DIVISION 11285. (TYPICAL AT EACH BUTTERFLY GATE MOTOR AT EAST AND WEST COFFERDAM).
- 11 FROM NEW 100 AMP FEEDER BREAKER IN MCC2 ROUTE 3 #2, 1 #8 GD OUT TO WEST SIDE SLUICE GATES.
- 12 ROUTE FROM EXISTING 20 AMP 2 POLE C/B IN PANEL "LB" (CIRCUIT 8) 2 #10, 1 #10 GD IN 1/2" CONDUIT OUT TO LIGHTING POLES AT WEST SIDE MONOLITH. ROUTE FROM EXISTING 20 AMP, 1 POLE SPARE C/B IN PANEL "LB" (CIRCUIT 14) 3 #10 (1 HOT, 1 SWITCH, 1 NEUTRAL) AND 1 #10 GD OUT TO RECEPTACLES AT WEST SIDE MONOLITH AND TO RECEPTACLES AND LIGHTS AT WEST COFFERDAM. THE LIGHTS AT COFFERDAM SHALL BE CONTROLLED THRU THE LIGHTING CONTACTOR.
- 13 FROM CONTROL PANEL #12 IN CONTROL HOUSE ROUTE 2-1/2" CONTROL CONDUITS EACH CONTAINING THREE 9/C #14 TYPE TC CONTROL CABLES OUT TO WEST SIDE SLUICE GATE CONTROLLERS. ROUTE ONE 9/C #14 TYPE TC CONTROL CABLE TO EACH GATE CONTROLLER.
- 14 30 AMP, 3 POLE 480 VOLT, NEMA 4X, STAINLESS STEEL, FUSED SWITCH (TYPICAL FOR ALL WEST SIDE SLUICE GATE MOTORS). PROVIDE 30 AMP FUSES IN SWITCH.
- 15 3 #10, 1 #10 GD FOR GATE POWER AND 9/C #14 TYPE TC CONTROL CABLE IN 1" CONDUIT. (TYPICAL FOR ALL WEST SIDE SLUICE GATE MOTORS).
- 16 NEW 20 AMP, 12 POLE, 208 VOLT LIGHTING CONTACTOR, ELECTRICALLY HELD WITH 120V OPERATING COIL. THE CONTACTOR SHALL BE RECESSED MOUNTED IN WALL ABOVE PANEL "LB" IN CONTROL ROOM. (SEE SHEET 9-2 FOR EXACT LOCATION).
- 17 FROM CONTROL PANEL #12 IN CONTROL HOUSE ROUTE ONE 1/2" CONTROL CONDUIT CONTAINING FOUR 9/C #14 TYPE TC CONTROL CABLES TO EXISTING PULLBOX IN STATION HOUSE. TERMINATE CABLES ON EXISTING TERMINAL BLOCKS IN BOX. THESE EXISTING CABLES GO OUT TO EXISTING VERTICAL PUMPS 1-4.
- 18 EXISTING CONTROL CONSOLE #12 LOCATED IN CONTROL HOUSE (SEE SHEET 9-2 FOR EXACT LOCATION). REFER TO SEWERAGE AND WATER BOARD SHEET 9-10 FOR NEW CONTROL EQUIPMENT (PUSHBUTTONS, PILOT LIGHTS, SELECTOR SWITCHES, AND TERMINAL BLOCKS) ASSOCIATED WITH CONTROL CONSOLE. CONTRACTOR SHALL SUPPLY ALL NEW ELECTRICAL EQUIPMENT SHOWN ON SHEET 9-10 AND SHALL ARRANGE EQUIPMENT IN EXISTING CONSOLE AS SHOWN ON THE CONSOLE LAYOUT.

SYMBOL	REVISIONS	DATE	APPROVED
U.S. ARMY ENGINEER DISTRICT, NEW ORLEANS CORPS OF ENGINEERS NEW ORLEANS, LOUISIANA			
IMC CONSULTING ENGINEERS LAKE PONCHARTRAIN, LA. AND VICINITY HURRICANE PROTECTION HIGH LEVEL PLAN FRONTING PROTECTION AT PUMP STATION #8 ORLEANS PARISH - JEFFERSON PARISH 17th STREET OUTFALL CANAL METAIR, LOUISIANA			
PARTIAL ELECTRICAL ONE LINE DIAGRAM			
DESIGNED BY: R.E.N.	DATE: SEPT. 1997	PLOT SCALE: 1	PLOT DATE: SEPT. 1997
DRAWN BY: T.R.E.	CADD FILE: P88-9-00.000	FILE NO. H-4-44654	
CHECKED BY: R.E.N.	SOLICITATION NO. DACW29-98-B-0112	DWG. 9-9 OF 10	
SUBMITTED BY:			

