

U.S. Department  
of Agriculture

Forest Service

National Technology  
and Development  
Program

7700—Transportation  
Management

0877 1801—SDTDC

May 2008



# **STREAM SIMULATION: An Ecological Approach to Providing Passage for Aquatic Organisms at Road-Stream Crossings**



Cover photo: Crooked River arch culvert on the Payette National Forest, Idaho. Installed 2006.

# **STREAM SIMULATION: An Ecological Approach To Providing Passage for Aquatic Organisms at Road- Stream Crossings**



by

**Forest Service Stream-Simulation Working Group**

National Technology and Development Program

San Dimas, CA 91773

May 2008

---

Information contained in this document has been developed for the guidance of employees of the U.S. Department of Agriculture (USDA) Forest Service, its contractors, and cooperating Federal and State agencies. The USDA Forest Service assumes no responsibility for the interpretation or use of this information by other than its own employees. The use of trade, firm, or corporation names is for the information and convenience of the reader. Such use does not constitute an official evaluation, conclusion, recommendation, endorsement, or approval of any product or service to the exclusion of others that may be suitable.

The U.S. Department of Agriculture (USDA) prohibits discrimination in all its programs and activities on the basis of race, color, national origin, age, disability, and where applicable, sex, marital status, familial status, parental status, religion, sexual orientation, genetic information, political beliefs, reprisal, or because all or part of an individual's income is derived from any public assistance program. (Not all prohibited bases apply to all programs.) Persons with disabilities who require alternative means for communication of program information (Braille, large print, audiotape, etc.) should contact USDA's TARGET Center at (202) 720-2600 (voice and TDD). To file a complaint of discrimination, write USDA, Director, Office of Civil Rights, 1400 Independence Avenue, S.W., Washington, D.C. 20250-9410, or call (800) 795-3272 (voice) or (202) 720-6382 (TDD). USDA is an equal opportunity provider and employer.



## Table of Contents

---

PREFACE .....	xvii
ACKNOWLEDGEMENTS .....	xix
INTRODUCTION .....	xxiii

### **Chapter 1—Ecological Considerations for Crossing Design**

1.1 ECOLOGICAL CONCEPTS .....	1—1
1.1.1 Habitat .....	1—1
1.1.2 Aquatic Communities .....	1—3
1.1.3 Ecosystem Processes .....	1—4
1.2 ANIMAL MOVEMENT .....	1—9
1.2.1 Importance of Movement for Individual Animals .....	1—9
1.2.2 Ecological Functions of Movement .....	1—12
1.2.3 Movement Capabilities of Aquatic and Riparian Organisms .....	1—13
1.2.4 Barriers to Movement Providing Some Positive Benefit .....	1—21
1.3 POTENTIAL ADVERSE IMPACTS OF ROAD-STREAM CROSSING STRUCTURES .....	1—22
1.3.1 Effects on Channel Processes and Aquatic Habitats .....	1—22
1.3.2 Effects on Aquatic Organism Passage .....	1—27
1.3.3 Effects on Individual Animals .....	1—31
1.3.4 Reduced Access to Vital Habitats .....	1—33
1.3.5 Population Fragmentation and Isolation .....	1—33
1.3.6 Disruption of Processes That Maintain Regional Populations .....	1—34
1.3.7 Time and Geography .....	1—34
1.4 AN ECOSYSTEMS APPROACH .....	1—42

### **Chapter 2—Managing Roads for Connectivity**

2.1 REVIEW THE ROAD NETWORK .....	2—1
2.2 OPTIMIZE ROAD AND CROSSING LOCATIONS .....	2—2
2.3 INVENTORY BARRIERS AND SET PRIORITIES FOR PASSAGE RESTORATION .....	2—4
2.4 SET PROJECT OBJECTIVES AND DESIGN TO ACHIEVE THEM .....	2—5
2.4.1 Road Approaches to the Stream Crossing .....	2—11
2.5 CONSTRUCT AND MAINTAIN THE CROSSING .....	2—12
2.6 MONITOR THE CROSSING .....	2—14

# Stream Simulation

---

## Chapter 3—Introduction to Stream Simulation Chapter

3.1	WHAT STREAM SIMULATION IS AND WHAT IT ISN'T .....	3—1
3.2	KEY ELEMENTS AND LIMITATIONS OF STREAM SIMULATION .....	3—3
3.3	HOW COMPLEX DOES IT NEED TO BE? .....	3—7
3.4	ROADMAP FOR STREAM-SIMULATION DESIGN .....	3—8
3.4.1	Initial Watershed and Reach Review .....	3—9
3.4.2	Site Assessment.....	3—10
3.4.3	Stream-simulation Design.....	3—10
3.4.4	Final Design and Contract Preparation.....	3—11
3.4.5	Construction.....	3—11
3.4.6	Maintenance and Monitoring.....	3—12

## Chapter 4—Initial Watershed and Reach Review

4.1	REVIEW THE ROAD CONTEXT .....	4—1
4.2	REVIEW RESOURCE VALUES .....	4—3
4.3	EVALUATE WATERSHED RISK FACTORS.....	4—4
4.3.1	Geomorphic Hazards .....	4—5
4.3.2	History and Location of Land Cover Changes and Watershed Events .....	4—6
4.3.3	Offsite Channel Stability.....	4—7
4.4	CONDUCT THE INITIAL SITE RECONNAISSANCE.....	4—8
4.4.1	Construction Issues .....	4—21
4.5	ASSESS SITE SUITABILITY .....	4—21
4.6	DEFINING PROJECT OBJECTIVES AND INITIAL DESIGN CONCEPT .....	4—25
4.7	DOCUMENT YOUR FINDINGS .....	4—27
4.8	INITIAL REVIEW EXAMPLE.....	4—28

## Chapter 5—Site Assessment

5.1.	COLLECTING SITE DATA .....	5—1
5.1.1.	Sketch Map .....	5—2
5.1.2.	Topographic Survey .....	5—5
5.1.3.	Longitudinal Profile .....	5—8
5.1.3.1.	What and where to survey .....	5—8
5.1.3.2.	Length of the longitudinal profile .....	5—12

## Table of Contents

5.1.3.3. Grade controls .....	5—13
5.1.4. Cross Sections .....	5—16
5.1.4.1. Location and number of cross sections .....	5—16
5.1.4.2. Typical cross-section measuring points .....	5—17
5.1.5. Channel Types and Bed Mobility.....	5—23
5.1.6. Channel-bed and Bank-material Characteristics .....	5—24
5.1.6.1. Sampling strategies and methods .....	5—25
5.1.6.2. Key features.....	5—32
5.1.6.3. Wood.....	5—32
5.1.6.4. Bank materials and morphology .....	5—34
5.1.7. Preliminary Geotechnical Investigation .....	5—36
5.1.8. Road Travel-way and Construction Considerations .....	5—38
5.2. ANALYZING AND INTERPRETING SITE DATA .....	5—39
5.2.1. Interpreting Sediment Processes and Mobility .....	5—39
5.2.2. Analyzing the Longitudinal Profile.....	5—41
5.2.2.1. Identify longitudinal profile shape.....	5—47
5.2.2.2. Determining vertical adjustment potential .....	5—52
5.3. PROJECT SITE RISK ASSESSMENT.....	5—61
5.3.1. High Flood-plain Conveyance .....	5—61
5.3.2. Lateral Adjustment Potential and Alignment.....	5—65
5.3.3. Headcutting Potential .....	5—66
5.3.4. Debris .....	5—69
5.3.5. Unstable Channels .....	5—70
5.4. DOCUMENT KEY DESIGN CONSIDERATIONS AND RECOMMENDATIONS .....	5—71
5.5. REFERENCE REACH: THE PATTERN FOR STREAM-SIMULATION DESIGN.....	5—72
5.5.1. Reference Reach Data Required for Stream Simulation Design .....	5—76

## Chapter 6—Stream-Simulation Design

6.1 PROJECT ALIGNMENT AND PROFILE .....	6—1
6.1.1. Alignment .....	6—2
6.1.1.1. Risks of longer culverts .....	6—4
6.1.1.2. Channels skewed to the road .....	6—5
6.1.1.3. Culvert on a bend .....	6—7
6.1.1.4. Transitions .....	6—9

## Stream Simulation

---

6.1.2. Designing the Project Longitudinal Profile .....	6—11
6.1.2.1. Uniform channels with local scour and fill around an undersized culvert .....	6—14
6.1.2.2. Steep channels with large key features .....	6—15
6.1.2.3. Concave slope transitions .....	6—16
6.1.2.4. Convex slope transitions.....	6—20
6.1.2.5. Incised channels.....	6—21
6.1.3. Project Alignment and Profile Design: Two Examples.....	6—27
6.2. DESIGN OF THE STREAM-SIMULATION CHANNEL BED .....	6—37
6.2.1. General Procedures for Simulated Streambed Design .....	6—38
6.2.1.1. Bed material size and gradation in armored channels .....	6—38
6.2.1.2. Channel cross section .....	6—42
6.2.1.3. Bank and channel margin features.....	6—43
6.2.1.4. Key features .....	6—46
6.2.2. Bed Design Considerations for Specific Channel Types .....	6—48
6.2.2.1. Dune-ripple channels.....	6—48
6.2.2.2. Pool-riffle channels.....	6—51
6.2.2.3. Plane-bed channels .....	6—54
6.2.2.4. Step-pool channels .....	6—54
6.2.2.5. Cascade channels .....	6—56
6.2.2.6. Bedrock channels.....	6—57
6.2.2.7. Channels with cohesive bed material .....	6—58
6.3. CROSSING STRUCTURE DIMENSIONS AND ELEVATION.....	6—58
6.3.1. Culvert Width.....	6—59
6.3.2. Culvert Elevation and Height .....	6—61
6.3.3. Culvert Shape and Material .....	6—64
6.4. BED-MOBILITY AND STABILITY ANALYSIS .....	6—64
6.4.1. When is a Bed-mobility Analysis Necessary? .....	6—65
6.4.2. What Particle Sizes Are Analyzed? .....	6—66
6.4.3. What Flows Are Analyzed? .....	6—66
6.4.4. Bed Mobility Analysis Equations .....	6—66
6.4.5. Stability Analysis for Immobile Key Feature Rocks .....	6—68
6.5. MANAGING RISK FACTORS.....	6—68
6.5.1. Potential Culvert Failure Risks—Stream-simulation Culverts .....	6—69



## Table of Contents

6.5.1.1. Flood-plain constriction .....	6—72
6.5.1.2. Rapid lateral channel migration.....	6—76
6.5.1.3. Steepened channel .....	6—76
6.5.1.4. Downstream channel instability .....	6—77
6.5.1.5. Inlet control with submerged inlet.....	6—78
6.5.1.6. Long culvert .....	6—78
6.5.1.7. Initial lack of bed consolidation .....	6—79
6.5.1.8. Excessive infiltration into the streambed.....	6—80
6.5.2. Potential Culvert Failure Risks—All Culverts .....	6—80
6.5.2.1. Flow exceeds culvert capacity .....	6—80
6.5.2.2. Debris or sediment blockage .....	6—81
6.5.2.3. Stream diversion potential .....	6—82
6.6. DESIGN DOCUMENTATION .....	6—83

## Chapter 7—Final Design and Contract Preparation

7.1. PHASE OVERVIEW.....	7—1
7.2. CROSSING STRUCTURE SELECTION.....	7—5
7.2.1. Site Geometry .....	7—7
7.2.1.1. Dipping the road profile to prevent stream diversion .....	7—8
7.2.1.2. Low embankment options .....	7—8
7.2.2. Construction Considerations .....	7—10
7.2.3. Cost Considerations .....	7—11
7.2.4. Tips for Choosing Structures .....	7—14
7.3. STRUCTURAL DESIGN .....	7—14
7.3.1. The Crossing Structure .....	7—15
7.3.2. Footing Design.....	7—15
7.3.3. Structure Backfill .....	7—17
7.3.4. Existing Site Materials.....	7—19
7.4. HANDLING TRAFFIC DURING CONSTRUCTION.....	7—21
7.5. DEVELOPING SPECIFICATIONS.....	7—22
7.5.1 Submittals .....	7—23
7.5.2. Supplemental Specification 251: Streambed Construction.....	7—23

## Stream Simulation

---

7.5.2.1. Description .....	7—23
7.5.2.2. Materials .....	7—24
7.5.2.3. Construction methods .....	7—25
7.5.3. Developing SPS 705: Specifying Rock Sizes .....	7—30
7.6. DESIGNING FOR FLOOD AND DEBRIS FAILURE PREVENTION .....	7—34
7.7. PLANNING FOR EROSION AND POLLUTION CONTROL .....	7—34
7.7.1. General Erosion Control During Construction .....	7—35
7.7.2. Permanent Erosion Control Measures .....	7—37
7.7.2.1. Diversion-prevention dips .....	7—38
7.8. DEWATERING, BYPASS, AND WATER TREATMENT DURING CONSTRUCTION .....	7—39
7.8.1. Bypass Dams .....	7—41
7.8.2. Bypass Design .....	7—44
7.8.3. Sump Design .....	7—45
7.8.4. Sediment Treatment Methods .....	7—46
7.8.5. Backwatered Sites .....	7—48
7.8.6. Deep Fills .....	7—48
7.8.7. Large Streams .....	7—49
7.8.8. Small Streams .....	7—49
7.8.9. Bedrock Channels .....	7—49
7.8.10. Field Modifications .....	7—49
7.8.11. Pollution Control .....	7—50
7.9. SPECIAL CONTRACT REQUIREMENTS .....	7—50

## Chapter 8—Stream-Simulation Construction

8.1. BRIEF INTRODUCTION TO STREAM-SIMULATION CONSTRUCTION .....	8—2
8.1.1. Roles .....	8—2
8.1.2. Communications .....	8—3
8.1.3. Contact Administration Meetings .....	8—4
8.1.3.1. Prebid tour .....	8—4
8.1.3.2. Prewrite meeting .....	8—5
8.1.3.3. Prewrite field meeting .....	8—5
8.1.3.4. Final inspection/post-construction meeting .....	8—6
8.1.4. Construction and Inspection .....	8—6

## Table of Contents

8.1.5. Construction BMPs.....	8—6
8.1.6. Construction Survey and Tolerances.....	8—7
8.1.7. Permits and Permit Requirements.....	8—7
8.1.8. Contract Modifications/Design Changes .....	8—7
8.1.9. As-built Drawings and Final Construction Report .....	8—8
8.2. STREAM-SIMULATION CONSTRUCTION TOPICS.....	8—8
8.2.1. Safety .....	8—9
8.2.2. Construction Survey .....	8—10
8.2.3. Special Contract Requirements (H Clauses) .....	8—13
8.2.4. Signs and Traffic Control Plans .....	8—13
8.2.5. Erosion, Sediment, and Pollution Control .....	8—13
8.2.5.1. Reviewing erosion- and sediment-control plans .....	8—14
8.2.5.2. Pollution control and prevention plans .....	8—17
8.2.6. Dewatering and Sediment Removal .....	8—18
8.2.6.1. Protection of aquatic organisms when dewatering.....	8—19
8.2.6.2. Dewatering plan review.....	8—20
8.2.6.3. Dewatering inspection recommendations.....	8—22
8.2.6.4. Tips for collecting and treating sediment-laden water .....	8—26
8.2.7. Excavation.....	8—29
8.2.7.1. OSHA and excavation safety.....	8—29
8.2.7.2. Excavation—what can go wrong?.....	8—31
8.2.8. Structural Excavation .....	8—31
8.2.8.1. Bedrock and blasting.....	8—32
8.2.8.2. Settlement beneath foundations and pipes.....	8—33
8.2.9. Constructed Concrete Features .....	8—34
8.2.9.1. Concrete form inspection.....	8—34
8.2.9.2. Pouring concrete.....	8—35
8.2.9.3. Inspection recommendations for concrete placement .....	8—36
8.2.10 Culvert Installation .....	8—37
8.2.10.1. Closed-bottom culvert bedding .....	8—37
8.2.10.2. Open-bottom culvert attachment .....	8—38
8.2.10.3. Pipe assembly .....	8—38
8.2.10.4. Multiplate pipes.....	8—39

## Stream Simulation

---

8.2.10.5. Backfill and embankments.....	8—40
8.2.11. Stream-simulation Bed Material Placement .....	8—41
8.2.11.1. Size of streambed materials.....	8—42
8.2.11.2. Constructing the simulated streambed.....	8—44
8.2.11.2.1. Recommendations for placing material in open-bottom arches ...	8—45
8.2.11.2.2. Recommendations for placing material in embedded pipes .....	8—46
8.2.11.2.3. Placing channel rocks .....	8—48
8.2.12. Permanent Erosion Control Measures .....	8—49
8.2.12.1. Revegetation .....	8—49
8.2.12.2. Riprap inspection .....	8—52
8.2.13. General Road Construction.....	8—53
8.2.13.1. Roadway drainage structures.....	8—53
8.2.14. Demobilization/Cleanup .....	8—54
8.3. POST CONSTRUCTION.....	8—55
8.3.1. Post-construction Project Review .....	8—55
8.3.2. Post-construction Monitoring .....	8—56
8.3.2.1. Physical monitoring of structure performance .....	8—56
8.3.2.2. Physical monitoring of streambed performance.....	8—56

## Glossary

## References

## Appendix A—Geomorphic Principles Applied in Stream Simulation

A.1. WHY CONSIDER FLUVIAL PROCESSES IN CROSSING DESIGN? .....	A—1
A.2. THE WATERSHED CONTEXT .....	A—3
A.3. CHANNEL CHARACTERISTICS .....	A—6
A.3.1. Streambed Material .....	A—6
A.3.2. Channel Slope .....	A—10
A.3.3. Channel Pattern.....	A—13
A.3.4. Channel Dimensions, Confinement, and Entrenchment .....	A—17
A.3.5. Channel Bedforms .....	A—18
A.3.6. Flow Resistance or Channel Roughness .....	A—20

## Table of Contents

---

A.4. CHANNEL STABILITY AND EQUILIBRIUM .....	A—22
A.4.1. Equilibrium and Bankfull Flow .....	A—24
A.5. FLUVIAL PROCESSES .....	A—25
A.5.1. Sediment Dynamics .....	A—25
A.5.2. Vertical Channel Adjustment .....	A—27
A.5.3. Lateral Channel Adjustment .....	A—28
A.5.4. Flood-plain Inundation and Dynamics .....	A—30
A.6. CHANNEL CLASSIFICATION SYSTEMS.....	A—31
A.6.1. Montgomery and Buffington Channel Classification .....	A—31
A.6.2. Rosgen Channel Classification .....	A—39
A.7. UNSTABLE CHANNELS .....	A—41
A.7.1. Inherently Unstable Landforms and Channel Types .....	A—41
A.7.2. Channels Responding to Disturbances .....	A—43

### **Appendix B—Other Culvert Design Methods for Fish Passage**

B.1. HYDRAULIC DESIGN METHOD .....	B—1
B.2. HYBRID DESIGN AND ROUGHENED-CHANNEL DESIGN .....	B—2
B.3. VELOCITY SIMULATION .....	B—4
B.4. “NO-SLOPE” DESIGN.....	B—4

### **Appendix C—Site Assessment Check List**

### **Appendix D—Estimating Design Stream Flows at Road-Stream Crossings**

D.1. INTRODUCTION .....	D—1
D.2. DESIGN FLOW ESTIMATES .....	D—2
D.2.1. Design Flow Estimates at Gauged Sites .....	D—4
D.2.1.1. Weighted flood frequency.....	D—5
D.2.2. Design-flow Estimates Near Gauged Sites .....	D—6
D.2.2.1. Ungauged site on a gauged stream .....	D—7
D.2.2.2. Ungauged site near a gauged stream .....	D—9
D.2.3. Flow Estimates on Ungauged Streams .....	D—9
D.3. VERIFYING FLOW ESTIMATES AT UNGAUGED STREAMS .....	D—12

## Stream Simulation

---

### Appendix E—Methods for Streambed Mobility/Stability Analysis

E.1	FLOW HYDRAULICS: SHEAR STRESS AND UNIT DISCHARGE .....	E—1
E.1.1	Models for Calculating Flow Hydraulics .....	E—4
E.1.2	What Flows to Analyze .....	E—6
E.2	PARTICLE ENTRAINMENT IN NATURAL CHANNELS .....	E—6
E.2.1	Modified Critical Shear Stress Approach .....	E—10
E.2.2	Critical Unit Discharge Approach .....	E—12
E.2.3	Uncertainty in Predicting Particle Entrainment .....	E—14
E.3	SEDIMENT MOBILITY/STABILITY ANALYSIS EXAMPLE: SCHAFER CREEK TRIBUTARY .....	E—18
E.3.1	Channel and Road-stream Crossing Background Information .....	E—18
E.3.2	Modified Critical Shear Stress Approach.....	E—21
E.3.3	Critical Unit Discharge Approach.....	E—25
E.3.4	Summary .....	E—29
E.4	SIZING IMMOBILE KEY PIECES.....	E—30

### Appendix F—Channel Grade Control Structures

Boulder Weirs .....	F—1
Roughened channels.....	F—5
Rigid Weirs .....	F—6

### Appendix G—Additional Tools and Tips

G.1.	CONTRACT PREPARATION CHECKLIST .....	G—1
G.2.	SAMPLE PROJECT SCHEDULE .....	G—2
G.3.	ESTIMATED PROJECT COSTS: COMPARING DIFFERENT STRUCTURE TYPES AND SIZES .....	G—5
G.3.1.	12-foot and 18-foot Open-bottom Arch Multiplate Structures—20-foot Fill.....	G—5
G.3.2.	8-foot and 12-foot Embedded CMPs—20-foot Fill.....	G—8
G.3.3.	8-foot and 12-foot Embedded CMPs—12-foot Fill.....	G—11

## Table of Contents

---

G.4. TIPS FROM ENGINEERS AND BIOLOGISTS EXPERIENCED IN STREAM-SIMULATION CONSTRUCTION .....	G—14
G.4.1. Diversion, Dewatering, and Water Treatment System Components .....	G—14
G.4.1.1. Bypass and backwater dams .....	G—14
G.4.1.2. Pump types and characteristics .....	G—20
G.4.1.3. Sediment removal methods .....	G—21
G.4.2. Foundation and Footing Design .....	G—25
G.4.2.1. Overturning forces .....	G—25
G.4.2.2. Scour .....	G—26
G.4.2.3. Bedrock .....	G—26
G.4.2.4. Soil strength .....	G—26
G.4.3. Revegetation and Erosion Control .....	G—28
G.4.3.1. Salvaging and storing topsoil .....	G—30
G.4.3.2. Collecting seeds and cuttings for native species revegetation .....	G—31
G.4.3.3. Water quality monitoring .....	G—32
G.4.3.4. Training and quality control .....	G—32
G.4.3.5. Temporary soil stabilization until vegetation is fully established .....	G—33
G.4.3.6. Miscellaneous ‘things that can go wrong’ during construction .....	G—33
G.4.3.7. Seasonal work shutdown and resumption of work .....	G—34
G.4.3.8. Common problems with revegetation .....	G—35
G.4.3.9. Resources for revegetation and erosion control .....	G—38
G.4.4. Aquatic Organism Capture and Transport .....	G—39
G.4.4.1. South Fork Desolation Creek .....	G—40
G.4.4.2. Karnowski Creek habitat restoration .....	G—42

## Appendix H—Sample Contract Provisions

SUPPLEMENTAL SPECIFICATION 157—SOIL EROSION CONTROL .....	H—3
SUPPLEMENTAL SPECIFICATION 251—STREAMBED CONSTRUCTION .....	H—9
SUPPLEMENTAL SPECIFICATION 705—STREAMBED-SIMULATION MATERIALS .....	H—11
SPECIAL CONTRACT REQUIREMENTS (H-CLAUSES) .....	H—12





### Preface

This is a guide to stream simulation—a method for designing and building road-stream crossings intended to permit free and unrestricted movements of any aquatic species. The guide aims to help national forests achieve their goal of maintaining the physical and biological integrity of the stream systems they manage, including existing populations of fish and other wildlife species (see National Forest Management Act, 16 U.S.C. 1600-1616). Habitat fragmentation is an important factor contributing to population declines of many fish, and crossing structures that are barriers are a large part of the problem. Stream simulation provides continuity through crossing structures, allowing all aquatic species present to move freely through them to access habitats, avoid adverse conditions, and seek food and mates. Stream simulation applies to crossing structures on any transportation network, including roads, trails, and railroads. For brevity, the guide refers to all of these types of transportation infrastructure as ‘roads.’

Whether culverts or bridges, stream-simulation structures have a continuous streambed that mimics the slope, structure, and dimensions of the natural streambed. The premise of stream simulation is that since the simulation has very similar physical characteristics to the natural channel, aquatic species should experience no greater difficulty moving through it. Water depths and velocities are as diverse as those in a natural channel, providing passageways for all swimming or crawling aquatic species.

Work on this guide began in response to a set of project proposals from engineers and biologists concerned with designing culverts for anadromous fish passage in the Alaska, Pacific Northwest, and Northern Forest Service, U.S. Department of Agriculture regions. During the initial project scoping process, it became apparent that many other fish and nonfish species across the country are also harmed by passage barriers. At that point, the project’s focus expanded from anadromous fish to all aquatic organisms. Stream simulation is the technology most likely to achieve the goal of aquatic organism passage.

The idea of creating crossings that mimic the stream is not new (Katapodis 2005), but the technique was developed in its now best-known form in the Washington Department of Fish and Wildlife’s 1999 “Fish Passage Guidelines” (Bates 2003). The present guide builds on that foundation, expanding our understanding of stream simulation and adding the results of several more years of design and construction experience, much of it by Forest Service engineers, biologists, and geomorphologists. The intent is to meet the needs of the Forest Service for a flexible design process for aquatic organism passage at road-stream crossings. The guide is for project

## **Stream Simulation**

---

teams that include members from several disciplines. It aims to help each team member better understand the challenges and considerations pertinent to the other disciplines, as well as their own. Although organized to suit the project design, construction, and management processes of the Forest Service, the guidance should also be helpful for other groups.

Stream-simulation technology is relatively new and changing rapidly. The bulk of the experience reflected in this guide's content comes from Alaska, and the Pacific Northwest coastal and inland States. The guide's authors, editors, and reviewers encourage practitioners in other landscapes to adapt the methods described here to local stream processes, and to contribute their findings to the expanding collection of experience and guidelines. We anticipate great strides in our ability to effectively and efficiently simulate streams through crossings, as forests apply, monitor, and modify the technology in vastly different areas.

### Acknowledgements

Many people have contributed to this guide in a variety of ways. What started as a relatively restricted task—to collect design recommendations from a small group of people experienced in stream simulation—grew into a more extensive guide that now includes topics on final engineering design and construction. Because stream simulation is a relatively new way of handling the restoration of stream ecosystems during road-stream crossing projects, unknowns and debatable issues remain. As this guide evolved, these gray areas required clarification through lively discussions, debates, critiques, and the patient support of too many people to name here. We, the editors and principal authors, thank all who participated in this process.

### Contributing Editor

Kim Clarkin, hydrologist, Forest Service, San Dimas Technology and Development Center (SDTDC) project leader, San Dimas, CA.

### Principal Authors

Robert A. Gubernick, engineering geologist, Forest Service, Tongass National Forest, Alaska.

Daniel A. Cenderelli, geomorphologist, Forest Service, Stream Systems Technology Center, Fort Collins, CO.

Kozmo Ken Bates, consulting fish passage engineer, Olympia, WA.

David Kim Johansen, geotechnical engineer, Forest Service, Willamette and Siuslaw National Forests, Oregon.

Scott D. Jackson, herpetologist, and Director of the Natural Resources and Environmental Conservation Extension Program, University of Massachusetts, Amherst, MA.

### Technical Advisors

*The technical advisors have considerable experience and expertise in fish passage design, and contributed significantly to the development of many of the techniques described in this guide:*

Mark R. Weinhold, hydrologist and civil engineer, Forest Service, White River National Forest, Colorado.

Traci L. Sylte, hydrologist and civil engineer, Forest Service, Lolo National Forest, Montana.

## Stream Simulation

---

### Other Contributors

*The following people collaborated closely with the working group and made important contributions to the technical content and presentation of the guide:*

William V. Crane, civil engineer, Forest Service (retired), SDTDC, and contributing editor for the final engineering design and construction sections.

Mark A. Fedora, hydrologist, Forest Service, Eastern Region, Ironwood, MI.

Michael J. Furniss, hydrologist, Forest Service, Pacific Northwest and Pacific Southwest Research Stations, Arcata, CA.

Kathleen Moynan, fishery biologist, U.S. Department of the Interior, Fish and Wildlife Service, Portland, OR

Brian W. Riggers, fishery biologist, Forest Service, Lolo National Forest, Montana.

John Sanchez, fishery biologist, Forest Service, Siuslaw National Forest, Oregon.

### Other Assistance

*Thanks also to the following people who provided photos, graphics, examples, and expertise:*

All unattributed photos in this guide were contributed by Forest Service employees.

Rowan Baker, U.S. Department of the Interior, Fish and Wildlife Service, Portland, OR.

Jack N. Conyngham, U.S. Army Corps of Engineers, Research and Development Center, Vicksburg, MS.

Kurt Fausch, Colorado State University, Fort Collins, CO.

Craig J. Fischenich, U.S. Army Corps of Engineers, Research and Development Center, Vicksburg, MS.

Thomas Gillins, Forest Service, Intermountain Region, Ogden, UT.

Ben Hipple, Forest Service, Payette National Forest, McCall, ID.

Jack Holcomb, Forest Service, Southern Region, Atlanta, GA.

Mark Hudy, Forest Service, Eastern and Southern Regions, Harrisonburg, VA.

Shawn Jones, Earthwork Consulting LLC, Gresham, OR.

Gordon Keller, Forest Service, Plumas National Forest, Quincy, CA.

Michael S. Kellett, Forest Service, Boise National Forest, Boise, ID.

## Acknowledgements

---

Michael Love, Love and Associates, Eureka, CA.

Robert Newbury, Newbury Hydraulics, Inc., Okanagan Centre, BC, Canada.

Dan Rhodes, U.S. Department of the Interior, National Park Service, Yellowstone National Park.

Alan Richmond, University of Massachusetts, Amherst, MA.

Brett Roper, Forest Service, Intermountain Research Station, Logan, UT.

Bill Shelmerdine, Forest Service, Olympic National Forest, Olympia, WA.

Ross Taylor, Ross Taylor and Associates, McKinleyville, CA.

Roger Thoma, Ohio State University, Columbus, OH.

### Technical Editors

Natalie Reid, consultant and editor, Albuquerque, NM.

Wendy Masri, consultant (systems engineering and technical documentation), and technical editor during the early stages of document development, Sierra Madre, CA.

### Graphic Artists

Susan Christensen, Forest Service, Tongass National Forest, Alaska.

Deborah Mucci, Forest Service, Missoula Technology and Development Center, Montana.

George Toyama, Forest Service, San Dimas Technology and Development Center, California.

L'Tanga Watson, Forest Service, Angeles National Forest, California.

Paul Karr, Flathead, Idaho.

### Reviewers

Bob Barnard, Washington Department of Fish and Wildlife, Olympia, WA.

Bart Bergendahl, U.S. Department of Transportation, Federal Highway Administration, Central Federal Lands Highways, Denver, CO.

Mark Browning, U.S. Department of Transportation, Federal Highway Administration, Western Federal Lands Highways, Vancouver, WA.

Kristin Bunte, Colorado State University, Fort Collins, CO.

Michael J. Furniss, Forest Service, Pacific Northwest and Pacific Southwest Research Stations, Arcata, CA.

Tom Gillins, Forest Service, Intermountain Region, Ogden, UT.

John Kattel, Forest Service, Northern Region, Missoula, MT.

Russ Lafayette, Forest Service, Eastern Region, Milwaukee, WI.

Tom Lisle, Forest Service, Pacific Southwest Research Station, Arcata, CA.

Michael Love, Love and Associates, Eureka, CA.

Mark Miles, Alaska Department of Transportation, Anchorage, AK.

Bruce Reiman, Forest Service (retired), Intermountain Research Station, Boise, ID.

Julianne Thompson, Forest Service, Tongass National Forest, Alaska.

Marcin Whitman, California Department of Fish and Game, Sacramento, CA.

### Purpose of the Guide and Its Intended Audience

*Words shown in  
bold  
throughout this  
document are  
defined in the  
glossary*

The intent of this guide is to:

- Explain to land and road managers and a general audience:
  - Why providing stream continuity at road-stream crossings is critical for maintaining aquatic animal populations and habitats.
  - How stream simulation works to provide stream continuity at road-stream crossings.
- Guide practitioners working in multidisciplinary design teams through the assessment, design, and construction phases of a stream-simulation project.

Stream simulation is an approach to designing crossing structures (usually culverts), that creates a structure that is as similar as possible to the natural channel. When channel dimensions, slope, and **streambed structure** are similar, water velocities and depths also will be similar. Thus, the simulated channel should present no more of an obstacle to aquatic animals than the natural channel.

The first part of the guide (chapters 1 and 2) builds the case for stream continuity at crossings and gives a general overview of how to achieve continuity using stream-simulation methods. This part addresses a general audience, including managers responsible for roaded ecosystems. The remainder of the guide is for project teams responsible for either building a new crossing or replacing a crossing structure where full aquatic organism passage is a goal. This guide does not deal with the question of when full aquatic organism passage is necessary at a site. That decision depends on local policy and ecological needs.



Figure 1—Project team at a crossing site in New Hampshire.

## Stream Simulation

---

The greatest challenge of stream simulation is that it requires expertise in different technical fields. This guide does not teach all the technical concepts and methods needed for designing and constructing a stream-simulation crossing. Rather, it assumes that people skilled in engineering, contract administration, hydrology, geomorphology, and biology work together as a team throughout the process. The guide aims to help each member understand the challenges and considerations pertinent to the other disciplines, as well as to their own. Although different specialists may take the lead at different times, the whole team should be available for consultation throughout the project.

### Background

Streams and roads are long, linear networks whose functions include transporting material and organisms across the landscape. Being narrow and linear, both streams and roads are highly susceptible to blockages. The two systems frequently intersect, and at the junctions each can pose an obstacle to the other's continuity. In the past, most road-stream crossing design has aimed at protecting the road and minimizing traffic interruptions. Less attention has been given to protecting stream functions, such as sediment transport, fish and wildlife passage, or the movement of woody debris. Not surprisingly, many culverts disrupt the movement of aquatic organisms and impair aquatic habitats.

The numbers of road-stream junctions are huge. On National Forest System lands in Washington and Oregon, there are over 6,250 road-stream crossings on fish-bearing streams—approximately one crossing per every 3.6 miles of stream. According to Dave Heller, fishery biologist for the Pacific Northwest Region, in March 2004 about 90 percent of nonbridge (mostly culvert) crossings were considered to be at least partial barriers to anadromous fish passage. These barriers blocked about 15 percent of fish-bearing stream miles on national forest lands in the region (figure 2).

Until recently, where fish were a serious concern, designing culverts for passage of a target species (the “design fish”) during its migration season was considered best practice. This practice, however, often does not achieve the best *ecological* results. For example, considerable resources have gone into facilitating passage of adult salmon and steelhead migrating to their spawning grounds, only for fishery biologists to find that accommodations made for adults did not even begin to cover the needs of juveniles of the same species. Sustaining a population demands that all life stages must succeed, and fry, juveniles, and adults have different movement needs and capabilities.



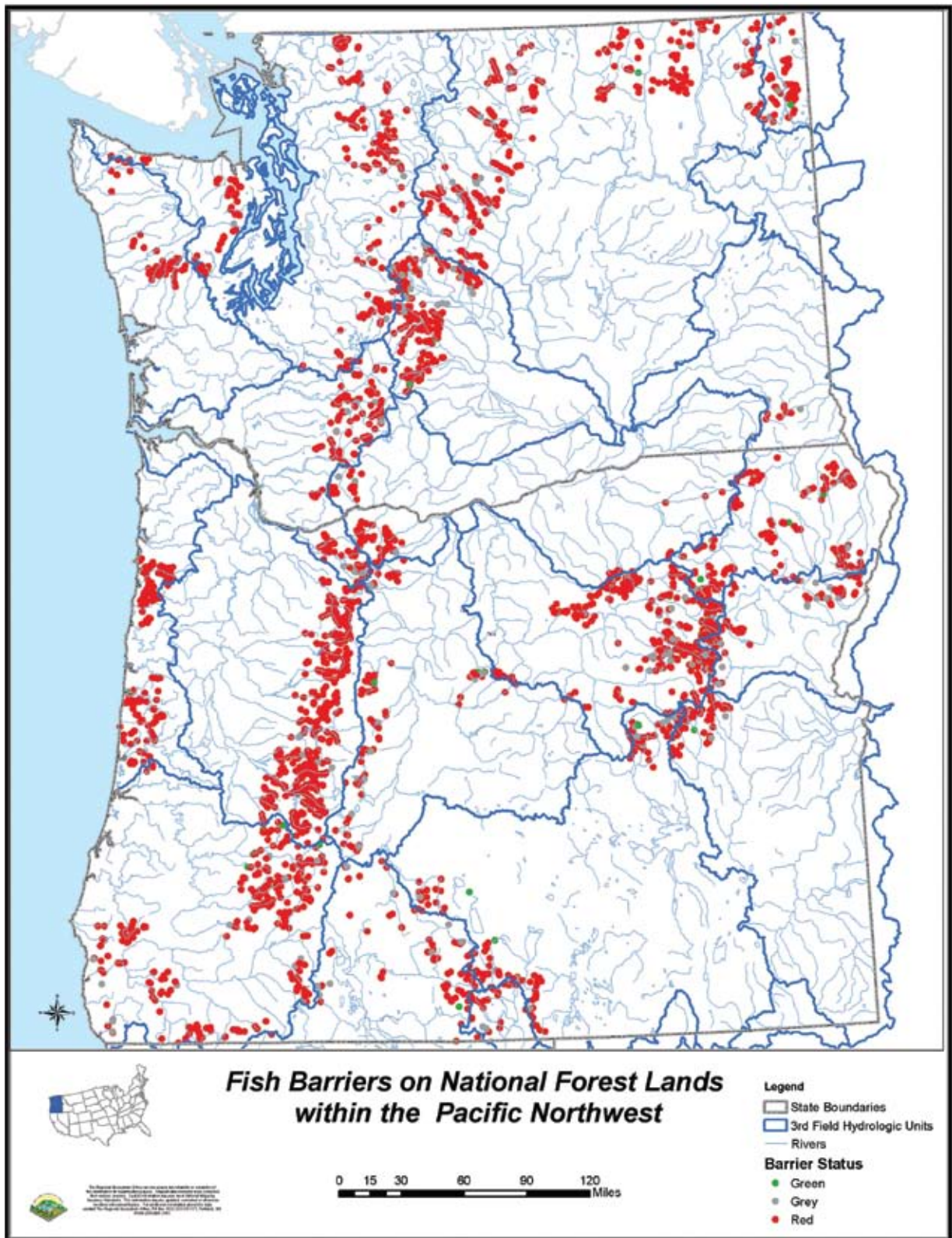

Figure 2—Forest Service Pacific Northwest Region map of road-stream crossing barrier status, 2005. Red dots indicate road-stream crossings that, at least partially, blocked passage of juvenile and/or adult anadromous salmonids.

## Stream Simulation

---

As chapter 1 will show, focusing on a single desirable species is not enough: The entire aquatic ecosystem is linked, and all species depend on each other for food and other essential interactions. As survival of a “target species” depends on a healthy and diverse ecosystem, it is essential to focus on habitat quality and continuity for *aquatic communities* rather than for individual species. Without an ecosystem-based approach to road-stream crossings, we will be at risk of facilitating passage for particular fish species while at the same time undermining the ecological integrity of the ecosystems on which these fish depend.



Figure 3. Culvert on the Boise National Forest prevents migration of kokanee salmon.

Stream simulation supports the ecosystem-based approach to road-stream crossing design and aims to provide full aquatic organism passage; that is, all aquatic and semiaquatic species should be able to travel through the crossing structure with no greater impediment than the natural channel would offer. The crossing, therefore, acts as neither a barrier nor a filter that passes only certain individuals, species, or age groups (life stages). Moreover, because a stream-simulation crossing accommodates the full channel width, it does not impede the downstream transport of floodwater, sediment, or woody debris as much as narrower, traditional culverts do. Stream simulation thus provides for not only the long-term sustainability of the entire aquatic community, but also a more durable roadway that is less susceptible to damage by high flows and **debris** blockage.

### Structure and Scope of the Guide

The first two chapters of this guide summarize the ecological consequences of habitat fragmentation caused by road-stream crossing barriers, and outline the steps necessary for restoring connectivity. These chapters answer the following two questions: Why is stream continuity at road-stream crossings important? and, How do we create it? Managers faced with making fiscally significant decisions about providing habitat connectivity at crossings should find these chapters especially useful.

**Chapter 1**, Ecological Considerations for Crossing Design, discusses when and why aquatic species need to move, what they require to be able to move, and what the consequences of barriers to individuals, populations, and communities are. Biologists should note that this guide does not describe how to determine where, when, or for which species passage is required. This guide also does not cover setting priorities for barrier removal.

**Chapter 2**, Managing Roads for Continuity, is a very brief overview of the planning, design, construction, and monitoring practices that can solve road-stream crossing barrier problems, including best management practices (**BMPs**). This overview is intended for land managers who participate in setting project objectives and making policy decisions that affect crossing projects. The chapter places stream simulation in context within a range of crossing design approaches.

The next six chapters describe the steps or phases of a stream-simulation design project. The process is applicable to new and replacement crossings, and to crossing removals. The focus is on forest roads; however, the concepts and general approach are applicable to crossings on other parts of the transportation system such as trails, highways, and railroads.

Chapters 3 through 8 are addressed to members of multidisciplinary project teams responsible for the assessment, design, and construction of road-stream crossings. Readers who are unfamiliar with stream morphology and processes can refer to appendix A for a brief introduction to geomorphic terms and concepts used throughout the assessment and design process.

## Stream Simulation

---

**Chapter 3**, Introduction to Stream Simulation, provides an overview of the process of stream-simulation design and construction. It defines and describes stream simulation and discusses limitations on its application.

Since this guide is intended as a reference, the descriptions of each phase of a stream-simulation project are comprehensive, including many complicating circumstances that may or may not pertain to a specific project. On any actual project, only factors and issues relevant to that project need to be considered. The level of detail in the assessment and design process should depend on the size, complexity, and risk of the project. Once teams gain experience, they can tailor the design process to the needs of each site.

**Chapter 4**, Initial Watershed and Reach Review, describes the large-scale assessments of watershed and aquatic resources and transportation needs that provide context for the project. At this stage, the project team takes a look at the “big picture.” The team also conducts a rapid reconnaissance of the **project reach** to verify that the road and crossing are well located, to identify risks, and to formulate preliminary project objectives.

**Chapter 5**, Site Assessment, describes the process of collecting and analyzing the geomorphic and other site data that are the basis for stream-simulation design.

**Chapter 6**, Stream-Simulation Design, shows practitioners how to use the assessment information in designing the simulated channel through the road-stream crossing. Note: To cover many road and stream settings with the design procedure, the authors have synthesized many years of experience in stream-simulation design and consulted experts throughout the country. Nonetheless, the guide primarily reflects experience in the Inland and Pacific Northwest. The technology is still in development. While culverts up to 15-percent slope have been constructed with these methods, such methods have not been used extensively on very low-gradient streams in fine sediments, cohesive soils, or densely vegetated streambeds.

Chapters 7 and 8 describe the final engineering design and construction phases. They are primarily directed to the project engineer and contract administrator, but all team members should find the material useful for understanding the elements and process of final design and construction. Consultation with the entire project team is essential in these final phases, especially when contract changes become necessary.

**Chapter 7**, Final Design and Contract Preparation, discusses structural design and contract preparation. It includes making the final decision on structure type, as well as on materials and contract requirements that are unique or that may need more emphasis in stream simulation projects.

**Chapter 8**, Stream-Simulation Construction, discusses the construction planning and implementation actions that are especially important to both the success of stream-simulation crossing construction projects and the protection of aquatic species and habitats. It offers field construction experience on stream-simulation projects and aims to help new practitioners avoid common mistakes.

This guide does not deal in detail with the last phase of all road-stream crossing projects—maintenance and monitoring (a brief discussion is in section 8.3.2). Monitoring is especially important on stream-simulation projects, since it is the only way to collect the information necessary for continually improving crossing design and construction practices. This guide is not the last word in this rapidly evolving field, and the authors anticipate with enthusiasm the growth of knowledge and experience that application of these principles in different environments will bring.

A glossary and a series of appendixes appear at the end of this guide. The glossary will be particularly useful for understanding terms used by a discipline in which the reader may not be well versed. As the material in certain chapters is directed towards team members with specific expertise, definitions of terms common within the discipline under discussion may not appear in the text. The glossary is therefore quite comprehensive, and readers should make good use of it.

# Stream Simulation

---

## Chapter 1—Ecological Considerations for Crossing Design

### 1.1 ECOLOGICAL CONCEPTS

Rivers and streams are more than mere conduits for water and fish. They are long, linear ecosystems made up of the physical environment, communities of organisms, and a variety of ecological processes that shape and maintain these ecosystems over time (figure 1.1). The long-term conservation of important aquatic resources (such as fish) requires the maintenance of healthy and ecologically viable ecosystems. As this chapter will show, road crossings have the potential to undermine the ecological integrity of roaded river and stream systems in a number of ways. To ensure the productivity and viability of river and stream ecosystems, we must protect and restore the quality of the physical environment (habitat), maintain intact communities of aquatic organisms, and take care not to disrupt critical ecological processes.



*Figure 1.1—Long-term conservation of aquatic resources requires the maintenance of healthy and ecologically viable ecosystems.*

#### 1.1.1 Habitat

To survive, an organism must have access to all habitats it needs for basic life functions. For many species, these needs for access occur throughout an organism's life cycle. Habitat is a combination of physical

## Stream Simulation

---

and biological characteristics of an area or areas, which are essential for meeting the food and other metabolic needs, shelter, breeding, and overwintering requirements of a particular species. For some species, habitat can be as small as individual rocks or the spaces between pebbles in the streambed. For others, it can include many miles of rivers, streams, **flood plains**, wetlands, and ocean.

The size and distribution of sediment particles and pore spaces within the streambed is particularly important for small and sedentary organisms. Water depth and velocity, as well as the physical and chemical properties of water, are also important elements of habitat for aquatic organisms. Substrate and hydrological characteristics of rivers and streams often vary in predictable ways, depending on whether a particular area is a cascade, riffle, run, pool, **side channel**, **backwater**, or flood plain. The size and complexity of these habitat types affect the abundance and diversity of organisms using those areas. The amount and distribution of habitat types within a river or stream **reach** will, in turn, determine whether the area serves as appropriate habitat for larger and more mobile species. The types, amount, and distribution of habitat types vary, depending on the size and gradient of a river or stream and its association with a significant flood plain (figure 1.2).



*Figure 1.2—The complexity of habitat types affects the abundance and diversity of organisms inhabiting the stream as well as the resilience and persistence of animal populations. Photo: Scott Jackson, University of Massachusetts.*



## Chapter 1—Ecological Considerations for Crossing Design

---

At any of these scales—from individual rocks in a streambed to particular habitat types (riffles, pools, cascades) to an entire river system—the particular area’s characteristics will determine what species are likely to be present. The tendency of areas to form structurally and functionally distinct portions of the landscape (for example, riffles, pools, runs, flood plains, **headwater streams**, **tidal rivers**) means that organisms that inhabit these areas often form distinct assemblages of species called communities. These communities of organisms and the physical environment they inhabit are what constitute ecosystems.

### 1.1.2 Aquatic Communities

Natural communities are more than mere collections of organisms. Species that make up communities are interconnected by a variety of ecological relationships, such as nutrient cycling and energy flow, predator-prey relationships, competition, and species interdependency. For example, a single stream reach may support a variety of fish species competing with each other for food and appropriate habitat. Diverse communities of invertebrates are essential for providing a food base for fish throughout the year. Disease organisms, parasites, or predators may differentially affect species and thus can affect the balance of competition among these fish.

The presence or absence of fish can affect whether other species are able to use river or stream habitats. Many amphibians, to breed successfully, require aquatic habitats that are fish free. These species may use flood-plain pools or **intermittent** sections of streams as long as fish regularly are not present. On the other hand, numerous species of North American freshwater mussels require specific fish hosts to complete reproduction (figure 1.3). Larval stages (glochidia) of these mussels attach themselves to the gills or fins of host fish (or in one case, host salamanders), a process essential for proper development and dispersal. The nature of these interdependencies is such that freshwater mussels are unable to occupy otherwise appropriate habitat if their particular fish hosts are not present.

Loss of species due to extirpation (extermination) of local populations or the exclusion of species due to migratory barriers (e.g., **anadromous** fish) has the potential to alter and undermine the sustainability of natural communities. Similarly, the presence or introduction of nonnative species can seriously degrade natural communities. Nonnative species may prey upon, compete, or interbreed with native species, and may serve as vectors for disease transmission.

## Stream Simulation

---



*Figure 1.3—A broken-ray mussel uses a mantle-flap lure to attract host darter that it will infect with glochidia. Photo: Chris Barnhart, Missouri State University.*

### 1.1.3 Ecosystem Processes

Other ecosystem processes that affect the composition and balance of organisms within a community include hydrology; the movement of sediment, woody debris, and other organic material; and natural disturbances that can significantly change the physical and biological characteristics of ecosystems.

As the defining feature of aquatic systems, the amount, distribution, movement, and timing of water is a critical factor in shaping aquatic communities. Many organisms time their life cycles or reproduction to take advantage of or avoid specific hydrological conditions. Flowing waters also transport sediment downstream, changing the substrate characteristics of areas contributing and receiving the material. Sediment lost downstream is normally replaced by material transported from farther upstream. **Woody debris** is a habitat feature for many species and a factor that can significantly change the physical and biological characteristics of streams. Debris dams or partial dams (deflectors) can create pools and scour holes, and change patterns of sediment deposition within the stream channel (figure 1.4).

## Chapter 1—Ecological Considerations for Crossing Design

---

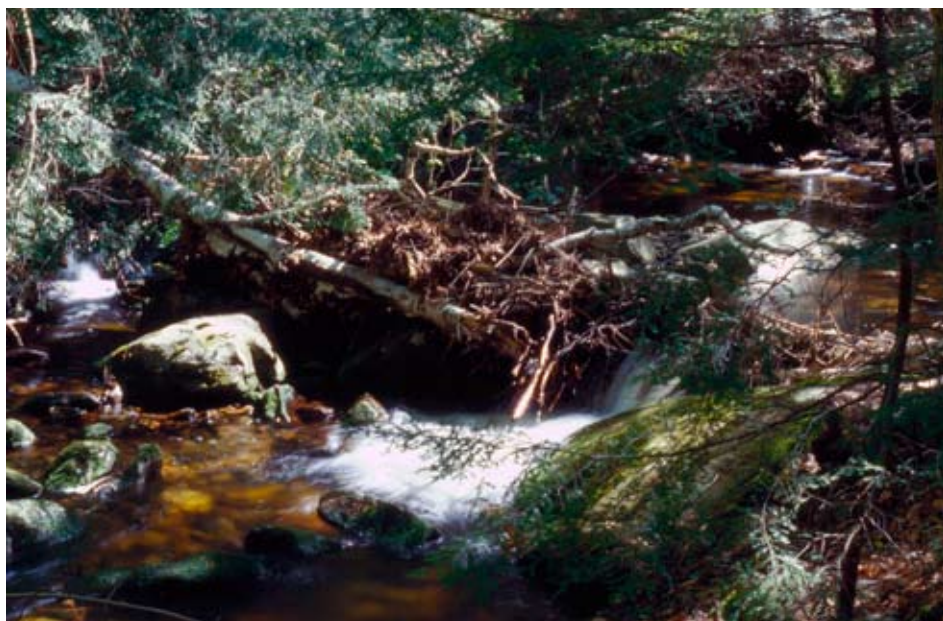

*Figure 1.4—Debris dams can create pools and scour holes, and change patterns of sediment deposition within the stream channel. Photo: Scott Jackson, University of Massachusetts.*

Natural disturbances, such as floods, drought, and ice scour can interrupt more regular cycles of stream flow, sediment transport, and the amount and distribution of woody debris. However, not only are these disturbances part of larger patterns of physical and biological change that help define aquatic ecosystems, but they also are generally responsible for defining channel characteristics.

Organisms too, move through river and stream ecosystems. These movements range from regular movements necessary for accessing food, shelter, mates, nesting areas, or other resources, to significant shifts in response to extreme conditions brought about by natural disturbances.

### **1.1.4 Viability and Persistence of Populations**

Populations are groups of organisms that regularly interact and interbreed. Animal movements are necessary to maintain continuous populations, and constraints on movement often delineate one population from another. The ability of a population to remain genetically viable and to persist over time is related to both its size and its degree of interaction with other populations of the same species.

## Stream Simulation

---

An important consideration for maintaining viable populations is maintaining sufficient genetic variability within populations. Small populations are at risk of losing genetic variability due to **genetic drift**, and very small populations may be subject to the negative consequences of **inbreeding depression**. Over the short term—depending on a species' life history characteristics—the minimum population size necessary to maintain genetic diversity ranges from 50 to 200 or more individuals (Franklin 1980; Soulé 1980). For longer-term genetic stability, estimates often range from 500 to 5,000 or more individuals (examples are provided in Lemkuhl 1984; Reiman and Allendorf 2001; Reiman and McIntyre 1993; Fausch et al. 2006).

Fausch et al. (2006) provide an excellent synthesis of the literature on population size, viability, and population isolation for salmonids. Fausch et al. (2006) note that true “viability” (in the sense of sustainability of a population over time) also may require the ability of populations to adapt and evolve to changing environmental conditions. Long-term conservation of species and ecological functions may require greater numbers of individuals and amounts of genetic variability than that required for mere maintenance or “persistence” of small population isolates. Landscape attributes and the range or percentage of life history types present (e.g., migratory versus nonmigratory forms) also appear to strongly influence persistence and viability of salmonids (Neville et al. 2006; Fausch et al. 2006).

Given the narrow, linear configuration of streams and rivers, animal movements are critical for maintaining populations large enough to remain viable. Smaller populations may be able to persist, despite their small size, if they are connected to larger, regional populations. Connections occur when individuals move from one population to another. For some species, dispersing juveniles are responsible for these movements between populations. For other species, dispersal occurs via adults. Such movements maintain gene flow among populations, helping to maintain genetic health. They may also represent movements of surplus animals from one population to another, perhaps to one that could not support itself on its own reproduction. This supplementation of failing populations from “source” populations is referred to as “the rescue effect.” Finally, areas of appropriate habitat that may be temporarily vacant due to local extinction can be recolonized by individuals from nearby populations. Stochastic (random) risks such as catastrophic disturbances (landslides, debris flows, toxic spills) even when localized can easily eradicate small isolated populations. Reiman and McIntyre (1993) provide additional background information on stochastic risks to small, isolated populations.

## Chapter 1—Ecological Considerations for Crossing Design

---

As part of a long-term study of brook trout (*Salvelinus fontinalis*) in western Massachusetts, Letcher et al. (2007) used data on survival and fish movement within the population to model estimated time to extinction under various scenarios. Under one scenario that simulated placement of barriers to upstream movement into two tributaries, local population extinction was predicted in two to six generations. These barriers also increased the probability of network-wide extinction in both tributaries and in a 1-kilometer section of the main stem. Once disconnected from the tributary populations the network-wide population could only be maintained via a large influx of individuals (7 to 46 percent of the total population) immigrating into the population from downstream areas.

## Stream Simulation

---

### Understanding ecosystems: A case study of fragmentation

The lack of population data over long periods of time—whether decades or hundreds of years—means that our understanding of population viability and vulnerability is largely based on theoretical concepts and population modeling. These theories and models predict that population extinction is more likely to occur in smaller populations and that the dispersal of individuals between populations is important for maintaining both genetic viability and local and regional populations in the face of population extinctions (Leigh 1981; Shaffer 1981; Fahrig and Merriam 1985; Shaffer and Samson 1985; Hanski and Gilpin 1991).

One recent study provides an excellent illustration of the impact of fragmentation in riverine systems. This study, by Kentaro Morita and Shoichiro Yamamoto (2002), focused on populations of white-spotted charr (*Salvelinus leucomaenis*) occupying mountain streams in Japan. The white-spotted charr is a salmonid fish that occurs as both large migrant individuals and small resident fish that normally interbreed in unaltered streams. Many of the mountain streams that charr use have been fragmented by small erosion-control dams that prevent fish from moving upstream. Above these dams, charr populations are sustained only by the smaller, resident fish.

Morita and Yamamoto surveyed both dammed and undammed stream segments for the presence of charr in appropriate habitat. Based on habitat conditions, they concluded that charr should have been able to establish populations in all dammed sites. However, although charr populations were found in all surveyed undammed sites, charr were absent in 32.7 percent of dammed sites. The results indicated that the probability of charr occurring in dammed stream segments decreased with decreasing watershed area and increasing isolation period. Further, this study also found evidence of genetic deterioration in populations above dams (compared to populations below dams), including lower genetic diversity, higher morphological asymmetry, and genetically based lower growth rates.

Results of this white-spotted charr study are consistent with predictions of increased vulnerability for smaller and more isolated populations. Genetic and population consequences resulting from fragmentation occurred over a relatively short period of time (30 to 35 years). That the probability of occurrence was related to watershed size suggests that the smallest populations were the most vulnerable. The relationship between isolation period and probability of occurrence suggests that additional populations may well be lost over time.

The situation of small dams on headwater streams in Japan may be comparable to United States watersheds that contain road crossings with substandard culverts. Culverts that block the upstream movement of fish and other organisms effectively isolate populations above these crossings. Areas with relatively small amounts of habitat upstream of the crossing will be most vulnerable to population loss. Over time, the failure of more and more populations is expected, and the disruption of metapopulation dynamics is likely to keep these areas of suitable habitat unoccupied.

Studies of other riverine species have yielded similar results. Genetic effects correlated with small habitat patches and isolation have been documented for Lahontan cutthroat trout (Neville et al. 2006). Habitat patch size (a surrogate for population size) and isolation have been found to be significantly correlated with the presence or absence of animal populations for bull trout (Dunham and Rieman 1999), cutthroat trout (*Oncorhynchus clarki*) (Dunham et al. 1997; Harig and Fausch 2002), and spring salamanders (*Gyrinophilus porphyriticus*) (Lowe and Bolger 2002). Harig and Fausch (2002) point out that large interconnected stream networks not only are likely to support larger populations of fish, but are likely to provide the complexity of habitat types required by these fish throughout their life cycles.

### 1.2 ANIMAL MOVEMENT

#### 1.2.1 Importance of Movement for Individual Animals

Animals move through rivers and streams for a variety of reasons. Some movements are regular daily movements to find food and avoid predators. It is not unusual for aquatic animals to forage at night and seek shelter during the day. Examples include juvenile bull trout and Atlantic salmon, American eel, hellbenders, and many other species of stream salamanders. The crayfish *Orconectes virilis* typically moves in the open at night, ranging upstream or downstream as much as 82.5 feet or more before returning to the same daytime area (Hazlett et al. 1974).

Changes in habitat conditions, such as temperature, water depth, or flow velocity, may require organisms to move to areas with more favorable conditions. During the summer, for example, many salmonid species move up into cool headwater streams to avoid temperature stress in mainstem waterways. When conditions become too dry, these animals shift to areas with suitable water. Flood-plain side-channels and sidewall-channels fed by ground water also provide thermal refuges for fish and other aquatic organisms.

In many stream systems where natural disturbances cause significant habitat variability, access to refuge habitat is especially important. Humans, too, can cause disturbances that require fish to seek refuge habitats. For example, major highways parallel many streams, and toxic spills in streams are not uncommon. When these occur, fish must have the ability to move to unaffected habitats.

Some animal movements are seasonal and therefore linked to the reproductive biology of the species. During the breeding season, animals move to find mates, and smaller individuals may have to move to avoid areas dominated by larger, territorial adults. A common strategy among river and stream fish is to segregate habitats used by adults from those used by juvenile fish. Adult fish typically use habitats in areas of deeper water and more stable hydrology than those in which they spawn. They migrate to spawning areas that have higher productivity or fewer predators, such as flood plains and headwater streams. In these areas, recently hatched fish can take advantage of decreased predation or higher productivity, with the large number of juveniles compensating for the risks inherent in these more variable habitats (Hall 1972).

## Stream Simulation

---

The most dramatic examples of breeding movements are the long-range migrations of anadromous fish, including various species of salmon, sea-run trout, shad and other herring species, sturgeons, and other fish. By contrast, the common eel is a catadromous species—living as adults in freshwater and migrating to the ocean to breed.

Adult salmon live in the ocean until the breeding season, when they migrate long distances to reach spawning streams. As they become larger, juvenile salmon hatched in these streams make their way downstream to the ocean, where the large marine food base can support much higher growth rates than freshwater environments can provide. Other fish species make similar but less dramatic migrations to reach spawning habitats. Pike and pickerel move into vegetated flood plains to spawn. Many “nonmigratory” fish (for example, some species of trout, suckers, and freshwater minnows) use headwater streams as spawning and nursery habitat.

In contrast to fish, many stream salamanders use intermittent headwater streams as adults but deposit their eggs in more perennial areas of the stream. The semiaquatic adults can readily move up into headwaters to exploit the productivity of these areas. The salamanders’ less mobile larvae are aquatic, needing areas of more reliable, year-round surface water.

As organisms move through their various life stages, they need access to areas that meet a variety of habitat requirements that may change as the organisms grow and develop. Sometimes spawning habitat doubles as nursery habitat for juvenile fish or larval amphibians. In other cases the survival needs of eggs (for example, cool temperatures, specific substrates, or well-oxygenated water) may greatly differ from those required by juveniles or larvae (appropriate cover, more persistent hydrology, lower flow velocities, or adequate food supplies). Adult fish may require deeper water and larger cover objects. In Wisconsin, brown trout were observed to move more than 9.6 miles downstream to overwintering sites that were too warm for trout during the summer (Meyers et al. 1992).

In dynamic environments like rivers and streams, the location and quality of habitats are everchanging. Large woody debris is an important component of many stream ecosystems. Large logs in the stream can dam up water or create plunge pools on the downstream side of the log. Accumulations of woody debris can change the local hydraulics of the



## Chapter 1—Ecological Considerations for Crossing Design

stream, scouring some areas and depositing the material in other places (figure 1.5). Woody debris that forms jams across the stream can create large and relatively deep pools. These features (woody debris, scour holes, pools, deposited gravel) are important habitat characteristics. However, they are not permanent features; woody debris will eventually break up or move downstream. Flooding, substrate composition, and woody debris work together to shape river and stream channels, water depth, and flow characteristics, creating a shifting mosaic of habitats within riverine systems. In these dynamic environments movement is critical for aquatic organisms to be able to avoid unfavorable habitat conditions and to find and exploit areas of vacant habitat.

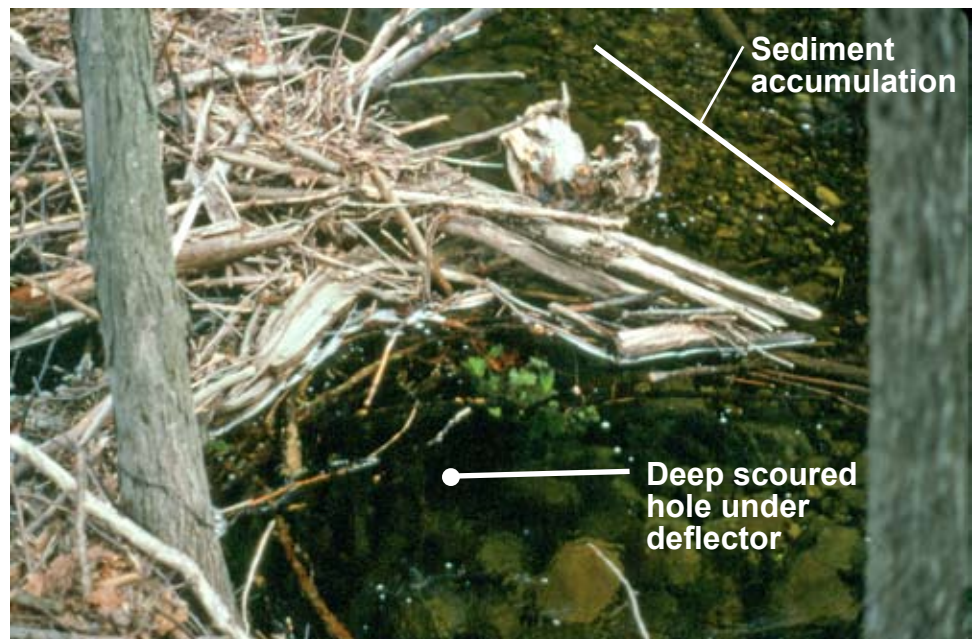

*Figure 1.5—Woody debris has altered the local hydraulic conditions in such a way that a deep hole has been scoured out beneath and just upstream of the ‘deflector,’ with fresh gravel deposited on the downstream side. Photo: Scott Jackson, University of Massachusetts.*

In the intermittent Colorado plains streams that provide habitat for the Arkansas darter (figure 1.6), habitat changes seasonally with regular wet and dry cycles. During dry periods, darters rely on ground-water-fed refuge pools. The number, distribution, and quality of these pools change in response to drought, winter conditions (pool freezing), and flooding that occur every few years or decades on average. Occasional flash floods scour out new pools and fill others. To persist in these streams in this ever-changing landscape, Arkansas darters must rely on long-distance movements to locate and colonize pools (Labbe and Fausch 2000).

## Stream Simulation

---



Figure 1.6—Arkansas darter. Photo: Kurt Fausch, Colorado State University.

For a time, fisheries biologists thought that fish species such as trout generally stayed put, except for specific periods of movement for breeding or avoiding unfavorable conditions. However, we now see that a significant proportion of these fish make regular and remarkably long-range movements (ranging behavior) that allow individuals to locate and exploit favorable habitat within these ever-shifting mosaics (Gowan et al. 1994). For a detailed summary of salmonid fish movement within rivers and streams see Northcote (1997).

### 1.2.2 Ecological Functions of Movement

Although movement and migration present obvious advantages for individual organisms, these movements are also important for maintenance of populations over time. Animal movement has several important ecological functions responsible for maintaining populations and ecosystems.

Survival of individual animals, facilitation of reproduction, and the maintenance of continuous populations (sufficient to prevent genetic differentiation) are important functions of movement at a population level. Extreme events, such as floods, debris flows, and droughts, may force entire populations to avoid unfavorable conditions by moving. Provided that no barriers prevent the movement of individual animals back into

## Chapter 1—Ecological Considerations for Crossing Design

---

the areas, populations will reoccupy the habitat once conditions have improved. Among aquatic communities, the movement of animals helps maintain the balance between predators and prey, and facilitates more efficient use of food-based energy within the system.

Dispersal of individuals regulates population density. These dispersing individuals maintain gene flow among populations and may supplement populations where **recruitment** is unable to keep pace with the loss of individuals. For many small species, especially invertebrates, dispersal of individuals provides a mechanism for colonizing habitat, allowing local populations to come and go as habitat is created or eliminated, while maintaining viable regional populations.

Movement is an important ecosystem process for upstream cycling of nutrients and organisms. Within aquatic ecosystems there is a tendency for organisms and nutrients to shift downstream. This tendency has been documented for a number of amphibians, including tailed frogs, boreal toads, and a variety of stream salamanders. The upstream movement of individuals counters this biological displacement and returns nutrients to upstream portions of these systems. When adult salmon migrate upstream and die, they transport essential nutrients to spawning streams, a process that can have an enormous impact on the productivity of those streams (for example, Levy 1997; Wipfli et al. 1999).

Some streams on the Great Plains support a number of minnow species that produce semibuoyant eggs during high-flow conditions. This buoyancy mechanism allows the spawn of adult fish inhabiting perennial upstream areas to drift many miles downstream into intermittently flooded portions of streams running through the plains. With this reproductive strategy, not only is downstream drift important, but unimpeded movement of young fish into more persistent upstream sections is also essential for maintaining minnow populations.

### 1.2.3 Movement Capabilities of Aquatic and Riparian Organisms

The timing of animal movements varies by species and lifestages. Often this means that, at virtually all times of year, one or more species is moving (figure 1.7). Movements may be between areas of shallow and deeper water or between the water's edge and midstream. Animal movements may be downstream (intentionally or unintentionally) or upstream. For many organisms inhabiting small streams, lateral movements or movements between surface and deeper water within the

## Stream Simulation

stream channel are severely constrained. Under these circumstances, upstream and downstream movements become all the more important for these organisms. Also important are movements between the stream channel and adjacent flood plains, as well as upstream and downstream through flood plains and riparian areas. For rivers with large flood plains, these movements are especially important.

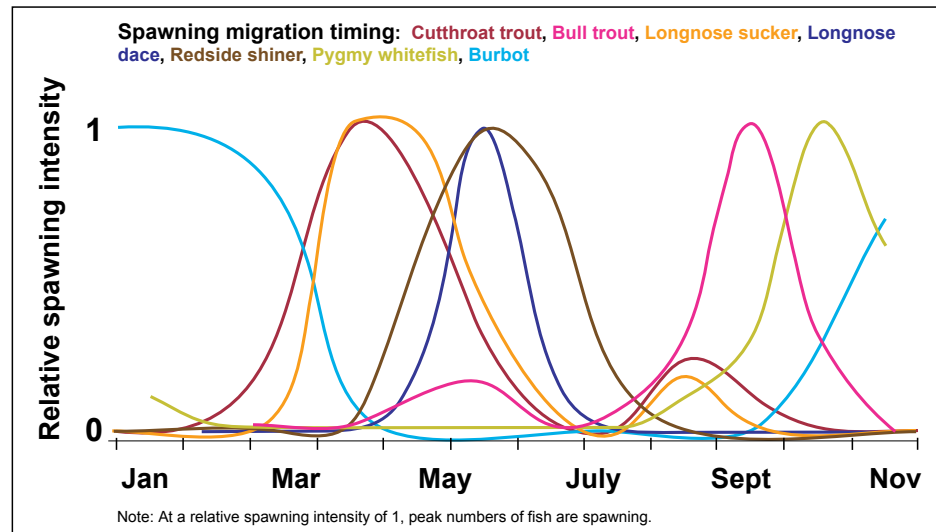

Figure 1.7—Migration timing for a fish community in British Columbia or Alaska. There is virtually no time when migration barriers do not pose a problem for at least one species. Graphic: Brett Roper, Forest Service. Data from Scott and Crossman 1973.

Some organisms are weak swimmers capable of moving only relatively short distances unless displaced by floods or attached to other animals or woody debris. Others are strong swimmers with the capacity for long-distance movements and the ability to move upstream against strong currents. In between are a whole host of species: some with the capacity for strong bursts of swimming but with a tendency to stay put; and others—some crayfish, for example—that are capable of long-distance movements but typically crawl rather than swim.

For fish, swimming ability is highly variable among species. While terms related to swimming ability do not have standardized meaning, most researchers use three categories to describe swimming ability (Beamish 1978). These include (1) burst speed (relatively high speeds that can be maintained for only a few seconds), (2) prolonged swimming speed (including the range of speeds between burst and sustained), and (3) sustained speed (speeds that can be maintained for long periods without fatigue). Swimming speeds are significant factors affecting the ability of animals to move through river and stream ecosystems. Burst speed is most

## Chapter 1—Ecological Considerations for Crossing Design

---

relevant for physical barriers that require jumping or short sections of relatively high water velocity. Prolonged speed is important for crossing longer sections of fast water. Long-distance movements of migratory fish and the ability of fish to maintain position in the stream channel for long periods of time depend on the sustained speed of fish.

There are a number of uncertainties in using data on the swimming abilities of fish for hydraulic design of stream crossings. For several reasons, the available data may not reflect how wild fish behave in real streams:

- Most swim-speed data currently available were developed by forcing fish to swim at a constant speed in a laboratory swimming tunnel. Such conditions are not ideal for developing estimates of a fish's volitional swimming ability.
- Actual swim performance is affected by a host of environmental and physiological factors ranging from water quality (temperature, dissolved oxygen, toxins) to fish condition (disease, spawning status, exercise history, body fat).
- Individual fish of the same species have widely varying swimming capabilities.
- Ordinary swim-performance tests do not include the effects of turbulence.

Most swim-speed data are based on the assumption of a constant relationship between fish swim speed and water velocity. Peake (2004) discovered that free-swimming fish increased their mean ground speed (swimming speed minus water velocity) in response to higher water velocity. Due to their increase in ground speed, small mouth bass actually decreased their passage time as velocity increased.

The fact that swim speed data do not perfectly represent real fish performance in the field does not mean the data are not useful for designing crossing structures. On the contrary, hydraulic design has been used extensively to provide passage for spawning adult trout and salmon, and for other fish for which data exist. It is the best method in many situations, such as retrofits, jacked pipes, and highly altered streams. Nonetheless, we know very little about the majority of fish species, especially small fish (including juveniles). We know even less about the swimming abilities of nonfish species that inhabit rivers and streams.

## Stream Simulation

---

A number of relatively large aquatic animals that inhabit rivers and streams rarely are considered in terms of barriers to movement (figure 1.7). Much of the United States supports large species of aquatic salamanders (species that rarely or never venture forth on land). Mudpuppies, waterdogs, hellbenders, sirens, and amphiumas are fully aquatic salamanders that range in adult size from about 1 foot to over 3 feet in length (figure 1.8). The Oklahoma salamander and the Pacific giant salamanders of the West Coast are other aquatic salamanders that are vulnerable to movement barriers.



*Figure 1.8—Mudpuppy. Photo: Alan Richmond, University of Massachusetts.*

Significant portions of the United States support softshell and musk turtles (figure 1.9)—aquatic reptiles that rarely travel overland. Movements of spiny softshell turtles are almost exclusively aquatic, with the exception of nesting and basking. In Arkansas, these turtles moved on 85 percent of the days they were tracked, with average daily movements of 403 to 465 feet per day. Some individuals moved more than 2,970 feet per day. Annual home-range length for these animals averaged between 4,620 and 5,775 feet (Plummer et al. 1997).

Although little is known about the swimming abilities of amphibians and reptiles, they are not believed to be strong swimmers, relative to migratory fish. Many species may rely more on crawling than swimming, yet movement and population continuity are essential to the survival of their populations. When moving upstream, aquatic amphibians and turtles are thought to seek out lower velocity sections of streams and take advantage of boundary layers (low-velocity zones) along the stream bottom and bank

## Chapter 1—Ecological Considerations for Crossing Design

---

edges. Some salamanders may require relatively continuous cover on the stream bottom, moving from rock to rock to reduce exposure to predators or high velocities (figure 1.10).



Figure 1.9—Spiny softshell turtle. Photo: Gary Stolz, U.S. Fish and Wildlife Service (USFWS) digital image library (<http://images.fws.gov/default.cfm>)



Figure 1.10—Northern dusky salamander. Photo: Scott Jackson, University of Massachusetts.

Although some crayfish can travel overland, many species are fully aquatic. Some have been documented moving long distances within streams, and all most likely depend on smaller scale movements to

## Stream Simulation

---

maintain continuous and interconnected populations. Crayfish are dominant components of headwater stream systems of the Ozarks and southern Appalachians, rivaling aquatic insects in importance (figure 1.11). Some headwater populations have been isolated long enough (due to natural conditions) to become separate species. In these United States regions, headwater streams support many rare crayfish with very limited distribution. Further population fragmentation could imperil entire species of crayfish.



*Figure 1.11—The Grandfather Mountain crayfish (Cambarus eeseehensis) is only found in the headwaters of the Linville River, North Carolina, upstream of the Linville River falls. This species does not leave the stream and cannot travel overland around a barrier. Photo: Roger Thoma, Ohio State University.*



## Chapter 1—Ecological Considerations for Crossing Design

---

As a group, the most vulnerable animal species in the United States are freshwater mussels. Over 70 percent of the 297 species native to the United States and Canada are endangered, threatened, or of special concern (Williams et al. 1993). Although adult mussels have a very limited capacity for movement, typically dispersal occurs when larvae (glochidia) attach themselves to host fish or salamanders. Therefore, survival and persistence of freshwater mussel populations depends on the capacity of the host fish or salamander to move through river and stream systems. Many endangered mussels depend on small, sedentary host fish that are typically weak swimmers and therefore highly vulnerable to movement barriers.

River and stream ecosystems contain many other species about which we know little except that they appear to have limited capacities for movement. These species include worms, flatworms, leeches, mites, amphipods, isopods, and snails. Collectively, these often overlooked taxa account for a significant amount of the biomass and diversity of river and stream ecosystems. For most, swimming ability is less relevant than the ability to move through streambed substrates. Although large numbers of invertebrates can often be supported in relatively small areas, appropriate habitats may be patchy and dynamic. In these situations, a regional population is generally maintained through cycles of local extinction and colonization in response to changes in habitat conditions. Scour and deposition related to flooding or changes in stream hydraulics (for example, debris dams and deflectors) may destroy habitat in some areas while creating suitable habitat in others. How these organisms move upstream any significant distance is unclear. That some mechanism must exist is a reasonable assumption; otherwise, populations would continually shift downstream as upstream populations are lost to local extinctions. One possible mechanism for such movements is when larger animals transport small organisms or eggs, perhaps in association with adhered sediment or debris.

Many weak swimmers and crawling species take advantage of boundary zones along bank edges and the stream bottom where water velocities are much lower than in the water column. Under natural conditions, the movement of some stream organisms depends on the diversity of channel structure and hydraulics typically found in natural streams. This diversity creates alternate pathways throughout the channel bed and along the bankline; if any point in the channel is a **barrier** (high-velocity or high-turbulence zones) other less strenuous pathways are generally available. Maintenance of unfragmented stream bottom and bank-edge habitats is the best strategy for maintaining continuous and interconnected populations for a variety of weak-swimming species.

## Stream Simulation

---

In addition to aquatic organisms, riparian wildlife use rivers and streams as travel corridors. These species include semiaquatic animals, such as muskrat, mink, otter, frogs, stream salamanders, turtles, and snakes (figures 1-12 through 14). Within the larger landscape, rivers and streams provide vital links connecting wetland, aquatic, and terrestrial ecosystems. In developed areas, rivers and streams often represent the only available travel corridors for many wildlife species. In arid environments, stream channels and riparian corridors offer wet and humid conditions during extended dry periods, and serve as movement corridors for terrestrial and semiaquatic amphibians.



Figure 1.12—River otters. Photo: Jim Leopold, USFWS digital image library.



Figure 1.13—Muskrat. Photo: R. Town, USFWS digital image library.

## Chapter 1—Ecological Considerations for Crossing Design

---



Figure 1.14—Snapping turtle. Photo: Scott Jackson, University of Massachusetts.

### 1.2.4 Barriers to Movement Providing Some Positive Benefit

In some circumstances, barriers to animal movement may serve a useful purpose. When natural barriers have been in place for long periods, isolated populations can become genetically distinct or evolve into separate species. For example, a population of brook trout in western Massachusetts isolated for more than 400 generations (approximately 910 years) above a natural barrier has evolved demographic characteristics distinct from populations in neighboring tributaries (Letcher et al. 2007). Individuals in the isolated population have higher early survival rates and reproduce at smaller sizes, traits that may have been instrumental in the persistence of this isolated population. The loss of the natural barriers could result in the genetic swamping of a distinct population that has not yet fully differentiated into a separate species. Removal of natural barriers can also provide access for organisms that might successfully outcompete rare and geographically restricted species, or allow transmission of parasites and disease from one population to another.

Artificial barriers, such as road crossings, dams, and diversions, also can have positive benefits. Where stocked or introduced strains of fish are genetically different from native populations, movement barriers may protect the native fish from contamination by outside genotypes. Movement barriers also can be important for containing the spread of exotic, invasive species, such as the zebra mussel, Asiatic clam, and rusty crayfish.

## Stream Simulation

---

Many populations of native trout in the inland West are vulnerable to the negative effects of introduced salmonids. Artificial barriers are viewed as a potential tool for protecting native populations from the negative genetic and population effects of introduced species. However, the use of such barriers comes with risks. Native populations isolated above these barriers may not be large enough to persist. There also may be negative consequences for other, nontarget species. Fausch et al. (2006) offer a well thought-out framework for analyzing the risks and tradeoffs associated with constructing an artificial barrier to isolate a population and protect it from invasive species.

Relying on substandard road-stream crossings to prevent the spread of invasive species is unwise. While such structures may serve to inhibit movement of invasive species, they may not be **complete barriers** to passage. When exclusion of exotic species is the goal, structures should be designed with the specific objective of blocking movement of the target (undesired) organisms.

### 1.3 POTENTIAL ADVERSE IMPACTS OF ROAD-STREAM CROSSING STRUCTURES

Traditional culverts can impact aquatic animals directly. However, they also can affect aquatic-animal habitats by means of their effects on stream channels and flood plains. These impacts are not universally adverse, but beneficial effects are less common than detrimental ones.

#### 1.3.1 Effects on Channel Processes and Aquatic Habitats

Streams do the vast majority of their habitat construction and valley modification work—mobilizing, **sorting**, and depositing sediments, woody debris, and ice—at a range of higher flows. The highest flows approach or exceed the conveyance capacity of many stream crossings on low-volume roads; therefore, the potential for stream crossings to alter the fundamental processes that create and renew physical geometry and habitat properties of the channel and valley bottom is high.

#### Aggradation Upstream

Road-stream crossings that are narrower than the incoming channel can cause upstream backwatering during high flows (figure 1.15). In many cases, debris enhances this tendency by plugging the structure. The backwatering usually results in sediment deposition, which can extend a distance of several channel widths upstream of a narrow culvert. These

## Chapter 1—Ecological Considerations for Crossing Design

---

sediment and debris accumulations at the pipe inlet can constitute fish passage barriers (figure 1.16). The accumulation steepens the local gradient, sometimes accelerating flow at the inlet beyond the velocity against which fish can swim, especially at the upstream end of the journey through the pipe.



*Figure 1.15—Many crossing structures are narrower than the stream and block fluvial processes that maintain aquatic habitats. The structures also impede aquatic species passage. Photo: Scott Jackson, University of Massachusetts.*



*Figure 1.16—Debris and sediment at culvert inlet can be a fish barrier. Photo courtesy of Ross Taylor and Associates, McKinleyville, California.*

## Stream Simulation

**Aggradation** also can be induced by a crossing structure that is skewed with respect to the stream. As a cost-efficiency measure to minimize culvert length, culverts are sometimes installed perpendicular to the road and skewed relative to the stream channel. Where these pipes force flow to turn abruptly at the inlet, they may induce sediment deposition (see skew discussion in section 6.1.1). Skewed-pipe outlets often aim flow at one bank, causing it to erode. A skewed alignment is not always harmful; where the culvert width is nearly as wide as the channel, a mild skew can create an eddy that functions as a resting area for fish.

### Degradation Downstream

Because water speeds up inside a culvert, which is usually narrower and smoother than the natural channel, the water flowing out the downstream end surges out as a jet at high flows, scouring (degrading) the streambed (figure 1.17). The degradation usually occurs during the first few years after construction. Scouring can create good habitat; the deepest pool in the affected reach may be the outlet plunge pool. However, it also creates a vertical discontinuity that often stops or impedes passage of aquatic animals. Because the scoured streambed is lower in elevation, the streambanks are taller and may be less stable. Plunge pools caused by local scour at culvert outlets usually do not extend further than 3- to 6-channel widths below the culvert.

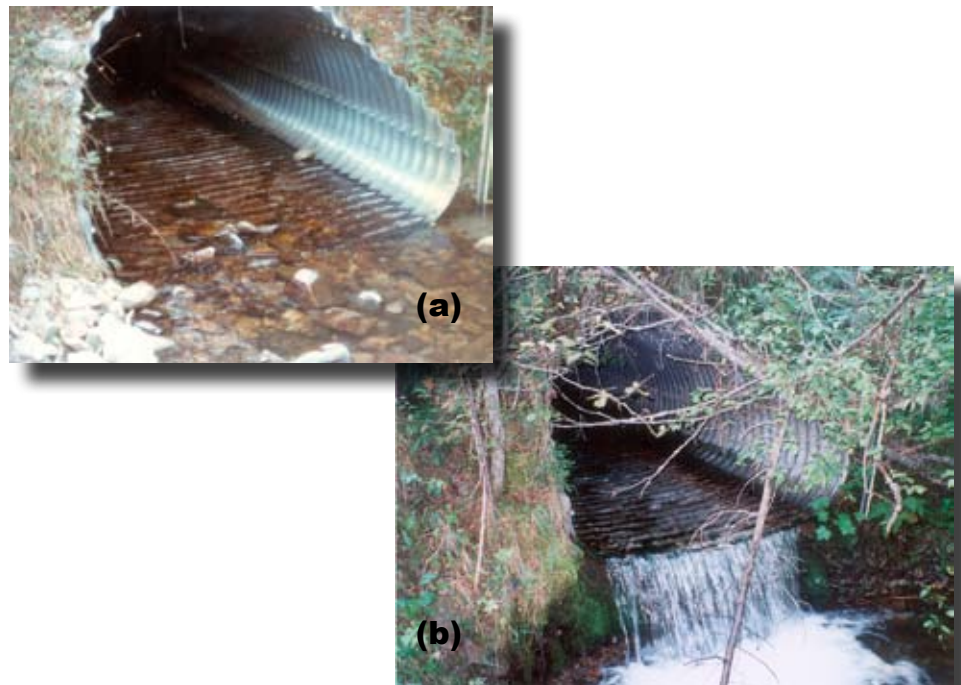

*Figure 1.17—High-velocity discharge from undersized culverts causes downstream scour. (a) Culvert was placed at grade in 1979. (b) By 1998, undersized culvert had caused over 1 foot of downstream scour.*

## Chapter 1—Ecological Considerations for Crossing Design

### Plugged Culverts

Debris-plugged inlets often are found to be responsible for crossing and fill failures due to overtopping during floods (Furniss et al. 1998) (figure 1.18). Plugged culverts act as small dams, and overtopping flows can cause partial or complete fill failure. Alternatively, where the road slopes away from the crossing, flow will divert down the road. If the flow then runs across the road onto a hillslope, it may erode a gully that can contribute sediment to the stream (Furniss et al. 1997). The diverted flow may reach another channel, increasing flow there and causing that channel to erode and enlarge.



Figure 1.18—Culvert-crossing failure after flooding, Plumas National Forest, California.

### Flood-plain Hydrology

Almost all streams have an adjacent valley bottom of some width. The stream may inundate the valley bottom frequently (every 1 to 3 years) or infrequently (greater than 50-year **recurrence interval**). During floods, water, sediment, and woody debris move down-valley across the flood plain creating new habitats, such as side channels and debris accumulations. Roadfills approaching crossings are often raised above the flood-plain surface, creating a bottleneck at flows higher than bankfull, and locally changing the erosional and depositional processes that maintain the diverse flood-plain habitats. The extent and duration of upstream flood-plain backwatering shown in figure 1.19 are unusual, but the photos demonstrate the concept.

## Stream Simulation

---

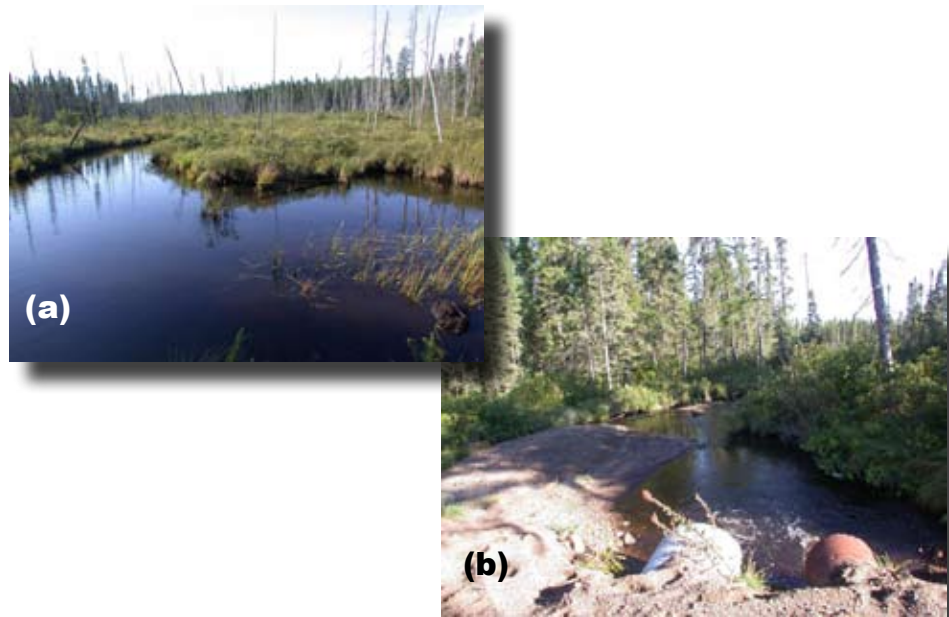

*Figure 1.19—Roadfill effects on flood-plain hydrology—Minnesota. (a) Meandering channel with half-mile-wide flood plain remains backwatered for several weeks during snowmelt runoff, and sediment deposition extends for thousands of feet upstream. High water tables have killed the flood-plain trees. (b) Downstream view from same point as (a).*

The channel itself can be affected when sediment transport into the downstream reach is reduced, as in figure 1-19. When **overbank flows** are funneled through the culvert, streambed scour tends to occur at the culvert outlet. Bank erosion can occur at both the inlet and outlet.

### Direct Habitat Loss and Degradation

Replacing the natural streambed and banks with an artificial crossing structure usually results in direct loss of some habitat value. Culvert crossings provide very little habitat within the culvert. Some habitat can be provided if the culvert is sufficiently embedded with substrate that is similar to the natural streambed. Open-bottom or arch culverts and bridge crossings often maintain natural streambeds, although some habitat may be lost to footings, piers, and abutments. Fords may or may not significantly affect habitat near the crossing, depending on how much the **ford** alters the streambed, banks, and water-surface elevations (figure 1.20).





*Figure 1.20—Elevated concrete-slab ford eliminates aquatic habitat area directly underneath the structure and blocks fish passage at low flows. However, it may not significantly alter the character of aquatic habitats upstream and downstream.*

Erosion and sedimentation are two significant impacts of road crossings. They often occur during construction if **BMPs** are not used, but they also can occur even when BMPs are in place. Ongoing erosion of embankments, the road surface, and drainage ways are of more long-term concern. Excess sedimentation degrades river and stream habitats by increasing suspended solids in the water and altering downstream substrate and channel characteristics. Increased turbidity in the water can adversely affect visual predators and increase the amount of inorganic particles (relative to organic particles) available to filter feeders downstream.

### 1.3.2 Effects on Aquatic Organism Passage

There are a variety of ways by which crossing structures can impede or prevent the movement of animals:

#### **Inlet or Outlet Drop**

Elevation drops at the inlet or outlet or within a crossing structure can create physical barriers to many animal species. Not all stream-dwelling aquatic species have strong jumping capabilities, and many subadult life stages of strong jumpers are not well enough developed to navigate vertical drops associated with crossing structures. In addition, outlet pools often have insufficient depth to allow fish to jump into structures (figure 1.21).

## Stream Simulation

---



Figure 1.21—Outlet drop formed by scour at the downstream end of an asphalt apron. Photo: Scott Jackson, University of Massachusetts.

### Physical Barriers

Clogged or collapsed culverts and trash racks can block animal movement. Weirs or baffles, which are typically designed to facilitate fish passage by increasing depth or decreasing local velocities within a crossing structure, can be barriers for nontarget weak-swimming or crawling species.

### Excessive Water Velocities

Water velocities can be too high to pass fish or other organisms during some or all of the year. As stream-discharge increases, velocities within culverts increase correspondingly. Average velocities can easily exceed 10 feet per second, a speed far greater than the prolonged swim speed of most fish. In addition, culverts usually contain no resting areas for aquatic species attempting to pass through them. The result is that the animal may have to swim the entire length of the structure at burst speeds, and may exhaust itself before reaching the end of the culvert.

In corrugated metal pipes, the corrugations moderate velocities near the culvert wall, and fish use those lower velocity areas. Depending on the flow, culvert average velocities can be much higher than water velocity in the swimming zone inside corrugated metal pipes (Behlke et al. 1991). Average velocity is more likely to represent the swimming zone in smooth-walled concrete box culverts and steep bare-metal pipes.

## Chapter 1—Ecological Considerations for Crossing Design

### Absence of Bank-edge Areas

Because certain organisms utilize bank edges for movement in natural stream channels it is possible that the absence of those bank edges may at least inhibit, if not prevent, passage by weak-swimming or crawling organisms (figure 1.22). Constructing a crossing structure that allows for bank-edge areas is often challenging, because of the increased cost associated with the larger structure needed. However, long-term costs to species may justify the additional cost of constructing a structure that provides bank-edge areas.



*Figure 1.22—This box culvert has a concrete floor and no shallow edges for crawling-species passage. Photo: Scott Jackson, University of Massachusetts.*

**Excessive Turbulence** When a culvert creates more turbulence than the natural channel, the associated aeration and chaotic flow pattern can disorient aquatic species, inhibit their swimming ability, and block their passage. Turbulence barriers are common downstream of perched culverts; at some flows fish may not even be able to approach culvert outlets. Baffles, riprap, or other **roughness** elements designed to reduce the water velocity can also create turbulence that blocks movement. Turbulence at culvert inlets can also block passage.

### Insufficient Water Depth

Absence of a low-flow channel can result in water depths too shallow to allow passage for fish or other organisms (figure 1.23). In streams with highly variable flows, the challenge is constructing a structure capable of passing high flows while still maintaining a defined low-flow channel

## Stream Simulation

---

similar to the natural streambed. In these systems the most successful structures are often those that provide bank edges and a flood plain within the structure. When designing these types of crossings, project teams need to pay particular attention to the size, location, and spacing of substrate within the structure to emulate the natural streambed as closely as possible.



*Figure 1.23—Lack of a low-flow channel results in insufficient water depth in these box culverts. Photo: Scott Jackson, University of Massachusetts.*

### Discontinuity of Channel Substrate

Crossing structures that lack any natural substrate or contain substrates (including riprap, baffles, or other armoring) that contrast with the natural stream channel create discontinuities in streambed habitats. Many benthic (streambed-dwelling) organisms are confined to the streambed and can only move through, or over the surface of, appropriate substrates. Hyporheic zones (saturated stream sediments below the surface of the streambed) typically support a host of invertebrate species including copepods, ostracods, amphipods, nematodes, tardigrades, rotifers, oligochaete worms, and early instars of aquatic insects. Fauna in the hyporheic zone are an important contributor to nutrient cycling and food-chain support in river and stream communities.

Much of the movement of benthic organisms is downstream as passive drift. However, rare upstream movements must also occur to compensate for this drift and ensure that upgradient sections of streams do not become depleted over time. The flying adult stage of most aquatic insects provides

## Chapter 1—Ecological Considerations for Crossing Design

---

an obvious opportunity for upstream movement. However, noninsect invertebrates most likely require other mechanisms, such as movement through the streambed or attachment to larger organisms for upstream movement. There is some concern that streambed discontinuities caused by crossing structures may disrupt and fragment populations of these benthic organisms. Vaughan (2002) offers a thorough discussion of crossing effects on invertebrates.

### Summary: How Crossing Structures Can Impede Movement

- Debris accumulation
- Inlet or outlet drops
- Physical barriers (weirs, collapsed culverts)
- Water velocities exceed swimming ability (too fast for too long)
- Absence of bank-edge areas
- Excessive turbulence
- Insufficient water depth
- Discontinuity of channel substrate

### 1.3.3 Effects on Individual Animals

If not properly designed, road-stream crossings can block animal movements, delay migration (a process made worse where many crossings exist), and cause physiological stress as animals expend energy passing both natural and artificial obstacles (Fleming 1989) (figure 1.24). Delays in movement also can result in overlap of individuals that typically occupy different stream reaches. For example, culverts often concentrate migrating fish in large pools at their outlets. These pools often provide resident fish habitat, and residents can experience increased predation or competition from migrants when such overlap occurs. Increased susceptibility to fishing pressure and stress associated with overcrowding can also occur when fish movements are delayed at crossings.

## Stream Simulation

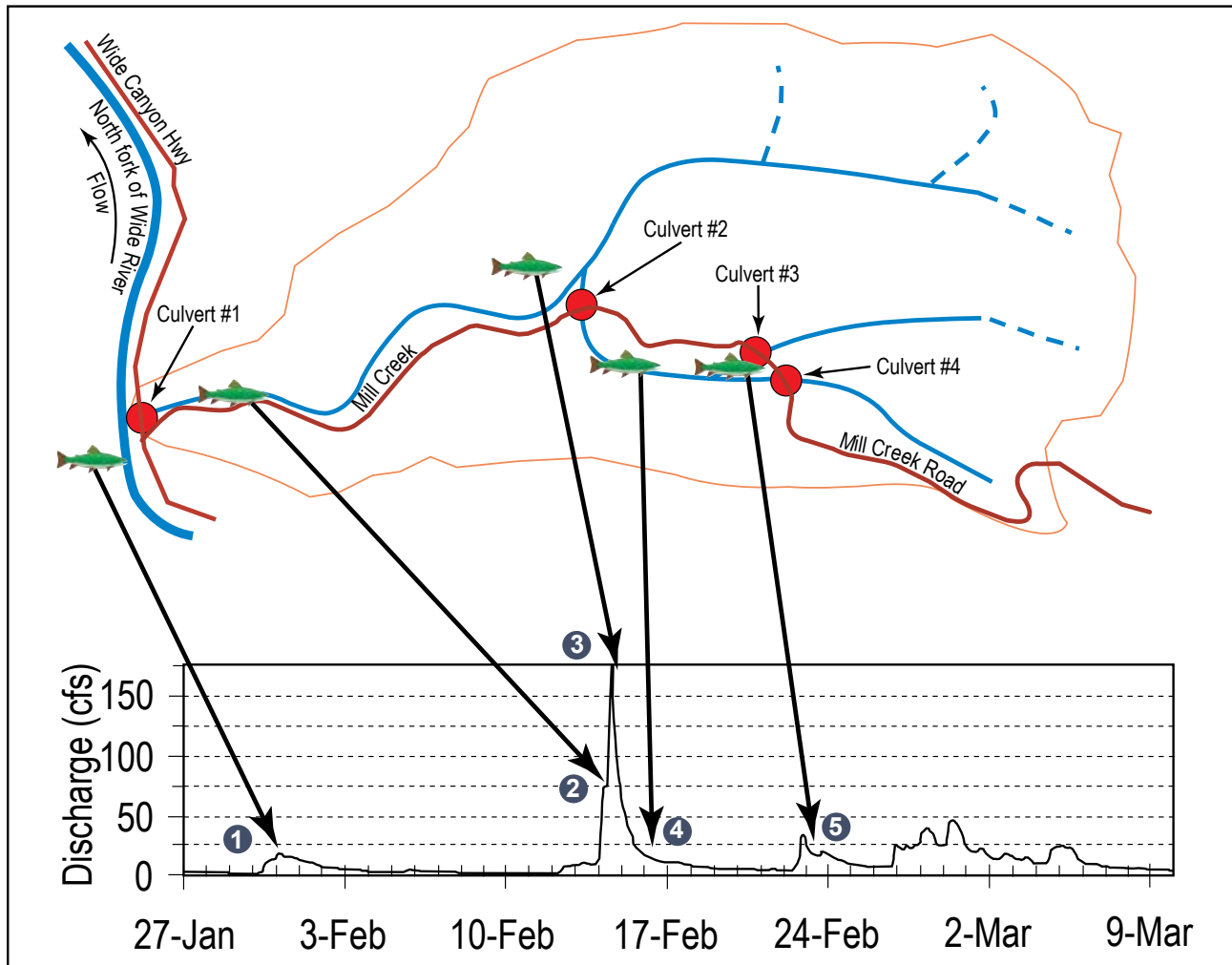

1. Fish enters North Fork of Wide River and swims to mouth of Mill Creek. Culvert 1 is low-flow barrier, water too shallow.
2. After 2 weeks of waiting for sufficient water depth, the fish passes through culvert 1 as flow rises.
3. Fish reaches culvert 2 as flow begins to recede. Velocity in culvert too high. Fish repeatedly attempts to swim through culvert.
4. Fish successfully passes through culvert 2 after flow drops. Water depth in upstream channel has become insufficient.
5. After waiting 7 days for flows to rise again, the fish is able to swim upstream to culverts 3 and 4 but outlets are perched too high.
6. Finding no mates, the fish migrates further downstream to spawn, 4 weeks after first arriving at the mouth of Mill Creek.
7. South Fork of Mill Creek remains unseeded, with young-of-the-year concentrated in the lower portion of the watershed.

Figure 1.24—Hypothetical example of the cumulative effects of delaying spawning salmon at a series of culverts. Used by permission of Mike Love, Love and Associates, Eureka, CA.

## Chapter 1—Ecological Considerations for Crossing Design

---

Riparian wildlife may choose to cross over the road surface rather than pass through a crossing structure that does not have banks or other dry passage. However, if physical barriers, such as fencing or Jersey barriers are present, passage across the roadway may be blocked. Even where passage over the road is not blocked physically, if the road supports high-traffic volumes, individual animals are likely to be killed trying to cross. For some long-lived species with low reproductive rates, such as turtles, roadkill can undermine the viability of populations significantly. Stream-simulation structures generally offer dry passage opportunities for riparian-dependent species, since the structures are wide enough that the channel edges are dry much of the year.

### 1.3.4 Reduced Access to Vital Habitats

Crossing structures may be complete barriers—essentially blocking passage for all aquatic species—or they selectively may pass some species or lifestages while blocking others. Even for a particular species a partial barrier may allow passage for only the strongest swimming individuals in a population. Partial barriers are sometimes referred to as “filters” because of their selective nature in facilitating passage. Other structures may be barriers at certain times of the year (high-flow or low-flow conditions) but not others. For some species, the timing of movement is critical and temporary or seasonal barriers might seriously impact survival or reproduction within a population.

Crossings that are partial or complete barriers may reduce access to vital habitats. These vital habitats can be spawning areas, nursery habitat for juvenile fish, foraging areas, refuge from predators, deepwater refuges, or other seasonal habitats. With restricted access to vital habitats, we would expect populations of affected fish or wildlife to be reduced or lost altogether [figure 1.25 (a) through (c)]. For important fisheries, reduced access to vital habitats can result in a significant reduction in productivity.

### 1.3.5 Population Fragmentation and Isolation

To the extent that road-stream crossings act as barriers to animal passage, they can fragment and isolate populations [figure 1.26 (a) through (c)]. Smaller and more isolated populations are vulnerable to genetic change and extinction from chance events. Genetic changes may result from **genetic drift** that occurs in small populations, or via **inbreeding depression** in very small populations. Local extinctions can result from demographic chance events (change in sex ratio), natural disturbances, or human impacts. As crossings contribute to population fragmentation and isolation, they undermine the viability of animal populations. (For examples of how this may have impacted riverine species, see: Dunham et al. 1997; Dunham and Rieman 1999; Harig and Fausch 2002; Letcher et al. 2007; Lowe and Bolger 2002; Morita and Yamamoto 2002; Neville et al. 2006).

## Stream Simulation

---

### 1.3.6 Disruption of Processes That Maintain Regional Populations

Decreased animal movement can undermine processes that help maintain regional populations over time. Barriers to movement can block the exchange of individuals among populations, eliminating gene flow and disrupting the ability of “source” populations to support declining populations nearby. Barriers to dispersing individuals also eliminate opportunities for recolonizing vacant habitat after local extinction events [figure 1.27 (a) through (f)]. (For examples affecting riverine species see Cooper and Mangel 1999; Dunham and Rieman 1999; Letcher et al. 2007; Lowe and Bolger 2002; Morita and Yamamoto 2002).

### 1.3.7 Time and Geography

When road-stream crossings result in the loss or degradation of habitat, impacts, such as those caused by erosion and sedimentation, are immediately obvious. Portions of streams may no longer provide habitat for certain species. As a result, the abundance and diversity of aquatic organisms inhabiting those stream sections changes. By contrast, adverse impacts that result from the disruption of ecosystem processes, including the restriction of animal movement, are not as obvious and may take years to fully manifest themselves.

The loss or degradation in habitat conditions from changes in hydrology, sediment transport, or the movement of woody debris within a river or stream, may occur over many years. It may result in gradual changes that, over time, reduce the amount of suitable habitat for aquatic organisms. With less available habitat, populations will become smaller and more vulnerable to genetic changes or local extinctions. As these smaller areas of suitable habitat become separated by increasing amounts of unsuitable habitat, animal movements become even more important for maintaining the viability of populations.

The problem of dams, culverts, and other barriers to fish passage is an obvious concern for migratory fish, especially anadromous, adfluvial (lake-dwelling fish that migrate to streams to spawn), and fluvial fish. Because anadromous fish travel such long distances and must often pass many potential barriers to reach their spawning grounds, barriers to passage can result in significant and immediate impacts on these species. Where barriers prevent nonmigratory animals from accessing vital habitats, populations of certain species may quickly disappear from river and stream systems. These losses may or may not be noticed, depending on whether the species is closely monitored. As changes in habitat or barriers to movement cause populations to become smaller and more isolated, we can expect a gradual and continual loss of species over time. Because mechanisms for the recolonization of habitat made vacant by local extinctions have been disrupted, species loss is a cumulative process that can eventually undermine the stability of ecosystems.



## Chapter 1—Ecological Considerations for Crossing Design

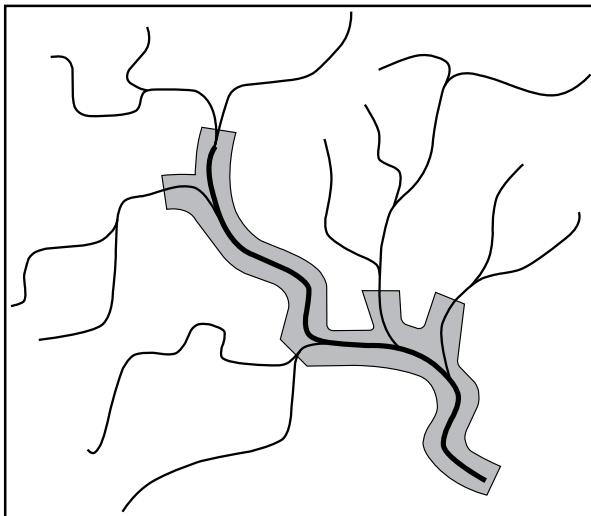

**(a)** For most of the year a population of brook trout occupies the mainstem of a stream network.

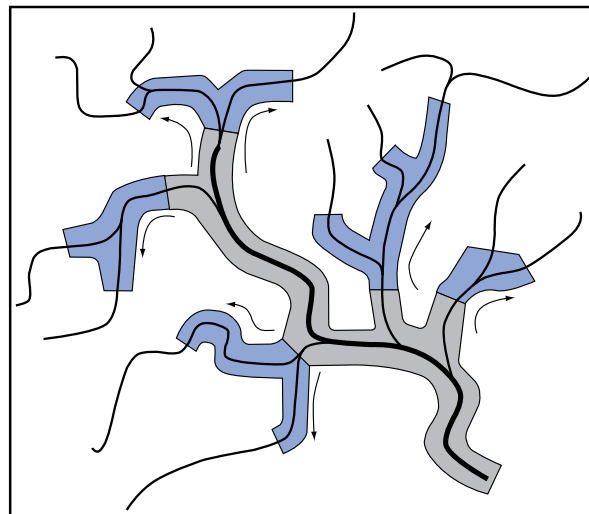

**(b)** During spawning season, adult fish move into the headwater tributaries to mate and deposit eggs.

**(c)** Construction of a road with substandard culverts blocks access to some of the spawning areas. With reduced access to these vital habitats, the stream network can support only a fraction of its previous population.

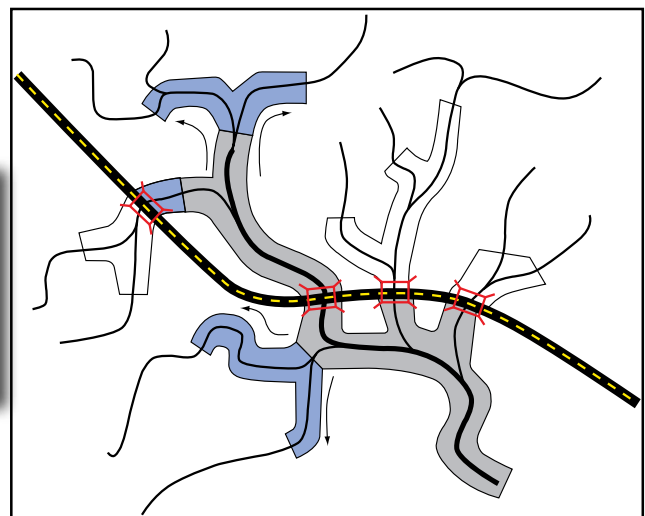
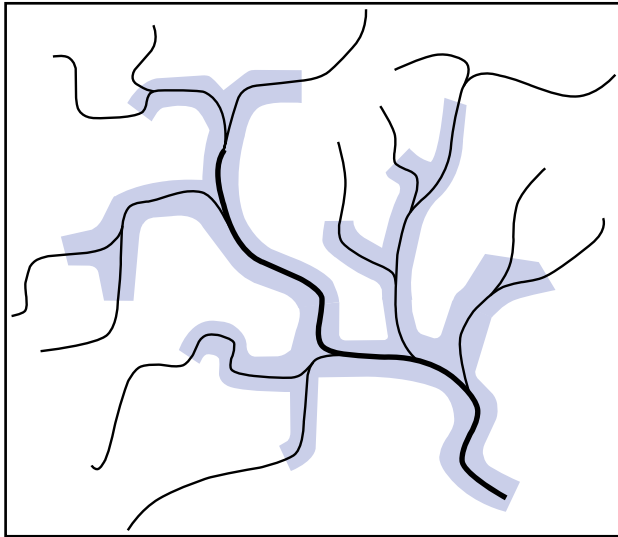
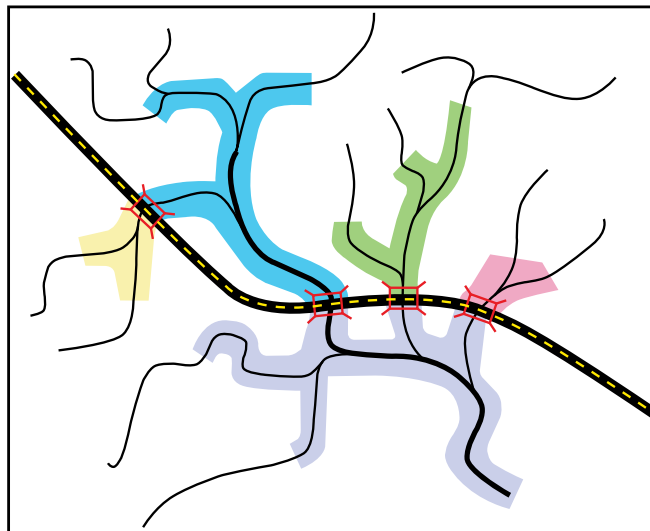

Figure 1.25 (a) through (c)—Hypothetical example of population effects of barrier culverts that reduce access to spawning areas.

## Stream Simulation



**(a)** This stream network supports a continuous population of Pacific Giant Salamanders, an aquatic species with limited swimming abilities (occupied area illustrated in purple).



**(b)** After construction of a road with substandard culverts the population is fragmented into five smaller and more isolated populations.

**(c)** Smaller and more isolated populations are more vulnerable to genetic changes and local extinctions due to chance events. Over time, as these smaller populations fail, the salamander is eliminated from a significant portion of the suitable habitat available in this drainage.

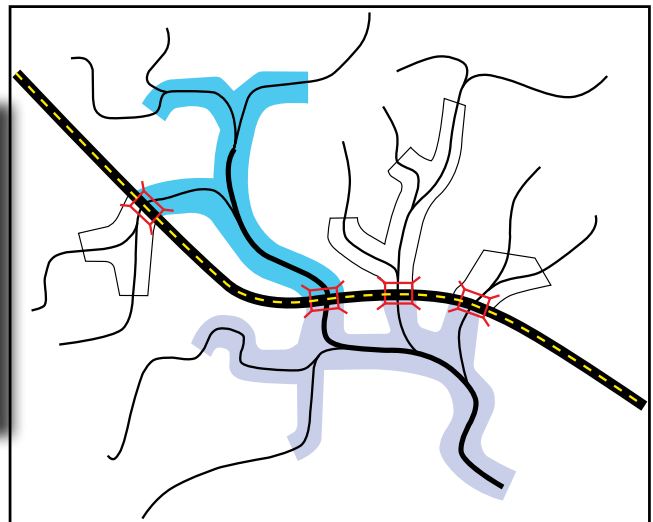
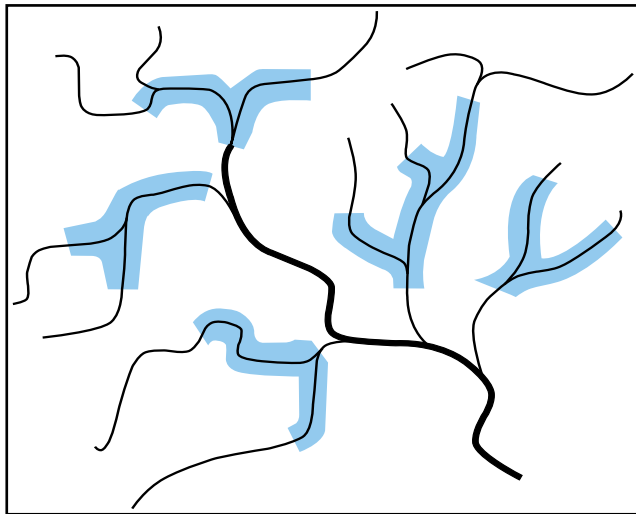

Figure 1.26 (a) through (c)—Hypothetical example of effects of barrier culverts that isolate populations.

## Chapter 1—Ecological Considerations for Crossing Design



**(a)** The headwaters of this stream network support populations of the Appalachian Brook Crayfish.

**(b)** Although the mainstem is not suitable as habitat, crayfish are still able to move through the area to occasionally exchange individuals among populations. Such exchanges facilitate gene exchange and can allow source populations to supplement and maintain populations that would otherwise be declining.

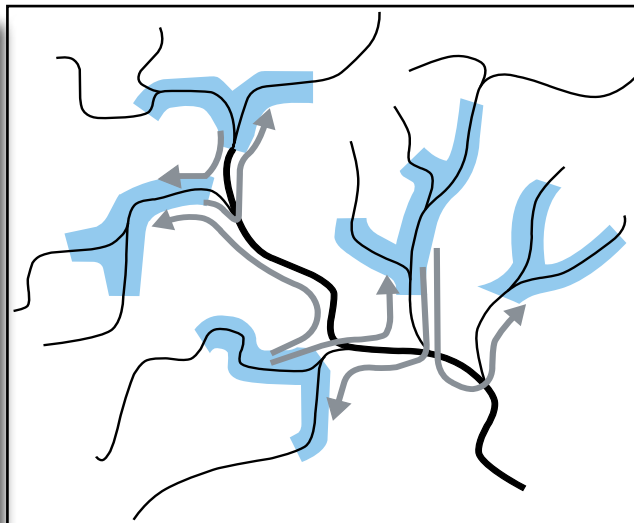

**(c)** In a period of extended drought it would not be unusual to lose one or more of the small crayfish populations. However, dispersal of individuals from populations nearby would recolonize some of the areas.

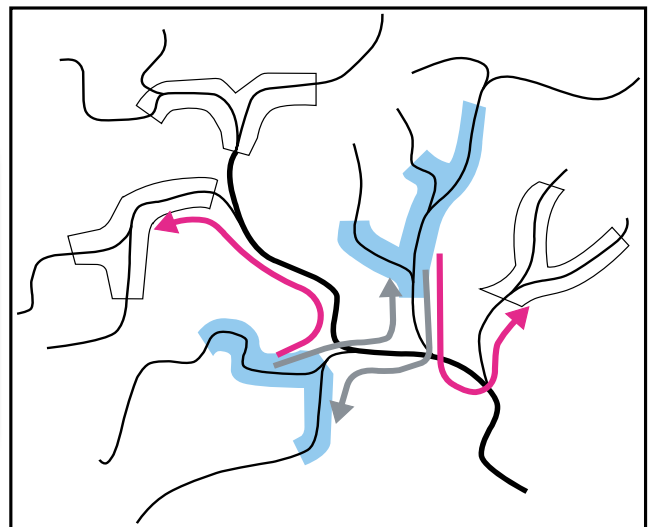
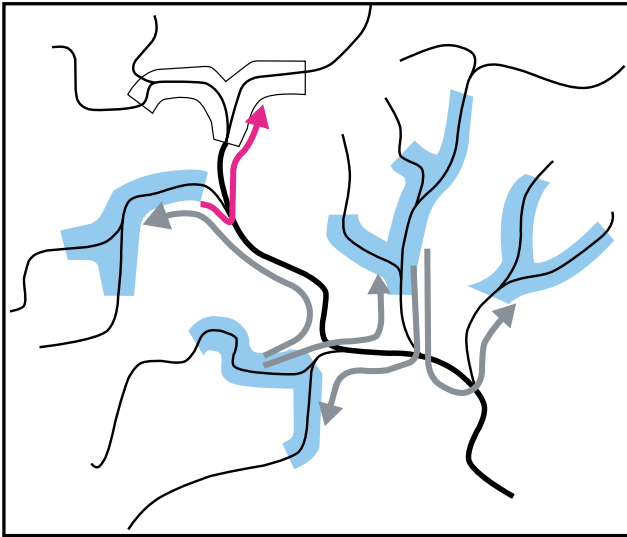
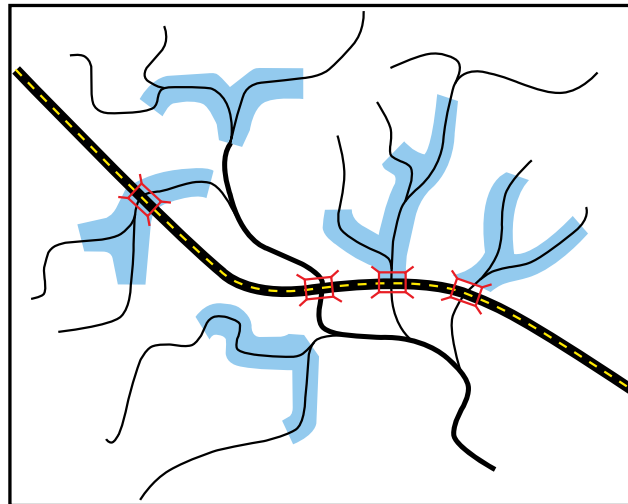

Figure 1.27 (a) through (c)—Hypothetical example of population effects of barrier culverts that prevent recolonization after catastrophic disturbances.

## Stream Simulation



**(d)** Once these areas are recolonized, they can serve as a base to reestablish a population in the more distant tributary. Maintenance of a regional population structure eventually allows all suitable habitat in the area to be reoccupied after the drought.



**(e)** The presence of a road with substandard culverts blocks movement of individuals among populations.

**(f)** Tributaries that had supported populations that failed due to genetic effects of fragmentation or natural disturbance such as drought, can no longer be recolonized by dispersing individuals from nearby populations.

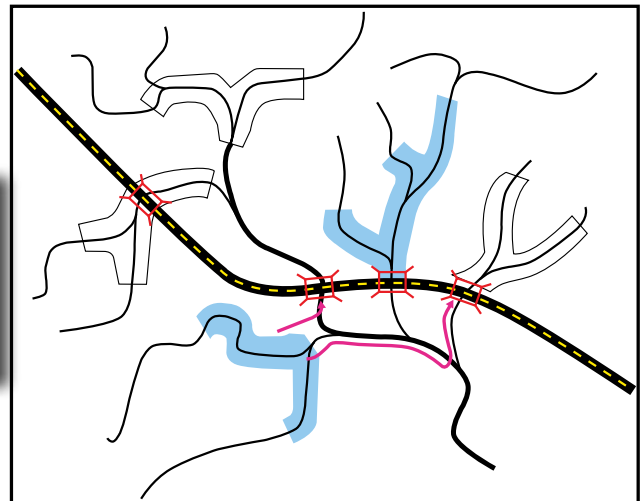

Figure 1.27 (d) through (f)—Hypothetical example of population effects of barrier culverts that prevent recolonization after catastrophic disturbances.

## Chapter 1—Ecological Considerations for Crossing Design

---

Although the effects of population fragmentation and isolation may take years to occur, these effects are nonetheless important. A Canadian study found that the diversity of birds, reptiles, amphibians, and plants in 30 Ontario wetlands was negatively correlated with the density of paved roads on land up to 1.2 miles from the wetlands (Findlay and Houlihan 1997). The study calculated that an increase in hard-surface road density of less than 1-linear-mile per acre would have approximately the same impact on species richness as the loss of half the wetland area. Further analysis of the data, including data of the road network from 1944, revealed an even more significant negative relationship between roads and species richness (Findlay and Bourdages 2000). The inference drawn from this was that lower species diversity today may be the result of roads and highways built many years ago. These studies suggest that, despite taking decades for the ultimate impact of roads to be apparent, the impacts can be quite significant. Thurow et al. (1997) concluded from a study of seven salmonid fish in the Interior Columbia River and portions of the Klamath River and Great Basin that the proportion of areas with healthy populations (strongholds) declined from 0.58 in roadless watersheds to 0.16 in watersheds that exceeded 4 kilometers of road per square kilometer.

Another important consideration of scale is that of landscape position and the geographic extent of impacts. Culverts are the crossing structures most often used for small streams. Typically, little consideration is given to the ecology of these small streams, probably because they are perceived as being less important than larger streams and rivers. However, small streams are extremely important to the ecology of river and stream ecosystems and support species of fish and wildlife that are not found in larger waterways (Meyer et al. 2007). A road network that crosses every tributary of a river could have a large effect on the entire system.

**Zero-, first- and second-order streams** account for most of the total stream miles within any watershed. They cumulatively provide much more habitat area for aquatic organisms than large rivers. Small streams are also highly productive systems, owing to their relationships with adjacent upland habitats (figure 1.28). These areas of high productivity are often used for spawning and nursery habitat by fish that normally inhabit larger waterways as adults.

Even intermittent and very small **perennial streams** play an important role in transporting invertebrates, detritus, and other organic matter that fuel downstream food webs (Wipfli et al. 2007). One study in Alaska estimated that fishless headwater streams export enough invertebrates downstream to feed 100 to 2,000 young-of-the-year salmonids per kilometer (0.6 mile)

## Stream Simulation

---

of salmonid habitat (Wipfli and Gregovich 2002). In another study (of Sagehen Creek in California), researchers estimated that 39 to 47 percent of rainbow trout in the population spawn in an intermittent tributary that flows for less than half the year (Erman and Hawthorne 1976). Bryant et al. (2004) emphasized the importance of small, high-gradient streams to fish communities in southeast Alaska.



*Figure 1.28—Headwater streams are important habitats for aquatic species.  
Photo: Scott Jackson, University of Massachusetts.*

Small streams provide important summer habitat for cold-water fish that move up into headwater streams to escape unfavorably warm conditions in ponds and rivers. Headwater streams also provide a significant amount of woody debris input to mountainous stream systems.

In addition to providing critical habitat for fish, small streams support many animals that do not occur in larger streams and rivers. These include species of stream salamanders, crayfish, and probably countless other invertebrate species. Many rare species of crayfish are confined to a very limited number of small streams.

## Chapter 1—Ecological Considerations for Crossing Design

---

When considering the impacts or potential impacts of a crossing, project teams should consider the cumulative effect of all barriers to movement, such as crossings, dams, and other significant discontinuities (channelized, intermittent, dewatered, or piped sections) within the watershed (see figure 1.29). The greater the number of artificial barriers and discontinuities, the more threatened the ecosystem. Because small streams make up the larger proportion of stream miles within a watershed, these headwater systems are particularly vulnerable to fragmentation by crossings. On the other hand, because stream systems are convergent, a passage barrier low in the watershed (close to confluence with an ocean or other important water body) can block migratory fish access to entire stream networks. Setting priorities for limited resources calls for a watershed perspective, evaluating restoration opportunities in terms of both habitat quality and river and stream continuity.

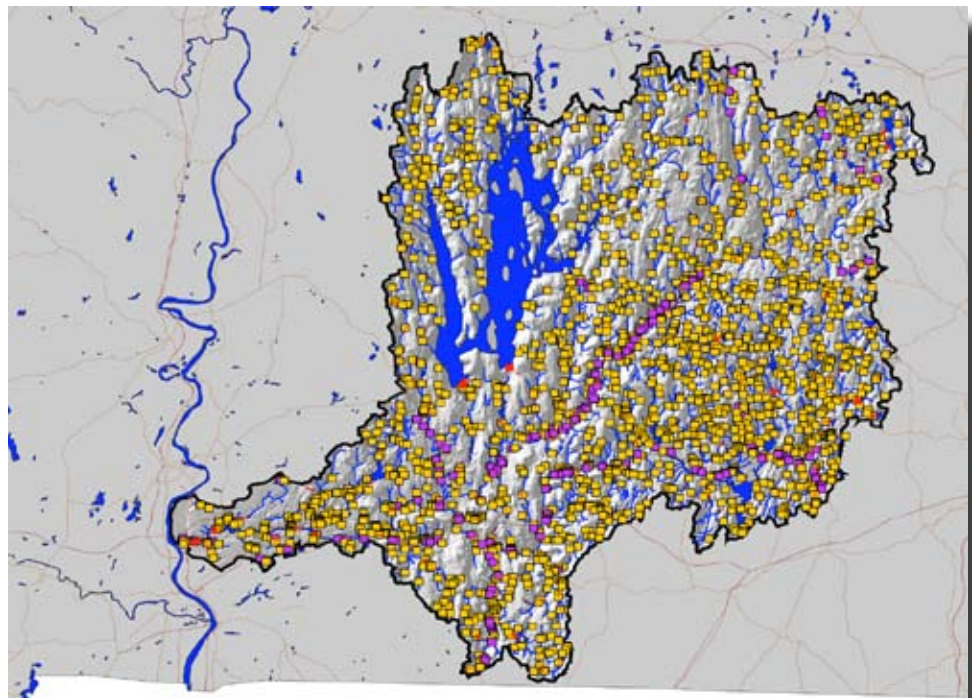

*Figure 1.29—Aquatic organism passage barriers in the 721-square mile Chicopee River watershed, Massachusetts, include 195 old small-scale industrial dams and 2,230 rail and road crossings.*

### 1.4 AN ECOSYSTEMS APPROACH

The impacts of substandard crossing structures on migratory fish affect rivers and streams up and down the Atlantic, Pacific, and Gulf coasts of the United States. The importance of migratory fish as fisheries resources and the status of some as federally “threatened” or “endangered” species has focused much attention on fish passage for migratory species. A large amount of time, money, and effort have been expended on the issue of passage barriers for migrating adults. Unfortunately, some efforts to promote upstream passage for adult fish have failed to provide passage for the juvenile stages of the same species. Strategies that focus solely on adult fish but don’t address all life stages for a particular species are unlikely to maintain populations over time.

As strategies are adjusted for passage issues for both adult and juvenile stages of migratory fish, we must avoid replacing one type of short-term thinking with another. Even when a particular species is the primary target for management, management strategies that ignore the community and ecosystem context for that species cannot succeed. Conservation strategies that focus only on target species—without careful planning to maintain habitat quality, passage for the variety of aquatic organisms in the stream, and other ecosystem processes—may succeed in the short term, but they undermine long-term prospects for success.

*“If the biota, in the course of eons, has built something we like but do not understand, then who but a fool would discard seemingly useless parts? To keep every cog and wheel is the first precaution of intelligent tinkering.”*

— Aldo Leopold

Given the large number of species that make up most river and stream communities and the lack of information about swimming abilities and passage requirements for most organisms, using a species-based design to meet the movement needs of an aquatic community is impractical in many cases. An ecosystems approach is the most practical way of maintaining both the viable populations of organisms that make up aquatic communities and the fundamental integrity of river and stream ecosystems. Such an approach focuses on maintaining the variety and quality of habitats, the connectivity of river and stream ecosystems, and the essential ecological processes that shape and maintain these ecosystems over time.



## Chapter 1—Ecological Considerations for Crossing Design

---

### THREE GUIDING PRINCIPLES FOR THE DESIGN OF ROAD-STREAM CROSSINGS

To preserve or restore all important elements of aquatic ecosystems, crossing structures should be designed following these three principles:

**1. The design should fit both the stream and the road, not just the road.**

Crossing designs must accommodate the stream—the stream's geomorphic processes and anticipated changes over the life of the structure—not simply road or transportation needs. Project teams must factor both systems into the design.

**2. Minimum intervention in the stream process results in the least risk.**

Crossings should present the least possible obstacle to stream processes. Streams move water, wood, sediment, and organisms. Crossings should be designed, constructed, and maintained to permit movement of these components to the greatest degree possible.

**3. Crossings should present no greater challenge to organism movement than the stream being crossed.**

Crossings should not fragment aquatic habitats. Avoiding fragmentation means reproducing the natural conditions of the stream being crossed. The key is matching the structure to the stream, both in form and process.

Stream simulation is one approach to road-stream crossings that protects habitats, maintains ecological processes, and sustains aquatic communities. The stream-simulation approach avoids flow constriction during normal conditions by using structures at least as wide as the natural channel. The constructed stream channel within the culvert is designed to insure adequate water depth during low-flow conditions and resist scouring during flood events. Well-designed stream-simulation culverts can maintain the continuity of stream bottom and hydraulic conditions, thereby facilitating passage for aquatic organisms.

Designing culverts to avoid channel constriction and maintain appropriate channel conditions within the structure is a relatively simple and effective approach for accommodating the normal movements of aquatic organisms and preserving (or restoring) ecosystem processes that maintain habitats and aquatic animal populations. Where passage for riparian and terrestrial wildlife is desired, stream-simulation structures can be adapted for wildlife preferences (see Forman et al. 2003).

Connectivity is key to the successful functioning of both roads and rivers. Ultimately, our goal should be to create a transportation infrastructure that does not fragment or undermine the essential ecological infrastructure of the land.

# Stream Simulation

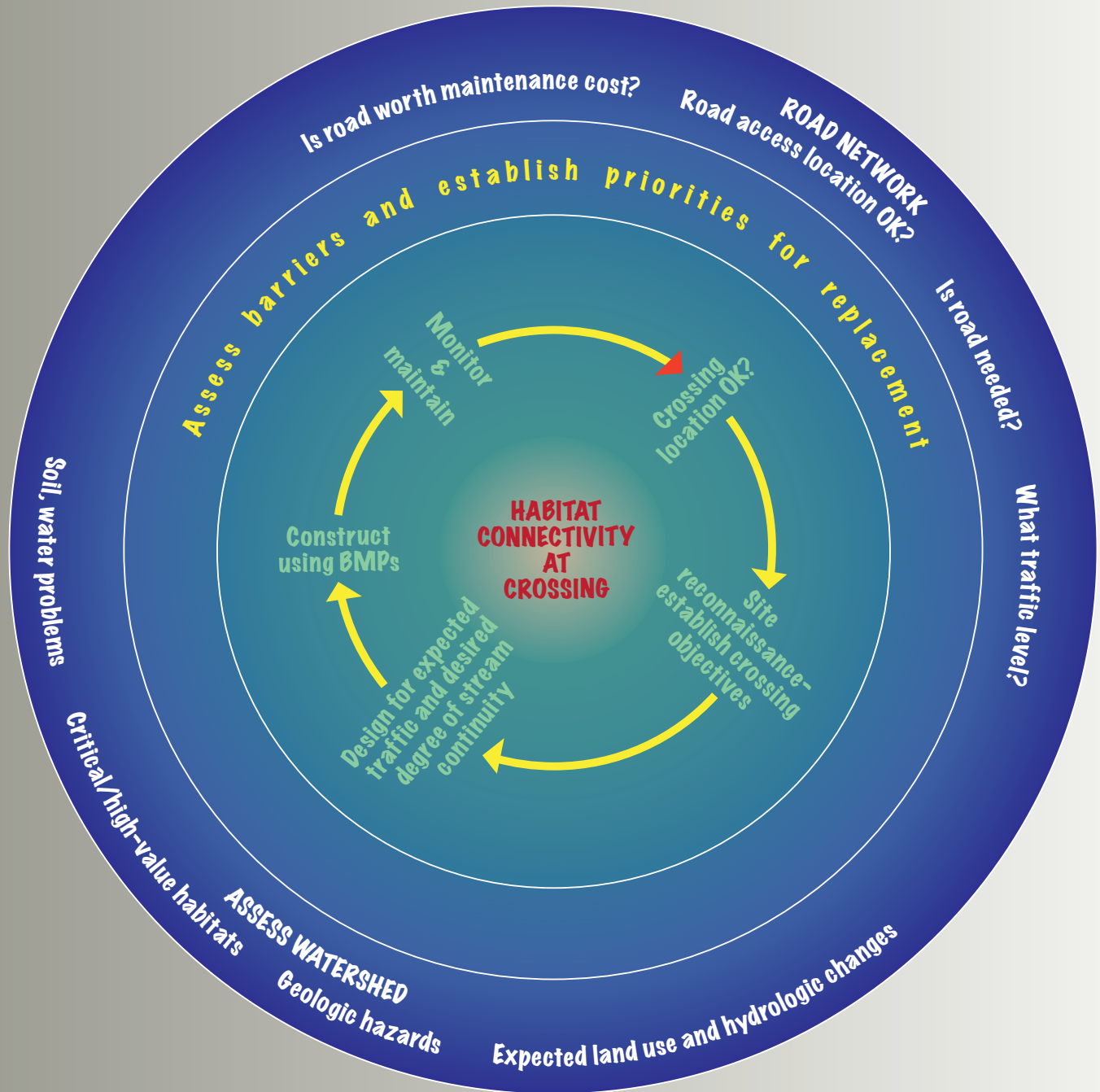

Figure 2.1—General process for providing habitat connectivity at road-stream crossings begins with large-scale assessments and drills down to site-scale design and monitoring.

## Chapter 2—Managing Roads for Connectivity

---

Chapter 1 showed that to maintain or restore the long-term viability of stream ecosystems and aquatic populations, roads and road-stream crossings must protect **stream connectivity**. This chapter briefly describes the planning, design, and implementation work needed to provide for stability and continuity in both road and stream networks. The chapter is a summary overview for land managers and decisionmakers among other readers, highlighting actions that protect aquatic habitat. Setting project objectives is emphasized here because it is one of the most important actions that require managers' participation. Chapters 4 and 5 provide more detail about formulating project objectives during the project development process.

Figure 2.1 shows the general sequence of steps required for constructing crossings that maintain or restore stream connectivity—from large-scale transportation system planning to project construction and site monitoring. The feedback loop from monitoring to planning and design is an essential step without which experience cannot improve the technology. Because crossing design is not a perfect science, project teams need to learn quickly from their mistakes if they are to avoid repeating them year after year.

### 2.1 REVIEW THE ROAD NETWORK

Before deciding on the location or design of any particular road or structure, project teams should review the area road network to ensure that it is as efficient and environmentally benign as possible. Creating a road system that is safe, efficient (that is, minimum length to meet access objectives), and protective of the aquatic and terrestrial environment calls for considering a variety of elements from a broad range of disciplines.

For road systems on national forest lands, “Roads Analysis: Informing Decisions About Managing the National Forest Transportation System” (USDA Forest Service 1999) provides a framework for analysis supporting broad-scale, strategic planning. This framework includes a comprehensive set of questions that transportation-planning teams should ask about the areas and facilities they are evaluating. The procedure poses each question in the context of an overall analysis at several scales, citing resources for assistance in determining the relevance of each question. Planning for transportation needs and mitigating environmental effects is often referred to as “access and transportation management”—an application of roads analysis, with the goal of planning the development of the transportation system over a decade or more.

## Stream Simulation

The roads-analysis process should answer the first question in any road-crossing planning effort: Is the road needed? Before going on to the next step in crossing planning, be sure this question has been answered. Compare the access benefit against the resources and other costs the road incurs, and then ask: Is it worth it? (figure 2.2). The process helps avoid the expensive mistake of retrofitting a crossing for organism passage on a road that may soon undergo decommissioning.

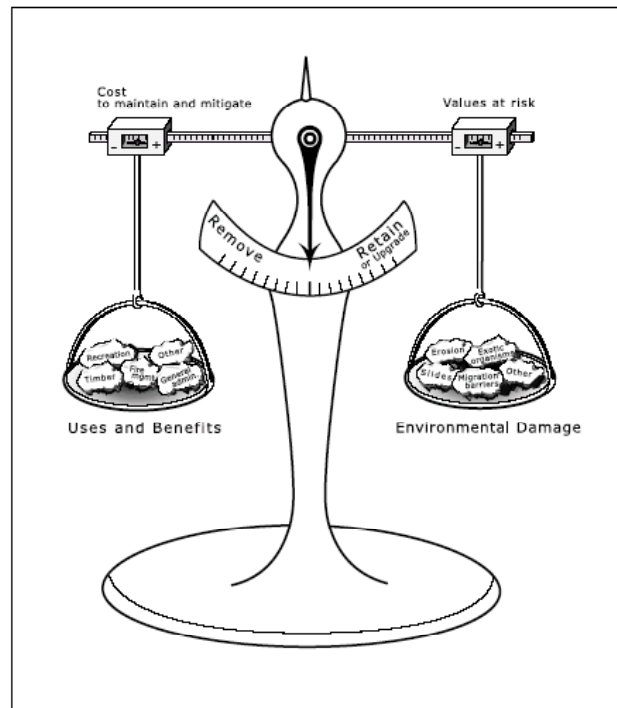

Figure 2.2—Remove or Retain? The cost-risk analysis. From USDA Forest Service 1999.

## 2.2 OPTIMIZE ROAD AND CROSSING LOCATIONS

Many forest roads were originally constructed where access was easiest—in the valley bottom. Despite the damage they may have caused over the years, many of those roads are still maintained. Before doing any upgrade work on a road, check that it is located properly. As all crossings result in some impacts to streams, the first principle is locating roads to avoid stream crossings, wherever doing so is feasible and consistent with transportation and other environmental considerations. All options for locating roads should be explored, because the more roads that are near streams or cross streams, the greater the potential adverse cumulative effects (figure 2.3). Roads that either run along streams or have many crossings, or both, should be considered for relocation or decommissioning. Relocating roads is often the only approach to mitigating the impact of old roads built in streamside areas. Many roads

## Chapter 2—Managing Roads for Connectivity

have alternative routes that access the same places, and these are good candidates for decommissioning. Where stream crossings are unavoidable, their number should be the bare minimum.

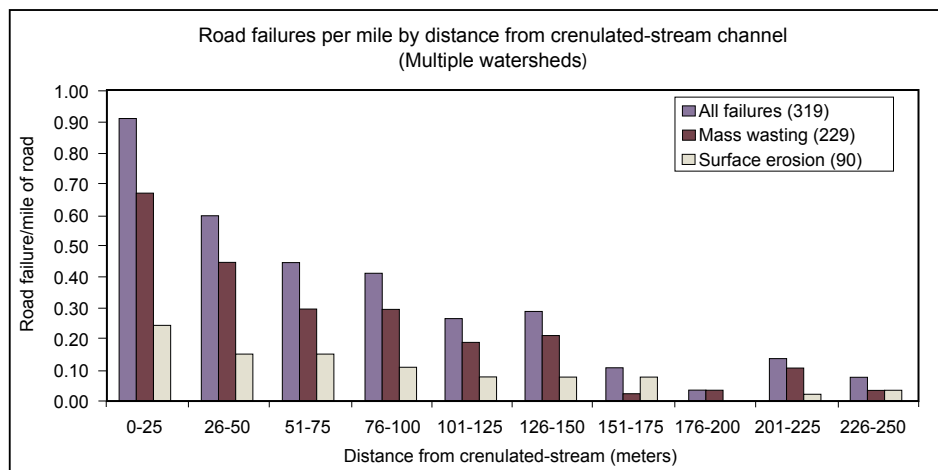

Figure 2.3—Road proximity to streams is usually strongly correlated with road failures, problems, and risks to aquatic ecosystems. From USDA Forest Service 1999.

Conduct a thorough geologic review of areas traversed by the road. If a road is in a high-hazard location, such as steep, wet, or unstable slopes, or streamside areas, consider removing, relocating, or modifying it to reduce its effects (figure 2.4). Also, identify critical or high-value habitats (wetlands, spawning grounds), and avoid them if possible. Road alignment and roadfills should avoid isolating  **flood plains**, constricting or realigning channels, or constraining channel migration, so that riparian and aquatic habitats retain their natural character.



Figure 2.4—Road located on a geologically unstable slope causes massive landslides, Bolivia.

## Stream Simulation

---

Try to locate roads away from high-value areas that are sensitive to disturbances created by road users. Roads can provide access for poaching, introduce exotic and invasive organisms, contribute to declines in rare or unique native vertebrate populations, or otherwise increase the potential of damage to important habitats.

As we will see later, crossing location is a critical element in stream-simulation design because location affects the risks associated with processes like shifting stream alignments, flood-plain constriction, and **debris flows**.

### 2.3 INVENTORY BARRIERS AND SET PRIORITIES FOR PASSAGE RESTORATION

There are several systems for evaluating culverts for their impacts on aquatic animal passage and other ecosystem processes (Taylor and Love 2003; Clarkin et al. 2003; Coffman 2005). After these evaluations are done, a process for prioritizing **barrier** crossings for remediation is needed. Priority setting should take into account the habitat quality in the river or stream and surrounding areas, upstream and downstream conditions, as well as the number of barrier crossings and other barriers on and off national forest lands (resource and risk assessments are described in sections 4.2 and 4.3). In some cases, dealing with other problems, such as the impacts of water withdrawals, restoration of in-stream habitat, or control of exotic invasive species, may be a higher priority than upgrading substandard culverts.

To maximize positive outcomes and avoid unintended consequences, using a watershed-scale approach to restoring connectivity is critical. The diversity and complexity of stream ecosystems impede the creation of precise formulas for weighing the various costs, benefits, and other factors that affect decisions about whether and how to replace substandard-crossing structures. Clearly, priorities for restoring connectivity depend in part on biological values in an area. High priority goes to areas with high biological diversity or productivity or with other special values, such as migration-route connectivity. However, because many other social, economic, logistical, and engineering elements go into prioritizing crossing replacement, the project team should weigh and balance them all before recommending priorities.

### 2.4 SET PROJECT OBJECTIVES AND DESIGN TO ACHIEVE THEM

The level of stream and flood-plain connectivity at a site has tremendous implications for transportation efficiency, safety, cost, **fluvial** changes, ecological effects, longevity, maintenance needs, and so on. Again, the most successful approaches to defining the appropriate degree of connectivity involve an active partnership between engineers, **geomorphologists**, hydrologists, and biologists, using an ecosystems approach for each case. At every site, the project team should analyze resource values, ecological risks and consequences, future management constraints, and access needs (see chapter 4). From that analysis, they can recommend what level of stream and valley continuity to aim for.

Federal land managers should be aware of at least three Federal laws when making decisions about the degree of connectivity at a new or replacement crossing:

- The 1973 Endangered Species Act [16 U.S.C. §§ 1531-1544].
- The Clean Water Act, 1977 amendment of the 1972 Federal Water Pollution Control Act Amendments [33 U.S.C. §§ 1251-1387].
- The 1976 National Forest Management Act [16 U.S.C §§ 1600-1616].

All these laws contain provisions that apply at road-stream crossings.

Ecologically speaking, crossing objectives can range from providing for full **flood-plain functioning** and large-animal passage to providing capacity for a certain flood, with no consideration of either animals or woody debris.

A corresponding continuum of design approaches exists (figure 2.5). The degree of stream and habitat connectivity decreases as we move from crossings designed for minimum interference with flood plain and valley processes to those designed simply for passing a flood of a certain frequency. Stream simulation is in the middle of this continuum. The structure types shown on figure 2.5 are not the only ones that correspond to the stated objectives; they simply illustrate the degree of connectivity. In addition to ecological objectives, the design approach will vary according to many criteria, such as traffic volume and type.

# Stream Simulation

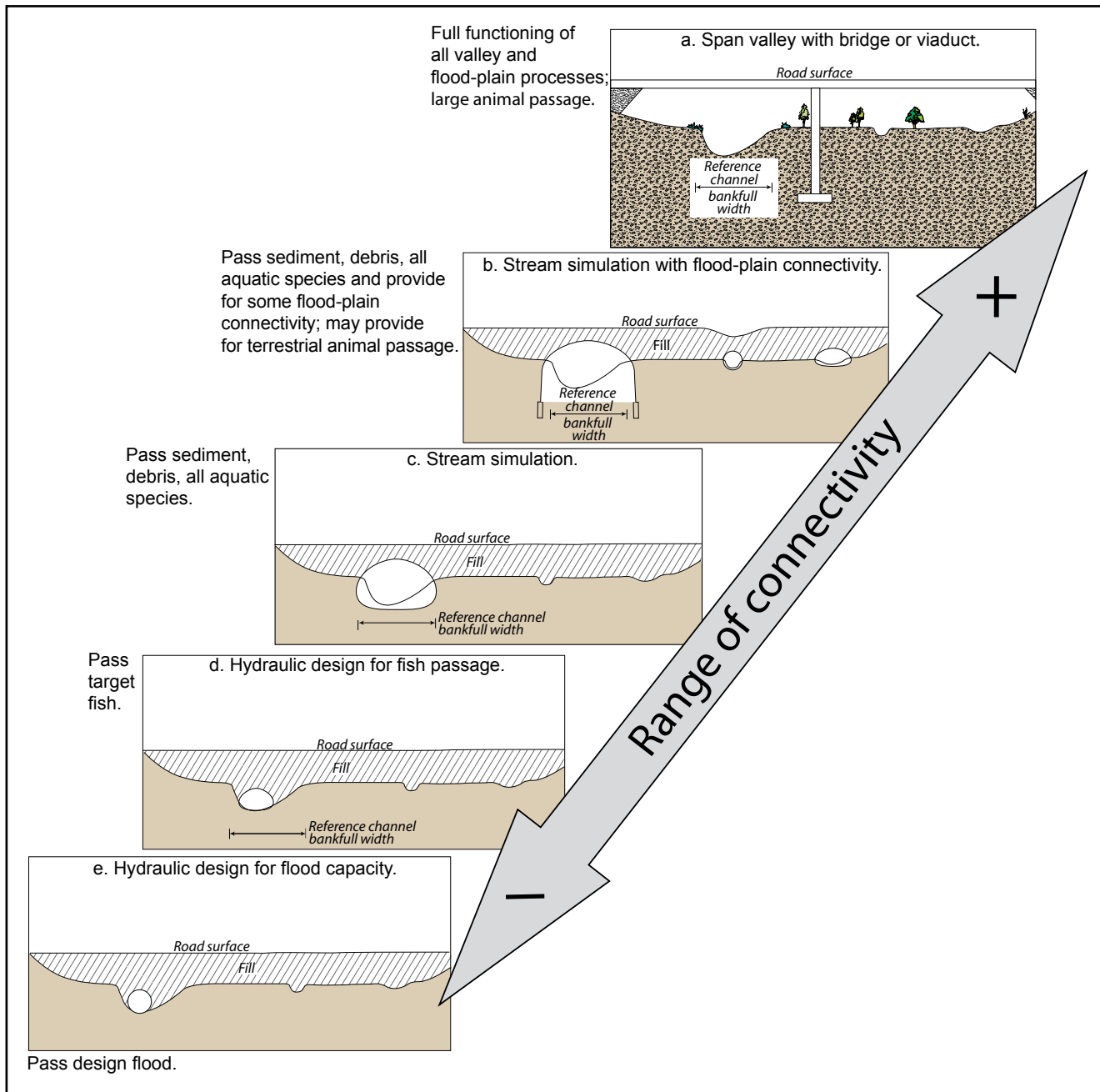

Figure 2.5—Range of crossing ecological objectives and examples of corresponding design approaches.



## Chapter 2—Managing Roads for Connectivity

---

Most sites will have a suite of biological, geomorphic, hydraulic, and/or infrastructure objectives. Some of these may conflict. The goal is to balance all the objectives appropriately and design a structure that optimizes achievement of all of them.

The team may have to modify objectives as the assessment and design process progresses. Site and other constraints that limit the degree to which certain objectives can be achieved may become evident as project planning progresses. Site conditions, public safety, land ownership, and cost are some of the many possible constraints. As the team learns more about the site, they are likely to engage in a healthy and challenging discussion about the achievability of objectives, feasibility of structure types, and best design approaches. An open and balanced discussion with due consideration for all aspects of the project is most likely to produce the best overall plan.

Following are examples of some of the ecological objectives and design approaches that a team might recommend for a site. There will be many other objectives related to, for example, local regulations, traffic safety, vehicle types, project footprint, associated infrastructure, etc.

### Full Valley and Flood Plain Functioning

A team might recommend minimal interference with valley and flood plain processes where:

- The stream is shifting rapidly across a wide **valley flat**.
- There are many **side channels** used by juvenile fish or other aquatic species.
- The valley flat is a migration corridor for large mammals and traffic is high on the road.
- The full range of riparian habitat diversity must be sustained as critical habitat.

This objective might guide the project toward a bridge and/or viaduct that spans the valley flat [figure 2.5(a)]. On very low volume roads where traffic interruptions are acceptable, other less expensive ways to maintain a high level of valley and channel connectivity may be appropriate, such as **fords** and dips. In some situations, well-designed fords can help maintain flood plain connectivity by keeping the approach road low across the flood plain. However, maintaining passage for aquatic organisms across fords is challenging, and requires designing the structure to fit the needs of the specific site (Clarkin et al. 2006).

## Stream Simulation

---

### Minimal Interference with Flood Plain Habitats and Transport of Water, Sediment, and Debris on Flood Plains

Flood plains are extremely important components of the aquatic system. During floods, water, sediment, and woody debris may move across flood plains, constructing important and unique habitats. Flood-plain stability—and **channel stability**—may depend on deposition of sediment and debris from upstream and on maintenance of the natural flooding regime. Flood-plain continuity is therefore an important value in many locations. Side channels are often important habitats on active flood plains, calling for preservation of aquatic organism passage in these smaller channels, too. In figure 2.5(b), culverts are placed in side channels and swales to achieve this objective. In other situations, such as little-used roads, ephemeral flow, seasonal closure, simple rocked dips may offer adequate passage.

### Terrestrial Animal Passage

Wildlife species primarily associated with stream ecosystems, and others that use riparian areas as movement corridors, may need passage through a crossing structure if the road has a high volume of traffic and/or very high, steep fillslopes. For some species of wildlife, such as muskrat and stream salamanders, maintaining **streambed continuity** (with a stream-simulation structure) may be adequate. Many other species prefer to use banks or dry streambed areas to cross through structures. Figure 2.5(b) shows a structure slightly wider than the **bankfull** channel that offers dry passage for some terrestrial animals.

Larger wildlife species are thought to have minimum requirements for the height of the structure (in many cases minimum requirements are not known). These species may be sensitive to the relative “**openness**” of the structure. [A structure’s openness ratio is defined as the cross-sectional area of the crossing opening divided by the structure’s length, and is usually stated in meters.] A few studies of structure use by deer, for example, indicate that these species need openness ratios of at least 0.6, and that ratios of 1.0 or greater are preferred (Brudin 2003; Reed 1981). The Wildlife Crossing Toolkit ([www.wildlifecrossings.info](http://www.wildlifecrossings.info)) provides information on terrestrial wildlife requirements.

Compared to other crossing structures, bridges are more likely to facilitate the passage of riparian and terrestrial wildlife, because they are more open and shorter in the along-stream direction. When sized properly, open-bottom arches are similar to bridges; the arches maintain the continuity of the streambed, allow unrestricted flow during normal conditions, and

## Chapter 2—Managing Roads for Connectivity

---

### Fish and Other Aquatic Organism Passage

typically allow the passage of some woody debris. Project teams may sometimes be tempted to rule out bridges or open-bottom structures in the beginning of the design process because of high cost. However, when the lifetime costs and resource effects are considered together, these structure types may sometimes be the best overall solution.

Ideally, crossing structures should constitute no greater restriction on movement for fish (including juvenile and relatively small resident fish) and other aquatic organisms, such as amphibians, reptiles, and crayfish, than the organisms confront in the stream itself. Unnatural physical barriers, such as inlet or outlet drops, debris racks, weirs, baffles, or other structures that would block movement of aquatic organisms should be avoided if at all possible. Keep in mind, however, that creating passage where there was none originally may be just as undesirable as creating a barrier (see Fausch et al. 2006).

Stream-simulation design is appropriate where passage is desired for all aquatic organisms present in the channel. Structures include open- and closed-bottom structures, but in all cases the streambed is continuous through the structure. [Figures 2.5(b) and (c) show stream-simulation structures; (b) goes further and provides for partial flood-plain connectivity.] Since streambed width, slope, and composition are all similar to the natural channel, stream-simulation structures accommodate the normal movements of aquatic organisms and preserve (or restore) the transport processes that maintain habitats and aquatic animal populations. Weak-swimming and crawling species may need appropriate bank-edge habitat for movement. Again, where passage for riparian and terrestrial wildlife is desired, teams should adapt structures to meet minimum height and openness requirements.

Hydraulic design [figure 2.5(d)] has been used for decades as the primary design tool for fish passage at road crossings all over the world. Hydraulic design optimizes the hydraulic effects of culvert size, slope, material, and length to create water depths and velocities suited to the swimming ability of a target fish. It can be appropriate when designing for a small number of target species with similar requirements, if the hydraulic requirements of those species are known. In current practice, the weakest-swimming species and lifestage of concern is usually selected to set velocity criteria, with the assumption that this also provides for the stronger swimmers. This design method and the uncertainties associated with it are covered in appendix B.

## Stream Simulation

---

### Passage of Watershed Products

Streams move water, sediment, and organic materials such as wood and detritus. Maintaining natural channel slope, width, and alignment through crossings is the best way to permit these stream functions to maintain the channel and flood plain downstream. Substantial decreases in slope or channel width will tend to restrict the movement of watershed products and contribute to higher maintenance costs and a risk of crossing failure.

### Minimal Risk of Crossing Failure

Culvert failures usually do much more damage than bridge or ford failures because of the amount of fill that is mobilized within the channel. Teams will find many approaches to minimizing both the probability of failure and its consequences. Stream-simulation design reduces the probability of failure by matching channel width, which generally provides capacity for rare flood flows plus debris and sediment. Carefully designed transitions between structure and stream also minimize the probability of failure. Nonetheless, any crossing can fail, so where the risks and consequences of failure are high, designing for a “soft” failure is a wise strategy. Such a design strategy may mean providing a dip at the crossing to prevent stream diversion, and/or armoring a portion of the fill to sustain overtopping flow.

### Invasive Species Barrier

In a world where exotic species are invading many aquatic habitats, managers sometimes may have to erect or maintain a barrier to protect a population. The value of protecting a population from invasives sometimes outweighs the increased risk to both target populations and other species when habitat is restricted. Fausch et al. 2006 present a framework for evaluating these tradeoffs that may help in making these decisions.

Culvert barriers are often designed hydraulically [figure 2.5(d)] so that they are perched higher than the target fish can jump, or have faster water velocities than the fish can swim. Steep or perched crossing structures not specifically designed as barriers may not reliably block invaders because they may be passable at some flows or to some individual animals.

### Control Stream Bed Elevations on an Incising or Incised Channel

Where a **headcut** is progressing upstream and the existing crossing is protecting the upstream channel from incision, the team may recommend maintaining the **grade control** function. This might happen, for example, where the roadfill backs up water and creates an unusually valuable wetland habitat. A full-bottom culvert or ford can function as a grade control, but to provide for aquatic species passage, the installation may require special measures, such as a specially designed side channel.

## Chapter 2—Managing Roads for Connectivity

**Channel Restoration** Where a channel has incised downstream of the existing culvert and degraded important habitat, the team may recommend restoring both passage and habitat. This work would involve restoring the channel to an elevation and sinuosity that makes the transition across the road crossing as close to seamless as possible. These projects may be more extensive and expensive than those in which only the crossing is treated.

### 2.4.1 Road Approaches to the Stream Crossing

The effectiveness of any structure depends on how well its design fits the site. Size, alignment, and provision for **overbank flows** and woody debris passage all influence the long-term sustainability and passage effectiveness of structures. Part of the challenge of fitting the structure into the site and minimizing ecological damage is designing the road approaches to the crossing and implementing needed **BMPs**. For example, where the road crosses an active flood plain, the continuity of water, sediment, and debris transport along the flood plain depends on drainage through the roadfill. Side-channel culverts, and culverts or dips on flood-plain swales and other locations across the flood plain might be necessary for maintaining flood-plain habitats and passing aquatic species that use those features.

Other design BMPs act to hydrologically disconnect the road from the stream. Their purpose is to leave no continuous surface flow path from the approach road to the stream during runoff events, so that water quality is protected from road-derived pollutants. These BMPs include:

- Ensuring that drainage ditches discharge muddy storm runoff to a vegetated buffer area or a constructed sediment trap rather than the stream.
- Stabilizing road fills effectively so that sediment production is minimized, not chronically disturbing road fills during road maintenance, and revegetating or rearmoring them for stability where needed.
- Outsloping road surfaces for surface drainage dispersal wherever possible. (Outsloping minimizes needed excavation, hydrologic connectivity, drainage concentration, and maintenance needs. Backup cross-drainage may be necessary where outsloped running surfaces become rutted.) (<http://www.stream.fs.fed.us/water-road/w-r-pdf/surfaceshape.pdf>)
- Armoring road surfaces where necessary to prevent erosion and sediment transport to the stream.

## Stream Simulation

---

- Ensuring that stream crossings do not have **diversion potential**. (<http://www.stream.fs.fed.us/water-road/w-r-pdf/diversionpntl.pdf>)
- Anticipating and preventing maintenance problems, and disturbing well-cured roads and trails only when needed for safety or drainage.
- Monitoring roads, trails, and crossings at regular intervals after large storms, and promptly remedying problems.

### 2.5 CONSTRUCT AND MAINTAIN THE CROSSING

The next step is to build the new crossing, ensuring adequate protection of the aquatic ecosystem during construction. This step involves timing and sequencing of installation, appropriate construction methods, and use of BMPs for water quality and aquatic habitat protection.

Timing is important for reducing the environmental impacts of crossing construction. Construction sites may be more vulnerable to erosion—and organisms that inhabit the stream or river may be especially sensitive to impacts—during certain times of the year. For example, many freshwater mussels shed their larvae directly into the water, where the larvae drift downstream until they encounter host fish. These releases occur at specific times of the year, varying according to species. During spawning season, fish may require natural flow conditions to reach **headwater** spawning areas. Likewise, some life stages (eggs, larvae, fry) cannot easily move to avoid unfavorable conditions, such as periods of higher-than-normal turbidity, or dewatering of the stream channel. Before determining the most favorable time for construction, therefore, teams should identify species using the stream or river and understand their specific life cycles and habitat requirements. Except where species are particularly vulnerable during low-flow conditions, timing construction during periods of low flow is usually best. In practice, the ‘work window’ is often specified in the State permit for in-channel work.

The best construction practices are those that reduce the amount of erosion and sedimentation; minimize the extent, abruptness, and duration of streamflow changes; and avoid the creation of physical barriers to animal passage (figure 2.6). Where tradeoffs need to be made among these considerations, knowledge of watershed conditions, the species present, and their ecological needs should guide decisionmaking.

## Chapter 2—Managing Roads for Connectivity

---



*Figure 2.6—Isolating the construction area at a bridge reconstruction site in Yellowstone National Park. Photo: Dan Rhodes, National Park Service.*

Water quality, channel integrity, and downstream habitats are always at risk in crossing construction and retrofit projects. Diligent attention to erosion and sedimentation controls and stormwater management during and after construction is essential. Common events such as summer thunderstorms can have important negative effects if teams do not anticipate them when planning for erosion control.

Maintenance and restoration of **riparian vegetation** is another important BMP. Riparian vegetation helps anchor banks, maintains channel form, provides shade and temperature control, contributes nutrients essential for productivity in small streams, provides large woody debris that shapes stream channel environments, and is an important component of habitat for riparian wildlife. (See chapters 7 and 8 for descriptions of construction methods that protect aquatic and riparian resources.)

### 2.6 MONITOR THE CROSSING

Only by monitoring can we know whether our methods meet our objectives. Before beginning, teams must clearly delineate monitoring objectives and determine what data they need to achieve the desired confidence in the results. Several types or levels of monitoring exist:

*Implementation monitoring* occurs during and/or immediately after construction, when the project team checks whether construction BMPs are being implemented and determines whether the structure was installed as designed. Regardless of what further monitoring is planned, as-built surveys or the plans annotated by the contract administrator (with changes made during construction) should be permanently filed, so that future changes can be identified.

*Effectiveness monitoring* answers the question: is the structure performing as intended? It does not need to be complex and time consuming, and can be as simple as the team visiting the site to see whether streambed continuity is being maintained over time. This monitoring can also be incorporated into regularly scheduled road safety checks. In an evolving technology such as stream simulation, this type of monitoring is essential for verifying whether design methods need modification. In some cases, installation problems may reduce a structure's effectiveness, and team members need feedback so that they may correct for past mistakes or poor decisions and continue to improve the process.

*Validation monitoring* (determining how well species can actually move through a structure) is more complex. It should be done as an administrative study, designed and conducted in cooperation with university or other researchers. Much has been learned from past experience, especially from detailed case studies that result from careful validation monitoring (see, for example, Lang et al. 2004). Continued monitoring of crossing structures—with particular attention to innovative designs and a broad range of species—will ensure that we know how well our efforts to protect stream ecosystems are succeeding and how we can improve those efforts.





## Stream Simulation

---



*Figure 3.1—Roaring River crossing site before-and-after culvert replacement in 2007, Boise National Forest, Idaho.*

## Chapter 3—Introduction to Stream Simulation

### 3.1 WHAT STREAM SIMULATION IS AND WHAT IT ISN'T

Stream simulation is a method of designing crossing structures (usually culverts), with the aim of creating within the structure a channel as similar as possible to the natural channel in both structure and function. The premise is that the **simulated channel** should present no more of an obstacle to aquatic animals than the adjacent natural channel.

Stream simulation developed when people began to realize how important it is to provide passage for the variety of aquatic species and lifestages present in most streams, and how difficult that is to accomplish in a bare or baffled culvert. To solve the passage problem simultaneously for many different species with different movement capabilities and timing needs, stream simulation takes a very different approach from hydraulic design. Stream simulation does not target specific fish or other species for passage, nor does the designer need to match species-specific water velocity, water depth, or crossing length criteria. Instead, a continuous streambed that simulates natural channel width, depth, and slope connects the reaches up- and downstream of the crossing. The simulation creates the diverse water depths and velocities, hiding and resting areas, and moist-edge habitats that different species need for movement (figure 3.1). Given the similar conditions, we can safely presume that the simulated channel inside the crossing presents no more of an obstacle to movement than the adjacent natural channel. Stream simulation crossings are larger than traditional crossings, and therefore less prone to debris plugging. This can benefit the road by reducing any tendency for debris plugging to cause overtopping or flow diversion.

The goal in stream simulation is to set the stage so that the simulated channel adjusts to accommodate a range of flood discharges and sediment/debris inputs, without compromising aquatic organism passage and without having detrimental effects on up- or downstream reaches. For the simulated streambed to maintain itself through a broad range of flows, stream processes that control sediment and debris transport and maintain hydraulic diversity must function similarly to the natural channel. In other words, flows that transport sediment and debris and rework the channel bed should not be constrained or accelerated inside the crossing structure. **Bankfull** flow is widely recognized as a good estimator of the **channel-forming flow** in stable alluvial rivers (Wolman and Miller 1960;

## Stream Simulation

---

Andrews 1980; Hey 1997) (see appendix A.4.1). Therefore, as a working criterion, we ensure that the channel inside the structure is at least as wide as bankfull width in the **reference reach**. Although this criterion is by no means the only characteristic of a self-maintaining stream-simulation structure, it is an essential one.

First, the simulated channel is designed. Then the crossing structure—either a bridge or culvert—is fitted over and around it. Its width depends strongly on project objectives, and it may exceed reference reach bankfull width if necessary for achieving objectives such as bed stability or amphibian or terrestrial animal passage.

Simulations are not exact replications of real stream channels. Features we cannot recreate inside crossing structures include:

- Natural light.
- Cohesive soils.
- Channel-spanning or embedded wood.
- Debris jams.
- Bankline vegetation.
- Channel bends.
- **Flood-plain functions.**

Features that provide **roughness** in a stream channel are essential for stabilizing the bed and creating the depth and velocity variations needed for aquatic species passage. Though we cannot duplicate these characteristics, we can simulate some of them with large rock. For example, to simulate natural banklines, we can place immobile rock along the channel margin in various arrangements that mimic the natural streambank. We can also use rock to simulate the grade-stabilizing functions of embedded **debris**.

For these and other reasons, the design is not a perfect simulation of the natural channel. Where to draw the boundaries of “stream simulation” is not always clear. Although stream simulation is most often described in terms of performance (providing passage for all aquatic organisms), since we are unable to verify free mobility for all aquatic organisms at a site, success is likely to remain somewhat subjective.

## Chapter 3—Introduction to Stream Simulation

---

Real stream channels are tremendously diverse and complex, with some degree of unpredictability in their response to runoff events and land management. Even using sophisticated quantitative methods for design, we cannot guarantee that a simulated streambed will sustain itself through the full range of flows it may experience. Moreover, our knowledge is continually expanding as we build more structures and as floods test those structures. While this guide synthesizes years of experience to date, the authors have tried throughout to make its limitations clear.

*“Always use the best data and methods available at the time.”*

—Dr. Charles Behlke

### 3.2 KEY ELEMENTS AND LIMITATIONS OF STREAM SIMULATION

The reference reach is the key element of a stream-simulation design. A natural stable **reach**, preferably upstream and near the project (see section 5.4), becomes the design template. The reference reach must satisfy the physical conditions of the crossing site, especially the slope, and it must be self-sustainable inside a confined structure. In other words, flows interacting with the bed and the structure walls will dynamically maintain the streambed within the structure. In high flows, although some features of the simulated bed may be immobile, other streambed materials should mobilize and restructure themselves similarly to the natural channel; sediment transported from upstream should replace eroded material.

Setting the stage for self-sustainability in the simulated channel means establishing basic characteristics of the reference reach, such as gradient, cross-section shape, bank configuration, and bed material size and arrangement. The reference reach need not reflect the average conditions in the natural channel; however, the condition should not be extreme. We assume that if we can simulate a reach representative of the natural channel, passage will be as good as in the natural channel. This is a virtual certainty in the many cases where the reference reach is very near the project site and represents the **project reach** as it would be if the crossing had never been constructed.

## Stream Simulation

---

The ideal of simulating a stable reference reach inside the crossing structure may not be feasible in certain common situations. These situations include highly unstable channels that are rapidly changing, such as after a major flood, where no stable reference reach exists. Other examples are inherently unstable landforms subject to frequent disturbances, such as alluvial fans (figure 3.2) and **debris torrent**-prone channels. Even stable sites where channel changes occur frequently, such as active meandering streams, are undesirable sites for any rigid structure. The ideal solution is to relocate the crossing and/or the road. Where relocation is not feasible, the project team must predict potential **channel adjustments** for the life of the structure and design for them.



*Figure 3.2—Active alluvial fan channel where flows have deposited gravel over the fan surface.*

Channels in wide, active **flood plains** present a challenge to stream simulation if the structure has to accommodate a large amount of flow that normally spreads across the flood plain. Funneling flood-plain flows through the structure can exert the sort of pressure on the simulated streambed that a reference reach connected to the flood plain never sees. Chapter 6 (section 6.5.1.1) gives a detailed discussion of design solutions.

## Chapter 3—Introduction to Stream Simulation

---

On some occasions the crossing needs to maintain a steeper-than-natural grade. For example, where a long stream reach downstream of the road has incised, the crossing might be retained as a **grade control** to protect the upstream channel. For such sites, the project team may have to search the stream to find a reference reach of the desired (steeper) slope. How far a simulation can diverge from the natural slope of the project reach and still achieve full passage remains uncertain (see section 5.5). The key question is whether the channel immediately upstream of the crossing will be able to supply the size and volume of sediment that the simulated channel needs. Section 6.1.2.3 discusses designing simulations steeper than the natural channel.

Assuming downstream **channel incision** is not ongoing, the ideal way to handle crossings with large elevation drops is channel restoration. Instead of steepening the culvert to tie the upstream and downstream elevations together, the design restores the incised segment to its natural elevation, sinuosity, and diversity. In some cases, to achieve sustainability, restoration of a long reach becomes necessary.

Channel restoration can restore more than aquatic species passage at the crossing; it also can restore aquatic habitat where that habitat has been simplified or destabilized. Section 6.1.2.3 covers the channel restoration option, but details of channel design are beyond the scope of this guide. For more information on channel restoration, see Federal Interagency Stream Restoration Working Group (1998) and Saldi-Caromile et al. (2004).

Many older culverts have caused sediment deposition upstream and local scour downstream (even when the channel has not incised), leaving an elevation difference that the replacement project must deal with. A simple method of handling this situation is to simply reconnect the streambed and allow it to regrade naturally. However, in some cases undesirable ecological effects could result. For example, a small wetland may have developed above the old culvert, and that wetland may now be providing valuable habitat to amphibians. Or an important spawning habitat may exist downstream, where sediment should be minimized. Section 5.3.3 describes some of these considerations.

## Stream Simulation

---

What constitutes “stream simulation” in these less straightforward situations is not entirely clear: How far can the characteristics of the constructed channel diverge from the natural channel before some aquatic species is impeded? How much steeper than the surrounding reaches can the simulated bed be? We might find a short, steep natural reach somewhere upstream, and ask: Can we use this reach as a valid reference reach? To answer this, we should keep a couple of basic questions in mind:

- Does the natural reach impede movement of aquatic species?
- Are the local controls on sediment supply, transport, and bed stability similar to the culvert site?

If the reach passes these tests, most practitioners would consider it a valid reference reach.

Where teams can find no reference reach steep enough to achieve site objectives, they can reasonably use a hybrid design procedure for the structure’s streambed. This technique simulates the streambed materials and structure that would be expected in nature at the desired slope. However, the major structural features of the bed are designed to be immobile because, if washed away, they would not be replaced by upstream rock of the same size (see appendix B). The structure may or may not pass all aquatic species at the site; the further the design departs from the characteristics of the natural channel, the less likely it is to pass all aquatic species that are present. To maximize the project’s resource benefits and minimize its natural resources costs, the project team and managers must weigh these compromises and trade-offs that some situations necessitate.



### 3.3 HOW COMPLEX DOES IT NEED TO BE?

All these factors may make the design method for stream simulation seem complex, but the key is to tailor the level of effort to the complexity of the site. Complicated sites, such as those listed below, require a careful, detailed design process.

#### CROSSING DESIGN IS MORE CHALLENGING WHEN A CHANNEL IS:

- Unstable (laterally or vertically).
- Undergoing rapid meander shift or bank erosion.
- Severely incised below the crossing.
- Severely **aggraded** above the crossing.
- Subject to debris flows, hillslope erosion events, or other large sediment inputs upstream of the crossing.
- Steeper than 6 percent.
- Made up of intermittent bedrock exposures in the streambed (see section 8.2.10).

Simple sites may not need detailed assessment, and their design is often straightforward. As teams gain experience, they can streamline the process appropriately for each site.

Part of the reason why the stream-simulation process appears complex is that it is inherently multidisciplinary. It requires considerable expertise and experience in diverse disciplines. The project team should include members who understand aquatic wildlife biology and ecology, so that they can identify passage needs, participate in setting project objectives, and protect wildlife during construction. **Fluvial** geomorphology and hydrology are important to understanding the watershed processes that the design must accommodate and the fluvial processes and channel features that must be simulated through the crossing. Civil engineering and hydraulics are essential to designing a fixed structure that will withstand the dynamic stream and valley environment. As no single person can competently cover all these areas of scientific and engineering knowledge, stream-simulation projects always involve a team of people experienced in applying these sciences (figure 3.3). Sometimes other specialists will be needed at especially complicated sites. In all cases, good communications between disciplines is crucial throughout the project.

## Stream Simulation



Figure 3.3—Multidisciplinary project team on initial reconnaissance of a project site.

### 3.4 ROADMAP FOR STREAM-SIMULATION DESIGN

Figure 3.4 shows the phases of a stream-simulation project, somewhat modified from phases defined by Jim Doyle (fishery biologist, Mount Baker-Snoqualmie National Forest). Except for stream-simulation design, the phases are essentially the same as for any crossing design project. Figures at the beginning of each of the following chapters will expand figure 3.4 to show details of the actions and considerations pertinent to each phase. It will function throughout the guide as a navigational “road map” to the project development process.

The project phases are identified primarily as a way of organizing this guide. The actual process of stream-simulation design is not linear. The phases overlap, and the team may have to go back and forth between phases when knowledge gained in a particular phase forces reevaluation of earlier conclusions. Often—especially at complex sites—a decision taken in one phase must be revisited in light of new information in later phases. The process starts with a broad view, and focuses down to smaller scales and more detail as the project develops.

## Chapter 3—Introduction to Stream Simulation

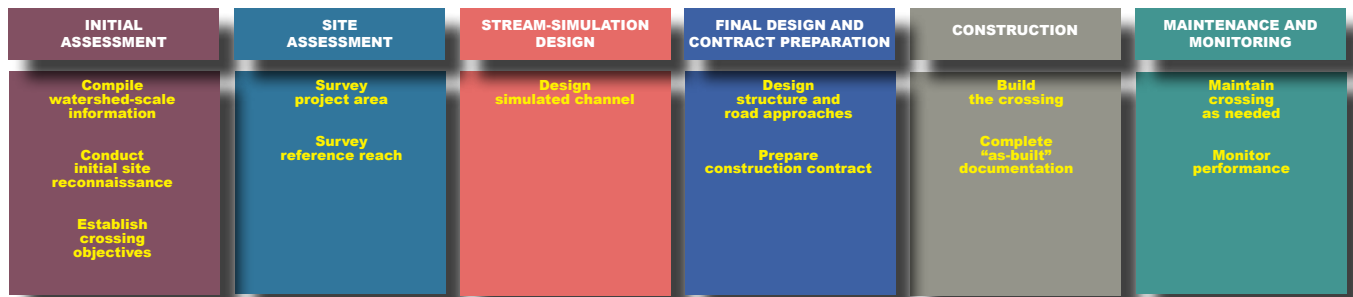

Figure 3.4—Steps in the stream-simulation design and construction process.

### 3.4.1 Initial Watershed and Reach Review

Unless you are well versed in the field of fluvial geomorphology, read appendix A before plunging into the stream-simulation process. Appendix A introduces geomorphic terms and concepts that are used throughout this guide and that are essential to understanding stream simulation.

In this phase (discussed in chapter 4) the project team reviews the access and travel management plan to verify that the road is both necessary and well located. They collect existing biological and physical watershed-scale information as background for project planning and for helping to interpret observations from the site-assessment phase. Placing the crossing site in the context of the road network and the watershed helps ensure recognition of ‘big picture’ risks, consequences, and opportunities.

Additionally, the team does an initial site walk-through reconnaissance, looking at site-specific risks such as woody debris, sediment accumulation potential, and the elevation drop through the crossing.

Assessment of site risks and suitability for stream simulation begins now, and continues through the site assessment and design phases. If risks are high, the team can plan for a higher level of detail in subsequent phases. This initial review should be done before replacing any crossing structure.

## Stream Simulation

---

### 3.4.2 Site Assessment

The site assessment (chapter 5) is a detailed survey and analysis of the project site, including channel and road longitudinal profiles, cross sections, and channel bed materials. It also includes a survey of the reference reach that will be the template for the simulated stream channel. From the results of the assessment, the project team develops a set of specific design objectives, and provides the information needed to design the **simulated channel**.

### 3.4.3 Stream-simulation Design

Stream-simulation design (chapter 6) begins with establishing the crossing alignment and the longitudinal profile of the simulated channel. Assuming that stream simulation is feasible, the next steps are to:

- Design the simulated channel based on channel characteristics of the reference reach.
- Size the crossing structure.
- Verify bed mobility and stability, where necessary.

At the end of this phase, the simulated stream-channel design is complete, and we know the area and depth the structure will have to cover. Although the focus in this guide is primarily on culverts, the same principles apply to bridges, and the team does not have to make a final choice of structure type until phase 4, final design.

## Chapter 3—Introduction to Stream Simulation

### 3.4.4 Final Design and Contract Preparation

In this phase, final design and contract preparation (chapter 7), the engineer-designer completes the structural design and details of the overall installation. Contract drawings and specifications are prepared, including stream simulation bed construction details, as well as water quality, wildlife, and other environmental protections. The level of engineering expertise necessary in this phase of the project depends on site conditions and risk, but in all cases the engineer-designer is part of the project team. Working through the details, the engineer-designer may discover that certain design objectives cannot be met or that changes in the preliminary design are needed. In this case, he or she should communicate with other team members, who may be able to suggest alternate solutions and should review any changes. Communication with the **Contracting Officer's Representative (COR)** is also crucial for predicting and solving problems that may arise during construction.

At this point, if not before, the COR should become a member of the project team. The COR should review the design during contract preparation, to become familiar with the critical design elements and to comment on the practicality of contract specifications and special requirements. As he or she will have to deal with any contract changes or unforeseen site conditions, the COR should understand earlier design decisions thoroughly. Good communication and mutual trust among team members make it much easier to handle sudden challenges during the construction process.

### 3.4.5 Construction

Contracting officers, CORs, and inspectors take the lead in phase 5 (construction, chapter 8), which begins when the solicitation is advertised. Again, to help manage changes in project design or unexpected conditions as they arise, the COR should keep other team members informed about progress, and make them aware of construction issues. For example, the biologist may need to be involved in trapping and moving the aquatic organisms at the site before construction and dewatering begin. The fluvial geomorphology specialist who participated in the design may also be able to advise on channel construction. Specialists' continued involvement will help assure the design objectives are accomplished as intended.

## Stream Simulation

---

### 3.4.6 Maintenance and Monitoring

Road-maintenance personnel need to be informed about critical design elements that may not be obvious—especially any grade controls, bank stabilization, or sediment control measures that may require occasional maintenance. Over time, road maintenance staff may be not only the caretakers but also the most regular monitors of crossing condition.

Stream simulations are expected to have lower maintenance needs, since their larger size decreases the probability of them plugging and overtopping. Nonetheless, some maintenance needs will undoubtedly arise. Unforeseen watershed or climatic events and channel adjustments may occur, perhaps changing the simulated streambed in ways that impair passage. Floods exceeding the structure's capacity certainly will cause a need for maintenance. All stream-simulation projects should prepare for maintenance and emphasize both monitoring and sharing monitoring results as a way of improving these design methods as rapidly as possible.

This guide covers maintenance and monitoring only briefly (section 8.3.2), despite their importance. Maintenance, continued monitoring observations over time, and documentation are essential to further development of stream-simulation technology. Early stream-simulation design replacement structures should be monitored intensely to improve our understanding and knowledge of the stream-simulation assessment, design, and construction process. Such monitoring will ensure that (1) mistakes are not repeated on future installations and (2) knowledge gained on techniques and interpretations is applied on future installations.



## Stream Simulation

---

### Steps and Considerations in Initial Watershed and Reach Review

#### Review the road context

- Access needs
- Road location
- Road management objectives
- Landownership and partnership potential

#### Review watershed and site resource values

- Aquatic species, habitats, and conditions
- Terrestrial animal passage needs
- Flood-plain values
- Water uses

#### Evaluate watershed-scale risk factors

- Geomorphic hazards
- Event history
- Past and projected land management
- Crossing maintenance history
- Channel stability

#### Evaluate site risk factors

- Channel stability
- Potential for blockage by debris, ice, and/or sediment
- Flood-plain constriction
- Large elevation change across existing structure
- Channel sensitivity to change

#### Evaluate site suitability

#### Establish project objectives

- Traffic access requirements
- Degree of stream continuity
- Degree of flood-plain continuity
- Aquatic and terrestrial animal passage requirements
- Channel restoration

## RESULTS

#### Site suitability evaluation

- Type of crossing

#### Broad project objectives

- Full aquatic organism passage
- Terrestrial wildlife passage
- Full flood-plain continuity
- Channel restoration, etc.

Figure 4.1—Steps and considerations in initial watershed and reach review.



## Chapter 4—Initial Watershed and Reach Review

---

The first phase of the crossing-design project is the watershed-scale review and site reconnaissance (figure 4.1). It can be completed quickly at low-risk sites where stream and watershed conditions are well known. The process applies to replacements, removals, and new installations, and much of it applies to any crossing, whether or not it is a stream simulation.

The questions to answer in this phase are:

- Is the site suitable as a crossing location? Determining site suitability is mostly a matter of weighing risks and consequences. The team can learn a great deal about risks and environmental consequences in this phase by synthesizing historical, management, and watershed condition information. That information, along with a site walk-through, is usually sufficient for identifying sites that are unsuitable for any rigid structure and unsuitable for stream simulation.
- What are we trying to achieve with this project? Setting realistic project objectives requires knowledge of watershed and road network conditions that only a broad-scale review can provide. Setting realistic objectives also requires some understanding of the stream **reach**, which you can get from a quick reconnaissance of the site. Project objectives may later be validated, stated in more detail, or changed in light of new information.
- Do site characteristics and project objectives lend themselves to stream simulation? The feasibility of using stream simulation depends on both project objectives and site conditions. In this rapid initial review, you can identify some important site conditions that might make stream simulation infeasible or complicated, and decide whether to pursue stream simulation as an option. The broad overview also will indicate how complex the project is likely to be.

### 4.1 REVIEW THE ROAD CONTEXT

Note: Because most Forest Service crossing projects today are on already existing roads, this guide usually assumes the crossing-design project is for a replacement. For new crossings and crossing removals, the steps and considerations are essentially the same.

## Stream Simulation

---

**Before planning a crossing replacement, always ask the questions: *Is the road necessary? Is there a better location for the road and/or crossing?***

Consult existing planning documents, such as the area roads analysis and pertinent watershed analyses. Those analytical efforts should show:

- Location and type of the resources the road accesses.
- Long-term access needs in the area.
- Expected future development and its effects on road use and stability.
- Road standard needed.
- Stability and appropriateness of the current road location.

This information allows a reasonable evaluation of the long-term need for the road and whether it justifies expected maintenance requirements.

If a road analysis has been done (section 2.1), it will indicate whether the road should remain at its current location or could be relocated. If not, make those determinations before continuing.

Review **road management objectives** to identify traffic access requirements—an important component of the crossing project objective. What transportation needs are to be served, at what standard, for how long, at what cost? For some seasonally closed roads on **intermittent streams**, a **ford** or other low-water crossing may suffice. If a road is being closed or put into long-term storage, removing crossing structures might be an option until the road reopens. Roads that must stay open during all but the largest floods will require a structure that reliably passes not only large floods but also the sediment and **debris** they carry. Safety is a primary consideration.

After reviewing land ownership in the area, identify potential partners for passage and habitat restoration among downstream or upstream property owners. Other interested parties—such as watershed councils, county road departments, and wildlife interest groups—might be possible partners.

### 4.2 REVIEW RESOURCE VALUES

To build an understanding of the degree of passage required at a site, compile existing information on watershed- and site-resource values. Background information might come from stream surveys, watershed inventories, special uses databases, and the personal knowledge of forest specialists, among other sources. Where the crossing is a passage barrier, habitat value for upstream reaches is an especially critical piece of information. It helps establish the context and priority of a possible passage-restoration project. If existing information is not adequate, do the necessary field investigations.

Examples of potential resources values might include:

- Threatened or endangered aquatic species.
- Excellent or rare aquatic habitats (both up- and downstream of the crossing) that need protection from excessive sediment and other pollutants at all costs.
- Terrestrial animal travel routes (for example, the valley is an important migration corridor for large mammals).
- Specialized **flood-plain** habitats (for example, ground-water-fed channels provide crucial cool-water refuges for fish).
- Flood-plain water storage for flood attenuation, maintenance of base flows, and maintenance of riparian habitats.
- Domestic, municipal, or irrigation water supplies.
- Cultural or archeological resources.
- Recreation.
- Aesthetics.

Where high-value or unique resources could be affected, the consequences of partially blocking movement of animals, water, sediment, and/or debris may be unacceptable. Where severe consequences combine with a high risk of crossing failure, such as in areas subject to **debris torrents**, consider relocating the crossing to a more suitable location. The value and sensitivity of the resources at risk are also two of the factors that dictate the level of effort that should go into the design and the degree of **stream continuity** the crossing should provide (see also section 4.6).

## Stream Simulation

### 4.3 EVALUATE WATERSHED RISK FACTORS

Take a “big-picture” look at large-scale watershed conditions and processes that have or can influence the crossing reach. Some of them are:

- Geologic or geomorphic hazards.
- History of flooding and geologic/geomorphic events.
- Past, current, and anticipated land management in the contributing watershed.
- Regional channel instability (for example, downstream **channel incision**; see appendix A.7.2)

*Note: Appendix A describes geomorphic concepts used in stream simulation.*

Together with a field visit to the site, the watershed background information provides a basis for understanding how the channel has responded to watershed events in the past. This knowledge, in turn, helps predict the direction and degree of future channel change. Predicting future changes is critical because stream-simulation structures must accommodate future streambed changes. Key questions include:

- What events and processes led to the current channel form? Is the channel stable, or is it still adjusting to past events?
- What watershed changes are likely during the life of the structure? How might they affect runoff and **sediment loads**?
- What channel changes are likely during the life of the structure? How will the stream respond to large floods?

To answer these questions, it helps to know what the watershed has delivered in terms of floods, debris flows, droughts, etc., and how future land use changes might change flows and sediment and debris loads. On the site scale, it is important to know what current reach conditions are and how responsive (sensitive) the reach is to changes in water, sediment, and debris loads (see section 5.3). Depending on the complexity of the site and the watershed, these interpretations can be hard to make. Someone knowledgeable in watershed and channel processes should guide the team in interpreting watershed and channel risk factors.

## Chapter 4—Initial Watershed and Reach Review

### 4.3.1 Geomorphic Hazards

Research the geology, soil, vegetation, and hydrology of the general area. Interpret these characteristics in terms of their likely effect on watershed processes and site stability. If a watershed analysis has already been completed, this information will be available. If not, tailor the detail of the investigation to the apparent risks at the site. For example, a 3-foot-wide stream on a closed road may not require the same level of effort as a 20-foot-wide river on a highway.

Evaluate each site for its proximity to potentially unstable landforms that could dramatically change sediment and debris loading to the crossing reach (see sidebar info sources). Look for features such as:

- Slope stability problems such as landslides and **earthflows**.
- Snow-avalanche chutes.
- Debris torrent-prone channels.

In addition, the site itself may be located on an inherently unstable landform susceptible to sediment deposition or erosion (for example, alluvial fans, deltas, coastal bluffs). Geologic materials may be highly prone to erosion, such as unconsolidated glacial sands. These features raise red flags about site stability.

**Information Sources.** Information sources commonly available on national forests are watershed analyses, access- and travel-management plans, aquatic-habitat inventories, geographic information systems layers, Infra (Forest Service database housing information about constructed features on national forests) and the Natural Resources Information Systems (NRIS) database. U.S. Geological Survey professional papers, water-supply papers, technical reports, and surface-geology maps are valuable resources for helping identify geologic hazards. In more populated areas, State and local agency maps and reports are often available. Land-type maps with descriptions of dominant geomorphic processes and hazards are available on some forests. Do not rely solely on published information. Field and aerial photo interpretations are essential in identifying geomorphic hazards.

## Stream Simulation

---

### 4.3.2 History and Location of Land Cover Changes and Watershed Events

Information needed includes:

- Location of the reach in the watershed and in relation to landforms or activities that could influence water, sediment, and wood input to the channel such as: geomorphic hazards, in-channel gravel extraction operations, large-scale riparian forest harvest, road and crossing failures, dams, etc.
- History of watershed land use and road system.
- Maintenance history at crossing site.
- History of major hydrologic events such as fires, floods, **mass wasting**, and droughts.
- Recent flood events.
- Type and intensity of channel responses to those events.
- Projected land use and road system changes in the watershed.

This historical information is the background needed to develop an understanding of current reach condition as it relates to past events and current watershed conditions (see figure 4.2 for an example). Is the reach changing? How have past changes affected the existing crossing? What is the direction of change? For excellent formal examples of this type of historical watershed analysis, see Wissmar et al. (1994); McIntosh et al. (1994); and Stillwater Sciences (2005).

Collect information on crossing maintenance and failure history to get an idea of how well the existing structure has performed at the site. This information will give an idea of channel processes that affect the crossing, and help identify chronic problems that the new structure should solve.

In addition, analyze how runoff timing and amount and **sediment loads** may change in the future as a result of expected watershed events such as fires, landslides, or development. Project how the reach may respond to those changes.



Figure 4.2—Flood-damage surveys can provide historical context for stream condition. (a) On Gap Creek in northeastern Washington, extensive erosion occurred on a riparian road in unconsolidated glacial sands during a 1993 flood. (b) Sediment filled the channel for several years but this transport channel remained stable and the sediment progressively cleared out during subsequent high flows.

### 4.3.3 Offsite Channel Stability

Instability elsewhere in the watershed can affect a crossing structure over time. For example, a **headcut** could migrate upstream and undermine a structure. (Refer to appendix A, section A.7.2 for a discussion of headcuts and channel incision.) Alternatively, if an upstream reach is unstable, it could dramatically increase sediment and debris loading to the site. Since the crossing structure will have to accommodate any large, enduring changes in the channel, it is important to predict the magnitude, direction, and timing of likely channel changes.

## Stream Simulation

---

Detecting significant channel instability in the watershed is not always possible without field work. Where forest cover is not too dense, a time series of aerial photographs can show changes in channel reach **planform** and instability. Photos might show noticeable change in channel width, rapid growth and movement of depositional bars, and growth of alluvial fans at tributary mouths (Grant 1988). These changes frequently are associated with observable land uses such as mining, agriculture, subdivision and road development, or forest harvest. Channel incision is a common type of regional instability caused by channel straightening, gravel mining, or loss of an important **grade control** feature. Historical accounts of stream and watershed conditions sometimes are available in local libraries or from community elders.

### 4.4 CONDUCT THE INITIAL SITE RECONNAISSANCE

With this background knowledge about the watershed and the road, the project team should traverse the channel up- and downstream of the crossing to (a) get a general overview of channel conditions in the **project reach** and (b) identify key geomorphic features and potential channel stability concerns. The actual length of the reconnaissance depends in part on how much information already exists about the stream. If good stream surveys are not available, the reconnaissance may need to extend well upstream from the crossing to evaluate the extent, accessibility, and quality of habitat. If the team has confidence in the accuracy of the existing survey information, walk the channel for at least 30- to 50-channel widths up- and downstream of the crossing. The reconnaissance should be longer for more responsive channels, such as where the streambed is more mobile, or banks are sensitive to disturbance. Be sure to go far enough to confidently assess channel conditions outside the existing structure's area of influence.

“Read” the stream for clues about the magnitude of overbank floods and **channel-forming flows**, the frequency and type of sediment transport events, and other channel processes, such as debris transport, beaver influences, bank erosion, streambed aggradation and degradation, and general channel stability.

*(The sidebar provides a checklist of questions that might be a useful starting point.)* Identify unstable features that could affect the crossing, such as a sediment wave progressing downstream, an unstable debris jam that could fail, a potential landslide, or an active headcut. Consider how the crossing is aligned relative to the stream and whether the alignment could be improved. Be aware of recent large floods or other unique occurrences that might affect interpretations of channel conditions. Observing how the stream has responded to the existing crossing structure can help you predict stream responses when the structure is replaced.



## Chapter 4—Initial Watershed and Reach Review

### Initial Site Reconnaissance Tickler Checklist

Note: This checklist is not exhaustive. There are likely many other questions that should be answered in different environments. Modify it as needed.

- ✓ What effects has the existing crossing had on the stream? How high is the perch, if any?
- ✓ How prevalent is woody debris? What role does it play in channel structure and stability? How stable is it? Does the riparian area provide a future supply of wood?
- ✓ Is there a high-conveyance flood plain? Is there evidence of scour, sediment, and wood deposition on the flood plain? Locate **side channels** and swales. Are there culverts or dips at these locations?
- ✓ What processes modify the channel (for example, debris flows, meander shift, ice or debris jamming, beaver, etc.)?
- ✓ Are the banks stable?
- ✓ What are the dominant streambed materials and how mobile are they?
- ✓ Is culvert alignment creating stability problems (for example, with plugging, bank erosion)? Should alternative alignments be considered?
- ✓ Is the channel a **response** or a **transport reach**? What channel type is it?
- ✓ Are there natural or other barriers to aquatic species passage in the reach?
- ✓ Are there solid grade controls (e.g., boulder weirs, bedrock outcrops, high-stability log weirs) in the reach? These locations can function as end points for the longitudinal profile surveyed in the site assessment (chapter 5).
- ✓ Is the downstream reach incised? If so, should the crossing be retained as a grade control?
- ✓ Is there a reach similar to the project site nearby that might be a potential **reference reach**?
- ✓ What features might constrain construction activities at the site?
- ✓ Are there specialized habitats that require protection during construction?

## Stream Simulation

---

During the site reconnaissance, think through the elements of stream-simulation design (described in chapter 6) to verify that stream simulation is actually feasible at the site. Sketch a plan-view map of the channel and adjacent flood plain or valley side slopes. Annotate the map with observations, such as location of high flow marks, severe bank erosion, and bedrock outcrops. (See section 5.1.1 for more discussion on sketch maps.) Now is a good time to establish photo points. If multiple site visits become necessary, there may be opportunity to photograph the site at different flows. Locate the photo points on the sketch map, and mark them in the field.

Most importantly, focus on the stability of the existing channel and its responsiveness to water and sediment inputs from natural and anthropogenic disturbances. Since a stream-simulation design must accommodate the potential range of **channel adjustments** during the service life of the replacement structure, **channel stability** and responsiveness to disturbances strongly affect the design. In general, response reaches are more sensitive than transport reaches. As described in appendix A, section A.2, response reaches tend to have finer, more erodible materials, and are more prone to sediment deposition, channel widening, channel scouring, and **channel migration**. Knowledge of channel types (appendix A.6) can often help with interpreting channel responsiveness.

During the site assessment (chapter 5), channel characteristics affecting responsiveness and stability will be fully documented, but some channel characteristics and geomorphic settings that can complicate design are easily observable during the initial walk-through (see sidebar).

### Reach Conditions Requiring Special Consideration

- Existing structures with large elevation drops (perched).
- High **flood plain-conveyance**.
- Active lateral channel migration.
- Depositional reaches: alluvial fans, braided streams, concave stream reaches.
- Channels with large amounts of woody debris, especially channels prone to debris flows or within a debris-flow runout zone.
- Channels prone to icing.
- Channels with unusual **flow regimes**, such as estuarine channels with tidal influences, glacial-meltwater channels, palustrine (wetland) channels where ground water and area flooding are important influences, tributary channels backwatered by the mainstem.
- Channels with intermittently exposed bedrock.
- Unstable channels (laterally or vertically unstable).

These channel characteristics and geomorphic settings are not universally or equally hazardous. In most situations, designs that mitigate risks to acceptable levels are feasible. Usually, mitigating designs will affect project costs to some degree, so be aware from the outset that these conditions may entail additional costs.

Descriptions of channel characteristics and geomorphic settings requiring special consideration along with some of their field indicators follow:

### Existing structures with large elevation drops

Where substantial aggradation above and/or incision below the existing structure have occurred, the replacement structure design needs to address the large change in streambed elevation. Such situations can compromise the feasibility of stream simulation, and their implications are analyzed in full detail during the site assessment and design phases (chapters 5 and

## Stream Simulation

---

6). Documenting the situation now alerts managers that the design may require more than the usual care and effort. If the existing structure is functioning as a grade control on an incising channel (see appendix A.7.2), the team will need to consider whether to preserve the grade control.

### High flood plain-conveyance

**Overbank flows** may transport large quantities of sediment and debris on high-conveyance flood plains. These sites require special design elements to avoid putting the simulated streambed at risk by concentrating floodwaters through the crossing structure (see section 6.5.1.1). Geomorphic evidence of substantial flow on the flood plain includes: scoured channels or swales, slack-water sediment deposits, buried vegetation, trees scarred by floating debris, and small debris accumulations upstream of obstructions.

### Active lateral channel migration

Rapid channel shifting across the valley floor may cause alignment problems for the crossing and structure design will need to account for the rate and extent of lateral migration (figure 6.4).

Estimate channel-migration rates from historical aerial photographs, anecdotal information, and/or field observations, although the first two techniques may be difficult to use in small channels obscured by vegetation or located in remote areas. In meandering channels, consider the following characteristics when evaluating the risk of channel migration in the field:

- Condition, type, and successional stage (age) of vegetation on channel banks and bars. (These can sometimes indicate the rates of shifting and heights of flooding; for example, age of vegetation on existing point bars can indicate rate of bar growth. The root strength of bank plants with dense and/or deep rooting habits can limit channel shifting.)
- Presence of a cutoff channel, **abandoned channel**, or swale along an inner channel bend (on the point bar).
- Composition and stratigraphy of bank materials. (Are bank sediments cohesive or **noncohesive**? Are certain layers more resistant or susceptible to erosion?)
- Evidence of active bank scour on the outside of bends, such as pieces of bank, exposed root masses, or fallen whole trees or shrubs lying at the bank toe or in the stream. (Be careful not to confuse channel migration with bank erosion resulting from sediment accumulation above an undersized culvert that has forced flow against one or both banks.)

## Chapter 4—Initial Watershed and Reach Review

---

- Recent sediment deposition on point bars that has partially buried vegetation.
- Large in-channel debris accumulations, with evidence of flow diversion onto the adjacent flood plain or **terrace** surface.
- Extreme angles of stream approach to a culvert inlet. (These may indicate (1) that the stream has migrated since the existing structure was built, (2) that sediment deposition upstream from an undersized culvert initiated local bank erosion, changing the stream's angle of approach, or (3) the crossing was poorly aligned with the stream when installed.)

Some channel shifting in the immediate vicinity of a crossing may have been caused by the original crossing alignment. For example, where a straight culvert replaced a meander bend, the stream may have responded by eroding banks and developing new meanders to restore the original channel length. The severity of this response depends on the amount of channel shortening and the composition of streambed and streambank material.

Channel migration is likely to be slower on moderately entrenched and **entrenched channels** because the shifting channel must erode higher banks. However, it can happen. For example, debris jams that **backwater** the main channel can force water to overtop the adjacent terrace and incise into the surface. If the process continues, it can lead to **channel avulsion**.

**Depositional reaches** Braided streams, alluvial fans, and reaches where stream slope flattens tend to experience lateral channel shifting due to **aggradation** or sediment deposition on bars (figure 4.3). Review the aerial photos of the watershed above the reach, looking for active sediment sources, areas prone to mass wasting, etc. Consider how past land uses in the watershed affected erosion and sedimentation rates, and how expected land-use changes may affect them in future. Keep in mind that sediment deposition may be chronic (for example, land use may increase upstream bank erosion and long-term sediment supply) or episodic (for example, occasional landslides).

## Stream Simulation

---



*Figure 4.3—Depositional reach on Kiowa Creek, Colorado. The channel shifted location across the valley bottom during a flood several years before this photograph was taken, when aggradation put additional erosive pressure on banks.*

In general, it is far better to avoid locating a road on an alluvial fan. The potential for sediment deposition and channel shift on fans makes for severe maintenance headaches. If an alluvial fan location is unavoidable, observe the upper, middle, and lower sections of the fan for recent sediment deposition activity or active channel incision. Coarse sediment from the watershed may be actively depositing during flood events near the upper portion of the fan. The channel may split into poorly defined distributaries as it flows down the fan, and their locations may change as deposited sediment and/or debris jams block them. On some fans, the stream may have incised through the fan deposits, so that deposition is occurring further downstream. These observations help determine the least active section of the fan—the best place to locate the road crossing in a difficult geomorphic setting. However, this least active section of the fan may still have the potential to become more active during the service life of the structure.

## Chapter 4—Initial Watershed and Reach Review

---

### Channels with large amounts of woody debris

Observe the presence, stability, size, and accumulation potential of wood in the project reach, especially upstream of the road crossing. If large wood is abundant in or near the channel, wood may play an important role in maintaining channel stability and controlling grade. It may also pose a risk to the replacement structure.

The following questions help in evaluating woody debris risks and roles:

- Are there individual wood pieces or large woody debris structures in the channel? Is the woody debris well anchored, or is there evidence of recent transport? Are most of the wood pieces generally longer than channel **bankfull** width? (Pieces longer than bankfull width typically have limited mobility.)
- Is the wood mostly solid and likely to last, or is it decaying and subject to being washed away?
- If the watershed has a history of wood-dominated debris flows, is the crossing within the projected debris-flow runout zone?
- Are steps in the channel maintained by woody debris?
- Are there low-gradient channel segments with unusually fine bed material? (Check to see if these channel segments are controlled by embedded pieces of wood. Especially in fine-grained channels, even small pieces of wood can contribute to channel bed stability.)
- Do trees border the downstream channel assuring continued wood inputs to the channel? Do downstream channel conditions and stability depend on upstream woody debris inputs? (If so, wood transport through the crossing structure may be critical to the long-term stability of the whole reach.)
- Has woody debris been previously removed from this stream for fish habitat improvement, flood hazard mitigation, etc.?

Table 4.1 shows simple criteria for assessing the risk that woody debris may plug a crossing structure. Reaches may have any or all of the characteristics described for a particular class.

## Stream Simulation

Table 4.1—Qualitative criteria for assessing the risk of plugging by woody debris at a road-stream crossing structure

Woody Debris Risk	Description
<b>LOW</b>	<ul style="list-style-type: none"> <li>● Debris mostly absent or well anchored on banks and in channel.</li> <li>● Debris dispersed uniformly along the reach (i.e., it has not moved).</li> <li>● Available wood is much larger than the stream’s ability to move it (i.e., large trees in small streams).</li> <li>● Little or no wood available for local recruitment.</li> <li>● Bed material not anchored by debris.</li> <li>● Woody debris likely to remain at or near source area.</li> </ul>
<b>MODERATE</b>	<ul style="list-style-type: none"> <li>● Most wood pieces anchored in the channel bed or channel banks.</li> <li>● Potential for local recruitment of wood.</li> <li>● History of occasional maintenance to remove wood at the crossing.</li> <li>● Small translational slides or undercut slopes adjacent to channel.</li> </ul>
<b>HIGH</b>	<ul style="list-style-type: none"> <li>● Unstable accumulations of woody debris present along banks, gravel bars, and channel constrictions.</li> <li>● Most wood pieces not anchored to bed or banks.</li> <li>● Considerable wood available for local recruitment.</li> <li>● History of frequent maintenance to remove wood at the crossing.</li> <li>● Upstream watershed susceptible to debris flows.</li> </ul>



## Chapter 4—Initial Watershed and Reach Review



Figure 4.4—(a) A wood-controlled step exhibiting high stability. Note the large-diameter logs embedded in the bank. (b) A wood-controlled step exhibiting moderate stability, Mitkof Island, Alaska. (c) A wood-controlled step exhibiting low stability, New Hampshire. Note the small-diameter pieces and lack of embedment in the bank.

### Channels prone to icing

In cold regions, ice can play havoc with crossing structures, especially on low-gradient streams. During spring breakup, moving ice can hit and damage a structure. Ice jams can also dam the channel, potentially causing floodwaters to overtop the road. These problems are most common on **perennial streams** and near lake outlets. In wetlands, ground water seeping from streambanks can build thick layers of ice that sometimes reduce the size of culvert openings.

## Stream Simulation

---

Field evidence that ice jams and accumulations may pose a risk includes:

- Ice-impact scars on the upstream side of trees (on banks or overhanging the stream). These can be several feet up the tree because of ice dam break-out floods.
- Isolated piles of gravel or cobbles on the banks or flood plain before spring runoff. Sediments overlie snow, ice, or last year's old vegetation.
- Blocks of ice present on banks after spring thaw, especially near meander bends, on point bars, and above natural channel constrictions.
- Discontinuous scour holes or channels that begin on the flood plain away from the stream bank, then join the main channel downstream.
- Weeping cut banks or wetlands next to crossings.

To determine winter-ice thickness in the area, see USACE (1999).

### Channels with unusual flow regimes

Designing a stream-simulation crossing (a stable channel with streambed characteristics similar to the natural channel) requires the flow regime be well understood, whatever that regime may be. Some unusual flow conditions make design more difficult because of their unpredictability (for example, glacial meltwater, backwatered tributary). The fine-grained bed materials common in palustrine and estuarine channels can limit the feasibility of constructing an embedded culvert.

### Channels with intermittently exposed bedrock

Many times intermittent bedrock is a design advantage, because it limits the extent of vertical channel adjustment after placement of the new crossing. However, it also can be a problem. For example, if undetected until construction, bedrock can be a surprise obstruction to placing a culvert at the correct elevation. Likewise, if a crossing happens to be located just downstream of a natural bedrock **barrier** that is now buried under the backwater sediment wedge, the new installation will exhume the barrier.

The important thing is to notice the presence of shallow or intermittently exposed bedrock during the walk through. The team can then plan to determine its extent and design for it.

## Chapter 4—Initial Watershed and Reach Review

---

### Unstable channels

Stable channels vary from nearly static and unchanging to highly dynamic and adjustable. Distinguishing highly dynamic but stable channels from unstable ones can be difficult (see appendix A, section A.4). Truly unstable channels are undesirable locations for stream crossings. They are particularly undesirable for stream-simulation crossings because of the need to project the changes that are likely to occur over the crossing lifetime, and design for them. There may be no stable reference reach for a design template.

Assess overall channel stability outside the influence of the existing crossing. A single indicator of instability is not necessarily conclusive by itself. Look for other geomorphic evidence along the length of the reach that confirms or challenges your conclusion of channel instability. Indicators of stability or instability should be consistent throughout the reach. In addition, use stable channels in nearby similar landscape positions as benchmarks for comparison.

Recent sediment deposition may suggest a channel is unstable and undergoing aggradation (Pfankuch 1978; Copeland et al. 2001) (figure 4.5). Field evidence can include the following:

- Large, mid-channel bar deposits that have little or no vegetation.
- Loose bed material with fresh surfaces.
- Unusually high percentage of fine material on the streambed.
- Little difference between surface and subsurface streambed materials; poorly **armored streambed**.
- Flood-plain vegetation buried by deposited sediment.
- Upland dry-site vegetation located low on the bank or dead on the flood plain (indicates recent channel filling).

Evaluating bank stability is often key to determining whether a channel is stable or unstable. Field evidence can include:

- Substantial and consistent bank caving, toppling, or **slumping**.
- Irregular channel width and scalloped banks.
- Unstable undercuts.
- Tension cracks at elevations above bankfull.
- Shallow-rooted, sparse, or weak bank vegetation.
- Artificial bank armoring (riprap) may indicate past bank instability.

## Stream Simulation

---

High, unstable banks can also be associated with channel incision or gullying (figure 4.6). If a headcut has reached the existing culvert, you may find a distinct difference in bank height and stability between the up- and downstream channels. (See appendix A.7.2 and section 5.3.4 for descriptions of typical channel type changes associated with incising channels.)



*Figure 4.5—Massive gully erosion upstream (figure 4.6) caused channel filling and flood-plain sedimentation in this depositional reach, eastern Colorado.*



*Figure 4.6—Channel widening after recent incision, eastern Colorado.*

## Chapter 4—Initial Watershed and Reach Review

One useful procedure for rapidly assessing channel stability in the vicinity of road-stream crossings is by Johnson et al. (1999). Their procedure, which builds on several earlier methods (Pfankuch 1978; Simon and Downs 1995; Thorne et al. 1996; Rosgen 1996), is based on 13 qualitative and quantitative indicators, each of which is rated with a point system (table 4.2). These ratings are weighted and added, producing an overall stability rating for the channel at the crossing. Some of the site variables (11 through 13) help in evaluating channel response to the existing structure. Johnson et al. (1999) provide guidance on interpreting the results to identify the type of instability (lateral, vertical, large transport/deposition of debris or sediment) and stabilization needs at the site. Any reach-based assessment procedure like this should be interpreted in the context of larger-scale stability issues, such as regional incision. The team can then focus its efforts during the detailed site assessment on the major risks at the site.

### 4.4.1 Construction Issues

During the initial review, identify features that might limit construction access. Show them on the site sketch, and flag them to ensure that the site assessment survey will include them. Such features include:

- Utility corridors, buried utility lines.
- Wetlands.
- Soft soils.
- Critical habitats.
- Steep slopes.
- Rights-of-way.
- Property boundaries.
- Existing landings, opportunities for storage and staging areas.
- Roadway lines-of-sight.

### 4.5 ASSESS SITE SUITABILITY

The team can now make a first assessment of site suitability for the crossing. Again, if possible, avoid locations where rapid channel change can be anticipated (figures 4.7 and 4.8). Crossings in dynamic reaches have a higher *potential* for failure than a stable site. If the *consequences* of failure would also be high, seriously consider relocating to a more stable site. The cost of moving the road may be more than offset by the lower risk of damage to the road or to high-value habitats and by the lower maintenance requirements.

# Stream Simulation

Table 4.2—Stability indicators, descriptions, and ratings (Johnson et al. 1999, used with permission of the American Society of Civil Engineers)

**TABLE 1. Stability Indicators, Descriptions, and Ratings**

Stability indicator (1)	Ratings			
	Excellent (1–3) (2)	Good (4–6) (3)	Fair (7–9) (4)	Poor (10–12) (5)
1. Bank soil texture and coherence	Clay and silty clay; cohesive material	Clay loam to sandy clay loam	Sandy clay to sandy loam	Loamy sand to sand; noncohesive material
2. Average bank slope angle (Pfankuch 1978)	Bank slopes <3H:1V (18° or 33%) on both sides.	Bank slopes up to 2H:1V (27° or 50%) on one or occasionally both banks.	Bank slopes to 1.7H:1V (31° or 60%) common on one or both banks.	Bank slopes over 60% common on one or both banks.
3. Vegetative bank protection (Pfankuch 1978; Thorne et al. 1996)	Wide band of woody vegetation with at least 90% density and cover. Primarily hard wood, leafy, deciduous trees with mature, healthy, and diverse vegetation located on the bank. Woody vegetation oriented vertically.	Medium band of woody vegetation with 70–90% plant density and cover. A majority of hard wood, leafy, deciduous trees with maturing, diverse vegetation located on the bank. Woody vegetation oriented 80–90° from horizontal with minimal root exposure.	Small band of woody vegetation with 50–70% plant density and cover. A majority of soft wood, piney, coniferous trees with young or old vegetation lacking in diversity located on or near the top of bank. Woody vegetation oriented at 70–80° from horizontal often with evident root exposure.	Woody vegetation band may vary depending on age and health with less than 50% plant density and cover. Primarily soft wood, piney, coniferous trees with very young, old and dying, and/or monostand vegetation located off of the bank. Woody vegetation oriented at less than 70° from horizontal with extensive root exposure.
4. Bank cutting (Pfankuch 1978)	Little or none evident. Infrequent raw banks less than 15 cm high generally.	Some intermittently along channel bends and at prominent constrictions. Raw banks may be up to 30 cm.	Significant and frequent. Cuts 30–60 cm high. Root mat overhangs.	Almost continuous cuts, some over 60 cm high. Undercutting, sod-root overhangs, and side failures frequent.
5. Mass wasting or bank failure (Pfankuch 1978)	No or little evidence of potential or very small amounts of mass wasting. Uniform channel width over the entire reach.	Evidence of infrequent and/or minor mass wasting. Mostly healed over with vegetation. Relatively constant channel width and minimal scalloping of banks.	Evidence of frequent and/or significant occurrences of mass wasting that can be aggravated by higher flows, which may cause undercutting and mass wasting of unstable banks. Channel width quite irregular and scalloping of banks is evident.	Frequent and extensive mass wasting. The potential for bank failure, as evidenced by tension cracks, massive undercuts, and bank slumping, is considerable. Channel width is highly irregular and banks are scalloped.
6. Bar development (Lagasse et al. 1995)	Bars are mature, narrow relative to stream width at low flow, well vegetated, and composed of coarse gravel to cobbles.	Bars may have vegetation and/or be composed of coarse gravel to cobbles, but minimal recent growth of bar evident by lack of vegetation on portions of the bar.	Bar widths tend to be wide and composed of newly deposited coarse sand to small cobbles and/or may be sparsely vegetated.	Bar widths are generally greater than 1/2 the stream width at low flow. Bars are composed of extensive deposits of fine particles up to coarse gravel with little to no vegetation.
7. Debris jam potential (Pfankuch 1978)	Debris or potential for debris in channel is negligible.	Small amounts of debris present. Small jams could be formed.	Noticeable accumulation of all sizes. Moderate downstream debris jam potential possible.	Moderate to heavy accumulations of various size debris present. Debris jam potential significant.
8. Obstructions, flow deflectors, and sediment traps (Pfankuch 1978)	Rare or not present.	Present, causing cross currents and minor bank and bottom erosion.	Moderately frequent and occasionally unstable obstructions, cause noticeable erosion of the channel. Considerable sediment accumulation behind obstructions.	Frequent and often unstable causing a continual shift of sediment and flow. Traps are easily filled causing channel to migrate and/or widen.
9. Channel bed material consolidation and armoring (Pfankuch 1978)	assorted sizes tightly packed, overlapping, and possibly imbricated. Most material >4 mm	Moderately packed with some overlapping. Very small amounts of material <4 mm	Loose assortment with no apparent overlap. Small to medium amounts of material <4 mm	Very loose assortment with no packing. Large amounts of material <4 mm
10. Shear stress ratio [Eqs. (3)–(4)]	$\tau_s/\tau_c < 1.0$	$1.0 \leq \tau_s/\tau_c < 1.5$	$1.5 \leq \tau_s/\tau_c < 2.5$	$\tau_s/\tau_c \geq 2.5$
11. High flow angle of approach to bridge or culvert (Simon and Downs 1995) <sup>a</sup>	$0^\circ \leq \alpha \leq 5^\circ$	$5^\circ < \alpha \leq 10^\circ$	$10^\circ < \alpha \leq 30^\circ$	$\alpha > 30^\circ$
12. Bridge or culvert distance from meander impact point (Simon and Downs 1995) <sup>b</sup>	$D_m > 35$ m	$20 < D_m \leq 35$ m	$10 < D_m \leq 20$ m	$0 < D_m \leq 10$ m
13. Percentage of channel constriction (Simon and Downs 1995)	0–5%	6–25%	26–50%	>50%

Note: Ranges of values in ratings columns provide possible rating values for each factor.

<sup>a</sup> $\alpha$  = approach flow angle to bridge or culvert.

<sup>b</sup> $D_m$  = distance from bridge or culvert upstream to meander impact point.

## Chapter 4—Initial Watershed and Reach Review

### Brewster Creek Road Culvert Replacement, Lolo National Forest, Montana *Example provided by Traci Sylte*

Where Brewster Creek exits its narrow valley onto a wider, flatter flood plain, it deposits sediment and forms an alluvial fan (figure 4.7). The Brewster Creek road crosses near the head of the fan where sediment begins to deposit as the grade flattens.

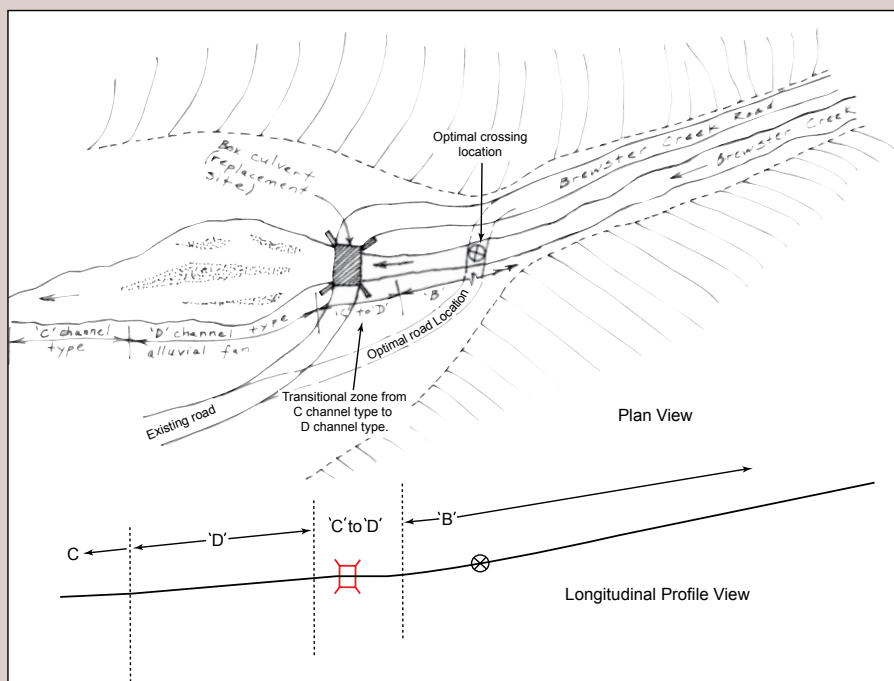

Figure 4.7—Brewster Creek crossing plan-view sketch. Original drawing by Traci Sylte.

The previous culvert, approximately half as wide as the bankfull channel, was full of sediment. As a result, the stream frequently overflowed the road. The forest replaced the culvert with a new bottomless box culvert in the same location. The new structure, which spans the bankfull width, was designed for fish passage. It was also designed to pass the 100-year flow, with some free board under the deck.

## Stream Simulation

---



*Figure 4.8—Brewster Creek road replacement box culvert, filled to 85 percent of its rise after 1 year.*

The year after construction, the new culvert also filled with sediment to about 85 percent of its rise. The stream still overflows the road frequently. A simple recognition that the crossing was located in a depositional zone, coupled with an easy road-location change to only 150 feet upstream (figure 4.7), could have avoided this problem.

Although stream simulation is possible at many risky sites, special design considerations are necessary. To mitigate such risks, make every effort to thoroughly understand current stream conditions and potential changes during the life of the project. Designing a structure that accommodates those changes and minimizes the potential for and/or the consequences of failure at such a site will take more effort and care. Both the design process and the structure itself may be more expensive than at simpler sites.



### 4.6 DEFINING PROJECT OBJECTIVES AND INITIAL DESIGN CONCEPT

Together with considerations of traffic access needs, maintenance requirements, safety, and funding, the geomorphic hazards and ecological values identified during the initial review provide the basis for defining preliminary project objectives. These objectives are preliminary because they may change as the team learns more about the site constraints and opportunities during the site assessment (chapter 5). Throughout the predesign phases of the project, the entire team—as well as the manager—should be involved as objectives are set or revised in light of new information. In cases where objectives conflict, priorities may be reshuffled. To make sure the objectives and priorities are clear and that all participants understand them in the same way, write objectives, and document any changes as they occur.

Objectives should respond directly to the risks and resource values associated with the project—by minimizing both the potential and consequences of failure, in accordance with the importance of the resources. For example, if conditions force a crossing to remain near high-quality spawning habitat, an important objective would be to minimize the risk of degrading that habitat; the project team might therefore consider a lower-risk structure, such as a valley-spanning bridge. If regional channel incision is occurring, one objective may be to preserve the crossing as a local **base-level control**. To minimize the risk to aquatic populations, at least partial passage could be provided by installing a bypass fishway or a fish ladder.

Some examples of ecological project objectives follow. Refer back to section 2.4 for a more detailed discussion of these objectives. [Road safety, traffic interruptibility, and other transportation system objectives also enter into a full objectives statement.]

- Provide passage for aquatic organisms.
- Minimize the risk of culvert plugging. On channels where the risk of plugging by wood, sediment, or ice is very high, objectives might be to minimize both the probability of plugging (by providing a large opening) and the consequences (by designing the structure to sustain overtopping flows and prevent stream diversion).

## Stream Simulation

---

- Maintain flood-plain functions and continuity. Where flood plains have important habitats formed during **overbank flows**, maintaining the natural flooding regime and providing for flood-water continuity down the valley may be important.
- Accommodate channel shifting. Where meanders are migrating rapidly across the flood plain, design the structure to accommodate channel movement as much as possible (see section 6.1.1.3).
- Provide terrestrial wildlife passage. Accommodate animals that use riparian areas for movement where traffic volume and/or fill height make crossing the road infeasible.
- Maintain grade control. Where a headcut is progressing upstream and the existing crossing is protecting upstream habitats, you may decide to maintain that protection. You might make the same decision where an undersized culvert backs up water and sediment, creating an unusually valuable wetland habitat. In cases like these, stream simulation may not be feasible, so the installation may require special measures, such as a fish ladder, ramp, or side channel, to provide for passage of some or all aquatic species.
- Restore a degraded channel. Where a channel has incised downstream of the existing culvert and degraded important habitat, an objective might be restoring both passage and habitat. This work would involve restoring the channel such that the transition across the road crossing is as nearly seamless as possible.
- Maintain a barrier against invasive exotic species. With this objective, stream simulation is not a design option. Undersized culverts sometimes function as partial or full **barriers**. Culverts not specifically designed for exclusion, however, may not be 100-percent effective, because some individual animals may be able to negotiate them at some flows.

Identifying preliminary objectives does not imply that the final design must fully achieve them. New information may cause the team to modify them, and more detailed project objectives will be formulated after the detailed site assessment. By this time, though, some of the site conditions or objectives that preclude stream simulation as a design option (maintaining a barrier), or that call its feasibility into question (maintaining a grade control) are known. The team probably has an initial idea of the type of structure (culvert or bridge) necessary for achieving the objectives.

Another result of the initial assessment is that the project's complexity is now known, and the team can judge the appropriate level of detail

## Chapter 4—Initial Watershed and Reach Review

---

for the site assessment and design efforts (see box below). Stable and straightforward sites do not require great detail for ensuring structure stability and aquatic organism passage. However, where the risk factors or project objectives make the project more complex or where traffic can only be briefly interrupted during construction, a higher level of effort is justified.

### Factors Determining Level of Site Analysis

1. Site history: Has the crossing structure failed before? Has it been a continual maintenance problem? What is the channel condition (historic and existing)?
2. Watershed history: Are there known active or historic geohazards (earthflow, landslides, etc.) in the watershed or in adjacent watersheds with similar characteristics (rock types, soils, vegetation, climate)?
3. Location: Where in the watershed is the site located, and on what type of landform) alluvial fan, glacial outwash plains, hillslope, etc.)?
4. Design life, road management objective, project constraints: Is this a highway or a logging road? What is the desired design life of a the structure? Are options at the site constrained by power lines, rights-of-way, property boundaries, or other infrastructures?
5. Channel type: What is the channel type? Is it sensitive to changes or fairly stable?
6. Is the channel incised or incising?
7. Consequences of failure: What will occur if the structure fails? What is the spatial relationship to sensitive resources (fish, riparian, vegetation, property, etc.), and how would failure impact them? What are the consequences of failure in terms of resources, monetary costs, loss of access, public safety?

## 4.7 DOCUMENT YOUR FINDINGS

Summarize the important findings from the watershed and reach review in a convenient format (narrative, map, form) for the project file. This documentation will continue to provide large-scale context and reminders of important offsite conditions throughout the project process, and will help you verify the level of detail needed for assessment. Include a complete set of photos taken from permanently marked photo points.

### 4.8 INITIAL REVIEW EXAMPLE

The following Mitkof Island, Alaska, example shows how a Tongass National Forest team documented the initial review and used it for risk assessment, site suitability determination, validation of project objectives, and preliminary decisions on structure type and design method. [The example uses the Rosgen (1994) channel classification system.]

For this example, information gathered in the office included:

- Location.
- Existing structure.
- Access and travel management.
- Area description.
- Geology.
- Soils.
- Vegetation.
- Site history.
- Slope stability.

The project team performed the following local-reach-scale assessments during their reconnaissance field visit:

- Channel types.
- Channel stability.
- Large woody debris risk.
- Risk of sediment retention.
- Streambank sensitivity.
- Site proximity to important or sensitive resources.

## Chapter 4—Initial Watershed and Reach Review

### Initial Geomorphic Assessment for Crossing 6235-17.59

*(Information provided by Bob Gubernick)*

**Location:** Mitkof Island, Southeast Alaska, Road 6235, milepost 17.59.

**Existing Structure:** The existing culvert does not pass spawning adults or juvenile salmonids due to a 1.9-foot perch at the outlet. Beaver activity occurs in the area, with a dam located in the culvert inlet (figure 4.9). This culvert is scheduled for replacement.

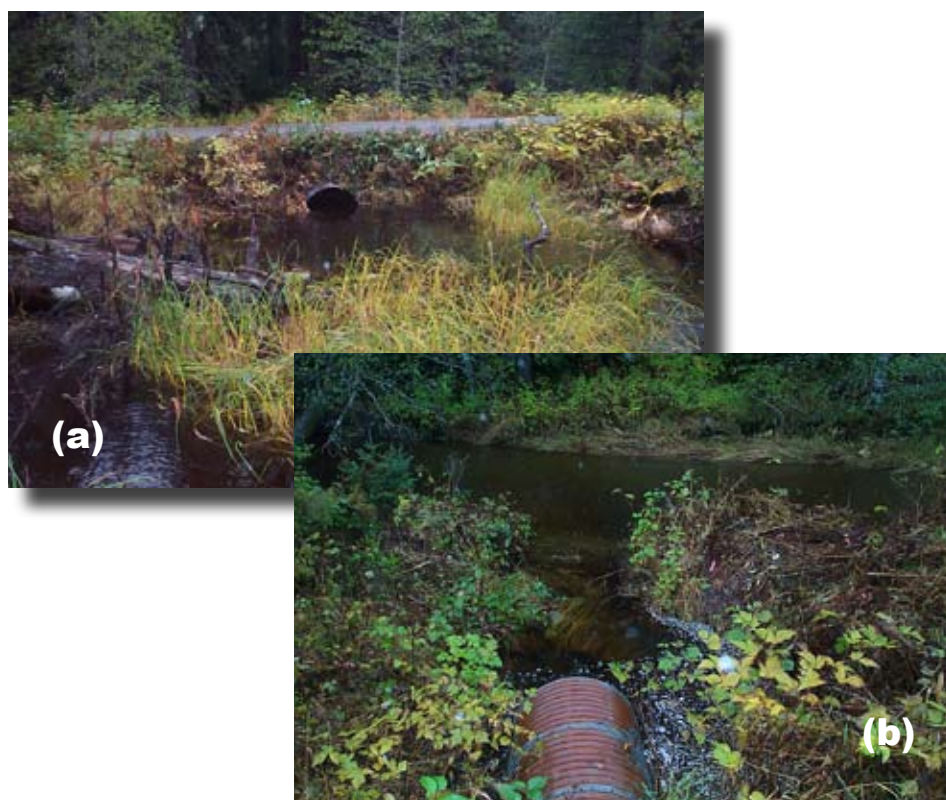

Figure 4.9—Existing culvert on Road 6235, milepost 17.59 (Tongass National Forest). (a) Culvert inlet. (b) Culvert outlet.

**Access and Travel Management:** Road 6235 is a permanent, high-use mainline arterial road (maintenance level 3), so traffic interruptions cannot be tolerated. The road must be safely passable by low-clearance vehicles in all weather conditions.

**Area Description:** The site is in a narrow valley bottom below a uniform hillslope. Descending the hillslope, the channel is steep and moderately incised. It enters the mainstem channel soon after reaching the broader, flatter flood plain. The crossing site is located near the slope transition between the hillslope and the wide flood plain.

## Stream Simulation

---

**Interpretation:** The site is a response reach that may be subject to sediment deposition at the transition to a flatter slope. Large vertical adjustments can occur.

**Geology:** The area is composed of sedimentary deposits (marine greywacke, mudstone, and conglomerates), andesitic-to-basaltic volcanic rocks, and regionally metamorphosed equivalents of these strata (source: Gerhels and Berg 1992).

**Interpretation:** Sedimentary and metasedimentary materials can vary greatly in durability and are usually platy in shape.

**Soils:** The hillslope soil is in the Kupreanof series (origin is weathered sedimentary rock). The valley bottom soil is silty **alluvium** (source: forest GIS layer).

**Interpretation:** Kupreanof series soils have high silt contents. On steep slopes, they are susceptible to translational landslides, which can initiate a debris flow or torrent. Check slope stability characteristics.

**Vegetation:** The hillslope is dominated by a mixed conifer series (Sitka spruce, western and mountain hemlock, cedar). The valley bottom is a sedge and bog plant community adjacent to the main channel. A mountain hemlock/blueberry series lies further from the channel (source: forest GIS layer). The area is primarily pristine (99+ percent), with only a small managed section (source: air photos 1985 and 1998). The forest anticipates no new management activities.

**Interpretation:** All plant series are composed of dense, deeply rooted vegetation that stabilizes banks and limits **lateral migration**.

**Site History:** The original culvert was installed in the late 1960s. Periodic beaver activity has caused continual maintenance problems (source: maintenance records and personal communication from maintenance foreman).

**Interpretation:** Beaver activity will limit options. To minimize long-term maintenance needs, consider structures with wide openings such as bridges or embedded box culverts with removable lids (vented fords). To avoid making the crossing more attractive to beavers, design will have to minimize road elevation.

**Slope Stability:** Air photos (1963, 1979, 1985) show no indications of slope instability (landslides, debris flows).

Hillslopes above the site range between 18- to 36-percent slope, decreasing to 16 percent on the lower slopes. The moderate slopes, available lower-slope run-out length of 1,500 feet, and lack of activity in 40 years of the

## Chapter 4—Initial Watershed and Reach Review

photo record indicate that the site has extremely low risk from debris flow or landslides (figure 4.10).

**Interpretation:** Slope stability is not a concern. Vertical clearance (to accommodate debris flows) is not an issue.

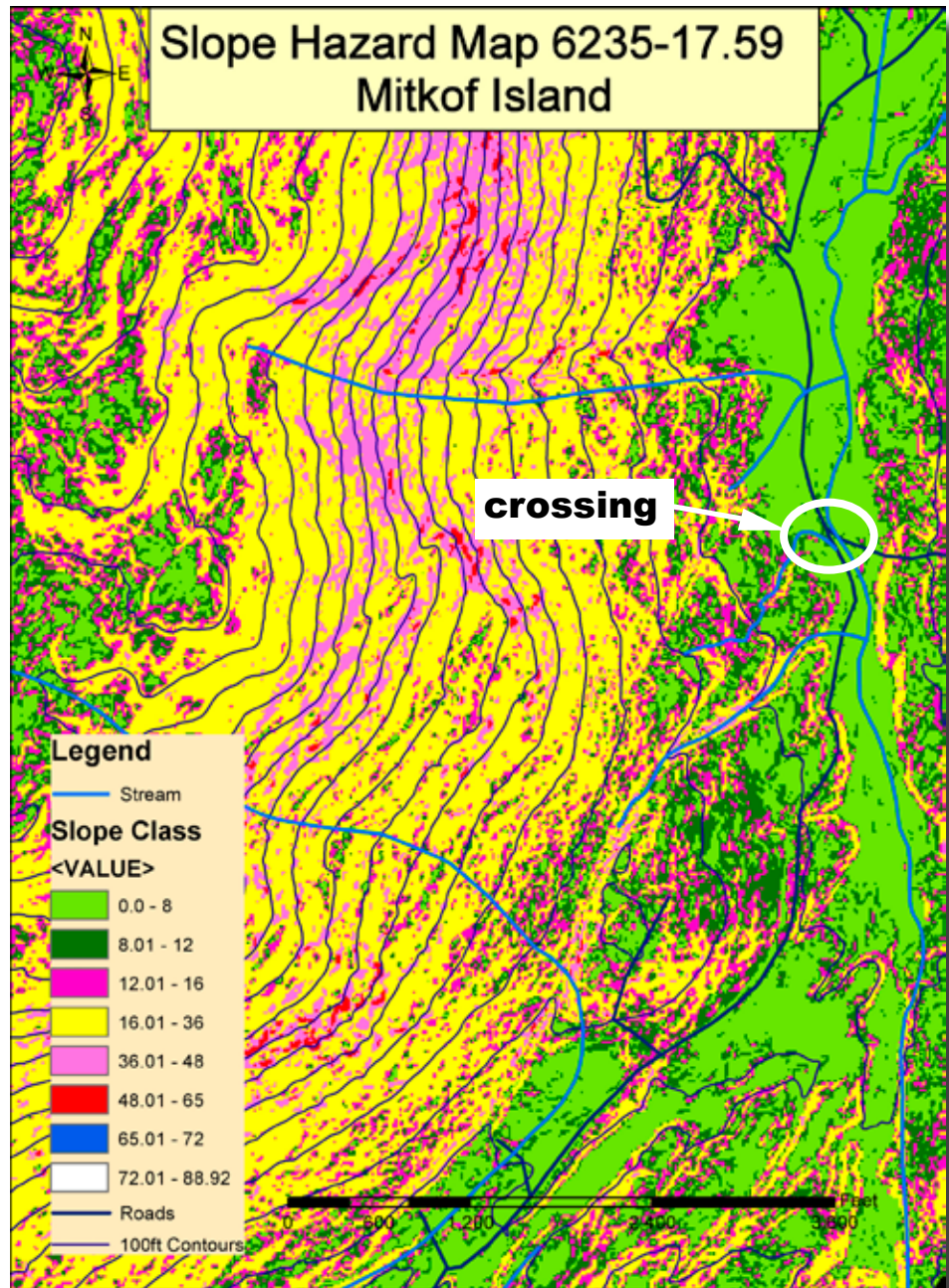

Figure 4.10—Map of slope classes above crossing. Slopes are mostly moderate in the upper watershed, and the risk of slope instability is low. Tongass National Forest GIS layer.

## Stream Simulation

---

### Channel Types:

- Hillslope: high-gradient, step-pool channels composed of bedrock, boulders, and/or cobbles (Rosgen A1a to A3).
- Valley bottom (above site): riparian wetland; low-gradient pool-riffle channel composed of silt and clay, with beaver activity (E6).
- Valley bottom (below site): moderately sloped pool-riffle channel composed primarily of gravels (C4).

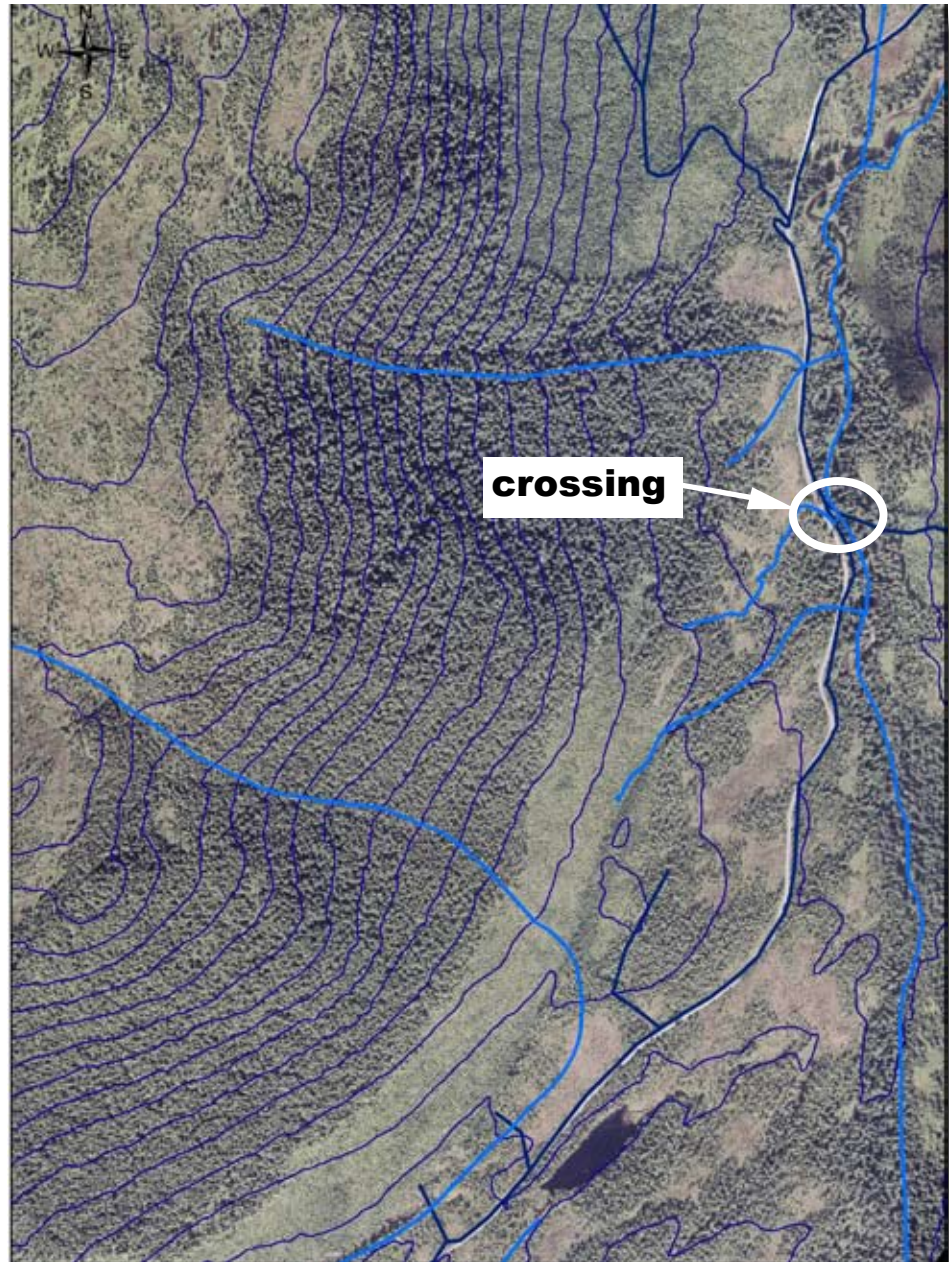

Figure 4.11—1985 aerial photo.



## Chapter 4—Initial Watershed and Reach Review

---

**Channel Stability:** The channel above the site is not visible on the 1963, 1979, or 1985 aerial photos (figure 4.11). Below the site, the channel appears stable, with no observable change in the photos. Neither the sequence of aerial photos nor the reconnaissance field visit shows any evidence of rapid channel change in either the tributary or the mainstem.

**Interpretation:** No system-wide base-level adjustments are visible or anticipated. No major adjustments in design are needed.

**Large Woody Debris Hazard:** Wood in the steep section of the channel is large (greater than 1-foot diameter) and is generally either well-embedded or in stable debris jams. Little debris transport is anticipated, and the site is far enough away from the edge of the valley bottom that the risk of plugging by large wood transported from upslope is low. However, the risk of plugging resulting from beaver activity is high.

**Interpretation:** Opening should be large, because of beaver activity.

**Risk of Sediment Retention:** Hillslope: low (**transport channel**). Valley bottom: high (**response channel**).

**Interpretation:** The beaver pond is an aggradational zone. If the pond is removed, the fine material also may need to be removed for water-quality protection.

**Streambank Sensitivity:** Sensitivity is low for both uplands and lowlands. Deep-rooted vegetation holds banks together both on the hillslope (mixed conifers) and on the flood plain (sedge, berry brush, and occasional conifer). Sedge and berry brush are extremely deep rooted and dense in the immediate up- and downstream reaches.

**Interpretation:** Banks can adjust to minor changes without destabilizing. Minor alignment changes should not pose a problem.

**Site Proximity to Important or Sensitive Resources:** Immediately adjacent to site (30 feet downstream) is high quality salmon-spawning habitat.

**Interpretation:** Proximity to spawning habitat means that site design should have a high safety factor. Sediment control is a major concern, given close proximity of the upstream pond.

## Stream Simulation

---

**Overall Risk Assessment:** Based on the stability of hillslopes, the channel types in the area, and on the photo record, overall risk is low.

Project Objectives:

- Provide free passage for aquatic species, sediment, and woody debris (stream-simulation design).
- Use culvert or low-profile bridge if cost effective. (Keep approach fills low. If selecting a culvert, design road for overtopping and minimize risk of sedimentation from beavers' plugging the culvert.)
- Minimize the installation's attractiveness to beaver by using as large an opening as possible.
- Remove beaver dam, but try to maintain some water depth upstream if possible.
- Minimize sediment released to the downstream spawning area during construction and over time.
- Maximize flood-plain connectivity by installing additional culverts in side channels and flood swales.



# Stream Simulation

---

## Steps and Considerations in Site Assessment

### Sketch a planview map

#### Topographic survey

- Site and road topography.
- Channel longitudinal profile.
- Channel and flood-plain cross sections.

#### Measure size and observe arrangement of bed materials

- Pebble count or bulk sample.
- Bed mobility and armoring.
- Bed structure type and stability (steps, bars, key features).

#### Describe bank characteristics and stability

#### Conduct preliminary geotechnical investigation

- Bedrock.
- Soils.
- Engineering properties.
- Mass wasting.
- Ground water.

#### Analyze and interpret site data

- Bed material size and mobility.
- Cross section analysis.
  - Flood-plain conveyance.
  - Bank stability.
  - Lateral adjustment potential.
- Longitudinal profile analysis.
  - Vertical adjustment potential.
- General channel stability.

#### Document key design considerations and recommendations.

## RESULTS

**Geomorphic characterization of reach.**

**Engineering site plan map for design.**

**Understanding of site risk factors and potential channel changes over structure lifetime.**

**Detailed project objectives, including extent and objectives of any channel restoration.**

**Design template for simulated streambed (reference reach).**

*Figure 5.1—Steps and considerations in site assessment.*

After verifying that the site is suitable for a crossing and will probably be suitable for stream simulation, the next step is to conduct a thorough site assessment. In this phase, you will collect the topographic and other data necessary for designing both the stream-simulation channel and the crossing structure and road approaches. Crossing-removal projects require virtually the same set of data and observations.

Interpret the additional information gathered here to predict how the structure and stream will interact, and to design a stable structure that avoids or minimizes adverse effects to the stream over the long term. Document your key considerations, findings, and recommendations. This work requires close communication among team members who are skilled in biology, geomorphology, hydrology, and engineering. A thorough understanding of channel form and **fluvial** processes—the basics of which are in appendix A—is essential for interpreting the site assessment information.

### 5.1 COLLECTING SITE DATA

Data collection for site assessment consists of surveying channel, valley and road topography, and tying the survey to observations of geomorphic and other features, including subsurface materials. Much of the assessment is aimed at understanding the site and the stream processes that will have to be accounted for in design of the new crossing. You need this understanding to predict channel changes expected over the structure's lifetime and design for them. Again, the level of effort and detail should correspond to the complexity of the site and the risks associated with placing a structure there.

The second goal of site assessment is obtaining a model for design of the **simulated channel**—that is, characterizing the reference reach. However, the **reference reach** must have a slope very similar to the slope of the simulated channel, and that slope will not be known for sure until the **project profile** design is complete (section 6.1.2). The actual reference reach cannot be identified with certainty until after that first design step. There are two ways to handle this logistically:

1. Enough data can be collected during the site assessment to characterize several potential reference reaches at different slopes. This avoids the need to revisit the site and collect additional data once the reference reach is selected during design (chapter 6).

## Stream Simulation

---

2. After analyzing the project area survey and determining one or more potential slopes for the simulated streambed, identify one or more applicable reference reach(es) from the longitudinal profile, and return to the site to characterize their cross-section dimensions, **entrenchment**, bed material, etc.

Section 5.5 goes into detail on selecting the reference reach. Channel morphologic data needed for the reference reach are summarized there.

Good documentation of the field observations is essential for interpreting the survey data, and a complete sketch map is a key complement to the narrative field notes.

### 5.1.1 Sketch Map

Often the site sketch map will have been started during the initial site reconnaissance (section 4.4). More information should be added as site assessment progresses. The sketch map helps in evaluating road and channel alignments, and interpreting survey results. Draw the map approximately to scale, and illustrate the spatial relationship of the channel and flood plain features and their relation to the road-stream crossing. As you walk through the reach drawing the map, take the opportunity to flag **key features**, cross sections, **bankfull** elevations, **flood-prone zone** limits, etc., to ensure their inclusion in the topographic survey.

The sketch is a plan view of the **project reach**, showing:

- Channel pattern (straight, meandering, or braided). On existing roads, attempt to estimate the location and pattern of the natural channel before the road was built.
- Channel and road alignments relative to each other.
- Channel width and variations in width.
- Channel units (pools, riffles, steps, etc.).
- Valley and flood plain features, such as **side channels**, width of the flood-prone zone, evidence of past flood elevations, **terraces**, valley slopes, **abandoned channels**, etc. It is sometimes possible to use abandoned channel segments to visualize the natural channel location and **planform** through existing crossings.
- Valley features that might influence construction, such as wetlands, old roads, utilities, and property boundaries.

- Important stream features such as large boulders or bedrock, large woody debris structures, gravel bars, submerged vegetation, vegetation changes, eroding banks, on-bank trees, bank irregularities, bankfull elevation markers.
- Location of detailed measurements, such as cross sections, pebble counts, and photo points.
- Survey instrument setup locations, benchmarks.
- Possible reference reaches (see section 5.5).

(For additional information and explanation regarding constructing a site sketch map, see Harrelson et al. 1994.)

### **Newbury Creek Site Assessment—Sketch Map**

The sketch map in figure 5.2 shows a crossing on Newbury Creek on the Olympic National Forest that we will follow through the site assessment process (figures 5.8 - 5.11 and 5.17).

The dotted lines bordering the stream channel on the sketch indicate the edges of the valley bottom, where the flatter valley surface meets the steeper side slopes. Note that the stream is closely bounded by a high terrace (GLFL) upstream of the culvert, and there are several places where bedrock is exposed in the channel. Downstream of the culvert, the valley broadens and a low terrace and flood plain (FPLT) border the channel. The crossing is located at a transition where the bedrock-controlled channel changes to an alluvial one that is less confined.

Upstream of the culvert, plane-bed segments are mixed in with pool-riffle segments (see appendix A for descriptions of these channel types). Downstream of the culvert, the channel type is pool-riffle, with riffles dominating. Gravel bars on the inside of bends are narrow (that is, little sediment is stored in the channel), and woody debris is not present in large amounts. Log weirs installed in the mid 1980s and early 1990s to increase pool habitat are both upstream and downstream of the crossing.

The road crosses the stream at a slight bend in the channel. Upstream of the road, a riprap blanket on the left bank (facing downstream) indicates there have been some erosion problems.

Later we will see how all of these observations enter into the site assessment recommendations for design.

# Stream Simulation

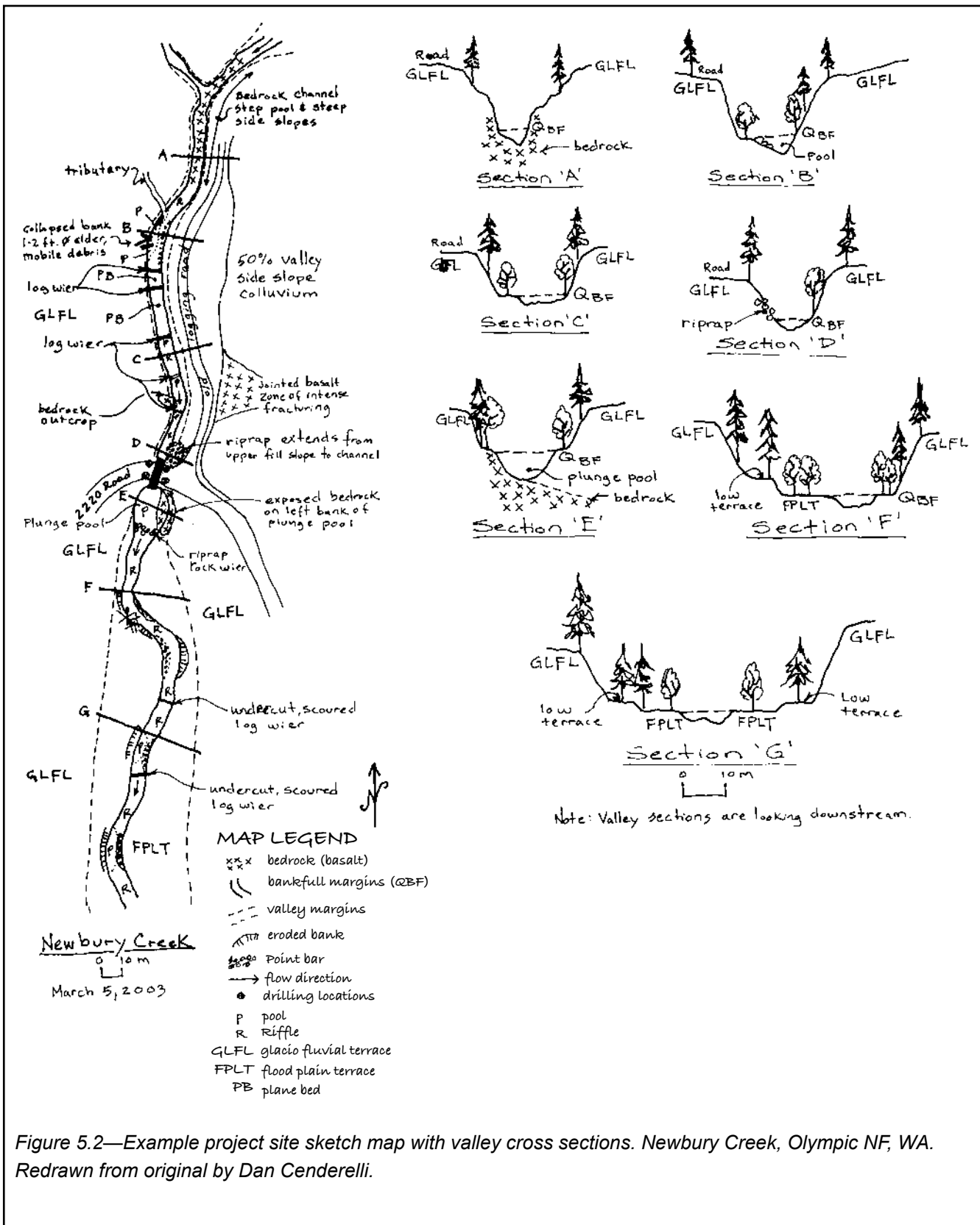

Figure 5.2—Example project site sketch map with valley cross sections. Newbury Creek, Olympic NF, WA. Redrawn from original by Dan Cenderelli.



### 5.1.2 Topographic Survey

The topographic survey has two overlapping objectives. It needs to include:

1. The detailed topographic data the project engineer needs to prepare the site plan, structural design, and the construction contract.
2. Geomorphic information required for designing the simulated streambed and tying it into the adjacent stream sections. Generally, this will involve a longer length of channel than traditional engineering site surveys at road-stream crossings.

Sometimes these two objectives are considered distinct from each other and two surveys are done separately. However, there are good reasons for doing a single integrated survey. First, any surveys must use the same elevation controls and benchmarks. Second, different team members have the expertise to observe different types of features and conditions. Working together on the survey is an excellent opportunity to exchange information and arrive at a common interpretation of site conditions and limitations.

This topographic survey can be seen as a standard engineering site survey expanded to include a longer reach of stream that may not be surveyed to the same level of detail. The engineering site survey is typically a radial survey in which points are not necessarily taken along straight transects. The product is a contour map. This part of the survey must extend far enough upstream and downstream from the road to support planning for alignment changes, channel restoration, and temporary road or stream diversions during construction. On the other hand, channel longitudinal profiles and cross sections, which are used for simulated channel design, are displayed as linear plots. If the radial survey covers the entire area in sufficient detail, the profile and cross sections can be generated from the digital elevation models. As the survey moves away from the worksite itself, however, it is more common to survey only those points needed for the longitudinal profile and cross sections. In either case, good notes and sketch map annotations are essential for identifying what each point is; without them the linear plots can be extremely difficult to interpret.

### Topographic Survey Methods

The standard engineering site survey collects an array of three dimensional points that, when plotted, is detailed enough to create a contour map that accurately represents the landform and site features. The key is look at the terrain and visualize the locations of the points that will accurately depict the shape of the terrain, both horizontally and vertically, and then survey those points so that the topographic map accurately represents the actual terrain in the field. Be sure to include not only the obvious slope breaks in the channel, etc., but also include points that define swales and high areas in the general landform.

There are several methods accurate enough for site topographic maps:

Traverse and cross sections. One method is to survey numerous cross-sections of the channel and valley at selected locations along a traverse. Be careful using this method—a cross section must be taken at every horizontal or vertical change along the stream to accurately draw a terrain model from the cross sections. The cross section method is not as accurate as the radial survey; it works best when the landform is fairly regular.

Radial survey. The recommended method is to survey key points that are not necessarily along straight transects; instead, each three dimensional point is defined by azimuth, distance, and elevation from a control point or set of control points. The array of points defines the topography and features on the map. This type of survey usually is done with a total station, which combines a theodolite, electronic distance meter, and data storage device in the same instrument. Data collected with a total station is electronically transferred to a computer and the contour map is quickly generated using software.

Combining the radial survey with the cross-section method can be efficient when the channel survey extends beyond the area where a contour map accurate enough for site layout purposes is needed. In this case, use the radial survey close to the crossing where accuracy is more important, and survey linear cross sections further out.

During the site survey, keep good notes and annotate the sketch map. The survey includes the following work items:

- Establish two horizontal reference points for each control point. (A control point is where the survey instrument is set up.) Two reference points per control point allow the set-up location to be relocated later. Often it is convenient to locate reference points at each end of the roadway outside of the construction work area.
- Establish vertical controls using temporary benchmarks. Benchmarks should be reoccupiable during and after construction.
- Clear vegetation, but limit vegetation removal to only what is necessary for facilitating safe travel and seeing the survey target. (Avoid destabilizing banks and removing large amounts of stream cover.)
- Survey all topographic break points.
- Collect enough topographic points to accurately detail the site (both road and stream), including locations of hazard trees or trees to retain, probe/boreholes, utilities, and property lines.
- Survey channel and valley features (**thalweg**, water's edge, top and bottom of banks, foot of valley slope or terraces, key **grade control** features, steps, gravel bars, bedrock exposure, etc.) in accordance with guidance in sections 5.1.3 and 5.1.4. Take more points around bends than in tangent sections, and take points at the top and bottom of banks vertically very close together if you plan to use **HEC-RAS** or another step-backwater model.
- Ensure enough ground and stream coverage to allow for potential road or stream realignment.

After completing the field survey, most surveyors and designers use a digital terrain or contour modeling program—such as AutoCad Land Development Desktop, Terramodel, Surfer, or Eagle Point—to create a topographic map for the site. As these software packages use break lines to control the interpolation between points, topographic break points (top and base of bank, toe of roadfill, etc.) must be accurately identified and surveyed. Be sure to plot the surveyed points on the map so that the accuracy of the contour lines that the program generates can be checked. If the design engineer does not conduct the survey, (s)he should ground-proof the contour map before starting final design.

## Stream Simulation

---

This guide does not go into further depth on standard engineering surveying procedures that are well documented elsewhere (see appendix A in USACE 2006). Instead, this guide focuses on the survey data and observations needed for designing the simulated streambed. These measurements and observations include:

- Channel longitudinal profile, key grade controls, scour depths.
- Cross-section channel geometry: top of bank, bottom of bank, etc.
- Width and elevation of valley surfaces; flood plain inundation frequency and depth.
- Streambed and bank materials.
- Channel and bank stability, sediment and **debris** processes.

### 5.1.3 Longitudinal Profile

The longitudinal profile is perhaps the single most valuable tool in the stream-simulation design process. It shows the natural channel gradient, the local gradient variability, the features controlling channel gradient, the depth and variability of scour, the length and spacing of **channel units**, such as pools, riffles, and steps, the length and depth of any accumulated sediment upstream from the culvert (channel aggradation), and the length and depth of channel scour downstream from the culvert (channel degradation). The longitudinal profile is necessary for determining the appropriate channel elevation and design gradient through the crossing, identifying a reference reach with a similar gradient, and determining the range of potential vertical streambed adjustment (**vertical adjustment potential**).

#### 5.1.3.1 What and where to survey

Use survey equipment capable of 0.01-foot precision to survey the longitudinal profile. This kind of precision is required for surveying benchmarks and water surface slope. Take ground shots to tenths of a foot. Include the inlet and outlet invert of the existing structure, road fill boundaries, and the center point of the road.

Most longitudinal profiles have highly variable local slopes reflecting different channel units, such as pools, riffles, steps, and cascades (figure 5-3). The survey should include enough points to clearly delineate these

units and the **streambed structures** (steps, pool tail crests, etc) that control their elevations. As described in appendix A.5.5, these channel units typically occur in repeating sequences, with regular spacing between them. Delineating units on the longitudinal profile enables us to mimic their dimensions and spacing if channel units, such as steps, are constructed inside the culvert, and it permits us to tie the constructed streambed into the adjacent channel units. Table 5-1 lists channel points and features to survey and describe in the survey notes.

Given the importance of selecting the survey points and making accurate observations about them, the person who will be primarily responsible for interpreting the survey and designing the simulated channel should run the rod. For each survey point, identify the local channel feature (e.g., pool, riffle crest, base of step, etc.), and note other relevant characteristics, such as size, packing, shape, and stability of the particles. These notes are critical for interpreting the longitudinal profile survey later.

Generally, points for the longitudinal profile should be along the thalweg—the deepest part of the channel and the main thread of flow. However, in some channels the thalweg is substantially longer than the channel centerline. In a meandering channel, for example, the thalweg swings to the pool near the outside of each bend, and thalweg slope can be much less than slope calculated from centerline length. In such cases, survey both thalweg and centerline points, distinguishing them with separate codes. Channel slope calculations will use the centerline points.

Steep channels often have randomly distributed scour holes that are not in the main center of flow. On these channels, represent the thalweg by selecting points along the general trend of deepest flow rather than zigzagging across the channel from hole to hole. Also survey centerline points, especially at grade controls like step crests, and use the centerline distances to calculate channel slope between grade controls.

# Stream Simulation

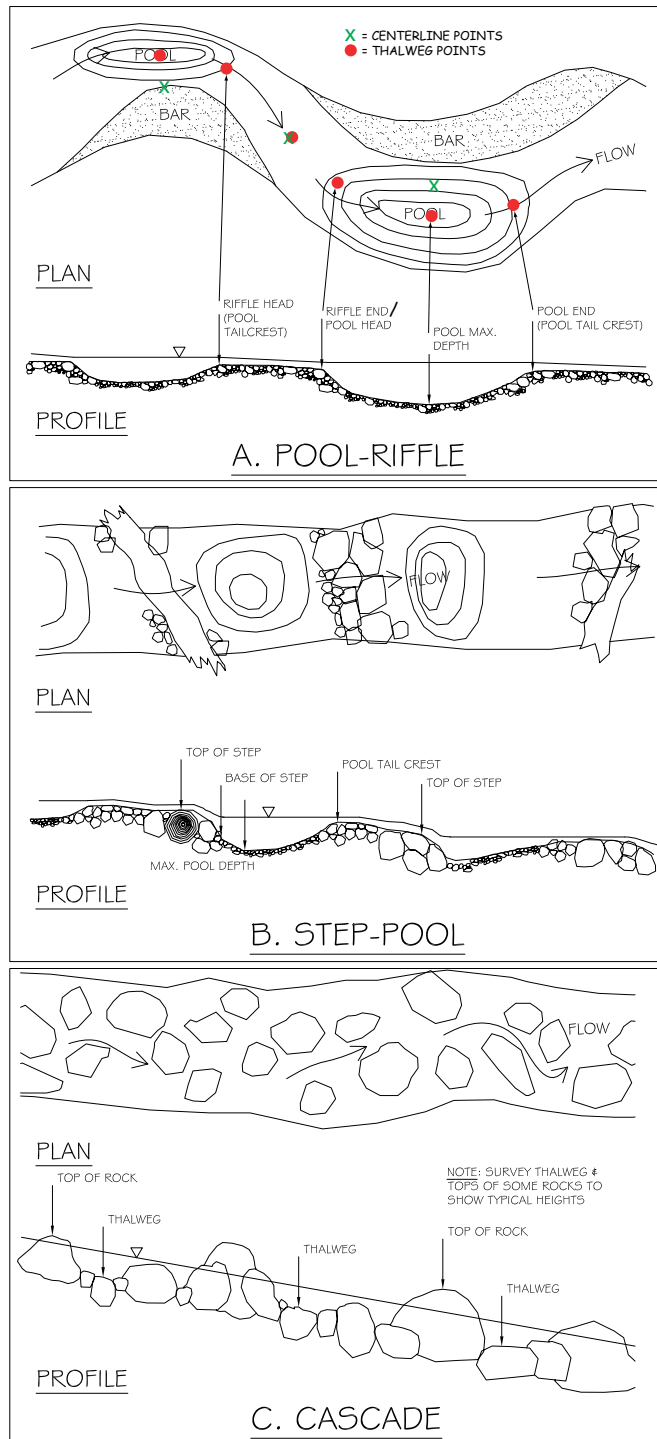

Figure 5.3—Typical measuring points needed to define the longitudinal profile for a pool-riffle channel (a), step-pool channel (b), and cascade channel (c). The plan view sketches show the approximate location of the main thread of water to survey. In the cascade channel, one would occasionally take a point on top of a rock to indicate the general height of the bed material.

Table 5.1—Longitudinal profile points and observations.

Profile points (include all major slope breaks)	Notes
Beginning (riffle head or pool tail crest) and end of riffles (figure 5.3a).	Note riffle head (pool tail crest) material, size and mobility.
Top and bottom of rock or wood steps (figure 5.3b).	Note step material, size, embedment, stability.
Beginning, end (pool tail crest), and maximum depth of pools (figure 5.3a and b)	Note what is causing the pool: a channel bend, bedrock outcrop, woody debris jam, a step formed by boulders, cobbles, woody debris, etc.
<b>Other Features</b>	
Features controlling grade and/or retaining sediment: large woody debris, small embedded wood, large rocks, beaver dams, etc.	Note size, durability of material, and mobility.
Changes in bed material size	May be associated with steps, embedded wood, mid-channel bars, bedrock outcrops, local aggradation above undersized culvert, etc. Characteristics like lower gradient and general lack of bed diversity distinguish aggraded areas above culverts from the rest of the channel.
Tributary junctions	Note tributary width, any sediment accumulation at junction.
Zones of bank instability	It is usually not necessary to survey these; just note their presence, height, materials, riparian vegetation, as needed.
Cross-section locations	Select cross sections along the longitudinal profile to characterize channel variations in width, depth, slope, bed material size, etc.).
Bankfull or ordinary high water elevations at various points along the profile	See box “Identifying Bankful Elevation” (section 5.1.4.2). Some jurisdictions require showing <b>ordinary high water</b> elevations on the site plan map.
Elevation and extent of sediment accumulation above undersized culvert	Field evidence might include gravel or sand bars. Bed may appear featureless or simplified as compared to the rest of the channel (due to burial of features).
Depth and extent of incision downstream of culvert	Field evidence might include coarser bed material than upstream of culvert; banks higher than upstream and possibly unstable; wider channel than upstream.

## Stream Simulation

---

### 5.1.3.2 Length of the longitudinal profile

The profile should be long enough to display on paper the general profile of the reach, including any grade breaks. If the profile extends beyond the detailed survey area (section 5.1.2), ensure the surveys are tied together with a common datum.

At most sites, the channel longitudinal profile extends 20-30 channel widths in each direction from the culvert. Generally, this ensures the profile meets the following criteria:

- Extends well beyond the influence of the existing crossing structure.
- Includes several sequences of repeating bedforms, for example pools and riffles, to get a good representation of their length, spacing, and slope. Including the range of variability in channel slopes, scour depths, and bedforms gives you a good chance of including a segment that can be used as a reference reach.
- Extends beyond the length of stream expected to adjust (usually to downcut) when the existing structure is replaced. Crossings with large elevation drops might require longer surveys because a longer reach of stream might adjust to the crossing replacement. Wherever possible, end the survey at stable points that will limit vertical adjustment, such as bedrock outcrops or other stable features

The reference reach is discussed in detail in section 5.5. The reference reach has characteristics (most importantly slope) similar to those of the crossing segment if the road were not there. Generally, the reference reach is upstream and outside the influence of the existing crossing, and is included in the longitudinal profile. In fact the longitudinal profile is often long enough to include several options for the reference reach. In some cases, however, you may need to look for a better reference reach at some distance from the crossing. The actual reference reach will be selected later (section 6.1.3) based largely on the design slope through the crossing.



### 5.1.3.3 Grade controls

Grade controls are key structural features that control channel elevation and grade, dissipate flow energy, and store sediment. On different channels, these grade controls might include steps, pool-tail crests (riffle crests), bedrock outcrops, large woody debris structures, beaver dams, or debris flow or landslide deposits. In stream-simulation design, it is important to know how mobile or immobile the key grade controls are relative to the life of the crossing structure, and evaluating their stability is an important part of the survey. If grade controls are highly unlikely to move over the life of the crossing structure, even during large floods, the design can rely on a stable longitudinal profile. If the grade controls move relatively frequently, the design will need to accommodate vertical adjustment in the channel. In this context, mobile bed structures do not necessarily imply an unstable channel. For example, a stable fine gravel bed stream is likely to be highly mobile and to adjust under even moderate flows; on average, though, it retains its equilibrium dimensions and slope (see appendix A, section A.3). Evaluating bed mobility is discussed further in section 5.1.5.

Stability of these grade-control structures depends on material strength and durability, size and orientation of the particles or wood pieces, and the feature's relationship to nearby structures (table 5.2). As the survey moves along the channel, the person holding the rod should document bedform length and width, as well as particle size, packing and embedment. They should also qualitatively evaluate the stability of the bed structures relative to the lifespan of the crossing. Manmade structures like diversion dams may play the same roles as natural structures, and the possibility that such structures might be removed will also need to be considered in design.

Table 5.3 lists specific types of channel-bed structures and describes characteristics for each type that lead to a qualitative rating as high, moderate, or low stability. The table offers an example of a rating system for **key feature** stability—a system that has proved useful in Alaska. Modify the table as needed to fit your area.

In low-gradient, fine-grained channels with highly mobile streambeds, there may be no persistent grade-control structures. Any combination of channel bends, submerged and embedded wood, bank irregularities or other bank **roughness** features, for example, overhanging or submerged vegetation, may control slope and roughness.

# Stream Simulation

Table 5.2—Factors contributing to channel-bed structure stability.

<b>Material strength</b>
<ul style="list-style-type: none"><li>• Durable vs. nondurable rock.</li><li>• Shape of the substrate – degree of angularity or roundedness.</li><li>• Condition of wood (sound or decayed – degree of decay).</li><li>• Diameter of wood (longevity).</li></ul>
<b>Orientation and size of particles and pieces</b>
<ul style="list-style-type: none"><li>• Key pieces (boulder, small cobble, wood, a combination of wood and rock) are large. Logs are well-anchored in the bank, so that the stream cannot cut around the end.</li><li>• Particles are <b>imbricated</b> and/or <b>embedded</b> rather than loose and readily available for transport.</li><li>• Wood has roots attached.</li><li>• Length of the wood in relation to stream width (logs are longer than stream width).</li></ul>
<b>Relationship to other bedform structures</b>
<ul style="list-style-type: none"><li>• Structures are/are not subjected to undermining if adjacent structure is lost.</li><li>• Immobile structures in the reach govern the extent of vertical and lateral adjustments.</li></ul>

Table 5.3—A qualitative method for determining channel-bed structure stability.

Structure composition	Stability Rating	Structure Characteristics
Bedrock	High	Bedrock ledges or falls span entire stream width
Boulder-cobble steps	High	Boulder-cobble steps span entire width of stream. Rocks are tightly keyed in place, and keyed-in material extends below base of scour pool below step.
Cobble-boulder or cobble-gravel pool tail crests or riffle crests	High	Cobble-boulder or cobble-gravel pool tail crests or riffle crests span the entire width of stream. Particles are tightly packed, embedded into the channel bed, and coarser than the remainder of the channel bed.
Log	High	Wood is sound and well anchored, spanning entire stream width.
Composite log and rock	High	Wood is sound and well anchored, may or may not span entire stream width. Rock pieces are well keyed in place and bridge gaps so that composite structure controls width from bank to bank.
Boulder-cobble steps, cobble-gravel steps	Moderate	Steps do not span entire width of stream or are loosely keyed in place. Keyed-in rocks may not extend below base of scour pool below step. Alternatively, step key pieces are not in contact with each other.
Cobble-boulder or cobble-gravel pool tail crests or riffle crests	Moderate	Pool tail crests span entire width of stream, but the largest particles are similar in size to those elsewhere observed along the channel bed. Alternatively, particles are moderately packed and/or moderately embedded into the channel bed.
Log	Moderate	Wood is rotten and punky. It may span entire stream width, but anchoring is susceptible to bank scour and movement during high flood events.
Composite log and rock, beaver dams	Moderate	Wood is rotten, punky, not anchored well, or does not span the entire stream width. Rock pieces are not well keyed in place and subject to movement at higher flood events. Rock bridges gaps so that structure extends from bank to bank, but there are indicators of lateral scour. Beaver dam is well constructed with a good distribution of large logs, small sticks and mud (but consider the possibility that even a stable dam could break during the life of the crossing structure).
Cobble-gravel steps or pool tail crests	Low	Steps do not span entire width of stream, and/or are composed of loosely packed materials. Pool tail crests are constructed of material no coarser than rest of stream bed.
Log	Low	Wood is very rotten and punky, may or may not span entire stream width, and anchoring is poor and susceptible to bank scour and movement during bankfull flood events. Indications of movement are visible where pieces are anchored into the bank.
Composite log and rock, beaver dams	Low	Wood is very rotten and punky, or structure is made of loosely packed pieces that are poorly anchored. Structure does not span entire stream width. Rock is small in size and subject to movement at bankfull flood events. Beaver dams are poorly constructed or old and inactive. Large key logs are not present.

## Stream Simulation

---

Where wood is present, describe its size, condition, mobility, and function. See section 5.1.6.3 for details on describing wood in the project area and reference reach.

### 5.1.4 Cross Sections

Cross sections represent the channel and flood-prone area as they vary with local slope, entrenchment, materials, etc. When viewed together, the plan view map, the longitudinal profile and cross sections provide a three-dimensional perspective of valley and channel topography. Relating the cross sections to the longitudinal profile and to bed-material observations helps one understand how the channel works in terms of erosion, deposition, and sediment transport. The goal is to understand the extent and causes of variability in channel width, depth, and particle sizes throughout the reach. Data from one or more cross sections in the reference reach will be used to design the simulated streambed.

Cross sections also provide information on the height and stability of banks. The question of whether to allow upstream incision at crossings where the downstream channel has incised should always take these variables into consideration.

As with the longitudinal profile, survey channel cross sections to at least 0.1 foot. Either ensure the topographic survey is detailed enough to generate accurate cross sections from the digital elevation model, or survey the cross sections individually. If cross sections are taken outside the topographic survey area, ensure the surveys use a common datum.

#### 5.1.4.1 Location and number of cross sections

At existing crossings, survey cross sections immediately upstream and downstream from the culvert to show the geomorphic effects of the existing crossing on channel conditions, channel and flood plain relationships, and construction accessibility. These cross sections will be important for designing smooth transitions at the inlet and outlet of the new crossing structure.

Base the number of cross sections for the project area as a whole on the variability in channel characteristics and on risks at the site. Understanding the variability in channel dimensions like width and depth is very important in properly sizing the simulated channel as well as the new structure. Channel dimensions vary depending on many factors, such as **entrenchment**, composition of the bed and banks, large woody debris, valley form, channel planform, channel gradient, and flood history. On relatively uniform channels, surveying two or three cross sections upstream and downstream from the crossing may be sufficient to adequately characterize the channel and its variability. On complex channels, to properly characterize the site, understand the risks, and provide a design template additional cross sections upstream and downstream from the crossing will be needed. Consider measuring cross sections on a representative range of channel units, such as riffles, pools, steps, runs, etc., and widths. Those measurements will provide various options for a reference reach and will help you understand the variability within the reference reach.

Be sure to cover the entire reach that may be part of the final project, including locations where you might install grade control structures or restore the channel. In some cases where the entrenchment ratio and apparent **flood-plain conveyance** are high, the designer may use a hydraulic step-backwater model such as **HEC-RAS** for quantifying flood-plain conveyance at different flood stages. If so, the designer should evaluate the terrain in the field, and locate the number of cross sections needed to accurately represent reach and flood-plain geometry in HEC-RAS.

### 5.1.4.2 Typical cross-section measuring points

Each cross section should include all major topographic slope breaks. Survey and describe all features (see table 5.4 and figure 5.4) that pertain to the cross section. Of these features, bankfull elevation is one of the most important.

## Stream Simulation

Table 5.4—Cross-section survey points and observations.

Survey and observation points: channel (include all major slope breaks)	Notes
<i>Top and bottom of banks</i>	<i>Sediment characteristics, vegetation type</i>
<i>Channel thalweg</i>	<i>Ensure cross-section location is shown on longitudinal profile.</i>
<i>Left and right bankfull elevations</i>	<i>Defines bankfull width; allows surveyors to estimate elevation of the floodprone zone. (See textbox “Identifying Bankfull Elevation” page 5—20)</i>
<i>Left and right edges of active streambed</i>	<i>Width of channel devoid of vegetation.</i>
<i>Changes in bed and bank materials</i>	<i>Bedrock, gravel bars, <b>colluvium</b>, etc. Note bank stability, bank vegetation type, rooting density, and depth.</i>
<i>Undercut banks</i>	<i>Measure dimensions of the undercut bank (depth and height). Small streams with dense vegetation can have ½ to ⅓ of their area in undercuts, enough to affect discharge and sediment entrainment estimates and the simulated-channel width.</i>
<i>Left and right edges of water at time of survey</i>	<i>If you measure flow at time of survey, these measurements permit calibrating hydraulic models for the cross section.</i>
<b>Survey and observation points: flood plain and valley bottom</b>	
<i>Edges of flood-plain channels and terrace(s) if applicable</i>	<b>Terrace</b> edges, toe of valley slope, top and bottom of flood-plain channel banks, etc. To ensure good coverage of floodable areas, include the entire floodprone zone: extend the cross sections to an elevation that is double the maximum bankfull depth measured from the channel thalweg (see figure 5.5).
<i>Side channels, flood swales, vegetation type transitions</i>	<i>Note evidence of flood-plain conveyance: scour, vegetation washed away, large woody debris accumulations on the flood plain. Describe the <b>roughness</b> elements on the flooded area: vegetation type and density, ground debris, topographic irregularity, etc.</i>
<i>Flood high water marks</i>	<i>Fine sediment on top of vegetation; debris caught in or wrapped around shrubs or trees; flood water line on trees or other flood-plain features.</i>

## Chapter 5—Site Assessment

An example of the features to include in a cross-section survey appears in figure 5.4.

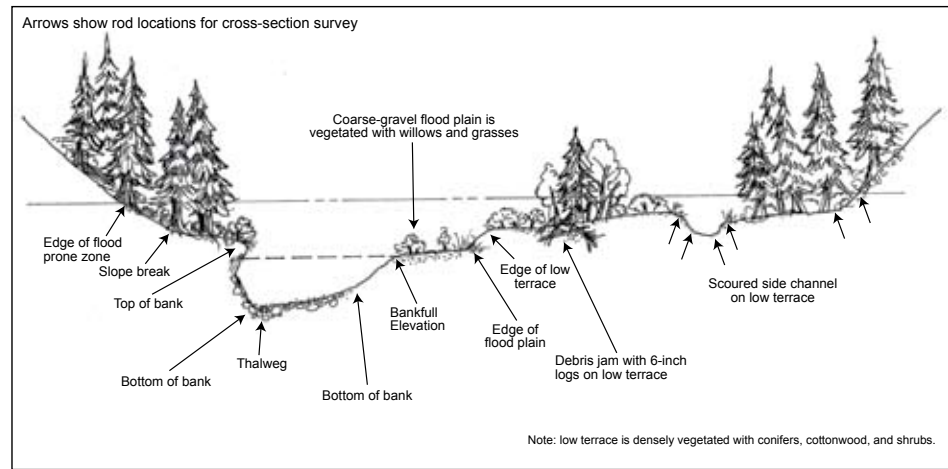

*Figure 5.4—Schematic channel cross section showing recommended survey points.*

Include the flood-prone area in the surveyed cross sections by extending the cross sections to an elevation that is double the **maximum bankfull depth** measured vertically from the channel thalweg (Rosgen 1996). This will encompass the frequently inundated flood plain (if one exists) and permit calculation of the entrenchment ratio (see appendix A section A.3.4). If the channel is confined or entrenched, the cross-section endpoints may be on the valley slope or a terrace.

Identify surveyed points in the survey notes, with descriptive comments. Since the cross section represents the channel segment, descriptions need not be limited to the cross-section line. The notes should describe the general character of the channel segment upstream and downstream of the cross section. They should also describe flood-plain features and characteristics, and flood-plain features should be included on the site sketch.

Understanding the interaction between the main channel and the adjacent valley surfaces is crucial in designing a crossing that obstructs flood-plain functions as little as possible. Where a flood plain is present, identify side channels, flood swales, and wetlands that should be considered during design. Make note of any indicators of recent flood elevations you find. There also may be evidence of beaver activity, rapid bank erosion, and lateral channel shift across the flood plain. Look for relict channels that

### Identifying Bankfull Elevation

Bankfull elevation is the point where water fills the channel just before beginning to spill onto the flood plain. Bankfull discharge is the flow in the channel (cubic feet per second) when the water surface is at bankfull elevation. Bankfull discharge typically occurs every 1 to 2 years (Leopold et al. 1964), but its frequency of occurrence can vary depending on channel type, hydrologic regime, and watershed conditions. Bankfull is recognized as a surrogate for the range of flows that maintain channel shape and size (Emmett 2004). It is often referred to as the effective discharge of a stream: the flow responsible for moving the most sediment (Dunne and Leopold 1978) and maintaining channel form. This is why bankfull flow width is the minimum structure width required for simulating and maintaining channel form and functions through a crossing.

Strictly speaking, bankfull applies only to alluvial streams with flood plains. In alluvial stream types, use some or all of the following indicators for recognizing bankfull elevation, depending on the situation (Harrelson et al. 1994):

- Elevation of the edge of an active flood plain (flood plain may be present as discontinuous patches).
- Elevation associated with the top of the highest depositional features such as point- and mid-channel bars.
- Changes in slope on the banks [figure 5.5(a)].
- Changes in particle size of bank materials (from coarser to finer).
- Changes in vegetation types (from moss to lichens, from grass to alder, etc.).
- Stain lines on rock and scour lines in moss and lichens.

Be careful when using vegetation as a geomorphic indicator as vegetation in some channels is inundated by bankfull flows. Depositional features should be the primary geomorphic indicator for identifying bankfull flow in alluvial channels.

Not all indicators will be present at each cross section. They vary with channel type, and false or confusing indicators have to be sorted out at each site. Flagging and surveying many bankfull elevations along a substantial length of channel helps to eliminate misleading indicators and is essential for accurate identification. The ideal method for consistently identifying bankfull elevations is to plot the bankfull longitudinal profile using points where bankfull was confidently identified. Then—where the profile crosses any cross section—that is the bankfull elevation at that cross section (Emmett 2004).

In **entrenched** and nonadjustable **channels** (bedrock or strongly **cohesive materials**), **ordinary high water (OHW)** level is used instead of bankfull



for stream-simulation design purposes. OHW marks are characteristic of frequent high flows that are sustained long enough that the vegetation or bank material is distinctly different from the adjoining higher ground. OHW marks in nonadjustable channels include many of the same features in the list for alluvial channels: stain lines on rocks, high points of depositional features, and vegetation changes. In figure 5.5(b), OHW is taken as the elevation of the boundary between the moss (which survives long submergence) and woody vegetation.



*Figure 5.5—(a) Bankfull elevation on an unentrenched alluvial channel. (b) Ordinary high water elevation in an entrenched coarse-grained channel without depositional features.*

There are numerous guides to using channel physical features for identifying bankfull elevations (e.g., Leopold et al. 1964; Williams 1978, Dunne and Leopold 1978; Harrelson et al. 1994; Rosgen 1994; Knighton 1998). The Forest Service has produced several multimedia presentations describing the techniques and procedures for identifying bankfull flow for different channel types in different parts of the country (USDA Forest Service 2003; USDA Forest Service 2005).

## Stream Simulation

---

may be blocked by the road fill, and consider whether they can and should be reconnected. Also note the smoothness or roughness of the flood-plain surface, because these characteristics influence the velocity of **overbank flows**. Together with entrenchment ratio and slope, roughness controls the volume of water conveyed on the flood plain (flood-plain conveyance). Figure 5.5(a) is an example of a rough flood plain, where grasses, shrubs, and trees slow overbank flows.

Field evidence of high flood-plain conveyance following a flood might include:

- Scoured flood-plain swales and side-channels.
- Scoured flood-plain surface.
- Impact scars high in trees or logs suspended above banks.
- Accumulations of large woody debris and/or sediment on flood plain.

Recognizing if and how an existing crossing has altered the natural channel's location and length can be important for correctly interpreting channel response, and designing the layout for the replacement. Often the aerial photo or the sketch map suggests the predisturbance planform. In the field, look for old abandoned channel segments, berms, or any other evidence that the channel was moved or that the culvert replaced a bend.

Cross sections also can help distinguish reaches where **channel incision** has occurred downstream of a crossing. In this case, the crossing structure is acting as a grade control protecting upstream reaches from **headcutting**, and the downstream reach may be quite different in cross section than the upstream reach. Compared to the channel upstream from the crossing, an **incised channel** downstream from the crossing may have:

- A lower **width-depth ratio**.
- Higher banks, with older vegetation higher on the bank.
- Over-steepened, failing banks.
- Cut into weathered bedrock, clay, or other nonalluvial material below the valley **alluvium**.
- A flat bed in cross section.
- No buried debris within the bed.
- Less gravel accumulation.
- Coarser bed material or a more armored bed.

### 5.1.5 Channel Types and Bed Mobility

Channel-type classification is a fundamental step toward understanding both current conditions and future channel changes. Classifying the channel—using both the Montgomery and Buffington and the Rosgen systems (see appendix A, section A.6)—can provide insights on the dominant geomorphic processes associated with the reach, and on the type and intensity of future channel response to a new or replacement structure, or to structure removal. For example, bedrock, cascade, and step-pool channels are **transport** channels that convey most of the sediment supplied to them and undergo minimal channel changes in response to all but very large disturbances (Montgomery and Buffington 1993, 1997). In contrast, plane bed, pool-riffle, and dune-ripple channels are **response** channels that may undergo substantial changes in response to disturbances (appendix A, table A.1).

In transport channels, the larger bed-forming rocks or logs are generally quite stable. They do not move in frequent floods, although finer bed material does move over or around them during bankfull and larger events. Because these bed structures—essential for energy dissipation—do not self-form in frequent floods, they need to be designed and constructed in the simulated streambed.

Response channel beds mobilize at flows from slightly above bankfull to much smaller flows, depending on the bed particle size and structure. For highly mobile channels, such as dune-ripple and fine-grained pool-riffle types, bed features are usually not constructed in the simulated channel, because they are expected to self-form during the first high flows after construction.

For intermediate channels, such as coarser pool-riffle and plane bed types, the frequency of bed mobility depends on such things as **armor**ing and **imbrication**. Evaluate the mobility of these channels in the field and determine whether bed structures should be constructed in the simulated channel. The decision will depend not just on bed mobility, but also on risk. In a high-risk channel—say, where the watershed has recently burned—the team might lean toward constructing bed structures to be sure energy dissipation functions are in full operation immediately.

## Stream Simulation

---

Design of stream-simulation channel-bed material varies depending on bed mobility in the natural channel, and the bed material sampling method also depends on it. Bed mobility is a distinguishing characteristic of Montgomery-Buffington channel types and they are used in the following discussion for that reason. Appendix A describes them more fully. For channel types with intermediate mobility (the coarser pool-riffle and plane-bed types), the team should judge mobility before sampling the bed material, and select the sampling method accordingly.

### 5.1.6 Channel-bed and Bank-material Characteristics

Characterizing bed and bank material and structure helps the team predict how the channel might respond to disturbances in the future, or how it might recover from past disturbances.

Two other specific objectives for characterizing bed and bank composition and structure are:

1. To design bed material sizes and arrangement for the simulated streambed.

The bed-material size distribution in the reference reach is the basis for the stream-simulation bed material mix. Likewise, the size of rocks or wood making up key energy dissipation and grade control features in the reference reach is the basis for sizing any stabilizing features in the stream simulation bed.

2. To understand bed material sizes and mobility in the reach upstream of the crossing.

As bed material is eroded from the simulated channel during high flows, the upstream reach must be able to resupply similar particle sizes at similar flows. If not, the simulation will not retain its intended bed characteristics. The bed may coarsen or be washed out.

Often, both these objectives can be achieved by sampling the streambed and describing banks in the reach upstream of the crossing and outside the crossing's area of influence. However, even when the reference reach is not upstream, the team will still need to assess bed material sizes, channel roughness, and bed mobility upstream of the crossing to assure they approximate those of the reference reach. The assessment need not be quantitative, but the team should satisfy itself that the upstream reach will indeed resupply the simulated streambed.

The bed and bank characteristics that are of primary interest in stream-simulation design are those of the reference reach. One strategy for data collection is to wait until the reference reach is selected before collecting detailed data. The alternative is to take enough data, while you are already onsite studying the reach, to support several possible reference reach selections.

### 5.1.6.1 Sampling strategies and methods

Sediment sizes vary longitudinally, laterally, and vertically across the channel bed, reflecting the spatial variability of **channel units** (for example, channel margin, thalweg, pools, riffles), small-scale bedforms (for example, particle clusters, **transverse bars**, longitudinal bars), and bed layers (for example, armor, subarmor).

*For the purpose of designing the simulation bed material*, the sample should represent the entire reference reach. Be aware of the variability in particle size distribution between different channel areas along the reference reach, and sample those areas proportionally to their coverage (Harrelson et al. 1994; Rosgen 1996; Bunte and Abt 2001).

*For detailed flow modeling*, bed-material sampling may need to be stratified by channel units, such as pools, riffles or steps. It may take several samples to represent the range of variability present (Reid et al. 1997; Wohl 2000; Bunte and Abt 2001). Data specific to a channel-unit might be needed, for example, if a designer wants to estimate the flow that mobilizes specific grade control structures in the natural channel (see section 6.4). The number of samples needed depends on the complexity of the channel and the objective. The designer/analyst should specify the amount and type of data that is required.

This section relies heavily on information from Bunte and Abt (2001) “Sampling Surface and Subsurface Particle Size Distributions in Wadable Gravel- and Cobble-Bed Streams for Analyses in Sediment Transport, Hydraulics and Streambed Monitoring,” published by the Forest Service, Rocky Mountain Research Station. The book is readily available from Rocky Mountain Research Station, Fort Collins, CO. We strongly recommend reading the many pertinent sections, especially those on sampling methods, rock size measurement techniques, sample sizes, and armoring.

## Stream Simulation

---

Except as described below for different channel types, bed surface material is normally characterized by measuring particles in place using the pebble-count method, and sampling in a grid pattern. Measure 100 to 400 particles selected either systematically along a measuring tape or from the toe of the boot in a heel-to-toe walk (Wolman 1954; Bunte and Abt 2001). For well-sorted (poorly graded) streambeds, 100 particles are sufficient; for poorly-sorted (well graded) streambeds, up to 400 particles are necessary.

The grid is formed by spanning the channel with a measuring tape repeatedly along the channel at close intervals. The sampling interval along the transect is one to two times the diameter of the largest particle. The grid method is the preferred sampling technique for pebble counts in cobble and boulder materials as well as gravel, because it reduces the bias against sampling the very small and very large particles. For purposes of stream-simulation bed design, pebble counts should include the channel bed between the base of each bank, and exclude the banks themselves. Review Bunte and Abt (2001) for details about selecting and measuring particles and laying out the sampling scheme. If the pebble count represents an entire reach, ensure the tape placements adequately cover the range of variability present in the reach.

Pebble count results are reported as a cumulative frequency distribution of particle sizes. In conventional notation,  $D_{50}$  (reported in millimeters) represents the median particle size; fifty percent of all particles are finer. Likewise, 84 percent of all particles are finer than  $D_{84}$ . The pebble count parameters most commonly used in stream simulation bed design are  $D_{95}$  (representing the largest mobile particles),  $D_{84}$ , and  $D_{50}$ . Where immobile particles function as key energy dissipation and grade control features, their sizes also are used in design.

Distinguishing alluvial particles (those moved by the current river) from rocks that are not mobile is important. Immobile rocks may have fallen or slid into the stream during a landslide or **debris torrent**, or they may have been transported by ice-rafting. These rocks are generally much larger than the largest alluvial rocks, commonly two to three **particle size classes** larger. If they are mistaken for the largest mobile particle size, the simulated bed may end up with much coarser bed material than the reference reach. Nonalluvial material can be recognized by its limited distribution along the channel, and by its larger size. Rocks derived from the adjacent hillslopes (by landslides, rockfalls, etc.) are usually angular to subrounded, rather than round, and may therefore look out of place in the stream. Section 5.1.6.2 describes data collection for nonalluvial material and other key features.

Table 5.5 summarizes the recommended methods for characterizing bed sediment in different channel types for stream-simulation design purposes. The channel types are described in more detail in appendix A, section A.6.1.

Table 5.5—Bed sediment sampling and observations for different Montgomery and Buffington (1997) channel types.

REFERENCE CHANNEL TYPE	TYPICAL CONDITIONS					RECOMMENDED SEDIMENT SAMPLING METHOD FOR BED DESIGN
	Bed material	Dominant roughness & structural element	Slope <sup>1</sup>	Entrenchment	Streambed mobility	
Dune-ripple: high mobility	Sand to medium gravel	Sinuosity, bedforms, banks. Small debris may provide structure.	Low	Slight	Termed "live bed"; significant sediment transport at most flows	<ul style="list-style-type: none"> <li>Visual estimate representing whole reference reach or</li> <li>Bulk sample/sieve</li> <li>Note role of wood in stabilizing bed</li> </ul>
Pool-ripple and plane-bed: mobile	Gravel, may be slightly armored	Bars, pools, grains, sinuosity, banks	<1.5%	Slight	Near bankfull	<ul style="list-style-type: none"> <li>If fine gravels (up to 16 mm), same as dune/ripple</li> <li>Grid pebble count<sup>2</sup></li> <li>If armored, note armor thickness and packing. Visually estimate percent fines in subsurface layer</li> </ul>
Pool-ripple and plane-bed: intermediate mobility	Gravel to cobble, usually armored	Grains, banks	<4%	Slight to entrenched	Features controlling streambed elevations (riffle crests) mobilize at flows greater than bankfull	<ul style="list-style-type: none"> <li>Grid pebble count</li> <li>If armored, note armor thickness and packing. Visually estimate percent fines in subsurface layer</li> <li>Measure dimensions of 10-25 of the largest rocks on upstream portion of riffle crests.</li> </ul> <p>* Note imbrication, embeddedness, consolidation, particle shape</p>

<sup>1</sup> Slope is not diagnostic of Montgomery and Buffington channel types. Ranges given here include extremes. Typically, pool-riffle channels are <1.5%; plane bed channels are 1.5% to 3%, and step-pool channels are 3% to 6.5%. Forced channels can have steeper slopes.

<sup>2</sup> For the grid method, measurement points are spaced at one to two times the diameter of the largest particle. Transects are also located at that spacing.

# Stream Simulation

REFERENCE CHANNEL TYPE	TYPICAL CONDITIONS					RECOMMENDED SEDIMENT SAMPLING METHOD FOR BED DESIGN
	Bed material	Dominant roughness & structural element	Slope <sup>1</sup>	Entrenchment	Streambed mobility	
Step-pool	Cobble to boulder	Steps, pools, banks. Debris may be an important component of streambed structure.	3–8%	Moderately entrenched to entrenched	Fine material moves over larger grains at frequent flows. Bed-forming rocks move at higher flows depending on size; often $>Q_{30}$ .	<ul style="list-style-type: none"> <li>Grid pebble count.</li> <li>Measure 10–25 step-forming rocks individually. Sample enough to get a range representative of all the steps in the reference reach.</li> <li>If steps are on wood, measure wood diameter and step height.</li> </ul>
Cascade	Boulder	Grains, banks	$>3.5\%$ (usually $>6.5\%$ )	Entrenched	Smaller bed material moves at moderate frequencies (floods higher than bankfull). Larger rocks are immobile in flows less than $\sim Q_{50}$ .	<ul style="list-style-type: none"> <li>Grid pebble count.</li> </ul>
Bedrock	Rock with sediment of various sizes in transport over rock surface	Bed and banks.	Any	Any	Bedload moves over bedrock at various flows depending on its size. May be thin layer of alluvium over bedrock. Wood can strongly affect sediment mobility.	<ul style="list-style-type: none"> <li>Visually characterize alluvial material patches or use pebble count. Note features controlling sediment accumulation (e.g., wood).</li> </ul>
Channels in cohesive materials	Silt to clay	Sinuosity, banks, bed irregularities	Any	Any	Fine sediment moves over immobile bed at moderate flows depending on its size. May be thin layer of alluvium over immobile bed.	<ul style="list-style-type: none"> <li>No estimate needed—bed cannot be constructed of cohesive materials.</li> </ul>

<sup>1</sup> Slope is not diagnostic of Montgomery and Buffington channel types. Ranges given here include extremes. Typically, pool-riffle channels are  $<1.5\%$ ; plane bed channels are  $1.5\%$  to  $3\%$ , and step-pool channels are  $3\%$  to  $6.5\%$ . Forced channels can have steeper slopes.



***Dune-ripple and fine-grained pool-riffle channel types: high mobility.***

Streambeds composed primarily of medium gravel and finer materials (less than 16 millimeters) are generally dune-ripple or pool-riffle channel types. Visual estimates of dominant particle size classes are normally sufficient on these channels. Estimate maximum particle size, and percentages of the bed covered by different size classes, such as coarse gravel, medium gravel, fine and very fine gravels, sand, and silt/clay. (Particle-size classes are defined in appendix A, table A.1.) Platts et al. (1983) recommended doing this along transects, visually estimating the particle-size class that comprises the largest part of each 1-foot section. Visual estimation is adequate in these fine-grained channels because it is generally not necessary to design the simulated bed material as carefully as in less mobile streambeds. The fine particles move at very frequent flows (below bankfull), and the simulated streambed reshapes itself rapidly as new material is transported into it from upstream.

If more certainty about the particle size distribution is needed, then use bulk-sampling and standard laboratory sieve analysis to characterize the entire particle-size distribution for medium-gravel and finer channels. See Bunte and Abt (2001), section 4.2.2, for recommended sampling procedures.

***Pool-riffle and plane-bed channel types: mobile.*** Streambeds in these channels mobilize at flows near bankfull, and bed features are expected to form naturally in the simulated channel within a short period of time after construction. In these mobile channels, the bed-material sample should represent the whole reference reach. Use the grid pebble-count method, tailoring the number of individual particles measured to the variability in bed material sizes.

Not all pool-riffle and plane-bed channels are mobile, so evaluate as many mobility indicators as possible. Besides small particle sizes, indicators of relatively frequent mobilization include the absence of algal stains or moss on particles, steep faces and a lack of vegetation on bars, and loose bed material. Be careful if doing this evaluation shortly after a large flood; particle packing is looser after the bed mobilizes during such a flood. If it has been some time since a high flow, lesser flows will have reworked the streambed particles so that they are more tightly packed (Reid et al. 1985).

The degree of armoring also influences streambed mobility. Gravel-bed streams frequently have surface layers that are coarser than the

## Stream Simulation

subsurface (appendix A, figure A.6). In such armored channels, the size and packing of the armor layer strongly influences streambed mobility, while the subsurface fines limit flow infiltration and control subsurface flow. Inspect the material underneath the surface and compare it to the surface to determine whether a streambed is armored (appendix A, figure A.6). If it is armored, the subsurface has a much higher content of fines (particles less than 2 millimeters in diameter including silt and clay). The armor layer median particle size ( $D_{50}$ ) is usually 1.5- to 3-times larger than the subsurface material, and can be up to 4-times larger (Reid et al. 1998; Bunte and Abt 2001). Characterizing both armor and subarmor layers is important for designing realistic bed material for the simulation. Figure 5.6 illustrates the difference between surface and subsurface material in a gravel-cobble stream in Colorado.

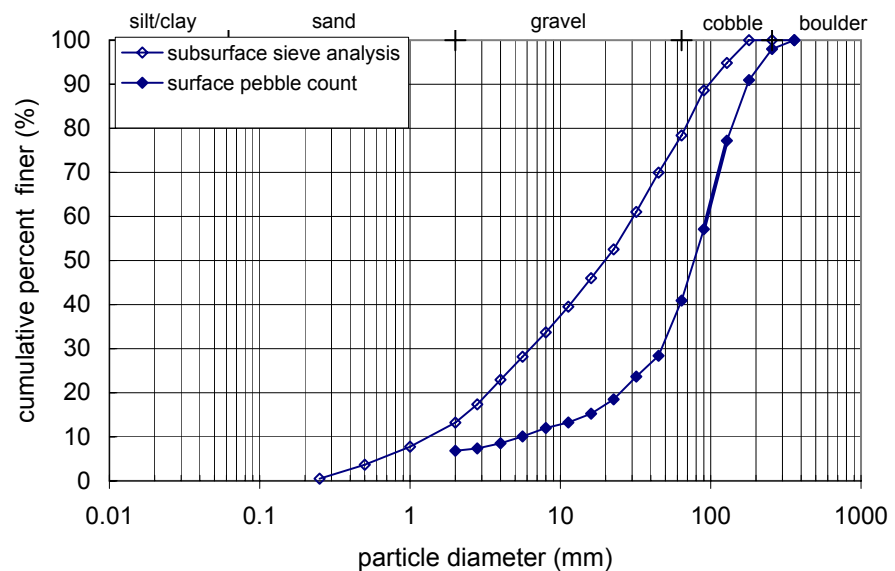

Figure 5.6—Surface armor and subsurface particle size distribution curves for the South Fork Cache la Poudre River (data from Bunte 2004). The surface armor was characterized by a pebble count. The subsurface was bulk sampled and sieved. Although the subsurface has a higher content of fines, it also includes the full range of coarser sizes found in the surface armor.

Visually estimating the subsurface fines content is usually adequate for stream-simulation design purposes. Sometimes you may be able to find an exposed scour pool, where you can clear off the exposed surface from a bank and estimate the content of fines. Otherwise, remove the coarse armor layer (usually one to two particles thick) from a bed area 1.5 to 2.0 square meters (16 to 22 square feet). If the area is submerged, use a

plywood shield to protect it from flowing water (Bunte and Abt 2001, p. 209). Estimate the percent area covered by fines, including fine gravels, sands, silts, and clay. These estimates will determine the content of sand (less than 2 millimeters) and silt/clay (less than 0.063 millimeters) in the simulation bed mix. Note any unusual situations, such as a layer of cobbles overlying very fine sediments.

***Pool-riffle and plane-bed channel types: intermediate mobility.*** In steeper, coarser pool-riffle channels, where particle sizes increase to very coarse gravel and cobble, streambed mobility is likely to decrease. This is especially true for **imbricated**, embedded, consolidated or heavily **armored streambeds** (see section 4.4, table 4-2). Particle shape and angularity also affect mobility: mobilizing angular particles requires higher **shear stresses** than mobilizing spherical particles of similar size (Reid and Frostick 1996). Flat, disc-shaped particles are usually well imbricated, making them more resistant to **entrainment** (Carling 1992).

As in the mobile channels, measure bed material using a pebble count method that samples the different channel units proportionally to their areas within the reach. In these coarser channels, tightly packed or embedded rocks making up the heads of riffles (or pool-tail crests) may be stable up to flows much larger than bankfull. It's important to distinguish these less mobile grade controls where they exist. The whole-channel pebble count includes the riffle crests where the grid crosses them, but a separate assessment of the larger particle sizes comprising the upper segment of the riffle crests is also needed, so that these key features can be constructed in the simulated channel. Measuring 10 to 25 of the largest rocks on the riffle crests is probably sufficient. (Figure 5.8 shows an example of bed material evaluation in an intermediate-mobility pool-riffle channel.) Also note any other characteristics that influence mobility. If the rocks are tightly imbricated, embedded, or packed, particle size alone may not be an adequate index of stability of the grade controls. Where rocks are highly asymmetrical, it may be necessary to measure the long, short, and intermediate axes to describe their relative dimensions and create appropriate specifications later.

***Step-pool and cascade-channel types: low mobility.*** Assess particle sizes on these channel types using grid-based pebble counts covering the entire streambed. For step-pool channels, measure on the order of 10-25 step-forming rocks, separately if necessary. Again, for highly asymmetrical particles, measuring dimensions of all three axes may be necessary to write a good specification. Where steps are formed by wood, measure log

## Stream Simulation

---

diameters. Ensure a good representation of the range of sizes of the step-forming rocks or wood in the reach as a whole. Measurements of the step-forming features comprise the first estimate of rock size for the steps in the stream simulation design bed. Design the overall bed mix from the whole-channel pebble count that includes the step-forming rocks only where the grid crosses them.

### 5.1.6.2 Key features

In stream-simulation practice, the term key feature means any element on the streambed or banks that is large and immobile enough to control channel slope and dimensions, affect water velocity and flow direction, and/or retain sediment over a fairly long period of time. Key features often play crucial roles in maintaining the stability and diversity of the streambed and stream banks. Key features are either permanently immobile or, as in the case of the pool-tail crests and steps mentioned above, they are low-to-intermediate mobility grade controls that cannot be expected to form naturally within a culvert in a reasonable period of time. In addition to bedforms like steps, they include large wood, rock outcrops, large living tree roots, large boulders, etc.

Key features are characterized separately from the alluvial material so their functions can be replaced in the stream-simulation channel. They should be shown on the site sketch map and surveyed and noted during the topographic survey. Where water drops over a feature, include the height of the drop in the surveyed longitudinal profile. It will probably be used directly in the simulated channel design. Field notes should cover type, condition, size, function, and stability of each key feature (see section 5.1.3.3). Possible functions include providing grade control, hydraulic roughness, and bank stability. In some cases, key features may prevent the channel from shifting laterally or widening.

Table 5.6 is an example of a form that can be used to summarize the field notes describing wood and other key features.

### 5.1.6.3 Wood

Note: all wood is included in table 5.6 even when it may not be a long-lasting key feature. The table classifies the wood by size, and describes each category in terms of diameter, length, condition (rotten or sound), amount or spacing, and function. This is simply a handy way to summarize the field observations for later reference during design. Where logs or trees are true key features, their size and stability should be noted individually and they should be located on the site sketch.

## Chapter 5—Site Assessment

Table 5.6—Example key-feature summary table.

KEY FEATURE SUMMARY					
Key feature	Size	Function	Spacing	Plunge height (bed elevation change)	Condition & mobility/ stability
<i>Wood debris and live trees</i>	6"-15"	<i>G</i>	@ 15'	0.4'-0.7'	<i>Rotten— low stability</i>
	10"-15" <i>tree diameter</i>	<i>C</i>	<i>continuous on left bank</i>		<i>Live tree root systems</i>
	36" <i>tree diameter</i>	<i>R,C,B</i>	@ 20' <i>both banks</i>		<i>Live tree root systems</i>
<i>Large boulders</i>	40" x 23" x 15"	<i>R,C,B</i>	<i>irregular</i>		<i>immobile</i>
	37" x 18" x 18"	<i>R,C,B</i>	<i>irregular</i>		<i>immobile</i>
<i>Bedrock</i>	<i>None</i>				
<i>Bedforms (steps, clusters, pool tail crests, etc.)</i>	<i>Steps are formed by wood (6"-15")</i>	<i>See above</i>			

Function key: Grade control, Roughness, Bank stability, lateral Confinement

## Stream Simulation

---

Wood need not be a long-lasting key feature to exert strong effects on channel morphology. For example, **woody debris**, living trees and roots, and other roughness elements can reduce bed-surface particle size by dissipating some of the boundary shear stress that would otherwise be exerted on the bed. Because the shear stress on the bed is less, the bed responds by becoming finer than it would otherwise be (Buffington and Montgomery 1999a).

Even small pieces of wood can affect the channel. In sand and fine-gravel-bed streams, buried fine woody debris can stabilize the bed at a steeper slope than it would otherwise sustain. Make sure to note the frequency and size of the fine debris if it is present and playing this role. If the stream-simulation bed design does not include the stabilizing effects of the small wood, the bed material may scour.

### 5.1.6.4 Bank materials and morphology

Streambanks can be relatively straight and uniform, or irregular with localized sections projecting into the channel. Woody vegetation and rock projecting from banks into the channel can have a substantial effect on channel form and processes by increasing **flow resistance**, obstructing or deflecting flow, stabilizing banks, and influencing erosional and depositional processes on the streambed (Poff et al. 1998). Bank irregularities also influence channel margin habitat for aquatic species by creating lateral scour pools and depositional zones. These habitats can be critical for passage of weak-swimming species that need slow and/or shallow water along the channel margin.

Mimicking the diversity, roughness, and shape of the channel margins and banks is important for simulating the degree of hydraulic roughness in the reference reach and for satisfying aquatic organism passage objectives. Where bank irregularities are important for edge habitat, bank stability, or channel roughness (figure 5.7), measure their spacing and length, that is, the distance they extend out into the channel. Note the type (large woody debris, standing trees, rock) and size of material that forms the bank protrusions. These features can be simulated with rock.



*Figure 5.7—Channel margin diversity in Ore Creek, Oregon.*

Understanding bank stability is also important when considering the effects of potential downcutting after a culvert replacement. Because there is often an elevation differential across older culverts, some adjustment of the longitudinal profile is likely during or after replacement with a stream-simulation culvert. If the replacement structure causes the upstream channel to degrade, the stability of the banks becomes an issue. Their stability may affect the decision about whether or how to control any headcutting that may occur (see section 5.3.3).

Qualitatively evaluate bank stability by observing:

- Bank materials and their layering.
- Rooting depth, density, and root sizes.
- Large, stable woody debris on banks.
- Live trees and shrubs that may overhang the banks.
- Evidence of active bank erosion such as vegetated chunks lying near the edge of the streambed.

### 5.1.7 Preliminary Geotechnical Investigation

The initial assessment phase (chapter 4) included collecting existing information on site geology from geological reports, watershed analyses, or past projects in the area. Usually these reports provide only general geological information. Complete a field geotechnical investigation to evaluate if a more detailed study of subsurface material properties is needed, and to help determine the cost and feasibility of the proposed project. The geotechnical site investigation assesses the spatial variability and physical characteristics of soil and bedrock, and the presence of ground water.

The list that follows summarizes the geological and geotechnical observations that may be needed. These observations apply to any site, whether steam-simulation design is used or not. Techniques are not discussed in detail because they are standard engineering practice. Ensure the geotechnical data are tied to the common datum of the topographic site survey.

#### **Bedrock.**

- Location, elevation.
- Type, durability, dip, strike, orientation, thickness (these characteristics become important at bridge or open-bottom arch sites).
- Structural features (fracture and joint patterns, width, depth, orientation, continuous or discontinuous, extent, shear, and fault zones).
- Weathering (distribution and extent).

#### **Soil.**

- Type (Unified Soil Classification System).
- Physical characteristics (thickness, cementation, occurrence).
- Engineering properties of the materials at the site.
- Durability.
- Plasticity.
- Load-bearing capacity (friction angle, cohesion, unit weight).
- Permeability.

#### **Mass-wasting risk at the site (Benda and Cundy 1990).**

- Debris flow.
- Slides and rock falls.

#### **Ground water**

- Occurrence and distribution.
- Relationship to topography.



## Chapter 5—Site Assessment

---

At most sites, sufficient subsurface data can be collected using simple hand methods (probing, hand augering, drop hammer, shallow excavations, etc.) Probing is a simple method of estimating some subsurface conditions, such as relative density of subsurface material, depth to bedrock, depth to probe refusal, and type of subsurface material (Williamson 1987). It is appropriate on most low-volume forest roads where no pavement is planned and the design structure is a culvert.

The probe is ½-inch galvanized steel pipe (actual dimensions are approximately ¾-inch outside diameter) and uses an 11-pound slide hammer for driving the probe into the soil. Stouter probes—such as stainless steel—may be needed in coarse-bed channels where rock is likely to be encountered. Probe immediately upstream and downstream of the existing structure and laterally across the stream (at least to bankfull width), including the area that the structure will cover. If bedrock is encountered during excavation, probe beyond bankfull width to develop more accurate estimates of excavation quantities. To assess localized changes in subsurface material and bank composition, extend the probing to the banks away from the fillslopes. Probe in scour holes to obtain information deeper in the subsurface. If riprap precludes probing near the culvert outlet, probe farther downstream and in the bank areas near the outlet. Include probe site locations on the site sketch, and flag them for the topographic survey. Using the surveyed surface elevations of each probe hole, calculate the elevation of the probed depth. For a more in-depth discussion of probing, see Williamson (1989).

During low-flow conditions, the plunge pool immediately downstream from an undersized culvert often has well-exposed scoured banks. Descriptions of sediments in the banks may provide insights into the material beneath the existing culvert. The vertical stratigraphy of the plunge pool sediments can highlight geotechnical concerns, such as the load-bearing capacity of the underlying sediments (how much weight the material can support), dewatering (how much ground water is expected and whether flow diversion is feasible), and susceptibility of the sediment to scour. Bank seepage can indicate potential problems with ground water during construction.

The results from the preliminary investigation may indicate the need for a more intensive, detailed geotechnical investigation involving core drilling, seismic surveying, and/or ground penetrating radar to fully characterize the geology at the road-stream crossing. Such an investigation may be desirable anyway if the site has high associated risks and costs. For example, if the replacement structure might be a bridge or an open-bottom

## Stream Simulation

---

arch, and the preliminary geotechnical investigation shows that there is soft material at the site, a detailed geotechnical investigation will be required.

### 5.1.8 Road Travel-way and Construction Considerations

Logistical constraints affect what you can do at any site. During the site assessment and preliminary design, identify all the limitations that could constrain design. A list of common constraints follows:

- Vertical constraints: Maximum road grade, and fixed or required elevations influence structure type and clearance and impact the site layout.
- Horizontal constraints: Issues of site visibility and maximum or minimum curve radius can affect site layout.
- Right of way and property boundaries: These affect the length of stream segment that can be regraded, along with the type and length of structure that can be installed.
- Utilities and property developments: These can affect the ability to reconfigure the site.
- Material constraints: Unavailability of materials may require a compromise on material used or an alternative design solution to stream simulation.
- Site access: Access issues may affect the type of equipment you can use, as well as the feasibility of regrading the channel profile. The availability of space for storing materials can also affect the construction schedule.
- Road closure and detour feasibility: The importance of a road for public travel and access during construction may constrain construction activities.
- Time constraints: Regulatory limitations to protect threatened or endangered species may limit the ‘work window’ to a few weeks out of the year. This can preclude some construction techniques, such as building cast-in-place concrete footings.

These logistical constraints may limit the extent of regrading or the type of structure, forcing a less-than-ideal solution for the site. For instance, a narrow right-of-way may force a steeper-than-ideal project profile to limit the footprint of the work.

The site assessment should answer other construction-related questions as well:

- Are the existing crossing embankment materials suitable for backfill? (See section 7.3.4.)
- What onsite materials (trees, downed logs, **riparian vegetation**, topsoil, large rocks) are suitable for possible inclusion in the stream-simulation design or stabilization plan?
- Are there nearby areas that might be suitable for treating dirty water by filtration through soil and vegetation? (See section 7.8.4.)
- What is the **diversion potential** at the site? Where would diverted water go?
- Where might topsoil and construction materials be stockpiled?
- Will streambank stabilization measures be necessary upstream or downstream? If so, what kinds of measures are needed?

## 5.2 ANALYZING AND INTERPRETING SITE DATA

### 5.2.1 Interpreting Sediment Processes and Mobility

Site assessment documentation for bed mobility should include:

- Channel types upstream and downstream of the crossing.
- Apparent bed mobility in upstream reach, and mobility indicators: degree of armoring, imbrication, bed structures, dominant particle sizes.
- Evaluation of whether grade controls need to be constructed in the stream simulation design bed.

Information for the reference reach should include:

- For gravel and coarser channels, particle size distribution curve(s) including particle sizes of grade controls if necessary.
- A visual estimate of subsurface fines.
- A qualitative description of the degree of armoring and the apparent stability of the armor layer (determined by packing, particle shape, etc.).
- For highly mobile streambeds, qualitative evaluation of particle sizes: maximum mobile particle size, dominant class, range of sizes present.
- Key feature type, size, function.

## Stream Simulation

---

In all cases, describe any effects of the existing crossing structure on bed material sizes to help in predicting channel response to removal or replacement.

The composition and characteristics of bed and bank material can provide insight on the frequency of sediment transport, channel stability, and sediment supply. These insights are important during design when decisions must be made about regrading the project profile, realigning the crossing structure or the adjacent reaches, and designing streambed structures that move at similar flows to the reference reach.

### **Newbury Creek Site Assessment—Bed Material**

Figure 5.8 shows pebble-count data from a riffle in a potential reference reach downstream of the existing culvert at the Newbury Creek site [see figure 5.2 and 5.10(b)]. The bed is well-armored, tightly packed, and imbricated. Well-established moss can be seen on the largest particles, suggesting that riffle particles do not move very frequently. The channel type is pool-riffle with intermediate mobility. Riffle-crest particles were measured separately. A sample of 10 of the largest rocks on the riffle crest averaged 244 millimeters in diameter, which is in the large cobble range. The surface layer has less than 1-percent sand and finer material, but a visual estimate of subsurface **fin**s is about 20 percent.

Field notes indicate that gravel bars on the insides of bends are narrow, woody debris is not present in large amounts, and little sediment is stored in the channel. From the initial assessment, there is a low-gradient meadow a short distance upstream of the crossing reach. The meadow reach traps most sediment moving down Newbury Creek, and the supply of sediment to the crossing reach is fairly low. Aggradation is unlikely to be a major issue at this site.

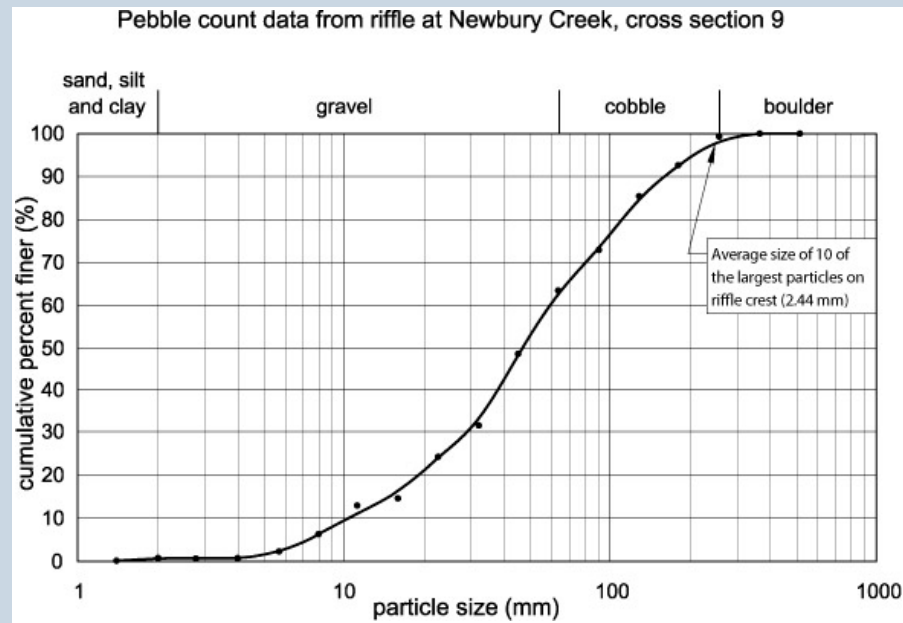

Figure 5.8—Particle-size distribution curve from a potential reference reach in the vicinity of cross sections 8 and 9. Cross sections are located on figure 5.9.

### 5.2.2 Analyzing the Longitudinal Profile

Plot the surveyed longitudinal profile and cross sections, and annotate them from the survey notes to help interpret the relationships between channel characteristics and stream processes. Locate the cross sections and bed material site(s) on the longitudinal profile, as well as the grade controls and other features that were identified in the field (table 5-1). Channel slope typically varies considerably along the longitudinal profile, directly reflecting the influences of large woody debris, slope and bank failures, bedrock, bedforms, and spatial variability of bed-material sizes. Integrating all of this information allows assessment of how streambed elevations and the longitudinal profile may change over the life of the project.

Usually, plotting the profile and cross sections with a vertical exaggeration (VE) between 2 and 10 makes them easier to interpret, as it makes segments with different slopes stand out from each other. Beware of using large VE's, however, especially on streams with steep (greater than 6 percent) slopes and high steps. Too much VE can give the misleading impression of many short channel segments.

## Stream Simulation

---

On the cross-section plots, show bankfull width and floodprone width, and identify key geomorphic features. Plotting all the cross sections at the same scale makes it easier to visualize changes in cross section dimensions along the channel.

The following steps are a systematic way of analyzing the longitudinal profile. Having the annotated cross sections handy will help with the analysis and interpretation.

1. Visually identify pools and grade controls. Identify geomorphic controls on pool formation (e.g., log, boulder weir, channel bend, culvert outlet plunge pool, etc.). Document the type and stability of the grade controls.
2. Delineate slope segments by drawing straight lines connecting successive grade controls. End a segment when the next grade control does not fall on the straight line. Calculate segment gradients, and combine adjacent segments when their slopes do not differ by more than 20 to 25 percent. For each of the final segments, determine (a) segment length, (b) the number and distance between grade controls, and (c) maximum pool scour depth.
3. Identify the length and depth of aggradation and degradation associated with the existing crossing. Identifying these areas of local aggradation and degradation helps in assessing the response of the channel to the existing structure, and predicting the channel's response to a new structure.
4. Identify the shape of the longitudinal profile to interpret the dominant geomorphic processes occurring at the crossing, and predict channel adjustments after the replacement structure is installed. Section 5.2.2.1 describes profile shapes and their implications for stream-simulation design.
5. Determine upper and lower vertical adjustment potential lines for the streambed through the crossing as if no crossing structure was present (section 5.2.2.2).

### **Newbury Creek Site Assessment Longitudinal Profile Analysis Steps 1 Through 3**

Figure 5.9 is the annotated longitudinal profile for Newbury Creek (sketch map is shown in figure 5.2). The longitudinal profile plot identifies the surveyed cross sections, and it shows channel features such as log weirs (installed in the 1980s and early 1990s to improve aquatic habitat), bankfull and flood plain surface elevations, and exposed bedrock. Bedrock occurs at the base of pools associated with log weirs upstream from the crossing.

Figure 5.10 shows two typical cross sections upstream and downstream of the crossing (locations are on the longitudinal profile). The upstream cross section (a) is substantially more entrenched, bounded by the adjacent slope on one side and a high glaciofluvial terrace on the other. The downstream channel (b) is less entrenched; the adjacent surface is a low terrace only slightly higher than bankfull elevation.

**Step 1.** Pools are identified on figure 5.9, as are grade controls, which include bedrock steps, moderate-to-high stability pool-tail crests (the heads of riffles) and low-to-moderate stability log weirs. Pool-tail crests are designated high stability when composed of tightly packed and embedded boulders and cobbles. Pool-tail crests of more loosely packed cobbles and gravels are considered moderate stability (see table 5.3).

Upstream of the road, the channel is relatively straight (figure 5.2), and the primary controls on pool formation are obstructions created by bedrock steps and log weirs. Downstream of the road, the channel is more sinuous and the primary controls on pool formation are channel bends and obstructions created by log weirs that have partially failed (compare figures 5.2 and 5.9).

# Stream Simulation

segment	elevation change (ft)	segment length (ft)	gradient	% gradient difference between successive segments	maximum residual pool depth (ft)	number of grade controls	distance between grade controls (ft)
A	0.94	53.17	0.0178	n/a	1.54	2	53.2
B	0.41	81.53	0.0050	-71.9	0.34	2	81.7
C	2.68	185.21	0.0145	190.4	1.07	4	62.0, 101.7, 21.6
D	1.78	92.69	0.0193	32.9	2.29	3	57.7, 34.8
E	0.73	11.01	0.0665	245.2	0.99	2	11.2
culvert	0.27	72.09	0.0037	-94.4	4.38	2	72.2
F	5.70	234.28	0.0243	55.15	0.82	3	145.7, 88.6
G	1.27	66.25	0.0192	-21.0	1.70	2	66.3
F,G	6.97	300.53	0.0232	-4.6 <sup>a</sup>	1.70	4	145.7, 88.6, 66.3
H	4.69	151.32	0.0309	60.8 <sup>b,c</sup>	0.68	3	92.2, 59.1

a. Percent gradient difference when compared to slope segment F.

b. Percent gradient difference when compared to slope segment G.

c. When compared to combined slope segments of F and G, the percent gradient difference is 33.3%.

- channel-bed profile
- pool
- top of bank/floodplain
- cross section location
- grade control
- ptc-H pool tail crest, high stability
- ptc-M pool tail crest, moderate stability
- st-H step, high stability
- lw-M log weir, moderate stability
- lw-L log weir, low stability
- slope segments (A,B,C,D,E,F,G,H)

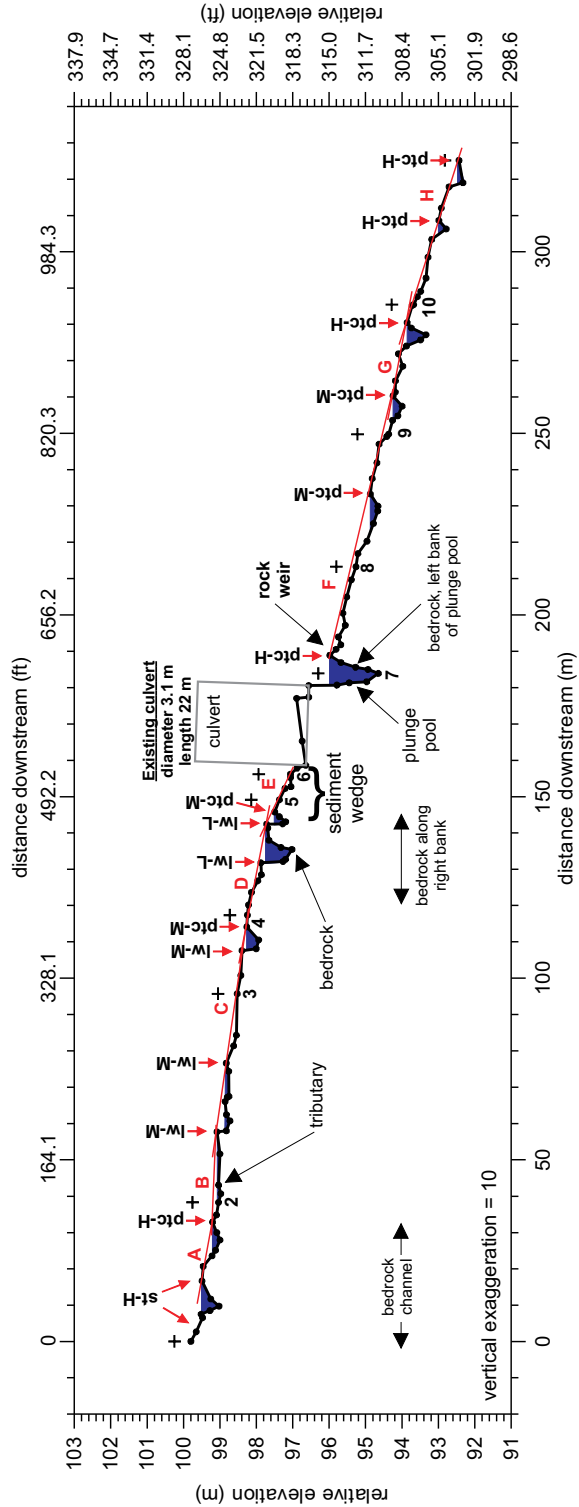

Figure 5.9—Longitudinal profile of Newbury Creek, Olympic National Forest, showing various channel features.



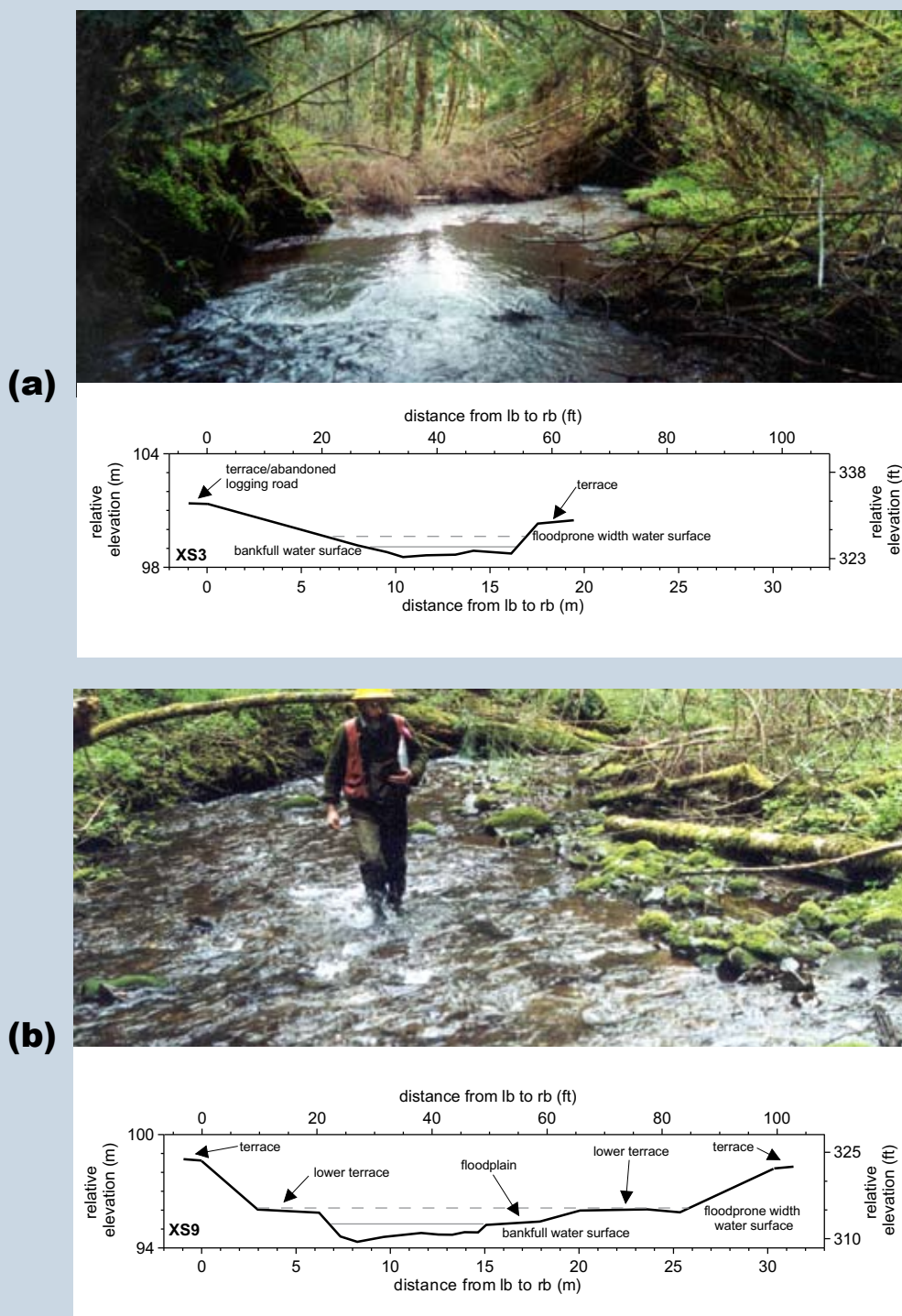

Figure 5.10—Newbury Creek cross-section profiles and photos. (Cross-sections are plotted looking downstream and their locations are shown in figure 5.9.) (a) Looking downstream toward cross sections 3 and 4 (photo taken between cross section 2 and cross section 3). Two log weirs are visible. In the background a bedrock outcrop is exposed on the right bank of the channel. (b) Looking downstream at cross section 9.

## Stream Simulation

---

**Step 2.** The channel upstream of the road has five segments ranging from 0.5 to 6.7 percent slope. Downstream of the road, three segments were initially identified. Segments F and G were combined because their slopes differ by only 21 percent and the segments are the same channel type. Grade control spacing and maximum residual pool depth for each segment are summarized in the table in figure 5.9.

**Step 3.** Like most undersized culverts, the one at Newbury Creek has an area of sediment deposition immediately upstream of the inlet. Low sediment loads (due to the upstream meadow) and the steep, confined channel keep the sediment wedge small. Nonetheless, because the culvert is nearly flat (0.4 percent), some minor deposition has occurred in the culvert.

The plunge pool downstream of the culvert outlet is much deeper than other pools. Residual pool depth is 4.4 feet, about twice the residual depth of pools that form naturally elsewhere in the channel. The plunge-pool tail crest is a constructed rock weir of angular rocks (riprap) much larger than the native bed material (600 to 750 millimeters) (figure 5-11).

Steps 4 and 5 of the Newbury Creek longitudinal profile analysis are in sections 5.2.2.1 and 5.2.2.2, respectively.



*Figure 5.11—Outlet of existing culvert on Newbury Creek, Olympic National Forest, Washington.*

### 5.2.2.1 Identify longitudinal profile shape

Bedforms, woody debris, bedrock, etc, are not the only possible controls on channel slope. Slope also may vary where the crossing is located at a geomorphic transition, where the downstream channel has incised, or where the crossing itself has modified channel slope by causing sediment deposition upstream.

Many forest roads are located at geomorphic transitions—natural terrain breaks such as the edge of a valley at the base of the hillslope, or on a natural bench. These terrain breaks [figure 5.12 (c), (d), and (e)] can create an abrupt change in stream slope, influencing the shape of the profile and affecting sediment transport along the channel. Project teams need to identify these transitions and understand their potential effects on sediment transport and channel stability to accommodate them in the design.

#### Uniform

A uniform profile has no slope transition, making this the ideal crossing situation [figure 5.12 (a)]. Even where the profile is uniform, though, aggradation upstream of an undersized culvert [figure 5.12 (b)] can reduce the local slope. Such a profile can be mistaken for convex [figure 5.12 (d)] if the surveyed longitudinal profile does not extend beyond the aggradation, or if the aggradation is not recognized. Field evidence of aggradation upstream of an undersized culvert can include a relatively high gravel deposit in the center of the channel above the existing structure, a widened and/or divided channel, bank erosion, or a bar deposit just upstream from the culvert with finer sediment than at other locations. An aggraded reach may also appear simpler and more homogenous because structural features such as steps may be buried by sediment. **Backwater** aggradation is not limited to uniform profiles, of course. It can occur upstream of any undersized culvert.

#### Concave

A concave transition is an abrupt slope transition from steep to flatter [figure 5.6 (c)], such as on a flat valley bottom near the toe of a hillslope. Such an area is a natural depositional zone, where sediment accumulation through the crossing structure can reduce the structure's hydraulic capacity (see figures 4.7 and 4.8). Occasionally, sediment deposition can also plug the channel, and cause the stream to cut a new channel in a different location. If the excavation for a replacement structure cuts into the bed of the steeper reach and no upstream grade control exists, upstream headcutting and additional sediment deposition may result.

## Stream Simulation

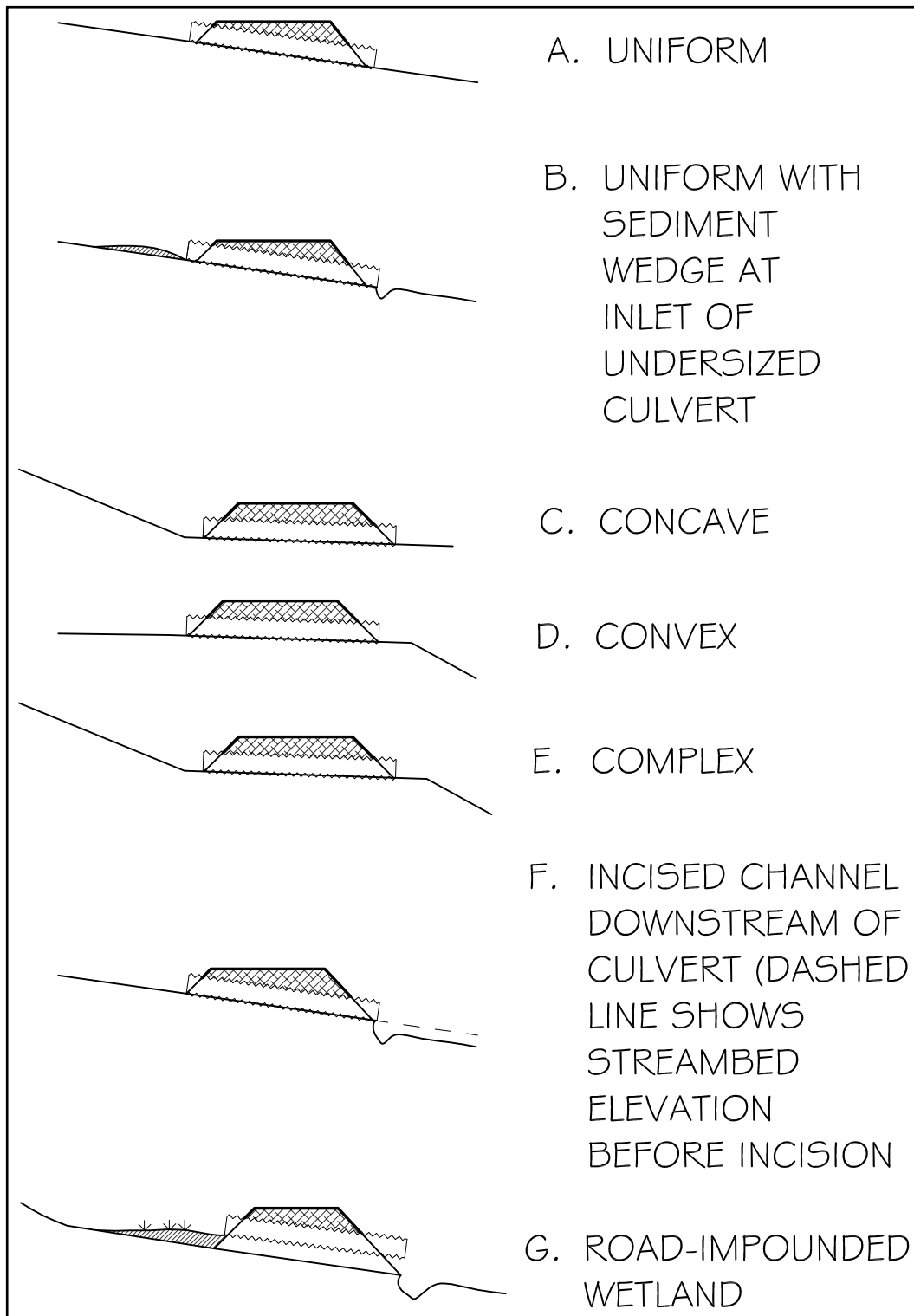

Figure 5.12—Longitudinal profile shapes: (a) uniform; (b) uniform reach affected by local scour and aggradation due to undersized culvert; (c) concave transition; (d) convex transition; (e) complex transition; (f) incised channel; (g) road-imponded wetland.

### Convex

A convex transition is a slope transition from a mild slope to a steeper one [figure 5.12 (d)]. Depending on how close the crossing is to the grade break, flow acceleration resulting from either the structure or a disturbance during construction can destabilize bed structures that control the downstream grade. Destabilization, in turn, could create a headcut that might migrate upstream through the structure and undermine it.

### Complex

A complex transition is a profile with both a convex and concave shape [figure 5.12 (e)]. This type of transition has both the upstream problems of the concave type and the downstream problems of the convex type.

A road crossing placed at a convex or concave site may exacerbate the natural tendency toward aggradation or degradation if the crossing constricts the stream, or construction disrupts key grade controls. This can lead to a perpetual need for maintenance and the chronic channel disturbance associated with it. Consider road relocation away from concave or convex sites. Even though relocation may appear expensive, it may sometimes be cheaper than long-term costs associated with maintaining a poorly located crossing.

### Local scour versus regional incision

Longitudinal profiles at culverts often show that the culvert is perched, but the elevation differential can have several causes: the downstream channel may have incised since the culvert was installed [regional incision, figure 5.12 (f)]; high velocity flow from the culvert outlet may have scoured a local plunge pool [figure 5.12 (b)]; or the culvert may have been placed too high during construction [figure 5.12 (g)]. Distinguishing local scour from regional incision is important, because the scale of the design solutions will be very different (see also section 6.1.2.1).

The vertical offset between the upstream and downstream channel bed profiles is a primary tool for determining whether degradation at the culvert is a local effect or the result of larger-scale channel incision (review appendix A). In figures 5.12 (b) and (g) and 5.13 (a), channel scour is local. When the downstream profile is extended upstream beyond the influence of the culvert, the profile aligns vertically with the upstream channel. The culvert is perched, but the perch is caused by local scour. In contrast, in figure 5.12 (f) and 5.13 (b), when the downstream profile is extended, it is approximately parallel to the upstream channel but at a lower elevation. A longitudinal profile with this channel-bed offset identifies an incised channel where the existing culvert is functioning as a grade control.

## Stream Simulation

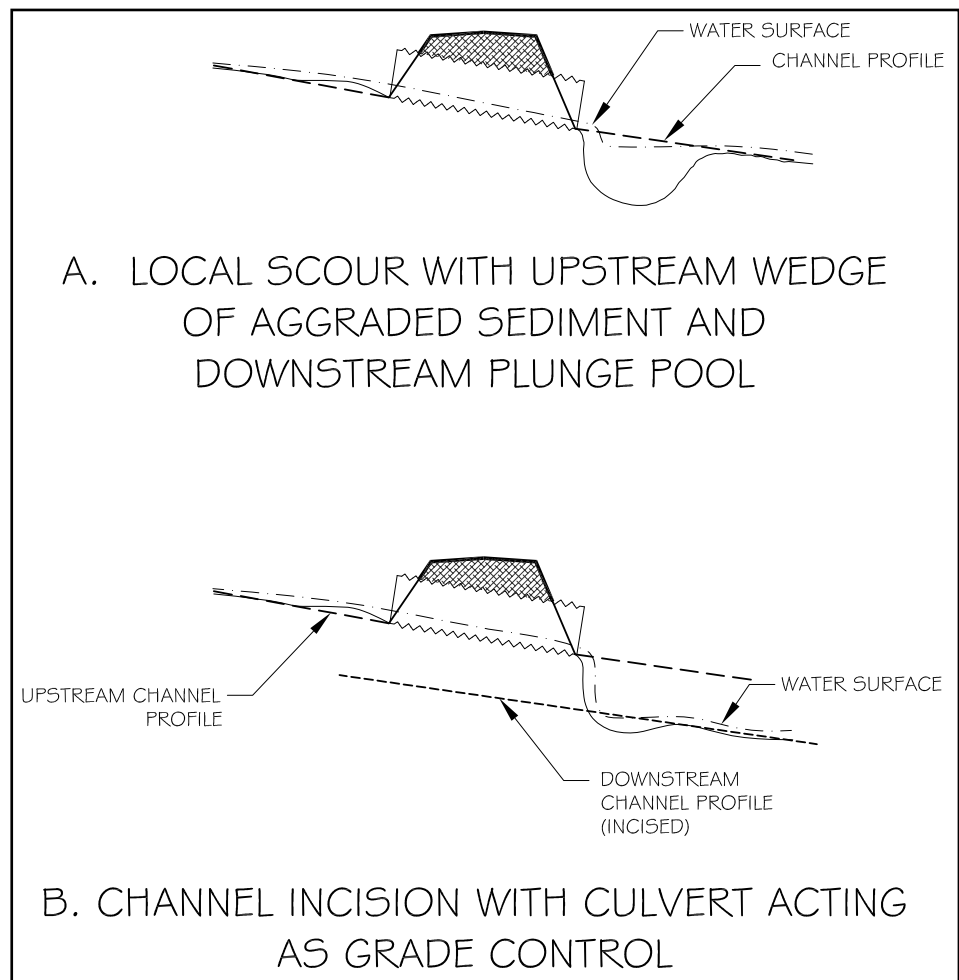

Figure 5.13—Distinguishing (a) downstream local scour from (b) channel incision.

Channel-bed offsets on either end of a culvert can also occur from other causes. For example, a natural slope transition can sometimes appear as an offset (figure 5.12 (c), (d), or (e)). Abrupt changes in streambed elevations also occur in steep streams where bedrock or large logs control steps. If the existing culvert was placed on top of an earlier failed culvert, the upstream channel could have massively aggraded, and both road and streambed profiles are higher than otherwise. Or, the culvert could have been constructed on a bedrock ledge. In all these cases, it is less likely that the upstream and downstream profiles would be parallel. Field observations and historical information about the crossing will help define which of several possible causes is responsible for the change in streambed elevation.

Cross sections are an excellent way to verify whether a downstream reach is incised (see appendix A, section A.7.2). An incised channel downstream from a crossing structure where the crossing is functioning as a grade control will have different cross-section characteristics from the unincised upstream channel (see end of section 5.1.4.2). Bed material also is likely to be different—possibly coarser—with less accumulation of gravel or fines.

### **Newbury Creek Site Assessment**

#### **Longitudinal profile analysis step 4, identify profile shape**

At first glance, the Newbury Creek longitudinal profile (figure 5.9) leads one to suspect that the downstream reach may have incised. When a straight line along the downstream grade controls (the longitudinal profile) is extended upstream of the culvert, it is substantially lower than the upstream streambed. However, several pieces of evidence suggest this is not a case of channel incision. For one, the cross sections (figure 5.10) indicate that the banks downstream are not higher than those upstream; in fact, the downstream reach is less—not more—entrenched. There is no evidence of bank instability and no indication that either bed or banks have adjusted to a lowering of the channel bed.

The evidence confirms what the site sketch (figure 5.2) suggested—that the crossing is located at a geomorphic transition. The valley is narrow and controlled by bedrock upstream from the crossing, and the valley is wider and alluvial downstream from the crossing. The road crosses the stream at the head of the alluvial valley. The longitudinal profile shape is complex due to local steepening immediately upstream from the crossing, where bedrock outcrops in segment D constrict the channel for a short distance.

See figure 5.17 for step 5 of the longitudinal profile analysis for the Newbury Creek site.

## Stream Simulation

---

For incised channels, verify the cause, scale, extent and stage of incision if at all possible. For design of any crossing, it is important to know whether incision is actively progressing, stabilizing, or recovering. If the cause is an upstream-migrating headcut, comparing the downstream reach to the channel evolution model (appendix A, section A.7.2) can help determine the stage of evolution. If the cause is a local influence, such as removal of woody debris or loss of a local grade control, then, with time, the bed may aggrade naturally back to its original profile. To accelerate the recovery process, the crossing project could include restoring the incised section to grade.

### Road-impounded wetlands

Some road crossings with culverts that are undersized or that were installed too high cause ponding upstream (figure 5.12(g)). The ponding causes sediment deposition, which reduces the supply of sediment to the downstream channel. At these sites, the longitudinal profile usually shows an aggradation wedge, bed material is likely to be distinctly finer upstream than downstream, and vegetation may be different. The team will need to choose whether to preserve the wetland area, remove it, or allow it adjust naturally to a stream simulation replacement culvert. Because of a general loss of wetland habitat in some basins, resource managers are often motivated to preserve these wetland areas.

To preserve the wet area and provide some measure of aquatic organism passage, a design method other than stream simulation is usually needed. Stream simulation may not be possible in these cases because simulating the natural channel slope, form, and processes through the crossing would cause incision in the upstream wet area when some or all of the accumulated sediment is remobilized. On the other hand, if you design an over-steepened channel to preserve the wetland, the channel would not be self-sustaining because the sediment sizes necessary for sustaining the steeper slope could not be transported through the wetland to the channel. (Refer to appendix B for design methods other than stream simulation. Use these methods where the channel through the crossing must be substantially steeper than the natural channel, and achieving stream simulation objectives is unlikely.)

### 5.2.2.2 Determining vertical adjustment potential

One of the first steps in stream-simulation design involves selecting the gradient and elevation for the streambed that will be constructed—that is, the project profile. (See section 6.1.2.2 for detailed discussion of project profiles. It might be a good idea to review that section now, to get an idea



of how the design uses the interpretations discussed here.) Before selecting the project profile, however, the team needs to predict the elevations between which the stream bed might vary over the service life of the structure: the vertical adjustment potential (VAP). The upper and lower VAP lines represent respectively the highest and lowest likely elevations of any point on the streambed surface in the absence of any crossing structure. This section describes the considerations that go into forecasting the VAP lines for the structure's lifetime. There is no cookbook approach to selecting the upper and lower VAP lines; they are based on the team's interpretation of conditions and processes in the stream that might affect the elevation of the channel in the future.

Depending on channel type and condition, processes that can change the streambed elevation, whether permanently or temporarily, include:

- Channel incision caused by downstream base-level change.
- Increased flows or sediment inputs resulting from land management changes or climatic events in the watershed.
- Aggradation or degradation at a slope transition.
- Erosion and deposition of key features like boulders, steps, and large woody debris.
- Channel scour and fill during floods and debris flows.
- Headcutting upstream of a larger replacement culvert, as aggraded sediment is mobilized.
- Pool formation.

Try to predict what types of changes might occur and estimate how the channel might respond to those changes. Consider first the potential for large-scale, long-term channel change, such as deposition due to debris flow, or regional channel incision due to base-level changes downstream. Then consider local changes, such as movement of one of more key features or formation of a debris jam. Predicting how such changes may affect bed elevations is necessarily subjective; use every available piece of field and historical evidence available. Be conservative where the probability of vertical adjustment is high, such as where large amounts of wood are in the channel, or where channel incision is expected. If you are uncertain how the channel might change in the future, design conservatively and consider getting additional expertise to help predict future conditions.

## Stream Simulation

---

In channels where large wood or rock steps control bed elevation, if these key features do not move, they will control the lower limit of vertical adjustment for the lifetime of the replacement structure. On the other hand, loss or outflanking of one or more of these key features could cause a large change in bed elevation over some length of stream as the channel adjusts toward a new equilibrium. The length of stream affected depends on the stability of the adjacent grade controls and on the depth of channel bed lowering. Usually, the material from the failed step moves only a short distance downstream, filling in the downstream pool and reorganizing the bed to form a new grade control. See the Fire Cove Road VAP analysis, figures 5.14 and 5.15.

If the key features are less stable, project how bed elevations are likely to change when they move. In intermediate and low-mobility channels, some amount of channel-bed fluctuation will always occur as wood pieces or rock grade controls enter or move through the channel, or as bedforms and bend locations change. Debris jams or buried small debris can temporarily retain sediment upstream, and they may form a scour pool downstream. If the debris moves, how will the stream adjust? Generally, the height of the grade controls, (log or rock steps, pool-tail crests, debris accumulations) indicates the scale of bed adjustment expected after one or a series of grade controls moves.

In stable channels where the bed surface as a whole is not expected to change (e.g., due to **base level** lowering or changes in flow), the depth of ordinary pools is a reasonable estimate of the lowest likely bed elevation in any slope segment. Unusually deep pools formed by large key features would not be considered in this analysis since they would not form inside a culvert. The depth of surveyed pools, however, represents only a snapshot-in-time of a dynamic channel that undergoes scour and fill during high flows. Limited research has shown that, in armored gravel-cobble bed streams, flood scour depths are on the order of twice the thickness of the armor layer, or about twice  $D_{90}$  (Bigelow 2005; Haschenburger 1999). It makes sense in these cases to expect that—temporarily at least—the bed may be that much lower than the bottoms of pools. If the level of risk warrants, the lower VAP line can be lowered to account for that.

Channel incision that affects long stream reaches can occur due to a variety of causes. Downstream influences include in-stream gravel mining or channel straightening that cause a headcut to begin moving upstream; upstream causes might be an upstream dam that reduces sediment loads, or any land management activity that reduces infiltration and increases peak runoff rates. Predicting the lower VAP line under these conditions requires

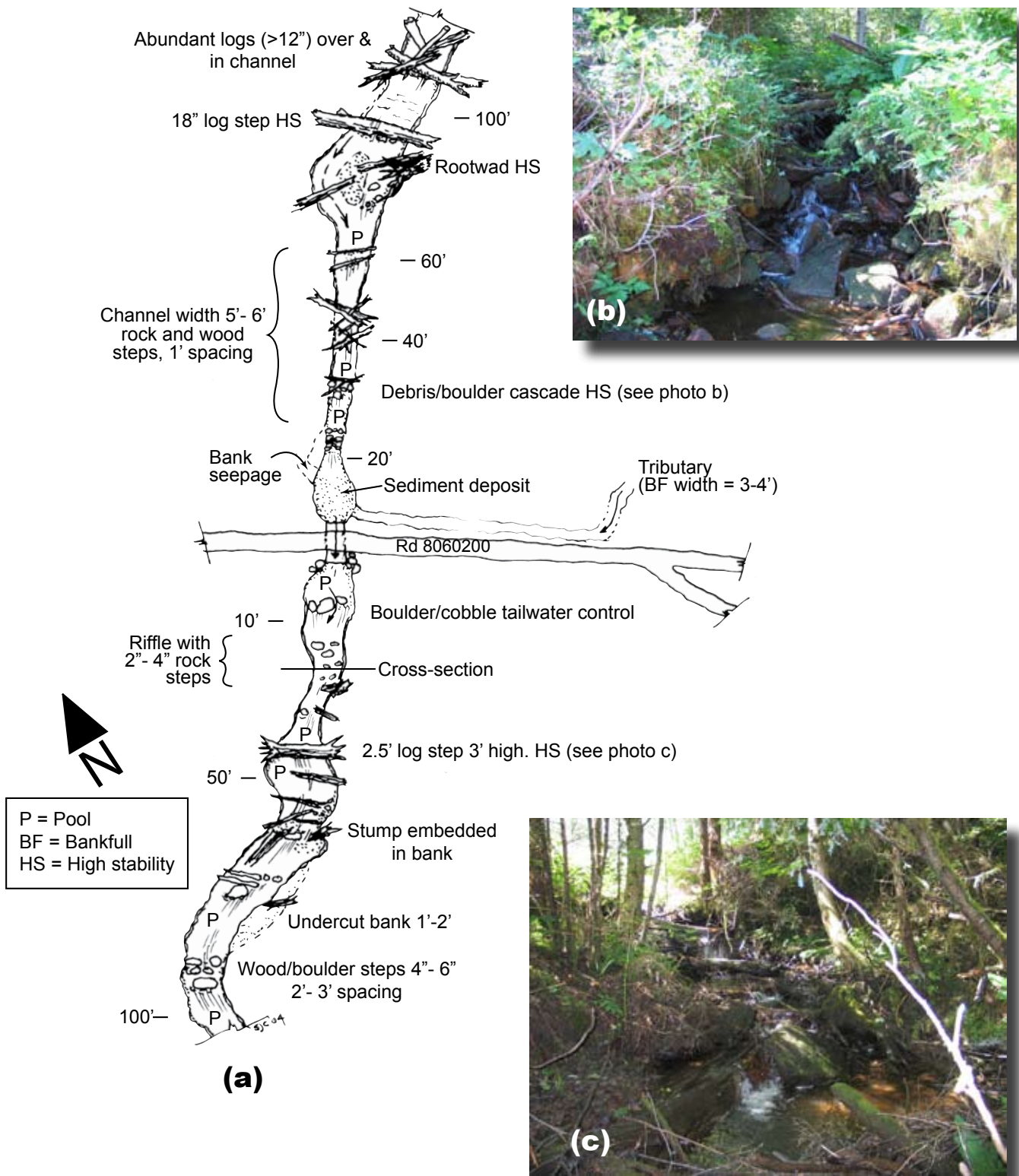

Figure 5.14—Fire Cove Road crossing, Tongass National Forest, Alaska: (a) site sketch; (b) looking upstream from the crossing at a high-stability step/cascade; (c) downstream of the crossing looking upstream at a high-stability log step (road is in light background area).

## Stream Simulation

The Fire Cove Road crossing on the Tongass National Forest is a good example of predicting vertical adjustment potential (VAP) in a steep stream with large log steps (figure 5.14). In this example, no regional channel incision or aggradation is expected. The solid, well-embedded 2.5-foot diameter log about 50 feet downstream of the culvert [figure 5.14(c)] is a key feature controlling the grade. Just upstream of the culvert is a high-stability feature: a debris-and-boulder cascade where bed elevation is unlikely to change. Figure 5.15 shows two alternatives for the lower VAP line at this site. VAP line 1 assumes the stable downstream log does not move over the lifetime of the project. VAP line 2 indicates how deeply new pools in the project reach could scour if the log does move. Headcutting would end at the high-stability cascade section even if the downstream grade control is lost.

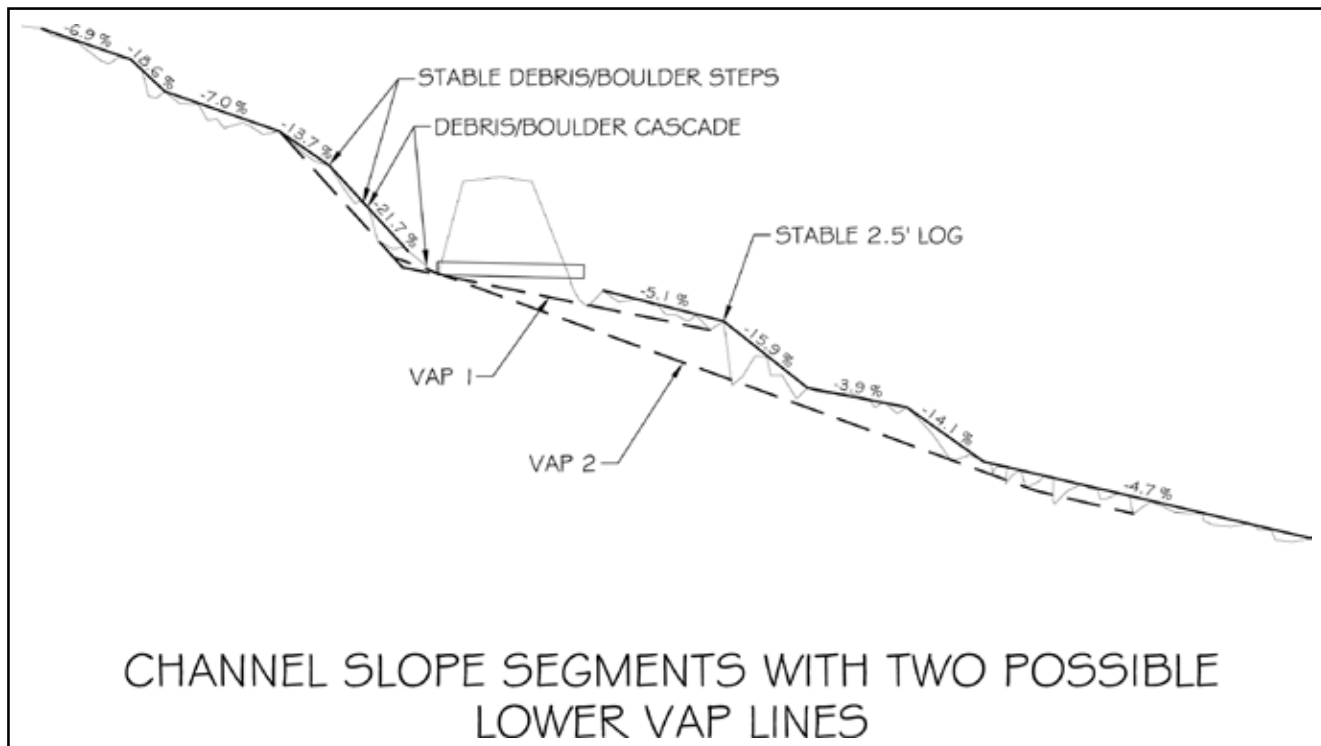

Figure 5.15—Longitudinal profile with two possible lower VAP lines for the Fire Cove Road crossing. Either of the two lower VAP lines could be used depending on how stable the downstream control is judged to be. In chapter 6, we will see how this crossing was actually designed (figure 6.7).

estimating how much of this large-scale incision may occur at the crossing site, and then adding the depth of pool scour to that estimate.

Also think about any features or processes upstream that may cause the channel to rise. Some examples are:

- Headcuts, bank failures, landslides, or debris flows occurring upstream may create a potential for large amounts of sediment deposition in the structure. Debris released by the headcut can exacerbate the deposition problem. (See Benda and Cundy 1990, for a method of predicting the risk of debris flow deposition).
- Formation of a debris jam and sediment accumulation behind it can easily cause local bed elevations to rise.
- Evidence of recent aggradation or heavy bedload movement may indicate the channel is aggrading, or it may be recovering from aggradation.
- If the channel is unnaturally lacking in debris, consider whether trees falling into the stream in the future might retain sediment and raise the channel-bed elevation.
- Crossings located on tributaries near their junctions with a larger river may experience aggradation if they are backwatered by high flows in the river.

Using all the information, draw at least two lines on the longitudinal profile to show the range of possible future bed elevations at the site (figure 5.16). Delineate the lines for channel segments outside the influence of the existing structure, and then connect them through the project reach as though no structure were there. Draw them approximately parallel to the average grade of each slope segment unless bedrock or other immobile controls dictate a different slope.

The scenarios represented in figure 5.16 illustrate how the VAP lines were delineated in three different hypothetical cases. Figure 5.16 (a) shows the longitudinal profile of a 10-foot-wide stream crossing a road in a 4-foot culvert. The channel profile shape is uniform, and the stream is in dynamic equilibrium. Watershed conditions are stable; there is no reason to expect regional channel incision due either to headcut migration from downstream or to changes in flow or sediment loads. The channel is an armored gravel-cobble pool-riffle channel with some woody debris. Pools not associated with large key features or the existing undersized culvert are a maximum of 2 feet deep. The lower VAP line is at 2.8 feet below the

## Stream Simulation

existing profile, 0.8 foot being added as a safety factor for potential scour during floods. The depth of potential scour is estimated as twice the  $D_{90}$  size of 0.4 foot.

The upper VAP line in figure 5.16 (a) is at the top of the 2.5-foot-high bank because debris accumulations in this vicinity can extend that high. The top of the bank is the maximum elevation to which sediment could aggrade behind such an accumulation.

Figure 5.16 (b) shows the same channel after a 2.5-foot headcut moved up from downstream and was stopped by the existing culvert. The incised channel profile is 2.5 feet lower than the undisturbed (upstream) channel profile projected downstream. Here, if the culvert were not in place, the headcut could continue to move upstream causing incision up to 2.5 feet. Thus, the lower VAP line is 2.8 feet below the *incised-channel* longitudinal profile. Downstream of the road, a 3-foot-high debris jam of small trees that were undermined by bank erosion constitutes one piece of evidence for locating the upper VAP line at 3 feet above the incised channel profile (below the top of the bank). Again, if the culvert were not in place, the headcut would continue migrating upstream, and upstream VAP conditions would be essentially the same as those downstream.

Figure 5.16(c) is a very different scenario, a concave profile. The road is located where a steep (8 percent) step-pool channel meets the valley floor of a larger river. Downstream of the transition zone, the stream meanders across the valley on a 2-percent grade to join the river. The steeper channel currently appears stable, but the height and composition of the banks at the valley edge show that the channel has deposited substantial sediment and debris there during past floods. Private property makes road relocation impossible here.

The upper VAP line in this example is drawn at the top of the 2-foot-high banks in the valley section, and at the top of the higher banks in the slope transition section. We are presuming that at least short reaches of channel can fill to the top of the bank behind debris accumulations. The lower VAP lines in each channel segment are below the bottoms of the pools by a depth of two times  $D_{90}$ .

As shown in figure 5.16(c), where a channel has distinct gradebreaks, VAP lines can be drawn in segments. The high- and low-potential profiles might not be parallel where some feature will limit the possible channel elevation from going higher (e.g., flood-plain elevation) or lower (e.g., bedrock). Drawing several possible profiles—to show the range that might be expected at the site, given the existing grade controls and how they might change—is helpful. Where substantial uncertainty in the degree of potential vertical adjustment exists (e.g., in a channel with a highly mobile bed and good potential for debris jam formation), you might increase the range of potential vertical adjustment to offset the risk of error. Note your assumptions and relevant observations on the profile.

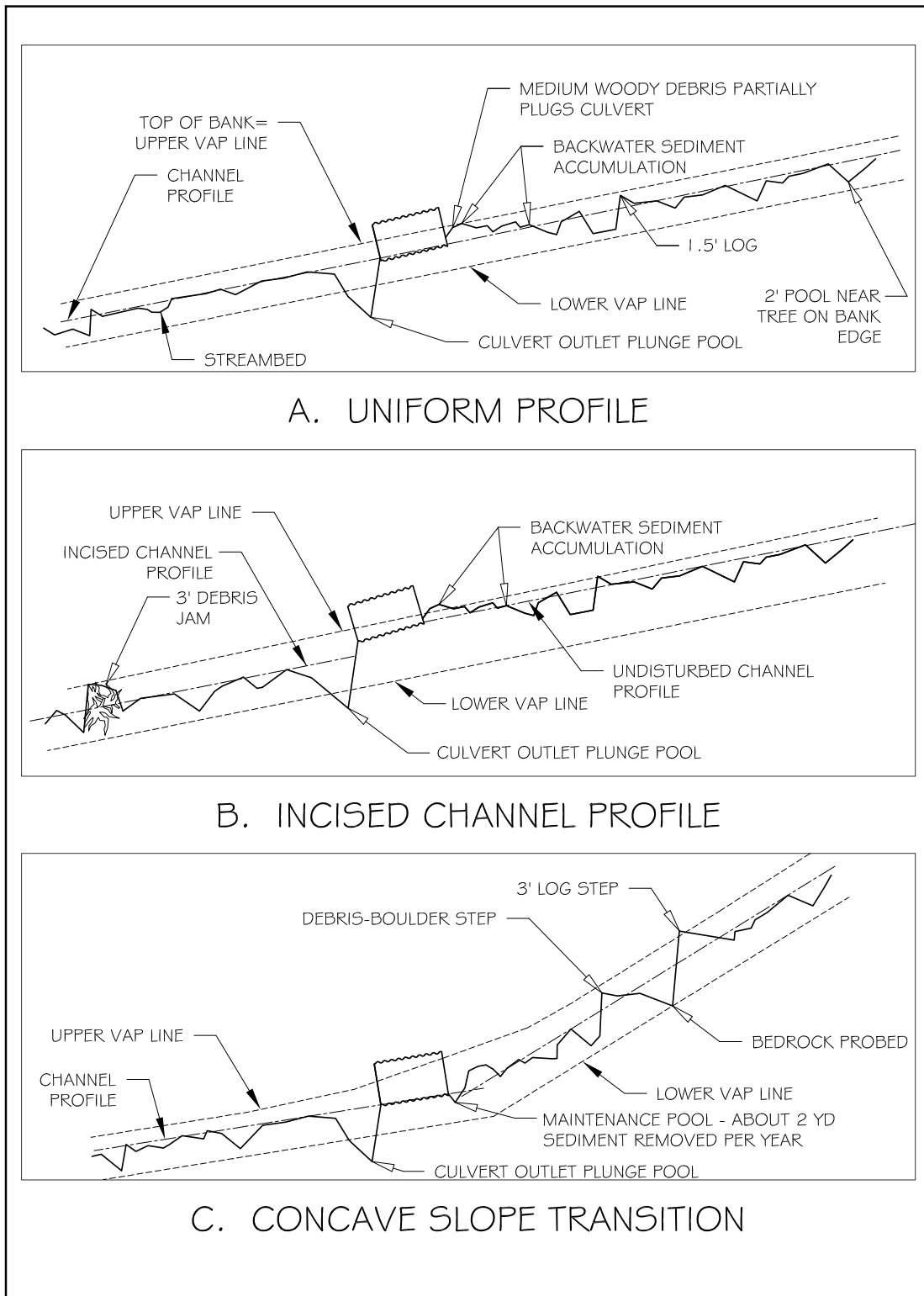

Figure 5.16—Range of vertical adjustment potential for three longitudinal profile types: (a) uniform profile, (b) incised channel profile, (c) concave slope transition. The “channel profile” lines are the “slope segment” lines drawn in step 2 of the longitudinal profile analysis (section 5.2.2).

# Stream Simulation

## Newbury Creek Site Assessment Longitudinal profile analysis step 5, determine vertical adjustment potential

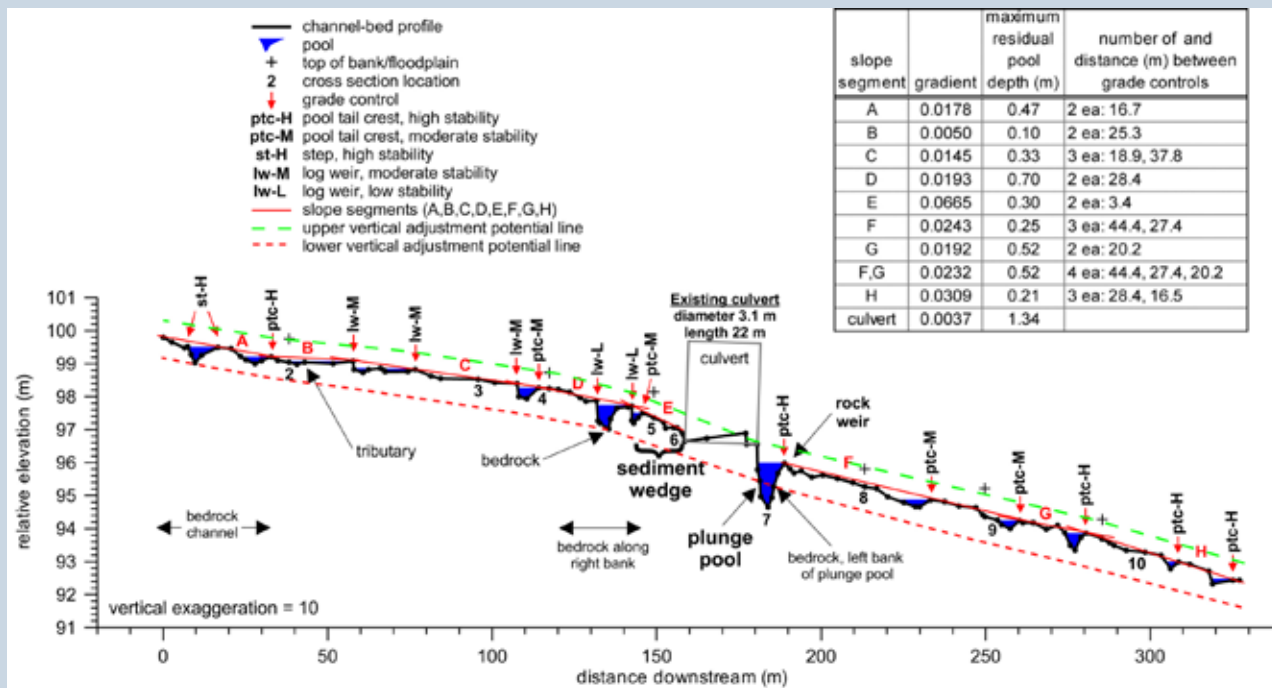

Figure 5.17—Newbury Creek longitudinal profile showing vertical adjustment potential.

As noted in the previous Newbury Creek sidebar (section 5.2.2.1), the channel downstream of the crossing has not incised, and there is no reason to expect incision in the future. Therefore, the lower VAP line includes only the maximum residual depth of pools (1.6 feet) for each slope segment, plus the anticipated flood scour depth (1.3 feet, twice the  $D_{90}$  of 0.65 foot). The lower VAP line is therefore 2.9 feet below and parallel to the slope segment lines except where bedrock forces the projected lower VAP line higher (segments A and D, and cross section 7).

The upper limit of vertical adjustment potential is taken as the top of the bank, and again the line approximately parallels the slope segment lines. Near the culvert inlet, the line is lower than the upper bank because backwater from the undersized culvert has caused the streambed to aggrade there. When the culvert is removed, the aggraded material is expected to erode and the streambed should stabilize at its natural, lower elevation.



### 5.3 PROJECT SITE RISK ASSESSMENT

Continuing to build on the initial assessment and the longitudinal profile analysis, assess all risks at the site. Use all available data and observations to interpret current project site conditions, predict potential channel changes, and identify significant risks that the design will have to deal with. Review the site suitability determination in light of your more in-depth understanding of the site.

Sometimes, design issues are associated with specific channel types (see table 5.7). For example, slightly entrenched channels have wide flood plains which can convey high flows during floods. Such road-stream crossings have risks associated with flood-plain constriction and **lateral channel migration**. Other risks can pertain to any channel type, depending on watershed and reach conditions.

#### 5.3.1 High Flood-plain Conveyance

When it occurs, high flood-plain conveyance (i.e., a high flow on the flood plain during floods) is an important factor affecting design. When flood-plain conveyance is high and overbank flow occurs frequently, it may be necessary to install other flood-plain drainage structures under or across the road. The objective is to avoid funneling overbank flows through the main crossing structure, which would destabilize the simulated streambed in the culvert. Alternatively, a bridge or viaduct could be considered as a replacement structure.

To determine whether high flood-plain conveyance is an important issue at the site, estimate the depths and velocity of recent overbank flows. Use observations of past flood elevations and flood-plain scour and deposition features (section 5.1.4.2), together with historical flood data. Flood-plain vegetation and erosional and depositional features observed during the cross-section surveys may indicate recent overbank flow depths and should give a qualitative indication of the frequency and intensity of overbank flows. The presence of flood swales or side channels, for example, indicates enough overbank flow to cause significant scour. These channels, which can convey large amounts of flow, also may be important refuge or juvenile habitat for aquatic species. Identify them as key locations for flood conveyance and, where appropriate, aquatic organism passage. Be sure to evaluate whether evidence of overflow on the flood plain upstream

# Stream Simulation

Table 5.7—Crossing design issues associated with specific channel characteristics.

CHANNEL CHARACTERISTIC	COMMON MAJOR ISSUES FOR CROSSING DESIGN	SPECIFIC RISKS	POSSIBLE DESIGN SOLUTIONS (SEE ALSO TABLE 6.7)
<i>High flood-plain conveyance, frequent overbank flow</i>	<p>Crossing may constrict flood-plain flow, increasing velocities through crossing structure.</p> <p>Road approach may block flow in flood plain, causing backwater ponding.</p>	<ul style="list-style-type: none"> <li>• Simulated bed may not be sustainable.</li> <li>• Depositional/erosional processes that maintain flood-plain habitats can be interrupted.</li> </ul>	<ul style="list-style-type: none"> <li>• Add overbank flow surfaces inside culvert.</li> <li>• Widen simulated channel.</li> <li>• Add flood-plain culverts and/or road dips for floodrelief and flow distribution.</li> <li>• Add flood-plain culverts or road dips.</li> <li>• Consider permeable roadfill (6.5.1.1).</li> </ul>
<i>Channel migrating laterally across valley floor</i>	<p>Alignment may change over time so that stream approaches inlet at a greater angle. Bank and roadfill erosion is progressive as alignment worsens.</p>	<ul style="list-style-type: none"> <li>• Increased probability of sediment/debris blockage at inlet.</li> <li>• Culvert capacity may be reduced due to aggradation or inlet energy losses.</li> <li>• Bed scour can occur in stream simulation culvert inlet.</li> </ul>	<ul style="list-style-type: none"> <li>• Relocate crossing.</li> <li>• Widen crossing structure.</li> <li>• Build inlet transition (6.1.1.4).</li> <li>• Build structure that can be moved in future.</li> </ul>
<i>Large elevation drop across existing structure caused by downstream incision</i>	<p>Preventing upstream incision requires over-steepening the structure's profile and/or adjacent reaches.</p> <p>Lowering the crossing to the level of the downstream channel may initiate a headcut moving upstream.</p>	<ul style="list-style-type: none"> <li>• Some aquatic species may not pass steepened crossing.</li> <li>• Simulated streambed may not be sustainable if upstream reach does not provide amount or size of sediment required.</li> <li>• Habitat loss or degradation upstream.</li> <li>• Upstream channel incision can isolate stream from flood plain.</li> <li>• Upstream channel incision can destabilize banks.</li> </ul>	<ul style="list-style-type: none"> <li>• Reconsider designed project profile (6.1.2.3).</li> <li>• Design steepened profile using appropriate permanent grade controls (Appendix B.2).</li> <li>• Restore incised channel to original grade.</li> <li>• Extend length of project to permit controlled incision upstream. Consider moderate-stability grade control structures upstream to control rate of headcut migration.</li> <li>• Restore downstream channel to original grade.</li> <li>• Mitigate specific risks.</li> </ul>
	<p>If channel is still incising, dimensions, elevation and grade may change over the structure lifetime.</p>	<ul style="list-style-type: none"> <li>• Crossing structure and/or grade control structures may become perched or fail.</li> </ul>	<ul style="list-style-type: none"> <li>• Wait to replace crossing structure until incision has stopped.</li> <li>• Size culvert (or foundation) to accommodate possible range of profiles (see section 5.2.2.2).</li> <li>• Add downstream grade controls to control incision (6.1.2.3).</li> <li>• Restore channel to original grade.</li> </ul>

Table 5.7—Crossing design issues associated with specific channel characteristics (continued).

CHANNEL CHARACTERISTIC	COMMON MAJOR ISSUES FOR CROSSING DESIGN	SPECIFIC RISKS	POSSIBLE DESIGN SOLUTIONS (SEE ALSO TABLE 6.7)
<p><i>Channels transporting high volumes of woody debris or sediment, or subject to debris flows</i></p>	<p>Crossing structure may plug and fail.</p>	<ul style="list-style-type: none"> <li>• Road and aquatic habitat damage.</li> <li>• Frequent maintenance may be needed.</li> <li>• Traffic interruptions may be long.</li> </ul>	<ul style="list-style-type: none"> <li>• Consider structures with removable tops for clean-out.</li> <li>• Harden approaches and fill for overtopping.</li> <li>• Prevent stream diversion if crossing is overtopped.</li> </ul>
<p><i>Concave transitions (6.1.2.2) including braided streams and alluvial fans</i></p>	<p>Channel may aggrade and/or shift location.</p>	<ul style="list-style-type: none"> <li>• Sediment deposition may reduce culvert capacity.</li> <li>• Debris may block inlet.</li> <li>• Stream may move across fan or valley away from culvert.</li> </ul>	<ul style="list-style-type: none"> <li>• Relocate crossing away from transition or alluvial fan.</li> <li>• Build structure that can be moved in future.</li> <li>• Use wider, higher crossing structure (e.g., bridge).</li> <li>• Adjust project profile to intermediate grade (section 6.2.2.2).</li> <li>• Avoid destabilizing steeper upstream reach during construction.</li> <li>• Size structure to accommodate vertical adjustment potential.</li> </ul>
<p><i>Convex transition (6.1.2.2)</i></p>	<p>Downstream bed may be destabilized during construction or during floods.</p>	<ul style="list-style-type: none"> <li>• Headcut moves upstream through culvert.</li> <li>• Habitat loss or degradation upstream.</li> <li>• Upstream channel incision can isolate stream from flood plain.</li> <li>• Upstream channel incision can destabilize banks.</li> <li>• Crossing structure and/or grade control structures may become perched or fail.</li> </ul>	<ul style="list-style-type: none"> <li>• Reevaluate vertical adjustment potential; consider lowering VAP line to accommodate risk of headcutting.</li> <li>• Construct new grade controls or reinforce natural controls.</li> <li>• Widen structure to avoid concentrated outflow.</li> </ul>

# Stream Simulation

Table 5.7—Crossing design issues associated with specific channel characteristics (continued).

CHANNEL CHARACTERISTIC	COMMON MAJOR ISSUES FOR CROSSING DESIGN	SPECIFIC RISKS	POSSIBLE DESIGN SOLUTIONS (SEE ALSO TABLE 6.7)
Channels with large key features (large wood, boulders) controlling slope and roughness (6.1.2.2)	Key features must be simulated inside the structure.	<ul style="list-style-type: none"> <li>Simulated key features are of different material (i.e., rock simulates logs) and may not function the same (eg., diversifying water velocity, retaining sediment).</li> <li>Simulated features may trap sediment and debris to form a dam.</li> </ul>	<ul style="list-style-type: none"> <li>Select materials and construct key features carefully.</li> <li>Use shorter, wider crossing structure.</li> </ul>
Bedrock	Key features (wood) may stabilize alluvial veneer over bedrock in reference reach.	<ul style="list-style-type: none"> <li>Alluvial veneer may not be self-sustainable in culvert without stable key features.</li> </ul>	<ul style="list-style-type: none"> <li>Span channel without disturbing streambed and banks.</li> <li>Construct fixed key features to retain alluvium.</li> </ul>
Cohesive material (silt/clay)	Bed construction inside pipe is not practical because silt/clay material cannot be moved and stabilized.	<ul style="list-style-type: none"> <li>Constructed bed (or no bed) may not simulate natural channel and aquatic species may not be able to move through.</li> </ul>	<ul style="list-style-type: none"> <li>Span channel without disturbing streambed and banks.</li> </ul>

of the road crossing might simply be the result of flow constriction at an existing undersized crossing. If so, a larger structure may be all that is needed to solve the problem.

Flood-plain observations will also help in selecting a roughness factor for flood-plain flow estimation, if you intend to use a model such as WinXSPRO or HEC-RAS.

### 5.3.2 Lateral Adjustment Potential and Alignment

On streams with a high potential for lateral channel migration, the channel's angle of approach to the crossing structure may become more acute over time. As described in appendix A, a poor alignment is an especially important risk factor in streams transporting woody debris. Evidence of past channel shifting (e.g., an acute angle of approach to the culvert inlet, bank erosion on one bank) can help in evaluating the risk to the replacement structure. Also consider factors, such as current bank stability (section 5.1.6.4), land use and vegetative condition, and probable future land use changes.

Understanding the natural channel's (pre-disturbance) pattern is essential for proper layout of a stream-simulation installation. Culverts shorten and steepen channels when they replace a bend. In the case of a stream-simulation culvert, such an increase in channel slope could put the simulated streambed at risk. Using the sketch map and field observations, try to detect the natural channel location and pattern. This would be the starting point for designing the replacement crossing alignment.

It is especially important to consider natural **channel pattern** where a crossing must be located on a meandering stream. Several options are described in section 6.1.1 for minimizing risk by keeping the crossing short, aligning it with the stream, and providing efficient transitions. Preview that section and consider the various alignment options (figure 6.4) while still in the field. Observations of bed and bank stability are vital in selecting the least damaging option. If a skewed culvert-to-channel alignment is being considered, bank materials and stability will determine whether bank stabilization measures are needed near the inlet or outlet. Where channel straightening cannot be avoided, the channel may respond by eroding either its banks or its bed. Try to predict likely channel responses to such changes by considering the relative resistance of bed and bank materials.

### 5.3.3 Headcutting Potential

Even in a uniform longitudinal profile, simply replacing an undersized culvert with a larger one set lower in elevation can cause the adjacent stream reaches to adjust. Sediment accumulated above the old culvert remobilizes, although usually the adjustment is not large enough to create a problem. Where the downstream reach has incised, however, headcutting upstream of the replacement structure (section 5.2.2.2) can be substantial enough to affect buried infrastructure, destabilize streambanks, modify aquatic habitats, etc. Decide whether to control such a headcut or allow it to progress upstream, considering the trade-offs between the extent and duration of impacts, versus the benefit of allowing the channel to evolve to a natural self-sustaining condition.

Deciding how to handle any expected headcutting requires answers to questions such as the following:

- How much headcutting is likely if no controls are implemented? How far upstream might it go?
- What effects will the expected headcut have on streambed and banks? How long will they last?
- Should headcutting be prevented?
- Should headcutting be allowed to occur at an uncontrolled rate?
- Should the rate of headcutting be slowed by temporary grade controls?

Before making these decisions, be aware of the types of effects headcuts can have. Bates (2003) identified the following physical, biological, and infrastructure issues for teams to consider when determining whether to control a headcut or allow it to occur.

#### Extent of headcut

The upstream distance that a headcut can travel depends on the stream slope, bed composition, sediment supply to the reach, and the presence of stable debris and/or large rock in the channel. The extent of headcutting is usually less in coarse-grained or debris-laden channels than in finer-bedded streams, because the headcut is more likely to encounter a stable grade control that prevents it from moving further upstream. A channel with a high supply of mobile bed material will reach equilibrium more rapidly than a channel with a low rate of sediment supply.

### Condition of upstream channel and banks

Where a reach has aggraded above an undersized culvert, the channel can stabilize and return to its natural condition after some headcutting occurs through the aggraded area. If the upstream banks are already marginally stable, however, the degrading channel can undermine and destabilize them.

### Habitat impacts of upstream channel incision

Allowing a large headcut to travel freely upstream can damage aquatic habitats. For example, a newly incised channel may be narrow and confined, with habitat diversity and stability reduced because the channel cannot access its flood plain during high flows. Although the channel may evolve back into its initial configuration (appendix A, figure A.28), substantial bank erosion and habitat instability may persist for a long time, up to a century in some cases (figure 5.18). Where bedrock is shallow, a headcut may expose it; and, if no debris or sediment structure is left, the stream will have difficulty trapping new sediments to recover habitat diversity and stability. Some bedrock (such as siltstone) is easily erodible once exposed. A headcut can also cause enough incision to leave side channels perched, inaccessible, or dry. Avoid headcuts in such areas. Restoring incised stream channels may require substantial channel reconstruction with wood and/or rock structures.



*Figure 5.18—Major channel instability occurring on the Homochitto River, MS. Bank erosion and widening follow channel incision on this fine-grained channel.*

## Stream Simulation

---

Wetlands have formed upstream of many undersized or perched culverts. Although artificial, these wetlands may perform important functions for the riparian ecosystem. Carefully consider their fate when replacing culverts.

### **Presence of fish or other organisms**

A headcut can pose a short-term risk of loss of organisms in the bed or pools just upstream of a culvert. The bed may scour at a lower flow than normal in a headcutting situation. Eggs and fry in the gravels may be lost.

### **Habitat impacts to downstream channel from sediment release**

The risk to downstream aquatic habitats depends on the volume and rate of sediment released by a headcut, as well as the transport capacity in downstream reaches. Downstream of large headcuts, not only will the total volume of sediment in transport increase, but sediment will move at lower flows until the upstream channel and banks have stabilized. Sediment deposition may occur in streambed areas not normally subject to deposition. Small headcuts may not pose much risk at all to downstream reaches in many steep mountain streams.

### **Decrease in culvert and channel capacity from initial slug of bed material**

Where bed material is mobile, allowing an uncontrolled headcut upstream of a culvert may result in mobilizing a slug of material during a single flow event. As this material moves through the culvert and the downstream channel, it can reduce the capacity of both. A loss of capacity can result in additional deposition and, in extreme cases, can fill the entire channel and plug the culvert.

Allow less headcutting where the culvert and/or channel have even a short-term risk of plugging by sediment and debris. Consider similar limitations where structures further downstream are at risk from a loss of channel capacity or where banks are at risk of erosion.

### **Proximity of upstream utilities and structures**

If a headcut is allowed to continue upstream, it can jeopardize structures in or beneath the channel or on the banks. Asking the utility company to visit the site and locate any lines is common practice. Be aware of the potential effects of increased bank erosion on structures near the channel.



### Potential for new fish passage barriers within the degraded channel

Consider the potential for channel incision to create barriers to passage of fish or other aquatic species. Buried logs, nonerodible materials, and infrastructure, such as buried pipelines, are commonly exposed by channel headcuts. As the channel headcuts to such a feature, the feature itself may become a new fish passage barrier. Adding to the difficulty, these problems may occur where they are not visible from the project site, where access is more difficult, or across a property boundary. In addition, upstream culverts could become perched, or, if they are embedded, their beds may wash out.

Readers may also want to consult Castro's 2003 discussion of headcutting considerations for the planning phase of a culvert replacement or removal project.

### 5.3.4 Debris

To determine whether woody debris poses a potential hazard to the crossing structure, evaluate the stability, size, and accumulation potential of wood in the project reach, especially upstream of the road crossing. Look for debris accumulations, and dead or undermined trees that could fall into the stream. Review the debris risk assessment in section 4.3, the key-feature summary in table 5.6, and include historical information. Ask the following questions:

- Is the crossing in a land type where floods transport large wood?
- Has the existing structure ever had problems with woody debris plugging?
- Are other nearby structures subject to plugging?
- How large is the wood in transport?
- What is the condition of wood in the reach? Is it durable, or fragile enough to break apart in transport?

To project future debris availability and stability, consider the long-term management plan in the watershed upstream of the crossing. Are debris inputs likely to change?

Where wood is an important structural component of the channel, also consider whether downstream channel conditions and stability depend on

## Stream Simulation

---

upstream woody debris inputs. If so, wood transport through the crossing structure may be critical to the long-term stability of the whole reach.

In general, stream-simulation culverts with good alignments tend to be large enough that debris passes freely through. However, difficulties might occur with large wood and rootwads in low-profile structures or where structures are poorly aligned with the stream.

### 5.3.5 Unstable Channels

If the channel is unstable (rapidly incising, aggrading, shifting laterally, etc. See **channel stability** in glossary), the design will have to deal with changing conditions as the stream evolves toward a new equilibrium. Any work performed in these situations must factor in both reach-scale and watershed-scale processes:

- What is the cause of the channel instability? Is it caused by local land-use activities? Higher peak flows, due to watershed development? Downstream channel incision? Sudden, large lateral movements? Extensive bank failures?
- What is the proximity and extent of channel instability in relation to the crossing?
- Are any restoration activities already planned for improving channel stability?
- What are the anticipated dimensions and configuration of the recovered channel? What is the time frame for recovery?

Where a channel has been recently disturbed by **mass wasting** events or extreme floods, consider leaving the road closed to allow time for the channel to adjust to the new conditions. If the road must be reopened, consider whether a channel restoration project is feasible, given watershed conditions and trends. If restoration is not feasible, the stream-simulation design approach may not work, and you might need to use an alternative design style (see appendix B).

If stream simulation is chosen, then it is important to estimate not only the vertical adjustment potential but also future channel dimensions and pattern. The uncertainty about channel change, as well as the unpredictability of future disturbances, can make this kind of prediction a very uncertain. Only a qualified and experienced team should perform the

site assessment and replacement structure design on an unstable channel—and, even then, the team should plan for maintenance.

### 5.4 DOCUMENT KEY DESIGN CONSIDERATIONS AND RECOMMENDATIONS

At this point, document the results of the site assessment by summarizing the project site characteristics listed below. See also the assessment checklist in appendix C.

Project reach characteristics and risks:

- Longitudinal profile; what key features control channel slope? How mobile are they?
- Downstream channel incision; is the crossing acting as grade control?
- Vertical adjustment potential.
- Bed material size and mobility.
- Bank materials, height, and stability.
- Variability in channel bankfull width; what controls differences in width?
- Potential for lateral channel shift and bank erosion.
- Estimate of bankfull and 100-year flows.
- Flood-plain conveyance; sites for flood-plain drainage structures.
- Flood-plain constriction potential.
- Geotechnical concerns: soft soils, bedrock, ground water.
- Key grade controls that anchor the longitudinal profile and that should not be disturbed in construction.
- Habitats requiring special protection in design and during construction.
- Site logistical constraints (property boundaries, infrastructure, etc.).
- Construction and maintenance access.
- Sensitive areas (to avoid during construction) in vicinity of crossing.
- Potential locations for construction equipment and materials storage.
- Construction recommendations: topsoil and vegetation salvage needs and opportunities, potential areas for dispersing and filtering sediment-laden water pumped from the excavation, etc.

## Stream Simulation

---

Also, document interpretations of important geomorphic processes that may affect the site, the new structure, and the feasibility of a stream-simulation design. How will the channel respond to the replacement or removal of the crossing? How should the channel and/or road be modified to accommodate a new structure? With this detailed understanding of the site, revisit the project objectives defined earlier, and develop them into specific design objectives. If stream simulation appears to be infeasible, consider other design methods (see appendix B). Site-specific design objectives might deal with some of the following topics:

- Need for alignment control.
- Need for grade controls outside the crossing.
- Need for channel restoration or habitat protection.
- Special sediment control or stabilization measures needed at road crossing or in stream.
- Characteristics needed for aquatic species passage.
- Characteristics needed for passage of semi-aquatic and terrestrial species.

A key task is to agree on the channel characteristics needed to achieve the desired degree of passage. For example, if weak-swimming species, amphibians, and small mammals that depend on channel margins for movement need to pass through the structure, the structure will need to be wide enough to maintain **banklines** or dry margins at low to moderate flows.

### 5.5 REFERENCE REACH: THE PATTERN FOR STREAM-SIMULATION DESIGN

The reference reach will not be finally selected until the project profile design is complete (see section 6.1). However, geomorphic data on one or more potential reference reaches are generally collected during the site assessment. For that reason, criteria for selecting a reference reach are discussed here, along with the additional data requirements.

The ideal reference reach represents the physical, hydrologic, and hydraulic characteristics of the channel that would be at the culvert site if the road did not exist. This ideal will not always be achieved because the reference reach depends on the project profile—the longitudinal profile of the stream simulation channel to be constructed. The project profile may have to differ from the natural channel slope for a number of reasons (section 6.1). Although the reference reach may not represent historical

or average conditions of the project reach, it must be within the range of variation found in the vicinity. Looking at the range of variability in slope, width, etc. in the project area can provide an idea of how far a stream segment can depart from average and still be stable in the system.

Slope is a primary criterion for selecting a reference reach because it drives sediment erosion, transport, and deposition. These processes, in turn, control sediment characteristics at a given location in the channel. Thus, the reference reach slope must be similar to the design slope through the crossing. However, keep in mind that the reference reach is simulated in its entirety; width, slope, length, channel shape, bed characteristics, and roughness are all included in the simulation. The reference reach also should be similar in cross-section dimensions and entrenchment to the reaches upstream and downstream of the crossing. It represents the channel that will reconnect those reaches without creating flow discontinuities.

The reference reach is a stable reach upstream or downstream from the crossing but always outside the influence of the existing structure. The factors that control channel dimensions (water discharge, sediment supply) in the reference reach must be similar to those that will control the simulation. At most sites, a reference reach can be identified close to the crossing, and the site data collected during the site assessment typically include a reach suitable for use as a reference. Occasionally, the most suitable reference reach may be some distance from the crossing site. There is no problem with this, so long as flow and **sediment regimes** are very similar. The reference reach should not be separated from the crossing by a major tributary junction, sediment source, or sediment sink.

The following considerations go into selecting a reference reach:

- The reference reach should be out of the area of influence of the existing crossing. Generally, it is upstream of the crossing to avoid any downstream channel changes the crossing may have caused. However, it can also be downstream if crossing effects are localized, and channel dimensions and slope are more appropriate to simulate at the crossing.
- The reference reach channel slope should be similar to the project profile slope through the road-stream crossing. Before selecting a final reference reach, determine the alignment and profile for the crossing project (section 6.1).
- Cross-section dimensions in the reference reach should be similar to the reaches near crossing. Entrenchment also should be similar.

## Stream Simulation

---

- Flow and sediment regimes at the reference reach should be similar to those at the crossing. No major tributary junctions or sediment sources should be between the reference reach and the crossing. The reference-reach bed material must be similar in size and mobility to the reach upstream of the crossing that will supply sediment to the stream-simulation channel.
- The length of the reference reach should be at least as long as the road-stream crossing structure.
- Determine the stability of both the reference reach and project reach. The reference-reach approach for channel design applies only to relatively stable channels.
- Where possible, avoid selecting a highly sinuous reference reach. A good method for testing the feasibility of using a particular reach as a reference reach is to visualize it enclosed in a culvert. Consider the characteristics that cannot be simulated, and whether they might compromise the simulation.
- Consider the distribution of channel units upstream and downstream from the road-stream crossing. For example, pool locations and spacing may dictate that the simulated channel include a run or pool. The reference reach should include those channel units.

At new crossings, the undisturbed natural channel at the site is the reference reach. Ideally, you would build the crossing over the stream without disturbing it.

Where the site has a concave- or convex-profile shape, it may be necessary to measure possible reference reaches upstream and downstream of the crossing. Near grade breaks, a common method of reconnecting the two different slope segments is by constructing an intermediate-gradient transition inside the pipe. Elements of both upstream and downstream reaches may be incorporated in the design (see for example figure 6.8). Theoretically, a similar transition reach on another nearby stream could be used as the reference reach, but it is relatively uncommon to find streams and watersheds that are that comparable.

If a long reach outside the new structure will be regraded, conduct the reference-reach survey more carefully than in simpler cases. In this case, the data will have to support design of not only the simulated streambed inside the crossing structure, but also a channel-reconstruction project.

In the reconstructed reach outside of the road-stream crossing, features typically not built inside a structure (such as soil banks, planform characteristics, and large-wood grade controls) will be constructed and stabilized.

If the stream channel in the crossing vicinity has been recently disturbed, it is likely to be in a state of flux, evolving toward an equilibrium shape and grade. If the road can remain closed for an extended period, wait to construct the crossing until the stream reestablishes some measure of stability. Otherwise, you may be able to find a reference reach upstream of the disturbance.

For streams undergoing regional channel incision, if the headcut will be allowed to progress upstream through the crossing site, use downstream reaches that have already stabilized as the reference reach. Accommodate changes expected as the channel evolves (see appendix A, section A.7.2). If the crossing will be retained as a grade control, select a reference reach that has a gradient similar to the simulated-streambed design gradient.

The incised channel is one possible situation where the channel through the crossing may have a steeper grade than the adjacent reaches. Project objectives (e.g., avoid channel incision upstream, preserve wetland habitat above crossing) or constraints (e.g., rights-of-way, property boundaries) may dictate the steeper grade. In cases like these, achieving stream simulation may or may not be possible, depending on whether reference reaches at the necessary grade exist. Until better information becomes available about how much of a difference is sustainable, a reasonable guideline is to keep the simulated channel within 25 percent of the slope of the reference reach.

If the immediate area clearly cannot provide a reference reach, be sure you understand why not. If the reason is that the channel is highly unstable or the reach has characteristics like tortuous meanders that cannot be simulated inside a crossing structure, reconsider whether the crossing location is a good one. If the crossing cannot be moved, stream simulation may not be an appropriate design strategy.

## Stream Simulation

---

Where no appropriate reference reach exists close to the road-stream crossing, it is occasionally possible to find a reach with similar discharge, slope, streambed materials, and channel type elsewhere in the same watershed or a nearby watershed. Use great care here. Species inhabiting the project reach must be able to negotiate the transposed channel. Also, this kind of transfer may not result in a sustainable simulation because of the differences in particle size or amount of sediment input from the upstream reach. In cases when data is transferred from a reach with a different drainage area from the project site, a regional relationship between drainage area and bankfull width and depth may allow you to size the simulated channel correctly. Refer to Rosgen (1994, 1996) for procedures on scaling channel dimensions from regional relationships between channel dimensions and drainage area. However, again, be aware that, in this situation, sediment availability could be quite different, and the reach upstream of the simulated channel may not be able to supply the size and amount of sediment that the steeper reach needs for long-term sustainability. If long-term streambed sustainability appears unlikely, stream simulation may not be feasible, and you may have to settle for a hybrid or other design strategy (see appendix B).

### 5.5.1 Reference Reach Data Required for Stream Simulation Design

Assuming that the reference reach is included in the longitudinal profile already surveyed, most or all of the data needed for design may already be in hand. Additional data collection and analysis of the longitudinal profile, cross sections, and other survey data may be needed to define the following reference-reach characteristics.

- Residual pool depth (figure 5.19). Average residual pool depth is used in stream simulation design to determine how deeply to embed a full-bottom culvert, and it is considered in decisions about how deep to construct foundations for an open-bottom structure. Pools formed by unusual controls that would not be simulated in a culvert (debris jams, large logs, large boulders) should not be included here.
- Size, spacing, height, and mobility of grade controls and other key features (figure 5.19).
- Bed material size distribution, degree of armoring (see section 5.2.1).
- Bankfull channel dimensions: depth, width, and width variability.
- Bank or channel margin structure and diversity.



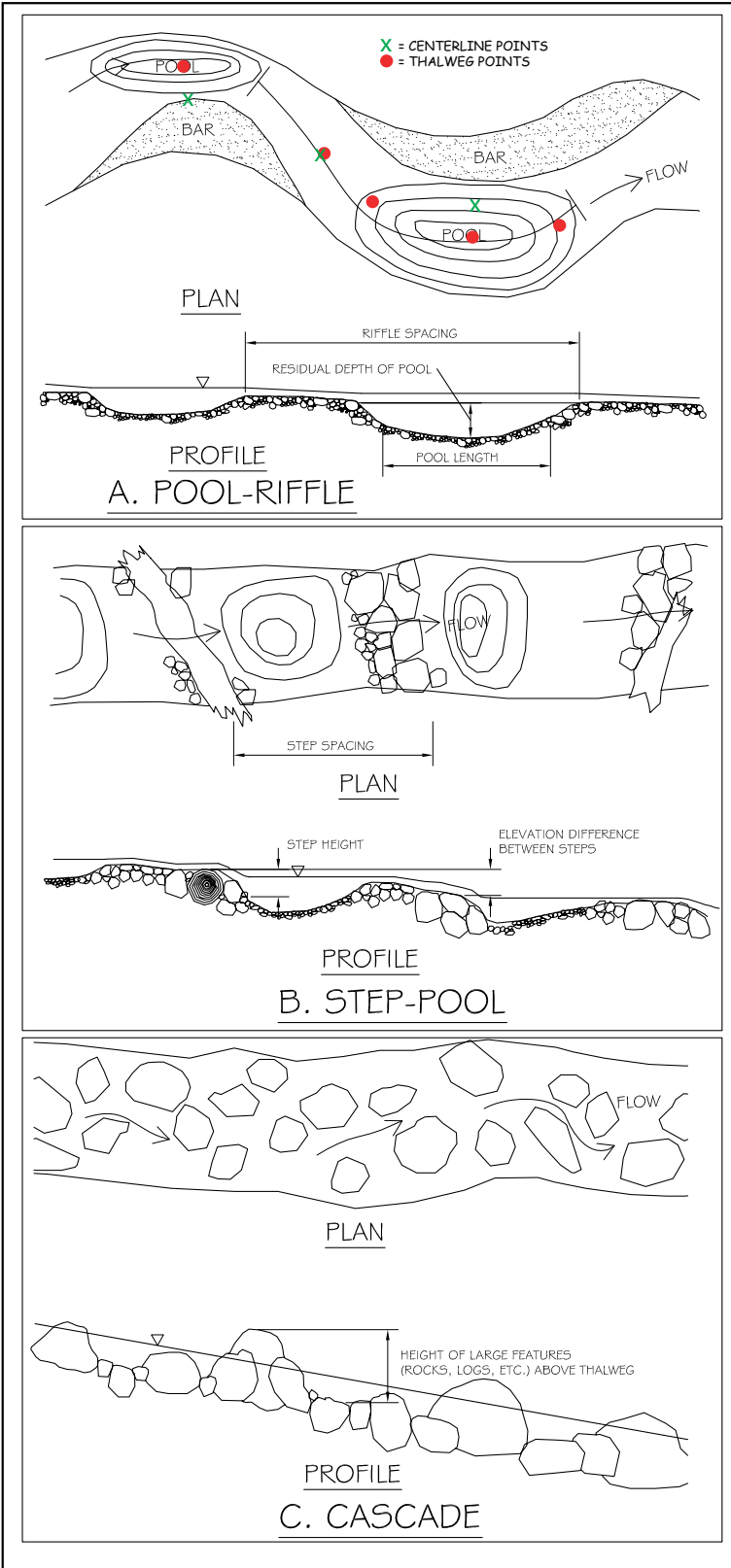

Figure 5.19—Some reference reach longitudinal profile measurements.

# Stream Simulation

---

## Steps and Considerations in the Stream-simulation Design

### **Determine project alignment and profile**

- Crossing alignment relative to road and channel.
- Lateral channel adjustment potential.
- Vertical adjustment potential.
- Upstream and downstream project profile control points.

### **Verify reference reach and stream simulation feasibility**

- Reference reach slope similar to project profile.
- Reference reach length similar to crossing structure.
- Reference reach bed characteristics, and water and sediment inputs similar to crossing site.

### **Design bed material size and arrangement**

- Bed mix particle size gradation.
- Bank rock size and placement.
- Key feature rock sizes and placement (clusters, bars, steps, etc.).

### **Select structure size and elevation**

- Channel bankfull width including margins.
- Range of possible streambed profiles (vertical adjustment potential)
- Flood and woody debris capacity.
- Largest rock sizes in bed.
- Results of bed mobility analysis.

### **Verify stability of simulated streambed inside structure**

- Bed mobility similar to reference reach and upstream reach.
- Key features stable during high bed design flow.

### **Document design decisions and assumptions**

## **RESULTS**

### **Sketches or descriptions of project elements**

- Simulated streambed longitudinal profile, cross section dimensions.

### **Grade controls, bank stabilization measures, etc. in upstream and downstream channel segments**

### **Stream-simulation bed material gradation**

### **Bed material placement including banks, edges, overbank flow surface**

### **Flood-plain drainage structures**

### **Crossing structure dimensions and invert elevation**

*Figure 6.1—Steps and considerations in the stream-simulation design.*

## Chapter 6—Stream-Simulation Design

---

In this phase of the project, the team integrates the information from the watershed and site assessments and designs the streambed through the crossing—the stream-simulation channel. The crossing structure is then designed to fit around the stream-simulation channel. The design process is not linear: as design decisions are made, previous steps may have to be repeated to include or compensate for changes that affect their results. Whoever takes the lead in this phase should ensure that all team members continue to be involved as needed. Issues relevant to all fields (biology, hydrology, geomorphology, engineering, construction) may arise in this phase of the project.

Match the level of care in design to the risks at the site. If the site is prone to channel change or if the consequences of failure would be severe, recheck assumptions, use multiple methods to estimate stability, be more careful with stabilization outside the crossing structure, get help from experienced designers, etc.

### 6.1 PROJECT ALIGNMENT AND PROFILE

The first step in stream-simulation design—as with any crossing design project—is to establish the project layout in three dimensions, including:

- The two-dimensional plan view that connects the upstream and downstream channels through the crossing.
- The streambed longitudinal profile that connects stable points upstream and downstream of the crossing.

The longitudinal profile and the plan view must be considered together because they are interdependent. When a culvert straightens the natural channel, as most culverts do, it also shortens and steepens the channel, increasing the velocity and energy of flow through the culvert. Figure 6.2 shows how straightening a channel reduces its length and increases its gradient.

The first step in designing the project layout is to understand the natural channel location and pattern through the crossing area. There may be various types of evidence: sometimes the natural pattern is obvious from a plan map; sometimes the site survey produces clues about a previous channel location, such as an **abandoned channel** segment. A relocated or realigned channel may have eroded one bank near the existing culvert inlet as it tried to reestablish its natural pattern, or it may have incised in response to straightening. Understanding the natural **channel pattern** helps explain how the existing culvert affected both stream length and slope. Try to formulate different layout options that approximate the natural pattern so that the replacement culvert conforms better to the natural channel.

## Stream Simulation

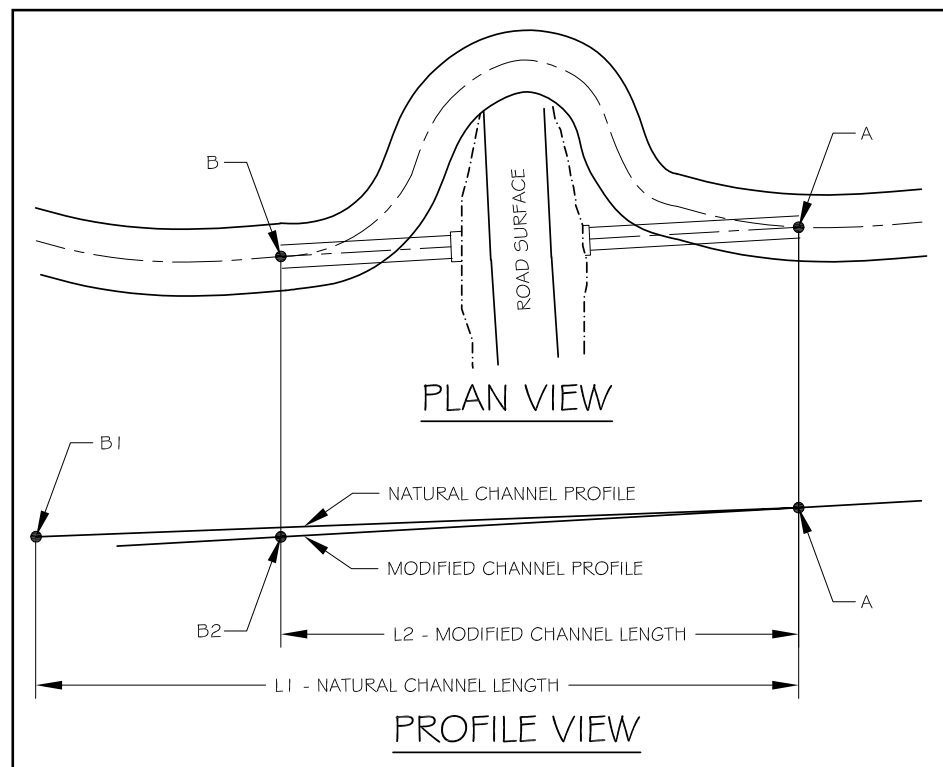

Figure 6.2—Cutting off a bend results in channel length and slope changes.

Ideally, the project layout approximates the natural channel pattern and slope at the site. The simplest situations occur where the crossing is a new installation and/or the road crosses perpendicular to a stable, uniform stream channel. In such cases, the existing channel defines the project layout and profile. For more complex sites, evaluate the tradeoffs associated with the issues discussed in sections 6.1.1 and 6.1.2. It may be worthwhile to compare the pros and cons of a number of different profiles and alignments to find the best combination.

### 6.1.1. Alignment

Culvert alignment is the orientation of the culvert structure relative to both the road and the stream channel. If the road crosses a straight uniform channel at right angles, the upstream and downstream channel reaches can be easily connected through a straight crossing. Alignments, however, are often not this simple.

## Chapter 6—Stream-Simulation Design

---

A crossing that best maintains ecological connectivity over the long term has a channel cross-section area, slope, and streambed similar to that of the upstream channel, and does not disrupt the natural channel pattern.

Poor structure alignment with respect to the stream (skew) is a perennial source of problems. Over 90 percent of culvert failures studied after the 1995–96 floods in the Pacific Northwest resulted from debris plugging and sediment accumulations attributable in part to poor alignment (Furniss et al. 1998). Pieces of wood may rotate as they approach a skewed culvert, increasing their likelihood of lodging at the inlet. Energy losses due to the channel bend at a skewed inlet mean that backwatering and sediment deposition frequently occur upstream (even if the inlet is not plugged). Local bed scour inside the culvert inlet is a common problem caused by the inlet contraction or because flow is focused to one side. A skewed inlet or outlet can also cause severe bank erosion outside the culvert by directing the flow at erodible banks. Because all of these risks are associated with high flows, visualize the flow patterns at high flows when considering alignment.

The relationship between the **radius of curvature** ( $R_c$ ) of the upstream bend and **bankfull** width is an indicator of the level of risk posed by a skewed alignment (refer to figure 6.6). When  $R_c$  is greater than 5 times bankfull width, sediment and debris transport are essentially the same as on a straight channel. As  $R_c$  decreases, the risk of affecting sediment and debris transport increases and when  $R_c$  is less than twice bankfull width, the risk of impeding sediment and debris transport is substantial. More flow is forced to the outside of the bend, and large eddies form on the inside of the bend, impeding flow and reducing the effective width of the channel (Bagnold 1960; Leopold et al. 1964). Figure 6.6 shows a skewed culvert where the radius of curvature is well within the danger zone.

Aligning a properly sized structure parallel to the upstream channel minimizes the risk of backwatering, sediment deposition, debris blockage, and capacity exceedence for that structure. However, aligning the crossing structure with the channel often results in a skewed alignment relative to the road, which can require a longer structure and/or the installation of headwalls.

## Stream Simulation

---

### 6.1.1.1. Risks of longer culverts

Longer culverts are less forgiving of erroneous design assumptions or construction inadequacies. The longer the structure, the higher the risk that hydraulic energy is not adequately dissipated within the culvert. The length of the crossing structure should not be longer than the **reference reach** (section 5.5). When a culvert would exceed the length of the reference reach, consider alternative structures, such as bridges.

One hazard of longer culverts in meandering streams is that they are more likely to cutoff channel bends and steepen the channel (figure 6.2), increasing the risk of streambed instability inside the culvert.

In steep channels, which are usually straighter than flatter ones, channel straightening is less of a risk. However, steep channels often have jutting banks, debris jams, large exposed rootwads, and abrupt bends, all of which add **roughness** and dissipate energy. Take care, when designing long culverts on steep streams, to ensure that energy is adequately dissipated. Otherwise, the streambed may wash out of the culvert.

Always consider minimizing structure length to manage risk. In some locations, shifting the road location to avoid a bend can be a solution. You can also shorten structures by:

- Adding retaining walls and/or wingwalls: in some cases, this adds cost to the project.
- Lowering the road elevation to reduce the width of the roadfill.
- Steepening the embankment: on high volume roads, required additional safety measures may increase cost.

Increasing structure width can partially mitigate the risks associated with long culverts. A wider culvert permits more lateral variability in the channel and provides space for **overbank flows** inside the structure. Space will also be available inside the wider culvert for replicating reference channel roughness by placing large rocks as roughness elements.

There is no universal rule about which is better: a longer culvert with a good alignment relative to the stream, or a shorter crossing with a poor alignment. Do not reduce culvert length by realigning the channel to be normal to the road without first evaluating the tradeoffs associated with the poorer alignment relative to the stream. One of the tradeoffs is a higher risk of debris-plugging; however, stream simulation culverts are less subject to debris-plugging because they are as wide as the natural stream channel. If a site has easy access for maintenance, the benefit of a shorter

## Chapter 6—Stream-Simulation Design

skewed culvert may outweigh that of the better-aligned but longer one. These decisions are highly site specific.

### 6.1.1.2. Channels skewed to the road

One common alignment challenge is shown in figure 6.3, where the road is aligned at an acute angle to the stream. Three alignment options for this situation are:

- (a) Matching culvert alignment to stream alignment.
- (b) Realigning the stream to minimize culvert length.
- (c) Widening and/or shortening the culvert.

A project can combine elements of all three options. Other possible approaches include relocating the road to a better stream alignment or building a bridge with a wider span.

Of the options above, (b) entails the greatest risk. The risks listed in table 6.1 should be evaluated and compared for projects where the road crosses the stream on a strongly skewed alignment. Minor skews are not likely to have important effects on the stream. The effects and impacts listed in table 6.1 are general, and may not apply to all situations.

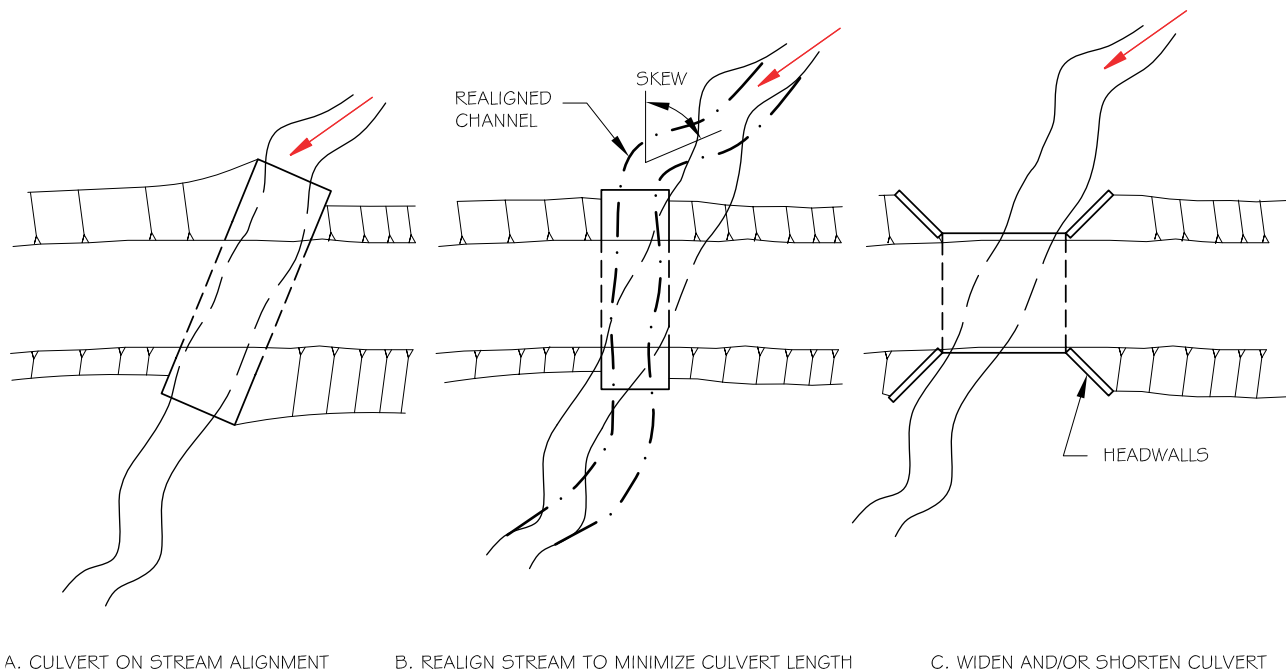

Figure 6.3—Three alignment options for a culvert where the road crosses the stream at an acute angle (high road-to-channel skew).

# Stream Simulation

Table 6.1—Comparison of alignment options, attributes, and associated effects for road crossings acutely skewed relative to the stream channel

Alignment Option	Attributes	Associated Effects and Comparison of Options
a. Crossing on stream alignment	Inlet and outlet match channel alignment.	<ul style="list-style-type: none"> <li>● Risk of debris and/or sediment blockage is low.</li> </ul>
	Culvert is long.	<ul style="list-style-type: none"> <li>● Permanent direct loss of aquatic habitat is highest.</li> <li>● Risk of bedform failure in the simulated channel and loss of aquatic organism passage is higher than in shorter culverts</li> </ul>
	Culvert is skewed to road.	<ul style="list-style-type: none"> <li>● Special design and construction methods may be required.</li> </ul>
	Inlet is skewed to channel.	<ul style="list-style-type: none"> <li>● Probability of blockage by debris and sediment is greatest.</li> <li>● Passage of aquatic organisms may be blocked at times.</li> <li>● Risk of culvert failure is greatest.</li> </ul>
b. Realign channel	Channel, riparian area and banks are disturbed.	<ul style="list-style-type: none"> <li>● Riparian area is removed, and habitat impacted.</li> <li>● Newly constructed and/or oversteepened banks are less stable and risks of bank failure or erosion are higher.</li> <li>● Realignment may extend beyond right-of-way.</li> </ul>
	Channel grade is flattened due to added length.	<ul style="list-style-type: none"> <li>● Risk of upstream aggradation is increased.</li> <li>● Need for maintenance to remove sediment is increased.</li> </ul>
	Outlet may be skewed to channel.	<ul style="list-style-type: none"> <li>● Risk of bank erosion downstream is greatest.</li> </ul>
	Inlet and outlet match channel alignment.	<ul style="list-style-type: none"> <li>● Risk of debris and/or sediment blockage or plugging is low.</li> </ul>
c. Widen and/or shorten culvert	Open area is large.	<ul style="list-style-type: none"> <li>● Culvert capacity is greatest; lowest risk of culvert failure.</li> <li>● Risk of failure due to debris blockage or plugging is lowest.</li> <li>● Opportunities for passage of aquatic and terrestrial organisms are greatest.</li> </ul>
	Construction duration may be long.	<ul style="list-style-type: none"> <li>● Risk of construction activity detrimentally affecting wildlife is greatest.</li> <li>● Road closure is required for longer time.</li> <li>● Project may be most expensive.</li> </ul>
	Channel area covered by project is small.	<ul style="list-style-type: none"> <li>● Permanent direct habitat loss is least.</li> </ul>



### 6.1.1.3. Culvert on a bend

Another common alignment problem arises where the crossing is located at a bend in the channel (figure 6.4). Where road relocation is not feasible, the same three options pertain: matching channel alignment, realigning the stream, and widening and/or shortening the culvert.

None of these options necessarily stands alone. The best solution might be optimizing a combination of skew, culvert length, and culvert width changes. Table 6.2 lists attributes and effects of each channel-bend option.

Consider how far the channel is likely to migrate laterally during the life of the project (sections 4.4 and 5.3.2). Options for accommodating expected changes include the following:

- Widen the culvert and offset it in the direction of meander movement.
- Control meander shift at the inlet with appropriate bank stabilization measures or training structures, such as rock weirs or J-hook vanes.

If banklines are constructed within the culvert, the rocks on the outside bank (the bank in the direction of channel shift) will be exposed to higher shear stresses and might therefore need to be bigger than bank rocks in other locations (see section 6.4.2).

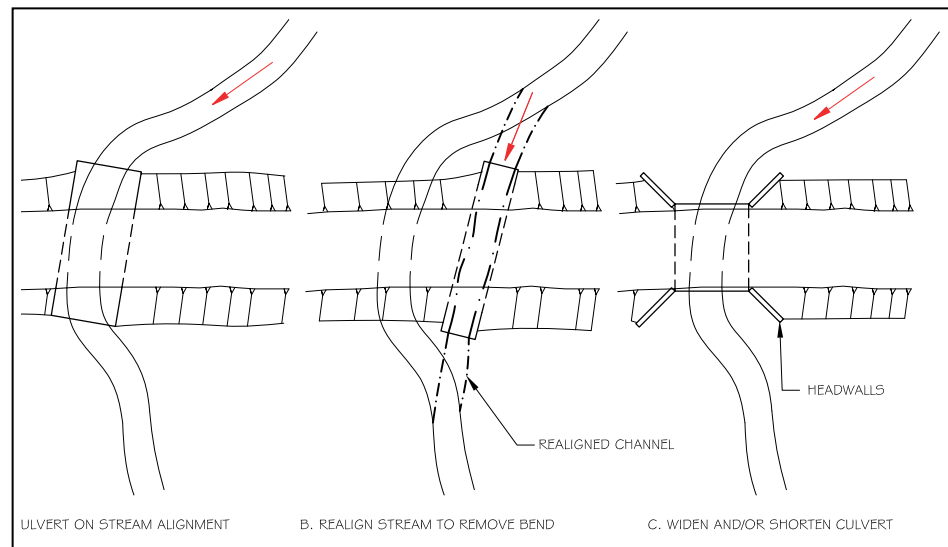

Figure 6.4—Three alignment options for a culvert on a channel bend.

# Stream Simulation

Table 6. 2—Comparison of alignment options, attributes, and associated effects for a road crossing on a channel bend

Alignment Option	Attribute	Associated Effects and Comparison of Options
a. Crossing on stream alignment	Bend location results in skewed outlet.	<ul style="list-style-type: none"> <li>● Risk of bank erosion downstream is higher.</li> </ul>
	Bend location results in skewed inlet.	<ul style="list-style-type: none"> <li>● Risk of upstream sediment deposition and debris blockage increased over straight alignment.</li> <li>● Likelihood of bank erosion upstream increased.</li> </ul>
	Channel bends in culvert.	<ul style="list-style-type: none"> <li>● Natural bend characteristics (increased shear on outside of bend, pool, point bar) may not be feasible in a culvert.</li> </ul>
b. Realign channel	Disturbance to channel, banks, and riparian area.	<ul style="list-style-type: none"> <li>● Riparian area is removed and habitat impacted.</li> <li>● Channel realignment is excavated through high ground leaving bank slopes vulnerable to erosion or failure.</li> </ul>
	Inlet and outlet match channel alignment.	<ul style="list-style-type: none"> <li>● Risk of debris and/or sediment blockage is low.</li> </ul>
	Channel is shortened and steepened.	<ul style="list-style-type: none"> <li>● Risk of bedform failure in the structure is higher.</li> <li>● Risk of upstream headcutting is higher than other options.</li> <li>● Realignment may extend project beyond right-of-way.</li> </ul>
c. Widen and/or shorten culvert	Culvert length is short, open area is large.	<ul style="list-style-type: none"> <li>● Hydraulic capacity is greatest.</li> <li>● Risk of culvert failure is least.</li> <li>● Risk of passage obstruction and culvert failure due to debris blockage or plugging is least.</li> <li>● Opportunities for passage of aquatic and terrestrial organisms are greatest.</li> </ul>
	Construction duration may be long.	<ul style="list-style-type: none"> <li>● Risk of detrimental effects due to construction is greatest.</li> <li>● Road closure is required for longer time.</li> <li>● Project may be most expensive.</li> </ul>
	Channel area covered by project is low.	<ul style="list-style-type: none"> <li>● Permanent direct habitat loss is least.</li> </ul>

## Chapter 6—Stream-Simulation Design

For long pipes on bends, a curved pipe offers an alternative solution. A curved pipe is a series of culvert sections formed into a bend that preserves the inlet and outlet channel alignments, as well as channel length and slope (figure 6.5). Curved pipes might be useful, for example, in incised channels where alignment cannot be changed, or where property boundaries limit alignment options. They require special culvert design, special product, and careful construction. The simulated streambed should have the characteristics associated with a bend of similar radius of curvature. For example, the design might anticipate the formation of a pool at the apex of the bend and include a higher bank there.



*Figure 6.5—Curved concrete pipe installation at Arrington Development, Durham, North Carolina, June 2001. (Pipe is 142 feet long, with a 24-foot span and a 7-foot rise.) Courtesy of CON/SPAN Bridge Systems.*

Many projects require comparing the relative merits of a longer versus a steeper culvert, or a poor channel-to-culvert alignment versus a channel realignment. See section 6.1.4 for an example from the Tongass National Forest where all these alternatives were considered.

### 6.1.1.4. Transitions

Transitions into and out of the culvert are important, especially if the alignment is not ideal. A good transition can smooth an abrupt change of flow direction. It can also eliminate poor inlet conditions caused by a previous pipe; for example, the wedge of sediment deposited upstream of an undersized culvert might be removed, and the widened channel might be restored to its normal width. Design the transition by contouring the banklines smoothly, beginning at the natural streambank upstream,

## Stream Simulation

continuing through the section to be modified by the project, and into the crossing (figure 6.6).

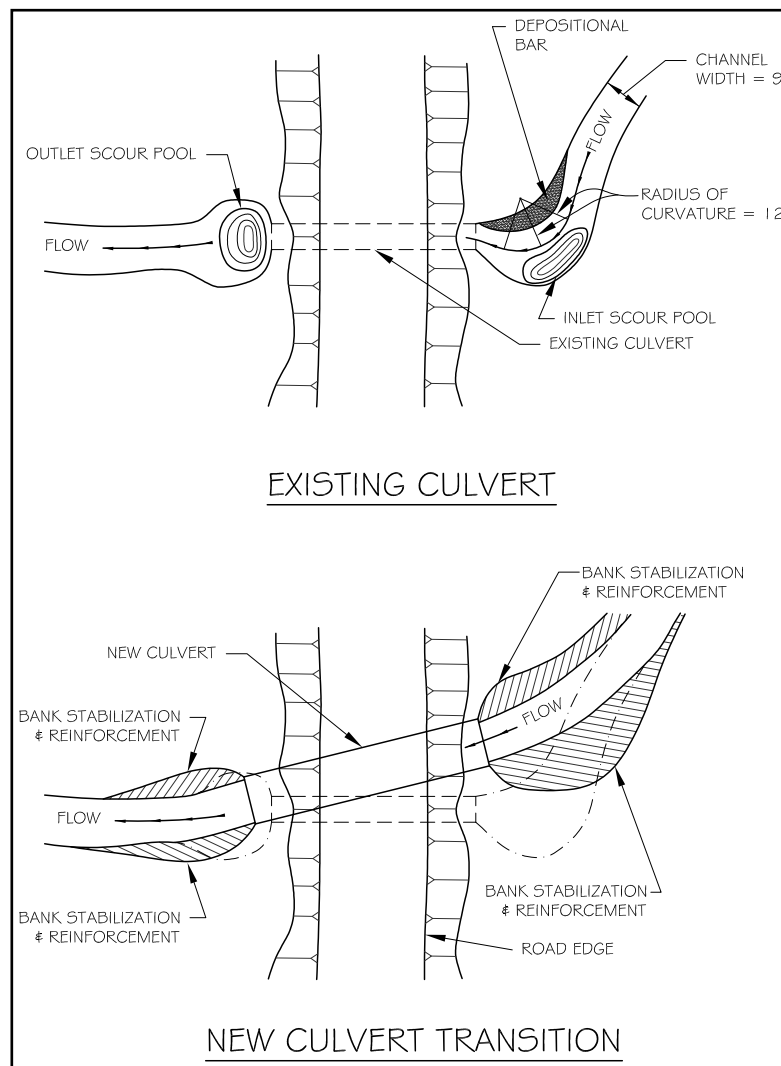

*Figure 6.6—Channel bend upstream of existing culvert has a radius of curvature less than two times bankfull width ( $R_{c/w} = 1.3$ ), with serious potential to obstruct sediment and woody debris. New culvert is realigned, and banklines are excavated and reinforced to create smooth transitions at inlet and outlet.*

If the stream must make a turn into the inlet, the bend should be no sharper than bends in the natural channel, so that debris that moves in the channel will also move through the structure. Visualize the bend during high flow when most debris will be moving.

A poor transition will exacerbate all of the alignment risks that the previous section described. For example, where a channel widens

## Chapter 6—Stream-Simulation Design

---

immediately upstream of the culvert inlet (as in basins excavated during road maintenance), the wider basin causes pieces of floating wood to swing perpendicular to the channel and plug the culvert inlet. The wider cross section also reduces the shear stress exerted by flow, thereby reducing sediment-transport capacity per unit of channel width. As a consequence, both woody debris and sediment tend to accumulate (Furniss et al. 1998).

On the other hand, a replacement culvert that is much wider than the existing one may direct water against streambanks that have encroached into the stream channel below the previous narrow culvert. Consider the possible effects of bank erosion, and transition the culvert bed and/or banks into the natural streambanks to minimize erosion risk. Banklines built within a stream-simulation culvert should be continuous with the upstream- and downstream-channel banklines. Rebuilding eroded banks around an outlet scour pool, such as in figure 6.6, usually requires filling the pool.

A good way to evaluate transitions is to compare the cross section of the **simulated channel** with the natural channel upstream and downstream from the crossing. The geometry and dimensions of the adjacent cross sections should be similar to one another.

### 6.1.2. Designing the Project Longitudinal Profile

The project profile represents the surface of the streambed that will be constructed through the project reach to connect the upstream and downstream channel profiles. It corresponds to the slope segments discussed in section 5.2.2, which connect the **grade controls** in the natural channel. At new culvert installations where the road alignment is perpendicular to the stream, the existing channel longitudinal profile *is* the project profile. The project-profile analysis is one of the most critical elements in a stream-simulation design, whether the project is a new crossing, a replacement, or a crossing removal. A good project-profile analysis ensures that the new structure will accommodate expected future vertical streambed adjustment.

The scale of any channel adjustment problem caused by the previous culvert determines the scale of the solution. The project profile can be short if no large scale vertical adjustment is anticipated, such as where nearby stable steps or bedrock outcrops anchor the ends of the profile. The project profile will be longer where upstream aggradation and downstream

## Stream Simulation

---

incision at an undersized culvert create a large elevation drop. The profile will be longer still if large-scale downstream channel incision has occurred. In this case, connecting the upstream and downstream channels requires dealing with potential upstream headcutting (and/or downstream channel rehabilitation) over a longer stream reach.

Designing the project profile involves the following steps.

1. Identify stable endpoints for the project profile.

Select stable grade control features upstream and downstream of the crossing that will anchor each end of the project profile. They should be stable enough that they will not be affected by removal of the existing crossing structure. Profile endpoints might be bedrock outcrops or highly stable steps, riffle crests, debris accumulations (e.g., large, well-embedded logs), etc. Several features may be good candidates for stable endpoints, and you might evaluate various project profiles using different combinations of endpoints. In this context, ‘stable’ means the bedform will last as long as the structure lifetime. It does not necessarily have to be permanently immobile. The cobbles on a high-stability riffle crest (table 5.3), for example, may mobilize in the 10- or 25-year flood, but the riffle crest itself will remain at or very near its current location and elevation if the channel is stable.

If the downstream channel is incised, the lower VAP line (section 5.2.2.2) indicates the length and depth of potential channel incision upstream. Most alluvial bedforms higher than the lower VAP line would not be expected to constitute stable endpoints in this case. If you decide to allow a headcut to progress through the crossing, the upstream project profile endpoint would need to be upstream of the projected extent of incision. Alternatively, if you decide to maintain the crossing as a grade control, you may need to construct permanent grade control structures as the project profile endpoints (see section 6.1.3).

2. Delineate possible project profiles.

Draw one or more tentative project profiles between sets of control points to connect the upstream and downstream segments across the crossing. The project profile should extend at least as far upstream and downstream as the new culvert installation could directly affect the channel. The profile does not show bed topography, only the elevation and slope of the streambed that will be constructed (see figure 6.7 for an example). Calculate slope and length of the profile options.

## Chapter 6—Stream-Simulation Design

---

The best project profile is a uniform one beginning and ending on stable bedforms. However, some project profiles may have two segments with different grades. Sites with convex or concave profiles, for example, might have more than one segment. In these cases, we recommend the slope break be outside the culvert. The incised channel solution in figure 6.10 (c) is an example of a project profile in two segments. The same type of segmented project profile, with the steeper section constructed outside the culvert, could be used at any site where the elevation change exceeds the slope of available reference reaches and where the adjacent natural channel is stable enough to sustain the transition.

### 3. Verify the reference reach.

After identifying one or more good project-profile options, recheck the reference reach tentatively identified during the site assessment (section 5.5). Determine whether it adequately represents the preferred slope. The reference reach should be straight, and as long as the crossing structure. Ideally the reference reach should also be as long as the project profile, but this is not always feasible on meandering streams or where wood is a frequent bed feature. If the tentative reference reach does not match the desired project profile, evaluate other slope segments in the site survey (section 5.2.2) as a possible reference reach.

If the site assessment survey did not include a reach as long as the project profile and within 25 percent of its slope, revisit the site to see if the natural channel includes reaches closer to your needs. If not, consider controlling the project profile to more closely fit an available reference reach (section 6.1.2.5). This need commonly arises when (1) there has been a large amount of aggradation upstream and deep local scour downstream of an undersized crossing or, (2) the downstream channel has incised and the existing culvert is acting as a grade control to prevent upstream headcut migration, or (3) the natural channel profile is concave, convex, or complex.

If profile modification will not work, the remaining options for crossing design are to:

- Use a hydraulic or hybrid design method to achieve partial passage (see appendix B) or,
- Locate a reference reach on a different channel that has similar landscape characteristics: valley type, streambed materials, watershed size, hydrologic regime, etc. This option has strong limitations (see section 5.5).

## Stream Simulation

---

### 4. Adjust VAP lines if necessary.

Where the project profile will be controlled by permanent grade control structures, the VAP lines may require adjustment to correspond with the project profile and reference reach. Examples are shown in figures 6.10b and 6.10c, which show an incised-channel site where the project profile will be controlled to avoid headcutting upstream of the replacement culvert. The lower VAP line in and upstream of the culvert is adjusted upward since the constructed grade controls will stop the progress of incision.

### 5. Locate key bed features.

Based on the reference reach, determine the spacing, height, and location of any bedforms that need to be constructed. Bedforms are generally spaced based on average spacing in the reference reach. Tying them into the endpoint bedforms, however, sometimes requires varying bedform spacing. Meander bends, which control pool locations, must also be considered when locating the bedforms in the project reach. The average spacing may need to be varied to locate the pool appropriately in relation to the bend. Limit the variability in spacing to the range found in the reference reach.

The following sections describe project profile delineation on various channel profile types.

### **6.1.2.1 Uniform channels with local scour and fill around an undersized culvert**

In uncomplicated channels with uniform profiles (not incised), the project profile simply connects profile control points in the upstream and downstream channels at the same slope as the channel profile. The design slope is the same as the upstream and downstream channels. In figure 5-16a, for example, the project profile is the existing channel profile extended through the crossing. The replacement project entails nothing more than installing an appropriately sized and embedded culvert and filling the scour pool. Since the volume of sediment accumulated above the culvert inlet is not large, the sediment can be allowed to regrade naturally if desired. The project footprint will be quite limited.

In some cases, the amount and extent of aggraded sediment upstream of an undersized culvert are so large that allowing the sediment to flush through the system all at once would be undesirable. In such cases, the team may elect to place control structures in the aggraded reach to meter sediment movement more gradually. This will extend the project's footprint.



### 6.1.2.2 Steep channels with large key features

On streams controlled by large **key features** (bedrock outcrops, large woody debris, stable debris jams, boulder steps, manmade structures), the project profile reflects the team's assessment of the probability that key features might move. In the Fire Cove Road example (site sketch and VAP analysis shown in section 5.2.3), several project profiles were evaluated under different assumptions about potential movement of the upstream and downstream key features.

Recall that the Fire Cove Road crosses a wood-forced step-pool Rosgen A channel, where a 2.5-foot-diameter log about 50 feet downstream of the culvert (figure 5.14c) controls channel slope across the crossing. A debris-and-boulder cascade over 20 percent slope is about 30 feet upstream of the culvert. The existing culvert slope is 5-percent, flatter than the adjacent channel, where slopes range between 6 and 22 percent. In spite of the complex profile shape, this steep transport channel has had no problems with aggradation at the culvert inlet.

Figure 6.7 displays possible project profiles at the Fire Cove Road crossing. The steepest profile assumes that the downstream log control moves or will be removed, and that a boulder step in the middle of the cascade also may move. For solid anchor points, this profile uses the highly stable boulder-log structure at the top of the cascade upstream of the crossing, and a log-boulder complex further downstream of the crossing. The intermediate slope profile also assumes the downstream control moves. Both of these steeper profiles would entail constructing a very steep simulated streambed with a design gradient of over 6 percent. These options would not only avoid any potential aggradation problems but also would result in a channel where stability does not depend on the downstream log.

The flattest profile in figure 6.7 has a 4.6-percent slope, and assumes that no existing grade controls move. This design project profile was used because the probability is very low that either of the nearest grade controls will move over the lifetime of the new culvert. The existing culvert, at a 5-percent grade, had no problems with aggradation. This option preserves the valuable pool habitat in the vicinity of the culvert, and requires the least channel regrading. A reference reach with a similar slope exists downstream of the crossing.

## Stream Simulation

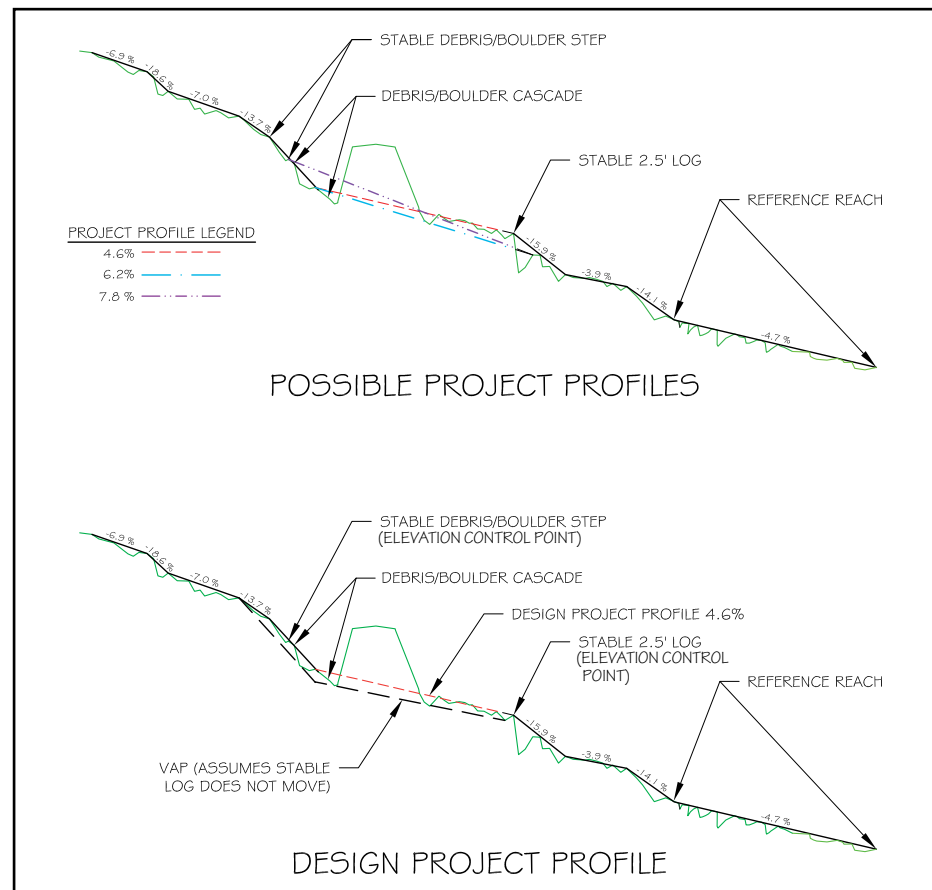

Figure 6.7—Project-profile options on a channel with large key features, and the selected project profile: Fire Cove Road, Tongass National Forest, Alaska.

### 6.1.2.3 Concave slope transitions

The concave transition (see section 5.2.1.4) is common, because many roads are located at the outer edge of valleys, where the steeper sideslope meets the valley floor. Shear stress decreases abruptly with the change in channel slope, and these areas are natural sediment depositional zones. A crossing that constricts the stream will exacerbate the natural tendency toward sediment deposition. Even where no constriction exists, natural aggradation can reduce a structure's hydraulic capacity.

If a culvert has to remain at or near a concave grade break where it could be affected by aggradation, the project profile should include the grade break. Figure 6-8a shows an undersized culvert at a concave-channel transition, along with the upper and lower VAP lines. No regional channel incision is anticipated here, so the lower VAP line is drawn below the typical depth of pools in each segment. The upper VAP line here is at

## Chapter 6—Stream-Simulation Design

---

the top of the streambank. The channel has downcut through a sloping bench (an old depositional surface) where the hillside meets the valley bottom. Upstream of the crossing on the hillside is an entrenched step-pool channel; downstream is a less well-entrenched pool-riffle channel.

Replacement option 1 would be the desirable project profile if a reference reach can be found at an intermediate grade. Such a reference reach might be a steep, riffle-dominated reach with transverse bars, like the project profile shown in figure 6.8b. This alternative reduces risk by moving the probable locus of aggradation away from the culvert, where maintenance can access the channel if necessary. Note that the lower VAP line has been adjusted upward in this scenario, because the project profile is raised and its elevation is controlled by constructed riffle crests. Option 2 (figure 6.8c) involves oversizing the structure so as to accommodate any aggradation that may occur. The project profile is a smooth transition between the profiles of both adjacent channel segments. This alternative is less than ideal because of the difficulty of predicting future aggradation (see section 4.5, Brewster Creek example).

Table 6.3 lists and compares common options for design solutions at concave transitions. Note that the vertical curve of the roadway influences design options, because it controls how much the road surface can be raised to allow more room for sediment deposition in the crossing structure.

## Stream Simulation

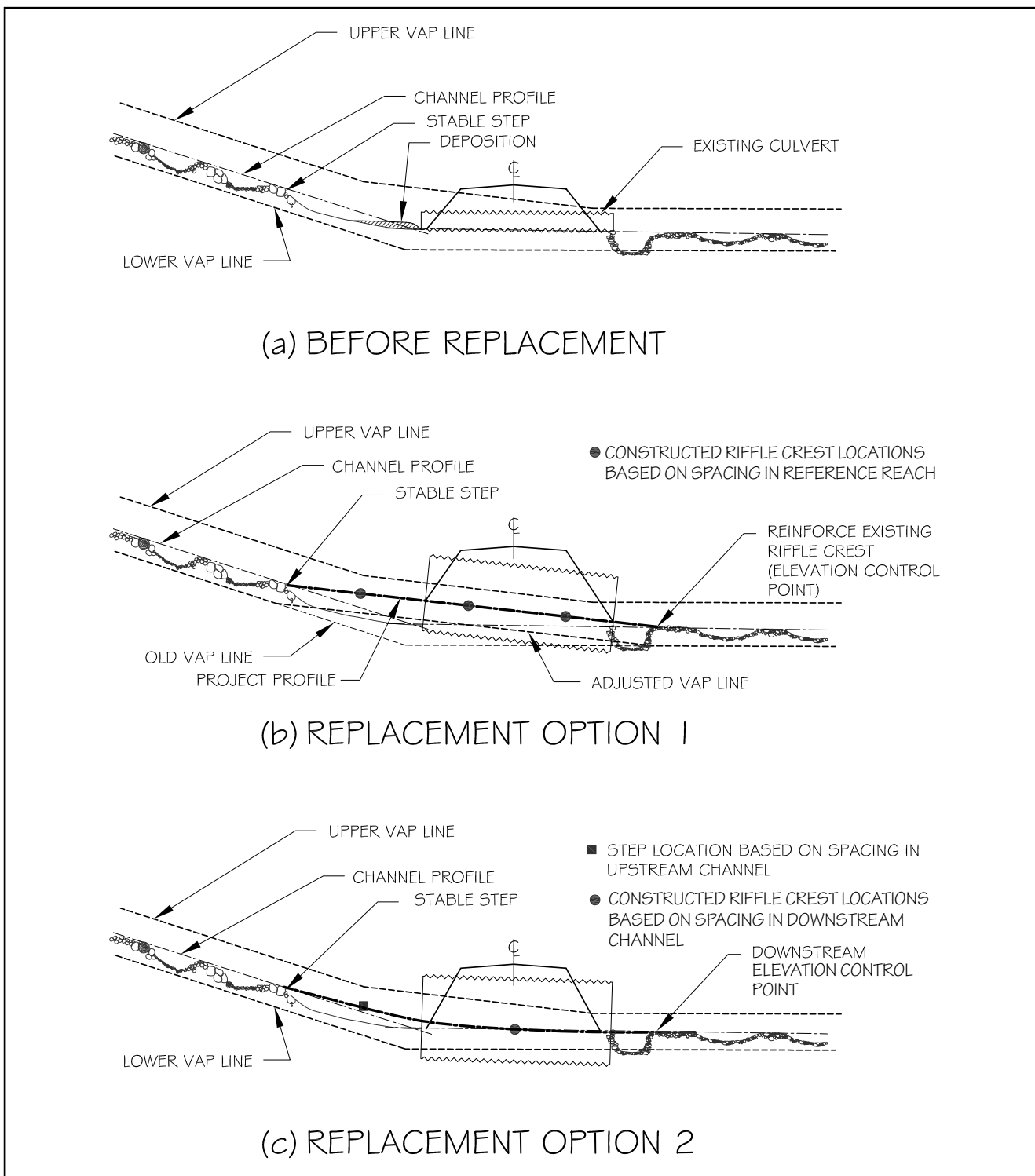

Figure 6.8—Hypothetical determination of VAP lines and project profile at a concave transition: (a) undersized culvert before replacement showing upper and lower VAP lines; (b and c) two options for possible project profiles inside replacement culverts (see text). Steps or constructed riffle crests could be designed for these installations, based on bedform spacings in the respective reference reaches (see sections 6.2.2.4 and 6.2.2.2).

Table 6.3—Design options for concave transitions

Profile Option	Attributes	Associated Effects and Comparison of Options
Relocate crossing away from grade break.	Places crossing upstream or downstream of the depositional zone.	<ul style="list-style-type: none"> <li>● Most reliable solution.</li> <li>● Reduces maintenance requirements.</li> <li>● Depending on road alignment, can have undesired trade-offs, e.g., changes in sight distance, safe driving speeds, etc.</li> </ul>
Adjust channel profile to ensure sediment is transported through the crossing.	Steepens profile inside pipe and moves grade transition away from culvert.	<ul style="list-style-type: none"> <li>● Only possible when downstream channel is steeper than ~1% and somewhat entrenched (so flow does not spread out and deposit sediment immediately downstream of culvert).</li> <li>● Carries risk that downstream deposition may progress upstream toward crossing (important on low gradient alluvial fans).</li> <li>● Depositional area may be moved to channel reach not adjusted to it, or on another property.</li> <li>● Road grade may be raised to accommodate steeper culvert; diversion potential can increase.</li> </ul>
Oversize culvert to accommodate sediment accumulation (to upper VAP line).	Allows aggradation without sacrificing structure performance.	<ul style="list-style-type: none"> <li>● Road grade may need to be raised to accommodate larger culvert.</li> <li>● Only desirable where geometric road requirements can be met without causing a potential for stream diversion (i.e., road approaches should slope down to crossing).</li> </ul>
Design for long term maintenance.	<p>High potential profile is estimated based on site history, sediment sources, amount of debris moving in system, etc.</p> <p>Alternatives include:</p> <ul style="list-style-type: none"> <li>● Embedded concrete boxes with removable lids.</li> <li>● Bridge.</li> <li>● Excavated sediment pond accessible to maintenance equipment upstream of crossing.</li> </ul>	<ul style="list-style-type: none"> <li>● Estimate of high potential profile (and therefore culvert size) is subject to considerable uncertainty.</li> <li>● Useful where roadway constraints or rapid sedimentation rates make other options infeasible.</li> <li>● Requires a maintenance commitment.</li> <li>● Upstream excavation carries a risk of destabilizing the steeper channel upstream and possibly causing a headcut and/or loss of aquatic habitat.</li> </ul>

## Stream Simulation

### 6.1.2.4 Convex slope transitions

Where the channel gradient steepens downstream of a crossing, there is an inherent risk of headcutting unless permanent grade controls exist or are constructed. Traditional culverts at these locations control streambed elevations, but stream-simulation culverts do not function that way. Local headcutting might occur due to disturbance during construction or movement of local grade controls (steps, short cascades) during floods. The risk depends on the stability of the grade controls. Unless grade controls are highly stable, protecting the simulated streambed in the replacement culvert may require constructing additional grade control structures.

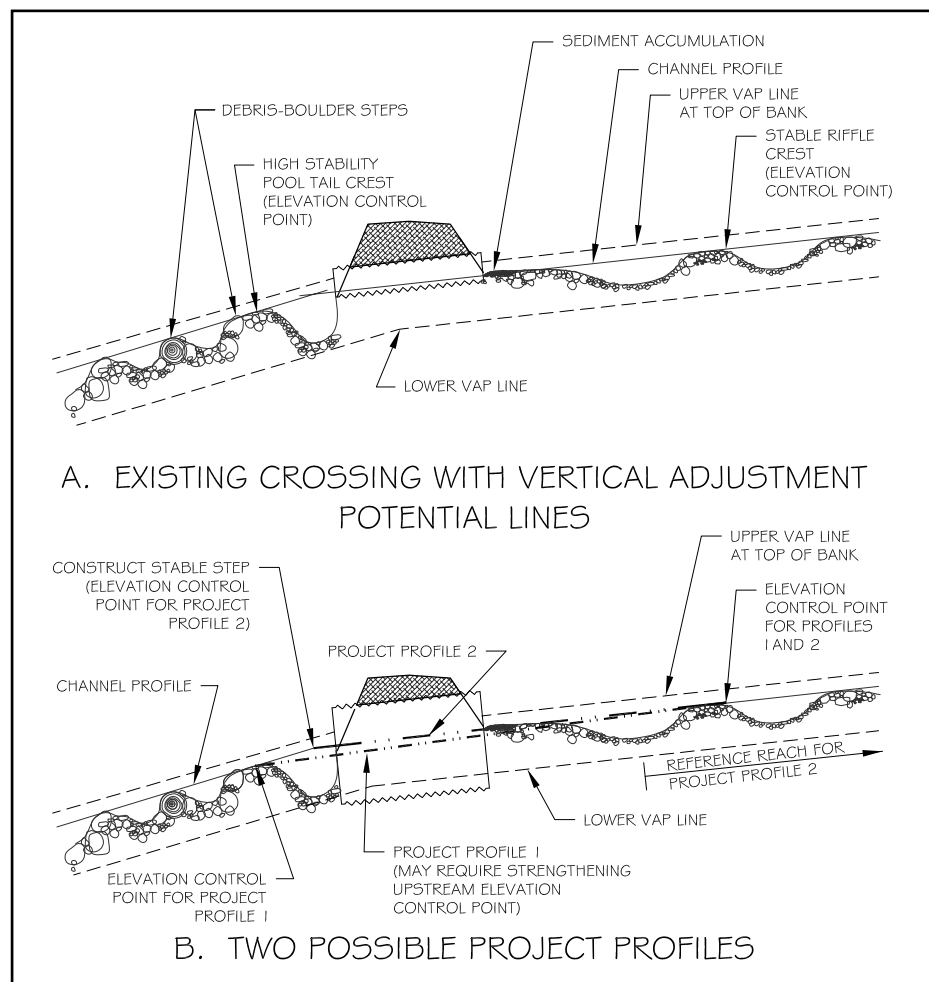

Figure 6.9—Road crossing near convex slope transition. (a) Existing crossing with bed topography, channel profile, and VAP lines. (b) Two possible project profiles.

## Chapter 6—Stream-Simulation Design

Figure 6.9a shows a crossing near a convex slope transition, where a pool-riffle channel breaks to a steeper step-pool channel. If one or more of the downstream steps is destabilized by construction or a flood, the downstream channel could incise to approximately the height of the grade controls. In this example, we are not anticipating regional channel incision such as might occur with a base level change somewhere downstream. We are only designing for local bed elevation changes that could occur if one or two log or boulder grade controls move during a flood. If regional channel incision were anticipated, the lower VAP line in figure 6.9a would need to be lowered to account for that, or permanent steps would need to be constructed downstream.

Two possible project profiles are delineated in figure 6.9(b). Both start at the same upstream elevation control point—a stable riffle crest. Profile 1 has a slope intermediate between the two adjacent channel segments. It could be selected if a reference reach with a similar slope exists nearby, and if the elevation control points are stable enough to sustain the steeper slope. Both the outlet pool-tail crest (the downstream profile control point) and the upstream riffle would need to be highly stable structures to make this a viable option. Profile 2 extends the channel profile of the upstream reach through the new crossing, and would require constructing an immobile grade-control structure downstream of the new culvert to maintain the slope. The reference reach for profile 2 would be the reach immediately upstream of the culvert.

### 6.1.2.5 Incised channels

Where a culvert is protecting the upstream channel from incision, but the amount of prospective incision is acceptable, you may decide to simply lower the culvert and allow the upstream channel to regrade naturally. Once again, see section 5.3.3 for a checklist of things to consider when deciding whether to allow incision to progress. Either ensure incision downstream of the crossing is not ongoing, limit it by constructing permanent grade controls, or provide adequate depth to accommodate it.

One way of mitigating some of the effects of expected **channel incision** is to limit the rate of upstream headcut migration using temporary grade-control structures, such as scattered, buried, or other rock structures, which are expected to fail over time. Although you can place woody debris for the same purpose, be aware of the potential impact on the culvert, should that debris move.

## Stream Simulation

---

Where the projected VAP is *not* tolerable, several options exist for adjusting and controlling the project profile. Most of these situations are where the downstream channel has incised, and the depth or extent of possible upstream incision is unacceptable. Again, the first step in dealing with these situations is to identify stable grade controls (or control points that can be stabilized) upstream and downstream of the crossing, and connect those points to delineate a tentative project profile. Determine the slope of the profile and verify that a reference reach exists at that slope. If the project profile exceeds the slope of potential reference reaches, adjusting the profile may be possible using one or more of the following strategies.

- Reconstruct the incised channel to pre-incision conditions.
- Steepen the culvert.
- Lower the culvert and steepen the adjacent reach(es); control grade with key features like boulder weirs or logs, or constructed grade-control structures.

Figure 6.10 illustrates these options and table 6.4 describes and compares them. Many projects include a combination of two or all of these options.

Projects dealing with large-scale channel incision are often much longer than those dealing only with local scour because they require restoring or controlling streambed elevations on the adjacent channel segments. The objective is to smooth the transition between the unincised channel upstream and the incised channel downstream so as to avoid impeding aquatic organism passage. Right-of-way limits, property boundaries, and other infrastructure can sometimes constrain the length of the project. However, do not automatically assume that they do. Instead, consider options that cross or move these features if those options have advantages.

### Reconstruct the channel

Channel reconstruction [figure 6.10(a)] should be considered as an option in any project associated with an incised channel. Channel reconstruction is the reestablishment of equilibrium channel dimensions, structure, and grade, with the goal of achieving a self-sustaining channel that can remain in **dynamic equilibrium** over the long term. It is a more elegant, durable way of correcting a large elevation drop resulting from channel incision, as opposed to forcing the culvert into an artificially oversteepened profile. Reconstruction might involve realigning a straightened channel to restore meander pattern and length at its original elevation. Oversteepened banks could be laid back and the excess material used to build the incised bed back up to an elevation that provides access to the culvert.



## Chapter 6—Stream-Simulation Design

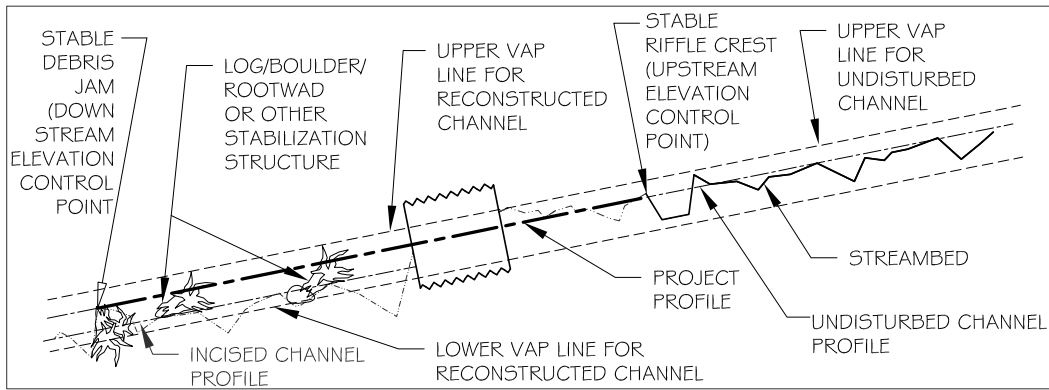

### A. RECONSTRUCT CHANNEL

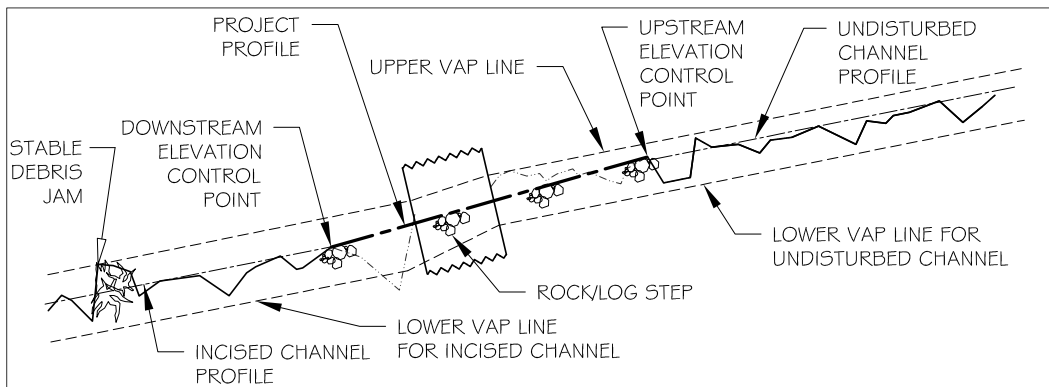

### B. STEEPEN STREAM SIMULATION CHANNEL AND CULVERT

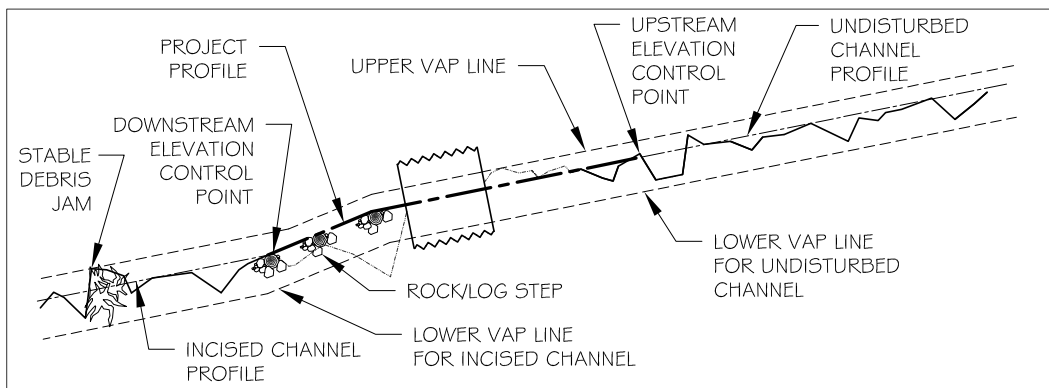

### C. STEEPEN ADJACENT CHANNEL SEGMENT

NOTE: THESE DESIGN OPTIONS ARE FOR  
INCISED CHANNEL SHOWN IN FIGURE 5-16B

APPROXIMATE VERTICAL EXAGGERATION = 12%

Figure 6.10—Several project-profile options for an incised channel (reference figure 5.16b). (a) Reconstruct channel; (b) steepen stream-simulation channel; (c) steepen adjacent channel segments The lower VAP lines represent the lowest channel elevations expected over the life of the replacement structure given the profile controls constructed in each case. Incision is judged to have ended.

# Stream Simulation

Table 6.4—Comparison of project-profile design options for incised channels

Profile Option	Attributes	Potential Effects and Comparison of Options
a. Reconstruct channel.	May restore downstream channel to natural length and grade.	<ul style="list-style-type: none"> <li>● Greatest habitat gain of the three options.</li> <li>● Most self-sustaining of the three options.</li> <li>● Risk that downstream channel may continue to incise if the cause of instability is not resolved.</li> </ul>
	Project scope includes longer reach than other options.	<ul style="list-style-type: none"> <li>● Initial disturbance may be more extensive and construction cost may be higher. Potential issues with property boundaries or rights-of-way, short-term wildlife habitat impacts.</li> </ul>
	Usually includes habitat improvements.	<ul style="list-style-type: none"> <li>● Creates or enhances in-channel, flood plain and/or riparian habitats.</li> </ul>
	Often improves channel flood-plain connectivity.	<ul style="list-style-type: none"> <li>● Improves flood-plain water storage and other flood-plain functions.</li> </ul>
	Avoids abrupt slope changes along profile.	<ul style="list-style-type: none"> <li>● Stream-simulation crossing is more sustainable and less vulnerable to headcutting or sediment deposition.</li> </ul>
b. Steepen culvert.	Higher streampower and coarser rock in simulation than in adjacent reach.	<ul style="list-style-type: none"> <li>● Risk that simulation will be unsustainable if upstream reach does not resupply the same caliber of sediment eroded from culvert.</li> <li>● More likely an impediment to aquatic species passage than other options (minimize this risk by staying within 25% of reference reach slope for stream simulation).</li> </ul>
c. Lower culvert and steepen upstream and/or downstream reaches.	Slope transitions at upstream and/or downstream ends of culvert.	<ul style="list-style-type: none"> <li>● Risk of headcutting upstream and sediment deposition downstream.</li> <li>● Grade controls may be required upstream and/or downstream.</li> </ul>
	Natural banklines and roughness elements (especially wood) in open channel dissipate energy and help stabilize the steepened reaches	<ul style="list-style-type: none"> <li>● Less risk of simulated channel instability compared to (b).</li> <li>● Less risk of impeding passage compared to (b) because the variety of pathways is greater.</li> </ul>
d. Lower culvert and allow upstream headcutting.	Maintains channel connectivity through crossing but permits free channel incision.	<ul style="list-style-type: none"> <li>● Potential effects of allowing upstream headcutting are outlined in section 5.3.3.</li> </ul>

## Chapter 6—Stream-Simulation Design

---

Before deciding to reconstruct a channel, it is critical to understand the cause of channel incision. Channel incision can sometimes result from long-term watershed changes (for example, in land use and the amount, timing, and distribution of runoff). In that case restoring the channel to historic, predisturbance conditions may not be possible and the channel should be designed for current and future **flow regimes**. Understanding the stage of incision is also crucial. If incision is still on-going, it could destabilize the reconstructed channel. Channel reconstruction may not be feasible for many reasons, and you should evaluate feasibility before deciding to implement this option. See the Federal Interagency Stream Restoration Working Group (1998) for an introduction to the channel-reconstruction planning process.

The reconstructed channel must tie into a stable downstream base-level control so that incision does not recur. The downstream control in figure 6.10(a)—a stable debris jam—would probably not be considered an adequate elevation control point in real life. Most channel-reconstruction projects would involve reconstruction of a longer reach, with either a more solid downstream control, such as bedrock, or a more gradual tie into the incised channel. The downstream channel might be reconstructed at a slightly steeper gradient to tie gradually back into the natural channel. Designing the steeper reconstructed channel would require finding a reference reach at that steeper gradient.

A project that includes reconstruction of an incised channel can extend a considerable distance downstream. It may have habitat-restoration values that go far beyond passage of aquatic organisms. For example, such a project can restore in-stream, riparian, and flood-plain habitats and channel **flood-plain** interactions; reconnect **side channels** previously blocked by the roadfill; and stabilize eroding banks. Channel reconstruction may be the most expensive option, but such a project is likely to be more self-sustaining and lower in maintenance costs than others.

### Steepen the stream-simulation channel

A more local solution to the incised-channel problem is to steepen the simulated channel [figure 6.10(b)]. Look at the site longitudinal profile and consider the variability of reach slopes. You may find short punctuated steps that are steeper than the average gradient; these could serve as a reference reach if they are long enough. If necessary, go back and investigate beyond the surveyed longitudinal profile.

## Stream Simulation

---

How much steeper than the reference reach can the stream-simulation channel be? The increase should not be great, because at some point, the bed material in the simulated channel must be so much larger than in the upstream reach that the upstream reach cannot replenish it if it erodes. In other words, the simulation will not be self-sustainable. Keep in mind that the premise of stream simulation is that the simulated channel is close enough to the natural one that organisms will move through it equally easily. If the difference between the slopes is great—especially if the steeper slope requires a different channel shape or bed material for stability—aquatic organisms may not be able to move through at the same flows as in the natural channel. Stream simulation may not be feasible in that case.

Bates et al. (2003) suggest a slope increase of no more than 25 percent of the natural or reference reach. The suggestion is a conservative guideline, as we have no data thus far to support a specific criterion. We use a maximum *percent* change of slope, because a flatter channel is much more sensitive to a given absolute change than a steeper one. For example, increasing a 1-percent slope channel by 1, to create a 2-percent channel, is a substantial change, whereas increasing a 10-percent slope channel by the same amount, to create an 11-percent channel, is reasonable. We recommend doing a bed-mobility analysis (section 6.4) for any slope greater than the reference reach, even if the slope of the simulation channel is within the 125-percent guideline.

### Steepen adjacent reaches

The reaches upstream and/or downstream of the culvert can be steepened, either as an alternative to or in addition to the steepened crossing [figure 6.10(c)]. Steepening channels outside of a culvert is less risky for the following reasons:

- If necessary, the channel can be widened.
- The culvert wall does not constrict high flows.
- Natural banklines and channel margins provide the added benefit of vegetation for roughness and root strength.
- It is easier to repair grade-control structures outside culverts.

Reference-reach features are the basis for designing the dimensions and spacing of grade controls such as those shown in figures 6.10(b) and 6.10(c) (see sections 6.2.2.2 and 6.2.2.4). Such structures should not be placed near the culvert inlet to avoid exposing them to unusual flow patterns near the inlet at flows higher than bankfull.

Appendix F briefly describes some common grade-control structures used to steepen reaches upstream and downstream of crossings. Where channel incision has occurred and control structures are the sole means of maintaining elevation and grade downstream of a culvert, these structures should be long-lasting and stable enough to maintain the designed elevation. The designer must assess the possibility that further incision downstream of the project could create a passage **barrier** at the lowest bed control and/or jeopardize the controls and the project.

### 6.1.3 Project Alignment and Profile Design: Two Examples

#### Newbury Creek Crossing Project Profile and Reference Reach

In chapter 5, we used the Newbury Creek crossing on the Olympic National Forest to demonstrate the site-assessment process, including analysis of the longitudinal profile and VAP. Here we examine how the alignment and project-profile issues were handled at the Newbury Creek site, which channel segment was selected as the reference reach and how bedforms were spaced in the design channel. Newbury Creek illustrates a case where the VAP was acceptable, and the project profile did not require modification to control vertical adjustment.

Figure 6.11 shows that the original culvert straightened a slight bend on Newbury Creek, which explains the need for riprap on the east bank just above the inlet. The degree of straightening is slight, and the replacement culvert requires no alignment adjustments.

Figure 6.12 shows the longitudinal profile with two possible project profiles drawn between stable grade-control features upstream and downstream of the crossing. The downstream elevation control point for both profiles is the riprap rock weir at the outlet pool tail crest (photo in figure 5.11). The flatter profile uses bedrock as the upstream elevation control point, assuming that the sediment wedge above the existing culvert will erode. Erosion of the sediment wedge is expected to destabilize the log weirs and other grade controls in the steeper reach above the crossing, allowing for some channel downcutting there. Slope of this profile is 2.26 percent, less than 3 percent steeper than combined segments F/G, which are downstream of the crossing and can function as a reference reach.

# Stream Simulation

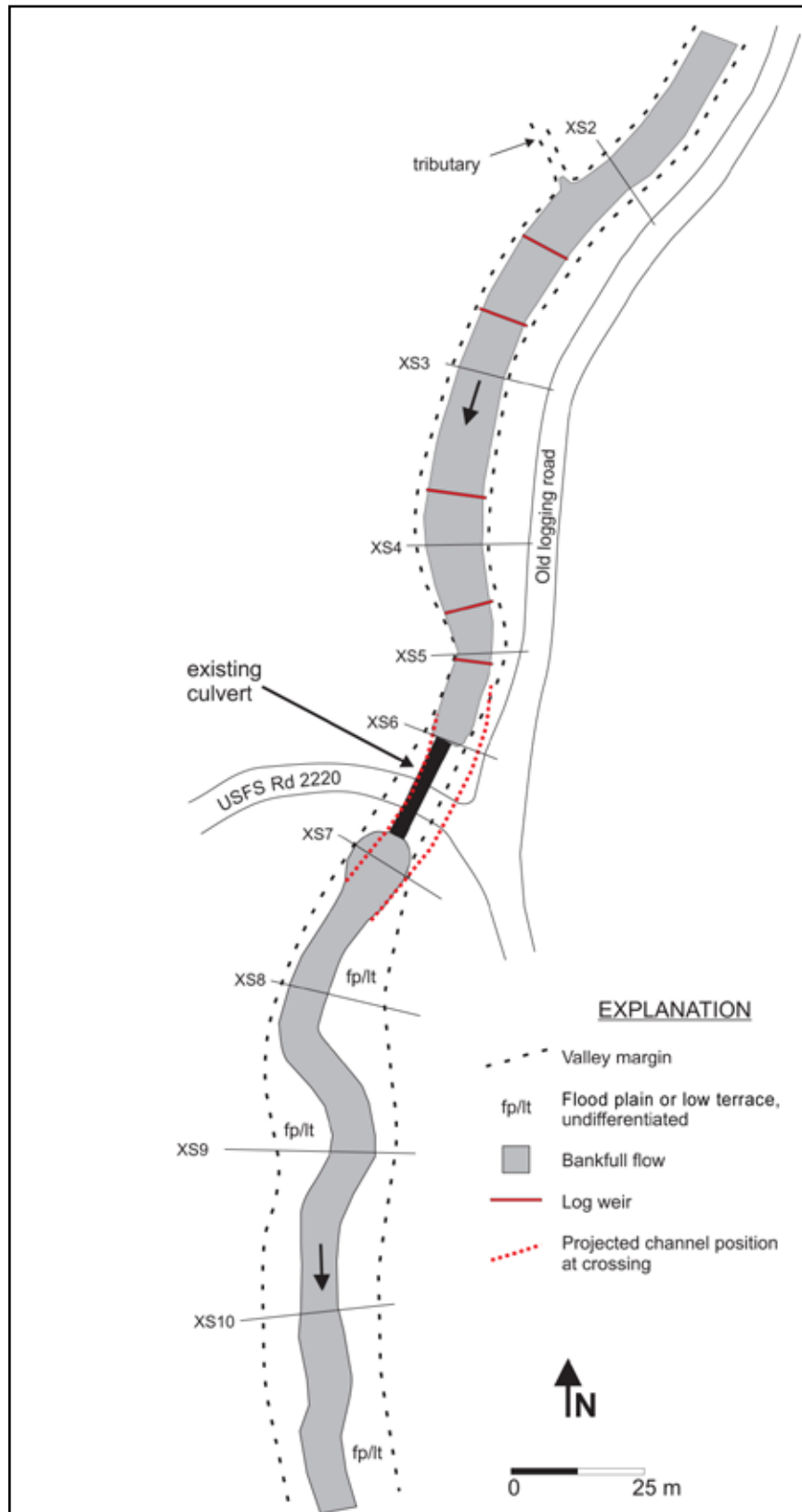

Figure 6.11—Newbury Creek site plan map showing interpretation of natural channel alignment.

# Chapter 6—Stream-Simulation Design

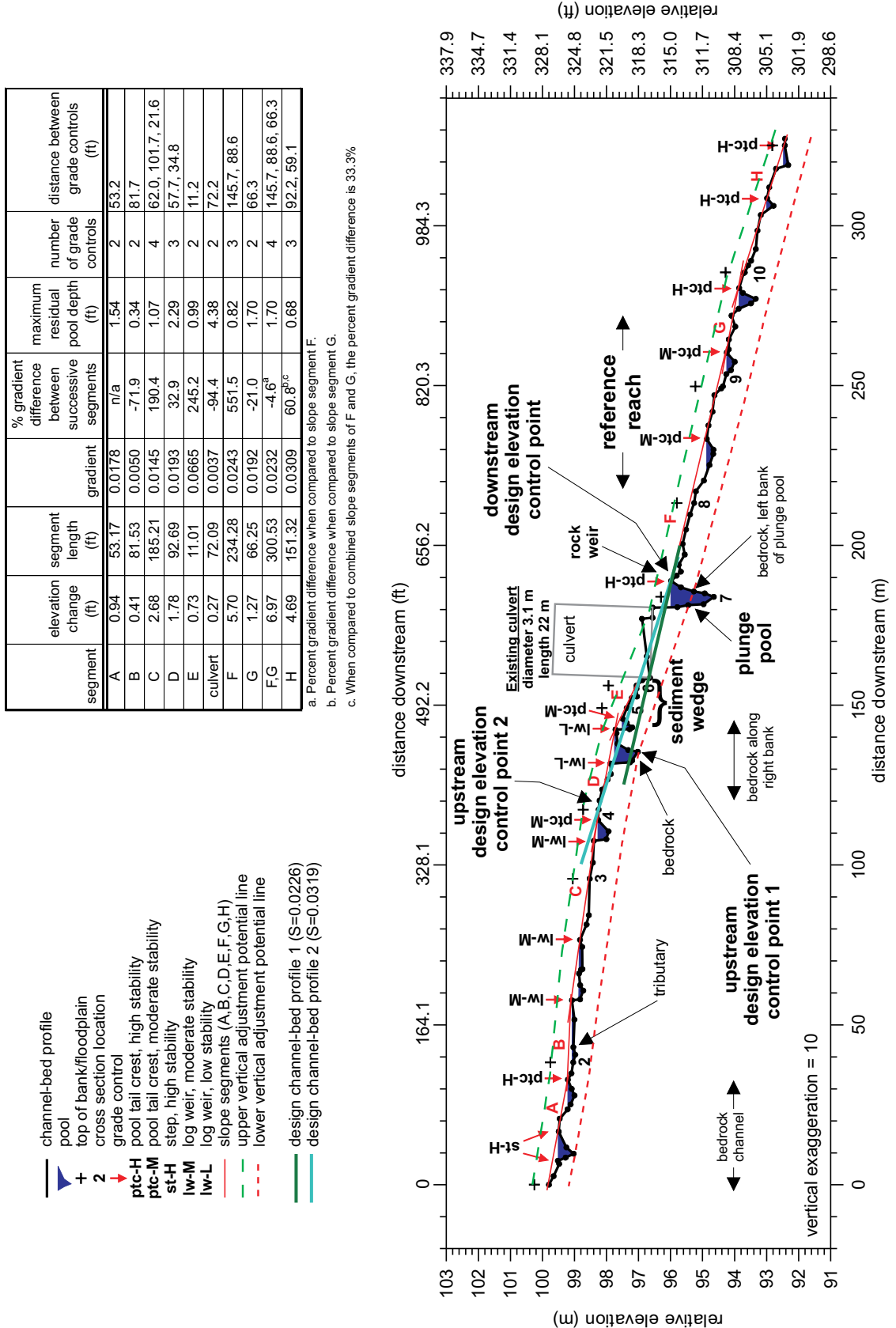

Figure 6.12—Newbury Creek: two possible project profiles.

# Stream Simulation

segment	elevation change (ft)	segment length (ft)	% gradient difference between successive segments	maximum residual pool depth (ft)	number of grade controls	distance between grade controls (ft)
A	0.94	53.17	n/a	1.54	2	53.2
B	0.41	81.53	-71.9	0.34	2	81.7
C	2.68	185.21	190.4	1.07	4	62.0, 101.7, 21.6
D	1.78	92.69	0.0193	2.29	3	57.7, 34.8
E	0.73	11.01	0.0665	0.99	2	11.2
F	5.70	234.28	0.0243	4.38	2	72.2
G	1.27	66.25	0.0192	0.82	3	145.7, 88.6
FG	6.97	300.53	0.0232	1.70	2	66.3
H	4.69	151.32	0.0309	0.68	4	145.7, 88.6, 66.3

a. Percent gradient difference when compared to slope segment F.  
 b. Percent gradient difference when compared to slope segment G.  
 c. When compared to combined slope segments of F and G, the percent gradient difference is 33.3%.

- channel-bed profile
- pool
- top of bank/floodplain
- cross section location
- grade control
- pool tail crest, high stability
- ptc-M pool tail crest, moderate stability
- st-H step, high stability
- lw-M log weir, moderate stability
- lw-L log weir, low stability
- slope segments (A,B,C,D,E,F,G,H)
- upper vertical adjustment potential line
- lower vertical adjustment potential line
- design channel-bed profile 1 (S=0.0226)
- design bedform locations (head of riffles)
- fill plunge pool with channel-bed material
- base of footing of replacement structure (on bedrock)
- predicted long-term bed surface (headcut, erosion)

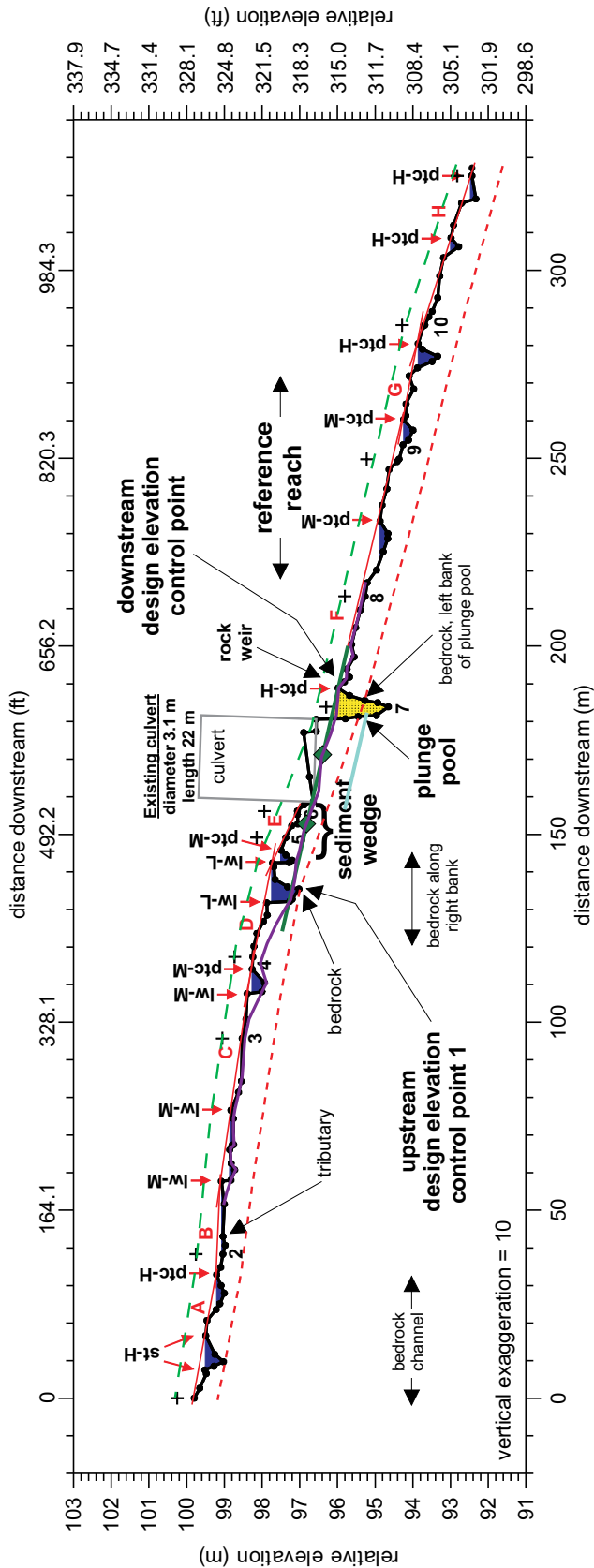

Figure 6.13—Newbury Creek channel profile anticipated after channel response to culvert replacement.



## Chapter 6—Stream-Simulation Design

---

For the steeper alternative profile, the upstream elevation control point is a medium-stability pool tail crest composed of gravel and small cobbles. Slope of this project profile is 3.19 percent, and if it were selected the steepest section of this complex profile would extend through the culvert. Because the grade is about 38-percent steeper than segments F/G, some downstream aggradation might be expected with this alternative; however, as seen earlier, the probability of aggradation is low in this stream. Segment H is steep enough to constitute a viable reference reach for this alternative. Both potential profiles are well within the VAP lines.

The lower gradient project profile was chosen because of the lower risk associated with the lower gradient, and the lack of confidence that the medium-stability pool tail crest (elevation control point 2) would remain stable at the steeper grade. The steeper alternative might have required construction of more grade controls, extending the project's footprint further upstream than the selected alternative.

Figure 6.13 shows the expected final channel profile after culvert replacement, in-channel construction, and projected future channel adjustments. The riffle crests ("head of riffles") are similar in spacing to the pool tail crests in the reference reach. Minor local downcutting may occur upstream of elevation control point 1 as the log weirs deteriorate and fail. Shallow bedrock will limit downcutting, and trees falling into the channel may offset it. The projected final profile in figure 6.13 is an estimate based on all those considerations.

### **Tongass National Forest, Mitkof Island, Road 6245**

The 6245 road crossing is a situation where culvert replacement could have caused unacceptable channel incision. Avoiding incision in this case required modifying the crossing alignment. The example does not showcase an ideal solution; however, it does demonstrate the trade-offs between channel alignment and slope that are sometimes needed. At this site, no ideal solution existed and the final alignment required substantial engineering control.

### ***Existing condition***

The unnamed stream at this crossing is a 6- to 10-foot-wide step-pool channel (Rosgen A3) with steps formed of cobbles, boulders, and wood. Average channel slope is 6.4 percent, with short steep segments up to 20 percent. The gravel layer on the streambed is thin, and bedrock outcrops frequently. The existing 36-inch pipe has a slope of 3.5 percent, and was probably constructed with a perch. Currently, the outlet **invert** is perched 2.7 feet above the outlet tail crest of the outlet plunge pool (figure 6.14).

## Stream Simulation

---

Natural grade controls upstream and downstream of the road indicate that the segment now covered by the crossing was at least 7 percent. Flatter segments where log jams control grade (one is just downstream of the crossing) provide good spawning gravels, which are in short supply in this watershed.



*Figure 6.14—Looking upstream at outlet of existing pipe, road 6245. Photo: Chinook Engineering.*

The log jam controlling the flat reach immediately downstream of the crossing is only moderately stable, and is likely to readjust or fail over the life of the replacement. The lower VAP line in figure 6.15 (longitudinal profile) accounts for the probability that the log jam may move, and that incision could progress upstream, as sequential steps readjust to the steeper local slope. There is little or no risk of larger-scale (regional) channel incision here.

The existing culvert approximates the natural channel alignment, and it lines up well with the upstream reach. The sharp bend downstream of the outlet is a natural bend, but erosion caused by the crossing has made the bend more acute. The pipe is skewed relative to both the road and the downstream channel (figure 6.15 planview). Issues with both alignment and vertical adjustment potential complicate stream-simulation design at this site.

# Chapter 6—Stream-Simulation Design

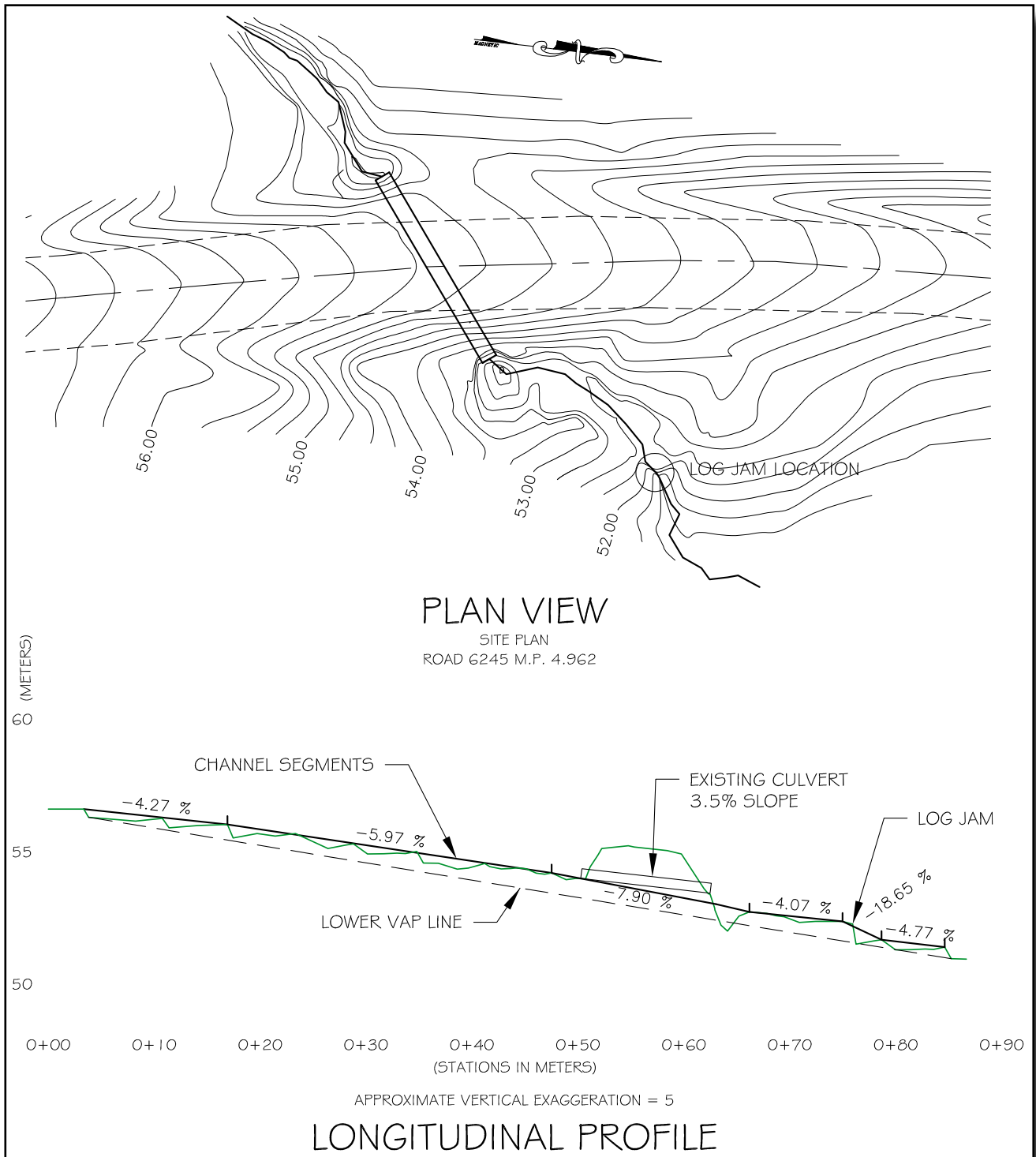

Figure 6.15—Existing condition: planview and longitudinal profile.

## Stream Simulation

### Options for stream-simulation replacement

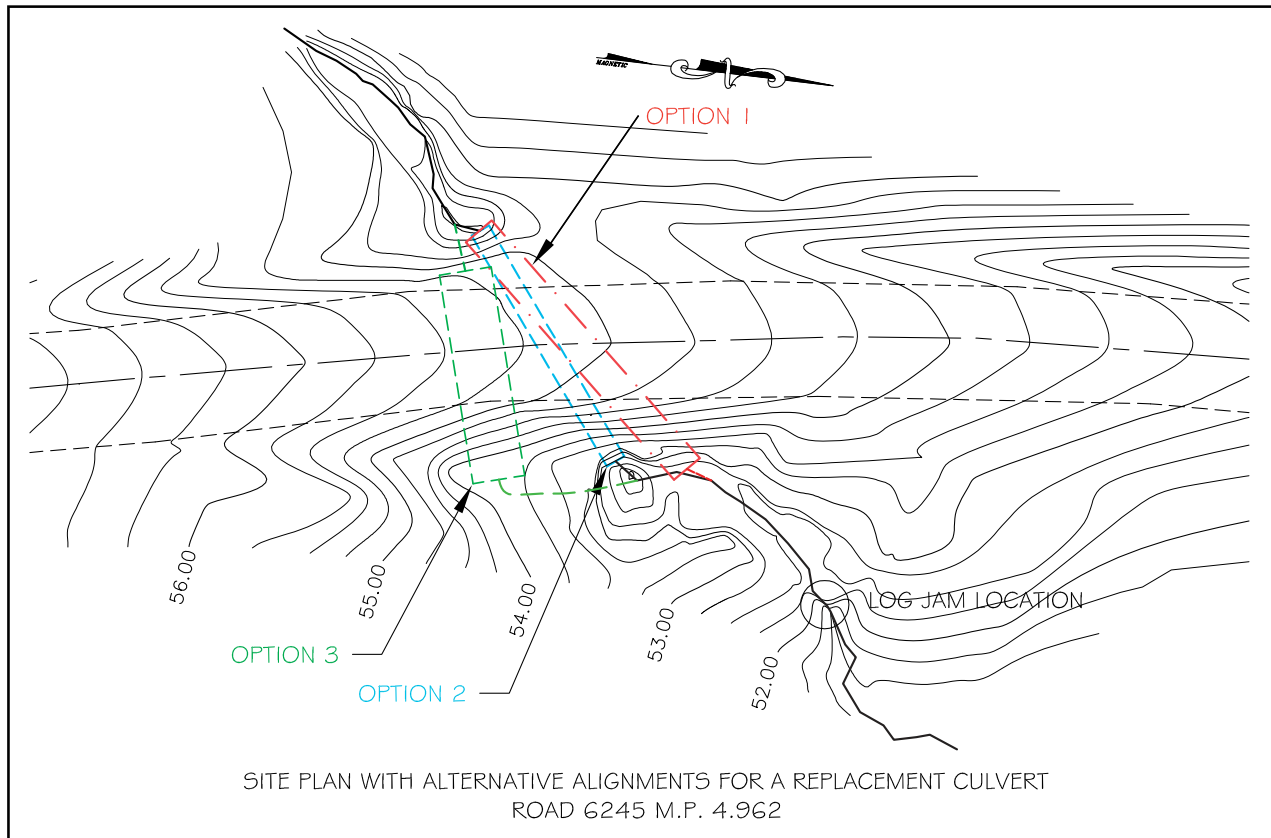

Figure 6.16—Alternative alignments for replacement culvert.

**Option 1** **Aligning culvert with channel.** To improve the culvert's hydraulic alignment, option 1 would increase skew relative to the road and lengthen the pipe (figure 6.16). Both inlet and outlet would be aligned with the stream, but the simulation would be steep—8.5 percent (figure 6.17). This slope is within the range of variability in the natural channel, but segments this steep are shorter than the culvert, and could not function as reference reaches. This alternative is also steeper than the upstream channel segment, and the streambed material for the simulation would need to be larger to achieve stability. In addition, the log jam, which is the downstream grade control, is only 30 feet downstream of the outlet pool in this option. When the log jam moves, incision through the simulation will be a real possibility unless additional grade controls are constructed.

## Chapter 6—Stream-Simulation Design

---

**Option 2 Using the existing culvert alignment.** This option has similar drawbacks to option 1: it is steep (7.9 percent) and only slightly further upstream from the questionably stable debris jam (figure 6.16). In addition, the bend at the outlet would require bank-stabilization measures.

**Option 3 Realigning the channel and shortening the culvert.** Option 3 accepts a poorer culvert-to-channel alignment at the outlet for the sake of a shorter and flatter pipe, and better control of VAP. The channel downstream of the crossing would be lengthened to meet the outlet of the pipe, which here is placed perpendicular to the road. The added channel length raises the outlet elevation so that culvert slope is only 6.25 percent, near the average channel slope for the entire reach, and only slightly steeper than the upstream reach.

**Selected design option** Option 3 was selected largely because no valid reference reach exists in the surveyed longitudinal profile (figure 6.15) for either option 1 or 2. In addition, the steeper culverts in options 1 and 2 would require larger streambed material for stability, creating a risk of loss of surface low flows due to infiltration into the streambed. The simulated channel would also be less self-maintaining because the flatter upstream reach may not resupply the larger bed material as it moves out of the culvert during floods.

In option 3, the simulated channel slope is similar to the slope of the upstream channel, and the simulated streambed is more likely to be self-maintaining; that is, sediment washed out of the simulation will be replaced by incoming sediment of similar size from the upstream reach. The upstream reach will serve as a reference reach. Option 3 constructs 21 feet of new channel at a moderate grade between the culvert outlet and the log jam [figure 6.18(a)]. When the jam does break up and the channel downcuts locally, two rock weirs constructed in the new channel segment will mitigate any risk to the stream-simulation channel in the culvert. A secondary benefit of the new channel segment is that it adds spawning habitat to the reach.

Because of the abrupt bend at the outlet, the culvert-channel transition is very important in this design, to avoid bank erosion and excessive sediment deposition. The design overwidens the bend at the outlet to leave space for a gravel bar that is expected to form at the inside of the bend [figure 6.18(a) and (c)]. Riprap is placed on the outer bank. The two rock weirs below the bend not only stabilize grade, but also bring the **thalweg** to the center of the channel. They are designed to be immobile during the 100-year flood.

# Stream Simulation

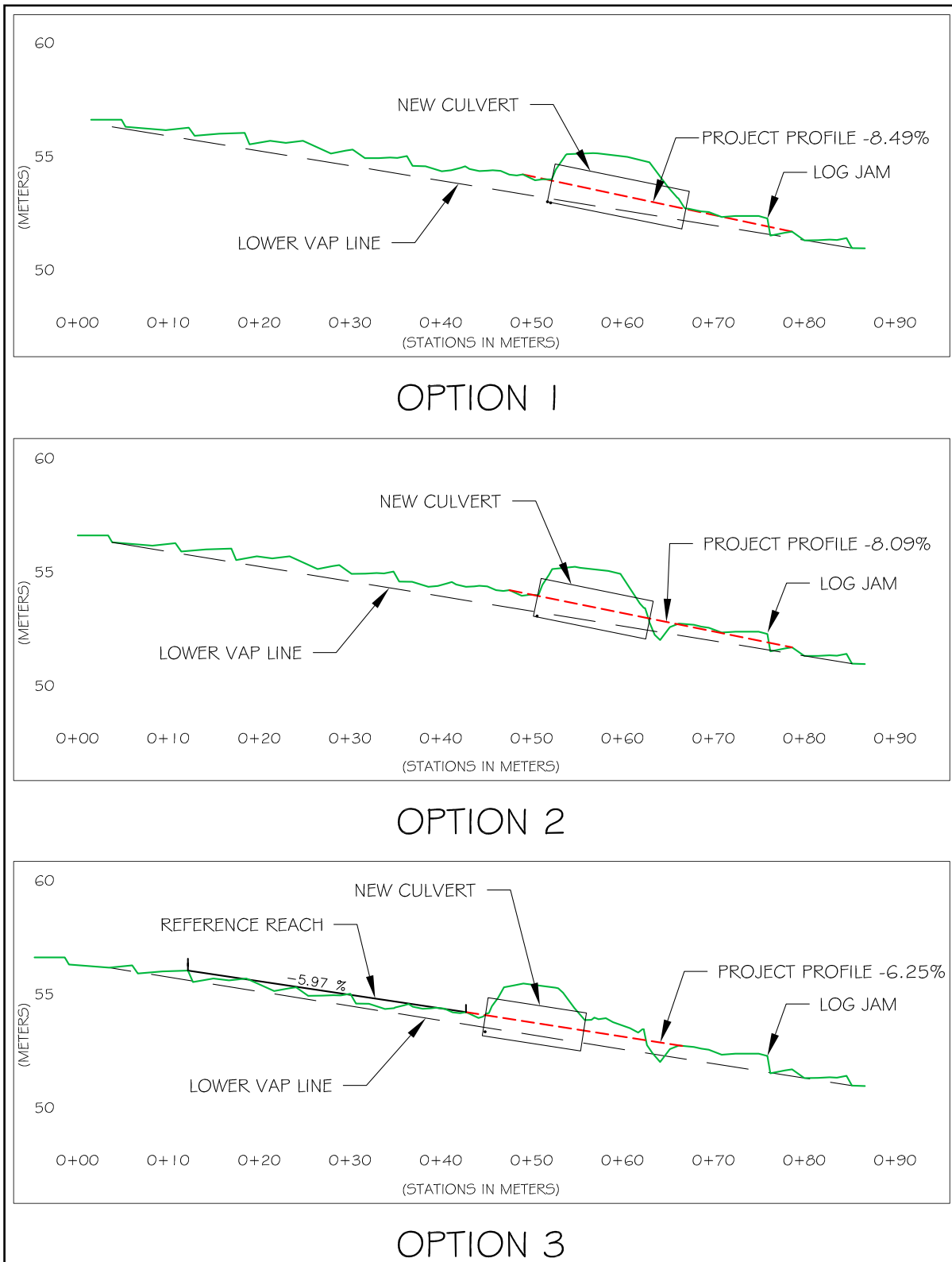

Figure 6.17—Channel and existing ground profiles associated with the alignment options. Project profiles are drawn between stable grade controls.

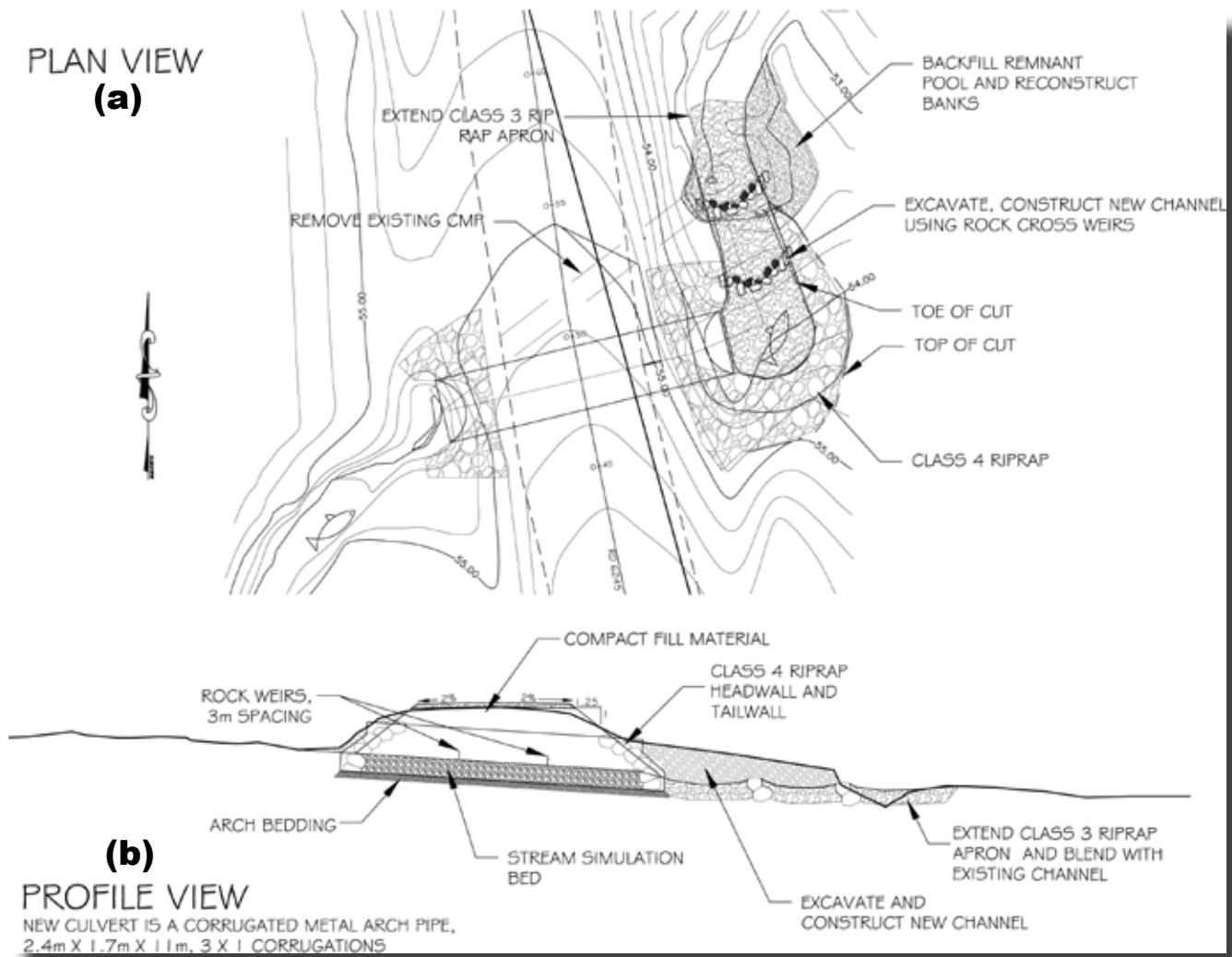

Figure 6.18—(a) Design site plan.(b) Design longitudinal profile.(c) Realigned channel at outlet.(d) Looking downstream through the finished stream simulation culvert. (Design by Robert Gubernick, Tongass National Forest, and Chinook Engineering.)

### 6.2 DESIGN OF THE STREAM-SIMULATION CHANNEL BED

After determining the best site layout (i.e., horizontal alignment and vertical slope profile), design the stream-simulation channel using the characteristics and dimensions of the reference reach.

This section describes design of the following streambed elements:

- Particle-size distribution of the bed material.
- Channel width and cross-section shape.
- Banklines, margins, and key features.
- Bedforms: pool-riffle, step-pool, or other sequences.

These elements control channel gradient and provide enough **flow resistance** (roughness) to maintain the diverse range of water depths and velocities needed for fish and other aquatic species passage. The reference reach is the template for all these elements. Flood conveyance considerations and other project objectives, such as terrestrial animal movement, will determine the amount of bank space allowed inside the structure.

One of the keys to stream-simulation design is creating roughness conditions that are similar to the reference reach. Total roughness depends on a number of features (see appendix A), including:

- Bed material particle-size distribution.
- Channel shape.
- Bedforms (fixed or mobile).
- Key features that constrict the channel and are major roughness elements.
- Vegetation.
- Bank irregularities.
- Channel bends.

Not all these features can be replicated inside the crossing structure, but the design still needs to approximate total reference-reach roughness. The following sections describe how to simulate those elements that can be simulated. Clearly, since channel bends cannot be simulated (except in very unusual circumstances—see section 6.1.1.3), a straight, uniform reference reach is ideal.



## Chapter 6—Stream-Simulation Design

Section 6.2.1 describes basic procedures for designing a simulated stream bed using reference reach characteristics. Section 6.2.2 covers special considerations for specific channel types. The key is to mimic those features in the reference reach that influence channel gradient, energy dissipation, bed stability, and physical and hydraulic diversity.

### 6.2.1. General Procedures for Simulated Streambed Design

#### 6.2.1.1. Bed material size and gradation in armored channels

Stream-simulation bed material is designed based on the reference reach particle-size distribution (see section 5.1.6.1). It should be well graded (consisting of a wide range of particle sizes), and it must include enough sand, silt, and clay (particles less than 2 millimeters in diameter) to fill voids between larger particles and reduce infiltration into the channel bed. The procedure described here produces a particle size distribution curve that approximates the reference reach. Later in the design process, particle sizes may need to be modified to deal with various risk factors; for example, you might increase particle sizes somewhat if the simulation needs to be slightly steeper than the reference reach (see section 6.5.1). Section 7.4.3 shows how to work the particle-size distribution curve into a contract specification.

If particle size results from a depth-integrated bulk sample of the reference reach are available, the simulation can have the same grain-size distribution as the bulk sample. However, bulk sampling is unusual in coarse-bedded streams because representative samples must be very large (section 5.1.6.1). Usually, stream-simulation bed-material gradation is based on the reference reach pebble count, which represents only the bed surface. In unarmored or weakly armored channels, the surface pebble count characterizes the entire streambed, and the simulation bed mix will have the same gradation as the pebble count. In armored channels, however, the surface pebble count underrepresents the smaller sizes in the subsurface, and therefore the smaller **particle size classes** must be either estimated or calculated. The  $D_{95}$ ,  $D_{84}$ , and  $D_{50}$  percentile particle sizes of the reference reach bed become the corresponding grain sizes of the stream-simulation gradation in both armored and unarmored channels.

The smaller grain sizes in the streambed are extremely important for **bed permeability** and stability. A porous bed can allow substantial infiltration and loss of surface flow. The simulation bed mix must therefore have enough fine materials (2 millimeters and finer) to fill the voids between

## Stream Simulation

---

the larger particles. Do not assume that the stream will transport sufficient fines to seal an open-graded bed surface, because a natural filling-in of the voids could take years. Cases exist where the entire summer streamflow infiltrated into the subsurface and flowed through the porous culvert bed for at least a decade after construction. The problem of loss of surface flow is especially critical in steep channels, where bed particles and voids between them are larger, and the steeper hydraulic slope can drive the flow into the subsurface.

Since pebble counts of armored bed surfaces underrepresent the finer material in the subsurface, grain sizes smaller than  $D_{50}$  must be determined another way. One method is the equation developed by Fuller and Thompson (1907), which defines dense sediment mixtures commonly used by the aggregate industry. This equation has not yet been widely field-tested for this application, so apply good professional judgment when using it.

The Fuller-Thompson equation is:

### Equation 6.1

$$P/100 = \left[ \frac{d}{D_{\max}} \right]^n$$

*where  $d$  is any particle size of interest,  $P$  is the percentage of the mixture smaller than  $d$ ,  $D_{\max}$  is the largest size material in the mix, and  $n$  is a parameter that determines how fine or coarse the resulting mix will be. An  $n$  value of 0.5 produces a maximum density mix when particles are round.*

The Fuller-Thompson equation can be rearranged to base the particle size determination on  $D_{50}$  rather than  $D_{\max}$ . Basing the calculation on  $D_{50}$  avoids a discontinuity in the particle size distribution curve, which otherwise occurs when the actual  $D_{50}$  is different from the value calculated from  $D_{\max}$ . The equations for  $D_{30}$ ,  $D_{10}$  and  $D_5$  are:

### Equation 6.2

$$D_{30} = 0.6^{1/n} D_{50}$$

### Equation 6.3

$$D_{10} = 0.2^{1/n} D_{50}$$

### Equation 6.4

$$D_5 = 0.1^{1/n} D_{50}$$

## Chapter 6—Stream-Simulation Design

To develop the particle-size distribution curve for the for the finer portion of the simulation bed mix, use  $n$  values between 0.45 and 0.70, a standard range for high-density mixes. The goal is a dense, well-graded bed mix with a percentage and type of fine material (sand, silt, clay) similar to the percentage and type in the reference reach subsurface. The fines are essential to limit infiltration into the bed and to help lock the larger pieces together. Type and percentage of fines vary with geology and stream slope, but generally the bed mix should contain at least 5-percent fines. If the  $D_5$  resulting from the Fuller-Thompson equation is larger than 2 millimeters (for  $n = 0.45$ , this occurs when  $D_{50}$  is larger than 330 millimeters or 13 inches), adjust the mixture so that fines comprise at least 5 percent. If your field estimates of fines (section 5.1.6.1) differ substantially from this, adjust the mixture to approximate the field composition.

Figure 6.19 shows how the results of the Fuller-Thompson method compared to field data for the South Fork Cache la Poudre River (figure 5.6). Field data for the surface armor are from a pebble count. The subsurface particle size distribution curve is from a sieved bulk sample.

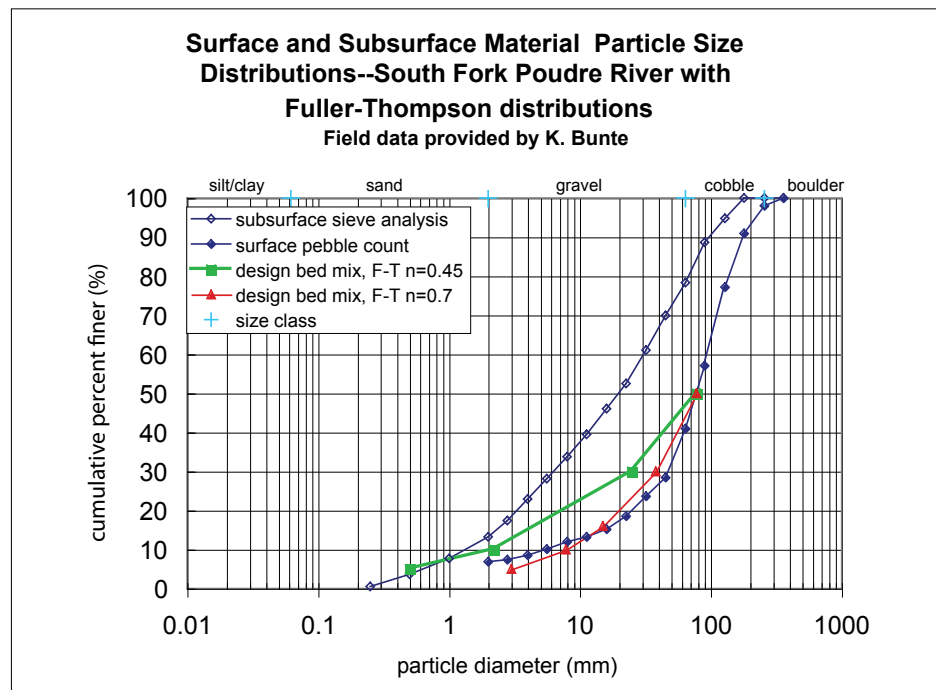

Figure 6.19—Bed material particle size distribution designed using the Fuller-Thompson method, compared to field data for the South Fork Cache la Poudre River. Field data provided by K. Bunte, 2004.

## Stream Simulation

---

The surface (“pebble count”) curve in figure 6.19 was used directly to define the larger particles of the design gradation. The lower half of the particle-size distribution curve can be anywhere between the two Fuller-Thompson distributions (labeled “F–T”) with  $n$  values of 0.45 and 0.70. In this case, selecting an  $n$  value of 0.45 produces a gradation with approximately 10-percent finer than 2 millimeters, a percentage close to the actual fines content in the subsurface.

Using the Fuller-Thompson method does not reproduce the natural subsurface particle size distribution in the reference reach subsurface, but it does result in a dense, well-graded distribution. Similar results may be obtained by smoothly redrawing the lower half of the particle size distribution curve by hand, such that the tail has an appropriate percentage of fines smaller than 2 millimeters.

Note that these design procedures result in a bed mix that is coarser overall than the reference reach subsurface gradation. This constitutes a safety factor for the simulated bed; if the bed scours, there will be additional armor material below the surface, and the resulting bed surface will become coarser and rougher.

The method of deriving a design gradation from the pebble count is not critical. What is critical is that the design gradation have the following key characteristics:

- Large particles ( $D_{95}$ ,  $D_{84}$ , and  $D_{50}$ ) that provide **bed structure** and buttress finer material should be accurately sized based on the reference reach. In channels where wood controls or influences the channel form, structures composed of angular rock can substitute for wood to simulate channel features in the crossing structure (see section 6.2.1.5).
- The entire bed mix should be **well graded** (poorly sorted). A dense, stable bed requires all particle sizes, so no gap in sizes should exist between any classes of material in the design bed mix. Ideally, each class of bed material that makes up the mix will be well graded, so that all sizes within the category are represented. This representation is especially important for the smaller-size fractions in a mixture that includes large particle sizes.
- The percentage of sand, silt, and clay should approximate the reference reach channel bed subsurface (visually estimated, see table 5.5), and should be adequate to limit bed permeability by filling voids between the larger particles. Including sand, silt, and clay in the simulation bed material commonly arouses concerns about

## Chapter 6—Stream-Simulation Design

water quality and habitat impacts, because some fine sediment in a freshly constructed bed will move during low flows, and could affect downstream fish habitats. Any such effects can be limited during construction by using water to wash the fine material down into voids between the larger particles in the bed (sections 7.5.2.3 and 8.2.11.2).

- Bed material rock should be durable, and it should be at least as angular as in the reference channel. If it is less angular, it may be significantly more mobile than intended. It makes sense to try to find local material, as it will more likely resemble the natural bed material.

### 6.2.1.2 Channel cross section

The width of the simulated channel is typically the bankfull width of the reference reach or greater. This is not necessarily equal to the culvert width (see section 6.3 for selecting culvert dimensions). Bank features and/or overbank flow surfaces may require additional culvert width.

In channels with **mobile beds** (dune-ripple, fine-grained pool-riffle), complex channel shapes like those that develop over time in a natural channel need not be constructed. However, some bank features should be constructed to set the stage for channel margins to develop (figure 6.20). Without constructed features, the bed initially tends to flatten into an unnatural flat surface. Then, the main thread of flow often migrates to the culvert wall and progressively erodes a trench along the wall.

In mobile channels, in addition to banks and any other key features, a roughly V-shaped low-flow channel can be constructed to help keep flow from hugging the culvert wall until a natural bed structure develops. The V-shape is not intended to persist; when high flows occur, they will redistribute the bed material and construct a diverse channel with a natural thalweg. The precise shape of the V-shaped initial low-flow channel is not critical; the channel in figure 6.20 has a 5h:1v lateral slope which is a reasonable starting point.

Stream simulations in less mobile channels are often constructed with some initial bed structure such as steps. Specifics for each channel type are described in section 6.2.2.

## Stream Simulation

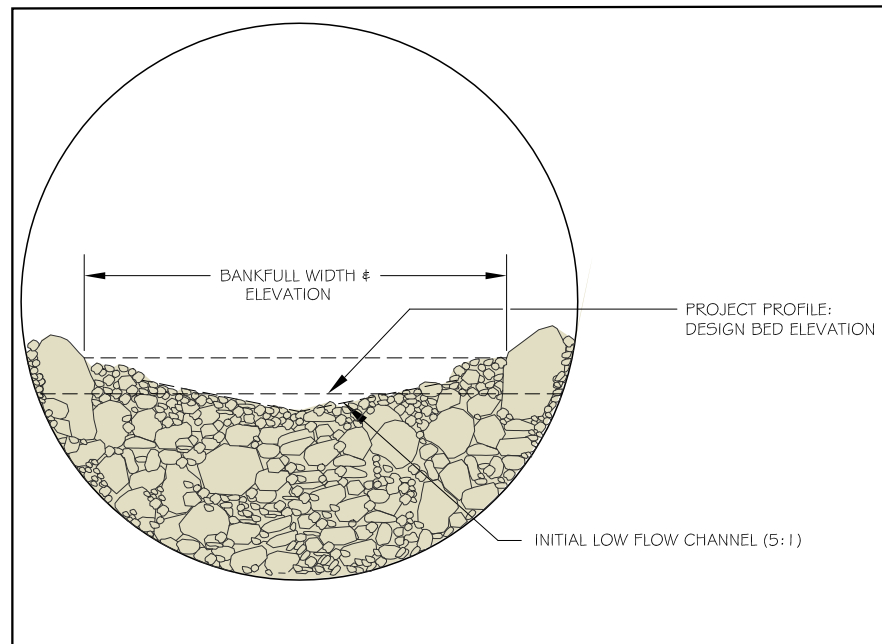

Figure 6.20—Channel cross-section shape in a stream-simulation channel with rock banks.

### 6.2.1.3 Bank and channel margin features

In natural channels, the diversity, roughness, and shape of channel margins and banklines are critical for movement of some species. For example, terrestrial animals may need dry passage; weak swimmers and crawling species may need margins of slow, shallow water with eddies in which they can rest. At flows between low-flow and bankfull, channel-edge diversity is necessary for accommodating the different movement capabilities of all aquatic species. Banks must continue through the inlet and outlet transitions.

Bars may form in a crossing structure—perhaps on just one side or through part of its length—and they may provide some of the benefits of a bankline. However, without root structure, cohesive soils, or the ability to scour into parent bed material, true banklines will not form naturally inside the structure. Therefore, specific channel-margin features should be designed into the project when they are needed for hydraulic roughness, habitat diversity, or for preventing channel trenching along culvert walls and protecting footings from scour. In designing the bankline/margin, use the reference reach bank height and bankline diversity (including frequency and size of wood or rock protrusions) as a guide. Where wood is an important feature on the channel banks, use permanent rock to simulate its functions.

## Chapter 6—Stream-Simulation Design

---

Because the intent is to create permanent bankline features, use material large enough to be stable during the **high bed design flow**. In the absence of vegetation, bank stability inside the structure will depend primarily on rock size, packing, clustering, and embedment. Base an initial estimate of rock size on the reference channel. As a starting point, bank material might be up to twice the size of  $D_{95}$  in the reference reach. If  $D_{95}$  is 3 inches or less, you can use 6-inch-minus quarry spalls or other rock. The size of rocks that appear to be immobile in the reference reach may also be a clue to sizing bankline rocks. Later in the design process (section 6.4.2), a stability analysis will verify that the bank rock and other key pieces are large enough to be immobile.

The simplest **bankline** is an irregular line of large rock placed along each wall (figure 6.20). Most natural banks are rougher and more diverse than that, and a discontinuous line of rocks or rock clusters may better simulate the reference reach (see figure 6.21). Clusters of rock obstruct any tendency to scour along the culvert wall, and help create the bed diversity that exists in natural channels where water deflects off bankline irregularities like woody debris or root-wads. Fill the spaces between individual bank rocks and between the rocks and the culvert wall with ‘filler’ material (section 7.5.3), so that the finer material helps to stabilize the larger rocks.

Overbank flow surfaces, or flood-plain benches, are sometimes constructed inside culverts (see 6.5.1.1). Construct them the same way as bank clusters or banklines, with the entire surface being stable rock infilled with filler material. The flood-plain bench should start at bankfull elevation on the margin of the bankfull channel, and slope up and out at about 10h:1v (figure 6.22).

One way of simulating a bankline in an open-bottom arch might be to roughen the concrete stem wall using embedded rocks or shaped concrete elements built into the wall. To our knowledge, no one has tested this method.

# Stream Simulation

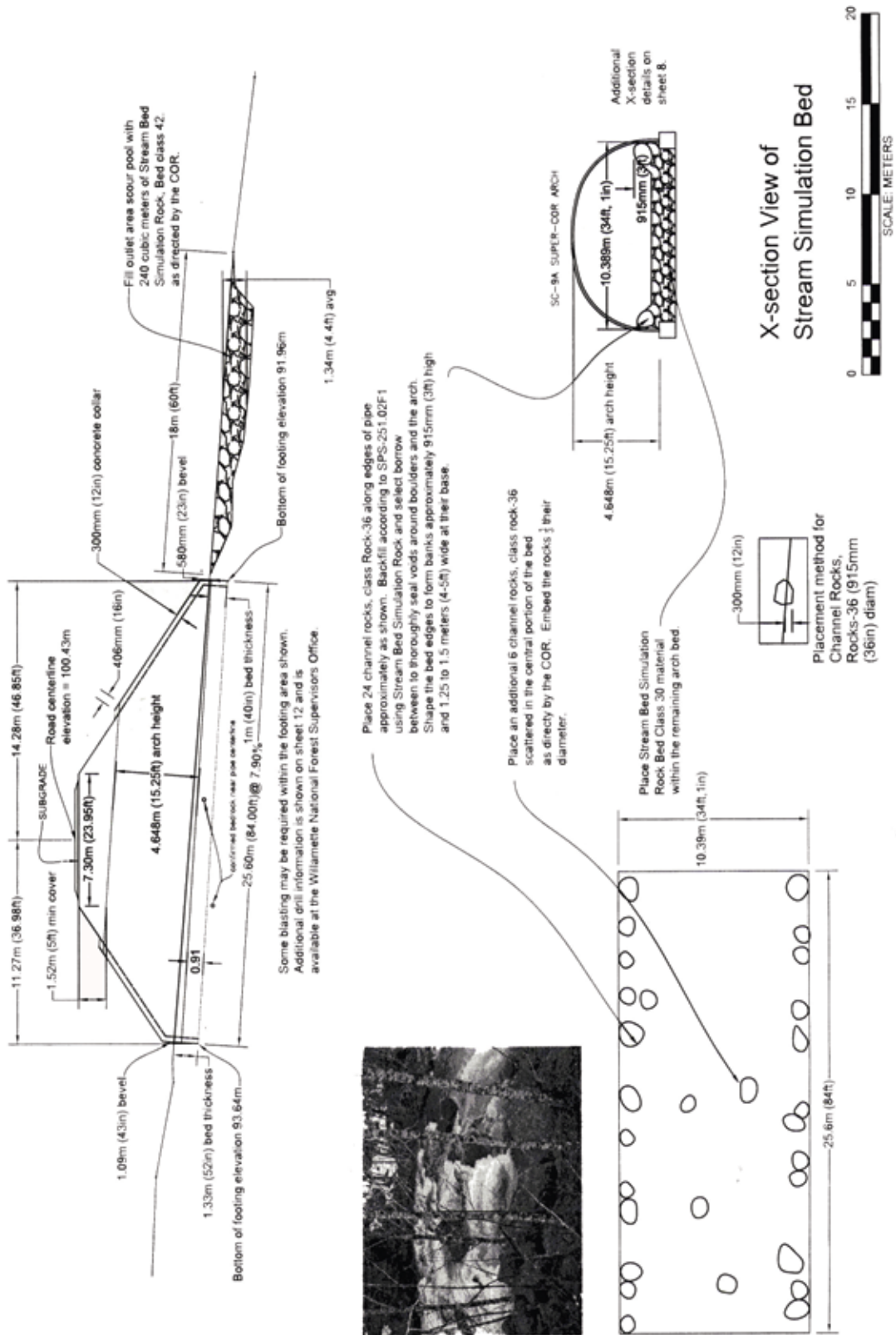

Figure 6.21—Open-bottom arch stream-simulation design showing bankline diversity. Design by Kim Johansen, Ore Creek, Siuslaw National Forest.



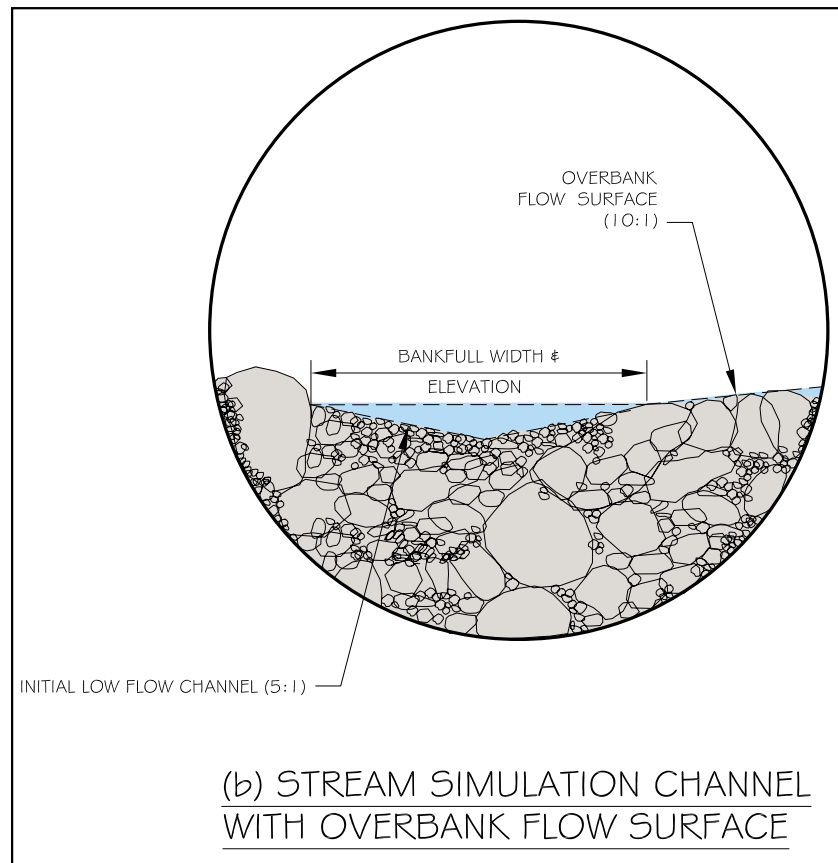

Figure 6.22—Stream-simulation channel with overbank flow surface.

### 6.2.1.4. Key features

Many forest streams have highly stable features, such as large wood, embedded or jammed wood, and large boulders, which may have fallen or slid into the stream or are remnants of glacial action. Other woody debris in the reference reach might take the form of small jams, buried wood that buttresses the bed and/or forms steps, or wood protruding from a bank. These ‘key features,’ often partially buried in the bed, may block part of the channel cross section and are long-lasting grade control and/or energy dissipation structures in the channel. Key features also include stable steps and **imbricated** or well-packed riffle crests that move only in infrequent high flows.

## Stream Simulation

---

Functions of these key features that need to be replaced in the simulated channel include buttressing the bed material and controlling grade, providing diverse hydraulic conditions that aquatic species can use for cover and resting areas, and providing hydraulic roughness.

*Streambed mobility is discussed in sections 5.1.6.1 and 5.1.6.2*

In current practice, key-feature roughness is simulated directly by imitating the size and distribution of individual elements using rock. Intermediate-mobility riffle crests and steps are constructed using rock sized like the rock forming those features in the reference reach (section 6.2.2.2). In the site assessment, separate measurements of 10 to 25 rocks from key features like riffle crests and steps were taken (section 5.1.6.1) as the basis for specifying rock sizes for these features. Slightly larger rock sizes, or more angular rock, may be needed to simulate the stabilizing effects of imbrication and particle packing in the natural channel that cannot be replicated in the simulation. Later in the design process (section 6.4), a bed mobility analysis will be conducted to check that these rocks are sized properly and will be as stable in the simulated channel as in the reference reach. In chapters 7 and 8—dealing with construction and contracting—these key-feature rocks are referred to as “**channel rocks.**” Various size classes of channel rock may be specified to simulate different channel-bed features.

Key features, such as embedded logs, often span the entire channel, and you should simulate them that way, constructing them like a step (see section 6.2.2.4), and simulating the height of the features in the reference reach. A cluster of rocks jutting out from the culvert wall can simulate a bank log in a natural stream, providing some edge diversity and helping prevent a low-flow trench next to the culvert wall. If space permits, simulate the roughness and functions of scattered or clustered boulders in the reference channel by placing the same general size and pattern of rocks in the stream simulation.

An alternative method of simulating roughness created by individual roughness elements in the reference reach would be to measure the total frontal area of all roughness elements in the reference channel and use boulders to reproduce it in the simulation. Ferro (1999) describes a method of quantifying the roughness created by various arrangements and concentrations of boulders placed on a gravel streambed. To our knowledge, this method has not yet been applied to stream-simulation design.

## Chapter 6—Stream-Simulation Design

For immobile key features, mimic the size of immobile rocks in the reference channel, and/or do a stability analysis (section 6.4). Rocks locked together in clusters are more stable than individual rocks and can be somewhat smaller. Angular rock is more stable than round rock. For these permanent key features, you can over-design rock sizes to reduce the risk of failure.

To protect the culvert floor, place large rocks carefully by embedding them into the bed mix rather than allowing them to drop directly on the culvert floor. Careful construction is essential, especially in steeper (greater than 6 percent) channels where less experience with stream-simulation construction exists. Energy dissipation by key features is critical for the stability of steep channel designs; if possible, consult with experienced stream-simulation practitioners about steep simulated-channel designs.

### 6.2.2. Bed Design Considerations for Specific Channel Types

*This discussion uses the channel classification system developed by Montgomery and Buffington (1997).*

The general procedures described in section 6.2.1 apply to all channel types. This section describes additional bed design considerations that apply to specific channel types. Table 6.5 summarizes important channel bed characteristics and channel design strategies for each type.

#### 6.2.2.1. Dune-ripple channels

Although dune-ripple channels are usually sand-bed streams (table 6.5), for design purposes we include channels with fine- and medium-gravel beds ( $D_{\max}$  is medium gravel, 16 millimeters or smaller). Creating custom bed material gradations (section 6.2.1.1) with these materials is impractical because  $D_{95}$ ,  $D_{84}$ ,  $D_{50}$ , etc., are close in absolute size. In addition, custom bed material designs usually are unnecessary for these fine materials. The bed typically mobilizes during moderate flows, and bed material turnover occurs frequently. Bank features may need to be constructed to avoid culvert wall trenching by providing edge diversity and the roughness present in the reference reach.

You might choose to allow the culvert to fill naturally with bed material if **sediment loads** are high and/or the culvert is backwatered by the downstream channel. This technique, however, has the potential to create a headcut in the upstream channel. Native bed material approximating

# Stream Simulation

Table 6.5—Bed material design considerations for various channel types

REFERENCE CHANNEL TYPE	TYPICAL CONDITIONS <sup>1</sup>			STREAM-SIMULATION DESIGN STRATEGIES
	Bed material	Dominant roughness and structural element <sup>2</sup>	Streambed mobility	
Dune-ripple	Sand to medium gravel	Sinuosity, bedforms, banks. Small debris may provide structure.	Termed “live bed”; significant sediment transport at most flows.	<ul style="list-style-type: none"> <li>● Simulated bed can be native bed material or imported dense mix based on reference reach.</li> <li>● Rock clusters (key features) added to simulate diversity from wood and bank shape.</li> <li>● Key features and banks designed to be immobile.</li> </ul>
Pool-ripple (mobile)	Fine to coarse gravel	Bars, pools, grains, sinuosity, banks	Bed is often armored; usually mobilizes near bankfull.	<ul style="list-style-type: none"> <li>● <math>D_{95}</math>, <math>D_{84}</math>, <math>D_{50}</math> based on reference reach.</li> <li>● Material smaller than <math>D_{50}</math> is dense mix based on <math>D_{50}</math>. (section 6.2.1.1)</li> <li>● Key features (rocks or rock clusters in bed and/or banks) added for diversity.</li> <li>● Key features and banklines designed to be immobile.</li> </ul>
Pool-ripple (intermediate mobility)	Coarse gravel to cobble	Bars, pools, grains, sinuosity, banks	Finer sediment moves over immobile armor layer at flows near bankfull. Armor layer mobilizes at higher flows.	<ul style="list-style-type: none"> <li>● <math>D_{95}</math>, <math>D_{84}</math>, <math>D_{50}</math> based on reference reach.</li> <li>● Material smaller than <math>D_{50}</math> is dense mix based on <math>D_{50}</math>.</li> <li>● Riffle crests constructed with material sized based on riffle crests in reference reach.</li> <li>● Key features, banklines designed to be immobile.</li> </ul>
Plane-bed	Gravel to cobble, usually armored	Grains, banks	May be either ‘mobile’ or ‘intermediate mobility’ (see pool-ripple).	<ul style="list-style-type: none"> <li>● <math>D_{95}</math>, <math>D_{84}</math>, <math>D_{50}</math> based on reference reach.</li> <li>● Material smaller than <math>D_{50}</math> is dense mix based on <math>D_{50}</math>.</li> <li>● Key features, banklines designed to be immobile.</li> </ul>
Step-pool	Cobble to boulder	Steps, pools, banks. Debris may add significant structure.	Fine material moves over larger grains at frequent flows. Bed-forming rocks move at higher flows depending on size; often $>Q_{30}$	<ul style="list-style-type: none"> <li>● Steps are spaced similar to reference reach</li> <li>● Step-forming rocks are sized to be immobile.</li> <li>● Smaller material size distribution is dense mix based on <math>D_{50}</math> of material other than steps in reference reach</li> <li>● Banklines designed to be immobile.</li> </ul>

<sup>1</sup> Based on Montgomery and Buffington (1997) with some modifications.

<sup>2</sup> Woody debris can be an important structural feature in any channel type.

Table 6.5—Bed material design for various channel types (continued)

REFERENCE CHANNEL TYPE	TYPICAL CONDITIONS <sup>1</sup>		STREAM-SIMULATION DESIGN STRATEGIES	
	Bed material	Dominant roughness and structural element <sup>2</sup>		Streambed mobility
Cascade	Boulder	Grains, banks	<p>Smaller bed material moves at moderate frequencies (floods higher than bankfull). Larger rocks are immobile in flows smaller than <math>\sim Q_{50}</math>.</p>	<ul style="list-style-type: none"> <li>● <math>D_{95}</math>, <math>D_{84}</math>, <math>D_{50}</math> based on reference reach.</li> <li>● Smaller material size distribution is dense mix based on <math>D_{50}</math>.</li> <li>● Key features, banklines designed to be immobile.</li> </ul>
Bedrock	Rock with sediment of various sizes in transport over rock surface	Bed and banks.	<p>Bedload moves over bedrock at various flows depending on its size. May be thin layer of alluvium over bedrock. Wood can strongly affect sediment mobility.</p>	<ul style="list-style-type: none"> <li>● Stream simulation bed is bedrock.</li> <li>● Banklines and roughness elements are important but difficult to design as stable.</li> <li>● Condition, extent, and shape of bedrock are important.</li> <li>● Bottomless structure reduces rock removal compared to full pipe and can be anchored and shaped to rock.</li> </ul>
Channels in cohesive materials	Silt to clay	Sinuosity, banks, bed irregularities	<p>Fine sediment moves over immobile bed at moderate flows depending on its size. May be thin layer of alluvium over immobile bed.</p>	<ul style="list-style-type: none"> <li>● Stable cohesive bed and banks cannot be constructed in culvert.</li> <li>● Culvert walls may simulate smooth natural clay banks.</li> <li>● Bottomless structure might leave clay bed undisturbed.</li> </ul>

<sup>1</sup> Based on Montgomery and Buffington (1997) with some modifications.

<sup>2</sup> Woody debris can be an important structural feature in any channel type.

## Stream Simulation

---

the reference reach size distribution may be available from the crossing excavation. If so, use it to fill the culvert. Since dune-ripple channels are not armored, mixing and replacing excavated bed material carries no great risk. Either use the bed material by itself, or supplement with imported material to make up the required channel-fill volume.

To achieve more or less the same initial mobility, use material that is similar to (and not larger than) the reference reach bed material. Rounded river rock is not always available as fill material, and quarried angular rock can be substituted. However, recognize that sediment mobility for angular rock may initially be somewhat lower than in the adjacent reaches. Including fines for sealing the bed is not necessary in these mobile channels.

Bed structures form readily in fine-grained channels, so building structure into the simulated channel generally is unnecessary. Nonetheless, consider the roughness characteristics of the reference reach. Small pieces of debris scattered and partially buried in the bed stabilize some fine-grained channels at slopes steeper than they would otherwise be. Although the small wood will be transported into the simulated channel over time, you may need to place it during construction if it is critical for maintaining initial slope. Again, bank features also may be needed to simulate the reference reach.

Dune-ripple streams are usually—though not always—unentrenched, and overbank flood-plain flows may occur frequently. The design issues associated with the road fill obstructing flood-plain flows (see section 6.5.1.1) can be very important. To accommodate some flood-plain flow and to avoid excessive bed and outlet scour at the culvert during floods, banklines and a flood-plain surface may be important components of a dune-ripple channel simulation. Off-channel flood-plain drainage structures also may be important.

### 6.2.2.2 Pool-riffle channels

The basic design process described in section 6.2.1.1 applies directly to mobile pool-riffle channels. For pool-riffle channels of *intermediate* mobility, riffle crests may need to be constructed as key features (6.2.1.4). Place constructed riffle crests or bars at locations on the project longitudinal profile where a riffle crest would naturally fit. Locate the riffle crests based on average riffle crest spacing in the reference reach unless the crossing site includes a channel bend where a pool is expected to form.

## Chapter 6—Stream-Simulation Design

In that case, locate the riffle crests where they would naturally fit upstream and downstream of the pool. Then, place any other constructed riffle crests at spacings within the range found in the reference reach (see riffle spacing, figure 5.19).

A constructed riffle crest is a structure that spans the channel as illustrated in figure 6.23. Rocks of similar size to reference reach riffle crest particles compose the structure (see section 5.1.6.1 for assessment procedure), and it is constructed with a low point in the center of the channel to help form the low-water channel. The objective is to establish grade control and energy dissipation structures with spacing and mobility similar to the reference reach.

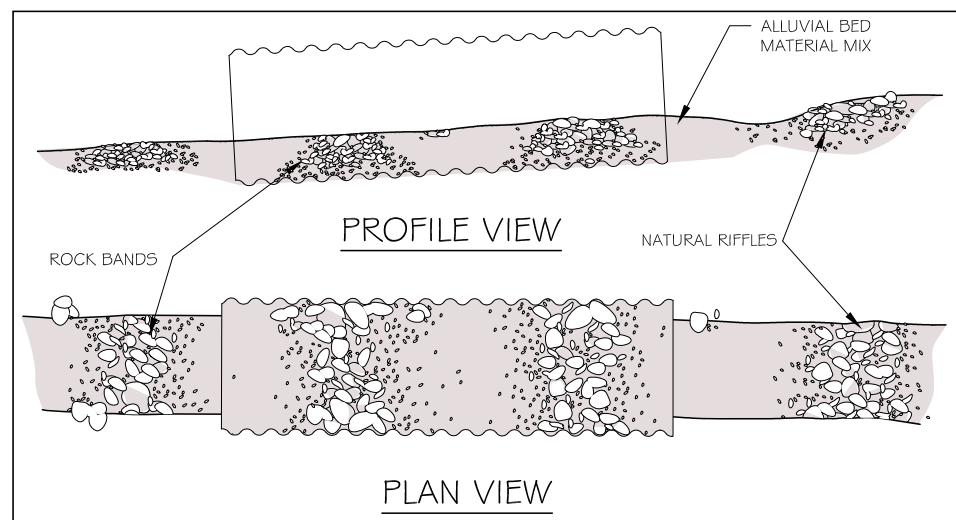

Figure 6.23—Placement of constructed riffle crests to simulate natural riffle crests of intermediate mobility.

*Refer to the Newbury Creek site assessment text boxes throughout chapter 5. They begin in section 5.1.1.*

Where imbrication, **embeddedness**, or any mode of particle packing increases the stability of riffle crests in the reference reach, constructed riffle crests will not achieve the same stability unless they are carefully constructed to replicate the particle packing. Figure 6.24 shows an example design, done by the Olympic National Forest project team for the simulated channel at Newbury Creek, which required constructing riffle crests by embedding rocks in an imbricated pattern. Recall that this is a cobble-bed pool-riffle channel, where riffle-crest materials are not mobilized until flows substantially exceed bankfull. Because the team did not expect bed structures to form rapidly, it decided to construct them. The **transverse bars** in figure 6.24 are analogous to riffle-crests in the reference reach. Rock spurs jutting out from the culvert wall mimic the indented and debris-strewn bankline in the reference reach. (see photo, figure 5.10).





### 6.2.2.3 Plane-bed channels

Plane-bed channels do not have regularly spaced bedforms. In these channels, although the bed is relatively featureless, large rocks protrude from the water surface at most times of the year. The basic design process (6.2.1.1) applies to plane-bed channels. Rock clusters along the culvert walls are recommended for helping to keep the thalweg from trenching along the wall and for fostering sediment deposition on channel margins. Bank features are important, because the bed itself has less hydraulic diversity than most channel types.

### 6.2.2.4 Step-pool channels

In this channel type, both steps and pools are important for energy dissipation and channel stability. Steps form when the largest particles in the bed congregate and support each other, creating a bedform that is more resistant to movement than the individual pieces. Usually boulders or logs form the step framework, which supports smaller cobbles and gravels. In nature, steps can take several decades to form (Madej 2001), depending on when channel-organizing flows occur and what key features are present. Bed-organizing flows are generally higher than bankfull; depending on the size and embedment of the step-forming materials, steps may not form at flows less than the 30-year flow or higher (Grant et al. 1990). Because steps are critical for energy dissipation and channel stability but are unlikely to form naturally in a short period of time, they should be constructed and monitored carefully after high flows.

Base step height and length on the reference reach, and keep step spacing within the range of variability observed in the reference reach (see figure 5.19). This ensures that step spacing is similar to the reference reach, while still allowing enough flexibility to tie the step-pool sequence into the stable profile endpoints. It also permits you to accommodate a channel bend that forces a pool in a specific location on the project plan and profile. Spacing is important because pools large enough for adequate energy dissipation must have room to develop, and each step affects the stability of the adjacent one. Steps in natural channels are typically spaced one- to four-channel widths apart and are closer in steeper channels.

To construct the steps, use rocks at least as large as the step-forming rocks in the reference reach. The rocks should have similar roundness or angularity. Embed or layer the rocks to below the expected depth of pool scour in such

## Stream Simulation

a way that the lower rocks support those above them. Construct steps with the expectation that individual rocks will adjust their position during high flows and lock together. Until the larger particles adjust and support each other, they are vulnerable to being scoured out of the culvert. Therefore, a conservative objective—designing the steps to be immobile for the life of the project—is a wise approach (section 6.4).

In a step-pool channel, even with a bankfull-width culvert, bed-organizing flows may be more confined than in the natural open channel, and shear stress in the culvert may be higher. Steps may not reform inside the culvert if the constructed ones wash out. For this reason and because of the potentially long time before new boulders might be recruited during subsequent high flows, designing steps for immobility is common practice. You can increase rock angularity and/or size (as compared to the reference reach) to increase stability.

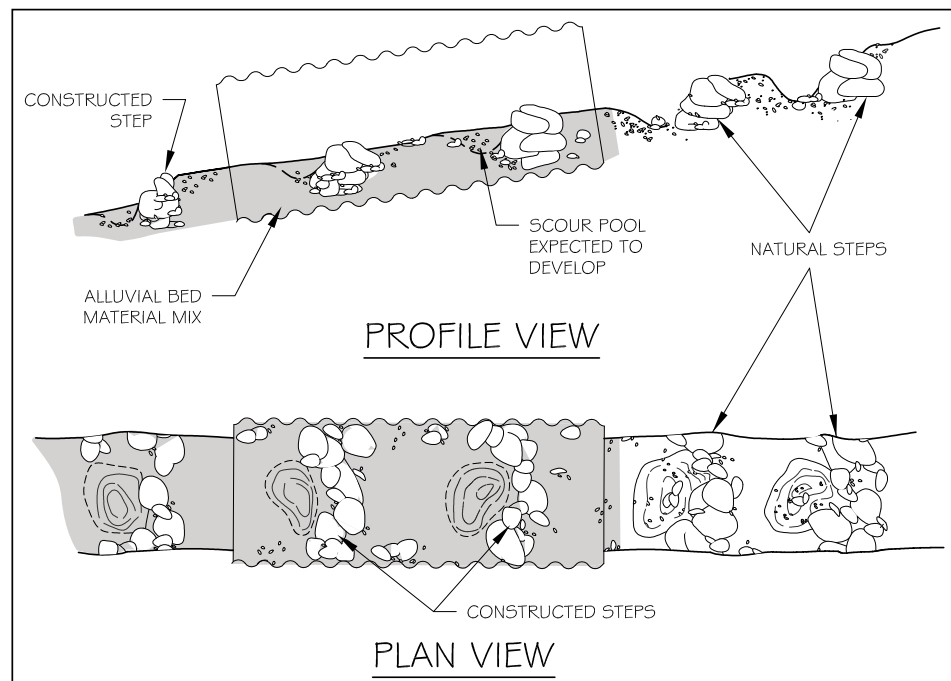

Figure 6.25—Schematic of step-pool stream-simulation design.

Aside from the steps themselves, design the step-pool bed mix based on the reference channel pebble count (see basic design process, section 6.2.1.1). Frequent high flows scour and replenish the finer material between steps as bedload moves through the system.

## Chapter 6—Stream-Simulation Design

Once the steps are in place, pools will form naturally during moderate flows and generally do not need to be constructed. Pools are typically wider than steps, and the simulated channel should be as wide as maximum pool width in the reference reach. This will allow pools to form that are large enough to achieve the same degree of energy dissipation as in the reference reach.

As a safety factor in steep (greater than 6 percent) simulations, bed retention sills are sometimes used for buttressing the steps and preventing material from sliding or washing out of the culvert. These sills may consist of metal, wood, or logs fastened in place. Unlike baffles, bed retention sills are not intended to control water velocity, and they do not extend above the surface of the streambed. Neither are they intended for placement in a bare pipe to trap bedload in transport. Place the tops of the sills below the lowest potential bed profile (lower VAP line), so that they will not be exposed above the streambed surface over the project lifetime (figure 6.26).

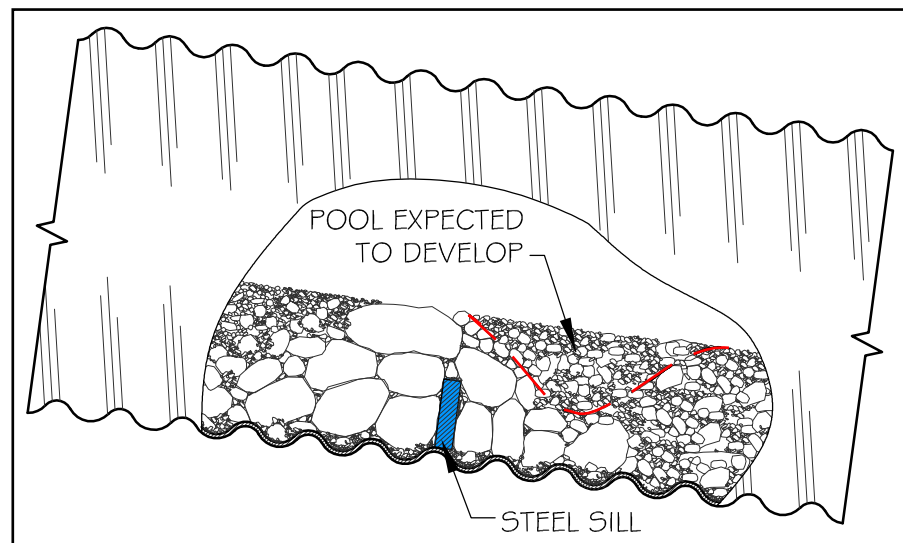

Figure 6.26—Profile view of steel bed-retention sill stabilizing a boulder step (cutaway view).

### 6.2.2.5 Cascade channels

Cascade channels are steep (greater than 8 percent), and their largest bed particles are large relative to normal flow depths (Montgomery and Buffington 1993). Energy is dissipated by water flowing over or around individual rocks. Smaller sediments move over or around the larger rocks at flows somewhat larger than bankfull. Rocks that are key to bed structure and stability, however, are immobile up to very high flows (greater than 50-year). Again, at these flows, shear stresses inside a pipe may be higher

## Stream Simulation

---

than in an open channel. Bed stability is critical in a simulation because, if the bed fails, the bare culvert is unlikely to recover naturally. On a simulation this steep, after sizing the bed material based on the reference reach, conduct a hydraulic stability analysis (section 6.4) to ensure that the largest bed-forming particles (e.g.,  $D_{84}$  and  $D_{95}$ ) are stable in the design flood. Also consider using bed-retention sills as in step-pool channels.

### 6.2.2.6 Bedrock channels

If a culvert is being replaced and the adjacent channel is primarily bedrock, investigate the channel and likely footing locations to determine bedrock location, elevation, and suitability for a foundation. If the road is located on a concave transition, be aware that the steeper channel upstream may be bedrock while the flatter culvert site is on erodible **fluvial** material.

If the bed at the site of a new crossing is sound bedrock continuous throughout the site, stream simulation may consist merely of placing an open-bottom arch culvert over the bedrock. Depending on the shape of the rock surface, you might anchor the entire footing to it, with a stem wall extending up to the bottom of the prefabricated culvert. The height of the footing and stem wall accommodate any variation in the bedrock surface. Where exposed bedrock is tilted, a deep, smooth channel may form along one wall of the culvert at low flow. In such situations, consider adding boulders for roughness and to deflect flow toward the center of the structure. You may need to use special construction procedures, such as embedding, anchoring, or clustering, to keep large boulders from rolling or sliding out of a bedrock channel.

Frequently, bedrock is exposed in the channel bottom while the streambanks are composed of alluvial or colluvial material. The banks may have large roughness elements, such as wood and single or clustered boulders. These may be important key features for retaining sediment and debris that provide diverse habitats and migration pathways in bedrock channels (McBain and Trush 2004). Channel margins and/or banklines therefore may be important to the objective of the project.

Bedrock channels sometimes exist where a bed of alluvial material has scoured, leaving the bedrock exposed. This exposure often occurs where woody debris has been removed or where a debris flow has scoured the channel to bedrock. Bedrock that does not show typical erosional features, such as fluting, longitudinal grooves, or potholes, could indicate that an alluvial veneer has recently washed away. In these cases, consider placing

## Chapter 6—Stream-Simulation Design

debris and/or immobile key feature rocks to help develop a natural alluvial bed and/or to stabilize a constructed bed. Exposed bedrock with no evidence of fluvial erosion also may result from channel incision caused by channel realignment and straightening during placement of the previous culvert. This can be a signal to seriously consider correcting the alignment during the replacement project.

### 6.2.2.7 Channels with cohesive bed material

A channel with cohesive bed or banks cannot be constructed inside a pipe. For new installations in cohesive bed channels, avoid disturbing the bed. The best stream-simulation alternative is probably to span such a channel completely, using a bridge or arch. Cohesive-bed channels often pose foundation challenges, and require a good geotechnical investigation.

## 6.3 CROSSING STRUCTURE DIMENSIONS AND ELEVATION

Now, for the first time in the design process, we consider the crossing structure itself. Up to this point, we have used geomorphic design methods to define both the probable range of stream profiles at the site and the size, shape, materials, and arrangement of the stream-simulation channel bed. Now we size the structure by fitting it around the designed channel. This discussion is primarily about culvert design, but similar width and height considerations also apply to bridges.

Culvert elevation and dimensions are determined at this point because they affect the bed mobility calculations in the next design step. It may take several iterations to select the final dimensions, because the bed mobility calculations (section 6.4) may indicate the need to change culvert dimensions. Only the dimensions and elevation of the culvert are determined in this step; many other considerations enter into the final choice of structure type and materials. Section 7.2 discusses them at length.

One of the goals in stream simulation is that the simulated channel be self-sustaining. That means it must simulate the hydraulics of the natural channel at sediment-transporting flows, especially the flows that create and rearrange major bed structures. To achieve these objectives, the simulated channel must be free to adjust to changes in incoming flow and sediment loads, and the culvert must be large and embedded deeply enough to accommodate both vertical and lateral adjustments.

## Stream Simulation

---

Several factors go into determining culvert size and elevation. These include:

- The bankfull width of the channel.
- The width of any banklines and overbank surfaces.
- The range of possible bed profiles (VAP).
- The maximum sizes of alluvial and immobile rocks.
- The results from the bed stability and flow capacity analyses (6.4 and 6.5.2.1).

The structure must satisfy all these conditions at the same time.

### 6.3.1 Culvert Width

A variety of factors determine the structure width needed to achieve project objectives and to accommodate site conditions (see table 6.6).

*Table 6.6—Considerations affecting choice of stream-simulation culvert width*

<b>Based on project objectives:</b>
• Width of bankfull channel.
• Stability of the simulated streambed.
• Hydraulic capacity of the culvert.
• Risk of blockage by floating debris or beaver activity.
• Construction, repair, and maintenance needs.
• Passage of nonaquatic species.
• Meandering channel pattern.
• Protection of flood-plain habitats.
<b>Based on site characteristics:</b>
• High flood-plain conveyance and potential to concentrate overbank flows in culvert.
• Channel migrating laterally.
• Wider channel expected in future.
• Channel skewed to road crossing or crossing on channel bend.
• Ice plugging in cold climates.
• Large bed material relative to culvert width.

Extra structure width is necessary for creating a stable bankline without constricting the bankfull channel. In entrenched and moderately **entrenched channels**, the first estimate of culvert width is simply the width needed to span the simulated bankfull channel plus the size of the rocks used to construct the banks (figure 6.27). This initial estimate,

## Chapter 6—Stream-Simulation Design

of course, is subject to change depending on the results of the stability analysis of the bankline rocks. As noted in section 6.2.1.3, where the reference reach has a rough, irregular bankline, the simulated banks may be laterally deeper and may require more structure width.

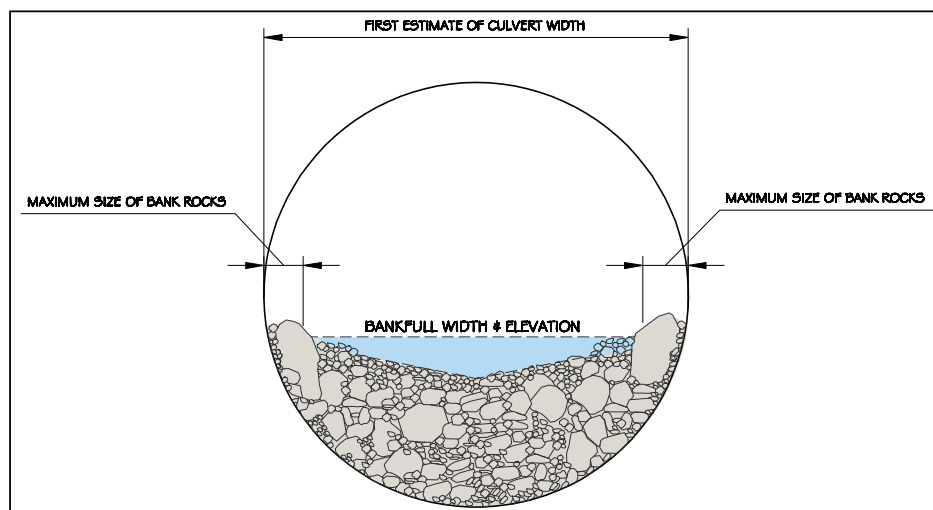

Figure 6.27—For a stream-simulation design with banks, minimum culvert width is bankfull width plus twice the maximum diameter of rocks used to construct the banks.

In an unentrenched channel with an active flood plain, the road fill could block overbank flood flows and force them through the culvert. Section 6.5.1.1 discusses at some length the risks associated with flow concentration in active flood plains and their possible solutions. Placing additional culverts or dips that permit flood-plain flow through or across the road fill may reduce the risk to acceptable levels. If not, you may also need additional culvert width to allow for an overbank-flow surface within the culvert (figure 6.22).

In choosing culvert width, also consider how the largest key-feature rocks (or rock clusters) in the simulated bed will interact with rock and wood pieces moving during high flows. A natural channel can usually scour around a large boulder or debris accumulation. In a culvert, however, a large individual boulder can create a constriction or form a bridge with other large particles, creating a culvert-wide drop structure or debris jam, and possibly limiting aquatic species passage, culvert capacity, and/or bed stability. A good guideline is that bankfull bed width inside the culvert should be at least four times the intermediate diameter of the largest immobile particles in the simulated bed.

## Stream Simulation

---

Early in their development, incising channels may look narrow, but they will widen with time because the banks become unstable and fail in response to bed lowering (Schumm et al. 1984). Size a stream-simulation culvert to anticipate the expected widening of the natural channel near the crossing. On the other hand, if a channel is unnaturally wide from disturbance, and you expect it to narrow in the future, size the culvert for the current channel, with the expectation that recovery will occur inside the culvert as in the adjacent reaches.

As noted in section 6.1.1, you may need to increase culvert width if the culvert is skewed to the road alignment or if natural lateral migration of the channel will likely create a skewed-inlet condition.

### 6.3.2. Culvert Elevation and Height

Points on the stream channel bed may at some time be at any elevation within the range of potential vertical adjustment (see section 6.1.2.2). The culvert invert elevation and culvert height must allow for these vertical bed elevation adjustments over time. The stream simulation bed should be thick enough (and the invert deep enough) to avoid exposing the bare culvert floor during floods, and to allow large particles to be supported by the finer bed matrix, even at the bottom of a pool at the lowest potential bed elevation (figure 6.28). To achieve this, set the elevation of the bottom of the culvert or footing below the lower VAP line, adjusted to include the estimated depth of streambed scour during floods (2 times  $D_{90}$ , see section 5.2.2.2). For bottomless culverts, structural design of the footing and any engineering scour analysis that may be conducted may dictate a lower elevation (see section 7.3.2). Placement of bank rocks to protect footings may also affect their depth.

Once the culvert invert elevation is set, determine the culvert height needed to maintain flood and debris capacity when the bed is at its highest possible elevation. Setting the widest point of a round culvert at or above the highest potential bed elevation is an efficient design technique because it uses the full width of the culvert. Generally it also ensures headroom for floodwater and debris, although very large floating debris may not clear the inlet of the pipe during very high flows.

Recheck both culvert height and width after selecting the high bed-design flow. The bed-design flow is the highest flow that immobile particles are designed to sustain without moving. They are unlikely to remain in place if the culvert inlet becomes submerged and pressurized during a flood. For stability, we



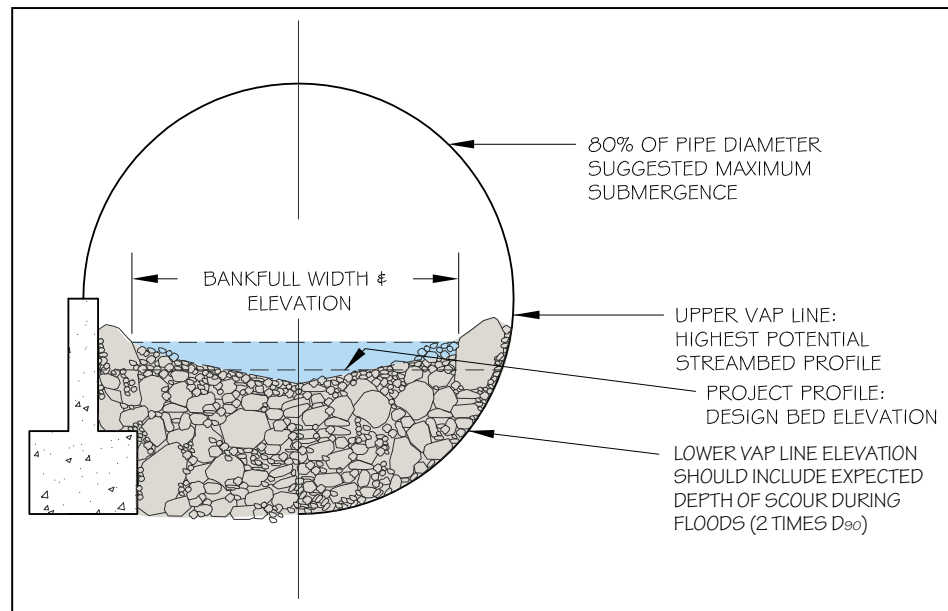

Figure 6.28—Embedment for full-pipe and bottomless culverts.

recommend that the inlet not exceed 80-percent submergence during the high bed-design flow, 67 percent where woody debris is a significant concern. Ensure that the actual free space is large enough to accommodate the size of debris moving in the channel. Naturally, this does not apply to submergence caused by backwatering when water levels are similar on both sides of the crossing.

The culvert also must be able to convey the structural-design flow. Flows that exceed the structural-design flow may destroy the crossing or cause the stream to divert down the road. Select the structural- and bed-design flows based on tolerable probabilities of exceedence (section 6.5.2.1) and the consequences of each type of failure. The two flows may be different, because the consequences of each failure type are different. For example, you may be able to accept the bed's washing away in a lower flow than one that could destroy the entire structure—because the bed material is replaceable. Where bed-load transport is high enough, sediment will be replenished, and the bed may reconstruct itself as the flood recedes. Provide a safety factor for invert depth and/or culvert height commensurate with the level of uncertainty and the risk of failure. Where the consequences of failure are large, use a larger culvert or a deeper footing.

## Stream Simulation

### Hypothetical small-stream culvert sizing example

Some small streams can have a relatively large range of vertical adjustment potential. A good example is a 4-foot-wide meadow stream with densely vegetated 1-foot-high banks and pools as deep as 1 foot. Bed material  $D_{90}$  and  $D_{95}$  are 2 inches and 2.5 inches, respectively. After delineating the VAP lines on the longitudinal profile, we find that at the cross section shown in figure 6.28 the upper VAP line is at the top of the banks, and the lower VAP line is 1.33 feet below the project profile. The lower VAP line here includes 1 foot for reference reach pool depth, and 0.33 foot to allow for the depth of scour during floods (2 times  $D_{90}$ ).

The culvert should be wide enough to allow for placement of bank rocks, which are needed for simulating reference reach bank roughness. An initial estimate of the size of stable bank rocks is 2 times  $D_{95}$  or 0.4 foot (see section 6.2.1.4). The first estimate of culvert width is 4.8 feet: 4 feet to accommodate bankfull width, and 0.8 foot to allow for stable rocks on both banks. The culvert also should be embedded deeply enough that the channel bed never scours to bare metal. In this example, we could conveniently use a 5-foot round culvert. Then, if the invert is 0.25 foot below the lower VAP line (2.6 feet below the upper VAP line at bankfull elevation), the project profile (bed elevation to be constructed) will be at 32 percent of culvert height, and the upper VAP line will be at 52 percent.

Next, check culvert capacity for the eventuality that the streambed aggrades to the upper VAP line. Ideally, the culvert will be large enough to allow passage of the bed design flow with at least 1 foot of headroom (80-percent submergence). Assuming headroom is adequate, embedding the culvert slightly below the lower VAP line is simply a small additional safety factor; it may or may not be necessary depending on site risk factors affecting scour potential.

After you analyze bed stability (section 6.4), you may need to reevaluate culvert size.

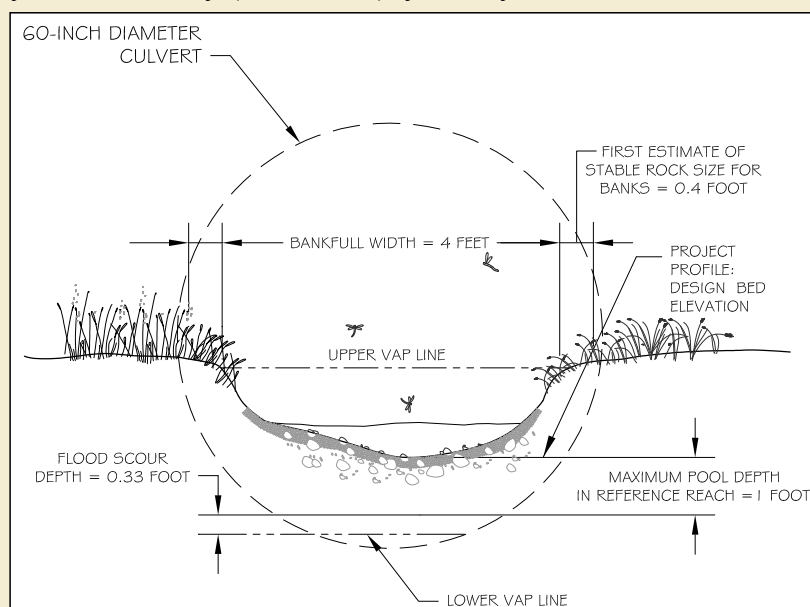

Figure 6.29—Hypothetical example of using reference reach channel size and bed material (described in text) to size a small culvert. VAP lines shown in the figure were determined from a longitudinal profile analysis. This drawing does not show the designed simulated channel bed; rather, it shows how the culvert would fit around the reference reach.

### 6.3.3 Culvert Shape and Material

Aside from the size, elevation, and alignment issues already discussed, most of the considerations for culvert shape and material involve site conditions, designer preference, and cost. These considerations include:

- Commercial availability.
- Structure longevity.
- Road elevation and fill height.
- Streambed and culvert constructability.
- Construction time, sequencing, and allowable ‘in-water’ work period.
- Soil-bearing capacity.
- Site access.
- Flood capacity.

Guidance for selecting culvert shape and material is in section 7.2.

### 6.4 BED-MOBILITY AND STABILITY ANALYSIS

The purpose of bed-mobility/stability analysis is to answer the following questions:

***Do the bed materials in the simulation move at the same flows as those in the reference reach?***

The analysis is useful where the simulated channel design differs from the reference reach with respect to slope or entrenchment. At other sites, the analysis may or may not be needed, depending on channel type, risks associated with the site, etc.

***Do key particles that control channel form and hydraulics stay in place during the high bed-design flow (section 6.4.5)?***

The bed-mobility analysis compares critical flow for **entrainment** (the flow at which a particle just begins to move) in the reference reach to critical flow in the culvert for the particle size of interest. Except for the least mobile channel types (coarse step-pool and cascade channels), stream simulations should be designed such that bed particles of similar size become mobile at similar flows in the reference reach and the stream-simulation reach:

**Equation 6.5**       $Q_{c \text{ culvert}} \approx Q_{c \text{ reference reach}}$

## Stream Simulation

---

where  $Q_c$  is the critical **entrainment flow** (or the critical shear stress) for the particle size of interest. When this goal is achieved, the amount and size of incoming and outgoing sediment balance, maintaining the bed structure and bed forms that are necessary for aquatic organism passage. In the mobile channel types, only banklines and other large key features are routinely designed to be permanently stable.

If the simulated channel closely mimics the reference reach, bed-mobility analysis will show that similar particle sizes move at similar flows in both channels. If the simulation is steeper than the reference reach, the designer can use the analysis results to adjust the simulation design for similar bed mobility. Adjustments can be made to one or a combination of design parameters, such as bed-material size, channel width, and flood-plain capacity within the culvert. Adding flood-plain relief dips or pipes and changing the project profile are other ways to adjust the design.

To ensure that the simulation achieves its objectives, keep it within the range of natural variability in the reference reach. As a rule of thumb, increase slope, bed-material sizes, and/or active or bankfull channel width no more than about 25 percent unless you have a clear understanding of the implications of a greater change.

### 6.4.1 When is a Bed-mobility Analysis Necessary?

Mobility analysis usually is not conducted on low-gradient, fine-grained response channels where the bed is fully mobile during frequent high flows. After a flood, such channels reestablish preflood-channel form more quickly than coarser-grained channels. In straightforward projects (e.g., a stable, moderately entrenched, moderate-gradient, gravel pool-riffle channel where the culvert bed closely replicates the reference reach) you can assume similar bed mobility. Again, bed-mobility analysis usually is not necessary.

Intermediate-mobility channels (coarse pool-riffle, plane-bed, and perhaps some cobble step-pool channels) do require a bed-mobility analysis. They may be fully mobile at flows that are fairly frequent (5- to 10-year **recurrence interval**), yet infrequent enough that a partial bed failure may not recover to its preflood channel form within a reasonable time. In these channels, risks may justify evaluating whether the same sizes are entrained in both the structure and the reference reach over a range of flows from bankfull to the high design flow (see the example illustration of such an analysis in appendix E).

## Chapter 6—Stream-Simulation Design

It is most important to analyze bed mobility when the slope or entrenchment of the simulated channel differs somewhat from the reference reach. Sections 6.5.1.1 and 6.5.1.2 discuss the analysis in greater detail.

### 6.4.2 What Particle Sizes Are Analyzed?

Generally bed-mobility analysis is done on the portion of the bed material that provides structure, stability, and roughness, that is, the larger sizes.  $D_{84}$  is the recommended grain size to analyze in most cases because when  $D_{84}$  is mobile, most of the smaller bed sediments are mobile as well.  $D_{95}$  also can be used as a more conservative indicator of ‘bed mobility.’ Where riffle crests or bars are designed and built, as in the Newbury Creek example (figure 6.23), the particle-size class used to construct those features would be analyzed. The aim of the mobility analysis is not to make the channel stable; the goal is to create a channel bed in the simulation reach that has similar sediment transport characteristics to the reference reach.

### 6.4.3 What Flows Are Analyzed?

This is a comparative analysis, which does not require working with a flow of any predetermined return interval. First, find the flow that entrains  $D_{84}$  or  $D_{95}$  in the reference reach. Then, determine whether the same flow entrains  $D_{84}$  in the simulated channel. To verify that the calculated critical flow is valid, estimate its recurrence interval and compare it to the bed mobilization flow ranges listed in table 6.5 for the channel type.

If the critical flow in the simulation is different from that in the reference reach, various design parameters can be adjusted until the same flow moves  $D_{84}$  in the simulation. See section 6.5 and appendix E for examples and more explanation.

### 6.4.4 Bed Mobility Analysis Equations

Bed mobility is evaluated using equations that estimate the critical flow for entrainment of specified particle sizes (the flow at which a particle just begins to move). Because these equations do not apply equally to all stream types, and because a great many variables are involved, this guide devotes appendix E to presenting and discussing them.

## Stream Simulation

---

Briefly, the most useful equations for stream-simulation applications are:

- The critical unit discharge equation (Bathurst 1987).

This equation estimates the critical unit discharge (flow per unit channel width) at which a particle of a certain size will begin to move in a steep, rough channel. The equation applies to steep (3.6 to 5.2 percent), gravel-cobble channels where water depth is shallow compared to the size of the bed material.

- The modified critical shear stress equation.

This equation can be used to assess particle stability in channels with gradients less than 4 to 5 percent and  $D_{84}$  particles ranging between 10 and 250 millimeters.

Like all hydraulic and hydrologic models, these equations approximate and simplify the real world. The Bathurst and modified critical shear stress equations apply best in alluvial settings; they do not account for the stabilizing effects of key features, such as embedded debris or **colluvium**. All the equations are based on empirical field and laboratory studies with data sets of limited size and variability, and they should be applied within those limits. In some cases, where it is not evident which equation is most appropriate, use more than one and compare the results. Understanding why the results differ can be important in developing a good design. Appendix E describes in some depth the background and limitations of the equations. It also provides examples of applying the equations to stream-simulation problems.

Do not allow the equations to drive the design. Instead, use them as tools to validate the design and check the results against your understanding of how the channel will function in real life. Visualize how the channel will look and function as it adjusts over time, and use the equations to help predict bed mobility in different channel/structure configurations. The equations allow you to test the sensitivity of the bed to changes in different design parameters (e.g., slope, width, bed-material size). Test sensitivity by varying design values in the equations to see if the changes greatly affect the results. The risk of error is less when changes to the results are small.

If increasing bed-material size or channel width by 25 percent is not sufficient to match bed mobility in the simulated channel with bed mobility in the reference reach, review section 6.5 on managing risk in various situations. You may need to consider selecting a new project profile. Alternatively, you may decide that stream simulation is not feasible at the site.

### 6.4.5 Stability Analysis for Immobile Key Feature Rocks

The stability of key features that are intended to be permanent is crucial to a stream-simulation installation's long-term sustainability. Because of the closed boundary in a culvert, a large flood may exert higher shear stresses and cause more turbulence than an open channel. Particles of a given size may move at lower flows than in the reference reach, and large rocks may not be replaced as the flood recedes. Loss of bed structure—possibly of the whole bed—could be essentially permanent. Therefore, design these structural pieces to be immobile at the high bed design flow:

**Equation 6.6.**  $Q_{c \text{ key feature in culvert}} \geq Q_{\text{bed design}}$

where  $Q_c$  is the critical entrainment flow (or critical shear stress) for the rock size of interest.

This analysis consists of verifying that the bed-design flow will not mobilize the rocks that comprise the key features. The bed-mobility equations described in 6.4.4 and appendix E can be used for this analysis. Their results should be compared to results from equations developed to size boulder clusters and riprap blankets (appendix E.4). Accurately estimating entrainment flow for rocks that are embedded in much finer material is difficult, so it is wise to compare the results of several equations. The best validation is the size of material that appears to be immobile in the reference reach.

## 6.5 MANAGING RISK FACTORS

This section recaps the risks associated with stream-simulation culverts as well as other culvert types, and outlines approaches to mitigating them. Section 6.5.1 focuses on risks specific to stream-simulation installations, while section 6.5.2 looks at risks that apply to all culverts.

In any situation, there are two ways to “manage” risk:

First, *reduce the probability* of failure by identifying the processes or conditions that could lead to failure, and by mitigating them in design or construction. “Failure” in this context means not only structural failure (culvert washes out, flow diverts down road, etc.), but also failure to achieve stream-simulation objectives. Simply having bed

## Stream Simulation

---

material inside a culvert does not constitute stream simulation. For the project lifetime the simulated streambed should maintain a suite of characteristics similar to those found in the natural channel near the culvert (bed material type and structure, channel dimensions, flow velocities and depths). Any of the risk factors listed in table 6.7 could lead to failure.

Second, recognize that any crossing can fail in an extreme event, and design to *reduce the consequences* of failure. Methods for reducing failure consequences include preventing diversions down the road or ditch if water overtops the road fill, armoring road fill overflow dips, and ensuring that the culvert is accessible and large enough to permit future access for maintenance and repair. Chapter 7 discusses these strategies in more detail.

### 6.5.1 Potential Culvert Failure Risks—Stream-simulation Culverts

An installation can have multiple failure risks; evaluate and mitigate each risk in the context of all the others. For example, a straight culvert and road fill placed over a sinuous stream in a wide active flood plain constrict the flood plain and shorten the channel. In addition to adding flood-plain relief dips or pipes and increasing culvert width to mitigate these risks, you could also increase the size of the bed material. However, increasing bed-material size to mitigate for flood-plain constriction, and then again to mitigate for channel straightening, could defeat the purpose of stream simulation. A bed-mobility analysis integrates the risk factors, and is frequently the key to determining the magnitude of the risk and finding appropriate ways to mitigate it. In table 6.7, asterisks denote design strategies that involve bed-mobility analysis.

If bed-mobility analysis indicates that the simulated streambed materials will move at lower flows than in the reference reach, revisit the site to see if you can find a more appropriate reference reach. For example, if you have selected a project profile that is steeper than the reference reach, see if a natural-channel reach exists at the higher slope—one that may be appropriate as an reference reach. Be sure the new reach meets all the requirements, such as similar length, flow regime, sediment loading, and if possible entrenchment (see section 5.4). Other design solutions may have to be considered also, such as modifying the project profile or enlarging the culvert.



Table 6.7—Potential risk conditions and design strategies

RISK FACTOR	DESIGN / CONSTRUCTION STRATEGY	OUTCOME OF DESIGN STRATEGY
Flood-plain constriction.	Widen culvert*	<ul style="list-style-type: none"> <li>● Permits high flows to occupy wider 'flood plain' inside culvert.<sup>1</sup></li> </ul>
	Increase bed material size.*	<ul style="list-style-type: none"> <li>● Increases bed stability.<sup>1</sup></li> </ul>
	Add flood plain relief culverts, road overflow dips.*	<ul style="list-style-type: none"> <li>● Avoids flow concentration.</li> </ul>
	Place layer of large rock under simulated bed.	<ul style="list-style-type: none"> <li>● Reduces risk of complete loss of all embedment.</li> <li>● Reduces risk of upstream headcutting if simulation fails.</li> <li>● Requires larger culvert to allow for combined depth of rock layer and fully vertically adjustable streambed.</li> </ul>
Rapid lateral channel migration.	Widen culvert and offset it in the direction of expected channel shift.	<ul style="list-style-type: none"> <li>● Slows development of channel-to-culvert skew caused by channel shift.</li> <li>● Stream-simulation channel may function normally for a longer period of time before being constrained by culvert.</li> </ul>
	Provide best possible culvert alignment: stabilize banks; provide flow control structures such as rock weirs or J-hooks.	<ul style="list-style-type: none"> <li>● Prevents channel movement.</li> <li>● May move channel alignment problems to reaches further from culvert.</li> </ul>
Steepened channel: culvert steeper than reference reach.  Note: if a slope steeper than 125% of the reference reach is required, consider alternative designs or design methods (appendix B).	Minimize slope increase; modify downstream and/or upstream channel.	<ul style="list-style-type: none"> <li>● Simulation is more sustainable over long term.</li> </ul>
	Increase bed material size.*	<ul style="list-style-type: none"> <li>● Increases bed stability.<sup>1</sup></li> </ul>
	Increase width of stream-simulation channel, widen culvert.*	<ul style="list-style-type: none"> <li>● Reduces shear stress inside culvert.<sup>1</sup></li> </ul>
	If simulation is step-pool type, install bed retention sills.	<ul style="list-style-type: none"> <li>● Reduces risk of loss of structural rocks.</li> </ul>
Downstream channel instability.	Verify vertical adjustment potential, and ensure simulated bed is deep enough and culvert is large enough to accommodate range of potential profiles.	<ul style="list-style-type: none"> <li>● Allows for natural variation in streambed elevation as long as actual degradation is within projected limits.</li> </ul>
	Provide adequate downstream grade controls.	<ul style="list-style-type: none"> <li>● Ensures simulated bed is protected from downstream headcut.</li> <li>● Grade controls themselves may become passage barriers.</li> </ul>
	Use full-bottom pipe or deepen foundation of open-bottom structure; place layer of large rock under simulated bed.	<ul style="list-style-type: none"> <li>● Deeper foundation reduces probability of structural failure by undermining.</li> <li>● Reduces adjustment potential of simulation.</li> <li>● If simulated bed is eroded, the bed is more likely to reconstruct itself on rough rock surface than on bare metal.</li> </ul>
Pressurized inlet. (Inlet is submerged; outlet is not submerged)	Increase culvert size to limit headwater depth during high bed design flow to 80% of culvert height above bed.	<ul style="list-style-type: none"> <li>● Reduces incidence of very high water velocity in culvert.</li> <li>● Roadway vertical curve can be problem with round culverts.</li> </ul>
	Add flood-plain relief culverts and/or road overflow dips.*	<ul style="list-style-type: none"> <li>● Lower water elevation upstream of crossing.</li> </ul>
Submerged inlet.	Optimize inlet alignment and transition; bevel pipe inlet.	<ul style="list-style-type: none"> <li>● Lowers inlet energy loss and increases culvert capacity.</li> </ul>

Note: <sup>\*\*\*</sup> denotes strategies that can be designed using bed-mobility analysis. Mobility analysis may indicate a need for bed material larger than reference reach, a wider culvert, flood-plain culverts or dips, bed sills, etc.

<sup>1</sup> These strategies are effective within limits. See sections 6.5.1.1 and 6.5.1.3 for their limitations.

# Stream Simulation

Table 6.7—Potential risk conditions and design strategies (continued)

RISK FACTOR	DESIGN / CONSTRUCTION STRATEGY	OUTCOME OF DESIGN STRATEGY
Long culvert.	<p>Minimize length of culvert using headwalls, lower road profile, etc.</p> <p>Add safety factor to stability analysis (e.g., increase bed material size or culvert width).*</p>	<ul style="list-style-type: none"> <li>● Allows use of shorter culvert.</li> <li>● Compensates for compounding design flaws.</li> </ul>
Initial lack of bed consolidation.	<p>Compact bed layers during construction.</p> <p>Wash fines in between and around larger material to embed and stabilize it.</p> <p>Hand-place key bed features for stability.</p> <p>Construct thicker streambed (to elevation higher than design project profile).</p>	<ul style="list-style-type: none"> <li>● Increases initial bed stability.</li> <li>● Increases initial bed stability.</li> <li>● Increases initial bed stability.</li> <li>● Increases construction cost.</li> <li>● Allows for initial streambed erosion.</li> </ul>
Excessive infiltration into streambed.	<p>Design and use well-graded bed material mix (section 6.2.1.1) with adequate content of sand, silt and clay.</p> <p>Construct densely packed streambed by compacting bed in layers and/or jetting fines into bed layers.</p>	<ul style="list-style-type: none"> <li>● Smaller particles fill voids between larger particles.</li> <li>● Minimize large void spaces in new streambed.</li> </ul>
Debris blockage, debris flows.	<p>Increase culvert size: Limit headwater depth during high bed design flow to 80% culvert height above bed; ensure open area is large enough for debris being transported.</p> <p>Ensure efficient transition from upstream channel (match alignment and width); bevel pipe inlet.</p> <p>Harden fill: design for overtopping and cleanup; plan for possible streambed maintenance after overtopping.</p> <p>Provide inlet riprap or other protection.</p> <p>Provide access for maintenance.</p> <p>Increase culvert size.</p>	<ul style="list-style-type: none"> <li>● Provides space for debris to float through culvert.</li> <li>● Facilitates debris and sediment passage.</li> <li>● Structure and road survive overflow and debris blockages.</li> <li>● Reduce stream bank erosion caused by backwater eddies during very large flood events.</li> <li>● Allows removal of debris jam in culvert or at inlet.</li> <li>● Reduces probability of exceeding culvert capacity or blocking with debris</li> </ul>
Stream diversion.	<p>Provide roadway dip over culvert. Sag vertical curve to avoid diversion during floods and minimize fill height; armor fill.</p> <p>Provide ditch dams; redesign road ditches to direct flood and overtopping water to erosion resistant areas.</p>	<ul style="list-style-type: none"> <li>● Contains overtopping flow at crossing.</li> <li>● Minimizes flood damage to soils and habitats.</li> <li>● Prevent a stream diversion into a roadside ditch downgrade from the crossing.</li> <li>● Reduce erosion caused by overtopping flows.</li> </ul>

Note: “\*\*” denotes strategies that can be designed using bed-mobility analysis. Mobility analysis may indicate a need for bed material larger than reference reach, a wider culvert, flood plain culverts or dips, bed sills, etc.

1 These strategies are effective within limits. See sections 6.5.1.1 and 6.5.1.3 for their limitations.

### 6.5.1.1 Flood-plain constriction

A wide active flood plain is often considered a highly valuable hydrologic and biological resource. Overbank flows and sediment moving down a flood plain build and maintain many of the unique flood-plain habitats that can be critical for some aquatic and terrestrial species (Naiman et al. 1992). Project objectives will usually include protecting and/or restoring flood-plain processes and habitats.

The major challenge in constructing a sustainable stream-simulation culvert on a **high-conveyance flood plain** is the potential for the road fill to block overbank flood flows and force them to concentrate through the culvert. In such installations, bed scour inside the culvert occurs at lower flows than in the natural channel upstream. Material eroded out of the culvert may not be replenished, and the culvert is at risk of bed failure during floods. The inlet area is more susceptible to scour than other areas of the culvert under these conditions, because water-surface elevation drops abruptly as the water moves from the backwatered flood plain into the culvert inlet. The inlet may scour even when hydraulic conditions in the rest of the culvert are similar to the reference reach.

Depending on the site, you may want to use a combination of some or all of the following design strategies to mitigate the risk.

#### Minimize flow concentration

In valleys with very high flood-plain resource values, such as important aquatic and riparian habitats, consider building a viaduct or bridge that spans as much of the active flood plain as possible. For stable multichannel systems (**anastomosing** channels), consider providing for stream simulation on each channel.

Another strategy is to keep the road fill as low across the flood plain as is feasible given traffic needs. If the road can be closed during floods, designing it for overtopping can avoid the need for many flood-plain culverts. Combining some flood-plain culverts with a low road fill designed for overtopping allows smaller floods to drain under the road without forcing a road closure. Larger floods overtop the road so that the road fill does not work like a dam funneling water through the main crossing structure.

## Stream Simulation

Provide flood-plain culverts and/or dips at swales, side-channels, and other locations as needed (figure 6.30). Add enough drainage structures to avoid unduly concentrating flow in any one area. Maximize the cross sectional area of dips, and armor them to sustain expected flow depths and velocities as well as the drop over the downstream edge. Providing well distributed flood-plain culverts and dips minimizes the risk that flood-plain flows concentrated in a single side channel might divert and capture the main channel. Nonetheless, side channels may carry more flow than normal because of the **backwater** caused by the road fill, and the potential for them to scour should be examined during the design process. In some cases buried rock may need to be installed just downstream of a flood plain or side-channel culvert to prevent incision. Be aware of the potential for woody debris to plug flood-plain culverts, and provide enough dips to handle flood-plain flow if needed.

Side-channels are sometimes important fish habitat requiring aquatic organism passage. Culverts at these sites should simulate the size and character of the side channel, while providing protection against scour that flow concentration may cause.

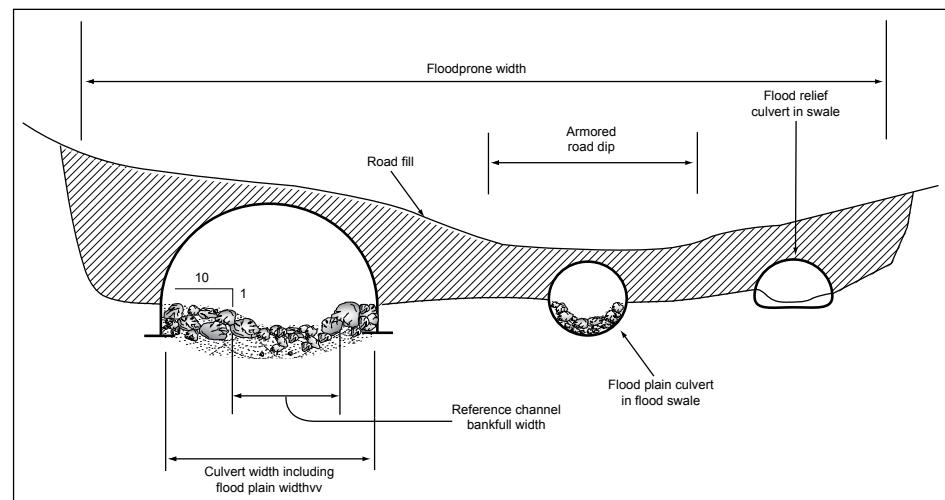

Figure 6.30—Stream simulation on an unentrenched channel may include a flood-plain surface inside the culvert and flood-plain relief culverts and dips.

Permeable roadfills can replace flood-plain culverts in some situations. Permeable fills are constructed with coarse granular fill, such as 2- to 6-inch rock, sandwiched between layers of geotextile. On the downstream side, the base of the fill has a small toe drain of geotextile and rock to let water exit the fill safely without scouring (Pekuri, personal

## Chapter 6—Stream-Simulation Design

---

communication). Although a permeable roadfill can allow a more natural and uniform movement of water and maintain some flood-plain function, it does not allow movement of most aquatic species or debris. For more information on permeable fills, see USDA Forest Service 1996.

### Conduct a backwater and bed mobility/stability analysis

These analyses should be done at any site where significant overbank flow is expected on the flood plain. We particularly recommend it where the entrenchment ratio (flood-prone width: bankfull width) is around 6 or higher. This recommendation is based on model results for several forested flood plains in western Washington. This entrenchment ratio threshold will be lower for smoother, unforested flood plains with high conveyance.

Compare the critical unit discharge or critical shear stress in the stream-simulation channel to the reference reach during a range of flows that will be constricted by the road. The choice of which flows to analyze depends on risks at the site and on flow conveyance. A 10-year recurrence interval flood seems a reasonable minimum flow to use for this analysis in mobile channels with considerable movement of bed material. In intermediate-mobility channels, the flood that moves  $D_{84}$  in the reference reach might be a good choice for a minimum flow for this analysis.

The reference reach critical shear stress or critical unit discharge for this analysis is not the average of the entire floodway. Instead, the analysis considers only the flow within the bankfull or **active channel** width, because that is the flow condition that entrains sediment on the reference reach bed. Use a step-backwater model like HEC-RAS to predict backwatering behind the road fill, accounting for the effects of multiple flood-plain culverts and/or road dips planned for the site. Compare the reference reach shear stress or unit discharge to the stream-simulation channel, factoring in the additional flood-plain flow that will be forced through the culvert.

If you have already added flood-plain relief dips and pipes to the design, and shear stresses are still higher in the main channel culvert than in the reference channel, the following two strategies provide options for offsetting the difference. These two strategies should normally be combined.

## Stream Simulation

---

### Increase culvert width

Widen the pipe and construct a flood-plain surface inside. The width of the simulated bankfull channel should remain the same to avoid aggradation during moderate flows, and possible loss of low-flow passage. The constructed flood plain will relieve some of the excess shear stress by accommodating some of the overbank flow. All surfaces above the bankfull channel should slope toward the bankfull channel at a slope of about 10h:1v (see figures 6.22 and 6.30).

Widening the culvert is not a panacea. Channel adjustments inside the pipe are likely to change the installation over time. For example, unless the culvert flood-plain surface is wide enough that water depth and velocity in the simulated active channel are similar to the reference reach, the simulated channel may incise. After that, flood flows will not access the overbank surface as easily, water depth and velocity at flows above bankfull will increase, and the original problem will not have been solved. For this reason, widening the culvert is generally combined with increasing bed material particle sizes.

### Increase bed material particle size

As mentioned previously, particle size can be changed only to a moderate degree if the simulated bed is expected to be self-sustainable. We recommend not increasing  $D_{84}$  more than 25-percent over the reference reach.

If you increase bed-material sizes, increase each size class  $D_{50}$  and higher by the same percentage, and recalculate the finer particle sizes to maintain the dense-bed mixture (review section 6.2.1.1 bed design). Consider how the new particle-size distribution will fit into the channel context and whether that distribution is likely to achieve stream-simulation objectives.

If an unacceptable risk of bed failure still exists after all the mitigation measures above have been applied, place individual large rocks in the bed to buttress the bed and provide additional roughness. Another option is to bury a layer of riprap deeply below the simulated streambed. The riprap should be deep enough that under normal conditions the simulated bed can scour and fill on top of it without being affected by it. Thus, the depth of the stream-simulation bed on top of the rock layer should be the same as if it were on top of the culvert floor (section 6.3). Base the thickness of the riprap sublayer on a riprap design protocol such as the U.S. Army Corps of Engineers method referenced in appendix E. That method requires a thickness not less than the  $D_{\max}$  stone, or 1.5 times  $D_{50}$ , whichever is larger.

### 6.5.1.2 Rapid lateral channel migration

Where a channel is experiencing rapid lateral shift, culvert-to-channel skew will intensify over time. Section 6.1.1.1 described the problems associated with skew, and ways to mitigate them. If a channel is shifting very rapidly, the most effective solutions might be relocating the road to a more stable site, or placing a temporary structure that can be moved.

Table 6.7 lists possible solutions for channels where lateral shift is less extreme. They include widening the culvert and offsetting it in the direction of expected shift. Adjust the size of bankline rocks if needed to accommodate a deeper pool that can form as the bend becomes more acute. Bank-stabilization and flow-training structures such as rock weirs or **J-hook vanes** can be built above the crossing to slow down or minimize channel shift.

### 6.5.1.3 Steepened channel

Section 6.1.2.3 described conceptual design options for sites where the downstream channel is incised. As emphasized there, downstream-channel rehabilitation may be the solution with the highest probability of long-term success, as opposed to maintaining a culvert as grade control.

Steepening the simulated channel relative to the reference reach increases bed slope and shear stress (compared to the reference reach) and creates a higher potential for bed failure. Increases of up to 25 percent in particle size and/or channel width are likely to be within the range of variance of most natural channels and constitute a reasonable design limit. Nevertheless, conduct a bed mobility analysis whenever the stream-simulation channel is steeper than the reference reach.

The analysis may suggest that an increase in bed-material size or channel width is necessary to offset the increase in slope. An increase in channel width reduces the calculated average shear stress to resemble a flatter reference reach. Do not accept such a solution without thinking through how it will work in the real simulation. For example, in a natural channel, short, steep reaches are normally narrower than average rather than wider, with larger bed material and/or key pieces. If the thalweg in the steeper simulation incises so that flow width narrows, the calculated increase in stability due to increased channel width may not persist. In such a situation, burying a layer of large-size rock below the simulated streambed

## Stream Simulation

---

to prevent excess scour might be a useful added safety factor. An added benefit of the extra channel width is that it provides capacity for large floods, making failure less likely.

Where the reference reach is steeper than the channel immediately upstream, analyze the mobility of the larger particle sizes in the simulated channel compared to the same sizes in the upstream reach that will be supplying sediment. Those sizes should be mobile at similar flows in both reaches in order for the simulated channel to be self-sustaining.

Avoid steepening a channel past a geomorphic threshold (see table 6.5 and appendix A, figure A.25) that would—in nature—make the channel a different type. Staying within the 25-percent guideline will usually prevent the design from exceeding a channel-type threshold; however, if a threshold would be exceeded, first verify that a more appropriate reference reach does not exist. For example if the reference reach is a 4-percent plane-bed channel but the required crossing slope is 5 percent, investigate whether step-pool reaches exist nearby. If no more appropriate reference reaches exist, consider building the appropriate channel type as a hybrid design. In this example, the hybrid installation would be a step-pool channel. Steps would be designed for immobility during the high bed-design flow, because if the step-forming rocks wash away, they may not be replenished from upstream. If either a step-pool channel or one with other key features (such as wood) is steepened, consider decreasing the spacing of steps or key features to increase roughness. (See appendix B for more on hybrid design.)

### 6.5.1.4 Downstream channel instability

If the elevation of the channel bed downstream of the crossing degrades beyond the range to which the project can adjust, the simulated streambed could fail to function. If a risk of continued channel degradation downstream could jeopardize the structure, reevaluate your plans to control VAP (section 6.1.2.3). Consider restoring the downstream channel and/or adding grade control structures to support the project profile.

Design conservatively. Take extra care in projecting VAP and, if possible, ensure that the culvert can accommodate it. One safety measure is to use a full-bottom pipe with a layer of large rock placed below the simulated bed. Even if the simulated bed partially or entirely washes away, the opportunity to reconstruct it will still exist. The layer of large rock will



## Chapter 6—Stream-Simulation Design

protect the upstream reach from channel incision. In a bottomless pipe, increase the depth of footings. Consider placing a layer of immobile rock below the streambed elevation and constructing the simulated bed on top of it, giving the bed enough depth to make normal vertical adjustments (such as scour pools).

### 6.5.1.5 Inlet control with submerged inlet

A stream-simulation bed will likely fail if the culvert is in inlet control, especially if the inlet is submerged and a high head differential exists between inlet and outlet. These conditions produce a strong flow contraction in the pipe near the inlet. In culverts flowing in inlet control, supercritical flow—a very high velocity flow extremely rare in alluvial channels—occurs in at least part of the pipe.

Conduct a culvert analysis and verify that supercritical flow does not occur at the high bed-design flow. FishXing and HEC-RAS with the lid function are good tools to use for this because they analyze flow inside the barrel of an embedded or open-bottom pipe. Be conservative, because high-flow hydrology, effects of debris, and culvert inlet losses are all uncertain.

If supercritical flow is likely to occur, or if the inlet may be submerged, one obvious solution is to increase the pipe's size. We recommend that headwater depth at the high bed-design flow not exceed 80 percent of the culvert opening above the bed (67 percent where debris is a significant hazard). Improving the culvert's alignment with the upstream channel and/or designing an efficient culvert inlet configuration, such as a wingwall, may lower the headwater and reduce the flow contraction near the inlet. Again, if the site has an active flood plain, adding flood-plain culverts and/or road dips will reduce flow concentration through the culvert.

### 6.5.1.6 Long culvert

Review section 6.1.1.1 on risks associated with long culverts. We can presume that a culvert can safely be as long as a straight reference reach at the same slope. If a culvert is longer than straight segments of the reference reach, it is likely that channel bends were straightened to construct the culvert; therefore, the simulated bed is not as rough as the natural channel. The excess culvert length exacerbates the risks of any design uncertainties, invalid assumptions, flaws, or construction inadequacies. Unfortunately, there is no specific hydraulic method for quantifying the risks of bed failure due to culvert length.

## Stream Simulation

---

As section 6.1.1.1 notes, the risk can be minimized by locating the crossing so that it avoids channel bends and minimizes culvert length. Adding headwalls and/or lowering the road fill may permit shortening the pipe. Other possible measures include adding a safety factor to the size and/or embedment of the culvert or the size of the bed material. Larger bed material or key roughness pieces will add roughness, thereby helping to dissipate energy in long culverts. However, be aware that the additional turbulence caused by the larger material may affect opportunities for aquatic species passage.

### 6.5.1.7 Initial lack of bed consolidation

In natural channels, hydraulic forces sort and structure bed materials so that they are in relatively stable positions and orientations. In newly constructed streambeds, the risk of bed failure during a flood is somewhat higher until moderate flows sort, structure, and consolidate the new bed. Characteristics like armoring and imbrication cannot be constructed, and must be allowed to develop naturally.

Although we cannot quantify this lower initial stability, there are several ways of managing the risk:

- Add extra material initially to allow for some bed erosion and consolidation.

Barnard (personal communication 2003) monitored steep stream-simulation channels after construction. He found that the constructed beds had lowered by about 20 percent of their depth in the first few years after construction, likely from a combination of **consolidation** and erosion of fine material. These were steep channels, and the material had not been consolidated or compacted during construction.

- For beds composed of grain sizes up to cobbles, compact the bed during installation.

Compaction can be done mechanically, by washing fines into the bed, or both. As bed material size increases, mechanical compaction becomes more difficult and more likely to damage the culvert. Bed structures such as steps and key features therefore become more important. These bed structures will support the alluvial part of the bed until it is consolidated. Ensure step and key-feature stability by specifying that individual rocks be placed so that they are in direct contact and support one another (see sections 6.2.2.4 and 7.5.2.3).

- Increase the size of the bed material slightly.
- Monitor the effects of high flows until bed structure develops, and be prepared to repair any bed failures.

### 6.5.1.8 Excessive infiltration into the streambed

The lack of natural **sorting** and bed consolidation also results in a potential for excessive streambed permeability and the risk of losing surface flow during low flows. A well-graded bed mix with at least 5-percent sand, silt, and clay content (section 6.2.1.1) is designed to avoid large empty spaces in the new, loose bed. Construction practices, such as ensuring the bed material is not segregated during handling, compacting the bed in layers and washing the fines into each layer help to reduce initial infiltration rates.

### 6.5.2 Potential Culvert Failure Risks—All Culverts

#### 6.5.2.1 Flow exceeds culvert capacity

Like all crossings, stream-simulation designs must be checked to ensure that the culvert will convey floods up to the high structural design flow (the flow that, if exceeded, could cause culvert failure). Even when flood-capacity calculations indicate the culvert has adequate capacity, however, the potential for structural failure exists. The 50- to 100-year recurrence-interval flow is commonly used as the high structural-design flow, with the notion that this reduces the risk to an appropriate level. However, in reality the probability of a 50- to 100-year flow occurring over the lifetime of a culvert is not low. Suppose, for example, that the designer expects a culvert to last for 50 years and wants to design it so that a structural failure does not have more than a 5-percent probability of occurring. According to the following equation, the design analysis would have to be based on the 1,000-year flood!

This equation calculates the probability ( $P_n$ ) that a flow with a given recurrence interval ( $T_r$ ) will occur at least once during a given timespan ( $n$ ):

**Equation 6.7** 
$$P_n = 1 - \left[ \frac{T_r - 1}{T_r} \right]^n$$

For  $n = 50$ -year project life, and  $P = .05$ ,  $T_r = 1,000$ -year recurrence-interval flood. That is, there is a 5-percent probability that a flood with a recurrence interval of 1,000 years will occur during any 50-year span. For any 50-year period, there is a 40-percent probability that the 100-year flood will occur, and a 64-percent chance that the 50-year flood will occur.

## Stream Simulation

---

Thus, there is a significant risk that the design flow—and even higher flows—will occur during a culvert’s lifetime. Although safety factors built into the design can offset errors and uncertainty in the flow estimates and other analyses, structures should be designed to be overtopped or to fail with minimal destructive consequences.

If a likelihood of debris and/or sediment plugging exists, the culvert hydraulic analysis should also factor in partial debris blockage of the culvert inlet.

### 6.5.2.2 Debris or sediment blockage

In forested environments with large amounts of woody debris, hydraulic calculations may not accurately predict culvert failures. Furniss et al. (1998) state:

“The loading of sediment and woody debris is difficult to predict and subject to the stochastic nature of landsliding, streambank erosion, treefall, and other processes that contribute these materials. We might be able to anticipate which crossings are more likely to fail based on upslope/upstream geomorphology, crossing inlet configuration, and hydraulic models, but we expect that actual failures will remain difficult to predict.”

Mitigate the risk of debris and sediment plugging the culvert by matching culvert width and alignment to the upstream bankfull channel. Furniss et al. (1998) suggest limiting headwater depths at the maximum design flow to 50 to 67 percent of the culvert opening, to account for sediment and debris. Correct an over-widened basin upstream of the culvert, since it allows wood to rotate perpendicularly to the culvert, exacerbating plugging potential. If an undersized culvert has widened the upstream channel, restore the channel dimensions to those of the reference reach. Avoid damaging the banks further upstream and possibly increasing their erosion potential during construction.

Consider designing the entire crossing to sustain plugging and overtopping by hardening fillslopes and approaches, and preventing stream diversion down the road or ditch. Be sure to factor maintenance into the design.

### 6.5.2.3 Stream diversion potential

For every culvert design, when the preliminary design is complete, ask “if the culvert plugs, where will the flow go?” If a plugged culvert backwaters flood flow so that it enters a ditch sloping away from the crossing, water will flow along the ditch until it either crosses the road (see figure 6.31) or drains into another stream channel. If diverted water outlets onto the roadfill or a slope, it can jeopardize slope stability. In some cases, entire stream channels have been diverted out of their normal alignment onto steep slopes with no capacity to carry flow, and large gullies have formed, causing slope failures. Diverted flows that enter another stream channel can cause channel erosion there.

To mitigate the risk of stream diversion at a crossing where plugging is possible, first mitigate the potential for debris or sediment blockage as described above. Then, design the road surface to keep overflow localized at the crossing. For example, you might build a sag vertical curve into the road alignment over the crossing or place a diversion dip in the road surface (section 7.7.2.1).

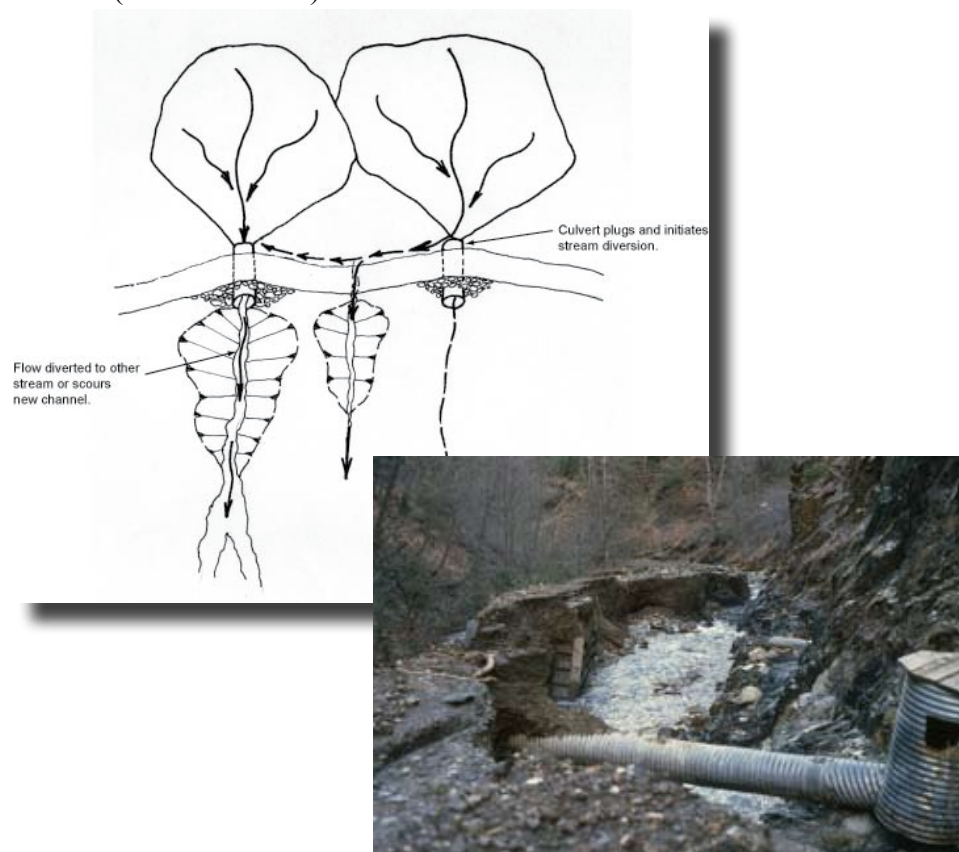

Figure 6.31—Stream diversion at plugged pipe. (inset: Stream diverted down road, Plumas National Forest 1997)

### 6.6 DESIGN DOCUMENTATION

Summarizing key site data, design assumptions, and decisions is important for others to understand the basis of the design. Good documentation is important for the final design phase (chapter 7) and during monitoring, when questions may arise about the intent of the stream-simulation design. Such documentation will also help reviewers and managers understand the project and design process well enough for permitting, prioritizing, and funding.

This completes the simulated-channel design. In the next step (chapter 7), the design engineer completes the design details for the installation and prepares the contract.



# Stream Simulation

---

## Steps and Considerations in Final Design

### Select structure type

- Project objectives and stream-simulation sustainability
- Fill height
- Construction issues
- Costs

### Design the crossing installation

- Foundations or bedding
- Structure
- Mitigate failure potential

### Specify streambed materials and placement

- Gradation
- Key features, bedforms, banks, grade controls
- Bed elevation
- Auxiliary grade-control structures up- and/or downstream of crossing structure

### Specify dewatering and water quality protection requirements

- Diversion system
- Animal protection and removal
- Sediment treatment system
- Rewatering

### Provide for short-term pollution control

### Provide for long-term stabilization (revegetation)

## RESULTS

### Contract solicitation package

Figure 7.1—Steps and considerations in final design.



## Chapter 7—Final Design and Contract Preparation

---

### 7.1 PHASE OVERVIEW

The previous chapters presented the tools needed for designing the stream-simulation channel, including size and orientation, streambed characteristics, and restoration needs outside the culvert. The next task is to finalize the design for the installation as a whole: to verify the engineering plans for both the crossing structure and the roadway, and to prepare the documents necessary for soliciting bids for construction.

At this point in the project the focus shifts to completing important design details, and project responsibility passes from the project team to the design engineer. The design details discussed in this chapter are either unique to stream-simulation projects or require more emphasis because the projects are generally bigger and take longer to construct than traditional culverts.

This phase of project design can be accomplished either with in-house resources or by contracting (or a combination of the two methods.) The assumption that Architectural and Engineering contractors require only minimal oversight can lead to poor results. As a minimum, the agency must have a staff with a level of technical expertise that allows them to recognize poor or inaccurate work, as well as enough skilled people to provide prompt and proper technical oversight for the contracted work. The design engineer is responsible for recognizing and correcting situations where expertise is not represented adequately within the team. Whether the final design is done in-house or by contract, the final product must be the same quality.

Develop construction drawings from the site plan produced during the site assessment (see section 5.1.2). Along with the original topography, the new plan includes profile and cross-section drawings of the new structure and its related channel features, details of the roadway, and other project details. This development process may take a few days to several weeks (depending on the complexity of the site,) and is often the most time-consuming part of design and contract development.

As you develop the detailed contract drawings of the stream-simulation design, numerous questions may arise that require consultation with the project team. This need for consultation, along with possibly short deadlines, will always add pressure and confusion to a project. Nevertheless, you should be proactive, communicating regularly with other members of the project team to solve design issues. Both the inspector

## Stream Simulation

---

and the contracting officer's representative (COR) can offer valuable information and assistance, particularly about construction techniques for difficult sites. Integrate these experts into your design team as the design progresses and include them in all pertinent communications. Definitely involve the COR in decisions about what aspects of the dewatering and erosion and pollution control plans must be performed inhouse.

Finally, assemble all elements of the project into a package that includes drawings, specifications, supplemental specifications, special contract requirements, and the contract boilerplate. The contracting officer then offers the contract package to the public for construction bids. The specifications and special contract requirements cover elements of the design that the detailed drawings cannot adequately describe. When the standard specifications do not adequately describe the work, write supplemental specifications to modify them. The Forest Service uses *Standard Specifications for Construction of Roads and Bridges on Federal Highway Projects* (FP-03: FHA, 2003b) for standard specifications. See appendix H for sample supplemental specifications. Special contract requirements (Federal Acquisition Regulations Section H—part of the contract boilerplate) cover other aspects of the project, such as water quality and environmental protection. Appendix H also includes examples of special contract requirements.

### Construction BMP Checklist

While completing the final design, consider the following list of BMPs that will help minimize sediment in the stream. These BMPs should be in the back of your mind as you make decisions on the project. Even as early in the final design as structure selection, **BMPs** can influence your decisions. Different types of structures involve different levels of site disturbance and different lengths of time for construction. All of the items on the BMP list are discussed in detail in either this chapter, chapter 8, or appendix G. Where ever appropriate, include these items in the contract to provide proper control during construction. To include them, place them in the specifications, the special contract requirements, or on the drawings.

#### **BMPs are usually required in construction permits**

Federal, State, and county permits often include required BMPs and performance standards (e.g., turbidity requirements). Apply for permits early, because these requirements must be in the special contract requirements, the erosion control plan, and may need notes and details in the drawings.

## Chapter 7—Final Design and Contract Preparation

### Stormwater Management, Erosion, and Sediment Control

- Minimize bare ground.
- Minimize impact to **riparian vegetation**.
- Prevent excavated material from running into water bodies and other sensitive areas.
- Use appropriate erosion barriers (silt fence, hay bales, mats, coir logs).
- Dewater before excavation.
- Manage sediment-laden water encountered during excavation.
  - ▲ Sediment basins.
  - ▲ Fabric, biobag, or hay-bale corrals.
  - ▲ Sand filter.
  - ▲ Geotextile filter bags.

As a quick check (not to replace required monitoring,) be sure that the turbidity of water 100 to 200 feet downstream of the site is not visibly greater than turbidity upstream of the project site.

### Dewatering

- Minimize the extent and duration of the hydrological disruption.
- Consider using bypass channels for maintaining some river and stream continuity during construction.
- Develop a storm management plan.
- Use dams to prevent **backwatering** of construction areas.
- Gradually dewater and rewater river and stream segments to avoid abrupt changes in streamflow and water temperature.
- If fish are present, prevent them from entering the construction site by placing block nets at the upstream and downstream ends of the dewatered section.
- Salvage aquatic organisms (fish, salamanders, crayfish, mussels) stranded during dewatering.
- Segregate clean bypass water from sediment-laden runoff or seepage water.
- Use antiseep collars.
- Use upstream sumps to collect ground water and prevent it from entering the construction site.
- Collect construction drainage from ground water, storms, and leaks, and treat it to remove sediment.
- Use a downstream sediment control sump to collect water seeping out of the construction area.
- Use fish screens around the bypass pipe intake.
- Use appropriate energy dissipators and erosion control at the outlet.
- Make sure to have adequate pumping capacity for handling storm flows.

## Stream Simulation

### Pollution Control

- Wash equipment to remove leaked petroleum products and avoid introduction of invasive species.
- Repair equipment before construction to minimize leaks.
- Be prepared to use petroleum-absorbing “diapers” if necessary.
- Locate refueling areas and hazardous material containment areas away from streams and other sensitive areas.
- Establish appropriate areas for washing concrete mixers, and prevent concrete wash water from entering rivers and streams.
- Take steps to prevent leakage of stockpiled materials into streams or other sensitive areas (i.e., locate the stockpiles away from water bodies and other sensitive areas, use sediment traps, cover during heavy rains).

### Streambed and Banks Within Structures

- Check construction surveys to ensure appropriate slopes and elevations.
- Use appropriately graded material that has been properly mixed before placing it inside the structure.
- Avoid segregation of bed materials.
- Compact the bed material.
- Wash in fines to ensure that fine materials fill gaps and voids.
- Construct an appropriate low-flow channel and **thalweg**.
- Carefully construct any designed bed forms to ensure functionality and stability.
- Where included in the design, construct well-graded banks for roughness, passage by small wildlife, and instream bank-edge habitat.
- Tie constructed banks into upstream and downstream banks.

### Soil Stabilization and Revegetation

- Ensure soil surface is rough enough to collect seeds and moisture.
- Implement seeding and planting plan for both short-term stabilization and long-term restoration of riparian vegetation.
- Water the vegetation to ensure adequate survival.
- Use seed, mulch and/or erosion control fabrics on steep slopes and other vulnerable areas.
- Avoid jute netting (which has been known to trap and kill fish and wildlife) near streams or rivers.
- Avoid placing gabions in contact with the stream (for the same reason as above.)

### Timing of Construction

- Generally, time construction for periods of low flow, observing any required work windows.
- Ensure all lifestages of resident aquatic species are protected adequately during construction.
- Consider whether construction should be limited during periods of high flows.

### 7.2 CROSSING STRUCTURE SELECTION

Search for specific products that will meet the stream, roadway, traffic, and construction needs according to earlier design decisions (see chapter 6.) A wide variety of structures may fit the site criteria, such as circular pipes, pipe arches, concrete or metal boxes, open-bottom concrete or metal arches, and many bridge types. All have their specific advantages and disadvantages. Use the structure type that best fits the specific needs and objectives of each crossing.

Developing a pool of local knowledge by gaining experience with various stream types and roadways is important. Study and compare options, and monitor projects objectively after construction. The goal is to learn which structures best meet project objectives by comparing their total costs (for example, planning, design, administration, contract, maintenance, replacement, and salvage) to the benefits they offer (for example, aquatic species passage, and long-term maintenance of channel form and function).

Stream-simulation sustainability influences structure type selection because the structure must accommodate the potential variation in channel alignment and bed elevation (section 6.1.) over its lifetime. Structure width and embedment depth were determined in chapter 6 and usually by now the project team has identified a tentative structure type. However, as you draw the structure and fit it into the site, better ways to meet project objectives may become evident. Construction objectives, such as the duration of construction, also may be important. With input from the project team, develop structure alternatives and identify costs, risks, site impacts, and effectiveness in meeting site objectives. The project team should review the alternatives and make a final decision on the structure choice before you proceed to the remaining design details.

One-piece embedded metal pipes are usually used on small streams because of their low cost and generally simple installation. Actual width is limited to what can be legally hauled to the site. Larger road-stream crossings may be constructed with a wide variety of structure types (see figures 7.2 through 7.6).

## Stream Simulation

---



Figure 7.2—1-piece corrugated metal pipe (embedded).



Figure 7.3—1-piece corrugated metal pipe arch (embedded).



Figure 7.4—1-piece open-bottom arch.



Figure 7.5—Multiplate open-bottom pipe arch.



Figure 7.6—Multiplate open-bottom box.

## Chapter 7—Final Design and Contract Preparation

---

While the design of a stream-simulation structure is based primarily on accommodating natural stream function, the roadway also influences the selection of the structure type, height, and length. Road-design (as opposed to stream-simulation design) features that will influence structure selection include:

- Rights-of-way limits.
- Road and site geometry.
- Traffic handling during construction.
- Initial and lifecycle costs.
- Lifespan.
- Risk.
- Environmental impacts caused by the construction.

Where more than one alternative satisfies the design criteria, consider designing several alternative crossings for the contract and advertise them as separate alternative bid items, so that the final design structure is based on cost. You can also define specific design criteria and request that a design firm analyze possible alternatives. Using more than one alternative is particularly useful when analysis of the alternatives requires design skills that are not readily available.

### 7.2.1 Site Geometry

Nearly all parameters of the site geometry influence structure design and selection. To ensure that all traffic can pass safely over the site, base the road width, horizontal and vertical alignment, and curve widening on standard geometric design methods. The following checklist indicates important roadway factors that affect the position, length, and shape of the structure:

- Horizontal and vertical alignment.
- Skew of structure to road centerline.
- Adequate curve widening.
- Adequate sight distance.
- Road intersections.
- Adequate fill cover over the crossing structure for the life of the structure.

## Stream Simulation

---

- Vertical curves and road surface.
- Type and thickness of roadway surface, shoulders, and slough widening.
- Widening for curbs and guardrail, where required.
- Proximity to existing utilities, both buried and overhead.

### 7.2.1.1. Dipping the road profile to prevent stream diversion

Where a risk of **debris** plugging and embankment overtopping exists, the stream-simulation design will call for a dip over the crossing structure or adjacent to it, down grade. This dip will prevent the stream from running down the road if the culvert overtops. Check the remaining fill height to see which structures will fit under the road grade with sufficient cover. On relatively low fills, a dip may mean that a low-profile structure is needed (see table 7.1). Consider how normal erosion and road grading will affect cover over the structure during its life. To maintain adequate cover to protect the structure, it may be necessary to add measures such as informative signs for maintenance crews or paving/hardening the dip.

### 7.2.1.2. Low embankment options

When the height of the road embankment is low compared to stream width, consider using a low-profile structure. Each culvert has a unique range of cover heights—that is, where the culvert will support the design load without failure. For circular pipe, pipe arch, and open-bottom arch structures, cover height becomes an issue when the fill height is less than about one-half the structure width plus the required cover. Cover height is important for metal culverts because they require the structural backfill to help support the load. Check the manufacturer’s literature for the allowable cover height range for the highest expected loads during the structure’s lifetime. Increasing pipe thickness may reduce the required cover. Although the cost will be higher, the structure’s lifespan will increase. Alternatively, investigate the feasibility of raising the road profile to gain proper cover over the structure. If neither of these alternatives is feasible, various structure types are available in low-profile shapes. Low-profile shapes tend to be more expensive than standard shapes.

Concrete boxes, vaults with lids, and precast bridges are often used at low-clearance crossings. The lid or roof can be structurally designed to act as the driving surface.



## Chapter 7—Final Design and Contract Preparation

Table 7.1 displays the variety of shapes available and height-to-width ratio (i.e., how “short” they are). Use this table to help choose a structure to fit beneath a low embankment.

*Table 7.1—Structures suitable for low-embankment sites, with approximate height-to-width values (will vary with manufacturer and material type)*

<b>EMBEDDED PIPE TYPE</b>	<b>Height-to-width ratio</b>
Pipe arch— single piece and multiplate	76-86% (subtract embedded depth)
Low-profile horizontal ellipse—multiplate	75% (subtract embedded depth)
Low-profile metal arch— steel or aluminum	32-50%
Low-profile concrete box culvert	3'—varies
<b>BOTTOMLESS PIPE TYPE</b>	<b>Height-to-width ratio</b>
Low-profile concrete arches (BEBO E-series)	30-36%
Bottomless box culvert, 5.5" x 15" corrugation—steel	22-42%
Bottomless box culvert, 2" x 6" corrugations— steel or aluminum	18-50%
<b>BRIDGE TYPE</b>	<b>Minimum clearance</b>
Various bridge options	~3'—varies

## Stream Simulation

### 7.2.2. Construction Considerations

Refer to section 6.5.1 and table 6.7. The table lists potential risks to long-term sustainability of the stream-simulation channel, along with design features that can reduce these risks. Several of the design strategies listed in table 6.7 affect the choice of structure size and type.

Table 7.2 highlights some of the construction issues that may affect structure selection and dimensions.

Table 7.2—Construction issues that may affect choice of structure

CONSTRUCTION RELATED PROBLEMS	SOLUTIONS
Pipe too small to construct stream-simulation bed.	<ul style="list-style-type: none"> <li>● Provide a minimum pipe height (diameter) of 6' to allow most workers to stand upright while constructing the streambed. Pipes as small as 5' have been used successfully. Smaller diameters can be used if they are constructed in half diameter sections, sections, but smaller pipes may not have enough embedment depth to accommodate natural fluctuations in streambed elevation.</li> <li>● Top-load an open-bottom or lidded culvert.</li> </ul>
Lengthy dewatering time (1-10 days) (Structures with poured concrete footings may take 1-4 weeks).	<ul style="list-style-type: none"> <li>● Use one-piece embedded pipe.</li> <li>● Use precast or metal footings for open-bottom arch.</li> <li>● Use a bridge with precast spread-footings.</li> </ul>
Excessive construction noise.	<ul style="list-style-type: none"> <li>● Avoid blasting, use nonexplosive methods.</li> <li>● Avoid pile driving.</li> </ul>
Lengthy construction time.	<ul style="list-style-type: none"> <li>● Use simple designs: CMPs, or prefabricated box culverts, or bridges where possible instead of complex, labor intensive structures.</li> </ul>
Near-surface bedrock	<ul style="list-style-type: none"> <li>● Use open-bottom culvert with concrete stemwalls formed to bedrock.</li> </ul>
Limited in-channel access	<ul style="list-style-type: none"> <li>● Use open-bottom or top-loaded culvert</li> </ul>
Poor foundation material	<ul style="list-style-type: none"> <li>● Use full-bottom pipe.</li> <li>● Lower the road if possible to reduce total dead load on the foundation soils.</li> <li>● Use a geotechnically designed foundation (geotextile, geogrids, etc.)</li> </ul>

## Chapter 7—Final Design and Contract Preparation

### 7.2.3. Cost Considerations

Cost considerations related to the design, material and labor, expected life, and ultimate replacement of the structure often influence structure selection (table 7.3). Changes in the structure's size may have an influence on the project cost but not proportionally; for example, a structure twice as large does not cost twice as much (see sample cost estimates in appendix G.3). Manufacturers will often help find the most economical structure shape for the design criteria. Structure types and sizes also influence maintenance and replacement costs; for instance, large structures, while initially more costly, also are less prone to flood damage and debris plugging.

Table 7.3 lists factors that affect total project costs (e.g., initial costs and projected lifetime and replacement costs).

Table 7.3— Cost factors that affect choice of structure

COST FACTOR	CONTROLLING FACTORS
Initial costs	<ul style="list-style-type: none"><li>● Structure type (one piece is less expensive than multiplate).</li><li>● Structure type (one piece embedded is less expensive than open-bottom arch in small sizes).</li><li>● Special shapes (squashed, low-profile, box).</li><li>● Special features (collars, thrust beams, special backfill, headwalls).</li><li>● Delivery.</li><li>● Shape control engineering (super-span culverts).</li><li>● Construction duration.</li></ul>
Durability and replacement cost	<ul style="list-style-type: none"><li>● Resistance to corrosion and abrasion (see table 7.4).</li><li>● Ability to salvage existing foundations and streambed (open-bottom arches and bridges) when replacing structure in the future.</li><li>● Vulnerability to flood damage.</li></ul>
Maintenance costs	<ul style="list-style-type: none"><li>● Debris removal. Structure type and size will influence debris-removal costs.</li><li>● Repairing flood-related damage to eroded streambanks, stream-simulation bed, grade-control structures.</li></ul>

## Stream Simulation

Table 7.4 lists the durability of different structure material types from the most durable to the least. To help weigh cost and durability, use tables 7.4 and 7.5 in conjunction with each other.

Table 7.4—Durability factors that affect choice of structure

DURABILITY FACTOR	STRUCTURE MATERIAL (listed in order of longest to shortest design life)
<p>Corrosion or deterioration rate.</p> <p>Soil pH and conductivity influence corrosion and deterioration rate in metal culverts. Increasing metal thickness, concrete strength, or adding special coatings will enhance longevity.</p> <p>See table 7.5.</p>	<ul style="list-style-type: none"> <li>● Prestressed concrete.</li> <li>● Reinforced concrete bridges and culverts.</li> <li>● Steel bridges — weathering steel or if maintained with paint.</li> <li>● Aluminum culverts.</li> <li>● Aluminized steel culverts.</li> <li>● Galvanized steel culverts.</li> <li>● Treated timber bridges (durability varies with treatment and climate).</li> <li>● Untreated timber bridges.</li> </ul>
<p>Abrasion rate.</p> <p>Size, shape, and flow rate of sediments influence abrasion rate.</p> <p>See Ault and Ellor 2000.</p>	<ul style="list-style-type: none"> <li>● Concrete.</li> <li>● Aluminum culverts (more vulnerable to abrasion in sandy sediment).</li> <li>● Aluminized steel culverts (more vulnerable to abrasion in cobble sediment).</li> <li>● Galvanized steel culverts (more vulnerable to abrasion in cobble sediment).</li> </ul>

## Chapter 7—Final Design and Contract Preparation

This table, from the Oregon Department of Transportation's Hydraulics Manual (ODOT 2005), is an example of the type of information that may be available and helpful in choosing a structure material appropriate for the site.

Table 7.5—Pipe material service life for Oregon (ODOT 2005) PIPE MATERIAL SERVICE LIFE: Average Years to Maintenance, Repair or Replacement Due to Corrosion (includes effects of scour as well)

Material	Location East or West of Cascades	Water & Soil pH	Soil Resistivity (ohm-cm)	Service Life (Years)
Galvanized Steel	East	4.5 – 6.0	1,500 – 2,000	30
	East	>6 – 7	1,500 – 2,000	35
	East	>7 – 10	1,500 – 2,000	40
	West	4.5 – 6.0	1,500 – 2,000	15
	West	>6 – 7	1,500 – 2,000	20
	West	>7 – 10	1,500 – 2,000	25
Aluminum	East or West	4.5 – 10	>1,500	75
Aluminized Steel	East	5 – 9	>1,500	65
	West	5 – 9	>1,500	50
Concrete	All Locations	4.5 – 10	>1,500	75+
Polyethylene	All Locations	4.5 – 10	>1,500	75

For galvanized steel, the service life increases for soil resistivity as follows:

Resistivity (ohm-cm)	Factor
2,000 – < 3,000	1.2
3,000 – < 4,000	1.4
4,000 – < 5,000	1.6
5,000 – < 7,000	1.8
> 7,000	2.0

The service life indicated is for 16-gauge metal pipes. Multiply the service life by the appropriate factor for different thickness:

Gauge	14	12	10	8
Factor	1.3	1.7	2.2	2.9

Bituminous-coated (AASHTO M190) metal pipe adds 10 years to the service life in all locations. Apply the factors from the previous two items to the total service life. (Many regions do not permit bituminous-coated pipes because of water quality issues.)

Soil resistivity or pH readings outside the indicated limits will require special design considerations.

## Stream Simulation

---

### 7.2.4 Tips for Choosing Structures

The following tips may be helpful when choosing between different structure types:

- Embedded pipes are most economical of all the structures and quick to construct, at least up to sizes where they become multiplate structures (12 to 15 feet, depending on the manufacturer); however, except for box culverts, these structures require large excavations.
- When fill heights are relatively low (one-half to two-thirds of design width), round and pipe-arch culverts may not fit under the embankment with sufficient cover. Consider using low profile and box structures, raising the fill height, or using a bridge. Fill is relatively inexpensive if raising the grade over the structure does not affect the road grade or alignment for a long distance. However, if the grade is raised over a long distance to accommodate a large pipe, fill costs may become excessive and there may be significant wetland impacts with large increases in the embankment height.
- In bottomless structures, and box culverts with lids, the streambed can be constructed from the top, reducing the need for equipment to operate in the channel.
- Embedded pipes more than 25 feet in diameter may have to be buried over 10 feet deep for filling to design width. These pipes therefore may not be practical if dewatering is either difficult or impossible, or if bedrock is too close to the surface.
- Compared to culverts, channel-spanning bridges tend to have lower risks and higher longevity, and provide better passage for aquatic, semiaquatic, and terrestrial animals. When they are close in cost to other structures, they are generally preferable.
- Bridges are worth considering for active **flood-plain** locations and debris-flow or landslide-prone areas where high clearance is necessary.

### 7.3 STRUCTURAL DESIGN

Design elements of the crossing structure include:

- Crossing structure.
- Foundation.
- Structural backfill.

### 7.3.1 The Crossing Structure

Pipe, pipe arch, and bottomless structures are constructed of either corrugated metal or reinforced concrete. Structural design is not necessary, because manufacturers supply this information in brochures and for individual projects to ensure correct use of their products. Culvert brochures usually have tables giving design solutions for various culvert dimensions, corrugation types, thickness, traffic loads, and range of fill heights. You can get this information directly from the manufacturer for specific designs. To do so, have the following minimum site information available before contacting them:

- Maximum traffic load.
- Fill height range.
- Soil weight.
- Soil type.
- Foundation bearing capacity.
- Structure dimensions.

Bridges are constructed of a variety of modular and individually engineered materials with steel, concrete, and wood as the common building materials. Structural bridge design or review is beyond the scope of this document. Whenever a bridge may be a suitable option, a bridge engineer should be part of the design team.

Standards for designing bridges, culverts, foundations, and backfill are in Standard Specifications for Highway Bridges, 17th edition (AASHTO 2002). Another good resource for all pipes is the installation manual for corrugated steel pipe, pipe arches, structural plate (NCSPA undated).

### 7.3.2 Footing Design

You must be able to recognize foundation situations that are risky or complex enough to require expert assistance for design of an open-bottom structure—or even to preclude such a structure. The geotechnical investigation conducted during the site assessment (section 5.1.7) should yield enough information for you to determine the degree of complexity and risk. Unsuitable soils or foundation conditions that will require further expert analysis include:

## Stream Simulation

---

- Silts and clays.
- Soils with high organic content.
- Unconsolidated soils.
- Bed rock.

If these materials are present, particularly if the site is geologically complex, a detailed site investigation is needed.

Footing design requires the following analyses:

- Structural analysis: quantifying and analyzing stresses on the footing, and adjusting footing dimensions until the load distributes evenly on the footing.
- Bearing capacity analysis: analyzing the soil bearing capacity for various footing depths and widths.
- Scour scenario analysis: ensuring that the worst-case scour condition leaves enough embedment depth to develop sufficient bearing capacity to support the foundation loads.
- Foundation design: designing the footing details, including reinforcement, culvert attachment, shape, and constructability aspects.
- Settlement estimation: estimating the amount of settlement expected to occur.

The above analyses are within the skills of most bridge, structural, foundation, geotechnical, and geological engineers. Ensure that the required expertise is available if you do not have all the skills necessary for designing bottomless arch or box-culvert footings. For more detailed discussion regarding footing design and foundations, see appendix G.4.2

The following example illustrates inadequate footing design methods. One type of open-bottom arch—a half-round corrugated metal pipe (CMP) with flat lengths of corrugated sheet metal welded on each edge of the arch to function as a footing (figure 7.7)—has been used in a number of locations to provide continuity in small streams. Some of these structures have failed because they were not adequately embedded and scour occurred under the corrugated sheet metal footings. Therefore, when considering using these less-expensive structures, use the same design procedures as you would use on larger more complex open-bottom arches. Ignoring proper design procedure makes failure likely.





Figure 7.7—Open-bottom pipe arch with metal footings.

### 7.3.3 Structure Backfill

Backfill material in the special backfill zone (figure 7.8) interacts with the structure to provide more strength than either material could provide by itself. Backfill requirements vary for different types and sizes of structures and are usually specified by the manufacturer. Backfill and compaction specifications for culverts are covered in FP-03, Section 209 under:

- Backfill material (for general backfilling of culverts).
- Lean concrete (for both bedding and partial backfill material).
- Bedding material (for placing beneath pipe structures as a leveling and piping prevention layer (figure 7.9).
- Foundation fill (for replacing unsuitable material and for long-span structures).

Choose foundation fill gradation A-1-a from FP-03, Section 705 for long-span (greater than 25 feet) structures, because you can easily place it and compact it to high strength without overstressing or distorting corrugated steel structures. Consult the structure manufacturer for specific recommendations.

## Stream Simulation

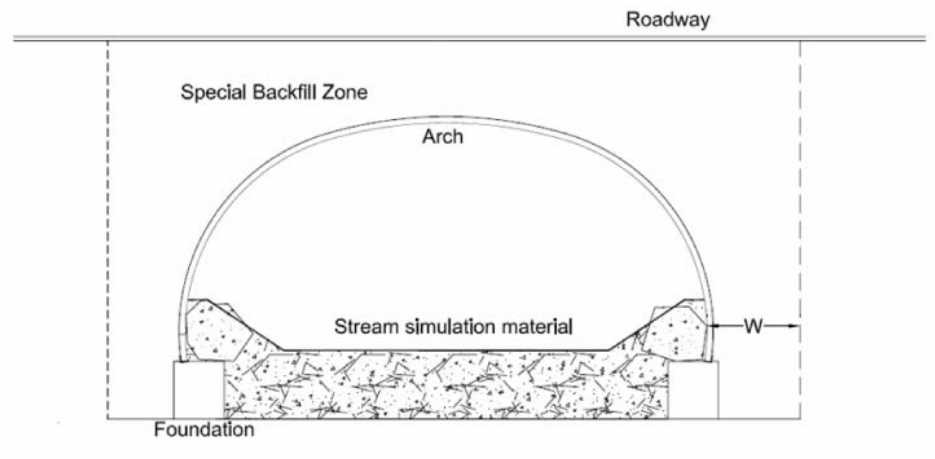

Figure 7.8—Special backfill zone for an open-bottom arch.



Figure 7.9—Shaping culvert bedding.

### 7.3.4 Existing Site Materials

The crossing design may be able to use several types of materials available on site; for example:

- Large boulders.
- Large **woody debris**.
- Bedding material from the old culvert.
- Streambed materials in areas that will be disturbed.
- Clearing debris.

These materials may be suitable for constructing streambed features such as steps, banks, or other **key features**. The old bedding (figure 7.10) may be useful in the stream-simulation bed material recipe (section 7.5.2.2), and clearing debris can be used for erosion control (figure 7.11).



*Figure 7.10—Old culvert bedding may be used in the stream-simulation bed mix.*

## Stream Simulation

---



*Figure 7.11—Clearing debris scattered for erosion control.*

Also evaluate the existing embankment to determine if the soil meets structural and general backfill requirements. Estimate whether additional backfill will be required or if a surplus exists. Old embankments sometimes have large trees and other surprises buried in them. These “surprises” are normally handled during construction under the changes clause. Trees and other native materials may be suitable for placement as instream structures upstream or downstream of the structure. The site assessment documentation should contain recommendations on how to use these materials on the project. You may place them in disturbed areas to control erosion, in riparian zones for habitat, or in the stream for additional aquatic habitat or **grade control**. Depending on long-term goals, trees and other native material may or may not be anchored to the bank; consult with the project team.

### 7.4 HANDLING TRAFFIC DURING CONSTRUCTION

Four options are generally available for accommodating or controlling traffic during the project.

- (1) Redirecting traffic to alternate routes.
- (2) Closing the road briefly (3 days to 1 week).
- (3) Providing an adjacent temporary road-stream crossing (often over the dewatering dam). Either ensure that the roadway has sufficient width, slope, traction, and geometric alignment to allow all expected traffic to use the bypass, or provide signs indicating vehicle limitations. Keep in mind that this option affects the dewatering system, clearing limits, excavation volumes, and traffic management efforts. Figure 7.12 illustrates this option but does not use the dewatering dam.
- (4) Passing traffic over the construction site while constructing the structure in two stages.
  - (a) Allow enough road-surface width for building more than half the new structure at one time. Sometimes, you can achieve the needed width by lowering the road surface temporarily.
  - (b) Construct a stable roadway to support traffic safely (according to Occupational Safety and Health Administration standards.) To support the excavation side of the embankment, you may need some form of retaining wall. (Because of the need to construct the road fill in two stages, this option may require a longer structure.)

Traffic bypasses can account for anywhere from 10 percent to as much as 50 percent of the total project cost, depending on the size of the project and the complexity of the bypass. The total cost of a traffic bypass includes the combined increased costs of slowing the construction work and adding traffic control personnel, signs, traffic control lights, and other project details. Figures H.4 and H.5 show examples of a sign plan and a gate plan.

## Stream Simulation



Figure 7.12—Typical construction site traffic bypass.

## 7.5 DEVELOPING SPECIFICATIONS

Chapter 6 covered design of particle-size gradations and other features of the simulated streambed using data from the reference reach. This section develops contract specifications based on the stream-simulation design. Stream-simulation construction contracts require modifying standard specifications to describe their specialized construction. The Forest Service uses Standard Specifications for Construction of Roads and Bridges on Federal Highway Projects (Federal Highways publication FP-03) for standard specifications. Use Specifications 151-Erosion Control, 251-Riprap, and 705-Materials for the parent specifications to describe dewatering, streambed construction, and streambed materials in stream-simulation projects. Appendix H provides examples of supplemental specifications.

All construction specifications that describe work to be done—specifications in FP-03 Divisions 200 through 600—consist of three parts:

- **Description:** This part describes the scope of work covered in the specification.
- **Materials:** This part nearly always refers to a materials specification. In the case of stream simulation, Supplemental Specification 705 covers rock and filler material.
- **Construction methods:** This part describes all features and how to construct them. Often, to clarify features difficult to describe in words, the specification refers to drawings.

## Chapter 7—Final Design and Contract Preparation

---

Some aspects and requirements of stream-simulation construction will be unfamiliar to contractors, even those with instream experience. Well-written notes and specifications for aspects outside the normal practice will allow bidding that is more accurate and minimizes expensive change orders.

### 7.5.1 Submittals

You may often use specifications to require the contractor to design and submit a plan for portions of the project work for approval. When using this method, expected results should normally be specified—not methods for performing the work. For some work, contractor design is more appropriate, allowing the contractor to perform the work in a manner that best fits his or her work methods and, most important, making the contractor responsible for the end result. Allow reasonable time for a submittals process, i.e., adequate time for the contractor to design and submit the proposal for the specified work and adequate time for a thorough but timely agency review of the proposal. Work items often specified in the contract and designed or performed by the contractor through a submittals process are:

- Quality control.
- Construction surveying.
- Temporary erosion and pollution control.
- Dewatering and water treatment.
- Storm management plan.
- Structural backfill materials.
- Concrete mix designs.
- Stream-simulation bed mixture.
- Revegetation.

### 7.5.2 Supplemental Specification 251: Streambed Construction

#### 7.5.2.1 Description

The description is an introduction to the specification. Briefly describe the features— especially unique features—that you want to construct under this specification. (See appendix H for an example of Supplemental Specification 251.)

## Stream Simulation

---

### 7.5.2.2 Materials

The Materials section of Supplemental Specification 251 should refer to material specification Supplemental Specification 705 (section 7.5.3). Supplemental Specification 251 includes a description of work required to achieve the gradations specified in Supplemental Specification 705.

The streambed may contain material that you can salvage from the excavation and use for at least a portion of the stream-simulation bed mix. Excavated material that appears too dirty to use may simply be the natural subsurface layer, which is often much richer in fines than the surface of an **armored streambed**. At some culvert-replacement sites, natural streambed materials may be covered by the old culvert bedding material (figure 7.10). Bedding depths can vary, depending on the roughness of the underlying channel surface or whether the channel is incised or not.

Consider making provisions in the contract for using the native streambed material if it meets gradation requirements. Alternatively, native material can be part of the recipe for the streambed-simulation bed mix. If the material cannot be used for the streambed-simulation bed, it can be used elsewhere on the project as common excavation for other backfill. Provide locations for stockpiling, mixing, and disposing of the material depending on the final determination for the use of the onsite materials.

The drawback to using onsite materials in the bed mix recipe is that you will not know the mix proportions when the project is advertised. It may be far more expedient and economical for the project not to depend on onsite materials. If, during construction, you determine the onsite materials are useable, the government can take a deduction for using the onsite material in lieu of purchased or hauled material through a change order.

If you are going to include onsite materials in your bed mix, you must sample the onsite materials and determine their gradation. The best time to sample is during excavation of the existing structure. Two sampling methods can be used: the pebble count method (section 5.1.6.1), or bulk sampling. Keep in mind that representative samples of material for bulk sampling where the largest particles are over 4 to 5 inches must be several hundred pounds (reference American Society for Testing and Materials standard C136-06). If sampling and gradation testing of onsite materials is performed after the contract is awarded, contract administrators will use a change order to incorporate the onsite materials.



## Chapter 7—Final Design and Contract Preparation

---

Once the gradations of all the materials (both onsite and commercial) have been determined, determine the proportions of each material that will be needed to produce the stream-simulation bed mix (the gradation specified in Section 705, see figure 7.17). The process of developing a stream-simulation bed mix recipe is identical to developing a mix design for Portland cement or asphalt concrete from several differently graded stockpiles.

Sampling can be done in-house or by the contractor. Specify either option in the materials section of Supplemental Specification 251.

### Sampling by the contractor

Specify a submittal for the bed-mix recipe (the proportions of the different aggregate stockpiles to be used in the bed mix) based on the gradations determined during the stream-simulation design (see section 6.2.1.1.) The contractor will develop the mix recipe as a submittal using materials recovered from the site excavation, from commercially available materials, or from a mix of both.

### Sampling by contract administrators

Specify in the contract that the engineer will perform sampling and testing during structure excavation and that the bed-mix recipe will be designed “in-house.” Be sure to include a provision that (a) states that the contractor cannot proceed with any streambed construction until the analysis and streambed-simulation recipe are complete and, (b) provides a reasonable length of time for the sampling, testing, and analysis.

### 7.5.2.3 Construction methods

To develop the Construction Methods section of Supplemental Specification 251, use or modify the example in appendix H to describe features such as:

- Stream-simulation bed cross section and profile.
- Low-water thalweg.
- Steps, constructed riffle crests.
- Banks, edge features.
- Rock clusters.
- Grade-control structures.

## Stream Simulation

---

- Handling of known or discovered natural key features (for example, bedrock, natural rock steps that are part of the stream-simulation design).

Describe the streambed features designed in chapter 6 in detail in the contract and show them on the contract drawings. (See figure H.9 and H.14, and section 6.2.) Determine which onsite materials, if any, can be used for constructing these features, and incorporate those materials and features into the specification. If possible, use detail drawings and refer to them with the specification. Include language in the specification or special contract requirements that provides protection for the structure against damage while streambed materials are placed.

Constructing streambeds and other features inside very small culverts usually involves hand labor (figure 7.13). Hand labor will be required to help seal streambeds and for compaction close to the structure where compaction by equipment is impossible. (See also figure 8.16.)



*Figure 7.13—Hand labor walk-behind equipment.*

## Chapter 7—Final Design and Contract Preparation

### Stream-Simulation Bed Details

Supplemental Specification 251 (appendix H) covers placing streambed material. It specifies the size, depth, surface profile, and compaction of the bed material, as well as layer placement when needed.

You may need fine-grained filler material (referred to as “select borrow” in the sample specification) to fill in voids between larger rocks and against the sides of the culvert. As discussed in chapter 6, the filler material is washed into the voids in the streambed (figure 7.14), reducing streambed permeability and helping to keep the streamflow on the surface during low-flow periods. This practice also reduces the loss of fines and thus decreases turbidity during the initial rewatering.



Figure 7.14—Washing filler material into the voids in the stream-simulation bed.

## Stream Simulation

---

When using footings in high-risk scour areas, specify placing a layer of larger more stable streambed material against the footings to prevent scour of the footings (figure 7.15). Provide for protecting the stemwalls and the structure during construction.



Figure 7.15—Footing armor.

### Channel Margins

Continuous channel banklines or other margin features, such as rock clusters, are part of the stream-simulation design (section 6.2.1.3). The margins may be a single row of rocks, or they may be wide enough to simulate a flood plain in the culvert (figure 6.22). Banks should be constructed carefully to limit void space between the large rocks. Voids should be filled by jetting or flooding in filler material.



Figure 7.16—Newly constructed (2006) stream-simulation channel and banks, Surveyor Creek, Lolo National Forest, ID. The top of the bank is at bankfull elevation, indicated by the painted line. Note the transition between natural banks outside and constructed banks inside the culvert.

## Chapter 7—Final Design and Contract Preparation

---

### Key Features

Key features are grade-control or diversity-enhancing structures consisting of rock or wood, placed to mimic natural conditions where they are called for in stream-simulation design plans. Ensure rock is carefully placed to produce the desired degree of stability. Individual rocks and rock clusters should be embedded a minimum of one-third of their size.

The stream-simulation plans may also call for steps, bands of riffle-sized rock, and rock clusters (figures 6.23, and 6.25). In steep step-pool channels where steps must be as stable as natural steps, the rocks must be carefully placed, bearing against—and interlocked with—other step rocks (section 6.2.2.4). Steps generally have two tiers, an upper tier of rocks immediately upstream and a lower tier of footer rocks below and immediately downstream of the upper tier, to prevent scour and undermining (figure H.9).

In pool-riffle channels, the stream-simulation design may call for constructed riffle crests to simulate intermediate mobility key features like pool tailouts, and promote natural development of diverse bed structures over time. Construct these by placing streambed material to full depth for a distance along the length of the culvert, then switching to coarser material for the width of the band, alternating this pattern through the length of the culvert (section 6.2.2.2). Both bands and the rest of the channel are shaped with a low-flow thalweg, so that the cross section dips in the middle and rises toward the walls of the structure (figure H.15).

Where bank stability and/or habitat requires placing wood outside the structure, place it with about two-thirds of the tree's length on the bank, with the remainder lying in or over the water and pointing upstream at a sharp angle. The wood must be well buried, anchored, or large enough to remain immobile. To ensure these features will be stable for the life of the structure, work with an experienced biologist or hydrologist. Where possible, develop site-specific designs to use available local materials.

### 7.5.3 Developing SPS 705: Specifying Rock Sizes

Section 705 specifies characteristics of aggregates, including the gradation of the materials used for various purposes. To modify Section 705 for stream simulation, we need to specify the gradations of all the materials needed for the features discussed in the Supplemental Specification 251, Construction Methods. The project team has already developed a gradation curve for the bed mix (section 6.2.1.1), with units of millimeters, the most common units used for pebble counts. The bed-gradation specification must be in a format that material suppliers understand. Generally, this format is a table of sieve sizes, with percent-finer values (the percentage of aggregate by weight passing the particular sieve) accompanied by a percentage range of tolerances (for example, 50-percent passing through the sieve, plus or minus 5 percent, expressed “45% - 55%”).

If using bulk sampling, simply insert the values determined from the laboratory analysis of the sample into table 705-7 (figure 7.18), and use the table in Supplemental Specification 705.

If using the particle-size distribution curve from chapter 6, do the following:

- Determine the closest sieve sizes (the next largest) to the  $D_{95}$ ,  $D_{84}$ ,  $D_{50}$ ,  $D_{30}$ , and  $D_{10}$  values (or other key values) on the particle-size distribution curve, and insert those values in table 705-7 (figure 7.18).
- Verify that the sieve size is no more than 5-percent greater than the desired particle size. If the size is greater, choose another point on the distribution curve, close to the desired size, that better coincides with a standard sieve.
- Using the particle-size distribution curve, find for each sieve size the percent-finer value on the vertical axis (figure 7.17). Insert those values in table 705-7. (These are the values for the stream-simulation bed gradation, expressed as “percent finer values.”)
- To provide flexibility, use a tolerance range of 10 percent (plus or minus 5 percent) for each sieve size. Generally, no less than 5-percent fines (finer than number 8 sieve) are allowed in the manufactured streambed-simulation rock. The stream-simulation bed mix design (6.2.1.1) may specify a different fines content based on the reference reach. Similarly, 90 to 100 percent of the material should pass the  $D_{95}$  size.
- For the filler material, use 1-inch minus or  $D_{16}$ , whichever is smaller. (A minimum of 50 percent of the filler material should pass the sieve representing the  $D_5$  value of the streambed-simulation bed.)

## DEVELOPING THE GRADATION TABLE FROM THE PARTICLE SIZE DISTRIBUTION CURVE

1. Particle size distribution curve from the pebble count
2. Add US standard sieve sizes to the horizontal axis of the distribution curve
3. Lines from sieve sizes to intersect the distribution curve
4. Lines from the intersections on the distribution curve to the vertical axis (% finer)
5. Values intersected on the vertical axis of the distribution curve are values for the gradation table

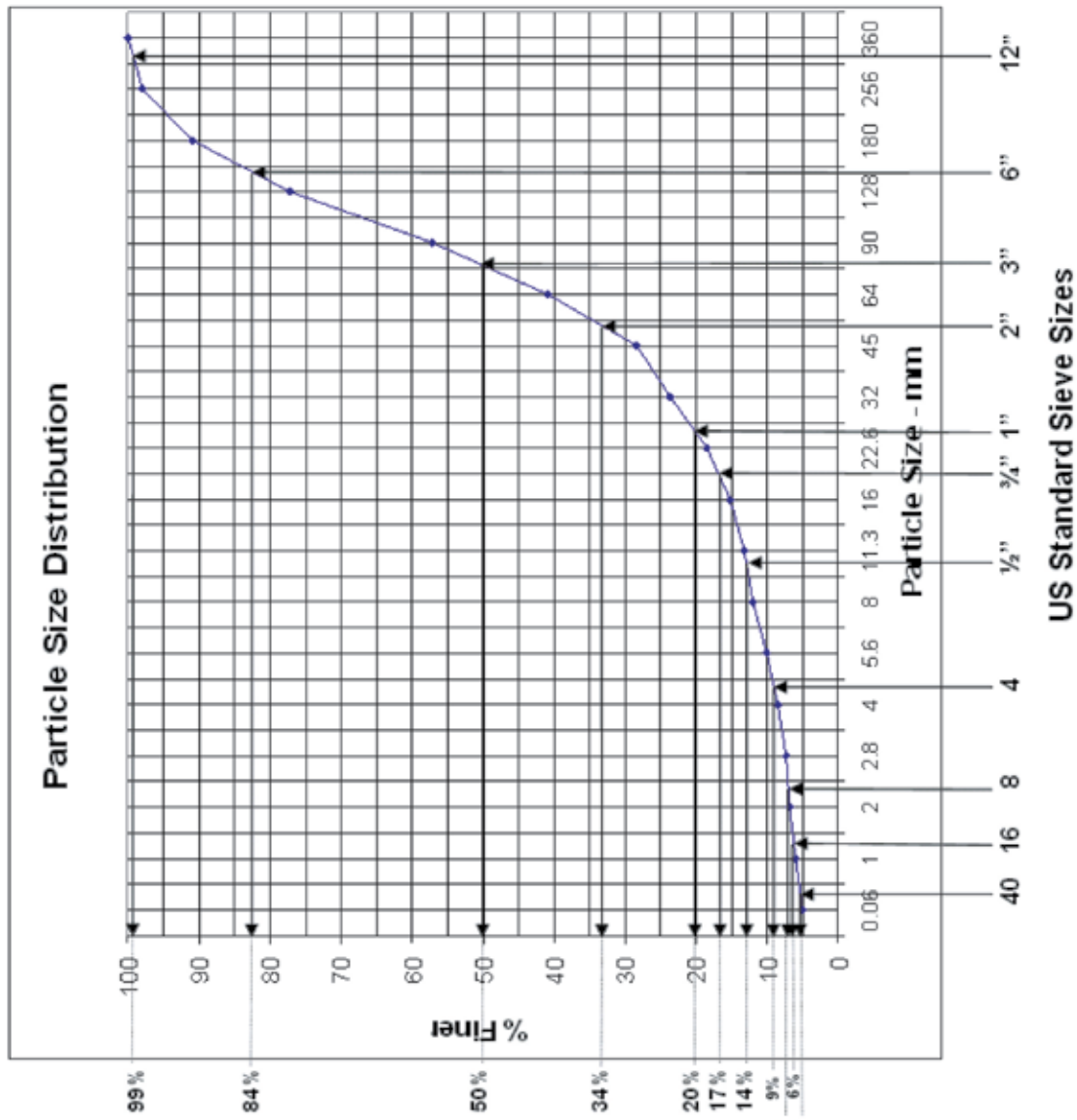

Figure 7.17—Developing a gradation table from a particle-size distribution curve.

## Stream Simulation

Using the values determined from the curve in figure 7.17, fill in the values in the table in figure 7.18.

Standard sieve	Stream simulation bed material (percent finer)	Filler material (percent finer)
12"	90-100	
6"	79-89	
3"	45-55	
2"	29-39	
#4	4-14	
3/4"		100
#40		≥ 50

- (1) U.S. Standard Sieve size closest to  $D_{100}$ ,  $D_{84}$ ,  $D_{50}$ ,  $D_{30}$ ,  $D_{10}$ , are: 12", 6", 3", 2", #4
- (2) Filling in the corresponding % finer values allowing +/- 5% of the value from the distribution curve:
  - 12" = 99% +/- 5% = 94-104  
(use 90-100)
  - 6" = 84% +/- 5% = 79-89
  - 3" = 50% +/- 5% = 45-55
  - 2" = 34% +/- 5% = 29-39
  - #4 = 9% +/- 5% = 4-14
- (3) Finally, filling in the values for filler material: Sieve sizes closest to  $D_{16}$  and  $D_5$  are 3/4" and #40.

Figure 7.18—Example of table 705-7, Project Requirements for Stream-Simulation Bed Material.

## Channel Rocks

For the purpose of definition in the construction contract, “**channel rocks**” are rock materials needed for constructing key features, such as steps, constructed riffle crests, banks, and clusters. Specify them separately from the stream-simulation material, using sizes already determined for key features in section 6.2.1.3 and 6.2.1.4. Not only diameter but also shape characteristics are important. For example, elongated rocks interlock better and can form a more stable feature in the simulated streambed.



## Chapter 7—Final Design and Contract Preparation

Table 705-4 (figure 7.19) defines the channel rock size classes and lists approximate weights and acceptable range of rock diameters for each class. Size classes are shown on the drawings for each key feature in the design.

Table 705-4 Size Requirement for Channel Rocks

Channel Rock Class (diameter, inches)	Approximate Weight (pounds)	Median Axis Dimension & Variation in inches
Rock-4	3	4 +/- 1
Rock-6	10	6 +/- 1
Rock-9	33	9 +/- 2
Rock-12	80	12 +/- 2
Rock-16	185	16 +/- 2
Rock-20	365	20 +/- 2
Rock-24	630	24 +/- 3
Rock-30	1,230	30 +/- 3
Rock-36	2,120	36 +/- 4
Rock-42	3,370	42 +/- 4
Rock-48	5,030	48 +/- 5
Rock-54	7,160	54 +/- 5
Rock-60	9,820	60 +/- 6

Figure 7.19—Table 705-4 defines channel rock-size classes.

An example of Supplemental Specification 705 for stream simulation is in appendix H. Tables 705-4 (size requirement for channel rocks) and 705-7 (gradation requirements for stream simulation bed material) are added to the standard specification. In the example in appendix H, channel rocks are required to have a long axis at least 33-percent longer than the median axis. The 133-percent elongation should be field verified for each site. In places where you are constructing permanent features from the channel rocks, you may wish to specify that the rocks are to be fractured and angular.

### 7.6 DESIGNING FOR FLOOD AND DEBRIS FAILURE PREVENTION

See table 6.7 and section 6.5.2 for discussion of risks caused by high flows, woody debris, and sediment, along with methods of minimizing those risks. Additional information is available in Furniss et al. 1997.

### 7.7 PLANNING FOR EROSION AND POLLUTION CONTROL

An erosion and sedimentation-control plan details the suite of methods and tools that will be used to minimize sediment delivery to the stream channel during and after construction. The plan contains actions and practices that occur before, during, and after construction, including long-term stabilization elements, such as the revegetation plan. Depending on the site and conditions, the plan may include the following elements:

#### **Before-construction actions**

- Planning for water quality monitoring during and after construction.
- Salvaging and storing topsoil.
- Salvaging plants or cuttings.

#### **During-construction actions**

- Construction timing and sequencing.
- Site dewatering and rewatering.
- Treating water.
- Providing short-term erosion control on disturbed areas and storage piles.
- Preventing and controlling pollution from equipment and facilities.
- Methods of stabilizing disturbed areas, such as placing rocks and logs for long-term bank stabilization.
- Special treatment of imported or excavated streambed material, such as segregating stockpiles to prevent contamination or covering them to prevent loss.

#### **Post-construction actions**

- Removing temporary erosion- and sediment-control measures.
- Revegetating the site.
- Maintaining the site.

## Chapter 7—Final Design and Contract Preparation

---

Federal, State, and county permits often include BMPs and performance standards (for example, turbidity requirements) that apply directly to the erosion-control plan. Be sure to include these requirements in the special contract requirements and the erosion-control plan as well as any notes and detail drawings that you may need. You may need to create detailed drawings, applying the BMPs to specific site features and paying for them directly via pay items in the contract.

Including the major features of erosion control in the design gives the project team maximum input into long- and short-term erosion control. Including major features of the dewatering system, long-term revegetation, and site-stabilization plans in the design will also provide greater overall project efficiency. For example, you can clean and retain sediment-retention basins (constructed to control storm flows in the contributing road ditches during construction) as long-term ditch sediment-control measures.

### 7.7.1 General Erosion Control During Construction

The most important rule for erosion control is to minimize site disturbance within the limits of project goals. First, mark clearing and disturbance limits, and reduce the disturbed area as much as possible. Second, control potential erosion by covering disturbed surfaces (for example, storage piles), or by routing water away from them (for example, using stormwater controls). Third, capture and treat sediment-laden water before releasing it to the stream. Fourth, provide for long-term stabilization of the site through revegetation and other permanent measures.

Standard specifications and contract clauses allow you to (a) specify erosion-control measures, (b) specify outcomes and require the contractor to submit an erosion-control plan to meet them, or (c) combine the two methods. Risk to the owner (the government in this case) is greater when methods and measures are specified, because the responsibility for any failure then remains with the owner. Performance-based specifications are generally encouraged for this reason.

Erosion control can be paid directly as a separate pay item, or made incidental to other work such as installation of the culvert and paid under that pay item. A successful result with either method depends primarily on diligent and consistent enforcement of the requirements. Be sure to include contract language requiring the contractor to maintain all erosion control and prevention features.

## Stream Simulation

---

Consider the following items for the temporary erosion prevention, control, and treatment plan:

- Construction site layout with clearing limits.
- Work schedule, including timing of erosion-control items.
- Dewatering and sediment treatment plan (see section 7.8).
- Storm management plan.
- Sediment-trapping silt fences or straw bales.
- Drainage-control plans directing water away from disturbed areas.
- Ditches and check dams.
- Road drainage details.
- Ditch relief culvert details.

You may need to include the following in your special contract requirements to cover temporary erosion and sediment control:

- Cover aggregate stockpiles to prevent wind and rainfall erosion.
- Cover excavated slopes to reduce surface erosion.
- Sweep and clean off road surfaces.
- Submit a storm management plan, including the following as a minimum:
  - ▲ List of contacts including contract administration and contractor personnel.
  - ▲ Site specific list of action items, for example:
    - Maintain erosion control measures including ditches, barriers, silt fences, etc.
    - Maintain the construction bypass system and any components, such as trash screens.
    - Have extra pumping capacity onsite ready to use in emergency.
    - Block traffic or provide traffic control if necessary.

## Chapter 7—Final Design and Contract Preparation

- If the project is longer than one construction season:
  - ▲ Be prepared for an early winter storm and construct over-winter erosion-control measures early.
  - ▲ Provide for periodic maintenance checks during winter and during spring runoff.
  - ▲ Inspect and maintain all erosion-control measures before spring restart of construction.
  - ▲ Remove and dispose of temporary erosion-control measures and accumulated sediment after construction and after the site has stabilized.

For projects that could extend over more than one construction season, see appendix G.4.3.7.

### 7.7.2 Permanent Erosion Control Measures

*Specifications that have an end result are much easier to administer than process-oriented specifications.*

Develop necessary drawing details and special-project specifications for permanent erosion control on roads, road embankments, streambanks, and other disturbed areas.

Many long-term stabilization measures, such as in-channel wood, streambank rocks, and engineered slope-stabilization measures, are design features included in Supplemental Specification 251. Where vegetation may be difficult to establish in a mat thick enough to provide erosion control, combine vegetation with other measures such as riprap, root wads or logs, or erosion-control matting.

Typical components of a long-term stabilization plan include:

- Seeding, mulching, and planting of exposed soils.
- Scattering construction slash on exposed soil areas for erosion control.
- Ditches, relief culverts, and dips that drain to natural sediment-filtering vegetation and stable landforms where runoff can infiltrate, rather than running directly into the stream.
- Erosion protection for road cut-and-fill embankments.

## Stream Simulation

---

- Integrated streambank protection:
  - ▲ Although riprap is generally very successful and stable, it is sometimes not aesthetically desirable on some visually sensitive sites and may not be desirable due to habitat loss.
  - ▲ For vegetation, use native plant species such as willows, groundcovers, and other native species.
  - ▲ Other bioengineering methods (WDFW 2003).

For detailed discussion on revegetation, see appendix G.4.3.

### 7.7.2.1 Diversion-prevention dips

In many cases, a diversion-prevention dip will be an essential part of the permanent erosion control system (section 6.5.2.3). Diversion-prevention dips provide a drainage pathway across the road to avoid stream diversion down the road (figure 7.20). Design the dip without severe grade changes that exceed the design standard for the road and could pose a traffic hazard. Make sure the dip will capture all the overtopping water and carry it in a controlled way to the intended relief drainage pathway. Plan to plug any continuous road ditches on the downgrade side of the stream crossing to prevent them from diverting ponded water down the road.



*Figure 7.20—Diversion-prevention dip on the Plumas National Forest, California. The diversion dip is located just down the road from the stream crossing because the crossing is on a tight curve.*

## Chapter 7—Final Design and Contract Preparation

---

When a culvert plugs and sends water over the road through the relief dip, the water tends to pool relatively gently on the upstream side. However, once through the relief dip and over the road, the water rushes down the much steeper embankment slope and can cause considerable erosion. Make sure the downstream slope of the relief dip is well protected with vegetation and or riprap.

A relief dip also may be used to provide stormflow relief by means of a controlled failure. In such a scenario, the dip is protected from erosion in the same way as other fillslope areas. If the stream-simulation structure plugs, the stormflow causes failure at the relief dip location, preventing the stormwater from running down the road and thereby limiting overall damage.

A good diversion-prevention dip has the following characteristics:

- Accommodates the critical vehicle at the design speed.
- Cross section is adequate to contain the design stormflow volume.
- Outsloped at less than 5 percent.
- Incorporates embankment erosion-control measures.
- Associated ditches are plugged to prevent floodwater escape down the ditch.

### 7.8 DEWATERING, BYPASS, AND WATER TREATMENT DURING CONSTRUCTION

Live streams require dewatering to prevent mixing soil with streamwater during construction. Unless subsurface water exists, a dry streambed may not require dewatering. However, if water quality is an issue, create and implement a reliable bypass plan for handling stormflows. Summer storm events may be the most intense storms during the year in some areas, and unusual events can happen at any time.

Often, engineers do not take dewatering seriously enough. Although the dewatering system does not have to be elaborate, it needs to work effectively. The bypass dam is the first line of defense on the project, and the downstream sediment collection point—whether an excavated pool, an existing scour pool, or a dammed pool—is the last. These components of the dewatering system must work well and reliably. The failure of a dewatering system can cause serious damage to the stream habitat, delay the project, and result in cost overruns.

## Stream Simulation

---

Only a gross estimate of the amount of surface and subsurface water and sediment that need capturing and treating can be made until the site is actually excavated. We recommend that the engineer and a hydrologist work together on the dewatering-system design, and take into account historical flows during the construction season. Be sure to require that the contractor provide adequate pumping ability, regardless of project conditions, and to have a backup pump always available for handling stormflows and taking over if the primary pump malfunctions.

A successful dewatering and bypass system does all of the following:

- Captures streamflow and successfully diverts it around the project.
- Handles stormflows without failure, with backup pumps readily available onsite.
- Captures water that seeps around the bypass before it reaches the excavation, and reroutes and treats it (if necessary) before releasing it back to the stream.
- Captures and removes sediments from water that seeps into the excavation from its edges or from springs, mixes with soil and becomes turbid.
- Does not **backwater** the site.
- Captures water that seeps into the excavation from downstream and either treats it or—if it is kept clean—releases it back into the stream.
- Protects fish and other species of concern by providing suitable screens on all pump intakes in areas containing aquatic organisms.
- Accomplishes dewatering in a controlled manner, slowly and in stages, allowing capture and transport of aquatic organisms out of the construction area.
- Accomplishes rewatering by releasing any large pools of water dammed during construction in a slow, controlled manner avoiding downstream water heating during rewatering.
- Provides for fish passage around the construction site where necessary.

Supplemental Specification 157 (example in appendix H) requires the contractor to take the measures necessary for dewatering and treating sediment to meet turbidity requirements. Figure 7.21 shows a generic dewatering plan demonstrating key components of a complete plan, including a stop-work requirement to permit relocating aquatic species



## Chapter 7—Final Design and Contract Preparation

---

before the dewatering takes place. An actual dewatering plan, however, is site-specific; details, configuration, and components of the plan will vary by site. Appendix G.4.1 includes more detailed information on elements of the bypass and dewatering system.

The length of time the bypass and dewatering system must be in place varies with each project. Small embedded pipes or precast structures may only require a site to be dewatered for a few days or less. Projects with cast-in-place concrete usually need at least 2 weeks. Sites requiring a bypass road may require continuous dewatering until the bypass road is removed. Complex projects may require more than one construction season, along with bypasses capable of handling high-flow events throughout the year.

### 7.8.1 Bypass Dams

As long as the existing culvert is still in place, you can direct water through it and use it for the bypass. Once the culvert is removed, however, you will need a bypass dam or convenient natural pool to gather water, direct it into a transport structure, and divert it around the project site. This bypass dam or pond location is important. By locating it close to the excavation, you create the best chance of capturing most of the water entering the construction site. Using a natural pool, when one is conveniently available, will reduce the height of the bypass dam. When doing extensive upstream channel work, use more than one bypass dam to capture the flow from springs and side drainages. Do not locate bypass dams on any stream features that control the channel gradient (e.g., steps, or pool tail-outs). Those features tend to allow more seepage beneath a dam built on top of them than other more well-graded and smoother channel areas. If constructing the dam in those locations is the only option, preserve stream stability by reconstructing those features as close as possible to the original features.

Three different methods for diverting water are in common use:

- **Pumping and transport hoses:** A gas, diesel, or electric pump pumps from a stream pool or an excavated sump during the entire dewatering period, diverting the water around the site and back into the stream. Float switches control the pumps as water levels fluctuate to save energy and keep the pumps from running dry. Screens must be used to protect organisms (figure G.5) and must be maintained—if screens plug, pumps lose efficiency or can run dry. See the biologist on the project team for help in sizing this screen.

# Stream Simulation

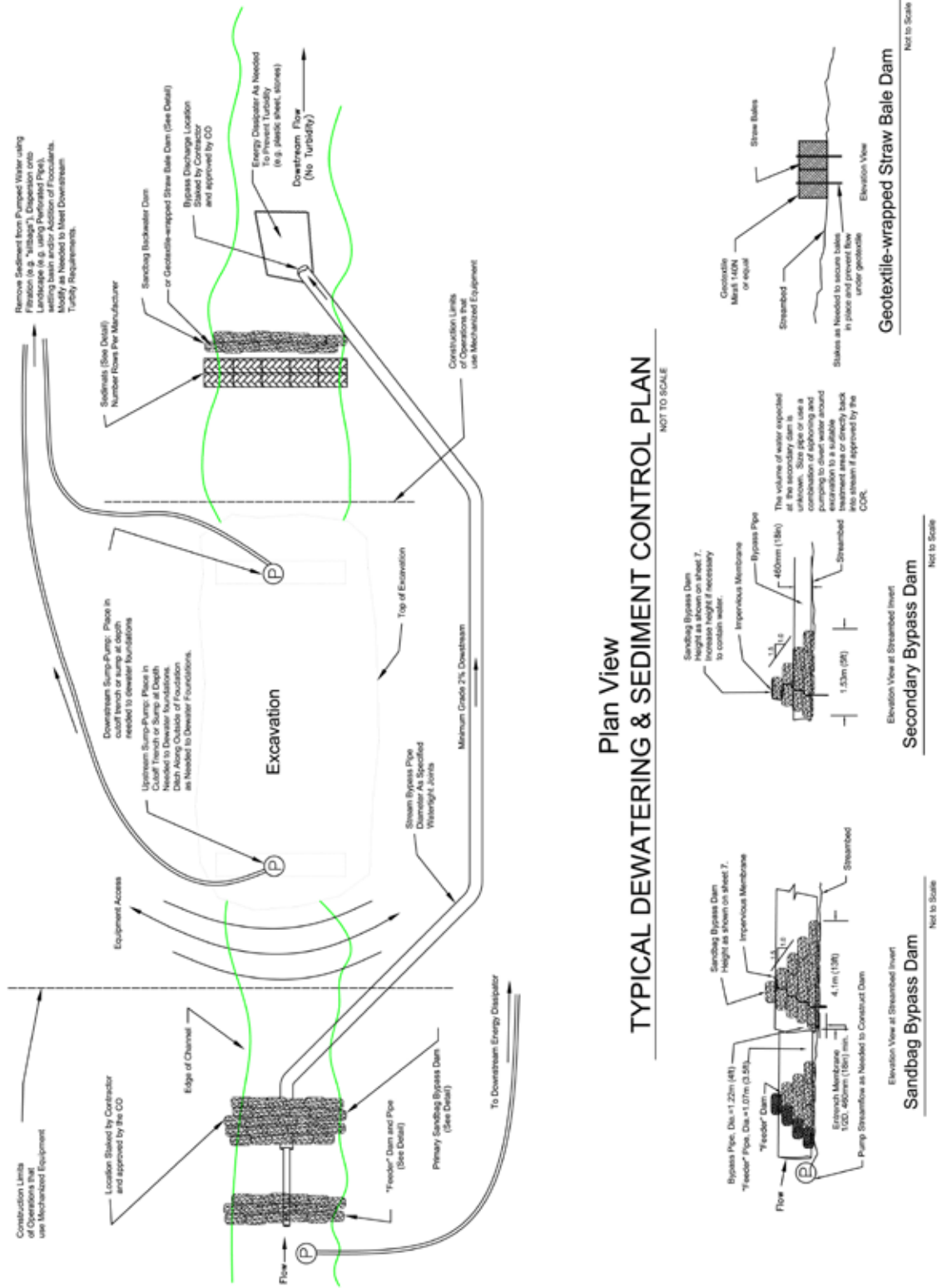

Figure 7.21—Dewatering system details—generic drawing.

## Chapter 7—Final Design and Contract Preparation

---

Pumping systems that will reliably convey the bypass design flow can be complicated to design where water must be pumped up, or far away. You may want to contact the pump manufacturer to verify system design is adequate.

- **Bypass dam and pipe:** This method uses a single dam and bypass pipe to dewater the site. Construct the bypass dam from an impermeable membrane and a support structure. The dam can be made of excavated streambed materials, small or very large sandbags, waterbags, or other materials (section G.4.1.1). Since the bypass dam impounds water, it must be stable (e.g., if using streambed materials, you need minimum slopes of 1:1 upstream and 1:1.5 downstream). Place a membrane upstream of the dam, embedded 2 to 4 feet into the stream bottom and sides, to intercept subsurface flow and prevent seepage through bank materials when the dam pools water. If possible, construct the dam adjacent to a pool or excavation, where the membrane can line the entire dam and pool edge to the bottom to maximize capture of subsurface flow. Weigh down the membrane to keep it from floating. Cut a hole in the membrane smaller than the bypass pipe, stretching it around the pipe and binding it to the pipe to make an impermeable seal. The trench for the bypass pipe often collects some of the leakage from the bypass dam. If the water is clean, you can pump it upstream to eventually flow through the bypass pipe. If it is not clean, you can allow it to flow downstream to the sumps or to flow in an erosion-protected ditch alongside the bypass pipe, where it can be captured and treated. Leaves and woody debris can plug the diversion inlet and quickly cause overtopping of the diversion dam; consider placing a coarse mesh screen or fence upstream of the pipe inlet a few feet and tying it back into the diversion dam to catch debris before it can plug the inlet.
- **Feeder dam, bypass dam, and pipe:** This method uses an additional dam to pool and divert water with pumps during the construction of the main bypass dam. This method allows easier construction of the main dam and is more suitable in larger streambeds where dewatering is difficult due to subsurface flows and permeable bank materials. Any water that seeps by the feeder dam collects between the two dams and enters the annular area created by placing the smaller bypass pipe in the feeder dam into the larger bypass-dam pipe. In practice, the two-dam system will make the bypass much more efficient and reduce the amount of seepage that reaches the excavation (see figure 7.21). However, this system is more costly and is only necessary when subsurface flows make construction of the bypass dam difficult.

## Stream Simulation

---

Creating a good seal of the bypass dam can be difficult. Expect about 95-percent capture in a good system. If the amount of seepage is a problem, consider deepening or lengthening the membrane to decrease seepage.

### 7.8.2 Bypass Design

Size the bypass pipe to carry the highest flow reasonably expected to occur during construction, including surface and subsurface flows. The project team should determine the design flow for the bypass system after assessing risks and consequences of exceeding the design flow. Note that some State permits set a minimum return frequency for the design storm for bypass systems.

We recommend that a hydrologist estimate surface flow rates, and that either a hydrologist or a geologist help estimate subsurface flow volumes. (See appendix D for a brief discussion of methods for estimating streamflow.) Once you have estimated the design-flow volume for the bypass, design the pipe to carry the flow at an inlet depth of one pipe diameter or less. You can examine various pipe sizes and inlet-flow depths to find a pipe size and dam height capable of carrying the peak flow without overtopping the bypass dam or plugging the pipe with leaves or woody debris. To determine flow depth at the inlet and water velocity at the pipe gradient, use culvert-design charts or software such as FishXing or HY-8. (You can find FishXing and HY-8, as well as other useful hydraulic software downloads, at the Federal Highway Administration's Hydraulic Engineering Web site: <http://www.fhwa.dot.gov/engineering/hydraulics/software.cfm>.) Be sure that the bypass dam is at least as high as the calculated backwater at the pipe inlet, preferably higher by at least 6 inches to 2 feet, depending on the stream size, slope, and risk. Costs for the pipe and bypass dam are significant. Evaluate various scenarios to determine the least expensive reliable combination.

The bypass pipe requires protection from the considerable thrust that occurs at elbows and bends (both horizontal and vertical.) Weigh down or bury bypass pipes at elbows, bends, and vertical curves to prevent the pipes from moving or coming apart at the couplings.

To prevent seepage into the excavation, the pipe should have sealed joints. Given specifications, manufacturers can provide a pipe with a reliable seal. The pipe usually goes in a trench adjacent to the excavation. Use the calculated pipe velocity to design appropriate outlet erosion-control

## Chapter 7—Final Design and Contract Preparation

---

measures or a suitable pool to dissipate energy and reduce damage to organisms that may be transported downstream through the bypass pipe (for gravity bypass systems).

On some relatively flat sites, you can divert water into a natural or constructed channel around the project. The channel can be a lined ditch, raised sandbag, or other type of channel structure. Design the channel to carry the high flow expected either during the construction season, or, for multiseason projects, the expected annual high flow.

Other bypass options that you can design or allow in the contract include:

- (1) A constructed erosion-resistant transport ditch lined with rock or a membrane.
- (2) An existing flood-plain channel.
- (3) Isolated footing areas, with sandbags maintaining streamflow through the center of the project.
- (4) Pumping or siphoning the water through hoses 100 percent of the dewatering time.

Of these four, either you or your hydrologist can design the first three or check them for capacity. For pumping and siphoning systems, because of the difficulty in estimating flows, your best bet is to estimate the needed capacity, then plan on adjusting the capacity in the field.

### 7.8.3 Sump Design

Use sumps to collect ground water or seepage that escapes capture by the bypass dam (figure 7.21). Locate one or more at low points at the upstream and downstream ends of the excavation area. The upstream sump captures any ground water or seepage that gets past the bypass dam. If this water contains sediment, collect the water for further treatment before it reenters the stream channel (see figures 8.5 and 8.6). The downstream sump collects any sediment and drainage seeping through the area from any source and is the final insurance against sediment entering the stream. If a scour pool already exists at the culvert outlet, the downstream sump may not need to be excavated. If no scour pool exists, construct a waterproof downstream dam to create a sump below the excavation.

To help determine the correct pump size for the estimated seepage into the sump, pump manufacturers provide pump-performance curves (volume versus head). Depending on the application, pumps range from relatively small electric sump pumps to large gasoline- or diesel-powered

## Stream Simulation

---

pumps. Automatic float switches for controlling the pumps are available (see figure 8.7). Electric sump pumps are lower in capacity than engine-powered trash pumps (see appendix G.4.1.2).

One way to estimate seepage rates to determine pump capacity needed is to do a pump test near the channel. The pump test is normally done during a geotechnical investigation. It consists of determining how long it takes for seepage to refill a pit of known volume that has been pumped dry.

Estimate the sump collection areas and draw them on the site plan. Because seepage volumes and pumping requirements are only estimates, the design should be conservative. The sump must be large enough to capture all seepage and deep enough so the pump always has enough head to work properly. The contract can also state a requirement that “all sump water must be captured and treated before being released back into the live stream.”

The upstream sump may contain clean water that can be pumped directly back into the stream. If the water does not need treatment, pumping it either into the live-stream channel above the bypass dam or directly into the bypass system to avoid unnecessary treatment is often a convenient tactic. The downstream sump is the main collection point for sediment-laden water from excavation and other site disturbances, and it will always require treatment.

### 7.8.4. Sediment Treatment Methods

Using soil information and/or onsite drilling records, you can predict the type of sediment likely to be trapped in the sump. Due to the presence of suspended silt and clay, all projects will generate some turbidity. While sand-sized sediments settle quickly, silt and clay take much longer to settle; this water must be treated before being released into the stream channel.

A common and often suitable method of treating sediment-laden water is by natural filtration through soil and vegetation adjacent to the stream. Forest soils with thick layers of organic material, dense ground covers, and soils with at least moderate permeabilities at least 100 feet from a streambed can provide good filtering media for sediments (figure 8.8). You can use a perforated-pipe drainfield, or even irrigation sprinklers to disperse water over a broad area. Be aware that highly permeable riparian areas close to the stream may be ineffective for filtration.

## Chapter 7—Final Design and Contract Preparation

---

The project team may have located suitable filtration areas during the site assessment. If none are in the immediate vicinity, you can transport water further away in roadside ditches, swales, excavated ditches, or piping systems to more suitable treatment areas.

A variety of alternative sediment-treatment methods exist (also see appendix G.4.1.3):

- Use a subsurface drain in low-permeability material. Construct it by excavating a hole and filling it with drain rock to increase the absorption area and head.
- Pump sediment into small constructed pools to remove coarse sediment before treating for silt and clay. The ground disturbance associated with large settling ponds may be excessive on most sites.
- In treatment pools, ponds, or containers, include chemical polymers or natural-based flocculants such as:
  - ▲ Polyacrylamide (PAM), such as Chemco 9107GD and 9836A (Tobiason et al. 2001).
  - ▲ Chitosan-based water clarifier, such as Storm-Klear Liqui-Floc (For more information on polymer use for water treatment, see “Conclusions” in the following article: [http://www.forester.net/ec\\_0101\\_polymer.html](http://www.forester.net/ec_0101_polymer.html).)
- Filter sump water, using sediment-filter bags similar to those from JMD Company (see [http://www.jmdcompany.com/Enviro-Protection\\_bag.cfm](http://www.jmdcompany.com/Enviro-Protection_bag.cfm) ).



Figure 7.22—Typical silt-fence installation.

## Stream Simulation

---

Silt fences are typically capable of trapping only small quantities of liquid, sand, and coarse silts, down to about 125 microns. They effectively can control overland sediment transport, but are not useful in deeper water, which overtops the silt fence as it becomes plugged with sediment. Include requirements to maintain silt fences when they are used; once the silt fence is filled, it is useless until maintained.

### 7.8.5 Backwatered Sites

Where the stream is not entrenched and is relatively flat, the excavation may be backwatered easily. Any excavation done in a backwatered site will produce a large volume of dirty water that may require extensive, high-volume treatment methods. Study the long profile to determine the backwatering potential and need for a downstream dam (in addition to the upstream bypass dam). Backwater dams are similar to bypass dams and use the same construction methods. If the backwater is deep, hydrostatic forces on the dam can be substantial, and the dam may require an engineering design. If little water is present, straw bales and plastic sheeting may be all you need for a backwater dam. Another possible solution when there is sufficient grade is lengthening the bypass pipe and outletting water further from the excavation.

Some backwatered sites, especially those adjacent to pools or reservoirs, cannot be dewatered effectively. In those cases, consider different structure types and construction methods that will reduce water quality impacts. For instance, a precast structure may be better suited to this kind of site than a cast-in-place structure. Bridges with driven-pile foundations or spread-footings near the ground surface will cause little impact to the site. Embedded pipes that can be placed quickly may also be suitable, especially if they do not require significant excavation because they are located in a backwatered “pool” location.

### 7.8.6 Deep Fills

At crossings with deep fills, carefully consider where to locate the bypass pipe to minimize the amount of excavation required for its placement. An open-bottom arch may be more desirable at this kind of site, because the existing pipe can be left in place to act as the dewatering pipe while the arch is constructed around it. Using an open-bottom arch may require a wider structure than selected in chapter 6. You will need to use sandbags or other damming materials to direct the water into the culvert while keeping it out of the excavation. When the existing pipe must finally be removed, you will need to either pump the water or route it through a bypass pipe while the streambed is prepared.



## Chapter 7—Final Design and Contract Preparation

---

If constructing an embedded pipe, consider construction methods that require the least time, because you will have to divert the stream during the entire construction. To avoid future leaks in the fill, remove the bypass pipe as the embankment is constructed.

### 7.8.7 Large Streams

Large streams may require the full suite of dewatering techniques described so far. The key to determining when to cut back or increase dewatering details is to evaluate the risks of failure. For example, when stream sediments contain large quantities of fines, more stringent measures to recover the fine material may be required to meet turbidity requirements. Although collecting all the water on a project before it reaches the excavation is often difficult, providing a conservative sediment-control system is better than causing stream turbidity problems, especially in sensitive habitat.

### 7.8.8 Small Streams

Although the dewatering system does not have to be elaborate, it does need to work effectively. The failure of a dewatering system on a small stream can sometimes cause just as much damage as a failure on a larger project.

### 7.8.9 Bedrock Channels

Sediment control is relatively easy in bedrock channels. The key is to create a well-sealed dewatering dam at the upstream end. Once the bedrock is cleaned off and dried, little sediment will be generated. Nonetheless, expect seepage from banks and through the dewatering dam. Because the water that has seeped in will almost never be clean, especially during excavation, construct a downstream sediment trap.

### 7.8.10 Field Modifications

Because streamflow and seepage volumes are hard to predict and can be highly variable, expect some modification of the dewatering plan in the field by contract administrators working in conjunction with you, the project team, and the contractor. Some modifications may also be necessary for optimizing the system for site conditions that become evident only during excavation.

## Stream Simulation

---

### 7.8.11 Pollution Control

Use special contract requirements, Federal Acquisition Regulations (FAR) Section H, to include pollution controls on a project. (See section 7.9.)

Typically, pollution controls include:

- Equipment washing—to prevent bringing in invasive plant species or petroleum-product pollution.
- Equipment repair—to prevent hydraulic leaks before beginning work.
- Petroleum-absorbing “diapers”—to be on hand and close by.
- Specially constructed fueling areas to contain spills.
- Limitations on camping and control of garbage and litter.
- Onsite toilets.

For jobs involving placing concrete in forms, locate suitable waste areas for dumping bad concrete and for washing mixers before concrete work begins. Never allow concrete washwater and fresh concrete to enter live streams, because the cement in the concrete is deleterious (due to the lye content) to all aquatic species.

Controlling invasive species and disease is a very important part of pollution control. Invasive plants may be accidentally imported into the project area from remote sources of soil, rock, plant, and seed materials. Ensure that the erosion- and pollution-control plan includes provisions against contaminating the project with invasive species (either plants or animals). Provide for washing equipment before bringing it to the project and when using vehicles to haul materials to or from contaminated areas. In addition, to ensure that soil and aggregate sources do not contain invasive plant species, provide for surveying the aggregate sources before using them. Do not use any aggregate source that has invasive plants.

## 7.9 SPECIAL CONTRACT REQUIREMENTS

Special contract requirements or “H-clauses” modify the main contract clauses or FAR. Following is a summary of the content of H-clauses typically used with aquatic organism passage contracts (see appendix H). These clauses often cover items also specified on the drawings, specifications, and supplemental specifications. Note: In this section, clauses are numbered as a typical contract for reference between chapter 7, chapter 8, and appendix H. Some of these clauses may or may not apply to your contract and thus your numbering may be different.

## Chapter 7—Final Design and Contract Preparation

---

### Clauses related to species protection

- H.1—Seasonal Restrictions: H.1 specifies the overall dates for the work period, site disturbance, and in-water work. If extensions for site disturbance and in-water work periods are necessary, contact the project team biologist.
- H.13—Protection of Habitat of Endangered, Threatened, and Sensitive Species: H.13 specifies measures to protect plants or animals listed as threatened or endangered. If measures are inadequate or new species are found, the Government may unilaterally modify or cancel the contract. Discovery of threatened, endangered, or sensitive species requires notifying the contracting officer. Site dewatering methods fall under this clause.

### Clauses related to water quality

- H.3—Landscape Preservation: H.3 replaces FAR clause 52.236, Control of Erosion, Sedimentation, and Pollution, and specifies requirements for:
  - ▲ Protecting vegetation outside clearing limits.
  - ▲ Preventing fuel and oil pollution.
  - ▲ Preventing or removing objectionable materials deposited in water bodies.
  - ▲ Specifying erosion- and pollution-control measures that must be available onsite.
  - ▲ Specifying turbidity limits and monitoring frequency.
  - ▲ Submitting contractor's plans and obtaining approval—before construction—for the following work items (all which have the potential for causing sedimentation and pollution of the stream and work area):
    - Clearing and grubbing.
    - Removing existing pipe.
    - Dewatering and water treatment.
    - Erosion control.
    - Excavating.
    - Placing channel rock, streambed simulation rock, and select borrow.
    - Placing structural concrete.

## Stream Simulation

---

- H.4—Moisture Sensitive Soils: H.4 requires the contractor to design bypass and temporary roads to support highway-legal loads during construction. It also requires the contractor to repair any damage associated with unsuitable material (such as saturated backfill), that would result in silt deposits in streams.
- H.16—Final Cleanup: H.16 requires removing trash and unused material, and requires sweeping and washing the road surface to remove sediment.

### **Clauses related to pollution control:**

- H.14—Sanitation and Servicing Requirements: H.14 requires approval for camping, as well as the placing of oil-absorbing mats under stationary landing equipment and during equipment servicing.

### **Clauses related to structure or material changes:**

- H.5—Value Engineering (VE): H.5 requires that the project team review VE proposals and it limits the use of VE proposals that change the functional service of a facility. (Typically, a change in structure type will not be suitable unless it is an upgrade, such as a sufficiently wide and durable bridge for a culvert structure.)
- H.6—Product Substitution: H.6 requires that the substitution meet the “or equal” clause in all respects, along with written documentation and testing information verifying that the substituted material meets specification requirements. The contractor is responsible for any other modification that the substitution causes. The project team must review any substitution of materials.
- H.10—Control of Material: H.10 specifies the type of excavation expected on the project, along with earthwork tolerances. It requires testing and written documentation of onsite materials to meet project specifications. (Although stream-simulation material is not earthwork, that material still must be placed accurately.) H.10 also specifies requirements for treating borrow, storage, stockpile, and disposal areas.

## Chapter 7—Final Design and Contract Preparation

---

### Clauses related to traffic:

- H.7—Road Use and Maintenance: H.7 specifies requirements for road closures, traffic controls, and permits. Traffic-control plans are often subject to change after contract award. Contact the project team if a proposed change would affect either the project timeline or any physical site detail.
- H.9—Prosecution of Work: H.9 specifies requirements for providing for public safety throughout the construction (including traffic controls), and notifying the public when the construction work, e.g., road closures or blasting, will affect the public.
- H.11—State Permits: H.11 requires the contractor to obtain and follow State permits.
- H.17—Protection of Improvements: H.17 requires the contractor to protect improvements at the site throughout the construction. The contractor must replace signs, and other site features disturbed by construction, unless the contract specifically says otherwise.

### Clauses related to safety:

- H.15—Potential Safety Hazards: H.15 requires the contractor to provide safe working conditions. Occupational Safety and Health Administration (OSHA) regulations apply for working in excavations and for working in confined areas. (For example, using power equipment to place stream materials inside a culvert is covered by OSHA clauses covering working in trenches, working in the vicinity of operating equipment, and working in the vicinity of excavated slopes.)

### Miscellaneous clauses:

- H.2—Physical Data (FAR 52.236-4): H.2 states that physical conditions indicated on the drawings and in the specifications are the result of site investigations by the Government and that the Government is not responsible for the contractor's use of the site. H.2 also describes the normal fire season. (Many forests and regions have a fire plan describing the contractor's fire-related responsibilities, including types of equipment that must be kept onsite, hours that may be worked during high fire danger, people to contact in case of fire, preventive measures, and fire weather updates.)
- H.8—Construction Stakes, Lines, and Grades: H.8 specifies requirements for contractor surveys and for protecting survey control points.
- H.12—Protection of Cultural Resources: H.12 requires protecting and reporting any cultural resources discovered during the project (stream settings are often cultural-resource sites). The Government may unilaterally modify or cancel the contract under this clause.

## **Stream Simulation**

---

### **Major Steps in the Stream-simulation Construction**

**Let contract**

**Inspect and control all aspects of crossing construction**

**Document the installation as-built**

### **RESULTS**

**The completed stream simulation crossing**

**Baseline for monitoring**

*Figure 8.1—Major steps in the stream-simulation construction.*

## Chapter 8—Stream-Simulation Construction

---

This chapter focuses on contract administration, addressing itself primarily to the contracting officer (CO), the contracting officer's representative (COR), and the inspectors. The chapter is not intended to stand alone. It builds on material presented earlier in this guide, because it is essential that people involved in construction have a good understanding of project design elements and objectives. Ideally, the COR who takes primary responsibility at this stage was also involved in the design phase, at least in a consulting role, and is already familiar with the design of the project.



*Figure 8.2—Open-bottom arch stream-simulation culvert on Wilson Creek, Boise National Forest, Idaho.*

This chapter describes how to administer construction of the complete project, paying particular attention to unique and special emphasis elements that make stream-simulation projects different. Although many aspects of these projects are identical to other road-construction and stream-crossing projects, stream-simulation projects are often large structures, and they require streambed construction (figure 8.2). These considerations, along with more rigid survey and construction tolerances, add significantly to the complexity of construction. Proper attention to detail, continual indepth assessment of site details as the project progresses, good communication, and careful, informed decisionmaking are equally important for the construction phase.

## Stream Simulation

---

This chapter emphasizes factors critical to the performance of stream-simulation structures, including:

- Construction survey.
- Structure grade control.
- Structure alignment.
- Structure foundation and backfilling.
- Stream-simulation bed construction.

### 8.1 BRIEF INTRODUCTION TO STREAM-SIMULATION CONSTRUCTION

The following subsections highlight areas where contract administration for stream-simulation projects differs somewhat from traditional stream-crossing projects. None of this is intended to replace policy and direction in the Forest Service Manual and Handbook, it merely emphasizes topics that are either unique to stream simulation, or that sometimes cause problems in construction.

For policy and direction for contract administration on Forest Service contracts, go to Forest Service Handbook (FSH) 6309.11 Contract Administration. The Road Construction Handbook is FSH 7709.57, and FSH 7709.56b contains guidance for Transportation Structures including major and minor culverts. For policy and direction for the Forest Service Engineering Construction Certification Program, go to FSH 7109.17 Engineering Certification. For the entire self-study Engineering Construction Certification program, go to the Engineering Manual 7115 series of manuals. You can download these documents from the Forest Service internal Web site. (Other public lands agencies may have similar programs and policy.)

#### 8.1.1 Roles

For a stream-simulation project, the project team includes individuals not always found on construction projects. The experience of hydrologists, geomorphologists, and fisheries biologists is essential to the success of aquatic organism passage projects. In some cases, these specialists may be participating in the engineering project development process for the first time. The key personnel working on most stream-simulation projects are listed below. Depending on the complexity of the project and the availability of personnel, some of those listed may or may not be members of a specific project team.



## Chapter 8—Stream-Simulation Construction

---

- Land manager (district ranger or forest supervisor).
- Contracting officer (CO).
- Contracting officer's representative (COR).
- Inspector(s).
- Project team— subject matter specialists.
  - ▲ Designer.
  - ▲ Geotechnical or structural engineer.
  - ▲ Hydrologist/geomorphologist.
  - ▲ Fisheries biologist.
- Contractor.

### 8.1.2 Communications

Because good communication is critical for construction projects, we reemphasize it here. All communications must be complete, accurate, and honest. During the final design process, the design engineer must determine the needs of the land manager, the project team, and the permitting agencies, and convert those requirements into accurate drawings, specifications, and other contract requirements. Otherwise, intelligent communication with the contractor becomes impossible. The contractor, in turn, must construct the project precisely to the contract drawings and specifications. Many of the concepts involved in stream-simulation projects may be new to many contractors; for example, the tight tolerance for elevation control is not widely known in the low-volume road construction industry, and in many cases, the work requires hand labor. The entire process, therefore, requires a great deal of time, commitment, and communication among all the members of the project team including contractors and contract administrators.

Contract administrators may not completely understand all the performance details of the structure or its stream-simulation design features. Therefore, when unexpected problems arise on a project, contract administrators should immediately contact the designer for input leading to solutions that preserve design performance.

Similarly, the project team and design engineer should involve contract administrators early in the planning process. The separation in many organizations between planning/design and contract administration

## **Stream Simulation**

---

imposes artificial barriers and decreases the level of communication. Both the COR and the inspector can provide good information on project constructability, and valuable advice on the types of hazards that exist at particular construction sites. Their knowledge of the capabilities and limitations of various types of equipment is extremely valuable to project teams choosing site location or considering construction access. CORs and inspectors may be able to solve problems that are difficult to solve without firsthand field experience; they may be able to offer solutions that are simpler and less costly, while providing the same level of effectiveness. Therefore, contract administration personnel should be involved early in the project-development process.

### **8.1.3 Contact Administration Meetings**

This section discusses meetings that are particularly important to stream-simulation projects. For successful stream-simulation projects, formal contract administration meetings include the following:

#### **8.1.3.1 Prebid tour**

This meeting is particularly important for stream-simulation projects, which may be unfamiliar to some potential bidders. The prebid tour is an onsite meeting during solicitation, allowing the offering agency and prospective bidders to view the project together to clarify the project drawings, specifications, and contract requirements before bidding. Generally attending are the CO, designers, COR, inspectors, and prospective bidders. Having the project team at this meeting is often useful, as they can explain the rationale behind any special construction features in the design. If stream simulation is relatively new in an area, it may be desirable to begin with an office slide show illustrating the different aspects of an installation.

Often, during the prebid tour and other reviews, questions will arise regarding the project that cannot be answered through the solicitation. In this case, the CO will issue an amendment to the solicitation. The amendment provides the necessary clarification and provides identical information to all bidders to ensure fair and equal competition.

## Chapter 8—Stream-Simulation Construction

### 8.1.3.2 Pework meeting

This is the first meeting after the contract has been awarded. It is generally an office meeting for reviewing the contract, including contract clauses, special contract requirements, drawings, specifications, and any final clarifications with the successful bidder. This meeting gives everyone a chance to discuss and reinforce any special or unusual contract requirements, such as permit requirements or special construction requirements.

Generally attending are the CO, COR, inspector(s), a district or program representative, the design engineer, and the contractor. Having the project team present is useful, as they can explain why special construction requirements for stream-simulation construction are important to the success of the project. The CO or the COR should brief the team members beforehand on contract authority, to avoid potentially embarrassing breaches during the meeting (project team members do not ordinarily have contract authority). The Notice to Proceed is usually issued at this meeting.

### 8.1.3.3 Pework field meeting

This is the first field meeting between the contract administration personnel and the contractor. Additional attendees might include a district representative and possibly a representative from the permitting agency. On complex projects, the designer should be present, to provide any necessary clarification of the drawings and specifications. Again, members of the project team should be present to explain the importance of special construction requirements unique to stream-simulation construction. The meeting will cover the overall project, with an emphasis on such initial items as surveying, clearing, dewatering, traffic bypass (if appropriate), project limits, temporary erosion control, storage and stockpile areas, camping, and general land use, as well as any permit requirements. At this meeting, contract administration personnel should establish day-to-day working relationships, communications channels, and ground rules.

## **Stream Simulation**

---

### **8.1.3.4 Final inspection/post-construction meeting**

The final formal onsite construction meeting reveals to all team members the results of their collective efforts in designing and constructing a stream-simulation project. At this point, work on the project is essentially complete, and the project is ready for use, except for a few small “clean up” items. The project is inspected in its entirety, and the final punch list of items needing completion is finalized. Ideally, all project team members and contract administrators should participate in this meeting, and all parties should express, objectively, what went right or wrong with the project. Lessons learned should be well documented with suggestions for future projects. When the punch-list items are completed, the project is formally accepted, and final payment is processed.

### **8.1.4 Construction and Inspection**

In many respects, stream-simulation projects are no different than other stream-crossing projects. However, some features make stream-simulation projects different and more complex. The way the streambed is treated inside the structure as well as up and downstream of the crossing generally differs from past construction of stream crossings. The structure infill is the most unique feature of any stream-simulation project; its proper construction is vital to its performance. Upstream and downstream controls also play critical roles in the way that the infill of the structure performs. All of these features need your extra attention, because of the strict tolerances required for proper performance and because of the relative newness of these features to the construction industry. In addition, much of this work must be performed by hand, particularly in small structures.

### **8.1.5 Construction BMPs**

BMPs for construction are in section 7.1, in the Construction BMP checklist. All of the items in the BMP list are discussed in detail in either this chapter, chapter 7, or appendix G. The list provides an excellent “watch list” for protecting the construction site, the stream and aquatic organisms during construction, as well as for proper construction of the stream-simulation channel inside the culvert.

## Chapter 8—Stream-Simulation Construction

### 8.1.6 Construction Survey and Tolerances

Surveying for a stream-simulation project requires more time and attention than normal (section 8.2.2). For stream-simulation projects, both the construction survey and the original site survey require great accuracy and attention to detail. Construction tolerances on stream-simulation projects are likewise critical. Small changes in gradient, location, or bed material can profoundly affect the structure's performance.

For example, if the gradient in the structure is steeper than designed, the resulting increase in stream velocity can cause the infill to wash out of the structure. If the gradient is shallower than designed, the resulting decrease in stream velocity can cause the stream to deposit material in the structure. In either case, the structure will not match the stream long profile and may cause an aquatic passage barrier to form at the inlet or outlet. If the structure is placed with a change in alignment, similar consequences could occur, with poor inlet or outlet performance or unanticipated bank erosion. If the bed material does not include enough fine material, the infill may be permeable enough to allow the stream to travel below the surface. If this happens, low flow may not be deep enough to provide for aquatic organism passage, or the channel may become completely dry.

### 8.1.7 Permits and Permit Requirements

Generally, stream-simulation projects are constructed under permit from State and Federal agencies. Permits may include strict requirements on protection of aquatic species, levels of suspended sediment, and construction pollutants. Often a seasonal restriction on the construction timeframe (often called the “construction window”) defines when construction can actually occur on the site during a normal year. Along with these restrictions, permits will include requirements for site closure, including seasonal closures (if the construction will take more than one season to complete).

### 8.1.8 Contract Modifications/Design Changes

Given so many variables, projects seldom flow from beginning to end without a contract modification (i.e., a change order). With such complex projects, anticipating every site problem during the final design is difficult, if not impossible. In addition, once onsite, the contractor, inspector, or COR may find a simpler, more effective, or more economical way of accomplishing the intent of the design and may initiate a proposal for a modification. (In this document, the terms “change order” and “contract modification” are interchangeable.)

## Stream Simulation

---

Whatever the need is for the modification, the process for solving the problem is the same. Whoever identifies a problem proposes a solution (along with team help, if necessary), and the COR estimates the cost. Depending on the complexity of the problem, all members of the project team may need to review the proposed solution. The contractor's input to the solution of any design change can be invaluable, particularly in the area of construction methods and constructability. The designer will provide the engineering solution, with input from contract administration personnel and the remainder of the project team and the contractor.

### 8.1.9 As-built Drawings and Final Construction Report

As-built drawings begin with the contract drawings for the project. All change orders, including minor deviations, are clearly marked and the drawings modified, so that they accurately depict the structure as it was finally constructed. While time-consuming, this process is key to the success of future projects. Being able to study the current generation of projects—through the “as-built” drawings and the final construction report—gives future designers a better understanding of similar projects.

For Forest Service projects, FSM 7721.36 requires a final construction report. Specific requirements for the document are included in FSH 7709.57, Chapter 7. Contract-administration personnel prepare the final construction report. Its purpose is to provide background for future similar projects, and it should thoroughly and objectively document “lessons learned” (both good and bad).

## 8.2 STREAM-SIMULATION CONSTRUCTION TOPICS

The remainder of this chapter emphasizes areas of work that require special attention in stream simulation. It provides lists of items to be routinely checked and lists of common problems, with possible solutions and helpful hints. This section will follow the work progress of a typical project, beginning with Section H “Special Contract Requirements” and ending with the final cleanup and post-construction monitoring.

The first item on the construction project is planning. The contractor is required to submit a project schedule. The purpose of the schedule is not only to track the contractor's work progress, but also to give you—the COR—a useful tool for work planning. When the contractor submits the

## Chapter 8—Stream-Simulation Construction

---

schedule, be sure that it provides realistic information that will benefit the contract-administration process. Obviously, the contractor must update the schedule periodically to reflect current progress of the project (see figure G-1 for a sample project schedule.) A project schedule can take many forms, ranging from showing proposed work progress on a calendar to using detailed Gantt or Critical Path Charts. At the very least, the schedule should identify project start and completion dates and proposed timeframes for important work items such as:

- Construction survey.
- Mobilization.
- Stream diversion and dewatering.
- Aquatic organism capture and transport (timeframe for others to perform work).
- Existing structure removal when applicable.
- Clearing.
- Structure excavation.
- Structure installation.
- Structure backfill.
- Road reconstruction.
- Site cleanup and demobilization.
- Seasonal site closure for projects spanning more than one construction season.

### 8.2.1 Safety

Inspect the contractor's operations to ensure that all work is accomplished safely. (An inspector who witnesses unsafe acts that lead to an accident and does not intervene can be held personally liable.) Most safety issues are standard ones for a variety of construction projects, including operations for excavation, confined spaces, concrete placement, heavy lifting, underground utilities, power equipment, potential fire hazards, and machinery. Be familiar with FSH 7709.57 section 2.5 and Occupational Safety and Health Administration (OSHA) regulations that apply to the particular project. Safety is a personal responsibility, as well as the contractor's responsibility. (For OSHA regulations, go to [http://www.osha.gov/dts/osta/otm/otm\\_v/otm\\_v\\_2.html](http://www.osha.gov/dts/osta/otm/otm_v/otm_v_2.html).)

## Stream Simulation

---

Follow OSHA regulations when working with power equipment in a confined space. When installing streambed material inside the culvert with power equipment, or working in the narrow spaces between footings and excavated slopes, consider:

- Replacing some power equipment work with hand labor.
- Providing large fans to exhaust air from confined spaces.
- Other placement methods.

In addition to OSHA regulations governing construction, you should emphasize safety for both contract administration personnel and anyone visiting the job site. (See Forest Service Health and Safety Code Handbook, FSH 6709.11.)

Perform a job hazard analysis. Identify job tasks, their known hazards, and abatement actions for each hazard. For each project, fill out a FS-6700-7 job hazard analysis (JHA), and file it in the project folder. Review the JHA before going to project sites.

### 8.2.2 Construction Survey

This phase of the project requires more attention to detail than ordinary stream-crossing projects. The COR, the inspector, the project team, and the contractor should visit the site together to create a thorough understanding of the site, design objectives, and details. Visually examine the site to make sure that it looks like the drawings. Spot check elevations to find obvious discrepancies in the survey or design. Because streams change occasionally between site surveys and construction, design changes may be necessary. Always contact the project team with any questions about the location of project features when the drawings differ from actual site conditions.

Protect control points that were established during original topographic survey. They are important references that are necessary to establish construction stakes for the project, for monitoring the construction, for developing as-built drawings, and for monitoring the project in the future. Control points may consist of a reference point on any permanent structure. One simple control point is a 24- to 48-inch reinforcing bar, driven into soil by hand a safe distance away from the maintained roadway and stream in a stable location. Locate offset reference stakes in the area of the culvert inlet and/or outlet in locations where they will not be disturbed by construction or potential stormflows but where they can be easily checked during the project.



## Chapter 8—Stream-Simulation Construction

An error in placing the foundation or bedding can badly affect the outcome of the entire project (figure 8.3), and may result in the eventual failure of the stream-simulation bed or the culvert structure.



*Figure 8.3—Results of a survey error. Footings were constructed 2 feet higher than the designed location because of a construction survey error. Always doublecheck surveys!*

In figure 8.3, the footings were constructed approximately 2 feet higher than designed, due to a contractor survey error that the inspector did not catch. The stream-simulation bed still had to be constructed to match the stream profile, so that the footings were not embedded as deeply as designed.

This error resulted in:

- An increased risk of the foundation being undermined by scour.
- Less fill (on the inside of the footings) for resisting the overturning forces (on the outside) thereby reducing the safety factor for overturning and bearing capacity.
- Insufficient cover height over the pipe, which was designed for minimum cover. To compensate, the contractor had to raise road grade 2 feet, creating an obvious hump in the road profile and limiting some truck traffic.

## Stream Simulation

---

Inspectors should verify contractor surveys by checking—and rechecking—the work. Mistakes in the survey and construction staking will affect the entire project. Your job is to insist on accuracy at all stages.

### Survey Inspection Checklist

Take care of the following items before beginning any work on the site:

- ✓ Verify control points, which are typically established during the original topographic survey (section 5.1.2).
- ✓ Reestablish any missing control points and, if necessary, establish additional control points to aid construction of the stream channel and any channel restoration work.
- ✓ Resolve discrepancies with the surveyor and design engineer before construction begins.
- ✓ Clearly mark all clearing and construction limits, especially near the stream channel, with stakes and flagging.
- ✓ Clearly mark stockpile-storage areas, waste areas, and borrow-source areas with stakes or flagging.
- ✓ Review and establish any proposed construction access with the contractor.
- ✓ Document agreements on a work order.
- ✓ Ensure accurate placement of slope stakes and references for the road travel way, embankment limits, and all excavation slopes.
- ✓ Check that erosion and sediment control and dewatering/sediment removal features are properly located.
- ✓ Check construction stakes to ensure accurate location of the structure, especially the elevation, position, grade, alignment, excavation slopes, and width.

## Chapter 8—Stream-Simulation Construction

### 8.2.3 Special Contract Requirements (H Clauses)

Review the contract for any special contract requirements in section H or in other sections of the contract. Review Section H requirements, Standard Specifications and Supplemental Specifications, not only for special requirements but also for any potential conflicts between them. If conflicts exist, notify the CO and design engineer to resolve them. See appendix H for sample H clauses, and section 7.9 for a summary of the clauses.

### 8.2.4 Signs and Traffic Control Plans

The contract may require a traffic-control plan. Options usually include: a traffic detour onto other roads, a traffic bypass over the site or adjacent to it, or a traffic barrier.

If a change in public traffic access is necessary, be aware that it can affect other aspects of the project. For example, a change may require constructing a temporary road, lengthening the culvert, or moving the dewatering dam and bypass pipe. It may cause additional resource damage, and in some cases, may even increase the cost enough to make a bridge more practical and economical.

### 8.2.5 Erosion, Sediment, and Pollution Control

Maintaining water quality throughout the project (by preventing erosion, and preventing sediment and pollutants from entering streams) should be a major focus for contract administration. Most sediment is generated during embankment and foundation excavation, and by erosion of freshly disturbed slopes, constructed embankments, stockpiles, and road surfaces. (See section 8.2.6 for dewatering. Check section H, Special Contract Requirements, for turbidity requirements.)

*Erosion control* means that the soil remains in place, either undisturbed or protected with a protective covering such as mulch, rock, or a membrane.

*Sediment control* means that soil already eroded is captured and prevented from harming the stream or sensitive riparian areas. Sediment control includes dewatering the site to prevent sediment transport downstream and capturing the sediment with sediment-trapping mats, dams, or silt fences. See appendix G figures G.8 and 9 for example drawings of temporary erosion and sediment control features.

### 8.2.5.1 Reviewing erosion- and sediment-control plans

If the guidelines in chapter 7 were followed, the contract does not specify specific methods of erosion and sediment control. Instead, it makes the contractor responsible for the end result of meeting the requirements spelled out in the supplemental specifications and section H. For ease of contract administration, if any changes in the contractor's plan are required, write them in terms of "end results" or performance rather than specifying specific methods.

The contract may have specific sections relating to erosion and pollution control, such as a Supplemental Specification 157, or a special contract requirement similar to H3 (appendix H). If not, make sure that the specifications and drawings adequately cover any erosion and sediment control requirements in the National Environmental Policy Act document (including BMPs) and in the water quality permit.

Normally, the contractor is required to submit a plan for erosion, sediment, and pollution control (H.3, appendix H). The erosion-control plan can consist of a variety of erosion-prevention and sediment-trapping methods. These methods and details can be obtained from a variety of sources, including instream work permit requirements (BMPs), standard engineering practices, and standard OSHA requirements for excavations and preventing slope failures.

Review the erosion and sediment plan with the project team and ensure it protects the site as required in the contract. Much more detail on erosion and sediment control is in sections 7.7 and 7.8, but some common methods are:

- Erosion control
  - ▲ Minimize cleared and disturbed area.
  - ▲ Dewater the construction area (section 8.2.7).
  - ▲ Use slope treatments, such as seed, mulch, erosion-control fabrics, geotextile fabrics, and membrane, during and after construction.
  - ▲ Maintain temporary erosion and sediment control measures.
  - ▲ Provide armor and/or ditch dam energy dissipators for newly constructed or maintained road drainage ditches.

## Chapter 8—Stream-Simulation Construction

---

- ▲ Control erosion at lead-out ditches and pipe outlets.
- ▲ Prevent road surface runoff from entering the excavation by using surface dips, berms, or outsloping the road.
- ▲ Maintain road surfaces and drainage systems during the contract.
- ▲ For disturbed areas, stockpile sites, and waste areas, scatter clearing slash and debris, seed and mulch, and slope to drain. (Long slopes over about 50 feet are broken by water collection ditches or berms to dissipate energy and control runoff.)
- ▲ Cover temporary stockpiles with an impermeable membrane to prevent erosion and control moisture.
- Sediment control
  - ▲ Place silt fences, straw bales, or other sediment trapping systems at the bottom of excavated slopes, and temporary drainages.
  - ▲ Use sumps for collecting sediment-laden water upstream and downstream of construction, and in bypass pipe ditches.
  - ▲ Locate the area for the water treatment/sediment removal system and verify the system will function as intended at that location.
  - ▲ Use pumps (or gravity when possible) for transporting water to treatment areas.
  - ▲ Monitor and maintain pumping equipment during dewatering operations.
  - ▲ Install erosion controls in the treated water release area if not being released directly into the stream.
  - ▲ Ensure prescribed method for removing sediment functions as intended. Identify alternative methods if more treatment is necessary.
  - ▲ Wash paved road surfaces at the end of the project to prevent sediment from entering the stream, and to restore safe traffic conditions.

The Storm Action Plan should require monitoring and maintaining erosion and sediment control measures and immediate repair or replacement in the case of damage.

## Stream Simulation

---

### Temporary Erosion and Sedimentation Control Inspection Checklist

For maximum effectiveness, make certain that appropriate erosion-control measures are in place at the beginning of site-disturbance activities. (Refer to sections 7.7 and 7.8.) Tips on handling common problems that arise with erosion and sediment controls are in appendix G.4.3.6.

Inspect and monitor the following activities during each site visit throughout construction, and make changes as necessary to control sediment production. Verify that:

- ✓ The dewatering system is installed according to the approved dewatering plan and is functioning properly.
- ✓ Sediment collection systems are installed according to the approved erosion-control plan and are functioning properly.
- ✓ Excavation and waste stockpiles are protected from rainfall and are located where they will not fail or erode directly into the stream. In locations where protection is not practical, be sure sediment-control measures are in effect.
- ✓ Drainage from open excavations, fresh cut banks, and embankments is captured and treated.
- ✓ Water treated and discharged back to the stream meets contract requirements. (Ground water intrusion will increase sediment production. Despite the best dewatering efforts, ground water seepage occurs at many sites. Drainage may come from many different places and increase substantially during storm events.)
- ✓ The contractor takes measures to reduce sediment production, such as by minimizing bucket spill into construction area drainage and by avoiding slope failures in over-steepened excavations. (Because all water discharged back to the stream requires treatment to remove sediments, remind the contractor that it may be more cost effective to reduce sediment production during excavation in order to reduce the amount of water treatment necessary—especially in silt-clay rich soils.)
- ✓ No excavated slopes remain vulnerable to erosion or failure. (If left for long periods (days) these slopes may benefit from using a membrane cover. Assess the slope condition frequently. While membrane covers can be helpful, covering slopes will also slow drying the soil in embankments and in turn cause sloughing. Keep in mind that excavated slope erosion is often the largest source of sediments on the project.)
- ✓ The contractor is careful when loading and hauling wet materials, especially near the site. Be sure that the contractor either avoids spilling excess soil onto the road during haul or provides a means of preventing this sediment from entering the stream. (Sediments around loading areas can be trapped with berms or sand bags. Existing roadside vegetation may provide sufficient trapping elsewhere.)
- ✓ All sediment- and erosion-control methods function as intended. (Silt fences filling with soil and/or water will fail, either by structure failure or by overflowing, unless the soil is removed before the sediment traps fill.)
- ✓ For multiple-year projects, the contract should contain adequate site protection provisions covering conditions peculiar to the site at the end of each work season. (If additional protection is necessary because of expected storm events, snowmelt, frost heave, ravel, wind, etc., the inspector and the project team should initiate a change order to encompass the necessary work. If the area has a history of vandalism, for example, vehicle barriers may be necessary to close the site to traffic, especially during hunting season or other high-use in recreation periods.)

### 8.2.5.2 Pollution control and prevention plans

The primary sources of pollution on a project are vehicle fuels, hydraulic fluids, lubricants, invasive plants and animals carried in on equipment, and human waste. Special contract requirements specify methods, procedures, and rules to follow to reduce the risk of pollution. Depending on the contract, the contractor may be required to submit a pollution-control plan.

Be proactive in ensuring that the contract meets water-quality and soil-protection goals. Items such as hydraulic oil or other fluid leaks can cause serious damage in a very short time. To meet project and environmental requirements, deal with spills immediately and firmly. Review plans and operations to ensure that construction activities comply at all times with specified pollution control objectives. Make sure that protections are in place or are ready to deploy immediately when necessary.

Special contract requirements generally include all or some of the following. See also sections 7.8.11 and 7.9, and H-clause 3 in appendix H.

- Landscape Preservation and Hazardous Materials
  - ▲ Written approval required for operating equipment in live streams.
  - ▲ Service equipment only in approved areas.
  - ▲ Transport waste offsite.
  - ▲ Treatment for general construction debris. (Usually, the contract will require that construction debris be removed to an off-forest site according to local, State, and Federal regulations.)
- Hazardous Materials
  - ▲ Spill plan submittal.
    - Specifies hazardous material cleanup kit.
    - Specifies which materials must be on hand to contain spills.
    - Specifies that required spill containment devices, pads, and booms are onsite and ready to deploy immediately.
  - ▲ Review the spill plan and require modifications as necessary to meet project objectives and goals.
- Industrial Camps
  - ▲ Self-contained toilet facilities onsite.

## Stream Simulation

---

- Equipment Cleaning
  - ▲ Pressure-wash equipment to remove foreign terrestrial, aquatic weed, and animal species.
  - ▲ Repair fuel, lubricant, and hydraulic leaks.
  - ▲ Inspect daily (depending on activity).

### 8.2.6 Dewatering and Sediment Removal

A dewatering system bypasses the streamflow around the site and removes most of the water from the excavation area of the project (figure 8.4). (See appendix H for a sample dewatering supplemental specification, and figures H.6, 7, 8, and 13 for sample dewatering system drawings.) Water that escapes the bypass system—by flowing around or beneath the dam or seeping into the excavation—must be captured and treated to remove the sediments before returning it to the stream. In areas prone to seasonal storms during the construction season, even channels with dry stream beds may require dewatering plans. A simpler system than that shown in figure 8.4 may be suitable in such areas.



*Figure 8.4. Diversion dam and gravity pipe bypass system. Bypass road is visible in the background, and excavation in main road is just beyond it.*

Excavation activities produce most of the sediments on a project. As part of the dewatering, encourage the contractor to avoid inadvertently mixing excavated soil and water. Not mixing soil and water will reduce the amount of water needing treatment and reduce the risk of exceeding turbidity levels in the stream. The contractor will also find this practice advantageous because it reduces water-treatment costs.



## Chapter 8—Stream-Simulation Construction

### 8.2.6.1 Protection of aquatic organisms when dewatering

To maximize protection of aquatic organisms, review the dewatering plan and the species-removal plan with the biologist and contractor in the field before beginning construction. When endangered and threatened species are present, dewatering may take on critical importance, and regulatory agency personnel may review it in the field. See appendix G.4.4 for case examples of dewatering and species protection for a stream crossing and a stream-restoration project.

Dewatering often traps aquatic animals, and construction activities in the dewatered stream channel frequently kill organisms that have retreated into moist gravels. To avoid stranding, stressing, or killing aquatic organisms: dewater gradually, capture the organisms, and transport them to the best available stream habitat above or below the construction site.

No standard method exists for capturing and handling aquatic organisms. The biological opinion from the regulatory agency should cover the methods for endangered species act-listed species. State fish and game agencies are a good source for guidelines for handling captured aquatic organisms. Generally, placing captured fish in a bucket of water kept at ambient stream temperature is best. The exact methods for capture and transport will depend on channel features such as dimensions, shape, substrate size, and location of hiding places. Choose trap and transport techniques that reduce stress on individuals selected for protection.

To determine a practical and reliable way to dewater, collect and transport aquatic organisms, and rewater the site in a controlled and staged manner, the contractor, inspector, and project biologist should coordinate their timing and work together. The construction contractor generally does not perform aquatic organism removal, but the contract should provide a stop-work requirement that allows time for that work (section 7.8). It is important to ensure that when dewatering begins enough qualified personnel are present to collect and move species safely and efficiently. The contractor and inspector may also be able to help with species transport under the guidance of the fish biologist. For example, if aquatic organisms will be transported over rough ground to an upstream or downstream habitat, the contractor's assistance in clearing a pathway for this effort may be extremely helpful.

## Stream Simulation

---

Protecting aquatic organisms also includes:

- Minimizing damage to aquatic habitat by limiting turbidity and sedimentation of the streambed.
- Minimizing water temperature increases by avoiding vegetation removal and retaining shade. Before implementing any proposed changes to clearing limits, review them with the project biologist.
- Preventing the spread of invasive species such as zebra mussels, snail species, and weeds. Be sure that all tools and equipment are thoroughly cleaned before they are brought to the construction site.
- Avoiding chemical contamination and rapid changes in water temperature.
- Adhering to the instream construction window, which is usually determined by the permit. The timing is set to avoid critical aquatic organism life cycle periods such as migration and spawning.

### 8.2.6.2 Dewatering plan review

If the contract does not contain a dewatering and water-treatment plan but instead requires the contractor to submit one, review the contractor's submittal carefully. Be sure it includes the elements described in section 7.8. Review Supplemental Specification 157 and the sample dewatering plan drawings in appendix H for features that may be used on the project. A successful dewatering plan includes the following:

- A diversion dam to direct water into a bypass pipe or pump system to capture the majority of stream flow. About 90- to 95-percent capture is considered successful. The dam must have sufficient height and width for stability.
- A method for temporarily pumping or diverting water around the bypass dam area during its construction.
- Screens on pump intakes to prevent leaves and other debris and aquatic organisms from entering the pumps.
- A hydraulically designed water bypass system (leak-proof pipe, lined-ditch, or pump system) capable of handling construction-season flow conditions, including possible storm flows.

## Chapter 8—Stream-Simulation Construction

---

- A sump above the excavation to collect water seeping past the diversion dam; and a pump, bypass ditch, or other means for transporting the water to the treatment system (figure 8.5). (If the water is clean, it can be pumped back upstream to the bypass system to reduce the load on the water treatment system.)
- A sump immediately downstream from the excavation to collect sediment-laden seepage water, and a means to transport it to a treatment system (figure 8.6).
- Sump pumps that are capable of handling expected flows.
- A specific sediment-removal method, including backup if the preferred method fails.
- A storm action plan that includes both Government and contractor contacts along with specific action items for avoiding a catastrophic failure.



*Figure 8.5—Upper sump collects water that bypasses or seeps through the diversion dam.*

## Stream Simulation



*Figure 8.6—Lower sump collects water bypassing the construction. The hose on the right is discharge from the upper sump. The water is pumped from the sump to a treatment area where the water is dispersed in the vegetation.*

The design engineer, COR, and inspector should all review the dewatering and sediment-removal plan carefully to ensure that the objectives are understood, and that the plan is effective at collecting and treating dirty water, meets hydraulic needs, and allows for project limitations such as rights-of-way and instream work permit requirements.

### **8.2.6.3 Dewatering inspection recommendations**

Because the amount of ground water can vary significantly and is difficult to predict before construction begins, the dewatering plan should allow for necessary adjustments. If the dewatering plan was written as an end-result or performance-based specification, the contractor must be prepared to make appropriate changes to the dewatering system to eliminate sedimentation. Either the COR or the inspector must be quick to recognize any potential failure of the dewatering system and require any necessary changes.

## Chapter 8—Stream-Simulation Construction

Above all, all sites must have a method of capturing and treating sediment and drainage downstream of the project (sections 7.8.3 and 7.8.4). The method usually consists of a sump and pump system that feeds the dirty water to a treatment system. This system is the project's final opportunity to keep sediment out the stream.

Follow the approved diversion plan exactly, adjusting it only to fit the site. Contact the design engineer if changes are necessary. If something is not working correctly, have the contractor repair it immediately, because the integrity of the individual design elements is key to preventing leaks from reaching the stream.

### Dewatering System Inspection Checklist

Check the following items to ensure that the dewatering system protects aquatic species and functions properly:

#### ***Bypass dams and downstream backwater dams.***

- ✓ Dam materials are tightly packed.
- ✓ Dam elevation is correct (provides for flood capacity).
- ✓ Dam length and width is correct. (Even though the dam is small, it is still a dam and must be stable and safe.)
- ✓ Membrane is properly installed, embedded into banks and stream bottom to the dimensions specified (or as necessary to intercept both surface and subsurface water).
- ✓ The dam has a reasonably good seal against the streambed, bank, and bypass pipe. (Expect some seepage to get past the dam; collecting 100 percent of the water is nearly impossible.)

#### ***Stream bypass by pumping***

- ✓ Screens are on all pump intakes.
- ✓ Pump intake is placed deep enough that the entire screen is submerged, providing enough head for the pump to operate efficiently.
- ✓ Pump capacity is sufficient to pump entire stream around construction area. Multiple or unusually large pumps are required in larger stream flows. Pumps and stream flows are measured differently. One cubic foot per second (typical streamflow unit) equals 448 gallons per minute (typical pump measurement).
- ✓ During excavation activities, check all pumps until the excavation water clears. (Pumps may have to run constantly, and you may need one or more backup pumps.)

## Stream Simulation

---

### ***Stream bypass by gravity through pipe.***

- ✓ Pipe capacity is adequate to pass required streamflow for the construction season and any anticipated extensions. Pipe capacity can be determined with either pipe-flow nomographs or software such as HY-8.
- ✓ The pipe is effectively sealed to the dam according to specification (section 7.8.1).
- ✓ Pipe diameter, material type, joint type, and sealer or gasket must be as specified.
- ✓ Pipe joints are straight, unstressed, and leakproof.
- ✓ Pipe is placed at the designed grade and elevation.
- ✓ The pipe outlet area is scour resistant. If downstream fish passage is allowed, outlet is placed in a pool or other suitable release area.
- ✓ Any seepage from the diversion dam that flows into the bypass pipe ditch is collected in a sump before it enters the stream. (If it is very clean [test it to be sure] it can be pumped back into the stream).

### ***Stream bypass by gravity into existing side or constructed channel.***

- ✓ The diversion channel slope, width, and bank slopes are constructed as designed. These characteristics ensure stability and keep the channel scour-resistant. Supplemental erosion control measures may consist of: rock lining, a membrane, straw, check dams, geotextiles, etc.
- ✓ The area between the channel and the construction area must be sufficiently stable to prevent an accidental diversion into the construction area, and to prevent channel seepage from reaching the excavation area. (Reinforce the channel, if necessary.)

### ***Stream bypass and water treatment system—general.***

- ✓ Check the pipe diversion inlet daily. Make sure that any debris such as leaves and twigs are removed periodically. If screens are required on the pipe or on pumps and hose inlets, cleaning may be required daily, especially in areas of significant leaf fall during construction.
- ✓ Enough fuel is available to keep pumps running up to 24 hours a day, when required, to prevent stream sedimentation during storm events.
- ✓ System includes automatic pump control floats to conserve fuel and maintain pool elevation within an acceptable range (figure 8.7)
- ✓ Backup pumps and extra pump capacity (including fuel) are onsite to accommodate increased stream flows during storm events.
- ✓ Where storms, vandalism, or other events could cause a system malfunction, check the system daily—including weekends.



Figure 8.7—Pump controls: float switches are attached to stake in sump.

### ***Dewatering and aquatic-organism removal.***

- ✓ The project team biologist is kept informed of the contract schedule, so that he or she can be present for species removal during dewatering.
- ✓ A staged (slow, controlled) dewatering procedure is clearly understood and agreed to by the contractor.
- ✓ Necessary equipment such as buckets, nets, shock equipment, and dip nets are onsite before dewatering begins.
- ✓ Equipment necessary for special-capture methods is on hand if needed for listed species.
- ✓ All equipment is cleaned before it is brought to the site as well as when it leaves the site, to protect against introducing invasive species.
- ✓ The release area is located and a safe pathway from the dewatering area to the release area has been cleared.
- ✓ Before dewatering begins, enough people for the capture/removal job are in place.
- ✓ Dewatering begins gradually so that aquatic organisms are not stranded in the dry streambed.

## Stream Simulation

---

### 8.2.6.4 Tips for collecting and treating sediment-laden water

#### Upstream sump

- Maintain sump pool volume with enough capacity to prevent flooding the excavation.
- Capture the seepage and pump it to the treatment system. The water may eventually clear enough for pumping back into the stream.
- For both convenience and reliability, run all sumps from a central electric generator.

#### Water collection within the excavation area

- Collect as much water as possible within the excavation area. Then concentrate and divert the water away from loose soil to reduce sedimentation.
- Maintain the drainage area between the foundations and excavation edge by removing accumulated soil deposits and debris.

#### Downstream sump

- This sump is important, as it offers the last chance for collecting and diverting dirty water for treatment (figure 8.6).
- Use the downstream sump at all times to capture and divert dirty water to the treatment system.
- Be sure that the sump-pool capacity is sufficient for stormflows, especially if sedimentation rate is high.
- Have enough pumps to handle seepage during storm events, and keep pumps in good working order.
- Keep transport hoses for sediment removal stable and leak-free to avoid causing erosion or allowing sediment to enter live streams.
- Use a downstream backup instream filter in case the downstream sump capacity is exceeded. The filter may be geotextile wrapped straw bale or other sediment filter.
- Ensure that the backup sediment filter is constructed and positioned properly, and sealed against the streambed.
- Monitor the filter to ensure that it remains effective but do not expect it to completely eliminate turbidity in the stream.



## Chapter 8—Stream-Simulation Construction

### Downstream dam

- On flat sites or in deep water, you may need a downstream dam to prevent backwatering of the excavation and sump.
- Construct the dam the same way as the upstream bypass dam and size it according to the downstream need.

### Water treatment methods

- Follow contract drawings and specifications. If the system is not working, follow normal contract protocol and modify the contract. (Again, performance-based specifications will make the specified end result the contractor's responsibility.) Be sure that water released into the forest for natural filtering (figure 8.8) does not “short circuit” back to the stream untreated. (See various filtration and water treatment methods in sections 7.8.4 and appendix G.4.1.3.)
- Untreated or inadequately treated water will yield high turbidity levels in the stream below the construction site. To enforce turbidity requirements in the contract, know how to check stream turbidity levels during construction, or know who can. If necessary, ask the project team for help with this item.



*Figure 8.8—Natural filtration on the forest floor isolated from the stream channel is one means of treating sediment-laden water.*

## Stream Simulation

### Dewatering and water treatment—what can go wrong?

- Unanticipated floods and thunderstorms (see figure 8.9) exceeding normal conditions can overwhelm dewatering systems sending flow through excavation areas, causing soil erosion, structure damage, and stream turbidity and sedimentation.
- Hydraulic failure of dewatering dams or pipes can occur.
- Poorly designed or constructed systems may fail during normal summer storms, creating damage similar to that of an unanticipated large flood event. (This scenario is preventable.)
- Stockpiles located close to the stream may not be covered in time to prevent saturation or erosion. The material may become unusable long enough to cause a delay in the project.
- Sediment capture and treatment systems may not provide adequate treatment, allowing dirty water to reenter the stream and calling for additional methods to prevent harm to aquatic organisms from sediment, turbidity levels, or toxicity.
- Equipment such as pumps and generators can break down.
- Equipment breakdowns can leak petroleum products into the project site, requiring an expensive hazmat-treatment action.
- Generators or pumps can run out of fuel when no one is onsite.
- Sumps and pumps can be too small to keep water from exceeding sump capacity.
- Bypass pipes or channels can leak drainage into excavation or embankment areas.
- Early freezing, wet weather, fires, or other unanticipated emergencies can set back the entire project.

Figure 8.9 shows what happened when a flood—300 percent of normal high summer flow volume—exceeded the capacity of the bypass dam. The bypass structure was overtopped, and water diverted through the construction area, causing erosion, high turbidity in the stream, and partial infilling of concrete forms with fine sediments.



Figure 8.9—Unusual summer storm overwhelms bypass system. (a) Looking downstream at bypass pipe, now in mid-channel. (b) Looking downstream through the open excavation.

## Chapter 8—Stream-Simulation Construction

### 8.2.7 Excavation

In this document, excavation refers to all excavation (including removal of the road embankment surrounding an existing pipe structure) except structural excavation. Section 8.2.10 covers structural excavation which is defined as the part of the excavation necessary to install the new structure, including its footings.

Check the contract for specific requirements and encourage the contractor to minimize the length of dewatering time. If erosion protection measures, such as silt fences at the base of embankments, are in place and working well, delaying dewatering until excavation is close to stream channel level may be suitable. If possible use the existing culvert while excavating the existing road embankment to place the bypass. Otherwise, temporary dewatering with pumps will be necessary before the bypass can be constructed.

#### 8.2.7.1 OSHA and excavation safety

Maintain safe, stable slopes during excavation, and be aware of conditions that indicate slope instability. The slope ratio either is stated on the contract drawings or is governed by OSHA regulations. OSHA guidelines regulate maximum slopes and configurations for trenches and excavations up to 20 feet deep. A registered professional engineer must design excavations deeper than 20 feet. OSHA recognizes that excavating is one of the most hazardous construction operations. Therefore, it revised OSHA Part 1926, Subpart P, Excavations, of 29 CFR 1926.650, .651, and .652 to make the standard easier to understand, to permit the use of performance criteria where possible, and to provide construction employers with options when classifying soil and selecting employee protection methods. Contract administrators must thoroughly understand this document!

The common hazards for embankment excavation (table 8.1) may be encountered at stream crossings. A number of stresses and deformations can occur in an open cut or trench. For example, increases or decreases in moisture content can adversely affect the stability of a trench or excavation. OSHA classifies soil into five categories and recommends maximum excavation slope angles for various benching and trenching options.

# Stream Simulation

Table 8.1—Slope failure mechanisms (OSHA 1999)

**TENSION CRACKS.** Tension cracks usually form at a horizontal distance of 0.5 to 0.75 times the depth of the trench, measured from the top of the vertical face of the trench.

**SLIDING.** Sliding or sluffing may occur as a result of tension cracks.

**TOPPLING.** In addition to sliding, tension cracks can cause toppling. Toppling occurs when the trench's vertical face shears along the tension crack line and topples into the excavation.

**SUBSIDENCE AND BULGING.** An unsupported excavation can create an unbalanced stress in the soil, which, in turn, causes subsidence at the surface and bulging of the vertical face of the trench. If uncorrected, this condition can cause face failure and entrapment of workers in the trench.

**HEAVING OR SQUEEZING.** Bottom heaving or squeezing is caused by the downward pressure created by the weight of adjoining soil. This pressure causes a bulge in the bottom of the cut, as illustrated in the drawing above. Heaving and squeezing can occur even when shoring or shielding has been properly installed.

**BOILING.** Boiling is evidenced by an upward water flow into the bottom of the cut. A high water table is one of the causes of boiling. Boiling produces a "quick" condition in the bottom of the cut, and can occur even when shoring or trench boxes are used.

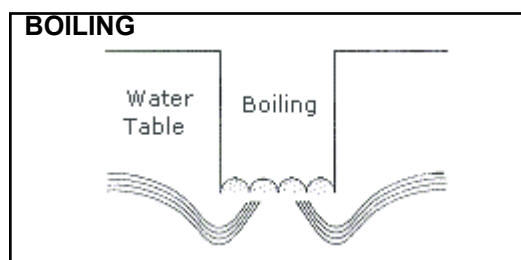
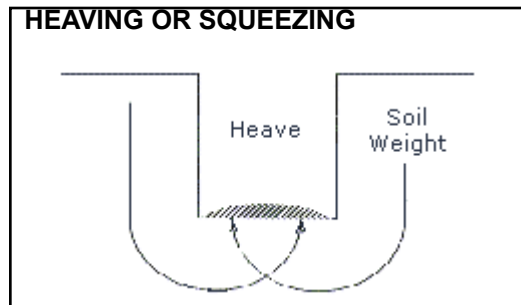
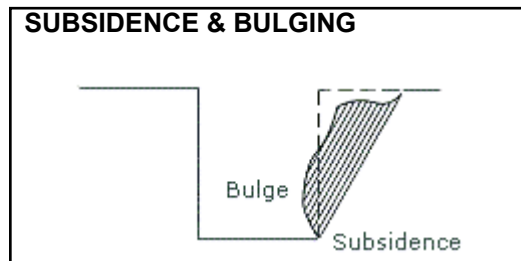
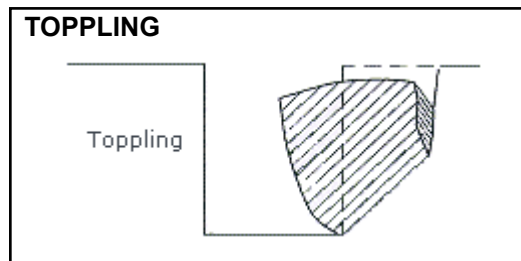
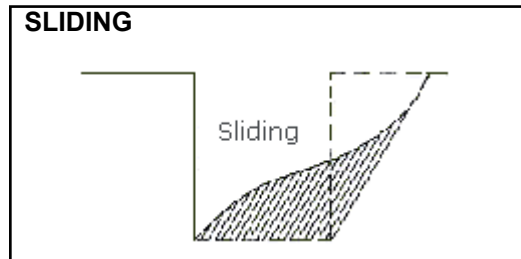
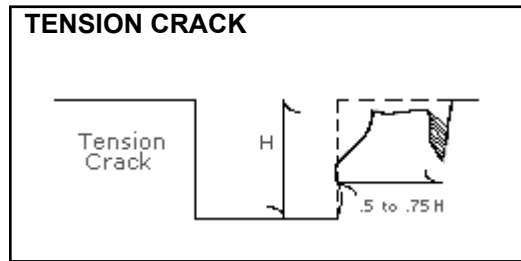

### 8.2.7.2 Excavation—what can go wrong?

- Inaccurate construction survey (double-check the stakes for location and elevation before beginning excavation).
- Excavation slope failure.
- Intense rainstorms, erosion.
- Dewatering system failure during flood event.
- Springs within excavation area causing slope instability or generating large amounts of sediment.
- Very weak subsurface. (Contact the design engineer to determine a suitable solution, such as subgrade reinforcement or a foundations design change.)
- Bedrock is unexpectedly encountered, making redesign of footings or structure necessary.

### 8.2.8 Structural Excavation

The final embankment excavation, structural excavation, and removal of existing structures create the most sediment and turbidity. To capture and treat the construction water as this work proceeds, the dewatering system must be functioning properly.

To verify that the final depth and location of the excavation are correct, make an accurate survey check as the bottom of the excavation approaches the design depth. You can use a rebar or pipe probe to locate the bedrock depth.

As the excavation approaches the final depth, the design engineer should review the foundation materials to verify soil-bearing capacity, verify that conditions match design assumptions, and approve the foundation conditions. Be prepared to have the contractor reinforce soft areas with subgrade reinforcement material, such as free draining crushed rock. A geotextile may be useful as a filter and reinforcement.

## Stream Simulation

---

If appropriate under the contract (section 7.5.2.2), examine the material beneath the culvert and determine if any material can be salvaged. Such material may include:

- Gravel bedding for the existing pipe: This bedding may be usable for part of new culvert bedding.
- Streambed materials: The project team may decide to either keep them in place or remove them for processing with other streambed materials. Streambed materials must meet specification requirements.
  - ▲ The material may appear “dirtier” than other streambed surface materials. (This “dirt” is often only natural subsurface fines.)
  - ▲ If streambed material is removed during construction, it is often too wet and its moisture content may need to be reduced before replacement into the structure. Place it in a separate stockpile and protect from contamination from other materials.
- Soil embankment and backfill: These may meet backfill requirements for the new structure.
- All materials: Must meet contract specifications and must be tested for gradation and other engineering properties.

Keep the foundation area relatively dry. To facilitate subsurface drainage away from the work area and avoid pooling, you may find it helpful to start the excavation downstream of the structure and extend it upstream. This approach also improves the work area and reduces erosion and turbidity. Concentrate seepage into one or more flow paths; ensure that the downstream sump is deep enough and that the pump has enough capacity to keep water levels below the bottom of the excavation.

### 8.2.8.1 Bedrock and blasting

If the excavation encounters bedrock (or other unsuitable material) that was not detected earlier and that interferes with the foundation, contact the design engineer to identify an appropriate solution. Changes made in culvert alignment or elevation without consultation can seriously affect stream-simulation stability.

Blasting may be necessary when bedrock is encountered. Contact the project biologist before proceeding for help with developing a blasting plan. Blasting may be prohibited during certain time periods to protect

## Chapter 8—Stream-Simulation Construction

species, such as nesting birds or listed fish. Such time periods and concerns should be listed in project National Environmental Policy Act documents. Fish near blast sites may suffer swim bladder rupture, tissue and organ damage, or internal bleeding. The damage to fish depends on the size of the charge, distance to the fish, depth of water, substrate type, and the size and species of fish (Keevin 1997).

If the design engineer anticipated blasting on the project, the contract will include FP03 section 205. If blasting is added to the contract because of a design change, include FP03 section 205 and require an approved blasting plan. The contractor must submit the plan and obtain approval in writing before doing any preparatory work (i.e., drilling) for blasting. Obtain the help of a blasting expert to review the blasting plan.

### 8.2.8.2 Settlement beneath foundations and pipes

Settlement should be limited to avoid adversely affecting alignment, grade, and structural shape. The amount of settlement depends on soil properties and compaction. Contact the design engineer to verify that soil conditions meet design values. If very soft materials (such as wet clay, silt, or other soft plastic fine-grained soils) are unexpectedly present, foundation soils may need reinforcement or replacement or the footings may need redesigning. Differential settlement—caused by the footing’s settling more over the soil region than the bedrock region of the foundation—will create undue stress on the structure.

#### Recommendations for Structural Excavation Inspection

Verify that :

- ✓ Foundation soils have been tested for shear strength and results meet design assumptions.
- ✓ Foundation excavation elevation and location are correct.
- ✓ Either the design engineer or the geotechnical engineer approved the foundation conditions.
- ✓ The contractor has completed the required compaction testing and compaction meets contract requirements.
- ✓ There is plenty of operating space for equipment for structure assembly and placement of footings, forms, steel, and concrete.

## Stream Simulation

### 8.2.9. Constructed Concrete Features



Figure 8.10—Concrete forms and reinforcing during concrete pour.

#### 8.2.9.1 Concrete form inspection

When inspecting concrete forms, verify that:

- Shop drawings and contract drawings agree with each other. Resolve any discrepancies. Send a copy of the drawings to—and discuss any potential changes with—the design engineer.



## Chapter 8—Stream-Simulation Construction

---

- ▲ Note that a change in arch shape may result in a change in the foundation design shape or position.
- Forms match design drawings and that dimensions are correct.
- Forms are stable and well braced to withstand the hydraulic stresses of the fresh concrete. Forms for deep footings and stem walls may require design by a licensed engineer.
- Embedded bolts and fixtures are installed in the formwork.
  - ▲ Anchor positions and angles are correct for open bottom arch location.
  - ▲ For multiplate pipes, hardware for collars and haunch beams is installed according to manufacturer's instructions. (For large complex structures, manufacturers often provide their own inspector for forms and hardware.)
  - ▲ Channels are installed correctly per the manufacturer's instructions.
- Reinforcing bars match design drawings for bar sizes, spacing, and position.
- Bars are tied down to prevent movement during concrete pour.
- Bottoms of footings are flush with excavation or plugged, to prevent concrete leaks into stream water.
- Water is diverted away from forms, if possible, to prevent diluting concrete.
  - ▲ Seal concrete is used if water is present in forms.
- The work site is safe and workers have a safe place to stand during concrete pour.

### 8.2.9.2 Pouring concrete

Discuss common problems and contingency plans with the contractor in advance; for example, pump trucks can plug, concrete can spill, forms can be damaged, concrete can arrive early or late, and mistakes or poor planning may cause cold joints. Concrete should be tested for quality to ensure it meets specifications.

Do not spill concrete, cement, or concrete additives into the stream. Concrete and related products that mix with water and enter live streams can kill fish very quickly because high pH levels (cement contains lye) are corrosive to fish gills.

## Stream Simulation

---

Special concrete placement methods may be necessary when standing or running water is present in or adjacent to forms. To avoid mixing with standing or flowing water, seal concrete (normal concrete with an extra sack of cement) may provide a more stable mass. The pump hose should touch existing wet concrete when the hose is near any water to prevent mixing the concrete with water. Ensure that water does not pond on the excavation side of forms, where it can be forced through concrete joints and wash away concrete and expose reinforcing steel.

When standing water cannot be pumped from the form, it can be displaced with the fresh concrete. Placing the concrete involves putting the concrete pump hose on the footing bottom in the lowest elevation of the ponded water. Keep the pump hose at the foundation bottom. As concrete is pumped in, the water is displaced. Avoid movement that would agitate the concrete mass and mix the cement with water, such mixing would dilute and weaken the concrete, as well as risk getting cement in the stream water.

When running water is present, place the pump hose at the source of entry to quickly form a plug. The plug seals the leak during the concrete pour and leaves the hose submerged in the concrete. As you encounter other leaks, plug them in the same manner.

### 8.2.9.3 Inspection recommendations for concrete placement

Before the pour, verify that:

- ✓ The concrete design mix was approved including admixtures.
- ✓ The foundation forms have been approved.
- ✓ Test equipment and test cylinders are onsite before the first concrete truck arrives.
- ✓ The contractor's equipment is checked and operable (pump if applicable, vibrator and a spare).
- ✓ There is adequate access for equipment and personnel before concrete is ordered.
- ✓ A safe and appropriate place to dump excess or reject concrete has been designated.
- ✓ A safe and appropriate place to wash out the interior of the concrete mixer has been designated.

## Chapter 8—Stream-Simulation Construction

During the pour, check that:

- ✓ Concrete is not outside the allowed time, and slump or percent air is correct. (Otherwise, reject the concrete.)
- ✓ Forms do not shift and fail. If this occurs, stop the concrete pour and repair forms. Concrete delivery may have to be delayed and concrete already onsite may have to be dumped.

Most things that go wrong on a concrete pour—if not solved immediately—lead to a cold joint. If necessary, prepare the joint before the concrete hardens with a rough unfinished surface to develop effective friction. When lateral forces are high, form keyways to increase the shear strength of the joint.

Contact the design engineer for advice on correcting mistakes on any concrete pour.

### 8.2.10 Culvert Installation

#### 8.2.10.1 Closed-bottom culvert bedding

Closed-bottom culverts require bedding material to be placed and shaped to match the bottom of the structure. The top of the bedding should conform to the design elevation, slope, and alignment of the pipe. Have the contractor place the soil tight against the structure to prevent subsurface stream flow and to develop soil-structure stress interaction.

Verify the following for the culvert bedding:

- ✓ Bedding material is the correct gradation and thickness.
- ✓ Bedding elevation and alignment match the design elevation for the structure inverts.
- ✓ Bedding shape reasonably matches pipe shape in approximately the center third of the pipe before placing pipe. (See figure 7.9.) A plywood form may be useful for shaping the bedding.
- ✓ Bedding is sufficiently compacted to prevent culvert distortion during bedding and backfill operations. The following two methods are typically used to avoid leaving voids in the culvert bedding:

## Stream Simulation

---

- ▲ Voids beneath the culvert are filled by pushing and tamping bedding material into place.
- ▲ Voids are filled with low-strength, high-slump (flowable) concrete called “controlled low strength material.” This material is used in place of shaped and tamped bedding.

With controlled low-strength material (CLSM), ensure that the contractor secures the pipe by placing some of the stream-simulation bed material inside, or by weighting the top of the pipe with soil (to keep it from floating as the heavy CLSM flows under the pipe). To avoid distortion, check that the pipe is fully assembled before contractor places backfill material or CLSM.

### 8.2.10.2 Open-bottom culvert attachment

Open-bottom structures have footings usually made of concrete, steel, or aluminum. Open-bottom culverts come in a variety of shapes, including metal half-circle arches, low-profile arches, and boxes; high-profile arches, pear shapes, and ellipses, as well as concrete boxes. These structures attach to footings with bolted connections or grouted slots. Be aware of the manufacturer’s requirements, including any certifications required to install their products.

For attachments, verify that embedded bolts and fixtures, and grouted slot-type culvert attachments, meet contract requirements and, if applicable, shop drawings. See figure H.11.

When metal footings are used for open-bottom arches, placing some stream-simulation material between the footings before full pipe assembly is possible, as long as backfill on the outside of the footing is brought up in equal lifts. This method is risky, however, because the footings can shift, making the remaining arch assembly difficult or impossible without resetting the footings.

### 8.2.10.3 Pipe assembly

All pipe segments require careful handling and alignment to maintain their shape, so they can be properly joined to form a watertight seal. Pipe transporting and handling must be according to manufacturer’s recommendations to prevent damage and assure proper fit. Concrete box culverts are rigid and easily aligned for a tight fit. Metal pipes are flexible,

## Chapter 8—Stream-Simulation Construction

depending on their material, thickness, corrugation depth, and dimensions. To slide into proper position, they often need small adjustments during placement.

Leaks can lead to loss of water from the stream-simulation bed or piping of backfill outside the culvert, leading to eventual structure failure. Metal pipe joints are very susceptible to differential movement and shape change during the backfill operation. Deflection and variations in shape of the pipe on either side of the joint can result in joint leaks. Careful assembly is critical to making a leak-proof joint. The joints are either grouted or sealed with waterproof joint wrap, according to the manufacturer's recommendations. For information on pipe couplings for metal pipes, see National Corrugated Steel Pipe Association Installation Manual.

### Pipe Assembly Inspection Checklist

- ✓ Check for careful handling of pipes upon delivery, transport to location, and assembly to ensure that they are within shape tolerance and that watertight joints are constructible. Reject materials that do not meet specification (reference AASHTO Standard Specification M36-01 for corrugated steel pipe manufacturing tolerances, zinc coating, etc.)
- ✓ Verify that culvert materials match those specified in the contract.
- ✓ Review coupling materials and installation instructions to ensure that the couplings are properly fitted around the entire pipe joint.
- ✓ Reject leaking joints. (The manufacturers and the design engineer can help solve joint problems.)

### 8.2.10.4 Multiplate pipes

Multiplate pipes are manufactured in a wide variety of shapes. They consist of multiple corrugated metal plates assembled with bolts and tightened to a specific torque. Because the weakest places in a multiplate pipe are the joints, make sure that all required bolts are installed and tightened to specifications.

Small multiplate pipes may be assembled offsite and placed in one piece. They are not designed to be coupled together in segments like one-piece

## Stream Simulation

---

pipes. Instead, they can be partially assembled, placed, and the remaining plates can be bolted on later one at a time. Large multiplate pipes are usually assembled in place. Wide-span multiplate structures sometimes have special assembly requirements. The manufacturer may either send its own inspector or provide guidelines for monitoring shape during assembly and backfill operations. Obtain details covering structural plate installations from the pipe manufacturer, particularly on large structures.

### 8.2.10.5 Backfill and embankments

For embedded pipes, begin backfilling as soon as bedding is completed and the structure is in place. For open-bottom arches with footings poured in place, backfilling can begin as soon as the concrete has cured long enough (i.e., usually 80 percent of full specified strength) to withstand backfill forces up to the top of the footings. After the arch or box is in place, place the remaining backfill. Leave the dewatering system in place until the backfill is high enough to prevent the stream from flowing along and outside the structure in the event of a sudden storm. The inspector should monitor the shape of metal culverts during backfill and compaction. Many structures require a specific width of special structural backfill on either side of the structure.

#### Backfilling Tips

- Place backfill at the proper moisture content in thin lifts, according to the specifications on both sides of the footing or culvert.
- Ensure that all backfill material meets the project specifications, especially within special backfill zone areas next to the structure. (Controlled compaction is required on most culvert installations. Check the specifications; the contractor is usually required to provide quality control testing.)
- To prevent damage to the structure, use hand-operated compaction equipment near the structure (e.g., hand-operated in confined areas and machine-compacted in broad areas).
- To prevent damage to the structure, provide a fully compacted, minimum cover height above the pipe before allowing construction equipment or other traffic to cross the structure. Construction equipment may require more cover than design traffic; check fill height tables for the structure or check with the manufacturer.

See National Corrugated Steel Pipe Association Installation Manual for additional information on installing culverts.



*Figure 8.11—Example of uneven backfill and compaction. The right side was backfilled before the left side instead of even lifts on both sides, causing the distortion visible in this photo. The distortion induces eccentric loadings on the footings, as well as bending stresses at the anchor bolts on both footings.*

### 8.2.11 Stream-simulation Bed Material Placement

The most important detail of a stream-simulation project is the streambed which, when constructed properly, will enable a variety of aquatic organisms in the stream to travel up and down through the structure at will. Large flood events are likely to occur during the life of the structure. Therefore, the quality of construction is critical to developing the design channel form with the energy-dissipating structures (inside the stream-crossing structure) that ensure sustainability over time.

Contract drawings will show, at a minimum, a shaped streambed in the structure, usually sloping downward toward the center to form a low-water channel. Other features common to many sites include cross-channel steps formed with large rocks, raised stream banks along the interior culvert edges, and fields or clusters of large rocks (figure 8.12). Sills (see section 6.2.2.4) are occasionally attached to the culvert before bed placement, to help support rock steps in the culvert. Their design is unique to each project.

## Stream Simulation

---



*Figure 8.12—Newly constructed (2007) step-pool channel inside culvert on Eustache Creek, Lolo National Forest, Idaho. Two visible rock weirs (steps) have their lowest points offset to provide some sinuosity at low flow. The top of the sloped banks is bankfull elevation.*

Review the stream-simulation design and the natural streambed with the design engineer, and examine local features and discuss placement details with the contractor. If the streambed design needs modifying for any reason, contact the design engineer immediately to fix the problem before making any changes. Failure to understand all of the stream-simulation parameters can easily lead to error during construction and result in failure of the stream-simulation bed.

### **8.2.11.1 Size of streambed materials**

The gradations, depth, configuration, and extent of the streambed materials are provided in the contract (section 7.5.3, figure 7.18). Review the contract specifications and drawing details, especially the streambed rock gradation, to determine the size and gradation of the mix. To ensure that the correct materials are obtained and that they are correctly placed inside the structure, discuss these details with the design engineer and contractor in advance. The gradation of the streambed materials is critical to the performance of the streambed simulation.



## Chapter 8—Stream-Simulation Construction

Table 8.2—Example of a stream-simulation bed material recipe

% Passing	Sieve Size	% Volume	Volume	Material Source Identified
100	12 in	16% of volume is 6 to 12 in	1cy	Boulders borrowed from: glacial outwash borrow source
84	6 in	34% of volume is 1.5 to 6 in	2cy	Unwashed river dredging from McKenzie River
50	1.5 in	34% of volume is 0.5 to 1.5 in	2cy	same
16	0.5 in	16% of volume is 1/8 to 0.5 in	1cy	same
5	0.125 in	5% of volume is smaller than 0.125 in	0.3cy	Excess excavation from coarse sand-silt road embankment soil

The contract should specify streambed material sources. Sources may include onsite material, borrow sites, quarry sites, road maintenance rock fall debris piles, and commercial quarries. Material produced in a quarry can be crushed and screened to the proper gradation. Very large boulders may be hard to obtain from some quarries, but are sometimes available on site in the form of old riprap or colluvium. The design engineer should have identified such material in the contract.

If the material comes from different sources, gradations and quantities of the individual materials will have to be determined to establish a recipe for the mixture. The mix recipe states the proportions of each material type in the mix, and the mixed material requires testing to ensure the proper gradation is being supplied. When reviewing stockpiles of materials for suitability, familiarity with and use of the pebble-count method—for estimating the volumetric or weight-based material gradation—is useful. Channel rocks are generally large and easy to measure. Samples of smaller bed material (see section 7.5.2.2) can be taken to a laboratory for sieve analysis. Use standard submittal procedures for the stream-simulation bed mix recipe (table 8.2) if the contractor is responsible for it. Have the design engineer review the mix design (recipe) before allowing delivery of the materials to the site.

## Stream Simulation

---

Regardless of the source(s), make sure that the materials from different sources are well mixed. If materials are mixed onsite, be sure the mixing area is large enough to accommodate all the stockpiles and equipment. If the mixing is done elsewhere, be aware that transport can cause mixed materials to segregate somewhat. Do not attempt to mix the material inside the structure.

### 8.2.11.2 Constructing the simulated streambed

This is a critical step in the project construction. The inspector and a project team member should be on site to review the constructed bed and ensure that the final shape, slope and details are correct before rerouting water through the structure.

Final bed height should be measured at the center of the surface pieces, not at the top of the largest rocks.

If necessary, wash the surface to force fines deeper into the bed to reduce the permeability of the bed (figure 7.14). The sump pump may be used for washing the bed material in with water from the sump. The downstream sump will capture sediment generated during the washing.

#### General Inspection Checklist for Placing Streambed Materials (all structures)

Verify that:

- Gradation of stream-simulation bed materials meets specifications.
- Specified compaction methods are followed for every lift.
- Material is carefully tamped around large rock features, to provide good interlocking and low permeability.
- Voids in stream-simulation bed material are filled after each lift by washing filler material into the voids and tamping by hand.
- Elevations are correct during placement to ensure the bed surface is shaped correctly.
- Fill elevation line is painted accurately on the inside of the pipe for the contractor and for monitoring after construction.
- Grade stakes for the bed are accurately placed, especially where the bed extends outside the structure.

## Chapter 8—Stream-Simulation Construction

- Large channel rocks are incorporated into the first or second upper lifts and placed as shown in the drawings (this step is important as the channel rocks are embedded in the stream-simulation bed material—not placed on top of it).
- Proper equipment is used for more delicate work.
- The stream-simulation bed is the proper shape according to the drawings.

### 8.2.11.2.1 Recommendations for placing material in open-bottom arches

Constructing a streambed in an open-bottom arch is relatively easy, because the material can be placed before the arch is set in place (figure 8.13). Headroom does not limit the size of the equipment as in closed structures. An excavator is usually used for placing bed materials, and tracked or rubber-tired equipment can be used for compacting the bed.

- Place the bed, compacted in layers, at the same time that the backfill outside of the footing is being compacted (figure 8.14). This should prevent the footing from moving, and avoids excessive horizontal loading on the stem walls.
- Use proper compaction equipment to ensure there is no damage to the structure as well as to provide proper compaction.



Figure 8.13—Machine placing stream-simulation material. It took 4 days to place 600-cubic yards.

## Stream Simulation



*Figure 8.14—Newly constructed stream-simulation bed for a bottomless arch. The stream-simulation bed material is manufactured rock from a commercial source. Footing backfill and stream-simulation bed material were backfilled and compacted at the same time. Placing the stream-simulation bed is much easier before the structure is in place.*

### **8.2.11.2.2 Recommendations for placing material in embedded pipes**

Since embedded pipes are closed structures filled nearly half-full with streambed material (figure 8.15), installing the streambed usually requires hand labor or small equipment (e.g., rubber-tired loaders, garden-sized tractors and trailers, small dozers that can run on a cushion of previously placed bed material).

- Take precautions to avoid damage to the galvanized coating in steel pipes during bed placement.
  - ▲ Do not push material along the culvert bottom; pushing removes galvanizing, speeding up corrosion of the culvert and shortening the life of the structure.
  - ▲ End-dump streambed materials.

## Chapter 8—Stream-Simulation Construction

- Use rubber-tired equipment whenever possible, to avoid accidental steel-track damage to the structure.
  - ▲ If the contractor must use a tracked vehicle, place a cushion of fine streambed material in front of the vehicle, deep enough to spread the load and protect the culvert invert from the track grousers.
- Avoid overfilling buckets, and remove spilled material from the travel path.
- The contractor may use hand labor to place streambed materials. With smaller structures, hand placement is often the only option (figure 8.16).

Once material is dumped, it can be spread by hand (or by machine, if clearance allows). A good way to place the bed material is working up from the downstream end, and placing lifts on an angle sloping down in the upstream direction. This technique allows dumping, spreading, and compacting subsequent loads on this slope while maintaining maximum headroom for the remaining length of the culvert for transporting material. It is also a good way of meeting placement and compaction requirements, and it facilitates placing larger channel rocks in the culvert. In small culverts, it is easiest to place lifts full length in the culvert.



Figure 8.15—Bobcat placing bed material to marked elevation.

## Stream Simulation



*Figure 8.16—Assuring proper cross-section shape, rock-band spacing and placement of channel rocks and footers often require hand work.*

### 8.2.11.2.3 Placing channel rocks

Placing channel rocks is a somewhat subjective aspect of construction, calling for careful observation of the existing channel. Depending on the project, some features will need well-interlocked rocks in some places and individual or clusters of rocks elsewhere. Because the placement process is very difficult to specify precisely, it is a difficult procedure to enforce. To make the job more difficult, since the channel rocks are embedded, they must be placed during the construction of the stream-simulation bed and the bed material must be compacted around the channel rocks.

- Check the contract for sizes and any shape requirements of channel rocks.
- Check the contract for details for the locations and placement of channel rocks (figure 8.17).
- When constructing steps with footers, footers should extend deeper than the projected depth of pools that will form in the future.
- Because machinery is necessary for moving large rocks, use care to avoid damaging the structure.

## Chapter 8—Stream-Simulation Construction

- Positioning large rocks often requires fitting them together so that they interlock for stability. This often requires several attempts to obtain an acceptable fit.
- Pack with finer material by hand, or place by machine and wash fines in for a tight, stable fit.

Figure 8.18 illustrates the difference between loosely and tightly packed rock structures—both scenarios are important in stream simulation. With few exceptions the rocks in figure 8.18(a) are not well interlocked. In most cases, individual rocks can move independently. The step in figure 18(b) is tightly packed and the rocks are well interlocked. Moving any piece requires moving adjacent pieces as well. Well-interlocked rock is much more stable in a stream channel.

### 8.2.12 Permanent Erosion Control Measures

Permanent erosion control measures may include conserving and replacing topsoil; planting erosion-control grasses, ground covers, and larger plants; and placing individual rocks, riprap, logs, reinforced slopes, or retaining walls for bank stabilization. Although most of these are outside the scope of this document, they may be included in the contract.

The project should have provisions for stabilizing banks disturbed by construction, and may include provisions to mitigate some anticipated post-construction stream-channel changes. These provisions may include large wood, root wads, biotechnical plantings, plant cuttings, large rock placements, or special stream structures. As these features or structures may be unfamiliar to the contractor and the inspector, contact the design engineer for assistance for placing these structures. Pay special attention to the quality of work on these structures. To withstand multiple flood events during the life of the structure, they will need solid construction.

#### 8.2.12.1 Revegetation

The planned vegetation may have specific planting requirements, and it may require water or mulch during dry spells. Some projects may require an irrigation system to adequately water the plants. Erosion control fabrics or mulch may be placed to stabilize soil while vegetation becomes established. For a discussion of common problems with revegetation and erosion control, and their solutions, see appendix G.4.3.

# Stream Simulation

## COOK CREEK STREAM CROSSING STEP-POOL STEP DETAILS

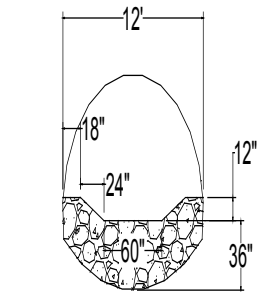
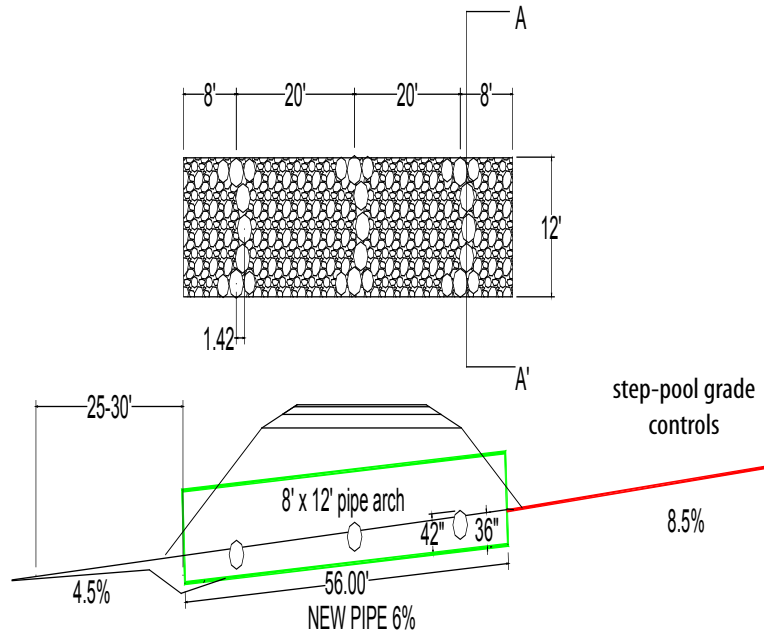

Infill pattern for streambed-simulation material.

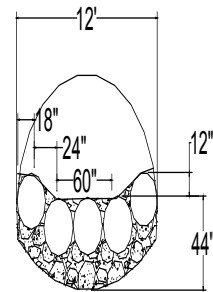

Step-pool step boulder details x-section AA'.

Figure 8.17—Stream-simulation bed details.



## Chapter 8—Stream-Simulation Construction



Figure 8.18—Streambed features such as steps must be well interlocked to withstand large flood events. (a) Poorly interlocked rock; (b) a tightly interlocked rock step.

### 8.2.12.2 Riprap inspection

Riprap commonly is used for stabilizing streambanks at culvert entrances, channel edges, embankments, and steep slopes. Over-steepened slopes can be stabilized with a thin layer (rockery) or thick layer (buttress).

Riprap is designed to be a well-graded but free-draining material because it lacks fine aggregates. Riprap is much more stable when well graded; a cluster of large rocks does not have the same interlocking forces as well graded riprap material. To be stable in a stream setting when covering a streambank, either the riprap must sit on a stable surface such as bedrock, or a foundation of riprap must be constructed below the possible scour zone to support the mass.

Riprap design generally includes:

- Enough thickness (twice  $D_{\max}$ ) to provide good interlocking with other riprap materials.
- A maximum slope limit of 1:1 (1½:1 is preferable).
- Geotextile behind and beneath to prevent piping of soil through the riprap (piping can eventually undermine the riprap's stability).

Inspectors should check:

- ✓ Riprap gradation by measuring individual pieces. Adjust riprap gradation as necessary to obtain specified gradation.
- ✓ The staking for the riprap limits.
- ✓ The specified placement method.
- ✓ The final product for thickness, interlocking, slope, height, and width.
- ✓ Riprap is placed flush with the existing channel edge to avoid restricting the stream channel (requires excavating the streambank).

### 8.2.13 General Road Construction

- Ensure that road construction does not damage the structure.
- Ensure loose soil is not spilt where it will erode directly into the stream without being treated.
- Make sure that survey-control points are protected. If control points are disturbed or destroyed by construction, the contractor may have to provide additional surveying or even roadway design.
- Check the embankment slope, width, and height during construction. Correcting an error in the embankment after construction is complete is both difficult and costly.

#### 8.2.13.1 Roadway drainage structures

- Make sure that road surface runoff drains into areas that can filter the water before it enters the stream directly.
- Configure road dips or surface-shape changes to divert road-surface runoff before the stream crossing. Make sure that outsloped roadways drain onto stable landforms.
- Ensure that culverts draining onto disturbed areas have downpipes or other means to carry water beyond vulnerable areas.
- In erosion-prone areas, spread slash, straw, or other erosion-control materials to stabilize bare soil.

For diversion prevention dips (see 7.7.2.1)

- Make sure that longer tapers and gentler rate of grade change are provided where lowboys must be accommodated (figure 8.19).
- Verify that downslope erosion protections are in place.
- Plug any downgrade ditches or other escape routes to prevent downgrade flooding of the roadway.
- Ensure that aggregate surfacing is spread evenly throughout the dip. A very common mistake is to grade the aggregate surfacing thin at the high part of the dip and thick at the low part of the dip, thereby seriously reducing the capacity of the dip.

## Stream Simulation



Figure 8.19—The grade change at this dip is too severe to accommodate a lowboy, which has high-centered on top of the dip..

### 8.2.14 Demobilization/Cleanup

Check the contract and specifications for any special requirements. Always ensure that the following items have been taken care of:

- ✓ All construction debris cleaned up, hauled off, and disposed of according to specifications, special contract requirements, and local regulations.
- ✓ Campsites cleaned up according to specifications and special contract requirements.
- ✓ Hazmat items removed and cleaned up according to specifications, special contract requirements, and local regulations.
- ✓ Sediments cleaned or washed from roadways according to specifications and special contract requirements to prevent washing directly into the stream.
- ✓ Stockpile areas, waste areas, and aggregate pits treated and cleaned up according to specifications and special contract requirements.
- ✓ Temporary erosion and sediment controls removed and cleaned up. Trapped sediments removed and properly disposed of.
- ✓ Drainage and final erosion control measures in place and functional.

### 8.3 POST CONSTRUCTION

#### 8.3.1 Post-construction Project Review

After construction is complete, an extremely important step—and the final item on the project timeline—is the post-construction project review. Even though this review process is time-consuming, review the project from beginning to end—and beyond. Your review observations on this project will contribute invaluable insight for the success of future projects. Include answers to the following questions:

- Overall thoughts and impressions
  - ▲ Was the project a success?
  - ▲ What went well with the construction?
  - ▲ What problems were encountered?
  - ▲ How were these problems solved?
- Project development and design process
  - ▲ How well did communications work?
  - ▲ Did you have the proper mix of project team members?
  - ▲ How would you assess the available skills?
  - ▲ Is the proper skill mix available within the organization?
  - ▲ Should the agency solicit more specialized help for the next project?
- Advertisement and solicitation for bids/proposals
  - ▲ Was the prebid meeting helpful? Could it be improved? Did it answer all questions? If not:
  - ▲ Did the amendment process answer all questions?
- Construction
  - ▲ Was the contract adequate?
  - ▲ Were specifications clear and sufficient?
  - ▲ Did you have special contract requirements?
  - ▲ Were the drawings accurate and clear?
  - ▲ Were the supplemental specifications clear?
  - ▲ Were design and project team personnel available for promptly solving unforeseen issues?
  - ▲ How would you rate the contractor's performance (necessary for best value contracting)?

## Stream Simulation

---

Reviewing and discussing the development of the project—and the time and people involved—is extremely beneficial to all team members and the organization as a whole. The discussion should lead to the following questions (and probably more):

- How would you go about project planning and development for future projects to improve the overall process efficiency, communications, design quality, and project overhead costs?
- What worked well on this project? What did not work well? How would you avoid those issues on the next project?

### 8.3.2 Post-construction Monitoring

Post-construction monitoring provides invaluable information, not only about the design and construction of the particular project, but also about how to improve aquatic organism passage design in general. Detailed review and analysis of project features, such as the structure, stream simulation bed, any stream restoration, and erosion control features, will provide very useful information. These lessons learned add to the knowledge base for developing informed decisions on future projects.

#### 8.3.2.1 Physical monitoring of structure performance

A convenient method for physically monitoring the structure is the bridge inventory. The method uses a standard form listing physical features and conditions of bridges and major culverts, and it adds physical information into the INFRA database and the Federal Highways National Bridge Inventory. Major culverts—which many stream-simulation projects are—are included in the inventory.

Monitoring to date shows that most stream-simulation structural failures are due to poor bedding material placement, poor backfill compaction, unstable footing design, and flood damage where pipes or bed material were undersized.

#### 8.3.2.2 Physical monitoring of streambed performance

The Forest Service culvert-assessment procedure (Clarkin et al. 2005) includes observations of streambed depth and continuity through the structure, as well as basic culvert details. Many recently inventoried culverts have this information and it should be kept up to date as culverts are replaced. The assessment procedure has been modified and expanded

## Chapter 8—Stream-Simulation Construction

---

for use as a monitoring tool on some forests. Forms modified for monitoring include observations and measurements of general channel changes both in the stream and in the structure.

Here are some simple observations for monitoring the success of a stream-simulation project:

- Overall examination: Is there a continuous channel through the culvert, without excessive jumps or velocity barriers?
- Photos taken from the same points year after year, with the same camera or lens.
  - ▲ Inlet upstream and downstream.
  - ▲ Outlet upstream and downstream.
  - ▲ Bed details.
  - ▲ From the road upstream, downstream, and along road both directions.
  - ▲ Other strategic points: Specific stream features or areas expected to undergo changes such as scour and deposition.
- Presence of bed material in the pipe: What has changed?
- Stability of constructed bed forms: What has changed?
- Bed material depth measurement from the top of the culvert, and references painted on the culvert wall.
- Long-profile survey for comparing channel adjustment over time.
- Either channel cross sections near the culvert and in strategic spots, or a complete site plan (which is sometimes quicker and more informative) for monitoring channel alignment changes.

The amount of data you collect will depend on your monitoring objectives, and your ability to analyze and keep track of the data. Commonly cited problems in both embedded pipes and open-bottom arches involve bed material scour.

# Stream Simulation

---



**A** **Abandoned channel**—An inactive channel. One example is an oxbow isolated by a meander cutoff. Abandoned channels also occur where streambed aggradation causes the stream to overflow and shift to a new location.

**Active channel**—A portion of the channel that is somewhat lower than bankfull, as in the following definition: “the portion of the channel commonly wetted during and above winter base flows... identified by a break in rooted vegetation or moss growth on rocks along stream margins” (Taylor and Love 2003). The ordinary high water mark is sometimes given as the elevation defining the active channel.

**Adjustable channel**—A channel where dimensions, slope, planform, etc. change relatively readily in response to changes in inputs of water, sediment, and debris. See response reach.

**Aggradation**—The accumulation of sediment on a streambed, causing streambed elevation to rise.

**Alluvium**—Sediment deposited by flowing water, as for example on streambeds, flood plains, and alluvial fans. Alluvium does not refer to subaqueous deposits in lakes and seas.

**Anastomosing**—A type of channel with multiple channels that separate, meander, braid, or remain relatively straight and then rejoin. (A.3.3) Well-vegetated islands separate individual channels. Generally have low bed load and stable banks.

**Anadromous**—Fish that are born and rear in freshwater, travel to the ocean, then return to spawn in their natal stream.

**Armored streambed**—In gravel- and cobble-bed streams, the bed is often segregated into a coarser surface layer (the armor layer) over a finer subsurface. This is due to winnowing of the finer particles from the surface that is exposed to the force of flow. (A.3.1 and figure A.5)

**Arroyo**—Flat-floored gullies of ephemeral or intermittent streams in arid or semiarid areas. Arroyos are often formed in unconsolidated alluvium and have steep walls. They are dry much of the time, but flash floods can transform them into dangerous torrents.

**B** **Backwater**—An area where water-surface elevation is controlled by some downstream obstruction, such as a constricting bridge, dam, or prevailing countercurrent.

**Bankfull**—Describes the volume of flow, and the flow width or depth associated with the bankfull elevation: that point where water fills the channel just before beginning to spill onto the flood plain. See also active channel. For more discussion of bankfull, see section 5.1.4.2.

**Bankline**—The sloping ground bordering a stream that confines flow in its natural channel for a range of flows below bankfull.

## Stream Simulation

---

**Barrier**—A natural or manmade structure that impedes or prevents movement.

A partial barrier prevents movement of (1) some individuals, or some species some or all of the time, or (2) all species and individuals some of the time. The meaning of this term varies with context, and should be defined whenever used.

A complete barrier prevents movement of all individuals of the species being discussed all the time.

**Base level and base-level control**—The level below which a stream cannot erode its bed. The ultimate base level is sea level, although there can be local base levels, such as a resistant formation or lake. A base-level control is any structure or feature that prevents downcutting below its elevation.

**Bed permeability**—The ability of the channel bed materials to transmit fluid. Permeability depends on the size voids between particles, how well the voids are connected, and the tortuosity of the path that the water travels. Surface flow over a permeable bed may infiltrate so that, at low flows, most or all of the water flows below the surface.

**Bedforms**—Accumulations of bed material in an alluvial channel formed by stream flow over the channel bed. Ripples, dunes, and antidunes are bedforms found mainly in sand-bed channels. Pebble clusters and transverse bars are bedforms found in gravel-bed streams. Steps form in cobble- and boulder-bed streams.

**Bedload transport rates**—The volume rate of sediment moving on the bed by rolling, sliding, or saltation. Bedload transport rates depend on the transport capacity of the flow, and on the surface characteristics of the bed (packing, armoring).

**BMPs**—Best management practices are guidelines and procedures for the protection of water quality and beneficial uses during land management activities.

**C Channel adjustment**—Changes in channel cross-sectional form, bed configuration, planimetric geometry, and channel bed slope in response to changes in flow, sediment type, and sediment and debris loads. Channels can adjust very slowly (e.g., downcutting over decades or centuries) or rapidly (e.g., sudden channel shift during floods).

**Channel avulsion**—Sudden switching of the main flow into a new channel. Avulsion can happen, for example, when aggradation or debris jams cause backwatering, overflow, channel incision in a new location, and stream capture (Hooke 1997).

**Channel incision**—The process of channel bed lowering (also downcutting or degradation). ‘Regional’ channel incision is downcutting over a long length of channel, sometimes on a watershed scale. Many causal factors can enter into regional channel incision, including base level lowering, increases in peak or total flows, and decreases in sediment load.

**Channel migration**—Change in channel location, commonly caused by bank erosion, point bar formation, and/or channel avulsion.

**Channel pattern**—Describes the channel in planview; most common terms are straight, meandering, anastomosing, and braided. (A.3.3)

**Channel rocks**—A term used in some construction contracts for large rocks used to simulate various types of channel-bed structures and key features, such as banks, steps, boulder clusters, bars, etc. Gradation is specified separately from the stream-simulation bed mix. Placement in the stream-simulation channel often requires special methods (see 7.5.3).

**Channel stability**—Stable channels adjust to a wide range of flows and sediment loads by eroding and depositing sediments; however, their dimensions and slope fluctuate around averages that remain approximately constant over periods of decades or longer. This means that, on average, the amount of sediment coming into a stable reach is the same as the amount leaving it. Unstable channels are those experiencing large rapid changes in dimensions or slope. (See section A.4)

**Channel unit**—Section of stream with characteristic bed topography, water-surface slope, depth, and velocity; for example, pool, riffle, step, etc.

**Channel-forming flow**—Flow that represents a range of flows which determines channel parameters, such as cross-sectional geometry and meander wavelength. It also can be thought of as the flow which performs the most work by transporting the most sediment. It is sometimes called dominant discharge, and is often equated with bankfull discharge. (A.4.1)

**Channelized stream**—A stream that has been altered by straightening and (usually) deepening (see channelization). Streams are sometimes channelized along roads to drain marshy acreage for farming, or to control flooding.

**Complete barrier**—See barrier.

**Consolidation**—Describes a sedimentary unit in terms of bulk density or how closely packed the grains are. After deposition, the unit becomes more compact as particles adjust under the weight of overlying materials.

**Cohesive materials**—Silt and clay-rich materials that are bound together by attractive forces. Compared to sands, cohesive materials are strong when dry, are more resistant to surface erosion, and have lower permeability. Cohesive streambanks tend to fail due to toppling or caving when banks are undercut or saturated.

**Colluvium**—Soil and rock that has been moved by gravity processes, such as in landslides, debris flows, avalanches, or rock falls.

**Confined channel**—A channel that is unable to shift laterally because it is bounded by valley walls, or other topographic or manmade boundary.

## Stream Simulation

---

**Contracting officer's representative (COR)**—In the Forest Service, the contracting officer (CO) is responsible for all contract actions. The COR represents the CO in the field, evaluating the progress of the contract and recommending contract actions when necessary.

**Cost-risk analysis**—A way to assess the desirability of a long-range project by weighing the probability that a costly event will occur in the future against the current cost of a project. For example, in urban flood control planning, engineers might weigh the cost of building higher levees against the probability and consequences of a large flood.

**Cutoff channel**—Forms when flow takes a shortcut between two points along the stream, straightening the channel and increasing the slope. Neck cutoffs develop across meander bends; chute cutoffs develop over point bars. Cutoffs occur when streams can no longer transport the sediment load at the current gradient.

**D Debris**—Material transported by the stream, such as wood or sediment. Commonly used to refer to woody debris.

**Debris torrent**—A rapid channelized flow of water mixed with rock, soil, and mud. Debris torrents are generally caused by saturation of the land surface or snowpack by heavy rains.

**Dewatered stream**—A stream affected by water withdrawals or upstream storage. Flow is lower than it would be naturally, and even if there is some water flowing, water temperature, depth, and continuity may be problems for aquatic organisms.

**Dip of rock**—The angle, measured perpendicular to strike, that a tilted bed or fault forms with the horizontal.

**Discontinuous flood plains**—Flood plains that are patchy or are obstructed in the longitudinal direction along a channel. Discontinuous flood plains occur where the valley is narrow or constricted by natural or manmade features.

**Diversion potential**—The possibility for streamflow to leave its established channel and flow down a road or ditch that slopes away from a road-stream crossing (Moll 1997).

**Dynamic equilibrium**—A stream channel is considered to be in dynamic equilibrium when channel dimensions, slope, and planform do not change radically even though they constantly adjust to changing inputs of water, sediment, and debris. See channel stability.

**E Earthflow**—A landform formed by (usually) slow movement of a mass of soil and rock downhill. They usually occur in fine-grained materials and may move slowly over a period of years. Earthflows most often terminate in a lobelike form.

**Embeddedness**—Describes the degree to which the voids between larger sedimentary particles are filled with finer grains. Embedded gravel streambeds may be less mobile than unembedded ones because fines filling the gaps between the larger rocks reduce the surface area exposed to the pressure of water.

**Entrainment (sediment)**—The initiation of motion of a sediment particle by flowing water.

**Entrainment flow**—The lowest flow at which a particle first begins to move.

**Entrenched channel/entrenchment**—A channel that does not have a wide flood-prone zone (Rosgen 1994). May be gullied or confined. (Section A.3.4 discusses entrenchment)

**Ephemeral stream**—A stream that flows briefly only in direct response to precipitation or snowmelt (Wilson and Moore 1998).

**F** **Fines**—Streambed particles smaller than 2 millimeters in diameter: sand, silt, and clay.

**Flashy**—Describes a flow regime characterized by large floods with short peaks. Arid-climate rivers are often flashy.

**Flood frequency analysis**—The process of analyzing a multiyear record of peak flows (usually a gauging station record) to determine the probability that a flood equaling or exceeding a given magnitude will occur in any year or during a period of years. (D.2)

**Flood plain**—The flat-lying area adjacent to a channel that is flooded on a fairly frequent basis and is being constructed by the stream. (See section A.5.4)

**Flood-plain conveyance**—Refers to the volume and rate of flow carried on the flood plain during floods. In this guide, the term is used qualitatively (high or low). Rougher flood plains with forest or dense shrubby vegetation would be considered lower-conveyance flood plains, whereas smoother grassy surfaces are higher-conveyance flood plains. (5.3.1)

**Flood-plain function**—Flood-plain functions include the temporary storage of sediment and floodwater. Flood plains may also provide diverse habitat for both aquatic and terrestrial wildlife, support riparian vegetation that shades and supplies nutrients and debris to the stream, and they may be movement corridors for large mammals. (See also valley flat.)

**Flood-prone zone**—The valley bottom area up to an elevation of twice maximum bankfull depth, measured vertically above the thalweg, at any channel/valley cross section. Flood-prone width is the width of that zone at a given cross section.

**Flow boundary**—The wetted perimeter, or contact zone between stream flow and the channel bed and banks.

**Flow regime**—Describes how flow in a stream is distributed throughout the year or across years, both in terms of discharge volume and timing.

**Flow resistance**—Drag force exerted on flowing water by its boundary. Flow resistance is the force that opposes the downslope component of the weight of water (the driving force) and controls water velocity. (A.3.6)

## Stream Simulation

---

**Fluvial**—Of or pertaining to rivers or streams.

**Forced channel**—Montgomery and Buffington (1993 and 1997) define forced channels as those in which flow obstructions (such as wood) “force” a channel morphology that is different from what would exist if the obstructions were not present. For example, a wood-forced step-pool channel has log steps.

**Fords**—A stream crossing where the road surface is elevated only slightly or not at all above the channel bed.

**Free-surface resistance**—A component of flow resistance associated with the boundary between the water surface and the atmosphere. Caused by the distortion of the water surface by waves and hydraulic jumps.

**Freshet**—A flood of any size resulting from rainfall or snowmelt.

**G** **Gaining streams**—An effluent stream, or a stream with a channel below the water table so that base flow is provided from the zone of saturation. Antonym: losing stream.

**Genetic drift**—A primary mechanism of evolution, by which gene frequency in a population changes from one generation to the next, due to chance processes rather than natural selection, mutations, or immigration. Genetic drift is especially important in small populations. (from Wikipedia and Primate Info Net [Online]. 2008, January)

**Geomorphologist**—A scientist who studies landforms and land surface processes. Geomorphology is the study of the classification, description, nature, and origin of landforms.

**Grade control**—Anything that controls channel elevation and therefore local channel slope. Grade controls can be natural streambed structures or manmade dams, sills, culverts, etc. As used in this guide, the term most commonly refers to natural structures, such as logs, riffle crests, boulder steps, etc. See also key features and base level. See section 5.1.3.3.

**Granular materials**—Sediment made up of small rock fragments, or grains.

**H** **Headcut**—An abrupt change in channel bed elevation resulting in local steepening. Headcuts may be nearly vertical, or more gradual, depending on grain size and consolidation of channel materials.

**Headwater streams**—Streams at the upstream end of a drainage network. Headwater streams are most often classified as first- and second-order streams (see **zero-, first-, and second-order streams**).

**HEC-RAS**—Hydrologic Engineering Center, River Analysis System: a step-backwater model for estimating streamflow velocity and other flow characteristics in a river reach.

**High bed-design flow**—A high flow, which when exceeded may mobilize rocks designed to be permanently immobile and possibly cause the simulated streambed to wash out of the culvert (See section 6.3.2).

**Hydraulic jump**—An abrupt change in water depth at a transition from supercritical to subcritical flow, forming a stationary wave. Hydraulic jumps occur in a number of situations: over significant obstacles in the bed, below a vertical drop, or where an expansion or contraction of the flow occurs.

**Hydraulic radius**—The ratio of a stream's cross-sectional area to its wetted perimeter. In wide, rectangular channels the depth often is used to approximate hydraulic radius. (Figure E-2)

**Hydro-physiographic province**—A region with characteristic climate, geology, landforms, and vegetation. The relief features and landforms of a hydro-physiographic province differ significantly from surrounding regions, e.g., Valley and Ridge and Coastal Plain in Eastern United States; Basin and Range and Great Plains in Western United States.

**Imbricate/imbrication**—Overlapping arrangement of rocks in a stream, similar to overlapping of shingles on a roof. Imbricated rocks are more resistant to entrainment than loosely-packed rocks.

**Inbreeding depression**—A reduction in overall health and vigor of individuals in a population as a result of breeding with close relatives over multiple generations (Primate Info Net [Online]. 2008, January)

**Incised channel**—See channel incision.

**Intermittent stream**—A stream that flows part of the year. Intermittent streams generally flow continuously for a month or several months during and after the rainy or snowmelt season—the time of year when the ground water table is high enough to supply surface flow.

**Invert**—The bottom of a full-bottom culvert.

**J-K J-hook vane**—A streambank stabilization structure designed to reduce near-bank shear stress on the outside bank at channel bends. The structure causes scour in the center of the channel, maintaining sediment transport capacity (Rosgen 2006).

**Karst**—A type of topography formed on limestone, and characterized by dissolution features such as sinkholes, caverns, and underground streams.

**Key features**—Anything in the stream channel that the current stream either cannot move or that moves only in infrequent floods, and that plays an important role in channel morphology and stability. Key features may control grade, provide roughness, retain bed material, and stabilize banks, among other functions. They can be rocks, logs, living trees, roots, etc. (5.1.6.2)

## Stream Simulation

---

**L** **Lateral accretion**—Sediment deposition along one bank as a river migrates across its flood plain and erodes the opposite bank. Point bars are a common lateral accretion feature.

**Lateral migration**—see channel migration.

**Longitudinal rib or bar**—A ridge of gravel, cobbles, or pebbles extending along the channel parallel to flow. Like transverse ribs, these ridges are microtopographic features found in gravel-bed streams.

**Losing streams**—Streams that lose surface flow as water percolates into their beds to the water table.

**M** **Mass wasting**—The downslope movement of soil and rock material under the direct influence of gravity. Examples include rockslides, landslides, earthflows, and soil creep.

**Maximum bankfull depth**—In any channel cross section, the distance from the streambed's lowest point (thalweg) vertically up to bankfull elevation.

**Meander belt**—The zone along the valley floor across which a meandering stream shifts its channel from time to time. It may be 15 to 18 times the stream width. (Wilson and Moore 1998)

**Mobile-bed channels**—Channels where streambed materials move frequently, even at relatively low flows below bankfull.

**N** **Nickpoint or Knickpoint**—An abrupt drop, or point of inflection, in the longitudinal profile of a stream. Usually associated with a lowering of base level, nickpoints migrate upstream and can cause rapid channel incision upstream. See also headcut.

**Noncohesive**—Lacking in attractive forces that cause particles to stick together, so that resistance to erosion is based on intergranular friction. Granular materials (e.g., sands, gravels) are generally noncohesive.

**O** **Openness**—The opposite of confinement. Some species are reluctant to enter a structure if it appears to be too confining, possibly due to lack of light or security (predator ambush potential or lack of escape routes). Openness is often expressed as the ratio of the cross-section area of a structure's opening ( $m^2$ ) divided by structure length (m).

**Ordinary high water**—Water surface elevation below bankfull, defined variously by different entities. It is defined as follows in Bates (2003): “The Ordinary High Water mark can usually be identified by physical scarring along the bank or shore, or by other distinctive signs. This scarring is the mark along the bank where the action of water is so common as to leave a natural line impressed on the bank. That line may be indicated by erosion, shelving, changes in soil characteristics, destruction of terrestrial vegetation, the presence of litter or debris, or other distinctive physical characteristics.”

**Outsloping**—Cross-sectional road-surface profile that is angled slightly away from the cutbank. This method of road construction is used to disperse water from the road surface rather than allowing it to flow directly into a stream.



**Overbank flow**—Water flowing outside the channel boundary over the adjacent land surface. Overbank flow generally occurs during floods or when in-channel flow is constricted.

**P Particle size class**—Named categories with standard ranges of sediment particle sizes (e.g., sand, silt, gravel, cobble, etc.). See table A-1.

**Pebble clusters**—Microtopographic bed features, on the scale of 10 to 100 centimeters in length, oriented along the local streamline in gravel-bed streams. Generally, an obstacle protrudes above neighboring grains allowing both upstream and downstream accumulation of smaller grains. Pebble clusters are known to delay both entrainment and transport of constituent class, and to reduce bedload transport rates by increasing flow resistance.

**Perennial stream**—A stream that flows year round.

**Permeable roadfill**—Fill material (soil and rock) with a relatively high capacity for transmitting water used to construct road embankments that permit through-flow of water. Objective is often permitting overbank flood flows to filter through the embankment rather than forming a solid dam across the flood plain.

**Pivot angle**—The angle of repose for noncohesive sediment. The angle that a particle, with a particular diameter, has to overcome when rolling over a particle, with a different diameter, that is partly underneath and partly in front of it.

**Planform**—The channel pattern, or the appearance of a stream from above. The most common categories are straight, meandering, and braided. (A.3.3)

**Plasticity**—The ability to be molded into a different shape without breaking, and to retain that shape when the deforming force is removed.

**Pool spacing**—The distance between two successive pools, measured from pool tail to pool tail or pool head to pool head.

**Profile control structure**—A structure placed to control grade and elevation of the simulated channel, such as a log or boulder weir. Profile controls can be inside or outside the culvert.

**Project profile**—The streambed longitudinal profile designed for construction in and around the new crossing structure.

**Project reach**—The stream segment that will be affected by the project, including segments not directly constructed, but expected to adjust to the changes made by the project.

## Stream Simulation

---

**R** **Radius of curvature**—Describes the tightness of a meander bend (figure A-11).

**Reach**—A stream segment. Usually refers to a stream section that is somewhat homogenous, and can be characterized based on discharge, depth, area, or slope. A reach can also be the length of stream between two gauging stations, between two tributary junctions, or between any two points.

**Recruitment**—Introduction of woody debris or other elements into a stream from banks, valley walls, and from upstream. Wood can be recruited by trees falling into the channel, by landslides, or by transport from upstream. Recruitment can also mean the addition of individual animals to a population.

**Recurrence interval**—The average time interval, in years, between occurrences of a hydrologic event of a given or greater magnitude. The probability remains the same from year to year for any event of any recurrence interval. A 20-year event will not necessarily occur once every 20 years, but the probability that the event will occur in any given year is 0.05.

**Reference reach**—A natural stable channel reach used as the design template for stream simulation. (3.2, 5.5)

**Regulated river**—River whose flow is controlled by artificial means such as a dam.

**Residual pool depth**—Maximum depth of a pool, measured from pool bottom to the pool tail crest (or riffle head). See figure 5.19.

**Residual soil**—Soil formed from the underlying rock.

**Response reach**—A stream reach that adjusts to changes in flow and sediment loads by changing its morphology. Changes can include widening or narrowing, straightening or increasing sinuosity, incising, aggrading, etc. Generally, response reaches have erodible bed and bank material, and they tend to be flatter than transport reaches. When upstream sediment inputs increase, sediment tends to deposit in response reaches.

**Riparian vegetation**—Vegetative community located near a body of water such as a stream. Riparian vegetation significantly influences and is significantly influenced by its adjoining body of water.

**River dynamics**—Processes and mechanisms of channel change; water, sediment and debris transport; and interactions between the channel and surrounding area;

**Road management objective**—A statement of the intended purpose of a road, as well as standards for its design, management, and maintenance.

**Roughness (and relative roughness)**—Channel characteristic that causes a drag on flow, limiting velocity and increasing diversity. Roughness elements include grains, bedforms, woody debris, manmade structures, and bank irregularities. Relative roughness is the ratio of hydraulic radius to grain size. As depth increases with discharge at a cross section, relative roughness decreases and the effects of grain roughness are drowned out.

**S Sediment load**—The amount or volume of sediment that is being transported by a stream, including both bed load (sediment that rolls or bounces along the streambed) and suspended load (finer sediment that travels suspended in the water column).

**Sediment regime**—Describes how sediment transport in a stream is distributed throughout the year or across years, in terms of particle size, amount, and timing.

**Sediment transport capacity**—The maximum amount of sediment that a given flow can move in a stream channel.

**Shear stress**—a measure of the hydrodynamic (erosive) force exerted by flowing water on channel bed and banks (see sections A.5.1 and E.1).

**Side channel**—A secondary channel that carries a small volume of the total flow. Many processes for side channel development exist; for example, a side channel can be an abandoned meander bend, or it may have formed by scour during overbank flood flows.

**Simulated channel**—The stream simulation channel bed contained in the crossing installation, generally inside the culvert.

**Slump**—Type of mass wasting event in which a mass of rock or unconsolidated material slides along a concave slide plane.

**Sorting**—A process that occurs during sediment transport events by which sedimentary particles are segregated by size, shape or weight. A well-sorted streambed is composed of a narrower range of sediment sizes than a poorly-sorted streambed.

**Stage**—The elevation of the water surface in a stream channel. A flood stage is the elevation of the water surface during the flood.

**Stream connectivity**—Describes the transfer of matter, energy, and organisms by water within and between all components of the stream ecosystem including the channel, flood plain, and alluvial aquifer.

**Stream corridor**—The stream channel and associated riparian area, including the flood plain.

**Streambed continuity**—Describes how well connected (or how fragmented) the streambed is along its length. Weirs, baffles, bare culverts, etc. disrupt streambed continuity and may limit movement of benthic organisms and aquatic and riparian-dependent species that require dry or shallowly-submerged surfaces for movement.

**Streambed structure**—The geomorphic forms comprising a streambed: channel units such as pools and riffles, steps, etc.; grade controls; bank configuration and composition.

**Strike of rock**—The geographic direction and angle between true north and a horizontal line of any planar geologic feature: bedding, faults, or dikes.

## Stream Simulation

---

**Structural design flow**—A high flow which, when exceeded may cause the crossing structure to fail. (Contrasts to high bed design flow.)

**T Terrace**—A relatively level bench or flat steplike surface above the flood plain. An alluvial terrace is the relict of a former flood plain before regional uplift or increase in discharge caused erosion and incision into the former flood plain. Other types of terraces include marine terraces and structural terraces.

**Thalweg**—The longitudinal profile line, or line connecting the lowest points along a streambed. (5.1.3)

**Tidal rivers**—Coastal rivers influenced by tidal fluctuations.

**Transport reach**—A stream reach that resists changes in morphology when flows and sediment loads change. Transport reaches are generally steeper and coarser-grained than response reaches. When sediment input increases, the added load is simply transported through the reach.

**Transverse bars**—Relatively broad flat surfaces with a crest oriented perpendicular to flow. Transverse bars are at least several particles in length (from upstream to downstream) and can extend completely or partially across the channel. They typically form downstream of pools where flow begins to diverge as the channel widens, and are located at the pool-tail crest (or riffle head). Coarse-grained bars are typically well armored with particles that are tightly packed and well imbricated. They may be immobile up to high discharges, and usually function as reach-scale hydraulic grade controls.

**V Valley flat**—The area adjacent to the channel that is relatively flat and is bordered by hillslopes. The valley flat may include the flood plain and one or more terraces. Also valley floor or valley bottom.

**Vertical accretion**—Process of accumulation of sediment on flood plains during overbank flows.

**Vertical adjustment potential**—the vertical range of possible streambed elevations over the life of the structure (5.2.2.2).

**W Well-graded**—Refers to coarse-grained sediments that have a continuous distribution of particle sizes, such that smaller grains fill the spaces between the larger grains (AGI 1962).  
Synonym: poorly sorted.

**Width-depth ratio**—Bankfull width divided by mean bankfull depth (average across the cross section). (A.3.4).

**Woody debris**—Logs, limbs, and rootwads found in streams. Woody debris plays important roles in stream ecosystems by increasing boundary roughness and flow resistance; providing storage areas for sediment and organic material; providing cover for fish; controlling grade and increasing profile and substrate diversity.

**Z** **Zero-, first-, and second-order streams**—Stream ordering is a system of classifying stream segments based on location in the drainage network. A zero-order stream is an unchannelized valley or swale. First-order streams are segments with no tributaries. Second-order streams are formed by the junction of two first-order streams.

# Stream Simulation

---

## References

---

- A** Abbe, T. B.; Montgomery, D. R. 1996. Large woody debris jams, channel hydraulics, and habitat formation in large rivers. *Regulated Rivers: Research and Management*. 12, 201-221.
- Abt, S. R.; Wittler, R. J.; Ruff, J. F.; LaGrone, D. L.; Khattak, M. S.; Nelson, J. D.; Hinkle, N. E.; Lee, D. W. 1988. Development of riprap design criteria by riprap testing in flumes: phase II; Follow-up Investigations Volume 2, NUREG/CR-4651, ORNL/TM-10100/V2, prepared for U.S. Nuclear Regulatory Commission, Washington D.C.
- American Association of State Highway and Transportation Officials. 2002. Standard specifications for highway bridges, 17th edition (HB-17). Washington DC: American Association of State Highway and Transportation Officials. 1,028 p.
- Andrews, E. D. 1979. Scour and fill in a stream channel, East Fork River, western Wyoming. U.S. Geological Survey Professional Paper 1117. 49 p.
- Andrews, E. D. 1983. Entrainment of gravel from naturally sorted riverbed material: *Geological Society of America Bulletin*. 94, 1,184-1,192.
- Andrews, E. D.; Parker G. 1987. Formation of a coarse surface layer as the response to gravel mobility. In: *Sediment transport in gravel-bed rivers*, Thorne, C. R.; Bathurst, J. C.; Hey, R. D. (eds). New York: John Wiley and Sons. 269-300.
- Arcement, G. J., Jr.; Schneider, V. R. 1989. Guide for selecting Manning's roughness coefficient for natural channels and flood plains. U.S. Geological Survey Water-Supply Paper 2339. 38 p.
- Ault, P; Ellor, J. A. 2000. Durability analysis of aluminized type 2 corrugated metal pipe. FHWA-RD-97-140. McLean VA: Federal Highway Administration. 106 p.
- B** Bagnold, R. A. 1960. Some aspects of the shape of river meanders. U.S. Geological Survey Professional Paper 282E. 135-144.
- Barnard, R. 2003. [Personal communication]. June 11. Olympia, WA: Washington Department of Fish and Wildlife.
- Barnes H. H., Jr. 1967. Roughness characteristics of natural channels. U.S. Geological Survey Water-Supply Paper 1849. 213 p.

## **Stream Simulation**

---

- Bates, K. K. 2003. Design of road culverts for fish passage. Washington Department of Fish and Wildlife. <http://wdfw.wa.gov/hab/engineer/cm/>, accessed 1/20/06.
- Bathurst, J. C. 1985. Flow resistance estimation in mountain rivers. American Society of Civil Engineers. *Journal of Hydraulic Engineering*. 111:625-641.
- Bathurst, J. C. 1987. Critical conditions for bed material movement in steep, boulder-bed streams. In: *Erosion and Sedimentation in the Pacific Rim*. Wallingford, U.K.: Institute of Hydrology, IAHS Publication. 133, 91-6.
- Bathurst, J. C. 1997. Environmental river flow hydraulics. In: Thorne, C. R.; Hey, R. D.; Newson, M. D., eds. *Applied Fluvial Geomorphology for River Engineering and Management*. Chichester, U.K.: Wiley and Sons. 69-93.
- Bathurst, J. C.; Graf, W. H.; Cao, H. H. 1987. Bed load discharge equations for steep mountain rivers. In: Thorne, C. R.; Bathurst, J. C.; Hey, R. D., eds. *Sediment Transport in Gravel-bed Rivers*. Chichester, U.K.: Wiley and Sons. 453-77.
- Beamish, F. W. H. 1978. Swimming capacity. In: Hoar, W. S.; Randall, D. J., eds. *Fish Physiology*. Volume VII. New York: Academic Press. 101-187.
- Behlke, C. E.; Kane, D. L.; McLean, R. F.; Travis, M. D. 1991. Fundamentals of culvert design for passage of weak-swimming fish. FHWA-AK-RD-90-10.
- Benda, L. E.; Cundy, T. W. 1990. Predicting deposition of debris flows in mountain channels. *Canadian Geotechnical Journal*. 27(4):409-417.
- Bigelow, P. E. 2005. Testing and improving predictions of scour and fill depth in a northern California coastal stream. *River Research and Applications*. 21: 909-923.
- Brayshaw, A. C.; Frostick, L. F.; Reid, I. 1983. The hydrodynamics of particle clusters and sediment entrainment on coarse alluvial channels. *Sedimentology*. 30, 127-43.
- Brown, S. A.; Clyde, E. S. 1989. Design of riprap revetment. Hydraulic Engineering Circular 11. U.S. Federal Highway Administration, McLean VA. NTIS # PB89-218424. 169 p.
- Browning, M. C. 1990. Oregon culvert fish passage survey. Vancouver, WA: U.S. Department of Transportation, Federal Highway Administration, Western Federal Lands Division.



## References

---

- Brudin, C. O. 2003. Wildlife use of existing culverts and bridges in north central Pennsylvania. In: 2003 Proceedings of the International Conference on Ecology and Transportation. Irwin, C. L.; Garrett, P.; McDermott, K. P., eds. Raleigh, NC: North Carolina State University, Center for Transportation and the Environment. 344-352.
- Bryant M. D.; Zymonas, N. D.; Wright, B. E. 2004. Salmonids on the fringe: abundance, species composition, and habitat use of salmonids in high-gradient headwater streams, southeast Alaska. *Transactions of the American Fisheries Society*. 133:1,529-1,538.
- Buffington, J. M.; Montgomery, D. R. 1997. A systematic analysis of eight decades of incipient motion studies, with special reference to gravel-bedded rivers. *Water Resources Research*. 33, 1,993-2,029.
- Buffington, J. M.; Montgomery, D. R. 1999a. Effects of hydraulic roughness on surface textures of gravel-bed rivers. *Water Resources Research*. 35(11): 3,507-3,521.
- Buffington, J. M.; Montgomery, D. R. 1999b. Effects of sediment supply on surface textures of gravel-bed rivers. *Water Resources Research*. 35(11): 3,523-3,530.
- Bunte, K. 2004. [Personal communication]. Fort Collins, CO: Engineering Research Center, Colorado State University.
- Bunte, K.; Abt, S. R. 2001. Sampling surface and subsurface particle-size distributions in wadable gravel-and cobble-bed streams for analyses in sediment transport, hydraulics, and streambed monitoring. Gen. Tech. Rep. RMRS-GTR-74. Fort Collins, CO: U.S. Department of Agriculture, Forest Service, Rocky Mountain Research Station. 428 p.
- C** Carling, P. A. 1992. In-stream hydraulics and sediment transport. In: Calow, P.; Petts, G. E., eds. *The Rivers Handbook*. Oxford, U.K.: Blackwell Publishing. 101-125.
- Castro, J. 2003. Geomorphic impacts of culvert replacement and removal: avoiding channel incision. Portland, OR: U.S. Fish and Wildlife Service, Oregon Fish and Wildlife Office. <http://library.fws.gov/Pubs1/culvert-guidelines03.pdf>
- Castro, J. M.; Jackson, P. L. 2001. Bankfull discharge recurrence interval and regional hydraulic geometry relationships. Patterns in the Pacific Northwest, USA. *Journal of American Water Resources Association*. 37(5):1,249-1,262

## **Stream Simulation**

---

- Chin, A. 1989. Step pools in stream channels. *Progress in Physical Geography*. 13, 391-407.
- Chow, V. T. 1959. *Open-channel hydraulics*. New York: McGraw-Hill Book Company. 679 p.
- Chow, V. T.; Maidment, D. R.; Mays, L.W. 1988. *Applied hydrology*. New York: McGraw-Hill Book Company. 572 p.
- Church, M. 1978. Paleohydrological reconstructions from a holocene valley fill. In: Miall, A. D. ed. *Fluvial Sedimentology*. Calgary: Canadian Society of Petroleum Geologists, Memoir 5. 743-772.
- Clarkin, K.; Connor, A.; Furniss, M.; Gubernick, B.; Love, M.; Moynan, K.; WilsonMusser, S. 2003. National inventory and assessment procedure for identifying barriers to aquatic organism passage at road-stream crossings. San Dimas, CA: U.S. Department of Agriculture, Forest Service, National Technology and Development Program, San Dimas Technology and Development Center.  
<http://fsweb.sdtdc wo.fs.fed.us/programs/eng/aopxing/>
- Clarkin, K. L.; Keller, G.; Warhol, T.; Hixson, S. 2006. Low-water crossings: geomorphic, biological, and engineering design considerations. 0625-1808—SDTDC. San Dimas, CA: U.S. Department of Agriculture, Forest Service, National Technology and Development Program, San Dimas Technology and Development Center. 360 p.
- Coffman, J. S. 2005. Evaluation of a predictive model for upstream fish passage through culverts. Harrisonburg, VA: James Madison University. 104 p. Thesis.
- Cooper, A. B.; Mangel, M. 1999. The dangers of ignoring metapopulation structure for the conservation of salmonids. *Fisheries Bulletin*. 97(2): 213-226.
- Cooper, R. M. 2006. Estimation of peak discharges for rural, unregulated streams in western Oregon. Oregon Water Resources Department. Open File Report SW 06-001. 86 p.
- Copeland, R. R.; McComas, D. N.; Thorne, C. R.; Soar, P. J.; Jonas, M. M.; Fripp, J. B. 2001. Hydraulic design of stream restoration projects. ERDC/CHL TR-01-28. Vicksburg, MS: U.S. Army Corps of Engineers, Coastal and Hydraulics Laboratory, Engineer Research and Development Center, Waterways Experiment Station. 109 p.

- D** Dunham, J. B.; Rieman, B. E. 1999. Metapopulation structure of bull trout: influences of physical, biotic, and geometrical landscape characteristics. *Ecological Applications*. 9(2): 642-655.
- Dunham, J. B.; Vinyard, G. L.; Rieman, B. E. 1997. Habitat fragmentation and extinction risk of Lahontan cutthroat trout. *North American Journal of Fisheries Management*. 17: 1,126-1,133.
- Dunne, T.; Leopold, L. B. 1978. *Water in environmental planning*. New York: W.H. Freeman and Co.
- E** Emmett, W. W. 2004. A historical perspective on regional channel geometry curves. *Stream Notes* January 2004. Fort Collins, CO: U.S. Department of Agriculture, Forest Service, Rocky Mountain Research Station, Stream Systems Technology Center. Available at: <http://www.stream.fs.fed.us>
- Erman, D. C.; Hawthorne, V. M. 1976. The quantitative importance of an intermittent stream in the spawning of rainbow trout. *Transactions of the American Fisheries Society*. 105: 675-681.
- F** Fahrig L.; Merriam, G. 1985. Habitat patch connectivity and population survival. *Ecology*. 66(6): 1,762-1,768.
- Fausch, K. D.; Rieman, B. E.; Young, M. K.; Dunham, J. B. 2006. Strategies for conserving native salmonid populations at risk from nonnative fish invasions: tradeoffs in using barriers to upstream movement. Gen. Tech. Rep. RMRS-GTR-174. Fort Collins, CO: U.S. Department of Agriculture, Forest Service, Rocky Mountain Research Station. 44 p.
- Federal Emergency Management Agency. 1995. Flood insurance study guidelines and specifications for study contractors: Federal Emergency Management Report, FEMA 37. 200 p.
- Federal Highway Administration. 2003. Manual on uniform traffic control devices. [Online]. Available: <http://mutcd.fhwa.dot.gov> [7/18/2007].
- Federal Highway Administration. 2003b. Standard specifications for construction of roads and bridges on federal highway projects. FP-03. [Online]. Available: <http://www.wfl.fha.dot.gov/design/specs/fp03.htm> [7/9/07].

## Stream Simulation

---

- Federal Interagency Stream Restoration Working Group. 1998. Stream Corridor Restoration: Principles, Practices, and Processes. PB 98158348. Available from National Technical Information Service at. <http://www.ntis.gov>
- Ferro, W. 1999. Evaluating friction factor for gravel-bed channel with high boulder concentration. *Journal of Hydraulic Engineering*. 125(7): 771-778.
- Fetherston, K. L.; Naiman, R. J.; Bilby, R. E. 1995. Large woody debris, physical process, and riparian forest development in montane river networks of the Pacific Northwest. *Geomorphology*, 13, 133-144.
- Findlay, C. S.; Bourdages, J. 2000. Response time of wetland biodiversity to road construction on adjacent lands. *Cons. Biol.* 14(1): 86-94.
- Findlay, C. S.; Houlihan, J. 1997. Anthropogenic correlates of species richness in Southeastern Ontario wetlands. *Conservation Biology*. 11: 1,000-1,009.
- Fischenich, C.; Seal, R. 2000. Boulder clusters. Technical Note ERDC TN-EMRRP-SR-11. Vicksburg, MS: U.S. Army Engineer Research and Development Center. Ecosystem Management Restoration Research Program EMRRP Technical Notes Collection. <http://el.ercd.usace.army.mil/elpubs/pdf/sr11.pdf> accessed 6/11/2007.
- Fleming, D. F. 1989. Effects of spawning run delay on spawning migration of arctic grayling. Fairbanks, AK: University of Alaska, Alaska Cooperative Fisheries Research Unit, Unit Contribution #29.
- Food and Agriculture Organization of the United Nations. 2002. Fish passes - Design, dimensions and monitoring. Originally published in German by the German Association for Water Resources and Land Improvement (DVWK) in 1996. Translated and published in English by Food and Agriculture Organization of the United Nations.
- Forman, R. T. T.; Sperling, D.; Bissonette, J. A.;[and others]. 2003. *Road Ecology*. Washington: Island Press. 481 p.
- Franklin, I. R. 1980. Evolutionary change in small populations. In: Soulé, M. E.; Wilcox, B.A. (eds). *Conservation Biology: An Evolutionary-Ecological Perspective*. Sunderland, MA: Sinauer Associates. 135-149.

## References

---

- Fuller, W. B.; Thompson, S. E. 1907. The laws of proportioning concrete. *Journal of the Transportation Division, American Society of Civil Engineers*. Volume 59. Paper No. 1053. 67-143.
- Furniss, M. J.; Ledwith, T. S.; Love, M. A.; McFadin, B. C.; Flanagan, S. A. 1998. Response of road-stream crossings to large flood events in Washington, Oregon, and Northern California. 9877-1806—SDTDC. In: *Water-Roads Interaction Technology Series*. San Dimas, CA: U.S. Department of Agriculture, Forest Service, National Technology and Development Program, San Dimas Technology and Development Center. 14 p.
- Furniss, M. J.; Love, M.; Flanagan, S. A. 1997. Diversion potential at road-stream crossings. 9777-1814—SDTDC. In: *Water-Roads Interaction Technology Series*. San Dimas, CA: U.S. Department of Agriculture, Forest Service, National Technology and Development Program, San Dimas Technology and Development Center. 12 p.
- G** Gehrels, G. E.; Berg, H. C. 1992. Geologic map of southeastern Alaska. U.S. Geological Survey Miscellaneous Investigation Series MAP 1-1867. 24 p.
- Gowan, C.; Young, M. K.; Fausch, K. D.; Riley, S. C. 1994. Restricted movement in resident stream salmonids: a paradigm lost? *Canadian Journal Fisheries and Aquatic Sciences*. 51: 2,626-2,637.
- Grant, G. 1988. The RAPID technique: a new method for evaluation of downstream effects of forest practices on riparian zones. Gen. Tech. Rep. PNW-220. Portland, OR: U.S. Department of Agriculture, Forest Service, Pacific Northwest Forest Research Station. 40 p.
- Grant, G. E.; Swanson, F. J.; Wolman, M. G. 1990. Pattern and origin of stepped-bed morphology in high-gradient streams, western Cascades, Oregon. *Geological Society of America Bulletin*. 102, 340-352.
- H** Hall, C. A. 1972. Migration and metabolism in a temperate stream ecosystem. *Ecology*. 53(4): 585-604.
- Hanski, I.; Gilpin, M. E. 1991. Metapopulation dynamics: brief history and conceptual domain. *Biological Journal of the Linnean Society*. 42: 3-16.
- Hardison, C. H. 1971. Prediction error of regression estimates of streamflow characteristics at ungauged sites. U.S. Geological Survey Professional Paper 750-C. 228-236.

## Stream Simulation

---

- Hardy, T.; Palavi, P.; Mathias, D. 2005. WinXSPRO, A channel cross section analyzer, user's manual, Version 3.0. Gen. Tech. Rep. RMRS-GTR-147. Fort Collins, CO: U.S. Department of Agriculture, Forest Service, Rocky Mountain Research Station. 95 p.
- Harig, A. L.; Fausch, K. D. 2002. Minimum habitat requirements for establishing translocated cutthroat trout populations. *Ecological Applications*. 12(2): 535-551.
- Harrelson, C. C.; Rawlins, C. L.; Potyondy, J. P. 1994. Stream channel reference sites: an illustrated guide to field technique. Gen. Tech. Rep. RM-245. Fort Collins, CO: U.S. Department of Agriculture, Forest Service, Rocky Mountain Forest and Range Experiment Station. 61 p.
- Haschenburger, J. K. 1999. A probability model of scour and fill depths in gravel-bed channels. *Water Resources Research*. 35, 2,857-2,869.
- Hazlett, B.; Rittschof, D.; Rubenstein, D. 1974. Behavioral biology of the crayfish *Orconectes virilis* L. Home Range. *American Midland Naturalist*. 92(2): 301-319.
- Hey, R. D. 1997. Stable river morphology. In: Thorne, C. R.; Hey, R. D.; Newson, M. D. eds. *Applied Fluvial Geomorphology for River Engineering and Management*. Chichester, U.K.: Wiley and Sons. 223-236.
- Hickin, E. J. 1984. Vegetation and river channel dynamics. *Canadian Geography*. 28, 111-126.
- Hicks, D. M.; Mason, P. D. 1998. Roughness characteristics of New Zealand rivers. National Institute of Water and Atmospheric Research, ltd. Water Resources Publications. Englewood, CO. 329 p.
- Hooke, J. M. 1997. Styles of channel change. In: Thorne, C. R.; Hey, R. D.; Newson, M. D. eds. *Applied Fluvial Geomorphology for River Engineering and Management*: Chichester, U.K.: Wiley and Sons. 237-268.
- I** Interagency Advisory Committee on Water Data. 1982. Guidelines for determining flood flow frequency. Water Resources Council Bulletin 17B. 28 p.
- J** Jackson, W. L.; Beschta, R. L. 1982. A model of two-phase bedload transport in an Oregon coast range stream. *Earth Surface Processes and Landforms*. 7, 517-27.

## References

---

- Jarrett, R. D. 1985. Determination of roughness coefficients for streams in Colorado. Water-Resources Investigations Report 85-4004. Denver, CO: U.S. Geological Survey. 54 p.
- Johnson, P. A.; Gleason, G. L.; Hey, R. D. 1999. Rapid assessment of channel stability in vicinity of road crossing. *Journal of Hydraulic Engineering*. 25(6): 645-651.
- Julien, P. Y. 1995. *Erosion and sedimentation*. New York: Cambridge University Press. 280 p.
- K** Katapodis, C. 2005. Developing a toolkit for fish passage, ecological flow management, and fish habitat works. *Journal of Hydraulic Research*. 43(5): 451-467.
- Keevin, T. M., Ph.D.; Hempen, G. L., Ph.D., P.E., R.G. 1997. The environmental effects of underwater explosions with methods to mitigate impacts. U.S. Army Corps of Engineers, August 97. (<https://www.denix.osd.mil/denix/Public/ES-Programs/Conservation/WaterX/water1.html#toc>).
- Knighton, D. 1998. *Fluvial forms and processes: A new perspective*. London: Arnold. 383 pp.
- Komar, P. D. 1987. Selective grain entrainment and the empirical evaluation of flow competence. *Sedimentology*. 34, 1,165-1,176.
- Komar, P. D.; Carling, P. A. 1991. Grain sorting in gravel-bed streams and the choice of particle sizes for flow-competence evaluations. *Sedimentology*. 38, 489-502.
- Komar, P. D.; Li, Z. 1986. Pivoting analyses of the selective entrainment of sediments by shape and size with application to grain threshold. *Sedimentology*. 33, 425-36.
- Koster, E. H. 1978. Transverse ribs; their characteristics, origin, and paleohydraulic significance. In: Miall, A. D. ed. *Fluvial Sedimentology*. Canadian Society of Petroleum Geologists. Memoir 5, Calgary. 161-86.
- L** Lang, M.; Love, M.; Trush, W. 2004. Improving stream crossings for fish passage. Report prepared for U.S. Department of Commerce, National Marine Fisheries Service, Southwest Region. Contract 50ABNF800082 by Humboldt State University Foundation. 128 p.

## Stream Simulation

---

- Leigh, E. G., Jr. 1981. The average lifetime of a population in a varying environment. *Journal of Theoretical Biology*. 90: 213-239.
- Lemkuhl, J. F. 1984. Determining size and dispersion of minimum viable population for land management planning and species conservation. *Environmental Management*. 8: 167-176.
- Leopold, L. B.; Wolman, M. G.; Miller, J. P. 1964. *Fluvial processes in geomorphology*. New York: Dover Publications, Inc.
- Letcher, B. H.; Nislow, K. H.; Coombs, J. A.; O'Donnell, M. J.; Dubreuil, T. L. 2007. Population response to habitat fragmentation in a brook trout population. *Public Library of Science-Biology*.
- Levy, S. 1997. Pacific salmon bring it all back home. *BioScience*. 47(10): 657-660.
- Lewin, J.; Macklin, M. G.; Newson, M. D. 1988. Regime theory and environmental change—irreconcilable concepts? In: White, W. R. ed. *International conference on river regime*. Chichester, U.K.: Wiley and Sons. 431-445.
- Limerinos, J. T. Determination of the Manning coefficient from measured bed roughness in natural channels: U.S. Geological Survey Water-Supply Paper 1898-B. 47 p.
- Linsley, R. K.; Kohler, M. A.; Paulhus, J. L. 1982. *Hydrology for engineers*. Third edition. New York: McGraw-Hill Book Company. 508 p.
- Lowe, W. H.; Bolger, D. T. 2002. Local and landscape-scale predictors of salamander abundance in New Hampshire headwater streams. *Conservation Biology*. 16(1):183-193.
- M** Macklin, M. G.; Lewin, J. 1997. Channel, floodplain and drainage basin response to environmental change. In: Thorne, C. R.; Hey, R. D.; Newson, M. D. eds. *Applied Fluvial Geomorphology for River Engineering and Management*. Chichester, U.K.: Wiley and Sons. 15-45.
- Madej, M. A. 2001. Development of channel organization and roughness following sediment pulses in single-thread, gravel bed rivers. *Water Resources Research*. 37(8): 2,259-2,272.



## References

---

- McBain, S.; Trush, W. 2004. Attributes of Bedrock Sierra Nevada River Ecosystems. Stream Notes, January 2004. Fort Collins, CO: U.S. Department of Agriculture, Forest Service, Rocky Mountain Research Station, Stream Systems Technology Center. <http://www.stream.fs.fed.us>
- McCuen, R. H. 2003. Modeling hydrologic change: statistical methods. Washington D.C.: Lewis Publishers. 433 p.
- McIntosh, B. A.; Sedell, J. R.; Smith, J. E.; Wissmar, R. C.; Clarke, S. E.; Reeves, G. H.; Brown, L. A. 1994. Historical changes in fish habitat for select river basins of Eastern Oregon and Washington. Northwest Science. 68 Special Issue.
- Meyer J. L.; Strayer, D. L.; Wallace, J. B.; Eggert, S. L.; Helfman, G. S.; Leonard, N.E. 2007. The contribution of headwater streams to biodiversity in river networks. Journal of the American Water Resources Association. 43(1): 86-103.
- Meyer-Peter, E.; Muller, R. 1948. Formulas for bed-load transport: Stockholm: International Association of Hydraulic Engineering and Research. Proceedings 2nd Meeting. 39-64.
- Meyers et al. 1992 as cited in Fausch, K. D.; Torgersen, C. E.; Baxter, C. V.; Li, H.W. 2002. Landscapes to Riverscapes: bridging the gap between research and conservation of stream fishes. BioScience. 52(6): 483-498.
- Moll, J. 1997. Glossary of water-road interaction terminology. In: Water/road interaction technology series. 9777-1806—SDTDC. San Dimas, CA: U.S. Department of Agriculture, Forest Service, National Technology and Development Program, San Dimas Technology and Development Center. 16 p.
- Montgomery, D. R.; Buffington, J. M. 1993. Channel classification, prediction of channel response, and assessment of channel condition. Report TFW-SH10-93-002 prepared for the SHAMW committee of the Washington State Timber, Fish, and Wildlife Agreement. 84 p.
- Montgomery, D. R.; Buffington, J. M.; 1997. Channel classification, prediction of channel response, and assessment of channel condition. GSA Bulletin. 109(5): 596-611.
- Morita, K.; Yamamoto, S. 2002. Effects of habitat fragmentation by damming on the persistence of stream-dwelling charr populations. Conservation Biology. 16(5): 1,318-1,323.

## Stream Simulation

---

- N** Naiman, R. J.; Beechie, T. J.; Benda, L. E.; Berg, D. T.; Bisson, P. A.; MacDonald, L. H.; O'Connor, M. D.; Olson, P. L.; Steel, E. A. 1992. Fundamental elements of ecologically healthy watersheds in the Pacific Northwest Coastal Ecoregion. In: Watershed Management: Balancing Sustainability and Environmental Change, Naiman, R. J. ed. New York: Springer-Verlag, Inc.
- Nanson, G. C.; Croke, J. C. 1992. A genetic classification of floodplains. *Geomorphology*. 4, 459-486.
- National Corrugated Steel Pipe Association (NCSPA). No date. Installation manual for corrugated steel pipe, pipe arches, structural plate. [Online]. Available: [http://www.ncspa.org/images/InstallManual\\_00.pdf](http://www.ncspa.org/images/InstallManual_00.pdf) [12 July 2007].
- Nelson, J. M.; Shreve, R. L.; McLean, S. R.; Drake, T. G. 1995. Role of near-bed turbulence structure in bed transport and bed form mechanics. *Water Resources Research*. 31, 2,071-2,086.
- Neville, H. M.; Dunham, J. B.; Peacock, M. M. 2006. Landscape attributes and life history variability shape genetic structure of trout populations in a stream network. *Landscape Ecology*. 21: 901-916.
- Newbury, R.; Gaboury, M. N. 1993. Stream analysis and fish habitat design: a field manual. Gibsons, BC Canada: Newbury Hydraulics Ltd. [Online]. Available: <http://www.newbury-hydraulics.com>. [7/6/07]
- Northcote, T. G. 1997. Potamodromy in Salmonidae – living and moving in the fast lane. *North American Journal of Fisheries Management*. 17: 1029-1,045.
- O** Occupational Health and Safety Administration (OSHA). 1999. Excavations: hazard recognition in trenching and shoring. OSHA technical manual section V chapter 2. Washington D.C.: Office of Science and Technology Assessment. [Online] Available: [http://www.osha.gov/dts/osta/otm/otm\\_v/otm\\_v\\_2.html](http://www.osha.gov/dts/osta/otm/otm_v/otm_v_2.html) [2007, July 27]
- Omang, R. J. 1992. Analysis of the magnitude and frequency of floods and the peak flow gaging network in Montana. U.S. Geological Survey Water Resources Investigations Report 92-4048. Helena, MT.
- Oregon Department of Transportation, Highway Department. 2005. Hydraulics Manual. [Online]. Available: [http://www.oregon.gov/ODOT/HWY/GEOENVIRONMENTAL/hyd\\_manual\\_info.shtml](http://www.oregon.gov/ODOT/HWY/GEOENVIRONMENTAL/hyd_manual_info.shtml). [16 July 2007].

- P** Peake, S. 2004. An evaluation of the use of critical swimming speed for determination of culvert water velocity criteria for smallmouth bass. *Transactions of the American Fisheries Society*. 133: 1,472-1,479.
- Pennsylvania Department of Environmental Protection (DEP). 2000. Erosion and sediment pollution control program manual. [On-line]. Available: [http://www.filtrexx.com/downloads/Penn\\_DEP\\_Erosion\\_and\\_Sediment\\_Control\\_Manual.pdf](http://www.filtrexx.com/downloads/Penn_DEP_Erosion_and_Sediment_Control_Manual.pdf) [2007, August 3].
- Pfankuch, D. J. 1978. Stream reach inventory and channel stability evaluation: a watershed management procedure. Unpublished report. Missoula, MT: U.S. Department of Agriculture, Forest Service, Northern Region. 25 p.
- Platts, W. S.; Megahan, W. F.; Minshall, G.W. 1983. Methods for evaluating stream, riparian, and biotic conditions. Gen. Tech. Rep. INT-138. Ogden, UT: U.S. Department of Agriculture, Forest Service, Intermountain Forest and Range Experiment Station. 70 p.
- Plummer, M. V.; Mills, N. E.; Allen, S. L. 1997. Activity, habitat, and movement patterns of softshell turtles (*Trionyx spiniferus*) in a small stream. *Chelonian Conservation and Biology*. 2(4): 514-520.
- R** Reed, D.F. 1981. Mule deer behavior at a highway underpass exit. *Journal of Wildlife Management*. 45(2): 542-543.
- Reid, I.; Bathurst, J. C.; Carling, P. A.; Walling, D. E.; Webb, B. W. 1997. Sediment Erosion, Transport, and Deposition. In: Thorne, C. R.; Hey, R. D.; Newson, M. D. eds. *Applied Fluvial Geomorphology for River Engineering and Management*. Chichester, U.K.: Wiley and Sons. 96-133.
- Reid, I.; Frostick, L. E. 1994. Fluvial sediment transport and deposition. In: Pye, K. (ed), *Sediment transport and depositional processes*. Oxford: Blackwell Scientific Publications. 89-156.
- Reid, I.; Frostick, L. E.; Latmn, J. T. 1985. The incidence and nature of bedload transport during flood flows in coarse-grained alluvial channels. *Earth Surface Processes and Landforms*. 10, 33-44.
- Richardson, E. V.; Simons, D. B.; Julien, P.Y. 1990. *Highways in the River Environment*. FHWA-HI-90-016. Design and training manual for U.S. Department of Transportation, Federal Highway Administration. 683 p.

## Stream Simulation

---

- Rieman, B. E.; Allendorf, F. W. 2001. Effective population size and genetic conservation criteria for bull trout. *North American Journal of Fisheries Management*. 21: 756-764.
- Rieman, B. E.; McIntyre, J. D. 1993. Demographic and habitat requirements for the conservation of bull trout *Salvelinus confluentus*. Gen. Tech. Rep. INT-302. U.S. Department of Agriculture, Forest Service, Intermountain Research Station.
- Riggs, H. C. 1973. Regional analysis of streamflow characteristics. U.S. Geological Survey Techniques of Water Resources Investigations, Book 4, Chapter B3. 15 p.
- Rosgen, D. L. 1996. Applied river morphology. Pagosa Springs, CO: Wildland Hydrology.
- Rosgen, D. L. 1994. A classification of natural rivers. *Catena*. 22, 169-199.
- Rosgen, D. L. 2006. The cross-vane, w-weir and J-hook vane structures: their description, design and application for stream stabilization and river restoration. Web-published by Wildland Hydrology, Inc. Available: [www.wildlandhydrology.com](http://www.wildlandhydrology.com) [June 2007].
- S** Saldi-Caromile, K.; Bates, K.; Skidmore, P.; Barenti, J.; Pineo, D. 2004. Stream habitat restoration guidelines: final draft. Co-published by the Washington Departments of Fish and Wildlife and Ecology and the U.S. Fish and Wildlife Service. Olympia, WA. Available at <http://wdfw.wa.gov/hab/ahg/shrg/>
- Schumm, S. A. 1977. The fluvial system. New York: Wiley and Sons.
- Schumm, S. A.; Harvey, M. D.; Watson, C. C. 1984. Incised channels. Littleton, CO: Water Resources Publications. 220 p.
- Shaffer, M. L. 1981. Minimum population sizes for species conservation. *BioScience*. 31(2): 131-134.
- Shaffer, M. L.; Samson, F. B. 1985. Population size and extinction: a note on determining critical population sizes. *American Naturalist*. 125: 144-152.
- Shvidchenko, A. B.; Pender, G. 2000. Flume study of the effect of relative depth on the incipient motion of coarse uniform sediments. *Water Resources Research*. 36(2) 619-628.

## References

---

- Simon, A.; Downs, P. W. 1995. An interdisciplinary approach to evaluation of potential instability in alluvial channels. *Geomorphology* 12. 215-232.
- Simons, Li and Associates. 1982. Engineering analysis of fluvial systems. Fort Collins, CO. Simons, Li and Associates. 1,128 p.
- Soulé, M. E. 1980. Thresholds for survival: maintaining fitness and evolutionary potential. In: Soulé, M. E.; Wilcox, B. A. eds. *Conservation Biology: An Evolutionary-Ecological Perspective*. Sunderland, MA: Sinauer Associates. 151-167.
- Stillwater Sciences. 2005. Santa Clara River Parkway Floodplain Restoration Feasibility Study: Assessment of Geomorphic Processes (DRAFT REPORT). Prepared for the California State Coastal Conservancy. Berkeley CA.  
<http://www.santaclarariverparkway.org/newsfolder/wkb/projects/scrfeasibility> accessed 8/9/2006
- Stuckey, M. H.; Reed, L. A. 2000. Techniques for estimating magnitude and frequency of peak flows for Pennsylvania streams. U.S. Geological Survey Water resources Investigations Report 00-4189. 22 p.
- Sumioka, D. L.; Kresch, D. L.; Kasnick, K. D. 1997. Magnitude and frequency of floods in Washington. U. S. Geological Survey, Water Resources Investigations Report 97-4277. 91 p.
- T**aylor, R. N.; Love, M. 2003. Fish passage evaluation at stream crossings. Part IX, California Salmonid Stream Habitat Restoration Manual, 1998 3rd edition. California Department of Fish and Game. <http://www.dfg.ca.gov/nafwb/manual.html> accessed 1/6/06.
- Thomas, B. E.; Hjalmerson, H. W.; Waltemeyer, S. D. 1993. Methods for estimating magnitude and frequency of floods in the southwestern United States. U. S. Geological Survey Open File Report 93-419. 91 p.
- Thomas, D. M.; Benson, M. A. 1969. Generalization of streamflow characteristics from drainage watershed characteristics. U.S. Geological Survey Open-File Report. 45 p.
- Thomas, D. B.; Abt, S. R.; Mussetter, R. A.; Harvey, M. D. 2000. A design procedure for sizing step-pool structures. Fort Collins CO: Mussetter Engineering, Inc. [Online] Available: [http://www.crwcd.org/page\\_5](http://www.crwcd.org/page_5). [7/6/07]

## Stream Simulation

---

- Thorne, C. R. 1990. Effects of vegetation on riverbank erosion and stability. In: Thornes, J. B. ed. *Vegetation and Erosion*. New York: Wiley and Sons. 125-144.
- Thorne, C. R. 1997. Channel types and morphological classification, in Thorne, C. R.; Hey, R. D.; Newson, M. D. eds. *Applied Fluvial Geomorphology for River Engineering and Management*. Chichester, U.K.: Wiley and Sons. 175-222.
- Thorne, C. R.; Allen, R. G.; Simon, A. 1996. Geomorphological river channel reconnaissance for river analysis, engineering and management. *Transactions of the Institute of British Geographers* 21. 469-483.
- Thurrow, R. F.; Lee, D. C.; Rieman, B. E. 1997. Distribution and status of seven native salmonids in the interior Columbia River basin and portions of the Klamath River and Great Basins. *North American Journal of Fisheries Management*. 17, 1,094-1,110.
- Tinkler, K. J.; Wohl, E. E. 1998. A primer on bedrock channels. In Tinkler, K. J.; Wohl, E. E. eds. *Rivers over Rock: Fluvial Processes in Bedrock Channels*. American Geophysical Union Geophysical Monograph 107. 1-18.
- Tobiason, S.; Jenkins, D.; Molash, E.; Rush, S. 2000. Polymer use and testing for erosion and sediment control on construction sites: Recent experience in the Pacific Northwest. In: *Proceedings Conference 31, 21-25 February 2000*. International Erosion Control Association, Steamboat Springs, CO.
- U** U. S. Army Corps of Engineers. 1994. *Engineering and Design - Hydraulic Design of Flood Control Channels*. EM-1110-2-1601.  
<http://www.usace.army.mil/publications/eng-manuals/em1110-2-1601> accessed 1/20/06
- U. S. Army Corps of Engineers. 1999. *Ice Engineering*. EM-1110-2-1612.
- U. S. Army Corps of Engineers. 2006. *Control and topographic surveying*. EM-1110-1-1005. Final draft at <http://crunch.tec.army.mil/Information/Publications/em1110-1-1005draft/toc.htm>. accessed 3/5/2007.
- U.S. Department of Agriculture, Forest Service. 1996. *Managing roads for wet meadow ecosystem recovery*. FHWA-FLP-96-016. U.S. Department of Agriculture, Forest Service, Southwestern Region.

## References

---

- U.S. Department of Agriculture, Forest Service. 2003. Identifying bankfull stages in the eastern and western United States. DVD. Fort Collins, CO: U.S. Department of Agriculture, Forest Service, Rocky Mountain Research Station, Stream Systems Technology Center.
- U.S. Department of Agriculture, Forest Service. 2005. Guide to identification of bankfull stage in the northeastern United States. 4 CDs. Gen. Tech. Rep. RMRS-133-CD. Fort Collins, CO: U.S. Department of Agriculture, Forest Service, Rocky Mountain Research Station, Stream Systems Technology Center.
- U.S. Department of Agriculture, Natural Resources Conservation Service. 2001. Design of rock weirs. Engineering Technical Note 13. Boise, ID: U.S. Department of Agriculture, Natural Resources Conservation Service.
- V** Vaughan, M. D. 2002. Potential impact of road-stream crossings (culverts) on the upstream passage of aquatic macroinvertebrates. Report prepared for the USDA Forest Service. [Online]. Available at: [http://www.xerces.org/pubs\\_merch/](http://www.xerces.org/pubs_merch/) [30 July 2007].
- W** Wilson, W. E.; Moore, J. E. eds. 1998. Glossary of hydrology. Alexandria, VA: American Geological Institute. 248 p.
- Washington Department of Fish and Wildlife. 2003. Integrated streambank protection guidelines. Washington State Aquatic Habitat Guidelines Program. <http://wdfw.wa.gov/hab/ahg/ispdoc.htm>
- Whitaker, J. G.; Jaeggi, M. N. R. 1982. Sediment availability and the predication of storm-period sediment yields. In: Walling, D. E. ed. Recent Developments in the Explanation and Prediction of Erosion and Sediment Yield. International Association of Hydrological Sciences Publication 133. 177-194.
- Whitaker, J. G. 1987. Sediment transport in step-pool streams. In Thorne, C. R.; Bathurst, J. C.; Hey, R. D. eds. Sediment transport in gravel-bed rivers. Chichester, U.K.: Wiley and Sons. 545-570.
- Wiberg, P. L.; Smith, J. D. 1987. Calculations of the critical shear stress for motion of uniform and heterogeneous sediments. Water Resources Research. 23(8): 1,471-1,480.
- Wiley, J. B.; Atkins, J. T., Jr.; Tasker, G. D. 2000. Estimating magnitude and frequency of peak discharges for rural, unregulated streams in West Virginia. U.S. Geological Survey Water Resources Investigations Report 00-4080. 93 p.

## **Stream Simulation**

---

- Williams, G. P. 1978. Bankfull discharge of rivers. *Water Resources Research* 14, 1,141-1,158.
- Williamson, D. 1989. Geotechnical field methods. *Engineering Field Notes*. Washington DC: U.S. Department of Agriculture, Forest Service, Engineering.
- Wipfli, J. S.; Hudson, J. P.; Chaloner, D. T.; Caouette, J. P. 1999. Influence of salmon spawner densities on stream productivity in Southeast Alaska. *Canadian Journal of Fisheries and Aquatic Science*. 56, 1,600-1,611.
- Wipfli, J. S.; Richardson, J. S.; Naiman, R. J. 2007. Ecological linkages between headwaters and downstream ecosystems: transport of organic matter, invertebrates, and wood down headwater channels. *Journal of the American Water Resources Association*. 43(1): 72-85.
- Wipfli, M. S.; Gregovich, D. P. 2002. Export of invertebrates and detritus from fishless headwater streams in southeastern Alaska: implications for downstream salmonid production. *Freshwater Biology*. 47, 957-969.
- Wissmar, R. C.; Smith, J. E.; McIntosh, B. A.; Li, H. W.; Reeves, G. H.; Sedell, J. R. 1994. A history of resource use and disturbance in riverine basins of Eastern Oregon and Washington. *Northwest Science*. 68 Special Issue.
- Wohl, E. E.; Cenderelli, D. A. 2000. Sediment deposition and transport patterns following a reservoir sediment release. *Water Resources Research*. 36, 319-333.
- Wohl, E. E. 2000. *Mountain Rivers: Washington, D.C.*: American Geophysical Union. *Water Resources Monograph*. 14, 320.
- Wolman, M. G. 1954. A method of sampling coarse river-bed gravel. *Transactions of American Geophysical Union*. 35, 951-56.
- Wolman, M. G.; Miller, J. P. 1960. Magnitude and frequency of forces in geomorphic processes. *Journal of Geology*. 68, 54-74.





# Stream Simulation

---

## Appendix A—Geomorphic Principles Applied in Stream Simulation

---

This appendix very briefly reviews fluvial processes (i.e., processes pertaining to river or stream action) and channel characteristics that project teams consider when evaluating site conditions at road-stream crossings and designing stream-simulation structures. Chapters 4, 5, and 6 describe how teams apply these concepts in stream-simulation site assessment and design.

Training and experience in geomorphology are essential for assessing channel conditions, interpreting channel responses and fluvial processes, and designing a simulated streambed. Most hydrologists, **geomorphologists**, geotechnical engineers, and hydraulic engineers already will be familiar with many of the concepts we are presenting here. If you are a reader for whom the material is new, the information in this appendix is not adequate for developing journey-level geomorphology skills. You may want to review the references cited here and attend training courses to expand your knowledge. Project team members are responsible for recognizing when additional expertise must be brought in—especially when channel conditions are complex and difficult to interpret (see sidebar in section 3.3).

### A.1 WHY CONSIDER FLUVIAL PROCESSES IN CROSSING DESIGN?

Streams are dynamic systems that can readily change in response to human or natural disturbances. Streams continually erode sediment and wood from their boundaries and redeposit that material at other locations in the channel. Many streams also shift location laterally across the valley bottom. Streambed elevations change as the stream transports, deposits, and stores **woody debris** and sediment. During floods, streams overflow the flood-plain surface, eroding and depositing sediment and debris, and constructing riparian habitats.

Road-stream crossings are rigid structures that lock the stream in place and elevation, preventing these normal dynamic processes. In the past, crossings have typically been narrower than the stream, causing backwatering and sediment deposition at the inlet [figure A.1(a)]. Narrow culverts also increase water velocity causing channel scour in or downstream of the crossing [figure A.1(b)].

## Stream Simulation

---

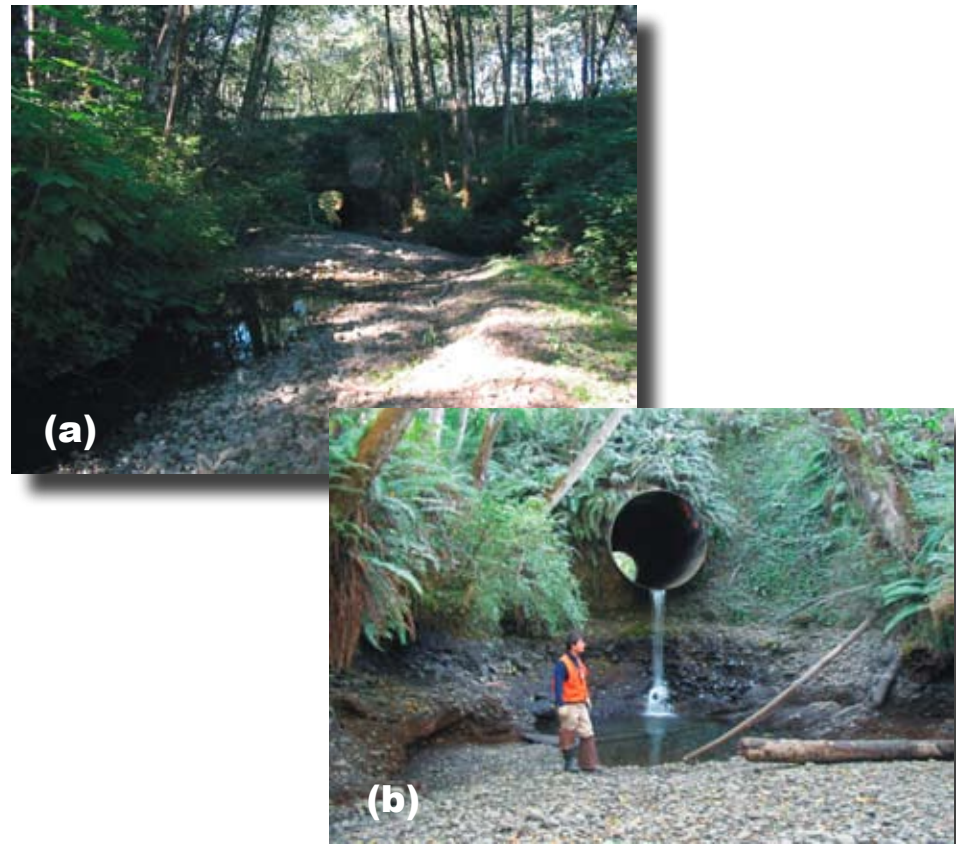

*Figure A.1—(a) Aggraded (filled) channel upstream of narrow culvert; (b) incised (scoured) channel downstream of culvert, Save Creek, Olympic National Forest, Washington.*

As chapter 1 explains, such channel responses to culverts can ultimately inhibit or prevent aquatic species passage. These responses also can cause massive problems—both for the road and the stream—during large floods. Plugging with **debris** and sediment is common at culverts. Fill failure or stream diversion can follow, as the water overtops the road or runs along the road until it pours off onto a hillslope or into another drainage (figure 1.17). Scouring at narrow bridges or open-bottom arches can also cause these structures to fail.

Stream-simulation design provides for both aquatic species passage and long-term stability of the structure and the constructed streambed. Within the limits of a necessarily rigid structure, stream simulation aims to provide enough space for the stream channel to adjust to changing flows and **sediment loads**, just as the natural channel does. To achieve this objective, the project team must understand how fluvial processes

## Appendix A—Geomorphic Principles Applied in Stream Simulation

---

shape the current channel at a site. The team must be able to predict future channel responses to changes in watershed and climatic conditions, and they must also be able to predict how the channel will respond to the new crossing structure.

### A.2 THE WATERSHED CONTEXT

The site's location in the watershed is important. Depending in part on their position in the watershed, channel **reaches** (stream segments with relatively homogenous characteristics) can be divided into three general types (Montgomery and Buffington 1993, 1997):

- (1) Source reaches are headwater channels with few if any fluvial characteristics. Hill-slope processes such as surface erosion and soil creep deliver sediment to these channels, which store it until large flow events or debris flows scour it out.
- (2) Transport reaches are typically steep streams that tend to resist erosion, because they have persistent bed and bank structures dominated by large particle sizes (boulders, cobbles, gravels, and wood). Although these reaches store some sediment (e.g., behind pieces of woody debris), in general they have high transport capacities. When sediment supply increases, they tend to pass the increase quickly to lower-gradient reaches. Channel morphology does not change very much in response to changes in water or sediment inputs.
- (3) Response reaches are lower-gradient reaches where sediment transport is limited by relatively low transport capacity. That is, when sediment supply from upstream increases, it is likely to deposit in a response reach. The reach will often respond to changes in sediment supply or discharge by making large adjustments in channel size, shape, slope, or pattern. As Montgomery and Buffington (1993) point out, the first response reach downstream of a series of transport reach is likely to be an extremely sensitive site when water or **sediment regimes** change in the upstream watershed.

This appendix refers to these reach types throughout. They are helpful as shorthand descriptors of likely channel responsiveness to environmental change. Understanding the differences between streams in their responsiveness to environmental changes is very important in stream-simulation design.

## Stream Simulation

While some watersheds have a more or less regular sequence of source, transport, and response reaches from headwaters to mouth (figure A.2), reach types are often distributed in a more complex way. Local geologic controls can create meandering mountain meadow streams (response reaches) near the headwaters, and very steep transport reaches may be near the downstream end of tributaries on river breaks.

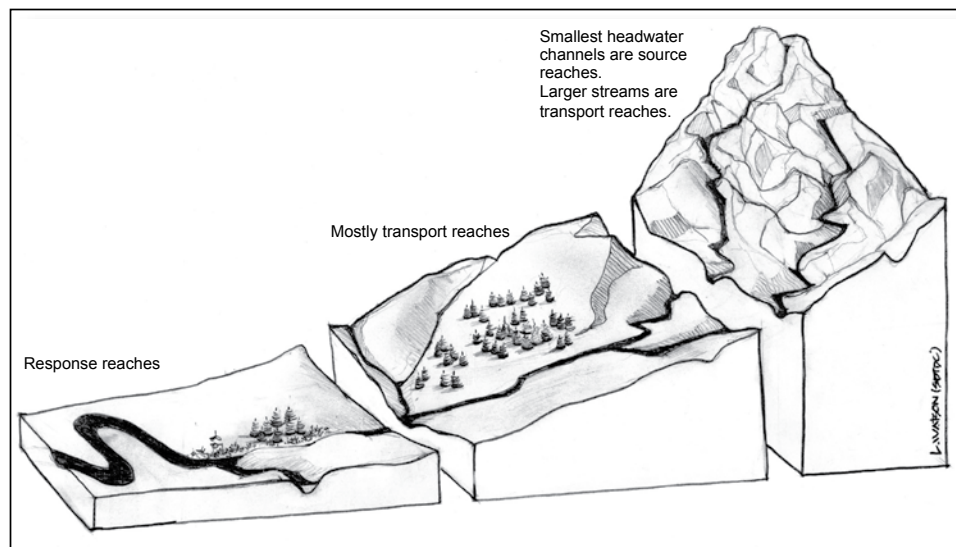

Figure A.2—Idealized distribution of reach types in a watershed. Drawn by L'Tanga Watson.

As integral parts of the watershed ecosystem, streams reflect the effects of climate, geology, soils, vegetation, basin shape, and land use in the watershed. These factors control water and sediment inputs to the stream. In turn, water and sediment, interacting with **riparian vegetation** and channel boundary materials, control fluvial processes and determine channel characteristics.

Much can happen to change these controlling factors over the lifetime of a crossing structure. Land use is changing rapidly in many areas, particularly near national forest boundaries where people can build homes and interface directly with “nature.” Road building is continuing in some locations, and roads are being improved for recreation access. Off-road vehicle use can affect the hydrologic system, as can grazing and fire. In many locations, streams are experiencing or recovering from large-scale mining, logging, and removing of woody debris. All these changes can have large individual and cumulative effects on the hydrologic regime. Even a single unusual flood can create large, long-lasting changes in a stream system, requiring decades for recovery.

## Appendix A—Geomorphic Principles Applied in Stream Simulation

---

Obviously, what happens upstream in a watershed affects downstream channel reaches. However, downstream-land use or river changes also can affect upstream areas if they induce **channel incision** (i.e., downcutting). For example, **channelization** for urban or agricultural development speeds up water flow, increases its erosive power and causes channels to incise. Removal of woody debris from a channel, e.g., to reduce the risk of flooding can have the same effect. Gravel-mining operations that dig in-channel pits can lower the **base level** for all upstream reaches. These actions often produce **headcutting**, in which an oversteepened **nickpoint** migrates upstream (figure A.3), causing the bed to incise until it equilibrates at a lower, less erodible slope. Many existing culverts are functioning as **grade controls**, protecting upstream reaches from channel incision caused by migrating headcuts.

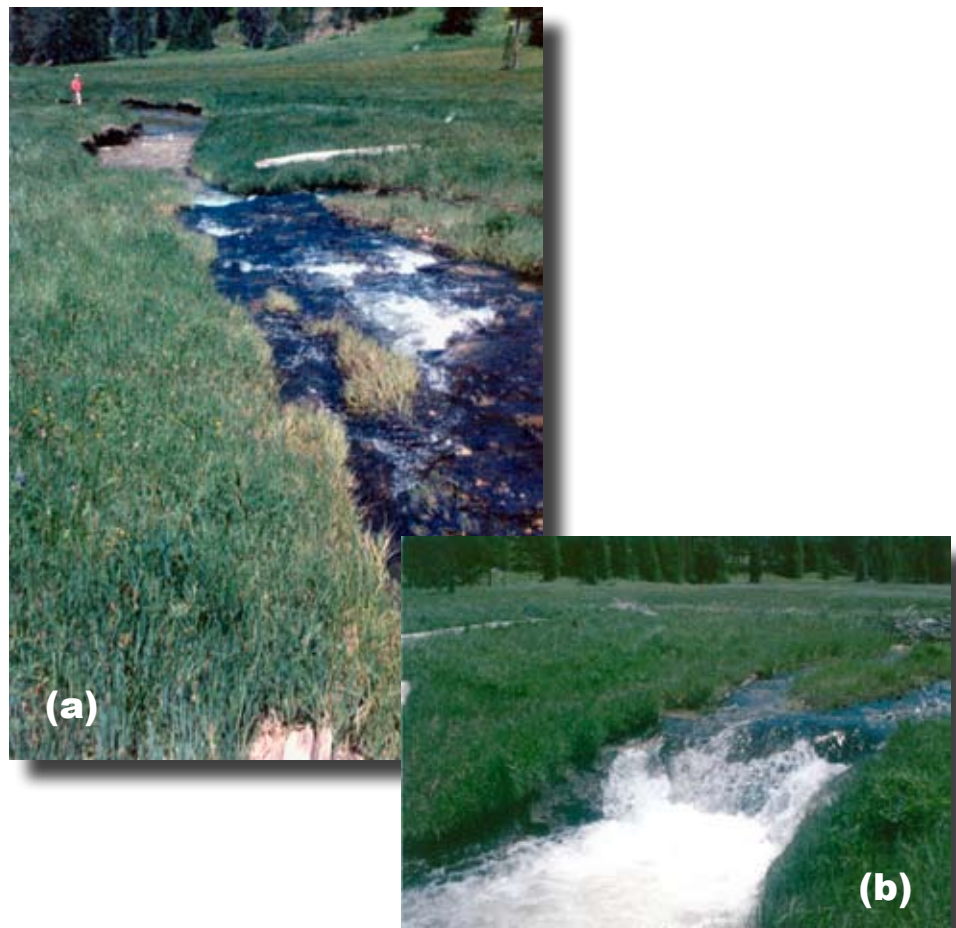

*Figure A.3—Active nickpoint migrating upstream, Meadow Creek, Nez Perce National Forest, Idaho. (a) Looking downstream across nickpoint; (b) looking upstream at nickpoint. Bright streambed indicates recently mobilized material.*

## Stream Simulation

---

Cause and effect can be difficult to determine, not only because unseen offsite changes may be affecting a site but also because a significant lag time may exist between cause and effect. For example, headcuts related to channel straightening in the 1960s were still actively migrating upstream in northern Mississippi in the 1980s (Harvey et al. 1983). There can also be cascading effects. If bank vegetation is removed (e.g., by agriculture, logging, grazing, or construction) from a particularly sensitive reach, the channel may respond dramatically. Bank erosion could cause the affected reach to widen significantly, releasing large volumes of sediment. That sediment may be deposited in a downstream reach, potentially destabilizing streambanks there.

Existing channel conditions may depend on factors or events far removed spatially and temporally from the site. To understand the past and predict future channel responses, analyze the temporal sequence and spatial distribution of watershed activities. This information is critical to making informed and accurate interpretations of channel conditions at the road-stream crossing. This analysis is part of phase 1 of a stream-simulation project—the initial watershed review (see chapter 4).

### A.3 CHANNEL CHARACTERISTICS

#### A.3.1 Streambed Material

A channel reach can be described as bedrock, colluvial, or alluvial according to the composition of its bed and banks (Montgomery and Buffington 1997; Knighton 1998). Bedrock channels have considerable segments of resistant bedrock (in excess of 50 percent) exposed along the **flow boundary** or the bedrock may be overlaid by a thin veneer of **alluvium**, i.e., material transported by the stream (Tinkler and Wohl 1998) (figure A.4). Bedrock channels tend to be quite stable. Many are situated in narrow valleys and lack flood plains. The lack of sediment in bedrock channels indicates that sediment is efficiently transported through the reach (Montgomery and Buffington 1997). Even in these transport reaches, however, there are usually localized, transient sediment accumulations behind woody debris or other channel features, and these accumulations may form very important habitats for aquatic species (McBain and Trush 2004).

Channels composed of material deposited by gravity-driven processes such as creep, surface erosion, debris flows, landslides, and rockfalls are referred to as colluvial channels (a type of source reach, figure A.2). Typically, they are located in the steep headwater areas of the watershed,



## Appendix A—Geomorphic Principles Applied in Stream Simulation

---

where **mass wasting** is the dominant geomorphic process (Montgomery and Buffington 1993, 1997). Colluvial channels are composed of angular boulders, cobbles, gravels, and sands. Normal (shallow) streamflow is insufficient for mobilizing most of the material; intermittent debris flows are the primary process for mobilizing and delivering the coarse colluvial material downstream (Montgomery and Buffington 1997).



*Figure A.4—Bedrock channels are transport reaches.*

Alluvial channels are composed of alluvium; that is, their bank and bed materials were transported and deposited by the stream. They are able to adjust their form by eroding and depositing sediment in response to changes in flow and sediment transport conditions. The frequency and degree of **channel adjustment** is strongly related to particle size; channels composed of gravel and small cobbles (figure A.5) are more responsive to flow and sediment supply changes, whereas channels composed of large cobbles and boulders are relatively stable at most flows and may only

## Stream Simulation

---

change form during infrequent, exceptional floods with large sediment inputs. Sand-bed channels are highly responsive, and their beds are usually continuously in motion at most flows.



Figure A.5—Alluvial response reach.

Channels in **cohesive materials** (with significant clay content) may or may not be alluvial. Many are incised into **residual soils**. Although their characteristics vary greatly depending on slope, in general they do not transport very much bed load. Most sediment is transported in suspension.

In channels composed of gravels, cobbles, and boulders, bed material is often segregated into two layers (figure A.6). The bed surface consists of a one- or two-grain-thick layer of coarser particles overlying smaller gravels or sands beneath the surface. This overlying coarse layer is referred to as the armor layer. The median particle size of the armor layer is usually 1.5- to 3.0-times coarser than the median particle size of the subarmor layer (Reid et al. 1998; Bunte and Abt 2001), although ratios as high as 6 and 7 have been reported (e.g., Andrews and Parker 1987; King et al. 2004; Barry et al. 2004). The presence of an armor layer indicates that the channel can transport more sediment than is available from upstream areas, whereas the lack of an armor layer indicates a balance between sediment supply and transport capacity (Montgomery and Buffington 1997). The armor layer increases the streambed's resistance to erosion. Once the armor breaches, however, the whole streambed can mobilize, and general scour occurs. In general, **unarmored streambeds** are more mobile than armored ones; that is, bed sediment moves at lower flows and more frequently in an unarmored streambed than it would in an armored one.

## Appendix A—Geomorphic Principles Applied in Stream Simulation

*Note: The particle size terminology we use in this document is from the Wentworth classification system, in which particle diameter doubles for each successive category (table A.1).*

Table A.1—Definitions of particle size categories used in this guide: Wentworth classification system

Particle Description	mm	inches
Bedrock	>2,048	80
Large – very large boulders	1,024 – 2,048	40 – 80
Medium boulders	512 – 1,024	20 – 40
Small boulders	256 – 512	10 – 20
Large cobbles	128 – 256	5 – 10
Small cobbles	64 – 128	2.5 – 5
Very coarse gravels	32 – 64	1.26 – 2.5
Coarse gravels	16 – 32	0.63 – 1.26
Medium gravels	8 – 16	0.31 – 0.63
Fine gravels	4 – 8	0.16 – 0.31
Very fine gravels	2 – 4	0.08 – 0.16
Very coarse sands	1.0 – 2.0	0.04 – 0.08
Coarse sands	0.50 – 1.0	0.02 – 0.04
Medium sands	0.25 – 0.50	0.01 – 0.02
Fine sands	0.125 – 0.25	0.005 – 0.01
Very fine sands	0.062 – 0.125	0.002 – 0.005
Silts/clays	< 0.062	< 0.002



Figure A.6—The armor layer can be seen on this eroded gravel bar, Flathead River, Montana.

### A.3.2 Channel Slope

Slope is an important variable determining the overall energy of the stream for transporting water and sediment. Slope is also one of the channel characteristics most frequently altered by crossing structures that are undersized or installed at slopes different from that of the natural channel.

As a general rule, channel slope decreases going downstream in the watershed from the headwaters to the lower sediment deposition zone (figure A.2). Locally, the channel slope may steepen or flatten because of factors such as bedrock, coarser material, tectonic activity, and base-level changes (Knighton 1998). The general decrease in channel slope across the watershed corresponds to an increase in flood-plain width, channel sinuosity (see A.3.3), and average flow depth; a decrease in bed material size; and a decrease in the interactions between valley slopes and the stream. Steep channels usually have coarser sediments, discontinuous narrow flood plains or no **flood plains**, narrow valley bottoms, and relatively straight **planforms** when compared to low-gradient channels.

A base-level control is any structure that fixes the lowest elevation to which a stream reach can downcut. Common examples of base-level controls are very stable debris jams or concrete weirs. For a tributary, the ultimate base level is the elevation of the master stream at a tributary junction. When a base-level control is removed or altered, upstream channel slope changes concomitantly. Base-level control is an important concept in stream simulation. If the base-level control changes over the life of the structure, the altered slope may destabilize the simulated streambed.

At the reach scale, channel slope can be measured as the slope of the channel bed or as the slope of the water surface. It also can be measured along the thalweg (representing low flow) or along the midpoint of the channel (representing high flow). In stream-simulation design, the channel bed along both the thalweg and the **bankfull** water surface slope can be important (see section 5.2.2.2 bankfull sidebar).

## Appendix A—Geomorphic Principles Applied in Stream Simulation

---

The **thalweg** is a line running along the channel bed (i.e., longitudinally), connecting the lowest points. In figure A.7, the thalweg meanders along the bottom of the otherwise straight channel. The thalweg in figure A.7 is longer than the channel as a whole, because the thalweg bends back and forth along the channel bottom. The thalweg's longer length makes its slope lower than the average channel slope. As the water surface rises in this channel during a high-flow event, flow straightens out and slope increases.



*Figure A.7—This straight reach of the San Pedro River, Arizona, has a meandering thalweg.*

## Stream Simulation

Local channel slopes vary, reflecting the presence of multiple **bedforms** such as steps, riffles, pools, and obstructions (figure A.8). At higher flows, water surface slope evens out somewhat because bedforms are submerged.

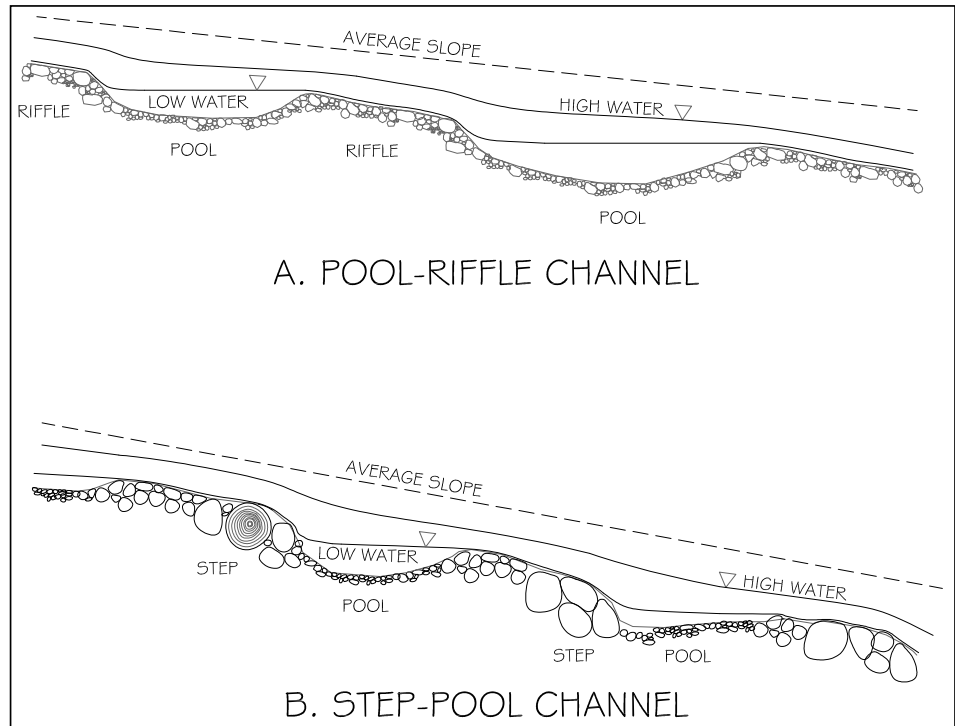

Figure A.8—Pool-riffle and step-pool channel profiles showing variable local slopes. From Knighton (1998). permission to use requested.

## Appendix A—Geomorphic Principles Applied in Stream Simulation

### A.3.3 Channel Pattern

Channel patterns—also referred to as planform characteristics—are usually classified as straight, meandering, braided, or anastomosing (figure A.9). Pattern is determined by factors like slope, confinement, sediment supply, channel and valley materials, and riparian vegetation (Knighton 1998).

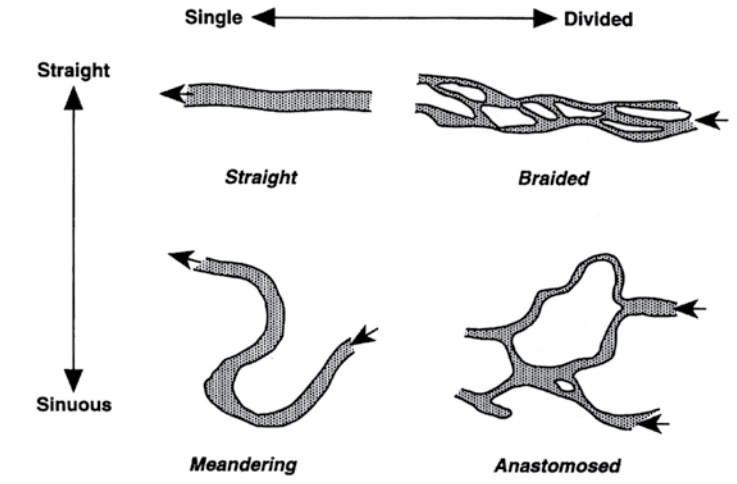

Figure A.9—Channel patterns. From Thorne et al. (1997), reproduced with permission from John Wiley and Sons, Ltd.

Straight alluvial channels are relatively rare in nature. Most streams tend to meander, unless they are tightly confined in a narrow valley or gully. Channel sinuosity—the ratio of stream length to valley length—describes the degree of meandering (see figure A.10). Meandering streams are inherently more dynamic, and their tendency to shift location across the valley bottom increases with sinuosity, bed load, and slope. The more erodible the banks, the more changeable the stream.

Meander wavelength ( $L$ ), amplitude ( $A$ ), and **radius of curvature** ( $R_c$ ) describe the geometry of individual meanders (figure A.11). The radius of curvature is of particular interest in stream-simulation design, because it affects the distribution of water velocities across the channel. At a bend, water velocity is higher near the outside bank than near the inside bank. This cross-sectional difference in velocity causes erosion on the outer bank and deposition on the inside bank, often resulting in meander shift. At road-stream crossings, radius of curvature can affect the risk of alignment changes over the life of the crossing (see section 6.1.1).

# Stream Simulation

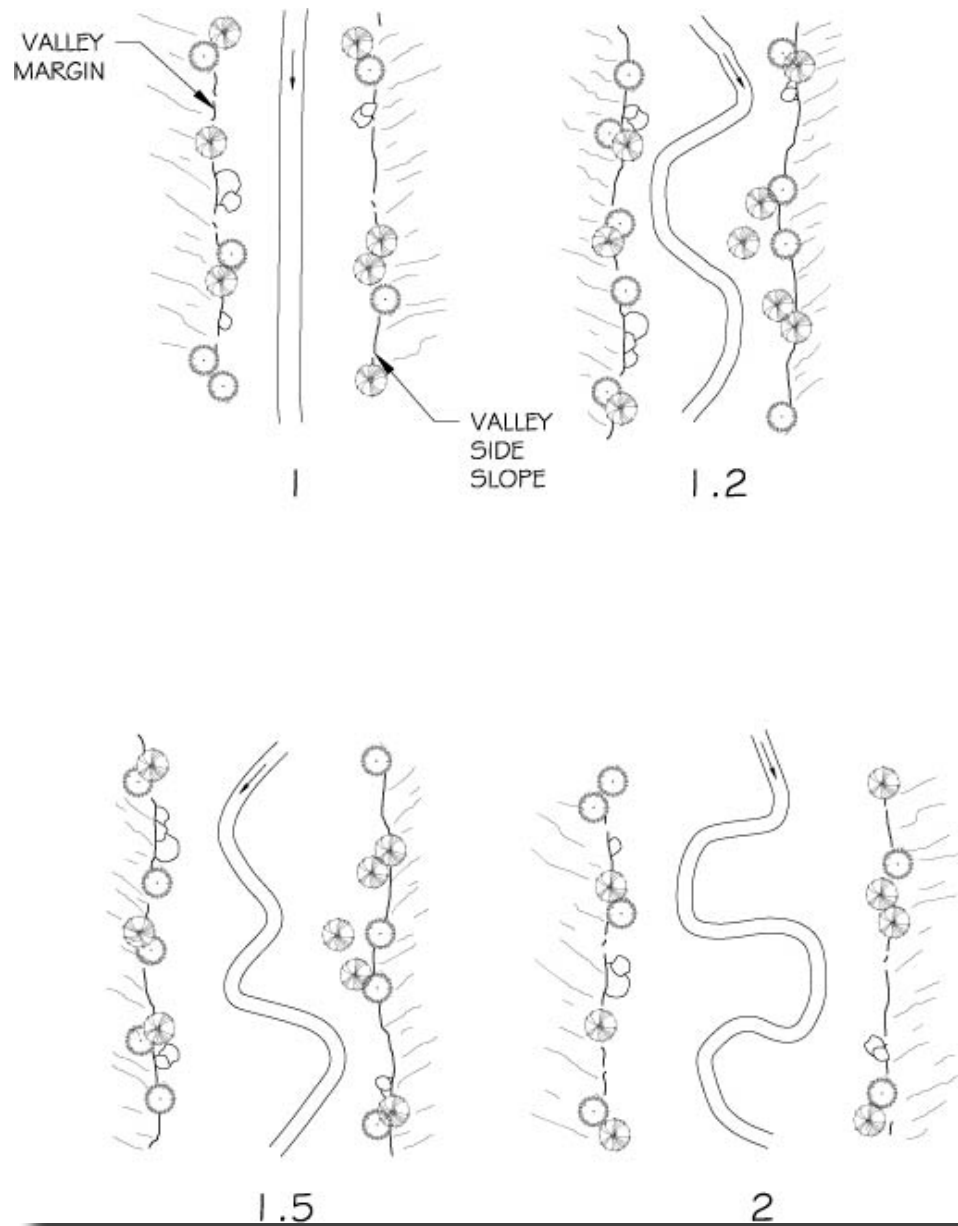

Figure A.10—Channel sinuosity is channel length divided by valley length.



## Appendix A—Geomorphic Principles Applied in Stream Simulation

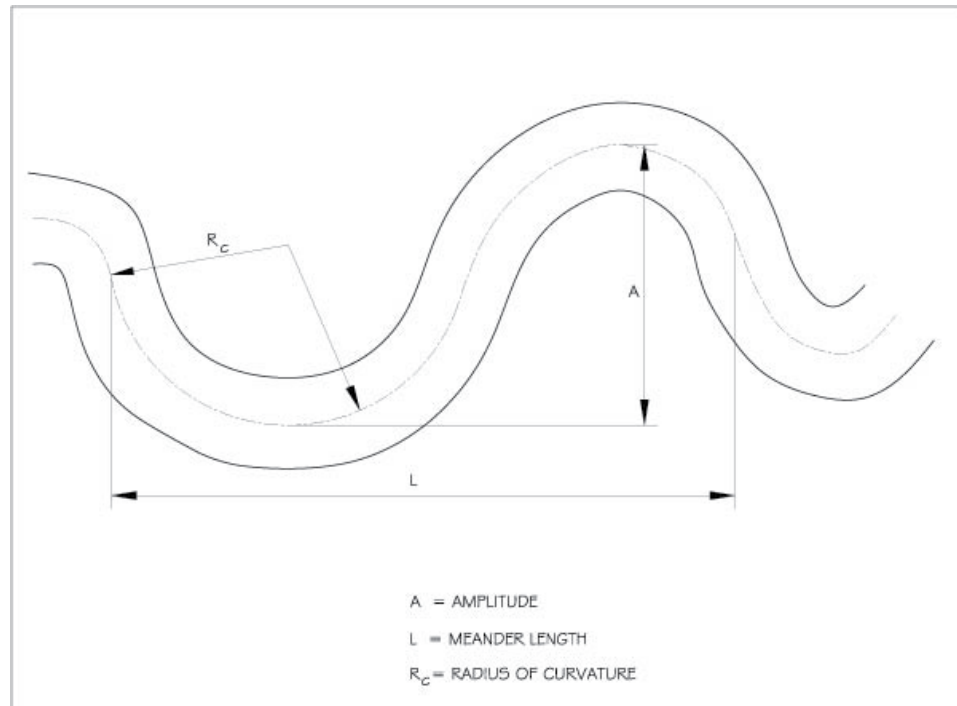

Figure A.11—Common meander geometry measurements.

Braided channels consist of multiple wide and shallow channels separated by poorly vegetated bar deposits. Individual channels and bars frequently shift position [figure A.12(b)]. A braided pattern indicates that sediment supply is high and that the channel bed and banks are readily eroded. Despite the fact that channels and bars continually shift, the size and slope of the channel within the limits of the braided area may remain the same. A braided channel like this is in **dynamic equilibrium** with existing geomorphic conditions (Knighton 1998).

Anastomosing channels are also multithreaded. However, the individual channels are separated by highly stable vegetated bars or islands [figure A.12(c)]. Anastomosing channels typically form in environments where the valley bottom is wide, flooding is highly variable, flood plains are frequently inundated, and banks are relatively resistant to erosion (Knighton 1998).

## Stream Simulation

---

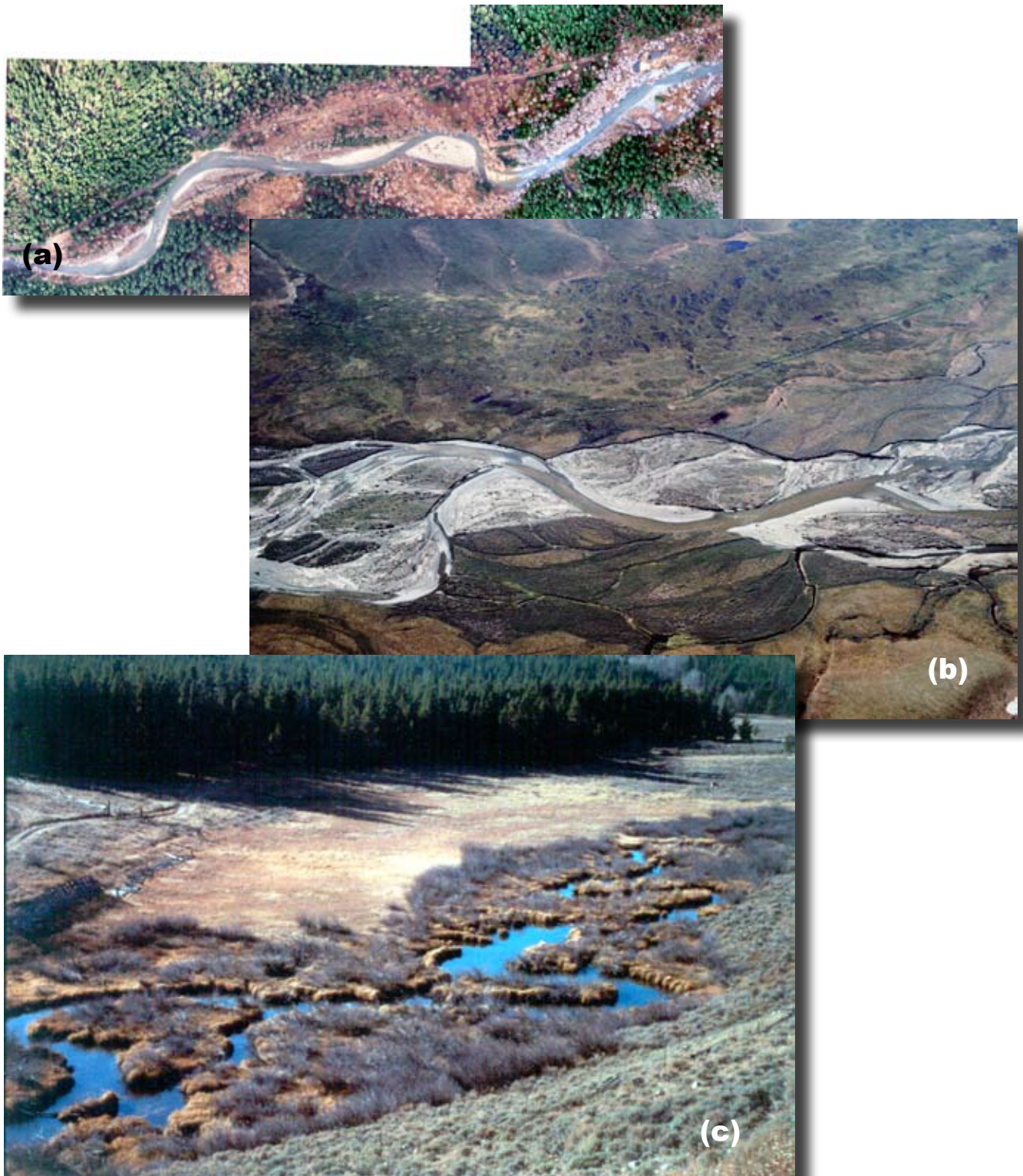

Figure A.12—Stream patterns (a) meandering reach on the Dosewallips River, Olympic National Forest, Washington; (b) braided river in the Arctic National Wildlife Refuge. (USFWS Alaska photo gallery); (c) anastomosing reach on Medicine Bow National Forest, Wyoming.

## Appendix A—Geomorphic Principles Applied in Stream Simulation

### A.3.4 Channel Dimensions, Confinement, and Entrenchment

Width-to-depth ratios are often used to characterize channel dimensions (usually bankfull channel dimensions—see section A.4.1). Low width-to-depth ratios indicate the channel is narrow and deep, whereas high width-to-depth ratios indicate that the channel is wide and shallow. Width-to-depth ratios, however, do not describe a cross-section's symmetry. Both symmetry and width-to-depth relations vary longitudinally along a given channel, and, in meandering channels, they are strongly influenced by the cross-section's location relative to bends. Cross sections located at channel bends typically have asymmetric shapes reflecting the pool and point bar (channel type C, figure A.13), whereas cross sections in straight channel segments have symmetrical, more rectangular shapes (channel type B, figure A.13).

Vegetation strongly influences channel shape. Banks densely vegetated with deep-rooted species have narrower and deeper channels than those with thinly vegetated, grassy banks (Hey and Thorne 1986). The cohesiveness of the bank material also influences channel shape. Channels with cohesive banks (silts and clays) have narrower and deeper channels than channels with **noncohesive** (sand, gravel) banks (Knighton 1998).

The term “channel entrenchment” describes the degree to which flow is vertically contained (figure A.13). That is, as discharge increases, flow in an entrenched stream is confined either by the valley walls or by steep, high streambanks. This guide uses Rosgen's (1994) definition of channel entrenchment: the ratio between flood-prone width and channel bankfull width. Flood-prone width is the width of the flood plain or valley bottom at an elevation two times the **maximum bankfull depth**. Generally, the flood-prone width is considered to correspond with floods having **recurrence intervals** of less than 50 years (Rosgen 1994).

Channels with entrenchment ratio values less than 1.4 are “entrenched,” indicating either that the valley bottom is narrow or that the adjacent valley surface is not frequently flooded (e.g., it is a terrace). Channels with entrenchment-ratio values greater than 2.2 are “slightly entrenched,” indicating that the flood-prone valley bottom surface is wide relative to the channel. Channels with entrenchment ratio values between 1.4 and 2.2 are considered moderately entrenched.

## Stream Simulation

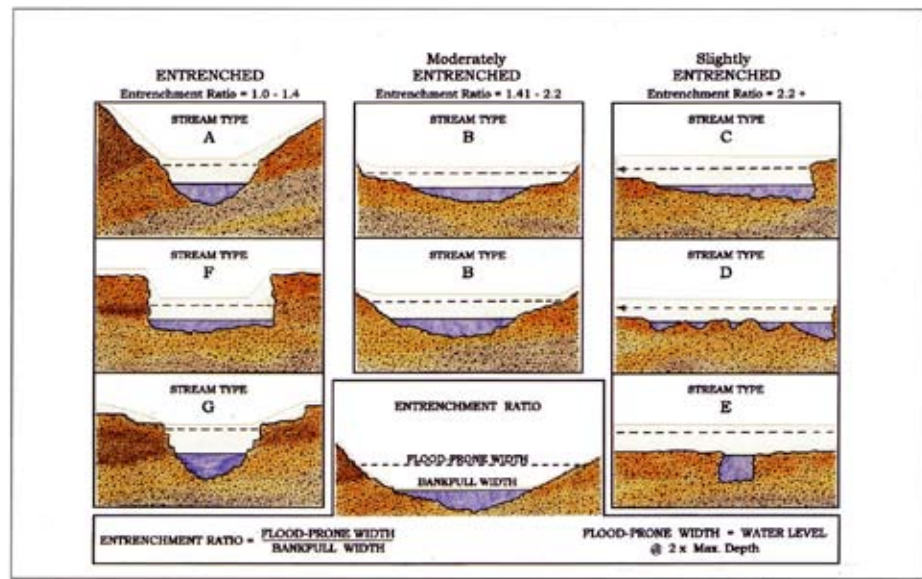

Figure A.13—Channel entrenchment (from Rosgen 1994).

In stream simulation we use the entrenchment ratio as an indicator of potential site risks associated with future alignment changes; that is, slightly entrenched channels tend to undergo alignment changes as they shift across the flood plain. Slightly entrenched channels also are more likely to have roadfills that obstruct flood plains. Flood-plain obstruction can cause problems for a crossing structure by concentrating flood flows through it.

### A.3.5 Channel Bedforms

Natural stream channels have a variety of **bed structures** known as bedforms, which reflect local variations in hydraulics, particle size, and sediment transport. In coarse-grained channels, structures such as **pebble clusters**, transverse ribs, and cobble-boulder steps cause complex flow patterns of convergence and divergence. These patterns in turn influence **bedload transport rates** and patterns (Brayshaw et al. 1983; Koster 1978; Whitaker and Jaeggi 1982). In sand-bed channels (figure A.14), the channel bed is easily mobilized into different bedforms (ripples, dunes, antidunes) that correspond to variations in flow intensity (Knighton 1998).

## Appendix A—Geomorphic Principles Applied in Stream Simulation

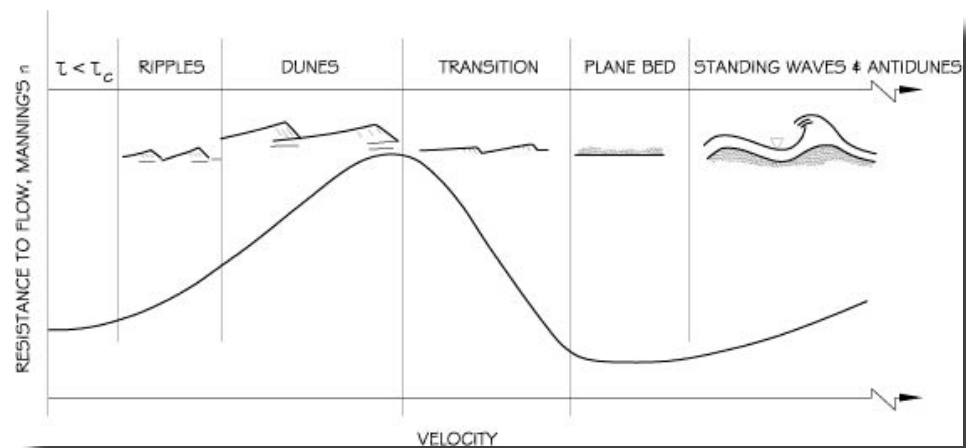

Figure A.14—Depending on flow intensity, bed structures such as ripples, dunes, and antidunes can form in sand bed channels, dramatically changing channel roughness. Redrawn after Simons, Li & Associates 1982.

In gravel-bed channels, the dominant form of bed topography tends to be alternating pools and riffles in low-gradient channels, and pools and steps in high-gradient channels. In pool-riffle channels, pools are scoured along the outer margins of channel bends and downstream from obstructions such as bedrock outcrops or large woody debris structures that locally constrict the channel. Pools and point bars are located at bends, and riffles are located in straight channel segments between successive meanders. At low flows, flow is deep and slow in pools, whereas flow in the adjacent, steeper riffles is shallow and fast (figure A.15). The average spacing between pools in a pool-riffle channel is generally between 5- to 7-channel widths, but spacing is variable along a given channel and can range from 1.5- to 23.3-channel widths (Keller and Melhorn 1978). The spacing of pool-riffle sequences can be influenced by large woody debris, large obstructions, or bedrock outcrops (Lisle 1986; Montgomery et al. 1995).



Figure A.15—A pool-riffle reach on the Flathead River, Montana.

## Stream Simulation

---

Step-pool sequences are common bedforms in high-gradient, coarse-bed alluvial channels. Steps are composed of cobbles, boulders, bedrock, and/or large woody debris that extend across the entire channel perpendicular or oblique to flow (figure A.16). Plunge pools form at the base of each step and often contain finer material. In step-pool channels, the spacing between steps ranges between 1- and 4-channel widths and is primarily a function of gradient, with less distance between steps as gradient increases (Whitaker 1987; Chin 1989; Montgomery and Buffington 1997). The height and length of steps are also a function of gradient, with step heights increasing and step lengths decreasing as gradient increases (Whitaker 1987; Grant et al. 1990).



*Figure A.16—Step-pool channel in northern Idaho.*

### A.3.6 Flow Resistance or Channel Roughness

Water velocity in a stream depends on channel resistance (**roughness**), as well as water depth and channel slope. A stream simulation mimics natural-channel roughness to keep velocities similar and to recreate the velocity diversity that allows for a wide variety of species to pass the crossing.

## Appendix A—Geomorphic Principles Applied in Stream Simulation

---

Total **flow resistance** is influenced by the combined interactions of channel-bed material, bedforms, water-surface and bed-surface slope variability, channel alignment, bank irregularities, and vegetation. Total flow resistance can be divided into the following three categories (Bathurst 1997; Knighton 1998):

- *Free-surface resistance* represents energy losses associated with surface waves and **hydraulic jumps** (e.g., flow plunging over a step).
- *Channel resistance* represents energy losses caused by water-surface and bed-surface slope variability (e.g., slope variability associated with pool-riffle and step-pool sequences), bank irregularities (e.g., bedrock outcrops, large woody debris complexes), and variability in channel alignment (e.g., channel bends).
- *Boundary resistance* represents energy losses caused by a number of factors, including grain roughness, form roughness, and vegetation roughness.

Channel resistance can be very significant in channels with many pieces of debris, rock outcrops or large boulders, and/or sharp bends. However, boundary resistance is the primary factor influencing total flow resistance of most channels (Limerinos 1970; Hey 1979; Bathurst 1985; Jarrett 1985). Boundary resistance includes the following components:

- Grain roughness represents energy losses caused by the size of the particles and the height to which they project into the flow: Larger particles have greater flow resistance than small particles.
- Form roughness represents energy losses caused by bedforms.
- Vegetation roughness represents energy losses associated with type and density of vegetation along channel banks. Taller, more rigid, and more densely packed stems increase vegetation resistance to flow and reduce shear stresses on bank and flood-plain surfaces (Arcement and Schneider 1989).

Boundary resistance varies with discharge, because the depth of water influences the degree to which the channel-bed sediments, bedforms, and bank vegetation interact with the flowing water. As water depth increases, the influence of grain and form roughness decreases while vegetation roughness increases, because more water is in contact with the bank vegetation. Boundary resistance on the flood plain, caused by microtopography, vegetation, etc., also controls the amount of water flowing over the flood plain (i.e., **flood-plain conveyance**).

## Stream Simulation

In gravel- and cobble-bed channels, grain roughness is the primary component of boundary resistance. In boulder-bed channels with step topography, the combination of individual particles (grain roughness) and steps (form roughness) determines boundary resistance. In sand-bed channels, form roughness is more important than grain roughness, because continual bedform changes (ripples, dunes, antidunes) cause variations in boundary resistance (figure A.14).

### A.4 CHANNEL STABILITY AND EQUILIBRIUM

Stable channels are channels that are not experiencing rapid, lasting change in dimensions or slope. While stable channels adjust to a wide range of flows and sediment inputs, their average dimensions remain the same over long periods (decades to centuries).

In the short term, a stable channel reach may adjust width, depth, and/or slope in response to a flow or sediment input event such as a flood or landslide. However, with time, channel dimensions return to the equilibrium state. On average, a stable reach is neither aggrading nor incising, neither widening nor narrowing, and the amount of sediment coming in is the same as the amount leaving it. Recognizing that such channels are stable but not static, we describe them as being in quasi-equilibrium (figure A.17).

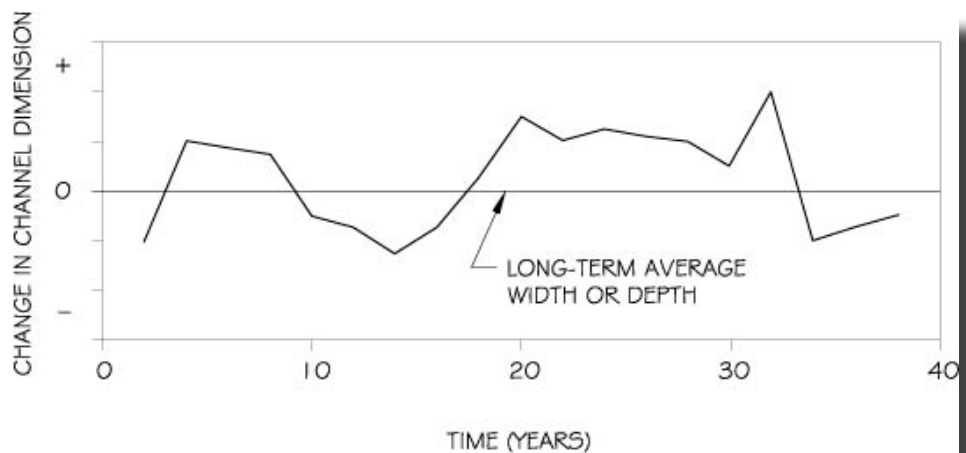

Figure A.17—In quasi-equilibrium channels, width and depth vary around long-term average values. After Schumm (1977).



## Appendix A—Geomorphic Principles Applied in Stream Simulation

---

For a channel to be in quasi-equilibrium, environmental conditions, such as the amount and timing of runoff and sediment input, also must be approximately constant (or changing very slowly) over the decade-to-century time scale. Base level also must remain the same. If these controls change enough to cross a “response threshold,” the destabilized channel can change dramatically and rapidly, going through a series of adjustments before reaching a new quasi-equilibrium state (Schumm 1977).

As we gain more understanding of climatic variability, and as human uses of land and rivers intensify, geomorphologists are increasingly skeptical about whether modern streams actually achieve quasi-equilibrium over “engineering time” (Macklin and Lewin 1997). El Niño and the North Atlantic Oscillation cause changes in rainfall regimes large enough to cause river adjustments (Lewin et al. 1988) on decade and longer time scales. In many forested environments, changing land management may be expected to progressively alter runoff and sediment-load regimes. Crossing designers should recognize the possibility that the conditions controlling stream morphology may not be stable over a structure’s lifetime. Watershed-scale investigations that deal with past, present, and future conditions, such as those outlined in chapter 4, are critical for providing the context needed for prudent design.

Most channels immediately adjacent to a narrow road-stream crossing structure adjust their form to establish a “new” quasi-equilibrium with the conditions imposed by the undersized structure (culvert). Typical responses include aggradation and channel widening immediately upstream from the culvert inlet, and channel widening and incision immediately downstream from the culvert outlet. These adjustments make the channel more efficient in transporting sediment and dissipating flow energy, and create a more stable channel form. However, these same adjustments may prevent aquatic organisms from migrating freely along the **stream corridor**. A stream-simulation structure will restore stream and ecological connectivity at the road-stream crossing. During and after construction of the stream-simulation structure, the channel will adjust its form to establish a new quasi-equilibrium.

## Stream Simulation

### A.4.1 Equilibrium and Bankfull Flow

Observable channel characteristics are the result of both a range of past discharges and the temporal sequence of floods. Nonetheless, a single discharge value is commonly used to represent the “**channel-forming flow**” (Knighton 1998). Bankfull discharge—the maximum discharge the channel can contain before water overtops its banks onto the flood plain—is generally taken to represent the channel-forming discharge in response channels and moderate-gradient transport channels. In many environments, bankfull is a peak that is equaled or exceeded frequently—about every 1½ to 2 years. Because this peak is frequent and because it usually transports a significant amount of sediment, it is generally found to transport more sediment cumulatively than any other flow over a long period of time (Hey 1997).

Since water and sediment inputs continually fluctuate, the channel continually adjusts. However, unless it is truly unstable, its dimensions will vary around equilibrium values that can often be consistently related to bankfull discharge (Emmett and Wolman 2000) (see figure A.18). Based on these relationships, bankfull discharge is often used as the reference discharge for designing channels (Hey 1997). We use bankfull in stream simulation for the same reason.

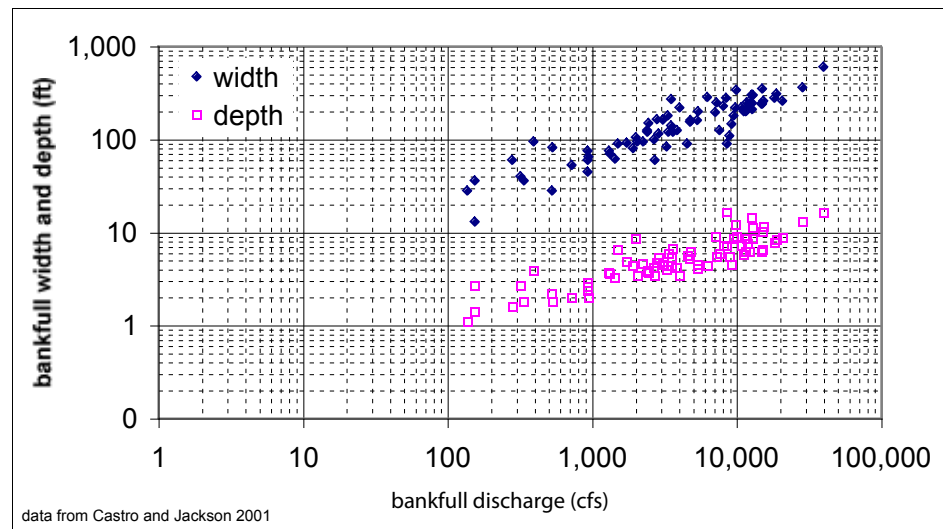

Figure A.18—Relationship of bankfull channel dimensions (determined in the field using geomorphic indicators) to bankfull discharge (determined from gauge records at observed bankfull elevation). Data from Castro and Jackson (2001).

## Appendix A—Geomorphic Principles Applied in Stream Simulation

---

Bankfull is not the channel-forming flow in all streams. In steep transport streams with large bed material, the flow that moves the large, structural bedforms can be much higher (i.e., less frequent) than in low-gradient alluvial channels. The channel-forming flow may be the 25-year flow or higher in a boulder-bed channel, depending on sediment inputs from the watershed (Montgomery and Buffington 1996; Grant et al. 1990).

### A.5 FLUVIAL PROCESSES

This section describes key processes that both are created and affected by channel morphologic characteristics such as pattern, channel shape, slope, and bed structure. Understanding these processes is central to designing a stream-simulation structure that can sustain itself in the changing stream environment over the long term.

#### A.5.1 Sediment Dynamics

The morphology of a channel reflects the interaction between hydrodynamic forces acting on the channel bed and the resisting forces of the materials that make up the channel bed. When the hydrodynamic (lift and drag) forces exceed the resisting forces (particle weight and friction), sediment is entrained (mobilized), transported, and later deposited, causing the channel to change its form or grain-size distribution.

Generally, sediment is entrained and transported as water rises and peaks in a runoff event, and it is deposited again as high flow recedes. Stability of a constructed streambed—like all streambeds—depends on the balance between entrainment and transport of bed material and resupply by deposition of material transported from upstream.

Entrainment of noncohesive sediments by flowing water depends on:

- Sediment properties: size, shape, density, **pivot angle**.
  - ▲ Larger, heavier particles require faster deeper flow to move. Angular rocks tend to lock together better than rounded rocks, and they resist rolling. Elongated rocks tend to ‘shingle’ or **imbricate** (overlap) along the direction of flow, and they can form very resistant bed surfaces.

## Stream Simulation

---

- Channel-bed composition: particle packing and orientation, **sorting**, distribution of bedforms, and degree of particle exposure to flow.
  - ▲ In poorly sorted channel beds, the stability of a particle is influenced by the particles adjacent to it (Andrews 1983; Wiberg and Smith 1987; Komar 1987) (figure E.1). Smaller particles are shielded behind larger particles in poorly sorted beds, and stronger flows are necessary for entraining them than in a well-sorted bed. Larger particles, in contrast, are entrained at weaker flows than in a well-sorted bed, because they project into the flow. Particles that project higher are more exposed to the force of the water, and this increased exposure enhances their entrainment despite their greater weight.
- Flow hydraulics: velocity, slope, water depth, and turbulence.

Shear stress is a measure of the hydrodynamic force exerted by flow on the channel bed and banks. Critical shear stress for a particle is the force that entrains it, that is, that initiates its motion by lifting it off or dragging it along the bed.

Water velocity and shear stress vary with local changes in channel slope controlled by such things as woody debris, rock weirs, steps, or gravel bars. These bed structures flatten local slope so that the upstream bed retains smaller particles than a bed of uniform slope. Even small embedded pieces of wood can control slope. In stream simulation, average slope is an important parameter, but the team must also pay attention to the bed structures that control slope and create both ‘sediment storage sites’ and diverse pathways for animal movement.

Understanding the relative mobility of different bed materials and structures is also critical. For example, sand-bed channels are highly mobile, and their beds are continuously in motion at most flows. In some gravel- and cobble-bed channels, the surface of coarse gravels and cobbles is relatively stable during frequent, moderate floods, although large quantities of sands and gravels move over the coarse surface layer (Jackson and Beschta 1982). Many gravel-bed streams are armored, and their tightly packed surface layers have been winnowed of finer materials. These intermediate-mobility streams may transport very little sediment until flow is able to breach the armor layer. Cobble- and boulder-bed channels are quite resistant to erosion, and these large rocks move only

## Appendix A—Geomorphic Principles Applied in Stream Simulation

during infrequent, exceptional floods (Montgomery and Buffington 1993; Knighton 1998). During frequent, moderate floods, however, large quantities of sand and gravel can be transported over and around the relatively immobile cobble and boulder structures.

### A.5.2 Vertical Channel Adjustment

As high flow entrains sediment, parts of the streambed may lower or rise by inches or even feet. Then, as flow recedes and **sediment transport capacity** drops, the scoured or filled sections may return to their pre-flood elevation (Andrews 1979). After the event, that scour and fill occurred may not be at all evident, because the streambed often equilibrates at the same elevation as before. Stream-simulation culverts need enough headroom and bed depth to permit these processes to occur. High flow scour and fill is less important in streambeds that are resistant to erosion (e.g., where bed material is large, well-packed, or imbricated).

Longer-lasting vertical changes occur when sediment or water regimes change, or when channels are straightened or cleared of debris. Channels aggrade (fill) when sediment supplied from upstream exceeds the local transport capacity, and they degrade or incise (cut) when the reverse is true. Aggradation is the vertical rise in the bed elevation, a rise resulting from sediment deposition, which can occur upstream of a backwater structure such as a beaver dam or an undersized culvert. Aggradation is a common risk at concave slope transitions (figure 5.12). It also can occur if flow is removed from a channel by diversion or if sediment loads increase as a result of land use changes.

Channel incision (or degradation) is a lowering of channel elevation that occurs when local erosion exceeds deposition of sediment transported from upstream. Following are some familiar locations where channel incision commonly occurs:

- Stream reaches below dams, which cut off the supply of sediment and alter the **flow regime**.
- Forest streams where wood that controlled grade has been removed.
- Watersheds where the frequency or magnitude of peak flows has increased due to land cover or climatic changes.

Channel incision can create a self-reinforcing feedback loop. As the channel deepens, larger and larger floods are contained within its banks. The stream bed experiences increasing shear stress, and continues to incise until it encounters erosion-resistant material.

## Stream Simulation

---

All these processes can severely affect simulated streambeds. Project teams should understand the direction and magnitude of probable vertical channel change over the lifetime of the planned structure, and they should design the structure to accommodate those changes.

### A.5.3 Lateral Channel Adjustment

Many styles of lateral channel adjustment exist, and some of them occur in response to vertical adjustments. Aggrading channels tend to widen because, as the channel fills, flows apply more erosive pressure to the banks (figure 4-3). On the other hand, sediment deposition also can result in channel narrowing if vegetation is able to colonize new bar deposits along the banks. Although incising channels are initially narrow, they tend to widen as their banks become taller and more prone to sloughing (figures 4.6 and A.28).

Another fluvial process important in stream-simulation design is lateral-channel migration. As described in chapter 1, lateral shifting can change the stream's alignment to a crossing, and affect the crossing's ability to pass water, sediment, and debris. A crossing located on a channel bend may need to be positioned asymmetrically over the channel to accommodate future channel shifting. If the bend is sharp or the rate of channel migration is high, alternative solutions such as a bridge spanning the zone of potential lateral migration may be necessary.

In narrow valleys where the valley walls are close to the channel, the potential for lateral-channel migration is limited. However, streams in wide alluvial valleys shift position laterally across the valley bottom, and the process may be either gradual or rapid. Low-gradient sand and gravel channels gradually shift by meander migration; during frequent, moderate floods, the stream erodes the outer banks of bends and builds the point bar on the inside bank. Sudden and pronounced lateral shifting can occur during infrequent, large-magnitude floods or when water scours around obstructions such as sediment or wood accumulations.

The rate of meander migration depends on:

- Bend geometry (tighter bends tend to migrate faster).
- The resistance of the outer bank to erosion (bank height, materials, vegetation, moisture, etc.).
- The magnitude and duration of the hydraulic forces acting on the bank (Knighton 1998).

## Appendix A—Geomorphic Principles Applied in Stream Simulation

Certain types of sinuous planform patterns indicate a systematic downstream, down-valley meander migration, while others indicate a process of periodic bend cut-offs (Thorne 1997; Knighton 1998) (figure A.19).

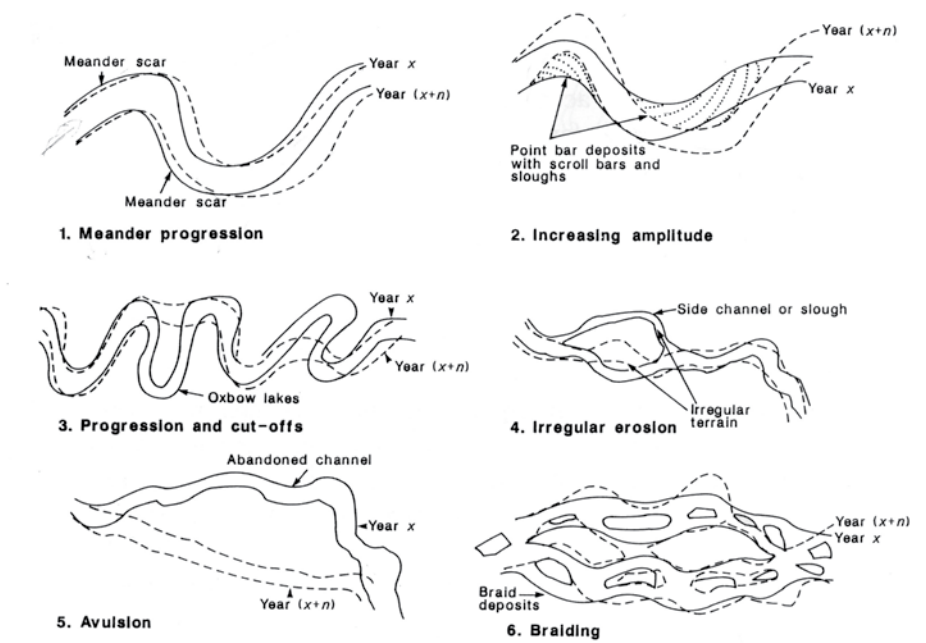

Figure A.19—Types of lateral-channel adjustment. From Thorne (1997).  
Reproduced with permission from John Wiley & Sons, Ltd.

Regardless of valley width, standing trees and large woody debris in and along the stream can substantially affect channel processes by increasing flow resistance, affecting bank erodibility, and providing obstructions to flow (Hickin 1984; Thorne 1990). Large woody debris deposited in and along channel/flood-plain margins can alter **channel patterns** by diverting flow around the obstruction or creating low-velocity zones where sediment and organic matter deposit (Fetherston et al. 1995; Abbe and Montgomery 1996). This deposition in turn provides fresh surfaces for the establishment of new vegetation. Depending on the vegetation type, rooting strength can stabilize those surfaces and influence the degree of later channel migration.

Bank vegetation has a strong influence on lateral adjustability. Deep-rooted native species often provide very strong bank reinforcement. If native species are replaced by shallower-rooted exotic plants, bank erosion can accelerate, causing the channel to widen or increasing the rate of meander migration.

## Stream Simulation

---

### A.5.4 Flood-plain Inundation and Dynamics

A flood plain is a valley surface being constructed as the current stream deposits sediment. It is a temporary sediment storage area along the valley bottom, composed of sediments deposited during overbank floods. In meandering, low-gradient channels with relatively large, well-developed flood plains, **lateral accretion** is the dominant flood-plain formation process. In other words, the flood-plain surface is formed as the stream builds point bars during meander migration (Nanson and Croke 1992). In steep channels with narrow, **discontinuous flood plains**, **vertical accretion** (sediment deposition on top of the flood plain) is the dominant flood-plain forming process, because coarse channel sediments inhibit channel lateral migration (Nanson and Croke 1992).

Flow occurs frequently over a true flood plain (whenever bankfull discharge is exceeded). Other, higher flat valley surfaces (terraces) are flooded at less frequent intervals. Terrace surfaces are not being constructed by the current stream, although it may be eroding them. Both low terraces and flood plains can have erosion and deposition features, and the “**flood-prone zone**” (figure A.13) may encompass both.

Flood plains are key elements affecting channel stability in many response reaches. The stream’s ability to overflow the flood plain limits channel erosion during high flows by limiting flow depth inside the main channel. During a flood, flow in the main channel is fast and deep, while flow over the flood-plain surface is slower and shallower. There is growing recognition that riparian forests play a significant role in the development of channel and flood-plain morphology. These forests stabilize flood plains during high flows and contribute large woody debris in and along channels that modifies flow hydraulics and sediment transport (e.g., Thorne 1990; Abbe and Montgomery 1996).

The density and type of vegetation on the flood plain influence the velocity and depth of flow over its surface, thereby influencing flood-plain conveyance, which is the water discharge (volume per unit time) across the flood plain or flood-prone zone. Flood-plain conveyance is a very important variable at a stream-simulation crossing, because during a flood the volume of flow on a high-conveyance flood plain may be so large that it requires special handling to avoid concentrating flow through the crossing.



## **Appendix A—Geomorphic Principles Applied in Stream Simulation**

---

### **A.6 CHANNEL CLASSIFICATION SYSTEMS**

To provide a framework for assessing channel conditions, interpreting fluvial processes, predicting channel responses, and making design recommendations, this guide uses the channel-type classifications that Montgomery and Buffington (1993, 1997) and Rosgen (1994, 1996) developed. Both classifications are useful in stream simulation for somewhat different purposes.

As the information in this appendix only summarizes these classifications briefly, we strongly encourage you to read the original papers.

#### **A.6.1 Montgomery and Buffington Channel Classification**

The Montgomery and Buffington channel-classification system is based primarily on streambed structure (bedforms). The classification, which applies to mountain streams, identifies six distinct alluvial channel types and two nonalluvial channel types (bedrock and colluvial, section A.3.1). The classification of the alluvial types is based on bed structure and the resulting channel roughness and energy dissipation characteristics. Montgomery and Buffington (1993, 1997) also distinguish “forced morphologies,” in which flow obstructions (such as wood) “force” a channel morphology that is different from what would exist if the obstructions were not present.

## Stream Simulation

Cascade channels (figure A.20) generally occur on steep slopes (i.e., about 10- to 30-percent slope), and are frequently confined by valley walls. Their beds are ‘disorganized,’ with cobbles and boulders scattered or clustered throughout. Small pools that do not span the entire channel width—and tumbling, turbulent flow over the individual rocks—characterize this type. The large particles that form the bed mobilize only during very large floods (50- to 100-year flows), and they may include hillslope-derived materials (e.g., colluvium from debris flows, rock falls) as well as fluvially placed sediments.

Step-pool reaches (figure A.21) have large rocks or pieces of wood that form channel-spanning steps, usually spaced at about one to four channel widths. Below each step is a pool containing finer sediment. Because energy is efficiently dissipated as flow falls into the pools, this bed structure is more stable than would be expected for a less organized streambed. The steps mobilize and reform during large floods, but finer sediment moves over the steps during moderate high flows. Typical average channel slopes range from 3- to 10-percent slope.

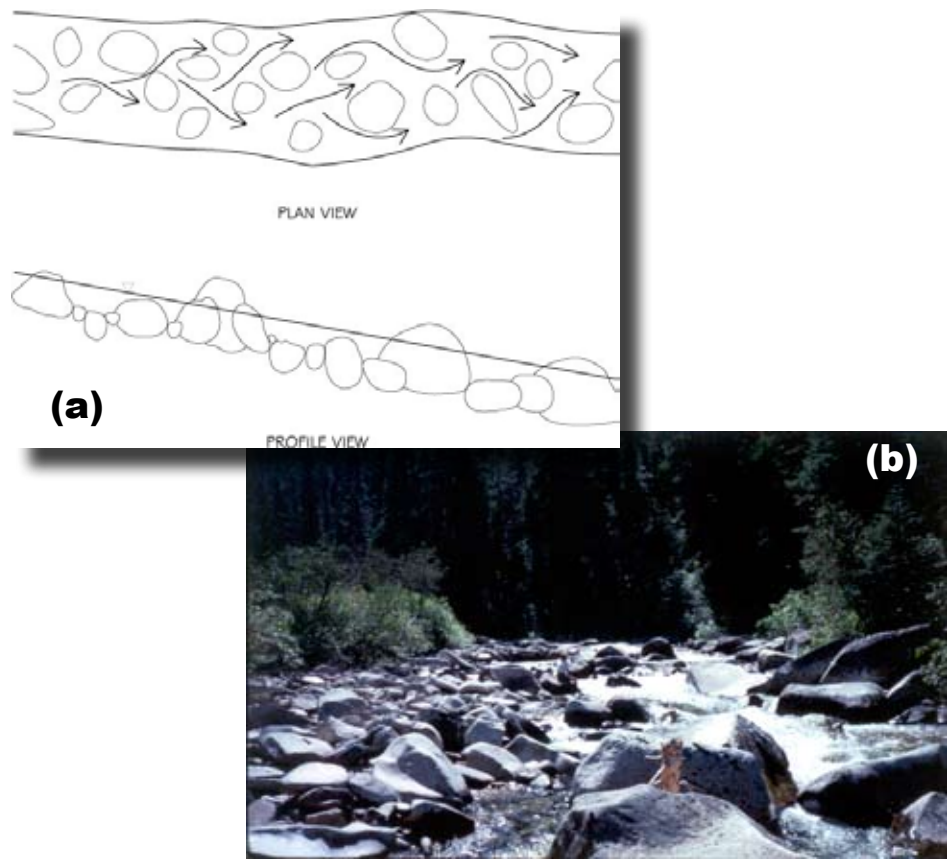

Figure A.20—Cascade reach: (a) schematic planview and profile, and (b) cascade reach on Selway River, Idaho.

## Appendix A—Geomorphic Principles Applied in Stream Simulation

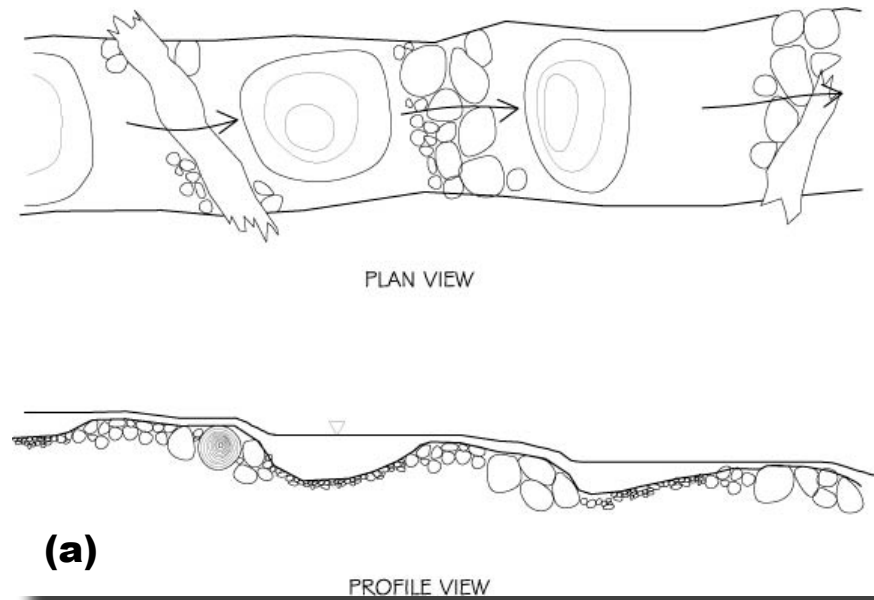

Figure A.21—Step-pool reach: (a) schematic planview and profile, (b) step-pool reach on Boulder Creek, Colorado, and (c) forced step-pool channel, Mitkof Island, Alaska.

## Stream Simulation

Plane-bed reaches (figure A.22) “have long stretches of relatively featureless bed” (Montgomery and Buffington 1993, 1997) without organized bedforms. They are on “moderate to high slopes in relatively straight channels,” usually with armored gravel-cobble beds. Bed mobilization occurs at flows near bankfull. In Rosgen’s system, a plane-bed reach might be either a B- or G-channel type, and could have bed material as fine as sand.

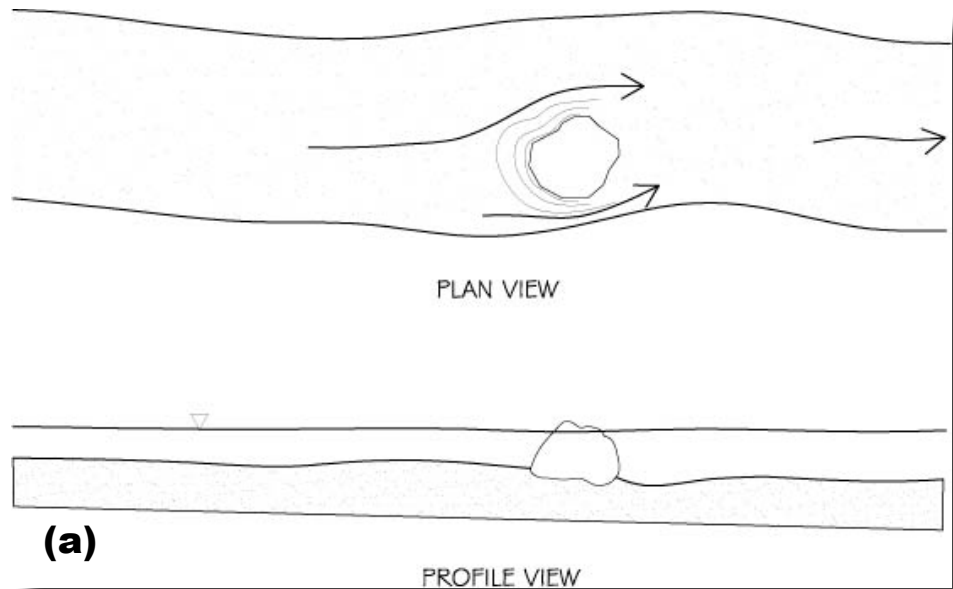

Figure A.22—Plane-bed reach: (a) schematic planview and profile, and (b) plane-bed reach on the Sitkum River, Washington.

Pool-riffle reaches (figure A.23) have longitudinally undulating beds, with a repeating sequence of bars, pools, and riffles regularly spaced at about 5- to 7-channel widths apart. Large woody debris can alter the spacing. These

## Appendix A—Geomorphic Principles Applied in Stream Simulation

channels, which usually have flood plains, may be sand- to cobble-bedded streams. Depending on their degree of armoring, bed mobilization may occur at or below bankfull. These may be Rosgen C, E, or F streams (see section A.6.2 for Rosgen classifications).

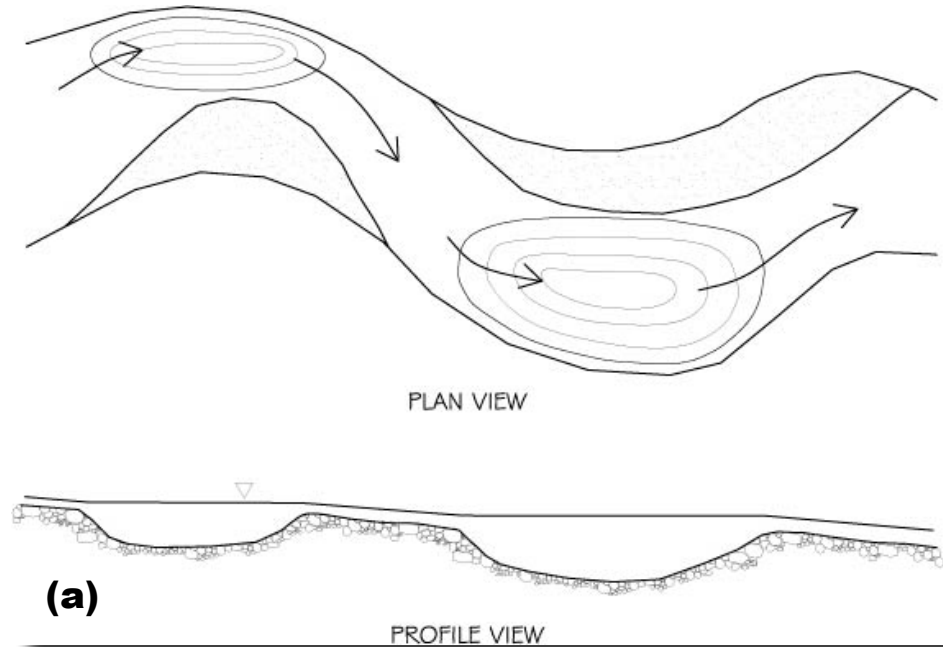

Figure A.23—Pool-riffle reach: (a) schematic planview and profile, (b) pool-riffle reach on Libby Creek, Washington.

## Stream Simulation

Dune-ripple reaches (figure A.24) have low gradients with sand and fine-gravel beds. These streambeds transport sediment at virtually all flows, and the bedforms change depending on water depth and velocity (figure A.14). If the channel is sinuous, these streams also can have point bars.

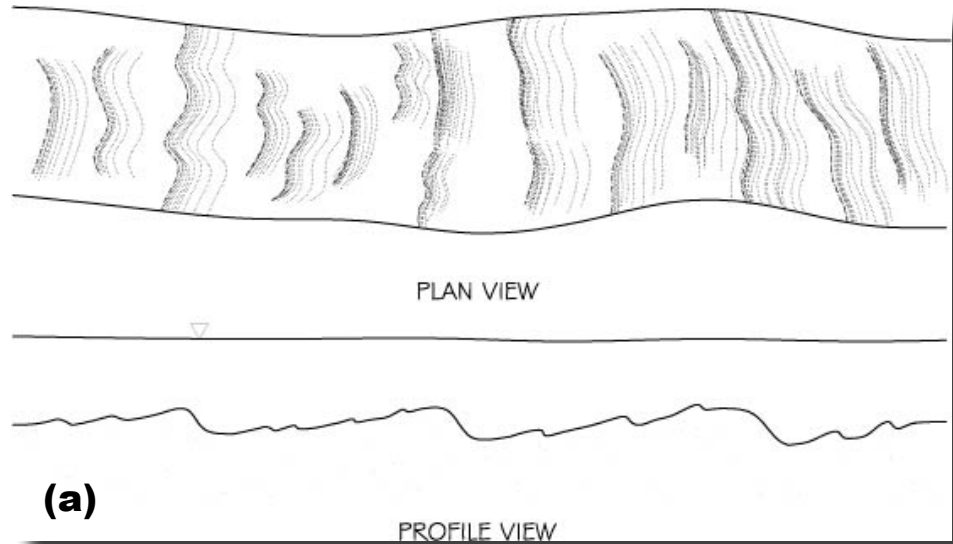

Figure A.24—Dune-ripple reach: (a) schematic planview and profile, and (b) dune-ripple reach on Coal Creek, Washington. Photo: Kozmo Ken Bates.

## Appendix A—Geomorphic Principles Applied in Stream Simulation

---

Because the Montgomery and Buffington channel types are based on streambed morphology, they are highly useful for stream-simulation design, where we mimic bed structure and channel roughness to create a **simulated channel** that will adjust similarly to its surrounding reaches. Each type is uniquely adjusted to the relative magnitudes of sediment supply and transport capacity. This relationship determines how sensitive the channel is to changes in water and sediment inputs.

Montgomery and Buffington (1997) were able to determine for each channel type the typical frequency with which the streambed is mobilized (table A.2). Knowing the typical frequency is important for stream simulation, because the simulated bed should mobilize at the same flows as the surrounding reaches. Transport reaches such as cascade and step-pool channels, for example, are relatively stable. The coarse bed material that controls channel form in these channel types mobilizes only in infrequent floods, although finer sediments and debris are efficiently conveyed over the large rocks during normal high flows. Response reaches such as pool-riffle and dune-ripple channels can experience significant and persistent changes in channel dimension, slope, and planform when hydrologic conditions and sediment supply change. These channels offer more challenge to crossing designers than do the more stable transport reach types. Chapter 6 outlines design options for stream simulations in various channel types. See Montgomery and Buffington (1993, 1997) for a complete explanation of their classification system.

# Stream Simulation

Table A.2—Characteristics of channel types (adapted from Montgomery and Buffington, (1993, 1997)

REACH TYPE		TYPICAL CONDITIONS					
		Bed material	Dominant roughness and structural elements <sup>1</sup>	Slope <sup>2</sup>	Entrenchment	Streambed mobility	
Alluvial reaches	Response reaches	Dune-ripple	Sinuosity, bedforms, banks. Small debris may provide structure.	<0.1%	Slight	Termed "live bed"; significant sediment transport at most flows.	
		Pool-riffle	Bars, pools, grains, sinuosity, banks.	0.1-2%	Slight	Armored beds usually mobilize near bankfull.	
		Plane-bed	Grains, banks.	1-3%	Slight to entrenched	Near bankfull or at higher flows, depending on grain size.	
Nonalluvial reaches	Transport reaches	Step-pool	Steps, pools, banks. Debris may add significant structure.	3-6%	Moderately entrenched to entrenched	Fine material moves over larger grains at frequent flows. Bed-forming rocks move at higher flows depending on size; often $>Q_{30}$ .	
		Cascade	Grains, banks.	6-30%	Entrenched	Smaller bed material moves at moderate frequencies (floods higher than bankfull). Larger rocks are immobile in flows smaller than $\sim Q_{30}$ .	
		Bedrock	Bed and banks.	Any	Any	Bedload moves over bedrock at various flows depending on its size. May be thin layer of alluvium over bedrock. Wood can strongly affect sediment mobility.	
		Channels in cohesive materials (si/cl)	Sinuosity, banks, bed irregularities.	Any	Any	Fine sediment moves over immobile bed at moderate flows depending on its size. May be thin layer of alluvium over immobile bed.	

<sup>1</sup> Any channel type can be 'forced.' In forced channels, woody debris is an important structural element.

<sup>2</sup> Slope is not a diagnostic criterion, and slope ranges overlap more than the 'typical' values in this table reflect. Slope ranges shown here are from figures 16 and 19 in Montgomery and Buffington (1993). See also figure 6 and related text in Montgomery and Buffington (1997).



## Appendix A—Geomorphic Principles Applied in Stream Simulation

### A.6.2 Rosgen Channel Classification

Rosgen's (1994) major channel types are based on the following channel variables: entrenchment, **width-depth ratio**, pattern, and gradient. Rosgen's major channel type classes are particularly useful in stream simulation because they reflect the degree of channel entrenchment—an important variable for assessing risks associated with stream simulation. Streams with high entrenchment ratios (unentrenched channels, Rosgen types C, DA, and E) have relatively wide flood plains that may be flooded frequently. To avoid concentrating overbank flood-plain flows through the pipe, teams must incorporate special design features in stream-simulation installations on these channel types. Streams with low-entrenchment ratios (**entrenched channels**, Rosgen types A, B, and G) have fewer risks associated with flood-plain inundation and lateral adjustment potential.

Each of Rosgen's nine major channel types (see figure A.25) has typical slope ranges that can be quite broad. Subgroups within each of the major types are divided by bed material type and designated with numbers. Rosgen's system does not specifically consider channels where woody debris is a dominant influence on morphology.

Rosgen (1994) developed interpretations of each channel type's sensitivity to a disturbance, its recovery potential, susceptibility to bank erosion, and reliance on vegetation for form and stability. His interpretations about channel responses to disturbance are very useful for predicting how the channel might change when some change occurs in water or sediment input, when local conditions (such as riparian vegetation) change, or during and after channel incision (see also section A.7). Project teams need to consider these potential changes when assessing site and watershed risks and potential channel responses to the crossing (chapter 4).

# Stream Simulation

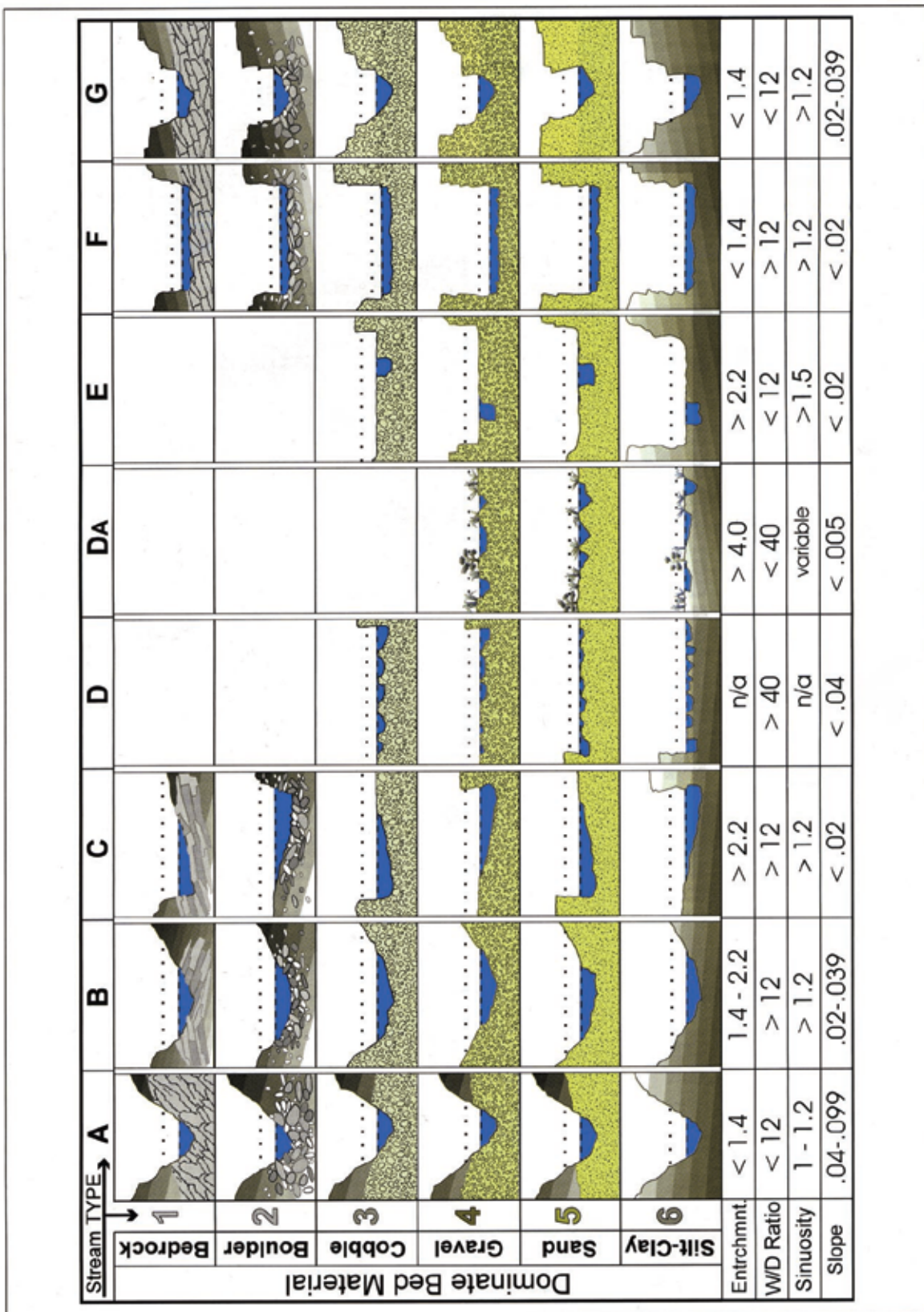

Figure A.25—Channel types defined by Rosgen (1994). Used by permission.

## Appendix A—Geomorphic Principles Applied in Stream Simulation

### A.7 UNSTABLE CHANNELS

#### A.7.1 Inherently Unstable Landforms and Channel Types

Some channel types are inherently unstable; that is, they are naturally subject to rapid changes in channel location, dimension, or slope. Certain landforms also are naturally unstable, and the channels that drain them are subject to episodic (and sometimes unpredictable) changes, which may destabilize them for a period of time. Like streams affected by unusually large floods or other events, recovery can take years or decades, depending on channel resilience after disturbance.

*Braided streams* [figure A.12(b)] are difficult sites for road-crossing structures, because they have high sediment loads that can plug structures and because individual channels can change location during floods. These streams are best avoided as crossing sites. (However, where the braided channel as a whole is confined and unable to shift location, a team might consider an open structure that crosses the entire channel.)

*Active alluvial fans* are located where a **confined channel** emerges into a wider valley, spreads out, and deposits sediment (figure A.26). During high debris-laden flows, so much sediment may be deposited that it blocks the major channel; consequently, flow jumps to a new location and forms a new channel. Several channels may be active at once. Crossing structures can be isolated when the channel changes location, and structures can also exacerbate the likelihood of channel shift if they plug frequently. Even where a fan does not appear to be active, it still constitutes a risky location for structures of any kind, because a rare flood/debris flow event can result in catastrophic sediment deposition.



Figure A.26—Alluvial fan bordering the Noatak River, Alaska. Photo: USFWS Alaska Image Library.

## Stream Simulation

---

For all of these reasons, avoid placing new crossings on fans and braided channels.

*Arroyos* are incised or incising channels, usually with ephemeral flow regimes. They are found in semiarid and arid environments where high flows are often extremely **flashy**. Little or no riparian vegetation may border an arroyo channel, and the banks can be highly erodible. During high flows, the channel may carry large amounts of sediment and debris, and may be prone to shifting location. Some of these channels are braided, and the problems they pose for crossings of any kind are the same as those for braided streams.

On or near *slopes prone to mass wasting*, large erosional events can be expected to cause significant changes in the downstream channel (figure A.27). Even stable transport reaches, if they are immediately downstream of a slope prone to landslides, **earthflow**, gullying, or severe bank erosion, can be expected to undergo flow events where sediment loads are high enough to cause a culvert to plug. In steep terrain, where many crossings exist on a single channel, the domino effect of a single crossing failure can cascade downstream and actually cause a debris flow. Unconsolidated fine-grained glacial deposits are especially subject to rapid surface erosion and slumping, and we can expect channels draining them to experience large bed-elevation changes from both headcutting and episodic sediment inputs from surrounding slopes. Sites located at the transition point between a transport and response reach are particularly vulnerable to sediment deposition during large erosional events.



Figure A.27—Stream eroding the toe of a **slump** is likely to transport large volumes of sediment that may plug downstream culverts.

## Appendix A—Geomorphic Principles Applied in Stream Simulation

---

*Unconfined meandering streams* on wide flood plains are prone to channel shift by meander migration, as described earlier. Such streams are nonetheless considered to be in equilibrium as long as they maintain consistent channel dimensions and slope. In many cases, their rate of meander migration may be slow relative to the life of the structure. However, land development and management frequently accelerate this natural process of channel migration, a consideration to bear in mind before investing in a crossing structure. A shifting channel can move so that it no longer approaches the crossing perpendicularly—and a sharp angle of approach tends to increase sediment deposition above the inlet by forcing the water to turn. Likewise, a sharp angle increases the potential for debris blockage and therefore overtopping failure.

An additional effect of crossings on such channels is that their approaches are often on roadfill raised above seasonally wet or inundated flood plains. Blocking the flood plain obstructs to some degree the erosional and depositional processes that construct and maintain flood plains and the diverse habitats they offer. The roadfill may obstruct **side channels** that are essential habitats and migration corridors for fish. Forcing the **overbank flows** to concentrate in the structure can also cause scour through or downstream of the crossing.

### A.7.2 Channels Responding to Disturbances

Streams that have been destabilized by changes in vegetative cover, **base level control**, climatic events, earthquake, etc., can undergo major changes in elevation, channel width and depth, and/or other characteristics before returning to a quasi-equilibrium state. The changes often occur in a predictable sequence, represented conceptually as channel-evolution models.

One classic channel-evolution model is especially important to understand during work on stream crossings. This model (Schumm, Harvey, and Watson 1984) describes channel incision that could be due either to channelization (channel straightening and/or constriction), base-level lowering, or increases in runoff. In this model (figure A.28), an unentrenched stream downcuts, banks become unstable and erode, and the channel widens until a new flood plain and/or unentrenched stream system establishes at the lower elevation.

## Stream Simulation

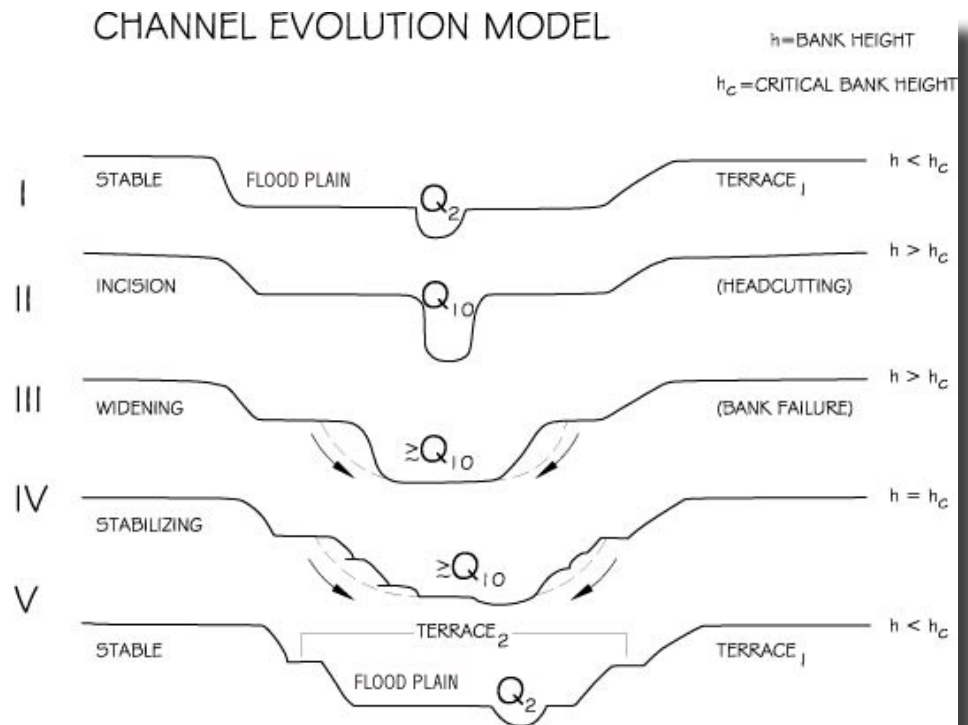

Figure A.28—Channel evolution model shows how a channel evolves from active incision to stabilization (Castro 2003).

Channel incision progresses upstream unless the headcut is checked by a natural- or engineered-grade control, such as a road-stream crossing structure. Downstream reaches are at a later stage in the evolutionary sequence than upstream ones, and can therefore be useful for predicting the magnitude of changes to be expected upstream. This evolution can take years, decades, or centuries, depending on the resistance of the materials being eroded, and can affect entire drainage basins. Tributaries far removed from the original cause of incision can be affected as headcuts move up the main channel and lower the base level for tributaries. The stages are more clearly distinguishable in streams with cohesive bed and banks where actively eroding features (eroding banks, nickpoints) hold steep slopes. In **granular materials** (figure A.3), the features are less easily distinguished because they are less abrupt (Federal Interagency Stream Restoration Working Group 1998). Where channel segments upstream and downstream of a crossing have very different characteristics, understanding whether those differences are due to channel evolution or some other cause is critical to a stream-simulation design.

If it is not possible to avoid an unstable channel by relocating the crossing, predict the direction of future change, and design the structure to accommodate it. Doing all of this well requires a background and experience in fluvial geomorphology and **river dynamics**.



# Stream Simulation

---



## Appendix B—Other Culvert Design Methods for Fish Passage

---

Several methods exist for designing culverts for fish passage. Different methods produce different levels of passability for various aquatic species. This appendix briefly describes common design methods other than stream simulation. The method descriptions are only intended to put stream simulation in the context of the other methods. They do not include enough detail for design.

### B.1 HYDRAULIC DESIGN METHOD

Hydraulic design has been used for decades as the primary (if not the only) design method for fish passage culverts at road crossings. It has been included in design manuals and applied on roads in many countries, and Bates (2003) provides a detailed description of it. Still used as a primary design concept in many locations, hydraulic design also is used for retrofitting impassable culverts to improve their passability.

The goal of hydraulic design is creating water depths and velocities suited to the swimming ability of a target fish at the range of flows when the fish moves in the natural channel. To accomplish this, the design process simultaneously considers the hydraulic effects of culvert size, slope, material, and length. The resulting culvert size is usually narrower than the stream channel **bankfull** width.

Maximum average velocity and turbulence in the culvert cross-section are basic design criteria in the hydraulic method. Increasing hydraulic **roughness**—by adding baffles or by embedding the pipe—increases resistance to flow and is one way to reduce water velocity. Theoretically, increasing turbulence can always reduce the calculated velocity in a steep channel to a level that is passable by specific species. However, if the flow becomes too turbulent, the velocity barrier has simply been converted to a turbulence barrier. Turbulence can be quantified as the energy dissipation per unit volume of water, referred to as the energy dissipation factor (EDF). Bates (2003) suggests limitations of EDF appropriate to the passage of adult salmon. However, we have little data on the subject, and no EDF limits have been suggested for other species or life stages.

Another problem with hydraulic design is the paucity of biological information available for a prudent design. We know little about movement timing and capabilities of many species of fish and other organisms that migrate through the **stream corridor**. Species—and even different life stages within species—move at different times of the year, during different flow conditions. The variability in movement timing and swimming

## Stream Simulation

---

capabilities means that designing culverts to meet specific depth, velocity, and turbulence requirements for multiple species during all flow conditions is impractical. (Refer to chapter 1, section 1.2.3 for a discussion of problems related to using existing biological data for hydraulic design.)

The hydraulic design method targets distinct species of fish without necessarily accounting for the requirements of nontarget species. Different species use the variety of habitats in a stream channel for movement. As chapter 1 notes, many weak-swimming or crawling species use the slow water at bank edges and along the stream bottom itself. Specific detailed information about the hydraulics in these boundary layers would be necessary to account for those areas in a design. The hydraulic option also does not deal with the ecological and habitat issues at road crossings discussed in chapter 1, sections 1.1.3 and 1.3.1.

## B.2 HYBRID DESIGN AND ROUGHENED-CHANNEL DESIGN

Hybrid design and roughened-channel design are styles of hydraulic design that create a nonadjustable streambed inside of a culvert to pass at least some aquatic species. The channel usually resembles the general shape of a natural channel although it may be quite different from the channel in which it is constructed. These design methods are useful when stream simulation is not feasible. Their purpose may be to provide:

- A crossing structure steeper than the natural channel slope (as in an **incised channel**).
- A streambed that will be stable in the absence of bed material supply from upstream (as below a lake).
- A stable streambed where no **reference reach** can be located (as in an unstable channel).

A roughened channel is a well-graded mix of rock and sediment with enough roughness to sustain the required gradient and enough hydraulic diversity to provide passage for some fish. The design method is hydraulic, combining channel dimensions, slope, and bed material to create the water depths, velocities, and low-turbulence conditions that a target species can negotiate. Ideally, a channel is roughened to the point where the potential energy available at the upstream end of a reach is consistently dissipated in

## Appendix B—Other Culvert Design Methods for Fish Passage

---

turbulence through the reach and no excess kinetic energy is present within the reach or at the downstream end. The velocity-simulation method (B.3) is similar, except that velocity simulation takes its velocity criteria from the natural channel rather than from published swim-performance values for a target species.

To improve fish passage, roughened channels can be designed to have **banklines**, shallow water margins, and other diversity. Nonetheless, a roughened channel is essentially a hydraulic design. The bed material is not intended to evolve as a natural channel with bed material being scoured and replenished; instead, it is a fixed, semirigid structure. Although individual rocks are expected to adjust position, the larger grain sizes are designed for permanence. Because culverts with roughened channels often are steeper and more confined than the natural upstream channel, **recruitment** of the larger rock in the bed from upstream is not expected. In other words, if large material is scoured, it will not be replaced, and the entire channel will therefore degrade.

If excess infiltration into the roughened channel bed and loss of low surface flow are to be prevented, bed porosity must be controlled. Smaller grains that control the porosity in the roughened channel may gradually be washed out of the bed. If material transported from the natural channel is too small to be trapped in the voids of the roughened channel bed, the bed will become porous.

A hybrid is a roughened channel designed to be similar in shape and **bed structure** (but not bed mobility) to the channel type that would naturally occur at the required culvert slope (see slope ranges for different channel types in table A.2). For example, if a culvert has to maintain a slope of 6 percent in a 3-percent reach, the culvert streambed could be designed as a step-pool channel even if the natural channel is a pool-riffle type. The steps—the structural elements of the bed—would be designed to be stable at all flows, because sediment from upstream is not expected to replenish the larger bed particles if they are eroded away. The culvert streambed will be enriched by smaller sediments moving across the top of the larger material and depositing temporarily. Because a hybrid has hydraulic microenvironments more similar to those of a natural channel, we expect it to pass more species and life-stages than a roughened channel or other hydraulic design.

## Stream Simulation

---

For the hybrid design, bed structure might be based on a reference reach of the appropriate channel type and slope, if one exists in the area. If not, the streambed could be designed using stable channel design methods such as those described in USDA-NRCS (2001). Examples of hybrid-type designs in open channels are in Castro (2003), who describes artificial step-pool and cascade reaches, and Newbury (1993). (For more examples and design details of various hybrid channels currently used in Europe and elsewhere, see FAO/DVWK 2002.)

### B.3 VELOCITY SIMULATION

Browning (1990) described a hydraulic design method that uses the natural channel for determining permissible velocities in the culvert. In this method, velocities in the culvert are allowed to be 25-percent greater than those calculated for the natural channel during a 2-year flood event. Browning also recommends equalizing velocities for a range of flows. There are no specific limitations on culvert slope, width, or length, and depending on how the method is applied, there may or may not be a limitation on the structures or features used within the culvert for controlling the velocity. Similar to the hydraulic method, baffles or permanent rock can be used for controlling velocity, with no consideration of the effects of resulting turbulence on fish passage. Performance of the method will likely vary depending on the capability of the culvert to hold bed material, the occurrence of floods that may scour the bed out, and the supply of bed material load in the stream.

### B.4 “NO-SLOPE” DESIGN

The Washington Department of Fish and Wildlife (Bates 2003) developed “no-slope” design as a regulatory option to simplify fish passage design and permitting for private landowners with short crossings under driveways. The no-slope option requires few technical calculations and results in reasonable culvert sizes.

According to the no-slope design method, the bed within the culvert must be at least as wide as the channel bankfull width. Current thinking is that width should be somewhat greater. The culvert is level, and the downstream invert is countersunk below the channel bed by a minimum of 20 percent of the culvert diameter or rise. The upstream invert is countersunk by a maximum of 40 percent of the culvert diameter or rise.

## **Appendix B—Other Culvert Design Methods for Fish Passage**

---

These countersinking requirements limit (a) the channel slope on which you can install this kind of a culvert and/or (b) the length of any culvert that may be designed with this concept. Variations of the method might simply limit the slope and length, allowing the culvert to be sloped. A culvert designed by this method must also be checked for adequate flood capacity.

The published description of this method (Bates 2003) does not suggest installing a bed, nor does it consider bed stability. However, before countersinking a bare culvert into a channel, the designer should consider the potential effects on the channel. Replacing a barrier culvert with a larger embedded culvert can create a headcut. Without an understanding of the effects of such a headcut, the replacement could pose a substantial risk to channel stability (see section 5.3.3).

## **Stream Simulation**

---

## Appendix C—Site Assessment Checklist

### ROAD

- ✓ Long-term commitment and plans for the road.
- ✓ Road management objectives.
- **Location of road and crossing.**
  - ✓ Road and crossing maintenance history: chronic maintenance problems.
  - ✓ Vertical and horizontal constraints on road grade and location.
  - ✓ Rights-of-way.
- **Associated infrastructure.**
- **Fillslopes: height, stability.**
- **Construction closure and detour options.**

### WATERSHED RISK FACTORS

- ✓ Geologic or geomorphic hazards (landslides, avalanches, debris torrents, etc.).
- ✓ History of flooding and geomorphic events.
- ✓ Land management history and projected future change: expected changes in sediment and/or flow regimes.
- ✓ Channel stability offsite (location/type/potential to affect site.)

### EXISTING STRUCTURE

- **Dimensions, slope, fill, perch.**
- **Material, condition.**
- **Structure skew to stream and road.**
  - ✓ Flood-plain constriction.
  - ✓ Site restrictions/sensitive areas.
  - ✓ Type of barrier (partial or complete).
  - ✓ Fish and other aquatic organisms affected by barrier.
    - Endangered species.
    - Timing, swimming ability.

- ✓ Terrestrial species affected.
- ✓ Barriers upstream and downstream from structure.
- ✓ Structure priority for replacement.

### RESOURCE VALUES

- ✓ Aquatic- and riparian-dependent fish and wildlife populations.
- ✓ Aquatic habitats requiring protection.
  - Quality and extent upstream from structure.
  - Critical habitats downstream.
  - Flood-plain habitats.
  - Work window timing.
- ✓ Terrestrial animal migration routes/specialized habitats.
- ✓ Flood-plain habitats; wetlands.
- ✓ Critical flood-plain water storage.
- ✓ Water supply.
- ✓ Recreation.

### PROJECT REACH

- **Annotated site sketch**
  - ✓ Geomorphic features: channel and valley.
  - ✓ Road features.
  - ✓ Significant vegetation.
  - ✓ Land ownership.
  - ✓ Utilities.
  - ✓ Potential lateral adjustment.
  - ✓ Potential construction access.
  - ✓ Photo points.
  - ✓ Cross section, key feature locations.
- **Channel morphology**
  - ✓ Channel type.
  - ✓ Natural channel location.
    - Alignment.

## Stream Simulation

---

- ✓ Longitudinal profile.
  - Stable endpoints.
  - Key features; mobility.
  - Residual pool depths/scour potential.
  - Natural channel elevation, gradient, and vertical adjustment potential.
- ✓ Cross sections.
  - Bankfull width; variability in width.
  - Bank height.
  - Flood-prone zone width; flood-plain conveyance.
  - Flood-plain roughness.
  - Additional cross sections for backwater model.
- ✓ Bed material.
  - Pebble count or other estimate of gradation.
  - Armoring.
  - Key features; size and mobility.
- ✓ Soils/foundation materials.
- ✓ Ground water.

### ■ Channel stability

- ✓ Channel response to existing structure.
- ✓ Vertical adjustment potential.
  - Bed mobility.
  - Perch.
- ✓ Lateral adjustment potential.
  - Bank stability.
- ✓ Flood-plain conveyance.
- ✓ Plugging potential.
  - Woody debris.
  - Ice.

### ■ Risk Assessment

- ✓ Site history (flood history, past/future land use, geologic/hydrologic setting, etc.).
- ✓ Potential for change in sediment loading/flow regime.

- ✓ Vertical adjustment potential.
- ✓ Headcut potential and effects.
- ✓ Aggradation potential and projected effects.
- ✓ Lateral adjustment potential and effects.
- ✓ High flood-plain conveyance; constriction potential.
- ✓ Habitats.

## STATEMENT OF PROJECT OBJECTIVES (section 4.6)

- ✓ Road.
  - Traffic level; interruptibility; safety.
  - Maintenance.
  - Diversion potential.
- ✓ Stream-simulation channel.
  - Desired design features.
  - Structure design flow.

## REFERENCE REACH

- ✓ Preliminary selection.
- ✓ Longitudinal profile.
  - Gradient.
  - Key features: types, spacing, height.
  - Channel roughness.
- ✓ Cross section
  - Channel form/geometry.
  - Bankfull width.
  - Entrenchment.
  - Channel margins and banklines.
- ✓ Bed material.
  - Bed material: gradation, armoring, angularity.
  - Key features: particle sizes, packing/consolidation.
  - Bed mobility.







## Appendix D—Estimating Design Stream Flows at Road-Stream Crossings

### D.1 INTRODUCTION

Assessing the stability of any crossing structure requires estimating design peak flows for the site. This appendix provides guidance and resources for estimating peak flows at gauged and ungauged sites. It is intended as a desk reference rather than an introduction to hydrologic analysis.

Two types of design flows apply to stream-simulation design:

- structural-design flows, for evaluating the structural integrity and stability of the culvert, bridge, etc., during flood events.
- **bed-design flows**, for evaluating the stability of the particles intended to be permanent inside a drainage structure.

Design flows are the flows that, if exceeded, may cause failure of the structure or the bed. The two design flows may be different if the consequences of bed failure are different from those of complete structural failure (see risk discussion in section 6.5.2.1). For example, if the acceptable risk of bed failure is 4 percent in any one year, the bed design flow would be the flow that is exceeded on average only every 25 years—the 25-year flow. The acceptable risk of losing the structure might be lower, perhaps only 1-percent per year, in which case the 100-year flow would be the structural-design flow. These design flows are often taken to be the same in real applications, but it is important to understand the concept that design flows are determined based on acceptable risks and consequences.

All stream-simulation designs require estimating the structural and bed design flows. Some designs also require further hydraulic analysis—comparing key-piece entrainment flows in the reference reach to those in the project reach (appendix E). For the comparative analysis, we do not need to know the flow recurrence interval. However, determining the recurrence interval can be an independent check on the reasonableness of your estimate of entrainment flow. The frequency of the estimated flow can be compared to the bed-mobilization frequencies listed in table 6.5 for each channel type, or to field observations of actual floods of known recurrence interval.

Estimating flood flows on small watersheds is particularly difficult, because relatively few stream gauges exist on small streams. The U.S. Geological Survey (USGS) maintains nearly 6,000 gauges, 26 percent of

## Stream Simulation

---

which are on or within 10 miles of national forest lands. However, only 132 gauges are on streams with a contributing area of less than 5 square miles, and only 22 of those are on or within 10 miles of a national forest (figure D.1). Fewer still have a long-term flow record to allow for accurate estimates of extreme events.

More inactive gauges exist than active ones and the historic records from inactive gauges are also very useful for estimating flood flows. There are 407 inactive gauged sites with a contributing area of less than 5 square miles and within 10 miles of a national forest.

The lack of gauging stations in small, forested watersheds requires the analyst to use varied approaches, employing multiple flow-estimation methods to arrive at the best estimate of design flows. Methods can be grouped according to the project site's proximity to a stream gauge:

- Direct application of gauge data.
- Extrapolation of flow estimates from gauged sites.
  - ▲ To ungauged sites on the same stream.
  - ▲ To ungauged sites on nearby streams.
- Predictions in ungauged basins with regional regression equations.

To meet project objectives, teams must invest appropriate time and effort in developing both structural- and bed-design flows. If structural-design flows are underestimated, then the risk of hydraulic failure is likewise underestimated. Conversely, if design flows are overestimated, both immobile bed particles and the structure itself may be oversized.

## D.2 DESIGN FLOW ESTIMATES

Many sources of streamflow data exist. Stream gauges are most commonly operated by State or Federal agencies or by utilities. The best and most reliable data are generally those published by the USGS, which has well-defined protocols for data collection and quality control. Gauge data collected without defined protocols and documentation may be of lesser quality. At the National Water Information Systems (NWIS) Web site (<http://water.usgs.gov/nwis/>), you can download gauge station information, field measurements, summary statistics, and mean daily flow, peak flow, and partial peak flow data.

## Appendix D—Estimating Design Stream Flows at Road/Stream Crossings

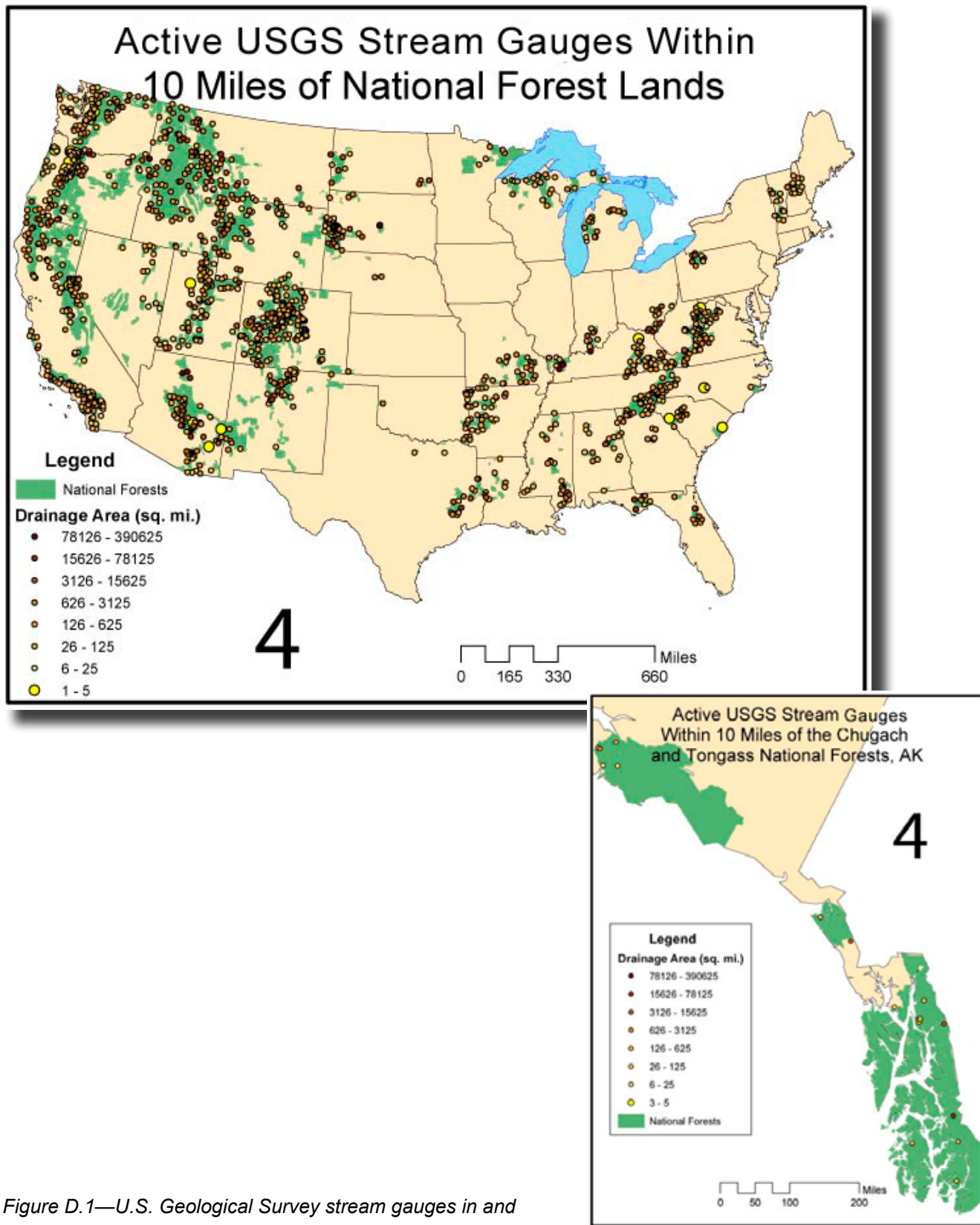

Figure D.1—U.S. Geological Survey stream gauges in and near national forests.

## Stream Simulation

---

Professional papers and reports are a good source of historical flow data, regional regression equations, and other flow estimation tools. USGS publications for estimating flows describe the methods to be used for each State. Check the National Flood Frequency Program (NFF) Web site for the electronic documentation for the State in which your project lies: <http://water.usgs.gov/software/nff.html>).

### D.2.1 Design Flow Estimates at Gauged Sites

Although aquatic organism passage projects rarely occur at a gauged site, it may be necessary to analyze data from nearby gauges to determine flows of particular recurrence intervals (flood frequency) in the vicinity.

Accuracy of flood frequency estimates at a gauged site depends on the length of record of the gauge. The longer the period of record, the better the estimate. As an example, figure D.2 shows the measured peak discharges for the period of record for the gauge on the North River in Alabama. Notice how the estimated magnitude of the 100-year flood ( $Q_{100}$ ) changes as different time periods are considered. In the development of flood frequency estimates, the general recommendation is that a gauge station have a minimum of 10 years of record. Gauges with fewer than 10 years of data can be used to develop flow estimates for frequent floods (e.g.,  $Q_2$ ), but they should not be used for higher recurrence interval flood flows.

For flood flow estimates for infrequent events (e.g., 25- to 100-year floods) at a gauged site, use the guidelines in Bulletin 17b (Interagency Advisory Committee on Water Data, 1982 [http://www.floodmaps.fema.gov/pdfarchive/dl\\_flow.pdf](http://www.floodmaps.fema.gov/pdfarchive/dl_flow.pdf)). The bulletin suggests using the Log-Pearson type III flood-frequency distribution. The required three parameters for this distribution are the mean, standard deviation, and skew of the logarithms of the annual series of peak streamflows. To determine the values of the parameters, follow the guidelines in the bulletin. In addition to Bulletin 17b, other useful references for flood-frequency analysis include McCuen (2003), Chow et al. (1988), and Linsley et al. (1982).

## Appendix D—Estimating Design Stream Flows at Road-Stream Crossings

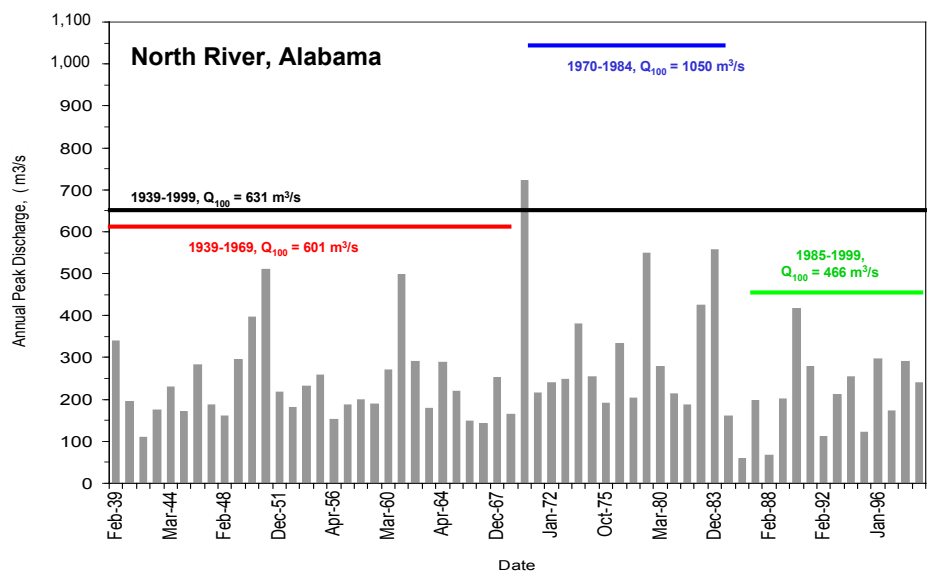

Figure D.2—Variation in peak discharge estimates over different periods of record.

To facilitate flood-frequency analysis using the methods recommended in Bulletin 17b, you can download computer programs from private vendors or the USGS. The USGS program is called PEAKFQ; the most current version (4.1) is a DOS version, last updated in February 2002. You can download the program and user guide at [http://water.usgs.gov/software/surface\\_water.html](http://water.usgs.gov/software/surface_water.html).

As part of the NFF Program, the USGS has completed flood-frequency analyses for most of their gauges with adequate data. The NFF Web site (<http://water.usgs.gov/software/nff.html>) has the information for each State, summarizing estimated discharges for a range of flood frequencies. Be aware of the date on which the summary was last updated; it may not include the most recent years of data.

### D.2.1.1 Weighted flood frequency

Because a gauging station's period of record is limited, computed flood-frequency values may contain some bias. The period of record for the station may or may not include years when large floods occurred (see figure D.2). Flood-frequency values calculated from a record that includes several large floods will be very different from one that happens to lack any large floods. To improve the reliability of the estimate—especially for gauges with short periods of record—you can weight the flow computed from streamflow data ( $Q_G$ ) for a specific recurrence interval (RI) with the

## Stream Simulation

---

same RI flow computed from regression equations ( $Q_R$ ). The weighting is based on the number of years of record for the gauging station and the equivalent period of record for the regression equation (see equation D.1). The equivalent period of record for the regression equation is the number of years of actual gauge record that would be required for producing the same accuracy as the equation. Hardison (1971) describes the calculations involved in estimating an equivalent number of years of record. For many States, equivalent years of record for regional regression equations are displayed on the NFF Web site.

To obtain a weighted flood frequency for a gauging station, multiply the flow estimate for the station by the years of record at the station ( $N$ ), and multiply the flow computed from the appropriate regional regression equation by the equivalent years of record ( $N_E$ ). Add the two values and divide by the sum of the years of record to obtain a weighted flood frequency for the stream at the gauging station (Stuckey and Reed 2000). Weighting of flood frequency records using the following equation is also discussed in detail by Cooper (2002) and Wiley et al. (2000).

### Equation D.1

$$Q_W = (Q_G \times N + Q_R \times N_E) / (N + N_E)$$

where:

$Q_W$  = Weighted discharge for a return interval of T-years.

$Q_G$  = T-year discharge computed from measured streamflow data.

$Q_R$  = T-year discharge computed from regional regression equations.

$N$  = Number of years of record at the gauging station.

$N_E$  = Equivalent years of record for regional regression equations.

## D.2.2 Design-flow Estimates Near Gauged Sites

Flood frequency estimates at gauged sites must be in hand before you can estimate flood flows at ungauged sites.



## Appendix D—Estimating Design Stream Flows at Road-Stream Crossings

### D.2.2.1 Ungauged site on a gauged stream

If a project site is on the same stream as a gauge, you can calculate peak discharges at the ungauged site by weighting the gauge data by a ratio of drainage areas (e.g., Thomas et al. 1993; Sumioka 1997) as follows:

#### Equation D.2

$$Q_{(\text{ungauged})} = Q_{(\text{gauged})} (A_{\text{ungauged}} / A_{\text{gauged}})^x$$

where:

Q = Discharge.

A = Basin area at gauge site and project site.

x = Slope exponent of the curve (power function) relating Q to A for suitable gauges in the **hydro-physiographic province**.

The slope exponent ( $x$ ) accounts for the difference between the ways in which larger basins and smaller basins react to precipitation. Larger basins usually have smaller peak discharges per unit area than smaller basins, because of differences in the amount of water storage (in ponds and soils), time of concentration, and spatial differences in precipitation during a storm. The exponent  $x$  is approximately the same value as the average exponent on basin area in the regional regression equation for that flood region.

If necessary, you can directly determine the value of the exponent for any subset of gauges simply by plotting the flow estimates from flood-frequency analysis for a given recurrence interval (dependent variable) against drainage area (independent variable), and fitting a power function through the data (figure D.3). You can then average the drainage area exponents determined from this regression for several RI flows, to produce a single exponent for each flood region. However, you do not usually have to do this analysis, because the slope exponent is often reported by flood region in the USGS publications for individual States (see NFF Web site).

## Stream Simulation

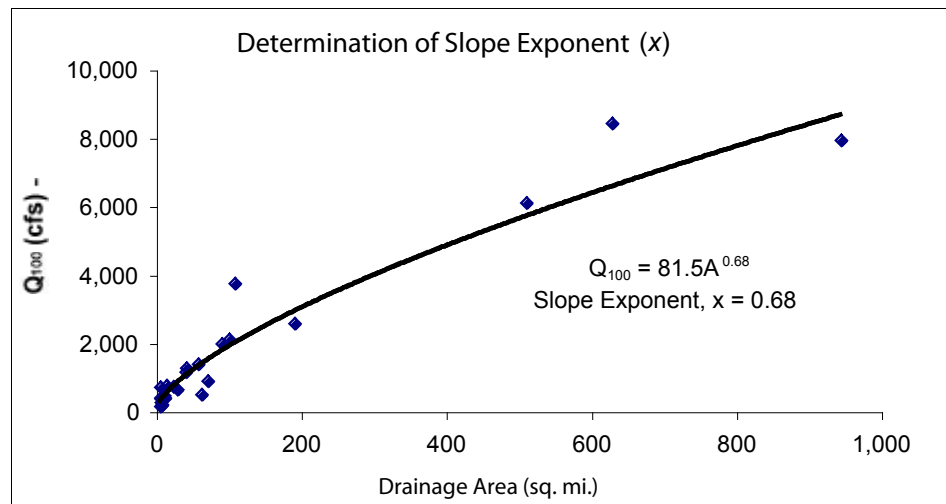

Figure D.3—Typical example of the relationship of drainage area to flow of a specific recurrence interval (or exceedence probability), for determining the exponent (x) in equation D.2.

Equation D.2 is valid as long as the drainage area of the ungauged site is between 0.5 and 1.5 times the area of the gauged site and the watersheds have similar characteristics. If the watersheds differ appreciably in topography, vegetative cover, geology, etc., make the peak discharge estimates using appropriate regional regression equations.

Some investigators (e.g., Wiley et al. 2000; Stuckey and Reed 2000) recommend a different method of transferring gauged data to an ungauged site. This method uses a linear correction factor for the difference in drainage areas between the gauged and ungauged sites (equation D.3).

### Equation D.3

$$C_u = C_g - [2(|A_g - A_u|) / A_g](C_g - 1)$$

where:

$C_u$  = Correction factor for the ungauged site.

$C_g$  = Weighted flow for the gauged site ( $Q_w$  from equation 1) divided by the regional regression estimate of the flow for the gauged site ( $Q_R$ ).

$A_g$  = Drainage area at the streamflow gauge.

$A_u$  = Drainage area at the ungauged site.

## Appendix D—Estimating Design Stream Flows at Road-Stream Crossings

The flow estimate for the ungauged site is determined by multiplying the correction factor for the ungauged site ( $C_u$ ) by the regional regression estimate for the ungauged site. Decide which transfer method (equation 2 or 3) to use, given the recommendations in the applicable USGS **flood frequency analysis** documentation within the NFF program (FEMA 1995).

### D.2.2.2 Ungauged site near a gauged stream

If the project site is near a gauge—even if the project site is not in the same watershed—you can often use the gauge data to estimate design flows. The methodology is the same as that presented in section D.2.2.1. When extrapolating the data from a specific gauged site to a site in a nearby watershed, the two sites must have similar:

- Precipitation.
- Drainage area and shape.
- Orographic expression.
- Aspect.
- Vegetation.
- Lithology/geology.

Again, when you transfer gauge data to an ungauged site, the basin area should be within 0.5 to 1.5 times that of the gauged site. The accuracy and validity of the flow estimates are directly tied to the similarity of watershed characteristics between the gauged and ungauged sites. As the differences between the watersheds increase, be more cautious in using this technique. Be familiar with the gauged site and recognize the hydrologic influence of lakes, water diversions, **regulated rivers**, or dams. In addition, be cautious when using gauges on **losing streams** in arid areas, in **karst** terrain, or in areas with evident regional ground water contributions to streamflow. Extrapolation in these situations can produce invalid results.

### D.2.3 Flow Estimates on Ungauged Streams

You can also estimate peak stream flows for an ungauged watershed from equations that relate peak flows to climatologic and physical characteristics of the watershed (Thomas and Benson 1969; Riggs 1973). The equations are derived using multiple linear regression techniques. This generalization or regionalization of peak discharges from measured to unmeasured watersheds is known as “regional regression analysis.” Defining regions of relatively consistent geography, geology, and hydrology improves the accuracy of regional regression equations. States have different numbers

## Stream Simulation

---

of equations, depending on the number of flood regions they have defined. For example, the State of Colorado has a different set of regional regression equations for each of five different flood regions; New Mexico has eight flood regions, and Maine has one.

For most States, the USGS has completed regional regression analyses and developed predictive equations. First, gauge-site peak discharges corresponding to a suite of recurrence intervals are computed using the flood-frequency analysis techniques discussed previously. These peak flows are then used as dependent variables in a multiple regression analysis against independent variables such as drainage area, mean basin elevation, mean maximum January air temperature, area of lakes and ponds, etc. Although the list of independent variables is extensive, only a small subset correlates well enough with peak flows to be used in predictive equations. Drainage area and some measure of precipitation are commonly the most important variables. The form of the regional regression equations takes the general form:

### Equation D.4

$$Q = b_0 + b_1x_1 + b_2x_2 + \dots + b_mx_m$$

Where  $Q$  represents the predicted streamflow for a selected recurrence interval and  $x_1, x_2, \dots, x_m$  represent the  $m$  watershed characteristics used as predictive variables. The regression coefficients  $b_1, b_2, \dots, b_m$  define the relationship among variables and are determined from the measured data in the flood region.

Published regression equations typically provide some measure of their accuracy. The standard errors of prediction typically range between 30 and 60 percent, although some exceed a standard error of 100 percent. An example of predictions using regional regression equations from Oregon (figure D.4) shows the range of potential error included within 95-percent prediction limits.

All of the published regional regression equations have limitations. First, they should only be applied where basin characteristics are within the limits of those used for developing the equations. For example, if regional regression equations were developed from gauges with drainage areas between 10 and 100 square miles, the accuracy of those equations is suspect for a site with a 5-square-mile drainage area.

## Appendix D—Estimating Design Stream Flows at Road-Stream Crossings

A second limitation is that the names of the independent variables within the regional regression equations do not necessarily convey the method by which they should be quantified. For example, watershed slope can be characterized in a variety of ways. Carefully read the supporting documentation for the equations to fully understand the methodology in which the predictor variables are determined.

Third, regressions may not be applicable in areas with unique hydrologic features affecting floods, such as seeps or springs that contribute large parts of streamflow or areas with extremely high soil permeability (Omang 1992).

Fourth, be aware that urbanization, roads, timber harvest, streamflow diversions, or other land use changes will affect water yield and can thus have an influence on calculated design flows.

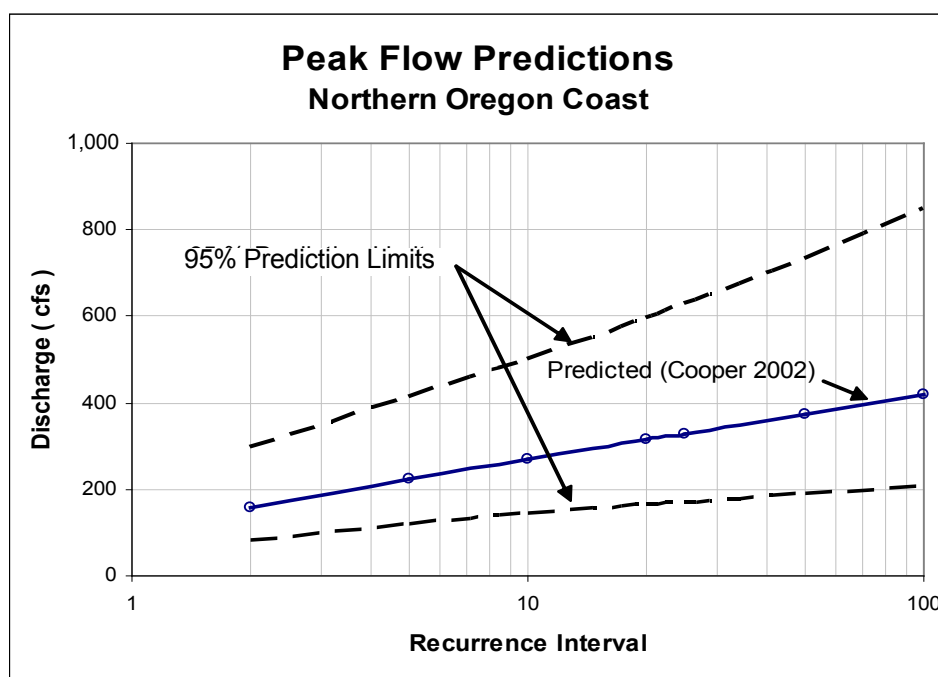

Figure D.4—Example of prediction errors associated with regional regression equations.

### D.3 VERIFYING FLOW ESTIMATES AT UNGAUGED STREAMS

Given the potential errors in estimating flows at ungauged sites, using field data to check flow estimates can greatly enhance their credibility. Keep in mind that the accuracy-checking methods described here are likely to allow detection only of gross errors.

One method of verifying flood-flow predictions at ungauged sites is to compare the predictions to real flows that were observed or that left evidence on the landscape from which to calculate flow. Information about flood frequency and water-surface elevations can come from querying long-time residents and/or identifying historic flood markers in the field. Knowing the flood elevation and the morphology of the stream **reach**, you can use a hydraulic model to route a calculated flood flow (e.g.,  $Q_{100}$ ) through the stream reach. Compare the modeled water-surface elevation for the predicted flow to observed or field-identified flood levels to get an idea of whether your estimate is reasonable. Although you rarely know exactly what recurrence interval the historic flood was, news accounts or anecdotal information from residents often offer some indication of how unusual the flood was. You also can compare the modeled water-surface elevation to a geomorphic feature, such as a **terrace**, for which you can identify an approximate frequency of flooding. This check helps verify that the predictions are at the right order of magnitude so long as watershed changes (dam building, development of impervious areas, etc.) have not altered flow frequencies from those observed in the past.

The routing analysis requires a measured cross section (or series of cross sections) and stream gradient at the site, along with some estimate of **flow resistance** in the channel and on the **flood plain**. You can perform hydraulic routing using Manning's or other equations (see Hardy et al. 2005) in uniform reaches or, for reaches where gradient or cross-sectional characteristics are changing, with **backwater** analysis programs such as HEC-RAS.

Accurately determining flow resistance (typically the Manning's **roughness** coefficient,  $n$ ) is a key element in hydraulic modeling aimed at verifying predicted flows. A number of publications are available for estimating channel roughness from photos (Barnes 1967) or descriptive tables (Chow 1959). Equations exist for estimating  $n$  from physical channel characteristics such as slope and sediment size distribution (e.g.,

## Appendix D—Estimating Design Stream Flows at Road-Stream Crossings

---

Bathurst 1985; Jarrett 1985). Other methods use a combination of photos and physical channel characteristics (Hicks and Mason 1998). A USGS publication also is available to estimate roughness characteristics of flood plains from photographs and site descriptions (Arcement and Schneider 1989). Although these methods can give good estimates of channel roughness, the preferred method is to perform discharge measurements at high flows, then use Manning's equation to back-calculate the actual roughness.

The most direct way of verifying the validity of calculated design flows is to check their reasonableness against measured values at nearby gauges (if they exist). Before doing so, check that the conditions affecting flow at the nearby gauge(s) (e.g., watershed characteristics and stream type) are similar to those at the project site. As a starting point, develop unit runoff relations at the local gauges: divide the flow for a given RI at the gauge by drainage area at the gauge to arrive at a discharge per unit area (i.e., cubic feet per second per square mile). These normalized values can provide a rough check on the magnitude of estimates made with regional regression equations at the project site.

**Bankfull** is the flow we can most confidently estimate from field observations alone, and when the field data confirms the bankfull discharge value estimated using regional regression equations or other indirect methods, we have more confidence in estimates of larger floods made using the same methods. (Depending on the region of the country, bankfull discharge at gauging stations often corresponds to a recurrence interval between 1 and 2 years.) At the project site, estimate bankfull discharge directly from a regional regression equation, if one is available for such a frequent flood. Alternatively, make a plot of discharge vs. RI (figure D.4), and extrapolate the curve to arrive at a flow estimate with the same recurrence interval as bankfull discharge. Then, route this estimate of bankfull flow through a representative cross section, using WinXSPRO (Hardy et al. 2005) or another hydraulic model, and check how well the calculated water surface matches the field-identified bankfull indicators. If the calculated discharge corresponds to a water-surface elevation significantly different from the bankfull indicators, adjustments in the calculated flood estimates may be necessary. On the other hand, if the calculated discharge is a reasonable representation of the bankfull **stage**, this suggests, although it doesn't guarantee, that flood predictions of higher recurrence intervals are reasonable. We recommend confirming the accuracy of higher recurrence interval floods using other methods such as those described above.

## Stream Simulation

---

Another way of checking on the reasonableness of an estimated flow is to check the Froude number (F) for that flow. The Froude number is a measure of whether flow is subcritical, critical, or supercritical. It is a ratio of inertial forces to gravitational forces and is calculated as follows:

### Equation D.5

$$Fr = V/\sqrt{gD}$$

where:

Fr = Froude Number

V = Average velocity = Q/A

g = Gravitational acceleration

D = Hydraulic mean depth = A/T

A = Cross-sectional area

T = Top width of water

If:

Fr < 1 the **flow regime** is subcritical.

Fr = 1 the flow regime is critical.

Fr > 1 the flow regime is supercritical.

Flows in natural channels are rarely critical or supercritical, so determining the Froude number for a calculated flood discharge at the project site may indicate whether problems with the estimate exist. For example, if the Froude number is greater than 1 for the calculated flood flow at the project site, this may indicate that the flow estimate is too high. Be sure to check the Froude number at local gauged sites. If the stream type is unusual (say, a bedrock channel), or the flow is extremely high, the high Froude number may be real.





# Stream Simulation

---

## Appendix E—Methods for Streambed Mobility/Stability Analysis

---

This appendix provides background on the use and limitations of several sediment entrainment equations that are the most practical for stream-simulation applications. These equations are used in stream-simulation design to verify whether the sediment sizes to be used in the simulation (sizes based on reference reach data) are as mobile or as stable as intended. Specifically, the purpose of these equations in stream-simulation design is to ensure that:

- Similar particle sizes move at similar flows in both the reference-reach channel and stream-simulation design channel.
- Key pieces (permanent features) in the stream-simulation design channel are stable for the high bed-design flow.

The equations are one set of tools that help the designer modify the simulation-bed width, the bed-material size, and/or the design slope to compensate for a difference between the stream-simulation channel and the reference reach. The difference might be a flow constriction (as in a wide **flood plain** that is blocked by the road fill), or a steeper slope. Within limits, designers can use these equations to change the design parameters so that a given-size particle moves at the same flow as in the reference reach.

The equations do not apply to all stream types and flow conditions. For example, they are not relevant to channels with cohesive soils making up their bed and banks. They do apply to alluvial channels composed of granular material where erosion occurs by entrainment of individual particles; however, each equation is applicable only in conditions similar to those for which it was developed. We strongly recommend that you understand the source, derivation, and limitations of these equations before you use them. It is always wise to compare results from more than one equation, and check those results for reasonableness in the field. Knowledgeable designers may elect to use other equations for specific applications, but the ones described here are a good starting point for many stream-simulation design situations.

### E.1 FLOW HYDRAULICS: SHEAR STRESS AND UNIT DISCHARGE

A particle on the streambed begins to move when drag and lift forces exerted by the flow on the particle exceed the forces resisting motion. Resisting forces include the submerged weight of the particle and intergranular friction between particles (figure E.1). The flow at which the particle just begins to move is called the critical flow or the critical entrainment flow.

## Stream Simulation

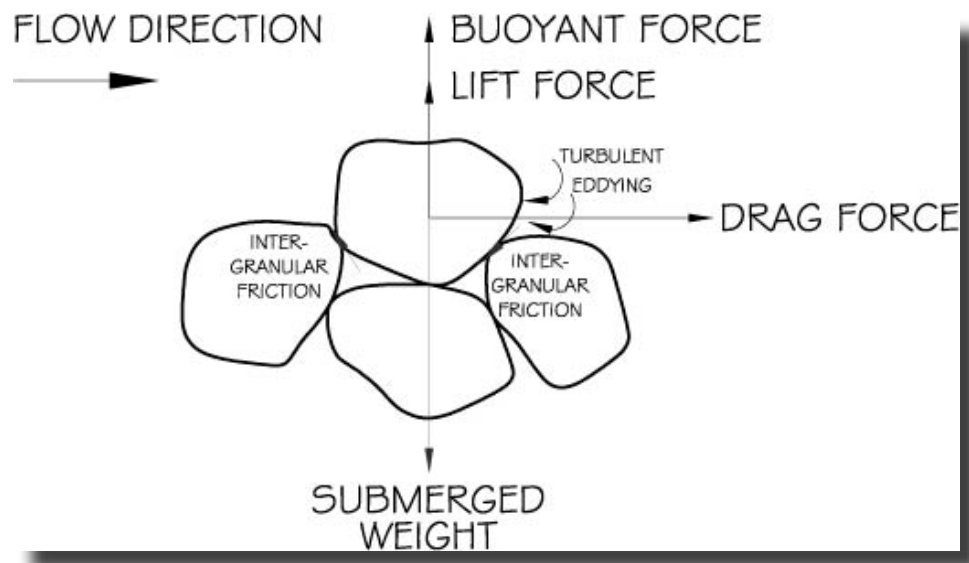

Figure E.1—Schematic diagram illustrating the interaction between drag and lift forces, the buoyant force, and resisting forces (submerged weight of the particle and intergranular friction between particles). Diagram is modified from Carling 1992; Julian 1995; and Knighton 1998.

There are two common approaches to quantifying the driving forces acting on a particle during any specific flow: average boundary shear stress and unit discharge.

The average boundary shear stress exerted by flowing water on its boundary is:

### Equation E.1

$$\tau = \gamma RS$$

where:

$\tau$  = average boundary shear stress (lb/ft<sup>2</sup>)

$\gamma$  = specific weight of water (62.4 lb/ft<sup>3</sup>)

$R$  = **hydraulic radius** (ft)

$S$  = energy slope or bed slope (ft/ft).

Hydraulic radius is average flow depth, determined by dividing the cross-section flow area by the wetted perimeter. Because we are most interested in the mobility or stability of particles on the channel bed, boundary shear stress is calculated for flows within the active stream bed width or

## Appendix E—Methods for Streambed Mobility/Stability Analysis

**bankfull** width (figure E.2). Use active streambed width for streams with gently sloping or vegetated banks where that part of the cross section is subject to substantially lower shear stresses than the rest of the bed and there is less evidence of sediment transport. Where bankfull width is substantially the same as active streambed width, as in rectangular channels, either can represent active-channel width. Flows outside of those boundaries (i.e., flood-plain flow) should not be included in the calculations because they will underestimate the boundary shear stress being exerted on the channel bed.

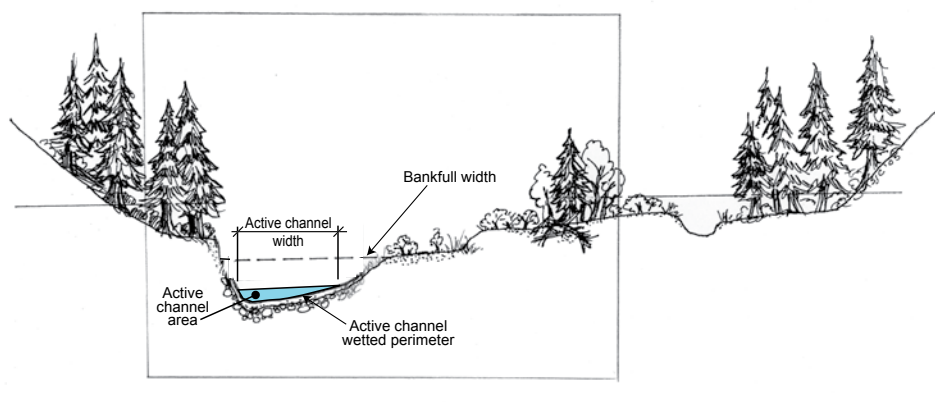

Figure E.2—Active channel width and hydraulic radius.

For channels with gradients greater than 1 percent, and where the flow depth is shallow with respect to the channel-bed particle size (relative submergence,  $R/D_{50}$  values less than 10), Bathurst (1987) suggested using discharge-per-unit width instead of average boundary shear stress for determining particle mobility. The reason is that water depth in such channels can be highly variable and is more difficult to measure accurately than discharge (Bathurst 1987). The following equation defines unit discharge:

### Equation E.2

$$q = Q/w$$

where:

$q$  is the unit discharge (cfs/ft or  $\text{ft}^2/\text{s}$ ; cms or  $\text{m}^2/\text{s}$ )

$Q$  is discharge (cfs or cms)

$w$  is the **active channel** width for bedload transport (ft or m) at a given cross section.

## Stream Simulation

---

Although there are no existing guidelines for defining the active-channel width for bedload transport, we suggest using the bed width between the lower banks to represent active-channel width because it is typically the zone of active bedload transport. The unit discharge should be determined for the portion of the total flow that occurs over the active channel bed (figure E.2). Calculating unit discharge using the total discharge instead of the portion of discharge occurring over the active-channel width would overestimate the flow actually exerting force on the active-channel bed. This overestimation of unit discharge would be magnified when floodwaters inundate a wide flood plain.

### E.1.1 Models for Calculating Flow Hydraulics

The hydraulic parameters in both equations 1 and 2 are calculated for a range of discharges and require the use of hydraulic models such as a cross section analyzer (e.g., WinXSPRO, <http://www.stream.fs.fed.us/publications/winxspro.html>) or **step-backwater** model (e.g., HEC-RAS, <http://www.hec.usace.army.mil/software/hecras/>). WinXSPRO uses a resistance-equation approach (e.g., Manning equation) and basic continuity to calculate channel geometry, flow hydraulics, and sediment transport potential at a single cross section (Hardy et al. 2005). Flow is assumed to be relatively uniform; that is, width, depth, and flow area are relatively constant along the channel, and the bed slope, water-surface slope, and energy slope are essentially parallel. WinXSPRO is also valid for gradually varied flow that is more typical of natural channels, so long as energy losses are primarily due to boundary friction (see section A.3.6). The program allows the user to subdivide the channel cross section so that overbank areas, mid-channel islands, and high-water overflow channels may be analyzed separately. The reliability of the WinXSPRO output data depends on the reliability of the cross section and bed slope data collected in the field for input into the program and the selection of channel boundary roughness or Manning's **roughness** coefficient ( $n$ ). Please refer to Hardy et al. (2005) for guidelines on collecting cross section and slope data, and the various methods available in the WinXSPRO program for determining channel roughness. WinXSPRO cannot model flow hydraulics through a culvert. We recommend modeling the stream-simulation design channel inside a culvert as an open channel, but with vertical walls having low roughness values as a surrogate for the culvert. Typically, stream-

## Appendix E—Methods for Streambed Mobility/Stability Analysis

---

simulation culverts are of sufficient width and capacity that the culvert shape has a negligible effect on flow hydraulics. However, if overbank flood-plain flows are being funneled through the culvert or the crossing is prone to **debris** jams, culvert shape could potentially affect flow hydraulics.

HEC-RAS utilizes the step-backwater method to calculate a one-dimensional, energy-balanced, water-surface profile that is a function of discharge, channel/flood-plain boundary roughness, and channel geometry (USACE 2006). For a specified discharge and assumed friction and form energy losses (channel/flood-plain boundary roughness, flow expansion/contraction) the step-backwater method iteratively calculates an energy-balanced, water-surface elevation between the surveyed cross-sections. When applying the step-backwater method to natural channels, the basic assumptions are that (1) flow is relatively steady or constant along the surveyed reach, (2) flow is gradually varied between successive cross sections, (3) flow is one dimensional, (4) slopes are less than 10 percent, and (5) the energy slope between successive cross sections is constant across the cross section. Based on the modeling results for a given discharge, various hydraulic parameters can be calculated at each cross section for both the total cross section and for sections of a subdivided cross section (e.g., channel, flood plain, channel banks, active bed width). The reliability of the HEC-RAS modeling results and subsequent hydraulic calculations depend on the accuracy with which surveyed channel/valley dimensions represent actual topography. The accuracy of estimating energy losses due to channel/flood-plain boundary roughness and to channel expansion/contraction also directly affects the reliability of model results. Please refer to USACE (2006) for guidelines on using the HEC-RAS step-backwater model. HEC-RAS can model flow through the stream-simulation design channel by using the “Lid” option. The cross-section data are entered as the bottom half of the structure and the “lid” data are entered as the top half of the culvert. Any culvert shape can be modeled, but the actual culvert shape the model uses will depend on the number of points the user inputs to define the pipe shape. Several cross sections with “lids” can be used to represent the length of the culvert. Stream-simulation culverts are almost always of sufficient width and capacity that flow is not pressurized; however, this can and should be verified in HEC-RAS at individual sites. Flow could become pressurized if a substantial volume of **overbank flow** is funneled through the culvert, or if a debris jam reduces the opening area and causes water to submerge the inlet.

## Stream Simulation

### E.1.2 What Flows to Analyze

Your choice of analysis flows for sediment entrainment will depend on the question you are trying to answer. The most common questions in stream simulation are:

At what flow (e.g., bankfull, 10-year flood, 50-year flood, 100-year flood, etc.) are the  $D_{84}$  and/or  $D_{95}$  particle sizes of the channel bed mobilized? The same flow should mobilize the  $D_{84}$  and  $D_{95}$  particle sizes in the reference-reach channel and the stream-simulation channel.

Are key pieces stable for the high bed-design flow (e.g., 10-year flood, 50-year flood, 100-year flood, etc.)? Rocks used as permanent features such as banks or roughness elements should not be mobilized by the high bed-design flow.

The following sections show how to answer these questions.

## E.2 PARTICLE ENTRAINMENT IN NATURAL CHANNELS

Many readers will be familiar with the Shields equation, which predicts critical shear stress for particle entrainment based on particle size. The Shields equation is most applicable in well-sorted streambeds composed of particles of a narrow range of sizes. For these streambeds, the relationship of forces driving and resisting particle movement at the moment of entrainment (figure E.1) can be expressed as a dimensionless ratio known as the Shields parameter:

### Equation E.3

$$\tau^* = \tau_c / (\gamma_s - \gamma) D$$

where:

$\tau^*$  is the Shields parameter

$\tau_c$  is the critical average boundary shear stress at which the sediment particle begins to move (lb/ft<sup>2</sup>)

$\gamma_s$  is the specific weight of the sediment particle (lb/ft<sup>3</sup>)

$\gamma$  is the specific weight of the fluid (lb/ft<sup>3</sup>)

D is the median size particle diameter of the channel bed (ft)



## Appendix E—Methods for Streambed Mobility/Stability Analysis

The Shields parameter—the dimensionless ratio of hydrodynamic forces acting on the bed to the submerged weight of the particles—has been determined experimentally for a wide range of particle sizes (table E.1). The parameter increases nonlinearly as the particle size increases from medium size sands to very coarse gravels (ranging from 0.029 to 0.050). For cobbles and boulders, the Shields parameter approaches a constant value of 0.054. However, Shvidchenko and Pender (2000) demonstrated that channel slope and flow depth influence the Shields parameter; the Shields parameter increases as slope increases and as flow depth with respect to particle size decreases.

Table E.1—Shield's parameter for different particle sizes. Modified from Julien 1995

Particle size classification	Particle size, $D$ (mm)	Angle of repose, $\phi$ (degrees)	Shield's parameter, $\tau^*$	Critical shear stress, $\tau_c$ (lb/ft <sup>2</sup> )
very large boulders	> 2,048	42	0.054	37.37
large boulders	1,024-2,048	42	0.054	18.68
medium boulders	512-1,024	42	0.054	9.34
small boulders	256-512	42	0.054	4.67
large cobbles	128-256	42	0.054	2.34
small cobbles	64-128	41	0.052	1.13
very coarse gravels	32-64	40	0.050	0.54
coarse gravels	16-32	38	0.047	0.25
medium gravels	8-16	36	0.044	0.12
fine gravels	4-8	35	0.042	0.057
very fine gravels	2-4	33	0.039	0.026

The equation used to determine the Shields parameter for gravels, cobbles, and boulders is  $\tau^* = 0.06 \tan\phi$ .

The Shield's parameter and critical shear stress values are for the smallest number in the particle-size interval.

Assuming  $\gamma_s = 165 \text{ lb/ft}^3$  and  $\gamma = 62.4 \text{ lb/ft}^3$ , equation 4 can be rearranged and simplified to calculate the critical shear stress to entrain a particle:

## Stream Simulation

---

### Equation E.4

$$\tau_c = \tau^* (102.6 D)$$

All equations can be used with either metric or English units, as long as the units are kept consistent. In metric units, equation 4 is  $\tau_c = \tau^* (16170 D)$ . The metric unit of shear stress is newtons/square meter ( $\text{N/m}^2$ ).

Most channels where bed mobility requires analysis for stream-simulation design are poorly sorted, that is they are made up of a wide variety of different particle sizes. In poorly sorted streambeds, the calculated values of  $\tau^*$  and  $\tau_c$  do not accurately predict sediment entrainment in the channel. To account for the variability of particle sizes in gravel- and cobble-bed channels,  $\tau^*$  is often assigned a constant value of 0.045 in the unmodified Shields equation. However, Buffington and Montgomery (1997), in a thorough review of past entrainment studies, found that the assumption of a constant value of 0.045 is not always appropriate; reference based and visually based values of  $\tau^*$  ranged from 0.052-0.086 and 0.030-0.073, respectively.

Subsequently, the Shields equation was modified for poorly sorted channels to account for the influence of adjacent particles on the stability of a given particle (Andrews 1983; Wiberg and Smith 1987; Komar 1987; Bathurst 1987). Because larger particles shield smaller ones, stronger flows are needed in poorly sorted streambeds for entraining the small particles when compared to streambeds composed of uniformly sized particles. Similarly, in poorly sorted streambeds, larger particles are entrained at weaker flows, because the larger particles project into the flow. This increased exposure enhances their entrainment despite their greater weight (figure E.3). In addition, the larger particles surrounded by smaller particles have smaller **pivoting angles**, causing them to rotate more easily from their resting position on the bed (Komar and Li 1986; Wiberg and Smith 1987).

## Appendix E—Methods for Streambed Mobility/Stability Analysis

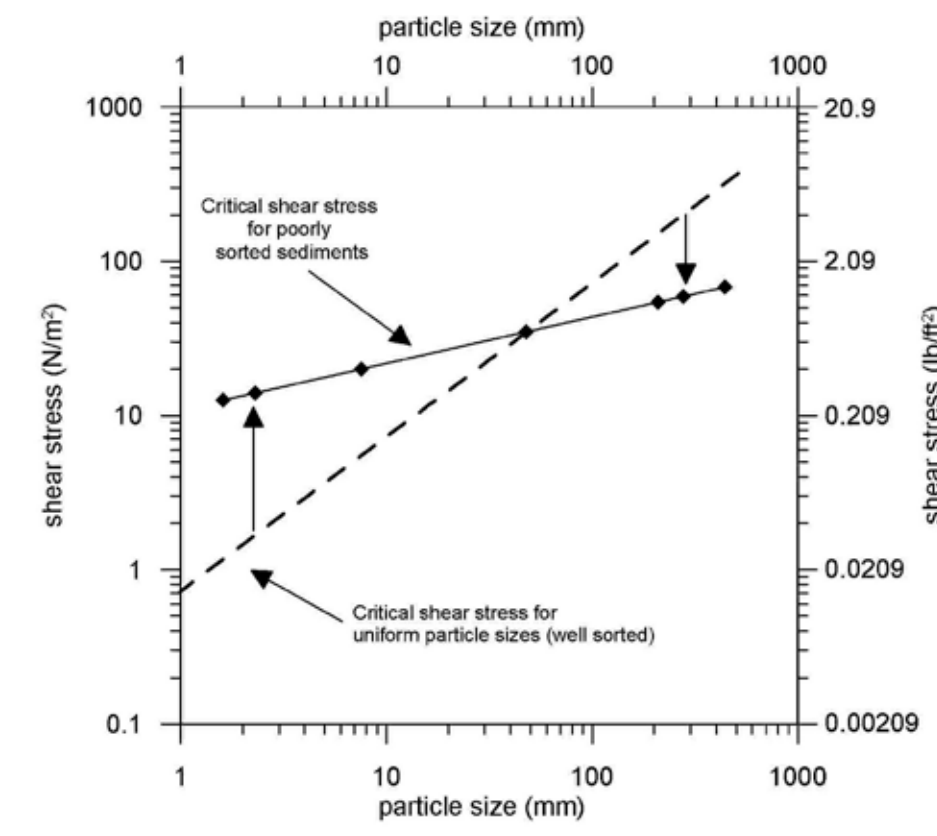

Figure E.3—Critical shear stress for well-sorted sediments compared to critical shear stress for poorly sorted sediments. Higher critical shear stress is needed to entrain smaller particles in poorly-sorted sediments because they are shielded by the larger particles. Lower critical shear stress is needed to entrain larger particles because their protrusion into the flow causes them to experience greater hydrodynamic forces. The critical shear stress line for the poorly-sorted sediments crosses the critical shear stress line for well-sorted sediment at the reference particle size ( $D_{50}$ ).

In the sections that follow, we examine two approaches for evaluating the stability of particles in poorly sorted channel beds: (1) modified critical shear stress and (2) critical unit discharge.

## Stream Simulation

### E.2.1 Modified Critical Shear Stress Approach

The modified critical shear stress equation is based on the relationship between the particle size of interest ( $D_i$ ) and  $D_{50}$ , which is assumed to be unaffected by the shielding/exposure effect (Andrews 1983; Bathurst 1987; Komar 1987, 1996; Komar and Carling 1991). For stream simulation, the particle size of interest,  $D_i$ , is usually  $D_{84}$  and/or  $D_{95}$ , because key **grade controls** are in this size range. When these particles begin to move, much of the streambed is in motion and the structure of the channel bed will change.

The modified critical shear stress equation (Komar 1987, 1997; Komar and Carling 1991) is as follows:

#### Equation E.5

$$\tau_{ci} = \tau_{D50}^* (\gamma_s - \gamma) D_i^{0.3} D_{50}^{0.7}$$

where:

$\tau_{ci}$  is the critical shear stress at which the sediment particle of interest begins to move (lb/ft<sup>2</sup> or N/m<sup>2</sup>).

$\tau_{D50}^*$  is the dimensionless Shields parameter for  $D_{50}$  particle size (this value can either be obtained from table E.1, or the value 0.045 can be used for a poorly sorted channel bed).

$D_{50}$  is the diameter (ft or m) of the median or 50th percentile particle size of the channel bed .

$D_i$  is the diameter (ft or m) of the particle size of interest. For stream simulation the particle size of interest is typically  $D_{84}$  and/or  $D_{95}$ .

Assuming  $\gamma_s = 165$  lb/ft<sup>3</sup> and  $\gamma = 62.4$  lb/ft<sup>3</sup>, equation 5 can be simplified to:

#### Equation E.6

$$\tau_{ci} = 102.6 \tau_{D50}^* D_i^{0.3} D_{50}^{0.7}$$

The modified critical shear stress equation is appropriate for assessing particle stability in riffles and plane-bed channels (i.e., where flow is relatively uniform or gradually varied between cross sections) with channel-bed gradients less than 0.05 (5 percent) and  $D_{84}$  particles ranging between 10 and 250 mm (2.5 to 10 inches). Because of the uncertainty

## Appendix E—Methods for Streambed Mobility/Stability Analysis

---

and variability of determining  $\tau_{D50}^*$  (see earlier discussion), multiple values should be used to assess how it influences the results. If the reference reach bed is tightly packed and/or **imbricated**, the Shields parameter and critical shear stress will be higher than in the newly constructed stream-simulation bed. The stream-simulation bed may need to have larger material to offset the difference in bed stability. Likewise, if angular material must be used for the stream-simulation bed, the Shields parameter and critical shear will be higher than for rounded river rock.

When applying the critical shear stress equation, be sure that the diameter for the particle size of interest (e.g.,  $D_{84}$  or  $D_{95}$ ) is not larger than 20 to 30 times the  $D_{50}$  particle diameter. For  $D_i/D_{50}$  ratios greater than 30, equation E.6 is not accurate because a large particle will roll easily over surrounding smaller sediments (Komar 1987, 1996; Carling 1992).  $D_{84}/D_{50}$  or  $D_{95}/D_{50}$  ratios are typically less than 5 in natural channels. However, where a design uses larger rock to create permanent, stable features such as banks or roughness elements, check that those rock diameters do not exceed 20 to 30 times  $D_{50}$ .

To determine critical entrainment flow at a given cross section using the modified shear stress approach, use the following process:

From equation E.6, find the critical shear stress ( $\tau_{ci}$ ) for the particle size of interest (e.g.,  $D_{84}$ ) at a given cross section. Assume  $\tau_{D50}^* = 0.045$  or use table E.1 to determine  $\tau_{D50}^*$  for the  $D_{50}$  particle size.

Calculate the boundary shear stress (equation E.1) within the active channel for a range of discharges using a hydraulic model such as WinXSPRO or HEC-RAS.

To determine whether the particle will move, compare the active-channel boundary shear stress for a particular flow to the critical shear stress for the particle size of interest. If the critical shear stress ( $\tau_{ci}$ ) of a given particle is less than the active-channel boundary shear stress ( $\tau$ ) being exerted on the particle by the flow, the particle will be entrained. If the critical shear stress ( $\tau_{ci}$ ) is greater than the active-channel boundary shear stress ( $\tau$ ) being exerted on the particle by the flow, the particle will not be entrained. See the sidebar in section E.2.3 for an example calculation.

## Stream Simulation

### E.2.2 Critical Unit Discharge Approach

For channels steeper than 1 percent ( $S = 0.01$ ) where the flow depth is shallow with respect to the channel bed particle sizes ( $R/D_{50} < 10$ ), water depth can be quite variable because large rocks or **wood** pieces on or near the surface influence depth (Bathurst 1987). For such channels, Bathurst et al. (1987) used flume data to construct the following equation, which predicts the critical unit discharge for entraining the  $D_{50}$  particle size in well-sorted sediments:

#### Equation E.7

$$q_{c-D50} = \frac{0.15 g^{0.5} D_{50}^{1.5}}{S^{1.12}}$$

where:

$q_{c-D50}$  is the critical unit discharge to entrain the  $D_{50}$  particle size  
(cfs/ft or ft<sup>2</sup>/s, cms/m or m<sup>2</sup>/s)

$D_{50}$  is the median or 50th percentile particle size (ft or m)

$g$  is gravitational acceleration (32.2 ft/s<sup>2</sup> or 9.8 m/s<sup>2</sup>)

$S$  is bed slope (ft/ft or m/m)

In the flume studies, particle sizes ranged between 3 and 44 mm (0.1 and 1.7 inches), the experimental bed materials were uniform (i.e., well-sorted), slopes ranged between 0.0025 and 0.20, and ratios of water depth to particle size approached 1 (Bathurst 1987).

Bathurst (1987) used equation E.7 to predict the entrainment of particles in poorly sorted channel beds, by comparing the particle size of interest (e.g.,  $D_{84}$  or  $D_{95}$ ) to a reference particle size. The reference particle size is the  $D_{50}$  particle size, which is assumed to move at the same flow as in a well-sorted channel. The critical unit discharge for entraining a particle size of interest is determined by:

## Appendix E—Methods for Streambed Mobility/Stability Analysis

---

### Equation E.8

$$q_{ci} = q_{c-D50} (D_i/D_{50})^b$$

where:

$q_{ci}$  is the critical unit discharge to entrain the particle size of interest (cfs/ft or ft<sup>2</sup>/s, cms/m or m<sup>2</sup>/s)

$D_i$  is the particle size of interest (mm)

$D_{50}$  is the median or 50th percentile particle size (mm)

The exponent  $b$  is a measure of the range of particle sizes that make up the channel bed. It quantifies the effects on particle entrainment of smaller particles being hidden and of larger particles being exposed to flow.

Calculate the exponent from:

### Equation E.9

$$b = 1.5(D_{84}/D_{16})^{-1}$$

where:

$D_{84}$  is the 84th percentile particle size (mm)

$D_{16}$  is the 16th percentile particle size (mm)

Equations E.8 and E.9 were derived from limited data and are most appropriate for assessing particle stability in riffles and plane-bed channels (i.e., where flow is relatively uniform or gradually varied between cross sections) with slopes ranging between 0.0360 and 0.0523, widths ranging between 20 and 36 feet,  $D_{16}$  particle sizes between 32 and 58 millimeters (1.3 and 0.67 inches),  $D_{50}$  particle sizes between 72 and 140 millimeters (2.8 and 5.5 inches), and  $D_{84}$  particle sizes between 156 and 251 millimeters (6 and 10 inches).

To determine the critical entrainment flow for a given particle size, use the following process (See the sidebar in section E.2.3 for an illustration):

- 1) Using equation E.7, calculate the critical unit discharge ( $q_{c-D50}$ ) needed to entrain the  $D_{50}$  particle size at any given cross section.
- 2) Using equation E.9, calculate the exponent ( $b$ ) based on the ratio between the  $D_{84}$  particle size and  $D_{16}$  particle size.
- 3) Using equation E.8, calculate the critical unit discharge ( $q_{ci}$ ) needed to entrain the particle size of interest at any given cross section (e.g.,  $D_{84}$  or  $D_{95}$ ).

## Stream Simulation

---

- 4) Using equation E.2, calculate the unit discharge within the active channel for a range of discharges using a hydraulic model such as WinXSPRO or HEC-RAS.

To determine whether the particle will move at any given discharge, compare the unit discharge for that flow to the critical unit discharge for the particle size of interest. If the critical unit discharge ( $q_{ci}$ ) of a given particle is less than the unit discharge ( $q$ ) being exerted on the particle by the flow, the particle will be entrained. If the critical unit discharge ( $q_{ci}$ ) is greater than the unit discharge ( $q$ ) being exerted on the particle by the flow, the particle will not be entrained.

### E.2.3 Uncertainty in Predicting Particle Entrainment

The modified critical shear stress equations (equations E.5 and E.6) and critical unit discharge equation (equation E.8) improved on the original critical shear stress equations (equations E.3 and E.4) by incorporating the effects of shielding and exposure on the entrainment of sediments. However, the modified critical shear stress and critical unit discharge equations do not account for other factors, such as:

#### Fluctuating flows

Fluctuating flows can cause temporary increases in near-bed, instantaneous stresses that cause particles to be entrained at lower values than predicted by average shear stress values acting on the bed (Nelson et al. 1995; Knighton 1998). Depending on channel and flow conditions, instantaneous shear-stress values near the bed can be 2 to 3 times greater than the average boundary shear stress (Richardson et al. 1990; Knighton 1998).



## Appendix E—Methods for Streambed Mobility/Stability Analysis

---

### Particle shape

Angular particles require higher shear stresses to move than spherical particles of similar size, because of a greater **pivot angle** associated with angular particles (Reid and Frostick 1994). Flat, disc-shaped particles are usually well imbricated, making the particles more resistant to entrainment (Carling 1992).

### Channel-bed structure

For channel beds composed of particles coarser than 8 millimeters (0.3 inch), Church (1978) demonstrated that the Shields parameter can vary by a factor of two, depending on whether the channel bed is loosely consolidated or tightly packed. Recently deposited sediments can be poorly packed, making it easier for those particles to be entrained than if they were tightly packed or highly consolidated (Church 1978; Reid and Frostick 1994). With time after a large flood, the bed consolidates as low flows slightly rearrange particles so that they are more tightly packed and more difficult to entrain (Church 1978). Reid et al. (1985) demonstrated that the shear stress needed to entrain particles could be up to three times higher than the average when the flood occurred after an extended period of no bed disturbance.

Although table E.1 and equations E.4, E.6, and E.8 suggest a distinct threshold at which a particle is entrained, the previous discussion makes clear that the entrainment of a particle does not occur at a distinct critical shear stress value, but instead may occur over a range of critical shear stresses. Nevertheless, the equations provide insights on the relative mobility of channel-bed sediments for a range of flows. If the flows that mobilize sediment in the reference reach are different than those in the stream-simulation design channel, these equations can help you assess whether the difference is significant, and whether the stream-simulation design channel needs to be adjusted so that its particle mobility is similar to that of the reference reach.

## Stream Simulation

### Using the equations to determine if $D_{84}$ moves at bankfull flow in the reference reach

The reference reach selected for a stream-simulation culvert on Example Creek is a pool-riffle reach with a gravel-cobble bed (figure E.4).



Figure E.4—Downstream view of Example Creek, a pool-riffle channel composed primarily of gravels and cobbles and local inputs of wood.

Bankfull flow, 106 cubic feet per second, was estimated using the HEC-RAS step-backwater model to generate a water-surface profile that matched bankfull elevations identified in the field using geomorphic indicators. The portion of flow over the active bed width was 102 cubic feet per second. Channel data for one of the cross sections are listed below:

Bankfull width ( $W_{bf}$ ) = 18.7 feet

Active bed width ( $w_a$ ) = 15.3 feet

Slope ( $s$ ) = 0.0142 feet/feet

Hydraulic radius for the active channel during bankfull flow ( $R_{bf}$ ) = 1 foot

$D_{84}$  = 120 mm (0.39 feet)

$D_{50}$  = 52 mm (0.17 feet)

$D_{16}$  = 27 mm (0.089 feet)

Determine whether the  $D_{84}$  particle moves at bankfull flow at this cross section.

#### Modified critical shear stress equation

Find critical shear stress for  $D_{84}$  using equation E.6:

$\tau_{D50}^* = 0.050$  (from table E.1) for 52 mm particles

$\tau_{ci} = 102.6 \tau_{D50}^* D_i^{0.3} D_{50}^{0.7}$  (equation E.6)

$\tau_{c-D84} = 102.6(0.050)(0.39 \text{ ft})^{0.3} (0.17 \text{ ft})^{0.7} = 1.12 \text{ lb/ft}^2$

Find the average boundary shear stress in the reference reach at bankfull flow ( $\tau_{bf}$ ) using equation E.1:

$\tau = \gamma RS$  (equation E.1)

$\tau_{bf} = (62.4 \text{ lb/ft}^2)(1 \text{ ft})(0.0142) = 0.90 \text{ lb/ft}^2$

The  $D_{84}$  particle is stable at bankfull flow because  $\tau_{c-D84}$  ( 1.12 lb/ft<sup>2</sup>) is greater than  $\tau_{bf}$  (0.90 lb/ft<sup>2</sup>)

The  $D_{84}$  particle size is stable at bankfull flow.

## Appendix E—Methods for Streambed Mobility/Stability Analysis

How well does the modified critical shear stress equation apply here?

- $D_{84}/D_{50} = 2.3$ , which is much less than 30.
- Slope < 5 percent.
- Channel unit is a riffle.
- $D_{84}$  particle size of 120 millimeter is between the range of 10 and 250 millimeters.

Conclusion: The modified critical shear stress equation (equation E.6) is applicable to this stream.

### Critical unit discharge equation

Find the critical unit discharge for  $D_{50}$  ( $q_{c-D50}$ ) using equation E.7:

$$q_{c-D50} = \frac{0.15 g^{0.5} D_{50}^{1.5}}{S^{1.12}} \quad (\text{equation E.7})$$

$$q_{c-D50} = \frac{(0.15)(32.2 \text{ ft/s}^2)^{0.5} (0.17 \text{ ft})^{1.5}}{0.0142^{1.12}} = 7.0 \text{ cfs/ft}$$

Calculate  $b$  (which quantifies the range in particle sizes) using equation E.9:

$$b = 1.5(D_{84}/D_{16})^{-1} \quad (\text{equation E.9})$$

$$b = 1.5(0.39 \text{ ft}/0.089 \text{ ft})^{-1} = 0.34$$

Find critical unit discharge for  $D_{84}$  ( $q_{c-D84}$ ) using equation E.8:

$$q_{ci} = q_{c-D50} (D_i/D_{50})^b \quad (\text{equation E.8})$$

$$q_{c-D84} = 7 \text{ cfs/ft} (0.39 \text{ ft}/0.17 \text{ ft})^{0.342} = 9.3 \text{ cfs/ft}$$

Calculate unit discharge in the reference reach active channel at bankfull flow using equation 2:

$$q = Q/w_a \quad (\text{equation E.2})$$

$$q = Q_{\text{bf-active ch}}/w_a = 102 \text{ cfs}/15.3 \text{ ft} = 6.7 \text{ cfs/ft}$$

The  $D_{84}$  particle is stable at bankfull flow because  $q_{c-D84}$  (9.3 cfs/ft) is greater than  $q_{\text{bf-active ch}}$  (6.7 cfs/ft). The results for critical unit discharge agree with those of the modified critical shear stress equation.

Is the critical unit discharge equation (equation E.8) appropriate for this stream?

- Slope > 1 percent.
- Channel unit is a riffle.
- $D_{16}$ ,  $D_{50}$ , and  $D_{84}$  are smaller than the particle sizes used to develop the critical unit discharge equation for  $D_{84}$ .
- $R_{\text{bf}}/D_{50} = 5.9$ , which is < 10 (low relative submergence).

Figure E.4 shows there are some scattered large roughness elements (logs and rocks) that appear to be higher than 1-foot ( $R_{\text{bf}}$ ) above the streambed. Conclusion: The critical unit discharge equation (equation E.8) should be used with caution since particle sizes are outside the range of particle sizes used to develop the equation.

## Stream Simulation

### E.3 SEDIMENT MOBILITY/STABILITY ANALYSIS EXAMPLE: SCHAFER CREEK TRIBUTARY

This example applies the modified critical shear stress and critical unit discharge approaches to a stream-simulation design on a tributary of Schafer Creek in the Olympic National Forest, Washington. The purpose is to (1) evaluate whether the stream-simulation design bed would have similar mobility/stability as the reference-reach channel and (2) adjust the stream-simulation design so that it has similar mobility and stability as the reference-reach channel. At this site, sediment mobility was actually evaluated for several reaches within the **project profile** to determine the range of sediment mobility; however, this example limits the discussion to comparing sediment mobility/stability between the stream-simulation design bed and the reference-reach channel.

#### E.3.1 Channel and Road-stream Crossing Background Information

The channel upstream and downstream from the road crossing has a plane-bed to pool-riffle morphology and is slightly to moderately confined with greater channel confinement downstream from the crossing. The channel upstream and downstream from the road-stream crossing has bankfull widths ranging between 5.5 and 7.6 meters (18 to 25 feet), pool residual depths ranging between 0.3 and 0.5 meters (1.0 to 1.6 feet), and channel gradients ranging between 1 and 2 percent (figure E.5). The channel-bed surface is composed primarily of gravel- and cobble-sized sediment. The channel bed is moderately to well armored; the subarmor layer consists of a poorly sorted mixture of cobbles, gravels, and sands. Channel **bed structures** in the riffles and plane-bed channel segments consist primarily of **transverse bars** or rock clusters composed of cobbles and small boulders.

The existing culvert at the crossing is undersized, in a deteriorated condition, and is a partial **barrier** to **anadromous** fish at various life stages and flows (figure E.6). The culvert is a round corrugated pipe with a diameter of 1.52 meters (5 feet) diameter and a length of 30.5 meters (100 feet). There is a 0.4-meter (1.3-foot) drop at the culvert outlet and the associated plunge pool has a residual pool depth of 2.1 meters (6.9 feet) which is four times deeper than other pools along the channel (figure E.5). Sediment accumulation at the culvert inlet extends about 25-meters (82 feet) upstream from the culvert (figure E.5). Based on evidence such as increased bank heights, undercut banks, and localized bank failures, the channel downstream from the road-stream crossing has incised about 0.5 to 1.0 meter (1.6 to 3.3 feet) (figure E.5).

# Appendix E—Methods for Streambed Mobility/Stability Analysis

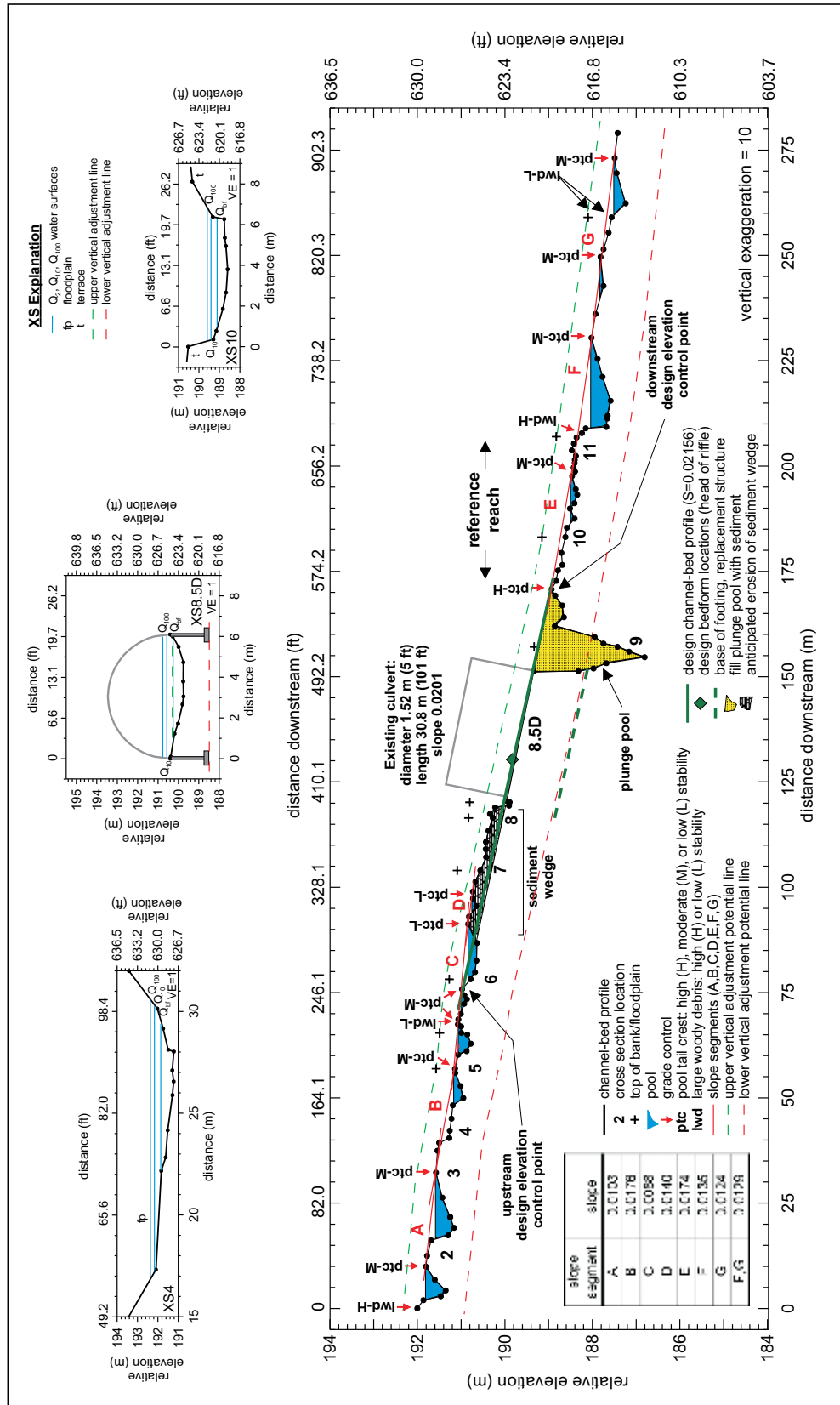

Figure E.5—A longitudinal profile and selected cross sections showing channel characteristics and dimensions along the Schafer Creek tributary.

## Stream Simulation

---



*Figure E.6—The culvert outlet and the upper segment of the reference-reach channel at the Schafer Creek tributary. Note the perch of the culvert outlet and its size relative to the channel.*

The Schafer Creek tributary site is an example of a common situation where an undersized culvert has created a moderate plunge at its outfall and the downstream channel has incised. In essence, the existing undersized culvert is acting as a **nickpoint** preventing **channel incision** from continuing upstream. In situations such as this, reestablishing geomorphic continuity between the upstream and downstream channels requires either a stream-simulation channel that is slightly steeper than the reference reach or extensive restoration of the downstream channel to raise the channel bed.

A downstream reference reach (XS10) was chosen because the stream is slightly steeper, more confined, and the bed is somewhat coarser than other segments of the channel; these characteristics are needed inside the replacement structure. The channel geometry and channel-bed sediment characteristics from XS10 were used to develop a preliminary design for the stream-simulation channel bed. The replacement structure for this crossing was a 6.1-meter (20-foot)-wide open-bottom arch; this width is similar to the bankfull width at XS10. The preliminary stream-simulation channel-bed design slope is 0.0216, which is 24-percent steeper than the reference-reach channel slope (figure E.5). The difference in slopes makes it important to check for similar mobility.

## Appendix E—Methods for Streambed Mobility/Stability Analysis

Both the modified critical shear stress and critical unit discharge approaches are applicable at this site based on channel characteristics and both were used in the sediment mobility/stability analyses for comparison (tables E.2 and E.3). The step-backwater model HEC-RAS was used to model flow hydraulics for a range of discharges between just below bankfull to just above the  $Q_{100}$  discharge. Using geomorphic indicators for bankfull and the HEC-RAS model, bankfull discharge was estimated to be 3 cubic meters per second ( $m^3/s$ ). Regional regression equations were used to predict the discharges for the  $Q_2$ ,  $Q_{10}$ ,  $Q_{50}$ , and  $Q_{100}$  floods. Selected hydraulic parameters from the model used in the sediment mobility/stability analyses are summarized in tables E.2 and E.3.

### E.3.2 Modified Critical Shear Stress Approach

Results from the modified critical shear stress analysis show that the  $D_{84}$  particle size of 160 millimeters in both the preliminary stream-simulation design channel and reference-reach channel has a critical shear stress ( $\tau_{c-D84}$ ) of  $81 \text{ N/m}^2$  (table E.2A-B). In the reference-reach channel the  $D_{84}$  particle size is mobilized at a lower discharge of about  $5 \text{ m}^3/s$  when the active channel boundary shear stress is  $82 \text{ N/m}^2$  (table E.2A and figure E.7). In contrast, the  $D_{84}$  particle size in the design channel is mobilized at a discharge of about  $4 \text{ m}^3/s$  when the active channel boundary shear stress is  $85 \text{ N/m}^2$  (table E.2B and figure E.7). The steeper slope in the preliminary design channel is the primary reason for the higher shear stresses when compared to the reference-reach channel for a given discharge. At this site, the project team decided not to reconfigure the channel to reduce the slope through the crossing. Instead they opted to increase the  $D_{50}$  and  $D_{84}$  particle sizes to achieve entrainment at the same discharge in both the design channel and reference-reach channel. The  $D_{50}$  and  $D_{84}$  particles were increased in size by 20 percent from 95 to 114 millimeters and 160 to 192 millimeters, respectively (table E.2C and figure E.7). These sediment-size adjustments increased the critical shear stress for the  $D_{84}$  particle ( $\tau_{c-D84}$ ) in the stream-simulation design channel from  $81 \text{ N/m}^2$  to  $97 \text{ N/m}^2$ . The changes are within the acceptable range of 25-percent difference in slope and particle size between the stream simulation and reference channels.

Table E.2—Summary of flow hydraulics and particle mobility/stability for the reference-reach channel and design channel using the modified critical shear stress approach

Recur- rence Interval	Dis- charge, Q (m <sup>3</sup> /s)	Flood- plain n value	Channel n value	Channel slope S <sub>c</sub>	Energy slope S <sub>e</sub>	Hydraulics						Particle Mobility/Stability					
						Total flow width W <sub>t</sub> (m)	Channel flow width W <sub>c</sub> (m)	Total hydraulic radius R <sub>t</sub> (m)	Channel hydraulic radius R <sub>c</sub> (m)	Total boundary shear stress τ <sub>t</sub> (N/m <sup>2</sup> ) <sup>b</sup>	Channel boundary shear stress τ <sub>c</sub> (N/m <sup>2</sup> ) <sup>b</sup>	D <sub>50</sub> (mm)	D <sub>84</sub> (mm)	Angle of repose φ	Shield's en-train- ment for D <sub>50</sub> τ* D <sub>50</sub>	Critical shear stress to en-train D <sub>84</sub> particle size τ <sub>c-D84</sub> (N/m <sup>2</sup> ) <sup>d</sup>	D <sub>84</sub> mobile (yes /no)
A. Reference reach cross section: XS10																	
	2.00	0.150	0.050	0.0174	0.0174	5.19	5.19	0.30	0.30	51	51	95	160	42	0.045	81	no
	3.00	0.150	0.050	0.0174	0.0174	5.55	5.55	0.37	0.37	63	63	95	160	42	0.045	81	no
	4.00	0.150	0.050	0.0174	0.0174	5.81	5.81	0.43	0.43	73	74	95	160	42	0.045	81	no
2	4.20	0.150	0.050	0.0174	0.0174	5.86	5.86	0.44	0.44	75	75	95	160	42	0.045	81	no
	5.00	0.150	0.050	0.0174	0.0174	6.01	6.01	0.47	0.48	80	82	95	160	42	0.045	81	yes
	6.00	0.150	0.050	0.0174	0.0174	6.10	6.01	0.52	0.53	89	91	95	160	42	0.045	81	yes
10	6.70	0.150	0.050	0.0174	0.0174	6.18	6.01	0.54	0.57	92	97	95	160	42	0.045	81	yes
	7.00	0.150	0.050	0.0174	0.0174	6.22	6.01	0.55	0.58	94	99	95	160	42	0.045	81	yes
25	7.80	0.150	0.050	0.0174	0.0174	6.30	6.01	0.58	0.62	99	106	95	160	42	0.045	81	yes
	8.00	0.150	0.050	0.0174	0.0174	6.32	6.01	0.59	0.63	101	108	95	160	42	0.045	81	yes
50	8.80	0.150	0.050	0.0174	0.0174	6.40	6.01	0.61	0.67	104	114	95	160	42	0.045	81	yes
	9.00	0.150	0.050	0.0174	0.0174	6.42	6.01	0.62	0.67	106	114	95	160	42	0.045	81	yes
100	9.90	0.150	0.050	0.0174	0.0174	6.51	6.01	0.65	0.71	111	121	95	160	42	0.045	81	yes
	10.00	0.150	0.050	0.0174	0.0174	6.52	6.01	0.65	0.72	111	123	95	160	42	0.045	81	yes
	11.00	0.150	0.050	0.0174	0.0174	6.61	6.01	0.68	0.76	116	130	95	160	42	0.045	81	yes

<sup>a</sup> τ<sub>t</sub> = γ R<sub>t</sub> S<sub>e</sub> (similar to equation E.1).

<sup>b</sup> τ<sub>c</sub> = γ R<sub>c</sub> S<sub>c</sub> (similar to equation E.1).

<sup>c</sup> τ\*<sub>D50</sub> was assumed to be 0.045. Alternative values could be obtained from table E.1.

<sup>d</sup> τ<sub>c-D84</sub> = 16170 (τ\*<sub>D50</sub>) (D<sub>84</sub>)<sup>0.3</sup> (D<sub>50</sub>)<sup>0.7</sup> (similar to equation E.5).



Table E.2—Summary of flow hydraulics and particle mobility/stability for the reference-reach channel and design channel using the modified critical shear stress approach (continued)

Recur- rence Interval	Dis- charge, Q (m <sup>3</sup> /s)	Flood- plain n value	Channel n value	Channel slope S <sub>c</sub>	Energy slope S <sub>e</sub>	Hydraulics					Particle Mobility/Stability						
						Total flow width W <sub>t</sub> (m)	Channel flow width W <sub>c</sub> (m)	Total hydraulic radius R <sub>t</sub> (m)	Channel hydraulic radius R <sub>c</sub> (m)	Total boundary shear stress τ <sub>t</sub> (N/m <sup>2</sup> ) <sup>a</sup>	Channel boundary shear stress τ <sub>c</sub> (N/m <sup>2</sup> ) <sup>b</sup>	D <sub>50</sub> (mm)	D <sub>84</sub> (mm)	Angle of repose φ	Shield's enrain- ment for D <sub>50</sub> τ* <sub>D50</sub>	Critical shear stress to enrain D <sub>84</sub> particle size τ* <sub>D84</sub> <sup>d</sup> (N/m <sup>2</sup> )	D <sub>84</sub> mobile (yes /no)
<b>B. Preliminary stream simulation design channel: XS8.5D</b>																	
	2.00	0.028	0.050	0.0216	0.0212	4.67	4.67	0.31	0.31	66	64	95	160	42	0.045	81	no
	3.00	0.028	0.050	0.0216	0.0211	5.49	5.47	0.36	0.36	76	75	95	160	42	0.045	81	no
	4.00	0.028	0.050	0.0216	0.0212	6.02	5.90	0.40	0.41	85	85	95	160	42	0.045	81	yes
2	4.20	0.028	0.050	0.0216	0.0212	6.07	5.90	0.41	0.42	87	87	95	160	42	0.045	81	yes
	5.00	0.028	0.050	0.0216	0.0211	6.09	5.90	0.45	0.47	95	97	95	160	42	0.045	81	yes
	6.00	0.028	0.050	0.0216	0.0211	6.07	5.90	0.49	0.52	104	107	95	160	42	0.045	81	yes
10	6.70	0.028	0.050	0.0216	0.0210	6.06	5.90	0.52	0.56	110	115	95	160	42	0.045	81	yes
	7.00	0.028	0.050	0.0216	0.0210	6.06	5.90	0.53	0.57	112	117	95	160	42	0.045	81	yes
25	7.80	0.028	0.050	0.0216	0.0209	6.05	5.90	0.56	0.61	119	125	95	160	42	0.045	81	yes
	8.00	0.028	0.050	0.0216	0.0209	6.05	5.90	0.57	0.62	121	127	95	160	42	0.045	81	yes
50	8.80	0.028	0.050	0.0216	0.0209	6.04	5.90	0.59	0.66	125	135	95	160	42	0.045	81	yes
	9.00	0.028	0.050	0.0216	0.0209	6.04	5.90	0.60	0.67	127	137	95	160	42	0.045	81	yes
100	9.90	0.028	0.050	0.0216	0.0208	6.02	5.90	0.63	0.71	133	145	95	160	42	0.045	81	yes
	10.00	0.028	0.050	0.0216	0.0208	6.02	5.90	0.63	0.71	133	145	95	160	42	0.045	81	yes
	11.00	0.028	0.050	0.0216	0.0208	6.01	5.90	0.66	0.75	140	153	95	160	42	0.045	81	yes

<sup>a</sup> τ<sub>t</sub> = γ R<sub>t</sub> S<sub>e</sub> (similar to equation E.1).

<sup>b</sup> τ<sub>c</sub> = γ R<sub>c</sub> S<sub>c</sub> (similar to equation E.1).

<sup>c</sup> τ\*<sub>D50</sub> was assumed to be 0.045. Alternative values could be obtained from table E.1.

<sup>d</sup> τ\*<sub>D84</sub> = 16170 (τ\*<sub>D50</sub>)<sup>0.3</sup> (D<sub>84</sub>)<sup>0.7</sup> (similar to equation E.5).

Table E.2—Summary of flow hydraulics and particle mobility/stability for the reference-reach channel and design channel using the modified critical shear stress approach (continued)

Recur- rence Interval	Dis- charge, Q (m <sup>3</sup> /s)	Flood- plain n value	Channel n value	Channel slope S <sub>c</sub>	Energy slope S <sub>e</sub>	Hydraulics						Particle Mobility/Stability					
						Total flow width W <sub>t</sub> (m)	Channel flow width W <sub>c</sub> (m)	Total hydraulic radius R <sub>t</sub> (m)	Channel hydraulic radius R <sub>c</sub> (m)	Total boundary shear stress τ <sub>t</sub> (N/m <sup>2</sup> ) <sup>a</sup>	Channel boundary shear stress τ <sub>c</sub> (N/m <sup>2</sup> ) <sup>b</sup>	D <sub>50</sub> (mm)	D <sub>84</sub> (mm)	Angle of repose φ	Shield's entrain- ment for D <sub>50</sub> τ* <sub>D50</sub>	Critical shear stress to entrain D <sub>84</sub> particle size τ <sub>c-D84</sub> (N/m <sup>2</sup> ) <sup>d</sup>	D <sub>84</sub> mobile (yes /no)
<b>C. Adjusted stream simulation design channel: XS8.5D</b>																	
	2.00	0.028	0.050	0.0216	0.0212	4.67	4.67	0.31	0.31	66	64	114	192	42	0.045	97	no
	3.00	0.028	0.050	0.0216	0.0211	5.49	5.47	0.36	0.36	76	75	114	192	42	0.045	97	no
	4.00	0.028	0.050	0.0216	0.0212	6.02	5.90	0.41	0.41	85	85	114	192	42	0.045	97	no
2	4.20	0.028	0.050	0.0216	0.0212	6.07	5.90	0.41	0.42	87	87	114	192	42	0.045	97	no
	5.00	0.028	0.050	0.0216	0.0211	6.09	5.90	0.45	0.47	95	97	114	192	42	0.045	97	yes
	6.00	0.028	0.050	0.0216	0.0211	6.07	5.90	0.49	0.52	104	107	114	192	42	0.045	97	yes
10	6.70	0.028	0.050	0.0216	0.0210	6.06	5.90	0.52	0.56	110	115	114	192	42	0.045	97	yes
	7.00	0.028	0.050	0.0216	0.0210	6.06	5.90	0.53	0.57	112	117	114	192	42	0.045	97	yes
	7.80	0.028	0.050	0.0216	0.0209	6.05	5.90	0.56	0.61	119	125	114	192	42	0.045	97	yes
25	8.00	0.028	0.050	0.0216	0.0209	6.05	5.90	0.57	0.62	121	127	114	192	42	0.045	97	yes
	8.80	0.028	0.050	0.0216	0.0209	6.04	5.90	0.59	0.66	125	135	114	192	42	0.045	97	yes
	9.00	0.028	0.050	0.0216	0.0209	6.04	5.90	0.60	0.67	127	137	114	192	42	0.045	97	yes
100	9.90	0.028	0.050	0.0216	0.0208	6.02	5.90	0.63	0.71	133	145	114	192	42	0.045	97	yes
	10.00	0.028	0.050	0.0216	0.0208	6.02	5.90	0.63	0.71	133	145	114	192	42	0.045	97	yes
	11.00	0.028	0.050	0.0216	0.0208	6.01	5.90	0.66	0.75	140	153	114	192	42	0.045	97	yes

<sup>a</sup> τ<sub>t</sub> = γ R<sub>t</sub> S<sub>e</sub> (similar to equation E.1).

<sup>b</sup> τ<sub>c</sub> = γ R<sub>c</sub> S<sub>e</sub> (similar to equation E.1).

<sup>c</sup> τ\*<sub>D50</sub> was assumed to be 0.045. Alternative values could be obtained from table E.1.

<sup>d</sup> τ<sub>c-D84</sub> = 16170 (τ\*<sub>D50</sub>) (D<sub>84</sub>)<sup>0.3</sup> (D<sub>50</sub>)<sup>0.7</sup> (similar to equation E.5).

## Appendix E—Methods for Streambed Mobility/Stability Analysis

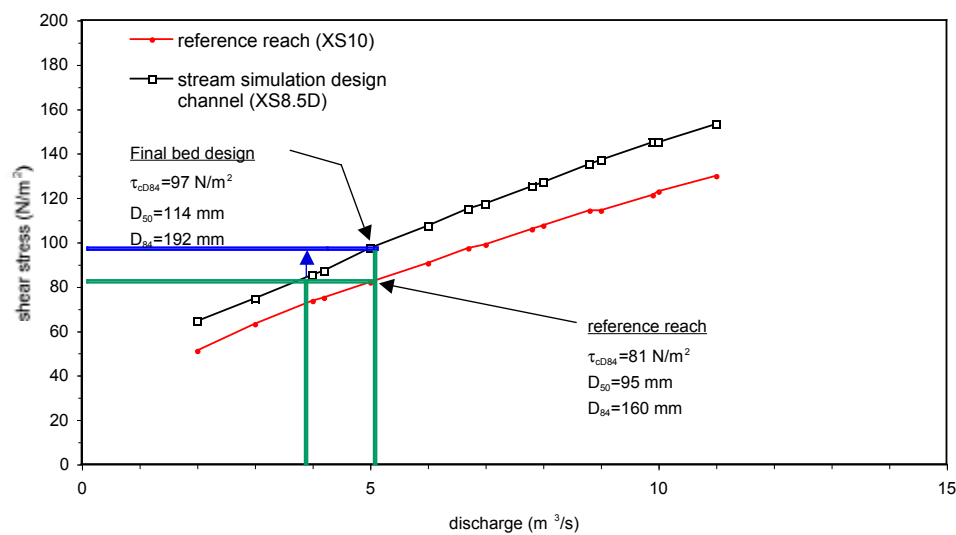

Figure E.7—Plot of shear stress versus discharge showing when the  $D_{84}$  particle is mobilized in the reference-reach channel and the preliminary stream-simulation design channel. To achieve similar  $D_{84}$  particle mobility in the stream-simulation design channel at the same flow as the reference-reach channel, the  $D_{50}$  and  $D_{84}$  particle sizes were increased in size by 20 percent to 114 mm and 192 mm, respectively.

### E.3.3 Critical Unit Discharge Approach

Results from the critical unit discharge analysis show that the  $D_{84}$  particle size of 160 millimeters has a critical unit discharge ( $q_{c-D84}$ ) of  $1.59 \text{ m}^2/\text{s}$  in the reference-reach channel, whereas it is  $1.25 \text{ m}^2/\text{s}$  in the preliminary stream-simulation design channel (table E.3A-B). The lower critical unit discharge in the design channel indicates the  $D_{84}$  particle size will mobilize at lower discharges when compared to the reference-reach channel because of the steeper slope (figure E.8). The  $D_{84}$  particle size is mobilized at a discharge of about  $7.8 \text{ m}^3/\text{s}$  in the reference-reach channel, whereas it is mobilized at a discharge of  $5.6 \text{ m}^3/\text{s}$  in the preliminary design channel. The unit discharges for the various discharges are similar between the reference-reach channel and the design-channel reach because they have similar active channel widths and entrenchment ratios (table E.3 and figure E.8). To achieve similar sediment mobility in the stream-simulation design channel at the same discharge as the reference-reach channel, the  $D_{16}$ ,  $D_{50}$ , and  $D_{84}$  particle sizes were increased from 43 to 50 millimeters, 95 to 112 millimeters, and 160 to 188 millimeters, respectively (table E.3C and figure E.8). These sediment size adjustments increased the critical unit discharge for the  $D_{84}$  particle ( $q_{c-D84}$ ) in the stream-simulation design channel from  $1.25 \text{ m}^2/\text{s}$  to  $1.59 \text{ m}^2/\text{s}$ .

Table E.3—Summary of flow hydraulics and particle mobility/stability for the reference-reach channel and design channel using the critical unit discharge approach

Recur- rence Interval	Hydraulics										Particle Mobility/Stability					
	Dis- charge, Q (m <sup>3</sup> /s)	Active Channel width discharge Q <sub>a</sub> (m <sup>3</sup> /s)	Flood plain n value	Channel n value	Total flow width W <sub>t</sub> (m)	Active channel width W <sub>a</sub> (m)	Total unit discharge q <sub>t</sub> (m <sup>2</sup> /s) <sup>a</sup>	Active channel unit discharge q <sub>a</sub> (m <sup>2</sup> /s) <sup>b</sup>	Channel slope S <sub>c</sub>	D <sub>16</sub> (mm)	D <sub>50</sub> (mm)	D <sub>84</sub> (mm)	Particle size range measure b <sup>c</sup>	Critical unit discharge for D <sub>50</sub> q <sub>c-D50</sub> (m <sup>2</sup> /s) <sup>d</sup>	Critical unit discharge to entrain D <sub>84</sub> particle size q <sub>c-D84</sub> (m <sup>2</sup> /s) <sup>e</sup>	D <sub>84</sub> particle mobile (yes/no)
<b>A. Reference reach cross section: XS10</b>																
	2.00	1.96	0.15	0.05	5.14	4.40	0.39	0.45	0.0174	43	95	160	0.40	1.29	1.59	no
	3.00	2.89	0.15	0.05	5.46	4.40	0.55	0.66	0.0174	43	95	160	0.40	1.29	1.59	no
	4.00	3.80	0.15	0.05	5.72	4.40	0.70	0.86	0.0174	43	95	160	0.40	1.29	1.59	no
2	4.20	3.98	0.15	0.05	5.76	4.40	0.73	0.90	0.0174	43	95	160	0.40	1.29	1.59	no
	5.00	4.69	0.15	0.05	5.93	4.40	0.84	1.06	0.0174	43	95	160	0.40	1.29	1.59	no
	6.00	5.54	0.15	0.05	6.04	4.40	0.99	1.26	0.0174	43	95	160	0.40	1.29	1.59	no
10	6.70	6.12	0.15	0.05	6.12	4.40	1.09	1.39	0.0174	43	95	160	0.40	1.29	1.59	no
	7.00	6.37	0.15	0.05	6.15	4.40	1.14	1.45	0.0174	43	95	160	0.40	1.29	1.59	no
25	7.80	7.03	0.15	0.05	6.24	4.40	1.25	1.60	0.0174	43	95	160	0.40	1.29	1.59	yes
	8.00	7.19	0.15	0.05	6.26	4.40	1.28	1.63	0.0174	43	95	160	0.40	1.29	1.59	yes
50	8.80	7.85	0.15	0.05	6.34	4.40	1.39	1.78	0.0174	43	95	160	0.40	1.29	1.59	yes
	9.00	8.01	0.15	0.05	6.36	4.40	1.42	1.82	0.0174	43	95	160	0.40	1.29	1.59	yes
100	9.90	8.74	0.15	0.05	6.44	4.40	1.54	1.99	0.0174	43	95	160	0.40	1.29	1.59	yes
	10.00	8.82	0.15	0.05	6.45	4.40	1.55	2.00	0.0174	43	95	160	0.40	1.29	1.59	yes
	11.00	9.62	0.15	0.05	6.55	4.40	1.68	2.19	0.0174	43	95	160	0.40	1.29	1.59	yes

<sup>a</sup> q<sub>t</sub> = Q / W<sub>t</sub> (similar to equation E.2).

<sup>b</sup> q<sub>a</sub> = Q<sub>a</sub> / W<sub>a</sub> (similar to equation E.2).

<sup>c</sup> b = 1.5(D<sub>84</sub>/D<sub>16</sub>)<sup>-1</sup> (equation E.9).

<sup>d</sup> q<sub>c-D50</sub> = 0.15 (g)<sup>0.5</sup> (D<sub>50</sub>)<sup>1.5</sup> (S)<sup>1.12</sup> (equation E.7).

<sup>e</sup> q<sub>c-D84</sub> = q<sub>c-D50</sub> (D<sub>84</sub>/D<sub>50</sub>)<sup>b</sup> (similar to equation E.8).

Table E.3—Summary of flow hydraulics and particle mobility/stability for the reference-reach channel and design channel using the critical unit discharge approach (continued)

Recur- rence Interval	Hydraulics										Particle Mobility/Stability					
	Dis- charge, Q (m <sup>3</sup> /s)	Active Channel width discharge Q <sub>a</sub> (m <sup>3</sup> /s)	Flood plain n value	Channel n value	Total flow width W <sub>t</sub> (m)	Active channel width W <sub>a</sub> (m)	Total unit discharge q <sub>t</sub> (m <sup>2</sup> /s) <sup>a</sup>	Active channel unit discharge q <sub>a</sub> (m <sup>2</sup> /s) <sup>b</sup>	Channel slope S <sub>c</sub>	D <sub>16</sub> (mm)	D <sub>50</sub> (mm)	D <sub>84</sub> (mm)	Particle size range measure b <sup>c</sup>	Critical unit discharge for D <sub>50</sub> q <sub>c-D50</sub> (m <sup>2</sup> /s) <sup>d</sup>	Critical unit discharge to entrain D <sub>84</sub> particle size q <sub>c-D84</sub> (m <sup>2</sup> /s) <sup>e</sup>	D <sub>84</sub> particle mobile (yes/no)
<b>B. Stream simulation preliminary design: XS8.5D</b>																
	2.00	1.99	0.15	0.05	4.35	4.11	0.46	0.48	0.0216	43	95	160	0.40	1.01	1.25	no
	3.00	2.96	0.15	0.05	4.90	4.27	0.61	0.69	0.0216	43	95	160	0.40	1.01	1.25	no
	4.00	3.89	0.15	0.05	5.54	4.27	0.72	0.91	0.0216	43	95	160	0.40	1.01	1.25	no
2	4.20	4.08	0.15	0.05	5.62	4.27	0.75	0.95	0.0216	43	95	160	0.40	1.01	1.25	no
	5.00	4.77	0.15	0.05	6.03	4.27	0.83	1.12	0.0216	43	95	160	0.40	1.01	1.25	no
	6.00	5.61	0.15	0.05	6.09	4.27	0.99	1.31	0.0216	43	95	160	0.40	1.01	1.25	yes
10	6.70	6.18	0.15	0.05	6.08	4.27	1.10	1.45	0.0216	43	95	160	0.40	1.01	1.25	yes
	7.00	6.43	0.15	0.05	6.07	4.27	1.15	1.51	0.0216	43	95	160	0.40	1.01	1.25	yes
25	7.80	7.09	0.15	0.05	6.06	4.27	1.29	1.66	0.0216	43	95	160	0.40	1.01	1.25	yes
	8.00	7.25	0.15	0.05	6.06	4.27	1.32	1.70	0.0216	43	95	160	0.40	1.01	1.25	yes
50	8.80	7.89	0.15	0.05	6.05	4.27	1.45	1.85	0.0216	43	95	160	0.40	1.01	1.25	yes
	9.00	8.06	0.15	0.05	6.05	4.27	1.49	1.89	0.0216	43	95	160	0.40	1.01	1.25	yes
100	9.90	8.78	0.15	0.05	6.04	4.27	1.64	2.06	0.0216	43	95	160	0.40	1.01	1.25	yes
	10.00	8.86	0.15	0.05	6.04	4.27	1.66	2.07	0.0216	43	95	160	0.40	1.01	1.25	yes
	11.00	9.65	0.15	0.05	6.03	4.27	1.82	2.26	0.0216	43	95	160	0.40	1.01	1.25	yes

<sup>a</sup> q<sub>t</sub> = Q / W<sub>t</sub> (similar to equation E.2).

<sup>b</sup> q<sub>a</sub> = Q<sub>a</sub> / W<sub>a</sub> (similar to equation E.2).

<sup>c</sup> b = 1.5(D<sub>84</sub>/D<sub>16</sub>)<sup>-1</sup> (equation E.9).

<sup>d</sup> q<sub>c-D50</sub> = 0.15 (g)<sup>0.5</sup> (D<sub>50</sub>)<sup>1.5</sup> (S)<sup>-1.12</sup> (equation E.7).

<sup>e</sup> q<sub>c-D84</sub> = q<sub>c-D50</sub> (D<sub>84</sub>/D<sub>50</sub>)<sup>b</sup> (similar to equation E.8).

Table E.3—Summary of flow hydraulics and particle mobility/stability for the reference-reach channel and design channel using the critical unit discharge approach (continued)

Recur- rence Interval	Hydraulics										Particle Mobility/Stability					
	Dis- charge, Q (m <sup>3</sup> /s)	Active Channel width discharge Q <sub>a</sub> (m <sup>3</sup> /s)	Flood plain n value	Channel n value	Total flow width W <sub>t</sub> (m)	Active channel width W <sub>a</sub> (m)	Total unit discharge q <sub>t</sub> (m <sup>2</sup> /s) <sup>a</sup>	Active channel unit discharge q <sub>a</sub> (m <sup>2</sup> /s) <sup>b</sup>	Channel slope S <sub>c</sub>	D <sub>16</sub> (mm)	D <sub>50</sub> (mm)	D <sub>84</sub> (mm)	Particle size range measure b <sup>c</sup>	Critical unit discharge for D <sub>50</sub> q <sub>c-D50</sub> (m <sup>2</sup> /s) <sup>d</sup>	Critical unit discharge to entrain D <sub>84</sub> particle size q <sub>c-D84</sub> (m <sup>2</sup> /s) <sup>e</sup>	D <sub>84</sub> particle mobile (yes/no)
<b>C. Adjusted stream simulation design channel: XS8.5D</b>																
	2.00	1.99	0.15	0.05	4.35	4.11	4.11	0.48	0.0216	50	112	188	0.40	1.29	1.59	no
	3.00	2.96	0.15	0.05	4.90	4.27	4.27	0.69	0.0216	50	112	188	0.40	1.29	1.59	no
	4.00	3.89	0.15	0.05	5.54	4.27	4.27	0.91	0.0216	50	112	188	0.40	1.29	1.59	no
2	4.20	4.08	0.15	0.05	5.62	4.27	4.27	0.95	0.0216	50	112	188	0.40	1.29	1.59	no
	5.00	4.77	0.15	0.05	6.03	4.27	4.27	1.12	0.0216	50	112	188	0.40	1.29	1.59	no
	6.00	5.61	0.15	0.05	6.09	4.27	4.27	1.31	0.0216	50	112	188	0.40	1.29	1.59	no
10	6.70	6.18	0.15	0.05	6.08	4.27	4.27	1.45	0.0216	50	112	188	0.40	1.29	1.59	no
	7.00	6.43	0.15	0.05	6.07	4.27	4.27	1.51	0.0216	50	112	188	0.40	1.29	1.59	no
25	7.80	7.09	0.15	0.05	6.06	4.27	4.27	1.66	0.0216	50	112	188	0.40	1.29	1.59	yes
	8.00	7.25	0.15	0.05	6.06	4.27	4.27	1.70	0.0216	50	112	188	0.40	1.29	1.59	yes
50	8.80	7.89	0.15	0.05	6.05	4.27	4.27	1.85	0.0216	50	112	188	0.40	1.29	1.59	yes
	9.00	8.06	0.15	0.05	6.05	4.27	4.27	1.89	0.0216	50	112	188	0.40	1.29	1.59	yes
100	9.90	8.78	0.15	0.05	6.04	4.27	4.27	2.06	0.0216	50	112	188	0.40	1.29	1.59	yes
	10.00	8.86	0.15	0.05	6.04	4.27	4.27	2.07	0.0216	50	112	188	0.40	1.29	1.59	yes
	11.00	9.65	0.15	0.05	6.03	4.27	4.27	2.26	0.0216	50	112	188	0.40	1.29	1.59	yes

<sup>a</sup> q<sub>t</sub> = Q / W<sub>t</sub> (similar to equation E.2).

<sup>b</sup> q<sub>a</sub> = Q<sub>a</sub> / W<sub>a</sub> (similar to equation E.2).

<sup>c</sup> b = 1.5(D<sub>84</sub>/D<sub>16</sub>)<sup>-1</sup> (equation E.9).

<sup>d</sup> q<sub>c-D50</sub> = 0.15 (g)<sup>0.5</sup> (D<sub>50</sub>)<sup>1.5</sup> (S)<sup>-1.12</sup> (equation E.7).

<sup>e</sup> q<sub>c-D84</sub> = q<sub>c-D50</sub> (D<sub>84</sub>/D<sub>50</sub>)<sup>b</sup> (similar to equation E.8).

## Appendix E—Methods for Streambed Mobility/Stability Analysis

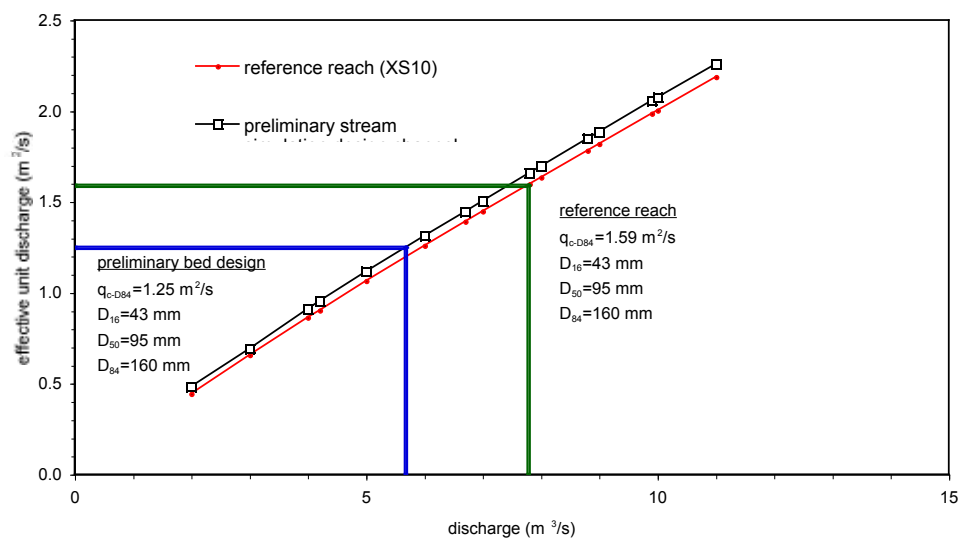

Figure E.8—Plot of unit discharge versus discharge showing when the  $D_{84}$  particle is mobilized in the reference-reach channel and the preliminary stream-simulation design channel. To achieve similar  $D_{84}$  particle mobility in the stream simulation design channel at the same flow as the reference-reach channel, the  $D_{16}$ ,  $D_{50}$ , and  $D_{84}$  particle sizes were increased in size by 17.5 percent to 50 mm, 112 mm, and 188 mm, respectively.

### E.3.4 Summary

The modified critical-shear stress and the critical unit-discharge analyses resulted in similar increases in the  $D_{50}$  and  $D_{84}$  particle sizes in the design channel to achieve similar mobility to the reference-reach channel. Although the discharge at which sediment mobility occurs is different between the two approaches, the direct comparison between the design channel and reference reach channel minimizes any differences in the end result (sizing of sediments) because the assumptions that go into the flow models and sediment mobility/stability analyses are the same between the design channel and reference-reach channel. Thus any errors in our assumptions used in the analyses cancel each other out between the design channel and the reference channel.

### E.4 SIZING IMMOBILE KEY PIECES

To size rocks intended to remain in place permanently (**banklines** and some **key features**), start from the size of rocks that appear to be immobile in the reference reach. Use all applicable equations to determine whether that size will move at the **high bed-design flow**. These rocks are often much larger than the rest of the stream-simulation material in which they are embedded, and accurately estimating critical entrainment flow is difficult because most equations do not account for such large size differences. Therefore, use several equations, compare their results, and size the key pieces accordingly.

One analysis procedure has been developed specifically for determining when individual large rocks move (by sliding or rolling) (Fischenich and Seal 2000). The analysis applies to boulders on a flat bed or on a sloped bank, whether embedded or resting on the surface.

Most equations for sizing large permanent rock material in streams are for designing riprap blankets, where rocks are embedded in a layer of other large rocks. These equations are not directly applicable to individual rocks or clusters, but they provide alternative estimates of stable rock sizes for comparison. One standard method is included in HEC-11 (Brown 1989). Rather than individual rock sizes, the method yields the median rock size for a stable riprap gradation in which  $D_{\max}$  is about 1.5 to 2 times  $D_{50}$ . This method uses either shear stress or water velocity to represent the driving forces for entrainment.

Two other riprap models developed by the U.S. Army Corps of Engineers (USACE) may be useful. They were developed from laboratory and analytical work for designing riprap bank protection and rock chutes such as spillways. For full descriptions of the two models, see EM 1110-2-1601 (USACE 1994). The manual is available at <http://www.usace.army.mil/publications/eng-manuals/em1110-2-1601>.

Both of the USACE riprap models are intended for the design of stable riprap banks and beds with angular rock. Angular rock locks and wedges together thereby resisting rolling and sliding. If using round rock, increase rock size to achieve the level of stability of an angular rock. Abt et al. (1988) studied the difference in stability of angular and rounded rock at slopes from 1 to 20 percent. Although the data set of Abt et al. (1998) is not large, the data indicated the round rock was stable when  $D_{50}$  was 40-percent greater than the angular rock.





# Stream Simulation

---

## Appendix F—Channel Grade Control Structures

---

This appendix briefly describes permanent **grade control** structures that are sometimes needed in the upstream and/or downstream **reaches** adjacent to a stream-simulation culvert. Their purpose is to control channel slope and elevation, and they are often used to raise the elevation of a channel that has incised downstream of a culvert. The objective is to avoid steepening the stream-simulation channel inside the culvert, and to allow the design slope to match an available **reference reach** (section 5.5). In some cases, grade-stabilization structures designed to adjust gradually in response to high flows are also used upstream of stream-simulation culverts to moderate the rate of erosion of a large wedge of sediment accumulated above an undersized culvert. Some grade control structures also can be shaped to improve **bankfull** flow alignment with the culvert inlet.

How well these structures provide passage for all aquatic organisms depends on how well they mimic structures found in the natural channel. The more rigid a control structure, and the more uniform in cross section and hydraulic characteristics, the less certain the provision of passage for aquatic organisms. The key to providing as unrestricted a passage as possible is to design the structure for maximum variety of passage opportunities (water depth, velocity, substrate). Determining with certainty how well specific aquatic organisms can pass grade-control structures may necessitate biological monitoring.

The information in this appendix is general and not adequate for design purposes. For details on design considerations, applications, and limitations, consult other references, such as the U.S. Department of Agriculture, Natural Resource Conservation Service (2001); Rosgen (2006); and Salde-Caromile et al. (2004).

The three most common types of artificial grade control structures are boulder weirs, roughened channels, and rigid weirs.

### Boulder Weirs

Boulder and log weirs can be designed to imitate natural steps (figure F.1). These weirs are appropriate grade controls in step-pool channels, and channels with forcing features such as large rock and **woody debris**. In other channels, the degree to which the weirs permit passage of aquatic organisms will vary.

## Stream Simulation

---



*Figure F.1—Natural boulder step on a tributary to the Entiat River, Willamette National Forest, Washington.*

Low weirs have been built for many years for backwatering perched culverts and low dams, and for controlling grade. Though many of those structures have deteriorated and disappeared over time, they can be durable and effective if well designed and constructed. Their success largely depends on the size and quality of material, the care and skill of the equipment operator, the supervision of construction, and the equipment used to place the rocks.

To create a long-lasting boulder weir, use durable rock shaped so that individual rocks can be keyed together. As somewhat angular boulders are much more stable than round ones, individually select specific rocks to fit together. A common guideline is to use rock twice the size of the largest mobile particles in the channel. The U. S. Department of Agriculture, Natural Resources Conservation Service 2001 suggests that  $D_{50}$  of weir rock be equal to what is calculated as stable riprap, and that  $D_{max}$  be twice that size. Keep in mind that scour depth is also a factor. For a 1-foot drop, place rocks on footer rocks embedded from 2.5 feet to 3.5 feet in gravel and sand beds, respectively. Boulders also can be sized conservatively using a stability analysis procedure published by Fischenich and Seal (2000) for individual boulders rolling or sliding on the streambed. Rosgen (2006) and Thomas et al. (2000) provide empirical methods for sizing rocks used for weirs and steps.

## Appendix F—Channel Grade Control Structures

Drop structures concentrate energy as water plunges over the crest, and turbulence and bed scour dissipate the energy. Bed scour can undermine the structure, and bank erosion can cut around the ends. Outflanking is one of the most common modes of failure. Designing the structures with a V-shape in both plan view and cross-section view helps prevent these types of failure.

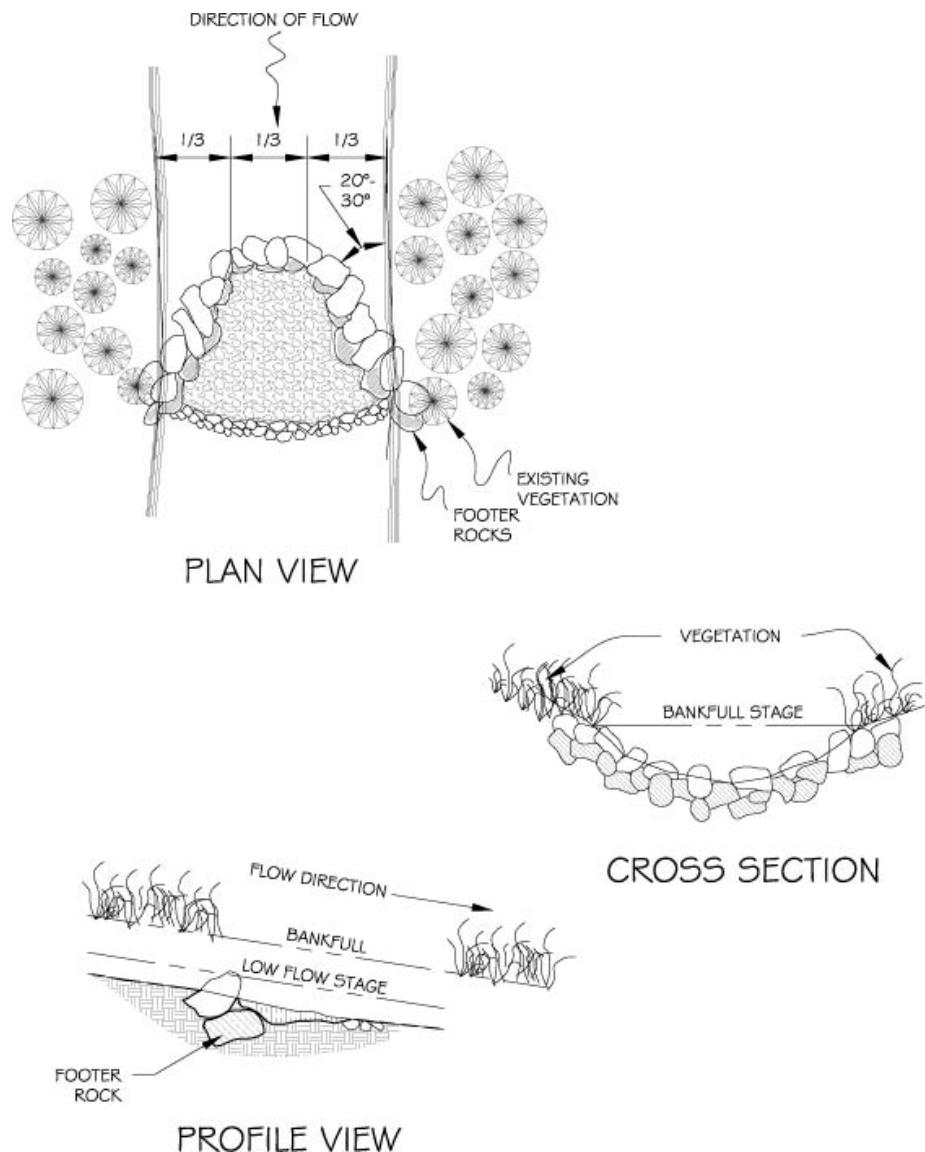

Figure F.2—Typical plan, cross section, and profile views of a rock weir, taken from a stream-simulation contract in Alaska.

## Stream Simulation

---

This V-shaped configuration in both plan and elevation views concentrates the spill towards the center of the channel as flow is directed perpendicular to each leg of the structure. This hydraulic condition tends to concentrate scour away from streambanks and can help maintain a natural and more complex channel cross section. The scour hole will be longer and the structures may therefore have to be placed further apart than if they are straight and horizontal. This concept applies to any style of drop structure. Variations on this shape can help guide flow around channel bends.

In plan view, the weir is shaped like an arch or a convex-upstream V, so that adjacent rocks support each other. Carefully place individual rocks with equipment that allows the rock to be rotated for precise alignment and fitting. Place footer rocks below the elevation of the final grade, to support a second row of rocks. Then place the top row of rocks against the footer boulders and slightly upstream of them, so that they are supported with multiple points of contact. Footer rocks should be placed so that they prevent the formation of a scour pool the top rock could roll into. However, they should not be so far in front or so high as to act as a splash pad that could prevent fish passage. When the arch is complete, each boulder bears against its downstream neighbor and—ideally—against the two footer rocks below it. The force of the streamflow and bedload will then transfer through the weir to the footer rocks and banks. Fitting the rocks together in this way often requires moving rocks several times.

In cross section, the weir crest should slope down toward the apex, approximating the intended cross section of the channel. To avoid outflanking, key boulders at the ends of the weir well back into the banks to at least bankfull elevation and backfill them securely. Place well-graded seal material with some fines on the upstream side of the control, to limit permeability and leakage. Bed material that accumulates on the upstream face of the weir provides much of the structural integrity and sealing of boulder weirs. Without continued **recruitment** of sediment for maintaining the weirs, they will become more porous, eventually leaking and becoming vulnerable to failure.

Boulder weirs carry the risk of domino failure. If one weir in a series fails, the risk of other failures increases, because the added head differential increases the plunging flow, scour, and hydrostatic forces on the next weir upstream. See Salde-Caromile (2004) for a fuller description of rock weirs and other drop structures, and Rosgen (2006) for a discussion of boulder weir styles and failure modes.

## Appendix F—Channel Grade Control Structures

**Roughened channels** Oversteepened channel segments have traditionally been designed as roughened channels, in which high bed-**roughness** limits water velocity to allow the passage of a target fish, and bed material is sized to be immobile at the design flow (see also appendix B). More recently, artificial pool-riffle, step-pool, and cascade reaches have been constructed for maintaining grades steeper than the reference reach or the project stream, but in a more naturalistic manner (figure F.3). We refer to these as “hybrid” designs because, while they are basically hydraulic designs, they also incorporate elements of natural channel design. See appendix B for a discussion of hybrid design.

Where a hybrid or roughened channel segment plays the role of grade control downstream of a stream-simulation culvert, design both control and culvert conservatively. If the control incises at all, the stream-simulation channel will also be at risk of incision. To minimize the risk, countersink the culvert deeper than normal.



*Figure F.3—Rock riffle used to **backwater** the outlet of a box culvert on Dickson Brook, Bay of Fundy, New Brunswick, Canada. Photo courtesy of Dr. Robert Newbury, Newbury Hydraulics, Okanagan Centre, British Columbia, Canada.*

## Stream Simulation

---

### Rigid Weirs

Rigid weirs are fixed, nondeformable structures used for precisely controlling the channel profile. They can be built out of logs, sheet piling, or concrete. One benefit of rigid weirs is that they can often be built at a steeper grade than other structures, thus minimizing the footprint of a project. Slopes steeper than about 5 percent require additional structure (floors and walls) to protect bed and banks.

Log sills (log weirs) span the entire channel and create a series of small drops, raising the downstream-water surface to the elevation of a culvert. Log sills are a low-cost, durable means of fish passable grade control for streams with moderate gradients and channel toe widths of less than about 30 feet. Although they are typically used downstream of a culvert, they may also be used upstream. Log sills include a variety of designs, including single logs, multiple stacked logs, straight weirs, angled weirs, and V-weirs. Any level sill should have a low-flow notch cut into it.

Simple, straight, double-log sills are the most secure. These require the least overall channel length and are the least costly of the styles. Other styles, such as sills that dip toward the middle of the channel or angle downstream, tend to create more channel and hydraulic complexity. Because of the recommended maximum slope for rigid weirs (5 percent), steepening a channel with a natural slope already greater than about 3 percent is difficult. In small channels, planks can be used instead of logs.

Precast concrete or steel sheet-pile weirs are other options for rigid controls. Their advantages are that they can be manufactured precisely, resulting in a good seal, with a varied cross section similar to the natural channel, and a crest shape specifically designed for fish passage. You can custom-design their installation to fit the needs of the site; for example, a single precast concrete unit could include a weir, a stilling basin, wing walls, and a head wall. Steel-pile weirs can be solid sheet-piles or H-piles with wood or precast concrete lagging between them. Concrete highway median barriers and “ecology blocks” are not recommended for use in grade-control structures; they commonly fail when used as weirs unless they are anchored for stability, modified to provide a sharp crest and a deep plunge pool, and sealed permanently to prevent leakage.

Straight, level, rigid weirs can have negative impacts on channels. They tend to create channels that are trapezoidal and very uniform in cross section. Even though full channel-spanning level structures may look like natural embedded wood structures, they lack the variety of passageways found in most complex natural structures. Poorly designed structures commonly fail by scouring either under or around the end of the structure. Rigid structures are more likely than adjustable rock structures to become barriers to fish passage when downstream scour occurs.





# Stream Simulation

---

## Appendix G—Additional Tools and Tips

Sections G.1 through G.3 of this appendix provide additional information that may be useful in stream-simulation final design and contract development. Section G.4 summarizes results from a workshop where construction engineers and biologists shared their experience doing major in-stream work. Participants identified common problems and solutions they had used or developed.

### G.1 CONTRACT PREPARATION CHECKLIST

#### ■ Plan views

- ✓ Plans drawn to scale with scale, north arrow, at least three reference points (more are preferred) outside of construction disturbance area.
- ✓ Clearing limits: all work areas covered by special project requirements, notes.
- ✓ Structure location: inlet and outlet **inverts** located with XYZ coordinates, or equivalent (taken from long profile).
- ✓ Extension of channel excavation and filling (taken from long profile).
- ✓ Road locations, edges, centerline, geometric description of curvature, widths, and curve widening, p-line, or XYZ coordinates.
- ✓ Channel work identified: bank erosion control features, **grade control**, channel linings.

#### ■ Dewatering system

- ✓ Location, height, and width of diversion dam.
- ✓ Bypass pipe size, length, location, coupling method.
- ✓ Sump locations, estimate of necessary flow and sump capacity.
- ✓ Backwater prevention method.
- ✓ Sediment treatment plan with methods, release point, extent.

#### ■ Footings

- ✓ Estimated bearing capacity parameters.
- ✓ Depth, width, and eccentricity from bearing capacity equations.
- ✓ Dimension of footing or footing options with enough width for arch attachment.
- ✓ Reinforced concrete details and calculate temperature steel.
- ✓ Quantities of concrete and reinforcing steel.
- ✓ Estimated construction time.

#### ■ Streambed Details

- ✓ Thalweg, slope, bank shape, material gradation(s).
- ✓ Step, bank, rock-placement details: elevations, spacing, diameters, and locations.
- ✓ Extent of streambed-simulation material, excavation, and infilling.
- ✓ Quantities of materials.
- ✓ Details for any retention structures (sills): construction, attachment, and backfilling.

#### ■ Structure Details

- ✓ Structural section, gauge or thickness requirement for live load, dead load.
- ✓ Minimum and maximum cover limits.
- ✓ Structures (drawn to scale) on elevation view showing bed material location relative to structure, special backfill zones.
- ✓ Special concrete structure details for collar headwalls, inlets, thrust beams, footings.
- ✓ Structure attachment to footing details.
- ✓ Structure length, all details necessary for costing.
- ✓ Structural excavation quantity, total excavation estimate.

#### ■ Details for creating a bypass road around project

- ✓ Traffic control plan with signs.
- ✓ Traffic bypass road design, including maximum grade, minimum width, surfacing, and curve radius.
- ✓ Over-structure embankment details, estimate of delay time during construction.

### G.2 SAMPLE PROJECT SCHEDULE

Figure G.1, a Gantt chart, shows which tasks in this project depend on others and how many actual workdays (weekends are included with workdays on this chart) are necessary for completing a hypothetical project. To get total contract time, the designer should add any anticipated shutdown time for fire and weather, as well as holidays and “contingency” days.

Most permits have a “construction window” of time when work is allowed to take place in the stream. This window protects spawning and migrating species and ensures ample time for “winterizing” a project if the project going to take more than one season. Using the project Gantt chart, you can fit the project into the construction window allowed in the permit and establish realistic start dates, completion dates, and a time estimate.

A thoughtful, well-constructed project schedule helps the contractor and inspector plan their work. It will help both to minimize unnecessary field trips and to plan for critical events such as aquatic organism capture and transport, compaction testing, and concrete pours (see figure G.2).

# Appendix G—Additional Tools and Tips

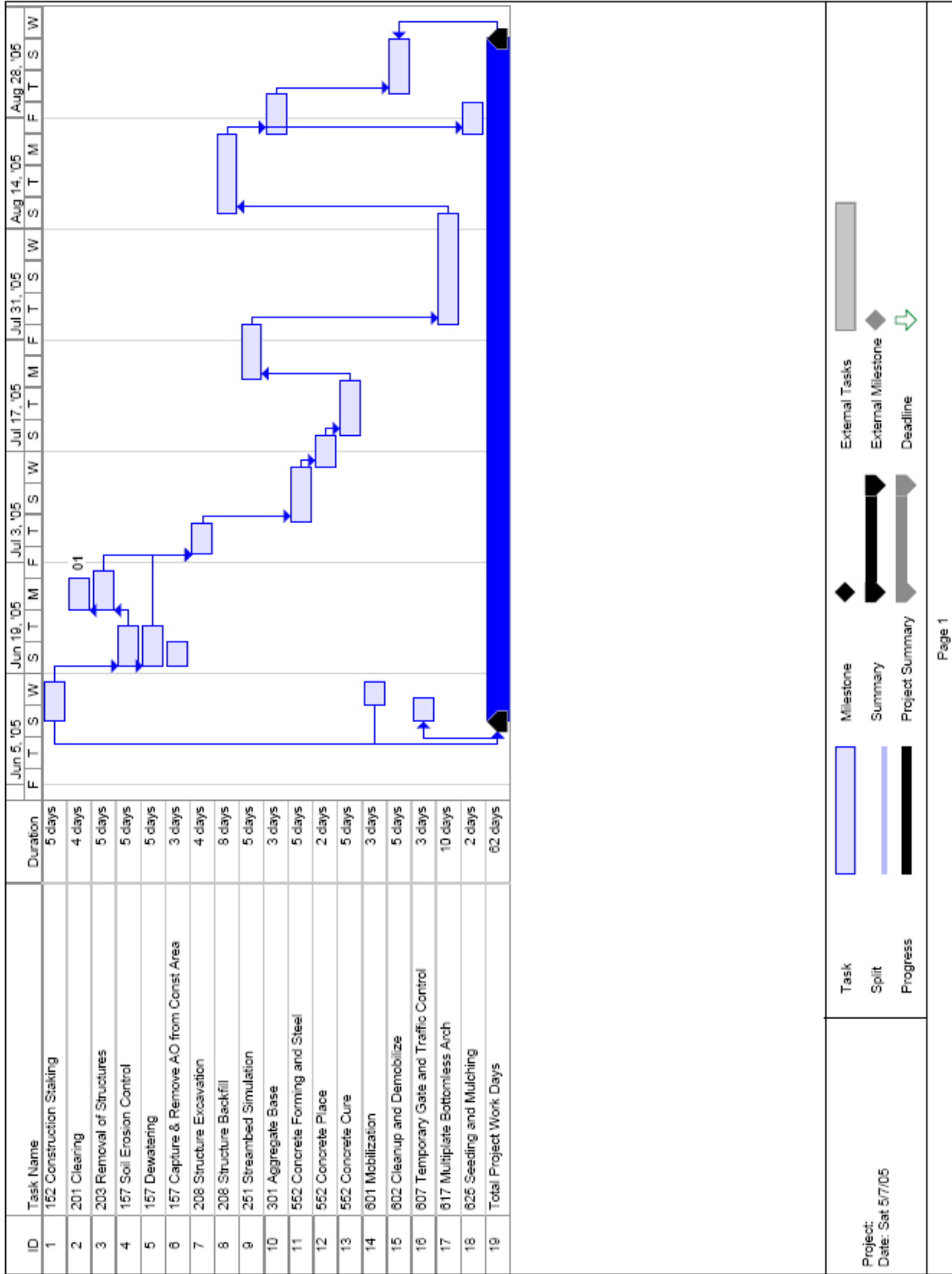

Figure G.1—Sample project schedule: Gantt chart.

# Stream Simulation

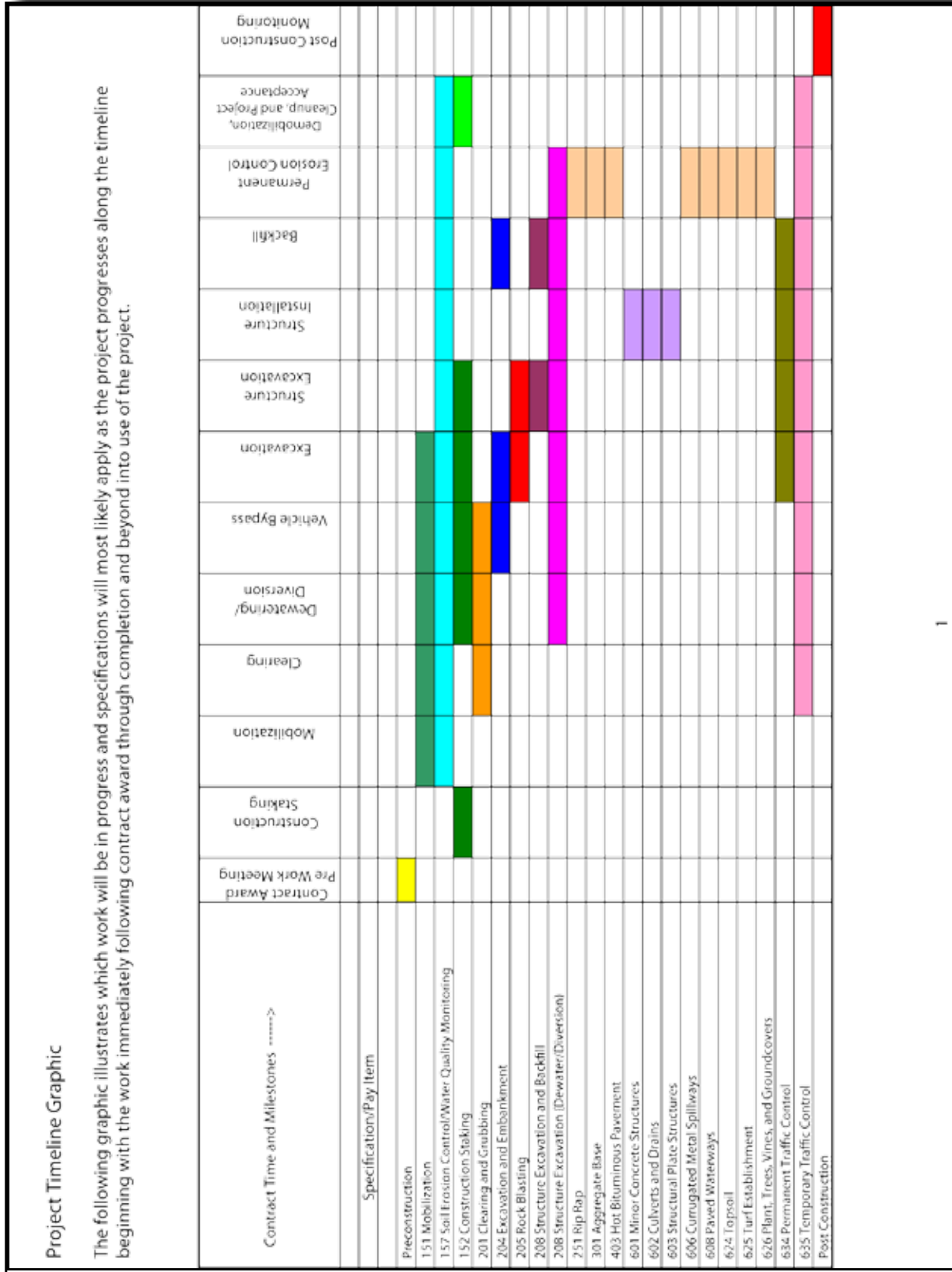

Figure G.2—This project construction timeline is a reminder of the specifications that apply at various phases of construction. Work under some specifications continues throughout much of the project.

### **G.3 ESTIMATED PROJECT COSTS: COMPARING DIFFERENT STRUCTURE TYPES AND SIZES**

#### **G.3.1 12-foot and 18-foot Open-bottom Arch Multiplate Structures—20-foot Fill**

Table G.1 compares estimated costs for two open-bottom arch multiplate structures on concrete footings, with step pools and stream-simulation bed, complete site dewatering and erosion control. Fill height is 20 feet; **bankfull** width is 12 feet.

# Stream Simulation

Table G.1—Sample cost estimates for 12-foot and 18-foot open bottom multiplate arches with 20-foot fill

Item No.	Description	Method of Measurement	Unit	Estimate Quantity 12'	Estimate Quantity 18'	Unit Price	Total for 12'	Total for 18'
152(02)	Construction staking and surveying (road)	AQ	Mile	0.2	0.2	\$5,000	\$1,000	Same
152(03)	Construction staking and surveying (structure)	AQ	Each	1	1	\$1,000	\$1,000	Same
201(03)	Clearing and grubbing, slash treatment methods for tops and limbs 12, logs 12, stumps 12, utilization of timber 2	LSQ	LS	All Req'd	All Req'd	\$1,500	\$1,500	Same
203(02)	Removal of existing 6-ft. dia. multiplate pipe, disposal method A	AQ	Ea	1	1	\$5,000	\$5,000	Same
157(19)	Soil erosion and pollution control	LSQ	LS	All Req'd	All Req'd	\$2,500	\$2,500	Same
157(20)	Dewatering and sediment control	LSQ	LS	All Req'd	All Req'd	\$15,000	\$15,000	Same
208(02)	Foundation fill (use mostly structural excavation, and bedding volume)	DQ	Cy	80	120	\$50	\$4,000	Add \$2,000
208(07)	Structural excavation	DQ	Cy	1,212	1,434	\$20	\$24,240	Add \$4,440
251(14)	Placed channel rock, rock-18, method D (2 steps constructed in pipe)	AQ	EA	16	24	\$80	\$1,280	Add \$480
251(15)a	Placed streambed simulation rock, bed class 12, method D	DQ	Cy	135	202	\$65	\$8,775	Add \$4,350
251(16)	Placed select borrow	DQ	Cy	8	12	\$50	\$400	Add \$200



## Appendix G—Additional Tools and Tips

Table G. 1—Sample cost estimates for 12-foot and 18-foot open bottom multiplate arches with 20-foot fill (continued)

Item No.	Description	Method of Measurement	Unit	Estimate Quantity 12'	Estimate Quantity 18'	Unit Price	Total for 12'	Total for 18'
301(10)	Untreated aggregate course, type base, grading C, compaction B	DQ	Cy	37	39	\$40	\$1,480	Add \$80
552(03)	Structural concrete, class A (AE), for footings	AQ	Cy	45 2' wide by 4' tall footings	55 2.5' wide by 4' tall footings	\$500	\$22,500	Add \$5,000
554(03)	Reinforcing steel	DQ	Lb	880	897	\$2.50	\$2,200	Add \$43
601(01)	Mobilization	LSQ	LS	All Req'd	All Req'd		\$12,940	\$16,118
607(03)	Gate temporary, type I barricade, size 4.9m wide by 800mm high (or other traffic-control features)	AQ	Each	2	2	\$2,250	\$4,450	same
617(06)	Galvanized steel corrugated open-bottom arch	AQ	Ft	12' by 6' by 76' @ \$435/ ft	18' by 9' by 74' @ \$650/ft		\$33,060	Add \$15,040
625(02)	Seeding, hydraulic method (with mulch)	DQ	acre	0.25	0.25	\$4,000	\$1,000	same
<i>Total estimate for 12' and 18' open bottom arches, fill height assumed at 20'</i>							<b>\$142,325</b>	<b>\$177,301</b>

**Cost difference = \$34,976 (24.5%)**

## Stream Simulation

---

### **G.3.2 8-foot and 12-foot Embedded CMPs—20-foot Fill**

Table G.2 compares estimated costs for two embedded pipe single-piece structures with step pools and stream-simulation bed, complete site dewatering, and erosion control. Fill height is 20 feet; bankfull width is 8 feet.

## Appendix G—Additional Tools and Tips

Table G.2—Sample cost estimates for 8-foot and 12-foot embedded CMPs with 20-foot fill

Item No.	Description	Method of Measurement	Unit	Estimate Quantity 8'	Estimate Quantity 12'	Unit Price	Total for 8'	Total for 12'
171(02)	Construction staking, precision C, method 1	AQ	Mile	0.2	0.2	\$5,000	\$1,000	Same
171(03)	Staking structures, precision C, method 1	AQ	Each	1	1	\$1,000	\$1,000	Same
201(03)	Clearing and grubbing, slash treatment methods for tops and limbs 12, logs 12, stumps 12, utilization of timber 2	LSQ	LS	All Req'd	All Req'd	\$100	\$1,000	Same
202(02)	Removal of existing 4-ft. dia. steel pipe, disposal method A	AQ	Ea	1	1	\$2,500	\$2,500	Same
157(19)	Soil erosion and pollution control	LSQ	LS	All Req'd	All Req'd	\$1,000	\$1,000	Same
157(20)	Dewatering and sediment control	LSQ	LS	All Req'd	All Req'd	\$8,000	\$8,000	Same
206(02)	Foundation fill (use mostly structural excavation, and bedding volume)	DQ	Cy	53	80	\$50	\$2,650	Add \$1,350
206(07)	Structural excavation	DQ	Cy	388	456	\$20	\$7,760	Add \$1,360
251(14)	Placed channel rock, rock-12, method D (2 steps constructed in pipe)	AQ	EA	16	24	\$65	\$1,280	Add \$480
251(15)a	Placed streambed simulation rock, bed class 6, method D, both pipes embedded 4' add 10% for adjacent channel work	DQ	Cy	78	98	\$65	\$5,070	Add \$1,300

# Stream Simulation

Table G.2—Sample cost estimates for 8-foot and 12-foot embedded CMPs with 20-foot fill (continued)

Item No.	Description	Method of Measurement	Unit	Estimate Quantity 8'	Estimate Quantity 12'	Unit Price	Total for 8'	Total for 12'
251(16)	Placed filler material	DQ	Cy	8	10	\$50	\$400	Add \$100
304(10)	Crushed aggregate, type base, grading C, compaction B	DQ	Cy	15	17	\$40	\$600	Add \$80
601(01)	Mobilization	LSQ	LS	All Req'd	All Req'd		\$5,240	\$6,390
607(03)	Gate temporary, type I barricade, size 4.9m wide by 800mm high (or other traffic control features)	AQ	Each	2	2	\$2,250	\$4,450	same
617(06)	Galvanized steel 3" by 1" corrugated pipe (installed)	AQ	Ft	8' diam by 76' @ \$200 /ft	12' diam by 74' @ \$300/ft	Always check for latest prices	\$15,200	Add \$7,000
625(02)	Seeding, hydraulic method (with mulch)	DQ	acre	0.25	0.125	\$4,000	\$500	same
<b>Total estimate for 8' and 12' embedded pipes, fill height assumed at 20'</b>							<b>\$57,650</b>	<b>\$69,110</b>

Cost difference = \$11,460 (20%)

### **G.3.3 8-foot and 12-foot Embedded CMPs—12-foot Fill**

Table G.3 compares estimated costs for two embedded pipe single-piece structures with step pools and stream-simulation bed, complete site dewatering, and erosion control. Fill height is 12 feet; bank full width is 8 feet.

# Stream Simulation

Table G.3—Sample and cost estimate for 8-foot and 12-foot embedded CMPs with 12-foot fill

Item No.	Description	Method of Measurement	Unit	Estimate Quantity 8'	Estimate Quantity 12'	Unit Price	Total for 8'	Total for 12'
171(02)	Construction staking, precision C, method 1	AQ	Mile	0.2	0.2	\$5,000	\$1,000	Same
171(03)	Staking structures, precision C, method 1	AQ	Each	1	1	\$1,000	\$1,000	Same
201(03)	Clearing and grubbing, slash treatment methods for tops and limbs 12, logs 12, stumps 12, utilization of timber 2	LSQ	LS	All Req'd	All Req'd	\$1,500	\$1,500	Same
202(02)	Removal of existing 4-ft. dia. steel pipe, disposal method A	AQ	Ea	1	1	\$3,000	\$3,000	Same
157(19)	Soil erosion and pollution control	LSQ	LS	All Req'd	All Req'd	\$2,500	\$2,500	Same
157(20)	Dewatering and sediment control	LSQ	LS	All Req'd	All Req'd	\$10,000	\$10,000	Same
206(02)	Foundation fill (use mostly structural excavation, ad bedding volume)	DQ	Cy	53	80	\$50	\$2,650	Add \$1,350
206(07)	Structural excavation	DQ	Cy	1148	1296	\$20	\$22,960	Add \$2,960
251(14)	Placed channel rock, rock-12, method D (2 steps constructed in pipe)	AQ	EA	16	24	\$65	\$1,280	Add \$480
251(15)a	Placed streambed simulation rock, bed class 6, method D, both pipes embedded 4' add 10% for adjacent channel work	DQ	Cy	78	98	\$65	\$5,070	Add \$1,300
251(16)	Placed filler material	DQ	Cy	8	10	\$50	\$400	Add \$100

## Appendix G—Additional Tools and Tips

Table G.3—Sample and cost estimate for 8-foot and 12-foot embedded CMPs with 12-foot fill (continued)

Item No.	Description	Method of Measurement	Unit	Estimate Quantity 8'	Estimate Quantity 12'	Unit Price	Total for 8'	Total for 12'
304(10)	Crushed aggregate, type base, g grading C, compaction B	DQ	Cy	37	39	\$40	\$1,480	Add \$80
601(01)	Mobilization	LSQ	LS	All Req'd	All Req'd		\$7,350	\$9,410
607(03)	Gate temporary, type I barricade, size 4.9m wide by 800mm high (or other traffic control features)	AQ	Each	2	2	\$2,250	\$4,450	same
617(06)	Galvanized steel 3" x 1" corrugated pipe (installed)	AQ	Ft	8' dia. by 76' @ \$200 /ft	12' dia. by 74' @ \$300/ft	Always check for latest prices	\$15,200	Add \$7,000
625((02)	Seeding, hydraulic method (with mulch)	DQ	acre	0.25	0.25	\$4,000	\$1,000	same
<b>Total estimate for 8' and 12' embedded pipes, fill height assumed at 20'</b>							<b>\$80,840</b>	<b>\$103,520</b>

**Cost difference = \$22,680 (28%)**

## Stream Simulation

### G.4 TIPS FROM ENGINEERS AND BIOLOGISTS EXPERIENCED IN STREAM-SIMULATION CONSTRUCTION

This section includes details about tools, procedures, and problems common in stream-simulation projects. Several subsections summarize results of a workshop in February 2004 where experienced construction engineers and biologists discussed the common problems that can arise in placing embedded pipes, and their solutions.

#### G.4.1 Diversion, Dewatering, and Water Treatment System Components

A dewatering plan contains the information in supplemental specification 157 (appendix H, figures H.7, H.8, and H.13).

Figures G.3 through G.6 from the State of Oregon Department of Transportation show various types of dewatering systems.

##### G.4.1.1 Bypass and backwater dams

Different bypass and **backwater** dam structures are suitable for different conditions. Commercial cofferdams provide an ideal solution under some circumstances, especially in larger projects.

Following are the advantages and disadvantages of different bypass and backwater dams:

Water-filled cofferdams: flexible bladders that conform to the ground to form a seal (figures 2.7 and G.4). (For additional information, see [www.waterstructures.com/](http://www.waterstructures.com/) , [www.aquabarrier.com](http://www.aquabarrier.com) , [www.portadam.com](http://www.portadam.com).)

- Advantages.

- ▲ Are flexible, conform to streambed surface.
- ▲ Can be quickly installed.
- ▲ Are reusable.

- Disadvantages.

- ▲ Are expensive.
- ▲ May not provide for inserting a pipe through the dam, although some do.





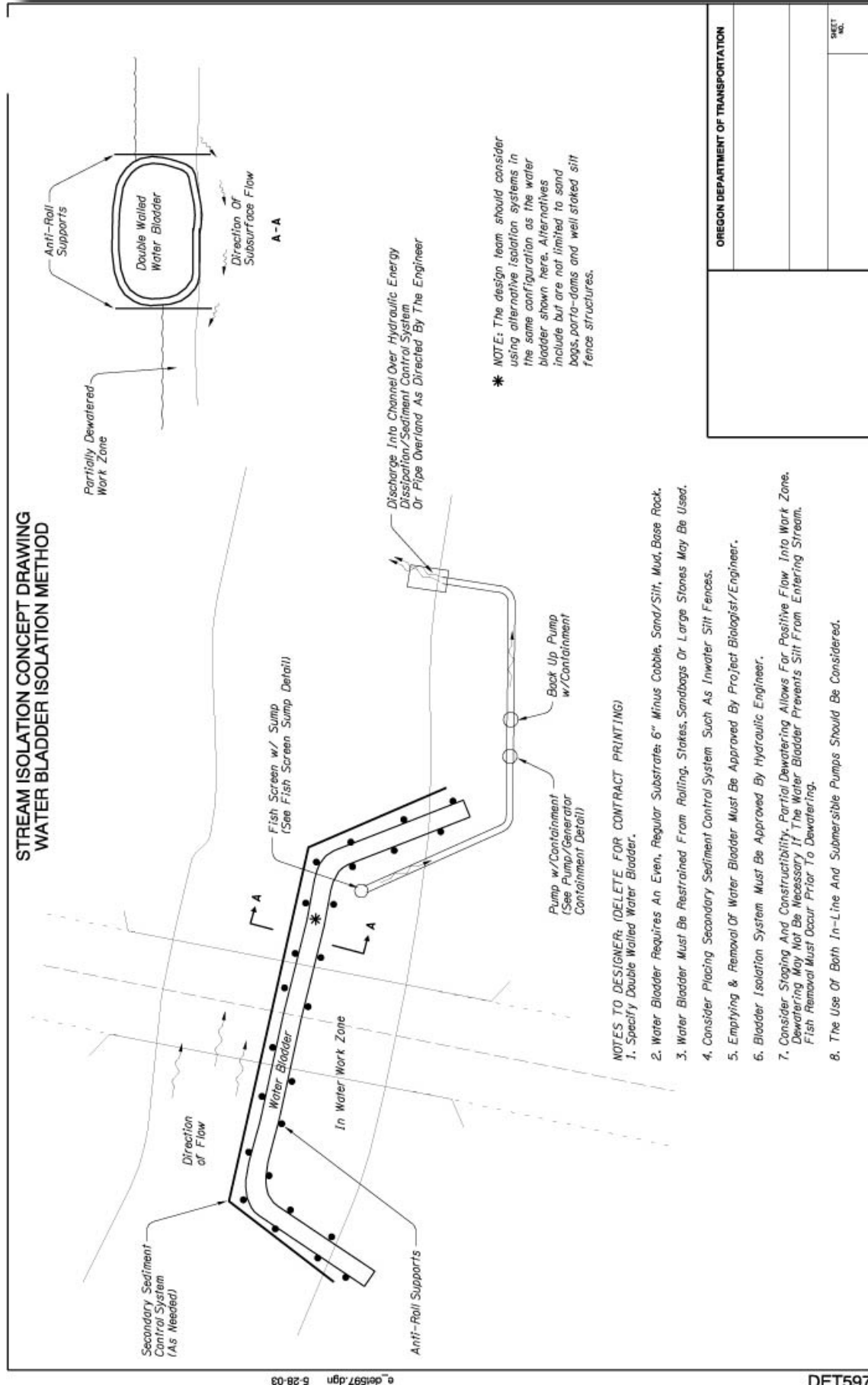

**NOTES TO DESIGNER: (DELETE FOR CONTRACT PRINTING)**

1. Specify Double Walled Water Bladder.
2. Water Bladder Requires An Even, Regular Substrate: 6" Minus Cobble, Sand/Silt, Mud, Base Rock.
3. Water Bladder Must Be Restrained From Rolling, Stokes, Sandbags Or Large Stones May Be Used.
4. Consider Placing Secondary Sediment Control System Such As Inwater Silt Fences.
5. Emptying & Removal Of Water Bladder Must Be Approved By Project Biologist/Engineer.
6. Bladder Isolation System Must Be Approved By Hydraulic Engineer.
7. Consider Staging And Constructibility. Partial Dewatering Allows For Positive Flow Into Work Zone. Dewatering May Not Be Necessary If The Water Bladder Prevents Silt From Entering Stream. Fish Removal Must Occur Prior To Dewatering.
8. The Use Of Both In-Line And Submersible Pumps Should Be Considered.

	<b>OREGON DEPARTMENT OF TRANSPORTATION</b>
SHEET NO.	

Figure G.4—Typical dewatering plan—water bladder isolation method—Oregon Department of Transportation.

**DEWATERING CONCEPT DRAWING  
FISH SCREENING AND  
PUMP/GENERATOR CONTAINMENT**

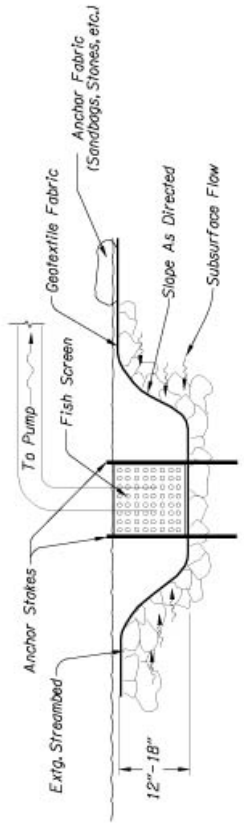

**Fish Screen Sump Detail**

- General Notes:**
1. Screen Mesh Openings Shall Not Exceed  $\frac{1}{12}$ " For Woven Wire Or Perforated Plate Screens, Or  $\frac{1}{16}$ " For Profile Wire Screens, With A Minimum 27% Open Area, If Fry-Sized Fish Are Never Present At The Site (By Determination Of ODFW) Screen Mesh Openings Shall Not Exceed  $\frac{1}{4}$ " For Woven Wire, Perforated Plate Screens, Or Profile Wire Screens, With A Minimum Of 40% Open Area.
  2. For Information Not Provided Here, See "Juvenile Fish Screen Criteria For Pump Intakes", Developed By National Marine Fisheries Service.
  3. Active Screening Systems Should Be Considered When Heavy Debris Is Expected.
- Formula For Minimum Effective Screen Area For Passive Screens:  $\frac{\text{Max. Flow (cfs)}}{0.2 \text{ (fps)}} = \text{Minimum Effective Screen Area (Ft}^2\text{)}$   
Calculated Screen Areas Shown At Right.

Effective Flow Rate Of Pump		Minimum Effective Screen Area (ft <sup>2</sup> )
Gallons Per Minute	Cubic Feet Per Second	
50	0.111	.560
100	0.223	1.11
150	0.334	1.67
200	0.446	2.23
250	0.557	2.79
300	0.668	3.34
400	0.891	4.46
500	1.114	5.57
600	1.337	6.68
700	1.560	7.79
800	1.782	8.91
900	2.005	10.02
1000	2.228	11.14
1200	2.674	13.37
1400	3.119	15.60
1600	3.565	17.83
1800	4.010	20.06
2000	4.456	22.28
3000	6.684	33.42

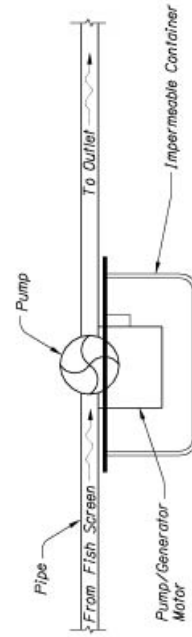

**PUMP/GENERATOR CONTAINMENT DETAIL**

- General Notes:**
1. Size Container To Hold All Fuel And Lubricants Stored In The Pump/Generator Motor
  2. Mechanically Fasten Pump/Generator Housing To Container
  3. Support Container To Prevent Overturning

OREGON DEPARTMENT OF TRANSPORTATION	
SHEET NO.	

Figure G.5—Typical dewatering details—fish screening and pump/generator containment—Oregon Department of Transportation.

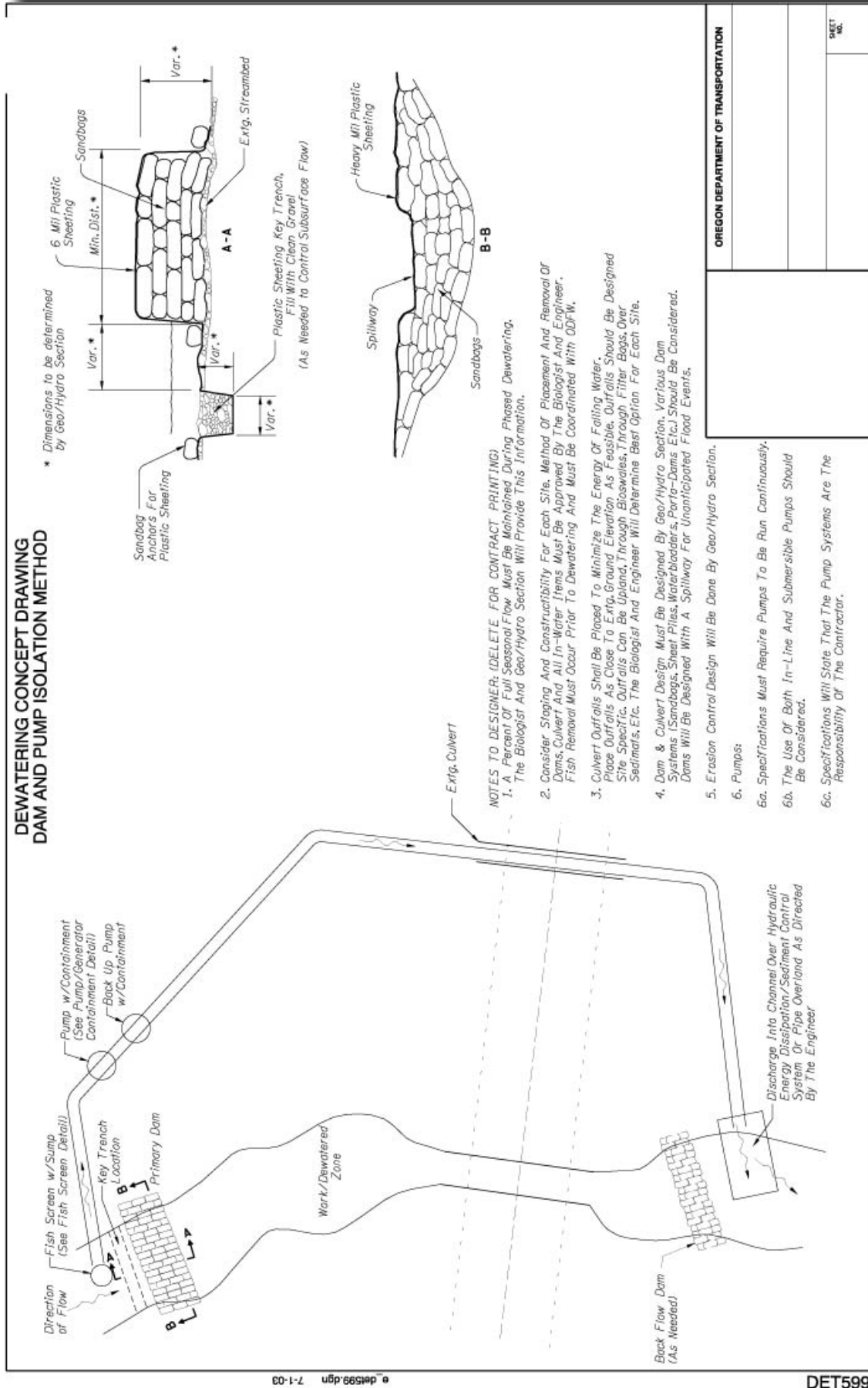

Figure G.6—Typical dewatering plan—dam and pump isolation method—Oregon Department of Transportation.

## Appendix G—Additional Tools and Tips

---

- ▲ May need to be placed on a smoothed surface for a good seal.
- ▲ May require the addition of a impermeable membrane for intercepting additional subsurface flow.

### Pile cofferdams

- Advantages.
  - ▲ Can form a tight seal without a membrane.
  - ▲ Are sturdy.
  - ▲ Can be used to dewater deep water.
  - ▲ Can be used as retaining walls to hold back both water and deep excavations.
  - ▲ Can be fitted to conform to the site.
- Disadvantages.
  - ▲ Are expensive (to mobilize pile driver).
  - ▲ Create noise and vibration impacts.
  - ▲ Sometimes difficult to remove.

### Sandbag dams

- Advantages.
  - ▲ Simple and easy to construct.
  - ▲ Create a good seal when used with an impermeable membrane liner.
  - ▲ Relatively inexpensive.
  - ▲ Conform to the site easily.
- Disadvantages.
  - ▲ Labor intensive.

## Stream Simulation

### G.4.1.2 Pump types and characteristics

Table G.4—Characteristics of various pumps. Information was drawn from company Web sites.

Brand/Model	Pump Type	Max Solids	GPM	CFS	Max Head
Little Giant 6E-CIA-RFSN	Sump/effluent	1/2"	50	0.11	20'
Multiquip MQD306H	Diaphragm	1.5"	85	0.19	25'
Tsurumi TE2-50HA	Centrifugal	3/8"	137	0.31	115'
Tsurumi TE2-80HA	Centrifugal	3/8"	264	0.59	105'
Tsurumi EPT2-50HA	Trash	1"	190	0.42	90'
Multiquip QP2TH self prime	Trash	1"	215	0.48	90'
Multiquip QP302TY diesel	Trash	1.5"	416	0.93	90'
Multiquip QP301TI self prime	Trash	1.5"	416	0.93	90'
Multiquip QP40TH self prime	Trash	2"	611	1.36	90'
Multiquip41TDY diesel	Trash	2"	611	1.36	90'
Multiquip MQ61TDH diesel	Trash	2"	1,083	2.41	100'
Multiquip MQ600TD80 diesel	Trash	3"	1,600	3.56	150'
6" Godwin CD150M Dri-Prime	Trash	3"	1,750	3.90	160'
8" Godwin CD225M Dri-prime	Trash	3 1/8"	3,250	7.24	180'
10" Godwin CD250M	Trash	3 1/8"	3,600	8.02	180'
10" Godwin CD300M	Trash	3 3/4"	3,601	8.02	180'
12" x 10" Godwin HL10M	Trash	3"	4,500	10.03	390'

Pumping conditions—combinations of volume, pressure head, suction head, site access, available power, and water condition—determine what size and type of pump to use.

#### Sump Pumps

Powered by electricity, these can handle small solids and low flows with moderate heads. Their best use is for removing minor amounts of clear seepage at the inlet and outlet dewatering sump ponds and for very small stream flows. You can use multiple pumps.

#### Diaphragm Pumps

Engine-powered, these can handle shallow depths and slurry water, can handle air without losing their prime, and can handle water with a solid content greater than 25 percent by volume. These work where centrifugal pumps will lose their prime or plug. Nicknames include mud hogs, mud hen, and mud sucker. These pumps use a diaphragm rather than an impeller, and are more durable than other pumps. Their best use is for dewatering muddy sump ponds.

## Appendix G—Additional Tools and Tips

### Trash Centrifugal Pumps

These are capable of handling large amounts of debris, with inlet diameters of 2 to 6 inches. They can handle solids, such as sticks, stones, and other debris. They can be quickly disassembled for service or inspection, and are available in diesel power. These are most suited for dewatering applications, such as diversion of flow during construction of dewatering dams, sump duty in large streams, and backup storm-water sump pumps.

### High-Pressure Centrifugal Pumps

These have high discharge and pressure. They are generally not capable of handling solids or even sandy water. Instead, they are used for wash-down equipment, or for irrigation and emergency standby pumps in areas with a high risk of fire. They are not suited for dewatering applications (except in very clean water as a help or backup pump). They may have use as a project high-pressure pump for washing fines into bed material from a clean-water source and for cleaning rock and soil off asphalt haul road surfaces.

### G.4.1.3 Sediment removal methods

Following are some common methods for removing sediment from construction-area water, along with some of the strengths and weaknesses of each method.

#### Gravity-based settling systems— large capacity *Sediment basins*

A pump inlet is attached to a floating suction hose placed in a stable location in the sump basin. The sump pump operation may be controlled by floats to save fuel and to control pool elevation. The dirty water is pumped to a basin with sufficient volume to hold both water and sediment long enough to allow it to settle and for water to seep into the surrounding soil or evaporate.

**Strengths:** Sediment basins hold large volumes of sediment. Such heavy settling sediments as sands settle out very effectively.

**Weaknesses:** As sediments settle into the basin, the retention time decreases, along with efficiency. These basins require a relatively large surface area. Silt and clay particles may take days or weeks to settle out, requiring the construction of a very large settling pond.

## Stream Simulation

---

### Tanks

There are two basic tank types: a standard storage tank with a single storage chamber, and a weir tank with multiple chambers to help increase settling efficiency. Tanks with capacities of up to approximately 18,000 to 21,000 gallons can be mobile.

**Strengths:** Mobile tanks eliminate the need for permanent dedication of space or construction of earthen dikes. The tanks can hold a large volume of solids before requiring clean out. Tanks require very little operational maintenance. The tanks can be operated in either batch or continuous operating modes. Properly designed tanks are easier to drain down than sediment basins, allowing a more rapid return to full storage capacity.

**Weaknesses:** Like sediment basins, tanks are rather ineffective in removing fine to medium-sized sediments. Mobile tanks have a limited storage capacity. A weir tank has a practical limit of 65 gallons per minute per tank for adequate sediment settling. (The flow capacity can be higher for larger sediments, such as large sands.) The tanks must be cleaned out when the project is completed.

### Passive Filtration Systems

#### Pressurized Sand Filters

Sand filters have a high filtering rate, meaning that the area they occupy is very small compared to sediment basins and tanks. A 100 gallon per minute sand filter will typically be 3 feet wide by 8 feet long. Sand filters produce reliable results. A portable sand filter using very fine sand can remove sediment down to the 50 micron range.

**Strengths:** They need only a small area. The ability to backwash makes a sand filter a very cost-effective choice in situations with medium to heavy sediments. For multiple-year projects, their setting-up, self-cleaning, backwashing capability makes them effective in removing large amounts of sediments. An automatic backwash controller eliminates the need for constant operational supervision.

**Weaknesses:** Sand filters do not effectively remove fine silts or clays. A medium-head pump is required for pressurizing the system. The backwash generates a concentrated waste stream that must be disposed of or treated by other methods.



## Appendix G—Additional Tools and Tips

### Bag Filters

These filters are lightweight fabric bags capable of filtering particles as small as fine sand (figure G.7). They are available in various sizes to suit project requirements. When full, they must be removed, generally by cutting and disposing of sediments.

**Strengths:** They are effective in removing heavy sediments. They are best used in vegetated areas where the vegetation is used as additional filtration.

**Weaknesses:** They will not remove such fine sediments as silts and clays until a filter cake builds up. The length of time it takes for a filter cake to develop is unpredictable. When the filter cake is built up, the flow rate diminishes. Bag filters become heavy with sediment and are difficult to remove. They are not reusable.

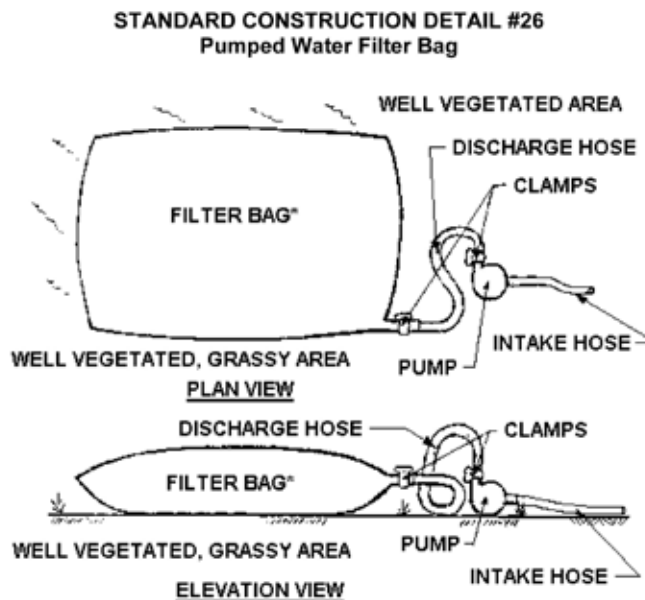

Filter bags shall be made from non-woven geotextile material sewn with high strength, double stitched "J" type seams. They shall be capable of trapping particles larger than 150 microns.

A suitable means of accessing the bag with machinery required for disposal purposes must be provided. Filter bags shall be replaced when they become  $\frac{1}{2}$  full. Spare bags shall be kept available for replacement of those that have failed or are filled.

Bags shall be located in well-vegetated (grassy) area, and discharge onto stable, erosion resistant areas. Where this is not possible, a geotextile flow path shall be provided. Bags shall not be placed on slopes greater than 5%.

The pump discharge hose shall be inserted into the bags in the manner specified by the manufacturer and securely clamped.

The pumping rate shall be no greater than 750 gpm or  $\frac{1}{2}$  the maximum specified by the manufacturer, whichever is less. Pump intakes should be floating and screened.

Filter bags shall be inspected daily. If any problem is detected, pumping shall cease immediately and not resume until the problem is corrected.

Figure G.7—Typical bag filter system (Pennsylvania DEP 2000).

## Stream Simulation

---

**Pressurized Bag Filters** These are fabric bags contained inside portable cylinders that allow the bags to be pressurized.

**Strengths:** They can be easily moved from one location to another. They are most effective in removing medium to heavy sediments.

**Weaknesses:** They do not efficiently remove fine sediments such as silts and clays. The smaller bag surface area and volume means that the sediment-holding capacity is much less than for gravity bag filters.

**Wound Cartridge Filters** These are tightly wound filaments that form a cartridge, which is used as the filter media inside pressurized cylinders.

**Strengths:** They are capable of removing silts and some clay not removed by sediment basins, sand filters, or bag filters. Wound cartridge systems provide the best sediment removal efficiency without the need for chemical treatment. They are highly portable and use a small area. Operational effectiveness is consistent.

**Weaknesses:** Wound cartridges will not remove colloidal clays. They have a low sediment-holding capacity.

## Polymer Treatment Systems

These systems work by adding a polymer to the untreated water, which creates a floc (a flocculent mass formed in a fluid through precipitation or aggregation of suspended particles). The flocs are either allowed to settle or are filtered out.

**Strengths:** Water-based polymer treatment systems provide consistent removal of fine sediments. They are highly effective in removing colloidal clays. The settling tanks or ponds can be designed to hold large quantities of sediments. Ground application of the polymer enhances erosion and sediment control simultaneously, at a low relative cost. Small in-hose cartridges are available for projects with small flow rates and small sediment loads.

**Weaknesses:** Water-based polymer treatment systems are water treatment systems (as opposed to the simple passive filtration systems used to remove sediment.) As such, they are more complex and costly than other sediment removal measures. Depending on local regulations, these systems may require a permit for use, as well as licensed personnel to design and monitor the system during operation.

### G.4.2. Foundation and Footing Design

#### Considerations

This section highlights several considerations that many designers miss during foundation design for open-bottom structures. Skilled designers should always review all preliminary and final designs.

#### G.4.2.1 Overturning forces

Actual foundation stresses are complex.

- On the fill side of the footing is pressure from the overlying embankment soil.
- On the streamside is a variable depth of saturated stream-simulation material that may change in depth from scour and aggradation during the project's lifespan.
- The footing receives the structure load at the angle of the structure to the footing.
- The foundation rests on material that may be saturated or partially saturated.
- The stress from the embankment weight and traffic can increase along the footing, ranging from none at the inlet and outlet to a variable amount at the embankment edges. This load can be averaged over the length of the footings.

The resulting load on a footing is a combination of overturning forces that create an eccentric load beneath the structure's leg. The footing is typically sufficiently offset to center the load and spread it evenly, thereby reducing peak soil stress. Short, wide footings (2 feet by 2 feet) experience a minimal eccentric load, which you may ignore under most circumstances. Taller footings develop increasing eccentricity with depth. To remove this eccentricity, move the center of footing to the center of the footing reaction. For most moderate or high strength soils, either a spread footing and stem wall or a rectangular or wedge-shaped footing will usually work. Concrete footings for arches tend to be massive, partly for constructability reasons.

Design each footing's reinforcement for the forces present, and then check to see if temperature steel is needed in addition. (Reinforcement for temperature is not normally added to structural steel.) Have a design engineer with expertise in reinforced concrete review the designs.

## Stream Simulation

---

### G.4.2.2 Scour

Open-bottom arch footings should extend to 2.5 to 5 feet below the lower vertical adjustment potential line identified in sections 5.2.2.2 and 6.1.2. Although footings are normally 2 to 5 feet wide, larger sizes may be necessary when scour potential is large or soils are soft.

Foundations are not inherently prone to scour, but material placed next to the foundations can scour if not sized properly for the hydraulic forces in the culvert during large flood events. Shaping the streambed and providing edge diversity can keep water from eroding a trench against the side of the culvert. Trench erosion tends to occur along footings because the smooth concrete surface provides less resistance to flow than a standard or deep corrugated culvert. The thickness of the stream-simulation bed against the structure edge is important for providing sufficient interlocking of large particles for stability.

To increase footing **roughness** and help hold sediment against the smooth concrete, use deeply textured concrete forms. You can construct a roughened surface from deeply textured forms by simply attaching lumber (2 by 4 or larger) to the inside of the formwork.

The top of the footing normally reaches above the bankfull height measurement of the channel. If the footing is constructed above the bankfull line, the structure itself will receive less abrasion from mobile stream sediments and therefore last longer.

### G.4.2.3 Bedrock

When bedrock is located at shallow depths or only slightly deeper than necessary for the foundation support, you can pour the footings directly onto the bedrock. Although placing a footing on rigid bedrock is not standard engineering practice, the procedure is safe as long as the design (a) contains an adequate safety factor and (b) requires good quality, well-compacted backfill. Use structural backfill (A-1-a) for all bedrock foundations. Doweling to attach footings to bedrock is seldom necessary, because of the high friction developed between rock and concrete. That high friction prevents movement under all but the most extreme debris-slide impacts.

### G.4.2.4 Soil strength

For sites with very soft soil, an embedded pipe or bridge with a driven pile footing may be a better option than a bottomless arch and footing. For

## Appendix G—Additional Tools and Tips

---

bridges, you can use a driven or drilled pile foundation to support the load on a deep, firm surface below the softer surface soils. Alternatively, you can drive piles deeply into soft substrates to produce enough support.

Settlement is a concern, especially with fine-grained streambeds. If the culvert is replacing an existing pipe and the embankment height is not changed, then the foundation may be consolidated and settle little under the new structure. If any special foundation treatment is required, it should be detailed on the drawings and covered with a supplemental specification based on the embankment compaction specification. For example, if settlement is projected to be excessive for the road standard, the foundation area can sometimes be excavated to a depth of stiffer material and backfilled with high-strength material. If doing so is not feasible, a bridge with pile foundations may be the only practical option to use.

Settlement of embankment and backfill material can cause drag forces in the culvert if the culvert cannot settle at the same rate or slightly more than the embankment. Be sure to analyze both the foundation material and backfill material for settlement potential.

### General principles for arch foundations

Chapter 12, article 12.1.6.3, in AASHTO Standard Specifications for Highway Bridges, Soil-Corrugated Metal Structure Interaction Systems (AASHTO 2002) is an excellent reference for footing design. The chapter lists the following design principles for arch foundations:

- Making the metal arch relatively unyielding or fixed, compared with the adjacent sidefill, is not a good idea.
- The footing design should provide uniform longitudinal settlement of acceptable magnitude, to reduce drag forces caused by **consolidation** of the adjacent roadfill.
- Footing reactions from the arch thrust should be calculated to act tangentially to the metal plate at its point of connection to the footing. For example:
  - ▲ Half-round arches have a 90-degree attachment angle.
  - ▲ Other arch shapes attach at an angle up to 20 degrees.
- Knowing the effect of the depth of the base of the footing and the direction of the footing reaction from the arch is important. The deeper the footing, the more eccentricity the arch-attachment angle will produce.

### G.4.3 Revegetation and Erosion Control

For a project to be successful, erosion control and revegetation must complement each other. Erosion control is a collection of tools working together; no single tool can be completely effective by itself. Success will come with a staged approach: first, minimize the amount of soil disturbed; second, stabilize whatever soil is disturbed; and, third, achieve long-term stabilization of all disturbed materials. Except in very arid environments, long-term site stabilization usually occurs only when the disturbed area is fully revegetated.

Temporary erosion and sediment control measures should be designed with the long-term stabilization plan in mind, so that they do not conflict. Where possible, design long-term measures into the short-term erosion control plan (figure G.8). For example, a steep ditch on an approach road needs both short- and long-term erosion and sediment control measures. Short-term sediment control might consist of sandbag check dams to be removed after construction, along with a sediment basin that will detain ditch runoff water both during the project and during stabilization.

Supplemental specifications for revegetation and erosion control should be written as performance-based specifications (for example, “% or # of plants must be alive in x years; downstream turbidity shall not exceed \_\_\_”). Do not specify methods: planting methods, watering intervals, filtration methods, silt fence locations, etc. Method-based specifications are difficult to administer, and failures are blamed on the method. With performance based specifications, contractors are free to choose the method that best suits their work style, and the responsibility for achieving the end product is theirs.

Environmental documents may require planting indigenous (native) species, providing for rapid site stabilization by seeding a pioneer species such as sterile wheat, or using bioengineering techniques. Note that the topic of revegetation includes several sub-categories, including:

- “Turf establishment” or “reseeding”—typically growing grasses, forbs, and sometimes shrubs from seed.
- “Plantings/cuttings” (involving the planting of container plants or the use of shrub cuttings).
- Bioengineered structures (willow wattles, live fascines, etc.).



<b>Colorado Department of Transportation</b> 4201 East Arkansas Avenue Denver, CO 80222 Phone: (303) 757-9883 FAX: (303) 757-9820	<b>Computer File Information</b> Path: <a href="http://www.dot.state.co.us/ftp/erproj/DesignSupport/NE/Standard/1/">www.dot.state.co.us/ftp/erproj/DesignSupport/NE/Standard/1/</a> Drawing File Name: 208010107.dwg Acad Version: R14 Scale: MA Units: English		<b>Standard Plan Revised</b> Date: _____ Comments: _____		<b>TEMPORARY EROSION CONTROL STANDARD PLAN NO.</b> M-208-1
	<b>Project Development Branch</b> SD		Issued By: Project Development Branch October 1, 2000		<b>CONTROL (Typical Layout)</b> Sheet No. 1 of 7

-12-

Figure G.8—Sample temporary erosion control drawing sheet 1 (Colorado Department of Transportation).

## Stream Simulation

---

Revegetation, particularly with native species, is an extensive topic that this guide presents only as an overview. (For bioengineered structures, see section G.4.3.9.)

Timing is critical in revegetation, particularly with native species. In some instances, plant materials must be grown from seed collected from the site. Doing so requires a project lead time of 1 to 2 years (and sometimes more). If you do not consider revegetation planning at the project's start, your oversight can delay the entire project.

### G.4.3.1 Salvaging and storing topsoil

In the contract, define topsoil by depth and rock/wood content. Topsoil refers to the uppermost soil horizon, usually 2 to 8 inches deep. Topsoil may include live vegetation less than 3 feet in height, limbs less than 3 inches in diameter, and organic duff.

Remove topsoil before doing anything else. To avoid compaction, do not drive on topsoil before, during removal, or after replacement.

If less topsoil is available for salvaging than you will need for revegetation:

- Use commercial mulches in place of topsoil. The mixture must be free of weed seeds, harmful bacteria or disease spores, and substances toxic to plant growth.
- Spread topsoil thin to maximize cover of the seed bank contained in topsoil.

To maintain and store “living soil:”

- Stipulate topsoil storage details in special contract requirements or supplemental specifications (depth of piles, length of storage time, number of moves, etc.).
  - ▲ After topsoil has been stored for extensive periods (i.e., 3 months for nonforest sites and 6 months for forest sites), spread it thin and allow it to revegetate.
  - ▲ Do not store conserved wetland sod for more than 1 month.
- Avoid contaminating topsoil with unsuitable material. Do not mix topsoil with subsoils.



## Appendix G—Additional Tools and Tips

---

- Designate topsoil stockpile location.
- Store topsoil close to where you found and removed it, to protect it from loss and contamination.
- Put up a sign indicating topsoil, to avoid mixing it with other excavated materials. Also designate the source location and return topsoil/seed bank to its original location.
- Avoid over-winter storage.
- Install sediment control measures around storage site.

Dealing with topsoil infested with noxious or invasive weeds:

- Specify that topsoil sources shall be free of weeds and invasive species.
  - ▲ Map known areas of infestation and control them mechanically or chemically. (Note: Before using herbicides, consult national herbicide **BMPs**.)
- Do not use infested topsoil. Enlist help from the project team for proper disposal or treatment.
- Make sure to pressure-wash or steam clean all incoming equipment.

Replacing topsoil on steeper slopes:

- You may need special equipment and manual methods for proper workmanship in difficult terrain. Design slopes with planting pockets and ledges that hold the soil in place to promote revegetation.

### **G.4.3.2 Collecting seeds and cuttings for native species revegetation**

Environmental documents sometimes require seedlings, which take 1 or 2 seasons to grow from seed. Plan at least 2 to 3 years in advance to have native plant materials available (i.e., to find and collect seed and cuttings).

- Understand safe storage requirements for the species you intend to use.

## Stream Simulation

---

### G.4.3.3 Water quality monitoring

- Thoroughly understand water quality permit and NEPA document requirements.
  - ▲ Include requirements in special contract requirements or supplemental specifications to make sure they are part of the contract.
- Before construction, establish the baseline for the following factors (or others as required by the permit or NEPA document):
  - ▲ Turbidity.
  - ▲ Temperature.
  - ▲ Dissolved oxygen.
- During construction, ensure that proper water quality monitoring methods are employed, and that monitoring frequency is adequate to meet permit or environmental document requirements.

### G.4.3.4 Training and quality control

- Effectively communicate which resources the erosion control plan protects.
  - ▲ Use well-written performance-based supplemental specifications.
  - ▲ Conduct an in-depth review of the erosion control plan, permit, and contract requirements with the contractor, the project team, and inspectors.
  - ▲ Use well-trained COR and inspectors for communicating and enforcing contract requirements.
- Ensure sufficient quality control.
  - ▲ Train designers and contract administrators in effective erosion control measures and temporary stabilization methods.
- If the contractor requests—or unexpected site conditions demand—a change to a previously permitted erosion control plan, review the design/protection criteria from NEPA document (what you are protecting and why). Consult with the project team before making a change to ensure the change will meet the intent of the original erosion control plan.

### G.4.3.5 Temporary soil stabilization until vegetation is fully established

Temporary methods for stabilizing disturbed soil (near streams) before permanent revegetation is fully established include:

- Temporary seeding (annual grass).
- Temporary cover such as plastic sheeting, mulch, netting.
- Rock blankets/riprap.
- Entrenched coir logs.
- Matting.
- Silt fence at ditch relief outlets.
- Chemical soil stabilizers.

‘In stream’ construction windows do not necessarily coincide with best streamside planting times. (These time differences often require two separate contracts—one for the crossing construction and one for revegetation.)

- Install and maintain temporary erosion control measures until revegetation criteria are met. Make sure that these measures are contract requirements. (If they are not in the contract before construction, add them through a contract modification.)

The agency must provide manpower and funding for several years, either to enforce revegetation and erosion control contract provisions or to maintain the erosion/revegetation plan after work on the contract has been accepted. The contractor is not responsible for erosion/revegetation work needed after the contract is closed.

### G.4.3.6 Miscellaneous ‘things that can go wrong’ during construction

“Maximum area disturbed” clause of contract is ignored.

- This clause is the first line of defense for sediment control, and is especially critical in rainy environments. Enforce contract requirements for maximum disturbance area.

## Stream Simulation

---

Occasionally, a contractor may deliberately violate water quality permit conditions. Actions that have been observed include shoveling sediment from a silt fence into the stream, and pumping muddy water from structure excavation into the stream.

- Check erosion control installations daily, especially after rain events.

Although silt fences must be maintained to remain effective, they are frequently placed in inaccessible locations.

- Use brush windrow wrapped with biodegradable fabric (may be left permanently).
- Ensure that a difficult location is important to long-term erosion control objectives. If the location is negotiable, work with permitting agency in design phase.

Temporary instream sediment traps (for example, filter cloth/lay-back trap) may trap too much sediment for hand removal.

- Do not construct such structures unless they are accessible by equipment for maintenance.
- Rely on erosion controls first. Always think of sediment controls as a last resort.

Large storm events may exceed capacity of erosion control system.

- Check history of large events during construction window and any information available on what measures worked at that time of year.
- Design for controlled failure and minimize consequences of failure.
- Place the burden of performance on the contractor—use performance-based specifications.

### **G.4.3.7 Seasonal work shutdown and resumption of work**

Design for temporary stabilization over winter. Plan longer-term sediment controls for multiseason projects or for shut-down in extreme weather conditions.

- Include provisions in supplemental specifications or special contract requirements for periodic maintenance.
- In the erosion control plan, define locations for sediment cleaned-out of silt fences, settling basins and other sediment control facilities.

## Appendix G—Additional Tools and Tips

---

Temporary stabilization for winter is often underbid and frequently overrun. In late fall, the contractor may be behind schedule and view this work as a second priority.

- Enforce contract requirements for temporary stabilization. The COR must remind the contractor of the requirements well in advance of seasonal closure and ensure the site is protected according to the contract.

Final maintenance of erosion control measures before seasonal shut down:

- Clean out silt fences.
- Water bar closed roads.
- Divert runoff to “safe” area with erosion control measures.
- Check periodically during winter for maintenance needs. (For example, rain on existing snow packs may cause greatly increased runoff and erosion.)
- Stabilize area left disturbed over winter.

Runoff-season drainage patterns may differ greatly from construction season.

- On south-facing cuts/slopes, frost will thaw more quickly.
- Muddy runoff may enter stream running over snow while silt fences are still buried under snow.
- On disturbed soils, fluffy surfaces will thaw faster and can slide on top of frozen surfaces.

Before construction resumes in the spring, inspect, maintain, and enforce all erosion control measures (all erosion control contract provisions).

### G.4.3.8 Common problems with revegetation

Revegetation is a critical element in the long-term stabilization of any construction project—and particularly vital to projects close to waterways requiring aquatic organism passage. The lack, or subsequent loss, of long-term stability can not only cause an otherwise successful project to fail but also damage the aquatic environment that the project originally intended to enhance.

## Stream Simulation

---

Common problems along with suggestions for *avoiding* or *solving* them follow. These problems have no quick or easy answers, so adequate research and planning are vital. Using performance-based specifications for revegetation, either as a part of the construction contract or as a separate contract, can avoid many of these problems by giving the revegetation contractor responsibility for successful vegetation establishment.

Plant materials specified in contract are not available.

- Call local plant nurseries or local Natural Resource Conservation Service (NRCS) office to identify plants that are or are not commercially available. NRCS offices can also help you distinguish native plants from nonnative plants for a given ecological setting. (While this work should have been done during the design phase, you may need to do it during construction if plant substitutions are required.)
- Develop a list of acceptable grass, forb, and shrub plants in the local area. Then refine this list to identify species that are:
  - ▲ Native or nonnative to that ecological area.
  - ▲ Commercially available as seed or container plantings.
  - ▲ Available to be collected (cuttings).
- Ensure you know the best time to plant each species, and which can substitute for others.
- To be successful, plant substitutions should ideally mimic the ecologic role of the originally specified plant (assuming that the role was identified). If the original plant was intended to thrive in a riparian zone, is the substituted plant an upland species? Will the plant stabilize the soil with deep or widespread roots, or is it intended to serve as ground cover to protect riparian soils from rainfall impact? As these details will vary with each project, you need to factor them in for the intent of the revegetation to be successful.
- If the plants will be commercially ordered, know the delivery schedule and ensure it meets the desired planting window.

## Appendix G—Additional Tools and Tips

---

Plant materials are at risk of dying or do not grow as quickly as desired. For example, work might be complete in the fall, as planned, but a drought makes it unlikely that the plants will survive.

- For projects encountering weather problems, either delay the revegetation work or modify the contract to do revegetation as a separate contract.
- If these options are not available, pay the contractor for watering the plants long enough for germination and establishment (typically several weeks, but possibly a month or two).
- Use “dry water,” a type of water-saturated gel that can be placed in the ground with container plants. (Guidelines based on successful experience are not widely available yet.)
- Native plants in many ecosystems may begin to establish themselves in the first year but may take 2 to 3 years to become fully established. Do not expect native plants to establish as quickly as some commercial turf grasses.

Plant materials do not grow at all. Improper selection, handling, or storage is a frequent cause.

- Base the revegetation specifications on site-specific conditions. To be successful, the revegetation specifications must include site-appropriate species. Sampling and analysis may be needed to characterize the soil materials that will be revegetated; if so, they should be specified.
- Develop guidelines for the proper storage, transportation, and handling of the specified plant materials. Contact local nurseries and offices of the NRCS to learn what methods are necessary.
- Provide necessary training for CORs and Inspectors regarding transporting, handling, storing, and planting seed or plants.

Plant materials are damaged or killed after successful establishment.

- In areas where herbicides are part of the weed eradication program, use grass species rather than forb (broad-leaf) species in the specifications, since grass is often more resistant to herbicides.

## Stream Simulation

---

- In areas where wild grazing animals are common, select species that are less attractive to grazing animals to reduce chances of heavy grazing.
- In areas where the herding of domestic animals is common, seek cooperation with local animal owners: Ask that they delay herding or provide alternate herding routes during the times critical to germination and establishment of permanent vegetation.

Invasive or noxious plants are observed on site before or after construction.

- Determine which plants are invasive. For a list of invasive or noxious plant species, by state, see the USDA Animal and Plant Health Inspection Service Web site, listed under Resources.
- Before construction, physically remove weeds observed on-site or treat them with herbicide methods where legal. (See NEPA documentation before using herbicides.)
- During construction, take a proactive approach to avoid inadvertently transporting invasive species to the site. Include in the special contract requirements or supplemental specifications the provision that all construction vehicles be washed before entering the construction area. This provision will minimize the transport of noxious weed seeds from other areas.
- Require plant seed used in revegetation be tested for the presence of invasive or noxious weed seeds at appropriate state seed labs.
- Do all you can to foster a healthy revegetated area—it will be more resistant to invasive or noxious weed species than areas that are not successfully revegetated.

### G.4.3.9 Resources for revegetation and erosion control

Lewis, Lisa. 2000. Soil bioengineering – an alternative to roadside management – a practical guide. 0077-1801—SDTDC. San Dimas, CA: U.S. Department of Agriculture, Forest Service, San Dimas Technology and Development Center. 44 p.

Luna, Tara; Dumroese, R. Kasten; Landis, Thomas D. 2006. Collecting dormant hardwood cuttings for western riparian restoration projects. 0624-2334—MTDC. Missoula, MT: U.S. Department of Agriculture, Forest Service, Missoula Technology and Development Center. <http://www.fs.fed.us/t-d/pubs/htmlpubs/htm06242334/> (Username: t-d, Password: t-d)



## Appendix G—Additional Tools and Tips

Salix Applied Earthcare. 2002. Erosion Draw 4.0 , (<http://www.erosiondraw.com/>), or SAE homepage: <http://www.salixaec.com>)

Salix Applied Earthcare. 2002. Bio Draw 2.0 , (<http://www.biodraw.com/>), or SAE homepage: <http://www.salixaec.com>)

U.S. Department of Agriculture. 2002. The PLANTS Database, Version 3.5 (<http://plants.usda.gov>). U.S. Department of Agriculture, Natural Resources Conservation Service, National Plant Data Center, Baton Rouge, LA 70874-4490.

U.S. Department of Agriculture. Various links to Noxious Weed lists and Federal Seed Act information (<http://www.aphis.usda.gov/ppq/weeds/nwauthor.html>)

### G.4.4 Aquatic Organism Capture and Transport

Following are recommended procedures for successfully capturing and transporting aquatic organisms during dewatering.

Block off site upstream and downstream. Set block nets to prevent organisms from entering the construction zone from upstream and downstream while the site is being dewatered.

Dewater all or part of the channel in stages. Dewatering slowly minimizes shock and harm to the organisms.

Trap and transport aquatic organisms. As the site is dewatered, trap organisms with dip nets and by hand. (Electroshocking may be necessary for some fish.)

Stage and control rewatering after the project is completed. Rewatering the site slowly prevents turbidity and temperature levels from rising suddenly, and minimizes harm and shock to aquatic organisms.

No standard method exists for capture and handling of aquatic organisms. The biological opinion from the regulatory agency should cover the methods for Endangered Species Act-listed species. State fish and game agencies are a good source for guidelines for handling captured aquatic organisms. As a general rule, place captured fish in a bucket of water kept at near stream temperature.

Knowing which fish, mollusks, crustaceans, and amphibian species inhabit each site is important, because different species are more easily captured at different stages of dewatering. Capture begins immediately after you have isolated the construction area with block nets. Capture stages for aquatic species encountered in Oregon are as follows:

## Stream Simulation

---

- Before actual dewatering begins, use nets and/or seines to efficiently capture juvenile salmon, adult and juvenile cutthroat trout, dace and red side shiners, other small minnow-like fish, and slow-moving amphibians.
- After dewatering begins and as the water level is dropping, capture red-legged frogs, mollusks, and crustaceans.
- When the water level at the site is drawn down, capture stream-bottom oriented fish, sculpin, and three-spine stickleback.
- After dewatering, capture stream-bottom species such as lamprey, because they come out of the substrate when the ground is disturbed.

Place traps and/or screens on the bypass system pumps and hoses. When using a passable pipe or channel bypass system, review the outlet, water depth, and velocity to ensure that aquatic organisms can pass through the system unharmed.

The following case examples demonstrate procedures for capturing and transporting aquatic organisms from construction sites. The principles are the same for stream restoration projects, as illustrated in the third example.

### G.4.4.1 South Fork Desolation Creek

Block nets were placed above and below the work site the day before construction started. Fish were removed from the construction site by electro-fishing (figure G.10). Captured fish were placed in 5-gallon buckets filled with water kept at stream temperature, and the buckets were carried downstream for release. Dewatering consisted of confining streamflow to the middle of the creek and dewatering the foundation trenches with pumps during placement of the precast concrete footings. As dewatering progressed in the foundation trenches, more aquatic organisms were captured and removed. Block nets were kept in place until construction was completed and the entire streambed within the open-bottom arch was rewatered. Figure G.11 shows block nets in place both upstream and downstream, with the stream diverted to the middle between the footings of the newly placed arch.

## Appendix G—Additional Tools and Tips



Figure G.10—South Fork Desolation Creek looking upstream. The crew captured fish trapped within the construction area as the foundation trenches were dewatered.



Figure G.11—South Fork Desolation Creek construction site showing block nets.

## Stream Simulation

### G.4.4.2 Karnowski Creek habitat restoration

Karnowski Creek was rerouted to the valley margin in the late 1800s when cross-valley drainage ditches were constructed to drain the valley bottom for pasture and hay land. During the habitat restoration project, the drainage ditches were plugged and Karnowski Creek was relocated in its historic midvalley location. Aquatic organisms were captured and relocated before, during, and after each ditch was dewatered, plugged, and backfilled. (See figures G.12 to G.13/9.) Figure G.14 shows the percentage of individuals of each species captured before plugging and after the ditches were fully plugged and dewatered. The majority of the salamanders, frogs, and lampreys were captured after plugging.



*Figure G.12—Trout and sculpin are seined from ditch prior to plugging, and captured with dip nets.*

## Appendix G—Additional Tools and Tips

---



*Figure G.13—Capturing aquatic organisms by hand as the site is dewatered.*

# Stream Simulation

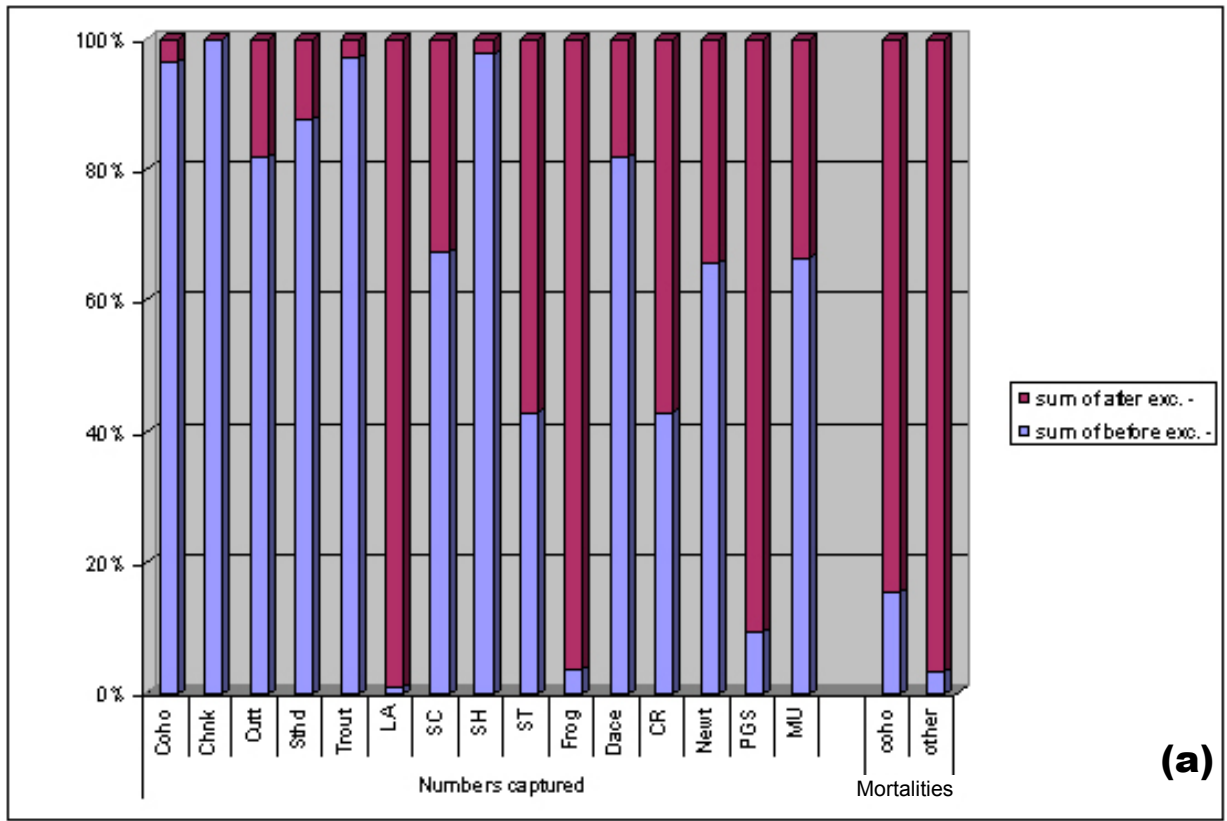

Common Name	Abbrev.
<i>coho salmon</i> .....	<i>coho</i>
<i>chinook salmon</i> .....	<i>chnk</i>
<i>cutthroat trout (1+)</i> .....	<i>cutt</i>
<i>steelhead trout (1+)</i> .....	<i>stlhd</i>
<i>trout (0+)</i> .....	<i>trout</i>
<i>pacific lamprey</i> .....	<i>LA</i>
<i>sculpin</i> .....	<i>SC</i>
<i>red-sided shiner</i> .....	<i>SH</i>
<i>three-spine stickleback</i> .....	<i>ST</i>
<i>red-legged frog</i> .....	<i>frog</i>
<i>dace</i> .....	<i>dace</i>
<i>crayfish</i> .....	<i>CR</i>
<i>newt</i> .....	<i>newt</i>
<i>pacific giant salamander</i> .....	<i>PGS</i>
<i>mussel</i> .....	<i>MU</i>
<i>coho mortalities</i> .....	<i>coho mort</i>
<i>other mortalities</i> .....	<i>other mort</i>

**(b)**

Figure G.14—(a) Percentages of total individuals of each species captured before and after dewatering. (b) Species identification table.



# Stream Simulation

---



## Appendix H—Sample Contract Provisions

This appendix includes sections from a contract developed on the Willamette National Forest in Oregon: the list of items, supplemental specifications, Section H - Special Contract Requirements, and drawings. The example contract documents can serve as “starting points” for your project, but they will need to be thoroughly modified for local conditions.

Table H 1—Sample schedule of items (Bid Schedule)

Item No.	Description	Method of Measurement	Unit	Estimate Quantity	Unit Price	Total
<i>Reconstruction of Road _____, mp _____</i>						
152(02)	Construction surveying and staking (road)	AQ	Sta	3	\$ _____	\$ _____
171(03)	Construction surveying and staking (structure)	AQ	Each	1	\$ _____	\$ _____
201(03)	Clearing and grubbing, slash treatment methods for tops and limbs 12, logs 12, stumps 12, utilization of timber 2	LSQ	LS	All Req'd	\$ _____	\$ _____
202(02)	Removal of existing 13-ft.-diameter multiplate pipe, disposal method A	AQ	Ea	1	\$ _____	\$ _____
204(19)	Soil erosion and pollution control	LSQ	LS	All Req'd	\$ _____	\$ _____
204(20)	Dewatering and sediment control	LSQ	LS	All Req'd	\$ _____	\$ _____
206(02)	Foundation fill	DQ	CY	1,565	\$ _____	\$ _____
206(07)	Structural excavation	LSQ	LS	All req'd	\$ _____	\$ _____
251(01)	Placed riprap, class 6, method A	DQ	CY	138	\$ _____	\$ _____
251(14)	Placed channel rock, rock-36, method D	AQ	EA	30	\$ _____	\$ _____
251(15)a	Placed streambed simulation rock, subarmor, method D	DQ	CY	315	\$ _____	\$ _____
251(16)	Filler material, placement method E	DQ	CY	26	\$ _____	\$ _____
301(10)	Untreated aggregate course, type base, grading C, compaction B	DQ	CY	84	\$ _____	\$ _____
552(03)	Structural concrete, class A (AE), for footings	AQ	CY	69	\$ _____	\$ _____

# Stream Simulation

Table H 1—Sample schedule of items (Bid Schedule) continued

Item No.	Description	Method of Measurement	Unit	Estimate Quantity	Unit Price	Total
<i>Reconstruction of Road _____ , mp _____</i>						
554(03)	Reinforcing steel	LSQ	LS	All Req'd	\$ _____	\$ _____
601(01)	Mobilization	LSQ	LS	All Req'd	\$ _____	\$ _____
607(03)	Gate temporary, type I barricade, size 16' wide x 2 8" high	AQ	Each	2	\$ _____	\$ _____
617(06)	Steel 5.75" x 15" corrugation long-span structure, plate zinc-coated, 34' span, 15' 3" rise, .25" thickness	AQ	FT	28	\$ _____	\$ _____
625(02)	Seeding, hydraulic method (with mulch)	DQ	Acre	0.12	\$ _____	\$ _____

## Appendix H—Sample Contract Provisions

### SUPPLEMENTAL SPECIFICATION 157—SOIL EROSION CONTROL

#### Description

##### 157.01

Add the following after the first sentence: The work shall also include stream bypass construction and dewatering.

#### Materials

##### 157.02 Requirements

Add the following:

Coarse Aggregate for Portland Cement Concrete.....	703.02
Plastic Lining.....	725.19
Bentonite.....	725.20
Erosion Control Culvert Pipe .....	713.15
Plastic Pipe .....	706.08
Aluminum-Alloy Corrugated Pipe .....	707.03
Metallic-Coated Corrugated Steel Pipe.....	707.02
Watertight Gaskets.....	712.03

#### Construction Requirements

##### 157.03 General

Add the following after the first paragraph:

The contractor's written plan shall include, as a minimum, the dewatering and sediment control requirements AS SHOWN ON THE DRAWINGS and in this specification. The contractor shall submit the complete plan at least 15 days prior to start of work and shall not commence work until approved in writing by the contracting officer. The plan shall be executed without modification unless authorized in writing by the contracting officer. The work shall be in conformance with applicable Federal, State, and local government regulations.

157.04 Controls and Limitations on Work. Add the following:

The contractor shall operate in a manner that will protect aquatic organisms.

Construct the dewatering and sediment control requirements AS SHOWN ON THE DRAWINGS, in accord with and according to the contractor's approved plan.

## Stream Simulation

---

Notify the contracting officer of the intention to dewater the stream at least 72 hours in advance. DO NOT REROUTE WATER until approved by the contracting officer. A fisheries biologist (approved by the contracting officer) and other Government personnel must be present and prepared to rescue aquatic organisms prior to rerouting of the stream. Work that would jeopardize fish shall not be permitted during the dewatering operation. Dewater the stream slowly and incrementally in order to facilitate the fish rescue. The rescue operation will generally take several hours.

The newly constructed simulated streambed must be approved by the contracting officer prior to releasing water through the project site. After approval, water shall be released slowly and incrementally over a period of at least 1 hour, or as approved by the contracting officer.

### 157.09 Diversions

Add the following:

**Stream Bypass Dam and Pipe.** Construct a sandbag dam and bypass pipe to divert the stream water around the excavation. A channel lined with an impermeable membrane may be substituted for the bypass pipe when approved by the contracting officer.

**Primary Bypass Dam.** Construct the sandbag dam in a dry condition by first pumping the stream around the dam, placing a feeder dam, or placing temporary sandbag cofferdam(s). Place the sandbag dam AS SHOWN ON THE DRAWINGS or approved by the contracting officer. Remove rocks and other irregularities from the streambed to form a smooth bedding for the dam. Place the dam so that water does not seep from the downstream side of the dam; if seepage occurs, improve the dam by adding sandbags, improving or adding seals, or adding pumping or other means to eliminate seepage from the dam.

**Bypass Pipe.** Place bypass pipe AS SHOWN ON THE DRAWINGS or approved by the contracting officer and in accordance with Section 603-Metal Pipe or 603B-Plastic Pipe. The upstream invert of the pipe shall be placed at the lowest point in the stream channel; remove rocks from the streambed, as needed. Install joints and elbows, as needed to accommodate the site layout. Use watertight seals, when SHOWN ON THE DRAWINGS. Lay of the pipe must be approved by the contracting officer prior to backfilling.

Compact the backfill according to method A. Allow water to pass through pipe only after a downstream splash apron has been prepared in a manner

## Appendix H—Sample Contract Provisions

---

that will protect the stream from scour and turbidity. The installation shall be constructed in a manner that avoids injury to aquatic organisms, such as fish being dashed onto sharp rocks at the outfall of the pipe.

**Feeder Dam and Pipe.** Construct a sandbag dam and pipe upstream of the primary bypass dam/pipe AS SHOWN ON THE DRAWINGS or approved by the contracting officer, for the purpose of feeding the streamflow into the primary bypass pipe and improving the efficiency of the primary bypass dam.

**Downstream Dam.** When water flows into the work area from downstream, place a sandbag or geotextile/straw-bale dam AS SHOWN ON THE DRAWINGS or approved by the contracting officer to prevent water from entering the work area.

**Sandbags.** Place sandbags AS SHOWN ON THE DRAWINGS or approved by the contracting officer. Prior to placing the lower rows of sandbags, remove the larger rocks from the streambed to form a smooth bed. Sandbags shall contain only clean sand or coarse concrete aggregate. The bags shall be loosely filled and tamped in place to minimize seepage between, under, and around the bags.

**Primary Dam Impermeable Membrane.** Place the membrane within the sandbag dam and entrenched in the streambed AS SHOWN ON THE DRAWINGS or approved by the contracting officer. The membrane shall have a minimum thickness of 10mil and be free of tears or punctures. Compact soil in the trench along bottom edge of the membrane to form a water seal; when approved by the contracting officer, a small amount of granular bentonite may be used along the bottom edge of the membrane to form a watertight seal between the membrane and the streambed. Cut a hole in the membrane to fit the bypass pipe and seal the membrane to the bypass pipe or the bypass pipe collar using such means such as adhesive strips to form a durable watertight seal.

**Bypass Pipe Collar.** Install and maintain a leak-proof pipe collar immediately downstream of the impermeable membrane AS SHOWN ON THE DRAWINGS or approved by the contracting officer. The collar shall be an Ethylene Propylene Diene Monomer (EPDM) liner having a thickness of 45mil. A smooth round hole shall be cut in the liner with diameter one-half that of the bypass pipe, and pulled over the end of the pipe into place. EPDM-seam tape and compression band(s) shall be used to form a durable watertight seal between the collar and the pipe. The liner

## Stream Simulation

---

shall extend to the sides and top by a distance of one pipe diameter. The lower edge of the collar shall be entrenched in the streambed along the downstream side of the dam's impermeable membrane. When approved by the contracting officer, a small amount of granular bentonite may be used along the bottom edge of the collar to form a watertight seal between the collar and the streambed.

**Pumps.** Install pumps as required to reroute the stream around the construction site and dewater foundations. When failure of a pump would result in movement of sediment or turbidity beyond the work area, a back-up pump shall be readily available.

**Bypass Pump.** When SHOWN ON THE DRAWINGS, supply and operate a pump that has the pumping capacity greater than the flow in the stream, to be used for installing and removing the gravity bypass pipe(s) and dam(s), and at other times to facilitate construction operations (and used during storms to supplement the gravity bypass). The pump shall be equipped with approved fish screens, appropriate suction and discharge hoses, fittings, and flow regulation equipment needed to route the stream around the construction site to the discharge point SHOWN ON THE DRAWINGS or approved by the contracting officer. Pumps shall be clean and free of leaks. Oil lubricant in the pump seal systems shall consist of food-grade mineral oil.

**Sump Pumps.** Supply two pumps capable of dewatering the structure foundation AS SHOWN ON THE DRAWINGS or approved by the contracting officer. Pumps shall be clean and free of leaks. Sediment in the sump pump discharge shall be removed from the water prior to reentering the waterway.

**Sump Water Discharge.** Discharge sump water AS SHOWN ON THE DRAWINGS or as approved by the contracting officer. Apply one or more methods to remove sediment from sediment-laden water. Apply additional methods, as needed, to eliminate all visual evidence that sump water discharge is causing a downstream turbidity increase. Monitor operations to insure continuing compliance with water quality requirements. Note, in the following methods, where a manufacturer is shown, there may be other manufacturers who supply similar products or methods of treatment. Unless stated otherwise, it is not our intent to endorse a particular manufacturer in this document. The reader should further research similar products.

## Appendix H—Sample Contract Provisions

---

**(a) Natural Vegetation/Soil Dispersal and Filtration.** Sump water may be discharged onto areas of ground most advantageous for dispersal and filtration of sediment, for example, flat heavily vegetated soil. When single point discharge does not function adequately, discharge sump water into a perforated pipe laid level so that the sump discharge will disperse over a wide area.

**(b) Silt Bag(s) Filtration.** Discharge sump water into a silt bag. The bag shall be constructed of Mirafi 180N, or approved equal, with sewn seam strengths of 90-percent efficiency according to ASTM D4632. The bag shall be constructed to hold and filter sump water. Place silt bag(s) on level ground above a layer of straw 1-foot thick.

**(c) Settling Basin(s).** Discharge sump water into a basin or basins. The basins may be premanufactured tanks, folding tanks, geotextile, or membranes placed over a sandbag or weed-free straw berm, or other similar basins designed to separate sediment from the water.

**Suspended Sediment Coagulation Agent.** When the above methods (a), (b), or (c) do not function adequately, add an approved coagulation agent to the water prior to discharging the water onto natural vegetation, silt bag(s), or settling basin(s) described in methods (a), (b), or (c). The flocculation agent shall be Chitosan-based Storm-Klear Gel-Floc, or an approved equal. Storm-Klear products are manufactured by Vanson HaloSource, Inc., and are distributed by Natural Site Solutions, Redmond, Washington. Use the suspended sediment coagulation agent according to the manufacturer's recommendations.

After placement of the simulated stream materials AS SHOWN ON THE DRAWINGS, wash the fines into the surface of the new streambed. Treat the sump water discharge as before.

**Sedimats.** Place Sedimats across the streambed AS SHOWN ON THE DRAWINGS or approved by the contracting officer and as recommended by the product manufacturer. The Sedimat is a proprietary product manufactured by Indian Valley Industries, Inc. and distributed by Columbia Storage Inc., Vancouver, Washington. Use Sedimats according to the manufacturer's recommendations.

## **Stream Simulation**

---

### **157.13 Maintenance and Cleanup**

Add the following:

Maintain all elements of the operation in order to dewater the foundation, facilitate construction, prevent harm to aquatic organisms, and prevent sediment and turbidity from entering the stream.

When removing the sandbag dam(s), sand must be removed from the waterway; if coarse concrete aggregate is used in the sandbags, the gravel may be distributed evenly across the waterway as directed by the contracting officer.

Geotextiles used in sediment control operations shall be removed from Government property after use.

Bare soil left from filtering or settling operations shall be shaped to drain, seed, and mulch with weed-free straw.

### **Measurement**

#### **157.15**

Add the following after the last item:

Measure dewatering and sediment control as a lump sum.



## Appendix H—Sample Contract Provisions

### SUPPLEMENTAL SPECIFICATION 251—STREAMBED CONSTRUCTION

#### Description

##### 251.01

Add the following after the first sentence:

The work shall include streambed-simulation construction.

#### Materials

##### 251.02 Requirements

(Add the following materials)

Channel Rock 705.07

Streambed-Simulation Rock 705.08

#### Construction Requirements

##### 251.04A Placed streambed-simulation rock and channel rocks

Add the following:

Prior to the start of construction, submit a written plan for obtaining, mixing, placing, and shaping streambed-simulation rock, channel rocks, and select borrow. The plan must indicate how the material will be tested to verify that it meets all of the requirements of this specification. Do not substitute onsite materials for material sources specified in the contract, unless a revised plan is first submitted and approved in writing by the contracting officer.

Placed stream-simulation rock is rock placed on a prepared surface to form a well-graded, low-permeability mass, similar in appearance and texture to the adjacent natural streambed. No metal track or rubber-tired equipment shall be driven on or operated directly on metal or concrete structure surfaces. Onsite excavation materials will only be accepted as substituting for specified source material, if it can be shown by the contractor to meet all of the requirements of the specified material. Material not meeting the gradation or diameters specified will not be accepted, unless approved in writing by the contracting officer.

**Method D, Machine Placed.** Place streambed-simulation-rock in one or more layers, not to exceed 6 inches or  $1.5 \times D_{84}$ , whichever is larger. Fill voids within each layer with filler material according to 251.10A before placing the next layer. Do not place streambed-simulation rock by methods that cause segregation or damage to the prepared surface or culvert surface. Place or rearrange individual rocks by mechanical methods to obtain a compact, low-permeability mass matching the stream-simulation

## Stream Simulation

---

bed details SHOWN ON THE DRAWINGS. Place channel rocks in the configurations and locations SHOWN ON THE DRAWINGS.

**Method E, End Dumped.** Dump streambed-simulation rock in one or more layers not to exceed 6 inches or  $1.5 \times D_{84}$  diameter, whichever is larger. Fill voids within each layer with filler material according to 251.10A before placing the next layer. Distribute larger rocks throughout the mass of stone. Obtain a uniformly dense, compact, low-permeability bed with a surface matching the stream-simulation bed details, as SHOWN ON THE DRAWINGS. Place filler material according to 251.10A. Place channel rocks in the configurations and locations as SHOWN ON THE DRAWINGS.

**Method F, Hand Placed.** Place stream-simulation rock by using hand labor. Material may be hand-carried, or carried in wheelbarrows and end-dumped to obtain its full thickness or in layers, if the depth exceeds 24 inches. Compact each load using hand-operated equipment to obtain a uniformly dense, compact, low-permeability bed with a surface matching the stream-simulation bed details as SHOWN ON THE DRAWINGS. Place filler material according to 251.10A before placing the next layer. Place channel rocks in the configurations and locations SHOWN ON THE DRAWINGS.

### **251.10A. Placed Filler Material**

Fill all voids between individual streambed-simulation rocks and all voids left during placement of channel rocks and streambed-simulation rock adjacent to footings, concrete structures, or corrugated pipes with select borrow as specified in Subsection 704.07. Use water pressure, metal tamping rods, and similar hand-operated equipment to force material into all surface and subsurface voids between the structure and rocks and between individual rocks. Fill shall extend to 100 percent of the rocks' height between layers and 67 percent of their height on the bed surface or as SHOWN ON THE DRAWINGS.

### **Measurement**

Add the following:

Measure placed channel rocks by each. Measure streambed-simulation rock by the cubic yard in place. Measure filler material by the cubic yard in place.

## Appendix H—Sample Contract Provisions

### SUPPLEMENTAL SPECIFICATION 705—STREAMBED-SIMULATION MATERIALS

Add the following:

705.07 Channel rocks – Channel rocks shall have a long axis 133 percent or longer than the median axis.

Table 705-4—Size requirement for channel rocks

Channel Rock Class (diameter, inches)	Approximate Weight (pounds)	Median Axis Dimension & Variation in inches
Rock-4	3	4 +/- 1
Rock-6	10	6 +/- 1
Rock-9	33	9 +/- 2
Rock-12	80	12 +/- 2
Rock-16	185	16 +/- 2
Rock-20	365	20 +/- 2
Rock-24	630	24 +/- 3
Rock-30	1,230	30 +/- 3
Rock-36	2,120	36 +/- 4
Rock-42	3,370	42 +/- 4
Rock-48	5,030	48 +/- 5
Rock-54	7,160	54 +/- 5
Rock-60	9,820	60 +/- 6

*Note: Rock classes are shown on the drawings for all key features to be constructed.*

Table 705-7– Project gradation requirements for streambed-simulation bed material, (inches)

Standard sieve	Stream-simulation bed material (percent finer)	Filler material (percent finer)

*Note: Figure 7.18 shows how to fill out table 705-7.*

## Stream Simulation

---

### SPECIAL CONTRACT REQUIREMENTS (H-CLAUSES)

#### H.1 SEASONAL RESTRICTIONS

For protection of resources, time restrictions will apply. Work will be conducted only during the time frames listed below:

- All work shall be completed between \_\_\_\_\_ and \_\_\_\_\_.
- Site disturbance and all other general construction work may not begin until \_\_\_\_\_, unless wildlife restrictions are waived by the district wildlife biologist.
- All in-water work is restricted to \_\_\_\_\_ through \_\_\_\_\_, unless extended by the (local permitting agency, such as Oregon Department of Fish and Wildlife).

#### H.2 PHYSICAL DATA (FAR 52.236-4) (APR 1984)

Data and information furnished or referred to below is for the contractor's information. The Government shall not be responsible for any interpretation of, or conclusion drawn from, the data or information by the contractor.

The indications of physical conditions on the drawings and in the specifications are the result of site investigations by the \_\_\_\_\_ (Forest Service, FHWA, etc.). The investigational methods have included the site survey as shown on the drawings and visual observations of the ground surface.

Weather conditions typical for this area indicate the following normal fire season: \_\_\_\_\_ to \_\_\_\_\_.

#### H.3 LANDSCAPE PRESERVATION

The contractor shall not remove, deface, injure, or destroy trees, shrubs, lawn, or natural features not designated for treatment. The contractor shall confine operations to within the clearing limits or other areas designated in the contract documents and prevent the depositing of rocks, excavated materials, stumps, or other debris outside of these limits. Material that falls outside of these limits shall be retrieved, disposed of, or incorporated in, the work as directed by the contracting officer.

## Appendix H—Sample Contract Provisions

---

**To prevent fuel and oil spills.** The contractor shall maintain storage facilities for oil or oil products on site; appropriate preventive measures shall be taken to insure that any spill of such oil or oil products does not enter any stream or other waters of the United States. When pumps are used near a stream, a fuel containment pan shall be placed under the pump to prevent fuel and oil contacting the soil in the event of a spill from the pump. If a spill of a petroleum product should occur in water, the contractor shall immediately notify the engineer and the (local Emergency Response System, such as Oregon Emergency Response System).

Servicing of all equipment shall be done only in the areas approved by the contracting officer. If the total oil or oil products storage exceeds 1,320 gallons or if any single container exceeds a capacity of 660 gallons, the contractor shall prepare a spill prevention control and countermeasures plan. Such a plan shall meet applicable EPA requirements (40 CFR 112), including certification by a registered professional engineer.

No objectionable material shall be allowed to enter any stream, river, lake, or other body of water. Material which falls in these areas shall be retrieved and disposed of, or incorporated into the work, as directed by the contracting officer. Damage to vegetation or structures outside the project limits shall be repaired, as directed by the contracting officer.

The contractor shall not operate equipment or otherwise disturb the natural vegetation and soil beyond the areas flagged on the ground or beyond 2 feet from the top of cuts or toes of fills.

Prior to the start of construction, the contractor shall submit to the engineer for approval a schedule and plan for soil erosion and pollution control measures for the following phases of work:

- Item 157—Dewatering And Sediment Control.
- Item 201—Clearing and Grubbing.
- Item 203—Removal of Structures and Obstructions.
- Item 209 or 208—Structural Excavation.
- Item 251—Channel Rock, Streambed Simulation Rock, Select Borrow.
- Item 552—Structural Concrete.

## Stream Simulation

---

The soil erosion and pollution control measures shall be designed to prevent any visually perceptible difference in turbidity of the water flowing 100 feet downstream of the project (when compared to the water upstream of the project). The plan shall incorporate, as a minimum but not limited to, the measures AS SHOWN IN THE DRAWINGS. The following control measures and materials shall be available on the project site:

- Plastic sheets or other suitable covers for exposed soil during rainstorms.
- Weed-free straw bales, silt fences or other similar erosion barriers placed at the lower edges of soil slopes that prevent soils from eroding into adjacent streams.
- Covering of all exposed areas of soils with certified weed-free straw mulch upon final completion of the work.
- Sump discharge for dewatering the excavation shall use settling ponds or distribution systems (for example, perforated pipe laid on the ground away from streams) placed in a manner that will cause water infiltration into the surrounding soils.
- Temporary stream diversions, as shown in the drawing or as improved upon by the contractor and approved by the engineer.
- Other measures and materials proposed by the contractor and approved by the contracting officer.

If construction activities cause a visually perceptible increase of stream turbidity for a period in excess of 30 minutes, the contractor shall cease the operations that are causing the turbidity and modify the control measures, as needed to prevent further pollution.

The contractor shall have a SPILL RESPONSE KIT on the project whenever equipment is operating. The spill kit shall be sufficient to absorb up to 34 gallons of oil and be designed to float on the surface, while absorbing oil and repelling water. The kit shall meet or exceed the physical properties of the “New Pig Products Spill Kit #408.”

Equipment shall be furnished on a fully operational basis of modern design and in good operating condition with no fuel or oil leaks. Repairs and move-in/move-out are the contractor’s responsibility. All equipment shall be power-washed to remove all foreign or noxious seeds/weeds prior to entering Forest Service land.

Straw shall be certified weed free.

## Appendix H—Sample Contract Provisions

---

### H.4 MOISTURE SENSITIVE SOILS

Contractors are cautioned that the roadway structure must be designed so that the completed road will support highway-legal loads during a limited-use season. Construction equipment often subjects the uncompleted roadway structure to loadings it was not designed to support. This is especially critical during periods of excessive moisture and will require careful selection and scheduling to permit efficient operation. The contractor at their expense shall correct any damage resulting from operations that render the material unsuitable for use or results in potential siltation of streams.

### H.5 VALUE ENGINEERING

Value engineering change proposals which change the service or function of a facility or produce irreconcilable conflicts with management objectives will not be considered.

The following work is excluded from consideration under the value engineering clause: NONE.

### H.6 PRODUCT SUBSTITUTION

Any modification of items, designs, materials, products, or equipment (including Government-furnished property), made necessary because of a substitution, shall be the responsibility of the contractor without adjustment in contract price or time. The contracting officer's approval of any substitute shall not affect the contractor's responsibility for such modification. Any and all substitutions shall be requested by the contractor after award of the contract has been made.

No approvals will be made prior to award.

The contractor shall provide written documentation and all testing information to verify that the proposed substitution product meets all the of the specification requirements.

### H.7 ROAD USE AND MAINTENANCE

#### *H.7.1 Use of Roads*

See Special Project Specification 104.021 for use authorization and limitations.

#### *H.7.2 Traffic Control*

The contractor may close Road \_\_\_\_\_ as needed for construction for a period not to exceed \_\_\_\_\_ consecutive days. During the times of closure,

## Stream Simulation

---

the contractor shall provide and maintain “Road Closed Ahead” signs and other devices at locations leading to the project site, as prescribed in the traffic control plan.

The contractor shall provide, erect, and maintain all necessary barricades, suitable and sufficient lights, danger signals, signs, and other traffic control devices; they shall take all necessary precautions for the protection of the work and safety of the public. Barricades and other obstructions shall be illuminated during the hours of darkness. Suitable warning signs shall be provided to control and direct traffic properly.

The contractor shall erect warning signs in advance to any place on the project, where operations may interfere with the use of the road or trail by traffic, and at all intermediate points, where the project crosses or coincides with an existing road or trail.

### **H.8 CONSTRUCTION STAKES, LINES, AND GRADES**

The Forest Service has placed control points at the project site. The hubs and stakes constitute the field control from which the contractor shall execute the work, and shall be left in place until the engineer approves their removal.

The contractor shall do all further surveying, staking, and engineering to establish the horizontal and vertical control necessary for the finished work to comply with the lines and grades shown on the drawings or stated in the specifications. This work is incidental to the pay items.

If any construction control points have been destroyed or displaced by the contractor’s negligence or operation, the contractor shall promptly notify the engineer. If these points are destroyed or displaced due to contractor’s negligence or operation, the cost of replacing them will be charged to the contractor.

In the case of any construction changes, the contractor shall cooperate with the engineer and facilitate the prompt reestablishment of the field control for the readjusted work.



## Appendix H—Sample Contract Provisions

---

### H.9 PROSECUTION OF WORK

The contractor shall conduct activities so that interference with the public shall be kept at a minimum. Any activities requiring any type of closure to the public will be scheduled with the COR at least \_\_\_\_ days in advance.

The contractor shall use measures and precautions necessary to warn and protect the public and Government personnel during work at the project site. Such actions include, but are not limited to, furnishing and maintaining barricades and signs around the work site and roping off the area.

For blasting precautions and methods, the contractor shall comply with State and Federal laws in regards to transportation, storage, and use of explosives. The contractor shall post a watchperson at a safe distance on all approaches to a blasting area on all approaching roads and trails. The contractor shall also notify all people in the vicinity prior to a detonation.

### H.10 CONTROL OF MATERIAL

#### H.10.1 Rights in and use of materials

The contractor may use on the project suitable stone, gravel, or sand encountered in the excavation that can be shown by testing and in written documentation that it meets the project specifications.

#### H.10.2 Excavation

\_\_\_\_\_ (specify type)

#### H.10.3 Material sources

Borrow sources, if needed, must be approved in advance by the engineer. Such borrow sources shall be restored to a natural appearance. Rocks and mineral soil excavated within the normal excavation shall be conserved and used, as needed where they meet project specifications and are approved in writing by the contracting officer.

#### H.10.4 Storage and stockpiling of materials

Materials shall be stored to assure the preservation of quality and fitness for the work. Stored materials shall be located to facilitate their prompt inspection. Sites on Forest Service-administered land, approved by the Forest Service, may be used for storage purposes and for the placing of the contractor's plant equipment. All storage sites provided by the Forest Service shall be restored at the contractor's expense. Contractor shall be responsible for making arrangements for storage on other than Forest Service-administered lands.

## **Stream Simulation**

---

### ***H.10.5 Local disposal sites***

Designated disposal sites for this project are as shown on the drawings.

### ***H.10.6 Earthwork tolerances***

Unless working tolerances are specified, all work performed and materials furnished shall be in reasonably close conformity with lines, grades, cross sections, dimensions, and material requirements shown on the drawings, indicated in the specifications, or designated on the ground. “Reasonably close conformity” shall be in compliance with what is reasonable and customary for manufacturing and construction tolerances.

### **H.11 STATE PERMITS**

Roads in the project work area necessary to complete the project are designated as “within the immediate construction project” for consideration under ORS 767.025 as to the nonapplicability of PUC requirements.

### **H.12 PROTECTION OF CULTURAL RESOURCES**

The location of known historic or prehistoric sites, buildings, objects, and properties related to American history, architecture, archeology, and culture (such as settler or Indian artifacts) protected by the American Antiquities Act of 1906 (16 U.S.C. 431-433), National Historic Preservation Act of 1966 (16 U.S.C. 470), and the Archeological Resources Protection Act of 1979 (PL 96-95 and 36 CFR 261.9(e)) shall be identified on the ground by the Forest Service. The Forest Service may unilaterally modify or cancel this contract to protect an area, object of antiquity, artifact, or similar object which is or may be entitled to protection under these acts regardless of when the area, object, or artifact was discovered or identified. Discovery of such areas or objects by either party shall be promptly reported to the other party.

The contractor shall protect all known and identified historic or prehistoric sites, buildings, objects, and properties related to American history, architecture, archeology, and culture against destruction, obliteration, removal, or damage during their operations. In accordance with 36 CFR 296.14(c) the contractor shall bear the costs of restoration, provided that such payment shall not relieve the contractor from civil or criminal remedies otherwise provided by law.

Wheeled or track-laying equipment shall not be operated within such areas except on roads. Unless agreed otherwise, trees shall not be felled into such areas.

## Appendix H—Sample Contract Provisions

---

### **H.13 PROTECTION OF HABITAT OF ENDANGERED, THREATENED, AND SENSITIVE SPECIES**

Location of areas needing special measures for protection of plants or animals listed as threatened or endangered under the Endangered Species Act of 1973, as amended, or as determined to be sensitive by the regional forester under authority of FSM 2670, are shown on the drawings and identified on the ground. Measures needed to protect such areas have been included elsewhere in this contract or are as follows: None.

If protection measures prove inadequate, if other such areas are discovered, or if new species are listed as federally threatened or endangered or as sensitive by the regional forester, the Forest Service may either cancel or unilaterally modify this contract to provide additional protection regardless of when such facts become known. Discovery of such areas by either contractor or inspector shall be promptly reported to the other party.

### **H.14 SANITATION AND SERVICING REQUIREMENTS**

Unless substitute measures or equipment are authorized in writing by the contracting officer, protection of air and water quality shall include the use of approved chemical toilets by all persons engaged in road construction or in removing timber under this contract while they are inside the forest boundary. Such facilities shall be furnished by contractor in quantities and at locations approved by the engineer. No habitation or overnight dwelling by employees of the contractor shall be permitted on national forest land without advance written approval from the contracting officer.

Oil-absorbing mats are required under all stationary landing equipment, or equipment being serviced within the forest boundary to prevent leaking or spilled petroleum-based products from contaminating soil and water resources. Such material will be furnished by the contractor and approved by the contracting officer.

The contractor agrees that all persons engaged in work under this contract will have a certificate from a medical doctor certifying them to be free from all diseases communicable through drinking water.

## Stream Simulation

---

### H.15 POTENTIAL SAFETY HAZARDS

Data and information furnished or referred to below is for the contractor's information. The government shall not be responsible for any interpretation of or conclusion drawn from the data or information by the contractor. This list shall not be deemed to be all-inclusive. The contractor shall bear the sole responsibility for taking all appropriate actions necessary to prevent accidents and injuries to individuals at the worksite.

The following checked activities have been identified by the government as potential safety hazards.

- Confined space entry.
- Temporary excavation/deep trenching/slope stability.
- Tree falling.
- Fall hazard from work heights exceeding 6 feet.
- Blasting.
- Traffic control on high-volume and/or high-speed and/or limited-visibility roads.
- Heavy equipment operation.
- Tree climbing and/or tower climbing.
- Fire hazards.
- Hazardous materials handling.
- Electrical hazard.
- Hydraulic and/or pneumatic and/or other high-pressure hazards.
- Mechanical hazards such as pulleys, springs, etc.
- Other \_\_\_\_\_.

### H.16 FINAL CLEANUP

Contractor shall remove and dispose all of their own trash and refuse from the contract area. Material to be removed includes, but is not limited to, camp refuse; for example, tin cans, aluminum foil, glass, paper, garbage, used engine oil, oil filters, oil cans, grease cartridges, etc. The contractor shall also remove and dispose of upon completion of the project, all stakes, old culverts, flagging, and similar debris within the project area. Roads shall be swept and washed to remove soil and rock materials. This cleanup is a subsidiary item for which no special payment will be made. All debris shall be removed from national forest land in accordance with State and local disposal requirements.

## Appendix H—Sample Contract Provisions

---

### H.17 PROTECTION OF IMPROVEMENTS

Unless otherwise agreed to in writing, the contractor shall remove the existing signs within the work area and reinstall them to their approximate existing locations.

### SAMPLE LIST OF PROJECT DRAWINGS

	Figure(s)
Title Sheet	H.1
Vicinity Map	H.2
Estimate of Quantities	H.3
Sign and Gate Plan	H.4, 5
Site Plan (topographic map, structure and road location, storage area location)	H.12
Dewatering Plan (including channel excavation work needing dewatering)	H.6, 7, 13
Dewatering Details (specification, drawing, additional design details)	H.8
Long Profile and Stream-simulation Details (abbreviated)	H.9, 14
Cross Sections and Stream-simulation Details	H.10, 15
Road Template and P-line Location (coordinates)	
Structure Design	
Structure Details	
Concrete Details (footing, collar, etc.)	H.11, 16
Drill Investigation Information	

---

*[Note—Some of these drawings will take more than one sheet.]*

---

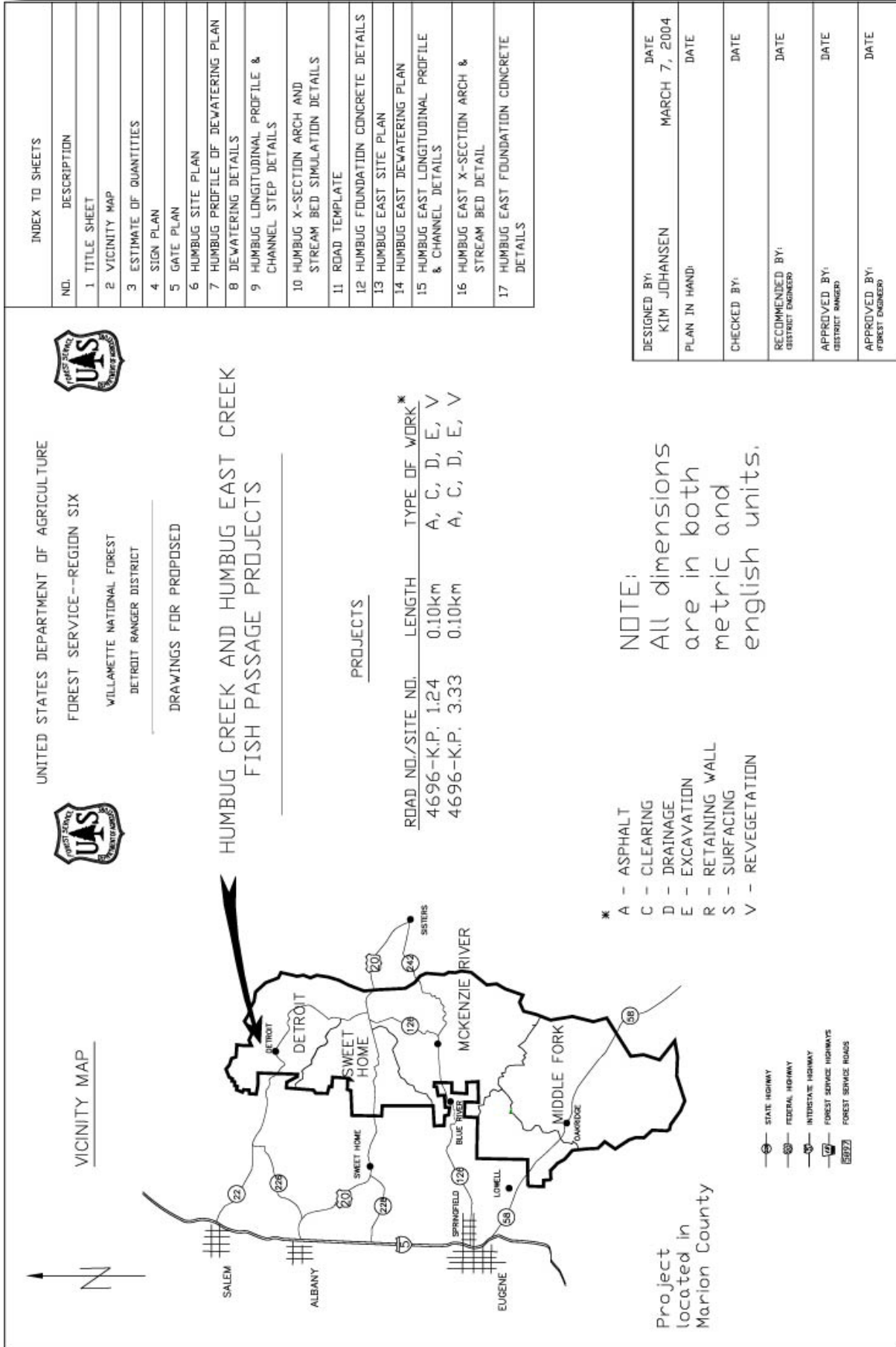

Figure H.1—Humbug Sheet 1: Title Sheet.

U.S.D.A. FOREST SERVICE		PACIFIC NORTHWEST REGION	
VICINITY MAP		HUMBUG & HUMBUG EAST CREEK	
Designed By:	DKJ	REV DATE	
Drawn By:	DKJ		
Reviewed By:			
DESCRIPTION		SHEET NUMBER TOTAL SHEETS	
		2 17	



# VICINITY MAP

# ROAD 4696

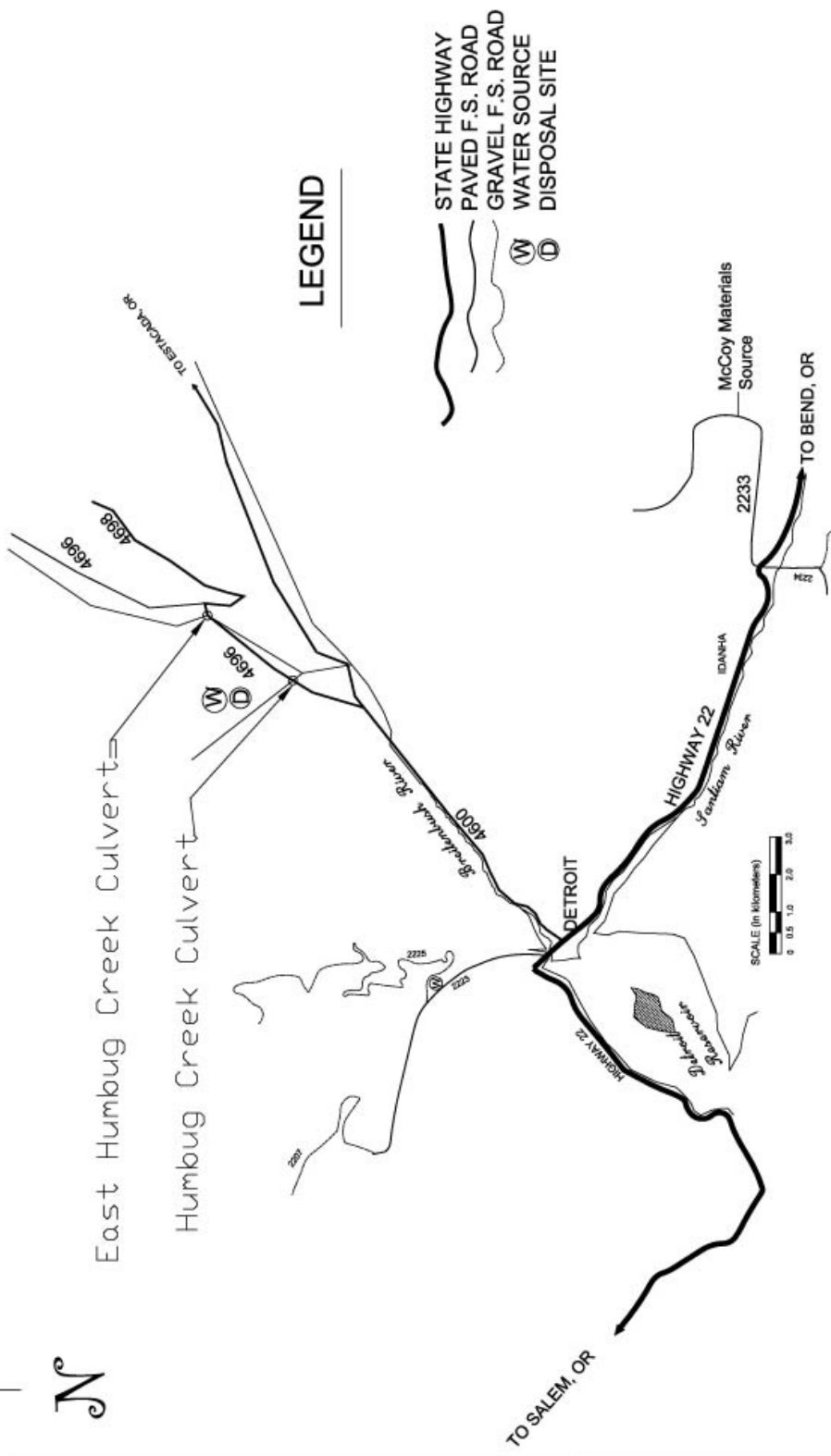

## LEGEND

- STATE HIGHWAY
- PAVED F.S. ROAD
- GRAVEL F.S. ROAD
- WATER SOURCE
- DISPOSAL SITE

Figure H.2—Humbug Sheet 2: Vicinity Map.

ESTIMATE OF QUANTITIES

ITEM NO.	DESCRIPTION	METHOD OF MEASURE	UNIT	ESTIMATED QUANTITY		TOTAL	Comments
				Humbug	Humbug East		
171(02)	Construction staking, precision C, Method 1	AQ	km	0.10	.10	.2	
171(03)	Staking structures, precision C, Method 1	AQ	Ea	1	1	2	
201(03)	Clearing and grubbing, slash treatment methods for tops and limbs 12, logs 12, stumps 12, utilization of timber 2	LSQ	LS	All Req'd	All Req'd	All Req'd	
202(02)	Removal of existing 13.5-Ft. and 14Ft. diameter multi-plate pipe and concrete headwall, disposal method A	AQ	Ea	1	1	2	
203(07)	Excavation, placement method 2	LSQ	LS	All Req'd		All Req'd	Stream channel excavation
204(19)	Soil erosion and pollution control	LSQ	LS	All Req'd		All Req'd	
204(20)	Dewatering and Sediment Control	LSQ	LS	All Req'd		All Req'd	
204(22)	Install Log-Jams	LSQ	LS	All Req'd		All Req'd	Move two large logs
206(02)	Foundation fill	DQ	m <sup>3</sup>	808	479	1287	Commercial source, AASHTO A-1-a
206(07)	Structural Excavation	LSQ	LS	All req'd		All req'd	
251(14)a	Placed Channel Rock, Rock class 20, method D	AQ	EA	66	30	96	Steps - commercial source
251(14)b	Placed Channel Rock, Rock class 30, method D	AQ	EA	54		54	Footer rocks - commercial source
251(14)c	Placed Channel Rock, Rock class 36, method D	AQ	EA	6		6	Bank boulders - commercial source
251(15)a	Placed Stream Bed Simulation Rock, Bed Class 9, method D	DQ	m <sup>3</sup>		118	118	Stream bed in culvert - commercial source
251(15)b	Placed Stream Bed Simulation Rock, Bed Class 15, method D	DQ	m <sup>3</sup>		146	146	Culvert banks - commercial source
251(15)c	Placed Stream Bed Simulation Rock, Bed Class 18, method D	DQ	m <sup>3</sup>	371		371	Stream bed in culvert - commercial source
251(16)	Placed Select Borrow	DQ	m <sup>3</sup>	20	15	35	To fill voids in stream bed material - commercial source
304(10)	Crushed aggregate, type base, grading C, compaction B	DQ	m <sup>3</sup>	63	59	122	Commercial source
403(01)	Hot asphalt concrete plant mix	VQ	Ton	63	59	122	
552(03)	Structural concrete, class A(AE), for footings	AQ	m <sup>3</sup>	63	52	115	Footings and collars
554(03)	Reinforcing steel	LSQ	LS	All Req'd	All Req'd	All Req'd	
601(01)	Mobilization	LSQ	LS	All Req'd	All req'd	All Req'd	
601(02)	Equipment Cleaning	AQ	Ea	1		1	All equipment before work begins
607(03)	Gate temporary, type I barricade, size 4.9m wide x 800mm high	AQ	Ea	2		2	
617(06)	Galvanized steel 145mm x 380mm corrugation open bottom arch long-span structure, plate asphalt-coated, 10998mm (36-feet, 1-inch) span, 5029mm (16.5-feet) rise, 7.1mm thickness	AQ	m	22.6		22.6	
617(05)	Galvanized steel 145mm x 380mm corrugation structure-plate box culvert, 10973mm (36-feet) span, 3175mm (10.5feet) rise, asphalt-coated, 7.1mm thickness	AQ	m		19.5	19.5	
625(02)	Seeding, hydraulic method (with mulch)	DQ	ha	0.05	0.05	0.10	

Figure H.3—Humbug E-W Sheet 3: Estimate of Quantities.

ESTIMATE OF QUANTITIES

HUMBUG & HUMBUG EAST CREEK



U.S.D.A. FOREST SERVICE

PACIFIC NORTHWEST REGION

Designed By: [ ]

Drawn By: [ ]

Reviewed By: [ ]

DATE: [ ]

DESCRIPTION: [ ]

SHEET NUMBER

317



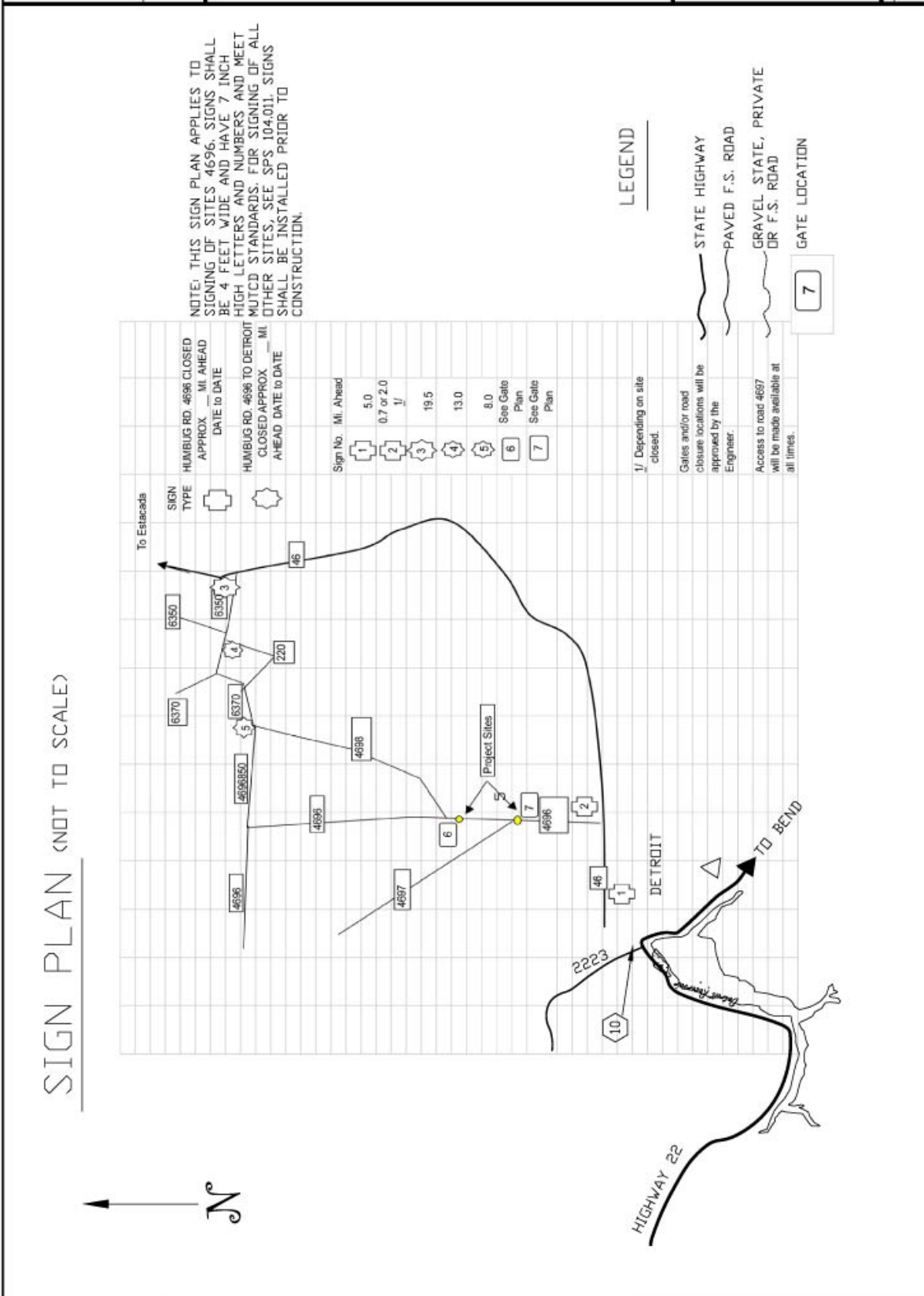
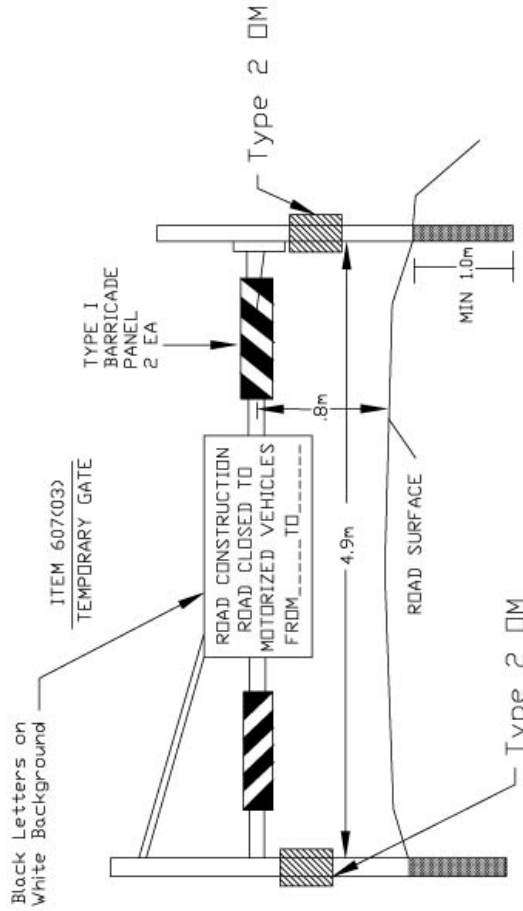

Figure H.4—Humbug Sheet 4: Sign Plan.

# GATE PLAN

(NOT TO SCALE)



NOTES:

- 1) Contractor shall submit gate design for approval by the COR before installation.
- 2) Install all gates and gate signs before work begins at site 4696.
- 3) Gate signs are incidental to gate, item 607(03).
- 4) Gate locations shall be approved by the Engineer before installation.
- 5) Gate shall be fabricated from steel I-beam, box beam, railroad rail, or pipe section of sufficient thickness and size to withstand being bent or pulled out of place.
- 6) Gate shall have a locking mechanism for 2-padlocks and the mechanism shall be protected from vandalism by a box or well surrounding the locks.
- 7) Powder River or farm type gate will not be acceptable.
- 8) Concrete Jersey Barriers may be provided in place of gates.

U.S.D.A. FOREST SERVICE PACIFIC NORTHWEST REGION	<h2 style="font-size: 2em;">GATE PLAN</h2>		SHEET NUMBER: 5 TOTAL SHEETS: 17
Designed By: DKJ Drawn By: DKJ Reviewed By:	<h2 style="font-size: 2em;">HUMBUG &amp; HUMBUG EAST CREEK</h2>		
REV. DATE:	DESCRIPTION:		

Figure H.5—Humbug Sheet 5 - Gate Plan.



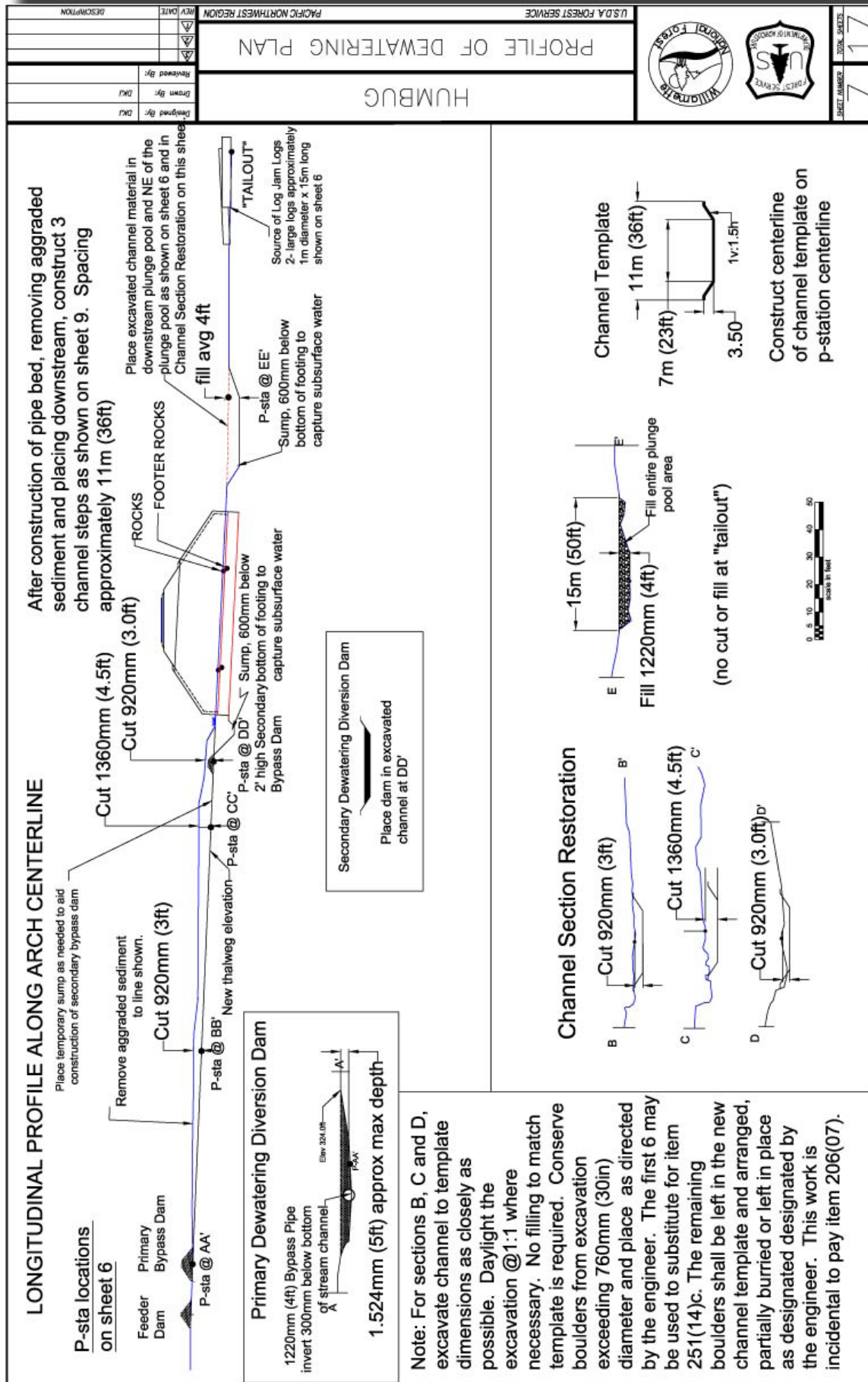

Figure H.7—Humbug West Sheet 7 - Profile of Dewatering Plan.



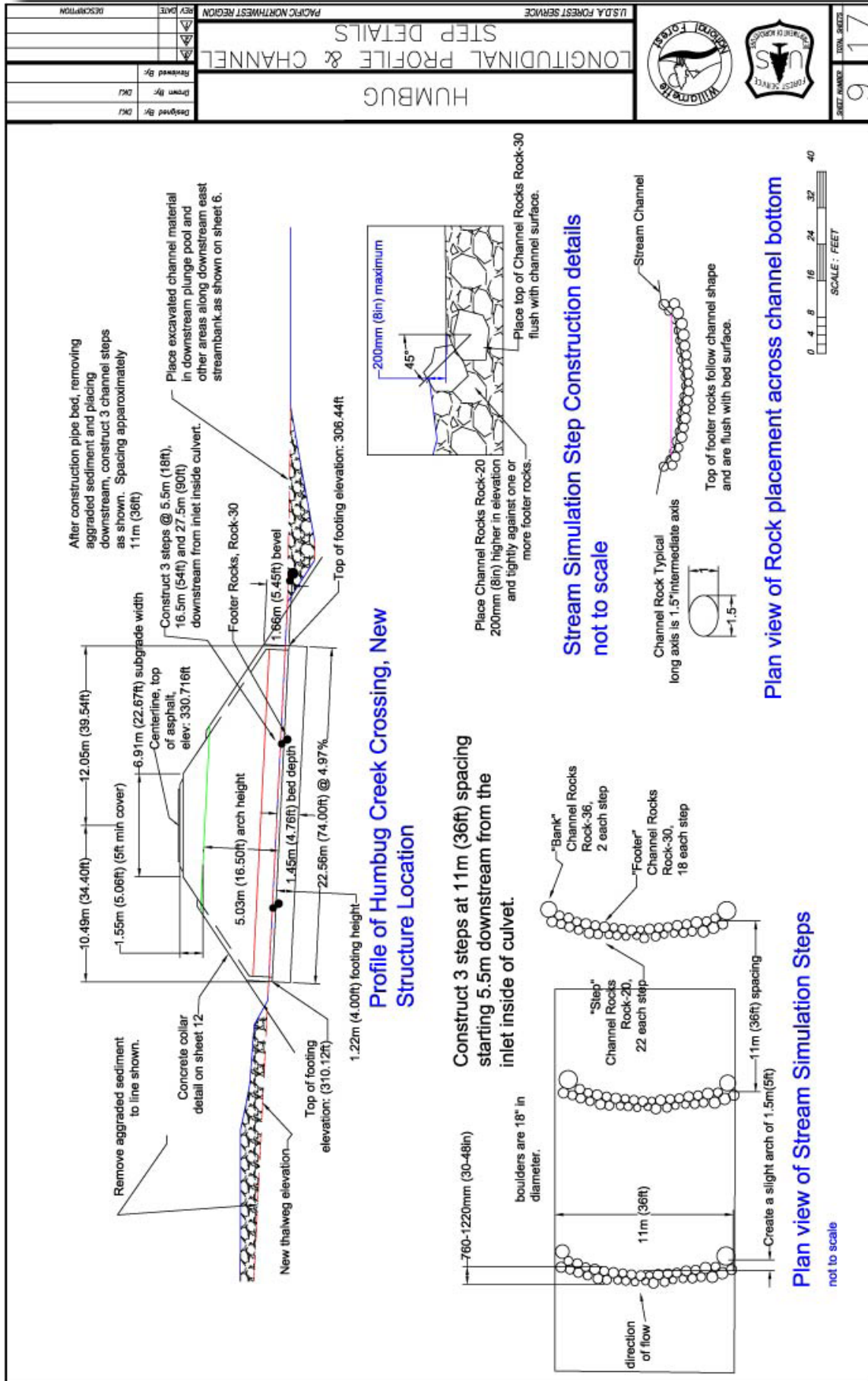

Figure H.9—Humbug West Sheet 9 - Long Profile and Grade Control Details.

# X-SECTION THROUGH CENTERLINE OF ROAD SURFACE.

Structural excavation limits and area requiring foundation fill, 1.829m wider than arch maximum width. Backfill must meet AASHTO M-145 classification A-1-a. foundation fill required from bottom of footing to subgrade



SCALE : FEET

Elevation @ top of asphalt centerline over arch 330.716

1.765m (5.79ft) @ centerline

bed elevation above footings 225mm (9in)

1v:1.5h

Bank height: 1.067m (3.50ft)

405mm (1.33ft)

bottom bed width: 7m (23ft)

9.354m (30.69ft) between footings

bottom of arch width 10.922m (35.83ft) to inside of corrugations SC15A Supercore Arch

Stream Bed Simulation Rock, Bed Class 18 Place largest pieces (>900mm) along bank well embedded with other stream bed simulation and select borrow material according to special specification 251.02F1

Arch height: 5.029m (16.5ft)

1.829m (6.00ft) foundation fill width

1220mm (4.00ft) footing depth

230mm (9in) from centerline of arch

1070mm (3.50ft) footing width

Foundation soils are boulders and smaller sediments.

U.S.D.A. FOREST SERVICE	PACIFIC NORTHWEST REGION	REVISIONS	DATE	DESCRIPTION
		<b>HUMBUG</b> <b>X-SECTION ARCH AND STREAM BED</b> <b>SIMULATION DETAILS</b>		
		Designed By: DKJ	Drawn By: DKJ	Reviewed By:
SHEET NUMBER: 1017 TOTAL SHEETS: 17				

Figure H.10—Humbug West Sheet 10 - Cross Section of Arch and Stream-Simulation Bed Details.

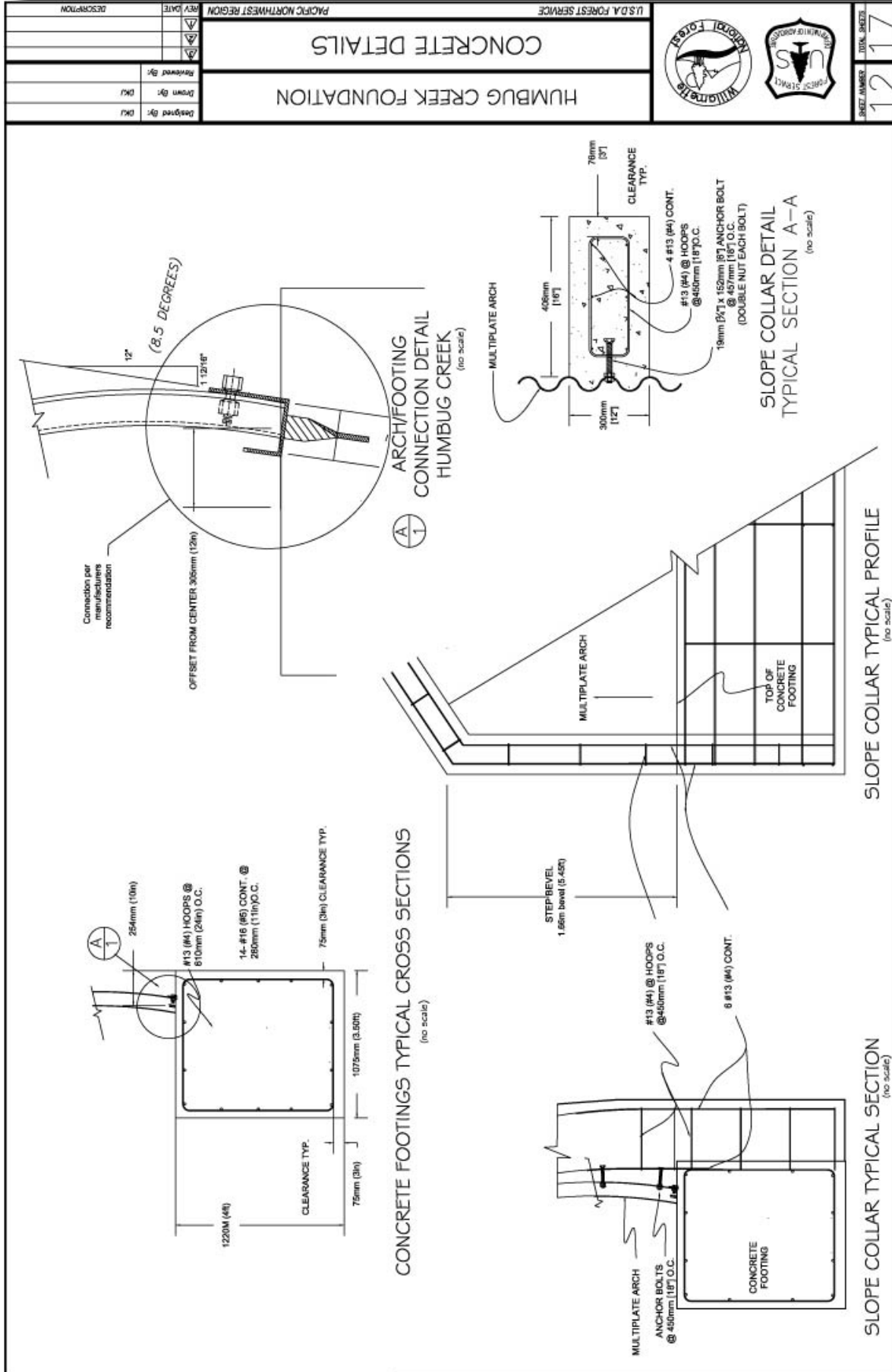
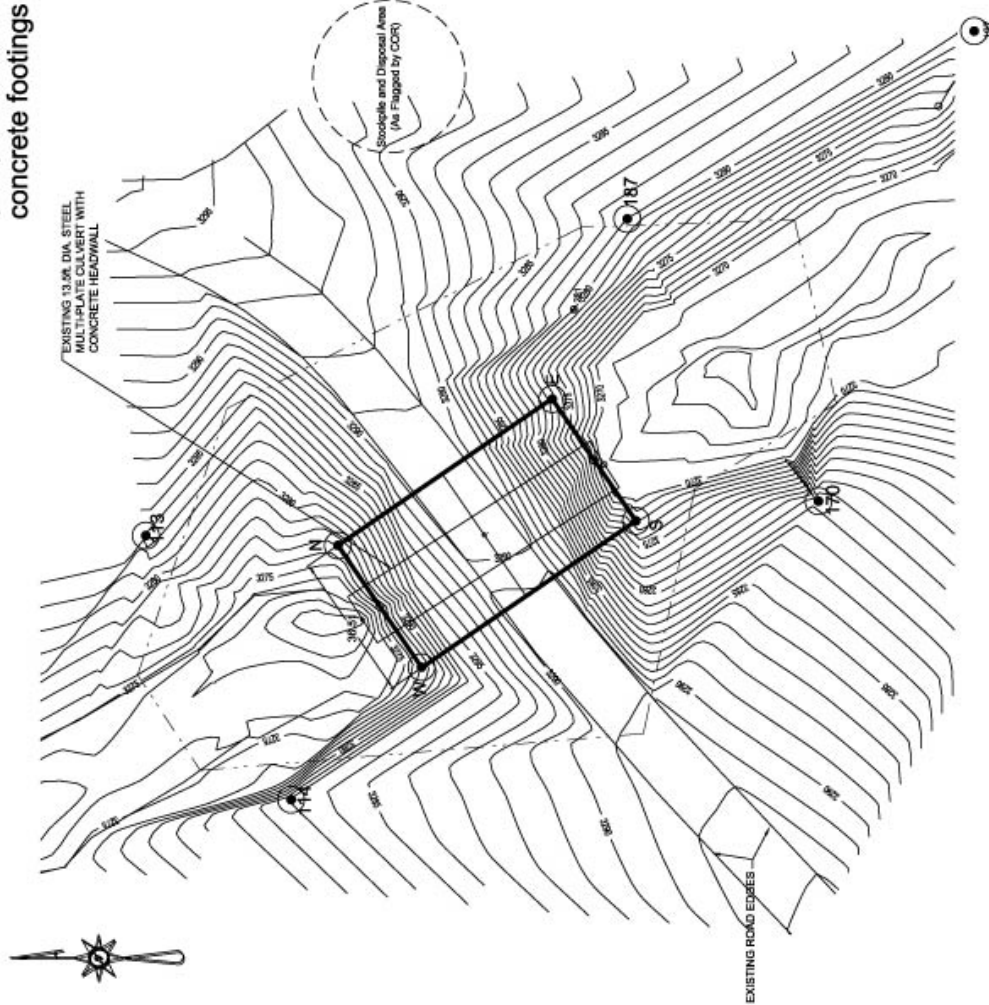

Figure H.11—Humbug West Sheet 12 - Foundation Details.



Replace existing culvert and headwall with a galvanized steel 145mm x 380mm corrugation, multi-plate box culvert, 10.973m (36ft) width x 3.175m (10ft 5in) span x 19.507m (64ft) long with concrete footings (footings not shown)



NOTES:

1. Remove and dispose of existing multi-plate pipe and concrete headwall off of government property.
2. Finish fill slopes 1.5H:1V slope or flatter to blend with surrounding slopes and culvert banks.
3. Finish soil slopes to drain, and track or wheel compact before seeding.
4. Conserve all material excavated from the area beneath the existing culvert and within the footing area. Material shall be stockpiled separately from other excavation and allowed to drain.
5. Treat all finished new and exposed slopes with seed and mulch as specified in Special Specification 625.032.
6. Waste site available at Humbug Creek project site. See sheet 6.

Point #	Easting	Northing	Elevation	Object
1	1011.681	1164.079	3280.64	hub - upstream
2	1000.000	1000.000	3279.49	rebar - upstream
3	1058.202	782.227	3289.96	pk nail - upstream
4	1172.544	687.847	3275.15	hub - upstream
281	1122.454	757.672	3280.01	rebar - upstream
113	863.513	1066.708	3284.01	iron post
114	827.715	1001.690	3283.06	iron post
170	697.836	1076.196	3280.74	iron post
197	744.93	1144.752	3281.06	iron post
123	809.708	1045.972	3270.81	old culvert inlet
188	750.153	1084.253	3269.18	old culvert cullet

New Structure Location: values are to top of footings				
N	795.128	1034.177	3276.37	centerline of arch corrugations
W	815.778	1064.29	3276.37	centerline of arch corrugations
S	742.396	1070.338	3274.90	centerline of arch corrugations
E	763.046	1100.461	3274.90	centerline of arch corrugations



H-33 Figure H.12—Humbug East Sheet 13 - Site Plan.

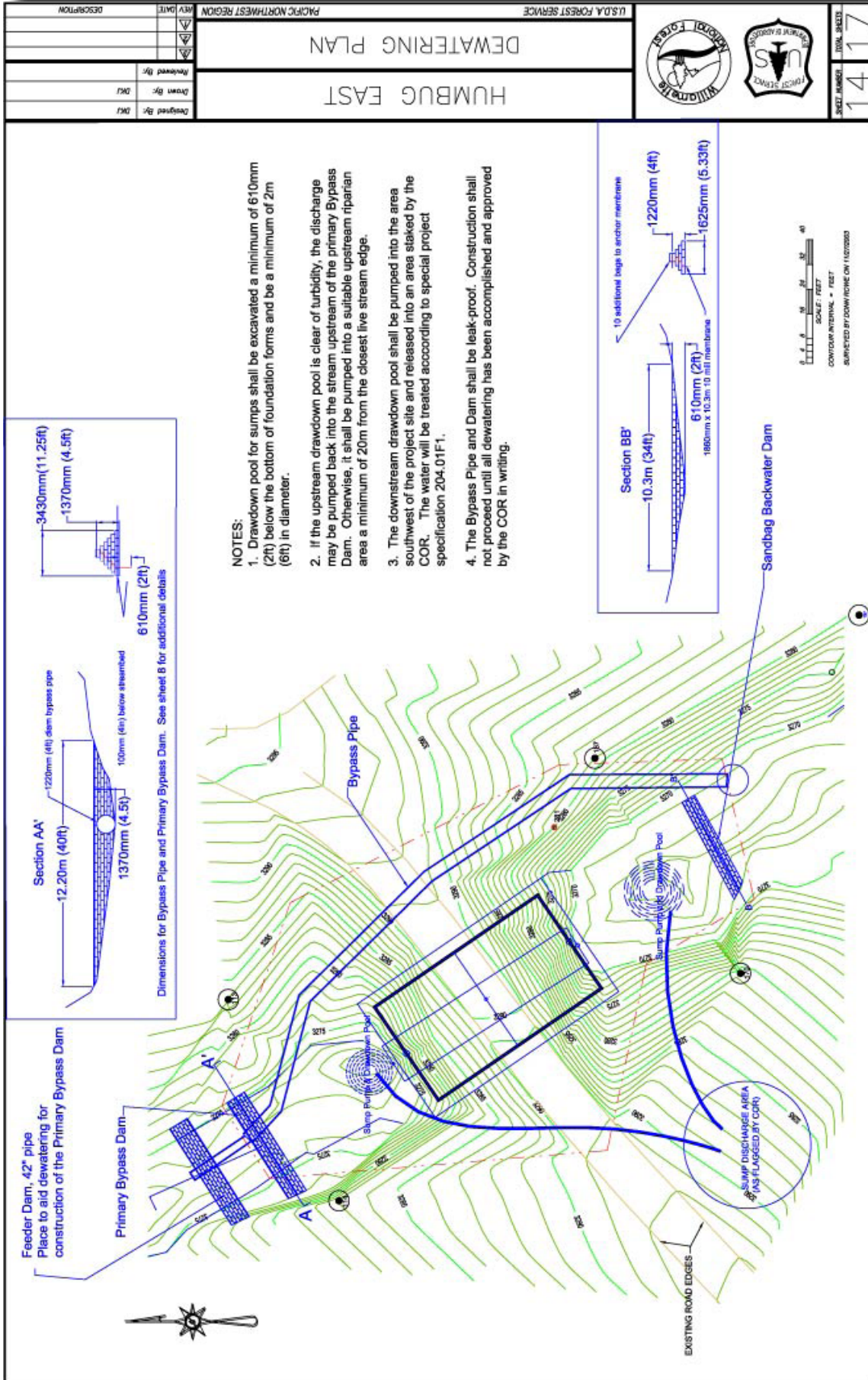

Figure H.13—Humbug East Sheet 14 - Site Plan with Dewatering System.

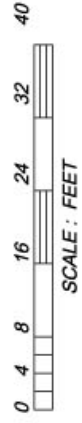
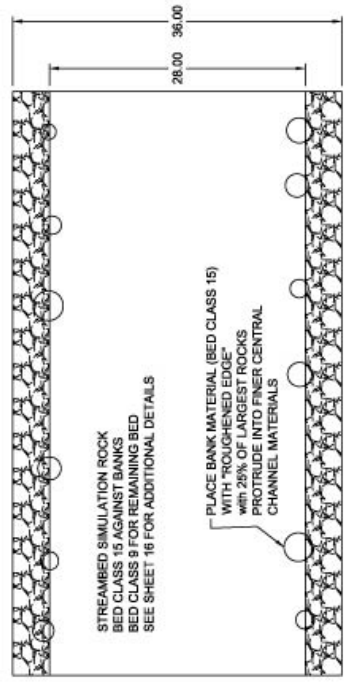
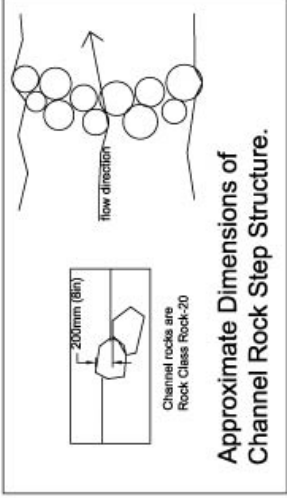
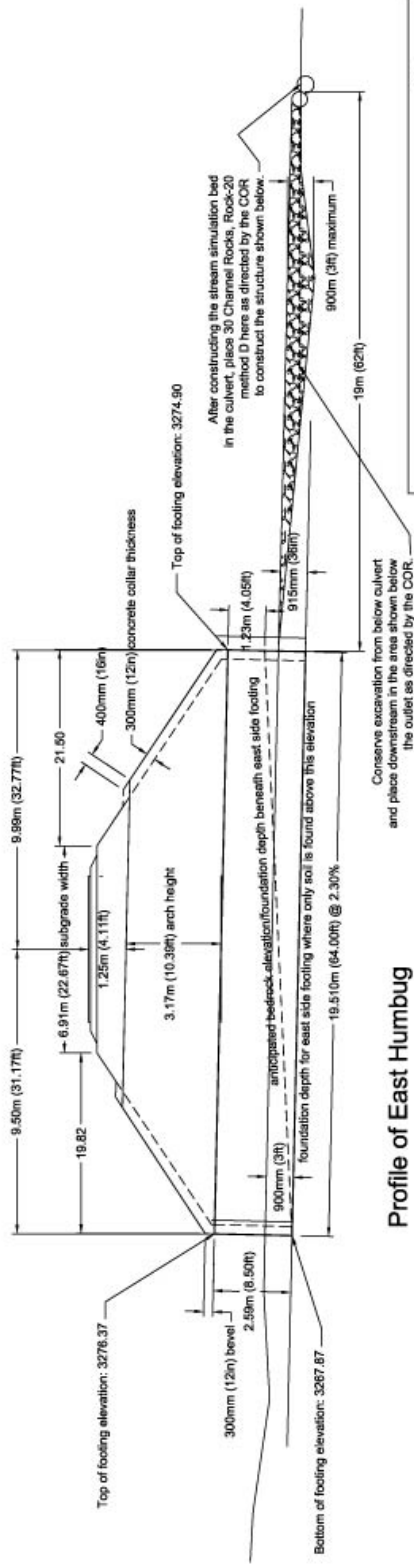
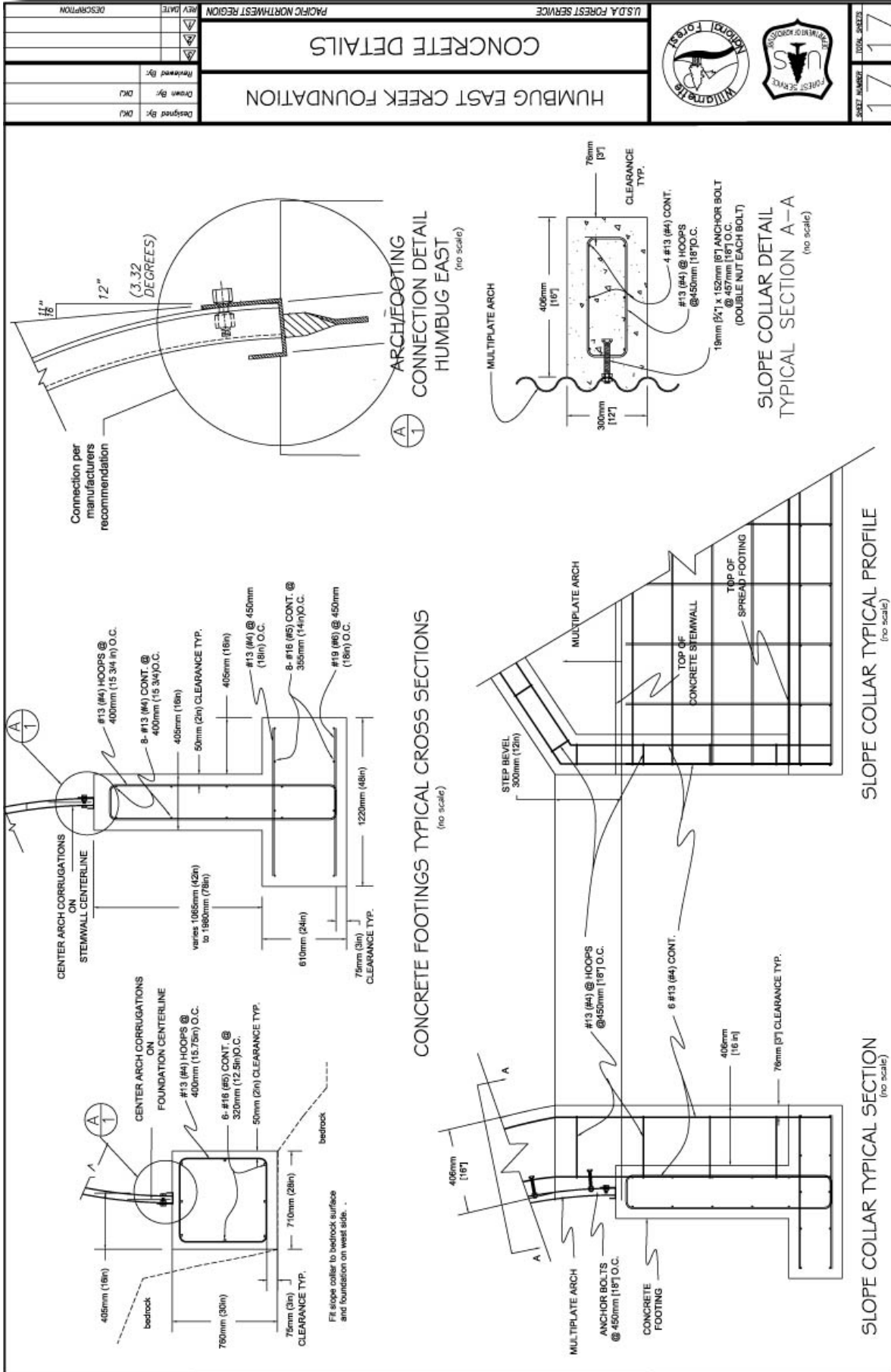

Figure H. 14—Humbug East Sheet 15 - Longitudinal Profile with Stream-Simulation Bed Details.





H-37

Figure H.16—Humbug Sheet 17 - Foundation Details.

