

**POTENTIAL WIND POWER  
COMPONENT MANUFACTURERS**

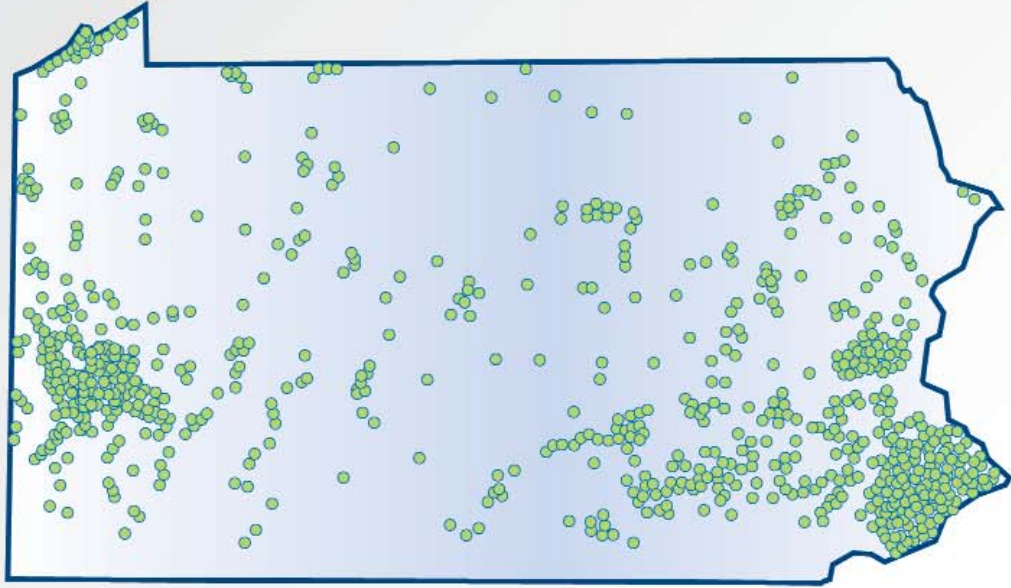

**19,588 NEW JOBS**

**POTENTIAL SOLAR POWER  
COMPONENT MANUFACTURERS**

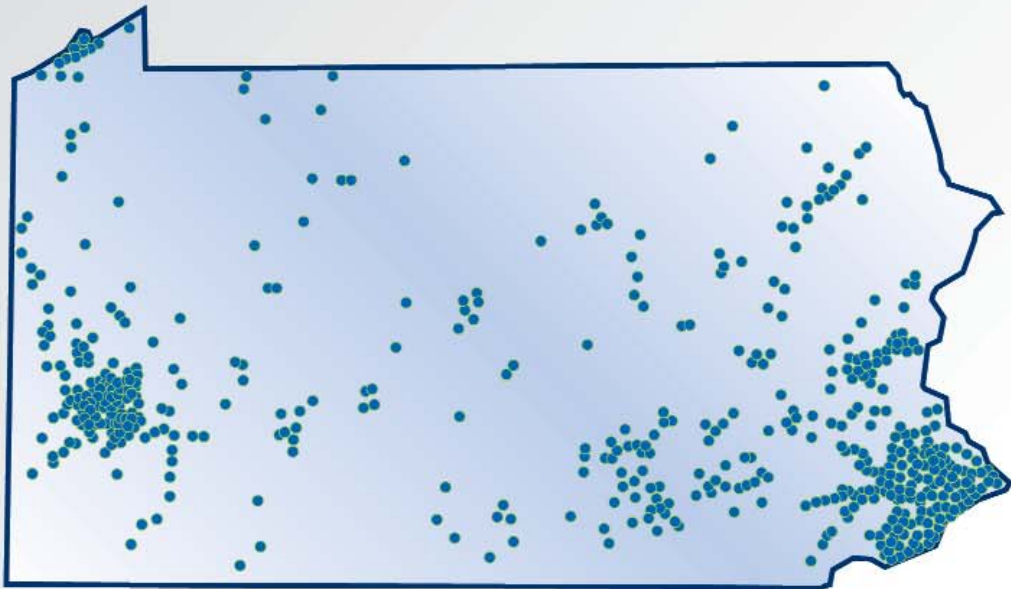

**15,697 NEW JOBS**

**PENNSYLVANIA'S  
ROAD TO ENERGY  
INDEPENDENCE**

**Building on  
Job Growth in  
Renewable Energy  
Component  
Manufacturing**



Summary of Findings  
Renewable Energy Policy Project  
Technical Report  
October 2006



# NEW CLEAN ENERGY JOB GROWTH

By passing the Advanced Energy Portfolio Standard, Pennsylvania led the way forward on energy policy. To build on this progress, coordinated efforts at the national level are necessary in order to develop energy security and stabilize carbon emissions.

As the report developed by the Renewable Energy Policy Project for the Apollo Alliance clearly demonstrates, a major commitment to renewable electric generation will reduce our security exposure, stabilize climate and provide a multi-billion dollar investment and reindustrialization program that will lead to new job growth in Pennsylvania.

## Analysing the Demand for Components

In 2004, the Renewable Energy Policy Project completed an analysis of modern, large wind turbine technologies. The results of this analysis were very encouraging both for the country as a whole and for Pennsylvania in particular.

A national program to develop renewable energy will benefit the regions and states that have the best renewable resource base - solar, wind, biomass and geothermal. It will also create a demand for billions of dollars of components, the parts that make up the finished renewable plants. This demand could, if accompanied by appropriate incentives, provide important new markets for domestic manufacturers that are already manufacturing equipment similar to the components that go into new renewable generation.

More than 75% of the potential new demand can be expected to flow to the 20 states that have suffered the greatest job losses. A program that supported the development of renewable energy projects while simultaneously supporting the development of a strong, advanced component manufacturing industry would benefit many states and regions.

The report breaks renewable generation technologies down into their component parts and then examines where traditional Pennsylvania industries exist that could, if provided with appropriate incentives, become suppliers of the billions of dollars of new parts that will be necessary.

The Report analyses the renewable energy industry assuming that the United States moves to stabilize carbon emissions. Stabilizing emissions of carbon requires adding 185,000 MW of new renewable projects each year. The Report looks at the total demand generated by a ten-year stabilization program and tracks that demand down to the individual industries capable of manufacturing the components.

## Revitalizing Pennsylvania Manufacturing

The national demand is allocated to individual states and eventually to the county level. Pennsylvania, of all the states, is ranked sixth as the greatest potential to generate new manufacturing activity to meet this demand.

This report outlines the potential for Pennsylvania from a national commitment to accelerate renewable energy development.

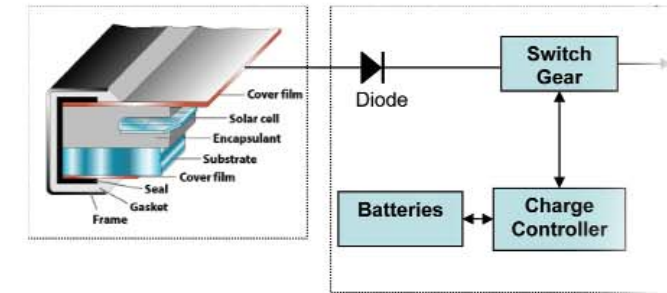
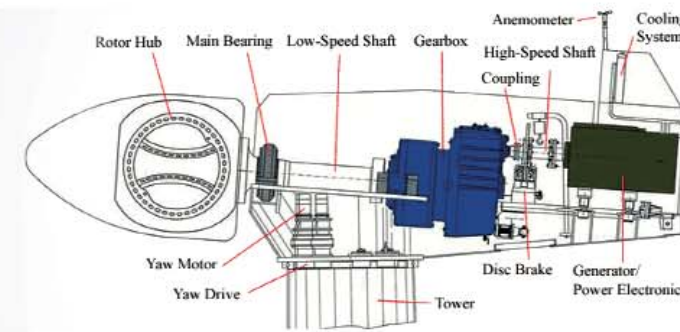

In all, there are more than 2,188 firms in Pennsylvania that are currently active in the industrial sectors that could supply the component parts to meet the demand necessary to deliver a wedge.

A major program to develop renewable energy will create a demand for the component parts that go into the renewable developments. A major portion of the potential benefits flowing from the development of renewable energy will go to the

manufacturers who supply the component parts. In order to capture as much of that potential as possible for domestic industry, the first step is to understand where the potential manufacturers are located and then devise the incentives that allow them to move efficiently into the industry.

In addition, the demand can support the creation of more than 42,000 new jobs related to the expanded manufacturing activity.

## Top 20 Counties in Pennsylvania

County	Firms	Wind		Solar		Geothermal		Biomass		Total	
		Millions \$	Jobs	Millions \$	Jobs	Millions \$	Jobs	Millions \$	Jobs	Millions \$	Jobs
York	118	\$484.90	2393	\$97.50	727	\$378.70	1311	\$123.80	484	\$1,084.90	4915
Berks	71	\$132.30	897	\$910.30	4341	\$10.30	41	\$5.90	26	\$1,058.80	5305
Lancaster	104	\$363.20	2246	\$135.40	793	\$5.90	34	\$30.30	200	\$534.80	3273
Allegheny	174	\$158.30	1045	\$197.60	667	\$36.20	189	\$74.50	394	\$466.60	2295
Montgomery	189	\$221.80	1464	\$141.40	591	\$43.40	226	\$26.90	153	\$433.50	2434
Erie	147	\$243.80	1704	\$105.80	622	\$19.40	120	\$60.90	387	\$429.90	2833
Lehigh	67	\$61.00	413	\$330.50	1571	\$2.60	17	\$5.90	38	\$400.00	2039
Bucks	204	\$166.40	1115	\$114.70	557	\$26.10	130	\$13.20	79	\$320.40	1881
Westmoreland	97	\$114.70	779	\$124.50	519	\$38.60	189	\$30.70	208	\$308.50	1695
Cumberland	26	\$51.70	334	\$182.90	762	\$2.50	13	\$4.40	20	\$241.50	1129
Crawford	24	\$43.10	299	\$181.60	752	\$0.30	1	\$0.70	5	\$225.70	1057
Luzerne	45	\$38.00	283	\$156.30	464	\$12.10	65	\$5.60	32	\$212.00	844
Northampton	62	\$80.10	584	\$40.70	130	\$16.30	102	\$45.30	311	\$182.40	1127
Beaver	33	\$131.80	866	\$21.20	117	\$2.10	7	\$3.30	17	\$158.40	1007
Philadelphia	90	\$68.00	465	\$70.30	371	\$10.50	70	\$4.50	28	\$153.30	934
Lawrence	30	\$40.10	248	\$94.00	495	\$10.20	74	\$7.90	48	\$152.20	865
Chester	84	\$32.70	217	\$96.40	525	\$5.10	31	\$14.00	93	\$148.20	866
Butler	54	\$58.70	368	\$13.90	80	\$54.10	338	\$12.60	74	\$139.30	860
Tioga	8	\$76.60	532	\$53.00	343	\$0.00	0	\$0.80	5	\$130.40	880
Lycoming	29	\$102.50	650	\$0.70	5	\$4.70	34	\$18.60	132	\$126.50	821

REPP had recently completed a study of the labor that goes into renewables which included a detailed survey of employment related to wind and solar PV. The overall manufacturing jobs/MW numbers found using the NAICS census method and shown in the table above agree well with the numbers found in

the previous REPP study, giving confidence in the above method. Having obtained a jobs/MW number, the jobs are allocated geographically according to the census manufacturing in the exact same manner that the investment was allocated.

## Manufacturing Jobs and Investment for 185,000 MW

Location	# of Firms	Jobs Wind	Jobs Solar	Jobs Geothermal	Jobs Biomass	Jobs Total
California	5,409	32,046	48,896	8,465	6,209	95,616
Texas	3,358	25,044	23,221	4,660	7,175	60,100
Illinois	2,289	30,010	19,298	3,396	3,875	56,579
Ohio	2,465	29,820	11,833	5,079	4,537	51,269
New York	1,925	18,523	14,617	8,150	6,640	47,930
Pennsylvania	2,188	19,588	15,767	3,402	3,911	42,668
Indiana	1,321	25,180	7,485	3,191	3,365	39,221
Michigan	2,050	24,350	6,644	1,502	2,281	34,777
North Carolina	1,096	10,964	11,062	2,810	3,708	28,544
Missouri	785	10,260	7,532	2,907	2,097	22,796

The component breakdown used to determine the data in these findings may be found in the complete report, available online at <http://www.apolloalliance.org>.