

# Innovative Distributed Power Grid Interconnection and Control Systems

**Final Report**  
**December 11, 2000 – August 30, 2005**

K. DePodesta  
*Gas Technology Institute*  
*Des Plaines, Illinois*

D. Birlingmair and R. West  
*Encorp, Inc.*  
*Windsor, Colorado*

**Subcontract Report**  
**NREL/SR-560-38982**  
**March 2006**

NREL is operated by Midwest Research Institute • Battelle Contract No. DE-AC36-99-GO10337



# Innovative Distributed Power Grid Interconnection and Control Systems

*Subcontract Report*  
NREL/SR-560-38982  
March 2006

**Final Report**  
**December 11, 2000 – August 30, 2005**

K. DePodesta  
*Gas Technology Institute*  
*Des Plaines, Illinois*

D. Birlingmair and R. West  
*Encorp, Inc.*  
*Windsor, Colorado*

NREL Technical Monitor: T.S. Basso  
Prepared under Subcontract No. ACL-1-30605-04

**National Renewable Energy Laboratory**  
1617 Cole Boulevard, Golden, Colorado 80401-3393  
303-275-3000 • [www.nrel.gov](http://www.nrel.gov)

Operated for the U.S. Department of Energy  
Office of Energy Efficiency and Renewable Energy  
by Midwest Research Institute • Battelle

Contract No. DE-AC36-99-GO10337

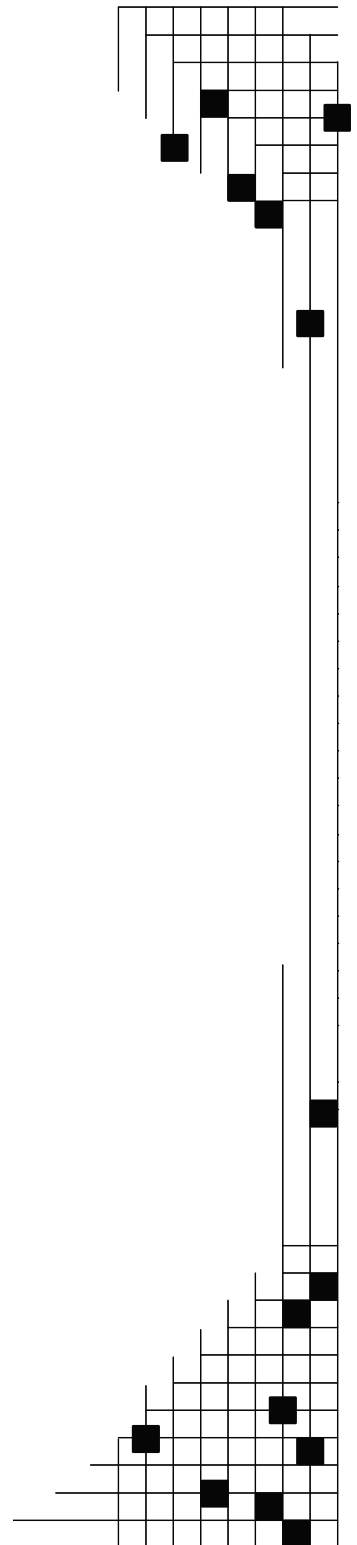

## NOTICE

This report was prepared as an account of work sponsored by an agency of the United States government. Neither the United States government nor any agency thereof, nor any of their employees, makes any warranty, express or implied, or assumes any legal liability or responsibility for the accuracy, completeness, or usefulness of any information, apparatus, product, or process disclosed, or represents that its use would not infringe privately owned rights. Reference herein to any specific commercial product, process, or service by trade name, trademark, manufacturer, or otherwise does not necessarily constitute or imply its endorsement, recommendation, or favoring by the United States government or any agency thereof. The views and opinions of authors expressed herein do not necessarily state or reflect those of the United States government or any agency thereof.

Available electronically at <http://www.osti.gov/bridge>

Available for a processing fee to U.S. Department of Energy and its contractors, in paper, from:

U.S. Department of Energy  
Office of Scientific and Technical Information  
P.O. Box 62  
Oak Ridge, TN 37831-0062  
phone: 865.576.8401  
fax: 865.576.5728  
email: <mailto:reports@adonis.osti.gov>

Available for sale to the public, in paper, from:

U.S. Department of Commerce  
National Technical Information Service  
5285 Port Royal Road  
Springfield, VA 22161  
phone: 800.553.6847  
fax: 703.605.6900  
email: [orders@ntis.fedworld.gov](mailto:orders@ntis.fedworld.gov)  
online ordering: <http://www.ntis.gov/ordering.htm>

**This publication received minimal editorial review at NREL**



Printed on paper containing at least 50% wastepaper, including 20% postconsumer waste

## **Acknowledgements**

The following personnel at GTI have contributed to the technical efforts covered in this report:

- Karen DePodesta, William Liss, Michele Dybel

The following personnel have contributed to the technical efforts covered by this report:

- Doug Birlingmair, Randall West, Larry Adams, Kevin Sauer, Arie Willenbrecht, Joshua Meyer, Bruce Heath, Harry Hunter, Don Simmons, Rick Dohmen, Chris Whitham

## **Trademarks**

Encorp, Encorp Intelligence, Encorp Power, *enpower*, *entelligent*, and Virtual Power Plant are trademarks of Encorp, Inc. LONWORKS, is a registered trademark of Echelon Corporation. Windows is a registered trademark of Microsoft Corporation in the United States and other countries. ISaGRAF is a registered trademark of ICS Triplex. All other brand or product names are trademarks of their respective holders.

## Executive Summary

The objective of this contract was to continue the advancement of distributed generation in the marketplace by making installations more cost-effective and compatible across the electric power system and energy management systems. This advancement was achieved by developing innovative grid interconnection and control systems.

Specifically, the overall goals were:

- To develop and demonstrate cost-effective distributed power (DP) grid interconnection products, software, and communication solutions applicable to improving the economics of a broad range of DP systems, including existing, emerging, and other power generation technologies.
- To enhance the features and capabilities of DP products to integrate with, interact with, and provide operational benefits to the electric power system and advanced energy management systems. This includes features and capabilities for participating in resource planning, the provision of ancillary services, and energy management.

These objectives are outlined with the following specific tasks:

<b>Contract Tasks</b>
Task 1: Develop Prototype Advanced Controller
Task 2: Develop Prototype Power Sensing Board
Task 3: Expanded Suite of Communication Capabilities
Task 4: Interface for Revenue-Grade Meter
Task 5: Demonstrate Interconnect DP Device
Task 6: Type Testing
Task 7: System Command and Control
Task 8: Demonstration of Controlled DP Resources

This final report provides the results of the work completed on the advanced grid interconnection controller, the command and control system, as well as two demonstration sites. This contract work achieved the following objectives:

- Realized significant cost savings compared to current industrial switchgear options.
- Reduced maintenance costs due to the benefits of integrated switchgear and controls systems and the power of remote monitoring, diagnostics, and communications, as well as the design of the Advanced Controller for field service and field support capabilities.
- Demonstrated compatibility with major electric power system communication protocols and building energy management communication protocols.
- Created the ability to integrate with a broad cross-section of energy generation technologies and energy load management technologies.

The following is a list of specific technical accomplishments that have been achieved under this contract:

- Designed, developed, and tested a prototype.
- Demonstrated the prototype design's functionality in the Chowchilla case study.

- Researched and published the Communication Study. This study identified the various types of communication used and the control features that would be desirable for remote monitoring and control of DP assets.
- Addressed Internet related security features that would be needed in the Advanced Controller.
- Developed the prototype design into a commercial product and released it for commercial use.
- Created a design in which most simple systems do not need a CPM because remote communications can be performed directly with the Advanced Controller. This eliminates an expensive component (and associated wiring and system complexity) that was prone to failing in the field.
- Designed the system so that it reduces the time required to initially load or upgrade an application. Large systems will take only a few minutes per control and single control download capability within a multiple control system is provided (more than a 100 times improvement in speed over the previous controller, especially in larger systems).
- Provided for a single user interface. Older controllers required designing the control with both LONWORKS tools and the ISaGRAF workbench tool, which complicated the designs and increased errors that were debugged late in system assembly.
- Utilized International Programming Languages to improve marketability and ease of use training for the control.
- Provided Application Simulation during the system design process to minimize design errors and correct these errors early, reducing manufacturing and site set-up times.
- Gave the application the ability to self-document during the design process. This saves many hours during the design process and ensures that the documentation is the same as the design.
- Provided a design with serviceability improvements. The current controller design requires the cover to be removed for access to wiring, LEDs, connectors, and the reset button. The Advanced Controller design provides cover-on accessibility for functions.
- Designed the Advanced Controller to allow field replacement and project archival. It provides an easier method to perform a field replacement and store or re-store the application project on the Advanced Controller. This is achieved with a Removable MultiMedia Flash Card interface, which will allow field replacement by on-site technicians, eliminating the need for an engineer to travel to the site to perform the field replacement.
- Designed the Advanced Controller to extensively document the firmware design, implementation logic, and control algorithms that were not available on the previous controller. This will greatly aid training new users and engineers, and aid debugging of issues that occur when using the new controller.
- Designed a system that provides a 20-fold performance improvement through the use of a high-speed controller central processing unit, along with a high-speed digital signal processing chip.
- Designed a system that reduces manufacturing costs (estimated reduction to be greater than 15%).
- Designed a system that increases control capabilities with the design of a patented active anti-islanding control scheme.

- Designed a system to further increased control capabilities with the design of a loss-of synchronization control scheme.
- Designed a system that reduces overall grid interconnect system capital and installation costs with the elimination of additional system hardware now intrinsic to the Advanced Controller (i.e., improved firmware and communications capabilities).
- Designed a system that includes compliance with current and projected industry standards for switchgear and interconnection devices.
- Designed a system that increases functionality for the DP customer.
- Designed a system that includes supporting software that encompasses the ISaGRAF Workbench Extension Tool and the Advanced Controller Commissioning Tool.
- Provided a design that is software configurable, eliminating separate hardware configurations for UPC, KWS, and PTC applications. This is a big cost savings-- it increases production volumes thereby lowering, inventory, support, and documentation costs, as well as simplifying marketing and sales efforts.
- Included an RTU (Remote Terminal Unit), which is focused on connecting and communicating with distributed resource subsystems. The RTU allows interface with utility-grade energy meters, engine controllers, fuel meters, etc. and feeds this information to higher-level systems. The Advanced Controller includes the following RTU capabilities:
  - Modbus devices (Server and Client)
  - LONWORKS devices (more standard implementation)
  - TCP/IP (Ethernet)
  - Additional RS232 and RS485 serial interfaces.
- Provided a standard Web browser interface for simple monitoring and operation.
- Provided a Web trending capability.
- Performed an extensive series of qualification and compliance tests on the Advanced Controller. The following actions were performed on prototype and production units, ensuring that a quality system was in place to maintain the quality of the controllers that would be manufactured.
  - Unit testing of each individual software unit that was developed
  - Bench-level testing of the controller system
  - Type testing as specified in IEEE 1547 and other applicable standards (temperature, mechanical shock/vibration, EMI, RFI, etc.)
  - Live on-generator system tests in a laboratory environment
  - Production and on-going reliability tests
  - Tracking and monitoring of field deployment issues
  - Corrective action and verification of all issues that were identified during the development and deployment of the Advanced Controller.
- Created the Remote Energy Management Command and Control (EMC), located in Windsor, Colorado. The EMC is capable of remotely monitoring and controlling distributed generation assets.
- Demonstrated the combined system at two demonstration sites:
  - Single generator application located in Colorado
  - Multi-generator, combined heat and power application in California
  - Both systems are supported by the EMC remote monitoring and control capabilities.

## Table of Contents

1.	Introduction.....	1
1.1	Background.....	1
1.2	Distributed Power Problem Statement.....	3
1.3	Interconnection Controller Problem Statement .....	3
2.	Contract.....	6
2.1.	Contract Overview .....	6
2.2.	Product Development Methodology.....	6
2.3.	System Architecture Technical Approach .....	7
3.	Summary of Tasks and Results.....	9
3.1.	Task 1 - Develop Prototype Advanced Controller.....	9
3.2.	Task 2 - Develop Prototype Power Sensing Board.....	11
3.3.	Task 3 - Expanded Suite of Communication Capabilities .....	12
3.4.	Task 4 - Interface for Revenue-Grade Meter .....	13
3.5.	Task 5 - Demonstrate Interconnect DP Device.....	14
3.6.	Task 6 - Qualification and Testing of the Advanced Controller.....	17
3.7.	Task 7 - Develop System Command and Control .....	19
3.8.	Task 8 - Demonstration of Controlled DP Resources.....	21
4.	Conclusions.....	24
5.	Appendix A: Product Development Methodology .....	29
6.	Appendix B: System Architecture Technical Approach.....	32
6.1	Control Layer.....	33
6.2	Data Acquisition Layer.....	34
7.	Appendix C: Advanced Controller Design .....	36
7.1	Hardware.....	37
7.1.1	Communications .....	39
7.2	Firmware.....	41
7.2.1	ISaGRAF Embedded PLC .....	42
7.2.2	Function Blocks .....	43
7.3	Advanced Controller Support Software.....	46
7.3.1	GWE .....	46
7.3.2	Advanced Controller Commissioning Tool.....	46
8.	Appendix D: Prototype Power Sensing Board.....	47
9.	Appendix E: Communications.....	52
9.1	Evolution of Communications Standards .....	52
9.2	Implications of Communication Standards Situation .....	53
10.	Appendix F: Task 5 Prototype Demonstration .....	54
10.1	System Overview.....	54
10.2	System Topology .....	56
10.3	Software .....	58
11.	Appendix G: Qualification / Type Testing .....	61
11.1	Definition of Testing / Overall Quality Strategy .....	61
11.2	Unit Testing (Lowest Level – Developer Level) .....	61
11.3	System Bench Testing.....	62
11.4	Compliance Testing/ Type Testing.....	63
11.4.1	Temperature/Humidity (Operating and Storage).....	63



11.4.2	Mechanical Shock and Vibration.....	63
11.4.3	UL .....	65
11.5	Live System Testing .....	65
11.6	Production / Manufacturing Testing .....	67
12.	Appendix H: System Command and Control .....	69
12.1	Communications Study.....	69
12.2	Internet Security Design Considerations .....	69
12.3	Market Analysis.....	71
12.4	Product Development Methodology and Results .....	73
12.4.1	Design Details – Data Transport.....	74
12.4.2	Design Details – Data Processing.....	75
12.4.3	EMC Data Examples.....	76
12.4.4	EMC Summary .....	77
13.	Appendix I: Demonstration of Controlled DP .....	78
13.1	Implementation Process .....	79
13.2	Demonstration Site One - Encorp Headquarters.....	82
13.2.1	Site Description.....	82
13.2.2	Advanced Controller Design of Site.....	83
13.2.3	Results of Testing .....	85
13.3	Demonstration Site Two - The Aquarium of the Pacific .....	87
13.3.1	Advanced Controller Design at Site .....	88
13.3.2	Results of Implementation / Testing .....	91
14.	Appendix J: IEEE Standards Activities .....	93

### **List of Figures**

Figure 1:	Typical Interconnection of Distributed Power Device.....	5
Figure 2:	Moving to a Digital Platform .....	8
Figure 3:	Moving to a Digital Based Platform.....	9
Figure 4:	PSM without Cover .....	12
Figure 5:	Chowchilla 48-MW Power Plant .....	15
Figure 6:	Advanced Controller for Qualification Testing.....	17
Figure 7:	Systems Test Facility at Encorp .....	18
Figure 8:	Advanced Controller Production Tester.....	18
Figure 9:	EMC System Architecture.....	20
Figure 10:	Demonstration Site One - Encorp Headquarters .....	22
Figure 11:	Demonstration Site Two - Aquarium of the Pacific.....	23
Figure 12:	Base Year Product Life Cycle Development Activity .....	30
Figure 13:	Option Year 1 Product Life Cycle Development Activity .....	31
Figure 14:	Moving to a Digital Platform .....	32
Figure 15:	Moving to a Digital-Based Platform .....	33
Figure 16:	Control System Architecture.....	34
Figure 17:	The Data Acquisition System.....	35
Figure 18:	Advanced Controller Hardware.....	36
Figure 19:	Digital Upgrade PCA Board.....	37
Figure 20:	Improved Accessibility of Advanced Controller.....	38
Figure 21:	Communications Ports Layout .....	39

Figure 22: Relative Complexity and Capability of Communication Standards (Burns, et al.) ....	52
Figure 23: Typical Chowchilla II Two-Engine Configuration .....	54
Figure 24: Chowchilla II Protective Relaying Scheme.....	55
Figure 25: VMM User Interface .....	58
Figure 26: Example One-Line Diagram .....	59
Figure 27: Generator Room Display.....	59
Figure 28: Generator Annunciator Display.....	60
Figure 29: Generator Metering Screen .....	60
Figure 30: Market Analysis .....	72
Figure 31: EMC System Architecture.....	73
Figure 32: Standard EMC Reports.....	76
Figure 33: Demonstration Site One - Encorp Headquarters .....	83
Figure 34: Demonstration Site One - Graphical Representation .....	84
Figure 35: Demonstration Site Two - Aquarium of the Pacific.....	87
Figure 36: System Layout.....	88
Figure 37: One-Line Diagram.....	89
Figure 38: Communications Diagram.....	90

### **List of Tables**

Table 1: PSM Measured Parameters.....	48
Table 2: PSM Three Phase Parameters .....	49
Table 3: Unit Testing Results .....	62
Table 4: System Bench Testing Results.....	63
Table 5: Dielectric Strength Tests.....	64
Table 6: Typical EMC Parameters.....	75
Table 7: Demonstration Checklist .....	79
Table 8: System Performance Data.....	91



# 1. Introduction

## 1.1 Background

Various industries, companies, and organizations have worked for decades to develop technologies and products to facilitate the growth of the distributed power (DP), or distributed generation (DG),<sup>1</sup> industry. Interest in the use of DG and storage has increased substantially over the past 5 years because of its potential to increase reliability and lower the cost of power delivery to the customer, particularly with customer-sited generation. The advent of competition and customer choice in the electric power industry has, in part, been the stimuli for this increased interest. These technologies can offer additional environmental benefits by utilizing renewable resources, such as biomass, and by employing combined heat and power systems that increase the overall efficiencies of the energy system. Also contributing to this trend has been the development of small, modular generation technologies, such as photovoltaics, microturbines, and fuel cells.

DP will be a key ingredient in the reliability, power quality, security, and environmental friendliness of the electric power system. By supporting customer choice, distributed power may be the long-term foundation for competition in the electric power industry.

The application of distributed generation technologies can bring many benefits. To realize these benefits and avoid negative impacts on system reliability and safety, the operational concepts to properly integrate them into the power system must be developed. The current power distribution system was not designed to accommodate active generation at the distribution level, particularly exporting power to other distribution customers. The technical issues of allowing this type of operation are significant. For example, control architectures that ensure safe and reliable DP operation, and that exploit the potential of DP to provide grid support, will require modernized system-protection design enhancements. This may require large amounts of information to be fed to advanced, intelligent local controllers that act quickly and operate local distribution areas for both local- and distribution-level benefits. New system architectures and enabling hardware and software will need to be developed.

Electricity regulation, zoning and permitting processes, and business practices that were developed under the old framework — an industry based on central-station generation and the ownership of generation facilities by regulated monopolies — can be barriers to the orderly development of market opportunities for DP in a restructured electric power industry.

The system integration issues related to DP are national issues that cut across a number of industries. By bringing together these various parties — hardware manufacturers (of photovoltaics, wind turbines, fuel cells, gas turbines, batteries, etc.), utilities, energy service companies, codes and standards organizations, state regulators and legislators, and others — there is a significant opportunity to address the technical, institutional, and regulatory barriers to distributed power. In fact, these very groups are working together on the technology and infrastructure issues.

---

<sup>1</sup> Although no uniform definition applies, distributed power and distributed generation generally refer to small power facilities of 10 MW or smaller.

This contract pursues technology development that will alleviate infrastructure barriers to DP. Under this contract, enabling hardware, control logic, and communications capabilities were developed, demonstrated, and validated in conventional and emerging DP technologies and products. The contract's success is the result of focusing on key enabling technologies and features built into system-level integrated solutions that work for customers and other stakeholders and participants in the DP market. These technologies and features have facilitated market participants to more fully capture and realize the benefits of DP products.

GTI's efforts to develop advanced grid interconnection products began in 1985 with benchmarking, surveying electric utilities for technical requirements, and performing distribution-level power system simulation studies. That effort yielded the first commercial multifunction solid-state protective-relaying package using digital signal processing (DSP) technology. Those efforts included joint testing with electric utilities to address new technology adoption challenges (e.g., the reluctance to shift from "tried and true" conventional electromechanical protection devices to integrated solid-state electronic equipment). Since being introduced, thousands of these multifunction protective-relaying systems have been used in DP system applications. Many companies followed suit with similar products, and electric utility acceptance increased tremendously for the new technology. That effort resulted in millions of dollars of capital, engineering, and maintenance cost savings and helped enable small DP and cogeneration projects to move from concept to reality.

As we head into the next decade, there is a critical need to support enabling technology that benefits increasingly smaller and more diverse DP products and that allows for interoperability between the DP source or sink and the grid. Because of the increased competition brought on by utility restructuring, the market will increasingly demand lower costs and more features (i.e., more value) from DP projects. Meeting these demands is essential to increasing the appeal and market acceptance of these systems.

The integration of a host of discrete DP generators into state-of-the-art Virtual Power Plants will be a major market achievement. Transparent solutions that can be employed with a diverse array of DP technologies and products will lead this movement. That application space includes:

- Conventional technologies (engines and turbines) using conventional fuels (natural gas and diesel) and unconventional fuels (waste fuels such as landfill gas)
- Emerging technologies (microturbines and fuel cells) operating on conventional and unconventional fuels
- Renewable technologies such as wind, solar, and small hydropower systems
- Small-scale cogeneration or combined heat and power (CHP) applications such as back-pressure turbines (BPT) that can be affordably connected
- Enabling the aggregation of DP capacity and energy to provide valuable ancillary services at the distribution and transmission level
- Enabling command and control strategies essential for the integration of DP into grid operations
- Energy management systems.

## **1.2 Distributed Power Problem Statement**

During the course of the past two decades, the independent power industry has thrived in the United States — at least for larger systems. Multi-megawatt simple-cycle and combined-cycle gas turbine power systems are the dominant technology choice for new power generation investments because of their favorable attributes of low cost, high efficiency, low emissions, and speed of project construction. In contrast, the market for small-scale power generation has not developed very substantially over this period.

There are many causes for the lagging nature of the DP market, including negative scaling effects for small power systems (i.e., higher cost per kilowatt with decreasing size), legitimate technical issues, inadequate product choices, and competitive responses from electric utilities. Examples of electric utility efforts to limit small DP market growth include long approval times and high costs for electric power system interconnection, special incentive rates to prevent customer loss, and high fees for standby power. More examples are contained in “Making Connections: Case Studies of Interconnection Barriers and their Impact on Distributed Power Projects” (NREL/SR-200-28053).

This National Renewable Energy Laboratory (NREL)/Department of Energy (DOE) report identified a 10-point action plan for addressing barriers to expanded DP use:

1. Adopt uniform technical standards for interconnection of distributed power to the grid.
2. Adopt testing and certification procedures for interconnection equipment.
3. Accelerate development of distributed power control technology and systems.
4. Adopt standard commercial practices for any required utility review of interconnection.
5. Establish standard business terms for interconnection agreements.
6. Develop tools for utilities to assess the value and impact of distributed power at any point on the grid.
7. Develop new regulatory principles compatible with distributed power choices in both competitive and utility markets.
8. Adopt regulatory tariffs and utility incentives to fit the new distributed generation model.
9. Establish expedited dispute resolution processes for distributed generation project proposals.
10. Define the conditions necessary for a right to interconnect.

Through NREL, DOE took steps to address these and other barriers to DP market growth through research, design, and development (RD&D) initiatives. An NREL 3-year competitive solicitation requiring cost sharing was won by GTI and Encorp to address technical development activities directly in support of action items 1 through 3 above. The result of the Base Year and Option Year One of contract work toward these objectives is the subject of this report. Other parallel DOE/NREL efforts are under way to address these and other action items. These efforts hold significant promise for reducing the barriers to DG and CHP system use in the United States.

## **1.3 Interconnection Controller Problem Statement**

As noted, many existing and emerging DP technologies suffer from relatively high total installed costs (in dollars per kilowatt). This is due in part to physical costs for interconnection equipment (e.g., switchgear, protective relays, and controls) as well as high “transaction costs” of working

with utilities and other parties to permit equipment for grid interconnection. These costs can escalate as the functionality of a DP installation strives to meet higher-level objectives, such as integrating and interacting with the electric power system (and its supervisory control systems) or with building energy management systems. In many instances, the small size of DP systems makes it difficult to justify the added cost for networking and customizing a product to a particular application. In addition, the small scale of many DP projects places them below *de minimis* size limits that distribution or transmission operators deem worthy of consideration. These factors make it difficult for small DP systems to provide value-added benefits to the electric power system (at least benefits that are monetized). This situation negatively affects the economic value of DP technologies — even though their aggregate capabilities have the potential to offer real benefits to the grid.

The DP industry also faces loss in value because of the inability of various products to work together. Lack of cross-platform compatibility exists among products ranging from turbines to engines, steam turbines, microturbines, fuel cells, wind turbines, photovoltaic systems, power quality systems (batteries and flywheels), and heat-recovery devices. This means that system integrators miss the potential for pooling resources in a manner similar to the Virtual Power Plant concept (where a number of smaller generators can be networked together and controlled to provide the equivalent of a multi-megawatt power plant or load center). A system integrator that can pool resources will be better positioned to provide valued services that will earn an economic return.

Encorp Power control systems and Virtual Power Plant™ software greatly simplified the task of managing and controlling a large number and wide variety of distributed resources — including engine generator sets, microturbines, fuel cells, wind turbines, and energy storage devices.

The current Encorp generator power control (GPC), with the power transfer control-enabled configuration, provides safe, reliable transfer of power between a single generator and the utility grid. Standard options include a wide variety of traditional control modules and open-communication protocols integrated into a single unit. The Encorp GPC with the kilowatt sharing-enabled configuration provides reliable paralleling of multiple generators. Combined with the Encorp utility power control (UPC), the kilowatt sharing-enabled GPC provides synchronizing and paralleling of multiple generators to the utility grid.

Although these products provide satisfactory features and value to customers today, a number of additional desirable features and functionalities are not resident in the existing GPC or competitor products. Research and design efforts are needed to provide greater functional integration, switchgear design simplicity, and cost reduction for the customer. Example needs include features to meet advanced communications, diagnostics, monitoring, and relay function expectations of customers as well as to ensure compliance with anticipated future interconnection standards within IEEE 1547.

A primary motivation for the IEEE 1547 standard is the desire of many market participants to rationalize and simplify the process for interconnecting a DP device with the electric power system. The following figure illustrates a typical interconnection scheme for a DP device with a generation source (labeled GS in Figure 1) supplying power at a customer site. In many

instances, the generation source is sized to meet a portion of the customer's peak power needs. Electricity is often not exported in this type of arrangement, but it could be in some instances. The generation source may also be used to provide emergency power in the event of loss of electric service.

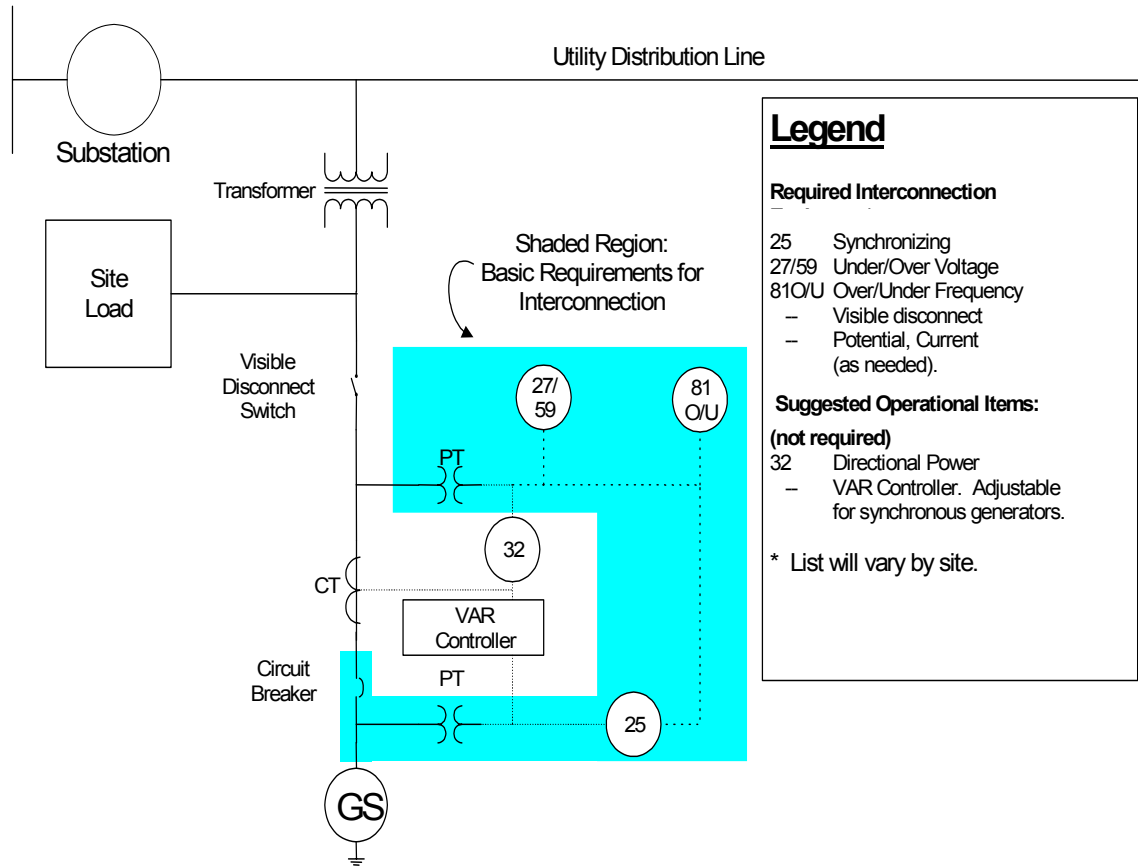

**Figure 1: Typical Interconnection of Distributed Power Device**

The IEEE 1547 standard is intended to be a performance-based document rather than a prescriptive document that lays out specific relay functions that must be incorporated into a device. This approach is in line with the evolution of the market during the past decade from discrete electromechanical relay devices toward integrated multifunctional, microprocessor-based interconnection and control systems that can perform a number of operations through control algorithms.

With the move toward performance-based standards, however, there is a desire to enable DP controller devices with higher-level functionality and safety features. For example, a concern among utilities is what happens to a DP generation source when a fault occurs on the utility distribution line (or electric power system). If a utility line breaker is open because of a temporary fault and subsequently reclosed, the DP device may inadvertently continue operating and be out of phase when the primary source is restored. In a worst-case scenario, a DP generation source may inadvertently supply power to a line that a service person thought was not energized.



These types of scenarios are raising expectations that DP products will provide higher levels of processing performance and control sophistication to address a range of issues that goes beyond conventional over and under voltage and frequency detection. A key element of this contract is the development of a high-performance computing platform that will allow high-speed monitoring and detection of system fault conditions and use of sophisticated algorithms that can address the host of potential application requirements for interconnecting a DP source into electric power systems.

## **2. Contract**

### **2.1. Contract Overview**

To address the technical and market needs of the evolving DP market, GTI and Encorp identified a multiyear plan. This effort began with the development of a new and significantly enhanced core controller technology and evolved into the development and demonstration of higher-level controls, software, communications capability, and functionality that captures the objective of improving the DP value proposition. In parallel, Encorp supported the development of the DG interconnection standards development — notably, the IEEE 1547 series of standards.

The specific tasks that were performed as part of this contract are as follows:

<b>Contract Tasks</b>
Task 1: Develop Prototype Advanced Controller
Task 2: Develop Prototype Power Sensing Board
Task 3: Expanded Suite of Communication Capabilities
Task 4: Interface for Revenue-Grade Meter
Task 5: Demonstrate Interconnect DP Device
Task 6: Type Testing
Task 7: System Command and Control
Task 8: Demonstration of Controlled DP Resources

This report provides a brief summary of each task Statement of Work (SOW) and technical results achieved on this contract. It references appendices that include additional details. This approach allows the reader to get a good overview of the contract and to allow in-depth coverage if the reader chooses to read more on a particular topic. Also included is a brief overview of the technical topics covered to orient the reader prior to covering the specific tasks.

### **2.2. Product Development Methodology**

Today’s business environment can be characterized by complexity, and the acceleration of everything from customer demands to production methods to the rate of change itself. In the face of these demands, organizations must continue to develop and deploy high-quality products that meet the customers’ needs. Organizations use development and business processes to help

achieve success. However, if the organization and management of people and processes breaks down, the net effect is reduced product quality.

Encorp analyzed numerous successful products that were being used throughout the electrical power industry and one key attribute was always evident: quality. The power industry demands even more quality from products than do several other industries. Products are expected to operate as anticipated in harsh environments, to be self-sufficient and reliable without maintenance for long periods of time and to work flawlessly when needed.

Refer to Appendix A for additional details on the product development methodology.

### **2.3. System Architecture Technical Approach**

Traditionally, when deploying power systems, several discrete analog devices would serve singular functions in the power system and would need to be integrated together for the system to function properly. This equipment is sometimes referred to as “custom” paralleling switch gear. Making all the different devices work together in a coordinated fashion is very difficult, cumbersome, prone to errors, and labor intensive. Each system deployed in this manner will be slightly different because of varying site, customer, and regulatory requirements. This adds to the complexity of the systems and increases the cost of deployment and maintenance by increasing the labor effort associated with each system’s design, manufacturing, and deployment. In addition, the collection and reporting of data from the numerous devices, (often analog devices) in the traditional switchgear breaks the chain of information. And breaking the information path impairs implementation of an intelligent DP system.

Encorp’s new Advanced Controller approach, developed as part of this contract, is to take the functionality that the analog devices provided and build them into software on a digital controller platform. This allows the “customization” of this equipment to be largely a configuration effort performed in software. The software reduces costs considerably during the design, assembly, and support phases of a project. This approach also provides additional user benefits in a simple user interface, greater built-in functionality, additional communications capabilities and remote monitoring as well as remote command and control functionality (Figure 2 and Figure 3 further highlight this philosophy).

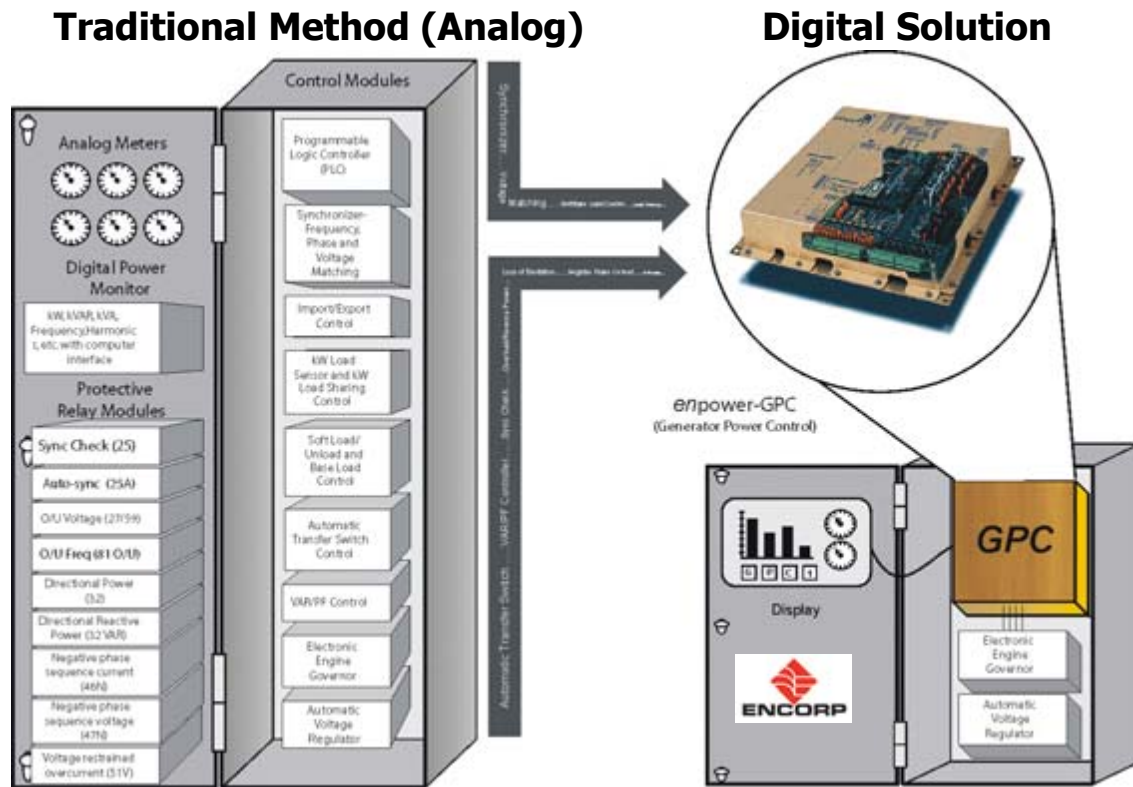
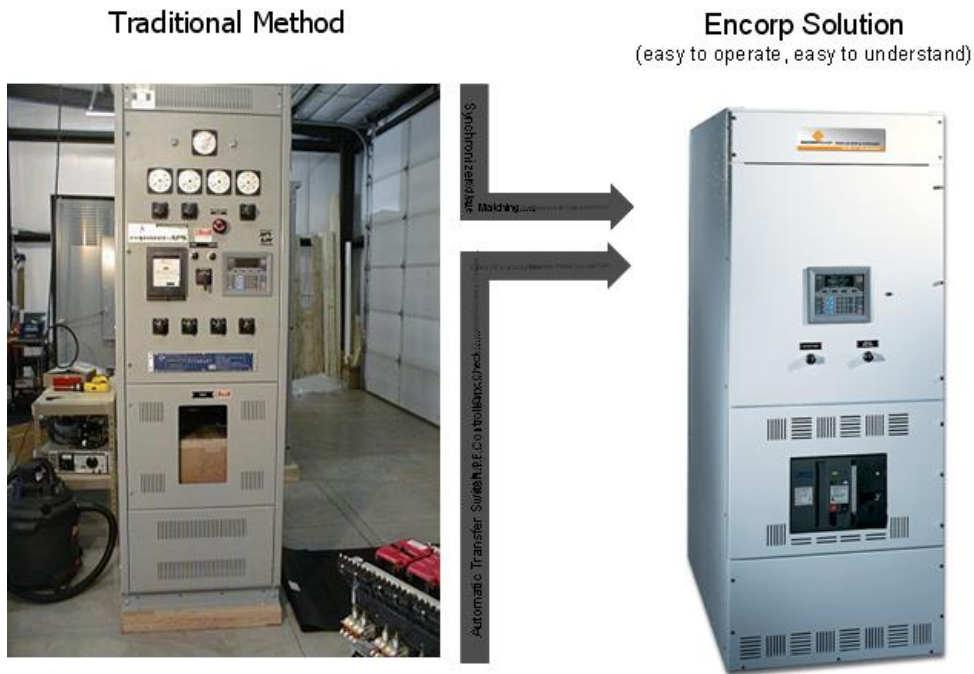

Figure 2: Moving to a Digital Platform



**Figure 3: Moving to a Digital Based Platform**

Refer to Appendix B for additional details on the system architecture.

### **3. Summary of Tasks and Results**

#### **3.1. Task 1 - Develop Prototype Advanced Controller**

##### **Task 1 - SOW Summary**

The SOW description follows.

This task is to develop a prototype controller by redesign of existing GPC product hardware to achieve even greater functional integration, cost reduction, and switchgear design simplicity than conventional products. This shall be achieved by incorporating an enhanced microprocessor, input/output (I/O) and communications features and capabilities; reallocating the circuit board functionality to incorporate basic monitoring, protection, and control features for the distributed power resource; as well as built-in Internet communications (rather than using a separate "gateway" as in the current architecture).

All necessary paralleling functions shall be further integrated into a single hardware device with extremely flexible object-oriented software for customizing the particular power system application (instead of customizing the switchgear cabinet hardware for every different site through many hours of engineering and custom manufacturing, assembly, and wiring).

### **Task 1 - Summary of Accomplishments**

The prototype controller module is the repository for firmware that coordinates the logic, features, functions, programmability, adaptability, and versatility of the Encorp GPCs. To provide price point and feature flexibility, the controller is designed to be flexible and expandable to meet the needs of both small and large DP equipment.

The CPU is the main processing element and communications hub. It incorporates a high-performance but cost-effective processor operating at sufficiently high processing speed to support the growing processing demands of DP applications and increased communications capabilities. It includes extensive memory support — including the capability to expand storage to support features such as data logging and trending.

The processor section of the prototype controller has extensive communications capabilities required by current and future applications. These capabilities include supporting LONWORKS, 100 Base-TX Ethernet, Controller Area Networks (CAN) interfaces, RS-232/485, and Modbus communications. The controller is designed to be flexible enough to handle a variety of other communications capabilities. The flexible memory design will allow the controller to expand or extend to meet a variety of future product features and applications. The controller has a watchdog timer and real-time clock.

With respect to interconnection, the prototype Advanced Controller design incorporates (among other features) the following functions<sup>2</sup>:

- Sync check (25)
- Autosynchronizer (25 A) with voltage matching, two modes available: frequency and phase matching and slip frequency.
- High-speed (160 millisecond) over/under voltage for generator and utility tie (27/59)
- High-speed (160 millisecond) over/under (O/U) frequency for generator and utility tie (81 O/U)
- Directional power (32)
- Directional reactive power (32 VAR)
- Reverse-phase/phase-balance current (46)
- Phase sequence voltage (47)
- Voltage-restrained over current (51V)
- AC time over current (51N)
- Anti-islanding relay

---

<sup>2</sup> IEEE Std C37.2 – 1996 (Reaff 2001), IEEE Standard Electrical Power System Device Function Numbers and Contact Designations

- Loss of synchronization relay (required for applications with stiffness ratio of 20 or less)
- Over-current relay (required for over 2megavolt-ampere [MVA] units)
- Form-C contact outputs

Refer to Appendix B for additional details on the product system architecture.

Refer to Appendix C for additional details on the Advanced Controller design.

## **3.2. Task 2 - Develop Prototype Power Sensing Board**

### **Task 2 - SOW Summary**

The SOW description follows.

This task includes determining the functional requirements for a prototype power sensing capability, and designing, developing, and testing this prototype power sensing functionality. This prototype power sensing board will significantly enhance the ability of the controller to fully comply with all interconnection requirements. Primary attributes of the new power sensing board will be a simpler design (for lower cost and end-user price) and ease of installation. It needs to be capable of supporting three phases. The design approach of the power sensing board shall provide the necessary computational support and high-data bus structure that enables interconnections compliant with existing standards.

### **Task 2 - Summary of Accomplishments**

The power sensor module (PSM) design is a stand-alone intelligent module powered by high-power DSP technology (Figure 4). The primary purpose of this module is to interface with multiphase voltage (potential) and current transformer inputs. This module will perform extensive signal processing, manage the input information, and transfer the resulting values to the controller module. This encompasses various electric power issues related to real and reactive power as well as harmonics.

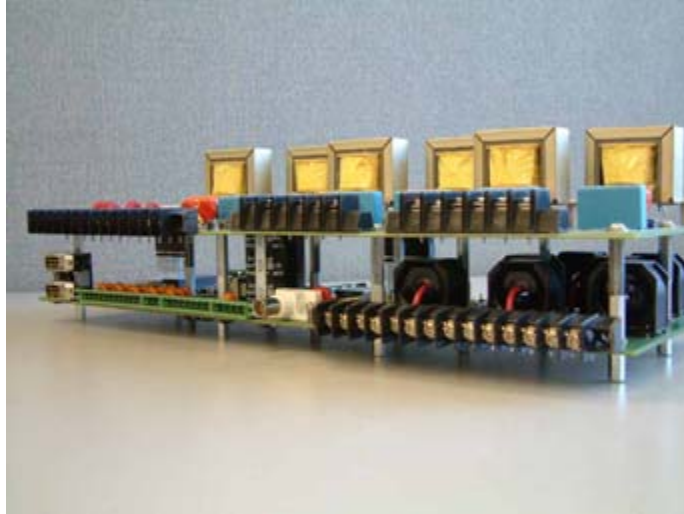

**Figure 4: PSM without Cover**

In addition, this module contains relay outputs for circuit breaker close/open control, digital inputs for auxiliary contact feedback, and solid-state digital outputs for relay targets or secondary circuit breaker control.

The prototype PSM module design has sufficient memory to allow up to 64 cycles of waveform information to be buffered to support an event-reporting application. In addition, the power sensor module software performs several high-speed protective relay functions (e.g., over/under voltage [27/59], over/under frequency [81 O/U], sync check [25], and loss of synchronism relay [78]).

Refer to Appendix D for additional details on the Prototype Power Sensor Module.

### **3.3. Task 3 - Expanded Suite of Communication Capabilities**

#### **Task 3 - SOW Summary**

The SOW description follows.

A key element of the Advanced Controller design is developing an enhanced set of communications capabilities. This includes multi-directional communications to: other DP units at the local site; facility energy management systems; monitoring, display and analysis programs at the local site; remote dispatch, metering, billing, and alarming systems; and service providers.

#### **Task 3 - Summary of Accomplishments**

A critically important element of this development effort is the incorporation of an expanded set of communication capabilities into the Advanced Controller. These capabilities include communication pathways to tie into existing and future energy management systems, electric utility command and control centers, independent system operator (ISO) and regional

transmission operator (RTO) organizations, and other participants. Communication technology is seen as an essential element of the long-term DG value proposition.

With regulatory and legislative changes transforming the electric power industry from a monopolistic to a deregulated and competitive industry, there is increasing need for information and data exchange among open systems and interoperability across multivendors' hardware. An example of this type of information exchange is contained in a key American Society of Heating, Refrigerating, and Air-Conditioning Engineers Inc. (ASHRAE) report produced by Martin Burns and Michael Kintner-Meyer. They identified the following as key communication information services:

1. Revenue meter reading (electricity, gas, water, steam)
2. Quality of service monitoring
3. Real-time-pricing transmission
4. Load management service
5. On-site generation supervisory control
6. Energy-efficiency monitoring
7. Weather reporting and forecasting services
8. Indoor air-quality monitoring
9. Dynamic demand bidding into a power exchange.

What is significant about these findings is that nearly all these services, with the exception of Item 8, can be provided by Advanced Controllers for DG.

Refer to Appendix E for additional details on communications.

### **3.4. Task 4 - Interface for Revenue-Grade Meter**

#### **Task 4 - SOW Summary**

The SOW description follows.

The Advanced Controller needs an interface for revenue-grade meters. This interface shall accommodate the numerous legacy meters in use as well as new bus-enabled metering devices. In addition to being able to perform all of the metering calculations to the requisite accuracy, the interface should also affordably access the revenue-grade meter information most DP deployments will require. The necessary interfaces shall be built into the hardware platform and software architecture.

#### **Task 4 - Summary of Accomplishments**

The specification of the controller includes the ability to interface with existing (or "legacy") electricity meter devices as well as the ability to provide stand-alone revenue-grade meter information.



With respect to interfacing with existing meters, the intent is initially to incorporate features common to the most widely used electric demand meters. Electric demand meters can include, or be modified to include, a pulse output. This is often done using what is referred to as a Form C relay, also known as a KYZ relay. In this nomenclature, the K is usually the common of a single-pole, double-throw (SPDT) relay, the Y contact is normally open, and the Z contact is normally closed. The relay device changes state between open and closed with each rotation (or partial rotation) of the meter disk. The KYZ output is also referred to as a pulse meter. With input on various factors associated with the meter device, the KYZ output can be used to provide revenue-grade information on power and energy usage. The meter design specification incorporates the ability to interface with KYZ-based meter signals.

In addition, the prototype PSM design of the new controller has revenue-grade metering capabilities. The controller is designed and will be tested to the power and energy accuracy requirements of ANSI C12.20-1998, Accuracy Class 0.5.

### **3.5.Task 5 - Demonstrate Interconnect DP Device**

#### **Task 5 - SOW Summary**

The SOW description follows.

This technology is seen as having application in large commercial, institutional, and industrial facilities as well as in small-scale biomass energy plants. Verify the functionality of the Advanced Controller, including the communications capabilities developed in tasks 1-4 in an operational setting. This task will demonstrate the benefits that will be derived from deploying the prototype Advanced Controller in a real world setting.

GRI will work with EPRI to leverage efforts on addressing advanced communication needs for DP systems.

#### **Task 5 - Summary of Accomplishments**

To document the first-hand market issues with the interconnection and communications of DP systems, a system case study was done on the Chowchilla II power generation station in Chowchilla, California. Encorp Inc. designed the controls and switchgear system for this complicated plant. The Chowchilla II system is a prototype version with some of the features and functions that would be implemented on the production version of the Advanced Controller being developed. This prototype hardware is not integrated in the same manner as planned on the Advanced Controller but serves as a model for the capabilities that would be integrated into the Advanced Controller.

The Chowchilla II power plant (Figure 5) is a 48-MW facility powered by 16 Duetz natural gas-fueled generator sets operating in parallel with the local utility. The plant is owned by NRG Energy and operated by NEO, a subsidiary of NRG Energy. The power facility, although located in California, is dispatched by NRG from offices in Minneapolis, Minnesota. The plant is

dispatched based on receiving a call from PG&E or in response to area energy pricing signals. The California ISO monitors the facility to determine capacity effect and demand scheduling.



**Figure 5: Chowchilla 48-MW Power Plant**

Individual generator power measurements are made by the Encorp controllers in the system. The power data is gathered and ultimately passed up to the communications processing modules (CPMs) in each system and sent to NRG and the California ISO for their use.

The Encorp communications system at the Chowchilla power generation facility brings together various software, system, and network topologies. As a result of this effort, the following results are realized.

- **On-Site Generation Supervisory Control**  
Supervisory control of the on-site generation is provided by the Encorp UPC/GPC controls and the local or remote desktop workstation (DWS). Supervisory control includes remote/local system dispatch, alarm monitoring and trending, event trending, dial out alarm notification, local/remote generator power level settings, and system power-level monitoring.
- **Generator Status/System Status Monitoring**  
The Encorp controls allow local and remote monitoring of a multitude of generator and system data points. These points include:
  - Inlet/Exhaust temperature
  - Coolant temperature
  - Crank case pressure
  - Starting air pressure
  - Lube oil pressure (before and after filter)
  - Lube oil level
  - Supply voltage

- Throttle position
  - Engine speed (revolutions per minute [RPM])
  - Generator bearing temps
  - Generator winding temps
  - Generator inlet/outlet air temps
  - Combustion chamber temperatures
  - Gas valve positions.
- **Load Management Service**  
Because this site is used exclusively for supplementing the existing distribution capacity, load management is limited to the ability to adjust the base load reference of the individual generators from a local or remote location via the DWS. Generator power limits and active demand levels are also available at the local or remote DWS.
  - **Indoor Air Quality Monitoring**  
Indoor air temperatures are measured and ventilation fans are operated automatically from the Encorp UPCs based on the air temperature of the facility.
  - **Revenue Meter Reading**  
This site did not incorporate revenue meter reading in the Encorp system. Revenue meter reading was integrated into the ISO distributed power generation hardware. However, the Encorp system is fully capable of receiving either real or pulse (KYZ) meter information and displaying the resultant demand information from those sources.
  - **Energy-Efficiency Monitoring**  
The Chowchilla power station did not require energy-efficiency monitoring. If at some point in the future there is a need for efficiency monitoring (heat rate versus kilowatt-hours), the Encorp software could be easily modified to provide such information.
  - **Weather Reporting and Forecasting Services**  
There were no requirements for weather reporting or forecasting services data or I/O for the operation of the Chowchilla project.

### **California ISO Data**

Numerous monitoring and control points are sent from the Encorp communications system to the California ISO via the DPG. A listing of all these points can be found in the California ISO DPG Technical Specifications via their Web site at [www.caiso.com](http://www.caiso.com).

Refer to Appendix F for additional details on the prototype Advanced Controller in the Chowchilla, California power plant.

### **3.6. Task 6 - Qualification and Testing of the Advanced Controller**

#### **Task 6 - SOW Summary**

The SOW description follows.

This task aims to ensure the overall quality of the Advanced Controller. Because of the critical nature of the DP systems the Advanced Controller will be managing, and the danger involved in having failures, a great deal of time and effort was devoted to ensuring the overall quality, reliability, and stability of the Advanced Controller. A test plan shall be drafted and then finalized that addresses the necessary environmental and functional test requirements. The type testing shall include complete written reports documenting the technical and environmental conditions and performance, test evaluation criteria, and, analysis of, and recommendations concerning, the adequacy of the test plan.

#### **Task 6 - Summary of Accomplishments**

Type testing of a new product is really a subset of the main area of concern, which is the overall quality of the product being developed. Encorp went beyond the original scope of the contract in ensuring quality through an exhaustive regiment of testing in all phases of the product lifecycle. Quality really starts during the design phase and involves manufacturing, suppliers, customers, engineering, type testing, bench testing, system testing, on-going reliability, and an approach to handle any field failures. The product should be engineered to meet or exceed the identified quality requirements in all of these areas. Figure 6 depicts the Advanced Controller used for qualification testing.



**Figure 6: Advanced Controller for Qualification Testing**

The quality of a product requires a systems approach over the life cycle of the product, from development through field reliability. This starts during the engineering phase using tools such as good requirements documents that are agreed to by the entire organization. The requirements are implemented utilizing a structured design methodology and simulation of the design where possible. During the design stage the overall goal is to perform an evaluation of critical signals, stack up tolerances, and create a product with some design margin in it. An early transition of firmware to the target system allows continuous board and code testing during development that improves the overall product stability. These tests are followed with further critical tests that are

performed on the engineering units, correcting issues that are identified prior to initiating the certification testing. Finally, performing the certification tests on products that have been produced from the planned production line can ensure a product that meets the requirements identified and that meets the market demands for a high quality, reliable product. (Figure 7 shows the test facility at Encorp)



**Figure 7: Systems Test Facility at Encorp**

The overall test approach has been summarized as follows:

- Engineering development tests (critical path analysis, design margin, firmware verification, etc.)
- Bench tests (subsystems/functions, systems single/multiple controllers, etc.)
- Production tests (ICT, Functional – board/module, calibration, burn-in, FGA, on-going reliability; Figure 8 shows the Advanced Controller Production Tester)
- Systems tests (subsystems/functions, on-generator, multiple generators, various control modes and applications)
- Certification Testing on production units “Type Tests” (IEEE, UL, ANSI, IEC).



**Figure 8: Advanced Controller Production Tester**

The key is to develop a strategy to address each of these areas to ensure the highest quality during each phase of the product’s lifecycle. For each test performed, testers wrote a detailed test procedure and test report.

Refer to Appendix G for additional details on testing and qualification of the Advanced Controller.

### **3.7. Task 7 - Develop System Command and Control**

#### **Task 7 - SOW Summary**

The SOW description follows.

Develop and deploy the software and communications systems that surround the Advanced Controller and allow remote monitoring as well as command and control of the DR unit. These software systems need to remotely interact with the Advanced Controller to enable the transfer of critical information for monitoring and to enable the controls to remotely dispatch the DP systems.

#### **Task 7 - Summary of Accomplishments**

Encorp developed the Energy Management Center (EMC), a fully functional command and control system that allows customers to monitor, analyze, and control DG assets via a secure Web-based interface.

When approaching this task, Encorp completed several design-related activities to obtain the most complete understanding of what software and communications subsystems were to surround the Advanced Controller to further enhance its functionality and overall quality. These activities included a detailed communications study, research and testing surrounding IT related security, and a comprehensive market analysis to enable a better understanding of the industry climate. This included detailed analysis of the broad range of DG projects that Encorp had implemented to date.

The knowledge gained while completing these activities was used to design, develop, and deploy the command and control system (EMC). Figure 9 portrays the EMC communications architecture. The EMC has been released into production as a commercial product and is being utilized by several customers, including the demonstration sites discussed later in this report.

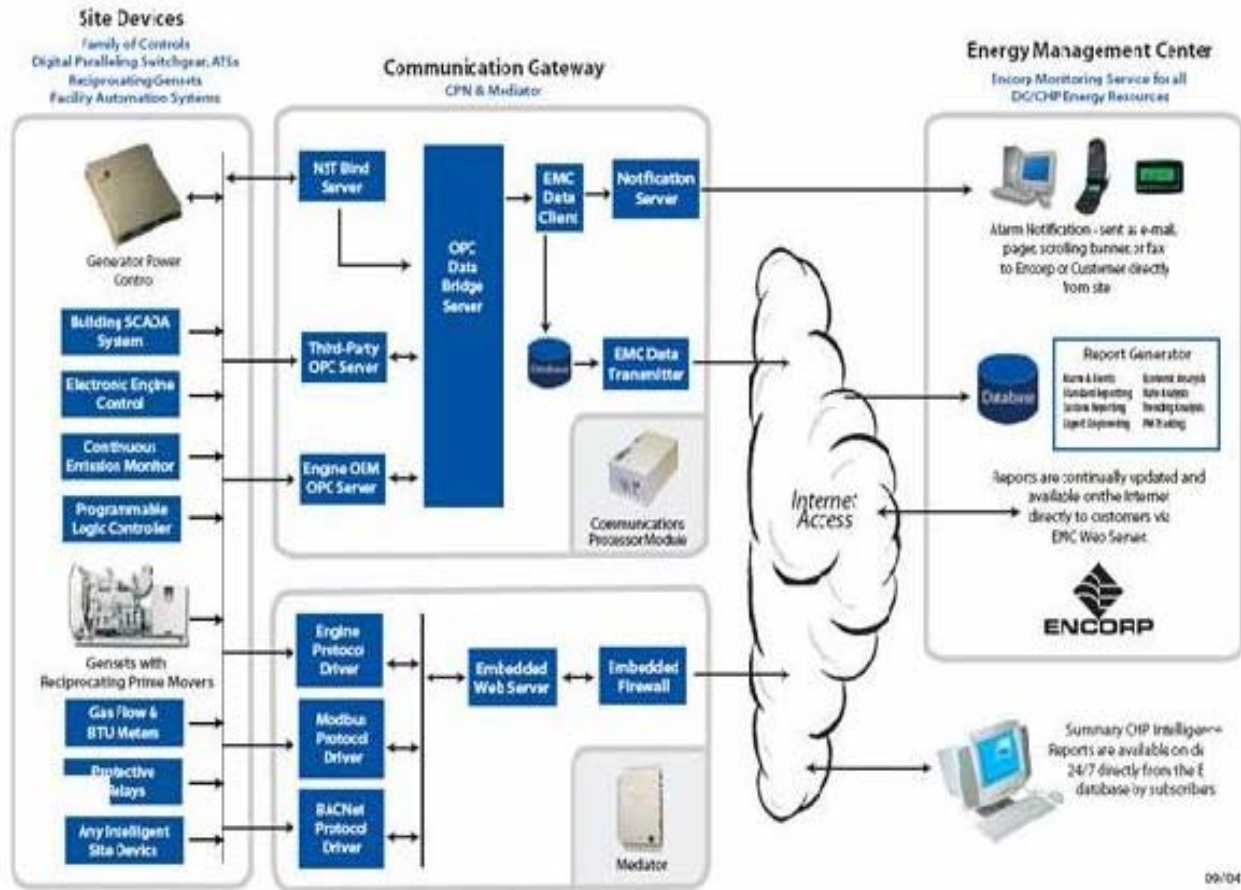

Figure 9: EMC System Architecture

Additionally, Encorp spent a considerable amount of time and resources to gather information regarding communications, security, and market conditions to ensure the overall quality of the EMC and the Advanced Controller. This information and the EMC system description are summarized in this report as well as a more detailed report that was completed earlier as part of this contract entitled “Distributed Generation Advanced Communications Study (ACL-1-30605-04)”.

Refer to Appendix H for additional details on System Command and Control architecture.

### **3.8. Task 8 - Demonstration of Controlled DP Resources**

#### **Task 8 - SOW Summary**

The SOW description follows.

Deploy and demonstrate the Advanced Controller in two diverse commercial demonstration sites. The demonstration shall use several physically separate, grid-connected DP resources to demonstrate the ability to provide autonomous site control, scheduled control from a dispatch center, and real time data monitoring and asset control from a network operations center that is representative of DP operations in a commercial environment. The DP resources shall be operated in accordance with commercially useful practices and the necessary monitoring of distribution operations shall be coordinated to determine the nature of any operational impacts.

#### **Task 8 - Summary of Accomplishments**

The final task to be completed was the demonstration of the Advanced Controller and EMC outside of the lab environment in an “uncontrolled” commercial deployment. To be sure that the Advanced Controller was adequately tested in this manner, the evaluation and selection of an appropriate demonstration site was essential. It was decided to utilize two demonstration sites to ensure broad coverage of commercially representative conditions.

Establishing the two ideal demonstration sites was based on the following selection criteria.

- **Location of site**
  - The site needed to be easily accessible by the development staff and the operations engineering staff to ensure a fast response to any problems. Locations that had enhanced security with restricted hours were not considered.
  - Testers targeted sites that represented a geographical marketplace where DG is prevalent to ensure a demonstration site that would be representative of the customers of the Advanced Controller.
- **Customer selection**
  - It was important to select appropriate customers who would allow testers to utilize their sites and in some cases their customer’s sites.
  - The customers needed to understand the benefits of the Advanced Controller and be willing to accept the risk if the demonstration did not go smoothly.
- **Retrofit**
  - It was decided to do the demonstration at two DG sites in which earlier generation Encorp controls were already deployed. This would allow a comparison of the existing structure with the Advanced Controller.



- Sites that were using the EMC prior to deploying the Advanced Controller were selected to have a “before” and “after” site profile based on the information that was being gathered through the EMC.

- **Compliance with National Environmental Policy Act (NEPA)**

These commercial sites were carefully selected to be representative of the current market place. Once the Advanced Controller was installed at these sites, testing and remote performance monitoring and analysis were performed.

Based on these criteria, the first site was Encorp’s Headquarters in Windsor, Colorado, and the second demonstration site was the Aquarium of the Pacific in Long Beach, California, in partnership with City Light and Power in Long Beach.

### **Demonstration Site One - Encorp Headquarters**

Encorp’s headquarters in Windsor, Colorado, was built and opened in 2001. The facility has 80,000 square feet that includes manufacturing facilities, office space, and a small data center. The facility utilizes power that is being distributed by Xcel Energy. The facility uses one Detroit Diesel Generator with a nameplate capacity of 535 KW to provide backup power in case of a utility outage. Due to the need for reliable power for the small data center, the site is representative of a critical power application that would be analogous to a telecommunications center or a hospital.

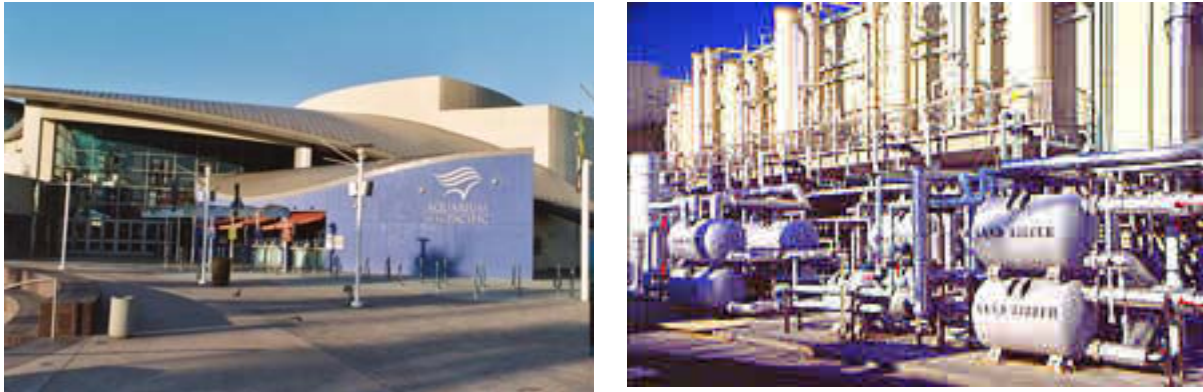

**Figure 10: Demonstration Site One - Encorp Headquarters**

### **Demonstration Site Two - The Aquarium of the Pacific**

The second demonstration site was the Aquarium of the Pacific (AOP) in Long Beach, California. AOP is one of the largest aquariums in the United States. It is home to more than 12,000 ocean animals that represent more than 1,000 different species. The beautifully architected 156,735-square-foot building is right next to the Pacific Ocean on the west side of downtown Long Beach. AOP was visited by over 1.1 million people in 2003, making it the third most attended cultural institution in the greater Los Angeles area. It is a strong asset to the

community, bringing in more than \$20 million in economic benefits to Long Beach and \$100 million to Los Angeles County annually.



**Figure 11: Demonstration Site Two - Aquarium of the Pacific**

### **Demonstration Observations**

The implementation results for the first demonstration sites were very positive. Transitioning the Advanced Controller into the hands of the engineering and operations team from the development team was eased tremendously because of the use of the ISaGRAF Workbench and standard IEC 61131 programming languages. The function blocks that provide the control algorithms were implemented along with the IEC standard functions, such as multiplexers and gates. This sped the implementation and facilitated easier customization needed to meet the particular nuances of the site's sequence of operation. These standard programming languages are another major benefit of the Advanced Controller, allowing industry engineers to quickly understand and use the Advanced Controller with minimal specialized training.

Improvements in speed and reliability surrounding data collection were also evident due to the Advanced Controller's data acquisition enhancements. This was very useful for remote monitoring, database storage, and generation of system health and status pages to the technical support cellular telephones and e-mails. The system was configured to generate an informational e-mail to the cellular phone of selected employees to indicate when the site was being powered solely by generation during the monthly load test, or if the site was down because of an emergency. During testing, the facility was seamlessly transferred to backup generation, so the e-mail messages provided the only indication to other plant personnel that the test was happening.

Construction and spring thunderstorms were the primary cause of most interruptions in utility electrical power. The event recording of the power conditions at the time of interruption was performed at a much faster frequency (1 second) to the standard database programs than by the previous communication channels. This enabled site personnel to know the cause and type of interruption more precisely than before.

Noticeable improvements were evident in the overall system maintenance as well. Having a single hardware and software platform lessened the site's complexity. This enabled the site to receive several firmware upgrades and feature enhancements with less overall testing than was previously possible. These features provided operational efficiencies that reduce the overall cost of system implantation and reduced the overall operational maintenance costs.

Having TCP/IP Ethernet on the Advanced Controller allowed the controls to be placed on the facility network. Although the Advanced Controller might have a dedicated network at many sites, the TCP/IP Ethernet interface allowed the controller to be tested with all of the communication traffic of the facility and not just the site. It also gave users the ability to monitor or demonstrate remote connections into the site.

In performance testing, the Advanced Controller exhibited a high degree of stability and "smoothness" as it was taken through the loading, unloading, base load control, and import control algorithms. In particular, the import control was able to control to within a +/- 10 kW level, where previously only +/- 20 kW was obtainable. In the base load mode, the export control limiter function transitioned from base load to export limiting function without any issues. The export limiting function comes into play when a base load level is set on the generator, but the site load decreases to the point where the export limiter decreases the generator load to maintain the desired export of power from the utility to the facility.

All software programming for the control, including communication settings and tunable configurations for the site, were backed up on the multimedia card (MMC). In the unlikely event of an Advanced Controller failure, the MMC card could be inserted into a replacement control and all software programming, custom settings, and performance tunings could be restored in a single step. This feature will greatly reduce field maintenance costs of deployed Advanced Controllers, allowing a control to be shipped and installed by on-site personnel, circumventing the need for an engineer to travel to the facility to replace the controller.

Refer to Appendix I for additional details on the two demonstration sites.

## **4. Conclusions**

This final report provides a summary of the successful results of the work completed on the advanced grid interconnection controller and the command and control system, as well as two demonstration sites.

This contract work achieved the following objectives:

- Significant cost savings compared to current industrial switchgear options.
- Reduced maintenance costs due to the benefits of integrated switchgear and controls systems and the power of remote monitoring, diagnostics, and communications, as well as the design of the Advanced Controller for field service and field support capabilities.
- Demonstrated compatibility with major electric power system communication protocols and building energy management communication protocols.

- Created the ability to integrate with a broad cross-section of energy generation technologies and energy load management technologies.

The following is a list of specific technical accomplishments that have been achieved under this contract.

- Designed, developed, and tested a prototype.
- Demonstrated the prototype design's functionality in the Chowchilla case study.
- Researched and published the Communication Study. This study identified the various types of communication used and the control features that would be desirable for remote monitoring and control of DP assets.
- Addressed Internet related security features that would be needed in the Advanced Controller.
- Developed the prototype design into a commercial product and released it for commercial use.
- Created a design in which most simple systems do not need a CPM because remote communications can be performed directly with the Advanced Controller. This eliminates an expensive component (and associated wiring and system complexity) that was prone to failing in the field.
- Designed the system so that it reduces the time required to initially load or upgrade an application. Large systems will take only a few minutes per control and single control download capability within a multiple control system is provided (more than a 100 times improvement in speed over the previous controller, especially in larger systems).
- Provided for a single user interface. Older controllers required designing the control with both LONWORKS tools and the ISaGRAF workbench tool, which complicated the designs and increased errors that were debugged late in system assembly.
- Utilized International Programming Languages to improve marketability and ease of use training for the control.
- Provided Application Simulation during the system design process to minimize design errors and correct these errors early, reducing manufacturing and site set-up times.
- Gave the application the ability to self-document during the design process. This saves many hours during the design process and ensures that the documentation is the same as the design.
- Provided serviceability improvements. The current controller design requires the cover to be removed for access to wiring, LEDs, connectors, and the reset button. The Advanced Controller design provides cover-on accessibility for functions.
- Designed the Advanced Controller to allow field replacement and project archival. It provides an easier method to perform a field replacement and store or re-store the application project on the Advanced Controller. This is achieved with a Removable multimedia flash card interface, which will allow field replacement by on-site technicians, eliminating the need for an engineer to travel to the site to perform the field replacement.
- Designed the system to extensively document the firmware design, implementation logic, and control algorithms that were not available on the previous controller. This will greatly aid training new users and engineers, and aid debugging of issues that occur when using the new controller.

- Designed a system that provides a 20-fold performance improvement through the use of a high-speed controller central processing unit, along with a high-speed digital signal-processing chip.
- Designed a system that reduces manufacturing costs (estimated reduction to be greater than 15%).
- Designed a system that increases control capabilities with the design of a patented active anti-islanding control scheme.
- Designed a system to further increased control capabilities with the design of a loss-of synchronization control scheme.
- Designed a system that reduces overall grid interconnect system capital and installation costs with the elimination of additional system hardware now intrinsic to the Advanced Controller (i.e., improved firmware and communications capabilities).
- Designed a system that includes compliance with current and projected industry standards for switchgear and interconnection devices.
- Designed a system that increases functionality for the DP customer.
- Designed a system that includes supporting software that encompasses the ISaGRAF Workbench Extension Tool and the Advanced Controller Commissioning Tool.
- Provided a design that is software configurable, eliminating separate hardware configurations for UPC, KWS, and PTC applications. This is a big cost savings-- it increases production volumes thereby lowering, inventory, support, and documentation costs, as well as simplifying marketing and sales efforts.
- Included an RTU (Remote Terminal Unit), which is focused on connecting and communicating with distributed resource subsystems. The RTU allows interface with utility-grade energy meters, engine controllers, fuel meters, etc. and feeds this information to higher-level systems. The Advanced Controller includes the following RTU capabilities:
  - Modbus devices (Server and Client)
  - Lon Work devices (more standard implementation)
  - TCP/IP (Ethernet)
  - Additional RS232 and RS485 serial interfaces.
- Provided a standard Web browser interface for simple monitoring and operation.
- Provided a Web trending capability.
- Performed an extensive series of qualification and compliance tests on the Advanced Controller. The following actions were performed on prototype and production units, ensuring that a quality system was in place to maintain the quality of the controllers that would be manufactured.
  - Unit testing of each individual software unit that was developed
  - Bench-level testing of the controller system
  - Type testing as specified in IEEE 1547 and other applicable standards (temperature, mechanical shock/vibration, EMI, RFI, etc.)
  - Live on-generator system tests in a laboratory environment
  - Production and on-going reliability tests
  - Tracking and monitoring of field deployment issues
  - Corrective action and verification of all issues that were identified during the development and deployment of the Advanced Controller.

- Created the Remote Energy Management Command and Control (EMC), located in Windsor, Colorado. The EMC is capable of remotely monitoring and controlling distributed generation assets.
- Demonstrated the combined system at two demonstration sites:
  - Single generator application located in Colorado
  - Multi-generator, combined heat and power application in California
  - Both systems are supported by the EMC remote monitoring and control capabilities.



## **5. Appendix A: Product Development Methodology**

Today's business environment can be characterized by complexity, and the acceleration of everything from customer demands, to production methods, to the rate of change itself. In the face of these demands, organizations must continue to develop and deploy high quality products that meet the needs of their customers. Organizations use development and business processes to help achieve success. However, if the organization and management of people and processes breaks down, the net effect is reduced quality of the products that are being developed.

Encorp analyzed numerous successful products that were being used throughout the electrical power industry and one key attribute was always evident: quality. The power industry demands quality from products even more than what is found in several other industries. Products are expected to operate as anticipated in harsh environments, to be self sufficient and reliable without maintenance for long periods of time, and to work flawlessly when needed.

Understanding these demands from business in general and the enhanced demands of the power industry, Encorp employed a proven product development process that ensures meeting the industry's high standards of quality. This development process is fairly simple but requires discipline at all levels of the organization.

This process is broken down into various sections in the life cycle of a product: concept, design, development, product validation, ramp to production, production, and end of life. Figure 12: Base Year Product Life Cycle Development Activity and Figure 13: Option Year 1 Product Life Cycle Development Activity; outline the relevant phases employed for the Advanced Controller development in the Base Year and in Option Year 1 of this contract work.



## Base Year Activities on the Advanced Controller

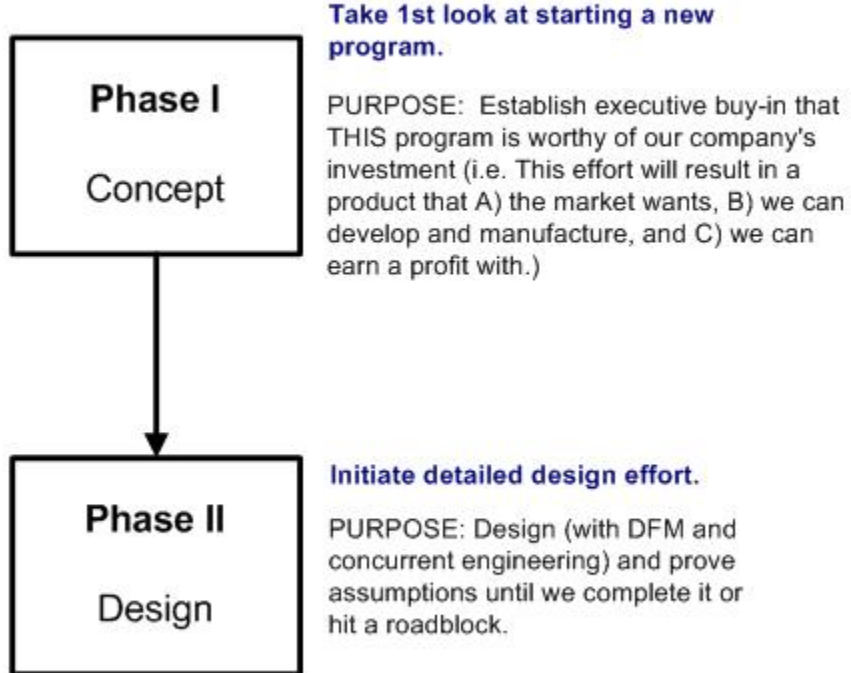

Figure 12: Base Year Product Life Cycle Development Activity (DFM – Design for Manufacturing)

### Option year 1 Activities on the Advanced Control

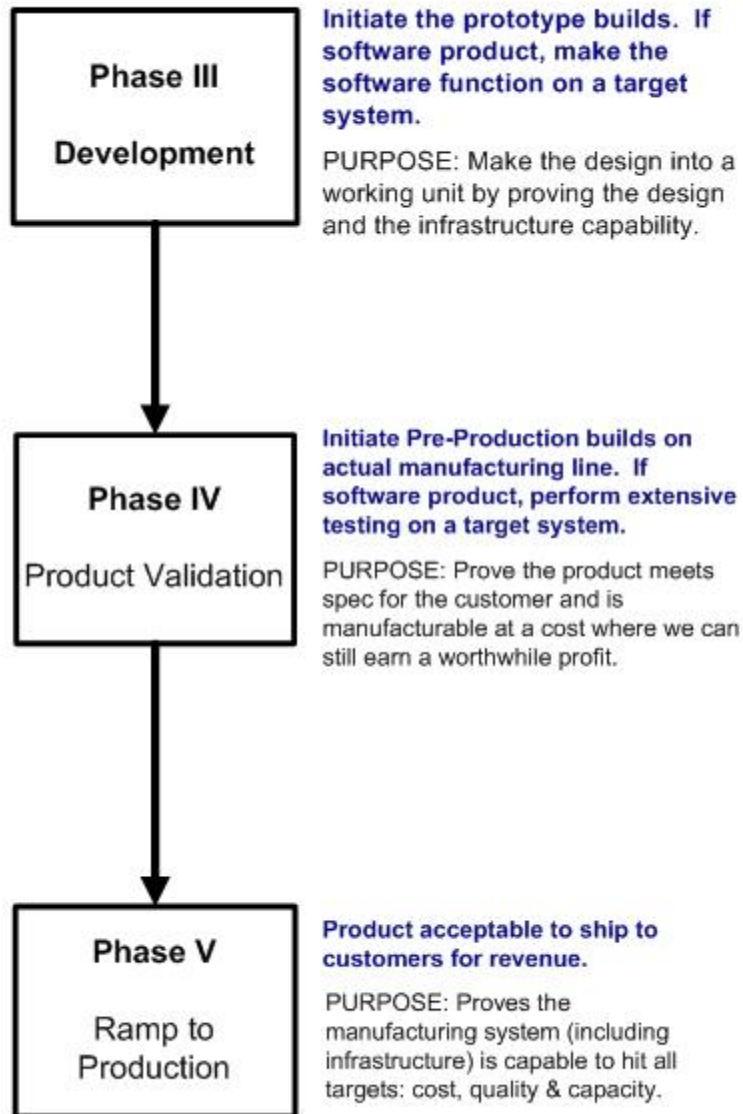

Figure 13: Option Year 1 Product Life Cycle Development Activity

## 6. Appendix B: System Architecture Technical Approach

Traditionally, when deploying power systems, several discrete analog devices would serve singular functions in the power system and would need to be integrated together for the system to function properly. This equipment is sometimes referred to as “custom” paralleling switchgear. Making all the different devices work together in a coordinated fashion is very difficult, cumbersome, prone to errors, and labor intensive. Each system deployed in this manner will be slightly different because of varying site, customer, and regulatory requirements. This adds to the complexity of the systems and increases the cost of deployment and maintenance by increasing the labor effort associated in each system’s design, manufacturing, and deployment.

The new Advanced Controller approach, developed as part of this contract, is to take the functionality that the analog devices provided and build them into software on a digital controller platform. This allows the “customization” of the equipment to be largely a configuration effort performed in software, allowing for cost savings during the design, assembly, and support phases of a project to be considerably less expensive. This approach also provides additional user benefits in a simple user interface, greater built-in functionality, additional communications capabilities, and remote monitoring, as well as remote command and control functionality. (Figure 14 and Figure 15 further highlight this philosophy.)

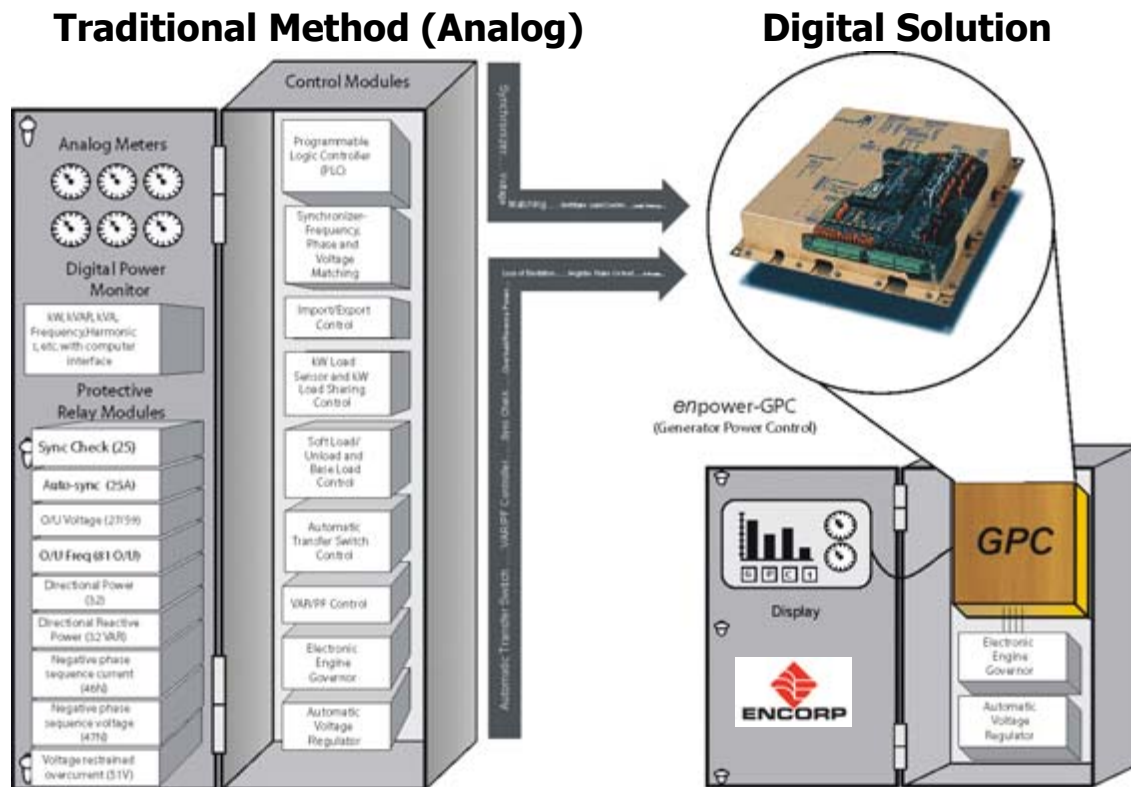
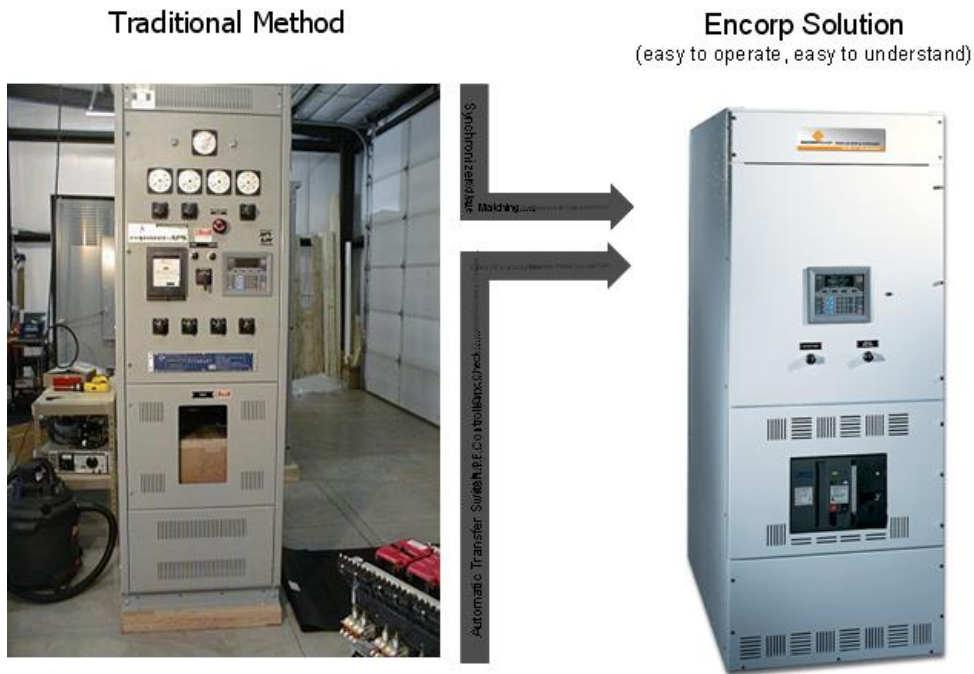

Figure 14: Moving to a Digital Platform



**Figure 15: Moving to a Digital-Based Platform**

Based on this approach, the overall system architecture has two major subsystems: the control layer and the data acquisition layer.

## 6.1 Control Layer

The control system uses the Advanced Controller developed under this contract to take in critical system information points, such as voltage, kW, and current, and make command decisions across the entire system. In the control system, the utility power control (UPC) is deployed at each utility entrance point in a facility.

In Figure 16 there are two UPCs deployed at each of the facility's two utility feeds. A generator power control (GPC) is deployed at each separate DG unit. Three GPCs are also deployed, one on each of the facility's reciprocating engines. Please note that the UPC and GPC are physically the same device and only the software configuration used in each device is different, providing the UPC and GPC functionality. This illustrates just one of the cost savings of the Advanced Controller approach. The savings are many, including those achieved by spreading direct and indirect costs over a higher volume of manufactured components, and the lower manufacturing costs that are realized with higher volumes. When these controls are deployed, they use the LONWORKS communications protocol to pass information amongst each other and make coordinated system-level decisions. This allows the control system to execute in various application modes, such as peak shaving and standby.

One of the major advantages of the Advanced Controller design is to minimize the communications traffic on the LONWORKS bus by just allowing critical generator control functions to occupy that bus. This improves system reliability and performance.

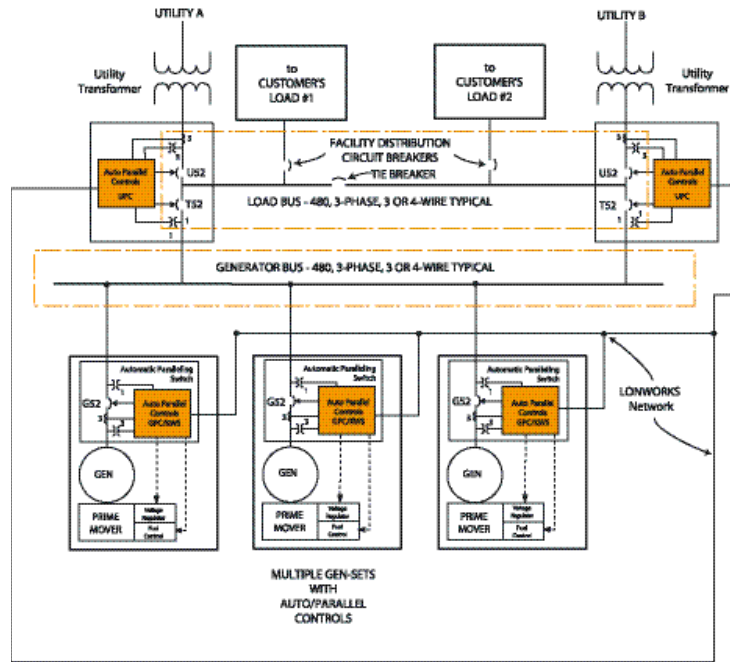

Figure 16: Control System Architecture

## 6.2 Data Acquisition Layer

The controls are also a critical part of the data acquisition layer. The primary purpose of this layer is to gather data from the controls and other sources of important data quickly. This data can then be consumed by applications and other systems. The most common system that is used in conjunction with data monitoring is traditional supervisory control and data acquisition (SCADA) packages.

These SCADA systems usually include:

- Historical trending servers to store larger amounts of data for later historical analysis and regulatory compliance (i.e., AQMD [Air Quality Management District], Joint Commission on Accreditation of Healthcare Organizations [JCAHO])
- Alarming servers to facilitate the immediate response to the systems' alert conditions
- Graphical display packages that represent the system in a logical, easy-to-use visual format via Web screens, on-site touch screens, or graphical applications on a workstation computer.

Building management systems (BMS) are another example of a downstream system that consumes data from the data acquisition system to make decisions about managing the building, based on what is going on with the power systems. This interaction is a very important feature of the Advanced Controller because it enables a building to coordinate demand response programs, which can greatly reduce a facility's overall cost of electricity (by removing peak loads from the electric power grid).

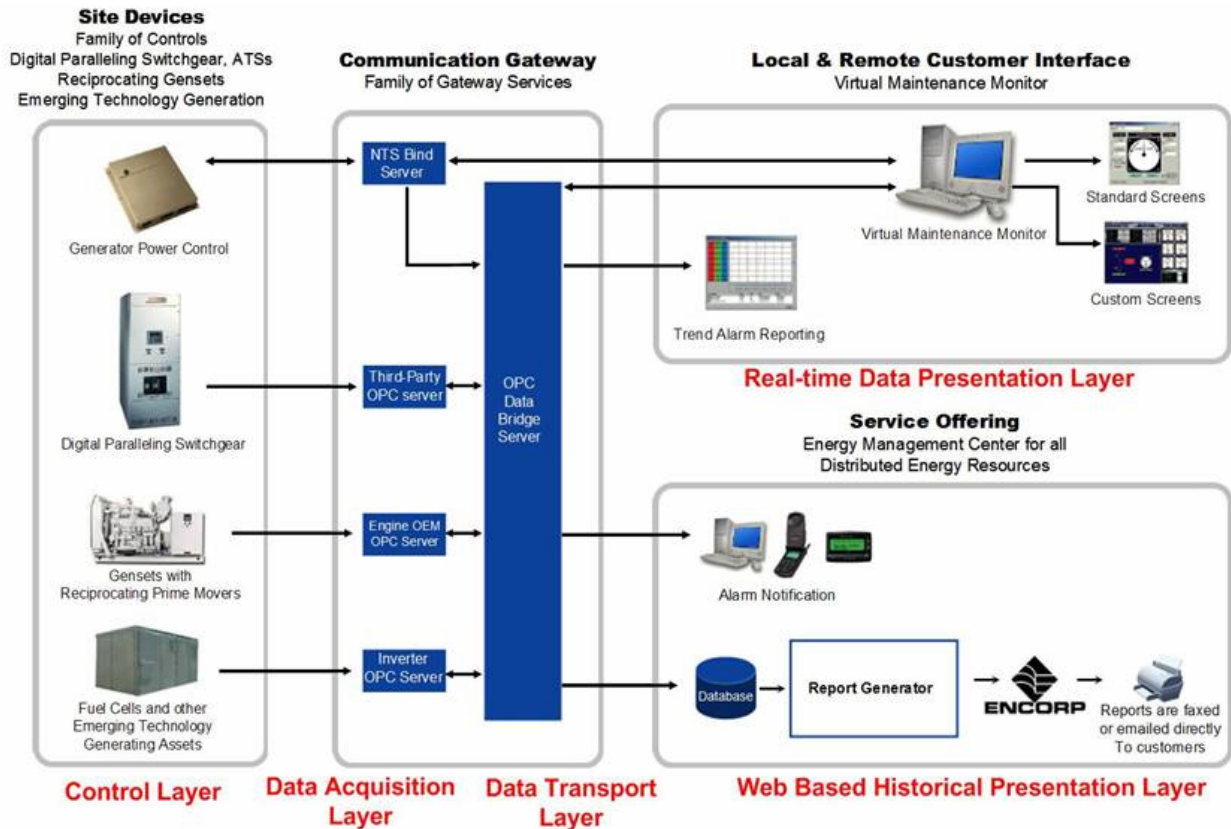

**Figure 17: The Data Acquisition System**

The data acquisition system must be very robust to ensure that operators can monitor equipment during times of critical operations. Also, because the data acquisition system is feeding other applications and downstream systems, speed and stability are always design considerations. Figure 17 is a system-wide example of the data acquisition system.

One of the challenges that were successfully overcome while developing the Advanced Controller was improving the performance and reliability of the data acquisition layer. This was successfully achieved by two major improvements to the Advanced Controller. The first improvement was separating the control layer communications from the data acquisition layer communications. Prior to this contract work, both layers utilized the LONWORKS network for messaging, which could lead to major slow downs on large systems. The Advanced Controller continues to use LONWORKS for inter-controller (inter-generator) communications, but has offloaded the data acquisition traffic to one of several different communications busses, the most common being high-speed Ethernet. The other improvement is the addition of the other communications busses, including four high-speed serial ports (with Modbus remote terminal unit (RTU) support and master/slave capabilities), two CAN bus ports and the aforementioned Ethernet port.



## 7. Appendix C: Advanced Controller Design

The purpose of this section is to explain in detail all the features and assets of the Advanced Controller developed as part of this contract. Throughout this section, design considerations and challenges that were successfully overcome will be highlighted. The Advanced Controller can be best explained in three separate parts:

- Hardware
- Firmware
- Support systems and software.

Though the Advanced Controller is divided into these three separate parts, be assured that the interaction between these different tiers is seamless and goes well beyond the necessary system speed requirements.

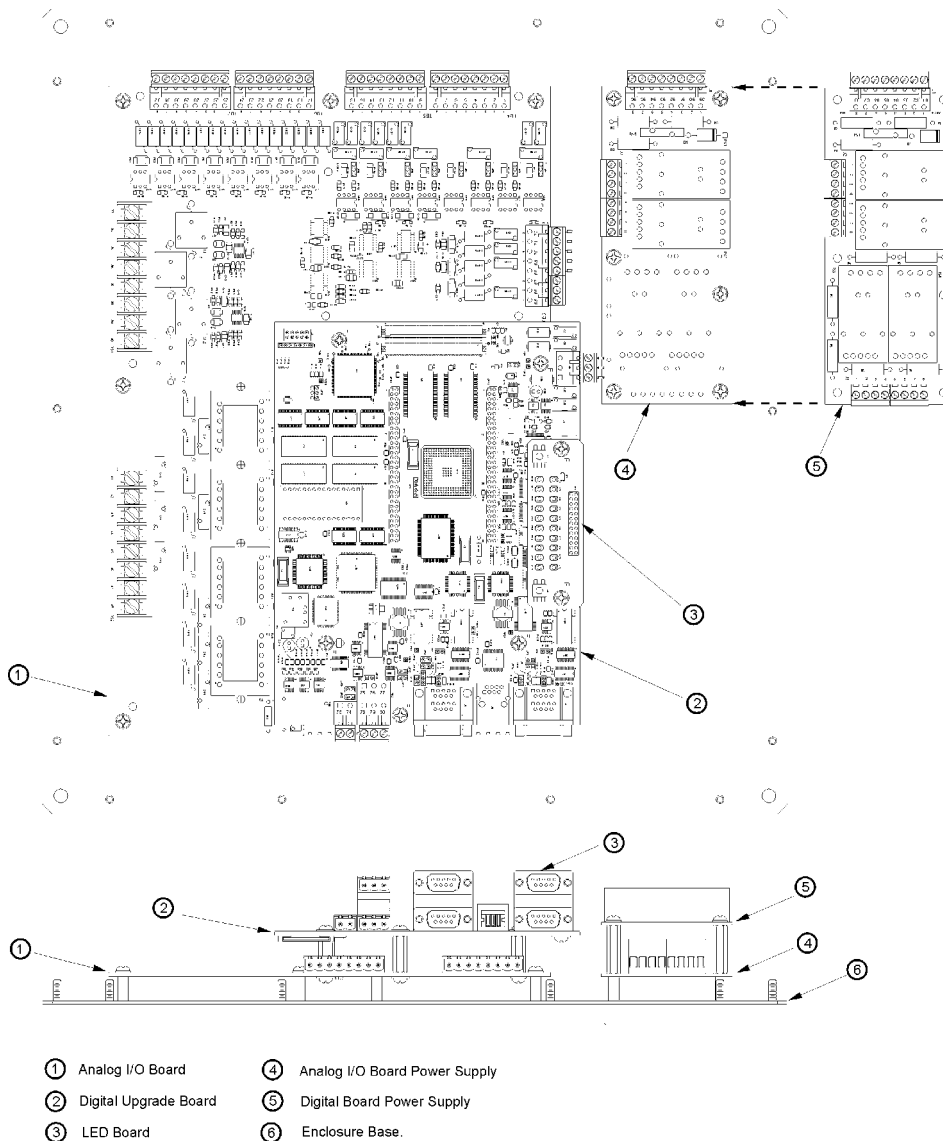
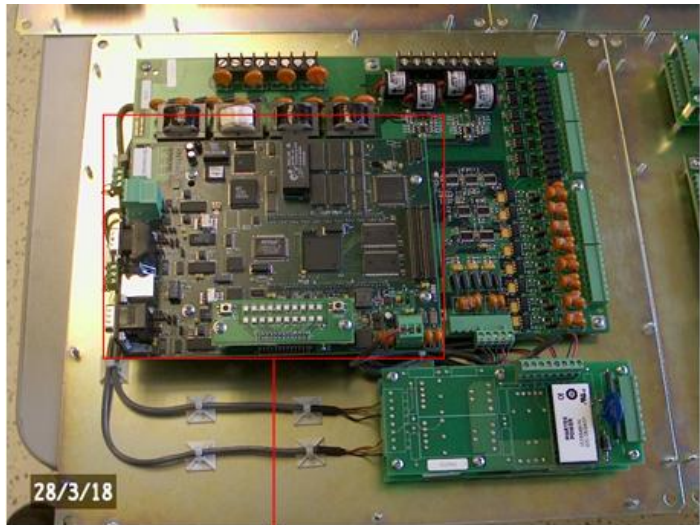

**Figure 18: Advanced Controller Hardware**

## 7.1 Hardware

The Advanced Controller hardware is composed of five major components, the digital upgrade PCA, the analog I/O PCA, the light emitting diode (LED) PCA, the power supplies PCA and the electronics packaging. Refer to Figure 18 for a diagram of these parts. Except for the Analog I/O PCA, these major components are either new designs or modified versions of the original controller platform.

The digital upgrade PCA is a new design that increases computation performance, adds increased communications connectivity, and provides enhanced field upgrade, mass storage, and data logging capabilities.



- New digital board**
- Top board on the control
  - “Brains” of the control

**Figure 19: Digital Upgrade PCA Board**

The computational performance was increased over the original control by adding a higher performance main processor, the MPC555 running at 40 megahertz (MHz) and a higher performance Neuron processor, the FT3150P-20 running at 20 MHz. The communications connectivity was increased by the addition of three serial ports (for a total of four), two CAN ports and a 10/100 Base-TX Ethernet port. The four serial ports are two each of RS-232 and RS-485 (2-wire or 4-wire). Field upgrade, mass storage, and data logging capabilities are facilitated using a removable Secure Data Multi-Media flash card. Refer to Figure 19 for a picture of the top of the Digital Upgrade PCA board.

Analog and I/O functionality is maintained by connecting the digital upgrade PCA to the current analog I/O PCA through the same connector used on the original control. The Advanced Controller has no additional analog or I/O functionality beyond that of the original GPC.

The LED PCA indicates the status of several electronic subsystems within the analog I/O and digital upgrade PCAs. It is mounted to the digital upgrade PCA via a 26-pin dual row connector. The LEDs are visible with the enclosure top cover installed. The RESET and LON Service switches are accessible with the enclosure top cover installed, improving the field maintenance of the Advanced Controller.

The electronics packaging is similar to that of the original controller, except that all terminal blocks, I/O connections, LED indicators, and the memory card are accessible with the enclosure



top cover installed. This also improves the field maintenance capabilities of the Advanced Controller. Figure 20 shows an example of the improved accessibility of the Advanced Controller. These hardware changes are major improvements for overall maintenance and on-site monitoring of the controller.

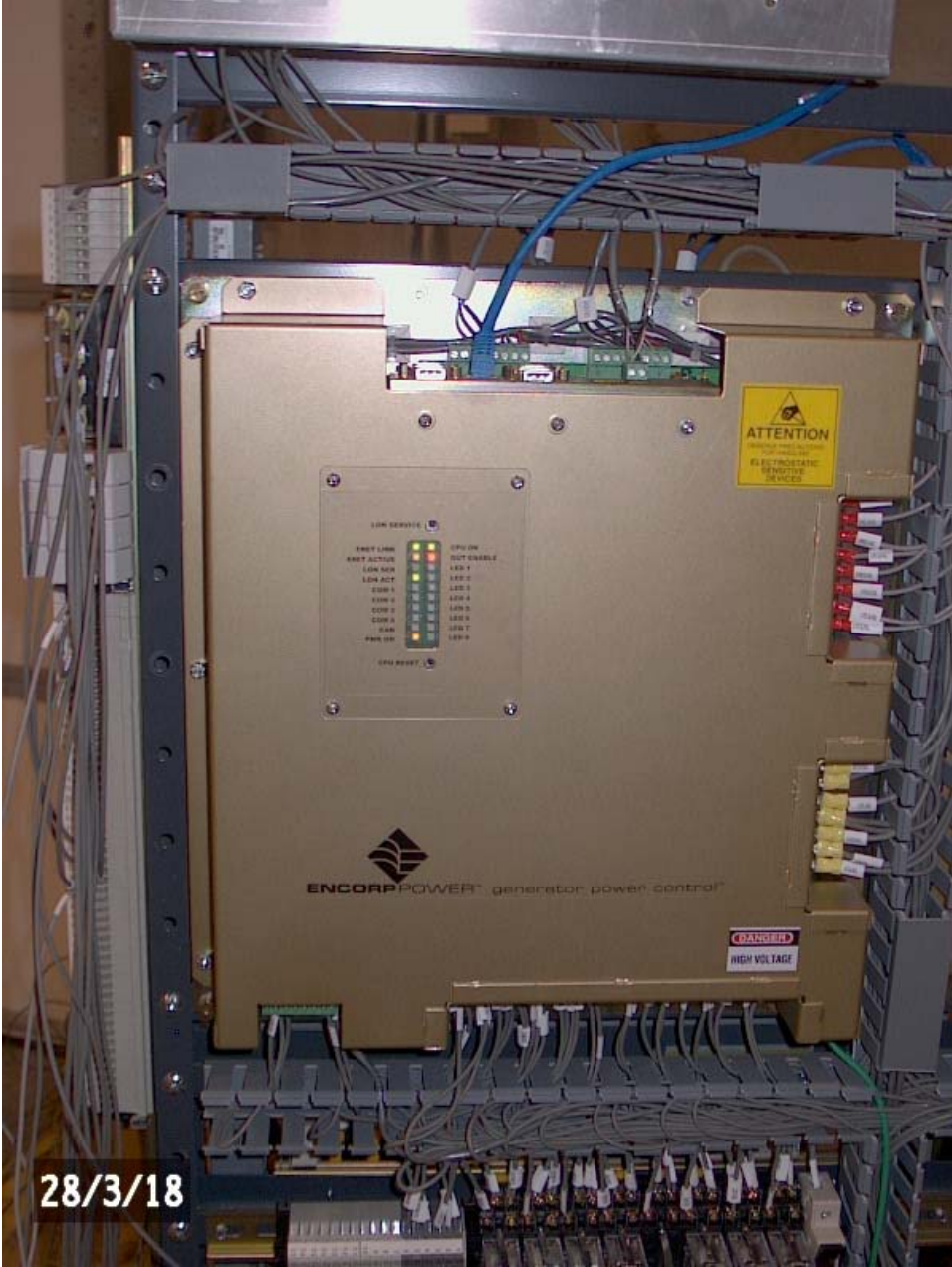
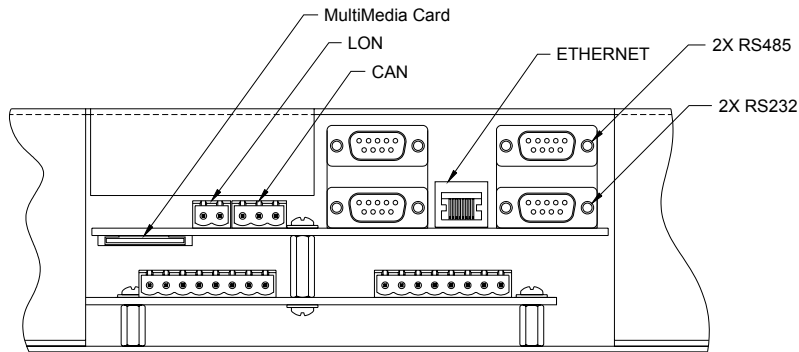

Figure 20: Improved Accessibility of Advanced Controller

### 7.1.1 Communications

For the Advanced Controller communications ports layout, refer to Figure 21.



**Figure 21: Communications Ports Layout**

#### Serial Communications

The GPC has four serial interfaces located on the digital board:

- Two optically isolated RS-232 ports, which are designated COM1 and COM3. These two ports are isolated from the core electronics, as well as from each other. The physical connector for each RS-232 port is a standard DB-9 male.
- Two optically isolated RS-485 ports, which are designated COM2 and COM4. These two ports are isolated from the core electronics, as well as from each other. The physical connector for each RS-485 port is a standard DB-9 male.

The serial interfaces are used for local user interfaces, programmable logic controller (PLC) monitoring, I/O expansion, remote monitoring, SCADA connection, bus-enabled revenue grade metering, and GPS receivers. The serial interfaces do not share a common ground for isolation purposes. The serial interfaces support the following features:

- Serial transmit and receive data only
- Two dedicated RS-232 and two dedicated RS-485, configurable for RS-485 2-wire or 4-wire operation
- 8 bit character size
- 1 or 2 software-programmable stop bits
- Baud rates of 4800; 9600; 19200; 28800; 38400; 57600; and 115,200
- Activity LED indicating that the controller is sending or receiving messages
- Self-powered
- 1000 volts root mean squared (VRMS) isolation to ground
- 700VRMS isolation between channels
- On-board jumper-selectable termination
- Jumper-selectable bias resistors for RS-485 multi-drop mode.

## **Ethernet**

The GPC has one Ethernet local area network (LAN) port located on the digital board PCA. The Ethernet interface operates at either 10 (megabits per second) Mbps or 100 Mbps, and supports the following features:

- Full Modbus TCP support
- Full or half duplex capability at 10 Mbps or 100Mbps
- 100BASE-TX physical interface that complies with IEEE 802.3
- Activity LED status indicator for transmit or receive activity
- Link OK LED status indicator for valid link connection
- RJ-45 connector physical interface (transformer isolated with a minimum 1500 VRMS isolation to meet IEEE 802.3)
- Communication error detection and indication built into the ISaGRAF workbench network communications setup
- Dynamic security to prevent damage in the event of a denial of service attack.

## **Echelon LONWORKS Port**

The LONWORKS network is used for communication between advanced controls and other devices. The LONWORKS implementation is also compatible with third-party products and network management tools. The Advanced Controller has one LONWORKS port located on the digital board. LONWORKS support includes software to provide automatic binding of system control object (SCO) variables for digital load sharing and communications without the need for a LONWORKS binding tool. The LONWORKS interface includes the following features:

- Activity LED that will turn on whenever the controller sends or receives messages
- Service Indicator LED
- Service pin switch used to trigger the control to broadcast a service message
- High-performance neuron processor running at 20 MHz
- Ability to withstand 1000 VRMS dielectric strength test for 1 minute
- LONWORKS software subsystem.

## **Controller Area Network (CAN) Ports**

The CAN ports were added to the Advanced Controller for future expandability. One port that has already been tested with a prototype version is dedicated to Encorp's Power Sensor Module (PSM). The other port was added in anticipation that it can be used to communicate with various engines in the future because CAN is a very popular communications medium on engines.

## 7.2 Firmware

The Advanced Controller can be deployed as a generator power control (GPC), which would control various DG types or a utility power control (UPC), which would coordinate system activity based on parameters being monitored from a facility's utility power entrance. The Advanced Controller utilizes a real time operating system (RTOS) to ensure reliability, stability, and enhanced security.

The same firmware is installed on all GPC and UPC controls. Functionality is determined entirely by the application program that is installed in the control.

The firmware includes the following features and functionality:

- ISaGRAF Embedded PLC software module, IEC 61131-3 Programming Languages
- Programmable, separately isolated switch inputs and solid-state relay driver outputs
- Setup and configuration with standard PC (no handheld programmer required)
- Embedded Web server
- Support for both Modbus client and server, allowing Modbus I/O expansion
- Manage and upgrade applications from offsite locations
- Upgradeable firmware
- Single point communications connection for application tools
- Single tool for application installation, configuration and test
- High-speed download of ISaGRAF applications
- High-speed data access and control through the ISaGRAF OPC server.

One of the main functions of the GPC embedded firmware is to support the ISaGRAF PRO Virtual Machine software environment. ISaGRAF PRO is a third party embedded software technology that supports open distributed control applications in a networked environment. The runtime target or Virtual Machine is an execution engine that runs on the Encorp platform and provides the application framework for the system. The Virtual Machine is downloaded and debugged from a PC application called the ISaGRAF PRO Workbench. The Workbench supports the five IEC 61131-3 programming languages (Structured Text, Sequential Function Chart, Flow Diagram, Ladder Logic, Instruction List), which provide the required flexibility for the application space.

The embedded firmware provides hardware drivers to interface the local hardware to the ISaGRAF PRO Virtual Machine. Local hardware support includes discrete inputs, discrete outputs, frequency bias output, voltage bias output, load share, potential transformer inputs, and current transformer inputs. Advanced digital signal processing is implemented for the potential transformer and current transformer inputs to provide true RMS power information, including harmonics.

ISaGRAF application function blocks support synchronizer, automatic transfer switch and import/export control, kW and kVAR load-sharing control with soft loading and unloading, base-load control and reactive power/power factor (VAR/PF) control.

### 7.2.1 ISaGRAF Embedded PLC

The Advanced Controller utilizes the ISaGRAF software environment from ICS Triplex. This environment includes two main components:

- Virtual Machine – a software engine that executes control algorithms on the Advanced Controller
- Workbench - a powerful application development environment for configuring all the elements of the Advanced Controller

#### Virtual Machine

When the Advanced Controller is built, a Virtual Machine (VM) is loaded into the embedded RTOS. This VM acts as an embedded PLC that runs target independent code (TIC) that has been generated by the Workbench.

#### Workbench

The ISaGRAF Workbench is the environment that allows development of multi-process control applications that run on the VMs of the Advanced Controller. The development process consists of creating projects made up of configurations that represent individual target nodes, on which one or more resources are downloaded. At runtime, the resources run on these target nodes.

Resources can be programmed using any of the five languages of the IEC 1131-3 standard:

- **Sequential Function Chart (SFC)**- a graphic language used to describe sequential operations. The process is represented as a set of well-defined steps, linked by transitions. A Boolean condition is attached to each transition. A set of actions is attached to each step. Conditions and actions are detailed by using other languages (ST, IL or LD). From conditions and actions, any function or function block in any language can be called.
- **Function Block Diagram (FBD)** - a graphic language that allows the programmer to build complex procedures by taking existing functions from the standard library or from the function or function block section.
- **Ladder Diagram (LD)** - a graphic representation of Boolean equations, combining contacts (input arguments) with coils (output results). The LD language enables the description of tests and modifications of Boolean data by placing graphic symbols into the program chart. LD graphic symbols are organized within the chart exactly as an electric contact diagram. LD diagrams are connected on the left side and on the right side to vertical power rails. These are basic graphic components of an LD diagram:
  - Left vertical power rail
  - Right vertical power rail
  - Horizontal connection line
  - Vertical connection line
  - Multiple connection lines (all connected together)
  - Contact associated with a variable
  - Coil associated to an output or to an internal variable

- **Structured Text (ST)** - is a high-level structured language designed for automation processes. This language is mainly used to implement complex procedures that cannot be easily expressed with graphic languages. ST language can be used to describe the actions within the steps and conditions attached to the transitions of the SFC or the actions and tests of the FC Language.
- **Instruction List (IL)** – is a low level language. Instructions always relate to the current result (or IL register). The operator indicates the operation that must be made between the current value and the operand. The result of the operation is stored again in the current result.
- **Flow Chart (FC)(language)** – a graphic language used to describe sequential operations. An FC diagram is composed of actions and tests. Between actions and tests are oriented links representing data flow. Actions and tests can be described with ST, LD, or IL languages. Functions and function blocks of any language (except SFC) can be called from actions and tests. An FC program can call another FC program for more complex operations. The called FC program is a subprogram of the calling FC program.

Resources are compiled to produce the TIC that the VMs will execute. Within the resources, variables are declared using simple types (Boolean, integer, real, string, and timer) or user-defined types such as arrays or structures, for defined variables, set up alarms, events, and trending. Furthermore, field communications connect variables to field equipment. Resources can share variables using a binding mechanism, develop projects on a Windows operating system development platform, using the project manager and language editors. Individual resources, from the configurations making up a project, are downloaded, using the ETCP network, onto target nodes running real-time operating systems. Communication between configurations can be implemented using the TCP/IP or any other network.

This tool also supports the ability to simulate running a project, using high-level debugging tools, before actually downloading configurations to the target nodes. This feature saves an abundance of time and money by allowing engineers to do simulated test runs of their control algorithms before going into the field.

The Workbench has powerful self-documenting capability. This feature allows the engineer to configure what elements of the project to be included in the final documentation and then the Workbench automatically builds a complete, coherently grouped document with all the selected information and a history of all the project modifications. This self-documenting feature saves time and money in the design and maintenance phases of projects.

### 7.2.2 Function Blocks

The Advanced Controller replaces the large number of external analog devices found in traditional switchgear cabinets with a single control that implements the same functions in software. The Advanced Controller retains the familiar distinction between devices by replacing each physical device with a corresponding software function block. The function blocks are wired together in software using the IEC 61131-3 programming languages.

The following is a list of some of the major function blocks that were designed as part of this contract and are built into the Advanced Controller.

- **Automatic Transfer Switch (ATS)** – This function block provides full ATS functionality. The ATS object can be operated as a soft transfer closed transition or an open transition transfer switch. It also has inputs to test the system (to simulate a utility outage) and to override the retransfer time delay and switch back to utility.
- **KW Control** – The KW control is used to control generator load in a multi-unit load sharing system. Several control options are available, including droop, load sharing, and baseload. The KW Controller in the KWS can also be used in client mode to a server UPC controller for import/export and baseload control when in parallel with the utility. The KWS Real Power Control provides closed loop proportional control of a generator's real power when it is paralleled to the utility.
- **KVAR/PF Control** - PF sharing, KVAR/PF control and voltage droop control modes will be supported in this block. Power control (QPC) provides closed loop control of generator reactive power in both bus and generator parallel operation. In bus parallel operation, either VAR or power factor control may be selected. In generator parallel operation it provides proportional VAR sharing and all units will cooperate in maintaining bus voltage at the specified level. In the generator parallel state, the QPC will share load with other GPC controls. In client mode, the KVAR/PF control will accept a VAR or PF reference signal from a UPC. The client control mode will be proportional and will not control bus voltage. The QPC is also available to accept remote voltage bias signals from a UPC for synchronizing the bus to the utility. Additionally, the voltage trim function may be used in this mode. In power factor control mode, the QPC tries to maintain a constant power factor, which means that the reactive power flow (VARs) will change proportionally with the amount of load on the generator.
- **Utility Real Power Control** - provides control of the utility power when the generators are paralleled to the utility by providing control signals to its other GPC controls. The UPC can send this master control signal to the GPC controls in several ways, depending on the desired KWS control operation. Baseload control, import/export control, process control, and ramp functions are also provided.
- **Utility KVAR/PF Control** - The Utility VAR/PF Controller provides closed loop control of utility reactive power. Either VAR or Power Factor control may be selected. The UPC reactive power control provides closed loop proportional, integral and derivative (PID) control of generator's reactive power when they are paralleled to the utility by providing signals to the GPCs. The GPC causes a change in the Voltage Regulator setpoint that will ultimately change the amount of excitation in the generator. When the generator is paralleled to the utility, the generator voltage is set by the utility. So, a change in generator excitation results in a change in the reactive power load on the generator. A reactive power GPC control will not attempt to regulate bus voltage.

- **Circuit Breaker Controller** - The circuit breaker control (CBC) object is a generic object designed to control a circuit breaker or a contactor. The CBC has momentary outputs to close and open the circuit breaker. The CBC also has a maintained output for control of a contactor for those applications containing a contactor instead of a circuit breaker. The CBC controls how long to hold the close output and open outputs on, to allow the breaker to close or to open. The CBC limits the number of close attempts as well as the minimum amount of time between close attempts. The CBC senses generator current and provides a fault output if the CBC sees generator current when the breaker/contactor is open. This indicates a breaker problem or that the auxiliary contact on the breaker/contactor has failed. The close input typically comes from the synchronizing relay and/or ATS blocks.
- **Auto Synchronizer Relay (25A)** - The synchronizer will provide synchronization control of either the generator or system. The Sync-Check Relay tests for proper voltage and phase conditions and initiates circuit breaker closure. Synchronizing functions are provided to ensure closure to the grid only when frequency, phase, and voltage are matched. The parameters for allowable frequency, phase, phase slip rate, and voltage are configurable within certain ranges to allow for adjusting the closure tolerances.
- **Engine Sequence Control** - The engine sequence control will provide basic start and stop control for a typical diesel or gas engine. The engine sequence control shall provide inputs for engine alarm and shutdown conditions, as well as lube pump cycle timing and purge cycle and cool down timing.
- **Energy Meter** - The E Meter will be designed to provide demand, power, and runtime information based upon ASHRAE standards documentation.
- **51V Voltage Restrained Overcurrent Curves** - A set of voltage restrained overcurrent curves will utilize three phase voltage and current inputs to calculate the time to overcurrent trip, based upon the selected curve. Curve selection will be through a configurable integer input to the object. Standard inverse time curves that comply with IEEE c.37-112 1996 will be supported in this object.
- **LONWORKS** - The product will support the use of LONWORKS to transmit messages between controllers.
- **Modbus I/O** - The Advanced Controller is capable of supporting multiple Modbus I/O devices with mixed address types using Modbus RTU protocol.
- **Calibration Function Block** – Provides offset and gain adjustments, which can be manipulated at run time by the user to actively adjust the operating range of analog inputs and outputs as needed.



### **7.3 Advanced Controller Support Software**

The purpose behind the applications that are included in the Advanced Controller's Support Software was to make the design, testing, deployment, and maintenance of DG projects that utilize the Advanced Controller as simple and intuitive as possible. Two applications are included in this category: the GWE and the Advanced Controller Commissioning Tool.

#### **7.3.1 GWE**

The GWE is a software tool that extends the functionality of the ISaGRAF Workbench to better meet the needs of the engineers that will be deploying the Advanced Controller. It provides additional support for some internal business processes and operations workflow processes. Some of the additional functionality that it includes is archiving project files, tracking project file versions, and adding security for the Advanced Controller's FTP server.

#### **7.3.2 Advanced Controller Commissioning Tool**

The Advanced Controller Commissioning Tool is a software application that was designed to provide assistance with the tasks surrounding the commissioning of a DG site using the Advanced Controller. The main functionality that this application delivers includes:

- Present aggregate real-time display data from the GPC.
- Allowing easy entry and display of most setup parameters
- Providing descriptive text for each control variable, and a comprehensive context sensitive help system
- Real-time trending for debugging system dynamics, including basic mathematical operations.

## **8. Appendix D: Prototype Power Sensing Board**

The power sensor module (PSM) design is a stand-alone intelligent module powered by high-power DSP technology. The primary purpose of this module is to interface with multiphase voltage (potential) and current transformer (PT and CT) inputs. This module will perform extensive signal processing and management of the input information and transfer the resulting values to the controller module. This encompasses various electric power issues related to real and reactive power as well as harmonics.

In addition, this module contains relay outputs for circuit breaker close/open control, digital inputs for auxiliary contact feedback, and solid-state digital outputs for relay targets or secondary circuit breaker control.

The prototype PSM module design has sufficient memory to allow up to 64 cycles of waveform information to be buffered to support an event-reporting application. In addition, the power sensor module software will perform several high-speed protective relay functions (e.g., over/under voltage [27/59], over/under frequency [81 O/U], sync check [25], and loss of synchronism relay [78]).

The following parameters will be measured and provided by the PSM design on all four phases.

**Table 1: PSM Measured Parameters**

Voltage RMS	V, selectable L-N or L-L
Current RMS	A
Watts RMS	P
True Power Factor	PF
VA RMS	$S = V * A$
VAR RMS	Q
Displacement PF	DPF
Fundamental W	P1
Fundamental VA	S1
Fundamental VAR	Q1
Voltage phase angle	Radians, relative to DFT window
Voltage harmonics	32nd, on demand
Current harmonics	32nd, on demand
Voltage total harmonic distortion	V THD
Voltage total odd harmonic distortion	V TOD
Voltage total even harmonic distortion	V TED
Current total harmonic distortion	I THD
Current total odd harmonic distortion	I TOD
Current total even harmonic distortion	I TED

The following parameters are provided by the PSM design on three phases:

**Table 2: PSM Three Phase Parameters**

Equivalent system voltage	$V_e = \sqrt{(V_a^2 + V_b^2 + V_c^2)} / 3$
Equivalent system current	$I_e = \sqrt{(I_a^2 + I_b^2 + I_c^2)} / 3$
Total W	$P_t = P_a + P_b + P_c$
System VA	$S_e = 3 * V_e * I_e$
Total VAR	$Q_t = Q_a + Q_b + Q_c$
Total true PF	$PF_t = P_t / S_e$
Total fundamental W	$P_{1t} = P_{1a} + P_{1b} + P_{1c}$
Total fundamental VA	$S_{1t} = S_{1a} + S_{1b} + S_{1c}$
Total fundamental VAR	$Q_{t1} = Q_{1a} + Q_{1b} + Q_{1c}$
Total displacement PF	$dPF_t = P_{1t} / S_{1t}$
Negative sequence voltage	$V_{2a} = 1/3 (V_a + a^*V_b + a^{2*}V_c)$ , where $a^*$ is the 120 degree vector operator and $a^{2*}$ is the 240 degree vector operator.
Positive sequence voltage	$V_{1a} = 1/3 (V_a + a^{2*}V_b + a^*V_c)$
Zero sequence voltage	$V_{0a} = 1/3 (V_a + V_b + V_c)$
Voltage sequence imbalance	$V_{2a} / V_{1a}$
Negative sequence current	$I_{2a} = 1/3 (I_a + a^*I_b + a^{2*}I_c)$
Positive sequence current	$I_{1a} = 1/3 (I_a + a^{2*}I_b + a^*I_c)$
Zero sequence current	$I_{0a} = 1/3 (I_a + I_b + I_c)$
Current sequence imbalance	$I_{2a} / I_{1a}$

The PSM design has several digital and relay outputs. These will enable control of external lamps and relays — including the ability to actuate high-current relays. This will be done while ensuring compliance with industry-recognized high-voltage isolation capability.

The PSM board design contains various PT inputs with the following properties:

- Nominal 120 V AC with a range of 40 V AC to 150 V AC
- Accuracy of  $\pm 0.25\%$  over temperature and time
- Maximum 0.2 VA burden at 120 V.

The PSM board design contains CT inputs with the following properties:

- Nominal 5 A with a maximum of 7 A
- Withstand 20-A continuous current
- Withstand 300-A transient current for 1 second
- Accuracy of  $\pm 0.25\%$  over temperature and time
- Maximum 0.2 VA burden at 5 A.

The IEEE 1547 draft standard establishes criteria and requirements for interconnecting distributed resources with electric power systems (EPSs). Protective relay functions are planned to comply with all requirements of this standard. The PSM design performs a minimum set of critical high-speed protective relay functions including:

- Under voltage/over voltage relay (three phase/one phase) (27/59)
- Frequency relay (81 O/U)
- Out-of-step protective relay (78)
- Synchronism check device (25).

Other functions can be incorporated, as needed, within the PSM or controller module.

The specification for each function follows:

#### **Under Voltage/Over Voltage Relay (Three Phase/One Phase) (27/59)**

The U/O voltage protection function will measure the effective (RMS) or fundamental voltage value of each phase-to-neutral or, alternatively, each phase-to-phase voltage. When the measured voltage is less than a minimum percentage set point or greater than a maximum percentage set point of base voltage (nominally 120 V), the PSM will issue a breaker open command through one of the high-speed relay outputs. These set points shall be adjustable to a minimum range of 50% to 120% of base voltage. The maximum time from the start of the abnormal condition to the relay contact output will be 48 milliseconds (ms).

Clearing time is the time between the start of the abnormal condition and the DP ceasing to energize the area EPS. Note that this time includes any delay in the circuit breaker or other interconnect device, so clearing-time adjustments must account for this delay — placing further emphasis on the need for high-speed detection and recognition. The voltage and clearing time set points will be field adjustable so an operator can specify different voltage settings or trip times to accommodate system requirements. Field-adjustable settings will be protected against unauthorized adjustment.

### **Frequency Relay (81 O/U)**

The PSM will follow the interconnected area EPS frequency within the range 59.3 hertz (Hz) to 60.5 Hz (on a 60-Hz base). At a minimum, the over/under frequency (81 O/U) protective relay will be adjustable between 57 Hz and 60.5 Hz. The maximum time from the start of the abnormal condition to the relay contact output will be 48 ms.

Clearing time is the time between the start of the abnormal condition and the DP ceasing to energize the area EPS. Note that this time includes any delay in the circuit breaker or other interconnect device, so clearing time adjustments must account for this delay. The frequency and clearing time set points will be field adjustable so an operator can specify different frequency settings or trip times to accommodate system requirements. Field-adjustable settings will be protected against unauthorized adjustment.

### **Out-Of-Step Protective Relay (78)**

Synchronous generators in applications with a stiffness ratio of 20 or less will be equipped with loss of synchronism (out-of-step) protective functions to isolate the DP from the area EPS without any intentional time delay. The solution to be implemented is described in “A Study Into a New Solution for the Problems Experienced With Pole Slipping Protection” by M.A. Redfern and M.J. Checksfield (*IEEE Transactions on Power Delivery*, Vol. 13, No. 2, April 1998).

### **Synchronism Check Device (25)**

The sync check device shall be adjustable to the following:

- Frequency difference ( $\Delta f$ , Hz), maximum of 0.1 Hz [Target +/- 0.01 Hz]
- Voltage difference ( $\Delta V$ , %), maximum of 3% of the base voltage [Target +/- 0.25%]
- Phase angle difference ( $\Delta \varnothing$ , °), maximum of 10% [Target +/- 1 degree].

Additional functions and protective relays that are implemented in the Power Sensor Module include:

- Anti-islanding relay (passive, or in conjunction with the Advanced Controller active anti-islanding signals)
- Directional Power (32) Relays
- Negative Sequence Current (46) Relays
- Negative Sequence Voltage (47) Relays
- Instantaneous Over Current (50P, N) Relays
- Over Current Relays (51P, N)
- Protective Relay Programmable Logic
- Circuit Breaker Controllers

## 9. Appendix E: Communications

### 9.1 Evolution of Communications Standards

The primary goal of communications standards is interoperability. Communications standards evolved primarily in the 1970s and 1980s. Because of the topology of various communication methods, many specialized communications protocols were developed for different application domains. In fact, in the 1990s, virtually every technical domain was represented by its own communications standards effort. The result was a cornucopia of standards that were domain specific. That is, the communications standards, besides providing for the generic goal of exchanging information, contained semantics and architectural elements that recognized specific industry requirements. An example of this is distributed network protocol (DNP), which recognized the “freezing” of data measurements in its communications services model. The advent of wide area network (WAN) connections to local area networks (LANs) introduced a new obstacle to interoperability. That is, the scope of applications evolved to overlap domains.

The following figure illustrates the relative complexity (and implicitly, relative cost) versus the capability of several application layers in communications protocols. The protocols shown in the figure are all suitable for interoperable exchange of measurement and control information such as a switch position (i.e., on/off).

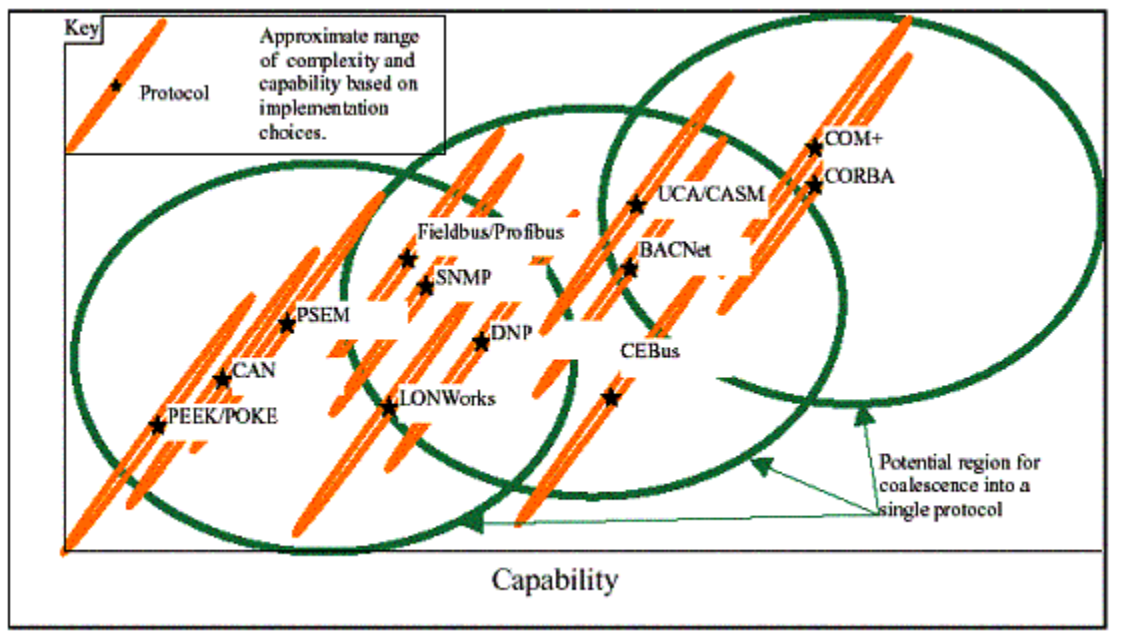

Figure 22: Relative Complexity and Capability of Communication Standards (Burns, et al.)

**Key:**

BACnet	ANSI/ASHRAE 135 protocol for Building Automation and Control Networks
CAN	Control Automation Network
CEBus	Electronic Industry Associations Consumer Electronic Bus, EIA 600
COM+	Microsoft Distributed Object Model
CORBA	Object Management Group Distributed Object Model
DNP	Distributed Network Protocol
Fieldbus/Profibus	Industrial control network
LONWORKS	Echelon's Local Operating Node communications protocol
PEEK/POKE	Metaphor for Basic programming language memory manipulation instructions
PSEM	Protocol for Electric Meters, ANSI C12.18, ANSI C12.19
SNMP	Internet Engineering Task Force's Simple Network Management Protocol RFC 1156/ RFC1157
UCA/CASM	EPRI Utilities Communication Architecture Common Application Services

## 9.2 Implications of Communication Standards Situation

Given the complexity of the communications landscape, it is imperative for the new controller design to incorporate sufficient capability and flexibility to accommodate historic communication protocols and practices as well as evolving developments (in terms of standards, devices, and methods).

A number of communications capabilities have been identified that would allow the controller to interface with higher-level systems for uses such as monitoring, display and analysis, remote dispatch, metering, billing, and alarming. Expanded communication capabilities are also desired for interface with other low-level devices for low-cost I/O, displays, and other original equipment manufacturer (OEM) controllers. Features included in the controller to support communications include:

- 100 Base-TX Ethernet with TCP/IP stack for high-level, high-speed communications
- CAN/DeviceNet (2 channels) for low-level, high-speed communications
- LONWORKS for low-level, long distance communication
- RS-232/485 (2 channels) for serial communications (Modbus will use one of these channels).

TCP/IP networking support will be provided with the RTCXnet network communication suite. The network communication suite is fully integrated with the RTXC kernel. The networking support will include TCP/IP, UDP, Address Resolution Protocol (ARP), Internet Control Message Protocol (ICMP), Domain Naming System (DNS) client, Dynamic Host Configuration Protocol (DHCP) client, Telnet, and Point-to-Point Protocol (PPP).



## 10. Appendix F: Task 5 Prototype Demonstration

To document the first-hand market issues with the interconnection and communications of DP systems, a system case study was done on the Chowchilla II power generation station in Chowchilla, California. Encorp Inc. designed the controls and switchgear system for this complicated plant. The implementation of Chowchilla II is a prototype version of some of the features and functions that would be implemented on the production version of the Advanced Controller being developed. This prototype hardware is not integrated in the same manner as planned on the Advanced Controller but serves as a model for the capabilities that would be integrated into the Advanced Controller.

### 10.1 System Overview

The Chowchilla II power plant is a 48-MW facility powered by 16 Duetz natural gas-fueled generator sets operating in parallel with the local utility.

The plant is owned by NRG Energy. The power facility, although located in California, is dispatched by from offices in Minneapolis, Minnesota. The plant is dispatched based on receiving a call from PG&E or in response to area energy pricing signals. The California ISO monitors the facility to determine capacity effect and demand scheduling.

Individual generator power measurements are made by the Encorp GPCs in the system. The power data is gathered and ultimately passed up to the communications processing modules (CPMs) in each system and sent to NRG and the California ISO for their use. Figure 23 illustrates a typical two-engine pair located in the plant. In total, the facility has 16 natural-gas engines.

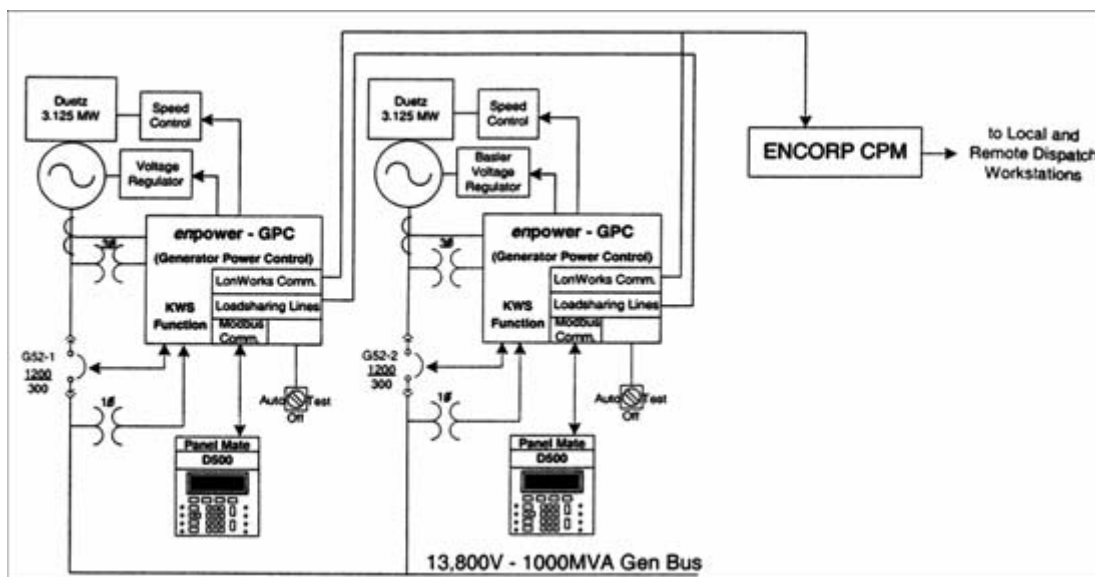

Figure 23: Typical Chowchilla II Two-Engine Configuration

As noted previously, the interconnection requirements for DP vary widely and typically entail more sophisticated and extensive protective relaying strategies for larger systems. Figure 24 illustrates the protective relaying scheme used in this application.

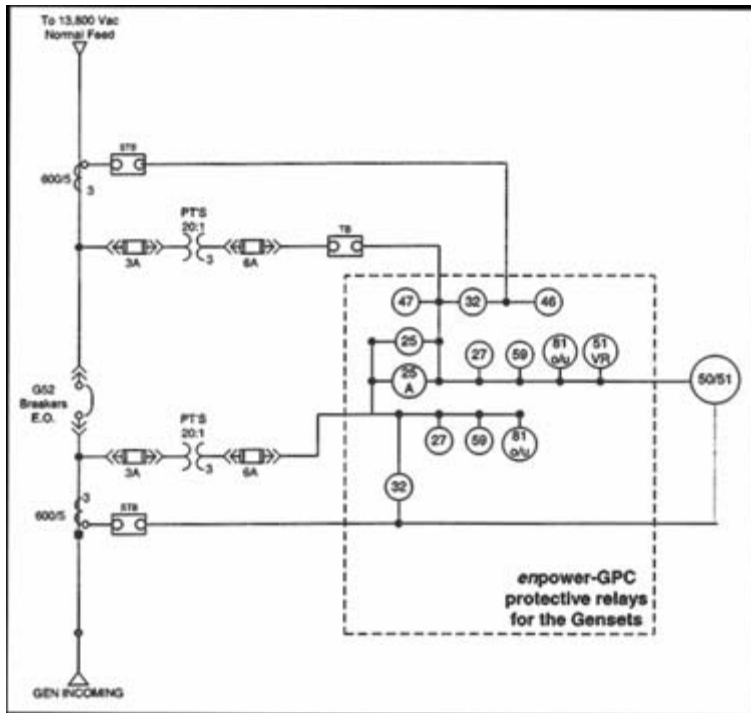

Figure 24: Chowchilla II Protective Relaying Scheme

The Encorp communications system at the Chowchilla power generation facility brings together various software, system, and network topologies. As a result of this effort, the following results are realized.

- **On-Site Generation Supervisory Control**  
Supervisory control of the on-site generation is provided by the Encorp UPC/GPC controls and the local or remote desktop workstation (DWS). Supervisory control includes remote/local system dispatch, alarm monitoring and trending, event trending, dial out alarm notification, local/remote generator power level settings, and system power-level monitoring.
- **Generator Status/System Status Monitoring**  
The Encorp controls allow local and remote monitoring of a multitude of generator and system data points. These points include:
  - Inlet/Exhaust temperature
  - Coolant temperature
  - Crank case pressure
  - Starting air pressure
  - Lube oil pressure (before and after filter)
  - Lube oil level

- Supply voltage
  - Throttle position
  - Engine speed (RPM)
  - Generator bearing temps
  - Generator winding temps
  - Generator inlet/outlet air temps
  - Combustion chamber temperatures
  - Gas valve positions.
- **Load Management Service**  
Because this site is used exclusively for supplementing the existing distribution capacity, load management is limited to the ability to adjust the base load reference of the individual generators from a local or remote location via the DWS. Generator power limits and active demand levels are also available at the local or remote DWS.
  - **Indoor Air Quality Monitoring**  
Indoor air temperatures are measured and ventilation fans are operated automatically from the Encorp UPCs, based on the facility's air temperature.
  - **Revenue Meter Reading**  
This site did not incorporate revenue meter reading in the Encorp system. Revenue meter reading was integrated into the ISO DPG hardware. However, the Encorp system is fully capable of receiving either real or pulse (KYZ) meter information and displaying the resultant demand information from those sources.
  - **Energy-Efficiency Monitoring**  
The Chowchilla power station did not require energy-efficiency monitoring. If, at some point in the future, the need for efficiency monitoring (heat rate versus kWh) is needed, the Encorp software could be easily modified to provide such information.
  - **Weather Reporting and Forecasting Services**  
There were no requirements for weather reporting or forecasting services data or I/O for the operation of the Chowchilla project.
  - **California ISO Data**  
Numerous monitoring and control points are sent from the Encorp communications system to the California ISO via the DPG. A listing of all these points can be found in the California ISO DPG Technical Specifications via the Web site at [www.caiso.com](http://www.caiso.com).

## 10.2 System Topology

The SCADA system at the Chowchilla power generation station is representative of Encorp's ability to design, configure, and implement complex communications schemes with distributed controls from numerous vendors. The Advanced Controller will enable work with a broader array of communication systems.

Each engine generator set has two points of data acquisition: (1) the Duetz TEM control, which monitors and controls engine parameters, and (2) the Encorp GPC-KWS control, which monitors and controls generator parameters. The GPC also provides protective relay functions for the generators. The overall system power is monitored and controlled by two Encorp Utility Power Controllers (UPCs). System operating parameters are monitored and controlled by two PLC Direct (Koyo) PLCs. House power is monitored and the house power breaker is controlled by an Encorp MMC.

Because of RS232 data loading concerns at the serial hubs, the data acquisition system is divided in half. Eight engine generator sets are served by each PLC, CPM, and DWS. The data is then gathered by each CPM and distributed via Ethernet to the Frame Relay and DPG for access by NEO and ISO. Hewlett Packard ProCurve network switches are used to switch Ethernet communications between the Koyo PLCs, DWSs, Frame Relay, and the CPMs.

The TEM controls communicate via Teletypewriter (TTY) current loop into a RS232 serial converter. The engine information is fed into a Rocket Port serial hub, which can handle up to eight RS232 serial inputs simultaneously. The serial hub interfaces with the native Windows operating system COM ports via Ethernet TCP/IP connection.

The Encorp GPC-KWS and UPC controls communicate via Echelon LONWORKS network to the Lon SLTA PCI card located in the CPM. They also communicate via RS232 port at 19.2 kilobytes per second (Kbps) with a local four-line variable frequency drive (VFD) display.

The Encorp MMC controls the house power breaker. The MMC provides house power metering information. Communications to the MMC will be through the LONWORKS OPC Server that resides on the CPM.

The CPM is an industrial PC operating on a Windows NT operating system platform. Its purpose is to serve as the communications collection point for the various distributed devices in the system. Dial-in capabilities are possible to the CPM via analog line into a 56-K modem.

Hewlett Packard ProCurve network switches are used to switch Ethernet communications between the Koyo PLCs, DWSs, Frame Relay, and the CPMs.

Local DWSs running Windows NT operating system are used to provide an HMI point for the operators of the system. They communicate with the CPM via Ethernet TCP/IP connection. Dial-out capabilities for the purposes of alarm annunciation via pager are possible through the 56-K modem on the DWS and an analog landline.

A SYSCO frame relay is used to provide SCADA to communicate plant information to NRG. The CPM provides data to the frame relay via Ethernet. The frame relay communicates with NRG via leased line provided by MCI Telecommunications.

A DPG module, serving as the Modbus master, polls the CPMs via RS485 serial communications, MODBUS protocol. Data points are sent from the DPG to the California ISO via DNP3.0 protocol over a 56-Kbps modem connection on the DPG.

### 10.3 Software

The Encorp Virtual Maintenance Monitor (VMM) software is a graphical user interface (GUI) run on a Delphi application layer. The VMM software usually resides in the CPM but may also be installed in remote terminals that require their own GUI. The VMM uses Distributed Component Object Module (DCOM) clients to access the data provided by the LONWORKS network. Custom pages for the VMM are designed by Encorp applications engineers to provide the end-user with useful information regarding the power generation system. Figure 25 shows the generator overview screen that is standard in the Encorp Intelligence VMM GUI.

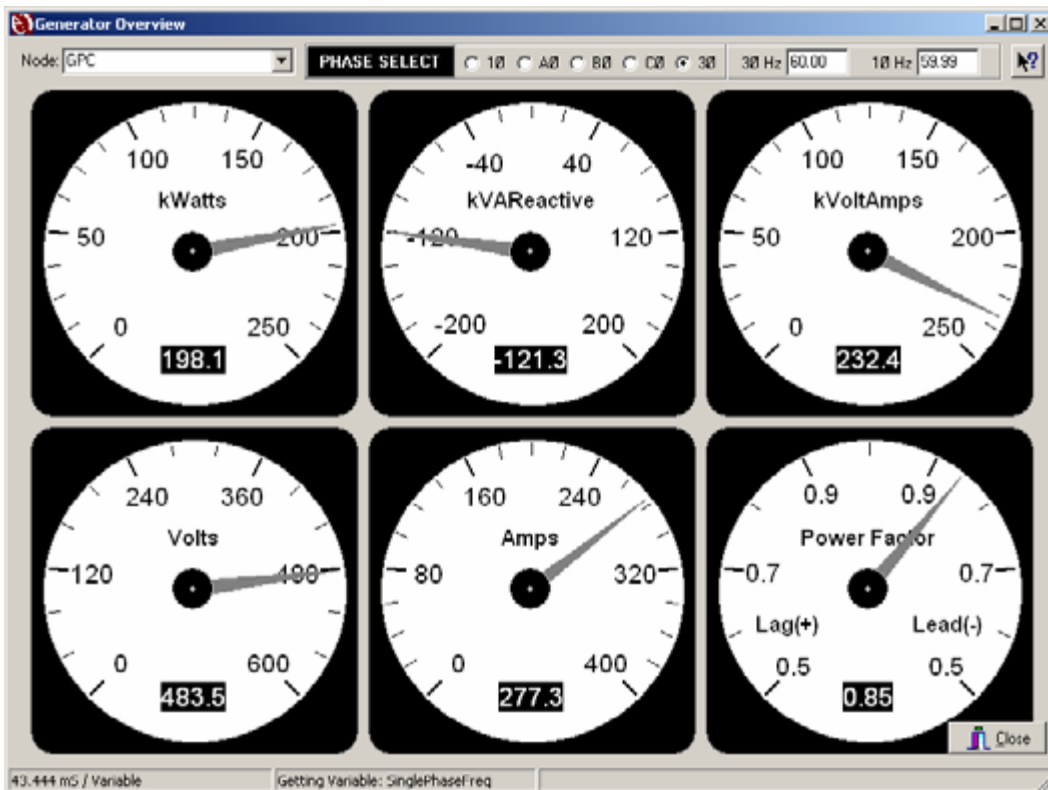

Figure 25: VMM User Interface

The Encorp Virtual Power Plant (VPP) server resides in the CPM and is used to provide access to the power generation system configuration and operating information. The number of units, capacity, status, and aggregate load information is available through the VPP server. A remote DWS running the VPP dispatch application is then used to poll the VPP server and issue dispatch commands to the site. A software interface is used to design graphic displays for various discrete, integer, and real data. The following — Figures 26, 27, 28, and 29 — illustrate various user interfaces for this application.

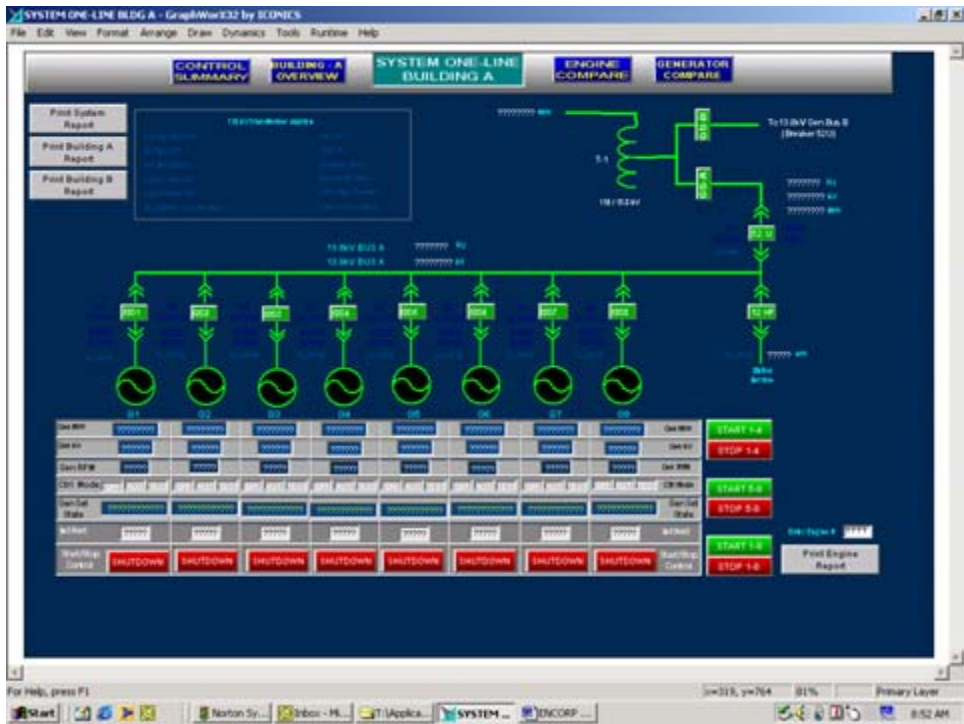

Figure 26: Example One-Line Diagram



Figure 27: Generator Room Display





Figure 28: Generator Annunciator Display



Figure 29: Generator Metering Screen

## **11. Appendix G: Qualification / Type Testing**

### **11.1 Definition of Testing / Overall Quality Strategy**

Type testing of a new product is really a subset of the main area of concern, which is the overall quality of the product being developed. Quality really starts during the design phase and involves manufacturing, suppliers, customers, engineering, type testing, bench testing, system testing, ongoing reliability, and an approach to handle any field failures. The product should be engineered to meet or exceed the identified quality requirements in all of these areas.

To build high quality into a product, the creators must use a systems approach over the life cycle of the product, from development through field reliability. This starts during the engineering phase, using tools such as good requirements documents that are agreed to by the entire organization. The requirements are implemented utilizing a structured design methodology and simulation of the design where possible. During the design stage, the overall goal is to perform an evaluation of critical signals, stack up tolerances, and create a product with some design margin in it. An early transition of firmware to the target system allows continuous board and code testing during development that improves the overall stability of the product. These tests are followed with more critical tests that are performed on the engineering units, correcting issues that are identified prior to initiating the certification testing. Finally, performing the certification tests on products that have been produced from the planned production line can ensure a product that meets the requirements identified and meets the market demands for a high quality, reliable product.

The overall test approach has been summarized as follows:

- Engineering development tests (critical path analysis, design margin, firmware verification, etc.)
- Bench Tests (subsystems/functions, systems single/multiple controllers, etc.)
- Production tests (ICT, Functional – board/module, calibration, burn-in, FGA, on-going reliability)
- Systems Tests (subsystems/functions, on-generator, multiple generators, various control modes and applications)
- Certification Testing on production units Type Tests (IEEE, UL, ANSI, IEC)

The key is to develop a strategy to address each of these areas to ensure the highest quality during each phase of the product's lifecycle. Each test performed had a detailed test procedure and test report written as part of this process.

### **11.2 Unit Testing (Lowest Level – Developer Level)**

Unit Tests verify that each of the Advanced Controller's individual subsystems, functions, and function blocks work as specified in the requirements document. Each piece of the Advanced Controller was tested individually and the results follow.



**Table 3: Unit Testing Results**

Test Type	Test Name	Test	Procedure	Report
<b>Resource/Subsystems</b>	Boot Loader	Pass	Complete	Complete
	File system	Pass	Complete	Complete
	ISaGRAF Port	Pass	Complete	Complete
	RTC – Real Time Clock	Pass	Complete	Complete
	Configuration Management	Pass	Complete	Complete
<b>I/O</b>	CAN ports	Pass	Complete	Complete
	FFT	Pass	Complete	Complete
	ISaGRAF I/O	Pass	Complete	Complete
	LONWORKS	Pass	Complete	Complete
	Ethernet	Pass	Complete	Complete
	Local I/O Driver	Pass	Complete	Complete
	Modbus	Pass	Complete	Complete
	Serial Ports	Pass	Complete	Complete
<b>Function Blocks</b>	ATS - ATS Control	Pass	Complete	Complete
	CBCCont – Circuit Breaker Control	Pass	Complete	Complete
	DTR – Definite Time Relay	Pass	Complete	Complete
	Energy and Demand Meters	Pass	Complete	Complete
	KWSCont – KW Sharing Control	Pass	Complete	Complete
	QPS – VAR Sharing Control	Pass	Complete	Complete
	PTC – PTC KW control	Pass	Complete	Complete
	QPC – PTC VAR/PF control	Pass	Complete	Complete
	SYNC – Synchronizer Control	Pass	Complete	Complete
	UPC – UPC KW Master Control	Pass	Complete	Complete
	UPCQ – UPC VAR/PF Control	Pass	Complete	Complete
	SCO – System Control	Pass	Complete	Complete

### 11.3 System Bench Testing

Bench testing focused on testing the Advanced Controller with two distinct methodologies. The first methodology put the control in simulated real life situations in which most of the controller’s functionality was tested in conjunction with other controllers, I/O devices, and monitoring equipment. These tests are designed to reveal what the realistic maximums are for the number of controls in a system, ISaGRAF program limitations, and communications bandwidth capabilities. The second testing methodology was designed to evaluate the control as a system in itself. This phase of testing included resource monitoring for controller CPU and memory space. It also tested all the individual function blocks to verify that they interacted correctly with other function blocks within the system.

The following is a summary of this testing activity.

**Table 4: System Bench Testing Results**

Test Name	Test	Procedure	Report
Baseline Control	Passed	Complete	Complete
Load Typical Application	Passed	Complete	Complete
Max Number of GDU controls	Passed	Complete	Complete
Replace GDU	Passed	Complete	Complete
Modbus	Passed	Complete	Complete
LONWORKS	Passed	Complete	Complete
CAN Bus	Passed	Complete	Complete
Ethernet	Passed	Complete	Complete
CPU loading	Passed	Complete	Complete
DTR (Definite Time Relay)	Passed	Complete	Complete
Synchronizer	Passed	Complete	Complete
Energy and Demand Meters	Passed	Complete	Complete
Function block interaction tests	Passed	Complete	Complete

## 11.4 Compliance Testing/ Type Testing

### 11.4.1 Temperature/Humidity (Operating and Storage)

The Advanced Controller will operate over a temperature range of  $-20^{\circ}\text{C}$  to  $70^{\circ}\text{C}$ , to operate at 95 percent humidity noncondensing at  $38^{\circ}\text{C}$ , and will survive at a storage temperature range from minus  $55^{\circ}\text{C}$  to plus  $105^{\circ}\text{C}$ .

The Advanced Controller passed the following IEC tests:

- IEC 60068-2-1, Environmental Testing - Part 2: Tests -Tests A: Cold,  $-20^{\circ}\text{C}$  for 96 hours.
- IEC 60068-2-2, Basic Environmental Testing Procedures - Part 2: Tests-Test B: Dry Heat.  $+70^{\circ}\text{C}$  for 96 hours.
- IEC 60068-2-30, Environmental Testing-Part 2: Tests -Test DB and Guidance: Damp Heat. Cyclic.  $+40^{\circ}\text{C}$  at 93% humidity for 96 hours.

### 11.4.2 Mechanical Shock and Vibration

The Advanced Controller passed the following IEC tests:

- IEC 60255-21-1, Electrical Relays – Part 21: Vibration, Shock, Bump and Seismic Test on Measuring Relays and Protection Equipment- Section One: Vibration Tests (Sinusoidal), Vibration Response Class 1 0.5G, Vibration Endurance Class 1, and 1.0G.
- IEC 60255-21-2 Electrical Relays – Part 21: Vibration, Shock, Bump and Seismic Tests on Measuring Relays and Protection Equipment- Section Two: Shock and Bump Tests.
- IEC 60255-21-3, Electrical Relays – Part 21: Vibration, Shock, Bump and Seismic Tests on Measuring Relays and Protection Equipment- Section Three: Seismic, Class 2.

### 11.4.2.1 Electrical Testing

### 11.4.2.2 Dielectric Strength

The Advanced Controller passed the following tests:

*(Applied for 1 minute to each independent circuit to earth and applied for 1 minute between each independent circuit.)*

**Table 5: Dielectric Strength Tests**

Isolation	Minimum (Volts alternating current)
Analog Inputs	1500 V ac
Analog Outputs	1500 V ac
Analog Load Sharing Lines, from power input	1500 V ac
Digital Inputs	2500 V ac
High Current Digital Outputs	2500 V ac
Solid State Digital Outputs	2500 V ac
Power Supply, AC	3000 V ac
Power Supply, DC	1500 V ac
Potential Transformer Input	2500 V ac
Current Transformer Input	2500 V ac
LONWORKS	1000 V ac
Serial Ports	1000 V ac
CAN	1500 V ac

### 11.4.2.3 Surge Withstand/ Fast Transient

The Advanced Controller passed the following tests on the digital inputs, digital outputs, analog inputs, PT and CT inputs, analog outputs, and power supply:

- IEEE C37.90.1-1989, IEEE Standard Surge Withstand Capability (SWC) Tests for Protective Relays and Relay Systems.
  - Oscillatory 1.0 MHz, 3.0 kilovolts (kV).
  - 50 ps burst, 5.0 kV.
- IEC 61000-4-4, Electromagnetic Compatibility (EMC)
  - Part 4: Testing and Measurement Techniques
  - Section 4: Electrical Fast Transient Burst Immunity Test Basic EMC Publication.
  - Power supply, Level 4, 2.5 kilohertz (kHz), 4.0 kV.
  - I/O, Level 4, 5 kHz, 2.0 kV.
- IEC 61000-4-5, Electromagnetic Compatibility (EMC)
  - Part 4: Testing and Measurement Techniques
  - Section 5: Surge Immunity Test.
  - Power supply, Level 4, 4.0 kV.
  - I/O, Level 2, 1.0 kV.
- IEC 60255-5, Electrical Relays

- Part 5: Insulation Tests for Electrical Relays.
- Impulse voltage test: 0.5 Joule, 5000V.
- IEC 60255-22-1, Electrical Relays
  - Part 22: Electrical Disturbance Tests for Measuring Relays and Protection Equipment.
  - Part 1: 1 MHz Burst Disturbance Tests.

#### **11.4.2.4 Electrostatic Discharge**

The Advanced Controller passed the following IEC tests:

- IEC 61000-4-2, Electromagnetic Compatibility (EMC)
  - Part 4-2: Testing and Measurement Techniques – Electrostatic Discharge Immunity Test.
  - Level 4, Contact discharge 8 kV.
  - Air discharge 15 kV.

#### **11.4.2.5 Radiated Immunity**

The Advanced Controller passed the following IEC and IEEE tests:

- IEC 61000-4-3, Electromagnetic Compatibility (EMC)
  - Part 4-3: Testing and Measurement Techniques – Radiated, Radio Frequency, Electromagnetic Field Immunity Test.
  - Level 3, 80 to 1000 MHz, 10V/m.
- IEEE C37.90.2-1995, Standard for Withstand Capability of Relay Systems to Radiated Electromagnetic Interference from Transceivers
  - 10 V/m.

#### **11.4.2.6 Conducted Immunity**

The Advanced Controller passed the following IEC test:

- IEC 61000-4-6, Electromagnetic Compatibility (EMC)
  - Part 4: Testing and Measurement Techniques
  - Section 6: Immunity to Conducted Disturbances, Induced by Radio-Frequency Fields.
  - Class 3, 150 kHz to 80 MHz, 10 V maximum.

### **11.4.3 UL**

#### **11.4.3.1 UL Recognized Component**

The Advanced Controller will be UL Recognized as defined in Sections 29A and 30 of UL 508 and under Category Control Number (CCN) NMTR2.E188578 for the US and NMTR8.E188578 for Canada.

## **11.5 Live System Testing**

Live System testing is intended to provide as many different operating and product application scenarios as possible while maintaining an in-house controlled testing environment. This testing was performed in a live environment utilizing three generators.

These generators were wired and set up in the following system configurations:

- Single Unit No Utility Paralleling (standby operation)
- Single Unit Utility Paralleling

- Multiple Unit No Utility Paralleling
- Multiple Unit Utility Paralleling
- Multiple Unit with generator tie breaker
- Multiple Unit with interposing tie breaker
- Multiple Utility Feed (multiple System Controllers)

In these configurations, the Advanced Controller was tested running the following applications / test plans:

- Time of day start/stop
- Run time/demand metering
- KW Droop Control
- KW control
- I/E control
- VAR Control
- PF control
- KW Sharing
- PF Sharing
- Circuit breaker control
- Engine Protection
- Engine start / stop sequencing
- Generator Protection
- Synchronizing (slip and phase match)
- Voltage Matching
- Export Limiting
- Generator Sequencing
- Load Sequencing
- Manual Frequency and Voltage Adjust
- System Controller Synchronization
- System Controller KW Control
- System Controller KVAR/PF Control
- System Control Object (SCO)
- Power Transfer Control KW controller
- Power Transfer Control KVAR/PF controller

Each of these scenarios was documented with an engineering test plan. Once the plan was executed, the results and observations of that plan were documented in a test plan report. The Advanced Controller passed each of these tests successfully.

## 11.6 Production / Manufacturing Testing

### Production / Manufacturing Tests

To ensure the Advanced Controller maintains a high level of quality that was established during the design phase, production / manufacturing tests are performed as well as ongoing reliability testing to continually validate the product quality on production units. In the event any issues are discovered by these tests, root-cause analysis and corrective action are executed as part of a continuous improvement process.

The following are the tests that are necessary for production / manufacturing:

- **Manufacturing In Circuit Test** - The manufacturing in circuit test is utilized by manufacturers to verify the placement of the components, solder connections, and trace routing on the board. A “bed of nails” in circuit tester is programmed by the manufacturer to verify each board is built in the same manner as those that went through the design type tests. Failure on the in circuit tester is typically due to misplaced components, wrong valued components, shorts and opens from the board stuff, and solder processes used in producing the PCA.
- **Manufacturing Functional Test (Finished Goods Audit)** – Utilizing a functional test device, all digital board functions are verified for basic functional capabilities. This test also verifies the interaction of the various components used on each PCA that is produced.
- **Manufacturing Reliability Test** – This test is part of the initial qualification of the product. After the initial phase, these tests are reduced to a sample frequency. This sampling is what verifies that the product maintains the design qualities over time. It is intended to produce accelerated stress to hardware components that will then manifest themselves as a failure in the functional test of the device. A complete control is inserted into the thermal chamber, and cycled from minimum to maximum storage temperature with time allowed for thermal soaking at each end. The control is then brought to ambient level, stabilized, and then powered up and run through a functional test using the external functional tester. If this test is passed, the unit is ramped to maximum operating temperature and functionally tested there, after a suitable thermal soaking period. If this functional test is passed, the unit is lowered to its minimum operating temperature and functionally tested there, again after a suitable period for the board to stabilize at the minimum temperature. If this test is passed, the board is once again brought to ambient temperature, stabilized, and functionally tested for a final time. Operational test data is collected at the various temperatures and compared to each other for shifts in performance at the temperature extremes.

In addition to production / manufacturing tests, procedures are in place to test the system in a customer’s facility for which that the Advanced Controller is being designed, built and deployed. These procedures include:

- **Design Computer Simulation** –The project simulation feature built into ISaGRAF projects can be tested prior to the project configurations being loaded into the Advanced Controller. Catching errors early in the design process improves the quality of the project being implemented and lowers the overall project cost.

- **Engineering Review** - The engineering team reviews all the designs before going into a systems manufacturing process.
- **Lab Systems Testing** – After the system is built, the engineering team tests the full system on the manufacturing floor. If the system passes, it is shipped to the customer's facility.
- **Commissioning Testing** – Once the system has been deployed into the customer's facility, the field service team completes testing for all modes and deployed applications. This is usually done in the customer's presence and is a form of training. Once this is completed, the EMC (see section 7) is utilized to monitor key system parameters to be evaluated on an ongoing basis.

## **12. Appendix H: System Command and Control**

When approaching this task, Encorp completed several design-related activities to have the most complete understanding of what software and communications subsystems were to surround the Advanced Controller to further enhance its functionality and overall quality. These activities included a detailed communications study, research and testing surrounding IT related security, and a comprehensive market analysis to enable a better understanding of the industry climate. The market analysis included detailed examination of the broad range of DG projects that Encorp had implemented to date.

The knowledge gained while completing these tasks was used to design, develop, and deploy the Command and Control system (EMC). This product is being produced commercially and is used by several customers, including the demonstration sites discussed in Appendix I. Details of the EMC architecture and subsystems are outlined in the following subsections

### **12.1 Communications Study**

Encorp completed a communications study in September of 2004. The study results presented a comprehensive overview of current and future communication architecture options used in Distributed Generation/Combined Heat & Power (DG/CHP) systems and facility energy management systems.

The systems and subsystems represented have evolved over the years as product offerings engineered for various clients that needed certain capabilities. As the product and service offerings have strengthened, customers have demanded a more vertically integrated solution. The study covers the technology in function-level detail. It also covered several of the different types of standard communications protocols and company device manufacturers used when implementing solutions for DG power systems customers.

### **12.2 Internet Security Design Considerations**

Critical facilities such as data centers use power equipment to protect their facility and equipment in the event of a power failure. There are other very important considerations for these same facilities to ensure their safety and security. One very important concern is the security of all the IT systems surrounding the power and building management systems. Suppliers need to understand such issues and provide powerful products to ensure IT security as well as power reliability.

In the United States alone, network security breaches cost businesses an estimated \$10 billion per year. With the proliferation of the Internet, and the resulting growth of intranets and extranets, we are witnessing a remarkable shift toward more open computing and networking environments. While these new networked environments offer incredible opportunities for business improvements, it also dramatically increases the security challenge by introducing new "insiders" to enterprise networks.

As facility systems increase capabilities to include local area networks (LAN), browser-based accessibility, and more, the computing enterprise becomes extended beyond the corporate LAN.



Devices that access the corporate LAN increase internal security threats, vulnerabilities, and risks. The greatest threat from unauthorized users is their ability to circumvent security controls and use energy management systems to shut down power systems, creating power outages within the facility.

Facility systems now need IT standards. Any Web server can be hacked. Uses of Web servers in nontraditional IT environments are increasing and pose a whole new set of risks. Facility managers need to ensure that advanced security features are available within the hardware devices connecting to their facility equipment, systems, and devices. The computing industry has done a fairly good job of responding to market priorities by developing technologies to address corporate networks and information assets from the Internet and to unambiguously authenticate users. These same technologies can be used to solve the network security problem of facility systems and devices. What is needed now is not new technology, but an information technology approach to creating an internal security solution for the facility and power-related operations. Breaches are common and often result from a lack of security awareness on the part of a well-intentioned IT security staff.

### **Network Security Fundamentals:**

There are several basic elements in network security:

- **Access Control** – Businesses must make sure that information is available to users in a secure way. Once a person or system has been authenticated, their ability to access data and use systems is determined by access control.
- **Private Secure Communications** - A number of methods exist to secure the connections between systems. Internet Protocol Security (IPSec) has emerged as the most important protocol for establishing a secure connection. Using Internet standard IPSec protocols, the system should offer full end-to-end protection, including encrypted tunnels, for all communications. You should be able to easily create and control secure connections within your network infrastructure.
- **Network Intrusion Tools** - Security audit tools and techniques are designed to diagnose the vulnerability of a system, and the potential risks if the system is attacked. Intrusion detection systems are predicated on the assumption that an intruder can be detected by examining various parameters such as network traffic, user locations, and various file activities. Called “audit trails”, these records are analyzed for unusual and suspicious behavior.
- **Firewalling** - A firewall is a gateway that restricts and controls the flow of traffic between networks, typically between corporate networks and the Internet. Firewalls may also provide secure gateway services between internal networks. Firewalls monitor incoming and outgoing traffic and filter, redirect, repackage, and/or discard packets.
- **Authentication** - Authentication is the process of verifying an identity claimed by or for a system entity. Authentication can provide assurance that users (or systems) are who they say they are.
- **Encryption** -Encryption transforms some input into an output that is impossible to read without the proper key.

These design philosophies were employed in the design and implementation of both the Advanced Controller and the EMC. The Advanced Controller was rigorously tested using advanced network security tools to ensure it will withstand the threat of an attack. One tool that provided an especially complete set of tests was the Nessus tool. The Nessus runs more than 1200 tests to assess vulnerabilities of devices that are part of a local area network (LAN) environment. In deployments, it is strongly suggested to put the controls behind an industrial grade firewall. Considering the risk of not having adequate security, designing and testing the Advanced Controls to this standard was a “must have” requirement.

### **12.3 Market Analysis**

A large number of firms specialize in developing and deploying technologies for the communication and control for DG/CHP. In general, these firms can be classified into three industry segments: grid interface component providers, system integrators, and software service providers. The following text and Figure 30 describe these segments and leading companies relative to their position in the marketplace:

#### **Grid Interface Component Providers**

Equipment providers are often focused on grid interface and protective devices. These devices are the fundamental control elements of any DG/CHP interacting with the grid, generation, or energy storage devices. Firms such as Woodward Governor and Basler provide engine controls and protective relays that are frequently used in the DG market. Other firms such as ASCO or GE/Zenith provide grid interconnection equipment that lack many of the advanced functionalities implemented in the Advanced Controller developed on this contract.

#### **Systems Integrators**

Systems Integrators are divided into two categories. The first category is sophisticated OEMs, such as Wartsila that provide engines, generators, controls, automation software, and remote monitoring inside a single package. However, many of these OEMs use proprietary technologies that, by design, do not easily integrate with generators or software platforms provided by third parties. An open system, such as that used on the Advanced Controller, provides customers with greater flexibility, scalability, and long-term value.

The second category of Systems Integrators comprises a limited number of companies that act as engineering consultants or switchgear providers that offer integrated solutions. Firms such as Enercon do not manufacture engines or generators but package on-site power systems, which include grid-interface hardware, communications modules, and application software. The lack of affiliation with a generator OEM allows these rivals to adopt an open systems interface with a multitude of hardware and software platforms. As these systems designers have not developed integrated communication and control technologies, they tend to use disparate components and charge their customers on a time and materials basis. The core technologies for this contract work reduce engineering labor for system integration and are cost-competitive with current product offerings in the market place.

Industry Segment	Function	Segment Leaders	
<b>Software Services</b>	<b>Remote Access</b>	<b>Software Providers</b> <ul style="list-style-type: none"> <li>• Encorp</li> <li>• Alstom Energy Automation</li> <li>• Connected Energy</li> <li>• Energy Works</li> <li>• DTE Energy Technologies</li> </ul>	<b>Enabling Software Providers</b> <ul style="list-style-type: none"> <li>• Engage Networks</li> <li>• Itron / Silicon Energy</li> </ul>
<b>Systems Integrators</b>	<b>Integration of Generator with controls</b>	<b>Open Systems</b> <ul style="list-style-type: none"> <li>• Encorp</li> <li>• DTE Energy Technologies</li> <li>• Enercon</li> <li>• Northern Power Systems</li> </ul>	<b>Closed Systems</b> <ul style="list-style-type: none"> <li>• CAT-ISO</li> <li>• Cummins-Onan</li> <li>• Tecogen</li> <li>• Wartsila</li> </ul>
<b>Grid Interface Component Provider</b>	<b>Site Level / Local Controls</b>	<b>Device Controls</b> <ul style="list-style-type: none"> <li>• Encorp</li> <li>• Basler</li> <li>• Beckwith</li> <li>• Woodward</li> </ul>	<b>Grid Interface Equipment</b> <ul style="list-style-type: none"> <li>• Encorp</li> <li>• ASCO</li> <li>• Cutler-Hammer</li> <li>• GE/Zenith</li> <li>• Russelectric</li> </ul>

Figure 30: Market Analysis

### Software Services

A number of firms have established a beachhead by remotely monitoring, and in some cases dispatching, distributed generation assets. As the market for managed services is immature, none of these firms has a large pool of customers and many lack an understanding of generation and grid interface technologies. Few competitors have experience with operations and maintenance issues, and generally do not convert data into meaningful software applications to reduce operational costs and increase generator utilization. The ability to optimize generator performance, increase capacity factor, and reduce maintenance costs are unique skills in the managed services market.

As the energy market continues to liberalize, new entrants will emerge. However, similar to today's rivals, few entrants will be able to offer end-to-end solutions that integrate DG/CHP with the grid, other dispersed energy devices, intelligent electronic devices at the site, building automation systems, remote software applications, and the various energy markets.

## 12.4 Product Development Methodology and Results

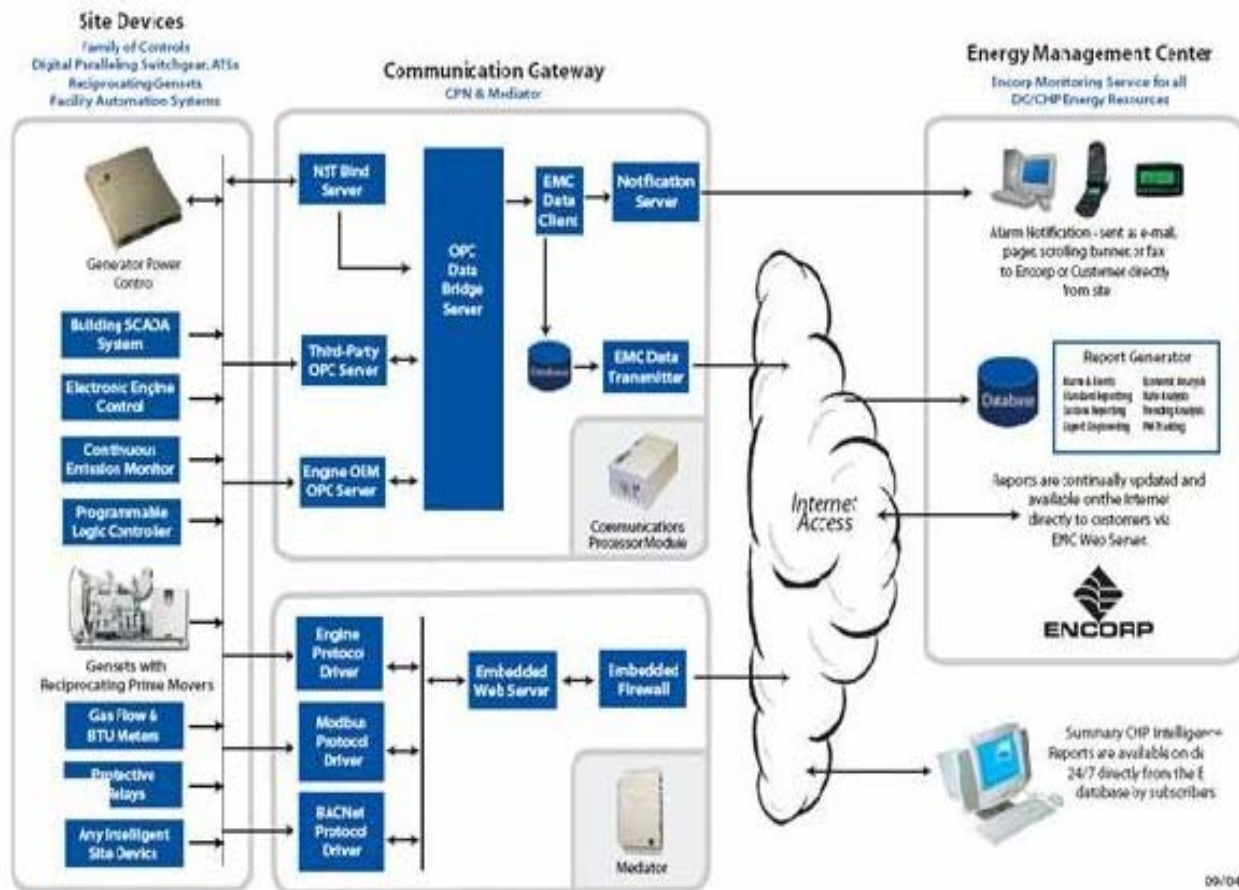

Figure 31: EMC System Architecture

The EMC (Figure 31) is a technologically advanced data collection and aggregation service, which continually provides updated reporting on detailed site parameters, overall operational efficiencies, and economic performance of DG/CHP resources. The EMC leverages modern communications infrastructure (i.e., the Internet / FTP / XML and supporting technologies) to effectively and securely deliver high-level summary data to end-users anywhere, anytime. The EMC uses a combination of proprietary and commercially available technologies to retrieve, aggregate, normalize, analyze, and then report on data from diverse DG/CHP systems. This ability to aggregate raw data into meaningful intelligence based on a site's engineering design and utility tariff helps customers maximize the value of their DG/CHP systems.

When a facility considers making significant capital expenditures for a distributed energy system, their decision is typically supported by detailed *pro forma* analyses. For certain types of facilities, the potential benefits for deploying CHP systems are highly attractive. They include:

- Reduced energy costs
- Reduced life-cycle costs
- Attractive return on investment

- Improved power reliability
- Improved economics for enhancing air quality.

A reliable means of tracking the performance of a complex DG/CHP system is a “must have” for site operators in order to receive the feedback necessary to adjust and optimize system parameters. As operational efficiency reaches its peak potential, site managers remain focused on the costs incurred in producing power versus buying it from utilities. Without effective tools, these costs (and savings) can remain hidden, leaving management in the dark regarding their equipment’s return on investment.

The EMC makes it possible to track cost savings from operating on-site power plants. Viewing summary data from a historical perspective allows usage patterns to emerge that facilitate intelligent operational decision making. The effort to effectively deploy and manage DG/CHP resources can seem daunting with the myriad of technical, maintenance, and financial issues.

#### **12.4.1 Design Details – Data Transport**

The EMC leverages the existing infrastructure typically seen at a DG site. Data coming off the data acquisition system is collected into an SQL server database every minute. Once every 15 minutes the EMC Transmitter performs an SQL query on the database for the last 15 records. The results of the query are stored in a Net Dataset. Once in the dataset, the transmitter executes a built in .Net method to convert the data into an XML file. As the XML file is generated, the EMC Transmitter logs on to the Encorp EMC external FTP site. The EMC Transmitter then transfers the XML file containing the last 15 minutes of data into a preconfigured folder. Once the file is on the FTP server, the EMC Receiver, which is running on the Encorp EMC network at Encorp’s headquarters, opens the XML file into a Microsoft.Net Dataset. Once the dataset is populated, the EMC Receiver then connects to the EMC production SQL Server and inserts the data into the corresponding customer table.

This architecture and the processes surrounding it have had multiple iterations of software releases to improve reliability and prevent any data loss. Some of the most challenging lessons that were learned from this architecture drove development on the EMC receiver. Device failure or lost communications would result in data loss. Encorp developed alarms at the EMC Receiver that alerts the proper support personnel to prompt immediate resolution. One other feature that was added was a 1-hour maintenance window in the early morning to provide time for backups of the databases both at the site level and the EMC level.

### 12.4.2 Design Details – Data Processing

Once the data has been entered into the customer specific database it will be accessible via the EMC website. The customer can log on using a secure password to see a custom view of all the sites that are entered under his or her profile. Reports that are available for the customer’s viewing are listed in a selection box. Also next to that selection box is a selection box that allows users to specify the “from” date and the “to” date. Once the customer selects the site, the report, and the timing parameters, he or she would then click the “view report” button.

A Web request is sent to a software class that handles all the database connections for the Web site. This class triggers a database-stored procedure that processes large amounts of data into usable information. A Crystal Report file then transforms the database-stored procedure results into an easy-to-read report.

Typical parameters for EMC based site		
Generator related	Generator related	Utility related
Alarm Status	Start Output Status	Amps
Fault Status	Hz	Amps A
Coolant Temp	kVA	Amps B
Fuel Flow Rate	kVAR	Amps C
Oil Pressure	kW	Power Factor
Amps	kWh	Volts A
Amps A	kWSP	Volts B
Amps B	Receiver Temp	Volts C
Amps C	Runtime	Hz
Demand	Oil Temp	kVA
Peak Demand	Oil Level	kVAR
Power Factor	Operating State	kW
Volts A	Exhaust Temp	Volts
Volts B	Air Inlet Temp	kWh
Volts C		Demand
Breaker Status		Peak Demand
Running Status		Breaker Status

**Table 6: Typical EMC Parameters**

There were several difficult design and process challenges that were overcome on the data processing system for the EMC. The biggest challenges included providing adequate security for customer data, ensuring acceptable speeds when processing reports via the SQL stored procedures, and finally, standardizing the methodology that the development team used to implement code that stressed long-term maintainability.

### 12.4.3 EMC Data Examples

Table 6 shows some of the typical parameters that are monitored on a “base” level EMC system. Figure 32 shows two of the reports typically included in the same “base” level EMC package.

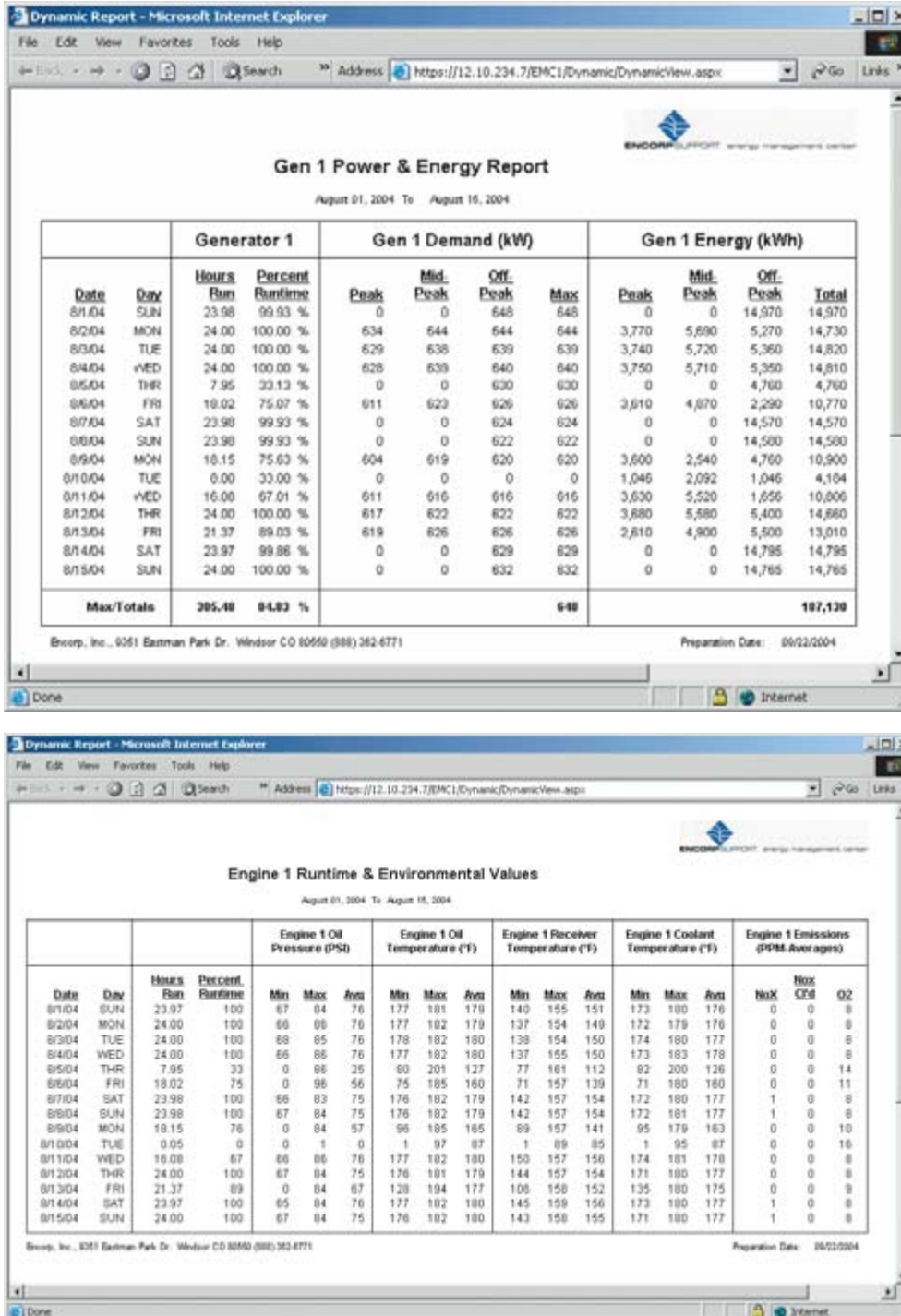

Figure 32: Standard EMC Reports

#### **12.4.4 EMC Summary**

By utilizing a rigorous design process, the EMC has had success in the market place. Customers can read their Web reports on a daily basis to ensure the cost savings that they initially expected have actually materialized. The EMC was built to meet the challenges in the present, as well as into the future. One key design decision was to pass XML files via FTP to the datacenter from the DG sites. By utilizing XML, the EMC can easily be integrated into several other systems with minimal effort.



### **13. Appendix I: Demonstration of Controlled DP**

The final task to be completed was the demonstration of the Advanced Controller and EMC outside of the lab environment in an “uncontrolled” commercial deployment. This is the most critical step in the product development process. To be sure the Advanced Controller was adequately tested in this manner, the evaluation and selection of a demonstration site was essential. It was decided to utilize two demonstration sites to ensure broad coverage of commercially representative conditions.

Establishing the two ideal demonstration sites was based on the following selection criteria.

- **Location of site**
  - The site needed to be easily accessible by the development staff and the operations engineering staff to ensure a fast response to any problems. Locations that had enhanced security with restricted hours were not considered.
  - Testers targeted sites that represented a geographical marketplace where DG is prevalent to ensure a demonstration site that would be representative of the customers of the Advanced Controller.
- **Customer selection**
  - It was important to select appropriate customers who would allow testers to utilize their sites and in some cases their customer’s sites.
  - The customers needed to understand the benefits of the Advanced Controller and be willing to accept the risk if the demonstration did not go smoothly.
- **Retrofit**
  - It was decided to do the demonstration at two DG sites in which earlier generation Encorp controls were already deployed. This would allow a comparison of the existing structure with the Advanced Controller.
  - Sites that were using the EMC prior to deploying the Advanced Controller were selected to have a “before” and “after” site profile based on the information that was being gathered through the EMC.
- **Compliance with National Environmental Policy Act (NEPA)**

Based on these criteria, the first site was Encorp’s Headquarters in Windsor, Colorado, and the second demonstration site was the Aquarium of the Pacific in Long Beach, California, in partnership with City Light and Power in Long Beach.

### 13.1 Implementation Process

Table 7 illustrates the process used to implement both demonstration systems.

**Table 7: Demonstration Checklist**

<b>System Checklist</b>	
<b>Phase</b>	<b>Details / Comments</b>
Customer kickoff meeting	
Site survey	
Preliminary design review w/ customer	Review preliminary design:
	Sequence of operations
	Control scheme
	Protection scheme
	Communications architecture
	Schedule of system implementation
	Customer / Engineer preliminary signoff
Sequence of operations	Black start / Standby
	Open or closed transition to generators
	Open or closed transition back to utility
Determine hardware design	Identify parts needed to meet requirements for control and communications
	Inventory the system's existing parts
	Change I/O modules from LONWORKS to Modbus I/O
	Modify the system bill of materials
	Design system to capitalize improved control and communications capability
Update wiring drawings	Update drawings to include the Advanced Controller behaving as a GPC/UPC/MMC
	Add wiring and Modbus I/O (remove Acromag DI, DO and AO on generators and replace with Modbus I/O)
	Add wiring and Modbus I/O (remove LONWORKS analog output remote I/O modules and replace with Modbus I/O)
	Update communications connections.
Control software	Create ISaGRAF for Advanced Controller based on existing bindings, ISaGRAF PLC code, and add new functionality.

## System Checklist

Phase	Details / Comments
	Setup each of the needed function blocks using application defaults (settings optimally tuned at site).
	Implement engine interactions (load sharing, voltage bias, etc.)
	Review CHP PLC code and verify that there are no changes required.
	Update sequence of operations.
Protection scheme	Determine the existing protection relays.
	Review relay settings with sequence of operations.
	Determine relay interactions with controls.
	Verify logic with utility protection relays.
	Verify logic with generator protection relays.
System bench test application	Simulate the application and all I/O logic using ISaGRAF software.
SCADA / Communications	Configure the Ethernet OPC server for Modbus TCP interface.
	Load the address list from the ISaGRAF Workbench into the OPC server.
	Update the addresses on the HMI screens.
	Update the addresses for the EMC data logger.
	Update the SCADA documentation.
	Bench test the application in simulation mode.
Equipment inspection	Inspect all hardware to be used at site.
	Power up test.
	Upload firmware to controls.
System simulation testing	Wire system up in lab as it would appear in the field.
	Execute system simulation tests from ISaGRAF Workbench.
	Test all I/O and SCADA screen interactions.
	All hardware packaged and shipped to site.
Preliminary site commissioning	Receive equipment.
	Inspect all equipment that was received.
	Implement wiring based on wiring diagrams.

## System Checklist

Phase	Details / Comments
Site commissioning	Install equipment.
	Equipment power up.
	Wire all controls and communications nodes.
	Power all equipment up into the system.
	Set protection and engine systems into test mode.
	Test interactions with engine / engine control.
	Verify control outputs to engine are properly scaled.
	Ensure output timing is adequate.
	Monitor and adjust both engine and control based on interaction.
	Test interactions with protective relays.
	Verify control outputs to protective relays are properly scaled and being received.
	Verify control inputs from protective relays are properly scaled and being received.
	Ensure timing for interactions are adequate between controls and protective relays.
	Monitor and adjust controls based on interaction.
	Commission the SCADA system.
	Set up network addresses.
	Set up OPC servers.
	Ensure variables from controls are updating in OPC server properly
Setup EMC logging through OPC server.	
Setup HMI screens through OPC server.	
Setup panel HMIs directly to control Modbus port.	
Commission alarm and trending servers.	
Ensure user settings are correct for network security.	
Ensure the OS and all server software is properly updated.	
Set EMC up to begin updates. Verify files are being properly created and sent.	
Final commissioning	Put system into "Run" mode. Monitor and adjust base on system interactions.
	Record all control and relay data at 1-minute samples and review data for irregularities.
	Review site design and implementation with customer.

System Checklist	
Phase	Details / Comments
	Train customer on SCADA system, system interaction.
	Customer and engineer sign off commissioning.
Final site acceptance	All documentation to be reviewed and updated as result of implementation.
	System alarms and data reviewed with customer at regular interval.
	Any irregular behavior reviewed with customer. System updated remotely as needed.
	Final documentation sent to customer.
	Final documentation archived.
	Final acceptance signed by engineer / customer.
	Ongoing monitoring and tech support provided as agreed to in initial contract.

## 13.2 Demonstration Site One - Encorp Headquarters

### 13.2.1 Site Description

Encorp's headquarters in Windsor, Colorado, was built and opened in 2001. The facility has 80,000 square feet that includes manufacturing facilities, office space, and a small data center. The facility utilizes power that is being distributed by Xcel Energy. The facility uses one Detroit Diesel Generator with a nameplate capacity of 535KW to provide backup power in case of a utility outage. Due to the need for reliable power for the small data center, the site is representative of a critical power application that would be analogous to a telecommunications center or a hospital.



**Figure 33: Demonstration Site One - Encorp Headquarters**

### **13.2.2 Advanced Controller Design of Site**

The system utilizes one Advanced Controller as both a GPC and a UPC. This mode of operation is referred to as a Power Transfer Control (PTC). In this mode, the Advanced Controller monitors all the incoming utility power and turns on the generator during any utility failures. The following is a high-level graphics representation of the site.

Xcel Energy Utility Feed

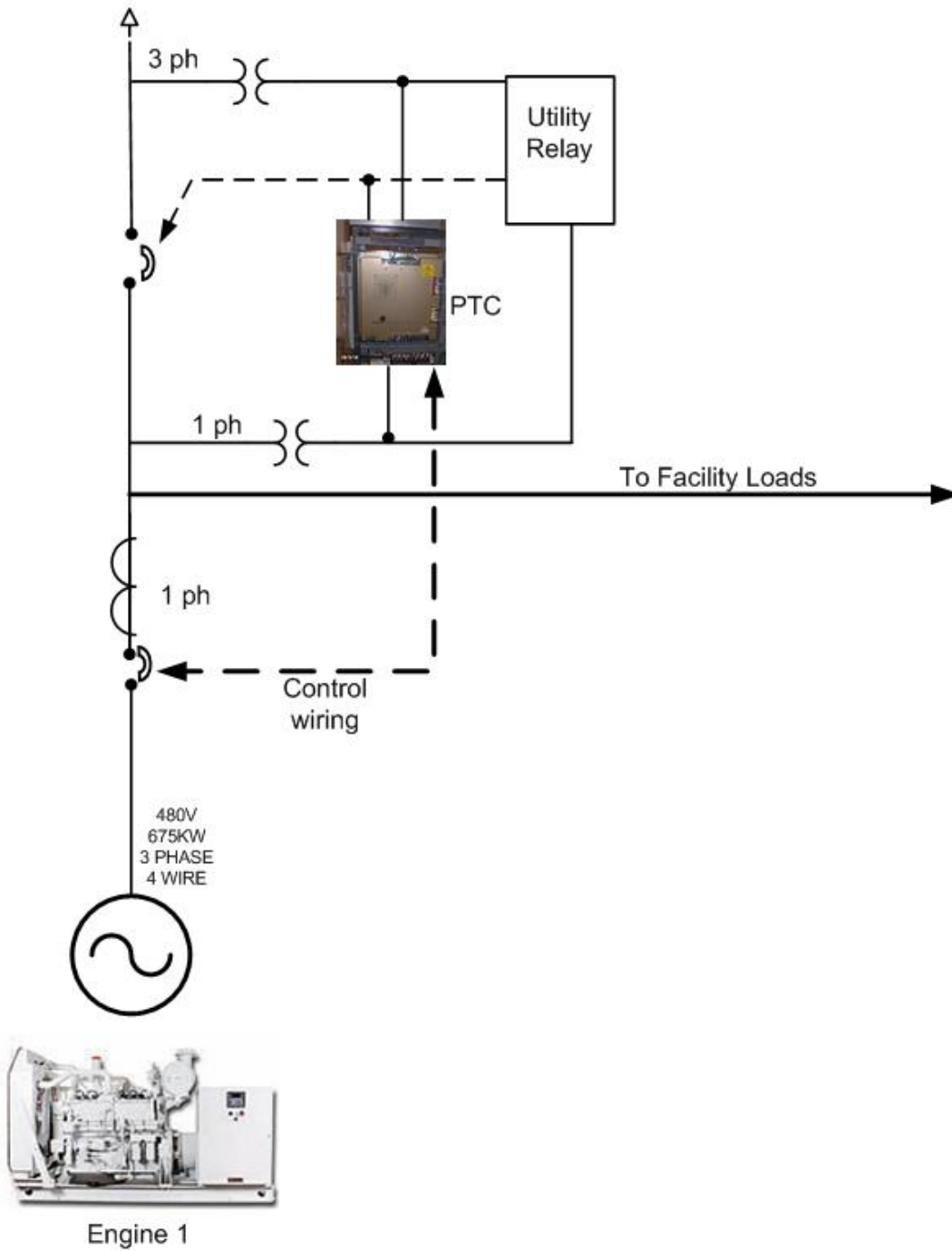

Figure 34: Demonstration Site One - Graphical Representation

### 13.2.3 Results of Testing

The implementation results for this first demonstration site were very positive. Transitioning the Advanced Controller into the hands of the engineering and operations team from the development team was eased tremendously because of the use of the ISaGRAF Workbench and standard IEC 61131 programming languages. The function blocks that provide the control algorithms were implemented along with the IEC standard functions such as muxes and gates. This sped the implementation and facilitated easier customization needed to meet the particular nuances of the site's sequence of operation. These standard programming languages are another major benefit of the Advanced Controller, allowing industry engineers to quickly understand and use the Advanced Controller with minimal specialized training.

Improvements in speed and reliability surrounding data collection were also evident because of the Advanced Controller's data acquisition enhancements. This was very useful for remote monitoring, database storage, and generation of system health and status pages to the technical support cellular telephones and emails. The system was configured to generate an informational email to the cellular phone of selected employees to indicate when the site was being powered solely by generation during the monthly load test or if the site was down because of an emergency. During testing, the facility was seamlessly transferred to backup generation, so the e-mail messages provided the only indication to other plant personnel that the test was happening.

Construction and spring thunderstorms were the primary cause of most interruptions in utility electrical power. The event recording of the power conditions at the time of interruption was performed at a much faster frequency (1 second) to the standard database programs than by the previous communication channels. This enabled site personnel to know the cause and type of interruption more precisely than before.

Noticeable improvements were evident in the overall system maintenance as well. Having a single hardware and software platform lessened the site's complexity. This enabled the site to receive several firmware upgrades and feature enhancements with less overall testing than was previously possible. These features provided operational efficiencies that reduce the overall cost of system implantation and reduced the overall operational maintenance costs.

Having TCP/IP Ethernet on the Advanced Controller allowed the controls to be placed on the facility network. Although the Advanced Controller might have a dedicated network at many sites, this allowed the controller to be tested with all of the communication traffic of the facility and not just the site. It also gave users the ability to monitor or demonstrate remote connections into the site.

In performance testing, the Advanced Controller exhibited a high degree of stability and "smoothness" as it was taken through the loading, unloading, base load control, and import control algorithms. In particular, the import control was able to control to within a +/- 10 kW level, where previously only +/- 20 kW was obtainable. In the base load mode, the export control limiter function transitioned from base load to export limiting function without any issues. The export limiting function comes into play when a base load level is set on the



generator, but the site load decreases to the point where the export limiter decreases the generator load to maintain the desired export of power from the utility to the facility.

All software programming for the control, including communication settings and tunable configurations for the site, were backed up on the MMC card. In the unlikely event of an Advanced Controller failure, the MMC card could be inserted into a replacement control and all software programming, custom settings, and performance tunings could be restored in a single step. This feature will greatly reduce field maintenance costs of deployed Advanced Controllers allowing a control to be shipped and installed by on-site personnel, circumventing the need for an engineer to travel to the facility to replace the controller. And finally, the team successfully executed all the tests identified in the aforementioned system checklist. This site will continue to provide critical power protection for the site and will act as a production test environment as new features are released.

### 13.3 Demonstration Site Two - The Aquarium of the Pacific

The second demonstration site was the Aquarium of the Pacific (AOP) in Long Beach, California. AOP is one of the largest aquariums in the United States. It is home to more than 12,000 ocean animals that represent 1,000 different species. The beautifully architected 156,735 square foot building is right next to the Pacific Ocean on the west side of downtown Long Beach. AOP was visited by over 1.1 million people in 2003 making it the third most attended cultural institution in the greater Los Angeles area. It is a strong asset to the community, bringing in more than \$20 million in economic benefits to Long Beach and \$100 million to Los Angeles County annually.



Figure 35: Demonstration Site Two - Aquarium of the Pacific

AOP has a very high-tech water filtration process that filters more than 900,000 gallons of salt water per hour. In that system there are 10 miles of piping, 79 life support circulating and exchanger pumps, 44 sand filters, 14 ozone chambers, and 14 de-gas chambers. AOP worked with City Light and Power of Long Beach to design a CHP system to offset the demand for utility power and utilize the heat coming off the twin 675kw Duetz natural gas generators throughout several critical processes in the facility. Figure 36 shows the layout of the generators and some of the CHP systems at the site.

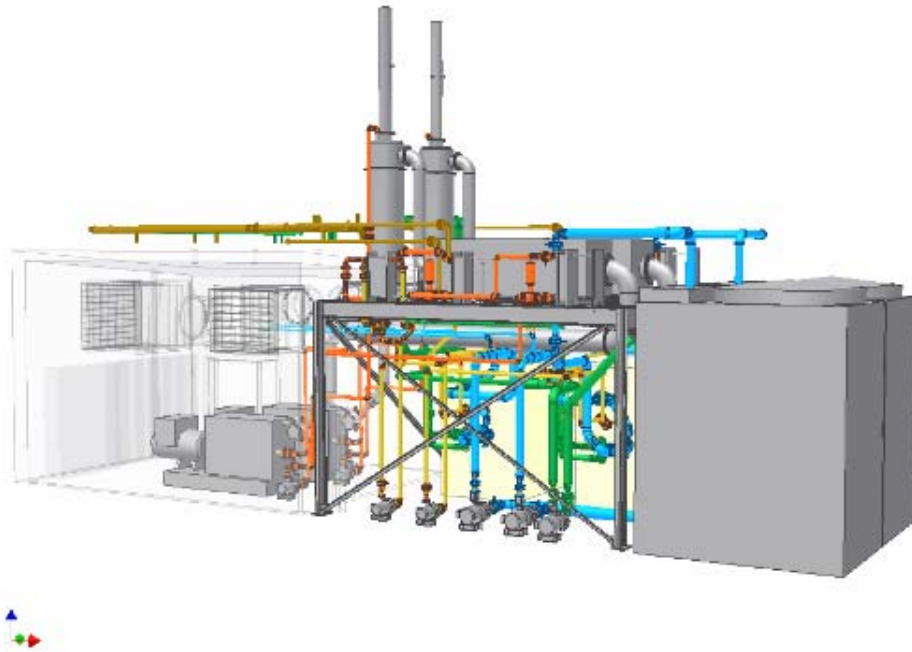

**Figure 36: System Layout**

### **13.3.1 Advanced Controller Design at Site**

The design consisted of four different controls: 2 GPCs, 1 UPC, and 1 Meter Monitoring Control (MMC). An Advanced Controller was used for each of these devices. Figure 37 and Figure 38 are the one-line diagram and the communications overview of the contract work.

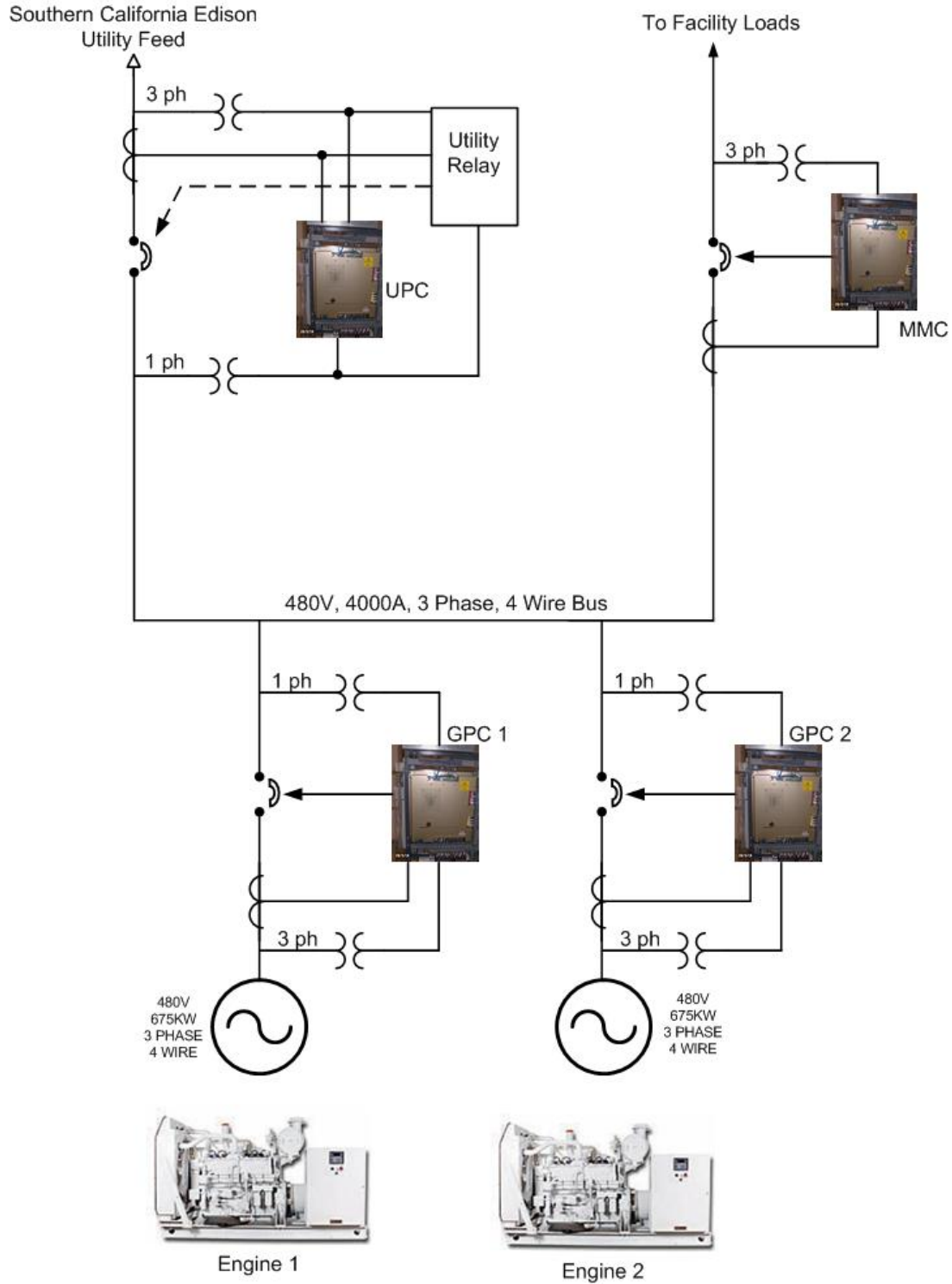
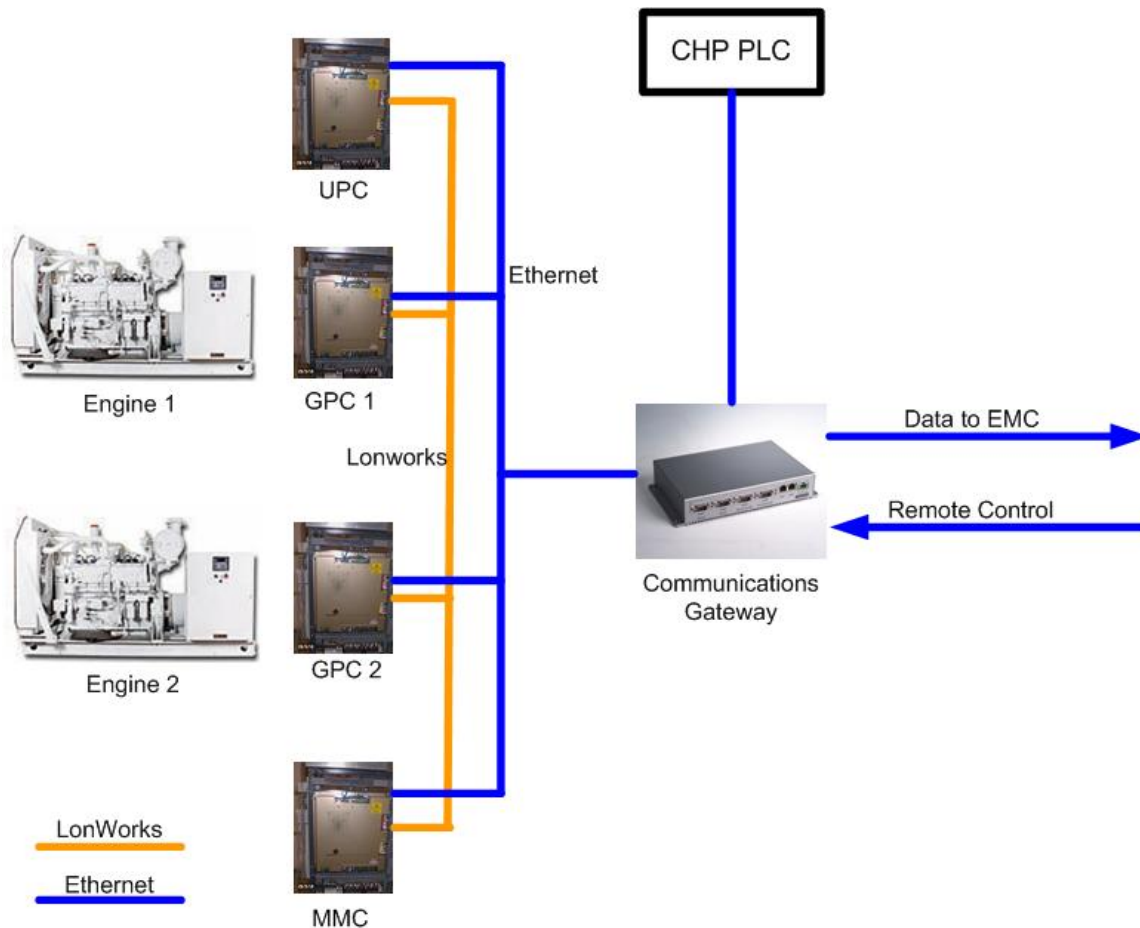

Figure 37: One-Line Diagram



**Figure 38: Communications Diagram**

The functional description of the site with the deployed controls follows.

- UPC – The utility power control watches the incoming utility. It is configured for three phase monitoring on the utility power side of the utility tie breaker and 1 phase of monitoring after the breaker. Based on the information it receives, it coordinates the rest of the controls through the LONWORKS connection.
- GPC1, GPC2 – These GPCs are used to monitor and control the two Gensets and a pair of generator tie breakers. The method for control on these Duetz engines is to send a KW setpoint for the engine to run against.
- MMC – this control is metering the facility load after it passes through a feeder breaker to provide the AOP with the load.
- CHP PLC – This is a PLC that gathers all the information about the facility’s CHP system.
- Communications gateway– This is the main computer at the site. It collects all the information from each control and the CHP PLC. Once the information is collected, it is stored in a database, displayed on a screen on site and remotely, and sent back to the EMC for archival and reports for data analysis. Some alarms generate e-mails to notify Encorp or site personnel.

### 13.3.2 Results of Implementation / Testing

The final signoff from the customer was received on June 1, 2005. The EMC continues to receive data from the site to be monitored and reviewed by the engineering team in conjunction with the customer. The following is a view of the system's performance over the month since the data recorded after the commissioning was complete.

**Table 8: System Performance Data**

Date	Engine 1		Engine 2		KWH Produced				Gas Flow (CF)
	Run Hrs	%	Run Hrs	%	Total	Peak	Mid	Off	
6/1/2005	23.72	98.82	23.72	98.82	26,808	0	14,890	11,918	312,200
6/2/2005	23.78	99.1	23.78	99.1	26,904	0	14,904	12,000	315,600
6/3/2005	23.77	99.03	23.77	99.03	26,602	0	14,710	11,892	313,600
6/4/2005	23.38	97.43	23.38	97.43	26,430	0	0	26,430	309,400
6/5/2005	23.55	98.13	23.55	98.13	26,070	0	0	26,070	307,900
6/6/2005	24	100	24	100	25,546	6,792	10,066	8,688	302,600
6/7/2005	23.98	99.93	23.98	99.93	24,872	6,742	10,136	7,994	297,900
6/8/2005	22.58	94.1	22.03	91.81	24,268	6,752	9,854	7,662	286,700
6/9/2005	23.85	99.38	23.85	99.38	26,048	6,709	10,176	9,163	308,400
6/10/2005	23.63	98.47	23.63	98.47	26,310	6,688	10,160	9,462	311,700
6/11/2005	23.72	98.82	23.72	98.82	26,117	0	0	26,117	309,300
6/12/2005	23.75	98.96	23.75	98.96	26,008	0	0	26,008	309,500
6/13/2005	23.52	97.99	23.52	97.99	26,031	6,618	10,101	9,312	311,600
6/14/2005	24	100	24	100	25,902	6,686	10,111	9,105	309,400
6/15/2005	24	100	24	100	25,795	6,686	10,127	8,982	306,900
6/16/2005	24	100	24	100	26,063	6,703	10,163	9,197	308,000
6/17/2005	21.97	91.53	24	100	25,062	6,746	9,691	8,625	294,600
6/18/2005	24	100	24	100	26,211	0	0	26,211	307,000
6/19/2005	24	100	24	100	26,039	0	0	26,039	306,700
6/20/2005	24	100	21.97	91.53	24,444	5,802	9,615	9,027	290,800
6/21/2005	24	100	21.93	91.39	24,592	6,336	9,276	8,980	291,200
6/22/2005	24	100	12.52	52.15	19,850	6,530	6,404	6,916	238,500
6/23/2005	24	100	24	100	26,122	6,746	10,251	9,125	308,100
6/24/2005	24	100	24	100	26,068	6,708	10,202	9,158	310,400
6/25/2005	23.4	97.5	23.78	99.1	25,988	0	0	25,988	306,700
6/26/2005	24	100	24	100	26,448	0	0	26,448	313,600
6/27/2005	24	100	21.52	89.65	24,378	6,238	9,152	8,988	291,400
6/28/2005	24	100	22.45	93.54	25,070	6,774	9,616	8,680	297,300
6/29/2005	22.27	92.78	24	100	25,236	6,746	9,808	8,682	302,300
6/30/2005	19.68	82.01	17.47	72.78	20,048	6,776	5,620	7,652	239,800
7/1/2005	23.32	97.15	22.38	93.26	20,820	4,238	8,276	8,306	258,800
7/2/2005	24	100	12.57	52.36	15,914	0	0	15,914	204,000
7/3/2005	24	100	7.3	30.42	17,716	0	0	17,716	214,600
<b>Totals:</b>	777.87	98.2%	730.57	92.2%	815,780	130,016	233,309	452,455	9,696,500

The system's runtime percentage is especially worth noting; there have been no long periods of downtime due to problems with the Advanced Controller.

The Advanced Controller has helped with time-based event analysis. The controls are configured to record important data to the database on the CPM at 1-second intervals. Previously, due to the amount of data, communication constraints, and graphically displayed data, only 10-second intervals were possible. The 1-second interval data allowed operators to pinpoint an on-engine condition as the source of a generator shutdown, allowing a quick resolution to the problem.

Improvements made to the functionality of the export limiter of the utility base load controller function block improved the generation efficiency at the site by providing a much smoother transition between the base load operation that the customer desires and the export limiting that the utility requires.

## 14. Appendix J: IEEE Standards Activities

In addition to conducting the technical tasks identified in Phase II during option year 1, there were concurrent support efforts in the development of interconnection standards through the IEEE 1547.1 - 1547.5 working groups and participation in several DOE Distributed Power Program (DPP) review meetings. Encorp has supported interconnection standards and has served on various IEEE 1547 committees.

The IEEE 1547 standards efforts were led by DOE through NREL, and have been instrumental in reducing the barriers to implementing and interconnecting DG with the electric power system.

The IEEE 1547 standards effort consists of the following:

- IEEE STD 1547 (2003) (Interconnection Standard) -- Chair: R. DeBlasio, NREL; > 500 volunteers developed or balloted standard.
- IEEE STD 1547.1 (2005) (Test Standard) -- Chair: J. Daley, ASCO Power Technologies, Inc., 82 members; ballot Fall 2004.
- P1547.2 (Guide to STD 1547) -- Chair: N. R. Friedman, Resource Dynamics Corporation, 96 members.
- P1547.3 (Guide for Monitoring, Information Exchange, and Control) -- Chair: F. Goodman, EPRI, 95 members.
- P1547.4 (DR Islanding Systems) – start Dec. 2003; Chair: B. Kroposki, NREL, 25 members.
- P1547.5 (Interconnection >10 MVA to Transmission Grid) – start Sept. 2004; Chair: M. N. Satyanarayan, Xcel Energy (membership).
- P1547.6 (DR on Secondary Networks) – start Mar 2005; Chair: J. L. Koepfinger, IEEE Standards Board Emeritus (establishing membership).

The benefits of the IEEE 1547 standards efforts include:

- Safeguards against hazards
- Fostering quality design and manufacture
- Increasing competitiveness in industry
- Creating and expanding markets
- Facilitating trade and commerce
- Ensuring that products meet quality standards so that users need not be concerned with further testing or evaluation of the product
- Accelerating engineering advances and implementation, interoperability, and installation
- Assisting increased quality and reliability achievement
- Simplifying compliance to needs, permitting, and rules
- Promoting advanced communications; software platforms interchangeability
- Enabling enhanced DR systems and grid intelligence
- Lowering cost and deploying projects more quickly.



# REPORT DOCUMENTATION PAGE

Form Approved  
OMB No. 0704-0188

The public reporting burden for this collection of information is estimated to average 1 hour per response, including the time for reviewing instructions, searching existing data sources, gathering and maintaining the data needed, and completing and reviewing the collection of information. Send comments regarding this burden estimate or any other aspect of this collection of information, including suggestions for reducing the burden, to Department of Defense, Executive Services and Communications Directorate (0704-0188). Respondents should be aware that notwithstanding any other provision of law, no person shall be subject to any penalty for failing to comply with a collection of information if it does not display a currently valid OMB control number.

**PLEASE DO NOT RETURN YOUR FORM TO THE ABOVE ORGANIZATION.**

<b>1. REPORT DATE (DD-MM-YYYY)</b> March 2006		<b>2. REPORT TYPE</b> Subcontract Report		<b>3. DATES COVERED (From - To)</b> 12/11/00 – 08/30/05	
<b>4. TITLE AND SUBTITLE</b> Innovative Distributed Power Grid Interconnection and Control Systems: Final Report, December 11, 2000 - August 30, 2005				<b>5a. CONTRACT NUMBER</b> DE-AC36-99-GO10337	
				<b>5b. GRANT NUMBER</b>	
				<b>5c. PROGRAM ELEMENT NUMBER</b>	
<b>6. AUTHOR(S)</b> K. DePodesta, D. Birlingmair, and R. West				<b>5d. PROJECT NUMBER</b> NREL/SR-560-38982	
				<b>5e. TASK NUMBER</b> DP05.1001	
				<b>5f. WORK UNIT NUMBER</b>	
<b>7. PERFORMING ORGANIZATION NAME(S) AND ADDRESS(ES)</b> Gas Technology Institute 1700 South Mount Prospect Road Des Plaines, IL 60018-1804				<b>8. PERFORMING ORGANIZATION REPORT NUMBER</b> ACL-1-30605-04	
<b>9. SPONSORING/MONITORING AGENCY NAME(S) AND ADDRESS(ES)</b> National Renewable Energy Laboratory 1617 Cole Blvd. Golden, CO 80401-3393				<b>10. SPONSOR/MONITOR'S ACRONYM(S)</b> NREL	
				<b>11. SPONSORING/MONITORING AGENCY REPORT NUMBER</b> NREL/SR-560-38982	
<b>12. DISTRIBUTION AVAILABILITY STATEMENT</b> National Technical Information Service U.S. Department of Commerce 5285 Port Royal Road Springfield, VA 22161					
<b>13. SUPPLEMENTARY NOTES</b> NREL Technical Monitor: T.S. Basso					
<b>14. ABSTRACT (Maximum 200 Words)</b> The contract goal was to further advance distributed generation in the marketplace by making installations more cost-effective and compatible with existing systems. This was achieved by developing innovative grid interconnection and control systems.					
<b>15. SUBJECT TERMS</b> distributed generation; distributed power; interconnection; advanced controller; DG; DP; distributed energy resources; DER; grid; remote monitoring; diagnostics; grid communication					
<b>16. SECURITY CLASSIFICATION OF:</b>			<b>17. LIMITATION OF ABSTRACT</b> UL	<b>18. NUMBER OF PAGES</b>	<b>19a. NAME OF RESPONSIBLE PERSON</b>
<b>a. REPORT</b> Unclassified	<b>b. ABSTRACT</b> Unclassified	<b>c. THIS PAGE</b> Unclassified			<b>19b. TELEPHONE NUMBER (Include area code)</b>