

A0006789



DEPARTMENT OF THE ARMY

NEW ORLEANS DISTRICT CORPS OF ENGINEERS

P.O. BOX 60267

NEW ORLEANS, LOUISIANA 70160-0267

REPLY TO
ATTENTION OF:

SOLICITATION NO. DACW29-94-B-0047

3 May 1994

FOR: LAKE PONTCHARTRAIN, LOUISIANA AND VICINITY, HIGH LEVEL PLAN, LONDON AVENUE OUTFALL CANAL, PARALLEL PROTECTION, MIRABEAU AVENUE TO ROBERT E. LEE BLVD., WEST BANK; MIRABEAU AVENUE TO LEON C. SIMON BLVD., EAST BANK FLOODWALL, ORLEANS PARISH, LOUISIANA

TO OPEN: 8 June 1994, 2:00 P.M., LOCAL TIME AT PLACE OF BID OPENING.

- I. NOTE THE AFFIRMATIVE ACTION PROGRAM REQUIREMENT OF THE EQUAL OPPORTUNITY CLAUSE WHICH MAY APPLY TO THE CONTRACT RESULTING FROM THIS SOLICITATION.
- II. NOTE THE CERTIFICATION OF NONSEGREGATED FACILITIES IN THIS SOLICITATION. Bidders, offerors and applicants are cautioned to note the "Certification of Non-segregated Facilities" in the solicitation. Failure of a bidder or offeror to agree to the certification will render his bid or offer non-responsive to the terms of solicitations involving awards of contracts exceeding \$10,000 which are not exempt from the provisions of the Equal Opportunity clause.

BIDS MUST PROVIDE FULL, ACCURATE AND COMPLETE INFORMATION AS REQUIRED BY THIS SOLICITATION AND ITS ATTACHMENTS. THE PENALTY FOR MAKING FALSE STATEMENTS IN BIDS IS PRESCRIBED IN 18 U.S.C. 1001. (FAR 52.214-4 APR 1984)

DESCRIPTION AND MAGNITUDE OF WORK: THE WORK CONSISTS OF CLEARING SELECTIVE DEMOLITION; CUTTING EXISTING STEEL SHEET PILING; PULLING, CLEANING AND DELIVERING EXISTING STEEL SHEET PILING; DRIVING NEW STEEL SHEET PILING; CONSTRUCTION REINFORCED CONCRETE I-TYPE FLOODWALLS ON EXISTING AND NEW STEEL PILING; CONCRETE SLOPE PAVEMENT, DRIVING STEEL SHEET PILING UNDER SOUTH CENTRAL BELL TELEPHONE CABLES AND NEW ORLEANS SEWERAGE & WATER BOARD 10-FOOT RELOCATING SEWERAGE AND WATER BOARD FEEDER CABLES; MODIFYING EXISTING UTILITIES; DEGRADING EXISTING LEVEES; PLACING EMBANKMENT; FERTILIZING, SEEDING AND MULCHING.

CAUTION TO BIDDERS: In delivery of hand-carried bids, bidders are cautioned to allow sufficient time for delays which may be encountered as a result of frequent trains which are subject to block all access roads to place of bid opening for various lengths of time. Such delays DO NOT permit acceptance or consideration of late bids.

NOTE: ALL WORK UNDER THESE SPECIFICATIONS WILL BE PERFORMED IN ACCORDANCE WITH THE PROVISIONS OF EM 385-1-1 "CORPS OF ENGINEERS SAFETY AND HEALTH REQUIREMENTS MANUAL," DATED OCTOBER 1992.

SOLICITATION, OFFER, AND AWARD (Construction, Alteration, or Repair)	1. SOLICITATION NO. DACW29-94-B-0047	2. TYPE OF SOLICITATION <input checked="" type="checkbox"/> SEALED BID (IFB) <input type="checkbox"/> NEGOTIATED (RFP)	3. DATE ISSUED 5/3/94	PAGE OF PAGES 1/2
--	---	--	--------------------------	----------------------

IMPORTANT - The "offer" section on the reverse must be fully completed by offeror.

4. CONTRACT NO.	5. REQUISITION/PURCHASE REQUEST NO. ED0000-4031-0144	6. PROJECT NO. DACW29-94-B-0047
7. ISSUED BY US ARMY ENGR DIST NEW ORLEANS PO BOX 60267 NEW ORLEANS LA 70160-0267	CODE ISSUE1	8. ADDRESS OFFER TO OFFER1 US ARMY ENGR DIST NEW ORLEANS ATTN CELMN-CT PO BOX 60267 NEW ORLEANS LA 70160-0267
9. FOR INFORMATION CALL:	A. NAME Sheila W. Enclade SC1	B. TELEPHONE NO. (include area code) (NO COLLECT CALLS) (504) 862-1514

SOLICITATION

E: In sealed bid solicitations "offer" and "offeror" mean "bid" and "bidder".

THE GOVERNMENT REQUIRES PERFORMANCE OF THE WORK DESCRIBED IN THESE DOCUMENTS (Title, identifying no., date):

11. The Contractor shall begin performance within 10 calendar days and complete it within 540 calendar days after receiving award, notice to proceed. This performance period is mandatory, negotiable. (See _____.)

12A. THE CONTRACTOR MUST FURNISH ANY REQUIRED PERFORMANCE AND PAYMENT BONDS? (If "YES," indicate within how many calendar days after award in Item 12B.) <input checked="" type="checkbox"/> YES <input type="checkbox"/> NO	12B. CALENDAR DAYS 007
--	-------------------------------

13. ADDITIONAL SOLICITATION REQUIREMENTS:

- A. Sealed offers in original and 0 copies to perform the work required are due at the place specified in Item 8 by 1400 (hour) local time 6/8/94 (date). If this is a sealed bid solicitation, offers must be publicly opened at that time. Sealed envelopes containing offers shall be marked to show the offeror's name and address, the solicitation number, and the date and time offers are due.
- B. An offer guarantee is, is not required.
- C. All offers are subject to the (1) work requirements, and (2) other provisions and clauses incorporated in the solicitation in full text or by reference.
- D. Offers providing less than 30 calendar days for Government acceptance after the date offers are due will not be considered and will be rejected.

14. NAME AND ADDRESS OF OFFEROR (Include ZIP Code) DUNS NO. CODE FACILITY CODE	15. TELEPHONE NO. (Include area code) 16. REMITTANCE ADDRESS (Include only if different than Item 14)
---	--

17. The offeror agrees to perform the work required at the prices specified below in strict accordance with the terms of this solicitation, if this offer is accepted by the Government in writing within _____ calendar days after the date offers are due. (Insert any number equal to or greater than the minimum requirement stated in Item 13D. Failure to insert any number means the offeror accepts the minimum in Item 13D.)

AMOUNTS ▶

18. The offeror agrees to furnish any required performance and payment bonds.

19. ACKNOWLEDGMENT OF AMENDMENTS
(The offeror acknowledges receipt of amendments to the solicitation - give number and date of each)

AMENDMENT NO.	DATE								

20A. NAME AND TITLE OF PERSON AUTHORIZED TO SIGN OFFER (Type or print)	20B. SIGNATURE	20C. OFFER DATE
---	----------------	-----------------

AWARD (To be completed by Government)

21. ITEMS ACCEPTED:

22. AMOUNT	23. ACCOUNTING AND APPROPRIATION DATA
------------	---------------------------------------

24. SUBMIT INVOICES TO ADDRESS SHOWN IN (4 copies unless otherwise specified)	ITEM 26	25. OTHER THAN FULL AND OPEN COMPETITION PURSUANT TO <input type="checkbox"/> 10 U.S.C. 2304(c)() <input type="checkbox"/> 41 U.S.C. 253(c)()
--	------------	--

26. ADMINISTERED BY CODE New Orleans Area Office P.O. Box 60267 Foot of Prytania Street, Rm. 186 New Orleans, LA 70160-0267	27. PAYMENT WILL BE MADE BY Disbursing Officer U.S. Army Engineer District, New Orleans P.O. Box 60267 New Orleans, LA 70160-0267
--	---

CONTRACTING OFFICER WILL COMPLETE ITEM 28 OR 29 AS APPLICABLE

<input type="checkbox"/> 28. NEGOTIATED AGREEMENT (Contractor is required to sign this document and return _____ copies to issuing office.) Contractor agrees to furnish and deliver all items or perform all work, requisitions identified on this form and any continuation sheets for the consideration stated in this contract. The rights and obligations of the parties to this contract shall be governed by (a) this contract award, (b) the solicitation, and (c) the clauses, representations, certifications, and specifications incorporated by reference in or attached to this contract.	<input type="checkbox"/> 29. AWARD (Contractor is not required to sign this document.) Your offer on this solicitation, is hereby accepted as to the items listed. This award consummates the contract, which consists of (a) the Government solicitation and your offer, and (b) this contract award. No further contractual document is necessary.
---	---

30A. NAME AND TITLE OF CONTRACTOR OR PERSON AUTHORIZED TO SIGN (Type or print)	31A. NAME OF CONTRACTING OFFICER (Type or print)
30B. SIGNATURE	30C. DATE
31B. UNITED STATES OF AMERICA	
BY	31C. AWARD DATE

SOLICITATION NO. DACW29-94-B-0047

BIDDING SCHEDULE
 (To be attached to Bid Form)
 LAKE PONTCHARTRAIN, LOUISIANA AND VICINITY, HIGH LEVEL PLAN
 LONDON AVE. OUTFALL CANAL, PARALLEL PROTECTION,
 MIRABEAU AVE. TO LEON C. SIMON BLVD. FLOODWALL,
 ORLEANS PARISH, LOUISIANA

Item No.	Description	Estimated Quantity	Unit	Unit Price	Est. Amt.
0001.	Mobilization and Demobilization	Lump Sum	LS		
0002.	Clearing and Grubbing	Lump Sum	LS		
0003.	Selective Demolition	Lump Sum	LS		
0004.	Pedestrian Bridge Demolition	Lump Sum	LS		
0005.	Embankment, Semicompacted Fill	Lump Sum	LS		
0006.	Structural Excavation and Backfill	Lump Sum	LS		
0007.	Fertilizing, Seeding, and Mulching	8	AC		
0008.	Cutting Off Existing AZ-18 Sheet Piling	Lump Sum	LS		
0009.	Pull, Clean, Salvage and Deliver Existing AZ-18 Steel Sheet Piling	Lump Sum	LS		
0010.	Redrive Existing AZ-18 Steel Sheet Piling	Lump Sum	LS		
0011.	Piling, Steel Sheet, Type PZ-22	187,844	SF		
0012.	Piling, Steel Sheet, Type PSA-23	997	SF		
0013.	Painting	Lump Sum	LS		
0014.	Reinforced Concrete Floodwalls	Lump Sum	LS		
0015.	Concrete Slope Pavement	188	SY		
0016.	Utility Modifications	Lump Sum	LS		

SOLICITATION NO. DACW29-94-B-0047

BIDDING SCHEDULE
 (To be attached to Bid Form)
 LAKE PONTCHARTRAIN, LOUISIANA AND VICINITY, HIGH LEVEL PLAN
 LONDON AVE. OUTFALL CANAL, PARALLEL PROTECTION,
 MIRABEAU AVE. TO LEON C. SIMON BLVD. FLOODWALL,
 ORLEANS PARISH, LOUISIANA

Item No.	Description	Estimated Quantity	Unit	Unit Price	Est. Amt.
0017.	Temporary Relocation Of Feeder Lines	Lump Sum	LS		
0018.	Permanent Relocation Of Feeder Lines	Lump Sum	LS		
0019.	Erosion Control				
0019AA.	First 10,670 Linear Feet	10,670	LF		
0019AB.	All Over 10,670 Linear Feet	2,700	LF		
0020.	Temporary Flood Protection And Cofferdams	Lump Sum	LS		
0021.	Miscellaneous Metals	Lump Sum	LS		
TOTAL				\$	

Award will be made as a whole to one bidder.

NOTE: Bidders shall furnish unit prices for all items listed on schedule of bid items which require unit prices. If the bidder fails to insert a unit price in the appropriate blank for required items but does furnish an extended total or an estimated amount for such items, the Government will deem his unit price to be the quotient obtained by dividing the extended estimated amount for that line item by the quantity. IF THE BIDDER OMITTS BOTH THE UNIT PRICE AND THE EXTENDED ESTIMATED AMOUNT FOR ANY REQUIRED ITEM, HIS BID WILL BE DECLARED NON-RESPONSIVE. The quantity shown for Bid Item No. 0019AB is for evaluation purposes only. Payment for this item will be made on the basis of the actual quantity used.

VARIATIONS IN ESTIMATED QUANTITIES - SUBDIVIDED ITEMS. EFARS 12.402(100)--JUL 89. The Variations in Estimated Quantities clause is applicable only to Item No. 0019.

a. Variation from the estimated quantity in the actual work performed under any second or subsequent sub-item or elimination of all work under such a second or subsequent sub-item will not be the basis for an adjustment in contract unit price.

b. Where the actual quantity of work performed for Item No. 0019 is less than 85% of the quantity of the first sub-item listed under such items, the Contractor will be paid at the contract unit price for that sub-item for the actual quantity of work performed and, in addition, an equitable adjustment in contract price shall be made in accordance with the clause FAR 52.212-11, "Variations in Estimated Quantities".

c. If the quantity of work performed under Item No. 0019 exceeds 115% or is less than 85% of the total estimated quantity of the sub-items under that item, and/or if the quantity of work performed under the second sub-item or any subsequent sub-item under Item No. N/A exceeds 115% or is less than 85% of the estimated quantity of any such sub-item, and if such variation causes an increase or a decrease in the time required for performance of this contract the contract completion time will be adjusted in accordance with the clause FAR 52.212-11, "Variations in Estimated Quantities".

INDEX

DIVISION 2 - SITEWORK

Para. No.	Paragraph Title	Page No.
SECTION C2A - ENVIRONMENTAL PROTECTION		
C2A-1.	SCOPE	C2A-1
C2A-2.	QUALITY CONTROL	C2A-1
C2A-3.	APPLICABLE REGULATIONS	C2A-2
C2A-4.	NOTIFICATION	C2A-2
C2A-5.	NPDES STORM WATER DISCHARGE RULE	C2A-2
C2A-6.	SUBCONTRACTORS	C2A-2
C2A-7.	IMPLEMENTATION	C2A-2
C2A-8.	PROTECTION OF LAND RESOURCES	C2A-3
C2A-9.	PROTECTION OF WATER RESOURCES	C2A-4
C29-10	RESERVED	C2A-4
C2A-11.	PROTECTION OF FISH AND WILDLIFE	C2A-4
C2A-12.	JANITOR SERVICES	C2A-4
C2A-13.	DISPOSAL OF CLEARED AND GRUBBED MATERIAL AND OTHER DEBRIS	C2A-5
C2A-14.	MAINTENANCE OF POLLUTION CONTROL FACILITIES DURING CONSTRUCTION	C2A-5
C2A-15.	REPORTING OF POLLUTION SPILLS	C2A-5
C2A-16.	MEASUREMENT AND PAYMENT POLLUTION PREVENTION PLAN	C2A-5 C2A-6
SECTION C2B - CLEARING AND GRUBBING		
C2B-1.	SCOPE	C2B-1
C2B-2.	QUALITY CONTROL	C2B-1
C2B-3.	GENERAL REQUIREMENTS	C2B-1
C2B-4.	CLEARING	C2B-2
C2B-5.	GRUBBING	C2B-2
C2B-6.	DISPOSAL OF DEBRIS	C2B-3
C2B-7.	MEASUREMENT AND PAYMENT	C2B-4
SECTION C2C - STRUCTURAL EXCAVATION AND BACKFILL		
C2C-1.	SCOPE	C2C-1
C2C-2.	QUALITY CONTROL	C2C-1
C2C-3.	EQUIPMENT	C2C-4
C2C-4.	STRUCTURAL EXCAVATION AND FILL	C2C-5
C2C-5.	EXCAVATION IN BORROW AREAS	C2C-6
C2C-6.	GOVERNMENT-FURNISHED BORROW AREAS	C2C-7
C2C-7.	CONTRACTOR-FURNISHED BORROW AREAS	C2C-8
C2C-8.	EXCAVATION IN OTHER AREAS	C2C-13
C2C-9.	MEASUREMENT AND PAYMENT	C2C-14

INDEX

DIVISION 2 - SITEWORK

Para. No.	Paragraph Title	Page No.
SECTION C2D - FERTILIZING, SEEDING AND MULCHING		
C2D-1.	SCOPE	C2D-1
C2D-2.	QUALITY CONTROL	C2D-1
C2D-3.	AREAS TO BE TREATED	C2D-2
C2D-4.	COMMENCEMENT, PROSECUTION AND COMPLETION	C2D-2
C2D-5.	MATERIALS	C2D-2
C2D-6.	SUBMITTALS	C2D-4
C2D-7.	SPECIAL EQUIPMENT	C2D-4
C2D-8.	PREPARATION OF GROUND SURFACE	C2D-5
C2D-9.	APPLICATION OF FERTILIZER	C2D-5
C2D-10.	SEEDING	C2D-5
C2D-11.	APPLYING AND ANCHORING MULCH	C2D-6
C2D-12.	MOWING	C2D-6
C2D-13.	MEASUREMENT	C2D-7
C2D-14.	PAYMENT	C2D-7
SECTION C2E - EMBANKMENT		
C2E-1.	SCOPE	C2E-1
C2E-2.	QUALITY CONTROL	C2E-1
C2E-3.	EQUIPMENT	C2E-2
C2E-4.	EMBANKMENT FOUNDATION PREPARATION	C2E-4
C2E-5.	EMBANKMENT MATERIALS	C2E-4
C2E-6.	EMBANKMENT CONSTRUCTION	C2E-5
C2E-7.	CROSS SECTIONS AND ZONING OF MATERIALS	C2E-7
C2E-8.	GRADE TOLERANCES	C2E-7
C2E-9.	SLIDES	C2E-7
C2E-10.	MEASUREMENT AND PAYMENT	C2E-8
SECTION C2F - CHAIN-LINK FENCE		
C2F-1.	SCOPE	C2F-1
C2F-2.	APPLICABLE PUBLICATIONS	C2F-1
C2F-3.	MATERIALS	C2F-2
C2F-4.	INSTALLATION	C2F-3
C2F-5.	MEASUREMENT AND PAYMENT	C2F-5

INDEX

DIVISION 2 - SITEWORK

Para. No.	Paragraph Title	Page No.
SECTION C2G - STEEL SHEET PILING		
C2G-1.	SCOPE	C2G-1
C2G-2.	RELATED WORK SPECIFIED ELSEWHERE	C2G-1
C2G-3.	APPLICABLE PUBLICATIONS	C2G-1
C2G-4.	QUALITY ASSURANCE	C2G-1
C2G-5.	SUBMITTALS	C2G-1
C2G-6.	QUALITY CONTROL	C2G-3
C2G-7.	DELIVERY, STORAGE AND HANDLING	C2G-3
C2G-8.	MATERIALS	C2G-4
C2G-9.	INSTALLATION	C2G-6
C2G-10.	QUANTITIES	C2G-9
C2G-11.	MEASUREMENT AND PAYMENT	C2G-9
SECTION C2H - TEMPORARY FLOOD PROTECTION		
C2H-1.	SCOPE	C2H-1
C2H-2.	QUALITY CONTROL	C2H-1
C2H-3.	GENERAL	C2H-1
C2H-4.	DESIGN	C2H-1
C2H-5.	TEMPORARY FLOOD PROTECTION REQUIREMENTS	C2H-2
C2H-6.	INSTALLATION	C2H-3
C2H-7.	WATER REMOVAL	C2H-3
C2H-8.	MEASUREMENT AND PAYMENT	C2H-3
SECTION C2I - MODIFICATIONS TO EXISTING UTILITIES		
C2I-1.	SCOPE	C2I-1
C2I-2.	APPLICABLE PUBLICATIONS	C2I-1
C2I-3.	QUALITY CONTROL	C2I-2
C2I-4.	SUBMITTALS FOR APPROVAL	C2I-2
C2I-5.	QUALITY OF WORK	C2I-2
C2I-6.	PIPE SLEEVES AND ACCESSORIES	C2I-3
C2I-7.	MODIFICATIONS TO EXISTING UTILITIES	C2I-3
C2I-8.	MEASUREMENT AND PAYMENT	C2I-4
SECTION C2J - SELECTIVE DEMOLITION		
C2J-1.	SCOPE	C2J-1
C2J-2.	QUALITY CONTROL	C2J-1
C2J-3.	GENERAL REQUIREMENTS	C2J-1
C2J-4.	EXECUTION	C2J-2
C2J-5.	DISPOSAL OF MATERIALS	C2J-3
C2J-6.	MEASUREMENT AND PAYMENT	C2J-3

INDEX

DIVISION 2 - SITEWORK

Para. No.	Paragraph Title	Page No.
SECTION C2K - INCIDENTAL PAVING		
C2K-1.	SCOPE	C2K-1
C2K-2.	APPLICABLE PUBLICATIONS	C2K-1
C2K-3.	QUALITY CONTROL	C2K-2
C2K-4.	PAVING MATERIALS	C2K-2
C2K-5.	CITY STREETS	C2K-3
C2K-6.	MISCELLANEOUS PAVING	C2K-4
C2K-7.	SIGNS AND BARRICADES	C2K-4
C2K-8.	MEASUREMENT AND PAYMENT	C2K-4

LAKE PONTCHARTRAIN, LOUISIANA AND VICINITY, HIGH LEVEL PLAN
LONDON AVE. OUTFALL CANAL, PARALLEL PROTECTION,
MIRABEAU AVE. TO LEON C. SIMON BLVD. FLOODWALL,
ORLEANS PARISH, LOUISIANA

SECTION C - TECHNICAL SPECIFICATIONS

TABLE OF CONTENTS

DIVISION 1 - NOT USED

DIVISION 2 - SITE WORK

- SECTION C2A - ENVIRONMENTAL PROTECTION
- SECTION C2B - CLEARING AND GRUBBING
- SECTION C2C - STRUCTURAL EXCAVATION AND BACKFILL
- SECTION C2D - FERTILIZING, SEEDING, AND MULCHING
- SECTION C2E - EMBANKMENT
- SECTION C2F - CHAIN-LINK FENCE
- SECTION C2G - STEEL SHEET PILING
- SECTION C2H - TEMPORARY FLOOD PROTECTION
- SECTION C2I - MODIFICATIONS TO EXISTING UTILITIES
- SECTION C2J - SELECTIVE DEMOLITION
- SECTION C2K - INCIDENTAL PAVING

DIVISION 3 - CONCRETE

- SECTION C3A - FORMWORK FOR CONCRETE
- SECTION C3B - REINFORCING STEEL
- SECTION C3C - EXPANSION JOINTS
- SECTION C3D - CAST-IN-PLACE STRUCTURAL CONCRETE

DIVISION 4 - NOT USED

DIVISION 5 - METALS

- SECTION C5A - MISCELLANEOUS METALWORK
- SECTION C5B - METALWORK FABRICATION, MACHINE WORK, AND
MISCELLANEOUS PROVISIONS

DIVISIONS 6 THROUGH 8 - NOT USED

DIVISION 9 - FINISHES

- SECTION C9A - PAINTING

DIVISIONS 10 THROUGH 15 - NOT USED

DIVISION 16 - ELECTRICAL

- SECTION C16A - CATHODIC PROTECTION
- SECTION C16B - ELECTRICAL WORK

INDEX

SECTION C2A - ENVIRONMENTAL PROTECTION

Para. No.	Paragraph Title	Page No.
C2A-1.	SCOPE	C2A-1
C2A-2.	QUALITY CONTROL	C2A-1
C2A-3.	APPLICABLE REGULATIONS	C2A-2
C2A-4.	NOTIFICATION	C2A-2
C2A-5.	NPDES STORM WATER DISCHARGE RULE	C2A-2
C2A-6.	SUBCONTRACTORS	C2A-2
C2A-7.	IMPLEMENTATION	C2A-2
C2A-8.	PROTECTION OF LAND RESOURCES	C2A-3
C2A-9.	PROTECTION OF WATER RESOURCES	C2A-4
C2A-10.	RESERVED	C2A-4
C2A-11.	PROTECTION OF FISH AND WILDLIFE	C2A-4
C2A-12.	JANITOR SERVICES	C2A-4
C2A-13.	DISPOSAL OF CLEARED AND GRUBBED MATERIAL AND OTHER DEBRIS	C2A-5
C2A-14.	MAINTENANCE OF POLLUTION CONTROL FACILITIES DURING CONSTRUCTION	C2A-5
C2A-15.	REPORTING OF POLLUTION SPILLS	C2A-5
C2A-16.	MEASUREMENT AND PAYMENT POLLUTION PREVENTION PLAN	C2A-5 C2A-6

SECTION C2A - ENVIRONMENTAL PROTECTION

C2A-1. SCOPE. The work covered by this section consists of furnishing all labor, materials and equipment, and performing all work required for the prevention of environmental pollution during and as the result of construction operations under this contract except for those measures set forth in other provisions of these specifications. For the purpose of this specification, environmental pollution is defined as the presence of chemical, physical, or biological elements or agents which adversely affect human health or welfare; unfavorably alter ecological balances of importance to man; or degrade the utility of the environment for esthetic and recreational purposes. The control of environmental pollution requires consideration of air, water, and land, and involves noise, solid waste-management and management of radiant energy and radioactive materials, as well as other pollutants.

C2A-2. QUALITY CONTROL.

C2A-2.1 General. The Contractor shall establish and maintain quality control for environment protection to assure compliance with contract specifications and maintain records of his quality control for all construction operations including but not limited to the following:

- (1) Submit plan of Environment Pollution Control (Include in the plan, the inclosed Pollution Prevention Plan requirements).
- (2) Procure applicable Federal, State, and Local regulations on pollution control.
- (3) Air Pollution - Checks made on dust, smoke, noise.
- (4) Water Pollution - Checks made on disposal of water, oil, etc.
- (5) Land Pollution - Checks made on disposal of debris, restoration of temporary construction sites, etc.
- (6) Monitoring in accordance with the National Pollution Discharge Elimination System (NPDES).
- (7) Training Course for Employees.

C2A-2.2 Reporting. The original and two copies of these records, as well as the records of corrective action taken, shall be furnished the Government daily. Format of report shall be as prescribed in the Special Clause entitled "CONTRACTOR QUALITY CONTROL".

C2A-3. APPLICABLE REGULATIONS. In order to prevent, and to provide for abatement and control of any environmental pollution arising from construction activities in the performance of this contract, the Contractor and his subcontractors shall comply with the National Pollution Discharge Elimination System (NPDES) General Permit requirements, all applicable Federal, State, and Local laws, and regulations concerning environmental pollution control and abatement.

C2A-4. NOTIFICATION. The Contracting Officer will notify the Contractor in writing of any non-compliance with the foregoing provisions and the action to be taken. The Contractor shall, after receipt of such notice, immediately take corrective action. Such notice, when delivered to the Contractor or his authorized representative at the site of the work, shall be deemed sufficient for the purpose. If the Contractor fails or refuses to comply promptly, the Contracting Officer may issue an order stopping all or part of the work until satisfactory corrective action has been taken. No part of the time lost due to any such stop orders shall be made the subject of a claim for extension of time or for excess cost of damages by the Contractor.

C2A-5. NPDES STORM WATER DISCHARGE RULE. This project is authorized to discharge storm water associated with construction activity under the terms and conditions imposed by EPA's National Pollutant Discharge Elimination System storm water general permit. A Notice of Intent (NOI) and our Pollution Prevention Plan (PPP) tailored to the construction site is attached at the end of this section. The Contractor shall complete, sign, and submit the NOI to the U.S. Environmental Protection Agency (EPA) forty-eight hours before the start of construction and shall comply with all applicable pollution prevention controls, monitoring, and reporting requirements.

C2A-6. SUBCONTRACTORS. Compliance with the provisions of this section by subcontractors will be the responsibility of the Contractor.

C2A-7. IMPLEMENTATION. Within 10 days after receipt of notice to proceed, or otherwise directed below, the Contractor shall:

- (1) Submit in writing his proposals for implementing environmental pollution control and disposal of debris.

- (2) Meet with representatives of the Contracting Officer to develop mutual understanding relative to compliance with this provision and administration of the environmental pollution control program.

- (3) Submit a signed copy of the NPDES NOI before conducting any professional service identified in the storm water pollution prevention plan.

C2A-8. PROTECTION OF LAND RESOURCES.

C2A-8.1 General. The land resources with the project boundaries and outside the limits of permanent work performed under this contract shall be preserved in their present condition or be restored to a condition after completion of construction that will appear to be natural and not detract from the appearance of the project. The Contractor shall confine his construction activities to areas defined by the plans or specifications, including borrow areas to be cleared. The following additional requirements are intended to supplement and clarify the requirements of Contract Clauses for "PROTECTION OF EXISTING VEGETATION, STRUCTURES, UTILITIES, AND IMPROVEMENTS," "OPERATIONS AND STORAGE AREAS", and "CLEANING UP".

C2A-8.2 Prevention of Landscape Defacement. Except in areas to be cleared and as provided in paragraph C2A-8.3, the Contractor shall not deface, injure, or destroy trees or shrubs, nor remove or cut them without the approval of the Contracting Officer. Felling of trees shall be performed in such a manner as to avoid damage to trees to be left standing. Where trees may possibly be defaced, bruised, injured, or otherwise damaged by the Contractor's operations or equipment; he shall protect adequately such trees. Earth that is displaced into uncleared areas shall be removed. All monuments and markers shall be protected before beginning operations near them. Any trees or other landscape feature scarred or damaged by the Contractor's equipment or operations shall be restored as nearly as possible to its original condition at the Contractor's expense. Trees that are scarred shall be immediately painted with an acceptable tree wound paint. Any trees which are damaged beyond restoration shall be removed and disposed of as directed in paragraph C2A-12.

C2A-8.3 Temporary Excavation and Embankments. If the Contractor proposes to construct temporary roads or embankments and excavation for plant and/or work areas, he shall obtain approval of the Contracting Officer prior to start of such temporary work.

C2A-8.4 Post-Construction Cleanup or Obliteration. The Contractor shall obliterate all signs of temporary construction facilities such as haul roads, work areas, structures, foundations of temporary structures, stockpiles of excess or waste materials upon completion of construction. The Contractor will be required to restore the construction area to near natural conditions which will permit the growth of vegetation.

C2A-8.5 Recording and Preserving Historical and Archeological Finds. All items having any apparent historical or archeological interest which are discovered in the course of any construction activities shall be carefully preserved. The

Contractor shall leave the archeological find undisturbed and shall immediately report the find to the Contracting Officer so that the proper authorities may be notified.

C2A-9. PROTECTION OF WATER RESOURCES.

C2A-9.1 Contamination of Water. The Contractor shall not pollute lakes, ditches, rivers, bayous, canals, groundwater, waterways, or reservoirs with fuels, oils, bitumens, calcium chloride, insecticides, herbicides, or other similar materials harmful to fish, shellfish, or wildlife, or materials which may be a detriment to outdoor recreation.

C2A-9.2 Disposal of Materials. The methods and locations of disposal of materials, wastes, effluents, trash, garbage, oil, grease, chemicals, etc., within the right-of-way limits shall be such that harmful debris will not enter lakes, ditches, rivers, bayous, canals, groundwater, waterways, or reservoirs by erosion, and thus prevent the use of the area for recreation or present a hazard to wildlife.

C2A-9.3 Erosion Control. Surface drainage from cuts and fills within the construction limits, whether or not completed, and from borrow and waste disposal areas, shall, if turbidity producing materials are present, be held in suitable sedimentation ponds or shall be graded to control erosion within acceptable limits. Temporary erosion and sediment control measures such as berms, dikes, drains, hay bales, erosion control fences or curtains, or sedimentation basins, if required to meet the above standards, shall be provided and maintained until permanent drainage and erosion control facilities are completed and operative. The area of bare soil exposed at any one time by construction operations shall not exceed that necessary to perform the work. Stream crossings by fording with equipment shall be limited to control turbidity and in areas of frequent crossings temporary culverts or bridges shall be installed. Any temporary culverts or bridges shall be removed upon completion of the project. Fills and waste area shall be constructed by selective placement to eliminate silts or clays on the surface that will erode and contaminate adjacent streams.

C2A-10. RESERVED.

C2A-11. PROTECTION OF FISH AND WILDLIFE. The Contractor shall at all times perform all work and take such steps required to prevent any interference of disturbance to fish and wildlife. The Contractor will not be permitted to alter water flows or otherwise disturb native habitat adjacent to the project area which are critical to fish or wildlife.

C2A-12. JANITOR SERVICES. The Contractor shall furnish daily janitorial services for all the offices, shops, laboratories, or other buildings being used by the Contractor or

Government employees, whether existing or Contractor furnished, and perform any required maintenance of the facilities and grounds during the life of the contract. Toilet facilities shall be kept clean and sanitary at all times. Services shall be performed at such a time and in such a manner to least interfere with the operations but will be accomplished only when the buildings are in daily use. Services shall be accomplished to the satisfaction of the Contracting Officer. The Contractor shall also provide daily trash collection and cleanup of the buildings and adjacent outside areas, snow removal as required, and shall dispose of all discarded debris in a manner approved by the Contracting Officer.

C2A-13. DISPOSAL OF CLEARED AND GRUBBED MATERIAL AND OTHER DEBRIS. All debris resulting from construction operations on this contract shall be disposed of in accordance with paragraph C2B-6.

C2A-14. MAINTENANCE OF POLLUTION CONTROL FACILITIES DURING CONSTRUCTION. During the life of this contract the Contractor shall maintain all facilities constructed for pollution control under this contract as long as the operations creating the particular pollutant are being carried out or until the material concerned has become stabilized to the extent that pollution is no longer being created. Early in the construction period the Contractor shall conduct a training course that will emphasize all phases of environmental protection.

C2A-15. REPORTING OF POLLUTION SPILLS. In the event that an oil spill or chemical release occurs during the performance of this contract, the Contractor is required to contact the National Response Center, telephone number 1-800-424-8802 as soon as possible, or if telephone communication is not possible, the nearest U.S. Coast Guard office may be contacted by radio to report the spill, (33 CFR 153.203). The Contractor shall comply with any instructions from the responding agency concerning containment and/or cleanup of the spill.

C2A-16. MEASUREMENT AND PAYMENT. No separate measurement or payment will be made for environment protection. Payment for the work covered under this section will distributed throughout the existing bid items.

POLLUTION PREVENTION PLAN

The Contractor shall review the Pollution Prevention Plan for compliance. In addition, the Contractor shall ascertain that his subcontractors have reviewed the plan, and that they comply with its provisions. The Pollution Prevention Plan is as follows:

(1) The project is located in New Orleans, Louisiana, along both sides of The London Ave. Outfall Canal between Mirabeau Ave. and Leon C. Simon Blvd. on East Side and; Mirabeau Ave. and Robert E. Lee Blvd. on West Side. The approximate latitude and longitude of the project site is 30°00'00" and 90°04'00" respectively. The work consists of constructing approximately 8,600 linear feet of reinforced concrete capped I-wall on new sheet piling; approximately 1,360 linear feet of reinforced concrete capped I-wall on existing AZ-18 steel sheet piling; tie in existing floodwall to new I-wall; pulling, salvaging, and delivering approximately 275 linear feet of existing AZ-18 steel sheet pile; pulling approximately 1,700 linear feet of existing sheet pile; demolition of approximately 6,050 linear feet of existing concrete capped I-wall; relocating existing utilities; reshaping the existing levee crown; and fertilizing and seeding. No hauled fill will be required.

(2) The total project area is 27 acres. Two acres are expected to undergo excavation during the construction contract.

(3) The project site consists of existing levees and flat vegetated grass areas. The floodside of the existing levee drains storm water runoff into the London Ave. Outfall Canal, which drains into Lake Pontchartrain. Floodside drainage is covered under our Lake Pontchartrain and Vicinity Environmental Impact Statement (EIS) and Section 404 of the Clean Water Act (CWA). On the protected side of the existing levee, storm water drains into the Sewerage and Water Board drainage system to existing pumping stations. These pumping stations discharge into outfall canals which drain into Lake Pontchartrain. The Contractor will construct erosion control limits as indicated on the contract plans and specifications to provide for abatement and control of any environmental pollution arising from construction activities in the performance of this contract. The erosion control consists of hay bales. The hay bales will be near the construction easement line, connecting at each end to the existing levee to provide a closed system of protection. The Contractor, at his option, may elect to provide a silt fence in lieu of the hay bales. There are no state or local storm water management controls.

(4) Upon completion of the work, all disturbed areas shall be fertilized, seeded and mulched.

(5) The estimate of runoff coefficient for the project site is 0.3. There is no increase in impervious area after construction is completed.

(6) Lake Pontchartrain is the receiving water.

Appendix C — NOI Form Instructions

See Reverse for Instructions

Form Approved. OMB No. 2040-0044
Approval symbol: 0-3-92

NPDES
FORM



United States Environmental Protection Agency
Washington, DC 20460

Notice of Intent (NOI) for Storm Water Discharges Associated with Industrial Activity Under the NPDES General Permit

Submission of this Notice of Intent constitutes notice that the party identified in Section I of this form intends to be authorized by a NPDES permit issued for storm water discharges associated with industrial activity in the State identified in Section II of this form. Becoming a permittee obligates such discharger to comply with the terms and conditions of the permit. ALL NECESSARY INFORMATION MUST BE PROVIDED ON THIS FORM.

I. Facility Operator Information

Name: U.S. ARMY CORPS OF ENGINEERS Phone: 504 862 1265

Address: PO Box 60267 Status of Owner/Operator: F

City: NEW ORLEANS State: LA ZIP Code: 70116

II. Facility/Site Location Information

Name: LP & L LONDON AVE MIRB TO LEON SI

Is the Facility Located on Indian Lands? (Y or N) N

Address: _____

City: NEW ORLEANS State: LA ZIP Code: 70112

Latitude: 30 00 00 Longitude: 90 04 00 Quarter: _____ Section: _____ Township: _____ Range: _____

III. Site Activity Information

MS4 Operator Name: ORLEANS PARISH NEW ORLEANS LA

Receiving Water Body: LAKE PONTCHARTRAIN

If You are Filing as a Co-permittee, Enter Storm Water General Permit Number: _____ Are There Existing Quantitative Data? (Y or N) N Is the Facility Required to Submit Monitoring Data? (1, 2, or 3) 1

SIC or Designated Activity Code: Primary: 60 2nd: _____ 3rd: _____ 4th: _____

If This Facility is a Member of a Group Application, Enter Group Application Number: _____

If You Have Other Existing NPDES Permits, Enter Permit Numbers: _____

IV. Additional Information Required for Construction Activities Only

Project Start Date: 10/20/94 Completion Date: 1/13/95 Estimated Area to be Disturbed (in Acres): 1.0 Is the Storm Water Pollution Prevention Plan in Compliance with State and/or Local Sediment and Erosion Plans? (Y or N) Y

V. Certification: I certify under penalty of law that this document and all attachments were prepared under my direction or supervision in accordance with a system designed to assure that qualified personnel properly gather and evaluate the information submitted. Based on my inquiry of the person or persons who manage the system, or those persons directly responsible for gathering the information, the information submitted is, to the best of my knowledge and belief, true, accurate, and complete. I am aware that there are significant penalties for submitting false information, including the possibility of fine and imprisonment for knowing violations.

Print Name: C. J. NICHOLS, D. F. E. Y.

Date: 11/12/93

Signature: *[Handwritten Signature]*

INDEX

SECTION C2B - CLEARING AND GRUBBING

Para. No.	Paragraph Title	Page No.
C2B-1.	SCOPE	C2B-1
C2B-2.	QUALITY CONTROL	C2B-1
C2B-3.	GENERAL REQUIREMENTS	C2B-1
C2B-4.	CLEARING	C2B-2
C2B-5.	GRUBBING	C2B-2
C2B-6.	DISPOSAL OF DEBRIS	C2B-3
C2B-7.	MEASUREMENT AND PAYMENT	C2B-4

SECTION C2B - CLEARING AND GRUBBING

PART 1 - GENERAL

C2B-1. SCOPE. The work covered by this section consists of furnishing all plant, labor, equipment, and materials, and performing all operations necessary for the clearing and grubbing of the areas specified herein or indicated on the drawings, for the removal and disposal of all cleared and grubbed materials, and for the filling of all holes caused by grubbing operations, as specified herein.

C2B-2. QUALITY CONTROL. The Contractor shall establish and maintain quality control for clearing and grubbing operations to assure compliance with contract requirements, and maintain records of his quality control for all construction operations including but not limited to the following:

(1) Clearing. Station to station limits, transverse clearing limits from applicable baseline; percentage of area complete; type of material.

(2) Grubbing. Station to station limits, transverse grubbing limits from applicable baseline; percentage of area complete; type of material.

(3) Disposition of Cleared and Grubbed Materials. Method and location of disposition; damage to timber or improvements which are not to be cleared.

C2B-2.1 Reporting. The original and two copies of these records of inspections and tests, as well as the records of corrective action taken, shall be furnished to the Government daily. Format of the report shall be as prescribed in the Special Clause entitled "CONTRACTOR QUALITY CONTROL".

C2B-3. GENERAL REQUIREMENTS. All clearing and grubbing work for embankments shall be completed at least 500-feet in advance of embankment and floodwall construction. If regrowth of vegetation or trees occurs after clearing and grubbing and before placement of fill, the Contractor will be required to clear and grub the area again prior to embankment construction, and no payment will be made for this additional clearing and grubbing. In areas around the bridges, the Contractor shall cut down all trees and brush to ground level in a manner that will not disturb the existing ground profile. The method shall be submitted to the Contracting Officer for approval.

C2B-4. CLEARING.

C2B-4.1 General. Clearing, unless otherwise specified, shall consist of the complete removal above the ground surface of all trees, stumps, down timber snags, brush, vegetation, old piling, rip rap, loose stone, abandoned structures, fencing and similar debris. Debris in the canal such as trash, sunken boats, appliances, broken concrete, tires, shopping carts, oil drums, mattresses, and any other obstructions shall be cleared within a 5-foot strip contiguous with the existing floodwall.

C2B-4.2 Vegetation. Vegetation to be removed shall consist of grass, bushes, and weeds. Close-growing grass and other vegetation shall be removed from areas to receive semicompacted or compacted fill to provide a complete bare earth surface immediately prior to foundation preparation. Removal of vegetation from the side of existing levees shall be limited to 1,000-feet in advance of embankment placement or floodwall construction. Acceptance of the vegetation removal operation shall precede the initiation of foundation preparation in the area from which vegetation has been removed.

C2B-4.3 Areas to be Cleared.

C2B-4.3.1 General. The entire area to be disturbed by reshaping of the levee crown, construction of the new floodwall, and removal of the existing floodwall together with strips 5-foot wide contiguous thereto shall be cleared. The Contractor shall trim tree limbs to a minimum within the construction servitude lines, necessary for maintaining the minimum clearance for the construction.

C2B-4.3.2 Borrow Areas. Only those portions of borrow areas from which borrow material will actually be obtained under this contract shall be cleared to the extent necessary to provide materials free from unsuitable matter as described in paragraph C2E-5.2.

C2B-5. GRUBBING.

C2B-5.1 General. Grubbing shall consist of the removal of all stumps, roots, buried logs, old piling as shown on plans, old paving, old foundations, pipes, drains, and other unsuitable matter as described in paragraph C2E-5.2.

C2B-5.2 Areas to be Grubbed. Grubbing shall be performed within the limits of the floodwall together with the 5-foot strips contiguous thereto. All roots and other projections over 1½-inches in diameter shall be removed to a depth of 3-feet below the natural surface of the ground or surface of existing embankments and to a depth of 3-feet below the subgrade for the foundation of structures. The areas to be grubbed are those

specific areas within the limits specified herein above from which trees, stumps, down timber, snags, old piling, abandoned structures, and other projections have been removed.

C2B-5.3 Borrow Areas. Only those portions of borrow areas from which borrow material will actually be obtained under this contract shall be cleared to the extent necessary to provide materials free from unsuitable matter as described in paragraph C2E-5.2.

C2B-5.4 Pipes and Drains. The Contractor shall inform the Contracting Officer of all pipes and drains not shown on the drawings which are encountered during grubbing. Such pipes and drains shall not be removed or disturbed until so directed by the Contracting Officer. Material excavated in the process of removing pipes and drains and found to be unsuitable shall be disposed of as specified in paragraph C2B-6.1. Material excavated and found to be suitable shall be used to refill the excavated area.

C2B-5.5 Filling of Holes. All holes caused by grubbing operations and removal of pipes and drains shall be backfilled with suitable material in 12-inch layers to the elevation of the adjacent ground surface, and each layer compacted to a density at least equal to that of the adjoining undisturbed material.

PART 2 - PRODUCTS (NOT USED)

PART 3 - EXECUTION

C2B-6. DISPOSAL OF DEBRIS.

C2B-6.1 General. All debris resulting from clearing and grubbing operations shall, be disposed of by removal from the site.

C2B-6.2 Removal from Site of Work. The Contractor shall remove all debris from the site of the work. Such disposal shall comply with all applicable Federal, State, and Local laws. The Contractor shall, at his option, either retain for his own use or dispose of by sale or otherwise, such materials of value. The Government is not responsible for the protection and safekeeping of any materials retained by the Contractor. If debris from clearing operations is placed on adjacent property, the Contractor shall obtain, without cost to the Government, additional right-of-way for such purposes. Such material shall be so placed as not to interfere with roads, drainage or other improvements and in such a manner as to eliminate the possibility of its entering into channels, ditches, or streams. The Contractor shall submit written evidence to the Contracting Officer that he has obtained

from the property owner permission for disposal of material on the owner's property. The written evidence shall consist of an authenticated copy of the conveyance under which the Contractor acquired the property rights and access thereto, prepared and executed in accordance with the laws of the State of Louisiana. If temporary rights are obtained by the Contractor, then the period of time shall coincide with the Special Clause entitled "COMMENCEMENT, PROSECUTION AND COMPLETION OF WORK" hereof, plus any extension authorized under Contract Clause entitled "DEFAULT (FIXED-PRICE CONSTRUCTION)", subparagraph (b) (1). However, delay resulting from acquisition of additional rights-of-way for alternate disposal areas will not qualify as excusable delays.

C2B-7. MEASUREMENT AND PAYMENT. No measurement will be made for clearing, grubbing, and vegetation removal. Payment for clearing, grubbing, and vegetation removal will be made at the contract lump sum price for "Clearing and Grubbing". Price and payment shall constitute full compensation for furnishing all plant, labor, material and equipment and performing all operations necessary for clearing, grubbing, and vegetation removal of the areas specified herein or indicated on the drawings, for removing and disposing of all cleared, grubbed, and vegetation removal materials, and for filling holes resulting from grubbing operations.

INDEX

SECTION C2C - STRUCTURAL EXCAVATION AND BACKFILL

Para. No.	Paragraph Title	Page No.
C2C-1.	SCOPE	C2C-1
C2C-2.	QUALITY CONTROL	C2C-1
C2C-3.	EQUIPMENT	C2C-4
C2C-4.	STRUCTURAL EXCAVATION AND FILL	C2C-5
C2C-5.	EXCAVATION IN BORROW AREAS	C2C-6
C2C-6.	GOVERNMENT-FURNISHED BORROW AREAS	C2C-7
C2C-7.	CONTRACTOR-FURNISHED BORROW AREAS	C2C-8
C2C-8.	EXCAVATION IN OTHER AREAS	C2C-13
C2C-9.	MEASUREMENT AND PAYMENT	C2C-14

SECTION C2C - STRUCTURAL EXCAVATION AND BACKFILL

PART 1 - GENERAL

C2C-1. SCOPE. The work covered by this section consists of furnishing all plant, labor, materials, equipment, and performing all operations necessary for structural excavation and fill, excavation and backfill for construction of the floodwalls, and other incidental work as specified herein or as shown on the drawings.

C2C-2. QUALITY CONTROL. The Contractor shall establish and maintain quality control for excavation operations to assure compliance with contract requirements and maintain records of his quality control for all construction operations including but not limited to the following:

- (1) Equipment. Type, size, and suitability for construction of the prescribed work.
- (2) Excavation. Check grade, slopes, and dimensions for compliance with design sections.
- (3) Grade Tolerances. Check fills to determine if placement conforms to prescribed grade and design section.
- (4) Construction. Layout, maintaining existing drainage, moisture control, thickness of layers, spreading and compacting.
- (5) Classification of soils, placing and compacting of structural fill, and density tests.
- (6) Control Testing.

(a) Contractor Testing. The Contractor shall perform all control testing such as soil classification, control compaction curves, and in-place density. The Contractor shall perform as a minimum, the specified number of each of the tests to demonstrate to the satisfaction of the Contracting Officer that the work is in compliance with the specifications. Testing shall be performed by a Government approved testing agency or organization. Criteria used for obtaining Government approval shall be in accordance with ASTM D 3740. Tests performed shall be pursued in a such a manner that the results are obtained and furnished to the Government within 24 hours. The following tests are required to provide adequate control:

1. Soil Classification Tests. Determination of soil classification shall be in accordance with the Unified Soil Classification System. Atterberg Limits Test required for soil

classification shall be performed in accordance with U.S. Army Corps of Engineers Laboratory Soil Testing Manual. One Atterberg test shall be obtained from the sample material used for each control compaction curve and one shall be obtained from the sample material used for each in-place density test. If the Nuclear Method is used, the material to be tested shall come from within a radius of 12-inches of the center of the in-place density test site. The soil classification obtained from in-place density tests will serve as the basis for determining the applicable control compaction curves.

2. Control Compaction Curves - Compacted Fills.

Control compaction curves shall be established in accordance with ASTM D 698. Two control compaction curves will be required for each type of random material from each source. Where construction operations result in blending of several types of material prior to or during fill placement within the embankment design sections, two control compaction curves will be required for each resulting blend of material and will be utilized in lieu of those required for the "unblended materials". The average of the two tests shall be the controlling optimum moisture content and maximum density, subject to verification by the Contracting Officer.

3. In-Place Density Tests.

In-place density tests for backfill material shall be made in accordance with ASTM D 2922 or ASTM D 1556. The minimum frequency for performing the density test shall be two density tests per lift per 500 linear feet for the length of the floodwall for the structural fill placed next to the floodwalls. Lifts which are placed on the opposite sides of the floodwall will be considered as individual lifts for each side of the floodwall. The location of the test shall be representative of the area being tested or as directed by the Contracting Officer. Density tests performed in accordance with ASTM D 2922 shall be verified by in place density test results obtained from ASTM D 1556. One verification test will be required for every ten nuclear density tests performed. The nuclear test and the verification test shall be conducted concurrently at the same site and on the same material.

4. Moisture Content Tests.

Moisture content tests at each density test location shall be taken to assure compliance with requirements for fill placement within the design sections as specified in paragraph C2C-4.2. Determination of moisture content shall be performed in accordance with ASTM D 2216 in conjunction with the ASTM sand cone in-place density test and ASTM D 3017 or ASTM D 2216 in conjunction with the ASTM D 2922 nuclear in-place density test.

5. Density and Water Content Control.

For each in-place density test the Contractor shall determine the percent of ASTM D 698 maximum dry density and the percent plus or minus of optimum water content using the control compaction curve for the same type material. The results of the in-place density and

moisture content test shall be reported to the Contracting Officer's representative by the end of the working day following the in-place density test.

6. In addition to the above frequency of tests, additional tests are required as follows:

a. Where the Contracting Officer's representative has reason to doubt the adequacy of the compaction or moisture control.

b. Where the Contractor is concentrating fill operations over a relatively small area.

c. Where special compaction procedures are being used.

d. When embankment materials change substantially, the Contracting Officer may direct additional testing.

e. Areas not meeting the specified density shall be retested at no additional cost to the Government, after corrective measures have been applied.

C2C-2.1 Reporting. The original and two copies of these records of inspections and tests, as well as the records of corrective action taken, shall be furnished to the Government daily. Format of the report shall be as prescribed in the Special Clause entitled "CONTRACTOR QUALITY CONTROL".

C2C-2.2 Applicable Publications. The following publications of the issues listed below, but referred to before and thereafter by the basic designation only, form a part of this specification to the extent indicated by the references thereto:

C2C-2.2.1 American Society for Testing and Materials (ASTM) Standard.

- | | |
|-----------|---|
| D 698-91 | Laboratory Compaction Characteristics of Soils Using Standard Effort (12,400ft-lbf/ft ³) (600 kN-m/m ³) |
| D 1556-90 | Density and Unit Weight of Soil in Place by the Sand-Cone Method |
| D 2216-90 | Laboratory Determination of Water, (Moisture) Content of Soil and Rock |
| D 2922-91 | Density of Soil and Soil-Aggregate in Place by Nuclear Methods (Shallow Depth) |

D 3017-88 Water Content of Soil and Rock In-Place By
Nuclear Methods(Shallow Depth)

D 3740-88 Evaluation of Agencies Engaged in the Testing
and/or Inspection of Soil and Rock as Used in
Engineering Design and Construction

C2C-2.2.2 U.S. Army Corps of Engineers Laboratory Soils
Testing Manual.

EM 1110-2-1906, Atterberg Limits Test
Rev. 1 May 1980

PART 2 - PRODUCTS

C2C-3. EQUIPMENT.

C2C-3.1 Hand Tampers. Hand tamping or other approved methods shall be used in the preparation for compaction of fill within 2-feet of any floodwall or structure, and for utility lines where vehicular equipment cannot be used. These hand tampers should be power driven hand operated type.

C2C-3.2 Alternative Compaction Equipment. The Contractor may propose to use alternative types of compaction equipment not included in these specifications. The suitability of the alternative equipment shall be demonstrated to the Contracting Officer by a field test conducted by and at the expense of the Contractor. The alternative compaction equipment shall be capable of properly compacting the soil so that no planes of weakness or laminations are formed in the fill. The field test shall consist of compacting a minimum of three layers of an area of embankment with the alternative type equipment. Testing and inspection of the area shall then be performed by the Contractor at no additional cost to the Government. Procedures for constructing and testing the area will be provided by the Contracting Officer. Each proposed alternative type of equipment shall be capable of compacting a layer of soil not less than 8-inches thick to 90 percent maximum density as determined by ASTM 698. If sufficient previous testing has been performed on the alternative compaction equipment proposed by the Contractor to verify the suitability of the equipment to the Contracting Officer's satisfaction, the Contracting Officer may determine that the above-specified field test is not required.

PART 3 - EXECUTION

C2C-4. STRUCTURAL EXCAVATION AND FILL.

C2C-4.1 Structural Excavation. The Contractor shall make all excavations required for construction of the new floodwall, and for removal of obstructions on or near the surface which prevent driving piles to their required penetration. The Contractor shall design and provide all necessary shoring, bracing, sheeting, underpinning, and/or supports as may be required for the work. The Contractor shall also provide, as necessary, such sumps, pumps, or ditches which may be required to dewater the excavations. Suitable material from required structural excavation shall be used in the structural fill. Unless otherwise specified material classified by the Unified Soil Classification System (as shown on the Soil Boring Legend) as gravels (GW, GP, GM), and sands (SW, SP, SM) shall not be used unless suitably blended with less pervious material to the extent that it no longer classifies as these materials. Materials determined to be unsuitable by the Contracting Officer shall be ordered wasted.

C2C-4.2 Structural Fill, I-Wall Section. Structural backfill is defined as any soil material which is placed within 2-feet of the vertical faces of the concrete I-wall section. The Contractor shall fill all excavations to final grade. Structural fill shall be placed in successive layers not to exceed 8-inches and compacted to 90 percent maximum density as determined by ASTM D 698, at a moisture content of plus 5 to minus 3 percent of optimum. Material for structural fill shall be obtained from the required structure excavation, and shall be free from unsuitable material. Structural fill shall not be placed in water or upon frozen ground. Structural fill shall not be placed against concrete structures for a minimum of 14 days after the concrete is placed. The Contractor may at his expense place fill sooner if he furnishes and tests cylinders to demonstrate that the concrete has achieved 75 percent of its design capacity.

C2C-4.3 Unsuitable Materials. Materials which are classified as unsuitable structural fill are defined as material containing organic matter, sticks, branches, roots, brick, concrete, rock, and other debris.

C2C-4.3.1 Frozen Materials. Under no circumstances shall frozen earth, snow or ice be placed in the fill. The Contracting Officer may require the wasting of frozen material.

C2C-4.4 Dressing. The fill shall be brought to not less than the prescribed design cross section at all points. Unreasonable roughness of surface shall be dressed out to permit fertilizing and seeding operations.

C2C-4.5 Shoring. The Contractor shall provide all necessary shoring, bracing, sheeting, underpinning, and/or supports as may be required for the construction of the floodwall. A design and the method of installing the proposed shoring shall be submitted to the Contracting Officer for approval at least 30 days prior to its actual intended use. Upon completion of the structure, the Contractor shall remove the shoring at the direction of the Contracting Officer or his representative. The void created by the shoring removal shall be backfilled and the surface area shall be treated to match the existing surface prior to the installation of the shoring. Excavations more than 5-feet deep shall be shored unless shown otherwise on the drawings. Additional requirements for shoring shall be in accordance with Section 25, "Excavations" of EM 385-1-1, the Corps of Engineers Safety Manual.

C2C-5. EXCAVATION IN BORROW AREAS.

C2C-5.1 General. The Contractor shall submit an excavation plan in writing for approval by the Contracting Officer, allowing 30 days for review, and shall not begin excavation until the Contracting Officer's approval has been received. The plan shall contain, as a minimum, the following:

(1) A written statement within 30 days after receipt of notice to proceed indicating whether the Contractor proposes to use:

- (a) Government-furnished borrow areas;
- (b) Contractor-furnished borrow areas; or
- (c) a combination of Government-furnished and Contractor-furnished borrow areas.

(2) For Contractor-furnished borrow areas, the plan shall contain all the information required by paragraph C2C-7.1 and the Contractor's proposals for implementing Section C2A, "ENVIRONMENTAL PROTECTION", insofar as that section applied to borrow areas.

(3) The Contractor's proposed methods for draining and keeping dry during excavation the borrow areas excavated under this contract.

(4) The Contractor's proposed methods for draining borrow areas excavated under this contract which may be flooded by high river stages.

(5) The Contractor's proposals for making optimum use of available borrow, including the Contractor's proposed methods for smoothing the bottom of the borrow pits after having completed use of the pits.

(6) A plan for the stockpiling embankment material before it is transported to the project site to included locations, stockpile heights, slopes and limits.

C2C-5.2 Clearing Borrow Areas. Borrow areas shall be cleared to the extent necessary to provide materials free from unsuitable matter as described in paragraph C2C-4.3. Certain stumps and areas containing masses of organic matter or other unsuitable material may be left in place upon approval of the Contracting Officer.

C2C-5.3 Unsuitable Materials. Materials from borrow areas or required excavation which, as defined in paragraph C2C-4.3, are unsuitable for structure backfill material will be ordered wasted and shall be disposed of in abandoned portions of the borrow pit. The material shall be shaped so that its surface is free from abrupt changes in grade and shall be sloped to drain. Where possible, unsuitable materials in borrow areas shall not be removed.

C2C-6. GOVERNMENT-FURNISHED BORROW AREAS

C2C-6.1 Use of Bonnet Carre' Spillway as Borrow Area. Government-furnished borrow and stockpile areas for exclusive use in the performance of this contract have been established in the Bonnet Carre' Spillway at the location and within the representative limits shown on the drawings. Borrow and stockpiling from this source shall be performed in accordance with applicable notations on the drawings and as provided in these specifications. No stockpiling of material at right angles to the spillway axis will be permitted during these months. Sand haulers' permits grant a permittee 20 calendar days in which to remove equipment and stockpiled sand from his tract after the date of receipt of the notice from the Government to vacate a tract. The Contractor shall give written notice to the Contracting Officer that will allow at least 30 calendar days for affected sand hauler permit termination and grant obstructed occupancy of the borrow area to the Contractor. Should the Contractor elect not to use this Government-furnished source of borrow or any portion of it, he may be required to relinquish any of all portions of this borrow area for resumption of permitted sand removal or use by other Government contractors. Excavation grade shall be to slope and depth shown on the drawings. For excavation in the Bonnet Carre' Spillway borrow area, a tolerance of 1-foot above or below the prescribed grade and cross section shown will be permitted. To maximize the suitable clay yield of the borrow area for structural backfill, stripping of overlaying materials in advance of clay removal shall be limited to two weeks and erosion from stockpiles of unsuitable material shall be diked or ditched to drain away from suitable borrow material. The Contractor shall maintain a minimum of 10-feet between the toe of unsuitable material and top of the borrow area cut. Stockpiles of clay shall be limited to a two week supply between January 1 and June 30 of

each year to assure opportunity for removal and conservation of materials in the event operation of the spillway becomes necessary. A permittee may be allowed to remove stripped material, provided that removal does not interfere with contract work. River water may seep through the Bonnet Carre' Structure when the river stage at Bonnet Carre' is at elevation +16.0 NGVD or above, and if and when spillway operation requires demobilization and remobilization in the Bonnet Carre Spillway borrow area, and equitable adjustment under the provision entitled "DEFAULT (FIXED-PRICE CONSTRUCTION)" of the Contract Clauses will be made. The Contractor shall cooperate and coordinate his use of mutual haul road with others.

C2C-6.2 Borrow Areas Requirements. Borrow areas shall conform to requirements prescribed herein and as shown on the drawings. The permissible depths in the borrow areas are indicated on the drawings, but the right is reserved in accordance with the provision entitled "CHANGES" of the Contract Clauses, to modify the permissible depths in accordance with subsurface conditions determined as work proceeds. The bottom of the pits excavated under this contract shall be left relatively smooth. Abrupt changes in grade shall be avoided. The borrow areas excavated under this contract shall be drained and kept dry during excavation, as excavation will not be permitted in water nor shall excavated material be scraped, dragged or otherwise moved through water. Drainage of borrow areas shall be accomplished by ditching, sump pumping or other approved methods. The borrow areas excavated under this contract and flooded from high river stages shall be drained and allowed to dry as quickly as practicable after the high river stage has passed. Abrupt changes in borrow area alignment shall be avoided. To make optimum use of available borrow, the excavation of the borrow areas, shall be made continuous throughout the length of the borrow areas to the permissible borrow depths, and at the width necessary to provide the required quantity of suitable material, and in such a manner That all suitable available material within the required width will be utilized.

C2C-7. CONTRACTOR-FURNISHED BORROW AREAS.

C2C-7.1 General. The Contractor, at his option, may use borrow areas other than those indicated provided that their locations and dimensions are approved by the Contracting Officer. All costs arising or growing out of the use of Contractor-furnished borrow areas shall be borne by the Contractor. The Contracting Officer will exercise strict quality control to assure that the Contractor-furnished borrow sites are of a size sufficient only to complete work covered under this contract. The character of the material therein, as indicated by Government-selected tests of soil samples performed by an approved independent laboratory at the Contractor's expense, must be equal

to or better than the Government-furnished borrow material. The Contractor shall submit the information described in paragraphs C2C-7.4 and C2C-7.5 to the Contracting Officer for review and approval.

C2C-7.2 Time Extensions. No time extension to the contract completion date will be granted to the Contractor for delays incurred in obtaining Contractor-furnished borrow areas. The Contractor shall be solely responsible for any and all damages, claims for damages, and liability of any nature whatsoever arising from or growing out of the use of borrow areas other than those furnished by the Government.

C2C-7.3 Approval. Approval of the location and dimensions of the Contractor-furnished borrow area shall neither relieve the Contractor from his obligation to furnish satisfactory material to the project, commit the Government in any way to the acceptance of unsatisfactory material, nor commit the Government to the acceptance of the responsibility for the character, quantity, or availability of material in Contractor-furnished borrow areas.

C2C-7.4 Submittal Package Requirements. The following information shall be submitted by the Contractor in a single, complete package in quadruplicate. The Contractor shall allow a minimum of ninety (90) days, after the receipt of the package, for the Government's review, processing, and approval.

- (1) Property rights documentation.
- (2) Zoning classification.
- (3) Louisiana Department of Transportation and Development (LADOTD) permits and approvals.
- (4) Maps as follows:
 - a. Location and Direction map.
 - b. Topographic map(s) with scale of 1:24,000.
 - c. Layout map with dimensions and property reference points.
 - d. Soil boring location map.
- (5) Plotted cross sections.
- (6) Soil boring logs and report, and laboratory soil classification test results.
- (7) Cultural resources investigation report.

- (8) Certified agronomist test results.
- (9) Excavation plan.
- (10) Environmental protection plan.

C2C-7.5 Submittal Package Requirements in Detail.

C2C-7.5.1 Property Rights Documentation. Written evidence that the Contractor has acquired the property rights and access to the proposed alternate borrow area(s) he intends to use on this contract. The written evidence shall consist of an authenticated copy of the land owner's conveyance under which the land owner has acquired the property rights and access thereto, prepared and executed in accordance with the laws of the State of Louisiana; and written evidence that the Contractor has acquired the property rights and access thereto by agreement with the land owner. This agreement between the land owner and the Contractor may be provisional on the Government's approval of the Contractor's proposed borrow area. If temporary rights are obtained by the Contractor, then the period of time should coincide with the Special Clause entitled "COMMENCEMENT, PROSECUTION AND COMPLETION OF WORK", hereof, plus a reasonable time for any extension granted for the completion of the contract work.

C2C-7.5.2 Zoning Classification. Written evidence that the property intended for use as an alternate borrow area contains the proper zoning classification that will allow the Contractor to excavate the property and use it as a borrow area. This evidence shall consist of a letter from the local land zoning office stating the zoning classification of the proposed alternate borrow area.

C2C-7.5.3 Maps. The following maps shall be provided:

(1) A map of the general area giving detailed instructions on how to get to the alternate borrow area from the nearest major highway.

(2) A topographic map(s) (quadrangle) with a scale of 1:24,000 with the location of the borrow area superimposed.

(3) A layout map of the borrow area showing the dimensions of the borrow area, locations of soil borings, and reference points tied to the property boundaries. The map shall show the location and dimensions of any haul road that exists or is intended to be constructed to help the Contractor in his hauling operation. The map shall also show the location and dimensions of any protection dikes which will help the Contractor drain and keep the borrow area dry.

(4) The most recent parish surface soils map with the location of the borrow area superimposed.

C2C-7.5.4 Plotted Cross Sections. Plotted cross sections of the alternate borrow area in sufficient quantity (maximum of 300 ft. intervals) to give a true representation of the topography of the alternate borrow area. The proposed excavation lines shall be superimposed on these cross sections, so that an accurate computation of the available material can be made.

C2C-7.5.5 Soil Boring Logs and Report, and Laboratory Soil Classification Test Results. Soil borings of the Contractor-furnished borrow area, witnessed by a Government representative, shall be made by the Contractor to a depth of at least 5-feet below the depth of planned excavation. The borings shall be furnished by the Contractor at a spacing that will adequately define the material in the pit but in no case spaced greater than 500-feet on centers. Borings along the proposed borrow area boundary shall be located no farther than one-half of the boring spacing in the pit or 250-feet, whichever is less. Soil samples from these borings will be classified in accordance with the Unified Soil Classification system and shall include water content determinations based on the dry weight of the representative soil samples, taken at each 2.5-feet of depth of the boring or change in strata. These representative soil samples shall be submitted to an approved independent laboratory, properly labeled and sealed in an airtight container to preserve the natural water content for laboratory determination. The resulting classification and water content determination and borrow area boring logs shall be submitted to the Contracting Officer for determination of the suitability of the material for construction use. Soil boring locations shall be shown on the layout map required by paragraph C2C-7.5.3(3).

C2C-7.5.5.1 If examination of the submitted soil samples confirms that the material in the Contractor-furnished borrow area is as or less permeable than the material in the Government-furnished borrow area, the Contractor-furnished borrow material may be used in levee embankment provided the quality of the material is otherwise satisfactory. However, if the material in the Contractor-furnished borrow area is more permeable than material in the Government-furnished borrow area indicated, the Contractor-furnished borrow material may be used in landside berms provided the quality of the material is otherwise satisfactory, but shall not be used in levee embankment regardless of its quality.

C2C-7.5.6 Cultural Resources Investigation Report. A written report by a professional archeologist which meets the report requirements of the Louisiana Division of Archeology and explains the results of the field investigation made by him of the Contractor-furnished borrow area. The field investigation shall consist of a comprehensive inspection of the proposed borrow area, including access roads, and shall be adequate enough to determine if any cultural resources that are eligible for listing in the National Register will be impacted. This report will be evaluated

by the Contracting Officer and the Corps' cultural resources specialists to determine the adequacy of the cultural resources investigation to discharge the Corps' cultural resource responsibilities. The Corps' cultural resource specialist will consult with the Louisiana State Historic Preservation Officer (SHPO) and all other required agencies. All costs of mitigating adverse effects to cultural resources, if required, shall be borne by the Contractor. It is the responsibility of the contractor to ensure that significant cultural resources are not impacted by his proposed excavation.

C2C-7.5.7 Hazardous, Toxic, and Radiological Waste Assessment. An initial Hazardous, Toxic, and Radiological Waste Assessment (HTRW #001) was prepared for the project on 30 July 1993. Findings indicated minimal risk exists for encountering hazardous or toxic wastes during the course of constructing the project.

C2C-7.5.8 Certified Agronomist Test Results. Written results of tests performed by a certified public or private agronomist to prescribe whatever modifications, if any, will have to be made to Section C2D, "FERTILIZING AND SEEDING, AND MULCHING" to insure a satisfactory growth of grass. The substitute borrow area material shall be free of deleterious chemicals which would impede the satisfactory growth of grass. All costs associated with the testing of the alternate borrow area material and modifying Section C2D, "FERTILIZING, AND SEEDING AND MULCHING" to insure an adequate growth of grass shall be borne by the contractor.

C2C-7.5.9 Excavation Plan. The Contractor shall provide the Contracting Officer a plan for clearing, stripping, and excavating materials from the proposed Contractor-furnished borrow area. In his plan, the Contractor shall show work areas, stockpile areas, etc, all within his leased or owned property boundaries. The Contractor shall not work or move material outside the boundaries of the approved limits of his borrow area. The Contractor shall indicate in writing and show on his layout plans details of the following:

(1) A stockpile plan for cleared and stripped material and debris to include disposal areas.

(2) The locations for disposal of unsuitable material discovered in the borrow area. Location of any haul roads constructed to help the Contractor in his hauling operations.

(3) A plan for stockpiling embankment material before it is transported to the project site to include locations, stockpile heights, slopes, and limits.

(4) The method and route for transporting the excavated material from the Contractor-furnished borrow area to the project site.

(5) The proposed methods for draining and keeping dry during excavation the borrow area excavated under this contract, including any protection dikes constructed to alleviate drainage problems.

(6) A complete list of excavation and transportation equipment planned for use in his operations.

(7) The Contractor's proposed sequence of excavating the borrow area showing starting and ending work locations.

(8) A list of the permits required and issuing office.

C2C-7.5.10 Environmental Protection Plan. A proposal for implementing Section C2A, "ENVIRONMENTAL PROTECTION" of this contract insofar as that section applies to borrow areas.

C2C-7.6 Government Performed Environmental Assessment. The Government is required to perform an environmental assessment on all new proposed borrow areas without regard to the source. An environmental assessment requires a minimum of ninety (90) days for review, processing, and approval time by the Government. Before the Government will commence the environmental assessment, the contractor must submit all of the above items as a single, complete package. The Contracting Officer reserves the right to disapprove the use of Contractor-furnished borrow areas located in woodlands or wetlands.

C2C-8. EXCAVATION IN OTHER AREAS. Excavation from other areas shall consist of degrading the existing levee, and removal of unsuitable materials defined in paragraph C2C-4.3. Care shall be exercised by the Contractor in excavating to the lines and grades shown and in removing earth materials so as not to excavate below the grades specified or depth directed. Excavation below the lines and grades specified or the depth directed shall be backfilled by the Contractor at his expense. The grade tolerances for levee excavation shall be as specified in paragraph C2C-8.4.

C2C-8.1 Suitable Materials. Excavated materials which are suitable for incorporation in the structural fill or levee embankment shall either be placed directly therein, or stockpiled at no additional cost to the Government and subsequently used in the backfill or fill as required.

C2C-8.2 Unsuitable Materials. Materials from required excavation which, as defined in paragraph C2C-4.3, are unsuitable for structural fill or levee embankment shall be disposed in accordance with paragraph C2B-6.2.

C2C-8.3 Levee Excavation. Levee excavation below the lines and grades specified shall be brought to grade with suitable material with each layer placed and compacted as specified in paragraph C2C-4.2.

C2C-8.4 Grade Tolerances. All embankments shall be constructed to the design grade and cross section shown on the drawings. For structural backfill, at all points, a tolerance of 3/10 of 1-foot above the prescribed design grade and cross section shown will be permitted in the final dressing provided that the crown of the levee drains, there are no abrupt humps or depressions in surfaces or bulges in the width of the crown, and the side slopes are uniform. Any partial fill or temporarily stockpiled material placed within the design section shall not exceed the design grade or design slopes of the embankment by more than 6-inches, and shall have side slopes not steeper than 1V on 3H.

C2C-9. MEASUREMENT AND PAYMENT.

C2C-9.1 Structural Excavation and Backfill. Structural excavation and backfill as defined herein will not be measured for payment. Payment for structural excavation and backfill will be made at the contract lump sum price for "Structural Excavation and Backfill". Price and payment shall include all cost of excavation for the floodwall, full cost of transporting and placing backfill, compacting and dressing, control testing and all other cost incident thereto.

C2C-9.2 Waste Materials. Materials ordered wasted by the Contracting Officer will be measured for payment by the cubic yard, and quantities will be determined by the average end area method. The basis of measurement will be a survey of the area prior to and after the excavation. Payment for materials ordered wasted will be made by an equitable adjustment under the provision entitled "CHANGES" of the Contract Clauses.

C2C-9.3 Excavation in Borrow Areas. No separate measurement or payment will be made for excavation in borrow areas required by this section. Payment shall be included in the applicable contract prices for the items of which the work is incidental.

INDEX

SECTION C2D - FERTILIZING, SEEDING AND MULCHING

Para. No.	Paragraph Title	Page No.
C2D-1.	SCOPE	C2D-1
C2D-2.	QUALITY CONTROL	C2D-1
C2D-3.	AREAS TO BE TREATED	C2D-2
C2D-4.	COMMENCEMENT, PROSECUTION AND COMPLETION	C2D-2
C2D-5.	MATERIALS	C2D-2
C2D-6.	SUBMITTALS	C2D-4
C2D-7.	SPECIAL EQUIPMENT	C2D-4
C2D-8.	PREPARATION OF GROUND SURFACE	C2D-5
C2D-9.	APPLICATION OF FERTILIZER	C2D-5
C2D-10.	SEEDING	C2D-5
C2D-11.	APPLYING AND ANCHORING MULCH	C2D-6
C2D-12.	MOWING	C2D-6
C2D-13.	MEASUREMENT	C2D-7
C2D-14.	PAYMENT	C2D-7

SECTION C2D - FERTILIZING, SEEDING AND MULCHING

PART 1 - GENERAL

C2D-1. SCOPE. The work provided for herein consists of furnishing all plant, labor, equipment, and materials, and performing all operations necessary for finished dressing, fertilizing and seeding areas as specified herein and as indicated on the drawings. Fertilizing, seeding and mulching of the new embankment shall be performed upon completion of embankment construction in minimum lengths of 500-feet. The period of the year in which fertilizing, seeding and mulching operations are performed in a particular area will determine the seeding specification in Table I which shall be followed for that area. Only one of the seeding specifications listed in Table I will be required for each particular area.

C2D-2. QUALITY CONTROL.

C2D-2.1 General. The Contractor shall establish and maintain quality control for finished dressing, fertilizing, seeding and mulching operations and shall maintain records of his quality control for all construction operations including, but not limited to, the following:

(1) Preparation of Ground Surface. Location and quality of finished dressing, including necessary clearing, filling, or dressing out of washes, smoothness and uniformity of surfaces, and time of year.

(2) Fertilizing. Quality of materials. Areas fertilized, quantity applied, and method of application.

(3) Seeding. Quality and type of seed, area covered, rate of application, quantity of seed used, and method of distribution.

(4) Mulching. Quality of materials, area mulched, quantity applied, method of application.

(5) Maintenance and Repair. Location and type of maintenance problems and remedial treatment performed.

(6) Watering. Quality of water, area watered, quantity applied, and method of application.

(7) Sodding. Quality, size of sod, source, placing, spacing, covering, and compaction.

C2D-2.2 Reporting. The original and two copies of these records of inspections and tests, as well as the records of corrective action taken, shall be furnished the Government daily. Format of the report shall be as prescribed in the Special Clause entitled "CONTRACTOR QUALITY CONTROL".

C2D-3. AREAS TO BE TREATED. Fertilizing, seeding and mulching shall be performed on all disturbed areas within the construction limits and on all newly constructed embankments.

C2D-4. COMMENCEMENT, PROSECUTION, AND COMPLETION.

C2D-4.1 General. Preparation of the ground surface, fertilizing, seeding and mulching operations shall be accomplished during the applicable growing season as specified in Table I. Mulching may be applied to areas as indicated in paragraph C2D-11.

C2D-4.2 Sequence of Work. The sequence of operations for work prescribed in this section, except mowing, shall be as follows:

- (1) Preparation of Ground Surface.
- (2) Fertilizing.
- (3) Seeding.
- (4) Watering.
- (5) Mulching.

Fertilizing and seeding operations shall commence upon completion of a length of 1,000-feet of embankment. At no time shall such fertilizing, seeding and mulching operations be more than 1,000-feet behind completed portions of embankment unless approved by the Contracting Officer.

PART 2 - MATERIALS

C2D-5. MATERIALS.

C2D-5.1 Fertilizer. Fertilizer shall be uniform in composition and free-flowing. The fertilizer shall meet the requirements for commercial fertilizer and shall contain, per acre, 60 pounds of available nitrogen, 60 pounds of available phosphorous, and 60 pounds of available potash. The fertilizer shall be delivered to the site in bags or other convenient containers or delivered in bulk. If delivered in bags or containers, the fertilizer shall be fully labeled in accordance with the applicable state fertilizer laws and shall bear the name, tradename or trademark, and warranty of the producer. Should the

commercial fertilizer be furnished in bulk, the Contractor shall furnish certified weight tickets and a certified quantitative analysis report, in triplicate, from a recognized testing laboratory certifying the nutrient ratio of the materials.

C2D-5.2 Soil for Repairs. For fill of areas to be repaired, soil shall be of a quality at least equal to that which exists in areas adjacent to the area to be repaired. Soil used shall be relatively free from roots, stones, and other materials that hinder grading, planting, and maintenance operations and shall be free from objectionable weed seeds and toxic substances.

C2D-5.3 Seed. Seed labeled in accordance with U.S. Department of Agriculture Rules and Regulations under the Federal Seed Act shall be furnished by the Contractor. Seed shall be furnished in sealed, standard containers unless written exception is granted. Seed that is wet or moldy or that has been otherwise damaged in transit or storage will not be acceptable. The specifications for seeds shall conform to the following and be seeded at the following rates:

Table I

<u>Seeding Period and Grasses to be Used</u>	<u>Minimum Purity</u>	<u>Minimum Germination</u>	<u>Minimum Rate Lbs/Acre</u>
2 March - 14 September			
Hulled common Bermuda grass	95	87	50
15 September - 1 March			
Unhulled common Bermuda grass	95	87	50
Ryegrass	97	82	35

C2D-5.4 Water. Water shall be free from oil, acid, alkali, salt, and other substances harmful to growth of grass.

C2D-5.5 Mulch. The wood fiber shall be furnished and applied by the Contractor. Materials that contain noxious grass or weed seeds that might be detrimental to the seeding operation or to adjacent farmland will not be acceptable.

C2D-5.5.1 Wood Cellulose Fiber Mulch. The wood cellulose fiber mulch with tackifier for use with hydraulic application equipment shall consist of wood cellulose fiber. The mulch shall be processed to contain no growth or germination inhibiting factors, and dyed an appropriate color to facilitate visual metering of application of the materials. The mulch material shall be supplied in packages having a net weight not in excess of 100 pounds. The wood cellulose fiber mulch shall contain not in excess of 10 percent moisture, air dry weight basis. The wood cellulose fiber mulch shall be manufactured so that after addition and agitation in slurry tanks, with water, and any other additives, the fibers in the material will become uniformly

suspended to form a homogeneous slurry, and that when hydraulically sprayed on the ground, the material will form a blotter like ground cover which, after application, will allow the absorption of moisture and allow rainfall or mechanical watering to percolate to the underlying soil. The Contractor shall be prepared to submit, on request, certification from the supplier that laboratory and field testing of the product has been accomplished, and that the product meets the foregoing requirements.

C2D-6. SUBMITTALS. The Contractor shall submit the following items in accordance with the Special Clause entitled "SUBMITTALS".

C2D-6.1 Fertilizer. Duplicate signed copies of invoices from suppliers shall be furnished. Invoices shall show quantities and percentage of nitrogen, phosphorus, and potash. Upon completion of the project, a final check of the total quantity of fertilizer used will be made against total area treated, and if minimum rates of application have not been met, an additional quantity of material sufficient to make up the minimum application rate shall be distributed as directed.

C2D-6.2 Seed. The Contracting Officer shall be furnished duplicate signed copies of statements certifying that each container of seed delivered is labeled in accordance with the Federal Seed Act and is at least equal to the requirements specified in paragraph C2D-5.3. This certification shall be obtained from the supplier and shall be furnished on or with all copies of seed invoices.

C2D-6.4 Mulch. Representative samples of the materials proposed for use shall be submitted for approval.

PART 3 - EXECUTION

C2D-7. SPECIAL EQUIPMENT.

C2D-7.2 Wood Cellulose Fiber Mulch Spreader. Hydraulic equipment used for the application of slurry of prepared wood pulp shall have a built-in agitation system with an operating capacity sufficient to agitate, suspend, and homogeneously mix a slurry containing up to 300 pounds of fiber for each 1000 gallons of water. The slurry distribution lines shall be large enough to prevent stoppage. The discharge line shall be equipped with hydraulic spray nozzles that will provide even distribution of the slurry on the various slopes to be mulched. The slurry tank shall have a minimum capacity of 1,000 gallons and shall be mounted on a traveling unit, which may be either self-propelled or drawn by a

separate unit, that will place the slurry tank and spray nozzles near the areas to be mulched so as to provide uniform distribution without waste.

C2D-8. PREPARATION OF GROUND SURFACE.

C2D-8.1 General. Equipment, in good condition, shall be provided for the proper preparation of the ground and for handling and placing all materials. Equipment shall be approved by the Contracting Officer before work is started.

C2D-8.2 Clearing. Prior to grading and tilling, vegetation and debris that may interfere with fertilizing, seeding and mulching operations shall be mowed, grubbed, and raked; and shall be disposed of satisfactorily, as specified in paragraph C2B-6.

C2D-8.3 Grading. Previously established grades and slopes shall be maintained in a true and even condition on the areas to be fertilized, seeded and mulched. Necessary repairs to previously graded areas shall be repaired with material as described in paragraph C2D-5.2. The material shall be placed and compacted in accordance with paragraph C2D-4.2. Where grades have not been established, the areas shall be graded as shown, or as directed by the Contracting Officer, and all surfaces shall be left in a true and even condition.

C2D-8.4 Tillage. After the areas required to be fertilized, seeded and mulched have been brought to the specified grades, the soil shall be tilled to a depth of at least 2-inches by plowing, disking, harrowing, or other approved method until the condition of the soil is acceptable. The work shall be performed only during periods when, in the opinion of the Contracting Officer, beneficial results are likely to be obtained. When drought, excessive moisture, or other unsatisfactory conditions prevail, the work shall be stopped when directed. Undulations or irregularities in the surface to be fertilized, seeded and mulched shall be dressed before the next specified operation.

C2D-9. APPLICATION OF FERTILIZER.

C2D-9.1 Fertilization of Areas to be Seeded. Fertilizer, as specified in paragraph C2D-5.1, shall be distributed uniformly over areas to be seeded and shall be incorporated into the soil to a depth of at least 2-inches by disking, harrowing, or other acceptable methods. Incorporation of fertilizer may be part of the operation specified in paragraph C2D-8.4.

C2D-10. SEEDING.

C2D-10.1 General. The applicable seed shall be sown at the rate and time as indicated in Table I, unless otherwise directed in writing. A satisfactory method of sowing shall be employed, using approved mechanical power-drawn seeders, mechanical hand-

seeders, broadcast-seeders, or other approved methods. When delays in operations extend the work beyond the most favorable planting season for the species designated, or when conditions are such by reason of drought, high winds, excessive moisture, or other factors that satisfactory results are not likely to be obtained, work shall be halted as directed by the Contracting Officer and resumed only when conditions are favorable or when approved alternative or corrective measures and procedures have been effected. If inspection during or after seeding operations indicates that areas have been left unplanted or other areas have been skipped, additional seed shall be applied if so directed by the Contracting Officer.

C2D-10.2 Broadcast Seeding. If the broadcast method of seeding is used, seed shall be broadcast with approved sowing equipment and distributed uniformly over designated areas. Seed shall be covered to an average depth of $\frac{1}{4}$ -inch by brush harrow, spike-tooth harrow, chain harrow, cultipacker, or other approved devices. Seed shall not be broadcast during windy weather.

C2D-10.3 Hydraulic Seeding. If the hydraulic method of seeding is used, seeds shall be combined with fertilizer and mulch and applied uniformly with equipment meeting the requirements of paragraph C2D-7.2.

C2D-10.4 Damage To Seeding. The Contractor shall be fully responsible for any damage to the seeded areas caused by his operations. Areas that become damaged as a result of poor workmanship or failure to meet the requirements of the specifications may be ordered repaired and reseeded to specification requirements, without additional cost to the Government.

C2D-11. APPLYING AND ANCHORING MULCH.

C2D-11.1 Mulching. During the period of 15 Dec through 1 Feb, the Contractor may elect to seed, providing he mulches at his own expense immediately thereafter.

C2D-11.2 Wood Cellulose Fiber Mulch. Wood cellulose fiber mulch, as specified in paragraph C2D-5.6.1, shall be applied uniformly on the soil at the rate of 1800 pounds per acre during the seeding operation with equipment as specified in paragraph C2D-7.2.

C2D-12. MOWING. The seeded areas shall be mowed with approved mowing equipment to a height of 3- to 4-inches whenever the height of vegetation becomes 6- to 8-inches. When the amount of cut grass is heavy, it shall be removed to prevent destruction of the underlying turf. The Contractor shall be responsible for mowing until the physical completion of all items of the contract.

C2D-13. MEASUREMENT. Measurement for fertilizing, seeding and mulching satisfactorily performed, will be made by the acre. Measurement will be to the nearest foot and units computed to the nearest one-hundredth of an acre. No measurement will be made for placement of material required for any necessary repairs as described in paragraph C2D-8.3.

C2D-14. PAYMENT. Payment for fertilizing, seeding and mulching measured as described in paragraph C2D-13 and other incidental work, except disposal of debris, will be made at the contract price per acre for "Fertilizing, Seeding and Mulching". Prices and payments shall constitute full compensation for furnishing all plant, labor, materials and equipment and performing the work, including any necessary repairs, in accordance with these specifications.

INDEX

SECTION C2E - EMBANKMENT

Para. No.	Paragraph Title	Page No.
C2E-1.	SCOPE	C2E-1
C2E-2.	QUALITY CONTROL	C2E-1
C2E-3.	EQUIPMENT	C2E-2
C2E-4.	EMBANKMENT FOUNDATION PREPARATION	C2E-4
C2E-5.	EMBANKMENT MATERIALS	C2E-4
C2E-6.	EMBANKMENT CONSTRUCTION	C2E-5
C2E-7.	CROSS SECTIONS AND ZONING OF MATERIALS	C2E-7
C2E-8.	GRADE TOLERANCES	C2E-7
C2E-9.	SLIDES	C2E-7
C2E-10.	MEASUREMENT AND PAYMENT	C2E-8

SECTION C2E - EMBANKMENT

PART 1 - GENERAL

C2E-1. SCOPE. The work covered by this section consists of furnishing all plant, labor, equipment, and materials, except as otherwise specified in Section C2C, "STRUCTURAL EXCAVATION AND BACKFILL", and performing all operations in connection with modification of the existing embankments, dressing the levee crown, and other incidental earthwork as may be necessary to complete the embankments, as shown on the drawings, and as herein after specified. Fill and backfill for structures are covered in Section C2C.

C2E-2. QUALITY CONTROL.

C2E-2.1 General. The Contractor shall establish and maintain quality control for embankment construction operations to assure compliance with contract requirements, and maintain records of his quality control for all construction operations including but not limited to the following:

- (1) Equipment. Type, size, and suitability for construction of the prescribed work.
- (2) Foundation Preparation. Breaking surface in advance of embankment construction, and during fill placement when necessary, drainage of foundation and partially completed fill.
- (3) Materials. Suitability.
- (4) Construction. Layout, maintaining existing drainage, moisture control, thickness of layers, spreading and compacting.
- (5) Grade and Cross Section. Crown width, crown slope, side slopes, and grades.
- (6) Grade Tolerances. Check fills to determine if placement conforms to prescribed grade and cross section.
- (7) Slides. Location and limits; methods and equipment used where remedial work has been directed.
- (8) Moisture Control. Moisture content determination to conform with limits as specified in paragraph C2E-6.1.2.
- (9) Compliance Surveys. Upon completion of suitable reaches of embankment, the Contractor shall perform, plot and submit compliance cross section surveys at a maximum of 300-foot intervals and all P.I.'s, curve P.C.'s, P.T.'s, levee transitions

and breakpoints. They shall be plotted by the Contractor on a minimum scale of 1-inch equals 10-feet horizontally and 1-inch equals 5-feet vertically with the theoretical design cross section and allowable grade tolerances superimposed thereon.

C2E-2.2 Reporting. The original and two copies of these records of inspections and tests, as well as the records of corrective action taken, shall be furnished to the Government daily. Format of the report shall be as prescribed in the Special Clause entitled "CONTRACTOR QUALITY CONTROL".

C2E-3. EQUIPMENT.

C2E-3.1 Tamping Rollers.

C2E-3.1.1 Tractor-Drawn. Tractor-drawn tamping rollers shall consist of one or more units. Each unit shall consist of a cylindrical drum not less than 48-inches in length and not less than 40-inches in diameter. Each drum shall have staggered feet uniformly spaced over the cylindrical surfaces so as to provide approximately 3 tamping feet for each 2 square feet of drum surface. The tamping feet shall be 7- to 11-inches in clear projection from the cylindrical surface of the roller, and shall have a face area of not less than 5 nor more than 10 square inches. The drums shall be water or sand and water ballasted. The weight of the roller when fully loaded shall be not less than 1150 pounds per linear foot of drum length and when empty shall be not more than 850 pounds per foot of drum length. The Contractor will be required to vary the amount of ballast in the drums to obtain optimum compactive effort for the material being compacted. The roller shall be equipped with cleaning devices, so designed and attached as to prevent the accumulation of material between the tamping feet. These cleaning devices shall be maintained at their full and correct alignment throughout the periods of use of the roller. The rolling units of multiple-type tamping rollers shall be pivoted on the main frame in a manner which will permit the units to adapt themselves to uneven ground surfaces and to rotate independently. The roller shall be pulled by a tractor at a speed not to exceed 3.5 miles per hour.

C2E-3.1.2 Self-Propelled. At the option of the Contractor, self-propelled tamping rollers may be used in lieu of tractor-drawn tamping rollers, provided these rollers conform to the towed roller requirements for the length and spacing of tamping feet, the empty weight per foot of drum, and cleaning devices. However, self-propelled rollers exceeding the empty weight requirement may be used, provided that by substitution of tamping feet having a face area not exceeding 14 square inches, the nominal foot pressure on the tamping feet of the self-propelled roller can be adjusted to approximate the foot pressure of the towed roller for the particular working conditions. Self-propelled rollers conforming to the above requirements but with tamping feet exceeding the 14-square-inch maximum face area may be approved for

use provided the Contractor demonstrates to the satisfaction of the Contracting Officer, by field tests performed in accordance with the provisions of C2E-3.4, that the roller can properly compact and fill without creating planes of weakness or laminations. For the self-propelled rollers in which steering is accomplished through the use of rubber-tired wheels, the tire pressures shall not exceed 40 pounds per square inch. The roller shall be operated at a speed of not more than 3.5 miles per hour.

C2E-3.2 Rubber-Tired Rollers. Rubber-tired rollers shall have a minimum of four wheels per axle equipped with pneumatic tires. The tires shall be of such size and ply as to be capable of being operated at tire pressures between 80 and 100 pounds per square inch at a 25,000-pound wheel load. The roller wheels shall be located abreast and so designed that each wheel will carry approximately equal load in traversing uneven ground. The spacing of the wheels shall be such that the distance between the nearest edges of adjacent tires is not greater than 50 percent of the rated tire width of a single tire. The roller shall have a rigid steel frame provided with a body suitable for ballast loading so that the load per wheel may be varied, as directed by the Contracting Officer, from 18,000 to 25,000 pounds. The roller shall be towed at speeds not to exceed 3.5 miles per hour.

C2E-3.3 Crawler-Type Tractors. Crawler-type tractors used for spreading or compaction shall weigh not less than 20,000 pounds, shall exert a unit tread pressure of not less than 6 pounds per square inch, and shall be operated at speeds not to exceed 3.5 miles per hour.

C2E-3.4 Alternative Compaction Equipment. The Contractor may propose to use alternative types of compaction equipment not included in these specifications. The suitability of the alternative equipment shall be demonstrated to the Contracting Officer by a field test conducted by and at the expense of the Contractor. The alternative compaction equipment shall be capable of properly compacting the soil so that no planes of weakness or laminations are formed in the fill. The field test shall consist of compacting a minimum of three layers of an area of embankment with the alternative type equipment. Testing and inspection of the area shall then be performed by the Contractor at no additional cost to the Government. Procedures for constructing and testing the area will be provided by the Contracting Officer. Each proposed alternative type of equipment shall be capable of compacting a layer of soil not less than 12-inches thick. A minimum of four complete passes over each layer of the test fill will be required for each type of alternative equipment that is allowed for use, unless in the course of constructing the test fill the Contractor is able to demonstrate that proper compaction can be obtained with fewer passes. Alternative type equipment shall be operated at speeds not to exceed 3.5 miles per hour. If sufficient previous testing has been performed on the alternative compaction equipment proposed by the Contractor to verify the

suitability of the equipment to the Contracting Officer's satisfaction, the Contracting Officer may determine that the above-specified field test is not required.

C2E-3.5 Miscellaneous Equipment. Scarifiers, disks, spring-tooth or spike-tooth harrows, spreaders, power tampers, and other equipment shall be types suitable for construction of embankment.

C2E-3.6 Sprinkling Equipment. Sprinkling equipment shall be designed to apply water uniformly and in controlled quantities to variable widths of surface.

PART 2 - PRODUCTS (NOT USED)

PART 3 - EXECUTION

C2E-4. EMBANKMENT FOUNDATION PREPARATION.

C2E-4.1 After clearing and grubbing and any required excavation of the embankment foundation similar cavities and depressions shall be broken down, where so directed, to flatten out the slopes. The entire earth surface on or against which fill is to be placed shall be thoroughly broken to a depth of 6-inches. If for any cause, this broken surface becomes compacted in such a manner that, in the opinion of the Contracting Officer, a plane of seepage or weakness might be induced, it shall again be adequately scarified before depositing material thereon. All scarifying and breaking of ground surface shall be done parallel to the centerline of the levee. All of the foregoing work shall be completed at least 200-feet but not greater than 500-feet in advance of the embankment construction.

C2E-4.2 Drainage. The foundation receiving fill and all partially completed fill shall be kept thoroughly drained.

C2E-4.3 Frozen Ground. No fill shall be placed upon frozen ground.

C2E-5. EMBANKMENT MATERIALS.

C2E-5.1 General. The embankment shall be constructed of earth obtained from the borrow areas. The embankment shall be constructed of earth that is free from unsuitable and frozen materials as defined in C2E-5.2 and C2E-5.3. Unless otherwise specified in levee construction, material classified by the Unified Soil Classification System (as shown on the Soil Boring Legend) as gravels (GW, GP, GM) and sands (SW, SP, SM) shall not be used unless suitably blended with less pervious material to the extent that it no longer classifies as these materials.

C2E-5.2 Unsuitable Materials. Materials which are classified as unsuitable for embankment or fill or backfill material are defined as masses of organic matter, sticks, branches, roots, and other debris.

C2E-5.3 Frozen Materials. Under no circumstances shall frozen earth, snow, or ice be placed in an embankment. The Contracting Officer may require the wasting of frozen material in order that construction may proceed, and such material wasted, if directed by written order of the Contracting Officer, will be paid as specified in paragraph C2C-6.2.

C2E-6. EMBANKMENT CONSTRUCTION.

C2E-6.1 Semicompacted Fill.

C2E-6.1.1 General. Semicompacted fill shall not be placed in water. The materials for semicompacted fill shall be placed or spread in layers, the first layer not more than 6-inches in thickness and the succeeding layers not more than 12-inches in thickness prior to compaction. Layers shall be started full out to the slope stakes and shall be carried substantially horizontal and parallel to the levee centerline with sufficient crown or slope to provide satisfactory drainage during construction. When the surface of any compacted layer is too smooth to bond properly with the succeeding layer, it shall be adequately scarified before the next layer is placed thereon.

C2E-6.1.2 Moisture Control.

C2E-6.1.2.1 Borrow Area Material. The Contractor shall control the moisture content of the borrow material placed in the embankment. Material placed in the fill shall have a moisture content ranging between the following limits:

<u>Type of Material</u>	<u>Moisture Content (In percent dry weight)</u>	
	<u>Maximum</u>	<u>Minimum</u>
ML	26	15
CL	28	18
CH	37	20

NOTE: SEE UNIFIED SOIL CLASSIFICATION CHART FOR EXPLANATION OF SYMBOLS AND PLASTICITY CHART FOR CLASSIFICATION DETERMINATION, BOTH CONTAINED IN THE CONTRACT DRAWINGS. THE PERCENTAGES USED ABOVE APPLY TO THE GOVERNMENT-FURNISHED BORROW PIT. IF THE CONTRACTOR ELECTS TO USE AN ALTERNATE PIT, NEW PERCENTAGES WILL BE PROVIDED BY THE CONTRACTING OFFICER.

The Contractor shall perform the necessary work in moisture control to bring the borrow material within the moisture content ranges specified above. If the borrow material is too wet, it shall either be stockpiled and allowed to drain before it is placed in the embankment cross section of the wet material shall

be processed by disking and harrowing, until the moisture content is reduced significantly. If the borrow material is too dry, it shall either be prewet in the borrow area, or sufficient moisture shall be uniformly distributed in each layer before compacting. The Contractor shall perform a minimum of one moisture content test per work shift in which semicompacted fill from the borrow area has been placed within the design section. The Contractor shall perform Atterberg limit tests on three separate soil samples taken from each borrow pit area at locations determined by the Contracting Officer. No additional payment will be made for any moisture control or moisture control testing required in this subparagraph.

C2E-6.1.3 Compaction. When the conditions of the spread layers are satisfactory, each layer shall be compacted by any of the following methods at the option of the Contractor:

(1) Tamper-Type Roller. Four complete passes over each layer will be required. If tamping rollers are used in tandem, not more than two rows will be permitted, and in such case, one trip of tandem rollers over any surface will be considered as two passes. When tamping rollers are used in tandem, the tamper foot spacing shall be offset so that the circumferential rows on the rear drums are in line with the midpoint of the circumferential rows of the forward drums. Each pass of the tamping roller shall overlap the preceding or adjacent pass by not less than 1.0-foot.

(2) Rubber-Tired Roller. Two complete passes over each layer will be required.

(3) Crawler-Type Tractor. Three complete passes over each layer will be required. The tractor will not be considered to be compacting while spreading materials.

C2E-6.1.4 Definition of Pass. A pass shall consist of one complete coverage of the surface of a layer by the treads of the roller, tractor, or other compacting equipment. Portions of the embankment which the compacting equipment cannot reach for any reason shall be compacted by an approved method to the density at least equal to that of the surrounding embankment.

C2E-6.1.5 Additional Compaction. If, in the opinion of the Contracting Officer, the desired compaction of any portion of the embankment cannot be secured by the minimum number of passes specified, additional complete passes shall be made over the surface area of such designated portion until the desired compaction has been obtained, and an equitable adjustment in the contract price and time will be made.

C2E-6.2 Erosion Control During Construction. Prior to the beginning of construction, the Contractor shall provide erosion control by placing bales of hay, weighing at least 50 pounds minimum, end to end, along Construction Servitude Limit as shown

on the drawings. Placement of haybales shall be restricted to a maximum of 500-feet ahead of embankment and floodwall construction. The bales of hay should be placed and anchored with steel hooks to keep them from moving. The haybale placement shall be only as directed by the Contracting Officer. After fertilizing and seeding, but prior to final acceptance, the Contractor shall spread uniformly over the protected side any remaining material trapped by hay bales and fertilize and seed the disturbed areas. The Contractor shall maintain the erosion protection (hay bales) throughout the life of the contract or until requirements are met such that the hay bales may be removed. The hay bales shall be removed following completion of the project.

C2E-6.3 Dressing. The entire embankment including topsoil where specified, shall be brought to not less than the prescribed design cross section, within allowable tolerance, at all points. Unreasonable roughness of the surface shall be dressed out to permit fertilizing and seeding operations.

C2E-7. CROSS SECTIONS AND ZONING OF MATERIALS. Unless otherwise specified, the dimensions and slopes shall conform to the applicable cross sections, with allowable tolerance, shown on the drawings.

C2E-8. GRADE TOLERANCES. All embankments shall be constructed to the design grade and cross section shown on the drawings. For semicompacted fill, at all points, a tolerance of 3/10 of 1-foot above or below the prescribed design grade and cross section shown will be permitted in the final dressing provided that the crown of the levee drains, there are no abrupt humps or depressions in surfaces or bulges in the width of the crown, and the side slopes are uniform. Any partial fill or temporarily stockpiled material placed within the design section shall not exceed the design grade or design slopes of the embankment by more than 3/10-foot, and shall have side slopes not steeper than 1V on 3H.

C2E-9. SLIDES. Should a slide occur in any part of the embankment during its construction, or after its completion, but prior to its acceptance, the Contractor shall, upon written order of the Contracting Officer, either cut out and remove the slide from the embankment and then rebuild that portion of the embankment, or construct a stability berm of such dimension, and placed in such manner, as the Contracting Officer shall prescribe. In case the slide is caused through fault of the Contractor, the foregoing operations shall be performed at no additional cost to the Government. In case the slide is not the fault of the Contractor, the repair shall be made by an equitable adjustment under the Contract Clause entitled "CHANGES". The method of slide correction will be determined by the Contracting Officer.

C2E-10. MEASUREMENT AND PAYMENT.

C2E-10.1 Semicompacted Fill. No measurement will be made for semicompacted fill placed as embankment material. Semicompacted material placed as required in embankments including material excavated in connection with degrading existing levees, fill and backfill, will not be measured for payment. Payment will be made at the contract lump sum price for "Embankment, Semicompacted Fill". Price and payment shall constitute full compensation for furnishing all plant, labor, equipment and material, and performing all operations necessary for excavation, foundation preparation, and placing and compacting the material.

C2E-10.2 Erosion Control. Measurement for erosion control will be by the linear foot satisfactory placed. Payment for erosion control as specified herein will be made at the contract unit price per linear foot for "Erosion Control." Price and payment shall constitute full compensation for furnishing all plant, labor, materials and equipment and performing all operations necessary for erosion control, including the placement and maintenance of hay bales throughout the contract period, final dressing, cleanup and removal.

INDEX

SECTION C2F - CHAIN-LINK FENCE

Para. No.	Paragraph Title	Page No.
C2F-1.	SCOPE	C2F-1
C2F-2.	APPLICABLE PUBLICATIONS	C2F-1
C2F-3.	MATERIALS	C2F-2
C2F-4.	INSTALLATION	C2F-3
C2F-5.	MEASUREMENT AND PAYMENT	C2F-5

SECTION C2F - CHAIN-LINK FENCE

PART 1 - GENERAL

C2F-1. SCOPE. The work covered by this section consists of removing existing fence on top of westside I-wall across the canal from Pumping Station No. 4 and installing new fence as shown on drawings. The work also consists of removing existing fence and gate on east side near Pumping Station No. 4.

C2F-2. APPLICABLE PUBLICATIONS. The publications listed below form a part of this specification to the extent specified herein. The publications are referred to in the text by the basic designation only.

C2F-2.1 American Society for Test and Materials (ASTM) Standards.

ASTM C 94	Ready-Mixed Concrete
ASTM F 883	Padlocks
A 153-82	Zinc-Coated (Hot Dip) on Iron and Hardware
A 569-85	Steel, Carbon (0.15 Maximum, Percent), Hot Rolled Sheet and Strip, Commercial Quality

C2F-2.2 American Welding Society (AWS).

AWS WZC (1972)	Welding Zinc-Coated Steels
----------------	----------------------------

C2F-2.3 Federal Specification (FS).

FS RR-F-191/GEN (Rev K)	Fencing, Wire and Post, Metal (and Gates, Chain-Link Fence Fabric, and Accessories)
FS RR-F-191/1 (Rev D)	Fencing, Wire and Post, Metal (Chain-Link Fence Accessories)
FS RR-F-191/2 (Rev D)	Fencing, Wire and Post, Metal (Chain-Link Fence Accessories)
FS RR-F-191/3 (Rev D)	Fencing, Wire and Post, Metal (Chain-Link Fence Posts, Top Rails and Braces)
FS RR-F-191/4 (Rev D)	Fencing, Wire and Post, Metal (Chain-Link Fence Accessories)

PART 2 - PRODUCTS

C2F-3. MATERIALS. Materials shall conform to the following.

C2F-3.1 Chain Link Fence. Refer to FS RR-F-191/GEN.

C2F-3.1.1 Chain-Link Fabric. Chain-link fabric shall be FS RR-F-191/1, Type I, zinc-coated steel wire with minimum coating weight of 2.0 ounces of zinc per square foot of coated surface. Fabric shall be fabricated of 9-gage wire woven in 2-inch mesh. Fabric height shall be 6-feet. Fabric shall be twisted and barbed on the top selvage and knuckled on the bottom selvage.

C2F-3.1.2 Gate. Gate shall be the type and swing shown. Gate frames shall be constructed of Class 1 Grade A or B, steel pipe, size SP2, as specified in FS RR-F-191/3. Gate fabric shall be as specified for chain-link fabric. Each end member of gate frames shall be extended sufficiently above the top member to carry three strands of barbed wire in horizontal alignment with barbed wire strands on the fence. Gate leaves more than 8-feet wide shall have either intermediate members and diagonal truss rods or shall have tubular members as necessary to provide rigid construction, FS RR-F-191/2. Gate leaves less than 8-feet wide shall have truss rods or intermediate braces. Intermediate braces shall be provided on all gate frames with an electro-mechanical lock. Gate fabric shall be attached to the gate frame by method standard with the manufacturer except that welding will not be permitted. Latches, hinges, stops, keepers, rollers, and other hardware items shall be furnished as required for the operation of the gate. Latches shall be arranged for padlocking so that the padlock will be accessible from both sides of the gate. Stops shall be provided for holding the gates in the open position.

C2F-3.1.3 Posts. Posts shall be in accordance with FS RR-F-191/3, zinc-coated; Class 1 Grade A or B, steel pipe; Class 3, formed steel sections; or Class 6, steel square sections. Class 4, steel H-section may be used for line posts in lieu of line post shapes specified for the other classes. Sizes shall be as shown on the drawings. Line posts and terminal (corner, gate, and pull) posts selected shall be of the same class throughout the fence. Gate post shall be either round or square, subject to the limitation specified in FS RR-F-191/3. Chain-link fence on west side I-wall at Pumping Station No. 4 will be mounted on the I-wall itself.

C2F-3.1.4 Braces and Rails. Braces and rails shall be FS RR-F-191/3, zinc-coated, Class 1, Grade A or B, steel pipe, size SP1. Class 3, formed steel sections, size FS1, conforming to FS RR-F-191/3, may be used as braces and rails if Class 3 line posts are furnished.

C2F-3.1.5 Accessories. Accessories shall be in accordance with FS RR-F-191/4. Ferrous accessories shall be zinc or aluminum coated. Truss rods shall be furnished for each terminal post. Truss rods shall be provided with turnbuckles or other equivalent provisions for adjustment. Barbed wire shall be zinc or aluminum coated, 4 point barbed type, 14-gage steel wire. Barbed wire support arms shall be the single arm type and of the design required for the post furnished. Tie wire for attaching fabric to rails, braces, and posts shall be 9-gage steel wire.

C2F-3.1.6 Barbed Tape. Barbed tape shall be stainless steel conforming to the requirements of MS MIL-B-52489. Reinforced barbed tape may be used in lieu of the barbed tape. Sixteen-gage stainless steel twistable wire ties shall be used for attaching the barbed tape to the barbed wire.

C2F-3.2 Concrete. Concrete shall be in accordance with ASTM C 94, using 3/4-inch maximum size aggregate, and having minimum compressive strength of 3000 psi at 28 days. Grout shall consist of one part portland cement to three parts clean, well-graded sand and the minimum amount of water to produce a workable mix.

C2F-3.3 Padlocks. Padlocks shall be in accordance with ASTM F 883, Type P01, Grade 2, Size 1-3/4 inch. Padlocks shall be keyed alike and each lock shall be furnished with two keys. State POC name and address of whom he keys are to be given to by COR after completion.

C2F-3.4 Reinforcement. Reinforcement shall be in accordance with Section C3B, "REINFORCING STEEL".

PART 3 - EXECUTION

C2F-4. INSTALLATION

C2F-4.1 General. Fence shall be installed to the lines and grades indicated. The area on either side of the fence line shall be cleared to the extent indicated. Line posts shall be spaced equidistant at intervals not exceeding 10-feet. Terminal (corner, gate, and pull) posts shall be set at abrupt changes in vertical and horizontal alignment. Fabric shall be continuous between terminal posts; however, runs between terminal posts shall not exceed 500-feet. Damage to the galvanized surface due to welding shall be repaired with "repair sticks" of zinc-cadmium alloys or zinc-tin-lead alloys per AWS WZC.

C2F-4.2 Excavation. Post holes shall be cleared of loose material. Waste material shall be spread where directed. The ground surface irregularities along the fence line shall be eliminated to the extent necessary to maintain a 2-inch clearance between the bottom of the fabric and finish grade.

C2F-4.3 Posts. Posts shall be set plumb and in alignment. Posts shall be in accordance with the contract drawings.

C2F-4.4 Top Rail. Top rail shall be supported at each post to form a continuous brace between terminal posts. Where required, sections of top rail shall be joined using sleeves or couplings that will allow expansion or contraction of the rail. Bottom rail shall be installed as indicated on the drawings.

C2F-4.5 Tension Wires. Tension wires shall be installed along the bottom of the fence line and attached to the terminal posts of each stretch of the fence. Bottom tension wire shall be installed within the bottom 6-inches of the installed fabric. Tension wire shall be pulled taut and shall be free of sag.

C2F-4.6 Chain-Link Fabric. Chain link fabric shall be installed on the side of the post indicated. Fabric shall be attached to terminal posts with stretcher bars and tension bands. Bands shall be spaced at approximately 15-inch intervals. The fabric shall be installed and pulled taut to provide a smooth and uniform appearance free from sag, without permanently distorting the fabric diamond or reducing the fabric height. Fabric shall be fastened to line posts at approximately 15-inch intervals and fastened to all rails and tension wires at approximately 12-inch intervals. Fabric shall be cut by untwisting and removing pickets. Splicing shall be accomplished by weaving a single picket into the ends of the rolls to be joined. The bottom of the installed fabric shall be 2-inches (plus or minus $\frac{1}{2}$ -inch) above the ground or new I-wall. After the fabric installation is complete, the fabric shall be exercised by applying a 50-pound push-pull force at the center of the fabric between posts. The use of a 30-pound pull at the center of the panel shall cause fabric deflection of not more than 2.5-inches when pulling fabric from the post side of the fence. Every second fence panel shall meet this requirement. All failed panels shall be resecured and retested at the Contractor's expense.

C2F-4.7 Barbed Wire Supporting Arms and Barbed Wire. Barbed wire supporting arms and barbed wire shall be installed as indicated and as recommended by the manufacturer. Supporting arms shall be anchored to the posts in a manner to prevent easy removal with hand tools. Barbed wire shall be pulled taut and attached to the arms with clips or other means that will prevent easy removal.

C2F-4.8 Gates. Gates shall be installed at the locations shown. Hinged gates shall be mounted to swing as indicated. Latches, stops, and keepers shall be installed as required. Padlocks shall be attached to gates or gate posts with chains and hinge pins, and hardware shall be welded or otherwise secured to prevent removal.

C2F-5. MEASUREMENT AND PAYMENT. Work on chain-link fences and gates, and concrete posts will not be measured for payment. Payment for chain link fences and concrete posts will be included in the contract lump sum price for "Pedestrian Bridge Demolition". Price and payment shall include all costs for removal and replacement of the chain link fences and gates, and concrete posts as shown on the drawings.

INDEX

SECTION C2G - STEEL SHEET PILING

Para. No.	Paragraph Title	Page No.
C2G-1.	SCOPE	C2G-1
C2G-2.	RELATED WORK SPECIFIED ELSEWHERE	C2G-1
C2G-3.	APPLICABLE PUBLICATIONS	C2G-1
C2G-4.	QUALITY ASSURANCE	C2G-1
C2G-5.	SUBMITTALS	C2G-1
C2G-6.	QUALITY CONTROL	C2G-3
C2G-7.	DELIVERY, STORAGE AND HANDLING	C2G-3
C2G-8.	MATERIALS	C2G-4
C2G-9.	INSTALLATION	C2G-6
C2G-10.	QUANTITIES	C2G-9
C2G-11.	MEASUREMENT AND PAYMENT	C2G-9

SECTION C2G - STEEL SHEET PILING

PART 1 - GENERAL

C2G-1. SCOPE. The work covered by this section consists of furnishing all plant, equipment, labor and materials and performing all operations in connection with the installation of Contractor furnished steel sheet piling in accordance with these specifications and applicable drawings.

C2G-2. RELATED WORK SPECIFIED ELSEWHERE.

C2G-2.1 Metalwork Fabrication. Section C5B, "METALWORK FABRICATION, MACHINE WORK, AND MISCELLANEOUS PROVISIONS".

C2G-2.2 Painting. Section C9A, "PAINTING".

C2G-3. APPLICABLE PUBLICATIONS. The following American Society for Testing and Materials (ASTM) standards of the issues listed below and referred to thereafter by basic designation only form a part of this specification to the extent indicated by the references thereto:

A 36-91	Structural Steel
A 328-90	Steel Sheet Piling
A 572-91	High-Strength Low-Alloy Columbian-Vanadium Steels of Structural Quality
A 325-91c	High-Strength Bolts for Structural Steel Joints

C2G-4. QUALITY ASSURANCE. Requirements for material tests, workmanship and other measures for quality control shall be as specified herein and in Section C5B, "METALWORK FABRICATION, MACHINE WORK, AND MISCELLANEOUS PROVISIONS".

C2G-4.1 Materials Tests. Sheet piling and appurtenant materials shall be tested and certified by the manufacturer to meet the specified chemical, mechanical and section property requirements prior to delivery to the site.

C2G-5. SUBMITTALS. The Contractor shall submit descriptions of sheet piling driving equipment, shop drawings, test procedures, test reports and certificates, sheet piling driving records and other submittals to the Contracting Officer for approval as required. Submittals and associated work not satisfactory to the Contracting Officer will be rejected.

C2G-5.1 Equipment Descriptions. Complete descriptions of sheet piling driving equipment including hammers, extractors, protection caps and other installation appurtenances shall be submitted for approval prior to commencement of work.

C2G-5.2 Shop Drawings. Shop drawings for sheet piling, including fabricated sections, shall be submitted for approval and shall show complete piling dimensions and details, driving sequence and location of installed piling. Shop drawings shall include details and dimensions of templates and other temporary guide structures for installing piling, and shall provide details of the method of handling piling to prevent permanent deflection, distortion or damage to piling interlocks.

C2G-5.3 Materials Test Certificates. Materials test certificates shall be submitted for each shipment and identified with specific lots prior to installing piling. Identification data should include piling type, dimensions, section properties, heat analysis number, chemical composition, mechanical properties and mill identification mark.

C2G-5.4 Driving Records. Records of the sheet piling driving operations shall be submitted after driving is completed. These records shall provide a system of identification which shows the disposition of approved piling in the work, driving equipment performance data, piling penetration rate data, piling dimensions and top and bottom elevations of installed piling. The format for driving records shall be as directed by the Contracting Officer.

C2G-5.5 Jacking of PZ-22 Steel Sheet Piling in Segments Under Existing Telephone Cables (TC-1), 10-Foot Diameter Steel Siphon Tube (ST-1) and 50-inch Diameter Steel Discharge Tube (DT-1). The Contractor shall submit, for approval, details for installing the sheet piling at these locations. Details shall include the following:

- (1) Excavation details and shoring design.
- (2) Step by step procedure of sheet pile installation, placement, driving, jacking, etc., is outlined on Drawings (Dwgs.) 40 thru 43. The installation procedure shown on the drawings is a suggested procedure and the Contractor can submit his own procedure for approval.
- (3) Sheet pile fabrication.
- (4) Proposed number of segments per sheet pile section to be driven.

The Contractor shall not damage these pipes and any damage done by his operation shall be repaired at his own expense. The limits for painting the sheet piling are shown on the Dwgs. 37 and 38. For painting details, see section C9A, "PAINTING".

C2G-6. QUALITY CONTROL

C2G-6.1 General. The Contractor shall establish and maintain quality control for pile driving operations to assure compliance with contract specifications and maintain records of his quality control for all construction operations including, but not limited to, the following:

- (1) Full and proper engagement of interlocks.
- (2) Driving (pile hammer and rate of operation).
- (3) Final position; depth of penetration; tip and cut-off elevations.
- (4) Length of cover plate and weld size.
- (5) Accurate location, alignment and plumbness of piling.
- (6) Manufacture and driving of fabricated sections.
- (7) Stockpiling and storage.
- (8) Cutting and splicing (welding).
- (9) Uplift and vertical tolerances after driving.
- (10) Pulled piles and re-driving.
- (11) Removal and disposal of damaged piles.
- (12) Location and elevation of any obstruction encountered and action directed by Contracting Officer.

C2G-6.2 Reporting. The original and two copies of these records and tests, as well as the records of corrective action taken, shall be furnished to the Government daily. Format of the report shall be as prescribed in the Special Clause entitled "CONTRACTOR QUALITY CONTROL".

C2G-7. DELIVERY, STORAGE AND HANDLING. Materials delivered to the site shall be new and undamaged and shall be accompanied by certified test reports. Steel sheet piling shall have the manufacturer's logo and mill identification mark, which corresponds to the certified test reports, stamped on each unspliced length in a minimum of two locations. Sheet piling shall be stored and handled in the manner recommended by the manufacturer to prevent permanent deflection, distortion or damage to the interlocks. Storage of sheet piling should also facilitate required inspection activities. Piling shall not be delivered to the site prior to receipt of written approval from the Contracting Officer.

PART 2 - MATERIALS

C2G-8. MATERIALS.

C2G-8.1 Steel for sheet piling shall conform to the requirements of ASTM A 328. Sheet piling, including special fabricated sections, shall be of the type and dimensions indicated on the drawings, and be of a design such that when in place they will be continuously interlocked throughout their entire length. All sheet piling shall be provided with standard pulling holes located approximately 4-inches below the top of the pile, unless otherwise shown or directed. Piling shall have the properties equivalent to those listed in the following table:

PROPERTIES OF SECTIONS

Type of Section	Nominal Web Thickness (Inches)	Section Modulus (in. ³ /Ft. of Wall)	Moment of Inertia (in. ⁴ /Ft. of Wall)	Nominal Section Depth (In.)	Minimum Interlock Strength (Lbs/Lin In.)	Theoretical Driving Width (In.)
PZ 22	.375	18.1	84.4	9	- - - -	22
PSA 23	.375	2.4	- - -	- -	12,000	16

C2G-8.1.1 Substitute Sheet Pile Sections. The Contractor may elect to substitute for the sheet piling shown on the contract drawings and specified above, in accordance with paragraphs C2G-8.1.1.1 or C2G-8.1.1.2 below. Combinations of substitute piling types shall not be permitted.

C2G-8.1.1.1 At no additional cost to the Government, new Z-type steel sheet piling conforming to ASTM A 328, with a minimum material thickness of .335-inches, a maximum overall width of 26-inches and meeting the following section properties, may be substituted in kind for the listed sections:

Section Designated on Contract Drawings	Substitute Section	
	Minimum Section Modulus (In. ³ /Ft. of Wall)	Nominal Depth (Inches)
PZ 22	18.1	9 ± 15%

C2G-8.1.1.2 At no additional cost to the Government, new Z-type steel sheet piling conforming to ASTM A 572 Grade 50, with a minimum material thickness of .335-inches, a maximum overall width of 26-inches and meeting the following section properties, may be substituted in kind for the listed sections:

Substitute Section

Section Designated on Contract Drawings	Minimum Section Modulus (In. ³ /Ft. of Wall)	Nominal Depth (Inches)
PZ 22	14.00	9 ± 15%

C2G-8.1.1.3 When proposing substitute piling, the Contractor shall submit, for approval, the following items at no additional cost to the Government:

(1) Complete shop drawings of the proposed sections showing the dimensions and details of the alternate piling including all fabricated and corner sections.

(2) A complete layout of the alternate sheet piling. The P.I. Stations and I-wall transition lengths shall remain unchanged. Typical concrete I-wall monolith lengths may be altered to better accommodate the substitute piling driving widths. It shall be the Contractor's responsibility to make any adjustments necessary in his formwork so that the architectural treatment of the concrete is properly maintained.

C2G-8.1.2 All new sheet piling shall be provided in full lengths.

C2G-8.2 Rolled Corners. Rolled corners, formed with new sheet piling, shall be of the types and dimensions shown on the drawings. Any proposed variations from the details shown on the drawings shall be submitted for approval of the Contracting Officer. The sheet pile types shall be as required for the corners being manufactured and shall conform to the requirements of ASTM A 328 and all other requirements stated above for new piling.

C2G-8.3 Fabricated Sections. Fabricated sections shall conform to the requirements stated herein, the details shown on the drawings and the piling manufacturer's recommendations for fabricated sections. Metalwork fabrication for sheet piling sections shall conform to the requirements of Section C5B. Steel plates and angles used to fabricate the special sections shall conform to ASTM A 36.

C2G-8.4 Pull, Clean, Salvage, and Deliver Existing Steel Sheet Piling. The Contractor shall pull, clean and salvage approximately 273 linear feet of existing AZ-18 sheet piling north of Mirabeau Ave. on the east bank. The pulled piles shall be cleaned with a jet of water. The Contractor shall redrive approximately twenty linear feet of these sheet piling as shown on plans. The Contractor shall repair the protective coating on AZ-18 sheet piling prior to re-driving. For paint requirements see Section C9A, "PAINTING". The Contractor shall blast clean from

the top of the pile to 4-inches above the bottom of the concrete I-wall to remove any remaining coal tar epoxy paint prior to redriving. The Contractor shall deliver remaining sheet piling to the Orleans Levee Board's maintenance yard, 6920 Franklin Ave., N.O., LA 70122, at no additional cost. The Contractor shall notify Mr. Max Hearn of the Orleans Levee District at 246-8000 thirty (30) days prior to delivery. Cut-offs shall become the property of the Contractor and shall be removed from the worksite.

C2G-8.5 Cutting-Off Existing Steel Sheet Piling. The Contractor shall cut-off existing AZ-18 steel sheet piling between Filmore Ave. and Pumping Station No. 4 and PZ-27 and AZ-10 steel sheet piling between Pumping Station No. 4 and Robert E. Lee Blvd. to the required elevation as shown on the drawings. After cutting-off above steel sheet piling to the required elevation, the contractor shall cut standard pulling holes located approximately 4-inches below the top of the pile and blast clean from the top of the pile to 4-inches above the bottom of the concrete I-wall to remove any remaining coal tar epoxy paint.

C2G-9. INSTALLATION. No work shall begin until the sheet pile layout and concrete monolith layouts are approved.

C2G-9.1 Placing and Driving.

C2G-9.1.1 Placing. Any excavation required within the area where sheet pilings are to be installed shall be completed prior to placing sheet pilings. Pilings shall be carefully located as shown on the drawings. Pilings shall be placed as true to line as possible. Suitable temporary wales, templates, or guide structures shall be provided to insure that the piles are placed and driven to the correct alignment. Piles shall be placed in a plumb position with each pile interlocked with adjoining piles for its entire length, so as to form a continuous diaphragm throughout the length of each run of piling wall. Interlocks shall be properly engaged.

C2G-9.1.2 Driving. All piles shall be driven to the depths shown on the drawings and shall extend to the cut-off elevation indicated. A tolerance of 1½-inches above or below the indicated cut-off elevation will be permitted. Pilings shall be driven by approved methods so as not to subject the pilings to damage and to insure proper interlocking throughout their lengths. Pile hammers shall be maintained in proper alignment during driving operations by use of leads or guides attached to the hammer. A protecting cap shall be employed in driving, when required, to prevent damage to the tops of pilings. Pilings damaged during driving or driven out of interlock shall be removed and replaced. All piles shall be driven without the aid of a water jet. Adequate precautions shall be taken to insure that piles are driven plumb. Sheet piling shall not be driven more than ¼-inch per foot out of plumb in the plane of the wall nor more than 1/8-inch per foot out of plumb perpendicular to the plane of the wall. If at any time the

forward or leading edge of the piling wall is found to be out-of-plumb more than $\frac{1}{4}$ -inch per foot in the plane of the wall or $\frac{1}{8}$ -inch per foot perpendicular to the plane of the wall, the assembled piling shall be driven to the required depth and tapered pilings shall be provided and driven to interlock with the out-of-plumb leading edge or other approved corrective measures shall be taken to insure the plumbness of succeeding pilings. The maximum permissible taper for any tapered piling shall be $\frac{1}{4}$ -inch per foot of length. Unless specifically indicated otherwise, each run of piling wall shall be driven to grade progressively from the start and pilings in each run shall be driven alternately in increments of depth to the required depth or elevation. On each day of sheet pile driving, the Contractor shall stab only the number of piles that can be driven to grade by the end of the day, and all piling stabbed shall be driven to grade by the end of each working day except that the last two piles may remain tapered up to receive the next day's piles. No pile shall be driven to a lower elevation than those behind it in the same run except when the piles behind it cannot be driven deeper or in areas where there will be wall penetrations or obstructions are encountered. In this case, piling will be allowed to remain above final grade until the obstruction is removed or the penetration is completed. Alternately, if it is determined that an obstruction cannot be removed, the Contractor shall make such changes in design alignment of the pile structure as may be deemed necessary by the Contracting Officer to insure the adequacy and stability of the structure. Payment for the additional labor and materials necessitated by such changes will be made by an equitable adjustment under the Contract Clause entitled "CHANGES". If the piling next to the one being driven tends to follow below final grade, it may be pinned to the next adjacent piling. The Contractor is advised that buried stumps or similar debris may be encountered periodically on the sheet pile wall alignment and appropriate consideration should be given to hard driving conditions should they occur. Piles shall not be driven within 100-feet of concrete less than 7 days old nor within 30-feet of concrete less than 28 days old.

C2G-9.1.3 Emergency Locking System on Pile Driving Head.

All pile driving equipment shall be equipped so as to prevent piles from falling when a single or multiple power failure occurs after the pile driving head is attached to the pile. The jaws of vibratory hammers shall be equipped with devices such that upon loss of hydraulic pressure, the jaws will not release the pile.

C2G-9.2 Cutting Off and Splicing.

Piles extending above grade in excess of the specified tolerance, and which cannot be driven deeper, shall be cut off to the required grade. The Contractor shall also trim the tops of piles excessively battered during driving, when directed to do so, at no cost to the Government. Cut-offs shall become the property of the Contractor and shall be removed from the worksite. Piles driven below the elevations indicated for the top of piles and piles which, because

of damaged heads, have been cut off to permit further driving and are then too short to reach the required top elevation, shall be extended to the required top elevation by welding an additional length, when directed, without cost to the Government. Should splicing of additional lengths be necessary, the splice shall consist of an approved butt joint with a weld that fully penetrates the web. Welded extensions shall be a minimum of 6-inches in length. Piles adjoining spliced piles shall be full length unless otherwise approved. When piles are to be driven in sections and spliced together, they shall be delivered on site in full lengths and cut for splicing only after delivery. Only those portions of the originally uncut pile shall be spliced together to form the final in-place full-length pile. Splices for these piles shall conform to the details shown on the drawings. Welding of splices shall conform to the requirements of Section C5B. Ends of pilings to be spliced together shall be squared before splicing to eliminate dips or camber. Pilings shall be spliced together with concentric alignment of the interlocks so that there are no discontinuities, dips or camber at the abutting interlocks. Spliced pilings shall be free sliding and able to obtain the maximum swing with contiguous pilings. The Contractor may cut holes in the piles for bolts, rods, drains or utilities at locations and of sizes shown on the drawings or as directed. All cutting shall be done in a neat and workmanlike manner. Bolt holes in steel piling shall be drilled or may be burned and reamed by approved methods which will not damage the remaining metal. Holes, other than bolt holes, shall be reasonably smooth and of the proper size for rods and other items to be inserted.

C2G-9.3 Inspection of Driven Piling. The Contractor shall inspect the interlocked joints of driven pilings extending above ground. Pilings found to be damaged or driven out of interlock shall be removed and replaced at the Contractor's expense.

C2G-9.4 Pulling and Redriving. The Contractor may be required to pull selected piles after driving, for test and inspection, to determine the condition of the piles. Any pile so pulled and found to be damaged to the extent that its usefulness in the structure is impaired shall be removed from the work and the Contractor shall furnish and drive a new pile to replace the damaged pile. Piles pulled and found to be in satisfactory condition shall be redriven.

C2G-9.5 Void Backfill. Where voids adjacent to the steel sheet piling are induced by pile driving operations or caused by the removal of existing sheetpiling, the Contractor shall pump out all rain water and backfill with a cement-sand-bentonite slurry. The Contractor shall backfill with a cement-sand-bentonite slurry by the tremie or pump down method such that any water in the void is not mixed with but displaced by the slurry. The slurry shall consist of one part cement and two parts bentonite, and three parts sand mixed with enough water to produce a slurry liquid

enough to thoroughly fill voids but have no less than twelve pounds of solids per gallon. The sand portion of the slurry shall meet the following gradation:

SAND GRADATION

<u>U.S. STANDARD SIEVE SIZE</u>	<u>REQUIRED PERCENT PASSING BY WEIGHT</u>
3/8-inch	100
No. 4	100 - 90
No. 200	20 - 0

C2G-9.6 Painting. Piling shall be painted in accordance with Section C9A, "PAINTING".

C2G-9.7 Vibration Monitoring.

C2G-9.7.1 Scope. An independent testing laboratory retained by the Orleans Levee District will monitor vibrations during pile driving operations. If more than one pile driving rig is in operation at any time, each rig shall be independently monitored. Vibration monitoring during other Contractor operations may be done at the discretion of the Orleans Levee District.

C2G-9.8 Preconstruction Survey.

C2G-9.8.1 Scope. An independent party retained by the Orleans Levee District will perform the preconstruction survey of residential properties prior to the commencement of work.

C2G-10. QUANTITIES. The estimated quantities of sheet piling listed in the unit price schedule of the contract are given for bidding purposes only. Sheet piling quantities for payment shall consist of the square feet of piling acceptably installed between the indicated top and tip of pile elevations.

C2G-11. MEASUREMENT AND PAYMENT.

C2G-11.1 Measurement.

C2G-11.1.1 PZ-22 Sheet Piling. The length of PZ-22 sheet pile driven or pulled will be measured to the nearest tenth of a linear foot and converted to square feet for payment purposes. The square footage will be determined by multiplying the number of piles times the measured length acceptably driven below the cut-off elevation shown on the drawings times the theoretical driving width of the pile. The number of piles paid for shall not exceed the number of piles indicated on the approved shop drawings. When driven piles are directed to be cut off before reaching penetration depths shown on the drawings, that portion cut off will be measured for payment on the basis of its total length, provided that the length is not greater than the difference

between the total length of piles shown on the plans for that location and the length of piles driven below the point of cut-off. No deduction will be made for holes cut for drains and utilities, in computing the square footage of steel sheet pile structures.

C2G-11.1.2 AZ-18 Sheet Piling. No separate measurement will be made for redriving and repairing the protective coating on AZ-18 prior to redriving approximately twenty linear feet of salvaged AZ-18 steel sheet piling.

C2G-11.1.3 Fabricated Sections. The length of the PSA-23 bent corners or fabricated sections and bent corners driven or pulled will be measured to the nearest tenth of a linear foot and converted to square feet for payment purposes. The square footage will be determined by multiplying the number of piles times the measured length acceptably driven below the cut-off elevation shown on the drawings times the theoretical driving width of the pile. The number of piles paid for shall not exceed the number of piles indicated on the approved shop drawings. When driven piles are directed to be cut off before reaching penetration depths shown on the drawings, that portion cut off will be measured for payment on the basis of its total length, provided that the length is not greater than the difference between the total length of piles shown on the plans for that location and the length of piles driven below the point of cut-off. No deduction will be made for holes cut for drains and utilities, in computing the square footage of steel sheet pile structures.

C2G-11.1.4 Steel Sheet Piling Cofferdams. Steel sheet piling used for temporary flood protection will not be measured for payment.

C2G-11.1.5 Existing Sheet Piling. No separate measurement will be made for existing steel sheet piling to be pulled, cleaned, salvaged, and delivered. Sheet pile jacked under utilities on the West Bank will be measured to the nearest tenth of a linear foot and converted to square feet for payment purposes.

C2G-11.1.6 Cut-off Piling. No separate measurement will be made for cutting of existing AZ-18 sheet piling at the required elevation.

C2G-11.1.7 Void Backfill. The sheet piling void backfill will not be measured for payment.

C2G-11.2 Payment.

C2G-11.2.1 PZ-22 Sheet Piling. Payment for PZ-22 steel sheet piling quantities will be made at the contract price per square foot for "Piling, Steel Sheet, Type PZ-22". Prices shall include all costs of furnishing, driving, cutting holes, splicing, backfilling voids, and all other work incidental thereto.

C2G-11.2.2 AZ-18 Sheet Piling. Payment for redriving salvaged AZ-18 steel sheet piling will be made at the contract lump sum price for "Redriving Existing AZ-18 Steel Sheet Piling". Prices shall include all costs of removing coal tar epoxy paint, driving, cutting holes, splicing, backfilling voids, and all other work incidental thereto.

C2G-11.2.3 Fabricated Sections. Payment for fabricated sections and bent corners and each special PSA-23 bent corners will be made at the contract price per square foot for "Piling, Steel Sheet, Type PSA-23". Prices shall include all cost of fabricating, adding cover plates, furnishing, driving, cutting holes, splicing, backfilling voids, and all other work incidental to acceptably installing the steel sheet piling.

C2G-11.2.4 Temporary Flood Protection. Piling used for temporary flood protection will be paid in accordance with Section C2H, "TEMPORARY FLOOD PROTECTION".

C2G-11.2.5 Existing Sheet Piling. Payment for existing sheet piling quantities to be pulled, cleaned with jet of water, salvaged, and delivered will be made at the contract lump sum price for "Pull, Clean, Salvage, and Deliver Existing AZ-18 Steel Sheet Piling."

C2G-11.2.6 Cut-Off Piling. Payment for cutting off existing AZ-18 sheet piling at required elevation shall be paid at the contract lump sum price for "Cutting Off Existing AZ-18 Sheet Piling". Price shall include cutting and disposal of the sections, installing handling holes, removal of coal tar epoxy paint, and all other work incidental thereto.

C2G-11.2.7 Cut-Offs and Splices. Cut-offs and/or splices which are required to construct the sheet pile structures as shown on the drawings and as specified herein, and which are necessitated due to Contractor negligence in any procedure required to install such structures shall be provided at no additional cost to the Government. Cut-offs and/or splices which are required through no fault of the Contractor shall be paid for by lump sum payments of \$10.00 per cut-off and \$25.00 per splice. Additionally, the portion of a Contractor furnished pile which is cut off and not reused when the Contractor is deemed to be not at fault, shall be paid for at 70 percent of the applicable contract unit price for the amount measured in accordance with C2G-11.1 above.

C2G-11.2.8 Pulled Piles. Piles which are directed to be pulled and found to be in good condition will be paid for at the contract price (or furnishing and driving the pile in its original position plus 50 percent of that amount for the cost of pulling and redriving the pile. When piles are pulled and found to be defective and/or damaged due to Contractor negligence, no payment

will be made for originally furnishing and driving such piles, nor for the operation for pulling. Piles replacing defective or damaged piles will be paid for at the applicable contract unit price. Piles which are pulled and found to be damaged through no fault of the Contractor, will be paid for at 100% of the applicable unit price for the damaged pile and 100% of the applicable unit price for driving the replacement pile. The cost of pulling the damaged pile shall be paid for at 25% of the applicable contract unit price.

INDEX

SECTION C2H - TEMPORARY FLOOD PROTECTION

Para. No.	Paragraph Title	Page No.
C2H-1.	SCOPE	C2H-1
C2H-2.	QUALITY CONTROL	C2H-1
C2H-3.	GENERAL	C2H-1
C2H-4.	DESIGN	C2H-1
C2H-5.	TEMPORARY FLOOD PROTECTION REQUIREMENTS	C2H-2
C2H-6.	INSTALLATION	C2H-3
C2H-7.	WATER REMOVAL	C2H-3
C2H-8.	MEASUREMENT AND PAYMENT	C2H-3

SECTION C2H - TEMPORARY FLOOD PROTECTION

PART 1 - GENERAL

C2H-1. SCOPE. The work covered by this section consists of furnishing all plant, labor, materials, equipment, and performing all operations necessary for designing, installing, and removing temporary protection, including any necessary cofferdams, and incidental work as required or specified herein.

C2H-2. QUALITY CONTROL. The Contractor shall establish and maintain quality control for temporary protection operations to assure compliance with contract requirements and maintain records of his quality control for all construction operations including but not limited to the following:

(1) Equipment. Type, size, and suitability for construction of the prescribed work.

(2) Construction. Layout, excavation, drainage.

C2H-2.1 Reporting. The original and two copies of these records of inspections and tests, as well as the records of corrective action taken, shall be furnished to the Government daily. Format of the report shall be as prescribed in the Special Clause entitled "CONTRACTOR QUALITY CONTROL".

C2H-3. GENERAL. The Contractor shall indemnify and hold the Government harmless against any loss or damage sustained by him arising out of or attributable to failure of temporary protection structures of his own design.

C2H-3.1 No work on temporary protection or cofferdams will be allowed prior to receipt of written approval by the Contracting Officer, specified in paragraph C2H-4.1.

C2H-3.2 The Contractor's construction of the temporary protection or cofferdam shall in no way affect the stability of the existing flood protection.

C2H-4. DESIGN. Work required for construction of certain reaches of I-wall may require protection by self-sustaining and/or braced cofferdams. The design and layout of these cofferdam systems shall be the sole responsibility of the Contractor and shall comply with the following:

C2H-4.1 The design calculations shall be performed by a registered professional engineer licensed to practice in the State of Louisiana. The Contractor shall submit the copies of the professional engineer's design along with the Contractor's drawings showing the layout of his proposed temporary cofferdam

with all pertinent dimensions and material types and sizes to be used for the construction of such structures in the bound form to the Contracting Officer for approval. The Contractor's design shall also include materials he plans to use for the temporary cofferdams. All materials selected by the Contractor shall meet the requirements of applicable sections of these Specifications.

C2H-4.2 The Contractor's design of the temporary cofferdam shall be such that it will insure stability and integrity of all new and existing flood protection system. Revisions to the Contractor's design and layout of these structures as may be required to obtain approval by the Contracting Officer shall be furnished at no additional cost to the Government.

C2H-4.3 In addition to his responsibility for the design and layout of the temporary cofferdam systems, the Contractor shall also be responsible for construction, maintenance and subsequent removal and disposal of the cofferdam systems. Also, all excavated materials shall become the property of the Contractor and shall be disposed of in accordance with Section C2C, "STRUCTURAL EXCAVATION AND BACKFILL," and Section C2E, "EMBANKMENT."

PART 2 - PRODUCTS (NOT USED)

PART 3 - EXECUTION

C2H-5. TEMPORARY FLOOD PROTECTION REQUIREMENTS. Temporary flood protection will be required whenever a section of the existing floodwall is removed prior to the new floodwall being sufficiently completed to withstand flood waters from S&WB operations or tidal surges. Sufficiently completed is defined as the time when the concrete cap reaches a compressive strength of 3000 psi. The required height of the temporary protection depends on the time of the year and the amount of existing protection lowered or removed at any one time.

C2H-5.1 Non-Hurricane Season. Non-hurricane season extends from 1 December to 31 May. During this period, temporary protection between Mirabeau Ave. and Leon C. Simon Blvd. must be constructed to a minimum elevation of 6.75 NGVD. The maximum length of temporary protection or cofferdam below the height of the existing floodwall permitted at any one time is 750 linear feet.

C2H-5.2 Hurricane Season. Hurricane season extends from 1 June to 30 November. During this period, the temporary protection or cofferdam height shall be a minimum elevation of 11.5 NGVD or alternatively, the Contractor may elect to only dismantle a segment of existing floodwall that can be closed within a 24 hour

period. The maximum length of temporary protection below elevation 11.5 NGVD in that instance will be 300-feet. Those areas below elevation 11.5 NGVD must meet the requirement for non-hurricane season as specified in paragraph C2H-5.1 at all times. Areas below elevation 11.5 NGVD will be considered breaches in the protection. If the Contractor elects the later alternative, he shall develop and submit for approval, plans including methods, equipment, materials and actions to close breaches in the flood protection in the event that a hurricane threatens the area. The sheet pile material for closing such breaches shall be stockpiled at the site in accordance with paragraph C2H-5.2.2. Plans for closing breaches in the floodwall shall be updated semi-annually to reflect status of construction progress. Prior to removing any existing levee protection, the Contractor shall have an approved plan of interim protection.

C2H-5.2.1 Emergency Closures. In the event of an impending hurricane or storm, the Contractor shall complete a closure of all breaches in the flood protection within 24 hours after being directed to do so by the Contracting Officer. The closure of breaches shall provide flood protection to a height of 11.5 NGVD. The closure shall be made with steel sheet piling.

C2H-5.2.2 The stockpiling of emergency sheet piling is required. Storage of materials and equipment to perform the closures shall be adjacent to where they would be used or other readily accessible areas.

C2H-6. INSTALLATION. The Contractor shall make all provisions required for the construction of temporary protection or cofferdams.

C2H-7. WATER REMOVAL. It shall be the responsibility of the Contractor to provide, maintain and operate the pumps of adequate capacities, for the removal of the water that may find its way into the excavation within the area protected by the temporary protection or cofferdam systems, from whatever sources throughout the life of this project. The discharge from the pumps shall be into outlet channel on floodside.

C2H-8. MEASUREMENT AND PAYMENT. No measurement will be made for work required by this section. Payment for temporary protection and/or cofferdams, including design, installation, and removal; stockpiling of emergency closure materials and equipment; and all incidental work as specified herein will be included in the contract lump sum price for "Temporary Flood Protection and Cofferdams". Price and payment shall constitute full compensation for furnishing all plant, labor, materials and equipment for work required by this section.

C2H-8.1 Emergency Closures. Payment for all work required for the installation and removal of the required emergency closures during impending high water stages or storm tidal surges, will be made under the Contract Clause entitled "CHANGES".

INDEX

SECTION C2I - MODIFICATIONS TO EXISTING UTILITIES

Para. No.	Paragraph Title	Page No.
C2I-1.	SCOPE	C2I-1
C2I-2.	APPLICABLE PUBLICATIONS	C2I-1
C2I-3.	QUALITY CONTROL	C2I-2
C2I-4.	SUBMITTALS FOR APPROVAL	C2I-2
C2I-5.	QUALITY OF WORK	C2I-2
C2I-6.	PIPE SLEEVES AND ACCESSORIES	C2I-3
C2I-7.	MODIFICATIONS TO EXISTING UTILITIES	C2I-3
C2I-8.	MEASUREMENT AND PAYMENT	C2I-4

SECTION C2I - MODIFICATIONS TO EXISTING UTILITIES

PART 1 - GENERAL

C2I-1. SCOPE. The work covered by this section consists of furnishing all plant, labor, equipment, shop drawings, and materials required to perform the operations in connection with the modification of existing utilities. The work specified herein includes providing passage of utility lines through the new floodwall and removing portions of existing utilities as specified. The Contractor shall be responsible for coordinating with the utility owners, and all work required to facilitate the passage of utilities through the sheet piling, as shown on the drawings. All work shall be inspected and approved by the Contracting Officer before covering with backfill. No elevations, slopes, or dimensions of existing utilities shall be changed unless specified on the drawings or otherwise directed by the Contracting Officer. Coordination requirements with the effected utility owners are specified in the Special Clause entitled "COORDINATION OF WORK".

C2I-2. APPLICABLE PUBLICATIONS. The publications listed below form a part of this specification to the extent specified herein. The publications are referred to in the text by the basic designation only.

C2I-2.1 American Society for Test and Materials (ASTM) Standards.

A 53-84 Pipe, Steel, Black and Hot-Dipped, Zinc-Coated, Welded and Seamless

C2I-2.2 American Welding Society, Inc. (AWS) Publications.

D1.1-92 Structural Welding Code - Steel

C2I-2.3 Federal Specification (Fed Spec.).

SS-S-210 A Sealing Compound, Preformed Plastic, for Expansion Joints and Pipe Joints

C2I-2.4 American National Standards Institute (ANSI).

A21.10

A21.11

C2I-3. QUALITY CONTROL.

C2I-3.1 General. The Contractor shall establish and maintain quality control for utility modification operations to assure compliance with the contract specifications and maintain records of his quality control for all construction operations including but not limited to the following:

(1) checking construction operations and certifying compliance with applicable sections of the specifications,

(2) checking operations including concrete work, welding, and earth work, and certifying with applicable sections of the specifications,

(3) checking materials to be used in utility modification, including plastic sealant, clamps, pipe sleeves, and casting seals and pipe sleeves attached to sheet piling. The Contractor shall certify that all materials are in compliance with applicable regulations.

C2I-3.2 Reporting. The original and two copies of these records of tests, as well as the records of corrective action taken shall be furnished to the Government daily. Format of report shall be as prescribed in the Special Clause entitled "CONTRACTOR QUALITY CONTROL".

C2I-4. SUBMITTALS FOR APPROVAL.

C2I-4.1 Schedule. Thirty days before work is performed on any utility, the Contractor shall prepare and submit for approval of the Contracting Officer a schedule indicating the proposed date and time each utility service will be interrupted and the date and time of permanent replacement.

C2I-4.2 Shop Drawings. The Contractor shall prepare and submit for the approval of the Contracting Officer complete shop drawings showing details of the sleeves, casing seals, and couplings.

C2I-5. QUALITY OF WORK.

C2I-5.1 All excavation and backfill adjacent to the floodwall required for modifications to existing utilities shall conform to the applicable provisions of Section C2C, "STRUCTURAL EXCAVATION AND BACKFILL."

C2I-5.2 All work for passage of existing utilities through the steel sheet piling and all piping shall conform to the applicable details shown on the drawings and applicable provisions herein. The work shall be inspected and approved by the Contracting Officer before covering with backfill.

C2I-5.3 All welding shall conform to the applicable provisions of AWWA C 206 and AWS D1.1.

PART 2 - PRODUCTS

C2I-6. PIPE SLEEVES AND ACCESSORIES.

C2I-6.1 Cooperation With Owners. The Contractor shall carefully plan and expeditiously prosecute his work in such manner as to cause the least interruption to services of the S&WB feeder lines. The Contractor shall coordinate the utility modifications with the utility owners so that no delay, interference or access problems occur.

C2I-6.2 Materials.

C2I-6.2.1 Steel Pipe Sleeves. Steel pipe sleeves for utility modifications shall meet the requirements of ASTM A 53, Type S, Grade B, and shall be of the shapes and sizes shown on the drawings.

C2I-6.2.2 Neoprene Rubber Sleeve and Stainless Steel Bands and Clamps. Neoprene rubber sleeves type casing seal with stainless steel bands and clamps shall be as manufactured by Pipeline Seal and Insulator Co., model "C", or approved equal.

C2I-6.2.3 Plastic Sealant. Plastic sealant shall conform to the applicable provisions of Fed. Spec. SS-S-210A.

C2I-6.2.4 Other Materials. All other materials shall conform to the applicable requirements indicated on the drawings or in other sections of the specifications.

C2I-6.3 Cutting Holes in Piling. Holes for installing pipe sleeves shall be appropriate size and shall be located in the web of the steel sheet piling. The location shall be at the elevation shown on the drawings.

PART 3 - EXECUTION

C2I-7. MODIFICATIONS TO EXISTING UTILITIES.

C2I-7.1 South Central Bell (S.C.B.) Item TC-1 & TC-2. S.C.B. will abandon underground cables (TC-2). The Contractor will be required to jack PZ-22 steel sheet piling in segments under aerial conduits (TC-1) on the West Bank. The work on these lines will be in accordance with Section C2G of these specifications. The Contractor will drive the sheet piling through the abandoned underground telephone cables.

C2I-7.2 Sewerage and Water Board of New Orleans (S.&W.B.) Items.

C2I-7.2.1 Electric Feeder Lines 340, 400, 422, and 432. The work on these lines will be in accordance with Section C16B of these specifications.

C2I-7.2.2 S & WB Items: 10-Foot Diameter Steel Siphon Tube (ST-1) and 50-Inch Diameter Discharge Tube (DT-1). The work on these lines will be in accordance with Section C2G of these specifications.

C2I-7.3 Department of Streets Items

C2I-7.3.1 Filmore Ave. Pedestrian Bridge (PB-1) and Robert E. Lee Blvd. Pedestrian Bridge (PB-2). The Contractor shall completely remove the timber pedestrian bridges at Filmore Ave. and Robert E. Lee Blvd.

C2I-7.3.2 Concrete Steps (CS-1, CS-2, CS-3, & CS-4). The Contractor shall remove concrete steps as shown on the drawings.

C2I-7.4 New Orleans Public Service, Inc. (N.O.P.S.I.) Items. Overhead powerlines, items P-1, P-2, P-5 and P-6 will be de-energized by N.O.P.S.I. before pile driving and during construction of concrete cap, and re-energized by N.O.P.S.I. after pile driving operation and construction of concrete cap is complete. Power pole for powerline P-5 on East Bank will be relocated by N.O.P.S.I.

C2I-8 MEASUREMENT AND PAYMENT. Modifications to existing utilities will not be measured for payment. Payment for modifications to existing utilities will be made at the contract lump sum price for "Utility Modifications". Payment for the electric feeder line relocations will not be included under "Utility Modifications". Prices and payment shall constitute full compensation for furnishing all labor, equipment, and materials required to perform the work specified above.

INDEX

SECTION C2J - SELECTIVE DEMOLITION

Para. No.	Paragraph Title	Page No.
C2J-1.	SCOPE	C2J-1
C2J-2.	QUALITY CONTROL	C2J-1
C2J-3.	GENERAL REQUIREMENTS	C2J-1
C2J-4.	EXECUTION	C2J-2
C2J-5.	DISPOSAL OF MATERIALS	C2J-3
C2J-6.	MEASUREMENT AND PAYMENT	C2J-3

SECTION C2J - SELECTIVE DEMOLITION

PART 1 - GENERAL

C2J-1. SCOPE. The work covered by this section consists of furnishing all plant, equipment, labor, and materials and to perform all operations necessary for demolition and removal of existing facilities as shown on the drawings and specified herein. Demolition includes floodwall and concrete removal as indicated herein and shown on the drawings, removal of the pedestrian timber bridges near Filmore Ave. and Robert E. Lee Blvd. and removal of concrete steps as indicated herein and shown on the drawings.

C2J-2. QUALITY CONTROL

C2J-2.1 General. The Contractor shall establish and maintain quality control for demolition operations to assure compliance with contract requirements, and maintain records for his quality control for all demolition operations including but not limited to the following:

(1) Demolition. Location and identification of all items to be demolished, percentage of demolition completed, and methods of demolition.

(2) Safety Protection and Access. Procedures for assuring the safety of persons and property subject to damage and injury resulting from demolition operations. Provisions for maintenance of access around the site of demolition work.

(3) Disposition of Materials. Method and location of disposition; and damage to existing structures or improvements.

C2J-2.2 Reporting. The original and two copies of those records and tests, as well as the records of corrective action taken, shall be furnished to the Government daily. Format of this report shall be prescribed in the Special Clause entitled "CONTRACTOR QUALITY CONTROL".

PART 2 - PRODUCTS (NOT USED)

PART 3 - EXECUTION

C2J-3. GENERAL REQUIREMENTS. The Contractor shall ensure the work covered herein is performed in a safe and orderly manner. The Contractor shall submit his demolition procedures for approval to the Contracting Officer. The use of explosives will not be

permitted. No demolition will be permitted until temporary protection measures in accordance with Section C2H, "TEMPORARY FLOOD PROTECTION", are in place.

C2J-3.1 Submittals. A minimum of 30 days prior to commencement of the work, the Contractor shall submit for approval his proposal plan to accomplish the work specified herein. This proposal shall include but not be limited to the following:

(1) Demolition. Methods and equipment to be used.

(2) Protection of New Floodwall. Methods and equipment used to ensure the new floodwall is not damaged during demolition operations.

(3) Holding Site. Location and method of supporting items to be temporarily stored.

(4) Disposition Site. Documentation demonstrating the disposal site is to be in compliance with all applicable Federal, State and local laws.

C2J-4. EXECUTION. The Contractor shall remove (1) the existing concrete floodwall, cutting off or redriving of the existing AZ-18 sheet piling as shown on the drawings, removing or cutting off the existing MP-112 sheet piling as shown on the drawings; (2) Pedestrian Bridge at Filmore Ave. and Robert E. Lee Blvd.; (3) concrete steps and sidewalks leading to the bridges as indicated herein and shown on the contract drawings.

C2J-4.1 Sheet Pile Wall. The Contractor shall remove the entire concrete cap on the existing sheet pile wall as indicated on the plans and in accordance with these specifications. The cap shall be carefully removed so as not to damage the new floodwall, existing channel lining, existing bridges, or any other structures in the vicinity of the work. In areas where the new floodwall alignment coincides with the existing floodwall alignment, the existing sheet piling shall be removed in its entirety. In areas where the elevation specified on the drawings is below finish grade, the sheet pile shall be removed so that its top is a minimum of 6-inches below finished grade.

C2J-4.2 Pedestrian Bridge at Filmore Ave. and Robert E. Lee Blvd.. The Contractor shall entirely remove the pedestrian bridges including the concrete steps leading to the bridges. Pilings shall be pulled and holes filled with one part cement and two parts bentonite and three parts sand mixed with sufficient water to produce a slurry liquid enough to thoroughly fill voids but have no less than 12 pounds of solids per gallon. The sand portion of the slurry shall meet the following gradations:

<u>U.S. Standard Sieve Size</u>	<u>Sand Gradation</u>	<u>Required Percent Passing by Weight</u>
3/8-inch		100
No. 4		100-90
No. 200		20-0

The top 3-feet of the hole shall be filled with structural concrete, 3000 psi mix.

C2J-4.3 Other Structures. The Contractor shall remove and dispose of all other existing structures or remains of structures which may exist within the limits of work as indicated on the contract drawings and as specified herein. The Contractor should verify the number, size and location of all existing structures within his work and access areas, by visiting the site.

C2J-5. DISPOSAL OF MATERIALS. The Contractor shall remove the debris and materials resulting from demolition. Such disposal shall comply with all applicable Federal, State, and local laws, The Contractor shall, at his option, either retain for his own use or dispose of by sale or otherwise, such materials of value. The Government is not responsible for the protection and safekeeping of any materials retained by the Contractor. Such materials shall be removed from the site of the work before the date of completion of the work. Such materials shall be placed so as not to interfere with roads, drainage or other improvements and in such a manner as to eliminate the possibility of its entering into channels, ditches, or canals. The contractor shall remove and properly dispose the existing rip rap from the area between Mirabeau Ave. and Filmore Ave.

C2J-6. MEASUREMENT AND PAYMENT. Selective demolition will not be measured for payment.

C2J-6.1 Pedestrian Bridges. Payment for demolition of the pedestrian bridges at Filmore Ave. and Robert E. Lee Blvd., will be made at the contract lump sum price for "Pedestrian Bridge Demolition". Price and payment shall include all costs for removal and disposal of all specified surface and subsurface obstructions and all incidental work as specified herein.

C2J-6.2 Selective Demolition. Payment for all other demolition which includes but is not limited to removing the existing concrete floodwall and sheet piling, concrete steps for Pedestrian Bridges at Filmore Ave. and Robert E. Lee Blvd., rip rap and all other structures, will be paid at the contract lump sum price for "Selective Demolition". Price and payment shall include all costs for removal and disposal of all specified surface and subsurface obstructions, and all incidental work as specified herein.

INDEX

SECTION C2K - INCIDENTAL PAVING

Para. No.	Paragraph Title	Page No.
C2K-1.	SCOPE	C2K-1
C2K-2.	APPLICABLE PUBLICATIONS	C2K-1
C2K-3.	QUALITY CONTROL	C2K-2
C2K-4.	PAVING MATERIALS	C2K-2
C2K-5.	CITY STREETS	C2K-3
C2K-6.	MISCELLANEOUS PAVING	C2K-4
C2K-7.	SIGNS AND BARRICADES	C2K-4
C2K-8.	MEASUREMENT AND PAYMENT	C2K-4

SECTION C2K - INCIDENTAL PAVING

PART 1 - GENERAL

C2K-1. SCOPE. The work covered by this section consists of furnishing all plant, equipment, labor and materials and performing all operations in connection with resurfacing asphalt, concrete curbing, removal and replacement of subbase, base and surface courses, and all other roadway appurtenances not covered elsewhere in these specifications. At least one lane (12-feet wide) shall be kept open for traffic during all construction operations in any public street. See the Special Clause entitled "Traffic Control".

C2K-2. APPLICABLE PUBLICATION. The following publications of the issues listed below, but referred to thereafter by basic designation only, form a part of this specification to the extent indicated by the references thereto:

C2K-2.1 Code Of The City Of New Orleans.

Section 61-92 Provisions for Public Safety and Traffic Movement

C2K-2.2 Louisiana Standards Specifications for Roads and Bridges (LSSRB) 1982 Edition. State of Louisiana Department of Transportation and Development.

501	Asphaltic Concrete Mixtures
504	Asphaltic Tack Coat
706	Concrete Walks, Drives and Incidental Paving
707	Curbs and Gutters
713	Temporary Signs, Barricades and Pavement Markings
724	Pavement Patching, Widening and Joint Repair
1002	Asphaltic Materials
1003.03	Base Course Aggregates
1005.01	Joint Fillers

C2K-2.3 American Society for Testing and Materials (ASTM).
Corresponding CRD Standards are indicated where available.

D 698-78

Moisture Density Relations of Soils and
Soil-Aggregate Mixture

C2K-2.4 Testing Procedures Manual (TPM), Louisiana Department
of Transportation and Development (LDOTD), Volume 2.

TR 401 (Method A) In-place Density (Sand Cone)

TR 418 (Method C) Moisture-Density Relationships

C2K-3. QUALITY CONTROL.

C2K-3.1 General. The Contractor shall establish and maintain quality control for paving operations to assure compliance with contract requirements and maintain records of his quality control for all construction operations including, but not limited to the following.

(1) Check asphalt, concrete, and aggregate materials, and job mix for compliance with contract requirements; and inspect the plant mixes in accordance with the applicable LDOTD specifications.

(2) Verify that prepared fill and base surfaces are ready to receive paving materials and that the requirements of the test specified herein have been met prior to applying paving materials.

(3) Check coverage rate of application of primer and paving materials.

(4) Installation of traffic signs.

C2K-3.2 Reporting. The original and two copies of these records and tests, as well as the records of corrective action taken, shall be furnished to the Government daily. Format of report shall be prescribed in the Special Clause entitled "CONTRACTOR QUALITY CONTROL".

PART 2 - PRODUCTS

C2K-4. PAVING MATERIALS.

C2K-4.1 Joint Filler. LSSRB Section 1005.01.

C2K-4.2 Asphaltic concrete binder and wearing courses shall be Type 1 meeting the requirements of LSSRB Section 501.

C2K-4.3 Base Materials.

C2K-4.3.1 Crushed Stone. Crushed stone shall be from the sources listed in the Special Clause entitle "STONE SOURCES", and shall consist of hard, durable particles of stone from coarse to fine, reasonably free of sticks and other foreign matter and shall meet the requirements of LSSRB Section 1003.03(d).

C2K-4.3.2 Crushed Concrete. Crushed concrete shall consist of hard, durable particles of crushed concrete from coarse to fine, reasonably free of sticks and other foreign matter and shall meet the following gradation requirements:

<u>U.S. Sieve</u>	<u>Percent Passing</u>
1-1/2"	100
1"	90 - 100
3/4"	70 - 100
No. 4	35 - 65
No. 40	12 - 32
No. 200	5 - 12

The fraction of crushed concrete material passing the No. 40 sieve shall conform to the following requirements:

Liquid Limit ----- (Max) 25
Plasticity Index --- (Max) 6

C2K-4.4 Asphaltic tack coat shall be as specified in LSSRB Section 504 except that only cut back asphalt (Grade RC-70 or RC-250) shall be used.

PART 3 - EXECUTION

C2K-5. CITY STREETS.

C2K-5.1 The Contractor shall repave the areas damaged due to his construction activities on London Drive. The Contractor shall, at no direct payment, conduct a pre-construction photograph survey of London Drive. All other streets damaged by the Contractor's operations shall be repaired in accordance with paragraph C2K-6.

C2K-5.1.1 The excavations shall be brought up to an elevation to receive a 8-inch thick (compacted) base with suitable base material fill compacted in accordance with paragraph C2E-6.1.3. The base shall be compacted to a minimum of 95% of maximum density as determined by TPM Designation: TR 418 (Method C). The in-place density of the base course shall be determined in accordance with TPM Designation: TR 401 (Method A). One density test shall be taken at each location where compacted fill is required. If any density value falls below that required, two additional tests shall be taken within 5-feet of the failing test

location and an average of the 3 tests will be used as the density value for that area. In the event that this averaged value fails to meet the required density, compaction shall continue until the required density is obtained.

C2K-5.1.2 All surfaces of existing pavement which are to have new asphalt placed against them shall be cleaned and an asphaltic tack coat applied in accordance with LSSRB specifications, Section 504.05 prior to placing asphalt.

C2K-5.1.3 Street Binder Course and Wearing Course. A 3¼-inch thick asphalt binder course and a 1¼-inch thick asphalt wearing course shall be laid over the completed base. An asphaltic tack coat shall be applied in accordance with LSSRB Section 504.05 between the binder and wearing courses. Both courses shall meet the requirements of LSSRB Section 501. Copies of the design mix shall be furnished to the Contracting Officer's (COR) representative for approval.

C2K-5.2 All curbs and gutters removed or damaged as a result of construction activities shall be replaced in accordance with Section 707.

C2K-6. MISCELLANEOUS PAVING. Sidewalks and other miscellaneous paving not covered elsewhere in this section that have been removed or damaged due to construction activities shall be replaced in accordance with LSSRB Section 706.

C2K-7. SIGNS AND BARRICADES. The Contractor shall furnish, install, and maintain, all necessary barricades, warning signs, danger signals, speed regulatory signs, directional signs and all other traffic devices, required by these specifications and contract drawings, or the Contracting Officer, in accordance with the Code Of The City Of New Orleans, La., Sections 61-92, "Provisions for Public Safety and Traffic Movement". Additional requirements for traffic control are specified in the Special Clause entitled "TRAFFIC CONTROL".

C2K-8. MEASUREMENT AND PAYMENT. No separate measurement or payment will be made for work specified herein. Payment will be included in the contract lump sum price for "Utility Modifications". The price and payment shall constitute full compensation for performing all operations necessary in construction and maintenance of the streets, parking areas traffic control management, and signing, and all other roadway appurtenances not covered elsewhere in these specifications. Excavation and backfill required for work specified herein outside the limits of I-wall construction shall be included in the contract lump sum price for "Utility Modifications."

INDEX

DIVISION 3 - CONCRETE

Para. No.	Paragraph Title	Page No.
SECTION C3A - FORMWORK FOR CONCRETE		
C3A-1.	RELATED WORK SPECIFIED ELSEWHERE	C3A-1
C3A-2.	APPLICABLE PUBLICATIONS	C3A-1
C3A-3.	QUALITY CONTROL	C3A-1
C3A-4.	SUBMITTALS	C3A-2
C3A-5.	DESIGN	C3A-2
C3A-6.	MATERIALS	C3A-3
C3A-7.	INSTALLATION	C3A-4
C3A-8.	CHAMFERING	C3A-4
C3A-9.	COATING	C3A-5
C3A-10.	REMOVAL	C3A-5
C3A-11.	MEASUREMENT AND PAYMENT	C3A-5
SECTION C3B - REINFORCING STEEL		
C3B-1.	SCOPE	C3B-1
C3B-2.	RELATED WORK SPECIFIED ELSEWHERE	C3B-1
C3B-3.	APPLICABLE PUBLICATIONS	C3B-1
C3B-4.	QUALITY CONTROL	C3B-1
C3B-5.	SUBMITTALS	C3B-2
C3B-6.	MATERIALS	C3B-2
C3B-7.	INSTALLATION	C3B-3
C3B-8.	MEASUREMENT AND PAYMENT	C3B-4
SECTION C3C - EXPANSION JOINTS		
C3C-1.	SCOPE	C3C-1
C3C-2.	RELATED WORK SPECIFIED ELSEWHERE	C3C-1
C3C-3.	APPLICABLE PUBLICATIONS	C3C-1
C3C-4.	QUALITY ASSURANCE	C3C-1
C3C-5.	SUBMITTALS	C3C-2
C3C-6.	MATERIALS	C3C-3
C3C-7.	INSTALLATION	C3C-3
C3C-8.	MEASUREMENT AND PAYMENT	C3C-4
SECTION C3D - CAST-IN-PLACE STRUCTURAL CONCRETE		
C3D-1.	RELATED WORK SPECIFIED ELSEWHERE	C3D-1
C3D-2.	APPLICABLE PUBLICATIONS	C3D-1
C3D-3.	QUALITY ASSURANCE	C3D-4
C3D-4.	EVALUATION AND ACCEPTANCE	C3D-5

INDEX

DIVISION 3 - CONCRETE

Para. No.	Paragraph Title	Page No.
SECTION C3D - CAST-IN-PLACE STRUCTURAL CONCRETE (CONTINUED)		
C3D-5.	SUBMITTALS	C3D-8
C3D-6.	MATERIALS	C3D-11
C3D-7.	MIXTURE PROPORTIONING	C3D-12
C3D-8.	PRODUCTION EQUIPMENT	C3D-16
C3D-9.	CONVEYING EQUIPMENT	C3D-18
C3D-10	PREPARATION FOR PLACING	C3D-20
C3D-11	PLACING	C3D-22
C3D-12	FINISHING	C3D-24
C3D-13	CURING AND PROTECTION	C3D-27
C3D-14	PLACING NON-SHRINK GROUT	C3D-29
C3D-15	CONTRACTOR QUALITY CONTROL	C3D-30
C3D-16	MEASUREMENT AND PAYMENT	C3D-37

INDEX

SECTION C3A - FORMWORK FOR CONCRETE

Para. No.	Paragraph Title	Page No.
C3A-1.	RELATED WORK SPECIFIED ELSEWHERE	C3A-1
C3A-2.	APPLICABLE PUBLICATIONS	C3A-1
C3A-3.	QUALITY CONTROL	C3A-1
C3A-4.	SUBMITTALS	C3A-2
C3A-5.	DESIGN	C3A-2
C3A-6.	MATERIALS	C3A-3
C3A-7.	INSTALLATION	C3A-4
C3A-8.	CHAMFERING	C3A-4
C3A-9.	COATING	C3A-5
C3A-10.	REMOVAL	C3A-5
C3A-11.	MEASUREMENT AND PAYMENT	C3A-5

SECTION C3A - FORMWORK FOR CONCRETE

PART 1 - GENERAL

C3A-1. RELATED WORK SPECIFIED ELSEWHERE.

C3A-1.1 Cast-In-Place Structural Concrete. Section C3D.

C3A-1.2 Reinforcing Steel. Section C3B.

C3A-1.3 Expansion Joints. Section C3C.

C3A-2. APPLICABLE PUBLICATIONS. The following publications, referred to hereafter by basic designation only, form a part of this specification to the extent indicated:

C3A-2.1 American Concrete Institute (ACI) Standards.

ACI 347R-88 Recommended Practice for Concrete Formwork

C3A-2.2 U.S. Department of Commerce, National Institute of Standards and Technology (NIST). Product Standard (PS).

PS 1-83 For Construction and Industrial Plywood

C3A-3. QUALITY CONTROL.

C3A-3.1 Forms, embedded items, ties and other accessories as specified in paragraph C3A-6.2, shall be inspected in sufficient time prior to each concrete placement by the Contractor in order to certify to the Contracting Officer that they are ready to receive concrete. Inspection of forms for concrete shall include a detailed evaluation of leakage control measures, type and application of release agent, and form cleanliness to avoid dirt transfer to the concrete.

C3A-3.2 Reporting. The results of each inspection shall be reported in writing and shall include, but not limited to, the following:

- (1) Removal of extraneous material from forms.
- (2) Check of joints for mortar tightness.
- (3) Type of form material required for the concrete finish.
- (4) Falsework and/or bracing.

- (5) Alignment, tolerances, and dimensions.
- (6) Chamfering.
- (7) Form coating.

The original and two copies of these reports, as well as corrective action taken, shall be furnished to the Government daily. The format of these reports shall be as prescribed in the Special Clause entitled "CONTRACTOR QUALITY CONTROL".

C3A-4. SUBMITTALS.

C3A-4.1 Shop Drawings. Drawings and design computations for all formwork including pre-fabricated forms, shall be submitted at least 45 days before either fabrication on site or before delivery of prefabricated forms. The drawings and data submitted shall include the type, size, quantity and strength of all materials of which the forms are to be made; the plan for jointing of facing panels; details affecting the appearance; type and location of form ties; and the assumed design values and loading conditions. The submittals are also required when prefabricated forms are bought or rented by the Contractor from a supplier. The drawings for concrete exposed to view shall be form plans and shall identify form joints, form tie locations, location and details for rustications at all locations, details of leakage control measures, the method of attaching form liners, and all other details which can affect visual quality.

C3A-4.2 Manufacturers Literature. Manufacturers literature shall be submitted for plywood, concrete form hard board, form accessories, form lining, prefabricated forms, and form coating proposed for use.

C3A-4.3 Form Liner. After shop drawings have been approved, a 2-foot by 2-foot square sample section of the form liner of the special finish shall be submitted for approval.

PART 2 - PRODUCTS

C3A-5. DESIGN. The design and engineering of the formwork, as well as its construction, shall be the responsibility of the Contractor. The submittals shall include the member properties, allowable material stresses and form dimensions. The computations shall include the design of individual members for stress and deflection load diagrams are also required. The approval of the design is required before any concrete is placed. The formwork shall be designed for loads, lateral pressure and allowable stresses in accordance with Chapter 2 of ACI 347R. Forms shall have sufficient strength to withstand the pressure resulting from placement and vibration of the concrete and shall have sufficient

rigidity to maintain specified tolerances. For Class A finish, the design shall be made to limit deflection of facing material between studs as well as deflection of studs and walers to 0.0025 times the span. Forms to incorporate the textured form liner finish shall be designed to permit rapid filling to avoid cold joints and lift lines.

C3A-6. MATERIALS.

C3A-6.1 Forms shall be fabricated with facing materials that produce the specified construction tolerance requirements of paragraph C3D-4.2 and the surface requirements of paragraph C3D-4.3.

C3A-6.1.1 Class "A" Finish. This class of finish shall apply to all exterior formed surfaces not covered by backfill. The form facing material shall be composed of new, well-matched tongue and groove lumber; or new plywood panels conforming to NIST Product Standard PS-1, Grade B Concrete Form, Class I; High Density Overlay, all Exterior Type. The Grade B Side shall be stamped as such and shall face the concrete.

C3A-6.1.2 Class "D" Finish. This class of finish shall apply to all unexposed surfaces. The sheathing may be of wood or steel.

C3A-6.1.3 Textured Form Liner Finish. This class of finish shall apply to locations as shown on the drawings. It shall be obtained by use of textured form liners conforming to the details shown on the drawings. Liners shall be 1½-inch fractured fin polyurethane elastomeric form liner. Liner shall be secured to the forms by methods recommended by the liner manufacturer and in such a manner that impressions of nail heads, screw heads, washers, and similar features will not be imparted to the surface of the concrete.

C3A-6.2 Form Accessories. Ties and other similar form accessories to be partially or wholly embedded in the concrete shall be of a commercially manufactured type. After the ends or end fasteners have been removed, the embedded portion of metal ties shall terminate not less than 2-inches from any concrete surface either exposed to view or exposed to water. Plastic snap ties may be used in locations where the surface will not be exposed to view. Form ties shall be constructed so that the ends or end fasteners can be removed without spalling the concrete. Safety factors for form ties, anchors and hangers shall comply with the standards of ACI 347R, Table 2.4. No form ties which leave a formed hole completely through the floodwall will be allowed.

C3A-6.3 Form Coating. Form coating shall be a commercial formulation of satisfactory and proven performance that will not bond with, stain or adversely affect concrete surfaces and will

not impair subsequent treatment of concrete surfaces depending upon bond or adhesion nor impede the wetting of surfaces to be cured with water or curing compounds.

PART 3 - EXECUTION

C3A-7. INSTALLATION.

C3A-7.1 Forms. Forms shall be mortar tight, properly aligned and adequately supported to produce concrete surfaces meeting the surface requirements of paragraph C3D-4.3 and conforming to construction tolerance of paragraph C3D-4.2. Where concrete surfaces are to be permanently exposed to view, joints in form panels shall be arranged to provide a pleasing appearance. Where forms for continuous surfaces are placed in successive units, care shall be taken to fit the forms over the completed surface so as to obtain accurate alignment of the surface and to prevent leakage of mortar. All possible efforts shall be made to minimize the occurrence of butt joints in the forms. Forms shall not be re-used if there is any evidence of surface wear and tear or defects which would impair the quality of the surface. All surfaces of forms and embedded materials shall be cleaned of any mortar from previous concreting and of all other foreign material before concrete is placed in them. The failure of a form or any system used in conjunction with a form in the placement of a floodwall that in any way affects the integrity of the form or tolerance of the floodwall shall necessitate the immediate removal of the form and any concrete placed prior to the failure. All costs for removal, clean up and salvage of reinforcing shall be borne by the Contractor. Any material removed shall not be returned to service until it has been satisfactorily shown to the Contracting Officer or his representative, that the cause for the failure has been corrected and proper steps have been added to the Contractor's Quality Control Plan to prevent a recurrence.

C3A-7.2 Tieing. Form tie bolts shall not be located within the textured surface or form liner portion of the walls. They shall be installed so as to prevent leakage. Prevention of leakage through tie holes shall be the responsibility of the Contractor.

C3A-8. CHAMFERING. All exposed joints, edges and external corners shall be chamfered by molding placed in the forms unless the drawings specifically state that chamfering is to be omitted or as otherwise specified. When wood chamfering strips do not prevent leakage of paste or water, an elastomeric type shall be employed. Chamfered joints shall not be permitted where earth or rockfill is placed in contact with concrete surfaces. Chamfered joints shall be terminated a sufficient distance outside the limit of the earth or rockfill so that the end of the joints will be clearly visible.

C3A-9. COATING. Forms for exposed or painted surfaces shall be coated with form oil or a form-release agent before the form or reinforcement is placed in final position. The coating shall be used as recommended in the manufacturer's printed or written instructions. Forms for unexposed surfaces may be wet with water in lieu of coating immediately before placing concrete, except that in cold weather with probable freezing temperatures coating shall be mandatory. Surplus coating on form surfaces and coating on reinforcing steel and construction joints shall be removed before placing concrete. Coatings that discolor concrete or are incompatible with their concrete materials are prohibited.

C3A-10. REMOVAL. Forms shall not be removed without approval and all removal shall be accomplished in a manner which will prevent injury to the concrete. Forms shall not be removed before the expiration of the minimum time indicated in paragraph C3A-10.2, except as otherwise directed or specifically authorized. When conditions of the work are such as to justify the requirement, forms will be required to remain in place for a longer period.

C3A-10.1 Inspection of Concrete Placement. The Contractor shall place the first monolith in it's entirety and remove the formwork as indicated in paragraph C3A-10 prior to placing concrete in any other monolith. The Contractor shall notify the Contracting Officer's representative immediately after the forms are removed so that an on-site inspection of the concrete work can be made. No patching or repair shall be permitted until after the inspection is made. Curing operations shall not be altered. Recommendations, as a result of the inspection, shall be made part of the Contractor's Quality Control for all future concrete work.

C3A-10.2 Unsupported Concrete. Formwork for walls, columns, sides of base slabs and other vertical type forms not supporting the weight of concrete shall not be removed in less than 18 hours of cumulative time, not necessarily consecutive, after concrete placement is completed during which the temperature of the air surrounding the concrete is above 50°F.

C3A-11. MEASUREMENT AND PAYMENT. No separate measurement or payment will be made for formwork and all costs in connection therewith shall be included in the contract unit or lump sum prices for the items of work to which the work is incidental.

INDEX

SECTION C3B - REINFORCING STEEL

Para. No.	Paragraph Title	Page No.
C3B-1.	SCOPE	C3B-1
C3B-2.	RELATED WORK SPECIFIED ELSEWHERE	C3B-1
C3B-3.	APPLICABLE PUBLICATIONS	C3B-1
C3B-4.	QUALITY CONTROL	C3B-1
C3B-5.	SUBMITTALS	C3B-2
C3B-6.	MATERIALS	C3B-2
C3B-7.	INSTALLATION	C3B-3
C3B-8.	MEASUREMENT AND PAYMENT	C3B-4

SECTION C3B - REINFORCING STEEL

PART 1 - GENERAL

C3B-1. SCOPE. The work covered by this section consists of furnishing all equipment, materials and labor for providing and placing steel bars, steel welded wire fabric, and accessories for concrete reinforcement.

C3B-2. RELATED WORK SPECIFIED ELSEWHERE.

C3B-2.1 Formwork. Section C3A, "FORMWORK FOR CONCRETE".

C3B-2.2 Joints. Section C3C, "EXPANSION JOINTS".

C3B-2.3 Concrete. Section C3D, "CAST-IN-PLACE STRUCTURAL CONCRETE".

C3B-3. APPLICABLE PUBLICATIONS. The following publications of the issues listed below, but referred to thereafter by basic designation only, form a part of this specification to the extent indicated by the references thereto:

C3B-3.1 American Concrete Institute (ACI) Standards.

ACI 318-89 Building Code Requirements for Reinforced Concrete

SP-66 ACI Detailing Manual - 1980

C3B-3.2 American Society for Testing and Materials (ASTM) Standards.

A 615-87a Deformed and Plain Billet-Steel Bars for Concrete Reinforcement

E 8-88 Tension Testing of Metallic Materials

C3B-4. QUALITY CONTROL.

C3B-4.1 Materials Tests. The Contractor shall have required material tests performed by an approved laboratory to demonstrate that the materials are in conformance with the specifications. Tension tests shall be performed on full cross section specimens in accordance with ASTM E 8, using a gage length that spans the extremities of specimens with welds or sleeves included. Tests shall be at the Contractor's expense.

C3B-4.2 General. The Contractor shall establish and maintain quality control for proper installation of all work covered in this section to assure compliance with contract

specifications and maintain records of his quality control for all construction operations including but not limited to the following:

- (1) Minimum concrete cover of reinforcement steel.
- (2) Number, size, and location of placement.
- (3) Maintain adequate splicing lengths where required.

C3B-4.3 Reporting. The original and two copies of these records and tests, as well as the records of corrective action taken, shall be furnished to the Government daily. Format of the report shall be as prescribed in the Special Clause entitled "CONTRACTOR QUALITY CONTROL".

C3B-5. SUBMITTALS.

C3B-5.1 Shop Drawings. The Contractor shall prepare and submit complete shop drawings to the Contracting Officer for approval in accordance with specified requirements. Shop drawings shall include the details of bar supports including types, sizes, spacing and sequence.

C3B-5.2 Test Reports. Certified test reports of reinforcement steel showing that the steel complies with the applicable specifications shall be submitted to the Contracting Officer by the Contractor. Reports shall be furnished for each steel shipment and shall be identified with specific lots prior to use of the steel in the work.

C3B-5.3 Disposition Records. A system of identification which shows the disposition of specific lots of approved materials in the work shall be established prior to placing any reinforcement and submitted to the Contracting Officer before completion of the contract.

PART 2 - MATERIALS

C3B-6. MATERIALS.

C3B-6.1 Reinforcing Steel. Billet-steel bars shall conform to ASTM A 615, Grade 60 for bar sizes 3 through 11, including the following requirements:

- (1) Tension test specimens shall be bars of full cross section as rolled for all sizes.
- (2) The bend test requirements shall be based upon 180 degree bends of full size bars for all grades of steel. The bend diameters for bend tests shall be as indicated in the following table and shall be measured on the inside of bars:

<u>Bar Size</u>	<u>Maximum Diameter</u>
#3, #4 and #5	4 bar diameters
#6, #7 and #8	5 bar diameters
#9, #10 and #11	5 bar diameters

C3B-6.2 Reinforcing Steel Accessories.

C3B-6.2.1 Bar Supports. Bar supports shall conform to ACI Publication SP-66. Bar supports for formed surfaces exposed to view or to be painted shall be plastic protected wire, stainless steel, or precast concrete supports. Precast concrete supports shall be wedge-shaped, not larger than 3½-inches x 3½-inches, of thickness equal to that indicated for concrete cover, and shall have an embedded hooked tie-wire for anchorage. If formed surface is exposed to view, precast concrete supports shall be the same quality, texture, and color as the finish surface.

C3B-6.2.2 Wire Ties. Wire ties shall be 16-gage or heavier black annealed wire.

PART 3 - EXECUTION

C3B-7. INSTALLATION. Reinforcement steel and accessories shall be placed as specified and as shown on contract drawings and approved shop drawings. Placement details of steel and accessories not specified or shown on the drawings shall be in accordance with ACI Publication SP-66 or ACI 318. Reinforcement shall be fabricated to shapes and dimensions shown, placed where indicated within the specified tolerances, and adequately supported during concrete placement. At the time of concrete placement all steel shall be free from loose, flaky rust, scale (except tight mill scale), mud, oil, grease, or any other coating that might reduce the bond with the concrete.

C3B-7.1 Hooks and Bends. Reinforcement bars may be mill or field bent. All bars shall be bent cold unless otherwise authorized. No bars partially embedded in concrete shall be field bent unless indicated on the drawings or otherwise authorized. All hooks or bends shall be in accordance with ACI 318.

C3B-7.2 Placing Tolerances.

C3B-7.2.1 Spacing of Bars. Bars shall be spaced as indicated on the drawings or as otherwise directed. The spacing between adjacent bars and the distance between layers may not vary from the indicated position by more than one bar diameter nor more than 1-inch, whichever is less.

C3B-7.2.2 Concrete Cover. The minimum clear cover of main reinforcement steel shall be as indicated on the drawings. The allowable variation for minimum cover shall be as follows:

<u>MINIMUM COVER</u>	<u>MAXIMUM COVER</u>
6"	6-1/2"
4"	4-3/8"
3"	3-3/8"
2-1/2"	2-3/4"
2"	2-1/4"
1-1/2"	1-3/4"
1"	1-1/8"
3/4"	7/8"

C3B-7.3 Splicing. Splices in reinforcement steel shall be as specified, shown on the drawings or as directed by the Contracting Officer. Bars may be spliced at alternate or additional locations at no additional cost to the Government, subject to the approval of the Contracting Officer. Except as provided herein, all splicing shall be in accordance with approved splicing procedures and the requirements of ACI 318. Bars larger than No. 11 shall be spliced with mechanical connectors or butt welded in accordance with ACI 318. The splice shall be submitted to the Contracting Officer for approval.

C3B-7.3.1 Lap Splices. Lap Splices shall be used only for bars smaller than size #14. Bar laps may be placed in contact and securely tied or spaced transversely apart to permit the embedment of the entire surface of each bar in concrete, but shall not be spaced farther apart than one-fifth the required length of lap nor 6-inches. Lengths of laps for bars shall conform to the requirements shown on the drawings.

C3B-8. MEASUREMENT AND PAYMENT. No separate measurement or payment will be made for reinforcement bars and accessories. Payment for furnishing and placing reinforcement bars and accessories shall be included in the contract prices for the items of work to which the reinforcement bars and accessories are incidental.

INDEX

SECTION C3C - EXPANSION JOINTS

Para. No.	Paragraph Title	Page No.
C3C-1.	SCOPE	C3C-1
C3C-2.	RELATED WORK SPECIFIED ELSEWHERE	C3C-1
C3C-3.	APPLICABLE PUBLICATIONS	C3C-1
C3C-4.	QUALITY ASSURANCE	C3C-1
C3C-5.	SUBMITTALS	C3C-2
C3C-6.	MATERIALS	C3C-3
C3C-7.	INSTALLATION	C3C-3
C3C-8.	MEASUREMENT AND PAYMENT	C3C-4

SECTION C3C - EXPANSION JOINTS

PART 1 - GENERAL

C3C-1. SCOPE. This section covers the materials, techniques and workmanship requirements for forming expansion joints in concrete.

C3C-2. RELATED WORK SPECIFIED ELSEWHERE. Major requirements for concrete work are specified in Section C3D, "CAST-IN-PLACE STRUCTURAL CONCRETE".

C3C-3. APPLICABLE PUBLICATIONS. The following publications of the issues listed below, but referred to thereafter by basic designation only, form a part of this specification to the extent indicated by the references thereto:

C3C-3.1 American Society for Testing and Materials (ASTM) Standards. (With corresponding U.S. Army Corps of Engineers Handbook for Concrete and Cement (CRD) Specifications where indicated.)

D 1751-83
(CRD-C 508) Preformed Expansion Joint Fillers for Concrete Paving and Structural Construction (Non-extruding and Resilient Bituminous Types)

D 1752-84
(CRD-C 509) Preformed Sponge Rubber and Cork Expansion Joint Fillers and Concrete Paving and Structural Construction

C3C-3.4 U.S. Army Corps of Engineers Handbook for Concrete and Cement (CRD) Specifications.

CRD-C 513-74 Rubber Waterstops

CRD-C 572-74 Polyvinylchloride Waterstops

C3C-4. QUALITY ASSURANCE.

C3C-4.1 Materials Tests.

C3C-4.1.1 Non-Metallic Waterstops. Samples of materials and splices as required in paragraph C3C-5.2 shall be visually inspected and tested by and at the expense of the Government for compliance with CRD-C 513 or CRD-C 572, as applicable. If a sample fails to meet the specification requirements, new samples shall be provided and the cost of retesting will be deducted from payments due the Contractor at the rate of \$650.00 per material sample retested and \$100.00 per splice sample retested.

C3C-4.2 Qualifications of Splicing Procedures for Waterstops. Procedures for splicing waterstops shall be demonstrated in the presence of the Contracting Officer for approval.

C3C-4.2.1 Non-Metallic Waterstops. Procedures and performance qualifications for splicing non-metallic waterstops shall be demonstrated by the manufacturer at the factory and the Contractor at the job site by each making three splice samples of each size and type of finished waterstops for inspection, testing and subsequent approval.

C3C-5. SUBMITTALS.

C3C-5.1 Test Reports. Certified manufacturer's test reports shall be provided for premolded expansion-joint filler strips, and waterstops to verify compliance with the applicable specification.

C3C-5.2 Samples. The Contractor shall submit waterstop materials and splice samples for inspection and testing and shall identify so as to indicate manufacturer, type of material, size and quantity of material and shipment represented. Each materials sample shall be a piece not less than 12-inches long cut from each 200-feet of finished waterstop furnished, but not less than a total of four linear feet of each type and size furnished. For spliced segments of waterstops to be installed in the work, one splice sample of each size and type for every 50 splices made in the factory and every 10 splices made at the job site shall be furnished for inspection and testing. The splice samples shall be made using straight run pieces with the splice located at the mid-length of the sample and finished as required for the installed waterstop. The total length of each splice sample shall be not less than 12-inches long. Test samples shall be furnished at least 60 days prior to the installation of waterstops in the work.

C3C-5.2.1 Transportation of Samples for Testing. Costs incidental to the transportation of samples or materials will be borne by the Contractor. The samples of the waterstop shall be obtained in the presence of a Contracting Officer's Representative. Samples of materials for test verification and acceptance testing by the Government shall be coordinated with the CO for shipping instructions and delivered to the Corps of Engineers Division Laboratory, f.o.b., at the following address:

Waterways Experiment Station
3909 Halls Ferry Road
Vicksburg, Mississippi

PART 2 - PRODUCTS

C3C-6. MATERIALS.

C3C-6.1 Premolded Expansion Joint Filler Strips. Premolded expansion joint filler strips shall conform to ASTM D 1751 or ASTM D 1752, Type I or resin impregnated fiberboard conforming to the physical requirements of ASTM D 1752.

C3C-6.2 Non-Metallic Waterstops. Rubber waterstops shall conform to CRD-C 513. Polyvinylchloride waterstops shall conform to CRD-C 572.

PART 3 - EXECUTION

C3C-7. INSTALLATION. Joint locations and details, including materials and methods of installation of joint fillers and waterstops, shall be as specified, shown on the drawings and as directed. In no case shall any fixed metal be continuous through an expansion joint.

C3C-7.1 Expansion Joints. Premolded filler strips shall be accurately positioned and secured against displacement to clean, smooth concrete surfaces. Material used to secure premolded fillers to concrete shall not harm the concrete. The groove shall be thoroughly cleaned of all laitence, curing compound, foreign materials, and protrusions of hardened concrete. Any dust shall be blown out of the groove with oil-free compressed air.

C3C-7.2 Waterstops. Waterstops shall be installed in joints as shown on the drawings or as otherwise directed. Waterstops shall be carefully and correctly positioned during installation to eliminate faulty installation that may result in joint leakage. Adequate provision shall be made to support and protect the waterstops during the progress of the work. Any waterstop punctured or damaged shall be replaced or repaired at the Contractor's expense. The concrete shall be thoroughly consolidated in the vicinity of the waterstop. Suitable guards shall be provided to protect exposed projecting edges and ends of partially embedded waterstops from damage when concrete placement has been discontinued.

C3C-7.2.1 Splices. Joints in waterstops shall be spliced together by qualified splicers using the approved splicing procedures to form a continuous watertight diaphragm.

C3C-7.2.1.1 Non-Metallic Waterstops. All splices shall be made on a bench in a temporary shop provided at the site of the installation or at the manufacturer's plant. A miter guide and portable power saw shall be used to cut the ends to be joined to

insure good alignment and contact between joined surfaces. The continuity of the characteristic features of the cross section of the waterstop shall be maintained across the splice.

C3C-7.2.1.1.1 Rubber Waterstops. Splices shall be vulcanized in accordance with the manufacturer's recommendations.

C3C-7.2.1.1.2 Polyvinylchloride Waterstops. Splices shall be made by heat sealing the adjacent surfaces in accordance with the manufacturer's written recommendations. A thermostatically controlled electric source of heat shall be used to make all splices. The correct temperature at which splices should be made will differ with the material concerned but the applied heat should be sufficient to melt but not char the plastic. Waterstops shall be reformed at splices with a remolding iron with ribs or corrugations to match the pattern of the waterstop. The spliced area, when cooled and bent by hand in as sharp an angle as possible, shall show no sign of separation.

C3C-8. MEASUREMENT AND PAYMENT.

C3C-8.1 Expansion Joints and Waterstops. No separate measurement or payment will be made for expansion joints and waterstops, and all costs in connection therewith shall be included in the contract unit or lump sum prices for the items of work to which the work is incidental.

C3C-8.2 Expansion Joint Fillers. No separate measurement or payment will be made for furnishing, cutting, and installing the expansion joint filler and all costs in connection therewith shall be included in the contract prices for the items of work to which the work is incidental.

INDEX

SECTION C3D - CAST-IN-PLACE STRUCTURAL CONCRETE

Para. No.	Paragraph Title	Page No.
C3D-1.	RELATED WORK SPECIFIED ELSEWHERE	C3D-1
C3D-2.	APPLICABLE PUBLICATIONS	C3D-1
C3D-3.	QUALITY ASSURANCE	C3D-4
C3D-4.	EVALUATION AND ACCEPTANCE	C3D-5
C3D-5.	SUBMITTALS	C3D-8
C3D-6.	MATERIALS	C3D-11
C3D-7.	MIXTURE PROPORTIONING	C3D-12
C3D-8.	PRODUCTION EQUIPMENT	C3D-16
C3D-9.	CONVEYING EQUIPMENT	C3D-18
C3D-10.	PREPARATION FOR PLACING	C3D-20
C3D-11.	PLACING	C3D-22
C3D-12.	FINISHING	C3D-24
C3D-13.	CURING AND PROTECTION	C3D-27
C3D-14.	PLACING NON-SHRINK GROUT	C3D-29
C3D-15.	CONTRACTOR QUALITY CONTROL	C3D-30
C3D-16.	MEASUREMENT AND PAYMENT	C3D-37

SECTION C3D - CAST-IN-PLACE STRUCTURAL CONCRETE

PART 1 - GENERAL

C3D-1. RELATED WORK SPECIFIED ELSEWHERE.

C3D-1.1 Expansion Joints. Section C3C

C3D-1.2 Reinforcing Steel. Section C3B

C3D-1.3 Formwork for Concrete. Section C3A

C3D-2. APPLICABLE PUBLICATIONS. The following publications referred to thereafter by basic designation only, form a part of this specification to the extent indicated:

C3D-2.1 American Concrete Institute (ACI) with Corresponding CRD Standard Indicated Where Available.

211.1-91
(CRD-C99) Standard Practice for Selecting Proportions for Normal, Heavyweight and Mass Concrete

305R-91 Hot Weather Concreting

318-89 Building Code Requirements for Reinforced Concrete

C3D-2.2 American Society for Testing and Materials (ASTM) with Corresponding CRD Standard Indicated Where Available.

C 29-91a (CRD-C 106) Unit Weight and Voids in Aggregate

C 31-91 (CRD-C 11) Making and Curing Concrete Test Specimens in the Field

C 33-90 (CRD-C 133) Concrete Aggregates

C 39-86 (CRD-C 14) Compressive Strength of Cylindrical Concrete Specimens

C 42-90 (CRD-C 27) Obtaining and Testing Drilled Cores and Sawed Beams of Concrete

C 70-79 (CRD-C 111) Surface Moisture of Fine Aggregate

C 94-92 (CRD-C 31) Ready-Mixed Concrete

C 127-88 (CRD-C 107) Specific Gravity and Absorption of Coarse Aggregate

C 128-88 (CRD-C 108)	Specific Gravity and Absorption of Fine Aggregate
C 136-84a (CRD-C 103)	Sieve Analysis of Fine and Coarse Aggregates
C 143-90a (CRD-C 5)	Slump of Hydraulic Cement Concrete
C 150-92 (CRD-C 201)	Portland Cement
C 171-91 (CRD-C 310)	Sheet Materials for Curing Concrete
C 172-90 (CRD-C 4)	Sampling Freshly Mixed Concrete
C 192-90a (CRD-C 10)	Making and Curing Concrete Test Specimens in the Laboratory
C 231-90b (CRD-C 41)	Air Content of Freshly Mixed Concrete by Pressure Method
C 260-86 (CRD-C 13)	Air-Entraining Admixtures for Concrete
C 309-91 (CRD-C 304)	Liquid Membrane-Forming Compounds for Curing Concrete
C 494-92 (CRD-C 87)	Chemical Admixtures for Concrete
C 566-89 (CRD-C 113)	Total Moisture Content of Aggregate by Drying
C 595-92c (CRD-C 203)	Blended Hydraulic Cements
C 597-83 (CRD-C 51)	Pulse Velocity Through Concrete
C 618-92a (CRD-C 255)	Fly Ash and Raw or Calcined Natural Pozzolan for Use as a Mineral Admixture in Portland Cement Concrete
C 803-90 (CRD-C59)	Penetration Resistance of Hardened Concrete
C 805-85 (CRD-C 22)	Rebound Number of Hardened Concrete
C 1017-92 (CRD-C 88)	Chemical Admixtures for Use in Producing Flowing Concrete
C 1064-86 (CRD-C 3)	Temperature of Freshly Mixed Portland Cement Concrete
C 1077-91a (CRD-C 553)	Laboratories Testing Concrete and Concrete Aggregates for Use in Construction and Criteria for Laboratory Evaluation

C 1107-91 (CRD-C 621) Packaged Dry, Hydraulic Cement Grout
(Non-Shrink)

D 75-87 (CRD-C 155) Sampling Aggregates

C3D-2.3 Concrete Plant Manufacturer's Bureau (CPMB).

9th Revision (CRD-C 514) Concrete Plant Standards (1 Jan
90)

C3D-2.4 National Institute of Standards and Technology
(NIST), Formerly National Bureau of Standards.

Handbook 44 Specifications, Tolerance and Other
1992 Edition Requirements for Commercial Weighing and
Measuring Devices

C3D-2.5 U.S. Army Corps of Engineers Handbook for Cement and
Concrete (CRD-C).

94-66 Surface Retarders

100-75 Sampling Concrete Aggregate and Aggregate
Sources and Selection of Material for
Testing

104-80 Calculation of Fineness Modulus of
Aggregate

112-69 Surface Moisture in Aggregate by Water
Displacement

143-62 Meters for Automatic Indication of
Moisture in Fine Aggregate

400-63 Water for Use in Mixing or Curing
Concrete

521-81 Frequency and Amplitude of Vibrators for
Concrete

C3D-2.6 Louisiana Standard Specifications for Roads and
Bridges (LSSRB) 1982 Edition, State of Louisiana, Department of
Transportation and Development (LDOTD).

1003.02 Aggregates for Portland Cement Concrete
and Mortar

C3D-2.7 Federal Specification (Fed. Spec.).

A-A-1555 Water Paint, Powder (Cementious, White
and Colors)

C3D-3. QUALITY ASSURANCE.

C3D-3.1 Preconstruction Sampling and Testing.

C3D-3.1.1 Aggregates. The aggregate sources listed in the Special Clause entitled "AGGREGATE SOURCES" have been determined to be capable of producing materials of a quality acceptable for this project. Proposed materials produced from similar strata, or of similar quality as those originally tested, will be approved. If the Contractor proposes to furnish aggregates from a source not listed in the Special Clause entitled "AGGREGATE SOURCES", samples consisting of not less than 500 pounds of each size coarse aggregate and 300 pounds of fine aggregate taken under the supervision of the Contracting Officer in accordance with CRD-C 100 shall be delivered to the Waterways Experiment Station (3909 Halls Ferry Road) in Vicksburg, MS within 15 days after notice to proceed. Sampling and shipment of samples shall be at the Contractor's expense. From 90 to 120 days will be required to complete evaluation of the aggregates. Testing by and at the expense of the Government will be in accordance with applicable CRD or ASTM test methods. Tests to which aggregate may be subjected are specific gravity, absorption, cycles of freezing and thawing in concrete, alkali-aggregate reaction, organic impurities, and any other test necessary to demonstrate that the aggregate is of a quality that is at least equivalent to those sources listed in the Special Clause entitled "AGGREGATE SOURCES".

C3D-3.1.2 Cementitious Materials, Admixtures, Curing Compound. At least 60 days in advance of concrete placement, the Contractor shall notify the Contracting Officer of the source of materials, along with sampling location, brand name, type, and quantity to be used in the manufacture and/or curing of the concrete.

C3D-3.1.2.1 Air-Entraining Admixture or other chemical admixtures that have been in storage at the project site for longer than 6 months or that have been subjected to freezing will be retested at the expense of the Contractor when directed by the Contracting Officer and will be rejected if test results indicate non-compliance with C3D-6.3.

C3D-3.2 Construction Testing By Government. The Government will sample and test aggregates and concrete to determine compliance with the specifications. The Contractor shall provide facilities and labor as may be necessary to assist the Government in procurement of representative test samples. Samples of aggregates will be obtained at the point of batching in accordance with ASTM D 75. Concrete will be sampled in accordance with ASTM C 172. When cylinders are molded, slump and air content will be determined in accordance with ASTM C 143 and ASTM C 231, respectively. Test samples for each class of concrete will be taken at least once every 8-hour shift or for every 150 cubic yards placed, whichever requires more samples. From each sample,

three compression test specimens will be made in accordance with ASTM C 31. Compression test specimens will be protected and cured while in the field in accordance with paragraphs 9.1 and 9.2 of ASTM C 31. If cylinders are not delivered to the testing laboratory within 24 to 48 hours, they will be submerged in a water tank provided by the Contractor, where the surrounding water temperature is maintained by the Contractor at $73.4 \pm 3^{\circ}\text{F}$. Cylinders will be transported with cushioning material and in accordance with ASTM C 31. Compression testing will be performed in accordance with ASTM C 39. One cylinder will be tested at 7 days for information and two will be tested at 28 days (90 if pozzolan used) for acceptance.

C3D-4. EVALUATION AND ACCEPTANCE.

C3D-4.1 Concrete Strength. The strength of the concrete will be considered satisfactory so long as the averages of all sets of three consecutive test results equals or exceeds the specified compressive strength, f'_c , and no individual test (average of two companion cylinders) result falls below f'_c by more than 500 pounds per square inch. Additional analysis or testing may be required at the Contractor's expense when the strength of the concrete in the structure is considered potentially deficient.

C3D-4.1.1 Investigation of Low-Strength Test Results. When any individual strength test of standard-cured companion test cylinders falls below f'_c by more than 500 pounds per square inch or if tests of field-cured cylinders indicate deficiencies in protection and curing, steps shall be taken to assure that the load-carrying capacity of the structure is not jeopardized. Nondestructive testing in accordance with ASTM C 597, C 803, or C 805 may be permitted by the Contracting Officer to determine the relative strengths at various locations in the structure as an aid in evaluating concrete strength in place or for selecting areas to be cored. Such tests, unless properly calibrated and correlated with other test data, shall not be used as a basis for acceptance or rejection.

C3D-4.1.2 Testing of Cores. When the strength of concrete in place is considered potentially deficient, cores shall be obtained and tested in accordance with ASTM C 42. At least three representative cores shall be taken from each member or area of concrete in place that is considered potentially deficient. The location of cores will be determined by the Contracting Officer to least impair the strength of the structure. If the concrete in the structure will be dry under service conditions, the cores shall be air dried (temperature 60°F to 80°F , relative humidity less than 60 percent) for 7 days before testing and shall be tested dry. If the concrete in the structure will be more than superficially wet under service conditions, the cores shall be tested after moisture conditioning in accordance with ASTM C 42. Concrete in the area represented by the core testing will be

considered adequate if the average strength of the cores is equal to at least 85 percent of the specified strength requirement and if no single core is less than 75 percent of the specified strength requirement.

C3D-4.1.3 Load Tests. If the core tests are inconclusive or impractical to obtain or if structural analysis does not confirm the safety of the structure, load tests may be directed by the Contracting Officer in accordance with the requirements of Chapter 20 of ACI 318. Concrete work evaluated by structural analysis or by results of a load test shall be corrected in a manner satisfactory to the Contracting Officer. All investigations, testing, load tests, and correction of deficiencies will be performed and approved by the Contracting Officer at the expense of the Contractor, except that if all concrete is found to be in compliance with the plans and specifications, the cost of investigations, testing, and load tests will be at the expense of the Government.

C3D-4.2 Construction Tolerances. Variation in alignment, grade, and dimensions of the structures from the established alignment, grade, and dimensions shown on the drawings shall be within the tolerances specified in the following tables:

TABLE 1

CONSTRUCTION TOLERANCES FOR REINFORCED CONCRETE STRUCTURES

(1) Variations from the plumb:	In any 10-feet of length....	1/4-inch
a. In the lines and surfaces of columns, piers, and walls and in arrises	Maximum for entire length...	1-inch
b. For exposed corner columns, control-joint grooves, and other conspicuous lines	In any 20-feet of length.... Maximum for entire length...	1/4-inch 1/2-inch
(2) Variation from the level or from the grades indicated on the drawings:	In any 10-feet of length.... In any bay or in any 20-feet of length.....	5/16-inch 3/8-inch
a. In slabs and in arrises	Maximum for entire length...	3/4-inch
b. In exposed horizontal grooves, and other conspicuous lines	In any bay or in any 20-feet of length..... Maximum for entire length...	1/4-inch 1/2-inch
(3) Variation wall lines from established position in plan	In any 20-feet..... Maximum.....	1/2-inch 1-inch

- (4) Variation in the sizes
locations of wall openings
 - Minus..... 1/4-inch
 - Plus..... 1/2-inch

- (5) Variations in cross-sectional
dimensions of columns and
beams and in the thickness
of slabs and walls
 - Minus..... 1/4-inch
 - Plus..... 1/2-inch

- (6) Footings:
 - a. Variation of dimensions
in plan
 - Minus..... 1/2-inch
 - Plus..... 2-inches
when formed or plus 3-inches when
placed against unformed excavation.

 - b. Misplacement of
eccentricity
 - 2 percent of the footing width in the
direction of misplacement but not more
than..... 2-inches

 - c. Reduction in thickness
 - Minus..... 5 percent
of specified thickness

C3D-4.2.1 Level and Grade Tolerance Measurements for Slabs.
 Level and grade tolerance measurements for slabs shall be made as soon as possible after finishing. When forms or shoring are used, the measurements shall be made prior to removal.

C3D-4.3 Surface Requirements. The surface requirements for the classes of finish required by C3A-6.1, shall be as hereinafter specified. Allowable irregularities are designated "abrupt" or "gradual" for purposes of providing for surface variations. Offsets resulting from displaced, misplaced, or mismatched forms, or sheathing, or by loose knots in sheathing, or other similar form defects, shall be considered "abrupt" irregularities. Irregularities resulting from warping, unplaneness, or similar uniform variations from planeness, or true curvature, shall be considered "gradual" irregularities. "Gradual" irregularities will be checked for compliance with the prescribed limits with a 5-foot template, consisting of a straightedge for plane surfaces and a shaped template for curved or warped surfaces. In measuring irregularities, the straightedge or template may be placed anywhere on the surface in any direction, with the testing edge held parallel to the intended surface.

<u>Class of Finish</u>	<u>Irregularities (Maximum Allowed)</u>	
	<u>Abrupt, Inches</u>	<u>Gradual, Inches</u>
A	1/8	1/4
D	1	1
Textured Form Liner	1/8	1/4

C3D-4.4 Appearance. Permanently exposed surfaces shall be cleaned, if stained or otherwise discolored, by a method that does not harm the concrete and that is approved by the Contracting Officer.

C3D-5. SUBMITTALS.

C3D-5.1 Test Reports.

C3D-5.1.1 Concrete Mixture Proportions. Concrete mixture proportions shall be determined by the Contractor in accordance with the requirements in C3D-7, and submitted for approval. The quantities of all ingredients per cubic yard and nominal maximum coarse aggregate size that will be used in the manufacture of each quality of concrete shall be stated. Proportions shall indicate the weight of cement, pozzolan (if used), and water; weights of aggregates in a saturated surface-dry condition; and the quantities of admixtures. The submission shall be accompanied by test reports from a laboratory complying with ASTM C 1077 which show that proportions thus selected will produce concrete of the qualities indicated. The submission shall provide information specified in C3D-7.5, and if applicable, and C3D-7.3. Concrete compression strength results submitted shall include specific gravity and absorption of fine and coarse aggregates determined by ASTM C 128 and ASTM C 127, respectively; slump; air content; and concrete temperature. No substitution shall be made in the source or type of materials used in the work without additional tests to show that the new materials and quality of concrete are satisfactory. The mix proportions shall be submitted for approval at least 30 days in advance of the time when the first concrete will be placed.

C3D-5.1.2 Cement and Pozzolan. Cement and pozzolan will be accepted on the basis of the manufacturer's certification of compliance, accompanied by mill test reports, stating that materials meet the requirements of the specification under which they are furnished. Certification and mill test reports shall be from current production and be representative of the particular lot furnished. No cement or pozzolan shall be used until notice of acceptance has been given by the Contracting Officer. Cement and pozzolan will be subject to check testing from samples obtained at the mill, at transfer points, or at the project site, as scheduled by the Contracting Officer, and such sampling will be by or under the supervision of the Government at its expense. Material not meeting specifications shall be promptly removed from the site of work.

C3D-5.1.3 Reserved.

C3D-5.1.4 Non-shrink Grout.

C3D-5.1.4.1 General. Descriptive literature of the grout proposed for use shall be furnished together with a certificate from the manufacturer stating that it is suitable for the application or exposure for which it is being considered. In addition, a detailed plan shall be submitted for approval, showing equipment and procedures proposed for use in mixing and placing the grout.

C3D-5.1.4.2 Prepackaged Material. Prepackaged material requiring only the addition of water will be accepted on the basis of certified laboratory test results showing that the material meets the requirements of ASTM C 1107. When fine aggregate is to be added, the Contractor shall also furnish for approval the mixture proportions together with certified copies of laboratory test results indicating that the mixture is in conformance with the requirements of ASTM C 1107.

C3D-5.1.4.3 Mixture Proportions. Mixture proportions using a volume-change controlling ingredient shall be submitted for approval. The submittal shall include the mixture proportions of all ingredients and certified copies of laboratory test results indicating that the materials and the mixture is in conformance with the requirements of ASTM C 1107.

C3D-5.1.5. Aggregates. Information identifying the aggregate source to be used along with gradation tests for fine and coarse aggregates shall be submitted for approval. The gradation test for fine aggregate shall include the No. 8 and No. 30 sieve sizes.

C3D-5.1.6 Water. The name of the source of mixing and curing water (and documentation that mixing water meets CRD-C 400, if undrinkable) shall be submitted for conformance with C3D-6.5.

C3D-5.2 Manufacturer's Certificate.

C3D-5.2.1 Reserved.

C3D-5.2.2 Impervious-Sheet Curing Materials. Impervious-sheet curing materials shall be certified for compliance with all specification requirements.

C3D-5.2.3 Air-Entraining Admixtures. Air-entraining admixtures shall be certified for compliance with all specification requirements.

C3D-5.2.4 Other Chemical Admixtures. Other chemical admixtures shall be certified for compliance with all specification requirements.

C3D-5.2.5 Curing Compound. Curing compound shall be certified for compliance with all specification requirements.

C3D-5.3 Review of Plant, Equipment, and Methods.

C3D-5.3.1 Batch Plant. Details of the data on concrete plant shall be submitted for review by the Contracting Officer for conformance with C3D-8.1 and C3D-8.2.

C3D-5.3.2 Mixers. The make, type, and capacity of concrete mixers proposed for mixing concrete shall be submitted for review by the Contracting Officer for conformance with C3D-8.1 and C3D-8.3. The results of the initial mixer uniformity tests as required in C3D-15.2.12 shall be submitted at least 5 days prior to the initiation of placing.

C3D-5.3.3 Conveying. A description of the methods and equipment for transporting, handling, and depositing the concrete shall be submitted for review by the Contracting Officer for conformance with C3D-9.

C3D-5.3.4 Placing. A description of all placing equipment and methods shall be submitted for review by the Contracting Officer for conformance with C3D-11.

C3D-5.3.5 Joint Cleanup. A description of the methods and equipment proposed for joint cleanup and waste disposal shall be submitted for review by the Contracting Officer for conformance with C3D-10.4.

C3D-5.3.6 Curing. A description of the curing media, equipment and methods to be used shall be submitted for review by the Contracting Officer for conformance with C3D-13.

C3D-5.3.7 Cold-Weather Requirements. If concrete is to be placed under cold-weather conditions, a description of the proposed materials, methods, and protection shall be submitted for approval by the Contracting Officer for conformance with C3D-11.3 and C3D-13.5.

C3D-5.3.8 Hot-weather Requirements. If concrete is to be placed under hot-weather conditions, a description of the proposed materials and methods shall be submitted for approval by the Contracting Officer for conformance with C3D-11.4 and C3D-12.1.1.

PART 2 - PRODUCTS

C3D-6. MATERIALS.

C3D-6.1 Cementitious Materials. Cementitious materials shall be portland cement, portland-pozzolan cement, or portland cement in combination with pozzolan and shall conform to appropriate specifications listed below.

C3D-6.1.1 Portland Cement. ASTM C 150, Type I or II, low alkali, except the maximum amount of C_3A in Type I cement shall be 15 percent.

C3D-6.1.2 High-Early-Strength Portland Cement. ASTM C150, Type III, low alkali, used only when specifically approved in writing.

C3D-6.1.3 Reserved.

C3D-6.1.4 Portland-Pozzolan Cement. ASTM C 595, Type IP with Table 2 mortar expansion limits.

C3D-6.1.5 Pozzolan. Pozzolan shall conform to ASTM C 618, Class C or F, with the alkali requirements of Table 1a and with the requirements for multiple factor, drying shrinkage, and uniformity of Table 2A.

C3D-6.1.6 Pozzolan-Modified Portland Cement. ASTM C 595, Type I PM with Table 2 mortar expansion limits.

C3D-6.2 Aggregates. Aggregates shall be produced from the sources and under the conditions described in C3D-3.1.1 and the Special Clause entitled "AGGREGATE SOURCES". Fine and coarse aggregates shall conform to the grading requirements of either ASTM C 33 or LSSRB 1003.02. The quality of all aggregates shall conform to ASTM C 33. The nominal maximum size shall be as listed in C3D-7.2.3.

C3D-6.3 Chemical Admixtures. Chemical admixtures to be used, when required or permitted, shall conform to the appropriate specification listed below:

C3D-6.3.1 Air-Entraining Admixture. ASTM C 260.

C3D-6.3.2 Reserved.

C3D-6.3.3 Water-Reducing or Retarding Admixtures. ASTM C 494, Type A, B, or D.

C3D-6.3.4 High-Range Water Reducer. ASTM C 494, Type F or G. The admixture may be used only when approved by the Contracting Officer, such approval being contingent upon particular mixture control as described in the Contractor's Quality Control Plan.

C3D-6.4 Curing Materials.

C3D-6.4.1 Impervious-Sheet Materials. ASTM C 171, type optional, except polyethylene film, if used, shall be white opaque.

C3D-6.4.2 Membrane-Forming Curing Compound. ASTM C 309, Type 1-D or 2, Class B.

C3D-6.5 Water. Water for mixing and curing shall be fresh, clean, drinkable, and free of injurious amounts of oil, acid, salt, sugar, or alkali, except that undrinkable water may be used if it meets the requirements of CRD-C 400.

C3D-6.6 Non-Shrink Grout. Non-shrink grout shall conform to ASTM C 1107 and shall be a commercial formulation suitable for the application proposed.

C3D-6.7 Expansion Joint Filler. Expansion joint filler shall be Grade 3 or better Redwood heartwood, Western Red Cedar heartwood or CCA pressure treated lumber with a minimum retention of 0.40 pcf. Wooden expansion joint material shall be certified by the manufacturer and the grade of lumber and the CCA retention, if applicable, marked on each piece of wood before shipment.

C3D-6.8 Joint Sealer. Joint sealer shall be capable of being placed on the slope shown at manufacturer recommended placing temperatures and in accordance with Section C6-8. Sealer shall comply with ASTM D 3406 or BRSS M-41: Class A, C, R, or S. Preliminary acceptance of the sealer will be based on a certificate of compliance or manufacturer's literature which states compliance together with manufacturer's literature detailing the recommended application method and equipment. Final acceptance of the sealant will be based on a successful field demonstration.

C3D-7. MIXTURE PROPORTIONING.

C3D-7.1 General. For each portion of the structure, mixture proportions shall be selected so that the following requirements are met.

C3D-7.2 Properties.

C3D-7.2.1 Specified Compressive Strength. Specified compressive strength, f'_c , shall be as follows:

Compressive Strength (psi)

Structure or Portion of Structure

3,000 @28* days

2,500 @28* days

2,000 @28* days

* 90 if pozzolan used

Floodwalls

4-inch stabilization slab

8-inch slope pavement

C3D-7.2.2 Maximum Water-Cementitious Ratio. The maximum water-cementitious ratio shall be as follows:

Water-Cementitious Ratio, by wt

Structure or Portion of Structure

0.58

0.64

All other features

4-inch stabilization slab

and 8-inch slope pavement

C3D-7.2.3 Nominal Maximum-Size Coarse Aggregate. Nominal maximum-size coarse aggregate shall be either 1½-inch or 1-inch except ¾-inch nominal maximum-size coarse aggregate shall be used when any of the following conditions exist: (1) the narrowest dimension between sides of forms is less than 7½-inches; the depth of the slab is less than 4½-inches; the minimum clear spacing between reinforcing and sheet piling is less than 2-inches; or the minimum clear spacing between reinforcing is less than 2-inches; (2) in the fractured fin section of the floodwall.

C3D-7.2.4 Air Content. Air content as determined by ASTM C 231 shall be between 4 and 7 percent except that when the nominal maximum size coarse aggregate is ¾-inch, it shall be between 5 and 7 percent.

C3D-7.2.5 Slump. The slump shall be determined in accordance with ASTM C 143 and shall be within the range of 1-inch to 4-inches. Where placement by pump is approved, the slump shall not exceed 6-inches and shall remain within a 3-inch band.

C3D-7.2.6 Pozzolan Content. If pozzolan is used, it shall be limited to a maximum of 35 percent by absolute volume of the total cementitious materials.

C3D-7.3 Determining Standard Deviation. Test records from which a standard deviation is calculated shall:

(1) represent materials, quality control procedures, and conditions similar to those expected at the proposed work;

(2) not be from a project where the allowable changes in materials and/or proportions were more restricted than for the proposed work;

(3) represent concrete produced to meet a specified strength or strengths, f'_c , within 1000 psi of that specified for the proposed work;

(4) consist of at least 30 consecutive tests or two groups of consecutive tests totaling at least 30 tests;

(5) be from different batches;

(6) be the average of strengths from two cylinders made from the same sample of concrete and tested at the age indicated in C3D-7.2; and

(7) be from concrete that was produced within one year of the time when concrete placement is expected to begin for the proposed work.

C3D-7.3.1 For 30 Test Records. Use an unmodified standard deviation and calculate f_{cr} as specified in C3D-7.4.1.

C3D-7.3.2 For 15 to 29 Test Records. Where a concrete production facility does not have 30 test records, but does have a record based on 15 to 29 consecutive tests, a modified standard deviation may be established as the product of the standard deviation based on 15 to 29 tests and modification factor from the following table. Calculate f_{cr} as specified in C3D-7.4.1.

<u>Number of Records *</u>	<u>Modification Factor for Standard Deviation</u>
15	1.16
20	1.08
25	1.03
30 or more	1.00

*Interpolate for intermediate numbers of records.

C3D-7.3.3 For Less Than 15 Test Records. No standard deviation is needed. Calculation of f_{cr} shall be as specified in C3D-7.4.2.

C3D-7.4 Required Average Compressive Strength, f_{cr} . In meeting the strength requirements specified in C3D-7.2.1, the selected mixture shall have proportions so as to produce an f_{cr} exceeding f'_c as indicated below.

C3D-7.4.1 For 15 to 30 Records. If a standard deviation is calculated as specified in C3D-7.3.1 or C3D-7.3.2, f_{cr} shall be determined based on the value of f'_c and the standard deviation, S , as follows:

<u>Standard Deviation, S</u>	<u>Required Average Compressive Strength, f_{cr} (psi)</u>
Less than or equal to 505	$f'_c + 1.34 S$
Greater than 505	$(f'_c + 2.33 S) - 500$

C3D-7.4.2 For Less Than 15 Records. When a concrete production facility does not have field strength test records for calculation of standard deviation, f_{cr} , shall be determined based on the value of f'_c as follows:

<u>Specified Compressive Strength, f'_c (psi)</u>	<u>Required Average Compressive Strength, f_{cr} (psi)</u>
Less than 3000	$f'_c + 1000$
3000-5000	$f'_c + 1200$

C3D-7.5 Documenting Average Strength. Documentation that proposed concrete proportions produce the required average strength, f_{cr} , determined in C3D-7.4 shall be based on previous field experience (C3D-7.5.1) or laboratory trial batches (C3D-7.5.2).

C3D-7.5.1 Field Experience. Required average strength can be documented by field experience if compressive strength test records consisting of not less than 10 consecutive tests and encompassing a period of not less than 60 days are used. Test records shall represent similar materials to those proposed and similar conditions to those expected. Changes in materials, conditions, and proportions within the test record shall not have been more closely restricted than those for the proposed work.

C3D-7.5.2 Laboratory Trial Batches. The laboratory used to develop information required by this section shall comply with ASTM C 1077.

C3D-7.5.2.1. Representative Samples. Representative samples for all concrete materials proposed for this project and a copy of this section of the contract specifications entitled "CAST-IN-PLACE STRUCTURAL CONCRETE" shall be delivered to the laboratory that performs the concrete proportioning at least 60 days (120 when pozzolan used) before concrete placement is expected to begin. Samples of approved aggregates shall be obtained in accordance with the requirements of ASTM D 75. Samples of materials other than aggregate shall be representative of those proposed for the project and shall be accompanied by manufacturer's test reports indicating compliance with applicable specification requirements. When all of these materials have been delivered, the name, address, and phone number of this laboratory and a list of the sources and types of all concrete materials shall be submitted to the Contracting Officer.

C3D-7.5.2.2. Trial Mixtures. Trial mixtures having proportions, consistencies, maximum slump and maximum air content suitable for the work shall be made based on ACI 211.1, using at least three different water-cementitious ratios which will produce a range of strengths encompassing those required for the work. The maximum water-cementitious ratios required in C3D-7.2.2 include the total weight of cement plus pozzolan, converted from absolute volume as described in ACI 211.1. Trial mixtures shall be designed in accordance with the procedure in ACI 211.1, Chapter 6, using the absolute volume basis for determining the required amount of fine aggregate. Format for submittal of mixture proportions shall be in accordance with ACI 211.1, paragraph 7.3.7.2. The dry rodded weight per cubic foot of the coarse aggregate shall be determined according to ASTM C 29; the fineness modulus of the fine aggregate shall be determined according to CRD-C 104; and the yield, slump and air content shall be reported. For each water-cementitious ratio at least three test cylinders for each test age shall be tested in accordance with ASTM C 39 at 7 and 28 days (also 90 if pozzolan used). From these test results a curve shall be plotted and submitted showing the relationship between water-cementitious ratio and strength at design age.

PART 3 - EXECUTION

C3D-8. PRODUCTION EQUIPMENT.

C3D-8.1 Capacity. The batching and mixing equipment shall have a capacity of at least 30 cubic yards per hour.

C3D-8.2 Batching Plant. Batching plant shall conform to the requirements of the Concrete Plant Standards of CPMB and as specified; however, rating plates attached to batch plant equipment are not required.

C3D-8.2.1 Equipment. The batching controls shall be semiautomatic, or automatic. The semiautomatic batching system shall be provided with interlocks such that the discharge device cannot be actuated until the indicated material is within the applicable tolerance. The batching system shall be equipped with an accurate recorder or recorders that meet the requirements of the Concrete Plant Standards of CPMB. Separate bins or compartments shall be provided for cement, pozzolan and each size group of aggregate. Aggregates shall be weighed either in separate weigh batchers with individual scales or cumulatively in one weigh batcher on one scale. Aggregate shall not be weighed in the same batcher with cement, or pozzolan. If both cement and pozzolan are used, they may be weighed cumulatively provided that the portland cement is weighed first. If weighed, water shall not be weighed cumulatively with another ingredient. Water batcher filling and discharging valves shall be so inter-locked that the discharge valve cannot be opened before the filling valve is fully

closed. An accurate mechanical device for measuring and dispensing each admixture shall be provided. Each dispenser shall be interlocked with the measuring and discharging operation of the water so that each admixture is separately measured and discharged automatically in a manner to obtain uniform distribution throughout the batch in the specified mixing period. Admixtures shall not be combined prior to introduction in water or sand. The plant shall be arranged so as to facilitate the inspection of all operations at all times. Suitable facilities shall be provided for obtaining representative samples of aggregates from each bin or compartment.

C3D-8.2.2 Scales. The weighing equipment shall conform to the applicable requirements of NIST Handbook 44, except that the accuracy shall be plus or minus 0.2 percent of scale capacity. The Contractor shall provide standard test weights and any other auxiliary equipment required for checking the operating performance of each scale or other measuring devices. The tests shall be made at the frequency required in C3D-15.2.4 and in the presence of a Government inspector.

C3D-8.2.3 Batching Tolerances.

C3D-8.2.3.1 Weighing Tolerances. Whichever of the following tolerances is greater shall apply, based on required scale reading.

<u>Material</u>	<u>Percent of Required Weight</u>	<u>Percent of Scale Capacity</u>
Cementitious materials	±1	±0.3
Aggregate	±2	±0.3
Water	±1	±0.3
Admixture	±3	±0.3

C3D-8.2.3.2 Volumetric Tolerances. For volumetric batching equipment, the following tolerances shall apply to the required volume of material being batched:

- Water: Plus or minus 1 percent
- Admixtures: Plus or minus 3 percent

C3D-8.2.4 Moisture Control. The plant shall be capable of ready adjustment to compensate for the varying moisture content of the aggregates and to change the weights of the materials being batched. An electric moisture meter complying with the provisions of CRD-C 143 shall be provided for measuring moisture in the fine aggregate. The sensing element shall be arranged so that the measurement is made near the batcher charging gate of the sand bin or in the sand bathcer.

C3D-8.3 Mixers.

C3D-8.3.1 General. The mixers shall not be charged in excess of the capacity recommended by the manufacturer. The mixers shall be operated at the drum or mixing blade speed designated by the manufacturer. The mixers shall be maintained in satisfactory operating condition, and the mixer drums shall be kept free of hardened concrete. Should any mixer at any time produce unsatisfactory results, its use shall be promptly discontinued until it is repaired.

C3D-8.3.2 Concrete Plant Mixers. Concrete plant mixers shall be tilting, non-tilting, horizontal shaft, or vertical-shaft type, or pugmill type and shall be provided with an acceptable device to lock the discharge mechanism until the required mixing time has elapsed. The mixing time and uniformity shall conform to all the paragraphs in ASTM C 94 applicable to central-mixed concrete.

C3D-8.3.3 Truck Mixers. Truck mixers, the mixing of concrete therein, and concrete uniformity shall conform to the requirements of ASTM C 94. A truck mixer may be used either for complete mixing (transit-mixed) or to finish the partial mixing done in a stationary mixer (shrink-mixed). Each truck shall be equipped with two counters from which it will be possible to determine the number of revolutions at mixing speed and the number of revolutions at agitating speed.

C3D-9. CONVEYING EQUIPMENT.

C3D-9.1 General. The conveying equipment shall have a capacity of at least 30 cubic yards per hour. Concrete shall be conveyed from mixer to forms as rapidly as practicable and within the time interval in C3D-11.2 by methods that will prevent segregation or loss of ingredients. Any concrete transferred from one conveying device to another shall be passed through a hopper that is conical in shape and shall not be dropped vertically more than 8-feet, except where suitable equipment is provided to prevent segregation and where specifically authorized.

C3D-9.2 Buckets. The interior hopper slope shall be not less than 58 degrees from the horizontal, the minimum dimension of the clear gate opening shall be at least 5 times the nominal maximum size aggregate, and the area of the gate opening shall be not less than 2 square feet. The maximum dimension of the gate opening shall not be greater than twice the minimum dimension. The bucket gates shall be essentially mortar tight when closed and may be manually, pneumatically, or hydraulically operated except that buckets larger than 2 cubic yards shall not be manually operated. The design of the bucket shall provide means for positive regulation of the amount and rate of deposit of concrete in each discharge position.

C3D-9.3 Transfer Hoppers. Concrete may be charged into nonagitating hoppers for transfer to other conveying devices. Transfer hoppers shall be capable of receiving concrete directly from delivery vehicles and have conical-shaped discharge features. The machine shall be equipped with a hydraulically operated gate and with a means of external vibration to effect complete and easy discharge. Concrete shall not be held in nonagitating transfer hoppers more than 30 minutes.

C3D-9.4 Trucks. Truck mixers operating at agitating speed or truck agitators used for transporting plant-mixed concrete shall conform to the requirements of ASTM C 94. Nonagitating equipment may be used for transporting plant-mixed concrete over a smooth road when the hauling time is less than 15 minutes. Bodies of nonagitating equipment shall be smooth, watertight, metal containers specifically designed to transport concrete, shaped with rounded corners to minimize segregation, and equipped with gates that will permit positive control of the discharge of the concrete.

C3D-9.5 Chutes. When concrete can be placed directly from a truck mixer, agitator, or nonagitating equipment, the chutes attached to this equipment may be used. A discharge deflector shall be used when required by the Contracting Officer. Separate chutes and other similar equipment will not be permitted for conveying concrete except when specifically approved.

C3D-9.6 Belt Conveyors. Belt conveyors may be used when approved. Such conveyors shall be designed and operated to assure a uniform flow of concrete from mixer to final place of deposit without segregation of ingredients or loss of mortar and shall be provided with positive means for preventing segregation of the concrete at the transfer points and the point of placing. Belt conveyors shall be constructed such that the idler spacing shall not exceed 36-inches. If concrete is to be placed through installed horizontal or sloping reinforcing bars, the conveyor will discharge concrete into a hopper through a pipe or elephant trunk that is small enough in diameter and long enough to extend through the reinforcing bars. In no case shall concrete be discharged to free fall through the reinforcing bars.

C3D-9.7 Pump Placement. Concrete may be conveyed by positive displacement pump when approved. The pumping equipment shall be piston or squeeze pressure type. The pipeline shall be rigid steel pipe or heavy duty flexible hose. The inside diameter of the pipe shall be at least 3 times the nominal maximum-size coarse aggregate in the concrete mixture to be pumped but not less than 4-inches. The maximum-size coarse aggregate shall not be reduced to accommodate the pumps. The distance to be pumped shall not exceed limits recommended by the pump manufacturer. The concrete shall be supplied to the concrete pump continuously.

When pumping is completed, concrete remaining in the pipeline shall be ejected without contamination of concrete in place. After each operation, equipment shall be thoroughly cleaned, and flushing water shall be wasted outside of the forms.

C3D-10. PREPARATION FOR PLACING.

C3D-10.1 Embedded Items. Before placement of concrete, care shall be taken to determine that all embedded items are firmly and securely fastened in place as indicated on the drawings, or required. Embedded items shall be free of oil and other foreign matter such as loose coatings of rust, paint, and scale. The embedding of wood in concrete will be permitted only when specifically authorized or directed. Voids in sleeves, inserts, and anchor slots shall be filled temporarily with readily removable materials to prevent the entry of concrete into voids.

C3D-10.2 Concrete on Earth Foundations. Earth surfaces upon which concrete is to be placed shall be clean, damp, and free from frost, ice, and standing or running water. Prior to placement of concrete, the earth foundation shall have been satisfactorily compacted in accordance with the provisions of Section C2C.

C3D-10.3 Joints. Within 15 days after completion of the required curing period, all debris, dirt, laitance and curing compound shall be removed from all types of joints by sandblasting or another approved method. Immediately after cleaning, all joints shall be filled with sealant utilizing equipment and methods recommended by the sealant manufacturer. All joints shall be filled to within 1/8 plus or minus 1/16-inch below the pavement surface. The Contractor shall be careful not to over fill or under fill the joints. Joints in the new concrete slope pavement will be aligned with joints of the existing slope pavement.

C3D-10.3.1 Construction Joints. Construction joints shall be constructed where new pavement abutts existing new pavement in the direction parallel to the levee centerline. The surface of any existing new pavement against which new pavement is to be placed, shall be chipped and wire brushed to the extent necessary to remove damaged and unsound concrete and provide a clean surface. A 3/4-inch wide by 1-3/8-inch deep recess as shown shall be constructed for sealant. At all other locations throughout the limits of the job, construction joints will not be permitted unless approved by the Contracting Officer.

C3D-10.3.2 Dummy Joints. Dummy joints within the slabs shall be constructed a maximum distance of 10-feet from each other. These joints shall be 3/4-inch to 1-inch wide and 1-3/8-inches deep and shall extend from one end of the pavement to the other, in the direction perpendicular to the levee centerline.

C3D-10.3.3 Expansion Joints. Expansion joints shall be constructed perpendicular to the levee centerline at 80-foot maximum intervals, where new pavement abutts existing old pavement and at locations where the Contractor stops the pavement operation on any day. Expansion joint filler shall be continuous the full width of each slab. Expansion joints shall also be constructed parallel to the levee centerline where the pavement meets the floodwall. Expansion joints shall consist of $\frac{1}{2}$ -inch thick actual size expansion joint filler topped with joint sealant, as shown on the drawings. Above the expansion joint filler, to the top surface of the pavement, the joint shall be formed with a $\frac{1}{2}$ -inch block of wood. This block shall remain in place for 24 hours or longer as determined by the Contracting Officer, if block removal operations cause breakage of the pavement.

C3D-10.4 Construction Joint Treatment.

C3D-10.4.1 General. Concrete surfaces to which other concrete is to be bonded shall be prepared for receiving the next lift or adjacent concrete by cleaning with either air-water cutting, sandblasting, or high pressure water jet. The surfaces of construction joints shall be kept continuously wet for the first 12 hours during the 24-hour period prior to placing concrete.

C3D-10.4.2 Cleaning.

C3D-10.4.2.1 Air-Water Cutting. Air-water cutting of a construction joint shall be performed at the proper time and only on horizontal construction joints. The surface shall be cut with an air-water jet to remove all laitance and to expose clean, sound, mortar and coarse aggregate, but not so as to undercut the edges of the larger particles of aggregate. The air pressure used in the jet shall be 100 pounds per square inch plus or minus 10 pounds per square inch, and the water pressure shall be just sufficient to bring the water into effective influence of the air pressure. When approved by the Contracting Officer, a retarder complying with the requirements of CRD C 94 may be applied to the surface of the lift in order to prolong the period of time during which air-water cutting is effective. Prior to receiving approval, the Contractor shall furnish samples of the material to be used and shall demonstrate the method to be used in applications. After cutting, the surface shall be washed and rinsed as long as there is any trace of cloudiness of the wash water. The surface shall again be washed just prior to placing the succeeding lift. Where necessary to remove accumulated laitance, coatings, stains, debris, and other foreign material, sandblasting will be required as the last operation before placing the next lift.

C3D-10.4.2.2 High-Pressure Water Jet. A stream of water under a pressure of not less than 3,000 pounds per square inch may be used for cleaning. Its use shall be delayed until the concrete

is sufficiently hard so that only the surface skin or mortar is removed and there is no undercutting of coarse- aggregate particles. Where the cleaning occurs more than 2 days prior to placing the next lift or where work in the area subsequent to the cleaning causes dirt or debris to be deposited on the surface, the surface shall be cleaned again as the last operation prior to placing the next lift. If the water jet is incapable of a satisfactory cleaning, the surface shall be cleaned by sandblasting.

C3D-10.4.2.3 Sandblasting. When employed in the preparation of construction joints, sandblasting shall be performed as the final operation completed before placing the following lift. The operation shall be continued until all accumulated laitance, coatings, stains, debris, and other foreign materials are removed. The surface of the concrete shall then be washed thoroughly to remove all loose materials. The surface shall again be washed just prior to placing the succeeding lift.

C3D-10.4.2.4 Waste Disposal. The method used in disposing of waste water employed in cutting, washing, and rinsing of concrete surfaces shall be such that the waste water does not stain, discolor, or affect exposed surfaces of the structures, or damage the environment of the project area. The method of disposal shall be subject to approval.

C3D-10.4.2.5 Surface Condition. The surface of the lift shall be damp at the time of placement of the next lift and shall be free of standing water.

C3D-11. PLACING.

C3D-11.1 General. The placing equipment shall have a capacity of at least 30 cubic yards per hour. Concrete placement will not be permitted when, in the opinion of the Contracting Officer, weather conditions prevent proper placement or consolidation. Concrete shall be deposited as close as possible to its final position in the forms, and in so depositing, there shall be no vertical drop greater than 5-feet except where suitable equipment is provided to prevent segregation and where specifically authorized. Depositing of the concrete shall be so regulated that it may be effectively consolidated in horizontal layers 1½-feet or less in thickness with a minimum of lateral movement. The amount deposited in each location shall be that which can be readily and thoroughly consolidated. Sufficient placing capacity shall be provided so that concrete placement can be kept plastic and free of cold joints while concrete is being placed.

C3D-11.2 Time Interval Between Mixing and Placing. Concrete shall be placed within 30 minutes after discharge into nonagitating equipment. When concrete is truck mixed or when a truck mixer or agitator is used for transporting concrete mixed by

a concrete plant mixer, the concrete shall be delivered to the site of the work, and discharge shall be completed within 1½ hours after introduction of the cement to the aggregates. When the length of haul makes it impossible to deliver truck-mixed concrete within these time limits, batching of cement and a portion of the mixing water shall be delayed until the truck mixer is at or near the construction site.

C3D-11.3 Cold-Weather Placing. Concrete shall not be placed without a procedure approved in accordance with C3D-5.3.7 when the concrete is likely to be subjected to freezing temperatures before the expiration of the curing period. The ambient temperature of the space adjacent to the concrete placement and surfaces to receive concrete shall be above 32°F. The placing temperature of the concrete having a minimum dimension less than 12-inches shall be between 55°F and 75°F. The placing temperature of the concrete having a minimum dimension greater than 12-inches shall be between 50°F and 70°F. Heating of the mixing water or aggregates will be required to regulate the concrete-placing temperatures. Materials entering the mixer shall be free from ice, snow, or frozen lumps. Salt, chemicals, or other materials shall not be mixed with the concrete to prevent freezing.

C3D-11.4 Hot-Weather Placing. Concrete shall be properly placed and finished with approved procedures in accordance with C3D-5.3.8. The concrete placing temperature shall not exceed 90°F. Cooling of the mixing water and/or aggregates will be required to obtain an adequate placing temperature. An approved retarder shall be used to facilitate placing and finishing when concrete temperatures exceed 85°F. Steel forms and reinforcement shall be cooled prior to concrete placement when steel temperatures are greater than 120°F. Conveying and placing equipment shall be cooled if necessary to maintain proper concrete-placing temperature.

C3D-11.5 Consolidation. Immediately after placement, each layer of concrete, including flowing concrete, shall be consolidated by internal vibrating equipment. Vibrators shall not be used to transport concrete within the forms. Hand spading may be required with internal vibrating along formed surfaces permanently exposed to view. Vibrating equipment shall at all times be adequate in number of units and power to properly consolidate the concrete. A spare vibrator shall be kept on the job site during all concrete placing operations. Form or surface vibrators shall not be used unless specifically approved. Vibrators of the proper size, frequency, and amplitude shall be used for the type of work being performed in conformance with the following requirements:

<u>Application</u>	<u>Head Diameter Inches</u>	<u>Frequency VPM</u>	<u>Amplitude Inches</u>
Thin walls, beams, etc.	1½ - 2½	9,000 - 13,500	0.02 - 0.04
General construction	2 - 3½	8,000 - 12,000	0.025 - 0.05

The frequency and amplitude shall be within the range indicated in the table above as determined in accordance with C3D-15.2.9. The vibrator shall be inserted vertically at uniform spacing over the entire area of placement. The distance between insertions shall be approximately 1½ times the radius of action of the vibrator. The vibrator shall penetrate rapidly to the bottom of the layer and at least 6-inches into the preceding layer if such exists. It shall be held stationary until there is a general cessation in escape of large bubbles of entrapped air at the surface of the concrete (generally 5 to 15 seconds) then withdrawn slowly at about 3-inches per second.

C3D-12. FINISHING.

C3D-12.1 Unformed Surfaces.

C3D-12.1.1 General. The ambient temperature of spaces adjacent to surfaces being finished shall be not less than 50°F. In hot weather when the rate of evaporation of surface moisture, as determined by use of Figure 2.1.5 of ACI 305R, may reasonably be expected to exceed 0.2 pound per square foot per hour, provisions for windbreaks, shading, fog spraying, or wet covering with a light-colored material shall be made in advance of placement. These protective measures shall be taken as quickly as finishing operations will allow. All unformed surfaces that are not to be covered by additional concrete or backfill shall have a float finish, unless a trowel finish is specified, and shall be true to the elevation shown on the drawings. Surfaces to receive additional concrete or backfill shall be brought to the elevation shown on the drawings and left true and regular. Exterior surfaces shall be sloped for drainage unless otherwise shown on the drawings or as directed. Joints shall be carefully made with a jointing or edging tool. The finished surfaces shall be protected from stains or abrasions.

C3D-12.1.2 Float Finish. Surfaces shall be screeded and darbied or bullfloated to bring the surface to the required finish level with no coarse aggregate visible. No water, cement, or mortar shall be added to the surface during the finishing operation. The concrete, while still green but sufficiently hardened to bear a man's weight without more than about a ¼-inch indentation, shall be floated to a true and even plane. Floating may be performed by use of suitable hand floats or power-driven equipment. Hand floats shall be made of magnesium or aluminum.

Tolerance for a floated finish shall be true plane within 5/16-inch in 10-feet as determined by a 10-foot straightedge placed anywhere on the slab in any direction.

C3D-12.1.3 Trowel Finish. A trowel finish shall be applied to the top surfaces of all walls and columns. Concrete surfaces shall be finished with a float finish, and after surface moisture has disappeared, the surface shall be troweled to a smooth, even, dense finish free from blemishes including trowel marks. Tolerance shall be true planes within 5/16-inch in 10-feet as determined by a 10-foot straightedge placed anywhere on the slab in any direction.

C3D-12.1.4 Broom Finish. A broom finish shall be given to all horizontal surfaces of the slabs. The concrete shall be screeded and floated to required finish plane with no coarse aggregate visible. After surface moisture disappears, the surface shall be broomed or brushed with a broom or fiber bristle brush in a direction transverse to that of the main traffic or as directed by the Contracting Officer.

C3D-12.2 Formed Surfaces. Within 24 hours after form removal, all fins and loose materials permanently exposed to view shall be removed and all tie rod holes and defective concrete repaired. Tie holes that are not accessible within 24 hours after form removal may be repaired at a later date. All voids and honeycombs exceeding ½-inch in diameter permanently exposed to view and all tie-rod holes, permanently exposed or not, shall be reamed or chipped and filled with dry-pack mortar. Defective areas larger than 36 square inches in any surface, permanently exposed or not, shall be delineated in a rectangular shape by a saw cut a minimum depth of 1-inch. All defective concrete in the delineated area shall be removed and replaced with carefully placed and compacted concrete. The cement used in the mortar or concrete for all surfaces permanently exposed to view shall be a blend of portland cement and white cement properly proportioned so that the final color when cured will be the same as adjacent concrete. Temperature of the concrete, ambient air, replacement concrete, or mortar during remedial work including curing shall be above 50°F. The prepared area shall be dampened, brush-coated with a neat cement grout or with an approved epoxy resin, and filled with mortar or concrete. The mortar shall consist of 1 part cement to 2½ parts fine aggregate. The quantity of mixing water shall be the minimum necessary to obtain a uniform mixture and to permit placing. Mortar shall be thoroughly compacted in place and struck off to adjacent concrete. Replacement concrete shall be drier than the usual mixture and thoroughly tamped into place and finished. Forms shall be used if required. Metal tools shall not be used to finish permanently exposed surfaces. The patched areas shall be cured and protected in accordance with paragraph C3D-13.

C3D-12.2.1 General. Surfaces, unless other type of finish is specified, shall be left with the texture imparted by the forms except that defective surfaces shall be repaired as described in C3D-12.2. Other types of finishes shall be applied to the following structures or portions of structures:

<u>Type of Finish</u>	<u>Structure or Portion of Structure</u>
Textured	As indicated on the drawings
2 coats of Cementitious Paint Color: Pearl Gray	The top and both sides of the exposed floodwall surface to 6 inches below final grade.

Unless painting of surfaces is required, uniform color of the concrete shall be maintained by use of only one mixture without changes in materials or proportions for any structure or portion of structure that is exposed to view or on which a special finish is required. The form panels used to produce the finish shall be orderly in arrangement, with joints between panels planned in approved relation to openings, building corners, and other architectural features. The finished surface of the textured finish shall duplicate the preapproved sample panel, prepared in accordance with C3A-4.4. Forms shall not be reused if there is any evidence of surface wear or defects that would impair the quality of the surface.

C3D-12.2.2 Textured Finish. This type of finish shall be applied where specified to conform to details shown on the drawings by use of approved textured form liners. Liner panels shall be secured in the forms by methods recommended by the manufacturer, but not by methods that will permit impressions of nail heads, screw heads, washers, or the like to be imparted to the surface of the concrete. Edges of textured panels shall be sealed to each other to prevent mortar leakage. The sealant used shall not stain the concrete.

C3D-12.2.3 Cementitious Paint Finish. As approved by the Contracting Officer and after all required patching, cleaning and correction of major imperfections have been completed, the concrete surfaces identified above shall be given a cementitious paint finish as hereinafter described. The finish shall not be applied before the initial 72 hour moist curing period is complete. The temperature of the air adjacent to the surface shall be not less 50°F for 24 hours prior to and 24 hours following the application of the finish. If the temperature of the air adjacent to the surface is above 90°F, the surface shall be cooled prior to the application of the finish by hosing with clean water until it reaches a temperature of 85°F. The finish for any area shall be completed in the same day and the limits of a finished area shall be made at natural breaks in the finished surface. The surface to be finished must be structurally sound,

clean and free of dirt, form marks, loose mortar particles, paint, films, protective coatings, efflorescence, laitance, etc. The cementitious paint finish shall consist of dampening the surface ahead of the cementitious paint application with clean water. The cementitious paint shall be applied to the areas specified above at a rate of two pounds per square yard of surface area per coat. The coating shall be uniform, completely filling all pits, air bubbles, and surface voids. All cementitious paint shall conform to Fed. Spec. A-A-1555(color:pearl gray). All cementitious paint shall be prepared and applied in accordance with manufacturer's written recommendations. The mixing liquid for cementitious paints shall contain one part "Acryl 60", or equal, to three parts clean water. Uniform color of the cementitious paint shall be maintained by use of only one mixture, with no changes in materials or proportions for any structure or portion of a structure on which this finish is required.

C3D-13. CURING AND PROTECTION.

C3D-13.1 General. All concrete shall be cured by an approved method for a period of 7 days. Immediately after placement, concrete shall be protected from premature drying, extremes in temperatures, rapid temperature change, and mechanical injury. All materials and equipment needed for adequate curing and protection shall be available in working order at the placement site prior to the start of concrete placement. Concrete shall be protected from the damaging effects of rain for 12 hours and from flowing water for 14 days 7 days with Type III cement. Concrete shall be shielded from direct rays of the sun for 3 days. No fire or excessive heat shall be permitted near or in direct contact with concrete at any time.

C3D-13.2 Moist Curing. Moist-cured concrete shall be maintained continuously (not periodically) wet for the entire curing period. Vertical surfaces shall be cured using soaker hoses, fog sprayers or sprinklers. Burlap may be used to assist moist curing provided that the wall and burlap are kept continuously saturated, including nights and weekends, and the burlap is kept in contact with the concrete being cured. If water or curing materials stain or discolor concrete surfaces that are to be permanently exposed, they shall be cleaned as required in C3D-4.4. Where wooden form sheathing is left in place during curing, the sheathing shall be kept wet at all times. Horizontal surfaces may be moist cured by ponding, by covering with a minimum uniform thickness of 2-inches of continuously saturated sand, or by covering with saturated nonstaining burlap or cotton mats. Horizontal construction joints may be allowed to dry for 12 hours immediately prior to the placing of the following lift.

C3D-13.3 Membrane Curing. Concrete may be cured with an approved curing compound in lieu of moist curing except that membrane curing will not be permitted on any surface to which a cementitious paint finish is to be applied, or on any surface containing protruding steel reinforcement.

C3D-13.3.1 Pigmented Curing Compound. A pigmented-type curing compound may be used on surfaces that will be covered with backfill when the project is completed.

C3D-13.3.2 Application. The curing compound shall be applied to formed surfaces immediately after the forms are removed and prior to any patching or other surface treatment except the cleaning of loose sand, mortar, and debris from the surface. The surfaces shall be thoroughly moistened with water, and the curing compound applied as soon as free water disappears. The curing compound shall be applied to unformed surfaces as soon as free water has disappeared. The curing compound shall be applied in a two-coat continuous operation by approved motorized power-spraying equipment operating at a minimum pressure of 75 pounds per square inch and at a uniform continuous coverage of not more than 400 square feet per gallon for each coat. The second coat shall be applied perpendicular to the first coat. Concrete surfaces that have been subjected to rainfall within 3 hours after curing compound has been applied shall be resprayed by the method and at the coverage herein specified. All concrete surfaces on which the curing compound has been applied shall be adequately protected for the duration of the entire curing period from pedestrian and vehicular traffic and from any other cause that will disrupt the continuity of the curing membrane.

C3D-13.4 Impervious-Sheet Curing. The following concrete surfaces may be cured using impervious sheets: horizontal surfaces only. All surfaces shall be thoroughly wetted and be completely covered with waterproof paper, polyethylene film, or polyethylene-coated burlap having the burlap thoroughly water-saturated before placing. The covering shall be laid with light-colored side up. The covering shall be lapped not less than 12-inches and securely weighted down or shall be lapped not less than 4-inches and taped to form a continuous cover with completely closed joints. The sheets shall be weighted to prevent displacement so that they remain in contact with the concrete during the specified length of curing. Coverings shall be folded down over exposed edges of slabs and secured by approved means. Sheets shall be immediately repaired or replaced if tears or holes appear during the curing period.

C3D-13.5 Cold Weather. When the daily outdoor low temperature is less than 32°F, the temperature of the concrete shall be maintained above 40°F for the first 7 days after placing. In addition, during the period of protection removal, the air temperature adjacent to the concrete surfaces shall be controlled so that concrete near the surface will not be subjected to a

temperature differential of more than 25°F as determined by observation of ambient and concrete temperatures indicated by thermometers furnished by the Government as required and installed adjacent to the concrete surface and 2-inches inside the surface of the concrete. The installation of the thermometers shall be made by the Contractor at such locations as may be directed. Curing compounds shall not be used on concrete surfaces that are maintained at curing temperature by use of free steam.

C3D-14. PLACING NON-SHRINK GROUT.

C3D-14.1 Cementitious Grout.

C3D-14.1.1 General. Concrete surfaces shall be rough, clean, and free of oil, grease, and laitance, and they shall be damp. Metal surfaces shall be clean and free of oil, grease, and rust.

C3D-14.1.2 Nonshrink Grout shall conform to the requirements of C3D-5.1.4 and C3D-6.6. For clearance of 2-inches or more, the mixture shall include by weight 1½ parts of sound, clean, uncrushed gravel conforming to size No. 8, Table 2, ASTM C 33 in combination with fine aggregate conforming to to ASTM C 33, to 1 part portland cement unless otherwise recommended by the material manufacturer. Water content shall be the minimum that will provide a flowable mixture and completely fill the space to be grouted without segregation, bleeding, or reduction of strength.

C3D-14.1.2.1 Mixing and Placing. Mixing and placing shall be in conformance with the material manufacturer's instructions and as specified therein. Ingredients shall be thoroughly dry mixed before adding water. After adding water, the batch shall be mixed for 3 minutes. Batches shall be of size to allow continuous placement of freshly mixed grout. Grout not used within 30 minutes after mixing shall be discarded. The space between the top of the concrete or masonry-bearing surface and the plate shall be filled solid with the grout. Forms shall be of wood or other equally suitable material for retaining the grout and shall be removed after the grout has set. The placed grout shall be worked to eliminate voids; however, overworking and breakdown of the initial set shall be avoided. Grout shall not be retempered or subjected to vibration from any source. Where clearances are unusually small, placement shall be under pressure with a grout pump. Temperature of the grout, and of surfaces receiving the grout, shall be maintained at 65°F to 85°F until after setting.

C3D-14.1.2.2 Curing. Grout and parge coats shall be cured in conformance with C3D-13.

C3D-14.2 Grout at Repair Areas. Grout used for repairing the existing concrete wall at the temporary closures shall conform to the requirements of C3D-5.1.4 and C3D-6.6. The grout shall be Concrete Standard Liquid, High Early Strength Bonding Adhesive

as manufactured by Master Builders Technologies, or an approved equal. Application shall be in accordance with the manufacturer's recommendations. The existing concrete shall be drilled at the dowel locations shown on the drawings, and the holes cleaned of all loose material. The holes shall be suitably roughened to provide a good bonding surface.

C3D-15. CONTRACTOR QUALITY CONTROL.

C3D-15.1 General. The Contractor shall perform the inspection and tests described in C3D-15.2, and based upon the results of these inspections and tests, he shall take the action required in C3D-15.3 and submit reports as required in C3D-15.3 and C3D-15.4. The laboratory performing the tests shall conform with ASTM C 1077. The individuals who sample and test concrete or the constituents of concrete as required in this specification shall have demonstrated a knowledge and ability to perform the necessary test procedures equivalent to the ACI minimum guidelines for certification of Concrete Field Testing Technicians, Grade I.

C3D-15.2 Inspection Details and Frequency of Testing.

C3D-15.2.1 Fine Aggregate.

C3D-15.2.1.1 Grading. At least once during each shift in which concrete is being delivered, there shall be one sieve analysis and fineness modulus determination in accordance with ASTM C 136 and CRD-C 104, respectively, for the fine aggregate or for each fine aggregate, if it is batched in more than one size or classification. The location at which samples are taken may be selected by the Contractor as the most advantageous for control. However, the Contractor is responsible for delivering fine aggregate to the mixer within specification limits. Results of tests shall be reported in writing.

C3D-15.2.1.2 Moisture Content. When in the opinion of the Contracting Officer the electric moisture meter is not operating satisfactorily, at least four tests for moisture content shall be conducted in accordance with either ASTM C 70, C 566, or CRD-C 112 during each 8-hour period of mixing plant operation. The times for the tests shall be selected randomly within the 8-hour period. An additional test shall be made whenever the slump is shown to be out of control or excessive variation in workability is reported by the placing foreman. When the electric moisture meter is operating satisfactorily, at least two direct measurements of moisture content shall be made per week to check the calibration of the meter.

C3D-15.2.2 Coarse Aggregate.

C3D-15.2.2.1 Grading. At least once during each shift that concrete is being delivered, there shall be a sieve analysis in accordance with ASTM C 136 for each size group of coarse

aggregate. The location at which samples are taken may be selected by the Contractor as the most advantageous for production control. However, the Contractor is responsible for delivering the aggregate to the mixer within specification limits. A test record of samples of aggregate taken shall show the results of the five most recent tests including the current test. The Contractor may adopt limits for control coarser than the specification limits for samples taken other than at the batch plant bins to allow for degradation during handling. Results of tests shall be reported in writing.

C3D-15.2.2.2 Moisture Content. A test for moisture content of each size of coarse aggregate in accordance with ASTM C 566 or CRD-C 112 shall be made at least once a shift. When two consecutive readings for smallest size coarse aggregate differ by more than 1.0 percent, frequency of testing shall be increased to that specified for fine aggregate in C3D-15.2.1.2. These results shall be used to adjust the added water in the control of the batch plant.

C3D-15.2.3 Deleterious Substances. When in the opinion of the Contracting Officer a problem exists in connection with deleterious substances in fine or coarse aggregates, tests shall be made in accordance with ASTM C 33 at a frequency not less than one per week. Results of tests shall be reported in writing.

C3D-15.2.4 Scales.

C3D-15.2.4.1 Weighing Accuracy. The accuracy of the scales shall be checked by test weights at least once a month for conformance with the applicable requirement of C3D-8.2.2. Such tests shall also be made whenever there are variations in properties of the fresh concrete that could result from batching errors. Results of tests shall be reported in writing.

C3D-15.2.4.2 Batching and Recording Accuracy. Once a week the accuracy of each batching and recording device shall be checked during a weighing operation by noting and recording the required weight, recorded weight, and the actual weight batched. The Contractor shall provide the necessary calibration devices and confirm that the admixture dispensers described in C3D-8.2.1 are operating properly. Results of tests shall be reported in writing.

C3D-15.2.5 Batch-Plant Control. The measurement of all constituent materials including cement, pozzolan, each size of aggregate, water, and admixtures shall be continuously controlled. The aggregate weights and amount of added water shall be adjusted as necessary to compensate for free moisture in the aggregates. The amount of air-entraining admixture shall be adjusted to control air content within specified limits. A report shall be prepared indicating type, amount and source of cement used, type, amount, and source of pozzolan used, amount and source of

admixtures used, aggregate source, the required aggregate and water weights per cubic yard, amount of water as free moisture in each size of aggregate, and the batched aggregate and water weights per cubic yard for each class of concrete batched during plant operation. The report shall be furnished to a representative of the Contracting Officer upon delivery of the concrete.

C3D-15.2.6 Concrete.

C3D-15.2.6.1 Air Content. At least two tests for air content shall be made on randomly selected batches of each class of concrete during each 8-hour period of concrete production or at least once a day when concrete is placed. Additional tests shall be made when excessive variation in workability is reported by the placing foreman or Government inspector. Tests shall be made in accordance with ASTM C 231. For concrete having a nominal maximum aggregate size of 1-inch or 1½-inches, the average of each set of two tests shall be plotted on a control chart on which the average is set at 5.5 percent and the upper and lower control limits at 7 and 4 percent, respectively. For concrete having a nominal maximum aggregate size of ¾-inch, the average shall be set at 6.0 percent and the upper and lower control limits at 7.0 and 5.0 percent, respectively. The control charts shall be furnished to a representative of the Contracting Officer.

C3D-15.2.6.2 Slump. At least two slump tests shall be made on randomly selected batches of each class of concrete during each day's concrete production in accordance with ASTM C 143. Additional tests shall be made when excessive variation in workability is reported by the placing foreman or Government inspector. The average of each set of two tests shall be plotted on a control chart on which the upper and lower limits are set 1.5 inches above and below the mid-range value. The range shall be plotted on a control chart on which the upper control limit is 3.0-inches. The control chart shall be furnished to a representative of the Contracting Officer.

C3D-15.2.7 Preparation for Placing. Foundation or construction joints, forms, and embedded items shall be inspected in sufficient time prior to each concrete placement by the Contractor in order to certify to the Contracting Officer that they are ready to receive concrete. The results of each inspection shall be reported in writing on LMN Form 1246, and shall be submitted to a representative of the Contracting Officer prior to placement of concrete.

C3D-15.2.8 Placing. The placing foreman shall supervise all placing operations, shall determine that the correct quality of concrete or grout is placed in each location as directed by the Contracting Officer, and shall be responsible for measuring and recording concrete temperatures, ambient temperature, weather conditions, placement time, placement duration, yardage placed,

and placement method . Concrete temperatures shall be determined in accordance with ASTM C 1064. A report shall be furnished in writing to a representative of the Contracting Officer.

C3D-15.2.9 Vibrators. The frequency and amplitude of each vibrator shall be determined in accordance with CRD-D 521 prior to initial use and at least once a month when concrete is being placed. Additional tests shall be made when a vibrator does not appear to be adequately consolidating the concrete. The frequency shall be determined while the vibrator is operating in concrete with the tachometer being held against the upper end of the vibrator while almost submerged and just before the vibrator is withdrawn from the concrete. The amplitude shall be determined with the head vibrating in air. Two measurements shall be taken, one near the tip and another near the upper end of the vibrator head, and these results averaged. The make, model, type, and size of the vibrator and frequency and amplitude results shall be reported in writing.

C3D-15.2.10 Curing.

C3D-15.2.10.1 Moist Curing. At least once each calendar day during the curing period, an inspection shall be made of all areas subject to moist curing. The surface moisture condition shall be reported in writing.

C3D-15.2.10.2 Curing Compound. No curing compound shall be applied until it has been verified that the compound is properly mixed and ready for spraying. At the end of each operation, the quantity of compound used and the area of concrete surface covered shall be reported, and the rate of coverage in square feet per gallon shall be computed. The report shall state whether coverage is uniform.

C3D-15.2.10.3 Impervious-Sheet Curing. At least once each calendar day during the curing period, an inspection shall be made of all areas being cured using impervious sheets. The condition of the covering and the tightness of the laps and tapes shall be noted and recorded.

C3D-15.2.11 Protection. At least once each calendar day during the curing period, an inspection shall be made of all areas subject to cold-weather protection. Deficiencies shall be noted. During removal of protection, measurement of concrete and ambient temperatures shall be recorded at least hourly. A report shall be furnished in writing to a representative of the Contracting Officer.

C3D-15.2.12 Mixer Uniformity.

C3D-15.2.12.1 Concrete Plant Mixer. At the start of concrete placing, and at least once every 6 months when concrete is being placed, uniformity of concrete shall be determined. The

tests shall be performed in accordance with ASTM C 94. Whenever adjustments in mixer or increased mixing times are necessary because of failure of any mixer to comply, the mixer shall be retested after adjustment. Results of tests shall be reported in writing.

C3D-15.2.12.2 Truck Mixers. At the start of concrete placing and at least once every 6 months when concrete is being placed, uniformity of concrete shall be determined in accordance with ASTM C 94. The truck mixers shall be selected randomly for testing. When satisfactory performance is found in one truck mixer, the performance of mixers of substantially the same design and condition of blades may be regarded as satisfactory. Results of tests shall be reported in writing.

C3D-15.3 Action Required.

C3D-15.3.1 Fine Aggregate.

C3D-15.3.1.1 Grading. When the amount passing any sieve is outside the specification limits, the fine aggregate shall be immediately resampled and retested. If there is another failure on any sieve, the fact shall immediately be reported to the Contracting Officer, and immediate steps shall be taken to rectify the situation.

C3D-15.3.1.2 Moisture. Whenever the moisture content of the fine aggregate changes by 0.5 percent or more, the scale settings for the fine-aggregate batcher and water batcher shall be adjusted directly or by means of a moisture compensation device.

C3D-15.3.2 Coarse Aggregate Grading. When the amount passing any sieve is outside the specification limits, the coarse aggregate shall immediately be resampled and retested. If the second sample fails on any sieve, that fact shall be reported to the Contracting Officer. Where two consecutive moving averages of five tests are outside specification limits, that fact shall be reported to the Contracting Officer's representative, and immediate steps shall be taken to correct the grading.

C3D-15.3.3 Deleterious Substances. When the results for a deleterious substance are outside the specification limit, the aggregate shall be resampled and retested for the deleterious substance that failed. If the second sample fails, that fact shall be reported to the Contracting Officer. When material finer than No. 200 sieve for coarse aggregate exceeds the specification limit, immediate steps, such as washing or other corrective actions, shall be initiated.

C3D-15.3.4 Scales. Whenever either the weighing accuracy or batching accuracy is found not to comply with specification requirements, the plant shall not be operated until necessary adjustments or repairs have been made. Discrepancies in recording accuracies shall be corrected immediately.

C3D-15.3.5 Concrete.

C3D-15.3.5.1 Air Content. Whenever points on the control chart approach the upper or lower control limits, an adjustment should be made in the amount of air-entraining admixture batched. If a single test result is outside the specification limit, such adjustment is mandatory. As soon as practical after each adjustment, another test shall be made to verify the correctness of the adjustment. Whenever a point falls above the upper control limit for range, the dispenser shall be calibrated to ensure that it is operating correctly and with good reproducibility. Whenever two consecutive points for either average or range are outside the control limits, a representative of the Contracting Officer shall be notified. Whenever the air content departs from the specified range, the concrete shall not be delivered to the forms.

C3D-15.3.5.2 Slump. Whenever points on the control chart approach the upper or lower control limits, an adjustment should be made in the batch weights of water and fine aggregate. The adjustments are to be made so that the total free water does not exceed that amount specified in the approved mixture proportions based on the free water available with the fine aggregate and that amount of water batched. If the adjustments to the batch weights of water and fine aggregate do not satisfactorily produce the required slump, the mixture shall be reportioned to meet the specified criteria and resubmitted to the Contracting Officer for approval. When a single slump is outside the control limits, such adjustment is mandatory. As soon as practical after each adjustment, another test shall be made to verify the correctness of the adjustment. Whenever the slump exceeds the upper limit stipulated in C3D-7.2.5, the concrete shall not be delivered to the forms. Whenever two consecutive slump tests, made during a period when there was no adjustment of batch weights, produce a point on the control chart for range above the upper control limit, the slump shall be considered to be out of control, and the additional testing for aggregate moisture content required in C3D-15.2 shall be undertaken.

C3D-15.3.6 Placing. The placing foreman shall not permit placing to begin until he has verified that an adequate number of acceptable vibrators in working order and with competent operators are available. Placing shall not be continued if any pile of concrete is inadequately consolidated. If any batch of concrete fails to meet the temperature requirements, immediate steps shall be taken to improve temperature controls.

C3D-15.3.7 Curing.

C3D-15.3.7.1 Moist Curing. When a daily inspection report lists an area of inadequate curing, the required curing period for that area shall be extended by 1 day.

C3D-15.3.7.2 Curing Compound. When the coverage rate of curing compound is less than that specified or when the coverage is not uniform, the entire surface shall be sprayed again.

C3D-15.3.7.3 Impervious-Sheet Curing. When a daily inspection report lists any tears, holes, or laps of joints that are not completely closed, the tears and holes shall promptly be repaired or the sheets replaced, the joints closed, and the required curing period for those areas shall be extended by 1 day.

C3D-15.3.8 Protection. When any concrete temperature during the period of protection or protection removal fails to comply with the specifications, that fact shall be reported to the Contracting Officer, and immediate steps shall be taken to correct the situation.

C3D-15.3.9 Mixer Uniformity. When a mixer fails to meet mixer uniformity requirements, either the mixing time shall be increased or adjustments shall be made to the mixer until compliance is achieved.

C3D-15.4 Pavement Acceptance Testing.

C3D-15.4.1 Thickness. Concrete slope pavement shall have a minimum thickness of 8-inches. Vibrations from this will be paid in accordance with C-20. The pavement shall be cored in accordance with ATSM C 42 to check its thickness except that 2-inch diameter cores shall be acceptable. After the required curing period, a core shall be obtained for every 400 square feet of pavement at locations and time intervals to be determined by the Contracting Officer. Samples shall be obtained and the core holes refilled with a 2000 psi minimum compressive strength concrete or grout mix in the presence of the Contracting Officer. Cores will be measured by the Contracting Officer in accordance with ASTM C-174. If the sample reveals a thickness of less than 7½-inches, the result shall apply to the adjacent 20 squares only. The remaining 180 squares will then be cored in groups of 20 at locations directed by the Contracting Officer.

C3D-15.4.2 Compressive Strength. Companion sets, each consisting of 3 concrete cylinders, shall be prepared by the Contractor in accordance with ASTM C 31 in the presence of the Contracting Officer. One companion set shall be prepared. It shall be clearly labeled on the sides of the cylinder molds, initially cured according to ASTM C 31 paragraphs 9.1 and 9.2, and protected and transported by the Contractor to the Government testing laboratory according to ASTM C 31. Cylinders should be delivered to

the New Orleans District Soils and Materials Testing Lab located in New Orleans, LA at the foot of Prytania Street between the hours of 9:00 AM and 3:30 PM on federal workdays. The cylinders will be tested by the Government at Government expense. One cylinder will be tested at 7 days for information. The other 2 companion cylinders will be tested at the age of 28 days (90 days if pozzolan is used) and averaged to determine payment.

C3D-15.5 Reports. All results of tests shall be reported as required. Each report shall include the updating of control charts covering the entire period from the start of the construction season through the current week. During periods of cold-weather protection, reports of pertinent temperatures shall be made daily. These requirements do not relieve the Contractor of the obligation to report certain failures immediately as required in preceding paragraphs. Such reports of failures and the action taken shall be confirmed in writing in the routine reports. The Contracting Officer has the right to examine all Contractor quality control records.

C3D-16. MEASUREMENT AND PAYMENT. Concrete for the floodwall will not be measured for payment. Payment for concrete will be made at the contract lump sum price for "Reinforced Concrete Floodwall". Reinforced concrete floodwall consists of base slabs, stabilization slabs, columns, walls, waterstops, reinforcing steel, formwork, finishes, expansion joint filler, and other components incidental thereto which price shall include the cost of all labor, materials and the use of all equipment and tools required to complete the concrete work. Concrete for the slope paving will be measured in square yard. Payment for paving will be made at the contract unit price per square yard for "Concrete Slope Pavement". Price and payment shall include the cost of preparation, maintenance and restoration of levee slope, crown backfilling, including making, curing, protecting and transporting concrete cylinders, coring filling core holes, sealing joints and furnishing all plant, labor and materials (including concrete and reinforcing steel) used in the construction of the slope pavement. Price adjustments, in accordance with the following table apply for both thickness and strength. Payment will be made only on the adjustment for the greater reduction.

PAYMENT SCHEDULE FOR 8-INCH THICK CONCRETE SLOPE PAVEMENT

<u>Compressive Strength (psi)</u> <u>(28* - day)</u>	<u>Percent of Contract Unit Price</u>	<u>Thickness (Inches)</u>	<u>Percent of Contract Unit Price</u>
2000 and above	100%	8 and above	100%
1750 to 1999	95%	7.75 to 7.99	95%
1600 to 1749	80%	7.5 to 7.74	80%
1200 to 1599	50%	7.0 to 7.49	50%
Below 1200	Remove** (0%)	Below 7.0	Remove**(0%)

* 90 if pozzolan used.

** Removed pavement shall be replaced and tested then paid for according to this table.

The Contracting Officer will withhold 15 percent of the payment for concrete slope pavement pending satisfactory results of cylinder breaks and coring.

INDEX

DIVISION 5 - METALS

Para. No.	Paragraph Title	Page No.
--------------	-----------------	-------------

SECTION C5A - MISCELLANEOUS METALWORK

C5A-1.	SCOPE	C5A-1
C5A-2.	QUALITY CONTROL	C5A-1
C5A-3.	SUBMITTALS	C5A-2
C5A-4.	FABRICATED AND MANUFACTURED ITEMS	C5A-2
C5A-5.	WORKMANSHIP	C5A-4
C5A-6.	MEASUREMENT AND PAYMENT	C5A-5

SECTION C5B - METALWORK FABRICATION, MACHINE WORK,
AND MISCELLANEOUS PROVISIONS

C5B-1.	SCOPE	C5B-1
C5B-2.	APPLICABLE PUBLICATIONS	C5B-1
C5B-3.	QUALITY CONTROL	C5B-2
C5B-4.	SUBMITTALS	C5B-3
C5B-5.	GENERAL	C5B-4
C5B-6.	BOLTS, NUTS AND WASHERS	C5B-4
C5B-7.	STRUCTURAL FABRICATION	C5B-5
C5B-8.	WELDING	C5B-6
C5B-9.	SHOP ASSEMBLY	C5B-9
C5B-10.	MISCELLANEOUS PROVISIONS	C5B-9
C5B-11.	INSTALLATION	C5B-10
C5B-12.	MEASUREMENT AND PAYMENT	C5B-10

INDEX

SECTION C5A - MISCELLANEOUS METALWORK

Para. No.	Paragraph Title	Page No.
C5A-1.	SCOPE	C5A-1
C5A-2.	QUALITY CONTROL	C5A-1
C5A-3.	SUBMITTALS	C5A-2
C5A-4.	FABRICATED AND MANUFACTURED ITEMS	C5A-2
C5A-5.	WORKMANSHIP	C5A-4
C5A-6.	MEASUREMENT AND PAYMENT	C5A-5

SECTION C5A - MISCELLANEOUS METALWORK

PART 1 - GENERAL

C5A-1. SCOPE. The work covered by this section consists of furnishing all plant, labor, materials and equipment, and furnishing and installing the miscellaneous metalwork as shown on the drawings and specified herein and shall include, but is not limited to, the following items:

C5A-1.1 Reserved.

C5A-1.2 Corrosion Resistant Steel (C.R.S.).

C5A-1.2.1 Settlement reference bolts.

C5A-1.2.2 Identification tag for reference bolts.

C5A-1.2.4 Bolts, anchor bolts, threaded studs, washers, nuts, seal retaining bars, and seal deflecting bars.

C5A-1.3 Fabricated Steel.

C5A-1.3.1 Joint between new I-wall to existing floodwall.

C5A-1.3.2 Galvanized floodwall ladders.

C5A-1.3.3 Bolt brackets for attaching ladders to wall.

C5A-1.4 Manufactured Products.

C5A-1.4.1 Flexible bonding jumpers for bonding of piling as specified in Section C16A, "CATHODIC PROTECTION".

C5A-1.4.2 Galvanized 18 gage steel sheet metal.

C5A-1.4.3 Bicycle locks, plastic sealant and grout as specified herein.

C5A-2. QUALITY CONTROL.

C5A-2.1 General. The Contractor shall establish and maintain quality control for proper fabrication and installation of all work covered in this section to assure compliance with contract specifications and maintain records of his quality control for all construction operations including but not limited to the following:

- (1) Fabrication.
- (2) Protective coating.
- (3) Placement and protection.
- (4) Material compliance with plans and specifications.

C5A-2.2 Reporting. The original and two copies of these records and tests, as well as the records of corrective action taken, shall be furnished to the Government daily. Format of the report shall be as prescribed in the Special Clause entitled "CONTRACTOR QUALITY CONTROL".

C5A-3. SUBMITTALS.

C5A-3.1 Shop Drawings. The Contractor shall prepare and submit for approval, complete shop drawings and descriptive literature showing details of all auxiliary items required as indicated herein or on the contract drawings. Shop drawings shall indicate computed weights of structural steel and approval of shop drawings will constitute acceptance of the computed weights shown on these drawings.

C5A-3.2 Manufacturer's Certification. The galvanizing compound shall be certified for compliance with all specification requirements.

PART 2 - PRODUCTS

C5A-4. FABRICATED AND MANUFACTURED ITEMS.

C5A-4.1 General. Fabrication and placement of all fabricated items shall be as indicated on the drawings and shall conform to the applicable provisions of Section C5B, "METALWORK FABRICATION, MACHINE WORK, AND MISCELLANEOUS PROVISIONS".

C5A-4.2 Materials.

C5A-4.2.1 Corrosion Resistant Steel. Corrosion resistant steel shall conform to Federal Specification QQ-S-766C (up to and including amendment 6), Class 304. High strength corrosion resistant steel shall conform to ASTM A 276-84, Type 431. Corrosion resistant steel bolts, nuts and washers shall conform to the applicable provisions of paragraph C5B-12 except that the material shall be corrosion-resistant steel.

C5A-4.2.2 Seal Plates. Seal plates shall be solid corrosion-resistant steel ASTM A 263-84 of the sizes and dimensions indicated on the drawings.

C5A-4.2.2.1 Seal Plates may be spliced at the Contractor's convenience and at no cost to the Government. The Contractor shall not commence work on any seal plate splice until the procedure has been approved by the Contracting Officer.

C5A-4.2.2.2 Seal Retaining Bars. Seal retaining bars shall be solid corrosion-resistant steel ASTM A 263-84 of the sizes and dimensions indicated on the drawings. Seal retaining bars may be spliced at the Contractor's convenience and at no cost to the Government. The Contractor shall not commence work on any seal plate splice until the procedure has been approved by the Contracting Officer.

C5A-4.2.3 Bicycle Lock. The bicycle locks shall be No. 8029A21 Long Shackle Laminated Brass Padlock, keyed alike, as shown in McMaster-Carr Supply Co., Catalog 91, or equal for use at fence gates.

C5A-4.2.4 Stainless Steel Bolts, Hex Cap Screws, Nuts, Washers, and Set Screws.

C5A-4.2.4.1 Stainless Steel Bolts and Hex Cap Screws. Stainless steel bolts and hex cap screws shall conform to ASTM F 593, Group 2, Alloy 316, Condition CW.

C5A-4.2.4.2 Stainless Steel Nuts. Stainless steel nuts shall conform to ASTM F 594, Group 2, Alloy 316, Condition CW.

C5A-4.2.4.3 Stainless Steel Washers. Stainless steel washers shall conform to Fed. Spec. FF-W-928, Type A, Grade 1 (Sizes: Light and Heavy), Class B (Alloy 316).

C5A-4.2.4.4 Stainless Steel Set Screws. Stainless steel set screws shall conform to Fed. Spec. FF-S-200A(2), Type I, Style 1, Alloy 304.

C5A-4.2.5 Plastic Sealant. This sealant shall conform to the applicable provisions of Federal Specification SS-S-00210 "Sealing Compound, Preformed Plastic, for Expansion Joints and Pipe Joints".

C5A-4.2.6 Neoprene Rubber Sheets. ASTM D 2000, M2BC 407 of the dimensions shown on the drawings.

C5A-4.3 Galvanizing. Hot-dip galvanizing or zinc coating applied on products fabricated from rolled, pressed, or forged steel shapes, plates, bars, and strips shall comply with ASTM A 123. Hot-dip galvanizing or zinc coatings on assembled steel products shall comply with ASTM A 386. Weight of coatings shall be as designated in Table 1 of the ASTM specification for class and thickness of material to be coated, but in no case shall it be less than 1.25 oz. per square foot.

C5A-4.4 Expansion Anchors. Fed. Spec. FF-S-325, Group II, Type 4, Class 1. Nail driven types will not be acceptable. Anchors shall be galvanized unless otherwise indicated.

C5A-4.5 Ladders. Ladders shall be fixed-rail metal ladders conforming to the requirements of ANSI A14.3 and to details shown on the drawings. Ladders shall be fabricated of steel conforming to ASTM A 36-89, and shall be galvanized after fabrication as specified in paragraph C5A-4.3. Fabrication of ladders shall consist of solid section rod rungs fitted into holes in bar side rails and welded. Splices in side rails shall be made using full penetration welds and shall be a smooth transition between connecting ends without sharp or extensive projections. All welds shall be ground smooth. Ladders shall be anchored to supported structures as shown on the drawings and specified in paragraph C5A-4.4.

C5A-4.5.1 Security Door. A security door shall be provided for each ladder as shown. Expanded metal for the security door shall be galvanized carbon steel flattened mesh, size $\frac{1}{2}$ -inch, overall thickness of 0.050-inches. Field weld damaged areas shall be coated as specified in paragraph C5A-4.3.

PART 3 - EXECUTION

C5A-5. WORKMANSHIP. All metalwork fabrication and machine work shall comply with the applicable provisions of Section C5B. All parts shall be properly fabricated, assembled and installed to conform to the shapes, sizes and dimensions indicated on the contract drawings and approved shop drawings.

C5A-5.1 Settlement Reference Bolts. Upon installation of the settlement reference bolts the Contractor shall determine elevations of each bolt and submit his results to the Contracting Officer. The Contracting Officer will then submit the results to Engineering Division of the New Orleans District of the Corps of Engineers.

C5A-5.2 At Transition From New I-Wall To Existing Floodwall. The steel sheet piling slip joint shall be surrounded by 18 gage steel sheet metal, as shown on the drawings. The space between the sheet metal and the steel sheet piling shall be filled with a plastic sealant.

C5A-5.6 Shop Painting. Corrosion-resistant and galvanized steel items shall not be painted. Corrosion-resistant steel shall be cleaned as specified in paragraph C5B-15.2. Anchors to be bedded in concrete will not be painted.

C5A-6. MEASUREMENT AND PAYMENT. Unless otherwise specified herein, any materials or operations used in conjunction with installation or as part of metalwork which is not included in the cost of other items of work listed in the bidding schedule shall not be measured for payment. Payment for miscellaneous metalwork will be included in the contract lump sum price for "Miscellaneous Metals". This price and payment shall constitute full compensation for furnishing and installing all miscellaneous metalwork indicated on the drawings and/or herein specified which is not specified to be paid for under other items of work listed on the bidding schedule.

INDEX

SECTION C5B - METALWORK FABRICATION, MACHINE WORK,
AND MISCELLANEOUS PROVISIONS

Para. No.	Paragraph Title	Page No.
C5B-1.	SCOPE	C5B-1
C5B-2.	APPLICABLE PUBLICATIONS	C5B-1
C5B-3.	QUALITY CONTROL	C5B-2
C5B-4.	SUBMITTALS	C5B-3
C5B-5.	GENERAL	C5B-4
C5B-6.	BOLTS, NUTS AND WASHERS	C5B-4
C5B-7.	STRUCTURAL FABRICATION	C5B-5
C5B-8.	WELDING	C5B-6
C5B-9.	SHOP ASSEMBLY	C5B-9
C5B-10.	MISCELLANEOUS PROVISIONS	C5B-9
C5B-11.	INSTALLATION	C5B-10
C5B-12.	MEASUREMENT AND PAYMENT	C5B-10

SECTION C5B - METALWORK FABRICATION, MACHINE WORK,
AND MISCELLANEOUS PROVISIONS

PART 1 - GENERAL

C5B-1. SCOPE. This section specifies general workmanship requirements, applicable to the fabrication, assembly and testing of various items of metalwork to insure conformance with the specifications. These requirements are in addition to those contained in the specification sections covering the specific items of work or indicated on the drawings.

C5B-2. APPLICABLE PUBLICATIONS. The following publications of the issues listed below but referred to thereafter by basic designation only form a part of this specification to the extent indicated by the references thereto or as required.

C5B-2.1 American National Standards Institute (ANSI).

B4.1-67 Preferred Limits and Fits for Cylindrical
(Rev. 1987) Parts

B46.1-85 Surface Texture (Surface Roughness, Waviness
and Lay)

C5B-2.2 American Society for Testing and Materials (ASTM).

A 123-89a Zinc (Hot-Galvanized) Coatings on Products
Fabricated from Rolled, Pressed, and Forged
Steel Shapes, Plates, Bars, and Strip

A 325-91c Structural Bolts, Steel, Heat Treated, 120/105
KSI Minimum Tensile Strength

A 380-88 Cleaning and Descaling Stainless Steel Parts,
Equipment, and Systems

A 490-91a Heat-Treated Steel Structural Bolts, 150 KSI
(1035 MPa) Tensile Strength

A 514-88 Plate, Steel, High Yield Strength, Quenched
and Tempered Alloy, Suitable for Welding

C5B-2.3 American Society of Mechanical Engineers Boiler and
Pressure Vessel Code (ASME BPVC).

Section IX-92 Welding and Brazing Qualifications

C5B-2.4 American Welding Society, Inc. (AWS).

D 1.1-92 Structural Welding Code-Steel

C5B-2.5 Department of Defense (DOD).

DOD-P-21035A Paint, High Zinc Dust Content, Galvanizing
(NAVY) Repair (Metric)

C5B-2.6 Federal Specifications (Fed. Spec.).

FF-S-85C(1) Screw, Cap, Slotted and Hexagonhead
FF-B-575C Bolts, Hexagon and Square
TT-P-645B Primer, Paint, Zinc-Chromate, Alkyd Type
FF-W-92 B Washers, Metal, Flat (Plain)
FF-N-836D(3) Nuts, Square, Hexagon, Cap Slotted, Castle,
 Knurled, Welding and Single Ball Seat

C5B-2.7 Military Specifications (Mil. Spec.).

MIL-C-18480B Coating Compound, Bituminous, Solvent, Coal
(DOCKS) Tar Base

C5B-2.8 Military Standards (MIL-STD).

MIL-STD-000248B Welding and Brazing Procedure and Performance
 Qualification

C5B-2.9 Research Council on Riveted and Bolted Structural
Joints of the Engineering Foundation (RCRBSJ).

Specification for Structural Joints Using ASTM A 325 or A 490
Bolts

C5B-3. QUALITY CONTROL.

C5B-3.1 Tests of Materials. The Contractor shall, at his expense, perform analyses and tests to demonstrate that all materials are in conformity with the specifications. The Contractor shall have required material tests and analyses performed and certified by an approved laboratory to demonstrate that materials are in conformity with the specifications. These tests and analyses shall be performed and certified at the Contractor's expense. Tests shall conform to the requirements of the particular sections of these specifications for the respective items of work unless otherwise specified or authorized. Tests shall be conducted in the presence of the Contracting Officer if so required. Should the Contractor desire to use stock materials not manufactured specifically for the work covered by these specifications, he shall submit evidence, satisfactory to the Contracting Officer, that such material conforms to the requirements of the specifications. Detailed tests of these materials will then not be required, if so approved by the

Contracting Officer. Tests, except where modified, shall be made as indicated in the respective detailed specifications or on the drawings and, unless otherwise authorized, in the presence of the Contracting Officer. The Contractor shall furnish specimens and samples for additional independent tests and analyses upon request by the Contracting Officer. Specimens and samples shall be properly labeled and prepared for shipment.

C5B-3.2 Special Test Requirements.

C5B-3.2.1 Nondestructive Testing. When doubt exists as to the soundness of any material part such part may be subjected to any form of nondestructive testing determined by the Contracting Officer. This may include ultrasonic, magnaflux, dye penetrant, x-ray, gamma ray or any other test that will thoroughly investigate the part in question. The cost of such investigation will be borne by the Government. Any defects will be cause for rejection and rejected parts shall be replaced and retested at the Contractor's expense.

C5B-3.2.2 Tests of and Structural Units. The details for testing various structural units shall conform to the requirements of the particular sections of these specifications covering these items. Each complete structural unit, as required by other sections of these specifications, shall be assembled and tested in the shop in the presence of the Contracting Officer unless otherwise directed by the Contracting Officer. Waiving of tests, however, will not relieve the Contractor of responsibility for any fault in workmanship or material that occurs before the completion of the contract or guarantee. The details for tests on the various structural units shall conform to the requirements of the applicable sections of these specifications.

C5B-3.3 Workmanship. Workmanship shall be of the highest grade and in accordance with the best modern practices to conform with the specifications for the item of work being furnished.

C5B-3.4 Quality Control. The Contractor shall establish and maintain a quality control system to assure compliance with the contract requirements and shall maintain records of all quality control operations covered by these specifications.

C5B-4. SUBMITTALS. Contractor submittals shall be in accordance with the specifications and as herein specified.

C5B-4.1 Shop Drawings. Shop drawings shall be submitted to the Contracting Officer for approval. Drawings shall include catalog cuts, templates, fabrication and assembly details and type, grade and class of materials as appropriate. Elements of fabricated items inadvertently omitted on contract drawings shall be detailed by the fabricator and indicated on the shop drawings.

C5B-4.2 Lists of Materials. The Contractor shall furnish the Contracting Officer 3 copies of all purchase and mill orders, shop orders for materials and work orders, including all new orders placed by Contractors and old orders extended by each supplier. The Contractor, at the time of submittal of shop drawings, shall furnish a list designating the material to be used for each item. Where mill tests are required, purchase orders shall contain the test site address and the name of the testing agency. The Contractor shall also furnish a shipping bill or memorandum of each shipment of finished pieces or members to the project site, giving the designation mark and weight of each piece, the number of pieces, the total weight, and if shipped by rail in carload lots, the car initial and number. Copies of certified shipping bills, in duplicate, shall be submitted promptly to the Contracting Officer.

C5B-4.3 Schedule of Welding Procedures. A complete schedule of welding procedures as described in C5B-10.1.3 below shall be submitted to the Contracting Officer and approved before fabrication is commenced.

C5B-4.4 Certificates. Certificates for material tests, examinations, and welding procedure and operator qualifications shall be submitted for approval as specified.

PART 2 - PRODUCTS

C5B-5. GENERAL. All nuts shall be equipped with washers where indicated on the drawings. Beveled washers shall be used where bearing faces have a slope of more than 1:20 with respect to a plane normal to the bolt axis.

C5B-6. BOLTS, NUTS AND WASHERS. The finished shank of each bolt shall be long enough to provide full bearing and washers shall be used to provide full grip when the nut is tightened.

C5B-6.1 Bolts. Bolts, including anchor bolts and fitted bolts, shall conform to the applicable provisions of Federal Specification FF-B-575, Type 4, standard thread, size as noted, and carbon steel or ASTM A 325 unless indicated otherwise on the drawings or in other section of the specifications.

C5B-6.2 Nuts. Nuts shall conform to the applicable provisions of Federal Specification FF-N-836, Type II, Style II, standard thread, size as noted, and carbon steel or ASTM A 325 unless indicated otherwise on the drawings or in another section of the specifications.

C5B-6.3 Cap Screws. Cap screws shall conform to the applicable provisions of Federal Specification FF-S-85, Type I, Style 2s, or Type II, Style 10p, standard thread unless indicated otherwise on the drawings or in another section of the specifications.

C5B-6.4 Washers. Washers shall conform to the applicable provisions of Federal Specification FF-W-92, Type A, Grade I, Class A, unless indicated otherwise or in another section of specifications.

PART 3 - EXECUTION

C5B-7. STRUCTURAL FABRICATION.

C5B-7.1 Material. Material must be straight before being laid off or worked. If straightening is necessary it shall be done by methods that will not impair the metal. Sharp kinks or bends shall be cause for rejection of the material. Material with welds will not be accepted except, where welding is definitely specified, indicated on the drawings, or otherwise approved. Bends, except for minor details, shall be made by approved dies, press brakes or bending rolls. Where heating is required precautions shall be taken to avoid overheating the metal and it shall be allowed to cool in a manner as not to destroy the original properties of the metal. Flame cutting of material other than structural steel shall be subject to approval and, where proposed, shall be indicated on shop drawings. Shearing shall be accurately done and all portions of the work shall be neatly finished. Corners shall be square and true unless otherwise shown on the drawings. Re-entrant cuts shall be filleted to a minimum radius of 3/4-inch unless otherwise approved. Finished members shall be free from twists, bends and open joints. Bolts, nuts and screws shall be tight.

C5B-7.2 Dimensional Tolerances for Structural Work. Dimensions shall be measured by means of an approved calibrated steel tape of approximately the same temperature as the material being measured at the time of measurement. The overall dimensions of an assembled structural unit shall be within the tolerances indicated on the drawings or as specified in section of these specifications for the item of work. Except as required to meet the requirements above, an allowable variation of 1/32-inch is permissible in the overall length of component members with both ends milled; individual component members without milled ends shall not deviate from the dimensions shown on the drawings by more than 1/16-inch for members 30-feet or less in length and by more than 1/8-inch for members over 30-feet in length.

C5B-7.3 Structural Steel Fabrication. Structural steel may be cut by mechanically guided or hand guided torches provided an accurate profile with a smooth surface which is free from cracks and notches is obtained. Surfaces and edges to be welded shall be prepared in accordance with AWS D1.1, Subsection 3.2. Where structural steel is not to be welded chipping or grinding will not be required except as necessary to remove slag and sharp edges of mechanically guided or hand guided cuts not exposed to view. Hand guided cuts which are to be exposed or visible shall be chipped, ground or machined to sound metal.

C5B-8. WELDING.

C5B-8.1 Structural Steel.

C5B-8.1.1 General. Unless otherwise authorized or specified, welding of structural steel shall be by an electric arc welding process using a method which excludes the atmosphere from the molten metal. Welding, unless otherwise specified or authorized shall conform to the applicable provisions of AWS D1.1, Sections 1 thru 7, 9, 10 and 11.

C5B-8.1.2 Welding Equipment. All items of welding equipment shall conform to the requirements of AWS D1.1.

C5B-8.1.3 Welding Procedures. The Contractor shall prepare for submission to the Contracting Officer a complete schedule of welding procedure which shall consist of detailed procedure specifications for each structure to be welded and tables or diagrams showing the procedure to be used for each required joint. The schedule shall conform to the provisions of AWS D1.1, Sections 2, 3, 4, 7 and 9 and applicable provisions of Section 10, include filler metal requirements, preheat and interpass temperature requirements and any stress relief heat treatment, and show types and locations of welds designated on the drawings and/or in the specifications to receive nondestructive examination. The procedures shall be such as to minimize residual stresses and distortion of the completed weldment. Procedures shall be qualified by tests as prescribed in AWS D1.1, Section 5 except for prequalified procedures described in AWS D1.1, Subsection 5.1. Properly documented evidence of compliance with all requirements of these specifications for previous qualification tests shall establish the joint welding procedure as prequalified. Each procedure shall be clearly identified as being either prequalified or qualified by tests. The test welding and specimen testing must be witnessed and the test report document signed by a representative of the Contracting Officer. The Contractor will be directed or authorized to make any changes in previously approved welding procedures that are deemed necessary or desirable by the Contracting Officer. Approval of any procedure, however, will not relieve the Contractor of the responsibility for producing a finished structure meeting all requirements of these specifications.

C5B-8.1.4 Qualification of Welders and Welding Operators. Welding operators, welders, and tack welders shall be qualified and requalified if necessary for the particular type of work to be done. Qualification shall be in accordance with AWS D1.1, Section 5, MIL-STD-248 or the ASME BPVC, Section IX. The Contractor shall certify by name to the Contracting Officer the welders and welding operators so qualified, including the date of qualification and code and procedures under which qualified. Prior qualification may be accepted if welders have performed satisfactory work under the code for which qualified within the preceding three months. The Contractor shall require the welder and welding operators to repeat the qualifying tests when, in the opinion of the Contracting Officer, his work indicates a reasonable doubt as to proficiency. In such cases, he shall be recertified, as above, if he successfully passes the retest; otherwise, he shall be disqualified until he has successfully passed a retest. All expenses in connection with qualification and requalification shall be borne by the Contractor.

C5B-8.1.5 Technique.

C5B-8.1.5.1 Filler Metal. The electrode, electrode-flux combination and grade of weld metal shall conform to the appropriate AWS specification for the base metal and welding process being used. Only low hydrogen electrodes shall be used for manual shielded metal-arc welding regardless of the thickness of the steel. The AWS designation of the electrodes to be used shall be included in the schedule of welding procedures to be furnished by the Contractor. To maintain low moisture of low hydrogen electrodes, a controlled temperature storage oven shall be used at the job site as prescribed by AWS D1.1, Subsection 4.5.

C5B-8.1.5.2 Preheat and Interpass Temperature. Preheating shall be performed as required by AWS D1.1, Subsection 4.2 and 4.3 or as otherwise specified except that the temperature of the base metal shall be at least 70°. The weldments to be preheated shall be slowly and uniformly heated by approved means to the prescribed temperature, held at that temperature until the welding is completed and then permitted to cool slowly in still air.

C5B-8.1.5.3 Stress-Relief Heat Treatment. Where stress relief heat treatment is specified or shown on the drawings, it shall be in accordance with the requirements of AWS D1.1, Subsection 4.4, unless otherwise authorized or directed by the Contracting Officer.

C5B-8.1.6 Workmanship. Workmanship for welding shall be in accordance with AWS D1.1, Section 3 and other applicable requirements of these specifications.

C5B-8.1.6.1 Preparation of Base Metal. Prior to welding the Contractor shall inspect surface to be welded to assure compliance with AWS D1.1, Subsection 3.2.

C5B-8.1.6.2 Temporary Welds. Temporary welds required for fabrication and erection shall be made under the controlled conditions prescribed herein for permanent work. All temporary welds shall be made using low-hydrogen welding electrodes and by welders qualified for permanent work as specified elsewhere in these specifications. Preheat furnished for temporary welds shall be as required by AWS D1.1 for permanent welds except that the minimum temperature shall be 120°F in any case. In making temporary welds arcs shall not be struck in other than weld locations. Each temporary weld shall be removed after serving its purpose and ground flush with adjacent surfaces.

C5B-8.1.6.3 Tack Welds. Tacks welds that are to be incorporated into the permanent work shall be subject to the same quality requirements as the permanent welds, and shall be cleaned and thoroughly fused with permanent welds. Preheating shall be performed as specified above for temporary welds. Multiple-pass tack welds shall have cascaded ends. Defective tack welds shall be removed before permanent welding.

C5B-8.1.7 Inspection. Welding shall be subject to inspection by the Contracting Officer to determine conformance with the requirements of AWS D1.1, the approved welding procedures, and provisions stated elsewhere in these specifications. The Contracting Officer will require nondestructive examination of designated welds and may require supplemental examination of any joint or coupon cut from any location in any joint. The Contractor shall maintain an approved inspection system and perform required inspections in accordance with the Contract Clause of this contract entitled "CONTRACTOR INSPECTION SYSTEM".

C5B-8.1.7.1 Visual Examination. Prior to any welding, the Contractor shall visually inspect the preparation of material for welding to assure compliance with Section 3 of AWS D1.1. All completed welds shall be cleaned and carefully examined for insufficient throat or leg sizes, cracks, undercutting, overlap, excessive convexity or reinforcement, and other surface defects to insure compliance with the requirements of AWS D1.1, Section 3 and Section 9, Part D. Defects shall be corrected as provided in C5B-10.1.7.4 below.

C5B-8.1.7.2 Test Coupons. The Government reserves the right to require the Contractor to remove coupons from completed work when doubt as to soundness cannot be resolved by nondestructive examination. Should any two coupons cut from the work of any welder show strengths, under test, less than that specified for the base metal it will be considered evidence of negligence or incompetence and such welder shall be removed from the work. When coupons are removed from any part of a structure, the members cut shall be repaired in a neat workman like manner with joints of the proper type to develop the full strength of the members, with peening as approved or directed to relieve residual stress. The

expense for removal and testing of the coupons, repair cut members and the performance of nondestructive examination of repairs shall be assigned to the Government or the Contractor in accordance with the Contract Clause of this contract entitled "INSPECTION AND ACCEPTANCE".

C5B-8.1.7.3 Supplemental Examination. The Government reserves the right to perform supplemental nondestruction examinations as deemed necessary when the soundness of any weld is in doubt and to detect cracking or similar defects that might occur during shipment or erection and before final acceptance by the Government. The cost of such inspection will be borne by the Government. The repairs and the reexamination of repairs will be performed by the Contractor at no additional cost to the Government.

C5B-8.1.7.4 Repairs. Defective weld metal shall be removed by air carbon-arc or oxygen gouging to sound metal. Oxygen gouging shall not be used on ASTM A 514 steel. The surfaces shall be thoroughly cleaned before welding. The resulting cavities shall be rewelded in compliance with Article 6.6 of AWS D1.1. When deemed necessary by the Contracting Officer the Contractor shall submit a welding repair plan for approval before repairs are made. Welds that have been repaired shall be retested by the same methods used in the original inspection. All costs of repairs and testing shall be borne by the Contractor, except for repair of members cut to remove test coupons which were found to contain acceptable welds.

C5B-8.1.7.5 Oxygen Cutting. In all oxygen cutting, flame shall be so adjusted and manipulated as to avoid cutting beyond the prescribed lines. Cut surfaces and edges shall be left free of slag.

C5B-9. SHOP ASSEMBLY. Unless otherwise specified, each machinery and structural unit furnished shall be assembled in the shop to determine the correctness of the fabrication and matching of the component parts. Assembly in the shop shall be in the same position as final installation (closed position) in the field unless otherwise specified. Assembly and disassembly work shall be performed in the presence of the Contracting Officer. Errors or defects disclosed shall be immediately remedied by the Contractor without cost to the Government. Before disassembly for shipment, each piece of a structural shall be match-marked to facilitate erection in the field. The location of match-marks shall be indicated by circling with a ring of white paint after the shop coat of paint has been applied or as otherwise directed.

C5B-10. MISCELLANEOUS PROVISIONS.

C5B-10.1 Cleaning of Corrosion-Resisting Steel. After fabrication, oil, paint and other foreign substances shall be removed from corrosion-resisting steel surfaces. Cleaning shall

be done by vapor degreasing or by the use of cleaners of the alkaline, emulsion or solvent type. After the surfaces have been cleaned they shall be given a final rinsing with clean water followed by a 24-hour period during which the surfaces are intermittently wet with clean water and then allowed to dry for the purpose of inspecting the clean surfaces. The surfaces shall be visually inspected for evidence of paint, oil, grease, welding slag, heat treatment scale, iron rust or other forms of contamination. If evidence of foreign substance exist, the surface shall be cleaned in accordance with the applicable provisions of Section 6 of ASTM A 380. The proposed method of treatment shall be furnished for approval. After treatment the surfaces shall be visually reinspected. Brushes used to remove foreign substances shall utilize only stainless steel or nonmetallic bristles. Any contamination occurring subsequent to the initial cleaning shall be removed by one or more of the methods indicated above.

C5B-10.2 Protection of Finished Work.

C5B-10.2.1 Machined Surfaces. Machined surfaces shall be thoroughly cleaned of foreign matter. All finished surfaces shall be protected by suitable means. Unassembled pins and bolts shall be oiled and wrapped with moisture resistant paper or protected by other approved means. Finished surfaces of ferrous metals to be in bolted contact shall be washed with a rust inhibitor and coated with an approved rust resisting compound for temporary protection during fabrication, shipping and storage periods.

C5B-11. INSTALLATION.

C5B-11.1 General. All parts to be installed shall be thoroughly cleaned. Where units or items are shipped as assemblies they will be inspected by the Contracting Officer prior to installation. Bolts and screws shall be tightened firmly and uniformly, but care shall be taken not to overstress the threads. When a half nut is used for locking a full nut, the half nut shall be placed first and followed by the full nut. Threads of all bolts, except high strength bolts, nuts and screws shall be lubricated by graphite and oil before assembly. Threads of corrosion-resisting steel bolts and nuts shall be coated with an approved anti-galling compound. Driving and drifting bolts or keys will not be permitted.

C5B-11.2 Alignment and Setting. Each structural unit shall be accurately aligned by the use of steel shims or other approved methods so that no distortion of any member occurs before it is fastened in place.

C5B-12. MEASUREMENT AND PAYMENT. No separate measurement and payment will be made for the material and work covered under this section and all costs in connection therewith shall be included in the applicable contract price for the items to which the work pertains.

INDEX

DIVISION 9 - FINISHES

Para. No.	Paragraph Title	Page No.
SECTION C9A - PAINTING		
C9A-1.	SCOPE	C9A-1
C9A-2.	QUALITY CONTROL	C9A-1
C9A-3.	DEFINITIONS AND NOMENCLATURE	C9A-1
C9A-4.	APPLICABLE PUBLICATIONS	C9A-2
C9A-5.	SAMPLING AND TESTING	C9A-3
C9A-6.	SUBMITTALS	C9A-4
C9A-7.	PACKAGING, LABELING, DELIVERY, AND STORAGE OF PAINTS	C9A-6
C9A-8.	SAFETY AND HEALTH PROVISIONS	C9A-6
C9A-9.	SPECIAL PAINT FORMULAS	C9A-19
C9A-10.	CLEANING AND PREPARATION OF SURFACES TO BE PAINTED	C9A-20
C9A-11.	PAINT APPLICATION	C9A-21
C9A-12.	PAINT SYSTEMS TO BE APPLIED--NUMBER OF COATS AND FORMULAS	C9A-26
C9A-13.	PROTECTION OF NON-PAINTED ITEMS AND CLEANUP	C9A-27
C9A-14.	MEASUREMENT AND PAYMENT	C9A-27

INDEX

SECTION C9A - PAINTING

Para. No.	Paragraph Title	Page No.
C9A-1.	SCOPE	C9A-1
C9A-2.	QUALITY CONTROL	C9A-1
C9A-3.	DEFINITIONS AND NOMENCLATURE	C9A-1
C9A-4.	APPLICABLE PUBLICATIONS	C9A-2
C9A-5.	SAMPLING AND TESTING	C9A-3
C9A-6.	SUBMITTALS	C9A-4
C9A-7.	PACKAGING, LABELING, DELIVERY, AND STORAGE OF PAINTS	C9A-6
C9A-8.	SAFETY AND HEALTH PROVISIONS	C9A-6
C9A-9.	SPECIAL PAINT FORMULAS	C9A-19
C9A-10.	CLEANING AND PREPARATION OF SURFACES TO BE PAINTED	C9A-20
C9A-11.	PAINT APPLICATION	C9A-21
C9A-12.	PAINT SYSTEMS TO BE APPLIED--NUMBER OF COATS AND FORMULAS	C9A-26
C9A-13.	PROTECTION OF NON-PAINTED ITEMS AND CLEANUP	C9A-27
C9A-14.	MEASUREMENT AND PAYMENT	C9A-27

SECTION C9A - PAINTING

PART 1 - GENERAL

C9A-1. **SCOPE.** The work covered by this section of the specifications consists of furnishing all plant, labor, equipment, appliances, and materials and in performing all operations in connection with preparation of surfaces and application of paint and other specified materials. This work shall be accomplished in complete and strict accordance with the specifications and the applicable drawings and shall be subject to the terms and conditions of the contract.

C9A-2. QUALITY CONTROL.

C9A-2.1 **General.** The Contractor shall establish and maintain quality control for painting operations to assure compliance with contract specifications and maintain records of his quality control for all construction operations including but not limited to the following:

- (1) Cleaning and preparation of surfaces.
- (2) Paint and formulations.
- (3) Number of coats and rates of applications.
- (4) Protection of paint surfaces.
- (5) Safety and industrial hygiene monitoring.

C9A-2.2 **Reporting.** The original and two copies of these records and tests, as well as the records of corrective action taken, shall be furnished to the Government daily. Format of this report shall be as prescribed in the Special Clause entitled "CONTRACTOR QUALITY CONTROL".

C9A-3. DEFINITIONS AND NOMENCLATURE.

C9A-3.1 **Paint.** The term "paint" as used herein includes emulsions, enamels, paints, stains, varnishes, sealers, and other coatings, organic or inorganic, whether they be used as prime, intermediate, or finish coats. This definition does not include troweled or sprayed-metal coatings.

C9A-3.2 **Shop Painting.** The term "shop painting" as referred to herein and/or on the drawings covers surface preparation and painting operations conducted in a shop, mill, or plant, before shipment of paint-receiving items to the project site.

C9A-3.3 Field Painting. The term "field-painting" as referred to herein and/or on the drawings covers surface preparation and painting operations conducted at the project site.

C9A-3.4 Touch-up Painting. The term "touch-up painting" refers to the application of paint on small areas of painted surfaces to repair mars, scratches, and other defects where the coating has deteriorated in order to restore the coating to an unbroken condition.

C9A-3.5 Repainting. The term "repainting" designates the cleaning and recoating with the same or similar materials originally used on extensive areas on which the existing coatings have deteriorated or otherwise have not provided adequate protection.

C9A-4. APPLICABLE PUBLICATIONS.

C9A-4.1 American Conference of Governmental Industrial Hygienists (ACGIH) Publications.

Guidelines to the Selection of Chemical Protective Clothing, Volumes I and II.

Threshold Limit Values for Chemical Substances and Physical Agents in the Work Environmental and Biological Exposure Indices.

C9A-4.2 American National Standards Institute (ANSI) Standards.

Z87.1- 79 Practice for Occupational and Educational Eye and Face Protection

Z358.1- 81 Emergency Eyewash and Shower Equipment

C9A-4.3 American Society for Testing and Materials (ASTM) Publications.

D 561-82 Carbon Black Pigment for Paint

D 1186-87 Nondestructive Measurement of Dry Film Thickness of Nonmagnetic Coatings Applied to Ferrous Base

D 4417 Field Measurement of Surface Profile of Blast Cleaned Steel

E 97-82 45-deg, 0-deg, Directional Reflectance Factor of Opaque Specimens by Broad-Band Filter Reflectometry

C9A-4.4 Code of Federal Regulations (CFR).

- 29 CFR 1910 General Industry Standards
29 CFR 1926 Construction Industry Standards

C9A-4.5 Federal Acquisition Regulations.

- 52.236-13 Accident Prevention
Apr 84

C9A-4.6 Federal Standards (Fed. Std.).

- No. 313 Material Safety Data, Transportation Data and
Disposal Data for Hazardous Materials Furnished
to Government Activities

No. 595 Color

C9A-4.7 National Institute for Occupational Safety and
Health (NIOSH) Publications.

- 87-108 Respirator Decision Logic
84-100 NIOSH Manual of Analytical Methods

C9A-4.8 Steel Structures Painting Council Specifications
(SSPC).

- SSPC-SP 1 Solvent Cleaning
SSPC-SP 5 White Metal Blast Cleaning
SSPC-Paint 16 Coal Tar Epoxy-Polyamide Black Paint

Available from: Steel Structures Painting Council, 4400 Fifth
Avenue, Pittsburgh, PA 15213

C9A-4.9 U.S. Army Corps of Engineer Publications.

- EM 385-1-1 Safety and Health Requirements Manuals

C9A-4.10 Special Formulations. Special formulations
indicated herein that are not covered by Federal or other
nationally recognized standard specifications are specified below
in paragraph C9A-9.

C9A-5. SAMPLING AND TESTING.

C9A-5.1 General. Batches of paint which the Contractor
proposes to use shall be stored in an approved shelter on the
project site or segregated at the source of supply sufficiently in
advance of need to allow 30 days for sampling and testing. The

Contractor shall notify the Contracting Officer when the paint is available for sampling. Sampling of each batch will be witnessed by a representative of the Contracting Officer unless otherwise specified or directed. Samples of paint submitted for approval shall be clearly labeled to indicate formula or specification number and nomenclature, batch number, batch quantity, color, date made, and applicable project contract number. Where specifically indicated herein or where indicated in a standard specification for a finished product, separate samples of ingredient materials shall be furnished. The ingredient samples shall be clearly identified by commercial name, trade designation, manufacturer, batch or lot number, and such other data as may be required. Testing of paint for compliance with the specifications will be performed at the U.S. Army Construction Engineering Research Laboratory at Interstate Research Park, 2902 Newmark Drive, P.O. Box 4005, Champaign, IL, 61820, ATTN: Paint Laboratory, at no expense to the Contractor except that the cost of testing any sample representing material that replaces previously rejected material will be deducted from payments to the Contractor at the rate of \$300.00 dollars for each replacement sample.

C9A-5.2 Special Paint Formulations Not Covered by Standard Specifications.

C9A-5.2.1 Solvents in epoxy paints and thinners are subject to analysis by programmed temperature gas chromatographic methods and/or spectrophotometric methods, employing the same techniques which give reproducible results on prepared control samples known to meet the specifications. If the solvent being analyzed is of the type consisting primarily of a single chemical compound (or a mixture of two or more such solvents) interpretation of the test results shall take cognizance of the degree of purity of the individual solvents as commercially produced for the paint industry.

C9A-6. SUBMITTALS. The following statements, reports, plans, and samples shall be submitted to the Contracting Officer for approval.

C9A-6.1 Special Formulation Paints and Thinners. Two (2) one-quart samples of each batch of Coal Tar Epoxy type paint and thinners shall be submitted to the Contracting Officer for approval. Where samples of ingredient materials are required, see C9A-9.4, Paint Formulations; they shall be of one-half pint in size and shall be labeled with the name of the ingredient manufacturer as well as the trade name or designation of the product. When the required quantity of any paint is 10 gallons or less, samples of the paint and ingredient materials need not be submitted; but instead the Contractor shall submit a signed certificate from the paint manufacturer showing the percentage of each ingredient used to produce the material and a statement that

the material complies with all of the requirements of the formulation. Each ingredient shall be clearly identified as provided for above.

C9A-6.2 Federal and Military Specification Paints and Thinners. When the required amount of a material of a particular type or color is more than 50 gallons, the Contractor shall submit a one-quart sample of each batch he proposes to use. When the required quantity of any type is 50 gallons or less, he shall supply either of the following:

(1) A certified test report showing the results of required tests made on the material and a statement that it meets all of the specification requirements.

(2) A certified test report showing the results of required tests made on a previous batch of paint produced by the same firm using the same ingredients and formulation except for minor differences necessitated by a color change and a statement that the previous batch met all of the specification requirements. He shall also supply a report of tests on the proposed batch showing the following properties applicable to the material specifications: color, gloss, drying time, opacity, viscosity, weight per gallon, and fineness of grind.

C9A-6.3 Proprietary Brands of Paints. When the required quantity of a particular type or color of a paint covered by a Federal or Military Specification is 10 gallons or less, a proprietary name brand, shelf item paint of the same type and with similar properties to the material specified may be proposed without sampling. To receive consideration, the paint must be in the original container with the manufacturer's label affixed. The Contractor shall submit a statement from the supplier that the paint is appropriate as to type, color, and gloss and is a premium grade of paint.

C9A-6.4 Safety and Health Submittal. The following is a listing of Safety and Health submittal items required by this contract. The submittals shall be provided as required in the Safety and Health Provisions of C9A-8.

- (1) Qualifications and Experience Statement.
- (2) Accident Prevention Plan.
 - (a) Administrative Requirements
 - (b) Activity Hazard Analysis Procedures
 - (c) Respiratory Protection Program
 - (d) Material Safety Data Sheet

- (e) Airborne Sampling Plan
- (f) Ventilation Assessment
- (g) Worker Hazard Communication Program
- (y) Medical Surveillance Program
- (i) Other Safety and Health Submittal Items as required in EM 385-1-1.

(3) Results of Airborne Sampling:

- (a) Laboratory Conducted-within 5 working days after taking samples.
- (b) Direct Reading Instrumentation - same day as taken.

C9A-7. PACKAGING, LABELING, DELIVERY, AND STORAGE OF PAINTS. Paints shall be so processed and packaged as to ensure that within a period of one year from date of manufacture, they will not gel, liver or thicken deleteriously, or form gas in the closed container. Paints, unless otherwise specified or permitted, shall be packaged in standard containers not larger than five gallons in size, with removable friction or lug-type covers. Each container of paint or separately packaged component thereof shall be clearly and durably labeled to indicate the purchaser's order number, date of manufacture, manufacturer's batch number, quantity, color, component identification, and the designated name, formula or specification number of the paint together with special labeling instructions, when specified. Paint shall be delivered to the job in unbroken containers. Paints that can be harmed by exposure to cold weather shall be stored in ventilated, heated shelters. All paints shall be stored under cover from the elements and in locations free from sparks and flames.

C9A-8. SAFETY AND HEALTH PROVISIONS.

C9A-8.1 General. The Contractor shall comply with the safety and health provisions contained herein in addition to those provisions contained in the Contract Clause entitled "ACCIDENT PREVENTION", FAR 52.236-13. These additional provisions are intended to amplify those contained in the aforementioned clause. In any conflict between the "ACCIDENT PREVENTION" clause and this section, the provisions of this section shall govern. The Contractor shall develop all required safety and health plans and procedures consistent with current Federal regulations as described in 29 CFR 1910, Occupational Safety and Health Standards; 29 CFR 1926, Safety and Health Regulations for Construction; EM 385-1-1, US Army Corps of Engineers Safety and Health Requirements Manual; the permissible exposure limits (PELs) contained in the latest edition of the American Conference of

Governmental Industrial Hygienist's (ACGIH) booklet entitled, "Threshold Limit Values for Chemical Substances and Physical Agents in the Work Environment and Biological Indices with Intended Changes"; and the provisions of these specifications. The Contractor shall comply with the more stringent PELs contained in either 29 CFR Part 1910 or the ACGIH booklet. In order to comply with these specifications, the Contractor shall prepare for review and approval, specific safety and occupational health submittal items identified in paragraph C9A-6.4 and as further described in C9A-8.2 below.

C9A-8.2 Safety and Health Submittal Requirements.

C9A-8.2.1 Qualifications and Experience Statement. The contractor shall submit for approval, a written Qualification(s) and Experience statement signed and dated by the Contractor and the "Qualified and Competent person(s)" as defined in EM 385-1-1, that the Contractor has selected to develop the required safety and health submittal items and who will act as the Contractor's on-site safety and health representative(s) during the contract period. Approval of this submission must be obtained prior to the submission of other required safety and health submittal items.

C9A-8.2.2 Accident Prevention Plan. The criteria included in EM 385-1- 1, TABLE 1-1, "Suggested Contractor's Accident Prevention Plan Format", as amplified below, shall be followed by the Contractor when preparing his Accident Prevention Plan. The plan at a minimum shall include each of the topic areas listed below but, may include other safety and health criteria as deemed necessary. Each topic shall be developed in a concise manner to include management and operational aspects.

C9A-8.2.2.1 Administrative Requirements.

(1) Administrative responsibilities for effecting the Accident Prevention Plan (i.e., identification and accountability of Contractor personnel responsible for accident prevention).

(2) Local requirement, if any, which must be complied with (i.e., noise control, traffic problems, parking and other similar items).

(3) Methods proposed to control and coordinate the work of Subcontractors, including list of Subcontractors.

(4) Plans for layout and use of temporary construction buildings, facilities and equipment including how the Contractor plans to control those of Subcontractors.

(5) Plans for initial indoctrination, continued safety education, and training for the Contractor's and Subcontractor's employees. The Safety Indoctrination Plan shall include, but may not be limited to, the following:

(a) General policy and pertinent provisions of EM 385-1-1, the Contractor's Accident Prevention Plan, and Activity Hazard analyses.

(b) General safety and occupational health rules.

(c) Responsibilities and authorities of employees during the contract including accident reporting, protection of property and safety of others.

(d) Procedure for reporting and correcting unsafe conditions or practices.

(e) Identification of specific hazards of the tasks (assignments) employees are to perform and the administrative (standard operating procedures), engineering and personal protective controls to mitigate those hazards.

(f) Procedures and schedules of safety meetings for indoctrination and training of supervisor and employees. Requirements for employee indoctrination and continued training by project safety officer shall include the following and as further defined in paragraphs C9A-8.2.2.2 to C9A-8.2.2.9.

1. Training of Contractor's employees for compliance to the Contractor Activity Hazard Analyses of the Accident Prevention Plan.

2. Material handling.

3. Heavy equipment.

4. Electrical (including temporary electrical)

5. Safe clearance procedures.

6. Fire and explosion protection and prevention.

7. Reserved.

8. Respiratory protection equipment (selection, fit, use, inspection, maintenance, storage, training, and other criteria in accordance with EM 385-1-1, Section .05.EB.).

9. Hazard communication for employees to include identification of potential hazards, effects of exposure and control measures to be used for chemical products and physical agents that may be encountered during the performance of work on this contract, and other criteria in accordance with 29 CFR Part 1910.1200.

10. Training in the use and understanding of material safety data sheets and chemical product hazard warning labels.

11. Selection, use, inspection, maintenance, and storage of personal protective clothing and equipment.

12. Communication methods and systems to be used (i.e., voice, hand signals, radios or other means).

13. Safe work procedures on or around water areas (water safety).

14. Personal hygiene (washing and cleaning facilities, sanitation, eating, smoking and drinking requirements).

15. Training in types, use of, and safety features of portable and fixed mechanical supply and exhaust ventilation systems.

16. Hearing protection.

17. Training in Contractor substance abuse control.

18. Medical surveillance.

19. Emergency medical and first aid requirement per EM 385-1-1, Section 3.

20. Fire fighting and other emergency plans and procedures.

21. Emergency equipment and supplies (i.e., emergency eyewash/shower and absorbent media for cleaning up spills and other equipment and supplies).

(6) Plans for continuous job clean up, and safe access and egress at the job site.

(7) Plans for emergency procedures (i.e., ambulance service, fire protection, water-related accidents and other site specific emergencies that could occur).

(8) Plans for job site safety inspection, industrial hygiene, and worker and environmental monitoring of hazardous chemical and physical agents.

(9) Record keeping procedures. Provide detailed description of methods and procedures proposed for collecting and maintaining required records such as medical monitoring,

industrial hygiene, environmental sampling and analysis, safety inspections, safety meetings, and other records required by Federal, state and local regulations.

(10) Procedures for accident investigations and reporting (See EM 385-1-1, Section 01.D).

(11) Description and sketch of temporary power distribution system.

(12) Procedures and details of fall protection systems.

(13) Description of safe clearance procedures.

C9A-8.2.2.2 Activity Hazard Analysis Procedures. The Contractor shall develop Activities Hazard Analysis Procedures as part of the Accident Prevention Plan. The procedures shall define how the Contractor will implement the Activity Hazard Analysis in accordance with the criteria in EM 385-1-1 as further described below:

(1) In accordance with the requirements of EM 385-1-1 Section 1, paragraph 01.A.09, the Contractor shall, prior to the beginning of each major phase of work, prepare an Activity Hazard Analysis (phase plan) for that work phase. This analysis shall address the hazards for each activity to be performed in that work phase and shall detail procedures and safeguards necessary to eliminate the hazards or reduce the risks to an acceptable level.

(2) The Contractor shall develop this Analysis to identify the sequence of work, the specific safety and health hazards anticipated, and the control measures to be implemented to minimize or eliminate each hazard. The Activity Hazard Analysis shall be job specific and shall address the following major points:

(a) Activity being performed (i.e. identify major phase).

(b) Sequence of work.

(c) Hazards to be controlled.

(d) Control measure(s) to mitigate the hazards.

(3) A work phase in the analysis is defined as a major operation involving a type of work which presents hazards that must be abated or controlled and which has not been experienced in previous operations, or when a new Subcontractor or work crew is to perform work. For example, major phases include site preparation, sandblasting, surface cleaning (to include abrasive blasting) and painting.

(4) The Analysis for each major work phase will be discussed by the Contractor and Construction Officer's representative. Work shall not proceed on that phase until the Contractor's Activity Hazards Analysis Procedures has been approved by the Contracting Officer Representative.

C9A-8.2.2.3 Reserved.

C9A-8.2.2.4 Respiratory Protection Program. As part of the Accident Prevention Plan, the Contractor shall develop a comprehensive written respiratory protection program in accordance with OSHA regulation 29 CFR Part 1910.134 and EM 385-1-1, Section 05.E and consistent with the guidance contained in the National Institute for Occupational Safety and Health (NIOSH) document entitled Respirator Decision Logic (DHHS (NIOSH) Publication No. 87-108). Copies of this document may be obtained by contacting NIOSH Publications in Cincinnati, Ohio at (513) 533-8280. The program shall define policies and procedures for the selection, fit-testing, use, training, maintenance, cleaning, storage, record keeping, and medical requirements for users. The program shall include a listing of the type of respirators to be worn and their National Institute for Occupational Safety and Health and/or Mine Safety and Health Administration (NIOSH/MSHA) approval statements and numbers.

C9A-8.2.2.5 Material Safety Data Sheets. The Contractor shall fully detail procedures for obtaining and providing material safety data sheets (MSDSs) for hazardous materials that will be brought onto the job site. For the purpose of the Contract, hazardous materials are those described by Federal Standard 313 (latest version) and the OSHA Hazard Communication Standard 29 CFR Para 1910.1200. MSDSs for hazardous materials furnished by the Government are appended to this Contract document. MSDSs for Contractor furnished hazardous materials must be obtained from the product manufacturer, importer, distributor, or supplier and a copy shall be provided to the government's on-site representative prior to use.

C9A-8.2.2.6 Airborne Sampling Plan. The Contractor shall develop and submit an air sampling plan as part of the Accident Prevention Plan detailing the NIOSH, Factory Mutual, or Underwriters Laboratories approved equipment, equipment calibration procedures, sampling methods and analytical procedures to be used based on the type of work to be performed, and anticipated toxic contaminants to be generated. The Contractor shall review the constituents of the paint systems, thinners, cleaners and abrasive media as well as confined spaces to be entered to determine the scope of the sampling plan. The sampling plan shall provide for approved methods of sampling and analysis by NIOSH sampling and analytical methods. The Contractor shall submit the name of the Laboratory to be used to conduct the analysis of any collected air samples. The Laboratory shall be accredited by American Industrial Hygiene Association (AIHA) as

described in paragraph C9A-8.8.1.2. The Plan shall note procedures to provide details of how the Contractor will provide to the Contracting Officer Representative the laboratory conducted analysis of air sampling within 5 working days of the sample date, and the results from direct-reading instrumentation on the same day the samples were collected.

C9A-8.2.2.7 Ventilation Assessment. The Contractor shall submit for approval the method to be used to provide ventilation assessment required by C9A-8.8.1.1.

C9A-8.2.2.8 Worker Hazard Communication Program. The Contractor shall submit a worker hazard communication program for his employees consistent with 29 CFR 1910.1200 and state and local worker "right-to-know" rules and regulations. The program shall detail how the Contractor's employees will be informed of the constituents of the paint systems, thinners, solvent cleaners, abrasive blasting media, and other materials used, as well as their potential hazards and toxic effects; how they will be informed of control measures that may be taken to prevent or minimize exposure; how they will also be informed of any exposure hazards associated with removal of surface coatings materials. This submittal shall show how the hazardous materials to be used or generated during work operations are to be identified, and how employees will be informed of the hazards prior to beginning the work task(s). In addition, the program shall detail how the Contractor will ensure, prior to usage, that all Government and Contractor furnished containers of paints, thinners or other hazardous materials are labeled in accordance with the requirements of the OSHA Hazard Communication Standard 29 CFR Para 1910.1200. The program shall describe procedures to ensure that workers will not open any chemical product containers which are improperly labeled and how the Government's on-site representative will be informed of any chemical product containers furnished by the Government that are properly labeled. The program shall also detail the requirements for labeling a product after it has been transferred from a labeled shipping container to a secondary container to ensure that information required by the OSHA Hazard Communication standard is placed on the secondary container.

C9A-8.2.2.9 Medical Surveillance. The Contractor shall describe how he will provide medical surveillance to his workforce as required in paragraph C9A-8.9.1, and provide a statement from the examining physician indicating the name of each employee who has been medically evaluated as described in paragraph C9A-8.9.1 and cleared to perform the work required by the Contractor. The statement shall detail any physical limitations, the employee's physical and psychological capability to wear respiratory protective equipment and perform job related tasks, and bear the date of the medical evaluation, the physician's name, signature and telephone number. The Contractor shall state how he will make

potential employees fully aware that facial hair cannot interfere with the sealing surface or valve function of respirators required to be worn.

C9A-8.3 Abrasive Blasting.

C9A-8.3.1 Hoses and Nozzles. Hoses and hose connections of a type to prevent shock from static electricity shall be used. Hose lengths shall be joined together by approved couplings of a material and type designed to prevent erosion and weakening of the couplings. The couplings and nozzle attachments shall fit on the outside of the hose and shall be designed to prevent accidental disengagement. A deadman type control device shall be provided at the nozzle end of the blasting hose to cut off the flow in the event the blaster loses control of the hose.

C9A-8.3.2 Blasting Helmets. Blasting operators shall be protected by MSHA/NIOSH approved air-line fed abrasive blasting helmets of a continuous flow, positive pressure type. Breathing air, source of supply and other respirator criteria shall conform to the requirements EM 385-1- 1, Section 05.E.

C9A-8.3.3 Protective Clothing. Blasting operators shall be protected against injury from impact of blast abrasives by wearing appropriate protective equipment, including heavy canvas or leather gloves and aprons or equivalent protection. Safety shoes or boots shall be worn. Hearing protectors shall be worn during all blasting operations.

C9A-8.3.4 Workers Other Than Blasters. Workers other than blasting operators working in close proximity to abrasive blasting operations, shall be protected by utilizing MSHA/NIOSH approved half face or full face air purifying respirators equipped with high efficiency particulate air (HEPA) filters, eye protection meeting or exceeding ANSI Standard Z87.1 (latest revision) and hearing protectors (ear plugs and/or ear muffs). Representative air sampling, in the breathing zone of the worker, shall be obtained prior to permanent issuance of any respiratory protection to assure that the protection factor of the respirator is not exceeded. Air sampling will not be required when non-silica containing abrasive blasting material (1% free silica content or less) is used and it has been established that the surface coating to be removed will not generate toxic airborne particulates (for example lead or chromates).

C9A-8.4 Cleaning With Compressed Air. Cleaning with compressed air is prohibited, except where the pressure has been reduced to less than 30 psi (pounds per square inch) or the air hose is equipped with a pressure reducing valve. Persons using high pressure compressed air for blow down after abrasive blasting operations shall be protected by the same equipment required for abrasive blasters in paragraphs C9A-8.3.2 and C9A-8.3.3 above.

C9A-8.5 Cleaning With Solvents.

C9A-8.5.1 Ventilation and Respiratory Protection. Where cleaning activities using solvents are being carried out in areas that the Contractor's on-site safety and health representative has determined are NOT confined or enclosed spaces, persons conducting such cleaning shall wear as a minimum, MSHA/NIOSH approved chemical cartridge/canister half or full face piece air-purifying/respirators that have sorbent suitable for the chemical properties of the anticipated gas/vapor contaminant(s) and for the anticipated exposure levels. Whenever high airborne concentration of particulates are anticipated or encountered during cleaning with solvents, approved air-purifying chemical cartridge/canister respirators that have a particulate prefilter suitable for the specific type(s) of gas/vapor and particulate contaminant(s) and for the exposure concentration shall be worn. Air monitoring shall be conducted in the breathing zone of the worker to determine specific solvent vapor concentrations prior to the permanent issuance of respiratory equipment to assure that the Assigned Protection Factor (APF) of the respirator is not exceeded. APF is defined as the anticipated workplace level of respiratory protection provided by a properly functioning respirator or class or respirators to a percentage of properly fitted and trained users. The maximum specified use concentration for a respirator shall be determined by multiplying the permissible exposure limit for the contaminant by the protection factor assigned to a class of respirators. (Refer to the NIOSH document, respirator decision logic, for guidance).

C9A-8.5.2 Protective Clothing. Exposure of skin and eyes to solvents shall be avoided by utilization of appropriate chemical resistant gloves, apron, clothing (if applicable), safety goggles and face shield. Guidance regarding selection of appropriate clothing may be obtained by consulting the American Conference of Governmental Industrial Hygienists publication "Guidances to the Selection of Chemical Protective Clothing", VOLS I & II, 1987. Copies may be obtained by contacting ACGIH in Cincinnati, Ohio (513) 661-7881.

C9A-8.6 Pretreatment of Metals and Concrete With Acids.

C9A-8.6.1 Personal Protective Equipment. Exposure of skin and eyes to acids shall be avoided by wearing appropriate acid resistant gloves, apron, clothing (if applicable), approved safety goggles and face shields.

C9A-8.6.2 Emergency Equipment. The following requirement for the acid pretreatment operation is in addition to that required by paragraph 03.A.05 of EM 385 1-1. In accordance with ANSI Z 358.1, an emergency eye wash which provides at least 15 minutes of continuous clean water flow, and a deluge shower shall be provided for the acid pretreatment operation.

C9A-8.7 Mixing Epoxy Resin Formulations.

C9A-8.7.1 Ventilation. Local exhaust ventilation shall be provided in the area where the curing agent and resin are mixed. This ventilation shall be capable of providing at least 100 linear feet per minute of air flow at the mixing station.

C9A-8.7.2 Personal Protective Equipment. Exposure of skin and eyes to Epoxy Resin components shall be avoided by wearing appropriate chemically resistant gloves, apron, safety goggles and face shields meeting or exceeding the requirements of ANSI Standard Z 87.1.

C9A-8.7.3 Medical Precautions. Individuals who have a history of sensitivity to epoxy resin systems shall have been medically evaluated before any exposure could occur. Individuals who are medically evaluated as exhibiting a sensitivity to epoxy resins should not conduct work tasks or otherwise be exposed to such chemicals. Individuals who develop a sensitivity shall be immediately removed from further exposure and medically evaluated.

C9A-8.7.4 Emergency Equipment. An emergency eyewash capable of providing at least 15 minutes of continuous water flow, and a deluge shower shall be provided within close proximity to the Epoxy Resin Mixing Operation in accordance with ANSI Standard Z358.1.

C9A-8.7.5 Special Conditions. Smoking shall be prohibited during all Epoxy Resin Mixing operation.

C9A-8.8 Paint Application.

C9A-8.8.1 Fire and Explosion Prevention.

C9A-8.8.1.1 Reserved.

C9A-8.8.1.2 Atmospheric Testing. The Contractor shall implement the Airborne Sampling Plan required by C9A-8.2.2.6 above. Representative air samples shall be collected to determine if toxic contaminants are being generated in concentrations that may be harmful to workers. The Contractor shall utilize NIOSH approved sampling and analytical methods as described in the NIOSH Manual of Analytical Methods (latest revision). A copy may be obtained by contacting NIOSH Publication in Cincinnati, Ohio at (513) 533-8287. Laboratories utilized to analyze samples shall be AIHA accredited and shall have demonstrated proficiency in the analysis to be performed as evidenced by successful passing participation in the joint NIOSH/AIHA Analytical Testing Proficiency Program (PAT). A listing of AIHA approved laboratories and PAT participants may be obtained by calling AIHA in Akron, Ohio (216) 762-7294. Confined spaces shall be tested prior to and continuously during painting operations, to determine the effectiveness of the ventilation system (see C9A-8.2.2.3).

Intrinsically safe oxygen, combustible gas and other monitoring instruments to be used in confined spaces, certified by FM and/or Underwriters Laboratories for use in Class 1, Division 1, Group A, B, C and D hazardous areas, shall be used to determine if adequate levels of oxygen and safe concentrations of combustibles or toxic contaminants exist. A minimum level of 19.5% oxygen and a maximum concentration of 20% of the Lower Explosive Limit for combustible materials are mandatory requirements for safe work in these spaces, except for the zone within 5-feet in any direction from an operating spray nozzle. Periodic testing, shall also be conducted in confined space areas adjacent to the area where spray painting is occurring and in areas where the air is being exhausted from the confined space to ensure safe concentrations of oxygen, combustibles and toxic contaminants are maintained. All air monitoring equipment shall be calibrated prior to each use and rechecked after each use. The oxygen and combustible gas meter(s) shall be equipped with an audible alarm which signals unsafe levels of oxygen and/or combustibles gases.

C9A-8.8.1.3 Explosion Proof Equipment. All electrical wiring, lights, and other equipment located in the paint spraying area shall be of the explosion proof type designed for operation in Class I, Division 1, Group D, Hazardous Locations as required by the National Electrical Code. Electrical wiring, motors and other equipment outside of, but within 20-feet of any spraying area, shall not spark and shall conform to the provisions for Class I, Division 2, Group 2, Hazardous Locations. Electric motors used to drive exhaust fans shall not be placed inside spraying areas or ducts. Fan blades and portable air ducts shall be constructed of nonferrous materials. All motors and associated control equipment shall be properly maintained and grounded. The metallic parts of air moving devices, spray guns, connecting tubing and all duct work shall be electrically bonded and the bonded assembly shall be grounded.

C9A-8.8.1.4 Further Precautions. Workers shall wear non sparking safety shoes. All solvent drums taken into the spraying area shall be placed on non-ferrous surfaces and shall be grounded. Metallic bonding shall be maintained between containers and drums when materials are being transferred. Insulation on all power and lighting cables shall be inspected to ensure that the insulation is in excellent working condition and is free of all cracks and worn spots. Cables should be further inspected to ensure that no connections are within 50-feet of the operation, that lines are not overloaded, and that they are suspended with sufficient slack to prevent undue stress or chafing.

C9A-8.8.1.5 Ignition Sources. Ignition sources, to include lighted cigarettes, cigars, pipes, matches or cigarette lighters, shall be prohibited in areas of solvent cleaning, paint storage, paint mixing of paint application.

voice, signal line, radio or other means) shall be maintained between workers inside confined space and stand-by personnel outside at all times.

C9A-8.8.2.2 Protective Clothing and Equipment. All workers shall wear safety shoes or boots, appropriate gloves to protect against the chemical to be encountered and breathable protective full body covering during spray painting applications. Where necessary for emergencies, protective equipment such as life lines, body harnesses or other means of personnel removal shall be utilized during confined space work.

C9A-8.9 Medical Status.

C9A-8.9.1 Medical Evaluation. Prior to the start of work and annually thereafter, all Contractor employees working with or around paint systems thinners, blast media, those required to wear respiratory protective equipment, and those who will be exposed to high noise levels, shall be medically evaluated for the particular type of exposure they may encounter. The evaluation shall include:

(1) Audiometric testing and evaluation of employees who will work in the noise environments.

(2) Vision Screening (employees who use full face-piece respirators shall not wear contact lenses).

(3) Medical evaluation shall include but shall not be limited to the following:

(a) Medical history, including but not limited to alcohol use, with emphasis on liver, kidney and pulmonary systems, and sensitivity to chemicals to be used on the job.

(b) General physical examination with emphasis on liver, kidney and pulmonary system.

(c) Determination of the employee's physical and psychological ability to wear respiratory protective equipment and perform job related tasks.

(d) Determination of baseline values of biological indices for later comparison to changes associated with exposure to paint systems and thinners or blast media which include:

1. liver function tests to include SGOT, SGPT, GGPT, alkaline phosphatase, bilirubin.

2. complete urinalysis

3. EKG (employees over age forty)

C9A-8.8.2 Health Protection.

C9A-8.8.2.1 Respirators. Contractor shall implement the Respirator Protection Program developed in paragraph C9A-8.2.2.4. During all spray painting operations, spray painters shall use approved SCBA or SAR (airline) respirators, unless valid air sampling has demonstrated contaminant levels to be consistently within concentrations that are compatible with air purifying respirator protection factors. All respiratory equipment shall be selected and used in accordance with EM 385-1-1, 05.E and 29 CFR 1910.134 and consistent with the guidance contained in the NIOSH document, Respirator Decision Logic. During all confined space spray painting operations, only MSHA/NIOSH approved SCBA with half face or full face piece operated in pressure demand or other positive pressure mode or a SAR (airline) with a half or full face piece or painters helmet, hood or suit operated in pressure demand or other positive pressure mode in combination with an auxiliary SCBA (emergency escape bottle) operated in pressure demand, or other positive pressure mode shall be used. Auxiliary SCBA must be of such duration to permit escape to safety if air supply is interrupted. All employees who wear air-purifying type respirators shall be quantitatively or qualitatively fit-tested, using NIOSH approved procedures, for the specific type air-purifying respirators they will wear. Persons with facial hair that interferes with the sealing surface of the facepiece to face seal or interferes with respirator valve function shall not be allowed to perform work requiring respirator protection. Airpurifying chemical cartridge/canister half or full face piece respirators that have a particulate prefilter and are suitable for the specific type(s) of gas/vapor and particulate contaminant(s) may be used for non-confined space painting, mixing, and cleaning (using solvents), provided the measured or anticipated concentration of the contaminant(s) in the breathing zone of the exposed worker, does not exceed the Assigned Protection Factor (APF) for the respirator, and the gas/vapor has good warning properties or the respirator assembly is equipped with a NIOSH approved End of Service Life Indicator for the gas(es)/vapor anticipated or encountered. Where paint contains toxic elements such as lead, cadmium, chromium or other toxic particulates that may become airborne during painting in non-confined spaces, air purifying half face and full face piece respirators or powered air purifying respirators, equipped with appropriate gas vapor cartridges in combination with a high efficiency filter or an appropriate canister incorporating a high efficiency filter shall be used. Stand-by personnel used for all confined space operations shall be equipped with SCBA with a minimum breathing air supply of 30 minutes. Individuals selected to act as stand-by personnel shall be medically evaluated to ensure that they are physically and psychologically able to perform rescue duties while wearing a SCBA. In addition, they shall be thoroughly trained in confined space monitoring techniques, communications to be used, and emergency rescue techniques. Communications (i.e., visual,

4. blood urea nitrogen (bun)
5. serum creatinine
6. pulmonary function test, FVC and FEV
7. chest x-ray (if medically indicated)
8. blood lead (for individuals where it is known there will be an exposure to materials containing lead)
9. other criteria that may be deemed necessary by the Contractor's physician.
10. physician's statements for individual employees that medical status would permit specific task performance.

C9A-8.9.2 Change in Medical Status. Any employee whose medical status has changed negatively due to work related chemical and/or physical agent exposure while working with or around paint systems and thinners, blast media, or other chemicals shall be evaluated by a physician and the Contractor shall obtain a physicians statement as described in paragraph C9A-8.9.1(3)(d)10 above prior to allowing the employee to return to those work tasks. The Contractor shall notify the Contracting Officer in writing of any negative changes in employee medical status and the results of the physician's reevaluation statement.

PART 2 - PRODUCTS

C9A-9. SPECIAL PAINT FORMULAS. The ingredient materials described in this paragraph are applicable only to the special paint formulations not covered by standard specifications specified hereinafter and not to those finished-product coatings governed by Federal or other standard specifications.

C9A-9.1 General. Special paints shall have the composition as indicated in the formulas listed herein. Where so specified, certain components of a paint formulation shall be packed in separate containers for mixing on the job.

C9A-9.2 Colors and Tints. Colors shall conform to the listed chip of Fed. Std. 595. If not specified or otherwise prescribed, the color shall be that naturally obtained from the required pigmentation.

C9A-9.3 Coal Tar Epoxy. Coal Tar Epoxy (Black) Paint (Formula C-200a) shall conform to SSPC-Paint 16 manufactured with Type 1 pitch. In addition to standard labeling, container labels shall include the term, "Corps of Engineers Formula C-200a." Finished

product samples submitted for approval shall be accompanied by a list showing all of its raw material ingredients, the name of the manufacturer of each, and the trade name and/or code designation by which the producer identifies his ingredient product.

C9A-9.4 Ingredient Materials and Thinners for Special Paint Formulations. The following ingredient materials apply only to those paints whose formulations are shown above in detail.

C9A-9.4.1 Pigments and Suspending Agents.

C9A-9.4.1.1 Carbon Black. Carbon black shall conform to ASTM D 561, Type I or II.

PART 3 - EXECUTION

C9A-10. CLEANING AND PREPARATION OF SURFACES TO BE PAINTED.

C9A-10.1 General. Surfaces to be painted shall be clean before applying paint or surface treatments. Deposits of grease or oil shall be removed in accordance with SSPC-SP1, "Solvent Cleaning" prior to mechanical cleaning. Solvent cleaning shall be accomplished with mineral spirits or other low-toxicity solvents having a flashpoint above 100°F. Clean cloths and clean fluids shall be used to avoid leaving a thin film of greasy residue on the surfaces being cleaned. Items not to be prepared or coated shall be protected from damage by the surface preparation methods. Machinery shall be protected against entry of blast abrasive and dust into working parts. Cleaning and painting shall be so programmed that dust or other contaminants from the cleaning process do not fall on wet, newly painted surfaces, and surfaces not intended to be painted shall be suitably protected from the effects of cleaning and painting operations. Welding of, or in the vicinity of, previously painted surfaces shall be conducted in a manner to prevent weld spatter from striking the paint and to otherwise reduce coating damage to a minimum; paint damaged by welding operations shall be restored to original condition. Surfaces to be painted that will be inaccessible after construction, erection, or installation operations are completed shall be painted before they become inaccessible.

C9A-10.2 Ferrous surfaces subject to extended periods of immersion or otherwise as required shall be dry blast cleaned to SSPC-SP 5. The blast profile unless otherwise specified shall be 1.5 to 2.5 mils as measured by ASTM D 4417, Method C. Appropriate abrasive blast media shall be used to produce the desired surface profile and to give an angular anchor tooth pattern. If recycled blast media is used, an appropriate particle size distribution shall be maintained so that the specified profile is consistently obtained. Steel shot or other abrasives that do not produce an angular profile shall not be used. Weld spatter not dislodged by

blasting shall be removed with impact or grinding tools and the areas reblasted prior to painting. Surfaces shall be dry at the time of blasting. Blast cleaning to SSPC SP5 shall be done in the field and, unless otherwise specifically authorized, after final erection. Within eight hours after cleaning, prior to the deposition of any detectable moisture, contaminants, or corrosion, all ferrous surfaces blast cleaned to SSPC SP5 shall be cleaned of dust and abrasive particles by brush, vacuum cleaner, and/or blowdown with clean, dry compressed air, and given the first coat of paint. All abrasives used in sandblasting operations shall contain less than 1% silica, unless otherwise approved in writing by the Contracting Officer. The surfaces if shop blasted, shall be shop coated with the first and second coats of the specified paint system as specified in the paint system instructions. The shop coating shall be maintained in good condition by cleaning and touching up in areas damaged during the construction period. Appearance of pinpoint or general rusting prior to application of field coats will be considered as evidence of poor workmanship, requiring reblasting and repainting at no added cost to the Government. Prior to the field application of subsequent coats, soiled areas of the shop coating shall be thoroughly cleaned and all welds or other unpainted or damaged areas shall be cleaned and coated in such a manner as to make them equivalent to adjacent, undamaged paint surfaces.

C9A-11. PAINT APPLICATION.

C9A-11.1 General. The finished coating shall be free from holidays, pinholes, bubbles, runs, drops, ridges, waves, laps, excessive or unsightly brush marks, and variations in color, texture, and gloss. Application of initial or subsequent coatings shall not commence until a Government representative has verified that atmospheric conditions and the surfaces to be coated are satisfactory or has waived specific verification. All paint coats shall be applied in such manner as to produce an even, continuous film of uniform thickness. Edges, corners, crevices, seams, joints, welds, rivets, and other surface irregularities shall receive special attention to ensure that they receive an adequate thickness of paint. Spray equipment shall be equipped with traps and separators and where appropriate, mechanical agitators, pressure gages, pressure regulators, and screens or filters. Air caps, nozzles, and needles shall be as recommended by the spray equipment manufacturer for the material being applied. Airless-type spray equipment shall be used only on broad, flat or otherwise simply configured surfaces, except that it may be employed for general painting if the spray gun is equipped with dual or adjustable tips of proper types and orifice sizes.

C9A-11.2 Mixing and Thinning. Paints shall be thoroughly mixed, strained where necessary, and kept at a uniform composition and consistency during application. Paste or dry powder pigments specified to be added at the time of use shall, with the aid of powered stirrers, be incorporated into the vehicle or base paint

in such a manner as to produce a smooth, homogeneous mixture, free of lumps and dry particles. Where necessary, in the opinion of the Government inspector, to suit conditions of surface, temperature, weather, and method of application, the packaged paint may be thinned immediately prior to use by the addition of not more than one pint per gallon of the proper thinner, provided that this general limitation shall not apply when more specific thinning instructions are provided. Paint that has been stored at low temperature, shall be brought up to at least 70°F before being mixed and thinned, and its temperature in the spray tank or other working container shall not fall below 60°F during the application. Paint that has deteriorated in any manner to such degree that it cannot be restored to essentially its original condition by customary field-mixing methods shall not be used and shall be removed from the project site. Paint and thinner that is more than one year old shall be sampled and submitted for testing to determine its suitability for application.

C9A-11.3 Atmospheric and Surface Conditions. Paints shall be applied only to surfaces that are above the dew point temperature and that are completely free of moisture as determined by sight and touch. In no case shall any paint be applied to surfaces upon which there is detectable frost or ice. Except as otherwise specified, the temperature of the surfaces to be painted and of air in contact therewith shall be not less than 45°F during paint application nor shall paint be applied if the surfaces can be expected to drop to 32°F or lower before the film has dried to a reasonably firm condition. During periods of inclement weather, painting may be continued by enclosing the surfaces and applying artificial heat, provided the minimum temperatures and surface dryness requirements prescribed above are maintained. Paint shall not be applied to surfaces heated by direct sunlight or other sources to temperatures that will cause detrimental blistering, pinholing, or porosity of the film.

C9A-11.4 Time Between Surface Preparation and Painting. Surfaces that have been cleaned and/or otherwise prepared for painting shall be primed as soon as practicable after such preparation has been completed prior to any deterioration of the prepared surface.

C9A-11.5 Method of Paint Application. Unless otherwise specified, paint shall be applied by brush or spray. Special attention shall be directed toward ensuring adequate coverage of edges, corners, crevices, pits, rivets, bolts, welds, and similar surface irregularities. Other methods of application to metal surfaces shall be subject to the specific approval of the Contracting Officer. Whenever application of paint by a specific method to a surface is permitted or directed, it is to be understood that all areas inaccessible to that method shall be coated by alternate means.

C9A-11.6 Coverage and Film Thickness. The actual surface area covered per gallon of paint shall not exceed the spreading rates prescribed for specific paints. Where no spreading rate is specified, the paint shall be applied at a rate normal for the type of material being used. In any event, the combined coats of a specified paint system shall completely hide base surface and the finish coats shall completely hide undercoats of dissimilar color.

C9A-11.6.1 Measurements on Ferrous Metal. Where dry film thickness requirements are specified for coatings on ferrous surfaces, measurements shall be made with one of the thickness gages listed below. They shall be calibrated and used in accordance with ASTM D 1186. They shall be calibrated using plastic shims with metal practically identical in composition and surface preparation to that being coated, and of substantially the same thickness (except that for measurements on metal thicker than $\frac{1}{4}$ -inch, the instrument may be calibrated on metal with a minimum thickness of $\frac{1}{4}$ -inch). The instruments shall be calibrated in the thickness range expected to be encountered and the range of accuracy determined. If thickness readings are encountered outside of the calibrated range, the instrument shall be recalibrated and measurements retaken. The instruments shall be calibrated or calibration verified prior to, during and after each use. Authorized thickness gages:

Mikrotest, Elektro-Physik, Inc.
Inspector Gage, Elcometer Instruments, Ltd.
Positest, Defelsko Corporation
General Electric, Type B, General Electric Company
Minitector, Elcometer Instruments, Ltd.
Positector 2000, Defelsko Corporation

C9A-11.7 Progress of Painting Work. Where field painting on any type of surface has commenced, the complete painting operation, including priming and finishing coats, on that portion of the work, shall be completed as soon as practicable, without prolonged delays. Sufficient time shall elapse between successive coats to permit them to dry properly for recoating, and this period shall be modified as necessary to suit adverse weather conditions. Paint shall be considered dry for recoating when it feels firm, does not deform or feel sticky under moderate pressure of the finger, and the application of another coat of paint does not cause film irregularities such as lifting or loss of adhesion of the undercoat. All coats of all painted surfaces shall be unscarred and completely integral at the time of application of succeeding coats. At the time of application of each successive coat, undercoats shall be cleaned of dust, grease, overspray, or foreign matter by means of airblast, solvent cleaning, or other suitable means. Cement and mortar deposits on painted steel surfaces, not satisfactorily removed by ordinary cleaning methods, shall be brush-off blast cleaned and completely repainted as required. Undercoats of high gloss shall, if necessary for

establishment of good adhesion, be scuff sanded, solvent wiped or otherwise treated prior to application of a succeeding coat. Field coats on metal shall be applied after erection except as otherwise specified and except for surfaces to be painted that will become inaccessible after erection.

C9A-11.8 Contacting Surfaces. When riveted or ordinary bolted contact is to exist between surfaces of ferrous or other metal parts of substantially similar chemical composition, such surfaces will not be required to be painted but any resulting crevices shall subsequently be filled or sealed off with paint. Contacting metal surfaces formed by high-strength bolts in friction-type connections shall not be painted. Where a nonmetal surface is to be in riveted or bolted contact with a metal surface, the contacting surfaces of the metal shall be cleaned and given three coats of the specified primer. Unless otherwise specified, corrosion-resisting metal surfaces, including cladding therewith, shall not be painted.

C9A-11.9 Drying Time Prior to Immersion. Painted surfaces that are to be immersed in water shall be permitted a final drying time as long as practicable; but in any event, the following minimum requirements shall be met. The cold-applied coal tar system shall not be immersed until the final coat has dried at least seven days. Minimum drying periods may be required to be increased up to twofold if the drying temperature is below 65°F and/or if the immersion exposure involves considerable abrasion.

C9A-11.10 Protection of Painted Surfaces. Where shelter and/or heat are provided for painted surfaces during inclement weather, such protective measures shall be maintained until the paint film has dried and discontinuances of the measures is authorized. Items that have been painted shall not be handled, worked on, or otherwise disturbed until the paint coat is fully dry and hard. All metalwork coated in the shop or field prior to final erection shall be stored out of contact with the ground in such manner and location as will minimize the formation of water-holding pockets, soiling, contamination, and deterioration of the paint film, and damaged areas of paint on such metalwork shall be cleaned and touched-up without delay. The specified first overall field coat of paint shall be applied within a reasonable period after the shop coat before weathering of the shop coat becomes extensive.

C9A-11.11 Special Directions for Mixing and Applying Coal Tar Epoxy (Black) Paint (Formula C-200a).

C9A-11.11.1 Mixing. Component B shall be added to previously stirred Component A and thoroughly mixed together with a heavy-duty mechanical stirrer just prior to use. The use of not more than one pint of xylene thinner per gallon of paint will be permitted in order to improve application properties and extend pot life. Where applicable, an approved thinner which complies

with air pollution regulations shall be substituted for xylene. The pot life of the mixed paint, extended by permissible thinning, may vary from two hours in very warm weather to five or more hours in cool weather. Pot life in warm weather may be extended by: precooling the components prior to mixing; cooling the mixed material; and/or by slow, continuous stirring during the application period. The mixed material shall, in any event, be applied before unreasonable increases in viscosity take place.

C9A-11.11.2 Application. Spray guns shall be of the conventional type equipped with a fluid tip of about 0.09-inch diameter and external atomization, seven-hole air cap. Material shall be supplied to the spray gun from a bottom withdrawal pot or by means of a fluid pump; hose shall be $\frac{1}{2}$ -inch in diameter. Atomization air pressure shall not be less than 80 psi. High-pressure airless spray equipment may be used only on broad, simply configured surfaces. Brush application shall be carried out with a stiff-bristled tool heavily laden with material and wielded in a manner to spread out the coating smoothly and quickly without excessive brushing. The coverage rate of the material is approximately 110 square feet per gallon per coat to obtain 20 mils (dry thickness) in a two-coat system. The minimum amount of paint applied in any coat shall be such that the deposited material flows together and provides a coherent, pinhole-free film. To promote uniformity of thickness, the direction of the spray passes (or finish strokes if brushed) of the second coat shall be at right angles to those of the first where practicable.

C9A-11.11.3 Subsequent Coats. Except at the high temperatures discussed below, the drying time between coal tar epoxy coats shall be not more than 72 hours, and application of a subsequent coat as soon as the undercoat is reasonably firm is strongly encouraged. Where temperature for substrate or coating surface during application or curing exceeds or can be expected to exceed 125°F as the result of direct exposure to sunlight, either the surfaces shall be shaded by overhead cover or the interval between coats shall be reduced as may be found necessary to avoid poor intercoat adhesion, here defined as inability of two or more dried coats of coal tar epoxy paint to resist delamination when tested aggressively with a sharp knife. Under the most extreme conditions involving high ambient temperatures and sun-exposed surfaces, the drying time between coal tar epoxy coats shall not exceed 10 hours, and the reduction of this interval to a few hours or less is strongly encouraged. Where the curing time of a coal tar epoxy undercoat exceeds the above (i.e., 72 hours of curing at normal temperatures or 10 hours at extreme conditions), or where the undercoat develops a heavy blush, frequently caused by its being subjected to moisture soon after application, it shall be given one of the following treatments before the subsequent coat is applied:

(1) Etch the coating surface lightly by brush-off blasting, using fine sand, low air pressure and a nozzle-to-surface distance of approximately 3-feet.

(2) Remove the blush and/or soften the surface of the coating by wiping it with cloths dampened with 1-methyl-2-pyrrolidone solvent or with Bitumastic 2CB solvent marketed by the Koppers Company, Inc. The solvents may be applied to the surface by fog spraying followed by wiping, but any puddles of solvent must be mopped up immediately after they form. The subsequent coat shall be applied in not less than 15 minutes or more than three hours after the solvent treatment.

C9A-11.11.4 Ambient Temperature. Coal tar epoxy paint shall not be applied when the receiving surface or the ambient air is below 50°F, unless it can be reasonably anticipated that the average ambient temperature will be 50°F or higher for the five-day period subsequent to the application of any coat.

C9A-11.11.5 Safety. In addition to the safety provisions in para C9A-8 above, other workmen as well as painters shall take extra care to avoid inhaling atomized particles of coal tar epoxy paint and to avoid contact of the paint with the skin.

C9A-12. PAINT SYSTEMS TO BE APPLIED--NUMBER OF COATS AND FORMULAS.

C9A-12.1 General. The required paint systems and the surfaces to which they shall be applied are shown in paragraph C9A-12.2 below. Supplementary information follows:

C9A-12.1.1 Fabricated and Assembled Items. Items that have been fabricated and/or assembled into essentially their final form and that are customarily cleaned and painted in accordance with the manufacturer's standard practice will be exempted from equivalent surface preparation and painting requirements described herein, provided that: (1) surfaces primed (only) in accordance with such standard practices are compatible with specified field-applied finish coats, (2) surfaces that have been primed and finish painted in accordance with the manufacturer's standard practice are of acceptable color and are capable of being satisfactorily touched up in the field, and (3) items expressly designated herein to be cleaned and painted in a specified manner are not coated in accordance with the manufacturer's standard practice if different from that specified herein.

C9A-12.1.3 Surface Preparation. The method of surface preparation and pretreatment shown in the tabulation of paint systems is for identification purposes only. Cleaning and pretreatment of surfaces prior to painting shall be accomplished in accordance with detailed requirements hereinbefore described.

C9A-12.2 Paint Systems and Painting Schedule. See C9A-12.3 below for supplementary application instructions pertaining to the following paint system:

SYSTEM NO. 6

Items or surfaces to be coated: Both sides of sheet pile as follows:

The limits of painting of steel sheet piling under utilities TC-1, ST-1 & DT-1 on West Bank are shown on the drawings 40-43. Interlock grooves of the sheet piling shall not be painted. The unpainted portions of sheet piling which are to be embedded in concrete shall be free from surface contaminants such as oil, loose particles, or similar conditions that would prohibit bonding between the concrete and the sheet piling. Before redriving existing AZ-18 steel sheet piling on East Bank from approximately Sta. 99+91.07 EB/L to Sta. 100+10.42 EB/L, the Contractor will touch up any paint damaged on both sides of AZ-18 steel sheet piling.

<u>Surface Preparation</u>	<u>Paint Formulas to be Applied</u>		
	<u>1st Coat</u>	<u>2nd Coat</u>	<u>3rd Coat</u>
Approaching white metal blast cleaning	Coal tar epoxy (black) C-200a	Coal tar epoxy (black) C-200a	Coal tar epoxy (black) C-200a (if needed to attain required thickness)

C9A-12.3 Supplementary Application Instructions. Surfaces shall be coated with the system indicated in the schedule and/or noted on the drawings in accordance with the following instructions:

C9A-12.3.1 System No. 6. The coal tar epoxy paint shall be applied by brush or spray in not less than two coats to provide a total thickness at any point of not less than 16 mils. The specified film thickness shall be attained in any event and any additional (beyond two) coats needed to do so shall be applied at no additional cost to the Government. See safety provisions and special direction for applying coal tar epoxy paint.

C9A-13. PROTECTION OF NON-PAINTED ITEMS AND CLEANUP. Walls, equipment, fixtures and all other items in the vicinity of the surfaces being painted shall be maintained free of damage by paint or painting activities. Prompt cleanup of any paint spillage and prompt repair of any painting activity damage shall be required.

C9A-14. MEASUREMENT AND PAYMENT. No separate measurement and payment will be made for painting. Payment for all painting work performed and for all materials furnished under the section of the specifications will be included in the contract prices for the items on which the work is performed.

INDEX

DIVISION 16 - ELECTRICAL

Para. No.	Paragraph Title	Page No.
SECTION C16A - CATHODIC PROTECTION		
C16A-1.	SCOPE	C16A-1
C16A-2.	QUALITY CONTROL	C16A-1
C16A-3.	BONDING	C16A-1
C16A-4.	BONDING, I-WALL	C16A-1
C16A-5.	BOND CABLES	C16A-1
C16A-6.	MEASUREMENT AND PAYMENT	C16A-2
SECTION C16B - ELECTRICAL WORK		
C16B-1.	SCOPE	C16B-1
C16B-2.	OVERVIEW	C16B-1
C16B-3.	SCHEDULING OF WORK	C16B-2
C16B-4.	APPLICABLE PUBLICATIONS	C16B-2
C16B-5.	GENERAL	C16B-3
C16B-6.	APPROVAL OF MATERIALS AND EQUIPMENT	C16B-3
C16B-7.	RESERVED	C16B-4
C16B-8.	MATERIALS AND WORKMANSHIP	C16B-4
C16B-9.	CONCRETE	C16B-5
C16B-10.	WARNING TAPE	C16B-5
C16B-11.	CONDUIT	C16B-5
C16B-12.	MEDIUM VOLTAGE CABLE	C16B-5
C16B-13.	DETAILED MEDIUM VOLTAGE CABLE SPECIFICATIONS	C16B-6
C16B-14.	GROUNDING	C16B-8
C16B-15.	TESTS	C16B-8
C16B-16.	TEMPORARY REMOVAL OF S&WB FEEDER CABLE FROM SHEETPILE WALL	C16B-11
C16B-17.	CABLE LENGTHS	C16B-13
C16B-18.	PLACING OF CONCRETE	C16B-13
C16B-19.	WARNING TAPE	C16B-14
C16B-20.	BACKFILLING	C16B-14
C16B-21.	RESERVED	C16B-14
C16B-22.	INSPECTION AND TESTING	C16B-14
C16B-23.	CLEANING OF DUCTS	C16B-15
C16B-24.	HANDLING AND INSTALLATION OF CABLE	C16B-15
C16B-25.	ACCEPTANCE TESTS OF INSTALLED CABLE	C16B-16
C16B-26.	REPLACING DEFECTIVE CABLE	C16B-16
C16B-27.	SPLICES AND TERMINATIONS	C16B-16
C16B-28.	MEASUREMENT AND PAYMENT	C16B-17

INDEX

SECTION C16A - CATHODIC PROTECTION

Para. No.	Paragraph Title	Page No.
C16A-1.	SCOPE	C16A-1
C16A-2.	QUALITY CONTROL	C16A-1
C16A-3.	BONDING	C16A-1
C16A-4.	BONDING, I-WALL	C16A-1
C16A-5.	BOND CABLES	C16A-1
C16A-6.	MEASUREMENT AND PAYMENT	C16A-2

SECTION C16A - CATHODIC PROTECTION

PART 1 - GENERAL

C16A-1. SCOPE. The work covered by this section consists of furnishing all plant, labor, material, and equipment required to electrically bond the piling as shown on the drawings and as specified herein to permit installation of a cathodic protection system.

C16A-2. QUALITY CONTROL.

C16A-2.1 General. The Contractor shall establish and maintain quality control for bonding operations to assure compliance with contract specifications and maintain records of his quality control for all construction operations including, but not limited to the installation of bond cables.

C16A-2.2 Reporting. The original and two copies of these records and tests, as well as the records of corrective action taken, shall be furnished to the Government daily. The format of the report shall be as prescribed in the Special Clause entitled "CONTRACTOR QUALITY CONTROL".

PART 2 - PRODUCTS

C16A-3. BONDING.

C16A-3.1 Reinforcing Bar. A. No. 6 reinforcing bar shall be used for electrically bonding sheet piles.

C16A-3.2 Bond Cables. Bond Cables shall be cathodic protection, type CPS, cables, 7-strand, #4 AWG, Class B, uncoated annealed copper conforming to ASTM B-3 and B-8. Insulation shall be black, high molecular weight polyethylene. Insulation wall thickness shall be a minimum of 110 mils.

PART 3 - EXECUTION

C16A-4. BONDING, I-WALL. The sheet piles shall be electrically bonded together with a No. 6 reinforcing bar and bond cables as indicated in C16A-5.

C16A-5. BOND CABLES. Bond cables shall be welded to the piling using an exothermic type process. Welded joints shall be coated with splicing epoxy to obtain a moisture proof joint. The welding process shall be such that the heat of welding will not

damage the insulation on the wire. The welding process shall be the Cadweld process of Erico Products, Inc., or equal. Epoxy shall completely cover welded joints and extend 2-inches over cable insulation.

C16A-6. MEASUREMENT AND PAYMENT. No measurement will be made for cathodic protection. Payment for furnishing and installing the No. 6 reinforcing bars and for the bond cables will be included in the contract price for which the work is incidental.

INDEX

SECTION C16B - ELECTRICAL WORK

Para. No.	Paragraph Title	Page No.
C16B-1.	SCOPE	C16B-1
C16B-2.	OVERVIEW	C16B-1
C16B-3.	SCHEDULING OF WORK	C16B-2
C16B-4.	APPLICABLE PUBLICATIONS	C16B-2
C16B-5.	GENERAL	C16B-3
C16B-6.	APPROVAL OF MATERIALS AND EQUIPMENT	C16B-3
C16B-7.	RESERVED	C16B-4
C16B-8.	MATERIALS AND WORKMANSHIP	C16B-4
C16B-9.	CONCRETE	C16B-5
C16B-10.	WARNING TAPE	C16B-5
C16B-11.	CONDUIT	C16B-5
C16B-12.	MEDIUM VOLTAGE CABLE	C16B-5
C16B-13.	DETAILED MEDIUM VOLTAGE CABLE SPECIFICATIONS	C16B-6
C16B-14.	GROUNDING	C16B-8
C16B-15.	TESTS	C16B-8
C16B-16.	TEMPORARY REMOVAL OF S&WB FEEDER CABLE FROM SHEETPILE WALL	C16B-11
C16B-17.	CABLE LENGTHS	C16B-13
C16B-18.	PLACING OF CONCRETE	C16B-13
C16B-19.	WARNING TAPE	C16B-14
C16B-20.	BACKFILLING	C16B-14
C16B-21.	RESERVED	C16B-14
C16B-22.	INSPECTION AND TESTING	C16B-14
C16B-23.	CLEANING OF DUCTS	C16B-15
C16B-24.	HANDLING AND INSTALLATION OF CABLE	C16B-15
C16B-25.	ACCEPTANCE TESTS OF INSTALLED CABLE	C16B-16
C16B-26.	REPLACING DEFECTIVE CABLE	C16B-16
C16B-27.	SPLICES AND TERMINATIONS	C16B-16
C16B-28.	MEASUREMENT AND PAYMENT	C16B-17

SECTION C16B - ELECTRICAL WORK

PART 1 - GENERAL

C16B-1. SCOPE. The work covered by this section consists of furnishing all plant, labor, equipment, and materials, except as otherwise specified, and performing all operations in connection with relocation of the Sewerage and Water Board (S&WB) feeder cables, including testing of cable, excavation and trenching, and other incidental work as may be necessary to complete the relocations, as shown on the drawings, and as hereinafter specified.

C16B-2. OVERVIEW. The Contractor is hereby advised of the existence of several Sewerage and Water Board 6,600 volt steel armored submarine primary distribution feeder cables presently installed on the existing sheet pile wall or buried in the levee which must be protected throughout the course of the work and/or replaced with new feeder cables as shown on the plans. Feeder 340 was installed in 1969, Feeder 400 was installed in 1959, and feeder 422 was installed in 1953.

C16B-2.1 The feeders are vital to the drainage system power distribution network of the Sewerage and Water Board and are intended to remain serviceable throughout the term of the contract. Clearance for personnel protection will be required daily using the following procedure:

C16B-2.1.1 The Contractor shall contact the Sewerage and Water Board Power Dispatcher at 865-0575 as early as possible each day he intends to perform work in close proximity to the feeders and desires clearance for protection of his personnel and equipment. The power dispatcher will either advise the Contractor that prevailing weather conditions prevent clearance of the feeders, or will deenergize the feeders and sign same out to the Contractor representative's name. No attempt to restore power can be made unless the Contractor representative's name has been personally removed from the feeder through the Power Dispatcher's office. Additionally, Corps of Engineers safety requirements necessitate the use of lockout/tagout procedures in compliance with the October 1992 edition of EM 385-1-1. Lockout/tagout procedures shall be developed in conjunction with S&WB.

C16B-2.1.2 The Contractor shall maintain a telephone at the job site at which he can be reached during the day should emergency conditions arise which will require reenergization of the feeder.

C16B-2.1.3 At the expiration of each day that the feeders have been cleared, the Contractor's representative shall call the Power Dispatcher and remove his name from the feeders. Test power will be applied to the feeders to verify their integrity and service ability.

C16B-2.1.4 The Contractor shall furnish, in addition to the job site telephone number, both his home number and that of his immediate supervisor.

C16B-2.2 Other clearance and sign-up requirements may be made by the Power Dispatcher and shall be adhered to by the Contractor if conditions warrant a deviation from the procedures outlined above.

C16B-2.3 Be advised that the S&WB may deny a de-energizing request due to prevailing weather conditions and such denial may impact work dependent on de-energization or movement of the feeder.

C16B-2.4 Power outages required by Contract No. 2 will take precedence over those required by Contract No. 3. Construction for Contract No.2 should be finished by June 1995.

C16B-3. SCHEDULING OF WORK.

C16B-3.1 The Contractor is hereby advised that continuous and proper operation of the London Ave. Canal Pumping Station are vital to the Health, Safety, and Welfare of the Orleans District of the City of New Orleans. The Contractor shall perform no work or cause any equipment or system outage which may jeopardize the operation of the station or of the electrical feeders indicated on the plans.

C16B-3.2 Feeder outages are required and shall be allowed to complete the work of this contract. The Contractor shall coordinate his work leading up to and during said outages with the S&WB who shall be given 48 hours minimum advanced notice of his desire to schedule an outage, and shall abide by the particular cautions, requirements, and possible restrictions set by the S&WB. Special permission must be granted for feeders to be left de-energized for more than an eight hour workday.

C16B-4. APPLICABLE PUBLICATIONS. The publications listed below, form a part of this specification to the extent referenced. The publications are referred to in the text by the basic designation only.

C16B-4.1 Institute of Electrical and Electronics Engineers (IEEE) Standard.

No. 142-1982

Recommended Practice for Grounding of
Industrial and Commercial Power Systems

C16B-4.2 National Fire Protection Association (NFPA)
Publication.

70-1990
& Errata

National Electrical Code

C16B-4.3 Underwriters Laboratories Inc. (UL) Publications.

Electrical Construction Materials Directory (May 1987)

UL 1072-86

Medium-Voltage Power Cables

C16B-4.4 American Society of Testing and Materials (ASTM).

B 8-86

Concentric -Lay-Stranded Copper
Conductors, Hard, Medium Hard, or Soft

C16B-4.5 Industrial Cable Engineers Association, Inc.
(ICEA).

A-68-516

C16B-5. GENERAL.

C16B-5.1 Rules. The installation shall conform to the requirements of NFPA 70, unless more stringent requirements are indicated herein or shown.

C16B-5.2 Coordination. The drawings indicate the extent and the general location and arrangement of equipment, conduit, and wiring. The Contractor shall become familiar with all details of the work and verify all dimensions in the field so that the equipment will be properly located and readily accessible. If any conflicts occur necessitating departures from the drawings, details of and reasons for departures shall be submitted to the Contracting Officer for approval prior to implementing any change.

C16B-5.3 Standard Products. Material and equipment shall be a standard product of a manufacturer regularly engaged in the manufacture of the product and shall essentially duplicate items that have been in satisfactory use for at least 2 years prior to bid opening.

C16B-6. APPROVAL OF MATERIALS AND EQUIPMENT. Materials and equipment will be approved based on the manufacturer's published data.

C16B-6.1 Underwriters Laboratories Inc. (UL) Publications. The label or listing of the Underwriters Laboratories Inc., will be accepted as evidence that the materials or equipment conform to the applicable standards of that agency. In lieu of this label or listing, the Contractor shall submit a statement from a nationally recognized, adequately equipped testing agency indicating that the

items have been tested in accordance with required procedures and that the materials and equipment comply with all contract requirements.

C16B-6.2 Non-Underwriters Laboratories Inc. (UL) Publications. For other than equipment and materials specified to conform to UL publications, a manufacturer's statement indicating complete compliance with the applicable Federal Specification, or standard of the American Society for Testing and Materials, National Electrical Manufacturers, or other commercial standard, is acceptable.

C16B-6.3 Shop Drawings. Shop drawings shall be submitted to the Contracting Officer for approval and shall consist of a complete list of equipment and materials, including manufacturer's descriptive and technical data; catalog cuts; and any special installation instructions that may be required. A plan of operation for moving the feeders to their temporary and permanent locations shall be included.

C16B-6.4 Hazardous Energy Control Plan. The Contractor shall develop and submit a hazardous energy control plan. Requirements are specified in EM 385-1-1, October 1992 edition. Lockout/tagout procedures shall be developed in conjunction with S&WB.

C16B-7. RESERVED.

C16B-8. MATERIALS AND WORKMANSHIP.

C16B-8.1 All materials and equipment shall be new and unused, shall comply with all applicable standards of IEEE, ANSI and NEMA, and shall bear the approved device label of the Underwriter's Laboratories, Inc., if such equipment or materials has been tested and listed by UL.

C16B-8.1.1 The work as installed is subject to the approval of the Contracting Officer and the Sewerage and Water Board. Workmanship shall be of the highest quality conforming to the best electrical installation practice. Any work or material which is rejected must be removed immediately and replaced. No sub-standard work will be accepted. It is the intent of these specifications to receive work of the highest caliber and degree of workmanship. All work shall be performed in a workmanlike manner utilizing the highest standards and procedures currently in effect.

C16B-8.1.2 The Contractor shall continuously maintain adequate protection of all his work from damage and shall protect S&WB property from injury arising in connection with his work. He shall assume cost for repair of any such damage, injury, or loss.

He shall adequately protect adjacent properties and facilities of other owners. A plan for protecting the feeders during construction activities shall be developed and submitted for approval.

PART 2 - PRODUCTS

C16B-9. CONCRETE. All concrete used for feeder encapsulation shall be 1500 psi, colored red by ten (10#) pounds dye mixed per cubic yard of concrete. Mixing shall be accomplished in the truck.

C16B-10. WARNING TAPE. A 6-inch wide brilliant yellow or orange polyethylene tape shall be installed above underground cables a maximum of 8-inches below grade. Tape shall be imprinted "Caution Sewerage and Water Board Buried Electric Line Below". The tape shall be ITT Blackburn UT6, or approved equal.

C16B-11. CONDUIT.

C16B-11.1 Conduit shall be rigid, heavywall, hot-dipped zinc galvanized steel conduit. All threads shall be galvanized after cutting. Conduit shall bear the UL label and shall conform to UL and ANSI C 80.1.

C16B-11.2 All nuts, bolts, washers, fasteners, etc., shall be brass or type 316 stainless steel. Plated or bare steel hardware shall not be used.

C16B-11.3 Provide galvanized steel end bells at each end of conduit duct to prevent damage to new cable when pulling cable through conduit.

C16B-12. MEDIUM VOLTAGE CABLE.

C16B-12.1 Medium Voltage 15 KV Power Cable shall be a 3/C, #500 MCM, 37 strands, uncoated bare copper, .020" extruded semiconducting strand shield, .220" Okoguard EPR Insulation, .040" extruded semiconducting insulation shield, longitudinal Black-White-Blue .188"x.002" Polyester Strips, .005" bare copper tape shield 12.5% overlap, cabled with moisture resistant fillers RF tape, neoprene filled cloth binder tape, .110" copper bearing lead, .095" Okoseal Flame Retardant PVC jacket suitable for CT use, 15 KV, and 133% Insulation Level.

C16B-12.2. All cable furnished shall comply with all applicable paragraphs of C16B-13. Submittal data shall be complete with all necessary data sheets, documentation, specifications, etc., necessary and proper to show complete compliance with the detailed specifications, including compliance with all guaranteed test values.

C16B-12.3. Cable as specified above shall be as manufactured by the Okonite Company of Ramsey, New Jersey, or Approved Equal. Bidders are advised that cross-linked Polyethylene Cables or Cables offering drain wire shielding or non-extruded semiconductors is not considered equal and will not be accepted. Cables conforming to the extrusion requirements of conductor semicon/insulation/insulation semicon screen but which utilize construction methods other than single-pass triple tandem extrusion will not be accepted.

C16B-12.4 All cable shall be manufactured in the United States. Foreign manufactured cable will not be accepted. Cables offering insulation material compounded outside the United States will be considered foreign and will not be accepted.

C16B-13. DETAILED MEDIUM VOLTAGE CABLE SPECIFICATIONS.

C16B-13.1 General Cable Description.

C16B-13.1.1 Basic cable construction shall consist of stranded copper conductors, extruded semiconducting thermosetting strand screen, extruded ethylene propylene rubber insulation, extruded semiconducting thermosetting insulation screen (strand screen, insulation, and insulation screen shall be applied in the triple extrusion process), uncoated copper shielding tape, necessary fillers and overall lead covering with PVC outer jacket.

C16B-13.1.2 Cable shall be single conductor Type MV-90 shielded copper medium voltage 15 KV at 133% insulation levels. UL listed as Type MV-90 rated as 90°C normal continuous, 130°C emergency and 250°C short circuit.

C16B-13.2 Conductors. The conductor shall be uncoated copper, Class B stranded as per ASTM B-8 with 37 strands and shall comply with the requirements of UL1072, ICEA S-68-516 and AEIC CS6.

C16B-13.3 Insulation System. The conductor insulation system shall be composed of an extruded strand screen, extruded EPR insulation, and extruded thermosetting insulation screen, all applied in a single pass utilizing the triple extrusion process.

C16B-13.3.1 Strand Screen. The strand screen shall consist of an ethylene propylene rubber based extruded semiconducting thermosetting compound applied over the conductor. The screen shall be clean stripping from the conductor and inseparable bonded to the overlaying insulation.

The thickness of the conductor screen shall be 20 mils with an 80% minimum point.

The D-C volume resistivity of the extruded conductor shield shall not exceed 50 meter-ohms at 90 degrees C when tested.

The strand screen shall meet the requirements of ICEA S-68-516, AEIC CS6 and UL 1072.

C16B-13.3.2 Insulation. The insulation shall be a flexible thermosetting high dielectric strength compound based on an ethylene-propylene elastomer.

It shall be contrasting in color from the extruded strand and the insulation screens and shall be compliant with the physical and aging requirements specified hereinafter. The ethylene content of the elastomer used in the insulation compound shall not exceed 72% by weight of ethylene to limit the degree of susceptibility to treeing experienced by highly crystalline materials.

The minimum average thickness of the insulation shall not be less than 220 mils.

C16B-13.3.3 Insulation Screen. The insulation screen shall consist of an ethylene propylene rubber based semiconducting thermosetting compound applied over the insulation with a volume resistivity not in excess of 75 ohm-meters at 90 degrees C when tested per AEIC CS-6.

The extruded screen shall be clean stripping and shall have a peel strength from the insulation between 6 and 18 lbs./0.5-inch width when tested per AEIC CS-6.

The thickness of the extruded screen shall be 50 mils with an 80% minimum point.

The entire thickness of the insulation screen shall be contrasting in color from the insulation.

C16B-13.4 Metallic Shield. The outer insulation screen shall be covered with a 5 mil copper tape shield. It shall be applied helically with 12½% nominal overlap. Standard tape shields shall be uncoated copper, shielding on cable rated for Tray Service shall be tinned, coated copper tape.

C16B-13.5 Jacket. The overall jacket shall be polyvinyl chloride with 110 mil jacket thickness, applied over 0.110-inch lead covering.

C16B-13.6 Operating Experience. The medium voltage power cable shall have a performance record demonstrating a minimum of fifteen (15) years successful operation experience in utility and industrial power cable applications.

C16B-13.7 Cable Identification. Cable shall be identified in accordance with AEIC-CS6. Cable surface shall be printed with manufacturer's identification, type of insulation, size of conductor, rated voltage, year of manufacture, insulation thickness and UL listing.

C16B-14. GROUNDING. Except where specifically indicated otherwise, all exposed noncurrent carrying metallic parts of electrical equipment, metallic raceway systems, and neutral conductor of the wiring system shall be grounded.

C16B-15. TESTS. After the wiring system installation is completed, and at such time as the Contracting Officer may direct, the Contractor shall conduct an operating test for approval. The equipment shall be demonstrated to operate in accordance with the requirements of this specification. The test shall be performed in the presence of the Contracting Officer. The Contractor shall furnish all instruments and personnel required for the tests, and the S&WB will furnish the necessary electric power.

C16B-15.1 Routine Tests of Factory Reel Lengths.

C16B-15.1.1 Conductor Resistance. Conductor DC resistance shall comply with UL 1072, IECA S-68-516, and AEIC CS6 requirements as applicable.

C16B-15.1.2 Production Tests.

C16B-15.1.2.1 Conductors shall meet the electrical resistance requirements of ICEA S-68-516 Section 2.5.

C16B-15.1.2.2 Insulation Resistance test shall be performed in accordance with requirement of ICEA S-68-516, Part 6.28. Each cable shall have an insulation resistance not less than that corresponding to the insulation resistance constant of at least 50,000 megohms-1000-feet at 15.6°C.

C16B-15.1.2.3 A high voltage AC and DC test shall be performed in accordance with Part 6.27 of ICEA S-68-516 at the AC and DC test voltage given in Table V below.

C16B-15.1.2.4 Each reel of completed cable shall withstand for a period of 5 minutes the 60 cycle AC test voltage and a period of 15 minutes the D.C. test voltage. The completed cable shall be tested with the voltage applied between conductor and shield with the cable in air in accordance with ICEA, UL and AEIC standard as applicable.

C16B-15.1.2.5 Shield resistance is measured and recorded from end to end on the completed cable.

TABLE V

Rated Voltage KV	Insulation Thickness	5 Minute A.C. Withstand Test KV	15 Minute D.C. Withstand Test KV
	133% Level	133% Level	133% Level
15	220	33	80

C16B-15.1.3 Corona Test. Each reel of completed cable shall be subjected to the partial discharge extension level test performed in accordance with the test procedure described in Section G of AEIC AS6. The partial discharge in picocoulombs shall not exceed the values in the following Table VI.

TABLE VI

Picocoulombs	5	5	20	35	50
All Voltage					
Rated Cable Voltage (KV)	Corresponding Test Voltage (KV)				
15	8.5	13.0	17.5	21.5	26.0

C16B-15.1.4 Test Reports.

C16B-15.1.4.1 Manufacturer shall furnish one (1) certified copy of test results for all routine and factory production tests, as specified above, for approval prior to shipment. Test results shall clearly indicate compliance or the cable shall be rejected as unsuitable for use.

C16B-15.1.4.2 Any cable shipped and/or installed without acceptance by the Contracting Officer and S&WB shall be rejected and no payment shall be made therefor.

PHYSICAL AND ELECTRICAL CHARACTERISTICS OF ETHYLENE PROPYLENE RUBBER DIELECTRIC

When samples from completed cable are tested in accordance with the ICEA specifications, the vulcanized insulation shall meet the following values:

	<u>ICEA</u>	<u>Guaranteed</u>
1. Physical Requirements Unaged		
Tensile min. psi @ 15.6C	700	1200
Elongation % min.	250	250
200%, Modulus, psi min. @ 15.6C	N.R.	600

PHYSICAL AND ELECTRICAL CHARACTERISTICS OF
ETHYLENE PROPYLENE RUBBER DIELECTRIC (CONTINUED)

2.	Aging Requirements		
	After Air Oven for 168 hrs @ 121C		
	Tensile, % of unaged, min.	75	90
	Elongation % of unaged, min.	75	85
3.	Ozone Resistance		
	After 24 hrs. @ 0.025 to 0.030%	N.R.	No Cracks
4.	Dielectric Traits @ 15.6 C		
	SIC @ 80V/mil, max.	4	3
	% Power Factor @ 80V/mil max.	2	1
	IR Constant (K) min.	20,000	50,000
5.	Electrical Traits @ 90C		
	After 24 hrs. water immersion @ 90C	N.R.	
	SIC, 80V/mil max.		3
	% pf		1.5
	After 26 wks. water immersion @ 90C	N.R.	
	SIC, 80V/mil max.		3.1
	% pf		1.5
	Stability Factor		
	(pf @ 80-40V/mil) max.		0.2
6.	Mechanical Water Absorption		
	168 hrs @ 70C, mg./sq. in, max.	N.R.	5
7.	Accelerated Water Absorption		
	EM60-75C		
	SIC after 24 hrs. max	4	4
	Increase in SIC, % max.		
	1-14 days	3.5	3.5
	7-14 days	1.5	1.5
	Stability Factor after 14 days max.	1.0	1.0
	Alternate to Stability Factor		
	1-14 days max.	0.5	0.5
8.	Degree of Cure		
	Heat distortion, % max.		10
	Hot Creep, % Elongation max.	50	50
	Set, % max.	5	5

PHYSICAL CHARACTERISTICS OF
POLYVINYLCHLORIDE JACKET

When tested in accordance with the ICEA specifications, the jacket shall meet the following values:

	<u>ICEA</u>	<u>Guaranteed</u>
1. Physical Requirements Unaged		
Tensile min. psi	1500	1500
Elongation min. %	100	100
2. Aging Requirements		
After Air Oven for 120 hrs @ 100C		
Tensile, min. % of unaged	85	85
Elongation, min. % of unaged	60	60
3. Oil Immersion Requirements		
In ASTM #2 Oil for 4 hrs. @ 70C		
Tensile, min. % of unaged	80	80
Elongation, min. % of unaged	60	60
4. Heat Distortion		
Air Oven, 1 hr. @ 121C, % max.	50	50
5. Heat Shock		
Air Oven, 1 hr. @ 121C	No Cracks	No Cracks
6. Cold Bend		
After one hr. @ -35C	No Cracks	No Cracks

PART 3 - EXECUTION

C16B-16. TEMPORARY REMOVAL OF S&WB FEEDER CABLE FROM SHEETPILE WALL.

C16B-16.1 Feeder Cable Relocations.

C16B-16.1.1 Feeder 340. From Stations 70+20.27 to 84+40.35 EB/L and Stations 85+50.38 to 99+91.07 EB/L, the Contractor shall temporarily relocate cable from its existing position into a trench on the canal side of the existing floodwall as indicated on the drawings. From Stations 99+91.07 to 100+17.54 EB/L, the underground existing cable will remain in its existing position and the Government Contractor shall relocate it to a permanent position after constructing the new floodwall as shown on the drawings. Subsequent to floodwall construction, relocate cable from the trench to a permanent position on the new floodwall. Splices will be required in the cable as shown on the drawings.

C16B-16.1.2 Feeder 400. From Sta. 70+37.50 to Sta. 84+64.22 WB/L and stations 85+80.50 to 101+47.29 WB/L, the Contractor shall temporarily relocate cable from its existing position into a trench on the canal side of the existing floodwall as indicated on the drawings. Splices will be required in cable as shown on the drawings. Subsequent to floodwall construction, relocate cable from the trench to a permanent position on the new floodwall.

C16B-16.1.3 Feeder 422. From Sta. 99+99.23 to 101+38.90 WB/L, the Contractor shall temporarily relocate cable from its existing position on existing concrete slope pavement on the canal side of the existing floodwall as indicated on the drawings. From Sta. 99+88.47 to Sta. 100+17.54 EB/L, the underground existing cable will remain in its existing position. Splices will be required in cable as indicated on the drawings. Subsequent to floodwall construction, relocate cable from the existing position to a permanent position as shown on the drawings. The Contractor shall protect FL-422 on canal side of west bank by providing split galvanized steel casing with clamps. The steel casing shall be of sufficient diameter and strength and details shall be submitted to the Contracting Officer for approval.

C16B-16.1.4 Feeder 422. The existing feeder crosses thru the concrete collar of I-wall at approximate Station 101+38.90 WB/L. The cable crossing through I-wall shall be done according to the details shown on the drawings.

C16B-16.1.5 Feeder 432. from Sta. 70+00.00 to Sta. 99+97.00 EB/L the existing feeder 432 runs under the east bank levee on land side of the existing floodwall. The Contractor shall locate this cable prior to setting the fence posts for the temporary construction fence.

C16B-16.1.6 The Contractor shall note that the temporary and permanent location of FL-340, FL-400, and FL-422 may require short lengths of new conduit and cable with splices. Any required additional lengths of conduit, cable and resulting splices, shall be provided at no additional cost to the Government. the Contractor has an option to submit other alternatives to temporarily relocate feeder lines for the Contracting Officer's approval.

C16B-16.2 Care shall be taken to avoid excessive or erratic movement of the feeder with special attention paid to the existing splices which cannot withstand any great degree of movement or bending. Any existing splices damaged shall be repaired by the Contractor, at no expense to the Government. As the work removing the existing sheetpile wall cap progresses, the Contractor shall cover the lowered feeder with a strip of $\frac{1}{2}$ -inch thick steel plate of width sufficient to span the slot created for the feeder. A thermal insulation blanket shall be laid over the plate and shall

be placed between the feeder and the sheet piling to protect the cable from heat created by cutting of the wall below the concrete cap. The wall shall be cut-off where indicated on the drawings.

C16B-16.3 The Contractor is cautioned to use extreme care in lifting each cap section away from the sheet piling so that the cap cannot fall in close proximity to the feeder, or in any way bear directly upon the cable.

C16B-16.4 After completion of the work of cap removal and construction of the new floodwall, the Contractor shall reattach the feeders to the new floodwall. For Feeder Lines 400, 422, and 340, attachment to the wall shall be by means of 5-inch trade size malleable iron conduit one hole clamp with clamp back. The clamps shall be spaced on a maximum of 4-foot centers along the entire length of the cable. Clamps shall be attached to the wall with 5/8-inch high strength corrosion resistant steel bolts, lockwashers, and nuts.

C16B-16.5 Clamps shall be provided as required, in addition to those specified above, to support any existing splices. These clamps shall be placed within 12-inches of the splice on both sides. Sufficient buildup of spacers shall be used to allow clamp contact with the feeder without causing deflection of the cable in the areas of the whipping joints. Bolt length shall be increased accordingly.

C16B-16.6 After final positioning of the feeder, the Contractor shall replace levee fill material which was originally moved.

C16B-17. CABLE LENGTHS. The Contractor shall verify all cable measurements between cable splices including allowance for cable elevation changes, and shall be responsible for the correctness of the cable lengths prior to purchase of cable. No extra charge or compensation will be allowed because of any difference between the actual measurements and those indicated on the drawings or estimated in these specifications. Any difference which might be discovered by the Contractor shall be submitted to the Contracting Officer before proceeding with the work.

C16B-18. PLACING OF CONCRETE.

C16B-18.1 FL-422 and FL-340 on eastside shall be encapsulated in 1500 psi light weight concrete from approximate Stations 99+88.47 EB/L to 100+17.54 EB/L. FL-422 on westside shall be encapsulated in 1500 psi light weight concrete on land side of new floodwall at approximate Station 101+38.90 WB/L. The Contractor shall match existing encapsulated concrete for FL-422.

C16B-18.2 No concrete for encapsulating feeders shall be poured without the S&WB and Contracting Officer or his representative in attendance. All newly installed or disturbed buried feeders shall be encapsulated in concrete.

C16B-18.3 Prior to pouring, the trench shall be completely de-watered and shall be maintained free of standing water until concrete has been placed.

C16B-18.4 The concrete for cable wrapping may be placed in the trench without the use of forms; but if, for his own convenience, the Contractor desires to use forms, no payment will be made therefor. Where the Contractor has carried his excavation outside the lines of the work as established by the drawings, the Contractor shall either use forms or pour concrete the full width of the excavation without additional payment for the additional forms or concrete required therefor.

C16B-19. WARNING TAPE. Installation of tape shall be witnessed by a representative of the S&WB and the Corps.

C16B-20. BACKFILLING. The Contractor shall backfill the trench and all excavated areas. Backfill shall be applied in 6-inch layers and shall be thoroughly tamped as each layer is applied. Density of compacted backfill material shall equal or exceed that of surrounding undisturbed ground.

C16B-20.1 The Contractor shall return the surface to match existing surroundings.

C16B-20.2 The Contractor shall remove all debris and excavated material from job site and completely clean project area.

C16B-20.3 All sheeting, rangers, braces used for the purpose of bracing and protecting the trench excavation shall be removed prior to backfilling. The excavation shall be completely filled to proper grade as specified herein.

C16B-21. RESERVED.

C16B-22. INSPECTION AND TESTING.

C16B-22.1 All work will be inspected by the Contracting Officer and S&WB Engineer. The Contractor shall conduct phase-out test on the feeder after completion of all splicing and terminating. The Contractor shall be liable for any necessary rearrangement, extensions, etc., if not in phase.

C16B-22.2 Phase Testing requires the connection of three (3) potential transformers, furnishing by the S&WB, across an open circuit breaker with the transformer primary leads spanning the open circuit. Two (2) sources of generation are applied to the

open breaker and if in phase, secondary connected lights will alternate from bright to dark simultaneously. The Contractor's responsibility is to connect the potential transformer leads as directed and replace and insulate the feeder connections after testing is complete. Contractor shall also be responsible for pick up and return of potential transformers at S&WB Electric Shop, 8801 Spruce St., New Orleans, LA.

C16B-23. CLEANING OF DUCTS.

C16B-23.1 The new ducts are composed of 5-inch heavy wall galvanized steel conduits as shown on the plans.

C16B-23.2 The Contractor shall flush the new ducts using water from nearest available supply or Hydrant until thoroughly cleaned. Contractor shall then swab out all ducts to remove any residual dirt and debris. Contractor shall then pull a full size solid Mandrell through each duct prior to insertion of cable.

C16B-23.3 The Contractor shall cap or plug the cleaned ducts to prevent entry of foreign matter, water, dirt, debris, etc. prior to installation of the cable.

C16B-24. HANDLING AND INSTALLATION OF CABLE.

C16B-24.1 The Contractor shall pull all cable into cleaned and prepared ducts using natural fiber, polyethylene, nylon, etc. rope only; wire rope or steel cable will not be allowed.

C16B-24.2 Cable shall be effectively lubricated using wire pulling compound, such as Ideal Yellow 77, or equal, approved for the particular type and form of cable insulation and jacket. No oil or grease shall be used.

C16B-24.3 The Contractor shall provide and construct all rigs, braces, anchors, sheaves, etc. necessary to pull the cable into the ducts without excess strain or exceeding the bending radius of the conductor. The cable or conductors shall be installed in such manner and by such methods as to insure against damage to the insulation, damage to the outer jacket, or stretching of the conductor.

C16B-24.4 Cable shall be pulled directly from reels supported on Reel Dolly or jack stands. Each reel of lead covered cable shall have a special Pulling Eye Attachment (Catalog No. (MPE-3/C-50-SN) as manufactured by the Okonite Co. or Approved Equal to facilitate careful handling of cable during the critical pulling phase of cable installation. The pulling eye attachment shall be furnished and installed by the cable manufacturer. Contractor shall not unreel cable on the ground or street and pull therefrom. All pulling shall be directly on the copper conductors-basket type pulling grips are unaccepted.

C16B-25. ACCEPTANCE TESTS OF INSTALLED CABLE. The Contractor shall supply all labor and equipment required for D.C. Hi-Pot testing of all new medium voltage cable installed on this project and the initial energization of this cable as directed by the Sewerage and Waterboard. The Hi-Pot testing shall be done in strict accordance with the cable manufacturer's field testing recommendations and the following:

C16B-25.1. Voltage shall be applied to each cable in steps until the final test voltage is reached. Leakage current shall be read and recorded at each voltage level. 15 Kv cable test voltage shall be 55 Kv DC, maximum.

C16B-25.2. After reaching the final level of test voltage, the voltage shall be held for a minimum of fifteen (15) minutes and the leakage current read and recorded every minute.

C16B-25.3. The Contracting Officer and S&WB shall witness the Hi-Pot testing and shall be notified at least twenty-four (24) hours prior to the scheduled start of such tests.

C16B-25.4. Leakage current readings shall be recorded for each increment of the voltage step increase and at one (1) minute intervals during the fifteen (15) minute hold period at the final voltage level. The resulting test reports shall be submitted to the Contracting Officer.

C16B-26. REPLACING DEFECTIVE CABLE.

C16B-26.1 Where the cable proves defective by test after installation, the Contractor shall remove and reinstall as much of its length as is necessary in order to eliminate the defect.

C16B-26.2 The Contractor shall bear all costs associated with furnishing and installing new cable, and shall perform any and all necessary splicing at no cost to the Government.

C16B-27. SPLICES AND TERMINATIONS.

C16B-27.1 The Contractor shall make all splices and terminations, unless noted otherwise on the drawings.

C16B-27.2 He shall use on the cable manufacturer's recommended or furnished kits. He shall use sleeves which are crimped with a hydraulic machine only. The Contracting Officer and Sewerage and Water Board reserves the right to accept or reject the splicer and his equipment, event if a splice is in progress. Splice kits shall be submitted for approval prior to beginning any splices.

C16B-27.3 Splice kits and all splicing tools and equipment shall be presented for inspection twenty-four hours before starting work.

C16B-27.4 If the kits or tools and equipment are not suitable or are inadequate in amount and condition, the splicer shall not start work until the deficiencies have been corrected to the satisfaction of the Contracting Officer.

C16B-27.5 Each 15 KV cable splice shall be encased in a lead sleeve with a single opening on each end to accommodate the lead jacket cable which is wiped on both ends. Three (3) conductor lead covered 15 KV splice kits manufactured by Mac Products, Inc. shall be used.

C16B-27.6 The lead wipe shall be accomplished using the hand wipe Solder Method. Sealing of splice sleeve to lead jacketing by use of bar or string solder applied with a torch will not be permitted.

C16B-27.7 The splicer must have made splices of the same type and voltage range in the last five years to be acceptable.

C16B-27.8 The name, address and telephone number of the splicers shall be furnished to the Contracting Officer. Training record and splicing record, with the name of the person responsible for the electrical installation, shall be submitted two weeks prior to any splicing or termination work.

C16B-27.9 Once a splice has begun, it shall be worked until completed. The Contractor shall be responsible for all splices for a period of one year after completion of contract.

C16B-27.10 Refer to detail on following page for lead covered 15 KV 3/C cable splice, suitable for direct burial.

C16B-28. MEASUREMENT AND PAYMENT. Modifications to and replacement of existing S&WB feeder lines will not be measured for payment. Payment for the electric feeder line relocations will be made at the applicable contract lump sum price for "Temporary Relocation Of Feeder Lines", and "Permanent Relocation Of Feeder Lines". Prices and payment shall constitute full compensation for furnishing all labor, equipment, and materials required to perform the work specified above. Contractors price shall include all work relating to feeder relocations and to new feeders and splices as specified.

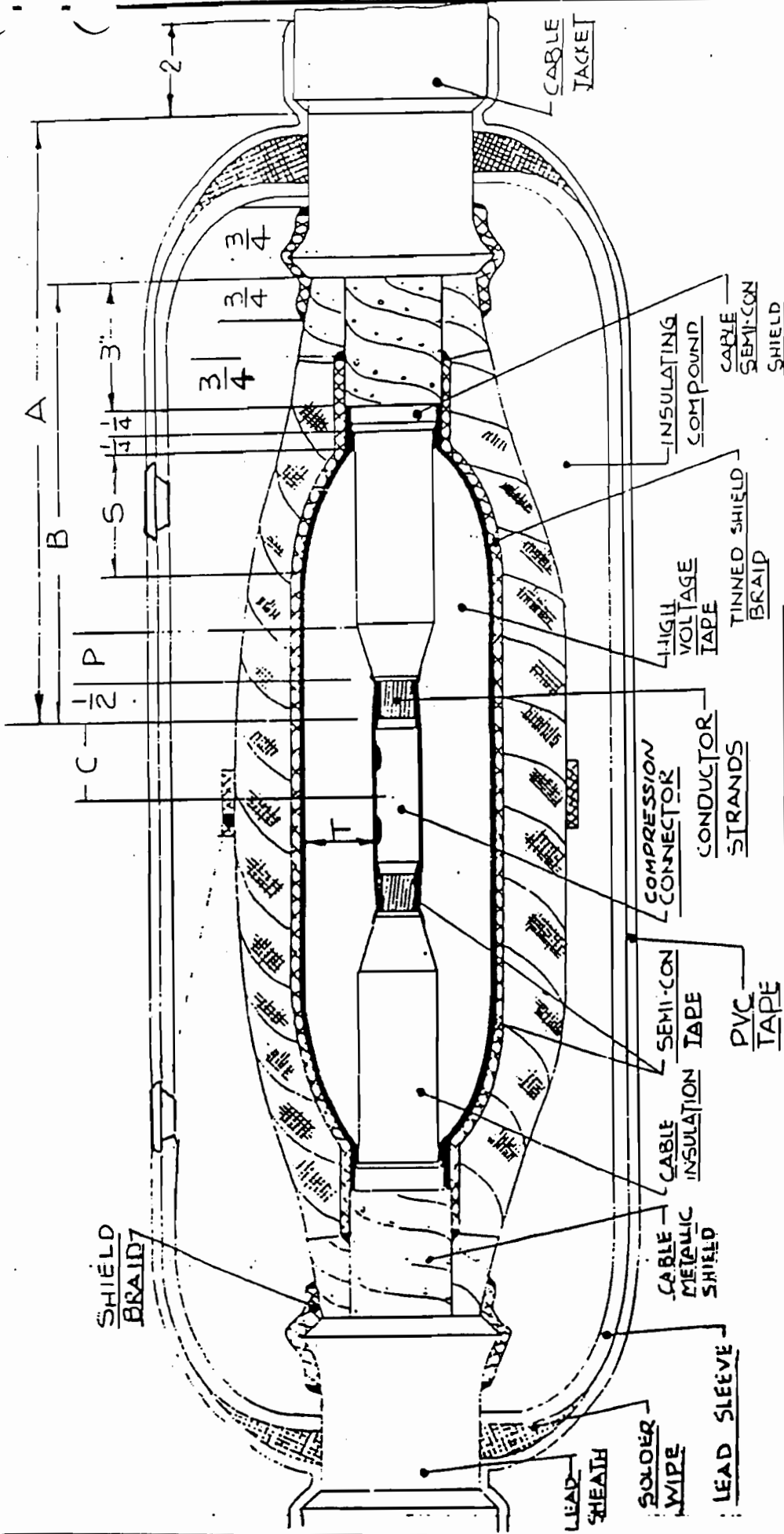

VOLTAGE	A	B	C	S	P	T
15kv. ungr.	15"	9 1/4"	1 1/8"	3 1/4"	2"	3/8"

STRAIGHT SPICE 3/8 POLYMERIC INSULATED,
LEAD COVERED, SHIELDED

NOTE: SIZE CABLE SLEEVE FOR 400 MCM X 500 MCM.

INDEX

SECTION H - SPECIAL CLAUSES

Para. No.	Paragraph Title	Page No.
H-1	COMMENCEMENT, PROSECUTION, AND COMPLETION OF WORK	H-1
H-2	LIQUIDATED DAMAGES	H-1
H-3	CONTRACT DRAWINGS, MAPS AND SPECIFICATIONS	H-1
H-4	CONTRACTOR QUALITY CONTROL	H-2
H-5	EQUIPMENT OWNERSHIP AND OPERATING EXPENSE SCHEDULE	H-8
H-6	PHYSICAL DATA	H-9
H-7	LAYOUT OF WORK	H-10
H-8	QUANTITY SURVEYS	H-10
H-9	DAMAGE TO WORK	H-10
H-10	SAFETY PROVISIONS	H-10
H-11	INSPECTOR'S FIELD OFFICE	H-15
H-12	CONSTRUCTION SIGNS	H-16
H-13	RIGHTS-OF-WAY	H-17
H-14	SUBMITTALS	H-18
H-15	CERTIFICATES OF COMPLIANCE	H-18
H-16	RESERVED	H-19
H-17	COMMERCIAL WARRANTY	H-19
H-18	PAYMENT FOR MOBILIZATION AND DEMOBILIZATION	H-19
H-19	ENVIRONMENTAL LITIGATION	H-19
H-20	TIME EXTENSIONS FOR UNUSUALLY SEVERE WEATHER	H-20
H-21	PERFORMANCE OF WORK BY CONTRACTOR	H-21
H-22	UTILITIES AND IMPROVEMENTS	H-21
H-23	PERMISSIBLE HOURS OF OPERATION	H-22
H-24	HANDBOOK FOR CONCRETE AND CEMENT	H-22
H-25	AGGREGATES SOURCES	H-22
H-26	CONTINUING CONTRACTS	H-24
H-27	STONE SOURCES	H-25
H-28	RESERVED	H-27
H-29	RESERVED	H-27
H-30	TRAFFIC CONTROL	H-27
H-31	FLOOD PROTECTION PLAN	H-29
H-32	COORDINATION OF WORK	H-30
H-33	ORDER OF WORK	H-32

SECTION H - SPECIAL CLAUSES

H-1 COMMENCEMENT, PROSECUTION, AND COMPLETION OF WORK (FAR 52.212-3 - 1984 APR). The Contractor shall be required to (a) commence work under this contract within 10 calendar days after the date the Contractor receives the notice to proceed, (b) prosecute the work diligently, and (c) complete the entire work ready for use not later than 540 calendar days after the date of receipt by him of notice to proceed. The time stated for completion shall include final cleanup of the premises.

H-2 LIQUIDATED DAMAGES. (FAR 52.212-5 - 1984 APR).

a. If the Contractor fails to complete the work within the time specified in the contract, or any extension, the Contractor shall pay to the Government as liquidated damages, the sum of \$_____ for each day of delay.

b. If the Government terminates the Contractor's right to proceed, the resulting damage will consist of liquidated damages until such reasonable time as may be required for final completion of the work together with any increased costs occasioned the Government in completing the work.

c. If the Government does not terminate the Contractor's right to proceed, the resulting damage will consist of liquidated damages until the work is completed or accepted.

H-3 CONTRACT DRAWINGS, MAPS AND SPECIFICATIONS. (DFARS 252.236-7001 - 1991 DEC).

a. The Government--

(1) Will provide the Contractor, without charge, five sets (unless otherwise specified) of large-scale contract drawings and specifications except publications incorporated into the technical specifications by reference;

(2) Will furnish additional sets on request, for the cost of reproduction; and

(3) May, at its option, furnish the Contractor one set of reproducible, or half-size drawings, in lieu of the contract drawings in paragraph a.(1) of this clause.

b. The Contractor shall--

(1) Check all drawings furnished immediately upon receipt;

(2) Compare all drawings and verify the figures before laying out the work;

(3) Promptly notify the Contracting Officer of any discrepancies; and

(4) Be responsible for any errors which might have been avoided by complying with this paragraph b.

c. Large scale drawings shall, in general, govern small scale drawings. Figures marked on drawings shall, in general, be followed in preference to scale measurements.

d. Omissions from the drawings or specifications or the misdescription of details of work which are manifestly necessary to carry out the intent of the drawings and specifications, or which are customarily performed, shall not relieve the Contractor from performing such omitted or misdescribed details of the work, but shall be performed as if fully and correctly set forth and described in the drawings and specifications.

e. The work shall conform to the specifications and the contract drawings identified on the following index of drawings:

<u>Title</u>	<u>File No.</u> and	<u>Drawing No.</u>
Lake Pontchartrain, LA and Vicinity, High Level Plan, London Ave. Outfall Canal, Parallel Protection, Mirabeau Ave. To Robert E. Lee Blvd., West Bank and Mirabeau Ave. To Leon C. Simon Blvd., East Bank Orleans Parish, Louisiana	H-4-40295	1 THRU 73 Ref. Dwg. R1

H-4 CONTRACTOR QUALITY CONTROL (CQC) - (16 MAY 1988).

a. General. The Contractor shall establish and maintain an effective quality control system in compliance with the Contract Clause entitled "Inspection of Construction". The quality control system shall consist of plans, procedures, and organization necessary to provide materials, equipment, workmanship, fabrication, construction and operations which comply with contract requirements. The system shall cover construction operations both onsite and offsite, and shall be keyed to the proposed construction sequence.

b. Coordination Meeting. Before start of construction, the Contractor shall meet with the Contracting Officer (CO) or his authorized representative (COR) and discuss the Contractor's quality control system. During the meeting, a mutual understanding of the system details shall be developed, including the forms for recording the CQC operations, control activities, testing, administration of the system for both onsite and offsite work, and the interrelationship of the Contractor's management and control with the Government's inspection. Minutes of the meeting shall be prepared and signed by both the Contractor and the CO or

COR. The minutes shall become a part of the contract file. There may also be occasions when subsequent conferences will be called to reconfirm mutual understandings.

c. Quality Control Plan.

(1) General. The Government will consider an interim plan for the first 30 days of operation. However, the Contractor shall furnish for approval by the Government, not later than 15 days after receipt of Notice to Proceed, the Contractor Quality Control (CQC) Plan within which he proposes to implement the requirements of Contract Clause entitled "INSPECTION OF CONSTRUCTION". The plan shall identify personnel, procedures, instructions, records, and forms to be used. If the Contractor fails to submit an acceptable QC plan within the time herein prescribed, the CO or COR may refuse to allow construction to start if an acceptable interim plan is not furnished or withhold funds from progress payments in accordance with the Contract Clause entitled "PAYMENTS UNDER FIXED-PRICE CONSTRUCTION CONTRACTS" until such time as the Contractor submits an acceptable final plan.

(2) The Quality Control Plan. This plan shall include as a minimum, the following:

(a) A description of the quality control organization, including chart showing lines of authority and acknowledgement that the CQC staff shall implement the three phase control system for all aspects of the work specified and shall report to the project manager or someone higher in the Contractor's organization.

(b) The name, qualifications, duties, responsibilities, and authorities of each person assigned a QC function.

(c) A copy of the letter to QC manager signed by an authorized official of the firm, which describes the responsibilities and delegates the authorities of the QC manager.

(d) Procedures for scheduling and managing submittals, including those of subcontractors, offsite fabricators, suppliers and purchasing agents.

(e) Control testing procedures for each specific test. (Laboratory facilities will be approved by the Contracting Officer).

(f) Reporting procedures including proposed reporting formats.

(g) A list of the definable features of work. A definable feature of work is a task which is separate and distinct from other tasks and has separate control requirements.

(3) Acceptance of Plan. Acceptance of the Contractor's plan is required prior to the start of construction. Acceptance is conditional and will be predicated on satisfactory performance during the construction. The Government reserves the right to require the Contractor to make changes in his CQC plan and operations as necessary to obtain the quality specified.

(4) Notification of Changes. After acceptance of the QC plan, the Contractor shall notify the CO in writing of any proposed change. Proposed changes are subject to acceptance by the CO or COR.

d. Quality Control Organizations.

(1) CQC System Manager. The Contractor shall identify an individual, within his organization at the site of the work, who shall be responsible for overall management of CQC and have the authority to act in all CQC matters for the Contractor. This CQC System Manager shall be approved by the CO or COR.

(2) Personnel. A staff shall be maintained under the direction of the system manager to perform all QC activities. The actual strength of the staff during any specific work period may vary to cover work phase needs, shifts, and rates of placement. The personnel of this staff shall be fully qualified by experience and technical training to perform their assigned responsibilities.

e. Submittals. Submittals shall be as specified in the Special Clause entitled "SUBMITTALS". The CQC Organization shall be responsible for certifying that all submittals are in compliance with the contract requirements.

f. Control. Contractor Quality Control is the means by which the Contractor assures himself that his construction complies with the requirements of the contract plans and specifications. The controls shall be adequate to cover all construction operations, including both onsite and offsite fabrication, and will be keyed to the proposed construction sequence. The controls shall include at least three phases of control for all definitive features of work as follows:

(1) Preparatory Inspection Phase. This phase shall occur prior to beginning any work or any definable feature of work. It shall include a review of contract requirements; a check to assure that all materials and/or equipment have been tested, submitted and approved; a check to assure that provisions have

been made to provide required control testing; examination of the work area to ascertain that all preliminary work has been completed; and a physical examination of materials, equipment and sample work to assure that they conform to approved shop drawings or submittal data and that all materials and/or equipment are on hand. The Contracting Officer's Representative (COR) shall be notified at least 24 hours in advance of beginning any of the required action of the preparatory inspection. The Contractor must submit a written agenda of the topics to be discussed at the preparatory meeting on the day prior to the meeting date. The results of the preparatory inspections shall be documented by separate minutes prepared by the CQC representative and attached to the daily QC report. Subsequent to the preparatory phase and prior to commencement of work, the Contractor shall instruct applicable workers as to the acceptable level of workmanship required in his CQC plan in order to meet contract specifications.

(2) Initial Phase. This phase must be accomplished at the beginning of the definable feature of work. This phase shall include a check of preliminary work, verify full compliance, establish level of workmanship, resolve all differences, and check safety to include compliance with hazard analysis. The Contracting Officer's representative shall be notified at least 24 hours in advance of the inspection of the initial phase. Separate minutes of this phase shall be prepared by the CQC representative and attached to the daily QC Report. The initial phase should be repeated for each new crew to work on site, or if acceptable standards of workmanship are not being met.

(3) Follow-up Phase. Daily inspections shall be performed to assure continuing compliance with contract requirements, including control testing, until completion of the particular feature of work. The inspections shall be made a matter of record in the CQC documentation as required below. Final follow up inspections shall be conducted and all deficiencies corrected prior to the start of additional work.

g. Tests.

(1) Testing Procedures. The Contractor shall perform tests specified or required to verify that control measures are adequate to provide a product which conforms to contract requirements. The Contractor shall procure the services of an industry recognized testing laboratory or he may establish an approved testing laboratory at the project site. A list of tests which the Contractor is to perform shall be furnished as a part of the CQC plan to the Contracting Officer. The list shall give the test name, specification paragraph containing the test requirements, and the personnel and laboratory responsible for each type of test. The Contractor shall perform and record the following activities and provide the following data:

(a) Verify that testing procedures comply with contract requirements.

(b) Verify that facilities and testing equipment are available and comply with testing standards.

(c) Check test instrument calibration data against certified standards.

(d) Verify that recording forms, including all of the test documentation requirements, have been prepared.

(2) Testing.

(a) Capability Check. The COR will have the right to check laboratory equipment in the proposed laboratory for compliance with the standards set forth in the contract specifications and to check the laboratory technician's testing procedures and techniques.

(b) Capability Re-Check. If the selected laboratory fails the capability check, the Contractor will be assessed a charge of \$1,500 to reimburse the Government for each succeeding re-check of the laboratory or the checking of a subsequently selected laboratory. Such costs will be deducted from the contract amount due the Contractor.

(c) Project Laboratory. If the Contractor uses an on site testing laboratory, the COR will have the right to utilize the laboratory and equipment to make assurance tests and to check the Contractor's testing procedures, techniques, and test results at no additional cost to the Government.

(d) Transportation of Samples for Testing. Costs incidental to the transportation of samples or materials will be borne by the Contractor. Concrete test cylinders shall be delivered by the Contractor to the NOD soils lab for testing on federal workdays between 9 A.M. and 3 P.M. Samples of materials for test verification and acceptance testing by the Government shall be coordinated with the CO for shipping instructions and delivered to the Corps of Engineers Division Laboratory, f.o.b., at the following address:

For Water Stop Samples.

Waterways Experiment Station
3909 Halls Ferry Road
Vicksburg, Mississippi 39180-6199

h. Completion Inspection. At the completion of all work or any increment thereof established by a completion time stated in the Special Clause entitled "COMMENCEMENT, PROSECUTION, AND COMPLETION OF WORK" or stated elsewhere in the specifications, the

CQC System Manager shall conduct a completion inspection of the work and develop a 'punch list' of items which do not conform to the approved plans and specifications. Such a list shall be included in the CQC documentation as required by paragraph i. below and shall include the estimated date by which the deficiencies will be corrected. The CQC System Manager or his staff shall make a second completion inspection to ascertain that all deficiencies have been corrected and so notify the Contracting Officer's Representative. The completion inspection and any deficiency corrections required by this paragraph will be accomplished within the time stated for completion of the entire work or any particular increment thereof if the project is divided into increments by separate completion dates.

i. Documentation.

(1) The Contractor shall maintain current records of quality control operations, activities, and tests performed including the work of suppliers and subcontractors. These records shall be on an acceptable form and shall include factual evidence that required activities or tests have been performed, including but not limited to the following:

- (a) Type and number of control activities and tests involved.
- (b) Results of control activities and tests.
- (c) Nature of defects, causes of rejection, etc.
- (d) Proposed remedial action.
- (e) Corrective actions taken.

In addition, these records shall indicate a description of trades working on the project, the numbers of personnel working, and the weather conditions encountered, and acknowledgement of instructions given by the Government Representative.

(2) These records shall cover both conforming and defective or deficient features and shall include a statement that supplies and materials incorporated in the work comply with the contract. Legible copies of these records shall be furnished to the CO daily.

j. Safety. The Contractor shall perform a daily safety inspection of the jobsite, equipment, or separate segments thereof. The inspection shall be performed by the Contractor's job supervisory staff, a company safety specialist, a safety consultant, or a safety representative of the compensation insurance carrier. The results shall be documented, along with

any corrective action taken, on the quality control report or on a form attached to the quality control report, such as a Corps of Engineers Safety Inspection Checklist or insurance carrier's inspection format.

k. Notification of Noncompliance. The Contracting Officer will notify the Contractor of any noncompliance with the foregoing requirements. The Contractor shall, after receipt of such notice, immediately take corrective action. Such notice, when delivered to the Contractor or his representative at the site of the work, shall be deemed sufficient for the purpose of notification. If the Contractor fails or refuses to comply promptly, the Contracting Officer may issue an order stopping all or part of the work until satisfactory corrective action has been taken. No part of the time lost due to any such stop orders shall be made the subject of claim for extension of time or for excess costs or damages by the Contractor.

l. Payment. Separate payment will not be made for providing and maintaining an effective Quality Control program as required above, and all costs associated therewith shall be included in the applicable unit prices or lump sum prices contained in the Bidding Schedule. (ER 1180-1-6)

H-5 EQUIPMENT OWNERSHIP AND OPERATING EXPENSE SCHEDULE.
(EFARS 31.105--JUL 89).

a. Allowable cost for construction and marine plant and equipment in sound workable condition, owned or controlled and furnished by a Contractor or Subcontractor at any tier shall be based on actual cost data for each piece of equipment or groups of similar serial and series for which the Government can determine both ownership and operating costs from the Contractor's accounting records. When both ownership and operating costs cannot be determined from the Contractor's accounting records, equipment costs shall be based upon the applicable provisions of EP 1110-1-8, "Construction Equipment Ownership and Operating Expense Schedule," Region III. Working conditions shall be considered to be average for determining equipment rates using the schedule unless specified otherwise by the Contracting Officer. For equipment not included in the schedule, rates for comparable pieces of equipment may be used or a rate may be developed using the formula provided in the schedule. For forward pricing, the schedule in effect at the time of negotiations shall apply. For retrospective pricing, the schedule in effect at the time the work was performed shall apply.

b. Equipment rental costs are allowable, subject to the provisions of FAR 31.105(d) (2) (ii) and FAR 31.205-36, and substantiated by certified copies of paid invoices. Rates for equipment rented from an organization under common control, lease-purchase or sale-leaseback arrangements will be determined using the schedule except that rental costs leased from an organization

under common control that has an established practice of leasing the same or similar equipment to unaffiliated leases are allowable. Costs for major repairs and overhaul are unallowable.

c. When actual equipment costs are proposed and the total amount of the pricing action is over \$25,000, cost or pricing data shall be submitted on Standard Form 1411, "Contract Pricing Proposal Cover Sheet." By submitting cost or pricing data, the Contractor grants to the Contracting Officer or an authorizing representative the right to examine those books, records, documents and other supporting data that will permit evaluation of the proposed equipment costs. After price agreement the Contractor shall certify that the equipment costs or pricing data submitted are accurate, complete and current.

NOTE: A copy of the manual can be obtained from the Government Printing Office (GPO) by calling (202) 783-3238. The cost will be \$9.50. (Stock number: Volume 3, # S/N-008-022-00256-1.)

H-6 PHYSICAL DATA (FAR 52.236-4 - 1984 APR). Data and information furnished or referred to below is for the Contractor's information. The Government shall not be responsible for any interpretation of or conclusion drawn from the data or information by the Contractor.

a. The indications of physical conditions on the drawings and in the specifications are the result of site investigations by surveys and borings.

b. Field notes, representative soil sample(boring 5-LUG only), field and laboratory test results, and other data on which this information is based are available at U.S. Army Engineer District, New Orleans, Corps of Engineers, ATTN: CELMN-ED, Foot of Prytania Street, P.O. Box 60267, New Orleans, Louisiana 70160-0267, and access thereto may be had upon request.

c. Weather Conditions. Data on weather conditions may be obtained from the National Weather Service.

d. Transportation Facilities. Public streets serve the general area. Use of public streets shall be predicated on the provisions of the Special Clause entitled "TRAFFIC CONTROL".

e. Hydrographs shown on the drawings do not constitute a prediction.

H-7 LAYOUT OF WORK. (FAR 52.236-17--APR 1984). The Contractor shall lay out its work from Government-established baselines and bench marks indicated on the drawings, and shall be responsible for all measurements in connection with the layout. The Contractor shall furnish, at its own expense, such stakes, templates, platforms, equipment, tools, materials, and labor required to lay out any part of the work. The Contractor shall be responsible for executing the work to the lines and grades shown on the drawings. The Contractor shall also be responsible for maintaining and preserving all stakes and other marks established by the Contracting Officer until authorized to remove them. If such marks are destroyed by the Contractor or through its negligence before their removal is authorized, the Contracting Officer may replace them and deduct the expense of the replacement from any amounts due or to become due to the Contractor.

H-8 RESERVED.

H-9 DAMAGE TO WORK. The responsibility for damage to any part of the permanent work shall be as set forth in the Contract Clauses of the contract entitled "PERMITS AND RESPONSIBILITIES". However, if, in the judgement of the Contracting Officer, any part of the permanent work performed by the Contractor is damaged by flood, earthquake, hurricane or tornado, which damage is not due to the failure of the Contractor to take reasonable precautions or to exercise sound engineering and construction practices in the conduct of the work, the Contractor shall make the repairs as ordered by the Contracting Officer and full compensation for such repairs will be made at the applicable contract unit price or lump sum prices as fixed and established in the contract. If, in the opinion of the Contracting Officer, there are no contract unit or lump sum prices applicable to any part of such work, an equitable adjustment pursuant to the Contract Clause entitled "CHANGES" will be made as full compensation for the repairs of that part of the permanent work for which there are no applicable contract unit or lump sum prices. Except as herein provided, damage to all work (including temporary construction), utilities, materials, equipment and plant shall be repaired to the satisfaction of the Contracting Officer at the Contractor's expense, regardless of the cause of such damage.

H-10 SAFETY PROVISIONS.

a. Accident Investigations and Reporting. Refer to the Oct 1992 edition of EM 385-1-1, Section 01.D. Accidents shall be investigated and reports completed by the immediate supervisor of the employee(s) involved and reported to the Contracting Officer or his representative within one working day after the accident occurs. A written report of all mishaps occurring on the project shall be submitted to the Contracting Officer's Representative within four calendar days following the incident. All data

reported must be complete, timely and accurate. A follow-up report shall be submitted when the estimated lost time days differs from the actual lost time days.

b. Accident Prevention Program. Refer to Contract Clause entitled "ACCIDENT PREVENTION" of this contract. Within 15 days after receipt of Notice of Award of the contract, and at least 7 days prior to the prework conference, four copies of the Accident Prevention Program shall be submitted to the Contracting Officer for review and approval. The program shall be prepared in the following format:

(1) An executed LMV Form 358-R, Administrative Plan (available upon request), see TABLE 1-1 of EM 385-1-1.

(2) An executed LMV Form 359-R, Activity Hazard Analysis (available upon request), see TABLE 1-1 of EM 385-1-1.

(3) A copy of company policy statement regarding accident prevention.

(4) When marine plant and equipment are in use under a contract, the method of fuel oil transfer shall be included on LMV Form 414R, Fuel Oil Transfer, (available upon request). (Refer to 33 CFR 156).

The Contractor shall not commence physical work at the site until the program has been approved by the Contracting Officer, or his authorized representative. At the Contracting Officer's discretion, the Contractor may submit his Activity Hazard Analysis only for the first phase of construction provided that it is accompanied by an outline of the remaining phases of construction. All remaining phases shall be submitted and accepted prior to the beginning of work in each phase. Also refer to Section 1 of EM 385-1-1.

c. Comprehensive Hazard Communication Program. The Contractor shall develop, implement, and maintain at the workplace a written, Comprehensive Hazard Communication Program (see Section 01.B of EM 385-1-1) that includes identification of potential hazards as prescribed in 29 CFR Part 1910.1200, effects of exposure and control measures to be used for chemical products and physical agents that may be encountered during the performance of work on this contract, provisions for container labeling, Material Safety Data Sheets, and employee training program, and other criteria in accordance with 29 CFR Part 1910.1200. Training shall include communication methods and systems to be used (i.e., voice, hand signals, radios or other means), and training in the use and understanding of material safety data sheets and chemical product hazard warning labels. Prior to bringing hazardous substances, as defined in 29 CFR 1910.120, onto the job site, the Hazard Communication Program and the Material Safety Data Sheets of each

substance shall be submitted to the Contracting Officer and made available to the Contractor's employees as part of his Accident Prevention Program.

d. Daily Inspections. The Contractor shall perform daily safety inspections and record them on the forms approved by the Contracting Officer. Reports of daily inspections shall be maintained at the jobsite in accordance with subparagraph j of the Special Clause entitled "CONTRACTOR QUALITY CONTROL (CQC)". The reports shall be records of the daily inspections and resulting actions. Each report shall include, as a minimum, the following:

- (1) Phase(s) of construction underway during the inspection.
- (2) Locations of areas where inspections were made.
- (3) Results of inspections, including nature of deficiencies observed and corrective actions taken, or to be taken, date, and signature of the person responsible for its contents.

e. Safety Sign. The Contractor shall furnish, erect, and maintain a safety sign at the site, as located by the Contracting Officer. The sign shall conform to the requirements of this paragraph and the drawing included at the end of these Special Clauses. The lettering shall be black, the castle red, and the background white. Upon request, the Government will furnish two decals of the engineer castle. When placed on a floating plant, the sign may be half size. The sign shall be erected as soon as practicable, but not later than 15 calendar days after the date established for commencement of work. The data required shall be current.

f. Ground Fault Protection. Electrical equipment used on this contract shall be equipped with ground fault circuit interrupters in accordance with EM 385-1-1, Section 11.C.05.

g. Haul Roads. Whenever practical, one-way haul roads shall be used on this contract. Haul roads built and maintained for this work shall comply with the following:

- (1) One-way haul roads for off-the-road equipment; e.g., belly dumps, scrapers, and off-the-road trucks shall have a minimum usable width of 25 ft. One-way haul roads for over-the-road haulage equipment only (e.g., dump trucks, etc.) may be reduced to a usable width of 15 ft. When the Contracting Officer determines that it is impractical to obtain the required width for one-way haul roads (e.g., a road on top of a levee), a usable width of not less than 10-feet may be approved by the Contracting Officer, provided a positive means of traffic control is implemented. Such positive means shall be signs, signals, and/or signalmen and an effective means of speed control.

(2) Two-way haul roads for off-the-road haulage equipment shall have a usable width of 60-feet. Two-way haul roads for over-the-road haulage equipment only may be reduced to a usable width of 30-feet.

(3) Haul roads shall be graded and otherwise maintained to keep the surface free from potholes, ruts, and similar conditions that could result in unsafe operation.

(4) Grades and curves shall allow a minimum sight distance of 200-feet for one-way roads and 300-feet for two-way roads. Sight distance is defined as the centerline distance an equipment operator (4.5-feet above the road surface) can see an object 4.5-feet above the road surface. When conditions make it impractical to obtain the required sight distance (e.g., ramps over levees), a positive means of traffic control shall be implemented.

(5) Dust abatement shall permit observation of objects on the roadway at a minimum distance of 300-feet.

(6) Haul roads shall have the edges of the usable portion marked with posts at intervals of 50-feet on curves and 200-feet (maximum) elsewhere. Such markers shall extend 6-feet above the road surface and, for nighttime haulage, be provided with reflectors in both directions.

h. Safety Fence. The Contractor shall provide, erect, and maintain a temporary safety fence around the limits of work including the Access and Staging Areas. The fabric for the safety fence shall be zinc coated hog wire mesh, 39-inches in height. Posts shall be round wood posts at least 6½-feet long, 3½-inches in diameter, and may be untreated or steel T-posts, 6-feet long. Posts shall extend at least 39-inches above ground and shall be spaced at 10-feet on center. Swing gates shall be at least 12-feet wide by 39-inches high. The swing gate frame shall be fabricated of either 1-3/8-inch O.D. tubular steel, or ½-inch angle iron brace with an adjustable brace wire to prevent sagging. Gates shall be fitted with hinges and shall be supported by 1-3/8 inch O.D. tubular steel posts embedded in 3-feet of concrete. The fabric from the gates shall be the same as that for the fence. All gates shall be closed and padlocked at the end of each work day. When necessary, an owner of a facility located within the limits of work will obtain keys from the levee district. The Contractor shall provide and maintain on the fence "KEEP OUT" signs every 100-feet facing out from the work. Details of the safety fencing and location shall be submitted to the Contracting Officer for approval. No separate measurement or payment will be made for this work. Payment for all work associated with the safety fence shall be distributed amongst the existing bid items.

i. Hurricane Plan. A detailed plan for protection and evacuation of personnel and plant, in the event of an impending hurricane or storm, is required as an enclosure to the Contractor's Accident Prevention Program. This plan shall be submitted to the Contracting Officer, or his representative, for review prior to the preconstruction conference. The plan shall include at least the time each phase of the plan will be put in effect. The time shall be the number of hours remaining for the storm to reach the worksite if it continues at the predicted speed and direction.

j. Means of Escape for Personnel Quartered, or Working on Floating Plant. Two means of escape shall be provided for assembly, sleeping, and messing areas on floating plants. For areas involving 10 or more persons, both means of egress shall be through standard size doors opening to different exit routes. Where nine or fewer persons are involved, one of the means of escape may be a window (minimum dimensions 24 in. by 36 in.) which leads to a different exit route. Refer to Section 19 of EM 385-1-1.

k. Emergency Alarms and Signals.

(1) Alarms. Emergency alarms shall be installed and maintained on all floating plant requiring a crew where it is possible for either a passenger or crewman to be out of sight or hearing from any other person. The alarm system shall be operated from the primary electrical system with standby batteries on trickle charge that will automatically furnish the required energy during an electrical-system failure. A sufficient number of signaling devices shall be placed on each deck so that the sound can be heard distinctly at any point above the usual background noise. All signaling devices shall be so interconnected that actuation can occur from at least one strategic point on each deck.

(2) Signals.

(a) Fire Alarm Signals. The general fire alarm signal shall be in accordance with paragraph 97.13-15b of the Coast Guard Rules and Regulations for Cargo and Miscellaneous Vessels, Sub-Chapter I, 1 Sep 77 (CG 257).

(b) Abandon Ship Signals. The signal for abandon ship shall be in accordance with paragraph 97.13-15c of the reference cited in (a) above.

(c) Man-Overboard Signal. Hail and pass the word to the bridge. All personnel and vessels capable of rendering assistance shall respond.

H-11 INSPECTOR'S FIELD OFFICE.

a. The Contractor shall furnish, throughout the contract period, for the exclusive use of the Government employees, a temporary waterproof building, or trailer, to be utilized as a field office. It shall be conveniently located at the site of construction and shall be independent of any building, or trailer, used by the Contractor. Toilet facilities and potable water shall be provided within the Inspector's office. It shall be equipped with approved electrical wiring, private telephone service with an answering machine, at least one ceiling lamp receptacle, at least one double convenience outlet, and the required switches and fuses, to provide 110-volt power for lighting and operating a desk calculator. It shall be equipped with an air conditioning unit to provide cooling in warm or hot weather, and a heater, properly installed and vented in accordance with the National Fire Protection Association Code, for heating in cold weather, as required. The Contractor shall make the necessary arrangements to obtain or to generate the power required to operate the air conditioning unit, lights, and electric calculators and the power or fuel required for the heater, and shall bear the cost thereof. A drafting table providing a working surface having dimensions of at least 4-feet by 6-feet (which may consist of a piece of plywood, at least 3/4-inch thick, hinged to a wall of the building with hinged legs) shall be installed in the building. The building shall have a built-in locker, extending from the floor to the ceiling, having dimensions of at least 2-feet by 5-feet, with a shelf 12-inches from the top, and one door equipped with two hinges, a hasp and a padlock. The outside door of the building and the window frames shall be equipped with iron security guards. The door shall also be equipped with butt hinges and a cylinder lock. One draftsman's stool, two strong chairs and one desk shall be provided. The building or trailer shall conform to the following minimum requirements:

Ceiling height, not less than	6-feet 9-inches
Floor space, no less than	240 square feet
Windows, not less than	2
Doors, outside	1
Rooms	1

Screens over doors and windows; walls and ceilings shall be insulated; and interior walls finished.

b. The building, or trailer, shall be removed by the Contractor after completion of all work under this contract and before final acceptance thereof. No separate payment will be made for furnishing, maintaining, providing the prescribed utilities, and removing the inspector's field office, but the cost of the same shall be distributed throughout the existing bid items. In

the event the Contractor fails to furnish the required facilities, the Government may elect to procure the required facilities and deduct all costs from amounts due or to become due under this contract.

c. The Contractor shall provide daily janitorial services for this and other buildings at the site throughout the life of the contract. The cost of this service shall be distributed throughout the existing bid items and there shall be no separate payment.

H-12 CONSTRUCTION SIGNS. The use of signs to identify Corps managed or supervised design, construction, and rehabilitation projects - both for military and civil works is an important part of efforts to keep the public informed of Corps work. For this purpose, a construction project sign package has been adopted. This package consists of a project identification sign.

The sign shall be displayed and mounted for reading by passing viewers. The sign placement location will be designated by the Contracting Officer.

The panel sizes and graphic formats have been standardized for visual consistency throughout all Corps operations.

Panels are fabricated using HDO plywood with dimensional lumber uprights and bracing. The sign faces are non-reflective vinyl.

All legends are to be die-cut or computer-cut in the sizes and typefaces specified and applied to the white panel background following the graphic formats shown in Appendix A thru D to these Special Clauses.

Mounting and fabrication details, and a display of this sign is shown in Appendix A thru D.

Special applications or situations not covered in these guidelines should be referred to the Contracting Officer.

See Appendix A thru D at the end of these Special Clauses for the construction project sign package.

Project Sign Information: (refer to page 16.2 of Appendix A)

a. Legend Group 1, Corps relationship to project:

"Construction
Supervised by:" _____

b. Legend Group 2:

"U.S. ARMY
CORPS OF ENGINEERS
NEW ORLEANS DISTRICT."

c. Legend Group 3, Project Title:

d. Legend Group 4, Project Locations:

e. Legend Group 5, Contractor:

f. Legend Group 6, Project Sponsor:

BOARD OF COMMISSIONERS
ORLEANS LEVEE DISTRICT
NEW ORLEANS, LOUISIANA

H-13 RIGHTS-OF-WAY.

a. Rights-of-way for construction purposes and for access through private lands to the work site will be furnished by the Government without cost to the Contractor, as shown on the contract drawings. If the right-of-way for access is used by the Contractor, he shall, at his expense, be required to do all work necessary to make such right-of-way suitable for traveling to and from the work site. Upon completion of the contract work, any such access roadway and right-of-way furnished by the Government shall be left in a condition satisfactory to the Contracting Officer.

b. The Contractor shall procure, without expense or liability to the Government, all additional lands, access roads, or rights-of-way desired for his own convenience in the performance of the work. The Contractor shall notify the Contracting Officer of his intention and, if required by the Contracting Officer, secure clearances from both the Louisiana

State Historical Preservation Office and the Louisiana Archaeological and Antiquities Commission. Any agreements or permits with levee boards, parishes, or political subdivisions for moving material and equipment will also be the responsibility of the Contractor. Any delays to the Contractor resulting from delays in procuring such additional lands, access roads, right-of-way, or permits for moving material and equipment for his own use will not be made a basis of any claim for increase in the cost or time of performance of the work. The Contractor shall make his own investigations to determine the conditions, restrictions, and difficulties which may be encountered in the transportation of material and equipment to the work site.

H-14 SUBMITTALS. Within 15 days after receipt of notice to proceed, the Contractor shall complete and submit to the Contracting Officer, in duplicate, submittal register ENG Form 4288 listing all submittals and dates. In addition to those items listed on ENG Form 4288, the Contractor shall furnish submittals for any deviation from the plans or specifications. The scheduled need dates must be recorded on the document for each item for control purposes. In preparing the document, adequate time (minimum of 30 days or more) will be allowed for review and approval and possible resubmittal. Scheduling shall be coordinated with the approved progress schedule. The Contractor's Quality Control representative shall review the listing at least every 30 days, update and review every 60 days, and take appropriate action to maintain an effective system. Copies of updated or corrected listings shall be submitted to the Contracting Officer upon request, in the quantity specified. Payment will not be made for any material or equipment which does not comply with contract requirements. (ER 415-1-10 Jun 1991).

NOTE: The submittal listing in tabular form, of technical items the Contractor shall submit to the Contracting Officer, as indicated in the contract requirements is attached at the end of the Special Clauses. This register is not necessarily complete, and the Contractor shall be responsible for developing a comprehensive register.

H-15 CERTIFICATES OF COMPLIANCE. Any certificates required for demonstrating proof of compliance of materials with specification requirements shall be executed in 3 copies. Each certificate shall be signed by an official authorized to certify on behalf of the manufacturing company and shall contain the name and address of the Contractor, the project name and location, and the quantity and date or dates of shipment or delivery to which the certificates apply. Copies of laboratory test reports submitted with certificates shall contain the name and address of the testing laboratory and the date or dates of the tests to which the report applies. Certification shall not be construed as relieving the Contractor from furnishing satisfactory material, if, after tests are performed on selected samples, the material is found not to meet specified requirements.

H-16 RESERVED.

H-17 COMMERCIAL WARRANTY. The Contractor agrees that the standard commercial equipment furnished under this contract shall be covered by the most favorable commercial warranties the manufacturer gives to any customer for such equipment, and that the remedies provided herein are in addition to and do not limit any rights afforded to the Government by any other clause of this contract. Two copies of the warranties shall be furnished by the Contractor to the Contracting Officer.

H-18 PAYMENT FOR MOBILIZATION AND DEMOBILIZATION (DFARS 252.236-7004 (b) (2) - 1991 DEC.).

a. The Government will pay all costs for the mobilization and demobilization of all of the Contractor's plant and equipment at the contract lump sum price for this item.

(1) Sixty percent (60%) of the lump sum price upon completion of the Contractor's mobilization at the work site.

(2) The remaining forty percent (40%) upon completion of demobilization.

b. The Contracting Officer may require the Contractor to furnish cost data to justify this portion of the bid if the Contracting Officer believes that the percentages in paragraphs a.(1) and (2) of this clause do not bear a reasonable relation to the cost of the work in this contract.

(1) Failure to justify such price to the satisfaction of the Contracting Officer will result in payment of--

(a) Actual mobilization costs at the completion of mobilization;

(b) Actual demobilization costs at the completion of demobilization; and

(c) The remainder of this item in the final payment under this contract.

(2) The Contracting Officer's determination of the actual costs in paragraphs b.(1) of this clause is not subject to appeal.

H-19 ENVIRONMENTAL LITIGATION (1974 NOV OCE).

a. If the performance of all or any part of the work is suspended, delayed, or interrupted due to an order of a court of competent jurisdiction as a result of environmental litigation, as defined below, the Contracting Officer, at the request of the Contractor, shall determine whether the order is due in any part

to the acts or omissions of the Contractor or a Subcontractor at any tier not required by the terms of this contract. If it is determined that the order is not due in any part to acts or omissions of the Contractor or a Subcontractor at any tier other than as required by the terms of this contract, such suspension, delay, or interruption shall be considered as if ordered by the Contracting Officer in the administration of this contract under the terms of the "SUSPENSION OF WORK" clause of this contract. The period of such suspension, delay or interruption shall be considered unreasonable, and an adjustment shall be made for any increase in the cost of performance of this contract (excluding profit) as provided in that clause, subject to all the provisions thereof.

b. The term "environmental litigation", as used herein, means a lawsuit alleging that the work has an adverse effect on the environment or that the Government has not duly considered, either substantively or procedurally, the effect of the work on the environment.

H-20 TIME EXTENSIONS FOR UNUSUALLY SEVERE WEATHER.

a. This provision specifies the procedure for determination of time extensions for unusually severe weather in accordance with the contract clause entitled "DEFAULT (FIXED PRICE CONSTRUCTION)". In order for the Contracting Officer to award a time extension under this clause, the following conditions must be satisfied.

(1) The weather experienced at the project site during the contract period must be found to be unusually severe, that is, more severe than the adverse weather anticipated for the project location during any given month.

(2) The unusually severe weather must actually cause a delay to the completion of the project. The delay must be beyond the control and without the fault or negligence of the Contractor.

b. The following schedule of monthly anticipated adverse weather delays is based on National Oceanic and Atmospheric Administration (NOAA) or similar data for the project location and will constitute the base line for monthly weather time evaluations. The Contractor's progress schedule must reflect these anticipated adverse weather delays in all weather dependent activities.

**MONTHLY ANTICIPATED ADVERSE WEATHER DELAY WORK
DAYS BASED ON (5) DAY WORK WEEK**

<u>JAN</u>	<u>FEB</u>	<u>MAR</u>	<u>APR</u>	<u>MAY</u>	<u>JUN</u>	<u>JUL</u>	<u>AUG</u>	<u>SEP</u>	<u>OCT</u>	<u>NOV</u>	<u>DEC</u>
(6)	(5)	(4)	(4)	(4)	(6)	(9)	(6)	(5)	(4)	(4)	(4)

c. Upon acknowledgement of the Notice to Proceed (NTP) and continuing throughout the contract, the Contractor will record on the daily CQC report, the occurrence of adverse weather and resultant impact to normally scheduled work. Actual adverse weather delay days must prevent work on critical activities for 50 percent or more of the Contractor's scheduled work day.

The number of actual adverse weather delay days shall include days impacted by actual adverse weather (even if adverse weather occurred in previous month), be calculated chronologically from the first to the last day of each month, and be recorded as full days. If the number of actual adverse weather delay days exceeds the number of days anticipated in paragraph b, above, the Contracting Officer will convert any qualifying delays to calendar days, giving full consideration for equivalent fair weather work days, and issue a modification in accordance with the contract clause entitled "DEFAULT (FIXED PRICE CONSTRUCTION)". (ER 415-1-15 dated 31 Mar 89).

H-21 PERFORMANCE OF WORK BY CONTRACTOR (FAR 52.236-1 -1984 APR). The Contractor shall perform on the site, and within his own organization, work equivalent to at least twenty percent (20%) of the total amount of the work to be performed under the contract. This percentage may be reduced by a supplemental agreement to this contract, if, during performing the work, the Contractor requests a reduction and the Contracting Officer determines that the reduction would be to the advantage of the Government.

H-22 UTILITIES AND IMPROVEMENTS.

a. All known utilities within the limits of the work, such as pipes, communication lines, power lines, etc., that would interfere with construction work will be removed, modified or relocated by local interests or utility companies at no cost to the Contractor unless otherwise noted in the plans and/or specifications. The Contractor, however, shall cooperate with the authorities or company representatives and shall conduct his operations in such manner as to result in a minimum of inconveniences to the owners of said utilities. The Contractor shall notify each utility owner by certified mail no sooner than 90 days but at least 45 days prior to the date utilities must be moved and provide a copy of these notifications to the Contracting Officer.

b. Any unidentified pipes or structures which may be found within the limits of the work during the course of construction shall not be disturbed nor shall construction or excavation be performed at these locations unless and until approved by the Contracting Officer. Payment for ordered excavation, if any, will be made in accordance with the Contract Clause entitled "DIFFERING SITE CONDITIONS".

H-23 PERMISSIBLE HOURS OF OPERATION. No work shall be done between 6:00 p.m. and 7:30 a.m., nor shall work be allowed on Saturdays, Sundays, or legal holidays without permission of the Government.

H-24 HANDBOOK FOR CONCRETE AND CEMENT (CRD-C). The handbook for concrete and cement can be obtained from U.S. Army Engineer Waterways Experiment Station, ATTN: Publications Specification, Information Services Branch, P.O. Box 631, Vicksburg, Mississippi 39180.

Complete Ed. (Vol. 1 and 2) \$10.00

Supplements and revisions to the Handbook are sold on a subscription basis at the price of \$8.00 per year per copy of Handbook. Separate CRD-C Specifications are available for distribution without charge in limited quantities only.

H-25. AGGREGATE SOURCES.

(OCT 93)

a. Concrete aggregates meeting the quality requirements of these specifications have been produced from the sources listed below:

<u>Producer</u>	<u>Nearest Town to Pit *</u>	<u>Pit Designation</u>
A. B. Chisum Gravel Co.	Sicily Island, IA	A. B. Chisum Sand & Gravel Plant A
American Sand & Gravel Co.	Hattiesburg, MS	Plant E
American Sand & Gravel Co.	Hattiesburg, MS	Hornsby Pit
B & B Gravel, Inc.	Grangeville, IA	Harris Pit
Blain Sand & Gravel, Inc.	Crystal Spring, MS	Aimwell Pit
D. & J. Construction	Aimwell, IA	Three Rivers Quarry
Dravo Basic Materials Co., Inc.	Smithland, KY	Harvey Pit
Feliciana Sand & Gravel Co.	Jackson, IA	Mckowen Pit
Feliciana Sand & Gravel Co.	Jackson, IA	Thompson Pit
Feliciana Sand & Gravel Co.	Jackson, IA	Pit # 715-11
Jackson Ready-Mix Concrete Co.	Crystal Springs, MS	G-2 (Butler Pit)
Lambert Gravel Co., Inc.	Bains, IA	Anacoco Pit
Louisiana Industries, Inc.	DeRidder, IA	Dinkman Plant
Louisiana Industries, Inc.	Grangeville, IA	Hatcher Plant
Louisiana Industries, Inc.	Grangeville, IA	Hornsby Plant
Louisiana Industries, Inc.	Grangeville, IA	Odom Plant
Louisiana Industries, Inc.	Grangeville, IA	Paradise Pit
Louisiana Industries, Inc.	Ball, IA	Perryville Pit
Louisiana Industries, Inc.	Perryville, IA	Price Plant
Louisiana Industries, Inc.	Enon, IA	Woodworth Plant
Louisiana Industries, Inc.	Woodworth, IA	Perry & Easterly Leases
Mears Sand & Gravel Co.	Watson, IA	Woodworth Plant
Mid-State Material Co., Inc.	Woodworth, IA	Easterly lease
Quick Sand & Gravel, Inc.	Watson, IA	Plant 6
Rebel Sand & Gravel Co.	Watson, IA	

Rebel Sand & Gravel Co.	Watson, LA	Plant 6c
Rebel Sand & Gravel Co.	Watson, LA	Plant 9
Reed Crushed Stone Co., Inc.	Gilbertsville, KY	Gilbertsville Quarry
Standard Gravel Co.	Pearl River, LA	Nicholson Plant (Nic-7)
Standard Gravel Co. (C-10 & CZ-30 Leases)	Enon, LA	Enon Pit
Thomas Sand & Gravel Co., Inc.	Grangeville, LA	Carter #2 Pit
T. L. James & Co., Inc.	Pearl River, LA	Pit # 1
T. L. James & Co., Inc.	Pearl River, LA	Pit # 3

* "Nearest Town to Pit" according to LDOTD Official State Highway Map.

Further information on these pits can be obtained from the Geology Section of the U. S. Army Corps of Engineers District Office in New Orleans.

b. Concrete aggregates may be furnished from any of the above listed sources or at the option of the Contractor may be furnished from any other source designated by the Contractor and approved by the Contracting Officer, subject to the conditions hereinafter stated and as specified in Section C3D.

c. After the award of the contract, the Contractor shall designate in writing only one source or one combination of sources from which he proposes to furnish aggregates. If the Contractor proposes to furnish aggregates from a source or from sources not listed above, he may designate only a single source or single combination of sources of aggregates. If a source for coarse and/or fine aggregate so designated by the Contractor is not approved for use by the Contracting Officer, the Contractor may not submit for approval other sources but shall furnish the coarse and/or fine aggregate, as the case may be, from a source listed above at no additional cost to the Government.

d. Approval of a source of concrete aggregate is not to be construed as approval of all material from that source. The right is reserved to reject materials from certain localized areas, zones, strata, or channels, when such materials do not conform to the quality requirements of ASTM C 33-86 (CRD-C 133), Concrete Aggregates. Aggregate gradations shall be in accordance with the specified requirements of Section C3D. Materials produced from any source, including those listed above, shall also meet all the requirements of Section C3D of the Technical Specifications.

e. It is the Contractor's responsibility to determine that the aggregate source or combination of sources selected is capable of supplying the quantities and gradations needed and at the rates needed to maintain the scheduled progress of the work. The inability of a source or combination of sources to maintain the necessary volume shall not be the basis for any claim for a time extension.

H-26 CONTINUING CONTRACTS (EFARS 52.232-10001 - 1985
JAN HQ USACE).

a. This is a continuing contract, as authorized by Section 10 of the River and Harbor Act of September 22, 1922, (33 US Code 621). The payment of some portion of the contract price is dependent upon reservations of funds from future appropriations. The responsibilities of the Government are limited by this clause notwithstanding any contrary provision of "PAYMENT UNDER FIXED-PRICE CONSTRUCTION CONTRACTS" or any other clause of this contract.

b. (1) The sum of \$ _____ has been reserved for this contract and is available for payments to the Contractor during Fiscal Year 1994. The Energy and Water Development Appropriations Act, 1994, (PL 102-377, 2 October 1992) directed that a continuing contract be awarded to undertake this work. If Congress does not appropriate funds in future years for such work, the contract may be terminated for the convenience of the Government.

(2) Failure to make payments in excess of the amount currently reserved, or that may be reserved from time to time, shall not entitle the Contractor to a price adjustment under the terms of this contract except as specifically provided in paragraphs (d) and (e) below. No such failure shall constitute a breach of this contract, except that this provision shall not bar a breach-of contract action if an amount finally determined to be due as a termination allowance remains unpaid for one year due solely to a failure to reserve sufficient additional funds therefore.

c. (1) The Government may at any time reserve additional funds for payments under the contract if there are funds available for such purpose. The Contracting Officer will promptly notify the Contractor of any additional funds reserved for the contract by issuing an administrative change order to the contract.

(2) If earnings will be such that funds reserved for the contract will be exhausted before the end of any fiscal year, the Contractor shall give written notice to the Contracting Officer of the estimated date of exhaustion and the amount of additional funds which will be needed to meet payments due or to become due under the contract during that fiscal year. This notice shall be given not less than 45 nor more than 60 days prior to the estimated date of exhaustion.

d. (1) No payments will be made after exhaustion of funds except to the extent that additional funds are reserved for the contract. The Contractor shall be entitled to simple interest on any payment that the Contracting Officer determines was actually earned under the terms of the contract and would have been made except for exhaustion of funds. Interest shall be computed from the time such payment would otherwise have been made until

actually or constructively made, and shall be at the rate established by the Secretary of the Treasury pursuant to Public Law 92-41, 85 STAT 97, for the Renegotiation board, as in effect on the first day of the delay in such payment.

(2) Any suspension, delay, or interruption of work arising from exhaustion or anticipated exhaustion of funds shall not constitute a breach of this contract and shall not entitle the Contractor to any price adjustment under the "SUSPENSION OF WORK" clause or in any other manner under this contract.

(3) An equitable adjustment in performance time shall be made for any increase in the time required for performance of any part of the work arising from exhaustion of funds or the reasonable anticipation of exhaustion of funds.

e. If, upon the expiration of sixty (60) calendar days after the beginning of the fiscal year following an exhaustion of funds, the Government has failed to reserve sufficient additional funds to cover payments otherwise due, the Contractor, by written notice delivered to the Contracting Officer at any time before such additional funds are reserved, may elect to treat his right to proceed with the work as having been terminated. Such a termination shall be considered a termination for the convenience of the Government.

f. If at any time, it becomes apparent that the funds reserved for any fiscal year are in excess of the funds required to meet all payments due or to become due the Contractor because of work performed and to be performed under the contract during the fiscal year, the Government reserves the right, after notice to the Contractor, to reduce said reservation by the amount of such excess.

H-27 STONE SOURCES.

(NOV 93)

a. On the basis of information and data available to the Contracting Officer, stone meeting the quality requirements of these specifications has been produced from the sources listed below:

<u>Producer</u>	<u>Nearest Town to Pit *</u>	<u>Pit Designation</u>
B. E. Construction Co. Bellefontaine Quarry, Inc.	Murfreesboro, AR Florissant, MO (Fort Bellefontaine, MO)	Murfreesboro Quarry Bellefontaine Quarry
Boorhem Fields, Inc. Bussen Quarries, Inc. Central Stone Co.	Black Rock, AR Mehlville, MO Withers Mill, MO (Monroe City, MO)	Valley Stone Quarry Bussen Quarry Pit # 1
Central Stone Co.	Darby, MO (Crystal City, MO)	Plattin Quarry

Central Stone Co.	Perry, MO	Pit # 9
Dravo Basic Material Co., Inc.	Cherokee, AL	Cherokee Quarry
Dravo Basic Material Co., Inc.	Smithland, KY	Three Rivers Quarry
Farmers Limestone Co.	Uniontown, MO	Farmers Limestone Quarry
Gifford-Hill and Co.	Delight, AR	Delight Quarry
Granite Mountain Quarries	Sweet Home, AR	Granite Mountain Quarry # 1
Hardin County Materials Co.	Cave In Rock, IL	Plant # 1
H. M. B. Construction Co.	De Queen, AR	H. M. B. Quarry
Hoover Incorporated	Iuka, MS	Waldrop Quarry
Industrial Mineral Products Division/3M	Little Rock, AR	3M Arch Street Quarry
Little Rock Quarry Co., Inc.	Caddo Valley, AR	De Roche Creek Quarry
Little Rock Quarry Co., Inc.	Little Rock, AR	Little Rock Quarry
Pine Bluff Sand and Gravel Co.	Delaware, AR	River Mountain Quarry
Reed Crushed Stone Co., Inc.	Lake City, KY	Gilbertsville Quarry
Tower Rock Stone Co.	Scott City, MO	Grays Point Quarry
Tower Rock Stone Co.	St. Genevieve, MO	Tower Rock Stone Quarry
Vulcan Materials Co.	Iuka, MS	Iuka Plant
Vulcan Materials Co.	Tuscumbia, AL	Tuscumbia Plant (Quarry #114)
West Lake Quarry & Material Co.	Neelys Landing, MO	Neelys Landing Quarry

* "Nearest Town to Pit" according to Rand McNally Road Atlas copyrighted 1990.

Further information on these pits can be obtained from the Geology Section of the U. S. Army Corps of Engineers District Office in New Orleans.

b. Stone may be furnished from any of the above listed sources, or at the option of the Contractor may be furnished from any other source designated by the Contractor and accepted by the Contracting Officer, subject to the conditions hereinafter stated.

c. It is the Contractor's responsibility to determine that the stone source or combination of sources selected is capable of supplying the quantities and gradations needed and at the rate needed to maintain the scheduled progress of the work.

e. After the award of the contract, the Contractor shall designate in writing only one source or one combination of sources from which he proposes to furnish stone. If the Contractor proposes to furnish stone from a source not listed above, he may designate only a single additional source for stone. Samples for acceptance testing shall be provided as required by Section C2K of the Technical Specifications. If a source for stone so designated by the Contractor is not accepted for use by the Contracting

Officer, the Contractor may not propose other sources but shall furnish the stone from a source listed above at no additional cost to the Government.

f. Acceptance of a source of stone is not to be construed as acceptance of all material from the source. The right is reserved to reject materials from certain localized areas, zones, strata, or channels, when such materials are unsuitable for stone as determined by the Contracting Officer. Materials produced from a listed or unlisted source shall meet all requirements of Section C2K of these Technical Specifications.

H-28 RESERVED.

H-29 RESERVED.

H-30 TRAFFIC CONTROL. The Contractor shall be responsible for traffic control as follows:

a. The Contractor shall prepare a traffic control plan in accordance with applicable provisions of Section 97-TRAFFIC ACCOMMODATIONS, of "General Specifications for Street Paving and Temporary Surfacing" published by the City of New Orleans and Part VI - "Traffic Controls for Street and Highway Construction Maintenance, Utility and Emergency Operations" of the "Manual of Uniform Traffic Control Devices" by the Federal Highway Administration, as adopted by Louisiana Department of Transportation and Development. The Contractor shall keep the portion of the project being used by public traffic, whether through or local, in such condition (including mail delivery) that traffic will be adequately accommodated. He shall also provide and maintain, in a safe manner, all required temporary approaches or crossings, intersections with roads, streets, business parking areas, residences and garages are also included. The Contractor shall be responsible for supplying, maintaining and moving, when necessary, adequate barricades, warning signs and lights to safely inform the traveling public as to the location of the work at all times. The traffic plan shall be accompanied by a written concurrence from the City's Traffic Engineer for the Contracting Officer's approval.

b. The Contractor shall meet with the Director of the Department of Streets of the City of New Orleans, or his authorized representative to discuss the traffic control plan. Prior to the beginning of the construction, the Contractor shall submit to the City Traffic Engineer for approval:

(1) A plan for the proposed route on which construction materials and equipment are to be transported to or from the construction site. This shall consist of a map depicting the proposed access routes to and from the worksite for each phase of the project. These routes will be approved or revised as necessary to establish an alternate which is acceptable. Also,

the Department of Streets reserves the right to revise approved routes during the course of the project should problems arise or should this otherwise become necessary.

(2) A detour plan showing proposed routes for local traffic and transient traffic on which locations of detour traffic control devices and construction zone or work zone traffic control devices are shown. Traffic control device applications and methods shall be in compliance with Part VI of the MANUAL ON UNIFORM TRAFFIC CONTROL DEVICES.

(3) Locations where flagmen will be required.

These plans shall include name and telephone number of responsible personnel in charge of the project.

The Contractor shall seek the approval of the City Traffic Engineer for any traffic related plan change, including removal or addition of traffic control devices before or during the course of construction.

All existing traffic control devices which are in conflict with the construction of the work zone traffic control plan shall be covered or removed by the Contractor and the removed devices returned to the city signal shop or sign shop at 2823 Lafitte Street. All existing devices left in the construction or work zone shall be maintained in good condition by the Contractor during the course of construction.

All removed traffic control devices shall be restored to their original position and orientation by the Contractor prior to the time of final inspection.

c. In preparing the traffic control plan, the Contractor shall observe that only 1 lane of Mirabeau and Filmore Ave. may be affected by construction activities at any one time, and only 1 lane of Robert E. Lee and Leon C. Simon Blvd. may be affected by construction activities at any one time.

Should the Contractor elect to use the Mirabeau Avenue, Filmore Ave., Robert E. Lee Blvd., or Leon C. Simon Blvd. Bridge for construction activities, the following shall be required:

(1) A plan for traffic control at the bridges shall be prepared and approved in accordance with paragraphs a and b above.

(2) Vehicles and construction equipment shall not exceed the current permissible loadings of the Department of Streets, City of New Orleans.

(3) The bridge shall be cleared daily by the Contractor during soil hauling and concrete operations.

(4) Any damage to the bridge, sustained as a result of Contractor activities, shall be immediately repaired by the Contractor.

The Contractor will be permitted access to the job site via public streets as follows: Mirabeau Ave., Filmore Ave., Robert E. Lee Blvd., Leon C. Simon Blvd., Pratt St., and London Dr. where sufficient rights-of-way exists. The Contractor shall contact the Traffic Engineer of the Department of Streets, City of New Orleans for the prior approval of the proposed access route which could provide the access to the jobsite. The Contractor shall be required to fill in the Construction Access Plan (Hauling Route) Form for the proposed access plan prior to the construction of the project. This form is available at the Traffic Engineering Division, Department of Streets, City of New Orleans, 1300 Perdido Street, Room 6W02, New Orleans, LA 70112. Vehicles shall not exceed the maximum permissible loads as governed by Sections 38-168, 38-169, 38-169.1 of the Code of the City of New Orleans.

Additionally, the Contractor shall ensure that residents and business establishments have access to their property and driveways at all times.

d. Daily upkeep of the roads and streets, including cleaning up spillage of any hauled material as a result of hauling activity, shall be maintained to insure continuous traffic access.

e. The Contractor shall coordinate all traffic management with Mr. Elmer Darwin of the New Orleans Department of Streets at telephone number (504) 565-6844. When the Contractor initiates any construction activity which impacts a public street, he shall, in accordance with the Department of Streets, work as expeditiously as practicable and return said streets to normal operations as soon as possible.

H-31 FLOOD PROTECTION PLAN. Before any existing flood protection is reduced, the Contractor shall have and maintain a minimum of 300-feet of steel sheet piling on hand. The lengths should be a minimum of 20-feet. Due to the temporary loss in height of flood protection against hurricane induced flooding as a result of the floodwall construction, during hurricane season not more than 300 linear feet of the existing levee protection shall be removed until a corresponding section of floodwall is completed. Hurricane season extends from 1 June to 30 November. During non-hurricane season not more than 750-feet of the existing levee protection shall be removed until a corresponding section of floodwall is completed. By at least 1 May the Contractor shall begin to reduce the 750-foot gap to achieve the required 300-foot gap by hurricane season beginning 1 June. The Contractor shall develop and submit for approval, plans including methods,

equipment, materials and actions to close breaches in the flood protection in the event that a hurricane threatens the area. Plans for closing breaches in the floodwall shall be updated semi-annually to reflect status of construction progress. Prior to removing any existing levee protection, the contractor shall have an approved plan of interim protection as specified in Section C2H.

a. In the event of an impending hurricane or storm, the Contractor shall complete a closure of all breaches in the flood protection within 24 hours after being directed to do so by the Contracting Officer. The closure shall be made with steel sheet piling.

b. The stockpiling of emergency closure materials is required. Storage of materials and equipment to perform the closures shall be adjacent to where they would be used or other readily accessible areas.

H-32 COORDINATION OF WORK.

a. All required relocation work shall be fully coordinated by the Contractor with the facility owners so that no delays or adverse impacts are experienced. Any difficulty encountered when attempting to contact a facility owner shall be promptly brought to the attention of the Contracting Officer.

b. The Contractor shall notify the facility owners, by certified mail with copies furnished to the Contracting Officer and the Orleans Levee District, no sooner than 90 days but at least 45 days prior to starting any work which will impact their facilities.

- (1) Mr. Stevan Spencer
Chief Engineer
Orleans Levee District
Administration Bldg., Suite 202
Lakefront Airport
New Orleans, LA 70124
(504) 243-4048
- (2) Mr. Jack Huercamp
Chief of Newtworks
Sewerage and Water Board
900 Peoples Ave.
New Orleans, LA
(504) 942-3891
- (3) Mr. Pierre Champagne
South Central Bell
6767 Bundy Road
Third Floor South
New Orleans, LA 70127
Tel. (504) 245-5723
Fax. (504) 245-1210

- (4) Mr. David Cook
New Orleans Public Service, Inc.
Attn: Mail Unit MR-213
P.O. Box 60340
New Orleans, LA 70160
(504)595-3889
- (5) Mr. Jim Webb
Department of Streets
1300 Perdido St.
Room 6W02
New Orleans, LA 70112
(504) 565-6844
- (6) Mr. Elmer Darwin
Department of Streets
1300 Perdido St.
Room 6W02
New Orleans, LA 70112
(505) 565-6844

c. All facilities will be relocated concurrent with floodwall construction and in accordance with Section C2I.

d. The following conditions will apply to the Contractor's operations in the vicinity of the referenced owner's facilities:

(1) South Central Bell (SCB) and New Orleans Public Service, Inc. (NOPSI). NOPSI will work on their facilities, subsequent to proper notification, to allow floodwall construction to progress. It should be understood that they intend to perform the work on an as need basis, but not all at once. SCB will work on their facilities until June 30, 1994. The Contractor shall fully coordinate his plans with SCB and NOPSI.

(2) Sewerage and Water Board (S&WB). The Contractor shall relocate FL-340, FL-400, and FL-422 in accordance with the applicable provisions of section C16B of these specifications.

e. The Contractor shall provide and maintain traffic control as specified in the Special Clause entitled "TRAFFIC CONTROL". The Contractor shall coordinate all traffic management outlined therein with Mr. Elmer Darwin of the New Orleans Department of Streets at telephone number (504)565-6844. When the Contractor initiates any construction activity which impacts a public street he shall, in coordination with the Department of Streets, work as expeditiously as practicable and return said street to normal operations as soon as possible.

f. The Contractor shall coordinate with Mr. Jim Webb of the Department of Streets for the removal of the Filmore Ave. and Robert E. Lee Blvd. Pedestrian Bridges.

g. An independent party retained by the Orleans Levee District will perform the preconstruction survey of residential properties prior to the commencement of work.

h. An independant testing laboratory retained by the Orleans Levee District will monitor vibrations during pile driving operations. If more than one pile driving rig is in operation at any time, each rig shall be independently monitored. Vibration monitoring during other Contractor operations may be done at the discretion of the Orleans Levee District.

H-33 ORDER OF WORK. The first item of work at the floodwall site shall be for the Contractor to develop and submit for approval, a sheetpile layout and concrete monolith (I-wall) layout. No excavation, sheet pile driving, or other work dependent upon the alignment and layout of the floodwall shall proceed until such approval is recieved.

General Decision Number LA940013

Superseded General Decision No. LA930013

State: Louisiana

Construction Type:
Heavy

County(ies):

JEFFERSON

ORLEANS

ST BERNARD

ST CHARLES

ST JOHN THE BAP

ST TAMMANY

HEAVY CONSTRUCTION PROJECTS (Excluding Work on Treatment Plants)

Modification Number

0

Publication Date

02/11/1994

COUNTY(ies):

JEFFERSON
ORLEANS

ST BERNARD
ST CHARLES

ST JOHN THE BAP
ST TAMMANY

SULA2026A 09/05/1991

	Rates	Fringes
HEAVY CONSTRUCTION:		
CARPENTERS	12.21	2.60
CONCRETE FINISHERS	13.22	1.68
ELECTRICIANS	12.62	1.68
LABORERS:		
Common	7.54	
PAINTERS	11.83	1.18
PIPELAYERS	8.29	
REINFORCING STEEL SETTERS	12.69	3.08
TRUCK DRIVERS	7.76	
POWER EQUIPMENT OPERATORS:		
Backhoes	10.37	
Bulldozers	10.00	
Front End Loaders	11.61	2.50

WELDERS - Receive rate prescribed for craft performing
operation to which welding is incidental.

Unlisted classifications needed for work not included within the
scope of the classifications listed may be added after award only
as provided in the labor standards contract clauses (29 CFR
5.5(a) 1(ii)).

END OF GENERAL DECISION

SUBMITTAL REGISTER
(ER 415-1-10)

TITLE AND LOCATION		CONTRACTOR													CONTRACT NO.										
TRANS-MITTAL NUMBER	ITEM NUMBER	SPECIFICATION PARAGRAPH NUMBER	DESCRIPTION OF ITEM SUBMITTED	TYPE OF SUBMITTAL										CLASSIFICATION			CONTRACTOR SCHEDULE DATES		CONTRACTOR ACTION		GOVERNMENT ACTION		REMARKS	SPECIFICATION SECTION	
				DATA	DRAWINGS	INSTRUCTIONS	SCHEDULES	STATEMENTS	REPORTS	CERTIFICATES	SAMPLES	RECORDS	INFORMATION ONLY	GOVERNMENT APPROVED	REVIEWER	SUBMIT	APPROVAL NEEDED BY	MATERIAL NEEDED BY	CODE	DATE	SUBMIT TO GOVERNMENT	CODE			DATE
a.	b.	c.	d.	e.	f.	g.	h.	i.	j.	k.	l.	m.	n.	o.	p.	q.	r.	s.	t.	u.	v.	w.	x.	y.	z.
	1	C2A-7	Environmental Pollution Control and Disposal of Debris	X																					
	2	C2B-3	Clearing & Grubbing	X																					
	3	C2B-6.2	Disposal Permission		X																				
	4	C2C-3.2	Compaction Equipment	X																					
	5	C2C-4.5	Shoring Plan	X																					
	6	C2D-5.1	Fertilizer Certificates		X	X																			
	7	C2D-6.1	Fertilizer Invoices								X														
	8	C2D-6.2	Seed									X													
	9	C2E-2.1	Compliance Surveys	X	X																				
	10	C2F-3.1	Security Chain-Link Fence	X																					
	11	C2F-4.1	Security Fence	X																					
	12	C2G-5.1	Pile Driving Equipment	X																					
	13	C2G-5.2	Sheet Pile Shop Dwg.	X																					
	14	C2G-5.3	Materials Test Certificates								X														
	15	C2G-5.4	Driving Records									X													
	16	C2G-5.5	Details of Telephone Cables, 10" Siphon, and 50" Discharge Pipe	X	X	X																			
	17	C2G-8.1.1.3	Shop Dwg. of Alternate Piling	X																					
	18	C2G-8.1.1.3	Layout of Alternate Piling	X	X																				
	19	C2G-8.2	Rolled Corners	X	X																				
	20	C2H-4.1	Temporary Cofferdams	X	X																				
	21	C2H-5.2 & H-31	Breach Closures	X	X	X																			
	22	C2I-4.1	Utility Schedule																						
	23	C2I-4.2	Utility Shop Dwg.	X																					
	24	C2J-3.1	Demolition Plan	X	X							X													

SUBMITTAL REGISTER
(ER 415-1-10)

TITLE AND LOCATION		CONTRACTOR													CONTRACT NO.										
TRANS-MITTAL NUMBER	ITEM NUMBER	SPECIFICATION PARAGRAPH NUMBER	DESCRIPTION OF ITEM SUBMITTED	TYPE OF SUBMITTAL										CLASSIFICATION			CONTRACTOR SCHEDULE DATES			CONTRACTOR ACTION			GOVERNMENT ACTION		REMARKS
				DATA	DRAWINGS	INSTRUCTIONS	SCHEDULES	STATEMENTS	REPORTS	CERTIFICATES	SAMPLES	RECORDS	INFORMATION ONLY	GOVERNMENT APPROVED	REVIEWER	SUBMIT	APPROVAL NEEDED BY	MATERIAL NEEDED BY	CODE	DATE	SUBMIT TO GOVERNMENT	CODE	DATE		
a	b	c	d	e	f	g	h	i	j	k	l	m	n	o	p	q	r	s	t	u	v	w	x	y	
	25	C2K-5.1.3	Course Design Mix	X																					
	26	C3A-4.1	Formwork Shop Drawings	X	X																				
	27	C3A-4.2	Manufacturer's Literature	X																					
	28	C3A-4.3	Form Liner								X														
	29	C3A-5	Formwork Design	X	X																				
	30	C3B-5.1	Shop Drawings	X																					
	31	C3B-5.2	Test Reports						X																
	32	C3B-5.3	Disposition Records								X														
	33	C3B-7.3	Splicing	X																					
	34	C3C-5.1	Expansion Joint Test Reports						X																
	35	C3C-5.2	Expansion Joint Samples								X														
	36	C3D-5.1.1	Concrete Mixture Proportions	X																					
	37	C3D-5.1.2	Cement & Pozzolan	X						X															
	38	C3D-5.1.4	Non-Shrink Grout Plan	X	X																				
	39	C3D-5.1.5	Aggregates	X																					
	40	C3D-5.1.6	Water												X										
	41	C3D-5.2	Manufacturer's Certificate																						
	42	C3D-5.3.1	Batch Paint	X																					
	43	C3D-5.3.2	Concrete Mixers							X															
	44	C3D-5.3.3	Conveying							X															
	45	C3D-5.3.4	Placing							X															
	46	C3D-5.3.5	Joint Cleanup							X															

SUBMITTAL REGISTER
(ER 415-1-10)

TITLE AND LOCATION		CONTRACTOR																		CONTRACT NO.					
TRANS-MITTAL NUMBER	ITEM NUMBER	SPECIFICATION PARAGRAPH NUMBER	DESCRIPTION OF ITEM SUBMITTED	TYPE OF SUBMITTAL												CLASSIFICATION		CONTRACTOR SCHEDULE DATES			CONTRACTOR ACTION		GOVERNMENT ACTION		REMARKS
				DATA	DRAWINGS	INSTRUCTIONS	SCHEDULES	STATEMENTS	REPORTS	CERTIFICATES	SAMPLES	RECORDS	INFORMATION ONLY	GOVERNMENT APPROVED	REVIEWER	APPROVAL NEEDED BY	MATERIAL NEEDED BY	CODE	DATE	SUBMIT TO GOVERNMENT	DATE	CODE	DATE		
a	b	c	d	e	f	g	h	i	j	k	l	m	n	o	p	q	r	s	t	u	v	w	x	y	
	47	C3D-5.3.6	Curing				X																		
	48	C3D-5.3.7	Cold-weather Requirements				X																		
	49	C3D-5.3.8	Hot-Weather Requirements				X																		
	50	C3D-15.2.1	Fine Aggregate						X																
	51	C3D-15.2.2	Coarse Aggregate						X																
	52	C3D-15.2.3	Deleterious Substances						X																
	53	C3D-15.2.4	Scales						X																
	54	C3D-15.2.5	Batch-Paint Control						X																
	55	C3D-15.2.6	Concrete						X																
	56	C3D-15.2.7	Preparation for Placing						X																
	57	C3D-15.2.8	Placing						X																
	58	C3D-15.2.9	Vibrators						X																
	59	C3D-15.2.10	Curing						X																
	60	C3D-15.2.11	Protection						X																
	61	C3D-15.2.12	Mixer Uniformity						X																
	62	C5A-3.1	Shop Dwg.				X	X																	
	63	C5A-3.2	Manufacturer's Certificate							X															
	64	C5A-5.1	Settlement Reference Bolts				X																		
	65	C5B-3.1	Tests of Materials								X														
	66	C5B-4.1	Shop Dwg.				X																		
	67	C5B-4.2	Lists of Materials						X																
	68	C5B-4.3	Welding Procedures						X																
	69	C5B-4.4	Material Certificates								X														

SUBMITTAL REGISTER
(ER 415-1-10)

TITLE AND LOCATION		CONTRACTOR													CONTRACT NO.	SPECIFICATION SECTION										
TRANS-MITTAL NUMBER	ITEM NUMBER	SPECIFICATION PARAGRAPH NUMBER	DESCRIPTION OF ITEM SUBMITTED	TYPE OF SUBMITTAL										CLASSIFICATION			CONTRACTOR SCHEDULE DATES			CONTRACTOR ACTION			GOVERNMENT ACTION			REMARKS
				DATA	DRAWINGS	INSTRUCTIONS	SCHEDULES	STATEMENTS	REPORTS	CERTIFICATES	SAMPLES	RECORDS	INFORMATION ONLY	GOVERNMENT APPROVED	REVIEWER	SUBMIT	APPROVAL NEEDED BY	MATERIAL NEEDED BY	CODE	DATE	SUBMIT TO GOVERNMENT	CODE	DATE	CODE	DATE	
a.	b.	c.	d.	e.	f.	g.	h.	i.	j.	k.	l.	m.	n.	o.	p.	q.	r.	s.	t.	u.	v.	w.	x.	y.		
	70	C5B-8	Castings		X																					
	71	C5B-10.1.3	Welding Schedule			X																				
	72	C5B-10.1.4	Welder Qualifications					X																		
	73	C5B-10.1.7.4	Welding Repair Plan	X	X																					
	74	C16B-6.1	UL Publications			X										DD										
	75	C16B-6.3	Shop Dwg.	X	X											DD										
	76	C16B-12.1	Medium Voltage Cable	X	X											DD										
	77	C16B-27.8	Splicer Information					X								DD										
	78	H-15	Certificates of Compliance								X															
	79	H-22	Utility Owner's Notification									X														
	80	H-25	Aggregate Sources			X																				
	81	H-27	Stone Sources			X																				
	82	H-30	Traffic Control	X	X																					
	83	H-32	Coordination of Work									X														
	84	H-33	Order of Work	X	X																					

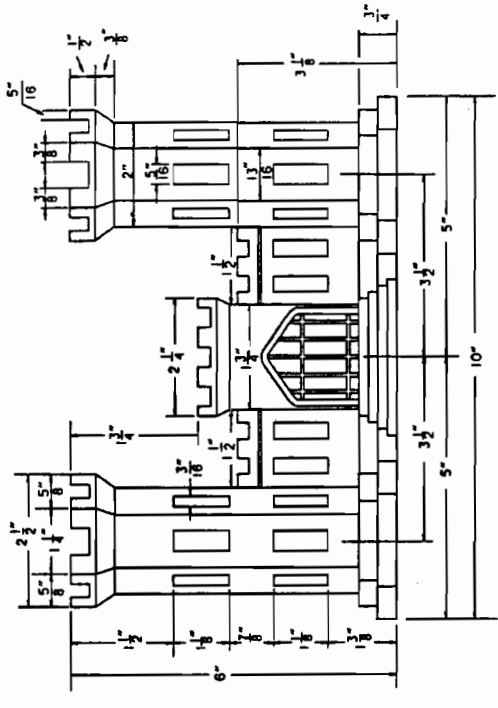
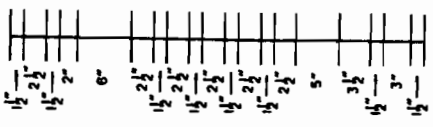
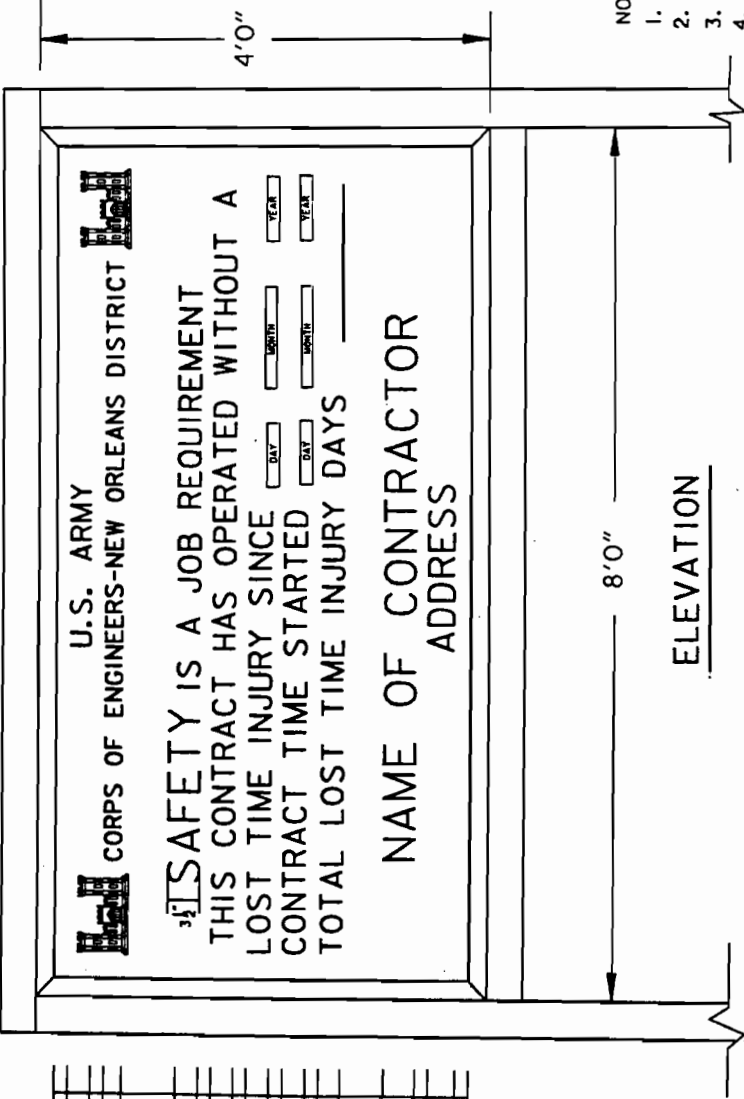

ENGINEER CASTLE DETAIL

NOTES:

1. CONTRACTOR SHALL CONSTRUCT AND MAINTAIN A DURABLE SIGN AS SHOWN.
2. WOOD IN CONTACT WITH GROUND SHALL BE TREATED LUMBER.
3. ALL EXPOSED SURFACES SHALL BE WHITE HOUSE PAINT.
4. LETTERING SHALL BE BLACK.
5. ENGINEER CASTLE SHALL BE RED. DECALS FURNISHED BY GOVERNMENT MAY BE USED IN LIEU OF DETAIL.
6. 22 GA. STEEL METAL MAY BE USED IN LIEU OF PLYWOOD.

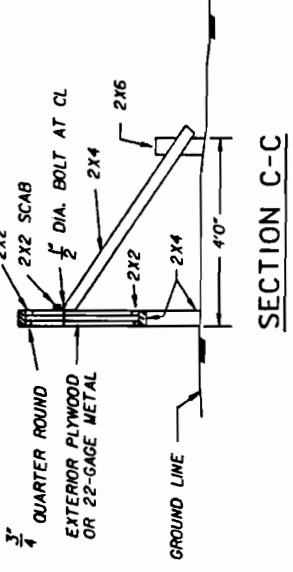
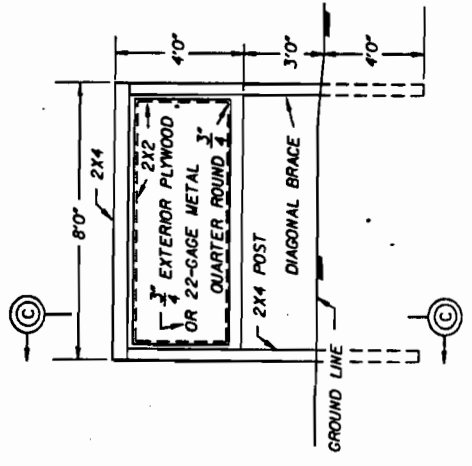

SCALE: NONE

1 FEB 1992

U S ARMY ENGINEER DISTRICT NEW ORLEANS
CORPS OF ENGINEERS
NEW ORLEANS LOUISIANA



SAFETY SIGN

Below are two samples of the construction project identification sign showing how this panel is adaptable for use to identify either military (top), or civil works projects (bottom). The graphic format for this 4' x 6' sign panel follows the legend guidelines and layout as specified below. The large

4' x 4' section of the panel on the right is to be white with black legend. The 2' x 4' section of the sign on the left with the full Corps signature (reverse version) is to be screen printed Communications Red on the white background.

page- Mounting and fabrication details are provided on page 16.4.

Special applications or situations not covered in these guidelines should be referred to the District/Division sign coordinator.

~~This sign is to be placed with the Safety-Performance Sign shown on the following~~

Legend Group 1: One- to two-line description of Corps relationship to project.
Color: White
Typeface: 1.25" Helvetica Regular
Maximum line length: 19"

Legend Group 2: Division or District Name (optional). Placed below 10.5" Reverse Signature (6" Castle).
Color: White
Typeface: 1.25" Helvetica Regular

Legend Group 3: One- to three-line project title legend describes the work being done under this contract.
Color: Black
Typeface: 3" Helvetica Bold
Maximum line length: 42"

Legend Group 4: One- to two-line identification of project or facility (civil works) or name of sponsoring department (military).
Color: Black
Typeface: 1.5" Helvetica Regular
Maximum line length: 42"

Cross-align the first line of Legend Group 4 with the first line of the Corps Signature (US Army Corps) as shown.

Legend Groups 5a-b: One- to five-line identification of prime contractors including: type (architect, general contractor, etc.), corporate or firm name, city, state. Use of Legend Group 5 is optional.
Color: Black
Typeface: 1.25" Helvetica Regular
Maximum line length: 21"

All typography is flush left and rag right, upper and lower case with initial capitals only as shown. Letter- and word-spacing to follow Corps standards as specified in Appendix D.

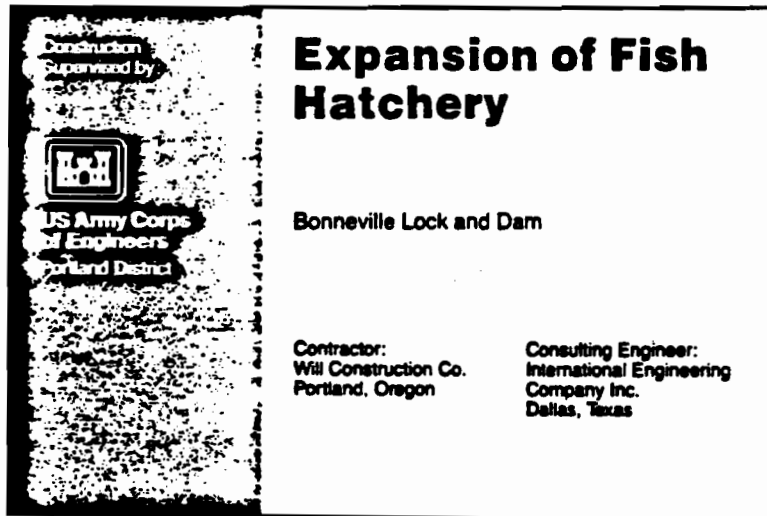
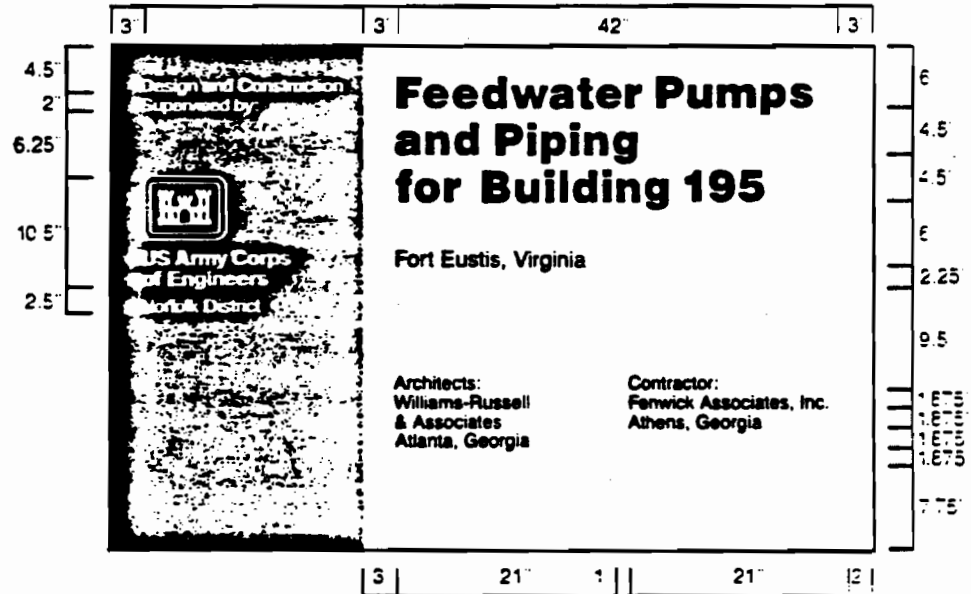

Sign Type	Legend Size	Panel Size	Post Size	Specification Code	Mounting Height	Color Bkg/Lgd
CID-01	various	4' x 6"	4' x 4"	HDO-3	48"	WH-RD/BK

All Construction Project Identification signs and ~~Safety Performance signs~~ are to be fabricated and installed as described below. The signs are to be erected at a location designated by the contracting officer and shall conform to the size, format, and typographic standards shown on

pages 16.2-3. Detailed specifications for HDO plywood panel preparation are provided in Appendix B.

For additional information on the proper method to prepare sign panel graphics, contact the District sign coordinator.

Shown below the mounting diagram is a panel layout grid with spaces provided for project information. Photocopy this page and use as a worksheet when preparing sign legend orders.

The sign panels are to be fabricated from .75" High Density Overlay Plywood. Panel preparation to follow HDO specifications provided in Appendix B.

Sign graphics to be prepared on a white non-reflective vinyl film with positionable adhesive backing.

All graphics except for the Communications Red background with Corps signature on the project sign are to be die-cut or computer-cut non-reflective vinyl, pre-spaced legends prepared in the sizes and typefaces specified and applied to the background panel following the graphic formats shown on pages 16.2-3.

The 2' x 4' Communications Red panel (to match PMS-032) with full Corps signature (reverse version) is to be screen printed on the white background. Identification of the District or Division may be applied under the signature with white cut vinyl letters prepared to Corps standards. Large scale reproduction artwork for the signature is provided on page 4.8 (photographically enlarge from 6.875" to 10.5").

Drill and insert six (6) .375" T-nuts from the front face of the HDO sign panel. Position holes as shown. Flange of T-nut to be flush with sign face.

Apply graphic panel to prepared HDO plywood panel following manufacturers' instructions.

Sign uprights to be structural grade 4" x 4" treated Douglas Fir or Southern Yellow Pine, No.1 or better. Post to be 12' long. Drill six (6) .375" mounting holes in uprights to align with T-nuts in sign panel. Countersink (.5") back of hole to accept socket head cap screw (4" x .375").

Assemble sign panel and uprights. Imbed assembled sign panel and uprights in 4' hole. Local soil conditions and/or wind loading may require bolting additional 2" x 4" struts on inside face of uprights to reinforce installation as shown.

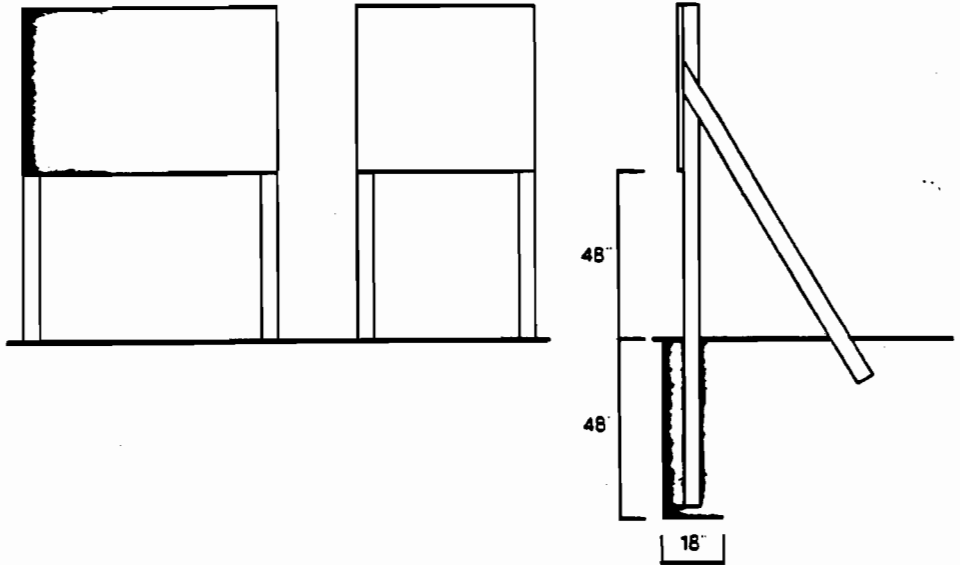

Construction Project Sign
Legend Group 1: Corps Relationship

- 1. _____
- 2. _____

Legend Group 2: Division/District Name

- 1. _____
- 2. _____

Legend Group 3: Project Title

- 1. _____
- 2. _____
- 3. _____

Legend Group 4: Facility Name

- 1. _____
- 2. _____

Legend Group 5a: Contractor/A&E

- 1. _____
- 2. _____
- 3. _____
- 4. _____
- 5. _____

Legend Group 5b: Contractor/A&E

- 1. _____
- 2. _____
- 3. _____
- 4. _____
- 5. _____

~~Safety Performance Sign~~
~~Legend Group 1: Project Title~~

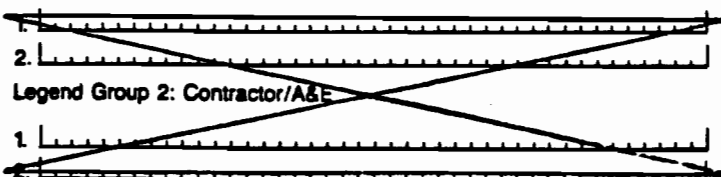

**Specifications: General Conditions
(Cont'd.)**

B.2b

6. Engineering Criteria (Cont'd)

The required footing size and depth as specified in the two right columns of the diagram below, will depend on the criteria listed in the aforementioned columns. Use the diagram to select the appropriate footing configuration. Any conditions that go beyond the criteria shown below shall be engineered on a site-by-site basis.

Footing Diagram

Post Size	Frost Depth	Post Number	HAGL	Panel Size (sq. ft.)	Panel Height	Footing Cross Section	Footing Depth
4" x 4", 4" x 6", 6" x 6"	0" - 30"	1	42"	≤9	≤4' - 6"	1' - 6"	2' - 6"
					>4' - 6"	1' - 6"	4' - 0"
				>9	na	1' - 6"	4' - 0"
			60"	≤7	≤3' - 6"	1' - 6"	2' - 6"
				>3' - 6"	1' - 6"	4' - 0"	
		>7		na	1' - 6"	4' - 0"	
		2	42"	≤20	≤5' - 0"	1' - 6"	2' - 6"
				>5' - 0"	1' - 6"	4' - 0"	
	>20			na	1' - 6"	4' - 0"	
		60"		≤16	≤4' - 0"	1' - 6"	2' - 6"
				>4' - 0"	1' - 6"	4' - 0"	
	>16			na	1' - 6"	4' - 0"	
4" x 4", 4" x 6", 6" x 6"	30" - 36"	1	42"	≤10	≤5' - 0"	1' - 6"	3' - 0"
					>5' - 0"	1' - 6"	4' - 0"
				>10	na	1' - 6"	4' - 0"
			60"	≤9	≤4' - 6"	1' - 6"	3' - 0"
				>4' - 6"	1' - 6"	4' - 0"	
		>9		na	1' - 6"	4' - 0"	
		2	42"	≤24	≤6' - 0"	1' - 6"	3' - 0"
				>6' - 0"	1' - 6"	4' - 0"	
	>24			na	1' - 6"	4' - 0"	
		60"		≤20	≤5' - 0"	1' - 6"	3' - 0"
				>5' - 0"	1' - 6"	4' - 0"	
	>20			na	1' - 6"	4' - 0"	
4" x 4", 4" x 6", 6" x 6"	36" - 48"	1,2	na	na	na	1' - 6"	4' - 0"
6" x 8", 9" x 9"	0" - 48"	1,2,3	na	na	na	2' - 0"	4' - 0"

1.1 Sign

1. Materials

Panel shall be fabricated from HDO plywood, 60-60 non-oiled resin impregnated fiber, black in color. All Douglas Fir exterior marine-grade, to meet product standard PSI-83; or all exterior plywood PSI-83 group 1, with B grade veneers on both sides. Each panel should be edge-branded marine-grade HDO EXT PSI-83; or HDO B-B G I EXT PSI-83, 7 PLY.

Panel shall be .75" thick unless otherwise specified. Panel dimensions shall have a tolerance of ±.125". No cleats or joints shall be permitted for panels with a dimension smaller than or equal to 10'-5".

Panels shall have corners with a safety radius of .187" unless otherwise specified.

Edges shall be rounded or beveled to a radius of .09375".

All surfaces shall be flat and smooth. Core gaps to be filled with polyester body filler, Bondo, or approved equal. Finish-sand all edges and panel face. Back surface shall be sanded with 50-60 grit sand paper.

All drilling shall be done with high-speed drills, using solid backing to avoid chipping.

All cutting shall be done with high-speed saws. Rotary saw blades to be carbide tipped. Power saws shall have little or no set and as much lead as possible. Blades on table saws shall not extend more than 1", and not less than .5" through panel. Panels will be fed through slowly to avoid damage to overlay.

Panels to be stored shall be stacked flat on a clean surface in an enclosed and well-ventilated area; do not store on concrete surfaces.

Wood frame shall be constructed of construction heart Redwood lumber. Dimension length of frame 2" longer than finished panel, to create a reveal. Lumber sizes vary depending on post dimensions.

Post Size	Lumber
6"	2" x 4"
9"	4" x 4"
12"	4" x 4"

Intermediate support members shall be installed for large size panels.

Panel Size	Support Member(s)
0'-0" to 5'-11"	0
6'-0" to 11'-11"	1
12'-0" to 17'-11"	2
18'-0" and up	3

Metal frame shall be fabricated from Aluminum 6061-T6 "Z" bar, 3" x 2.6875" x 2.6875". Construction, attachment and placement is described on specific sign panel pages where reinforcement may be required.

Solid post shall be fabricated of one piece construction heart Redwood lumber, per grading rules of the California Redwood Association, or better. For dimensions larger than 4" x 4", treated Douglas Fir No.1 or better; Southern Yellow Pine No.1 or better shall be used. All post sizes shall be .5" less than nominal dimensions, and will be sanded smooth prior to finishing. All materials shall be well-seasoned and free of any defects. Douglas Fir and Yellow Pine shall be weathered a minimum of one (1) year after installation prior to stain application.

Glue-laminated post can be used as an alternate for dimensions 4" x 6" or larger and shall be constructed of clear heart, kiln-dried Redwood only.

All complete sign panel and post assemblies must be pre-drilled and assembled in the shop prior to shipment to check alignment and ensure proper fit once installed. Panels manufactured as separate units shall be pre-drilled with hardware inserted in place.

1.2 Hardware

Panel attachment to post or brace shall be 3/8" socket head cap screws, 3/8" washers and 4-prong straight barrel T-nuts. T-nut to be countersunk and back-filled with Bondo, or approved equal, flush to front of panel. Cap screw head to be countersunk a minimum of .25" below the surface of post.

Panel attachment to frame shall be
 - 2" x 2" aluminum keyhole receiving plate, to be attached to panel with four (4) No.12 flat head wood screws. A slot of .5" deep shall be routed to receive hex bolt.
 - .375" lag bolt with .5625" hex head and .5625" hex nut. Bolt shall be threaded through frame leaving .125" of shaft expos-

ed on either side after attaching hex nut. Panel with keyholes is hung on hex head or nut. Four (4) keyholes shall be used per panel for dimensions up to 8'-0". Larger panels must use six (6) plates per panel.

Wood frame assembly hardware shall be 2" x 2" or 3" x 3" aluminum angle bracket, to be attached to frame with six (6) .375" lag bolts, or approved equal.

Wood frame attachment hardware shall be .5" x 6" lag bolts to attach frame to sign posts.

1.3 Laminates

Adhesive for post construction and duplex HDO panels shall be phenolic resornicol moisture resistant, or approved equal. Application must be performed within 15 minutes between the first glue application and the final setting of the clamps. The surface of each joint face shall be completely covered with adhesive.

Air temperature shall be between 70-90 degrees Fahrenheit during drying of

boards, glue application and curing process. Lumber to be dried not less than 24 hours prior to gluing.

Moisture contents of lumber to be glued shall be between 12-15%, with a 3% margin between wettest and driest piece.

Surface joints shall be smooth and true, free from machine joining marks and chipped or loosened grain.

1.4 Finishes

Paint shall be Benjamin Moore No.120-60 poly-silicone enamel, or approved equal. Apply one (1) coat to the back and edge of the panel as a primer, prior to application of retro-reflective sheeting, and one (1) coat after application to seal the edge. Sheeting shall be masked before painting, and shall be removed immediately after enamel application. A minimum of 4±.25 mil. dry film thickness shall be applied (two generous coats). Front of panel where retro-reflective sheeting will be applied shall not be painted.

Stain shall be semi-transparent waterproof, anti-bacterial redwood stain to match Corps Brown, Olympic brand redwood stain No. 715, or approved equal. Apply with brush or roller to posts. Stain shall be thoroughly mixed prior to and during application to ensure even pigmentation. Posts will be dried a minimum of 24 hours prior to shipping.

Paint room facilities shall be well-ventilated, dust-free and enclosed. Air temperature shall not be less than 65 degrees Fahrenheit during application of paint.

Cleaning of the panels shall be performed prior to application of paint or retro-reflective sheeting, to remove parting agent on panel surface. Areas to be painted shall be scrubbed with petroleum hydrocarbon solvent, Toluene, Socal No. 1, or approved equal, using an abrasive synthetic fiber pad. Wipe the surface clean with mineral spirits.

Finished sanding shall be performed prior to the application of the first and second coat of paint. Paint must be thoroughly dried before sanding. All sanding residue shall be removed from the sign with tack cloth. Do not sand panel after applying the second coat of finish paint.

2. Graphics

2.1 Retro-reflective sheeting

Background and legend shall be engineer grade, premium quality, wide angularity enclosed lens retro-reflective material to meet or exceed the standards of:

– General Services Administration, Federal Supply Service specification *L-S-300-C, Reflectivity 1*.

– U.S. Department of Transportation, Federal Highway Administration, *Standard Specifications for Construction of Roads and Bridges on Federal Highway Projects*, current edition *FP-85 Sections 633.06 and 718.01*.

Background and legend shall use sheeting from the same manufacturer. Mixing of sheeting from different manufacturers shall not be permitted.

No more than twelve (12) months will have elapsed from date of purchase to the date of application.

Background application to HDO Plywood shall be as described by the manufacturer and approved by the designated representative of the Corps of Engineers. Corps Brown and all highway colors may be either pressure-sensitive or heat-activated applied. Special waterway colors are only available with pressure-sensitive adhesive.

Panels shall be covered with one unspliced sheet, unless the dimension is

larger than 48" in vertical direction. Splices shall be positioned so as not to fall within legends. Top piece shall overlap bottom piece by a minimum of .5", but not more than .75". Spliced sheets shall be color matched.

Background shall be adhered to front of sign panel prior to legend application.

Legend application shall be as described by the manufacturer and approved by the designated representative of the Corps of Engineers and may be either pressure-sensitive or heat-activated applied. No loose or curled edges, bubbles or blisters shall be permitted.

Legend shall be adhered to sign panel after application of background sheeting.

Top edge treatment shall be Avery No.961, 3M No.639 clear film 3" wide, or approved equal. Film shall be applied in 24" strips, beginning from each outside edge and taping toward center of sign. Film shall overlap at least 2" at each joint.

Heat-activated sheeting shall be double-cycled through the vacuum applicator, one time when applying the background sheeting and one time when applying the legend.

~~All items listed below shall conform to material specifications as described on page B.4-4b for HDO plywood signs, unless otherwise instructed on this page.~~

1 Panel, .75" thick.

2 Solid or glue laminated post, 4" x 4", 4" x 6", 6" x 8", or 8" x 8". Post size shown here reflects the HAGL and does not include the section under ground. For footing see page B.2a-b.

3a-c Panel attachment hardware. For attachment see detail 5, page B.7-2.

~~NOTE: Double-faced signs shall be installed identical to single-faced signs, with a second sign panel mounted flush to the back of the sign post, see detail 6, page B.7-2. After mounting, cover socket head cap screw with circular patch of retro reflective sheeting matching panel sign face.~~

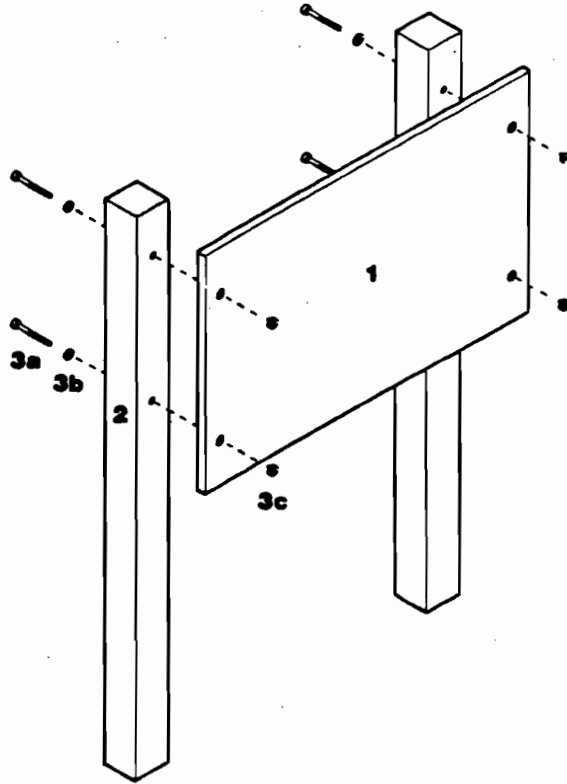

Exploded View

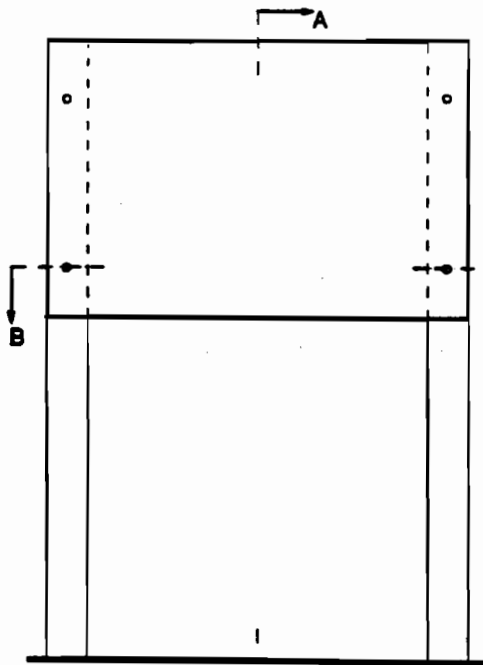

Front View

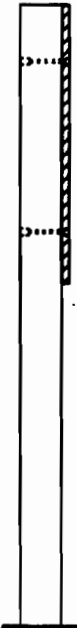

Cross Section A-A



Cross Section B-B

~~All items listed below shall conform to material specifications as described on page B.4-4a for HDO plywood signs, unless otherwise instructed on this page.~~

1 Panel, .75" thick. Panel may require reinforcement, using a "Z" bar attached to the back of the sign panel. See page B.4-4a for further specifications. Splices shall be fabricated as per manufacturers' instructions. In case a splice occurs at location of a "Z" bar, apply .75" HDO back piece(s) to act as full-length shims at location of other "Z" bar(s).

2 Solid or glue laminated post, 4" x 4", 4" x 6", 6" x 6", or 6" x 8". Post size shown here reflects the HAGL and does not include the section under ground. For footing and numbers of posts see pages B.2a-b and B.4-4a. An additional third post shall be positioned equally between the two other posts.

3a Panel attachment hardware, .375" socket head cap screws, .375" washers and 4-prong straight barrel T-nuts. T-nut to be countersunk and backfilled with Bondo or approved equal, flush to front of panel. Cap screw head to be countersunk a minimum of .25" below the surface of post. For attachment, see detail 5, page B.7-2.

3b Additional panel hardware, 3" x 2.6875" x 2.6875" "Z" bar .25" thick, .375" washers, .375" hex nuts, .25" 4-prong T-nuts, and .25" hex head cap screws. To be used when "Z" bar is applied for reinforcement, as specified in the diagram on page B.4-4a. For attachment, see detail 8, page B.7-3.

NOTE: Sign construction and panel attachment varies with panel size. For correct placement see following page B.4-4a.

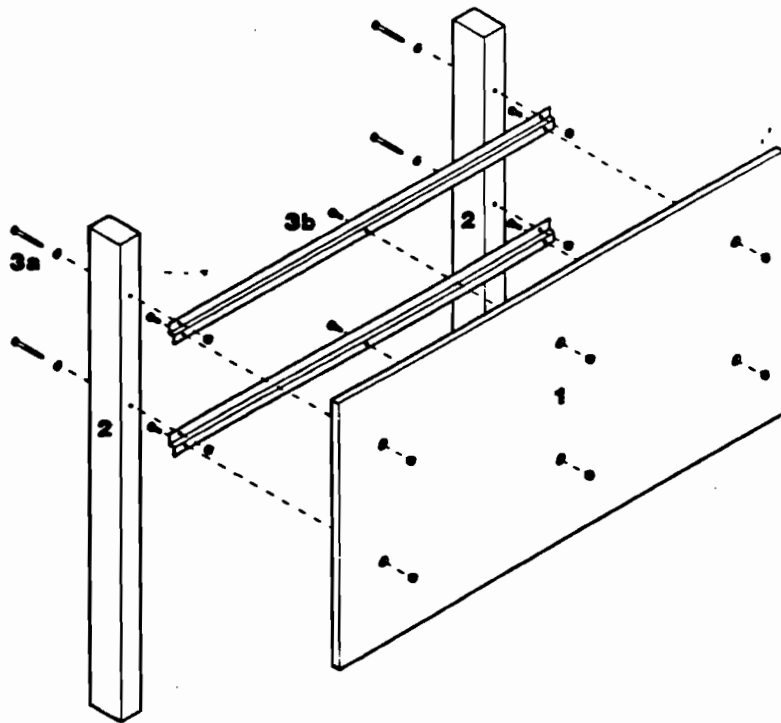

Exploded View

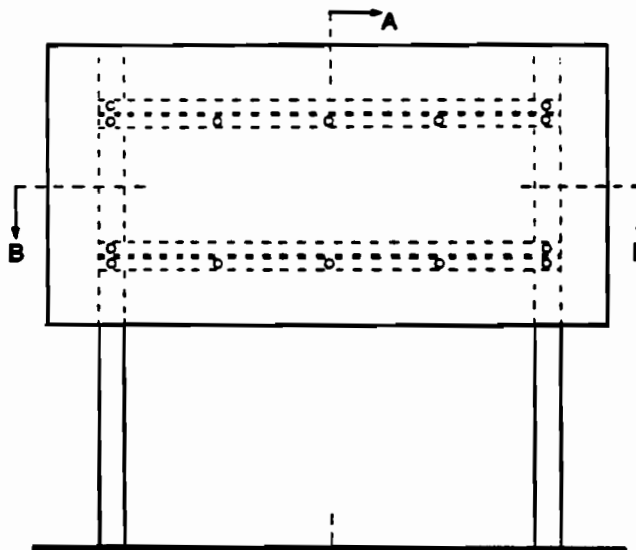

Front View

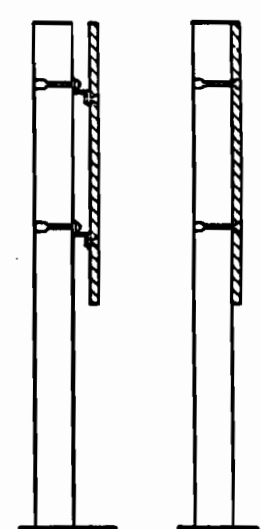

Cross Section A-A, With "Z" Bar

Cross Section A-A, Without "Z" Bar



Cross Section B-B, With "Z" Bar



Cross Section B-B, Without "Z" Bar

Detail 3

- A** .3125" socket head cap screw and .3125" washer, countersunk at least .25" from the surface of the sign post.
- B** Solid or glue laminated post.
- C** Sign panel with 2" x 1.25" routed endstrip creating a .5" reveal.

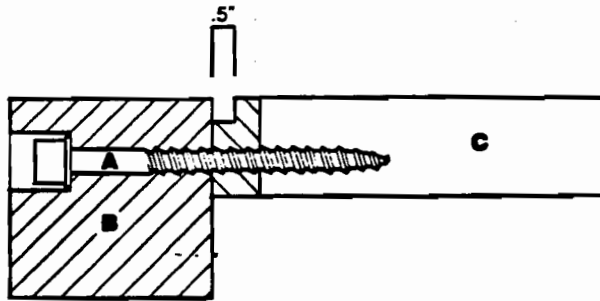

Detail 4

- A** .3125" socket head cap screw and .3125" washer, countersunk at least .25" from the surface of the sign post.
- B** Solid or glue laminated post.
- C** Sign panel with 2" x 1.25" routed endstrip creating a .5" reveal.

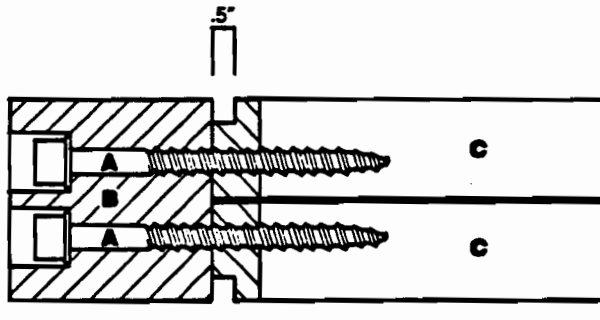

Detail 6

- A** .375" socket head cap screws and .375" washer, countersunk at least .25" from the surface of the sign post.
- B** .375" 4-prong straight barrel T-nut, countersunk and back-filled with Bondo or approved equal, flush to the front of the panel.
- C** Retro-reflective sheeting, applied after insertion of the hardware to the sign panel.
- D** Solid or glue laminated post.
- E** HDO sign panel.

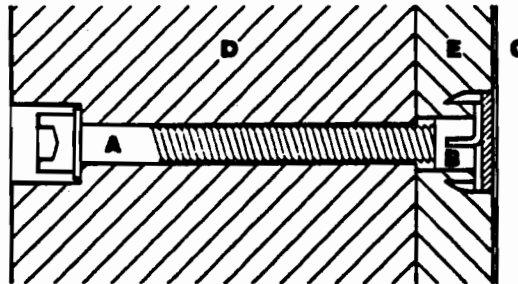

Detail 6

- A** .375" socket head cap screw and .375" washer, countersunk flush to the front of the sign panel.
- B** .375" 4-prong straight barrel T-nut, countersunk and back-filled with Bondo or approved equal, flush to the front of the panel.
- C1** Retro-reflective sheeting, applied after insertion of the hardware to the sign panel.
- C2** Retro-reflective circular patch matching panel sign face.
- D** Solid or glue laminated post.
- E** HDO sign panel.

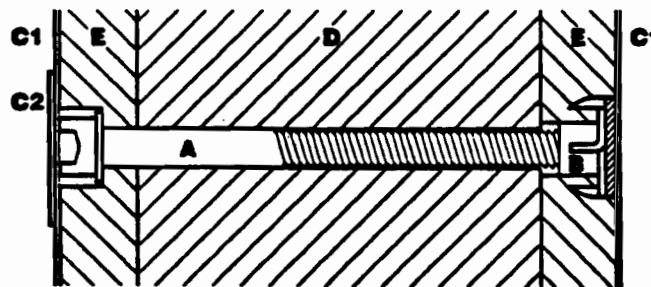

Detail 7

- A** .375" socket head cap screw and .375" washer, countersunk at least .25" from the surface of the sign face.
- B** .375" metal or plastic capped nut.
- C** Retro-reflective sheeting.
- D** Solid or glue laminated post.
- E** Aluminum sign panel.

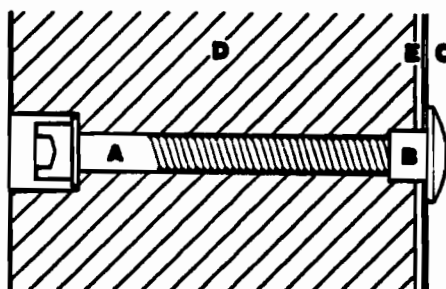

Detail 8

A .25" stainless steel hex head cap screw with .25" flat stainless steel and .25" PVC washer.

B .25" 4-prong straight barrel T-nut, countersunk and back-filled with Bondo or approved equal, flush to the front of the panel.

C 3" x 2.6875" x 2.6875" aluminum 6061-T6 "Z" bar, .25" thick.

D .375" socket head cap screw and .375" washer, countersunk at least .25" from the surface of the sign post.

E .375" zinc-plated hex nut with .375" zinc-plated flat washer.

F Glue laminated or solid post.

G HDO sign panel.

H Retro-reflective sheeting, applied after insertion of the hardware to the sign panel.

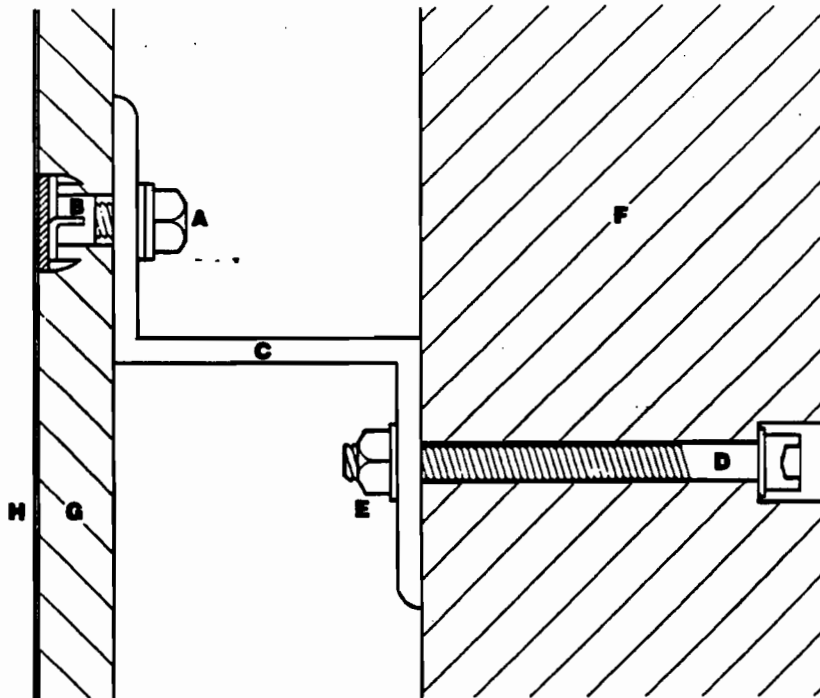

A 4" reverse version of the Corps of Engineers Communication Mark/Signature is shown on the inside of this foldout. This artwork has been prepared for applications to signage only and is not intended for other applications.

Some notes to remember when using the Mark:

- Reproduce art for signs using a distortion-free photo-mechanical process. Do not re-size the art by hand.
- Enlarge or reduce the Mark as a complete unit. Do not re-assemble as parts.

The height and width of sign panels for most of the signs in this manual are based on the size of the lettering (legend size) and length of the longest message line. The legend size, known as A, is determined by the viewing distance required. Using the sign format grid for the given

sign type, the panel height can then be established.

Legend length depends on the amount and length of words in the legend. Standardized signs have established legends; their lengths have been measured and the panel widths calculated. The dimen-

sions are shown in the matrix for each sign. For site specific signs (identification and directionals), legend lengths must be calculated on an individual basis. The system explained below will accurately determine the length of a given legend.

Step 1: Using the worksheet for the appropriate typeface (Helvetica Bold, page D.3; Helvetica Medium, page D.5), write out the legend, placing one character in each of the legend squares. A character is a letter-form, number or punctuation mark. Leave a blank square between each word. Write out the legend exactly as it will appear on the sign panel, using upper and lower case letters.

Letter-space															
Legend	J	.		P	e	r	c	y		P	r	i	e	s	t.
Letter-width															

Letter-space															
Legend		D	a	m		k		L	a	k	e				
Letter-width															

Step 2: In the space under each letter, put in the corresponding letter-width dimension from the table on the left of the worksheet. In the area above the space between letters, put in the value from the letter-spacing matrix for that typeface, (Helvetica Bold, page D.9; Helvetica Medium, page D.12). Note that some of the values in the matrix are negative. Below the blank space between words, put the value for the spacing square for that typeface (Helvetica Bold, .63, Helvetica Medium, .44). Treat the spacing square like any other character, putting in the appropriate letter-space from the matrix before and after it.

Letter-space		.23	.09	.36	.19	.23	.14	.05	.23	.36	.19	.23	.23	.19	.09	.33
Legend	J	.		P	e	r	c	y		P	r	i	e	s	t.	
Letter-width		1.48	.56	.63	1.77	1.58	1.06	1.52	1.64	.63	1.77	1.06	.55	1.56	1.47	1.0

Letter-space		.36	.19	.33	.36	.23	.05	.36	.19	.33	.05					
Legend		D	a	m		k		L	a	k	e					
Letter-width		.63	1.89	1.52	2.42	.63	2.0	.63	1.48	1.52	1.56	1.56				

Step 3: Add up all of the values in the top and bottom squares for each word. For long legends, it is helpful first to make subtotals for each word and word-space, mark them down, and then total all of the word lengths plus the word-spaces. This way, if the legends must be placed on more than one line, or the line break changes, the calculations for the new lines will be simple.

Letter-space		.23	.09	.36	.19	.23	.14	.05	.23	.36	.19	.23	.23	.19	.09	.33
Legend	J	.		P	e	r	c	y		P	r	i	e	s	t.	
Letter-width		1.48	.56	.63	1.77	1.58	1.06	1.52	1.64	.63	1.77	1.06	.55	1.56	1.47	1.0
		2.27	1.1		8.18			1.24		6.69						

Letter-space		.36	.19	.33	.36	.23	.05	.36	.19	.33	.05					
Legend		D	a	m		k		L	a	k	e					
Letter-width		.63	1.89	1.52	2.42	.63	2.0	.63	1.48	1.52	1.56	1.56				
		1.94	6.35		1.24	2.0	1.06		6.75							

Step 4: Add up all of the subtotals, both words and word-spaces. Divide this sum by 2. The result represents the legend length in relationship to A, legend size.

Total : 40.2
 $40.2 \div 2 = 20.1 A$

Step 5: To determine panel sizes for identification signs, use the worksheet on page D.4. For directional signs, use the worksheet on page D.6. For other signs, multiply the legend length by the legend size, A, to be used on the sign; round off to the nearest .125". This total will be the actual legend length. Refer to the appropriate grid to determine the actual panel size.

If A = 4' ; $20.1 \times 4' = 80.4'$
 Round off to 80.5'

Upper case	Lower case
A 2.08	a 1.52
B 1.80	b 1.59
C 1.94	c 1.52
D 1.89	d 1.59
E 1.70	e 1.58
F 1.58	f 1.03
G 1.94	g 1.55
H 1.81	h 1.52
I 0.83	i 0.55
J 1.48	j 0.55
K 2.02	k 1.58
L 1.48	l 0.56
M 2.16	m 2.42
N 1.83	n 1.53
O 2.03	o 1.60
P 1.77	p 1.58
Q 2.05	q 1.59
R 1.80	r 1.06
S 1.78	s 1.47
T 1.73	t 1.00
U 1.83	u 1.52
V 1.92	v 1.64
W 2.77	w 2.48
X 2.16	x 1.61
Y 2.06	y 1.64
Z 1.73	z 1.38

Numerals	Punctuation
1 1.05	\$ 1.63
2 1.63	& 2.00
3 1.63	- 0.89
4 1.72	: 0.56
5 1.69	,
6 1.72	. 0.56
7 1.55	
8 1.69	
9 1.69	
0 1.75	

Spacing Square
□ 0.63

Letter-space																				
Legend	□	□	□	□	□	□	□	□	□	□	□	□	□	□	□	□	□	□	□	□
Letter-width																				

Letter-space																				
Legend	□	□	□	□	□	□	□	□	□	□	□	□	□	□	□	□	□	□	□	□
Letter-width																				

Letter-space																				
Legend	□	□	□	□	□	□	□	□	□	□	□	□	□	□	□	□	□	□	□	□
Letter-width																				

Letter-space																				
Legend	□	□	□	□	□	□	□	□	□	□	□	□	□	□	□	□	□	□	□	□
Letter-width																				

Letter-space																				
Legend	□	□	□	□	□	□	□	□	□	□	□	□	□	□	□	□	□	□	□	□
Letter-width																				

Letter-space																				
Legend	□	□	□	□	□	□	□	□	□	□	□	□	□	□	□	□	□	□	□	□
Letter-width																				

Letter-space																				
Legend	□	□	□	□	□	□	□	□	□	□	□	□	□	□	□	□	□	□	□	□
Letter-width																				

Letter-space																				
Legend	□	□	□	□	□	□	□	□	□	□	□	□	□	□	□	□	□	□	□	□
Letter-width																				

Letter-space																				
Legend	□	□	□	□	□	□	□	□	□	□	□	□	□	□	□	□	□	□	□	□
Letter-width																				

Letter-space																				
Legend	□	□	□	□	□	□	□	□	□	□	□	□	□	□	□	□	□	□	□	□
Letter-width																				

Upper case	Lower case
A 1.81	a 1.34
B 1.64	b 1.45
C 1.88	c 1.41
D 1.70	d 1.44
E 1.51	e 1.47
F 1.45	f 0.84
G 1.88	g 1.44
H 1.64	h 1.33
I 0.44	i 0.38
J 1.3	j 0.39
K 1.75	k 1.44
L 1.40	l 0.39
M 2.00	m 2.16
N 1.66	n 1.33
O 1.94	o 1.52
P 1.53	p 1.45
Q 1.94	q 1.45
R 1.59	r 0.83
S 1.67	s 1.31
T 1.66	t 0.88
U 1.61	u 1.30
V 1.70	v 1.36
W 2.56	w 2.10
X 1.78	x 1.48
Y 1.70	y 1.42
Z 1.70	z 1.27

Numerals	Punctuation
1 0.91	\$ 1.63
2 1.44	& 1.78
3 1.53	- 0.78
4 1.59	: 0.44
5 1.53	, 0.44
6 1.59	. 0.44
7 1.41	
8 1.59	
9 1.56	
0 1.66	

Spacing Square
□ 0.44

Letter-space														
Legend	□	□	□	□	□	□	□	□	□	□	□	□	□	□
Letter-width														

Letter-space														
Legend	□	□	□	□	□	□	□	□	□	□	□	□	□	□
Letter-width														

Letter-space														
Legend	□	□	□	□	□	□	□	□	□	□	□	□	□	□
Letter-width														

Letter-space														
Legend	□	□	□	□	□	□	□	□	□	□	□	□	□	□
Letter-width														

Letter-space														
Legend	□	□	□	□	□	□	□	□	□	□	□	□	□	□
Letter-width														

Letter-space														
Legend	□	□	□	□	□	□	□	□	□	□	□	□	□	□
Letter-width														

Letter-space														
Legend	□	□	□	□	□	□	□	□	□	□	□	□	□	□
Letter-width														

Letter-space														
Legend	□	□	□	□	□	□	□	□	□	□	□	□	□	□
Letter-width														

Letter-space														
Legend	□	□	□	□	□	□	□	□	□	□	□	□	□	□
Letter-width														

Letter-space														
Legend	□	□	□	□	□	□	□	□	□	□	□	□	□	□
Letter-width														

In cases where computer-generated letter systems are not available, a letter-spacing guide and legend preparation system may be obtained through the Corps national sign coordinator.

The Corps letter-spacing guide uses a transparent letter assembly system. Letters, numerals and punctuation are printed on separate pieces of acetate. The

capital letters are 2" high; the lower case letters and punctuation are at their corresponding sizes. The legends are assembled at this capital letter height and photographically enlarged or reduced to create camera-ready artwork for any size sign. The acetate cells can be re-used indefinitely.

On the letter cells, printed above and

below the letters are alignment lines with marks indicating the right and left outermost edges of each letter (see Illustration a). The illustrations and instructions below will explain how to use the cells.

Please be sure to indicate the weight of Helvetica required (Bold, Medium, Regular) when requesting a set of cells.

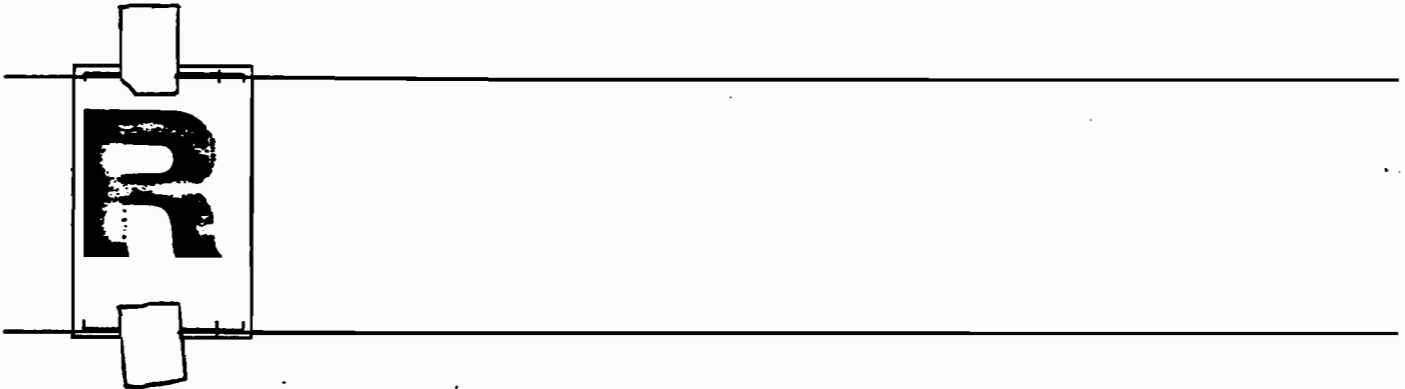

Illustration a



Illustration b



Illustration c

Letter-spacing Guide Instructions

Step 1: Draw two horizontal parallel lines, 3.5" apart and long enough to accommodate the words to be assembled. These lines will serve as a guide for aligning the corresponding lines on the acetate cells.

Step 2: Tape the first letter in place by aligning the lines on the acetate cells with the lines drawn in step one.

Step 3: Tape each subsequent letter in place by referring to the letter-spacing matrix for that typestyle: Helvetica Bold (page D.9),

Helvetica Medium (page D.12), and Helvetica Regular (page D.15).

Example: The first letter is capital "R". The next is a lower case "e". The matrix for Helvetica Bold on page D.9 indicates that the proper space between the "R" and the "e" is .19". Place the mark on the left side of the "e" .19" from the mark on the right side of the "R" cell. The next letter is a "c". The space between a "c" and an "e" is .19". Place the "c" so the left mark is .19" from the "e". Be sure that the lines above and below the letters are aligned with the lines drawn on the page.

Continue taping down all of the letters in place inserting the values shown in the matrix

between each letter.

Please note that a few of the values in the matrix are negative (such as "A" to "w"). In this case, the left mark of the "w" is to the left of the right mark of the "A", a distance of .13". Some values are zero (such as "v" to "e"). In this case, the left mark in the "e" will sit directly on the right mark of the "v"

Step 4: The taped acetate letters are then photographed with a photostat camera and the track lines are blocked out on the film negative. Illustration c shows the finished piece of photostat art.

To place one word after another with the proper word-space, place the spacing square (□), with the spacing indicated on the matrix, after the last letter of the first word, as shown in Illustration a below. Place the first letter of the second word the appropriate distance from the square,

as indicated in the matrix (Illustration b). After the first letter of the second word is in place, remove the square (Illustration c).



Illustration a



Illustration b

Recreation Area

Illustration c

Flush left alignment: When making a flush left alignment between two lines of type, a visual compensation must be made for certain letter forms. For example, if a line of type begins with a capital "N" and a second line of type begins with a capital "C", the second line will have to be positioned farther to the left than the first line in order to appear as though it is aligning (see Illustration d). All letters that require a compensation have a special increment on the letter cell marked "FL" for flush left (see Illustration e).

No Fish Cleaning

Flush Left Alignment

Illustration d

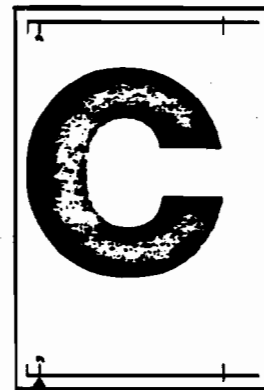

Illustration e

This typestyle is used for the legends of identification, recreation area, and industrial safety signs and as a headline typeface for construction, boundary and interpretive signs. Refer to each respective section for examples of its use on the various types of signs.

A full display of this alphabet is shown on the inside of this foldout. For use of the letter-spacing guide, follow instructions on pages D.7 and 8.

Use only the Helvetica Bold typeface as specified in this manual. Do not substitute another typestyle or any other typeface when preparing signs that specify Helvetica Bold.

Use only the specified methods for typesetting. All enlargements and/or reductions are to use a high-quality photographic process. All letter forms are to be sharp, crisp, and distortion-free.

	od go qs	bhi jkl	mp ru	vwy	ti	x	z	1	2	356 890	4	7	-	-	3	□	DE FG HI LM OP QR ST UV WX YZ	CGO OS	VW	A	J	T	Y			
aghnqu	.23	.33	.33	.14	.19	.19	.28						.28	.28	.28		.38									
bceops	.19	.23	.23	.05	.09	.05	.19						.23	.23	.23		.28	.28	.19	.05	.05	.14	-.05	-.19		
vwy	.05	.23	.19	.05	.19								.09	.05	.23		.23									
tz	.19	.33	.33	.23	.19		.28						.19	.28	.28		.33									
ix	.05	.28	.19	.09	.14								.0	.23	.23		.33									
r	.14	.23	.23	.19	.14								.14	.09	.23		.28									
dlij	.23	.32	.32	.19	.23	.23	.33						.28	.28	.28		.38									
14	.28	.37	.37	.28	.28	.23	.33	.28	.28	.32	.28		.23	.23	.23		.38									
2356890	.19	.33	.33	.23	.19	.09	.19	.19	.19	.23	.23	.19	.19	.23	.33		.33									
7	.05	.23	.19	.14			.05	.05	.14	.05	.28		.14	.14	-.05		.38									
&																	.05									
-	.23	.28	.28	.09	.19	0	.23	.23	.23	.09	.23	.19					.19									
..							.14	.23	.28	.09	.33						.09									
:							.28	.23	.33	.19	.33						.09									
\$.28	.28	.23	.28	.28															
□	.28	.38	.38	.28	.28	.23	.33	.28	.28	.33	.28	.23	.19	.23	.23		.38	.23	.23	.19	.19	.28	.14			
GHIJMN	.28	.38	.38	.28	.28	.23	.33	.28	.28	.33	.28			.23												
BCDOQS	.19	.23	.23	.14	.19	.09	.19	.19	.14	.19	.19			.09												
R	.19	.23	.23	.14	.19	.09	.19	.19	.14	.19	.19			.19												
VW	.05	.23	.09	.05			-.05	.05						.14												
KX	.0	.19	.05	0			0	0						.09												
A	.05	.19	.19	-.09	0	.09	.19	.05	-.09	.19	0			.14												
E	.19	.33	.33	.19	.23	.19	.28	.19	.19	.28	.23			.23												
F	.05	.28	.19	.19			.05	.19						.09												
L	.19	.28	.23	.14			.19	.14						.23												
P	.05	.23	.19	.14			.05	.14						.14												
T	.05	.28	.19	.14			-.05	.14						.14												
Y	.19	.14	0	-.09	0	-.14	.09	-.19	-.09	.09	0			.18												
Z	.23	.33	.28	.19			.23	.19						.23												

This typeface is used for secondary legends on interpretive, boundary and construction signs with Helvetica Bold primary legends. Helvetica Regular is also used on all building interior signs and as a text face for interpretive signs and exhibit captions.

A full display of this alphabet is shown on the inside of this foldout.

Use only the Helvetica Regular typeface as specified in this manual. Do not substitute another typestyle or any other typeface when preparing signs that specify Helvetica Regular.

Use only the specified methods for typesetting. All enlargements and/or reductions are to use a high-quality photographic process. All letter forms are to be sharp, crisp, and distortion-free.

	ac go qs	bh jk	np ru	wy	z	1	2	356 890	7	-	D	E	G	O	Q	V	W	A	J	T		
aglmnqu	.28	.38	.38	.19	.23	.23	.33				.28	.28	.28	.38								
bceops	.23	.28	.28	.09	.19	.09	.23				.19	.14	.19	.33	.33	.23	0	.09	.19	-.09	-.14	
wy	.09	.28	.23	.14	.19	.14	.19				.09	-.09	.09	.28								
ftz	.19	.33	.33	.23	.23	.19	.23				.14	.19	.23	.38								
lx	.09	.23	.19	.05	.09	.09	.14				-.14	.19	.19	.33								
r	.14	.23	.23	.14	.19	.09	.14				0	.09	.19	.28								
dij	.28	.38	.38	.23	.28	.23	.33				.28	.28	.28	.38								
14	.33	.38	.38	.28	.33	.28	.33	.33	.28	.33	.33	.28	.28	.33	.38	.38	.28	.28	.28	.28	.33	.23
2356890	.19	.33	.33	.23	.19	.23	.23	.19	.19	.23	.23	.23	.23	.14	.19	.28	.38					
7	.05	.23	.19	.09			.05	.05	.09	.09	.33	.19	-.19	.09	.33							
&														.14								
-	.23	.28	.28	.14	.14	0	.09	.23	.23	.14	.09	.14		.38								
.							.19	.28	.19	.09	.14			.14								
:							.19	.28	.23	.19	.23			.14								
\$.28	.28	.23	.23	.28			.28								
□	.33	.38	.38	.28	.33	.28	.33	.33	.38	.28	.33	.33	.28	.38	.28	.28						
GHJMNU	.33	.38	.38	.28	.33	.28	.33	.33	.28	.33	.33			.28								
BCDOQS	.23	.28	.28	.19	.23	.09	.19	.23	.19	.19	.23			.05								
R	.23	.33	.33	.19			.23	.19						.23								
VW	0	.28	.14	0			0	0						.19								
KX	.05	.19	.19	-.09			.05	-.09						.19								
A	.09	.23	.23	-.09	.04	.09	.19	.09	-.09	.19	.04			.19								
E	.19	.28	.28	.09	.19	.14	.23	.19	.09	.23	.19			.28								
F	0	.23	.09	0			0	0						.14								
L	.14	.33	.19	.09			.14	.09						.28								
P	.05	.23	.19	.09			.05	.09						.19								
T	.09	.28	.09	-.14			-.09	-.14						.14								
Y	.14	.18	.05	-.14	0	-.14	-.09	-.14	-.14	.09	0			.14								
Z	.14	.33	.23	.05			.14	.05						.28								

SECTION I
CONTRACT CLAUSES

- I.1 BASIS FOR SETTLEMENT OF PROPOSALS (EFARS 49.113(100))
- I.2 DEFINITIONS (SEPT 1991)--ALTERNATE I (APR 1984)
- I.3 OFFICIALS NOT TO BENEFIT (APR 1984)
- I.4 GRATUITIES (APR 1984)
- I.5 COVENANT AGAINST CONTINGENT FEES (APR 1984)
- I.6 RESTRICTIONS ON SUBCONTRACTOR SALES TO THE GOVERNMENT (JUL 1985)
- I.7 ANTI-KICKBACK PROCEDURES (OCT 1988)
- I.8 REQUIREMENT FOR CERTIFICATE OF PROCUREMENT INTEGRITY--MODIFICATION (NOV 1990)
- I.9 PRICE OR FEE ADJUSTMENT FOR ILLEGAL OR IMPROPER ACTIVITY (SEP 1990)
- I.10 LIMITATION ON PAYMENTS TO INFLUENCE CERTAIN FEDERAL TRANSACTIONS (JAN 1990)
- I.11 STATUTORY PROHIBITION ON COMPENSATION TO FORMER DEPARTMENT OF DEFENSE EMPLOYEES (DEC 1991)

- I.12 SPECIAL PROHIBITION ON EMPLOYMENT (APR 1993)
- I.13 PROHIBITION AGAINST RETALIATORY PERSONNEL ACTIONS (APR 1992)
- I.14 PROVISIONS OF INFORMATION TO COOPERATE AGREEMENT HOLDERS (DEC 1991)
- I.15 PROTECTING THE GOVERNMENT'S INTEREST WHEN SUBCONTRACTING WITH CONTRACTORS DEBARRED, SUSPENDED, OR PROPOSED FOR DEBARMENT (NOV 1992)
- I.16 VARIATION IN ESTIMATED QUANTITY (APR 1984)
- I.17 SUSPENSION OF WORK (APR 1984)
- I.18 AUDIT--SEALED BIDDING (APR 1985)
- I.19 PRICE REDUCTION FOR DEFECTIVE COST FOR PRICING DATA--MODIFICATION--SEALED BIDDING (DEC 1991)
- I.20 SUBCONTRACTING COST OR PRICING DATA--MODIFICATION--SEALED BIDDING (DEC 1991)
- I.21 UTILIZATION OF SMALL BUSINESS CONCERNS AND SMALL DISADVANTAGED BUSINESS CONCERNS (FEB 1990)
- I.22 SMALL BUSINESS DISADVANTAGED BUSINESS SUBCONTRACTING PLAN (JAN 1991)-ALTERNATE 1 (AUG 1989)
- I.23 UTILIZATION OF WOMEN-OWNED SMALL BUSINESS (AUG 1986)
- I.24 LIQUIDATED DAMAGES--SMALL BUSINESS SUBCONTRACTING PLAN (AUG 1989)
- I.25 UTILIZATION OF LABOR SURPLUS AREA CONCERNS (APR 1984)
- I.26 LABOR SURPLUS AREA SUBCONTRACTING PROGRAM (APR 1984)

- I.27 CONVICT LABOR (APR 1984)
- I.28 CONTRACT WORK HOURS AND SAFETY STANDARDS ACT--OVERTIME COMPENSATION (MAR 1986)
- I.29 DAVIS-BACON ACT (NOV 1992)
- I.30 WITHHOLDING OF FUNDS (FEB 1988)
- I.31 PAYROLLS AND BASIC RECORDS (FEB 1988)
- I.32 APPRENTICES AND TRAINEES (FEB 1988)
- I.33 COMPLIANCE WITH COPELAND ACT REQUIREMENTS (FEB 1988)
- I.34 SUBCONTRACTS (LABOR STANDARDS) (FEB 1988)
- I.35 CONTRACT TERMINATION--DEBARMENT (FEB 1988)
- I.36 COMPLIANCE WITH DAVIS-BACON AND RELATED ACT REGULATIONS (FEB 1988)
- I.37 DISPUTES CONCERNING LABOR STANDARDS (FEB 1988)
- I.38 CERTIFICATION OF ELIGIBILITY (FEB 1988)
- I.39 EQUAL OPPORTUNITY (APR 1984)
- I.40 AFFIRMATIVE ACTION COMPLIANCE REQUIREMENTS FOR CONSTRUCTION (APR 1984)
- I.41 AFFIRMATIVE ACTION FOR SPECIAL DISABLED AND VIETNAM ERA VETERANS (APR 1984)
- I.42 AFFIRMATIVE ACTION FOR HANDICAPPED WORKERS (APR 1984)

- I.43 EMPLOYMENT REPORTS ON SPECIAL DISABLED VETERANS AND VETERANS OF THE VIETNAM ERA (JAN 1988)
- I.44 CLEAN AIR AND WATER (APR 1984)
- I.45 DRUG-FREE WORKPLACE (JUL 1990)
- I.46 DRUG-FREE WORK FORCE (SEP 1988)
- I.47 BUY AMERICAN ACT--CONSTRUCTION MATERIALS (MAY 1992)
- I.48 RESTRICTIONS ON CERTAIN FOREIGN PURCHASES (MAY 1992)
- I.49 UTILIZATION OF INDIAN ORGANIZATIONS AND INDIAN-OWNED ECONOMIC ENTERPRISES (AUG 1991)
- I.50 AUTHORIZATION AND CONSENT (APR 1984)
- I.51 NOTICE AND ASSISTANCE REGARDING PATENT AND COPYRIGHT INFRINGEMENT (APR 1984)
- I.52 PATENT IDEMNITY --CONSTRUCTION CONTRACTS (APR 1984)
- I.53 RIGHTS IN SHOP DRAWINGS (APR 1966)
- I.54 ADDITIONAL BOND SECURITY (APR 1984)
- I.55 INSURANCE--WORK ON A GOVERNMENT INSTALLATION (SEP 1989)
- I.56 PLEDGES OF ASSETS (FEB 1990)
- I.57 PROSPECTIVE SUBCONTRACTOR REQUESTS FOR BONDS (SEP 1992)

- I.58 FEDERAL, STATE, AND LOCAL TAXES (JAN 1991)
- I.59 TAXES--CONTRACTS PERFORMED IN U.S. POSSESSIONS OR PUERTO RICO (APR 1984)
- I.60 SUPPLEMENTAL COST PRINCIPLES (DEC 1991)
- I.61 PAYMENTS UNDER FIXED-PRICED CONSTRUCTION CONTRACTS (APR 1989)
- I.62 INTEREST (JAN 1991)
- I.63 ASSIGNMENT OF CLAIMS (JAN 1986)
- I.64 PROMPT PAYMENT FOR CONSTRUCTION CONTRACTS (APR 1989)
- I.65 REDUCTION OR SUSPENSION OF CONTRACT PAYMENTS UPON FINDING OF FRAUD (AUG 1992)
- I.66 DISPUTES (DEC 1991)
- I.67 PROTEST AFTER AWARD (AUG 1989)
- I.68 CERTIFICATION OF CLAIMS AND REQUESTS FOR ADJUSTMENT OR RELIEF (APR 1993)
- I.69 DIFFERING SITE CONDITIONS (APR 1984)
- I.70 SITE INVESTIGATION AND CONDITIONS AFFECTING THE WORK (APR 1984)
- I.71 MATERIAL AND WORKMANSHIP (APR 1984)

- I.72 SUPERINTENDENCE BY THE CONTRACTOR (APR 1984)
- I.73 PERMITS AND RESPONSIBILITIES (NOV 1991)
- I.74 OTHER CONTRACTS (APR 1984)
- I.75 PROTECTION OF EXISTING VEGETATION, STRUCTURES, EQUIPMENT, UTILITIES AND IMPROVEMENTS (APR 1984)
- I.76 OPERATIONS AND STORAGE AREAS (APR 1984)
- I.77 USE AND POSSESSION PRIOR TO COMPLETION (APR 1984)
- I.78 CLEANING UP (APR 1984)
- I.79 ACCIDENT PREVENTION (NOV 1991)
- I.80 SCHEDULES FOR CONSTRUCTION CONTRACTS (APR 1984)
- I.81 SPECIFICATIONS AND DRAWINGS FOR CONSTRUCTION (APR 1984)
- I.82 MODIFICATION AND PROPOSALS--PRICE BREAKDOWN (DEC 1991)
- I.83 CHANGES (AUG 1987)
- I.84 PRICING OF CONTRACT MODIFICATIONS (DEC 1991)
- I.85 SUBCONTRACTS (FIXED-PRICE CONTRACTS) (APR 1991)
- I.86 GOVERNMENT PROPERTY (FIXED-PRICE CONTRACTS) (DEC 1989)
- I.87 GOVERNMENT FURNISHED PROPERTY (SHORT FORM) (APR 1984)

I.88 INSPECTION OF CONSTRUCTION (JUL 1986)

I.89 PREFERENCE FOR PRIVATELY OWNED U.S.-FLAG COMMERCIAL VESSELS (APR 1984)
--ALTERNATE II (APR 1984)

I.90 NOTIFICATION OF TRANSPORTATION OF SUPPLIES BY SEA (DEC 1991)

I.91 VALUE ENGINEERING --CONSTRUCTION (MAR 1989)--ALTERNATE I (APR 1984)

I.92 TERMINATION FOR CONVENIENCE OF THE GOVERNMENT (FIXED-PRICE) (APR 1984)
--ALTERNATE I (APR 1984)

I.93 DEFAULT (FIXED-PRICE CONSTRUCTION) (APR 1984)

I.94 AUTHORIZED DEVIATIONS IN CLAUSES (APR 1984)

SECTION I
CONTRACT CLAUSES

I.1 BASIS FOR SETTLEMENT OF PROPOSALS (EFARS 49.113(100))

"Actual costs will be used to determine equipment cost for a settlement proposal submitted on the total cost basis under FAR 49.206-2b. In evaluating a termination settlement proposal using the total cost basis, the following principles will be applied to determine allowable equipment costs:

- (1) Actual costs for each piece of equipment, or groups of similar serial or series equipment, need not be available in the contractor's accounting records to determine total actual equipment costs.
- (2) If equipment cost have been allocated to a contract using predetermined rates, those charges will be adjusted to actual costs.
- (3) Recorded job costs adjusted for unallowable and unallocable expenses will be used to determine equipment operating expenses.
- (4) Ownership costs (depreciation) will be determined using the contractor's depreciation schedule (subject to provisions of FAR 31.205-11).
- (5) License, taxes, storage and insurance costs are normally recovered as an indirect expense and unless the contractor charges these costs directly to contracts, they will be recovered through the indirect expense rate."

I.2 52.202-1 I DEFINITIONS (SEPT 1991)--ALTERNATE I (APR 1984)

(a) "Head of the agency" (also called "agency head") or "Secretary" means the Secretary (or Attorney General, Administrator, Governor, Chairperson, or other chief official, as appropriate) of the agency, including any deputy or assistant chief official of the agency; and the term "authorized representative" means any person, persons, or board (other than the Contracting Officer) authorized to act for the head of the agency or Secretary.

(b) "Contracting Officer" means a person with the authority to enter

into, administer, and/or terminate contracts and make related determinations and findings. The term includes certain authorized representatives of the Contracting Officer acting within the limits of their authority as delegated by the Contracting Officer.

(End of clause)

(R 7-503.1)

(R 7-602.1 1964 JUN)

(R 7-605.38)

(R 7-607.1)

(R 7-2101.1)

(R 1-7.602-1)

1.3 52.203-1 OFFICIALS NOT TO BENEFIT (APR 1984)

No member of or delegate to Congress, or resident commissioner, shall be admitted to any share or part of this contract, or to any benefit arising from it. However, this clause does not apply to this contract to the extent that this contract is made with a corporation for the corporation's general benefit.

(End of clause)

(R 7-103.19 1949 JUL)

(R 1-7.102-17)

1.4 52.203-3 GRATUITIES (APR 1984)

(a) The right of the Contractor to proceed may be terminated by written notice if, after notice and hearing, the agency head or a designee determines that the Contractor, its agent, or another representative--

- (1) Offered or gave a gratuity (e.g., an entertainment or gift) to an officer, official, or employee of the Government; and
- (2) Intended, by the gratuity, to obtain a contract or favorable treatment under a contract.

(b) The facts supporting this determination may be reviewed by any court having lawful jurisdiction.

(c) If this contract is terminated under paragraph (a) above, the Government is entitled--

- (1) To pursue the same remedies as in a breach of the contract; and

(2) In addition to any other damages provided by law, to exemplary damages of not less than 3 nor more than 10 times the cost incurred by the Contractor in giving gratuities to the person concerned, as determined by the agency head or a designee. (This subparagraph (c)(2) is applicable only if this contract uses money appropriated to the Department of Defense.)

(d) The rights and remedies of the Government provided in this clause shall not be exclusive and are in addition to any other rights and remedies provided by law or under this contract.

(End of clause)
(R 7-104.16 1952 MAR)

I.5 52.203-5 COVENANT AGAINST CONTINGENT FEES (APR 1984)

(a) The Contractor warrants that no person or agency has been employed or retained to solicit or obtain this contract upon an agreement or understanding for a contingent fee, except a bona fide employee or agency. For breach or violation of this warranty, the Government shall have the right to annul this contract without liability or, in its discretion, to deduct from the contract price or consideration, or otherwise recover, the full amount of the contingent fee.

(b) "Bona fide agency," as used in this clause, means an established commercial or selling agency, maintained by a contractor for the purpose of securing business, that neither exerts nor proposes to exert improper influence to solicit or obtain Government contracts nor holds itself out as being able to obtain any Government contract or contracts through improper influence.

"Bona fide employee," as used in this clause, means a person, employed by a Contractor and subject to the Contractor's supervision and control as to time, place, and manner of performance, who neither exerts nor proposes to exert improper influence to solicit or obtain Government contracts nor holds out as being able to obtain any Government contract or contracts through improper influence.

"Contingent fee," as used in this clause, means any commission, percentage, brokerage, or other fee that is contingent upon the success that a person or concern has in securing a Government contract.

"Improper influence," as used in this clause, means any influence that induces or tends to induce a Government employee or officer to give consideration or to act regarding a Government contract on any basis other

than the merits of the matter.

(End of clause)
(R 7-103.20 1958 JAN)
(R 1-1.503)
(R 1-7.102-18)

1.6 52.203-6 RESTRICTIONS ON SUBCONTRACTOR SALES TO THE GOVERNMENT (JUL 1985)

(a) Except as provided in (b) below, the Contractor shall not enter into any agreement with an actual or prospective subcontractor, nor otherwise act in any manner, which has or may have the effect of restricting sales by such subcontractors directly to the Government of any item or process (including computer software) made or furnished by the subcontractor under this contract or under any follow-on production contract.

(b) The prohibition in (a) above does not preclude the Contractor from asserting rights that are otherwise authorized by law or regulation.

(c) The Contractor agrees to incorporate the substance of this clause, including this paragraph (c), in all subcontracts under this contract.

(End of clause)

1.7 52.203-7 ANTI-KICKBACK PROCEDURES (OCT 1988)

(a) Definitions.

"Kickback," as used in this clause, means any money, fee, commission, credit, gift, gratuity, thing of value, or compensation of any kind which is provided, directly or indirectly, to any prime Contractor, prime Contractor employee, subcontractor, or subcontractor employee for the purpose of improperly obtaining or rewarding favorable treatment in connection with a prime contract or in connection with a subcontract relating to a prime contract.

"Person," as used in this clause, means a corporation, partnership, business association of any kind, trust, joint-stock company, or individual.

"Prime contract," as used in this clause, means a contract or contractual action entered into by the United States for the purpose of obtaining supplies, materials, equipment, or services of any kind.

"Prime Contractor" as used in this clause, means a person who

has entered into a prime contract with the United States.

"Prime Contractor employee," as used in this clause, means any officer, partner, employee, or agent of a prime Contractor.

"Subcontract," as used in this clause, means a contract or contractual action entered into by a prime Contractor or subcontractor for the purpose of obtaining supplies, materials, equipment, or services of any kind under a prime contract.

"Subcontractor," as used in this clause, (1) means any person, other than the prime Contractor, who offers to furnish or furnishes any supplies, materials, equipment, or services of any kind under a prime contract or a subcontract entered into in connection with such prime contract, and (2) includes any person who offers to furnish or furnishes general supplies to the prime Contractor or a higher tier subcontractor.

"Subcontractor employee," as used in this clause, means any officer, partner, employee, or agent of a subcontractor.

(b) The Anti-Kickback Act of 1986 (41 U.S.C. 51-58) (the Act), prohibits any person from--

(1) Providing or attempting to provide or offering to provide any kickback;

(2) Soliciting, accepting, or attempting to accept any kickback; or

(3) Including, directly or indirectly, the amount of any kickback in the contract price charged by a prime Contractor to the United States or in the contract price charged by a subcontractor to a prime Contractor or higher tier subcontractor.

(c)(1) The Contractor shall have in place and follow reasonable procedures designed to prevent and detect possible violations described in paragraph (b) of this clause in its own operations and direct business relationships.

(2) When the Contractor has reasonable grounds to believe that a violation described in paragraph (b) of this clause may have occurred, the Contractor shall promptly report in writing the possible violation. Such reports shall be made to the inspector general of the contracting agency, the head of the contracting agency if the agency does not have an inspector general, or the Department of Justice.

(3) The Contractor shall cooperate fully with any Federal agency investigating a possible violation described in paragraph (b) of this clause.

(4) The Contracting Officer may (i) offset the amount of the kickback against any monies owed by the United States under the prime contract and/or (ii) direct that the Prime Contractor withhold from sums owed a subcontractor under the prime contract the amount of the kickback. The

Contracting Officer may order that monies withheld under subdivision (c)(4)(ii) of this clause be paid over to the Government unless the Government has already offset those monies under subdivision (c)(4)(i) of this clause. In either case, the Prime Contractor shall notify the Contracting Officer when the monies are withheld.

(5) The Contractor agrees to incorporate the substance of this clause, including subparagraph (c)(5) but excepting subparagraph (c)(1), in all subcontracts under this contract.

(End of clause)

I.8 52.203-9 REQUIREMENT FOR CERTIFICATE OF PROCUREMENT INTEGRITY--MODIFICATION
(NOV 1990)

(a) Definitions. The definitions set forth in FAR 3.104-4 are hereby incorporated in this clause.

(b) The Contractor agrees that it will execute the certification set forth in paragraph (c) of this clause when requested by the Contracting Officer in connection with the execution of any modification of this contract.

(c) Certification. As required in paragraph (b) of this clause, the officer or employee responsible for the modification proposal shall execute the following certification:

CERTIFICATE OF PROCUREMENT INTEGRITY--MODIFICATION (NOV 1990)

(1) I, _____ [Name of certifier] am the officer or employee responsible for the preparation of this modification proposal and hereby certify that, to the best of my knowledge and belief, with the exception of any information described in this certification, I have no information concerning a violation or possible violation of subsection 27(a), (b), (d) or (f) of the Office of Federal Procurement Policy Act, as amended (41 U.S.C. 423), (hereinafter referred to as "the Act"), as implemented in the FAR, occurring during the conduct of this procurement _____ (contract and modification number).

(2) As required by subsection 27(e)(1)(B) of the Act, I further certify that to the best of my knowledge and belief, each officer, employee, agent, representative, and consultant of _____ [Name of Offeror] who has participated personally and substantially in the preparation or submission of this proposal has certified that he or she is familiar with, and will comply with, the requirements of subsection 27(a) of the Act, as implemented in the FAR, and will report immediately

to me any information concerning a violation or possible violation of subsections 27(a), (b), (d), or (f) of the Act, as implemented in the FAR, pertaining to this procurement.

(3) Violations or possible violations: (Continue on plain bond paper if necessary and label Certificate of Procurement Integrity--Modification (Continuation Sheet), ENTER "NONE" IF NONE EXISTS)

[Signature of the officer or employee responsible for the modification proposal and date]

[Typed name of the officer or employee responsible for the modification proposal]

+ Subsections 27(a), (b), and (d) are effective on December 1, 1990. Subsection 27(f) is effective on June 1, 1991.

THIS CERTIFICATION CONCERNS A MATTER WITHIN THE JURISDICTION OF AN AGENCY OF THE UNITED STATES AND THE MAKING OF A FALSE, FICTITIOUS, OR FRAUDULENT CERTIFICATION MAY RENDER THE MAKER SUBJECT TO PROSECUTION UNDER TITLE 18, UNITED STATES CODE, SECTION 1001.

(End of certification)

(d) In making the certification in paragraph (2) of the certificate, the officer or employee of the competing Contractor responsible for the offer or bid, may rely upon a one-time certification from each individual required to submit a certification to the competing Contractor, supplemented by periodic training. These certifications shall be obtained at the earliest possible date after an individual required to certify begins employment or association with the Contractor. If a Contractor decides to rely on a certification executed prior to the suspension of section 27 (i.e., prior to December 1, 1989), the Contractor shall ensure that an individual who has so certified is notified that section 27 has been reinstated. These certifications shall be maintained by the Contractor for a period of 6 years from the date a certifying employee's employment with the company ends or, for an agency, representative, or consultant, 6 years from the date such individual ceases to act on behalf of the Contractor.

(e) The certification required by paragraph (c) of this clause is a material representation of fact upon which reliance will be placed in executing this modification.

(End of clause)

1.9 52.203-10 PRICE OR FEE ADJUSTMENT FOR ILLEGAL OR IMPROPER ACTIVITY (SEP 1990)

(a) The Government, at its election, may reduce the price of a fixed-price type contract or contract modification and the total cost and fee under a cost-type contract or contract modification by the amount of profit or fee determined as set forth in paragraph (b) of this clause if the head of the contracting activity or his or her designee determines that there was a violation of subsection 27(a) of the Office of Federal Procurement Policy Act, as amended (41 U.S.C. 423), as implemented in the FAR. In the case of a contract modification, the fee subject to reduction is the fee specified in the particular contract modification at the time of execution, except as provided in subparagraph (b)(5) of this clause.

(b) The price or fee reduction referred to in paragraph (a) of this clause shall be--

(1) For cost-plus-fixed-fee contracts, the amount of the fee specified in the contract at the time of award;

(2) For cost-plus-incentive-fee contracts, the target fee specified in the contract at the time of award, notwithstanding any minimum fee or "fee floor" specified in the contract;

(3) For cost-plus-award-fee contracts--

(i) The base fee established in the contract at the time of contract award;

(ii) If no base fee is specified in the contract, 30 percent of the amount of each award fee otherwise payable to the Contractor for each award fee evaluation period or at each award fee determination point.

(4) For fixed-price-incentive contracts, the Government may--

(i) Reduce the contract target price and contract target profit both by an amount equal to the initial target profit specified in the contract at the time of contract award; or

(ii) If an immediate adjustment to the contract target price and contract target profit would have a significant adverse impact on the incentive price revision relationship under the contract, or adversely affect the contract financing provisions, the Contracting Officer may defer such adjustment until establishment of the total final price of the contract. The total final price established in accordance with the incentive price revision provisions of the contract shall be reduced by an amount equal to the initial target profit specified in the contract

at the time of contract award and such reduced price shall be the total final contract price.

(5) For firm-fixed-price contracts or contract modifications, by 10 percent of the initial contract price; 10 percent of the contract modification price; or a profit amount determined by the Contracting Officer from records or documents in existence prior to the date of the contract award or modification.

(c) The Government may, at its election, reduce a prime contractor's price or fee in accordance with the procedures of paragraph (b) of this clause for violations of the Act by its subcontractors by an amount not to exceed the amount of profit or fee reflected in the subcontract at the time the subcontract was first definitively priced.

(d) In addition to the remedies in paragraphs (a) and (c) of this clause, the Government may terminate this contract for default. The rights and remedies of the Government specified herein are not exclusive, and are in addition to any other rights and remedies provided by law or under this contract.

(End of clause)

I.10 52.203-12 LIMITATION ON PAYMENTS TO INFLUENCE CERTAIN FEDERAL TRANSACTIONS (JAN 1990)

(a) Definitions.

"Agency," as used in this clause, means executive agency as defined in 2.101.

"Covered Federal action," as used in this clause, means any of the following Federal actions:

(a) The awarding of any Federal contract.

(b) The making of any Federal grant.

(c) The making of any Federal loan.

(d) The entering into of any cooperative agreement.

(e) The extension, continuation, renewal, amendment, or modification of any Federal contract, grant, loan, or cooperative agreement.

"Indian tribe" and "tribal organization," as used in this clause, have the meaning provided in section 4 of the Indian Self-Determination and Education Assistance Act (25 U.S.C. 450B) and include Alaskan Natives.

"Influencing or attempting to influence," as used in this clause, means making, with the intent to influence, any communication to or appearance before an officer or employee of any agency, a Member of Congress, an

officer or employee of Congress, or an employee of a Member of Congress in connection with any covered Federal action.

"Local government," as used in this clause, means a unit of government in a State and, if chartered, established, or otherwise recognized by a State for the performance of a governmental duty, including a local public authority, a special district, an intrastate district, a council of governments, a sponsor group representative organization, and any other instrumentality of a local government.

"Officer or employee of an agency," as used in this clause, includes the following individuals who are employed by an agency:

(a) An individual who is appointed to a position in the Government under title 5, United States Code, including a position under a temporary appointment.

(b) A member of the uniformed services, as defined in subsection 101(3), title 37, United States Code.

(c) A special Government employee, as defined in section 202, title 18, United States Code.

(d) An individual who is a member of a Federal advisory committee, as defined by the Federal Advisory Committee Act, title 5, United States Code, appendix 2.

"Person," as used in this clause, means an individual, corporation, company, association, authority, firm, partnership, society, State, and local government, regardless of whether such entity is operated for profit, or not for profit. This term excludes an Indian tribe, tribal organization, or any other Indian organization with respect to expenditures specifically permitted by other Federal law.

"Reasonable compensation," as used in this clause, means, with respect to a regularly employed officer or employee of any person, compensation that is consistent with the normal compensation for such officer or employee for work that is not furnished to, not funded by, or not furnished in cooperation with the Federal Government.

"Reasonable payment," as used in this clause, means, with respect to professional and other technical services, a payment in an amount that is consistent with the amount normally paid for such services in the private sector.

"Recipient," as used in this clause, includes the Contractor and all subcontractors. This term excludes an Indian tribe, tribal organization, or any other Indian organization with respect to expenditures specifically permitted by other Federal law.

"Regularly employed," as used in this clause, means, with respect to an officer or employee of a person requesting or receiving a Federal contract,

an officer or employee who is employed by such person for at least 130 working days within 1 year immediately preceding the date of the submission that initiates agency consideration of such person for receipt of such contract. An officer or employee who is employed by such person for less than 130 working days within 1 year immediately preceding the date of the submission that initiates agency consideration of such person shall be considered to be regularly employed as soon as he or she is employed by such person for 130 working days.

"State," as used in this clause, means a State of the United States, the District of Columbia, the Commonwealth of Puerto Rico, a territory or possession of the United States, an agency or instrumentality of a State, and multi-State, regional, or interstate entity having governmental duties and powers.

(b) Prohibitions.

(1) Section 1352 of title 31, United States Code, among other things, prohibits a recipient of a Federal contract, grant, loan, or cooperative agreement from using appropriated funds to pay any person for influencing or attempting to influence an officer or employee of any agency, a Member of Congress, an officer or employee of Congress, or an employee of a Member of Congress in connection with any of the following covered Federal actions: the awarding of any Federal contract; the making of any Federal grant; the making of any Federal loan; the entering into of any cooperative agreement; or the modification of any Federal contract, grant, loan, or cooperative agreement.

(2) The Act also requires Contractors to furnish a disclosure if any funds other than Federal appropriated funds (including profit or fee received under a covered Federal transaction) have been paid, or will be paid, to any person for influencing or attempting to influence an officer or employee of any agency, a Member of Congress, an officer or employee of Congress, or an employee of a Member of Congress in connection with a Federal contract, grant, loan, or cooperative agreement.

(3) The prohibitions of the Act do not apply under the following conditions:

(i) Agency and legislative liaison by own employees.

(A) The prohibition on the use of appropriated funds, in subparagraph (b)(1) of this clause, does not apply in the case of a payment of reasonable compensation made to an officer or employee of a person requesting or receiving a covered Federal action if the payment is for agency and legislative liaison activities not directly related to a covered Federal action.

(B) For purposes of subdivision (b)(3)(i)(A) of this clause,

providing any information specifically requested by an agency or Congress is permitted at any time.

(C) The following agency and legislative liaison activities are permitted at any time where they are not related to a specific solicitation for any covered Federal action:

(1) Discussing with an agency the qualities and characteristics (including individual demonstrations) of the person's products or services, conditions or terms of sale, and service capabilities.

(2) Technical discussions and other activities regarding the application or adaptation of the person's products or services for an agency's use.

(D) The following agency and legislative liaison activities are permitted where they are prior to formal solicitation of any covered Federal action--

(1) Providing any information not specifically requested but necessary for an agency to make an informed decision about initiation of a covered Federal action;

(2) Technical discussions regarding the preparation of an unsolicited proposal prior to its official submission; and

(3) Capability presentations by persons seeking awards from an agency pursuant to the provisions of the Small Business Act, as amended by Pub. L. 95-507, and subsequent amendments.

(E) Only those services expressly authorized by subdivision (b)(3)(i)(A) of this clause are permitted under this clause.

(ii) Professional and technical services.

(A) The prohibition on the use of appropriated funds, in subparagraph (b)(1) of this clause, does not apply in the case of--

(1) A payment of reasonable compensation made to an officer or employee of a person requesting or receiving a covered Federal action or an extension, continuation, renewal, amendment, or modification of a covered Federal action, if payment is for professional or technical services rendered directly in the preparation, submission, or negotiation of any bid, proposal, or application for that Federal action or for meeting requirements imposed by or pursuant to law as a condition for receiving that Federal action.

(2) Any reasonable payment to a person, other than an officer or employee of a person requesting or receiving a covered Federal action or an extension, continuation, renewal, amendment, or modification of a covered Federal action if the payment is for professional or technical services rendered directly in the

preparation, submission, or negotiation of any bid, proposal, or application for that Federal action or for meeting requirements imposed by or pursuant to law as a condition for receiving that Federal action. Persons other than officers or employees of a person requesting or receiving a covered Federal action include consultants and trade associations.

(B) For purposes of subdivision (b)(3)(ii)(A) of this clause, "professional and technical services" shall be limited to advice and analysis directly applying any professional or technical discipline. For example, drafting of a legal document accompanying a bid or proposal by a lawyer is allowable. Similarly, technical advice provided by an engineer on the performance or operational capability of a piece of equipment rendered directly in the negotiation of a contract is allowable. However, communications with the intent to influence made by a professional (such as a licensed lawyer) or a technical person (such as a licensed accountant) are not allowable under this section unless they provide advice and analysis directly applying their professional or technical expertise and unless the advice or analysis is rendered directly and solely in the preparation, submission or negotiation of a covered Federal action. Thus, for example, communications with the intent to influence made by a lawyer that do not provide legal advice or analysis directly and solely related to the legal aspects of his or her client's proposal, but generally advocate one proposal over another are not allowable under this section because the lawyer is not providing professional legal services. Similarly, communications with the intent to influence made by an engineer providing an engineering analysis prior to the preparation or submission of a bid or proposal are not allowable under this section since the engineer is providing technical services but not directly in the preparation, submission or negotiation of a covered Federal action.

(C) Requirements imposed by or pursuant to law as a condition for receiving a covered Federal award include those required by law or regulation and any other requirements in the actual award documents.

(D) Only those services expressly authorized by subdivisions (b)(3)(ii)(A)(1) and (2) of this clause are permitted under this clause.

(E) The reporting requirements of FAR 3.803(a) shall not apply with respect to payments of reasonable compensation made to regularly employed officers or employees of a person.

(c) Disclosure.

(1) The Contractor who requests or receives from an agency a Federal

contract shall file with that agency a disclosure form, OMB standard form LLL, Disclosure of Lobbying Activities, if such person has made or has agreed to make any payment using nonappropriated funds (to include profits from any covered Federal action), which would be prohibited under subparagraph (b)(1) of this clause, if paid for with appropriated funds.

(2) The Contractor shall file a disclosure form at the end of each calendar quarter in which there occurs any event that materially affects the accuracy of the information contained in any disclosure form previously filed by such person under subparagraph (c)(1) of this clause. An event that materially affects the accuracy of the information reported includes--

(i) A cumulative increase of \$25,000 or more in the amount paid or expected to be paid for influencing or attempting to influence a covered Federal action; or

(ii) A change in the person(s) or individual(s) influencing or attempting to influence a covered Federal action; or

(iii) A change in the officer(s), employee(s), or Member(s) contacted to influence or attempt to influence a covered Federal action.

(3) The Contractor shall require the submittal of a certification, and if required, a disclosure form by any person who requests or receives any subcontract exceeding \$100,000 under the Federal contract.

(4) All subcontractor disclosure forms (but not certifications) shall be forwarded from tier to tier until received by the prime Contractor. The prime Contractor shall submit all disclosures to the Contracting Officer at the end of the calendar quarter in which the disclosure form is submitted by the subcontractor. Each subcontractor certification shall be retained in the subcontract file of the awarding Contractor.

(d) Agreement. The Contractor agrees not to make any payment prohibited by this clause.

(e) Penalties.

(1) Any person who makes an expenditure prohibited under paragraph (a) of this clause or who fails to file or amend the disclosure form to be filed or amended by paragraph (b) of this clause shall be subject to civil penalties as provided for by 31 U.S.C. 1352. An imposition of a civil penalty does not prevent the Government from seeking any other remedy that may be applicable.

(2) Contractors may rely without liability on the representation made by their subcontractors in the certification and disclosure form.

(f) Cost allowability. Nothing in this clause makes allowable or

reasonable any costs which would otherwise be unallowable or unreasonable. Conversely, costs made specifically unallowable by the requirements in this clause will not be made allowable under any other provision.

(End of clause)

I.11 252.203-7000 STATUTORY PROHIBITION ON COMPENSATION TO FORMER DEPARTMENT OF DEFENSE EMPLOYEES (DEC 1991)

(a) Definitions. As used in this clause--

(1) "Armed Forces" means the uniformed military services, excluding the U.S. Coast Guard.

(2) "Compensation" means any payment, gift, benefit, reward, favor, or gratuity which is provided directly or indirectly for services rendered by the person accepting such payment, gift, benefit, reward, favor, or gratuity, and which has a fair market value in excess of \$250. Compensation is indirectly provided if it is paid to an entity other than the individual, specifically in exchange for services performed by the individual.

(3) "Defense contractor" means an entity (including affiliates and subsidiaries which clearly engage in the performance of Department of Defense (DoD) contracts) that contracts directly with the DoD to supply goods or services. "Defense contractor" does not include a State or local government.

(4) "Designated agency ethics official" means a DoD officer or employee who has been appointed to administer the provisions of the Ethics in Government Act, as amended.

(5) "Former DoD employee" means a person who served in the DoD in a civilian position for which the rate of pay was equal to or greater than the minimum rate of pay for grade GS-13 of the General Schedule, or served in the Armed Forces in a pay grade of O4 or higher.

(6) "Former DoD official" means--

(i) A former DoD employee who spent the majority of working days during the last two years of DoD service performing a procurement function relating to:

(A) A DoD contract, at a site or plant that was owned or operated by the Contractor, and which was the principal location of such person's performance of that procurement function; or

(B) A major defense system and, in the performance of such

function, participated on any occasion personally and substantially in a manner involving decision making responsibilities with respect to a contract for that system through contact with the Contractor;

(ii) An individual who served in a civilian position for which the rate of pay is equal to or greater than the minimum rate of pay for a Senior Executive Service position or other executive position at the same or higher level, and an individual who served in the Armed Forces in the pay grade of O7 or higher, if such individual during the last two years of DoD service--

(A) Acted as one of the primary Government representatives in the negotiation with a defense contractor of a DoD contractual action in an amount in excess of \$10 million; or

(B) Acted as one of the primary Government representatives in the negotiation of a settlement of an unresolved claim of such a defense contractor in an amount in excess of \$10 million. An unresolved claim shall be, for the purposes of this section, valued by the greater of the amount of the claim or the amount of the settlement.

(7) "Major defense contractor" means any business entity which, during the Government fiscal year preceding the Government fiscal year in which compensation was first provided to a former DoD employee, was awarded DoD contracts in a total amount of \$10 million or more.

(8) "Major defense system" means a combination of elements that will function together to produce the capability required to fulfill a mission need. Elements may include hardware, equipment, software, or any combination thereof, but exclude construction or other improvements to real property. A system shall be considered a major defense system if--

(i) The DoD is responsible for the system and the total expenditures (based on fiscal year 1980 constant dollars) for research, development, test and evaluation for the system, are estimated to exceed \$75 million or the eventual total expenditure for procurement is estimated to exceed \$300 million; or

(ii) The system is designated a major system by the head of the agency responsible for the system.

(9) "Negotiation" means exchanges of positions between representatives of the Government and a contractor with the view of reaching agreement regarding respective liabilities of the parties on a particular contract or claim. It includes deliberations regarding contract specifications, terms of delivery, allowability of costs, pricing of change orders, etc.

(10) "Primary Government representative" means, if more than one Government representative is involved in any particular transaction, the official or officials supervising the Government's effort in the matter.

To act as a "representative" requires personal and substantial participation in the transaction, by personal presence, telephone conversation, or similar involvement with representatives of a Contractor.

(11) "Procurement-related function" (or "procurement function") means any function relating to--

- (i) The negotiation, award, administration, or approval of a contract;
- (ii) The selection of a Contractor;
- (iii) The approval of a change in a contract;
- (iv) The performance of quality assurance, operational and developmental testing, the approval of payment, or auditing under a contract; or
- (v) The management of a procurement program.

(b) Prohibition on compensation. (1) 10 U.S.C. 2397b and 2397c prohibit a major defense Contractor from offering or providing any compensation valued in excess of \$250 to a former DoD official who left DoD service on or after April 16, 1987, and who, while employed by DoD, performed procurement-related functions in connection with that defense Contractor. This prohibition runs for the two year period beginning on the date of the official's separation from service in DoD.

(2) The Contractor, if a major defense Contractor, agrees not to provide, for the two year period, any compensation to the former DoD official.

(3) DoD employees may request from their Designated Agency Ethics Official (DAEO) a written opinion on the applicability of 10 U.S.C. 2397b prior to the acceptance of compensation. If the opinion of the DAEO is that the law is not applicable, and that the individual may accept compensation from the Contractor, there shall be a conclusive presumption that the offering and the acceptance of such compensation is not a violation of the statute.

(c) Report concerning former DoD employees. (1) The Contractor shall submit a separate written report, as described in paragraph (c)(2) of this clause, for each calendar year covered by this contract (extending through final payment) if the calendar year commenced after the end of a Government fiscal year in which the Contractor was awarded one or more DoD contracts aggregating \$10 million or more. In multidivisional corporations, the corporate headquarters, and each segment which contracts directly with the Government, shall report separately. Each report shall list those persons employed or otherwise compensated, who are former DoD employees who left service on or after April 16, 1987, if--

(i) They were compensated by the Contractor during the reporting period; and

(ii) The compensation was provided within two years after the person left service in the DoD.

(2) The report shall contain:

(i) Each person's name and the agency in which the person was employed or served on active duty during the last two years of service with DoD;

(ii) Each person's job title(s) during the last two years of service with DoD, and a list of major defense systems on which each person performed any work;

(iii) A complete description (exclusive of proprietary information) of any work that each person is performing, or did perform, on behalf of the Contractor during the calendar year covered by the report. If the work is classified, the Contractor may use a generalized description which will not compromise its classified nature;

(iv) An identification of each major defense system on which each individual has performed any work on behalf of the Contractor.

(3) Submit each report not later than April 1 of the year following the end of the calendar year for which the report is being made. Send reports to the Office of the Assistant General Counsel (Legal Counsel), Standards of Conduct Office, ATTN: OAGC/LC, Pentagon, Washington, DC 20301-1600.

(4) A properly executed DD Form 1787 (Employment, Report of DoD and Defense Related) may be submitted to satisfy the reporting requirement as to any single person.

(5) The Contractor need not submit duplicate reports to the Government. Submission of a report meeting the requirements of this clause, under another, concurrent contract with DoD will satisfy the reporting requirement of this contract.

(d) Penalties for failure to comply--(1) Civil fines. A Contractor who knowingly offers or provides any compensation to a former DoD official in violation of the statute, and who knew or should have known that the acceptance of such compensation would be in violation of such statute, shall be subject to a civil fine, not to exceed \$500,000.

(2) Liquidated damages.

(i) For each knowing violation of the statutory prohibition on providing compensation, the Contractor agrees to pay to the Government as liquidated damages the greater of either \$100,000, or three times the total amount of compensation paid by the Contractor to the former DoD official during the period in which such compensation was in

violation of the statutory prohibition.

(ii) Liability for liquidated damages under this clause survives final payment under this contract and may be recouped against payments due under other contracts with the Contractor.

(iii) Liquidated damages will be computed based upon the number of actual violations by the Contractor, and not on the number of contracts in which this clause appears.

(3) Administrative penalty. If the Contractor knowingly fails to file a report in accordance with paragraph (c) of this clause, the Contractor shall be subject to an administrative penalty not to exceed \$10,000. The final determination of the penalty to be charged to the Contractor shall be made by the Secretary of Defense or designee after the Contractor is afforded an opportunity for an agency hearing on the record in accordance with agency hearing procedures. The Secretary's determination shall form a part of the record and shall be subject to judicial review under Chapter 7 of Title 5, United States Code.

(e) The rights and remedies under this clause are in addition to, and do not limit, any rights afforded the Government under this contract or as otherwise provided by law.

(End of clause)

I.12 252.203-7001 SPECIAL PROHIBITION ON EMPLOYMENT (APR 1993)

(a) Definitions.

As used in this clause--

(1) "Arising out of a contract with the DoD" means any act in connection with--

(i) Attempting to obtain,

(ii) Obtaining, or

(iii) Performing a contract or first-tier subcontract of any agency, department, or component of the Department of Defense (DoD).

(2) "Conviction of fraud or any other felony" means any conviction for fraud or a felony in violation of state or Federal criminal statutes, whether entered on a verdict or plea, including a plea of nolo contendere, for which sentence has been imposed.

(3) "Date of conviction" means the date judgment was entered against the individual.

(b) 10 U.S.C. 2408 provides that any individual who is convicted after September 29, 1988, of fraud or any other felony arising out of a contract

with the DoD is prohibited from:

(1) Working in a management or supervisory capacity on any DoD contract or first-tier subcontract;

(2) Serving on the board of directors of any DoD Contractor or first-tier subcontractor; or

(3) Serving as a consultant to any DoD Contractor or first-tier subcontractor.

(c) Unless waived, the prohibition in paragraph (b) applies for five years from the date of conviction.

(d) 10 U.S.C. 2408 further provides that a defense Contractor or first-tier subcontractor shall be subject to a criminal penalty of not more than \$500,000 if convicted of knowingly--

(1) Employing a person under a prohibition specified in paragraph (b) of this clause; or

(2) Allowing such a person to serve on the board of directors of the Contractor or first-tier subcontractor.

(e) In addition to the criminal penalties contained in 10 U.S.C. 2408, the Government may consider other available remedies, such as--

(1) Suspension or debarment;

(2) Cancellation of the contract at no cost to the Government; or

(3) Termination of the contract for default.

(f) The Contractor may submit written requests for waiver of the prohibitions in paragraph (b) of this clause to the Contracting Officer. Requests shall clearly identify--

(1) The person involved;

(2) The nature of the conviction and resultant sentence or punishment imposed;

(3) The reasons for the requested waiver; and,

(4) An explanation of why a waiver is in the interest of national security.

(g) The Contractor agrees to include the substance of this clause, appropriately modified to reflect the identity and relationship of the parties, in all first-tier subcontracts exceeding \$25,000.

(h) Pursuant to 10 U.S.C. 2408(c), defense contractors and subcontractors may obtain information as to whether a particular person has been convicted of fraud or any other felony arising out of a contract with the DoD by contacting the The Office of Justice Programs, The Denial of Benefits Office, U.S. Department of Justice, telephone (202) 307-1065.

(End of clause)

(a) Definitions.

As used in this clause--

(1) "Appropriate Government official" means

(i) An officer or employee of the Department of Defense responsible for command, direct staff assistance to a commander, contract administration, program management, audit, inspection, investigation, or enforcement of any law or regulation relating to Government procurement or the subject matter of the contract;

(ii) A Member of Congress or an officer or employee of Congress, the General Accounting Office, the Congressional Budget Office, or the Office of Technology Assessment; and

(iii) Any other officer or employee of the United States whose duties include the investigation or enforcement of any law, rule, or regulation relating to Government procurement or the subject matter of the contract.

(2) "Information concerning a contract" means information about cost, price, compliance with specifications, meeting the user's requirements, user safety, use or disposition of services, real property or personal property acquired under the contract, the procurement process (including competition, negotiation, award, and administration), and relationships with Government personnel, competitors, or subcontractors.

(b) Prohibition.

In accordance with 10 U.S.C. 2409a, the Contractor shall not discharge or otherwise discriminate against any employee with respect to the employee's compensation or terms and conditions of employment because the employee (or any person acting pursuant to a request of the employee) discloses to an appropriate Government official information concerning a defense contract, which information the employee reasonably believes evidences a violation of any Federal law or regulation relating to defense procurement or the subject matter of this contract.

(c) The Government will notify the Contractor upon receipt of any complaint filed under the provisions of this clause and Subpart 203.71 of the Defense FAR Supplement. The Contractor agrees to cooperate with the Government during its investigation of any such complaint.

(d) The Contractor shall inform all employees of--

(1) The prohibitions of this clause;

(2) Employees' rights under 10 U.S.C. 2409a; and

(3) Availability of procedures implementing the statute.

(End of clause)

I.14 252.205-7000 PROVISION OF INFORMATION TO COOPERATIVE AGREEMENT HOLDERS (DEC 1991)

(a) Definition.

"Cooperative agreement holder" means a State or local government; a private, nonprofit organization; a tribal organization (as defined in section 4(c) of the Indian Self-Determination and Education Assistance Act (Pub. L. 93-268; 25 U.S.C. 450(c))); or an economic enterprise (as defined in section 3(e) of the Indian Financing Act of 1974 (Pub. L. 93-362; 25 U.S.C. 1452(e))) whether such economic enterprise is organized for profit or nonprofit purposes; which has an agreement with the Defense Logistics Agency to furnish procurement technical assistance to business entities.

(b) The Contractor shall provide cooperative agreement holders, upon their request, with a list of those appropriate employees or offices responsible for entering into subcontracts under defense contracts. The list shall include the business address, telephone number, and area of responsibility of each employee or office.

(c) The Contractor need not provide the listing to a particular cooperative agreement holder more frequently than once a year.

(End of clause)

I.15 52.209-6 PROTECTING THE GOVERNMENT'S INTEREST WHEN SUBCONTRACTING WITH CONTRACTORS DEBARRED, SUSPENDED, OR PROPOSED FOR DEBARMENT (NOV 1992)

(a) The Government suspends or debar Contractors to protect the Government's interest. The Contractor shall not enter into any subcontract in excess of the small purchase limitation at FAR 13.000 with a Contractor that is debarred, suspended, or proposed for debarment unless there is a compelling reason to do so.

(b) The Contractor shall require each proposed first-tier subcontractor, whose subcontract will exceed the small purchase limitation at FAR 13.000, to disclose to the Contractor, in writing, whether as of the time of award of the subcontract, the subcontractor, or its principals, is or is not debarred, suspended, or proposed for debarment by the Federal Government.

(c) A corporate officer or a designee of the Contractor shall notify the Contracting Officer, in writing, before entering into a subcontract

with a party that is debarred, suspended, or proposed for debarment (see FAR 9.404 for information on the List of Parties Excluded from Procurement Programs). The notice must include the following:

- (1) The name of the subcontractor.
- (2) The Contractor's knowledge of the reasons for the subcontractor being on the List of Parties Excluded from Procurement Programs.
- (3) The compelling reason(s) for doing business with the subcontractor notwithstanding its inclusion on the List of Parties Excluded from Procurement Programs.
- (4) The systems and procedures the Contractor has established to ensure that it is fully protecting the Government's interests when dealing with such subcontractor in view of the specific basis for the party's debarment, suspension, or proposed debarment.

(End of clause)

I.16 52.212-11 VARIATION IN ESTIMATED QUANTITY (APR 1984)

If the quantity of a unit-priced item in this contract is an estimated quantity and the actual quantity of the unit-priced item varies more than 15 percent above or below the estimated quantity, an equitable adjustment in the contract price shall be made upon demand of either party. The equitable adjustment shall be based upon any increase or decrease in costs due solely to the variation above 115 percent or below 85 percent of the estimated quantity. If the quantity variation is such as to cause an increase in the time necessary for completion, the Contractor may request, in writing, an extension of time, to be received by the Contracting Officer within 10 days from the beginning of the delay, or within such further period as may be granted by the Contracting Officer before the date of final settlement of the contract. Upon the receipt of a written request for an extension, the Contracting Officer shall ascertain the facts and make an adjustment for extending the completion date as, in the judgement of the Contracting Officer, is justified.

(End of clause)

(R 7-603.27 1968 APR)

I.17 52.212-12 SUSPENSION OF WORK (APR 1984)

(a) The Contracting Officer may order the Contractor, in writing, to suspend, delay, or interrupt all or any part of the work of this contract for the period of time that the Contracting Officer determines appropriate for the convenience of the Government.

(b) If the performance of all or any part of the work is, for an unreasonable period of time, suspended, delayed, or interrupted (1) by an act of the Contracting Officer in the administration of this contract, or (2) by the Contracting Officer's failure to act within the time specified in this contract (or within a reasonable time if not specified), an adjustment shall be made for any increase in the cost of performance of this contract (excluding profit) necessarily caused by the unreasonable suspension, delay, or interruption, and the contract modified in writing accordingly. However, no adjustment shall be made under this clause for any suspension, delay, or interruption to the extent that performance would have been so suspended, delayed, or interrupted by any other cause, including the fault or negligence of the Contractor, or for which an equitable adjustment is provided for or excluded under any other term or condition of this contract.

(c) A claim under this clause shall not be allowed (1) for any costs incurred more than 20 days before the Contractor shall have notified the Contracting Officer in writing of the act or failure to act involved (but this requirement shall not apply as to a claim resulting from a suspension order), and (2) unless the claim, in an amount stated, is asserted in writing as soon as practicable after the termination of the suspension, delay, or interruption, but not later than the date of final payment under the contract.

(End of clause)
(R 7-602.46 1968 FEB)

1.18 52.214-26 AUDIT--SEALED BIDDING (APR 1985)

(a) Cost or pricing data. If the Contractor has submitted cost or pricing data in connection with the pricing of any modification to this contract, unless the pricing was based on adequate price competition, established catalog or market prices of commercial items sold in substantial quantities to the general public, or prices set by law or regulation, the Contracting Officer or a representative who is an employee of the Government shall have the right to examine and audit all books, records, documents, and other data of the Contractor (including

computations and projections) related to negotiating, pricing or performing the modification, in order to evaluate the accuracy, completeness, and currency of the cost or pricing data. In the case of pricing any modification, the Comptroller General of the United States or a representative who is an employee of the Government shall have the same rights.

(b) Availability. The Contractor shall make available at its office at all reasonable times the materials described in paragraph (a) above, for examination, audit, or reproduction, until 3 years after final payment under this contract, or for any other period specified in Subpart 4.7 of the Federal Acquisition Regulation (FAR). FAR Subpart 4.7, Contractor Records Retention, in effect on the date of this contract, is incorporated by reference in its entirety and made a part of this contract.

(1) If this contract is completely or partially terminated, the records relating to the work terminated shall be made available for 3 years after any resulting final termination settlement.

(2) Records pertaining to appeals under the Disputes clause or to litigation or the settlement of claims arising under or relating to the performance of this contract shall be made available until disposition of such appeals, litigation, or claims.

(c) The Contractor shall insert a clause containing all the provisions of this clause, including this paragraph (c), in all subcontracts over \$10,000 under this contract, altering the clause only as necessary to identify properly the contracting parties and the contracting office under the Government prime contract.

(End of clause)

I.19 52.214-27 PRICE REDUCTION FOR DEFECTIVE COST OR PRICING DATA--MODIFICATIONS--SEALED BIDDING (DEC 1991)

(a) This clause shall become operative only for any modification to this contract involving aggregate increases and/or decreases in costs, plus applicable profits, of more than \$100,000, or for the Department of Defense, the National Aeronautics and Space Administration, and the Coast Guard, more than \$500,000, except that this clause does not apply to any modification for which the price is--

(1) Based on adequate price competition;

(2) Based on established catalog or market prices of commercial items sold in substantial quantities to the general public; or

(3) Set by law or regulation.

(b) If any price, including profit, negotiated in connection with any modification under this clause, was increased by any significant amount because (1) the Contractor or a subcontractor furnished cost or pricing data that were not complete, accurate, and current as certified in its Certificate of Current Cost or Pricing Data, (2) a subcontractor or prospective subcontractor furnished the Contractor cost or pricing data that were not complete, accurate, and current as certified in the Contractor's Certificate of Current Cost or Pricing Data, or (3) any of these parties furnished data of any description that were not accurate, the price shall be reduced accordingly and the contract shall be modified to reflect the reduction. This right to a price reduction is limited to that resulting from defects in data relating to modifications for which this clause becomes operative under paragraph (a) above.

(c) Any reduction in the contract price under paragraph (b) above due to defective data from a prospective subcontractor that was not subsequently awarded the subcontract shall be limited to the amount, plus applicable overhead and profit markup, by which (1) the actual subcontract or (2) the actual cost to the Contractor, if there was no subcontract, was less than the prospective subcontract cost estimate submitted by the Contractor; provided, that the actual subcontract price was not itself affected by defective cost or pricing data.

(d)(1) If the Contracting Officer determines under paragraph (b) of this clause that a price or cost reduction should be made, the Contractor agrees not to raise the following matters as a defense:

(i) The Contractor or subcontractor was a sole source supplier or otherwise was in a superior bargaining position and thus the price of the contract would not have been modified even if accurate, complete, and current cost or pricing data had been submitted.

(ii) The Contracting Officer should have known that the cost or pricing data in issue were defective even though the Contractor or subcontractor took no affirmative action to bring the character of the data to the attention of the Contracting Officer.

(iii) The contract was based on an agreement about the total cost of the contract and there was no agreement about the cost of each item procured under the contract.

(iv) The Contractor or subcontractor did not submit a Certificate of Current Cost or Pricing Data.

(2)(i) Except as prohibited by subdivision (d)(2)(ii) of this clause, an offset in an amount determined appropriate by the Contracting Officer based upon the facts shall be allowed against the amount of a contract

price reduction if--

(A) The Contractor certifies to the Contracting Officer that, to the best of the Contractor's knowledge and belief, the Contractor is entitled to the offset in the amount requested; and

(B) The Contractor proves that the cost or pricing data were available before the date of agreement on the price of the contract (or price of the modification) and that the data were not submitted before such date.

(ii) An offset shall not be allowed if--

(A) The understated data was known by the Contractor to be understated when the Certificate of Current Cost or Pricing Data was signed; or

(B) The Government proves that the facts demonstrate that the contract price would not have increased in the amount to be offset even if the available data had been submitted before the date of agreement on price.

(e) If any reduction in the contract price under this clause reduces the price of items for which payment was made prior to the date of the modification reflecting the price reduction, the Contractor shall be liable to and shall pay the United States at the time such overpayment is repaid--

(1) Simple interest on the amount of such overpayment to be computed from the date(s) of overpayment to the Contractor to the date the Government is repaid by the Contractor at the applicable underpayment rate effective for each quarter prescribed by the Secretary of the Treasury under 26 U.S.C. 6621(a)(2); and

(2) For Department of Defense contracts only, a penalty equal to the amount of the overpayment, if the Contractor or subcontractor knowingly submitted cost or pricing data which were incomplete, inaccurate, or noncurrent.

(End of clause)

I.20 52.214-28 SUBCONTRACTOR COST OR PRICING DATA--MODIFICATIONS--SEALED BIDDING
(DEC 1991)

(a) The requirements of paragraphs (b) and (c) of this clause shall (1) become operative only for any modification to this contract involving aggregate increases and/or decreases in costs, plus applicable profits, expected to exceed \$100,000, or for the Department of Defense, the National Aeronautics and Space Administration, and the Coast Guard, expected to

exceed \$500,000, and (2) be limited to such modifications.

(b) Before awarding any subcontract expected to exceed \$100,000, or for the Department of Defense, the National Aeronautics and Space Administration, and the Coast Guard, expected to exceed \$500,000 when entered into, or pricing any subcontract modification involving aggregate increases and/or decreases in costs, plus applicable profits, expected to exceed \$100,000, or for the Department of Defense, the National Aeronautics and Space Administration, and the Coast Guard, expected to exceed \$500,000, the Contractor shall require the subcontractor to submit cost or pricing data (actually or by specific identification in writing), unless the price is--

- (1) Based on adequate price competition;
- (2) Based on established catalog or market prices of commercial items sold in substantial quantities to the general public; or
- (3) Set by law or regulation.

(c) The Contractor shall require the subcontractor to certify in substantially the form prescribed in subsection 15.804-4 of the Federal Acquisition Regulation that, to the best of its knowledge and belief, the data submitted under paragraph (b) above were accurate, complete, and current as of the date of agreement on the negotiated price of the subcontract or subcontract modification.

(d) The Contractor shall insert the substance of this clause, including this paragraph (d), in each subcontract that exceeds \$100,000, or for the Department of Defense, the National Aeronautics and Space Administration, and the Coast Guard, in each subcontract that exceeds \$500,000 when entered into.

(End of clause)

1.21 52.219-8 UTILIZATION OF SMALL BUSINESS CONCERNS AND SMALL DISADVANTAGED BUSINESS CONCERNS (FEB 1990)

(a) It is the policy of the United States that small business concerns and small business concerns owned and controlled by socially and economically disadvantaged individuals shall have the maximum practicable opportunity to participate in performing contracts let by any Federal agency, including contracts and subcontracts for subsystems, assemblies, components, and related services for major systems. It is further the policy of the United States that its prime contractors establish procedures to ensure the timely payment of amounts due pursuant to the terms of their

subcontracts with small business concerns and small business concerns owned and controlled by socially and economically disadvantaged individuals.

(b) The Contractor hereby agrees to carry out this policy in the awarding of subcontracts to the fullest extent consistent with efficient contract performance. The Contractor further agrees to cooperate in any studies or surveys as may be conducted by the United States Small Business Administration or the awarding agency of the United States as may be necessary to determine the extent of the Contractor's compliance with this clause.

(c) As used in this contract, the term "small business concern" shall mean a small business as defined pursuant to section 3 of the Small Business Act and relevant regulations promulgated pursuant thereto. The term "small business concern owned and controlled by socially and economically disadvantaged individuals" shall mean a small business concern (1) which is at least 51 percent unconditionally owned by one or more socially and economically disadvantaged individuals; or, in the case of any publicly owned business, at least 51 per centum of the stock of which is unconditionally owned by one or more socially and economically disadvantaged individuals; and (2) whose management and daily business operations are controlled by one or more of such individuals. This term also means a small business concern that is at least 51 percent unconditionally owned by an economically disadvantaged Indian tribe or Native Hawaiian Organization, or a publicly owned business having at least 51 percent of its stock unconditionally owned by one of these entities which has its management and daily business controlled by members of an economically disadvantaged Indian tribe or Native Hawaiian Organization, and which meets the requirements of 13 CFR 124. The Contractor shall presume that socially and economically disadvantaged individuals include Black Americans, Hispanic Americans, Native Americans, Asian-Pacific Americans, Subcontinent Asian Americans, and other minorities, or any other individual found to be disadvantaged by the Administration pursuant to section 8(a) of the Small Business Act. The Contractor shall presume that socially and economically disadvantaged entities also include Indian Tribes and Native Hawaiian Organizations.

(d) Contractors acting in good faith may rely on written representations by their subcontractors regarding their status as either a small business concern or a small business concern owned and controlled by socially and economically disadvantaged individuals.

(End of clause)

- (a) This clause does not apply to small business concerns.
- (b) "Commercial product," as used in this clause, means a product in regular production that is sold in substantial quantities to the general public and/or industry at established catalog or market prices. It also means a product which, in the opinion of the Contracting Officer, differs only insignificantly from the Contractor's commercial product.
- "Subcontract," as used in this clause, means any agreement (other than one involving an employer-employee relationship) entered into by a Federal Government prime Contractor or subcontractor calling for supplies or services required for performance of the contract or subcontract.
- (c) The apparent low bidder, upon request by the Contracting Officer, shall submit a subcontracting plan, where applicable, which separately addresses subcontracting with small business concerns and with small disadvantaged business concerns. If the bidder is submitting an individual contract plan, the plan must separately address subcontracting with small business concerns and with small disadvantaged business concerns with a separate part for the basic contract and separate parts for each option (if any). The plan shall be included in and made a part of the resultant contract. The subcontracting plan shall be submitted within the time specified by the Contracting Officer. Failure to submit the subcontracting plan shall make the bidder ineligible for the award of a contract.
- (d) The offeror's subcontracting plan shall include the following:
- (1) Goals, expressed in terms of percentages of total planned subcontracting dollars, for the use of small business concerns and disadvantaged business concerns as subcontractors. The offeror shall include all subcontracts that contribute to contract performance, and may include a proportionate share of products and services that are normally allocated as indirect costs.
 - (2) A statement of--
 - (i) Total dollars planned to be subcontracted;
 - (ii) Total dollars planned to be subcontracted to small business concerns; and
 - (iii) Total dollars planned to be subcontracted to small disadvantaged business concerns.
 - (3) A description of the principal types of supplies and services to be subcontracted, and an identification of the types planned for subcontracting to (i) small business concerns and (ii) small

disadvantaged business concerns.

(4) A description of the method used to develop the subcontracting goals in (1) above.

(5) A description of the method used to identify potential sources for solicitation purposes (e.g., existing company source lists, the Procurement Automated Source System (PASS) of the Small Business Administration, the National Minority Purchasing Council Vendor Information Service, the Research and Information Division of the Minority Business Development Agency in the Department of Commerce, or small and small disadvantaged business concerns trade associations).

(6) A statement as to whether or not the offeror included indirect costs in establishing subcontracting goals, and a description of the method used to determine the proportionate share of indirect costs to be incurred with (i) small business concerns and (ii) small disadvantaged business concerns.

(7) The name of the individual employed by the offeror who will administer the offeror's subcontracting program, and a description of the duties of the individual.

(8) A description of the efforts the offeror will make to assure that small business concerns and small disadvantaged business concerns have an equitable opportunity to compete for subcontracts.

(9) Assurances that the offeror will include the clause in this contract entitled "Utilization of Small Business Concerns and Small Disadvantaged Business Concerns" in all subcontracts that offer further subcontracting opportunities, and that the offeror will require all subcontractors (except small business concerns) who receive subcontracts in excess of \$500,000 (\$1,000,000 for construction of any public facility), to adopt a plan similar to the plan agreed to by the offeror.

(10) Assurances that the offeror will (i) cooperate in any studies or surveys as may be required, (ii) submit periodic reports in order to allow the Government to determine the extent of compliance by the offeror with the subcontracting plan, (iii) submit Standard Form (SF) 294, Subcontracting Report for Individual Contracts, and/or SF 295, Summary Subcontract Report, in accordance with the instructions on the forms, and (iv) ensure that its subcontractors agree to submit Standard Forms 294 and 295.

(11) A recitation of the types of records the offeror will maintain to demonstrate procedures that have been adopted to comply with the requirements and goals in the plan, including establishing source lists; and a description of its efforts to locate small and small disadvantaged business concerns and award subcontracts to them. The records shall

include at least the following (on a plant-wide or company-wide basis, unless otherwise indicated):

(i) Source lists, guides, and other data that identify small and small disadvantaged business concerns.

(ii) Organizations contacted in an attempt to locate sources that are small or small disadvantaged business concerns.

(iii) Records on each subcontract solicitation resulting in an award of more than \$100,000, indicating (A) whether small business concerns were solicited and if not, why not, (B) whether small disadvantaged business concerns were solicited and if not, why not, and (C) if applicable, the reason award was not made to a small business concern.

(iv) Records of any outreach efforts to contact (A) trade associations, (B) business development organizations, and (C) conferences and trade fairs to locate small and small disadvantaged business sources.

(v) Records of internal guidance and encouragement provided to buyers through (A) workshops, seminars, training, etc., and (B) monitoring performance to evaluate compliance with the programs's requirements.

(vi) On a contract-by-contract basis, records to support award data submitted by the offeror to the Government, including the name, address, and business size of each subcontractor. Contractors having company or division-wide annual plans need not comply with this requirement.

(e) In order to effectively implement this plan to the extent consistent with efficient contract performance, the Contractor shall perform the following functions:

(1) Assist small business and small disadvantaged business concerns by arranging solicitations, time for the preparation of bids, quantities, specifications, and delivery schedules so as to facilitate the participation by such concerns. Where the Contractor's lists of potential small business and small disadvantaged subcontractors are excessively long, reasonable effort shall be made to give all such small business concerns an opportunity to compete over a period of time.

(2) Provide adequate and timely consideration of the potentialities of small business and small disadvantaged business concerns in all "make-or-buy" decisions.

(3) Counsel and discuss subcontracting opportunities with representatives of small and small disadvantaged business firms.

(4) Provide notice to subcontractors concerning penalties and remedies for misrepresentations of business status as small business or small

disadvantaged business for the purpose of obtaining a subcontract that is to be included as part or all of a goal contained in the Contractor's subcontracting plan.

(f) A master subcontracting plan on a plant or division-wide basis which contains all the elements required by (d) above, except goals, may be incorporated by reference as a part of the subcontracting plan required of the offeror by this clause; provided, (1) the master plan has been approved, (2) the offeror provides copies of the approved master plan and evidence of its approval to the Contracting Officer, and (3) goals and any deviations from the master plan deemed necessary by the Contracting Officer to satisfy the requirements of this contract are set forth in the individual subcontracting plan.

(g)(1) If a commercial product is offered, the subcontracting plan required by this clause may relate to the offeror's production generally, for both commercial and noncommercial products, rather than solely to the Government contract. In these cases, the offeror shall, with the concurrence of the Contracting Officer, submit one company-wide or division-wide annual plan.

(2) The annual plan shall be reviewed for approval by the agency awarding the offeror its first prime contract requiring a subcontracting plan during the fiscal year, or by an agency satisfactory to the Contracting Officer.

(3) The approved plan shall remain in effect during the offeror's fiscal year for all of the offeror's commercial products.

(h) Prior compliance of the offeror with other such subcontracting plans under previous contracts will be considered by the Contracting Officer in determining the responsibility of the offeror for award of the contract.

(i) The failure of the Contractor or subcontractor to comply in good faith with (1) the clause of this contract entitled "Utilization of Small Business Concerns and Small Disadvantaged Business Concerns," or (2) an approved plan required by this clause, shall be a material breach of the contract.

(End of clause)

I.23 52.219-13 UTILIZATION OF WOMEN-OWNED SMALL BUSINESSES (AUG 1986)

(a) "Women-owned small businesses," as used in this clause, means small business concerns that are at least 51 percent owned by women who are United States citizens and who also control and operate the business.

"Control," as used in this clause, means exercising the power to make policy decisions.

"Operate," as used in this clause, means being actively involved in the day-to-day management of the business.

"Small business concern," as used in this clause, means a concern including its affiliates, that is independently owned and operated, not dominant in the field of operation in which it is bidding on Government contracts, and qualified as a small business under the criteria and size standards in 13 CFR 121.

(b) It is the policy of the United States that women-owned small businesses shall have the maximum practicable opportunity to participate in performing contracts awarded by any Federal agency.

(c) The Contractor agrees to use its best efforts to give women-owned small businesses the maximum practicable opportunity to participate in the subcontracts it awards to the fullest extent consistent with the efficient performance of its contract.

(d) The Contractor may rely on written representations by its subcontractors regarding their status as women-owned small businesses.

(End of clause)

I.24 52.219-16 LIQUIDATED DAMAGES--SMALL BUSINESS SUBCONTRACTING PLAN (AUG 1989)

(a) "Failure to make a good faith effort to comply with the subcontracting plan," as used in this subpart, means a willful or intentional failure to perform in accordance with the requirements of the subcontracting plan approved under the clause in this contract entitled "Small Business and Small Disadvantaged Business Subcontracting Plan," or willful or intentional action to frustrate the plan.

(b) If, at contract completion, or in the case of a commercial products plan, at the close of the fiscal year for which the plan is applicable, the Contractor has failed to meet its subcontracting goals and the Contracting Officer decides in accordance with paragraph (c) of this clause that the Contractor failed to make a good faith effort to comply with its subcontracting plan, established in accordance with the clause in this contract entitled Small and Small Disadvantaged Business Subcontracting Plans, the Contractor shall pay the Government liquidated damages in an amount stated. The amount of probable damages attributable to the Contractor's failure to comply, shall be an amount equal to the actual dollar amount by which the Contractor failed to achieve each subcontract

goal or, in the case of a commercial products plan, that portion of the dollar amount allocable to Government contracts by which the Contractor failed to achieve each subcontract goal.

(c) Before the Contracting Officer makes a final decision that the Contractor has failed to make such good faith effort, the Contracting Officer shall give the Contractor written notice specifying the failure and permitting the Contractor to demonstrate what good faith efforts have been made. Failure to respond to the notice may be taken as an admission that no valid explanation exists. If, after consideration of all the pertinent data, the Contracting Officer finds that the Contractor failed to make a good faith effort to comply with the subcontracting plan, the Contracting Officer shall issue a final decision to that effect and require that the Contractor pay the Government liquidated damages as provided in paragraph (b) of this clause.

(d) With respect to commercial products plans; i.e., company-wide or division-wide subcontracting plans approved under paragraph (g) of the clause in this contract entitled, Small Business and Small Disadvantaged Business Subcontracting Plan, the Contracting Officer of the agency that originally approved the plan will exercise the functions of the Contracting Officer under this clause on behalf of all agencies that awarded contracts covered by that commercial products plan.

(e) The Contractor shall have the right of appeal, under the clause in this contract entitled, Disputes, from any final decision of the Contracting Officer.

(f) Liquidated damages shall be in addition to any other remedies that Government may have.

(End of clause)

1.25 52.220-3 UTILIZATION OF LABOR SURPLUS AREA CONCERNS (APR 1984)

(a) Applicability. This clause is applicable if this contract exceeds the appropriate small purchase limitation in Part 13 of the Federal Acquisition Regulation.

(b) Policy. It is the policy of the Government to award contracts to concerns that agree to perform substantially in labor surplus areas (LSA's) when this can be done consistent with the efficient performance of the contract and at prices no higher than are obtainable elsewhere. The Contractor agrees to use its best efforts to place subcontracts in accordance with this policy.

(c) Order of preference. In complying with paragraph (b) above and with paragraph (c) of the clause of this contract entitled Utilization of Small Business Concerns and Small Disadvantaged Business Concerns, the Contractor shall observe the following order of preference in awarding subcontracts: (1) small business concerns that are LSA concerns, (2) other small business concerns, and (3) other LSA concerns.

(d) Definitions. "Labor surplus area," as used in this clause, means a geographical area identified by the Department of Labor in accordance with 20 CFR 654, Subpart A, as an area of concentrated unemployment or underemployment or an area of labor surplus.

"Labor surplus area concern," as used in this clause, means a concern that together with its first-tier subcontractors will perform substantially in labor surplus areas. Performance is substantially in labor surplus areas if the costs incurred under the contract on account of manufacturing, production, or performance of appropriate services in labor surplus areas exceed 50 percent of the contract price.

(End of clause)
(R 1-1.805-3(a))
(R 7-104.20(a) 1981 MAY)

1.26 52.220-4 LABOR SURPLUS AREA SUBCONTRACTING PROGRAM (APR 1984)

(a) See the Utilization of Labor Surplus Area Concerns clause of this contract for applicable definitions.

(b) The Contractor agrees to establish and conduct a program to encourage labor surplus area (LSA) concerns to compete for subcontracts within their capabilities when the subcontracts are consistent with the efficient performance of the contract at prices no higher than obtainable elsewhere. The Contractor shall--

(1) Designate a liaison officer who will (i) maintain liaison with authorized representatives of the Government on LSA matters, (ii) supervise compliance with the Utilization of Labor Surplus Area Concerns clause, and (iii) administer the Contractor's labor surplus area subcontracting program;

(2) Provide adequate and timely consideration of the potentialities of LSA concerns in all make-or-buy decisions;

(3) Ensure that LSA concerns have an equitable opportunity to compete for subcontracts, particularly by arranging solicitations, time for the preparation of offers, quantities, specifications, and delivery

schedules so as to facilitate the participation of LSA concerns;

(4) Include the Utilization of Labor Surplus Area Concerns clause in subcontracts that offer substantial LSA subcontracting opportunities; and

(5) Maintain records showing (i) the procedures adopted and (ii) the Contractor's performance, to comply with this clause. The records will be kept available for review by the Government until the expiration of 1 year after the award of this contract, or for such longer period as may be required by any other clause of this contract or by applicable law or regulations.

(c) The Contractor further agrees to insert in any related subcontract that may exceed \$500,000 and that contains the Utilization of Labor Surplus Area Concerns clause, terms that conform substantially to the language of this clause, including this paragraph (c), and to notify the Contracting Officer of the names of subcontractors.

(End of clause)
(R1-1.805-3(b))
(R 7-104.20(b) 1978 JUN)

1.27 52.222-3 CONVICT LABOR (APR 1984)

The Contractor agrees not to employ any person undergoing sentence of imprisonment in performing this contract except as provided by 18 U.S.C. 4082(c)(2) and Executive Order 11755, December 29, 1973.

(End of clause)
(R 7-104.17 1975 OCT)
(R 7-607.12 1975 OCT)
(R 1-12.204)

1.28 52.222-4 CONTRACT WORK HOURS AND SAFETY STANDARDS ACT--OVERTIME COMPENSATION (MAR 1986)

(a) Overtime requirements. No Contractor or subcontractor contracting for any part of the contract work which may require or involve the employment of laborers or mechanics (see Federal Acquisition Regulation (FAR) 22.300) shall require or permit any such laborers or mechanics in any workweek in which the individual is employed on such work to work in excess

of 40 hours in such workweek unless such laborer or mechanic receives compensation at a rate not less than 1 1/2 times the basic rate of pay for all hours worked in excess of 40 hours in such workweek.

(b) Violation; liability for unpaid wages; liquidated damages. In the event of any violation of the provisions set forth in paragraph (a) of this clause, the Contractor and any subcontractor responsible therefor shall be liable for the unpaid wages. In addition, such Contractor and subcontractor shall be liable to the United States (in the case of work done under contract for the District of Columbia or a territory, to such District or to such territory), for liquidated damages. Such liquidated damages shall be computed with respect to each individual laborer or mechanic employed in violation of the provisions set forth in paragraph (a) of this clause in the sum of \$10 for each calendar day on which such individual was required or permitted to work in excess of the standard workweek of 40 hours without payment of the overtime wages required by provisions set forth in paragraph (a) of this clause.

(c) Withholding for unpaid wages and liquidated damages. The Contracting Officer shall upon his or her own action or upon written request of an authorized representative of the Department of Labor withhold or cause to be withheld, from any moneys payable on account of work performed by the Contractor or subcontractor under any such contract or any other Federal contract with the same Prime Contractor, or any other Federally-assisted contract subject to the Contract Work Hours and Safety Standards Act which is held by the same Prime Contractor, such sums as may be determined to be necessary to satisfy any liabilities of such Contractor or subcontractor for unpaid wages and liquidated damages as provided in the provisions set forth in paragraph (b) of this clause.

(d) Payrolls and basic records. (1) The Contractor or subcontractor shall maintain payrolls and basic payroll records during the course of contract work and shall preserve them for a period of 3 years from the completion of the contract for all laborers and mechanics working on the contract. Such records shall contain the name and address of each such employee, social security number, correct classifications, hourly rates of wages paid, daily and weekly number of hours worked, deductions made, and actual wages paid. Nothing in this paragraph shall require the duplication of records required to be maintained for construction work by Department of Labor regulations at 29 CFR 5.5(a)(3) implementing the Davis-Bacon Act.

(2) The records to be maintained under paragraph (d)(1) of this clause shall be made available by the Contractor or subcontractor for inspection, copying, or transcription by authorized representatives of the Contracting Officer or the Department of Labor. The Contractor or

subcontractor shall permit such representatives to interview employees during working hours on the job.

(e) Subcontracts. The Contractor or subcontractor shall insert in any subcontracts the provisions set forth in paragraphs (a) through (e) of this clause and also a clause requiring the subcontractors to include these provisions in any lower tier subcontracts. The Prime Contractor shall be responsible for compliance by any subcontractor or lower tier subcontractor with the provisions set forth in paragraphs (a) through (e) of this clause.

(End of clause)

I.29 52.222-6 DAVIS-BACON ACT (NOV 1992)

(a) All laborers and mechanics employed or working upon the site of the work will be paid unconditionally and not less often than once a week, and without subsequent deduction or rebate on any account (except such payroll deductions as are permitted by regulations issued by the Secretary of Labor under the Copeland Act (29 CFR Part 3)), the full amount of wages and bona fide fringe benefits (or cash equivalents thereof) due at time of payment computed at rates not less than those contained in the wage determination of the Secretary of Labor which is attached hereto and made a part hereof, regardless of any contractual relationship which may be alleged to exist between the Contractor and such laborers and mechanics. Contributions made or costs reasonably anticipated for bona fide fringe benefits under section 1(b)(2) of the Davis-Bacon Act on behalf of laborers or mechanics are considered wages paid to such laborers or mechanics, subject to the provisions of paragraph (d) of this clause; also, regular contributions made or costs incurred for more than a weekly period (but not less often than quarterly) under plans, funds, or programs which cover the particular weekly period, are deemed to be constructively made or incurred during such period. Such laborers and mechanics shall be paid not less than the appropriate wage rate and fringe benefits in the wage determination for the classification of work actually performed, without regard to skill, except as provided in the clause entitled Apprentices and Trainees. Laborers or mechanics performing work in more than one classification may be compensated at the rate specified for each classification for the time actually worked therein; provided, that the employer's payroll records accurately set forth the time spent in each classification in which work is performed. The wage determination (including any additional

classifications and wage rates conformed under paragraph (b) of this clause) and the Davis-Bacon poster (WH-1321) shall be posted at all times by the Contractor and its subcontractors at the site of the work in a prominent and accessible place where it can be easily seen by the workers.

(b)(1) The Contracting Officer shall require that any class of laborers or mechanics, including helpers, which is not listed in the wage determination and which is to be employed under the contract shall be classified in conformance with the wage determination. The Contracting Officer shall approve an additional classification and wage rate and fringe benefits therefor only when all the following criteria have been met:

(i) Except with respect to helpers, as defined in section 22.401 of the Federal Acquisition Regulation, the work to be performed by the classification requested is not performed by a classification in the wage determination.

(ii) The classification is utilized in the area by the construction industry.

(iii) The proposed wage rate, including any bona fide fringe benefits, bears a reasonable relationship to the wage rates contained in the wage determination.

(iv) With respect to helpers, such a classification prevails in the area in which the work is performed.

(2) If the Contractor and the laborers and mechanics to be employed in the classification (if known), or their representatives, and the Contracting Officer agree on the classification and wage rate (including the amount designated for fringe benefits, where appropriate), a report of the action taken shall be sent by the Contracting Officer to the Administrator of the Wage and Hour Division, Employment Standards Administration, U.S. Department of Labor, Washington, DC 20210. The Administrator or an authorized representative will approve, modify, or disapprove every additional classification action within 30 days of receipt and so advise the Contracting Officer or will notify the Contracting Officer within the 30-day period that additional time is necessary.

(3) In the event the Contractor, the laborers or mechanics to be employed in the classification, or their representatives, and the Contracting Officer do not agree on the proposed classification and wage rate (including the amount designated for fringe benefits, where appropriate), the Contracting Officer shall refer the questions, including the views of all interested parties and the recommendation of the Contracting Officer, to the Administrator of the Wage and Hour Division for determination. The Administrator, or an authorized

representative, will issue a determination within 30 days of receipt and so advise the Contracting Officer or will notify the Contracting Officer within the 30-day period that additional time is necessary.

(4) The wage rate (including fringe benefits, where appropriate) determined pursuant to subparagraphs (b)(2) and (b)(3) of this clause shall be paid to all workers performing work in the classification under this contract from the first day on which work is performed in the classification.

(c) Whenever the minimum wage rate prescribed in the contract for a class of laborers or mechanics includes a fringe benefit which is not expressed as an hourly rate, the Contractor shall either pay the benefit as stated in the wage determination or shall pay another bona fide fringe benefit or an hourly cash equivalent thereof.

(d) If the Contractor does not make payments to a trustee or other third person, the Contractor may consider as part of the wages of any laborer or mechanic the amount of any costs reasonably anticipated in providing bona fide fringe benefits under a plan or program; provided, that the Secretary of Labor has found, upon the written request of the Contractor, that the applicable standards of the Davis-Bacon Act have been met. The Secretary of Labor may require the Contractor to set aside in a separate account assets for the meeting of obligations under the plan or program.

(End of clause)

1.30 52.222-7 WITHHOLDING OF FUNDS (FEB 1988)

The Contracting Officer shall, upon his or her own action or upon written request of an authorized representative of the Department of Labor, withhold or cause to be withheld from the Contractor under this contract or any other Federal contract with the same Prime Contractor, or any other Federally assisted contract subject to Davis-Bacon prevailing wage requirements, which is held by the same Prime Contractor, so much of the accrued payments or advances as may be considered necessary to pay laborers and mechanics, including apprentices, trainees, and helpers, employed by the Contractor or any subcontractor the full amount of wages required by the contract. In the event of failure to pay any laborer or mechanic, including any apprentice, trainee, or helper, employed or working on the site of the work, all or part of the wages required by the contract, the Contracting Officer may, after written notice to the Contractor, take such action as may be necessary to cause the suspension of any further payment,

advance, or guarantee of funds until such violations have ceased.
(End of clause)

I.31 52.222-8 PAYROLLS AND BASIC RECORDS (FEB 1988)

(a) Payrolls and basic records relating thereto shall be maintained by the Contractor during the course of the work and preserved for a period of 3 years thereafter for all laborers and mechanics working at the site of the work. Such records shall contain the name, address, and social security number of each such worker, his or her correct classification, hourly rates of wages paid (including rates of contributions or costs anticipated for bona fide fringe benefits or cash equivalents thereof of the types described in section 1(b)(2)(B) of the Davis-Bacon Act), daily and weekly number of hours worked, deductions made, and actual wages paid. Whenever the Secretary of Labor has found, under paragraph (d) of the clause entitled Davis-Bacon Act, that the wages of any laborer or mechanic include the amount of any costs reasonably anticipated in providing benefits under a plan or program described in section 1(b)(2)(B) of the Davis-Bacon Act, the Contractor shall maintain records which show that the commitment to provide such benefits is enforceable, that the plan or program is financially responsible, and that the plan or program has been communicated in writing to the laborers or mechanics affected, and records which show the costs anticipated or the actual cost incurred in providing such benefits. Contractors employing apprentices or trainees under approved programs shall maintain written evidence of the registration of apprenticeship programs and certification of trainee programs, the registration of apprentices and trainees, and the ratios and wage rates prescribed in the applicable programs.

(b)(1) The Contractor shall submit weekly for each week in which any contract work is performed a copy of all payrolls to the Contracting Officer. The payrolls submitted shall set out accurately and completely all of the information required to be maintained under paragraph (a) of this clause. This information may be submitted in any form desired. Optional Form WH-347 (Federal Stock Number 029-005-00014-1) is available for this purpose and may be purchased from the Superintendent of Documents, U.S. Government Printing Office, Washington, DC 20402. The Prime Contractor is responsible for the submission of copies of payrolls by all subcontractors.

(2) Each payroll submitted shall be accompanied by a "Statement of

Compliance," signed by the Contractor or subcontractor or his or her agent who pays or supervises the payment of the persons employed under the contract and shall certify--

(i) That the payroll for the payroll period contains the information required to be maintained under paragraph (a) of this clause and that such information is correct and complete;

(ii) That each laborer or mechanic (including each helper, apprentice, and trainee) employed on the contract during the payroll period has been paid the full weekly wages earned, without rebate, either directly or indirectly, and that no deductions have been made either directly or indirectly from the full wages earned, other than permissible deductions as set forth in the Regulations, 29 CFR Part 3; and

(iii) That each laborer or mechanic has been paid not less than the applicable wage rates and fringe benefits or cash equivalents for the classification of work performed, as specified in the applicable wage determination incorporated into the contract.

(3) The weekly submission of a properly executed certification set forth on the reverse side of Optional Form WH-347 shall satisfy the requirement for submission of the "Statement of Compliance" required by subparagraph (b)(2) of this clause.

(4) The falsification of any of the certifications in this clause may subject the Contractor or subcontractor to civil or criminal prosecution under Section 1001 of Title 18 and Section 3729 of Title 31 of the United States Code.

(c) The Contractor or subcontractor shall make the records required under paragraph (a) of this clause available for inspection, copying, or transcription by the Contracting Officer or authorized representatives of the Contracting Officer or the Department of Labor. The Contractor or subcontractor shall permit the Contracting Officer or representatives of the Contracting Officer or the Department of Labor to interview employees during working hours on the job. If the Contractor or subcontractor fails to submit required records or to make them available, the Contracting Officer may, after written notice to the Contractor, take such action as may be necessary to cause the suspension of any further payment. Furthermore, failure to submit the required records upon request or to make such records available may be grounds for debarment action pursuant to 29 CFR 5.12.

(End of clause)

(a) Apprentices. Apprentices will be permitted to work at less than the predetermined rate for the work they performed when they are employed pursuant to and individually registered in a bona fide apprenticeship program registered with the U.S. Department of Labor, Employment and Training Administration, Bureau of Apprenticeship and Training, or with a State Apprenticeship Agency recognized by the Bureau, or if a person is employed in his or her first 90 days of probationary employment as an apprentice in such an apprenticeship program, who is not individually registered in the program, but who has been certified by the Bureau of Apprenticeship and Training or a State Apprenticeship Agency (where appropriate) to be eligible for probationary employment as an apprentice. The allowable ratio of apprentices to journeymen on the job site in any craft classification shall not be greater than the ratio permitted to the Contractor as to the entire work force under the registered program. Any worker listed on a payroll at an apprentice wage rate, who is not registered or otherwise employed as stated in this paragraph, shall be paid not less than the applicable wage determination for the classification of work actually performed. In addition, any apprentice performing work on the job site in excess of the ratio permitted under the registered program shall be paid not less than the applicable wage rate on the wage determination for the work actually performed. Where a contractor is performing construction on a project in a locality other than that in which its program is registered, the ratios and wage rates (expressed in percentages of the journeyman's hourly rate) specified in the Contractor's or subcontractor's registered program shall be observed. Every apprentice must be paid at not less than the rate specified in the registered program for the apprentice's level of progress, expressed as a percentage of the journeyman hourly rate specified in the applicable wage determination. Apprentices shall be paid fringe benefits in accordance with the provisions of the apprenticeship program. If the apprenticeship program does not specify fringe benefits, apprentices must be paid the full amount of fringe benefits listed on the wage determination for the applicable classification. If the Administrator determines that a different practice prevails for the applicable apprentice classification, fringes shall be paid in accordance with that determination. In the event the Bureau of Apprenticeship and Training, or a State Apprenticeship Agency recognized by the Bureau, withdraws approval of an apprenticeship program, the Contractor will no longer be permitted to utilize apprentices at less than the applicable predetermined rate for the work performed until an acceptable

program is approved.

(b) Trainees. Except as provided in 29 CFR 5.16, trainees will not be permitted to work at less than the predetermined rate for the work performed unless they are employed pursuant to and individually registered in a program which has received prior approval, evidenced by formal certification by the U.S. Department of Labor, Employment and Training Administration. The ratio of trainees to journeymen on the job site shall not be greater than permitted under the plan approved by the Employment and Training Administration. Every trainee must be paid at not less than the rate specified in the approved program for the trainee's level of progress, expressed as a percentage of the journeyman hourly rate specified in the applicable wage determination. Trainees shall be paid fringe benefits in accordance with the provisions of the trainee program. If the trainee program does not mention fringe benefits, trainees shall be paid the full amount of fringe benefits listed in the wage determination unless the Administrator of the Wage and Hour Division determines that there is an apprenticeship program associated with the corresponding journeyman wage rate in the wage determination which provides for less than full fringe benefits for apprentices. Any employee listed on the payroll at a trainee rate who is not registered and participating in a training plan approved by the Employment and Training Administration shall be paid not less than the applicable wage rate in the wage determination for the classification of work actually performed. In addition, any trainee performing work on the job site in excess of the ratio permitted under the registered program shall be paid not less than the applicable wage rate in the wage determination for the work actually performed. In the event the Employment and Training Administration withdraws approval of a training program, the Contractor will no longer be permitted to utilize trainees at less than the applicable predetermined rate for the work performed until an acceptable program is approved.

(c) Equal employment opportunity. The utilization of apprentices, trainees, and journeymen under this clause shall be in conformity with the equal employment opportunity requirements of Executive Order 11246, as amended, and 29 CFR Part 30.

(End of clause)

1.33 52.222-10 COMPLIANCE WITH COPELAND ACT REQUIREMENTS (FEB 1988)

The Contractor shall comply with the requirements of 29 CFR Part 3, which

are hereby incorporated by reference in this contract.
(End of clause)

1.34 52.222-11 SUBCONTRACTS (LABOR STANDARDS) (FEB 1988)

(a) The Contractor or subcontractor shall insert in any subcontracts the clauses entitled Davis-Bacon Act, Contract Work Hours and Safety Standards Act--Overtime Compensation, Apprentices and Trainees, Payrolls and Basic Records, Compliance with Copeland Act Requirements, Withholding of Funds, Subcontracts (Labor Standards), Contract Termination--Debarment, Disputes Concerning Labor Standards, Compliance with Davis-Bacon and Related Act Regulations, and Certification of Eligibility, and such other clauses as the Contracting Officer may, by appropriate instructions, require, and also a clause requiring subcontractors to include these clauses in any lower tier subcontracts. The Prime Contractor shall be responsible for compliance by any subcontractor or lower tier subcontractor with all the contract clauses cited in this paragraph.

(b)(1) Within 14 days after award of the contract, the Contractor shall deliver to the Contracting Officer a completed Statement and Acknowledgment Form (SF 1413) for each subcontract, including the subcontractor's signed and dated acknowledgment that the clauses set forth in paragraph (a) of this clause have been included in the subcontract.

(2) Within 14 days after the award of any subsequently awarded subcontract the Contractor shall deliver to the Contracting Officer an updated completed SF 1413 for such additional subcontract.

(End of clause)

1.35 52.222-12 CONTRACT TERMINATION--DEBARMENT (FEB 1988)

A breach of the contract clauses entitled Davis-Bacon Act, Contract Work Hours and Safety Standards Act--Overtime Compensation, Apprentices and Trainees, Payrolls and Basic Records, Compliance with Copeland Act Requirements, Subcontracts (Labor Standards), Compliance with Davis-Bacon and Related Act Regulations, or Certification of Eligibility may be grounds for termination of the contract, and for debarment as a Contractor and subcontractor as provided in 29 CFR 5.12.

(End of clause)

1.36 52.222-13 COMPLIANCE WITH DAVIS-BACON AND RELATED ACT REGULATIONS (FEB 1988)

All rulings and interpretations of the Davis-Bacon and Related Acts contained in 29 CFR Parts 1, 3, and 5 are hereby incorporated by reference in this contract.

(End of clause)

1.37 52.222-14 DISPUTES CONCERNING LABOR STANDARDS (FEB 1988)

The United States Department of Labor has set forth in 29 CFR Parts 5, 6, and 7 procedures for resolving disputes concerning labor standards requirements. Such disputes shall be resolved in accordance with those procedures and not the Disputes clause of this contract. Disputes within the meaning of this clause include disputes between the Contractor (or any of its subcontractors) and the contracting agency, the U.S. Department of Labor, or the employees of their representatives.

(End of clause)

1.38 52.222-15 CERTIFICATION OF ELIGIBILITY (FEB 1988)

(a) By entering into this contract, the Contractor certifies that neither it (nor he or she) nor any person or firm who has an interest in the Contractor's firm is a person or firm ineligible to be awarded Government contracts by virtue of section 3(a) of the Davis-Bacon Act or 29 CFR 5.12(a)(1).

(b) No part of this contract shall be subcontracted to any person or firm ineligible for award of a Government contract by virtue of section 3(a) of the Davis-Bacon Act or 29 CFR 5.12(a)(1).

(c) The penalty for making false statements is prescribed in the U.S. Criminal Code, 18 U.S.C. 1001.

(End of clause)

(a) If, during any 12-month period (including the 12 months preceding the award of this contract), the Contractor has been or is awarded nonexempt Federal contracts and/or subcontracts that have an aggregate value in excess of \$10,000, the Contractor shall comply with subparagraphs (b)(1) through (11) below. Upon request, the Contractor shall provide information necessary to determine the applicability of this clause.

(b) During performing this contract, the Contractor agrees as follows:

(1) The Contractor shall not discriminate against any employee or applicant for employment because of race, color, religion, sex, or national origin.

(2) The Contractor shall take affirmative action to ensure that applicants are employed, and that employees are treated during employment, without regard to their race, color, religion, sex, or national origin. This shall include, but not be limited to, (i) employment, (ii) upgrading, (iii) demotion, (iv) transfer, (v) recruitment or recruitment advertising, (vi) layoff or termination, (vii) rates of pay or other forms of compensation, and (viii) selection for training, including apprenticeship.

(3) The Contractor shall post in conspicuous places available to employees and applicants for employment the notices to be provided by the Contracting Officer that explain this clause.

(4) The Contractor shall, in all solicitations or advertisements for employees placed by or on behalf of the Contractor, state that all qualified applicants will receive consideration for employment without regard to race, color, religion, sex, or national origin.

(5) The Contractor shall send, to each labor union or representative of workers with which it has a collective bargaining agreement or other contract or understanding, the notice to be provided by the Contracting Officer advising the labor union or workers' representative of the Contractor's commitments under this clause, and post copies of the notice in conspicuous places available to employees and applicants for employment.

(6) The Contractor shall comply with Executive Order 11246, as amended, and the rules, regulations, and orders of the Secretary of Labor.

(7) The Contractor shall furnish to the contracting agency all information required by Executive Order 11246, as amended, and by the rules, regulations, and orders of the Secretary of Labor. Standard Form 100 (EEO-1), or any successor form, is the prescribed form to be filed

within 30 days following the award, unless filed within 12 months preceding the date of award.

(8) The Contractor shall permit access to its books, records, and accounts by the contracting agency or the Office of Federal Contract Compliance Programs (OFCCP) for the purposes of investigation to ascertain the Contractor's compliance with the applicable rules, regulations, and orders.

(9) If the OFCCP determines that the Contractor is not in compliance with this clause or any rule, regulation, or order of the Secretary of Labor, this contract may be canceled, terminated, or suspended in whole or in part and the Contractor may be declared ineligible for further Government contracts, under the procedures authorized in Executive Order 11246, as amended. In addition, sanctions may be imposed and remedies invoked against the Contractor as provided in Executive Order 11246, as amended, the rules, regulations, and orders of the Secretary of Labor, or as otherwise provided by law.

(10) The Contractor shall include the terms and conditions of subparagraph (b)(1) through (11) of this clause in every subcontract or purchase order that is not exempted by the rules, regulations, or orders of the Secretary of Labor issued under Executive Order 11246, as amended, so that these terms and conditions will be binding upon each subcontractor or vendor.

(11) The Contractor shall take such action with respect to any subcontract or purchase order as the contracting agency may direct as a means of enforcing these terms and conditions, including sanctions for noncompliance; provided, that if the Contractor becomes involved in, or is threatened with, litigation with a subcontractor or vendor as a result of any direction, the Contractor may request the United States to enter into the litigation to protect the interests of the United States.

(c) Notwithstanding any other clause in this contract, disputes relative to this clause will be governed by the procedures in 41 CFR 60-1.1.

(End of clause)
(R 7-103.18 1978 SEP)
(R 1-12.803-2)
(R 7-607.13 1978 SEP)

1.40 52.222-27 AFFIRMATIVE ACTION COMPLIANCE REQUIREMENTS FOR CONSTRUCTION (APR 1984)

(a) Definitions.

"Covered area," as used in this clause, means the geographical area described in the solicitation for this contract.

"Director," as used in this clause, means Director, Office of Federal Contract Compliance Programs (OFCCP), United States Department of Labor, or any person to whom the Director delegates authority.

"Employer's identification number," as used in this clause, means the Federal Social Security number used on the employer's quarterly federal tax return, U.S. Treasury Department Form 941.

"Minority," as used in this clause, means--

(1) American Indian or Alaskan Native (all persons having origins in any of the original peoples of North America and maintaining identifiable tribal affiliations through membership and participation or community identification).

(2) Asian and Pacific Islander (all persons having origins in any of the original peoples of the Far East, Southeast Asia, the Indian Subcontinent, or the Pacific Islands);

(3) Black (all persons having origins in any of the black African racial groups not of Hispanic origin); and

(4) Hispanic (all persons of Mexican, Puerto Rican, Cuban, Central or South American, or other Spanish culture or origin, regardless of race).

(b) If the Contractor, or a subcontractor at any tier, subcontracts a portion of the work involving any construction trade, each such subcontract in excess of \$10,000 shall include this clause and the Notice containing the goals for minority and female participation stated in the solicitation for this contract.

(c) If the Contractor is participating in a Hometown Plan (41 CFR 60-4) approved by the U.S. Department of Labor in a covered area, either individually or through an association, its affirmative action obligations on all work in the plan area (including goals) shall comply with the plan for those trades that have unions participating in the plan. Contractors must be able to demonstrate participation in, and compliance with, the provisions of the plan. Each Contractor or subcontractor participating in an approved plan is also required to comply with its obligations under the Equal Opportunity clause, and to make a good faith effort to achieve each goal under the plan in each trade in which it has employees. The overall good-faith performance by other Contractors or subcontractors toward a goal in an approved plan does not excuse any Contractor's or subcontractor's failure to make good-faith efforts to achieve the plan's goals.

(d) The Contractor shall implement the affirmative action procedures in subparagraphs (g)(1) through (16) of this clause. The goals stated in the

solicitation for this contract are expressed as percentages of the total hours of employment and training of minority and female utilization that the Contractor should reasonably be able to achieve in each construction trade in which it has employees in the covered area. If the Contractor performs construction work in a geographical area located outside of the covered area, it shall apply the goals established for the geographical area where that work is actually performed. The Contractor is expected to make substantially uniform progress toward its goals in each craft.

(e) Neither the terms and conditions of any collective bargaining agreement, nor the failure by a union with which the Contractor has a collective bargaining agreement, to refer minorities or women shall excuse the Contractor's obligations under this clause, Executive Order 11246, as amended, or the regulations thereunder.

(f) In order for the nonworking training hours of apprentices and trainees to be counted in meeting the goals, apprentices and trainees must be employed by the Contractor during the training period, and the Contractor must have made a commitment to employ the apprentices and trainees at the completion of their training, subject to the availability of employment opportunities. Trainees must be trained pursuant to training programs approved by the U.S. Department of Labor.

(g) The Contractor shall take affirmative action to ensure equal employment opportunity. The evaluation of the Contractor's compliance with this clause shall be based upon its effort to achieve maximum results from its actions. The Contractor shall document these efforts fully and implement affirmative action steps at least as extensive as the following:

(1) Ensure a working environment free of harassment, intimidation, and coercion at all sites and in all facilities where the Contractor's employees are assigned to work. The Contractor, if possible, will assign two or more women to each construction project. The Contractor shall ensure that foremen, superintendents, and other onsite supervisory personnel are aware of and carry out the Contractor's obligation to maintain such a working environment, with specific attention to minority or female individuals working at these sites or facilities.

(2) Establish and maintain a current list of sources for minority and female recruitment. Provide written notification to minority and female recruitment sources and community organizations when the Contractor or its unions have employment opportunities available, and maintain a record of the organizations' responses.

(3) Establish and maintain a current file of the names, addresses, and telephone numbers of each minority and female off-the-street applicant, referrals of minorities or females from unions, recruitment sources, or

community organizations, and the action taken with respect to each individual. If an individual was sent to the union hiring hall for referral and not referred back to the Contractor by the union or, if referred back, not employed by the Contractor, this shall be documented in the file, along with whatever additional actions the Contractor may have taken.

(4) Immediately notify the Director when the union or unions with which the Contractor has a collective bargaining agreement has not referred back to the Contractor a minority or woman sent by the Contractor, or when the Contractor has other information that the union referral process has impeded the Contractor's efforts to meet its obligations.

(5) Develop on-the-job training opportunities and/or participate in training programs for the area that expressly include minorities and women, including upgrading programs and apprenticeship and trainee programs relevant to the Contractor's employment needs, especially those programs funded or approved by the Department of Labor. The Contractor shall provide notice of these programs to the sources compiled under subparagraph (g)(2) above.

(6) Disseminate the Contractor's equal employment policy by--

(i) Providing notice of the policy to unions and to training, recruitment, and outreach programs, and requesting their cooperation in assisting the Contractor in meeting its contract obligations;

(ii) Including the policy in any policy manual and in collective bargaining agreements;

(iii) Publicizing the policy in the company newspaper, annual report, etc.;

(iv) Reviewing the policy with all management personnel and with all minority and female employees at least once a year; and

(v) Posting the policy on bulletin boards accessible to employees at each location where construction work is performed.

(7) Review, at least annually, the Contractor's equal employment policy and affirmative action obligations with all employees having responsibility for hiring, assignment, layoff, termination, or other employment decisions. Conduct review of this policy with all onsite supervisory personnel before initiating construction work at a job site. A written record shall be made and maintained identifying the time and place of these meetings, persons attending, subject matter discussed, and disposition of the subject matter.

(8) Disseminate the Contractor's equal employment policy externally by including it in any advertising in the news media, specifically

including minority and female news media. Provide written notification to, and discuss this policy with, other Contractors and subcontractors with which the Contractor does or anticipates doing business.

(9) Direct recruitment efforts, both oral and written, to minority, female, and community organizations, to schools with minority and female students, and to minority and female recruitment and training organizations serving the Contractor's recruitment area and employment needs. Not later than 1 month before the date for acceptance of applications for apprenticeship or training by any recruitment source, send written notification to organizations such as the above, describing the openings, screening procedures, and tests to be used in the selection process.

(10) Encourage present minority and female employees to recruit minority persons and women. Where reasonable, provide after-school, summer, and vacation employment to minority and female youth both on the site and in other areas of the Contractor's workforce.

(11) Validate all tests and other selection requirements where required under 41 CFR 60-3.

(12) Conduct, at least annually, an inventory and evaluation at least of all minority and female personnel for promotional opportunities. Encourage these employees to seek or to prepare for, through appropriate training, etc., opportunities for promotion.

(13) Ensure that seniority practices job classifications, work assignments, and other personnel practices do not have a discriminatory effect by continually monitoring all personnel and employment-related activities to ensure that the Contractor's obligations under this contract are being carried out.

(14) Ensure that all facilities and company activities are nonsegregated except that separate or single-user toilet and necessary changing facilities shall be provided to assure privacy between the sexes.

(15) Maintain a record of solicitations for subcontracts for minority and female construction contractors and suppliers, including circulation of solicitations to minority and female contractor associations and other business associations.

(16) Conduct a review, at least annually, of all supervisors' adherence to and performance under the Contractor's equal employment policy and affirmative action obligations.

(h) The Contractor is encouraged to participate in voluntary associations that may assist in fulfilling one or more of the affirmative action obligations contained in subparagraphs (g)(1) through (16). The efforts of a contractor association, joint contractor-union,

contractor-community, or similar group of which the contractor is a member and participant may be asserted as fulfilling one or more of its obligations under subparagraphs (g)(1) through (16), provided the Contractor--

- (1) Actively participates in the group;
- (2) Makes every effort to ensure that the group has a positive impact on the employment of minorities and women in the industry;
- (3) Ensures that concrete benefits of the program are reflected in the Contractor's minority and female workforce participation;
- (4) Makes a good-faith effort to meet its individual goals and timetables; and
- (5) Can provide access to documentation that demonstrates the effectiveness of actions taken on behalf of the Contractor. The obligation to comply is the Contractor's, and failure of such a group to fulfill an obligation shall not be a defense for the Contractor's noncompliance.

(i) A single goal for minorities and a separate single goal for women shall be established. The Contractor is required to provide equal employment opportunity and to take affirmative action for all minority groups, both male and female, and all women, both minority and nonminority. Consequently, the Contractor may be in violation of Executive Order 11246, as amended, if a particular group is employed in a substantially disparate manner.

(j) The Contractor shall not use goals or affirmative action standards to discriminate against any person because of race, color, religion, sex, or national origin.

(k) The Contractor shall not enter into any subcontract with any person or firm debarred from Government contracts under Executive Order 11246, as amended.

(l) The Contractor shall carry out such sanctions and penalties for violation of this clause and of the Equal Opportunity clause, including suspension, termination, and cancellation of existing subcontracts, as may be imposed or ordered under Executive Order 11246, as amended, and its implementing regulations, by the OFCCP. Any failure to carry out these sanctions and penalties as ordered shall be a violation of this clause and Executive Order 11246, as amended.

(m) The Contractor in fulfilling its obligations under this clause shall implement affirmative action procedures at least as extensive as those prescribed in paragraph (g) above, so as to achieve maximum results from its efforts to ensure equal employment opportunity. If the Contractor fails to comply with the requirements of Executive Order 11246, as

amended, the implementing regulations, or this clause, the Director shall take action as prescribed in 41 CFR 60-4.8.

(n) The Contractor shall designate a responsible official to--

- (1) Monitor all employment-related activity to ensure that the Contractor's equal employment policy is being carried out;
- (2) Submit reports as may be required by the Government; and
- (3) Keep records that shall at least include for each employee the name, address, telephone number, construction trade, union affiliation (if any), employee identification number, social security number, race, sex, status (e.g., mechanic, apprentice, trainee, helper, or laborer), dates of changes in status, hours worked per week in the indicated trade, rate of pay, and locations at which the work was performed. Records shall be maintained in an easily understandable and retrievable form; however, to the degree that existing records satisfy this requirement, separate records are not required to be maintained.

(o) Nothing contained herein shall be construed as a limitation upon the application of other laws that establish different standards of compliance or upon the requirements for the hiring of local or other area residents (e.g., those under the Public Works Employment Act of 1977 and the Community Development Block Grant Program).

(End of clause)

(R 7-603.60 1978 SEP)

I.41 52.222-35 AFFIRMATIVE ACTION FOR SPECIAL DISABLED AND VIETNAM ERA VETERANS
(APR 1984)

(a) Definitions.

"Appropriate office of the State employment service system," as used in this clause, means the local office of the Federal-State national system of public employment offices assigned to serve the area where the employment opening is to be filled, including the District of Columbia, Guam, Puerto Rico, Virgin Islands, American Samoa, and the Trust Territory of the Pacific Islands.

"Openings that the Contractor proposes to fill from within its own organization," as used in this clause, means employment openings for which no one outside the Contractor's organization (including any affiliates, subsidiaries, and the parent companies) will be considered and includes any openings that the Contractor proposes to fill from regularly established "recall" lists.

"Openings that the Contractor proposes to fill under a customary and traditional employer-union hiring arrangement," as used in this clause, means employment openings that the Contractor proposes to fill from union halls, under their customary and traditional employer-union hiring relationship.

"Suitable employment openings," as used in this clause--

(1) Includes, but is not limited to, openings that occur in jobs categorized as--

- (i) Production and nonproduction;
- (ii) Plant and office;
- (iii) Laborers and mechanics;
- (iv) Supervisory and nonsupervisory;
- (v) Technical; and
- (vi) Executive, administrative, and professional positions compensated on a salary basis of less than \$25,000 a year; and

(2) Includes full-time employment, temporary employment of over 3 days, and part-time employment, but not openings that the Contractor proposes to fill from within its own organization or under a customary and traditional employer-union hiring arrangement, nor openings in an educational institution that are restricted to students of that institution.

(b) General. (1) Regarding any position for which the employee or applicant for employment is qualified, the Contractor shall not discriminate against the individual because the individual is a special disabled or Vietnam Era veteran. The Contractor agrees to take affirmative action to employ, advance in employment, and otherwise treat qualified special disabled and Vietnam Era veterans without discrimination based upon their disability or veterans' status in all employment practices such as--

- (i) Employment;
- (ii) Upgrading;
- (iii) Demotion or transfer;
- (iv) Recruitment;
- (v) Advertising;
- (vi) Layoff or termination;
- (vii) Rates of pay or other forms of compensation; and
- (viii) Selection for training, including apprenticeship.

(2) The Contractor agrees to comply with the rules, regulations, and relevant orders of the Secretary of Labor (Secretary) issued under the Vietnam Era Veterans' Readjustment Assistance Act of 1972 (the Act), as amended.

(c) Listing openings. (1) The Contractor agrees to list all suitable

employment openings existing at contract award or occurring during contract performance, at an appropriate office of the State employment service system in the locality where the opening occurs. These openings include those occurring at any Contractor facility, including one not connected with performing this contract. An independent corporate affiliate is exempt from this requirement.

(2) State and local government agencies holding Federal contracts of \$10,000 or more shall also list all their suitable openings with the appropriate office of the State employment service.

(3) The listing of suitable employment openings with the State employment service system is required at least concurrently with using any other recruitment source or effort and involves the obligations of placing a bona fide job order, including accepting referrals of veterans and nonveterans. This listing does not require hiring any particular job applicant or hiring from any particular group of job applicants and is not intended to relieve the Contractor from any requirements of Executive orders or regulations concerning nondiscrimination in employment.

(4) Whenever the Contractor becomes contractually bound to the listing terms of this clause, it shall advise the State employment service system, in each State where it has establishments, of the name and location of each hiring location in the State. As long as the Contractor is contractually bound to these terms and has so advised the State system, it need not advise the State system of subsequent contracts. The Contractor may advise the State system when it is no longer bound by this contract clause.

(5) Under the most compelling circumstances, an employment opening may not be suitable for listing, including situations when (i) the Government's needs cannot reasonably be supplied, (ii) listing would be contrary to national security, or (iii) the requirement of listing would not be in the Government's interest.

(d) Applicability. (1) This clause does not apply to the listing of employment openings which occur and are filled outside the 50 States, the District of Columbia, Puerto Rico, Guam, Virgin Islands, American Samoa, and the Trust Territory of the Pacific Islands.

(2) The terms of paragraph (c) above of this clause do not apply to openings that the Contractor proposes to fill from within its own organization or under a customary and traditional employer-union hiring arrangement. This exclusion does not apply to a particular opening once an employer decides to consider applicants outside of its own organization or employer-union arrangement for that opening.

(e) Postings. (1) The Contractor agrees to post employment notices stating (i) the Contractor's obligation under the law to take affirmative action to employ and advance in employment qualified special disabled veterans and veterans of the Vietnam era, and (ii) the rights of applicants and employees.

(2) These notices shall be posted in conspicuous places that are available to employees and applicants for employment. They shall be in a form prescribed by the Director, Office of Federal Contract Compliance Programs, Department of Labor (Director), and provided by or through the Contracting Officer.

(3) The Contractor shall notify each labor union or representative of workers with which it has a collective bargaining agreement or other contract understanding, that the Contractor is bound by the terms of the Act, and is committed to take affirmative action to employ, and advance in employment, qualified special disabled and Vietnam Era veterans.

(f) Noncompliance. If the Contractor does not comply with the requirements of this clause, appropriate actions may be taken under the rules, regulations, and relevant orders of the Secretary issued pursuant to the Act.

(g) Subcontracts. The Contractor shall include the terms of this clause in every subcontract or purchase order of \$10,000 or more unless exempted by rules, regulations, or orders of the Secretary. The Contractor shall act as specified by the Director to enforce the terms, including action for noncompliance.

(End of clause)
(R 7-103.27 1976 JUL)
(R FPR Temp. Reg. 39)

1.42 52.222-36 AFFIRMATIVE ACTION FOR HANDICAPPED WORKERS (APR 1984)

(a) General. (1) Regarding any position for which the employee or applicant for employment is qualified, the Contractor shall not discriminate against any employee or applicant because of physical or mental handicap. The Contractor agrees to take affirmative action to employ, advance in employment, and otherwise treat qualified handicapped individuals without discrimination based upon their physical or mental handicap in all employment practices such as--

- (i) Employment;
- (ii) Upgrading;

- (iii) Demotion or transfer;
- (iv) Recruitment;
- (v) Advertising;
- (vi) Layoff or termination;
- (vii) Rates of pay or other forms of compensation; and
- (viii) Selection for training, including apprenticeship.

(2) The Contractor agrees to comply with the rules, regulations, and relevant orders of the Secretary of Labor (Secretary) issued under the Rehabilitation Act of 1973 (29 U.S.C. 793) (the Act), as amended.

(b) Postings. (1) The Contractor agrees to post employment notices stating (i) the Contractor's obligation under the law to take affirmative action to employ and advance in employment qualified handicapped individuals and (ii) the rights of applicants and employees.

(2) These notices shall be posted in conspicuous places that are available to employees and applicants for employment. They shall be in a form prescribed by the Director, Office of Federal Contract Compliance Programs, Department of Labor (Director), and provided by or through the Contracting Officer.

(3) The Contractor shall notify each labor union or representative of workers with which it has a collective bargaining agreement or other contract understanding, that the Contractor is bound by the terms of Section 503 of the Act and is committed to take affirmative action to employ, and advance in employment, qualified physically and mentally handicapped individuals.

(c) Noncompliance. If the Contractor does not comply with the requirements of this clause, appropriate actions may be taken under the rules, regulations, and relevant orders of the Secretary issued pursuant to the Act.

(d) Subcontracts. The Contractor shall include the terms of this clause in every subcontract or purchase order in excess of \$2,500 unless exempted by rules, regulations, or orders of the Secretary. The Contractor shall act as specified by the Director to enforce the terms, including action for noncompliance.

(End of clause)
(R 7-103.28 1976 MAY)
(R FPR Temp. Reg. 38)

1.43 52.222-37

EMPLOYMENT REPORTS ON SPECIAL DISABLED VETERANS AND VETERANS OF THE VIETNAM ERA (JAN 1988)

(a) The contractor shall report at least annually, as required by the Secretary of Labor, on:

(1) The number of special disabled veterans and the number of veterans of the Vietnam era in the workforce of the contractor by job category and hiring location; and

(2) The total number of new employees hired during the period covered by the report, and of that total, the number of special disabled veterans, and the number of veterans of the Vietnam era.

(b) The above items shall be reported by completing the form entitled "Federal Contractor Veterans' Employment Report VETS-100."

(c) Reports shall be submitted no later than March 31 of each year beginning March 31, 1988.

(d) The employment activity report required by paragraph (a)(2) of this clause shall reflect total hires during the most recent 12-month period as of the ending date selected for the employment profile report required by paragraph (a)(1) of this clause. Contractors may select an ending date: (1) As of the end of any pay period during the period January through March 1st of the year the report is due, or (2) as of December 31, if the contractor has previous written approval from the Equal Employment Opportunity Commission to do so for purposes of submitting the Employer Information Report EEO-1 (Standard Form 100).

(e) The count of veterans reported according to paragraph (a) of this clause shall be based on voluntary disclosure. Each contractor subject to the reporting requirements at 38 U.S.C. 2012(d) shall invite all special disabled veterans and veterans of the Vietnam era who wish to benefit under the affirmative action program at 38 U.S.C. 2012 to identify themselves to the contractor. The invitation shall state that the information is voluntarily provided, that the information will be kept confidential, that disclosure or refusal to provide the information will not subject the applicant or employee to any adverse treatment and that the information will be used only in accordance with the regulations promulgated under 38 U.S.C. 2012.

(f) Subcontracts. The Contractor shall include the terms of this clause in every subcontract or purchase order of \$10,000 or more unless exempted by rules, regulations, or orders of the Secretary.

(End of clause)

1.44 52.223-2 CLEAN AIR AND WATER (APR 1984)

(a) "Air Act", as used in this clause, means the Clean Air Act (42 U.S.C. 7401, et seq.).

"Clean air standards," as used in this clause, means--

(1) Any enforceable rules, regulations, guidelines, standards, limitations, orders, controls, prohibitions, work practices, or other requirements contained in, issued under, or otherwise adopted under the Air Act or Executive Order 11738;

(2) An applicable implementation plan as described in section 110(d) of the Air Act (42 U.S.C. 7410(d));

(3) An approved implementation procedure or plan under section 111(c) or section 111(d) of the Air Act (42 U.S.C. 7411(c) or (d)); or

(4) An approved implementation procedure under section 112(d) of the Air Act (42 U.S.C. 7412(d)).

"Clean water standards," as used in this clause, means any enforceable limitation, control, condition, prohibition, standard, or other requirement promulgated under the Water Act or contained in a permit issued to a discharger by the EPA or by a State under an approved program, as authorized by section 402 of the Water Act (33 U.S.C. 1342), or by local government to ensure compliance with pretreatment regulations as required by section 307 of the Water Act (33 U.S.C. 1317).

"Compliance," as used in this clause, means compliance with--

(1) Clean air or water standards; or

(2) A schedule or plan ordered or approved by a court of competent jurisdiction, the EPA, or an air or water pollution control agency under the requirements of the Air Act or Water Act and related regulations.

"Facility," as used in this clause, means any building, plant, installation, structure, mine, vessel or other floating craft, location, or site of operations, owned, leased, or supervised by a Contractor or subcontractor, used in the performance of a contract or subcontract. When a location or site of operations includes more than one building, plant, installation, or structure, the entire location or site shall be deemed a facility except when the Administrator, or a designee, of the EPA determines that independent facilities are collocated in one geographical area.

"Water Act," as used in this clause, means Clean Water Act (33 U.S.C. 1251, et seq.).

(b) The Contractor agrees--

(1) To comply with all the requirements of section 114 of the Clean Air Act (42 U.S.C. 7414) and section 308 of the Clean Water Act (33 U.S.C. 1318) relating to inspection, monitoring, entry, reports, and

information, as well as other requirements specified in section 114 and section 308 of the Air Act and the Water Act, and all regulations and guidelines issued to implement those acts before the award of this contract;

(2) That no portion of the work required by this prime contract will be performed in a facility listed on the EPA List of Violating Facilities on the date when this contract was awarded unless and until the EPA eliminates the name of the facility from the listing;

(3) To use best efforts to comply with clean air standards and clean water standards at the facility in which the contract is being performed; and

(4) To insert the substance of this clause into any nonexempt subcontract, including this subparagraph (b)(4).

(End of clause)
(R 7-103.29 1975 OCT)
(R 1-1.2302)

I.45 52.223-6 DRUG-FREE WORKPLACE (JUL 1990)

(a) Definitions. As used in this clause,

"Controlled substance" means a controlled substance in schedules I through V of section 202 of the Controlled Substances Act (21 U.S.C. 812) and as further defined in regulation at 21 CFR 1308.11 - 1308.15.

"Conviction" means a finding of guilt (including a plea of nolo contendere) or imposition of sentence, or both, by any judicial body charged with the responsibility to determine violations of the Federal or State criminal drug statutes.

"Criminal drug statute" means a Federal or non-Federal criminal statute involving the manufacture, distribution, dispensing, possession or use of any controlled substance.

"Drug-free workplace" means the site(s) for the performance of work done by the Contractor in connection with a specific contract at which employees of the Contractor are prohibited from engaging in the unlawful manufacture, distribution, dispensing, possession, or use of a controlled substance.

"Employee" means an employee of a Contractor directly engaged in the performance of work under a Government contract. "Directly engaged" is defined to include all direct cost employees and any other Contractor employee who has other than a minimal impact or involvement in contract performance.

"Individual" means an offeror/contractor that has no more than one employee including the offeror/contractor.

(b) The Contractor, if other than an individual, shall--within 30 calendar days after award (unless a longer period is agreed to in writing for contracts of 30 calendar days or more performance duration), or as soon as possible for contracts of less than 30 calendar days performance duration--

(1) Publish a statement notifying its employees that the unlawful manufacture, distribution, dispensing, possession, or use of a controlled substance is prohibited in the Contractor's workplace and specifying the actions that will be taken against employees for violations of such prohibition;

(2) Establish an ongoing drug-free awareness program to inform such employees about--

(i) The dangers of drug abuse in the workplace;

(ii) The Contractor's policy of maintaining a drug-free workplace;

(iii) Any available drug counseling, rehabilitation, and employee assistance programs; and

(iv) The penalties that may be imposed upon employees for drug abuse violations occurring in the workplace;

(3) Provide all employees engaged in performance of the contract with a copy of the statement required by subparagraph (b)(1) of this clause;

(4) Notify such employees in writing in the statement required by subparagraph (b)(1) of this clause that, as a condition of continued employment on this contract, the employee will--

(i) Abide by the terms of the statement; and

(ii) Notify the employer in writing of the employee's conviction under a criminal drug statute for a violation occurring in the workplace no later than 5 calendar days after such conviction.

(5) Notify the Contracting Officer in writing within 10 calendar days after receiving notice under subdivision (b)(4)(ii) of this clause, from an employee or otherwise receiving actual notice of such conviction. The notice shall include the position title of the employee;

(6) Within 30 calendar days after receiving notice under subdivision (b)(4)(ii) of this clause of a conviction, take one of the following actions with respect to any employee who is convicted of a drug abuse violation occurring in the workplace:

(i) Taking appropriate personnel action against such employee, up to and including termination; or

(ii) Require such employee to satisfactorily participate in a drug abuse assistance or rehabilitation program approved for such purposes

by a Federal, State, or local health, law enforcement, or other appropriate agency.

(7) Make a good faith effort to maintain a drug-free workplace through implementation of subparagraphs (b)(1) through (b)(6) of this clause.

(c) The Contractor, if an individual, agrees by award of the contract or acceptance of a purchase order, not to engage in the unlawful manufacture, distribution, dispensing, possession, or use of a controlled substance in the performance of this contract.

(d) In addition to other remedies available to the Government, the Contractor's failure to comply with the requirements of paragraphs (b) or (c) of this clause may, pursuant to FAR 23.506, render the Contractor subject to suspension of contract payments, termination of the contract for default, and suspension or debarment.

(End of clause)

I.46 252.223-7004 DRUG-FREE WORK FORCE (SEP 1988)

(a) Definitions.

(1) "Employee in a sensitive position," as used in this clause, means an employee who has been granted access to classified information; or employees in other positions that the Contractor determines involve national security, health or safety, or functions other than the foregoing requiring a high degree of trust and confidence.

(2) "Illegal drugs," as used in this clause, means controlled substances included in Schedules I and II, as defined by section 802(6) of Title 21 of the United States Code, the possession of which is unlawful under Chapter 13 of that Title. The term "illegal drugs" does not mean the use of a controlled substance pursuant to a valid prescription or other uses authorized by law.

(b) The Contractor agrees to institute and maintain a program for achieving the objective of a drug-free work force. While this clause defines criteria for such a program, contractors are encouraged to implement alternative approaches comparable to the criteria in paragraph (c) that are designed to achieve the objectives of this clause.

(c) Contractor programs shall include the following, or appropriate alternatives:

(1) Employee assistance programs emphasizing high level direction, education, counseling, rehabilitation, and coordination with available

community resources;

(2) Supervisory training to assist in identifying and addressing illegal drug use by Contractor employees;

(3) Provision for self-referrals as well as supervisory referrals to treatment with maximum respect for individual confidentiality consistent with safety and security issues;

(4) Provision for identifying illegal drug users, including testing on a controlled and carefully monitored basis. Employee drug testing programs shall be established taking account of the following:

(i) The Contractor shall establish a program that provides for testing for the use of illegal drugs by employees in sensitive positions. The extent of and criteria for such testing shall be determined by the Contractor based on considerations that include the nature of the work being performed under the contract, the employee's duties, the efficient use of Contractor resources, and the risks to health, safety, or national security that could result from the failure of an employee adequately to discharge his or her position.

(ii) In addition, the Contractor may establish a program for employee drug testing--

(A) When there is a reasonable suspicion that an employee uses illegal drugs; or

(B) When an employee has been involved in an accident or unsafe practice;

(C) As part of or as a follow-up to counseling or rehabilitation for illegal drug use;

(D) As part of a voluntary employee drug testing program.

(iii) The Contractor may establish a program to test applicants for employment for illegal drug use.

(iv) For the purpose of administering this clause, testing for illegal drugs may be limited to those substances for which testing is prescribed by section 2.1 of Subpart B of the "Mandatory Guidelines for Federal Workplace Drug Testing Programs" (53 FR 11980 (April 11 1988)), issued by the Department of Health and Human Services.

(d) Contractors shall adopt appropriate personnel procedures to deal with employees who are found to be using drugs illegally. Contractors shall not allow any employee to remain on duty or perform in a sensitive position who is found to use illegal drugs until such time as the Contractor, in accordance with procedures established by the Contractor, determines that the employee may perform in such a position.

(e) The provisions of this clause pertaining to drug testing programs shall not apply to the extent they are inconsistent with state or local

law, or with an existing collective bargaining agreement; provided that with respect to the latter, the Contractor agrees that those issues that are in conflict will be a subject of negotiation at the next collective bargaining session.

(End of clause)

I.47 52.225-5 BUY AMERICAN ACT--CONSTRUCTION MATERIALS (MAY 1992)

(a) The Buy American Act (41 U.S.C. 10) provides that the Government give preference to domestic construction material.

"Components," as used in this clause, means those articles, materials, and supplies incorporated directly into construction materials.

"Construction materials," as used in this clause, means an article, material, or supply brought to the construction site for incorporation into the building or work. Construction material also includes an item brought to the site pre-assembled from articles, materials or supplies. However, emergency life safety systems, such as emergency lighting, fire alarm, and audio evacuation systems, which are discrete systems incorporated into a public building or work and which are produced as a complete system, shall be evaluated as a single and distinct construction material regardless of when or how the individual parts or components of such systems are delivered to the construction site.

"Domestic construction material," as used in this clause, means (1) an unmanufactured construction material mined or produced in the United States, or (2) a construction material manufactured in the United States, if the cost of its components mined, produced, or manufactured in the United States exceeds 50 percent of the cost of all its components. Components of foreign origin of the same class or kind as the construction materials determined to be unavailable pursuant to subparagraph 25.202(a)(3) of the Federal Acquisition Regulation (FAR) shall be treated as domestic.

(b) The Contractor agrees that only domestic construction material will be used by the Contractor, subcontractors, materialmen, and suppliers in the performance of this contract, except for foreign construction materials, if any, listed in this contract. (The foregoing requirements are administered in accordance with Executive Order No. 10582, dated December 17, 1954, as amended, and Subpart 25.2 of the FAR).

(End of clause)

I.48 52.225-11 RESTRICTIONS ON CERTAIN FOREIGN PURCHASES (MAY 1992)

(a) Unless advance written approval of the Contracting Officer is obtained, the Contractor shall not acquire for use in the performance of this contract--

(1) Any supplies or services originating from sources within the communist areas of North Korea, Vietnam, Cambodia, or Cuba;

(2) Any supplies that are or were located in or transported from or through North Korea, Vietnam, Cambodia, or Cuba; or

(3) Arms, ammunition, or military vehicles produced in South Africa, or manufacturing data for such articles.

(b) The Contractor shall not acquire for use in the performance of this contract supplies or services originating from sources within Iraq, any supplies that are or were located in or transported from or through Iraq, or any supplies or services from entities controlled by the Government of Iraq.

(c) The Contractor agrees to insert the provisions of this clause, including this paragraph (c), in all subcontracts hereunder.

(End of clause)

I.49 52.226-1 UTILIZATION OF INDIAN ORGANIZATIONS AND INDIAN-OWNED ECONOMIC ENTERPRISES (AUG 1991)

(a) This clause applies only if the contract includes a subcontracting plan incorporated under the terms of the clause entitled, Small Business and Small Disadvantaged Business Subcontracting Plan. It does not apply to contracts awarded based on a subcontracting plan submitted and approved under paragraph (g) of the clause at 52.219-9.

(b) Definitions. As used in this clause:

"Indian organization" means the governing body of any Indian tribe (as defined by 25 U.S.C. 1452(c)) or entity established or recognized by the governing body for the purposes of 25 U.S.C., Chapter 17.

"Indian-owned economic enterprise" means any Indian-owned (as determined by the Secretary of the Interior) commercial, industrial, or business activity established or organized for the purpose of profit, provided that Indian ownership shall constitute not less than 51 percent of the enterprise.

(c) The Contractor agrees to use its best efforts to give Indian organizations and Indian-owned economic enterprises the (25 U.S.C. 1544)

maximum practicable opportunity to participate in the subcontracts it awards to the fullest extent consistent with efficient performance of its contract.

(1) The Contractor may rely on the written representation of the Indian organization or Indian-owned economic enterprise.

(2) If the cost of subcontracting with an Indian organization or Indian-owned economic enterprise exceeds the cost of acquiring the supplies or services from a non-Indian source, the Contractor may request an adjustment to the following:

- (i) The estimated cost of a cost-type contract;
- (ii) The target cost of a cost-plus-incentive-fee prime contract;
- (iii) The target cost and ceiling price of a fixed-price incentive prime contract; or
- (iv) The price of a firm-fixed-price prime contract.

(3) The amount of the equitable adjustment to the prime contract shall be the lesser of--

- (i) The difference between the estimated cost, target cost or firm-fixed-price included in the subcontract initially awarded to the Indian organization or enterprise and the corresponding estimated cost, target cost or firm-fixed-price which would have been included in a subcontract with the otherwise low, non-Indian offeror; or
- (ii) Five percent of the estimated cost, target cost or firm-fixed-price included in the subcontract initially awarded to the Indian organization or enterprise.

(4) The Contractor has the burden of proving the amount claimed and must assert its request for an adjustment prior to completion of contract performance.

(d) The Contracting Officer shall decide the amount of the adjustment and modify the contract accordingly. The Contracting Officer's decision is final and not subject to the Disputes clause of this contract.

(End of clause)

I.50 52.227-1 AUTHORIZATION AND CONSENT (APR 1984)

(a) The Government authorizes and consents to all use and manufacture, in performing this contract or any subcontract at any tier, of any invention described in and covered by a United States patent (1) embodied in the structure or composition of any article the delivery of which is accepted by the Government under this contract or (2) used in machinery,

tools, or methods whose use necessarily results from compliance by the Contractor or a subcontractor with (i) specifications or written provisions forming a part of this contract or (ii) specific written instructions given by the Contracting Officer directing the manner of performance. The entire liability to the Government for infringement of a patent of the United States shall be determined solely by the provisions of the indemnity clause, if any, included in this contract or any subcontract hereunder (including any lower-tier subcontract), and the Government assumes liability for all other infringement to the extent of the authorization and consent hereinabove granted.

(b) The Contractor agrees to include, and require inclusion of, this clause, suitably modified to identify the parties, in all subcontracts at any tier for supplies or services (including construction, architect-engineer services, and materials, supplies, models, samples, and design or testing services expected to exceed \$25,000); however, omission of this clause from any subcontract, under or over \$25,000, does not affect this authorization and consent.

(End of clause)
(R 7-103.22 1961 JAN)

I.51 52.227-2 NOTICE AND ASSISTANCE REGARDING PATENT AND COPYRIGHT INFRINGEMENT
(APR 1984)

(a) The Contractor shall report to the Contracting Officer, promptly and in reasonable written detail, each notice or claim of patent or copyright infringement based on the performance of this contract of which the Contractor has knowledge.

(b) In the event of any claim or suit against the Government on account of any alleged patent or copyright infringement arising out of the performance of this contract or out of the use of any supplies furnished or work or services performed under this contract, the Contractor shall furnish to the Government, when requested by the Contracting Officer, all evidence and information in possession of the Contractor pertaining to such suit or claim. Such evidence and information shall be furnished at the expense of the Government except where the Contractor has agreed to indemnify the Government.

(c) The Contractor agrees to include, and require inclusion of, this clause in all subcontracts at any tier for supplies or services (including construction and architect-engineer subcontracts and those for material,

supplies, models, samples, or design or testing services) expected to exceed the dollar amount set forth in 13.000 of the Federal Acquisition Regulation (FAR).

(End of clause)
(R 7-103.23 1965 JAN)

I.52 52.227-4 PATENT INDEMNITY--CONSTRUCTION CONTRACTS (APR 1984)

Except as otherwise provided, the Contractor agrees to indemnify the Government and its officers, agents, and employees against liability, including costs and expenses, for infringement upon any United States patent (except a patent issued upon an application that is now or may hereafter be withheld from issue pursuant to a Secrecy Order under 35 U.S.C. 181) arising out of performing this contract or out of the use or disposal by or for the account of the Government of supplies furnished or work performed under this contract.

(End of clause)
(R 7-602.16 1964 JUN)

I.53 252.227-7033 RIGHTS IN SHOP DRAWINGS (APR 1966)

(a) Shop drawings for construction means drawings, submitted to the Government by the Construction Contractor, subcontractor or any lower-tier subcontractor pursuant to a construction contract, showing in detail (i) the proposed fabrication and assembly of structural elements and (ii) the installation (i.e., form, fit, and attachment details) of materials or equipment. The Government may duplicate, use, and disclose in any manner and for any purpose shop drawings delivered under this contract.

(b) This clause, including this paragraph (b), shall be included in all subcontracts hereunder at any tier.

(End of clause)

I.54 52.228-2 ADDITIONAL BOND SECURITY (APR 1984)

The Contractor shall promptly furnish additional security required to

protect the Government and persons supplying labor or materials under this contract if--

(a) Any surety upon any bond furnished with this contract becomes unacceptable to the Government;

(b) Any surety fails to furnish reports on its financial condition as required by the Government; or

(c) The contract price is increased so that the penal sum of any bond becomes inadequate in the opinion of the Contracting Officer.

(End of clause)

(R 1-7.103-2)

(R 1-7.602-17)

(R 7-103.9 1949 JUL)

(R 7-602.17 1976 OCT)

I.55 52.228-5 INSURANCE--WORK ON A GOVERNMENT INSTALLATION (SEP 1989)

(a) The Contractor shall, at its own expense, provide and maintain during the entire performance of this contract, at least the kinds and minimum amounts of insurance required in the Schedule or elsewhere in the contract.

(b) Before commencing work under this contract, the Contractor shall certify to the Contracting Officer in writing that the required insurance has been obtained. The policies evidencing required insurance shall contain an endorsement to the effect that any cancellation or any material change adversely affecting the Government's interest shall not be effective (1) for such period as the laws of the State in which this contract is to be performed prescribe, or (2) until 30 days after the insurer or the Contractor gives written notice to the Contracting Officer, whichever period is longer.

(c) The Contractor shall insert the substance of this clause, including this paragraph (c), in subcontracts under this contract that require work on a Government installation and shall require subcontractors to provide and maintain the insurance required in the Schedule or elsewhere in the contract. The Contractor shall maintain a copy of all subcontractors' proofs of required insurance, and shall make copies available to the Contracting Officer upon request.

(End of clause)

1.56 52.228-11 PLEDGES OF ASSETS (FEB 1990)

(a) Offerors shall obtain from each person acting as an individual surety on a bid guarantee, a performance bond, or a payment bond--

- (1) Pledge of assets; and
- (2) Standard Form 28, Affidavit of Individual Surety.

(b) Pledges of assets from each person acting as an individual surety shall be in the form of--

- (1) Evidence of an escrow account containing cash, certificates of deposit, commercial or Government securities, or other assets described in FAR 28.203-2 (except see 28.203-2(b)(2) with respect to Government securities held in book entry form) and/or;
- (2) A recorded lien on real estate. The offeror will be required to provide--

- (i) Evidence of title in the form of a certificate of title prepared by a title insurance company approved by the United States Department of Justice. This title evidence must show fee simple title vested in the surety along with any concurrent owners; whether any real estate taxes are due and payable; and any recorded encumbrances against the property, including the lien filed in favor of the Government as required by FAR 28.203-3(d);

- (ii) Evidence of the amount due under any encumbrance shown in the evidence of title;

- (iii) A copy of the current real estate tax assessment of the property or a current appraisal dated no earlier than 6 months prior to the date of the bond, prepared by a professional appraiser who certifies that the appraisal has been conducted in accordance with the generally accepted appraisal standards as reflected in the Uniform Standards of Professional Appraisal Practice, as promulgated by the Appraisal Foundation.

(End of clause)

1.57 252.228-7006 PROSPECTIVE SUBCONTRACTOR REQUESTS FOR BONDS (SEP 1992)

In accordance with section 806(a)(3) of Pub. L. 102-190, upon the request of a prospective subcontractor or supplier offering to furnish labor or material for the performance of this contract for which a payment bond has been furnished to the Government pursuant to the Miller Act, the Contractor shall promptly provide a copy of such payment bond to the

requestor.

(End of clause)

I.58 52.229-3 FEDERAL, STATE, AND LOCAL TAXES (JAN 1991)

(a) "Contract date," as used in this clause, means the date set for bid opening or, if this is a negotiated contract or a modification, the effective date of this contract or modification.

"All applicable Federal, State, and local taxes and duties," as used in this clause, means all taxes and duties, in effect on the contract date, that the taxing authority is imposing and collecting on the transactions or property covered by this contract.

"After-imposed Federal tax," as used in this clause, means any new or increased Federal excise tax or duty, or tax that was exempted or excluded on the contract date but whose exemption was later revoked or reduced during the contract period, on the transactions or property covered by this contract that the Contractor is required to pay or bear as the result of legislative, judicial, or administrative action taking effect after the contract date. It does not include social security tax or other employment taxes.

"After-relieved Federal tax," as used in this clause, means any amount of Federal excise tax or duty, except social security or other employment taxes, that would otherwise have been payable on the transactions or property covered by this contract, but which the Contractor is not required to pay or bear, or for which the Contractor obtains a refund or drawback, as the result of legislative, judicial, or administrative action taking effect after the contract date.

(b) The contract price includes all applicable Federal, State, and local taxes and duties.

(c) The contract price shall be increased by the amount of any after-imposed Federal tax, provided the Contractor warrants in writing that no amount for such newly imposed Federal excise tax or duty or rate increase was included in the contract price, as a contingency reserve or otherwise.

(d) The contract price shall be decreased by the amount of any after-relieved Federal tax.

(e) The contract price shall be decreased by the amount of any Federal excise tax or duty, except social security or other employment taxes, that the Contractor is required to pay or bear, or does not obtain a refund of, through the Contractor's fault, negligence, or failure to follow

instructions of the Contracting Officer.

(f) No adjustment shall be made in the contract price under this clause unless the amount of the adjustment exceeds \$250.

(g) The Contractor shall promptly notify the Contracting Officer of all matters relating to any Federal excise tax or duty that reasonably may be expected to result in either an increase or decrease in the contract price and shall take appropriate action as the Contracting Officer directs.

(h) The Government shall, without liability, furnish evidence appropriate to establish exemption from any Federal, State, or local tax when the Contractor requests such evidence and a reasonable basis exists to sustain the exemption.

(End of clause)

1.59 52.229-5 TAXES--CONTRACTS PERFORMED IN U.S. POSSESSIONS OR PUERTO RICO (APR 1984)

The term "local taxes," as used in the Federal, State, and local taxes clause of this contract, includes taxes imposed by a possession of the United States or by Puerto Rico.

(End of clause)

(AV 7-103.10(c) 1963 NOV)

(AV 1-11.401-3(a))

1.60 252.231-7000 SUPPLEMENTAL COST PRINCIPLES (DEC 1991)

When the allowability of costs under this contract is determined in accordance with Part 31 of the Federal Acquisition Regulation (FAR), allowability shall also be determined in accordance with Part 231 of the Defense FAR Supplement, in effect on the date of this contract.

(End of clause)

1.61 52.232-5 PAYMENTS UNDER FIXED-PRICE CONSTRUCTION CONTRACTS (APR 1989)

(a) The Government shall pay the Contractor the contract price as provided in this contract.

(b) The Government shall make progress payments monthly as the work proceeds, or at more frequent intervals as determined by the Contracting Officer, on estimates of work accomplished which meets the standards of quality established under the contract, as approved by the Contracting Officer. The Contractor shall furnish a breakdown of the total contract price showing the amount included therein for each principal category of the work, which shall substantiate the payment amount requested in order to provide a basis for determining progress payments, in such detail as requested by the Contracting Officer. In the preparation of estimates the Contracting Officer may authorize material delivered on the site and preparatory work done to be taken into consideration. Material delivered to the Contractor at locations other than the site may also be taken into consideration if--

(1) Consideration is specifically authorized by this contract; and

(2) The Contractor furnishes satisfactory evidence that it has acquired title to such material and that the material will be used to perform this contract.

(c) Along with each request for progress payments, the contractor shall furnish the following certification, or payment shall not be made:

I hereby certify, to the best of my knowledge and belief, that--

(1) The amounts requested are only for performance in accordance with the specifications, terms, and conditions of the contract;

(2) Payments to subcontractors and suppliers have been made from previous payments received under the contract, and timely payments will be made from the proceeds of the payment covered by this certification, in accordance with subcontract agreements and the requirements of chapter 39 of Title 31, United States Code; and

(3) This request for progress payments does not include any amounts which the prime contractor intends to withhold or retain from a subcontractor or supplier in accordance with the terms and conditions of the subcontract.

(Name)

(Title)

(Date)

(d) If the Contractor, after making a certified request for progress payments, discovers that a portion or all of such request constitutes a payment for performance by the Contractor that fails to conform to the

specifications, terms, and conditions of this contract (hereinafter referred to as the "unearned amount"), the Contractor shall--

(1) Notify the Contracting Officer of such performance deficiency; and
(2) Be obligated to pay the Government an amount (computed by the Contracting Officer in the manner provided in 31 U.S.C 3903(c)(1)) equal to interest on the unearned amount from the date of receipt of the unearned amount until--

(i) The date the Contractor notifies the Contracting Officer that the performance deficiency has been corrected; or

(ii) The date the Contractor reduces the amount of any subsequent certified request for progress payments by an amount equal to the unearned amount.

(e) If the Contracting Officer finds that satisfactory progress was achieved during any period for which a progress payment is to be made, the Contracting Officer shall authorize payment to be made in full. However, if satisfactory progress has not been made, the Contracting Officer may retain a maximum of 10 percent of the amount of the payment until satisfactory progress is achieved. When the work is substantially complete, the Contracting Officer may retain from previously withheld funds and future progress payments that amount the Contracting Officer considers adequate for protection of the Government and shall release to the Contractor all the remaining withheld funds. Also, on completion and acceptance of each separate building, public work, or other division of the contract, for which the price is stated separately in the contract, payment shall be made for the completed work without retention of a percentage.

(f) All material and work covered by progress payments made shall, at the time of payment, become the sole property of the Government, but this shall not be construed as--

(1) Relieving the Contractor from the sole responsibility for all material and work upon which payments have been made or the restoration of any damaged work; or

(2) Waiving the right of the Government to require the fulfillment of all of the terms of the contract.

(g) In making these progress payments, the Government shall, upon request, reimburse the Contractor for the amount of premiums paid for performance and payment bonds (including coinsurance and reinsurance agreements, when applicable) after the Contractor has furnished evidence of full payment to the surety. The retainage provisions in paragraph (e) of this clause shall not apply to that portion of progress payments attributable to bond premiums.

(h) The Government shall pay the amount due the Contractor under this

contract after--

- (1) Completion and acceptance of all work;
- (2) Presentation of a properly executed voucher; and
- (3) Presentation of release of all claims against the Government arising by virtue of this contract, other than claims, in stated amounts, that the Contractor has specifically excepted from the operation of the release. A release may also be required of the assignee if the Contractor's claim to amounts payable under this contract has been assigned under the Assignment of Claims Act of 1940 (31 U.S.C. 3727 and 41 U.S.C. 15).

(i) Notwithstanding any provision of this contract, progress payments shall not exceed 80 percent on work accomplished on undefinitized contract actions. A "contract action" is any action resulting in a contract, as defined in FAR Subpart 2.1, including contract modifications for additional supplies or services, but not including contract modifications that are within the scope and under the terms of the contract, such as contract modifications issued pursuant to the Changes clause, or funding and other administrative changes.

(End of clause)

1.62 52.232-17 INTEREST (JAN 1991)

(a) Notwithstanding any other clause of this contract, all amounts, except amounts that are repayable and which bear interest under a Price Reduction for Defective Cost of Pricing Data clause, that become payable by the Contractor to the Government under this contract (net of any applicable tax credit under the Internal Revenue Code (26 U.S.C. 1481)) shall bear simple interest from the date due until paid unless paid within 30 days of becoming due. The interest rate shall be the interest rate established by the Secretary of the Treasury as provided in Section 12 of the Contract Disputes Act of 1978 (Public Law 95-563), which is applicable to the period in which the amount becomes due, as provided in paragraph (b) of this clause, and then at the rate applicable for each six-month period as fixed by the Secretary until the amount is paid.

(b) Amounts shall be due at the earliest of the following dates:

- (1) The date fixed under this contract.
- (2) The date of the first written demand for payment consistent with this contract, including any demand resulting from a default termination.
- (3) The date the Government transmits to the Contractor a proposed

supplemental agreement to confirm completed negotiations establishing the amount of debt.

(4) If this contract provides for revision of prices, the date of written notice to the Contractor stating the amount of refund payable in connection with a pricing proposal or a negotiated pricing agreement not confirmed by contract modification.

(c) The interest charge made under this clause may be reduced under the procedures prescribed in 32.614-2 of the Federal Acquisition Regulation in effect on the date of this contract.

(End of clause)

I.63 52.232-23 ASSIGNMENT OF CLAIMS (JAN 1986)

(a) The Contractor, under the Assignment of Claims Act, as amended, 31 U.S.C. 3727, 41 U.S.C. 15 (hereafter referred to as "the Act"), may assign its rights to be paid amounts due or to become due as a result of the performance of this contract to a bank, trust company, or other financing institution, including any Federal lending agency. The assignee under such an assignment may thereafter further assign or reassign its right under the original assignment to any type of financing institution described in the preceding sentence.

(b) Any assignment or reassignment authorized under the Act and this clause shall cover all unpaid amounts payable under this contract, and shall not be made to more than one party, except that an assignment or reassignment may be made to one party as agent or trustee for two or more parties participating in the financing of this contract.

(c) The Contractor shall not furnish or disclose to any assignee under this contract any classified document (including this contract) or information related to work under this contract until the Contracting Officer authorizes such action in writing.

(End of clause)

I.64 52.232-27 PROMPT PAYMENT FOR CONSTRUCTION CONTRACTS (APR 1989)

Notwithstanding any other payment terms in this contract, the Government will make invoice payments and contract financing payments under the terms and conditions specified in this clause. Payment shall be considered as

being made on the day a check is dated or an electronic funds transfer is made. Definitions of pertinent terms are set forth in 32.902. All days referred to in this clause are calendar days, unless otherwise specified.

(a) Invoice Payments.

(1) For purposes of this clause, there are several types of invoice payments which may occur under this contract, as follows:

(i) Progress payments, if provided for elsewhere in this contract, based on Contracting Officer approval of the estimated amount and value of work or services performed, including payments for reaching milestones in any project:

(A) The due date for making such payments shall be 14 days after receipt of the payment request by the designated billing office. However, if the designated billing office fails to annotate the payment request with the actual date of receipt, the payment due date shall be deemed to be the 14th day after the date the Contractor's payment request is dated, provided a proper payment request is received and there is no disagreement over quantity, quality, or Contractor compliance with contract requirements.

(B) The due date for payment of any amounts retained by the Contracting Officer in accordance with the clause at 52.232-5, Payments Under Fixed-Price Construction Contracts, shall be as specified in the contract or, if not specified, 30 days after approval for release to the Contractor by the Contracting Officer.

(ii) Final payments based on completion and acceptance of all work and presentation of release of all claims against the Government arising by virtue of the contract, and payments for partial deliveries that have been accepted by the Government (e.g., each separate building, public work, or other division of the contract for which the price is stated separately in the contract):

(A) The due date for making such payments shall be either the 30th day after receipt by the designated billing office of a proper invoice from the Contractor, or the 30th day after Government acceptance of the work or services completed by the Contractor, whichever is later. However, if the designated billing office fails to annotate the invoice with the date of actual receipt, the invoice payment due date shall be deemed to be the 30th day after the date the Contractor's invoice is dated, provided a proper invoice is received and there is no disagreement over quantity, quality, or Contractor compliance with contract requirements.

(B) On a final invoice where the payment amount is subject to contract settlement actions (e.g., release of claims), acceptance

shall be deemed to have occurred on the effective date of the contract settlement.

(2) An invoice is the Contractor's bill or written request for payment under the contract for work or services performed under the contract. An invoice shall be prepared and submitted to the designated billing office. A proper invoice must include the items listed in subdivisions (a)(2)(i) through (a)(2)(ix) of this clause. If the invoice does not comply with these requirements, the Contractor will be notified of the defect within 7 days after receipt of the invoice at the designated billing office. Untimely notification will be taken into account in the computation of any interest penalty owed the Contractor in the manner described in subparagraph (a)(4) of this clause:

- (i) Name and address of the Contractor.
- (ii) Invoice date.
- (iii) Contract number or other authorization for work or services performed (including order number and contract line item number).
- (iv) Description of work or services performed.
- (v) Delivery and payment terms (e.g., prompt payment discount terms).
- (vi) Name and address of Contractor official to whom payment is to be sent (must be the same as that in the contract or in a proper notice of assignment).
- (vii) Name (where practicable), title, phone number, and mailing address of person to be notified in event of a defective invoice.
- (viii) For payments described in subdivision (a)(1)(i) of this clause, substantiation of the amounts requested and certification in accordance with the requirements of the clause at 52.232-5, Payments Under Fixed-Price Construction Contracts.
- (ix) Any other information or documentation required by the contract.

(3) An interest penalty shall be paid automatically by the designated payment office, without request from the Contractor, if payment is not made by the due date and the conditions listed in subdivisions (a)(3)(i) through (a)(3)(iii) of this clause are met, if applicable.

- (i) A proper invoice was received by the designated billing office.
- (ii) A receiving report or other Government documentation authorizing payment was processed and there was no disagreement over quantity, quality, Contractor compliance with any contract term or condition, or requested progress payment amount.
- (iii) In the case of a final invoice for any balance of funds due the Contractor for work or services performed, the amount was not subject to further contract settlement actions between the Government and the Contractor.

(4) The interest penalty shall be at the rate established by the Secretary of the Treasury under section 12 of the Contract Disputes Act of 1978 (41 U.S.C. 611) that is in effect on the day after the due date, except where the interest penalty is prescribed by other governmental authority. This rate is referred to as the "Renegotiation Board Interest Rate," and it is published in the Federal Register semiannually on or about January 1 and July 1. The interest penalty shall accrue daily on the invoice payment amount approved by the Government and be compounded in 30-day increments inclusive from the first day after the due date through the payment date. That is, interest accrued at the end of any 30-day period will be added to the approved invoice payment amount and be subject to interest penalties if not paid in the succeeding 30-day period. If the designated billing office failed to notify the Contractor of a defective invoice within the periods prescribed in subparagraph (a)(2) of this clause, then the due date on the corrected invoice will be adjusted by subtracting the number of days taken beyond the prescribed notification of defects period. Any interest penalty owed the Contractor will be based on this adjusted due date. Adjustments will be made by the designated payment office for errors in calculating interest penalties, if requested by the Contractor.

(i) For the sole purpose of computing an interest penalty that might be due the Contractor for payments described in subdivision (a)(1)(ii) of this clause, Government acceptance or approval shall be deemed to have occurred constructively on the 7th day after the Contractor has completed the work or services in accordance with the terms and conditions of the contract. In the event that actual acceptance or approval occurs within the constructive acceptance or approval period, the determination of an interest penalty shall be based on the actual date of acceptance or approval. Constructive acceptance or constructive approval requirements do not apply if there is a disagreement over quantity, quality, or Contractor compliance with a contract provision. These requirements also do not compel Government officials to accept work or services, approve Contractor estimates, perform contract administration functions, or make payment prior to fulfilling their responsibilities.

(ii) The following periods of time will not be included in the determination of an interest penalty:

(A) The period taken to notify the Contractor of defects in invoices submitted to the Government, but this may not exceed 7 days.

(B) The period between the defects notice and resubmission of the

corrected invoice by the Contractor.

(iii) Interest penalties will not continue to accrue after the filing of a claim for such penalties under the clause at 52.233-1, Disputes, or for more than 1 year. Interest penalties of less than \$1.00 need not be paid.

(iv) Interest penalties are not required on payment delays due to disagreement between the Government and Contractor over the payment amount or other issues involving contract compliance, or on amounts temporarily withheld or retained in accordance with the terms of the contract. Claims involving disputes, and any interest that may be payable, will be resolved in accordance with the clause at 52.233-1, Disputes.

(5) An interest penalty shall also be paid automatically by the designated payment office, without request from the Contractor, if a discount for prompt payment is taken improperly. The interest penalty will be calculated on the amount of discount taken for the period beginning with the first day after the end of the discount period through the date when the Contractor is paid.

(6) If this contract was awarded on or after October 1, 1989, a penalty amount, calculated in accordance with regulations issued by the Office of Management and Budget, shall be paid in addition to the interest penalty amount if the Contractor--

(i) Is owed an interest penalty;

(ii) Is not paid the interest penalty within 10 days after the date the invoice amount is paid; and

(iii) Makes a written demand, not later than 40 days after the date the invoice amount is paid, that the agency pay such a penalty.

(b) Contract Financing Payments.

(1) For purposes of this clause, if applicable, "contract financing payment" means a Government disbursement of monies to a Contractor under a contract clause or other authorization prior to acceptance of supplies or services by the Government, other than progress payments based on estimates of amount and value of work performed. Contract financing payments include advance payments and interim payments under cost-type contracts.

(2) If this contract provides for contract financing, requests for payment shall be submitted to the designated billing office as specified in this contract or as directed by the Contracting Officer. Contract financing payments shall be made on the _____ day after receipt of a proper contract financing request by the designated billing office. In the event that an audit or other review of a specific financing request

the ability of a subcontractor to furnish a performance bond and a payment bond;

(2) Permit the Contractor or subcontractor to make a determination that part or all of the subcontractor's request for payment may be withheld in accordance with the subcontract agreement; and

(3) Permit such withholding without incurring any obligation to pay a late payment penalty if--

(i) A notice conforming to the standards of paragraph (g) of this clause has been previously furnished to the subcontractor; and

(ii) A copy of any notice issued by a Contractor pursuant to subdivision (d)(3)(i) of this clause has been furnished to the Contracting Officer.

(e) If a Contractor, after making a request for payment to the Government but before making a payment to a subcontractor for the subcontractor's performance covered by the payment request, discovers that all or a portion of the payment otherwise due such subcontractor is subject to withholding from the subcontractor in accordance with the subcontract agreement, then the Contractor shall--

(1) Furnish to the subcontractor a notice conforming to the standards of paragraph (g) of this clause as soon as practicable upon ascertaining the cause giving rise to a withholding, but prior to the due date for subcontractor payment;

(2) Furnish to the Contracting Officer, as soon as practicable, a copy of the notice furnished to the subcontractor pursuant to subparagraph (e)(1) of this clause;

(3) Reduce the subcontractor's progress payment by an amount not to exceed the amount specified in the notice of withholding furnished under subparagraph (e)(1) of this clause;

(4) Pay the subcontractor as soon as practicable after the correction of the identified subcontract performance deficiency, and--

(i) Make such payment within--

(A) Seven days after correction of the identified subcontract performance deficiency (unless the funds therefor must be recovered from the Government because of a reduction under subdivision (e)(5)(i)) of this clause; or

(B) Seven days after the Contractor recovers such funds from the Government; or

(ii) Incur an obligation to pay a late payment interest penalty computed at the rate of interest established by the Secretary of the Treasury, and published in the Federal Register, for interest payments under section 12 of the Contracts Disputes Act of 1978 (41 U.S.C. 611)

is required to ensure compliance with the terms and conditions of the contract, the designated payment office is not compelled to make payment by the due date specified. For advance payments, loans, or other arrangements that do not involve recurrent submissions of contract financing requests, payment shall be made in accordance with the corresponding contract terms or as directed by the Contracting Officer. Contract financing payments shall not be assessed an interest penalty for payment delays.

(c) The Contractor shall include in each subcontract for property or services (including a material supplier) for the purpose of performing this contract the following:

(1) A payment clause which obligates the Contractor to pay the subcontractor for satisfactory performance under its subcontract not later than 7 days from receipt of payment out of such amounts as are paid to the Contractor under this contract.

(2) An interest penalty clause which obligates the Contractor to pay to the subcontractor an interest penalty for each payment not made in accordance with the payment clause--

(i) For the period beginning on the day after the required payment date and ending on the date on which payment of the amount due is made; and

(ii) Computed at the rate of interest established by the Secretary of the Treasury, and published in the Federal Register, for interest payments under section 12 of the Contract Disputes Act of 1978 (41 U.S.C. 611) in effect at the time the Contractor accrues the obligation to pay an interest penalty.

(3) A clause requiring each subcontractor to include a payment clause and an interest penalty clause conforming to the standards set forth in subparagraphs (c)(1) and (c)(2) of this clause in each of its subcontracts, and to require each of its subcontractors to include such clauses in their subcontracts with each lower-tier subcontractor or supplier.

(d) The clauses required by paragraph (c) of this clause shall not be construed to impair the right of Contractor or a subcontractor at any tier to negotiate, and to include in their subcontract, provisions which--

(1) Permit the Contractor or a subcontractor to retain (without cause) a specified percentage of each progress payment otherwise due to a subcontractor for satisfactory performance under the subcontract without incurring any obligation to pay a late payment interest penalty, in accordance with terms and conditions agreed to by the parties to the subcontract, giving such recognition as the parties deem appropriate to

in effect at the time the Contractor accrues the obligation to pay an interest penalty;

(5) Notify the Contracting Officer upon--

(i) Reduction of the amount of any subsequent certified application for payment; or

(ii) Payment to the subcontractor of any withheld amounts of a progress payment, specifying--

(A) The amounts withheld under subparagraph (e)(1) of this clause; and

(B) The dates that such withholding began and ended; and

(6) Be obligated to pay to the Government an amount equal to interest on the withheld payments (computed in the manner provided in 31 U.S.C. 3903(c)(1)), from the 8th day after receipt of the withheld amounts from the Government until--

(i) The day the identified subcontractor performance deficiency is corrected; or

(ii) The date that any subsequent payment is reduced under subdivision (e)(5)(i) of this clause.

(f)(1) If a Contractor, after making payment to a first-tier subcontractor, receives from a supplier or subcontractor of the first-tier subcontractor (hereafter referred to as a "second-tier subcontractor") a written notice in accordance with section 2 of the Act of August 24, 1935 (40 U.S.C. 270b, Miller Act), asserting a deficiency in such first-tier subcontractor's performance under the contract for which the Contractor may be ultimately liable, and the Contractor determines that all or a portion of future payments otherwise due such first-tier subcontractor is subject to withholding in accordance with the subcontract agreement, then the Contractor may, without incurring an obligation to pay an interest penalty under subparagraph (e)(6) of this clause--

(i) Furnish to the first-tier subcontractor a notice conforming to the standards of paragraph (g) of this clause as soon as practicable upon making such determination; and

(ii) Withhold from the first-tier subcontractor's next available progress payment or payments an amount not to exceed the amount specified in the notice of withholding furnished under subdivision (f)(1)(i) of this clause.

(2) As soon as practicable, but not later than 7 days after receipt of satisfactory written notification that the identified subcontract performance deficiency has been corrected, the Contractor shall pay the amount withheld under subdivision (f)(1)(ii) of this clause to such first-tier subcontractor, or shall incur an obligation to pay a late

payment interest penalty to such first-tier subcontractor computed at the rate of interest established by the Secretary of the Treasury, and published in the Federal Register, for interest payments under section 12 of the Contracts Disputes Act of 1978 (41 U.S.C. 611) in effect at the time the Contractor accrues the obligation to pay an interest penalty.

(g) A written notice of any withholding shall be issued to a subcontractor (with a copy to the Contracting Officer of any such notice issued by the Contractor), specifying--

(1) The amount to be withheld;

(2) The specific causes for the withholding under the terms of the subcontract; and

(3) The remedial actions to be taken by the subcontractor in order to receive payment of the amounts withheld.

(h) The Contractor may not request payment from the Government of any amount withheld or retained in accordance with paragraph (d) of this clause until such time as the Contractor has determined and certified to the Contracting Officer that the subcontractor is entitled to the payment of such amount.

(i) A dispute between the Contractor and subcontractor relating to the amount or entitlement of a subcontractor to a payment or a late payment interest penalty under a clause included in the subcontract pursuant to paragraph (c) of this clause does not constitute a dispute to which the United States is a party. The United States may not be interpleaded in any judicial or administrative proceeding involving such a dispute.

(j) Except as provided in paragraph (i) of this clause, this clause shall not limit or impair any contractual, administrative, or judicial remedies otherwise available to the Contractor or a subcontractor in the event of a dispute involving late payment or nonpayment by the Contractor or deficient subcontract performance or nonperformance by a subcontractor.

(k) The Contractor's obligation to pay an interest penalty to a subcontractor pursuant to the clauses included in a subcontract under paragraph (c) of this clause shall not be construed to be an obligation of the United States for such interest penalty. A cost reimbursement claim may not include any amount for reimbursement of such interest penalty.

(End of clause)

1.65 252.232-7006 REDUCTION OR SUSPENSION OF CONTRACT PAYMENTS UPON FINDING OF FRAUD (AUG 1992)

(a) 10 U.S.C. 2307(e) permits the head of the agency to reduce or suspend further payments to the Contractor upon a written determination by the agency head that substantial evidence exists that the Contractor's request for advance, partial, or progress payments is based on fraud. The provisions of 10 U.S.C. 2307(e) are in addition to any other rights or remedies provided the Government by law or under contract.

(b) Actions taken by the Government in accordance with 10 U.S.C. 2307(e) shall not constitute an excusable delay under the Default clause of this contract or otherwise relieve the Contractor of its obligations to perform under this contract.

(End of clause)

I.66 52.233-1 DISPUTES (DEC 1991)

(a) This contract is subject to the Contract Disputes Act of 1978, as amended (41 U.S.C. 601-613).

(b) Except as provided in the Act, all disputes arising under or relating to this contract shall be resolved under this clause.

(c) "Claim," as used in this clause, means a written demand or written assertion by one of the contracting parties seeking, as a matter of right, the payment of money in a sum certain, the adjustment or interpretation of contract terms, or other relief arising under or relating to this contract. A claim arising under a contract, unlike a claim relating to that contract, is a claim that can be resolved under a contract clause that provides for the relief sought by the claimant. However, a written demand or written assertion by the Contractor seeking the payment of money exceeding \$50,000 is not a claim under the Act until certified as required by subparagraph (d)(2) below. A voucher, invoice, or other routine request for payment that is not in dispute when submitted is not a claim under the Act. The submission may be converted to a claim under the Act, by complying with the submission and certification requirements of this clause, if it is disputed either as to liability or amount or is not acted upon in a reasonable time.

(d)(1) A claim by the Contractor shall be made in writing and submitted to the Contracting Officer for a written decision. A claim by the Government against the Contractor shall be subject to a written decision by the Contracting Officer.

(2) For Contractor claims exceeding \$50,000, the Contractor shall submit with the claim a certification that--

(i) The claim is made in good faith;

(ii) Supporting data are accurate and complete to the best of the Contractor's knowledge and belief; and

(iii) The amount requested accurately reflects the contract adjustment for which the Contractor believes the Government is liable.

(3)(i) If the Contractor is an individual, the certification shall be executed by that individual.

(ii) If the Contractor is not an individual, the certification shall be executed by--

(A) A senior company official in charge at the contractor's plant or location involved; or

(B) An officer or general partner of the Contractor having overall responsibility for the conduct of the Contractor's affairs.

(e) For Contractor claims of \$50,000 or less, the Contracting Officer must, if requested in writing by the Contractor, render a decision within 60 days of the request. For Contractor-certified claims over \$50,000, the Contracting Officer must, within 60 days, decide the claim or notify the Contractor of the date by which the decision will be made.

(f) The Contracting Officer's decision shall be final unless the Contractor appeals or files a suit as provided in the Act.

(g) At the time a claim by the Contractor is submitted to the Contracting Officer or a claim by the Government is presented to the Contractor, the parties, by mutual consent, may agree to use alternative means of dispute resolution. When using alternate dispute resolution procedures, any claim, regardless of amount, shall be accompanied by the certification described in paragraph (d)(2) of this clause, and executed in accordance with paragraph (d)(3) of this clause.

(h) The Government shall pay interest on the amount found due and unpaid from (1) the date the Contracting Officer receives the claim (properly certified if required), or (2) the date payment otherwise would be due, if that date is later, until the date of payment. Simple interest on claims shall be paid at the rate, fixed by the Secretary of the Treasury as provided in the Act, which is applicable to the period during which the Contracting Officer receives the claim and then at the rate applicable for each 6-month period as fixed by the Treasury Secretary during the pendency of the claim.

(i) The Contractor shall proceed diligently with performance of this contract, pending final resolution of any request for relief, claim, appeal, or action arising under the contract, and comply with any decision of the Contracting Officer.

(End of clause)

(a) Upon receipt of a notice of protest (as defined in 33.101 of the FAR) the Contracting Officer may, by written order to the Contractor, direct the Contractor to stop performance of the work called for by this contract. The order shall be specifically identified as a stop-work order issued under this clause. Upon receipt of the order, the Contractor shall immediately comply with its terms and take all reasonable steps to minimize the incurrence of costs allocable to the work covered by the order during the period of work stoppage. Upon receipt of the final decision in the protest, the Contracting Officer shall either--

(1) Cancel the stop-work order; or

(2) Terminate the work covered by the order as provided in the Default, or the Termination for Convenience of the Government, clause of this contract.

(b) If a stop-work order issued under this clause is canceled either before or after a final decision in the protest, the Contractor shall resume work. The Contracting Officer shall make an equitable adjustment in the delivery schedule or contract price, or both, and the contract shall be modified, in writing, accordingly, if--

(1) The stop-work order results in an increase in the time required for, or in the Contractor's cost properly allocable to, the performance of any part of this contract; and

(2) The Contractor asserts its right to an adjustment within 30 days after the end of the period of work stoppage; provided, that if the Contracting Officer decides the facts justify the action, the Contracting Officer may receive and act upon a proposal at any time before final payment under this contract.

(c) If a stop-work order is not canceled and the work covered by the order is terminated for the convenience of the Government, the Contracting Officer shall allow reasonable costs resulting from the stop-work order in arriving at the termination settlement.

(d) If a stop-work order is not canceled and the work covered by the order is terminated for default, the Contracting Officer shall allow, by equitable adjustment or otherwise, reasonable costs resulting from the stop-work order.

(e) The Government's rights to terminate this contract at any time are not affected by action taken under this clause.

(End of clause)

(a) Any contract claim, request for equitable adjustment to contract terms, request for relief under Pub. L. 85-804, or other similar request exceeding \$100,000 shall bear, at the time of submission, the following certificate given by an individual who has knowledge of the basis of the claim or request, knowledge of the accuracy and completeness of the supporting data, and knowledge of the claim or request:

I certify that the claim is made in good faith, that the supporting data are accurate and complete to the best of my knowledge and belief; and that the amount requested accurately reflects the contract adjustment for which the Contractor believes the Government is liable; and that I am duly authorized to bind the contractor with respect to the claim.

(Official's Name)

(Title)

(b) The certification in paragraph (a) of this clause requires full disclosure of all relevant facts, including cost and pricing data.

(c) The certification requirement in paragraph (a) of this clause does not apply to:

- (1) Requests for routine contract payments; for example, those for payment for accepted supplies and services, routine vouchers under cost-reimbursement type contracts, and progress payment invoices; or
- (2) Final adjustments under incentive provisions of contracts.

(d) In those situations where no claim certification for the purposes of 10 U.S.C. 2410e has been submitted prior to the inception of a contract dispute, a single certification, using the language prescribed by the Contract Disputes Act (41 U.S.C. 601 et seq.) but signed by an individual who has knowledge of the basis of the claim or request, knowledge of the accuracy and completeness of the supporting data, and knowledge of the claim or request, will satisfy the certification requirements of both statutes.

(e) If this is a request for equitable adjustment under a substantially completed contract or a completed contract, the certification will be expanded to include the following:

This claim includes only costs for performing the alleged

change, and does not include any costs which have already been reimbursed or which have been separately claimed. All indirect costs claimed are properly allocable to the alleged change in accordance with applicable acquisition regulations. I am aware that the submission of a false claim to the Government can result in the assessment of significant criminal and civil penalties and fines.

(End of clause)

I.69 52.236-2 DIFFERING SITE CONDITIONS (APR 1984)

(a) The Contractor shall promptly, and before the conditions are disturbed, give a written notice to the Contracting Officer of (1) subsurface or latent physical conditions at the site which differ materially from those indicated in this contract, or (2) unknown physical conditions at the site, of an unusual nature, which differ materially from those ordinarily encountered and generally recognized as inhering in work of the character provided for in the contract.

(b) The Contracting Officer shall investigate the site conditions promptly after receiving the notice. If the conditions do materially so differ and cause an increase or decrease in the Contractor's cost of, or the time required for, performing any part of the work under this contract, whether or not changed as a result of the conditions, an equitable adjustment shall be made under this clause and the contract modified in writing accordingly.

(c) No request by the Contractor for an equitable adjustment to the contract under this clause shall be allowed, unless the Contractor has given the written notice required; provided, that the time prescribed in (a) above for giving written notice may be extended by the Contracting Officer.

(d) No request by the Contractor for an equitable adjustment to the contract for differing site conditions shall be allowed if made after final payment under this contract.

(End of clause)

(R 7-602.4 1968 FEB)

(R 1-7.602-4)

I.70 52.236-3

SITE INVESTIGATION AND CONDITIONS AFFECTING THE WORK (APR 1984)

(a) The Contractor acknowledges that it has taken steps reasonably necessary to ascertain the nature and location of the work, and that it has investigated and satisfied itself as to the general and local conditions which can affect the work or its cost, including but not limited to (1) conditions bearing upon transportation, disposal, handling, and storage of materials; (2) the availability of labor, water, electric power, and roads; (3) uncertainties of weather, river stages, tides, or similar physical conditions at the site; (4) the conformation and conditions of the ground; and (5) the character of equipment and facilities needed preliminary to and during work performance. The Contractor also acknowledges that it has satisfied itself as to the character, quality, and quantity of surface and subsurface materials or obstacles to be encountered insofar as this information is reasonably ascertainable from an inspection of the site, including all exploratory work done by the Government, as well as from the drawings and specifications made a part of this contract. Any failure of the Contractor to take the actions described and acknowledged in this paragraph will not relieve the Contractor from responsibility for estimating properly the difficulty and cost of successfully performing the work, or for proceeding to successfully perform the work without additional expense to the Government.

(b) The Government assumes no responsibility for any conclusions or interpretations made by the Contractor based on the information made available by the Government. Nor does the Government assume responsibility for any understanding reached or representation made concerning conditions which can affect the work by any of its officers or agents before the execution of this contract, unless that understanding or representation is expressly stated in this contract.

(End of clause)

(R 7-602.14 1964 JUN)

(R 1-7.602-14)

(R 7-602.33 1965 JAN)

I.71 52.236-5

MATERIAL AND WORKMANSHIP (APR 1984)

(a) All equipment, material, and articles incorporated into the work covered by this contract shall be new and of the most suitable grade for

the purpose intended, unless otherwise specifically provided in this contract. References in the specifications to equipment, material, articles, or patented processes by trade name, make, or catalog number, shall be regarded as establishing a standard of quality and shall not be construed as limiting competition. The Contractor may, at its option, use any equipment, material, article, or process that, in the judgment of the Contracting Officer, is equal to that named in the specifications, unless otherwise specifically provided in this contract.

(b) The Contractor shall obtain the Contracting Officer's approval of the machinery and mechanical and other equipment to be incorporated into the work. When requesting approval, the Contractor shall furnish to the Contracting Officer the name of the manufacturer, the model number, and other information concerning the performance, capacity, nature, and rating of the machinery and mechanical and other equipment. When required by this contract or by the Contracting Officer, the Contractor shall also obtain the Contracting Officer's approval of the material or articles which the Contractor contemplates incorporating into the work. When requesting approval, the Contractor shall provide full information concerning the material or articles. When directed to do so, the Contractor shall submit samples for approval at the Contractor's expense, with all shipping charges prepaid. Machinery, equipment, material, and articles that do not have the required approval shall be installed or used at the risk of subsequent rejection.

(c) All work under this contract shall be performed in a skillful and workmanlike manner. The Contracting Officer may require, in writing, that the Contractor remove from the work any employee the Contracting Officer deems incompetent, careless, or otherwise objectionable.

(End of clause)

(R 7-602.9 1964 JUN)

1.72 52.236-6 SUPERINTENDENCE BY THE CONTRACTOR (APR 1984)

At all times during performance of this contract and until the work is completed and accepted, the Contractor shall directly superintend the work or assign and have on the work site a competent superintendent who is satisfactory to the Contracting Officer and has authority to act for the Contractor.

(End of clause)

(R 7-602.12 1978 OCT)

(R 1-7.602-12)

1.73 52.236-7 PERMITS AND RESPONSIBILITIES (NOV 1991)

The Contractor shall, without additional expense to the Government, be responsible for obtaining any necessary licenses and permits, and for complying with any Federal, State, and municipal laws, codes, and regulations applicable to the performance of the work. The Contractor shall also be responsible for all damages to persons or property that occur as a result of the Contractor's fault or negligence. The Contractor shall also be responsible for all materials delivered and work performed until completion and acceptance of the entire work, except for any completed unit of work which may have been accepted under the contract.

(End of clause)

1.74 52.236-8 OTHER CONTRACTS (APR 1984)

The Government may undertake or award other contracts for additional work at or near the site of the work under this contract. The Contractor shall fully cooperate with the other contractors and with Government employees and shall carefully adapt scheduling and performing the work under this contract to accommodate the additional work, heeding any direction that may be provided by the Contracting Officer. The Contractor shall not commit or permit any act that will interfere with the performance of work by any other contractor or by Government employees.

(End of clause)

(R 7-602.15 1964 JUN)

(R 1-7.602.15)

1.75 52.236-9 PROTECTION OF EXISTING VEGETATION, STRUCTURES, EQUIPMENT, UTILITIES, AND IMPROVEMENTS (APR 1984)

(a) The Contractor shall preserve and protect all structures, equipment, and vegetation (such as trees, shrubs, and grass) on or adjacent to the work site, which are not to be removed and which do not unreasonably

interfere with the work required under this contract. The Contractor shall only remove trees when specifically authorized to do so, and shall avoid damaging vegetation that will remain in place. If any limbs or branches of trees are broken during contract performance, or by the careless operation of equipment, or by workmen, the Contractor shall trim those limbs or branches with a clean cut and paint the cut with a tree-pruning compound as directed by the Contracting Officer.

(b) The Contractor shall protect from damage all existing improvements and utilities (1) at or near the work site, and (2) on adjacent property of a third party, the locations of which are made known to or should be known by the Contractor. The Contractor shall repair any damage to those facilities, including those that are the property of a third party, resulting from failure to comply with the requirements of this contract or failure to exercise reasonable care in performing the work. If the Contractor fails or refuses to repair the damage promptly, the Contracting Officer may have the necessary work performed and charge the cost to the Contractor.

(End of clause)
(R 7-602.34 1965 JAN)
(7-2101.13 1976 OCT)

1.76 52.236-10 OPERATIONS AND STORAGE AREAS (APR 1984)

(a) The Contractor shall confine all operations (including storage of materials) on Government premises to areas authorized or approved by the Contracting Officer. The Contractor shall hold and save the Government, its officers and agents, free and harmless from liability of any nature occasioned by the Contractor's performance.

(b) Temporary buildings (e.g., storage sheds, shops, offices) and utilities may be erected by the Contractor only with the approval of the Contracting Officer and shall be built with labor and materials furnished by the Contractor without expense to the Government. The temporary buildings and utilities shall remain the property of the Contractor and shall be removed by the Contractor at its expense upon completion of the work. With the written consent of the Contracting Officer, the buildings and utilities may be abandoned and need not be removed.

(c) The Contractor shall, under regulations prescribed by the Contracting Officer, use only established roadways, or use temporary roadways

constructed by the Contractor when and as authorized by the Contracting Officer. When materials are transported in prosecuting the work, vehicles shall not be loaded beyond the loading capacity recommended by the manufacturer of the vehicle or prescribed by any Federal, State, or local law or regulation. When it is necessary to cross curbs or sidewalks, the Contractor shall protect them from damage. The Contractor shall repair or pay for the repair of any damaged curbs, sidewalks, or roads.

(End of clause)
(R 7-602.35 1965 JAN)

1.77 52.236-11 USE AND POSSESSION PRIOR TO COMPLETION (APR 1984)

(a) The Government shall have the right to take possession of or use any completed or partially completed part of the work. Before taking possession of or using any work, the Contracting Officer shall furnish the Contractor a list of items of work remaining to be performed or corrected on those portions of the work that the Government intends to take possession of or use. However, failure of the Contracting Officer to list any item of work shall not relieve the Contractor of responsibility for complying with the terms of the contract. The Government's possession or use shall not be deemed an acceptance of any work under the contract.

(b) While the Government has such possession or use, the Contractor shall be relieved of the responsibility for the loss of or damage to the work resulting from the Government's possession or use, notwithstanding the terms of the clause in this contract entitled "Permits and Responsibilities." If prior possession or use by the Government delays the progress of the work or causes additional expense to the Contractor, an equitable adjustment shall be made in the contract price or the time of completion, and the contract shall be modified in writing accordingly.

(End of clause)
(R 7-602.39 1976 OCT)
(1-7.602.31)

1.78 52.236-12 CLEANING UP (APR 1984)

The Contractor shall at all times keep the work area, including storage

areas, free from accumulations of waste materials. Before completing the work, the Contractor shall remove from the work and premises any rubbish, tools, scaffolding, equipment, and materials that are not the property of the Government. Upon completing the work, the Contractor shall leave the work area in a clean, neat, and orderly condition satisfactory to the Contracting Officer.

(End of clause)
(R 7-602.40 1965 JAN)
(R 7-2101.21 1976 OCT)

1.79 52.236-13 ACCIDENT PREVENTION (NOV 1991)

(a) The Contractor shall provide and maintain work environments and procedures which will (1) safeguard the public and Government personnel, property, materials, supplies, and equipment exposed to Contractor operations and activities; (2) avoid interruptions of Government operations and delays in project completion dates; and (3) control costs in the performance of this contract.

(b) For these purposes on contracts for construction or dismantling, demolition, or removal of improvements, the Contractor shall--

- (1) Provide appropriate safety barricades, signs, and signal lights;
- (2) Comply with the standards issued by the Secretary of Labor at 29 CFR Part 1926 and 29 CFR Part 1910; and
- (3) Ensure that any additional measures the Contracting Officer determines to be reasonably necessary for the purposes are taken.

(c) If this contract is for construction or dismantling, demolition or removal of improvements with any Department of Defense agency or component, the Contractor shall comply with all pertinent provisions of the latest version of U.S. Army Corps of Engineers Safety and Health Requirements Manual, EM 385-1-1, in effect on the date of the solicitation.

(d) Whenever the Contracting Officer becomes aware of any noncompliance with these requirements or any condition which poses a serious or imminent danger to the health or safety of the public or Government personnel, the Contracting Officer shall notify the Contractor orally, with written confirmation, and request immediate initiation of corrective action. This notice, when delivered to the Contractor or the Contractor's representative at the work site, shall be deemed sufficient notice of the noncompliance and that corrective action is required. After receiving the notice, the Contractor shall immediately take corrective action. If the Contractor

fails or refuses to promptly take corrective action, the Contracting Officer may issue an order stopping all or part of the work until satisfactory corrective action has been taken. The Contractor shall not be entitled to any equitable adjustment of the contract price or extension of the performance schedule on any stop work order issued under this clause.

(e) The Contractor shall insert this clause, including this paragraph (e), with appropriate changes in the designation of the parties, in subcontracts.

(End of clause)

I.80 52.236-15 SCHEDULES FOR CONSTRUCTION CONTRACTS (APR 1984)

(a) The Contractor shall, within five days after the work commences on the contract or another period of time determined by the Contracting Officer, prepare and submit to the Contracting Officer for approval three copies of a practicable schedule showing the order in which the Contractor proposes to perform the work, and the dates on which the Contractor contemplates starting and completing the several salient features of the work (including acquiring materials, plant, and equipment). The schedule shall be in the form of a progress chart of suitable scale to indicate appropriately the percentage of work scheduled for completion by any given date during the period. If the Contractor fails to submit a schedule within the time prescribed, the Contracting Officer may withhold approval of progress payments until the Contractor submits the required schedule.

(b) The Contractor shall enter the actual progress on the chart as directed by the Contracting Officer, and upon doing so shall immediately deliver three copies of the annotated schedule to the Contracting Officer. If, in the opinion of the Contracting Officer, the Contractor falls behind the approved schedule, the Contractor shall take steps necessary to improve its progress, including those that may be required by the Contracting Officer, without additional cost to the Government. In this circumstance, the Contracting Officer may require the Contractor to increase the number of shifts, overtime operations, days of work, and/or the amount of construction plant, and to submit for approval any supplementary schedule or schedules in chart form as the Contracting Officer deems necessary to demonstrate how the approved rate of progress will be regained.

(c) Failure of the Contractor to comply with the requirements of the Contracting Officer under this clause shall be grounds for a determination by the Contracting Officer that the Contractor is not prosecuting the work

with sufficient diligence to ensure completion within the time specified in the contract. Upon making this determination, the Contracting Officer may terminate the Contractor's right to proceed with the work, or any separable part of it, in accordance with the default terms of this contract.

(End of clause)

(R 7-603.48 1965 JAN)

1.81 52.236-21 SPECIFICATIONS AND DRAWINGS FOR CONSTRUCTION (APR 1984)

(a) The Contractor shall keep on the work site a copy of the drawings and specifications and shall at all times give the Contracting Officer access thereto. Anything mentioned in the specifications and not shown on the drawings, or shown on the drawings and not mentioned in the specifications, shall be of like effect as if shown or mentioned in both. In case of difference between drawings and specifications, the specifications shall govern. In case of discrepancy in the figures, in the drawings, or in the specifications, the matter shall be promptly submitted to the Contracting Officer, who shall promptly make a determination in writing. Any adjustment by the Contractor without such a determination shall be at its own risk and expense. The Contracting Officer shall furnish from time to time such detailed drawings and other information as considered necessary, unless otherwise provided.

(b) Wherever in the specifications or upon the drawings the words "directed", "required", "ordered", "designated", "prescribed", or words of like import are used, it shall be understood that the "direction", "requirement", "order", "designation", or "prescription", of the Contracting Officer is intended and similarly the words "approved", "acceptable", "satisfactory", or words of like import shall mean "approved by", or "acceptable to", or "satisfactory to" the Contracting Officer, unless otherwise expressly stated.

(c) Where "as shown," "as indicated", "as detailed", or words of similar import are used, it shall be understood that the reference is made to the drawings accompanying this contract unless stated otherwise. The word "provided" as used herein shall be understood to mean "provide complete in place," that is "furnished and installed".

(d) Shop drawings means drawings, submitted to the Government by the Contractor, subcontractor, or any lower tier subcontractor pursuant to a construction contract, showing in detail (1) the proposed fabrication and assembly of structural elements, and (2) the installation (i.e., fit,

and attachment details) of materials or equipment. It includes drawings, diagrams, layouts, schematics, descriptive literature, illustrations, schedules, performance and test data, and similar materials furnished by the contractor to explain in detail specific portions of the work required by the contract. The Government may duplicate, use, and disclose in any manner and for any purpose shop drawings delivered under this contract.

(e) If this contract requires shop drawings, the Contractor shall coordinate all such drawings, and review them for accuracy, completeness, and compliance with contract requirements and shall indicate its approval thereon as evidence of such coordination and review. Shop drawings submitted to the Contracting Officer without evidence of the Contractor's approval may be returned for resubmission. The Contracting Officer will indicate an approval or disapproval of the shop drawings and if not approved as submitted shall indicate the Government's reasons therefor. Any work done before such approval shall be at the Contractor's risk. Approval by the Contracting Officer shall not relieve the Contractor from responsibility for any errors or omissions in such drawings, nor from responsibility for complying with the requirements of this contract, except with respect to variations described and approved in accordance with (f) below.

(f) If shop drawings show variations from the contract requirements, the Contractor shall describe such variations in writing, separate from the drawings, at the time of submission. If the Contracting Officer approves any such variation, the Contracting Officer shall issue an appropriate contract modification, except that, if the variation is minor or does not involve a change in price or in time of performance, a modification need not be issued.

(g) The Contractor shall submit to the Contracting Officer for approval four copies (unless otherwise indicated) of all shop drawings as called for under the various headings of these specifications. Three sets (unless otherwise indicated) of all shop drawings, will be retained by the Contracting Officer and one set will be returned to the Contractor.

(h) This clause shall be included in all subcontracts at any tier.

(End of clause)

(7-602.2 JUNE 1964 and 1-7.602-2)

(7-602.41 JAN 1965)

(7-602.47 APR 1966)

(7-602.54 OCT 1976 and 1-7.602-36)

1.82 252.236-7000 MODIFICATION PROPOSALS--PRICE BREAKDOWN (DEC 1991)

(a) The Contractor shall furnish a price breakdown, itemized as required and within the time specified by the Contracting Officer, with any proposal for a contract modification.

(b) The price breakdown--

(1) Must include sufficient detail to permit an analysis of profit, and of all costs for--

- (i) Material;
- (ii) Labor;
- (iii) Equipment;
- (iv) Subcontracts; and
- (v) Overhead; and

(2) Must cover all work involved in the modification, whether the work was deleted, added, or changed.

(c) The Contractor shall provide similar price breakdowns to support any amounts claimed for subcontracts.

(d) The Contractor's proposal shall include a justification for any time extension proposed.

(End of clause)

1.83 52.243-4 CHANGES (AUG 1987)

(a) The Contracting Officer may, at any time, without notice to the sureties, if any, by written order designated or indicated to be a change order, make changes in the work within the general scope of the contract, including changes--

- (1) In the specifications (including drawings and designs);
- (2) In the method or manner of performance of the work;
- (3) In the Government-furnished facilities, equipment, materials, services, or site; or
- (4) Directing acceleration in the performance of the work.

(b) Any other written or oral order (which, as used in this paragraph (b), includes direction, instruction, interpretation, or determination) from the Contracting Officer that causes a change shall be treated as a change order under this clause; provided, that the Contractor gives the Contracting Officer written notice stating (1) the date, circumstances, and source of the order and (2) that the Contractor regards the order as a change order.

(c) Except as provided in this clause, no order, statement, or conduct of the Contracting Officer shall be treated as a change under this clause or entitle the Contractor to an equitable adjustment.

(d) If any change under this clause causes an increase or decrease in the Contractor's cost of, or the time required for, the performance of any part of the work under this contract, whether or not changed by any such order, the Contracting Officer shall make an equitable adjustment and modify the contract in writing. However, except for an adjustment based on defective specifications, no adjustment for any change under paragraph (b) of this clause shall be made for any costs incurred more than 20 days before the Contractor gives written notice as required. In the case of defective specifications for which the Government is responsible, the equitable adjustment shall include any increased cost reasonably incurred by the Contractor in attempting to comply with the defective specifications.

(e) The Contractor must assert its right to an adjustment under this clause within 30 days after (1) receipt of a written change order under paragraph (a) of this clause or (2) the furnishing of a written notice under paragraph (b) of this clause, by submitting to the Contracting Officer a written statement describing the general nature and amount of the proposal, unless this period is extended by the Government. The statement of proposal for adjustment may be included in the notice under paragraph (b) above.

(f) No proposal by the Contractor for an equitable adjustment shall be allowed if asserted after final payment under this contract.

(End of clause)

I.84 252.243-7001 PRICING OF CONTRACT MODIFICATIONS (DEC 1991)

When costs are a factor in any price adjustment under this contract, the contract cost principles and procedures in FAR Part 31 and DFARS Part 231, in effect on the date of this contract, apply.

(End of clause)

I.85 52.244-1 SUBCONTRACTS (FIXED-PRICE CONTRACTS) (APR 1991)

(a) This clause does not apply to firm-fixed-price contracts and fixed-price contracts with economic price adjustment. However, it does apply to

subcontracts resulting from unpriced modifications to such contracts.

(b) "Subcontract," as used in this clause, includes but is not limited to purchase orders, and changes and modifications to purchase orders. The Contractor shall notify the Contracting Officer reasonably in advance of entering into any subcontract if the Contractor does not have an approved purchasing system and if the subcontract--

- (1) Is proposed to exceed \$100,000; or
- (2) Is one of a number of subcontracts with a single subcontractor, under this contract, for the same or related supplies or services, that in the aggregate are expected to exceed \$100,000.

(c) The advance notification required by paragraph (b) above shall include--

- (1) A description of the supplies or services to be subcontracted;
- (2) Identification of the type of subcontract to be used;
- (3) Identification of the proposed subcontractor and an explanation of why and how the proposed subcontractor was selected, including the competition obtained;
- (4) The proposed subcontract price and the Contractor's cost or price analysis;
- (5) The subcontractor's current, complete, and accurate cost or pricing data and Certificate of Current Cost or Pricing Data, if required by other contract provisions;
- (6) The subcontractor's Disclosure Statement or Certificate relating to Cost Accounting Standards when such data are required by other provisions of this contract; and
- (7) A negotiation memorandum reflecting--
 - (i) The principal elements of the subcontract price negotiations;
 - (ii) The most significant considerations controlling establishment of initial or revised prices;
 - (iii) The reason cost or pricing data were or were not required;
 - (iv) The extent, if any, to which the Contractor did not rely on the subcontractor's cost or pricing data in determining the price objective and in negotiating the final price;
 - (v) The extent, if any, to which it was recognized in the negotiation that the subcontractor's cost or pricing data were not accurate, complete, or current; the action taken by the Contractor and subcontractor; and the effect of any such defective data on the total price negotiated;
 - (vi) The reasons for any significant difference between the Contractor's price objective and the price negotiated; and
 - (vii) A complete explanation of the incentive fee or profit plan

when incentives are used. The explanation shall identify each critical performance element, management decisions used to quantify each incentive element, reasons for the incentives, and a summary of all trade-off possibilities considered.

(d) The Contractor shall obtain the Contracting Officer's written consent before placing any subcontract for which advance notification is required under paragraph (b) above. However, the Contracting Officer may ratify in writing any such subcontract. Ratification shall constitute the consent of the Contracting Officer.

(e) Even if the Contractor's purchasing system has been approved, the Contractor shall obtain the Contracting Officer's written consent before placing subcontracts that have been selected for special surveillance and so identified in the Schedule of this contract.

(f) Unless the consent or approval specifically provides otherwise, neither consent by the Contracting Officer to any subcontract nor approval of the Contractor's purchasing system shall constitute a determination (1) of the acceptability of any subcontract terms or conditions, (2) of the acceptability of any subcontract price or of any amount paid under any subcontract, or (3) to relieve the Contractor of any responsibility for performing this contract.

(g) No subcontract placed under this contract shall provide for payment on a cost-plus-a-percentage-of-cost basis, and any fee payable under cost-reimbursement subcontracts shall not exceed the fee limitations in subsection 15.903(d) of the Federal Acquisition Regulation (FAR).

(h) The Government reserves the right to review the Contractor's purchasing system as set forth in FAR Subpart 44.3.

(End of clause)

1.86 52.245-2 GOVERNMENT PROPERTY (FIXED-PRICE CONTRACTS) (DEC 1989)

(a) Government-furnished property. (1) The Government shall deliver to the Contractor, for use in connection with and under the terms of this contract, the Government-furnished property described in the Schedule or specifications together with any related data and information that the Contractor may request and is reasonably required for the intended use of the property (hereinafter referred to as "Government-furnished property").

(2) The delivery or performance dates for this contract are based upon the expectation that Government-furnished property suitable for use (except for property furnished "as is") will be delivered to the

Contractor at the times stated in the Schedule or, if not so stated, in sufficient time to enable the Contractor to meet the contract's delivery or performance dates.

(3) If Government-furnished property is received by the Contractor in a condition not suitable for the intended use, the Contractor shall, upon receipt of it, notify the Contracting Officer, detailing the facts, and, as directed by the Contracting Officer and at Government expense, either repair, modify, return, or otherwise dispose of the property. After completing the directed action and upon written request of the Contractor, the Contracting Officer shall make an equitable adjustment as provided in paragraph (h) of this clause.

(4) If Government-furnished property is not delivered to the Contractor by the required time, the Contracting Officer shall, upon the Contractor's timely written request, make a determination of the delay, if any, caused the Contractor and shall make an equitable adjustment in accordance with paragraph (h) of this clause.

(b) Changes in Government-furnished property. (1) The Contracting Officer may, by written notice, (i) decrease the Government-furnished property provided or to be provided under this contract, or (ii) substitute other Government-furnished property for the property to be provided by the Government, or to be acquired by the Contractor for the Government, under this contract. The Contractor shall promptly take such action as the Contracting Officer may direct regarding the removal, shipment, or disposal of the property covered by such notice.

(2) Upon the Contractor's written request, the Contracting Officer shall make an equitable adjustment to the contract in accordance with paragraph (h) of this clause, if the Government has agreed in the Schedule to make the property available for performing this contract and there is any--

(i) Decrease or substitution in this property pursuant to subparagraph (b)(1) above; or

(ii) Withdrawal of authority to use this property, if provided under any other contract or lease.

(c) Title in Government property. (1) The Government shall retain title to all Government-furnished property.

(2) All Government-furnished property and all property acquired by the Contractor, title to which vests in the Government under this paragraph (collectively referred to as "Government property"), are subject to the provisions of this clause. However, special tooling accountable to this contract is subject to the provisions of the Special Tooling clause and is not subject to the provisions of this clause. Title to Government

(4) The Contractor represents that the contract price does not include any amount for repairs or replacement for which the Government is responsible. Repair or replacement of property for which the Contractor is responsible shall be accomplished by the Contractor at its own expense.

(f) Access. The Government and all its designees shall have access at all reasonable times to the premises in which any Government property is located for the purpose of inspecting the Government property.

(g) Risk of loss. Unless otherwise provided in this contract, the Contractor assumes the risk of, and shall be responsible for, any loss or destruction of, or damage to, Government property upon its delivery to the Contractor or upon passage of title to the Government under paragraph (c) of this clause. However, the Contractor is not responsible for reasonable wear and tear to Government property or for Government property properly consumed in performing this contract.

(h) Equitable adjustment. When this clause specifies an equitable adjustment, it shall be made to any affected contract provision in accordance with the procedures of the Changes clause. When appropriate, the Contracting Officer may initiate an equitable adjustment in favor of the Government. The right to an equitable adjustment shall be the Contractor's exclusive remedy. The Government shall not be liable to suit for breach of contract for--

- (1) Any delay in delivery of Government-furnished property;
- (2) Delivery of Government-furnished property in a condition not suitable for its intended use;
- (3) A decrease in or substitution of Government-furnished property; or
- (4) Failure to repair or replace Government property for which the Government is responsible.

(i) Final accounting and disposition of Government property. Upon completing this contract, or at such earlier dates as may be fixed by the Contracting Officer, the Contractor shall submit, in a form acceptable to the Contracting Officer, inventory schedules covering all items of Government property (including any resulting scrap) not consumed in performing this contract or delivered to the Government. The Contractor shall prepare for shipment, deliver f.o.b. origin, or dispose of the Government property as may be directed or authorized by the Contracting Officer. The net proceeds of any such disposal shall be credited to the contract price or shall be paid to the Government as the Contracting Officer directs.

(j) Abandonment and restoration of Contractor's premises. Unless otherwise provided herein, the Government--

(1) May abandon any Government property in place, at which time all obligations of the Government regarding such abandoned property shall cease; and

(2) Has no obligation to restore or rehabilitate the Contractor's premises under any circumstances (e.g., abandonment, disposition upon completion of need, or upon contract completion). However, if the Government-furnished property (listed in the Schedule or specifications) is withdrawn or is unsuitable for the intended use, or if other Government property is substituted, then the equitable adjustment under paragraph (h) of this clause may properly include restoration or rehabilitation costs.

(k) Communications. All communications under this clause shall be in writing.

(l) Overseas contracts. If this contract is to be performed outside of the United States of America, its territories, or possessions, the words "Government" and "Government-furnished" (wherever they appear in this clause) shall be construed as "United States Government" and "United States Government-furnished," respectively.

(End of clause)

1.87 52.245-4 GOVERNMENT-FURNISHED PROPERTY (SHORT FORM) (APR 1984)

(a) The Government shall deliver to the Contractor, at the time and locations stated in this contract, the Government-furnished property described in the Schedule or specifications. If that property, suitable for its intended use, is not delivered to the Contractor, the Contracting Officer shall equitably adjust affected provisions of this contract in accordance with the Changes clause when--

(1) The Contractor submits a timely written request for an equitable adjustment; and

(2) The facts warrant an equitable adjustment.

(b) Title to Government-furnished property shall remain in the Government. The Contractor shall use the Government-furnished property only in connection with this contract. The Contractor shall maintain adequate property control records in accordance with sound industrial practice and will make such records available for Government inspection at all reasonable times, unless the clause at Federal Acquisition Regulation 52.245-1, Property Records, is included in this contract.

(c) Upon delivery of Government-furnished property to the Contractor, the

Contractor assumes the risk and responsibility for its loss or damage, except--

(1) For reasonable wear and tear;

(2) To the extent property is consumed in performing this contract;

or

(3) As otherwise provided for by the provisions of this contract.

(d) Upon completing this contract, the Contractor shall follow the instructions of the Contracting Officer regarding the disposition of all Government-furnished property not consumed in performing this contract or previously delivered to the Government. The Contractor shall prepare for shipment, deliver f.o.b. origin, or dispose of the Government property, as may be directed or authorized by the Contracting Officer. The net proceeds of any such disposal shall be credited to the contract price or shall be paid to the Government as directed by the Contracting Officer.

(e) If this contract is to be performed outside the United States of America, its territories, or possessions, the words "Government" and "Government-furnished" (wherever they appear in this clause) shall be construed as "United States Government" and "United States Government-furnished," respectively.

(End of clause)

(R 7-104.24(f) 1964 NOV)

I.88 52.246-12 INSPECTION OF CONSTRUCTION (JUL 1986)

(a) Definition. "Work" includes, but is not limited to, materials, workmanship, and manufacture and fabrication of components.

(b) The Contractor shall maintain an adequate inspection system and perform such inspections as will ensure that the work performed under the contract conforms to contract requirements. The Contractor shall maintain complete inspection records and make them available to the Government. All work shall be conducted under the general direction of the Contracting Officer and is subject to Government inspection and test at all places and at all reasonable times before acceptance to ensure strict compliance with the terms of the contract.

(c) Government inspections and tests are for the sole benefit of the Government and do not--

(1) Relieve the Contractor of responsibility for providing adequate quality control measures;

(2) Relieve the Contractor of responsibility for damage to or loss of

the material before acceptance;

(3) Constitute or imply acceptance; or

(4) Affect the continuing rights of the Government after acceptance of the completed work under paragraph (i) below.

(d) The presence or absence of a Government inspector does not relieve the Contractor from any contract requirement, nor is the inspector authorized to change any term or condition of the specification without the Contracting Officer's written authorization.

(e) The Contractor shall promptly furnish, without additional charge, all facilities, labor, and material reasonably needed for performing such safe and convenient inspections and tests as may be required by the Contracting Officer. The Government may charge to the Contractor any additional cost of inspection or test when work is not ready at the time specified by the Contractor for inspection or test, or when prior rejection makes reinspection or retest necessary. The Government shall perform all inspections and tests in a manner that will not unnecessarily delay the work. Special, full size, and performance tests shall be performed as described in the contract.

(f) The Contractor shall, without charge, replace or correct work found by the Government not to conform to contract requirements, unless in the public interest the Government consents to accept the work with an appropriate adjustment in contract price. The Contractor shall promptly segregate and remove rejected material from the premises.

(g) If the Contractor does not promptly replace or correct rejected work, the Government may (1) by contract or otherwise, replace or correct the work and charge the cost to the Contractor or (2) terminate for default the Contractor's right to proceed.

(h) If, before acceptance of the entire work, the Government decides to examine already completed work by removing it or tearing it out, the Contractor, on request, shall promptly furnish all necessary facilities, labor, and material. If the work is found to be defective or nonconforming in any material respect due to the fault of the Contractor or its subcontractors, the Contractor shall defray the expenses of the examination and of satisfactory reconstruction. However, if the work is found to meet contract requirements, the Contracting Officer shall make an equitable adjustment for the additional services involved in the examination and reconstruction, including, if completion of the work was thereby delayed, an extension of time.

(i) Unless otherwise specified in the contract, the Government shall accept, as promptly as practicable after completion and inspection, all work required by the contract or that portion of the work the Contracting

Officer determines can be accepted separately. Acceptance shall be final and conclusive except for latent defects, fraud, gross mistakes amounting to fraud, or the Government's rights under any warranty or guarantee.

(End of clause)

1.89 52.247-64 II PREFERENCE FOR PRIVATELY OWNED U.S.-FLAG COMMERCIAL VESSELS (APR 1984)--
ALTERNATE II (APR 1984)

(a) When ocean transportation is required to bring supplies, materials, or equipment to the construction site from the United States either for use in performance of, or for incorporation in, the work called for by this contract, the Contractor shall use privately owned U.S.-flag commercial vessels to the extent that such vessels are available at rates that are fair and reasonable for privately owned U.S.-flag commercial vessels.

(b) The Contractor shall not make any shipment exceeding 10 measurement tons (400 cubic feet) by vessels other than privately owned U.S.-flag commercial vessels without (1) notifying the Contracting Officer that U.S.-flag commercial vessels are not available at rates that are fair and reasonable for such vessels and (2) obtaining permission to ship in other vessels. If permission is granted, the contract price shall be equitably adjusted to reflect the difference in cost.

(c)(1) The Contractor shall submit one legible copy of a rated on-board ocean bill of lading for each shipment to both (i) the Contracting Officer and (ii) the Division of National Cargo, Office of Market Development, Maritime Administration, U.S. Department of Transportation, Washington, DC 20590. Subcontractor bills of lading shall be submitted through the Prime Contractor.

(2) The Contractor shall furnish these bill of lading copies (i) within 20 working days of the date of loading for shipments originating in the United States, or (ii) within 30 working days for shipments originating outside the United States. Each bill of lading copy shall contain the following information:

- (A) Sponsoring U.S. Government agency.
- (B) Name of vessel.
- (C) Vessel flag of registry.
- (D) Date of loading.
- (E) Port of loading.
- (F) Port of final discharge.

(G) Description of commodity.

(H) Gross weight in pounds and cubic feet if available.

(I) Total ocean freight revenue in U.S. dollars.

(d) Except for small purchases as described in 48 CFR 13, the Contractor shall insert the substance of this clause, including this paragraph (d), in all subcontracts or purchase orders under this contract.

(e) The requirement in paragraph (a) does not apply to--

(1) Small purchases as defined in 48 CFR 13;

(2) Cargoes carried in vessels of the Panama Canal Commission or as required or authorized by law or treaty;

(3) Ocean transportation between foreign countries of supplies purchased with foreign currencies made available, or derived from funds that are made available, under the Foreign Assistance Act of 1961 (22 U.S.C. 2353); and

(4) Shipments of classified supplies when the classification prohibits the use of non-Government vessels.

(f) Guidance regarding fair and reasonable rates for privately owned U.S.-flag commercial vessels may be obtained from the Division of National Cargo, Office of Market Development, Maritime Administration, U.S.

Department of Transportation, Washington, DC 20590, Phone: 202-426-4610.

(End of clause)

(R 1-19.108-2(b))

(R 7-603.41 1979 JUN)

I.90 252.247-7024 NOTIFICATION OF TRANSPORTATION OF SUPPLIES BY SEA (DEC 1991)

(a) The Contractor has indicated by the response to the solicitation provision, Representation of Extent of Transportation by Sea, that it did not anticipate transporting by sea any supplies. If, however, after the award of this contract, the Contractor learns that supplies, as defined in the Transportation of Supplies by Sea clause of this contract, will be transported by sea, the Contractor--

(1) Shall notify the Contracting Officer of that fact; and

(2) Hereby agrees to comply with all the terms and conditions of the Transportation of Supplies by Sea clause of this contract.

(b) The Contractor shall include this clause, including this paragraph (b), revised as necessary to reflect the relationship of the contracting parties, in all subcontracts hereunder.

(End of clause)

(a) General. The Contractor is encouraged to develop, prepare, and submit value engineering change proposals (VECP's) voluntarily. The Contractor shall share in any instant contract savings realized from accepted VECP's, in accordance with paragraph (f) below.

(b) Definitions. "Collateral costs," as used in this clause, means agency costs of operation, maintenance, logistic support, or Government-furnished property.

"Collateral savings," as used in this clause, means those measurable net reductions resulting from a VECP in the agency's overall projected collateral costs, exclusive of acquisition savings, whether or not the acquisition cost changes.

"Contractor's development and implementation costs," as used in this clause, means those costs the Contractor incurs on a VECP specifically in developing, testing, preparing, and submitting the VECP, as well as those costs the Contractor incurs to make the contractual changes required by Government acceptance of a VECP.

"Government costs," as used in this clause, means those agency costs that result directly from developing and implementing the VECP, such as any net increases in the cost of testing, operations, maintenance, and logistic support. The term does not include the normal administrative costs of processing the VECP.

"Instant contract savings," as used in this clause, means the estimated reduction in Contractor cost of performance resulting from acceptance of the VECP, minus allowable Contractor's development and implementation costs, including subcontractors' development and implementation costs (see paragraph (h) below).

"Value engineering change proposal (VECP)" means a proposal that--

- (1) Requires a change to this, the instant contract, to implement; and
- (2) Results in reducing the contract price or estimated cost without impairing essential functions or characteristics; provided, that it does not involve a change--

- (i) In deliverable end item quantities only; or
- (ii) To the contract type only.

(c) VECP preparation. As a minimum, the Contractor shall include in each VECP the information described in subparagraphs (1) through (7) below. If the proposed change is affected by contractually required

configuration management or similar procedures, the instructions in those procedures relating to format, identification, and priority assignment shall govern VECP preparation. The VECP shall include the following:

(1) A description of the difference between the existing contract requirement and that proposed, the comparative advantages and disadvantages of each, a justification when an item's function or characteristics are being altered, and the effect of the change on the end item's performance.

(2) A list and analysis of the contract requirements that must be changed if the VECP is accepted, including any suggested specification revisions.

(3) A separate, detailed cost estimate for (i) the affected portions of the existing contract requirement and (ii) the VECP. The cost reduction associated with the VECP shall take into account the Contractor's allowable development and implementation costs, including any amount attributable to subcontracts under paragraph (h) below.

(4) A description and estimate of costs the Government may incur in implementing the VECP, such as test and evaluation and operating and support costs.

(5) A prediction of any effects the proposed change would have on collateral costs to the agency.

(6) A statement of the time by which a contract modification accepting the VECP must be issued in order to achieve the maximum cost reduction, noting any effect on the contract completion time or delivery schedule.

(7) Identification of any previous submissions of the VECP, including the dates submitted, the agencies and contract numbers involved, and previous Government actions, if known.

(d) Submission. The Contractor shall submit VECP's to the Resident Engineer at the worksite, with a copy to the Contracting Officer.

(e) Government action. (1) The Contracting Officer shall notify the Contractor of the status of the VECP within 45 calendar days after the contracting office receives it. If additional time is required, the Contracting Officer shall notify the Contractor within the 45-day period and provide the reason for the delay and the expected date of the decision. The Government will process VECP's expeditiously; however, it shall not be liable for any delay in acting upon a VECP.

(2) If the VECP is not accepted, the Contracting Officer shall notify the Contractor in writing, explaining the reasons for rejection. The Contractor may withdraw any VECP, in whole or in part, at any time before it is accepted by the Government. The Contracting Officer may require that the Contractor provide written notification before

undertaking significant expenditures for VECP effort.

(3) Any VECP may be accepted, in whole or in part, by the Contracting Officer's award of a modification to this contract citing this clause. The Contracting Officer may accept the VECP, even though an agreement on price reduction has not been reached, by issuing the Contractor a notice to proceed with the change. Until a notice to proceed is issued or a contract modification applies a VECP to this contract, the Contractor shall perform in accordance with the existing contract. The Contracting Officer's decision to accept or reject all or part of any VECP shall be final and not subject to the Disputes clause or otherwise subject to litigation under the Contract Disputes Act of 1978 (41 U.S.C. 601-613).

(f) Sharing. (1) Rates. The Government's share of savings is determined by subtracting Government costs from instant contract savings and multiplying the result by (i) 45 percent for fixed-price contracts or (ii) 75 percent for cost-reimbursement contracts.

(2) Payment. Payment of any share due the Contractor for use of a VECP on this contract shall be authorized by a modification to this contract to--

(i) Accept the VECP;

(ii) Reduce the contract price or estimated cost by the amount of instant contract savings; and

(iii) Provide the Contractor's share of savings by adding the amount calculated to the contract price or fee.

(g) Subcontracts. The Contractor shall include an appropriate value engineering clause in any subcontract of \$50,000 or more and may include one in subcontracts of lesser value. In computing any adjustment in this contract's price under paragraph (f) above, the Contractor's allowable development and implementation costs shall include any subcontractor's allowable development and implementation costs clearly resulting from a VECP accepted by the Government under this contract, but shall exclude any value engineering incentive payments to a subcontractor. The Contractor may choose any arrangement for subcontractor value engineering incentive payments; provided, that these payments shall not reduce the Government's share of the savings resulting from the VECP.

(h) Data. The Contractor may restrict the Government's right to use any part of a VECP or the supporting data by marking the following legend on the affected parts:

"These data, furnished under the Value Engineering--Construction clause of contract _____, shall not be disclosed outside the Government or duplicated, used, or disclosed, in whole or in part, for any purpose other than to evaluate a value engineering change proposal

submitted under the clause. This restriction does not limit the Government's right to use information contained in these data if it has been obtained or is otherwise available from the Contractor or from another source without limitations."

If a VECP is accepted, the Contractor hereby grants the Government unlimited rights in the VECP and supporting data, except that, with respect to data qualifying and submitted as limited rights technical data, the Government shall have the rights specified in the contract modification implementing the VECP and shall appropriately mark the data. (The terms "unlimited rights" and "limited rights" are defined in Part 27 of the Federal Acquisition Regulation.)

(End of clause)

1.92 52.249-2 I TERMINATION FOR CONVENIENCE OF THE GOVERNMENT (FIXED-PRICE) (APR 1984)--
ALTERNATE I (APR 1984)

(a) The Government may terminate performance of work under this contract in whole or, from time to time, in part if the Contracting Officer determines that a termination is in the Government's interest. The Contracting Officer shall terminate by delivering to the Contractor a Notice of Termination specifying the extent of termination and the effective date.

(b) After receipt of a Notice of Termination, and except as directed by the Contracting Officer, the Contractor shall immediately proceed with the following obligations, regardless of any delay in determining or adjusting any amounts due under this clause:

(1) Stop work as specified in the notice.

(2) Place no further subcontracts or orders (referred to as subcontracts in this clause) for materials, services, or facilities, except as necessary to complete the continued portion of the contract.

(3) Terminate all subcontracts to the extent they relate to the work terminated.

(4) Assign to the Government, as directed by the Contracting Officer, all right, title, and interest of the Contractor under the subcontracts terminated, in which case the Government shall have the right to settle or to pay any termination settlement proposal arising out of those terminations.

(5) With approval or ratification to the extent required by the Contracting Officer, settle all outstanding liabilities and termination

settlement proposals arising from the termination of subcontracts; the approval or ratification will be final for purposes of this clause.

(6) As directed by the Contracting Officer, transfer title and deliver to the Government (i) the fabricated or unfabricated parts, work in process, completed work, supplies, and other material produced or acquired for the work terminated, and (ii) the completed or partially completed plans, drawings, information, and other property that, if the contract had been completed, would be required to be furnished to the Government.

(7) Complete performance of the work not terminated.

(8) Take any action that may be necessary, or that the Contracting Officer may direct, for the protection and preservation of the property related to this contract that is in the possession of the Contractor and in which the Government has or may acquire an interest.

(9) Use its best efforts to sell, as directed or authorized by the Contracting Officer, any property of the types referred to in subparagraph (6) above; provided, however, that the Contractor (i) is not required to extend credit to any purchaser and (ii) may acquire the property under the conditions prescribed by, and at prices approved by, the Contracting Officer. The proceeds of any transfer or disposition will be applied to reduce any payments to be made by the Government under this contract, credited to the price or cost of the work, or paid

(c) After expiration of the plant clearance period as defined in Subpart 45.6 of the Federal Acquisition Regulation, the Contractor may submit to the Contracting Officer a list, certified as to quantity and quality, of termination inventory not previously disposed of, excluding items authorized for disposition by the Contracting Officer. The Contractor may request the Government to remove those items or enter into an agreement for their storage. Within 15 days, the Government will accept title to those items and remove them or enter into a storage agreement. The Contracting Officer may verify the list upon removal of the items, or if stored, within 45 days from submission of the list, and shall correct the list, as necessary, before final settlement.

(d) After termination, the Contractor shall submit a final termination settlement proposal to the Contracting Officer in the form and with the certification prescribed by the Contracting Officer. The Contractor shall submit the proposal promptly, but no later than 1 year from the effective date of termination, unless extended in writing by the Contracting Officer upon written request of the Contractor within this 1-year period. However, if the Contracting Officer determines that the facts justify it, a termination settlement proposal may be received and acted on after 1

year or any extension. If the Contractor fails to submit the proposal within the time allowed, the Contracting Officer may determine, on the basis of information available, the amount, if any, due the Contractor because of the termination and shall pay the amount determined.

(e) Subject to paragraph (d) above, the Contractor and the Contracting Officer may agree upon the whole or any part of the amount to be paid because of the termination. The amount may include a reasonable allowance for profit on work done. However, the agreed amount, whether under this paragraph (e) or paragraph (f) below, exclusive of costs shown in subparagraph (f)(3) below, may not exceed the total contract price as reduced by (1) the amount of payments previously made and (2) the contract price of work not terminated. The contract shall be amended, and the Contractor paid the agreed amount. Paragraph (f) below shall not limit, restrict, or affect the amount that may be agreed upon to be paid under this paragraph.

(f) If the Contractor and Contracting Officer fail to agree on the whole amount to be paid the Contractor because of the termination of work, the Contracting Officer shall pay the Contractor the amounts determined as follows, but without duplication of any amounts agreed upon under paragraph (e) above:

(1) For contract work performed before the effective date of termination, the total (without duplication of any items) of--

(i) The cost of this work;

(ii) The cost of settling and paying termination settlement proposals under terminated subcontracts that are properly chargeable to the terminated portion of the contract if not included in subdivision (i) above; and

(iii) A sum, as profit on (i) above, determined by the Contracting Officer under 49.202 of the Federal Acquisition Regulation, in effect on the date of this contract, to be fair and reasonable; however, if it appears that the Contractor would have sustained a loss on the entire contract had it been completed, the Contracting Officer shall allow no profit under this subdivision (iii) and shall reduce the settlement to reflect the indicated rate of loss.

(2) The reasonable costs of settlement of the work terminated, including--

(i) Accounting, legal, clerical, and other expenses reasonably necessary for the preparation of termination settlement proposals and supporting data;

(ii) The termination and settlement of subcontracts (excluding the amounts of such settlements); and

(iii) Storage, transportation, and other costs incurred, reasonably necessary for the preservation, protection, or disposition of the termination inventory.

(g) Except for normal spoilage, and except to the extent that the Government expressly assumed the risk of loss, the Contracting Officer shall exclude from the amounts payable to the Contractor under paragraph (f) above, the fair value, as determined by the Contracting Officer, of property that is destroyed, lost, stolen, or damaged so as to become undeliverable to the Government or to a buyer.

(h) The cost principles and procedures of Part 31 of the Federal Acquisition Regulation, in effect on the date of this contract, shall govern all costs claimed, agreed to, or determined under this clause.

(i) The Contractor shall have the right of appeal, under the Disputes clause, from any determination made by the Contracting Officer under paragraph (d), (f), or (k), except that if the Contractor failed to submit the termination settlement proposal within the time provided in paragraph (d) or (k), and failed to request a time extension, there is no right of appeal. If the Contracting Officer has made a determination of the amount due under paragraph (d), (f), or (k), the Government shall pay the Contractor (1) the amount determined by the Contracting Officer if there is no right of appeal or if no timely appeal has been taken, or (2) the amount finally determined on an appeal.

(j) In arriving at the amount due the Contractor under this clause, there shall be deducted--

(1) All unliquidated advance or other payments to the Contractor under the terminated portion of this contract;

(2) Any claim which the Government has against the Contractor under this contract; and

(3) The agreed price for, or the proceeds of sale of, materials, supplies, or other things acquired by the Contractor or sold under the provisions of this clause and not recovered by or credited to the Government.

(k) If the termination is partial, the Contractor may file a proposal with the Contracting Officer for an equitable adjustment of the price(s) of the continued portion of the contract. The Contracting Officer shall make any equitable adjustment agreed upon. Any proposal by the Contractor for an equitable adjustment under this clause shall be requested within 90 days from the effective date of termination unless extended in writing by the Contracting Officer.

(l)(1) The Government may, under the terms and conditions it prescribes, make partial payments and payments against costs incurred by the

Contractor for the terminated portion of the contract, if the Contracting Officer believes the total of these payments will not exceed the amount to which the Contractor will be entitled.

(2) If the total payments exceed the amount finally determined to be due, the Contractor shall repay the excess to the Government upon demand, together with interest computed at the rate established by the Secretary of the Treasury under 50 U.S.C. App. 1215(b)(2). Interest shall be computed for the period from the date the excess payment is received by the Contractor to the date the excess is repaid. Interest shall not be charged on any excess payment due to a reduction in the Contractor's termination settlement proposal because of retention or other disposition of termination inventory until 10 days after the date of the retention or disposition, or a later date determined by the Contracting Officer because of the circumstances.

(m) Unless otherwise provided in this contract or by statute, the Contractor shall maintain all records and documents relating to the terminated portion of this contract for 3 years after final settlement. This includes all books and other evidence bearing on the Contractor's costs and expenses under this contract. The Contractor shall make these records and documents available to the Government, at the Contractor's office, at all reasonable times, without any direct charge. If approved by the Contracting Officer, photographs, microphotographs, or other authentic reproductions may be maintained instead of original records and documents.

(End of clause)
(R 1-8.701)
(R 7-103.21(b) 1974 OCT)
(R 1.8-703)
(R 7-602.29(a) 1974 APR)

I.93 52.249-10 DEFAULT (FIXED-PRICE CONSTRUCTION) (APR 1984)

(a) If the Contractor refuses or fails to prosecute the work or any separable part, with the diligence that will insure its completion within the time specified in this contract including any extension, or fails to complete the work within this time, the Government may, by written notice to the Contractor, terminate the right to proceed with the work (or the separable part of the work) that has been delayed. In this event, the Government may take over the work and complete it by contract or otherwise.

and may take possession of and use any materials, appliances, and plant on the work site necessary for completing the work. The Contractor and its sureties shall be liable for any damage to the Government resulting from the Contractor's refusal or failure to complete the work within the specified time, whether or not the Contractor's right to proceed with the work is terminated. This liability includes any increased costs incurred by the Government in completing the work.

(b) The Contractor's right to proceed shall not be terminated nor the Contractor charged with damages under this clause, if-

(1) The delay in completing the work arises from unforeseeable causes beyond the control and without the fault or negligence of the Contractor. Examples of such causes include (i) acts of God or of the public enemy, (ii) acts of the Government in either its sovereign or contractual capacity, (iii) acts of another Contractor in the performance of a contract with the Government, (iv) fires, (v) floods, (vi) epidemics, (vii) quarantine restrictions, (viii) strikes, (ix) freight embargoes, (x) unusually severe weather, or (xi) delays of subcontractors or suppliers at any tier arising from unforeseeable causes beyond the control and without the fault or negligence of both the Contractor and the subcontractors or suppliers; and

(2) The Contractor, within 10 days from the beginning of any delay (unless extended by the Contracting Officer), notifies the Contracting Officer in writing of the causes of delay. The Contracting Officer shall ascertain the facts and the extent of delay. If, in the judgment of the Contracting Officer, the findings of fact warrant such action, the time for completing the work shall be extended. The findings of the Contracting Officer shall be final and conclusive on the parties, but subject to appeal under the Disputes clause.

(c) If, after termination of the Contractor's right to proceed, it is determined that the Contractor was not in default, or that the delay was excusable, the rights and obligations of the parties will be the same as if the termination had been issued for the convenience of the Government.

(d) The rights and remedies of the Government in this clause are in addition to any other rights and remedies provided by law or under this contract.

(End of clause)
(R 1-8.709-1)
(R 7-602.5 1969 AUG)

I.94 52.252-6 AUTHORIZED DEVIATIONS IN CLAUSES (APR 1984)

(a) The use in this solicitation or contract of any Federal Acquisition Regulation (48 CFR Chapter 1) clause with an authorized deviation is indicated by the addition of "(DEVIATION)" after the date of the clause.

(b) The use in this solicitation or contract of any _____ (48 CFR _____) clause with an authorized deviation is indicated by the addition of "(DEVIATION)" after the name of the regulation.

(End of clause)

(NM)

END OF SECTION I

SECTION K
REPRESENTATIONS, CERTIFICATIONS AND OTHER STATEMENTS OF OFFERORS

K.1 DEFINITION OF SMALL BUSINESS CONCERN.

A. EXPLANATION OF TERM. "Small business concern" means a concern, including its affiliates, that is independently owned and operated, not dominant in the field of operation in which it is bidding on Government contracts, and qualified as a small business under the criteria and size standards in 13 CFR 121.(FAR 19-101)

B. SIZE STANDARDS FOR CONSTRUCTION AND SPECIAL TRADES.

1. CONSTRUCTION. A concern is small if its average annual receipts for its preceding 3 fiscal years did not exceed \$17 million. However, if 75 percent or more of the work (in terms of dollar value) called for by the contract is classified in one of the industries, subindustries, or classes of products listed in this paragraph, the concern is small if its average annual receipts for its preceding 3 fiscal years did not exceed the size standard for that industry, subindustry, or class of products. (See Division C, "Contract Construction", of the SIC Manual.)

2. DREDGING. A concern is small if (1) its average annual receipts for its preceding 3 fiscal years did not exceed \$13.5 million, and (2) at least 40 percent of the yardage in the contract's plans and specifications is dredged with equipment owned by the concern or obtained from another small business dredging concern. (FAR 19.102-1)

K.2 DEBARRED OR SUSPENDED BIDDERS.

By entering into this contract, the Contractor certifies that neither he nor any person or firm who has an interest in the Contractor's firm is a person ineligible to be awarded Government contracts by virtue of being suspended or debarred in accordance with FAR subpart 9.4.

K.3 NONDOMESTIC CONSTRUCTION MATERIALS

As required by the contract clause entitled "BUY AMERICAN ACT -

CONSTRUCTION MATERIALS (APR 1984)", the following is a list of items of Nondomestic Construction Materials the bidder proposes to use, showing quantity, unit price, and intended use of each item:

Item	Quantity	Unit Price	Intended Use
------	----------	------------	--------------

K.4

CONTRACTOR ESTABLISHMENT CODE (AUG 1989)(52.204-4)

In the block with its name and address, the offeror should supply the Contractor Establishment Code applicable to that name and address, if known, to the offeror. The number should be preceded by "CEC:" Offerors should take care to report the correct CEC and not a similar number assigned to the Offeror in a different system.

The CEC is a 9-digit code assigned to a contractor establishment that contracts with a federal executive agency. The CEC system is a contractor identification coding system which is currently the Dun and Bradstreet Data Universal Numbering System (DUNS). The CEC system is distinct from the Federal Taxpayer Identification Number (TIN) system.

The Government will obtain a Contractor Establishment Code for any awardee that does not have or does not know its CEC.

K.5

REQUIREMENT FOR CERTIFICATE OF PROCUREMENT INTEGRITY (NOV 1990)

(a) Definitions. The definitions at FAR 3.104-4 are hereby incorporated in this provision.

(b) Certifications. As required in paragraph (c) of this provision, the officer or employee responsible for this offer shall execute the following certification:

CERTIFICATE OF PROCUREMENT INTEGRITY

(1) I, _____, am the officer or employee responsible for the preparation of this offer and hereby certify that, to the best of my knowledge and belief, with the exception of any information described in this certificate, I have no information concerning a violation or possible violation of subsection 27(a), (b), or (f) of the Office of Federal Procurement Policy Act, as amended* (41.U.S.C. 423), (hereinafter referred to as "the Act"), as implemented in the FAR, occurring during the conduct of this procurement.

(2) As required by subsection 27(e)(1)(B) of the Act, I further certify that, to the best of my knowledge and belief, each officer, employee, agent, representative, and consultant of _____ personally and substantially in the preparation or submission of this offer has certified that he or she is familiar with, and will comply with, the requirements of subsection 27(a) of the Act, as implemented in the FAR, and will report immediately to me any information concerning a violation or possible violation of subsections 27 (a), (b), (d), or (f) of the Act, as implemented in the FAR, pertaining to this procurement.

(3) Violations or possible violations: _____
(Continue on plain bond paper if necessary and label Certificate of Procurement Integrity (Continuation Sheet), ENTER NONE IF NONE EXIST)

(4) I agree that, if awarded a contract under this solicitation, the certifications required by subsection 27(e)(1)(B) of the Act shall be maintained in accordance with paragraph (f) of this provision.

(Signature of the officer or employee responsible for the offer & date)

(Typed name of the officer or employee responsible for the offer)

+Subsections 27 (a), (b), and (d) are effective on December 1, 1990.
Subsection 27(f) is effective on June 1, 1991.

THIS CERTIFICATION CONCERNS A MATTER WITHIN THE JURISDICTION OF AN AGENCY OF THE UNITED STATES AND THE MAKING OF A FALSE, FICTITIOUS, OR FRAUDULENT CERTIFICATION MAY RENDER THE MAKER SUBJECT TO PROSECUTION UNDER TITLE 18, UNITED STATES CODE, SECTION 1001.

(End of certification)

(c)(1) For procurement using sealed bidding procedures, the signed certifications shall be submitted by each bidder with the bid submission except for procurements using two-step sealed bidding procedure (see subpart 14.5). For those procurements, the certifications shall be submitted with submission of the step two sealed bids. A certificate is not required for indefinite delivery contracts (see Subpart 16.5) unless the total estimated value of all orders eventually to be placed under the contract is expected to exceed \$100,000.

(2) For contracts and contract modifications which include options, a certificate is required when the aggregate value of the contract or contract modification and all options (see 3.104-4(e)) exceeds \$100,000.

(3) Failure of a bidder to submit the signed certificate with its bid shall render the bid nonresponsive.

(d) Pursuant to FAR 3.104-9(d), the Offeror may be requested to execute additional certifications at the request of the Government. Failure of an Offeror to submit the additional certifications shall cause its offer to be rejected.

(e) A certification containing a disclosure of a violation or possible violation will not necessarily result in the withholding of award under this solicitation. However, the Government, after evaluation of the disclosure, may cancel this procurement or take any other appropriate actions in the interests of the Government, such as disqualification of the Offeror.

(f) In making the certification in paragraph (2) of the certificate, the officer or employee of the competing contractor responsible for the offer may rely upon a one-time certification from each individual required to submit a certification to the competing

contractor, supplemented by periodic training. These certifications shall be obtained at the earliest possible date after an individual required to certify begins employment or association with the contractor. If a contractor decides to rely on a certification executed prior to the suspension of section 27 (i.e., prior to December 1, 1989), the Contractor shall ensure that an individual who has so certified is notified that section 27 has been reinstated. These certifications shall be maintained by the Contractor for 6 years from the date a certifying employee's employment with the company ends or, for an agent, representative, or consultant, 6 years from the date such individual ceases to act on behalf of the Contractor.

(g) Certifications under paragraphs (b) and (d) of this provision are material representations of fact upon which reliance will be placed in awarding a contract.

(End of provision)

K.6 52.203-2 CERTIFICATE OF INDEPENDENT PRICE DETERMINATION (APR 1985)

(a) The offeror certifies that--

(1) The prices in this offer have been arrived at independently, without, for the purpose of restricting competition, any consultation, communication, or agreement with any other offeror or competitor relating to (i) those prices, (ii) the intention to submit an offer, or (iii) the methods or factors used to calculate the prices offered;

(2) The prices in this offer have not been and will not be knowingly disclosed by the offeror, directly or indirectly, to any other offeror or competitor before bid opening (in the case of a sealed bid solicitation) or contract award (in the case of a negotiated solicitation) unless otherwise required by law; and

(3) No attempt has been made or will be made by the offeror to induce

any other concern to submit or not to submit an offer for the purpose of restricting competition.

(b) Each signature on the offer is considered to be a certification by the signatory that the signatory--

(1) Is the person in the offeror's organization responsible for determining the prices being offered in this bid or proposal, and that the signatory has not participated and will not participate in any action contrary to subparagraphs (a)(1) through (a)(3) above; or

(2)(i) Has been authorized, in writing, to act as agent for the following principals in certifying that those principals have not participated, and will not participate in any action contrary to subparagraphs (a)(1) through (a)(3) above _____

(insert full name of person(s) in the offeror's organization responsible for determining the prices offered in this bid or proposal, and the title of his or her position in the offeror's organization);

(ii) As an authorized agent, does certify that the principals named in subdivision (b)(2)(i) above have not participated, and will not participate, in any action contrary to subparagraphs (a)(1) through (a)(3) above; and

(iii) As an agent, has not personally participated, and will not participate, in any action contrary to subparagraphs (a)(1) through (a)(3) above.

(c) If the offeror deletes or modifies subparagraph (a)(2) above, the offeror must furnish with its offer a signed statement setting forth in detail the circumstances of the disclosure.

(End of provision)

K.7 52.203-4 CONTINGENT FEE REPRESENTATION AND AGREEMENT (APR 1984)

(a) Representation. The offeror represents that, except for full-time bona fide employees working solely for the offeror, the offeror--
[Note: The offeror must check the appropriate boxes. For interpretation of the representation, including the term "bona fide employee," see Subpart 3.4 of the Federal Acquisition Regulation.]

(1) has, has not employed or retained any person or company to solicit or obtain this contract; and

(2) has, has not paid or agreed to pay to any person or company employed or retained to solicit or obtain this contract any commission,

percentage, brokerage, or other fee contingent upon or resulting from the award of this contract.

(b) Agreement. The offeror agrees to provide information relating to the above Representation as requested by the Contracting Officer and, when subparagraph (a)(1) or (a)(2) is answered affirmatively, to promptly submit to the Contracting Officer--

(1) A completed Standard Form 119, Statement of Contingent or Other Fees, (SF 119); or

(2) A signed statement indicating that the SF 119 was previously submitted to the same contracting office, including the date and applicable solicitation or contract number, and representing that the prior SF 119 applies to this offer or quotation.

(End of provision)
(R 7-2002.1 1974 APR)
(R 1-1.505)

K.8 52.203-11 CERTIFICATION AND DISCLOSURE REGARDING PAYMENTS TO INFLUENCE CERTAIN FEDERAL TRANSACTIONS (APR 1991)

(a) The definitions and prohibitions contained in the clause, at FAR 52.203-12, Limitation on Payments to Influence Certain Federal Transactions, included in this solicitation, are hereby incorporated by reference in paragraph (b) of this certification.

(b) The offeror, by signing its offer, hereby certifies to the best of his or her knowledge and belief that on or after December 23, 1989,--

(1) No Federal appropriated funds have been paid or will be paid to any person for influencing or attempting to influence an officer or employee of any agency, a Member of Congress, an officer or employee of Congress, or an employee of a Member of Congress on his or her behalf in connection with the awarding of any Federal contract, the making of any Federal grant, the making of any Federal loan, the entering into of any cooperative agreement, and the extension, continuation, renewal, amendment or modification of any Federal contract, grant, loan, or cooperative agreement;

(2) If any funds other than Federal appropriated funds (including profit or fee received under a covered Federal transaction) have been paid, or will be paid, to any person for influencing or attempting to influence an officer or employee of any agency, a Member of Congress, an officer or employee of Congress, or an employee of a Member of Congress

on his or her behalf in connection with this solicitation, the offeror shall complete and submit, with its offer, OMB standard form LLL, Disclosure of Lobbying Activities, to the Contracting Officer; and

(3) He or she will include the language of this certification in all subcontract awards at any tier and require that all recipients of subcontract awards in excess of \$100,000 shall certify and disclose accordingly.

(c) Submission of this certification and disclosure is a prerequisite for making or entering into this contract imposed by section 1352, title 31, United States Code. Any person who makes an expenditure prohibited under this provision or who fails to file or amend the disclosure form to be filed or amended by this provision, shall be subject to a civil penalty of not less than \$10,000, and not more than \$100,000, for each such failure.

(End of provision)

K.9 52.204-3 TAXPAYER IDENTIFICATION (SEP 1992)

(a) Definitions.

"Common parent," as used in this solicitation provision, means that corporate entity that owns or controls an affiliated group of corporations that files its Federal income tax returns on a consolidated basis, and of which the offeror is a member.

"Corporate status," as used in this solicitation provision, means a designation as to whether the offeror is a corporate entity, an unincorporated entity (e.g., sole proprietorship or partnership), or a corporation providing medical and health care services.

"Taxpayer Identification Number (TIN)," as used in this solicitation provision, means the number required by the IRS to be used by the offeror in reporting income tax and other returns.

(b) All offerors are required to submit the information required in paragraphs (c) through (e) of this solicitation provision in order to comply with reporting requirements of 26 U.S.C. 6041, 6041A, and 6050M and implementing regulations issued by the Internal Revenue Service (IRS). If the resulting contract is subject to the reporting requirements described in FAR 4.903, the failure or refusal by the offeror to furnish the information may result in a 20 percent reduction of payments otherwise due under the contract.

(c) Taxpayer Identification Number (TIN).

TIN: _____
 TIN has been applied for.
 TIN is not required because:
 Offeror is a nonresident alien, foreign corporation, or foreign partnership that does not have income effectively connected with the conduct of a trade or business in the U.S. and does not have an office or place of business or a fiscal paying agent in the U.S.;
 Offeror is an agency or instrumentality of a foreign government;
 Offeror is an agency or instrumentality of a Federal, state, or local government;
 Other. State basis. _____
 (d) Corporate Status.
 Corporation providing medical and health care services, or engaged in the billing and collecting of payments for such services;
 Other corporate entity;
 Not a corporate entity;
 Sole proprietorship
 Partnership
 Hospital or extended care facility described in 26 CFR 501(c)(3) that is exempt from taxation under 26 CFR 501(a).
 (e) Common Parent.
 Offeror is not owned or controlled by a common parent as defined in paragraph (a) of this clause.
 Name and TIN of common parent:
 Name _____
 TIN _____
 (End of provision)

K.10 52.209-5 CERTIFICATION REGARDING DEBARMENT, SUSPENSION, PROPOSED DEBARMENT, AND OTHER RESPONSIBILITY MATTERS (MAY 1989)

(a)(1) The Offeror certifies, to the best of its knowledge and belief, that--
 (i) The Offeror and/or any of its Principals--
 (A) Are // are not // presently debarred, suspended, proposed for debarment, or declared ineligible for the award of contracts by any Federal agency;
 (B) Have // have not //, within a three-year period preceding this offer, been convicted of or had a civil judgment rendered

against them for: commission of fraud or a criminal offense in connection with obtaining, attempting to obtain, or performing a public (Federal, state, or local) contract or subcontract; violation of Federal or state antitrust statutes relating to the submission of offers; or commission of embezzlement, theft, forgery, bribery, falsification or destruction of records, making false statements, or receiving stolen property; and

(C) Are / / are not / / presently indicted for, or otherwise criminally or civilly charged by a governmental entity with, commission of any of the offenses enumerated in subdivision (a)(1)(i)(B) of this provision.

(ii) The Offeror has / / has not / /, within a three-year period preceding this offer, had one or more contracts terminated for default by any Federal agency.

(2) "Principals," for the purposes of this certification, means officers; directors; owners; partners; and, persons having primary management or supervisory responsibilities within a business entity (e.g., general manager; plant manager; head of a subsidiary, division, or business segment, and similar positions).

THIS CERTIFICATION CONCERNS A MATTER WITHIN THE JURISDICTION OF AN AGENCY OF THE UNITED STATES AND THE MAKING OF A FALSE, FICTITIOUS, OR FRAUDULENT CERTIFICATION MAY RENDER THE MAKER SUBJECT TO PROSECUTION UNDER SECTION 1001, TITLE 18, UNITED STATES CODE.

(b) The Offeror shall provide immediate written notice to the Contracting Officer if, at any time prior to contract award, the Offeror learns that its certification was erroneous when submitted or has become erroneous by reason of changed circumstances.

(c) A certification that any of the items in paragraph (a) of this provision exists will not necessarily result in withholding of an award under this solicitation. However, the certification will be considered in connection with a determination of the Offeror's responsibility. Failure of the Offeror to furnish a certification or provide such additional information as requested by the Contracting Officer may render the Offeror nonresponsible.

(d) Nothing contained in the foregoing shall be construed to require establishment of a system of records in order to render, in good faith, the certification required by paragraph (a) of this provision. The knowledge and information of an Offeror is not required to exceed that which is normally possessed by a prudent person in the ordinary course of business dealings.

(e) The certification in paragraph (a) of this provision is a material

representation of fact upon which reliance was placed when making award. If it is later determined that the Offeror knowingly rendered an erroneous certification, in addition to other remedies available to the Government, the Contracting Officer may terminate the contract resulting from this solicitation for default.

(End of provision)

K.11 252.209-7000 ACQUISITION FROM SUBCONTRACTORS SUBJECT TO ON-SITE INSPECTION UNDER THE INTERMEDIATE-RANGE NUCLEAR FORCES (INF) TREATY (DEC 1991)

(a) The Contractor shall not deny consideration for a subcontract award under this contract to a potential subcontractor subject to on-site inspection under the INF Treaty, or a similar treaty, solely or in part because of the actual or potential presence of Soviet inspectors at the subcontractor's facility, unless the decision is approved by the Contracting Officer.

(b) The Contractor shall incorporate this clause, including this paragraph (b), in all solicitations and contracts over the dollar limitation in section 13.000 of the Federal Acquisition Regulation, except those for commercial or commercial-type products.

(End of clause)

K.12 252.209-7001 DISCLOSURE OF OWNERSHIP OR CONTROL BY A FOREIGN GOVERNMENT THAT SUPPORTS TERRORISM (APR 1993)

(a) Definition.

"Significant interest," as used in this provision, means--

(1) Ownership of or beneficial interest in five percent or more of the firm's or subsidiary's securities. Beneficial interest includes holding five percent or more of any class of the firm's securities in "nominee shares," "street names," or some other method of holding securities that does not disclose the beneficial owner;

(2) Holding a management position in the firm, such as a director or officer;

(3) Ability to control or influence the election, appointment, or tenure of directors or officers in the firm;

(4) Ownership of ten percent or more of the assets of a firm such as

equipment, buildings, real estate, or other tangible assets of the firm; or

(5) Holding 50 percent or more of the indebtedness of a firm.

(b) Disclosure.

The Offeror shall disclose any significant interest the government of each of the following countries has in the Offeror or a subsidiary of the Offeror. If the Offeror is a subsidiary, it shall also disclose any significant interest each government has in any firm that owns or controls the subsidiary. If none, leave blank.

Country	Significant interest
(1) Cuba.....	_____
(2) Iran.....	_____
(3) Iraq.....	_____
(4) Libya.....	_____
(5) North Korea.....	_____
(6) Syria.....	_____

(End of provision)

K.13 52.214-2 TYPE OF BUSINESS ORGANIZATION--SEALED BIDDING (JUL 1987)

The bidder, by checking the applicable box, represents that--

(a) It operates as a corporation incorporated under the laws of the State of _____, an individual, a partnership, a nonprofit organization, or a joint venture; or

(b) If the bidder is a foreign entity, it operates as an individual, a partnership, a nonprofit organization, a joint venture, or a corporation, registered for business in _____.

(country)

(End of provision)

K.14 52.219-1 SMALL BUSINESS CONCERN REPRESENTATION (JAN 1991)

(a) Representation. The offeror represents and certifies as part of its offer that it /_/ is, /_/ is not a small business concern and that /_/ all, /_/ not all end items to be furnished will be manufactured or produced by a small business concern in the United States, its territories or possessions, Puerto Rico, or the Trust Territory of the Pacific Islands.

(b) Definition.

"Small business concern," as used in this provision, means a concern, including its affiliates, that is independently owned and operated, not dominant in the field of operation in which it is bidding on Government contracts, and qualified as a small business under the criteria and size standards in this solicitation.

(c) Notice. Under 15 U.S.C. 645(d), any person who misrepresents a firm's status as a small business concern in order to obtain a contract to be awarded under the preference programs established pursuant to sections 8(a), 8(d), 9, or 15 of the Small Business Act or any other provision of Federal law that specifically references section 8(d) for a definition of program eligibility, shall--

- (1) Be punished by imposition of a fine, imprisonment, or both;
- (2) Be subject to administrative remedies, including suspension and debarment; and
- (3) Be ineligible for participation in programs conducted under the authority of the Act.

(End of provision)

K.15 52.219-3 WOMEN-OWNED SMALL BUSINESS REPRESENTATION (APR 1984)

(a) Representation. The offeror represents that it /_/ is, /_/ is not a women-owned small business concern.

(b) Definitions.

"Small business concern," as used in this provision, means a concern, including its affiliates, that is independently owned and operated, not dominant in the field of operation in which it is bidding on Government contracts, and qualified as a small business under the criteria and size standards in 13 CFR 121.

"Women-owned," as used in this provision, means a small business that is at least 51 percent owned by a woman or women who are U.S. citizens and who

also control and operate the business.

(End of provision)
(R FPR Temp. Reg. 48 1978 DEC)

K.16 52.219-19 SMALL BUSINESS CONCERN REPRESENTATION FOR THE SMALL BUSINESS
COMPETITIVENESS DEMONSTRATION PROGRAM (JUL 1991)

(a) Definition.

"Emerging small business" as used in this solicitation, means a small business concern whose size is no greater than 50 percent of the numerical size standard applicable to the standard industrial classification code assigned to a contracting opportunity.

(b) (Complete only if the Offeror has certified itself under the provision at 52.219-1 as a small business concern under the size standards of this solicitation.)

The Offeror represents and certifies as part of its offer that it is, is not an emerging small business.

(c) (Complete only if the Offeror is a small business or an emerging small business, indicating its size range.)

Offeror's number of employees for the past 12 months (check this column if size standard stated in solicitation is expressed in terms of number of employees) or Offeror's average annual gross revenue for the last 3 fiscal years (check this column if size standard stated in solicitation is expressed in terms of annual receipts). (Check one of the following.)

No. of Employees	Avg. Annual Gross Revenues
<input type="checkbox"/> 50 or fewer	<input type="checkbox"/> \$1 million or less
<input type="checkbox"/> 51-100	<input type="checkbox"/> \$1,000,001-\$2 million
<input type="checkbox"/> 101-250	<input type="checkbox"/> \$2,000,001-\$3.5 million
<input type="checkbox"/> 251-500	<input type="checkbox"/> \$3,500,001-\$5 million
<input type="checkbox"/> 501-750	<input type="checkbox"/> \$5,000,001-\$10 million
<input type="checkbox"/> 751-1,000	<input type="checkbox"/> \$10,000,001-\$17 million
<input type="checkbox"/> Over 1,000	<input type="checkbox"/> Over \$17 million

(End of provision)

K.17 252.219-7000 SMALL DISADVANTAGED BUSINESS CONCERN REPRESENTATION (DoD CONTRACTS) (DEC 1991)

(a) Definition. "Small disadvantaged business concern," as used in this provision, means a small business concern, owned and controlled by individuals who are both socially and economically disadvantaged, as defined by the Small Business Administration at 13 CFR Part 124, the majority of earnings of which directly accrue to such individuals. This term also means a small business concern owned and controlled by an economically disadvantaged Indian tribe or Native Hawaiian organization which meets the requirements of 13 CFR 124.112 or 13 CFR 124.113, respectively. In general, 13 CFR Part 124 describes a small disadvantaged business concern as a small business concern--

- (1) Which is at least 51 percent unconditionally owned by one or more socially and economically disadvantaged individuals; or
- (2) In the case of any publicly owned business, at least 51 percent of the voting stock is unconditionally owned by one or more socially and economically disadvantaged individuals; and
- (3) Whose management and daily business operations are controlled by one or more such individuals.

(b) Representations. Check the category in which your ownership falls--

- Subcontinent Asian (Asian-Indian) American (U.S. citizen with origins from India, Pakistan, Bangladesh, Sri Lanka, Bhutan, or Nepal)
- Asian-Pacific American (U.S. citizen with origins from Japan, China, the Philippines, Vietnam, Korea, Samoa, Guam, U.S. Trust Territory of the Pacific Islands (Republic of Palau), the Northern Mariana Islands, Laos, Kampuchea (Cambodia), Taiwan, Burma, Thailand, Malaysia, Indonesia, Singapore, Brunei, Republic of the Marshall Islands, or the Federated States of Micronesia)
- Black American (U.S. citizen)
- Hispanic American (U.S. citizen with origins from South America, Central America, Mexico, Cuba, the Dominican Republic, Puerto Rico, Spain, or Portugal)
- Native American (American Indians, Eskimos, Aleuts, or Native Hawaiians, including Indian tribes or Native Hawaiian organizations)
- Individual/concern, other than one of the preceding, currently certified for participation in the Minority Small Business and Capital Ownership Development Program under Section 8(a) of the Small Business

Act

____ Other

(c) Certifications. Complete the following--

(1) The offeror is ____ is not ____ a small disadvantaged business concern.

(2) The Small Business Administration (SBA) has ____ has not ____ made a determination concerning the offeror's status as a small disadvantaged business concern. If the SBA has made a determination, the date of the determination was _____ and the offeror--

____ Was found by SBA to be socially and economically disadvantaged and no circumstances have changed to vary that determination.

____ Was found by SBA not to be socially and economically disadvantaged but circumstances which caused the determination have changed.

(d) Notification. Notify the Contracting Officer before contract award if your status as a small disadvantaged business concern changes.

(e) Penalties and Remedies. Anyone who misrepresents the status of a concern as a small disadvantaged business for the purpose of securing a contract or subcontract shall--

(1) Be punished by imposition of a fine, imprisonment, or both;

(2) Be subject to administrative remedies, including suspension and debarment; and

(3) Be ineligible for participation in programs conducted under authority of the Small Business Act.

(End of provision)

K.18 52.222-21 CERTIFICATION OF NONSEGREGATED FACILITIES (APR 1984)

(a) "Segregated facilities," as used in this provision, means any waiting rooms, work areas, rest rooms and wash rooms, restaurants and other eating areas, time clocks, locker rooms and other storage or dressing areas, parking lots, drinking fountains, recreation or entertainment areas, transportation, and housing facilities provided for employees, that are segregated by explicit directive or are in fact segregated on the basis of race, color, religion, or national origin because of habit, local custom, or otherwise.

(b) By the submission of this offer, the offeror certifies that it does not and will not maintain or provide for its employees any segregated facilities at any of its establishments, and that it does not and will not permit its employees to perform their services at

any location under its control where segregated facilities are maintained. The offeror agrees that a breach of this certification is a violation of the Equal Opportunity clause in the contract.

(c) The offeror further agrees that (except where it has obtained identical certifications from proposed subcontractors for specific time periods) it will--

(1) Obtain identical certifications from proposed subcontractors before the award of subcontracts under which the subcontractor will be subject to the Equal Opportunity clause;

(2) Retain the certifications in the files; and

(3) Forward the following notice to the proposed subcontractors (except if the proposed subcontractors have submitted identical certifications for specific time periods):

NOTICE TO PROSPECTIVE SUBCONTRACTORS OF REQUIREMENT FOR CERTIFICATIONS OF NONSEGREGATED FACILITIES.

A Certification of Nonsegregated Facilities must be submitted before the award of a subcontract under which the subcontractor will be subject to the Equal Opportunity clause. The certification may be submitted either for each subcontract or for all subcontracts during a period (i.e., quarterly, semiannually, or annually).

NOTE: The penalty for making false statements in offers is prescribed in 18 U.S.C. 1001.

(End of provision)
(R 7-2003.14(b)(1)(A) 1970 AUG)
(R 1-12.803-10(d))

K.19 52.222-22 PREVIOUS CONTRACTS AND COMPLIANCE REPORTS (APR 1984)

The offeror represents that--

(a) It /_/_ has, /_/_ has not, participated in a previous contract or subcontract subject either to the Equal Opportunity clause of this solicitation, the clause originally contained in Section 310 of Executive Order No. 10925, or the clause contained in Section 201 of Executive Order No. 11114;

(b) It /_/_ has, /_/_ has not, filed all required compliance reports; and

(c) Representations indicating submission of required compliance reports, signed by proposed subcontractors, will be obtained before subcontract awards.

(End of provision)

(R 7-2003.14(b)(1)(B) 1973 APR)

K.20 52.223-1 CLEAN AIR AND WATER CERTIFICATION (APR 1984)

The Offeror certifies that--

(a) Any facility to be used in the performance of this proposed contract is /_ / is not /_ / listed on the Environmental Protection Agency (EPA) List of Violating Facilities;

(b) The Offeror will immediately notify the Contracting Officer, before award, of the receipt of any communication from the Administrator, or a designee, of the EPA, indicating that any facility that the Offeror proposes to use for the performance of the contract is under consideration to be listed on the EPA List of Violating Facilities; and

(c) The Offeror will include a certification substantially the same as this certification, including this paragraph (c), in every nonexempt subcontract.

(End of provision)
(AV 7-2003.71 1977 JUN)
(AV 1-1.2302-1)

K.21 52.223-5 CERTIFICATION REGARDING A DRUG-FREE WORKPLACE (JUL 1990)

(a) Definitions. As used in this provision,

"Controlled substance" means a controlled substance in schedules I through V of section 202 of the Controlled Substances Act (21 U.S.C. 812) and as further defined in regulation at 21 CFR 1308.11 - 1308.15.

"Conviction" means a finding of guilt (including a plea of nolo contendere) or imposition of sentence, or both, by any judicial body charged with the responsibility to determine violations of the Federal or State criminal drug statutes.

"Criminal drug statute" means a Federal or non-Federal criminal statute involving the manufacture, distribution, dispensing, possession or use of any controlled substance.

"Drug-free workplace" means the site(s) for the performance of work done by the Contractor in connection with a specific contract at which employees of the Contractor are prohibited from engaging in the unlawful manufacture, distribution, dispensing, possession, or use of a controlled substance.

"Employee" means an employee of a Contractor directly engaged in the performance of work under a Government contract. "Directly engaged" is defined to include all direct cost employees and any other Contractor employee who has other than a minimal impact or involvement in contract performance.

"Individual" means an offeror/contractor that has no more than one employee including the offeror/contractor.

(b) By submission of its offer, the offeror, if other than an individual, who is making an offer that equals or exceeds \$25,000, certifies and agrees that, with respect to all employees of the offeror to be employed under a contract resulting from this solicitation, it will--no later than 30 calendar days after contract award (unless a longer period is agreed to in writing), for contracts of 30 calendar days or more performance duration; or as soon as possible for contracts of less than 30 calendar days performance duration, but in any case, by a date prior to when performance is expected to be completed--

(1) Publish a statement notifying such employees that the unlawful manufacture, distribution, dispensing, possession or use of a controlled substance is prohibited in the Contractor's workplace and specifying the actions that will be taken against employees for violations of such prohibition;

(2) Establish an ongoing drug-free awareness program to inform such employees about--

(i) The dangers of drug abuse in the workplace;

(ii) The Contractor's policy of maintaining a drug-free workplace;

(iii) Any available drug counseling, rehabilitation, and employee assistance programs; and

(iv) The penalties that may be imposed upon employees for drug abuse violations occurring in the workplace;

(3) Provide all employees engaged in performance of the contract with a copy of the statement required by subparagraph (b)(1) of this provision;

(4) Notify such employees in writing in the statement required by subparagraph (b)(1) of this provision, that as a condition of continued employment on the contract resulting from this solicitation, the employee will--

(i) Abide by the terms of the statement; and

(ii) Notify the employer in writing of the employee's conviction under a criminal drug statute for a violation occurring in the workplace no later than 5 calendar days after such conviction;

(5) Notify the Contracting Officer in writing within 10 calendar days

after receiving notice under subdivision (b)(4)(ii) of this provision, from an employee or otherwise receiving actual notice of such conviction. The notice shall include the position title of the employee; and

(6) Within 30 calendar days after receiving notice under subdivision (b)(4)(ii) of this provision of a conviction, take one of the following actions with respect to any employee who is convicted of a drug abuse violation occurring in the workplace:

(i) Take appropriate personnel action against such employee, up to and including termination; or

(ii) Require such employee to satisfactorily participate in a drug abuse assistance or rehabilitation program approved for such purposes by a Federal, State, or local health, law enforcement, or other appropriate agency.

(7) Make a good faith effort to maintain a drug-free workplace through implementation of subparagraphs (b)(1) through (b)(6) of this provision.

(c) By submission of its offer, the offeror, if an individual who is making an offer of any dollar value, certifies and agrees that the offeror will not engage in the unlawful manufacture, distribution, dispensing, possession, or use of a controlled substance in the performance of the contract resulting from this solicitation.

(d) Failure of the offeror to provide the certification required by paragraphs (b) or (c) of this provision, renders the offeror unqualified and ineligible for award. (See FAR 9.104-1(g) and 19.602-1(a)(2)(i).)

(e) In addition to other remedies available to the Government, the certification in paragraphs (b) or (c) of this provision concerns a matter within the jurisdiction of an agency of the United States and the making of a false, fictitious, or fraudulent certification may render the maker subject to prosecution under Title 18, United States Code, Section 1001.

(End of provision)

K.22 252.225-7031 SECONDARY ARAB BOYCOTT OF ISRAEL (JUN 1992)

(a) Definitions.

As used in this clause--

(1) "Foreign person" means any person other than a United States person as defined in section 16(2) of the Export Administration Act of 1979 (50 U.S.C. App. Sec 2415).

(2) "United States person" is defined in section 16(2) of the Export

Administration Act of 1979 and means any United States resident or national (other than an individual resident outside the United States and employed by other than a United States person), any domestic concern (including any permanent domestic establishment of any foreign concern), and any foreign subsidiary or affiliate (including any permanent foreign establishment) of any domestic concern which is controlled in fact by such domestic concern, as determined under regulations of the President.

(b) Certification.

By submitting this offer, the Offeror, if a foreign person, company or entity, certifies that it--

- (1) Does not comply with the Secondary Arab Boycott of Israel; and
- (2) Is not taking or knowingly agreeing to take any action, with respect to the Secondary Boycott of Israel by Arab countries, which 50 U.S.C. App. Sec 2407(a) prohibits a United States person from taking.

(End of clause)

K.23 252.247-7022 REPRESENTATION OF EXTENT OF TRANSPORTATION BY SEA (AUG 1992)

(a) The Offeror shall indicate by checking the appropriate blank in paragraph (b) of this provision whether transportation of supplies by sea is anticipated under the resultant contract. The term "supplies" is defined in the Transportation of Supplies by Sea clause of this solicitation.

(b) Representation. The Offeror represents that it--

_____ Does anticipate that supplies will be transported by sea in the performance of any contract or subcontract resulting from this solicitation.

_____ Does not anticipate that supplies will be transported by sea in the performance of any contract or subcontract resulting from this solicitation.

(c) Any contract resulting from this solicitation will include the Transportation of Supplies by Sea clause. If the Offeror represents that it will not use ocean transportation, the resulting contract will also include the Defense FAR Supplement clause at 252.247-7024, Notification of Transportation of Supplies by Sea.

(End of provision)

END OF SECTION K

REQUEST FOR ASSIGNMENT OF A COMMERCIAL AND GOVERNMENT ENTITY (CAGE) CODE

(See Instructions on Reverse)

Form Approved
OMB No. 0704-0134
Exp. Date: Jun 30, 1988

SECTION A - TO BE COMPLETED BY INITIATOR

1. REQUESTING GOVERNMENT AGENCY/ACTIVITY

a. NAME		b. ADDRESS (Street, City, State and Zip Code)	
2. TYPE CODE REQUESTED (X one)	3. EXCEPTION CODES		
a. PSCM	a. CAO		
b. MILSCAP	b. ADP		

4. INITIATOR

a. TYPED NAME (Last, First, Middle Initial)	b. OFFICE SYMBOL	c. SIGNATURE	d. TELEPHONE NO.
--	-------------------------	---------------------	-------------------------

SECTION B - TO BE COMPLETED BY FIRM TO BE CODED

1. FIRM

a. NAME (include Branch of, Division of, etc.)	b. ADDRESS (Street, City, State and Zip Code)
c. CAGE CODE (if previously assigned)	

2. FIRM PREVIOUSLY OPERATED UNDER OTHER NAME(S) OR OTHER ADDRESS(ES) SPECIFY THE PREVIOUS NAME(S) AND/OR ADDRESS(ES) (Use separate sheet of paper, if necessary)

3. PARENT COMPANY AND AFFILIATED FIRMS (X one, and complete as applicable)

a. NONE
b. CURRENTLY AFFILIATED WITH OTHER FIRMS (List name(s) and address(es) of such firms on a separate sheet of paper)
c. PREVIOUSLY AFFILIATED WITH OTHER FIRMS (List name(s) and address(es) of such firms on a separate sheet of paper)

4. PRIMARY BUSINESS CATEGORY (X one)		5. DISADVANTAGED SMALL BUSINESS STATUS (X one)		6. NUMBER OF EMPLOYEES	
a. MANUFACTURER		a. APPROVED BY SMALL BUSINESS ADMINISTRATION (SBA) FOR SECTION 8(a) PROGRAM		7. WOMAN OWNED BUSINESS (X one)	
b. DEALER/DISTRIBUTOR		b. OTHER DISADVANTAGED SMALL BUSINESS FIRM		a. YES	b. NO
c. CONSTRUCTION FIRM		c. NOT DISADVANTAGED SMALL BUSINESS FIRM		8. STANDARD INDUSTRIAL CLASSIFICATION (SIC) CODE(S)	
d. SERVICE COMPANY				a. PRIMARY	
e. SALES OFFICE				b. OTHER (Specify)	
f. OTHER (Specify)					

9. REMARKS

Blank area for remarks.

10. FIRM OFFICIAL

a. TYPED NAME (Last, First, Middle Initial)	b. DATE SIGNED (YYMMDD)	c. SIGNATURE	d. TELEPHONE NO.
--	--------------------------------	---------------------	-------------------------

INSTRUCTIONS FOR COMPLETING DD FORM 2051

GENERAL NOTE FOR PERSONNEL PREPARING OR PROCESSING THIS REPORT

Coding must be as indicated in the instructions. In cases where specific coding instructions are provided, reference must be made to the Department of Defense Manual for Standard Data Elements, DoD 5000.12-M. Noncompliance with either the coding instructions contained herein or those published in referenced manual will make the organization which fails to comply responsible for required concessions in data base communication.

SPECIFIC INSTRUCTIONS

SECTION A - TO BE COMPLETED BY THE INITIATING GOVERNMENT ACTIVITY	SECTION B - (Continued)
Item 1: Self-explanatory.	Item 4: Self-explanatory.
Item 2: Mark the type code being requested. 2a: A Federal Supply Code for Manufacturers (FSCM) five position all numeric code (e.g., 12345) which is used in the Federal Catalog System to identify a certain facility at a specific location which is a possible source for the manufacture and/or design control of items cataloged by the Federal Government; or, 2b: A MILSCAP code of five positions (e.g., 1A367). These are assigned to contractors which are nonmanufacturers or are manufacturers not qualifying for inclusion in the Federal Catalog System.	Item 5: A disadvantaged business firm is defined as a firm that is 51% or more, owned, controlled, and operated by a person(s) who is socially and economically disadvantaged. "Controlled" is defined as exercising the power to make policy decisions. "Operated" is defined as actively involved in the day-to-day management of the firm. Item 6: Enter the number of employees. This number should include the employees of all affiliates.
Item 3: If applicable, enter the exception DoD Activity Address Code for the Servicing Contract Administration Office (CAO) or ADP point.	Item 7: A woman-owned business is defined as a firm that is 51% or more, owned, controlled, and operated by a woman or women. "Controlled" and "Operated" are as defined in Item 5.
Item 4: Self-explanatory.	Item 8: The SIC Code is a Government Index used to identify business activity and indicates the function (manufacturer, wholesaler, retailer, or service) and the line of business in which the company is engaged. If multiple SIC Codes, indicate the primary first, next important, etc.
SECTION B - TO BE COMPLETED BY THE FIRM TO WHICH THE CODE WILL BE ASSIGNED	Items 9 and 10: Self-explanatory.
Items 1a and 1b: Self-explanatory.	NOTE: When any future changes are made to the coded facility; i.e., name change, location change, business sold or operations discontinued, etc., written notification stating the appropriate change should be sent to: <div style="text-align: right;"> Commander Defense Logistics Services Center ATTN: DLSC-EGC Federal Center Battle Creek, MI 49016 </div>
Item 1c: If a CAGE Code (FSCM or MILSCAP) was previously assigned, enter it in this block.	
Item 2: Self-explanatory.	
Item 3: If a block other than "None" is marked, identify the Parent company by a (P) beside the firm name.	

SECTION L
INSTRS., CONDS., AND NOTICES TO OFFERORS

L.1 Information regarding bidding material, bid guarantee, and bonds.

INFORMATION REGARDING BIDDING MATERIAL, BID GUARANTEE, AND BONDS.

This invitation for Bids No. DACW29-94-B-0047, Consists of the attached: Instructions to Bidders, Solicitation, Offer and Award (Standard Form 1442), Bidding Schedule, Representations and Certifications, Special Clauses, Secretary of Labor Wage Determination Decision No. _____ Specifications, Contract Clauses, and Drawings as listed in paragraph H-3

L.2 PROVISIONS TO BIDS OVER 25,000

The following provisions apply to bids in excess of \$25,000.00

(a) Bid Bonds. Each bidder shall submit with his bid a Bid Bond (Standard Form 24) with good and sufficient surety or sureties acceptable to the Government or other Bid Guarantee complying with FAR 52.228-1, in the penal sum of twenty percent (20%) of the bid price or \$3,000,000 whichever is lesser. The bid bond penalty may be expressed in terms of a percentage of the bid price or may be expressed in dollars and cents.

(b) Performance and Payment Bonds. Within 7 days after the prescribed forms are presented to the bidder to whom award is made for signature, a written contract on the form prescribed by the specifications shall be executed and two bonds, each with good and sufficient surety or sureties acceptable to the Government furnished: namely a performance bond (Standard Form 25) and a payment bond (Standard Form 25A). The penal sums of such bonds will be as follows:

(1) Performance Bond. The penal sum of the performance bond shall equal one hundred percent (100%) of the contract price.

(2) Payment Bond.

a. When the contract is \$1,000,000 or less, the penal sum will be fifty percent (50%) of the contract price.

b. When the contract price is in excess of \$1,000,000 but not more than \$5,000,000 the penal sum shall be forty percent (40%) of the contract price.

c. When the contract price is more than \$5,000,000, the penal sum shall be \$2,500,000.

Bonds shall be furnished by the Contractor to the Government prior to commencement of contract performance.

L.3

DRAWINGS

Sets of drawings, reduced to half-size and specifications will be furnished upon receipt of payment of \$25.00 per set. If individual plan sheets are requested, they will be furnished at the rate of \$.32 for half-size and \$1.40 for full size, for each sheet requested but with a minimum charge of \$1.00. The maximum charge shall not exceed the charge for a full set of plans. No refund of the payment for drawings will be made and the drawings need not be returned to the District Engineer. Additional copies of the specifications alone will be furnished an applicant at the rate of \$5.00 per copy. Payments shall be made by: company check, money order, or cashier check, and delivered to the Finance and Accounting Officer, U. S. Army Engineer District, New Orleans. Checks and money orders should be made payable to "FAO, USAED, New Orleans District".

L.4

SITE OF THE WORK

Bidders are advised that for purpose of applicability of Davis-Bacon Act and other contract labor standards provisions, "the site of the work" under the contract to be awarded pursuant to this Invitation may not be limited to the physical place(s) where the construction called for in the contract will remain when work on it has been completed. The "site of work" may include other adjacent or nearby property used by the Contractor or subcontractors during such construction. For example fabrication plants, mobile factories, batch plants, borrow pits, job headquarters, tool yards, etc., will be considered part of the site of the work provided: they are dedicated exclusively or nearly so to the performance of the contract and are so located in proximity to the actual construction location that it would be reasonable to include them (1971 NOV).

L.5

ARITHMETIC DISCREPANCIES. (EFARS 14.1/90)

(a) For the purpose of initial evaluation of bids, the following will be utilized in resolving arithmetic discrepancies found on the face of the bidding schedule as submitted by bidders:

(1) Obviously misplaced decimal points will be corrected:

(2) In case of discrepancy between unit price and extended price, the unit price will govern:

(3) Apparent errors in extension of unit prices will be corrected: and

(4) Apparent errors in addition of lump-sum and extended prices will be corrected:

(b) For the purposes of bid evaluation, the Government will proceed on the assumption that the bidder intends his bid to be evaluated on the basis of the unit prices, extensions, and

totals arrived at by resolution of arithmetic discrepancies as provided above and the bid will be so reflected on the abstract of bids.

L.6

PRE-AWARD INFORMATION

Each bidder shall, upon request of the Contracting Officer, furnish a statement of whether he is now or ever has been engaged in any work similar to that covered by the specifications herein, the dollar value thereof, the year in which such work was performed, and the manner of its execution, and giving such other information as will tend to show the bidder's ability to prosecute the required work. The "such other information" referred to above shall include but is not limited to the following:

(a) The name and address of the office or firm under which such similar work was performed.

(b) A list of key personnel available for the instant project and their qualifications.

(c) A copy of bidder's latest financial statement, including the names of banks or other financial institutions with which the bidder conducts business. If the financial statement is more than 60 days old, a certificate should be attached stating that the financial condition is substantially the same, or if not the same, the changes that have taken place. Such statement will be treated as confidential.

(d) A list of present commitments including the dollar value there of, and name of office under which the work is being performed.

L.7

WORK TO BE PERFORMED BY CONTRACTOR'S OWN ORGANIZATION.

Within 7 days after award the successful bidder/contractor shall furnish the Contracting Officer a description of the items of work which will be performed with its own forces and the estimated cost of those items. (See paragraph H-21 contained in the Special Clauses of the specifications.)

L.8

EQUIPMENT OWNERSHIP AND OPERATING EXPENSE SCHEDULE (1982 JUNE OCE).

Whenever a contact or modification of contract price is negotiated, the Contractor's cost proposals for equipment ownership and operating expenses shall be determined in accordance with the requirements of paragraph H-5 EQUIPMENT OWNERSHIP OPERATING AND EXPENSE SCHEDULE, contained in the Special Clauses section of the specifications. A copy of EP 1110-1-8 "Construction Equipment Ownership and Operating Expense Schedule" is available for review at the New Orleans District Office, Attn: Mrs. Sheila Enclade (telephone number 504-862-1514 or Mr. C. E. Settoon (telephone number 504-862-2726).

L.9

PRECONSTRUCTION CONFERENCE

The successful bidder and all known subcontractors will be required to attend a preconstruction conference prior to commencement of work. The successful bidder will also be

required to conduct a preconstruction conference with each sub-contractor who was not represented at the initial Government-conducted conference. Subcontractor conferences will be held in the presence of a designated Government Representative. When conferences are with second or lower tier subcontractors, attendance of representatives of the prime contractor, all higher tier subcontractors, and the Government will be required.

L.10 SITE VISIT ASSISTANCE

Assistance in visiting the site of the work may be obtained upon calling the New Orleans Area Engineer
Mr. Chester Ashley
P.O. Box 60267, Suite 186
New Orleans, LA 70160-0267
Telephone No. 504-862-1200

L.11 PROGRAM DATA

AUTHORITY: Public Law 89-298
89th Congress at 27 Oct 1965

APPROPRIATION: 96x3122, Construction General, Lake Pontchartrain
96x8862, Contributed Funds

L.12 MODIFICATIONS PRIOR TO DATE SET FOR OPENING BIDS.

The right is reserved, as the interest of the Government may require, to revise or amend the specifications and/or drawings prior to the date set for opening bids. Such revisions or amendments, if any, will be announced by an amendment or amendments to this Invitation for Bids. Copies of such amendments as may be issued will be furnished to all prospective bidders. If the revision or amendments are of a nature which require material changes in quantities or prices bid or both, the date set for opening bids may be postponed by such number of days as in the opinion of the District Engineer will enable bidders to revise their bids. In such case, the amendments will include an announcement of the new date of opening bids.

L.13

GOVERNMENT'S PRIVILEGE IN MAKING AWARDS.

The Government further reserves the right to make award on any or all schedules of any bid, unless the bidder qualifies such bid by specific limitation; also to make award to the bidder whose aggregate bid on any combination of bid schedules is low. For the purpose of this Invitation for Bids, the word "item" shall be considered to mean "schedule".

L.14

INFORMATION CONCERNING THIS INVITATION OR THE AWARD.

Prospective bidders may submit inquiries concerning this invitation or award of the contract by writing the District Engineer, Department of the Army, New Orleans District, Corps of Engineers, P.O. Box 60267, New Orleans, LA 70160-0267 or by calling (COLLECT CALLS NOT ACCEPTED) Mrs. Sheila Enclade, Const. Svc. Br. Contracting Division, Area Code (504) 862-1514 for information.

L.15

VALUE ENGINEERING.

Special attention is invited to the Contract Clause entitled "Value Engineering--Construction". The New Orleans District policy to authorize immediate payment to Contractors for their portion of VECP savings is an important step in providing adequate incentives to Contractors for their support of this program. Carefully review the contract documents for potential savings and submit ideas promptly upon award to maximize savings.

L.16

SIZE STANDARDS FOR SMALL BUSINESS CONCERNS.

The Standard Industrial Classification for the construction described herein is classified under the Standard Industrial Classification manual as Number 1629 . For purposes of this procurement a small business concern is defined as a concern whose average annual sales or receipts of the concern and its affiliates for the preceding three financial years has not exceeded \$17.0 million.

**SCHEDULE H - Annual Receipts Size Standards
For Purpose of Bidding For Construction
Contracts - Special Trade Contractors**

Census Classification Code	Industry, Subindustry, or Class of Products	Average 3-year Annual Receipts Size Standard (maximum in million)
1711	- Plumbing, Heating (Except Electric, and Air Conditioning	\$7
1721	- Painting, Paper Hanging, and Decorating	\$7
1731	- Electric Work	\$7
1741	- Masonry, Stone Setting, and other Stonework	\$7
1742	- Plastering, Drywall, Acoustical and Insulation Work	\$7
1743	- Terrazzo, Tile, Marble, and Mosaic Work	\$7
1751	- Carpentering and Flooring	\$7
1752	- Floor Laying and other Floor Work, not	\$7

	Elsewhere Classified	
1761	- Roofing and Sheet Metal Work	\$7
1771	- Concrete Work	\$7
1781	- Water Well Drilling	\$7
1791	- Structural Steel Erection	\$7
1793	- Glass and Glazing Work	\$7
1794	- Excavating and Foundation Work	\$7
1795	- Wrecking and Demolition Work	\$7
1796	- Installation or Erection of Building Equipment, Not Elsewhere Classified	\$7
1799	- Special Trade Contractors, Not Elsewhere Classified	\$7

L.17

HARBOR MAINTENANCE FEE

Offerors or bidders contemplating use of U.S. ports in the performance of contract work are subject to paying a harbor maintenance fee as authorized under Section 1402 of the Water Resource Development Act of 1986 (Public Law 99-662). The fee imposed by the act is equal to a percentage (as set forth by the Act and amendments thereto) of the value of the commercial cargo involved. Firms performing work under U.S. Government contracts are not exempt from the act. Offerors and bidders are responsible for ensuring that the applicable fee and associated cost are taken into consideration in the preparation of their offer or bid.

Information pertaining to the act and a list of U.S. ports which subjects the cargo to the harbor maintenance fee may be obtained from local U.S. Customs Service Offices or by writing to the Director, User Fee Task Force, Division of Inspection and Control, Room 4132, U.S. Customs Service, 1301 Constitution Avenue, N.W., Washington, D.C. 20229.

L.18

NEGOTIATIONS AFTER SEALED BIDDING

(a) This clause applies if after bid opening the Contracting Officer determines that all otherwise acceptable bids received are at unreasonable prices, or only one bid is received and the Contracting Officer cannot determine the reasonableness of the bid price, or no responsive bid has been received from a responsible bidder; or the bids were not independently arrived at in open competition, were collusive, or were submitted in bad faith.

(b) The Government has the option to reject all bids received in response to the sealed bid advertisement and initiate negotiation. Negotiations will include soliciting offers from each responsible bidder that submits a bid in response to the Invitation for Bid.

(c) If after bid opening the Contracting Officer determines under (a) above that negotiations are in the best interest of the Government, the following steps will be followed:

(1) An amendment to the sealed bid advertisement will be issued to each responsible bidder changing the Invitation for Bid Number to a Request for Proposal Number. The amendment will also make any necessary changes to the scope of work.

(2) A cover letter signed by the negotiator will accompany the amendment explaining the procedures to be followed during negotiations.

L.19

LIEN ON REAL ESTATE

The following format, or any document substantially the same, shall be used by the surety and recorded in the local recorder's office when a surety pledges real estate on Standard Form 28, Affidavit of Individual Surety.

I/we agree that this instrument constitutes a lien in the amount of \$_____ on the property described in this lien. The rights of the United States Government shall take precedence over any subsequent lien or encumbrance until the lien is formally released by a duly authorized representative of the United States. I/we hereby grant the United States the power of sale of subject property, including the right to satisfy its reasonable administrative costs, including legal fees associated with any sale of subject property, in the event of contractor default if I/we otherwise fail to satisfy the underlying () bid guarantee, () performance bond, () or payment bond obligations as an individual surety on solicitation/contract number _____. The lien is upon the real estate now owned by me/us described as follows:

(legal description, street address and other identifying description)

IN WITNESS WHEREOF, I/we have hereunto affixed my/our hand(s) and seal(s) this ____ DAY OF ____ 19__.

WITNESS:

_____(SEAL)

_____(SEAL)

I, _____, A Notary Public in and for the
(CITY) _____, (STATE) _____, do hereby certify
that _____, a party of parties to a certain Agreement
bearing the date ____ day of _____ 19__, and hereunto annexed,
personally appeared before me, the said _____ being personally
well known to me as the person(s) who executed said lien, and

acknowledged the same to be his/her/their act and deed.

GIVEN under my hand and seal this ____ day of ____ 19__.

NOTARY PUBLIC, STATE

My Commission expires:

L.20

QUANTITIES

Estimates of quantities involved in certain items of work for which bids are being solicited on a lump sum or job basis have been made for the use of the Government. Copies of these quantity estimates may be viewed/obtained by contacting the District Engineer, ATTN:

Mrs. Sheila Enclade , CELMN-CT-CC, U.S. Army Engineer District, New Orleans, Foot of Prytania Street, P.O. Box 60267, New Orleans, LA 70160-0267. It is expressly understood that the accuracy of these estimates is in no way warranted and that the furnishing of this information to a bidder will not relieve him of his responsibility to estimate the quantities involved.

L.21 252.204-7001 COMMERCIAL AND GOVERNMENT ENTITY (CAGE) CODE REPORTING (DEC 1991)

(a) The Offeror is requested to enter its CAGE code on its offer in the block with its name and address. The CAGE code entered must be for that name and address. Enter CAGE before the number.

(b) If the Offeror does not have a CAGE code, it may ask the Contracting Officer to request one from the Defense Logistics Services Center (DLSC). The Contracting Officer will--

- (1) Ask the Contractor to complete section B of a DD Form 2051, Request for Assignment of a Commercial and Government Entity (CAGE) Code;
- (2) Complete section A and forward the form to DLSC; and
- (3) Notify the Contractor of its assigned CAGE code.

(c) Do not delay submission of the offer pending receipt of a CAGE code.
(End of provision)

L.22 52.210-2 AVAILABILITY OF SPECIFICATIONS LISTED IN THE DOD INDEX OF SPECIFICATIONS
AND STANDARDS (DODISS) (SEP 1990)

Single copies of specifications cited in this solicitation may be obtained by submitting a written request to the supply point listed below. The request must contain the title of the specification, its number, date, applicable amendment(s), and the solicitation or contract number. A telephone order entry system is available with the use of a touch tone telephone. A Customer Number is required to use this system and may be obtained by written request to the address listed below or by telephone (215-697-2179). In case of urgency, telegraphic requests are acceptable. Voluntary standards, which are not available to Offerors and Contractors from Government sources, may be obtained from the organization responsible for their preparation, maintenance, or publication.

Standardization Document
Order Desk, Building 4, Section D
700 Robbins Avenue
Philadelphia, PA 19111-5094
Telex Number..... 834295
Western Union Number.... 710-670-1685
Telephone Number..... (215) 697-3321 Express shipment pickup)
Telephone Order Entry System (TOES) Numbers.....215-697-1187 through
and including 215-697-1197
(End of provision)

L.23 52.214-1 SOLICITATION DEFINITIONS--SEALED BIDDING (JUL 1987)

"Government" means United States Government.
"Offer" means "bid" in sealed bidding.
"Solicitation" means an invitation for bids in sealed bidding.
(End of provision)

L.24 52.214-3 AMENDMENTS TO INVITATIONS FOR BIDS (DEC 1989)

(a) If this solicitation is amended, then all terms and conditions which are not modified remain unchanged.

(b) Bidders shall acknowledge receipt of any amendment to this solicitation (1) by signing and returning the amendment, (2) by identifying the amendment number and date in the space provided for this purpose on the form for submitting a bid, (3) by letter or telegram, or (4) by facsimile, if facsimile bids are authorized in the solicitation. The Government must receive the acknowledgment by the time and at the place specified for receipt of bids.

(End of provision)

L.25 52.214-4 FALSE STATEMENTS IN BIDS (APR 1984)

Bidders must provide full, accurate, and complete information as required by this solicitation and its attachments. The penalty for making false statements in bids is prescribed in 18 U.S.C. 1001.

(End of provision)

(R 2-201(b)(xiii))

(R 1-2.201(a)(11))

L.26 52.214-5 SUBMISSION OF BIDS (DEC 1989)

(a) Bids and bid modifications shall be submitted in sealed envelopes or packages (unless submitted by electronic means) (1) addressed to the office specified in the solicitation, and (2) showing the time specified for receipt, the solicitation number, and the name and address of the bidder.

(b) Telegraphic bids will not be considered unless authorized by the solicitation; however, bids may be modified or withdrawn by written or telegraphic notice.

(c) Facsimile bids, modifications, or withdrawals, will not be considered unless authorized by the solicitation.

(End of provision)

L.27 52.214-6 EXPLANATION TO PROSPECTIVE BIDDERS (APR 1984)

Any prospective bidder desiring an explanation or interpretation of the solicitation, drawings, specifications, etc., must request it in writing soon enough to allow a reply to reach all prospective bidders before the submission of their bids. Oral explanations or instructions given before the award of a contract will not be binding. Any information given a prospective bidder concerning a solicitation will be furnished promptly to all other prospective bidders as an amendment to the solicitation, if that information is necessary in submitting bids or if the lack of it would be prejudicial to other prospective bidders.

(End of provision)
(R SF 33A, Para 3, 1978 JAN)

L.28 52.214-7 LATE SUBMISSIONS, MODIFICATIONS, AND WITHDRAWALS OF BIDS (DEC 1989)

(a) Any bid received at the office designated in the solicitation after the exact time specified for receipt will not be considered unless it is received before award is made and it--

(1) Was sent by registered or certified mail not later than the fifth calendar day before the date specified for receipt of bids (e.g., a bid submitted in response to a solicitation requiring receipt of bids by the 20th of the month must have been mailed by the 15th);

(2) Was sent by mail or, if authorized by the solicitation, was sent by telegram or via facsimile, and it is determined by the Government that the late receipt was due solely to mishandling by the Government after receipt at the Government installation; or

(3) Was sent by U.S. Postal Service Express Mail Next Day Service-Post Office To Addressee, not later than 5:00 P.M. at the place of mailing two working days prior to the date specified for receipt of bids. The term "working days" excludes weekends and U.S. Federal holidays.

(b) Any modification or withdrawal of a bid is subject to the same conditions as in paragraph (a) of this provision.

(c) The only acceptable evidence to establish the date of mailing of a late bid, modification, or withdrawal sent either by registered or certified mail is the U.S. or Canadian Postal Service postmark both on the envelope or wrapper and on the original receipt from the U.S. or Canadian Postal Service. Both postmarks must show a legible date or the bid, modification, or withdrawal shall be processed as if mailed late.

"Postmark" means a printed, stamped, or otherwise placed impression (exclusive of a postage meter machine impression) that is readily identifiable without further action as having been supplied and affixed by employees of the U.S. or Canadian Postal Service on the date of mailing. Therefore, bidders should request the postal clerk to place a legible hand cancellation bull's-eye postmark on both the receipt and the envelope or wrapper.

(d) The only acceptable evidence to establish the time of receipt at the Government installation is the time/date stamp of that installation on the bid wrapper or other documentary evidence of receipt maintained by the installation.

(e) The only acceptable evidence to establish the date of mailing of a late bid, modification, or withdrawal sent by U.S. Postal Service Express Mail Next Day Service-Post Office to Addressee is the date entered by the post office receiving clerk on the "Express Mail Next Day Service-Post Office to Addressee" label and the postmark on the envelope or wrapper and on the original receipt from the U.S. Postal Service. "Postmark" has the same meaning as defined in paragraph (c) of this provision, excluding postmarks of the Canadian Postal Service. Therefore, bidders should request the postal clerk to place a legible hand cancellation bull's-eye postmark on both the receipt and the envelope or wrapper.

(f) Notwithstanding paragraph (a) of this provision, a late modification of an otherwise successful bid that makes its terms more favorable to the Government will be considered at any time it is received and may be accepted.

(g) Bids may be withdrawn by written notice or telegram (including mailgram) received at any time before the exact time set for receipt of bids. If the solicitation authorizes facsimile bids, bids may be withdrawn via facsimile received at any time before the exact time set for receipt of bids, subject to the conditions specified in the provision entitled "Facsimile Bids." A bid may be withdrawn in person by a bidder or its authorized representative if, before the exact time set for receipt of bids, the identity of the person requesting withdrawal is established and the person signs a receipt for the bid.

(End of provision)

L.29 52.214-18 PREPARATION OF BIDS--CONSTRUCTION (APR 1984)

(a) Bids must be (1) submitted on the forms furnished by the Government

or on copies of those forms, and (2) manually signed. The person signing a bid must initial each erasure or change appearing on any bid form.

(b) The bid form may require bidders to submit bid prices for one or more items on various bases, including--

- (1) Lump sum bidding;
- (2) Alternate prices;
- (3) Units of construction; or
- (4) Any combination of subparagraphs (1) through (3) above.

(c) If the solicitation requires bidding on all items, failure to do so will disqualify the bid. If bidding on all items is not required, bidders should insert the words "no bid" in the space provided for any item on which no price is submitted.

(d) Alternate bids will not be considered unless this solicitation authorizes their submission.

(End of provision)
(R SF 22, Para 5, 1978 FEB)

L.30 52.214-19 CONTRACT AWARD--SEALED BIDDING--CONSTRUCTION (FEB 1986)

(a) The Government will evaluate bids in response to this solicitation without discussions and will award a contract to the responsible bidder whose bid, conforming to the solicitation, will be most advantageous to the Government, considering only price and the price-related factors specified elsewhere in the solicitation.

(b) The Government may reject any or all bids, and waive informalities or minor irregularities in bids received.

(c) The Government may accept any item or combination of items, unless doing so is precluded by a restrictive limitation in the solicitation or the bid.

(End of provision)

L.31 52.219-22 SIC CODE AND SMALL BUSINESS SIZE STANDARD (JAN 1991)

(a) The standard industrial classification (SIC) code for this acquisition is 1629.

(b)(1) The small business size standard is 17.0 million.

(2) The small business size standard for a concern which submits an

offer in its own name, other than on a construction or service contract, but which proposes to furnish a product which it did not itself manufacture, is 500 employees.

(End of provision)

L.32 52.228-1 BID GUARANTEE (APR 1984)

(a) Failure to furnish a bid guarantee in the proper form and amount, by the time set for opening of bids, may be cause for rejection of the bid.

(b) The offeror (bidder) shall furnish a bid guarantee in the form of a firm commitment, such as a bid bond, postal money order, certified check, cashier's check, irrevocable letter of credit, or, under Treasury Department regulations, certain bonds or notes of the United States. The Contracting Officer will return bid guarantees, other than bid bonds, (1) to unsuccessful bidders as soon as practicable after the opening of bids, and (2) to the successful bidder upon execution of contractual documents and bonds (including any necessary coinsurance or reinsurance agreements), as required by the bid as accepted.

(c) If the successful bidder, upon acceptance of its bid by the Government within the period specified for acceptance, fails to execute all contractual documents or give a bond(s) as required by the solicitation within the time specified, the Contracting Officer may terminate the contract for default.

(d) Unless otherwise specified in the bid, the bidder will (1) allow 60 days for acceptance of its bid and (2) give bond within 10 days after receipt of the forms by the bidder.

(e) In the event the contract is terminated for default, the bidder is liable for any cost of acquiring the work that exceeds the amount of its bid, and the bid guarantee is available to offset the difference.

(End of clause)

(R 1-10.103-3)

(R 7-2003.25 1964 JUN)

L.33 52.233-2 SERVICE OF PROTEST (NOV 1988)

(a) Protests, as defined in section 33.101 of the Federal Acquisition Regulation, that are filed directly with an agency, and copies of any

protests that are filed with the General Accounting Office (GAO) or the General Services Administration Board of Contract Appeals (GSBCA), shall be served on the Contracting Officer (addressed as follows) by obtaining written and dated acknowledgment of receipt from

Mrs. Diane K. Pecoul
Chief, Construction Service Branch
U.S. Army Corps of Engineers
P.O. Box 60267
New Orleans, LA 70160-0267
Telephone No. 504-862-2875

(b) The copy of any protest shall be received in the office designated above on the same day a protest is filed with the GSBCA or within one day of filing a protest with the GAO.

(End of provision)

L.34 52.242-13 BANKRUPTCY (APR 1991)

In the event the Contractor enters into proceedings relating to bankruptcy, whether voluntary or involuntary, the Contractor agrees to furnish, by certified mail, written notification of the bankruptcy to the Contracting Office responsible for administering the contract. This notification shall be furnished within five days of the initiation of the proceedings relating to bankruptcy filing. This notification shall include the date on which the bankruptcy petition was filed, the identity of the court in which the bankruptcy petition was filed, and a listing of Government contract numbers and contracting offices for all Government contracts against which final payment has not been made. This obligation remains in effect until final payment under this contract.

(End of clause)

END OF SECTION L

NOTICE TO CONTRACTOR

This solicitation contains two sets of goals for minority participation in construction crafts on this contract. They are the New Orleans Hometown Plan and the New Orleans Standard Metropolitan Statistical Area (SMSA).

Contractor will determine the goals applicable to him by the following:

Hometown Plan applies only to those contractors who are signatory to the Hometown Plan and utilizing crafts signatory to the plan.

New Orleans Standard Metropolitan Statistical Area (SMSA) applies to all contractors in the New Orleans SMSA area not signatory to the Hometown Plan, or utilizing crafts not signatory to the plan.

Federal Register/Vol. 45, No. 194/Friday, October 3, 1980

**SOLICITATION PROVISION
NOTICE OF REQUIREMENT FOR AFFIRMATIVE ACTION
TO ENSURE EQUAL EMPLOYMENT OPPORTUNITY**

The Bidder's attention is called to the "EQUAL OPPORTUNITY" and "LOCAL AFFIRMATIVE ACTION PLAN" clauses of the contract.

The acceptable ranges of minority manpower utilization, expressed in percentage terms, are as follows:

<u>Timetables</u>	<u>Goals for Minority Participation for Each Trade</u>	<u>Goals for Female Participation in Each Trade</u>
Indefinitely	20% - 23%	6.9%

The Bidder shall, within 5 days after a request therefor by the Contracting Officer of his duly authorized representative, submit the following information.

- (a) A list of the construction trades he intends to use, either directly or through subcontractors at any tier, in the performance of work covered by this solicitation;
- (b) A list of the labor organizations with which he has collective bargaining agreements and which are signatories to the Hometown Plan with respect to trades for which specific commitments to goals of minority manpower utilization are set forth in the Hometown Plan;
- (c) A list of the labor organizations with which he has collective bargaining agreements and which are not signatories to the Hometown Plan or which are signatories thereto but with respect to trades for which no specific commitments to goals of minority manpower utilization are set forth in the Hometown Plan, and
- (d) A list of all current construction work or contracts to which he is a party in any capacity in the covered area.

As used in this NOTICE and the contract to result from this solicitation:

- (a) "Hometown Plan" or "Plan" means the NEW ORLEANS Plan, consisting of "An Agreement for Implementation of Employment of Minorities in the New Orleans Building Construction Industry."
- (b) "The covered area" means Orleans, Jefferson, St. Bernard, St. Tammany, St. Charles, St. John, Lafourche, Plaquemines, Washington, Terrebonne, Tangipahoa*, Livingston** and St. James*** Parishes, Louisiana.
- (c) "Director, OFCC" means the Director, Office of Federal Contract Compliance, United States Department of Labor, or any person to whom he delegates authority; and
- (d) "Minority" means Negro, Spanish-surnamed American, Oriental, and American Indian, and includes both men and women.

*Area covered is east of the Illinois Central Railroad.

**Area covered is southeast of the line from a point of the Livingston & Tangipahoa Parish line adjacent from New Orleans and Baton Rouge.

***Area covered is southeast of a line drawn from the town of Gramercy to the point of intersection of St. James, Lafourche and Assumption Parishes.

NOTICE OF REQUIREMENT FOR AFFIRMATIVE ACTION TO ENSURE EQUAL EMPLOYMENT OPPORTUNITY (APRIL 1984)

(a) The offeror's attention is called to the Equal Opportunity clause and the Affirmative Action Compliance Requirements for Construction clause of this solicitation.

(b) The goals for minority and female participation, expressed in percentage terms for the Contractor's aggregate workforce in each trade on all construction work in the covered area, are as follows:

Goals for Minority Participation for Each Trade		Goals for Female Particip: for Each Trade
SMSA Counties MS	19.2%	6.9%
SMSA Counties LA	31.0%	6.9%
NON-SMSA Counties	27.7%	6.9%

These goals are applicable to all the Contractor's construction work performed the covered area. If the Contractor performs construction work in a geographical area located outside of the covered area, the Contractor shall apply the goals established for the geographical area where the work is actually performed. Goals are published periodically in the Federal Register in notice form, and these notices may be obtained from any Office of Federal Contract Compliance Program office.

(c) The Contractor's compliance with Executive Order 11246, as amended, and the regulations in 41 CFR 60-4 shall be based on (1) its implementation of the Equal Opportunity clause, (2) specific affirmative action obligations required by clause entitled "Affirmative Action Compliance Requirements for Construction," and (3) its efforts to meet the goals. The hours of minority and female employment and training must be substantially uniform throughout the length of the contract, and in each trade. The Contractor shall make a good faith effort to employ minorities and women evenly on each of its projects. The transfer of minority or female employees or trainees from Contractor to Contractor, or from project to project, for the sole purpose of meeting the Contractor's goal shall be a violation of the contract. Executive Order 11246, as amended, and the regulations in 41 CFR 60-4. Compliance with the goals will be measured against the total work hours performed.

(d) The Contractor shall provide written notification to the Director, Office of Federal Contract Compliance Programs, within 10 working days following award of a construction subcontract in excess of \$10,000 at any tier for construction work under the contract resulting from this solicitation. The notifications shall list the-

- (1) Name, address, and telephone number of the subcontractor;
(i) Employer identification number of the subcontractor;
- (2) Estimated dollar amount of the subcontract;
- (3) Estimated starting and completion dates of the subcontract; and

(4) Geographical area in which the subcontract is to be performed.

(e) As used in this Notice, and in any contract resulting from this solicitation the "covered area" is (FAR 52.222-23) Economic Area 113, New Orleans, LA as follows:

Standard Metropolitan Statistical Area

(SMSA) Counties

0920 Biloxi - Gulfport, MS ----- 19.2%

MS Hancock: MS Harrison: MS Stone

5560 New Orleans, LA ----- 31.0%

LA Jefferson; LA Orleans: LA St. Bernard; LA St. Tammany

Non-Standard Metropolitan Statistical Area

(NON-SMSA) Counties: ----- 27.7%

LA Assumption: LA Lafourche; LA Plaquemines; LA St. Charles;

LA St. James; LA St. John the Baptist; LA Tangipahoa:

LA Terrebonne: LA Washington; MS Forrest; MS Lamar; MS Marion:

MS Pearl River; MS Perry; MS Pike; MS Walthall

GOVERNMENT ESTIMATE OF REASONABLE
CONTRACT COSTS

PROJECT: LAKE PONTCHARTRAIN, LA AND VICINITY, HIGH LEVEL
PLAN, LONDON AVE. OUTFALL CANAL, PARALLEL PROTECTION,
MIRABEAU AVE. TO LEON C. SIMON & ROBERT E. LEE BLVD.
ORLEANS PARISH, LA.

Solicitation No: DACW29-94-B-0047

Amendments	0001	dated	MAY 26, 1994
	0002	dated	JUNE 2, 1994
	0003	dated	JUNE 7, 1994
		dated	
		dated	

FOR OFFICIAL USE ONLY
PROTECTIVE MARKING IS OBSOLETE

JUN 15 1994
7 8 9 10 11 12 1 2 3 4 5 6 PM

Bid Opening Date JUNE 15, 1994

U.S. ARMY ENGINEER DISTRICT, NEW ORLEANS
FOOT OF PRYTANIA STREET
NEW ORLEANS, LOUISIANA

COMMANDER: Kenneth H. Clow, Colonel, EN

DATE OF ESTIMATE: JUNE 7, 1994

ESTIMATORS: SETTON, BIVONA, NORMAND, PETITBON

REASONABLE CONTRACT ESTIMATE

Project: LONDON AVE OUTFALL CANAL, PARALLEL Invitation no. DACW29-
 PROTECTION, MIRABEAU AVE. TO LEON C. SIMON & ROBERT E. LEE 94-B-0047

Item No.	Description	Estimated Quantity	Unit	Unit Price	Estimated Amount
1.	Mobilization and Demobilization	Lump Sum	LS	\$166,500	\$166,500.00
2.	Clearing and Grubbing	Lump Sum	LS	\$75,360	\$75,360.00
3.	Selective Demolition	Lump Sum	LS	\$122,460	\$122,460.00
4.	Pedestrian Bridge Demolition	Lump Sum	LS	\$8,830	\$8,830.00
5.	Embankment, Semicompacted Fill	Lump Sum	LS	\$17,660	\$17,660.00
6.	Structural Excavation and Backfill	Lump Sum	LS	\$107,270	\$107,270.00
7.	Fertilizing, Seeding and Mulching	8	AC	\$2,120	\$16,960.00
8.	Cutting Off Existing AZ-18, RZ-10, and PZ-27 Sheet Piling	Lump Sum	LS	\$18,840	\$18,840.00
9.	Pull, Clean, Salvage and Deliver Existing AZ-18 Steel Sheet Piling	Lump Sum	LS	\$12,360.00	\$12,360.00
10.	Redrive Existing AZ-18 Steel Sheet Piling	Lump Sum	LS	\$940	\$940.00
11.	Piling, Steel Sheet, Type PZ-22	187,844	SF	\$9.00	\$1,690,596.00
12.	Piling, Steel Sheet, Type PSA-23	997	SF	\$11.10	\$11,066.70
13.	Painting	Lump Sum	LS	\$200	\$200.00
14.	Reinforced Concrete Floodwalls	Lump Sum	LS	\$2,303,190	\$2,303,190.00
15.	Concrete Slope Pavement	188	SY	\$35.10	\$6,598.80
16.	Utility Modifications	Lump Sum	LS	\$10,360	\$10,360.00
17.	Temporary Relocation of Feeder Lines	Lump Sum	LS	\$161,320	\$161,320.00
18.	Permanent Relocation of Feeder Lines	Lump Sum	LS	\$339,120	\$339,120.00
19.	Erosion Control				
	First 10,670 Linear Feet	10,670	LF	\$3.00	\$32,010.00
	All Over 10,670 Linear Feet	2,700	LF	\$3.00	\$8,100.00

Subtotal this page:

\$5,109,741.50

Continued on next page.

REASONABLE CONTRACT ESTIMATE

sheet 2 of 2

Project: LONDON AVE OUTFALL CANAL, PARALLEL Invitation no. DACW29-
 PROTECTION, MIRABEAU AVE. TO LEON C. SIMON & ROBERT E. LEE 94-B-0047

Item No.	Description	Estimated Quantity	Unit	Unit Price	Estimated Amount
Subtotal from previous page:					\$5,109,741.50
20.	Temporary Flood Protection and Cofferdams	Lump Sum	LS	\$65,350	\$65,350.00
21.	Miscellaneous Metals	Lump Sum	LS	\$16,490	\$16,490.00

TOTAL \$5,191,581.50

C/COST ENGR BR *Tom Willis*
 PROJ ENGR *no*
 C/DESIGN BR *Chapman*
 ASST C/ENGR DIV *aut*
 C/ENGR DIV *Plate*

APPROVED BY: *G. S. Kuhr*
 GREGORY S. KUHR
 LTC, EN
 Deputy

TIME: *12:35 pm* DATE: *6/15/94*

FOR OFFICIAL USE ONLY
 PROTECTIVE MARKING TO BE REMOVED

JUN 1 1994
 AM 7,8,9,10,11,12,1,2,3,4,5,6 PM

(17.0 million)

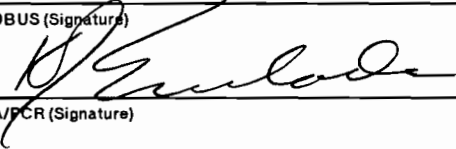
DATA ON PROPOSED PROCUREMENT				Requirement Control Symbol	
For use of this form, see AFARS; the proponent agency is OSA				SAOAS-72	
1A. CONTRACTING OFFICE US ARMY ENGR DIST NEW ORLEANS PO BOX 60267 NEW ORLEANS LA 70160		1B. BUYER Sheila W. Enclade (504) 862-1514		2. IDENTIFICATION NUMBER 00061-94	
3A. PR NUMBER ED0000-4031-0144		3B. SOLICITATION/CONTRACT MOD NUMBER DACW29-94-B-0047		4. FSC/SVC CODE Y260	
5. DESCRIPTION OF COMMODITY OR SERVICE (Include quantity) Lake Pont, LA & Vic, London Ave. Outfall Canal, Parallel Prot, Mirabeau Ave. to Leon C Simon Blvd, E.B., & Mirabeau					
6. SIC CODE 1629	7A. ESTIMATED COST 6,500,000.00	7B. VALUE OF OPTIONS 0.00	8. ESTIMATED DATE OF RELEASE 03/11/94	9. ESTIMATED DATE OF OPENING 01/31/94	
10. PROPOSED SYNOPSIS? <input checked="" type="checkbox"/> A. Yes <input type="checkbox"/> B. No, per FAR 5.202(a)() <input type="checkbox"/> C. Under \$25,000			11. PROPOSED SOLICITATION LIST		
D. DATE OF RELEASE TO CBD 01/31/94			A. TOTAL FIRMS	B. SB FIRMS	
12. PREVIOUS ACQUISITION			C. SDB FIRMS	D. HBCU/MI	
A. CONTRACT NO. DACW29-93-C-0050		B. CONTRACTOR River Road		13. SUBCONTRACTING PLAN IS REQUIRED? <input checked="" type="checkbox"/> Yes <input type="checkbox"/> No	
C. CONTRACT PRICE 1,112,350.00		D. CONTRACT QUANTITY 0.00			
14. METHOD OF ACQUISITION <input checked="" type="checkbox"/> A1. Full & Open Competition (F&OC) <input type="checkbox"/> A2. F&OC After Exclusion of Sources (Other than B Below) <input type="checkbox"/> B1. Small Business Set-Aside <input type="checkbox"/> B2. LSA Set-Aside <input type="checkbox"/> B3. Small Business Innovation Research Program <input type="checkbox"/> C. Other than F&OC - FAR 8 302-() <input type="checkbox"/> D. 8(a) <input type="checkbox"/> E. Small Disadvantaged Business Set-Aside <input type="checkbox"/> F. HBCU/MI Set-Aside <input type="checkbox"/> G. Small Purchase Procedures Other Than Small Business - Small Purchase Set-Aside <input type="checkbox"/> H. NISH/NIB			15. SIMILAR SUPPLIES/SERVICES ACQUIRED <input type="checkbox"/> A. First time buy <input checked="" type="checkbox"/> B. Previous acquisition: <input type="checkbox"/> (1) 8(a) <input type="checkbox"/> (2) Small Disadvantaged Business Set-Aside <input type="checkbox"/> (3) Small Business Set-Aside <input type="checkbox"/> (4) HBCU/MI Set-Aside <input type="checkbox"/> (5) Other Set-Aside <input checked="" type="checkbox"/> (6) None of above <input checked="" type="checkbox"/> C. Two or more SB offers on prior acquisition <input type="checkbox"/> D. One SDB offer within 10% of award price on prior acquisition		
16. MACOM USE					
17. REMARKS This is issued as "Unrestricted" in accordance with PL100-656.					
18A. PCO (Signature)				B. DATE	
19A. SADBUS (Signature) 		B. CHECK ONE CONCUR / NON CONCUR		C. DATE 01 Feb 94	
20A. SBA/PCR (Signature)				C. DATE	

A 6

<p>DACW29-94-B-0047</p> <p>\$25.00 Half Scale \$50.00 Full Scale</p>		
<p>Continental Const. Co., Inc. 5646 Shelby Oak Drive Memphis, TN 38134 ATTN: Rodney Waits FULL</p>	<p>The Hardaway Co. 945 Broadway Columbus, GA 31901-2730 ATTN: Ronald Hale ½</p>	<p>The Hardaway Co. 945 Broadway Columbus, GA 31901 ATTN: Mr. Ron Hale FULL</p>
<p>Pittman Construction Co., Inc. 110 Veterans Blvd., Ste. 325 Metairie, LA 70005 FULL</p>	<p>Professional Const. Service P.O. Box 26245 New Orleans, LA 70186 ½</p>	<p>Bayou Land & Marine Contractors 1018 Victory Dr Westwego, LA 70094 ½</p>
<p>Boh Bros. Const.Co., Inc. P.O. Drawer 53266 New Orleans, LA 70153 4-FULL</p>	<p>Hill Brothers Const. Highway 15 North P.O. Box 131 Falkner, MS 38629-0131 ½</p>	<p>Circle, Inc. 1204 A Engineers Rd. Belle Chasse, LA 70037 FULL</p>
<p></p>	<p>Team Services, Inc. P.O. Box 1001 Sta. 1 Houma, LA 70363 FULL</p>	<p>Skyline Steel Corp. 126 Tchefuncte Drive Covington, LA 70433 2-½ 2-½</p>
<p>Bayou Land & Marine Contractors 1018 Victory Dr. Westwego, LA 70094 ½</p>		
<p>Manufab Inc 129 Third St. Kenner, LA 70062 ½</p>	<p>Kostmayer Const Co. P.O. Box 74194 Metairie, LA 70033 FULL .</p>	<p>Johnson Bros. 2002 20th St., Ste. B-101 Kenner, LA 70062 ½</p>
<p>Fazzio Excavating Corp. 2200 Fazzio Rd. Chalmette, LA 70043 ½</p>	<p>Southeast Erosion Control 197 Diane Rd. Madisonville, LA 70447 ½</p>	
<p>C.L. Dill Co., Inc. P.O. Box 635 Belle Chasse, LA 70037 FULL</p>	<p>Metfab, Inc. 4566 St. Claude Ave. P.O. Box 3427 New Orleans, LA 70177 ½</p>	
<p>Prattini Electric Inc. 812 Little Farms Ave. Metairie, LA 70003 ½</p>		
	<p>1</p>	

Handwritten scribbles and marks in the bottom right corner of the page.

<p>DACW29-94-B-0047 \$25.00 Half Scale <i>Pg. 1</i> \$50.00 FULL Scale</p>	<p>B & K Construction Co., Inc. 1905 Highway 59 Mandeville, LA 70448</p>	<p>McMillion Dozer Service, Inc. 11204 Jefferson Highway River Ridge, LA 70123</p>
	<p>C.R. Pittman Co. Inc. 3021 Franklin Ave. New Orleans, LA 70122</p> <p>FULL</p>	<p>Maharrey-Houston Const. Co. P.O. Box 70250 Memphis, TN 38107-0250</p>
<p>Johnson Bros. Corp. of LA 2002 20th Street, Ste. B-101 Kenner, LA 70062</p> <p>3-1/2</p>	<p>L&A Contracting Co. P.O. Box 16749 Hattiesburg, MS 39404</p>	<p>Folk Const. Co., Inc. P.O. Box 772899 Memphis, TN 38177-2899</p>
	<p>Key Constructors, Inc. P.O. Box 16256 Jackson, MS 39236-6256</p>	<p>McGinnes Bros., Inc. 1502 Augusta, Suite 220 Houston, TX 77057</p>
<p>Hill Brothers Const.Co. Hwy. 15 North P.O. Box 131 Falkner, MS 38629-0131</p>	<p>Durocher Dock & Dredge, Inc. 958 N. Huron St. P.O. Box 8 Cheboygan, MI 49721</p> <p>2-1/2</p>	<p>Brand Marine Services, Inc. 5 Bokum Rd. P.O. Box 38 Essex, CT 06426</p> <p>Full</p>
	<p>Shappert Engineering Co. P.O. Box 5206 Rockford, IL 61125</p>	<p>Choctaw Transportation 1307 East Court St. Dyersburg, TN 38024</p>
<p>Four F Corporation P.O. Box 13427 Memphis, TN 38113</p>	<p>Syro, Inc. 1170 N. State Street Girard, Ohio 44420</p>	
<p>Ronald Adams Contractor, Inc. 1074 Hwy. 1 Thibodaux, LA 70301</p> <p>2-1/2</p>	<p>J.D. Fields & Co. 3200 Ridgelake Drive, Ste. 301 Metairie, LA 70002</p>	<p>Capitol Steel, Inc. P.O. Box 3219 Slidell, LA 70459</p>
<p>River/Road Const. Inc. P.O. Box 1406 Mandeville, LA 70470-1406</p>	<p>Rosiek Const Co., Inc. 2000 E. Lamar Blvd. #410 Arlington, TX 76006</p>	<p>Cajun Contractors, Inc. P.O. Box 104 Baton Rouge, LA 70821-0104</p> <p>FULL</p>
<p>Skyline Steel Corp. 126 Tchefonctc Dr. Covington, LA 70433</p>	<p>Rosiek Const Co., Inc. Route 2, Box 224 (Sardis Rd) Morrilton, ARK 72110</p>	<p>Contours Unlimited, Inc. 135 Horseshoe Rd. Schriever, LA 70395</p>
<p>T.L. James & Co., Inc. P.O. Box 20115 New Orleans, LA 70141-0115</p> <p>FULL, 2-1/2</p>	<p>Misener Marine Const., Inc. ATTN: Estimating Dept 5440 West Tyson Ave. Tampa, FL 33611</p>	
	<p>1</p>	

[SPECIAL INTEREST]

<p>DACM29-94-B-0047 \$25.00 Half Scale \$50.00 Full Scale Pg. 2</p>	<p>Industrial Erection & Maint. 78024 Hwy. 21 Bush, LA 70431 ½</p>	
<p>Mr. Michael Jackson Burk-Kleinpeter, Inc. 4176 Canal St. New Orleans, LA 70119 4-1/2</p>	<p>Richard McPhearson 513 Rayburn Ocean Springs, MS 39564 ½</p>	
<p>Mr. G. Joseph Sullivan General Superintendent Sewerage and Water Board of N.O. 625 St. Joseph St. New Orleans, LA 70165 3-1/2</p>	<p>Walter J. Barnes Electric Co. 432 Dakin St., P.O. Box 10458 Jefferson, LA 70181 ½</p>	
<p>Mr. Frank Stuart, Director Department of Streets 1300 Perdido St. New Orleans, LA 70112 1/2</p>		
<p>Mr. Pierre Champagne South Central Bell 6767 Bundy Rd. New Orleans, LA 70127 1/2</p>		
<p>Mr. David Cook, N. O. Public Service, Inc. Attn: Mail Unit MR-213 P. O. Box 60340 New Orleans, LA 70160 1/2</p>		
<p>Mitzy Mancuso Cox Cable New Orleans 2120 Canal St. New Orleans, LA 70112 1/2</p>		
	<p>1</p>	

Solicitation: DACW29-94-B-0047

FSC Class: Y260

<u>Bidder No.</u>	<u>Response</u>	<u>Vendor ID</u>	<u>Name/Address</u>
1	No	00000000	
2	No	00000026	Affolter Contracting Co., Inc. P.O. Box 1436 La Marque TX 77568
3	No	00000030	Al Johnson Construction Co. 3209 West 76th St. MINNEAPOLIS MN 55435
4	No	00000057	Anthony J. Bertucci Const.Co. P.O. Box 10563 Jefferson, LA 70181
5	No	00000061	Arna America, Inc. P.O. Box 21453 Denver CO 80221
6	No	00000079	Barber Bros. Contrg. Co., Inc. P.O. Box 66296 Baton Rouge, LA 708966296
7	No	00000092	BIG "O" CONSTRUCTION CO INC PO BOX 2442 LAFAYETTE LA 705022442
8	No	00000101	Boh Bros. Construction Co., Inc P.O. Drawer 53266 New Orleans LA 70153
9	No	00000118	C.L. Dill Co., Inc. P.O. Box 635 Belle Chasse, LA 70037
10	No	00000120	C.W. Smith Erosion Control, Inc P.O. Box 1277 Guthrie, LA 73044

15

Solicitation: DACW29-94-B-0047

FSC Class: Y260

Bidder No.	Response	Vendor ID	Name/Address
11	No	00000126	Caldwell Culvert Co. P. O. Box 770 Jackson MS 70816
12	No	00000136	Carthage Mills 1821 Summit Rd. Cincinnati, OH 45237
13	No	00000147	Chancellor & Son, Inc. 7474 Raleigh LaGrange Rd. Cordova, TN 38018
14	No	00000148	Charles W. Greeson & Sons, Inc 5978 Chandler Dr. Baton Rouge, LA 70808
15	No	00000150	Chemung Contracting Co. 1209 Upper Broadway Pine City, NY 14871
16	No	00000152	Circle, Inc. 1204 Engineers Rd. Belle Chasse, LA 70037
17	No	00000180	Country Construction P.O. Box 1102 Independence, LA 70443
18	No	00000211	Erosion Control Serv., Inc. P.O. Box 541 Simmesport, LA 71369
19	No	00000226	Davis Construction Co., Inc. 1314 Harbor Ave Memphis TN 381130164
20	No	00000241	Dickerman Overseas Contracting 210 E. Monument Ave Kissimmee FL 32741

Solicitation: DACW29-94-B-0047

FSC Class: Y260

<u>Bidder No.</u>	<u>Response</u>	<u>Vendor ID</u>	<u>Name/Address</u>
21	No	00000244	Dillingham Construction N.A. 5960 Inglewood Dr. P.O. Box 1089 Pleasanton CA 94566
22	No	00000254	DRAVO BASIC MATERIALS CO INC PO BOX 2150 KENNER LA 70063
23	No	00000255	Dredging & Hauling, Inc. P.O. Box 42 d/b/a Grant Contracting Co. Virginia IL 62691
24	No	00000282	FOLK CONSTRUCTION CO., INC. P.O. Box 772899 MEMPHIS TN 381772899
25	No	00000283	Ford Contracting Corp. P.O. Box 1208 Dyersburg TN 380251208
26	No	00000284	FORDICE CONSTRUCTION COMPANY P.O. Box 1101 ATTN: DAN FORDICE VICKSBURG MS 39181
27	No	00000286	Four F Corp. 1255 Harbor Ave. P.O. Box 13427 Memphis TN 38113
28	No	00000287	Four M Bridge, Inc. P. O. Box 424 Louisiana, MO 63353
29	No	00000299	G & W Construction Co., Inc. P.O. Box 9124 Houma LA 70361
30	No	00000326	Granite Construction Co. P.O. Box 699 Watsonville CA 95077

Solicitation: DACW29-94-B-0047

FSC Class: Y260

<u>Bidder No.</u>	<u>Response</u>	<u>Vendor ID</u>	<u>Name/Address</u>
31	No	00000328	Great Lakes Dredge & Dock Co. 3850 N. Causeway Blvd Ste 1830 Gulf Coast Division Metairie LA 70002
32	No	00000330	Griffin Dewatering P.O. Box 15221 Houston TX 77220
33	No	00000336	Guinn Brothers, Inc. P.O. Box 220 Oil City LA 71061
34	No	00000338	Guy F. Atkinson Co. 10 West Orange Ave., South San Francisco CA 94080
35	No	00000339	H & B Construction Co. of La. P.O. Box 7178 Buras LA 700417178
36	No	00000347	H M B Construction Co. P.O. Box 5606 Texrakrana TX 75505
37	No	00000363	Hill Brothers Construction Co P.O. Box 131, Highway 15 N. Falkner MS 38629
38	No	00000366	Holloway Construction Co. P.O.Box 2001, Union City TN 38261
39	No	00000374	ICOS Corp. Of America P.O.Box 749,124 S. Van Brunt Englewood NJ 076310749
40	No	00000389	Inquip Associates, Inc. P.O. Box 2182 Santa Barbara CA 93120

Solicitation: DACW29-94-B-0047

FSC Class: Y260

<u>Bidder No.</u>	<u>Response</u>	<u>Vendor ID</u>	<u>Name/Address</u>
41	No	00000402	J D FIELDS & CO INC 3200 RIDGELAKE DR/SUITE 301 METAIRIE LA 70002
42	No	00000404	J.E. Starnes Company P.O. Box 2550 Hickory NC 286032550
43	No	00000408	J.P. & Sons, Inc. 8229 River Road Waggaman LA 70094
44	No	00000409	J.R. Fertitta Contracting Co. 8 Rue Lemans Kenner LA 70065
45	No	00000428	Jordan Pile Driving, Inc. 301 N. Water Street P.O. Drawer 3004 Mobile AL 366523004
46	No	00000429	Judice Dirt Services, Inc. RT 2 Box 25 Caremcro LA 70520
47	No	00000442	Key Constructors, Inc. P.O. Box 16256 Jackson MS 39236
48	No	00000451	Krielow Brothers, Inc. P.O. Box 39 Roanoke LA 70581
49	No	00000452	L & R Constr. Co., Inc. Kaplan P.O. Box 761 Kaplan LA 70548
50	No	00000457	LaBauve Construction, Inc. P.O. Box 20017 Beaumont TX 77720

Solicitation: DACW29-94-B-0047

FSC Class: Y260

<u>Bidder No.</u>	<u>Response</u>	<u>Vendor ID</u>	<u>Name/Address</u>
51	No	00000459	Lane Const. Corp. 965 E. Main St. Meriden CT 06450
52	No	00000462	Larry Breaux Constr. Co., Inc. P.O. Box 274 Mansura LA 71350
53	No	00000478	List & Clark Construction Co. 6811 W. 63rd St. Overland Park KS 66202
54	No	00000482	LOUISIANA EROSION CONTROL 14643 GREENWELL SPRINGS ROAD GREENWELL SPRNG LA 70739
55	No	00000487	Lucien Q. Boulad 405 Audubon St. New Orleans LA 70118
56	No	00000488	LUHR BROTHERS INCORPORATED PO BOX 50 COLUMBIA IL 622360050
57	No	00000491	M Operating Co., Inc. 243 Arlington Rd. Jacksonville FL 32211
58	No	00000492	M & C Contractors, Inc. P.O. Box 221 St.Martinsville LA 70582
59	No	00000499	MACCAFERRI GABIONS 525 SURF STREET SUITE 242 LEWISVILLE TX 75067
60	No	00000502	Magruder Construction Co., INC P.O. Box 8 Eolia MO 63344

Solicitation: DACW29-94-B-0047

FSC Class: Y260

<u>Bidder No.</u>	<u>Response</u>	<u>Vendor ID</u>	<u>Name/Address</u>
61	No	00000503	Maharrey-Houston Constr. Co. P.O. Box 70250 Memphis TN 38107
62	No	00000512	Marsh Buggies, Inc. P.O. Box 814 Harvey LA 70059
63	No	00000526	Midwest Construction Co. P.O. Box 610 Nebraska City NE 68410
64	No	00000540	Moretrench American Corp. 7701 Interbay Blvd. Tampa FL 33616
65	No	00000545	Murphy Construction Co., Inc 1000 Murphy Rd. Chalmette LA 70043
66	No	00000554	Patton-Tully Transportation Co P.O. Box 28 Memphis, TN 381010028
67	No	00000559	Pearch & LeBlanc, Inc. P.O. Box 14505 Baton Rouge, LA 70898
68	No	00000565	Phillips and Jordan, Inc. 6621 Wilbanks Road Knoxville, TN 379121397
69	No	00000567	Pierce Foundations, Inc. P.O. Box 26817 New Orleans, LA 701866817
70	No	00000568	Pine Bluff Sand & Gravel Co. P.O. Box 7008 Pine Bluff, AR 71611

Solicitation: DACW29-94-B-0047

FSC Class: Y260

<u>Bidder No.</u>	<u>Response</u>	<u>Vendor ID</u>	<u>Name/Address</u>
71	No	00000576	Port Aggregates, Inc. P.O. Box 375 Jennings, LA 70546
72	No	00000595	Netherton Company, Inc. P.O. Drawer 9248 Shreveport, LA 711399248
73	No	00000636	R.L. Brink Corporation 4600 North 24th Street Quincy IL 62301
74	No	00000638	R.T. Case Co. 4026 So. Urbana Tulsa OK 74135
75	No	00000645	Ray's Construction, Inc. Rt. 2, Box 442R Marksville LA 71351
76	No	00000646	Ray Hardy, Inc. P. O. Box 81037 Atlanta GA 30366
77	No	00000648	Reasons Construction Co., Inc. 203 North 10th Ave. Humboldt TN 38343
78	No	00000653	Rene Cross Construction, Inc. P. O. Box 34 Belle Chasse LA 70037
79	No	00000664	RIVER VALLEY SERVICES, INC. 1700 SUN PLUS PKWY., SUITE D PORT ALLEN LA 70767
80	No	00000673	Ronald Adams, Contractor, Inc. 1074 Highway 1 Thibodaux LA 70301

Solicitation: DACW29-94-B-0047

FSC Class: Y260

<u>Bidder No.</u>	<u>Response</u>	<u>Vendor ID</u>	<u>Name/Address</u>
81	No	00000681	Rust Company, Inc. 920 West "A" St. Belleville IL 62220
82	No	00000683	Ryan Incorporated Eastern 7900 Sudley Rd., Suite 415 Manassas VA 22110
83	No	00000684	S.G. DAVIS, INC. 7427 Boyce Drive Baton Rouge LA 70809
84	No	00000685	S.J. COHEN COMPANY P. O. box 367 Blytheville AK 723160367
85	No	00000709	Shappert Engineering Co. P. O. Box 5206 Rockford IL 611250206
86	No	00000721	Smith Construction Co. P. O. Box 506 Harvey LA 70059
87	No	00000729	Southern Rock, Inc. P. O. Box 4666 Jackson MS 39216
88	No	00000738	SPACE, Inc. P. O. Box 65142 Baton Rouge LA 70896
89	No	00000747	Spinx Construction Services 2836 Kalurah Street Baton Rouge LA 70808
90	No	00000774	T.L. James & Co., Inc. P. O. Box 20116 New Orleans LA 701410116

Solicitation: DACW29-94-B-0047

FSC Class: Y260

Bidder No.	Response	Vendor ID	Name/Address
91	No	00000775	T.L. James & Co., Inc. P.O. Box 760 Vidalia LA 713730760
92	No	00000776	Tanner Heavy Equipment Co.Inc. 215 Tanner Road Leesville LA 71446
93	No	00000792	Terral Barge Line, Inc. Rt. 1, Box 40 Lake Providence LA 71254
94	No	00000813	Trek, Inc. P.O. Box 419 Bunkie LA 71322
95	No	00000854	W.H. Carder, Inc. P.O. Box C Gould AR 71643
96	No	00000855	W.J. Runyon & Son, Inc. P.O. Box 488 Vicksburg MS 39181
97	No	00000929	Excavators, Inc. 9 Melinda Dr. Little Rock AR 72209
98	No	00000931	General Engineering & Constr. P.O. Box 128 Scott LA 70583
99	No	00000943	McClelland Consultants Inc. 9921 St. Charles Rock Rd. St. Ann MO 63074
100	No	00000944	McGinnes Bros., Inc. 5837 Northdale St. Houston TX 77087

Solicitation: DACW29-94-B-0047

FSC Class: Y260

<u>Bidder No.</u>	<u>Response</u>	<u>Vendor ID</u>	<u>Name/Address</u>
101	No	00000949	Pentzien, Inc. 6969 Grover St. Omaha NE 68106
102	No	00000952	Rebel Contractors, Inc. P.O. Box 1535 Alvin TX 77512
103	No	00000953	Reed Crushed Stone Co., Inc. P.O. Box 35 Gilbertsville KY 42044
104	No	00000954	River Road Construction, Inc. P.O. Box 1406 Mandeville LA 704701406
105	No	00000955	Ryan Incorporated Central P.O. Box 206 Janesville WI 53547
106	No	00000974	Zaval-Tex Construction Co. 5480 Wa. Blvd. Beaumont TX 77707
107	No	00000976	Tola Asphalt Pavers, Inc. P.O. Box 5457 Texarkana TX 75505
108	No	00000984	Grillot Co., Inc. 2608 Engineers Rd. Belle Chasse LA 70037
109	No	00001054	Andrew A. Cheramie Marsh Bug. Route 3 Box 1050 Cutoff LA 70345
110	No	00001159	Wilco Marsh Buggies & Drag.Inc 1304 MacArthur Ave. Harvey, LA 70058

Solicitation: DACW29-94-B-0047

FSC Class: Y260

Bidder No.	Response	Vendor ID	Name/Address
111	No	00001169	W.A. Ellis Constr. Co. 21500 East 24 Highway Independence, MO 64056
112	No	00001225	BURKO CONSTRUCTION INC 4901 MUSIC STREET NEW ORLEANS LA 701225119
113	No	00001232	McMillion Dozer Service, Inc. 11204 Jefferson Highway River Ridge LA 70123
114	No	00001244	Theta II Enterprises, Inc. 206 Industrial Ave. C. Houma LA 70363
115	No	00001251	Metric Constructors, Inc. P.O. Box 52147 Jacksonville, FL 322012147
116	No	00001259	Angelo Iafrate Const. Co. 26400 Sherwood Warren, MI 48091
117	No	00001261	Erosion Control, Inc. P.O. Box 73581 Houston, TX 77273
118	No	00001278	NICOLON CORPORATION 3500 PARKWAY LANE SUITE 500 NORCROSS GA 30093
119	No	00001294	Syro Steel Company 1170 N. State St. Girard, OH 44420
120	No	00001344	B&K Construction 1905 Highway 59 Mandeville LA 70448

Solicitation: DACW29-94-B-0047

FSC Class: Y260

<u>Bidder No.</u>	<u>Response</u>	<u>Vendor ID</u>	<u>Name/Address</u>
121	No	00001350	Geo-Con, Inc./ Pennsylvania 4075 Monroeville Blvd Corporate 1 bldg. 2 Suite 400 Monroeville PA 15146
122	No	00001356	Reinforced Earth Co 1909 Central Dr.Suite200 Bedford TX 76021
123	No	00001358	Stelly Construction, Inc. P.O. Box 46 Arnaudville LA 70512
124	No	00001384	R.M. Walker Constr. Co. 5670 Haynes Blvd. New Orleans LA 70126
125	No	00001385	TERRYCO BUILDERS INCORPORATED 208 WEST MISSISSIPPI STREET RUSTON LA 71273
126	No	00001393	McCleary & Werchan Contractors P.O. Box 3562 Morgan City, LA 70381
127	No	00001433	Bayou Land & Marine Contractor 1018 Victory Dr. Westwego LA 70094
128	No	00001442	Durocher Dock & Dredge, Inc. 958 N. Huron Street Cheboygan MI 49721
129	No	00001448	SBA/M A BAHETH CONST CO INC P.O. BOX 45849 BATON ROUGE LA 70895
130	No	00001463	Diving Services International P.O.Box 2853, 1001 Parker Blvd Hammond LA 70404

Solicitation: DACW29-94-B-0047

FSC Class: Y260

<u>Bidder No.</u>	<u>Response</u>	<u>Vendor ID</u>	<u>Name/Address</u>
131	No	00001469	Byron E. Talbot Contractor, Inc P.O. Box 5658 Thibodaux LA 70302
132	No	00001502	Cirlot Co. 1204-B Engineers Rd. Belle Chase LA 70037
133	No	00001503	COLE'S CONSTRUCTION COMPANY 2036 WOODDALE BOULEVARD BATON ROUGE LA 70806
134	No	00001506	Stewart Constr. Co., Inc. 1040 Peters Rd. Harvey LA 70058
135	No	00001513	A. Boland Construction Co. 4668 Werner Dr. New Orleans, LA 70126
136	No	00001517	BETHLEHEM STEEL CORP 501 E THIRD ST RM 463 SPDO BETHLEHEM PA 180167699
137	No	00001543	Ellis Construction PO Box 871 Columbus MS 39703
138	No	00001544	Garner Construction Co., Inc. P.O. Box 658 Barling, AR 72923
139	No	00001555	Naylor Pipe Co. 1230 East 92nd St. Chicago IL 60619
140	No	00001579	Metric Consturctors, Inc. 6135 Park South Drive ATTN: Heavy Division Charlotte NC 28210

Solicitation: DACW29-94-B-0047

FSC Class: Y260

<u>Bidder No.</u>	<u>Response</u>	<u>Vendor ID</u>	<u>Name/Address</u>
141	No	00001597	Soletanche, Inc. 2824 W. Walnut St. Rogers AR 727560335
142	No	00001612	Plaquemine Contracting Co. Inc P.O. Box 2704 Morgan City LA 70381
143	No	00001615	Atlas Construction Co., Inc. P.O. Box 1260 Ruston, LA 71273
144	No	00001665	JOHNNY F SMITH/TRUCK AND DRAGLINE SERVICE PO BOX 1115 SLIDELL LA 70459
145	No	00001701	SBA/Firth Construction Co. Inc 8350 One Calais Baton Rouge LA 70809
146	No	00001707	Industrial Gravel Contrs of LA P.O. Box 80840 Baton Rouge, LA 70898
147	No	00001780	T.L. JAMES & CO., INC. P.O. Box 20115 New Orleans LA 701410115
148	No	00001800	Clement Brothers Company P. O. Box 1628 Hickory NC 28603
149	No	00001802	Hardy Construction Company P. O. Box 13276 Maumelle AR 72113
150	No	00001818	Johnson Bros. Corporation South Hwy. 22 Litchfield MN 55355

Solicitation: DACW29-94-B-0047

FSC Class: Y260

<u>Bidder No.</u>	<u>Response</u>	<u>Vendor ID</u>	<u>Name/Address</u>
151	No	00001836	Crain Brothers, Inc. P.O. Box 118 - Hwy. 82 Grand Chenier, LA 70643
152	No	00001846	CONSTRUCTION INDUSTRY ASSOC. OF NEW ORLEANS 3801 CANAL STREET NEW ORLEANS LA 70119
153	No	00001911	Harvey Honore Constr. Co., Inc. 10840 Highland Rd. Baton Rouge, LA 70810
154	No	00001912	Design Consortium Const., Inc. 5015 Magazine St. New Orleans, LA 701151795
155	No	00001971	L & A Contracting Co. P.O. Box 16749 Hattiesburg, MS 39407
156	No	00001985	Deluxe Contractors, Inc. P.O. Box 1087 Hwy. 31 North Breux Bridge LA 70517
157	No	00002096	DRAGON LIMITED INCORPORATED 2714 Independence St. Metairie LA 70006
158	No	00002137	Biloxi Prestress Concrete, Inc 215 Michael Industrial Blvd. Biloxi MS 39530
159	No	00002266	Avisco, Inc. ATTN: Avis A. Phillips P. O. Box 51683 Knoxville TN 379501683
160	No	00002317	Beverly Industries, Inc. P.O. Box 9016 Bridge City LA 70094

Solicitation: DACW29-94-B-0047

FSC Class: Y260

<u>Bidder No.</u>	<u>Response</u>	<u>Vendor ID</u>	<u>Name/Address</u>
161	No	00002331	Blurton Banks & Assoc., Inc. P.O. Box 12448 Jackson MS 392112448
162	No	00002370	Summit Construction, Co., Inc. 134 (R) Keller St. West Monroe LA 71292
163	No	00002426	F. H. Myers Const. Corp. 273 Plauche St. Harahan LA 70123
164	No	00002427	M&H Builders, Inc. P.O. BOX 39 Vacherie LA 700900039
165	No	00002428	J. Caldarera & Co., Inc. 201 Woodland Drive LaPlace LA 70068
166	No	00002500	C & C Marine, Inc. PO Box 1555 LaPlace LA 70069
167	No	00002527	V. Keeler & Company, Inc. P.O. Box 3424 New Orleans LA 70177
168	No	00002556	Contech Construction Products 2121 NORTH CAUSEWAY BLVD SUITE 150 METAIRIE LA 70001
169	No	00002565	WOODSON CONSTRUCTION CO., INC. P.O. Box 80337 Lafayette LA 70598
170	No	00002608	Valve Systems & Controls 11800 Industrial Blvd. #1 Baton Rouge LA 70809

Solicitation: DACW29-94-B-0047

FSC Class: Y260

<u>Bidder No.</u>	<u>Response</u>	<u>Vendor ID</u>	<u>Name/Address</u>
171	No	00002641	Economy Grassing Rt. 2, Box 2351 Ethel LA 70730
172	No	00002795	Earnest Morris Builders 3320 Edenborn Ave #1175 Metairie LA 700023321
173	No	00002884	Carlucci Construction Co. Inc 401 Meadow Street Cheswick PA 150241216
174	No	00003056	Reinforced Earth Co. 8614 Westwood Center Dr. #1100 Vienna VA 221822233
175	No	00003065	Ground Improvement Tech., Inc. 3285 Boggy Creek Road Kissimmee FL 34744
176	No	00003158	William S. Walter Const. Co 6124 Camp Street New Orleans LA 70118
177	No	00003162	G and A Trucking Company 14767 Lannette Detroit MI 48213
178	No	00003187	Biagas Enterprises PO Box 8681 New Orleans LA 70182
179	No	00003209	Southwind Construction Corp. 14649 Highway 41 North Evansville IN 47711
180	No	00003217	Maverick Construction, Inc. PO Box 21 Rosa LA 71364

Solicitation: DACW29-94-B-0047

FSC Class: Y260

<u>Bidder No.</u>	<u>Response</u>	<u>Vendor ID</u>	<u>Name/Address</u>
181	No	00003270	Blain Sand and Gravel, Inc. 812 N. President Street Jackson MS 39202
182	No	00003340	Saba Dredging Co., Inc. PO Box 363 Westwego LA 700960363
183	No	00003353	TERRA AQUA GABIONS P.O. Box 7546 RENO NV 89510
184	No	00003355	Ebasco Constructors, Inc. 400 West Grove St., Suite 300 Bellevue WA 980044405
185	No	00003357	Lee Kerby & Sons of La., Inc. Rt. 3, Box 155 Coushatta LA 71019
186	No	00003396	Baton Rouge Services, Inc. 8644 Briarwood Place Baton Rouge LA 70809
187	No	00003400	Elmo Green and Sons, Inc. PO Box 730 London KY 40741
188	No	00003404	BACHY, INCORPORATED 67 S. Bedford St., Ste. 400 W Burlington MA 01803
189	No	00003434	Westhill Terrace, Inc. P.O. Box 546 Cleburne TX 76031
190	No	00003478	Hammet Company, Inc. PO Box 992 Paducah KY 420020992

Solicitation: DACW29-94-B-0047

FSC Class: Y260

<u>Bidder No.</u>	<u>Response</u>	<u>Vendor ID</u>	<u>Name/Address</u>
191	No	00003506	River Equipment Company, Inc. PO Box 672 (609 Military) Benton AR 72015
192	No	00003513	Veronica Industries PO Box 641205 Kenner LA 70064
193	No	00003522	PCL Enterprises, Incorporated 2000 S. Colorado Blvd, Ste 400 Denver CO 80222
194	No	00003548	Construction Concepts, Inc. P.O. Box 970 Jeanerette LA 705440970
195	No	00003549	Construction Concepts, Inc. PO Box 970 Jeanerette LA 70544
196	No	00003616	Eustis Engineering 3011 28th Street Metairie LA 70002
197	No	00003637	Reece Contracting Co., Inc. P.O. Box 445 Hughes AR 72348
198	No	00003705	Balfour Beatty Const., Inc. 200 Bellevue Pkwy., Ste. 140 Wilmington DE 19809
199	No	00003713	SEC Electrical Contractor PO Box 8687 Metairie LA 70011
200	No	00003726	Earth Materials Testing Co, Inc Rt 3, Box 130 Arkadelphia AR 719230130

Solicitation: DACW29-94-B-0047

FSC Class: Y260

<u>Bidder No.</u>	<u>Response</u>	<u>Vendor ID</u>	<u>Name/Address</u>
201	No	00003738	Richard Price Contracting Co 25509 Walker S. Road Denham Springs LA 70726
202	No	00003747	Fortmayer Bushhog Service 11208 Willow Drive New Orleans LA 70131
203	No	00003774	B&S Equipment Co., Inc. 1713 Winchester Place Harvey LA 70058
204	No	00003792	Havon, Incorporated P.O. Box 19450 Houston TX 77224
205	No	00003793	G W Contractors, Inc. PO Box 23736 Harahan LA 70183
206	No	00003801	MGG PIPE & SUPPLY CO., INC. 228 St. Charles Ave, Ste 1136 New Orleans LA 70130
207	No	00003803	R-R CONTRACTORS INCORPORATED 2240 TOWER DRIVE DENJAM SPRINGS LA 70726
208	No	00003810	Amigo Marine Dredging, Inc. 3325 Galan Drive Kenner LA 70065
209	No	00003819	Sun Belt Builders, Inc. P.O. Box 236 Watson LA 70786
210	No	00003821	Paul Laine Company PO Box 11121 New Iberia LA 70562

Solicitation: DACW29-94-B-0047

FSC Class: Y260

<u>Bidder No.</u>	<u>Response</u>	<u>Vendor ID</u>	<u>Name/Address</u>
211	No	00003840	P. R. Contractors, Inc. 7465 Exchange Place, Ste. A Baton Rouge LA 70806
212	No	00003841	JOHNSON BROS CORP OF LA 2002 20TH STREET SUITE B-101 KENNER LA 700626289
213	No	00003847	INGRAM BARGE COMPANY AND INGRAM AGGREGATES 2011 ENGINEERS ROAD BELLE CHASSE LA 70037
214	No	00003912	LMB Excavating Contractors Inc Rt. 1, Box 530 Belle Chasse LA 70037
215	No	00003922	L. W. Matteson, Inc. #1 South Point Burlington IA 52601
216	No	00003923	COVE EQUIPMENT INCORPORATED 5687 MAIN HIGHWAY ST. MARTINVILLE LA 70582
217	No	00003972	R. J. Daigle & Sons Contr Inc PO Box 2134 Kenner LA 700622134
218	No	00003999	GABIONS LEMAC INCORPORATED PO BOX 160667 MOBILE AL 36616
219	No	00004020	Dinvaut & Associates Company 2534 Deers Street New Orleans LA 70117
220	No	00004145	Phylco Construction, Inc. 1072-A Highway 1 Thibodaux LA 70301

Solicitation: DACW29-94-B-0047

FSC Class: Y260

<u>Bidder No.</u>	<u>Response</u>	<u>Vendor ID</u>	<u>Name/Address</u>
221	No	00004162	American Excelsior Co. P.O. Box 10532 New Orleans LA 70181
222	No	00004198	Thigpen Construction Co., Inc. P.O. Box 810 St. Rose LA 70087
223	No	00004199	Anthony Resignola Const., Inc. PO Box 1520 Morgan City LA 70381
224	No	00004214	Costanza and Sons, Inc. 428 John Hopkins Drive Kenner LA 70065
225	No	00004273	Settoon Construction, Inc. 4601 Highway 70 Pierre Part LA 70339
226	No	00004353	Korte-Plocher Constr. Co., Inc P.O. Box 38 Highland IL 62249
227	No	00004354	Knowles Material Co. P. O. Box 1096 Jackson MS 39205
228	No	00004355	Talen's Marine & Fuel, Inc. HCR 63 Box 194-B Lake Arthur LA 70549
229	No	00004411	Cormier Shoring&Equipment Co. P.O. Box 220 Breux Bridge LA 70517
230	No	00004433	Jackson Ready-Mix Concrete, Inc 100 West Woodrow Wilson Ave Jackson MS 39213

Solicitation: DACW29-94-B-0047

FSC Class: Y260

<u>Bidder No.</u>	<u>Response</u>	<u>Vendor ID</u>	<u>Name/Address</u>
231	No	00004481	M & M Construction Co. 810 Eighth St. Norco LA 70079
232	No	00004552	Anderson Columbia Env., INC. P.O. Box 1386 Lake City FL 320561386
233	No	00004555	Northeast Miss. Limestone PO Box 807 Iuka MS 388520807
234	No	00004556	RTL Corporation P.O. Box 277 Norco LA 70079
235	No	00004558	C&N Construction Co., Inc. Rt. 1, Box 98 Falkner MS 38629
236	No	00004574	Jim Smith Contracting Co., Inc Route 1, Box 27 Grand Rivers KY 42045
237	No	00004575	Howard & Son Construction Co. Box 268 St Francisville LA 70775
238	No	00004588	G & L Contractors, Inc. P.O. Box 1736 Vicksburg MS 39181
239	No	00004592	Luhr Brothers, Incorporated P.O. Box 7886 Alexandria LA 713060886
240	No	00004660	Broome Construction, Inc. P.O. Box 16147 Hattiesburg MS 394046147

Solicitation: DACW29-94-B-0047

FSC Class: Y260

<u>Bidder No.</u>	<u>Response</u>	<u>Vendor ID</u>	<u>Name/Address</u>
241	No	00004662	T. Baker Smith & Son, Inc. P.O. Box 2266 Houma LA 70361
242	No	00004682	CC and S Corporation 2036 Betty Boulevard Marrero LA 70072
243	No	00004704	Gulf South Pil. & Constr. Inc. 1250 L&A Road Metairie LA 70001
244	No	00004725	Danny Creech & Sons Rt. 1, Box 205 Oak Grove LA 71263
245	No	00004726	Contours Unlimited, Inc. 135 Horseshoe Road Schriever LA 70395
246	No	00004779	Construction Aggregate Supply P.O. Box 23810 Harahan LA 70183
247	No	00004789	Hamp's Enterprises, Inc. 1816 N. Claiborne Avenue New Orleans LA 70116
248	No	00004882	Big River Industries, Inc. PO Box 66377 Baton Rouge LA 70896
249	No	00004896	Potashnick Construction, Inc. Hwy. 74 West, P.O. Box 190 Cape Gireadeau MO 637020190
250	No	00004905	John Ewing Construction, Inc. PO Box 130 Pointe Coupee Parish Morganza LA 70759

Solicitation: DACW29-94-B-0047

FSC Class: Y260

<u>Bidder No.</u>	<u>Response</u>	<u>Vendor ID</u>	<u>Name/Address</u>
251	No	00004931	Cameron Construction Co., Inc. P.O. Box 722 Cameron LA 70631
252	No	00005075	VULCAN/ICA 15000 INTRACOASTAL DRIVE NEW ORLEANS LA 70129
253	No	00005083	New Thought Finishing, Inc. 8266 Colony Court New Orleans LA 70126
254	No	00005131	Dumey Excavation Incorporated Rte 1, Box 90 Oran MO 63771
255	No	00005155	HUBCO INCORPORATED 4526 Office Park Dr. No. 8 Jackson MS 39206
256	No	00005171	REGINALD COOPER 2036 BETTY BOULEVARD MARRERO LA 700724614
257	No	00005189	J R AND R PO BOX 136 WALKER LA 70785
258	No	00005209	MAGNUM CONST/BILL ZEIGLER 4324 ARIZONA AVENUE KENNER LA 70065
259	No	00005284	A.E.S. CONSTRUCTION CO INC 7606 WESTBANK EXPRESSWAY MARRERO LA 70072
260	No	00005319	BERRY BROS GEN'L CONTRACTORS 1414 RIVER ROAD BERWICK LA 70342

Solicitation: DACW29-94-B-0047

FSC Class: Y260

<u>Bidder No.</u>	<u>Response</u>	<u>Vendor ID</u>	<u>Name/Address</u>
261	No	00005377	STRANCO INCORPORATED 70459 HIGHWAY 59 ABITA SPRINGS LA 70420
262	No	00005384	MCDONALD CONST INC OF SLIDELL PO BOX 5129 SLIDELL LA 70469
263	No	00005482	S E EROSION CONTROL INC 70291 F STREET COVINGTON LA 70433
264	No	00005502	Eastern Dredging & Constr, Inc P. O. Box 1263 Huntsville AL 35807
265	No	00005503	Sani Agri Service, Inc. 1420 W. Oak Eunice LA 70535
266	No	00005515	HAMILTON CONSTRUCTION COMPANY ATTN: BARRY HAMILTON ROUTE 1, BOX 161-B JONESVILLE LA 71343
267	No	00005530	WILSON MARSH EQUIPMENT COMPANY 1132 CHIPLEY STREET WESTWEGO LA 70094
268	No	00005578	MORRISON KNUDSEN CORPORATION ATTN: WILLIAM R CATLIN PO BOX 73 BOISE ID 83729
269	No	00005630	SHAPPERT ENGINEERING COMPANY PO BOX 1261 MORGAN CITY LA 70380
270	No	00005706	DIXIE LANDSCAPING & FENCING CO 3600 CASSITY ROAD SHREVEPORT LA 71107

Solicitation: DACW29-94-B-0047

FSC Class: Y260

<u>Bidder No.</u>	<u>Response</u>	<u>Vendor ID</u>	<u>Name/Address</u>
271	No	00005806	THOMAS SAND & GRAVEL CO INC RT 1 BOX 202T PINE GROVE LA 70453
272	No	00005836	VULCAN/ICA 15000 INTRACOASTAL DRIVE NEW ORLEANS LA 70129
273	No	00005843	CONTRACT DEWATERING SERVICES PO BOX 1 SARANAC MI 48881
274	No	00005863	ST MARTIN PARISH POLICE JURY PO BOX 9 ST MARTINVILLE LA 70583
275	No	00005906	CAMERON RENTAL EQUIPMENT RT 1, BOX 171 B CAMERON LA 70631
276	No	00005953	RANDALL AND SON'S INC 6850 CAROL PLANTATION ROAD THEODORE AL 36582
277	No	00005956	COOPER BEARING COMPANY 5795 THURSTON AVENUE VIRGINIA BEACH VA 23444
278	No	00006058	GREENCO MUD & RENTAL COMPANY ATTN: ROD RODRIGUES PO BOX 11652 NEW IBERIA LA 705621652
279	No	00006059	NICO SUPPLY CO., INC. ATTN: ROD RODRIGUES PO BOX 11555 NEW IBERIA LA 705021555
280	No	00006064	GEORGE F MARSHALL AND GORDON L BLACKWELL PO BOX 18447 RALEIGH NC 27619

Solicitation: DACW29-94-B-0047

FSC Class: Y260

<u>Bidder No.</u>	<u>Response</u>	<u>Vendor ID</u>	<u>Name/Address</u>
281	No	00006068	ENVIRONMENTAL DREDGING SERVICES INCORPORATED PO BOX 625 GRAMERCY LA 70052
282	No	00006074	FIRTH CONSTRUCTION CO INC 8350 ONE CALAIS PLACE BATON ROUGE LA 70809
283	No	00006109	LEE'S CONSTRUCTION 620 SERRAMONTE BLVD/#15 DALY CITY CA 94015
284	No	00006122	PLES JENNINGS JR/CONSTRUCTION 1740 HANO ROAD INDEPENDENCE LA 70443
285	No	00006125	HCI PUBLICATIONS 410 ARCHIBALD STREET KANSAS CITY MO 64111
286	No	00006163	DRAVO BASIC MATERIALS CONCORD ROAD/BOX 30 HOUMA LA 70360
287	No	00006324	BABIN TRUCKING SERVICE INC 113 PLYNOUTH STREET DENHAM SPRINGS LA 707262609
288	No	00006470	McKINLEY BULLDOZER AND TRUCKING SERVICE 1116 BEHRMAN AVENUE NEW ORLEANS LA 70114
289	No	00006597	CONERLY CORPORATION 7470 CAMBERLY DRIVE NEW ORLEANS LA 70128
290	No	00006701	A D BALLARD INCORPORATED 409 MCNABB STREET LAKE CHARLES LA 70601

Solicitation: DACW29-94-B-0047

FSC Class: Y260

<u>Bidder No.</u>	<u>Response</u>	<u>Vendor ID</u>	<u>Name/Address</u>
291	No	00006734	DEAN EQUIPMENT INCORPORATED 2212 WILTON STREET MARRERO LA 70072
292	No	00006751	RON ELDRIGE CONSULTING INC 213 SOUTH QUEENS DRIVE SLIDELL LA 70458
293	No	00006761	PORTADAM INCORPORATED 300 DAHLIA AVENUE WILLIAMSTOWN NJ 08094
294	No	00006838	RESEARCH CHEMICAL SERVICES, INC 2932 MONTERREY BLVD. SUITE 160 BATON ROUGE, LA 70814
295	No	00008201	REMIXER CONTRACTING CO., INC. 816 LOGANDALE ROAD HOUSTON, TX 77032
296	No	00008368	ORBICO INDUSTRIES INC. P.O.BOX 122 PRAIRIEVILLE, LA 70769
297	No	00008455	LA Dirt Haulers, Inc 121 Evia Lane Franklin LA 40538
298	No	00008458	Winford Co., Inc. P. O. Box 72250 330 Shed Road Bossier City LA 711722250
299	No	00008461	SHELBY STANGA 190 MIKE COOPER ROAD PONCHATOULA, LA 70454.
300	No	00008513	BIG O CONSTRUCTION CO INC P O BOX 2442 LAFAYETTE LA 705022442

Solicitation: DACW29-94-B-0047

FSC Class: Y260

<u>Bidder No.</u>	<u>Response</u>	<u>Vendor ID</u>	<u>Name/Address</u>
301	No	00008588	PITTMAN CONSTRUCTION CO INC PO BOX 8116 NEW ORLEANS LA 70182
302	No	00008589	EAGLE INDUSTRIAL CONST CORP PO BOX 1320 PRARIEVILLE LA 70769
303	No	00008599	TIC SOUTHEAT, INC. ATTN: BOB MARCEAUX 15881 AIRLINE HWY BATON ROUGE, LA 70817
304	No	00008622	Randex International 3425 Ridgelake Dr., Suite 101 Metairie LA 70002
305	No	00008623	Eagle Industrial Constr. Corp P. O. Box 1320 Prairieville LA 70769
306	No	00008645	Gates Construction Corp 208 Gates Road Little Ferry NJ 07643
307	No	00008664	Crowne Colony Builders, Inc. 122 Lisa Lane, Suite B Mandeville LA 70448
308	No	00008836	Summit-Beers Construction Co. P.O. Box 933 (411 N. Clarendon Avenue) Scottdale GA 30079
309	No	00008875	Daigle Bros. Construction 520 N. Hazel Sulphur LA 70663
310	No	00008876	Greathouse Const. Route 3 Box 301 Lake Charles LA 70605

Solicitation: DACW29-94-B-0047

FSC Class: Y260

Bidder No. -----	Response -----	Vendor ID -----	Name/Address -----
311	No	00008901	DIANNE'S CONSTRUCTION INC 25641 WALKER SOUTH RD/STE 6 DENHAM SPRINGS LA 70726
312	No	00008914	MS CONTRACTOR INCORPORATED 19550 FIFTH STREET PO BOX 278 CITRONELLE AL 36522
313	No	00008940	Scott Sander's Construction P.O. Drawer 391 Winnfield, LA 71483
314	No	00008941	J. A. Jones Construction Co. 6060 St. Albans St. Charlotte, NC 28287
315	No	00008943	Commercial Renovations 2233 Piedmont St. Kenner LA 70062
316	No	00008956	Modular Gabion Systems, Inc. P. O. Box 160667 Mobile, AL 366161667
317	No	00008957	EnviroMed Companies, Inc. Attn: Jeff D. Lindley 1874 Dallas Dr. Baton Rouge LA 70806
318	No	00008962	C.R. Pittman Construction Co. 3021 Franklin Ave. New Orleans LA 70122
319	No	00008970	Advance Service of America, P.O. Drawer 2525 Morgan City, LA 70381
320	No	00008980	Boscart Construction, Inc. 4046 Chancery Court N.W. Washington DC 20007

Solicitation: DACW29-94-B-0047

FSC Class: Y260

<u>Bidder No.</u>	<u>Response</u>	<u>Vendor ID</u>	<u>Name/Address</u>
321	No	00008983	GNG Construction 2840 Idaho Ave., Suite 115 Kenner LA 70062
322	No	00008986	Peter Judlin Inc. 10020 Old Gentilly Rd. New Orleans LA 70127
323	No	00008988	Mahab Construction Co., Inc. P.O. Box 2889 Covington LA 70434
324	No	00008990	Weststar Construction, Inc. 9345 Pettit Rd Baker LA 70714
325	No	00008991	The Finney Company, Inc. 348 Aero Drive P. O. Box 7795 Shreveport LA 711377795
326	No	00008992	Sweet Magnolia Landscaping Inc 5161 Baccich Street New Orleans LA 70122
327	No	00008993	Prible Construction 920 1/2 Opelousas Ave. New Orleans LA 70114
328	No	00008994	COBO SERVICES INCORPORATED 3805 HARING ROAD METAIRIE LA 70006
329	No	00008996	Leon Duplessis & Sons, Inc. P. O. Box 184 Belle Chasse LA 70037
330	No	00009018	Stelly Construction, Inc. P. O. Box 46 Arnaudville, LA 70512

Solicitation: DACW29-94-B-0047

FSC Class: Y260

Bidder No.	Response	Vendor ID	Name/Address
331	No	00009019	Sevenson Environmental Serv. 4521 Jamestown Ave., Suite 6 Baton Rouge LA 70808
332	No	00009025	ELECTRO-MAPPING #1 MEADOW BLVD/APT #124 SLIDELL LA 70460
333	No	00009036	Gulf Construction Group, Inc 1654 East 5th Street Panama City FL 32401
334	No	00009037	Blanco Excavation Contractors P. O. Box 74015 Metairie LA 70003
335	No	00009038	Xklen Corp 6300 Richmond #207 Houston TX 77057
336	No	00009043	Garden Genie 100 John Wild Rd Ponchatoula LA 70454
337	No	00009044	West & Assoc. International 2351 Energy Dr., Suite 3008 Baton Rouge LA 70808
338	No	00009047	G&E Engineering, Inc 4915 S.Sherwood Forest Blvd. Baton Rouge LA 70816
339	No	00009055	EMILE MARCHIVE P.O. BOX 15 WAKEFIELD LA 70784
340	No	00009058	Davis Truck Service, Inc. 1518 Cypremort Road Jeanerette LA 70544

Solicitation: DACW29-94-B-0047

FSC Class: Y260

Bidder No.	Response	Vendor ID	Name/Address
341	No	00009080	Coastal Environment Specialist Morgan "Chip" Vosburg P.O. Box 80011 Lafayette LA 705980011
342	No	00009082	Gulf Coast Trailing/Great Lakes Dredge & Dock-Joint Venture P.O. Box 20116 New Orleans LA 701410116
343	No	00009131	Alpha Mid-South, Inc. attn: William B. Moran, Sr. 3200 Concordia Ave Monroe LA 71201
344	No	00009153	Phylway Construction Inc. 1401 A Hwy 3185 Thibodaux LA 70301
345	No	00009156	East Arkansas Contractors, Inc P.O. Box 2513 West Helena AR 723900513
346	No	00009157	Jay Bearden Const. P.O. Box 5459 Pearl MS 39208
347	No	00009159	C.H. Heist Corporation attn: Glenn Webster 17830 Sotiles Lane Baton Rouge LA 70809
348	No	00009164	Southeast Contractors, Inc. P.O. Box 696 Greensburg LA 70441
349	No	00009190	F.G. Sullivan, Jr., P.O. Box 15196 Baton Rouge, LA 70895
350	No	00009191	Triple A Construction Company P.O. box 87 Old Hooker Road Silver Creek MS 39663

Solicitation: DACW29-94-B-0047

FSC Class: Y260

<u>Bidder No.</u>	<u>Response</u>	<u>Vendor ID</u>	<u>Name/Address</u>
351	No	00009193	Choctaw Transportation Co. P.O. Box 585 1307 East Court St. Dyersburg TN 38024
352	No	00009194	Edward Kraemer & Sons, Inc. 1020 W. Cliff Road Attn: Craig Meyn Burnsville, MN 55337
353	No	00009195	Southeast Contractors, Inc P.O. Box 696 Hwy 1042 West Greensburg LA 70441
354	No	00009273	CRAZY HORSE CONSTRUCTION CO P.O. BOX 326 FRANKLIN LA 70538
355	No	00009292	BRADLEY INDUSTRIAL TEXTILES, INC. P.O. BOX 254 VALPARAISO FL 32580
356	No	00009315	CASTEEL GROUP 126 TCHEFUNCTE DRIVE COVINGTON LA 70433
357	No	00009335	Louisiana Remediation Co. Attn: Reuben Ruiz 2932 Monterry Blvd., Suite 160 Baton Rouge LA 70814
358	No	00009352	CENTRAL INDUSTRIES INC PO BOX 1100 SCOTT LA 705831100
359	No	00009361	CUDD PRESSURE CONTROL INC PO BOX 1801 ELK CITY OK 73648
360	No	00009373	M.R> Dillard Construction P.O. Box 90446 Nashville TN 372090446

Solicitation: DACW29-94-B-0047

FSC Class: Y260

Bidder No. -----	Response -----	Vendor ID -----	Name/Address -----
361	No	00009417	Walter Toebe Construction Co 29001 Wall St. P. O. Box 407 Wixom MI 483930407
362	No	00009419	GEO-CON, Inc 1720 Westminister Denton TX 76205
363	No	00009423	People Construction Inc. 1905 N. MacArthur Dr. Alexandria LA 71301
364	No	00009424	Marine Contracting Corp. P. O. Box 44052 Lorain OH 44052
365	No	00009425	River City Railroad Contractor 3174 Park Ave Memphis TN 38111
366	No	00009427	Operational Technologies Corp 4100 N.W. Loop 410, Suite 230 San Antonio TX 782294253
367	No	00009435	Waste-Tech Services, Inc. 5959 Corporate Dr. Houston TX 77036
368	No	00009447	M.A. Baheth & Co., Inc. 7600 Airline Hwy Baton Rouge LA 70815
369	No	00009479	Roy Bailey Construction, Inc. P. O. Box 117 Creole, LA 70632
370	No	00009521	THORNTON COMPANY P. O. BOX 640271 KENNER LA 70064-0271

Solicitation: DACW29-94-B-0047

FSC Class: Y260

Bidder No. -----	Response -----	Vendor ID -----	Name/Address -----
371	No	00009549	BARRY CONCRETE CO. P. O. BOX 2998 LAFAYETTE LA 70502
372	No	00009556	PROFESSIONAL TECH SUPPORT SERV., INC. P. O. BOX 3414 BATON ROUGE LA 70821
373	No	00009557	L&A CONTRACTING CO. P.O. BOX 16749 HATTISBURG MS 39404-6749
374	No	00009567	MATERIALS MANAGEMENT GROUP, INC. 3520 GENERAL DEGAULLE DR., SUITE 3010 NEW ORLEANS LA 70114
375	No	00009577	PROFESSIONAL SERVICE INDUSTRIES, INC. 510 EAST 22ND STREET LOMBARD IL 60148
376	No	00009631	JONES BROS., INC. P.O. BOX 727 MT. JULIET TN 37122
377	No	00009702	PHYLWAY CONSTRUCTION, INC. 1401 A HWY 3185 THIBODAUX LA 70301
378	No	00009797	WESTWOOD, INC. 1610 W. CHURCH ST. HAMMOND LA 70401-2909
379	No	00009798	LAINE CONSTRUCTION CO. INC. P. O. BOX 80337 LAFAYETTE LA 70398-2909
380	No	00009899	SALVATION SERVICES, INC. P. O. BOX 7205 NEW ORLEANS LA 70186-7205

Solicitation: DACW29-94-B-0047

FSC Class: Y260

Bidder No.	Response	Vendor ID	Name/Address
------------	----------	-----------	--------------

Total vendors in bidders mailing list 380

The following individual certifies that he/she has reviewed the List of Parties Excluded from Federal Procurement or Non-Procurement Programs dated _____. Any vendors on this BML that appear on the List have been annotated and no solicitations have been issued to those vendors.

Date: _____

Signature: _____
Sheila W. Enclade
Contract Specialist
sc1



DEPARTMENT OF THE ARMY

NEW ORLEANS DISTRICT CORPS OF ENGINEERS

P.O. BOX 60267

NEW ORLEANS, LOUISIANA 70160-0267

REPLY TO
ATTENTION OF:

March 28, 1994

ADVANCE NOTICE TO BIDDERS
INVITATION NO. DACW29-94-B-0047
SUPPLEMENT NO. 1

LAKE PONTCHARTRAIN, LA & VICINITY, LONDON AVENUE
OUTFALL CANAL, PARALLEL PROTECTION, MIRABEAU AVENUE
TO LEON C. SIMON BLVD., EAST SIDE, & MIRABEAU AVENUE
TO ROBERT E. LEE BLVD., WEST SIDE, ORLEANS PARISH, LA

NOTICE TO PROSPECTIVE BIDDERS

Reference is made to Pre-Solicitation Notice dated February 3, 1994.

Block #3 - Date Solicitation Documents Available (Approx.), is changed from "11 March 1994" to "18 April 1994".

Block #4.B. - Offers To Be Received By Date, is changed from "12 April 1994" to "18 May 1994".

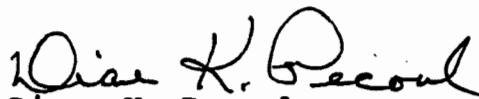
Diane K. Pecoul
Chief, Construction
Service Branch

PRE-SOLICITATION NOTICE (Construction Contract)	1. PROJECT NO.	2. DATE OF NOTICE	3. DATE SOLICITATION DOCUMENTS AVAILABLE (Approx.)	FORM APPROVED OMB NO.
	DACW29-94-B-0047	02/03/94	03/11/94	9000-0037

Public reporting burden for this collection of information is estimated to average 10 minutes per response, including the time for reviewing instructions, searching existing data sources, gathering and maintaining the data needed, and completing and reviewing the collection of information. Send comments regarding this burden estimate or any other aspect of this collection of information, including suggestions for reducing this burden, to the FAR Secretariat (VRS), Office of Federal Acquisition and Regulatory Policy, GSA, Washington, D.C. 20405; and to the Office of Management and Budget, Paperwork Reduction Project (9000-0037), Washington, D.C. 20503.

NOTE: The project number in Items 1 and 16 may be the same as the Invitation or Proposal Number.

4. OFFERS TO BE RECEIVED BY (at place specified for receipt of offers)	A. TIME 1400 A.M. P.M.	B. DATE (Month, day, year) 04/12/94	5. TIME FOR COMPLETION (Calendar days) 540
6A. ISSUING OFFICE (Name, address, and ZIP code) US ARMY ENGR DIST NEW ORLEANS PO BOX 60267 NEW ORLEANS LA 70160-0267 Sheila W. Enclade SC1		7. PROJECT TITLE AND LOCATION Lake Pont, LA & Vicinity, London Ave Outfall Canal, Parallel Prot, Mirabeau Ave to Leon C Simon Blvd. E.B., & Mibabeau Ave to Robert E Lee Blvd., W.B., Orleans Parish, LA	
6B. ROOM NO. 172	6C. TELEPHONE NO. (Include area code) (504) 862-1514		

INSTRUCTIONS: a. Solicitation Documents will be issued upon receipt of your affirmative response to this Pre-Solicitation Notice by the DUE DATE set forth in Item 15. b. If a charge is required under Item 8A, your affirmative response must include a check or money order in the applicable amount, made payable to Agency (shown in Item 9). Refund (when specified in Item 8B) will be made upon your return of the bid documents in good condition, without marks, notes, or mutilations, within 20 calendar days after the final date for receipt of offers. c. The Issuing Office, at its discretion, may make bid documents available to plan members of the Associated General Contractors, Chambers of Commerce, Dodge Reports, and other similar contractors' commercial service facilities. d. Bid guarantee is required with any bid in excess of \$25,000. Bid guarantee shall be in the amount of 20 percent of the amount of the bid, or \$3,000,000, whichever is less. For bid guarantee purposes, the amount of the bid is the aggregate of the Lump Sum Base Bid, all Alternates (if any), and the product(s) of each unit price (if any) multiplied by the applicable number of units shown on the Bid Form. e. NOTICE TO SMALL BUSINESS FIRMS: A program for the purpose of assisting qualified small business concerns in obtaining certain bid, payment, or performance bonds that are otherwise not obtainable is available through the Small Business Administration (SBA). For information concerning SBA's surety bond guarantee assistance, contact your SBA District Office.

8A. CHARGE FOR SOLICITATION DOCUMENTS \$ 25.00	8B. IS THIS CHARGE REFUNDABLE? <input type="checkbox"/> YES <input checked="" type="checkbox"/> NO	9. MAKE CHECK PAYABLE TO: FAO, USAED, NO
10. ESTIMATED COST RANGE OF PROJECT A. FROM \$ 5,000,000.00 B. TO \$ 10,000,000.00		11. OFFERS COVERING THE PROJECT RESTRICTED TO SMALL BUSINESS? <input type="checkbox"/> YES <input checked="" type="checkbox"/> NO
13. DESCRIPTION OF WORK (Physical characteristics)		12. SUBCONTRACTING PLAN REQUIRED? <input checked="" type="checkbox"/> YES <input type="checkbox"/> NO

Consists of clearing; selective demolition; cutting existing steel sheetpiling; pulling, cleaning, & delivering existing steel sheetpiling; driving new steel sheetpiling; construction reinforced concrete I-wall on existing and new steel sheetpiling; constructing reinforced concrete slope pavement, driving steel sheetpiling under South Central Bell telephone cables and New Orleans Sewerage and Water Board 10 foot diameter siphon tube and 50 inch diameter discharge pipe; relocating Sewerage and Water Board feeder cable; modifying existing utilities; degrading existing levees; placing embankment; fertilizing, seeding and grubbing. \$50.00 f/scale, Unrestricted.

The Energy & Water Development Appropriations Act, 1993, (PL102-377, 2 Oct 92) directed that a continuing contract be awarded to undertake this work & its inclusion in future budgets is uncertain. If Congress does not appropriate funds in future fiscal years for such work, the contract may be terminated for the convenience of the Government.

PLEASE PROVIDE TELEPHONE NUMBER AND FAX NUMBER IN BLOCK 17.
(If additional space is needed use reverse)

IMPORTANT: FAILURE TO COMPLETE AND RETURN THIS PART OF THE NOTICE TO THE ISSUING OFFICE, ON OR BEFORE THE DUE DATE SHOWN IN ITEM 15, MAY RESULT IN YOUR NAME BEING REMOVED FROM OUR MAILING LIST.

14. ACTION REQUESTED (Check applicable box)		15. DUE DATE 03/11/94
A. I AM INTERESTED IN BIDDING ON THIS PROJECT AS A: <input type="checkbox"/> PRIME CONTRACTOR <input type="checkbox"/> PRINCIPAL SUBCONTRACTOR	B. I AM NOT INTERESTED IN BIDDING ON THIS PROJECT. RETAIN MY NAME ON YOUR MAILING LIST.	16. PROJECT NO. DACW29-94-B-0047
C. REMOVE MY NAME FROM YOUR MAILING LIST.		

17. NAME, ADDRESS (City, State, ZIP code), AND TELEPHONE NUMBER OF FIRM

18. NAME AND TITLE OF FIRM REPRESENTATIVE	19. SIGNATURE OF REPRESENTATIVE	20. DATE SIGNED
---	---------------------------------	-----------------

U.S. ARMY ENGINEER DISTRICT, NEW ORLEANS
CORPS OF ENGINEERS
P.O. BOX 60267
NEW ORLEANS, LA 70160-0267

CELMN-CT-CC

FIRST - CLASS MAIL
POSTAGE & FEES PAID
U.S. ARMY CORPS OF ENGINEERS
NEW ORLEANS DISTRICT
PERMIT NO. 80

OFFICIAL BUSINESS

MAIL TO:

ED000040310144

DAW29-94-B-0047

Mr. Andry/2713
18 Jan 94

CELMN-ED-DS

MEMORANDUM FOR C/Contracting Div

SUBJECT: Lake Pontchartrain, LA and Vicinity, London Ave. Outfall Canal, Parallel Protection, Mirabeau Ave. to Leon C. Simon Blvd., East Bank, and Mirabeau Ave. to Robert E. Lee Blvd., West Bank, Orleans Parish, LA ED-94-144

Please issue a preinvitation notice for the subject invitation pursuant to FAR 36.302, to all prospective bidders. The following information is furnished for your use in preparing the notice:

a. Description of Work: The work consists of clearing; selective demolition; cutting existing steel sheetpiling; pulling, cleaning, and delivering existing steel sheetpiling; driving new steel sheetpiling; constructing reinforced concrete I-wall on existing and new steel sheetpiling; constructing reinforced concrete slope pavement, driving steel sheetpiling under South Central Bell telephone cables and New Orleans Sewerage and Water Board 10 foot diameter siphon tube and 50 inch diameter discharge pipe; relocating Sewerage and Water Board feeder cable; modifying existing utilities; degrading existing levees; placing embankment; fertilizing, seeding, and grubbing; and all other work incidental thereto.

*all 7th
goes to
description*

The Energy and Water Development Appropriations Act, 1993, (PL 102-377, 2 Oct 92) directed that a continuing contract be awarded to undertake this work and its inclusion in future budgets is uncertain. If Congress does not appropriate funds in future fiscal years for such work, the contract may be terminated for the convenience of the Government.

b. Engineering Division will furnish the specifications on or about 18 Feb 94 for advertising on or about 11 Mar 94. Please advertise this job for a period of 30 days. Award is scheduled for May 94.

c. The estimated time of completion is 540 calendar days after receipt of notice to proceed.

d. The estimated cost is between \$5,000,000 and \$10,000,000.

e. The solicitation will include 74 drawings and specifications.

f. Reproduction and labor costs are chargeable to account no. BEC21 30J9 L1 01ML.

g. Wage rates were requested on 18 Jan 94.

Shells
Rec'd 1/20/94
A-5

CELMN-ED-DS

18 Jan 94

SUBJECT: Lake Pontchartrain, LA and Vicinity, London Ave. Outfall Canal, Parallel Protection, Mirabeau Ave. to Leon C. Simon Blvd., East Bank, and Mirabeau Ave. to Robert E. Lee Blvd., West Bank, Orleans Parish, LA ED-94-144

h. The work is included in the FY-94 Detailed Project Schedule (PB-2A) for "Lake Pontchartrain", (CYP) BEC00, page 50, line 118B, dated 1 Jan 94.

for Robert Augerix
W. EUGENE TICKNER
Chief, Engineering Division

CF:
C/Prog Mgmt Ofc
C/Engr Ctrl Br
C/Stru Des Sec
C/CELMN-PP

PROCUREMENTS

* US Army Engr Dist New Orleans, PO Box 60267, New Orleans La. 70160

SOFTSHARE Order Number: 940204-0134PROCURE
Y --- LAKE PONT, LA & VICINITY, LONDON AVE OUTFALL CANAL, PARALLEL PROT,
MIRABEAU AVE TO LEON C SIMON BLVD., E.B., & MIRABEAU AVE TO ROBERT E LEE,
W.B., ORLEANS PARISH, LA SOL DACW29-94-B-0047 DUE 031194 POC Contract
Specialist, Sheila Enclade, (504) 862-1514 Consists of clearing;
selective demolition; cutting existing steel sheetpiling; pulling,
cleaning, & delivering existing steel sheetpiling; driving new steel
sheetpiling; constructing reinforced concrete I-wall on existing and new
steel sheetpiling; constructing reinforced concrete slope pavement,
driving steel sheetpiling under South Central Bell telephone cables and
New Orleans Sewerage and Water Board 10 foot diameter siphon tube and 50
inch diameter discharge pipe; relocating Sewerage and Water Board feeder
cable; modifying existing utilities; degrading existing levees; placing
embankment; fertilizing, seeding, and grubbing. \$25.00 charge for plans
and specifications, \$5.00 charge for specifications only. Unrestricted.
The Energy and Water Development Appropriations Act, 1993, (PL 102-377,
2 Oct 92) directed that a continuing contract be awarded to undertake
this work and its inclusion in future budgets is uncertain. If Congress
does not appropriate funds in future fiscal years for such work, the
contract may be terminated for the convenience of the Government. (0033)

MATCHING KEY WORDS:

1. age:army
2. age:orleans
3. age:70160

A-4

MEMORANDUM FOR C/Contracting Div. ATTN: CELMN-CT-CC

SUBJECT: REVISED Liquidated Damages for London Ave Outfall Canal, Parallel Protection, Mirabeau Ave to Leon C. Simon, East Bank, Mirabeau Ave to Robert E. Lee, West Bank, Orleans Parish, LA

1. Estimated costs to the Government directly resulting from failure to meet the required date(s) are as follows:

a. Construction Division S&I/S&A Costs:		
(1) New Orleans Area Office (Cost Per Day):		\$426.70
(2) Contract Administration Branch (Cost Per Day):		
1 GS-12 1 Hr @ \$33.13		\$33.13
1 GS-09 1 Hr @ \$23.48		\$23.48
1 GM-13 1/3 Hr @ \$36.81		\$12.27
1 GM-14 1/4 Hr @ \$41.04		\$10.26
Technical Indirect Rate of Const. Div. Labor:		
52% x \$ District Labor		\$41.15
(3) NOD Overhead on Labor (Cost Per Day):		
Area Office Labor	\$377.75	
Contr Admin Branch Labor	\$79.14	
	Subtotal	\$456.89
District Overhead Rate	41%	\$187.32
		Subtotal \$734.31
b. Interest During Construction:		
(5.625% x 0.95 x \$10,000,000 / 365)		\$1,464.04
(Interest Rate x 0.95 x Est. Cost/365)		
		Subtotal \$2,198.35
c. Extraordinary O&M (Locks & Pumping Plants)		
O&M Structure - O&M Replaced Structure		
\$0	\$0	\$0.00
		Total \$2,198.35

2. The amount of \$2,195.00 per day is approved for use in the Special Clauses of the subject specifications.

3. POC relevant to this subject is Lee Guillory, x2934.

1 Encl
Area Office Costs

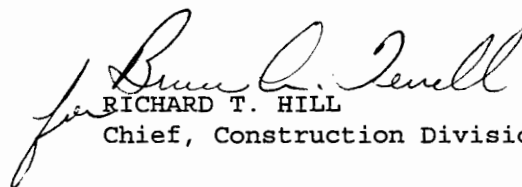
 RICHARD T. HILL
 Chief, Construction Division

A-2a

MEMORANDUM FOR Office of Counsel

SUBJECT: Lake Pontchartrain, LA and Vicinity, London Ave. Outfall Canal, Parallel Protection, Mirabeau Ave. to Leon C. Simon Blvd., East Bank, and Mirabeau Ave. to Robert E. Lee Blvd., West Bank, Orleans Parish, LA ED-94-144

1. Please obtain applicable wage rate determinations to be included in the subject solicitation. The estimated date for issuance of the solicitation is 11 Mar 94 and it is proposed to advertise for a period of 30 days. The estimated cost is approximately \$5,900,000.

2. The work consists of clearing; selective demolition; cutting existing steel sheetpiling; pulling, cleaning, and delivering existing steel sheetpiling; driving new steel sheetpiling; constructing reinforced concrete I-wall on existing and new steel sheetpiling; constructing reinforced concrete slope pavement, driving steel sheetpiling under South Central Bell telephone cables and New Orleans Sewerage and Water Board 10 foot diameter siphon tube and 50 inch diameter discharge pipe; relocating Sewerage and Water Board feeder cable; modifying existing utilities; degrading existing levees; placing embankment; fertilizing, seeding, and grubbing; and all other work incidental thereto.

3. The work is located in the metropolitan area of New Orleans.

W. EUGENE TICKNER
Chief, Engineering Division

CF:
C/Stru Des Sec
C/Contr Div

A-1d

CELMN-ED-DS

94-B-0047

Mr. Andry/2713
22 Feb 94

MMY

MEMORANDUM FOR Commander

SUBJECT: Lake Pontchartrain, LA and Vicinity, High Level Plan, London Ave. Outfall Canal, Parallel Protection, Mirabeau Ave. to Leon C. Simon Blvd., East Side, and Mirabeau Ave. to Robert E. Lee Blvd., West Side, Orleans Parish, LA ED-94-144

1. Attached for your review and approval are specifications for the subject work. Please note that the estimated cost for the subject work is over \$2.0 million (\$5,900,000). Although DIVR 1-1-3 and ER 1110-2-1200 delegate authority to the District Engineer (DE) to approve only plans and specifications for "all construction" costing less than \$2.0 million, Division has authorized DE approval (see attached memo) because these specifications have been through two levels of review, first by the A-E preparing the P&S, and secondly by New Orleans District.
2. All required reviews have been accomplished.
3. It is recommended that the specifications be approved.
4. Upon receipt of approval, it is proposed to advertise for bids for a period of 30 days.

Encl

for *Robert Augerius*
W. EUGENE TICKNER
Chief, Engineering Division

CF: C/Const Div

Rec'd 2-25-94

CELMN-DE 1st End

FOR C/Engr Div

Subject specifications have been approved.

Encl

for *Greg S. Kahr* LTC 00
MICHAEL DIFFLEY
Colonel, EN
Commanding

2/16



DEPARTMENT OF THE ARMY
LOWER MISSISSIPPI VALLEY DIVISION, CORPS OF ENGINEERS
P. O. BOX 80
VICKSBURG, MISSISSIPPI 39181-0080

REPLY TO
ATTENTION OF

CELMV-ED-TC (1105-2-10c)

01 OCT '93

MEMORANDUM FOR Commander, New Orleans District, ATTN: CELMN-ED-D

SUBJECT: Lake Pontchartrain, LA, and Vicinity, London Ave.
Outfall Canal, Parallel Protection, Mirabeau Ave. to Robert E.
Lee Blvd, East Side, Mirabeau Ave. to Leon C. Simon Blvd, West
Side, Orleans Parish, LA

1. Reference memorandum, CELMV-ED-T, 9 Mar 93, subject:
Approval of Plans and Specifications.

2. Being cognizant that the plans and specifications for the
subject work were prepared by an Architect-Engineer and that the
work is of a routine nature, the one level of review performed by
your office is considered to be sufficient. You are hereby
authorized to approve the subject plans and specifications.

FOR THE COMMANDER:

FRED H. BAYLEY III
Director of Engineering

MEMORANDUM FOR C/Contracting Div

SUBJECT: Lake Pontchartrain, LA and Vicinity, High Level Plan, London Ave. Outfall Canal, Parallel Protection, Mirabeau Ave. to Leon C. Simon Blvd., East Side, and Mirabeau Ave. to Robert E. Lee Blvd., West Side, Orleans Parish, LA ED-94-144

I certify that all appropriate biddability, constructibility, and operability comments received and reviewed by this office by 22 Feb 94 have been incorporated into the bid package. Feedback has been provided to reviewers for all non-incorporated comments. No significant changes have been made since the local review.

W. Eugene Tickner
W. EUGENE TICKNER
Chief, Engineering Division

Richard Hill
RICHARD HILL
Chief, Construction Division

CF:
C/Stru Des Sec
C/Const Div

*Read
2-23-94
JF*

A-16

7 Dec 93

MEMORANDUM FOR C/ Contracting Div

SUBJECT: Lake Pontchartrain, LA and Vicinity, London Ave. Outfall Canal, Parallel Protection, Mirabeau Ave. to Leon C. Simon Blvd., East Side, Mirabeau Ave. to Robert E. Lee Blvd., West Side, Orleans Parish, LA, Local Review Comments

1. Reference your local review comments on the subject job dated 8 Oct 93.
2. Enclosed is Burk-Kleinpeter's written responses to your comments.
3. Point of contact is Angela DeSoto, x2733.

Encl
as

W. EUGENE TICKNER
Chief, Engineering Division

A-16

CHAIRMAN OF THE BOARD
WM. R. "BIFF" BURK, III, PE
PRESIDENT
GEORGE C. KLEINPETER, JR., PE
SENIOR VICE PRESIDENTS
JAMES W. ARMBRUSTER
MICHAEL G. JACKSON, PE

WILLIAM R. BURK, JR. 1912-1986

BURK-KLEINPETER, INC.

ENGINEERS, ARCHITECTS, PLANNERS, ENVIRONMENTAL SCIENTISTS

4176 CANAL STREET
NEW ORLEANS, LOUISIANA 70119-5994

TELEPHONE (504) 486-5901

FAX (504) 488-1714

P. O. BOX 19087-NEW ORLEANS, LA. 70179

OVER 80 YEARS OF SERVICE

VICE PRESIDENTS

JOSEPH H. PRANGE, PE
BLAISE S. D'ANTONI, JR., PE
BRUCE L. BADON, AICP
OM P. DIXIT, PE
DALE R. JENSEN, PE
J. W. "BILL" GIARDINA, JR., PE

ENGINEERING ASSOCIATES

SURESH I. SHAH, PE
DANIEL S. CALUDA, JR.
LLOYD J. FITZPATRICK, JR.
HENRY M. PICARD, III, PE

PLANNING ASSOCIATES

PAUL L. WAIDHAS
RANDOLPH C. CARMICHAEL

ARCHITECTURE ASSOCIATE

BARRY SCAIRONO, AIA

November 30, 1993

Ref: London Ave. Canal Floodwalls
Contract No. 3
BKI Job Number 8407-08

A written response to the written 95% review comments from the Corps of Engineers.

I. Structural Design Comments.

1. Sheet pile design calculations for the entire project are submitted.
2. Since we are using PZ-22 sections for the tie-ins and for the siphon and discharge pipes, no separate design calculations are required. Separate reinforcement details are shown for the floodwall under siphon and discharge pipes.
3. Design calculations for the east and west side are checked and found consistent.
4. Concurred.
5. Specifications.
 - a. thru y. - Concurred.
6. Drawings.
 - a. thru k - Concurred.
 - l. Dwg. 38 - Casing will be extended up to elevation 14.40.
Therefore, no seal material is required for conduits.
 - m. Dwg. 39 - Concurred.
 - n. Dwg. 40 - #3 bars are used.
 - o. Dwg. 42 - All spliced are called out as "Permitted" on all drawings.
 - p. and q. - Concurred.

I. Structural Design Comments. (cont)

6. Drawings. (cont.)

- r. Dwg. 45 - S & WB requires a minimum distance of 3" between two clamps. The distance between the clamps satisfies this requirement. Also, the clearance between the feeders and the ladders is increased.
- s. Dwg. R4 - Concurred.
- t. Dwg. R2 and R3 - Concurred.
- u. Dwg. 55 - Fence posts will be secured cast-in-place to the I-wall.

II. CELMN-CT-CC Comments:

- 1 thru 7 - Concurred.

III. CELMN-CD-QM

Bidding Schedule

- 3. and 4. - Piling, steel sheet, Type PX-22 installed in full lengths or in segments is paid under one item.
- 5. thru 12. - Concurred.

SECTION C: Technical Specifications

- 13. thru 46. - Concurred.
- 47. - Does not Concur. FL-422 under siphon on west bank and FL-422 & FL-340 on east bank near Pumping Station No. 4 are encapsulated in concrete.

SECTION H: Special Clauses

- 48. - Does not Concur. Amount of liquidated damages to be filled in at the later date.
- 49. - Concurred.
- 50. - Does not Concur. See traffic control for details. Specific access are shown on the drawings.
- 51. and 52. - Concurred.
- 53. a. - Concurred.
- b. - Does not Concur. Do not want Contractor to damage existing homeowner's fence during construction. Therefore, safety fence is required to support hay bales and to protect existing homeowner's fence.
- 54. thru 56. - Concurred.

III. CELMN-CD-QM (cont.)

SECTION H: Special Clauses (cont.)

- 57. - Does not Concur. The Contractor is required to be in constant touch with the S & WB.
- 58. thru 64. - Concurred.

Drawings

- 65. - Concurred.
- 66. - Concurred. See typical sections for details.
- 67. - All of the existing sheet piles are structurally inadequate and do not meet the Government's Design Criteria.
- 68. - Concrete collars are required in order to protect the waterstop until the bridge closures are constructed in the future. The length of time is not known.

Drawings

- 69. - General Note 1.
Does not Concur. For this project, Contract No. 3, and also in COE Contract No. 2, azimuths are measured from the NORTH.
- 70. thru 72. - Concurred.
- 73. - Note has been added on Dwg. 6.
- 74. - Note has been added on typical sections. (East Side)
- 75. thru 88. - Concurred.
- 89. - Concurred. Posts shall be installed cast-in-place with I-Wall.
- 90. - The material available from levee excavation is unsuitable for embankment. An offsite borrow material section is included in the specifications.

IV. ED-FM (Gordon / Rome)

- 1. - Does not Concur. Paragraph C3A.4.4 mock-up-panel is deleted.
- 2. thru 7. - Concurred.
- 8. - Does not Concur.
- 9. thru 63. - Concurred.

IV. ED-FM (Gordon / Rome) (cont.)

- 64. - Does not Concur. London Drive is shown on the typical section on the east side from Robert E. Lee Blvd. to Leon C. Simon Blvd. This street may be damaged during construction and therefore, the "Incidental Paving" section is required.
- 65. thru 67. - Concurred.

V. CELMN-ED-DS

A

- 1. thru 3. - Concurred.
- 4. - Special Clauses: Does not concur with State Required Performance Bond. These requirements have been deleted at the request of Structural Design Section. "Stone Sources" are included.
- 5. - Concurred.

VI. CELMN-ED-DD/L

- 1. thru 5. - Concurred.
- 6. - H-6d Transportation Facilities. The use of Pratt Drive as vehicle access to the jobsite is still not verified. We are in contact with OLD & Dept. of Traffic of the City of New Orleans.
- 7. - Concurred.
- b. - Drawings: Concurred.

VII. CELMN-RE-AP

- 2. a, b. - Concurred.
- c. - Notes have been added in the plan drawings.
- d, e, f. - Concurred

8 October 1993

MEMORANDUM FOR: CELMN-ED

SUBJECT: Review of Plans and Specifications for London Ave. Outfall Canal, Parallel Protection, Mirabeau Ave. to Leon C. Simon Blvd., East Bank Mirabeau Ave. to Robert E. Lee Blvd., West Bank, Orleans Parish, LA

1. Plans and specifications for the subject job have been reviewed and the following are our comments.
2. Page B-1, estimated quantities are needed for items 0008 and 0015.
3. Page B-3, paragraphs b., 2nd line and c., 1st line, remove the AA behind the 0009.
4. Page C2A-5, paragraph C2A-7(3), delete this paragraph in its entirety. The NPDES Certification has been removed from Section K.
5. Page C2G-15, paragraph C2G-11.1, 4th line, "spuare" should read "square".
6. Page H-1, paragraph H-2a., leave dollar amount blank. This will be filled in at a later date when the liquidated damages are calculated for this job.
7. Page H-16, paragraph H-6, 3rd line, change "will" to "shall".
8. Attached for your information is a list of the clauses that will be put in Section I.
9. Contracting Division will put the updated clauses in Sections K and L.

FOR THE CHIEF, CONTRACTING DIVISION:

Diane K. Pecoul
Chief, Construction Service
Section

Enclosure

CF:
CELMN-CD-QR

ENCLOSURE
CELMN-CT-CC
PECUL
CELMN-CT-CC

MEMORANDUM FOR SEE DISTRIBUTION

SUBJECT: Review of Plans and Specifications for London Ave. Outfall Canal, Parallel Protection, Mirabeau Ave. to Leon C. Simon Blvd., East Bank, Mirabeau Ave. to Robert E. Lee Blvd., West Bank, Orleans Parish, LA

1. Please review the enclosed plans and specifications in sufficient detail to detect and correct errors or conflicts and return them at the earliest practicable date, but not later than 20 Sep 93, along with any comments and recommendations you consider necessary or desirable. All major comments on the drawings must be addressed in the responding memorandum. Only minor comments should be marked on the drawings.

3. The estimated cost is approximately \$ 10,000,000, beginning in fiscal year 94.

4. Charge all review work (except Cost Engineering Branch) to cost account no. BEC2130HZL10LML. Cost Engineering Branch's work is chargeable to account no. same as above.

5. In addition to the above:

a. Please send a copy of your review comments to Construction Division-Constructibility Review Section (CELMN-CD-QR) in addition to your normal distribution.

b. The Area Engineer will comply with paragraph 1-6.c.(3), Site Inspections, and paragraph 1-6.c.(4), Daily Cost of Inspection, of CDOM 1180-2-12, Office Memorandum for Supervision, Inspection, and Administration of Contracts, dated 15 May 1987.

c. Construction Division will include liquidated damage information.

d. Construction Division will initiate request (copy to Engineering Division) for authority to use Clause 52.236-16 ALT 1 in accordance with FAR 36.516.

e. (For Maintenance Dredging Projects Only) Operations and Readiness Division will include the status of compliance with Federal Regulation, Title 33 CFR, Part 209.145.

CELMN FL 622-R

3 Dec 92 (Edition of 1 May 91 is obsolete)

(Proponent:CELMN-ED-DS)

*Diane
Construc...*

CELMN-ED-DD

SUBJECT: Review of Plans and Specifications for London Ave.,
Outfall Canal, Parallel Protection, Mirabeau Ave. to Leon C.
Simon Blvd., East Bank, Mirabeau Ave. to Robert E. Lee Blvd.,
West Bank, Orleans Parish, LA

f. (X) Planning Division's review will include endangered
species, cultural resources, and EIS pertinent to these plans and
specifications.

g. (X) If forwarded to CELMV for review, Planning Division
will furnish data prescribed in paragraph 18(f) of CELMV
Supplement 1 dated 18 Jan 89 to ER 1110-2-1200.

h. () Cost Engineering Branch will include a statement
indicating the use of the Clause in DFARS 252.236-7004 (if
mobilization and demobilization exceeds \$50,000) and provide a
cost estimate based on the enclosed plans and specifications.

i. (X) Contracting Division, Construction Division, and
Operations and Readiness Division reviews will evaluate the
effectiveness of biddability, constructibility, and operability in
accordance with ER 415-1-11 and CELMV Suppl 1 to ER 415-1-11.

6. Point of contact is Walter Baomy, ext. 2656.



W. EUGENE TICKNER
Chief, Engineering Division

Encls

- Plng Div - 3 cyps plans & specs
- O&R Division - 2 cys ea encl
- Lafayette Area Office (ATTN: CELMN-CD-LA) - 5 cys encl
- Const Div - 3 cys ea encl (if job is for Lafayette Area Office)
- 8 cys ea encl (if job is for New Orleans Area Office)

DISTRIBUTION:

- C/CONST DIV
- C/O&R DIV
- C/PLNG DIV
- C/REAL ESTATE DIV
- C/CONTRACTING DIV
- C/SAF & OCC HEALTH OFF
- C/SEC OFFICE
- C/NOAO

(Page 2 of CELMN FL 622-R)

Jed

Mr. Terranova/2709
WAX 6 June 1994

CELMN-ED-DS

MEMORANDUM FOR C/Contracting Division

SUBJECT: Lake Pontchartrain, Louisiana and Vicinity, High Level Plan, London Avenue Outfall Canal, Parallel Protection, Mirabeau Avenue to Robert E. Lee Blvd., West Bank Floodwall; Mirabeau Avenue to Leon C. Simon Blvd. Floodwall, East Bank Floodwall; Orleans Parish, Louisiana ED-94-144

1. Please issue Amendment No. 0003 to Solicitation No. DACW29-94-B-0047, subject as above, as follows:

a. SPECIFICATIONS. Page C9A-27, Paragraph C9A-14. Delete paragraph C9A-14 in its entirety and substitute the following revised paragraph:

"C9A-14. MEASUREMENT AND PAYMENT. No measurement will be made for painting sheet piling. Payment for all painting work performed and for all materials furnished under the section of the specifications for painting sheet piling will be included in the contract lump sum price for "Painting". Price and payment shall constitute full compensation for furnishing all plant, labor, materials and equipment, including compliance with the safety and health provisions, all as specified herein."

B. DRAWINGS. No changes.

2. If practical, we request that the bid opening date of 15 June 1994 not be changed.

W. Eugene Tickner
W. EUGENE TICKNER
Chief, Engineering Division

CF:
C/Struc Des Sec
C/Cost Engr Br
C/Const Div
C/CELMN-PP (Broussard)

gat

Mr. Terranova/2709
1 June 1994

CELMN-ED-DS

MEMORANDUM FOR C/Contracting Division

SUBJECT: Lake Pontchartrain, Louisiana and Vicinity, High Level Plan, London Avenue Outfall Canal, Parallel Protection, Mirabeau Avenue to Robert E. Lee Blvd., West Bank Floodwall; Mirabeau Avenue to Leon C. Simon Blvd. Floodwall, East Bank Floodwall; Orleans Parish, Louisiana ED-94-144

1. Please issue Amendment No. 0002 to Solicitation No. DACW29-94-B-0047, subject as above, as follows:

A. SPECIFICATIONS.

(1) Page C2G-9

(a) Paragraph C2G-9.7.1. Delete paragraph C2G-9.7.1 in its entirety and substitute the following revised paragraph:

"C2G-9.7.1 Scope. The Contractor is advised that the Orleans Levee District will retain an independent testing laboratory to monitor vibrations during the pile driving operations. If more than one pile driving rig is in operation at anytime, each rig will be independently monitored. Vibration monitoring during the Contractor's other operations may be done at the discretion of the Orleans Levee District. ~~The Contractor shall order his operations to accommodate these activities of the Orleans Levee District.~~"

(b) Paragraph C2G-9.8.1. Delete paragraph C2G-9.8.1 in its entirety and substitute the following revised paragraph:

"C2G-9.8.1 Scope. The Contractor is advised that the Orleans Levee District will conduct an independent preconstruction survey of residential properties prior to the commencement of work."

(2) Page H-32

(a) Paragraph H-32g. Delete paragraph H-32g in its entirety and substitute the following revised paragraph:

"g. The Contractor is advised that the Orleans Levee District will conduct an independent preconstruction survey of residential properties prior to the commencement of work."

Revised
6-2-94
JE

CELMN-ED-DS

1 June 1994

SUBJECT: Lake Pontchartrain, Louisiana and Vicinity, High Level Plan, London Avenue Outfall Canal, Parallel Protection, Mirabeau Avenue to Robert E. Lee Blvd., West Bank Floodwall; Mirabeau Avenue to Leon C. Simon Blvd. Floodwall, East Bank Floodwall; Orleans Parish, Louisiana ED-94-144

(b) Paragraph H-32h. Delete paragraph H-32h in its entirety and substitute the following revised paragraph:

"h. The Contractor is advised that the Orleans Levee District will retain an independent testing laboratory to monitor vibrations during the pile driving operations. If more than one pile driving rig is in operation at any time, each rig will be independently monitored. Vibration monitoring during the Contractor's other operations may be done at the discretion of the Orleans Levee District. ~~The Contractor shall order his operations to accommodate these activities of the Orleans Levee District.~~"

B. DRAWINGS. No changes.

2. It is the opinion of the design engineer and project manager that the above changes are simple clarifications and will not affect bid prices. Therefore, we request that the bid opening of 8 June 94 not be changed if practical.



W. EUGENE TICKNER
Chief, Engineering Division

CF:
C/Struc Des Sec
C/Cost Engr Br
C/Const Div
C/CELMN-PP (Broussard)

[Handwritten signature]

Mr. Terranova/2709
24 May 1994

CELMN-ED-DS

MEMORANDUM FOR C/Contracting Division

SUBJECT: Lake Pontchartrain, Louisiana and Vicinity, High Level Plan, London Avenue Outfall Canal, Parallel Protection, Mirabeau Avenue to Robert E. Lee Blvd., West Bank Floodwall; Mirabeau Avenue to Leon C. Simon Blvd. Floodwall, East Bank Floodwall; Orleans Parish, Louisiana ED-94-144

1. Please issue Amendment No. 0001 to Solicitation No. DACW29-94-B-0047, subject as above, as follows:

A. SPECIFICATIONS.

(1) Bidding Schedule, Page B-1. Delete page B-1 in its entirety and substitute revised attached page B-1 therefor.

(2) Page C2C-1, Paragraph C2C-2. Delete item (2), Excavation, in its entirety, and substitute the following:

"(2) Excavation. Check grade, slopes, and dimensions for compliance with design sections. The Contractor shall have an option to degrade the existing landside levee to elevation 3.0 N.G.V.D. at any time to improve the accessibility for construction in the following reaches:

Station 69+15 to 73+00 EB/L
Station 85+20 to 100+00 EB/L

The Contractor shall have an option to degrade the existing landside levee only during non-hurricane season with a maximum water elevation of 6.75 N.G.V.D. in the following reaches:

<u>Reach</u>	<u>Degraded Levee Elevation</u>
70+50 to 84+50 WB/L	3.0
85+60 to 99+15 WB/L	3.5
100+40 to 119+85 WB/L	3.0
73+00 to 84+60 EB/L	3.0
102+30 to 119+40 EB/L	3.0
120+18 to 126+88 EB/L	4.0

The Contractor's hurricane plan shall include provisions for returning the levees to their original heights if new floodwall construction is not complete by the beginning of hurricane season. During hurricane season, the Contractor shall be prohibited to degrade existing levee until the new floodwall is complete and the concrete has attained a compressive strength of 3,000 psi."

A-1

CELMN-ED-DS

24 May 1994

SUBJECT: Lake Pontchartrain, Louisiana and Vicinity, High Level Plan, London Avenue Outfall Canal, Parallel Protection, Mirabeau Avenue to Robert E. Lee Blvd., West Bank Floodwall; Mirabeau Avenue to Leon C. Simon Blvd. Floodwall, East Bank Floodwall; Orleans Parish, Louisiana ED-94-144

(3) Page C2G-6.

(a) Add a following new paragraph after existing paragraph C2G-8.4, which begins on existing page C2G-5:

"C2G-8.4.1 Pull and Clean Existing AZ-18 Steel Sheet Piling. From Sta. 99+73.36 EB/L to Sta. 99+91.07 EB/L, the Contractor shall pull and clean existing AZ-18 steel sheet piling up to elevation 14.40 as shown on the drawings. The pulled portion of the piles shall be cleaned with a jet of water. The Contractor shall repair any damaged protective coating on AZ-18 sheet piling. For paint requirements, see Section C9A, "PAINTING."

(b) Paragraph C2G-8.5. In the third (3rd) line, change "AZ-10" to "RZ-10".

(4) Page C2G-10.

(a) Paragraph C2G-11.1.5. Add the following sentence after the last sentence: "No separate measurement will be made for approximately eighteen (18) linear feet of existing AZ-18 steel sheet piling to be pulled and cleaned up to elevation 14.40."

(b) Paragraph C2G-11.1.6. In the second (2nd) line, after "AZ-18", add ",RZ-10 and PZ-27".

(5) Page C2G-11, Paragraph C2G-11.2.6. In the second (2nd) and third (3rd) lines, after "AZ-18", add ",RZ-10 and PZ-27".

(6) Page C2J-3.

(a) Add the following new paragraph after existing paragraph C2J-4.3:

"C2J-4.4 Concrete Slope Pavement. The Contractor shall remove and dispose of existing slope pavement on west bank as indicated on Contract Drawings and as specified herein."

(b) Paragraph C2J-6.2. In the third (3rd) line, add "concrete slope pavement," after "sheet piling," .

(7) Page C16B-5, Paragraph C16B-12.1. In the third (3rd) line, change "0.040" to "0.032".

CELMN-ED-DS

24 May 1994

SUBJECT: Lake Pontchartrain, Louisiana and Vicinity, High Level Plan, London Avenue Outfall Canal, Parallel Protection, Mirabeau Avenue to Robert E. Lee Blvd., West Bank Floodwall; Mirabeau Avenue to Leon C. Simon Blvd. Floodwall, East Bank Floodwall; Orleans Parish, Louisiana ED-94-144

(8) Page C16B-7, Paragraph C16B-13.3.3. Change lines 9 and 10, which currently read "The thickness of the extruded screen shall be 50 mils with an 80% minimum point." to read as follows: "The thickness of the extruded screen shall have 32 mills minimum point."

(9) Page C16B-11, Paragraph C16B-16.1.1:

(a) Delete the second (2nd) sentence in its entirety and substitute the following revised sentence: "From stations 99+91.07 EB/L to 100+17.54 EB/L, the Contractor shall have an option to keep the underground existing cable in its existing position or temporarily relocate the cable from its existing position into a trench in case of any conflict which may occur during the construction".

(b) In the ninth (9th) line, after "relocate cable", add "either from its original position or".

(c) Add the following new sentence at the end of the paragraph: "Notching of steel sheet piling and split steel sleeves will be required to cross the cables thru sheet piling at approximate station 100+04.79 EB/L as shown on the drawings"

(10) Page C16B-12.

(a) Paragraph C16B-16.1.3.

1. Beginning on the second (2nd) line and continuing onto the third (3rd) line, change "its existing position on" to "existing sheet pile to".

2. Delete the second (2nd) sentence in its entirety and substitute the following revised sentence: "From stations 99+88.47 EB/L to sta. 100+17.54 EB/L the Contractor shall have an option to keep the underground existing cable in its existing position or temporarily relocate the cable from its existing position into a trench in case of any conflict which may occur during construction".

3. In the third (3rd) sentence, add "In case of insufficient cable length," before "Splices" (change the capital "S" in splices to a small "s").

CELMN-ED-DS

24 May 1994

SUBJECT: Lake Pontchartrain, Louisiana and Vicinity, High Level Plan, London Avenue Outfall Canal, Parallel Protection, Mirabeau Avenue to Robert E. Lee Blvd., West Bank Floodwall; Mirabeau Avenue to Leon C. Simon Blvd. Floodwall, East Bank Floodwall; Orleans Parish, Louisiana ED-94-144

(11) Page C16B-12, Paragraph C16B-16.1.4. Add the following new sentence at the end of the existing paragraph: "Notching of steel sheet piling and split steel sleeves will be required to cross the cables through the sheet piling at approximate station 101+38.90 WB/L and station 100+04.79 EB/L as shown on the drawings".

(12) Page H-24, Paragraph H-26b(1). In the first (1st) line, add "2,000,000.00" after "\$".

B. DRAWINGS.

(1) Delete existing Drawing (Dwg.) No. 37 of 73, File No. H-4-40295 in its entirety, and substitute revised attached Dwg. 37 of 73, File No. H-4-40295 therefor.

(2) Please make the following pen-and-ink changes:

(a) Drawing (Dwg.) No. 6 of 73, File No. H-4-40295. In the table entitled "EXISTING FACILITIES", add "(■)" after "NA" in the "DISPOSITION" column for item FL-432.

(b) Dwg. No. 13 of 73, File No. H-4-40295. In the "WEST PROFILE (CANAL SIDE ELEVATION)", the elevation of the bottom of new sheet piling from Sta. 100+27.61 to Sta. 101+66.95 is -20.0.

(c) Dwg. No. 19 of 73, File No. H-4-40295. In the detail entitled "SHEET PILE SPLICE AT TC-1, ST-1 & DT-1", change "STA. 100+42 WB/L FOR TC-1" to "STA. 100+47 WB/L FOR TC-1"; "STA. 101+27 WB/L FOR ST-1 & DT-1" to "STA. 100+34 WB/L FOR ST-1 & DT-1"; "STA. 100+58 WB/L FOR TC-1" to "STA. 100+52 WB/L FOR TC-1"; and "STA. 100+51 WB/L FOR ST-1 & DT-1" to "STA. 101+55 WB/L FOR ST-1 & DT-1".

(d) Dwg. No. 32 of 73, File No. H-4-40295. In the leftmost "SECTION A", change "APPROX. STA. 70+57.00 to 84+64.72 WB/L" to "APPROX. STA. 70+47.00 to 84+54.72 WB/L".

(e) Dwg. No. 32a of 73, File No. H-4-40295. In the center of the drawing, in the Table entitled "LIMITS OF FRACTURED FIN TEXTURE ON THE CANAL SIDE OF THE FLOODWALL", delete "70+47.00 TO 72+52.33 WB/L" and "70+26.77 TO 72+32.10 EB/L". Fracture fin texture will not be applied within these limits.

CELMN-ED-DS

24 May 1994

SUBJECT: Lake Pontchartrain, Louisiana and Vicinity, High Level Plan, London Avenue Outfall Canal, Parallel Protection, Mirabeau Avenue to Robert E. Lee Blvd., West Bank Floodwall; Mirabeau Avenue to Leon C. Simon Blvd. Floodwall, East Bank Floodwall; Orleans Parish, Louisiana ED-94-144

(f) Dwg. No. 42 of 73, File No. H-4-40295. In "SECTION B-B", change "16'-6"" to "21'-0"".

(g) Dwg. No. 48 of 73, File No. H-4-40295.

1. Change "PLAN" to "DETAIL ".

2. On the right side of the drawing, change "EXISTING FL-340 TO FL-422 TO REMAIN" to "EXISTING FL-340 AND FL-422 TO REMAIN".

3. The location of existing FL-432 from the fence corner to P.S. No. 4 is shown incorrectly. FL-432 turns right at the fence corner below the existing concrete slab.

(h) Dwg. No. 49 of 73, File H-4-40295. Please make the following changes to the "NOTES":

1. In third (3rd) line of Note 2.", change "€€AA" to ""AA"" and "€€BB" to ""BB"".

2. In the second (2nd) line of Note 4, change "€€BB" to ""BB"".

2. It is requested that the bid opening date of 8 June 1994 not be changed.



W. EUGENE TICKNER
Chief, Engineering Division

CF:
C/Struc Des Sec
C/Cost Engr Br
C/Const Div
C/CELMN-PP (Broussard)

SOLICITATION NO. DACW29-94-B-0047

BIDDING SCHEDULE

(To be attached to Bid Form)

LAKE PONTCHARTRAIN, LOUISIANA AND VICINITY, HIGH LEVEL PLAN
LONDON AVE. OUTFALL CANAL, PARALLEL PROTECTION,
MIRABEAU AVE. TO LEON C. SIMON BLVD. FLOODWALL,
ORLEANS PARISH, LOUISIANA

Item No.	Description	Estimated Quantity	Unit	Unit Price	Est. Amt.
0001.	Mobilization and Demobilization	Lump Sum	LS		
0002.	Clearing and Grubbing	Lump Sum	LS		
0003.	Selective Demolition	Lump Sum	LS		
0004.	Pedestrian Bridge Demolition	Lump Sum	LS		
0005.	Embankment, Semicompacted Fill	Lump Sum	LS		
0006.	Structural Excavation and Backfill	Lump Sum	LS		
0007.	Fertilizing, Seeding, and Mulching	8	AC		
** 0008.	Cutting Off Existing AZ-18, RZ-10 and PZ-27 Sheet Piling	Lump Sum	LS		
0009.	Pull, Clean, Salvage and Deliver Existing AZ-18 Steel Sheet Piling	Lump Sum	LS		
0010.	Redrive Existing AZ-18 Steel Sheet Piling	Lump Sum	LS		
0011.	Piling, Steel Sheet, Type PZ-22	187,844	SF		
0012.	Piling, Steel Sheet, Type PSA-23	997	SF		
0013.	Painting	Lump Sum	LS		
0014.	Reinforced Concrete Floodwalls	Lump Sum	LS		
0015.	Concrete Slope Pavement	188	SY		
0016.	Utility Modifications	Lump Sum	LS		

94-B-0047

MEMORANDUM FOR C/Contracting Div

SUBJECT: Lake Pontchartrain, LA and Vicinity, High Level Plan, London Ave. Outfall Canal, Parallel Protection, Mirabeau Ave. to Leon C. Simon Blvd., East Side, and Mirabeau Ave. to Robert E. Lee Blvd., West Side, Orleans Parish, LA ED-94-144

1. Subject technical specifications approved by Commander, NOD will be hand carried to Contracting Div on or about 28 Feb 94. Contract drawings will be furnished by Engr Div upon request.
2. You are requested to check specifications for compliance with procurement regulations and prepare the specifications for advertising and advertise for a period of 30 days. Award of this contract is scheduled for May 94.
3. Office of Counsel will furnish the applicable wage determination for this procurement.
4. Cost Engr Br of Engr Div will prepare the Government estimate.
5. Total estimated cost of payments to the Contractor is approximately \$5,900,000. Of this amount the sum of \$2,500,000 will be available for award in FY-94. (Fill in this amount in the Special Clause entitled "CONTINUING CONTRACTS".)
6. The work is being included in FY-94 Detailed Project Schedule (PB-2A) for "Lake Pontchartrain & Vic." (CYP) BEC00, page 50, line 118~~88~~ dated 1 Jan 94.
7. Reproduction, labor, and advertising are chargeable to account no. BEC21 ~~111R LN OLML.~~
30J9L10LML
8. The work is chargeable to appropriation 96X3122. The contract cost account number for this work is BEC21 111R LN OLML, (284), (VD).
9. Rights to technical data/software were considered for this action. It was determined that rights were not applicable for this contract.

for Robert Auger
 W. EUGENE TICKNER
 Chief, Engineering Division

See page 2 for copies furnished.

*Rec'd
 2/24/93
 A-1*

CELMN-ED-DS

22 Feb 94

SUBJECT: Lake Pontchartrain, LA and Vicinity, High Level Plan,
London Ave. Outfall Canal, Parallel Protection, Mirabeau Ave. to
Leon C. Simon Blvd., East Side, and Mirabeau Ave. to Robert E. Lee
Blvd., West Side, Orleans Parish, LA ED-94-144

CF:

Ofc of Counsel

C/Stru Des Sec

C/Cost Engr Br

C/Operation & Readiness Div

A/E, New Orleans A/O

C/CELMN-CD-C

C/Environmental Analysis Br, Plng Div

C/Real Estate Div

C/CELMN-PP

C/Engr Cntl Br

C/CELMN-PP-P



DEPARTMENT OF THE ARMY

NEW ORLEANS DISTRICT, CORPS OF ENGINEERS

P.O. BOX 60267

NEW ORLEANS, LOUISIANA 70160-0267

REPLY TO
ATTENTION OF:

SOLICITATION: DACW29-94-B-0047

FOR: Lake Pontchartrain, Louisiana and Vicinity, High Level Plan, London Ave. Outfall Canal, Parallel Protection, Mirabeau Ave. to Robert E. Lee Blvd., West Bank; Mirabeau Ave. to Leon C. Simon Blvd., East Bank Floodwall, Orleans Parish, Louisiana

TO OPEN:

- I. NOTE THE AFFIRMATIVE ACTION PROGRAM REQUIREMENT OF THE EQUAL OPPORTUNITY CLAUSE WHICH MAY APPLY TO THE CONTRACT RESULTING FROM THIS SOLICITATION.
- II. NOTE THE CERTIFICATION OF NONSEGREGATED FACILITIES IN THIS SOLICITATION. Bidders, offerors and applicants are cautioned to note the "Certification of Non-segregated Facilities" in the solicitation. Failure of a bidder or offeror to agree to the certification will render his bid or offer non-responsive to the terms of solicitations involving awards of contracts exceeding \$10,000 which are not exempt from the provisions of the Equal Opportunity clause.

BIDS MUST PROVIDE FULL, ACCURATE AND COMPLETE INFORMATION AS REQUIRED BY THIS SOLICITATION AND ITS ATTACHMENTS. THE PENALTY FOR MAKING FALSE STATEMENTS IN BIDS IS PRESCRIBED IN 18 U.S.C. 1001. (FAR 52.214-4 APR 1984)

DESCRIPTION AND MAGNITUDE OF WORK: The work consists of: clearing; selective demolition; cutting existing steel sheet piling; pulling, cleaning and delivering existing steel sheet piling; driving new steel sheet piling; constructing reinforced concrete I-Type floodwalls on existing and new steel piling; concrete slope pavement, driving steel sheet piling under South Central Bell Telephone Cables and New Orleans Sewerage & Water Board 10-foot diameter siphon tube and 50-inch diameter discharge pipe by hydraulic jacks; relocating Sewerage and Water Board feeder cables; modifying existing utilities; degrading existing levees; placing embankment; fertilizing, seeding and mulching; and all other incidental work thereto.

CAUTION TO BIDDERS: In delivery of hand-carried bids, bidders are cautioned to allow sufficient time for delays which may be encountered as a result of frequent trains which are subject to block all access roads to place of bid opening for various lengths of time. Such delays DO NOT permit acceptance or consideration of late bids.

NOTE: All work under these specifications will be performed in accordance with the provisions of EM 385-1-1 "Corps of Engineers Safety and Health Requirements Manual", dated October 1992. ^{Reviewed and Found to be Technically Sufficient.}

DeSoto/2733
BEC21 30J9 L1 01ML

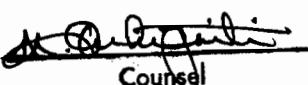
Approved.

 Counsel
 20 FEB '94
 Date

A-7a

CELMN-PP

22 April 1994

MEMORANDUM FOR C/Contracting Div

SUBJECT: Lake Pontchartrain Hurricane Protection Project, London Avenue Outfall Canal, Contract No. 3, Solicitation No. DACW29-94-B-0047

1. Please advertise the subject construction job for bids as soon as possible.
2. The Orleans Levee Board by letter dated 22 April 1994 has agreeded to provide the funds, prior to award, to cover the relocations work included in the job.

Encl

CF: w/Encl
CELMN-ED
CELMN-CT (Shiela Enclade)



Terral J. Broussard
Senior Project Manager

Handwritten initials/signature

rec'd. 4/22/94

243-4000

The Board of Commissioners

OF THE

Orleans Levee District

SUITE 202 — ADMINISTRATION BUILDING
NEW ORLEANS LAKEFRONT AIRPORT

New Orleans, La.

70126

PROTECTING YOU
AND YOUR FAMILY

April 22, 1994

Mr. Terral J. Broussard
Senior Project Manager
U. S. Army Corps of Engineers
P. O. Box 60267
New Orleans, Louisiana 70160-0267

RE: OLB Project No. 24902
London Avenue Canal (Contract 3)

Dear Mr. Broussard:

At a recent meeting between Colonel Clow, Commissioner Richard D. Sackett, and myself, the matter of funding the relocations for London Avenue Canal (Contract 3) was discussed. Subsequent to that meeting Commissioner Sackett has directed me to allow for the relocations to occur as a part of the construction contract.

You are hereby authorized to proceed to advertise for bids on this project in accordance with your letter of March 16, 1994.

Sufficient OLD funds are available to cover the anticipated costs.

Sincerely,

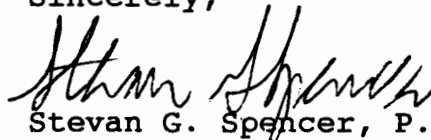

Stevan G. Spencer, P. E.
Chief Engineer

SGS:pns

xc: Robert G. Harvey, Sr.
Richard D. Sackett
Theodore Lange
Mary E. Herbert