

InSeT System

Inertial Sensor Tracking System

Technical Presentation

Underground Mine Safety For
Personnel Utilizing Inertial Sensors



InSeT Inertial Tracking System

Benefits of a Personnel Tracking System

- Safety

- Provides real time location of mine personnel, in the event of an emergency.
- Tracks personnel, as they move away from dangerous conditions.
- Provides rescue personnel with the most accurate and up-to-date locations of trapped personnel.
- Assists land survey personnel with quickly finding the optimum surface drilling location.
- Capable of “Voice Over” broadband communication.



InSeT Inertial Tracking System

Global Positioning System Limitations

GPS signals do not penetrate into the Earth, this does not provide assistance in locating mine personnel operating underground. At best GPS is used by the surface land survey crews.

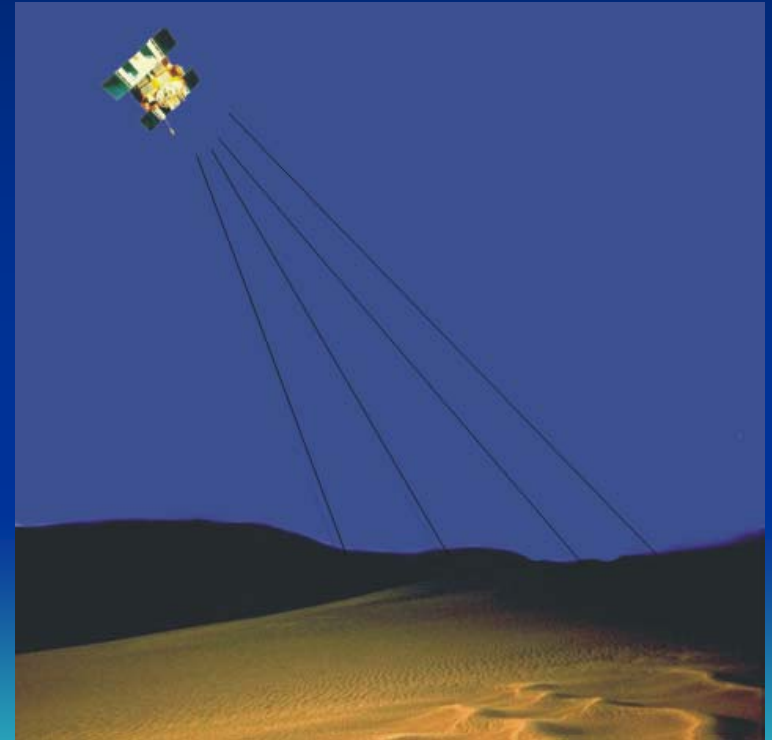

InSeT Inertial Tracking System

Electronic and Mechanical Components

- Most all components of the system are commercially available.
 - Charting software
 - Inertial Sensors
 - Micro-Electronics
 - Batteries
 - Server Computers and Wireless Ethernet
 - Military Specification Components
 - Shock isolation systems
- Integration of components into an operational tracking system, is what is required.



InSeT Inertial Tracking System

- Operates on the principle of Inertial Navigation
Submarines have been using this type of navigation system since the early 1960s.
- Uses wireless VHF broad band TCP/IP transceivers.
- Seam height determines frequencies to maximize “wave guide ducting” effect.
- Utilizes UPS and back up power systems to preserve operation.
- Computer monitor system is located away from the mine.
- Requires minimum attention from personnel, who are wearing the tracking devices.



InSeT Inertial Tracking System

- Principles of Inertial Navigation
 - Does not require external input for operation.
 - Motion of the inertial sensing instruments, from a known docking location, translates into a precise grid coordinate location.
 - Computing power and miniaturization has progressed to the point of making personal devices possible.
 - In 1960, the inertial sensor was slightly smaller than a Volkswagen.
 - Not to mention the computer and control cabinet were both the size of refrigerators.



InSeT Inertial Tracking System

- Computer monitor, located outside of mine, uses a grid system to plot the location of personnel.
- Zoom-in capability provides accuracy in location and tracking of personnel.
- All tracking devices have unique identification code.
- In an emergency situation, rescue personnel would each be assigned an InSeT tracking device.
 - Rescue personnel progress can be monitored as they attempt to reach trapped mine personnel.



InSeT Inertial Tracking System

Monitor Tracking Screen

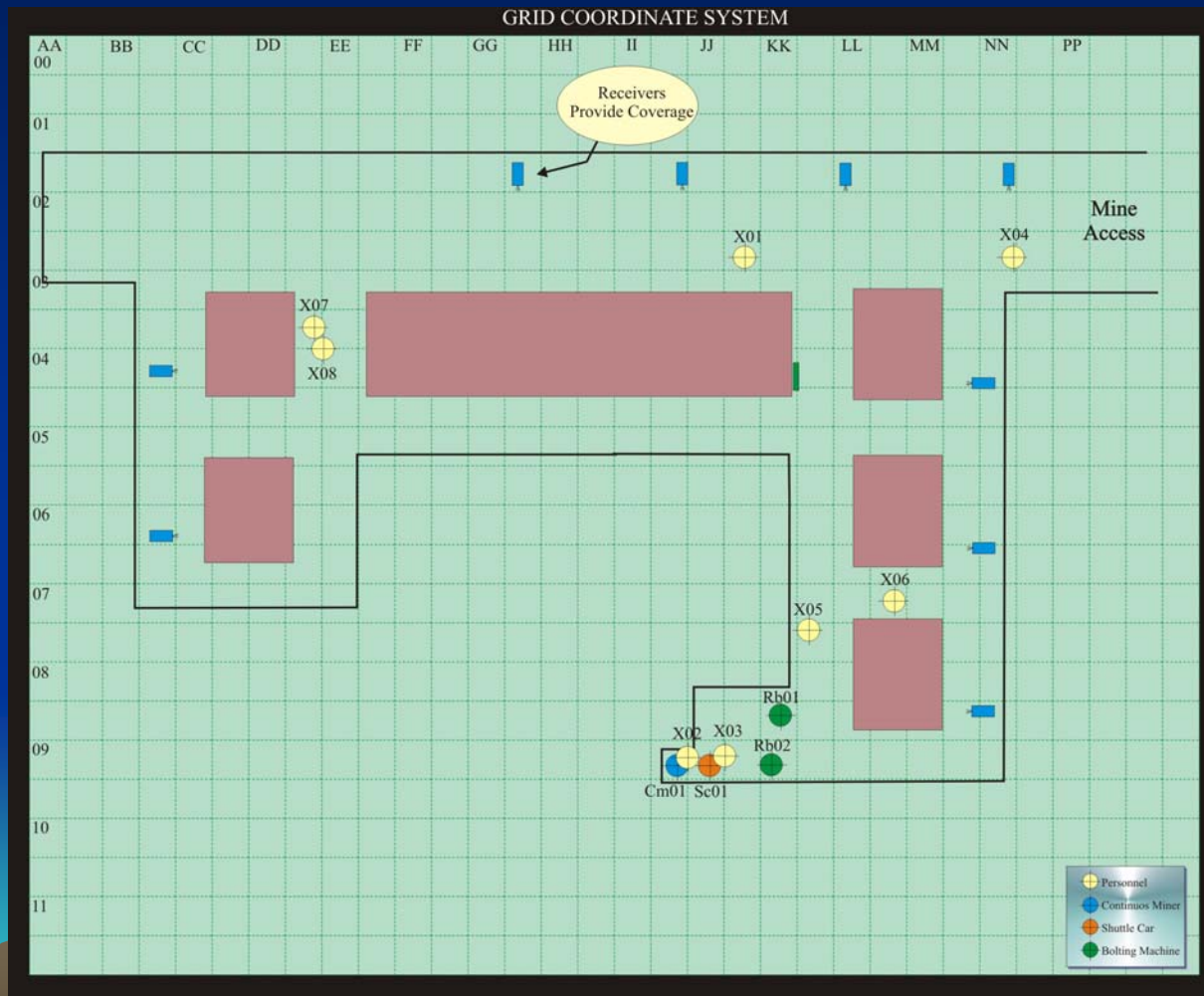

InSeT Inertial Tracking System

Monitor Tracking Screen - Zoom In

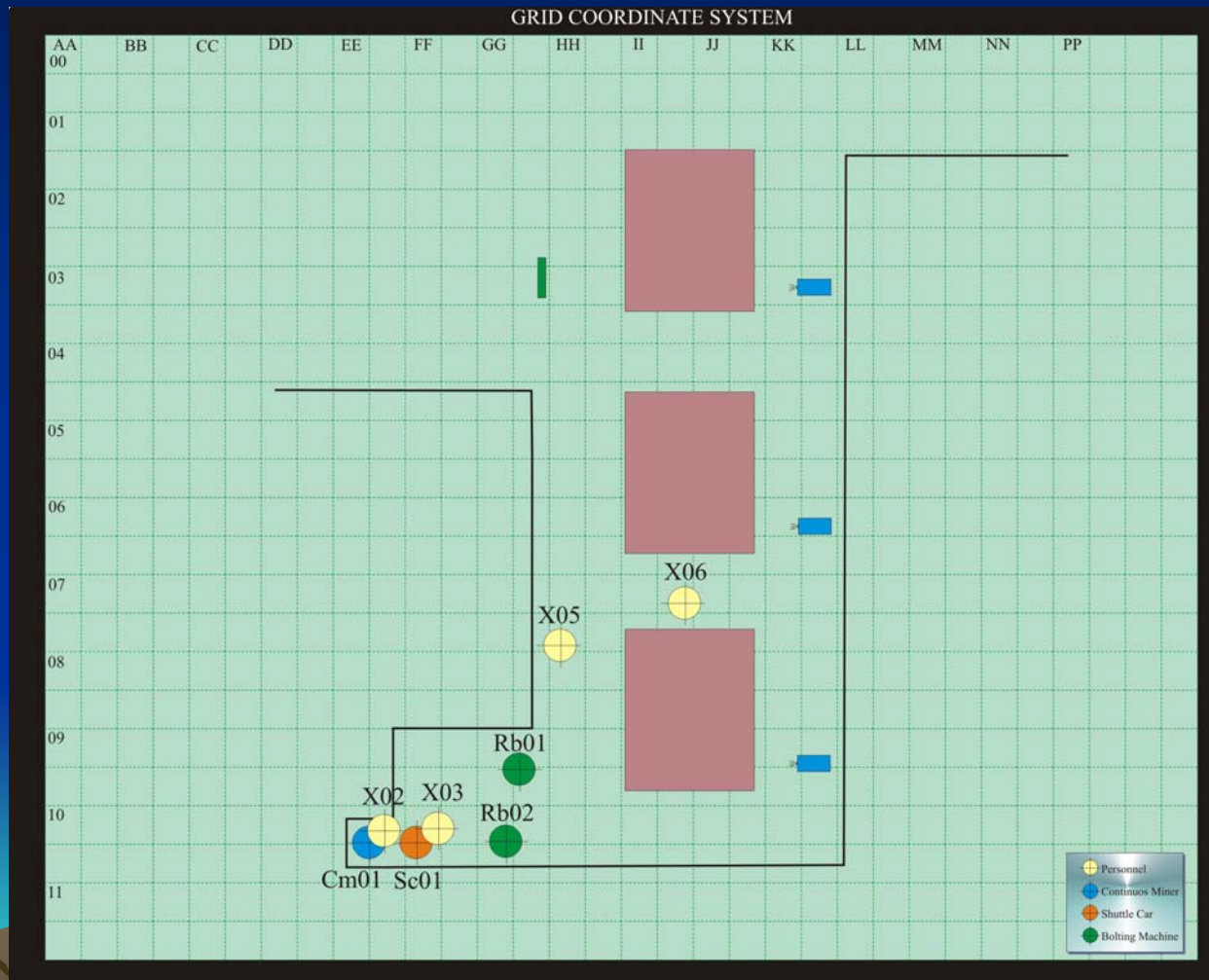

InSeT Inertial Tracking System

- The tracking device is “wearable”.
- Battery life is approximately 36 hours.
- Transmitting range is, typically, 1 mile enclosed.
- Docking station is optically aligned and set to the “grid coordinates” to provide known docking position to tracking devices and battery charging.



InSeT Inertial Tracking System

Sago Mine, Tallmansville, WV

The Sago Mine with the InSeT system installed.

- Broad band transceivers installed, 500-700 feet apart.
- Reception range is, typically, 1 mile for each transceiver.
- Multiple redundancy of transceivers.
- Transceivers are re-locatable.
- Transceivers do not depend on precise position installation.



InSeT Inertial Tracking System

Sago Mine Tallmansville, WV with InSeT Installed

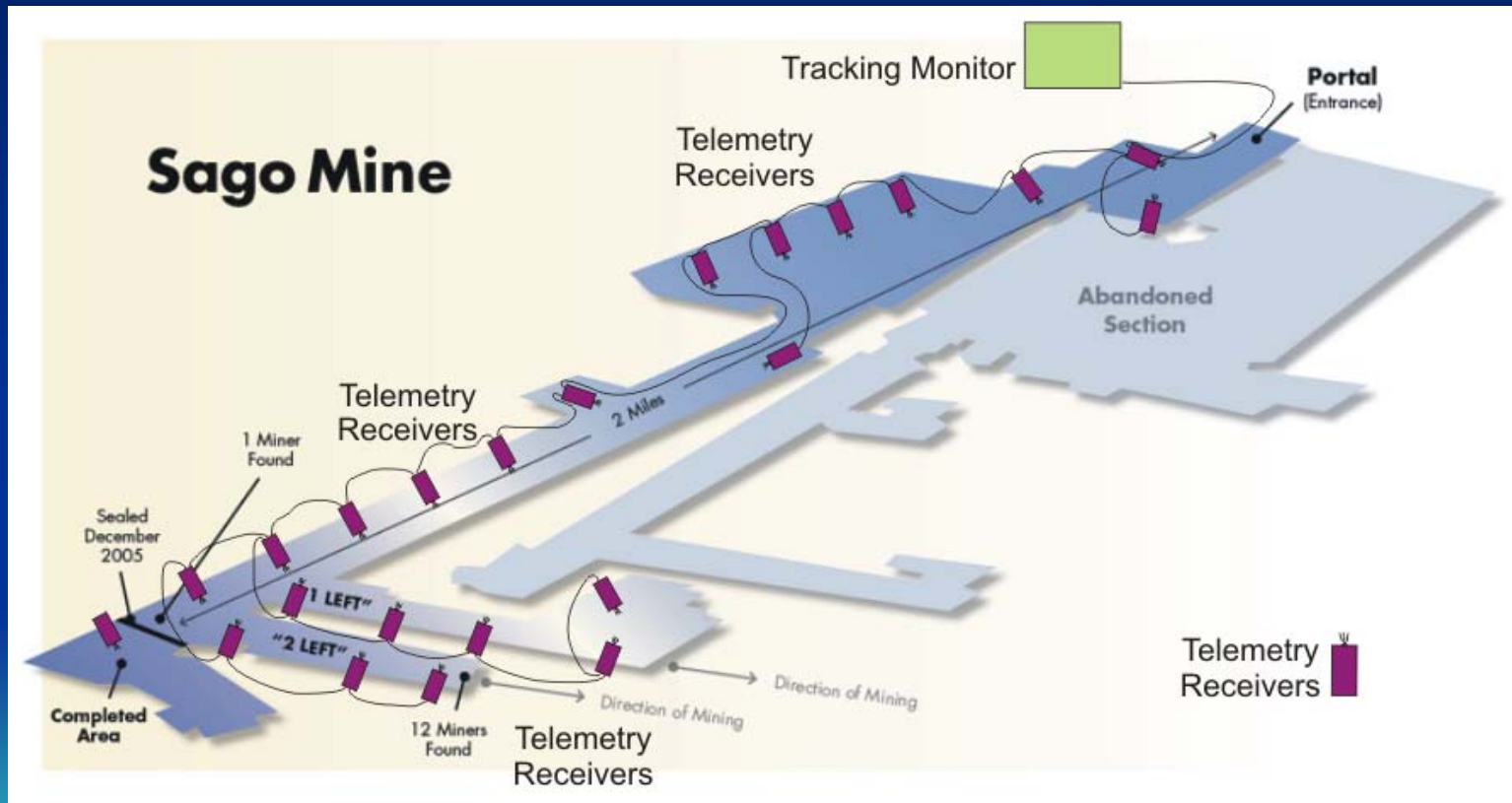

InSeT Inertial Tracking System

The Body Pack Transmitter

- Utilizes MEMS Technology 3 axis inertial sensor.
- Dedicated computer processor, firmware, and memory.
- On-board processor controlled battery management.
- Integrated Radio Frequency transmitter.



InSeT Inertial Tracking System

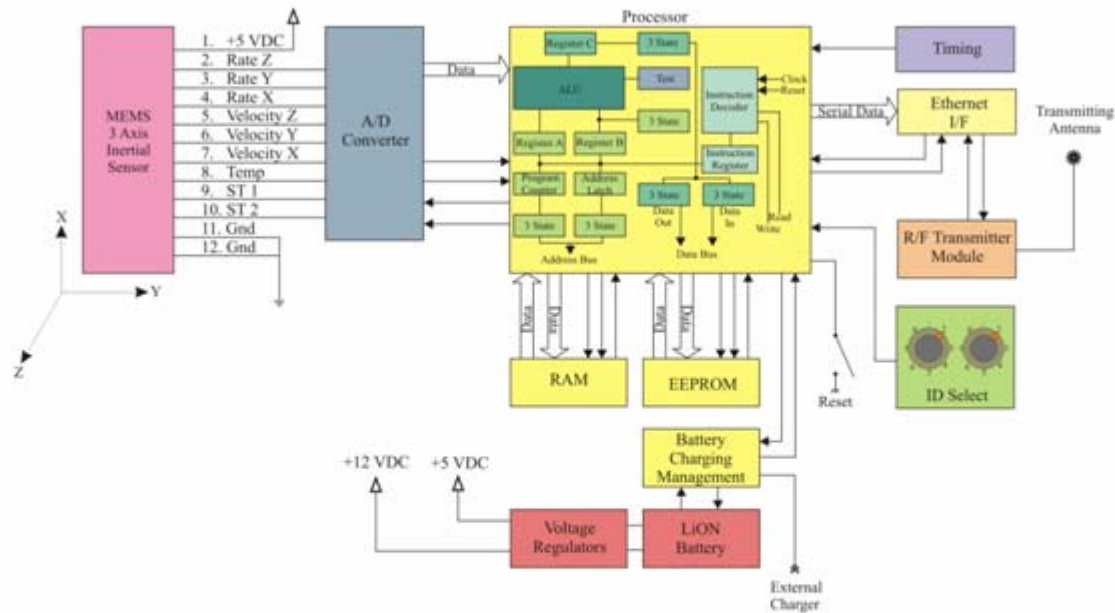

Inertial Characteristics

Vertical Axis is aligned to level in docking station. Z axis accelerometer constant in alignment is IG. System operates in strap down, without requirements of calibration indexing. Start up time for MEM sensor is less than 25 mS. Earth rate torquing is required for ECEF geographic coordinates. Initial position is based on $[we(L)^T]$ where "we" is earth rate and L is Latitude. When the sensor leaves the docking station all axes are dynamic with three axis velocity representing motion and attitude. The 3 dimensional velocities are extracted from three dimensional angular displacement to produce V_n , V_e , and V_v (Velocity north, Velocity east, and Velocity vertical). This is accomplished using a Direction Cosine Matrix (DCM), utilizing Euler parameters. The reciprocal of positive V_n is velocity south. For example $V_n = -2.3$ mph, this indicates motion in a northerly direction. When $V_n = 2.3$ mph, this indicates motion in a southerly direction. The system operates as a "strap down" inertial system, as no stabilization is required. MEM sensor architecture is such that it is immune to Shuler oscillations and does not require compensation, except for 24 hour earth rotational oscillation.

- 1) 3 AXIS MEMS INS - ONI23504
1.5" X 1.2" X 0.6" APPROX DIMENSIONS
- 2) TELEMETRY TRANSMITTER - 9XTEND-PKG-(X)
900 MHZ, 1 WATT MODULE
2.75: X 5.5" X 1.25" APPROX DIMENSIONS
- 3) PROCESSOR OUT PROTOCOL - ETHERNET
- 4) BATTERY - LITHIUM ION
A123 SYSTEMS
TOSHIBA
SONY
- 5) ALL CIRCUITRY TO BE 0404 SMD ON UP TO 7 LAYER PCB

Processor Options

1. Intel Pentium IV- 423 or 478 Pin
Intel Xeon
Itanium (64 bit)
Celeron (Low end-370 Pin)
2. AMD American Micro Devices
Athlon - 362 Pin
Duron (Low end - 362 Pin)

InSeT Inertial Tracking System

Telemetry Transceivers

- Transceivers are Wireless Broad Band TCP/IP protocol.
- Each transceiver has battery back-up power supply.
- Transceivers operate in full duplex mode.



InSeT Inertial Tracking System

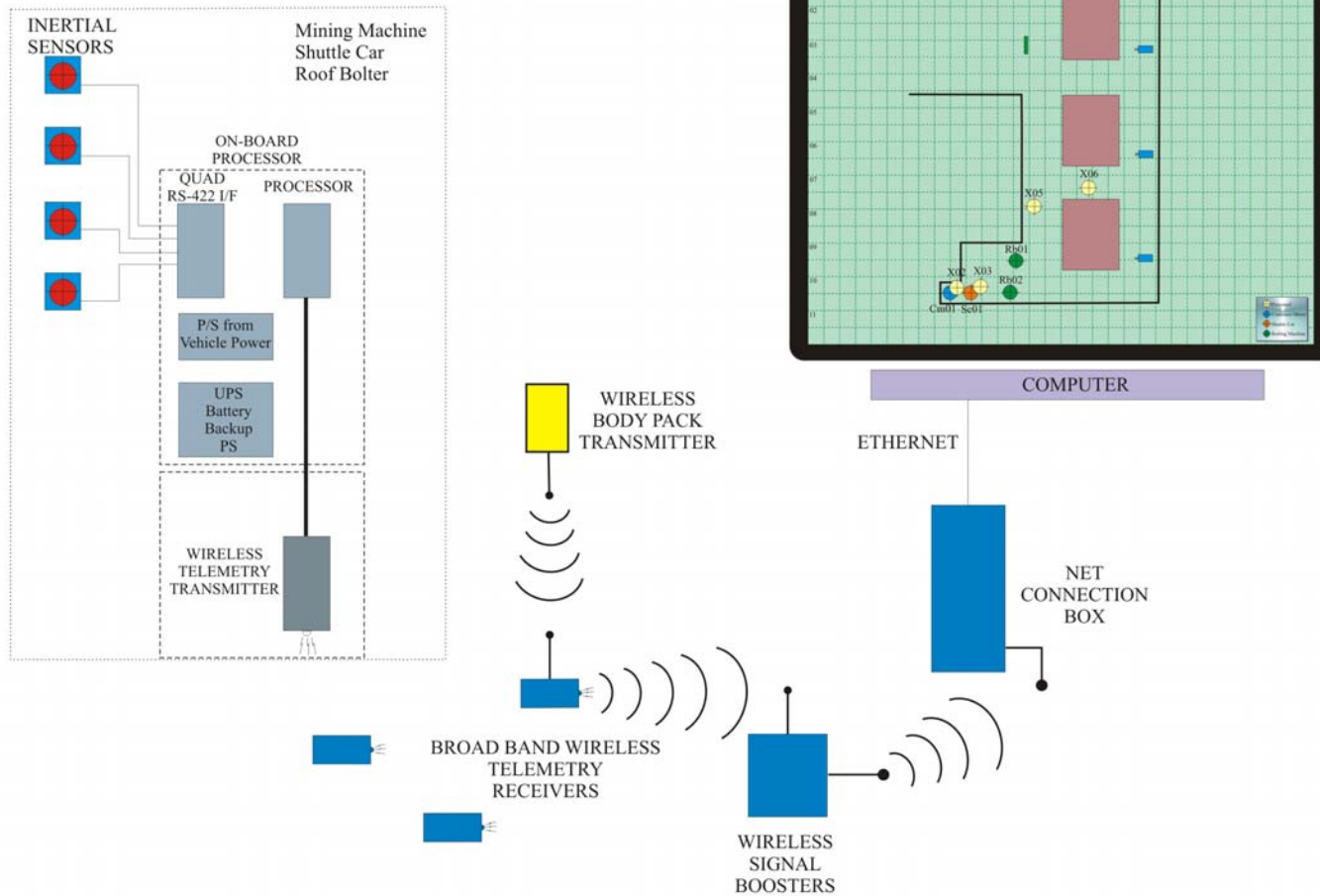

InSeT Inertial Tracking System

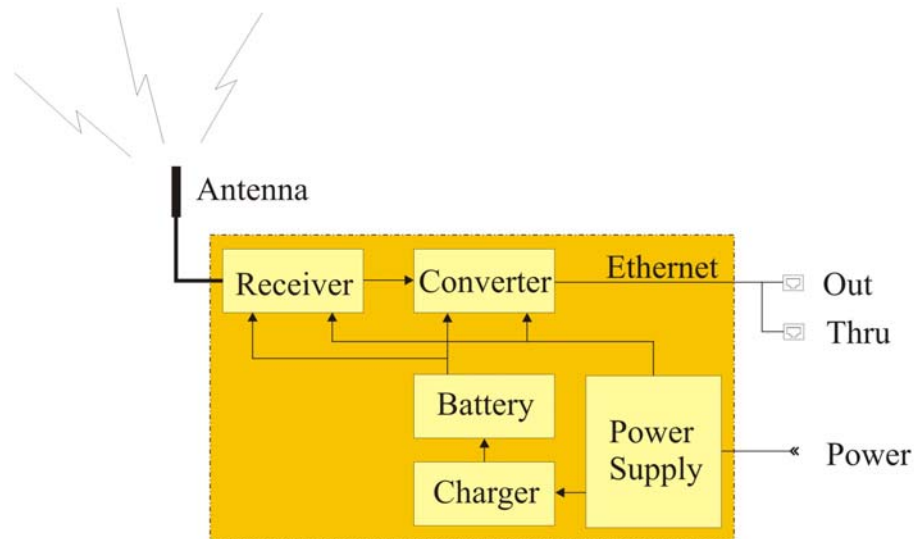

Notes

1. Telemetry receiver power is 120 VAC.
2. Power operates the receiver processor and battery charging circuits. When power is lost, the internal battery provides power for the receiver.
3. Receiver operating frequency is in the 900 Mhz operating band. This provides for area saturation coverage.
4. Ethernet connection is either wired or fiber optic.
5. Case is hardened casting with polymer coating, and water-proof for operation in extreme conditions.
6. Connectors shall be water-proof military specification for power and ethernet.
7. Power and ethernet cables shall be armored, water-proof, and chemical resistant to military specification.

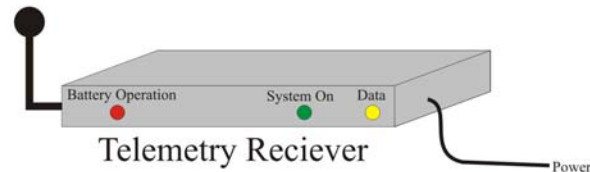

WiFi broadband with multiple redundancy is the next step.

InSeT Inertial Tracking System

Charging and Alignment Station

- Each wireless body pack is stored in the charger when not in use.
- The “battery charging and master reset” station provides a known position (docked) on the grid.
- The station is optically aligned to monuments located in the main tunnel. Monuments are set utilizing accepted geographic survey practices.



InSeT Inertial Tracking System

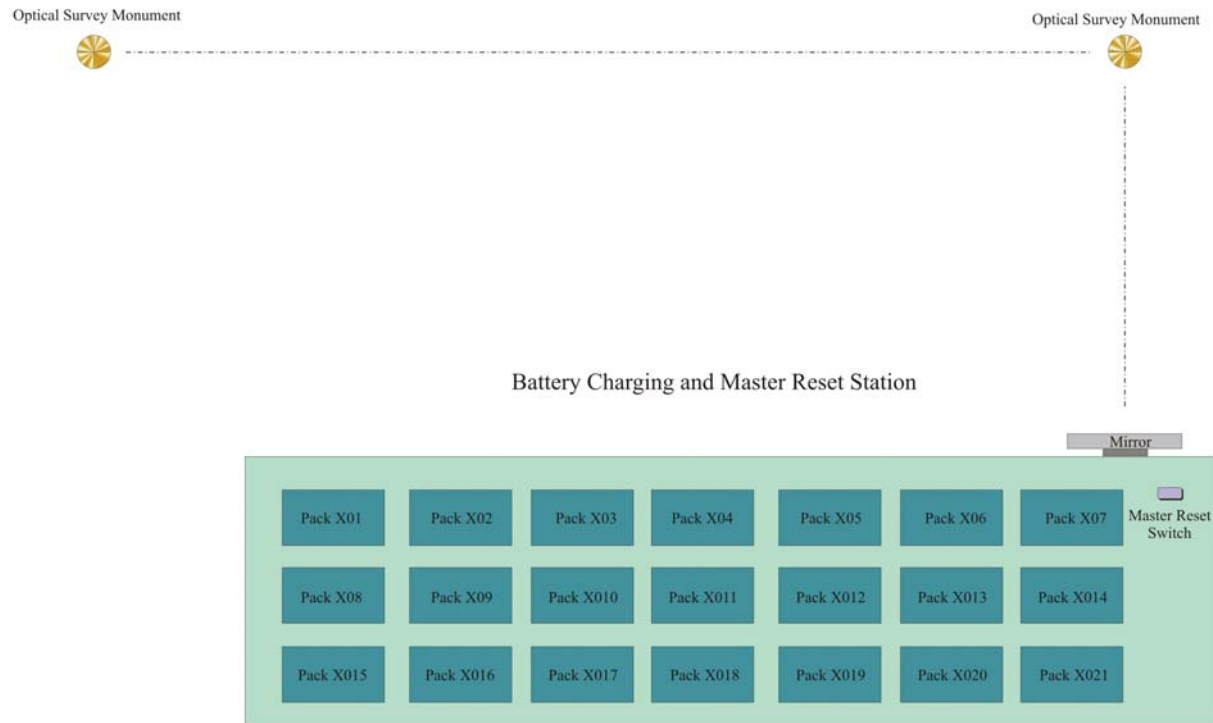

Optical survey equipment is required to precisely locate the position of the Master Reset Station. Use optical auto-collimator or Theodolite, as this procedure is located underground and is not suitable for GPS survey techniques. Preferable location of the monuments is just inside the mine access with a long optical shot of the mine to establish a reference LOS for integration of the mine grid system.

Precisely located by mechanical survey and programmed to system grid array. This provides storage, charging of the internal batteries, and reset of the navigation sensor to a precise geographic grid coordinate. The personnel trackers must be stored in this station at all times the devices are not in active use in the mine. The Master Reset switch must be activated prior to removing any of the tracking devices.

InSeT Inertial Tracking System

Normal and “Critical” Power Distribution

- The InSeT system includes Critical power distribution.
 - Propane powered generator.
 - Automatic bus loss detection and switching circuitry.
- Components of the system on the Critical power bus.
 - Main computer system.
 - Selectable broad band transceivers.
 - Monitor Screens.
 - Remote Monitor Screens.



InSeT Inertial Tracking System

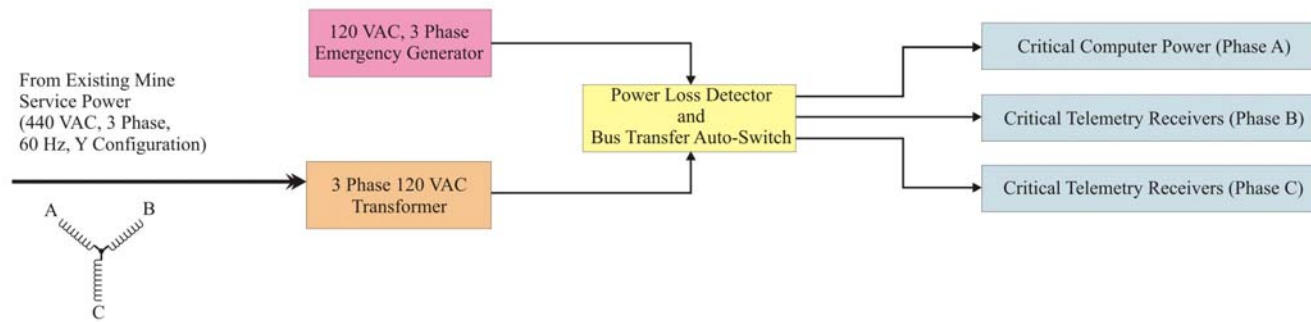

Notes

1. Primary 3 phase power feeds InSeT 3 phase power transformer to reduce the power to 3 phase, 120 VAC, 60 Hz power.
2. In the event of primary power failure, propane fueled emergency generator starts.
3. Automatic bus transfer switch transfers power from primary to emergency generator.
 - A) All telemetry receivers have battery backed UPS.
 - B) Main computer and monitors have battery backed UPS.
4. 3 Phase, 120 VAC power from emergency generator utilizes all 3 phases for maximum reliability.
5. Interim power, between loss of primary power and start of emergency power is handled by the computer UPS and each telemetry receiver UPS.
6. All power cables shall be military specification armored, low smoke, water proof, and chemical resistant.
7. All power plugs and connectors shall be military specification water proof and ruggedized, i.e. Cannon, ITT, Elco, etc.
8. All enclosures, which house components of the emergency power distribution network, shall be water proof and insulated from earth ground path.
9. All primary power shall be properly grounded.
10. Unless otherwise indicated, all power is 60 Hertz.

InSeT Inertial Tracking System

Operation In Extreme Conditions

- All components of the InSeT system adhere to military specifications for:

- High Temperature Life
- Operation in High Humidity
- Salt Spray
- Salt Atmosphere
- Mechanical Shock
- Thermal Shock
- Vibration

- Cabling shall be low smoke, chemical resistant, and armored.

- MIL-C-13377 and MIL-C-22613

- All connectors shall be waterproof and flame proof.

- MIL-C-55081 and MIL-C-55243



InSeT Inertial Tracking System

Inertial Sensing Tracking System

Benefits of a personnel and machine tracking system.

1. Safety

- A) Provides real time location of personnel in the event of an emergency.
- B) Tracks personnel, real time, as they move away from dangerous conditions.
- C) Provides rescue personnel with the most accurate and up-to-date location of trapped personnel.
- D) Assists land survey personnel with quickly finding the optimum surface drilling location.

2. Material

- A) Provides "last known location" of equipment in the event of an emergency for later recovery.
- B) Assists with equipment recovery effort, providing transmitters are operational.

1. Each wireless transmitter has both hard wired identification code and settable code to identify each transmitter.
2. All personnel transmitters are wireless and utilize MEMS inertial technology.
3. Machine transmitters are wireless and identification code is a combination of hardwired identification code and a manual set code.
4. Personnel inertial sensors must be reset prior to starting a shift at a known surveyed location, outside of the mine, but within transmitting distance of one of the telemetry sensors.
5. The battery is integrated with the transmitter and should be charged as a unit. Lithium Ion battery technology is used, with micro processor control of the battery charging circuitry.
6. 900 Mhz telemetry transmitters and receivers are used, due to the coverage in an enclosed space. Typically each Transmit/Receiver has an anticipated underground range of 1 mile.
7. Actual telemetry receiver locations should be determined by the reception signal strength, as the location of the receiver is not plotted on the tracking screen.
8. An accurate land survey, GPS preferred, is required to setting monuments to locate the "reset" station. Inertial navigation works on the principal of tracking motion from a known starting point. The greater accuracy of the known starting point, the greater accuracy of the inertial tracking device.
9. Data transfer protocol is wireless broadband Ethernet.
10. Redundancy is the key to reliability. Receivers in one part of the mine may become non-functional when power is interrupted, however due to the wireless operation of the personnel trackers and the reception from multiple receivers, the location of the personnel transmitters is known.
11. Continuous mining machine, Shuttle Cars, Roof Bolting Machines can reset positions from the operators personal tracking systems.
Example:
After the operator is in the machine, he / she depresses the "Reset Mining Machine" on the small operator touch screen display.
12. The small operator panel is a ruggedized touch panel consisting of a hardwired display with options for entering the operators personal system identification number and "Reset Machine Position?"; with Yes or No as the options available.