



Appendix E, Business Modeling Tools

Document Overview

This document identifies the methods and tools that will be used by the As-Is Trust business modeling team to document the Department's current Trust business model.

The selected methods and tools were chosen based on the following criteria:

- Compliance with existing Government Accounting Office (GAO) standards;
- Support for process and inter-process modeling requirements; and
- The degree to which resulting deliverables can be leveraged by ongoing Departmental efforts.

Using these criteria, a number of methods and tools were evaluated. The relative merits of each selected component are identified in the following sections.

Business Modeling Methods

IDEF0

IDEF0, published 1993 by the National Institute of Standards and Technology (NIST), is the GAO standard for graphically depicting processes and functions.

The primary strength of IDEF0 is that the method has proven effective in detailing activities for function modeling, the original structured analysis communication goal for IDEF0. IDEF0 will be used to model the As Is Trust Business processes. Activities for the processes will be described by their inputs, outputs, controls, and mechanisms (ICOMs). Additionally, the description of the activities of a system can be refined into the descriptive detail required for the decision-making task at hand.¹ Figure 1 illustrates how the business processes will be presented using the IDEF0 methodology.

¹ See www.idef.com/idef0.html for a comprehensive discussion of IDEF0 strengths and weaknesses.

IDEF0's major constraint from a business modeling perspective lies in its inability to document the inter-relationships among processes, the contributions that processes make to overall performance, the organizations that participate in the process and the metrics used to monitor procedural efficacy. The solution to these constraints is addressed in the following paragraphs.

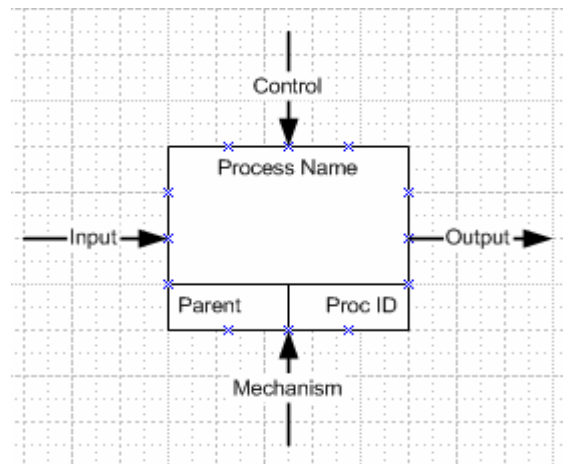

Figure 1. IDEF 0 Illustration

IDEF3

Also published by the NIST, IDEF3 captures precedence and causality relations between situations and events². While IDEF3 can be used to capture detailed characteristics of information systems that support business processes, IDEF3 will be used by the As Is Trust Business project to capture the precedence and causality relations between processes. The three causality indicators are:

where:

- ‘&’ = Process B AND Process C are BOTH executed whenever Process A is executed;

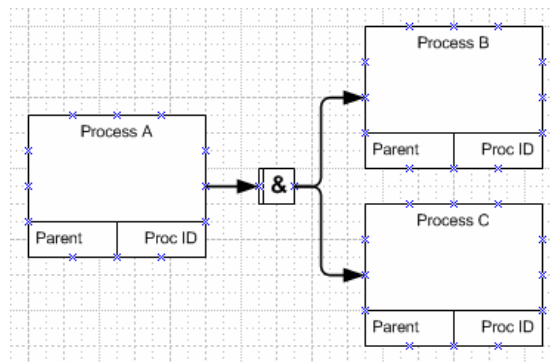

- ‘X’ = Process B OR Process C is executed whenever Process A is executed.

² See www.idef.com/idef3.html for an overview of IDEF3.

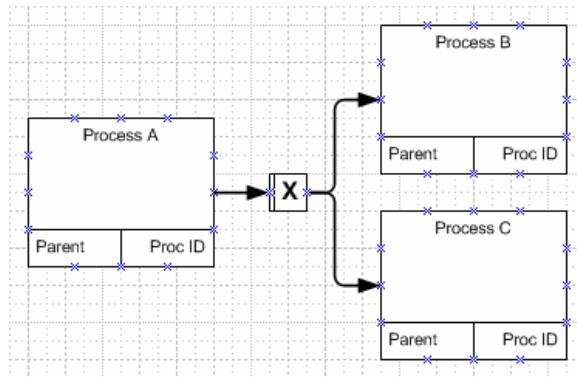

- ‘O’ = Process B OR Process C (or Process B AND Process C) is (are) executed whenever Process A is executed; and

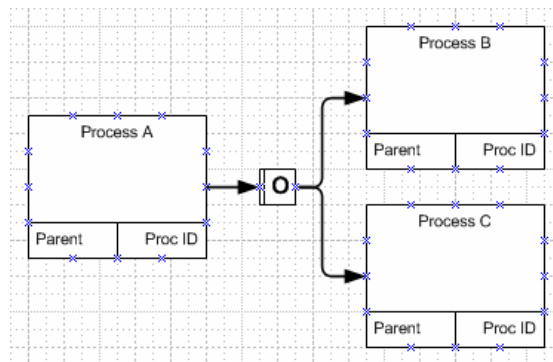

Capturing these relationships, the business modeling team can evaluate the impact of existing or proposed changes to the Department’s Trust business model.

Like IDEF0, IDEF3’s major constraint lies in its inability to document organizational contributions, process drivers and the metrics that will be used to monitor the efficacy of Trust-related DOI operations. The resolution to these constraints is addressed in the following paragraphs.

EDS TUIT Methodology

TUIT (Target, Understand, Innovate and Transform) is EDS’ overarching Business Process Reengineering methodology. Leveraging TUIT’s initial phases (Target and Understand) will enable the business modeling team to identify and document in the Access database critical process characteristics not addressed by IDEF0 and IDEF3. These characteristics include:

- Process contributions to DOI objectives



- Drivers affecting process performance
- Organizational contributions
- Performance metrics and measurements
- Process obligations (as opposed to controls)
- Initiating events
- Underlying systems of record

TUIT does not dictate the means by which process characteristics and relationships will be documented. These conventions are addressed by IDEF0 and IDEF3 above.

Business Modeling Tools

The selected tools support the methods and standards described above and enable the business modeling team to capture and analyze the Department's Trust business processes. The tools also enable the team to justify business and process improvement recommendations.

In order to facilitate the ongoing use of the modeling tools, the team interviewed the leaders of key Trust Reform initiatives to identify suites of tools that are already in use. The final selections are identified below:

Microsoft Office (Standard)

Standard Microsoft (MS) Office products will be used to manage (MS Project), analyze (MS Excel) and document (MS Word, MS PowerPoint) project deliverables. These tools are found throughout the Department and no significant training will be required for their use.

Standard Microsoft Office products do not, however, directly support the business modeling methodologies described above. The following tools provide that support.

Microsoft Visio

While not distributed as part of a packaged Microsoft Office solution, MS Visio is a fully integrated member of the Microsoft Office family. MS Visio is currently used within the Department to model the relationship between Trust-related business processes and the information technology systems that support those processes.

MS Visio incorporates direct support for IDEF0 and has been extended to support those elements of the IDEF3 standard that are required to describe the inter-process relationships. Specific symbols will be devised to graphically capture the drivers, organizational contributions and metrics that can be used to monitor process efficacy. The EDS team will identify the symbols prior to the initial training efforts.