

GOES N DATA BOOK



GOES N Data Book

Prepared for
**National Aeronautics and Space Administration
Goddard Space Flight Center
Greenbelt, Maryland 20771**

Pursuant to
Contract NAS5-98069

**Rev B
February 2005
CDRL PM-1-1-03**

This page left blank.

Contents

<i>Foreword</i>	<i>v</i>
<i>Preface</i>	<i>ix</i>
<i>Acknowledgements</i>	<i>xi</i>
1. <i>Mission Overview</i>	<i>1-1</i>
2. <i>Spacecraft Configuration</i>	<i>2-1</i>
3. <i>Imager</i>	<i>3-1</i>
4. <i>Sounder</i>	<i>4-1</i>
5. <i>Space Environment Monitor</i>	<i>5-1</i>
6. <i>Solar X-ray Imager</i>	<i>6-1</i>
7. <i>Image Navigation and Registration Subsystem</i>	<i>7-1</i>
8. <i>Communications Subsystem</i>	<i>8-1</i>
9. <i>Telemetry and Command Subsystem</i>	<i>9-1</i>
10. <i>Electrical Power Subsystem</i>	<i>10-1</i>
11. <i>Attitude Control Subsystem</i>	<i>11-1</i>
12. <i>Propulsion Subsystem</i>	<i>12-1</i>

Contents

13.	<i>Thermal Control Subsystem</i>	13-1
14.	<i>Deployment Mechanisms and Structures</i>	14-1
15.	<i>Spacecraft Support Ground System</i>	15-1
16.	<i>Spacecraft Mission Profile</i>	16-1
17.	<i>On-Orbit Mission Operations</i>	17-1
18.	<i>Instruments of Opportunity</i>	18-1
19.	<i>Technical Performance Summary</i>	19-1
20.	<i>Acronyms</i>	20-1

Foreword

The multimission Geostationary Operational Environmental Satellite (GOES) program is a key element in National Oceanic and Atmospheric Administration (NOAA) operations. GOES weather imagery and quantitative sounding data offer a continuous and reliable stream of environmental information used to support weather forecasting, severe storm tracking, and meteorological research. Evolutionary improvements in the geostationary satellite system since 1974 (i.e., since the first Synchronous Meteorological Satellite, SMS-1) have been responsible for making the current GOES system the basic element for U.S. weather monitoring and forecasting. Spacecraft and ground-based systems work together to accomplish the GOES mission.

GOES N-P will aid activities ranging from severe storm warnings to resource management and advances in science. GOES N-P data will add to the global community of knowledge, embracing many civil and government environmental forecasting organizations that work to benefit people everywhere and help save lives.

Designed to operate in geosynchronous orbit, 35,790 km (22,240 statute miles) above the equator, thereby remaining stationary relative to the earth's surface, the advanced GOES N-P spacecraft continuously view the continental United States, neighboring environs of the Pacific and Atlantic Oceans, and Central and South America. The three-axis, body-stabilized spacecraft design enables the sensors to "stare" at the earth and thus more frequently image clouds, monitor earth's surface temperature and water vapor fields, and sound the atmosphere for its vertical thermal and vapor structures. Thus the evolution of atmospheric phenomena can be followed, ensuring real-time coverage of short-lived dynamic events that directly affect public safety, protection of property, and ultimately, economic health and development. The GOES N-P series of spacecraft are the principal observational platforms for covering dynamic weather events and the near-earth space environment for the first decade of the 21st century. These advanced spacecraft enhance the capability of the GOES system to continuously observe and measure meteorological phenomena in real time, providing the meteorological community and scientists with improved observational and measurement data of the Western Hemisphere. In addition to short-term weather forecasting and space environmental monitoring, these enhanced operational services also improve support for atmospheric science research, numerical weather prediction models, and environmental sensor design and development.

Foreword

The main mission is carried out by the primary payload instruments, the Imager and the Sounder. The Imager and Sounder are Government-furnished equipment (GFE) manufactured by ITT Industries, Inc. The Imager is a multichannel instrument that senses radiant energy and reflected solar energy from the earth's surface and atmosphere and produces visible and infrared images of earth's surface, oceans, cloud cover, and severe storm developments. The Sounder provides data for vertical atmospheric temperature and moisture profiles, surface and cloud top temperature, and ozone distribution. Sounder data are also used in computer models to produce mid- and long-range weather forecasts.

A new Solar X-ray Imager (SXI), GFE manufactured by Lockheed Martin, will monitor the sun's X-rays for the early detection of coronal mass ejections and solar flares. This early warning is important because these solar flares affect not only the safety of humans in high-altitude missions, such as the Space Shuttle and International Space Station, but also military and commercial satellite communications. The GOES satellites also carry space environment monitoring instruments, built by Assurance Technology Corporation (formerly Panametrics Inc.), which monitor X-rays, extreme ultraviolet and particle emissions including solar protons, alpha particles, and electrons. These space environment monitoring instruments also include a magnetometer, built by Science Applications International Corporation (SAIC), which samples the Earth's magnetosphere. A data collection system (DCS) on GOES receives and relays environmental data sensed by widely dispersed surface platforms such as river and rain gauges, seismometers, tide gauges, buoys, ships, and automatic weather stations. Platforms transmit sensor data to the satellite at regular or self-timed intervals, upon interrogation by the satellite, or in an emergency alarm mode whenever a sensor receives information exceeding a preset level.

The GOES N-P satellites will also provide emergency communications (EMWIN). This subject is covered more fully in Section 8 of this document.

The GOES satellites transmit data collected to NOAA's Wallops, VA, ground station, which relays the data to the NOAA Satellite Operations Control Center (SOCC) in Suitland, MD. The information is then processed and distributed to users throughout the world. The search and rescue (SAR) subsystem onboard each GOES satellite is a dedicated transponder that relays the distress signals broadcast by UHF emergency locator transmitters (ELTs) carried on general aviation aircraft, emergency position indicating radio beacons (EPIRBs) aboard some classes of marine vessels, and portable personal locator beacons (PLBs). The SAR mission is performed by relaying the distress signals emitted from the ELT/EPIRBs via the GOES satellite to a Local User Terminal (LUT) ground station located within the field of view of the spacecraft.

Those desiring further information about the GOES system should contact the NOAA National Environmental Satellite, Data and Information Service (NESDIS) and/or search the following Internet addresses:

<http://www.noaa.gov/>

<http://www.nesdis.noaa.gov/>

<http://www.nws.noaa.gov/>

<http://www.ngdc.noaa.gov/>

<http://www.scijinks.nasa.gov/>

<http://www.sec.noaa.gov/>

<http://rsd.gsfc.nasa.gov/goes/>

<http://goes2.gsfc.nasa.gov/>

<http://www.lmsal.com/sxi/>

Foreword

This page left blank.

Preface

To further enhance the utility of the GOES system, this Data Book presents a summary and technical overview of the GOES N–P system, its satellites, subsystems, sensor suite, and associated ground communication and data handling subsystems. The Data Book is intended to serve as a convenient and comprehensive desktop technical reference for people working on or associated with the GOES N–P missions as well as general information suitable for public distribution. Sufficient technical information and performance data are presented to enable the reader to understand the importance of the GOES N–P mission, the system’s capabilities, and how it meets the needs of the users.

Certain performance data presented herein, e.g., Imager and Sounder radiometric performance, were predicted from or measured on previous GOES satellites. As the satellites undergo on-orbit operations and actual data are obtained, such technical information in this book may not necessarily reflect current capabilities. Furthermore, this Data Book is **not** meant to be a technical specification with absolute worst case performance numbers but rather a general document which informs the reader of nominal and typical GOES system performance and operational capabilities.

In January 1998, Hughes Space and Communications Company (HSC) of El Segundo, CA, was awarded contract number 98069 from NASA’s Goddard Space Flight Center in Greenbelt, MD. The contract included the design, manufacture, integration, and launch of two Geostationary Operational Environmental Satellites, GOES N and GOES O, with options for GOES P and GOES Q. In June 2003 the GOES P option was exercised and the GOES Q option was cancelled. The GOES program is funded, managed, and operated by the National Oceanic and Atmospheric Administration (NOAA). HSC became Boeing Satellite Systems (BSS) in October 2000. Upon completion of N through P, BSS will have built a total of eight spacecraft in the GOES series.

Based on the highly successful Boeing 601 spacecraft, the new satellites will more accurately locate severe storms and other weather phenomena, resulting in more precise warnings to the public. The three-axis Boeing 601 body-stabilized spacecraft design enables the primary sensors to “stare” at earth and thus frequently image clouds, monitor earth’s surface temperature, and sound earth’s atmosphere for its vertical temperature and water vapor distribution. Atmospheric phenomena can be tracked, ensuring real-time coverage of short-lived dynamic events, such as severe local storms, tropical hurricanes and cyclones, meteorological events that directly affect public safety, property, and ultimately, economic health and development.

Preface

BSS will furnish the communications subsystem with a search and rescue capability to detect distress signals from ships and airplanes, and will also furnish space environmental monitoring instruments and operator training. Ground station upgrades will be provided by Boeing's teammate Integral Systems Inc. Boeing will also integrate three government-furnished instruments: the Imager and Sounder built by ITT Industries, Inc., and an SXI built by Lockheed Martin.

Acknowledgements

This Data Book had major contributions from the following lead authors at Boeing Satellite Systems: Peter Landecker and Martin Gale (Entire Book, Overview, Preface, Foreword), Simin Peng and Thomas Krause (Spacecraft Configuration), John Munro (Imager, Sounder, SXI), Ing-Yung Tse (SXI), Betty Kwan and Fred Ralph (SEM), Douglas Hein (INR), Larry Pond (Communications), Dan Carlock (T&C), Bill Krummann (Power), David Uetrecht and Jeff Kurland (ACS), Jim Finseth (Propulsion), Raymond Lee and Kenneth Dopplick (Thermal). Bob Burns and Troy Conwell (Deployment Mechanisms and Structures), Thomas Firpo and Steven Lee (SSGS), Paul Birnbaum (Spacecraft Mission Profile), Gary Johnson (On-orbit Mission Operations), and George Sevaston (IOO).

Boeing GOES program management encouragement came from Peter Graf, Charles Maloney, and Steve Archer.

The Boeing publications effort was gratefully and superbly led by Christine Stevens.

Our special thanks to Dan Arnaud who reviewed the entire Data Book. The GSFC Customer Team was led by David Mitchell and David Martin, with Paula Everson coordinating customer inputs and comments. Larry Howell of ITT provided extensive information about the Imager/Sounder. Jaya Bajpayee of GSFC provided SXI details.

Acknowledgements

This page left blank.

1. Mission Overview

Mission Goals

The goals of the Geostationary Operational Environmental Satellite (GOES) system program are to:

- Maintain continuous, reliable operational, environmental, and storm warning systems to protect life and property
- Monitor the earth's surface and space environmental conditions
- Introduce improved atmospheric and oceanic observations and data dissemination capabilities
- Develop and provide new and improved applications and products for a wide range of federal agencies, state and local governments, and private users

To address these goals, the National Weather Service (NWS) and the National Environmental Satellite Data and Information Service (NESDIS) of the National Oceanic and Atmospheric Administration (NOAA) established mission requirements for the 21st century that are the basis for the design of the GOES N-P system and its capabilities. Figure 1-1 illustrates the GOES N satellite. The GOES system thus functions to accomplish an environmental mission serving the needs of operational meteorological, space environmental, and research users.

1. Mission Overview

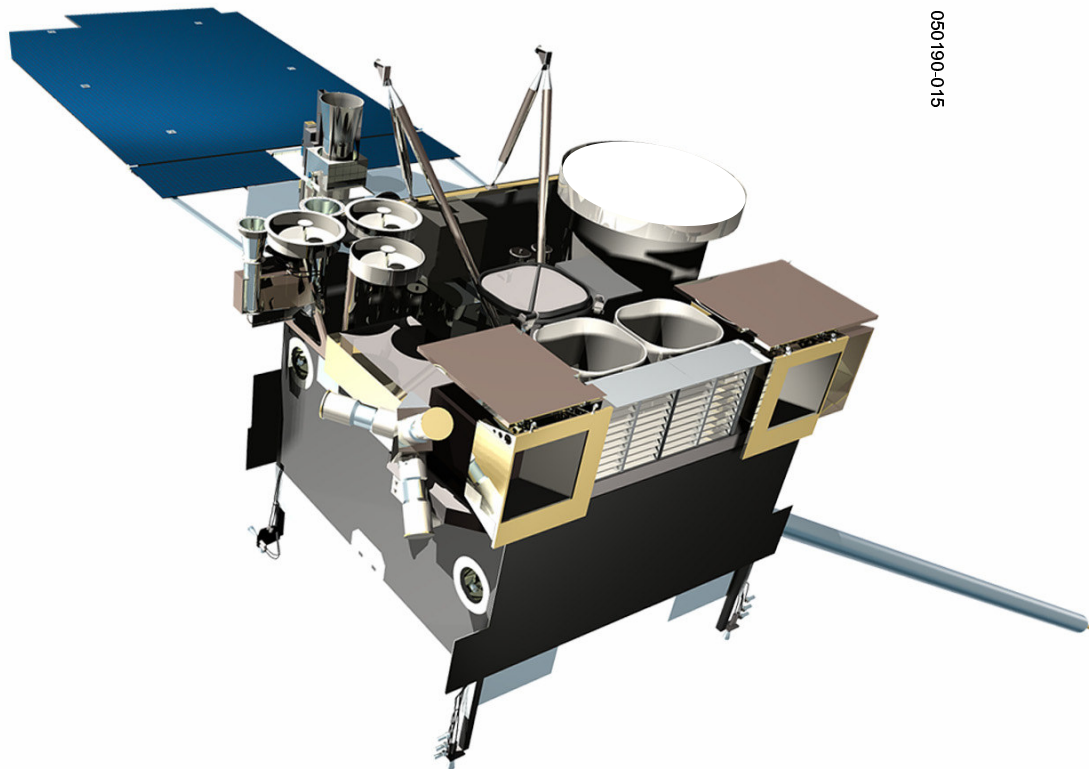

050190-015

Figure 1-1. GOES N Satellite

GOES System

To accomplish the GOES mission, the GOES N-P series of spacecraft perform three major functions:

- *Environmental sensing*—Acquisition, processing, and dissemination of imaging and sounding data, space environment monitoring data, and measurement of the near-earth space weather.
- *Data collection*—Interrogation and reception of data from earth surface-based data collection platforms (DCPs) and relay of such data to the National Oceanic and Atmospheric Administration (NOAA) command and data acquisition stations.
- *Data broadcast*—Processed data relay (PDR) of environmental sensor data. The relay of distress signals from aircraft or marine vessels to the search and rescue satellite-aided tracking system (SARSAT). The continuous relay of weather facsimile (WEFAX/LRIT) and other meteorological data to small users and the relay of emergency weather information to Civil Emergency Managers.

The three major mission functions are supported or performed by the following components of the GOES N-P payloads:

1. Mission Overview

Environmental remote sensing

- Imager (earth atmosphere)
- Sounder (earth atmosphere)
- Space environment monitor (SEM)
 - Energetic particle sensor (EPS)
 - High energy proton and alpha particle detector (HEPAD)
 - X-ray sensor (XRS)
 - Extreme ultraviolet (EUV) instrument
 - Magnetometers
- Solar X-ray Imager (SXI)

Data collection

- Data collection system (DCS)
- Search and rescue (SAR)

Data broadcast

- Processed data relay (PDR), WEFAX/LRIT and emergency weather information (EMWIN) transponders
- Sensor data and multi use data link (MDL) transmitter

Telemetry and Command

- The T&C system controls and monitors the health and safety of the spacecraft (Details of the T&C system can be found in Section 9).

The environmental remote sensing function is executed by the 5-channel Imager and the 19-channel Sounder, both of which offer fine spatial and spectral resolution. *In-situ* sensing is performed by the SEM covering an extensive range of energies. Sensed data are acquired, processed, and distributed to users in real time to meet observation time and timeliness requirements, including revisit cycles. Remotely sensed data are obtained over a wide range of areas of the western hemisphere, encompassing the earth's disk, selected sectors, and small areas. Area coverage also includes the ability needed to relay signals and data from ground transmitters and platforms to central stations and end users.

To accomplish the GOES system mission, space and ground segments are interconnected as shown in Figure 1-2.

1. Mission Overview

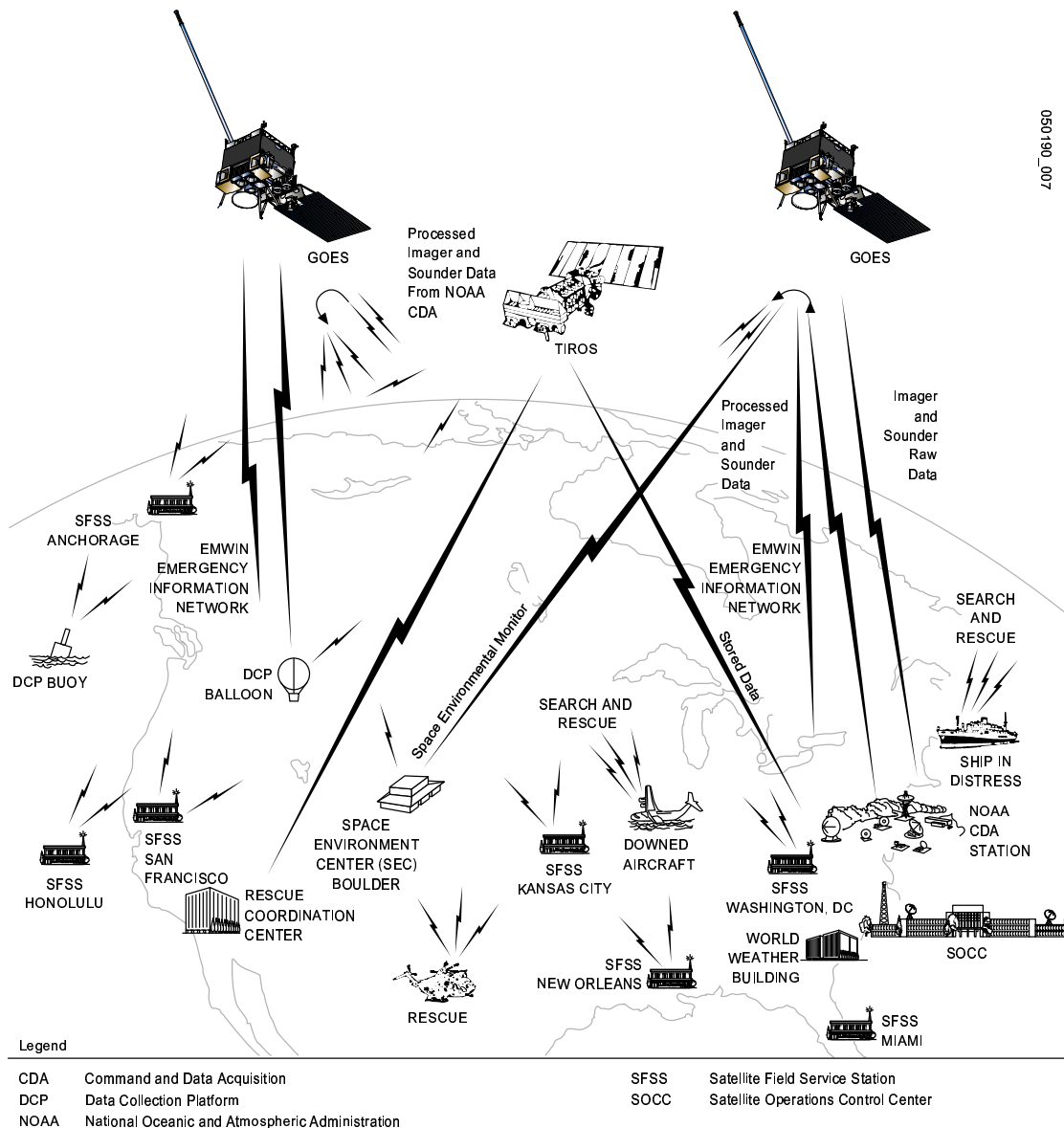

Figure 1-2. 21st Century Weather Watch System

Space Segment

The GOES N-P series of spacecraft are the prime observational platforms for covering dynamic weather events and the near-earth space environment for the 21st century. These advanced spacecraft enhance the capability of the GOES system to continuously observe and measure meteorological phenomena in real time, providing the meteorological community and atmospheric scientists of the western hemisphere with greatly improved observational and measurement data. These enhanced operational services improve support for short-term weather forecasting and space environment monitoring

1. Mission Overview

as well as atmospheric sciences research and development for numerical weather prediction models, meteorological phenomena, and environmental sensor design.

Observational Platform

The advanced GOES N-P spacecraft three-axis, body-stabilized design enables the sensors to “stare” at the earth and, thus, more frequently image clouds, monitor the earth’s surface temperature and water vapor fields, and sound the earth’s atmosphere for its vertical thermal and water vapor structures. Thus, the evolution of atmospheric phenomena can be followed, ensuring real-time coverage of short-lived, dynamic events, especially severe local storms and tropical cyclones. These are meteorological events that directly affect public safety, protection of property, and, ultimately, economic health and development. Various design features of the GOES spacecraft enable high volume, high quality data to be generated for the weather community. There are two important capabilities. The first is flexible scan control—a capability that allows small area coverage for improved short-term weather forecasts over local areas—and simultaneous, independent imaging and sounding. The second is precision on-orbit stationkeeping, coupled with three-axis stabilization, ensures a steady observational platform for the mission sensors, greatly increasing earth-referenced data location and measurement accuracy. To maintain location accuracy, an image navigation and registration (INR) methodology is employed. This methodology uses geographic landmarks and star locations sensed, via the primary instrument, and ranging via the spacecraft communications system to maintain that location accuracy. The INR subsystem provides daily imaging and sounding data on a precisely located, fixed earth coordinate grid without ground interpolation. Key GOES N-P spacecraft parameters are given in Table 1-1.

Imager

The GOES Imager is a five-channel, multi-spectral imaging radiometer, designed to sense emitted thermal energy and reflected solar energy from sampled areas of the Earth’s surface and atmosphere. The Imager provides data for use in determining cloud cover, cloud temperature and height, surface temperature, and water vapor. Using a two-axis gimballed scan mirror system, the Imager’s multi-element spectral channels simultaneously sweep an 8-km north-south (N-S) swath along an east-west (E-W) path at a fixed rate of 20° per second and cover a chosen area by a serpentine scan. The instrument is capable of full Earth imagery, sector imagery that contains the edge of the Earth, and various sizes of area scans totally enclosed within the Earth disk. Area scan selection permits rapid, continuous viewing of local regions for monitoring of mesoscale phenomena and accurate wind determination. Area scan size and location are definable to as small as one pixel to provide complete flexibility and are controlled by a defined set of ground issued commands. All spectral channels are spatially co-registered to each other. The Imager’s scanner, in conjunction with the visible detector array provides a star sensing capability to relate the spacecraft location to the scanned area.

1. Mission Overview

Sounder

The GOES Sounder is a 19-channel discrete-filter radiometer, designed to sense emitted thermal energy and reflected solar energy from sampled areas of the Earth's surface and atmosphere to provide data for computing vertical profiles of temperature and moisture, surface and cloud-top temperatures, and ozone distribution.

Table 1-1. GOES N-P Spacecraft Specifications

Communications and T & C		Power	
S-band	5 uplinks	Solar Array	
S/L-band	7 downlinks	End of life (10 years)	1.9 kW solstice, 2.08 kW equinox
UHF	1 downlink, 2 uplinks	Panels	1 wing with 1 panel of dual- junction gallium arsenide solar cells. Also solar cell circuits on the yoke panel.
T&C	2 downlink, 1 uplink	Batteries	24-cell Ni-H ₂ , 123 A-Hr
Propulsion		Mass	
Liquid apogee motor	110 lbf (490 N)	Separated mass	3217.3 kg (7092.9 lb)
Stationkeeping thrusters (bipropellant)	12 x2 lbf (9.25 N)	Dry mass	1545.7 kg (3407.6 lb)
		Propellant and pressurant	1671.6 kg (3685.3 lb)
Antennas		Launch Vehicle Compatibility	
2 S/L-band, cup-shaped with dipole		Delta IV	Atlas III
1 omni antenna			
1 UHF, cup-shaped with dipole			
2 L-band cup			
1 S-band horn			

The Sounder has multi-element detector arrays to perform simultaneous sampling of the radiation from a group of four stationary locations in the atmosphere at any given instant. These four fields of view (FOVs) are stepped to cover larger areas with a scan mirror. The infrared (IR) spectral definition is provided by a sequence of filters interposed in the radiation path at each step by a cooled rotating filter wheel. A total of 18 filters in three spectral bands, longwave (LW) (12 μm to 14.7 μm), midwave (MW) (6.5 μm to 11 μm), and shortwave (SW) (3.7 μm to 4.6 μm), are arranged along three

1. Mission Overview

concentric rings on the wheel for efficient use of sample time and optimal channel co-registration. In addition, a visible channel using uncooled silicon detectors also samples the same atmospheric locations. The 19 spectral channels provide outputs from each of the four FOVs in each sample (dwell) period, which may be chosen to be at 0.1, 0.2, or 0.4 second intervals. Optionally, scan lines can be skipped to increase area sounding rates.

A two-axis-gimbaled scan mirror system can generate frames of different sizes or locations by stepping the Sounder's FOVs by 280 μ rad along an east-west (E-W) path followed by a north-south (N-S) step of 1120 μ rad and retracing along a serpentine scan. The stepping motion of the scanner occurs when the optical path is blocked during every rotation of the filter wheel. The instrument is capable of full Earth sounding, sector sounding that contains the edge of the Earth, and various sizes of area scans totally enclosed within the Earth disk. Area scan selection permits rapid, sounding of local regions for monitoring of mesoscale phenomena. Area scan size and location are definable to as small as one pixel sounding location to provide complete flexibility and are controlled by a defined set of ground issued commands. The FOVs of the different channels are spatially co-registered. The Sounder scanner and a second visible detector array provide a star sensing capability to relate the spacecraft location to the scanned area.

Flexible Scan Control

Both the Imager and the Sounder employ a servo-driven, two-axis gimbaled mirror system in conjunction with a 31.1 cm (12.2 inch) diameter aperture Cassegrain telescope. As separate sensors, they allow simultaneous and/or independent surface imaging and atmospheric sounding. Each has flexible scan control, a feature enabling coverage of small areas as well as hemispheric (North and South America) and global scenes (earth's full disk), and close-up, continuous observations of severe storms and dynamic, short-lived weather phenomena. The GOES area scan capabilities for the Imager are illustrated in Figure 1-3. The scan capabilities of the Sounder are described in the paragraph above. Detailed information on the Imager can be found in Section 3 and on the Sounder in Section 4.

A priority scan feature allows improved scheduling of small area and mesoscale scans for short range forecasts and storm warnings. Imager large area scans of 3000 \times 3000 km (1864 \times 1864 statute miles) are accomplished in 3 minutes; small area scans of 1000 \times 1000 km (621 \times 621 statute miles) can be made in 41 seconds; the full earth can be imaged in 26 minutes. A 3000 \times 3000 km area can be sounded in 43 minutes.

Space Environment Monitor

The SEM instruments survey the sun and measures in situ its effect on the near-earth solar-terrestrial environment. Changes in this "space weather" can affect the operational reliability of navigation and communication systems, over-the-horizon radar, electrical power transmission, and, most significantly, human crews of the International Space Station, of high altitude aircraft and the U.S. space shuttle. This suite of space

1. Mission Overview

environmental monitoring instruments is used to determine when to issue forecasts and alerts of space weather conditions that may interfere with ground and space systems.

The XRS measures the X-ray flux from the sun and provides the primary measure of the magnitude of solar flares. The EUV sensor measures the extreme ultraviolet flux from the sun, which is the primary energy input to the upper atmosphere and ionosphere.

The EPS and HEPAD detect energetic electron and proton radiation trapped within earth's magnetic field as well as direct solar proton, alpha particles and cosmic rays.

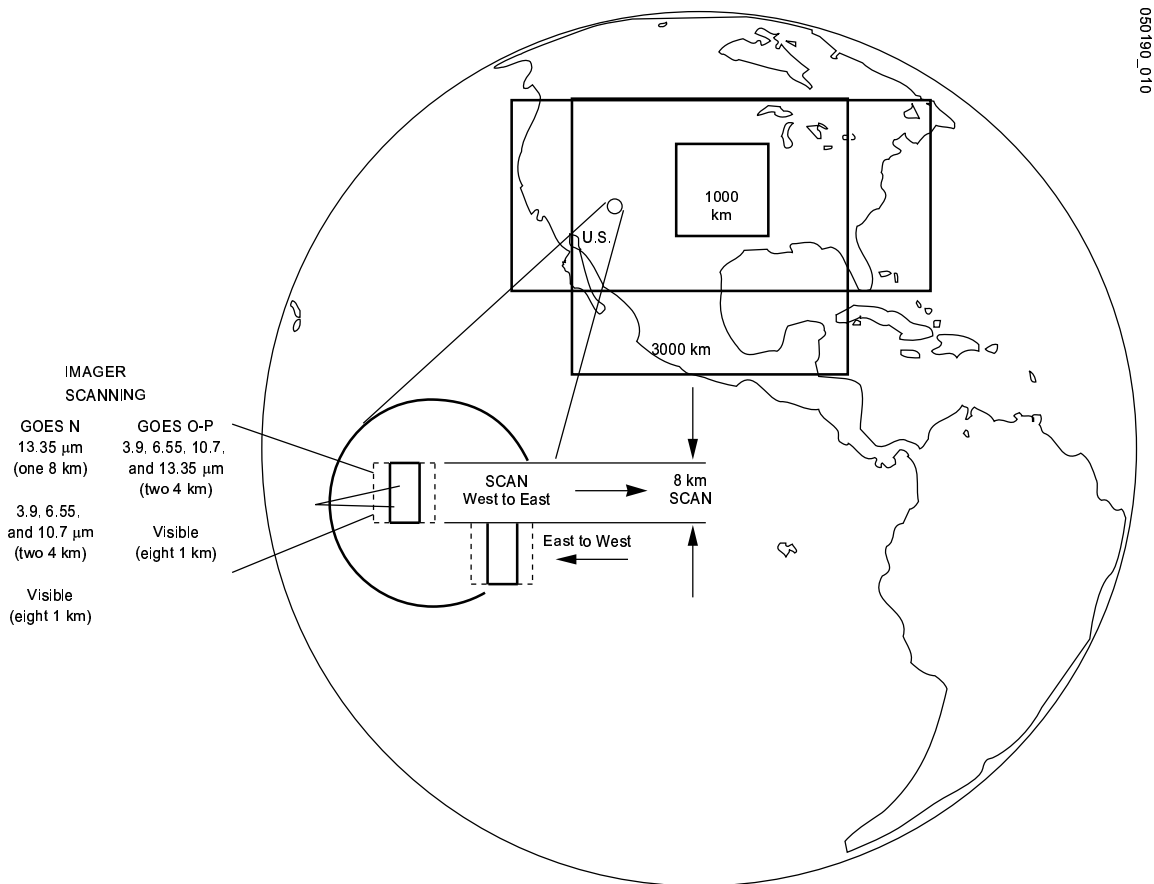

Figure 1-3. Imager Area Scan

The magnetometer measures three components of earth's magnetic field in the vicinity of the spacecraft and monitors variations caused by ionospheric and magnetospheric current flows.

1. Mission Overview

Solar X-Ray Imager

The Solar X-ray Imager (SXI) monitors solar disk activity and is used to determine when to issue forecasts and alerts of “space weather” conditions that may interfere with ground and space systems. It is used to locate coronal holes, locate flares on the solar disk, monitor for changes indicating coronal mass ejections, and observe solar active region size, morphology, and complexity. These data are used to predict high speed solar wind streams and solar flare forecasts. The SXI is considered separate from the SEM, and we use that organization in this Data Book. The SXI, XRS, and EUV are mounted on the solar array yoke in order to continuously face the sun.

Other Data Services

GOES also enhances services for receiving meteorological data from earth-based data collection platforms and relaying the data to end-users. A continuous, dedicated search and rescue transponder onboard the spacecraft immediately detects distress signals from downed aircraft or marine vessels and relays the signals to ground terminals to speed help to people in need. Increased communications capacity permits transmission of processed weather data and weather facsimile for small local user terminals in the western hemisphere. Emergency Managers Weather Information Network (EMWIN) relay is new for GOES N-P and is used to broadcast weather related emergency notifications to thousand of users.

Geographic Coverage

The GOES spacecraft, on-station 35,790 km (22,240 statute miles) above the equator and stationary relative to the earth’s surface, can view the contiguous 48 states and major portions of the central and eastern Pacific Ocean and the central and western Atlantic Ocean areas and the South American continent. Pacific coverage includes the Hawaiian Islands and the Gulf of Alaska. Because the Atlantic and Pacific basins strongly influence the weather affecting the United States, coverage is provided by two GOES spacecraft, one—GOES East—at 75° west longitude and the other—GOES West—at 135° west longitude. Geographic coverage for this configuration is shown in Figure 1-5. Alternately, if one spacecraft should fail, the remaining spacecraft can be moved to a central location (100° West) and provide coverage as illustrated in Figure 1-4. The term “useful camera coverage” referenced in the figure refers to the 60° circle coverage provided by the GOES satellite.

1. Mission Overview

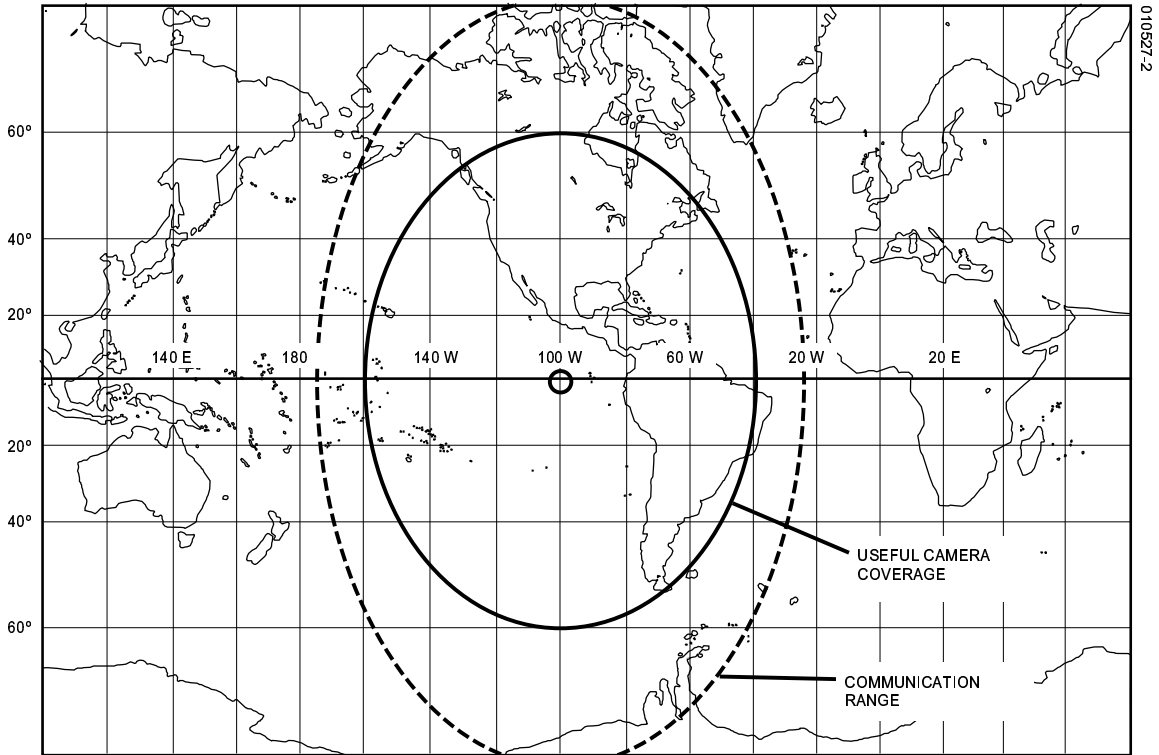

Figure 1-4. GOES Geographic Coverage for Backup One Satellite System

1. Mission Overview

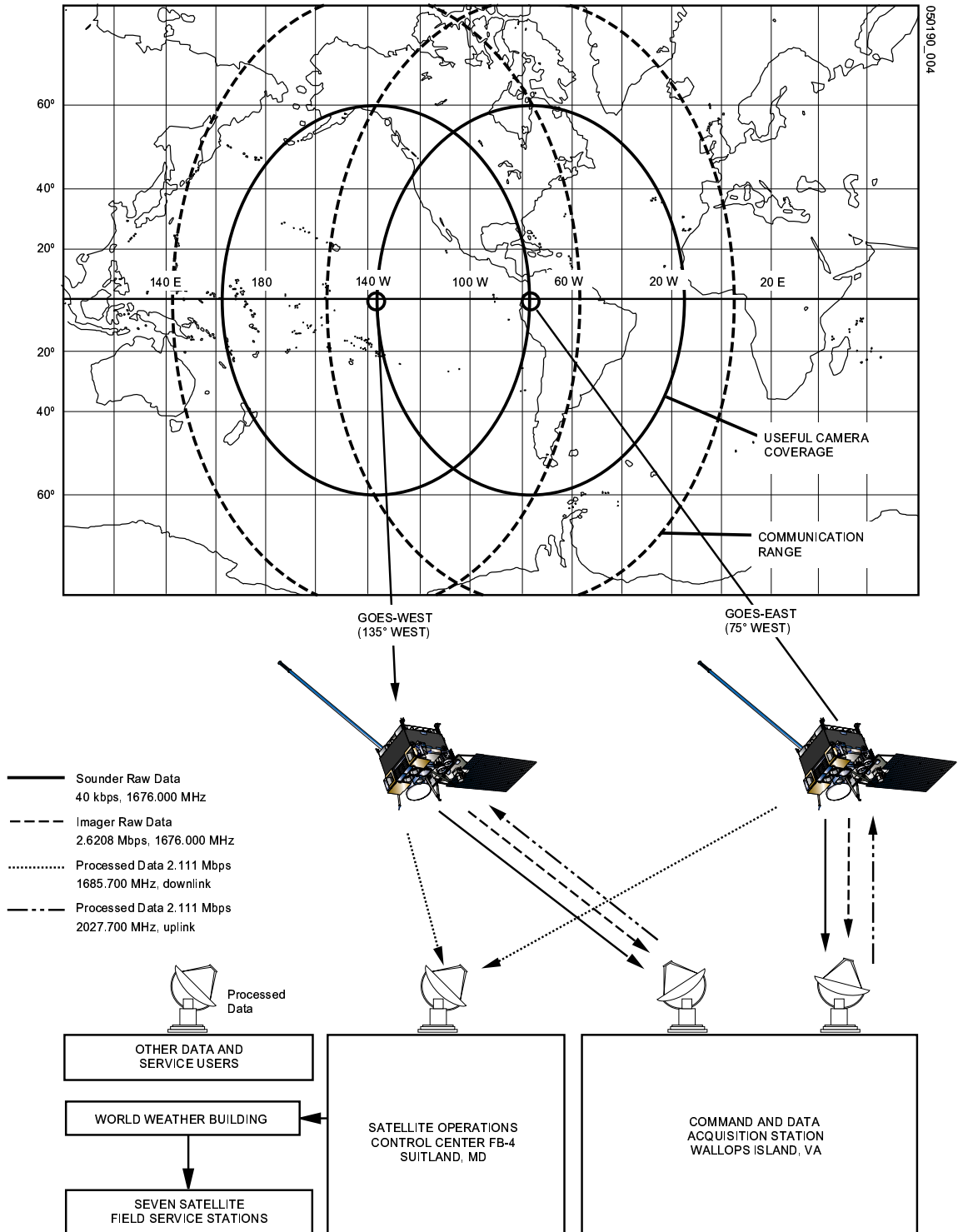

Figure 1-5. GOES Nominal Two Satellite Geographic Coverage and System Functional Architecture

1. Mission Overview

The combined footprint (radiometric coverage and communications range) of the two spacecraft encompasses earth's full disk about the meridian approximately in the center of the continental United States. Circles of observational limits centered at a spacecraft's suborbital point extend to about 60° north/south latitudes. The radiometric footprints are determined by the limit from the suborbital point, beyond which interpretation of cloud data becomes unreliable. At least one GOES spacecraft is always within line-of-sight view of earth-based terminals and stations. The command and data acquisition (CDA) station has a line of sight to both spacecraft so that it can uplink commands and receive downlinked data from each simultaneously. Data collection platforms within the coverage area of a spacecraft can transmit their surface-based sensed data to the CDA station and end user direct readout ground stations (DRGSs) via the onboard data collection subsystem. Similarly, ground terminals can receive processed environmental data, as well as EMWIN and WEFAX/LRIT transmissions.

Ground Segment

Raw Imager and Sounder data received at the NOAA CDA station are processed in the spacecraft support ground system (SSGS) with other data to provide highly accurate, earth-located, calibrated imagery and sounding data in near real time for retransmission via GOES spacecraft to primary end users, typically the NOAA NWS field service stations located throughout the United States. Operational management and planning are performed at the Satellite Operations Control Center (SOCC), where all elements of the system are monitored, evaluated, scheduled, and commanded.

Network Architecture

The communications links are shown in Table 1-2. These links, in conjunction with ground support equipment connectivity and data transmission paths, complete the interfaces among GOES N-P-specific and existing equipment, and are illustrated in Figures 1-2, 1-5, and 1-6. This network, transparent to current users, routes broadcast and mission data. The serial bit streams output by the Imager and the Sounder are transmitted on the L-band carrier by the sensor data transmitter. The GOES spacecraft signal is received at the CDA station, where it is demodulated and processed by the SSGS. The new uplink signal, containing calibrated, earth-located data, is uplinked from the CDA station to the spacecraft, where it is received by the S-band receiver, and converted to the appropriate transmit frequency. Before being multiplexed and retransmitted to user stations by the L-band transmit antenna, the signal is prefiltered to separate it from other uplinked signals.

1. Mission Overview

Table 1-2. Communications Links

Item	Source	Uplink, MHz	Downlink, MHz	Destination
Command	CDA station, DSN	2034.200	---	Spacecraft
Telemetry (including SEM)	Spacecraft	---	1694.000/2209.086	CDA station; DSN; Space Environment Center
Weather Facsimile (WEFAX/LRIT)	CDA station	2033.000	1691.000	Users
Data collection platform interrogate (DCPI)	CDA station	2034.900	468.825	DCP
Data collection platform report (DCPR)	DCP	Domestic: 401.900 International: 402.200	1694.500 1694.800	CDA station; users
Search and rescue (SAR)	Emergency locator transmitter (ELT)	Narrow Band: 406.025 Wide Band: 406.050	1544.500	Mission Control Center
MDL (diagnostic data)	Spacecraft	---	1681.500	SOCC, SEC
Emergency Managers Weather Information Network (EMWIN)	CDA station	2034.700	1692.700	Civil Emergency Managers
Processed Data Relay (PDR)	CDA station	2027.700	1685.700	Users
Sensor Data Downlink (SD)	Spacecraft	---	1676.000	CDA station

1. Mission Overview

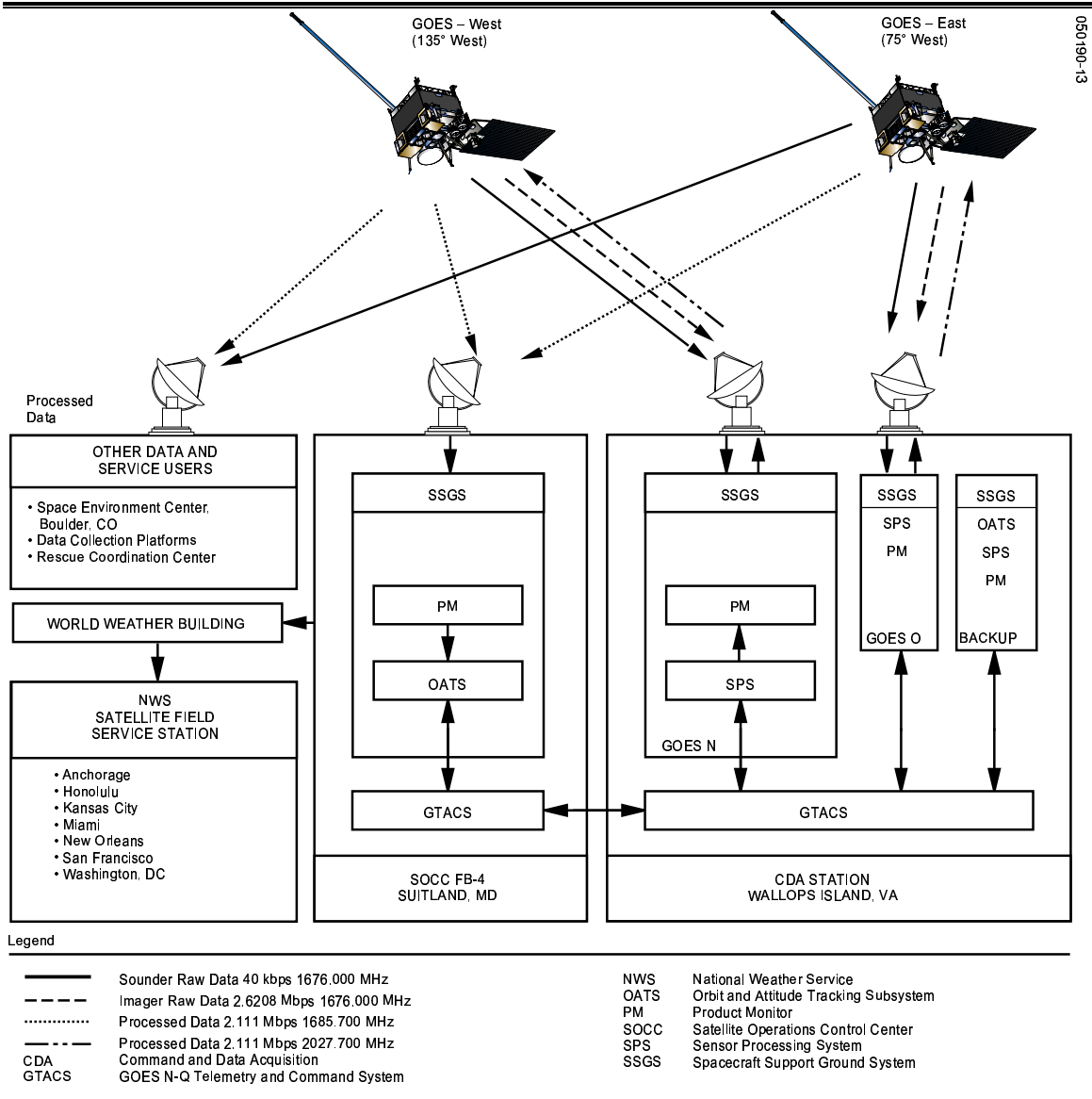

Figure 1-6. Data Transmissions

GOES Processed Data Relay

The GOES PDR data transmission format, referred to as GVAR (GOES Variable Data Format) is primarily used to transmit Imager and Sounder meteorological data. It also includes telemetry, calibration data, text messages, spacecraft navigation data, and auxiliary products. The PDR format originated in the operational visible infrared spin scan radiometer, atmospheric sounder (VAS) mode AAA of the earlier spin-stabilized GOES spacecraft. The AAA format consisted of a repeating sequence of 12 fixed-length, equal size blocks whose transmission was synchronized with spacecraft spin rate (that is, one complete 12-block sequence for each rotation). The range and flexibility of satellite operations are increased by the deployment of the three-axis stabilized

1. Mission Overview

GOES N-P spacecraft, which, like the GOES 8/12 spacecraft, employ two independent instruments, each with a scanning mirror having two degrees of freedom. The use of a fixed-length transmission format would have constrained the operational capabilities of the N-P spacecraft. To fully exploit these capabilities, the GVAR PDR format was developed for the GOES 8/12 spacecraft, supporting variable length scan lines while retaining as much commonality as possible with AAA reception equipment.

Spacecraft Support Ground System

The SSGS consists of components located at the CDA station on Wallops Island, VA, the Wallops Backup CDA station in Greenbelt, MD, and at the SOCC in Suitland, MD. The SSGS receives input streams of raw Imager and Sounder data from the spacecraft. Primary outputs are PDRs of those data streams in GVAR format. One GVAR-formatted output data stream is generated for each spacecraft downlink data stream. The GVAR data stream is transmitted to its corresponding GOES spacecraft for relay to primary system users as well as back to the CDA station and SOCC for other SSGS functions. SSGS elements communicate among each other via the GOES N-P telemetry and command system (GTACS). Within the SSGS, GVAR data are used primarily for monitoring the quality of processed instrument data (CDA station and SOCC), for determining spacecraft range and extracting landmark images as part of orbit and attitude determination, and for monitoring onboard computation of north/south and east/west image motion compensation to provide continuous scan frame registration. In addition, data from the MDL are received at the SOCC as an independent data link. These data are ingested and processed by the SSGS and used for diagnosing dynamic interactions among the instruments and the spacecraft. The MDL is also received by the Space Environment Center (SEC) in Boulder, CO, for the ingest of SXI and SEM data.

1. Mission Overview

This page left blank.

2. GOES Spacecraft Configuration

The GOES N-P spacecraft is a three-axis, body-stabilized design based on the successful Boeing 601 product line. It features instrument accommodation and design margins for low risk and growth. This permits the Imager and Sounder to continuously observe the earth and thus monitor, track, and acquire extensive data on dynamic weather events. The spacecraft and associated instrument subsystems summarized here are described in more detail in the respective sections of this data book.

On-Orbit Configuration

Figure 2-1 shows the GOES spacecraft in a fully deployed, on-orbit configuration. The Imager and Sounder instruments are colocated with the stellar inertial attitude sensors on a common baseplate supported by structural flexures and attached to the nadir panel. (+Z) The Imager and Sounder electronics, antennas, and multiplexers also reside on the nadir panel. The Imager and Sounder power supplies are mounted on the aft face (-Z) of the nadir panel along with bus electronics. See Figure 2-3 for a spacecraft expanded overview.

Reaction wheels are mounted to the aft corners of the spacecraft main body. The single panel solar array provides a clear Field of View (FOV) for the Imager and Sounder coolers, maximizing their radiometric performance. The solar array, populated with efficient dual-junction gallium arsenide solar cells, has been optimized to provide ample power while stowed for the spinning transfer orbit and when deployed in the on-orbit configuration. Dual junction cells minimize array size to support substantial Attitude Control System (ACS) momentum storage margins.

Clear FOVs are provided for all instrument apertures and thermal radiators. The Imager and Sounder radiant coolers have a near hemispherical FOV with only minor thermal backloading coming from the deployed magnetometer boom. Elimination of the solar sail used on GOES I-M removed the major contributor to thermal backloading and results in a measurable increase in radiometric performance.

The Solar X-Ray Imager (SXI), X-Ray Sensor (XRS), and Extreme Ultraviolet (EUV) sensor are mounted on an N-S gimballed platform attached to the solar array yoke. The Space Environment Monitor (SEM) instruments are located on the zenith (aft) -Z side of the spacecraft except for the energetic proton, electron, and alpha detectors, which are located on the exterior face of the south facing (-Y) bus radiator panel.

2. GOES Spacecraft Configuration

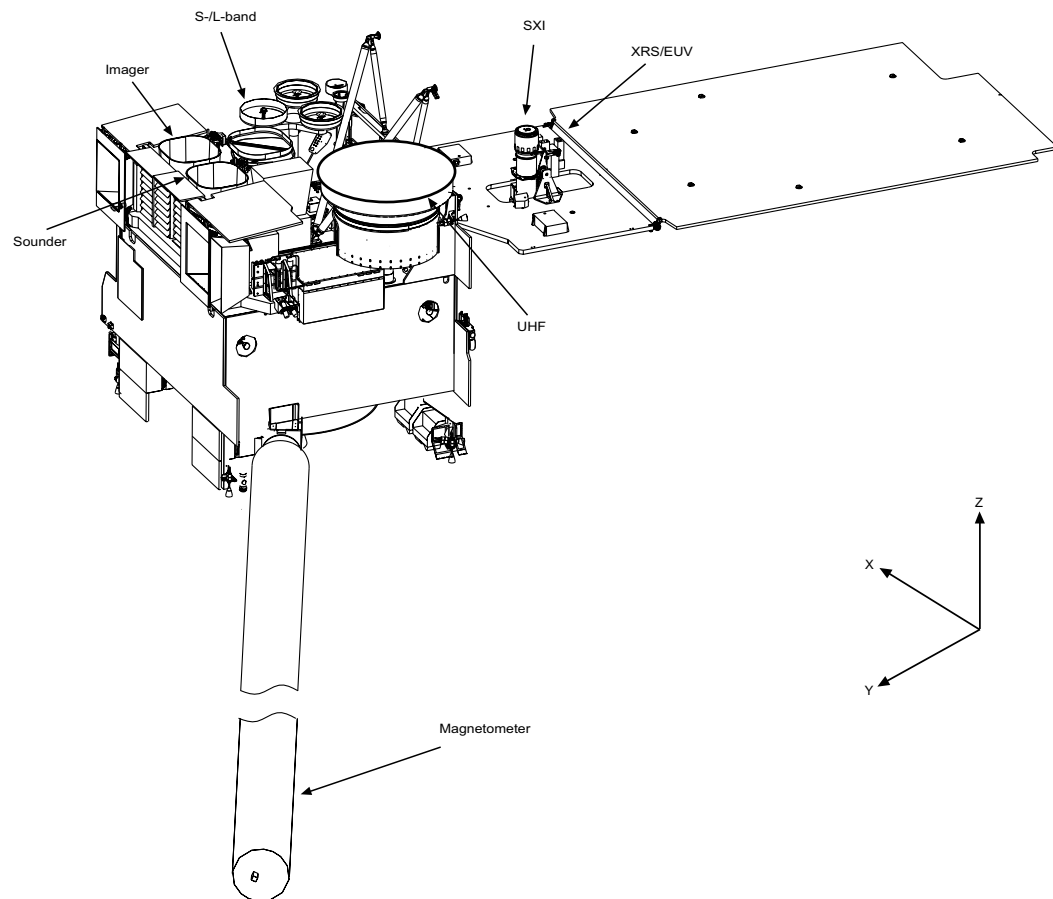

Figure 2-1. GOES N-P Spacecraft On-orbit Configuration

An uncontaminated magnetic field at the magnetometer is ensured by the use of an 8.5 meter boom. Detailed analysis has shown the boom to be fully compatible with the spacecraft control system with no impact on INR performance. The deployed boom is encapsulated by a “thermal sock” that averts distortion caused by differential shading and protects against thermal snap.

The basic GOES N-P bus provides most of the essential features required to satisfy GOES stringent electromagnetic compatibility requirements. Bus electronics and the major propulsion components are located inside the bus cavity, which is enclosed by an all aluminum exterior that functions as an EMI-tight Faraday cage.

2. GOES Spacecraft Configuration

Launch Configuration

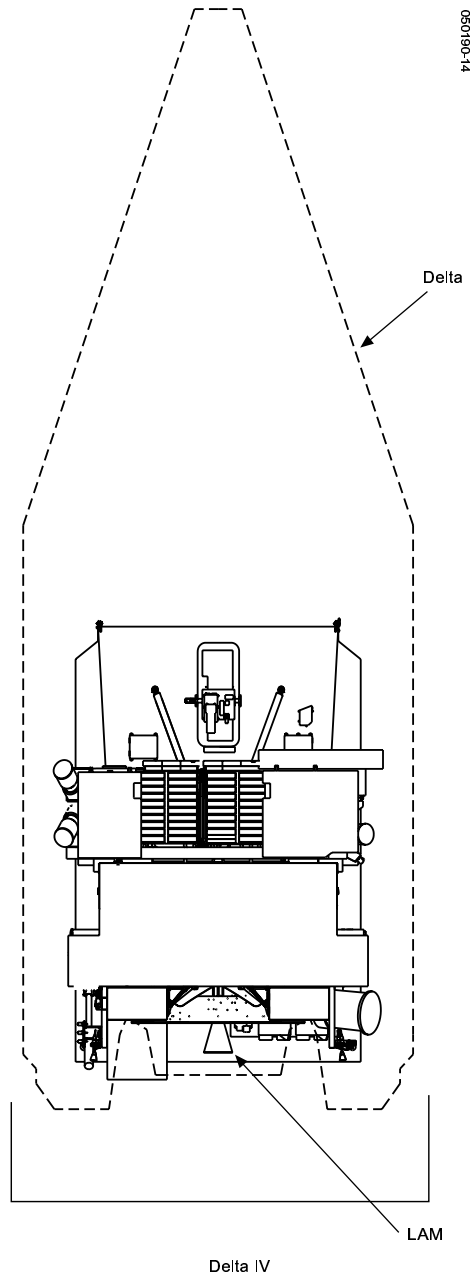

Figure 2-2. GOES N-P Launch Configuration

The compact stowed configuration is fully compatible with the Delta IV (Figure 2-2) as well as the Atlas III launch vehicle. Coupled loads analyses for both launch vehicles confirm adequate design margins for critical instrument launch loads and show robust margins on the bus, which has been qualified for payloads much larger than GOES N-P. For contamination protection, the Imager and Sounder apertures are covered during launch and ascent. Stowed mass properties support a benign separation and an

2. GOES Spacecraft Configuration

operationally simple, passively stable spinning transfer orbit mode, which is standard for all Boeing 601 spacecraft. Transfer orbit power is supplied by the stowed solar array. No time-critical deployments are associated with transfer orbit operations.

Boeing 601 Heritage

Spacecraft subsystems for GOES N-P retain extensive heritage from the on-going Boeing 601 product line. Primary structural modifications consist of adding the Imager/Sounder baseplate and magnetometer boom, resizing the solar array, redesigning the yoke, and adding Faraday enclosures for nadir mounted electronics. The communication subsystem consists of existing design components tailored for GOES requirements. The power electronics have been modified to include a 42 volt instrument bus, a single point ground, and low magnetics. Both controls and T&C electronics have been modified to accommodate instrument interfaces. Slip rings have been added to the Solar Array Drive (SAD)/Electrical Contact Ring Assembly (ECRA) to accommodate signals from the yoke-mounted instruments.

Subsystem Design and Margins Summary

The overall subsystem hardware architecture, along with component redundancy and key functional relationships, are shown in Figure 2-3. All subsystems have been designed to accommodate growth specified for the Government furnished equipment (GFE) instruments and show margin above this growth configuration. The following paragraphs briefly describe each subsystem.

Structure and Mechanisms

The major components of the structure subsystem are the cruciform assembly with propulsion supports, the north-south radiators, east-west closeout panels, a thrust tube, and the launch vehicle adapter interface. The propulsion tanks are mounted inside the bus cavity, which serves as the structural support and Faraday cage enclosure. The SAD, with its integral ECRA, provides the mechanical and electrical interface between the solar array and yoke-mounted sensors and the spacecraft bus. The Solar Array Actuator (SAA), which deploys the solar array, is the viscously damped spring-driven actuator used on the Boeing 601. The X-Ray Positioner (XRP) is a combination of the standard Boeing 601 motor, existing gearhead, and an existing Alternate Bearing Support (ABS).

Thermal

Thermal regulation of the spacecraft is accomplished through a combination of multi-layer insulation, radiators, and automatic heater control. The primary spacecraft radiator is located on the south side (-Y, solar panel facing). For high thermal dissipaters, flight-proven Boeing 601 heat pipes are used to channel thermal energy to the radiators.

2. GOES Spacecraft Configuration

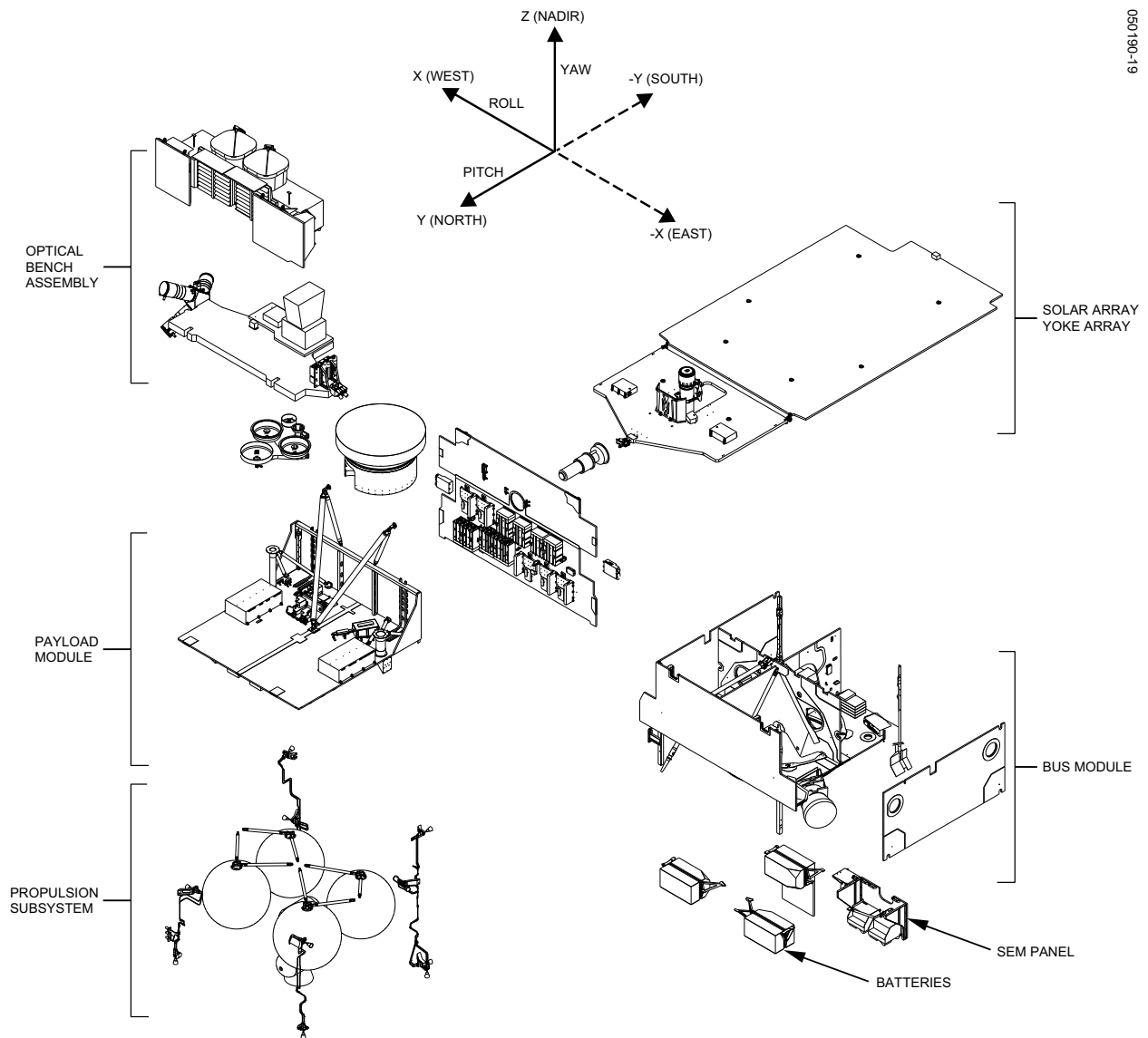

050190-19

Figure 2-3. GOES N-P Spacecraft Expanded Overview

Electrical Power Subsystem

The integrated power controller (IPC) coordinates the storage, regulation, and dissipation of the generated power. On-orbit solar array power is provided by a deployable solar array populated with high-efficiency dual-junction gallium arsenide solar cell circuits. A 24-cell nickel-hydrogen 123 A-hour battery, configured as three 8-packs, stores electrical energy. The power distribution units (PDUs) distribute fused load power via three closely regulated power buses at 53, 42, and 30 volts. Heater control relays are incorporated into each PDU to provide switching for heater loads.

2. GOES Spacecraft Configuration

Imager and Sounder

The Imager and Sounder are the two primary GOES instruments. The Imager is used to sense five channels of visible and infrared radiant and solar reflected energy from sampled areas of the earth. The Sounder is a 19 channel visible and infrared discrete filter radiometer that senses specific data parameters for atmospheric vertical temperature and moisture profiles, surface and cloud top temperature and ozone distribution. Both instruments are capable of providing full earth and sector imagery as well as scans of local regions. The Imager and Sounder are independent instruments that can be operated simultaneously. Both are GFE built by ITT.

Space Environment Monitor

The SEM subsystem is used to monitor the conditions of the space environment and to determine when to issue forecasts, alerts, and warnings. It provides alerts of space weather conditions that may interfere with ground and space systems. The subsystems consist of the XRS, the EUV sensor, EPS (consisting of the Magnetospheric Proton Detector [MAGPD], Magnetospheric Electron Detector [MAGED], Energetic Proton Electron Alpha Particle Detector [EPEAD]), HEPAD, and dual magnetometers. The magnetometers are mounted near the end of the 8.5 m boom and measure Earth's varying magnetic field in the vicinity of the spacecraft. The XRS and EUV detect solar x-ray and extreme ultraviolet (EUV) solar radiation. They are colocated with the SXI on the solar array yoke. Two EPEADs facing east and west are used to meet the coverage requirements for solar energetic protons, electrons, alpha particles and radiation belt electrons. The magnetospheric particle detectors consisting of the MAGED for electrons, and the MAGPD for protons cover the zenith hemisphere and are based on the detectors used in the POES/NOAA SEM suite. The HEPAD is the same unit currently being flown on GOES 8/12, oriented to look toward zenith, and meet the coverage requirements for high-energy solar protons and galactic cosmic rays.

Solar X-ray Imager (SXI)

The SXI is a GFE instrument built by Lockheed Martin and used to determine when to issue forecasts and alerts of "space weather" conditions that may interfere with ground and space systems. It consists of a telescope imaging the solar corona in the soft x-ray to XUV region of the electromagnetic spectrum. The SXI telescope is mounted on the x-ray positioner (XRP) and its three electronics boxes are mounted on the solar array yoke of the GOES spacecraft.

Telemetry and Command

The T&C subsystem is partitioned into an RF group and a digital electronics group. The RF group consists of an aft (-Z) omni antenna and forward (+Z) S-band and L-band horn antennas and transponders. The uplink command is received by both the forward S-band and aft omni antenna. CDA telemetry is transmitted via the aft omni and forward

2. GOES Spacecraft Configuration

L-band antenna. DSN telemetry is transmitted via the aft omni and forward S-band antenna during transfer orbit operations.

The digital group consists of the central telemetry and command units (CTCUs), remote telemetry and command units (RTCUs), and squib driver unit (SDU), all having Boeing 601 heritage. The CTCU decrypts and decodes the uplinked ground commands and multiplexes and formats the downlink telemetry into two simultaneous downlink data streams: one for the DSN link and one for the CDA link. The multi-use data link (MDL) analog data multiplexer within the instrument RTCU (IRTCU) multiplexes and formats the dynamics (e.g., instrument servo error) data, SXI image and housekeeping data and duplicates of the two spacecraft normal telemetry streams for transmission to the ground. The CTCU distributes spacecraft commands and gathers telemetry from the RTCUs via the bi-directional, redundant 1553 T&C databus. The squib driver unit (SDU) provides electrical power for pyrotechnic release devices.

Communications

The communications subsystem provides the antennas and transponders for the data repeater services, which include the PDR, SAR, WEFAX/LRIT, DCPI/DCPR, and EMWIN, and the on-board data transmit services, which include the SD and MDL. The communication antennas consist of two L-band and one S/L-band antennas on a common structure and a UHF cup dipole antenna. One of the L-band antennas is used for the SAR downlink. The UHF antenna receives both the SAR and DCPR uplink. The S/L-band antenna receives the S-band uplink as well as transmits the MDL and DCPR and WEFAX/LRIT downlink signals, and the other downlink L-band antenna is used for downlink of the SD, PDR, and EMWIN downlink services. Multiplexers are used in conjunction with the UHF, S/L-band, and L-band antennas, which handle multiple services. An S-band receiver amplifies and frequency translates uplink S-band signals for PDR, WEFAX/LRIT, EMWIN, and DCPI. A SAR/DCPR processor is used to receive the UHF uplink signal, amplify, frequency translate, and process the UHF SAR and DCPR signals. A common modulator unit is used for the SD and MDL digital data that is passed from the Imager/Sounder instrument and IRTCUs, respectively. The SAR/DCPR processor, S-band receiver, and MDL/SD modulator employ solid-state power amplifiers (SSPAs) to amplify the downlinks to the proper transmit level. All active hardware in the subsystem is fully redundant and cross-strapped by both passive power splitter/combiners and coaxial switches.

Propulsion

The bipropellant propulsion subsystem uses the hypergolic combination of monomethylhydrazine (MMH) fuel and nitrogen tetroxide (NTO) oxidizer for efficient thrust. Regulated helium pressurant is supplied to four spherical propellant tanks. Each tank incorporates a gallery type propellant management device (PMD) that delivers gas-free propellant to the thrusters. Independent latch valves (LV) allow selective propellant withdrawal for distribution control. A 490 N LAM is used for ascent maneuvers, while a suite of twelve 9.25 N thrusters provide attitude and spin speed control.

2. GOES Spacecraft Configuration

Attitude Control Subsystem

The ACS architecture consists of both transfer orbit and on-orbit attitude sensors and actuators, which are centrally coordinated by the attitude control electronics (ACE). The ACE contains the dedicated on-board processor. Primary software functions include attitude control, thruster operation, and solar array stepping. Additionally, the ACE autonomously handles routine spacecraft maintenance such as battery charge management, heater control, momentum management, and fault detection and correction. On-orbit attitude control is achieved by operating four high-capacity reaction wheels operated in a zero-momentum configuration, 3-for-2 redundant star trackers, and a hemispherical inertial reference unit (HIRU) for attitude determination. Slit-type sun sensors and earth sensors provide attitude references for the spin mode during transfer orbit operations. The ACE supports an analog and digital interface to the Imager and Sounder, which supplies mirror steering via image motion compensation (IMC) and dynamic motion compensation (DMC) signals. Thrusters and tank latch valves are operated directly by the ACE in support of maneuvers and momentum management.

3. Imager

The GOES N-P Imager instrument, GFE manufactured by ITT Industries, Inc., is a five-channel (one visible, four infrared) imaging radiometer designed to sense radiant and solar reflected energy from sampled areas of the earth. By means of a servo-driven, two-axis gimbaled mirror scan system in conjunction with a Cassegrain telescope, the Imager's multispectral channels can simultaneously sweep an 8 km north-to-south swath along an east-to-west/west-to-east path at a rate of 20° (optical) per second.

A view of the Imager instrument sensor module is shown in Figure 3-1 and key Imager instrument parameters are given in Table 3-1 and Table 3-2. The wavelength allocation to the Imager's channels is given in Table 3-3. A summary of Imager performance is given in Table 3-4.

NOTE: Throughout this section, the channels are numbered according to ITT's convention. In GVAR, the channels are numbered differently, specifically channel 3 is 6.5 μm , channel 5 is non-existent, and channel 6 is 13.3 μm . Reference Figures 3-5a and 3-5b for the GVAR channel numbers.

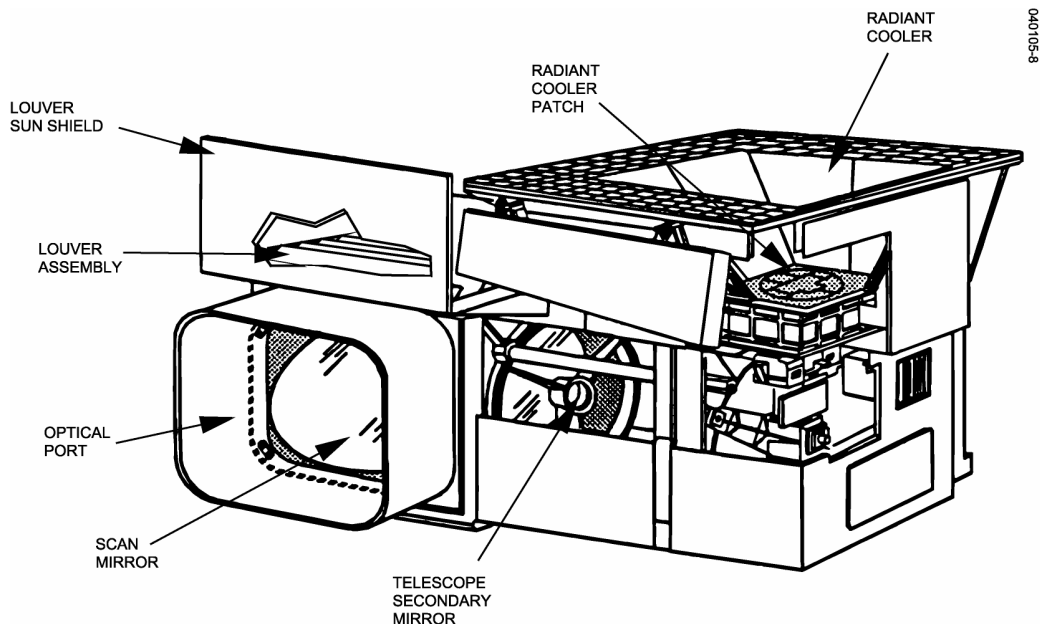

Figure 3-1. GOES N-P Imager Sensor Module

3. Imager

Table 3-1. Imager Instrument Characteristics

(Reference channel numbering convention note on page 3-1)

Channel	Detector Type	Nominal Square IGFOV at Nadir, km	
		GOES N	GOES O-P
1 (Visible)	Silicon	1	1
2 (Shortwave)	InSb	4	4
3 (Longwave 2)	HgCdTe	8	4
4 (Longwave 1)	HgCdTe	4	4
5 (Moisture)	HgCdTe	4	4

Table 3-2. Imager Instrument Performance Parameters

Parameter	Performance
FOV defining element	Detector
Channel-to-channel alignment	
Vis to IR	50 μ rad
IR to IR	28 μ rad
Radiometric calibration	Internal black body and space view
Signal quantizing	10 bits, all channels
Scan capability	Full earth, sector, and area
Output data rate	2,620,800 bps
Imaging areas	20.8° E-W by 21° N-S

Table 3-3. Imaging Channels Allocation

(Reference channel numbering convention note on page 3-1)

Channel No.	Wavelength Range, μ m	Range of Measurement	Meteorological Objective
1	0.52 to 0.71	0 to 100% albedo	Cloud cover
2	3.73 to 4.07	4 to 335 K	Nighttime clouds
3	13.00 to 13.70	4 to 320 K	Cloud cover and height
4	10.20 to 11.20	4 to 320 K	Sea surface temperature and water vapor
5	5.80 to 7.30	4 to 320 K	Water vapor

The Imager instrument consists of electronics, power supply, and sensor modules (Figure 3-2). The electronics module provides redundant circuitry and performs command, control, and signal processing functions; it also serves as a structure for mounting and interconnecting the electronic boards for proper heat dissipation. The electronics module is mounted on the subnadir panel external to the spacecraft and is enclosed by a Faraday cage (The Faraday cage is fabricated from thermal blankets.) The power supply module contains the converters, fuses, and power control for converting and distributing spacecraft 42 volt bus power to the Imager circuits. The power supply module is mounted inside the spacecraft on the subnadir panel.

Table 3-4. Imager Performance Summary

Parameter	Performance	
System absolute accuracy	Infrared channel ≤ 1 K Visible channel $\pm 5\%$ of maximum scene radiance	
System relative accuracy	Line to line	≤ 0.1 K
	Detector to detector	≤ 0.2 K
	Channel to channel	≤ 0.2 K
	Blackbody calibration to calibration	≤ 0.35 K
Star sense area	21° N-S by 23° E-W	
Imaging rate	Full earth ≤ 26 min	
Time delay	≤ 3 min	
Fixed Earth projection and grid duration	24 hours	
Data timeliness		
Spacecraft processing	≤ 30 sec	
Data coincidence	≤ 5 sec	
Imaging periods		
Image navigation accuracy at nadir (excluding diurnally repeatable distortion)	25 μ rad EW, 20 μ rad NS	
Registration within an image*	25 min	33 μ rad EW, 28 μ rad NS
Registration between repeated images*	48 hr	28 μ rad

*For spec orbit

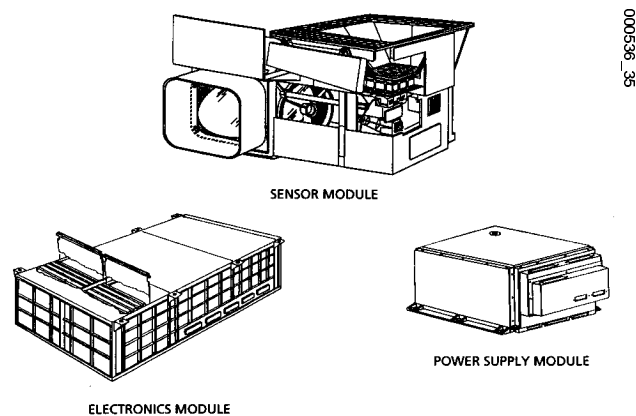

Figure 3-2. Imager Instrument Modules

3. Imager

The sensor module contains the telescope, scan assembly, detectors, and baseplate, along with the shields and louvers for thermal control. The sensor module is located on an optical bench which is located on the nadir face of the spacecraft.

The Imager optimizes the maximum signal flow of the optical, detection, and electronic subsystems in order to preserve the quality and accuracy of the sensed information. The scene radiance, collected by the Imager's optical system, is separated into appropriate spectral channels by beam splitters that also route the spectral energy to various visible and infrared (IR) detector sets where it is imaged onto the respective detectors for each channel. Each detector converts the scene radiance into an electrical signal that is amplified, filtered, and digitized; the resulting digital signal is routed to a sensor data transmitter for downlinking to a ground station.

A user may request one or a set of images that start at a selected latitude and longitude (or lines and pixels) and end at another latitude and longitude (or lines and pixels). The Imager scans locations in accordance with its command inputs. The image frame may include the entire earth's disk or any portion of it and the frame may begin at any time. Scan control is not limited in scan size or time; an entire viewing angle of 21° north-south (N-S) by 23° east-west (E-W) is available for star sensing. Imaging limits are 21° N-S by 20.8° E-W. Ground command can request up to 63 repeats of a given image. A frame sequence can be interrupted for "priority" scans; the system will scan a priority frame set or star sense, then automatically return to the original set.

Infrared radiometric quality is maintained by frequent views of space for reference. The space view interval is ground command selectable for space clamp mode for specific intervals of 9.2 or 36.6 seconds. In scan clamp mode, a space view will be taken at least every 2.2 seconds. Less frequent views of the full-aperture internal blackbody establishes a high-temperature baseline for calibration in orbit (via ground command or automatically). Repeat of this calibration every 10 minutes is more than adequate to maintain accuracy of the output data under the worst conditions of time and temperature. In addition to radiometric calibration, the amplifiers and data stream are checked regularly by an internal electronic staircase signal to verify stability and linearity of the output data.

Operation

The Imager is controlled via a defined set of command inputs. Position and size of an area scan are controlled by command, so the instrument is capable of full-earth imagery (21° N-S by 20.8° E-W), sector imagery that contains the edges of the earth's disk, and various area scan sizes totally enclosed within the earth scene. However, the maximum scan width processed by the operations ground equipment is 19.2°. Area scan selection permits continuous, rapid viewing of local areas for accurate wind determination and monitoring mesoscale phenomena. Area scan size and location are definable to less than one visible pixel, yielding complete flexibility.

To assist in inertial navigation, the Imager also offers a star sensing capability that can detect stars as dim as B0-class fourth magnitude. Once the time and location of a star is

predicted, the Imager is pointed to that location within its 21° N-S by 23° E-W field of view (FOV), and the scan is stopped. As the star image passes through the 1×8 km visible array, it is sampled at a rate of 21,817 samples per second. The star sense sensitivity is enhanced by increasing the electronic gain and reducing the noise bandwidth of the visible preamplifiers, permitting sensing of a sufficient number of stars for image navigation and registration (INR) purposes.

By virtue of its digitally controlled scanner, the Imager provides operational imaging from full earth scan to mesoscale area scans. Accuracy of location is ensured by the absolute position control system, in which position error is noncumulative. Within the instrument, each position is defined precisely, and any chosen location can be reached and held to a high accuracy. This registration accuracy is maintained along a scan line, throughout an image, and over time. Total system accuracies relating to spacecraft motion and attitude determination also include this allocated error.

Motion of the Imager and Sounder scan mirrors causes disturbances to the spacecraft attitude, which is partially reduced by spacecraft control. Further reduction of these disturbances is accomplished by using HIRU and star tracker (ST) sensed motion along with the commanded bus attitude to form a dynamic motion compensation (DMC) signal, which is applied in the scan servo-control loop to offset the residual attitude disturbance. With this technique, the Imager and Sounder are totally independent, maintaining image location accuracy regardless of the other unit's operational status. If needed, this dynamic motion compensation scheme can be disabled by command.

The ACS also generates compensation signals that counteract predictable spacecraft attitude, orbital, and structural-thermal effects within the spacecraft-instrument combination. Observations of residual compensation errors are used to generate new fit parameters for the next 24 hour period, during which they are used to generate compensation signals for updated disturbance predictions. Ground-developed corrective algorithms are fed to the instruments via the ACS as a total image motion compensation (IMC) signal that includes the dynamic motion compensation described above.

Yaw Flip Operation

There is an alternative spacecraft orientation option for the GOES N-P satellites known as the yaw flip configuration. In this mode, the satellite is rotated 180 degrees from its normal orientation, which results in the normally north facing side of the instruments facing toward the south during summer in the northern hemisphere. Yaw flip maintains the spacecraft in a configuration that prevents the sun from entering the radiant coolers.

This mode allows operation of the instruments with the patch temperature set to LOW year round as the radiant coolers are always pointing in a direction that permits operating under winter conditions. Without yaw flip, the patch temperature settings should be LOW for winter and MID for summer. MID can be used year round without yaw flip if there is no cooler degradation as the cooler should start life with a 3°C margin at the

3. Imager

MID setting for summer solstice. HIGH allows for operation in the summer should some cooler degradation occur.

It should be noted that all references to the scan coordinate system will be reversed when operating in the yaw flipped mode.

Sensor Module

The sensor module consists of a radiant cooler assembly, telescope, aft optics, preamplifiers, scan aperture sunshield, scan assembly, baseplate, scan electronics, and louver assembly. The scan assembly and telescope are mounted to a common baseplate. The aft optics separates the scene radiance into five spectral bands of interest. A passive louver assembly on north panel and electrical heaters on the baseplate aid thermal stability of the telescope and major components. A passive radiant cooler with a proportionally controlled heater maintains the IR detectors at 81 K during the 6 months of winter solstice season and then at 84 K for the remainder of the year for efficient operation. A backup temperature of 87 K is also provided. The visible detectors are at instrument temperature of 13 to 30 C. The preamplifiers convert the low-level signals to higher-level, low-impedance outputs for transmission by cable to the electronics module. An expanded view of the sensor module is given in Figure 3-3.

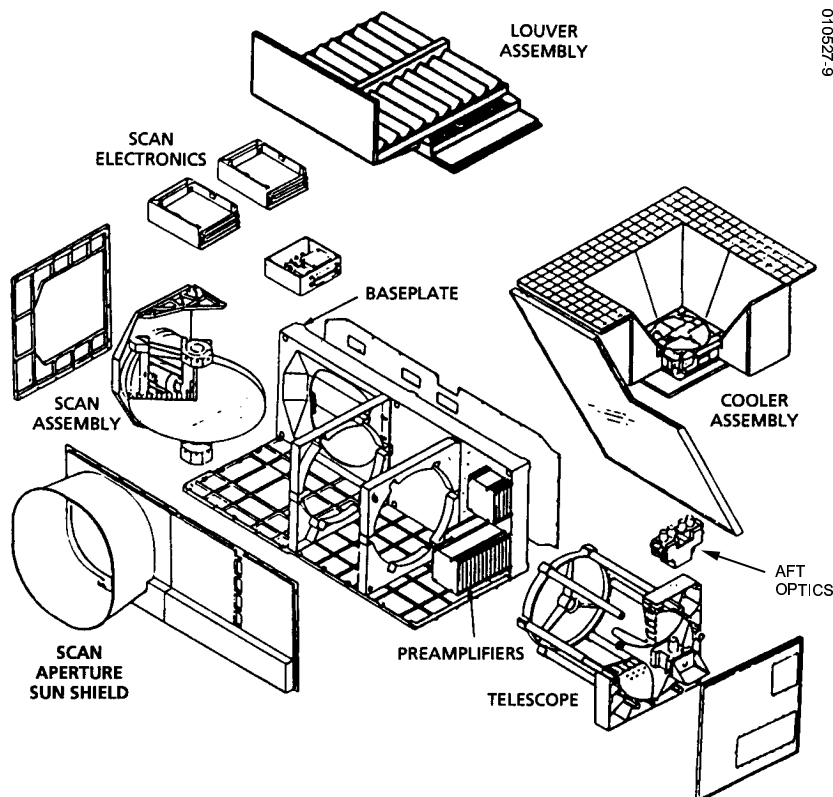

Figure 3-3. Sensor Module—Expanded View

Imager Optics

To gather emitted or reflected energy, the scanner moves a flat mirror to produce a bidirectional raster scan. Thermal emissions and reflected sunlight from the scene pass through a scan aperture protected by a sun shield, then the precision flat mirror deflects them into a reflective telescope. The telescope, a Cassegrain type with a 31.1 cm (12.2 inch) diameter primary mirror, concentrates the energy onto a 5.3 cm (2.1 inch) diameter secondary mirror. The surface shape of this mirror forms a F/6.8 focal length beam that passes the energy to the detectors via relay optics.

Dichroic beamsplitters (B/S) separate the scene radiance into the spectral bands of interest. The IR energy is deflected to the detectors within the radiative cooler, while the visible energy passes through a dichroic beamsplitter and is focused on the visible detector elements. The IR energy is separated into the 3.9, 6.55, 10.7, and 13.35 μm channels. These four beams are directed into the radiant cooler, where the spectral channels are defined by cold filters. Each of the four IR channels has a set of detectors defining the field size and shape. A schematic view of the Imager's optical elements is given in Figure 3-4.

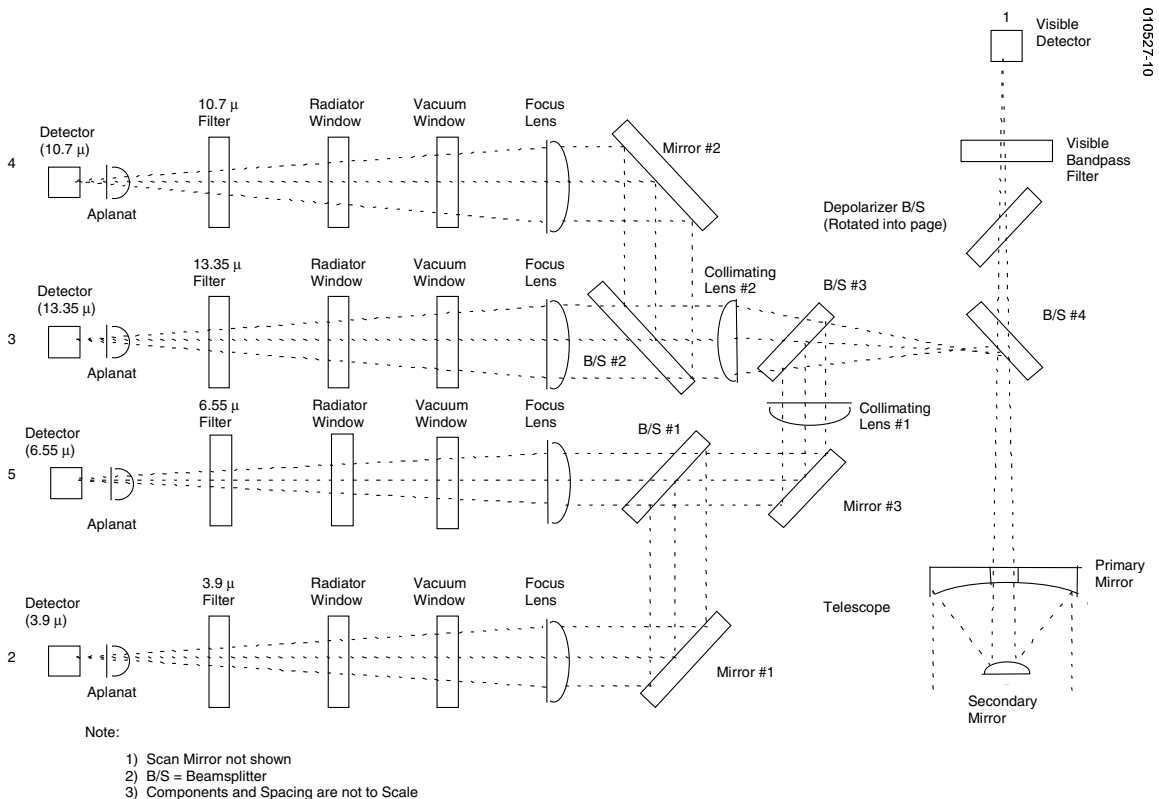

Figure 3-4. Imager Optical Elements
 (Reference channel numbering convention note on page 3-1)

3. Imager

Optical performance is maintained by restricting the sensor module total temperature range, and radiometric performance is maintained by limiting the temperature change between views of cold space (rate of change of temperature). Thermal control also contributes to channel registration and focus stability. Thermal control design includes:

- Maintaining the Imager sensor module as adiabatically (thermally isolated) as possible from the spacecraft structure.
- Controlling the temperature during the hot part of the synchronous orbit diurnal cycle (when direct solar heating enters the scanner aperture) with a north-facing radiator whose net energy rejection capability is controlled by a louver system.
- Providing makeup heaters within the sensor module to replace the thermal energy lost to space through the scan aperture during the cold portion of the diurnal cycle.
- Providing a sun shield around the scan aperture (outside the instrument FOV) to block incident solar radiation into the instrument, thus limiting the time the aperture can receive direct solar energy.

Detectors

(Reference channel numbering convention note on page 3-1)

The Imager instrument simultaneously acquires radiometric data in five distinct wavelengths or channels, each of which is characterized by a wavelength band denoting primary spectral sensitivity. The five channels are broadly split into two classes: visible (channel 1) and infrared (channels 2-5). For these five channels, the GOES N Imager contains a total of 22 detectors, and the GOES O-P Imager contains 24 detector elements.

Visible Channel

The visible silicon detector array (channel 1) contains eight detectors (v1 to v8). Each detector produces an instantaneous geometric field of view (IGFOV) that is nominally 28 μ rad on a side. At the spacecraft's subsatellite point, on the surface of the earth, 28 μ rad corresponds to a square pixel that is 1 km on a side.

Infrared Channels

(Reference channel numbering convention note on page 3-1)

The IR channels employ four-element InSb (Indium Antimonide) detectors for channel 2 (3.9 μ m), and four element HgCdTe (Mercury Cadmium Telluride) detectors for channels 4 (10.7 μ m) and 5 (6.55 μ m). A four-element set consists of two-line pairs providing redundancy along a line. Each detector in channels 2, 4, and 5 is square, with an IGFOV of 112 μ rad, corresponding to a square pixel 4 km per side at the subsatellite point. For GOES N, channel 3 (13.25 μ m) contains two square HgCdTe detectors, each with an IGFOV of 224 μ rad, resulting in a subsatellite pixel 8 km on a side. For GOES O-P, channel 3 will have a four-element detector set with a 4 km pixel identical to the other IR channels.

3. Imager

Element Configuration

The four IR detector arrays are configured in either a side 1 or a side 2 mode, either of which can be the redundant set by choosing side 1 or side 2 electronics. The entire visible channel array (v1 to v8) is always enabled. In side 1 mode, the IR channels have only their upper detectors (1-1 to 1-7) enabled and in side 2, only their lower detectors (2-1 to 2-7). Figures 3-5 through 3-7 illustrate the detector configuration. The GVAR numbering of the pixels is shown in Figure 3-5a and 3-5b.

Though physically separated in the instrument, the detector arrays are optically registered. Small deviations in this optical registration are due to physical misalignments during construction and assembly of the instruments and to the size of the detector elements. These deviations consist of fixed offsets that are corrected at two levels: 1) within the instrument sampling electronics and 2) on the ground by the operations ground equipment. No corrections are applied during star sensing. Because the combination of scan rate (20 deg/sec) and detector sample rate (5460 samples per second for IR and 21840 samples per second for visible) exceeds the pixel E-W IGFOV, the Imager over-samples the viewed scene. Each visible sample is 16 μ rad E-W, and each IR sample is 64 μ rad E-W.

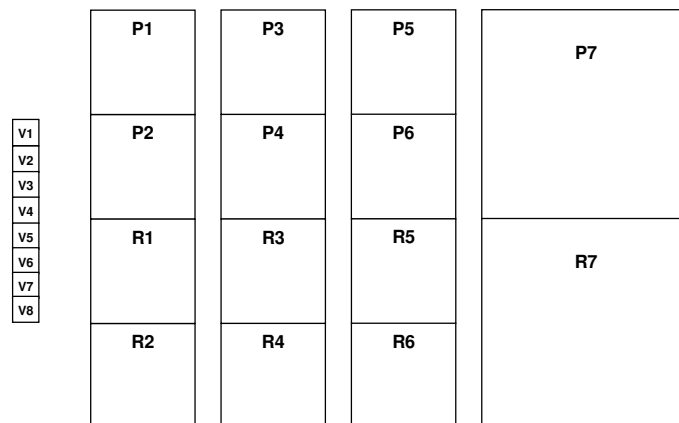

CHANNEL	1	2	3	4	6
CENTRAL WAVELENGTH (μ m)	0.65	3.9	6.5	10.7	13.3
DETECTOR IGFOV (μ radians)	28	112	112	112	224

Notes:
 μ m - micrometers (microns)
 μ radians - micro radians
 IGFOV - Instantaneous Geometric Field-of-View

Figure 3-5a. Imager Detectors (GOES N)

3. Imager

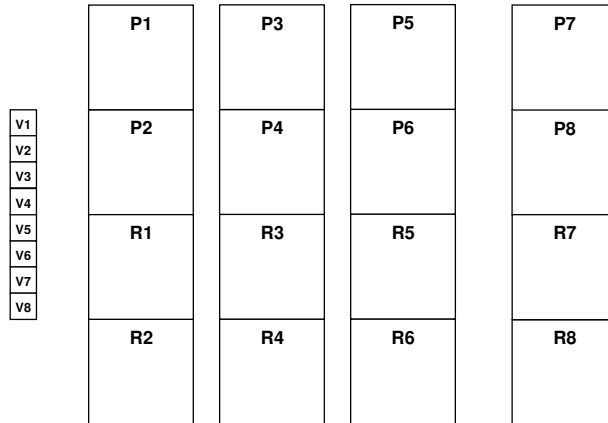

CHANNEL	1	2	3	4	6
CENTRAL WAVELENGTH (μm)	0.65	3.9	6.5	10.7	13.3
DETECTOR IGFOV (μradians)	28	112	112	112	112

Notes:
 μm - micrometers (microns)
 μradians - micro radians
 IGFOV - Instantaneous Geometric Field-of-View

Figure 3-5b. Imager Detectors (GOES O-P)

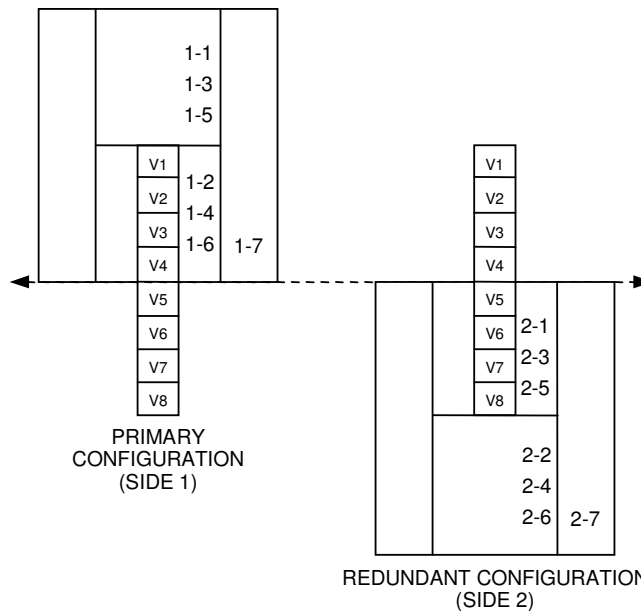

Figure 3-6a. Operational Configurations (GOES N)

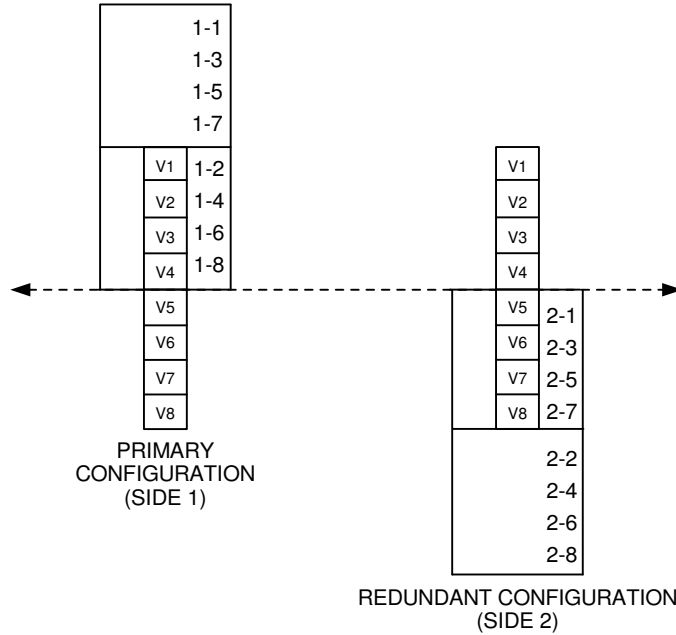

Figure 3-6b. Operational Configurations (GOES O-P)

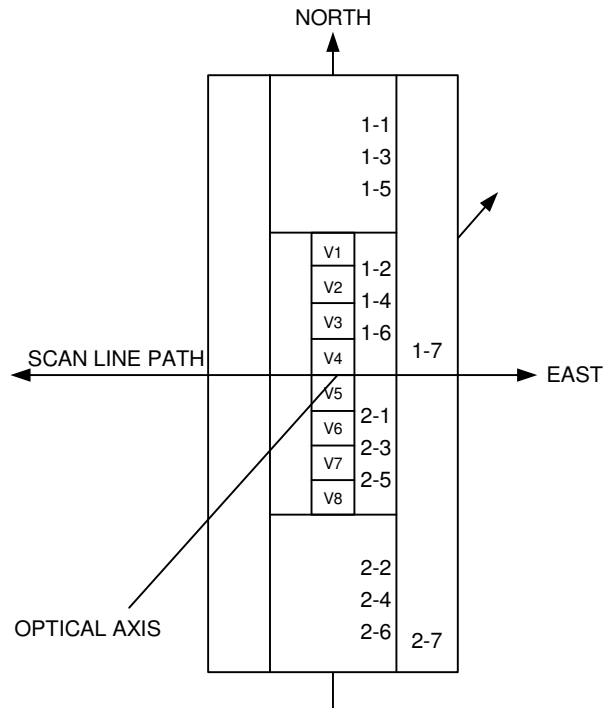

Figure 3-7a. Operational Configurations (GOES N)

3. Imager

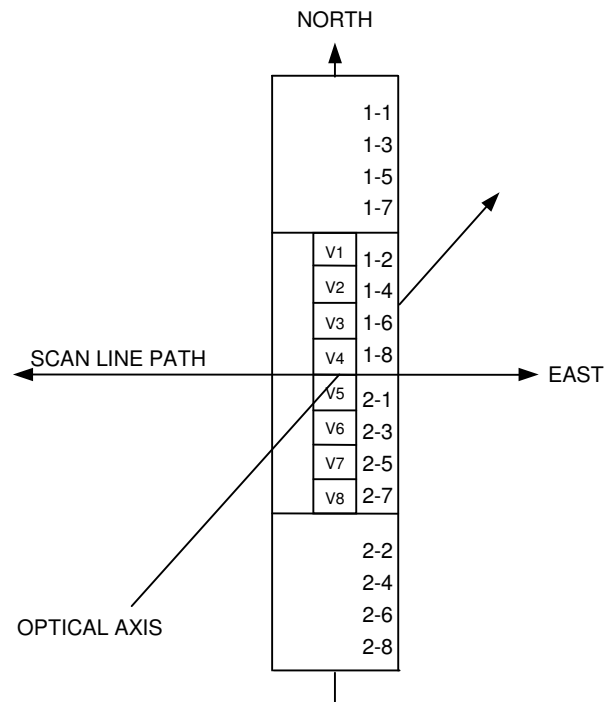

Figure 3-7b. Operational Configurations (GOES O-P)

Scan Control

The scanning mirror position is controlled by two servo motors, one for the N-S gimbal angle and one for the E-W scanning gimbal angle. Each servo motor has an associated Inductosyn that measures the mechanical shaft rotation angle. The scanning mirror position and, hence, the coordinate system used for the Imager are measured in terms of Inductosyn outputs. Scan control for both axes is generated by establishing a desired angular position for the mirror. The desired angle is input to an angular position sensor (one Inductosyn for each axis), which produces a displacement error signal. This signal is fed to a direct drive torque motor (one for each axis) that moves the mirror and sensor to the null location.

For E-W deflection, the direct-drive torque motor is mounted to one side of the scan mirror, and the position-sensing device (Inductosyn position encoder) is mounted on the opposite side. All rotating parts are on a single shaft with a common set of bearings. Using components of intrinsically high resolution and reliability, coupling of the drive, motion, and sensing is therefore very tight and precise. North-south motion is provided by rotating the gimbal (holding the above components) about the optical axis of the telescope. This rotating shaft has the rotary parts of another torque motor and Inductosyn mounted to it, again providing the tight control necessary.

Servo control is not absolutely accurate due to noise, drag, bearing imperfections, misalignment, and imperfections in the Inductosyns. The principal servo pointing and

registration errors are fixed pattern errors caused by the Inductosyn position sensor and its electronic drive unit. Variations in individual Inductosyn pole patterns, imbalance between the sine and cosine drives, cross-talk and feedthrough in these circuits, and digital-to-analog (D/A) conversion errors contribute to the fixed-pattern errors. These errors are measured at ambient conditions and the correction values stored in programmable read-only memory. Corrections are applied in the scanner as a function of scan address. The measured values of fixed pattern errors vary between $\pm 15 \mu\text{rad}$ (mechanical) with a frequency of up to four times the Inductosyn cycle; after correction, the error is reduced to within $\pm 4 \mu\text{rad}$. Variations of the fixed pattern error over temperature, life, and radiation conditions are minimized by design, and residual errors are accounted for in the pointing budget.

Drive and error sensing components used for the two drive axes are essentially identical. The E-W drive system has a coherent error integrator (CEI) circuit that automatically corrects for slight changes in friction or other effects. Control components are optimized for their frequency and control characteristics, and logic is developed for the precise control of position in response to a system-level control processor.

A schematic of the scan control circuitry is given in Figure 3-8.

Scan Operation

Scan control is initiated by an input command that sets start and end locations of an image frame. A location is defined by an Inductosyn cycle and increment number within the cycle, the increment number determining the value of sine and cosine for that location. Each E-W increment corresponds to $8 \mu\text{rad}$ of E-W mechanical rotation and $16 \mu\text{rad}$ of E-W optical rotation. Each N-S increment corresponds to $8 \mu\text{rad}$ of N-S mechanical and optical rotation. The distance between a present and start location is recognized, causing incremental steps ($8 \mu\text{rad}$) to be taken at a high rate (10 deg/sec) to reach that location. After the E-W slew is completed, the N-S slew begins. From the scan start position, the same pulse rate and increments are used to generate the linear scan. The scan mirror inertia smoothes the small incremental steps to much less than the error budget.

During an image scan at the scan line end location (where the commanded position is recognized), the control system enters a preset deceleration/acceleration. During this 0.2 second interval, the scan mirror velocity is changed in 32 steps by using a 32 increment cosine function of velocity control. This slows and reverses the mirror so that it is precisely located and moving at the exact rate to begin a linear scan in the opposite direction. During this interval, the N-S scan control moves the gimbal assembly $224 \mu\text{rad}$ (28 increments of $8 \mu\text{rad}$) in the south direction. Linear scanning and N-S stepping continue until the southern limit is reached.

Scan to space for space clamp, or to star sensing, or to the IR blackbody uses the same position control and slew functions as for scan and retrace. Command inputs (for star sensing or priority frames) or internal subprograms (for space clamp and IR calibration) take place depending on the type of command, time factors, and location.

3. Imager

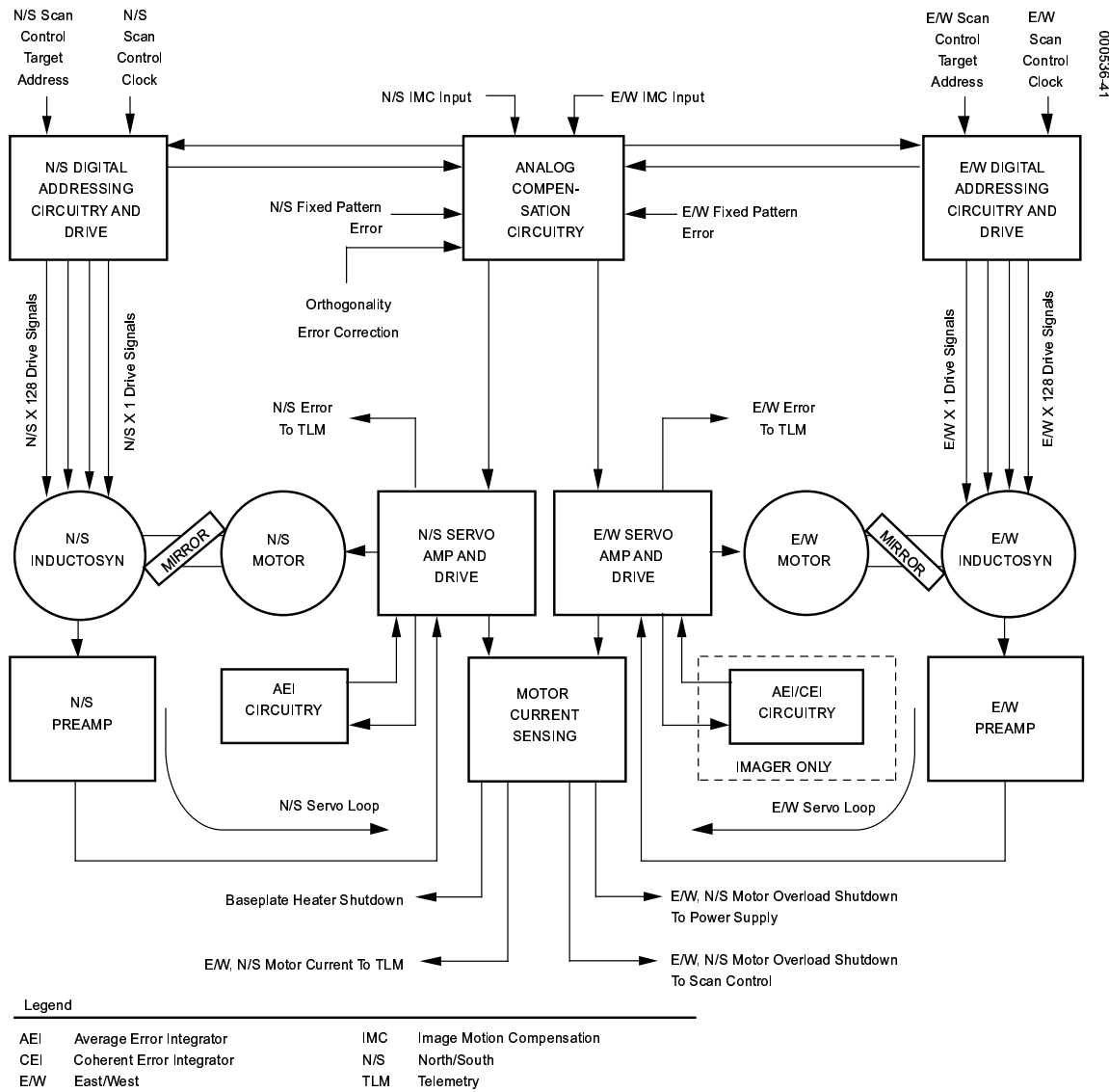

Figure 3-8. Scan Control Schematic

Image Generation

During imaging operations, a scan line is generated by rotating the scan mirror in the east-to-west direction (20 deg/sec optically) while concurrently sampling each active imaging detector (5460 per second for IR and 21840 per second for visible). At the end of the line, the scan mirror elevation is changed by a stepped rotation in the north-to-south direction. The next scan line is then acquired by rotating the scan mirror in the (opposite) west-to-east direction, again with concurrent detector sampling. Detector sampling occurs within the context of a repeating data block format. In general, all visible channel detectors are sampled four times for each data block while each active IR detector is sampled once per data block.

The mapping between cycles and increments and the instrument FOV are referenced to a coordinate frame whose origin is zero cycles and zero increments (northwest corner of the frame). In geostationary orbit, the earth will be centered within the frame, at instrument nadir, which corresponds closely to the spacecraft subsatellite point, also centered in the frame. The GVAR coordinate system is in line/pixel space and has its origin in the NW corner.

Three components making up the total misalignment in the sampled data are corrected by the instrument electronics and operations ground equipment:

- A fixed E-W offset caused by channel-to-channel variations in the signal processing filter delays.
- A fixed E-W and/or N-S offset caused by optical axis misalignments in the instrument assembly.
- A variable E-W and/or N-S offset caused by image rotation.

The Imager's coordinate system frame is shown in Figure 3-9, showing the earth disc centered in the instrument's coordinate frame, the $21^\circ \times 23^\circ$ operational FOV limit frame, and the $25^\circ \times 202^\circ$ mechanical limit frame. The earth disc subtends a 17.4° viewing angle from the geostationary altitude.

Electronics

The Imager electronics consist of a preamplifier and thermal control in the sensor assembly; command and control, telemetry, and sensor data processing contained in the electronics module; and the power supplies. The scan control electronics are contained in the electronics module. The servo preamplifiers are located at the scanner in the sensor module. A block diagram of the Imager's electronics is given in Figure 3-10.

Signal Processing

Preamplification of the low-level visible and IR channel signals occurs within the sensor module. These analog signals are routed to the electronics module, which amplifies, filters, and converts the signals to digital code. All channels in the visible and IR bands are digitized to one part in 1024 (10 bits), the visible for high-quality visible imagery and to aid star sensing capability, and the IR for radiometric measurement. Data from all channels move in continuous streams throughout the system, thus each channel's output must enter a short-term memory for proper placement in the data stream. Each channel is composed of a detector, preamplifier, analog-to-digital (A/D) converter, and signal buffer. All signal chains are totally independent and isolated. Redundant chains of signal processing circuitry are provided with each circuit ending in a line driver designed to interface with the spacecraft transmitter. (The video and formatter are redundant for the IR channels only.)

Electronic Calibration

Electronic calibration signals are injected into the preamplifiers of channels 3, 4, and 5 while the Imager is looking at space. Electronic calibration is inserted after the

3. Imager

preamplifiers of channels 1 and 2. Sixteen precise signal levels derived from a stepped D/A converter are inserted during the 0.2-second spacelook. The calibration signal, derived from a 10-bit converter of 0.5-bit accuracy, provides the accuracy and linearity for precise calibration.

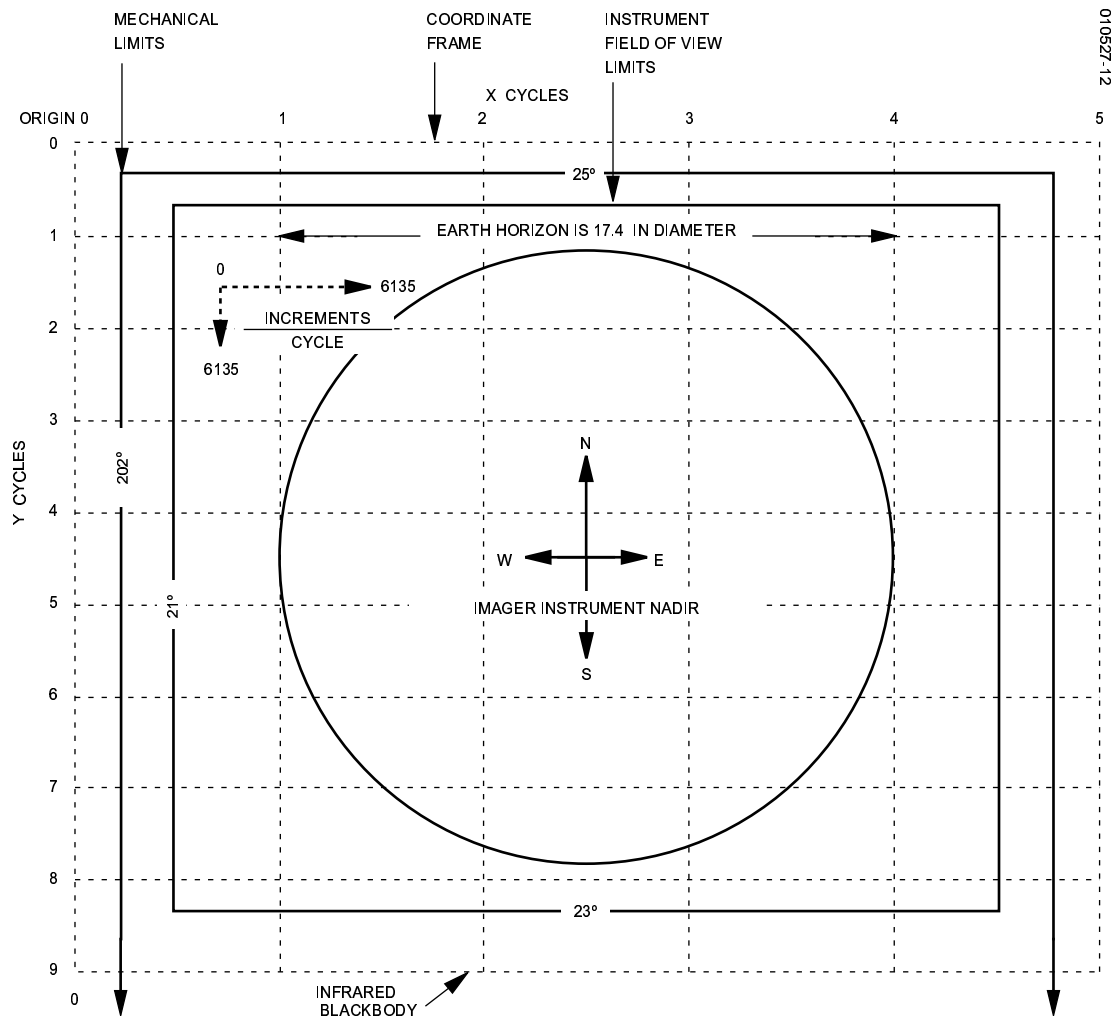

Figure 3-9. Imager Coordinate Frame

Visible Channel

Each detector element of the visible channel has a separate amplifier/processor. These current-sensing preamplifiers convert the photon-generated current in the high-impedance silicon detector into an output voltage, with a gain of about 10^8 V/A. These preamplifiers are followed by postamplifiers that contain electrical filtering and space clamping circuits. The digitization of the data signals is also part of the space clamp circuitry. The visible information is converted to 10-bit digital form, providing a range from near 0.1% to over 100% albedo. Differences of approximately 0.1% are discernible, and the linear digitization provides for system linearity errors of 0.5 bit in the conversion

process. The star sense channel uses the same visible channel detectors but boosts the gain by approximately four times and reduces the bandwidth.

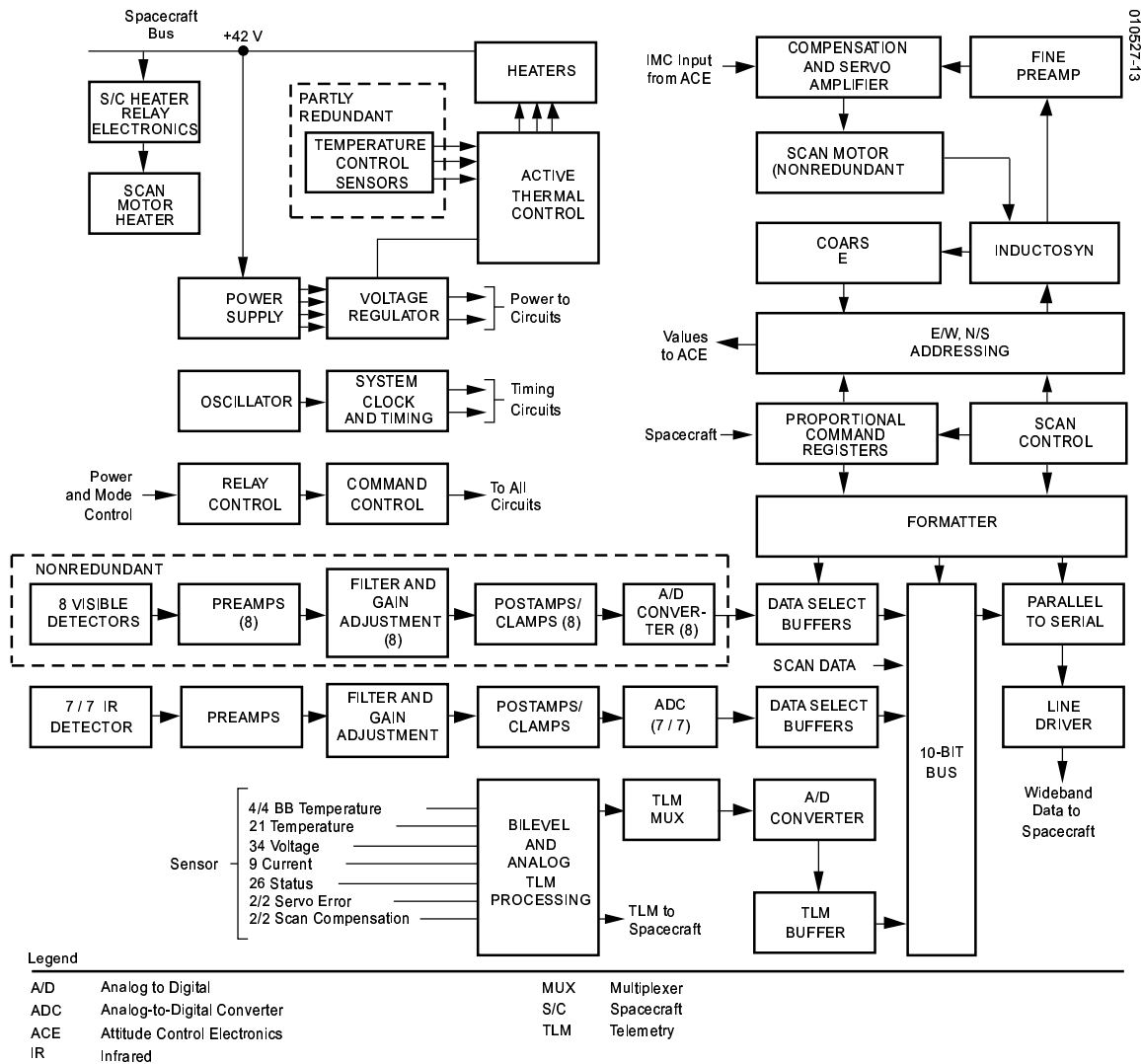

Figure 3-10. Imager Block Diagram

Infrared Channels

(Reference channel numbering convention note on page 3-1)

The IR channels have a separate amplifier/processor for each detector element. The 3.9 μm channel has a hybrid current sensing preamplifier for the high-impedance InSb detector. Individual preamplifiers for HgCdTe detector channels are mounted near the detectors in the sensor module.

The IR information is converted to 10-bit digital form, providing a range from near 0.1% to over 100% of the response range. Channels 3, 4, and 5 have a gain established for a

3. Imager

space-to-scene temperature of 320 K, while channel 2 has a dynamic range from space to 335 K. The 10-bit digital form allows the lowest calculated noise level to be differentiated. The digital system is inherently linear with A/D converter linearity and accuracy to 0.5 bit. The binary-coded video is strobed onto the common data bus for data formatting by the system timing and control circuitry.

Formatting

The data format of Imager information is made up of blocks of data generated in a given sample time period. The Imager scans an 8 km swath using combinations of 1 km visible detectors, and 4 and 8 km IR detectors. GOES O-P has 4 km IFOV detectors for all IR channels. Oversampling causes the IR data to be collected each 64 μ rad (2.28 km at nadir) using a data block format where the location of each bit within the data stream is completely identified, and all information can be separated and reformatted on the ground. The visible detectors are sampled four times during this 64 μ rad period, yielding a collection rate of 16 μ rad (0.57 km at nadir) per sample. The four sets of visible data combine with one set from each IR detector in each data block.

The formats consist of data blocks, 480 bits in a block, each block being broken into 48 10-bit words. The format sequence during an active scan begins with a start-of-line command from the scan control system that synchronizes the data formatter with scan control and occurs when the Imager mirror is at the start of a scan line. The header format follows, containing block synchronization and data block identifiers, spacecraft and instrument identification, status flags, attitude control electronics data, coordinates of the current scan mirror position, and fill bits to complete the data block. After the header block, active scan data blocks follow; these contain synchronization and data block identifiers, image motion compensation (IMC) data, servo error, and radiometric data.

When the mirror reaches the end of the scan line, a scan reversal sequence begins with three active scan data blocks that permit full collection of radiometric data to the end of the scan line. A trailer format, similar to the header format, identifies the 39 blocks of telemetry format data to follow.

Digital signal processing starts where data from the IR and visible detectors and telemetry merge via multiplexing and processing; a parallel-to-serial conversion and data multiplexing take place to bring sensor data together. Other information, such as synchronization pulses, scan location, and telemetry data, is assembled in the data select circuitry. These data are then passed through a line driver where pulse amplitude and impedance levels are set for the transmitter interface. These data are transmitted to the spacecraft at a rate of 2.6208 Mbits per second or 5460 blocks per second.

Power Supply

A block diagram of the Imager's power supply system is given in Figure 3-11. The power supply converts spacecraft main bus voltage (42 volts nominal) to the required instrument voltages. There are two sides (1 and 2) to the unit, each totally independent and selected by command, although only one side operates at a time.

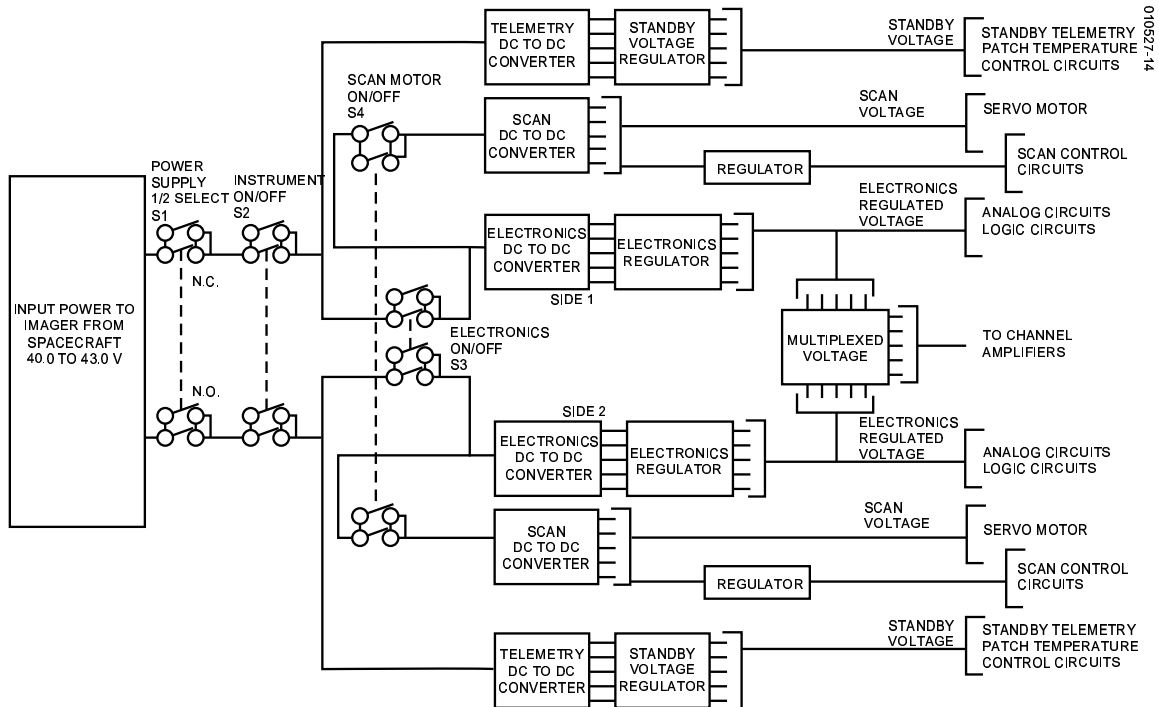

Figure 3-11. Power Supply Block Diagram

The power supply provides secondary power for the instrument by means of six DC/DC switching mode converters. Each redundant side of the instrument has three separate converters that supply power to 1) the telemetry circuits, 2) the scanner drive circuits, and 3) the remainder of the instrument electronics. The converters consist of synchronized switching circuits, transformers, rectifiers, and filters. The telemetry and electronics converters feed regulators to provide regulated voltage levels to the appropriate analog and logic circuits. The scan converter supplies power to the scan motor drive circuits and feeds a regulator to provide regulated voltage levels to scan control circuits. The converters are synchronized to 218 kHz, and the electronics and scan converters use a push-pull topology, while the telemetry converter uses a flyback configuration. A diode OR'ing circuit permits operation of all nonredundant circuits (command input circuitry, patch temperature control, visible detector circuits, etc) by either side. Control of the power supplies is achieved using relays for turn on, turn off, and side select. Ultimate protection for the spacecraft power bus is provided by having fuses on the input lines of the power supply.

3. Imager

This page left blank.

4. Sounder

The Sounder, GFE manufactured by ITT Industries, Inc., is a 19 channel discrete-filter radiometer that senses specific data parameters for atmospheric vertical temperature and moisture profiles, surface and cloud top temperature, and ozone distribution. As in the Imager, the Sounder is capable of providing full earth imagery, sector imagery (including earth's disk), and scans of local regions. The 19 spectral bands (seven longwave [LW], five midwave [MW], six shortwave [SW], and one visible) produce the prime sounding products. A cutaway view of the instrument is shown in Figure 4-1. Key instrument parameters are given in Tables 4-1 and 4-2. The wavelength allocation to the Sounder's channels is given in Table 4-3. A summary of Sounder performance is given in Table 4-4.

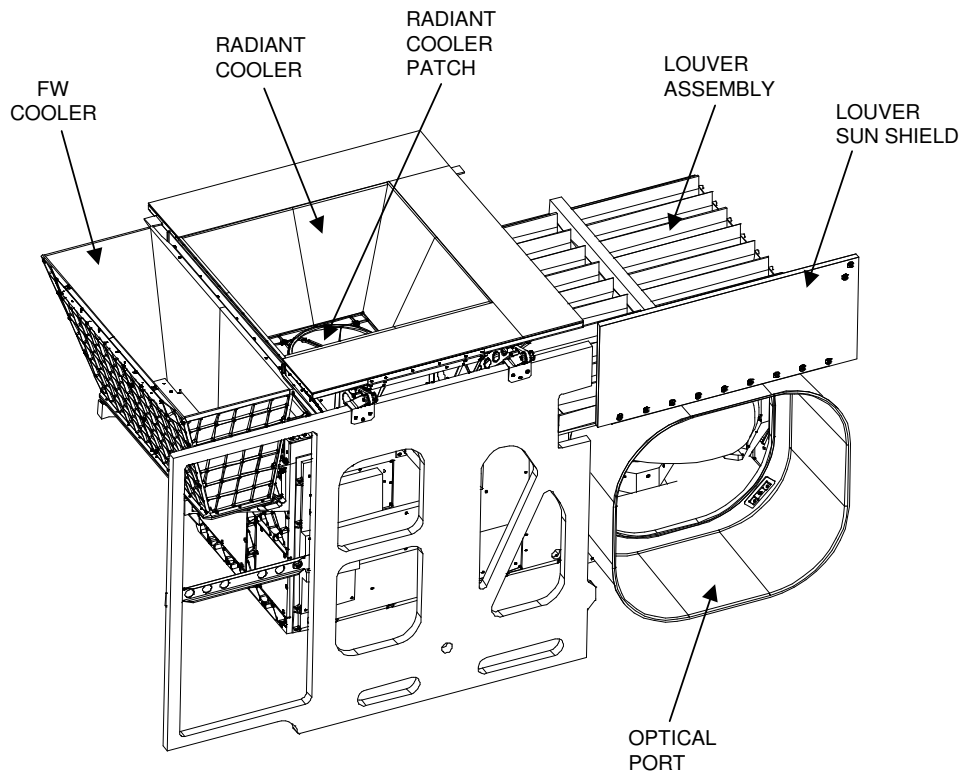

Figure 4-1. Sounder Sensor Module

4. Sounder

Table 4-1. Sounder Instrument Detectors and Fields of View

Channels	Detector Type	Nominal Circular IGFOV, μrad
1 to 7 (LW IR)	HgCdTe	242
8 to 12 (MW IR)	HgCdTe	242
13 to 18 (SW IR)	InSb	242
19 (visible)	Silicon	242
Star sense	Silicon	28*

* Square detectors

Table 4-2. Sounder Instrument Performance Parameters

Parameter	Performance
FOV defining element	Field stop
Telescope aperture	31.1 cm (12.2 in) diameter
Channel definition	Interference filters
Radiometric calibration	Space and 300 K IR blackbody
Field sampling	Four areas N-S on 280 μrad centers
Scan step angle	280 μrad (10 km nadir) EW
Step and dwell time	0.1, 0.2, 0.4 sec adjustable
Scan capability	Full earth and space
Sounding areas	10 km by 40 km to 60° N-S and 60° E-W
Signal quantizing	13 bits, all channels
Output data rate	40 kbps
Channel-to-channel alignment	22 or 36 μrad with respect to channel 8, depending on the channel

The Sounder instrument consists of sensor, electronics, and power supply modules. The sensor module contains the telescope, scan assembly, and detectors, all mounted on a baseplate with shields and louvers for radiation and heat control. The sensor module is located on the nadir face of the spacecraft. The electronics module provides redundant circuitry and performs command, control, and signal processing functions and also serves as a structure for mounting and interconnecting the electronic boards for proper heat dissipation. The electronics module is mounted on the subnadir panel, external to the spacecraft and is enclosed by a Faraday cage. (The Faraday cage is fabricated from thermal blankets.) The power supply module contains the DC/DC converters, fuses, and power control for converting and distributing spacecraft bus power to the Sounder circuits. The power supply module is mounted inside the spacecraft on the subnadir panel.

Table 4-3. Sounder Detectors Channel Allocation

Detector	Channel No.	Wavelength, μm	Wave No., cm^{-1}	Meteorological Objective and Max. Temp. Range
Longwave	1	14.71	680	Temperature Sounding (space–260 K)
	2	14.37	696	Temperature Sounding (space–260 K)
	3	14.06	711	Temperature Sounding (space–270 K)
	4	13.64	733	Temperature Sounding (space–290 K)
	5	13.37	748	Temperature Sounding (space–300 K)
	6	12.66	790	Temperature Sounding (space–315 K)
	7	12.02	832	Surface Temperature (space–330 K)
Midwave	8	11.03	907	Surface temperature (space–335 K)
	9	9.71	1030	Total Ozone (space–310 K)
	10	7.43	1345	Water Vapor Sounding (space–300 K)
	11	7.02	1425	Water Vapor Sounding (space–285 K)
	12	6.51	1535	Water Vapor Sounding (space–265 K)
Shortwave	13	4.57	2188	Temperature Sounding (space–310 K)
	14	4.52	2210	Temperature Sounding (space–295 K)
	15	4.45	2245	Temperature Sounding (space–275 K)
	16	4.13	2420	Temperature Sounding (space–330 K)
	17	3.98	2513	Surface Temperature (space–335 K)
	18	3.74	2671	Surface Temperature (space–335 K)
Visible	19	0.70	14367	Cloud (visible)

Note: All channels have sufficient dynamic range to view the internal blackbody calibration target at 320 K.

The Sounder's multidetector array simultaneously samples four locations of the atmosphere in 0.1 second intervals (0.2 and 0.4 second dwells at the same FOV are also commandable). Each field of view (FOV) provides output from 19 spectral channels in each sample period. Infrared (IR) spectral definition is provided by a rotating wheel that inserts selected filters into the optical path of the detector assembly; the filters are arranged in three concentric spectral bands on the wheel. The filter wheel rotates continuously at 10 Hz, and its rotation is synchronized with the stepping motion of the scan mirror.

A user may request by command a set of soundings that start at a selected latitude and longitude and end at another latitude and longitude. The Sounder responds to scan locations that correspond to those command inputs. The sounding frame may include the whole or any portion of the earth and the frame may begin at any time. The Sounder scan control is not limited in scan size or time; thus an entire viewing angle of 21° north-to-south by 23° east-to-west is available for star location or sounding frames. Requests for up to 16 repeats of a given location can be made by ground command. Capability is provided for interrupting a frame sequence for "priority" scans. The system will scan a priority frame set or star sense, then automatically return to the original set.

4. Sounder

Table 4-4. Sounder Instrument Performance Summary

Parameter	Performance	
System absolute accuracy	Infrared channel ≤ 1 K Visible channel $\pm 5\%$ of max scene radiance	
System relative accuracy	Line to line	≤ 0.25 K
	Detector to detector	≤ 0.40 K
	Channel to channel	≤ 0.29 K
	Blackbody calibration to calibration	≤ 0.60 K
Star sense area	21° N-S by 23° E-W	
Sounding rate	3000 by 3000 km ≤ 42 min	
Time delay	≤ 3 min	
Data timeliness		
Spacecraft processing	≤ 30 sec	
Sounding periods		
Image navigation accuracy at nadir (excluding diurnally repeatable distance)	30 μ rad	
Registration within 120 minute sounding	120 min	42 μ rad
Registration between repeated soundings	24 hr	42 μ rad

Radiometric quality is maintained by frequent (every 2 minutes) views of space for reference. Less frequent views (20 minutes) of the full aperture internal blackbody establish a high temperature baseline for instrument calibration in orbit. Further, the amplifiers and data stream are checked for stability by an electronic staircase signal during each blackbody reference cycle. Other aspects of the Sounder are the same as for the Imager.

Operation

The Sounder is controlled by a defined set of command inputs. The instrument is capable of full earth sounding and sector sounding, including various sounding area sizes totally enclosed within the earth scene. Area scan size can be as small as one sounding location. The sounding dwell at each step is selectable to be 0.1, 0.2, or 0.4 second. An optional capability is provided for skipping scan lines to increase the rate of area sounding at a dwell time of 0.2 second per sounding.

The Sounder's flexible operation includes a star sensing capability. Once the time and location of a star is predicted, the Sounder scanner is pointed to that location within its 21° N-S by 23° E-W field of view and the scan stopped. A separate linear array of eight silicon detectors with a 240 μ rad N-S coverage, similar to the Imager, is used. As the star

image passes through the detectors, the signal is sampled, then encoded and included in each Sounder data block for extraction and use at the ground station. The star sense detectors are sampled at 40 times per second.

Duplication of the four element array in each of the three bands (longwave, 12 μm to 14.7 μm ; midwave, 6.5 μm to 11 μm ; and shortwave, 3.7 μm to 4.6 μm) yields the spectral separation of the infrared bands; the filters are arranged on the wheel for efficient use of sample time and optimal channel coregistration. Each detector converts the atmospheric radiance into an electrical signal that is amplified, filtered, and digitized; the resulting digital signal is routed to a sensor data transmitter, for downlinking to a ground station.

By synchronizing filter wheel rotation with the scan mirror's stepping motion, all sampling is accomplished with the mirror in a stopped condition. Upon ground command, the scan system can generate frames of any size or location using west-to-east stepping and east-to-west stepping of 280 μrad , with a north-to-south step of 1120 μrad , continuing the pattern until the desired frame is completed. The visible channel (0.7 μm), not part of the filter wheel, is a separate set of uncooled detectors with the same field size and spacing. These detectors are sampled at the same time as the infrared channels (3, 11, and 18), providing registration of all sounding data.

By virtue of its digitally controlled scanner, the Sounder provides operational sounding from full earth scan to mesoscale area scans. Accuracy of location is provided by the absolute position control system in which position error is noncumulative. Within the instrument, each position is defined precisely and any chosen location can be reached and held to a high accuracy. This registration accuracy is maintained along a scan line, throughout an image and over time. Total system accuracies relating to spacecraft motion and attitude determination also include this allocated error.

Motion of the Imager and Sounder scan mirrors causes a small but well-defined disturbance of spacecraft attitude. The disturbances caused by each scan motion on the spacecraft are easily calculated by the attitude control subsystem (ACS). A compensating signal is developed and applied in the scan servo-control loop to bias scanning and offset the disturbance. This simple signal and control interface provides corrections that minimize any combination of effects. With this technique, the Imager and Sounder are totally independent, maintaining image location accuracy regardless of the other unit's operational status. If needed, this mirror motion compensation scheme can be disabled by command.

The ACS also provides compensation signals that counteract spacecraft attitude, orbital effects, and predictable structural-thermal effects within the spacecraft-instrument combination. These disturbances are detected from star sensing and land features. Ground-developed corrective algorithms are fed to the instruments via the ACS as a total image motion compensation (IMC) signal that includes the dynamic mirror motion compensation described above.

4. Sounder

Yaw Flip Operation

There is an alternative spacecraft orientation option for the GOES N-P satellites known as the yaw flip configuration. In this mode, the satellite is rotated 180 degrees from its normal orientation, and results in the normally north facing side of the instruments facing toward the south during summer in the northern hemisphere. Yaw flip maintains the spacecraft in a configuration that prevents the sun from entering the radiant coolers.

This mode allows operation of the instruments with the patch temperature set to LOW year round as the radiant coolers are always pointing in a direction that permits operating under winter conditions. Without yaw flip, the patch temperature settings should be LOW for winter and MID for summer. MID can be used year round without yaw flip if there is no cooler degradation as the cooler should start life with a 3° C margin at the MID setting for summer solstice. HIGH allows for operation in the summer should some cooler degradation occur.

It should be noted that all references to the scan coordinate system will be reversed when operating in the yaw flipped mode.

Sensor Module

The sensor module consists of a louver assembly, baseplate, scan assembly, scan aperture sun shield, preamplifiers, telescope, aft optics, filter wheel, and radiant cooler assemblies for the detectors and the filter wheel. The scan assembly and telescope are mounted on a common baseplate. A passive louver assembly and electrical heaters on the base aid thermal stability of the telescope and major components. A passive radiant cooler with a proportionally controlled heater maintains the infrared detectors at 82 K during the winter solstice season and 85 K for the remaining portion of the year (with 88 K as backup). The visible and star sense detectors are at instrument temperature of 13 to 30°C. Preamplifiers in the sensor module convert the low-level signals to higher level, low impedance outputs for transmission by cable to the electronics module. Figure 4-2 illustrates an expanded view of the sensor module.

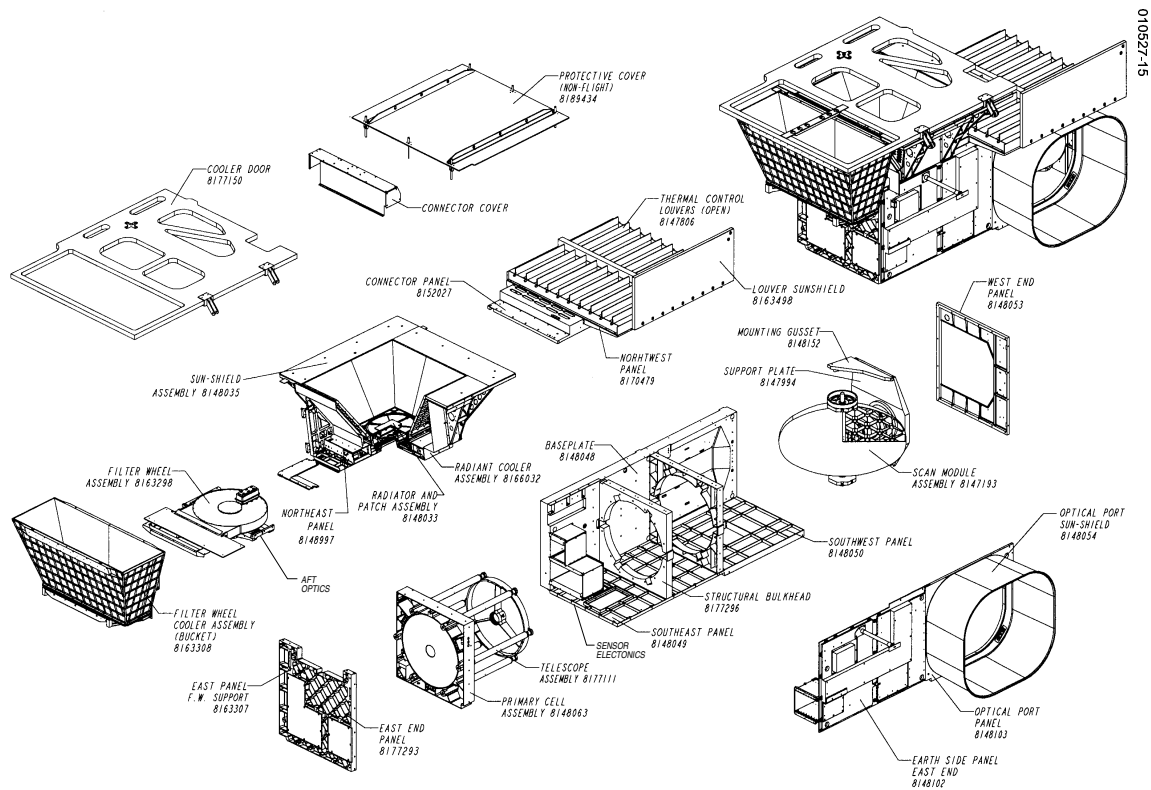

SENSOR ASSEMBLY - SOUNDER

Figure 4-2. Sensor Module—Expanded View

Sounder Optics

The Sounder telescope is similar to that of the Imager. Dichroic beamsplitters separate the scene radiance into the spectral bands of interest. The IR energy is deflected toward the detectors located on the coldest stage of the radiative cooler, while the visible energy passes through a dichroic beamsplitter and is focused on the visible (sounding and star) detector elements. The SW and MW bands are reflected by another dichroic beamsplitter and the LW is transmitted through it. Optical separation of the 18 IR channels takes place at the filter wheel assembly. Figure 4-3 illustrates the Sounder optical elements.

Filter Wheel

The filter wheel is a 28.2 centimeter (11.1 inch) diameter disk containing 18 filter windows divided into three concentric rings, one ring for each IR detector group. The outer ring contains seven LW channels, the middle ring contains six SW channels, and the inner ring contains five MW channels. Filter angular lengths are selected to provide nearly equal performance margin in each channel. The wheel has approximately one-

4. Sounder

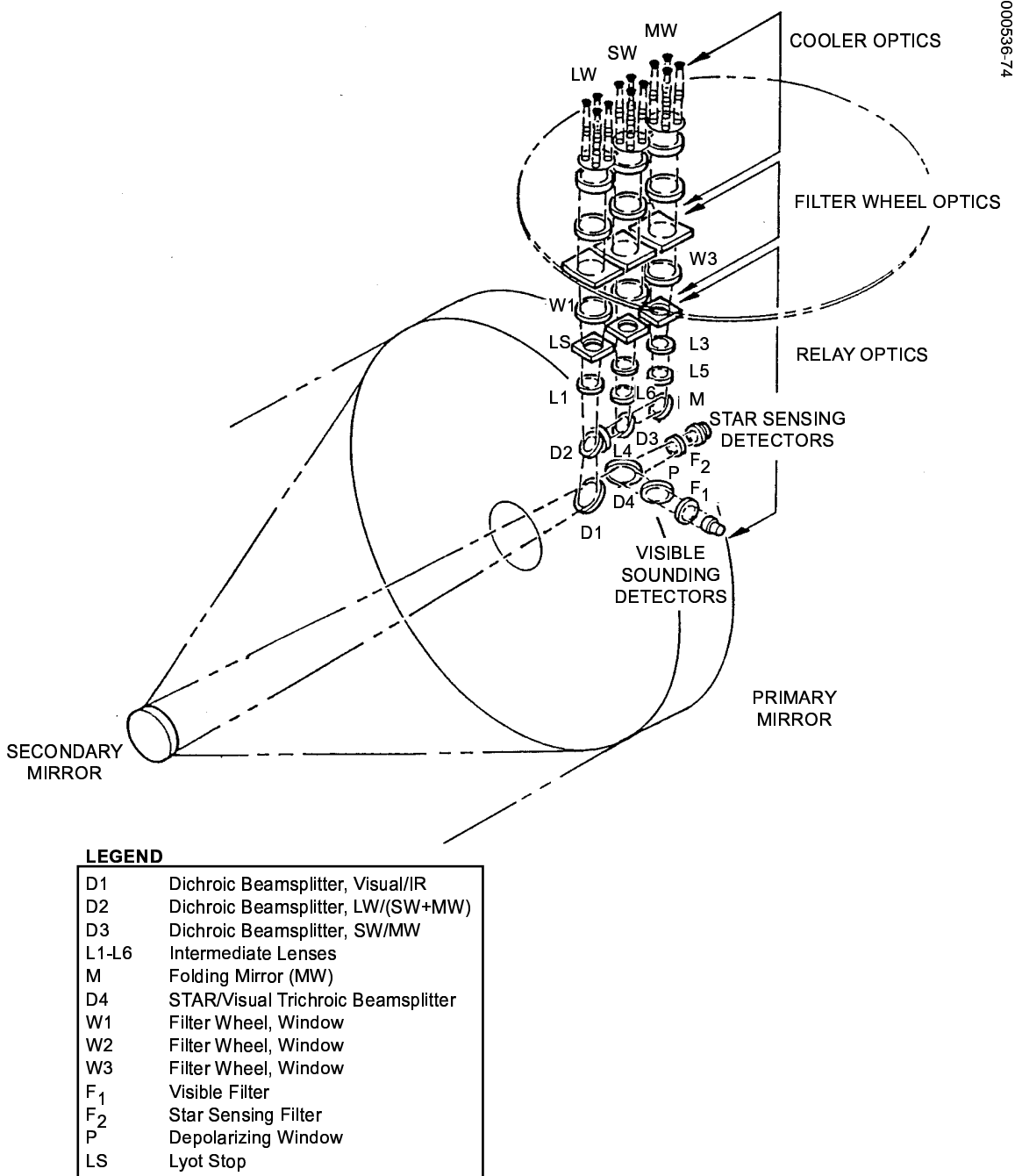

LEGEND

D1	Dichroic Beamsplitter, Visual/IR
D2	Dichroic Beamsplitter, LW/(SW+MW)
D3	Dichroic Beamsplitter, SW/MW
L1-L6	Intermediate Lenses
M	Folding Mirror (MW)
D4	STAR/Visual Trichroic Beamsplitter
W1	Filter Wheel, Window
W2	Filter Wheel, Window
W3	Filter Wheel, Window
F ₁	Visible Filter
F ₂	Star Sensing Filter
P	Depolarizing Window
LS	Lyot Stop

Figure 4-3. Sounder Optical Elements

fourth of its area clear of filters. By synchronizing the stepping of the scan mirror to occur in this “dead zone,” the wheel can continue rotating while the mirror steps to the next location and is stopped while the 18 channels are sampled. Stopping the mirror ensures that all channels sample the same column of the atmosphere; holding and

sampling in 0.075 second provides virtually simultaneous sampling of the channels. Figure 4-4 illustrates the filter wheel configuration.

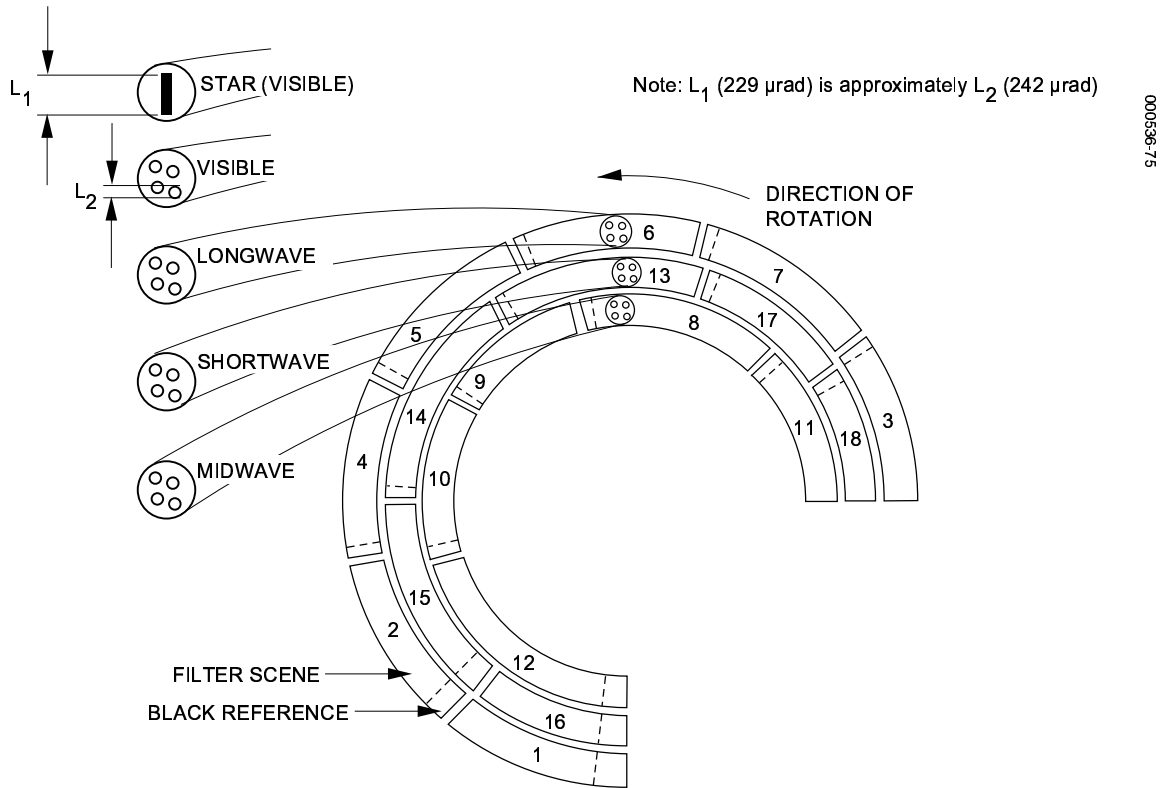

Figure 4-4. Filter Wheel and Channel Separation

The first channels to be sampled are high altitude sensors that have little spatial definition and are less affected by the settling characteristics of the scan mirror. The earth surface viewing channels are grouped near the end of the sounding period for maximum stability and coregistration. Though not viewed through the filter wheel, the visible detectors are gated so that they sample the same atmospheric column at the same time as the IR channels.

The filter wheel acts as the spectral defining element in the optics, though it also has a major effect on radiometric stability and signal quality. Each filter has a very narrow spectral bandpass, restricting the radiant input from the scene and contributions from optical parts in the path to the filter wheel. From filter wheel to detectors, there is no spectral limit other than a broadband limiting filter in the cooler. Any small deviation of radiance in this area may cause unwanted noise in the signal. To reduce emitted energy that might cause random noise and to provide very low background radiance input to the detectors, the filter wheel is cooled to approximately 212 K. The temperature of the filter wheel housing is brought to 210 K by thermal connection to a radiating surface.

4. Sounder

Heaters and a precision temperature control circuit maintains the housing within 1°C of the set temperature.

Detectors

The Sounder acquires radiometric data for 19 distinct wavelengths or channels through the use of four separate detector assemblies and a rotating filter wheel. This generates an 1120 μ rad N-S swath that is moved latitudinally in 280 μ rad (10 km) steps. A fifth detector array provides the Sounder with star sense capabilities. Each of the radiometric channels is characterized by a central wavelength denoting primary spectral sensitivity. The 19 channels are broadly split into two classes: visible (channel 19) and infrared (channels 1-18). Figure 4-5 illustrates the detector array arrangement.

Visible Channel

The visible silicon detector array (channel 19) contains four detectors, each with an instantaneous geometric field of view (IGFOV) of 242 μ rad in diameter set by the detectors size, corresponding to an 8.7 km (28 μ rad) diameter nominal pixel size at the spacecraft suborbital point. A star sensing array, consisting of a separate set of eight silicon detectors, is on the same mount and aligned to the center of the visible sounding detectors. It is identical to the Imager visible detector array but has 0.97 km (0.60 statute mile) resolution and 8.5 km (5.3 statute mile) array coverage.

Infrared Channels

The IR channels (1 through 18) are contained in three detector sets: LW, MW, and SW, each set consisting of four detectors. The fields of view are set by the field stops in a pattern the same as the visible channel.

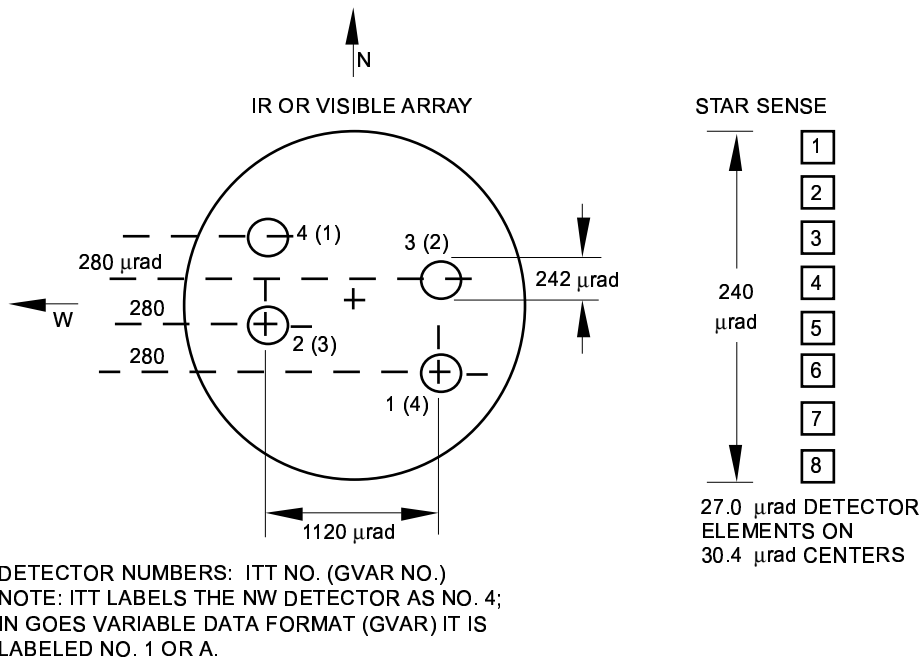

000536-76

Figure 4-5. IR, Visible, and Star Sense Detector Arrays

Element Configuration

Each of the field stop or detector patterns is arranged in the same asymmetric fashion, with a nominal focal plane configuration. The star sensing array and visible radiometric array have a clear optical path in the instrument. The three arrays dedicated to IR wavelengths (LW, MW, and SW) are optically located behind the filter wheel assembly, each handling a different region of the infrared spectrum. Although physically separated in the instrument, the four radiometric arrays are coregistered optically, resulting in automatic coalignment of the pixels for all 19 channels. Figure 4-6 illustrates the detector separation and scan pattern.

Scan Control

As in the Imager, the Sounder scans the selected image area in alternate lines (that is, west-to-east followed by east-to-west or vice versa) and is capable of scanning both north-to-south and south-to-north. The scanning mirror position is controlled by two servo motors, one for the N-S gimbal angle and one for the E-W scanning gimbal angle. Each servo motor has an associated Inductosyn that measures the mechanical shaft rotation angle. The scanning mirror position and, hence, the coordinate system used for the Sounder are measured in terms of Inductosyn outputs. Scan control for both axes is generated by establishing a desired angular position for the mirror. The desired angle is input to an angular position sensor (one Inductosyn for each axis), which produces a displacement error signal. This signal is fed to a direct drive torque motor (one for each axis) that moves the mirror and sensor to the null location. Figure 4-7 illustrates the scan control block diagram.

4. Sounder

For E-W deflection, the direct-drive torque motor is mounted to one side of the scan mirror and the position-sensing device (Inductosyn position encoder) is mounted on the opposite side. All rotating parts are on a single shaft with a common set of bearings. Using components of intrinsically high resolution and reliability, coupling of the drive, motion, and sensing is therefore very tight and precise. North-south motion is provided by rotating the gimbal (holding the above components) about the optical axis of the telescope. This rotating shaft has the rotary parts of another torque motor and Inductosyn mounted to it, again providing the tight control necessary.

The servo system is not absolutely accurate because of noise, drag, bearing imperfections, misalignment, and imperfections in the Inductosyn. Such inherent position-related errors cause pointing errors that preclude achieving the highest possible system accuracy. Slight variations of individual pole pairs cause a systematic pattern that is repeatable and measurable and can therefore be stored and subtracted to counteract the Inductosyn's inherent error. This fixed error pattern and other systematic factors are measured, encoded, and stored in read-only memory. By injecting this stored error signal into the main control loop, the effect of Inductosyn electromechanical errors and other systematic effects are reduced to less than one-fourth of their noncorrected values.

4. Sounder

010527-16

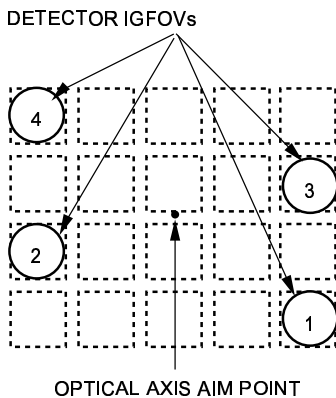
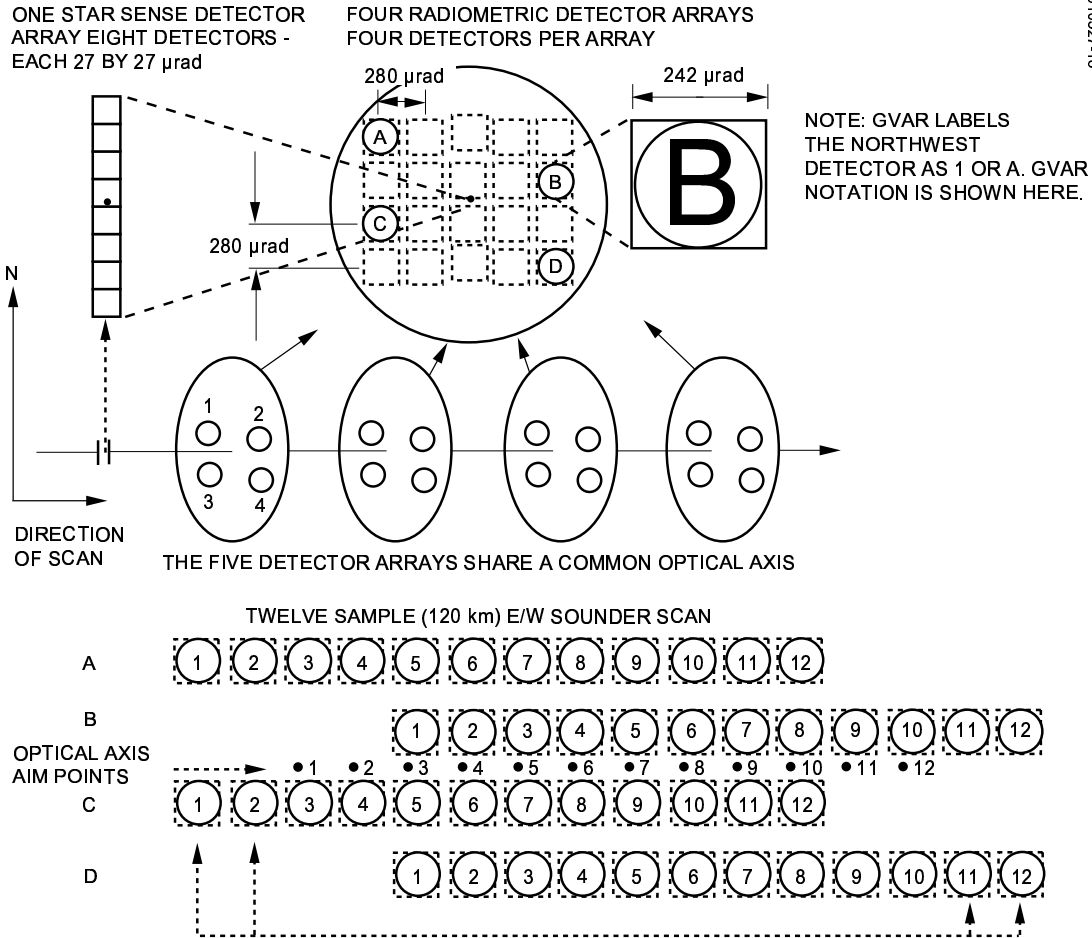

- Four Detectors Per Channel
- Each Detector Has 8.7 km (242.6 μ rad) IGFOV (Maximum)
- Neighboring Detectors On 10 km (280 μ rad) Centers In N/S Direction
- Sample Spacing 10 km (280 μ rad) in E-W Direction
- Channels Aim Point For a Sample Is:
 - 20 km (560 μ rad) East of 4 and 2 Detectors
 - 20 km (560 μ rad) West of 3 and 1 Detectors
 - 15 km (420 μ rad) South of 4 Detector
 - 5 km (140 μ rad) South of 3 Detector
 - 5 km (140 μ rad) North of 2 Detector
 - 15 km (420 μ rad) North of 1 Detector
- Detector Numbers As Identified In ITT Notation

Legend

- E/W East/West
GVAR Goes Variable Data Format
IGFOV Instantaneous Geometric Field of View
N/S North/South

NOTE: ITT LABELS THE NORTHWEST DETECTOR AS 4. ITT NOTATION IS SHOWN HERE.

Figure 4-6. Detector Separation and Scan Pattern

4. Sounder

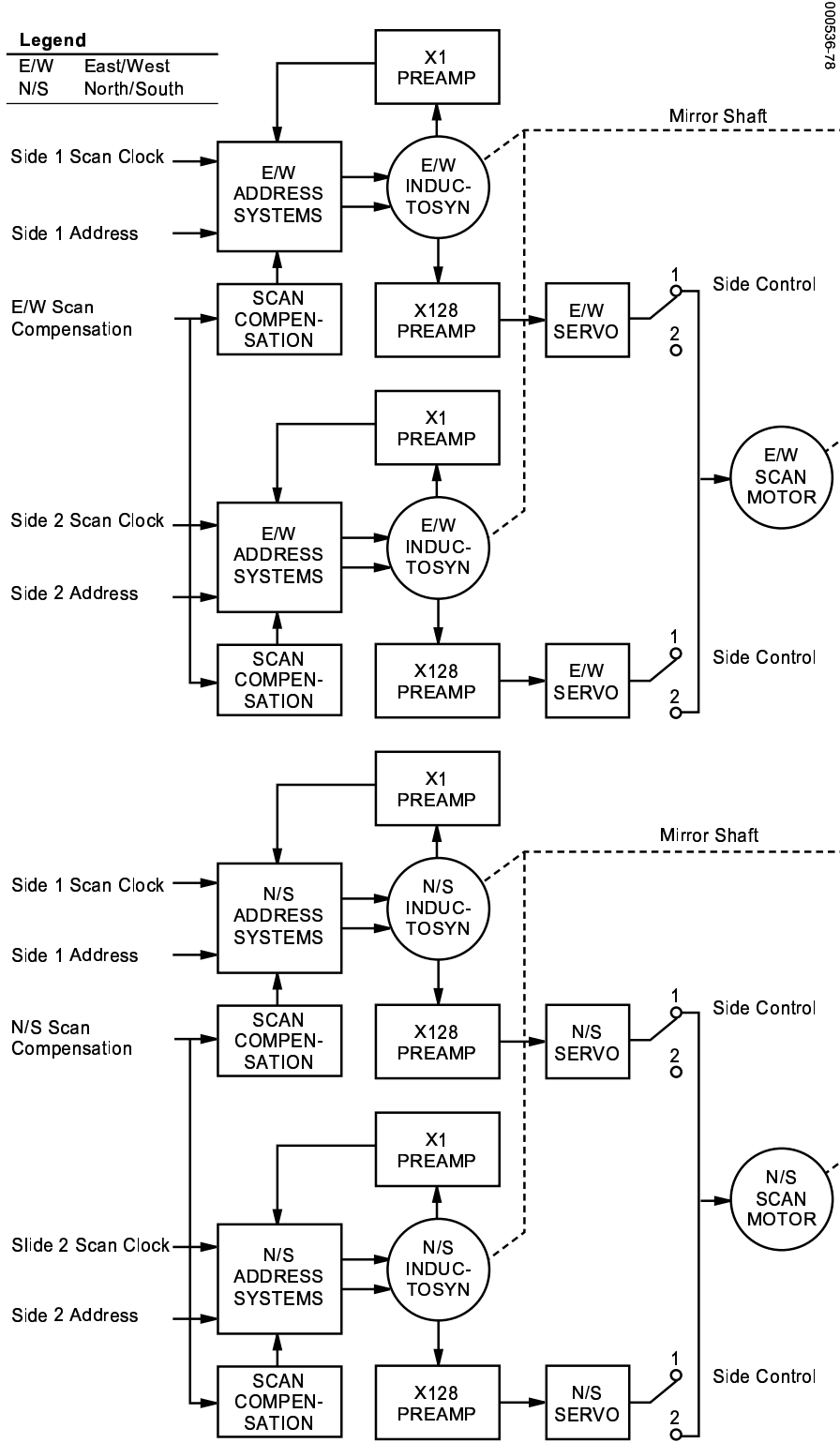

Figure 4-7. Scan Control Schematic

Drive and error sensing components used for the two drive axes are essentially identical. Control components are optimized for their frequency and control characteristics, and logic is developed for the precise control of position in response to a system-level control processor.

Scan Operation

Scan control is initiated by input commands that set start and end locations of a sounding frame. A location is identified by an Inductosyn cycle and increment number within that cycle, the increment number determining the value of sine and cosine for that location. Each E-W increment corresponds to 17.5 μ rad of E-W mechanical rotation or 35 μ rad of E-W optical rotation. Each N-S increment corresponds to 17.5 μ rad of N-S mechanical and optical rotation. The distance between a present and start location is recognized, causing incremental steps (17.5 μ rad) at a high rate (10 deg/sec) to reach that location. To minimize peak power demand the scan slews latitudinally, then longitudinally to a requested location.

Scan to space for space clamp or to star sensing, or to the IR blackbody uses the slew function. Command inputs (for star sensing or priority scan) or internal subprograms (for space clamp and IR calibration) take place at the proper time during a frame.

Sounding Generation

The E-W scan of the Sounder is acquired via a repeating sample-step-settle sequence that constitutes a 100 ms (single dwell), 200 ms (double dwell), or 400 ms (quadruple dwell) intervals. This is controlled by the filter wheel rotation. This step-settle sequence repeats until the end of the scan line is reached. At this point, a 100 ms interval is executed in which the mirror will be stepped 1120 μ rad (40 kilometers at the spacecraft subsatellite point) in the N-S direction, which is four times larger than the E-W scan step. At the conclusion of this interval, acquisition of the next scan line will be initiated in the opposite E-W direction using the sample-step-settle sequence. In the double (quadruple) dwell mode, two (four) detector samples are acquired at each step.

The mapping between cycles and increments and the instrument field of view are referenced to a coordinate frame whose origin is zero cycles and zero increments (southwest corner of the frame). In geostationary orbit, the earth will be centered within the frame, at instrument nadir, which corresponds closely to the spacecraft subsatellite point, also centered in the frame. The GVAR coordinate system for both the Imager and Sounder is in line/pixel space and has its origin in the NW corner. The Sounder's coordinate system frame is shown in Figure 4-8, showing the earth disc centered in the instrument's coordinate frame, the 21°x23° operational FOV limit frame and the 25°x202° mechanical limit frame. The earth disc subtends a 17.4° viewing angle from geostationary altitude.

4. Sounder

Electronics

The Sounder electronics module is similar to the Imager's, but with additional circuitry required for the filter wheel motor drive, synchronization, and channel registration. There is no coherent error integrator for the Sounder in the E-W direction, though an average error integrator (AEI) is active in the N-S and E-W directions to improve position accuracy. The AEI is a simple error correction circuit that acts upon the servo error signal to reduce that error to zero. The scan control electronics are contained in the electronics module. The servo preamplifiers are located at the scanner in the sensor module. Figure 4-9 illustrates the Sounder electronics block diagram

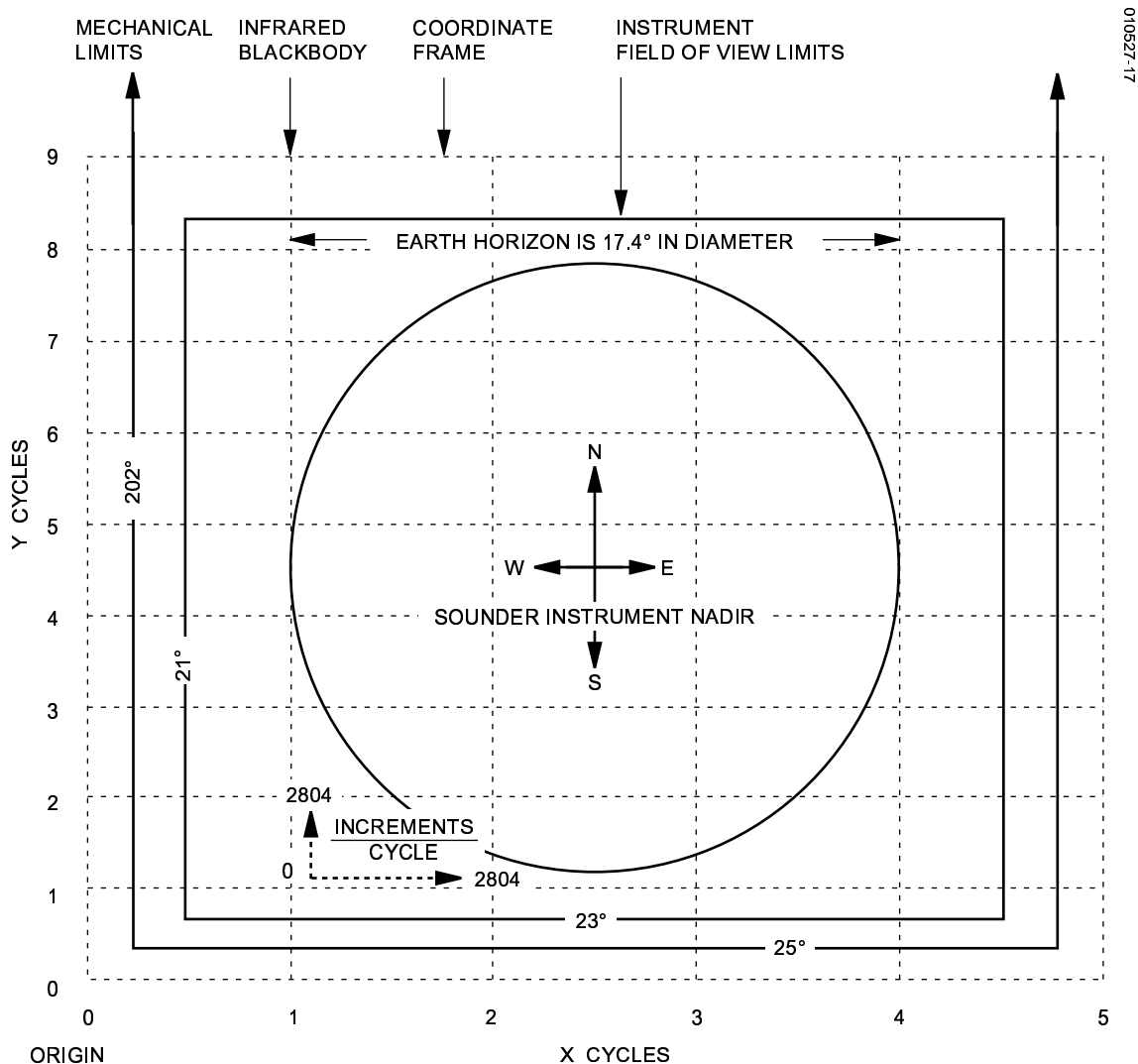

Figure 4-8. Sounder Coordinate Frame

Signal Processing

Preamplification of the low-level IR and visible channel signals occurs within the sensor module. These analog signals are sent to the electronics module, which amplifies, filters, and converts the signals to digital code. All channels in the visible and IR bands are digitized to one part in 8192 (13 bits), the visible for high-quality visible sensing, and the IR for radiometric measurement. The data from the star sensing channel is also digitized to 13 bits. Data from all channels move in continuous streams throughout the system; thus each channel's output must enter a short-term memory for proper formatting in the data stream. Each channel is composed of a detector, preamplifier, filter, postamplifier, analog-to-digital converter, and signal buffer. All signal chains are totally independent and isolated. Redundant chains of signal processing circuitry are provided with each circuit ending in a line driver designed to interface with the spacecraft sensor data transmitter.

Electronic Calibration

Electronic calibration signals are injected into the preamplifier of all channels while the Sounder is looking at space. Sixteen precise signal levels derived from a stepped digital-to-analog (D/A) converter are inserted during the 0.2 second spacelook. The electronic calibration signal is derived from a 10 bit converter having 0.5 bit accuracy, providing the accuracy and linearity for precise calibration. This is inserted into all preamplifiers of all channels, both visible and IR.

Visible Channels

The visible channel and star sensing detector arrays have a separate amplifier/processor for each detector element. These preamplifiers are current sensing types that convert the photon-generated current in the high impedance silicon detector into an output voltage, with a gain of about 10^8 V/A. The preamplifiers are followed by postamplifiers that contain electrical filtering and space clamping circuits. The digitization of the data signals is also part of the space clamp circuitry. The visible information is converted to 13 bit digital form, providing a range from near 0.1% to over 100% albedo for the visible channel. Differences of approximately 0.1% are discernible, and the linear digitization provides for system linearity errors of 0.5 bit in the conversion process.

Infrared Channels

The IR channels have a separate amplifier/processor for each detector element. Individual amplifiers for each detector are mounted near the detectors in the sensor module. The shortwave channel detectors (ch 13 to 18) have the first stage of the preamplifiers incorporated into the detector packages.

The IR information is converted to 13 bit digital form, providing a range from near 0.1% to over 100% of the response range. Each channel has a gain established for space-to-scene temperatures of 260 to 335 K. The 13 bit digital form allows the lowest calculated noise level to be differentiated. The digital system is inherently linear with analog-to-digital (A/D) converter linearity and accuracy to 0.5 bit. The binary coded video is strobed onto the common data bus for data formatting by the system timing and control circuitry.

4. Sounder

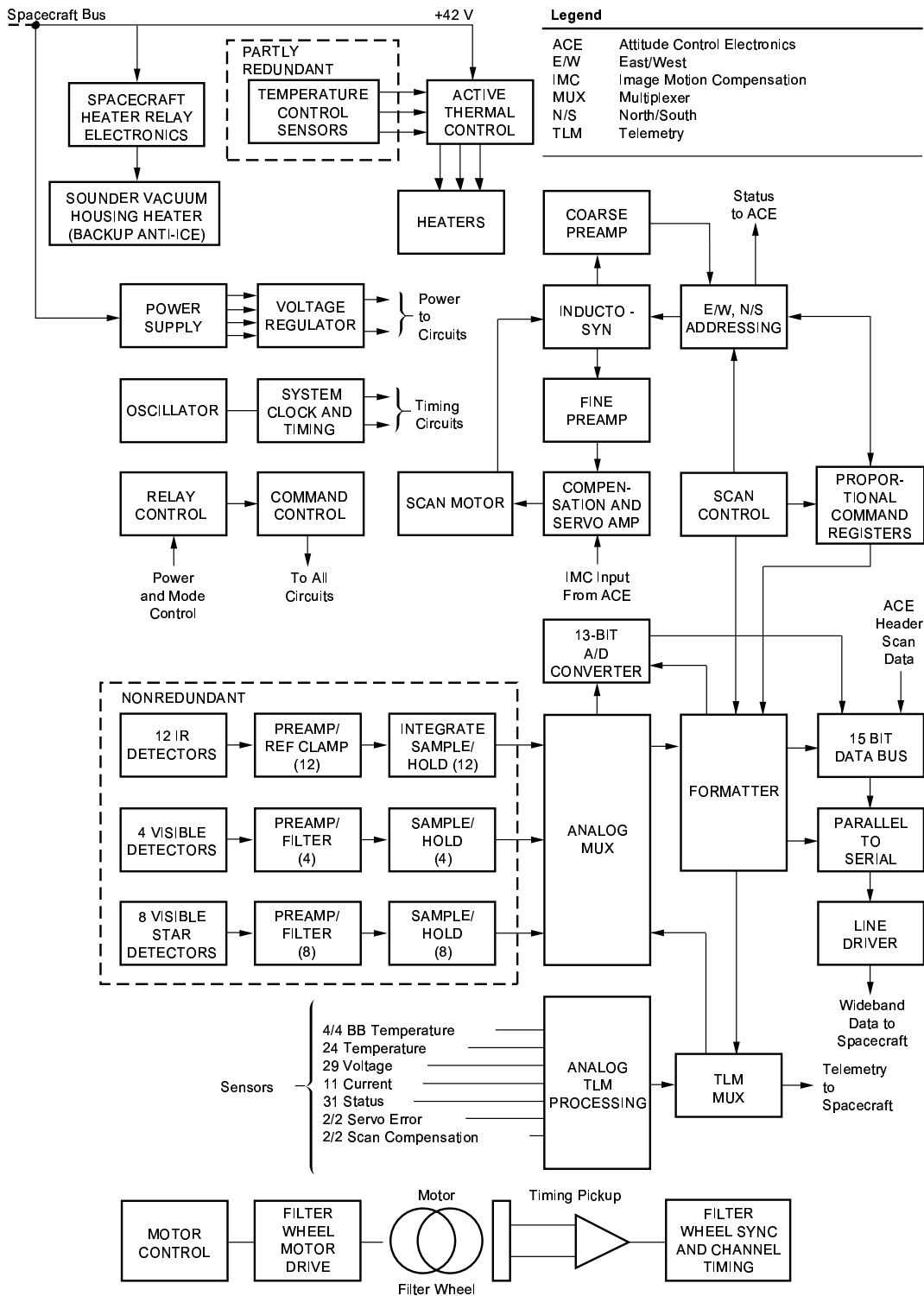

Figure 4-9. Sounder Electronic Block Diagram

Formatting

Digital signal processing starts where data streams from the IR and visible detectors and telemetry merge via multiplexing (a parallel-to-serial conversion and data multiplexing take place to bring sensor data together). Other information, such as synchronization pulses, scan location, and telemetry data, are assembled in the data select circuitry. The data are then passed through a line driver where pulse amplitude and impedance levels are set for the transmitter interface.

A Sounder data block is transmitted during the time it takes for the filter wheel to complete one revolution (0.1 second). Unlike the Imager, there is no concept of multiple data block types that are formatted differently as a function of their data content. All of the data is contained in a stream of Sounder data blocks of one type, where each data block contains 250 16 bit words transmitted at a data rate of 40 kbps or 10 blocks per second. A Sounder data block contains:

- Sounding data
- Star sense data
- Telemetry
- Header data
- Synchronization
- Spacecraft attitude data
- Scan position
- Scan control data

Power Supply

The block diagram of the Sounder power supply system is similar to that given for the Imager with the exception that the Sounder power supply contains two additional DC/DC converters to provide power for the filter wheel. The power supply converts spacecraft main bus voltage (42 volts nominal) to the required instrument voltages. There are two sides (1 and 2) to the unit, each totally independent and selected by command, although only one side operates at a time.

The power supply provides secondary power for the instrument by means of eight DC/DC switching mode converters. Each redundant side of the instrument has four separate converters that supply power to 1) the telemetry circuits, 2) the scanner drive circuits, 3) the filter wheel drive circuits, and 4) the remainder of the instrument electronics. The converters consist of synchronized switching circuits, transformers, rectifiers, and filters. The telemetry, electronics, and filter wheel supplies feed regulators to provide regulated voltage levels to the appropriate analog and logic circuits. The scan converter supplies power to the scan motor drive circuits and feeds a regulator to provide regulated voltage levels to scan control circuits. The converters are synchronized to 200 kHz and the Electronics and Scan converters use a push-pull topology while the

4. Sounder

Telemetry and Filter Wheel converters use a flyback configuration. A diode OR'ing circuit permits operation of all nonredundant circuits (patch temperature control, video amplifiers, etc.) by either side. Control of the power supplies is achieved using relays for turn on, turn off, and side select. Ultimate protection for the spacecraft power bus is provided by having fuses on the input lines of the power supply.

5. Space Environment Monitor

The space environment monitor (SEM) measures solar radiation in the x-ray and EUV region and the in-situ magnetic field and energetic particle environment at geosynchronous orbit, providing real-time data to the Space Environment Center (SEC). The SEC, the nation's "space weather" center, receives, monitors, and interprets a wide variety of solar terrestrial data, and issues reports, alerts, and forecasts for special events such as solar flares or geomagnetic storms. This information is important for military and civilian radio communication; satellite communication and navigation systems; electric power networks; geophysical exploration; shuttle and space station astronauts; high-altitude aviators; and scientific researchers. Boeing's SEM suite maximizes data continuity with the present GOES SEM database and satisfies the new SEM measurement requirements for extreme ultraviolet and magnetospheric particles. Related to the SEM suite is the Solar X-ray Imager (SXI), which is described in Section 6.

The SEM subsystem consists of multiple instruments used to monitor the near earth (geostationary altitude) space environment and observe solar x-ray (XRS) and extreme ultraviolet (EUV) output. Figure 5-1 illustrates the SEM instrument suite. An XRS/EUV instrument mounted on a positioning platform, fixed on the solar array yoke, observes solar output. The energetic particle sensor (EPS)/high energy proton and alpha detector (HEPAD) instrument measures the flux of protons, alpha particles, and electrons over an extensive range of particle energies. Two redundant three-axis magnetometers, mounted on a deployed 8.5 meter boom, operate simultaneously to measure Earth's geomagnetic field strength and variations in the vicinity of the spacecraft. The SEM instruments are capable of ground-command-selectable, in-flight calibration for monitoring on-orbit performance and ensuring proper operation.

XRS/EUV Instrument

The XRS/EUV sensor measures disk-integrated solar x-ray and EUV fluxes. The XRS/EUV consists of two channels in the x-ray sensor, five channels in the EUV sensor, and a Digital Processing Unit (DPU) that controls the instrument. The microprocessor based DPU supports both sensors, providing power, telemetry and command (T&C), and data processing. A schematic view of the XRS/EUV is shown in Figures 5-2 and 5-3. The spacecraft points the XRS/EUV sensor so that the field of view (FOV) is always pointed at the sun. The XRS/EUV sensor is mounted on a gimbaled x-ray positioner (XRP) on the spacecraft solar array yoke, coaligned with the SXI. The XRP can track the

5. Space Environment Monitor

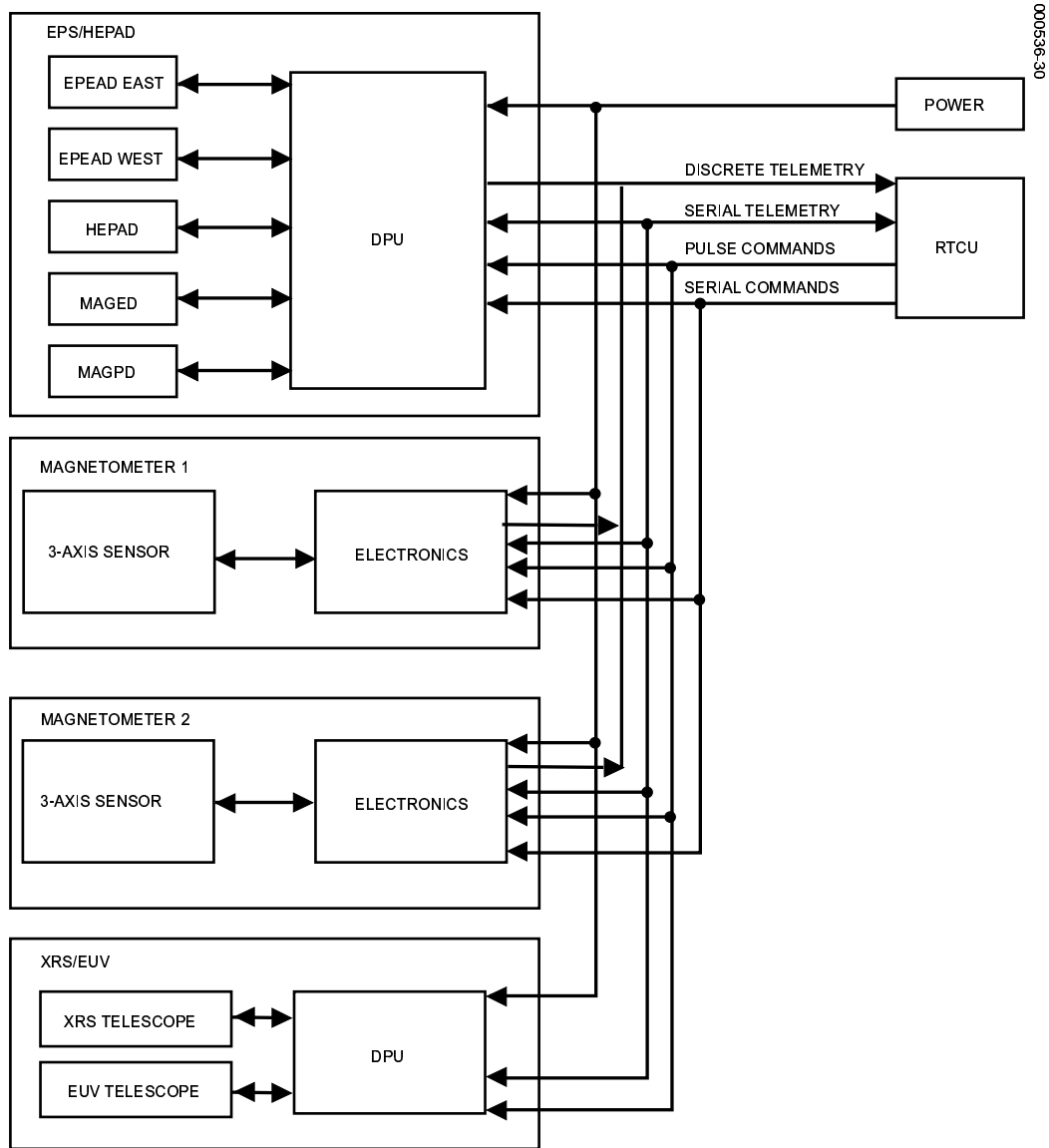

Figure 5-1. SEM Instrument Suite

sun along the elevation axis, while the yoke, along with the solar panel, is positioned by the spacecraft in the azimuth axis.

The XRS design is based on an ion chamber design from previous GOES spacecraft and the EUV sensor design is similar to one flown on the NASA SOHO spacecraft. The sensor telescopes use magnetic shielding to reduce the background from high energy electrons, and the detectors are all well shielded from ambient particles and bremsstrahlung effect.

5. Space Environment Monitor

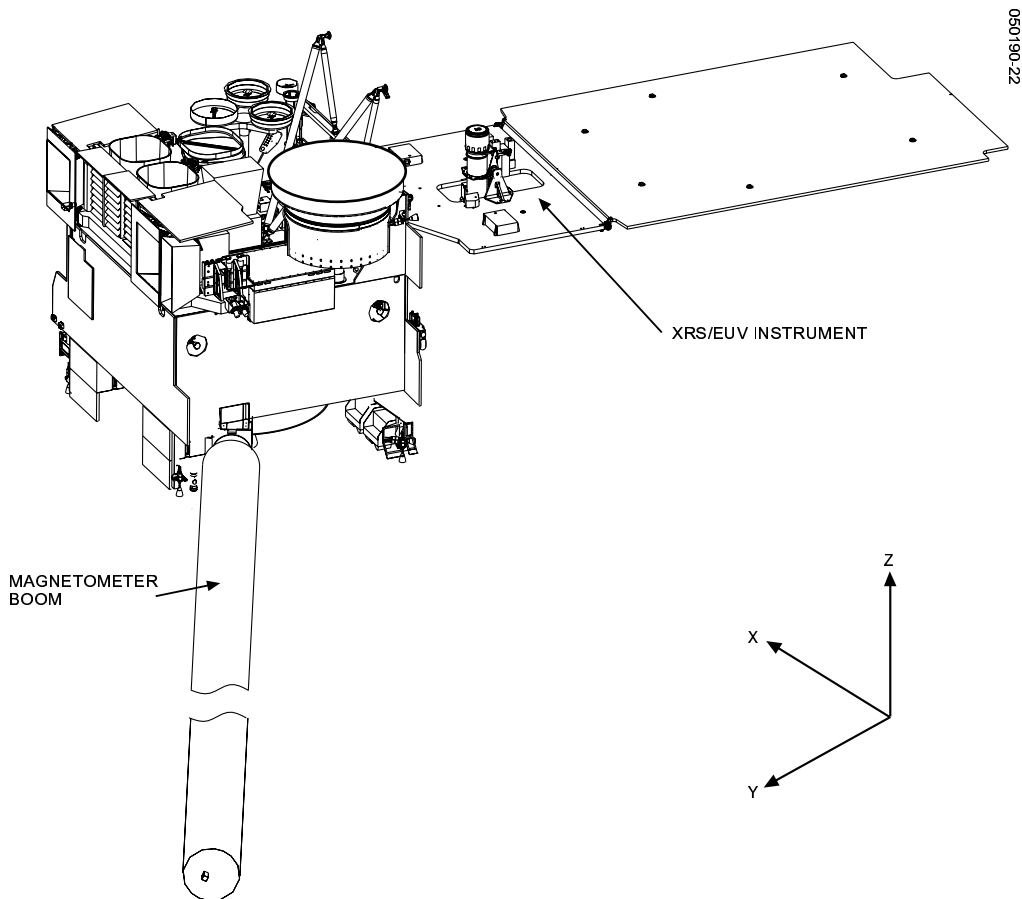

Figure 5-2. Deployed XRS/EUV Instrument—Schematic View

The XRS is an X-ray telescope that measures solar X-ray flux in two bands of 0.05–0.3 nm and 0.1–0.8 nm. The XRS assembly consists of a telescope collimator, sweeper magnet assembly, dual ion chamber and preamplifier subassemblies. Two ion chambers detect X-rays, one chamber for each spectral range. The detector output signals are processed by separate electronic channels that have a single range in each band, with the >5 decade dynamic range logarithmically compressed into a 15 bit data word. Data transmitted through the spacecraft PCM telemetry permit real time ground determination of the solar X-ray emission in the two spectral bands.

The aperture of the XRS features a pair of sweeper magnets to deflect incoming electrons away from the ion chambers so that only x-rays are admitted. The XRS/EUV shielding magnet assembly is balanced to minimize the magnetic signature induced at the spacecraft magnetometers.

5. Space Environment Monitor

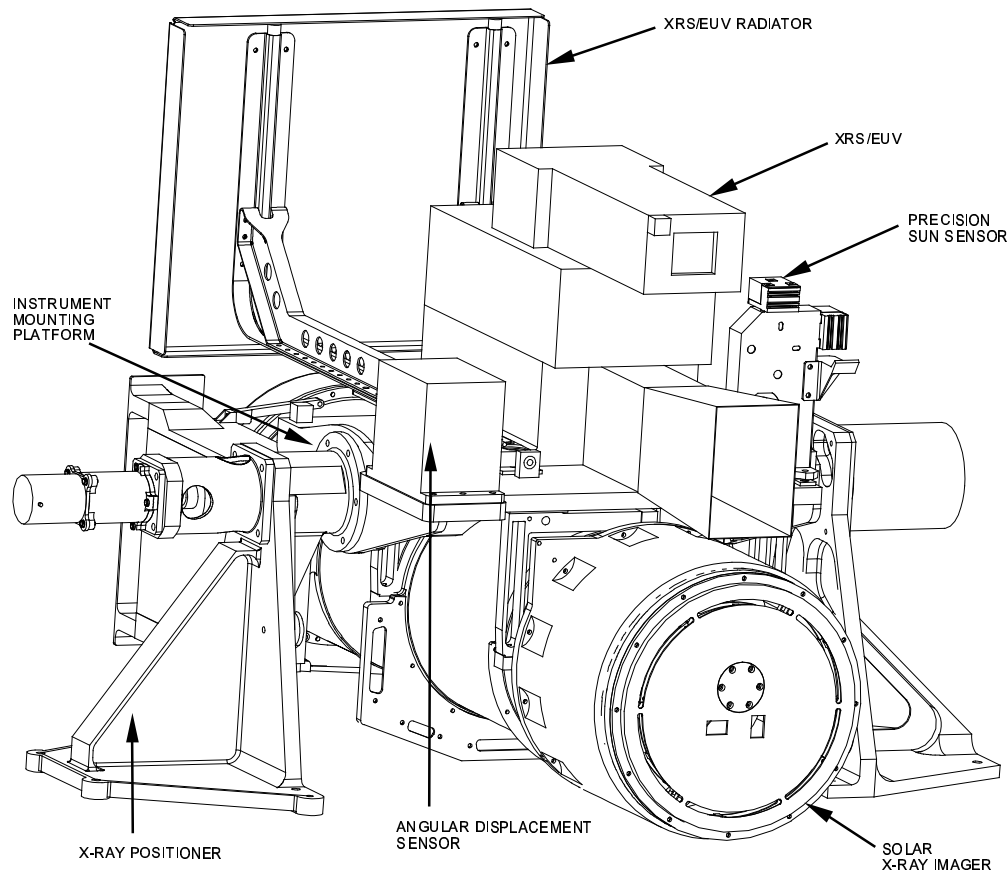

Figure 5-3. XRS/EUV/SXI Assembly

The five-channel EUV telescope uses transmission gratings, filters, and solid state detectors to measure the extreme ultraviolet flux in five wavelength bands centered at 10 nm, 30 nm, 60 nm, 80 nm, and 126 nm respectively. The five EUV channels are mounted on three optical benches with channel pairs A-B and C-D sharing components such as gratings and front apertures. The A-B channel pair uses a 5000 line/mm transmission grating, and the C-D channel pair uses a 2500 line/mm transmission grating. The E channel uses a 1667 line/mm transmission grating and one Lyman Alpha Filter. A strong magnetic field sweeps out electrons below 4 MeV. Radiation shielding of detectors further reduces bremsstrahlung effects.

The DPU contains the dc/dc converter and all processing electronics. The x-ray and EUV flux outputs are all digitized in the DPU and delivered to the spacecraft. The pre-amplifiers are located in the telescopes, close to the detectors (ion chambers for the XRS and solid state detectors [SSD] for the EUV). The EUV SSD analog signal processors use the same data compression algorithm as the XRS even though the required dynamic ranges are only 10^3 and 10^2 . The final signal digitization is done in the DPU, which provides the compressed data words to spacecraft telemetry. Each spacecraft minor frame contains four XRS/EUV 8-bit words. Table 5-1 summarizes XRS/EUV performance.

5. Space Environment Monitor

Table 5-1. XRS/EUV Performance Summary

Parameter	Performance	
Spectral bands		
XRS-A	0.05–0.3 nm	
XRS-B	0.1–0.8 nm	
EUV-A	5–15 nm	
EUV-B	25–34 nm	
EUV-C	20–65 nm	
EUV-D	20–82 nm	
EUV-E	119–127 nm	
Threshold flux, dynamic range		
	<u>Threshold Flux</u>	<u>Dynamic Range</u>
XRS-A	$5 \times 10^{-9} \text{ W/m}^2$	10 000
XRS-B	$2 \times 10^{-8} \text{ W/m}^2$	10 000
EUV-A	$1 \times 10^{-6} \text{ W/m}^2$	1 000
EUV-B	$2 \times 10^{-6} \text{ W/m}^2$	1 000
EUV-C	$1 \times 10^{-6} \text{ W/m}^2$	1 000
EUV-D	$2 \times 10^{-6} \text{ W/m}^2$	100
EUV-E	$1 \times 10^{-4} \text{ W/m}^2$	100
Threshold Sensitivity		
Signal to noise ratio, 10 second interval	30	
Resolution		
XRS, fluxes >20 times threshold	<2%	
EUV	0.25%, full scale	
Noise	Mean signal equal to the standard deviation of the data over a 10 second interval.	
Sampling rate		
XRS	Once every 2.048 sec	
EUV	Thrice every 32.768 sec	
Wavelength response	±5%	
Angular response		
Sensitivity varies less than 5%		
XRS	29.1 arc minutes	
EUV	30.1 arc minutes	
Pointing determination accuracy with respect to sun center	±2 arc minutes	

5. Space Environment Monitor

EPS/HEPAD Instrument

The EPS/HEPAD instrument is partially based on the previous GOES EPS/HEPAD design for the measurement of medium and high energy protons, electrons, and alpha particles, that originate from the sun, are trapped in the magnetosphere, or are generated by cosmic rays deep in space. The complete EPS/HEPAD instrument consists of two energetic proton, electron, and alpha detectors (EPEADs), a magnetospheric proton detector (MAGPD), a magnetospheric electron detector (MAGED), a high energy proton and alpha detector (HEPAD), and a DPU that controls the five sensors and interfaces with the spacecraft. EPS/HEPAD instrument locations on the GOES spacecraft are shown in Figure 5-4.

EPEAD

Protons in the energy range 0.74–900 MeV, alpha particles in the energy range 3.8–500 MeV, and high energy electrons in three energy ranges >0.6, >2, and >4 MeV are measured using two detector sets (EPEAD's) mounted on opposite sides of the spacecraft to provide the required equatorial angular coverage. The two EPEADs each contain a telescope assembly to measure the lower energy particles and a dome assembly to measure the higher energy particles. The dome detector also provides three integral electron flux measurements.

The telescope assembly uses two SSDs to measure the energy of protons and alpha particles in three bins each. These SSDs are shielded from electrons by a sweeper magnet and from light by a thin metal foil. Table 5-2 lists energy ranges for the telescope detectors.

The dome assembly contains three sets of two SSDs with differing shielding thicknesses to provide higher energy proton measurements in four bins, higher energy alpha particle measurements in three bins, and the three integral electron channels. Table 5-3 lists energy ranges for the dome detectors.

5. Space Environment Monitor

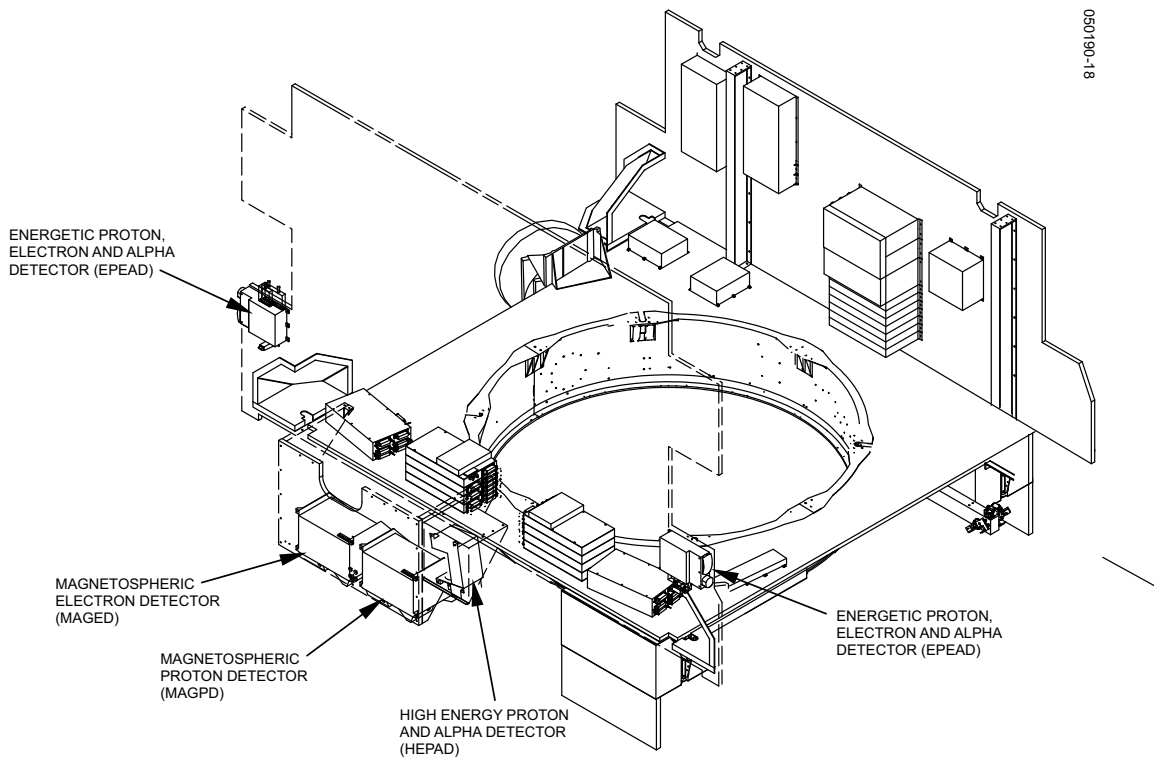

Figure 5-4. EPS/HEPAD Instrument Locations

Table 5-2. EPEAD Telescope Detector Energy Range

Particle	Channel	Range, MeV	Sample Time, sec
Proton	P1	0.74-4.2	8.2
Proton	P2	4.2-8.7	32.8
Proton	P3	8.7-14.5	32.8
Alpha	A1	3.8-9.9	32.8
Alpha	A2	9.9-20.5	32.8
Alpha	A3	20.5-61	32.8

5. Space Environment Monitor

Table 5-3. EPEAD Dome Detector Energy Range

Particle	Channel	Range, MeV	Sample Time, sec
Proton	P4	15–40	32.8
Proton	P5	38–82	32.8
Proton	P6	84–200	32.8
Proton	P7	110–900	32.8
Alpha	A4	60–160	32.8
Alpha	A5	160–260	32.8
Alpha	A6	330–500	32.8
Electron	E1	>0.6	4.1
Electron	E2	>2	16.4
Electron	E3	>4	16.4

MAGPD and MAGED

Magnetospheric protons and electrons are measured at nine pitch angle directions using two detector sets (MAGPD and MAGED). The detector sets are mounted on the anti-earth side of the spacecraft and measure protons or electrons at 0°, ±35°, and ±70° from the anti-earth direction in both the equatorial and the azimuthal plane. Each detector telescope has a full detection cone angle of 30°.

The MAGPD measures protons in five differential energy channels from 80–800 keV and is based on the SEM-2 MEPED instrument on the NOAA polar orbiting operational environmental spacecraft (POES). The MAGPD telescopes each have two SSDs that operate in an anticoincidence mode to provide the required proton channels. Sweeping magnets exclude electrons below several hundred keV. Table 5-4 lists the energy ranges for the MAGPD detectors.

The MAGED measures electrons in five differential energy channels from 30–600 keV and is also based on the SEM-2 MEPED instrument on the POES spacecraft. Physically, the MAGED is very similar to the MAGPD, the only difference being the detector assemblies. The MAGED telescopes each use a single SSD with a foil light shield and do not have sweeping magnets. Algorithms are provided to correct the electron channels for the proton contamination that is unavoidable with this detection system. Table 5-5 lists the energy ranges for the MAGED detectors. Table 5-6 summarizes the EPEAD, MAGPD, and MAGED performance.

Table 5-4. MAGPD Detector Energy Range

Channel	Range, keV	Sample Time, sec
MP1	80–110	16.4
MP2	110–170	16.4
MP3	170–250	16.4
MP4	250–350	32.8
MP5	350–800	32.8

5. Space Environment Monitor

Table 5-5. MAGED Detector Energy Range

Channel	Range, keV	Sample Time, sec
ME1	30–50	2.0
ME2	50–100	2.0
ME3	100–200	4.1
ME4	200–350	16.4
ME5	350–600	32.8

Table 5-6. EPEAD, MAGPD, and MAGED Performance Summary

Parameter	Performance
Dynamic range	From typical particle background levels to largest likely event levels
Stability	3%
Resolution	No worse than pseudolog compression of 19 to 8 bits, using 4 bits of mantissa and 4 bits of exponents
Noise	10 keV for electrons and protons at thresholds below 100 keV. 10% of threshold energies above 100 keV

HEPAD

The high energy proton and alpha detector (HEPAD) is based on the instrument on the previous GOES spacecraft but modified to provide channel count accumulation within the HEPAD unit. The HEPAD interfaces with the DPU, which controls the HEPAD and formats the accumulated counts and housekeeping data for spacecraft telemetry. The instrument uses two SSDs in a telescope arrangement with a Cerenkov radiator/photomultiplier tube (PMT) detector to measure relativistic protons and alpha particles. A triple coincidence among these three detectors sends a particle detection signal, and the PMT measures the energy. The HEPAD measures protons with energies above 330 MeV and alpha particles with energies above 2.56 GeV, as detailed in Table 5-7. The house keeping data for the HEPAD can be found in the T&C handbook. The last five rows of Table 5-7 are for diagnostic and calibration purposes. Table 5-8 summarizes the HEPAD performance.

5. Space Environment Monitor

Table 5-7. HEPAD Detector Energy Range

Particle	Channel	Range, MeV	Sample Time, sec
Proton	P8	330–420	32.8
Proton	P9	420–510	32.8
Proton	P10	510–700	32.8
Proton	P11	>700	32.8
Alpha	A7	2560–3400	32.8
Alpha	A8	>3400	32.8
Detector D1	S1	Diagnostic	4.1
Detector D2	S2	Diagnostic	4.1
PMT	S3	Alpha lamp low	4.1
PMT	S4	Alpha lamp mid	4.1
D1/D2 coincidence	S5	Fast coincidence	4.1

Table 5-8. HEPAD Performance Summary

Parameter	Performance
Field of view	Conical, ~34° half angle
Geometric factor	0.7-cm ² -sr
Dynamic range	From typical particle background levels to largest likely event levels
Accumulation efficiency	100%
Stability and accuracy	≤±15%
Count resolution	No worse than pseudolog compression of 19 to 8 bits, using 4 bits of mantissa and 4 bits of exponent
Contaminants	
Proton contamination in alpha channels	≤0.1%
Characterize response to penetrating electron in 2–13 MeV range	As specified
Lifetime	Ground commands to compensate for performance degradation during 5 year lifetime

Magnetometers

There are two magnetometers on the spacecraft. Each magnetometer consists of a triaxial fluxgate sensor and an electronics unit. Each magnetometer measures three orthogonal vector components of the magnetic field in the vicinity of the spacecraft. The three magnetometer axes are orthogonal to within ±0.5° and have a linear range of ±512 nanoTesla (nT). The determination of the ambient magnetic field in the vicinity of the spacecraft is continuous and simultaneous.

The excitation and feedback signals from the sensors are routed to magnetometer electronics units located within the spacecraft main body where the signals are processed and formatted for spacecraft telemetry. An analog signal processor demodulates the flux-gate signals to produce an analog voltage proportional to the field magnitude with

5. Space Environment Monitor

a polarity related to the direction of the field vector component being measured. Three analog signals representing the X, Y, and Z components of the surrounding magnetic field are digitized by a 16-bit analog-to-digital converter, producing as output a serial bit stream in which three groups of 16 bits are allocated to the polarity and magnitude of each of the three axes (a total of 48 bits).

The two three-axis magnetometers provide redundancy for measuring the geomagnetic field. One magnetometer is mounted at the end of the boom 8.5 meters away (outboard) from the spacecraft, and the second, 0.8 meters inboard from the first on the same boom. These large distances from the spacecraft significantly reduce magnetic effects from the spacecraft body. The magnetometer boom is shown in Figure 5-2. Table 5-9 summarizes the magnetic field measurement performance.

Table 5-9. Magnetic Field Measurement Performance Summary

Parameter	Performance
Dynamic range	± 512 nT, ambient field in any orientation
Resolution	0.03 nT
Accuracy	$< \pm 4$ nT without temperature correction $< \pm 1$ nT with temperature correction
Noise	≤ 0.3 nT, 3σ
Data rate	1.95 Hz
Bandwidth	0.5 Hz, 3 dB
Sensor axes orthogonality	Within $\pm 0.5^\circ$
Sensor orientation	$\leq \pm 1.0^\circ$, in spacecraft coordinates (accuracy knowledge)
Spacecraft field contamination	
Maximum permanent field per axis	± 100 nT
Sensor stability	$\pm 0.25^\circ$

5. Space Environment Monitor

This page left blank.

6. Solar X-Ray Imager

The Solar X-ray Imager (SXI), GFE manufactured by Lockheed Martin, is used to determine when to issue forecasts and alerts of “space weather” conditions that may interfere with ground and space systems. These conditions include ionospheric changes that affect radio communication (both ground-to-ground and satellite-to-ground) and magnetospheric variations that induce currents in electric power grids and long distance pipelines. These conditions can cause navigational errors in magnetic guidance systems, introduce changes in spacecraft charging, produce high energy particles that can cause single event upsets in satellite circuitry, and expose astronauts to increased radiation. The SXI will observe solar flares, solar active regions, coronal holes, and coronal mass ejections. Images from the SXI will be used by NOAA and U.S. Air Force forecasters to monitor solar conditions that affect space weather conditions, including the dynamic environment of energetic particles, solar wind streams, and coronal mass ejections emanating from the sun. These data can be used to issue forecasts of solar phenomena.

The SXI performs as part of the Space Environment Monitor (SEM) instruments and provides the means for obtaining the solar data required to:

- Locate coronal holes for prediction of high speed solar wind streams causing recurrent geomagnetic storms. These weakly emitting features accurately predict geomagnetic storms for the years near minimum solar activity when long lived holes are present on the sun.
- Locate the position of solar flares. Their locations, both on the disk and beyond the west limb, are used to forecast the magnitude of particle events.
- Monitor for changes indicating coronal mass ejections (CME) that may impact Earth and cause geomagnetic storms. Large-scale, long duration, possibly weakly emitting events, and brightening of coronal filament arcades are used as evidence of CMEs.
- Observe active region size morphology and complexity, and temperature and emissions measure, for flare forecasts.
- Monitor for active regions beyond the east limb that will be rotating onto the solar disk for solar activity forecasts.

6. Solar X-ray Imager

Other solar feature observations include flare properties, newly emerging active regions, X-ray bright points, and CME ejecta moving away from the sun at 1000 km/sec. To meet these objectives, the SXI images the solar corona in the soft X-ray to extreme ultraviolet (XUV to EUV) region of the electromagnetic spectrum. Full-disk solar images are provided with a 512 X 512 array with 5 arc second pixels in several wavelength bands from 6 to 60 Å (0.6 to 6 nm). A regular sequence of exposures that are downlinked at one-minute intervals is used to cover the full dynamic range needed to monitor solar activity.

The SXI instrument consists of a telescope assembly and three electronic boxes. The data electronics box (DEB) provides the instrument control, data management, and spacecraft interface. The Power Electronics Box (PEB) provides conditioned power to the entire instrument. Finally, the High Accuracy Sun Sensor (HASS) Electronics Box (HEB) provides precise two dimensional knowledge of the solar aspect with respect to the instrument line-of-sight at image integration time. The SXI telescope, along with other solar observing sensors, is mounted on an instrument mounting platform (IMP). Associated electronics boxes are on the solar array yoke of the GOES-N/P spacecraft, as shown in Figure 6-1. An SXI performance summary is given in Table 6-1. Further disturbance analysis given by Lemen et al (SPIE: Solar X-Ray Imager for GOES August 2003).

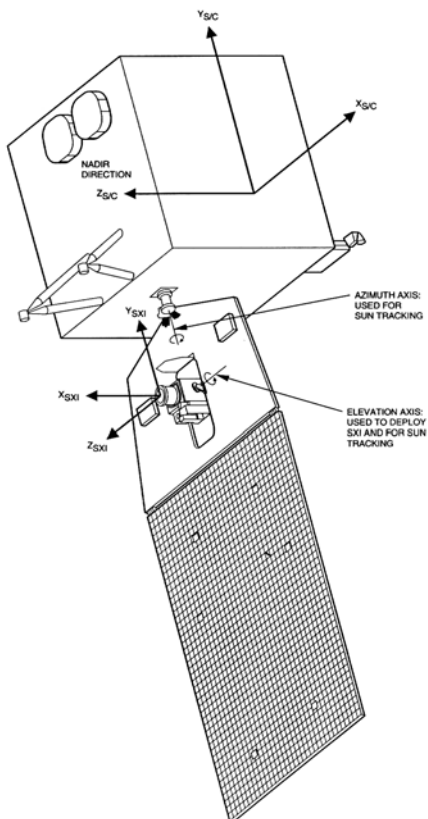

Figure 6-1. Solar X-ray Imager and Solar Array in Deployed Configuration

6. Solar X-ray Imager

Table 6-1. Solar X-ray Imager Performance Summary

<i>SXI Parameter</i>		<i>Performance</i>
Imaging exposure times		
Solar flare sites		<10 ms
Active regions		<100 ms
Coronal loops		<1 sec
Coronal hole boundaries		<10 sec
Spacecraft SXI boresight pointing (to center of solar disk)		Within 3 arc minute elevation, within 3.5 arc minute azimuth
Field of view		42 by 42 arc minute
Pixel size		5 by 5 arc second, square pixels
Spectral sensitivity (integration time 100 ms)		
Spectral band	Source	Minimum detectable photon radiance incident on the telescope entrance (photon cm ⁻² arc second ⁻² sec ⁻¹)
6 to 20 Å	Cu (13.3 Å)	85
6 to 60 Å	C (44.7 Å)	132
Dynamic range		1000 when measured with monochromatic illumination at 44.7 Å
Telemetry amplitude digitization		12 bits (linear or logarithmic channels)
Enpixeled energy		13.3 Å (Cu) 44.7 Å
On axis		26% 29%
10 arc minutes off axis		27% 32%
20 arc minutes off axis		52% 52%
Resolution (on axis)		7 arc seconds (full width half max)
SXI on-orbit useful life		3 years with a goal of 5 years (after 5 years ground storage)

Remote Sensing the Solar Corona

The GOES Solar X-ray Imager (SXI) will provide critical information for forecasting space weather events. These events originate in the outer atmosphere of the sun and propagate through the interplanetary medium where they may intersect earth's space environment. Like all atmospheres, the sun's has a temperature and density profile. The level that we see in visible wavelengths we call the photosphere, which is the effective 'surface' of the sun. The temperature of the photosphere is about 6000 K. Density decreases rapidly through the overlying chromosphere. Above the chromosphere is the corona (Figure 6-2), where temperatures rapidly climb to more than 10⁶ K. This is where all the 'action' happens that affects earth, and most of the emission at these temperatures is in X-rays. Figure 6-3 shows the spectrum of several coronal features along with the spectral response of the SXI with various filters.

6. Solar X-ray Imager

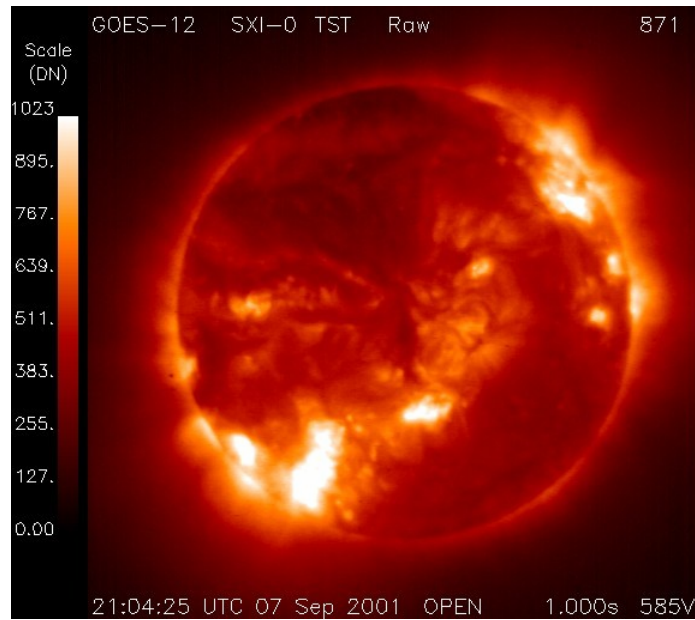

Figure 6-2. SXI Product Showing the Solar Corona (image courtesy Yohkoh)

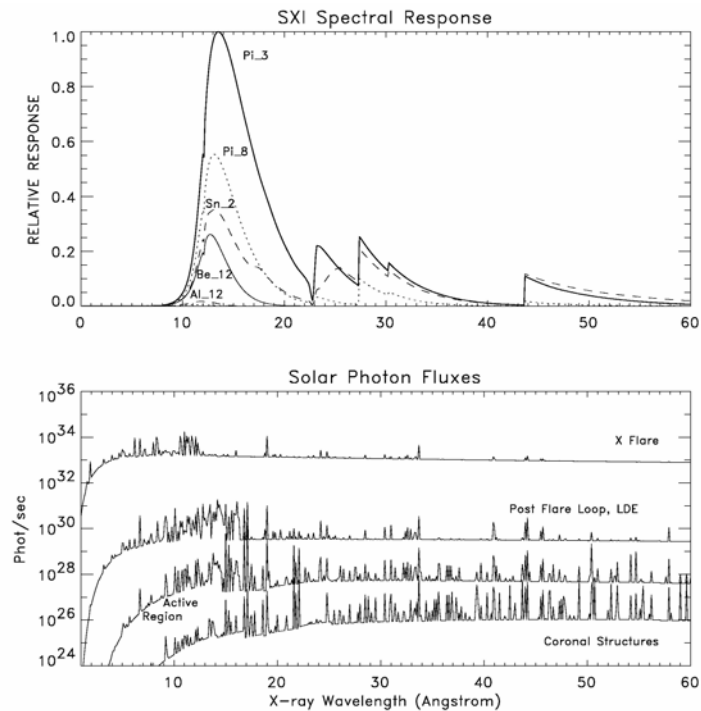

Figure 6-3. SXI Spectral Response Compared to Solar Emission

6. Solar X-ray Imager

Instrument System

The SXI is coaligned on the IMP with the combined X-ray Sensor and Extreme Ultraviolet Radiometer (XRS/EUV) and Precision Sun Sensor (PSS). The IMP is mounted to the X-ray positioner (XRP). The complete assembly including the XRP is called the XRS/EUV/SXI assembly, as shown in Figure 6-4. The XRP is attached to the solar array yoke in order to face the sun continuously.

The XRP is a single-axis gimbal aligned in the north-south direction, tracking the sun in solar declination. The solar array drive (SAD) assembly controls the east-west pointing of the yoke, tracking the diurnal motion of the sun. Both the XRP N-S pointing and the yoke E-W pointing are controlled during routine observations by spacecraft-provided closed-loop control systems utilizing the two-axes of the PSS as aspect sensors. Pointing adjustments to the XRP and SAD to correct for small misalignments of the PSS relative to the SXI and XRS/EUV are possible through ground command.

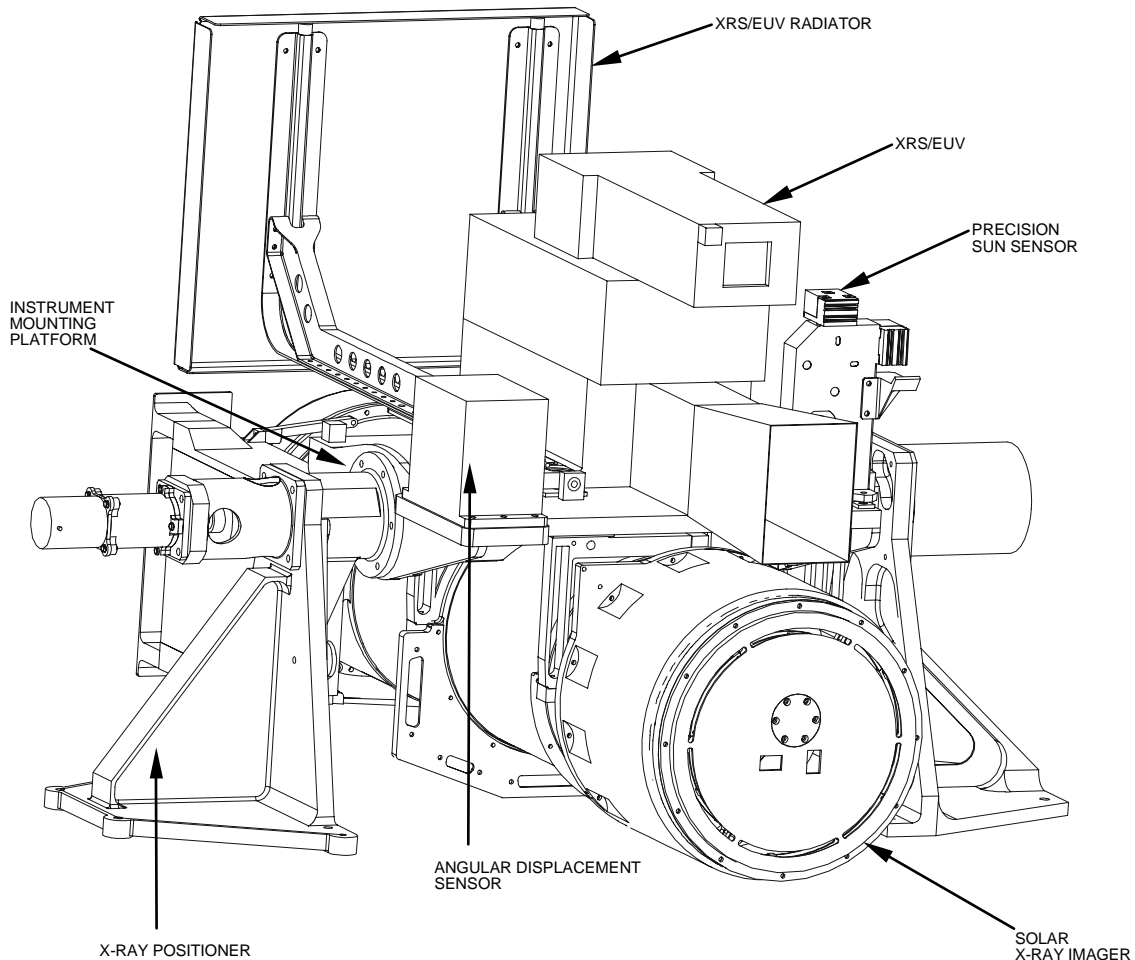

Figure 6-4. XRS/EUV/SXI Assembly Without Harness and Blankets

6. Solar X-ray Imager

Actuators for the control loops that track the sun are stepper motors with steps of about 25 arc seconds, or 5 SXI image pixels, in either axis. The annual cycle of solar declination is so slow that N-S stepping is not a concern for blurring the image during integration by the Charge Coupled Device (CCD). However, tracking the 15 arc seconds per second E-W diurnal drift requires an average of one such step each 1.66 seconds. Programmable image integration times of several seconds are required to achieve the desired signal in the CCD camera. Without an approach to pointing stabilization, the situation would be comparable to jerking a 35 mm camera in the middle of a timed exposure, i.e. a multiple exposure. To avoid such image degradation, the solar array stepping is interrupted for 20 seconds for each programmed exposure. The interruption starts 10 seconds before the start of image integration to allow for transient motions to decay. There then remains a stable period of up to 10 seconds for image integration before the solar array stepping is resumed.

When the solar array stepping is interrupted, the solar panel rotates with the spacecraft at the average rate of one rotation per day, or 15 arc seconds per second. This constant rate motion of the telescope during the exposure produces an unacceptably smeared image. To eliminate this effect, the HASS E-W axis data are used to step the image being integrated in the CCD synchronously with the motion of the focused image formed by the telescope mirror. This is analogous to sliding the film under the lens system of the 35 mm camera to produce a sharply focused image of a moving target. The image in the CCD can be stepped in increments of 1/3 SXI pixel, or 1.66 arc second. (See Gantner et al (SPIE: A System to Reduce Jitter for GOES-N-O-P Solar X-Ray Imagers.)

The total mass of the SXI (telescope and electronics) is 27.0 kg, of which 14.1 kg is the telescope assembly. Electrical connections to the GOES spacecraft cross the SAD interface through slip rings. Thirty-one signal rings and two power rings have been allocated to the SXI. The SXI science and housekeeping data are interfaced to the multiuse data link (MDL) in the GOES spacecraft. This MDL is capable of handling a SXI data rate of 100 kbps. The X-ray image data are transmitted from the spacecraft at a rate of approximately 1.5 images per minute. A limited amount of SXI health and safety data is provided in the pulse code modulated (PCM) data stream.

Operation

Operation of the SXI is controlled through the Data Electronics Box (DEB) via a RAD6000 microprocessor operating at 20 MHz. The microprocessor receives and interprets uplinked commands, controls the image sequencing, processes image data, controls interface peripherals, downlinks image and housekeeping data, and keeps the internal time to a resolution of better than 1 ms, as shown in Figure 6-5.

A watchdog timer provides closed-loop recovery from single event upset (SEU)-induced errors or other anomalous conditions that may cause the instrument to enter an undesirable state. Flight software periodically strobos the watchdog timer, resetting the count, as a method of indicating continued health and functionality.

6. Solar X-ray Imager

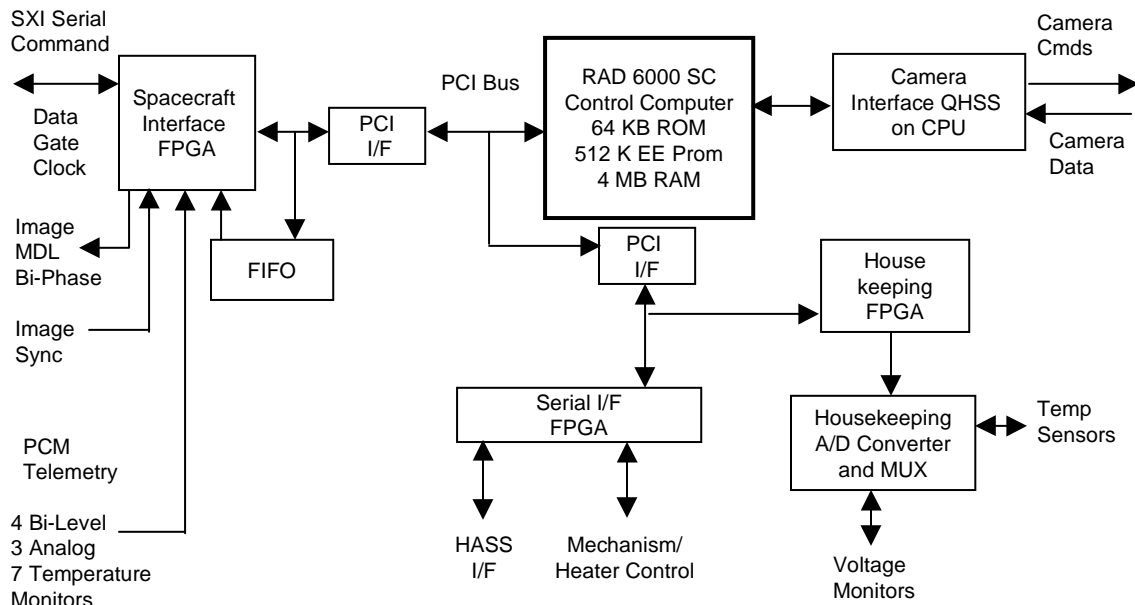

Figure 6-5. Functional Flow Diagram of SXI Microprocessor and DEB

The microprocessor controls the acquisition of image data, as well as the processing of data and transmission to the ground, and is shown in Figure 6-6. Based on tables stored in EPROM or uplinked into Random Access Memory (RAM), the processor generates commands to the camera electronics. The camera electronics only requires the receipt of configuration setup data, then autonomously takes an exposure. The camera has an internal oscillator and state-machine designed to reduce the load on the CPU. After a programmed exposure, the 512x512 image is read out line-by-line into redundant A or B channel amplifiers. The data is then converted to a 12 bit word, which is read out at 50K pixels/second and transferred to the Data Electronics Box.

The Camera Electronics Block develops the data from the CCD. The data are routed through two amplifiers (A and B) to provide correlated double sampling (CDS). CDS removes some noise in the CCD signal due to the uncertainty in the amount of charge remaining on the capacitor following a reset. The Data Electronics Interface Board combines the CCD image data, housekeeping, HASS pointing data, and memory dump data, and passes them to the spacecraft via the DEB interface board. SXI data are transmitted to ground by two paths, slow-speed telemetry (for housekeeping data), and via the MDL for the 100 kbps Image Data. The Telemetry Control Field Programmable Gate Array (FPGA) takes the packets received and formats them into CCSDS transfer frames, sending them out through the Bi-Phase Level (Manchester encoded) MDL interface to the spacecraft. The 26C31 MDL interface drivers are hot redundant going to two different Boeing Instrument Remote Telemetry and Command Units (IRTCU).

6. Solar X-ray Imager

The data can be received at SOCC (Flight Operations) in Suitland, MD and the NOAA Space Environment Center (SEC) in Boulder, CO. In general, image data are downlinked as rapidly as possible after they are acquired.

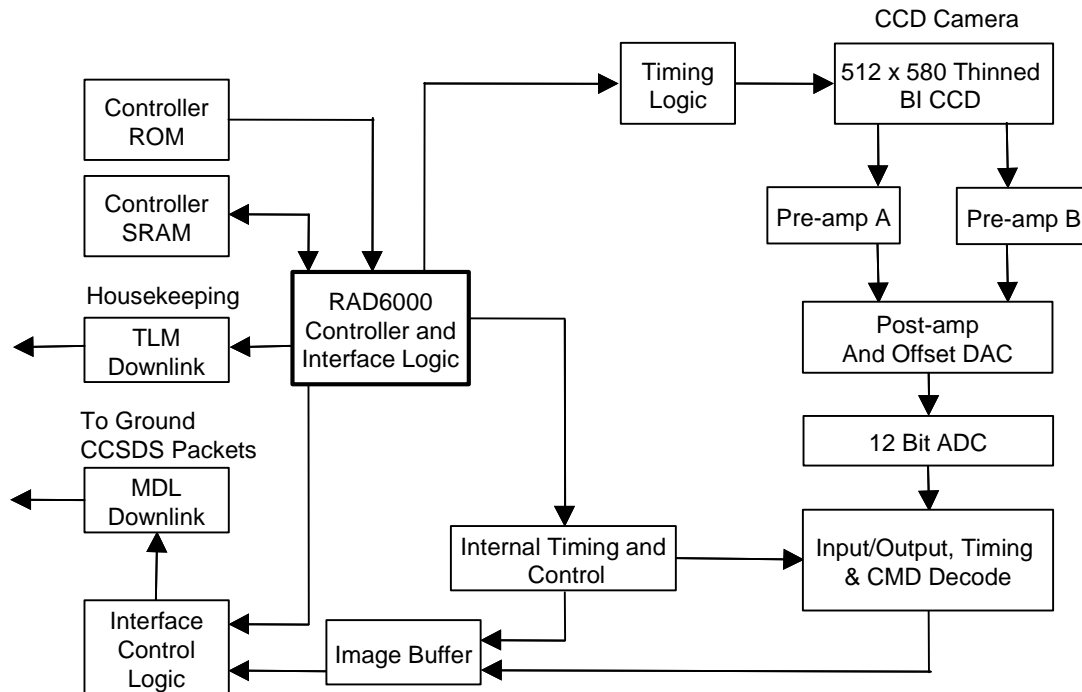

Figure 6-6. SXI Control System Logical Flow Diagram

Power

Electrical power is provided to the SXI via the power electronics module from the spacecraft +42 volt electrical power subsystem. The electrical interfaces to the spacecraft connect via slip rings across the yoke gimbals. The power required by the SXI is 60 Watts in daylight. The spacecraft provides power to the SXI instrument from the secondary bus that is regulated at 42.0 ± 0.5 V dc during sunlight operation. During eclipse, this primary power bus is controlled by battery voltage and a voltage regulator, which maintains the +42 volt bus. All SXI electronic power comes from this supply. The spacecraft primary bus (53 volt IPC) provides survival/standby heater power to the SXI. This power is protected with fuses within the spacecraft. The input power consumption by the SXI is:

- Sunlight: 60 Watts maximum from the 42 volt bus
- Eclipse: 80 Watts power, during operational, eclipse mode

Telescope Assembly

The telescope design consists of three basic groups: objective group, metering tube group, and focal plane group. The SXI telescope assembly is shown in Figure 6-7. Main

6. Solar X-ray Imager

components of the objective group are a hyperboloid-hyperboloid grazing incidence X-Ray mirror, entrance filters, the HASS, and a mirror mounting structure. The metering tube group consists of a metering tube and its mount. The focal plane group components are a CCD detector, filter wheel assembly, and CCD radiator.

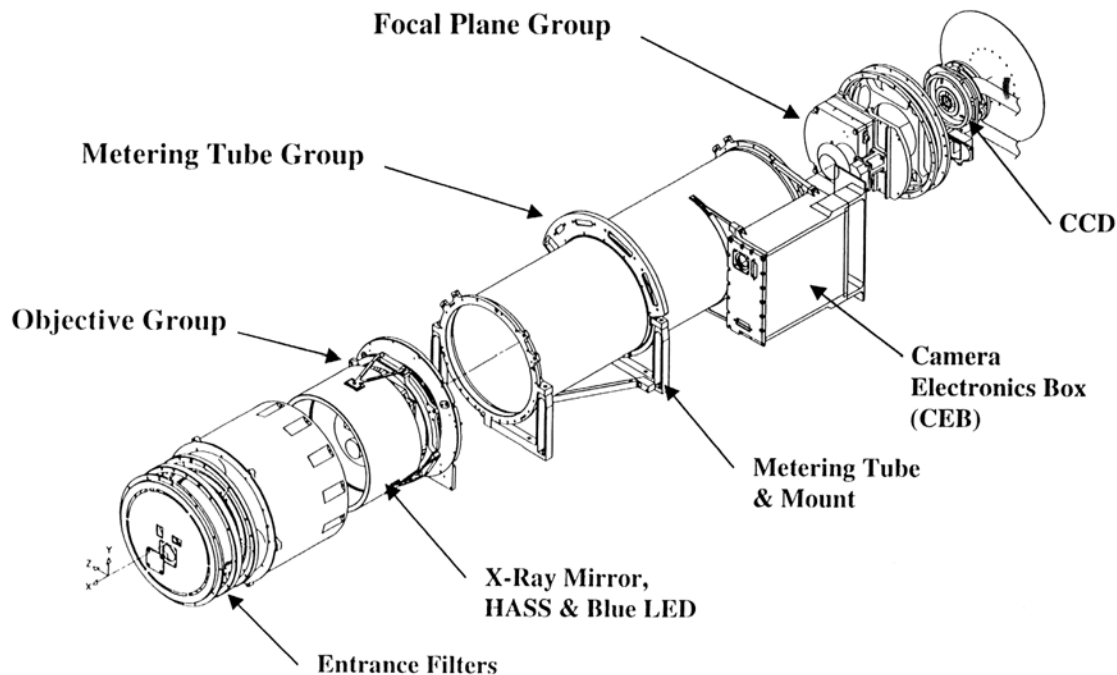

Figure 6-7. SXI Telescope Assembly

Objective Group

- Entrance Filter.* The entrance filter blocks solar ultraviolet, visible, and infrared radiation from the interior of the telescope, greatly reducing any contaminating signal originating outside the soft X-ray band. The filter is composed of a sandwich of aluminum, titanium, and polyimide. The sun-facing layer is aluminum about 1100 Å thick, which is the primary rejection element. Aluminum has a transmission window between 200-800 Å, but titanium is strongly absorbing in this region. A titanium layer 600 Å thick is therefore used to suppress the very strong He 304 Å chromospheric line that falls in this band. The 4000 Å thick polyimide substrate provides the strength needed to survive the launch loads.
- Mirror.* The mirror design consists of a grazing incidence mirror in hyperboloid-hyperboloid configuration (see: Patrick Thompson and James Harvey in *Optical Engineering*, Volume 39,1677-1691 (2000)). Both optical surfaces are fabricated from a single Zerodur element. The mirror is supported by six equally spaced titanium flexures bonded to super Invar pads, which are in turn bonded to the mirror. The flexures mate to a mounting ring attached to the optical bench. Nominal mirror parameters are given in Table 6-2.

6. Solar X-ray Imager

- *High Accuracy Sun Sensor (HASS)*. The pointing resolution required of the HASS by the SXI is 1.66 arc second. The HASS consists of a sun sensor head and a sun sensor electronics box. Various reticules and associated solar cells form the sensor head. The electronics package provides a FPGA and multiplexed processors for the coarse and fine sun data and for detecting sun presence. The sun angle output signals are passed through shift registers. The HASS output to the data electronics box is digital. Serial data interface circuits and control circuits provide command capability. The HASS provides pointing knowledge, which enhances on-board corrections for other pointing errors (e.g., jitter during exposures or “static” E-W pointing errors). This knowledge is used to reduce the effect of solar motion across the CCD camera. HASS features are given in Table 6-3.

Table 6-2. Nominal Mirror Parameters

<i>Optical Design</i>	<i>Hyperboloid-hyperboloid (Harvey-Thompson #17)</i>
Radius at principal plane	80 mm
Axial length of the primary and secondary	47.5 mm
Joint focal length	655 mm
Mirror mass	1.7 kg
Mirror material	Zerodur
Surface coating	None
Geometrical area	726 mm ²

Table 6-3. HASS Features

Field of view	±1.8° square
Resolution	1.66 arc second (each axis)
Sampling rate	32 Hz
Stray light rejection	>10.5° from optical axis
Power	0.63 watts
Mass	
– Sensor head	0.65 kg
– Electronics	1.8 kg

Metering Tube Group

The metering tube group or optical bench is both a metering structure for the optical system and a structural support member for the telescope assembly. As a metering structure, the optical bench maintains the separation between the mirror and the focal plane subassembly to ±10 microns over a temperature range of ±40°C. The tube is hand laid using sheets of carbon fibers impregnated with a cyanate ester resin. The bench material is highly hydrophobic and thermally stable thereby avoiding water vapor

6. Solar X-ray Imager

outgassing and possible condensation on the detector. The CCD camera electronics box is mounted on the outside of the metering tube.

Focal Plane Group

The focal plane group design incorporates three components: a mechanical shutter, two filter wheels and a CCD detector. These are all located in a single enclosure to minimize stray light effects.

The shutter enables exposure times from 1 ms to 10 seconds or greater. There are two independently controlled filter wheels, one behind another, each with six filter positions.

The CCD has an array of 512 x 580 16-micrometer pixels, each with a 5 arc second instantaneous field of view. The CCD is backside illuminated to allow detection of soft X-rays ($>60 \text{ \AA}$) and thinned to a thickness of about 9 micrometers. The CCD has a full well of over 150,000 electrons and incorporates an anti-blooming drain to minimize the impact of very bright sources in the image on normal signals. The CCD is mounted in a package made of Wolfmet, a material that closely matches the coefficient of expansion of the detector.

The CCD operating temperature is nominally between -30° to -60°C , and has negligible dark current and read noise. It has a wavelength dependent quantum efficiency greater than 0.6 and often above 0.8. Soft X-rays at 44.7 \AA generate about 75 electrons per photon detected and harder X-rays at 13.3 \AA generate about 255 electrons per photon detected.

A blue Light Emitting Diode in the objective group of the SXI can be used to illuminate the CCD for "aliveness" and functional tests as well as provide some "Flat Field" information.

Spectral Filtering

Two filter wheels having 6 positions each are located in series along the optical axis to provide broadband spectral filtering. Each wheel has one open position with no filter so that the remaining positions can be used individually. Nine of the 10 remaining positions are used for spectral analysis of the sun and contain six unique filter types (3 are redundant to make 9 total). One position on wheel 1 contains a clear glass element to evaluate scattered white light within the instrument. The filter types and positions are summarized in Tables 6-4 and 6-5.

The properties of the six unique analysis filters allow the imaging of different types of coronal features as well as the extraction of temperature information. The filter system is designed to minimize the effect on the image of any non-uniformity in the filter materials. The filters are sized so as to not obstruct or vignette the field of view. The filter wheel position is determined by the image sequence commanded by the ground. The various wavebands are selectable by the filters in conjunction with the other components contributing to the instrument response function (e.g., entrance filter, mirror, and detector).

6. Solar X-ray Imager

Table 6-4. Analysis Filter Assignments within the Filter Wheels

Position	1	2	3	4	5	6
Wheel 1	Open	Be 12	Tin	Glass	Thin Poly	Thick Poly
Wheel 2	BE 50	Al 12	Thin Poly	Open	Tin	Be 12

Table 6-5. Analysis Filter Summary

Filter	Wavelength, Å	Filter Material(s)	Thickness(s), µm
Thin Poly	6-60	poly/Al/Ti	0.30/0.12/0.03
Thick Poly	6-50	poly/Ai/Ti	0.45/0.27/0.18
Tin	6-70	poly/Sn	0.30/0.17
Al 12	6-14	Al	12.00
Be 12	6-20	Be	12.00
Be 50	6-12	Be	50.00

Operational Modes

The SXI operates in two basic modes: safehold and imaging. In addition, when turned off, the SXI still must be temperature controlled using 'survival' heaters. These operational modes are illustrated in Figure 6-8.

SXI Off

The SXI data system is unpowered and the outputs from the SXI dc/dc converters are inhibited. Power is provided for thermostatically controlled heaters from 53 Vdc bus. The temperatures are monitored by the GOES PCM telemetry system during this mode. The spacecraft systems provide the conditioning circuitry, with SXI providing calibrated thermistors. Temperatures monitored in this mode are mirror assembly, CCD assembly, data electronics box, and power electronics box.

Safehold Mode

The SXI defaults to this mode at power-up and no imaging is performed. The safehold mode is used to prepare the instrument to lose power and effects a programmed shutdown of the SXI subsystems. Commands to perform diagnostics and housekeeping are allowed in this mode and housekeeping data is downlinked. Modifications to image and sequence tables are permitted only in this mode. The safehold mode is entered either by ground command or by software if a serious hardware or commanding error is detected.

6. Solar X-ray Imager

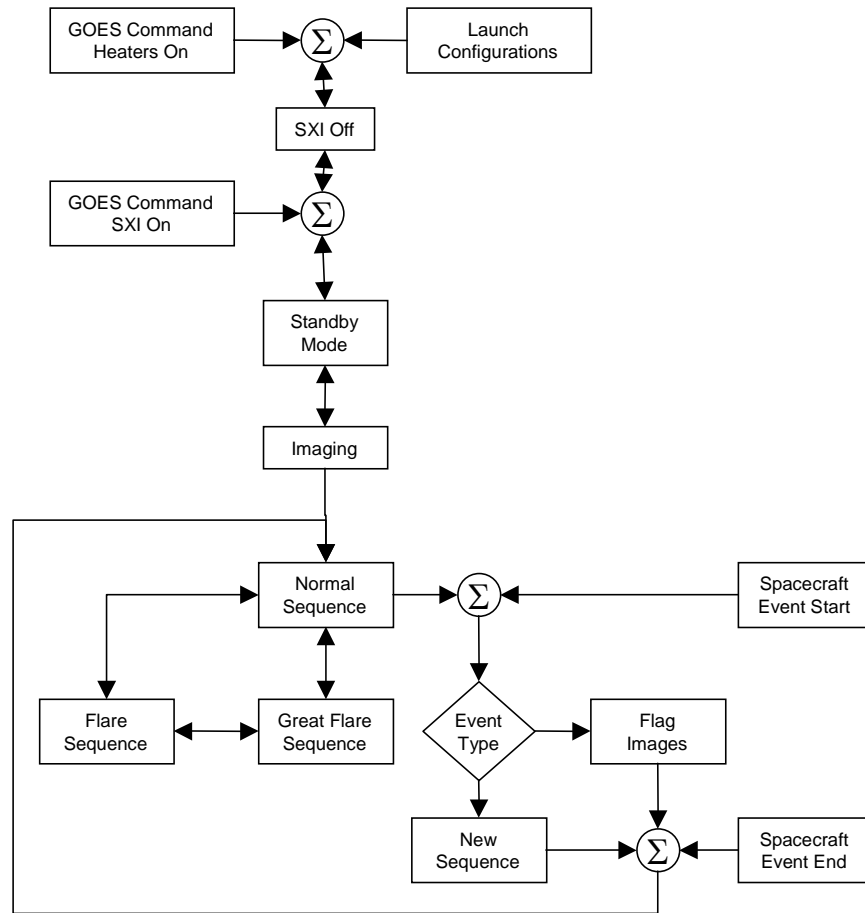

Figure 6-8. SXI Operational Modes Flow Diagram

Imaging Mode

This is the operational mode for the SXI. This mode may be entered only by ground command. In this mode the SXI can:

- Image the sun
- Take blue LED image for diagnostic purposes
- Take background flux images (shutter closed)

When in imaging mode there is significant capacity for autonomous sequence control and reaction to external events. For instance, the SXI can be set to recognize solar flares (or 'great flares') and transition into special image sequences. In addition, the SXI can react to spacecraft events, when appropriately informed, to either flag the images or change to a different sequence.

The normal controls for taking sequences of images exist as a set of stored tables representing filter type, exposure, etc. A particular image is described by its Frame

6. Solar X-ray Imager

Definition Block (FDB). A framelist is a sequence of FDBs to be executed in order. Sequence control selects a set of framelists to execute in parallel with priority based conflict resolution.

Ground Processing

GOES will downlink SXI images at a 40-60 second cadence on the MDL directly to NOAA's Space Environment Center (SEC) in Boulder, Colorado. SEC will process the data in real time for its use and for other collaborating agencies in predicting space weather. To meet this need, SEC corrects for known image defects, calibrates, and stores each image. Then, it processes the images to display on real time monitors, automatically locate flares, produce movie sequences, calculate coronal hole, boundaries and produce products for the general public. Further details and information on the processing at the SEC is available at <http://www.sec.noaa.gov/sxi/index.html>.

The general user will be able to view or browse the MPEG files or order the full - resolution images for research. The products available to the research community are level 0 (raw data), level 1, and level 2 data. The level 1 data will consist of single calibrated images which have had defects removed. Level 2 data will include multiple image products such as difference images, ratio images, wide dynamic range images, and movies. All levels of data will be archived at the NOAA National Geophysical Data Center (NGDC) located at <http://www.ngdc.noaa.gov>. An overview of the processing stream is shown in Figure 6-9.

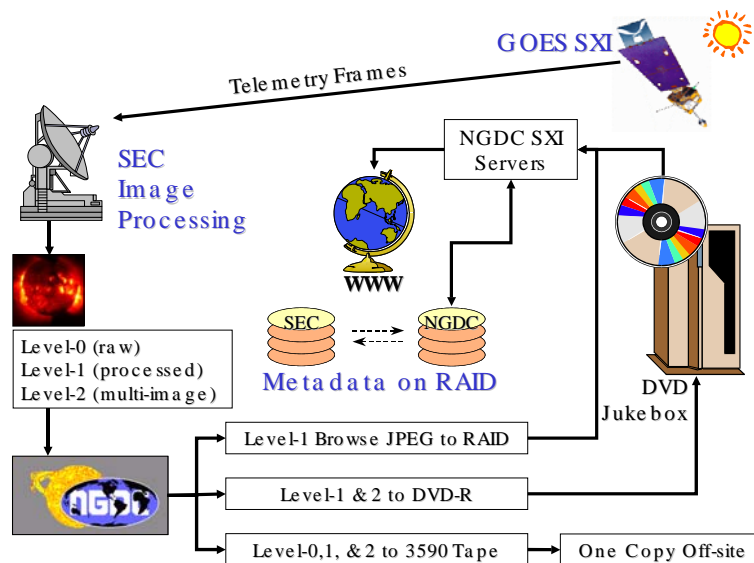

Figure 6-9. Processing Stream Overview

7. Image Navigation and Registration

The GOES N-P image navigation and registration (INR) system provides accurate earth location knowledge and control for each imager and sounder picture element (pixel). Image navigation refers to supplying knowledge of pixel earth locations in earth coordinates (latitude and longitude). Image registration refers to using that knowledge to actively control the pixel earth locations so that they are aligned to a predetermined fixed earth grid. The INR system produces images that are accurately mapped to earth coordinates and that overlay precisely from one image to the next without interpolation of the radiometric data.

The basic INR process originated on GOES I-M. The system has been upgraded on N-P to improve performance and extend operational coverage. The essential elements of the INR process are:

- A ground computer that determines orbit and attitude solutions
- The spacecraft attitude control system (ACS) that points the Imager and Sounder instruments toward earth
- Instrument mirror servos that scan the imaging detectors across the earth
- A mirror pointing compensation system in which the ACS generates correction signals to the mirror servos to adjust for the effects of orbit and attitude motion

Fundamental Basis for INR Approach

INR requirements are noted in Section 19.

The concept of an ideal image is fundamental to the INR system approach (Figure 7-1). The ideal image is that which would be achieved if:

- Spacecraft position conformed to a perfect geosynchronous orbit
- Instrument attitude was perfectly aligned to the orbit
- Instrument scan mirror control was perfect

The ideal image is characterized by a fixed one-to-one correspondence between earth locations (latitude and longitude) and commanded instrument scan angles (E-W and N-S mirror gimbal angles). In a real situation, of course, the orbit varies from the ideal due to eccentricity, inclination and longitude drift. The instrument attitude deviates

7. Image Navigation and Registration

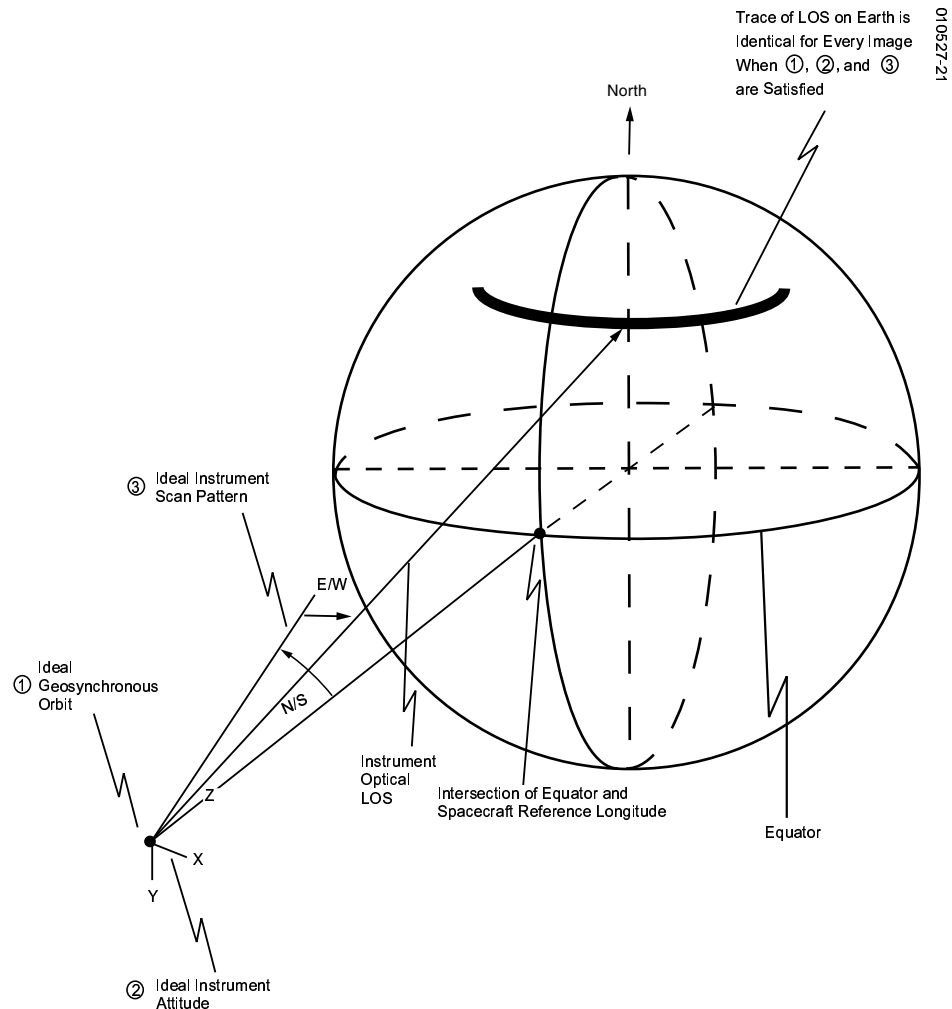

Figure 7-1. Ideal Image for Image Navigation and Registration

from the ideal due to short term spacecraft attitude control jitter and to longer term attitude variations driven by instrument and spacecraft thermal distortion. Finally, the instrument scan mirror servos are subject to various errors, both fixed pattern and dynamic errors. The goal of the INR system is to correct for or minimize all these various error sources to obtain images that are a close approximation to the ideal image.

The basic elements of the INR system design approach are:

- Orbit and attitude determination is performed periodically (may be performed more than once a day) in the spacecraft support ground system (SSGS) using spacecraft range and instrument star and landmark measurements. Predictions of daily orbit and attitude variations are generated in the SSGS and relayed to the spacecraft in parametric form via the image motion compensation (IMC) coefficient set.

7. Image Navigation and Registration

- The spacecraft ACS autonomously determines and controls the spacecraft bus attitude to a reference frame aligned to the orbit plane and the nadir direction. The ACS continuously senses bus attitude deviations induced by dynamic disturbances.
- The spacecraft ACS uses the IMC set to generate instrument scan mirror corrections for orbit and attitude variations. It uses the sensed bus attitude deviations to develop mirror corrections for short-term attitude variations (dynamic motion compensation [DMC]). Additionally, based on ground calibration data, the ACS generates mirror corrections for certain instrument fixed pattern errors (instrument systematic error compensation [ISEC]).
- The instrument scan mirror controllers execute commanded raster scan patterns while continuously applying the scan mirror corrections generated by the ACS.

Image Navigation

Image navigation solutions for the Imager and Sounder are produced in the SSGS. These solutions consist of predictions of orbit and attitude variations in parametric form. The IMC coefficient set is relayed to the spacecraft to enable image registration via mirror pointing compensation. Additionally, an equivalent set of coefficients, the orbit and attitude (O&A) set, is included in the navigation message embedded in the GOES variable (GVAR) format data stream. Thus, an end user of the GVAR data can accurately determine the earth locations of all image pixels whether IMC is turned on or off. The mode of INR system operation where IMC is turned off is called dynamic gridding mode. Only image navigation is supported in this mode. The mode of operation where IMC is turned on is called fixed gridding mode. This mode supplies images that are accurately navigated and registered to a fixed earth grid. Fixed or dynamic gridding mode may be selected independently for the imager and sounder.

Orbit and attitude determination is routinely performed in the SSGS every 24 hours. Orbit predictions are updated as needed during the course of the day to account for thruster momentum control maneuvers. With each firing of the thrusters there is generated a ΔV . Ranging data and imager landmark data are the observations used to determine the spacecraft orbit. Ranging measurements based on the round trip propagation time of the GVAR data stream are collected every 15 minutes. Imager landmark observations (scan angles corresponding to designated geographic features) are obtained from the GVAR data throughout the day. The typical landmark observation rate is about 100 landmarks per day, with visible channel data (1 km nadir resolution) used in daylight and IR channel data (4 km nadir resolution) used at night. Instrument star sense measurements, in conjunction with imager landmarks and, if available, sounder landmarks, are used to determine separate solutions for Imager and Sounder attitude. Typical star observation rates are four stars per half hour for each instrument.

7. Image Navigation and Registration

Image Registration

Image registration to a fixed earth grid (the “ideal” image) is provided when the onboard IMC correction for orbit and attitude variations is enabled. INR error sources include short term pointing errors, such as bus attitude control jitter and instrument servo errors, as well as errors in determining and applying the IMC correction. INR error sources will be discussed further below.

The effects of orbit and attitude variations on image registration determine the character of the IMC corrections. Over the course of a day, orbital motion causes two types of systematic error. The diurnal and secular variation of the subsatellite point causes image bias, meaning the center point of an image changes throughout the day in both E-W and N-S directions. Additionally, the changing perspective toward the earth produces image distortion, that is, earth location error that varies across an image with scan direction. Thermally induced attitude variations also have a diurnal cycle that can produce both image bias and image distortion. Thus, to provide properly registered images, the IMC corrections must possess a dynamic character with both time and scan angle dependence.

INR Functional Configuration

The INR system comprises elements on the spacecraft and ground (Figure 7-2). The major functional components are:

- Imager/Sounder mounting plate
- Stellar inertial attitude control system
- Instrument scan mirror servo
- Orbit and attitude prediction
- Instrument mirror pointing compensation: IMC, DMC, and ISEC
- Diagnostic and quality monitoring capabilities

7. Image Navigation and Registration

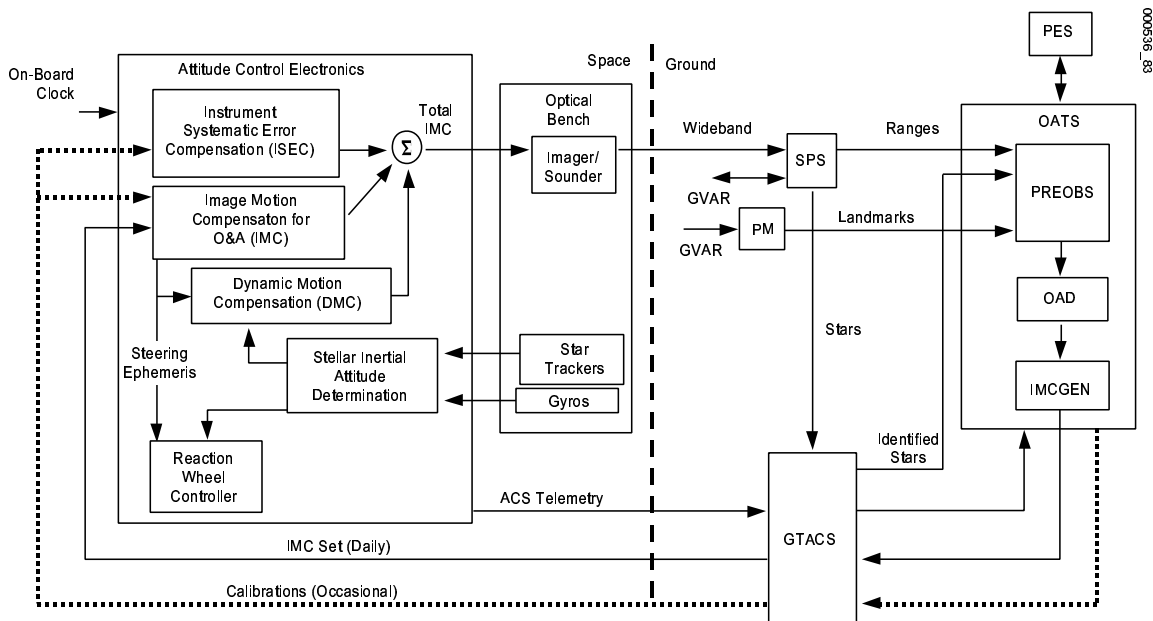

Figure 7-2. Image Navigation and Registration Functional Block Diagram

Imager/Sounder mounting plate. The imager and sounder are collocated with the spacecraft attitude sensors (star trackers and gyros) on a rigid structure that is highly resistant to thermal distortion. This structure provides a stable alignment between the ACS sensors and the payload instruments.

Stellar Inertial Attitude Control System. The ACS autonomously determines spacecraft orientation relative to the fixed stars. Data from multiple star trackers is compared to an onboard star catalog to update the onboard attitude estimate in a Kalman filter implementation. Data from a three-axis gyro set is used to propagate the attitude solution between star measurements. The flight software transforms from inertial coordinates to the desired earth reference coordinate frame using orbital predictions determined by the ground system and a time reference provided by a precision onboard clock. The bus attitude is controlled by a three-axis zero momentum system consisting of four canted reaction wheels. Bandwidth limitations on the bus controller prevent direct compensation for some dynamic disturbances. DMC uses the high data rate gyro output to sense bus dynamic disturbances and generate a mirror compensation signal that is passed to the instruments.

Instrument Servo. Each instrument contains a two-axis gimbaled scan mirror to point the optical line of sight (LOS). High bandwidth servos featuring inductosyn sensors and direct drive motors control the positioning of each gimbal axis.

7. Image Navigation and Registration

Orbit and Attitude Prediction. The orbit and attitude tracking system (OATS) within the SSGS processes observations of landmarks, instrument star sightings, and spacecraft range to fit parametric models of orbit and instrument attitude in a batch least squares implementation. The processing consists of three phases. The observation preprocessing function (PREOBS) corrects for certain systematic effects in the measurements and then computes residuals of the measurements relative to expected values. The orbit and attitude determination function (OAD) solves for orbit and attitude state variables. Finally, the IMC generation function (IMCGEN) produces the set of orbit and attitude model coefficients (the IMC set) that model the future orbit and attitude variation.

Instrument Mirror Pointing Compensation: IMC, DMC and ISEC. The spacecraft attitude control electronics (ACE) generates precision-timed analog signals to correct mirror pointing for the effects of orbit and long-term attitude variations (IMC), short-term attitude variations (DMC), and certain instrument fixed pattern errors (ISEC). The processing sequence begins in flight software with the evaluation of the time dependent orbit and attitude models defined by the IMC coefficient set. The software processing continues with scan angle dependent computations that yield E-W and N-S mirror pointing adjustments for IMC, DMC, and ISEC. A multichannel high speed signal interface supplies the ACE with the necessary scan angle information from the instruments. Finally, the flight software products are metered to high resolution ramp generation and digital-to-analog conversion electronic circuitry to produce the analog mirror compensation signals.

Diagnostic and Quality Monitoring Capabilities. The operational INR system is supplemented by spacecraft diagnostic data and off-line software tools that can be used to monitor and analyze INR system performance.

- *IMC Check.* An assessment of IMC implementation error may be performed in OATS using instrument IMC signal telemetry extracted from the GVAR data stream. The spacecraft telemetry is compared to expected values based on a ground software emulation of the flight IMC algorithm.
- *Dynamic Interaction Diagnostic (DID).* Analysis tools are available on the DID workstation to perform assessments of structural interactions on the spacecraft bus and within the instruments using angle displacement sensor (ADS) data and instrument servo error data contained in the multi-use data link (MDL) data stream. The DID has data interface with the MRS&S but not the SPS.
- *ACS Telemetry.* Routine spacecraft telemetry collected and archived on the GOES telemetry and command system (GTACS) may be used to verify basic ACS functioning. Additionally, dwell telemetry mode enables frequent sampling of designated ACE memory locations related to stellar inertial attitude determination, bus attitude control, and mirror compensation signal generation.
- *OATS Measurement Residuals.* Star, landmark, and range measurement residuals are routinely plotted in OATS to monitor INR performance trends. Landmark residuals are used to compute overall INR system performance metrics.

7. Image Navigation and Registration

- INR Performance Evaluation System (PES).** PES is a computer simulation of the INR system that may be used to conduct diagnostic studies of INR performance based on on-orbit data for individual error sources. PES contains analytical models of all INR error sources and simulates INR processes and operations on the ground and spacecraft. System impact assessments for anomalous error sources and the selection of optimum operational parameters to adjust for actual on-orbit performance characteristics are potential applications of the PES during the operational phase. PES is used only as an analytical tool.

INR System Operations and Data Flow

INR system support operations at the satellite operations and control center (SOCC) are characterized by a routine 24 hour cycle that accommodates the daily thruster firings for spacecraft momentum control. Additional INR support activities are undertaken for special operational periods and for maintenance of system calibrations.

Normal Operations. The daily cycle of INR support operations, illustrated in Figure 7-3, features the following sequence of events.

- OAD is performed once per day shortly before the end of the INR cycle.
- An IMC coefficient set and a table of imager and sounder star sense commands are generated from the OAD solution, uploaded to the spacecraft and then, at the start of the new cycle, enabled.

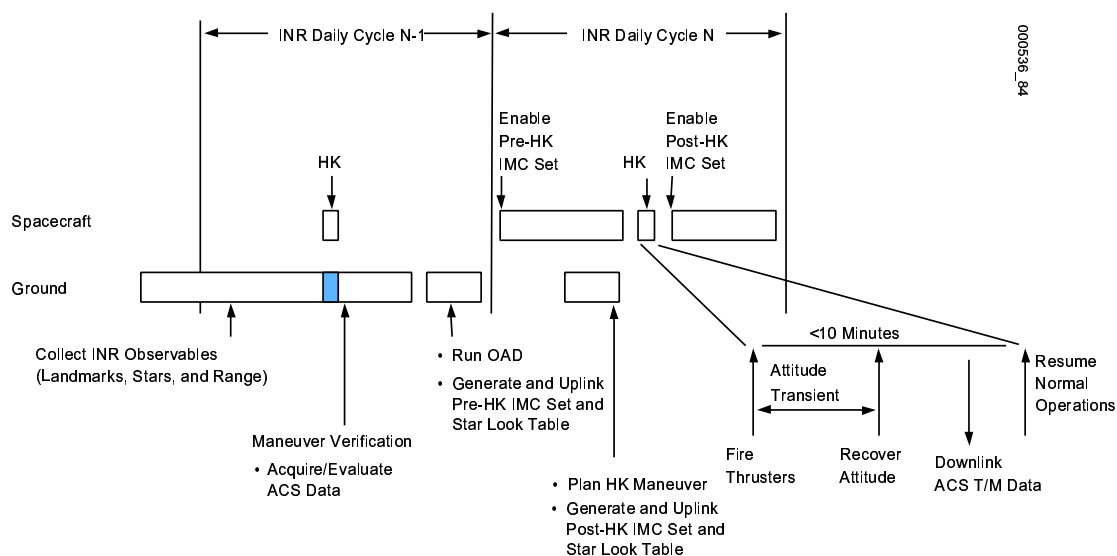

Figure 7-3. Image Navigation and Registration Sequence for Normal Operations

7. Image Navigation and Registration

- A new IMC set and star table are generated and uploaded shortly before the daily housekeeping maneuver. The pre-maneuver attitude prediction remains unchanged in the new IMC set, while the orbit prediction is modified in accordance with the anticipated maneuver ΔV .
- The stellar inertial ACS autonomously recovers from thruster induced attitude transients within the allowed 10 minute housekeeping interval. Normal INR operations resume with the new INR commands immediately after the housekeeping period.

Special Operations. The INR system operates during eclipse, post-yaw flip, and post-stationkeeping periods, generally with somewhat reduced performance levels compared to normal operations. Ground support activities are modified for these special periods by the addition of special OAD and IMC set generation runs.

Periodic Calibrations and Maintenance. The INR system requires minimal maintenance effort aside from generating the daily IMC set and star sense commands. Thruster calibration is periodically performed in the SSGS using spacecraft telemetry and OAD solutions. This off-line function provides more accurate maneuver ΔV predictions. ISEC parameters are also calibrated in off-line SSGS processing using stored star residual measurements.

INR System Data Flow. INR-related data flows between the spacecraft and SSGS components located at the command and data acquisition station (CDAS) and SOCC are illustrated in Figure 7-4. Major SSGS components and their functions for INR operations are listed below.

7. Image Navigation and Registration

- *Sensor Processing System (SPS)*. Performs preprocessing on raw spacecraft range and instrument star sense data. Generates GVAR data stream including insertion of image navigation message.
- *Product Monitor (PM)*. Performs landmark measurement extraction from the GVAR data.

INR Dynamic Environment

The INR system is subject to a broad spectrum of disturbance sources ranging from high frequency structural vibrations to slowly varying thermal distortion. Figure 7-5 provides an overview of the INR dynamic environment including disturbance sources, sensors and compensation methods.

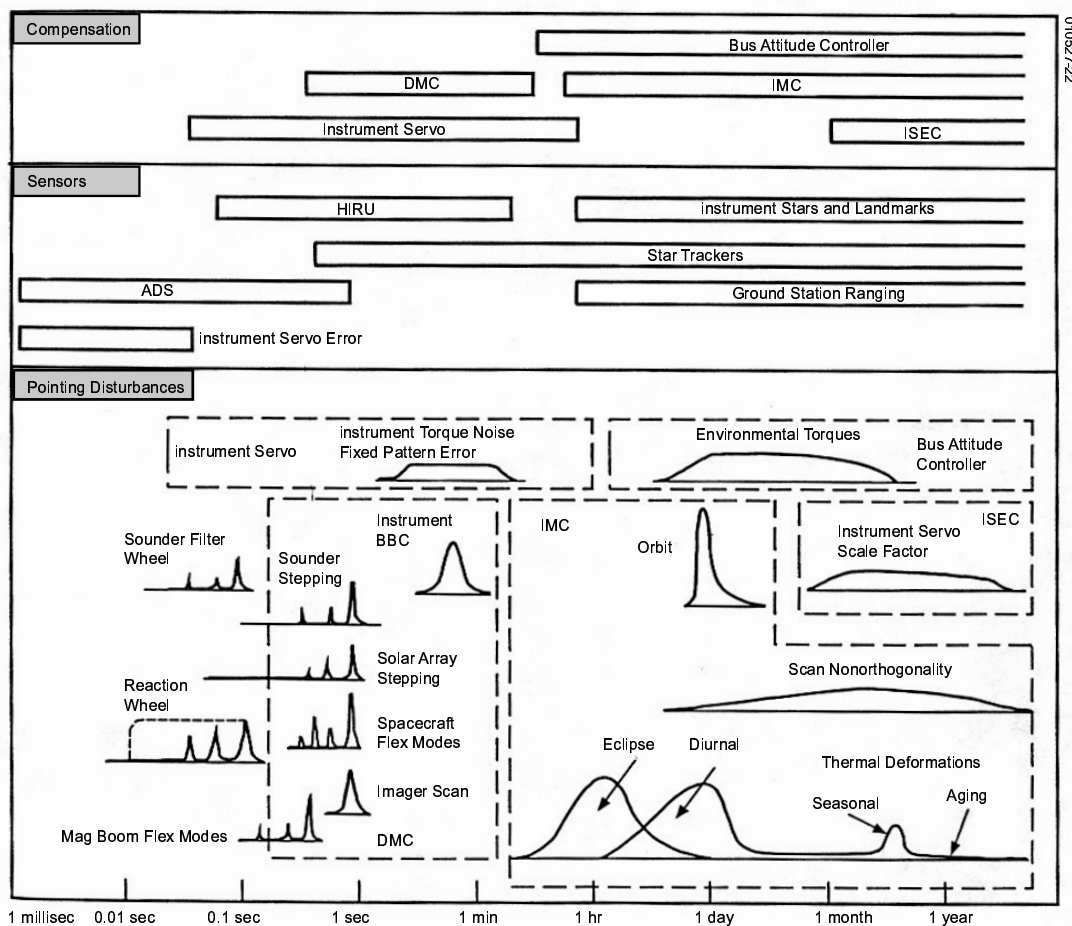

Figure 7-5. Image Navigation and Registration System Dynamic Characteristics

7. Image Navigation and Registration

Instrument Servo Errors. Instrument scan mirror control is subject to various dynamic disturbances including gimbal bearing noise, drive motor torque noise and structural interactions. Fixed pattern errors, meaning systematic errors that vary with scan direction, arise from gimbal encoder errors and internal optics misalignments. Some instrument fixed pattern errors may be calibrated with ground processing of instrument star measurements and corrected via ISEC on the spacecraft. Servo dynamic error, the difference between commanded and encoder-sensed gimbal angles, is recorded onboard and included in the MDL data stream for diagnostic purposes.

Spacecraft Attitude Control Errors. Dynamic disturbances to bus attitude include environmental torques, solar panel stepping, reaction wheel noise, instrument mirror motion and structural interactions. Thruster activity is always constrained to periods when the INR system is not operational. Stellar inertial system error sources include star tracker fixed pattern errors, random noise and gyro drift. The Kalman filter processing provides significant attenuation of high frequency star tracker errors. The ACS comprises two complementary compensation loops. Bus attitude control using reaction wheels is limited in bandwidth capability by bus structural modes. However, DMC exploits the considerably higher bandwidth capabilities of the instrument mirror servos to effectively extend the bandwidth of the spacecraft attitude control system. High frequency spacecraft motion is measured by an ADS unit (which measures angular rate) mounted adjacent to the instruments on the mounting plate; the data is included in the MDL data stream for diagnostic purposes.

Thermal Distortion Errors. Diurnal thermal variations induce distortion within the instruments and the spacecraft Imager/Sounder mounting structure. The resulting slowly varying pointing errors are sensed directly through the instruments using star and landmark observations. Compensation for thermal distortion is determined via attitude estimation on the ground and implemented via IMC on the spacecraft.

Orbit Errors. Orbital motion produces slowly varying pointing errors with both drift and periodic components. The orbital motion is sensed by instrument landmark and spacecraft range measurements. Compensation for orbital motion is determined via orbit estimation on the ground and implemented via IMC on the spacecraft. Compensation for the orbit perturbation from daily thruster maneuvers is determined via maneuver prediction on the ground using thruster calibration data and implemented via IMC.

Mirror Compensation Implementation Errors. Generation of the analog mirror compensation signals for IMC, DMC and ISEC is subject to flight software numerical and timing errors and to D-to-A converter nonlinearity and quantization errors. The resulting IMC implementation error behavior includes both random noise and scan angle dependent errors. Diagnostic data for the mirror compensation signal is available in imager/sounder telemetry at the SPS or at a reduced data rate at the PM. Sampled compensation signal data from the spacecraft bus side of the ACE-to-instrument interface is also available in the MDL data stream.

7. Image Navigation and Registration

This page left blank.

8. Communications Subsystem

The spacecraft communications subsystem provides requisite conditioning, transmission, reception, and routing of mission data signals and telemetry for the GOES space segment. It consists of eight major component groups that serve the following variety of functions:

- Imager and Sounder sensor data (SD) modulation and transmission
- Processed data relay (PDR)
- Weather facsimile (WEFAX/LRIT) relay
- Emergency managers weather information network (EMWIN) relay
- Multiuse data link (MDL) modulation and transmission
- Data collection platform interrogate (DCPI) relay
- Data collection platform report (DCPR) relay
- Search and rescue (SAR) data relay

Four antennas, each with full earth coverage beamwidth, support communications with the ground segment:

- S-band receive and L-band transmit cup-dipole
 - Receives the PDR, WEFAX/LRIT, EMWIN, and DCPI S-band uplink signals
 - Transmits the WEFAX/LRIT, MDL, and DCPR L-band downlink signals
- L-band transmit cup-dipole—transmits SD, PDR, and EMWIN L-band downlink signals
- UHF receive and transmit cup-dipole
 - Receives DCPR and SAR signals
 - Transmits DCPI signal
- L-band transmit cup-dipole: transmits SAR downlink signal

8. Communications Subsystem

The subsystem is configured as shown in Figure 8-1. Multiplexers are used to interface multiple signals with low RF loss into and/or out of an antenna. The two L-band output multiplexers and the UHF diplexer filter and separate the uplinks from the downlinks while combining the various transmit signals for the composite downlinks. The SAR transmit signal uses a single output filter. The output filtering also rejects unwanted out-of-band signals and harmonics. On the receive side, low noise amplification, frequency translation and channel filtering are within the S-band and UHF receivers. The channel filters separate the uplink signals—S-band: PDR, WEFAX/LRIT, EMWIN, DCPI; and UHF: DCPR, SAR—for subsequent frequency translation and high power amplification by their respective individual SSPAs. The DCPR and WEFAX/LRIT use linear SSPA amplification. The other services—SD, PDR, EMWIN, MDL, DCPI—use nonlinear SSPA amplification.

Space-Ground Communications Interfaces

The flexibility and multitude of services provided by the GOES spacecraft are functions of the communication interfaces between the spacecraft and ground, as are shown in Figure 8-2. The major system interfaces are those linking GOES N-P to the command

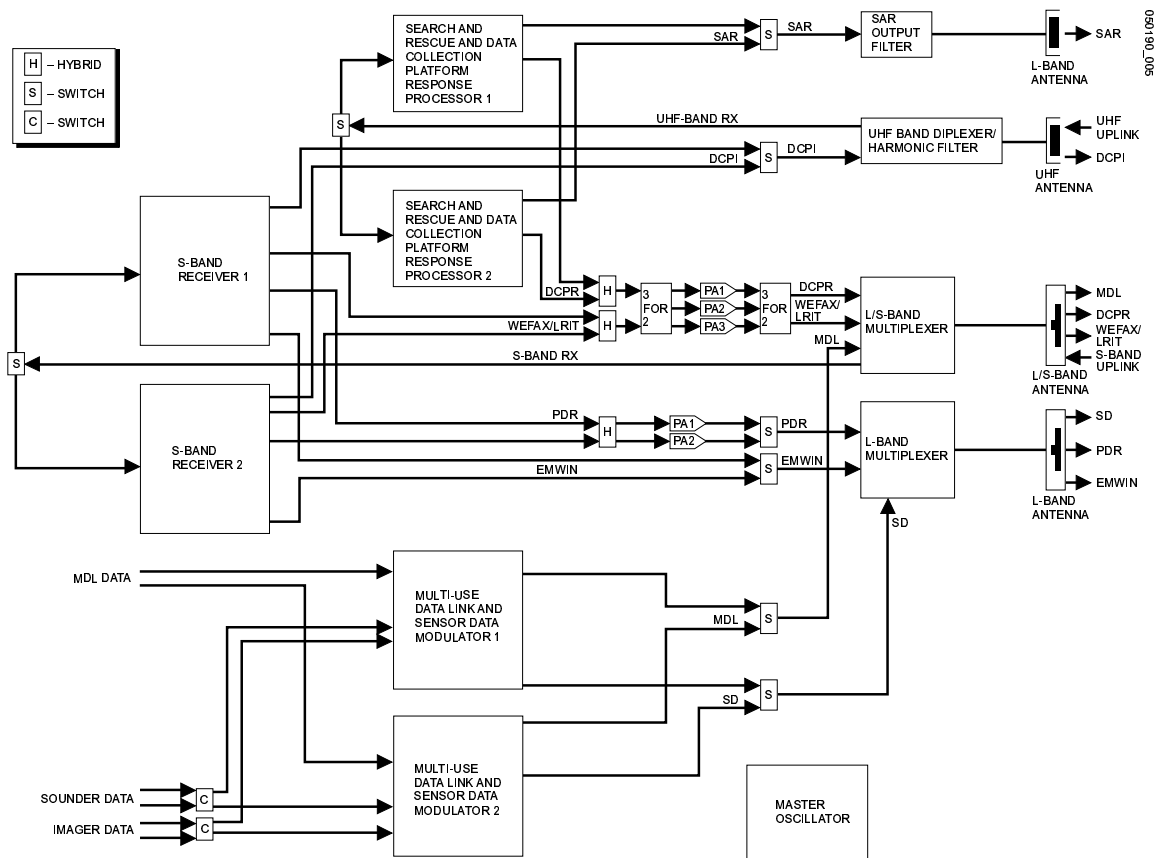
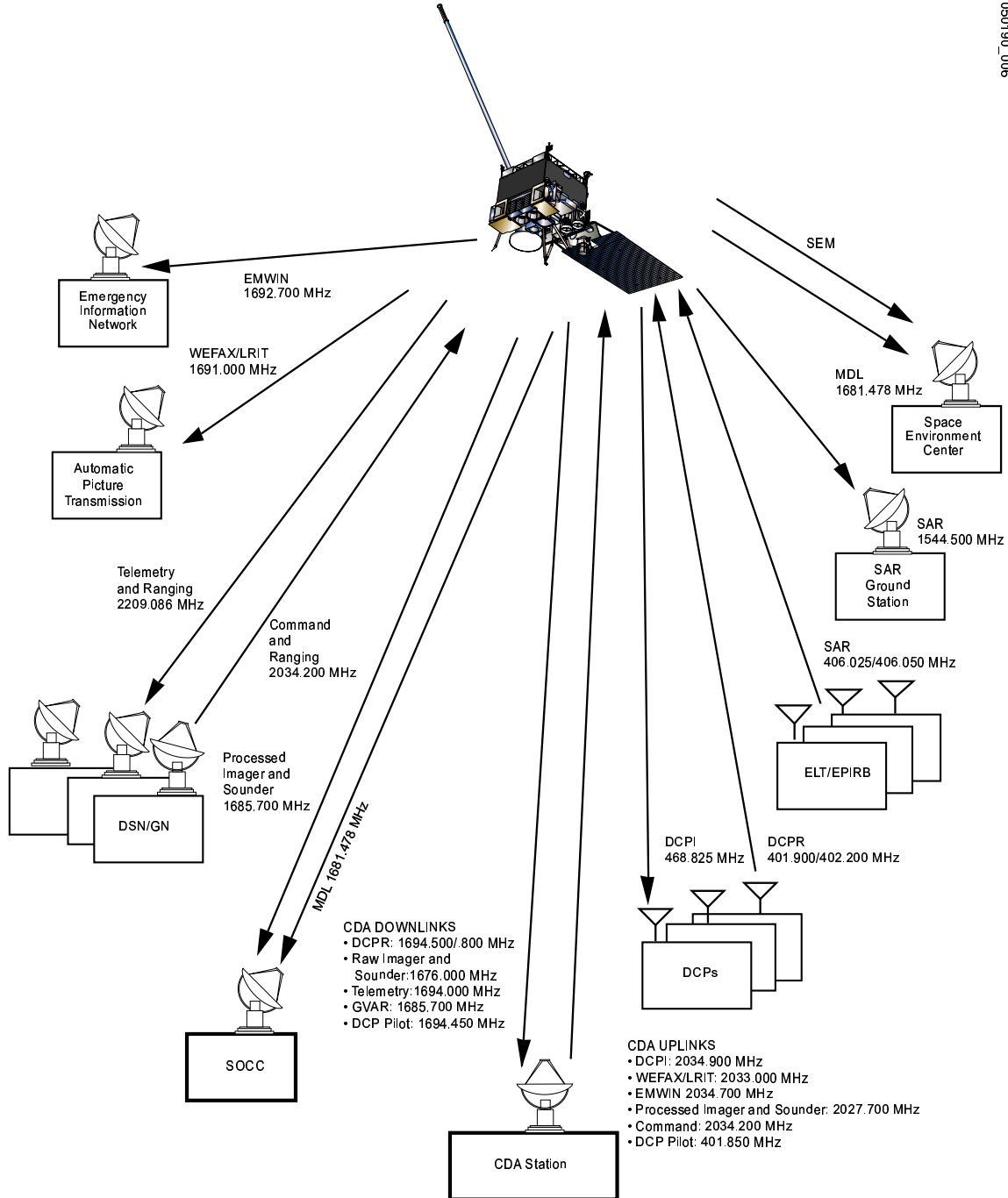

Figure 8-1. Communications Subsystem Configuration

8. Communications Subsystem

050190_006



Legend

CDA	Command and Data Acquisition	GN	Ground Network
DCP	Data Collection Platform	GVAR	GOES Variable Data
DCPI	Data Collection Platform Interrogate	MDL	Multise Data Link
DCPR	Data Collection Platform Report	SAR	Search and Rescue
DSN	Deep Space Network	SEM	Space Environment Monitor
ELT	Emergency Locator Transmitter	SOCC	Satellite Operations Control Center
EMWIN	Emergency Managers Weather Information Network	WEFAX/LRIT	Weather Facsimile
EPIRB	Emergency Position Indicator Response Beacon		

Figure 8-2. Space-ground Communications Interfaces

8. Communications Subsystem

and control ground stations, end user equipment, and communications service terminals. The principal interfaces are those between the spacecraft and the command and data acquisition (CDA) station, namely:

- CDA downlinks
 - Raw Imager and Sounder data
 - Data collection platform report
 - MDL data
 - Spacecraft telemetry
- CDA uplinks
 - Processed Imager and Sounder data (GVAR)
 - Data collection platform interrogation
 - Weather facsimile transmission/Low Rate Information Transmission
 - Emergency managers weather information network transmission
 - Spacecraft commands

Data Links

The space environment data are downlinked to the end user at the Space Environment Center in Boulder, Colorado, on the Multi-Use Data Link (MDL). The processed Imager and Sounder (calibrated, earth-located) data are downlinked to the Satellite Operations Control Center (SOCC) at Suitland, Maryland, then to the World Weather Building for subsequent distribution to end users, who are typically personnel manning satellite field forecast offices located throughout the United States. The processed data are also received directly by other Government and commercial users in the United States and other countries within view of the GOES satellites. The SOCC also receives diagnostic data from the MDL for further analysis.

Weather Facsimile Transmission/Low Rate Information Transmission (WEFAX/LRIT)

In 1991, the Coordinating Group for Meteorological Satellites (CGMS) began discussing the possible replacement of the current international standard for analog Weather Facsimile (WEFAX) Broadcast Services from geostationary meteorological satellites.

In July 1998, the LRIT global specifications were approved by the United States (NOAA), Europe (EUMETSAT), Japan (JMA/NASDA), China (CMA/SMC), and Russia (Planeta). Also, all participants at the meeting, except for the United States, committed to a specific planning date for implementing the LRIT requirements.

8. Communications Subsystem

In 1999, NOAA announced its plans to implement the LRIT format. The GOES-N series will manifest a complete transition to a new service. The new digital WEFAX/LRIT service is a combination of several information sources onto a single higher capacity broadcast (128 kbps) that contains significantly more meteorological data, imagery, charts and other environmental information.

Emergency Managers Weather Information Network Transmission

The emergency managers weather information network (EMWIN) transmission is a communication service provided through a transponder onboard the GOES satellite. EMWIN is a suite of data access methods that make available a live stream of weather and other critical emergency information. Each method has unique advantages. EMWIN's present methods in use or under development for disseminating the basic data stream include radio, Internet, and satellites (GOES and commercial satellites). As an integral part of its mission, the National Weather Service (NWS) recognizes the need to provide the emergency management community with access to a set of NWS warnings, watches, forecasts, and other products. In partnership with the Federal Emergency Management Agency (FEMA) and other public and private organizations, EMWIN is now evolving into a fully operational and supported NWS service.

Data Collection System

The GOES data collection system (DCS) collects near real-time environmental data from data collection platforms (DCPs) located in remote areas where normal monitoring is not practical. The DCS receives data from DCPs on aircraft, ships, balloons, and fixed sites in a region from Antarctica to Greenland and from the west coast of Africa to just east of the Hawaiian Islands, an area covered by the GOES satellites. The system encompasses almost every level of the atmosphere, land, and ocean. It is used to monitor seismic events, volcanoes, tsunamis, snow conditions, rivers, lakes, reservoirs, ice cover, ocean data, forest fire control, meteorological and upper air parameters, and to provide ground truth information. The GOES N-P satellite is compatible with the new data collection platform that have data transmission rates of 300 bps and 1200 bps and is also compatible with the older data collection platforms that have a data rate at 100 bps. On GOES satellites prior to N-P, only a small number of 300 and 1200 bps transmitters could be accommodated.

Search and Rescue

The search and rescue (SAR) subsystem onboard each GOES satellite is a dedicated transponder that relays the distress signals broadcast by UHF emergency locator transmitters (ELTs) carried on general aviation aircraft, emergency position indicating radio beacons (EPIRBs) aboard some classes of marine vessels, and portable personal locator beacons (PLBs). The SAR mission is performed by relaying the distress signals emitted from the ELT/EPIRBs via the GOES satellite to a Local User Terminal (LUT) ground station located within the field of view of the spacecraft. The UHF SAR distress signal is a digital signal that includes information identifying who the user is. This information may permit a Rescue Coordination Center to dispatch help to the downed aircraft, ship in distress, or individual carrying a PLB directly. If not, an emergency team could be

8. Communications Subsystem

alerted while waiting for a LEO SARSAT to fly over the beacon and provide a position based on doppler.

Telemetry, Command, and Ranging

Telemetry, command, and ranging (TC&R) data are downlinked and uplinked between a network of stations, including the Indian Ocean Remote Tracking Station, the NASA Deep Space Network (DSN), and NASA Ground Network (GN) stations for launch and orbit raising, and with the CDA station as the center for the origin of commands and reception of spacecraft telemetry during normal, on-orbit operations (see Section 9).

Subsystem Performance Summary

All services have excess statistical link margin of 1 dB at specification design levels.

Bit error rate limits are as follows:

- Sensor data Imager link 1×10^{-8}
- Sensor data Sounder link 1×10^{-8}
- Processed data relay 1×10^{-6}
- WEFAX/LRIT (coded) 1×10^{-8}
- EMWIN (coded) 1×10^{-8}
- MDL 1×10^{-8}
- Data collection platform Interrogate 1×10^{-5}
- Data collection platform report 1×10^{-6}
- SAR 1×10^{-5}

8. Communications Subsystem

Center Frequency Assignments

The GOES satellite center frequency assignments are given in Table 8-1.

Table 8-1. Center Frequency Assignments

Downlink CF	MHz	Uplink CF	MHz
UHF		UHF	
Data collection platform interrogation		Data collection platform report	
Frequency 1 - Spare	468.8125	Frequency band 1 - Domestic	401.900
Frequency 2 - East	468.8250	Frequency band 2 - International	402.200
Frequency 3 - West	468.8375		
L/S-band		SAR	
SAR	1544.500	Wideband mode	406.050
WEFAX/LRIT	1691.000	Narrowband mode	406.025
EMWIN	1692.700		
DCP report		S-band	
Frequency band 1	1694.500	WEFAX/LRIT	2033.000
Frequency band 2	1694.800	EMWIN	2034.700
Telemetry		DCP interrogation	
CDA station	1694.000	Frequency 1 - Spare	2034.8875
DSN	2209.086	Frequency 2 - East	2034.9000
DSN ranging	2209.086	Frequency 3 - West	2034.9125
SD - Raw Imager and Sounder data	1676.000	DSN ranging	2034.200
Processed data relay	1685.700	CDA station and DSN spacecraft command frequency	2034.200
MDL - Multiuse data	1681.4780	Processed data relay	2027.700

Sensor Data and Multiuse Data Link Modulators/Transmitters

The SD modulator and the MDL modulator (with its SSPA) share a common housing. The SD modulator accepts the two asynchronous baseband data streams from the Imager and the Sounder. The signals are simultaneously modulated onto the downlink carrier. The Imager data rate is 2.62 Mbps and the Sounder data rate is 40 kbps. The MDL modulator receives the data from the MDL data multiplexer. The data is modulated onto the downlink carrier at a data rate of 400 kbps. Redundancy S-switches for each service select the active string. Both signals are then routed to the output filters, multiplexers, and antennas for transmission.

8. Communications Subsystem

Processed Data Relay, Weather Facsimile/LRIT, and EMWIN Transponders

The PDR, WEFAX/LRIT, and EMWIN signals are received by the S-band receive antenna and demultiplexed by the S-band quadruplexer. The active receiver is selected by the S-switch. The active receiver amplifies the uplink band (using low-noise amplifiers) and downconverts it in frequency to an intermediate frequency for filtering. Each signal is individually filtered and then upconverted in frequency. The PDR receiver output is routed to the 2-for-1 redundant PDR SSPA. The WEFAX/LRIT receiver output is routed to the 3-for-2 redundant SSPAs that amplify the WEFAX/LRIT and DCPR signals individually in separate SSPAs (i.e. there is one redundant SSPA that can back up either the DCPR or the WEFAX/LRIT channel). The EMWIN receiver output is already amplified by an SSPA internal to the receiver. Each signal is individually filtered in its assigned output multiplexer and routed to an antenna for transmission. The PDR signal is 2.11 Mbps (2.374 advanced rate) and is band limited by the PDR filter, which has a bandwidth of about 5 MHz. The WEFAX/LRIT signal has an approximately 600 kHz bandwidth. The EMWIN signal has approximately 50 kHz bandwidth.

Data Collection Platform Interrogate Transponder

One of the DCPI uplink carriers is modulated at 100 bps at a center frequency of either 2034.8875, 2034.900, or 2034.9125 MHz. The signal shares the receive antenna and a low noise amplifier with the PDR, WEFAX/LRIT, and EMWIN signals. The receiver includes a channel filter that separates out the DCPI signal and routes it to an internal SSPA for power amplification to transmit power level. An output S-switch selects the active string and routes the signal to the UHF diplexer and antenna for transmission.

Data Collection Platform Report Transponder

Up to 233 DCPR signals may be accommodated in one of the two frequency bands (although 266 channels can be fitted in the allocated bandwidth, international agreements restrict usage to only 233 channels maximum) centered at either 401.900 or 402.200 MHz. These signals — at either 100 bps, 300 bps or 1.2 kbps — are received by the UHF antenna and routed via the diplexer to the SAR/DCPR processor. An input S-switch routes the signals to the active unit, where they are amplified (using low-noise amplifiers) and provided greater than 400 kHz, 3 dB bandwidth filtering in one of two selectable bands. The signals are then upconverted in frequency and amplified with automatic gain control. The output of the selected transponder is filtered and combined with the other S-band downlink signals by the output multiplexer, then transmitted to the ground via the S-band transmit antenna.

8. Communications Subsystem

Search and Rescue Transponder

The UHF antenna receives the uplink SAR signals. The uplink band is filtered by the UHF diplexer and routed to the active SAR/DCPR processor via the redundancy S-switch. The processor receives an uplink centered at one of two commandable center frequencies, 406.025 or 406.050 MHz, for narrowband and wideband modes, respectively. The uplink is filtered and downconverted by 406 MHz. These near-baseband signals are amplitude limited and then modulated onto a 1554.500 MHz carrier that is used as the SAR downlink. The SAR/DCPR processor uses an internal SSPA to raise the SAR downlink power for transmission. The output of the selected SAR/DCPR processor is passed through an output filter and finally transmitted via the dedicated SAR transmit antenna.

8. Communications Subsystem

This page left blank.

9. Telemetry and Command Subsystem

The GOES N-P telemetry and command (T&C) subsystem provides the functional interface between the spacecraft and ground command and control. It is composed of both radio frequency (RF) and digital (baseband) segments. Telemetry parameters describing the status, configuration, and health of the spacecraft payload and subsystems are downlinked to the Command and Data Acquisition (CDA) station and sent to the Satellite Operations Control Center (SOCC). Commands are received onboard the spacecraft for controlling mission operations and managing expendable resources. To perform these functions, the T&C subsystem's RF segment, configured as shown in Figure 9-1, comprises three antennas, two RF transponder units, and interconnecting microwave devices. The subsystem's digital segment, configured as shown in Figure 9-2, comprises redundant, distributed digital units including an internally redundant pyrotechnic squib driver unit. The T&C subsystem's RF segment configuration allows simultaneous operation of all T&C RF services without interference.

The T&C subsystem primarily interfaces with the NOAA Wallops CDA station during on-orbit operations. The NASA Deep Space Network (DSN) serves as a backup station for on-orbit operations and is the primary ground station for launch and orbit raising activities. The ground interfaces during orbit raising are with the DSN, Air Force Indian Ocean, and NASA Wallops CDA stations. These stations are compatible with the interface to the spacecraft T&C subsystem.

Telemetry

Information from the spacecraft provided via telemetry includes:

- Configuration status and housekeeping data from operational instruments
- Environmental sensing data from space environment monitor (SEM) instruments
- Configuration status and housekeeping data from various spacecraft subsystem units
- Health status for each receiver
- SSPA health status for each transmitter
- Power system parameters and voltages of critical electronic modules

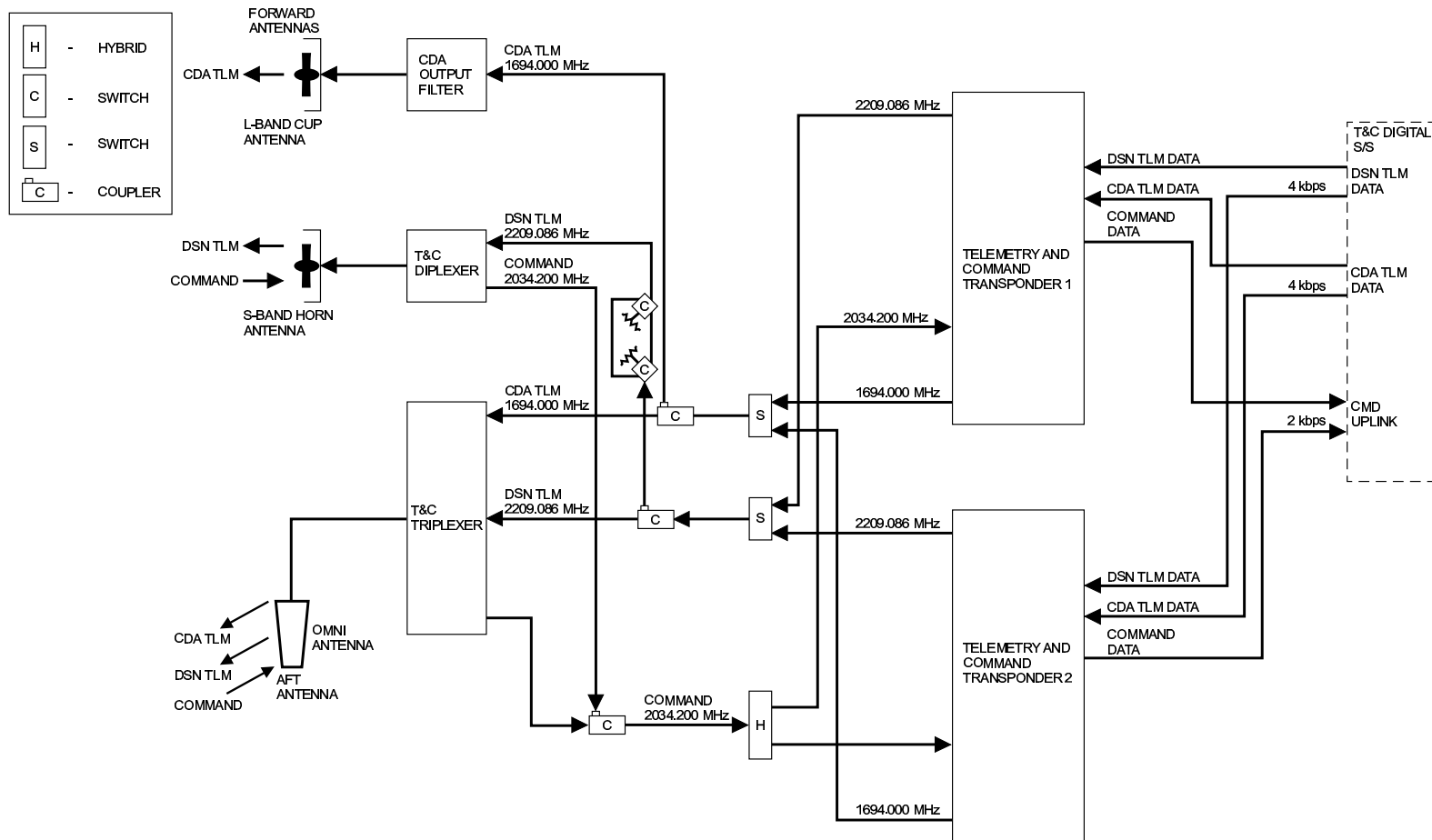

Figure 9-1. Telemetry and Command RF Subsystem Configuration

050190-12

9. Telemetry and Command Subsystem

9. Telemetry and Command Subsystem

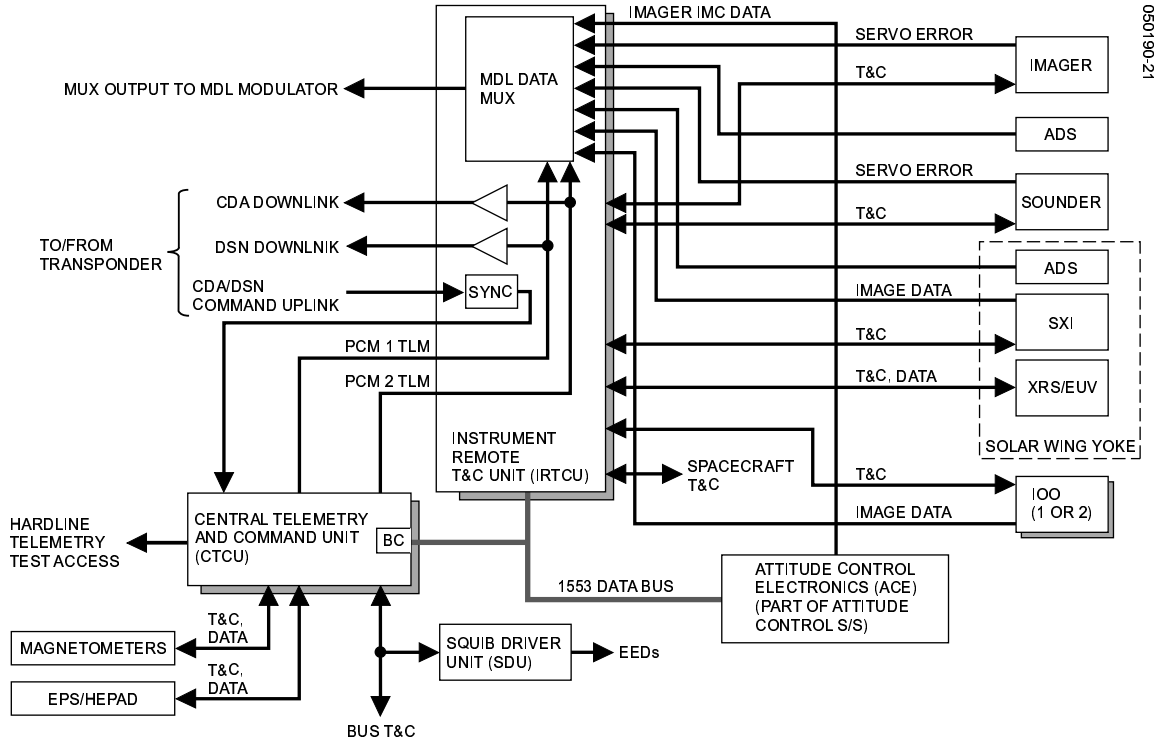

Figure 9-2. Telemetry and Command Digital Subsystem Configuration (Half-diagram)

- On/off status of all commandable equipment and heaters
- Temperatures of all major subassemblies
- Spacecraft attitude determination and control parameters
- Parameters of frame synchronization, spacecraft identification, command counter, secure mode operation, polycode, etc.

The telemetry function is “standby redundant,” meaning that only one unit of a given pair is enabled and operational at a time. Most spacecraft housekeeping telemetry, as well as magnetometer and energetic particle sensor (EPS)/high energy proton and alpha detector (HEPAD) telemetry, is gathered by one of two central telemetry and command units (CTCUs) located in the spacecraft bus module. Communications/RF telemetry, some spacecraft housekeeping telemetry, and all remaining instrument telemetry is gathered by one of two instrument remote telemetry and command units (IRTCUs) located in the spacecraft payload module. In turn, the CTCU designated as bus controller (BC) collects the data either from itself or other remote terminal (RT) or attitude control electronics (ACE) units on the MIL-STD-1553 digital data bus (DDB) and then multiplexes, encodes, and formats the data into two (normal/normal or normal/dwell) serial pulse code modulated (PCM) bit streams. Both normal and dwell PCM data are generated simultaneously by the selected BC CTCU; either normal or dwell PCM data are provided to the four telemetry transmitters. Only one of the two CDA transmitters can be on at a time, and only one of the two DSN transmitters can be

9. Telemetry and Command Subsystem

on at a time. Each operating transmitter can be independently configured to receive either normal or dwell PCM data. The telemetry downlink can be switched to either 1000 bps or 4000 bps. The telemetry data processed are either conditioned or unconditioned analog or bilevel, or serial digital (internal, external, or ACE). Most telemetry inputs are single-ended. For the Imager and Sounder, select analog data are received differentially to minimize susceptibility to noise. Each analog signal is converted into a digital signal at 12 bit resolution, but with few exceptions is downlinked in normal telemetry with a lower resolution of 8 bits. The telemetry segment of the T&C subsystem can dwell upon any channel, except for a few channels such as the serial digital data sources greater than 8 bits long, and a dozen analog channels identified in the document, *Subsystem Operating Requirements for the GOES N-Q Telemetry and Command—Digital*. During each word period, a PCM word and a dwell word are generated, making both normal and dwell PCM available for simultaneous transmission over two RF links.

Command

The command capability provides the spacecraft with:

- Receipt, decoding, processing, and distribution of uplink commands with
 - 2000 bps data rate
 - Uniquely defined spacecraft and CTCU addresses
 - Error detection polycode
- Pulse, SWSI, or serial (proportional, internal, or ACE) command types
- Switchable COMSEC command decryption and authentication
- Simultaneous DSN ranging and commanding
- Command uplink override of every automatic function

The uplink signal, which can contain command and ranging data simultaneously on the same carrier, is routed to both onboard command receivers. The receivers cannot be commanded off (that is, they are “active redundant”), and once they have acquired the carrier, they provide command data to each digital command unit/decoder, each of which is also active redundant. Following detection, locking and demodulation by the command receivers, and bit synchronization by the IRTCU, each command is decoded, processed, and distributed (either internally or over the MIL-STD-1553 DDB to the intended recipient) by the selected CTCU. Commands sent by the bus controller CTCU over the digital data bus are received by remote terminal or onboard processor units such as the CTCU, IRTCU, or ACE. Each CTCU can be operated in either a Bypass (clear text) or Secure (encrypted) mode, the latter of which precludes unauthorized commanding of the spacecraft. Every uplinked command is subjected to a validation process and, if found acceptable, is loaded and/or executed by the CTCU that was selected in the uplinked command. There are two modes of command execution: real-time via the CTCU and delayed buffering (verified, stored, or scheduled) via the ACE. In

9. Telemetry and Command Subsystem

the real-time mode, validation of the uplinked command is performed within the issuing CTCU; verification is typically provided by the end-user of the command. If no errors are detected, the command is executed. If an error is detected, processing of the command is halted and an error bit is telemetered to the ground station indicating that the command must be retransmitted. In the delayed buffering mode, the bits of the decoded command are telemetered back to the ground station for verification, and a subsequent execution message must be uplinked. The command unit outputs are completely redundant.

The squib driver unit (SDU) fires electrical pulses needed for space vehicle and instrument pyrotechnic devices. The SDU is suitable for igniting NASA standard initiators (NSI-1) tied to electro-explosive devices (EEDs) used to deploy mechanisms, release structural members, or pressurize the propulsion system. The unit is internally redundant and can drive up to 60 redundant bridgewires (up to one redundant pair simultaneously).

Data

The multi-use data link (MDL) provides a medium-rate (400 kbps) downlink of Imager and Sounder servo error and Imager IMC data. The MDL also provides yoke and Imager/Sounder mounting surface angular displacement sensor data (all differential analog data digitized to 12 bits resolution). Also included are serially digitized SXI data, both spacecraft PCM telemetry streams, plus two analog spares for future use. The MDL processing and multiplexing function resides within the IRTCUC.

Ranging

Ranging is performed to determine the spacecraft orbital elements during transfer and geosynchronous orbits. Channelized to the DSN transmitter only for downlink, ranging is accomplished by ground-commanding one of the DSN transponder ranging channels on and into the coherent mode. The ground station uplinks ranging tones to the command receivers, where they are routed to the selected DSN transmitter and downlinked to the ground station with the output (downlink) carrier frequency. In the coherent mode, the downlink carrier frequency is maintained at a ratio of 240 to 221 relative to the uplink carrier. With the ranging channel on, ranging and telemetry are provided simultaneously on the same downlink carrier.

9. Telemetry and Command Subsystem

This page left blank.

10. Electrical Power

The GOES N-P electrical power subsystem (EPS) provides conditioned power to all the spacecraft subsystems and instrument payloads from three regulated bus sources during sunlight and eclipse periods. The primary bus voltage of $53.1 \text{ V} \pm 0.25 \text{ V}$ is produced by regulating the solar array voltage during sunlight and the battery voltage during eclipse periods. This primary bus provides power to the communications, telemetry and command RF, attitude control (reaction wheels), and thermal subsystems. In addition to providing spacecraft subsystem power, the primary bus provides input power for the generation of two secondary buses. One of the secondary buses, which is regulated at 29.4 V to 30.3 V , provides power to the magnetometers, battery cell voltage monitor, telemetry and command subsystem, and the attitude control subsystem. The other secondary bus, which is regulated at $42.0 \text{ V} \pm 0.5 \text{ V}$, supplies the instrument payload power. The EPS consists of a single panel solar array with additional circuits on the solar array yoke, a single nickel-hydrogen battery, an integrated power controller (IPC), three power distribution units (PDUs), a battery cell voltage monitor (BCVM), and multiple relay load switches.

The EPS's primary function is to generate, store, condition, control, and distribute the required mission mode power. Figure 10-1 shows a top-level block diagram of the EPS. During sunlight operation, primary power is generated by the solar array to support the bus load and charge the battery. The solar array drive (SAD) rotates the solar array so that it tracks the sun throughout the orbit. The solar array features a large main panel and a solar array yoke. Both the main panel and the solar array yoke are populated with dual-junction GaAs solar cells. During eclipse or peak power periods, primary power is generated by the battery. The battery consists of 24 123-AHr nickel-hydrogen cells in series. The battery is packaged into three, 8-cell battery packs in series. A battery cell voltage monitor (BCVM) unit is used to monitor the battery cell voltages. The Integrated Power Controller (IPC) conditions, controls, and regulates the +53 V primary bus, the +42 V secondary bus, and the +30 V secondary bus. The IPC distributes the +42 V bus directly to the instrument loads. However, the +53 V bus and +30 V buses are sent to the power distribution units for distribution to their respective loads. There are two bus power distribution units (BPDUs) and one payload power distribution unit (PPDU). The BPDUs and PPDU fuse and distribute +53 V bus power and +30 V bus power. Load switching and signal turn-on and turn-off is provided by the load switch units.

10. Electrical Power

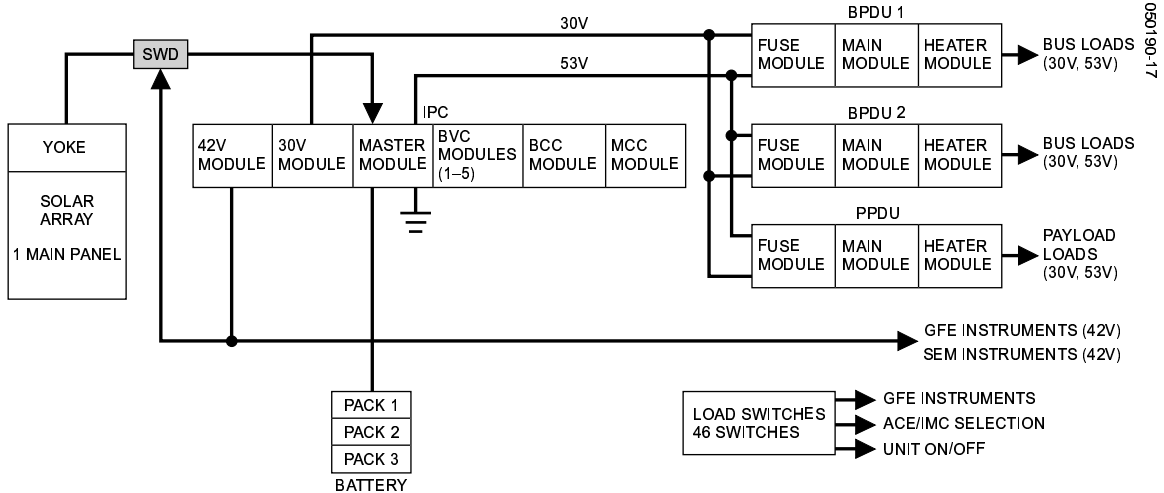
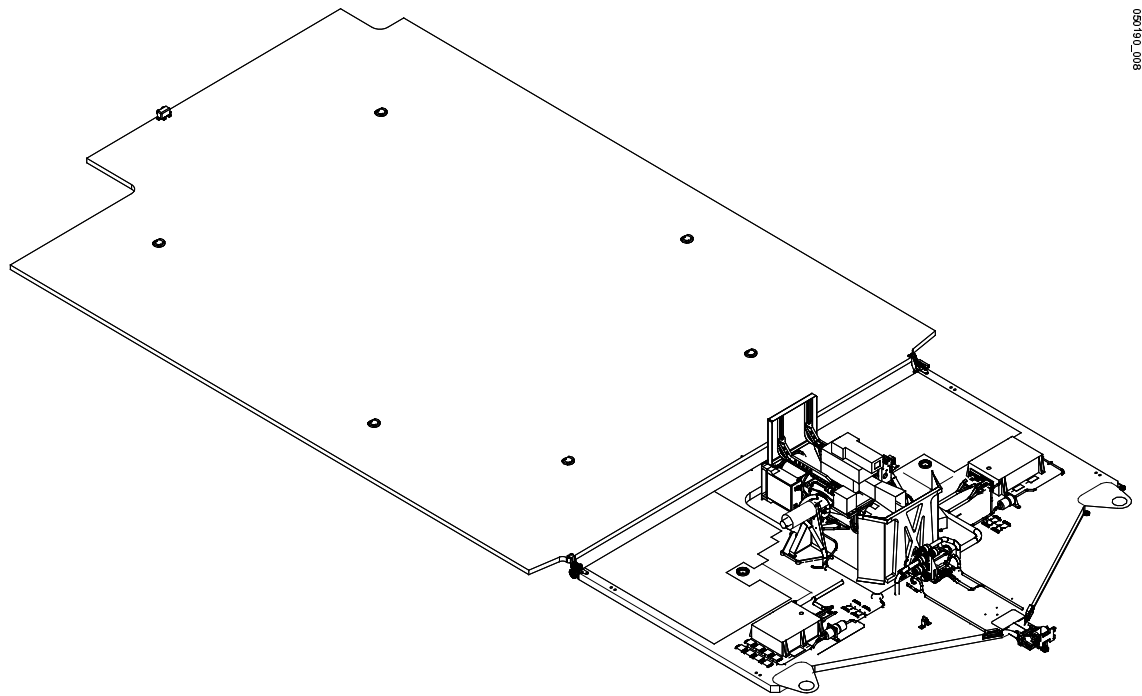

Figure 10-1. Electrical Power Subsystem Architecture

All EPS functions are on-line and operating during all mission phases. Prelaunch regulated power is supplied through an umbilical connection at the battery interface to the IPC. After preflight disconnection, battery power is available on the launch pad to perform any final electrical tests. During transfer orbit the solar array panel is stowed against the spacecraft body, ensuring a benign thermal environment. The solar panel alternates from being illuminated to being shadowed during the spin-stabilized portion of transfer orbit. When the solar array is illuminated by the sun during the spin-stabilized phase of the transfer orbit, the solar array generates sufficient power to support the load and charge the battery.

Solar Array

Primary power is supplied by a single solar array (Figure 10-2) composed of a main solar panel and a yoke panel populated with solar circuits. Both the main solar panel and the yoke panel are populated with dual-junction GaAs solar cells. Each circuit delivers a minimum EOL voltage of 54.8 V. Diode isolation is provided on each solar circuit. The solar array back-wiring retraces the circuit path to reduce out-of-plane magnetic effects and lower the induced magnetic dipole moment. Solar array primary power is delivered through solar array power slip rings to the IPC. Each individual solar array group is connected to a solar array drive (SAD) power slip ring. The solar array is attached to a single-axis, sun-tracking solar array drive (SAD) that rotates about the spacecraft pitch axis. The solar array remains stowed and attached to the spacecraft until orbit raising is completed. Pyrotechnic devices release the array and allow it to be deployed its on-orbit position. The solar array can produce an end-of-life, (EOL) summer solstice power of 1900 watts and an EOL autumnal equinox power of 2084 watts assuming no failures.



8007061050

Figure 10-2. Solar Array**Battery**

The single Ni-H₂ battery (Figure 10-3) is the secondary power source on the spacecraft. Its primary function is to store energy and provide power to the spacecraft when the solar array produces less than the required power to support the spacecraft load. The battery provides power during launch, orbit raising eclipses, on-orbit eclipses, and periods of peak power demand. The battery consists of 24 123-AHr nickel-hydrogen cells connected in series. The 24 cells of the battery are packaged into three battery packs. Each pack has eight cells connected in series. Harnessing between the battery packs connects the battery packs into a 24-cell 123-AHr battery. Each battery pack has magnetic cancellation harnessing to reduce the battery's magnetic dipole moment. To prevent the loss of the battery due to an open cell, each cell is equipped with bypass diodes in the charge path and bypass relay circuitry in the discharge path. Two strain gauge amplifier circuits mounted to two different cells within each battery pack measure cell pressure to establish the battery state of charge (SOC) for battery charge management. Three thermistors within each battery pack are used for monitoring the battery pack temperatures. Two of the three thermistors are used for on-orbit battery temperature monitoring and the third is used for battery temperature monitoring through the umbilical prior to launch. Thermostats within each battery pack are used to inhibit battery charging if the battery temperature exceeds 35 °C. Each battery pack is equipped with primary and redundant heaters which are controlled by the spacecraft processor to keep the battery packs above -10 °C. The battery heaters are located on each battery pack chassis and

10. Electrical Power

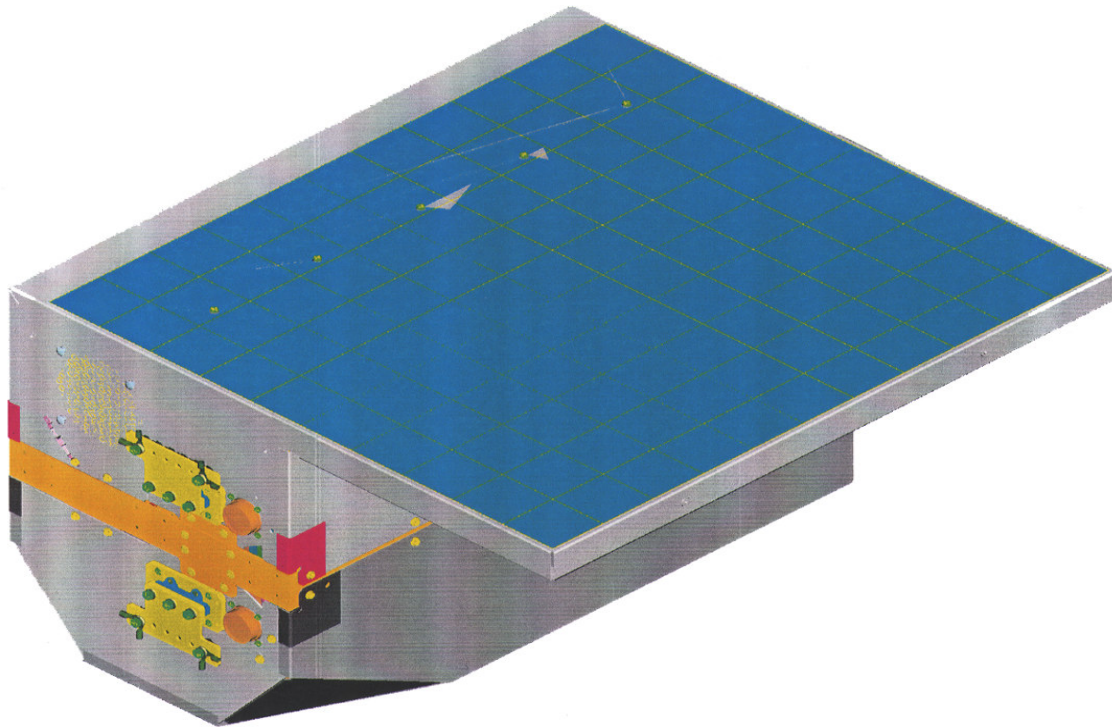
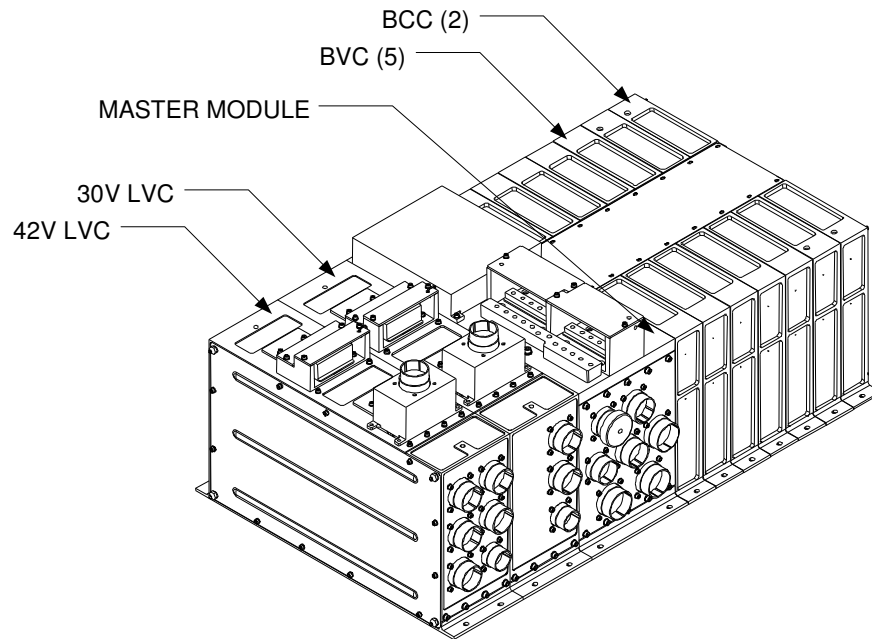

Figure 10-3. Battery

maintain the battery pack at software-selectable temperature settings. The default settings for the battery heaters are -8°C and -10°C .

Integrated Power Controller

The IPC is the source of all regulated power for the spacecraft. It conditions, controls, and regulates the +53 V primary bus and the +42 V and +30 V secondary buses. As indicated in Figure 10-4, the IPC consists of several modular units integrated together. The master module is the central control module of the IPC. The master module performs the following redundant functions: primary bus voltage and battery charge control, primary bus overvoltage clamping, serial telemetering and commanding, solar array current sensing, battery charge current and discharge current sensing, primary bus undervoltage detect and latch, housekeeping power generation, and driving of row and column relays. Other master module functions include primary bus voltage sensing, battery charge controller (BCC) input current sensing, and primary bus fault clearing through battery bypass diodes. The IPC's control functions are accomplished with pulse commanding and serial commanding through the IPC's master module. Pulse commanding to the IPC is used for primary and redundant bus and charge control selection, primary and redundant serial command decoder selection, connecting and

10. Electrical Power**Figure 10-4. Integrated Power Controller**

disconnecting the battery to the IPC during test, and enabling and disabling the +30 V and +42 V low voltage controller circuits. The IPC employs serial commanding for enabling and disabling the bus voltage limiting (BVL) and battery discharge controller (BDC) circuits of the IPC, enabling and disabling the BCCs, enabling and disabling battery over temperature shutdown, selecting charge rates, and resetting primary bus under voltage latches. Five bus voltage controllers (BVCs) provide primary bus regulation. Two BCCs charge the battery at the commanded charge rate. The master module accomplishes bus voltage control through an error voltage amplifier, which provides a central control signal. During sunlight operation, the bus voltage limiting (BVL) circuits of the BVC regulate the solar array voltage to produce the +53 V spacecraft bus voltage. Based on the master module's central control signal, the BVL circuits will shunt solar array current, bypass solar array current, or actively control solar array power to match the load demand to produce the +53 V bus. Similarly, the central control signal determines whether the BCCs will charge at the commanded charge rate or linearly reduce the charge rate to meet the spacecraft load demand. During eclipse operation, the central control signal will cause the BDC circuits of the BVCs to boost the battery voltage to produce the +53 V spacecraft bus voltage. The +53 V primary bus feeds low voltage controller modules to produce the secondary bus voltages. A +30 V low voltage controller (LVC) is used to produce the +30 V secondary bus, which is regulated at the IPC at +29.4 V to +30.3 V. A +42 V LVC is used to produce the +42 V secondary bus, which is regulated at the IPC at +41.5 to +42.5. The LVC converters can be enabled and disabled individually. Each converter has overvoltage protection and overcurrent protection to shutdown failing circuits. To meet stringent EMI/EMC requirements,

10. Electrical Power

common mode filtering and differential mode filtering are implemented on both the LVC input and output. The LVC input return is isolated from the LVC output return and the LVC chassis. The LVCs provide output voltage and input current telemetry to the spacecraft. Unfused power is delivered from the +30 V LVC and fused and unfused power is delivered from the +42 V LVC. The +42 V LVC delivers its power directly to the instrument loads. Regulated power from the +53 V bus and the +30 V bus is delivered to the power distribution units.

Power Distribution Units

The primary function of the power distribution units is to fuse and distribute +53 V bus and +30 V bus power to their respective loads. The BPDUs fuse and distribute +53 V bus power to the reaction wheels, propulsion transducers, squib driver unit, battery strain gauges, battery bypass reset, and load switch units. The PPDU fuses and distributes +53 V bus power to the telemetry and command RF and communications subsystem components. The BPDUs also fuse and distribute +30 V bus power to the attitude control electronics (ACE 1 & ACE 2), central telemetry and command unit (CTCU 1 & 2), star trackers, magnetometers, and hemispherical inertial reference units (HIRUs). The PPDU fuses and distributes +30 V bus power to the instrument remote telemetry and command unit (IRTCU) and angular displacement sensors (ADSs). Fuses are derated to 50% of their current rating for single fused outputs. For parallel fused outputs, the fuses have been derated to 25% of their current rating. Other key functions of the BPDUs and PPDU are sensing +53 V spacecraft bus current, sensing +53 V heater bus current, and distributing +53 V spacecraft heater power. The BPDUs and PPDU provide fused and switched +53 V heater power to spacecraft bus components. Thirty-six fused and switched heater outputs are provided within each PDU. In each PDU, 30 of the heater outputs are 1-A heater outputs and six are 2-A heater outputs. Primary and redundant serial commanding within each PDU enables individual heater turn-on and turn-off or simultaneous turn-off of all heaters. The PDUs also provide two 1-A relay switched outputs and a battery bypass reset function which are controlled through serial commanding. The BPDUs are shown in Figure 10-5.

Battery Cell Voltage Monitor

The BCVM provides cell voltage telemetry from each individual battery cell to the telemetry and command subsystem for incorporation into the flight telemetry. The cell voltages are sampled each telemetry frame. The BCVM is shown in Figure 10-6.

10. Electrical Power



Figure 10-5. Bus Power Distribution Unit

10. Electrical Power



Figure 10-6. Battery Cell Voltage Monitor

Relay Switches

The EPS includes relay switches that enable unit turn-on/turn-off and the reconfiguration of instrument functions. There are 48 such switches whose magnetic latching relays provide connect and disconnect functions. Each relay provides status telemetry to the telemetry and command subsystem for incorporation into the flight telemetry.

11. Attitude Control

The GOES N-P attitude control subsystem (ACS) provides attitude information and maintains the required spacecraft attitude for all mission phases from launch through end of life. The subsystem consists of redundant microprocessor-based control electronics, sun sensors, earth sensors, star trackers, gyros, reaction wheel assemblies (RWAs), a solar array drive (SAD), and an X-ray positioner (XRP) mechanism. A block diagram of the ACS is shown in Figure 11-1.

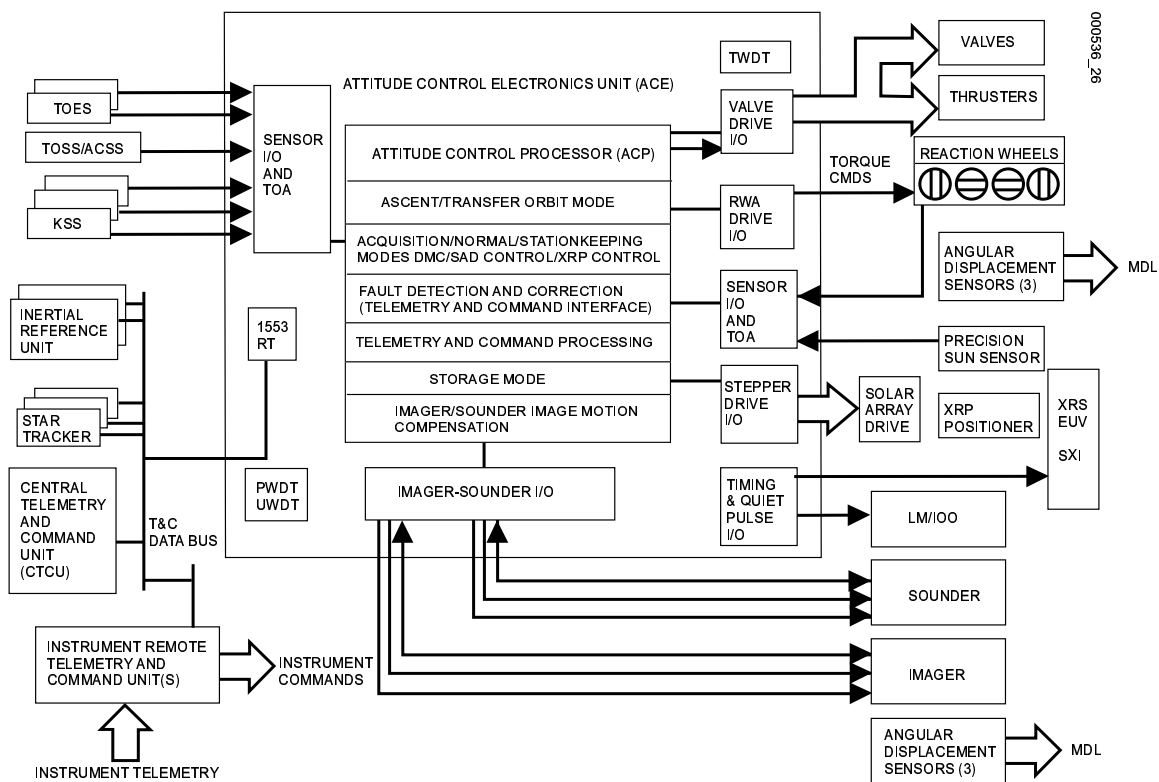

Figure 11-1. GOES Attitude Control Subsystem

11. Attitude Control

Normal on-orbit attitude control operations are based on a zero momentum concept that provides precise pointing for the Imager and Sounder, communications service equipment, and scientific instruments. Bus control is accomplished by applying torque to internal RWAs. The SAD and XRP articulate the suite of scientific instruments mounted on the instrument mounting platform (IMP). Twelve 9.25-N bipropellant thrusters provide attitude control during orbit maneuvers. The ACS during transfer orbit is mostly passive with control applied only during reorientations, spin speed changes, or liquid apogee motor (LAM) burns.

Attitude Control Electronics

The attitude control electronics (ACE) contains electronic circuitry and software to control spacecraft attitude, support battery charge management, maintain bus thermal control, perform fault detection and correction, and interface to the GFE Instruments. The ACE includes a microprocessor that performs attitude data processing and control algorithm calculations to close the loop between the sensors and the actuators. The ACE receives all commands to the subsystem as derived from the central telemetry and command unit, processes them, and coordinates related hardware functions. Most telemetry signals from the ACS are formatted in the ACE.

The various ACE control modes, illustrated in Figure 11-2. Each box in the figure corresponds to an ACE control mode, with the active sensors, actuators, and control algorithms indicated. The transitions between the modes are indicated either by a solid arrow for autonomous transitions or by a dashed arrow for ground-commanded transitions. The GOES mission timeline proceeds generally from the bottom of the figure to the top, which also reflects the use of increasingly sophisticated control algorithms to achieve the high levels of performance required by the GOES mission objectives. In the case of a fault requiring entry into safehold, the ACE will autonomously transition downward into a mode that employs simpler control algorithms consistent with spacecraft health and safety, as is described further below.

The interface electronics portion of the ACE provides appropriate time-of-arrival and analog-to-digital conversion, thruster control, positioner motor control, RWA speed regulation, time tagging, and instrument compensation signals. Analog sensors interfaced directly to the ACE include an infrared Transfer Orbit Earth Sensor [TOES] and several slit sun sensors used for transfer orbit, acquisition, and IMP control (transfer orbit sun sensor [TOSS], acquisition sun sensor [ACSS], and precision sun sensor [PSS]). Hemispherical keyhole sun sensors (KSSs) used to protect the Imager and Sounder and aid acquisition, interface directly to the ACE. A hemispherical inertial reference unit (HIRU) and star trackers (STs) interface with the ACE via the 1553 serial bus on which the ACE is a remote terminal. These various sensors provide attitude and rate data for processing by the ACE. Data from these units are also formatted and telemetered to the ground for mission operational checks of attitude determination performance.

11. Attitude Control

Reaction Wheels

Four wheels provide three-axis torque and momentum storage capability. The wheels are each capable of storing 75 N·m·s of momentum and of providing 0.2 N·m of reactive control torque. Nominal on-orbit operation uses all four wheels in order to provide pointing control.

Solar Array and IMP Positioning

The SAD and XRP positioning mechanisms, which respectively position the solar array and IMP, are used on orbit as a part of the ACS and included within its functional responsibilities. However, neither the SAD nor the XRP is involved in attitude control. The SAD structurally supports the yoke and solar array while articulating the rotation of the array about the spacecraft pitch axis, thus maintaining commanded sun pointing of the array and IMP. The SAD transfers power, control, and telemetry signals across slip rings at the rotary interface. The XRP structurally supports the instrument mounting platform (IMP) and rotates the IMP about an axis that is nominally perpendicular to both the array normal and the spacecraft pitch axis, thereby maintaining commanded sun pointing of the IMP.

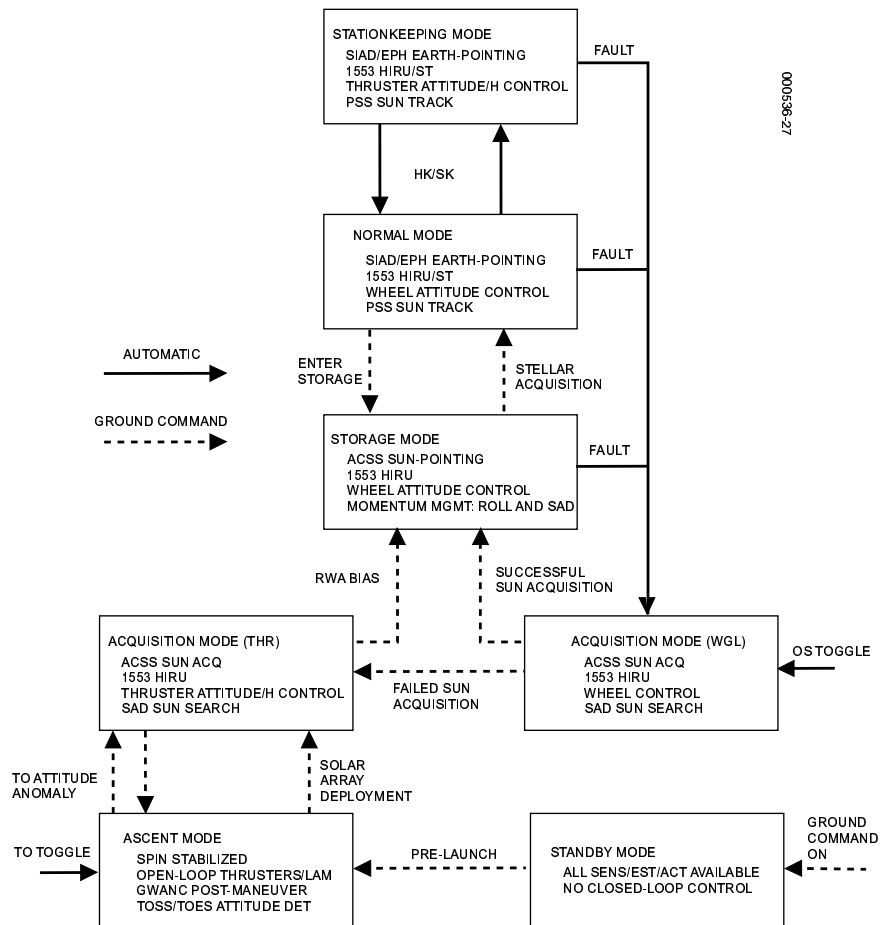

Figure 11-2. GOES Attitude Control Electronics Operational Modes

11. Attitude Control

Image and Dynamic Motion Compensation Support

The ACE provides compensation signals to the Imager and Sounder. These signals are made up of dynamic motion compensation (DMC) and image motion compensation (IMC). DMC provides a compensation signal to the Imager and Sounder servos based on processed attitude information from the HIRU and STs. DMC is able to compensate for disturbances that exceed the dynamic range of the bus attitude controller, allowing for highly accurate Imager and Sounder pointing that would not be possible using the bus controller alone. The IMC signal is generated from ground uploaded coefficients that represent orbit and instrument attitude profiles observed by the ground. The DMC and IMC signals support the image navigation and registration (INR) function.

Space Environment Monitor Support

The ACS supports the space environment monitor (SEM) payload. The SAD and XRP steer the IMP located on the solar array yoke to support SEM equipment dedicated to solar studies. To maintain sun pointing throughout the seasons, the IMP contains a yoke-mounted PSS that provides the ACE with sun pointing measurements necessary to derive closed-loop stepping profiles for the SAD and XRP. The SAD and XRP in turn move the IMP in east-west (azimuth) and north-south (declination) directions to track the sun, pausing every minute to provide a stable imaging environment for the Solar X-ray Imager (SXI). Upon ground command, the ACE can command the SAD or XRP to slew the IMP to any azimuth or declination position $\pm 25^\circ$ of the sun to facilitate instrument calibrations and/or background measurements.

Safehold: Sun Acquisition Mode

Sun Acquisition Mode (AQM) is the ACE-control mode that puts the spacecraft into a safe-hold configuration (i.e. a power/thermal-safe attitude). AQM may be either manually commanded or autonomously commanded by the on-board fault protection logic. While AQM is designed to place the spacecraft in a safe state without the use of thrusters, it may also be ground-commanded to use thrusters, as in the initial post-deployment acquisition sequence. The spacecraft can safely remain in AQM for up to 2 days without operator intervention, at which time the spacecraft should be transitioned into Storage Mode, as described below.

Except for the initial sun acquisition, AQM is invoked when the spacecraft loses stellar inertial attitude control or detects a situation that might endanger the spacecraft or spacecraft components. AQM is capable of controlling the spacecraft to attain and hold a sun-pointing attitude, and furthermore guarantees the safety of the primary imaging payload for a broad set of initial attitudes and rates. The fault protection design ensures that no anomaly, including an operator error in combination with a single latent failure, can cause the spacecraft to acquire a combination of attitude and rate that is unsafe for the payload. Using the output of the KSSs and ACSS in conjunction with control provided by the reaction wheels, AQM orients the spacecraft pitch axis perpendicular to the sun and places the sun midway between the spacecraft roll and minus yaw axes (see Figure 2-3). During the process of sun acquisition, but after the spacecraft is brought to a

11. Attitude Control

safe sun attitude with respect to instrument coolers, the solar array is slewed to face the sun while the spacecraft is simultaneously brought to a final safe sun attitude. In steady-state operation, the AQM rotates the spacecraft about the sun line in order to provide thermal, power, and attitude safety, as well as maximum telemetry and command access. Unlike STM, however, AQM does not control spacecraft momentum through periodic adjustments to the spacecraft sun-line rotation rate and solar array offset from sun normal.

Storage Mode

Storage Mode (STM) ensures spacecraft health and safety for long periods of time by providing autonomous momentum management in addition to sufficient solar array power and a safe/stable thermal environment. The spacecraft configuration in STM is equivalent to AQM. Placing the spacecraft in STM following an anomaly will provide extended periods of time for a technical response. STM is normally used for vehicle storage, autonomously controlling spacecraft momentum through periodic adjustments to the spacecraft sun-line rotation rate, and solar array offset from sun normal.

Stellar Inertial Attitude Determination (SIAD)

The attitude determination module in the ACP combines the measurements from the star trackers and HIRU to produce a precise on-board estimate of spacecraft attitude necessary to support the stringent INR requirements. The module uses HIRU rates corrected by computed error residuals. The module processes both HIRU data, and star position data to produce an optimal estimate of the spacecraft attitude.

The stars in the tracker FOV are identified by matching position and magnitude with stars in the on-board catalog. The star catalog is optimized to provide adequate brightness and spatial separation to ensure sufficient stars are available during operations. Updates to the star catalog may be uploaded to the ACE as required.

11. Attitude Control

This page left blank.

12. Propulsion

The GOES N-P propulsion subsystem provides the means for attitude control and the incremental velocities at apogee and perigee required for final injection into geostationary orbit. This is a bipropellant propulsion system consisting of one 490 N (110 lbf) liquid apogee motor (LAM) and twelve 9.25 N (2 lbf) low thrust thrusters (LTT) for attitude control. Monomethylhydrazine (MMH) is the fuel, and nitrogen tetroxide (NTO/MON-3) is the oxidizer. These hypergolic propellants are contained in four spherical tanks pressurized by helium (He) supplied from two cylindrical tanks. In-line filters are used to filter the pressurant and propellants. The propellants and pressurant are loaded into the propulsion subsystem through several fill and drain valves. These valves also allow offloading if necessary. Check valves are used upstream of the propellant tanks to mitigate propellant vapor migration into the pressurant tanks. A block diagram of the propulsion subsystem is given in Figure 12-1. Figure 12-2 illustrates various GOES propulsion subsystem components.

The 490 N thruster is a restartable unit designed for multiple transfer orbit firings. The 9.25 N thrusters provide attitude control during apogee thruster firing, stationkeeping, and on-orbit control throughout the mission.

After the orbit transfer maneuvers are completed, squib valves are fired isolating the high pressure portion of the subsystem, and the propulsion subsystem is operated in a blow-down mode for the remainder of the mission. Pressure transducers are used to monitor the pressure in the subsystem. A propellant management device (PMD) in each propellant tank controls the location of propellant in the zero-gravity space environment. This device enables gas-free propellant to be supplied to the tank outlet for all thruster firings throughout the spacecraft's operational life. Latch valves are located at the exit of each propellant tank to isolate the tanks during extended periods of nonuse and to control the spacecraft center of mass movement.

All GOES propulsion subsystem components have extensive Boeing Satellite Systems flight heritage. The GOES spacecraft is based on the Boeing 601 design.

12. Propulsion

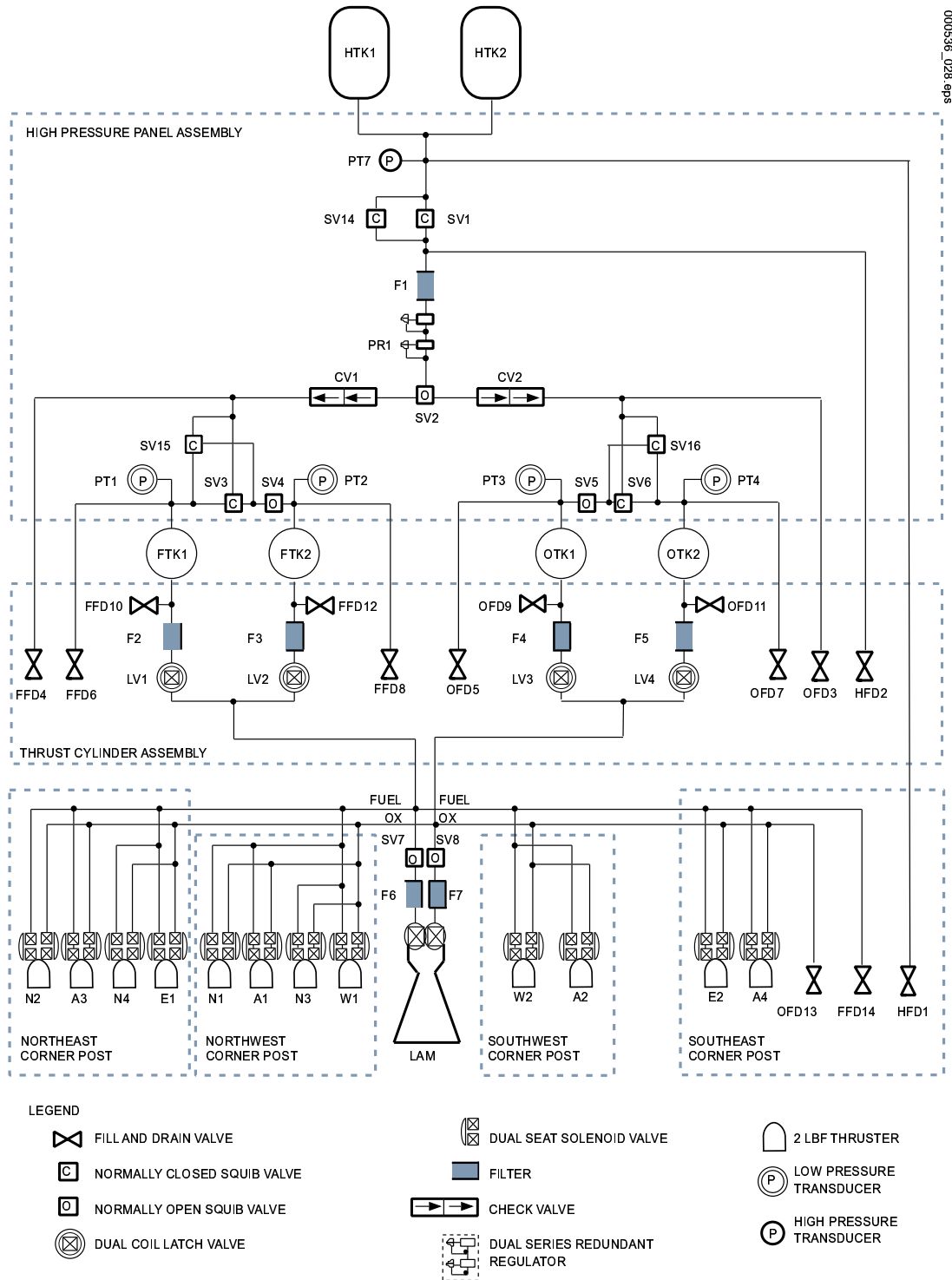

Figure 12-1. GOES Propulsion Subsystem

12. Propulsion



a) 490 NEWTON THRUSTERS



b) IN-LINE FUEL FILTER

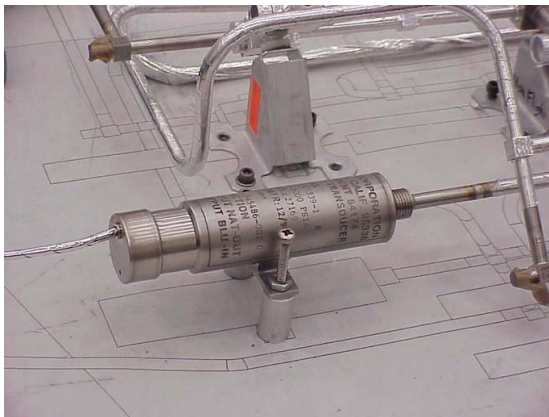

c) PRESSURE TRANSDUCER

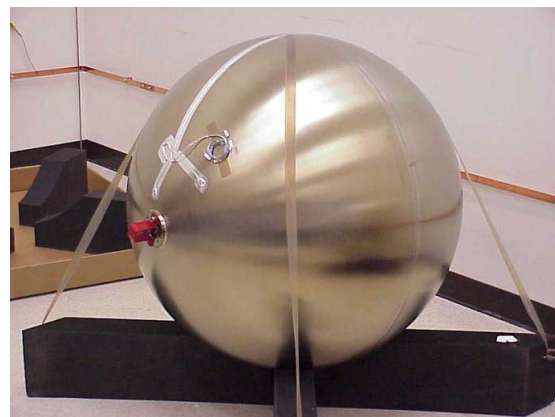

d) PROPELLANT TANK



e) 9.25 NEWTON THRUSTERS

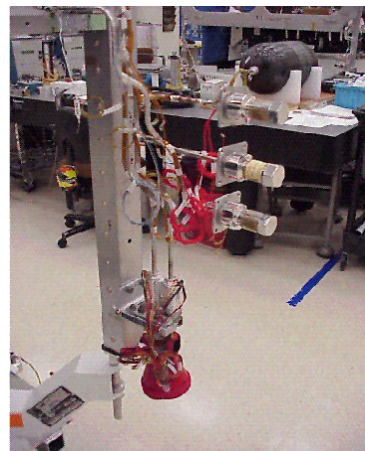

f) VARIOUS PROPULSION SUBSYSTEM COMPONENTS, INCLUDING HELIUM TANK (REAR RIGHT), FILL AND DRAIN VALVES (BOTTOM MIDDLE RIGHT), AND 9.25 N THRUSTER (BOTTOM CENTER)

Figure 12-2. Various GOES Propulsion Subsystem Components

12. Propulsion

The 9.25 N attitude control thrusters perform control operations required in geostationary orbit throughout the mission. These operations include:

- Sun acquisition and attitude maintenance
- Earth acquisition
- Momentum wheel spinup control
- Apogee dispersion correction
- North-south stationkeeping
- East-west stationkeeping
- On-orbit attitude control operations
- Station change (relocation in geostationary orbit)
- De-orbit at end of life

13. Thermal Control

The GOES N-P thermal control subsystem is designed to ensure that thermal requirements are met for all mission phases from launch to end of life. The GOES spacecraft uses Boeing 601 heritage techniques such as heat pipes, mirrors, multilayer insulation (MLI) blankets, and heaters to accommodate variations in spacecraft configuration, environmental heat loads, and degradation of materials to meet these requirements. The thermal features of GOES N-P are shown in Figure 13-1 for the stowed configuration and Figure 13-2 for the deployed operational configuration. An expanded view of the overall operational GOES spacecraft thermal features is shown in Figure 13-3.

Fixed conductance heat pipes, embedded in the honeycomb panels and bolted between the payload radiator and subnadir panel provide both heat transfer to the external radiators and heat spreading along the radiator panels. To provide additional heat spreading for some of the units, including the high power solid-state power amplifiers (SSPAs) and the transponder, thermal doublers are bonded under the units to the honeycomb panel interior surface. The east, west, nadir, and aft panels are blanketed to minimize daily diurnal temperature changes and maintain the spacecraft cavity within acceptable temperature ranges. The payload and bus radiator panels are oriented north and south to minimize direct solar heating. The bus radiator is also blanketed in portions to maintain internal temperatures on-orbit and during transfer orbit. All exterior radiator surfaces are covered with optical solar reflectors (OSR). Most units and all internal panels are painted black to maximize radiation heat transfer internally to the radiator panels. The integrated power controller (IPC) unit is mostly blanketed internally to thermally decouple the unit from the bus cavity to improve system thermal performance during transfer orbit conditions and minimize bus cavity environmental effects on-orbit. The reaction wheel assemblies (RWAs) are mounted external to the spacecraft near the bus panel. The RWAs dissipate heat primarily by conduction to an extension in the payload radiator panel. The subnadir shelf, which is passively coupled to the Imager/Sounder mounting plate through radiation, provides thermal control for the mounting of the Imager and Sounder electronic suites.

Active heaters (mostly controlled by the ACE) are installed for components that cannot maintain their minimum temperature requirements with only passive designs. This provides flexibility and power optimization by having multiple set points for various spacecraft configurations including transfer orbit, storage, and on-orbit. In addition, the ACE autonomously reconfigures the heaters during entry into Safehold Mode. These heaters

13. Thermal Control

are fully redundant and can be reprogrammed while on-orbit. In addition, there are electronically controlled heaters with fixed set points for several of the propulsion zones and all heaters on the yoke assembly. These heaters are fully redundant and are commandable on/off through mechanical relays. Most of the heaters are patch heaters, which are designed to meet the low magnetic dipole requirements of the magnetometer sensors. The heaters are mounted to the spacecraft panels or components as required. Extremely low magnetic heaters are used to maintain temperatures of the magnetometer sensors on the boom assembly.

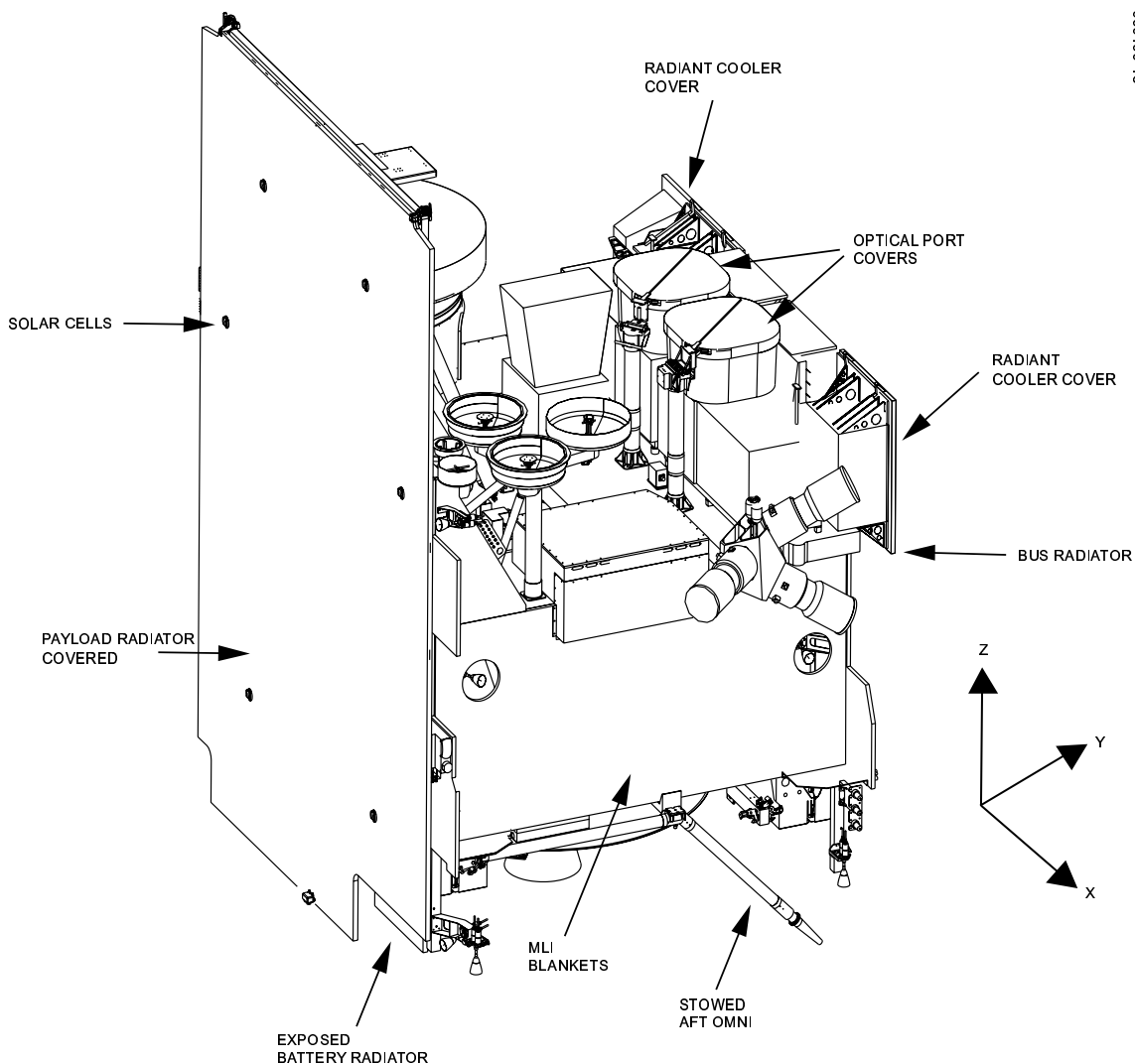

050190-16

Figure 13-1. GOES Thermal Control Features (Stowed Configuration)

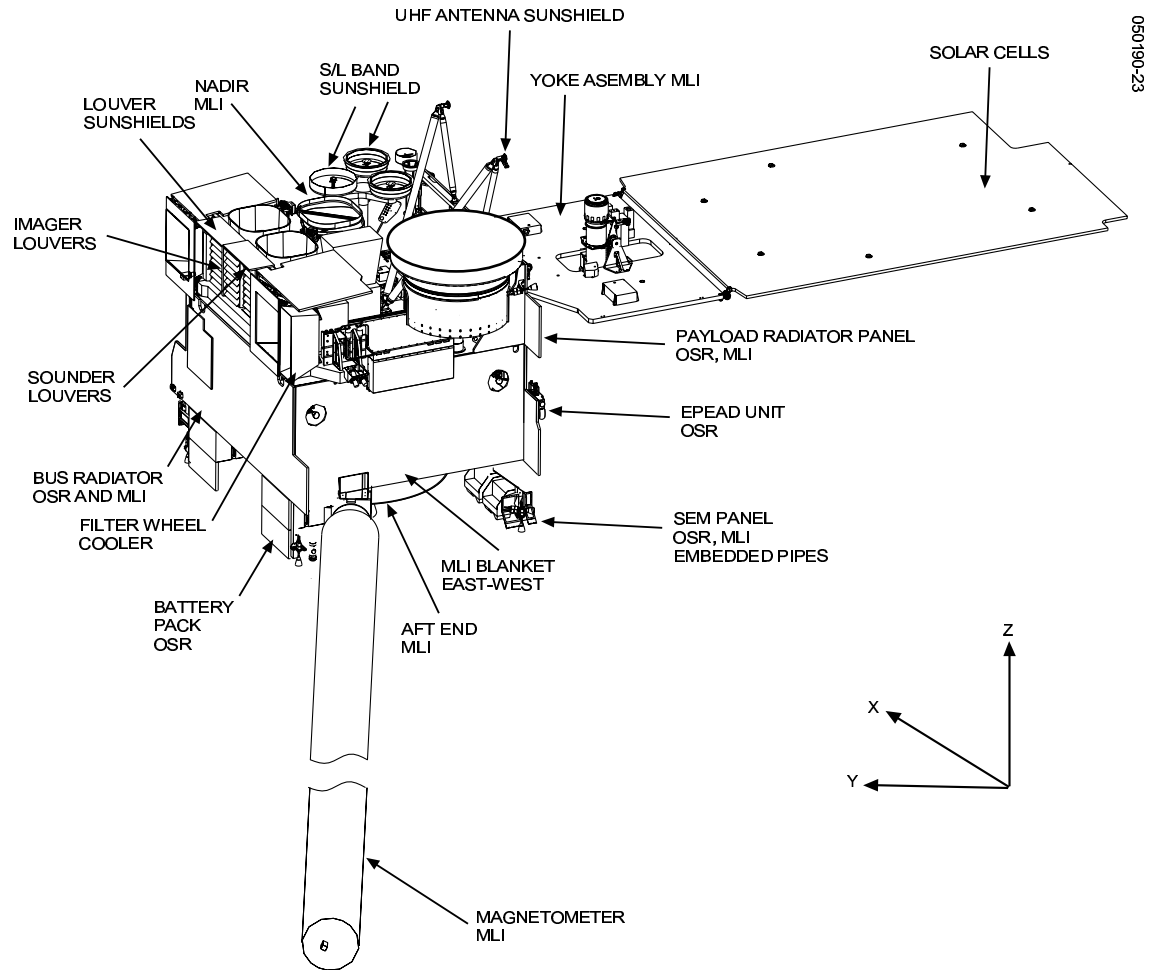

Figure 13-2. GOES Thermal Control Features (Deployed Configuration)

13. Thermal Control

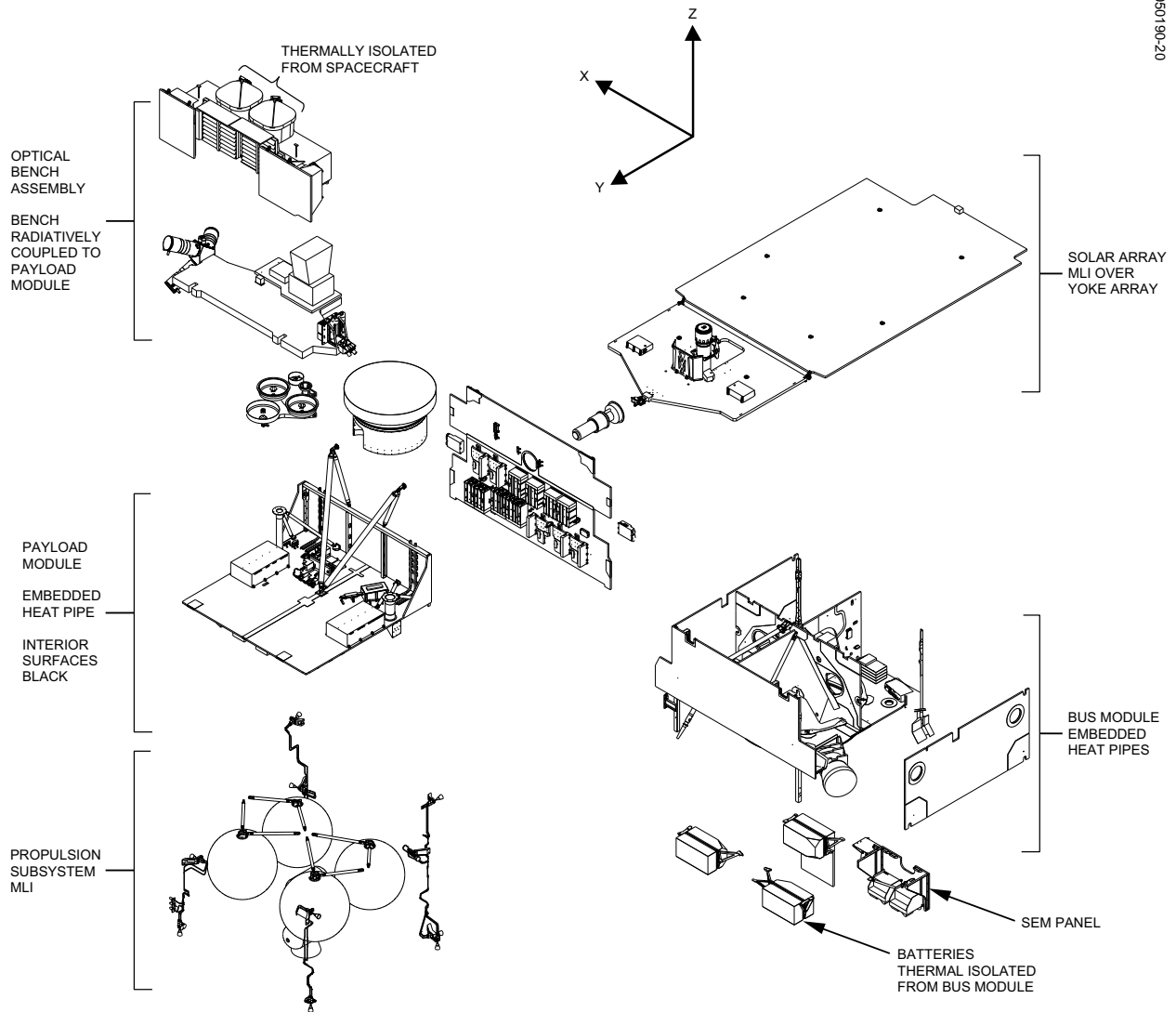

Figure 13-3. Expanded Overview of the GOES Spacecraft

Looped heat pipes are used to transport heat from the hemispherical inertial reference unit and star tracker assemblies to the external radiators. These pipes can be easily formed in multiple planes to accommodate difficult routing paths. In addition, to meet instrument requirements, the star tracker assembly is actively temperature controlled using the looped heat pipes with the ACE controlled heaters.

13. Thermal Control

A majority of the space environment monitor (SEM) units are mounted external to the bus cavity and are thermally isolated from the main spacecraft cavity. These instruments use the same thermal techniques as the spacecraft bus, including mirrored radiator panels with embedded heat pipes and heaters. Both magnetometers on the boom are completely blanketed and use an active heater control system to maintain acceptable temperatures. Two SEM units—the magnetospheric electron detector (MAGED) and magnetospheric proton detector (MAGPD)—are blanketed to minimize aft solar load on the instrument through the viewing port and are supplemented with heaters during no solar load conditions.

The batteries are mounted aft of the bus panel and are thermally isolated from the bus spacecraft cavity. They maintain their own temperature environment using both a mirrored radiator and spacecraft heater control.

The yoke panel, which tracks the sun along with the solar panel, uses blankets, heaters, and radiation through the anti-sun side to maintain the unit's thermal environment. The x-ray sensor/extreme ultraviolet sensor (XRS/EUV) uses an anti-sun facing radiator connected with heat pipes to the unit to dissipate heat. The heaters are mounted on the yoke panel and the gimbal assembly to maintain temperatures for the Solar X-ray Imager suite.

The spacecraft uses temperature telemetry to monitor the spacecraft's state of health, which is downlinked, as well as to provide data onboard the ACE for heater control. Two types of temperature sensors are used—thermistors and platinum resistors. The platinum resistors are used in applications requiring a large operational range, such as the solar panel or thrusters. Thermistors are used in all other applications, which have a narrower temperature range between -40°C and 70°C. Temperature sensors are located within or on units and on the spacecraft structure as required.

Imager and Sounder Thermal Control

The Imager and Sounder instruments are mounted on flexures on a nadir facing mounting plate. As shown in Figures 13-4 and 13-5, the optical and radiometric performance of the Imager and Sounder are maintained throughout the 24-hour orbit by a combination of louver cooling and electrical heating. Thermal control is divided into two primary areas: sensor module and detector radiant cooler assembly. First is thermal control for the sensor module as defined by the scan mirror and telescope assembly along with the Imager/Sounder mounting plate or telescope baseplate and all structural sidewalls. Second is thermal design of the detector radiant cooler assembly (and the filter wheel cooler assembly for the Sounder). These are treated separately from the first in as much as these two assemblies are intended to be adiabatic (thermally isolated) from the rest of the instrument; the thermal performance of one has little or no effect on the other.

13. Thermal Control

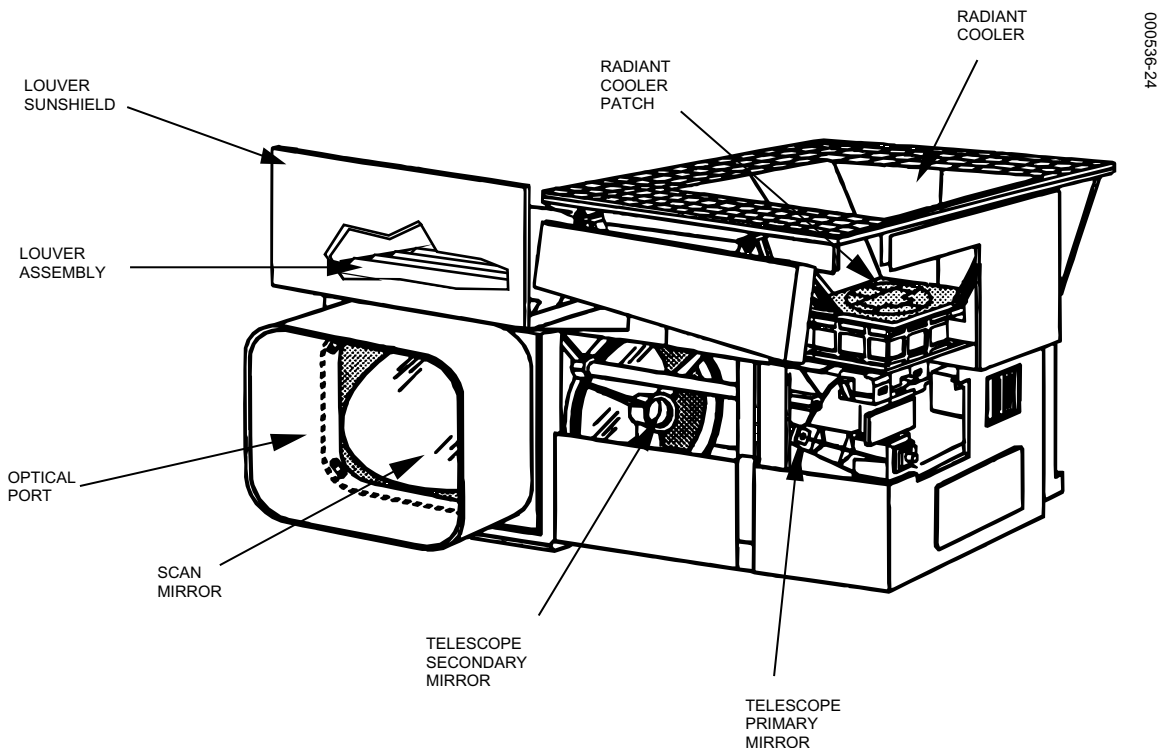

Figure 13-4. Imager Instrument Thermal Characteristics

Optical performance is maintained by restricting the total temperature range. Radiometric performance is maintained by limiting the temperature change between views of cold space (rate of change in temperature). Thermal control also contributes to channel registration and focus stability.

The basic thermal design concepts include:

- Maintaining the instrument sensor modules as adiabatic as possible from the rest of the spacecraft structure.
- Controlling the temperature during the hot part of the synchronous orbit diurnal cycle (when direct solar heating is received into the scanner aperture) with a north-facing radiator whose net energy rejection capability is controlled by a louver system.
- Providing makeup heaters within the sensor modules to replace the thermal energy lost to space through the scanner aperture during the cold portion of the diurnal cycle.

13. Thermal Control

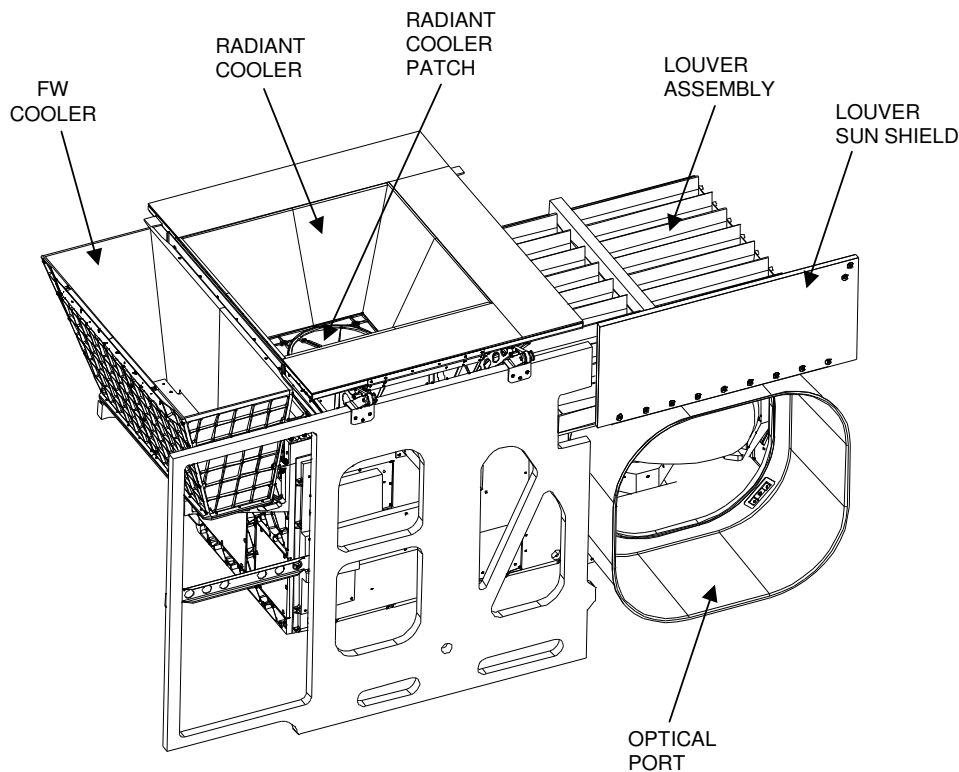

Figure 13-5. Sounder Instrument Thermal Characteristics

Additionally, a sun shield is provided around the scan aperture (just outside the instrument field of view) to block incident solar radiation into the instruments, thus limiting the time in a synchronous orbit day when the scanner can receive direct solar energy. Uncontrolled temperature variations are reduced by the sun shield around the scan cavity opening, a passive automatic louver-controlled cooling surface, and electrical heating. Electrical heat decreases temperature excursions during the cold part of the daily cycle, but increases the average temperature. To obtain lower temperature ranges, louver-controlled cooling is provided during the direct sunlight portion of the orbit. A sun shield is installed on the earth end of the louver system to reduce incident radiation.

MLI blankets are applied on the outside of all but the north side of the instruments. The covers over the radiant coolers and the optical ports are designed to provide thermal protection of the radiant cooler patch, and reduce heater power during transfer orbit. These covers have MLI blankets on both sides and are deployed onto the nadir face after reaching synchronous orbit.

13. Thermal Control

This page left blank.

14. Deployment Mechanisms and Structures

The GOES N-P spacecraft contains seven appendages and mechanisms that are stowed for launch and later deployed during transfer orbit or at various phases of on orbit testing. These deployable mechanisms and appendages are:

- Deployable aft blanket (DAB)
- Aft omni antenna
- Optical port covers
- Instrument radiant cooler covers
- Magnetometer boom
- Solar array
- X-ray positioner (XRP)

Each deployment is initiated by pyrotechnically driven bolt cutters or pin pullers. Each bolt cutter contains a redundant initiator and cutting anvil. Each pin puller contains redundant initiators that fire into a common chamber. The bolt cutters cut a tensioned bolt, which is retracted, into a bolt catcher. These deployments occur at three phases during the GOES mission.

- Immediately after separation from the launch vehicle, the DAB is deployed.
- On approximately day 19, the solar array is deployed. This is followed by release of the XRP and magnetometer boom deployment on days 20 and 21.
- The final set of deployments occurs after approximately 14 days of outgassing on orbit. The first of these deployments are the optical port covers. Deployment of the instrument radiant cooler covers follows approximately 14 days later.

14. Deployment Mechanisms and Structures

Deployable Aft Blanket

The DAB should be viewed as a pair of blankets with a launch lock rather than as a mechanism. The DAB consists of two semi-circular blankets that close out the aft section of the spacecraft. The blanket is held against the thrust cylinder by battens. The battens act as stiffeners that hold the blanket in the deployed position. When stowed, the battens are curved such that the restraining cords along the perimeter of the DAB reach the launch lock.

Aft Omni Antenna

The aft omni antenna is shown in Figure 14-1. The aft omni assembly consists of two tubes bonded and bolted into two fittings. The omni antenna is mounted to the end of the assembly. When deployed, the aft omni provides omni antenna coverage throughout transfer orbit.

Optical Port Covers

The optical port covers are two separate deployable covers that protect the imaging port of the Imager and Sounder prior to deployment. The port covers serve two purposes. First, the optical port is protected against falling debris during the launch and ascent phase of the mission. Secondly, the covers serve to limit heat loss through the optical ports during transfer orbit. Increased heater power would otherwise be required during

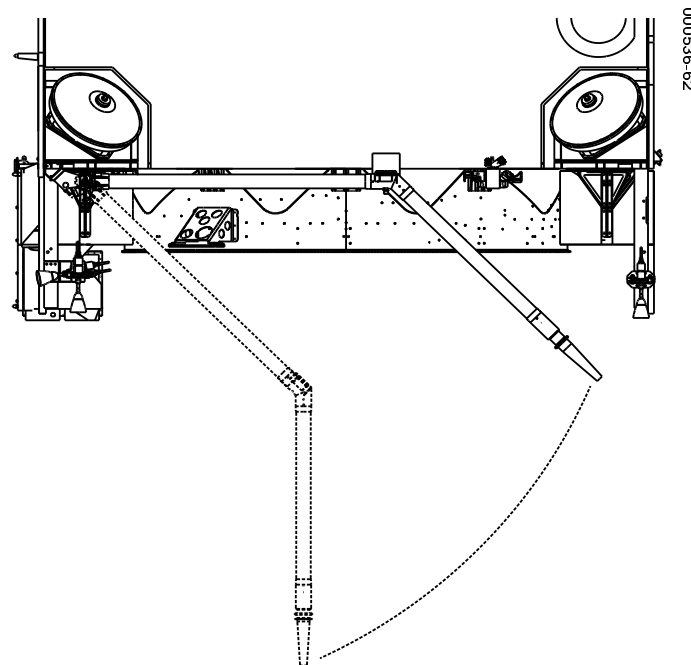

Figure 14-1. GOES Aft Omni Antenna

14. Deployment Mechanisms and Structures

transfer orbit. The optical port covers are deployed pyrotechnically using a bolt cutter. On command, the bolt cutter cuts a tensioned bolt that allows the hinge mechanism to rotate approximately 270° as shown in Figure 14-2. Each cover is deployed separately. Nominally the Sounder port cover is deployed first followed several seconds later by the Imager cover. Both bolt cutters contain redundant initiators in the event of a failure of the primary. Field of view analysis has been done with the covers deployed out of order (Imager first.) That analysis shows that the sensor field of view requirements are met in either configuration as shown in Figure 14-3. The location of the optical port covers on the Imager/Sounder mounting plate is shown in Figure 14-4.

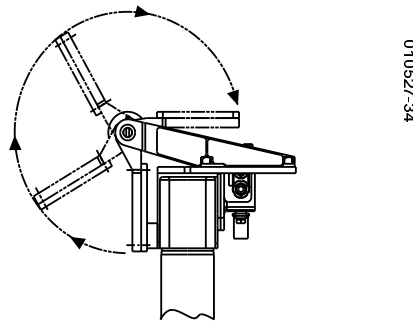

Figure 14-2. Optical Port Cover Deployment

Instrument Radiant Cooler Covers

There are two covers integral to the Imager and Sounder. Each instrument contains the release device, restraint cable, and hinge mechanism. The radiant cooler covers are deployed during in orbit testing after the initial outgassing period. The cooler covers perform the following functions:

- Protect the infrared detectors from being heated by direct sunlight during the launch and orbit raising period.
- Protect the radiant coolers and emitters from contamination during launch and orbit raising period.
- Reduce outgas heater power requirements at acquisition of geosynchronous orbit.

Figure 14-5 shows the Imager or Sounder instrument with the cover in the closed position.

14. Deployment Mechanisms and Structures

Magnetometer Boom

The magnetometer boom is a coilable truss element that is contained within a canister during launch and orbit raising. The deployed magnetometer boom is 8.5 meters long and contains two magnetometer sensors that are approximately 0.8 meters apart. The magnetometer boom is restrained by a pyrotechnic pin puller. The stored strain energy in the coiled boom elements provides the energy required to deploy the boom. Deployment speed is regulated by a friction damper that acts as a brake.

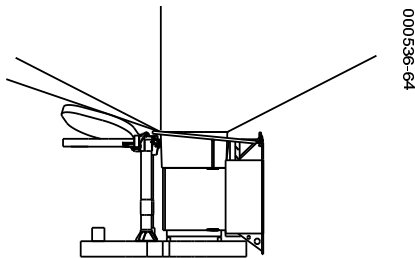

Figure 14-3. Imager and Sounder FOV requirements are met after the optical port cover is deployed.

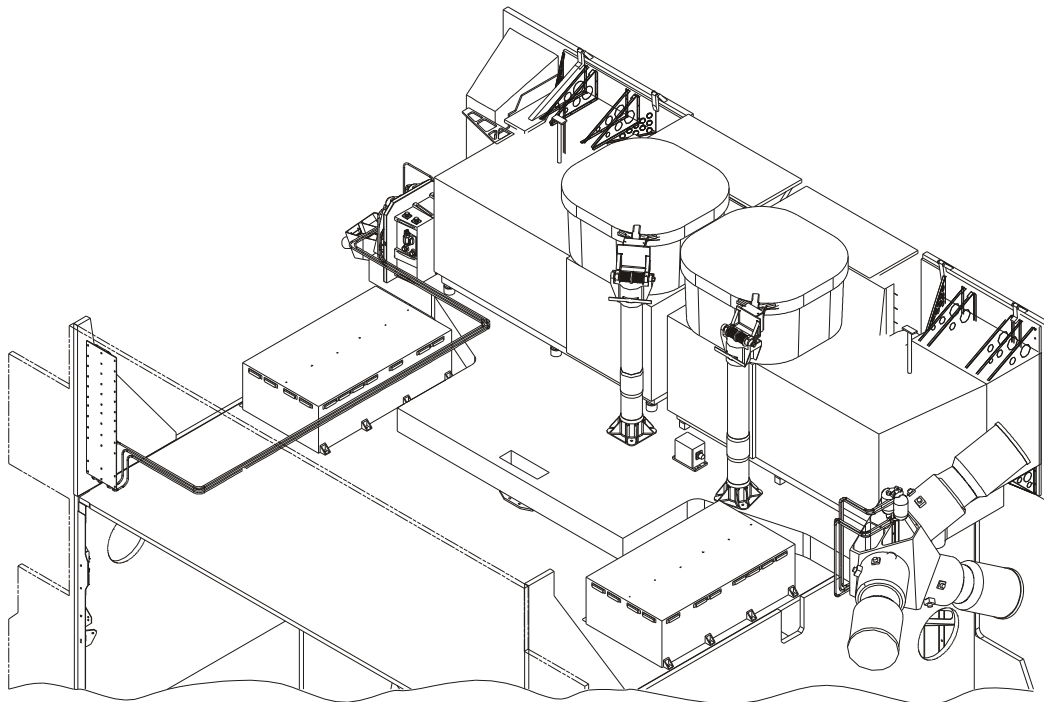

Figure 14-4. a) Optical Port Cover Locations—Stowed Configuration

14. Deployment Mechanisms and Structures

Solar Array

The GOES N-P solar array comprises two elements. The solar panel contains most of the solar cells that power the spacecraft. The solar array yoke serves as a platform for the solar observatory containing the SXI and XRS/EUV instruments as well as a precision sun sensor and angular displacement sensor. During launch, the solar array is restrained by six launch locks. Figure 14-6 shows both solar array elements. The solar array mates to the solar array drive through a 90° viscously damped hinge mechanism called the solar array actuator.

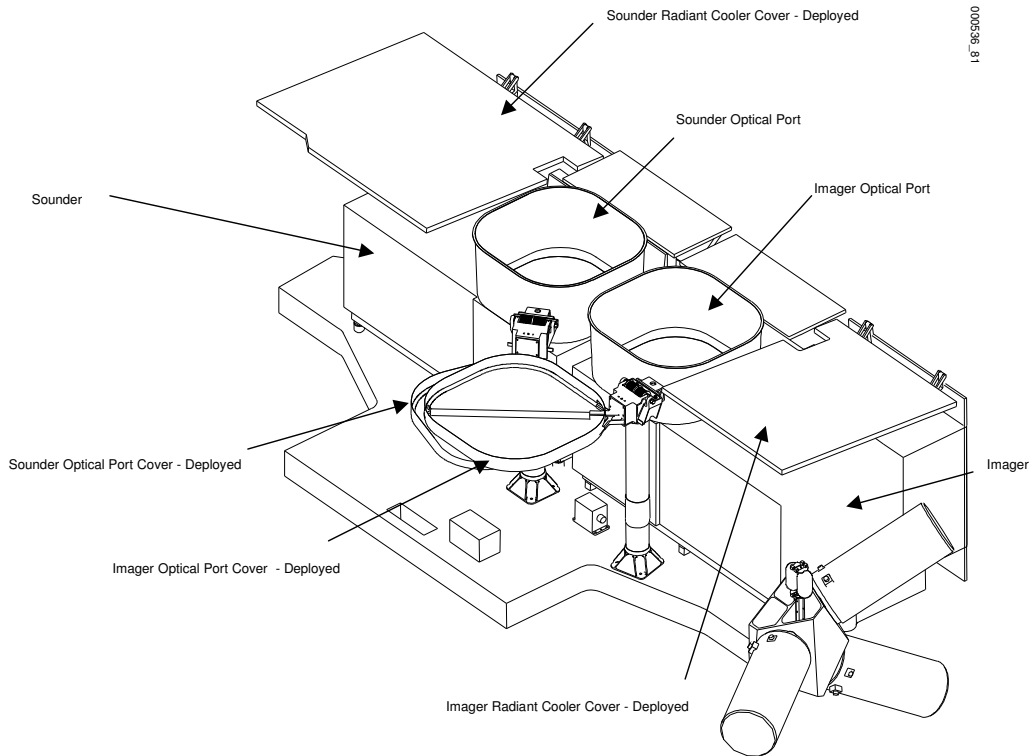

Figure 14-4. b) Optical Port Cover Locations—Operationally Deployed

14. Deployment Mechanisms and Structures

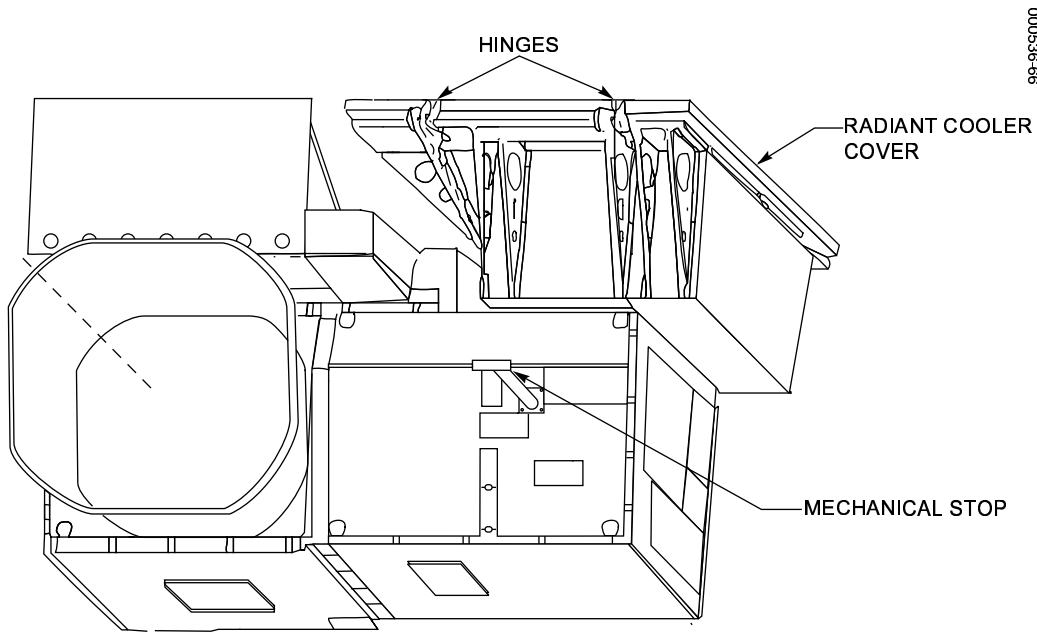

Figure 14-5. Instrument in Closed Position

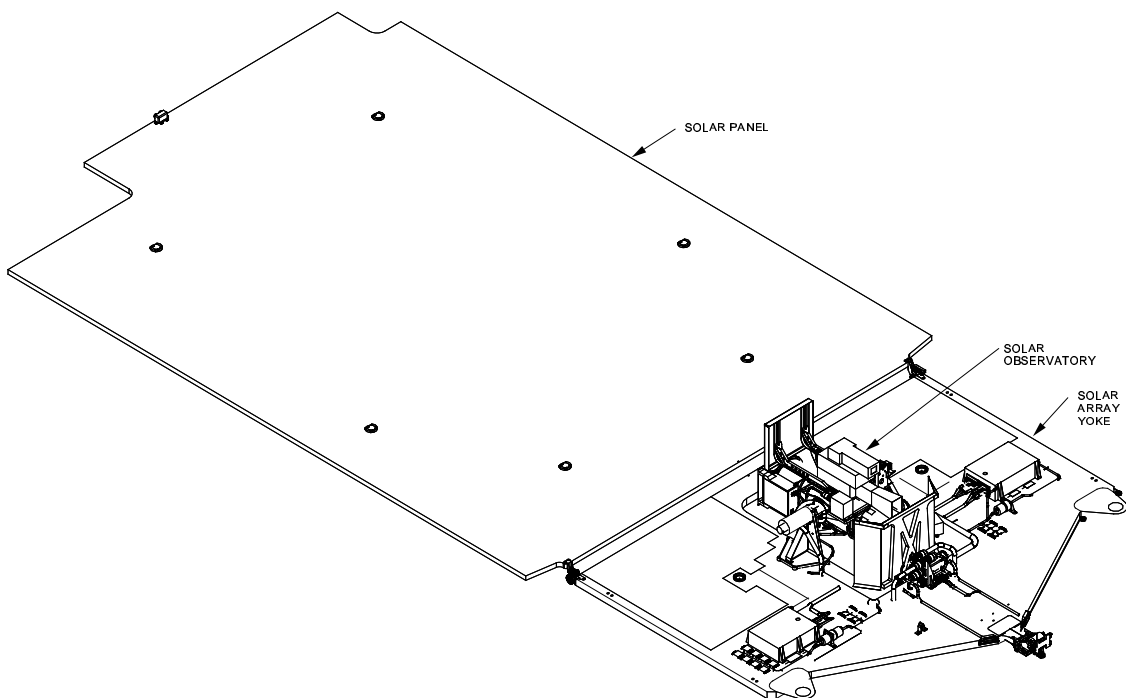

Figure 14-6. Elements of the GOES Solar Array

14. Deployment Mechanisms and Structures

The solar array is released by firing six pyrotechnic bolt cutters. The bolt cutters are fired in pairs. The top pair is fired first followed by the bottom pair, then the center pair. Solar array motion is initiated by push off springs located at each of the six launch lock locations. The spring forces separation of the panel and yoke from the spacecraft. After release of the launch locks, the solar array actuator deploys the solar array through a 90° angle and latches it in place. The two hinges located at the panel to yoke interface rotate 180° and latch. Coordination of the motion of the actuator, yoke, and panel is maintained by a coordination cable that connects the hinge in the solar array actuator to the hinge line at the yoke to panel interface.

X-ray Positioner

The XRP, shown in Figure 14-7, is a single axis closed loop control gimbal that rotates to maintain SXI pointing accuracy. The XRP rotates the entire solar observatory suite consisting of the SXI telescope, the XRS/EUV instrument, angular displacement sensor, and a precision sun sensor.

The XRP is locked during ascent and transfer orbit with two pyrotechnic pin pullers. One pin puller is located on each half of the XRP. When fired, the pin is retracted, releasing each half of the mechanism. Release is confirmed using motor current measurements. The XRP launch locks are fired after the solar array is deployed on station prior to the initial outgassing period.

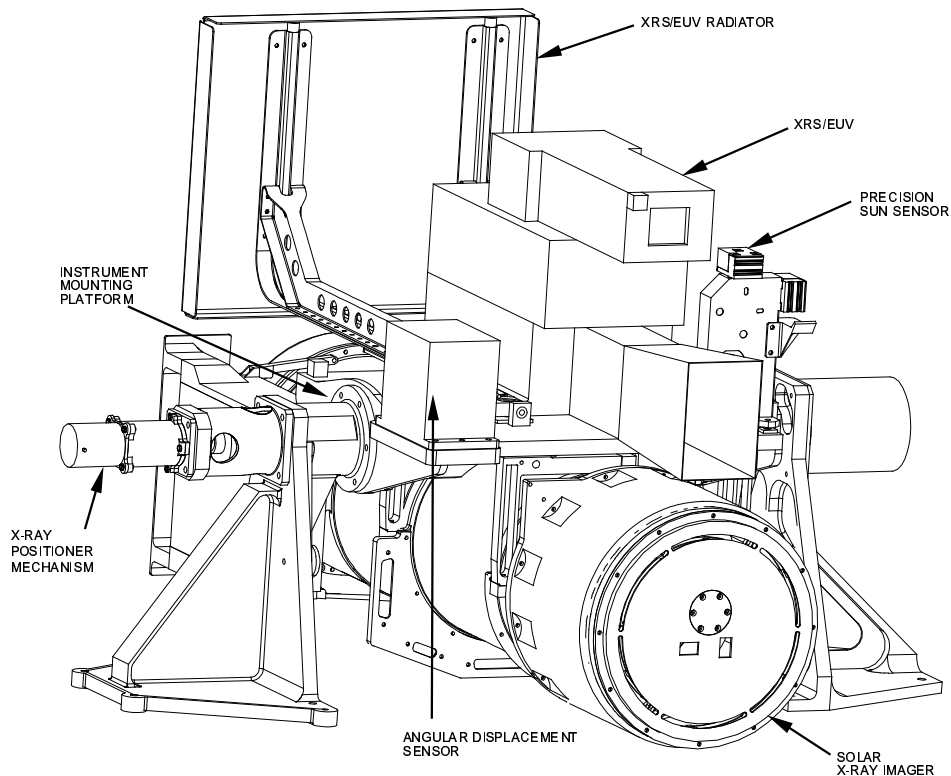

Figure 14-7. X-ray Positioner Mechanism

14. Deployment Mechanisms and Structures

Structure Subsystem

The GOES N-P spacecraft structure is based on the Boeing 601. The structure consists of honeycomb structural panels, which form a box. The honeycomb panels are mounted to corner posts that serve as primary load carrying elements to react to launch loads through the structure. Internal struts and stiffeners provide additional stiffness. An Imager/Sounder mounting plate, optical bench, is mounted on top of the box and also carries star trackers and the inertial reference unit. The Imager/Sounder mounting plate is thermally isolated from the spacecraft in order to limit the impact of spacecraft temperature changes on the Imager and Sounder performance. The spacecraft structure is optimized for weight efficiency. The entire structure is mounted on an adapter ring that provides a mating interface to the launch vehicle. The spacecraft primary structure is shown in Figure 14-8.

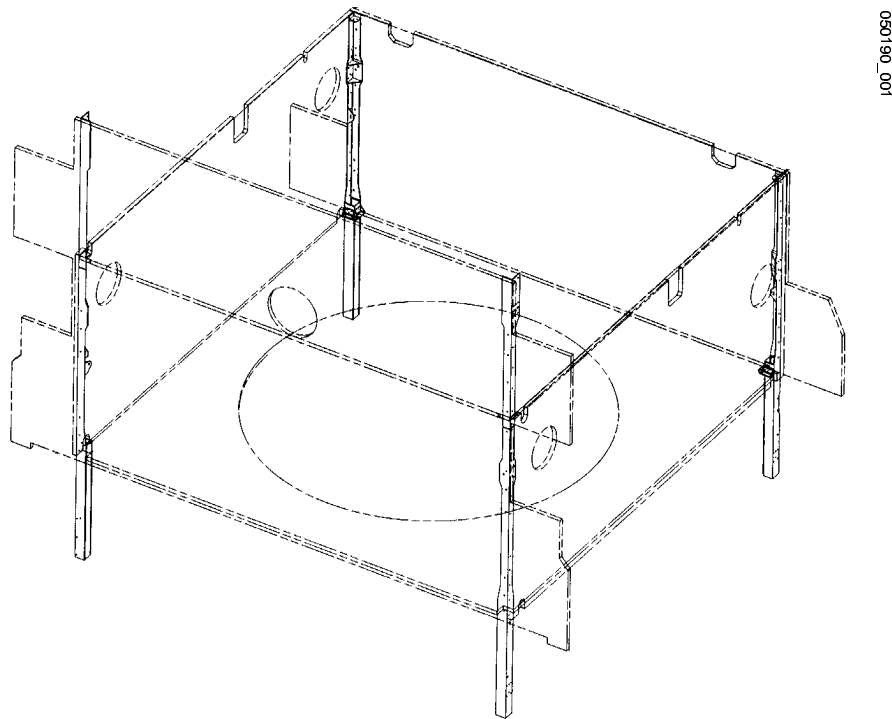

Figure 14-8. Spacecraft Primary Structure

15. Spacecraft Support Ground System

The GOES N-P spacecraft support ground system (SSGS)

- Generates spacecraft commands for uplink
- Processes telemetry downlinks, instrument data downlinks, and multi-use data link (MDL) data
- Generates the GOES variable (GVAR) data uplink to the spacecraft
- Determines the spacecraft orbit and attitude using star look, range, and landmark data
- Provides stationkeeping maneuver planning tools
- Monitors GVAR data broadcast quality.

The SSGS comprises seven elements:

- N-Q telemetry acquisition and command transmission system (NTACTS)
- GOES N-Q telemetry and command system (GTACS)
- Orbit and attitude tracking system (OATS)
- MDL receive system and server (MRS&S)
- Dynamic interaction diagnostic (DID)
- Sensor processing system (SPS)
- Product monitor (PM).

As shown in Figures 15-1 and 15-2, the GOES SSGS equipment resides at National Oceanic and Atmospheric Administration (NOAA) facilities at the locations below:

- Satellite Operations Control Center (SOCC) in Suitland, MD
- Wallops Command and Data Acquisition Station (CDAS) in Wallops, VA
- Wallops Backup (WBU) at the Goddard Space Flight Center (GSFC) in Greenbelt, MD, capable of supporting one GOES satellite
- Space Environmental Center (SEC) in Boulder, CO.

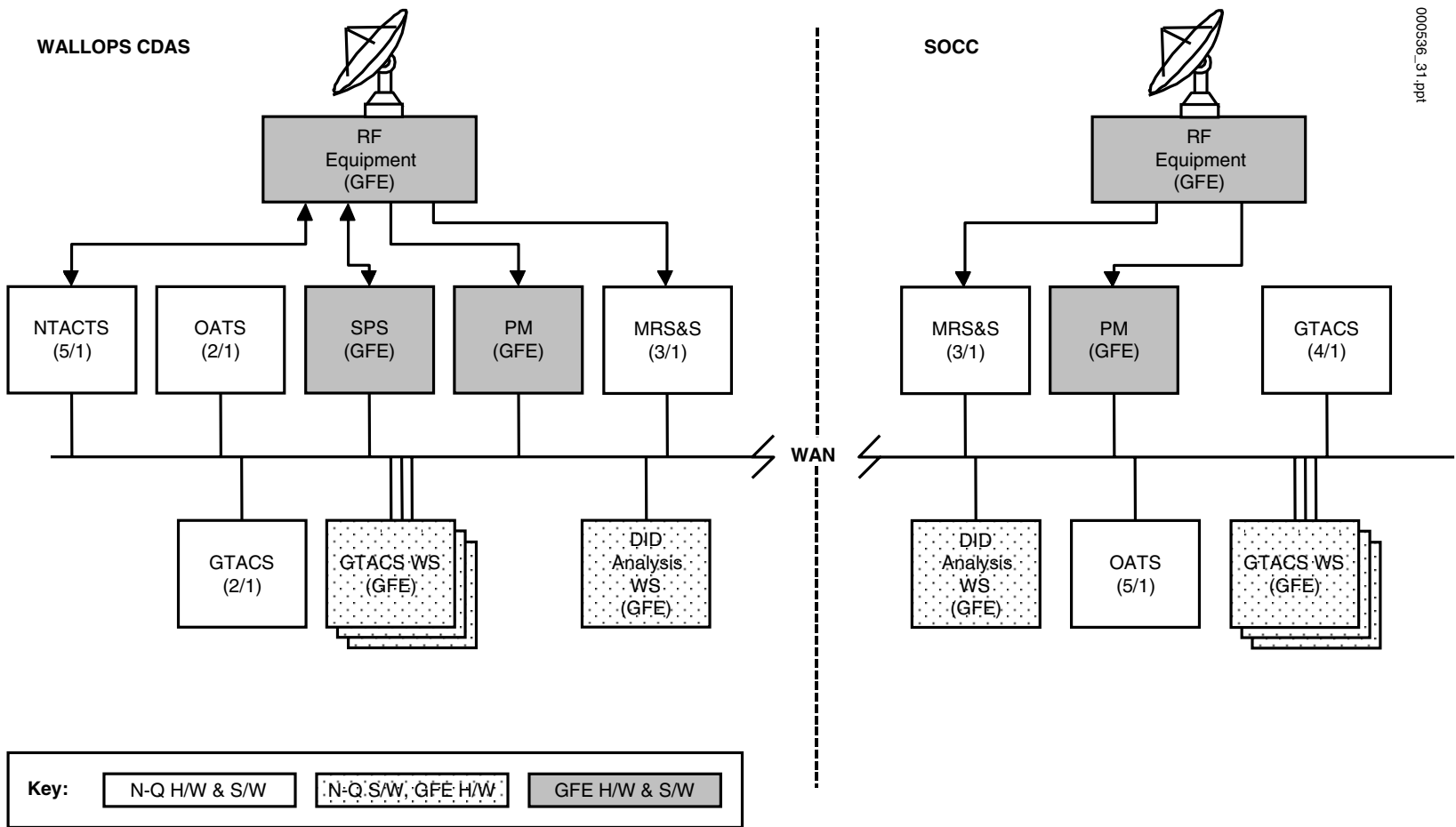

000536_31.ppt

Figure 15-1. GOES N-P SSGS Elements at the WCDAS and the SOCC

15. Spacecraft Support Ground System

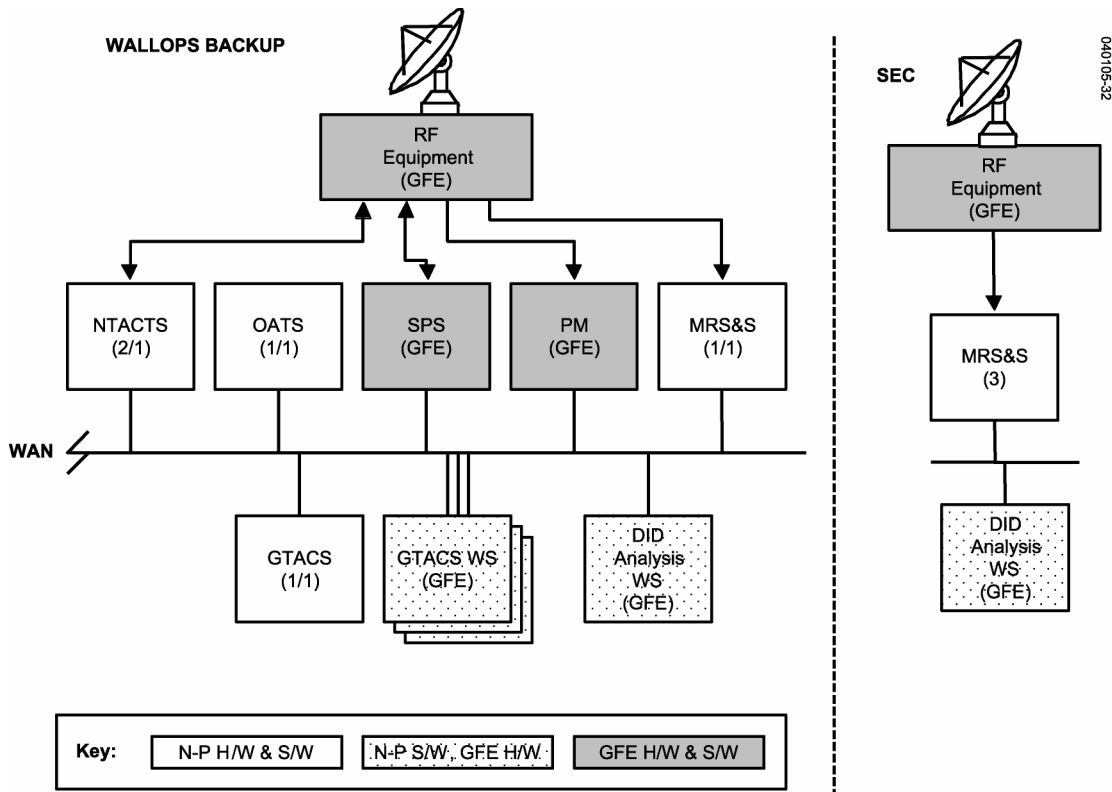

Figure 15-2. GOES N-P SSGS Elements at the WBU and the SEC

CDAS provides RF transmit and receive interface with the spacecraft for all functions; the SOCC receives only the GVAR and MDL signals. Primary GOES command, control, scheduling, and engineering operations activities are hosted at the SOCC, but complete backup capabilities are maintained at the Wallops CDAS and the WBU.

SSGS external interfaces include spacecraft telemetry and command (T&C), NASA 36 time code, and various spacecraft related databases. The SSGS receives several independent data streams from each spacecraft and processes the following data:

- Raw Imager and Sounder data is received at the NOAA CDAS and processed in the SPS resulting in highly accurate, earth-located, calibrated imagery and sounding data in near real time; star sense data, which is directed to OATS for use in attitude determination; and instrument health and safety data, which is directed to GTACS. This data is formatted as GVAR data and transmitted to its corresponding spacecraft for relay to principal users.
- GVAR data is received at the SOCC, CDAS, and WBU and processed by the PM and the SPS. The PM monitors the quality of the processed data and registers landmarks, and the SPS performs spacecraft ranging. These observation data are then used by OATS as part of the orbit and attitude determination process.

15. Spacecraft Support Ground System

- MDL data is received at the Wallops CDAS, SOCC, WBU, and SEC and processed by the MRS&S. This stream includes Imager and Sounder servo error data, Imager image motion compensation (IMC) data, angular velocity sensor data, Solar X-ray Imager (SXI) and, potentially, instrument of opportunity (IOO) instrument data, and spacecraft spacecraft pulse code modulated (PCM) telemetry. The MRS&S makes this data available to the DID for diagnosing dynamic interactions among the instruments and the spacecraft.
- Two streams of PCM data are received at the Wallops CDAS and WBU. The NTACTS provides bit and frame synchronization and passes the data on to GTACS for further processing. These streams contain spacecraft health and safety data used in monitoring spacecraft commanding performed on the ground or from stored commands on the spacecraft. The SEC derives SXI and space environment monitor (SEM) instrument data from the MDL stream for use in solar environment forecasting.

Spacecraft commanding is generated within GTACS. Bit-level, encrypted commands are transferred from GTACS to NTACTS, which provides the interface to the Government furnished equipment (GFE) RF system for uplink to the spacecraft.

The SOCC, the Wallops CDAS, and the WBU LANs are interconnected via routers at each site, which, in turn, are interconnected by landline circuits plus a leased 56 kbps domestic satellite circuit. Operations voice circuits are also provided via the landlines. The interconnectivity allows the exchange of both spacecraft operations data and status data among SSGS elements. The data exchange between GTACS and NTACTS uses the TCP/IP socket protocol.

N-Q Telemetry Acquisition and Command Transmission System (NTACTS)

NTACTS provides an interface between GTACS and the GFE RF systems at the Wallops CDAS and WBU for PCM telemetry receipt and spacecraft command transmission. The function of the NTACTS is similar to that of the TACTS in the GOES I-M SSGS; that is, supplying the GOES N-P ground segment of the space-to-ground and ground-to-space communications link. Each NTACTS services a single GOES N-P spacecraft and is able to receive two PCM telemetry streams as IF signals. NTACTS bit synchronizes, frame synchronizes, time tags, and formats the minor frame data for each stream for transmission to GTACS. NTACTS receives commands from GTACS in a form ready to uplink (encryption is already applied) and modulates an IF command signal that is passed to the GFE ground station RF equipment for transmission to the spacecraft. In support of the command link, NTACTS sweeps the carrier to establish carrier lock with the spacecraft at initiation of contact and transmits an idle pattern between commands to maintain lock. Each NTACTS can send telemetry data to multiple GTACS to provide receipt redundancy. However, NTACTS can establish a commanding connection to only one GTACS at a time. NTACTS also sends processing status data to GTACS.

15. Spacecraft Support Ground System

There are five NTACTS at the Wallops CDAS and two at the WBU. NTACTS communicates with GTACS via TCP/IP sockets.

GOES N-Q Telemetry and Command System (GTACS)

GTACS performs tasks similar to those performed by the GOES I-M telemetry and command system (GIMTACS) for the GOES N-P using a distributed system of servers and user workstations located at the SOCC, Wallops CDAS, and WBU. GTACS processes all real time and nonreal time spacecraft telemetry data, generates spacecraft commands, provides command schedule generation and upload capabilities, and performs ground system monitoring and control functions.

GTACS consists of four servers at the SOCC, two servers at the Wallops CDAS, and one server at the WBU. GTACS servers receive data streams from NTACTS (raw PCM minor frames), MRS&S (SXI housekeeping data), and SPS (Imager and Sounder housekeeping data) and process status information from each of these elements. The servers archive the raw data, decommutate and convert values to engineering units and check database limits, and provide the resulting parameter values to other processes such as user display. Each server can furnish these services concurrently for multiple spacecraft; the entire GTACS element can support up to eight spacecraft (including real and simulated spacecraft). The GTACS servers also support command generation and real time schedule execution (if schedule commanding is from the ground) and monitor the execution of onboard schedules. Binary commands nominally are encrypted using commercial encryption devices before transmission to NTACTS for uplink.

More than one server can be configured to receive data from a spacecraft, providing redundancy in case of a server or network failure. If multiple servers are configured to support one spacecraft, one server is configured as prime, with the other servers configured as backups. Only the prime server can generate spacecraft commands, and only one user on the prime has authority to issue commands. In a redundant configuration, servers at the CDAS and SOCC can support the same spacecraft. Nominally, the server at the CDAS will be configured as prime, enabling schedule related processing to continue uninterrupted in case of network failure between the SOCC and CDAS. Users at the SOCC can connect to either the CDAS or SOCC server for data service. Users at the CDAS will connect only to collocated servers.

Users interact with the system on GFE NT Intel-based workstations. A pool of GFE workstations can be used to support different missions and different aspects of those missions. The assigned user privileges and the corresponding software applications currently in use determine the functions which can be performed on that workstation. GTACS does not provide backward compatibility support for other missions.

15. Spacecraft Support Ground System

These workstations support three categories of user operations. First, a workstation can be configured to provide real time T&C operations for a specific spacecraft using data received from a GTACS server. Telemetry and system data points can be monitored using parameter text displays and plots. Users can also create and run procedures that make use of telemetry or other GTACS element data. Users can also monitor the status of SSGS elements and configure aspects of these elements.

Second, a workstation can be configured to analyze nonreal time data. Using this capability, a user can perform trending analysis, recall archived data, export data, and use additional analysis tools not applicable to real time data.

Third, a workstation can be configured to generate schedules. In this mode, a user can start with schedule building blocks and create a set of schedules for daily operations to be commanded either from the ground or from the spacecraft. These schedules are then distributed to other functions within GTACS either for execution or upload to the spacecraft. Schedules are nominally generated at the SOCC.

The GTACS support available at the WBU is similar to that at the Wallops CDAS, but its support capabilities are reduced due to its lower equipment count, principally only one antenna. Workstations at the SOCC can be configured to use the WBU server for real time T&C service, as can workstations within the WBU facility. However, workstations at the Wallops CDAS or the WBU will not nominally use a server at the other facility.

Orbit and Attitude Tracking System (OATS)

The OATS performs three major functions in support of mission operations using telemetry and status data obtained from GTACS, star sense and range data provided by the SPSs, and landmark and IMC data obtained from the PMs. The primary function is to provide daily computational support for implementing the orbit and attitude determination (OAD) and image navigation and registration (INR) processes. This support consists of a closed-loop sequence that:

- Ingests star, range, and landmark observations
- Determines spacecraft orbit and Imager and Sounder attitudes
- Determines station radio frequency interference (RFI), and solar and lunar intrusions into the Imager and Sounder
- Predicts eclipses
- Computes image motion compensation
- Determines star observation coordinates.

This daily support is performed both for normal operations and special operations such as during eclipses and yaw-flip maneuvers.

15. Spacecraft Support Ground System

The second major function of OATS is to plan, generate command data, and evaluate maneuvers such as daily momentum dumping, periodic stationkeeping, and repositioning maneuvers. The evaluation includes estimates of the remaining onboard propellant and calibration of the propulsion system.

Finally, OATS requests, accepts, and processes telemetry data such as evaluating thruster firing data and attitude control electronics (ACE) data to verify and calibrate IMC, stationkeeping, and reacquisition support. The OATS also supports the GTACS command-level schedule generation process, generating instrument commands for image frame coordinates and definitions and scheduling star looks.

OATS generates output such as:

- Orbit and Imager/Sounder attitude coefficients for the SPS
- IMC coefficients uplinked to the spacecraft via GTACS
- Star view command data to support Imager and Sounder star sense and sequence operation
- Maneuver planning information and spacecraft stationkeeping command data
- Commands required for daily reaction wheel momentum dumping
- Estimates of onboard propellant remaining
- Propulsion calibration parameters
- Orbit and station events prediction
- Sensor intrusion predictions
- Star tracker intrusion predictions during yaw-flip maneuvers
- Scan frame coordinates conversion
- IMC calibration factors
- Transformation between the IMC set J2000 and the star catalog true-of-date coordinates.

OATS functions are performed on primary and backup systems at the SOCC (five OATS total), with additional backup systems installed at the Wallops CDAS (two OATS total) and the WBU (one OATS). The backup systems are maintained with the most current data so that transfer to the backup OATS (either forced due to primary failure or orderly) may occur with little operational interruption. OATS also archives data for later analysis.

15. Spacecraft Support Ground System

OATS exchanges data with other SSGS elements. OATS communicates with GTACS and each other over an Ethernet LAN. OATS provides orbit and attitude related data to GTACS for schedule creation and for maneuver commanding. GTACS provides attitude-related data to OATS, as well as star sense data from SPS with acquisition times added. OATS also exchanges data with the PM and SPS via a gateway that handles protocol translation. These messages include data for spacecraft ranging, landmarks and image correction calibration data.

MDL Receive System and Server (MRS&S)

The MRS&S provides data ingest, archive, and data service to the DID for the MDL telemetry stream. The MDL stream contains data that can be used in analyzing spacecraft structure dynamic interactions in the DID. The data included in the MDL stream include Imager and Sounder servo error data, Imager IMC data, and angular displacement sensor data. These data complement instrument telemetry data received by the SPS. In addition to these data, the MDL telemetry stream also has four other telemetry streams embedded in it: two PCM telemetry streams (replications of the independently downlinked PCM telemetry streams), the SXI telemetry stream, and, potentially, the IOO telemetry streams. All of these data streams are packetized in MDL packets (not CCSDS) and multiplexed onto the MDL downlink.

Each MRS&S services one spacecraft. The MRS&S has an IF interface to the GFE RF system from which it receives the MDL telemetry stream. The MRS&S demodulates and bit synchronizes the MDL stream. The MRS&S then frame synchronizes this data to identify the MDL frames and packets. The MDL-specific dynamics data can be decommutated directly from these packets. The MRS&S demultiplexes these four telemetry streams back into four independent bit streams and then frame synchronizes each stream independently. The MRS&S does not decommutate any data from the SXI or IOO streams. The MRS&S decommutates a limited number of data points in the PCM streams required for analysis by the DID.

The MRS&S provides data to the DID via TCP/IP sockets. The DID requests specific MDL telemetry data points from the MRS&S either for real time service or for a specific time range contained in the MRS&S archive. The MRS&S sends data from the embedded SXI telemetry stream to the SXI analysis workstation via TCP/IP sockets. The MRS&S supplies SXI health and safety engineering data to GTACS. GTACS can also request the PCM streams from the MRS&S, providing an alternate path not requiring the spacecraft's T&C RF transmitters.

The SOCC and the Wallops CDAS each have three copies of the MRS&S, while the WBU has one copy. The Space Environment Center (SEC) in Boulder, Colorado, also has three copies of the MRS&S, which are used for receiving the SXI and PCM data streams, which contain the SEM instrument data.

15. Spacecraft Support Ground System

Dynamic Interaction Diagnostic (DID)

The DID provides data selection, plotting, and analysis tools, using data in the MDL telemetry stream to measure interaction between mechanical motion events (such as momentum/reaction wheel, solar array drive assembly, and Imager/Sounder mirror motion). The tools are used during initial on-orbit checkout to identify dynamic effects that produce excessive interaction and to support the development of operational scenarios that avoid or minimize such interaction. Diagnostic telemetry can be used at any time during subsequent spacecraft orbital operations for the same purpose. The MRS&S sends data to the DID via a TCP/IP socket connection. Using the DID data selection interface, the user can request parameters to be analyzed and that the MRS&S supply data for a specified time span or as it is received in real time.

The SOCC will have two copies of the DID, the Wallops CDAS and WBU will each have two copies, and the SEC will have one. A DID can support one spacecraft at a time. DID workstations are GFE. The DID workstations are also used to support functions other than the GOES N-P DID function, such as SXI analysis or GOES N-P DID analysis. The GOES N-P DID function provides similar capabilities to those provided by the GOES I-M DID, but is not backward compatible.

Sensor Processing System (SPS)

The SPSs perform all functions associated with processing Imager and Sounder instrument data from the GOES I-M and N-P spacecraft, one spacecraft per SPS. This element is GFE to GOES N-P. This description is included for context. Functions provided by the SPS include data ingest, including frame synchronization, decommutation by channel, detector scan alignment, and alternate scan line reversal; visible image normalization; IR radiometric calibration; earth location and Imager gridding annotation; reformatting of instrument data into the GVAR format; computation of Imager and Sounder space look, blackbody, electronic calibration and instrument telemetry statistics for inclusion in GVAR data stream; binary phase shift keyed (BPSK) modulation of the GVAR data stream; and spacecraft ranging. The modulated GVAR signal is passed to the GOES RF system for uplink to the spacecraft.

To support the orbit and attitude determination function of the OATS subsystem, the SPS also performs spacecraft range measurements using the GVAR data stream round trip propagation time, performs star crossing event measurements by processing Imager and Sounder star view data, and extracts periodic IMC and servo error data from the sensor data for use in the IMC quality check function performed by OATS.

Further, SPS sends wideband telemetry data, including command register echo information extracted from the Imager and Sounder data streams and scan position to GTACS every two to 10 seconds, as long as valid telemetry is being processed in the SPS. The telemetry message data consists of the latest values received for the telemetry words extracted from the telemetry blocks of the Imager turnaround sequence and telemetry words extracted from the Sounder blocks.

15. Spacecraft Support Ground System

There are four SPSs at the Wallops CDAS, one to support the GOES East spacecraft, one for the GOES West spacecraft, and two spares. One SPS is planned for the WBU. The spares typically provide hot backups, but can also be used to support testing or third spacecraft operations on a limited basis. The SPSs are interconnected via an Ethernet LAN and communicate with GTACS and OATS via an X.25 connection to a gateway at the CDAS. The SPSs send messages containing ranging and star sense data to OATS and instrument housekeeping telemetry and SPS status data to GTACS. SPSs send text messages and data to the PMs via the GVAR broadcast. The PMs send data, such as image alignment correction factors and visible detector normalization (destriping) tables to the SPSs via an X.25 interface.

The SPS subsystem also includes an analyst workstation capability at the SOCC, Wallops CDAS, and WBU through which analysts can access Imager and Sounder SPS archive data maintained at the CDAS for analysis purposes.

Product Monitor (PM)

The primary functions of the PMs are to monitor and analyze the quality of the image and nonimage data broadcast in the GVAR data stream, feeding back any required changes to the SPS, and to provide OATS with landmark registration and IMC quality check data in support of INR and attitude determination. This element is GFE to GOES N-P. This description is included for context.

In support of the orbit and attitude determination function, the PM provides landmark identification by storing, displaying, and registering small areas of Imager visible and infrared data (visible Sounder as backup) defined as landmark sectors. Landmark registration is performed by a semiautomatic (an automatic capability is being implemented) correlation of selected landmark sectors to previously stored landmark sectors referred to in landmark correlation chips. Once correlated, landmark measurement data in the form of earth location coordinates are sent to the OATS. The PM also captures the IMC and servo error data included in the GVAR data by the SPS and passes it to OATS, which provides quality checks of the INR function performed onboard the spacecraft.

Nearly identical PMs reside at the SOCC, Wallops CDAS, and WBU, with four, three, and one systems each, respectively. Each PM is capable of supporting one GVAR data stream at a time. One PM is normally assigned to the GOES East broadcast and the other to the GOES West broadcast. Under normal operational circumstances, the PMs at the Wallops CDAS perform only the monitoring function while the PMs at the SOCC perform the OATS support functions as well as the monitoring functions. In the backup operational configuration, with the OATS resident at the CDAS, the PM roles at the CDAS and SOCC are reversed.

15. Spacecraft Support Ground System

GOES Variable (GVAR) Transmission Format

The GVAR data transmission format was developed to allow full use of the capabilities of the advanced, three-axis stabilized spacecraft while retaining as much commonality as possible with receiving equipment presently in use from earlier spin-stabilized GOES spacecraft. The GVAR format is based on the operational visible and infrared spin scan radiometer atmospheric sounder (VAS) mode AAA format, which consisted of a repeating sequence of 12 fixed-length equal size blocks. The transmission of these blocks was synchronized with the spin rate of the earlier GOES spacecraft, that is, one complete 12 block sequence per satellite rotation.

The GVAR transmission sequence consists of 12 distinct blocks numbered 0 through 11. Blocks 0 through 10 are transmitted when an Imager scan line is completed. Block 10 is followed by a variable number of block 11s, according to what data are available for transmission (Figure 15-3).

15. Spacecraft Support Ground System

GVAR Data Block Type

Doc- ument	IR 1	IR 2	Visible 1	Visible 2	Visible 3	Visible 4	Visible 5	Visible 6	Visible 7	Visible 8	Sounder and Auxiliary Data	
GVAR Block Number	0	1	2	3	4	5	6	7	8	9	10	11
Word Size, Bits	8	10	10	10	10	10	10	10	10	10	10	6, 8, 10
Field Length, Words	8,040	68 - 21,008	51- 15,756	20 - 20,960	20 - 20,960	20 - 20,960	20 - 20,960	20 - 20,960	20 - 20,960	20 - 20,960	20 - 20,960	10,720/ 8,040/ 6,432
Number of Records	-	4/block	3/block	1/block	1/block	1/block	1/block	1/block	1/block	1/block	1/block	1- 8
IR Detector Data, Words	-	5,236	1 - 5,236	4 - 20,944	4 - 20,944	4 - 20,944	4 - 20,944	4 - 20,944	4 - 20,944	4 - 20,944	4 - 20,944	-

040105-33

Each GVAR block has

- 10,032-bit synchronization code
- 720-bit header
- N-bit information field
- 16-bit cyclic redundancy check

Block Characteristics

- Period 15.25 - 104.6 ms
- Synch Length 10,032 bits
- Header Word Length 8 bits/word
- Header Length 90 words (720 bits) (Triple Redundant)

Scan Characteristics

- Period Variable
- Block/Imager scan 11
- Bit Rate 2,111,360 b/s

- Blocks 0 and 11 have fixed length information field of 64,320 bits
- Blocks 1 through 10 have variable length information fields directly dependent on width of scan, with minimum information field of 21,440 bits
- A single Imager scan generates blocks 0 through 10 in sequence
- Blocks 0 through 10 may be followed by any number of block 11s (0-N) depending on data available; in priority order, the next block(s) transmitted will be:

- | | |
|--|----------------------|
| 1. Next Imager scan | Blocks 0 through 10 |
| 2. Imager compensation and servo errors | One block 11 |
| 3. Sounder compensation and servo errors | One block 11 |
| 4. Imager telemetry statistics | One block 11 |
| 5. Imager spacelook statistics and data | Six block 11s |
| 6. Imager calibration coefficients and limits | One block 11 |
| 7. Imager electronic calibration statistics and data | Two block 11s |
| 8. Imager blackbody statistics and data | Two block 11s |
| 9. Imager visible NLUT | Two block 11s |
| 10. Imager star sense data | Nine block 11s |
| 11. Sounder scan data | 2 to 523 block 11s |
| 12. Sounder telemetry statistics | One block 11 |
| 13. Sounder spacelook statistics and data | Five block 11s |
| 14. Sounder calibration coefficients and limits | Two block 11s |
| 15. Sounder electronic calibration statistics and data | Three block 11s |
| 16. Sounder blackbody statistics and data | Five block 11s |
| 17. Sounder visible NLUT | Nine block 11s |
| 18. Sounder star sense data | Nine block 11s |
| 19. GIMTACS text messages | One to two block 11s |
| 20. SPS text messages | One block 11 |
| 21. Auxiliary data | One to N block 11s |
| 22. Fill data | One block 11 |

Figure 15-3. GOES N-P Variable Data Transmission Format

15. Spacecraft Support Ground System

Spacecraft Emulator

The GOES N-P spacecraft emulator is a simulation platform that consists of the Applied Dynamics International (ADI) real time station (RTS) and computer workstations. The emulator is contained within a tower unit. It contains various spacecraft components, several compute engines, a Versa-bus Module Eurocard (VME) bus, a 1553 bus, and various software applications. The emulator provides the T&C interface, MDL interface, and Imager and Sounder messages to support SSGS integration and test. In addition, it provides high fidelity models of the spacecraft dynamics, sensors, and actuators, along with orbital and environmental models to support operational procedures development and mission and on-station operation rehearsals.

15. Spacecraft Support Ground System

This page left blank.

16. Spacecraft Mission Profile

To reach the required on-station location in geostationary orbit (station acquisition), the GOES spacecraft undergoes four distinct mission phases:

- *Launch phase*—From Delta IV liftoff to spacecraft separation
- *Transfer orbit phase*—Spacecraft separation to the last perigee motor firing (PMF)
- *Deployments, acquisition, and bus in-orbit test phase*—From the last PMF to Spacecraft in Normal Mode to engineering handover (from Boeing to NASA operators).
- *Post Launch Test and On Station* Performance testing of the payloads to initial operations

The nominal chronological sequence of orbit raising for a nominal transfer orbit consists of reorientation to apogee firing attitude, apogee motor firing (AMF) 1, AMF 2, AMF 3, AMF 4, and AMF 5. The spacecraft is passively spin stabilized around the +Z axis. After the last AMF, the solar array is deployed, and the spacecraft transitions to three-axis stabilization mode.

Ground Stations

Various ground centers and tracking stations are involved throughout the mission phases:

- Deep Space Network (DSN) stations at Canberra, Australia; Madrid, Spain; and Goldstone, CA, support orbit raising maneuvers with Goldstone acting as backup to the command and data acquisition (CDA) station when the spacecraft achieves synchronous orbit.
- Diego Garcia Station (DGS), an Air Force remote tracking station, is used for initial spacecraft separation telemetry and command (T&C) functions and to support the transfer orbit during the first 3 days.
- CDA station located at Wallops, VA, houses the T&C transmission system (NTACTS), portions of the spacecraft support ground system (SSGS), and GOES telemetry and command system (GTACS). The CDA performs spacecraft telemetry acquisition, formatting, command transmission, and ranging.

16. Spacecraft Mission Profile

- Satellite Operations Control Center (SOCC) houses the orbit and attitude tracking system (OATS), part of the SSGS, and GTACS. The SOCC is the prime control center during all mission phases. This station is also capable of receiving processed instrument data in GOES variable (GVAR) data format and multiuse data link (MDL) diagnostic data.

Launch and Injection

The GOES N-Q spacecraft are launched from Cape Canaveral Air Force Station Launch Complex 37B by a Boeing Delta IV rocket. Major flight events and times for the Delta IV mission are shown in Table 16-1. Spacecraft telemetry is provided through the launch vehicle telemetry until separation. The launch vehicle trajectory includes a third burn of the second stage at the transfer orbit apogee. This involves a long coast period (4 hrs) with the launch vehicle performing a slow roll maneuver to provide good thermal and power conditions for both the spacecraft and launch vehicle. The GOES spacecraft is separated from the upper stage of the Delta IV with a spin about its +Z axis at the time of ground station acquisition of signal. The +Z axis of the spacecraft is pointed to provide both good sun and communications, providing an effective T&C signal for first acquisition of signal and maintaining good power on the solar arrays. The Delta IV injects the spacecraft into a geosynchronous transfer orbit with the following orbital parameters: 41555 km apogee radius, 13000 km perigee, 12° inclination to begin the transfer orbit phase. The time from liftoff to separation is about 4.5 hours.

Table 16-1. Delta IV Major Mission Events

Event	Time Lapse from Ignition, sec
Ignition	0
Maximum dynamic pressure	61
Jettison ground lit solid motors	100
Main engine cutoff (MECO)	267
Second stage ignition	287
Jettison fairing	297
Second stage cutoff 1 (SECO-1)	757
Second stage restart	1385
Second stage cutoff 2 (SECO-2)	1628
Begin Coast Phase Roll	1620
End of Coast phase Roll	14400
Second Stage Restart	15001
Second Stage cutoff 3 (SECO-3)	15057
Spacecraft separation	15687

16. Spacecraft Mission Profile

Transfer Orbits

The spacecraft attitude at injection is oriented so as to maximize continuous T&C coverage by Canberra ground station and maximize sun angle on the solar array. The T&C omni antenna is initially in a stowed position for launch, but after initial station acquisition, it is deployed. The effective spacecraft T&C antenna pattern once deployed is a cardioid with a maximum $\pm 110^\circ$ look angle from the -Z axis. T&C visibility from the ground is obtained when the spacecraft's elevation angle with respect to the ground station local horizon is greater than 5° , and the ground station is within the spacecraft T&C antenna pattern. During transfer orbits, redundant and near-continuous coverage is provided by the three T&C stations (Goldstone, Madrid, and Canberra).

After acquisition of signal by Canberra is established and a command link verified, the omni antenna is fully deployed. The spacecraft is then configured for transfer orbit operations. This consists of pressurization of the propellant system and checkout of the thrusters and attitude control electronics (ACE).

The 490 N liquid apogee motor (LAM) is used to target the spacecraft into the proper geostationary orbit, that is, correct apogee radius, inclination, and ascending node. Propellant consumption and burn duration are minimized by using the LAM, which has higher specific impulse and higher thrust compared to the 9.25 N stationkeeping thrusters.

The launch and orbit raising mission phases are shown in Figure 16-2. Nominal transfer orbit parameters are given in Table 16-2. Optimum targeting also involves splitting the apogee maneuvers into several burns. Orbit and attitude determinations are performed throughout this period to assess maneuver performance, and the mission plan is adjusted to account for the actual performance of the system.

Table 16-2. Nominal Transfer Orbit Parameters

	Post Separation	Post AMF1	Post AMF2	Post AMF3	Post AMF4	Post AMF5
Perigee radius, km	13000	19532	35256	40488	41482	42155
Apogee radius, km	41555	41546	41525	41537	42168	42175
Inclination, deg	12.0	6.6	1.3	.48	0.42	.5
Period, hr	12.5	14.8	20.8	23.0	23.6	24.0

The size of the maneuvers and phasing are set up to target the initial longitude. These maneuvers will attain the geostationary orbit. Table 16-2 provides a nominal set orbit parameters for the transfer orbit sequence. The spacecraft arrives on station about 12 days after launch vehicle separation. During the post launch test period, which follows, the 9.25 N stationkeeping thrusters will be used to adjust the orbit and initialize the orbit for the operational stationkeeping cycle.

16. Spacecraft Mission Profile

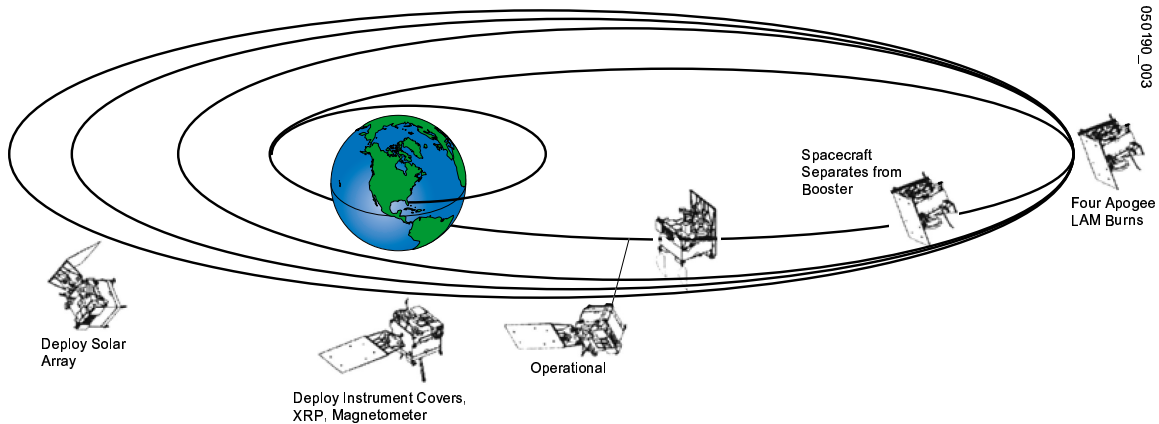

Figure 16-2. Launch and Orbit Raising Mission Phases

A set of mission plans detailing the maneuvers and showing ground station visibilities are provided as part of the Mission Operations Plan.

Deployments, Acquisitions, and Bus In-Orbit Test

After the last LAM burn is complete and the spacecraft is at the initial test longitude, a period of approximately 6 days passes until the spacecraft is configured for three-axis stabilization mode and tested in preparation for the extended post launch test phase. The first day is used to deploy the solar array. This begins with a spin down, a reorientation to the proper attitude, and the release of the array. Once the solar array is deployed, the spacecraft uses thrusters to acquire the sun. The spacecraft uses reaction wheels to maintain itself in a sun hold configuration. After this, the instrument mounting platform (IMP) is deployed, and the precision sun sensor (PSS) and XRS/EUV are initially checked out. The star trackers are then tested, and the stellar inertial attitude system is initialized. When this is complete, the spacecraft is placed in normal mode and slews to an earth-pointing orientation. The spacecraft is now operating as a three-axis stabilized spacecraft. The next few days are then devoted to configuring the battery and heaters, checking out communications payloads, deploying the magnetometer, turning on space environment monitor (SEM) instruments and testing those spacecraft subsystems that are going to be needed for post launch test. The last deployments prior to engineering handover are the deployment of the Imager and Sounder Optical Port Covers. At this point, the spacecraft is ready for engineering handover from Boeing operators to NASA operators.

16. Spacecraft Mission Profile

Post Launch Test Phase and On-Station Orbit

After the engineering handover is complete, post launch test begins, and the spacecraft is checked for proper performance before entering service at either of two assigned locations. At the 90 W checkout station, the orbit apogee and perigee radii will respectively be 156 km above and below the geosynchronous radius of 42,164 km. By international agreement for the GOES system, two spacecraft orbital positions have been assigned: 75° and 135° West longitudes. From these two vantage points, roughly over Ecuador and the Marquesas Islands, respectively, the GOES Imager and Sounder instruments cover both the Atlantic and Pacific oceans. The major operations performed upon station acquisition are:

- Outgas Imager and Sounder contaminants
- Activate and checkout Communications payload data services
- Deploy Imager and Sounder cooler covers
- Activate space environment monitor equipment
- Characterize and optimize Imager and Sounder radiometric performance
- Activate and evaluate Image Navigation and Registration
- Enter storage mode or begin on-station operations

Normal on-orbit operations entail periodic stationkeeping maneuvers that keep the spacecraft within a 0.5° inclination about the equator and within $\pm 0.5^\circ$ of the on-station longitude. These maneuvers are needed because of several forces that produce small changes over a short period of time: interactive effects of the sun's and moon's gravity, solar radiation pressure, and the earth's gravitational field. Stationkeeping is performed by a pair of east or west thrusters to maintain station longitude and a pair of north thrusters to maintain orbital inclination.

16. Spacecraft Mission Profile

This page left blank.

17. On-Orbit Mission Operations

The GOES N-P spacecraft are designed for a 10 year on-orbit lifetime that is separated into 8 years of active meteorological data collection and up to 2 years of storage. This document concerns itself only with the active science data collection aspect of the on-orbit mission. On-orbit operations consist of daily (routine) and periodic operations, both of which are planned in advance and executed as per the operations schedule. Routine operations driven by the on-board schedule include instrument commanding and one housekeeping period (for clock adjustments and momentum dumping) with the spacecraft on-board systems controlling the spacecraft attitude, systems monitoring, and maintaining general operations and health monitoring. Periodic operations entail infrequent events such as stationkeeping, space environment monitoring (SEM), x-ray sensor/extreme ultra violet (XRS/EUV) instruments, Solar X-ray Imager (SXI), precision sun sensor (PSS), and magnetometer instrument calibrations; eclipse operations, yaw flip (if necessary), and station relocation, which occur over the spacecraft's life.

Typical Daily Operations

Daily operations for the Imager and the Sounder are structured to primarily satisfy the meteorological needs of the NOAA National Weather Service (Figures 17-1 and 17-2). These operational scenarios for the GOES spacecraft Imager and Sounder also must comply with spacecraft state-of-health requirements and operational constraints. The initial, "Day 1" operational scenarios for GOES spacecraft feature one of three modes for the Imager: routine, rapid, and super-rapid scan. The Sounder has three modes that operate concurrently with the three Imager modes. The mode being used at any given time is related to the severity of the meteorological activity being observed.

Full Disk Scenario

The Imager full disk scenario consists of a full disk scan of the earth followed by star looks and a blackbody calibration. This sequence is repeated every half-hour. The full disk scan is changed to an extended northern hemisphere scan once every 6 hours. This allows sufficient time to perform the 10 minute spacecraft housekeeping activities.

The corresponding Sounder operations follow a summer scenario (June to November) or winter scenario (December to May) schedule. This schedule is 6 hours long and repeats itself immediately upon completion. The schedule starts with a full regional northern hemisphere sounding repeated three times at 1 hour intervals. Then, a full regional southern hemisphere sounding (winter mode) or a limited regional sounding and a

17. On-Orbit Mission Operations

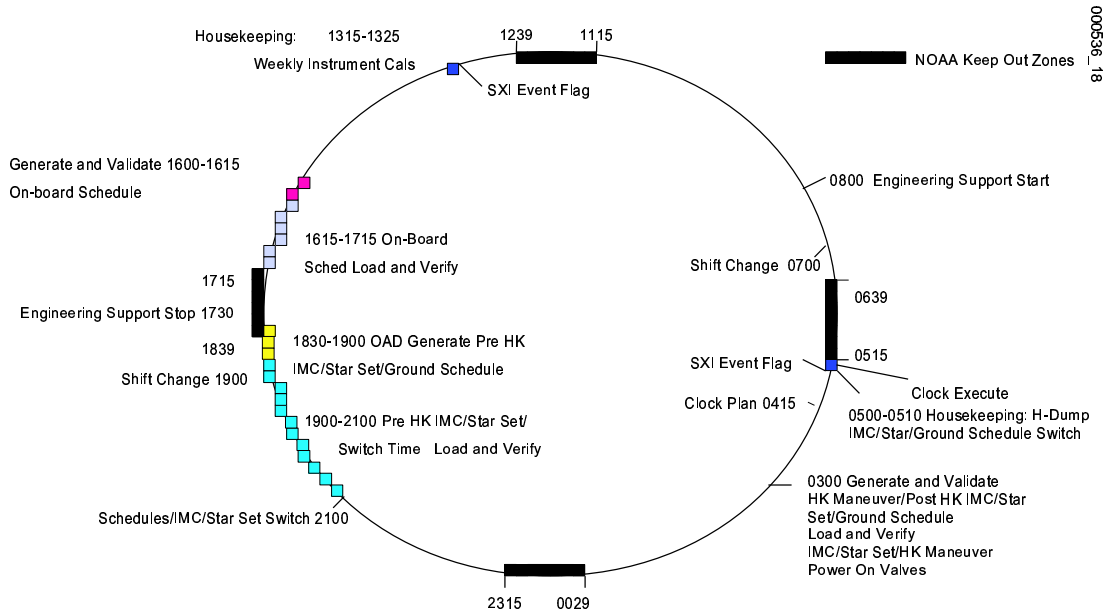

Figure 17-1. GOES-East Daily Timeline (SLT)

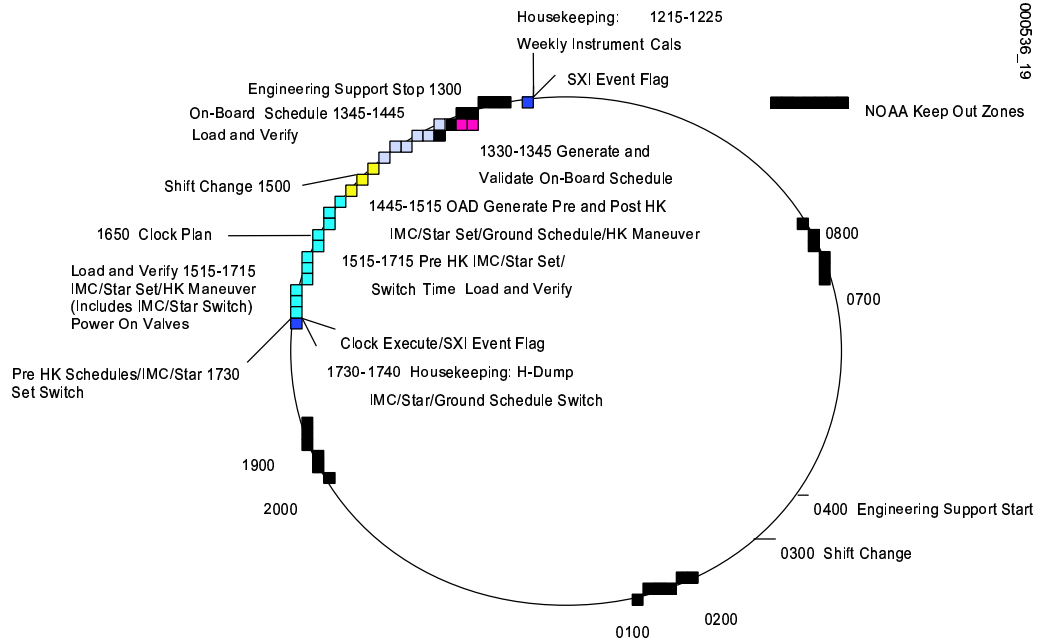

Figure 17-2. GOES-West Daily Timeline (SLT)

mesoscale sounding (summer mode) is conducted followed by a limited regional sounding. Spacecraft housekeeping activities are then performed to complete the 6 hour schedule. The soundings are interrupted for star looks each half-hour and for blackbody calibrations.

17. On-Orbit Mission Operations

Routine Mode

The Imager routine mode is a 3 hour sequence that repeats itself immediately upon completion. The sequence begins with a full disk scan, followed by the half-hour sequence of an extended northern hemisphere scan, a continental U.S. (CONUS) scan, and a southern hemisphere-south scan. This sequence is repeated five times. The last southern hemisphere-south scan is omitted every 6 hours to allow for spacecraft housekeeping. Star looks and blackbody calibrations are performed every half-hour.

The Sounder performs the same summer mode or winter mode schedule as the Imager full disk mode.

Rapid Scan Mode

This mode modifies the routine mode in order to focus on providing additional 1 minute duration sectors of severe storm regions.

The Sounder warning mode is performed in conjunction with the Imager rapid scan mode. This is a 6 hour sequence that repeats itself immediately upon completion. The schedule starts with a limited regional sounding then nine repeated mesoscale soundings. Then another limited regional sounding is performed, followed by eight mesoscale soundings and spacecraft housekeeping activities. The soundings are interrupted for star looks each half-hour and for blackbody calibrations.

Super Rapid Scan Mode

The Imager super rapid scan operation (SRSO) is a special schedule requested by the research community under the auspices of the NWS to study weather phenomena. The SRSO schedule is currently limited to one 6 hour period of the day and is activated on the spacecraft within one to two hours of the NWS request. The SRSO is a 6-hour schedule that combines northern hemisphere and 1-minute frames with a full disk frame every three hours and normal sounder frames. The 1-minute frames cover an area approximately 1500 km by 1500 km, and are repeated eight or nine times during a 30-minute period. Upon receipt of the SRSO request, the GOES scheduler enters the frame latitude and longitude center point and sends the schedule to OATS for conversion of the frame coordinates to instrument coordinates. The updated schedule is then uplinked to the spacecraft and activated when appropriate.

Scan Sector Boundaries and Durations

The typical Imager and Sounder scan sector boundaries and scan durations are for the operational scenarios described above (Tables 17-1 through 17-4). The boundaries assume that the GOES East satellite subpoint will be located at 75° West longitude.

17. On-Orbit Mission Operations

Imager/Sounder

Imaging and sounding are performed at predefined scan coordinates. When scan frame coordinates are required, the GOES telemetry and command system (GTACS) requests the orbit and attitude tracking system (OATS) to provide scan frame conversion from scan lines and pixel number (or longitude and latitude) to cycles and increments for use by the Imager and Sounder. GTACS also specifies the stepping mode of the Imager and Sounder as part of the request. In response, OATS converts scan coordinates to cycles and increments for the Imager and Sounder and sends scan start and stop coordinates and scan start and stop times. These data are then used by GTACS in the command message to the Imager and Sounder.

Table 17-1. GOES East Imager Scan Sectors: Boundaries and Duration for Day 1 Scenarios (Subsatellite Longitude: 75° West)

Frame Name	Boundaries (Latitude/Longitude)			
	North	South	West	East
Full Disk	Earth edge			
Northern Hemisphere	60°N	0°N	112°W	30°W
Northern Hemisphere—Extended	65°N	20°S	112°W	30°W
Southern Hemisphere—South	20°S	55°S	116°W	23°W
CONUS	60°N	14°N	112°W	64°W
Southern Hemisphere—Small Sector	0°	20°S	100°W	80°W
Northern Hemisphere—North	65°N	14°N	113°W	30°W
Northern Hemisphere—South	14°N	0°	113°W	30°W
Northern Hemisphere—Storm Sector	48°N	30°N	98°W	76°W
Southern Hemisphere—Abbreviated	0°	20°S	113°W	65°W

17. On-Orbit Mission Operations

Table 17-2. GOES East Imager Scan Sectors Timing Scenario

Mode	Half-hour	Sector	Start Time	Duration, min
Full Disk	1-11	Full Disk	00:00:00	26:16
	12	Northern Hemisphere—Extended	00:00:00	14:19
Routine	1, 7	Full Disk	00:00:00	26:16
		Northern Hemisphere—Extended	00:00:00	14:19
	2-6, 8-11	CONUS	00:15:00	4:45
		Southern Hemisphere—South	00:23:00	5:37
Rapid Scan	12	Northern Hemisphere	00:00:00	9:52
		CONUS	00:15:00	4:45
	1,7	Full Disk	00:00:00	26:16
		Northern Hemisphere	00:00:00	9:52
	2-6, 8-11	CONUS	00:10:06	4:45
		Southern Hemisphere—Small Sector	00:15:05	1:51
	12	CONUS	00:17:11	4:45
		CONUS	00:25:00	4:45
		Northern Hemisphere	00:00:00	9:52
		CONUS	00:10:06	4:45
		Southern Hemisphere—Small Sector	00:15:05	1:51
		CONUS	00:17:11	4:45

The sector scan start times are referenced at the start of each half-hour. The last 10 minutes of half-hour #12 are reserved for spacecraft housekeeping activities.

Table 17-3. GOES East Sounder Scan Sectors: Boundaries and Duration for Day 1 Scenarios (Subsatellite Longitude: 75° West)

Frame Name	Boundaries (Latitude/Longitude)				Scan Duration, min
	North	South	West	East	
Full Regional—Northern Hemisphere	51.5°N	23.3°N	120°W	63.6°W	52.1
Full Regional—Southern Hemisphere	20°S	50°S	130°W	75°W	52.0
Limited Regional	50°N	26°N	118°W	66°W	39.8
Mesoscale—CONUS	43.6°N	26.8°N	106.2°W	87.9°W	12.2
Mesoscale—Tropics	24.7°N	15.0°N	70.2°W	44.5°W	12.1

17. On-Orbit Mission Operations

Table 17-4. GOES East Sounder Scan Sectors Timing Scenario

Mode	Hour	Sector	Start Time	Duration, min
Summer (June- November)	1-4	Full Regional—Northern Hemisphere	00:05:00	52:06
	5	Limited Regional Mesoscale—Tropics	00:05:00 00:50:00	39:48 12:06
Winter (December – May)	1-4	Full Regional— Northern Hemisphere	00:05:00	52:06
	5	Full Regional— Southern Hemisphere	00:05:00	52:00
	6	Limited Regional— Southern Hemisphere	00:05:00	39:48
Warning	1, 4	Limited Regional	00:05:00	39:48
		Mesoscale	00:49:30	12:12
	2, 3, 5	Mesoscale	00:05:00	12:12
			00:20:00	
			00:35:00	
	6	Mesoscale	00:49:30	
			00:05:00	12:12
			00:20:00	
			00:35:00	

The sector scan start times are referenced at the start of each hour. The last 10 minutes of hour #6 are reserved for spacecraft housekeeping activities.

For its daily schedule, GTACS requests from OATS star sense command parameters of a specified duration. OATS responds with star sense coordinates in cycles and increments, dwell times, and look start time for each instrument. Start time is the time at which the pulse command, star-sense start is received at the instrument.

Spacecraft

The daily operational procedure for spacecraft subsystems are controlled by the attitude control electronics (ACE), which control the attitude, image motion compensation (IMC), and dynamic motion compensation (DMC) in support of instrument operations. It also controls bus systems monitoring via parameter checking. Attitude determination is achieved through the use of stellar inertial attitude determination (SIAD), which uses two of three star trackers. These star trackers, along with the hemispherical inertial reference unit (HIRU) continuously supply data to the ACE for attitude calculations. Attitude control is supplied by four reaction wheels, with thrusters being used for momentum dumping and delta velocity operations (stationkeeping, station change, deorbit). Up to two 10 minute housekeeping opportunities occur daily, one of which is used for momentum dumping and on-board clock adjustments and the other for the weekly instrument and PSS calibrations. Other activities can be placed into the second housekeeping period as needed for east-west stationkeeping. The momentum dumping is planned to occur around 6 a.m. Spacecraft Local Time (SLT) for the GOES East spacecraft and 6 p.m. for the GOES West spacecraft, which helps to reduce the frequency

17. On-Orbit Mission Operations

of east-west stationkeeping maneuvers. Other spacecraft activities that do not affect image navigation and registration (INR) operations are planned as necessary for spacecraft maintenance and include battery bias calibrations during eclipse season, magnetometer internal calibrations, and SEM calibrations not involving pointing changes.

Space Environment Monitor and Sun Pointed Instruments

The SEM is on and operational once the spacecraft reaches station. Sun pointed instruments are activated and calibrated after the solar array and instrument mounting platform (IMP) are deployed. Sun pointing for the solar array and all sun pointed instruments is maintained by the ACE using PSS inputs.

Image Navigation and Registration

To support INR, a parent image motion compensation (IMC) coefficient set and star set are generated every day and uploaded to the spacecraft. These are included along with the daily schedule uplink, and a new set is generated and uplinked for eclipse operations before any orbit perturbing maneuver (momentum dumps, east-west stationkeeping). OATS provides GTACS with the new IMC coefficient data set to be uploaded approximately 2 hours before the planned upload to the spacecraft. IMC operation for GOES East and GOES West is performed separately.

Periodic Operations

Periodic operations are infrequent but recurring events that are scheduled periodically through the spacecraft's on-orbit lifetime (Figure 17-3). These operations can be inserted into the daily operations schedule as needed and performed during one of the house-keeping intervals, the other scheduled functions being altered accordingly. Major periodic operations are:

- East-west stationkeeping (EWSK)
- North-south stationkeeping (NSSK)
- SEM and sun pointed instrument calibration

17. On-Orbit Mission Operations

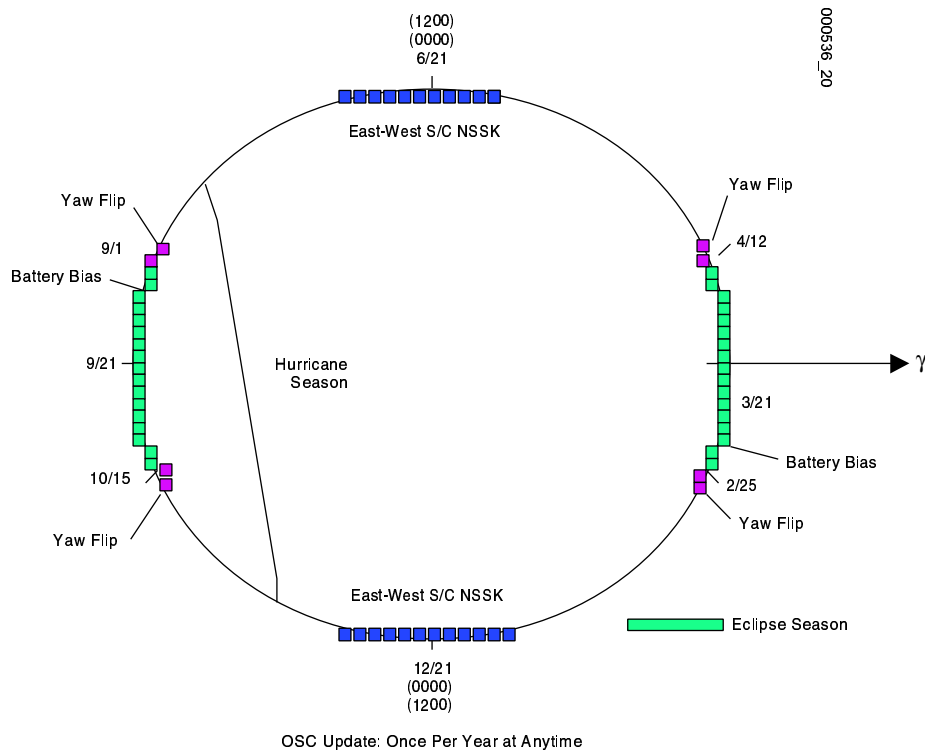

**Figure 17-3. GOES Yearly Operations
(Times in Parentheses are the Free
SAD Travel Maneuver Times for NSSK)**

- Sun/moon intrusion
- Thruster flushing
- Station relocation
- Eclipse operations
- Yaw flip
- On-board star catalog (OSC) update
- Leap second adjustments

17. On-Orbit Mission Operations

East-west Stationkeeping

East-west stationkeeping is required once every 2 to 4 months to counteract the effects of earth's triaxiality on spacecraft drift and solar radiation pressure on orbital eccentricity. The maneuver strategy is to start the stationkeeping cycle with the spacecraft at one edge of the longitude deadband ($\pm 0.5^\circ$), drifting across the deadband with negative perturbing acceleration. With an initial drift rate of just the right magnitude, the spacecraft drifts to the desired longitude, where an EWSK maneuver is applied to reverse the spacecraft drift and keep it within the deadband at the assigned station longitude (either 75° or 135° West). OATS software performs the necessary calculation for determining when to perform the maneuver and the corresponding command data for thruster selection and required duration. An east-west stationkeeping maneuver will be planned prior to entering eclipse season to avoid having to perform a thruster maneuver during eclipse season. East-west stationkeeping maneuvers will be performed during a second housekeeping period, with full INR operations recovery at the end of the housekeeping period.

North-south Stationkeeping

Once a year (for 0.5° inclination) north-south stationkeeping maneuvers are required to counteract the gravitational forces exerted by the sun and moon on the spacecraft. The maneuver strategy is to start the stationkeeping cycle with the spacecraft at one edge of the inclination deadband ($\pm 0.5^\circ$ of the equator) at the optimum node, allowing it to drift to zero inclination and then back to 0.5° . The maneuver is again performed to bring the spacecraft back to the beginning of the deadband (optimum node). This minimizes the velocity increment required and, hence, propellant used. OATS software performs the calculation for determining when to perform the maneuver and the corresponding command data.

The time period to perform the north-south stationkeeping maneuver is at solstice ± 30 days. This allows for at least 6 hours of lit earth observations following the maneuver while maintaining spacecraft requirements for solar array stay out zones for north thruster firings. It is recommended that one GOES (East or West) spacecraft north-south stationkeeping maneuver be performed in winter and the other spacecraft's maneuver be performed in the summer to eliminate schedule congestion and to ensure at least one fully operational spacecraft is available at all times.

SEM and Sun Pointed Instrument Calibration

The operation of the SEM and sun pointed instruments involve weekly in-flight calibrations of the magnetometer, XRS/EUV, SXI, and EPS/HEPAD. The magnetometer and EPS/HEPAD calibrations do not affect INR operations and can be performed at any time. XRS/EUV and SXI calibrations require the offset pointing of either the solar array or IMP from the sun and are scheduled to occur during a second housekeeping period. The XRS/EUV calibration is combined with the spacecraft PSS weekly calibration, which also requires offset pointing the solar array or IMP.

The XRS/EUV requires offset pointing from the sun, which includes the PSS requirement of a short span offset.

17. On-Orbit Mission Operations

The SXI requires an offset, which will be performed separately from the XRS/EUV and PSS calibration in order to ensure INR recovery following that calibration.

An in-flight calibration of the EPS/HEPAD is initiated by ground command to verify proper operation of the instrument and to adjust the photomultiplier tube high voltage for optimum performance. Once calibration is initiated, the IFC circuitry provides a series of calibration signals to the dome, telescope, and HEPAD amplification channels. The calibration sequence is self-terminating.

Magnetometer Calibration

A bias calibration is performed for the magnetometer after the LOR phase. The bias calibration requires the spacecraft to execute a series of slews. During the maneuver, attitude and sensor data is collected. The data is processed off line with a batch least square estimate to yield magnetometer axes alignment and biases.

Sun/Moon Intrusion

The sun, and to a lesser extent the moon, periodically interferes with spacecraft operations, affecting the Imager and Sounder radiometric reference, and degrading the INR accuracy. The sun affects telecommunications between the spacecraft and ground. The sun and moon at low declination can interfere with the Imager and Sounder. For the sun, this occurs during the eclipse season centered on the equinoxes (22 March and 22 September). Moon intrusion can occur at any time during the year, especially during eclipse season when the moon is full or nearly full as it reaches low declinations. The sun is also expected to cross the command and data acquisition (CDA) antenna beam and degrade spacecraft communications during eclipse season.

Upon request from GTACS, OATS computes the orbital events and sensor intrusions given a future time span and provides the intrusion start and end times, the sensor(s) being impaired (Imager, Sounder), and the edge (east or west for the Imager and Sounder). With these data, the GTACS scheduler determines when operations of a particular sensor are impaired and formulates commands to switch operating modes to account for the interference. The space clamp (radiometric cold reference) is disabled for the Imager/Sounder on the side of the scan line that is experiencing interference.

Image Interaction Diagnostics

Several periodic operations relate to the INR process: dynamic interaction diagnostics, mirror motion compensation tuning, and image motion compensation calibration.

- **Dynamic Motion Compensation (DMC)** is provided to adjust for excessive interaction due to mechanical motion events (such as reaction wheel, solar array drive assembly, and Imager/Sounder mirror motion). Measurement data consist of three-axis angular displacement from the HIRU, Imager and Sounder servo errors, and discrete event information related to solar array drive assembly and X-ray platform (XRP) motor stepping and Imager/Sounder mirror motion. The ACE continuously calculates DMC values and adds them to the IMC for INR pointing determination.

17. On-Orbit Mission Operations

- **Image Motion Compensation Calibration.** A set of baseline in-flight IMC scale factors is established during initial on-orbit startup operations. This baseline, updated yearly, compensates for errors introduced by the digital/analog converters in the ACE. The updated baseline provides the best agreement between commanded IMC offsets and actual instrument line-of-sight offsets. IMC calibration can be performed at any time if imaging and sounding operations are suspended during the IMC calibration period and the instruments are specifically configured to support the calibration process. IMC calibration involves performing a series of star sightings with different IMC offsets as defined by OATS. The resulting Imager and Sounder wideband data are used by OATS to update the east-west and north-south compensation scale factors, which are then transmitted to the spacecraft via GTACS.

Station Relocation

The spacecraft is capable of at least nine station changes during its orbital lifetime:

- From checkout location to an on-orbit storage location
- From the on-orbit storage location to the operational station location
- Three changes of operational station location while maintaining INR specifications ($\leq 1^\circ$ shift/day)
- Two emergency relocations ($\leq 3^\circ$ shift/day)
- From operational station location to end-of-life longitude
- Boost from geosynchronous orbit to super synchronous altitude for deorbit

On-station longitude is changed by applying an incremental velocity, typically at an apse, to maintain eccentricity within acceptable limits and change the radius of the opposite apse. If the velocity increment is applied in the direction of motion, the orbit radius is increased and the spacecraft drifts westerly with respect to earth; if applied opposite to the direction of motion, orbit radius is decreased, and the spacecraft drifts easterly. When the desired on-station longitude is reached, an incremental velocity of equal magnitude, but opposite direction, is applied at the same apse as the first to arrest the drift. The total maneuver is essentially a pair of east-west stationkeeping maneuvers separated by a period for the spacecraft to drift to its new station. OATS software computes the maneuver sequences that place the spacecraft on a specified longitude at a specified time.

17. On-Orbit Mission Operations

Eclipse Operations

The equinox seasons occur from about 28 February to 12 April for the vernal equinox and 31 August to 13 October for autumnal equinox. OATS determines the actual start times and duration of the solar eclipses that occur once a day during these seasons. Special IMC coefficient set and star set are generated and uplinked to the spacecraft for use during this period. During eclipse, the pre-eclipse IMC set is resurrected and renamed to allow for its use following the eclipse recovery period. A new feature of GOES N-P is that there is enough battery power for the Imager, Sounder, and other instruments and services to operate, uninterrupted, during eclipse.

Battery bias calibrations are performed at the beginning of eclipse season after the eclipse duration is greater than 30 minutes. This calibration ensures the full recharge of the batteries prior to reentering eclipse.

Yaw Flip

In order to prevent possible sun intrusion into the Imager and Sounder radiant cooler's field of view (FOV), it is possible to operate the GOES N-P spacecraft in either an upright or an inverted fashion. This maneuver entails a 180° yaw slew around noon SLT 9 days before or after each eclipse season. Before this period, fault protection cannot ensure protection from sun intrusion into the cooler's FOV, and increased operational activities during eclipse season may preclude the maneuver being performed during that period. The time of day (noon SLT) allows for both a stable thermal environment transition and eliminates large solar array motion during the maneuver.

It is recommended that one spacecraft be flipped before eclipse season entry and the other spacecraft flipped after eclipse season. Since estimates on the thermal recovery for resuming INR specifications are determined and updated each yaw flip, it is highly recommended that the same maneuver period (either pre- or post-eclipse season) be maintained for the same spacecraft for all future maneuvers in order to fine-tune these estimates and speed INR recovery.

On-board Star Catalog (OSC) Update

Once each year, the OSC is updated to compensate for star angular motion. This can be performed at any time using a ground software tool that allows for the update and uplink of either the entire OSC or individual 1° declination strips. The updates are epoched 6 months into the future to allow for the least impact of star angular motion over the following year. This can be performed while SIAD is active and for declination strips currently in use by SAID.

17. On-Orbit Mission Operations

Leap Second Adjustments

In the event that the UTC is adjusted for a leap second, both GOES spacecraft will be placed into a special housekeeping period at 0000 GMT on the day of the leap second. A clock adjustment will be performed to compensate for this change in UTC over the duration of the housekeeping period. Upon exit of the housekeeping period, the on-board clock will be synchronized with UTC within specifications.

Deorbit

At the end of its operational life, the spacecraft is raised 350 kilometers (217 statute miles) above synchronous altitude to allow other spacecraft to use the vacated orbital slot. In this deorbit maneuver, the thrusters impart an incremental velocity to the spacecraft, typically at an apse, in the direction of motion, producing an elliptical transfer orbit to the higher orbit radius and a westerly drift with respect to earth. The new orbit is circularized by a second velocity increment applied at the opposite apse in the direction of motion. The spacecraft subsystems and payloads are then shut down to eliminate unwanted transmissions.

17. On-Orbit Mission Operations

This page left blank.

18. Instruments of Opportunity

GOES N-P spacecraft were designed with provisions to accommodate up to two additional observational instruments, which are referred to as instruments of opportunity (IOO). The provisions include space on the nadir facing Imager/Sounder mounting plate, structural support capabilities, a defined clear field of view, power capacity, launch vehicle lifting capacity, thermal radiator area, telemetry and command channels, and data downlink bandwidth over the multi-use data link (MDL). In addition, the IOOs are provided with the inherent attitude control and knowledge capabilities and contamination control attributes of the GOES spacecraft.

Table 18-1 summarizes key spacecraft instrument accommodation parameters. The entries in the table refer to total IOO accommodations, which would necessarily be shared if two IOOs were flown on any single spacecraft. Additional details, including interface requirements on the IOOs, can be found in *Interface Requirements Document for Geostationary Operational Environmental Satellite (GOES) N-Q Instruments of Opportunity*, BSS GA27082, February 1999.

Table 18-1. Key IOO Accommodation Provisions

Parameter	Value
Mass	35 kg
Unobstructed fields of view	10° cone about nadir
Power source voltage	42 V
Maximum operational power	150 W
Telemetry channels	1 8-bit analog 9 8-bit conditioned analog
Command channels	6 pulse 1 serial
Science data down-link bandwidth	100 kbps
Timing signals	1 Hz pulse accurate to 1 msec plus 24 bit time tag
Heat dissipation	Roughly 100 to 250 W for mission allowable temperatures of roughly 5 to 70°C, respectively
Attitude control accuracy	Normal to spacecraft nadir face pointed to earth's center within 0.1° 3 sigma
Attitude knowledge accuracy	112 μrad 3 sigma at 8 Hz
Attitude stability	35 μrad 3 sigma over 1 sec

18. Instruments of Opportunity

Note that as of the date of publication of this document, no IOOs have been identified for flight on GOES N spacecraft. Instruments previously considered for flight included a lightning mapper, a volcanic ash tracker, and a special event storm staring imager. All future IOO flight opportunities are as announced, selected and arranged by the GOES Program Office at NOAA.

19. Technical Performance Summary

This section summarizes the typical and nominal capabilities of the GOES N-P system unless otherwise stated. The numbers quoted do not necessarily represent worst case parameter values for all extreme conditions in special modes.

General Spacecraft Data

Configuration	Body stabilized
Design life	10-yr (8-yr mission)
Launch vehicle	Delta IV
Maneuver lifetime	>10 years
Spacecraft dimensions	
Launch configuration envelope	
Width earth face	2.56 m (8.08 ft)
Height (Top of solar array to aft omni)	4.6 m (15 ft)
Depth	2.9 m (9.42 ft)
On-orbit configuration	
Array to body	6.0 m (19.25 ft)
Magnetometer to body (true length)	8.5 m (27.9 ft)
Overall length (Solar array to -Y radiator)	8.4 m (27.58 ft)
Overall height (Imager port to magnetometer boom)	9.1 m (29.83 ft)
Overall depth	2.9 m (9.42 ft)
Spacecraft mass	
Deployment mass	3217.3 kg (7092.9 lb)
Dry mass	1545.7 kg (3407.6 lb)
Propellant and pressurant	1671.6 kg (3685.3 lb)

19. Technical Performance Summary

Command

Receive

Frequency	2034.200 MHz
Minimum EOC antenna gain (on-orbit)	-2.95 dBi ($\pm 55^\circ$)
Minimum G/T	-60 dB/K
Uplink bit rate	2 kbps

Dynamic Range

Command only	-115 to -50 dBmi
Command and ranging	-115 to -50 dBmi

Transmission signal bandwidth

Without ranging	80 kHz
With ranging	250 kHz
Uplink bit rate	2000 bps
COMSEC	Selectable

Attitude Control Subsystem (ACS)

Transfer orbit	Passively stable, LAM and final spindown maneuver are 3-axis stabilized with thrusters	
On-orbit stabilization	3-axis stabilized zero momentum	
Pointing accuracy		
Antenna pointing (3σ)	<u>Maneuver Mode</u>	<u>Normal Mode</u>
Roll	$\pm 0.25^\circ$	$\pm 0.01^\circ$
Pitch	$\pm 0.20^\circ$	$\pm 0.01^\circ$
Yaw	$\pm 0.25^\circ$	$\pm 0.01^\circ$
Payload operations (with DMC)		
Roll	$\pm 6.0 \mu\text{rad}$	
Pitch	$\pm 9.0 \mu\text{rad}$	
Yaw	$\pm 6.0 \mu\text{rad}$	
Imaging stability (15 minute imaging interval)	$\pm 6.0 \mu\text{rad}$ N-S $\pm 9.0 \mu\text{rad}$ E-W	
Stationkeeping window		
North-south (N-S), latitude	$\pm 0.5^\circ$ about equator	
East-west (E-W), on-station	$\pm 0.5^\circ$ in longitude	

19. Technical Performance Summary

Propulsion Subsystem

Propellant	Bipropellant
Tank volumes/capacity	
Fuel—monomethylhydrazine (MMH)	367.8 L (12.99 ft ³)/319 kg (703 lb)
Oxidizer—nitrogen tetroxide (N ₂ O ₄)	367.8 L (12.99 ft ³)/529.5 kg (1167 lb)
Pressurant—helium	42.6 L (1.5 ft ³)
Total propellant mass required	
Fuel (2)	625 kg (1378 lb)
Oxidizer (2)	1043 kg (2299 lb)
Helium (2)	3.7 kg (8.2 lb)
Thrusters	
AOC (12)	9.25 Nm (2 lbf)
Apogee (1)	490 Nm (110 lb)

Electrical Power Subsystem

Solar array	Single axis, Sun tracking	
No. of panels	1 main panel and 1 yoke panel with solar cells	
Panel sizes	270.5 cm × 386.8 cm (106.5 in × 152.3 in) main panel, 231.1 cm x 183.2 cm (91.0 in x 72.1 in) yoke panel	
Power output, W	<u>Output</u>	<u>Nominal Load</u>
BOL summer solstice	2313	1751
BOL autumnal equinox	2562	1998
EOL summer solstice	1900	1759
EOL autumnal equinox	2084	2014
Batteries	1 Nickel-Hydrogen (3 packs)	
No. of cells	24 (8 cells/pack)	
Capacity	123 A-hr	
Depth of discharge	75% maximum with eclipse	
Eclipse load supported	1950 W, 72-minute eclipse	
Bus	Multiple bus system	
Voltage (sunlight)	53.1 ±0.25, 42.0 ±0.5, 30.0 ±0.3 V dc	
Voltage (eclipse)	Same	

19. Technical Performance Summary

Command & Data Acquisition (CDA) Station Telemetry

Transmission signal bandwidth	16 kHz
Data rate	4 kbps (nominal) or 1 kbps
Transmit	
Frequency	1694.000 MHz
Power	3.5 W
Antenna	
Minimum EOC Gain (90°)	-14dBi
Pattern	75% of 4pi steradian
EIRP Minimum EOL	15.9 dBmi

Deep Space Network Telemetry

Transmission signal bandwidth	2.5 MHz
Data rate	4 kbps (nominal) or 1 kbps
Transmit	
Frequency	2209.086 MHz
Power	8 W
Antenna	
Minimum EOC Gain	-14 dBi
Pattern	75% of 4pi steradian
EIRP Minimum EOL	20.3 dBmi

Deep Space Network Ranging

Receive	
Transmission signal bandwidth	250 kHz
Transmission frequency	2034.200 MHz
Transmit	
Frequency	2209.086 MHz
Power	8 W
Antenna	
Minimum EOC Gain	-14 dBi
Pattern	75% of 4pi steradian
EIRP-Minimum EOL	20 dBmi

19. Technical Performance Summary

Data Collection Platform Report (DCPR)

Transponder

Receive

Frequency, Domestic	401.900 MHz
Frequency, International	402.200 MHz
Minimum EOC antenna gain	13.1 dBi ($\pm 9^\circ$)
Minimum G/T	-18.7 dB/K
Dynamic range	Below noise to -100 dBmi
Transponder bandwidth, domestic	400 kHz
Transponder bandwidth, International	400 kHz

Transmit

Frequency, Domestic	1694.500 MHz
Frequency, International	1694.800 MHz
Power	4 W
Antenna	
Minimum EOC Gain	14.5 dBi ($\pm 9^\circ$)
Coverage	Earth
EIRP-Minimum EOL	46 dBmi

Data Collection Platform Interrogate (DCPI)

Transponder

Receive

Frequency, Spare	2034.8875 MHz
Frequency, East	2034.9000 MHz
Frequency, West	2034.9125 MHz
Minimum EOC antenna gain	10.1 dBi ($\pm 9^\circ$)
Minimum G/T	-17.2 dB/K
Dynamic range	-114 to -104 dBmi
Transponder bandwidth	25.4 kHz channel 200 Hz signal

Transmit

Frequency, Spare	468.8125 MHz
Frequency, East	468.8250 MHz
Frequency, West	468.8375 MHz
Power	4 W
Antenna	
Minimum EOC Gain	10.65 dBi ($\pm 9^\circ$)
Coverage	Earth
EIRP Minimum EOL	41.3 dBmi

19. Technical Performance Summary

Processed Data Relay (PDR)

Receive

Frequency	2027.700 MHz
Minimum EOC antenna gain	13.1 dBi ($\pm 9^\circ$)
Minimum G/T	-17.2 dB/K
Dynamic range	-96 to -86 dBmi
Transponder bandwidth	4.22 MHz

Transmit

Frequency	1685.700 MHz
Power	35 W
Antenna	
Minimum EOC Gain	14.5 dBi ($\pm 9^\circ$)
Coverage	Earth
EIRP Minimum EOL	55.5 dBmi

Multi-use Data Link (MDL)

Transmit

Transmission signal bandwidth	400 kHz
Frequency	1681.478 MHz
Power	8 W
Antenna	
Minimum EOC Gain	14.5 dBi
Coverage	Earth
EIRP-Minimum EOL	47.9 dBmi

Sensor Data

Transmit

Transmission signal bandwidth	5.24 MHz – Imager 80 kHz - Sounder
Frequency	1676.000 MHz
Power	5 W
Antenna	
Minimum EOC Gain	14.5 dBi
Coverage	Earth
EIRP-Minimum EOL	47.5 dBmi

19. Technical Performance Summary

Search and Rescue (SAR)

Receive

Frequency, wideband mode	406.050 MHz
Frequency, narrowband mode	406.025 MHz
Minimum EOC antenna gain	10.65 dBi ($\pm 9^\circ$)
Minimum G/T	-19.2 dB/K
Dynamic range	Below noise to -125 dBmi

Transponder bandwidth:

Wide/narrowband mode	80/20 kHz
----------------------	-----------

Transmit

Frequency	1544.500 MHz
Power	3 W
Antenna	
Minimum EOC Gain	14.6 dBi ($\pm 9^\circ$)
Coverage	Earth

EIRP-Minimum EOL	45.0 dBmi
-------------------------	-----------

Weather Facsimile/Low Rate Information Transmission (WEFAX/LRIT)

Receive

Frequency	2033.000 MHz
Minimum EOC antenna gain	13.1 dBi ($\pm 9^\circ$)
Minimum G/T	-17.2 dB/K
Dynamic range	-107 to -97 dBmi

Transponder bandwidth	586 kHz
-----------------------	---------

Transmit

Frequency	1691.000 MHz
Power	9 W
Antenna	
Minimum EOC Gain	14.5 dBi ($\pm 9^\circ$)
Coverage	Earth

EIRP-Minimum EOL	48.2 dBmi
-------------------------	-----------

19. Technical Performance Summary

Emergency Managers Weather Information Network (EMWIN)

Receive

Frequency	2034.700 MHz
Minimum EOC antenna gain	13.1 dBi
Minimum G/T	-17.2 dB/K
Dynamic range	-114 to -104 dBmi
Transponder bandwidth	50 kHz

Transmit

Frequency	1692.700 MHz
Power	3 W
Antenna	
Minimum EOC Gain	14.5 dBi
Coverage	Earth
EIRP Minimum EOL	43.2 dBmi

Imager Instrument

Field of view defining element	Detector
Optical field of view	Square
5-channel imaging	Simultaneously
Scan capability	Full earth/sector/area
Channel/Detector	Instantaneous FOV:
Visible/silicon	1 km
Shortwave/InSb	4 km
Moisture/HgCdTe	8 km (GOES-N), 4 km (GOES O-P)
Longwave 1/HgCdTe	4 km
Longwave 2/HgCdTe	4 km
Radiometric calibration	Space and internal blackbody
Signal quantizing	10 bits all channels
Frequency of calibration	
Space Look	2.2 sec for full disk; 9.2 or 36.6 sec for sector/area
Infrared Blackbody	10 minutes (Auto BB Cal), 30 minutes typical on-orbit operation
System absolute accuracy	IR channel $\leq 1K$ Visible channel 5% of maximum scene irradiance
System relative accuracy	IR channel $\leq 0.1 K$

19. Technical Performance Summary

Sounder Instrument

Field of view defining element	Field stop
Channel definition	Interference filters
19 Channels	
Longwave IR	7: 14.71–12.02 μm
Midwave IR	5: 11.03–6.51 μm
Shortwave IR	6: 4.57–3.74 μm
Visible	1 at 0.70 μm
Scan capability	Full earth and space
Frequency of calibration	
Space Look	2 minutes
Infrared Blackbody	20 minutes (Auto BB Cal), 30 minutes typical on-orbit operation
Nominal IGFOV	242 μrad , all channels
Sounding areas	10 \times 10 km 60° N-S and 60° E-W
Sounding period of 19 channels	100 ms
Sounding duration	all channels within 75 ms
North-south step size	1120 μrad
East-west step size	280 μrad
Signal quantizing	13 bits all channels
System absolute accuracy	IR channel \leq 1 K
System relative accuracy	IR channel \leq 0.1 K

Imager/Sounder Image Navigation and Registration (INR)

Imager Normal Operations Performance, μrad , 3σ

	<u>E-W</u>	<u>N-S</u>
Navigation	65*	65*
Within-frame registration (25 min)	54	54
Line-line shear (excluding Imager servo)	20	20
Frame-frame registration		
15 min	36	36
90 min	49	49
24 hr	114	114

* equivalent to 2 km ground resolution at nadir

19. Technical Performance Summary

Sounder Normal Operations Performance, μrad , 3σ

	<u>E-W</u>	<u>N-S</u>
Navigation	280*	280*
Within-frame registration (120 min)	84	84
Frame-frame registration		
90 min	84	84
24 hr	224	224

* equivalent to 10 km ground resolution at nadir

Earth Coverage

Full performance	0° to 65° earth central angle (ECA)
INR supported with reduced performance	65° to 70° ECA

Extended Operational Coverage

INR supported with reduced performance

- Post station keeping period
- Eclipse period
- Post yaw flip period

Additional Key INR Features

- Fixed gridding or dynamic gridding modes selectable independently for Imager and Sounder
- INR data available within 3 minutes
- Housekeeping interruptions: Max 2 per day at 10 minutes
- Stationkeeping recovery E/W, immediate recovery N/S. Full performance within 6 hours
- Orbit box: Full performance over ± 0.5 E-W x $\pm 0.5^\circ$ N-S
- INR system does not degrade instrument channel-channel registration
- INR diagnostic data provided

19. Technical Performance Summary

Solar X-ray Imager

<i>SXI Parameter</i>		<i>Performance</i>
Imaging exposure times		
Solar flare sites		<10 ms
Active regions		<100 ms
Coronal loops		<1 sec
Coronal hole boundaries		<10 sec
Spacecraft SXI boresight pointing (to center of solar disk)		Within 3 arc minute elevation, within 3.5 arc minute azimuth
Field of view		42 by 42 arc minute
Pixel size		5 by 5 arc second, square pixels
Spectral sensitivity (integration time 100 ms)		
Spectral band	Source	Minimum detectable photon radiance incident on the telescope entrance (photon cm ⁻² arc second ⁻² sec ⁻¹)
6 to 20 Å	Cu (13.3 Å)	85
6 to 60 Å	C (44.7 Å)	132
Dynamic range		1000 when measured with monochromatic illumination at 44.7 Å
Telemetry amplitude digitization		12 bits (linear or logarithmic channels)
Enpixeled energy	13.3 Å (Cu)	44.7 Å (C)
On axis		29%
10 arc minutes off axis		32%
20 arc minutes off axis		52%
Resolution		7 arc seconds (full width half max)
SXI on-orbit useful life		3 years with a goal of 5 years (after 5 years ground storage)

19. Technical Performance Summary

Space Environment Monitor (SEM)

Magnetometer

Function	Measure ambient magnetic field to ± 1 nT
Sensor element	Fluxgate probe
Sensor assembly	Redundant magnetometers, 3 orthogonal fluxgate probes each mounted on 8.5 m boom
Dynamic range	± 512 nT, any orientation
Resolution	0.03 nT
Sampling rate	Once every 0.512 sec

Solar X-ray sensor (XRS)

Function	Measure solar x-ray in 2 bands
Spectral bands	0.05–0.3 and 0.1–0.8 nm
Resolution: Fluxes	
>20 times threshold	$\leq 2\%$ of reading
Sampling rate	Once every 2.048 sec

Extreme Ultraviolet Sensor (EUV)

Function	Measure solar ultraviolet in 5 bands
Spectral band	5 from 5 to 127 nm
Resolution	0.25 percent, full scale
Sampling rate	3 times every 32.768 sec

Energetic Particles Sensor (EPS)

Function	Measure flux of proton, alpha particles and electrons in 26 energy bands from 0.03 to 500 MeV
Sensor elements	Solid state nuclear detectors
Sensor assemblies	2 EPEADs, 1 MAGED, 1 MAGPD
Sampling rate	Once every 8.2 to 32.8 sec
Dynamic range	From typical particle background levels to largest likely event levels

High Energy Proton and Alpha Particle Detector (HEPAD)

Function	Measure flux of protons and alpha particles from 330 to >3400 MeV in six energy bands
Spectral bands	
Protons	4 from 330 to >700 MeV
Alpha particles	2 from 2560 to >3400 MeV
Sensor assembly	2 solid state detectors in telescope arrangement with fused silica Cerenkov radiation/PMT detector
Field of view	Conical, $\sim 34^\circ$ half angle
Dynamic range	From typical particle background levels to largest likely event levels

20. Acronyms

ABS	alternate bearing support
ACE	attitude control electronics
ACS	attitude control subsystem
ACSS	acquisition sun sensor
A/D	analog to digital
ADC	analog to digital converter
ADI	Applied Dynamics International
ADS	angular displacement sensor
A-hr	Amp hour
AMF	apogee motor firing
AND	(a logical function, as in AND gate)
AQM	sun acquisition mode
ATC	Assurance Technology Corporation
BC	bus controller
BCC	battery charge control
BCVM	battery cell voltage monitor
BDC	battery discharge control
B/S	Beamsplitter
BSS	Boeing Satellite Systems
BVC	bus voltage control
BVL	bus voltage limiter
C	Celcius
CCD	charge coupled device
CCSDS	Consultative Committee for Space Data Systems
CDA	Command and Data Acquisition
CDAS	Command and Data Acquisition Station
CDRL	contract data requirements list
CDS	Correlated double sampling
CEI	coherent error integrator
CF	center frequency
cm	centimeters
CME	coronal mass ejection

20. Acronyms

COMSEC	communications security
CONUS	contiguous United States (lower 48 states)
CTCU	Central telemetry and command unit
D/A	digital to analog
DAB	deployable aft blanket
DCP	data collection platform
DCPI	data collection platform interrogate
DCPR	data collection platform report
DCS	data collection system
DDB	digital data bus
DEB	data electronics box
DGS	Diego Garcia station (USAF)
DID	dynamic interaction diagnostic
DMC	dynamic motion compensation
DoC	Department of Commerce
DPU	digital processing unit
DSN	Deep Space Network
ECRA	electrical contact ring assembly
EED	electro-explosive device
ELT	emergency locator transmitters
EMC	electromagnetic compatibility
EMI	electro mechanical interference
EMWIN	emergency managers weather information network
EPEAD	energetic proton, electron, and alpha detector
EOC	edge of coverage
EOL	end of life
EPIRB	emergency position indicating radio beacon
EPROM	erasable programmable read only memory
EPS	energetic particle sensor, electrical power subsystem
EUV	extreme ultraviolet
E-W, ew, E/W	east-west
EWSK	east-west stationkeeping
FDB	frame definition block
FEMA	Federal Emergency Management Agency
FOV	field of view
FPGA	field programmable gate array
ft	feet
GFE	government furnished equipment
GIMTACS	GOES I-M telemetry and command system
GMS	Geostationary Meteorological Satellite
GMT	Greenwich mean time; ground multiband terminal

20. Acronyms

GN	ground network
GOES	Geostationary Operational Environmental Satellite
GSFC	Goddard Space Flight Center
GTACS	GOES telemetry and command system
GVAR	GOES variable data format
HASS	high accuracy sun sensor
He	Helium
HEB	HASS electronics box
HEPAD	high energy proton and alpha particle detector
HgCdTe	Mercury Cadmium Telluride
HIRU	hemispherical inertial reference unit
HSE	Hughes spacecraft emulator
IF	intermediate frequency
IFC	in flight calibration
IFOV	instantaneous field of view
IGFOV	instantaneous geometric field of view
IMC	image motion compensation
IMCGEN	IMC generation function
IMP	instrument mounting platform
INR	image navigation and registration
IOO	instrument of opportunity
IOS	Indian Ocean Station
IP	internet protocol
IPC	Integrated power controller
IR	Infrared
IRTCU	instrument remote telemetry and command unit
ISEC	instrument systematic error compensation
ITT	ITT Industries, Inc.
KSS	Keyhole sun sensor
K	Kelvin temperature
km	kilometers
kw	kilowatts
LAM	liquid apogee motor
LAN	local area network
lb-f	pound-force
LED	light emitting diode
LEO	low earth orbit
LMATC	Lockheed Martin Advanced Technology Center
LOR	launch and orbit raising
LOS	line of sight

20. Acronyms

LRIT	Low Rate Information Transmission
LTT	low thrust thrusters
LVC	launch vehicle contractor
LW	long wave
m	meters
MAGED	magnetospheric electron detector
MAGPD	magnetospheric proton detector
MDL	multi-use data link
METEOSAT	Meteorological (European Space Agency) Satellite
min	minutes
MLI	multilayer insulation
MMC	mirror motion compensation
MMH	monomethylhydrazine
MRS&S	MDL receive system and server
MUX	multiplexer
MW	Mid wave
N	Newton
NASA	National Aeronautics and Space Administration
NESDIS	National Environmental Satellite, Data, and Information Service
NGDC	National Geophysical Data Center
NOAA	National Oceanic and Atmospheric Administration
NRZ	non-return to zero
N-S, ns, N/S	North-South
NSA	National Security Agency
NSI	NASA standard initiator
NSSK	north-south stationkeeping
NT	nano Tesla
NTACTS	N-Q telemetry acquisition and command transmission system
NTO	nitrogen tetroxide
NW	Northwest
NWS	National Weather Service
O&A	orbit and attitude
OAD	orbit and attitude determination
OATS	orbit and attitude tracking system
OBP	onboard processor
OGE	operations ground equipment
OPS	Operations
OSC	on-board star catalog
OSR	optical solar reflector
PCM	pulse code modulation
PDR	processed data relay

20. Acronyms

PDU	power distribution unit
PEB	power electronics box
PES	performance evaluation system
PLB	personal locator beacon
PM	product monitor
PMD	propellant management device
PMF	perigee motor firing
PMT	photo multiplier tube
POES	Polar-orbiting Operational Environmental Satellite
PSS	precision sun sensor
PWDT	Processor watch dog timer
QPSK	quadrature phase shift keyed
RAM	random access memory
RF	radio frequency
RT	remote terminal
RTS	real time station
RWA	reaction wheel assembly
SAA	solar array actuator
SAD	solar array drive
SAIC	Science Applications International Corporation
SAR	search and rescue
SARSAT	search and rescue satellite aided tracking
S/C	spacecraft
SCP	Spacecraft control processor
SD	sensor data
SDA	Subsystem design and analysis
SDU	squib driver unit
SEU	single event upset
SEC	Space Environment Center of NOAA
SEM	space environment monitor
SESC	Space Environment Services Center
SFSS	satellite field service station
SIAD	stellar inertial attitude determination
SLT	Spacecraft local time
SMS	Synchronous Meteorological Satellite
SPS	sensor processing system
SOC	state of charge
SOCC	Satellite Operations Control Center
SRSO	super rapid scan operation
SSD	solid state detector

20. Acronyms

SSGS	spacecraft support ground system
SSPA	solid state power amplifier
ST	star tracker
STM	storage mode
STDN	Satellite Tracking and Data Network
SW	short wave
SWD	solar wing drive
SWSI	single wire serial interface
SXI	Solar X-ray Imager
T&C	telemetry and command
TBS	To be specified (or supplied)
TC&R	telemetry, command, and ranging
TDRS	Tracking Data Relay Satellite
TLM	telemetry
TOSS	transfer orbit sun sensor
TWDT	thruster watch dog timer
UAQPSK	unbalanced asynchronous quadrature phase shift keyed
UQPSK	unbalanced quadrature phase shift keyed
UHF	ultrahigh frequency
UTC	universal time coordinated
UWDT	Unit watch dog timer
VAS	visible and infrared spin scan radiometer atmospheric sounder
VIS	visible
VME	versa-bus module eurocard
WBU	Wallops Backup
WEFAX	weather facsimile
WFC	wide field collimator
XRP	x-ray platform, x-ray positioner
XRS	x-ray sensor
XUV	extreme ultraviolet
μm	micrometers
μrad	microradians
1553 RT	1553 Data bus remote terminal



Boeing Satellite Development Center

The Boeing Company
P.O. Box 92919
El Segundo, California, USA