

*Presented by  
The Department of Veterans Affairs  
American Legion Auxiliary  
Help Hospitalized Veterans*

## **National Veterans Creative Arts Competition Booklet**

2  
0  
0  
7

This program is most beneficial to your patients when used as a part of therapy year round. This is where the therapy really occurs, on a daily basis in a clinical setting with creative arts therapists, recreation and occupational therapists, craft care specialists and other healthcare professionals using the arts as an avenue toward achievement of restorative related goals.

The competitions and Festival serve as methods by which veterans can receive recognition for their creative accomplishments. A great deal of this recognition is received at their local VA facility and all of you who participate in this process are to be congratulated.

The following are competition rules, information and tips for making your participation easier in the midst of your very busy schedule. If you have further questions or need assistance in any way, you may contact the national chairpersons or me at any time.

*Elizabeth Mackey, MT-BC  
Director, NVCAP*

*PLEASE NOTE changes for this year's competition marked with*



---

**Table of Contents**

---

How to request a video and NVCAF Internet address	2
National Rules	3,4,5,6
National Chairpersons	7,8
Tips for taking better videos and digital images	9
Entry Checklists	9,10,11,12
Journal of Rehabilitation Research and Development Opportunity	13
Station Numbers	14,15,16
Art Entry Form	17
Consent for Use of Picture and/or Voice Forms	18,20,22
Creative Writing, Dance, Drama or Music Solo Entry Form	19
Creative Writing, Dance, Drama or Music Group Entry Form	21
Consent to Release Medical Records or Health Information form (For Special Recognition, Military Combat and Senior Dance Division categories)	23
List of Entries Form - Visual Art	24,25
List of Entries Form - Performing Arts	26,27
Local Level Participation Form	28,29
★ <i>New Items</i> Art Division Rules, Categories, Judging Criteria	30-42
Creative Writing Rules, Categories, Judging Criteria	43-45
Dance Division Rules, Categories, Judging Criteria	46-49
Drama Division Rules, Categories, Judging Criteria	50-53
★ <i>New Items</i> Music Division Rules, Categories, Judging Criteria	54-59
Tips for organizing local competitions	60,61
Sample Press Release	62
Sample Visual Art brochure	63,64
Sample Performing Arts brochure	65,66

---

***To request a videotape of the Festival from a previous year, contact:***

---

Elizabeth Mackey, MT-BC (117)  
National Director  
VA Medical Center  
4801 Veterans Drive  
St. Cloud, MN 56303-2099  
E-mail: Elizabeth.Mackey@med.va.gov  
Telephone: 320-255-6351  
FAX#: 320-255-6327

The 2007 National Veterans Creative Arts Festival will be hosted by the  
St. Louis VA Medical Center during the week of October 22-29, 2007.

**Please check out The National Veterans Creative Arts Festival website for more  
information about entering this year's competition, at  
<http://www.creativeartsfestival.org>**

---

## ***National RULES***

---

1. All required forms must be completed and **postmarked to the National Chairpersons no later than APRIL 1, 2007** in order for veterans to be eligible to compete at the national level.
2. **ELIGIBILITY:** Veterans must be **active outpatients or inpatients** of a VA Medical Center, VA Outpatient Clinic, or reside in a state veterans home **BEFORE entering** your local competition. An eligible veteran can enter local competition at **only one VA facility per year**. He/she can submit an entry in creative writing, dance, drama or music categories with a veteran or group from another VA facility, but still represents and must go through his/her originating VA facility. This facility should be the site where he/she receives their primary treatment.
3. A veteran can have only **one entry per category** in each national division. Individual categories are listed within each division. The divisions are art with 50 categories, creative writing with 19 categories, dance with 34 categories, drama with 25 categories, and music with 42 categories. Judges reserve the right to move an entry to another category if the one listed is not appropriate. First place ties in a category at the local competition **MUST** be rejudged at the local level as only **one entry for each category** will be accepted **from each VA facility**. A formal competition is not required at the local level but is strongly encouraged. All eligible veterans should be given the opportunity to participate regardless of degree of talent.
4. No one veteran will be allowed to enter more than three (3) categories of any one division. This would not include groups of which he/she is a member. Veterans are only permitted to enter **one VA facility's** competition per year.
5. All entries in art, creative writing, dance, drama, and music must be accompanied by the appropriate **ENTRY FORM, and a signed, witnessed and dated RELEASE OF PICTURE AND VOICE FORM**. (Please use the forms provided to make the necessary copies.)
6. The national chairpersons and judges of the competitions reserve the right to disqualify an entry if the above rules are not followed.

---

## **National RULES - The Competition Phase**

---

1. Creative writing, dance, drama and music entries **must be three (3) minutes or less in length**. Any entries reaching the national level which are longer will be disqualified. **Send only the first place winners from your competition**. Only one winner for each category will be accepted from a VA facility.
2. **Once an entry has placed first** in the creative writing, dance, drama and music divisions at the national level of competition, **it is NOT eligible to be entered again**. **All artwork entered** (except for the Military Combat Experience (category #17) **must have been created after March 1, 2006**. \*All **videotapes** of creative writing, dance, drama and music entries must be recorded **after** March 1, 2006. **Creative writing, dance, drama, and music entries which have not placed first** at the national level of competition **should not be entered more than two consecutive years**.
3. **Creative writing entries** must be submitted on one single  $\frac{1}{2}$ " VHS videotape **in the order that the categories are listed in this book**. Videotapes that are not in correct order will be disqualified. **Review your entry tape and make a copy before mailing**. **Label your tape according to the instructions given below**. A 3.5" disquette of the text of **ALL creative writing entries MUST accompany the national entry form** in order for the entry to be accepted and judged at the national level of competition. Email attachments will also be accepted. Submit the videotape of the **creative writing entry(ies)** as well as a 3.5" disquette (or you may email Liz Nealy the text to Nealy.ElizabethF@med.va.gov), entry forms, list of entries and local level participation forms to the **National Creative Writing Chairperson, Liz Nealy, VAMC Houston, TX**.



**LABELING VIDEOTAPES:** Be sure to label the videotape sent to each division (creative writing, dance, drama, music) chairperson. Label it with the name, city and state of your VA facility and list the category numbers in order as they are presented on the tape.

4. **Dance entries** must be submitted on one single  $\frac{1}{2}$ " VHS videotape **in the order that the categories are listed in this book**. Videotapes that are not in correct order will be disqualified. **Review your entry tape and make a copy before mailing**. **Label your tape according to the instructions given in Rule #3, page 4 - The Competition Phase**. **Dance numbers MUST be accompanied by a lead sheet of the music in the correct key AND the cassette/CD accompaniment to be considered for invitation to the Festival**. Submit the dance videotape, lead sheet, cassette/CD, entry forms, list of entries and local level participation form to the **National Dance Chairperson, Jean Calhoun, VAMC Tomah, WI**.
5. **Drama entries** must be submitted on one single  $\frac{1}{2}$ " VHS videotape **in the order that the categories are listed in this book**. Videotapes that are not in correct order will be disqualified. **Review your entry tape and make a copy before mailing**. **Label your tape according to the instructions given in Rule #3, page 4 - The Competition Phase**. **A typewritten copy of the text of ALL drama entries MUST accompany the national entry form** in order for the entry to be accepted and judged at the national level of competition. Submit the drama videotape, typewritten copy of the text, entry forms, list of entries and local level participation forms to the **National Drama Chairperson, Suzanne Anderson, VAMC Knoxville, IA**.

---

## National RULES - The Competition Phase (continued)

---

6. **Vocal music entries** must be submitted on one single  $\frac{1}{2}$ " VHS videotape in the order that the categories are listed in this book. **Instrumental music entries** must be submitted on one single  $\frac{1}{2}$ " VHS videotape in the order that the categories are listed in this book. Videotapes that are not in correct order will be disqualified. **Review your entry tapes and make copies before mailing. Label your tapes according to the instructions given in Rule #3, page 4 - The Competition Phase. A lead sheet of music in the correct key for all musical numbers MUST accompany the national entry blank for the veteran(s) to be considered for invitation to the Festival. Submit the vocal music videotape, lead sheet, entry forms, list of entries and local level participation form to the National Music Chairperson, Jennifer Lewis, VAMC Temple, TX. Please note, the presence of any vocals require that an entry be classified as a VOCAL entry, not an instrumental entry. Submit the instrumental music videotape, lead sheet, entry forms and list of entries to the National Music Division Assistant, Veronica Andreassen, VAMC Durham, NC.**



7. **Groups in creative writing, dance, drama and music are not limited in number of group members. However, no more than 15 eligible veterans in one group will be funded by the Festival should the entry advance to that level of the competition.**



8. **Art entries** must be submitted as **digital images only. Do not submit the actual art, slide images or photographs of the art as they will be disqualified.** (See pages 11 and 12 - Art Division checklist - for specific information.)
9. There are two phases to the national level of the art competition. The first phase is by a DIGITAL format and will determine the top three entries in each category. By the end of May, the contact staff person listed on the entry form of each of these top three entries will be notified and requested to send the actual artwork to St. Louis, MO for the final phase of the national art competition. The phase two judges will determine 1<sup>st</sup>, 2<sup>nd</sup> and 3<sup>rd</sup> place in each category. All 1<sup>st</sup> place gold medal winners from the National Art Division Competition will be invited to the Festival.
10. The Department of Veterans Affairs reserves the right to withdraw any works for public display during the local or national competition phase.
11. Veterans in national first, second and third place groups of up to four in creative writing, dance, drama and music will each be presented a medal (non-veterans in the group will not receive medals). Groups of five (5) or more will be presented a plaque to be displayed in the Recreation area or other area designated by the Medical Center Director.
12. Each veteran **must** work with a **VA staff member** from the facility at which he/she receives his/her primary treatment in order to enter the competition, or risk disqualification.
13. VA contact staff will be notified via email with the 2007 competition results from each of the five divisions.

---

## National RULES - The Festival

---

1. Following the national judging, all of the first place-winning videotaped entries from the national competition in the creative writing, dance, drama and music divisions will advance for viewing and **possible** selection for inclusion in the 2007 Festival stage show performance. **SOME** of these first place-winning contestants will be invited to attend the National Veterans Creative Arts Festival to be hosted by the St. Louis VA Medical Center October 22-29, 2007. In addition, some of the second and third place entries from the creative writing, dance, drama and music divisions may also be considered for possible inclusion and invitation to participate in the stage show performance. Those invited to attend will be notified by June 30, 2007.

All national first place-winning contestants from the **art division** will automatically be invited to attend the Festival and will be notified via their VA contact staff person by June 30, 2007.

2. **For the art division:** Veterans who have received a gold medal in the same category from the art division for two consecutive years must enter a different category the third year in order to be invited to the Festival. Failure to comply with this rule will result in disqualification. **For the performing arts divisions:** Veterans may only be invited to the Festival in the same category for two consecutive years. Veterans attending the Festival in the same category in 2005 and 2006 must be a winner in a different category in 2007 to be invited to the Festival. The stage show selection committee reserves the right to make exceptions to this rule. Medals, ribbons, and plaques may be won in any category for any number of years.
3. Veterans may not enter the same creative writing, dance, drama and music entry again once it has won first place nationally. Failure to comply with this rule will result in disqualification of the entry. Additionally, veterans should be encouraged to enter new material each year rather than repeat entries.
4. Funding support and arrangements for travel to and from the National Veterans Creative Arts Festival for those invited veterans should be the responsibility of the local medical center. Housing, meals, ground transportation and other routine expenses during the Festival will be provided through national Festival funds. These expenses will be provided for up to 15 eligible veterans per group.
5. Those invited to participate in the National Veterans Creative Arts Festival will be notified via email to the VA contact staff person listed on the entry form, no later than June 30, 2007. Invited participants must decline or submit all required forms for participation in the Festival no later than August 15, 2007.
6. Veterans who are invited to the Festival must be prepared (either themselves or through their contact staff person) to send an Email including the words/lyrics of their entry in order for it to be placed in the show script. This includes lyrics for music, dance, and words/narration for all drama and creative writing pieces. Emails can be sent to [Suzanne.Anderson4@med.va.gov](mailto:Suzanne.Anderson4@med.va.gov).
7. Performance costumes for winning acts invited to the Festival will be the responsibility of the participant(s). All participants will be requested to bring black pants or skirts and white long sleeved collared shirts, but other production number costumes such as vests, hats, ties, etc., will be provided by the National Committee.



New

---

***National Chairpersons - Art Division***

---



***Please note: Slide images will no longer be accepted. All entries must be submitted in digital format.***

**It is recommended to overnight-mail your art division paperwork to the appropriate staff person. This ensures the ability of tracking all items.**

***Art Division - Fine Art Entries***

**Electronic digital image entries and forms to:**

Katy Ryan, CTRS (135R)  
National Art Chairperson  
VA Medical Center  
One Veterans Drive  
Minneapolis, MN 55417  
Fax: (612) 727-5643  
E-mail: Katharina.Ryan@med.va.gov

***Art Division - Applied Art Entries***

**Electronic digital image entries and forms to:**

Paula Moran, CTRS (11K)  
Visual Arts Assistant  
Northern AZ VAHCS  
500 North Hwy 89  
Prescott, AZ 86313  
FAX: (928) 776-6176  
E-mail: Paula.Moran@med.va.gov

***Art Division - Kit Entries***

**Electronic digital image entries and forms to:**

Mia Leber, CCS (11K)  
Visual Arts Assistant  
Jesse Brown VA Medical Center  
820 South Damen  
Chicago, IL 60612  
FAX: (312) 569-8041  
E-mail: Mia.Leber@med.va.gov

---

***National Chairpersons - Creative Writing, Dance, Drama and Music Divisions***

---

It is recommended to overnight-mail your creative writing, dance, drama and music division videotapes and paperwork to the appropriate staff person. This ensures the ability to track all items.

***Creative Writing Division - All Entries***

Entries on ½" VHS videotape,  
3.5" disquette (or you may email the text  
of the entry) and forms to:

Liz Nealy, CTRS (117RT)  
National Creative Writing Chairperson  
VA Medical Center  
2002 Holcombe Blvd.  
Houston, TX 77030  
FAX: (713) 794-7631  
E-mail: Nealy.ElizabethF@med.va.gov

***Dance Division - All Entries***

Entries on ½" VHS videotape,  
sheet music, CD/cassette of instrumental  
music and forms to:

Jean Calhoun, MT-BC (117M)  
National Dance Chairperson  
VA Medical Center  
500 East Veterans  
Tomah, WI 54660  
FAX: (608) 372-1227  
E-mail: Jean.Calhoun@med.va.gov

***Drama Division - All Entries***

Entries on ½" VHS videotape,  
written copy and forms to:

Suzanne Anderson, MT-BC (117R)  
National Drama Chairperson  
VA Central Iowa HCS  
1515 West Pleasant  
Knoxville, IA 50138  
FAX: (641) 828-5189  
E-mail: Suzanne.Anderson4@med.va.gov



*New*

***Music Division - VOCAL Entries***

Entries on ½" VHS videotape,  
sheet music and forms to:

Jennifer Lewis, RMT (117T-RT)  
National Music Chairperson  
Central Texas VA HCS  
1901 South 1st Street  
Temple, TX 76504-7497  
FAX: (254) 743-0495  
E-mail: Jennifer.Lewis@med.va.gov



*New*

***Music Division - INSTRUMENTAL Entries***

Entries on ½" VHS videotape,  
sheet music and forms to:

Veronica Andreassen, MA, MT-BC  
Music Division Assistant  
PM&RS 117C  
Durham VA Medical Center  
508 Fulton Street  
Durham, NC 27705  
E-mail: Veronica.Andreassen@med.va.gov



---

### ***Tips for taking BETTER VIDEOS: Creative Writing, Dance, Drama and Music Entries***

---

- Please take a few extra minutes preparing a video correctly in order to give your veteran the best chance possible during the judging process and to save HOURS of time with the judging process for our judges who donate their time.
- **Focus on the performer**, not the accompanists. Avoid taping from the back of the room. Stage presence cannot be judged if you cannot clearly see the performer.
- In the case of videotaping dance acts, be sure to focus on the feet. Whole-body videotaping for dance entries is highly recommended.
- **Sound control** is important! Clear audio makes a performance much easier (and enjoyable) to judge. Make sure your sound is good and balanced.
- **Don't tape your entire show and then just go back and erase those acts that are not going forward to the national level.** Consider holding your local competition and then videotaping ONLY the first place acts that will be sent forward to national.
- **Creative writing, dance, and drama entries** must be submitted on one single  $\frac{1}{2}$ " VHS videotape for each division in the order that the categories are listed in this book. *Videotapes that are not in correct order will be disqualified.*
- **Vocal music entries** must be submitted on one single  $\frac{1}{2}$ " VHS videotape in the order that the categories are listed in this book. *Videotapes that are not in correct order will be disqualified.*
- **Instrumental music entries** must be submitted on one single  $\frac{1}{2}$ " VHS videotape in the order that the categories are listed in this book. *Videotapes that are not in correct order will be disqualified.*
- Check your tape before you mail it and **make sure every act you intend to be on there is in fact there.** Every year there are facilities that have unintentionally left someone's act off the tape. **Label your tape according to the instructions given in Rule #3, page 4 - The Competition Phase.**
- **Be sure to make a copy of your final videotapes for your own file/library in the event of lost or damaged videotapes.**



New

---

### ***Tips for taking BETTER DIGITAL IMAGES: Art Entries***

---

- **The art piece should fill the photo** - get as close as possible so the piece fills the viewfinder of the camera.
- **Include the framing and matting of pictures** - these are part of the total presentation. Pedestals or bases that are part of the artwork should also be included in the slide.
- **Use soft pastel backgrounds rather than white backgrounds** - this can reduce glare.
- **Three-dimensional pieces may submit two images** - each image should show a different angle of the piece.
- **Watch for shadows on the background** - move the item being photographed away from the background to eliminate shadows.
- **Be alert for glare** - try changing the direction and location of the lighting or softening the light by bouncing it off a wall or screen.



New

---

### ***Entry Checklist***

**\*\*\*All entries *MUST* be postmarked by midnight of April 1, 2007.**

- ***Make Copies of all paperwork, videotapes and slides*** for your own files in the event of loss or damage incurred in the shipping process.

---

## ***Creative Writing, Dance, Drama and Music Divisions Checklist***

---

Refer to page 8 for each division chairperson's mailing address.

### **CREATIVE WRITING DIVISION**

Submit items below to the **National Creative Writing Chairperson, Liz Nealy**, Houston, TX.

- Entry and Consent form completed with all necessary information
- List of Entries form
- Local Level Participation form listing all entries from your Medical Center's Local Creative Writing division.
- $\frac{1}{2}$ " VHS videotape of the creative writing entries in the order that the categories are listed in this book. **Review your entry tape and make a copy before mailing.** Label your tape according to the instructions given in Rule #3, page 4 - The Competition Phase. ***Videotapes that are not in correct order will be disqualified.***
- **A 3.5" disquette including the text** of all creative writing entries **MUST** accompany the national entry form in order for the entry to be accepted and judged at the national level of competition. Email attachments will also be accepted.

---

### **DANCE DIVISION**

Submit items below to the **National Dance Chairperson, Jean Calhoun**, Tomah, WI.

- Entry and Consent form completed with all necessary information
- List of Entries form
- Local Level Participation form listing all entries from your Medical Center's local Dance competition.
- $\frac{1}{2}$ " VHS videotape of the dance entries in the order that the categories are listed in this book. **Review your entry tape and make a copy before mailing.** Label your tape according to the instructions given in Rule #3, page 4 - The Competition Phase. ***Videotapes that are not in correct order will be disqualified.***
- **A lead sheet or sheet music** in the correct key for all musical numbers **MUST** accompany the national entry form for the veteran(s) to be considered for invitation to the Festival.
- The cassette/CD instrumental accompaniment should also be submitted.
- Senior categories in dance must also submit a **Consent for Release of Medical Information** and a **VA contact staff person's written explanation** (25 to no more than 220 words) of the veteran's condition and specific talent.

---

### **DRAMA DIVISION**

Submit items below to the **National Drama Chairperson, Suzanne Anderson**, Knoxville, IA.

- Entry and Consent form completed with all necessary information
- List of Entries form
- Local Level Participation form listing all entries from your Medical Center's Local Drama competition.
- $\frac{1}{2}$ " VHS videotape of the drama entries in the order that the categories are listed in this book. **Review your entry tape and make a copy before mailing.** Label your tape according to the instructions given in Rule #3, page 4 - The Competition Phase. ***Videotapes that are not in correct order will be disqualified.***
- **A typewritten copy of the text** of all drama entries **MUST** accompany the national entry form in order for the entry to be accepted and judged at the national level of competition.

---

## *Creative Writing, Dance, Drama and Music Divisions Checklist (continued)*

---



New

*Please note that the music division has been divided into two sub-divisions, vocal and instrumental.*

### **MUSIC DIVISION - VOCAL**

Submit items below to the **National Music Chairperson, Jennifer Lewis**, Temple, TX.

- Entry and Consent form completed with all necessary information
- List of Entries form
- Local Level Participation form lists all entries from your Medical Center's Local Music competition. (Include vocal and instrumental entries on one form.)
- $\frac{1}{2}$ " videotape in the order that the categories are listed in this book. **Review your entry tapes and make copies before mailing. Label your tapes according to the instructions given in Rule #3, page 4 - The Competition Phase. Videotapes that are not in correct order will be disqualified.**
- **A lead sheet or sheet music** in the correct key for all musical numbers **MUST** accompany the national entry blank for the veteran(s) to be considered for invitation to the Festival.
- **All music Special Recognition entries and consent form** (page 23) are to be submitted to Jennifer Lewis.

### **MUSIC DIVISION - INSTRUMENTAL**

Submit items below to the **National Music Division Assistant, Veronica Andreassen**, Durham, NC.

- Entry and Consent form completed with all necessary information
- List of Entries form
- $\frac{1}{2}$ " videotape in the order that the categories are listed in this book. **Review your entry tapes and make copies before mailing. Label your tapes according to the instructions given in Rule #3, page 4 - The Competition Phase. Videotapes that are not in correct order will be disqualified.**
- **A lead sheet or sheet music** in the correct key for all musical numbers **MUST** accompany the national entry blank for the veteran(s) to be considered for invitation to the Festival.

**Please submit a Local Level Participation form listing all entries from your Medical Center's Local Music competition (vocal and instrumental) to Jennifer Lewis, Temple, TX.**

---

### ***Art Division Checklist***

---

- A completed Art Division **Entry Form** and **Consent for Use of Picture and/or Voice** with each entry submitted to the national level of competition.
- **One CD** with the jpeg images of all their first place entries in that division (all fine art first place entries on one CD, all applied art on one CD, all craft kits on one CD)
- **Contact sheets**, also called photo proof sheets, this printed page of all that division's thumbnail images is to include each entry's category and complete title along with the veteran's complete name. Each contact sheet must be labeled with the complete VA facility name as well as the division, i.e. fine arts, applied arts or craft kits. The contact sheets can be printed in black and white.
- **List of Entries** - List all the local first place entries from your site submitted to the National Art Competition.
- **2007 Local Level Participation** lists all entries from your Medical Center's Local Art competition. Mail this form to Katy Ryan, National Art Chairperson.

---

### ***Art Division Checklist (continued)***

---

- **SPECIAL RECOGNITION and MILITARY COMBAT EXPERIENCE categories:** Consent for Release of Medical Information Form and VA contact staff person's written explanation (25 to no more than 220 words) of why the veteran is deserving of special recognition. These **MUST** be included with each Special Recognition Category and Military Combat Experience entry or the entry will be disqualified.

---

### ***All Divisions Checklist***

---

All of the following **MUST** be included when shipping entries to the National Chairpersons of the Art, Creative Writing, Dance, Drama, and Music.

**List of Entries** - Visual Arts form (pages 24 and 25), Performing Arts form (pages 26 and 27)

- Submit one sheet to each national chairperson or visual arts assistant for the particular division entering. List entries *in order by category* as specified in this booklet. **The entries on the videotape for Creative Writing, Dance, Drama and Music Divisions must also be in order by category as listed in this booklet.**

**Entry form(s)** (pages 17, 19, 21)

- Solo, Group or Art entry form signed by the contact staff or designee

**Consent for Use of Picture/Voice** (pages 18, 20, 22)

- Must be signed by the veteran and a witness

**\*\*\*Please note: Special Recognition, Military Combat Experience (and Senior category in dance only) must also submit the following:**

**Consent to Release Medical Records form** (page 23)

- Must be signed by the veteran. A **written statement (25 to 220 words) by the veteran's VA contact staff person** explaining the veteran's condition and specific talent.

**Local Level Participation Form** (page 28, 29)

- Submit one sheet to each national chairperson for the particular division entering. This form is essential in recording data for statistical purposes.
  - In the art division, please submit the Local Level Participation Form for all three sub-divisions (fine art, applied art, and craft kits) from your Medical Center's Local Art competition to Katy Ryan, National Art Chairperson (see page 7 for complete mailing address).
  - In the music division, please submit the Local Level Participation Form for both sub-divisions (vocal and instrumental) from your Medical Center's Local Music competition to Jennifer Lewis, National Music Chairperson (see page 8 for complete mailing address).





The Department of Veterans Affairs *Journal of Rehabilitation Research and Development (JRRD)* is a bi-monthly publication that is distributed to an international audience of more than 7,300 readers. It is a peer-reviewed scientific research publication in the multidisciplinary field of disability rehabilitation. *JRRD* is a resource for scientists and doctors, as well as veterans with disabilities.

Entries from the first phase of the national art division competition will have the opportunity to possibly be reviewed by JRRD staff. Several entries will be selected to appear on various covers of the 2008 publications. **Signed consent will be needed from veterans who will allow images of their entries and Art Entry Forms to be forwarded to JRRD staff following the national art competition judging in June.** Please note the consent area on the Art Entry Form, page 17.

---

**STATION NUMBERS**

---

FACILITY CITY	STATION NUMBER
Akron CBOC	541D
Albany - Upstate NY HCS	528E
Albuquerque-New Mexico VA HCS	501
Alexandria VAMC	502
Altoona - James Van Zandt VAMC	503
Am Lake VA Puget Sound HCS	663A
Amarillo HCS	504
Anchorage - Alaska HCS&RO	463
Ann Arbor VA HCS	506
Appleton VA CBOC	695A
Asheville VAMC	637
Atlanta VA Medical Center	508
Augusta VA Medical Center	509
Baltimore - VA Maryland HCS	512
Batavia VA Western NY HCS	528A
Bath - Upstate NY HCS	528D
Baton Rouge	629Q
Battle Creek	515
Bay Pines	516
Bay Pines VA Regional Office	516B
Beckley VAMC	517
Bedford	518
Big Spring West Texas VA HCS	519
Biloxi/GPort VA GulfCoast HCS	520
Birmingham VAMC	521
Boise VAMC	531
Bonham - North Texas HCS	549A
BRECC	512A
Brecksville - Louis Stokes VAMC	541A
Brevard Clinic	673G
Brockton Campus - VA Boston HCS	523A
Bronx	526
Brooklyn VA NY Harbor HCS	630A
Buffalo VA Western NY HCS	528
Butler	529
Canandaigua - Upstate NY HCS	528B
Canton	541C
Castle Point VA Hudson Valley	620A
Charleston - Ralph Johnson VAMC	534
Chattanooga - Tenn Valley HCS	626C
Cheyenne VAMROC	442
Chicago - Jesse Brown VA HCS	537
Chillicothe	538

FACILITY CITY	STATION NUMBER
Cincinnati VAMC	539
Clarksburg - Louis Johnson VAMC	540
Cleveland - Louis Stokes VAMC	541
Coatesville	542
Columbia MO-Harry Truman VAMC	589C
Columbia SC - WJB Dorn VAMC	544
Columbus OPC	757
Crown Point - VA Chicago HCS	537C
Dallas - North Texas HCS	549
Danville - Iliana VA HCS	550
Dayton VA Medical Center	552
Daytona	573D
Denver - SOCO	554A
Denver - Eastern Colorado HCS	554
Des Moines VA CIHS	636C
Detroit - John D. Dingell VAMC	553
Dublin - Carl Vinson VAMC	557
Durham VAMC	558
East Orange VA NJ HCS	561
El Paso VAHCS	756
Erie	562
Fargo VAMROC	437
Fayetteville AR	564
Fayetteville NC	565
Fort Meade - VA Black Hills HCS	568
Fort Thomas VANH	539A
Fort Wayne VA N Indiana HCS	610A
Fresno - Central California HCS	570
Ft Myers OPC	516A
Ft Smith VA/CBOC	564B
Ft Harrison VA Montana HCS	436
Gainesville - N.FL/S.GA VA HCS	573
Grand Island Div VA NWIHS	636B
Grand Junction	575
Grand Rapids CBOC	515Q
Grayling	655A
Gulfport VAMC	520A
Hampton	590
Hines VA Hospital	578
Honolulu VA Pacific Is. HCS	459
Hot Springs - VA Black Hills HCS	568A
Houma CBOC	629GA
Houston M E DeBakey VAMC	580

FACILITY	STATION NUMBER
Huntington	581
Indianapolis - RL Roudebush VAMC	583
Iowa City VAMC	636E
Iron Mountain	585
Jackson GV Montgomery VAMC	586
Jacksonville	573J
Jamaica Plain - VA Boston HCS	523
Kansas City VA Heartland West	589
Kerrville - South Texas HCS	671A
Klamath Falls	692A
Knoxville VA CIHS Division	636D
Knoxville - Tenn Valley HCS	626K
Lake City-N.FL/S.GA VA HCS	573A
Lakeside - VA Chicago HCS	537A
Las Vegas VA S NV HCS	593
Lawton OPC	635B
Leavenworth VA E Kansas HCS	589B
Lebanon	595
Lexington	596
Lincoln Division VA NWIHS	636A
Little Rock - Central AR HCS	598
Livermore VA Palo Alto HCS	640B
Loma Linda VA HCS	605
Long Beach VA HCS	600
Longview CBOC	667C
Los Angeles ACC VA GLA HCS	691B
Los Angeles VA GLA HCS	691
Louisville	603
Lubbock	504Q
Madison-Wm S Middleton VAMC	607
Manchester	608
Marion IL VAMC	657C
Marion VA N Indiana HCS	610
Marlin	674B
Martinez	612
Martinsburg	613
McClellan CBOC	612B
Memphis	614
Miami VA Healthcare System	546
Middletown CBOC	552C
Miles City VA Montana HCS	436A
Milwaukee-C J Zablocki VAMC	695
Minneapolis VAMC	618
Monroe CBOC	667B
Montgomery CAVHCS	619
Montrose VA Hudson Valley HCS	620

FACILITY	STATION NUMBER
Mountain Home	621
Mt Vernon - Gene Taylor CBOC	564A
Murfreesboro - Tenn Valley HCS	626B
Muskogee VAMC	623
N Little Rock - Central AR HCS	598A
Nashville - Tenn Valley HCS	626
New Orleans	629
New York VA NY Harbor HCS	630
Newington - Connecticut HCS	689A
NGAG-Black Hills	702
North Chicago	556
Northampton	631
Northport	632
NVGAG-Black Hills	701
Oakland Park Outpatient Clinic	546R
Oklahoma City	635
Omaha Division VA NWIHS	636
Orlando OPC	673B
Palo Alto VA HCS	640
Pensacola Outpatient Clinic	520P
Perry Point VA Maryland HCS	512B
Philadelphia VAMC	642
Phoenix - Carl T Hayden VAMC	644
Pittsburgh Heinz	646A
Pittsburgh Highland Drive	646B
Pittsburgh University Drive	646
Poplar Bluff J J Pershing VAMC	657B
Portland OR VAMC	648
Prescott - North Arizona HCS	649
Providence	650
Reno VA Sierra Nevada HCS	654
Richmond CBOC	552H
Richmond VA - Hunter H. McGuire	652
Rittman National Cemetery	541E
Roseburg VA HCS	653
Sacramento VA N Ca HCS	612A
Saginaw - Aleda E. Lutz VAMC	655
Salem	658
Salisbury - WG Hefner VAMC	659
Salt Lake City VA HCS	660
San Antonio - South Texas HCS	671
San Diego VA HCS	664
San Francisco	662
San Juan	672
Santa Barbara ACC	691C
Seattle VA Puget Sound HCS	663

FACILITY	STATION NUMBER
Sepulveda ACC VA GLA HCS	691A
Sheridan	666
Shreveport-Overton Brooks VAMC	667
Sioux Falls	438
Spokane VAMC	668
Springfield CBOC	552G
St. Cloud	656
St. Louis VAMC JB Division	657A
St. Albans VA NY Harbor HCS	630B
St. Louis VAMC JC Division	657
Syracuse - Upstate NY HCS	528C
Tallahassee	573T
Tampa JA Haley VAMC	673
Temple - Central Texas HCS	674
Texarkana CBOC	667A
Togus	402
Toledo	506B
Tomah VA Medical Center	676
Topeka VA E Kansas HCS	589A
Tucson - Southern AZ VA HCS	678
Tulsa OPC	623Q
Tuscaloosa VA Medical Center	679
Tuskegee CAVHCS	619A
Valdosta	573V
Vancouver	648A
Waco - Central Texas HCS	674A
Walla Walla-JM Wainwright VAMC	687
Washington DC	688
West Haven - Connecticut HCS	689
West Palm Beach VAMC	548
West Roxbury - VA Boston HCS	523C
White City VA S Oregon Rehab	692
White River Junction	405
Wichita - Robert J Dole VAMC	589D00
Wilkes - Barre VAMC	693
Wilmington - VAMROC	460
Worcester - VA Boston HCS OPC	523D
Youngstown	541B

### State Veterans Homes

VH(first letter of city)STATE ABBREVIATION

Examples: Hastings, MN Veterans Home = VHhMN  
 Yountville, CA Veterans Home = VHyCA



**Art Entry Form** All fields on this form must be completed in detail or the entry will be disqualified.

Photocopy this form as needed. Each entry must have a completed form. Provide as detailed a description of the mediums and techniques used as possible. **PLEASE TYPE or PRINT, taking care to SPELL the VETERAN'S NAME CORRECTLY.**

Category number:	Category name:		
Sub-division: (check one)	<input type="checkbox"/> Fine Art	<input type="checkbox"/> Applied Art	<input type="checkbox"/> Craft Kit
Title of piece:			
<b>JPEG NAME</b> (only for first place pieces from your facility that are being submitted to the National level of competition):			
Date piece completed:			
Size of art piece in inches: <i>(Must meet size criteria as stated in Rule #7, page 30)</i>			
Height:	Width:	Depth:	
Mediums/techniques used: <i>(Include software program(s) used for Digital entries.)</i>			

**Veteran's Name:**

<b>VA Facility Representing:</b>			
<b>Station Number (Required):</b> <i>(See pages 14, 15 and 16 for a complete list of station numbers.)</i>			
Facility Address:	City:	State:	Zip:
Contact staff:	Routing Symbol:		
Phone:	<b>Email (Required):</b>		

**\*Note:** VA contact staff will be notified via email with the 2007 competition results. If the VA contact staff person *does not* have an email address and would like the information mailed to them, please check this box

\_\_\_\_\_ **Yes**, I would like my digital art image entry and Art Entry Form to be submitted to The Journal of Rehabilitation Research and Development, following the national competition judging, for consideration to appear on the cover of a 2008 publication. *(See page 13 of this booklet for an explanation of this opportunity.)*

\_\_\_\_\_ **No**, I do not consent to have my digital art image entry and Art Entry Form to be submitted to the Journal of Rehabilitation Research and Development, following the national competition judging in May.

\_\_\_\_\_  
*Signature of Veteran*

I verify the above veteran meets eligibility criteria as specified on page 3 and is approved to enter the 2007 National Veterans Creative Arts Competition as a representative of this Veterans Facility and that all information has been provided.

\_\_\_\_\_  
*VA Contact Staff Title and Signature*

**Department of Veterans Affairs**

CONSENT FOR USE OF PICTURE AND/OR VOICE

CONSENT OF (Name):

NOTE: The information requested on this form is solicited under the authority of title 38, United States Code. The execution of this form does not authorize disclosure of the materials specified below except for the purpose(s) stated. The specified material may be used within the VA for authorized purposes, such as for education of VA personnel or for VA research activities. It may also be disclosed outside the VA as permitted by law. If the material is part of a VA system of records, it may be disclosed outside the VA as stated in the "Routine Uses" in the "VA Privacy Act System of Records" published in the Federal Register. A copy of the "Routine Uses" is available upon request to the administrative officer of the VA facility involved. You do not have to consent to have your picture or voice taken, recorded, or used. Your refusal to grant your consent will have no effect on any VA benefits to which you may be entitled.

**I hereby voluntarily and without compensation authorize pictures and/or voice recording(s) to be made of me (or of the above-named individual if the individual is legally unable to give consent) by (specify the name of the VA facility, newspaper, magazine, television station, etc.):**

*The Department of Veterans Affairs National Veterans Creative Arts Program  
and media relating to the program.*

**While I am (describe the activity, if any to be photographed or recorded):**

*Competing, performing, being interviewed, or in any other way participating in the program.*

**I authorize disclosure of the picture and/or voice recording to (specify name and address of the organization, agency, or individual(s) to whom the release is to be made):**

*The Department of Veterans Affairs National Veterans Creative Arts Program.*

**I understand that the said picture(s) and/or voice recording(s) is intended for the following purpose(s):**

*Recognition of my creative arts talent and publicity of the program.*

I have read and understand the foregoing and I consent to the use of my picture and/or voice as specified for the above- described purpose(s). I further understand that no royalty, fee or other compensation of any character shall become payable to me by the United States for the use. I understand that consent to use my picture, video and/or voice recording is voluntary and my refusal to grant consent will have no effect on any VA benefits to which I may be entitled. I further understand that I may at any time exercise the right to cease being filmed, photographed or recorded, and may rescind my consent for up to a reasonable time before the picture, video or voice recording is used.

SIGNATURE OF INDIVIDUAL (veteran) OR OTHER LEGALLY AUTHORIZED PERSON:

DATE:

PERMISSION OBTAINED BY (Print contact staff Name - Title - Address):

(Name) \_\_\_\_\_ (Title) \_\_\_\_\_ (Address) \_\_\_\_\_

SIGNATURE OF INTERVIEWER (contact staff - same as above) OR INDIVIDUAL OBTAINING CONSENT:

DATE:

PRODUCTION TITLE:

*2007 National Veterans Creative Arts Program*

PRODUCTION NUMBER:

INDIVIDUAL'S (veteran) NAME:

IMPORTANT: This form must always be completed prior to the making or using pictures, or video or voice recording(s) of any VA patient. If any patient health or demographic information is to be provided or released with the picture, video or voice recording, VA Form 10-5345, Request for and Authorization to Release Medical Records or Health Information is required prior to the release of such data to any resource.

**Solo Entry Form****Creative Writing, Dance, Drama, Music**

Photocopy this form as needed. Each entry must have a completed form. **A lead sheet for dance and music entries and a typewritten copy of all creative writing and drama entries MUST be included with this form.** Be sure to label the videotape sent to each division (creative writing, dance, drama, music) chairperson. **Label it with the name, city, and state of your VA facility and list the category numbers in order as they are presented on the tape.**

PLEASE TYPE or PRINT, taking care to SPELL the VETERAN'S NAME CORRECTLY.

Division: (check one)	<input type="checkbox"/> CREATIVE WRITING	<input type="checkbox"/> DANCE	<input type="checkbox"/> DRAMA
	<input type="checkbox"/> MUSIC - VOCAL	<input type="checkbox"/> MUSIC - INSTRUMENTAL	
Category number:	Category name:		
Title of piece:			

**Creative Writing Division** - Name of Person(s) Reading the Entry:

*(Veteran who wrote the entry must be shown on the videotape.)*

**Dance Division** - Partner's name:

Type of dance (fox trot, jitterbug, waltz):

**Drama Division** - Author's name:

Multimedia Video category - A written statement must be submitted by the veteran's VA contact staff person explaining the process by which the veteran completed the multimedia entry.

Description must include mediums used and verification that the veteran created, directed and edited the entry solely by him/herself.

**Music Division** - Accompanist name:



New

Veteran's Name:	Veteran's Age:
-----------------	----------------

<b>VA Facility Representing:</b>			
<b>Station Number (Required):</b>			
<i>(See pages 14, 15 and 16 for a complete list of station numbers.)</i>			
Address:	City:	State:	Zip:
Contact staff:	Routing Symbol:		
Phone:	<b>Email (Required):</b>		

**\*Note:** VA contact staff will be notified via email with the 2007 competition results. If the VA contact staff person *does not* have an email address and would like the information mailed to them, please check this box

I have read all of the rules for each division in which I am entering. I understand that I must submit the following: **Creative Writing** - a typewritten copy of the text of my creative writing entry(ies) attached to each entry form(s); **Dance** - a lead sheet of the music and the cassette/CD accompaniment of the music included with each of my dance entry forms; **Drama** - a typewritten copy of the text of my drama entry(ies) attached to each entry form(s); **Music** - a lead sheet attached to each of my music entry forms and a typewritten copy of the lyrics.

\_\_\_\_\_  
*Signature of Veteran*

I verify the above veteran meets eligibility criteria as specified on page 3 and is approved to enter the 2007 National Veterans Creative Arts Competition as a representative of this Veterans Facility and that all information has been provided.

\_\_\_\_\_  
*VA Contact Staff Title and Signature*

**Department of Veterans Affairs**

CONSENT FOR USE OF PICTURE AND/OR VOICE

CONSENT OF (Name):

NOTE: The information requested on this form is solicited under the authority of title 38, United States Code. The execution of this form does not authorize disclosure of the materials specified below except for the purpose(s) stated. The specified material may be used within the VA for authorized purposes, such as for education of VA personnel or for VA research activities. It may also be disclosed outside the VA as permitted by law. If the material is part of a VA system of records, it may be disclosed outside the VA as stated in the "Routine Uses" in the "VA Privacy Act System of Records" published in the Federal Register. A copy of the "routine Uses" is available upon request to the administrative officer of the VA facility involved. You do not have to consent to have your picture or voice taken, recorded, or used. Your refusal to grant your consent will have no effect on any VA benefits to which you may be entitled.

**I hereby voluntarily and without compensation authorize pictures and/or voice recording(s) to be made of me (or of the above-named individual if the individual is legally unable to give consent) by (specify the name of the VA facility, newspaper, magazine, television station, etc.):**

*The Department of Veterans Affairs National Veterans Creative Arts Program  
and media relating to the program.*

**While I am (describe the activity, if any to be photographed or recorded):**

*Competing, performing, being interviewed, or in any other way participating in the program.*

**I authorize disclosure of the picture and/or voice recording to (specify name and address of the organization, agency, or individual(s) to whom the release is to be made):**

*The Department of Veterans Affairs National Veterans Creative Arts Program.*

**I understand that the said picture(s) and/or voice recording(s) is intended for the following purpose(s):**

*Recognition of my creative arts talent and publicity of the program.*

I have read and understand the foregoing and I consent to the use of my picture and/or voice as specified for the above- described purpose(s). I further understand that no royalty, fee or other compensation of any character shall become payable to me by the United States for the use. I understand that consent to use my picture, video and/or voice recording is voluntary and my refusal to grant consent will have no effect on any VA benefits to which I may be entitled. I further understand that I may at any time exercise the right to cease being filmed, photographed or recorded, and may rescind my consent for up to a reasonable time before the picture, video or voice recording is used.

SIGNATURE OF INDIVIDUAL (veteran) OR OTHER LEGALLY AUTHORIZED PERSON:

DATE:

PERMISSION OBTAINED BY (Print contact staff Name - Title - Address):

(Name) \_\_\_\_\_ (Title) \_\_\_\_\_ (Address) \_\_\_\_\_

SIGNATURE OF INTERVIEWER (contact staff- same as above) OR INDIVIDUAL OBTAINING CONSENT:

DATE:

PRODUCTION TITLE:

*2007 National Veterans Creative Arts Program*

PRODUCTION NUMBER:

INDIVIDUAL'S (veteran) NAME:

IMPORTANT: This form must always be completed prior to the making or using pictures, or video or voice recording(s) of any VA patient. If any patient health or demographic information is to be provided or released with the picture, video or voice recording, VA Form 10-5345, Request for and Authorization to Release Medical Records or Health Information is required prior to the release of such data to any resource.

**Group Entry Form**

**Creative Writing, Dance, Drama, Music**

Photocopy this form as needed. Each entry must have a completed form. Each veteran must submit a signed Release of Photo and Voice Consent form. **A lead sheet for dance and music entries and a typewritten copy of all creative writing and drama entries MUST be included with this form.** Be sure to label the videotape sent to each division (creative writing, dance, drama, music) chairperson. **Label it with the name, city, and state of your VA facility and list the category numbers in order as they are presented on the tape.**

PLEASE TYPE or PRINT, taking care to SPELL the VETERAN'S NAME CORRECTLY

Division: (check one) <input type="checkbox"/> CREATIVE WRITING <input type="checkbox"/> DANCE <input type="checkbox"/> DRAMA			
<input type="checkbox"/> MUSIC - VOCAL <input type="checkbox"/> MUSIC - INSTRUMENTAL			
Category number:		Category name:	
Title of piece:			
Group Name:			
Number of Veterans in group: _____ (See Rule #7 on page 5)			
<b>Creative Writing Division</b> - Name of Person(s) Reading the Entry: (Veterans who wrote the entry must be shown on the videotape.)			
<b>Dance Division</b> - Partner's Name (if appropriate):			
Type of dance (fox trot, jitterbug, waltz):			
<b>Drama Division</b> - Name of Author (if existing work):			
Multimedia Video category - A written statement must be submitted by the veteran's VA contact staff person explaining the process by which the veterans completed the multimedia entry. Description must include mediums used and verification that the veterans created, directed and edited the entry solely by themselves.			
<b>Music Division</b> - Accompanist's Name (if appropriate): _____ (List all accompanists - everyone that is visible or heard on the tape must be identified as an accompanist or eligible veteran.)			



<b>Group Information (attach additional sheet of paper if needed)</b>		
Veterans' Names	Age	Instrument

<b>VA Facility Representing:</b>			
<b>Station Number (Required):</b> <i>(See pages 14, 15 and 16 for a complete list of station numbers.)</i>			
Facility Address:		City:	State:      Zip:
Contact staff:			Routing Symbol:
Phone:		<b>Email (Required):</b>	

I verify the above veterans meet eligibility criteria as specified on page 3 and are approved to enter the 2007 National Veterans Creative Arts Competition as a representative of this Veterans Facility and that all information has been provided.

\_\_\_\_\_  
VA Contact Staff Title and Signature

PLEASE PHOTOCOPY THIS CONSENT FORM FOR EACH MEMBER OF THE GROUP.  
EACH MEMBER MUST SIGN A FORM.

Department of Veterans Affairs	
<p style="text-align: center; font-weight: bold;">CONSENT FOR USE OF PICTURE AND/OR VOICE</p>	<p style="text-align: center;">CONSENT OF <i>(Name)</i>:</p>
<p>NOTE: The information requested on this form is solicited under the authority of title 38, United States Code. The execution of this form does not authorize disclosure of the materials specified below except for the purpose(s) stated. The specified material may be used within the VA for authorized purposes, such as for education of VA personnel or for VA research activities. It may also be disclosed outside the VA as permitted by law. If the material is part of a VA system of records, it may be disclosed outside the VA as stated in the "Routine Uses" in the "VA Privacy Act System of Records" published in the Federal Register. A copy of the "routine Uses" is available upon request to the administrative officer of the VA facility involved. You do not have to consent to have your picture or voice taken, recorded, or used. Your refusal to grant your consent will have no effect on any VA benefits to which you may be entitled.</p>	
<p><b>I hereby voluntarily and without compensation authorize pictures and/or voice recording(s) to be made of me (or of the above-named individual if the individual is legally unable to give consent) by</b> <i>(specify the name of the VA facility, newspaper, magazine, television station, etc.):</i></p> <p style="text-align: center;"><i>The Department of Veterans Affairs National Veterans Creative Arts Program and media relating to the program.</i></p>	
<p><b>While I am</b> <i>(describe the activity, if any to be photographed or recorded):</i></p> <p style="text-align: center;"><i>Competing, performing, being interviewed, or in any other way participating in the program.</i></p>	
<p><b>I authorize disclosure of the picture and/or voice recording to</b> <i>(specify name and address of the organization, agency, or individual(s) to whom the release is to be made):</i></p> <p style="text-align: center;"><i>The Department of Veterans Affairs National Veterans Creative Arts Program.</i></p>	
<p><b>I understand that the said picture(s) and/or voice recording(s) is intended for the following purpose(s):</b></p> <p style="text-align: center;"><i>Recognition of my creative arts talent and publicity of the program.</i></p>	
<p>I have read and understand the foregoing and I consent to the use of my picture and/or voice as specified for the above- described purpose(s). I further understand that no royalty, fee or other compensation of any character shall become payable to me by the United States for the use. I understand that consent to use my picture, video and/or voice recording is voluntary and my refusal to grant consent will have no effect on any VA benefits to which I may be entitled. I further understand that I may at any time exercise the right to cease being filmed, photographed or recorded, and may rescind my consent for up to a reasonable time before the picture, video or voice recording is used.</p>	
<p>SIGNATURE OF INDIVIDUAL <i>(veteran)</i> OR OTHER LEGALLY AUTHORIZED PERSON:</p>	<p>DATE:</p>
<p>PERMISSION OBTAINED BY <i>(Print contact staff Name - Title - Address):</i></p> <p>(Name) _____ (Title) _____ (Address) _____</p>	
<p>SIGNATURE OF INTERVIEWER <i>(contact staff-same as above)</i> OR INDIVIDUAL OBTAINING CONSENT:</p>	<p>DATE:</p>
<p>PRODUCTION TITLE: <i>2007 National Veterans Creative Arts Program</i></p>	<p>PRODUCTION NUMBER:</p>
<p>INDIVIDUAL'S <i>(veteran)</i> NAME:</p>	<p>IMPORTANT: This form must always be completed prior to the making or using pictures, or video or voice recording(s) of any VA patient. If any patient health or demographic information is to be provided or released with the picture, video or voice recording, VA Form 10-5345, Request for and Authorization to Release Medical Records or Health Information is required prior to the release of such data to any resource.</p>

\*Use this form for the **Special Recognition,  
Military Combat Experience and Senior Dance Division** categories.

<b>Department of Veterans Affairs</b>	<b>REQUEST FOR AND CONSENT TO RELEASE MEDICAL RECORDS OR HEALTH INFORMATION</b>							
<p>The Paperwork Reduction Act of 1995 requires us to notify you that this information collection is in accordance with the clearance requirements of section 3507 of the Act. We may not conduct or sponsor, and you are not required to respond to, a collection of information unless it displays a valid OMB number. We expect that the time expended by all individuals completing this form will average 2 minutes. This includes the time to read instructions, gather the necessary facts and fill out the form. The purpose of this form is to specifically outline the circumstances under which we may disclose data.</p>								
<p>The execution of this form does not authorize the release of information other than that specifically described below. The information requested on this form is solicited under Title 38, U.S.C. The form authorizes release of information in accordance with the Health Insurance Portability and Accountability Act, 45 CFR Parts 160 and 164, 5 U.S.C. 552a, and 38 U.S.C. 5701 and 7332 that you specify. Your disclosure of the information requested on the form is voluntary. However, if the information including Social Security Number (SSN) (the SSN will be used to locate records for release) is not furnished completely and accurately, Department of Veterans Affairs will be unable to comply with the request. The Veterans Health Administration may not condition treatment, payment, enrollment or eligibility on signing in the authorization.</p>								
<b>ENTER BELOW THE PATIENT'S NAME AND SOCIAL SECURITY NUMBER IF THE PATIENT DATA CARD IMPRINT IS NOT USED.</b>								
<b>TO: DEPARTMENT OF VETERANS AFFAIRS</b> <i>(Print or type name and address of health care facility)</i>	<b>PATIENT NAME</b> <i>(Last, First, Middle Initial)</i>							
	<b>LAST FOUR NUMBERS OF SOCIAL SECURITY NUMBER:</b>							
<b>NAME AND ADDRESS OF ORGANIZATION, INDIVIDUAL OR TITLE OF INDIVIDUAL TO WHOM INFORMATION IS TO BE RELEASED</b> <i>The Department of Veterans Affairs National Veterans Creative Arts Competition and Festival.</i>								
<b>VETERAN'S REQUEST:</b> I request and authorize Department of Veterans Affairs to release the information specified below to the organization, or individual named on this request. I understand that the information to be released includes information regarding the following condition(s): <table style="width: 100%; border: none;"> <tr> <td style="width: 33%;"><input type="checkbox"/> DRUG ABUSE</td> <td style="width: 33%;"><input type="checkbox"/> TESTING FOR OR INFECTION WITH HUMAN</td> <td style="width: 33%;"><input type="checkbox"/> ALCOHOLISM OR ALCOHOL</td> </tr> <tr> <td><input type="checkbox"/> SICKLE CELL ANEMIA</td> <td><input type="checkbox"/> IMMUNODEFICIENCY VIRUS (HIV)</td> <td><input type="checkbox"/> ABUSE</td> </tr> </table>			<input type="checkbox"/> DRUG ABUSE	<input type="checkbox"/> TESTING FOR OR INFECTION WITH HUMAN	<input type="checkbox"/> ALCOHOLISM OR ALCOHOL	<input type="checkbox"/> SICKLE CELL ANEMIA	<input type="checkbox"/> IMMUNODEFICIENCY VIRUS (HIV)	<input type="checkbox"/> ABUSE
<input type="checkbox"/> DRUG ABUSE	<input type="checkbox"/> TESTING FOR OR INFECTION WITH HUMAN	<input type="checkbox"/> ALCOHOLISM OR ALCOHOL						
<input type="checkbox"/> SICKLE CELL ANEMIA	<input type="checkbox"/> IMMUNODEFICIENCY VIRUS (HIV)	<input type="checkbox"/> ABUSE						
<b>INFORMATION REQUESTED:</b> (Check applicable box(es) and state the extent or nature of the information to be disclosed, giving the dates or approximate dates covered by each) <table style="width: 100%; border: none;"> <tr> <td style="width: 33%;"><input type="checkbox"/> COPY OF HOSPITAL SUMMARY</td> <td style="width: 33%;"><input type="checkbox"/> COPY OF OUTPATIENT TREATMENT NOTE(S)</td> <td style="width: 33%;"><input type="checkbox"/> OTHER (Specify)</td> </tr> </table> <p><i>Information regarding the patient's current diagnosis and psychological or physical limitations that make it challenging when participating in creative arts therapy activities. This information will be released to the National Veterans Creative Arts Program for competition in the Special Recognition, Military Combat Experience and Senior Dance Division categories, and for possible inclusion in the 2007 Festival souvenir program booklet.</i></p>			<input type="checkbox"/> COPY OF HOSPITAL SUMMARY	<input type="checkbox"/> COPY OF OUTPATIENT TREATMENT NOTE(S)	<input type="checkbox"/> OTHER (Specify)			
<input type="checkbox"/> COPY OF HOSPITAL SUMMARY	<input type="checkbox"/> COPY OF OUTPATIENT TREATMENT NOTE(S)	<input type="checkbox"/> OTHER (Specify)						
<b>PURPOSE(S) OR NEED FOR WHICH THE INFORMATION IS TO BE USED BY INDIVIDUAL TO WHOM INFORMATION IS TO BE RELEASED:</b> <i>Competition in the Special Recognition, Military Combat Experience and Senior Dance Division categories of the 2007 National Veterans Creative Arts Competition. Possible inclusion in media kits and in the 2007 Festival souvenir booklet that will be distributed to audience members at the stage show performance on October 28, 2007 as well as Festival participants and guests. The booklet will also be given to VA facilities and other community groups nationwide post-Festival.</i>								
<b>NOTE: ADDITIONAL ITEMS OF INFORMATION DESIRED MAY BE LISTED ON THE BACK OF THIS FORM.</b>								
<b>AUTHORIZATION:</b> I certify that this request has been made freely, voluntarily and without coercion and that the information given above is accurate to the best of my knowledge. I understand that I will receive a copy of this form after I sign it. I may revoke this authorization, in writing, at any time except to the extent that action has already been taken to comply with it. Written revocation is effective upon receipt by the Release of Information Unit at the facility housing the records. Redisclosure of my medical records by those receiving the above authorized information may not be accomplished without my further written authorization and may no longer be protected. Without my express revocation, the authorization will automatically expire: (1) upon satisfaction of the need for disclosure; (2) on _____ (date supplied by patient); (3) under the following condition(s): <i>Upon the completion of the 2007 National Veterans Creative Arts Festival.</i>								
<b>I understand that the VA health care practitioner's opinions and statements are not official VA decisions regarding whether I will receive other VA benefits or, if I receive VA benefits, their amount. They may, however, be considered with other evidence when these decisions are made at a VA regional Office that specializes in benefit decisions.</b>								
<b>DATE</b>	<b>SIGNATURE OF PATIENT OR PERSON AUTHORIZED TO SIGN FOR PATIENT</b> (Attach authority to sign, e.g., POA)							
<b>FOR VA USE ONLY</b>								
<b>IMPRINT PATIENT DATA CARD</b> <i>(Name and Address)</i>	<b>TYPE AND EXTENT OF MATERIAL RELEASED</b>							
	<b>DATE RELEASED</b>	<b>RELEASED BY</b>						

---

**VISUAL ART - List of Entries Form**

---

- This form **MUST BE INCLUDED WITH EACH PACKET OF ENTRIES, FOR EACH VISUAL ART SUB-DIVISION**, i.e., a **LIST OF ENTRIES** with the fine art, another **LIST of ENTRIES** for the applied art and another for the craft kit entries
- Please **TYPE or PRINT LEGIBLY**.

Submit this completed form along with the other competition entry materials to the National Chairperson or Visual Arts Assistant of the art sub-division that the veteran is entering. The List of Entries is vital in assisting the National Chairperson and Visual Arts Assistant of each division with what is being entered from your Medical Center and **must be accurate** as to category number and name, spelling of veteran's names, JPEG name, and entry title.

Visual Art Sub-Division:			
<input type="checkbox"/> FINE ART	<input type="checkbox"/> APPLIED ART	<input type="checkbox"/> CRAFT KIT ART	
<b>VA Facility Representing:</b>			
<b>Station Number (Required):</b>			
<i>(See pages 14, 15 and 16 for a complete list of station numbers.)</i>			
Facility Address:		City:	State:      Zip:
Contact staff:			Routing Symbol:
Phone:	Email (Required):		

**\*Note: VA contact staff will be notified via email with the 2007 competition results.** If the VA contact staff person *does not* have an email address and would like the information mailed to them, please check this box

Please answer **both** of the following questions:

1. Total number of entries listed below: \_\_\_\_\_
2. Total number of eligible veterans listed below, **counting each veteran only once**: \_\_\_\_\_

Category #	Category Name	Complete Name of Veteran	JPEG Name	Title of Entry



**VISUAL ART - List of Entries (continued)**

Category	Complete Name	of Veteran	JPEG Name	Title of Entry
#	Category Name			

***PERFORMING ARTS - List of Entries Form***

- Photocopy this form for each division entered.
- This form **MUST BE INCLUDED WITH EACH PACKET OF ENTRIES FOR EACH DIVISION AND SUB-DIVISION.**
- Please **TYPE** or **PRINT LEGIBLY.**

Submit this completed form along with the other competition entry materials to the National Chairperson or Assistant of the division (or sub-division) that the veteran(s) are entering. **The List of Entries is vital** in assisting the National Chairperson and Visual Arts Assistant of each division with what is being entered from your Medical Center and must be accurate as to category name and number and spelling of veteran's names.

Performing Art Division:	<input type="checkbox"/> CREATIVE WRITING	<input type="checkbox"/> DANCE	<input type="checkbox"/> DRAMA
	<input type="checkbox"/> MUSIC - VOCAL	<input type="checkbox"/> MUSIC - INSTRUMENTAL	
<b>VA Facility Representing:</b>			
<b>Station Number (Required):</b> <i>(See pages 14, 15 and 16 for a complete list of station numbers.)</i>			
Address:	City:	State:	Zip:
Contact staff:		Routing Symbol:	
Phone:	Email (Required):		

**LIST ENTRIES IN ORDER BY CATEGORY.** This must also be the order of entries on the videotape for the creative writing, dance, drama, and music divisions.

Please answer **both** of the following questions:

1. Total number of entries listed below: \_\_\_\_\_
2. Total number of eligible veterans listed below, including soloists and group members, **counting each veteran only once:** \_\_\_\_\_

*\*# in Group means number of eligible veterans entered in this group entry.*

Category #	Category Name	Name of Veteran or Group	# in Group*	Title of Entry



Photocopy this form. **Submit one sheet to each national chairperson for each division. For all three art sub-divisions (fine art, applied art and craft kits), submit this form to Katy Ryan, National Art Chairperson. Submit this form for both music sub-divisions (vocal and instrumental) from your facility to Jennifer Lewis, National Music Chairperson.**

Log in each veteran in each of the five divisions in which you participate at the local level. The information can mostly be gathered from the entry blank if this is completed before your local selection. This form should be completed and submitted regardless of whether or not you had a local competition. It should include **every** veteran who has participated. We apologize if some of this information is repeated from other forms, but this form is sent on for data collection.

<b>VA Facility Representing:</b>		<b>Station Number (Required):</b>	
<b>Station Number (Required):</b> <i>(See pages 14, 15 and 16 for a complete list of station numbers.)</i>			
Address:		City:	State: Zip:
Contact staff:			Routing Symbol:
Phone:		<b>Email (Required):</b>	

**Data on all local participants:**

Division:    ART      CREATIVE WRITING      DANCE      DRAMA      MUSIC

Please answer **both** of the following questions:

1. Total Number of **Entries** in your 2007, Local Competition in this Division: \_\_\_\_\_
2. Total Number of **Veterans** who have entered your Local Competition in this Division: \_\_\_\_\_

Last Name	Initial	Age	Gender

Last Name	Initial	Age	Gender



---

## Art Division Rules

---

1. All artwork entered (except for the Military Combat Experience category #17) must have been completed after **March 1, 2006**.
2. Each Medical Center can submit **ONLY ONE (1) ENTRY IN EACH ART CATEGORY** to the National level of the Art Competition.
3. Complete the art entry form *with as much detail about medium or materials used as possible*. This information is shared with the Phase 1 judges while they are scoring each entry.
4. Artwork completed by **groups** of veterans (two or more people) **will not qualify** for entry into the National Art Competition.
5. Sets in the fine arts and applied arts can contain **NO MORE** than three (3) pieces. The pieces must relate to one another in an obvious way to the judges in order to be classified as a set. **NO SETS** are allowed in the kit categories, unless a single kit contains a set such as a set of suncatcher Christmas ornaments.
6. If an entry contains a craft kit, it must go into a craft kit category unless otherwise stated in the category definitions (i.e., soapstone carving kits go into the carving category).



7. **ARTWORK SIZE RESTRICTIONS** - Each National Art entry must be able to fit into **ONE box**. The box can be up to 150 lbs, up to 165 inches in length and girth combined. Length cannot exceed 108 inches. To measure packages use the following formula:

$$\text{Length} + 2x \text{ Width} + 2x \text{ Height}$$

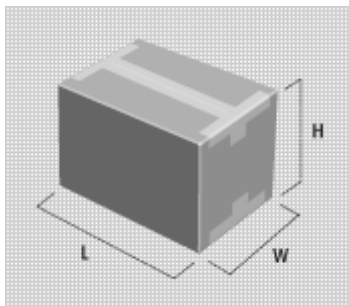

**Step 1.** Determining Length - Measure the longest side of the package, rounding to the nearest inch. This is your length.

**Step 2.** Determining Girth (2x Width + 2x Height). Measure the width of the package, rounding to the nearest inch. Multiply this number by 2. Measure the height of the package, rounding to the nearest inch. Multiply this number by 2. Add these two numbers together. This is your girth.

**Step 3.** Add the length and the girth together. This is your package measurement.

8. Entries that require assembling after unpacking and items shipped by freight will be **DISQUALIFIED**.
9. **GUNS** and **KNIVES** will **not** be accepted. Items with a blade-like form, such as a letter opener, with blades measuring 3 inches or more, will **not** be accepted due to VA regulations banning these items from VA facilities.

---

### ***Art Division Rules (continued)***

---

10. It is highly recommended that all paintings, drawings, watercolors, pastels, photographs, graphics, collages and digital art **be framed**. It is required that if the piece is to be mounted under a clear protective layer, that **PLEXIGLASS** be used. Pieces mounted under glass will be disqualified.
11. For the first phase of the national art competition, **only an ELECTRONIC IMAGE FILE in JPEG** format of the art on a **CD** will be accepted. Only **ONE** electronic jpeg image can be submitted for each work, though you may include **two** electronic jpeg images for each three-dimensional entry.
12. All CD's containing the electronic jpg images and forms for the 2007 National Art Competition **MUST** be **POSTMARKED** by April 1, 2007.
13. No one veteran will be allowed to enter more than three (3) categories into competition at the national level.
14. The Department of Veterans Affairs reserves the right to withdraw any works for public display during the local or national competition phase.
15. VA contact staff persons: Please explain to the veterans entering the art division competition that their artwork will be required to be available through the local and national competition process (February through May). All art entries that are selected as top three scoring entries in the first phase of the national competition in April will need to be shipped in May to St Louis, MO for the second phase of the national judging in June.

---

### ***Art Division Phase One Process***

---



Retain each of your facility's first place winning entries and store them in a secure place. Explain to your veterans that the first phase of the National Art Competition will use ***electronic digital image files in jpeg format***. The top three scoring entries in each category will be chosen before the end of May. The contact staff person listed on the entry form of each top placing entry will be notified. They will then be given information about shipping the actual art pieces and the deadlines for the final phase of the competition. All gold medal winners from the National Art Division Competition will be invited to participate in the Festival. Veterans will be presented ribbons and medals for the first three places of the National Art Competition.

*Note: VA contact staff will be notified via email with the 2007 competition results.*

---

## ***Electronic Digital Image Files***

---

- Images must be provided on a PC platform CD in JPEG format
  - File size must not exceed 1MB.
  - The maximum horizontal dimension is 1024 pixels and the maximum vertical dimension is 768 pixels.
  - The images are displayed by a data projector using sRGB color space and accordingly it is recommended that images use the same.



- Image file naming: **CategorynumberhyphenIMAGETITLE(abbreviation - first 5 letters of title)hyphenveteraninitialshyphenStationNumber.jpg** Use CAPS for Image title and use small letters for initials (first and last name initials of veteran artist) e.g. The JPEG image of an oil painting titled "Sands Of Time" created by John Doe from the Minneapolis VA Medical center would be named:

***02-SANDS-jd-618.jpg***

**Category #-FIRST 5 LETTERS OF TITLE-veteran initials-Station Number.jpg**

\*Note: For entries that are three-dimensional, 2 jpeg images can be submitted. The **second** image should be labeled as follows:

**Category #-FIRST 4 LETTERS OF TITLE2-veteran initials-Station Number.jpg**

**Do not use any spaces when naming the images.**

Each facility is asked to submit together in one package:

- **One CD-ROM** with the images of all their first place entries in that division (all fine art first place entries on one CD-ROM, all applied art on one CD-ROM, all craft kits on one CD-ROM)
- **Contact sheet**, also known as a **proof sheet**, of all that division's thumbnail images. At the top of the contact sheet the VA facility must be identified in addition to the division (fine art, applied art, or craft kits). Each thumbnail image must be labeled with the category name, complete entry title and the veteran's complete first and last name. The thumbnail sheets can be printed in black and white.
- **Entry Forms** for each entry
- A completed **List of Entries** form

**CD's sent to the national level of competition cannot be returned. Please make duplicate copies of the images and all paperwork for your records.**

**Station numbers** for naming JPEG files are listed on pages 14, 15, and 16 and a **sample contact sheet** is shown on page 33.



*Sample Contact Sheet*

CONTACT SHEET

FINE ART CATEGORIES

VA Facility Name

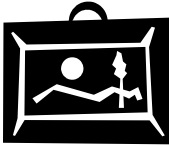

Category Name  
Title  
Veteran's Name



Category Name  
Title  
Veteran's Name



Category Name  
Title  
Veteran's Name

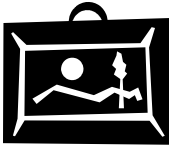

Category Name  
Title  
Veteran's Name



Category Name  
Title  
Veteran's Name



Category Name  
Title  
Veteran's Name

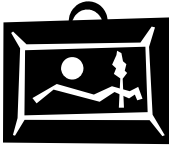

Category Name  
Title  
Veteran's Name



Category Name  
Title  
Veteran's Name



Category Name  
Title  
Veteran's Name



Category Name  
Title  
Veteran's Name



Category Name  
Title  
Veteran's Name



Category Name  
Title  
Veteran's Name



Category Name  
Title  
Veteran's Name



Category Name  
Title  
Veteran's Name

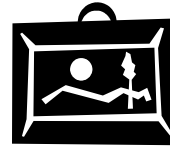

Category Name  
Title  
Veteran's Name

---

## ***Mailing forms and CD's***

---

- ALL Local Level Participation forms
- **Fine Art** entry forms
- Consent forms
- CD with JPEG images of the above categories
- Printed CONTACT SHEET with THUMBNAILS (small photo) of each fine art image, CATEGORY, TITLE and the COMPLETE NAME OF THE VETERAN ARTIST
- List of Entries listing fine art entries
- Special Recognition and Military Combat Experience entry, consent forms and write ups
- Veterans Day Poster images and entry forms are to be mailed to:

**Katy Ryan, CTRS (135R)**  
National Art Chairperson  
VA Medical Center  
One Veterans Drive  
Minneapolis, MN 55417

- 
- **Applied Art** entry forms
  - Consent forms
  - CD with JPEG images of Applied Art entries ONLY
  - Printed CONTACT SHEET with THUMBNAILS (small photo) of each applied art image, CATEGORY, TITLE and the COMPLETE NAME OF THE VETERAN ARTIST
  - List of Entries with your applied art entries are to be mailed to:

**Paula Moran, CTRS (11K)**  
Visual Arts Assistant  
Northern AZ VAHCS  
500 North Hwy 89  
Prescott, AZ 86313

- 
- **Craft Kit** entry forms
  - Consent forms
  - CD with JPEG images of Craft Kits ONLY
  - Printed CONTACT SHEET with THUMBNAILS (small photo) of each craft kit image, CATEGORY, TITLE and the COMPLETE NAME OF THE VETERAN ARTIST
  - List of Entries with your kit entries are to be mailed to:

**Mia Leber, CCS (11K)**  
Visual Arts Assistant  
Jesse Brown  
VA Medical Center  
820 South Damen Ave.  
Chicago, IL 60612

---

## Fine Art Categories

---



*Note: Please read the art rules and categories carefully as many items are new to the 2007 competition year.*

*New*

All Fine Art Category, Special Recognition and Military Combat Experience entry and consent forms, the CD with the jpg images of all Fine Art, Special Recognition and Military Combat first place entries, a contact sheet with thumbnail prints of the images along with category, title and veteran's name and a List of Entries cataloging your fine art, Military Combat Experience and Special Recognition entries (Categories 1-19) are to be submitted to KATY RYAN at the Minneapolis, Minnesota VA Medical Center.

Submit the Local Level Participation Form for ALL art categories (including Applied Art and Craft Kit categories) to Katy Ryan as well.

1. Acrylic Painting - The creation of original work by applying acrylic paint to a surface. The surface is not limited to canvas; it can be on wood, plaster, leather, metal, glass, etc.
2. Oil Painting - The creation of original work by applying oil paint to a surface. The surface is not limited to canvas; it can be on wood, plaster, leather, metal, etc.
3. Watercolor - The creation of work using watercolor paint. The surface is not limited to canvas; it can be on wood, plaster, leather, metal, etc.
4. Sculpture - The creation of three-dimensional forms by modeling (clay), casting (bronze) or assembling (welding) plastic or other hard materials into a work of art.
5. Carving - Three-dimensional pieces achieved by carving away unwanted material from the original whole piece of material. It may be in the round or in relief. *Lathe work* is included in this category. The material used includes stone, wood, ivory and other hard substances. *\*Note-HHV soapstone carving kits are to be included in this category.*
6. Original Design in Pyrography - A design burned into a surface by using wood burning tools. **The design MUST BE ORIGINAL.** This process is typically done on wood, but can also be done on leather and other surfaces. *If transfers or tracings are used, the piece must be entered in the Transfer/Engraving Art Kit category (50).*
7. Monochromatic Drawing - A monochromatic drawing consists of lines in a single color and may be done using pencil, ink, charcoal, etc.
8. Colored Drawing - A colored drawing consists of lines of two or more colors and may be done using colored pencils, markers, etc.
9. Pastels - A colored crayon consisting of pigment and binder (oil or chalk). A pastel is usually a painting rather than drawing because the color is applied in masses rather than in lines.
10. Graphics - A multiple-replica (more than one copy or print) art form. It consists of an original print or proof from a master plate created through such processes as lithography, etching, woodcut, engraving, etc. *Computer graphics must be entered into Digital Art (15).*

---

## ***Fine Art Categories (continued)***

---

11. **Pottery** - A functional piece (bowl, vase, pot, etc.) made with moist clay and hardened by heat. The form is created using a potter's wheel or it is shaped by hand, not slip cast in a mold and then altered. Items cast in a mold belong in one of the ceramic categories (category 20 or 21).

12. **Photography (B&W)** - A photograph developed in black and white using a film camera. Photographs are to be mounted and framed. Photos taken using a digital camera and/or reproduced using digital (computer-based) methods **MUST** be entered into Digital Photography (category 14).

13. **Photography (Color)** - A photograph developed in color using a film camera. Photographs are to be mounted and framed. Photos taken using a digital camera and/or reproduced using digital (computer-based) methods **MUST** be entered into Digital Photography (category 14).

14. **Digital Photography** - Included in this category are digital photos created using a digital camera or scanner and a computer along with graphics software. All original entries must be printed, mounted and framed to qualify for this competition. It is **REQUIRED** that the software programs used be listed in the "mediums/techniques used" section of the entry form. **ANIMATION AND VIDEOS WILL BE DISQUALIFIED.**

15. **Digital Art** - Art that was created using digital technology in the process of its creation. The work is created entirely with a computer and includes 2D graphics as well as 3D graphics. All original entries must be printed, mounted and framed to qualify for this competition. It is **REQUIRED** that the software programs used be listed in the "mediums/techniques used" section of the entry form. **ANIMATION AND VIDEOS WILL BE DISQUALIFIED.**

16. **Fine Art Mixed Media** - The use of two or more fine arts techniques in the creation of a single piece of decorative artwork.

### **17. Military Combat Experience**

To enter this category there are four requirements:

- The veterans must have experienced combat duty during World War II, Korean War, Vietnam, Gulf War, or current combat operations.
- The artwork must **relate to the veteran's personal experience in that war or conflict.**
- **A statement explaining how the art relates** to the veteran's wartime experience, composed by the veteran and/or his VA contact staff person of 25 to no more than 220 words **MUST** be included with each entry.
- A Consent for Release of Medical Information form, (page 23) signed by the veteran allowing us to reveal his/her diagnosis if applicable to the entry, must be included with entry.

The medium used must be a fine art or applied art medium. ***Kits are not allowed.*** Unlike the other art categories, there are **NO** restrictions as to when the artwork was created, however, entries submitted previously into this category are not eligible to compete. Entries in the Military Combat Experience category will be submitted to ***KATY RYAN, National Art Chairperson.***

---

## ***Visual Arts Special Recognition Categories***

---

The **Special Recognition** category of the visual arts division has been divided into two separate **categories**. The intent of these categories is to reinforce the concept of the arts as therapy, where an individual uses artistic expression to facilitate successful treatment outcomes. Entries and their accompanying written statements from the veteran's VA contact staff person should focus on how the arts are used by the individual(s) to rise above severe limitations. Entries submitted into the Art Special Recognition categories could be in the Fine Arts, Applied Arts or Kits division but should be sent to ***Katy Ryan, National Art Chairperson, VAMC Minneapolis.***

**18. Special Recognition PD (physical disability)** - Entries that recognize individuals who exhibit creative expression through the visual arts while possessing significant ***physical limitations***.

**19. Special Recognition MH (mental health challenges)** - Entries that recognize individuals who exhibit creative expression through the visual arts while possessing significant ***emotional or mental health challenges***.

Entries in each of the two Special Recognition categories **MUST** also include:

- **a written statement** (25 to no more than 220 words) of why the veteran is deserving of special recognition
- **a Consent for Release of Medical Information** form (page 23) signed by the veteran allowing us to reveal his/her diagnosis

A photograph showing the veteran working on his artwork would be helpful, but is not required.

---

## *Veterans Day Poster Submissions*

---

The Veterans Day Poster is *no longer* a category within the National Veterans Creative Arts competition. However, veterans who wish to submit electronic jpeg images for consideration of the 2007 Veterans Day Poster should submit the jpeg image, art entry form (page 17), and signed consent for release of picture and/or voice form (page 18) to:

Katy Ryan, National Art Chairperson (135)  
VA Medical Center  
One Veterans Drive  
Minneapolis, MN 55417  
E-mail Address: [Katharina.Ryan@med.va.gov](mailto:Katharina.Ryan@med.va.gov)

The criteria for submitting an electronic digital jpeg image of artwork for consideration as the Veterans Day Poster is as follows:

- The medium used must be a **fine art** or **applied art** medium.
- Artwork that satisfies diversity considerations and gives equal visibility to all branches of the military. If one ethnic group is depicted, then it is important to depict all ethnic groups. If one branch of the military is represented, then it is advised to include all branches.
- The artwork should convey the message "honoring all who served," as Veterans Day includes everyone who ever served in the military. Depicting **active duty** members in uniform would not be a correct representation of veterans.
- Patriotic imagery that conveys the "honoring all who served" theme is appropriate. This would include the old standbys such as flags and eagles, though adding to this concept is encouraged.

\*Please note that the Veterans Day National Committee will also be reviewing artwork from other artist sources and that it is not guaranteed that submissions via the National Veterans Creative Arts Program will be the one selected as the 2007 poster. The committee will review and select the artwork for the poster in May, 2007.

\*\*If chosen, the artist agrees to relinquish any and all rights to the poster. The poster will become public domain and will be used for Veterans Day purposes.

\*\*\*To view Veterans Day Posters from previous years, please visit the Veterans Day website at: <http://www.va.gov/vetsday> and click on "Veterans Day Posters."

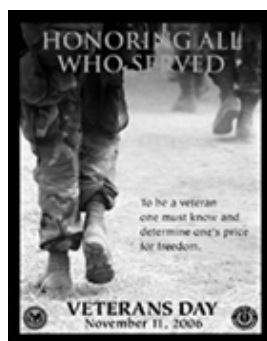

---

## ***Applied Art Categories***

---

All Applied Art Category entry and consent forms, the CD with the applied art jpg images, a contact sheet with thumbnail prints of the images along with category, titles and veteran's name and a List of Entries cataloging your applied art entries are to be submitted to **PAULA MORAN** at the Northern Arizona VA HCS in Prescott, Arizona.

20. **Glazed Ceramics** - Clay pieces formed by pouring slip in a mold, bisque fired, and then finished with the application of glaze(s) and fired. Entries that contain bisque pieces that are painted and/or stained, as well as glazed, are to be entered into the painted ceramic category.

21. **Stained or painted Ceramics** - Clay pieces formed by pouring slip in a mold, fired into bisque ware and finished with the application of stains or paints without any additional firing(s).

22. **Woodworking** - This refers to pieces constructed of wood that have a useful purpose, such as a jewelry box, a chess set, a clock, etc.

23. **Jewelry (not beads)** - Jewelry pieces made through casting, channeling, lost-wax, wire wrapping, etc. Jewelry incorporating beads should be entered in the Beadwork category (34).

24. **Crocheting/Knitting** - The use of yarn or thread and a crochet hook or knitting needles to create a pattern/design and useful object.

25. **Mosaic** - A design made by inlaying small colored pieces of hard material such as stone, sand, glass, wood, ceramic tiles, etc. into a surface to create a design or image. Wood intarsia and marquetry, are included in this category.

26. **Collage** - A design or image created by assembling and gluing pieces of paper, fabric, natural items such as sticks, leaves, dried or artificial flowers, foil scraps, beads or paint.

27. **Original Design in Needlework** - This includes stitchery, needlepoint, quilting, sewing a garment, soft sculpture, embroidery, cross stitch, and crewelwork etc. These are ***original designs created by the veteran*** that are usually worked on fabric (occasionally leather) with a needle to create a finished piece. It may be flat or three-dimensional. Pre-printed patterns on the fabric, the use of commercial patterns, charts or graphs would be in the Fabric Art Kits(48) or Needlework Kits category (49).

28. **Original Design in Fiber Arts** - The use of a substance that can be separated into threadlike parts to create an **original** design in latch hook, rug punching, string art, basketry or weaving. Pre-printed patterns on the fabric, the use of commercial patterns, charts or graphs would be in the Latch Hook Kits (43), Fabric Art Kits (48), or Needlework Kits category (49).

29. **Knotting** - Coarse lacework made by knotting cords, thread or other fibers. Beads, shells or other decorative materials may be used. Macramé and tatting are examples of techniques that are in the knotting category.

---

### ***Applied Art Categories (continued)***

---

**30. Leather Stamping** - Involves the use of shaped implements (stamps) to create an imprint onto a leather surface, often by striking the stamps with a mallet.

**31. Leather Carving/Tooling** -Uses metal implements to compress moistened leather in such a way as to give a three dimensional appearance to a two dimensional surface. The main tools used to "carve" leather include: swivel knife, veiner, beveler, pear shader, seeder, cam, and backgrounder. The swivel knife is held like a pencil and dragged along the leather to outline patterns. The other tools are punch-type implements struck with a wooden or raw hide mallet. The object is to add further definition by them to the cut lines made by the swivel knife.

**32. Metalwork** - The primary material used is metal. Tooling or punching a design or transfer, or metal assembled into a three-dimensional piece for decorative purposes are included in this category.

**33. Glasswork** - Glass is used as the primary medium. Examples would include stained glass, hand-blown glass, fused glass and glass etching. Commercially shaped glass items that have been painted would be in one of the Fine Arts Painting categories.

**34. Beadwork** - Beads of any kind are used to create a design. Examples would include beaded jewelry, beaded belts or other items made on a beading loom, etc.

**35. Scroll Saw/Fretwork** - Decorative open patterns cut out of wood or metal using a scroll saw and/or files.

**36. Applied Arts Mixed Media** - The use of two or more applied arts techniques to decorate or enhance an object created by the veteran.



---

## ***Kit Categories***

---

All Kit Category entry and consent forms, the CD with the kit jpg images, a contact sheet with thumbnail prints of the images along with titles and veteran's name and a List of Entries cataloging kit entries only are to be submitted to MIA LEBER at the Jesse Brown VAMC in Chicago, Illinois.

Kits = All materials needed to complete the project are supplied in the kit. Non-Help Hospitalized Veterans (HHV) craft kits are eligible.

***Only ONE KIT PER ENTRY.***

***Entries containing more than one kit will be disqualified.***

37. **Leather Kits** - Kits that come pre-cut, pre-punched, pre-embossed and ready to finish, stain and/or lace. If the unfinished leather is hand stamped, carved, or tooled by the veteran it should be entered in Applied Art Leather Stamping (30) or Applied Art Leather Carving/Tooling (31) categories.

38. **Wood Building Kits** - Wood kits that have a useful function such as birdhouses, carousels, cup racks, spice shelves, etc.

39. **Model Building (Plastic) Kits** - Plastic snap together or glue together kits. (Diorama's will not be accepted.)

40. **Model Building (Wood) Kits** - Wood model kits. (Diorama's will not be accepted.)

41. **Model Building (Metal) Kits** - Metal model kits. (Diorama's will not be accepted.)

42. **String Art Kits** - Kits that use string to establish a design. This category includes dream catcher kits and HHV beading kits that DO NOT involve the use of a needle.

43. **Latch Hook Kits** - Rug kits that come in a unit with the right amount and color of yarn in the kit and the pattern already printed on the canvas.

44. **Craft Coloring Kits** - A pre-printed design on fabric, paper, wood, canvas, rugs, etc that the veteran fills in with colors of their choice using colored pencils, markers, paint, etc.

45. **Figurine Painting** - Pre-formed plaster, plastic, metal or wood 3 dimensional figures that the veteran paints following a separate diagram and instructions included in the kit. There are no outlines on the piece indicating color application areas.

46. **Paint by Number Kits** - Involves applying oil, acrylic, or watercolor paints to the outlined numbered areas.

47. **Suncatcher or Sand Art Kits** - Suncatchers involve the application of transparent glass stains on a pre-formed and outlined plastic shape. Sand art involves colored sand applied to pre-shaped adhesive areas.

48. **Fabric Art Kits** - Kits involving the use of fabrics (cloth or yarn) to create a pre-printed pattern or design. Cut-n-tuck kits and paint on fabric kits would be included in this category.

---

**Kit Categories (continued)**

---

**49. Needlework Kits** - Kits utilizing yarn or thread applied with a needle to plastic, cloth or canvas. Embroider kits, crewel kits, needlepoint kits, etc., are in this category. Pieces created from pre-printed designs, the use of commercial patterns and graphs qualify for this category. *\*Note-HHV beading kits that involve the use of a needle are to be included in this category.*

**50. Transfer/Engraving Art Kits** - Copper tooling kits, foil scratch art kits and wood burning kits are included in this category which involves incising images, designs or patterns onto a surface by rubbing, scratching, burnishing, cutting or burning.

---

**Art Judging Criteria**

---

Judges at the 2007 National level of competition will be ranking each art entry according to merit in the following criteria:

- **Creativity/Originality** - artistic expression and uniqueness of perspective and execution.
- **Skill** - the ability exhibited through all aspects of the creative process.
- **Total Presentation** - continuity and completeness. Factors considered include title, mounting, framing, etc.

---

**Art Judges' Score Sheet**

---

Category number:		Category name:			
Title of piece:					
Size of art piece in inches		Height:	Width:	Depth:	
Materials/mediums used. Software program(s) used for Digital Art/Photo entries.					

CRITERIA	POINTS				
Creativity/Originality	1	2	3	4	5
Skill	1	2	3	4	5
Total Presentation	1	2	3	4	5

TOTAL SCORE: \_\_\_\_\_

---

## ***Creative Writing Division***

---

The Creative Writing Division differs from categories in the Drama Division which are judged on **performance** qualities (such as stage presence, expressiveness, and interpretation) of an entry. Entries submitted into the Creative Writing Division will be based upon the merit of the original work and will be judged on creative content, message clarity, use of language, originality of topic or idea, and overall strength.

\*Please note: Following the national creative writing judging process, the top three winners in each category will be notified via their contact staff person. The top three creative writing winning entries will be offered the opportunity for inclusion in a booklet that will be distributed in November, 2007.

---

## ***Creative Writing Division Rules***

---

1. **Creative writing entries must be videotaped and last three minutes or less in length.** Any entries reaching national competition that are longer will be disqualified.

2. All entries submitted into the Creative Writing Division must be original compositions written solely by the eligible veteran who is submitting the entry.

3. Entries may be performed by someone else, but the veteran author must also appear in the video. Specify on the Entry Form the name(s) of the person(s) reading the composition.



**New**

4. A 3.5 disquette including a document of the double-spaced text in lower and upper case letters **must** accompany the national entry form in order for the entry to be accepted and judged at the national level. Email attachments including the text will also be accepted. The name of the eligible veteran who wrote the piece must also be included on document. This applies to each entry in all creative writing categories.

5. If an entry has won a gold medal on the national level of competition in any category it **MAY NOT BE** re-submitted into the Creative Writing division in a subsequent year.

6. Judges reserve the right to move an entry to the appropriate category or disqualify the entry if rules are not followed.

7. If the composition is selected for inclusion in the National Veterans Creative Arts Festival stage show, the reader will be selected by the NVCAF national committee. The reader may or may not be the veteran author. The veteran author will be invited to attend the Festival and participate as a chorus member, if his/her entry is selected for inclusion in the Festival stage show.

*Note: VA contact staff will be notified via email with the 2007 competition results.*

---

## *Creative Writing Categories*

---

1. **Poetry - Humorous** - A verse composition of humorous nature, no longer than 48 lines in length, written by one eligible veteran.
2. **Poetry - Inspirational** - Same as #1, but of an inspirational nature.
3. **Poetry - Patriotic** - Same as #1, but relating to American patriotism.
4. **Poetry - Other** - Same as #1, but does not more appropriately meet the definitions of poetry-humorous, inspirational or patriotic categories.
5. **Essay - Humorous** - An essay written by one eligible veteran that is a discussion of a topic from the author's personal point of view as influenced by subjective experience and personal reflection, is a non-fiction work, often expository, and humorous in nature.
6. **Essay - Inspirational** - Same as #5, but of an inspirational nature.
7. **Essay - Patriotic** - Same as #5, but reflective of American patriotism.
8. **Essay - Other** - Same as #5, but does not more appropriately meet the definitions of essay-humorous, inspirational or patriotic categories.
9. **Personal Experience - Humorous** - A story or situation of humorous content that is **written by one eligible veteran in the first person** and conveyed about one's self.
10. **Personal Experience - Inspirational** - Same as #9, but with inspirational content.
11. **Personal Experience - Patriotic** - Same as #9, but with content that relates to American patriotism.
12. **Personal Experience - Other** - Same as #9, but does not more appropriately meet the definitions of personal experience-humorous, inspirational or patriotic categories. Could include wartime-related experiences, though stories/situations with wartime-related content may also be suitable for personal experience-humorous, inspirational or patriotic categories.
13. **Short, Short Story - Humorous** - A very short story, no longer than 300 words in length that is written by one eligible veteran and that is of humorous content.
14. **Short, Short Story - Inspirational** - Same as #13, but with inspirational content.
15. **Short, Short Story - Patriotic** - Same as #13, but with content that relates to American patriotism.
16. **Short, Short Story - Other** - Same as #13, but does not more appropriately meet the definitions of short, short story-humorous, inspirational or patriotic categories.
17. **Monologue/Duologue** - Monologue is a part of a script written by an eligible veteran for one actor. Duologue is a part of a script written by an eligible veteran for two actors.

---

***Creative Writing Categories (continued)***

---

**18. Group Creative Writing** - Any of the above categories (#1-17) but written by a group of eligible veterans. Any one person or persons may read the entry but all eligible veterans who contributed in writing the composition must appear in the video. Any compositions written by more than one eligible veteran will be entered in this category (Group Creative Writing) regardless of the type of composition.

---

***Creative Writing Special Recognition Category***

---

**19. Special Recognition** - Solo or group. Original entries that recognize individuals who exhibit creative expression through the use of creative writing while possessing significant physical or psychological limitations. The intent of this category is to reinforce the concept of the arts as therapy, where an individual uses artistic expression to facilitate successful treatment outcomes. Entries and their accompanying written statements from the veteran's VA contact staff person, should focus on how the arts are used by the individual(s) to rise above severe limitations.

Entries in this category **MUST** include:

- **a written statement** by the veteran's VA contact staff person explaining the veteran's condition and specific talent and
- **a Consent for Release of Medical Information** form (page 23) signed by the veteran allowing us to reveal his/her diagnosis
- Solo or Group Entry form
- **a Consent for Picture and/or Voice form(s)** (page 20,22) signed by the veteran

---

***Creative Writing Judges' Score Sheet***

---

- Judges at the 2007 National level of competition will be ranking each creative writing entry based on the following criteria.
- Please consider using this score sheet for your local competitions.

Veterans Name:	
Category number:	Category name:
Title of number:	

CRITERIA	POINTS									
Creative Content	1	2	3	4	5	6	7	8	9	10
Message Clarity	1	2	3	4	5	6	7	8	9	10
Use of Language	1	2	3	4	5	6	7	8	9	10
Originality of Topic or Idea	1	2	3	4	5	6	7	8	9	10
Overall Strength of Composition	1	2	3	4	5	6	7	8	9	10

**TOTAL SCORE \_\_\_\_\_**

---

### ***Dance Division Rules***

---

1. Dance entries will be **three (3) minutes or less**. Any entries reaching national competition which are longer will be disqualified.
2. If the veteran **sings at any time during the act, the entry will be disqualified**. Any vocal singing needs to be placed under a music category.
3. Dance entries will be judged based on the dance style and steps incorporated in the performance as opposed to the style or type of music selected.
4. No restrictions or qualifications shall be placed on the partner of dance soloists. **One partner per veteran will be allowed for dance group numbers if the type of dance requires partners, but at least 50% of any group shall be eligible veterans. Dance groups not requiring partners (such as line dance) MAY NOT be expanded with non-eligible veterans or any other individual.**
5. The **lead sheets AND cassette/CD instrumental accompaniment** of the dance division entries are **required to be included with each dance entry form** in order for the entry to be considered for possible inclusion in the Festival show, should the entry place first in the national competition. However, an entry may win a first place without music attached it will just not be eligible to be considered for the Festival show. In order to continue to provide the quality orchestra arrangements for the show, as in the past, this rule has become a necessity. Thank you for your compliance with this rule.

*Note: VA contact staff will be notified via email with the 2007 competition results.*

---

### ***Wheelchair Dance Categories***

---

Entries in categories 1-13 must involve movement of the wheelchair from one space to another. Entries involving one or more dancers in wheelchairs, regardless of the number of ambulatory dancers, automatically become wheelchair dance entries and should be placed in one of the following categories (1 to 13).

1. **Solo Structured Wheelchair Dance** - Pattern of movement of wheelchair to music in a choreographed routine. It is still considered a solo when one veteran dances with a non-veteran partner.
2. **Group Structured Wheelchair Dance** - Same as above, but with more than one person.
3. **Solo Novelty Wheelchair Dance** - Any movement of wheelchair to music where props or a different theme is used, that is innovative and for amusement value.
4. **Group Novelty Wheelchair Dance** - Same as #3, but with more than one person.
5. **Solo Country or Western Wheelchair Dance** - Dance patterns set to country music.
6. **Group Country or Western Wheelchair Dance** - Same as #5, but with more than one person. Circle dances may be included here.
7. **Solo Folk/Ethnic/Cultural Wheelchair Dance** - Dances associated with various cultures or countries.

---

### ***Wheelchair Dance Categories (continued)***

---

8. **Group Folk/Ethnic/Cultural Wheelchair Dance** - Same as #7, but with more than one person and/or partners. Examples may include Mexican Hat Dance, May Pole Dance, etc.
9. **Wheelchair Line Dance** - Set pattern of movement done with the wheelchair so individual ends up facing 2 or 4 walls. Suggest a minimum number of 3 to form the line.
10. **Interpretive Movement - Wheelchair Solo** - Interpreting song lyrics or feelings through hand movements or gestures. Example may include sign language or other hand movements. Wheelchair does not need to move.
11. **Interpretive Movement - Wheelchair Group** - Same as #10, but with more than one veteran.
12. **Liturgical Dance - Wheelchair** - Interpreting liturgical/religious music through body movement. (Music must be liturgical/religious.) This dance style is appropriate for use in churches or other places of public worship.
13. **Patriotic Dance - Wheelchair** - The use of any style dance with patriotic music. Dance style must be identified on entry form. Patriotic music is defined as music that denotes love and devotion to our great country.

---

### ***Dance Special Recognition Category***

---

14. **Special Recognition** - Solo or group. Wheelchair or ambulatory. Entries that recognize individuals who exhibit creative expression through the use of dance while possessing significant physical or psychological limitations. The intent of this category is to reinforce the concept of the arts as therapy, where an individual uses artistic expression to facilitate successful treatment outcomes.



New

Entries in these categories **MUST** include:

- **a written statement** by the veteran's VA contact staff person explaining the veteran's condition and specific talent
- **a Consent for Release of Medical Information form** (page 23) signed by the veteran allowing us to reveal his/her diagnosis
- **Solo or Group Entry form**
- **a Consent for Picture and/or Voice form(s)** (page 20,22) signed by the veteran

---

### ***Ambulatory Dance Categories***

---

Entries in categories 15-30 must include moving feet from one spot on the floor to another. There must be body movement!

15. **Solo Structured Ballroom** - American style structured ballroom dances such as the waltz, jitterbug/swing, cha-cha, tango, polka, etc. It is still considered a solo when one veteran dances with a non-veteran partner.
16. **Group Structured Ballroom** - Same styles as above but more than one couple dancing or the couple consists of 2 veterans.

---

### ***Ambulatory Dance Categories (continued)***

---

17. **Solo Tap, Jazz, or Ballet** - Traditional tap, jazz, or ballet patterns of movement choreographed to music in a routine. It is still considered a solo when one veteran dances with a non-veteran partner.
18. **Group Tap, Jazz, or Ballet** - Same as #17, but with more than one veteran.
19. **Solo Country or Western** - Country dance steps, such as the 2-step, to country or western music. It is still considered a solo when one veteran dances with a non-veteran partner.
20. **Group Country or Western** - Same as #19, with more than one person and/or partners. Square dancing and circle dances fall under this category.
21. **Solo Folk/Ethnic/Cultural** - Dances associated with various cultures or countries. Examples may include: Clogging, Jewish Hora, Jig, etc. It is still considered a solo when one veteran dances with a non-veteran partner.
22. **Group Folk/Ethnic/Cultural** - Same as #21, but with more than one person and/or partners. Examples may include: May Pole Dance, Mexican Hat Dance, etc.
23. **Solo Novelty** - Any different type of special movement done with props or set to a theme, which is innovative and for amusement value. It is still considered a solo when one veteran dances with a non-veteran partner.
24. **Group Novelty** - Same as #23, but with more than one veteran.
25. **Freestyle** - Must have three distinct patterns of movement that can be seen and repeated throughout the routine. New wave dances and hip-hop will fall into this category.
26. **Line Dance** - Set pattern of steps that repeat, with quarter or half turns facing 2 or 4 different walls. Suggest a minimum number of 3 veterans to form a line; no VA contact staff persons or volunteers may be included in the line.
27. **Interpretive Movement Solo** - Interpreting song lyrics or feelings through hand movements or gestures. An example may be sign language. Movement of feet not required; no singing.
28. **Interpretive Movement Group** - Same as #27, but with more than one veteran.
29. **Liturgical Dance** - Interpreting liturgical/religious music through body movement. (Music must be liturgical/religious.) This dance style is appropriate for use in churches or other places of public worship.
30. **Patriotic Dance** - The use of any style dance (ballet, waltz, two-step) with patriotic music. Dance style must be identified on entry form. Patriotic music is defined as music that denotes love and devotion to our great country.



---

### ***SENIOR Dance Categories***

---

The purpose of the senior categories is to allow veterans who may have experienced diminished physical functioning an opportunity to compete in a category with persons who are at a similar level and age. **The senior categories are special categories for veterans age 65 and older.** Entries may be ANY type of dance. Group members must all be eligible veteran inpatients or outpatients 65 years of age or older. As with other group entries, groups may not be expanded by staff, volunteers or ineligible veterans. If a partner is needed for the dance, then a staff member, volunteer or other person may be used, but the entry would be counted as a solo if only one veteran is present. Seniors may also enter other categories in the dance division as well (not to exceed three total).

- 31. **Senior Wheelchair Solo**
- 32. **Senior Wheelchair Group**
- 33. **Senior Ambulatory Solo**
- 34. **Senior Ambulatory Group**



Entries in these categories **MUST** include:

- **a written statement** by the veteran's VA contact staff person explaining the veteran's condition and specific talent
- **a Consent for Release of Medical Information** form (page 23) signed by the veteran allowing us to reveal his/her diagnosis
- **Solo or Group Entry form**
- **a Consent for Picture and/or Voice form(s)** (page 20,22) signed by the veteran

---

### ***Dance Judges' Score Sheet***

---

- Judges at the 2007 National level of competition will be ranking each dance entry according to merit in the following criteria.
- Please consider using this score sheet for your local competitions.

Veterans Name:	
Category number:	Category name:
Title of number:	

<b>CRITERIA</b>	<b>POINTS</b>									
<b>Stage Presence</b>	1	2	3	4	5	6	7	8	9	10
<b>Rhythm</b>	1	2	3	4	5	6	7	8	9	10
<b>Technique</b>	1	2	3	4	5	6	7	8	9	10
<b>Patterns</b>	1	2	3	4	5	6	7	8	9	10
<b>Creativity</b>	1	2	3	4	5	6	7	8	9	10
<b>Interpretation</b>	1	2	3	4	5	6	7	8	9	10

**TOTAL SCORE** \_\_\_\_\_

---

## ***Drama Division Rules***

---

1. **Drama entries must be three minutes or less in length.** Any entries reaching national competition that are longer will be disqualified.
2. If a drama entry requires a female character and no eligible female veterans are available, the part may be read by a female volunteer or staff member.
-  3. All veterans must speak in order for an entry to be considered a group entry. (Example, if one veteran is speaking and another is playing an instrument as accompaniment this would NOT qualify as a group entry but rather a solo entry with accompaniment.)
4. A typewritten copy of the text for all drama entries must be attached to each entry form. This applies to all drama categories.
5. Judges reserve the right to move an entry to the appropriate category or disqualify the entry if rules are not followed.
6. Veterans must perform each of their entries themselves on the videotape in order for the entry(ies) to be eligible for competition judging.

*Note: VA contact staff will be notified via email with the 2007 competition results.*

---

## ***Drama Categories***

---

*\*Note:* Veterans who wish to have their original work judged by **performance criteria** (that is, on stage presence, expressiveness and interpretation) should submit the entry into the **DRAMA** division in one of the categories below that best fits the entry. Veterans who wish to have their **original work** judged by criteria based upon the **merit of the composition** (that is, on creative content, message clarity, use of language, and originality of topic or idea) should submit the entry into the **CREATIVE WRITING** division. See pages 43-45 for a complete description, list of rules, listing of categories and judges score sheet for entries submitted into the Creative Writing Division.

1. **Solo Dramatic Prose** - A composition in ordinary speech or writing (not poetry) presented by one eligible veteran. (For example: a reading or excerpt from a speech.) Can be existing or original.
2. **Group Dramatic Prose** - A composition in ordinary speech or writing (not poetry) presented by two or more veterans. Can be existing or original.
3. **Solo Patriotic Prose** - A composition in ordinary speech or writing (not poetry) with content that relates to American patriotism. Presented by one eligible veteran. Can be existing or original.
4. **Group Patriotic Prose** - A composition in ordinary speech or writing (not poetry) with content that relates to American patriotism. Presented by two or more eligible veterans. Can be existing or original.
5. **Solo Religious Prose** - A composition in ordinary speech or writing (not poetry) with content that is of spiritual nature, presented by one eligible veteran. Can be existing or original.

---

### ***Drama Categories (continued)***

---

6. **Group Religious Prose** - A composition in ordinary speech or writing (not poetry) with content that is of spiritual nature, presented by two or more eligible veterans. Can be existing or original.
7. **Solo Comedy** - Any drama of light and amusing character presented by one eligible veteran. Can be existing or original.
8. **Group Comedy** - Any drama of light and amusing character presented by two or more eligible veterans. Can be existing or original.
9. **Solo Dramatic Poetry** - A verse composition presented by one eligible veteran. Can be existing or original.
10. **Solo Patriotic Poetry** - A verse composition with content that relates to American patriotism. Presented by one eligible veteran. Can be existing or original.
11. **Solo Religious Poetry** - A verse composition with content that is of spiritual nature, presented by one eligible veteran. Can be existing or original.
12. **Solo Comedy Poetry** - A verse composition of light and amusing character presented by one eligible veteran. Can be existing or original.
13. **Group Poetry** - A verse composition presented by two or more eligible veterans. Can be existing or original.
14. **Solo Interpretive Performance-Dramatic** - A presentation by one eligible veteran that involves acting, movement, and props. Original or existing.
15. **Group Interpretive Performance-Dramatic** - A presentation by two or more eligible veterans that involves acting, movement, and props. Original or existing.
16. **Solo Interpretive Performance-Comedy** - A presentation by one eligible veteran that is of light and amusing character involving acting, movement and props. Original or existing.
17. **Group Interpretive Performance-Comedy** - A presentation by two or more eligible veterans that is of light and amusing character involving acting, movement and props. Original or existing.
18. **Mime** - Solo or group. A presentation that imitates actions without words.
19. **Juggling** - The art of keeping several objects in motion in the air at the same time by alternatively tossing and catching them.
20. **Magic** - The art of producing illusions by sleight of hand.
21. **Puppetry/Ventriloquism** - Any act where the veteran(s) manipulates puppets and speaks in such a manner that his voice seems to be coming from the puppet.

---

### ***Drama Categories (continued)***

---

**22. Multimedia Video** - A video vignette three minutes or less in length that is **created, directed and edited completely by an eligible veteran or veterans**. The video must combine spoken **dialog and/or narration** in combination with one or more of the following: photography, graphics, music, sound effects.

Entries in this category **MUST** include:



*New*

- **a written statement by -/the veteran's VA contact staff person explaining the process by which the veteran(s) completed the multimedia entry. Description must include mediums used (i.e. photography, graphics, music, sound effects) and verification that the veteran(s) created, directed and edited the entry solely by himself/themselves.**

---

### ***Drama Special Recognition Category***

---

**23. Special Recognition** - Solo or group. Existing or original. Entries that recognize individuals who exhibit creative expression through the use of drama while possessing significant physical or psychological limitations. The intent of this category is to reinforce the concept of the arts as therapy, where an individual uses artistic expression to facilitate successful treatment outcomes. Entries and their accompanying written statements from the veteran's VA contact staff person, should focus on how the arts are used by the individual(s) to rise above severe limitations.

Entries in this category **MUST** include:

- **a written statement by the veteran's VA contact staff person explaining the veteran's condition and specific talent and**
- **a Consent for Release of Medical Information form (page 23) signed by the veteran allowing us to reveal his/her diagnosis**
- **Solo or Group Entry form**
- **a Consent for Picture and/or Voice form(s) (page 20,22) signed by the veteran**

---

### ***SENIOR Drama Categories***

---

The purpose of the senior categories is to allow veterans who may have experienced diminished physical functioning an opportunity to compete in a category with persons who are at a similar level and age. **The senior categories are special categories for veterans age 65 and older.** Entries may be ANY type of drama. Group members must all be eligible veteran inpatients or outpatients 65 years of age or older. As with other group entries, groups may not be expanded by staff, volunteers or ineligible veterans. If a female partner is needed for the entry, then a staff member, volunteer or other person may be used, but the entry would be counted as a solo if only one veteran is present. Seniors may also enter other categories in the drama division as well (not to exceed three total).

**24. Senior Drama Solo**

**25. Senior Drama Group**

---

## *Drama Judges' Score Sheet*

---

- Judges at the 2007 National level of competition will be ranking each drama entry based on the following criteria.
- Please consider using this score sheet for your local competitions.

Veterans Name:	
Category number:	Category name:
Title of number:	

### **CRITERIA**

### **POINTS**

#### Solo Categories

<b>Stage Presence</b>	<b>1</b>	<b>2</b>	<b>3</b>	<b>4</b>	<b>5</b>	<b>6</b>	<b>7</b>	<b>8</b>	<b>9</b>	<b>10</b>
<b>Expressiveness</b>	<b>1</b>	<b>2</b>	<b>3</b>	<b>4</b>	<b>5</b>	<b>6</b>	<b>7</b>	<b>8</b>	<b>9</b>	<b>10</b>
<b>Creativity</b>	<b>1</b>	<b>2</b>	<b>3</b>	<b>4</b>	<b>5</b>	<b>6</b>	<b>7</b>	<b>8</b>	<b>9</b>	<b>10</b>
<b>Interpretation</b>	<b>1</b>	<b>2</b>	<b>3</b>	<b>4</b>	<b>5</b>	<b>6</b>	<b>7</b>	<b>8</b>	<b>9</b>	<b>10</b>

**TOTAL SCORE \_\_\_\_\_**

#### Group Categories

<b>Stage Presence</b>	<b>1</b>	<b>2</b>	<b>3</b>	<b>4</b>	<b>5</b>	<b>6</b>	<b>7</b>	<b>8</b>	<b>9</b>	<b>10</b>
<b>Creativity</b>	<b>1</b>	<b>2</b>	<b>3</b>	<b>4</b>	<b>5</b>	<b>6</b>	<b>7</b>	<b>8</b>	<b>9</b>	<b>10</b>
<b>Interpretation</b>	<b>1</b>	<b>2</b>	<b>3</b>	<b>4</b>	<b>5</b>	<b>6</b>	<b>7</b>	<b>8</b>	<b>9</b>	<b>10</b>
<b>Consistency</b>	<b>1</b>	<b>2</b>	<b>3</b>	<b>4</b>	<b>5</b>	<b>6</b>	<b>7</b>	<b>8</b>	<b>9</b>	<b>10</b>
<b>Pacing</b>	<b>1</b>	<b>2</b>	<b>3</b>	<b>4</b>	<b>5</b>	<b>6</b>	<b>7</b>	<b>8</b>	<b>9</b>	<b>10</b>

**TOTAL SCORE \_\_\_\_\_**

---

## Music Division Rules

---



The music division has been divided into two sub-divisions, vocal and instrumental. All vocal music entries and accompanying paperwork should be sent to Jennifer Lewis, National Music Chairperson from Temple, TX. All Special Recognition entries and Local Level Participation paperwork should also be sent to Jennifer Lewis. All instrumental music entries and accompanying paperwork should be sent to Veronica Andreassen, National Music Division Assistant from Durham, NC.

1. Eligible veteran inpatients and outpatients **may submit no more than three(3) solos in any one division.** (example: Three music solos, three dance solos or three drama solos, all in different categories.)
2. Music entries will be **three(3) minutes or less.** Entries reaching national competition which are longer will be disqualified.
3. **Only one entry in any category may be submitted from each veteran facility.** If more than one eligible veteran enters a category at the veteran facility, there must be a process for selecting the one entry to advance to national competition for that category from that facility.
4. **Once an entry has placed first in the music division at the national level of competition, it is not eligible to be entered again.** (Example: if a veteran or group places first with a music selection in a category one year at the national level, the veteran or group may not enter that specific music selection again in the competition but he may enter that category again with a different music selection.) **Music that has not placed first at the national level of competition should not be entered more than two consecutive years.**
5. No restrictions or qualifications shall be placed on accompanists or conductors for musicians. However, **accompanists may only accompany and not take instrumental leads or solos.** There is no limit in the number of accompanists that may be utilized in an entry, as long as they are only accompanying. A band of musicians may accompany a vocal solo, vocal group, instrumental solo or instrumental group. (Example: an instrumental group consisting of eligible veteran inpatients or outpatients taking leads on saxophone, trumpet and guitar accompanied by non-lead staff or volunteers on piano, drums and bass.)
6. **The addition of staff, volunteer, veterans who are not current inpatients or outpatients to any entry other than as accompanists or conductors will result in disqualification.**
7. It should be noted that although the National Veterans Creative Arts Program recognizes the therapeutic value of participation of staff, volunteers and ineligible veterans in groups, it is essential in keeping with the fairness of the competition that **only eligible veteran inpatients or outpatients** are competing against each other.
8. The **lead sheets** of the music division entries are **required to be attached to each music entry form** in order for the entry to be considered for possible inclusion in the Festival show, should the entry place first in the national competition. However, an entry may win a first place without music attached, it will just not be eligible to be considered for the Festival show. In order to continue to provide the quality orchestra arrangements for the show, as in the past, this rule has become a necessity. Thank you for your compliance with this rule.

---

### ***Music Division Rules (continued)***

---

9. Only one voice may be present to be considered a solo. Once a second voice is added the **entry becomes a group entry and singers must meet eligibility requirements**. If back-up voices are present, they must be eligible veteran inpatients or outpatients and their inclusion would make the entry a **Vocal Group**. Back-up singing by staff, volunteers, ineligible veterans or karaoke will result in disqualification. Karaoke tapes must not include back-up singing but must be instrumental accompaniment only. **The presence of any vocal in a musical number will eliminate that number from competing in the instrumental area.**
10. Judges reserve the right to move an entry to the appropriate category or disqualify the entry if rules are not followed.
11. An original composition can be placed in categories other than original, but will be judged with criteria as stated on page 59.

*Note: VA contact staff will be notified via email with the 2007 competition results.*

---

### ***Vocal Solo Categories***

---



**\*Note:** Music categories have been renumbered. All vocal music entries (solo and group) should be sent to Jennifer Lewis, National Music Chairperson from Temple, TX.

- |                                                                                                                                                                                                                                                                                                                                                                                                                                                                                                                                                                                                                                                                                                                                           |                                                                                                                                                                                                                                                                                                                                                                                                                                                                                                                                                                                                                                                                                                                                                                                                                                                                                                                                                                                    |
|-------------------------------------------------------------------------------------------------------------------------------------------------------------------------------------------------------------------------------------------------------------------------------------------------------------------------------------------------------------------------------------------------------------------------------------------------------------------------------------------------------------------------------------------------------------------------------------------------------------------------------------------------------------------------------------------------------------------------------------------|------------------------------------------------------------------------------------------------------------------------------------------------------------------------------------------------------------------------------------------------------------------------------------------------------------------------------------------------------------------------------------------------------------------------------------------------------------------------------------------------------------------------------------------------------------------------------------------------------------------------------------------------------------------------------------------------------------------------------------------------------------------------------------------------------------------------------------------------------------------------------------------------------------------------------------------------------------------------------------|
| <ol style="list-style-type: none"><li>1. <u>Vocal Solo Country/Folk/Bluegrass</u></li><li>2. <u>Vocal Solo Pop</u></li><li>3. <u>Vocal Solo Jazz/Rhythm &amp; Blues</u></li><li>4. <u>Vocal Solo Classical</u> - Vocal music of established value and fame, of extended duration and greater stability. This does not include popular music.</li><li>5. <u>Vocal Solo Broadway</u> - Show Tunes, <b>not movies</b>. (Example: "People" would be acceptable as it is <b>also</b> from a Broadway show, <u>not</u> because it is from a movie. "New York, New York" would <u>not</u> be acceptable as it is from a 1977 Liza Minnelli movie.) <i>Specify the Broadway show after the title.</i></li><li>6. <u>Vocal Solo Rock</u></li></ol> | <ol style="list-style-type: none"><li>7. <u>Vocal Solo Comedy</u> - A vocal selection that is of light and humorous character.</li><li>8. <u>Vocal Solo Patriotic</u></li><li>9. <u>Vocal Solo Religious</u></li><li> 10. <u>Vocal Solo Song with Dance</u> - Vocal solo with choreographed dance movements, not merely gestures.</li><li>11. <u>Original Vocal</u> - Vocal solo or group. Original vocal compositions composed by one or more eligible veterans judged solely on the merits of the composition. Lyrics and music must be composed entirely by an eligible veteran/s and that veteran/s will be the one entered in this category. A performer or group other than the composer may perform the work, but the composer/s should be shown on the videotape. A copy of the lyrics <b>must</b> be attached to the entry form to aide the judges in evaluating the lyrics.</li></ol> |
|-------------------------------------------------------------------------------------------------------------------------------------------------------------------------------------------------------------------------------------------------------------------------------------------------------------------------------------------------------------------------------------------------------------------------------------------------------------------------------------------------------------------------------------------------------------------------------------------------------------------------------------------------------------------------------------------------------------------------------------------|------------------------------------------------------------------------------------------------------------------------------------------------------------------------------------------------------------------------------------------------------------------------------------------------------------------------------------------------------------------------------------------------------------------------------------------------------------------------------------------------------------------------------------------------------------------------------------------------------------------------------------------------------------------------------------------------------------------------------------------------------------------------------------------------------------------------------------------------------------------------------------------------------------------------------------------------------------------------------------|

---

## ***Vocal Group Categories***

---



**\*Note:** Music categories have been renumbered. All vocal music entries (solo and group) should be sent to Jennifer Lewis, National Music Chairperson from Temple, TX.

To meet the intent of the categories for **Vocal Group**, the group must have **more than one eligible veteran inpatient or outpatient singing**. (Example: One eligible veteran being accompanied on instruments by other eligible veterans does not meet the definition of a vocal group. Instead, that would be a vocal solo with accompanists.)

12. **Vocal Group Country/Folk/Bluegrass**

13. **Vocal Group Pop**

14. **Vocal Group Jazz/Rhythm & Blues**

15. **Vocal Group Classical** - Same as #4, but with more than one veteran.

16. **Vocal Group Broadway** - Same as #5, but with more than one veteran.

17. **Vocal Group Rock**

18. **Vocal Group Comedy** - Same as #7, but with more than one veteran.

19. **Vocal Group Patriotic**

20. **Vocal Group Religious**



21. **Vocal Group Song with Dance** - Vocal group with choreographed dance movements, not merely gestures.

---

## ***SENIOR Vocal Music Categories - Solo and Group***

---

The purpose of the senior categories is to allow veterans who may have experienced diminished physical functioning an opportunity to compete in a category with persons who are at a similar level and age. **Categories 22-23 are special categories for our senior eligible veterans age 65 and older**. Entries may be any type music. Group members must all be eligible veteran inpatients and outpatients 65 years of age or older. As with all other group categories, groups may not be expanded with staff, volunteers or ineligible veterans. There are not restrictions on accompanists or conductors. Seniors are not limited to these categories but may also enter any of the other categories.

22. **Senior Vocal Solo**

23. **Senior Vocal Group**



---

## ***Special Recognition Solo and Special Recognition Group Categories***

---



*New*

**Note: All Special Recognition Solo and Group entries should be submitted to Jennifer Lewis, National Music Chairperson from Temple, TX. This includes vocal and instrumental entries for these categories.**

These categories are for music entries that recognize individuals who exhibit creative expression through the use of music while possessing significant physical or psychological limitations. The intent of this category is to reinforce the concept of the arts as therapy, where an individual uses artistic expression to facilitate successful treatment outcomes. Entries and their accompanying written statements from the veteran's VA contact staff person should focus on how the arts are used by the individual(s) to rise above severe limitations.

**24. Special Recognition Solo**

**25. Special Recognition Group**

Entries in these categories **MUST** include:

- **a written statement by the veteran(s)' VA contact staff person explaining the veteran(s)' condition and specific talent**
- **a Consent for Release of Medical Information form signed by each veteran allowing us to reveal his/her diagnosis (page 23)**
- **Solo or Group Entry form**
- **a Consent for Picture and/or Voice form(s) (page 20,22) signed by the veteran**

---

## *Instrumental Solo Categories*

---



*\*Note:* Music categories have been renumbered. All instrumental music entries (solo and group) should be sent to Veronica Andreassen, National Music Division Assistant from Durham, NC.

26. Instrumental Solo Country/Folk/Bluegrass

27. Instrumental Solo Pop

28. Instrumental Solo Jazz/Rhythm & Blues

29. Instrumental Solo Classical - Instrumental music of established value and fame, of extended duration and greater stability. This does not include popular music.

30. Instrumental Solo Broadway - See #5.

31. Instrumental Solo Rock

32. Instrumental Solo Comedy - An instrumental selection of light and humorous character.

33. Instrumental Solo Patriotic

34. Instrumental Solo Religious

35. Instrumental Solo or Group Drums/Percussion - It is the intent of this category to showcase non-melodic percussion instruments, i.e. trap set, congas, bongos, spoons, rhythm instruments, etc. This category would exclude percussion instruments that can produce an obvious melody line, i.e. xylophone, vibraphone, marimba, etc. Accompaniment may be present as desired and may include melody line, but ONLY the percussionist will be judged.

36. Original Instrumental - Instrumental solo or group. Original compositions will be judged solely on the merit of the composition. A performer or group other than the composer may perform the work, but the composer should be shown on the videotape.

---

## *Instrumental Group Categories*

---

To meet the intent of the categories for **Instrumental Group**, the group must have **more than one eligible veteran inpatient or outpatient performing solos/leads or make other essential contributions musically to the entry other than just accompanying**. There are no limits to the number of accompanists in the group but care should be taken that non-eligible veteran inpatients or outpatients (i.e., staff, volunteers, veterans who are not current inpatients or outpatients) are not performing solos/leads. **The presence of any vocal in a musical number will eliminate it from competing in an instrumental category.**

37. Instrumental Group Country/Folk/Bluegrass/Jazz/Rhythm & Blues/Rock

38. Instrumental Group Pop/Classical/Broadway/Patriotic/Religious

39. Instrumental Comedy Group - Same as #18, but with more than one veteran.

40. Instrumental Group Handbells/Handchimes

---

**SENIOR Instrumental Categories - Solo and Group**

---



**\*Note:** Music categories have been renumbered. All instrumental music entries (solo and group) should be sent to Veronica Andreassen, National Music Division Assistant from Durham, NC.

The purpose of the senior categories is to allow veterans who may have experienced diminished physical functioning an opportunity to compete in a category with persons who are at a similar level and age. **Categories 41-42 are special categories for our senior eligible veterans age 65 and older.** Entries may be ANY type music. Group members must all be eligible veteran inpatients and outpatients 65 years of age or older. As with all other group categories, groups may not be expanded with staff, volunteers or ineligible veterans. There are not restrictions on accompanists or conductors. Seniors are not limited to these categories but may also enter any of the other categories.

- 41. Senior Instrumental Solo
- 42. Senior Instrumental Group

---

**Music Judges' Score Sheet**

---

- Judges at the 2007 National level of competition will be ranking each music entry based on the following criteria.
- Please consider using this score sheet for your local competitions.

Veterans Name:	
Category number:	Category name:
Title of number:	

**(All Categories EXCEPT Originals)**

<b>Intonation (unless piano)</b>	1	2	3	4	5	6	7	8	9	10
<b>Rhythm</b>	1	2	3	4	5	6	7	8	9	10
<b>Interpretation</b>	1	2	3	4	5	6	7	8	9	10
<b>Stage Presence</b>	1	2	3	4	5	6	7	8	9	10
<b>Blend &amp; Cohesiveness (if group)</b>	1	2	3	4	5	6	7	8	9	10

**TOTAL SCORE** \_\_\_\_\_

**(Categories 11 and 22 - Originals)**

<b>Melody Line</b>	1	2	3	4	5	6	7	8	9	10
<b>Rhythm</b>	1	2	3	4	5	6	7	8	9	10
<b>Style</b>	1	2	3	4	5	6	7	8	9	10
<b>Lyrics (if vocal)</b>	1	2	3	4	5	6	7	8	9	10

**TOTAL SCORE** \_\_\_\_\_

---

## ***Tips for Organizing Local Competitions***

---

**Set the date** for your local competition to occur between January 1 to March 10 each year. Since the deadline for submission of entries to the national level of competition is April 1, this will allow some time in March to complete the entry forms and prepare the art digital images on CD's and creative writing, dance, drama and music video tapes for mailing.

**Attempt to set a date that is open on your Facility Director's calendar.** Send a written invitation to the Director, Associate Director, Chief of Staff, and Coordinator of Voluntary Service.

**Request to appear on the agenda for VAVS quarterly meetings.** At this meeting you can inform volunteers of your local program and the possibility of the medical center having a winner or winners who may need assistance to participate in the Festival. This will give them an opportunity to attend your local competition and perhaps encourage them to assist you in getting your "winner" to the Festival.

**Publicity - One to one contact** still remains the most satisfactory means of being sure all the veterans are aware of the program. If each Creative Arts and Recreation VA contact staff person informs their own patients, the word will reach almost everyone. A **news release** could also be prepared with a request to your Public Affairs Officer to submit it to your local news media to reach more outpatients. **A sample press release is included in this booklet on page 62.** Use the posters included in your packet, or make several **posters** announcing your local entry procedure (who, where and when entries are accepted), competition date, time and place. Produce a simple brochure with the rules and other pertinent information. Sample **brochures** follow. These can be customized to your Medical Center by filling in information specific to your competition and copies made as needed. Display your brochures by the posters. Place the posters in prominent in-patient and out-patient areas. Start displaying your posters and brochures about one month before the date you will start accepting entries. If your Medical Center has a monthly newsletter, submit an **article** about your local show and ask that all staff encourage your veterans to participate. Send brochures and posters to satellite VA clinics affiliated with your Medical Center.

**Decide what you will give the winners in recognition of their accomplishment.** Also plan a certificate or other means of recognition for every veteran who enters. Ribbons have been enthusiastically received. Certificates are always good for all participants and are inexpensive if made in-house. Artwork should be awarded ribbons before public showing.

**Secure a minimum of five judges for the performing arts and five for the visual arts.** These may be Medical Center staff, but patients often feel more secure that the judging is fair if members of the community judge.

**If you or another member of the staff does not play the piano or another accompanying instrument, contact Voluntary Service for possible volunteers.** Other sources may be the Chaplain Service musician, local music teachers, local church musicians or the American Federation of Musicians. Veterans will usually perform better with an accompanist. A local drama teacher or a member of a community theater group may assist those participating in drama. Local dance teachers are frequently willing to assist your dancers and teachers and other community members who are versed in writing poetry, essays, etc. would be useful in judging the creative writing entries. Do not forget your Nursing staff, Psychology staff and other staff. Many of them have a variety of talents and experiences in the arts and are very happy to work with their patients in a modality different from their regular routine.

---

## ***Tips for Organizing Local Competitions (continued)***

---

**Work very closely with the coordinator of Voluntary Service** from the beginning so he/she is well aware of your potential needs. When possible it is helpful if sources of funding can be identified before the national judging is completed.

If artwork can be judged the day before the performance competitions, displaying those pieces can add to the festive atmosphere and give credit to veterans participating in all five areas of the arts.

**Request that each veteran complete and sign the entry and consent forms.** Use the information from the completed entry form to make the judges score sheets, arrange the order of the program, etc. When all participant forms have been completed, **double check to assure they are accurate AND READABLE.**

**Complete the LOCAL LEVEL PARTICIPATION sheet** before the show begins. It will then be ready to duplicate and mail to the National Chairperson with the tape and other required paperwork.

**As it is a rule at the national level, it is recommended that no one veteran be allowed to enter more than three (3) categories of any one division.** This would not include groups of which he/she is a member.

**If you do not have an auditorium, shows may be held in a gym, a dining hall, a ward day room, or many other places in your medial center. Some may even be held outdoors.**

**Have everything ready for the judges.** Make one set of the judges score sheets (one for each entry), then duplicate enough sets for all judges. Have one person tally the scores as the judges finish scoring each entry. Give your judges special recognition for their work.

Contact your gold medal winners within two days to complete any missing paperwork. You may also re-tape the creative writing, dance, drama and music winners if you wish, to give them some extra attention and opportunity to further polish their number before the national judging tape is submitted.

**Entries for creative writing, dance, drama, vocal music and vocal instrumental music will be submitted on one single ½" VHS videotape per division (2 videotapes for the music division) in the order that the categories are listed in this packet. The entire competition video SHOULD NOT be sent. SEND ONLY THE FIRST PLACE WINNERS FROM YOUR COMPETITION. ONLY ONE FOR EACH CATEGORY WILL BE ACCEPTED.**

**REVIEW YOUR ENTRY TAPE AND MAKE A COPY BEFORE MAILING.** Make copies of all important paperwork that may be difficult to secure later. Label the tape itself with a list **IN ORDER** of the acts appearing. Also include the enclosed list of entries completed with name, title and category **IN ORDER.**



**Take digital images of the local first place art.** Retain each of the first place art pieces in a secure place. If a piece is ranked in the top three of its category after the first phase of national competition, then the actual art piece will need to be shipped to the final phase of the national competition.

*(Date)*

For further information contact:  
*(Name, Phone Number)*

**SAMPLE PRESS RELEASE**  
**LOCAL VETERANS ART SHOW**

Artwork by veterans will be on display to the public at the *(Facility Location)* on *(Date)* from *(Time)*. It is estimated that over *(#)* pieces of art from among *(#)* different categories will be exhibited. Categories consist of fine art such as painting, drawing, sculpture and photography; applied art that includes ceramics, woodcarving, needlework and leatherwork; and craft kits such as string art, poster art and fabric art. Local artists will judge the artwork earlier in the day to determine first, second and third place in each category. The first place winning pieces will advance on to the national level where they will compete with entries submitted by veterans from other VA facilities around the country.

The competition is an annual event that provides veterans receiving treatment at VA facilities the opportunity to participate in creative self-expression in art, creative writing, dance, drama and music as part of their therapy, and to gain recognition for these artistic accomplishments. First place winners from the national competition will be invited to attend the National Veterans Creative Arts Festival, hosted this year by the St. Louis VA Medical Center in St. Louis MO, the week of October 22-29 with the art exhibit and stage show performance on Sunday, October 28.

---

---

## VA Art Show

Date:

Place:

Time:

---

---

### RESPONSIBILITY-LIABILITY

*All possible care will be taken in handling objects submitted for judging. However, the VA Medical Center cannot be responsible for any LOSS or DAMAGE.*

*No entries may be removed by the artists during the run of the judging. However, the VA Medical Center reserves the right to withdraw any works for public display.*

*The judges have the right to change the category of the entry if they deem it to be misplaced.*

### *JUDGING*

*A panel of judges from the local art community will use the following criteria: creativity, skill, & total presentation.*

---

---

Local first place entries in each art category will have the opportunity to compete in the 2007 National Art Competition.

Entries for the National Art Competition will be submitted as digital images of the art piece.

---

---

### To Enter or QUESTIONS

Contact:

## 2007 Veterans Fine Arts, Applied Arts and Crafts Competition



### PURPOSE

*The VA Art Competition and Show provide our veterans with an opportunity to be acknowledged for their artistic talents and skills.*

### **ENTRY DEADLINE:**

Contact

### Rules:

- To qualify for entry the artist must be an active outpatient or inpatient of the VA Medical Center, VA Outpatient Clinic, or resident of a state veterans home.
- All art must have been created since March 1, 2006, except for Military Combat Experience entries.
- The Medical Center staff and the judges have the right to change an entry's category as needed.
- The VA Medical Center reserves the right to withhold entries from public viewing as needed.

### Entry Deadline:

- A veteran can enter up to three ART categories, but ONLY one entry per category per veteran.
- It is recommended that hanging art is mounted, framed, and ready for display.
- Entries must WEIGH LESS than 150 pounds and cannot exceed the following dimensions:

**Girth** (all the way around the object either going from top to bottom and then all the way around the object or side to side and then all the way around the object, whichever is smallest) + (added to) **Length** (the distance from top to bottom or side to side, whichever is greatest) = NO MORE THAN 165 inches.

### Contact:

### Special Art Categories

**Special Recognition** - A description of the physical and/or mental health challenges the veteran overcame in order to accomplish the creation of his art is required to qualify for this category. The description, not to exceed 220 words can be written by the veteran or the veteran's VA contact staff person, nurse, physician or practitioner.

**Military Combat Experience** - The veteran must have experienced combat duty during World War II, Korean War, Vietnam, Gulf War, or current combat operations. The artwork must relate to the veteran's personal experience in that war or conflict. A statement explaining how the art relates to the veteran's wartime experience, composed by the veteran and/or his VA contact staff person of 25 to no more than 220 words MUST be included with each entry. The medium used must be a fine art or applied art medium. *Kits are not allowed.*

**Digital Photography** - Included in this category are digital photos created using a digital camera or scanner and a computer along with graphics software.

**Digital Art** - Art that was created using digital technology in the process of its creation. The work is created entirely with the computer and includes 2D graphics as well as 3D graphics.

All original entries in the Digital Photography and Digital Art categories must be printed, mounted and framed. It is REQUIRED that the software programs used be listed in the "mediums/techniques used" section of the entry form. ANIMATION AND VIDEOS WILL BE DISQUALIFIED.

### Applied Art and Fine Art Categories

Acrylic Painting                      Oil Painting  
Watercolor                              Sculpture  
Carving                                      Graphics  
Pastels                                      Pottery  
Colored Drawing  
Monochromatic Drawing  
Black and White Photography  
Color Photography  
Fine Art Mixed Media  
Glazed Ceramics  
Painted or stained ceramics  
Pyrography (original design)  
Woodworking  
Jewelry (no beads)  
Crocheting/Knitting  
Mosaic  
Collage  
Needlework (original design)  
Fiber Arts (original design)  
Knotting  
Leather Stamping  
Leather Carving/Tooling  
Metalwork  
Glasswork  
Beadwork  
Scroll Saw/Fretwork  
Applied Arts Mixed Media

### Kit Categories

Leather                                      Needlework  
Wood Building                          Craft Coloring Kits  
Fabric Art                                  Latch Hook  
Paint by Number  
Figurine Painting  
Transfer/Engraving Art Kits  
Model Building (Plastic, Wood or Metal)  
String Art/Dreamcatcher  
Suncatcher or Sand Art



For a specific listing of categories from each division contact:

### **RESPONSIBILITY/ LIABILITY**

All possible care will be taken during the rehearsal and taping process to insure the safety of all musical and supporting instruments and equipment. However, the VA Medical Center cannot be held responsible for any loss or damage incurred during these procedures.

Participants will be required to give written consent allowing the release of photo and voice for competition and publicity purposes.

*First place entries from the local competition will have the opportunity to submit a video tape of their entry to the National level of competition. All entries at the National level will be judged via the videotaped format.*

**Questions?**  
**Call**



## **National Veterans Creative Arts Program**

**2007**

### **Creative Writing, Dance, Drama & Music Competition**



### **PURPOSE**

The National Veterans Creative Arts Program goal is to showcase the talents of Veterans. The Creative Arts Competition and Festival provide our veterans with an opportunity to gain recognition for their creative accomplishments.

## ELIGIBILITY

Participants must be active outpatients or inpatients of the VA Medical Center before entering this competition. Only one entry per category is allowed.

*For more information and to schedule an appointment to videotape your performance, contact:*

## JUDGING

Judges for the competition are from the area's performing arts community.

Judges have the right to change the category of the entry if they deem it to be misplaced.

## JUDGING CRITERIA

Judges will use the following criteria as applicable to the specific category entered:

**Creative Writing:** Creative content, message clarity, use of language, originality and overall strength.

**Dance:** Stage presence (grace, style, rapport with audience), rhythm, technique, patterns (feet or chair), creativity and interpretation of music.

**Drama:** Stage presence (style, rapport with audience), expressiveness (articulation of speech), creativity, interpretation of work, consistency of theme, pacing (team work and line flow).

**Music:** Intonation, rhythm, interpretation, stage presence, blend and cohesiveness (if group), melody line, style, lyrics (if vocal).

## DIVISIONS

### ***Creative Writing Categories***

**that include:** Poetry, Essay  
Personal Experience  
Short, Short Story,  
Monologue/Duologue,  
Special Recognition



### ***Dance Categories that include:***

Solo & Group  
Ambulatory and Wheelchair  
Structured, Novelty  
Country, Line Dancing  
Folk/Ethnic/Cultural  
Interpretive Movement  
Tap, Jazz, Ballet  
Liturgical, Freestyle  
Senior and Special Recognition



### ***Drama Categories that include:***

Solo and Group Original &  
Existing Works  
Prose and Poetry  
Comedy  
Interpretive Performance  
Mime, Juggling, Magic  
Puppetry/Ventriloquism  
Multimedia Video  
Senior and Special Recognition



### ***Music Categories that include:***

Solo or Group  
Instrumental and Vocal  
Original Compositions  
Senior and Special Recognition

