

# 2004 Northwest Energy Efficient Manufactured Home Program In-Plant Inspection Manual



This Manual was revised and prepared by Reuben Greer, Brady Peeks, and Tom Hewes of the Oregon Department of Energy with assistance from the State Energy Offices of Idaho, Montana, and Washington. Design production was done by the Communications Section of the Oregon Department of Consumer and Business Services and printing by the Department of Administrative Services Print Services. The U-Factors that appear in Part III were developed by Bob Davis of Ecotope Inc. Original illustrations are by Coleen Stevenson, Thom Porterfield, and Carla Lovato, with revisions by Rosie Baker, Phil Fehrenbacher, and Shonnie Emerson.

January 2004

---

**TABLE OF CONTENTS**

	<b>Page</b>
Introduction .....	3
<b>Part I: Procedures and Figures of Proper Installations .....</b>	<b>7</b>
Floors and Duct Systems .....	9
Exterior Walls .....	26
Ceilings and Roofs .....	34
Windows and Doors .....	45
Ventilation and Heating .....	47
<b>Part II: Technical Specifications .....</b>	<b>49</b>
List of Sections .....	51
Design Qualification and Certification .....	55
Thermal Efficiency .....	60
Heating Systems .....	65
Moisture and Indoor Air Quality Control .....	67
On-Site Specifications .....	71
<b>Part III: Default U-Factors for NEEM Manufactured Homes .....</b>	<b>75</b>
List of Sections .....	77
General .....	79
Floors Over Unheated Spaces .....	80
Ceilings .....	86
Walls .....	94
Doors .....	96
Glazing .....	98
Infiltration .....	99
Appendix A: NEEM Protocols and Checklists .....	101
Appendix B: Certification Information and Labels .....	149
Definitions .....	155
Registration Card .....	Inside back cover
Change of Address Notice .....	Inside back cover



## Introduction

The Northwest manufactured home industry recognizes the value of energy efficiency — and so do home buyers. In 1995, due to the increasing demand for energy efficient housing, the state energy offices and the manufactured home industry created the industry funded Northwest Energy Efficient Manufactured Housing Program (NEEM). The NEEM program is a voluntary program funded by the manufactured housing industry and overseen by the State Energy Offices (SEO's) of Oregon, Idaho, Washington and Montana. Over twenty manufactured home producers who build or sell homes in the Northwest are certified to build under the NEEM program. The Northwest state energy offices inspect and certify manufactured homes built to this standard that are constructed in their respective states.

The Oregon Department of Energy maintains contracts with over twenty Northwest manufacturers who build and sell homes in the Northwest region under the NEEM program. The region-wide NEEM program ensures that every certified manufactured home sold in the Northwest is built with the same energy efficiency standards. The state energy offices receive additional support from U.S. Department of Energy State Energy Program, US DOE's Building America Program, the Bonneville Power Administration and regional utilities, Building Codes Agency of Oregon, Washington State Department of Labor and Industries, the State of Montana, the Earth Advantage Program, and the Northwest Power and Conservation Council.

Consumers can identify certified homes by looking for the Super Good Cents<sup>®</sup>, Natural Choice<sup>™</sup>, Energy Star<sup>®</sup> or Earth Advantage<sup>®</sup> logos. These logos ensure that the homebuyer is buying state-certified energy efficiency. In addition, homebuyers have greater flexibility in siting their certified home. Many building jurisdictions in the Northwest allow manufactured homes to be sited anywhere a single family home can be built — provided the home meets the state energy code. NEEM certified energy efficient manufactured homes exceed energy code standards in all Northwest states, thereby reducing placement restrictions.

Quality control staff and in-plant inspectors are critical to ensuring proper performance of homes built under the Northwest Energy Efficient Manufactured Home Program. They verify that items identified on the certificate for each home are installed and function as required.

This manual includes illustrations and explanations of construction details to build to Super Good Cents<sup>®</sup>, Natural Choice<sup>™</sup> and Energy Star<sup>®</sup> standards under the NEEM program. When in doubt about any construction detail, consult the Technical Specifications included in this manual, or discuss the issue with your state technical assistance provider:

**NEEM Hotline**

(888) 355-6277

**Oregon Department of Energy**

(503) 378-4040

Toll-Free in Oregon: (800) 221-8035

Fax: (503) 373-7806

**Idaho Department of Water Resources, Energy Division**

(208) 327-7900

Fax: (208) 327-7866

**Montana Department of Environmental Quality**

(406) 841-5200

Fax: (406) 841-5091

**Washington State University, Energy Office Extension**

(360) 956-2000

Fax: (360) 326-2046

# **PART I**

## **PROCEDURES AND FIGURES OF PROPER INSTALLATIONS**

General Installation Methods and  
Certification Requirements





## LIST OF FIGURES

Page

### FLOORS AND DUCT SYSTEMS

1. Transverse and Longitudinal Floor System Insulation .....	9
2. Upright Floor System Insulation .....	10
3. Floor Insulation at Recessed Entries .....	11
4. Furnace Boot Attachment to Trunk Duct for Transverse and Longitudinal Floors .....	12
5. Crossover Collar Attachment to Trunk Duct .....	13
6. Branch Duct Take-Off Fitting Connections to Trunk Duct .....	14
7. Branch Duct Attachments .....	15
8. Air Sealing Mis-Cut Register Holes in Ducts .....	16
9. Air Sealing Duct Extensions .....	17
10. Air Sealing Duct Ends .....	18
11. Sealing Register Boot Connections .....	19
12. Crossover Duct Connections .....	20
13. Through-Rim Crossover .....	21
14. Tub P-Trap Sealing: Trap Arm Above Floor .....	22
15. Tub P-Trap Sealing: Trap Arm Below Floor .....	23
16. Tub Enclosure Sealing .....	24
17. Sealing Dryer Duct Penetrations .....	25

### EXTERIOR WALLS

18. Insulation and Air Sealing at Exterior Walls .....	26
19. End-Wall Insulation Details .....	27
20. Angled Corner Air Sealing and Insulation .....	28
21. Insulation and Air Sealing at Recessed Wall Fixtures .....	29
22. Electrical Box Cut-Outs .....	30
23. Insulation and Air Sealing at Water Heater Closets with Exterior Access .....	31
24. R-Value Per Inch of Rigid Insulation .....	32
25. Effect of Compression on R-Values of Batt Insulation .....	33

**CEILING AND ROOFS**

26. Full Width Batts in Ceiling Cavities .....34

27. Flat Ceiling Insulation, Venting, and Air Sealing .....35

28. Vaulted Ceiling Insulation, Venting, and Air Sealing .....36

29. King Post and Heel Dimensions (in inches)  
for R-38 Vaulted Ceilings .....37

30. Recessed Light Insulation and Air Sealing .....38

31. Air Sealing Transitions Between Flat and Vaulted Ceilings .....39

32. Skylight Insulation and Air Sealing .....40

33. Passive Attic Ventilation .....41

34. Active Attic Ventilation .....42

35. Vent Fan Duct and Cap Installation .....43

36. Vent Fan with Flex Duct .....44

**WINDOWS AND DOORS**

37. Window Installation .....45

38. Door Installation .....46

**VENTILATION AND HEATING**

39. Whole House Ventilation .....47

40. Heat Recovery Ventilation (HRV) Setup .....48

## Floors and Duct Systems

Figure 1  
**TRANSVERSE AND LONGITUDINAL FLOOR SYSTEM INSULATION**

- Ensure floor insulation matches R-value indicated on the unit order.
- Avoid insulation compression and gaps. Compression reduces the R-value of insulation, lowering its resistance to heat loss. Gaps provide easy pathways for heat loss and reduce energy efficiency.
- Ensure rim joists are completely insulated around the entire perimeter of the floor. Adequately insulating the floor bays may require installation of full-width batts in the front and rear floor bays.
- Maintain loft of insulation around plumbing, mechanical, and electrical components.

See *Technical Specifications section 2.1.5*

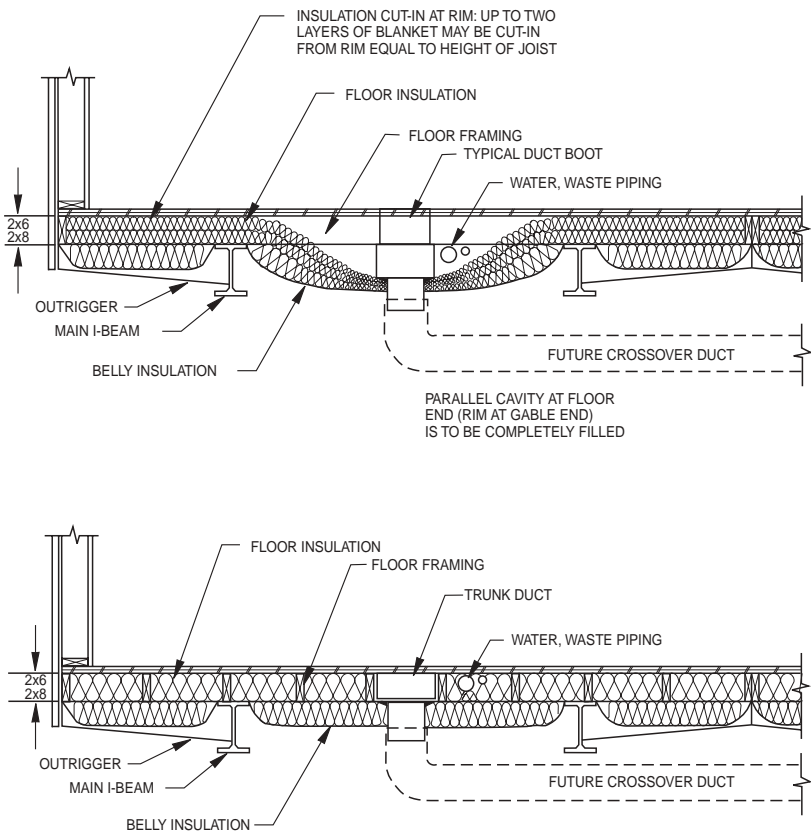
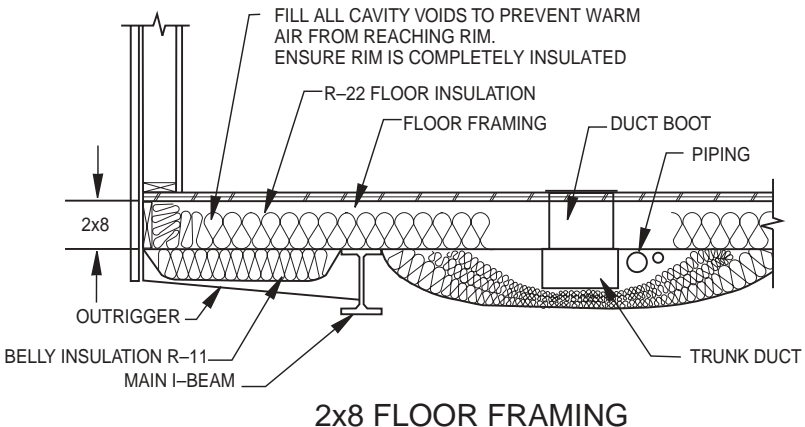
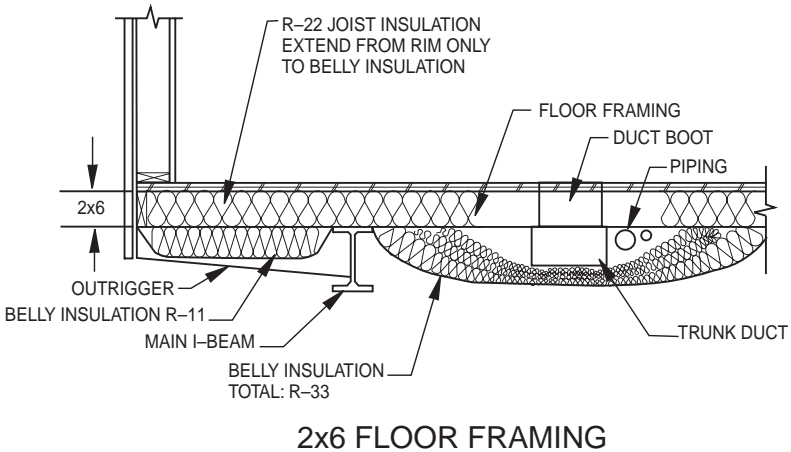

Figure 2  
**UPRIGHT FLOOR SYSTEM INSULATION**

- Ensure laid-in insulation overlaps R-33 belly insulation.
- Maintain loft of insulation around plumbing, electrical and mechanical components.
- Ensure rim joists are completely insulated around the entire perimeter of the floor.
- Do not extend insulation over the top of the heat duct. *Exception:* The front and rear floor bays should have full-length insulation across the floor to ensure complete insulation of rim joists. Insulation may extend over the heat duct if necessary.

See *Technical Specifications section 2.1.5*



### Figure 3 FLOOR INSULATION AT RECESSED ENTRIES

- Objective: Install insulation under recessed walls so that it meets floor insulation.
- Insulation strategy must ensure that vertical insulation is permanent — that it cannot be easily dislodged during transit.
- Insulation is required even if structural blocking is installed under a wall.
- Insulation is not required out to the floor rim when vertical insulation is provided under a recessed wall.
- Installing an air barrier along outside face of vertical batt is recommended.

See *Technical Specifications section 2.1.5*

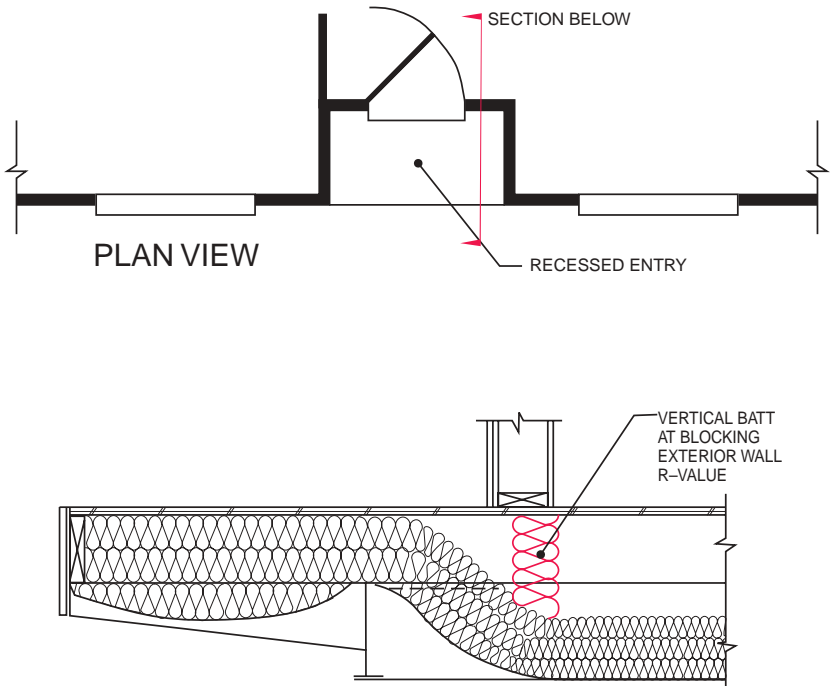

## Figure 4 FURNACE BOOT ATTACHMENT TO TRUNK DUCT FOR TRANSVERSE AND LONGITUDINAL FLOORS

- This is the most important duct system and air-sealing connection in the entire home. Poor alignment between the boot and the trunk or poor air sealing at this connection leads to significant losses in energy efficiency.
- Cut the trunk with an “X” cut and fold trunk material up into furnace boot to provide mechanical attachment and seal all four sides.
- Attach trunk material to furnace boot with mechanical fasteners.
- Air seal trunk material to furnace boot with mastic. Mastic will provide the most durability, but may need reinforcement with mesh tape to span gaps in the metal.

See [Technical Specifications section 3.3](#)

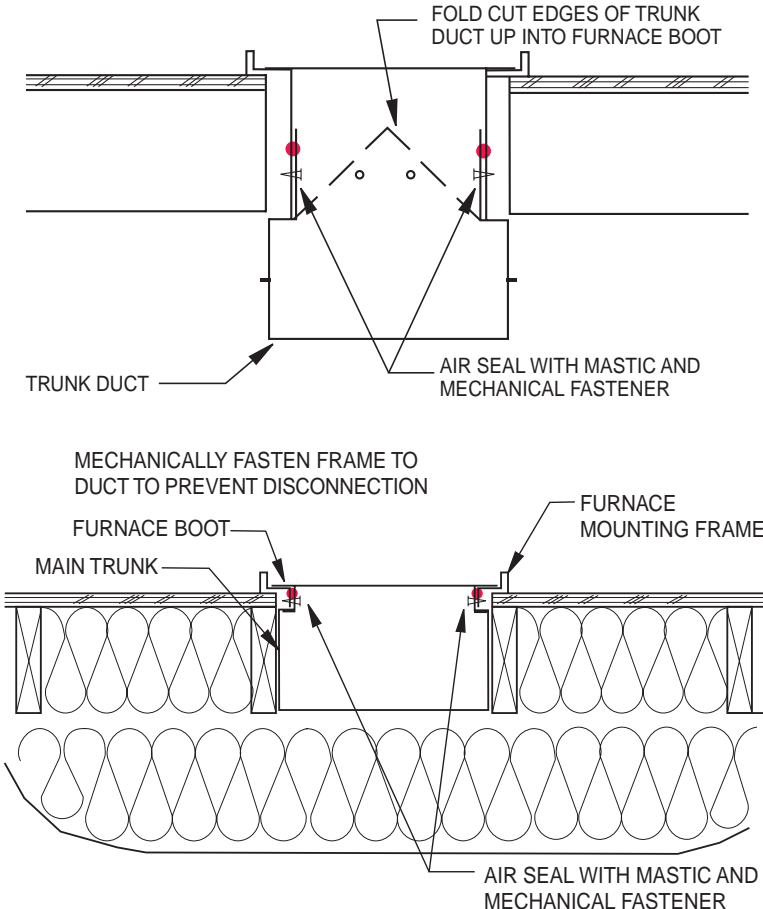

Figure 5

**CROSSOVER COLLAR ATTACHMENT TO TRUNK DUCT**

- Crossover collar attachments to the trunk are the next most important connections in the duct system. Leaky crossover collars will lead to efficiency penalties and comfort problems, especially if the collar is directly below the furnace boot.
- This connection can be severely stressed in the field when installers attach the crossover duct, so it needs to be very securely attached with mechanical fasteners and tightly air sealed with mastic.
- Joints and seams on the crossover collar itself should also be air sealed.
- This connection can come under stress if fitting not cut through bottom covering before chassis is attached to floor.

See [Technical Specifications section 3.3](#)

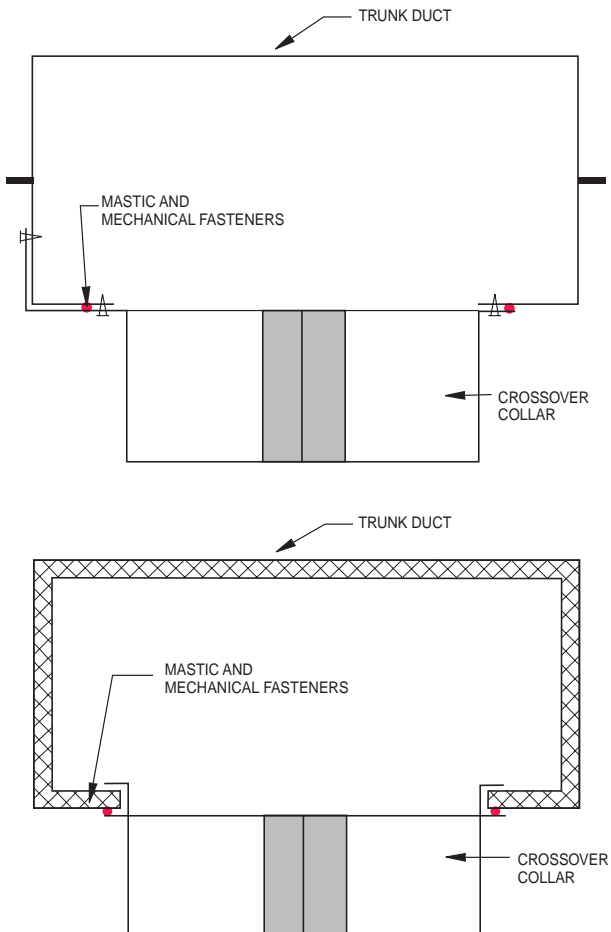
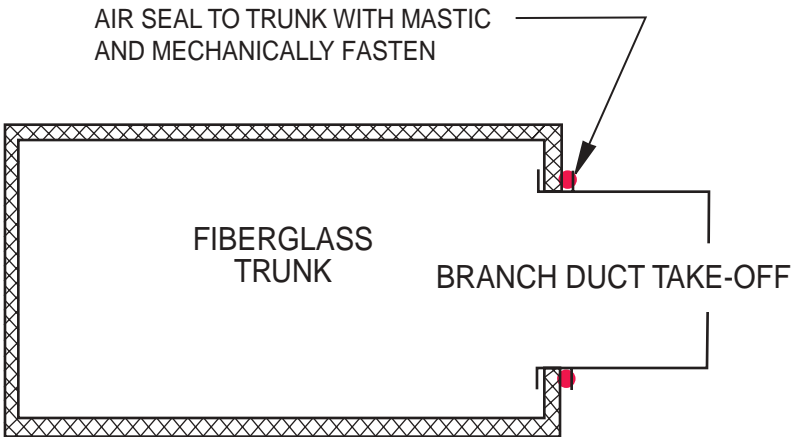
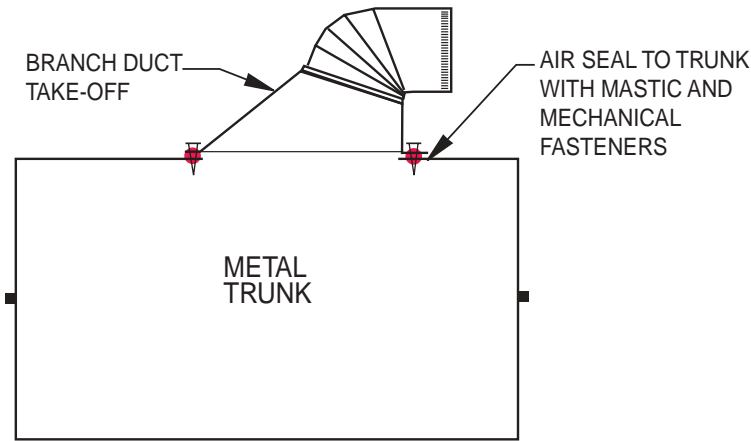

Figure 6  
**BRANCH DUCT TAKE-OFF FITTING CONNECTIONS  
TO TRUNK DUCT**

- Branch duct take-off fitting attachments to the trunk are also important connections in the duct system. Any fitting that is loosely attached to the trunk will cause major heat loss.
- Tightly connect the fitting to the trunk with mechanical fasteners.
- Air seal the connection with mastic.
- This connection can come under stress if fitting not cut through bottom covering before chassis is attached to floor.

See *Technical Specifications section 3.3*





## Figure 7 BRANCH DUCT ATTACHMENTS

- Attach branch ducts to branch take-off fittings with mechanical fasteners and air seal with mastic.
- Attach branch ducts to register boots with mechanical fasteners and air seal with mastic.
- For metal duct attachments: Cut holes in top and bottom of branch and make an X-cut in trunk duct. Place branch over trunk and apply mastic around cut hole between trunk and branch. Apply mastic to inner flaps of trunk duct and fold the flaps into the branch and mechanically fasten. Apply mastic between metal patch and branch duct and mechanically fasten.

See *Technical Specifications section 3.3*

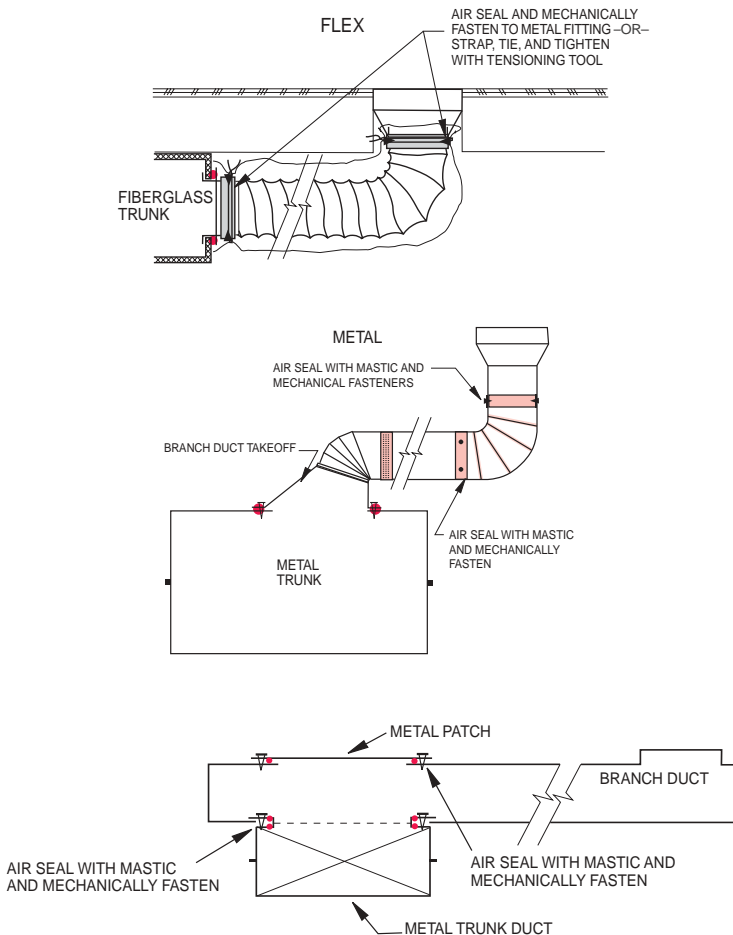

## Figure 8 AIR SEALING MIS-CUT REGISTER HOLES IN DUCTS

- If a register hole is mislocated along the trunk, fabricate a repair patch that is 1 inch larger than the hole on all sides, thoroughly air seal the patch to the trunk with mastic and mechanically fasten.
- Do not leave mis-cut register holes unpatched.

See *Technical Specifications section 3.3*

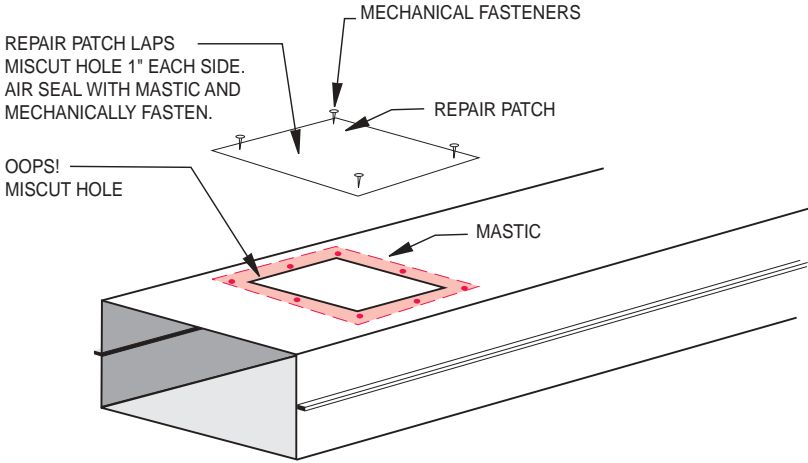

## Figure 9 AIR SEALING DUCT EXTENSIONS

- If a duct needs to be extended, make sure the connection between the original duct and the extension is thoroughly air sealed and securely attached with mechanical fasteners. This can be difficult since the side seams of the original duct have a tendency to collapse and create large gaps when extensions are slipped over them. Ensure that the duct extension is tight with mechanical fasteners and mastic.
- Option: fabricate an entire new duct that is the correct length.

See *Technical Specifications section 3.3*

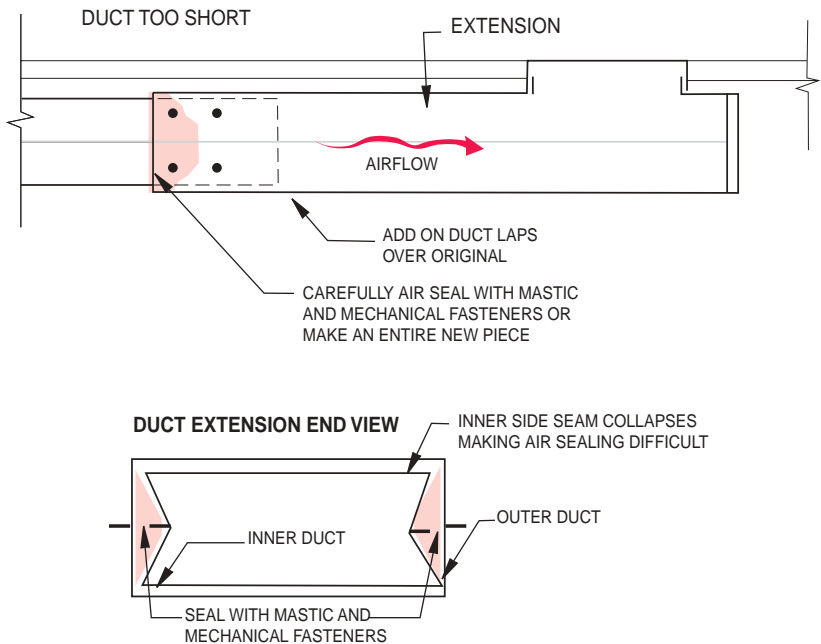

## Figure 10 AIR SEALING DUCT ENDS

- Completely seal duct ends with mastic and mechanically fasten.
- If duct board is used, closely follow the manufacturer's instructions to ensure proper taping.
- Making this duct detail tight will prevent significant heat loss.

See *Technical Specifications section 3.3*

FOLD SIDES IN FIRST  
THEN TOP AND BOTTOM.  
SEAL WITH MASTIC AND  
MECHANICALLY FASTEN

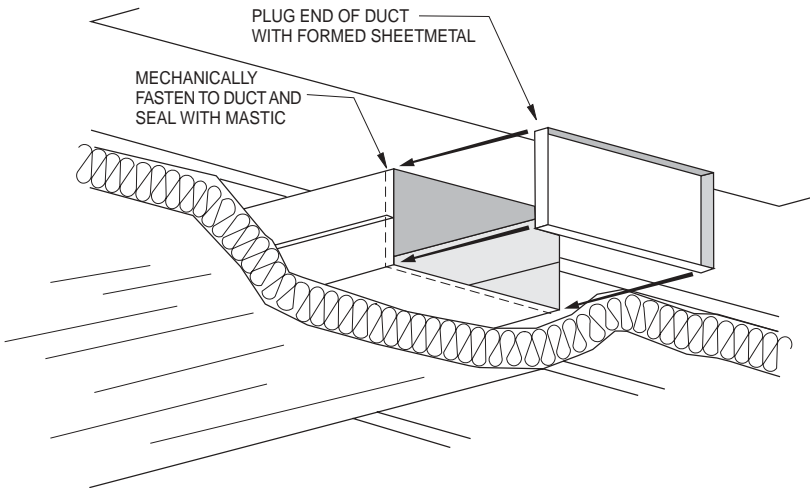
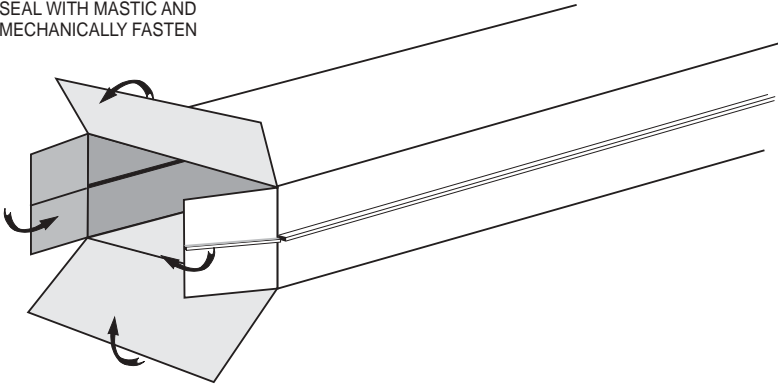
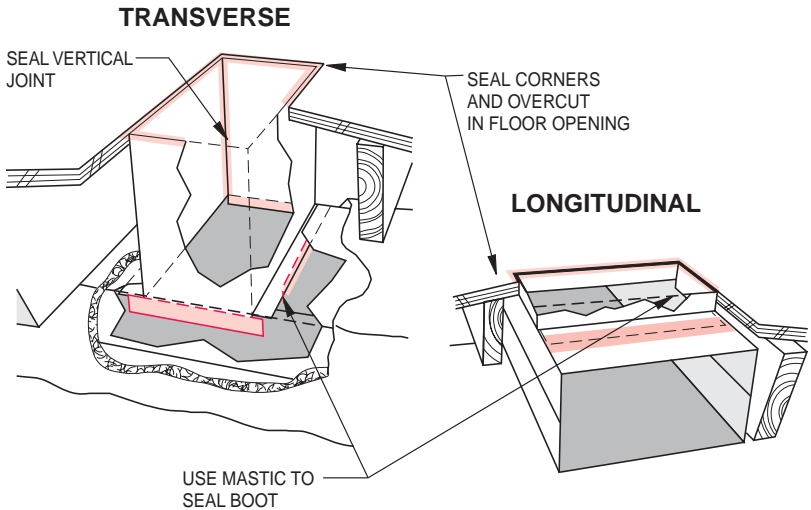

Figure 11  
**SEALING REGISTER BOOT CONNECTIONS**

- Air seal register boots to trunk duct with mastic/mesh.
- Mechanically secure boot to trunk to avoid disconnection.
- Seams in the register boot itself should be air sealed.
- The register boot must be sealed to the floor to avoid air leakage around the boot penetration.

See *Technical Specifications section 3.3*



## Figure 12 CROSSOVER DUCT CONNECTIONS

- When the correct crossover duct materials are not shipped with the home, the crossover connection on site is usually done badly. See NEEM specifications section 5.6 for crossover duct materials that are to be shipped with the home.

See *Technical Specifications* section 2.1.7, 5.6

### V-BOX CONNECTION

**NOTE:** SPLITTER BOXES REQUIRE THE SAME SEALING, FASTENERS, AND INSULATION AS V-BOXES

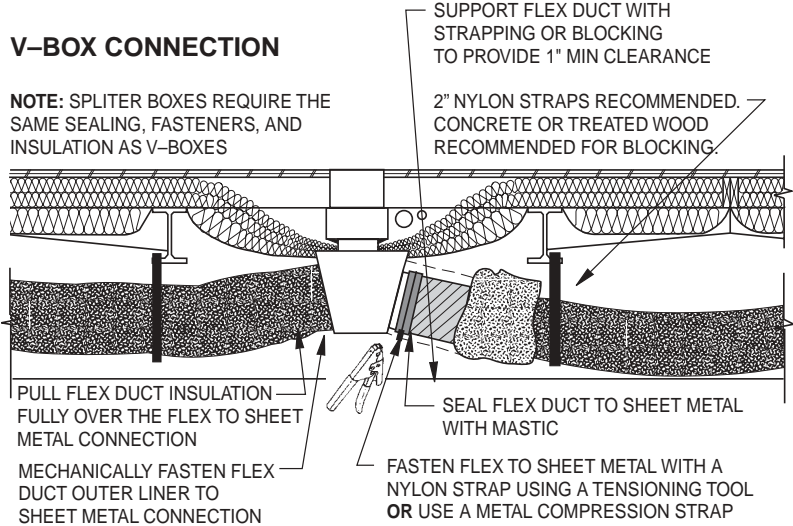

### STANDARD CROSSOVER CONNECTION

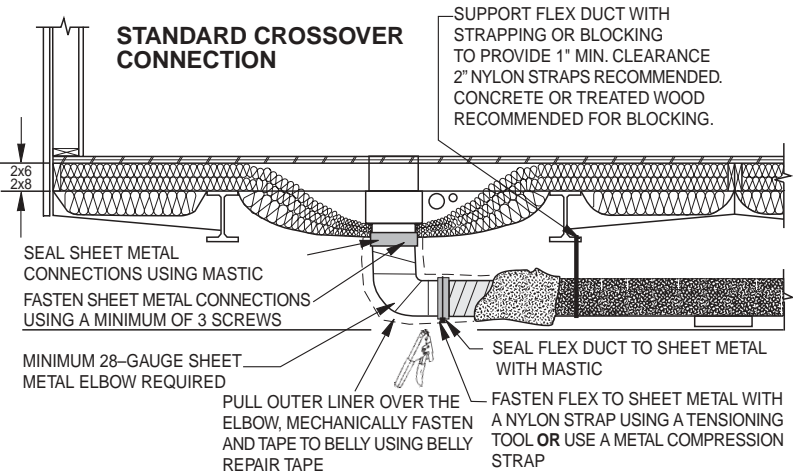

Figure 13  
**THROUGH-RIM CROSSOVER**

- Crossover branch duct extends to outer rim of floor and through cut out section of floor rim joist.
- Adhere outer gasket and mechanically fasten or install as approved by SEO and DAPIA.
- Contact DAPIA and SEO to ensure proper design to adequately carry airflow through crossover.
- Contact SEO for insulation detail below through-rim crossover duct.

See *Technical Specifications* section [3.2](#), [3.3](#), [5.6](#)

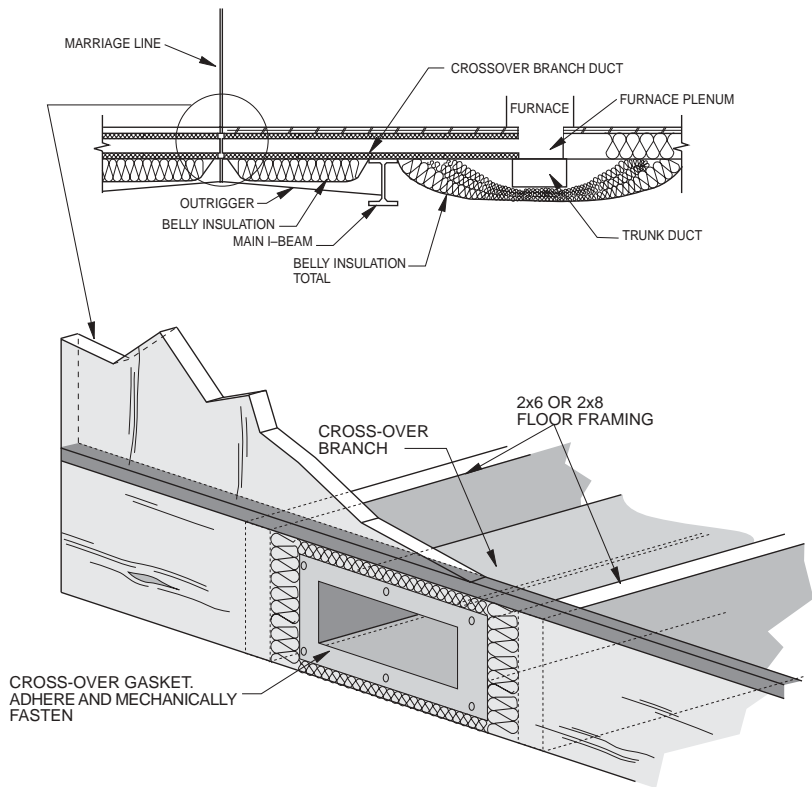

Figure 14  
**TUB P-TRAP SEALING: TRAP ARM ABOVE FLOOR**

- Seal all plumbing, electrical and mechanical penetrations through the floor to reduce heat loss and prevent condensation and moisture damage in floor cavity.
- Floor penetrations for tub trap arms are the most difficult to consistently seal. A well thought-out strategy is required.
- If a gasket is used to seal around the tub drain, seal the gasket to the floor and the drain.
- Consider adding an inspection procedure if the gasket is routinely cut for trap inspection or repair. Tape all cuts before shipping the home.

See *Technical Specifications section 2.4.1.3*

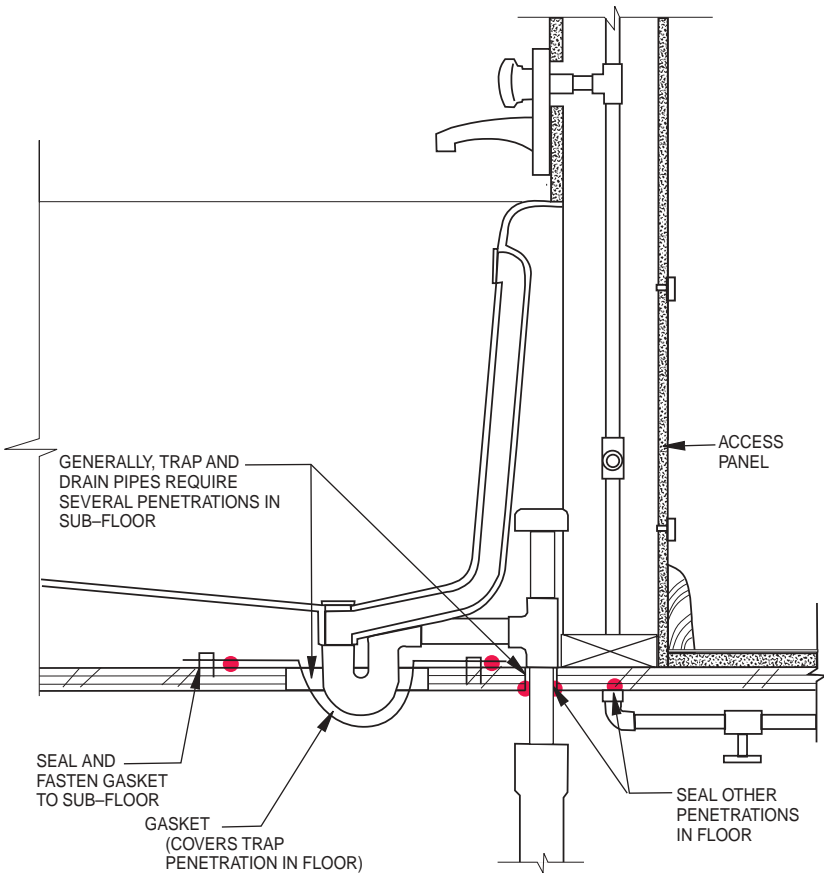



Figure 15  
**TUB P-TRAP SEALING: TRAP ARM BELOW FLOOR**

- Seal all penetrations. Sealing considerations outlined in Figure 13 also apply to sealing the tub P-trap when the trap arm is below the floor.

See *Technical Specifications section 2.4.1.3*

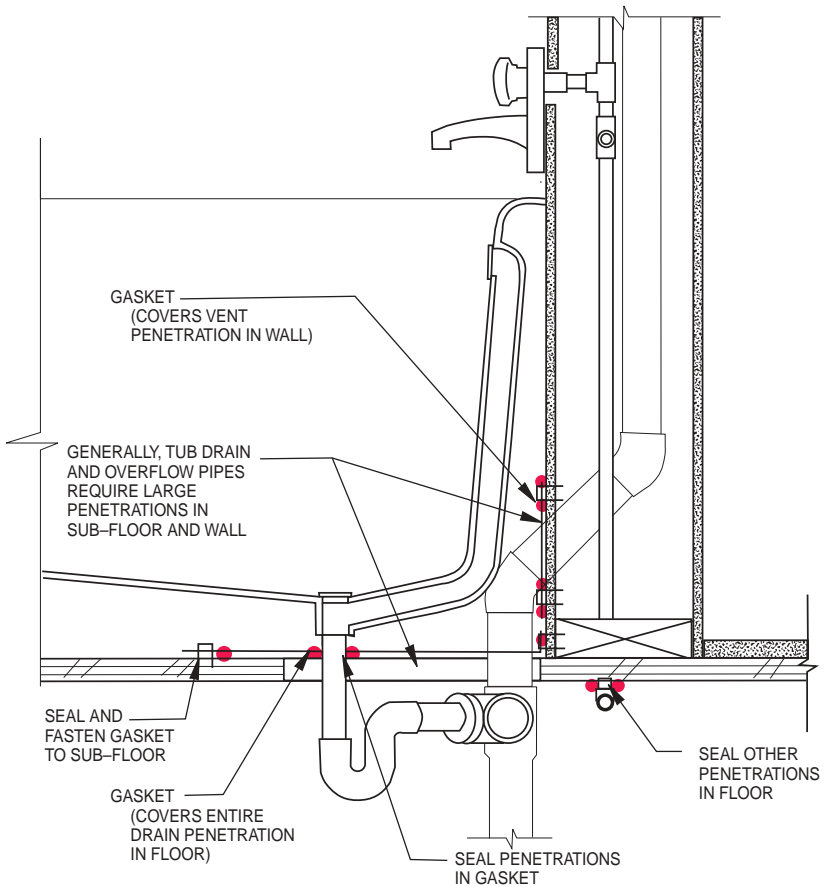

Figure 16  
**TUB ENCLOSURE SEALING**

- An alternative to sealing the cut-out in the floor for a one-piece tub is to seal around its entire perimeter — across the bottom on the floor and along the sides and back to the walls.
- Wallboard must be installed behind tub and sealed to the floor.
- Pedestal or drop-in type tubs cannot be sealed in this manner.

See *Technical Specifications section 2.4.1.3*

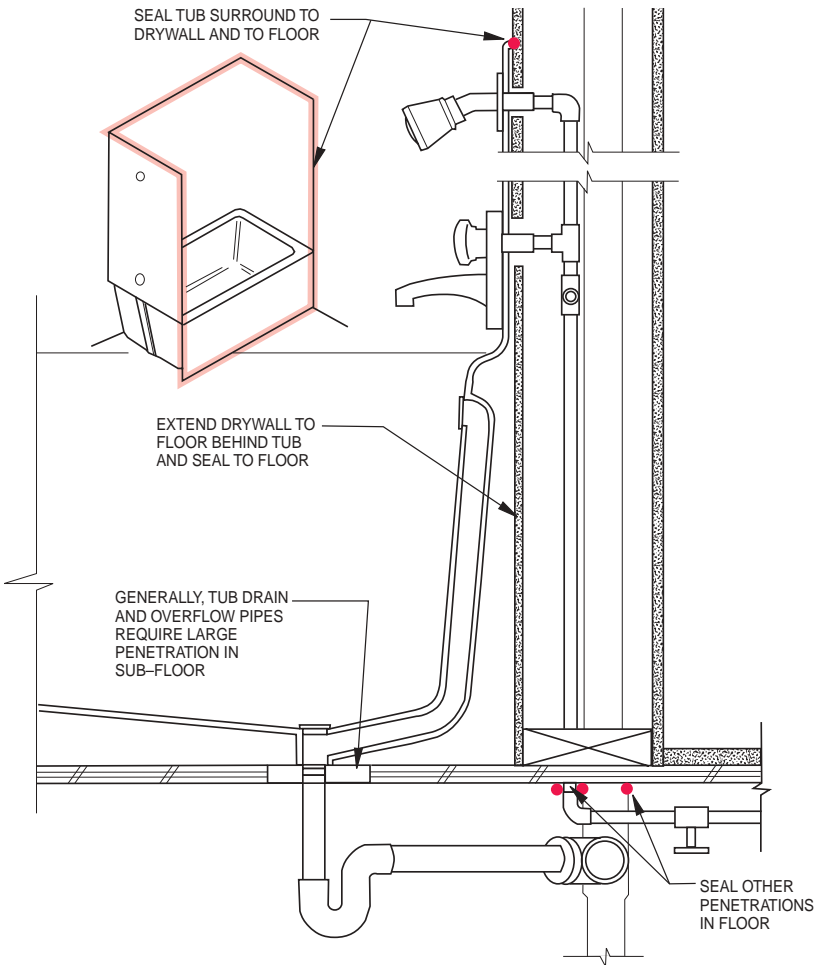
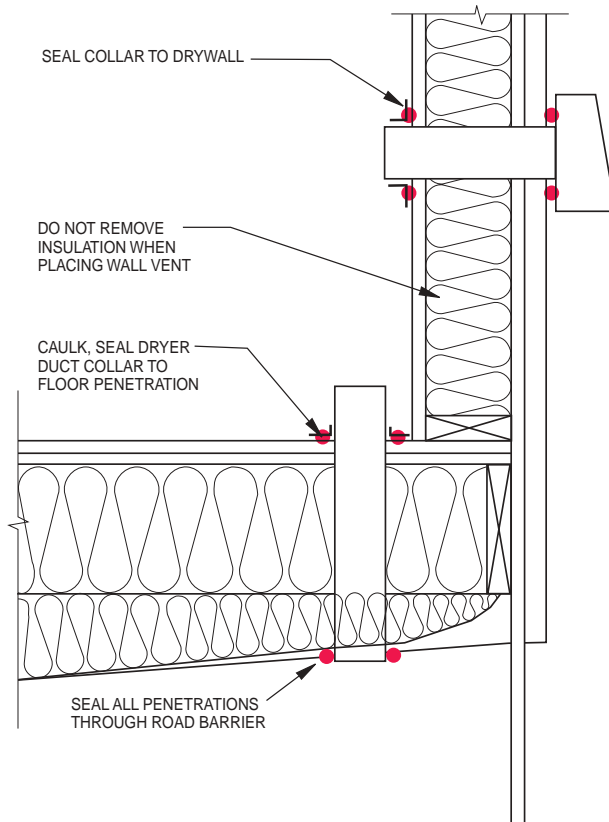

Figure 17

**SEALING DRYER DUCT PENETRATIONS**

- Any penetrations through the pressure envelope must be sealed. This includes dryer exhaust ducts through the floor or the exterior wall. In addition, all penetrations through the road barrier must be sealed.
- A dryer duct must be provided if a dryer is installed. The duct can run through the floor or exterior wall. In either case, the duct must be sealed where it passes through *interior* surfaces. Maintain loft of wall and floor insulation around the duct. Be careful not to push insulation to the side.
- If a dryer is not installed, a roughed-in duct opening must be provided. One way is to provide a hole through the floor or wall, with *sealed* covers on both the interior and exterior. Another way is to provide an exhaust tube that passes through the wall or floor that the dryer duct will attach to when installed. The tube must be sealed where it passes through the wall or floor.

See *Technical Specifications* section [2.4.1.3](#), [5.2](#)



## Exterior Walls

Figure 18  
**INSULATION AND AIR SEALING AT EXTERIOR WALLS**

- Install the R-value shown on the unit order.
- Avoid compression, voids and side-stapling of insulation.
- Install a vapor retarder rated at one perm or lower on the inside surface of exterior walls.
- Seal all electrical, plumbing and mechanical penetrations in walls.
- Seal the exterior wall to the floor and the ceiling. Use either caulk, foam tape, or tape and texture.

See *Technical Specifications* section [2.1.4](#), [2.4.1.3](#)

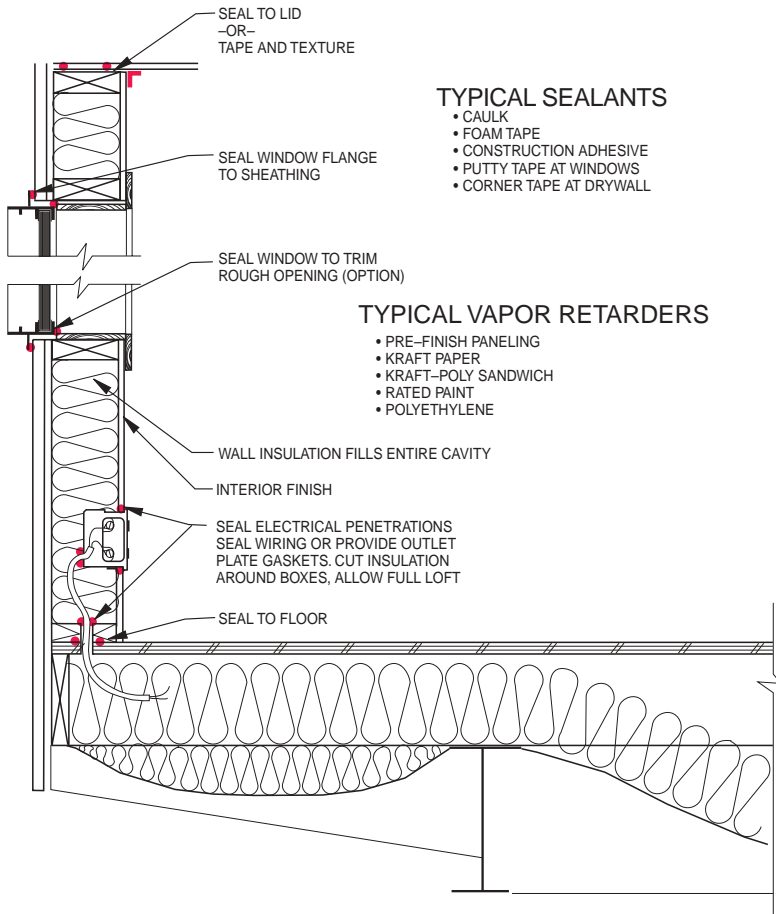

Figure 19

**END-WALL INSULATION DETAILS**

- Cut end-wall insulation at the same angle as the rake. Make sure to cut the insulation to the correct angle, using a bevel square or template, if necessary.
- Insulation should be cut to fit, full loft and have no gaps, voids or compression. Insulation that is poorly installed does not provide the full insulating value.

See *Technical Specifications* section [2.1](#), [2.1.4](#), [2.4.1.3](#)

INSULATION AT FULL LOFT.  
AVOID GAPS AND COMPRESSION  
CUT TO FIT ANGLED WALL CAVITIES.

- INSTALL FULL PIECE WITH ANGLE CUT AT TOP OF CAVITY
- PIECE IN AT BOTTOM OF CAVITY

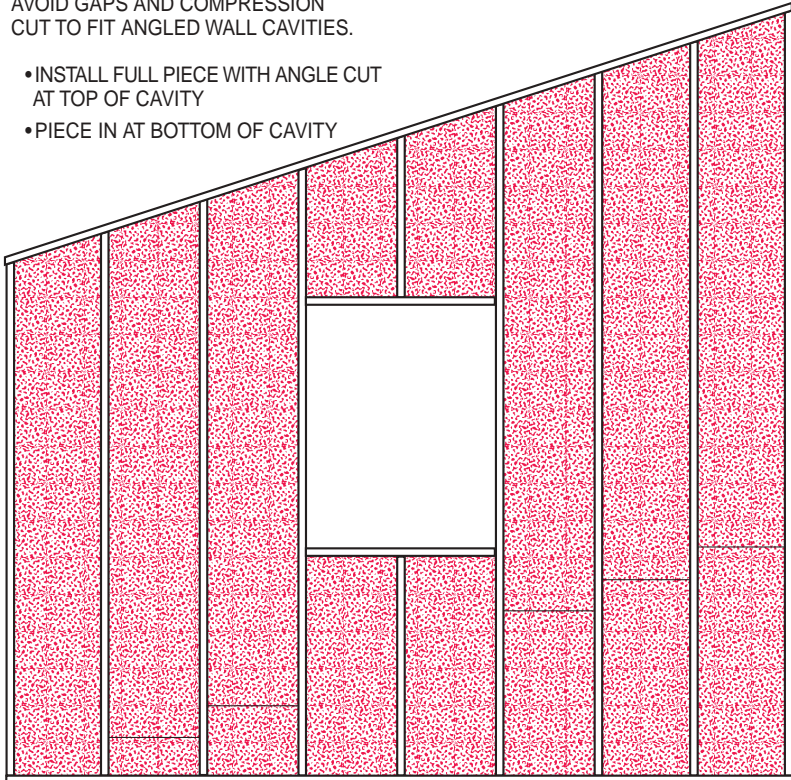

Figure 20  
**ANGLED CORNER AIR SEALING AND INSULATION**

- Back-in insulation at irregular cavities.

See *Technical Specifications* section [2.1.4](#), [2.4.1.3](#)

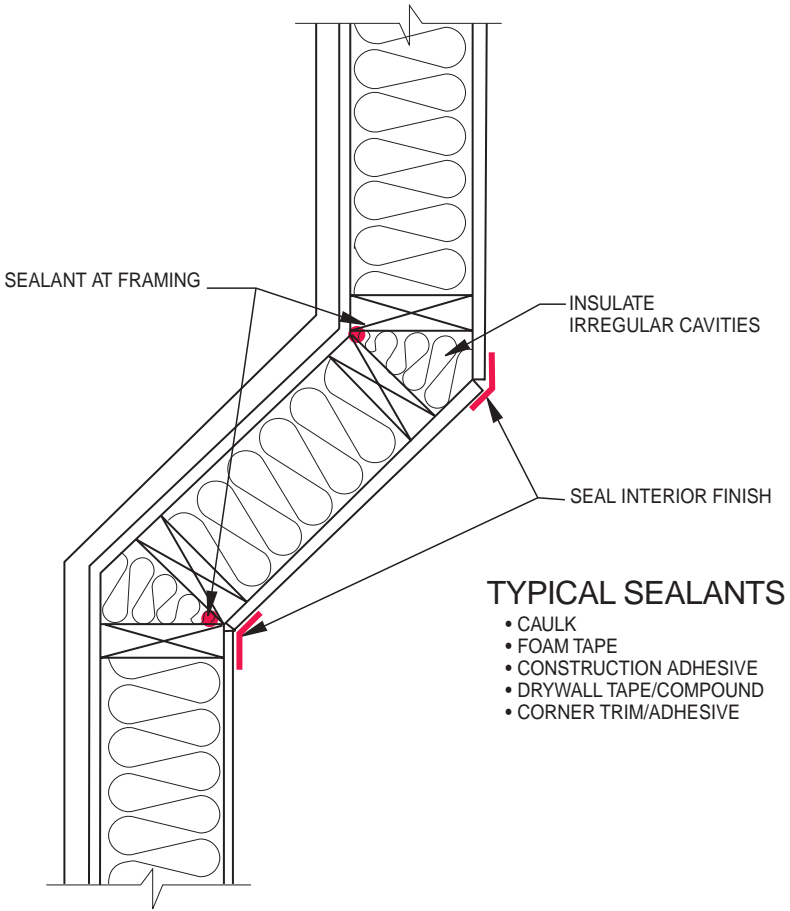
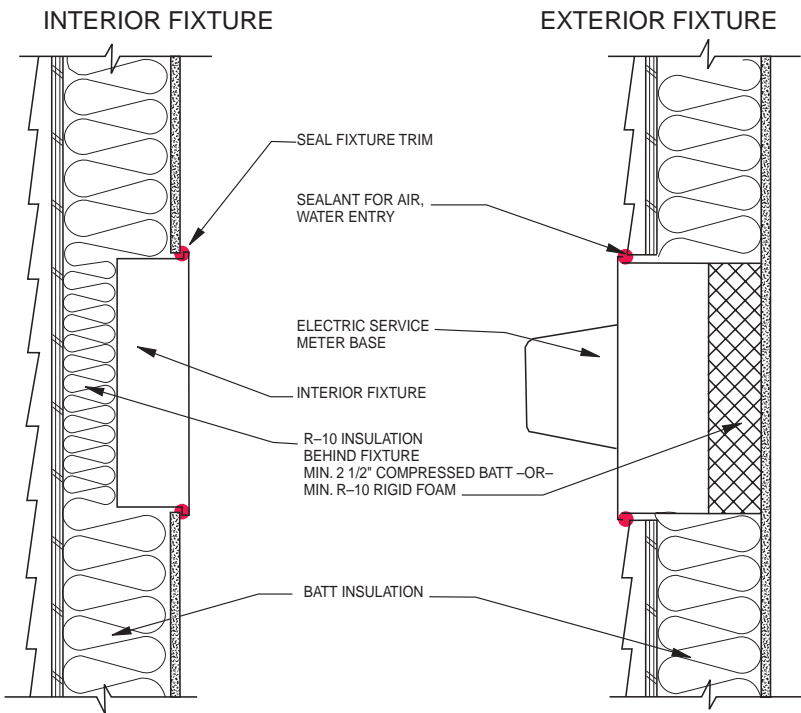

Figure 21

**INSULATION AND AIR SEALING AT RECESSED WALL FIXTURES**

- Install a minimum of R-10 insulation behind recessed wall fixtures, including main panels, meter bases and medicine cabinets. Use rigid foam or compressed wall insulation for these applications. Please refer to Figure 25 on Insulation Compression to ensure that the installed R-value of the insulation will not drop below R-10 due to compression. R-21 insulation can be compressed no more than 2-1/2 inches, for example, to achieve an R-10 insulation value.

See *Technical Specifications section 2.1.6*



## Figure 22 ELECTRICAL BOX CUT-OUTS

- Lofting or cutting out insulation around electrical boxes typically requires the cooperation of more than one department in the plant. Electricians must complete wiring and lofting of insulation before installation of the siding. Siding installers need to allow the electricians enough time for this. An alternative is to assign one person to work between wiring and siding stations to loft or cut out insulation around electrical boxes and any other exterior wall components.

See *Technical Specifications section 2.1.4*

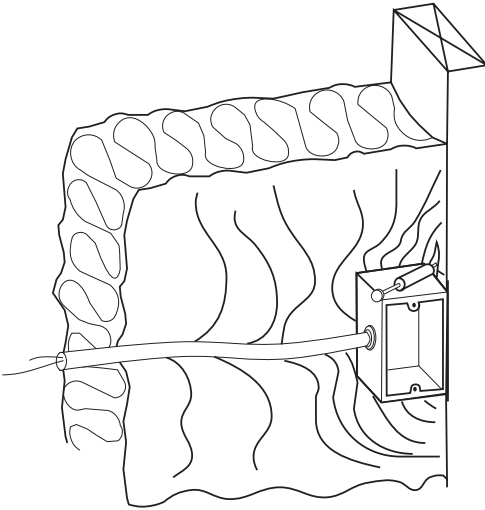

**WRONG**

INSULATION SMASHED  
BEHIND JUNCTION BOX  
AND CABLE

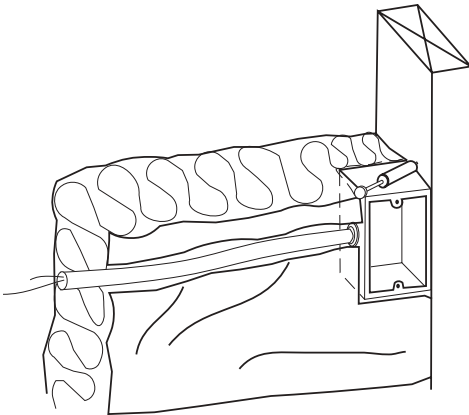

**CORRECT**

INSULATION CAREFULLY  
CUT TO FIT SNUGLY  
BEHIND JUNCTION BOX  
AND CABLE



Figure 23

## INSULATION AND AIR SEALING AT WATER HEATER CLOSETS WITH EXTERIOR ACCESS

- Water heater compartments with exterior access must be insulated to a level equal to the exterior wall R-value. Insulate the compartment door or the walls surrounding the compartment, or both.
- If this requirement is met solely by insulating the door, it must be sealed to the exterior wall and insulated to a level at least equal to the exterior wall R-value.
- Follow FMHCSS flame spread and fire-stopping requirements.

See *Technical Specifications section 2.1.4*

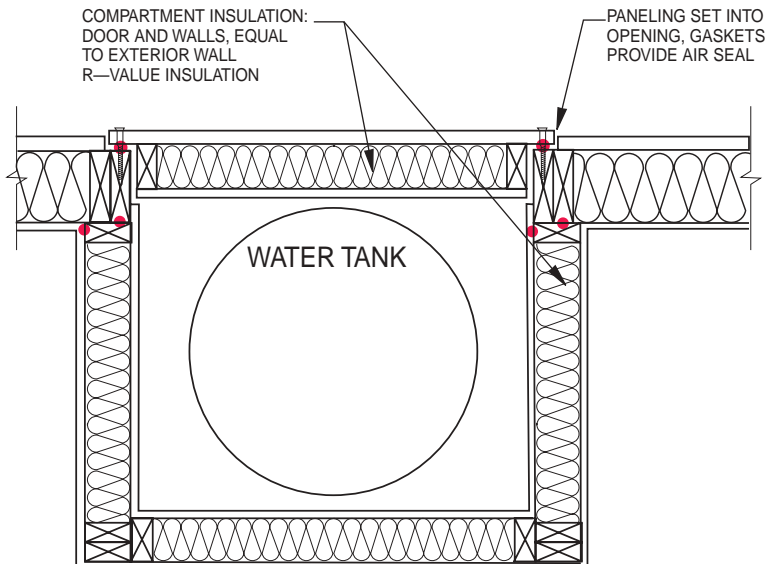
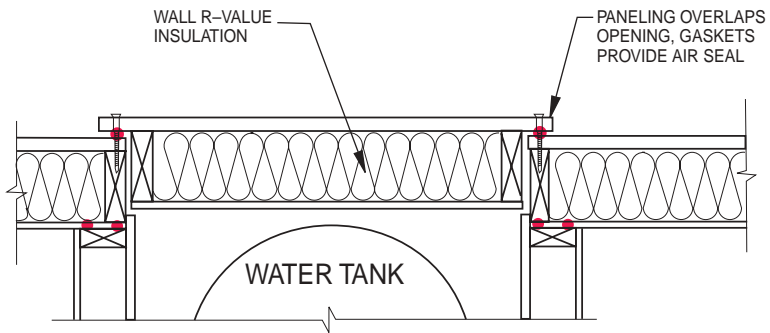
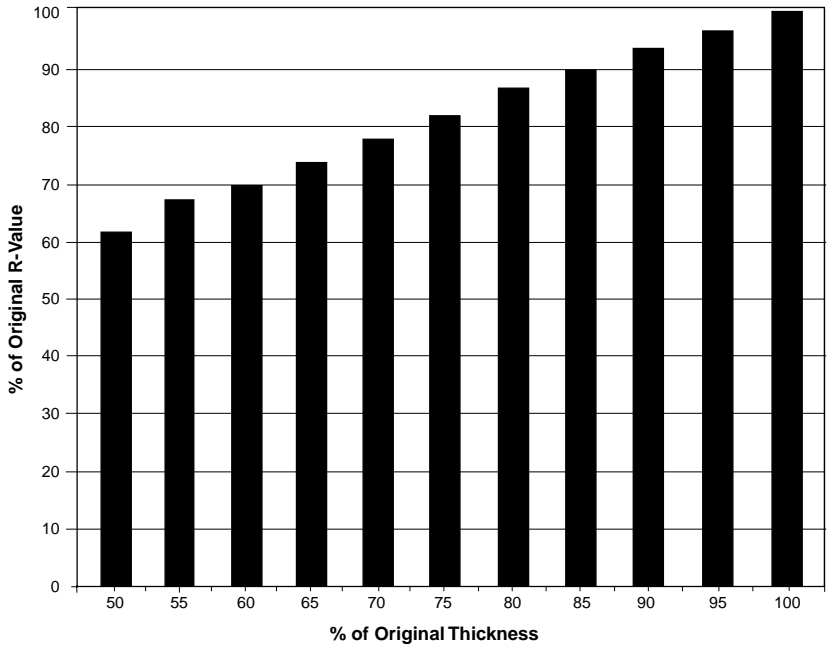

Figure 24  
**R-VALUE PER INCH OF RIGID INSULATION**

<b>Insulation Type</b>	<b>R-Value per Inch</b>	<b>Reference</b>
Expanded polystyrene	3.9	ASHRAE
Extruded polystyrene	5.1	Dow Chemical Group
Polyurethane	6.2	ASHRAE
Polyisocyanurate	7.2	Celotex Corp.
Phenolic foam	8.3	Manville Corp.

Figure 25  
**EFFECT OF COMPRESSION ON R-VALUES  
OF BATT INSULATION**



## Ceilings and Roofs

Figure 26

### FULL WIDTH BATTS IN CEILING CAVITIES

- Install insulation with the R-value shown on the unit order.
- Batts must be full width. If trusses are spaced 16 inches o.c., insulation batts must be 16 inches wide. If trusses are spaced 24 inches o.c., insulation batts must be 24 inches wide.
- If loose-fill or blown-in insulation is used, it must be installed to a specified density. Check the insulation manufacturer's instructions for bag count/R-value ratios. Maintain an accurate bag count and monitor insulation depth during installation.
- Full-width batts require that single wide trusses have a heel height of at least 8.5 inches.

See *Technical Specifications section 2.1.3*

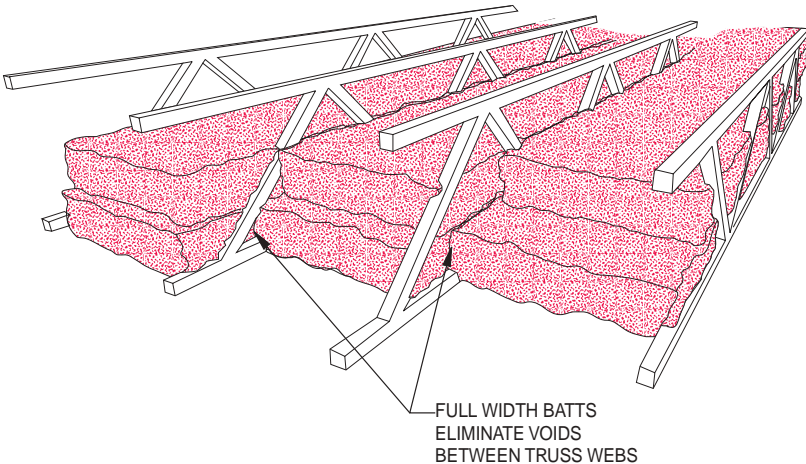

Figure 27

**FLAT CEILING INSULATION, VENTING, AND AIR SEALING**

- Cover the top plate of the exterior wall with insulation.
- A vapor retarder of one perm or less must be installed on the warm side of the roof cavity. If kraft-faced insulation is used, ensure that the kraft facing completely covers the ceiling between the trusses and that there are no tears. If a spray-on retarder is used, use a film gauge to measure for correct thickness.
- Seal all ceiling penetrations — around vent pipes, wires, fans, and light cups.

See *Technical Specifications* section [2.1.3](#), [2.4.1.3](#)

**CRUSHED BATT INSULATION**

CRUSHED BY BAFFLES TO  
MAINTAIN 1" VENTILATION PATH

**ATTIC VENTED AT RIDGE**

Figure 28  
**VAULTED CEILING INSULATION, VENTING, AND AIR SEALING**

- Cover the top plate of the exterior wall with insulation.
- Install a vapor retarder per flat ceiling requirements.
- Seal all penetrations through the ceiling.
- Install baffles at roof truss heels to prevent insulation from falling into the eaves.
- Blow insulation to 1" of top of roof truss until required depth is achieved. Ensure insulation is evenly distributed before installation of roof decking.
- Refer to section 3 in Part III for required insulation depths.

See *Technical Specifications* section [2.1.3](#), [2.4.1.3](#)

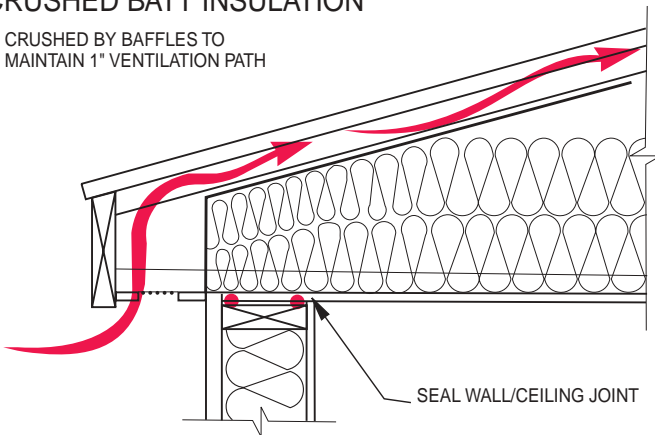
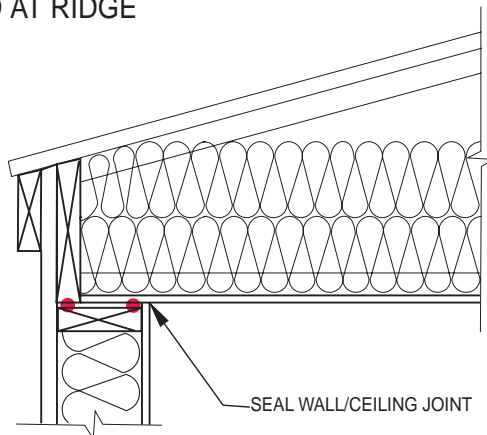
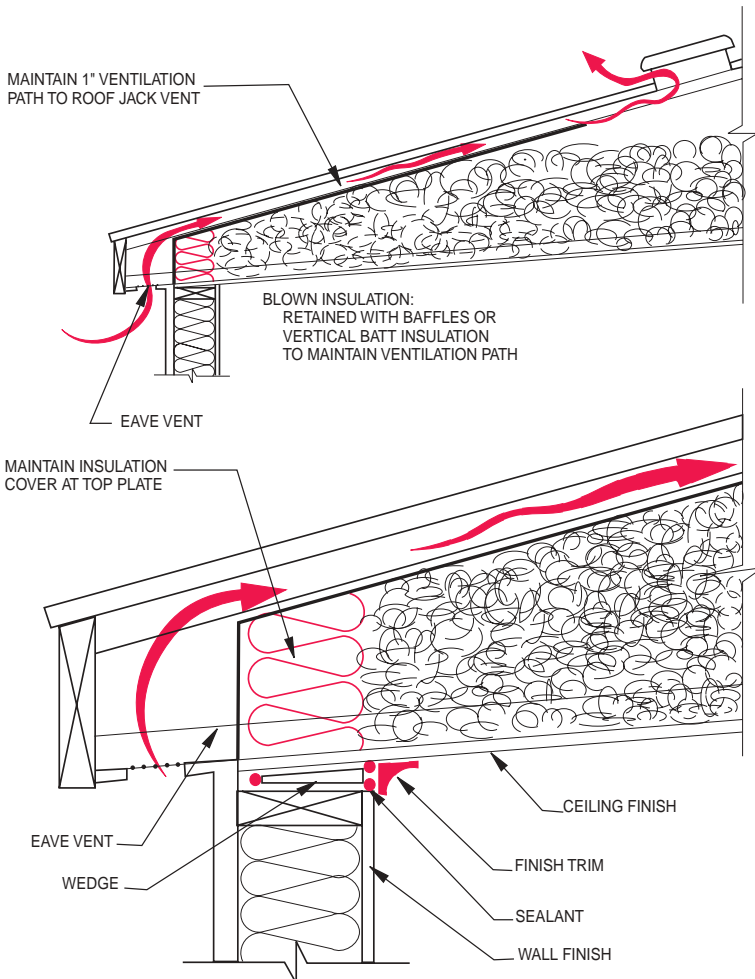
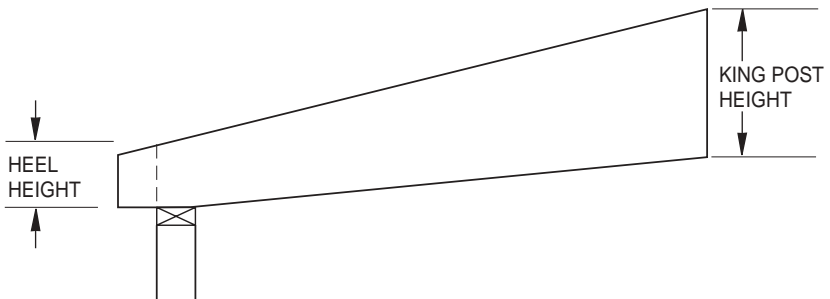

Figure 29  
**KING POST AND HEEL DIMENSIONS (IN INCHES)  
 FOR R-38 VAULTED CEILINGS\***

Heel Height	Blown Insulation	Batt Insulation	High-Density Batts
4.25	22	23	19.5
4.625	20.5	21	17
5	19.5	19.5	15.5
5.5	18	18	14
5.875	17	16.5	13.5
6.375	16	15.5	12.5
6.875	15	14.5	12
7.25	14	13.5	11
7.75	13.5	13	10.5
8.25	13	12.5	10
8.625	12.5	12	9.5
9.125	12	11.5	9

\*Example: For 5.875 inch heel height using blown insulation, the king post height must be at least 17 inches tall. See Part III, Section 3.



**Figure 30**  
**RECESSED LIGHT INSULATION AND AIR SEALING**

- Install a minimum of R-10 insulation above any recessed light fixture. Maintain a 1 inch air space above the insulation for roof ventilation.
- Insulation may be installed directly over the top of IC (insulation contact) rated light fixtures. They must be sealed at the ceiling finish.
- Fixtures that don't have an IC rating may be used if they are installed in a furred box. R-10 insulation must be installed above the box. Use rigid foam insulation. All joints in the box must be sealed.

See *Technical Specifications* section [2.1.6](#), [2.4.1.7](#)

**OPTION 1**

IC RATED DOUBLE CAN LIGHTS WITH LABEL  
2.0 CFM AIR MOVEMENT CF ASTM E238

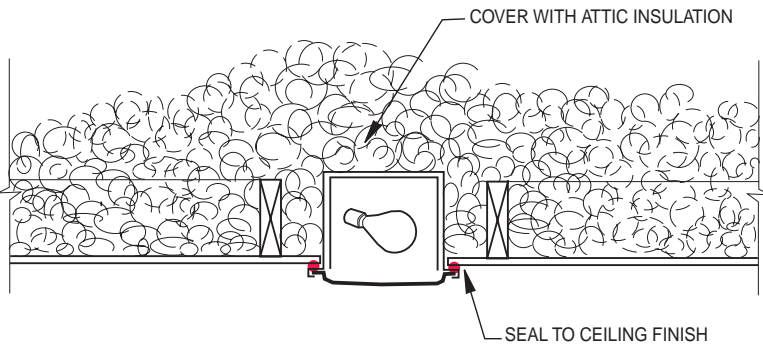

**OPTION 2**

NOT IC RATED  
NO CFM LABEL

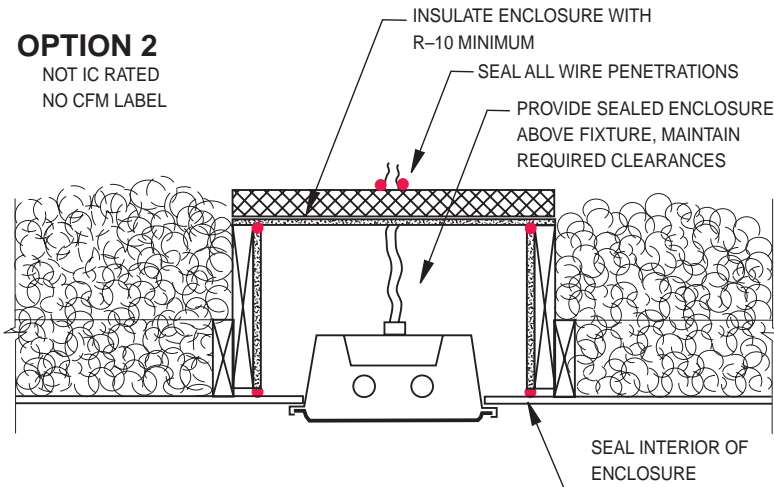



Figure 31  
**AIR SEALING TRANSITIONS BETWEEN FLAT  
AND VAULTED CEILINGS**

- Insulate the vertical portion of the transition that extends above the roof insulation to a level at least equal to the exterior wall R-value.
- Seal the interior ceiling finish at the junction between vaulted and flat ceilings.

See *Technical Specifications section 2.4.1.3*

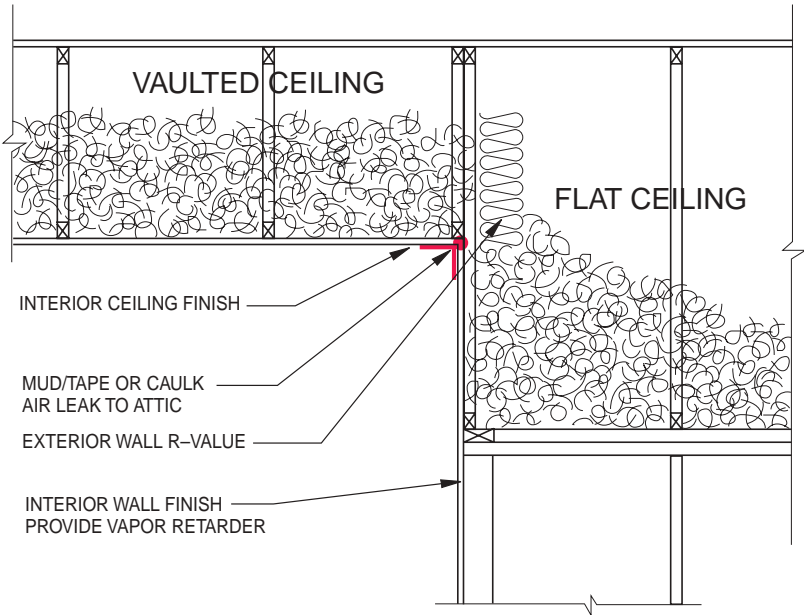
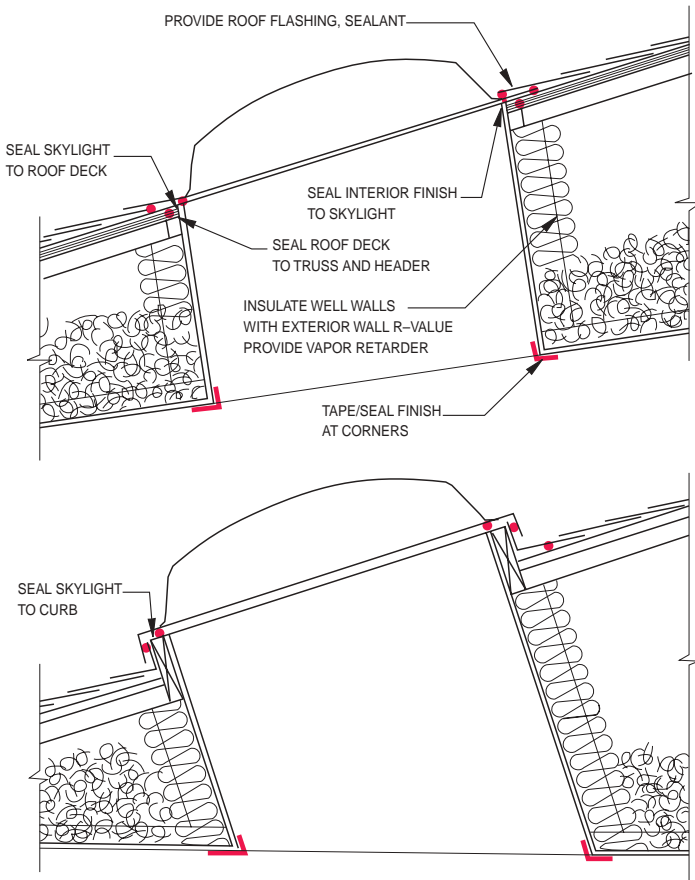

Figure 32  
**SKYLIGHT INSULATION AND AIR SEALING**

- Insulate the vertical portion of the skylight well that extends above the roof insulation to a level at least equal to the exterior wall R-value. Insulation must extend up to the roof decking.
- All joints in the skylight well must be sealed. If the interior finish of the well does not extend up past the edges of the roof decking, the roof decking must be sealed to the truss and well blocking.
- Skylight area must not exceed a total of 40 square feet. Skylights must be triple bubble or be NFRC-rated at U-.50 or as approved. Step flashings may be needed to avoid leaks at skylights.
- Insulation should be in direct contact with the skylight wallboard — be sure there is no airspace between the skylight shaft and the insulation.

See *Technical Specifications* section [2.1.3](#), [2.3.1](#), [2.3.5](#), [2.4.1.3](#)



## Figure 33 PASSIVE ATTIC VENTILATION

- High-low passive ventilation requires 1 square foot of net free vent area for every 300 square feet of ceiling area. The required vent ratio for one-level passive ventilation (gable or high vents) is 1/150.
- Both high-low and single-level ventilation require a 1 inch air space between the insulation and the roof decking.
- The FMHCSS require that adequate cross ventilation be maintained throughout the roof cavity. That means every roof bay must be baffled. This also applies to one-level ventilation.
- The ventilation strategy should be identified in the DAPIA package.
- Ensure that roof decking cut-outs for vents are large enough to accommodate net free areas of vent caps. Do not allow construction debris to fall into the roof cavity.

See *Technical Specifications section 4.2*

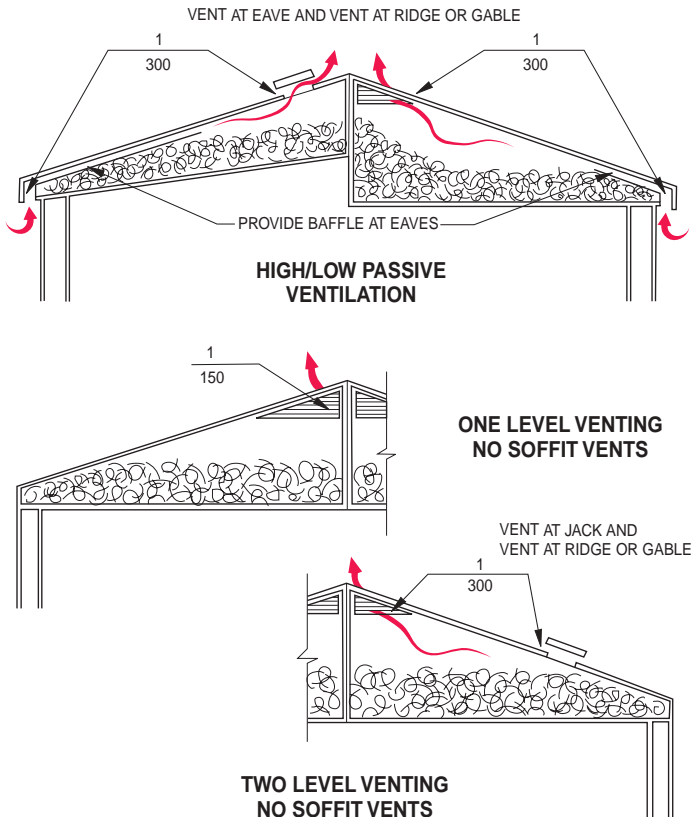

Figure 34  
**ACTIVE ATTIC VENTILATION**

- Whenever possible, passive attic ventilation should be chosen as the preferred ventilation strategy.
- If active ventilation is used, the system must be approved by both the State Energy Office and the DAPIA.
- The FMHCSS require cross ventilation in the roof cavity even with active ventilation. Consult the DAPIA package for approved methods.
- The attic ventilation system must not control the furnace blower to provide ventilation of the home.

See *Technical Specifications section 4.2*

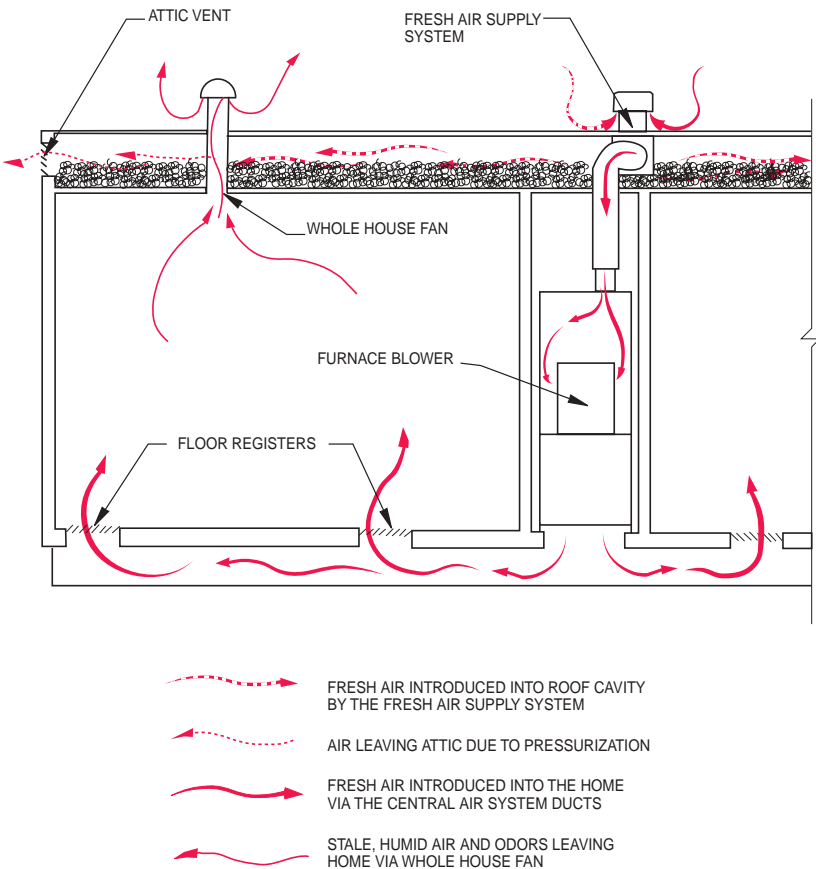

Figure 35  
**VENT FAN DUCT AND CAP INSTALLATION**

- Seal fan to the ceiling finish.
- Flash/seal the duct at the roof line.
- Use mastic or tape to seal the joints in the duct.
- Mechanically fasten duct to fan outlet and roof deck or vent cap.

See *Technical Specifications* section [2.4.1.5](#), [3.2](#), [4.3.4](#) to [4.3.8](#)

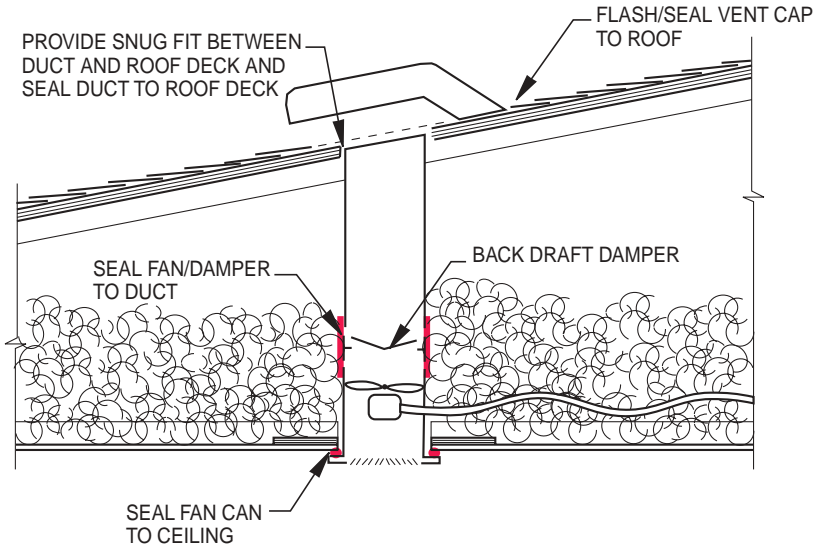
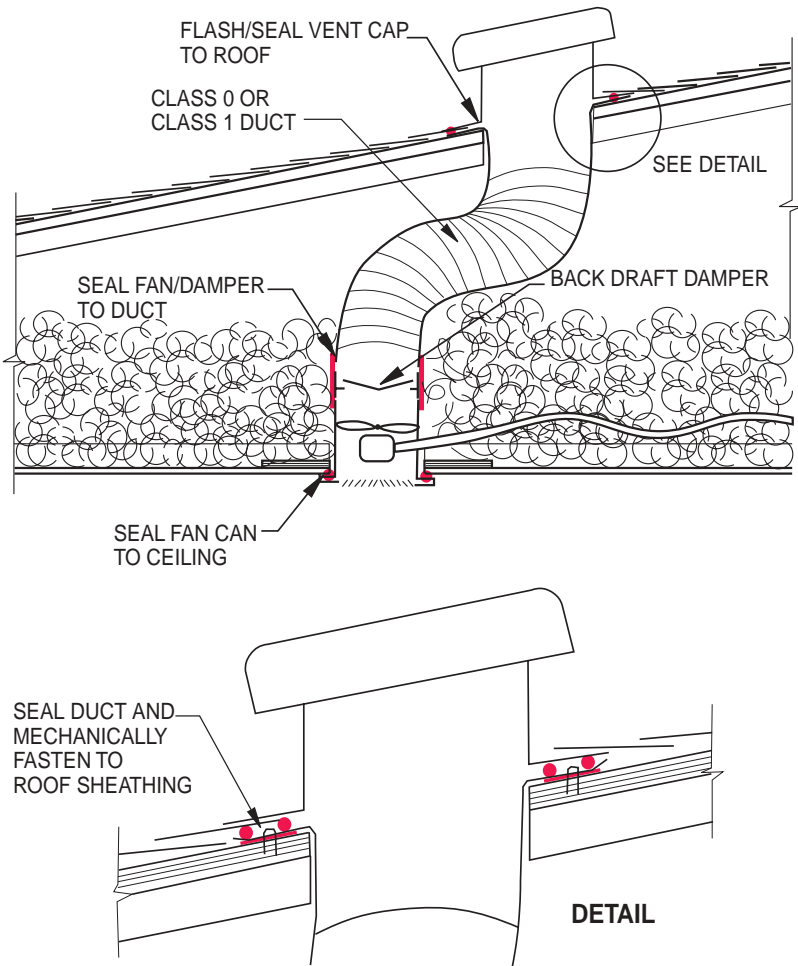

Figure 36  
**VENT FAN WITH FLEX DUCT**

- Fans must be ducted with class 0 or class 1 duct material (metal, semi-rigid metal, or metalized flex duct).
- Mechanically fasten duct to the fan outlet and vent cap or roof deck and seal all duct connection with mastic or tape.
- Flash/seal the duct at the roof line and seal fan to the ceiling finish.
- All non-vertical ventilation exhaust ducts extending more than two feet beyond the insulation shall comply with the FMHCSS and be insulated to at least R-4.

See *Technical Specifications* section [2.4.1.5](#), [3.2](#), [4.3.4](#) to [4.3.8](#)



## Windows and Doors

Figure 37

### WINDOW INSTALLATION

- Verify that the window matches the type specified in the unit order: low-e glass only or argon/low-e.
- All windows must bear both an NFRC label and an AAMA label. The NFRC label is on each glazing unit. The AAMA label is on the window frame.
- Glazing area-weighted average must be no greater than  $U=0.35$ .
- Seal window flanges with putty tape. Seal gaps at siding grooves under flanges.

See Technical Specifications section [2.3](#), [2.4.1.3](#)

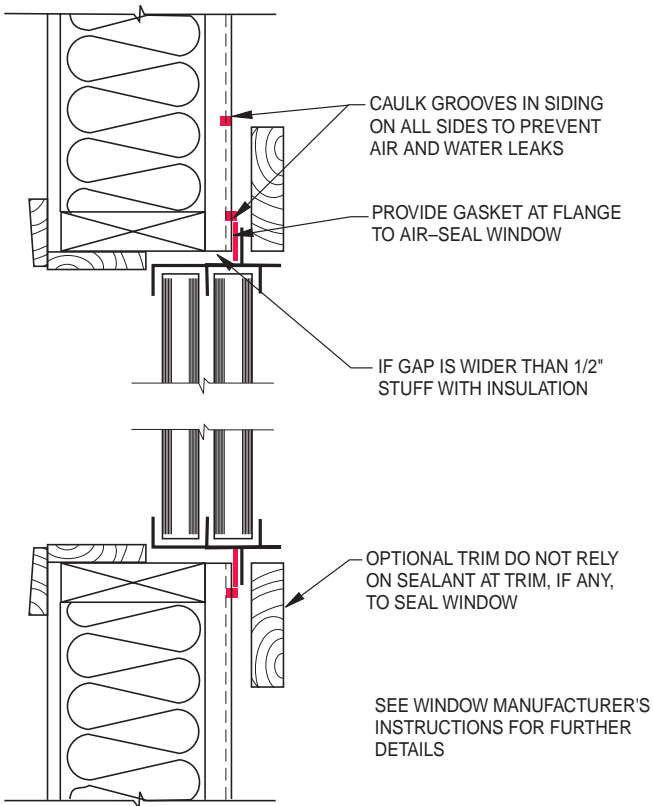

## Figure 38 DOOR INSTALLATION

- If door glazing exceeds 50 percent of the rough opening area, the entire door area must be counted as window area.
- If the area between the door jamb and the rough opening is greater than 1/2 inch, insulating material.
- Doors must bear an AAMA label, located on the door edge.
- Doors must be thermally broken or as approved.

See *Technical Specifications* section [1.4.3](#), [2.2](#)

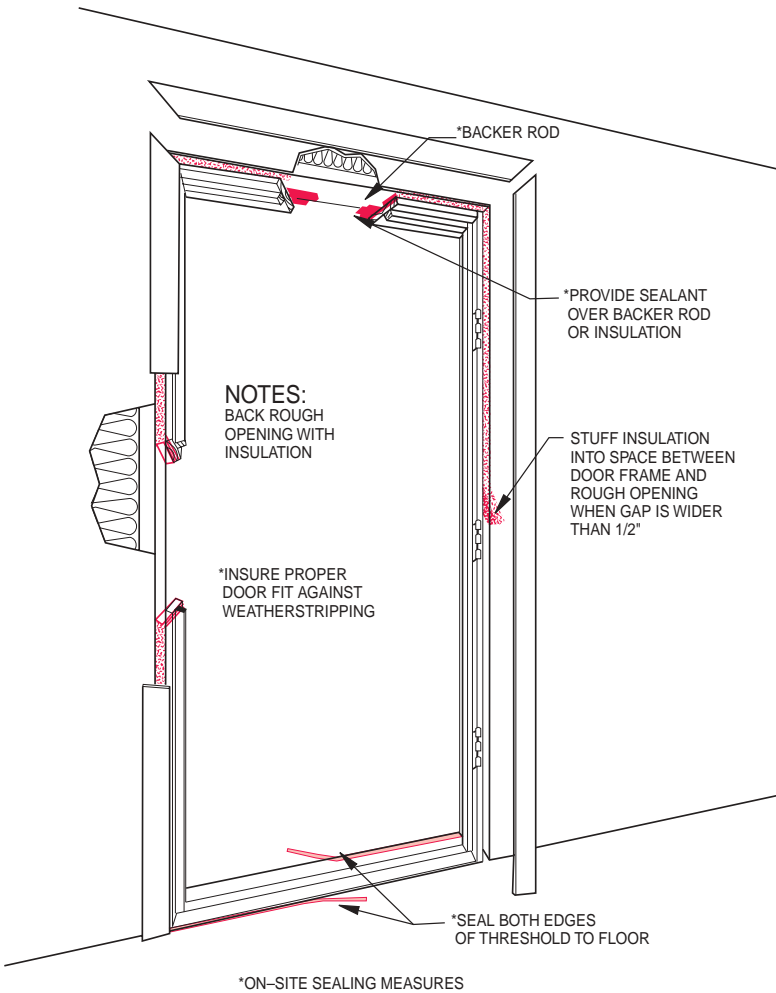



## Ventilation and Heating

Figure 39

### WHOLE HOUSE VENTILATION

- Tight, energy efficient homes need ventilation to help maintain acceptable indoor air quality. This is not optional.
- Verify that the whole house fan is capable of ventilating the house at a rate of 0.035 cfm/square foot of floor area to meet HUD ventilation specifications and that it meets NEEM ventilation specifications in 4.3.2.1.
- HUD and NEEM ventilation systems should be included in the DAPIA package.
- All whole house fans must have a sone rating no greater than 1.0.
- Ensure that ventilation system instructions are included in the “important papers” envelope for future homebuyer.
- Check with a State Energy Office representative to find out what whole house systems meet the requirements. Seek approval of any new system on the market that hasn’t already been approved for your plant.

See *Technical Specifications section 4.3*

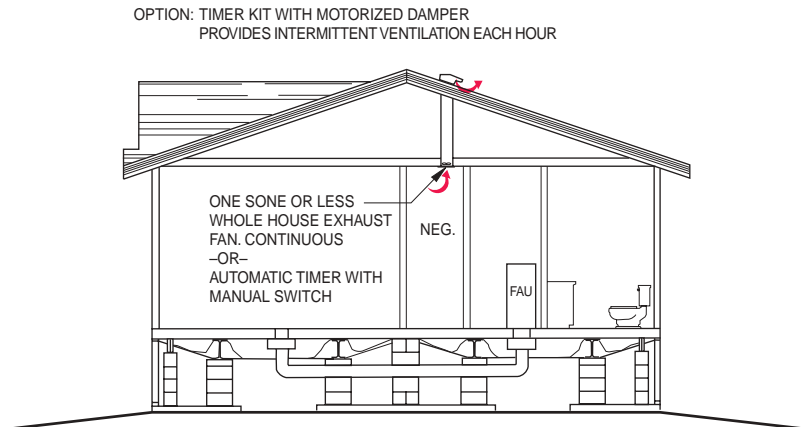
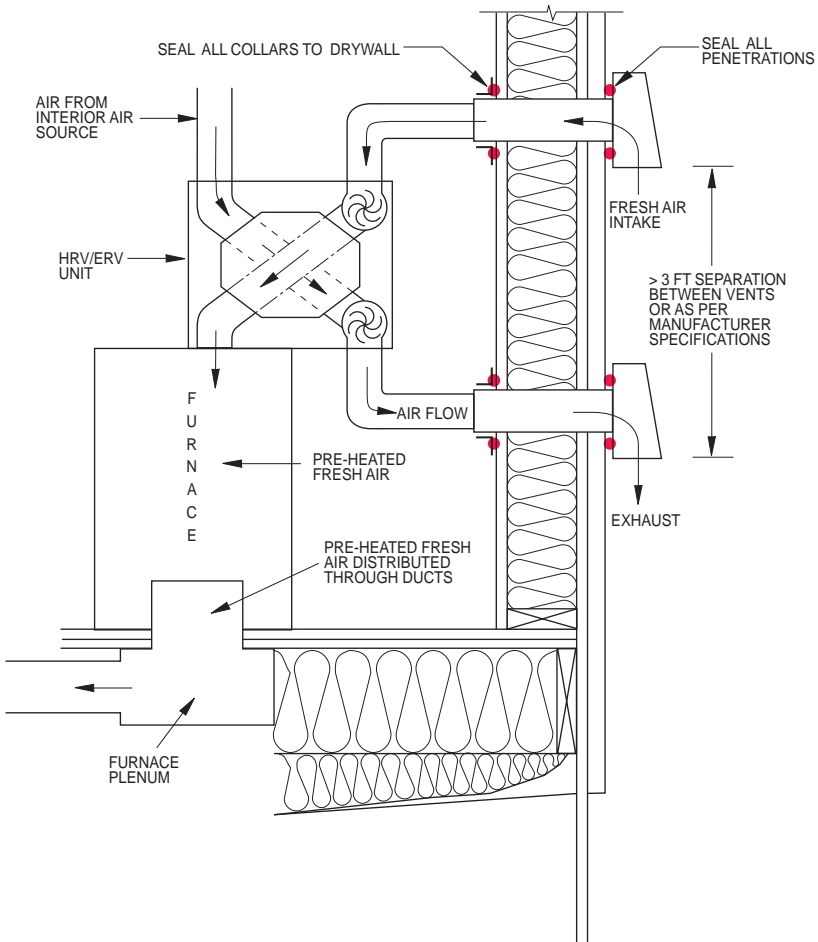

Figure 40  
**HEAT RECOVERY VENTILATION (HRV) SETUP**

- Air to Air Heat Exchangers (AAHX) shall be installed to manufacturer specifications and shall be DAPIA approved
- All penetrations through the building envelope shall be sealed.
- Contact the SEO for assistance with installation and system requirements.

See *Technical Specification section 4.3*



## **PART II**

### **TECHNICAL SPECIFICATIONS**

Detailed Explanations of Manufacturing  
Requirements with References to Figures in Part I

**January 2004**



---

**TABLE OF CONTENTS**

<b>Chapter</b>	<b>Page</b>
1. DESIGN QUALIFICATION AND CERTIFICATION .....	55
1.1 General .....	55
1.2 NEEM Reference Path .....	56
1.3 Plan Review .....	57
1.4 Qualification .....	57
1.4.1 Thermal Performance Standards .....	57
1.4.2 Energy Budgets .....	57
1.4.3 Prescriptive Standards .....	57
1.5 Solar Access .....	58
1.6 Certification .....	59
1.6.1 Plant Certification .....	59
1.6.2 Site Certification .....	59
1.7 Existing Codes and Regulations .....	59
2. THERMAL EFFICIENCY .....	60
2.1 General Insulation .....	60
2.1.1 Clearances .....	60
2.1.2 Access Hatches and Doors .....	60
2.1.3 Ceiling Insulation .....	60
2.1.4 Wall Insulation .....	61
2.1.5 Floor Insulation .....	61
2.1.6 Recessed Fixtures .....	61
2.1.7 Set-Up Kit .....	61
2.2 Doors .....	61
2.2.1 Thermal Ratings .....	62
2.2.2 Infiltration Ratings .....	62
2.3 Glazing and Skylights .....	62
2.3.1 Thermal Ratings .....	62
2.3.2 Infiltration Ratings .....	62
2.3.3 Secondary Windows .....	62
2.3.4 Structural Requirements .....	62
2.3.5 Skylights .....	63

Chapter	Page
2.4	<b>Air Leakage Control</b> ..... 63
2.4.1	Standard Air Leakage Control ..... 63
2.4.1.1	Windows ..... 63
2.4.1.2	Doors ..... 63
2.4.1.3	Caulking and Sealing ..... 63
2.4.1.4	Electric Outlets ..... 63
2.4.1.5	Ducts ..... 64
2.4.1.6	Wood Stoves and Fireplaces ..... 64
2.4.1.7	Recessed Fixtures ..... 64
2.4.2	<b>Building Air Tightness Standard</b> ..... 64
3.	HEATING SYSTEMS ..... 65
3.1	<b>Sizing</b> ..... 65
3.2	HVAC Ducts ..... 65
3.3	<b>Duct Sealing</b> ..... 65
3.3.1	Ductwork ..... 65
3.3.2	Duct Ends ..... 65
3.3.3	Duct Connections ..... 65
3.3.4	Mesh ..... 65
3.4	<b>Space and Water Heater Systems</b> ..... 65
3.4.1	Combustion Fuel Furnaces ..... 65
3.4.1.1	Combustion Furnace AFUE ..... 65
3.4.2	<b>Combustion Furnace Water Heaters</b> ..... 66
3.4.2.1	Combustion Water Heater Energy Factor .. 66
3.4.3	The Term “Readily Available” ..... 66
4.	MOISTURE AND INDOOR AIR QUALITY CONTROL ..... 67
4.1	<b>Moisture Vapor Transfer</b> ..... 67
4.2	<b>Attic Ventilation</b> ..... 67
4.3	<b>Mechanical Ventilation</b> ..... 67
4.3.1	Scope ..... 67
4.3.2	Non-Heat Recovery Ventilation ..... 68
4.3.2.1	Whole House Minimum Ventilation Air Flows and Sone Ratings ..... 68
4.3.2.2	Backdraft Dampers ..... 68
4.3.2.3	Controls ..... 68

<b>Chapter</b>	<b>Page</b>
4.3.3	<a href="#">Heat Recovery Ventilation (HRV) ..... 69</a>
4.3.3.1	Whole House Minimum Ventilation Air Flows ..... 69
4.3.3.2	Air Flow Balance ..... 69
4.3.3.2.1	Air Flow Measurements ..... 69
4.3.3.3	Controls ..... 69
4.3.4	<a href="#">Exhaust Duct Insulation ..... 70</a>
4.3.5	Exhaust Duct Termination ..... 70
4.3.6	Exhaust Duct Material ..... 70
4.3.7	Exhaust Duct Connections ..... 70
4.3.8	Spot Ventilation ..... 70
5.	<b>ON-SITE SPECIFICATIONS ..... 71</b>
5.1	<a href="#">General ..... 71</a>
5.2	<a href="#">Damage Repair ..... 71</a>
5.3	<a href="#">Air Sealing ..... 71</a>
5.3.1	Marriage Line ..... 71
5.3.2	Window and Door Frames ..... 71
5.3.3	Other Penetrations ..... 71
5.3.4	Building Air Tightness Standard ..... 71
5.4	<a href="#">Skirting/Foundation Fascia ..... 71</a>
5.5	<a href="#">Crawl Space Moisture Control ..... 72</a>
5.5.1	Ground Cover ..... 72
5.5.2	Crawl Space Ventilation ..... 72
5.5.3	Clothes Dryer ..... 72
5.5.4	Drains ..... 72
5.6	<a href="#">Crossover Connections ..... 72</a>
5.6.1	Crossover Ducts for the Heating Systems ..... 72
5.6.1.1	Crossover Duct Materials ..... 72
5.6.1.2	<a href="#">Sheet Metal Elbow ..... 73</a>
5.6.1.3	<a href="#">Crossover Duct Connections ..... 73</a>
5.6.1.4	Crossover Duct Vapor Retarder Connections ..... 73
5.6.1.5	<a href="#">Crossover Duct Support ..... 74</a>
5.6.2	<a href="#">In-Floor Crossover ..... 74</a>
5.7	<a href="#">Operational Checks ..... 74</a>
5.8	<a href="#">Homeowner Information ..... 74</a>





## CHAPTER 1 DESIGN QUALIFICATION AND CERTIFICATION

**1.1 General:** Electrically or gas heated HUD code manufactured residential buildings qualifying under the Northwest Energy Efficient Manufactured Home Program (NEEM) shall meet the requirements of this specification.

Any changes, corrections, or additions shall be made only with the written approval of the state energy offices. Interpretation and enforcement shall be under the authority of the Oregon, Idaho, Montana and Washington state energy offices (SEOs) for homes manufactured in their respective states.

The reference path for manufactured homes is listed on the following page in [Section 1.2](#).

## 1.2 NEEM Reference Path for Electrically or Gas Heated Manufactured Homes<sup>1</sup>

COMPONENT <sup>2</sup>		CLIMATE ZONE <i>All Climate Zones</i>
Ceilings	Flat	U-0.025
	Sloped	U-0.030
Walls	Above Grade	U-0.052
Floors	Steady State	U-0.033
Glazing	U-Factor	U-0.35
	Area (% of floor) <sup>3</sup>	15.0% <sup>4</sup>
Exterior Doors		U-0.19
Infiltration Rate <sup>5</sup>		0.35 ACH
Crossover Duct Insulation		R-8
Main trunk duct fully sealed with approved mastic <sup>6</sup>		

### Notes:

1. The heat loss coefficients in Part III shall be used to meet these standards.
2. Refer to Section 1.4.3 for an allowable component prescriptive path and method for path development.
3. Up to 7 ft<sup>2</sup> of ornamental, decorative, or security dual-glazed windows are allowed and not restricted by this requirement.
4. A home which is built to this reference path may have unlimited glazing to floor ratio, and if the U<sub>o</sub> of any component package is 0.0554 or less using the prototype stated in 1.4.3, (with the glazing area of 15 percent of the conditioned space), then homes built with that component package may have unlimited glazing.
5. Prescriptive air-sealing measures applied to achieve no more than 5.0 ACH<sup>50</sup> tested in the field combined with mechanical ventilation and pollutant source control in all homes. Refer to specification 2.4.2.
6. For metal duct, mastic and for ductboard approved metal tape must be used and all products must meet non-toxicity and performance specifications.

**1.3 Plan Review:** To qualify under the program, a building design must be reviewed and qualified by a state energy office representative.

**1.4 Qualification:** To qualify under the program, the building shall meet the reference path in Section 1.2 and use the component U-factors in Part III through **ONE** of the following three approaches (skylights totalling 40 ft<sup>2</sup> or less which do not exceed U-0.50 are exempt):

**1.4.1 Thermal Performance Standards** as calculated using WATTSUN (version 5.2 or later), Sunday (version 3.0) or other SEO approved methods.

**1.4.2 Energy Budgets** as calculated using WATTSUN (version 5.2 or later), Sunday (version 3.0), or other approved methods. No credit is given for heat pumps. For energy budget calculations which include contributions from solar gain, balanced heat recovery ventilation and the orientation of the home is not known, glazing shall be assumed to be evenly distributed among the four cardinal directions with a shading coefficient of 0.50, unless compliance with Section 1.5 can be demonstrated.

A maximum of 3 Btu/°F of thermal mass per ft<sup>2</sup> of conditioned floor area shall be assumed unless provisions are made at the site to add additional thermal mass. Any additional heat storage capacity shall be calculated using standard engineering practice.

**1.4.3 Prescriptive Standards** shall be developed by manufacturers based on the reference U-factors in Part III and glazing area in Section 1.2 for a 1,492 ft<sup>2</sup> prototype and approved by a state energy office representative. Additional prescriptive paths may be developed for the manufacturer based on the U-factors for alternate construction in Part III and meeting the provisions of Section 1.2.

The following example describes acceptable component prescriptive paths using approved ceiling, wall, and floor construction (based on the reference path in Section 1.2). All other prescriptive paths shall be approved by the SEOs based on component construction and Section 1.2.

### **Ceilings**

Sloped: Nominal R-38 blown

Flat: Nominal R-49 blown

### **Wall**

R-21 high density batt; 2x6 studs with 2-1/2 stud corner.

### **Floor**

R-33 cut-in or equivalent.

### **Door**

All exterior doors shall be a minimum of 1-1/2 inches thick with foam core and thermal break. The frame shall be of thermally improved material(s). Doors with dual glazing and less than 50 percent glazing area are acceptable.

### **Crossover Duct**

All crossover ducts shall be supplied by the manufacturer and insulated to R-8 or better.

### **Glazing and Skylights**

Glazing and skylights shall comply with the requirement of Section 2.3, including NFRC rating, certification, and labeling. Up to 40 ft<sup>2</sup> of non-NFRC rated skylight may be installed if it is triple bubble plastic or as approved for thermal equivalency according to [Section 2.3](#).

**1.5 Solar Access:** If passive solar design (i.e., effective solar glazing is 8 percent or more of floor area, increased thermal mass, minimum glazing transmissivity is 0.80 per pane, common living areas on south side, etc.) is used to qualify the house, solar gains shall be based upon actual sun and shading conditions at the site. Solar designs shall be accompanied by a sun chart, or approved equal, to document actual site conditions for current solar access.

A plot plan shall document future solar access by indicating on the site plan that the solar aperture will not be shaded by a hypothetical six-foot fence at the southern property line or by a hypothetical “pole” representing average building heights of houses, located at the center of the buildable area of adjacent lots to the south.

Solar glazing shall receive a minimum of 80 percent direct solar exposure between 9 a.m. and 3 p.m. during the heating season.

**1.6 Certification:** To be certified the building shall comply with these specifications both at the plant and on site.

**1.6.1 Plant Certification:** A manufacturer's quality control inspector shall certify that each home meets or exceeds all requirements set forth in Chapters 1-4 of these specifications.

An authorized plant inspector (certified and approved by the SEO) shall verify that each home has been inspected at least once during its construction and that the inspected measures meet or exceed the requirements of this specification.

**1.6.2 Site Certification:** An authorized utility or on-site inspector may certify that each home meets the requirements set forth in Chapter 5 of these specifications. (Utilities have the option to site inspect these homes.)

**1.7 Existing Codes and Regulations:** These specifications are intended to meet or exceed all applicable codes and federal regulations.

## CHAPTER 2 THERMAL EFFICIENCY

**2.1 General Insulation:** All insulating materials shall be installed according to the manufacturer's instructions to achieve proper densities, minimize voids, and maintain uniform R-values.

**2.1.1 Clearances:** Where required by applicable codes, or where specified in the following sections, proper insulation clearances shall be maintained.

Insulation installed around chimneys shall comply with manufacturer's recommendations. Where allowed by HUD codes and approved by the chimney or flue manufacturer, noncombustible insulation shall be installed around chimneys, flues, and exhaust ventilation ducts.

All ventilation baffles in attics/roofs shall be moisture resistant.

**2.1.2 Access Hatches and Doors:** Access doors from conditioned to unconditioned spaces (e.g., attics and crawl spaces) shall be weather-stripped and insulated to an R-value equivalent to the insulation on surrounding surfaces. Insulation shall not block the access passageway.

**2.1.3 Ceiling Insulation:** Ceiling insulation shall be installed to meet the nominal R-values specified in Part III or as approved. (Refer to Figures [26-29](#), [31](#), [32](#) in Part I)

Loose-fill insulation shall be installed to the depth and density specified by the manufacturer and to minimize voids at truss members and other ceiling penetrations.

Ceilings insulated with fiberglass batt insulation shall use full-width batts which cover the truss members and extend the entire length of the attic without visible gaps. All batts shall extend to the eave of the truss at full depth and be compressed by a baffle or by the roof sheathing.

**2.1.4 Wall Insulation:** Exterior wall insulation shall be installed in accordance with installation details in Part III or as approved. Insulation shall be installed to minimize compression and voids as a result of plumbing or wiring wall cavities. Where structural conditions allow, headers over windows and doors shall be insulated. Where structural conditions allow, insulation shall fill the cavity between corner studs and other wall structure materials. Spaces around window and door frames greater than 1/2 inch shall be filled with an insulating material. (Refer to [Figures 18-23](#) in Part I)

**2.1.5 Floor Insulation:** Floor insulation shall be in accordance with installation details in Part III, or as approved. Insulation shall fill floor joists to the manufacturer's insulation density or greater. No insulation batt shall be placed between the underside of the floor sheathing and the main trunk ducts except for duct wrap (if used). See [Section 2.1.7](#) for crossover duct requirements. (Refer to [Figures 1-3](#) in Part I)

**2.1.6 Recessed Fixtures:** Recessed fixtures (e.g., medicine cabinets, electrical panels, recessed lights, and heating equipment) shall not be installed in exterior walls or ceilings unless a minimum effective R-10 insulation can be installed between the fixture and the exterior of the building. (Refer to [Figures 21 and 30](#) in Part I)

**2.1.7 Set-Up Kit:** Manufacturers shall include in the shipment of the home all crossover duct materials described in [Section 5.6.1](#). In addition, the manufacturer shall include an approved marriage line sealer.

**2.2 Doors:** All doors shall be 1-1/2 inches minimum with foam core and thermal break. Doors with dual glazing that is less than 50 percent of the door area are acceptable. (Refer to [Figure 38](#) in Part I)

**2.2.1 Thermal Ratings:** U-factors for tested exterior doors shall be certified using either the AAMA 1503.1-1988 test procedure or the ASTM C-236 or C-976 test procedure.

Untested exterior doors shall use the default U-factors in Part III. Doors with less than 50 percent of the door area in glazing shall use door default U-factors. Doors with greater than 50 percent glazing shall use default U-factors for glazing with a frame material similar to the door.

**2.2.2 Infiltration Ratings:** Exterior doors shall be tested for air infiltration (cfm/lineal foot of perimeter for swinging doors and cfm/ft<sup>2</sup> of door for sliding doors) using ANSI/ASTM E-283-84, "Standard Test Method for Rate of Air Leakage Through Exterior Windows, Curtain Walls, and Doors." The doors shall be tested at a differential pressure of 1.57 lb/ft<sup>2</sup> (equivalent to 25 mph wind conditions). See [Section 2.4](#) for leakage rates.

## 2.3 Glazing and Skylights (Refer to Figures [32](#) and [37](#) in Part I)

**2.3.1 Thermal Ratings:** All primary windows and glass doors shall comply with the requirements set forth in the National Fenestration Rating Council's (NFRC) Fenestration Thermal Performance Rating, Certification and Labeling Program. Area-weighted average shall be no greater than U-0.35. All skylights must be of triple bubble construction or have a NFRC labeled U-factor not greater than 0.50.

**2.3.2 Infiltration Ratings:** Glazing shall be tested for air infiltration using ANSI/ASTM E-283-84, "Standard Test Method for Rate of Air Leakage Through Exterior Windows, Curtain Walls, and Doors." Glazing shall be tested at a differential pressure of 1.57 lb/ft<sup>2</sup> (equivalent to 25 mph wind conditions). See [Section 2.4](#) for leakage rates.

**2.3.3 Secondary Windows:** Secondary windows shall not be used to meet these technical specifications.

**2.3.4 Structural Requirements:** Window frames and sashes shall be constructed of vinyl, wood, or other approved materials. Vinyl frames and sashes shall be joined with external and internal welds.



**2.3.5 Skylights:** Skylights totalling 40 ft<sup>2</sup> or less that are equivalent to triple-bubble plastic construction (or as approved) are not included in qualifying the home. (Refer to [Figure 32](#) in Part I)

**2.4 Air Leakage Control:** All buildings shall use the following standard air leakage control method. An average air change rate of 0.35 house volumes/hour shall be used to calculate thermal losses.

**2.4.1 Standard Air Leakage Control:** All buildings qualifying with standard air leakage control shall comply with the following prescriptive requirements, or as approved.

**2.4.1.1 Windows:** Tested air leakage rates shall not exceed 0.3 cfm/linear foot.

**2.4.1.2 Doors:** Tested air leakage rates shall not exceed 0.2 cfm/linear foot of perimeter for swinging doors or 0.25 cfm/ft<sup>2</sup> of door area for sliding doors.

**2.4.1.3 Caulking and Sealing:** All penetrations through the building envelope shall be caulked or otherwise sealed to limit air leakage, including the following: (Refer to [Figures 14-18, 27, 28, 30-32, 36, 37](#) in Part I)

1. Seal all window and door frames to the building envelope to prevent air leakage. If the seal is made on exterior grooved siding, then the groove lines shall be sealed at the door or window frame;
2. Between all exterior wall sole plates and the structural floor, using two rows of caulking or approved alternate;
3. Around openings in the building envelope for heating systems, HVAC and ventilation ducts, plumbing, electricity, ceilings, and floors;
4. At openings in the ceiling (e.g., where ceiling panels meet interior and exterior walls, at exposed beams, wood stove flues, etc.); and
5. At all other penetrations in the building envelope.

**2.4.1.4 Electric Outlets:** All receptacles, switches, or other electric boxes in exterior walls shall be sealed or use outlet plate gaskets.

**2.4.1.5 Ducts:** HVAC ducts shall be sealed at all duct ends, joints, and corners, at junctions between outlet registers and interior surfaces, and at all places where ducts penetrate the building envelope. See [section 3.3](#) for duct sealing requirements. (Refer to [Figures 4-13, 35, 36](#))

**2.4.1.6 Wood Stoves and Fireplaces:** All combustion appliances shall comply with the FMHCSS.

**2.4.1.7 Recessed Fixtures:** Recessed fixtures (e.g., wall heaters, fans, medicine cabinets, electrical panels, etc.) shall be sealed to the component assembly to restrict air leakage into the building envelope.

Recessed lights shall comply with the FMHCSS and meet **ONE** of the following requirements:

1. They must be IC (insulation-contact) rated, double-can units sealed around the exterior to be airtight; or
2. IC rated units or fluorescent fixtures installed in a sealed "box" that extends the ceiling above the light fixture; or
3. IC rated units certified under ASTM E283 to have no more than 2.0 cfm air movement from the conditioned space to the ceiling cavity. The lighting fixture shall be tested at 75 Pascals or 1.57 lb/ft<sup>2</sup> pressure difference and have an attached label showing compliance.

The mounting flange on the exterior of the can, or the sealed "box," must be caulked to the ceiling finish/air barrier.

**2.4.2 Building Air Tightness Standard:** Any house tested shall not exceed 5.0 Air Changes per Hour (ACH) at 50 Pascals (Pa) and shall be tested in accordance with on-site protocols in Appendix A of the reference manual and comply with prescriptive measures in [Section 2.4.1](#) and [5.3](#).

## CHAPTER 3 HEATING SYSTEMS

**3.1 Sizing:** Heating systems shall be sized according to the FMHCSS and standard engineering practice, using an interior design temperature of 70°F and the standard ASHRAE winter design temperature (WDT) for the building location, or as approved.

**3.2 HVAC Ducts:** Ductwork for HVAC systems shall be installed to comply with the manufacturer's static pressure specifications.

**3.3 Duct Sealing** (Refer to Figures 4-11 in Part I)

**3.3.1 Ductwork** shall be sealed using approved flexible, heat-resistant approved sealant as appropriate. Metal ducts shall be sealed with mastic complying with UL 181A-M or UL 181B-M.

**Exception:** Seams and joints in rigid fiberglass duct-board may be sealed using tape specified by the duct manufacturer and installed according to the tape and duct manufacturers' specifications.

**3.3.2 Duct ends** shall be sealed to provide a complete air seal. Duct end sealing strategies shall be submitted to state energy offices for approval.

**3.3.3 Duct connections**, including register boots, furnace plenums, crossover taps and supply branches, shall be sealed with mastic complying with UL 181A-M or UL 181A-M. Furnace plenums shall be sealed to the furnace housing using flexible, heat-resistant sealant, as approved.

**3.3.4 Mesh:** Mastic shall not be used to span gaps of greater than 1/4 inch except when fiberglass mesh is used with mastic.

**3.4 Space and Water Heater Systems**

**3.4.1 Combustion fuel furnaces** shall meet the requirements of the Federal Manufactured Housing Construction and Safety Standards (FMHCSS).

**3.4.1.1 Combustion Furnace AFUE:** Combustion fuel furnaces shall have a minimum AFUE of 80 percent or the best AFUE readily available manufactured home furnace used by the manufacturer, whichever is higher. AFUE shall be that reported in the GAMA Directory.

**3.4.2 Combustion fuel water heaters** shall meet the requirements of the Federal Manufactured Housing Construction and Safety Standards (FHMCSS).

**3.4.2.1 Combustion Water Heater Energy Factor:** Combustion fuel water heaters shall have a minimum Energy Factor of 0.55 for 50 gallon, 0.56 for 40 gallon, and 0.58 for 30 gallon or the best Energy Factor for readily available manufactured home water heaters, whichever is higher. The Energy Factor shall be that reported in the GAMA Directory.

**3.4.3 The term “readily available”** means manufacturers can obtain the appliance through their normal supplier in reasonable time frames at an incremental price above the minimum efficiency stated in Sections 3.4.1.1 and 3.4.2.1. The appliances must be cost effective to the consumer in the analysis of the SEO, in consultation with the manufacturers. If 60 percent or more of the manufacturers routinely use an appliance with an AFUE higher than the minimum efficiency stated in Sections 3.4.1.1 or 3.4.2.1, the appliances shall be deemed readily available for other participating manufacturers.

## CHAPTER 4

### MOISTURE AND INDOOR AIR QUALITY CONTROL

**4.1 Moisture Vapor Transfer:** A vapor retarder of not more than 1.0 perm dry cup rating shall be installed in exterior walls, exterior ceilings, and exterior floors. It shall be installed according to the manufacturer's specifications on the warm side (in winter) of all insulation. The retarder shall be considered to be on the warm side if the R-value of the materials between it and the conditioned space is not more than 33 percent of the total R-value of the wall section at the insulated cavity.

**4.2 Attic Ventilation:** Adequate cross ventilation shall be maintained above all ceiling insulation by providing both low and high vents or gable-end vents. At least 1 ft<sup>2</sup> of net-free vent area shall be provided for every 300 ft<sup>2</sup> of ceiling area with 50 to 60 percent of the vent area located near the roof ridge and 40 to 50 percent located near the eaves. One-level venting may be used if adequate cross ventilation can be maintained. When only one-level venting is used, at least 1 ft<sup>2</sup> of net-free vent area shall be provided for every 150 ft<sup>2</sup> of ceiling area. Mechanical attic ventilation systems may be used to meet these requirements. (Refer to Figures 27, 28, 33, 34 in Part I)

A minimum clearance of one inch shall be maintained between attic insulation and the roof sheathing when soffit vents are used.

**4.3 Mechanical Ventilation:** A mechanical ventilation system shall be installed in all homes to provide the ventilation rates specified in this section. These specifications establish minimum criteria for designing and installing ventilation systems in FMHCSS homes built to these requirements.

**4.3.1 Scope:** These specifications represent the minimum ventilation system requirements for this program. Buildings using standard air leakage control shall comply with Section 4.3.2, "Non-Heat Recovery Ventilation" or 4.3.3, "Heat Recovery Ventilation," as a minimum.

**4.3.2 Non-Heat Recovery Ventilation:** This section is for designing and installing non-heat recovery ventilation systems for individual dwelling units that can provide the minimum ventilation airflows in Section 4.3.2.1 to the whole house, with spot ventilation for exhausting indoor contaminants from kitchens and bathrooms. (Refer to [Figure 39](#) in Part I)

**4.3.2.1 Whole House Minimum Ventilation Air Flows and Sone Ratings:** Whole-house ventilation systems shall have a minimum capacity of 0.035 cfm/ft<sup>2</sup> of floor area. In no case shall the installed ventilation capacity be less than 50 cfm or greater than 90 cfm. Surface-mounted fans shall have a HVI sone rating of 1.0 or less, or as approved. Remote-mounted fans are exempt from the sone rating requirement.

The SEO authorized inspector shall periodically test fan rated flows versus fan measured flow rate during SEO in-plant QA reviews.

**4.3.2.2 Backdraft Dampers:** A tight-fitting backdraft damper, capable of closing, shall be installed in whole house fans.

**4.3.2.3 Controls:** The whole-house fan shall have automatic and/or manual controls.

**Manual Control:** The manual control switch shall be readily accessible to the occupants and allow them to turn the fan on or off. The manual control switch shall be clearly identified as the whole house ventilation system with a legible, permanent label.

**Automatic Control:** For maximum ventilation effectiveness, fans should be run continuously or by automatic controls which shall include a time clock or cycle timers set to provide at least one sixteen hour on period per day or more, or as approved. Factory set default timer on-setting should be 4:00 p.m. to 8:00 a.m.

**Parallel Wiring:** The spot ventilation and whole house controls may be wired in parallel, allowing the same fan to perform both functions. A bath fan, for example, maybe wired to both the manual spot ventilation switch in the bathroom and to a centralized time clock.

**4.3.3 Heat Recovery Ventilation (HRV):** This section is for designing and installing AAHX systems to provide the minimum required ventilation air flows as outlined in 4.3.3.1 for whole house ventilation, using an Air to Air Heat Exchanger (AAHX). (Refer to [Figure 40](#) in Part I)

**4.3.3.1 Whole House Minimum Ventilation Air Flows:** HRV systems shall have a minimum capacity of 0.035 cfm/ft<sup>2</sup> of floor area.

The SEO authorized inspector shall periodically test rated flows versus AAHX measured flow rate and flow balance during SEO in-plant QA reviews.

**4.3.3.2 Air Flow Balance:** The AAHX shall be balanced, where balanced is defined as a supply and exhaust flow rate within 10%.

**4.3.3.2.1 Air Flow Measurements:** The supply and exhaust flow rates shall be measured anytime the system duct design size or lengths change from the original approved design.

**4.3.3.3 Controls:** The AAHX system shall have automatic and/or manual controls

**Manual Control:** The manual control switch shall be readily accessible to the occupants and allow them to turn the AAHX on or off. The manual control switch shall be clearly and permanently identified as the whole house ventilation system.

**Automatic Control:** For maximum ventilation effectiveness, the AAHX system should be run continuously or controlled by automatic controls which shall include a time clock or cycle timers set to provide at least one sixteen hour on period per day, or as approved. Factory set default timer on-setting should be 4:00 p.m. to 8:00 a.m.

**Spot Ventilation:** The spot ventilation and AAHX controls may be wired in parallel, in accordance with AAHX manufacturer installation procedures. This allows for the AAHX to replace spot fans by linking the spot ventilation areas to the centralized AAHX system. A bathroom, for example, may be ventilated by connecting both the manual spot ventilation switch in the bathroom to the centralized AAHX so that activating the switch in the bathroom runs the AAHX in a high speed mode.

**4.3.4 Exhaust Duct Insulation:** All non-vertical ventilation exhaust ducts extending more than two feet beyond the insulation shall comply with the FMHCSS and be insulated to at least R-4.

**4.3.5 Exhaust Duct Termination:** Exhaust ducts shall terminate outside the house, at least three feet from any air intake vents.

**4.3.6 Exhaust Duct Material:** Exhaust ducts shall be class 0 air duct (metal, rigid or semi-rigid) or class 1 air duct (metalized spiral wound flex duct).

**4.3.7 Exhaust Duct Connections:** All exhaust system duct connections shall be mechanically fastened and air-sealed.

**4.3.8 Spot Ventilation:** Spot ventilation fans shall comply with FMHCSS.



## CHAPTER 5 ON-SITE SPECIFICATIONS

**5.1 General:** The home shall be inspected on site to determine compliance with these specifications and manufacturer's instructions and/or local codes.

All site-built additions shall comply with local codes and/or utility requirements.

**5.2 Damage Repair:** Damage occurring to factory installed energy measures during transportation and setup shall be corrected with materials and methods approved by HUD. This includes any damage to belly fabric and floor insulation. Damage to windows, frames, and doors which affects thermal performance shall be repaired or replaced.

Any disturbance of insulation, belly fabric, or other energy related components due to plumbing, wiring, or other on-site work shall be corrected.

### 5.3 Air Sealing

**5.3.1 Marriage Line:** Non-porous caulking, foam, or weatherstripping shall be used to seal the marriage line. A sealant is required even if the walls and ceilings are taped and textured. If additional on-site sealing is required because of incomplete factory work, a non-porous air barrier shall be applied to complete the marriage line seal.

**5.3.2 Window and Door Frames:** Window and door frames shall be installed and adjusted according to the original equipment manufacturer's instructions to minimize air leakage and water penetration. (Refer to [Figures 37](#) and [38](#) in Part I)

**5.3.3 Other Penetrations:** All penetrations in the building envelope, such as for piping and wiring, recessed fixtures in walls and ceilings, swamp coolers, and exhaust fan housings shall be sealed with HUD approved materials.

**5.3.4 Building Air Tightness Standard:** Any house tested shall not exceed 5.0 Air Change per Hour (ACH) at 50 Pascals (Pa) and shall be tested in accordance with on-site protocols in Appendix A of the reference manual and comply with prescriptive measures in section [2.4.1](#) and section [5.3](#).

**5.4 Skirting/Foundation Fascia:** Skirting/foundation fascia shall be installed and all ventilation openings shall be screened or louvered. All other holes or gaps between the skirting and the ground shall be sealed.

## 5.5 Crawl Space Moisture Control

**5.5.1 Ground Cover:** A vapor retarder, consisting of 6 mil black polyethylene or approved linear low density poly, shall cover the ground throughout the entire crawl space. All joints shall be lapped at least 8 inches. The ground cover shall not contact wood that is not treated to prevent moisture damage.

**5.5.2 Crawl Space Ventilation:** Underfloor crawl spaces shall be vented by screened or louvered openings in the skirting. Such vents shall be located to provide cross ventilation through at least two opposing walls. The total net-free ventilation area shall be at least 1 ft<sup>2</sup> for each 150 ft<sup>2</sup> of underfloor area.

**5.5.3 Clothes Dryer:** The clothes dryer exhaust duct shall be vented to a termination outside the home. If the dryer vent passes through the floor into the crawl space, it shall be vented out through the skirting with no dips. (Refer to [Figure 17](#) in Part I)

**5.5.4 Drains:** All water drains, including condensate drains from air conditioning equipment shall be piped to the outside to drain away from the home.

**Exception:** Water heater overflow valve piping.

## 5.6 Crossover Connections:

**5.6.1 Crossover ducts for the heating systems,** shall comply with the following requirements: (Refer to [Figure 12](#) in Part I)

### 5.6.1.1 Crossover duct materials shall:

1. be labeled R-8 as a minimum insulation value;
2. have an exterior vapor retarder rated at 1.0 perm or less;
3. have an inner liner material which includes an interior spring-steel wire helix bonded within two layers of 57 gauge mylar polyester film, or approved equal;
4. have all tears, holes, and penetrations sealed;
5. include the crossover duct manufacturer's splice kit, if required;
6. have a minimum interior diameter of 10 inches, or as approved;

7. include a sheet metal elbow of at least 28 gauge to connect the collar to the crossover duct;
8. foil-backed butyl tape (NASHUA #322 or equivalent) or mastic duct sealant complying with UL 181A-M and UL 181B-M for all metal-to-metal connections;
9. include stainless steel, worm-drive clamps, or nylon straps; and
10. include a belly bottom tape approved by the manufacturer.

**5.6.1.2 Sheet Metal Elbow:** The sheet metal elbow shall be:

1. 28 gauge and secured to the vertical collar with sheet metal screws;
2. sealed at the connection to the vertical collar with foil-backed butyl tape or mastic duct sealant;
3. sealed at all seams of the adjustable elbow, if applicable, with foil tape or mastic; and
4. insulated to a minimum level of R-8, or as approved.

**Exception:** Sheet metal elbow may be omitted when crossover duct is of semi-rigid corrugated aluminum material. A semi-rigid duct shall be formed to connect to the collar without compression or sharp bends.

**5.6.1.3 Crossover Duct Connections:** Connections of the inner liner of the crossover duct shall be:

1. cut to minimize excess duct length and/or stress at the connections;
2. secured to the elbow with sheet metal screws, nylon tie straps, band clamps, or other mechanical fasteners; and
3. sealed to the elbow with tape or mastic.

**5.6.1.4 Crossover Duct Vapor Retarder Connections:** Connections of the exterior vapor retarder of the crossover duct shall be:

1. secured to the elbow, collar, or splice with clamps or straps; and
2. taped to the belly bottom where the crossover duct enters the belly with approved belly bottom tape.

**5.6.1.5 Crossover Duct Support:** The crossover duct shall be:

1. supported above the ground by strapping or blocking where clearances permit;
2. installed to avoid standing water;
3. installed to prevent compression and sharp bends which restrict airflow; and
4. installed to minimize stress at the connections.

**Note:** Where clearance permits, strapping is recommended over blocking because strapping decreases animal access to the duct.

**5.6.2 In-Floor Crossover:** In-floor duct crossover connections shall have an airtight seal or gasket between the rim joists. (Refer to [Figure 13](#) in Part I)

**5.7 Operational Checks:** All mechanical equipment, such as exhaust fans, fresh air inlets, and heating systems, shall operate properly. The whole house ventilation time clock, if installed, shall be set to the proper time. Controls shall be set to operate the whole house fan or fans for a minimum of two four hour periods per day. Windows and doors shall open and close easily and seal tightly.

**5.8 Homeowner Information:** If home is certified, then the manufacturer shall ensure that a homeowner ventilation brochure is included in the "important papers" envelope provided with the home. The manufacturer shall also explain the whole house and spot ventilation systems to the occupants and instruct them on how to set the whole house control(s). Homeowners should be advised that if time clocks are installed, they must be reset after power outages. See Appendix B for important documents and information for homeowners.

## **PART III**

### **DEFAULT U-FACTORS FOR NEEM MANUFACTURED HOMES**

Heat Loss Values and General Insulation  
Requirements for NEEM Compliance

**January 2004**



---

**TABLE OF CONTENTS**

<b>Chapter</b>	<b>Page</b>
1. GENERAL .....	79
1.1 Scope .....	79
1.2 Description .....	79
2. FLOORS OVER UNHEATED SPACES .....	80
2.1 General .....	80
2.2 Transverse Floor U-Factors .....	80
2.2.1 Cut-In Floor Insulation .....	80
2.2.1.1 U-Factors for Transverse (Cut-In) Floor Systems .....	81
2.2.2 Upright Floor Insulation .....	81
2.2.2.1 U-Factors for Floors Built in Upright Position .....	82
2.3 Longitudinal Floor U-Factors .....	83
2.3.1 U-Factors for Longitudinal Floor Systems .....	83
2.4 Blown-in Cellulose Floors .....	84
2.4.1 U-Factors for Cellulose Fill with Fiberglass Batt Under Duct Only .....	84
2.4.2 U-Factors for Cellulose Fill with Fiberglass Batt Under Duct Only .....	84
2.4.3 U-Factors for Cellulose Floor (Nominal R-30) with R-11 Batt Underneath Entire Assembly .....	85
2.4.4 U-Factors for Cellulose Floor with R-11 Batt Underneath Entire Assembly .....	85
3. CEILINGS .....	86
3.1 General .....	86
3.2 Installation for Sloped Ceilings .....	87
3.3 U-Factors for Flat and Sloped Ceilings with Blown-In Insulation .....	88
3.3.1 U-Factors for Blown Attics for Stabilized Cellulose and Soffit Vents .....	88
3.3.2 U-Factors for Blown Sloped Ceilings for Stabilized Cellulose and Soffit Vents .....	89
3.4 Maximum Depth Tables for Sloped Ceilings with Blown-In Insulation and Soffit Vents .....	90
3.4.1 Normal Density Rock Wool .....	90
3.4.2 High Density Rock Wool .....	90

<b>Chapter</b>	<b>Page</b>
3.5 Single-Wide Truss Maximum Depth .....	90
3.5.1 <a href="#">Stabilized Cellulose</a> .....	91
3.5.2 Normal Density Rock Wool .....	91
3.5.3 <a href="#">High Density Rock Wool</a> .....	92
3.6 U-Factors For Ceilings Insulated with Full Width Fiberglass Batts .....	92
3.6.1 U-Factors for Attics and Sloped Ceilings .....	92
3.6.2 <a href="#">U-Factors for Attics and Sloped Ceilings</a> .....	93
4. <a href="#">WALLS</a> .....	94
4.1 General .....	94
4.2 U-Factors for Post and Beam Walls .....	94
4.2.1 U-Factors for Post and Beam Wall Construction ...	94
4.3 <a href="#">U-Factors for Stress Skin Walls</a> .....	95
4.3.1 U-Factors for Stress Skin Walls .....	95
5. <a href="#">DOORS</a> .....	96
5.1 General .....	96
5.2 Component Description .....	96
5.3 7.5 Mph Adjustment .....	96
5.3.1 <a href="#">Default U-Factors for Exterior Doors</a> .....	97
6. <a href="#">GLAZING</a> .....	98
6.1 General .....	98
6.2 Framing Description .....	98
6.3 Component Description .....	98
7. <a href="#">INFILTRATION</a> .....	99
7.1 General .....	99



## CHAPTER 1 GENERAL

**1.1 Scope:** This section includes tables of heat loss coefficients for specified nominal insulation levels to comply with the Northwest Energy Efficient Manufactured Home Program (NEEM) Technical Specifications for Manufactured Homes. This section also includes default U-factors for windows and doors (15-mph table) that may be substituted for tested U-factors required for glazing compliance.

**1.2 Description:** These coefficients were developed specifically for the manufactured home industry using field data and procedures found in the 1993 Handbook of Fundamentals published by the American Society of Heating, Refrigerating, and Air-Conditioning Engineers (ASHRAE) and refined by data from the Residential Construction Demonstration Project for Manufactured Homes.

More component descriptions, calculations, assumptions, procedures, and diagrams are contained in the Technical Reference for Energy Efficient Manufactured Homes (Ecotope, 1996)<sup>1</sup>.

<sup>1</sup>Available through the state energy offices.

## CHAPTER 2

### FLOORS OVER UNHEATED SPACES

**2.1 General:** The following tables list heat loss coefficients for floors over unheated spaces, in Btu/°F-hr per ft<sup>2</sup> of floor. They are derived from procedures listed in the ASHRAE 1993 Handbook of Fundamentals for several commonly used installation methods, assuming a ventilation rate through the unheated space of 3.0 air changes per hour, an average outdoor temperature of 45°F, an average indoor temperature of 65°F, a three foot high crawl space with an area of 1,500 ft<sup>2</sup>, and 168 feet of perimeter. Floor joists are 2x6s placed 16 inches o.c. unless otherwise noted.

Steady state U-factors described in the following tables are calculated using only the conductivity of the insulation and framing components and represent the actual U-factors for a particular combination of floor framing and insulation. Duct conductive and air leakage losses are not factored into the floor system U-factor. A discussion of duct losses can be found in the Technical Reference for Energy Efficient Manufactured Homes (Ecotope, 1996). A crawl space buffer modifier is included in the steady state U-factor calculation.

**2.2 Transverse Floor U-Factors:** Descriptions and diagrams for transverse floor insulation systems are in Section 2.1 of the Technical Reference for Energy Efficient Manufactured Homes (Ecotope, 1996). In transverse floor systems, the joists are at right angles to the steel I-beams and are attached at points of intersection with lag bolts. Note that this application requires the use of the CUT-IN or UPRIGHT methods of insulation application. These methods lessen insulation compression and improve overall floor thermal performance.

**2.2.1 Cut-In Floor Insulation:** Insulation is installed while the floor system is upside down and before the steel frame is attached. Insulation is laid on the floor frame and main trunk duct to a nominal R-33 minimum. Then the first three feet of insulation extending in from the band joist are cut at each floor joist and the insulation is pushed into the floor joist cavity. The installation is completed with the application of the belly board and steel frame.

### 2.2.1.1 U-Factors for Transverse (Cut-In) Floor Systems (assumes floor framed with 2x6s)

Nominal Insulation R-Value	U-Factor <sup>1</sup>
R-19	0.048
R-22	0.044
R-22/33 <sup>2</sup>	0.037
R-33	0.032
R-44	0.030

<sup>1</sup>Does not include additional heat loss from ducts.

<sup>2</sup>R-22 cut-in to I-beam; R-33 belly insulation between I-beams.

**2.2.2 Upright Floor Insulation:** In this application the insulation is installed with the floor system in an upright position. The belly board and an R-11 belly blanket are placed over the entire steel frame. Then a second blanket (7 feet wide) is placed on center between the steel I-beams. This second blanket must be R-22 minimum. The insulated trunk duct is installed and the floor framing added. Additional batt insulation shall be installed between the floor joists and reach, but not cover, the main trunk duct. The floor joist insulation shall be R-19 minimum. U-factors for this floor system are shown in the following table.

**2.2.2.1 U-Factors for Floors Built in Upright Position  
(first two cases assume 2x6 floor joists)**

Nominal Insulation R-Value	U-Factor
R-30 <sup>1</sup>	0.028
R-32 <sup>2</sup>	0.026
R-41 <sup>3</sup>	0.024

<sup>1</sup> R-19 joist insulation that extends to edge of trunk duct plus R-11 belly insulation in outrigger area and R-33 elsewhere.

<sup>2</sup> R-21 high-density batt joist insulation plus insulation details described above in note 1.

<sup>3</sup> R-30 nominal insulation in joist cavities to edge of trunk duct assumes 2x8 floor joists plus R-11 belly blanket in outrigger area and R-33 under duct.

**2.3 Longitudinal Floor U-Factors:** Descriptions and diagrams for longitudinal floor insulation systems are in the Technical Reference for Energy Efficient Manufactured Homes (Ecotope, 1996). In longitudinal floor systems, the joists are parallel to the steel I-beams.

**2.3.1 U-Factors for Longitudinal Floor Systems  
(assumes floor framed with 2x6s)**

Nominal Belly Insulation	Nominal Joist Insulation	U-Factor
R-11	R-19	0.037
R-14	R-19	0.035
R-22	R-19	0.030
R-11	R-22	0.036
R-14	R-22	0.034
R-22	R-22	0.030
R-11	R-21 <sup>1</sup>	0.035
R-14	R-21 <sup>1</sup>	0.033
R-22	R-21 <sup>1</sup>	0.029

<sup>1</sup>High-density batt that is uncompressed in a 2x6 floor. The batt retains its full nominal R-value.

**2.4 Blown-in Cellulose Floors:** The following tables show the amount of cellulose needed between the I-beams; in all cases, the joist space between the rim joist and I-beam is to be filled completely. Fiberglass batting must be installed under the heating duct; some manufacturers choose to use a continuous layer of fiberglass batts under the entire floor.

**2.4.1 U-Factors for Cellulose Fill with Fiberglass Batt Under Duct Only (2x6 framing)**

Floor R-Value	Insulation Depth Between I-Beams	R-Value Needed Under Duct*	Floor U-Value
R-33	12"	R-13	0.033
R-22	6"	R-11	0.044
R-11	3"	R-11	0.055

**2.4.2 U-Factors for Cellulose Fill with Fiberglass Batt Under Duct Only (2x8 Framing)**

Floor R-Value	Insulation Depth Between I-Beams	R-Value Needed Under Duct*	Floor U-Value
R-33	9"	R-13	0.033
R-22	6"	R-11	0.041
R-11	3"	R-11	0.052

\*All 2x8 cases have full depth of cellulose (7 1/4") in outrigger joist bays.

\*R-value under duct is installed value; if there is compression, consult Table 3 in the Technical Reference for Energy Efficient Manufactured Homes (Ecotope, 1996) to find proper batt to install. For example, if an R-19 batt is compressed from 6" to 3.5", its actual R-value is 13.1.

### 2.4.3 U-Factors for Cellulose Floor (Nominal R-30) with R-11 Batt Underneath Entire Assembly (2x6 floor framing)

Dist. Rim to I-Beam	Insulation Depth Between I-Beams	R-Value Needed Under Duct	Floor U-Value
30"	9"	R-11	0.034
24"	9"	R-11	0.033

### 2.4.4 U-Factors for Cellulose Floor with R-11 Batt Underneath Entire Assembly (2x8 floor framing)

Dist. Rim to I-Beam	Insulation Depth Between I-Beams	R-Value Needed Under Duct	Floor U-Value
30"	9"	R-11	0.030
24"	9"	R-11	0.030
30"	12"	R-11	0.028
24"	12"	R-11	0.027

Joist bays between rim and I-beam filled in all cases.

Sloped area between I-beam and duct (1' wide) filled to average of joist depth and depth between I-beams.

R-11 batt is 50% compressed in outrigger area, 30% compressed sloped area, and uncompressed under duct.

Floor is 163" wide.

Crawlspace buffer (effectively about R-2) applied to each case.

## CHAPTER 3 CEILINGS

**3.1 General:** The following tables list heat loss coefficients for the opaque portion of exterior ceilings below vented attics and sloped ceilings, in Btu/°F-hr per ft<sup>2</sup> of ceiling. They are derived from procedures listed in the ASHRAE 1993 Handbook of Fundamentals and include the increased conduction for decreased insulation levels at the perimeter for smaller heel widths. Ceiling U-factors are modified for the buffering effect of the attic using the procedures in the ASHRAE Handbook and assuming a 1,500 ft<sup>2</sup> ceiling with 56 ft<sup>2</sup> of gable-end walls, a 2.75/12 pitch roof, indoor temperature of 70°F, outdoor temperature of 45°F, and a ventilation rate of 3.0 ACH. Sloped ceilings are assumed to have a king post with height of 17 inches.

Blown-in rock wool insulation applied to flat and sloped ceilings is assumed to have an installed K-value of 3.1 Btu-inch/hr-ft<sup>2</sup>-°F. It must be installed according to the manufacturer's specifications for density to achieve the nominal R-value in the truss space. Stabilized (wet-spray) cellulose is assumed to have an installed K-value of 3.63 Btu-inch/hr-ft<sup>2</sup>-°F. Both types of insulation settle somewhat during transport; stabilized cellulose settles much less than rock wool if installed properly. Trusses are assumed to be spaced 16" o.c.

If fiberglass batts are used to insulate the ceiling assembly, batts should be full-sized so that they cover the bottom truss chord when installed properly.



**3.2 Installation for Sloped Ceilings:** Maximum depths are calculated for R-38 and R-33 vaulted ceilings insulated with blown-in rock wool and stabilized (wet-spray) cellulose. These ceiling configurations are by far the most common encountered in the industry and are of particular interest because minimum clearances are less than for flat ceilings.

The ceiling cavity should be filled to within 1" of the top from the heel to the point of maximum depth. The maximum depth is shown as  $y_{ins}$  in the accompanying drawing. The maximum depth is attained at the specified horizontal distance ( $x_{ins}$ ) as measured from the outside of the top plate.

Maximum depths are rounded up to the nearest quarter inch. The  $x_{ins}$  measurement should be used as a general guideline.

A settling rate of 15 percent for rock wool is assumed; a settling rate of 5 percent for stabilized cellulose is assumed. The settling rates are based on field research performed by Oak Ridge National Laboratory.

Installed densities for cellulose and normal density rock wool are taken from manufacturers' literature. In cases where rock wool is blown to higher densities to reduce dust problems, the R-value per inch is higher than in normal density applications and settling is minimal. High density rock wool density and R-value per inch are based on field observation and laboratory thermal tests. Table 3.4.2 shows maximum depths for high density rock wool applications.

### MAXIMUM INSTALLATION DEPTH FOR SLOPED CEILINGS

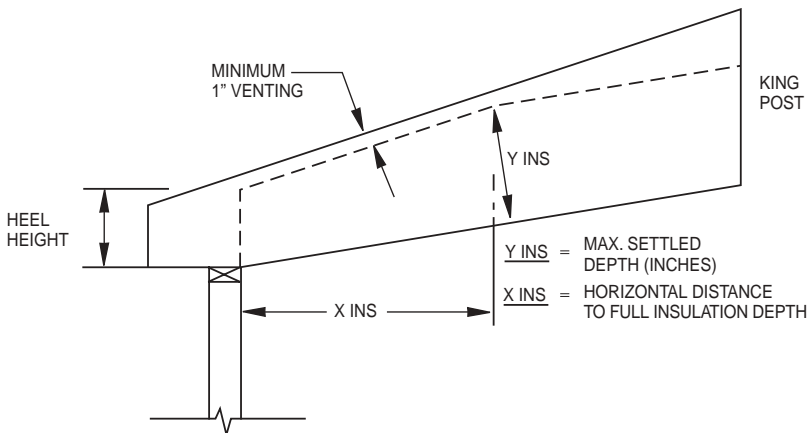

### 3.3 U-Factors for Flat and Sloped Ceilings with Blown-In

**Insulation:** Descriptions and diagrams of attics and sloped ceilings insulated with blown-in insulation are in the Technical Reference for Energy Efficient Manufactured Homes (Ecotope, 1996).

#### 3.3.1 U-Factors for Blown Attics for Stabilized Cellulose and Soffit Vents\*

Nominal R-Value	ATTIC			U-Factor (Btu/hr-ft <sup>2</sup> -°F)
	Depth at Heel (inches)	Settled Max Depth** (inches)	Distance to Max Depth (inches)	
30	3.5	8.25	20.2	0.034
	5.125		13.2	0.031
	8		0.0	0.030
33	3.5	9	23.8	0.032
	5.125		16.2	0.029
	8		4.2	0.028
38	3.5	10.5	29.7	0.029
	5.125		22.6	0.027
	8		10.1	0.025
44	3.5	12	36.8	0.028
	5.125		29.7	0.025
	8		17.2	0.022
49	3.5	13.5	42.7	0.027
	5.125		35.6	0.023
	8		23.1	0.020

\*Appropriate attic and vault buffer applied in each case.

\*\*Overblow by 5% to account for settling; depth listed is settled depth.

### 3.3.2 U-Factors for Blown Sloped Ceilings for Stabilized Cellulose and Soffit Vents

Nominal R-Value	Depth at Heel (inches)	VAULTS		
		U-Factor (Btu/hr-ft <sup>2</sup> -°F)	Settled Max Depth** (inches)	Distance to Max Depth (inches)
22	3.5	0.041	6.25	35
	5.125	0.041	6	12
	8	0.041	6	0
33	3.5	0.033	9.25	73
	5.125	0.033	8	40
	8	0.033	7.5	0
38	3.5	0.030	12.25	110
	5.125	0.030	9	56
	8	0.030	8.25	0
40	3.5	n/a	n/a	n/a
	5.125	0.029	10	72
	8	0.029	8.8	14
44	3.5	n/a	n/a	n/a
	5.125	0.028	10.5	79.5
	8	0.028	9	19
49	3.5	n/a	n/a	n/a
	5.125	0.026	12.75	111
	8	0.026	9.75	35

\*Appropriate attic and vault buffer applied in each case.

\*\*Overblow by 5% to account for settling; depth listed is settled depth.

### 3.4 Maximum Depth Tables for Sloped Ceilings with Blown-In Insulation and Soffit Vents

#### 3.4.1 Normal Density Rock Wool

Nominal R-value	U-Factor	Insulation Depth at Heel (inches)	Installed Density (lb/ft <sup>3</sup> )	Maximum Settled Depth (inches)	Distance from Plate to Max. Depth (inches)
38	0.030	5.125	1.9	13	80
		8	1.9	10.75	20
33	0.033	5.125	1.9	10.5	52

Notes: R-3.32/inch (settled R-value)

17" king post, roof pitch of 2.75:12

#### 3.4.2 High Density Rock Wool

Nominal R-Value	U-Factor	Insulation Depth at Heel (inches)	Installed Density (lb/ft <sup>3</sup> )	Maximum Settled Depth (inches)	Distance from Plate to Max. Depth (inches)
38	0.030	5.125	2.5	10	51
33	0.033	5.125	2.5	8.5	31

Notes: R-3.47/inch

17" king post, roof pitch of 2.75:12

**3.5 Single-Wide Truss Maximum Depth:** Single section homes will attain the U-factors listed in the preceding tables (U-0.030 for R-38 sloped ceiling and U-0.033 for R-33 sloped ceiling) if trusses are filled to the maximum depths listed in the following tables.

### 3.5.1 Stabilized Cellulose (wet spray with starch binder) for Single Section Home Ceilings

Insulation Nominal R-Value	Installed U-Factor	Maximum Depth at Heel (inches)	Density (lb/ft <sup>3</sup> )	Depth (y <sub>ins</sub> )	X <sub>ins</sub>
38	0.030	5.125	1.5	11.5	45
		8	1.5	9	12
33	0.033	5.125	1.5	8.25	20

Notes: R-3.68/inch (settled R-value)

Overall truss dimension is 158"

17" king post

### 3.5.2 Normal Density Rock Wool for Single Section Home Ceilings

Nominal R-Value	U-Factor	Insulation Depth at Heel (inches)	Installed Density (lb/ft <sup>3</sup> )	Maximum Depth (y <sub>ins</sub> )	X <sub>ins</sub>
38	0.030	5.125	1.9	13.5	48
		8	1.9	10.75	13
33	0.033	5.125	1.9	10.75	30

Notes: R-3.32/inch (settled R-value)

Overall truss dimension is 158"

17" king post

### 3.5.3 High Density Rock Wool for Single Section Home Ceilings

Nominal R-Value	U-Factor	Insulation Depth at Heel (inches)	Installed Density (lb/ft <sup>3</sup> )	Maximum Depth (y <sub>ins</sub> )	X <sub>ins</sub>
38	0.030	5.125	2.5	10.5	38
33	0.033	5.125	2.5	8.75	25

Notes: R-3.47/inch

Overall truss dimension is 158"

17" king post

### 3.6 U-Factors For Ceilings Insulated with Full Width Fiberglass Batts

#### 3.6.1 U-Factors for Attics and Sloped Ceilings (oversized batts, soffit vents, and trusses spaced 16" o.c.)

ATTIC			SLOPED CEILING		
Nominal R-Value	Insulation Depth at Heel (inches)	U-Factor	Nominal R-Value	Insulation Depth at Heel (inches)	U-Factor
30	3.5	0.033	30	3.5	0.036
	5.125	0.031		5.125	0.034
	8	0.031		8	0.032
38	3.5	0.028	38	3.5	0.033
	5.125	0.027		5.125	0.030
	8	0.026		8	0.028
49	3.5	0.024	40	3.5	—
	5.125	0.023	49	5.125	—
	8	0.022	—	8	—

## 3.6.2

**U-Factors for Attics and Sloped Ceilings  
(oversized batts, soffit vents, cardboard  
baffle, and trusses spaced 24" o.c.)**

ATTIC			SLOPED CEILING		
Nominal R-Value	Insulation Depth at Heel (inches)	U-Factor	Nominal R-Value	Insulation Depth at Heel (inches)	U-Factor
30	3.5	0.032	30	3.5	0.036
	5.125	0.031		5.125	0.033
	8	0.031		8	0.031
38	3.5	0.028	38	3.5	0.033
	5.125	0.026		5.125	0.030
	8	0.025		8	0.027
49	3.5	0.024	40	3.5	—
	5.125	0.022	49	5.125	—
	8	0.021	—	8	—

## CHAPTER 4

### WALLS

**4.1 General:** The following tables list heat loss coefficients for the opaque portion of walls, in Btu/°F-hr per ft<sup>2</sup> of wall. They are derived from procedures in the ASHRAE 1993 Handbook of Fundamentals. Framing factors are found in the Technical Reference for Energy Efficient Manufactured Homes (Ecotope, 1996).

Insulated headers shall be structural members over window and door openings which include a minimum of R-10 insulation in addition to the header itself. This may be compressed fiberglass, rigid insulation, or as approved.

**4.2 U-Factors for Post and Beam Walls:** Descriptions and diagrams are in the Technical Reference for Energy Efficient Manufactured Homes (Ecotope, 1996).

Post and beam wall structures use standard simple span design to achieve structural integrity. The engineering of these walls ignores the structural contribution of the sheathing. The result is more wood in the wall and increased thermal conductivity.

#### 4.2.1 U-Factors for Post and Beam Wall Construction

	Nom. Insul.	3-Stud Corner	w/R-1 Foam	2.5-Stud Corner	w/R-1 Foam
Insulated	R-19	0.061	0.057	0.060	0.057
Header	R-21*	0.056	0.053	0.055	0.052
	R-22	0.059	0.056	0.059	0.055
Solid Header	R-11	0.094	0.085	—	—
	R-13*	0.086	0.078	—	—
	R-15*	0.080	0.073	—	—
	R-19	0.064	0.059	—	—
	R-21*	0.059	0.055	—	—
	R-22	0.062	0.058	—	—

\*High density batt

Notes: Assumes framing at 16 inch o.c., single bottom plate and top plate.



One layer of exterior 5/8 inch siding is used in most cases. For manufacturers who use vinyl siding, calculations assume 3/8 inch plywood exterior sheathing and 1/4 inch faced foam core underlaying 4 mil vinyl siding.

Single layer of 1/2 inch interior gypsum wall board assumed.

R-11, R-13, R-15 cases use 2x4 studs.

**4.3 U-Factors for Stress Skin Walls:** Descriptions and diagrams are in the Technical Reference for Energy Efficient Manufactured Homes.

Stress skin walls derive their structural integrity from the interior and exterior sheathings and their interaction with the wall framing members. This interaction allows the wall to be built without structural headers for moderately sized window and door openings and without additional wall studs at corners and window and door jambs. "Single-stud" header means headers are built the same as the rest of the wall; no additional framing lumber is added.

#### 4.3.1 U-Factors for Stress Skin Walls

	Nom. Insul.	2-Stud Corner	w/R-1 Foam	2.5-Stud Corner	w/R-1 Foam
Single Stud	R-11	0.086	0.079	0.087	0.079
	R-19	0.058	0.054	0.058	0.054
Header	R-21*	0.052	0.049	0.052	0.049
	R-22	0.056	0.053	0.056	0.053
	R-13*	0.078	0.071	0.078	0.072
	R-15*	0.071	0.065	0.071	0.066
Insulated Header	R-19	—	—	0.058	0.055
	R-21*	—	—	0.053	0.050
	R-22	—	—	0.057	0.053

\*High density batt.

Note: Same framing spacing and exterior and interior sheathing assumed as for post and beam walls.

## CHAPTER 5

### DOORS

**5.1 General:** Table 5.3.1 lists heat loss coefficients for exterior doors in Btu/°F-hr per ft<sup>2</sup> of door. They are derived from the 1989 ASHRAE Handbook of Fundamentals, chapter 22, and from a compilation of U-factors tested according to AAMA or ASTM standards.

**5.2 Component Description:** Except where specified, the default values shown in Table 5.3.1 shall be used for all doors with less than 50 percent of their total area in glass. Doors with more than 50 percent glazing area are considered entirely window and must use window default U-factors in Chapter 6 for the entire door area.

All exterior door frames shall be made of thermally improved materials and their coefficients shall include heat loss through these frames. All coefficients listed in Table 5.3.1 include thermally improved frames.

**5.3 7.5 Mph Adjustment:** Coefficients listed under Table 5.3.1, "Default U-factors for Exterior Doors," shall be used for compliance. When qualifying homes using the Thermal Performance or Energy Budget methods, the default U-factors shall be adjusted to 7.5 mph equivalent values using the following equation:

$$U (7.5 \text{ mph}) = U (15 \text{ mph}) \times 0.931 + .0126$$

where:

U (7.5 mph) = default U-factor adjusted to 7.5 mph wind speed conditions

U (15 mph) = default U-factor at 15 mph wind speed conditions

Note: This adjustment is made automatically in the WATTSUN program. Therefore, use the 15 mph U-factors when running WATTSUN.

### 5.3.1 Default U-Factors for Exterior Doors

Type	15 Mph Default U-Factors
Fiberglass or TIM, 1-3/4 inch, foam, flush, no glazing	0.14
Fiberglass or TIM, 1-1/2 inch (min.), foam core	0.19
Metal (no thermal break), 1-1/2 inch, foam core	0.35
Wood, 1-1/2 inch, solid core	0.40

Notes: Except where specified, up to 50 percent of the door area may be glazed using double-glazed sealed units and a half-inch minimum air space.

U-factors are derived from ASHRAE, 1989.

U-factors apply to the entire rough door opening.

TIM refers to a metal skin door with thermal break.

## CHAPTER 6 GLAZING

**6.1 General:** Except for ornamental, decorative, or security-type glazing of up to 7 ft<sup>2</sup> without thermal break, all windows and sliding glass doors shall be certified and labeled for thermal performance under the National Fenestration Rating Council's (NFRC) certification program. NFRC U-factors shall be used to compute trade-offs between glazing and other building components.

**6.2 Framing Description:** Metal framed windows shall not be accepted in these specifications.

**6.3 Component Description:** Window area is based on rough opening dimensions. Doors with more than 50 percent glazing are considered all window. Window descriptions include patio doors and sliding glass doors.

## CHAPTER 7 INFILTRATION

**7.1 General:** The following procedure is used to calculate heat loss due to infiltration. Estimated seasonal average infiltration rates in air changes per hour (ACH) are given for the appropriate level of air leakage control. The air change rate shall be used in calculations for the Thermal Performance or Energy Budget approaches. Heat loss rate due to infiltration shall be computed using the following equation:

$$Q_{\text{infiltration}} = \text{House Volume} \times \text{ACH} \times \text{Heat capacity of air}$$

Numerically:

$$\text{BTU/hr} \times ^\circ\text{F} = (\text{ft}^3/\text{Vol}) \times (\text{Vol}/\text{hr}) \times (0.018\text{BTU}/^\circ\text{F} \times \text{ft}^3)$$

For example, to calculate the infiltration,  $Q$ , of a 15,500 ft<sup>3</sup> home with a natural leakage rate of .25 ACH/hr:

$$15500 \text{ ft}^3/\text{Vol} \times 0.25 \text{ Vol}/\text{hr} \times (0.018) \text{ Btu}/(^\circ\text{F} \times \text{ft}^3) = 70 \text{ Btu}/\text{hr} \text{ } ^\circ\text{F}$$

Air Leakage Control	Condition	Average Natural Leakage (house volume/hr)
Standard	Thorough caulking, good windows and doors	0.25



## **APPENDIX A:**

### **NEEM PROTOCOLS:**

- Home Intake Protocol
- On-Site Test Procedure
- In-Plant Review
- Specification Change Submittal Form





## STANDARD PROBLEM HOME INTAKE PROTOCOL

### Basic Instructions:

Collect the following information for each problem home. Save the information in a "Problem Home" file. We want to know how many people call us, the types of problems they complain about and what kind of response we delivered. Consult with ODOE to review this information and to determine if a site visit and testing should be scheduled or if some other response is more appropriate. If on-site testing is scheduled, use the "Standard Procedure for On-Site Tests of NEEM Homes." Tests help us find out what's wrong and help us determine how best to respond. Discuss the testing process with the homeowner. Notify the factory service representative of testing — they may want to be present. Problem homes are an important source of information about how NEEM homes perform. Once you are on-site, collect as much information as time permits and homeowners can tolerate. Share draft on-site test reports with other on-site testers at ODOE, WSU, IDWR, MTDEQ. Following review and comment, provide a final report to homeowner, to the manufacturer involved, to other interested parties as appropriate, to ODOE and to your "Problem Home" file.

### Basic Information:

Initially, it might be best to just listen to the homeowner and work on other sections of this form that **characterize the nature of the problem**. But be sure to collect as much of the following **basic information** as possible on the phone during intake conversations, and during follow-up investigations.

1. SGC, NC, ESTAR, Earth Advantage or  
Non SGC/NC/ESTAR/Earth Advantage (circle one)
2. Homeowner name: \_\_\_\_\_
3. Homeowner address: \_\_\_\_\_
4. Homeowner phone: \_\_\_\_\_
5. Manufacturer name: \_\_\_\_\_
6. NEEM ID no.: \_\_\_\_\_
7. HUD ID numbers: \_\_\_\_\_
8. Home Serial no.: \_\_\_\_\_
9. Dealer name/contact: \_\_\_\_\_
10. Dealer phone and/or previous seller: \_\_\_\_\_
11. Utility(s): \_\_\_\_\_
12. How long living in home: \_\_\_\_\_
13. Number of people living in home: \_\_\_\_\_

- 14. Single wide, double wide, triple wide (circle one)
- 15. Total heated floor area using outside dimensions: \_\_\_\_\_
- 16. Furnace, Heat Pump, AC, other: \_\_\_\_\_ (circle)
- 17. Manufacturer and model of HVAC system: \_\_\_\_\_
- 18. Hours and temperature during normal heating/cooling operation:  
\_\_\_\_\_
- 19. Hours and temperature during set-back of thermostat during heating/cooling: \_\_\_\_\_  
\_\_\_\_\_
- 20. Other heating sources: \_\_\_\_\_
- 21. Hours of ventilation system operation per day: \_\_\_\_\_
- 22. Outside air intake duct? With or without damper: \_\_\_\_\_
- 23. Discussed problems with: state, manufacturer, retailer, utility, other (circle those that apply)
- 24. Describe problem from start of intake to current status:  
\_\_\_\_\_  
\_\_\_\_\_  
\_\_\_\_\_  
\_\_\_\_\_

**Characterize Nature of Problem: (circle all that apply 1-5)**

**1. High bill complaints:**

**Action:** Get energy use from utility bills. Compare energy use to Ecotope chart. If energy use is within normal range, then send high bill form letter, cc file. If energy use is outside normal range, confirm correct crossover duct installation and explore other non-space heating end uses for potential causes of elevated use. If high usage is not explained, consult with ODOE re: site visit or other appropriate response. Sunday run on home?

- Describe bills: \_\_\_\_\_
- Bill higher than promised by: \_\_\_\_\_
- Describe promises made: \_\_\_\_\_
- Bill higher than neighbors with same size home.

**Action:** Confirm fuel type and heating system type the same, get neighbor's utility usage.

Describe: \_\_\_\_\_  
\_\_\_\_\_

- Bill higher than neighbors with different home.

**Action:** Get information on homes and energy usage.

Describe: \_\_\_\_\_  
\_\_\_\_\_

Bill higher than previous home.

**Action:** Get information on homes and energy usage.

Describe: \_\_\_\_\_  
 \_\_\_\_\_

Other: \_\_\_\_\_  
 \_\_\_\_\_

**2. Comfort/drafts:**

**Action:** Determine nature of draft problem (what, when, where, why), allowing homeowner to provide information without bias from interviewer. Use questions below to explore problem without biasing response, if possible.

- What kind of problems: \_\_\_\_\_
- When: \_\_\_\_\_
- Are other appliances running? What is happening when you notice the problem? \_\_\_\_\_
- When: (circle) HVAC on? HVAC off?
- Where: \_\_\_\_\_
- Where: Particular rooms? \_\_\_\_\_
- Where: (circle Y or N)
  - At electrical receptacles? ..... Y N
  - At marriage line? ..... Y N
  - Windows: around rough opening? ..... Y N
  - Windows: through window frame? ..... Y N
  - Windows: will not close tightly and/or lock? ..... Y N
  - Doors: air by-passes weather-stripping? ..... Y N
  - Doors: will not shut tight and lock? ..... Y N
  - Floor registers: cold air comes in when HVAC system is off? ..... Y N
  - Floor registers: cold air comes in when HVAC system is on? ..... Y N
  - Ventilation fans: cold air comes in when fans are off? .. Y N
  - Other (describe): \_\_\_\_\_

**3. Moisture/ventilation system/IAQ problems:**

**Action:** Determine nature of problem (what, when, where, why), allowing homeowner to provide information without bias from interviewer. Use questions below to explore problem, without biasing response, if possible. Determine if the spot and whole house exhaust fans are operational and being used. If fans are

not being used, educate the homeowner re: the importance of ventilation, ask occupants to start using them, send ventilation information. For interior moisture problems, request the homeowner re-contact you if operation of ventilation system does not improve moisture situation. For roof leaks and exterior problems, refer homeowner to factory service.

Describe problem: \_\_\_\_\_

Bathroom fan doesn't clear mirror/doesn't work? ..... Y N

Condensation on window frames or glass? ..... Y N

Which windows? \_\_\_\_\_

Roof leaks? Door leaks? Window leaks? ..... Y N

Describe locations: \_\_\_\_\_

Plumbing leaks? ..... Y N

Describe locations: \_\_\_\_\_

Water below home? ..... Y N

Describe source: \_\_\_\_\_

Kitchen exhaust fan does not seem to work? ..... Y N

Whole house fan noisy? ..... Y N

Fan controls OK? ..... Y N

Describe concern/problem: \_\_\_\_\_

Lingering odors in home with ventilation systems operating? ..... Y N

Describe odors: \_\_\_\_\_

Smoke from fireplace or woodstove comes into home under all conditions? ..... Y N

Describe: \_\_\_\_\_

Smoke from fireplace or woodstove comes into home under certain conditions? ..... Y N

Describe: \_\_\_\_\_

Visible mold present? ..... Y N

Describe locations: \_\_\_\_\_

Occupants experiencing health problems? ..... Y N

Describe: \_\_\_\_\_

Medical diagnosis of health problems? ..... Y N

Describe: \_\_\_\_\_

2. **Set-up issues:**

**Action:** Identify set-up errors, verify correct set-up from discussions with homeowners, SAA, dealer etc.

- Set-up damage to energy features repaired? ..... Y N  
Describe: \_\_\_\_\_
- Correct marriage line sealing? ..... Y N  
Describe: \_\_\_\_\_
- Correct door and window adjustment/sealing? ..... Y N  
Describe: \_\_\_\_\_
- Skirting in place and vented correctly? ..... Y N  
Describe: \_\_\_\_\_
- Ground cover in place? ..... Y N
- Clothes dryer vented correctly? ..... Y N
- Correct crossover duct installation, sealing and support? ... Y N  
Describe: \_\_\_\_\_
- Other set-up, site issues ..... Y N  
Describe: \_\_\_\_\_

5. **Other issues:**

- Is this really a NEEM home? ..... Y N  
**Action:** Confirm NEEM ID number in database. If yes, send compliance certificate to homeowner and request medallion and certification sticker from factory. If no, refer homeowner to dealer and factory for assistance.
- Can't heat/cool all room to same temperature ..... Y N  
Describe: \_\_\_\_\_  
**Action:** Confirm attempts to balance register flows. If you visit the home, provide register and return flow rates on floor plan.
- Homeowner believes insulation missing ..... Y N  
Describe: \_\_\_\_\_  
**Action:** Based on what? Determine how the homeowner know this.
- Other issues? ..... Y N  
Describe: \_\_\_\_\_  
\_\_\_\_\_  
\_\_\_\_\_

**Note other applicable information, documentation, comments, contacts, etc. Note what was done to resolve this complaint.**

\_\_\_\_\_  
\_\_\_\_\_  
\_\_\_\_\_  
\_\_\_\_\_



## STANDARDIZED PROCEDURE FOR ON-SITE TESTS OF NEEM HOMES

This document contains a description of the procedures that should be followed when on-site testing is done on homes produced in the Northwest Energy Efficient Manufactured Home Program, (NEEM) including Super Good Cents, Natural Choice, and Energy Star homes produced in Oregon, Washington and Idaho.

Tests help us find out what's wrong with a given home, if anything, and help us determine how best to respond. In addition to helping us solve particular problems, test records from problem homes are an important source of information about how NEEM homes perform in general.

When on-site tests are needed, the following approach is recommended:

- When you schedule testing with the homeowner, discuss the testing process with the homeowner so they know what to expect when you come to their home.
- Notify the factory service representative of tests you have scheduled in advance of testing — they may want to be present.
- Once you are on-site, be as productive as possible. Collect as much information as time permits and homeowners can tolerate.
- To expedite repairs or service, develop your draft report as soon as possible after the testing.
- Share draft on-site test reports with other on-site testers at ODOE, WSU, IDWR, MTDEQ.
- Following review and comment, provide a final report to homeowner, to the manufacturer involved, to other interested parties as appropriate, to ODOE and to your "Problem Home" file.

### **Core Items:**

At a minimum, gather the information requested in steps 1-17, 20-24, and 30-35. These items represent core pieces of information we want for each home.

### **Non-core items:**

Other tests may be appropriate and even necessary in particular situations. If the information will help you better characterize a problem and develop a solution, or if the information will help you educate the homeowner, factory or service crew about a particular issue, by all means, do the test.

Steps 18-19 are combustion safety tests that tell us if gas appliances in the home are correctly tuned and venting safely. Steps 25-29 collect information that enables us to express duct leakage in a home as a percent of air handler flow under normal operating conditions — called supply leakage ratio. If we have this information, energy penalties associated with duct leakage can be calculated. Supply leakage ratio is helpful in high bill situations. The ability to calculate energy penalties associated with duct leakage gives us a way to demonstrate to homeowners, the industry and potential funding agencies, the benefits of tightly built duct systems.

**Data Recording Sheet**  
**STANDARDIZED PROCEDURE FOR ON-SITE TESTS**  
**OF NEEM HOMES<sup>1</sup>**

**Basic Information**

Record the following information for each home:

1. **Date of test:** \_\_\_\_\_
2. **Report mailing date:** \_\_\_\_\_
3. **Manufacturer information:**

A) Manufacturer	B) Serial no.	C) HUD no.	D) No. of floor sections

4. **Dealer information:**

A) Dealer name	B) Complete mailing address	C) Phone

5. **Installer information or installation tag number if available:**

A) Installer name	B) Complete mailing address	C) Phone

<sup>1</sup>Based on diagnostic and field procedures developed by Florida Solar Energy Center, The Energy Conservatory and Ecoptope.



**6. NEEM information:**

A) SGC/NC/ESTAR sticker present? <input type="checkbox"/> Yes <input type="checkbox"/> No			
B) SGC/NC/ESTAR ID no.:		C) Path no.:	
D) Production date:			
Qualification measures	Listed measures	Installed measures	Notes/Complies? Y N
E) Ceiling:			
<input type="checkbox"/> Homeowner permission to open ceiling:			
F) Wall:			
<input type="checkbox"/> Homeowner permission to open wall:			
G) Floor:			
H) Window U-factor:			
I) Door:			
J) Whole house fan:			

**7. Homeowner information.** Refer to and/or complete information on the intake form.

A) Homeowner name	B) Complete mailing address	C) Phone

**8. Basic information about the house:**

- A) Obtain signed utility bill release statement.
- B) Note number of occupants: \_\_\_\_\_
- Note homeowner issues:
- C) Comfort problems? Describe/Locate: \_\_\_\_\_
- \_\_\_\_\_
- D) Hot or cold rooms? Describe/Locate: \_\_\_\_\_
- \_\_\_\_\_
- E) Drafts? Describe/Locate: \_\_\_\_\_
- \_\_\_\_\_
- F) High bills? Describe: \_\_\_\_\_
- \_\_\_\_\_
- G) Moisture problems? Describe/Locate: \_\_\_\_\_
- \_\_\_\_\_
- H) Air quality problems? Odors? See IAQ Assessment: \_\_\_\_\_
- \_\_\_\_\_
- I) Other? Describe/Locate: \_\_\_\_\_
- \_\_\_\_\_

J) Note thermostat set points:

	Set point	Set back	Set back hrs/day
Heating			
Cooling			

K) Note supplemental heating:

Type	Describe/use
<input type="checkbox"/> Portable electric?	
<input type="checkbox"/> Wood?	
<input type="checkbox"/> Gas?	

L) Note unusual or additional electric loads and describe use:

<input type="checkbox"/> Portable electric	<input type="checkbox"/> Water bed	<input type="checkbox"/> Well pump
<input type="checkbox"/> 2 <sup>nd</sup> refrigerator	<input type="checkbox"/> Freezer	<input type="checkbox"/> Hot tub
<input type="checkbox"/> Shop tools	<input type="checkbox"/> Heated outbuilding	<input type="checkbox"/> Fish tank
<input type="checkbox"/> Other:		
Description of use:		

9. **Floor plan.** Sketch the floor plan on quarter inch grid paper or obtain accurate floor plan from dealer or manufacturer.

Record accurate outside dimensions. Put a North arrow on the sketch. Sketch in interior rooms. Show heating register locations in each room. Measure sidewall height and ceiling peak height and note on sketch. Verify/measure window area. Recommended scale: 1/4 inch = 2 feet. While outside taking measurements for the sketch, you may want to do #20 and #21, which describe attic and crawlspace vents.

**10. Calculate heated floor area and house volume and note on sketch.**

Ventilation System Description/Air Quality Assessment:

<b>11. Measure relative humidity</b>	Readings and location:		
A) Outdoor			
B) Indoor			
<b>12. Record homeowner assessment of IAQ problems</b>	Yes	No	Location/notes:
A) Odors			
B) Moisture			
C) Mold			
D) Other			
<b>13. Note observed indoor pollutant sources</b>	Yes	No	Location/notes:
A) Smokers			
B) Cleaning agents			
C) Dirty furnace filter			
D) Dirty ducts			
E) Other			
F) Other			

**14. Whole House Ventilation System Information:**

A) Whole house fan manufacturer	B) Model no.	C) Location	D) Rated flow	E) Meas. flow	F) Problems?

G) Ventilation control type	H) Control location	I) Daily use	J) How is the system suppose to operate? Notes/problems:

**15. Describe fresh air system in home:**

A) Manufacturer or fresh air source	B) Model no.	C) Duct size	D) Timer? Yes/no	E) Motorized damper? Yes/no	F) Equipment condition/problems

**16. Describe spot ventilators in the home:**

A) Manufacturer/ model no.	B) Location	C) Rated flow	D) Meas. flow	Use: hrs./day	Notes/ problems

**17. Describe combustion appliances in the home:**

A) Type	B) Manufacturer	C) Model no.	D) Vent type	Notes/problems

18. **Ambient CO?** Using standardized preparation and test procedure, conduct Ambient CO test for each gas appliance. Record test below.

19. **CO Exhaust Flue?** Using standardized preparation and test procedure, conduct CO In Exhaust Flue test for each gas appliance. Record results below.

CO Test Results Record # 18 and 19

Appliance	CO ambient test results ppm	CO flue test results ppm	Notes

20. **Note type of attic ventilation.** See NEEM Manual Section 4.2.

A) Mechanical <input type="checkbox"/>	B) Manufacturer	C) Rated CFM	D) Control	E) Notes
F) Passive <input type="checkbox"/>	G) Soffit vents <input type="checkbox"/>	H) High vents <input type="checkbox"/>	I) Gable vents <input type="checkbox"/>	J) Notes

**21. Note type of crawlspace venting.** See NEEM Manual Section 5.5.2. See #35B, this document.

Type	Number of vents	Net free area/vent	Floor area	1/150?	Notes
<input type="checkbox"/> A) Typical screened vents					
<input type="checkbox"/> B) Masonry					
<input type="checkbox"/> C) Vented skirting					
<input type="checkbox"/> D) Other					

**22. Note window and door information:** Check window and door operation. Any operating problems? Contact with weather stripping?

A) Window manufacturer	B) NFRC U-factor	C) Description	D) Operation/closure	E) Notes/problems
F) Door manufacturer	G) U-factor	H) Description	I) Operation/closure	J) Notes/problems

**23. Heating/Cooling System Assessment:**

System type	Yes	No	Manufacturer	Model no.	Capacity
A) Electric furnace?					
B) Heat pump indoor unit?					
Heat pump outdoor unit?					
C) Gas furnace?					
D) Air conditioner?					

**24. House air pressure tests:**

Using standard procedure, measure and record house air pressure, main living area or combustion appliance zone wrt outside for the following conditions:

A) Baseline all systems off	
B) Forced air on, all interior doors open	
C) Forced air on, all interior doors closed	
D) Forced air plus exhaust devices on, worst case door position	
E) Exhaust devices only, worst case door position	
F) List exhaust devices:	
G) Recommendations:	

**25. Record furnace blower information.** Check which speed tap is connected with ammeter.

A) Blower manufacturer	B) Model no.	C) Speed tap setting

**26. Measure or calculate air handler flow.** If you have a flow grid, use the flow grid. If you don't have a flow grid, use the following temperature rise method. Turn up thermostat and let equipment run at least 5 minutes. For electric furnaces, use the following procedure. For a temperature rise method for gas furnaces, see Appendix.

1. Enter results as appropriate, below.

A) Measure temperature rise.

Measurement location	Degrees F	Degrees C	Notes
Return air temp. #1			
Supply air temp.			
Return air temp. #2			
Average return air temp.			
Supply minus return			

B) Measure and record furnace power use. Record element amps and volts, or ...

Element	Amps	Volts	Watts
Total			

Or clock the meter to measure power use

Meter power use factor		
Revolutions per minute	Baseline	Furnace

Watts =  $[3600 \times \text{power use factor} \times \text{revolutions/minute}] / 60$ .  
 Deduct any baseline power use to isolate furnace power use.

Show work:

C) Calculate SCFM or enter flow grid results. SCFM =  $[\text{Watts in} \times \text{constant}] / \Delta T$ . Where constant = 3.16 if using degree F or 1.75 if using degree C.

Show air handler flow calculation work or record flow grid results:

27. **Measure static pressure at supply plenum** if possible, or nearest supply register.

28. **Measure static pressure at supply registers (at least 4).** While doing this, do #30, too.

Supply plenum	S 1	S 2	S 3	S 4	S 5	S 6	S 7	S 8	S 9	S 10	S 11	S 12	S 13	S 14
	S 15	S 16	S 17	S 18	S 19	S 20								

29. **Calculate average system operating pressure** (50% supply plenum pressure/50% average supply register pressure).

Show work:

30. **Inspect ducts and duct sealing** at each register (at least 4) using flashlight and mirror. Note problems with duct and/or duct sealant.

Register no.	Type sealant			Notes/problems
Location	<input type="checkbox"/> Tape	<input type="checkbox"/> Mastic	<input type="checkbox"/> Other	

31. **Assess House Tightness:**

- A. Prepare house using standard procedure.
- B. Record make and model of house tester

Blower door manufacturer	Model no.

- C. Record outdoor and indoor temperature. Note degree F or C. Note wind condition.

Outdoor temperature	Indoor temperature	Wind condition



D. Record baseline air pressure: house wrt outside.

E. Conduct 25 Pa. and 50 Pa. test of house tightness. To check test, calculate flow exponent n. Calculate ach50, CFM natural, ACH natural

D) Baseline: house wrt outside		
E) Test	Near -50 Pa.	Near -25 Pa.
1) House wrt outside (P)		
2) Fan wrt house		
3) Fan configuration		
4) Flow/leakage (Q)		
5) N		
6) ACH50		
7) CFM natural		
8) ACH natural		

E5) Calculate "N":  $N \text{ house tightness} = \ln(Q_{50}/Q_{25})/\ln(P_{50}/P_{25})$ . If flow exponent is not between 0.5 and 0.75, retest and recalculate n.

Show work:

E6) Calculate ACH50:  $\text{ACH50} = \frac{\text{CFM}_{50} \times 60 \text{ min/hr.}}{\text{Volume}}$

Show work:

E7) Calculate CFM natural:  $\text{CFM natural} = \frac{\text{CFM}_{50}}{\text{Climate factor}}$

Climate factor (Davis: Zone 1: 27; Zone 2: 24; Zone 3: 21)

Show work:

E8) Calculate ACH natural: 
$$\text{ACH natural} = \frac{\text{CFM natural} \times 60 \text{ min/hr.}}{\text{Volume}}$$

Show work:

32. **Critique factory air sealing.** Survey and list house leakage locations, starting clockwise from the main entry door.

33. **Critique factory duct sealing.** Survey and record duct leakage locations using the pressure pan test procedure, starting clockwise from main entry door.

S1	S2	S3	S4	S5	S6	S7	S8	S9	S10
S11	S12	S13	S14	S15	S16	S17	S18	S19	S20

34. **Assess Duct Tightness:**

A. Total duct leakage test

1. Prepare for total duct tightness test using standard procedure.
2. Examine **furnace boot** sealing, note type of sealant and any problem with sealant.

Furnace boot	b) Sealant type			c) Sealant condition		
	<input type="checkbox"/> mastic	<input type="checkbox"/> tape	<input type="checkbox"/> other	<input type="checkbox"/> good	<input type="checkbox"/> bad	<input type="checkbox"/> ugly
Notes						

3. Test for total duct leakage at +25 Pa. and +50 Pa. Note where duct pressure is measured.

a) Tester attachment point:		
b) Location of duct pressure tap:		
Total duct leakage test	Test near +50 Pa.	Test near +25 Pa.
c) Duct wrt outside (P)		
d) Fan wrt outside		
e) Fan configuration		
f) Flow/leakage (Q)		
g) N		

G) Total duct leakage  $N = \ln(Q_{50}/Q_{25})/\ln(P_{50}/P_{25})$ . If flow exponent is not between 0.5 and 0.75, retest and recalculate n.

Show work:

B. Duct leakage to outside test

1. Prepare for duct leakage to outside test using standard procedure.
2. Test duct leakage to outside at 25 Pa. and 50 Pa. Note where duct pressure is measured. To check test, calculate flow exponent n.

a) Tester attachment point:		
b) Location of duct pressure tap:		
Duct leakage to outside test	Test near +50 Pa.	Test near +25 Pa.
c) House wrt outside (P)		
d) Ducts wrt house		
e) Fan wrt space where located		
f) Fan configuration		
g) Flow/leakage (Q)		
h) N		

- H) Duct leakage to outside  $N = \ln(Q_{50}/Q_{25}) / \ln(P_{50}/P_{25})$ . If flow exponent is not between 0.5 and 0.75, retest and recalculate n.

Show work:

With ducts pressurized, head for the crawlspace to check leakage at furnace boot, crossovers, or at locations identified by pressure pan test.

### 35. Assess Set-Up Issues:

Set-up item	Yes	No	Notes
A) Is skirting present?			
B) Proper crawlspace ventilation (see #21)			
C) Ground moisture barrier?			
D) Crossover duct? Size/R-value			
E) Leakage at metal elbow joints, seams, connections?			
F) Leakage at flex connections to elbow?			
G) Leakage at furnace drop connections?			
H) Crossover cut to length? Straight? Supported off ground?			
I) Leakage at duct connections to metal splices? Ts? Ys? Sealed?			
J) Metal crossover splice, Ts, Ys insulated?			
K) Centerline sealed?			
L) Belly fabric penetrations sealed?			
M) Evidence of moisture below home? Source?			
N) Other			
Other			

## STANDARDIZED PROCEDURE FOR ON-SITE TESTS OF NEEM HOMES\*

### Collect Basic Information:

Some basic information is collected inside the home and some will be found outside. Start with the outside stuff first: find the HUD tags, installer tags and do outside measurements for the home sketch if needed. While outside, it may be efficient to check attic ventilation item #20 and crawlspace ventilation item #21. Inside, get acquainted with homeowner, walk-around and through the home, get oriented, find out where things are that you need to check. It is important to find out where all the registers are, where particular comfort problems or moisture/air quality problems may be occurring. Serial numbers are on the HUD label inside the kitchen cabinet or on the NEEM label in the electrical panel. As you do this quick survey, prepare the house for the house air pressure and building tightness tests. Do item #11, relative humidity reading inside the home before your trips in and out of the home change the baseline condition.

Fill in the Basic Information portion of the data sheet, noting the following information:

1. **Date of test**
2. **Report date (when known)**
3. **Home manufacturer**, serial number, HUD number(s), number of floor sections.
4. **Dealer information**, in case dealer repairs are needed.
5. **Installer information**, in case installer repairs are needed.
6. **NEEM/NC information**. Number from sticker and qualification measures listed on the sticker. Note discrepancies between qualification measures and measures as found. Floor insulation can be checked when you do item 43. With homeowner permission, (signature on data sheet @ Wall) wall insulation can be checked by opening the wall covering inside a kitchen or bath cabinet. If you are going to open a wall, be prepared with proper tools and materials to close it up when you are done. With homeowner permission, (signature on data sheet @ Ceiling) ceiling insulation can be checked by removing a mushroom vent on the roof in each house section. Roof vents need to be replaced/ flashed correctly or you will cause a roof leak. If you don't know how to do this, arrange for dealership or factory service people to help you. In some cases it will be necessary to open the wall and ceiling. Don't do it if it is not needed to satisfy the homeowner. If we need to do it, get it done right.

\*Based on diagnostic and field procedures developed by Florida Solar Energy Center, The Energy Conservatory and Ecoptope.

7. **Homeowner information** so we can mail them a copy of the report.
8. **Ask the homeowner for other information about the home** and how it is operated. If we need to do a billing analysis, we need a signed bill release statement. Carefully listen and record items that the homeowner identifies as problems. When you do your tests, see what the tests show you about the problem areas or issues. When you write your report, be sure to respond to each homeowner item with the testing or other information you have obtained. Thermostat behavior, supplemental heat use, and additional load information may be needed to assess high bill complaints.
9. **Floor plan.** If you don't have a floor plan drawing from the dealer or manufacturer, make your own. Complete the sketch of the floor plan using 1/4 inch graph paper where 1/4 inch = 2 feet. Show interior room layout, sidewall height, ceiling peak height, main entry, register locations labeled S1, S2, etc. per #28.
10. **Calculate area of heated floor space and house volume and note on sketch.**

### VENTILATION SYSTEM DESCRIPTION AND AIR QUALITY ASSESSMENT

Record the following information on the house data sheet:

11. **Measure and record relative humidity** in the main living area using a sling psychrometer or digital moisture meter. Measure inside relative humidity before your trips in and out of the house or ventilation system testing change the baseline condition. Measure outside relative humidity. Note on data sheet where measurements are taken.
12. **Ask the homeowner to describe any air quality problems they may have noticed.** Note where or when these problems occur.
13. **You may notice air quality items** the homeowner does not think to mention. Describe/note any indoor air quality/health problems you notice that could significantly affect air quality such as smokers, cleaning compounds, dirt in the furnace filter or ducts and other items.
14. **Describe the whole house exhaust fan,** including fan manufacturer, model no., fan location, rated flow, measured flow, and any problems. Describe the whole house ventilation control type and location (high wall switch, standard wall switch, timer kit). Ask the homeowner about whole house fan use, estimate daily run time, noise, condition of equipment, how the system is supposed to operate, any problems. Run the whole house ventilation system to be sure all components are working as intended.

15. **Describe the fresh intake system** for the home including manufacturer, model no., size of duct if present, presence or absence of timer, presence or absence of motorized damper, condition of equipment, any problems. In some cases, other fans in the home will, in theory, be functioning as air intakes.
16. **Describe spot ventilators** in the home including manufacturer, location, model no., rated cfm, measured cfm, estimated use pattern, any problems. During the house tightness test, it is recommended that fans and their backdraft dampers be checked for leakage/air intake potential.
17. **Describe any combustion appliances** in the home including type of appliance, manufacturer, model no., vent type, any air path between the living space and the combustion chamber, any problems.
18. **Conduct Ambient CO test** for each gas appliance after 5 minutes of operation. Record test results on data sheet. Question: Does CO spill into the living space when gas appliances are operated?
  - A) Zero CO tester outside according to manufacturer's instructions.
  - B) Make sure all exhaust devices are off.
  - C) Test one combustion appliance at a time.
  - D) Allow combustion equipment being tested to operate for at least 5 minutes. Avoid trips in and out of the home during the warm-up period.
  - E) Measure ambient CO using CO tester.
  - F) Record measurements on data sheet. Note if results exceed Ambient CO Exposure Limits.

### Ambient CO Exposure Limits and Response Guidelines

Standard	Limit	Response Guideline
EPA 8 hour exposure	9 ppm	ventilate house, equipment repair recommended, continue testing, no duct repairs until equipment repairs complete and CO is within acceptable limits.
EPA 1 hour exposure	35 ppm	ventilate house, immediate repair required, stop testing until repairs are complete and CO is within acceptable limits.

19. **Conduct CO in exhaust flue test.** If you drill a hole in double wall vent pipe, patch it with a machine bolt (diameter of bolt = diameter of hole) buttered with high temp. silicone. Patch holes in single wall vent with metal tape. Question: Are gas appliances properly tuned for safe operation?

A) Zero CO tester according to manufacturer's instructions.

**Furnaces/water heaters/fireplaces:**

B) Measure CO in exhaust flue before draft diverter or barometric damper after at least 5 minutes of operation.

**Gas stoves:**

C) Measure peak CO in gas oven exhaust port during first five minutes of operation. Lift stove top for access to oven exhaust port.

D) Measure range top CO three feet above burners during first five minutes of operation.

E) Record measurements on test results form. Note if CO in flue exceeds Recommended Flue CO Limits.

### Recommended Flue CO Limits

Appliance	Limit	Source
Furnace/Water heater	100 ppm	Energy Conservatory
Gas range	25 ppm	George Tsongas

If measured flue CO exceeds limits, repairs and adjustments are needed and appliances should be re-tested to verify flue CO is within acceptable limits.

20. **Note type of attic ventilation.** Mechanical? (make, model, rated cfm, control, how system is supposed to operate.) Passive? (continuous soffit vents? Ridge vents or high mushroom vents? Gable end vents?)

21. **Note type of crawlspace venting.** Calculate net free area per vent. Record number of vents. Does vent net free area = 1/150 of heated floor space?

22. **Note window and door information.** Window manufacturer, NFRC U-factor, description, fresh air vents? Check window operation and note any operating problems? Door manufacturer, U-factor, description, operation problems, contact with weather-stripping? Re-check windows and doors for tight closure during house tightness testing.



### 23. Heating/Cooling System Assessment:

Record the following information on the data sheet:

- A) Electric furnace information including manufacturer, model no., heating capacity in kWh
- B) Heat pump information including: manufacturer, indoor unit model no., outdoor unit model no., capacities
- C) Gas furnace manufacturer, model no., output capacity
- D) Air conditioner information including: manufacturer, model no., capacity

24. **Conduct House Air Pressure Tests A-D** in each combustion appliance zone, if any, or in the main living area. CAZ/MLA wrt outside. Question: Do systems in this home change air pressure in CAZs so that current or future combustion appliances will have a difficult time drafting properly? Tools: digital manometer, pressure tap hoses. The blower door and duct tester are not used for these tests. If they are already set up, their fan openings must be sealed shut for the test.

#### A. Forced Air System On, All Doors Open

##### 1) Prepare House

- A) Close all exterior doors and windows.
- B) Turn off all exhaust devices.
- C) **Open** interior doors to all rooms containing supply registers.
- D) Close fireplace/woodstove damper. Close fireplace/woodstove doors.
- E) Remove furnace filter.
- F) Set up manometer read difference in air pressure, CAZ wrt outside.

##### 2) Test

- A) Record baseline air pressure difference, CAZ wrt outside, all systems off.
- B) Turn air handler fan on.
- C) Record difference in air pressure, CAZ wrt outside.

#### B. Forced Air System On, All Doors Closed

##### 1) Prepare House

- A) Close all exterior doors and windows.
- B) Turn off all exhaust devices.
- C) Close interior doors to all rooms containing supply registers.
- D) **Close** fireplace/woodstove damper. Close fireplace/woodstove doors.
- E) Remove furnace filter.
- F) Set up manometer read difference in air pressure CAZ wrt outside.

- 2) Test
  - A) Record baseline air pressure difference, CAZ wrt outside, all systems off.
  - B) Turn air handler fan on.
  - C) Record difference in air pressure, CAZ wrt outside.
- C. Forced Air System On, Exhaust Devices On, Worst Case Door Position
  - 1) Prepare House
    - A) Close all exterior doors and windows.
    - B) Close interior doors to all rooms containing supply registers.
    - C) Close fireplace/woodstove damper. Close fireplace/woodstove doors.
    - D) Remove furnace filter.
    - E) Set up manometer to read difference in air pressure CAZ wrt outside.
  - 2) Test
    - A) Air handler on.
    - B) All exhaust devices on.
    - C) Establish worst case door position. With the air handler and exhaust devices on, use the manometer to test air pressure differences, room wrt CAZ, for each room containing both an exhaust device and a supply register. If room wrt CAZ is negative, open the door. Otherwise, leave the door closed.
    - D) Once worst case door position is established, measure and record air pressure difference CAZ wrt outside.
- D. Exhaust Devices Only, Worst Case Door Position
  - 1) Prepare house.
    - A) Air handler off.
    - B) Exhaust devices remain on.
    - C) Establish new worst case door position. Using the manometer, check rooms with exhaust devices. With the door closed and the exhaust device on, measure air pressure difference, room wrt CAZ. If room wrt CAZ is negative, open the door. Otherwise, leave the door closed.

2) Test

- A) Once worst case door position is established, measure and record air pressure difference, CAZ wrt outside.

Repeat operating pressure tests for each separate combustion appliance zone. If depressurization in a combustion appliance zone is lower than (exceeds) the depressurization limits listed in the table below, Depressurization Limits for Combustion Systems, for the type of appliance involved, recommend installation of pressure relief measures that will bring the combustion appliance zone within recommended depressurization limits. Note: for Oregon Residential Tax Credit purposes, provide duct sealing and/or door closure pressure relief as needed so that CAZ wrt outside Forced Air On, All Doors Open and Forced Air On, All Doors Closed do not exceed -3 Pa.

## CANADIAN DEPRESSURIZATION LIMITS FOR COMBUSTION SYSTEMS

Type of Ventilation in Home	Continuous Pressure Limit (Pa)	Intermittent Pressure Limit (Pa)
<b>Open systems</b>		
*oil furnace w/barometric draft control	5	5
*oil-fired water heater with barometric draft control	5	5
*gas/propane furnace with draft hood	5	5
*gas/propane water heater with draft hood	5	5
*gas/propane fireplace B-vented with draft hood	5	5
<b>Closed Systems</b>		
*oil furnace with no barometric draft control	5	10
*oil water heater with no barometric draft control	5	10
*gas/propane furnace induced draft, no draft hood	5	10
*gas/propane water heater, induced draft, no draft hood	5	10
*pellet stove with gas-tight vent	5	10
<b>Sealed Systems (gas-tight, side-wall vented)</b>		
*oil furnace, power vented, low temp. side wall vent	10	20
*oil water heater, power vented side wall vent	10	20
*gas/propane condensing furnace/boiler	10	20
*gas/propane condensing water heater	10	20
*gas fireplace or insert, direct vent	10	20
<b>Advanced Wood Heater (EPA/CSA B415 Certified)</b>		
*woodburning stove EPA/CSA B415 Certified	5	7
*woodburning fireplace EPA/CSA B415 Certified	5	7
*woodburning fireplace insert EPA/CSA B415 Certified	5	7
*masonry heater	5	7
Conventional wood heaters		
*wood cooking range	5	5
*wood furnace/boiler	5	5
*wood fireplace, conventional with doors	5	5
Open wood or gas fireplace without doors	5	5

Canadian General Standards Board draft standard CGSB 51.71 "The Spillage Test."

Continuous pressure: pressure induced by a continuously operating ventilation system.

Intermittent pressure: pressure induced by an intermittently operating ventilation system.

25. **Record furnace blower information.** Manufacturer, model no. and speed tap setting(s). Check which speed tap is connected with ammeter.
26. **Measure or calculate air handler flow.** If you don't have a flow grid, measure air handler flow for electric furnaces using the following temperature rise method. For a gas furnace air handler flow measurement procedure see Appendix 1 of this form.
  - A. Turn up thermostat and let equipment run at least 5 minutes.
  - B. Record return air temperature. Specify degrees F or C.
  - C. Record supply plenum temperature or nearest supply register temperature.
  - D. Re-measure and record return air temperature.
  - E. Calculate average return air temperature.
  - F. Calculate delta-T.
  - G. Measure and record furnace power use. Record element amps and volts or clock the meter to measure power use. Clocking the meter: Power use in watts = [3600 x power use factor (from meter face) x no. revolutions per minute]/60. Deduct any baseline power use to isolate furnace power use.
  - H. Calculate SCFM.  $SCFM = [Watts\ in\ x\ constant] / \Delta T$   
Where constant = 3.16 if using degree F or 1.75 if using degree C.  
Show work. If you have a flow grid, record results.
27. **Measure static pressure at supply plenum.** Use pitot tube set to measure static, not velocity, pressure. End of pitot tube faces air flow.
28. **Measure static pressure at supply registers** (at least 4), starting clockwise from the main entry. Use pitot tube set to measure static pressure, not velocity pressure. End of tube at bottom of each boot, facing air flow. While measuring static pressure, check #30.
29. **Calculate average system operating pressure** (50% supply plenum pressure/50% average supply register pressure).
30. **Inspect ducts and duct sealing** at a selection of registers (at least 4) using flashlight and mirror. Note type of sealant, condition of sealant, other problems.
31. **Assess House Tightness**  
Tools: blower door, manometer. Note: test numbers 34, 35 and 36 are done with the house depressurized to -50 Pa. wrt outside. For efficiency, do all three tests together.

- A) Standard preparation for building tightness test
- 1) Verify exterior windows and doors are closed and latched.
  - 2) Open all interior doors including basement door. Door from house to garage and doors to other unheated zones should be closed.
  - 3) Open all supply and return registers.
  - 4) Turn off all exhaust devices (fans, dryer).
  - 5) Remove any hot coals from fireplace or woodstove. Close fireplace and woodstove flue dampers and doors. Seal as needed to avoid pulling ashes out of the firebox during the depressurization test.
  - 6) Set gas appliances to pilot setting. **Remember** to reset or re-light as needed before leaving.
  - 7) Lower heating system thermostat to prevent unit from coming on during test.
  - 8) Remove furnace filter.
  - 9) Set up blower door. Avoid restrictions within 3-4 feet of fan openings.
  - 10) Set up manometer to read pressure difference, house wrt outside and fan wrt house.
- B) Record blower door model and fan configuration (ring) used during test.
- C) Record outdoor and indoor temperature. Note wind conditions.
- D) Record baseline air pressure all systems off, house wrt outside and belly wrt house.
- E) Building Tightness Test
- 1) Depressurize the house to – 25 Pa. and -50 Pa. wrt outside. Adjust for baseline pressure if applicable.
  - 2) On the test results form, record
    - a) pressure difference, house wrt outside
    - b) pressure difference, fan wrt house. If fan pressure is less than -25 Pa. (-20, -15, -10 etc.) use a more restrictive ring.
    - c) fan configuration (ring)
    - d) fan flow/leakage in CFM using chart or manometer

- e) N. To see if the test was valid, calculate flow exponent n.

Use the following formula:  $N = \ln(Q_{50}/Q_{25}) / \ln(P_{50}/P_{25})$ . Ln = natural log. Note  $Q_{50}$  and  $Q_{25}$  are the flows through the blower door at the testing pressures (which are denoted  $P_{50}$  and  $P_{25}$ ). Depending on the test, you may not get the home to exactly -50 or -25 wrt outside. Use the exact delta P you measure when checking the flow exponent. For example, if the house gets to -48 Pa. for the high delta P, use this as the  $P_{50}$  in the equation. If the flow exponent is not between 0.50 and 0.75, repeat the test.

- 3) Calculate ACH 50.

$$\text{ACH50} = \frac{\text{CFM 50} \times 60 \text{ min/hr.}}{\text{Volume}}$$

- 4) Calculate CFM natural.

$$\text{CFM natural} = \frac{\text{CFM 50}}{\text{Climate factor}}$$

Climate factor (Davis): Zone 1: 27; Zone 2: 24; Zone 3: 21

- 5) Calculate Ach natural

$$\text{ACH natural} = \frac{\text{CFM natural} \times 60 \text{ min/hr.}}{\text{Volume}}$$

32. **Critique factory air sealing.** With house wrt to outside at -50 Pa., survey and record house leakage locations, starting clockwise from the main entry door. House preparation = same as #31.

34. **Critique factory duct sealing.** With house wrt outside at -50 Pa., survey and record duct leakage locations (pressure pan test). House preparation = same as #31. Use tight fitting foam block in plastic bag as pressure pan.

A) Set up manometer to read blocked register wrt house.

B) Starting clockwise from the main entry door, record the pressure number for each register on the data entry form.

35. **Assess Duct Tightness:**

A) Total Duct Leakage Test:  $DL_{\text{total}}$

This test measures leakage in the duct system both inside and outside of the building air barrier/heated space:

$$DL_{\text{total}} = DL_{\text{inside}} + DL_{\text{outside}}$$

Tools: duct tester, register plugs or temporary tape, cardboard, knife, screwdrivers.

- 1) Standard preparation for total duct leakage tests
  - A) All interior doors open.
  - B) All exhaust devices off.
  - C) Air handler off.
  - D) Seal all grilles and registers securely with temporary tape or other temporary sealant materials so that they are air tight and so that the seal will not blow off during the test. If the temporary seals are not sufficiently tight, the system will appear leakier than it really is under test conditions, and compliance with a performance standard will be difficult to assess.
  - E) The reference pressure for this test is outside air. Open exterior doors or windows in each area of the home as needed to neutralize any difference between inside and outside air pressure. For this test, while the duct tester is pressurizing the ducts, house pressure wrt outside should be 0 Pa.
  - F) Remove furnace filter.
  - G) Blower door is not used for this test, but if already set up, blower door fan can remain open for the test to help neutralize any pressure difference during the test between air pressure in the house and outside air pressure. See E above.
  - H) Fresh air ducts attached to the furnace should not be "in" this test. If duct tester is attached to furnace blower platform, the fresh air duct will not affect the test. If, for some reason the entire furnace cabinet will be in the test, seal the fresh air duct.
  - I) Attach the duct tester to the system being tested according to the testing equipment manufacturer's instructions, and so that the connection is air tight. The preferred method is to remove the furnace blower and attach the duct tester to the blower platform. Record duct tester attachment point.
  - J) Place the end of the hose measuring duct pressure in the supply plenum or duct within 3 feet of the duct tester attachment. If this is not possible, record duct pressure measurement point. Avoid placing end of hose facing air flow.
  - K) Run the duct tester to verify air tightness of duct tester attachment and register/grille seals.
- 2) While removing the furnace blower, examine furnace boot air sealing and note type of sealant and any problems with sealant.



- 3) Test for total duct leakage at +25 Pa. and +50 Pa.
- Pressurize** the duct system to +25 and +50 Pascals wrt outside air pressure. Record test pressures.
  - Record duct tester fan pressure wrt outside. If the duct tester fan pressure is less than -25 Pa. (-20, -15, -10 etc.) retest using the next smaller ring.
  - Record duct tester fan configuration: ring 1, 2, 3 or open.
  - Determine and record duct tester fan flow /total duct leakage using chart or manometer.
  - If ducts cannot be pressurized to +50 Pa. wrt outside/ house air pressure, use the following multipliers to convert CFM achieved at one of the lower pressures below to estimated CFM50.

Pressure Achieved	Multiplier for Estimated CFM50
25 Pa.	1.6
20 Pa.	1.8
15 Pa.	2.2
10 Pa.	2.9
5 Pa.	4.5

- F) Calculate the flow exponent “n”. If the flow exponent is not between 0.50 and 0.75, repeat the test.
- B) Test for duct leakage to outside. This test “zeros out” duct leakage occurring inside the building air barrier/ heated space and only measures leakage occurring outside heated space:  $DL_{outside} = DL_{total} - DL_{inside}$ .

Tools: Blower door, duct tester, digital manometer, register sealing materials.

- Standard preparation for testing duct leakage to outside
  - Exhaust devices off.
  - Turn air handler off
  - Seal all grilles and registers tightly.
  - Remove furnace filter and any pre-filters.
  - Close off any outside air ducts to the return. Fresh air ducts should be “out” of the test.
  - Close all exterior doors and windows.**
  - Turn off combustion appliances so they will not operate during test. Close fireplace or woodstove doors and dampers during the test. Turn gas appliance valves to pilot setting. **Remember** to reset/restart appliances after testing.

- H) Set up duct tester to pressurize the ducts. Attach at air handler cabinet or closest large return grille. The preferred method is to remove the furnace blower and attach the duct tester to the blower mounting platform. Avoid locating duct tester in air flow path of blower door. Record attachment point.
  - I) Set up digital manometer at the duct tester to read supply plenum pressure wrt house and duct tester fan pressure wrt the space in which the fan is located.
  - J) Place duct pressure tap in supply plenum within three feet of the connection point. If this is not possible, record duct pressure measurement point. Avoid having the tap face the air flow.
  - K) Run duct tester to verify the connection to the system is tight. Verify register and grille seals are tight. Turn duct tester off.
  - L) Set up blower door to **pressurize** the house. Reverse blower door in frame to avoid overheating; remove low flow plates.
- 2) Test duct leakage to outside at +25 Pa. and +50 Pa.
- A) Turn blower door on and **pressurize** house to +25 Pa. and +50 Pa. wrt outside. Record appropriate information for each test condition.
  - B) Turn duct tester on and pressurize duct system to 0 Pa. wrt house, i.e. no pressure difference across duct leaks located inside the house.
  - C) Check and re-adjust house pressure/duct pressure to reach test pressures.
  - D) Record house pressure wrt outside.
  - E) Record duct pressure wrt house.
  - F) Record duct tester configuration.
  - G) Record duct tester fan pressure wrt the space where it is located. If pressure of fan wrt space is less than -25 Pa. (-20, -15, 10, etc.) use next smaller ring.
  - H) Determine duct tester fan flow using chart or manometer and record duct leakage to outside.
  - I) Calculate flow exponent "n".
  - J) With ducts pressurized head for the crawlspace to check leakage below furnace boot, crossovers, or at locations identified by pressure pan test.

### 35. Assess Set-Up Issues:

Most of this happens in the crawlspace. Coveralls recommended. You need to stay clean because you have to go back inside the home. Take your measuring tape with you, flashlight, dust mask. Knee pads are really nice. You may need to undo a duct connection to inspect it. Take appropriate tools and supplies to repair any inspection related damage you plan to do to the duct or belly (razor knife, side cutters, zip ties, tie tightening tool, metal tape, belly tape, self tapping screws, driver) Don't cut your head open on the angle iron, or if you do, don't cut it open very much.

- A) Note presence or absence of skirting.
- B) Is the crawlspace properly vented? See #21.
- C) Ground moisture barrier present?
- D) Crossover duct size, R-value.
- E) Note leakage at metal elbow joints, seams, connections.
- F) Note leakage at flex duct connections to metal elbow.
- G) Note leakage at furnace drop/boot connections.
- H) Is the crossover duct properly cut to length, run straight and supported off the ground?
- I) Note leakage at crossover connections to metal splices, Ts, Ys.
- J) Note if metal splices, Ts, Ys are properly insulated.
- K) Is the centerline (s) properly sealed?
- L) Are belly penetrations sealed?
- M) Evidence of moisture below home?
- N) There may be other items — non-NEEM items — that you notice that are in need of repair. While we are there to focus on NEEM items, if other items need attention, identify them in your report as other items in need of attention.

## MEASURING AIR HANDLER FLOW ON GAS FURNACES WITH THE TEMPERATURE RISE METHOD

1. Select position to measure supply temperature. If possible, select a position out of direct view of the furnace heat exchanger. Drill holes big enough to admit temperature probe, if you have not already done this for the static pressure measurements.
2. Turn off all gas appliances except the furnace. Note or draw water heater temperature setting: \_\_\_\_\_
3. Turn up the furnace thermostat and let furnace run for at least 5 minutes.
4. Record return plenum temperature. Specify degrees F or C:  
\_\_\_\_\_
5. Record supply temperature. Specify degrees F or C:  
\_\_\_\_\_
6. Re-measure return temperature and calculate average return temperature: \_\_\_\_\_ Average: \_\_\_\_\_
7. Perform CO and combustion efficiency measurements after 5 minutes have elapsed. Record efficiency for each port in natural draft equipment or use single reading for induced draft equipment: \_\_\_\_/\_\_\_\_/\_\_\_\_/\_\_\_\_ Average: \_\_\_\_\_ %
8. Measure gas usage. Clock the time it takes for four revolutions of the smallest dial (usually 1/2 ft<sup>3</sup>).  
Record time needed for four revolutions: \_\_\_\_\_ in seconds.  
Record amount gas consumed in four revolutions: \_\_\_\_\_ ft<sup>3</sup>
9. Find raw furnace input energy using the following formula:  
Btuh in = {[3600 sec. (ft<sup>3</sup> gas consumed in four revs.)]/time needed for four revs.} x energy content for gas per ft<sup>3</sup>.  
Energy content for gas is usually about 1000 Btuh/ft<sup>3</sup> in the Northwest. Consult gas utility for exact figure.

Show work:

10. Multiply result from Step 10 by average combustion efficiency from Step 8 and record actual Btu/h input to supply air stream.

Show work:

11. Airflow in standard CFM (SCFM) = energy in (Step 11) x conversion factors /  $(T_s - T_r)$

$$\text{SCFM} = (\text{Btu/h input} \times 1.08_{-1}) / (T_s - T_r)$$

Show work:

12. Turn on any appliances you turned off earlier to as-found settings. Patch holes in ducts with metal tape. Patch hole in combined exhaust flue with machine bolt and high temperature silicone sealant.



**NORTHWEST ENERGY EFFICIENT  
MANUFACTURED HOME IN-PLANT REVIEW**

**Plant Staff Involved:** \_\_\_\_\_

**Floors**

**Serial numbers in stations:** \_\_\_\_\_/ \_\_\_\_\_/ \_\_\_\_\_/ \_\_\_\_\_/ \_\_\_\_\_

- 1. Batts/Blown-in cellulose/Mix
- 2. R \_\_\_\_\_ between I-beams to rim ....   
Product(s): \_\_\_\_\_
- 3. R \_\_\_\_\_ between I-beams .....   
Product(s): \_\_\_\_\_
- 4. Rims covered .....
- 5. R \_\_\_\_\_ batt below trunk .....
- 6. Floor penetrations sealed at:
  - Plumbing .....   
Note sealant: \_\_\_\_\_
  - Electrical .....   
Note sealant: \_\_\_\_\_
  - Tub/shower drains .....   
Note sealant: \_\_\_\_\_
  - Supply registers .....   
Note sealant: \_\_\_\_\_

**Ducts:**

- 1. Trunk ends .....
- 2. Crossover fitting/trunk .....
- 3. Takeoff fittings/trunk .....
- 4. Flex to metal fittings .....
- 5. Furnace boot/trunk .....
- 6. Register boot/trunk .....
- 7. Sealant: 15 mil butyl tape, mastic, both

**Walls**

**Serial numbers in stations:** \_\_\_\_\_/ \_\_\_\_\_/ \_\_\_\_\_/ \_\_\_\_\_/ \_\_\_\_\_

- 1. R \_\_\_\_\_ insulation .....
- 2. Vapor retarder in place .....   
Note type: \_\_\_\_\_
- 3. No uninsulated cavities .....
- 4. Insulation at full loft .....

- 5. Endwall batts cut to fit rake .....
- 6. Min. compression around  
elec. boxes/wiring .....
- 7. Min. R-10 behind recessed  
wall fixtures .....
- 8. Wall air sealing complete @  
Floor/wall seam .....   
Note sealant: \_\_\_\_\_  
Wiring holes .....   
Note sealant: \_\_\_\_\_  
Electrical outlets/switch  
boxes @ exterior walls .....   
Note sealant: \_\_\_\_\_  
Plumbing holes .....   
Note sealant: \_\_\_\_\_

### Ceiling/Roofs

Serial numbers in stations: \_\_\_\_\_/\_\_\_\_\_/\_\_\_\_\_/\_\_\_\_\_/\_\_\_\_\_

- 1. R \_\_\_\_ insulation .....   
Oversized fiberglass batts? .....   
Blown-in cellulose? .....   
Other: \_\_\_\_\_
- 2. Blown-in:  
1" airspace .....   
follows bottom of top cord  
until it achieves full depth .....   
then levels out for full depth  
coverage to ridge .....   
Baffles retain loosefill .....
- 3. Vapor retarder in place .....   
Note type: \_\_\_\_\_
- 4. Skylight wells/solar tubes have  
Wall R-value .....   
Insulation supported against



- skylight sidewall .....
- 5. Ceiling penetrations sealed:
  - Fan penetrations .....
  - Note sealant: \_\_\_\_\_
  - Wiring holes .....
  - Note sealant: \_\_\_\_\_
  - Plumbing holes .....
  - Note sealant: \_\_\_\_\_
- 6. Kitchen recessed lights  
in sealed box .....
- 7. Recessed can light have  
IC/air tightness sticker .....

**Windows/Patio Sliders**

**Serial numbers in stations:** \_\_\_\_\_/\_\_\_\_\_/\_\_\_\_\_/\_\_\_\_\_/\_\_\_\_\_

- 1. Approved window .....
- 2. NFRC U-factor: \_\_\_\_\_
- 3. Product: \_\_\_\_\_
- 4. Sealed @ RO .....
- Note sealant: \_\_\_\_\_
- 5. Glazing area limit ok .....

**Skylights**

**Serial numbers in stations:** \_\_\_\_\_/\_\_\_\_\_/\_\_\_\_\_/\_\_\_\_\_/\_\_\_\_\_

- 1. Approved skylight .....
- 2. Product: \_\_\_\_\_
- 3. Max 0.5 U-factor: \_\_\_\_\_
- 4. Skylight area: \_\_\_\_\_
- Sealed at top of well .....

**Exterior Doors**

**Serial numbers in stations:** \_\_\_\_\_/\_\_\_\_\_/\_\_\_\_\_/\_\_\_\_\_/\_\_\_\_\_

- 1. Approved R-5 door .....
- 2. Product: \_\_\_\_\_
- 3. Air sealed @ RO .....
- Note sealant: \_\_\_\_\_

## Ventilation System

Serial numbers in stations: \_\_\_\_\_/\_\_\_\_\_/\_\_\_\_\_/\_\_\_\_\_/\_\_\_\_\_

1. Approved whole house fan .....

Product: \_\_\_\_\_

Sound rating: \_\_\_\_\_

Rated cfm: \_\_\_\_\_

Measured cfm: \_\_\_\_\_

Control: \_\_\_\_\_

2. Control label .....

3. Terminates outside at least 3 feet from fresh air source .....

4. Approved fresh air source .....

Note source: \_\_\_\_\_

5. Approved bath fan .....

Product: \_\_\_\_\_

Rated cfm: \_\_\_\_\_

Measured cfm: \_\_\_\_\_

6. Approved kitchen fan .....

Product: \_\_\_\_\_

Rated cfm: \_\_\_\_\_

Measured cfm: \_\_\_\_\_

7. Fan duct connections sealed .....

## Space Heat/Water Heat/Combustion Appliance

Serial numbers in stations: \_\_\_\_\_/\_\_\_\_\_/\_\_\_\_\_/\_\_\_\_\_/\_\_\_\_\_

1. Electric furnace .....

Capacity: \_\_\_\_\_

2. Electric water heater .....

EF: \_\_\_\_\_

3. Gas furnace .....

AFUE: \_\_\_\_\_

4. Gas water heater .....

EF: \_\_\_\_\_

5. Non-sealed combustion appliance present? .....

Type: \_\_\_\_\_

Make/model: \_\_\_\_\_

### Ship Items

Serial numbers in stations: \_\_\_\_\_/ \_\_\_\_\_/ \_\_\_\_\_/ \_\_\_\_\_/ \_\_\_\_\_

1. R-8 crossover duct .....
2. Metal elbows .....
3. Center-line gasket .....

### Homeowner Materials

Serial numbers in stations: \_\_\_\_\_/ \_\_\_\_\_/ \_\_\_\_\_/ \_\_\_\_\_/ \_\_\_\_\_

1. Compliance certificate .....
2. Medallion .....
3. SGC/NC/ESTAR label .....
4. Ventilation brochure .....

### Total Duct Leakage Tests

SN of floor tested	E. Star 5% net @ 25 Pa	OR tax cr. 6% flr area @ 50 Pa.?	Meet NEEM	Test data
		Flr. Area _____		DwrtO <u>25</u> FwrtO <u>  </u> C <u>  </u> L <u>  </u> DwrtO <u>50</u> FwrtO <u>  </u> C <u>  </u> L <u>  </u> Notes:
		Flr. Area _____		DwrtO <u>25</u> FwrtO <u>  </u> C <u>  </u> L <u>  </u> DwrtO <u>50</u> FwrtO <u>  </u> C <u>  </u> L <u>  </u> Notes:
		Flr. Area _____		DwrtO <u>25</u> FwrtO <u>  </u> C <u>  </u> L <u>  </u> DwrtO <u>50</u> FwrtO <u>  </u> C <u>  </u> L <u>  </u> Notes:
		Flr. Area _____		DwrtO <u>25</u> FwrtO <u>  </u> C <u>  </u> L <u>  </u> DwrtO <u>50</u> FwrtO <u>  </u> C <u>  </u> L <u>  </u> Notes:
		Flr. Area _____		DwrtO <u>25</u> FwrtO <u>  </u> C <u>  </u> L <u>  </u> DwrtO <u>50</u> FwrtO <u>  </u> C <u>  </u> L <u>  </u> Notes:
		Flr. Area _____		DwrtO <u>25</u> FwrtO <u>  </u> C <u>  </u> L <u>  </u> DwrtO <u>50</u> FwrtO <u>  </u> C <u>  </u> L <u>  </u> Notes:

1. Provide comparison between measured leakage in these floors with NEEM target based on Davis, et. al. "Field Measurements of Heating System Efficiency in Nine Electrically Heated Manufactured Homes." Ecotope Inc., May 1996. Average leakage in these MAP homes was 125 cfm25 on site with crossover duct in place. Or: approx. 60 cfm 25 per floor section.
2. Notes: provide test data: **DwrtO** [Duct pressure wrt outside air pressure], **FwrtO** [Fan pressure wrt outside air pressure] **C** [fan configuration ring no.] **L** [Total duct leakage in cfm 25 or cfm 50]. Note production anomalies.



**Technical Specification Change Submittal**  
**Northwest Energy Efficient Manufactured Home**  
**Department of Energy**  
 625 Marion St. NE, Salem, OR 97301  
 Phone: (503) 378-4040, Toll free: 1-800-221-8035  
 Fax: (503) 373-7806

PROPOSED REVISIONS	
STAFF USE ONLY	
Submittal no.:	
(check one)	
<input checked="" type="checkbox"/>	One-year proposal
<input type="checkbox"/>	Three-year proposal

**Instructions:** Fill in the following information, attach all supplementary information including, but not limited to, justification based on technical and scientific facts and mail to the address listed above.

PROPONENT INFORMATION		
Name: John Leterdrip		Date: Dec. 15, 1998
Representing: Tall Timber City		Phone: None
Address or P.O. Box: City Hall		Fax no.: None
City: Tall Timber City	State: OR	ZIP: 97999
SPECIFICATION CHANGE INFORMATION		
Suggested revision to the <u>NEEM</u> specification.		
<p><b>Proposal</b> (including proposed new wording <u>underlined</u>, and identification of wording to be [deleted] and appropriate location:</p> <p>I think that 10 percent of the duct system in homes should be performance tested.</p>		
<p><b>Justification</b> (state problem to be solved, reason for proposal and description of development history, including sources and references, as applicable):</p> <p>To provide better quality control for duct systems and to better ensure energy efficiency.</p>		
Estimated cost impact: \$1600 plus testing home		
<p><b>Sample formula:</b> <math>U \times M \times L \times D = C \text{ or } S</math>  <math>30 \times \\$25 \times \\$20 \times \\$0 = (+) \\$1350</math></p> <p>Number of Units per structure (added or deleted) x Material cost per unit x Labor cost per unit x Design cost per unit = Total Cost (+) or Savings (-) per structure</p> <p style="text-align: center;"><i>Attach additional sheets as necessary.</i></p>		



**Technical Specification Change Submittal**

**Northwest Energy Efficient Manufactured Home**

**Department of Energy**

625 Marion St. NE, Salem, OR 97301

Phone: (503) 378-4040, Toll free: 1-800-221-8035

Fax: (503) 373-7806

**PROPOSED REVISIONS**

STAFF USE ONLY

Submittal no.:

\_\_\_\_\_

(check one)

- One-year proposal
- Three-year proposal

**Instructions:** Fill in the following information, attach all supplementary information including, but not limited to, justification based on technical and scientific facts and **mail to the address listed above.**

**PROPONENT INFORMATION**

Name:		Date:
Representing:		Phone:
Address or P.O. Box:		Fax no.:
City:	State:	ZIP:

**SPECIFICATION CHANGE INFORMATION**

Suggested revision to the: \_\_\_\_\_ specification.

**Proposal** (including proposed new wording underlined, and identification of wording to be [deleted] and appropriate location:

**Justification** (state problem to be solved, reason for proposal and description of development history, including sources and references, as applicable):

**Estimated cost impact:** \_\_\_\_\_

**Sample formula:**

$$U \times M \times L \times D = C \text{ or } S$$

$$30 \times \$25 \times \$20 \times \$0 = (+) \$1350$$

Number of Units per structure (added or deleted) x Material cost per unit x Labor cost per unit x Design cost per unit = Total Cost (+) or Savings (-) per structure

*Attach additional sheets as necessary.*

**Original material is considered to be the submitter's own idea based on or as a result of own experience, thought, or research, and to the best of individual's knowledge is not copied from another source.**

# **APPENDIX B:**

## **CERTIFICATION AND REGISTRATION INFORMATION**





## IMPORTANT PAPERS FOR OCCUPANTS

The following materials should be in the “important papers” envelope that the factory ships to the dealer. The papers are placed in a kitchen drawer and shipped with the home or are mailed to the dealer:

- The NEEM ventilation guide explains the importance of using the whole house ventilation system.
- Instructions for operating the automatic timer, if present, shows how to set and change the ventilation schedule. Make sure the control manufacturer ships instructions with the control and the electricians don’t throw away the instructions.
- The certificate of compliance is a record of measures installed in the home. The siting utility checks the certificate at set-up. In-plant quality control staff or the state in-plant inspection agency should verify all inspection items.
- A label indicating energy efficiency measures installed in the home should be attached to the door of the electrical panel before the home leaves the plant.
- Tax credit and utility incentive forms: state credits and utility incentives may be available to homeowners for purchasing a NEEM certified home, as well as homes that have their duct systems tested by state certified testers and meet duct leakage standards set by the states.

# Northwest Energy Efficient Manufactured Home Program CERTIFICATE OF COMPLIANCE

**(FOR USE ONLY BY AUTHORIZED AGENT)**

Owner: Doe, John	Serial #: 00000
Address: Unknown	Model #: SGC
Corvallis, OR 97339	CFA: 1080.0

Msg. phone: 123-4567

NEEM #: 16877	Received date: 9/05/03
	Production date: 9/05/03

HUD #1:	HUD #3:
HUD #2:	HUD #4:

Dealership: XYZ Homes

Manufacturer: XYZ Inc. Homes - Oregon      Phone: 800-123-6789

**QUALIFICATION CRITERIA**

This home qualifies according to NEEM Technical Specifications, using NEEM prescriptive path 1F. (A record of approval is on file at the Oregon Department of Energy.)

**HOME INFORMATION**

Floor: 1 R-11 blankets under entire belly	CL38 window glz:	171.0ft <sup>2</sup>
2 R-11 blankets between I-beams	CL48 window glz:	0.0ft <sup>2</sup>
2 R-11 batts from rim past I-beam	CL52 window glz:	0.0ft <sup>2</sup>
	Skylight area:	0.0ft <sup>2</sup>
Wall: 1 R-21 wall batts	SGD area:	0.0ft <sup>2</sup>
x R-xx insulated sheathing	<b>Total glazing:</b>	<u>171.0 ft<sup>2</sup></u>

Ceiling/roofs, Flat: x R-xx oversized batts, or R 49 bags  
 Slope: x R-xx oversized batts, or R 38 bags

*The manufacturer certifies that this home has been built in accordance with NEEM Technical Specifications.*

Manufacturer: \_\_\_\_\_ Date: \_\_\_\_\_

**IN-PLANT CERTIFICATION: (IPIA/SEO USE ONLY)**

\_\_\_\_\_  
 \_\_\_\_\_  
 IPIA/SEO agent signature: \_\_\_\_\_ Date: \_\_\_\_\_

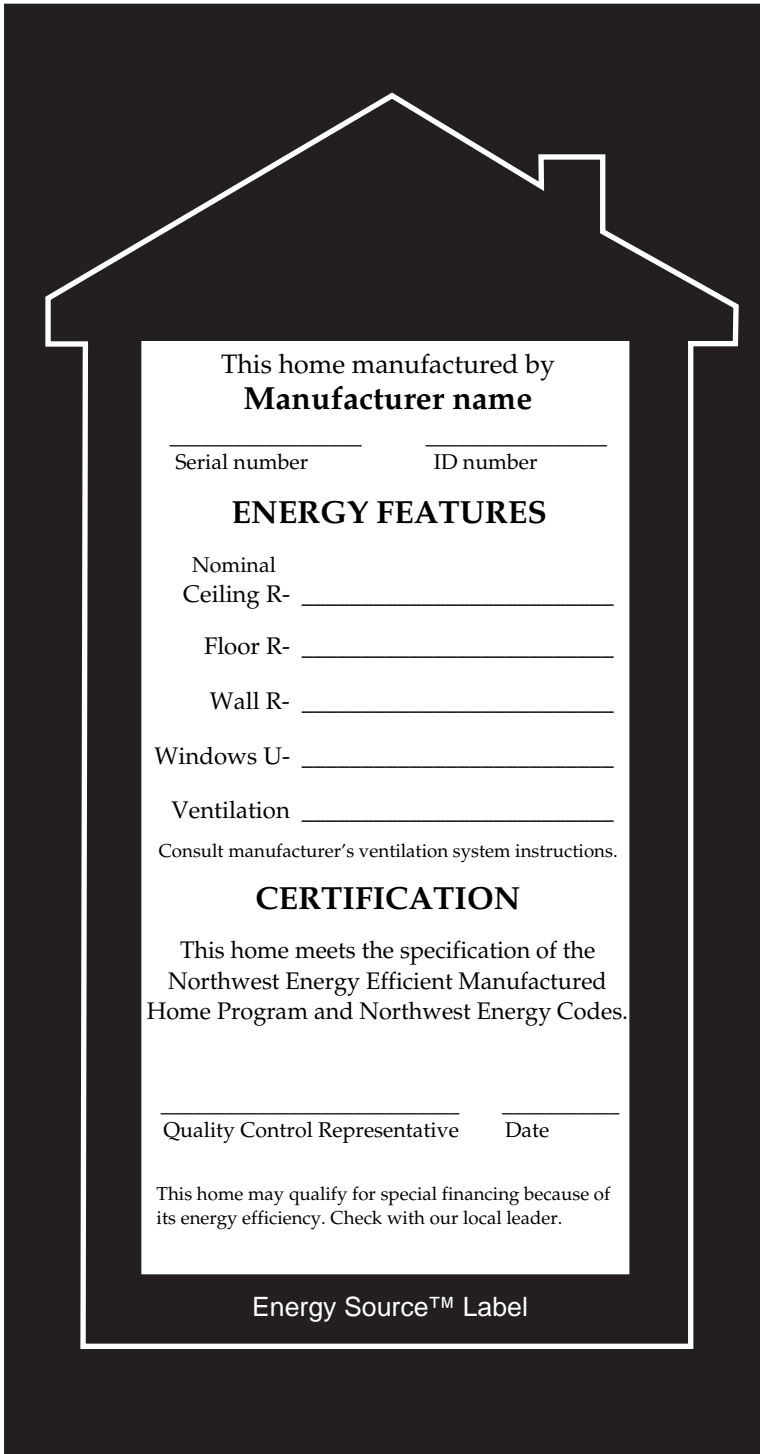
The form is a white rectangular label with a black border, shaped like a house with a chimney. It contains text for identifying the manufacturer, recording energy features, and certifying the home's compliance with energy codes. The label is set against a black background.

This home manufactured by  
**Manufacturer name**

Serial number \_\_\_\_\_ ID number \_\_\_\_\_

**ENERGY FEATURES**

Nominal  
Ceiling R- \_\_\_\_\_

Floor R- \_\_\_\_\_

Wall R- \_\_\_\_\_

Windows U- \_\_\_\_\_

Ventilation \_\_\_\_\_

Consult manufacturer's ventilation system instructions.

**CERTIFICATION**

This home meets the specification of the  
Northwest Energy Efficient Manufactured  
Home Program and Northwest Energy Codes.

Quality Control Representative \_\_\_\_\_ Date \_\_\_\_\_

This home may qualify for special financing because of  
its energy efficiency. Check with our local leader.

Energy Source™ Label



## **DEFINITIONS**

## DEFINITIONS

**ACH:** Air Changes an Hour. Rate at which air in a home is cycled by ventilation.

**AFUE:** Annual Fuel Utilization Efficiency. Efficiency rating of home heating systems.

**Air, Makeup:** Outside air supplied to replace exhaust air or augment recirculated, heated interior air.

**Air, Outdoor:** Air taken from the external atmosphere and, therefore, not previously circulated through the conditioned space.

**Air, Return:** The air stream passing from the conditioned space to the mechanical ventilation device, consisting of stale indoor air.

**Air Seal:** Sealing a component as to prevent air-leakage.

**ANSI:** American National Standards Institute.

**Approved Equal, or Approved:** Approved in writing by a designated approving agent.

**“As Approved”:** Requiring the permission of the appropriate State Energy Office of which the home is being constructed.

**ASHRAE:** American Society of Heating, Refrigerating and Air Conditioning Engineers.

**ASTM:** American Society for Testing and Materials.

**Authorized:** Under the authority of the Oregon Department of Energy, either by contract or as designated.

**Authorized Agent:** An authorized agent designated or contracted by the Oregon Department of Energy to certify or withhold certification of manufactured homes.

**Belly:** The space in a manufactured home above the bottom layer of floor insulation and below the structural subfloor and between the I-beams and axles which support the home.

**Boot:** A heating system supply duct that runs from the furnace to the main trunk duct and/or a duct connection from the main trunk duct to a delivery register.

**BTU:** British Thermal Unit. A measurement of energy/heat output.

**Building Envelope:** Building components enclosing conditioned spaces.

**Certify, Certification:** Verification by an authorized agent that a specific manufactured home meets the NEEM technical specifications.

**CFM:** Cubic Feet per Minute. Rate of airflow a ventilation fan produces.

**Component:** A part of the shell that contains conditioned space (e.g., walls, ceilings, floors, windows and doors).

**Conditioned Space:** All spaces normally maintained at temperatures above 50°F during the heating season.

**Continuous Air Barrier:** A system of materials installed during construction designed to greatly restrict air transfer to or from the conditioned space through unintentional openings in the building envelope.

**Crossover Duct:** A heating system supply duct that connects the furnace-side trunk duct to the trunk duct of other sections that comprise the home.

**Damper:** A device used to control airflow through an air outlet, inlet, or duct.

**DAPIA:** Design Approval Primary Inspection Agency.

**Floor:** A section of a manufactured home that is independently manufactured and transported from factory to site where it is combined with one or more floors to complete the home. The terms floor and section are used interchangeably in these specifications.

**Floor Area:** Total gross floor area of the conditioned space calculated using exterior dimensions.

**FMHCSS:** Federal Manufactured Home Construction and Safety Standards, Oct. 26, 1994.

**Full-Width Batts:** Fiberglass insulation material for ceilings that is cut into strips the same width as the center-to-center spacing of the roof trusses. The installed batt spreads over the top of each truss bottom chord and fills around the struts. Also called oversized batts.

**GAMA:** Gas Appliance Manufacturers Association.

**Glazing:** All areas, including frames, in the shell of a conditioned space that let in natural light, including skylights, sliding, or swinging glass doors, and glass block walls.

**Glazing Area:** Total area of glazing is based on the rough opening dimensions, including the glass, sash, and frame.

**HUD:** Housing and Urban Development.

**HVAC:** Heating, Ventilating, & Air Conditioning.

**HVI:** Home Ventilating Institute.

**IC-Rated:** A lighting fixture rated by a nationally recognized testing laboratory to be safe when covered with insulation. Care should be taken not to seal an IC-rated unit when such sealing would void its rating.

**Insulation Loft:** Insulation that keeps its “fluffiness,” thereby maintaining its R-value. Insulation that is not compressed.

**IPIA:** In-Plant Primary Inspection Agency.

**Longitudinal Floor:** A floor structure system where the framing members that support the floor surface run parallel to the I-beam which supports the entire floor system.

**Main Trunk Duct:** A heating system supply duct that runs the length of a manufactured home section and delivers heated air to the section through branch ducts or boots attached to the floor registers.

**Manufactured Housing:** All housing produced in a factory under the FMHCSS.

**Marriage Line:** The seam where separately manufactured sections are joined together at the site.

**Mastic:** A water-based adhesive used for sealing ductwork. Must comply with UL 181A-M or UL 181B-M.

**NFRC:** National Fenestration Rating Council. Organization that rates the window, door and skylight energy performance properties.

**Nominal R-Value:** The rated R-value of an insulating material, excluding framing, when installed at its specified thickness and density.

**Primary Window:** See “Window, Primary.”



**R-Value:** Thermal resistance measured in °F-ft<sup>2</sup>-hr/Btu. Nominal R-value shall mean thermal resistance of insulation (excluding structural or sheathing components, air films, etc.) as specified by the manufacturer according to recognized trade and engineering standards, or approved equal.

**Register:** An air terminal device with a built-in damper.

**Secondary Window:** See “Window, Secondary.”

**SEO:** State energy office. The SEOs are the Washington State University Extension Energy Program, Oregon Department of Energy, Energy Division of the Idaho Department of Water Resources and the Montana Department of Environmental Quality.

**Shading Coefficient:** The ratio of solar energy that is transmitted by glazing to total solar energy transmitted by one-eighth inch thick single-pane glass.

**Shall:** Denotes a mandatory program requirement.

**Skirting:** The permanent enclosure that surrounds the perimeter of a sited manufactured home.

**Skylight:** A glazing surface with a slope of less than 60 degrees from the horizontal plane.

**Sloped Ceiling:** A ceiling without a vented attic space above. An enclosed joist or rafter space is formed by ceilings applied directly to the underside of roof joists or rafters.

**Sone:** Internationally recognized unit of loudness that simplifies reporting sound output. One sone is approximately equivalent to the sound of a quiet refrigerator in a quiet kitchen.

**Spot Ventilation:** A system of ventilation that exhausts conditioned air at the source of pollution, such as kitchen or bathroom fans.

**Sun Chart:** A projection of the shading profile of objects against the annual path of the sun as seen at window height at the site in question.

**Thermal Break:** Material with a low thermal conductivity that separates materials with higher heat conductivity and acts as a thermal barrier.

**Transverse Floor:** A floor structure system where the framing members that support the floor surface run perpendicular to the I-beam which supports the entire floor system.

**Truss Spacing:** The center to center measure between roof trusses as they are placed along each home section.

**U-Factor:** Thermal transmittance per unit time through a unit area of a particular body or assembly (including boundary films) divided by the temperature differential across the assembly (Btu/hr-ft<sup>2</sup>-°F). The U-factor applies to combinations of materials in series along a given heat flow path or the area weighted average of several parallel heat flow paths.

**Vapor Retarder:** A layer of low-moisture transmissivity material (not more than 1.0 perm dry cup) placed over the warm side (in winter) of insulation.

**Ventilation:** The process of supplying and removing air by natural or mechanical means to and from any space. Such air may or may not be conditioned.

**Ventilation, Net:** The total supply airflow adjusted by the amount of cross leakage to determine the net fresh air supply.

**Ventilation Rate (VR):** The total volume of air introduced into a conditioned space per unit time, in cubic feet per minute (cfm).

**Walls (exterior):** Any member or group of members that defines the exterior boundaries or courts of a building with a slope of 60 degrees or greater from the horizontal plane and that separates conditioned from unconditioned spaces.

**Warm Side:** The air streams going to and from the conditioned space and to and from the mechanical ventilation device.

**WDT:** Winter Design Temperature.

**Whole House Ventilation:** A system that exhausts conditioned air at a central location at continuously or at intervals to remove stale air and introduce fresh air into the conditioned space.

**Window, Primary:** A window acting as the primary barrier between the exterior atmospheric elements and the interior of the structure.

**Window, Secondary:** A window used on the exterior or interior of, and in tandem with, a primary window for the purpose of energy conservation. Secondary windows are not intended to be used by themselves as primary windows.

## REGISTRATION CARD

If you would like to be kept up to date on the Northwest Energy Efficient Manufactured Home Program (NEEM) by receiving copies of related communications, interpretations, and specification change notices, fill out and mail this card to the Oregon Department of Energy.

Name: \_\_\_\_\_

Representing: \_\_\_\_\_

Street address: \_\_\_\_\_

City, State, ZIP: \_\_\_\_\_

## CHANGE OF ADDRESS NOTICE

If you are moving and would like to remain on our mailing list to receive updates on the Northwest Energy Efficient Manufactured Home Program (NEEM), please fill out and mail this card to the Oregon Department of Energy.

Name: \_\_\_\_\_

Representing: \_\_\_\_\_

Street address: \_\_\_\_\_

City, State, ZIP: \_\_\_\_\_

---

---

---

Return Name & Address (optional)

PLACE  
STAMP  
HERE

Oregon Department of Energy  
625 Marion St. NE  
Salem, OR 97301-3737

---

---

---

Return Name & Address (optional)

PLACE  
STAMP  
HERE

Oregon Department of Energy  
625 Marion St. NE  
Salem, OR 97301-3737

# **Northwest Energy Efficient Manufactured Home Program**

Toll-free: (888) 355-6277

## **Oregon Department of Energy**

Toll-free in Oregon: (800) 221-8035  
(503) 378-4040

## **Idaho Department of Water Resources, Energy Division**

(208) 327-7900

## **Montana Department of Environmental Quality**

(406) 841-5200

## **Washington State University, Energy Office Extension**

(360) 956-2000



**Oregon Department of Energy  
625 Marion St. N.E.  
Salem, OR 97301-3737**

