

H A W A I I A N

D E S I G N  
Strategies for Energy Efficient Architecture

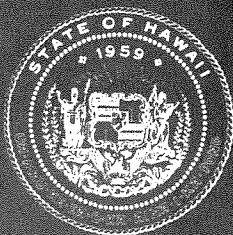
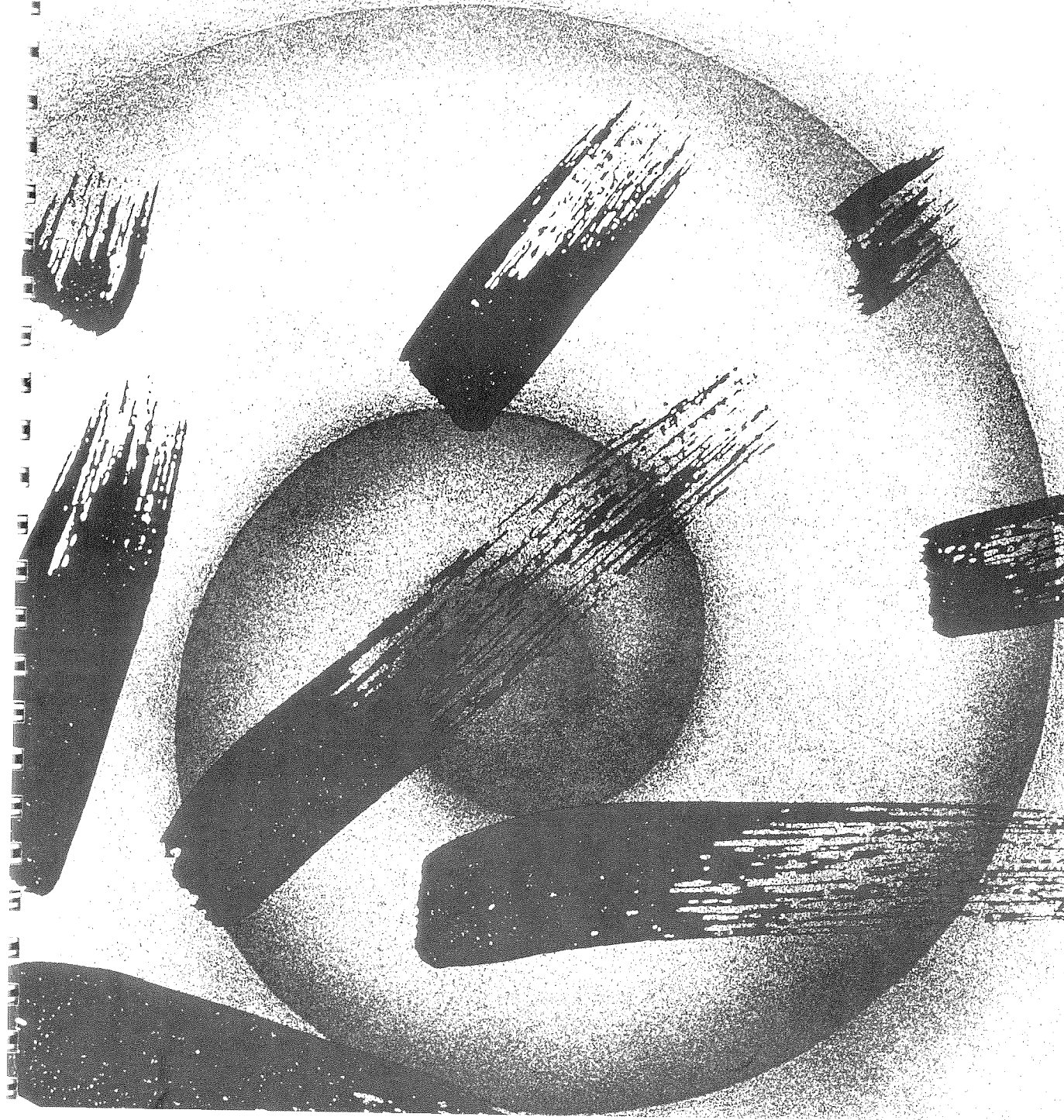

H A W A I I A N

D E S I G N

Strategies for Energy Efficient Architecture

*Prepared by the Honolulu Chapter/The American Institute of Architects  
for The Department of Business, Economic Development & Tourism,  
Energy Division, State of Hawaii/1990*

**Authors**

*TRB/Hawaii, Ltd.*

**Kent Royle, AIA, Project Manager**  
**Cliff Terry, AIA, Principal in Charge**

**Contributing Editors**

**Edward Arens, Ph.D.**  
**William L. Beaton, AIA**  
**Charles Eley, AIA**  
**Frederick H. Kohloss, P.E.**

**HC/AIA Energy Committee**

**Shirley Cruthers, Executive Vice President**  
**Doug Collinson, AIA**  
**Fred Creager, AIA**  
**Pat Kuehn, AIA**  
**Charles Nishimoto, AIA**  
**Andrew Yanoviak, AIA**

**Illustration**

**Anne Ellett**  
**Keith Ito**  
**Elden Ito**

**Book Design**

**Ito Design Associates**

## P R E F A C E

This book presents seven strategies for energy efficient architectural design in Hawaii. It provides architects with practical design guidelines to serve as a basis for decision making during the conceptual and schematic stages of a project.

This book represents the second phase of a broad educational effort undertaken by HC/AIA to promote energy efficient architectural design. The next two phases of this project include a slide-show and a seminar series further expanding on these design strategies. The project is sponsored by the Energy Division, Department of Business, Economic Development & Tourism (DBED), State of Hawaii.

In a parallel project, DBED is currently proposing revisions to the counties' codes regulating energy consumption in buildings. The focus of the later phases of this HC/AIA project will be to assist architects in complying with these revised energy codes.

We hope you find this book a useful first step towards making Hawaii's buildings, and Hawaii's future, energy efficient.

*This report was funded by the U.S. Department of Energy, Grant No. DE-FG03-80-62013 and does not necessarily reflect the views of the DOE.*

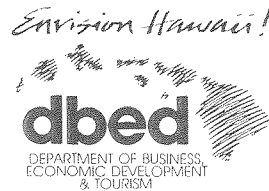

This report has been cataloged as follows:

Royle, Kent.

Hawaiian design, strategies for energy efficient architecture. By Kent Royle and Cliff Terry. Prepared by the Honolulu Chapter/The American Institute of Architects for the Department of Business, Economic Development & Tourism, Energy Division, State of Hawaii, Honolulu: Energy Division, Dept. of Business, Economic Development & Tourism, State of Hawaii, 1990.

I. Architecture and energy conservation-Hawaii. I. Terry, Cliff. II. American Institute of Architects (Honolulu Chapter). III. Hawaii. Dept. of Business, Economic Development & Tourism, Energy Division  
NA2542.3.R6.1990

# CONTENTS

<b>A</b>	INTRODUCTION .....	5
	ENERGY USE .....	8
	CLIMATE .....	10

## DESIGN STRATEGIES

<b>B</b>	ORIENTATION & BUILDING FORM .....	13
<b>C</b>	SOLAR CONTROL .....	19
<b>D</b>	DAYLIGHTING .....	23
<b>E</b>	NATURAL VENTILATION .....	29
<b>F</b>	LANDSCAPING .....	35
<b>G</b>	BUILDING SYSTEMS & MATERIAL SELECTION .....	37
<b>H</b>	EQUIPMENT EFFICIENCY .....	43
<b>I</b>	IMPLEMENTATION .....	47
	ENERGY AND THE DESIGN PROCESS .....	48
	LIFE CYCLE COSTING .....	50
	RETROFITS .....	51
	ENERGY CODES .....	52
	INCENTIVES .....	53
	CONCLUSION .....	54
<b>J</b>	BIBLIOGRAPHY .....	55
<b>K</b>	SUNDIAL .....	57



A.1 *Honolulu Hale, 1927. An image of Hawaiian architecture of the past. An interior courtyard covered by sliding skylights provides light and ventilation to the surrounding offices. Architects: Miller, Rothwell, Dickey & Wood. Photo: Max Raksusat.*

The focus of this book is on architectural decisions made during the programming, schematic design, and design development stages of a project. The greatest opportunities for energy conservation exist during these stages. Many architects view energy conservation as a design challenge for engineers. However, a building's siting, configuration, skin, glazing, and use determine the demand for mechanical cooling and lighting.

In effect, the architect creates the demand for energy and the engineer supplies it. If the architect fails to make an effort early in the design process, there is little chance that the building will be energy efficient, no matter how skilled the engineer.

This book presents seven design strategies with the potential to increase the energy efficiency of Hawaii's buildings. In addition to serving as a reference, the book is

intended to inspire designers to integrate "energy" into the design process. Energy concerns need to be given importance equal to other programmatic requirements when designing or redesigning a building. Relatively simple energy conservation measures offer the potential to dramatically reduce a building's energy consumption. This is underscored by the fact that energy costs often exceed construction costs when examined over a building's life span.

When appropriate we have attempted to quantify potential energy cost savings associated with each design strategy. These cost estimates are based on computer simulations for a hypothetical office building and hotel in Hawaii. For background information on these cost estimates refer to the report by Charles Eley in the economics section of the bibliography.

## ENERGY - A PATH TO OUR FUTURE?

Over the years Hawaii's unique architecture has contributed to the islands' sense of place and image as "paradise." The Hawaiian heiau and the missionaries' thick-walled coral churches stand as reminders of Hawaii's social history. Many of the buildings commonly defined as Hawaiian have a tropical, if not indigenous, feel. These buildings respond sensitively to the surroundings, the climate, and our images of the "good life" in Hawaii. Examples of typically Hawaiian architecture include the "plantation" style commercial buildings found in Lihue and Hanapepe, Kauai. Plantation style structures often feature elaborate, western-style false fronts with wide canopies shading the sidewalk and storefront below. The civic buildings of the 1920's and 1930's,

A.2 *Hawaii State Library, 1913.*  
*Land scaped courtyard*  
*provides readers with light,*  
*air and views. Architect:*  
*Henry Whitfield. Courtyard*  
*Addition: C.W. Dickey.*  
*Photo: Max Raksasat.*



such as Honolulu Hale (Fig. A.1) and the Hawaii State Public Library (Fig. A.2), group rooms around an open courtyard for light and fresh air.

The Hawaiian hip roof covering many of the islands' homes has become a Hawaiian symbol almost as distinctive as the palm tree (Fig. A.3). The early hotels of Waikiki

remind us with their open lanais and lush landscaping that a building can be grand yet inviting (Fig. A.4).

This Hawaiian architecture can and should be used in defining and developing the future architecture of Hawaii, especially its residential architecture. However it has not provided the answers nor the clues to our future direction in commercial and highrise development. We have many notable examples of fine commercial and highrise architecture of which to be proud, buildings that are aesthetically pleasing, highly functional, well planned, and well designed. However, we do not as yet have a commercial and highrise

vernacular that is truly "Hawaiian".

It is our hope that future Hawaiian architecture may evolve out of a commitment to create energy efficient buildings. This architecture would better fit Hawaii and her people's needs by being sensitive and responsive to Hawaii's lifestyle, to each building site, and to our unique climate. This does not imply a step back into the past, but instead a step forward into the future. It involves using age-old design with the new techniques and technology available to us today.

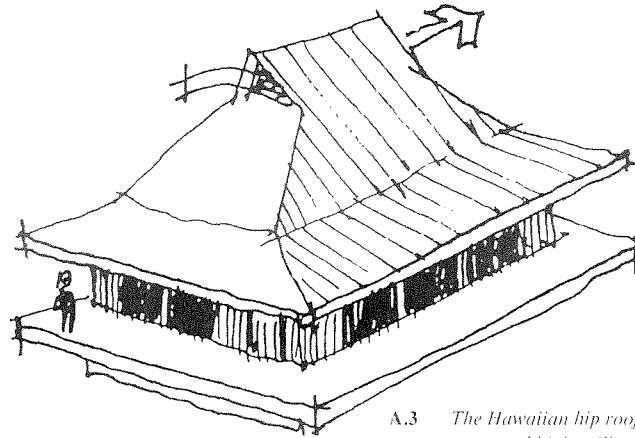

A.3 The Hawaiian hip roof incorporates gable vents and high ceilings for ventilation with broad overhangs for shading. Reprinted from Pearson, 1978.

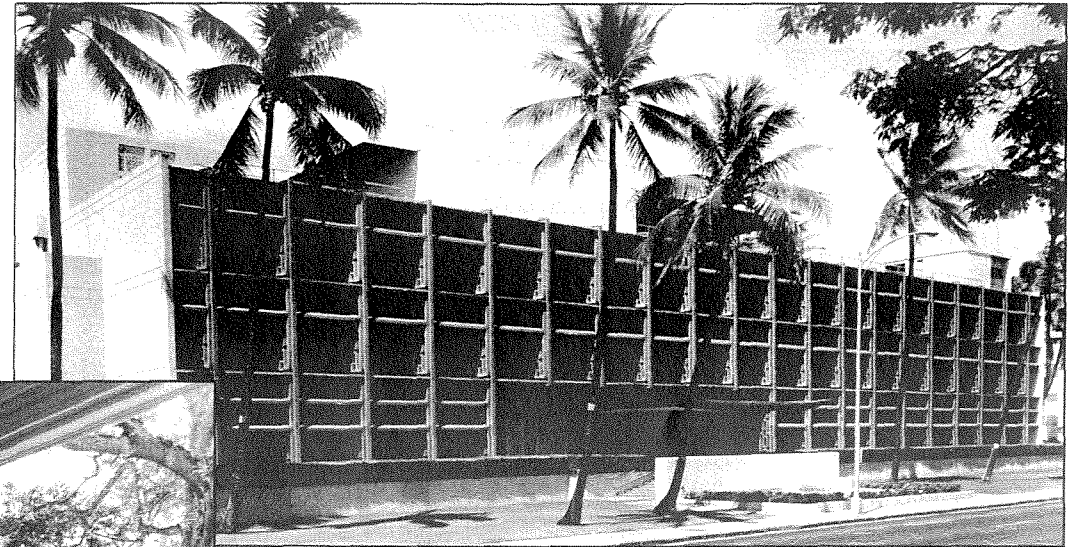

A.4 The Moana Hotel, 1901. Spacious lanais and extensive landscaping invite guests to enjoy Hawaii's climate. Architect: Hagen. Renovation: Virginia D. Murison/Chapman Desai Sakata Joint Venture Architects. Photo: Max Raksasat.

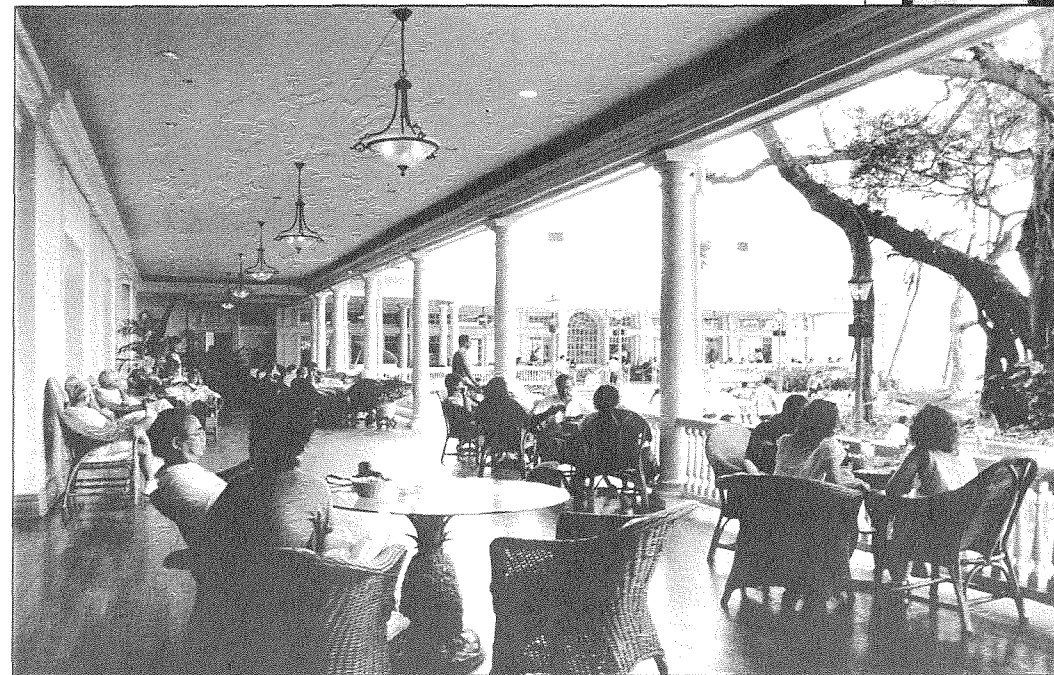

A.5 Board of Water Supply Building, 1958. Notice the effective sun screen system on the makai elevation. Architect Wood, Weed & Associates. Photo: Max Raksasat.

ENERGY USE IN HAWAII

Even though the "energy crunch" has temporarily lessened here and around the world, the fact remains that Hawaii is even now heavily dependent on oil for her energy and will remain so for the foreseeable future. Petroleum accounts for about 90% of Hawaii's total energy supplies, far above the national average of 45% (Fig. A.6). Because the islands are volcanic in origin, there are no fossil fuel deposits such as oil, coal, and natural gas as found on the mainland, and very little hydroelectric potential.

Our nearly total dependence on imported petroleum makes the state especially vulnerable to economic and social disruptions arising from sudden shortages in supply or increases in price. More than \$1 billion leaves the state to pay for oil each year. This represents approximately 10% of our Gross State Product, which is drained from the islands' economy.

More than one quarter of the state's oil is used to make electricity, the majority of which is consumed in buildings (Fig. A.7). The price of electricity and the cost of operating buildings in Hawaii are high compared to many mainland states (Fig. A.8).

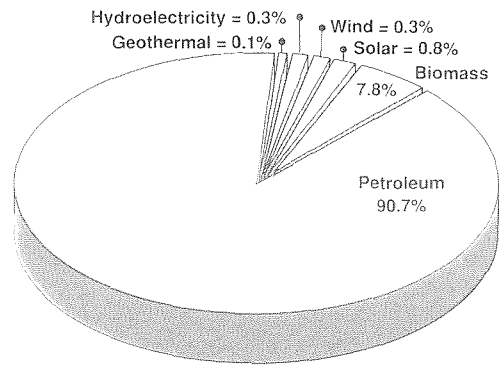

A.6 Source: DBED, State Energy Resource Coordinator's (SERC) Report.

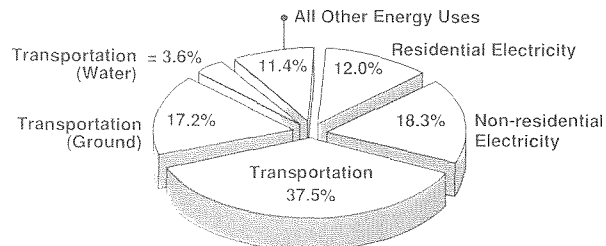
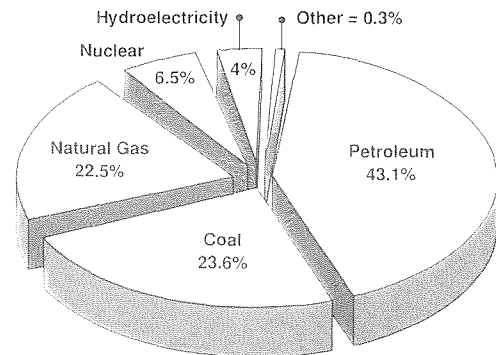

A.7 Hawaii's energy consumption 1987. Source: SERC Report

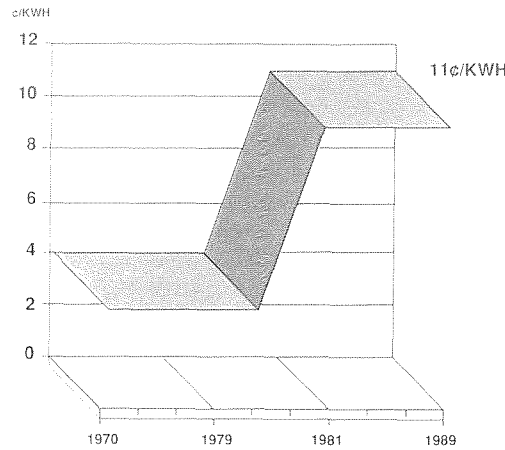

A.8 Price of electricity in Hawaii (cents/kwh).

ENERGY USE IN BUILDINGS

There are two primary sources of heat gain in a building that create the need for ventilation or air conditioning. The first source is **external** heat gain, which is primarily the heat of the sun that penetrates the glass and skin of the building. The second is **internal** heat gain which refers to heat generated by lights, people and equipment inside the building. The ability to reduce energy consumption in a tropical climate is directly related to the design's effectiveness in reducing heat gain, both external and internal, and reducing the demand for air conditioning and electric lighting.

A typical commercial interior space, even without any solar or convective heat gain from the outdoors, will have an internal heat gain from lights, people and equipment of about 15 to 25 BTU per hour per square foot of floor area. Perimeter spaces, such as private offices 10 feet deep from

A.9 Basis for preparing operating cost analysis for commercial establishments. Source: HECO and F.H. Kohloss Associates 1989.

BUILDING TYPE	POWER SUPPLY (Watt/sq. ft.)	ENERGY CONSUMPTION (kWh/sq. ft.-month)	LOAD FACTOR (kWh consumption / kW demand)
<b>OFFICE BUILDINGS</b>			
Air Conditioned	6-9 (net rentable)	1-1/2 to 3 (net rentable)	300-375
Non Air Conditioned	3 (net rentable)	1 - 2	-
<b>RESIDENCES</b>			
Air Conditioned	-	0.6	-
Non Air Conditioned	-	0.3	-
<b>HOTELS</b>			
Air Conditioned	1-2.5 kW/room	-	500-6000
<b>HOSPITALS</b>			
Air Conditioned	8	-	490
Non Air Conditioned	4	-	-
<b>SUPERMARKETS</b>			
Air Conditioned	12-15	-	550
<b>DEPARTMENT STORE</b>			
Air Conditioned	8-8.25 gross or 11-12 sales area	3 - 3.5	450-500
<b>SMALL RETAIL</b>			
Air Conditioned	8.5 sales area	-	-
<b>WAREHOUSE</b>			
Storage	1	-	-
Office	-	-	-
Air Conditioned	6.5	-	-
Non Air Conditioned	3	-	-



the windows, will have typical heat gains from internal and external sources from about 40 to 100 BTU per hour per square foot of floor area. These gains translate into the demands for electricity shown in *Figure A.9*.

*Figures A.9 and A.10* show typical energy consumption in commercial and multi-family residential buildings. Energy consumption is much greater in these building types than in single-family residences. The majority of Hawaii's single-family residences are not air conditioned and therefore use little energy in comparison to commercial buildings. This book will focus on improving the energy efficiency of commercial and multi-family residential structures where architectural design measures are most effective. Improving the energy efficiency of water heaters and appliances offers the greatest potential for conserving energy in residences (*Fig. A.11*).

ENERGY CONSERVATION IN BUILDINGS

Improving the energy efficiency of Hawaii's buildings, both old and new, offers tremendous potential to save each client substantial sums of money by reducing operating, and sometimes construction, costs. In the long run, conservation will stimulate the islands' economy by reducing our dependence and expenditure on imported oil. Buildings today can be designed to use one third to one fifth of the energy their predecessors did thirty years ago. For example, the typical tall, glass-faced building of the 1960's consumed energy at an annual rate of 150,000 to 250,000 BTU's per square foot. In the late 1970's the United States General Services Administration established a target of 55,000 BTU's per square foot per year for the design of new federal office buildings, and many state energy codes allow less than that. *Figure*

*A.12* illustrates how progressively more stringent standards have reduced the energy used for cooling, lighting and fans in California. Such energy savings, multiplied over a building's forty plus year life-span, are profound.

This book will focus primarily on improving the energy efficiency of new construction. The potential for cost-effective architectural measures to conserve energy is much greater in new construction than in retrofitting to existing buildings. In retrofits, mechanical and electrical modifications generally offer the greatest area of potential savings, although some architectural options exist and will be discussed in section I.

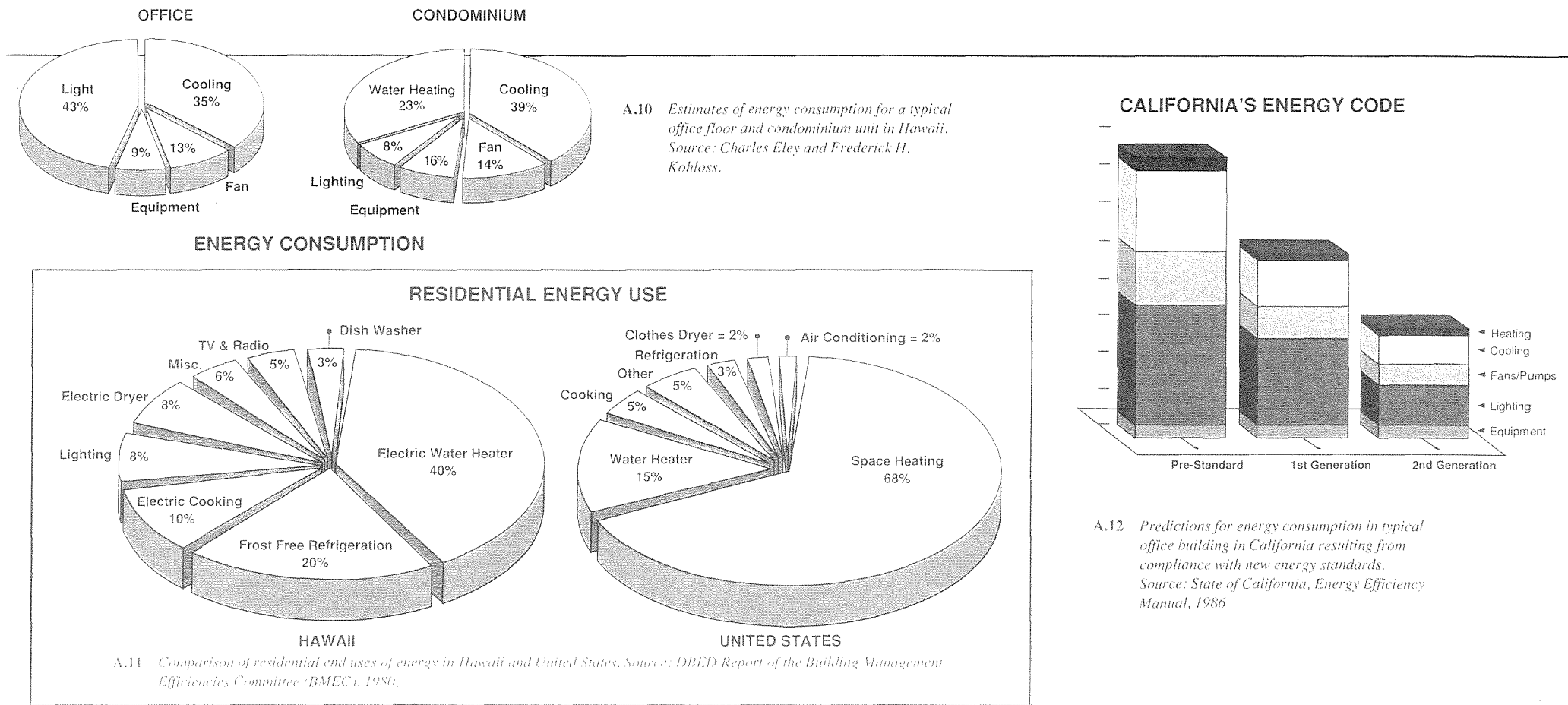

CLIMATE

Ask tourists or newcomers what prompted them to come to Hawaii and chances are climate will be at the top of their list. Hawaii's climate reflects the interaction of the latitude, the surrounding ocean, the tradewinds, and the rugged topography. The Hawaiian Island chain, stretching from 19 degrees to 22 degrees north latitude, experiences little seasonal variation in day length and is exposed to high sun angles throughout the year. These factors result in a relatively constant amount of incoming solar energy over the year and partially explain why seasonal changes in temperature are small when compared with the mainland.

Another reason for the slight temperature variation is the continual flow of fresh ocean cooled tradewinds across the islands. Although the temperature near sea level remains virtually constant, the rugged configuration of the land produces marked variations in wind speed, cloudiness and especially rainfall from one locality to another.

The ancient Hawaiians recognized two seasons: Kau, the high-sun period corresponding to warm temperatures and steady trade winds; and Ho'oilo, the cooler period when tradewinds are less frequent and widespread rainfall is more common. Climatologists today are in general agreement with the Hawaiian system of a five month dry season (May-September) and a seven month wet season (October-April).

TEMPERATURE

Hawaii's climate is characterized by very small temperature fluctuations (Fig. A.14). In downtown Honolulu the warmest month is August, with an average temperature of 78.4°F. The coldest is February, at 71.9°F. The range between coldest and warmest months averages only 6.5°F. At Hilo the range is 5°F. and at Lihue 8°F. The daily temperature swing (diurnal) is also very slight. Ranges of 8° to 15°F. are most common in areas exposed to the tradewind air, as on the north and east coasts of Hawaii, Maui, Oahu, and Kauai. Ranges of 15° to 20°F. are most common on the leeward coasts and locations several miles inland from the windward coasts.

A.13 Adapted from Pearson, 1978.

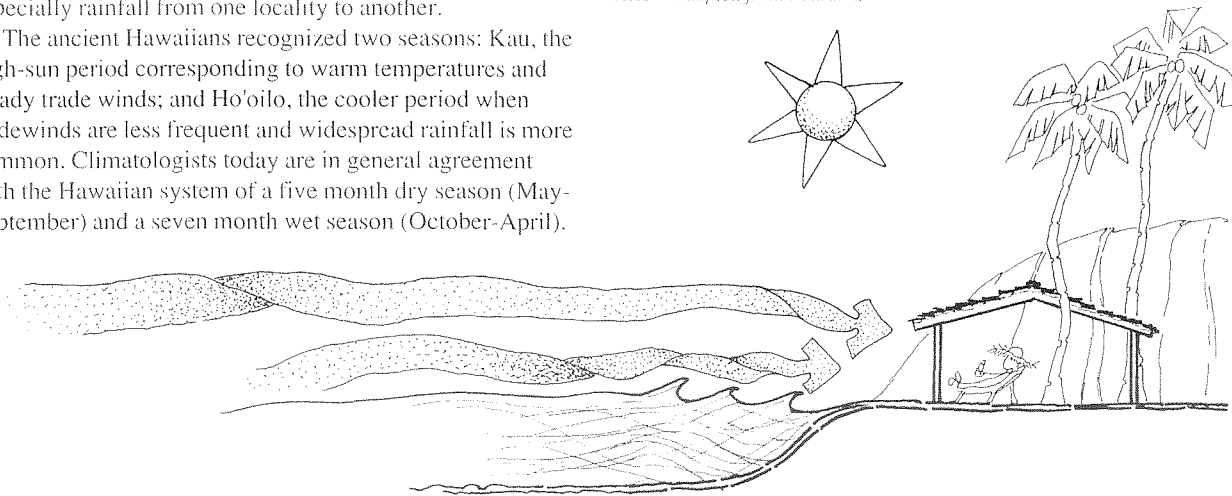

A.14 Weather data for Hilo, Honolulu, Lihue and Kahului. Source: U.S. Department of Commerce.

HILO, HAWAII/NORMALS, MEANS AND EXTREMES													
LATITUDE: 19° 43'N LONGITUDE: 155° 04'W	JAN	FEB	MAR	APR	MAY	JUNE	JULY	AUG	SEP	OCT	NOV	DEC	YEAR
TEMPERATURE °F:													
NORMALS													
-DAILY MAXIMUM	79.5	79.0	79.0	79.7	81.0	82.5	82.8	83.3	83.5	83.0	80.9	79.5	81.2
-DAILY MINIMUM	63.2	63.2	63.9	64.9	66.1	67.1	68.0	68.4	68.0	67.5	66.3	64.3	65.9
EXTREMES													
-RECORD HIGHEST	91	92	93	89	94	90	89	93	92	91	90	93	94
-RECORD LOWEST	54	53	54	56	58	60	62	63	61	62	58	55	53
NORMAL DEGREE DAYS													
-COOLING (base 65°F)	198	176	202	222	267	294	322	338	324	319	258	214	3134
% OF POSSIBLE SUNSHINE	47	46	41	35	37	43	42	42	44	39	34	37	41
PRECIPITATION (INCHES)													
-WATER EQUIVALENT													
-NORMAL	9.42	13.47	13.55	13.10	9.40	6.13	8.68	10.02	6.63	10.01	14.88	12.86	128.15
WIND													
-MEAN SPEED (MPH)	7.5	7.7	7.6	7.4	7.3	7.1	6.9	6.8	6.7	6.7	6.7	7.2	7.1
-PREVAILING DIRECTION THROUGH 1963	SW	SW	SW	WSW	WSW	WSW	WSW	WSW	WSW	SW	WSW	SW	WSW

HONOLULU, OAHU/NORMALS, MEANS AND EXTREMES													
LATITUDE: 21° 20'N LONGITUDE: 157° 56'W	JAN	FEB	MAR	APR	MAY	JUNE	JULY	AUG	SEP	OCT	NOV	DEC	YEAR
TEMPERATURE °F:													
NORMALS													
-DAILY MAXIMUM	79.9	80.4	81.4	82.7	84.8	86.2	87.1	88.3	88.2	86.7	83.9	81.4	84.2
-DAILY MINIMUM	65.3	65.3	67.3	68.7	70.2	71.9	73.1	73.6	72.9	72.2	69.2	66.5	69.7
EXTREMES													
-RECORD HIGHEST	87	88	88	89	93	92	92	93	94	94	93	89	94
-RECORD LOWEST	53	53	55	57	60	65	67	67	66	64	58	54	53
NORMAL DEGREE DAYS													
-COOLING (base 65°F)	236	221	291	321	388	423	468	496	468	450	348	279	4389
% OF POSSIBLE SUNSHINE	63	65	69	67	69	71	74	75	75	68	61	59	68
PRECIPITATION (INCHES)													
-WATER EQUIVALENT													
-NORMAL	3.79	2.72	3.48	1.49	1.21	0.49	0.54	0.60	0.62	1.88	3.22	3.43	23.47
WIND													
-MEAN SPEED (MPH)	9.6	10.3	11.4	12.0	11.9	12.7	13.3	13.0	11.4	10.6	10.8	10.5	11.5
-PREVAILING DIRECTION THROUGH 1963	ENE	ENE	ENE	ENE	ENE	ENE	ENE	ENE	ENE	ENE	ENE	ENE	ENE

A.15 Wind rose for the Honolulu International Airport. Data from National Weather Service.

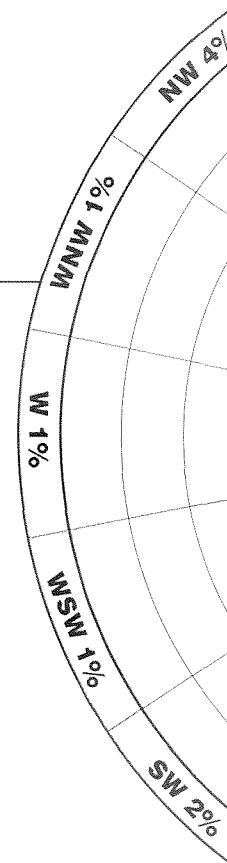



SUNLIGHT

Although Hawaii's climate is gentle, the tropical sun can drastically affect a building's heat load and the resulting requirement placed on the air conditioning system. The solar radiation falling on the roof and walls of a building at 21° north latitude is shown in *Figure A.16*. Each arrow represents approximately 300 BTU/sq.ft. per day received by each surface. In winter, the south side and the roof receive the greatest amount of radiation in roughly equal amounts. The sunpath diagram (*Fig. A.17*) shows that from the spring equinox until the fall equinox the sun rises north of east and sets north of west. The sun's path becomes increasingly higher at midday and progressively northerly at dawn and dusk approaching the summer solstice. For approximately two weeks on either side of the summer solstice the sun never enters the southern sky in Hawaii. With the high summer sun the roof receives the most solar gain. Note that the north facade receives almost twice as much sunlight in summer as the south facade.

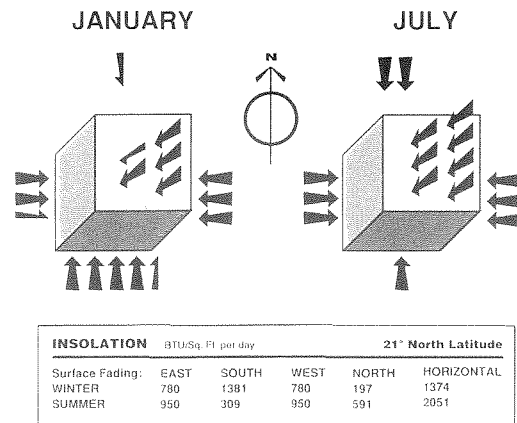

A.16 Solar heat gain on a building of 21° north latitude. Each arrow represents approximately 300 BTU/sq. ft. per day. Source: F.H. Kohloss after Olgyay.

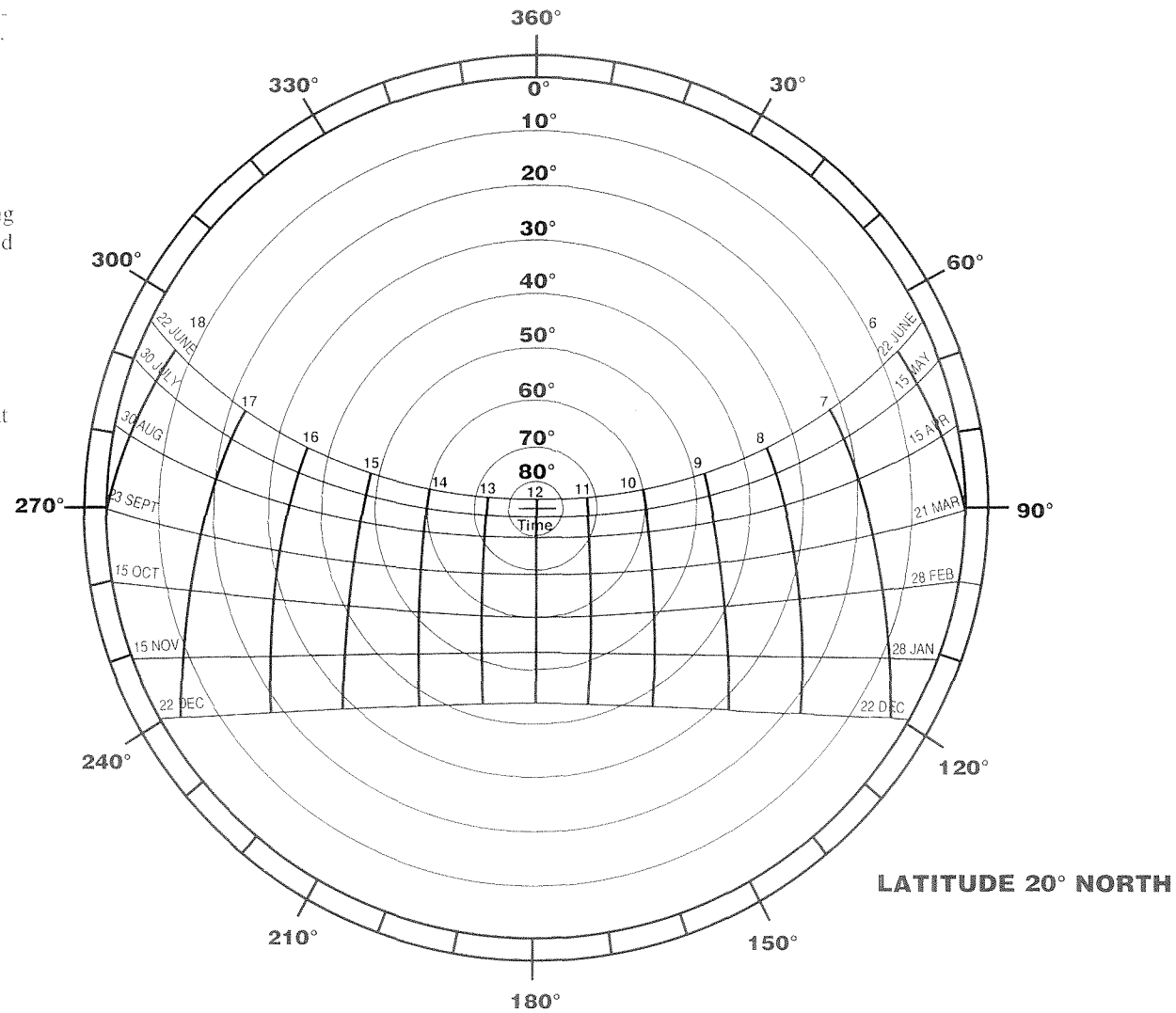

A.17 Sun path diagram for 20° north latitude.

ORIENTATION AND BUILDING FORM  
Design Strategies

**B.1** *The Digital Equipment Corporation Building, 1979. The upper floors step out to shade the glass below. Architects: Anderson Reinhardt. Photo: Max Raksasat.*



The orientation and configuration of a building are critically important due to their strong influence on the design of effective (and economical) solar control and daylighting systems, and their impact on the performance of naturally ventilated buildings. Building orientation determines the amount of solar radiation falling on the walls and roof of the building, and the ventilative effectiveness of the building's openings. Building shape determines the amount of exterior surface area for a given enclosed volume (surface to volume ratio) (Fig. B.2). Building shape also determines the depth to which daylight can penetrate and the effectiveness of cross ventilation.

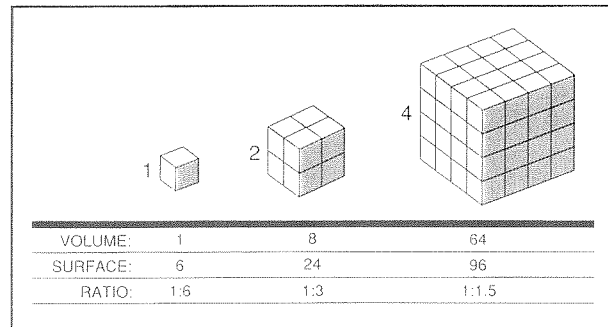

B.2 As the surface area of a building increases the enclosed volume increases rapidly. Internal gains become much more significant in larger buildings.

ORIENTATION FOR SOLAR CONTROL

In Hawaii, it is desirable to minimize the wall area and especially glass area facing east and west. These orientations receive long periods of exposure to the hot summer sun and are difficult to shade effectively. The optimal shape for thermal consideration is a rectangular building with the long faces oriented north and south. A variation of 15-20 degrees from true south has little effect on the thermal performance of a small building (Figs. B.3 and B.4).

ORIENTATION FOR DAYLIGHTING

Traditionally, artists and others have prized light from the north sky for its uniformity and color. Aside from very slight differences in the color spectrum, the light from the north sky is no different from the east, west or south. The difference arises because orientations other than north receive more direct sun, making the light seem more intense and variable. If adequate shading is provided, all orientations can be used successfully for daylighting.

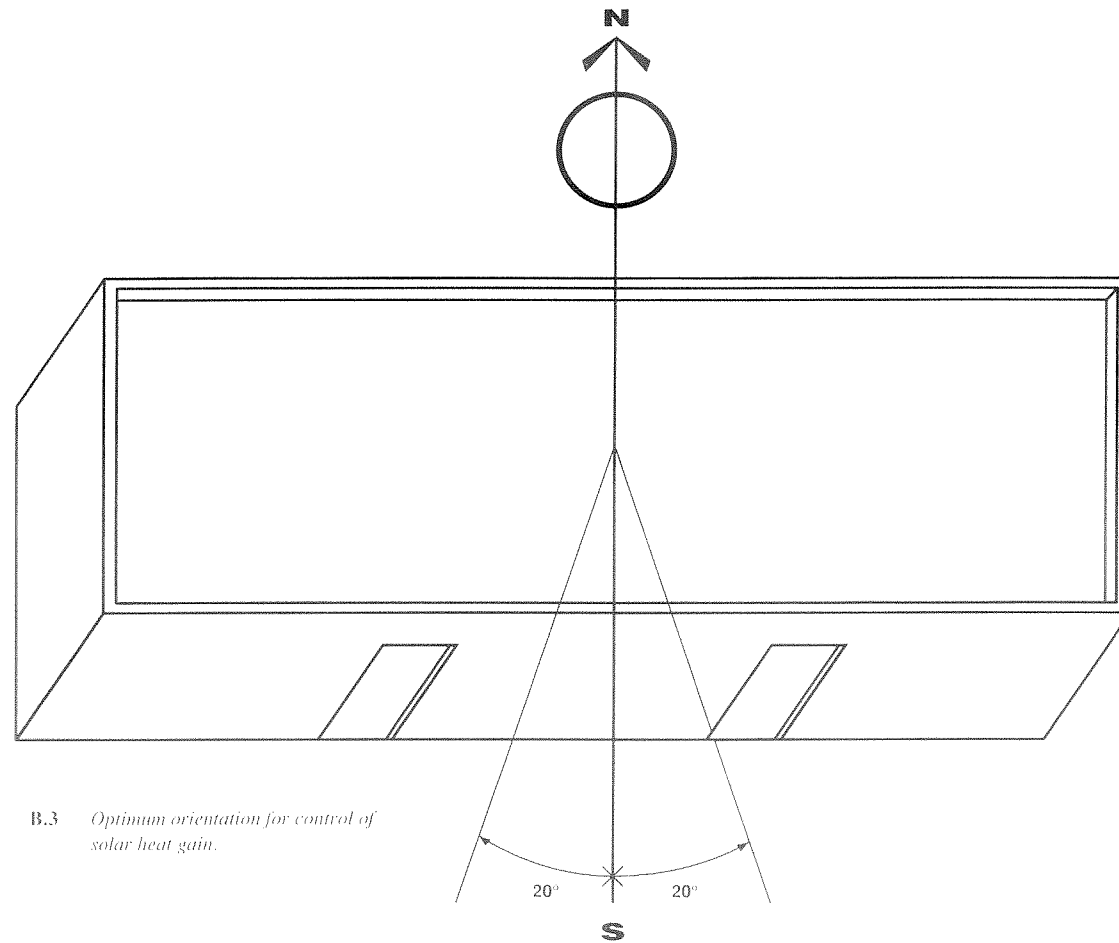

B.3 Optimum orientation for control of solar heat gain.

ORIENTATION FOR VENTILATION

Optimum orientation for ventilation depends on window location as well as the direction of the prevailing winds. For good ventilation it is desirable to have high average air velocity with air flow distributed throughout all occupied parts of the room. **When openings are in adjacent walls, the optimal ventilation occurs when the long building face is perpendicular to the wind** (Fig. B.5). A shift of 20-30 degrees from perpendicular will not seriously impair the building's ventilation. Winds approaching at 45 degrees result in average interior velocities that are 15-20% lower than those which occur when the wind approaches perpendicular to the building face.

When windows are in opposite walls, rotating the building 45 degrees with respect to the prevailing wind

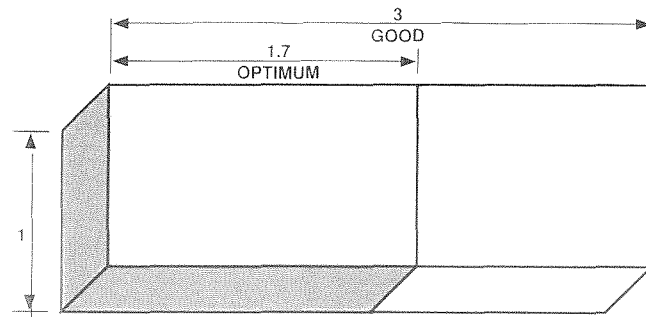

B.4 Optimum proportions of plan (width to length) are shown by shaded areas and good proportions by the outer dimensions. Source: Olgyay.

direction provides the highest average velocities and best overall distribution of air movement within the space (Fig. B.6). Wind approaching at 90 degrees is 15-20% less effective. Wind parallel to the openings produces ventilation depending entirely on fluctuations in the wind and is therefore very uncertain.

When conflicts exist between optimal solar and wind orientations, solar considerations usually take precedence. Inlets for natural ventilation can often be designed for less than optimal wind orientations more easily than solar control devices can be designed for low sun angles. This is espe-

cially true in high rise construction where building orientation to reduce solar gains is most important.

Areas of Hawaii in which the trade winds blow from the east pose a problem for designers wishing to avoid low sun angles. Rooms with exterior walls facing north and south will be protected from the low sun but experience little air movement (Fig. B.7) Rooms with exterior walls oriented

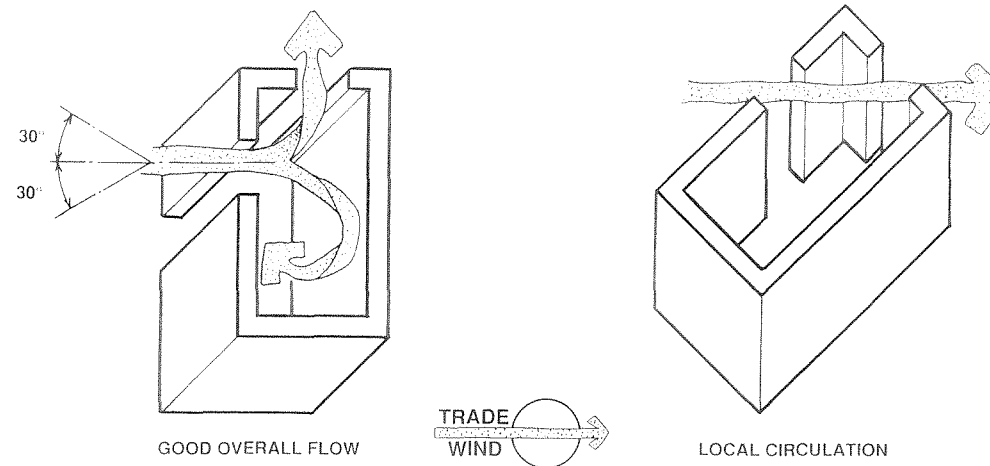

B.5 Optimum orientation for ventilation for rooms with openings on adjacent sides.

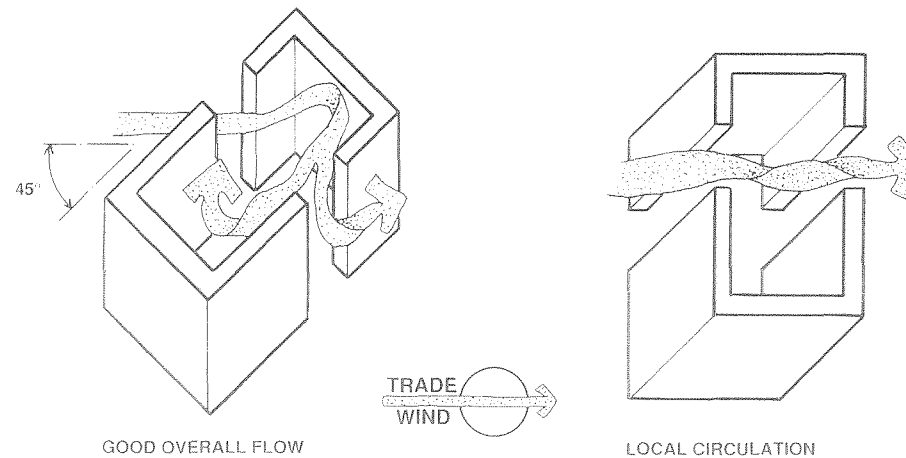

B.6 Optimum orientation for ventilation for rooms with openings on opposite sides.

towards the breeze will be difficult to shade (Fig. B.8). Figures B.9 and B.10 show how carefully placed exterior walls or staggering the rooms can satisfy requirements for both ventilation and solar control.

It is possible to partially compensate for improper orientation and shape with the design of the building envelope to minimize unwanted solar gain. Such design measures include light-colored wall surfaces, exterior shading systems for windows, and extra insulation. If these measures are followed in low rise buildings, the change in internal temperature respect to orientation may be negligible. In carefully designed, low rise buildings ventilation has the greater effect on internal conditions; therefore orientation with respect to the prevailing wind should take precedence over solar considerations.

BUILDING FORM

Naturally ventilated buildings should have a narrow cross section to maintain ample air velocities. These buildings generally have single loaded corridors, often with exterior circulation. All habitable rooms must have two external openings for cross ventilation. Heat, noise and odor-generating spaces such as kitchens, baths and mechanical rooms should be placed on the leeward side.

For air conditioned buildings it is desirable to have a compact plan to minimize the surface area exposed to the sun. Attic ventilation and insulation above the ceiling are desirable when appropriate. Exterior openings should be well sealed to minimize the loss of cooled air.

Obviously daylighted spaces need to be close to exterior walls or the roof. In multi-story buildings, rooms can be grouped around atriums and courtyards for light. Figure B.11 illustrates building shapes that increase the perimeter zone in which daylight can be used.

ZONING

Organizing spaces according to their different cooling, lighting and ventilation needs can reduce energy consumption. Rooms which require little cooling or light (closets, storage, garage, laundry rooms, mechanical chases, stairways, for example) can be placed on the east or west exposures of the building to act as buffer spaces to minimize the east/west solar gains. (Fig. B.12) Corridors and lanais may serve a dual function as shading devices if placed on the south, southeast, or southwest side of an elongated building facing one of these directions. Rooms that generate heat (such as computer rooms and laundries) should be placed near the building's ventilative outlets or be separately ventilated to minimize heat gain to the rest of the building. These areas should also be separated with insulated partitions from the rest of the building.

RESOLVING CONFLICTS BETWEEN OPTIMAL SOLAR AND WIND ORIENTATION

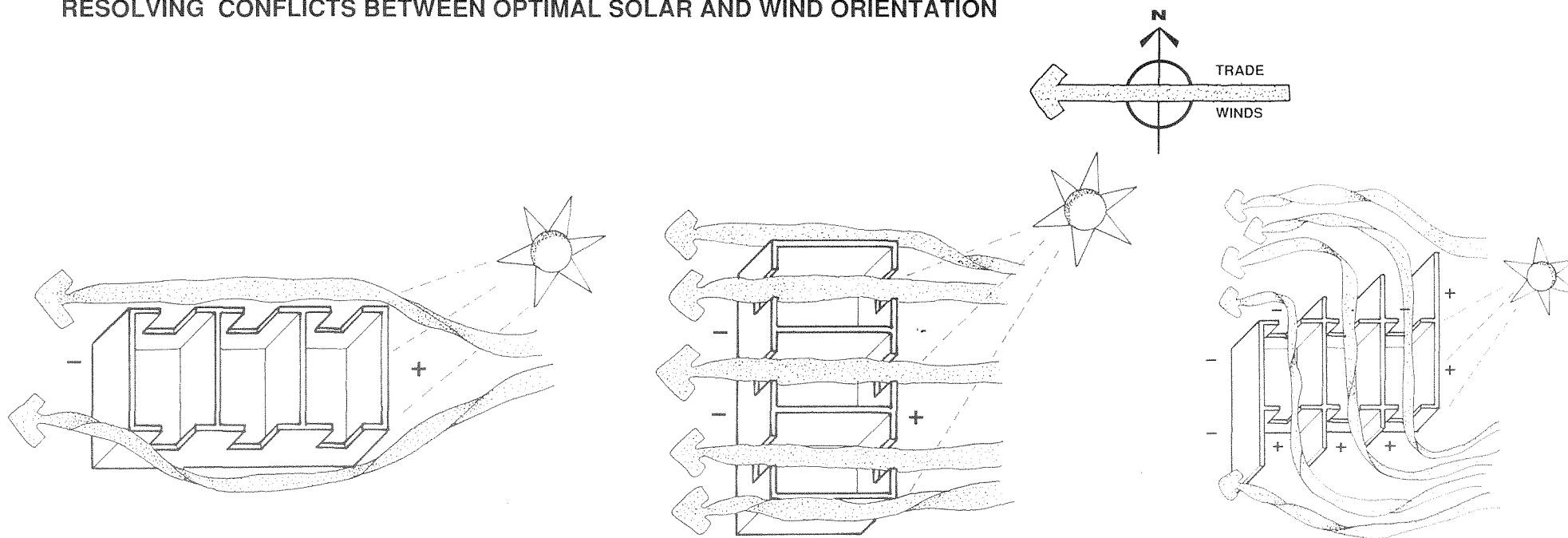

B.7 Rooms oriented north - south are shaded but experience little air movement.

B.8 Rooms oriented east - west have good ventilation but may be difficult to shade.

B.9 Wingwalls can increase ventilation through rooms oriented north - south.



## ANALYSIS METHODS

Analysis of the energy impact of a building's orientation and configuration begins in the programming phase. During this phase the constraints and opportunities unique to the site, the building type, and the program can be evaluated for their effect on the project's energy efficiency. Research, experience and intuition are the primary analysis tools.

As potential solutions are identified in the schematic design phase, the energy performance of each design option can be evaluated. Assumptions can be made concerning the location and type of glazing, the construction of the opaque envelope, lighting and other building systems. With these assumptions a load analysis can be performed for each schematic design to determine cooling loads. Load analysis involves calculating:

- internal heat gain due to lighting, equipment and people;
- solar gain through glazing;
- heat gain through opaque surfaces; and
- latent heat gain due to high humidity.

These calculations can be performed on a hand calculator following procedures in the ASHRAE Handbook of Fundamentals. However, the many programs available to simulate energy performance on the personal computer dramatically increase the speed and the accuracy of these calculations.

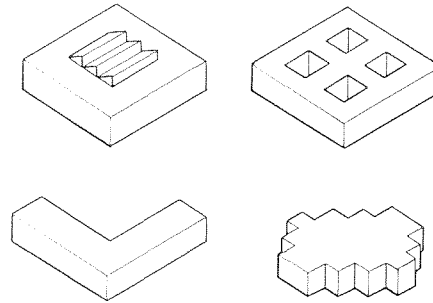

**B.11** A building's form can increase the potential for daylighting.

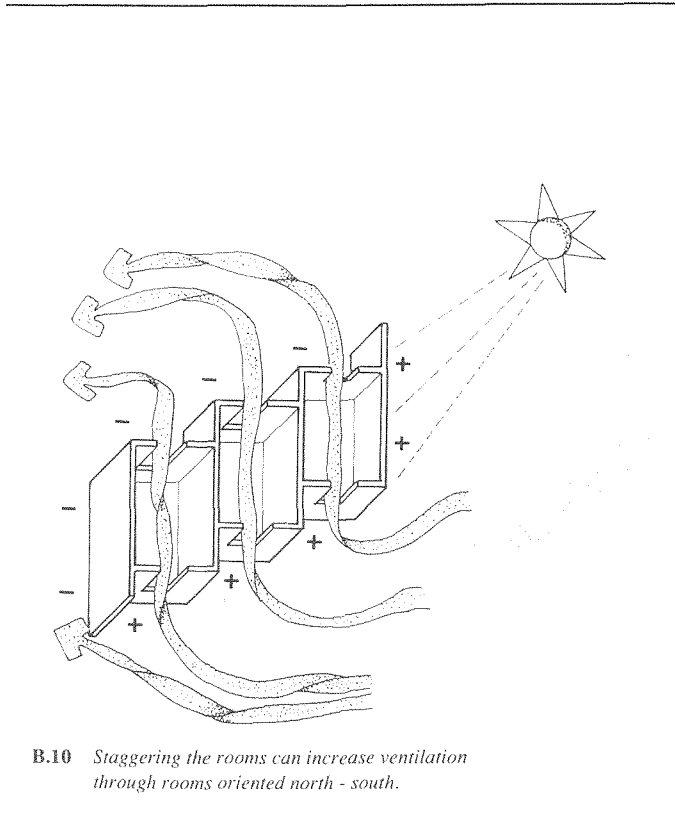

**B.10** Staggering the rooms can increase ventilation through rooms oriented north - south.

These load analyses indicate the relative energy performance of each schematic design option. They can also be used for preliminary economic and life-cycle cost studies. The load analysis can inform the designer as to how energy will be used in the building, helping to target areas that offer the greatest potential energy savings.

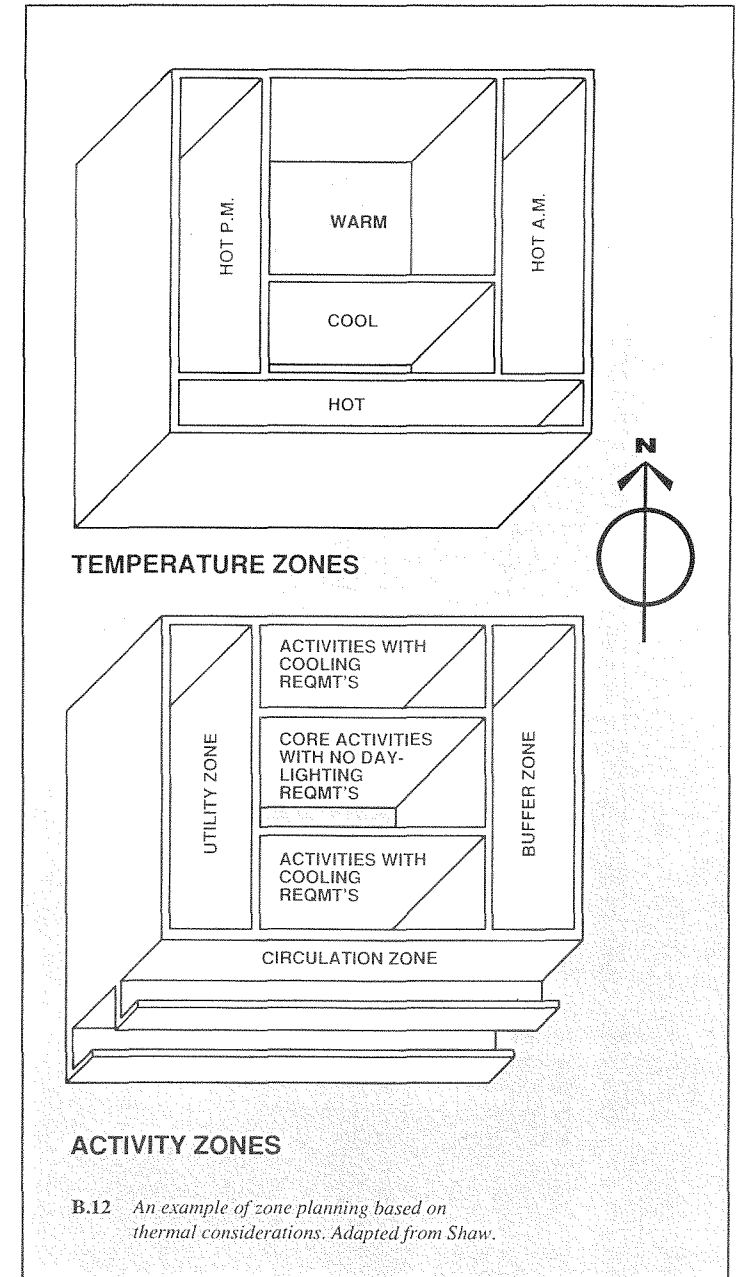

## ACTIVITY ZONES

**B.12** An example of zone planning based on thermal considerations. Adapted from Shaw.

ENERGY IMPACT

The energy impact of building orientation and configuration depends primarily on the amount and type of glazing on each orientation. With large amounts of glass and a glazing system that allows large solar heat gains, the impact of orientation on operating costs is substantial.

Computer simulations were performed to determine the impact of various orientations on the operating costs for office and multi-family residential buildings in Hawaii. The results are plotted on graphs (Fig. B.13). The impact on operating costs for various amounts of glass expressed as a window wall ratio (WWR) multiplied by the shading coefficient (SC) of the glass for each orientation is shown. The WWR represents the ratio of glass area to total wall area for each orientation. The SC describes the effectiveness of the glass and any shading system in excluding solar heat gain. The

shading coefficient is the ratio of the total solar heat gain through windows, with any exterior or interior shading devices, compared to the total heat gain through an unshaded, single glazed, clear window.

The interior zone of the office building has an annual operating cost of about \$.60/sq. ft. for cooling. The cost for cooling the office average perimeter zone without windows is about \$.96/sq. ft. per year.

With identical envelope design and window size on all orientations, north orientations use less energy than south, east and west orientations. Effective shading will lower the shading coefficient, thus lowering the operating costs associated with the south, west and east orientations.

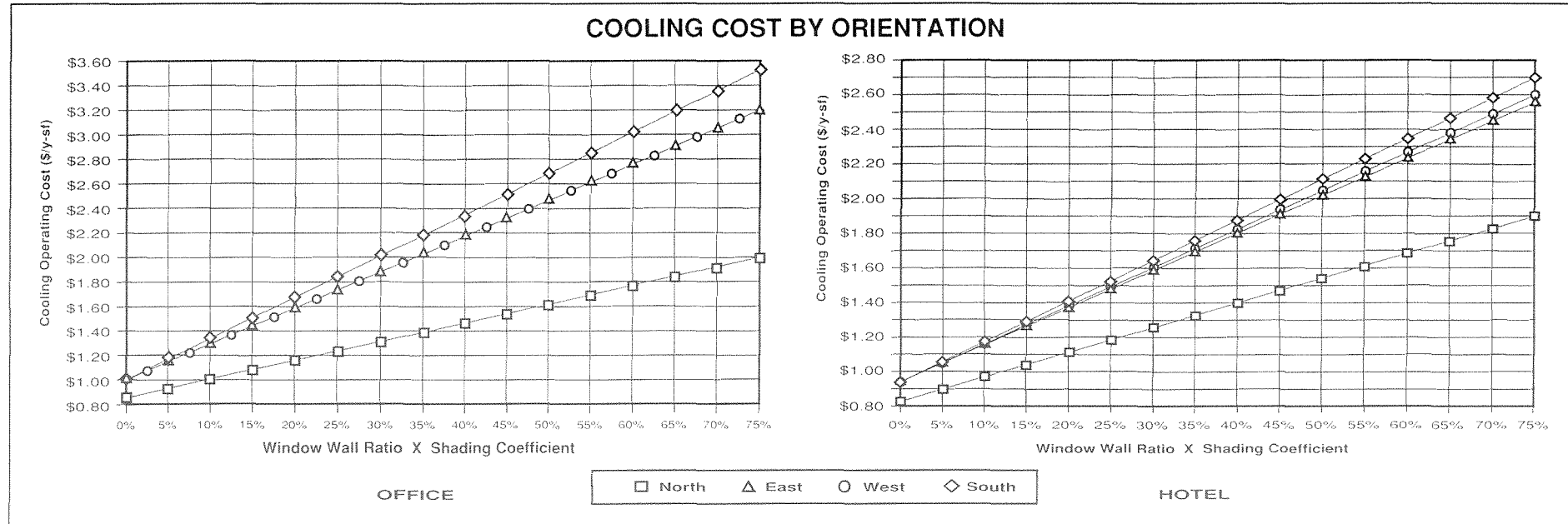

B.13 Annual cooling cost for unshaded office and hotel windows by orientation. The graph plots cooling cost vs glass area multiplied by the shading coefficient of the glass. Source: Eley

SOLAR CONTROL  
Design Strategies

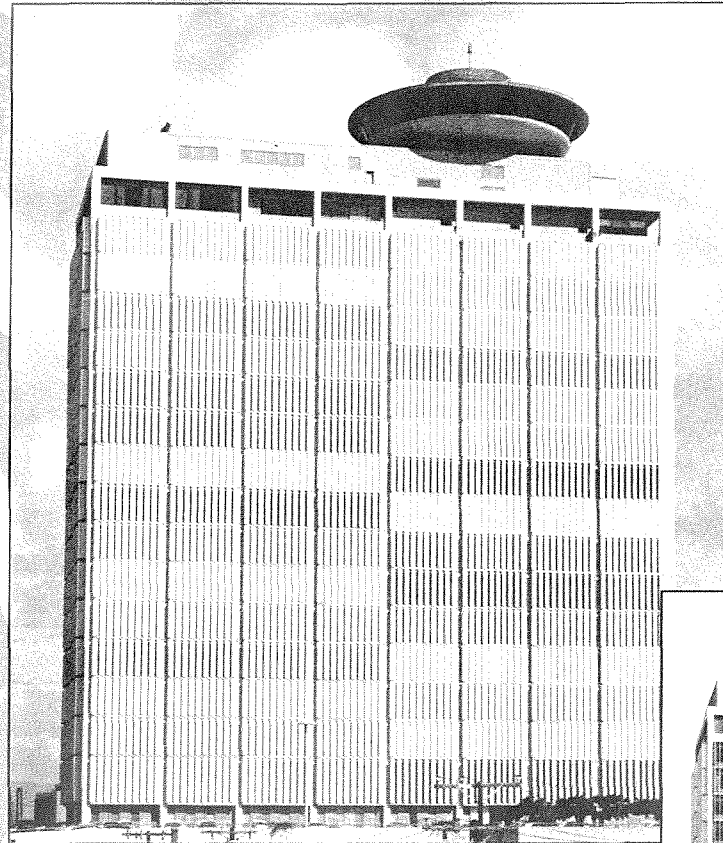

C.1 *The Ala Moana Building, 1962. Operable sunshading opens and closes in response to the sun's position. Architect: John Graham. Photograph: Max Raksasat.*

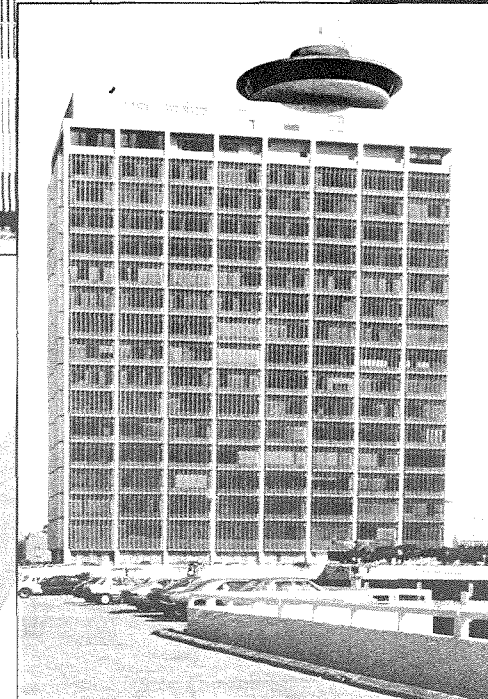

The goal of solar control is simple: to keep the sun's radiant heat from penetrating through the glass and the building's external envelope. **The key to effective shading is to intercept the heat outside the building.** The effectiveness of a shading system is determined by its position: outside, on the surface, or inside the glass, in declining order of effectiveness. Internal devices such as curtains and blinds do little to stop the heat from penetrating the building. Once this heat is inside, the building's air-conditioning system must be designed to remove it.

A wide variety of shading strategies are open to the designer ranging from building scale solutions to shading individual windows. The choice of an optimum shading system will vary, not only from building to building but also with the orientation of each of a building's facades.

At the building scale, designers have used large overhead canopies to shade the entire structure. Although the windows are the most critical areas to shade, such a "parasol" will also reduce the heat gain through the roof and walls as well as provide cool and comfortable exterior spaces. Another building scale approach is self-shading.

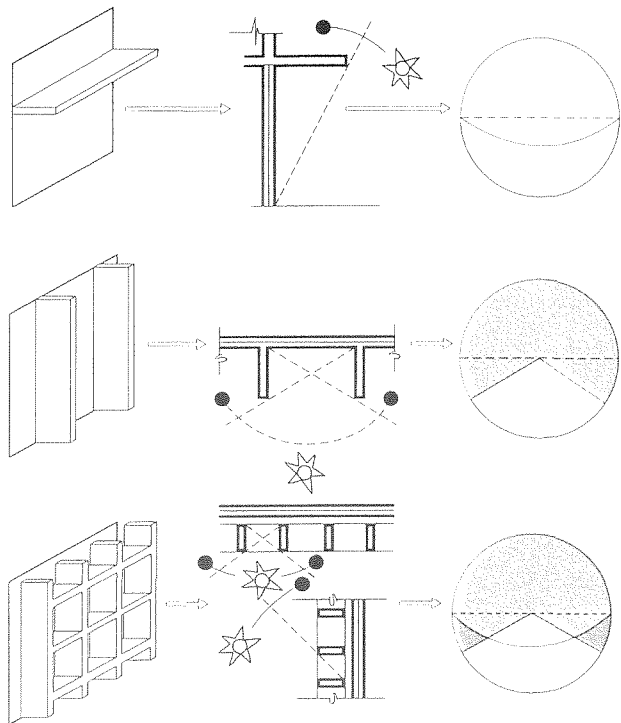

C.2 Overhangs, fins and eggcrates. Source: Olgyay.

The building may be stepped in section so that the upper floors provide shade for the windows on the lower floors. (Figs. B.1 and I.1) Alternately, a building's plan may be arranged so that its east and west windows are protected.

Overhangs and eaves are effective against the high midday sun, particularly on the south side (Fig. C.2). In Hawaii, lanais often provide this needed shade while functioning as circulation or outdoor living space. For the lower morning and afternoon sun, vertical fins are desirable on the east and west facade. These fins may be perpendicular to the window; angled, to block the later afternoon sun; or movable, changing position in response to the sun's position. The Ala Moana Building in Honolulu features a shading system of movable fins (Fig. C.1).

Solar control devices for individual windows include exterior and interior shades as well as coatings and films

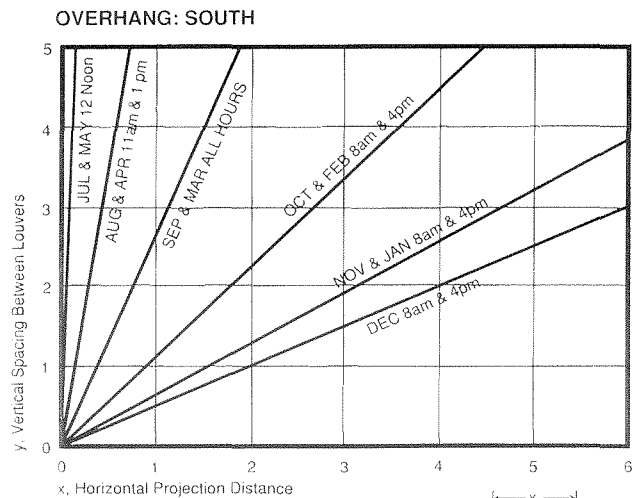

C.3 Required overhang length to shade a south facing window at 21 degrees north latitude between 8:00 a.m. and 4:00 p.m. Overhang length calculated for the 21st day of each month. Calculations by Phil Haisley, AIA.

applied to the glass. Awnings are popular exterior devices on low rise commercial buildings. Fiberglass or metal shade screens are often cost effective for low rise commercial and residential applications and are capable of reducing solar

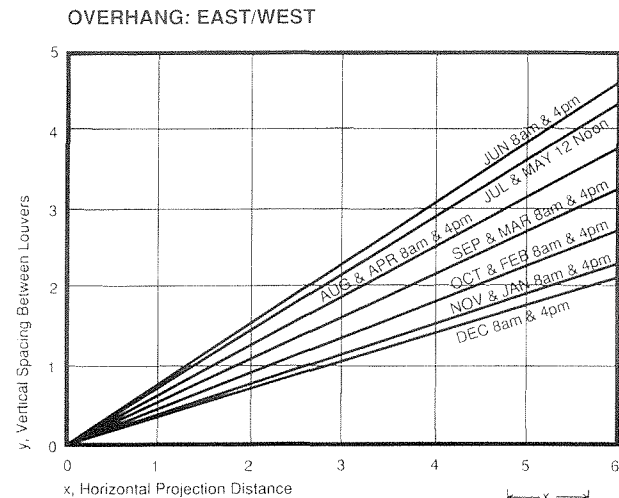

C.4 Required overhang length to shade an east or west window at 21 degrees north latitude between 8:00 a.m. and 4:00 p.m. Length calculated for the 21st day of each month. Calculations by Phil Haisley, AIA.

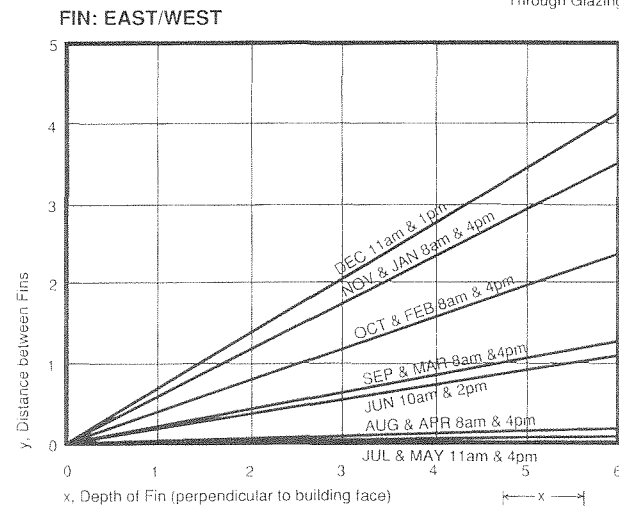

C.5 Required fin length to shade an east or west facing window for 21st day of each month between 8:00 a.m. to 4:00 p.m. Calculations by Phil Haisley, AIA.

heat gain up to 70% in comparison to unshaded clear glass.

Reflective glazing and films can be effective in reducing solar heat gain, often with a corresponding reduction in light (see Glazing, section G). Window film retrofit applications often have an extremely rapid payback. A study was performed to determine the economics of adding window film to two Hawaii buildings, a high rise hotel with clear glazing and a high rise condominium with bronze glazing. The analysis predicted the

energy cost savings would equal the film cost in 0.8 to 1.3 years for the hotel and 2.4 to 4.3 years for the condominium, depending on the type of film used.

Inside windows, the mini blind has become almost the standard for shielding office workers from glare and direct sun. The color of these blinds is significant. A white blind is about 20% more effective in reducing heat gain than a dark blind.

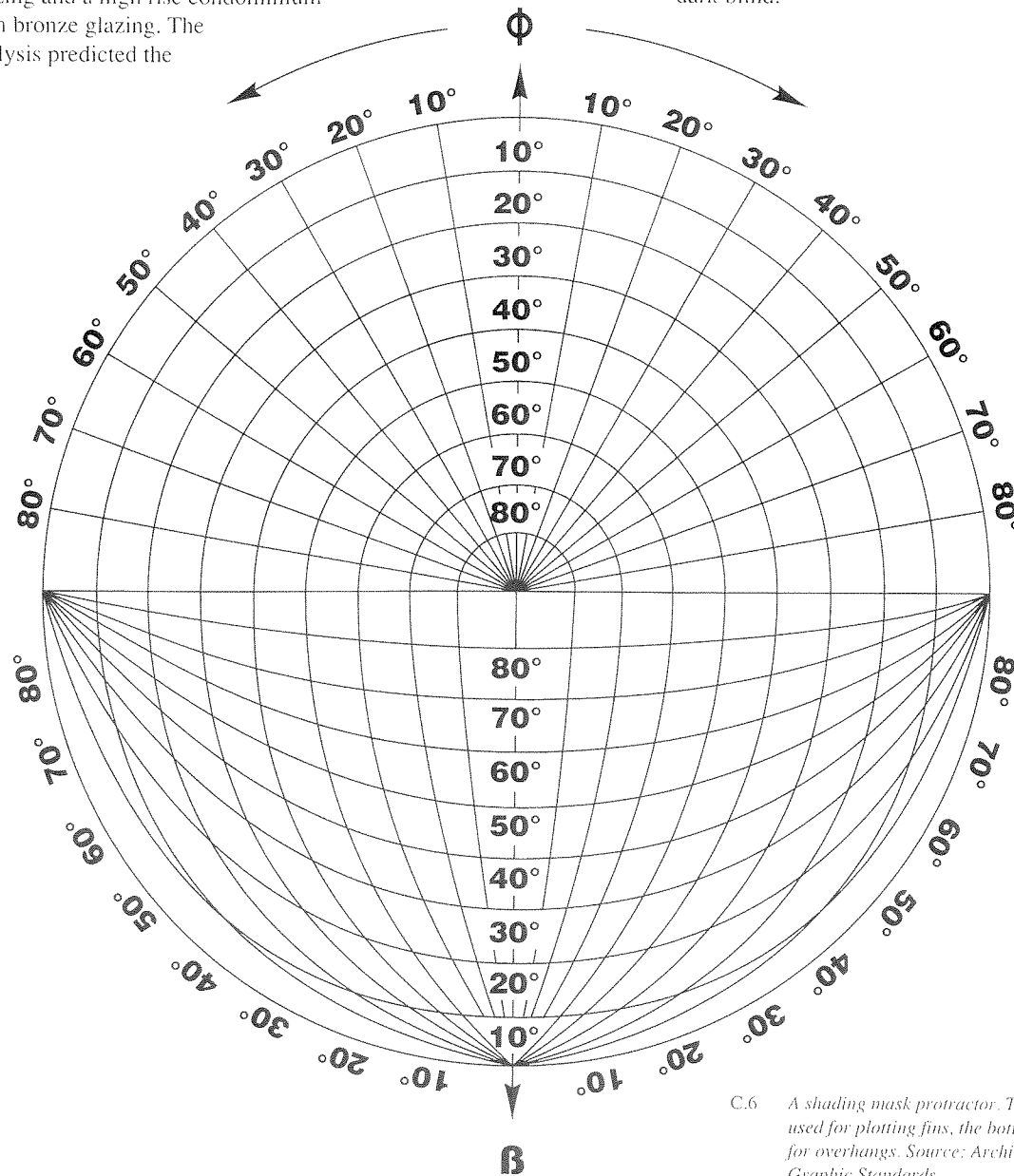

C.6 A shading mask protractor. The top half is used for plotting fins, the bottom half is for overhangs. Source: Architectural Graphic Standards.

SHADING ANALYSIS METHODS

The first step is to determine when shade is required. For most of Hawaii 100% shade is desirable all of the time. However, a designer may consider not providing shade for periods when the building will not be occupied or when the site is shaded by adjacent buildings or topography. A simple method of determining when the site will be in shade is to plot adjacent features on a sun path diagram (Fig. A.17).

Once the period of time that shading is required has been established, overhangs and fins can be sized using the graphs in Figure C.3, C.4 and C.5. The required overhang length (x) for a given window height (y) to provide shade on a south facing window between the hours of 8 am and 4 pm is graphed in Figure C.3. Each line on the graph represents the required overhang length to provide shade for the 21st day of the month listed. The design hour requiring the longest overhang is listed for each month. Figure C.4 can be used to size overhangs to provide shade for windows facing east, from 8 am to noon, or windows facing west, between noon and 4 pm. Figure C.5 can be used to size vertical fins on east or west facing windows during the same periods. For east and west facing windows overhangs are most

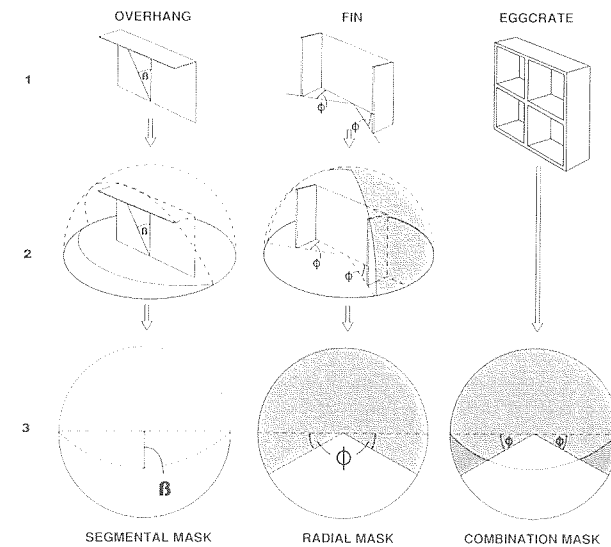

C.7 Construction of a shading mask onto a sun path diagram. Source After Olgay

effective for summer months while fins are most effective for winter months. This indicates that an eggcrate device would provide the most shade for a given projection.

A shading mask can be constructed on a shading mask protractor (Fig. C.6) for the type and dimensions of the device under consideration (i.e: overhang, fin or eggcrate) (Fig. C.7). This protractor can then be overlaid onto a sunpath diagram to determine the times that shade will be provided (Fig. A.17). A sun angle calculator is a simple and useful tool for designing shading devices, and is available for \$10 from the Libbey-Owens-Ford Co., 811 Madison Avenue, Toledo, Ohio 43695. The effectiveness of shading can be quickly verified by taking a simple scale model outside and using a sundial (see section K).

COST EFFECTIVENESS

Fixed overhangs are the most common type of shading device used in Hawaii. The cost of adding an overhang to a building is highly dependent on the method of construction. Overhangs can be constructed of concrete, metal, cloth (awnings), wood and other materials. They are often an extension of the roof or floor plane. With this assumption, the incremental cost of adding a five foot deep concrete overhang was estimated to be \$14.50/per square foot of floor area in the perimeter zone of the hypothetical office building developed for this cost analysis.

The benefit from an overhang depends on the window orientation as well as the dimensions of the overhang and the window. The benefits are greatest on the south orientation, about equal for the east and west, and smaller on the north. The operating cost savings for different lengths of overhang are plotted in Figure C.9. The length of the overhang is described by the projection factor (PF). The PF is the length of the overhang measured from the surface of

the glazing divided by the distance from the window sill to the bottom of the overhang (Fig. C.8). Each line on the graphs represent the cost savings for a separate orientation and window wall ratio (WWR). By comparing the construction cost above to the cost savings shown in Figure C.9, the simple payback of adding an overhang can be determined.

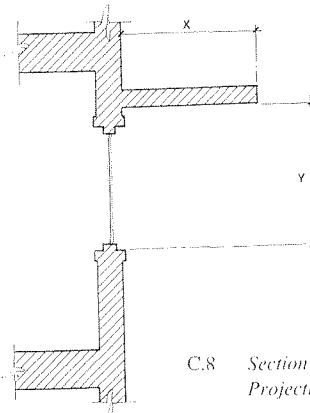

C.8 Section through window showing Projection Factor:  $PF = x/y$ .

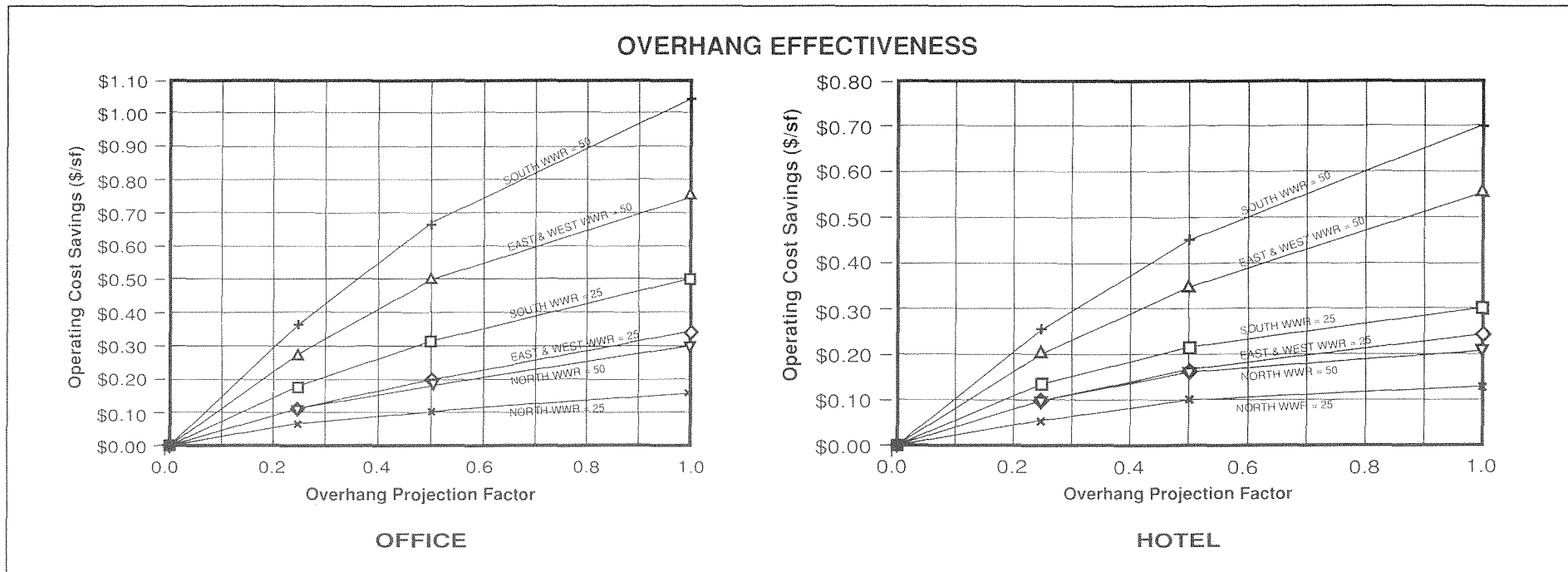

C.9 Overhang operating cost savings for offices and hotels for each orientation. Reductions in perimeter zone operating cost are shown for 2 window wall ratios (WWRs) for each orientation. Source: Eley

DAYLIGHTING  
Design Strategies

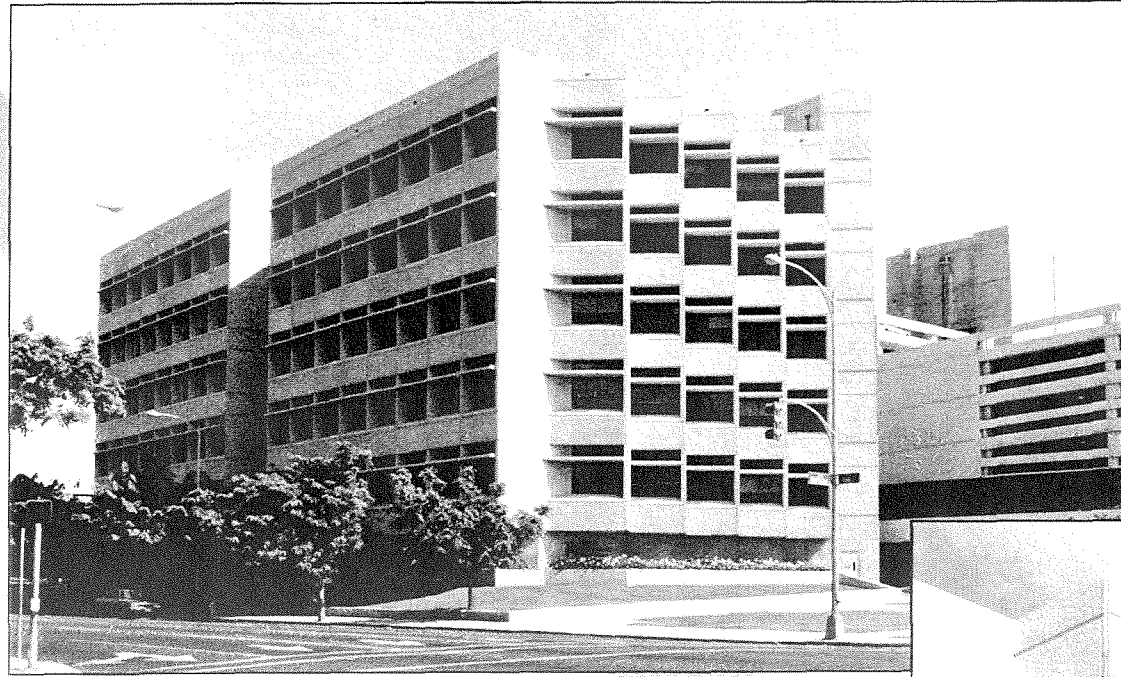

*D.1&2 Kaiser Clinic, Honolulu, 1984. Lightshelves  
bounce light deep into physicians' offices.  
Architect: Architects Hawaii. Energy  
Consultant: TRB Hawaii. Photographs:  
Max Rakasat.*

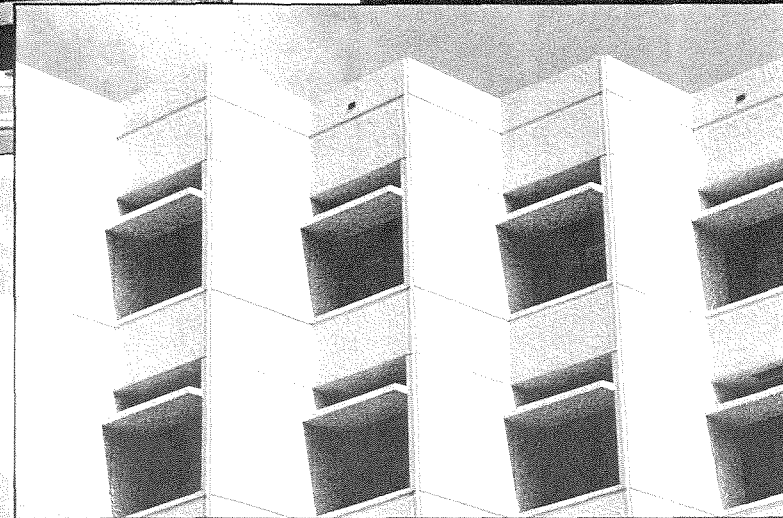

Every room with a window uses daylight to some extent. However, daylighting refers to the controlled use of daylight to reduce the demand for electric lighting. This is commonly accomplished by using various devices to bounce or diffuse light deep into a space.

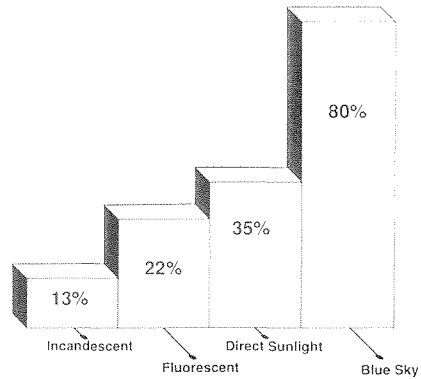

LIGHT SOURCE EFFICIENCY

D.3 The efficiency of various light sources (ratio of usable light to heat gain).  
Source: Lord.

THE CASE FOR DAYLIGHTING

A well designed daylighting system, incorporating automatic lighting controls, can achieve up to a 50% savings in electric power for lighting a building's 10 - 15 foot deep perimeter zone. Diffuse daylight is four times as efficient as fluorescent fixtures in terms of providing usable light without the associated heat gain (Fig. D.3). This is important for thermal comfort in both naturally ventilated and air conditioned buildings. **In air conditioned buildings, energy savings can be compounded by a corresponding decrease in a building's air conditioning load.**

Daylighting can also significantly reduce peak power demand charges. **The maximum potential for energy savings from daylighting occurs when ambient light levels, solar heat gain and electric power consumption are all at their peaks.**

DAYLIGHTING DESIGN STRATEGIES

In design of daylit spaces, direct skylight and sunshine should be avoided (Fig. D.5). Direct sunshine causes unwanted heat gain and excessive glare. Even on overcast days, the ambient light level in Hawaii is many times greater than is needed for most lighting needs inside buildings (Fig. D.4). Required interior light levels range from 30 to 200 foot candles, depending on task and occupancy. The strategy in daylighting is to re-direct and diminish ambient light so it can be delivered in a useful form to interior spaces. Direct sunshine should be used as a light source only after it is reflected off several surfaces. Direct view of the sky should also be avoided as the excessive differences in brightness can be uncomfortable.

For even illumination, daylight should be bounced off of surrounding surfaces (Fig. D.6). Although each bounce will reduce the intensity of light, light reflecting off many surfaces will even brightness patterns and reduce glare. Since

SUN INTENSITY, HAWAII

MONTH/MONTHS	8AM & 4PM		10AM & 2PM		NOON	
	clear	overcast	clear	overcast	clear	overcast
JUNE	5,000 ft.cd.	2,000	8,700	3,600	12,000	4,100
MAY & JULY	4,500	1,700	8,000	3,200	9,700	3,500
APRIL & AUGUST	4,200	1,400	7,600	2,600	9,200	3,100
MARCH & SEPTEMBER	4,000	1,200	7,300	2,200	8,600	2,500
FEBRUARY & OCTOBER	3,500	1,000	6,500	1,800	7,800	2,100
JANUARY & NOVEMBER	3,000	700	5,600	1,500	6,800	1,700
DECEMBER	2,400	500	4,700	1,100	5,700	1,500 ft.cd.

D.4 Sun intensity chart for Hawaii (in foot candles).

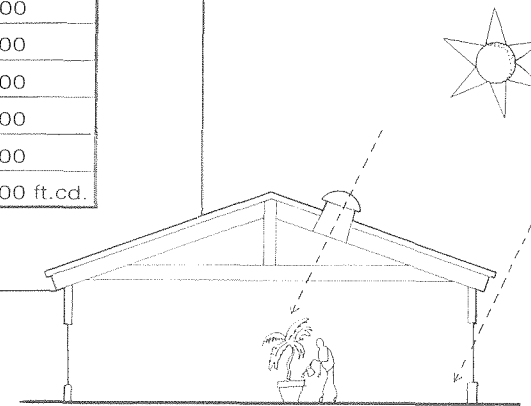

D.5 Direct sunshine should be avoided or used sparingly in non-critical task areas.  
Source: Evans.



the amount of light bouncing off the surface is proportional to its reflectance, light colored surfaces work best for daylighting. In a room with windows in one wall, a light colored ceiling, opposite wall and side walls are important in that order. Light colored flooring is less important but the floor should not be extremely dark.

It is desirable to bring daylight in a space as high as possible (Fig. D.7). The height of a window is more important than its width for maintaining even distribution and quantity of light (Fig. D.8). The proportions of a room, particularly the relationship of ceiling height to the room's depth, are also important for even illumination (Fig. D.9). The rule of thumb for rooms with windows on one side suggests that the depth of the room should not be greater than 2-1/2 times the height of the window wall.

Skylights, clerestories, atriums, light shafts, and fabric structures are common devices used to bring light in high and deep into a building's interior. Diffuse white skylights offer a great amount of light with the least amount of heat gain and cost, and thus have been popular in industrial appli-

cations. Direct view of skylights should be shielded in offices, classrooms and other critical task areas as they are much brighter than the surrounding ceiling. Clear skylights in Hawaii should be shielded from the direct sun as much as possible. Clerestories offer the lighting advantages of skylights with easier control of heat gain and waterproofing. A clerestory used in conjunction with a light shelf is useful for distributing light and shielding direct view of the sky.

Clustering rooms around an atrium is a useful device for bringing light into a building's interior as well as creating dramatic spatial relationships. When a covered atrium is used in Hawaii, particular care must be paid to the solar geometry, light transmissivity, and size of the opening to prevent overheating. In general, direct sunlight should not be allowed into

a covered atrium, especially if it is over an air-conditioned space.

Solar control devices should be used to filter daylight. Landscaping, shading devices, curtains, and blinds can be used for more even light distribution. Venetian blinds, when clean and properly adjusted, provide excellent control over glare and daylight distribution (Fig. D.10). Light shelves combine the effective solar control of an overhang with a reflective surface to bounce light up to the ceiling and deep into a building's interior (Figs. D.2 and I.8).

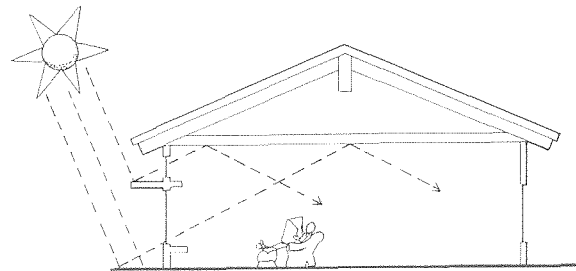

D.6 Bounce daylight off surrounding surfaces to soften and spread it. Source: Evans

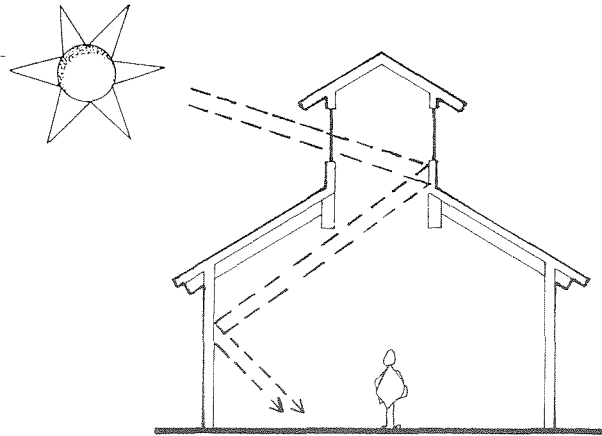

D.7 Bring daylight in high...and let it down softly. Source: Evans.

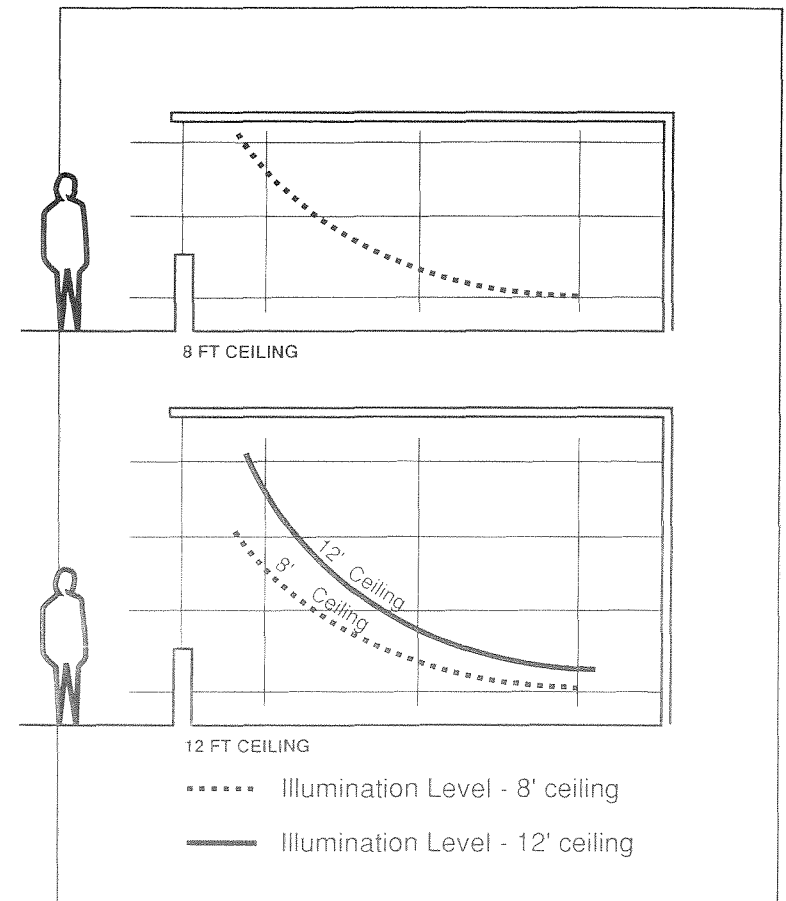

D.8 The effect of window height on interior light levels. Source: Evans.

INTEGRATION WITH ELECTRIC LIGHTING

For daylighting to save energy, the electric lights must be dimmed or turned off. Without controls on the electric lighting, large areas of windows or skylights will have an adverse effect on the operating cost. Large glazed areas will increase the solar heat gain, raising the air conditioning load.

**Photometrically controlled, automatic dimming devices should be installed in all daylit areas. The layout or circuiting of electric lighting should also be arranged to provide maximum benefit from daylight.** These systems are commonly installed with manual overrides.

DAYLIGHTING ANALYSIS METHOD

Architectural models can be useful at many levels of lighting exploration. The appropriate scale and level of detail depends on the purpose of the model (*Fig. D.12*). Daylighting models can be tested under direct sky using a sundial (section K) or inside under lamps or an artificial sky (*Fig. D.11*). When quantitative analysis is desired, light levels can be measured inside the model and compared with exterior light levels. The ratio of the light levels inside vs. outside is called the daylight factor (DF). The daylight factor is useful for comparing measurements conducted under differing condi-

tions. Also, since the daylight factor is a ratio, accurate measurements can be achieved if the same sensor measures both values, regardless of the calibration of the sensor.

Numerous mathematical techniques have been devised which determine either the actual illuminance or the daylight factor. Many of the more complex techniques have been developed into computer programs, some with elaborate graphic capabilities. These programs offer a rapid method to obtain quantitative light levels and explore design alternatives. Most commercially available programs are limited to rectangular geometries.

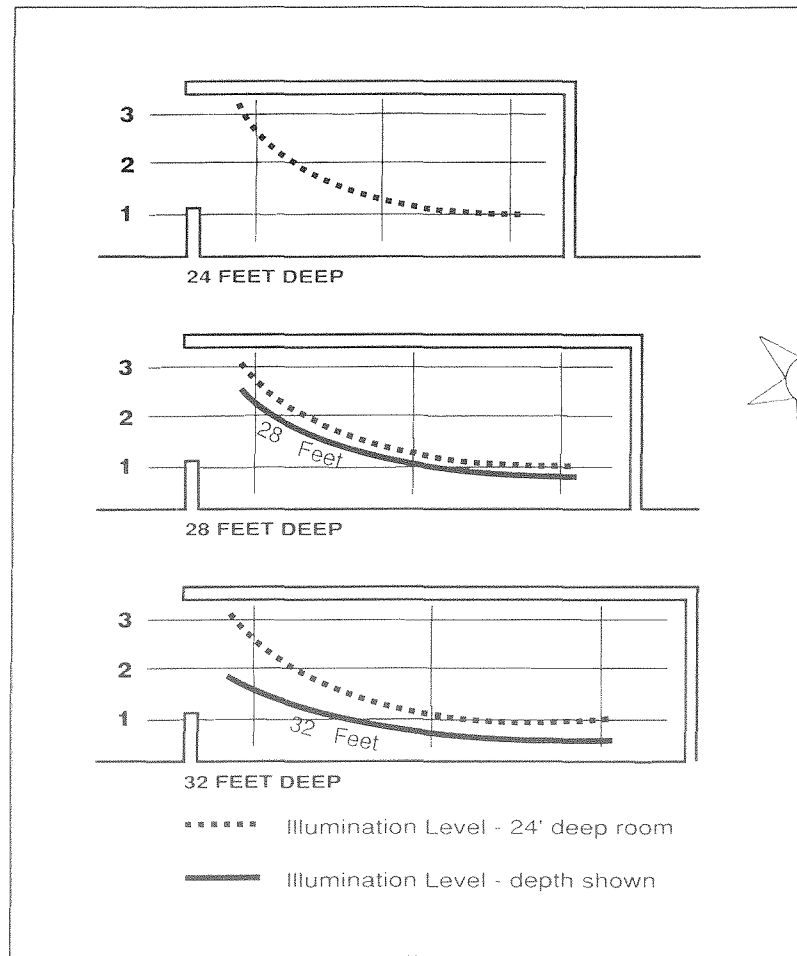

D.9 The illumination for all portions of a room decreases as a room increases in depth. Source: Evans.

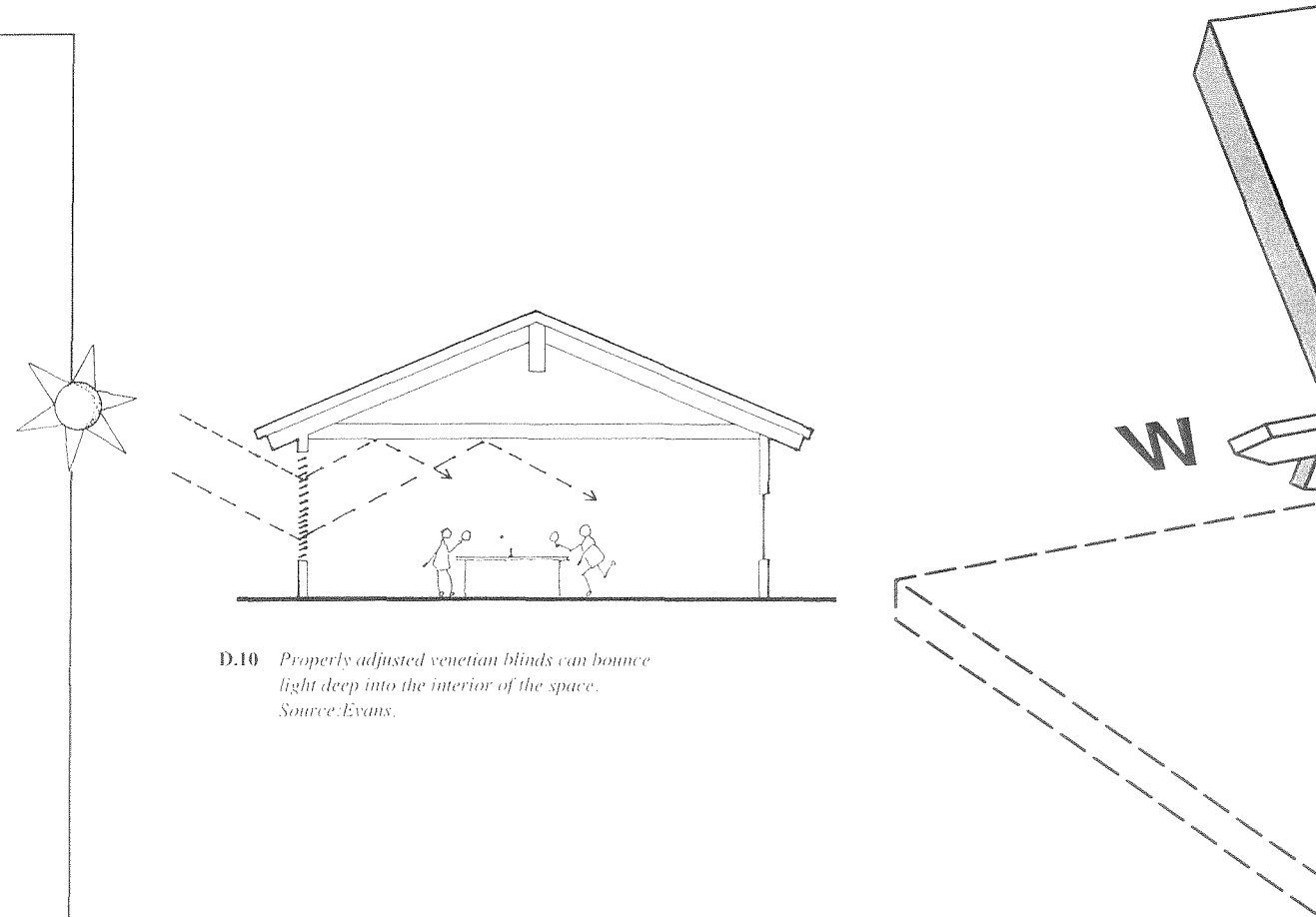

D.11 A sundial can be used to position a model for accurate studies of shading and daylighting systems. Source: Moore.

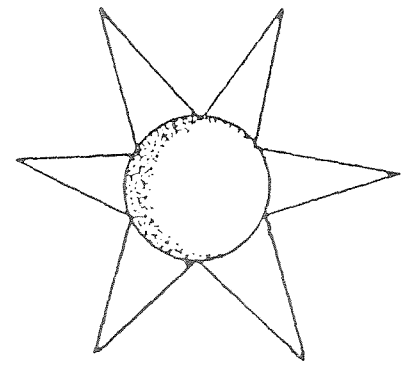
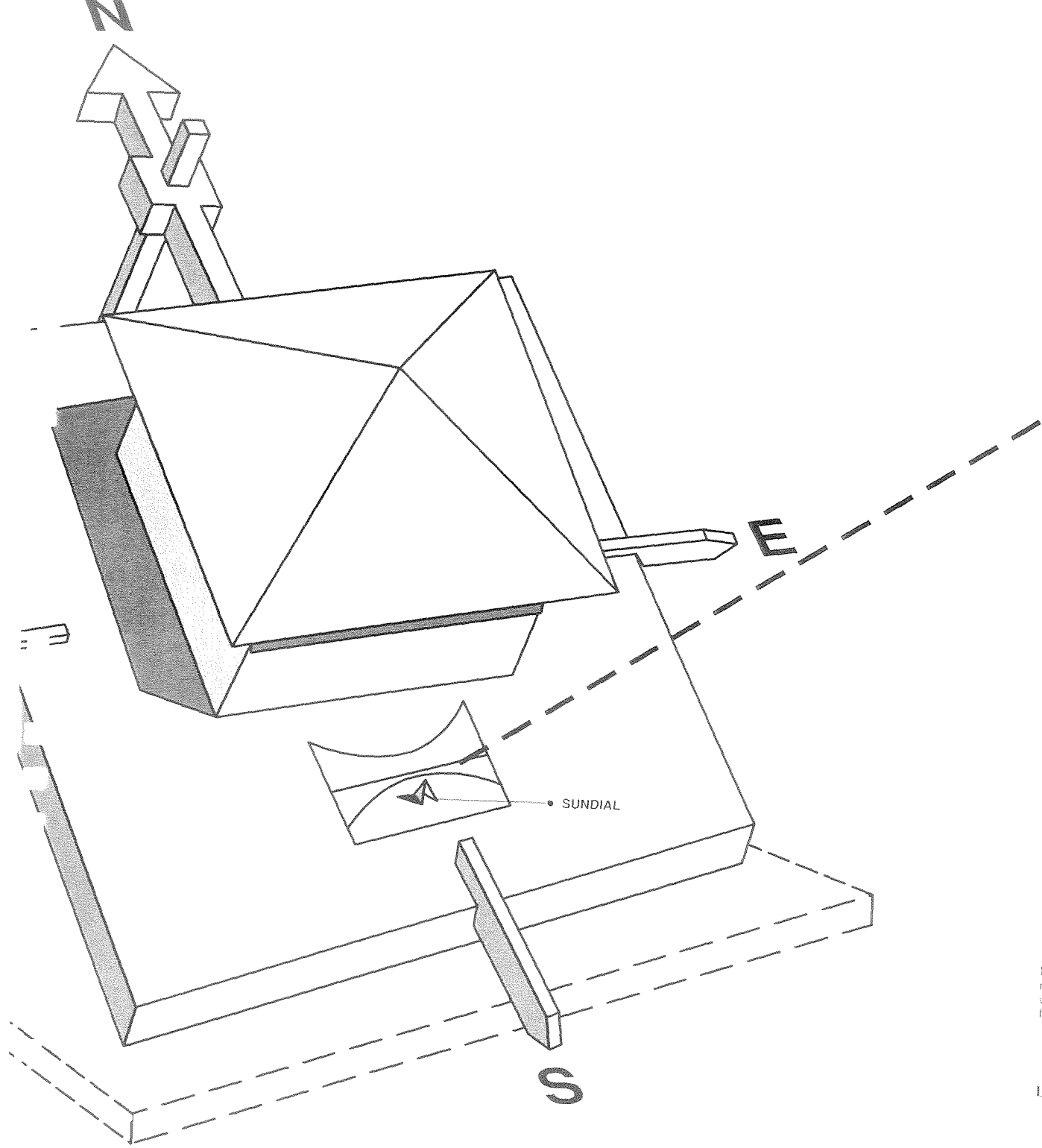

**DAYLIGHT MODELS**

PURPOSE	REQUIREMENT	DETAIL
Study massing and availability of daylight.	1/16" = 1'-0" 1/8" = 1'-0"	Building and site geometry. Accurate building and surface reflectances. Draw windows on surface.
Study possible window and skylight shapes and locations for quality and quantity of daylight.	1/4" = 1'-0"	Building and site geometry. Major interior partitions. Window and skylight openings. (no fenestration detail) Accurate interior and exterior reflectances.
Refine lighting design. Determine illumination levels.	1/2" = 1'-0"	Accurate interiors of windows and skylights including glazing. Accurate reflectance and surface character of walls, floors and ceiling. Interior furnishing.
Model exact replica of rooms to accurately verify light levels or for detail photography.	1-1/2" = 1'-0"	Model as much as physically possible.

D.12 The appropriate scale and level of detail from model depend on its purpose. Source: Schiller.

COST EFFECTIVENESS

The cost effectiveness of windows and skylights for daylighting depends on the amount and type of glass, the lighting level required and the type of dimming controls used.

The cost of daylighting controls is about \$0.50/sq. ft. for step (on/off) controls. Step controls can be disturbing to occupants, especially on overcast days when illumination levels are changing. Continuous dimming controls are less perceivable and are estimated to cost \$1.00/sq. ft.

Carefully designed skylights can provide cost effective daylighting in low rise buildings. An economic analysis

suggests that about 3-5% of the roof area in skylights is optimal. The skylights should be distributed as uniformly as possible. *Figure D.13* show the operating cost for lighting and cooling plotted against the percentage of roof area used for skylights.

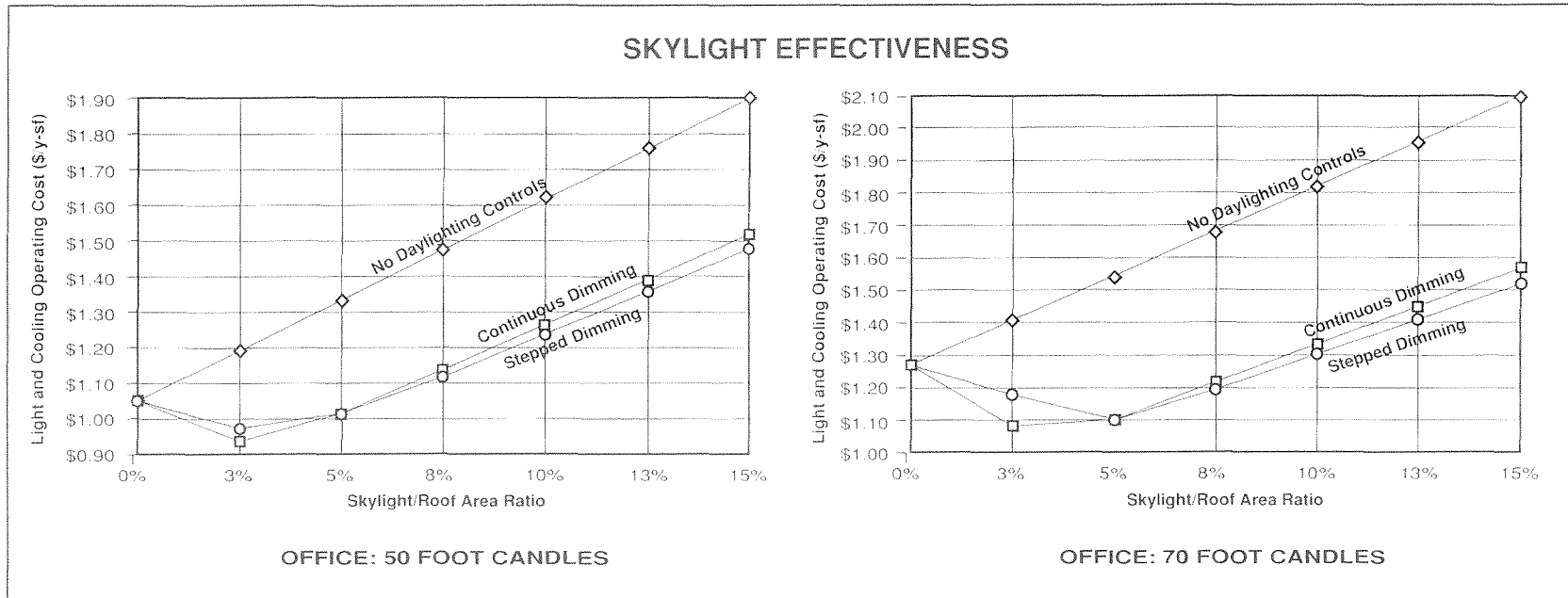

D.13 Operating cost vs skylight area for offices requiring 50 and 70 fc of illumination. Source: Eley

# NATURAL VENTILATION Design Strategies



**E.1&2** USS Arizona Hall, 1984. This US Navy highrise barracks is cooled by natural ventilation. Architect: Media 5 Limited. Energy Consultant: TRB Hawaii. Photograph: Angie Salbosa.

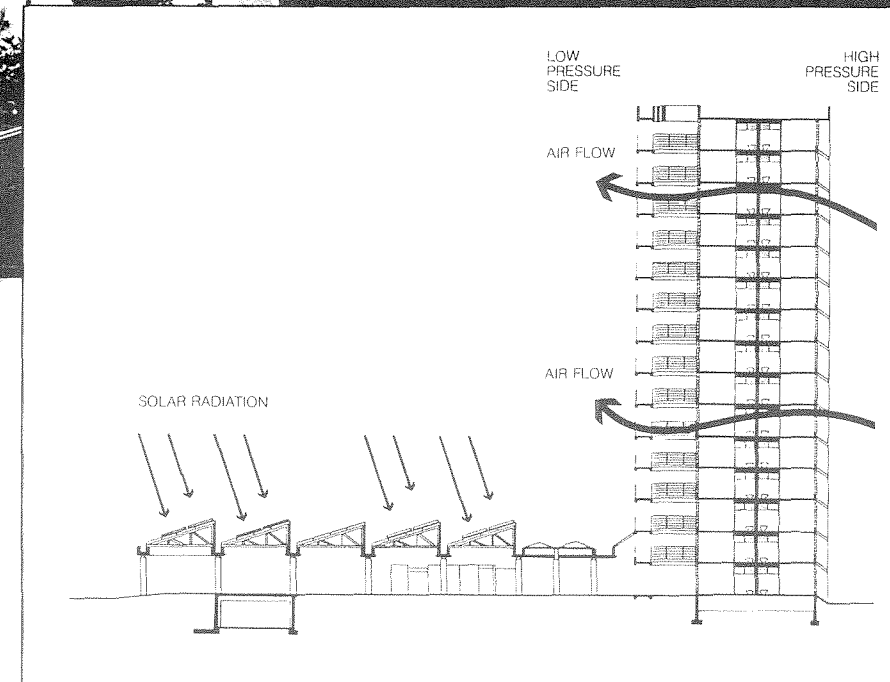

A properly designed, naturally ventilated building can provide comfortable climatic conditions throughout a major portion of the year in Hawaii. When augmented by an auxiliary mechanical system, such as ceiling fans or mechanical ventilation, comfort can be provided for most people and situations throughout the entire year. In addition, a naturally ventilated building will provide significant energy and capital investment savings since an air conditioning system will not be installed or operated. Successful use of natural ventilation requires detailed design analysis during the early phases of a project.

SITE SELECTION AND PLANNING

**Consideration of the wind and thermal implications of site planning and selection must be given the highest priority for successful natural cooling.** Buildings must be designed to take advantage of the favorable (and mitigate the adverse) characteristics of the site and its microclimate. For buildings using natural ventilation, this includes avoiding enclosed valleys and sheltered locations, maintaining adequate building spacing (avoiding wind shadows and wakes), and organizing the site layout to increase interior air velocities and minimize interior heat gain.

Sites near the crests of hills or ridges may provide increased exposure to winds while valleys and sheltered locations may lack the required air velocities. Ridgecrests can receive wind speeds which are often 20% to 80% higher than the surrounding flat ground (Fig. E.3). In very windy locations such sites may suffer from too much wind, causing potential structural and driven rain problems.

DESIGN STRATEGIES

When the wind strikes an obstruction, a wake zone forms downwind. Within this wake, wind velocities will decrease and wind direction will be changed. To maintain maximum exposure to the wind for ventilation, buildings should be sited outside the wake of any obstruction to allow each to act in isolation. To achieve this, **a clear spacing of at least 5H (5 x the height of the upwind building) is required** (Fig. E.4). Building spacing of less than 1.5H (1-1/2 x the height of the upwind building) may result in the establishment of a stable vortex or roller of trapped air, and ventilation through the downwind building can be quite weak. For spacing between 1.5H and 5H, intermittent vortices may occur and ventilation in the downwind building will be

E.3

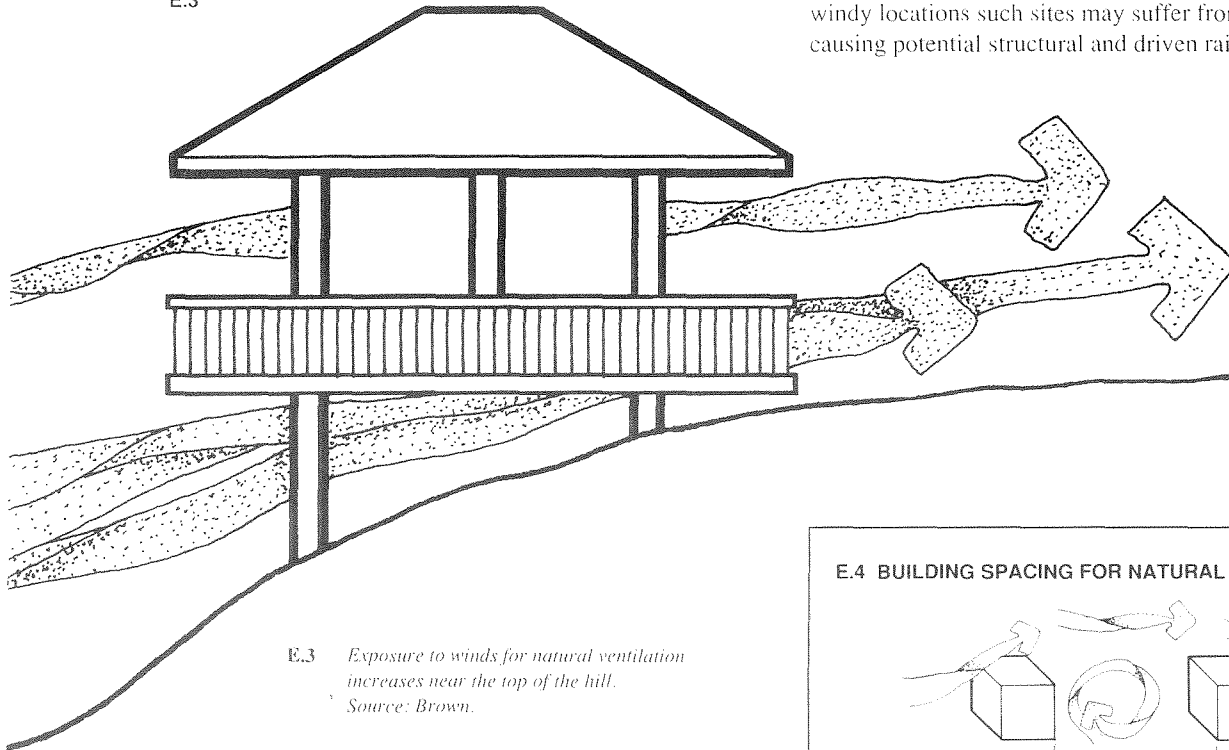

E.3 Exposure to winds for natural ventilation increases near the top of the hill.  
Source: Brown.

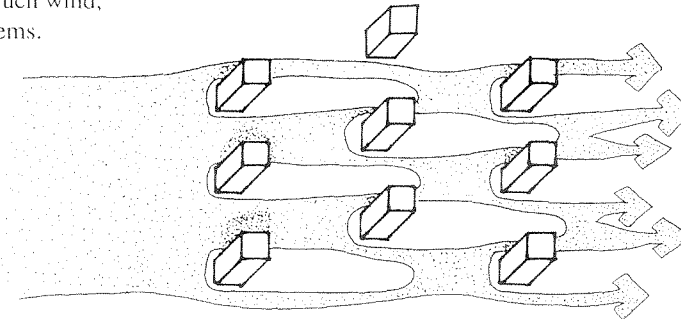

STAGGERING BUILDINGS FOR VENTILATION

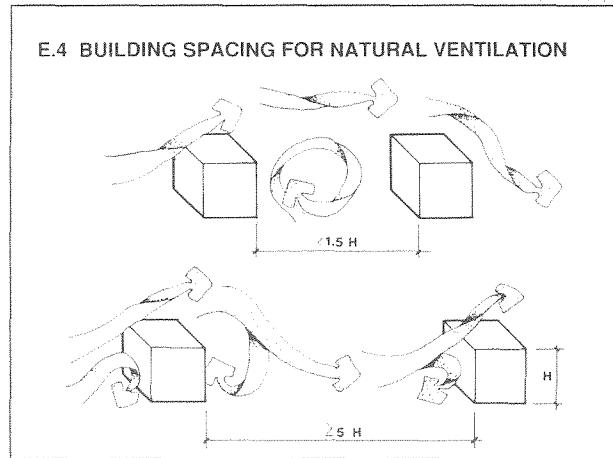

E.4 BUILDING SPACING FOR NATURAL VENTILATION

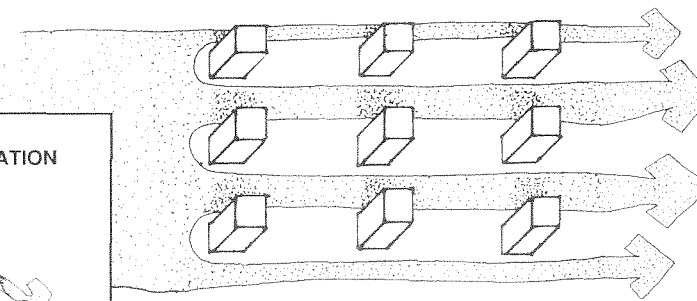

E.5 A checkerboard grid of buildings can maintain the potential for natural ventilation in a high density development.

sporadic and much less effective.

Buildings and landscaping can be designed to minimize the wake effect and allow for closer building spacing. If the buildings are staggered in a checkerboard pattern perpendicular to the wind, ventilation can be maintained for all buildings (Fig. E.5).

**E.6 SURFACE PRESSURES**

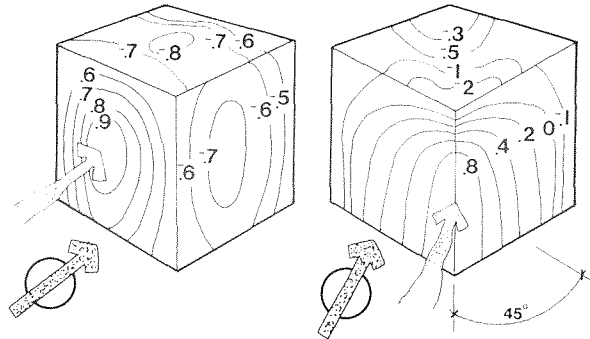

E.6 Surface pressures vary with wind direction. Openings in both positive and negative pressure zones are required for cross ventilation. Source: Architecture March 1989.

**PLACEMENT OF OPENINGS**

As wind strikes a building, a high pressure zone is created in front (upwind) of the object and a lower pressure area is created behind the object in the wake zone. Positive pressure on the windward side forces air into the building and negative pressure on the leeward side pulls it out of the building (Figs. E.6 and E.7)

The rate of interior air flow is determined by the magnitude of the pressure difference across the building and the resistance to air flow of the openings. The size, shape, type, and location of openings, especially the inlets, determine the velocity and pattern of the internal air flow. When designing and placing windows for ventilation, the following factors must be considered:

- a) the predominant wind direction;
- b) the building envelope and landscaping configuration which may hinder or facilitate natural ventilation of the interior spaces;
- c) the location and type of inlet, which have the largest effect on the air flow pattern through the space;
- d) the location and type of outlet, which have less effect on the air flow pattern;
- e) the velocity and distribution pattern of the air flow, which have the most effect on body cooling (the number of air changes per hour is relatively insignificant); and
- f) changes in indoor air flow direction, which tend to retard air speed.

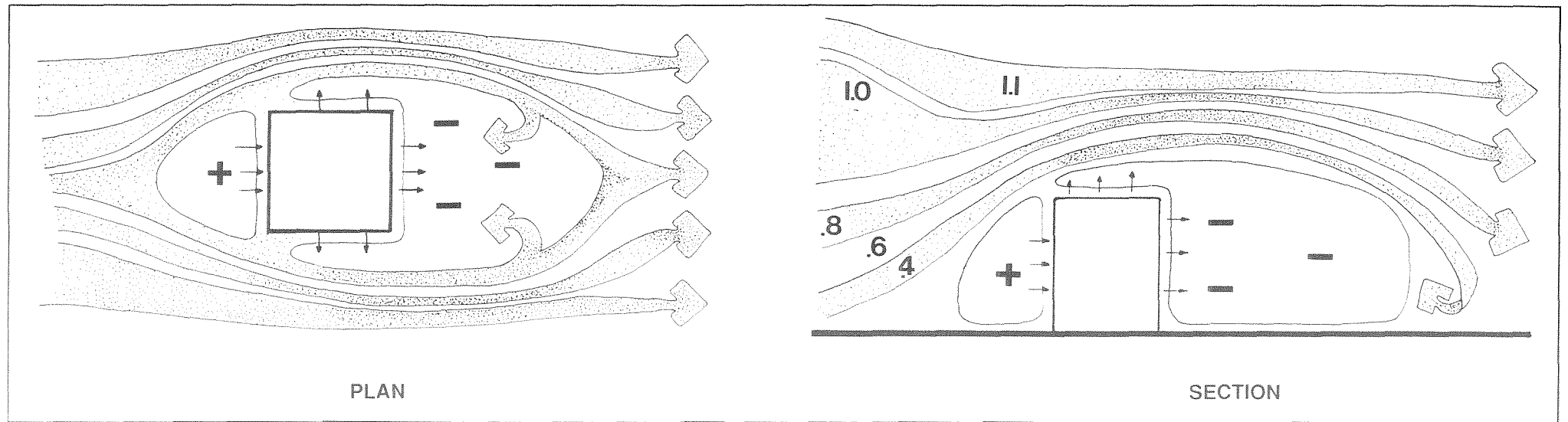

E.7 Airflow and pressure zones around a building.

OPENINGS FOR CROSS VENTILATION

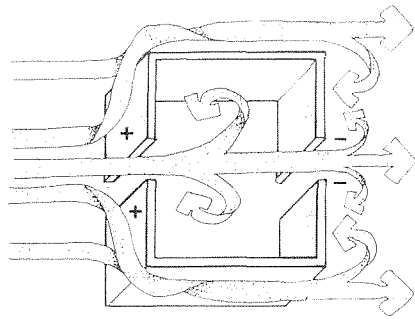

E.8 Airflow through a building ventilated by windward and leeward windows.

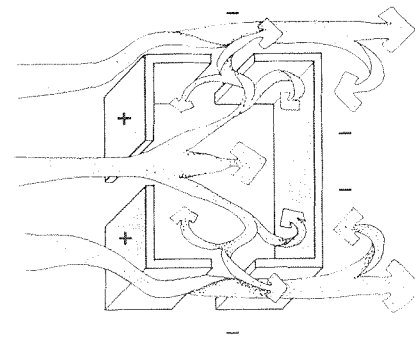

E.9 Airflow through a building ventilated by windward and side windows.

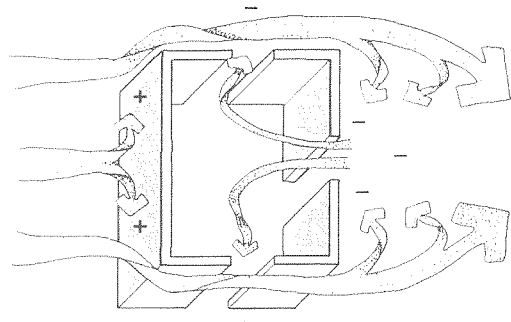

E.10 Poor ventilation results with openings on the leeward and sidewalls only as all windows are in suction.

CROSS VENTILATION

Cross ventilation provides the greatest interior velocities and best overall air distribution pattern. Openings in both positive and negative pressure zones are required for effective cross ventilation (Figs. E.8 and E.9). Placement of openings for effective cross ventilation depends on the room shape and the wind direction. (See Orientation for Natural Ventilation pg. 30.) Air flow through a building with all of its windows located on the leeward and side-walls results in poor ventilation as the pressure difference between the windows will be very small (Fig. E.10).

When windows are restricted to only one surface, ventilation is usually weak and independent of the wind direction. Average internal wind speed will not change significantly with increasing window size. One-sided ventilation can be made effective when two openings are placed on the windward face, the wind angle is oblique (20-70 degrees), the windows are as far apart as possible, and deflectors, such as wingwalls, are used (Fig. E.11).

HEIGHT OF WINDOWS

For wind driven ventilation, the height of the inlet has a great effect on the air flow pattern in a room while the height of the outlet has little influence on interior air flow. Positive pressures built up on the windward face of the building can direct air flow up to the ceiling or down to the floor of a room. Pressures are related to the relative area of wall above and below the window. Thus, a window located high on the wall directs air flow up to the ceiling because the positive pressure built up on the building face is larger below the window than above it (Fig. E.12). There is usually an abrupt drop (up to 25%) in air speed below the level of the inlet sill. For body cooling, the best location for windows is at or below body level. Remember that body level changes with room use; body level in a bedroom is at bed height, while body level in an office is at sitting height.

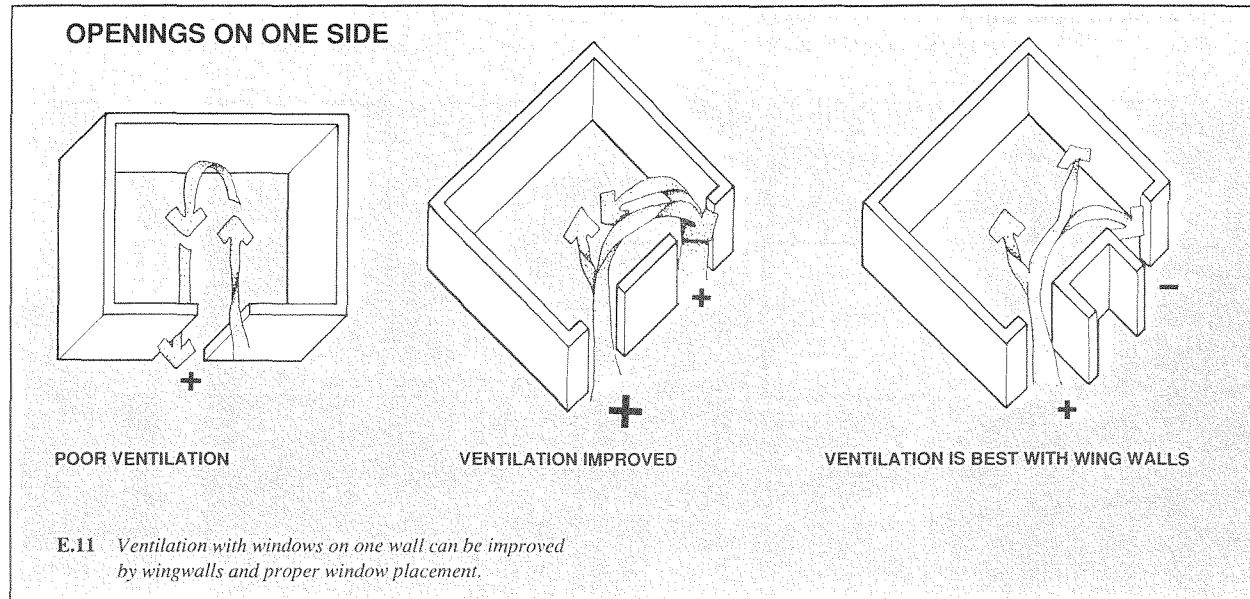

E.11 Ventilation with windows on one wall can be improved by wingwalls and proper window placement.



WINDOW SELECTION

Many types of windows can be used successfully for natural ventilation (Figs. E.13 and E.14). **The shape of the inlet window is the most important factor in determining the efficiency of wind cooling.** A horizontal shape is best at capturing and admitting winds for a variety of angles of wind incidence. The optimal shape has been found to be 8 times as wide as tall; however, smaller width to height ratios are also effective. In cross-ventilated rooms, the velocity of air flow is mainly determined by the area of the smallest opening. Average indoor velocity is highest when outlet area/inlet area equals 1.25. Thus, roughly equivalent inlet and outlet areas result in good overall air flow. For maximum air changes in cross ventilated rooms, use the largest area of openings possible with inlet areas equal to, or slightly smaller than, the outlet area.

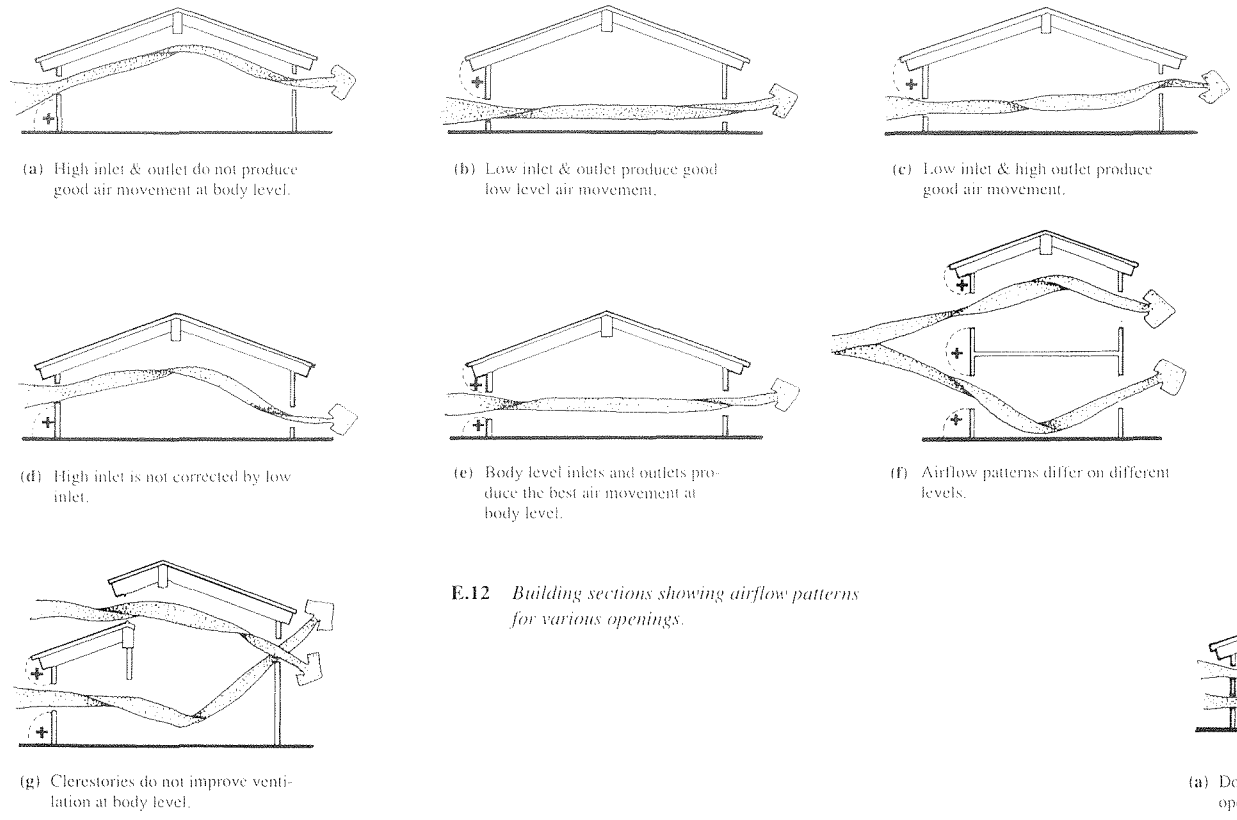

E.12 Building sections showing airflow patterns for various openings.

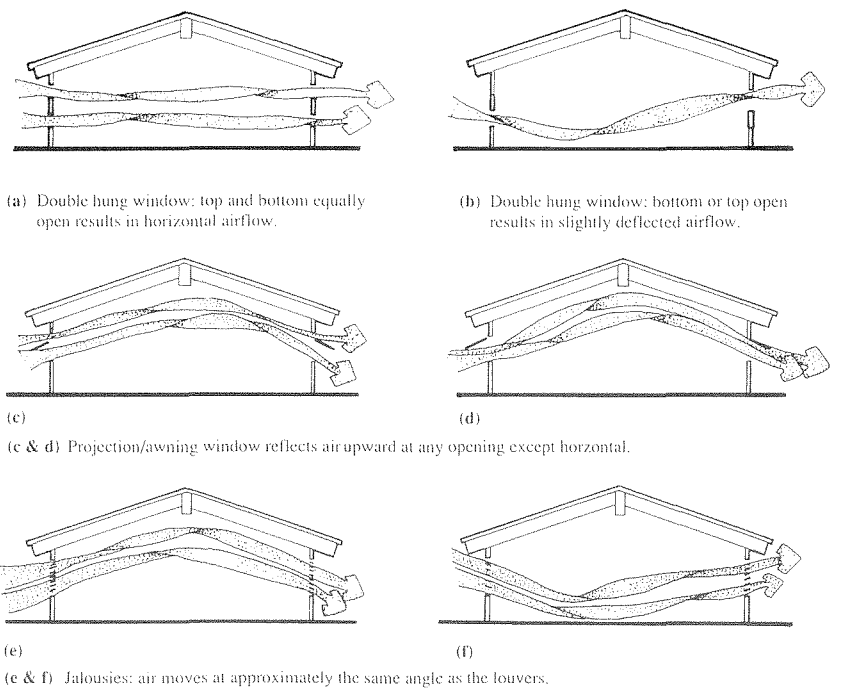

E.14 Building sections showing airflow patterns for various window types.

WINDOW SECTION FOR NATURAL VENTILATION			
WINDOW TYPE	INTERIOR AIR FLOW	MAX. OPEN AREA (%)	RECOMMENDATION FOR NATURAL VENTILATION
Double hung or Horizontal sliding	Horizontal in the same direction as the outside airflow. Some airflow leakage between panes.	50%	Should be located at level and directly in front of zone where airflow is desired.
Vertical pivot or Casement	Control of airflow along horizontal plane. Airflow leakage between open sash and frame and over top and bottom of open sash.	50-90%	Effects similar to wingwalls. Use at the level that airflow is desired.
Horizontal projection or awning	Upward unless fully open.	50-90%	Best placed below zone where airflow is desired.
Jalousie or Central pivot	Control airflow along horizontal vertical plane. Airflow at about the same as the louvers.	60-90%	Good placed at any height. Cannot be fully sealed. Maximum vertical control of airflow.

E.13

## INTERIOR PLANNING AND FURNISHINGS

Open planning of interiors and furnishings will prevent decreases in the effectiveness of natural ventilation, thus maintaining comfort for the occupants. Partitions and interior walls usually divert the air from its most direct path from inlet to outlet, lowering interior velocities and changing air flow distributions. To maintain high interior velocities for natural ventilation, interior walls perpendicular to the flow should be placed close to the outlet. Placement of walls or partitions can also affect air flow beneficially. Walls can be used to "split" air flow and create better overall air distribution in rooms with poor exterior orientation (Fig. E.15).

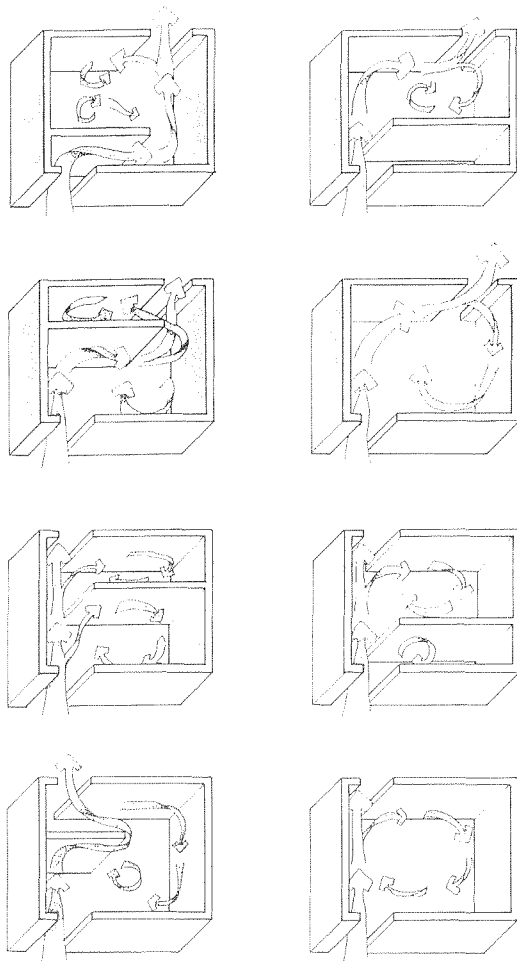

E.15 Air flow patterns with internal partitions.

## FANS

Fans are often required to supplement natural ventilation in the absence of wind. Fans reduce cooling requirements in two ways: by exhausting heat from the building's interior and by creating increased air movement within a living space. Ceiling or portable fans are most useful for bodily cooling and are often required for each primary occupied space to ensure that comfort will be maintained during periods of low wind, extreme temperature and humidity, or during heavy rain when the windows may be shut (Fig. E.16).

Whole-house fans are useful for removing built-up heat from building interiors, but the interior velocities created are in general too low for bodily cooling. Whole-house fans are usually located in the attic and use roughly one-tenth of the energy of air conditioners. Attic vents approximately twice the area of the fan should be used. It is possible to combine both a whole-house fan and ceiling or portable fans in one building.

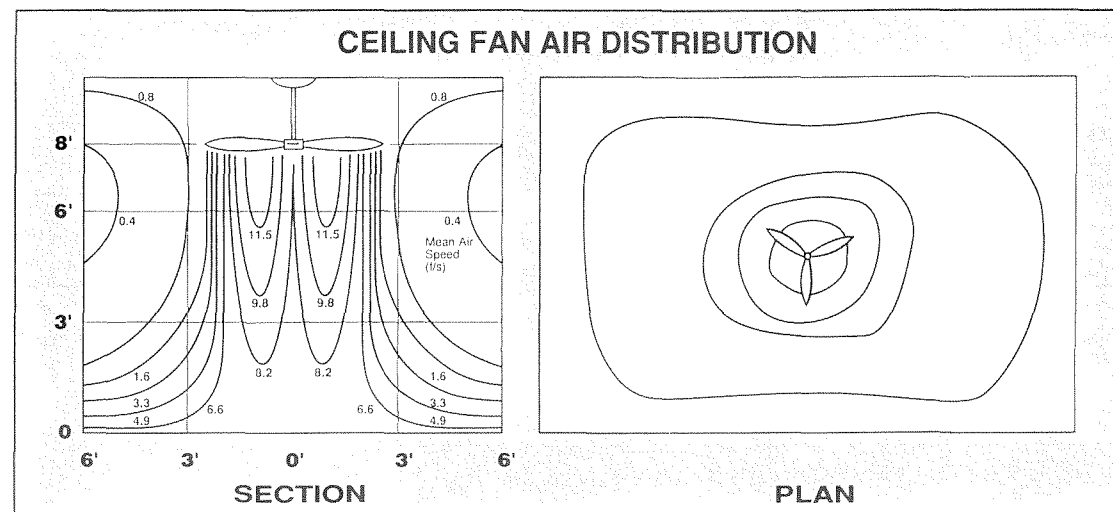

E.16 Air distribution patterns for ceiling fans.

LANDSCAPING  
Design Strategies

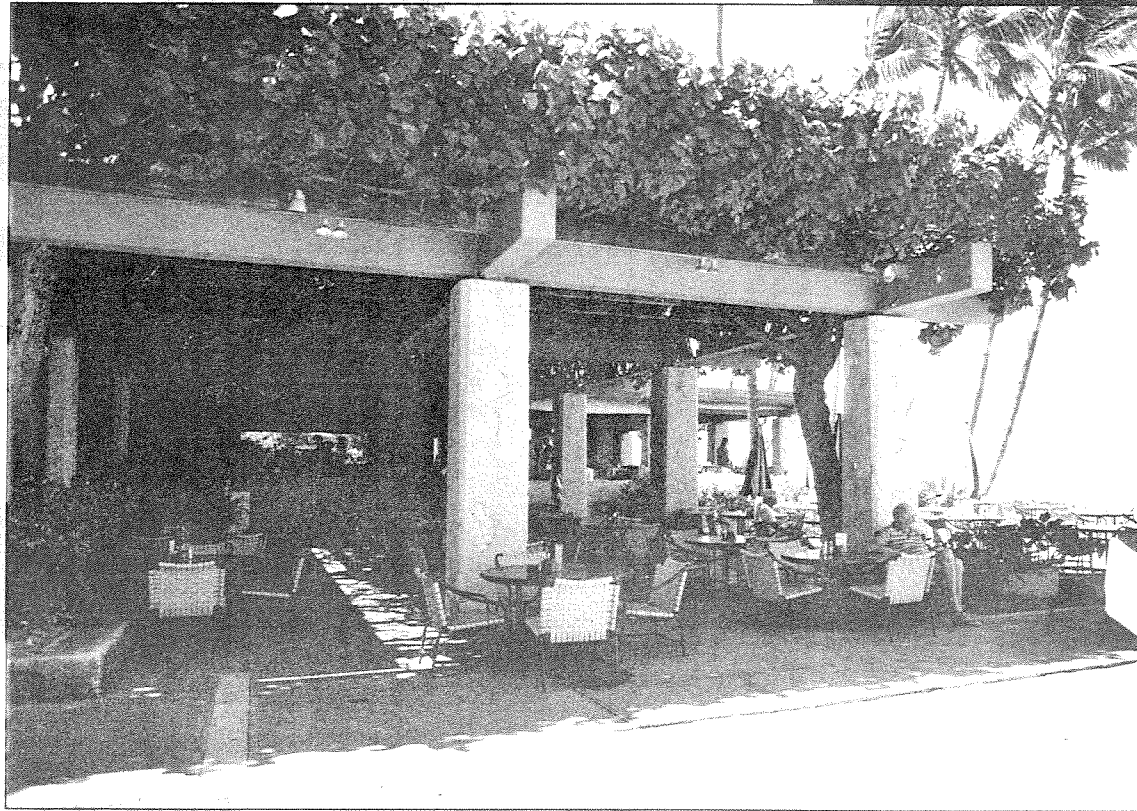

F.1 *The Outrigger Canoe Club, 1964. A trellis shades dining area. Architects: Ossipoff, Snyder & Rowland with Wimberly Whisenand Allison Tong & Goo. Photo: Max Raksasat*

Landscape provides visual relief and interest as well as a sense of comfort and well being. Landscaping can play a major role in energy conservation by providing shade, reducing heat and glare, and directing breezes.

LANDSCAPING FOR SOLAR CONTROL

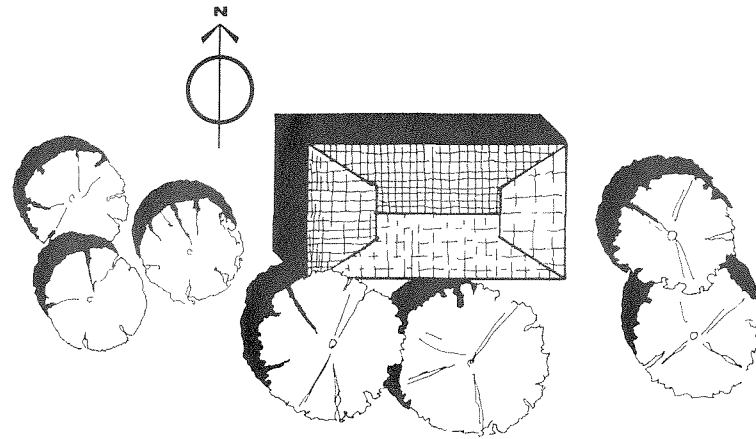

F.2 Landscape locations for shading

LANDSCAPE FOR SOLAR CONTROL

The shape and orientation of a building will usually determine how plants and trees should be located to provide shade at the right times of the day (Fig. F.2). Medium height trees a short distance from the east side will provide shade through the late morning. From around 10:00 am to 2:00 pm, tall trees are necessary to shade the roof from high sun. Afternoon sun from the west and northwest requires lower plants and shrubs than does the morning sun, since it is hotter and more intense. Trellises and hedges are particularly well suited to shading windows, the most critical areas to shade (Fig. F.3).

Attention should also be focused on shading the ground and particularly the pavement around a building. This can be especially important if a parking lot is located on the windward side of the building, since the air temperature immediately above an asphalt surface can reach upwards of 120 - 150 degrees F. Even downwind, a hot paved surface will radiate heat towards the building, increasing the air conditioning load.

Temperatures over grassy surfaces on a sunny day are 10 to 14 degrees cooler than those over exposed soils. Ground cover can also reduce glare around the building.

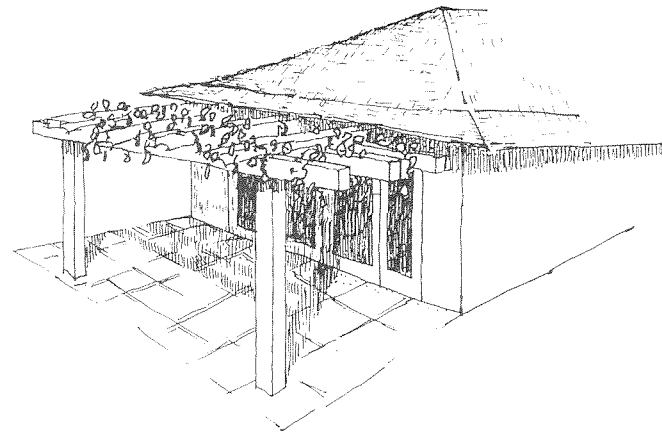

F.3 A trellis can provide shade.

LANDSCAPE FOR NATURAL VENTILATION

Rows of trees and hedges can form wingwalls which direct air toward or away from buildings. For ventilation, it is generally best to orient tall planting perpendicular to the window wall to channel air flow toward the opening, provided that solar control is maintained (Fig. F.4). Vegetation can create areas of higher wind velocities by funneling air through a narrow opening. An increase in air flow 25% above that of the upwind velocity can be achieved by planting (Fig. F.5). Sunlit open areas with man-made surfaces may heat the air above them and should be minimized on the windward side of naturally ventilated buildings. Ground cover is useful in reducing both the temperature and dust upwind from a naturally ventilated building.

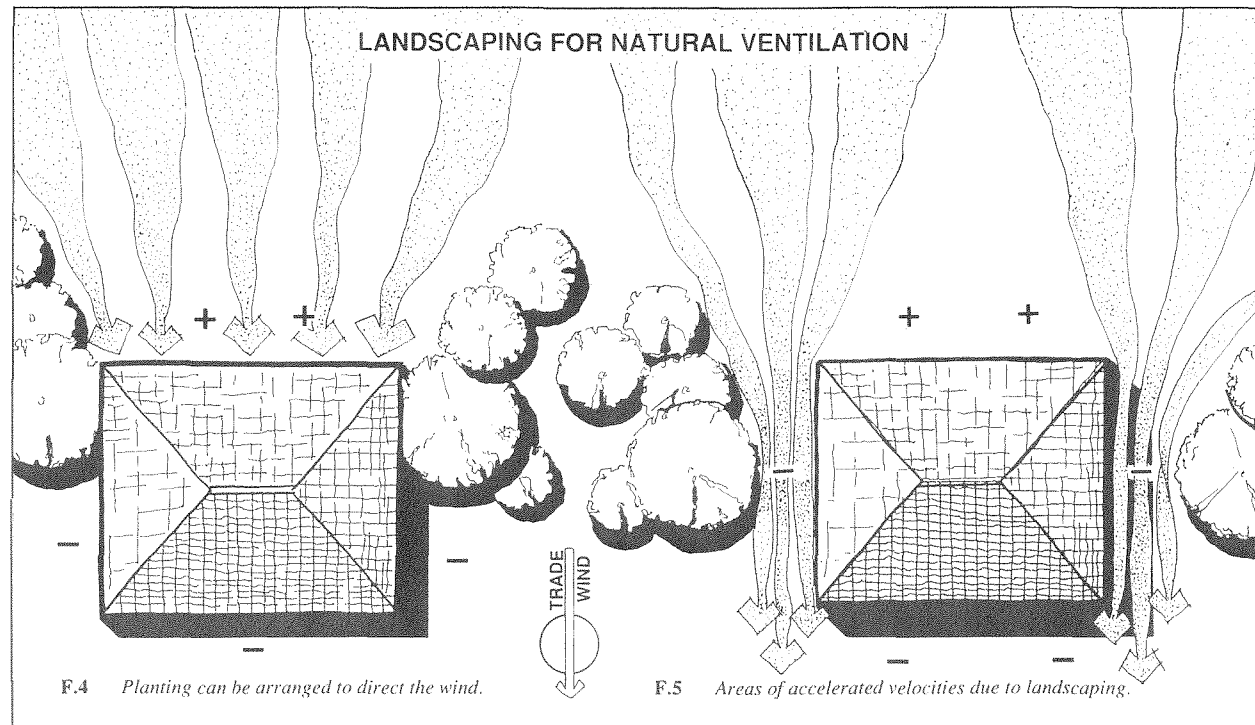

F.4 Planting can be arranged to direct the wind.

F.5 Areas of accelerated velocities due to landscaping.

BUILDING SYSTEMS &  
MATERIAL SELECTION  
Design Strategies

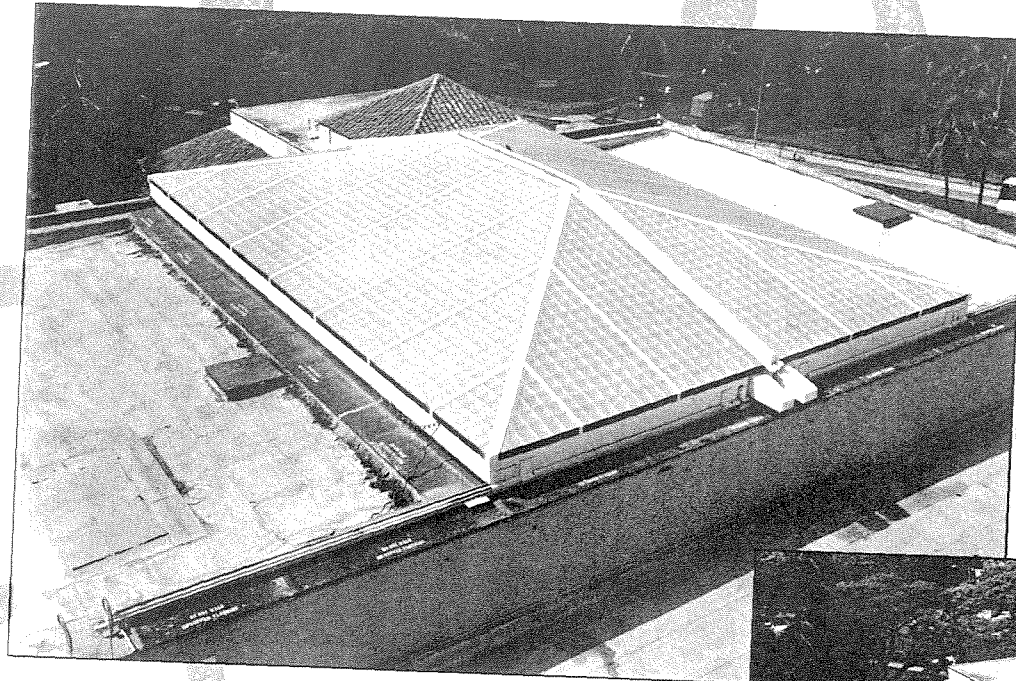

*G.I&2 Honolulu Hale Renovation, 1986. A moisture sensor triggers the large fiberglass skylight to slide over the central courtyard at Honolulu Hale when it rains. Photo: Max Raksasat.*

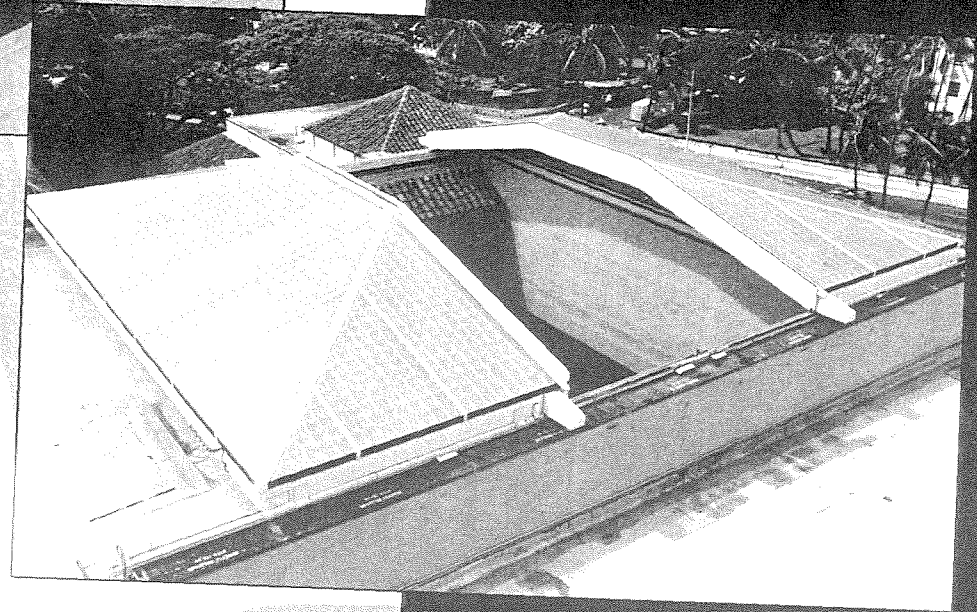

The architect's selection of building systems and materials will dramatically affect the building's energy performance. In our sub-tropical climate, the major source of heat gain is radiant heat through windows, roofs, and walls, usually in that order. To reduce the amount of heat that penetrates a building's exterior envelope, the materials selected should be capable of reducing both conductive and radiant heat flow.

The designer should look at each building surface and determine which materials can provide the optimum combination of characteristics to both reduce heat gain and meet other design objectives. Because it is difficult to determine intuitively the optimum combination of materials for energy performance today, designers frequently utilize computer energy analysis during the schematic and design development phases to help decide which combination of materials offers the best performance characteristics for the least cost.

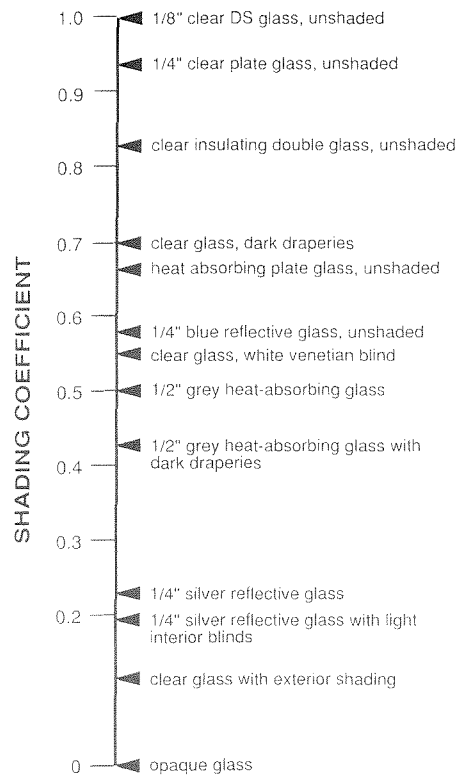

G.3 Shading coefficients for various glass types. Typical shading coefficients vary by manufacturer. Source: Lord.

GLAZING

Glazing is one of the most important building material selections that an architect makes. **The size and location of windows and type of glass chosen are often the major determinants of a building's energy performance.**

Glazing also impacts the building's aesthetics, interior environment, and long term maintenance cost. From an energy performance standpoint, glazing material should have a high daylight transmission and a low shading coefficient, particularly if the glass is unshaded (Figs. G.3 and G.4). Clear glass has both high daylight transmittance and shading coefficient, making it most useful in combination with exterior shading systems. Highly reflective and dark solar bronze glazings exclude heat effectively, yet limit the amount of daylight

penetrating the building's interior. Some green tinted glazings offer a good compromise between solar control and daylighting.

Double glazing is becoming the standard on the mainland and low emissivity (Low-E) coatings are becoming popular. Low-E coatings reduce solar heat gain, but for durability must be used in a double glazed window. As the temperature difference between a building's interior and exterior is generally small in Hawaii, double glazing is not required. In a computer simulation the cost savings for a perimeter zone of an office building were considered for Hawaii's climate substituting double for single glazing. Double glazing saved approximately \$20 per year, resulting in a 70 year payback.

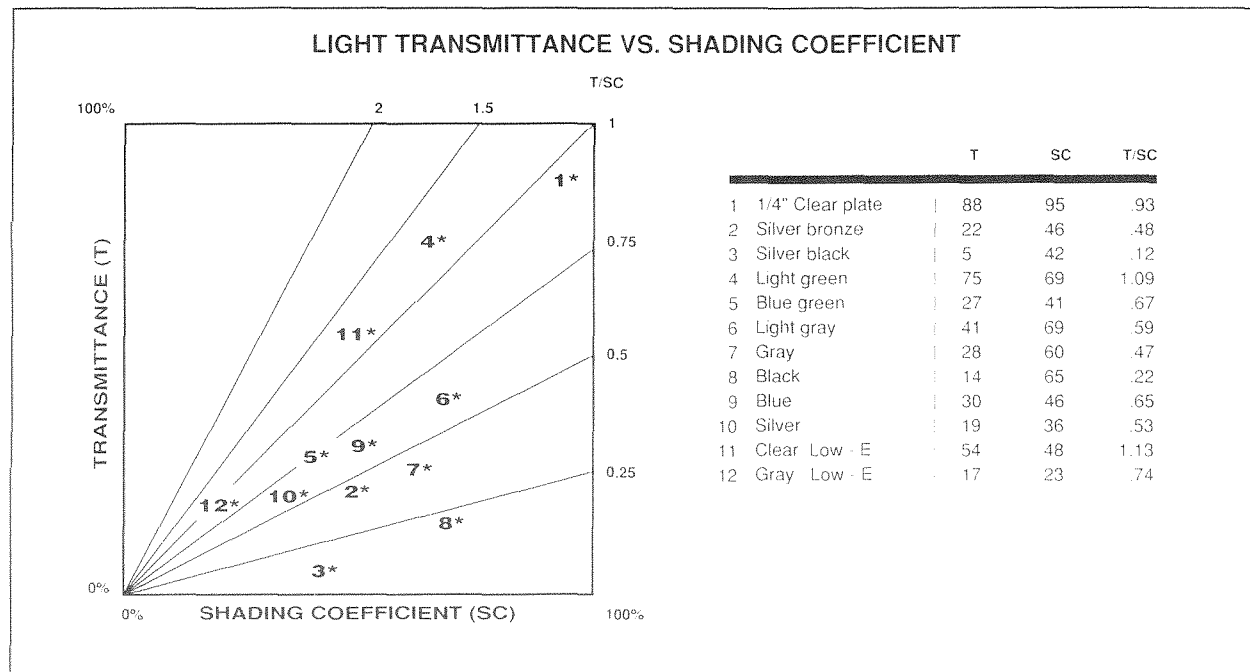

G.4 Light transmittance vs shading coefficient for various glass types. Source: Schiller.

## INSULATION

Insulation of one form or another is desirable in many types of buildings, particularly in roofs and walls heavily exposed to solar radiation. Insulation will be most effective in low rise, "roof dominated" buildings and have less effect in high rise buildings as their cooling loads are generated primarily by solar gain through glazing and by internal heat gain.

## ROOF AND CEILING INSULATION

A background study aimed at revising Hawaii's energy code recommends that the most cost effective level of insulation is R- 8 (approximately one inch) when rigid insulation is used above the roof deck (*Fig. G.5*). Computer simulations were performed to determine the appropriate level of insulation when fiberglass batt insulation could be used. Increasing the insulation level from uninsulated to R-11 to R-19 decreased the annual cooling operating cost from \$1.08/sq. ft. to \$0.92/sq. ft. to \$0.88/sq. ft. in the perimeter zones (*Fig. G.6*).

Vented attics, such as the Hawaiian hip roof, can significantly reduce cooling costs and improve thermal comfort. Computer simulations show that adding a second roof to shade an uninsulated roof reduced the annual cooling operating cost by \$0.24/sq. ft. in offices and \$0.19/sq. ft. in hotels/residences. The effectiveness of a vented attic is reduced but is still significant when compared with an

G.5 Life cycle cost analysis for rigid insulation applied under roofing.

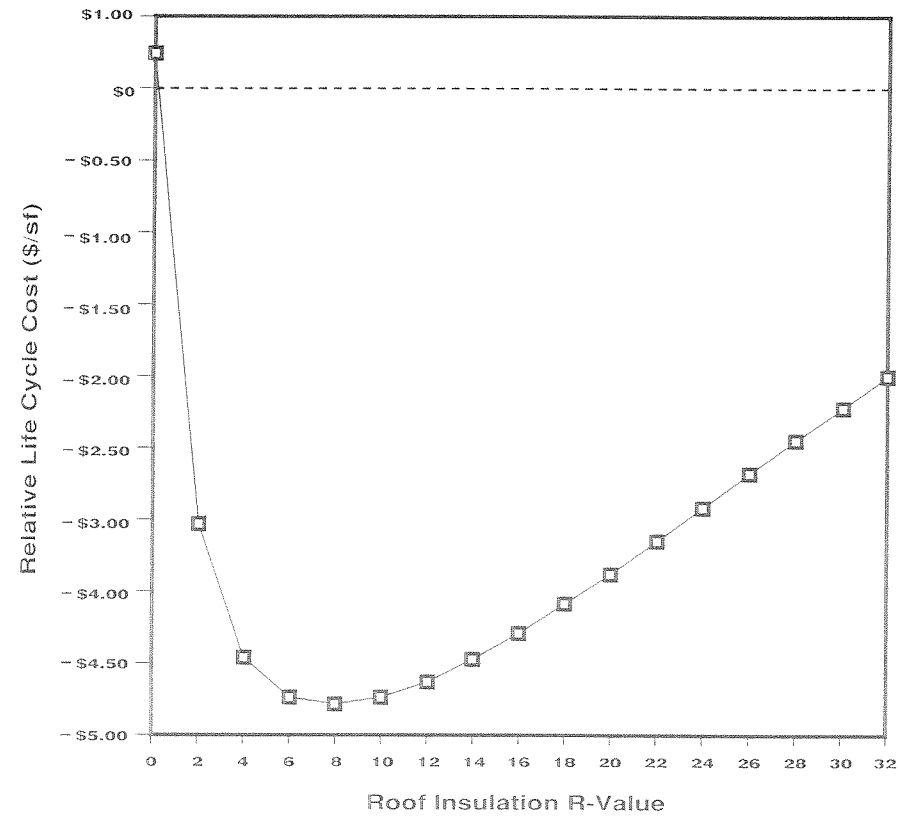

insulated roof. Laying R-11 batt insulation on the ceiling and ventilating the attic space reduces the annual cooling cost about \$0.10/sq. ft. in offices. In hotels/residences, savings are slightly less, at about \$0.06/sq. ft. These are idealized examples that assume the attic is perfectly ventilated, and air temperature in the attic never rises. In most vented attics the benefits will be reduced but still significant.

Ceiling insulation is also important for thermal comfort in naturally ventilated buildings because it decreases the mean radiant temperature of the ceiling. A study of ceiling

insulation and comfort in naturally ventilated buildings was performed to determine whether proposed energy code revisions should apply to buildings without air conditioning. This study found that adding R-19 insulation to an office with adequate air movement for natural ventilation reduces the period of discomfort in the afternoon from 36% to 12% of the time.

WALL INSULATION

The materials and labor associated with R-11 fiberglass batt wall insulation in framed walls add about \$0.46 per sq. ft. of wall area. In our case study, operating costs were reduced by about \$0.10/sq. ft. for offices resulting in a simple payback of 3.7 years (Fig. G.7). For hotels/residences, operating costs are reduced by about \$0.08/sq. ft. with a simple payback of 4.6 years. Adding insulation to an 8-inch thick masonry wall offered no savings in operating costs. In fact, operating costs were found to be slightly higher for insulated mass walls in this study.

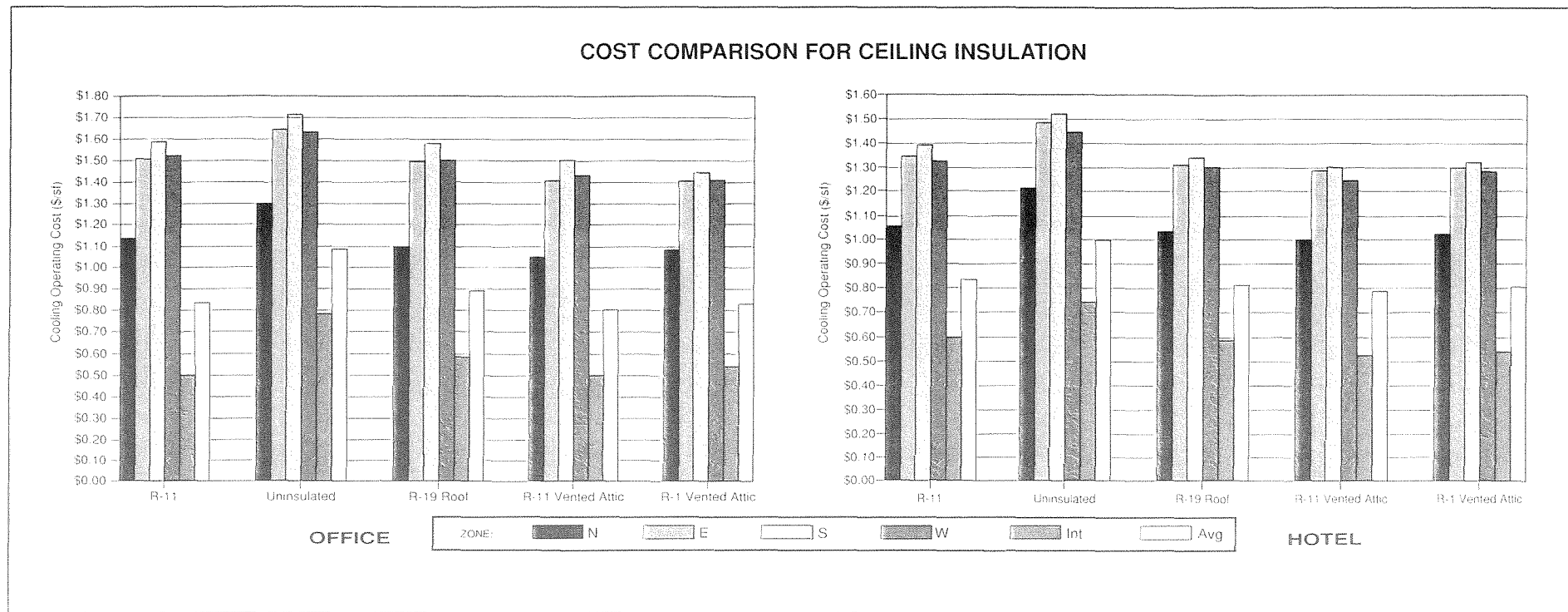

G.6 Operating cost comparisons for various roof insulation options for offices and Hotels. Source: Eley.



RADIANT BARRIER INSULATION

Most forms of thermal insulation restrict conductive and convective heat flow by trapping layers of still air, much like a down jacket. Stopping the flow of heat into a building through radiation may be more important in Hawaii, particularly in roofs and attics. In attic spaces, radiant barriers are most effective either draped over or fastened to the underside of the top chord of a truss or rafter system (Figs. G.8 and G.9). For roofs without attics and in wall systems, radiant barriers can be installed facing unvented or, preferably, vented air spaces. Radiant barrier systems will be most effective for roofs, unshaded west and east walls, and other wall applications (in that order).

COLOR

The effect of surface color on heat gain into a building's interior can be quite pronounced under the intense tropical sun. Any solar radiation not reflected by a building's roof and walls is absorbed, raising the surface temperature. The darker the surface color, the more solar radiation it will absorb and the hotter it will become (Fig. G.10). Measurements in Israel showed the surface temperature of a medium gray colored roof was elevated as much as 55°F. above a whitewashed roof.

The effect of color on the surface temperature of walls varies with their orientation with the greatest temperature swings occurring on walls facing east and west. Surface temperatures for medium gray colored walls facing east and

west were measured up to 41°F. above the outside air temperature of 77°F. Measurements on whitewashed walls under the same conditions resulted in an increase of less than 6°F. above the surrounding air.

The effect of these increased surface temperatures on interior comfort and air conditioning loads depends on the construction and the amount of insulation in the wall or roof system. If the exterior wall or roof is massive, there will not be sharp interior rises in interior temperature. However, the average temperature of the thick wall will be raised, resulting in less comfortable conditions. If the wall or roof is thin and uninsulated, variations in external color will greatly affect the air conditioning load and comfort inside of the building.

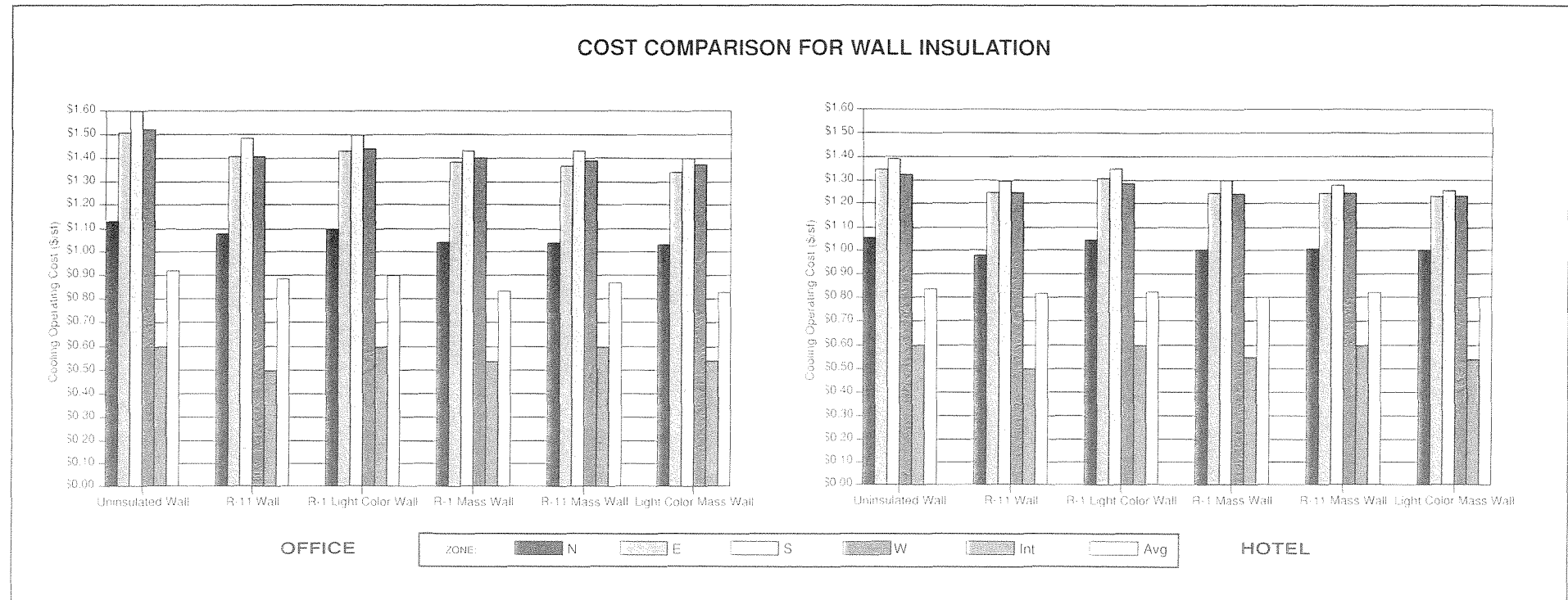

G.7 Operating cost comparisons for various wall insulation options for offices and Hotels. Source: Eley.

Computer simulations were performed to evaluate the cost savings in Hawaii for changing the wall surface color from an absorptivity of 0.7, (red brick or bare concrete) to absorptivity of 0.4 (a white painted surface). Painting the walls white reduced the annual operating cost an average of \$0.07/sq. ft. in the perimeter zone for framed walls with no insulation (Fig. G.7). The impact is expected to be less significant for insulated walls. Over massive walls, changing the color reduces the annual operating cost an average of \$0.03/sq. ft. in the perimeter zones.

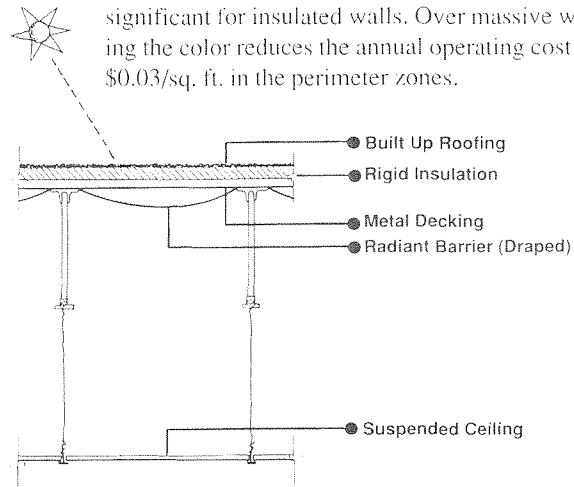

G.8 Radiant barrier construction for a typical flat roof commercial building. Source: RSEC Design Notes.

ROOFING

A study of the effectiveness of a variety of roofing membranes as a barrier to radiant heat gain is being conducted by Don Shaw, AIA and Fred Creager, AIA at the University of Hawaii. Preliminary results confirm that the color of the roofing has a dramatic effect on interior heat gain, especially in uninsulated roofs. They also note that light colored roofing is a much more effective radiant barrier than aluminized coatings. This is due to the fact that the emittance (ability of a surface to radiate heat) of a shiny metallic surface is only 6-23% as high as that of a white surface. Another surprising finding is that a rough surface texture can be a significant factor in reducing the heat gain through the roofing. The study suggests that a rough surface, such as gravel, increases the surface area and thus the cooling potential of winds blowing over the surface of the roof.

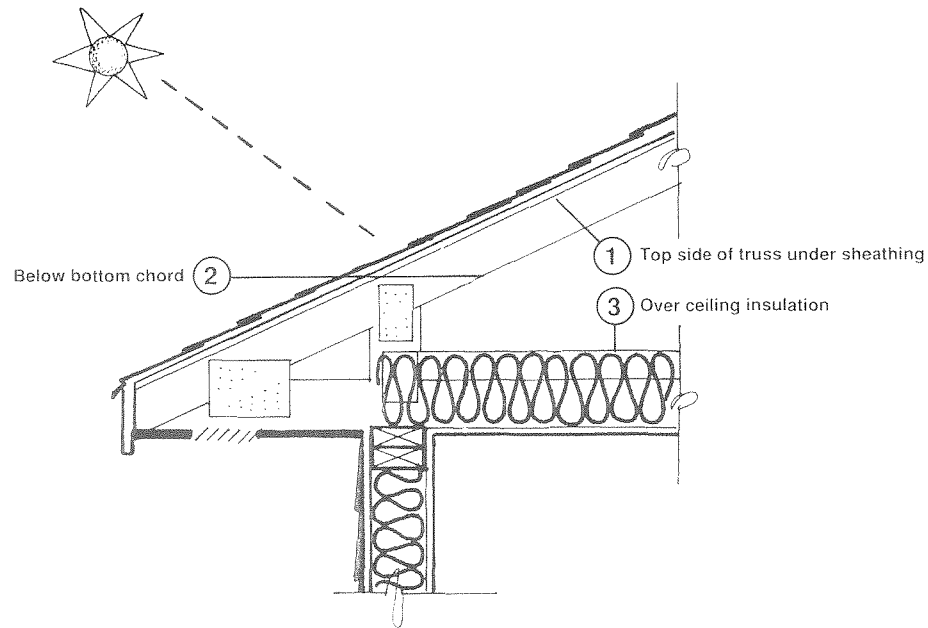

G.9 Attic section with three possible locations for a radiant barrier. Source: RSEC Design Notes.

THERMAL MASS

Massive building materials such as concrete and masonry, when directly exposed to building's interior, can act as a great thermal flywheel. The highs and lows of temperature variation are less extreme. Thermal mass is most effective in areas of the country that experience large diurnal swings in temperature. Most areas in Hawaii experience small diurnal temperature swings rendering thermal mass less effective here than in many mainland locations.

SURFACE REFLECTANCE PERFORMANCE

COLOR	%
White	80-85
Light gray	45-70
Dark gray	20-25
Ivory white	70-80
Ivory	60-70
Pearl gray	40-70
Buff	30-50
Tan	20-40
Brown	25-50
Green	20-30
Olive	50-60
Azure blue	35-40
Pink	50-70
Cardinal red	20-25
Red	20-40
Black	10

Approximate Reflection Factors

Source: Evans, Benjamin H., *Daylight in Architecture*, Copyright 1981 Reprinted by permission of McGraw-Hill Book Co., New York

G.10 Reflectances of colors in the visual spectrum. Source: Evans.

# EQUIPMENT EFFICIENCY

## Design Strategies

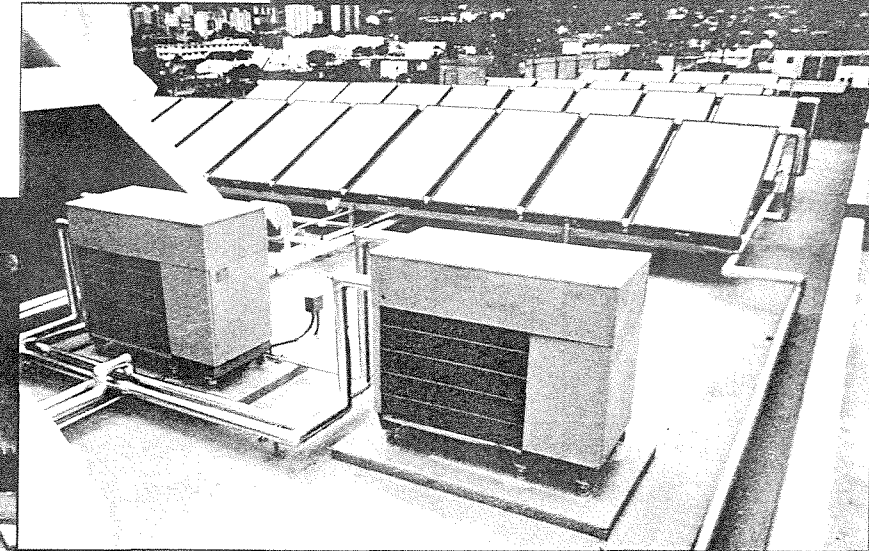

H.1 *Banyan Street Manor Condominium, 1977. Solar collectors for water heating were designed as an integral part of the building. Architects: Milton Sher & Associates. Solar design and photograph: Mike Bean.*

H.2 *Crystal Park Condominiums, 1983. Heat pumps provide back up for solar collectors. Architect: Jo Paul Rogstad. Solar design and photograph: Mike Bean.*

The design of an energy conserving building requires the coordinated effort of an experienced, competent design team. The architect should clearly communicate goals regarding energy efficiency to the mechanical and electrical engineers early in the design process. Before schematic design begins, the project team should discuss the most reasonable energy conservation strategies relative to the project's scope and budget. The architect should monitor the engineer's equipment and lighting selections to ensure that promising alternatives have not been overlooked.

## AIR CONDITIONING

Hawaii's humid semi-tropical climate presents design problems distinct from temperate zone buildings. When natural ventilation cannot be utilized, the relatively uniform annual temperature is too warm for human comfort, and the relative humidity can become too high for building interiors.

An internal temperature of about 74°F. with humidity ranging from 50 to 65% is ideally comfortable for occupants dressed for business in Hawaii. In Honolulu, the outdoor temperature is higher than 74°F. for about 85% of the total annual hours between 8:00 am and 6:00 pm. The outdoor air relative humidity in Hawaii ranges generally from 40 to 80%. A typical early afternoon figure is 60%. If indoor relative humidity in air conditioned buildings exceeds 65%, mold and microorganisms may become a nuisance, particularly in the cooled supply ducts.

With relatively dense urban areas, the high cost of construction, and our desire for optimal comfort, Hawaii uses air conditioning extensively, particularly for institutional, commercial, and highrise residential occupancies. A determination of whether a space is to be air conditioned should be made before architectural design begins. In Hawaii's climate, an architectural compromise to design a building both for part-time air conditioned use and part-time non-air conditioned use is generally not energy efficient.

Air conditioning is indicated for areas with high internal heat generation, dense occupancy, poor orientation, lack of external sun shading, the need for temperature or humidity control, or occupant preference. An air conditioning system must be sized to remove internal heat gains from lights, people and equipment; heat gain from solar radiation; and must also be capable of cooling and dehumidifying the outdoor air required for ventilation. If occupants neither need nor want air-conditioning most of the time, supplemental cooling such as room air conditioners can be effective in small areas.

Typical average (not peak) values for cooling ventilation air in commercial spaces are about 5 to 10 BTU/hr per square foot of floor area.

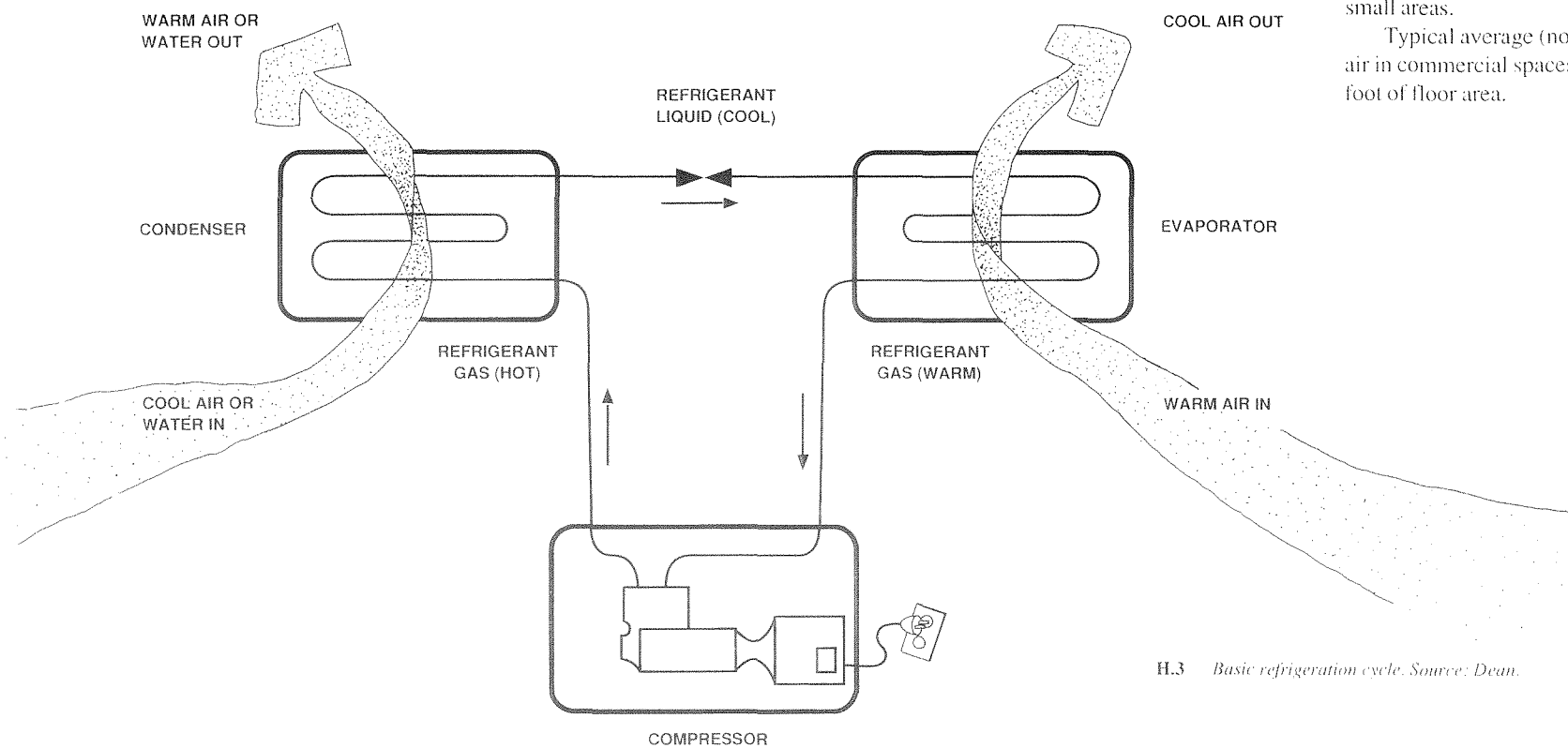

H.3 Basic refrigeration cycle. Source: Dean.

For cooling, air conditioning equipment must have a refrigeration system which removes heat and water vapor from the building and discharges it to the outdoors; a transport system of air, or of chilled water and air, to distribute the cooling; a filtration system to clean the indoor air; and an automatic control system for operation (Fig. H.3).

Air conditioning equipment must be selected to cope with maximum heat gains, yet be sufficiently flexible to operate properly at low-load times. There should be sufficient zones (separate temperature-controlled areas) to match load variations due to change in sun position, occupancy, lighting, or equipment operation.

Smaller air conditioning systems use unitary or packaged air conditioners in which all of the required components are factory installed in one (self-contained) or two (split-system)

major assemblies. For bigger air conditioning systems, field assembled systems are more frequently used. When properly designed and installed they can be more energy efficient than unitary systems (Fig. H.4).

Most air in air conditioned buildings is recirculated, cleaned by filtration, and then re-conditioned. Some outdoor air must be introduced and an equivalent amount exhausted or allowed to exfiltrate to provide ventilation. Ventilation is needed to dilute internally generated contaminants and odors. A relatively small movement of air into and out of buildings occurs by normal infiltration and exfiltration through cracks and small openings, and by opening exit doors. This is usually insufficient for adequate ventilation. To conform to health regulations and for good ventilation practice, outdoor air should be filtered and introduced through the air-conditioning apparatus for proper distribution within the building. Higher ventilating rates are required for areas with heavy smoking or high occupant density.

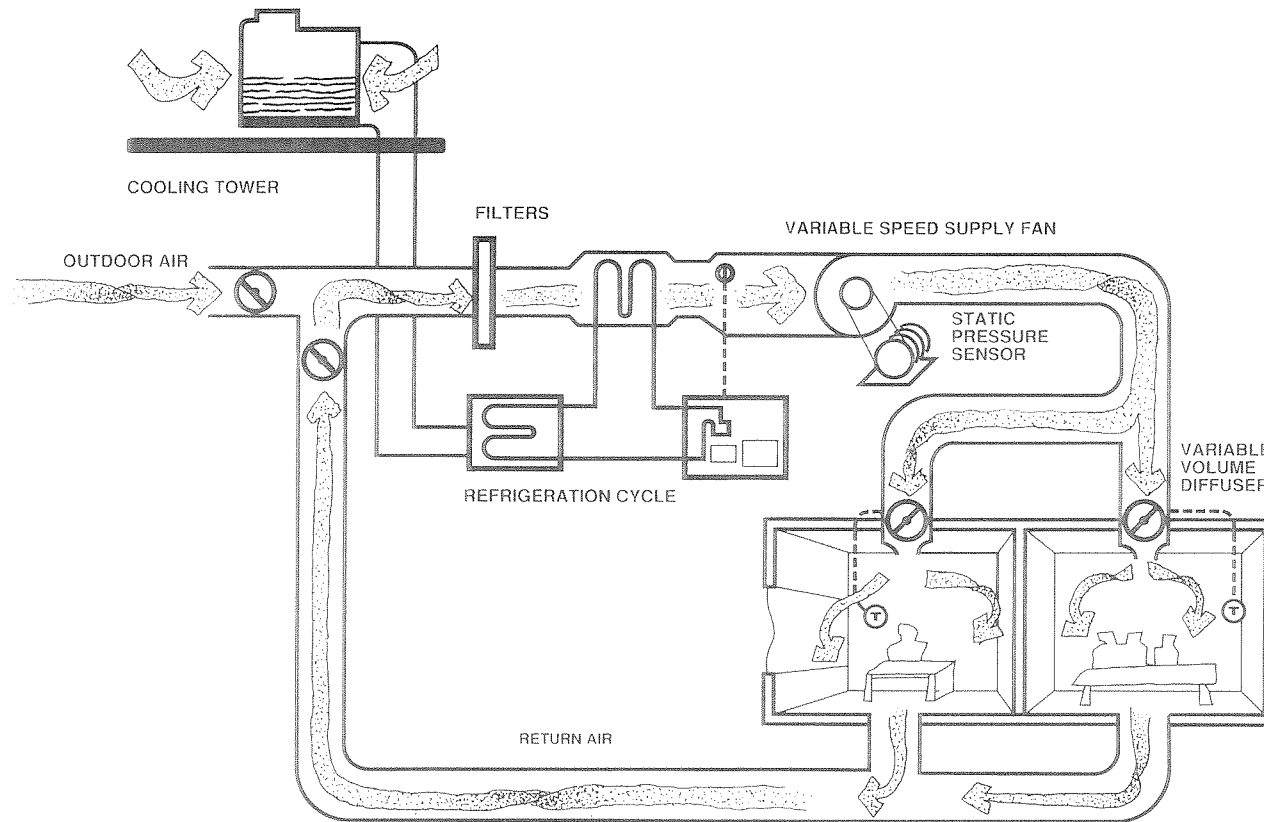

H.4 Variable air volume air-conditioning system. Source: Dean.

#### HUMIDITY CONTROL

The amount of dehumidification desired is often more than can be achieved even with efficient air conditioning system operation. Package air conditioners and poorly designed, installed or operated field assembled systems can result in indoor spaces with up to 70% or higher relative humidity.

For most comfort cooling, properly designed air conditioning can keep the relative humidity within reasonable bounds of 55 to 60%. The most practical way to obtain low relative humidity is to overcool the air to condense out more water vapor, then reheat the air a little so it does not chill occupants and make the conditioned space too cold. There is usually a significant capital cost penalty for reheat. The operating cost, however, is even greater unless solar heat or waste heat from the air-conditioning system's refrigeration can be used.

A heat pipe is a device that can reduce humidity while consuming little electricity. As return air passes through the coil on one side of a heat exchanger, the air is cooled, reducing its humidity. This air is then chilled below the desired temperature by the air conditioner. The cool supply air is passed through coils on the other side of the heat exchanger where it is reheated, using "waste heat" extracted from the return air (Fig. H.5).

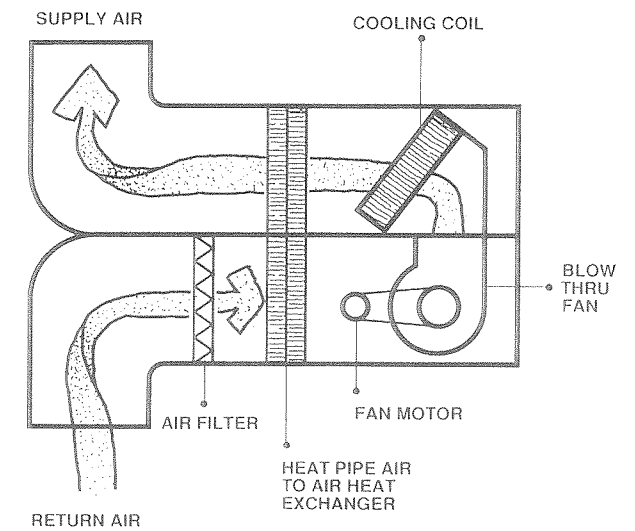

H.5 A heat pipe heat exchanger can reduce humidity in an air-conditioning system using only additional fan energy.

## WASTE HEAT

All of the heat removed from a space by an air conditioning system plus the heat equivalent of the electrical power operating the refrigeration is discharged into the atmosphere. Some of this heat can be reused by a "heat pump", a refrigeration machine which can be used to heat domestic water, or to preheat it when temperature limits are too low.

Condensers of air conditioning systems can be water cooled. The condenser's cooling water can then be used either to reheat conditioned air to control humidity or as domestic hot water. Simplicity of system design is necessary for efficient operation.

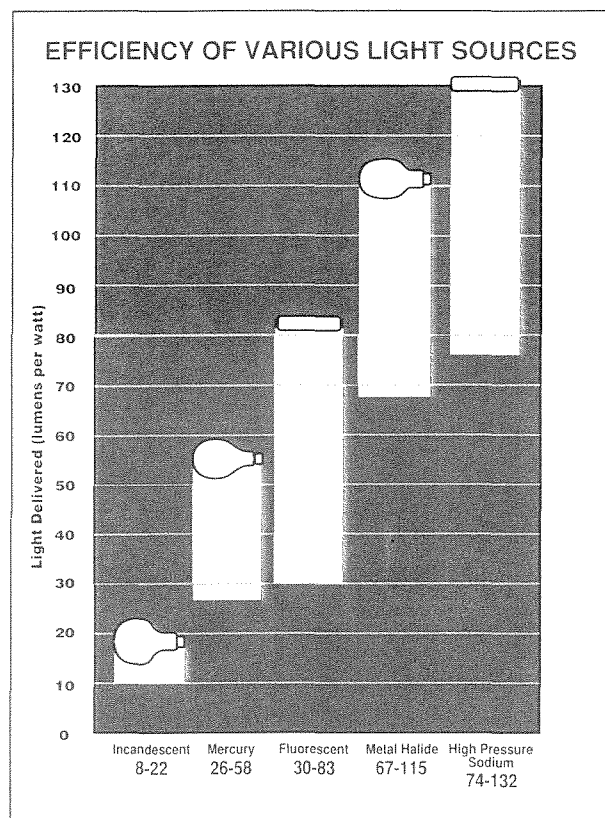

H.6 Source: U.S. Department of Energy.

## LIGHTING

Lighting is a major source of heat to be removed by air-conditioning systems. Incandescent lamps emit far more heat per unit of light than other electric light sources (*Fig. H.6*). Their use should be restricted to lights that are usually not on, or where there is a need for a particular lighting effect. The commercial lighting workhorse is the fluorescent lamp. Significant energy savings can be achieved by selecting energy efficient lamps, ballasts and luminaires.

There are many building lighting applications in which H.I.D. (high intensity discharge) metal halide or high pressure sodium lamps may be used, at an efficiency level higher than fluorescent lamps.

Good lighting design results from cooperation between the architect, electrical engineer, and other interior design professionals. Often specific pre-knowledge of uses within a space will permit the use of task lighting to the proper degree, with a lower level of ambient lighting.

Good lighting of office space can usually be achieved with under two watts per square foot of floor area. For every reduction of one watt for lighting of air conditioned space, there is an additional 0.35 to 0.50 watts savings in air conditioning equipment electric power consumption.

## SYSTEM OPERATION

Building energy management systems are becoming more practical with more standardization of microprocessor equipment controls. Institutional and large commercial facilities will benefit most from such a well-planned energy management system.

Good maintenance and operation are major considerations in all building mechanical and electrical system design. Simple designs with adequate access for servicing equipment and a competent operating and maintenance program will save far more energy than almost all design refinements introduced to save energy.

IMPLEMENTATION

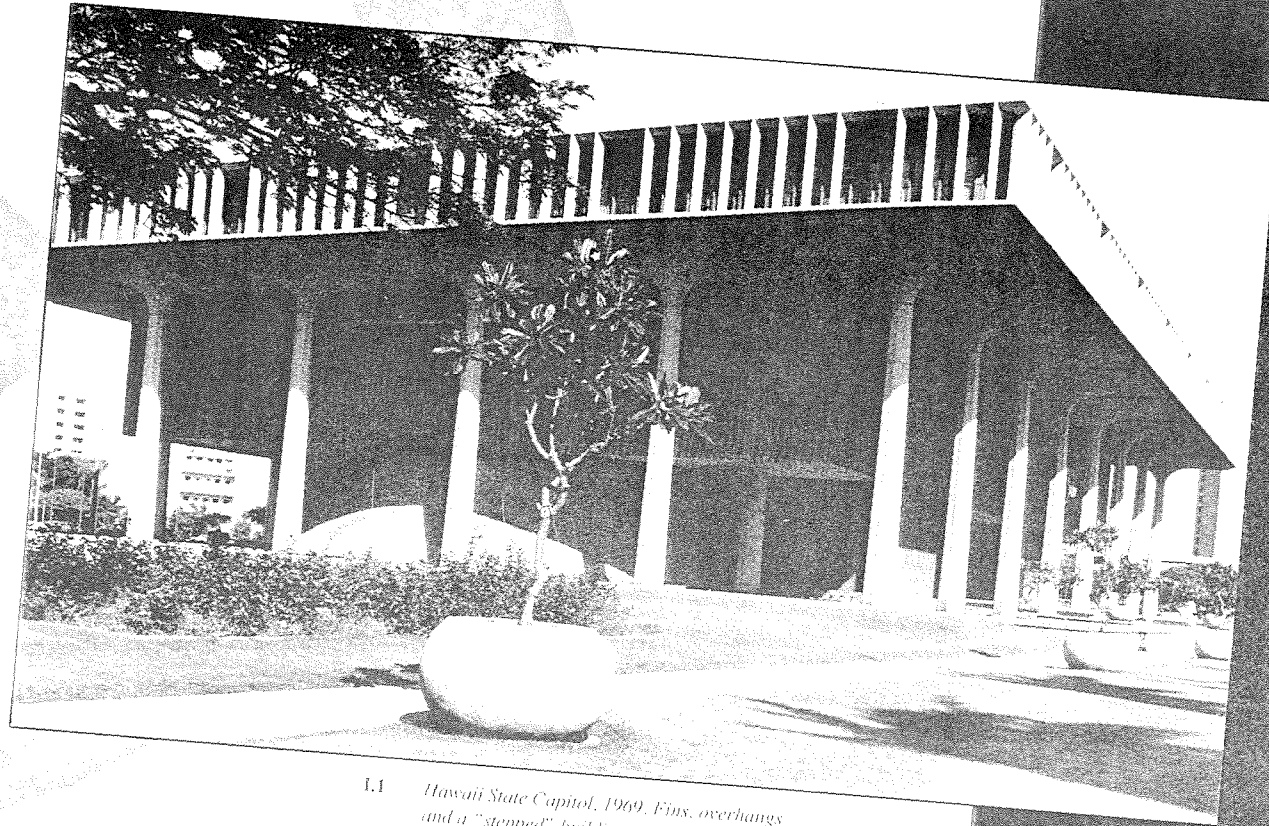

I.I *Hawaii State Capitol, 1969. Fins, overhangs and a "stepped" building section are used for shading. Architects: Belt, Lemmon & Lo with John Carl Warnerke & Associates.*

The ultimate success of any of these design strategies depends on how well they are integrated into the complex process of architectural design. It is the architect's responsibility as a professional to demand satisfactory energy performance in each building design, just as he demands structural integrity. Effective integration occurs when energy issues are considered at each phase of the design process.

In the predesign stage the unique problems and opportunities regarding energy should be identified. This often involves investigation of the program, the building type and the site. Information is collected to ensure that the decision-making process related to energy concerns is accurate.

Energy performance targets and goals for the project should be established in the programming stage. Design strategies with the potential to reduce significant energy consumption should also be identified in this phase.

The schematic design phase offers the greatest potential for energy savings (Fig. 1.2). Ideally, several schematic designs would be developed incorporating the most appropriate design strategies identified in the programming stage. An

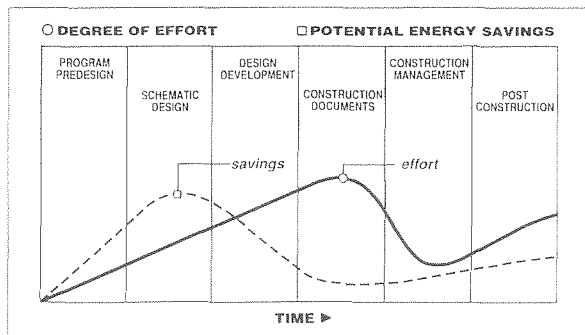

1.2 Energy savings achievable at each phase of design. Source: Shaw.

energy analysis considering construction and operating costs would be prepared for each scheme. This analysis should focus on issues such as building configuration, orientation, and zoning.

In the design development phase the architectural, structural, mechanical and electrical systems of the building should be defined. Architectural energy related issues at this stage of design include glazing selection and placement, the thermal characteristics of the building envelope, and the design of shading devices. Computer simulations are particularly appropriate during this phase.

Specifications for energy conservation products require the most attention during the construction document phase. To obtain a building permit, an energy analysis to demonstrate compliance with Hawaii's energy codes is often required from the architect or engineer.

In the latter phase of construction management, checks to verify the proper operation of the building's air conditioning and other systems are important.

At building occupancy, proper documentation and training for the building's managers and occupants are of vital importance. Occupant education, combined with proper maintenance and operation, may save more energy than all design refinements.

#### THE PROJECT TEAM

A united team effort on many levels in the building design process is vital to the design of a successful energy efficient building. This team effort must involve more than rhetoric. Without planning, patience, and action, we will accomplish very little. Within individual firms there must be a commitment to the team approach in energy conscious design. The team must work closely together from the first day. A special consultant or energy engineer should be included on the team. This may or may not be the mechanical/electrical engineer, depending on the firm's understanding of architectural energy analysis.

Within the Hawaii Council/The American Institute of Architects there is a pressing need for communicating new ideas concerning Hawaii's specific energy problems and solutions, including an emphasis on continued education. Sharing new ideas, identifying practical, proven design strategies in a cooperative framework does not have to co-opt the competitive spirit between firms; creativity will continue to render unique, diverse and interesting design solutions. As a profession, we are alone in our reluctance to share the fruits of our individual experiments, successes, and failures. Imagine doctors and scientists as reluctant to share their research as we are; the fields of science and medicine would be where the field of energy technology is today!

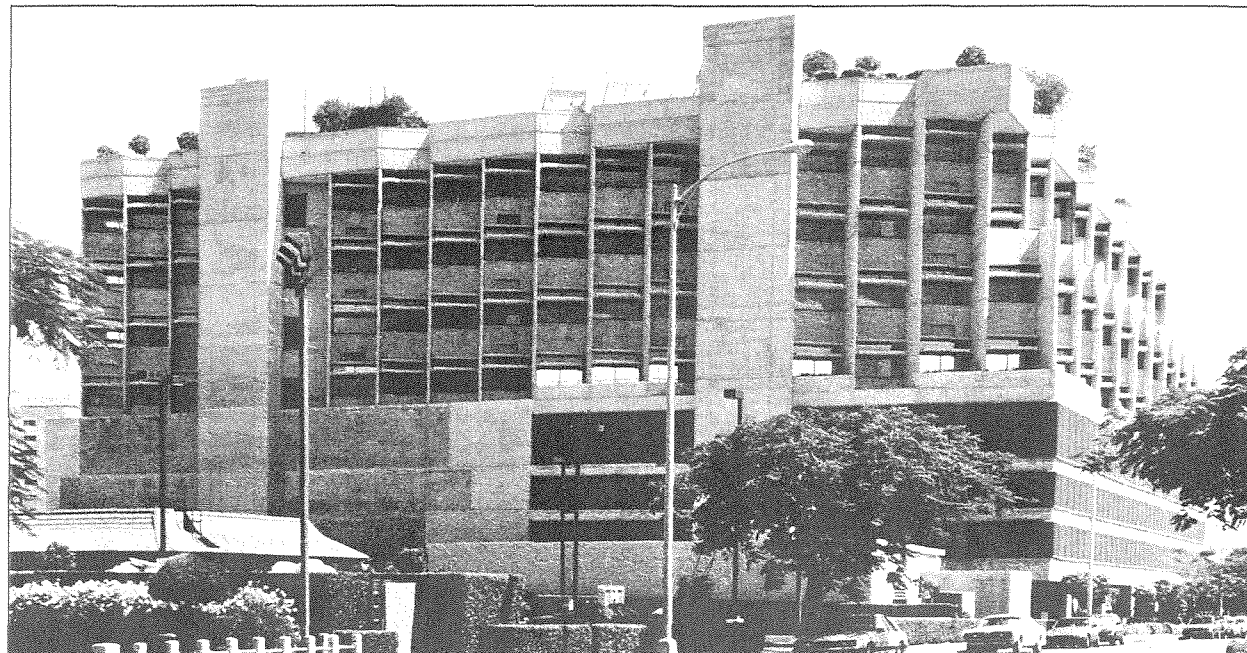

1.3 HMSA Center, 1983. Architect: The CJS Group. Photo: Max Raksasat.



CASE STUDY: THE HMSA CENTER

The headquarters of the Hawaii Medical Service Association (HMSA) in Honolulu is an example of an office building design that incorporated energy concerns from the earliest stages of planning (Fig. 1.3). The CJS Group - Architects considered several schematic design alternatives including a single high rise tower, twin towers and a mid-rise scheme. Energy analyses were performed for each of these options which considered the potential for daylighting and solar control. A mid-rise scheme was selected featuring a four-story office above a four-story parking structure (Fig. 1.4). This choice was deemed to be the most energy efficient, resulting in lower operating and construction costs. At this stage of design a more extensive energy analysis was performed. Computer simulations were used to perform 14 parametric studies to explore glazing, lighting and insulation choices. Computer analysis was also performed to assist in the design of external shading systems for the building.

The design of the HMSA Center incorporates concrete fins and overhangs that control solar heat and glare while

bouncing daylight deep into the interior (Fig. 1.5). Tinted glass is used below a light shelf to control glare while clear glass is used above for greater light penetration. At the center of the building is a four story deep courtyard. A space frame covered with translucent fabric allows diffuse light to enter the courtyard and the surrounding offices (Fig. 1.6). The lighting and air conditioning are controlled by a computerized energy management system.

The design was estimated to reduce the demand for electric lighting by 35% and reduce the air conditioning load by 41% as compared to a reflective glass box resulting in significant saving over many years. The additional cost for energy conservation features is estimated to be 7-1/2%. If the energy management system (which also includes systems for building maintenance, security and fire protection) is excluded, the cost of energy conservation in the HMSA Center is only 5% of the construction cost.

THE CLIENT

The owner or developer must have an interest and make a commitment to constructing an energy efficient building. If this commitment is not made in the very beginning of the project, there is little chance that the final building will be energy efficient. The architect can foster this interest through his marketing effort. The dollar savings potential of energy conservation should not be overlooked as a real selling tool. Architects with energy analysis experience can determine the actual costs and savings for each project. This can be a valuable decision making tool for the client. Energy efficiency must be addressed frankly and openly with each potential client and appropriate fees must be charged to cover increased design costs. The increased design costs are often very small in comparison to potential operating cost savings.

Until recently, the developer's commitment to energy efficiency was frequently dependent on whether he pays his own utility bills. This situation is changing as tenants become more sophisticated, sometimes discovering that their energy costs exceed their rents.

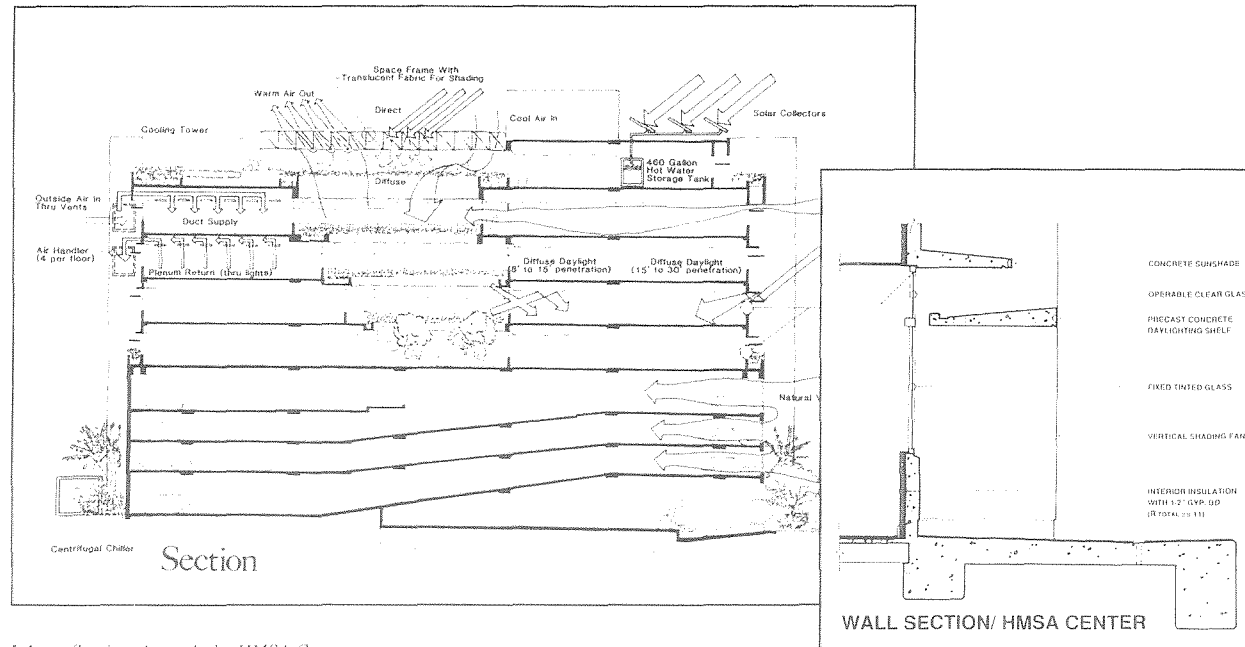

1.4 Section through the HMSA Center.

1.5 Detail of light shelf and shading devices on the HMSA Center.

1.6 Courtyard of the HMSA Center. Photo: Max Raksasat.

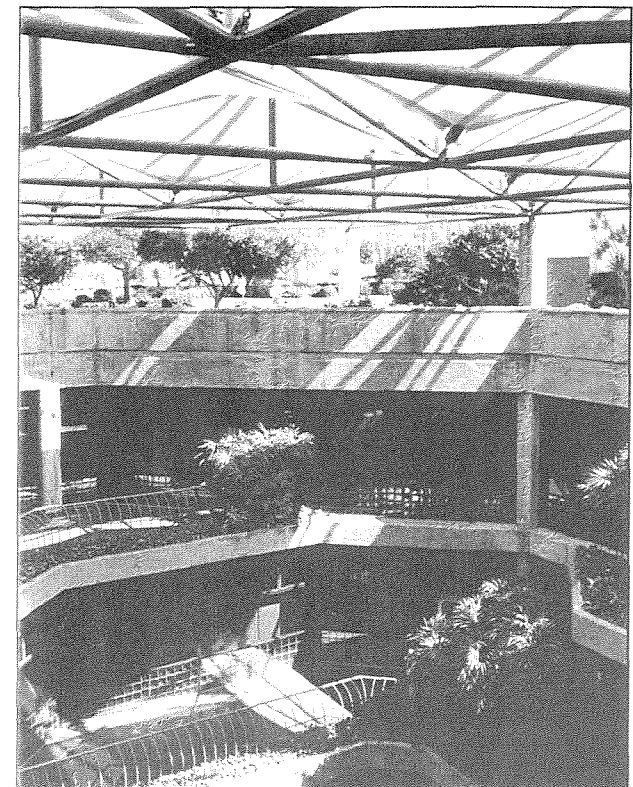

## CASE STUDY: THE INTELECT BUILDING

The Intellect building is an example of an energy efficient building constructed for tenant occupancy (Fig. 1.7). The building was developed by Castle and Cooke for occupancy by Intellect, manufacturers of digital computer equipment.

In the design of the Intellect Building the architects, Anderson Associates, and energy consultants TRB/Hawaii focused on daylight and shading. Scale models were built to test light levels and shading effectiveness for a variety of schematic designs. Computer simulations were used to model the energy use of the air-conditioning system for each design. Life-cycle cost estimates for each design were developed from this information.

The final design of the Intellect Building features light shelves to bounce the light deep into the space (Fig. 1.8).

Large fins and overhangs shade the glass. Light sensors automatically adjust the intensity of the fluorescent fixtures in response to the amount of daylight available. It was estimated that the additional investment in energy conservation features amounted to less than 4% of the building's base construction cost or approximately \$135,000. While this building has not been monitored to determine actual energy savings, predicted energy savings are on the range of \$30,000-35,000 per year. The predicted payback for the additional investment was approximately 4.2 years. Castle and Cooke believed that there was value associated with such a design that could be recovered when the building was sold. Meanwhile, tenants enjoy lower operating costs, resulting in a building that is attractive for leasing.

Developers should consider the monetary value of a more acceptable interior environment. Tenants are interested in their employees' job satisfaction for productivity reasons, and can pay more for natural light, access to shaded windows, and natural ventilation. The "sick building" syndrome is primarily observed in buildings with artificially maintained interior environments.

1.7 *The Intellect Building, 1984. Architect: Anderson Associates. Energy Consultants: TRB/Hawaii. Photo: Max Raksasat.*



## LIFE-CYCLE COSTING

For the developer, the bottom line, or critical question is: how much does it cost and how much can I save? To answer this question, the architect should be prepared to undertake a life cycle cost analysis.

Life-Cycle Costing (LCC) is a form of cost/benefit analysis by which an economic assessment of competing design alternatives can be made. It deals only with factors that can be measured in dollars and thus should be viewed as one factor in a comprehensive scope of decision making.

LCC is a method of comparing the return on a particular investment with the return on a hypothetical "best possible" investment offered anywhere else. The discount rate (also

1.8 *Details of fins and light shelves on the Intellect Building. Photo: Max Raksasat.*

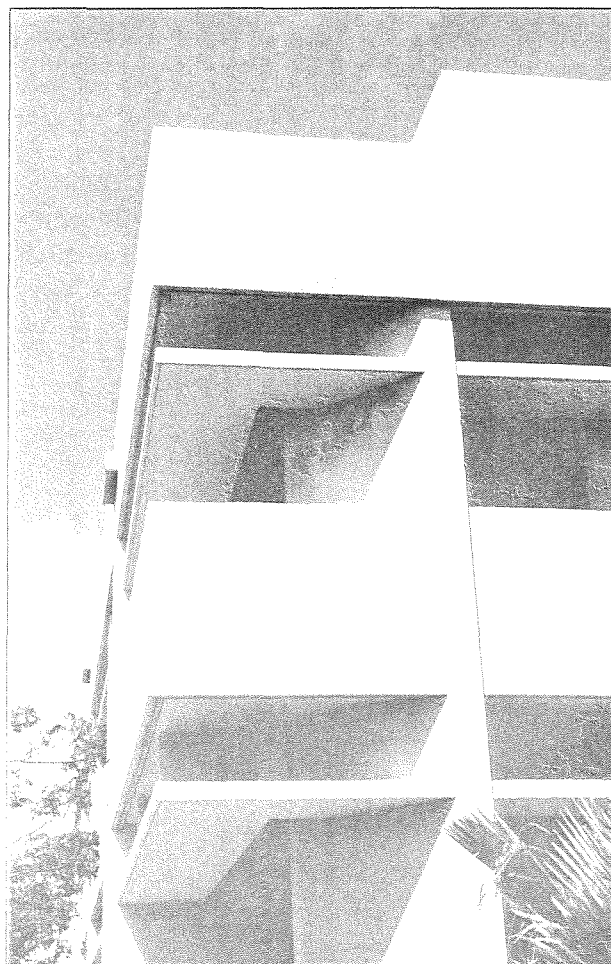

called the opportunity rate) is the return that money could earn if placed in this hypothetical investment. If the potential after-tax return of this hypothetical "best investment" is not known, the borrowing rate is sometimes used as the discount rate.

The benefit of energy conservation measures is extremely sensitive to the discount rate used. High discount rates tend to favor projects with quick payoffs over projects with deferred benefits.

Many of the calculations in LCC involve moving sums of money backwards and forwards through time (Fig. 1.9). This is necessary to convert present dollars and future dollars to equivalent amounts. The LCC analysis converts all money to its net present value. Cost/benefit analyses used in this book have been expressed in terms of simple payback. The simple payback period is equal to the added initial cost divided by the annual savings. These analyses ignore the time value of

money. Other values often calculated in an LCC analysis include a comparison of the break-even point between two investments and the rate of return on investment.

Alexander Shaw makes two good points concerning life cycle cost analysis in the book "Energy Design for Architects". First, a multi-systems approach to optimization of the building as a whole produces more desirable results than LCC applied to individual building components. Second, for the results of an LCC analysis to be integrated into the design, it is important that the analysis be completed early in the design process. As the design process progresses, many options relating to building orientation, configuration, daylighting and other strategies can no longer be effectively integrated.

For existing buildings, the obvious first step for improving the energy efficiency is to determine the existing energy use patterns. Energy audits are available through the Energy Division of the State Department of Business & Economic Development and are designed to identify potential areas of energy savings.

There are three levels of retrofits that can be identified (Fig. 1.10). The first is quick-fixes. From an architectural standpoint, improving inefficient window systems often makes the most sense. Reflective film can be applied to

I.9 Formulas for life cycle cost analysis.  
Source: Shaw.

$F = P (1 + i)^y$	• Single Compound Amount (SCA) adjusts a single value from present to future (P to F)
$P = F \frac{1}{(1 + i)^y}$	• Single Present Worth (SPW) adjusts a single sum from the future to the present (F to P)
$F = A \frac{(1 + i)^y - 1}{i}$	• Single Compound Amount (SCA) adjusts a single value from present to future (P to F)
$A = F \frac{i}{(1 + i)^y - 1}$	• Single Present Worth (SPW) adjusts a single sum from the future to the present (F to P)
$A = P \frac{i(1 + i)^y}{(1 + i)^y - 1}$	• Uniform Present Worth (UPW) adjusts equal annual increments to a single present value (A to P)
$P = A \frac{(1 + i)^y - 1}{i(1 + i)^y}$	
<p>where: P = Present Value                      F = Future Value                      A = Equivalent Annual Cost                      i = Interest Rate                      (opportunity or discount rate)                      y = Study Period (years)</p>	

I.10 Retrofit Options

QUICK FIXES	INTERMEDIATE MEASURES	MAJOR EFFORTS
Air Conditioning Window Film Relamp Fixtures Rate Study Operational Plan	Building Colors Reglazing Insulation Roof Materials Replace Equipment Landscaping Shading Devices EMC System	New Building Skin New Mechanical System New Lighting System Major Shading Devices Daylighting Interior Plan Changes EMC System

unshaded glass to reduce the air-conditioning load. Weather-stripping and sealing of loose fitting doors and windows in an air conditioned building will keep cool air from escaping. This is especially true when jalousie windows are used in an air conditioned building. Other quick-fixes are primarily mechanical and electrical.

Among the intermediate measures, there are more options related to architectural decisions. These involve changing building colors so that they are more reflective, reglazing, using insulation in the roof and walls, changing roofing materials, adding landscaping, and incorporating external shading.

Major efforts involve more capital-intensive investments to increase energy efficiency and could include incorporating a new building skin; incorporating major shading devices, which potentially include daylighting systems; and perhaps changing the plan of the interior layout to be more effective.

In 1978 the Hawaii State Legislature mandated that all counties adopt energy efficiency building standards based on the ASHRAE Model Standard 90-75. Honolulu's Building Department amended Chapter 53 of the Uniform Building Code (UBC) to local conditions and adopted it with the 1979 UBC. Chapter 53 incorporated building envelope heat transmission criteria, as well as air conditioning and service hot water equipment criteria, based on the ASHRAE standard. The lighting portion of the chapter was locally amended to adopt instead a simple lighting limit, in watts per square foot of floor area, for various types of buildings. The principal difficulty with Chapter 53 was that it emphasized energy conservation during cold weather, and did not accurately handle a climate like Hawaii's. The Honolulu Building Department further revised the energy conservation provisions with the adoption of the 1982 and the current 1985 UBC. The Honolulu Building Code, Article 7, "Energy Conservation" applies to new buildings and additions (Fig. 1.11). Article 7 has prescriptive requirements governing the design of the building envelope, HVAC systems, electric

lighting and distribution systems (Fig. 1.12). There is a provision for alternative designs that requires the building uses no more energy than a similar building conforming to the Article, with an energy analysis requirement as proof.

It has become clear that the "component" approach to building envelope requirements used in Article 7 fails to account for important interactions between internal loads and various features of the building envelope, such as glazing, orientation and shading. ASHRAE has since completed a major revision (ASHRAE 90.1P) to the standard on which Article 7 is based. Extensive computer simulations of designs complying with the revised standard demonstrate significant, cost-effective reductions in energy consumption while ensuring flexibility for the designer (Fig. 1.13).

1.11

SCOPE OF ARTICLE 7, HONOLULU ENERGY CODE	
BUILDING TYPE	ENERGY CODE REQUIREMENTS
New construction	Must comply with all provisions except when exempted below
Additions & alterations	Must comply with all provisions when UBC Standards for new construction apply
Buildings not heated or cooled	Exempt from exterior envelope & air conditioning system provisions
Building using < 1 watt/ft. sq.	Exempt from entire article
Dwelling units using less than one ton (12,000 BTU's/Hr) of air conditioning	Exempt from entire article except conservation of hot water
Special institutional and industrial process requirements	May exceed the article's requirements, but only to the minimum required for the application

1.12

PRESCRIPTIVE REQUIREMENTS OF ARTICLE 7, HONOLULU ENERGY CODE	
COMPONENT	REQUIREMENT
Building Envelope	Limits transmission of heat through wall and window assemblies, roof and skylight assemblies
HVAC Systems	Governs system design and equipment performance
Ducts & Piping	Requires insulation
Lighting	Establishes lighting power limit, light switching requirements
Electrical Distribution	Establishes minimum power factor

1.13 Energy use by building type comparing ASHRAE standards 90-75(A), 90A-1980(B) and 90.1P(C). Source: ASHRAE Journal

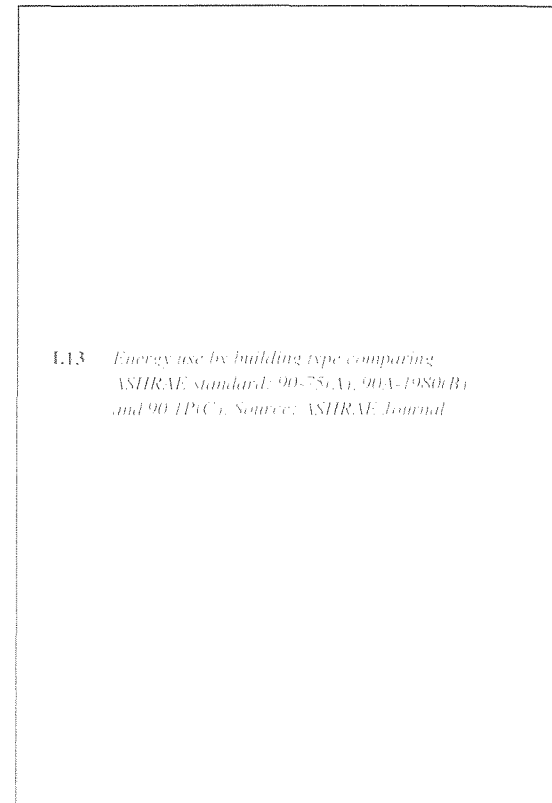

## INCENTIVES

A new energy code for Hawaii is being developed based on this revised standard (ASHRAE 90.1P) as well as requirements of the second generation California Code. A draft of the proposed new code for Hawaii will be reviewed by design professionals, building code officials, building owners and managers, and others who will be affected by the proposed requirements.

The development of real financial incentives by the State to encourage building owners to go beyond the minimum effort required by code is of vital importance. In California and other states, incentives are offered for owners to comply with more stringent energy codes in the period before code compliance becomes mandatory. This provides the state with a test group to work out questions of interpretation and application before adoption by the public at large. An additional benefit is that a group of design professionals and building department officials would become familiar with the standards, easing their acceptance.

Hawaii could also offer incentives for owners and developers to adopt energy conservation features beyond those mandated by codes (Fig. 1.14). An incentive program could

also be considered to increase the energy efficiency of existing buildings.

In some states the Public Utilities Commission has required utilities to offer incentives on the grounds that conservation measures avoid the capital costs required to construct new power plants. There is a good precedent for incentives to conserve energy. Hawaii state law provides tax relief for expenditures by building owners to use solar energy in lieu of fossil fuel or electricity.

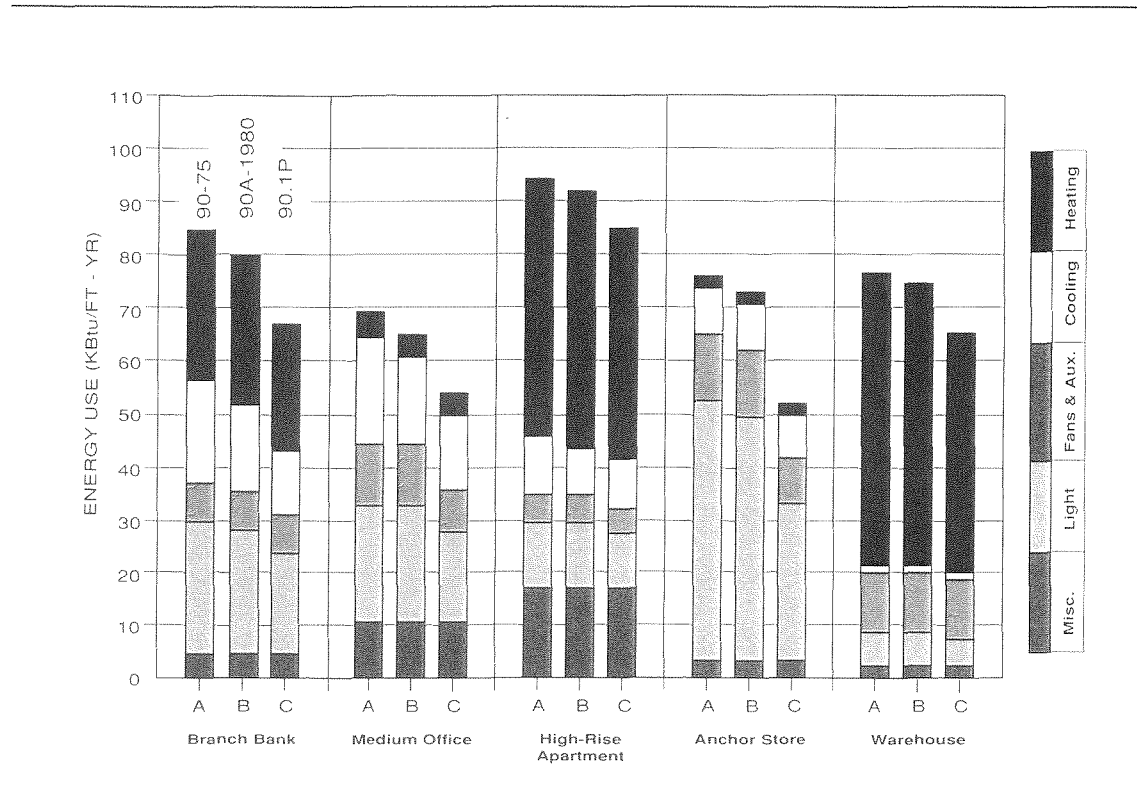

INCENTIVES FOR ENERGY EFFICIENCY	
MONETARY	Tax Credits
	Direct Incentive Payments
	Rebate Programs
DESIGN ASSISTANCE	Energy Hotline
	Direct Design Assistance through Consultants or Staff
	Design Awards Programs
REGULATORY	Priority Building Permit Processing
	Floor Area Ratio (FAR) Bonuses
OTHER	Utility Conservation Programs
	Design Competitions

1.14 Possible governmental incentives to promote energy efficient design.

Public attention and interest in energy conservation will wax and wane with the available supply, and current prices, of fuel and electricity. However, the finite supply of fossil fuels guarantees that this issue will not disappear. Moreover, continuing problems such as the "greenhouse effect", continued instability in the Middle East, and the U. S. trade deficit underscore the pressing need for energy conservation.

As professionals we must look beyond the day-to-day shifts in public opinion and plan for the future. Many of the buildings designed today will exist in the year 2030 and beyond. As architects, our attention and commitment to energy efficiency today will benefit our clients, and Hawaii's people, for many years to come.

This reference list includes a library name code and call letters when possible. The following Honolulu libraries are listed:

DBED	<i>Dept. of Business, Economic Development &amp; Tourism Library</i>
DOE	<i>Dept. of Energy Library</i>
HAML	<i>University of Hawaii, Hamilton Library</i>
HSL	<i>Hawaii State Library</i>
SINC	<i>University of Hawaii, Sinclair Library</i>

## ARCHITECTURE AND ENERGY, GENERAL

- American Institute of Architects. *Shading and Sun Control*. AIA, 1981. SINC NA2542.S6.S5 1981.
- Brown, G. Z., *Sun, Wind and Light: Architectural Design Strategies*. New York: Wiley, 1985. HSL 720.47B; SINC NA2542.3.B76
- Fathy, Hassan, Walter Shearer and al-Rahmon Sultan. *Natural Energy and Vernacular Architecture: Principles and Examples with Reference to Hot Arid Climates*. Chicago: University of Chicago Press, 1986. SINC, NA7117.A74 F3 1986.
- Giovani, B. *Men, Climate and Architecture*, 2nd Ed., New York, Van Nostrand Reinhold, 1981. HSL 720G.
- International Energy Agency. *Energy for Buildings: Microprocessor Technology*. Washington: IEA, 1986. SINC TJ. 163.5. B84 E543 1986.
- Markus, Thomas A. and Edwin N. Morris. *Buildings, Climate and Energy*. London: Pitman, 1980. SINC NA2541.M37.
- Olgay, Victor. *Design with Climate: Bioclimatic Approach to Architectural Regionalism*. Princeton: Princeton University Press, 1963. SINC, NA 2540.044.
- Predesign Energy Analysis*, 1980. DOE CS0171.
- Shaw, Alexander. *Energy Design for Architects*. Englewood Cliffs: Fairmont Press, 1989. SINC NA2542.3.E47 1989.
- Stein, Richard G. *Architecture and Energy*. Garden City: Anchor Press, 1977. HSL. 721S; SINC NA2542.3.E47 1989.
- Watson, Donald. *Energy Conservation Through Building Design*. New York: McGraw-Hill, 1979. HSL 721E; SINC TJ163.5.B84 E54.
- Wright, Frank Lloyd. *The Natural House*. New York: Horizon Press, 1954. SINC NA7208.W68.

## BUILDING TYPES

- Beedle, Lynn S. *Monograph on Planning and Design of Tall Buildings*. New York: American Society of Civil Engineers, 1978. SINC, TH845.C68 1978.
- Cook, Jeffrey. *Award-Winning Passive Solar House Designs*. New York: McGraw-Hill, 1984. SINC, TH 7414.A92.
- Saxon, Richard. *Atrium Building: Development and design*, 2nd ed. London: Architectural Press, 1986. HSL 720S; SINC NA 4160.S28 1986.

## CODES AND STANDARDS

- Crawley and Briggs. "The Value". *ASHRAE Journal*. 27(1985): 11(November).
- Kelly, James, Bruce Maeda and Frederick Barryman. *Energy Efficiency Manual, Second Generation: Nonresidential Standards*, 2nd ed. California Energy Commission, September 1986. Doc. #P400-86-010.

## DAYLIGHTING

- Evans, Benjamin H., AIA. *Daylight in Architecture*. New York: Architectural Record Books, 1981. HSL 720.47E; SINC NA2542.S E9.
- Lam, William M. C. *Sunlighting us Formgiver for Architecture*. New York: Van Nostrand Reinhold, 1986. HSL 720.147L; SINC NA2542.S6 L35 1986.
- Lord, David. *Design For Light*, Technical Publication 81:1, School of Architecture, University of Hawai'i-Manoa.
- Robbins, Claude L., *Daylighting: Design and Analysis*. New York: Van Nostrand Reinhold, 1986. HSL 729.2R; SINC TH7791.R3 1986.
- Schiler, Mark, ed. *Simulating Daylight with Architectural Models*. Daylighting Network of North America.

## DESIGN IN THE TROPICS

- Beaton, Will and James Reinhardt. "A Path to Our Future". *Hawaii Architect: Journal of the HSI/AIA* 10(1981): 3(March). DBED, TV 163.3.
- Fry, Edwin Maxwell and Jane Dew. *Tropical Architecture in the Dry and Humid Zones*. New York: Reinhold, 1964. HSL, 720.9F; SINC NA2540.F69.
- Guam Energy Office. P. O. Box 2950, Agana, Guam 96910, (671)734-4452.
- Jones, J.B., Stephen Lander and Mark Ruth. *Energy Conscious Residential Design for a Tropical Isle*.
- Maruyama and Associates. "Keeping Cool in the Tropics", November 1980.
- Koenigsburger, Otto H. *Manual of Tropical Housing and Building*. London: Longman, 1974. SINC TH153.M35
- Koenigsburger, Otto H. and Robert Lynn. *Roofs in the Warm Humid Tropics*. London: Architecture Association, 1965. SINC TH2431.K57.

Konya, Allan. *Design Primer for Hot Climates*. London: Architectural Press, 1980. HSL 721K; SINC NA2542.T7 K66.

Pearson, Jim and Cliff Terry. *Hawaii Home Energy Book*. Honolulu: University of Hawaii Press, 1978. SINC TJ163.2S.U6 P4.

Saini, Balwant Singh. *Architecture in Tropical Australia*. London: Architecture Association, 1970. SINC NA1600.S23.

#### ECONOMICS

Eley, Charles. "Building Envelope Energy Analysis". Report prepared for Hawaii Society of the American Institute of Architects, 1989.

Meyer, William T. *Energy Economics and Building Design*. New York: McGraw-Hill, 1983. HSL 721M; SINC NA2542.3.M4 1983.

#### ELECTRICAL/MECHANICAL SYSTEMS

*ASHRAE Handbook Series*. Atlanta: American Society of Heating and Air Conditioning Engineers:

*Equipment*. 1983. HAML TH7345.A8 1983

*Fundamentals*. 1989. HAML TH7201.A82 1989

*HVAC Systems and Applications*. 1987. HAML TH7005.A825 1987.

*Refrigeration Systems and Applications*. 1986. HAML TH7005.A84 1986.

Hunt, V. Daniel. *Handbook of Energy Technology: Trends and Perspectives*. New York: Van Nostrand Reinhold, 1982. HAML Ref TJ163.2.H874.

Kaufman, John E. and Jack F. Christensen. *IES Lighting Handbook*. New York: Illuminating Engineering Society of North America:

*1984: Reference*. 1984. HAML ref TK4161.I37 1984.

*1987 Applications Volume*. 1987. HAML ref TK4161.I452 1987.

McGuinness, William J., Benjamin Stein and John Reynolds. *Mechanical and Electrical Equipment for Buildings*, 7th Ed. New York: Wiley, 1986. HAML, TH6010.M38 1986

*Proceedings of the Third Workshop on the Use of Solar Energy for the Cooling of Buildings*. Newark: Publications Office, 1978. HAML TH7687.5. W67, 1978.

Richmond, Ronald C. *Guidebook on Photovoltaics Applications in Hawaii*. Honolulu: State of Hawaii Department of Planning and Economic Development, 1984. SINC/HAML TK2960.R53 1984.

#### HAWAII-CLIMATE

Armstrong, R. Warwick and James Allan Bier (University of Hawaii Department of Geography). *Atlas of Hawaii*. Honolulu, University of Hawaii Press, 1973. SINC/HAML G3000.H36 1973.

Blumenstock, David Irving (Environmental Data Service). *Climates of the States: Hawaii*. Washington: U.S. Government Printing Office, 1967. HAML (Hawaiian Collection) QC993.U44 1967.

Falicoff, Waqidi, George Koide and Patrick Takahashi. *Solar/Wind Handbook for Hawaii: Technical Application for Hawaii, the Pacific Basin and Sites Worldwide with Similar Climatic Conditions*. Honolulu: Natural Energy Institute, 1979. SINC/HAML TJ810.F35

#### HAWAII-ENERGY SITUATION

"Energy Options: The Architect's Role" *Hawaii Architect: Journal of the HS/AIA*. 9(1986): 9(September).

Flavin, Christopher. *Energy and Architecture: The Solar and Conservation Potential*. Washington: Worldwatch Institute, 1980. DBED/HAML TJ163.5B84 F52

Muller, Justus. *Hawaii's Natural Energy Resources: 1976*. Honolulu: Hawaii National Energy Institute, 1976. SINC/HAML TJ1 163.25.H3 H388 1976

*DPED. Report of the Building Management Efficiencies Committee*. Honolulu, Department of Planning and Economic Development, 1980. DBED.

*Hawaii Energy Resources Coordinator's Annual Report. Fiscal year 1987-1988*. Honolulu: DBED, 1988. DBED.

#### LANDSCAPE

Robinette, Gary O. and Charles McClenon. *Landscape Planning for Energy Conservation*. New York: Van Nostrand Reinhold, 1983. HAML SB475.9E53 L36 1983.

#### MATERIALS/SYSTEMS

Manuel, Don. *Building Systems Energy Management Workbook*. Honolulu: DBED. DBED TJ 163.H346.

Rush, Richard. *The Building Systems Integration handbook*. New York: Wiley, 1986. HAML TH145.B844 1986.

#### NATURAL VENTILATION

Cable, John H. *Building Redesign and Energy Challenges*. Washington: AIA, 1984. SINC NA 2542.3.B8 1984.

Maddex, Diane. *New Energy from Old Buildings*. Washington: Preservation Press, SINC, NA 2542.3.N49.

TRB Hawaii, Ltd. "Cooling Buildings by Natural Ventilation", *Design Manual 11.02*. Report prepared for the Department of the Navy, Naval Facilities Engineering Command.

#### SITE PLANNING

McHarg, Ian L. *Design with Nature*. Garden City: American Museum of Natural History, 1971. SINC HC110.ES M3 1971.

Ridgeway, James and Carolyn S. Projansky. *Energy Efficient Community Planning: A Guide to Saving Energy and Producing Power at the Local Level*. Emmaus, PA: JG Press, 1979 HSL 233.8R; SINC HD9502.U52 R528.

Solar Energy Information Data Bank, Solar Energy Research Institute, 1617 Cole Boulevard, Golden, Colorado 80401:

*Land Use and Site Design for Energy Conservation*. 1985.

*Solar Envelope Zoning: Recommendations for Energy Conservation Standards and Guidelines for New Commercial Buildings*. 1983.

Tabb, Phillip. *Solar Energy Planning: A Guide to Residential Settlement*. New York: McGraw-Hill, 1984. HSL 711.4T; HAML TJ810.T27 1984.

White, Edward T. *Site Analysis: Diagramming Information for Architectural Design*. Tucson, Architectural Media, 1983. SINC, NA2540.5W48 1983.



SUNDIAL



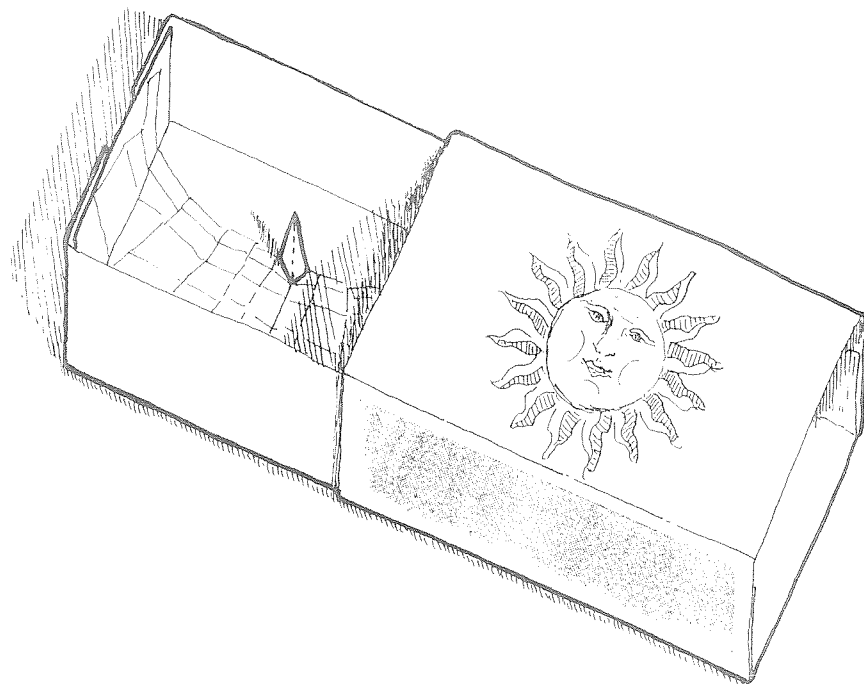

## MATCH BOX SUNDIAL

- 1 Cut out the matchbox, cover and gnomon along the solid lines and fold along the dotted lines.
- 2 Secure the four corners of the sundial and the cover flap with glue.
- 3 The sundial should be dimensionally stable with all angles at 90°.
- 4 Glue the gnomon upright at the "△" just above the north arrow.

The sundial should be placed close to the model being studied and both oriented correctly north-south. Outdoors the dial and model can be rotated until the sun casts a shadow at the desired time and date on the sundial. All shadows will now be in their correct position.

COVER

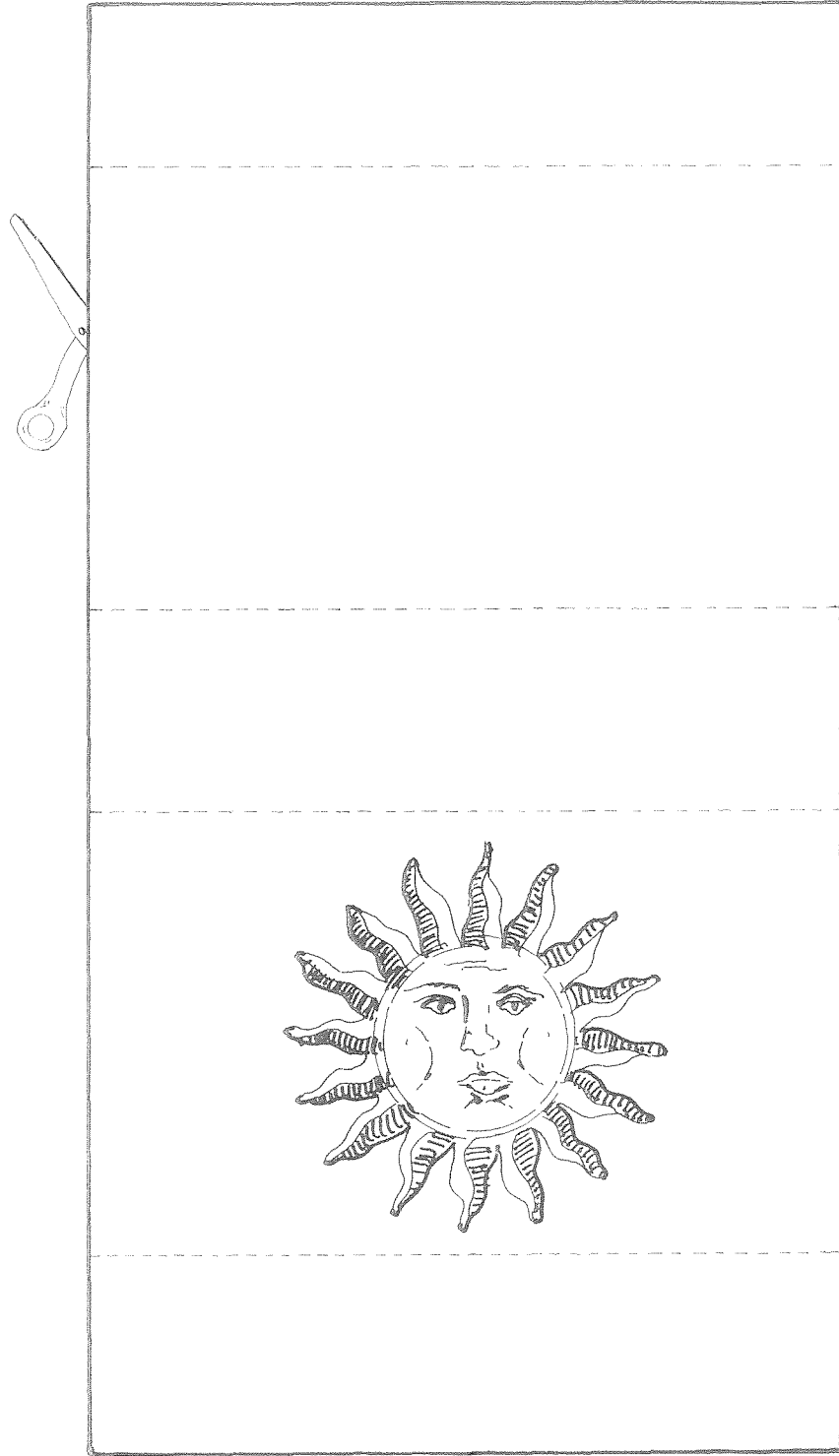

MATCHBOX

