

The NIST logo is rendered in a bold, white, sans-serif font. The background of the entire page is a vertical split: the left side is a blue-to-green gradient with a faint grid pattern, and the right side is a red-to-orange gradient with a stylized flame pattern. A large, semi-transparent circular graphic is centered behind the text.

**NIST**

**National Institute of  
Standards and Technology**  
Technology Administration,  
U.S. Department of Commerce

**BUILDING  
& FIRE  
RESEARCH  
LABORATORY**

**Activities,  
Accomplishments  
& Recognitions**

The letters 'BERL' are rendered in a very large, white, sans-serif font, spanning across the middle of the page. The letters are semi-transparent, allowing the background patterns to be seen through them. The 'B' and 'E' are on the left side, and the 'R' and 'L' are on the right side.

**BERL**



# CONTENTS

BFRL at a Glance .....	1
Director's Message .....	3
BFRL Accomplishments.....	4
<b>GOAL 1</b>	
<b>Enhanced Building Performance</b>	
Healthy and Sustainable Buildings .....	4
Cybernetic Building Systems.....	9
<b>GOAL 2</b>	
<b>Fire Loss Reduction</b>	
Fundamental Fire Science .....	14
Advanced Fire Service Technologies.....	20
Fire Standards, Codes and Testing.....	26
Reduced Risk of Fire Spread .....	30
<b>GOAL 3</b>	
<b>High Performance Construction Materials and Systems</b>	
Service Life Prediction (SLP) of Polymeric Materials.....	38
HYPERCON: Prediction and Optimization of Concrete Performance .....	48
Construction Integration and Automation Technologies (CONSIAT).....	53
<b>GOAL 4</b>	
<b>Homeland Security</b>	
Investigation of the World Trade Center Disaster .....	58
Research and Development for the Safety of Threatened Buildings.....	60
Standards Activities .....	70
Staff Highlights and Awards .....	82
Finances and Organization.....	90
More Information About BFRL.....	92

## BFRL AT A GLANCE

### BFRL MISSION

Meet the measurement and standards needs of the building and fire safety communities.

### BFRL VISION

*The source of critical tools – metrics, models, and knowledge – used to modernize the building and fire safety communities. Our programs are identified, developed, carried out, the results implemented, and consequences measured in partnership with key customer organizations.*

### BFRL GOALS

The building and fire communities (builders, suppliers, owners and fire safety professionals) strive to increase productivity; construct better buildings, faster, at lower cost; and own buildings that are fire safe, less costly to operate, and have less impact on the environment. To meet the needs of these communities BFRL is focusing on four goals.

- **Enhanced Building Performance:** to provide the means to assure buildings work (better) throughout their useful lives. The strategy for meeting this goal is to provide knowledge, measurements and tools to optimize building life-cycle performance.
- **Fire Loss Reduction:** to enable engineered fire safety for people, products, and facilities; and enhance fire fighter effectiveness.

- **High Performance Construction Materials and Systems:** to enable scientific and technology-based innovation to modernize and enhance the performance of construction materials and systems.

- **Homeland Security:** to develop and implement the standards, technology, and practices needed for cost-effective improvements to the safety and security of buildings and building occupants, including evacuation, emergency response procedures, and threat mitigation.

### BFRL RESOURCES

- 140 full time staff with expertise in measurement, material and system performance, mathematical modeling, non-destructive testing, and diagnostics
- \$40 million annual budget
- Unique facilities including:
  - Building Integrated Photovoltaic Testbed
  - Mobile Solar Tracker Facility
  - High Temperature Guarded Hot Plate
  - Tri-directional Test Facility
  - Large Structures Testing Laboratory
  - Fire Emulator/Detector Evaluator
  - Large Fire Test Facility
  - Virtual Cement and Concrete Test Laboratory
  - Integrating Sphere UV Exposure Chamber
  - Virtual Cybernetic Building Test Bed
  - Well Stirred Reactor/Plug Flow Reactor
  - Residential Fuel Cell Testing Laboratory
  - Cone Calorimeter

### BFRL WEB SITE

*[www.bfrl.nist.gov](http://www.bfrl.nist.gov)*





## MESSAGE FROM THE DIRECTOR



The Building and Fire Research Laboratory (BFRL) at the National Institute of Standards and Technology (NIST) is the nation's primary resource for measurements and standards for the building and fire safety communities. We strive to be the primary source of critical tools – metrics, models, and knowledge – needed to support innovation and industrial competitiveness in this sector of the economy.

The industries we serve are huge and disaggregated. U.S. construction and buildings was a \$1.4 trillion industry in 2004, representing 13% of the gross domestic product and employing between 5 and 7 percent of the U.S. workforce or 10 million workers.

This value consists of the new facilities put in place plus significant investments in renovation and maintenance and repair. During the same period, fire costs totaled more than \$200 billion, equivalent to 2% of the gross domestic product. These costs include property losses, injuries and deaths, the cost of engineering fire safety into today's buildings, and the operating costs of the U.S. fire services.

Our investments are focused on reducing losses from fire and potential losses due to terrorism, as well as supporting the industry to innovate and

improve performance of materials, products, and processes of construction. We are a leading advocate for the development of performance standards as a method of enabling innovation. The development of fundamental understanding and knowledge and its translation into accurate performance prediction is critical before effective performance standards can be put in place.

BFRL is involved in a wide range of scientific, engineering, and investigative work for the building and fire safety communities. The time has long passed when any single organization like ours can act alone and expect to make a major impact on the numerous issues facing the industries we serve. We must build an extensive network and work together to tackle these issues. This will greatly enhance all our chances for success. I encourage you to contact us to explore joint work.

A handwritten signature in black ink that reads "James E. Hill". The signature is written in a cursive, flowing style.

Dr. James E. Hill  
Director, Building and Fire  
Research Laboratory

# ENHANCED BUILDING PERFORMANCE

TO PROVIDE THE MEANS TO ASSURE BUILDINGS WORK (BETTER) THROUGHOUT THEIR USEFUL LIVES. THE STRATEGY FOR MEETING THIS GOAL IS TO PROVIDE KNOWLEDGE, MEASUREMENTS AND TOOLS TO OPTIMIZE BUILDING LIFE CYCLE PERFORMANCE.

GOAL

The first strategic focus to achieve the goal of Enhanced Building Performance is to develop measurement methods, fundamental data, simulation models, and life cycle environmental and economic analysis tools to support Healthy and Sustainable Buildings.

The second strategic focus for achieving Enhanced Building Performance is to develop, test, integrate, and demonstrate open Cybernetic Building Systems. The word “cybernetics” comes from the Greek word “steersman” and is defined as the science of control and communication of complex systems. A Cybernetic Building System involves energy management, fire detection, security, transport systems, energy providers, one or more utilities, an aggregator, and numerous service providers, and information handling and complex control at many different levels.

## Healthy and Sustainable Buildings

### Intended Outcome and Background

The intended outcome of the Healthy and Sustainable Buildings Program is to make available measurement methods, test methods, fundamental data, simulation models, and life cycle environmental and economic analysis tools to support healthy buildings and the wide-spread use of sustainability in design, construction, and operation of buildings and their systems/subsystems.

Global climate change is considered by many as one of the most pressing challenges of the 21st century. Scientific opinion on this matter varies significantly, from the view that contributions to global warming are negligible, to the view that man-made carbon emissions are a disaster in progress, requiring immediate substantial reductions in the emission of the so-called greenhouse gases, principally carbon dioxide.

The purpose of the International Climate Change Conference, held in Kyoto, Japan in 1997, was to accelerate the pace of international action on climate change. If adopted by the United States, the legally binding international Kyoto protocol would translate for the U.S., into a 7 percent reduction in the 1990 levels of carbon emissions by 2010. The U.S. building sector shares almost equally with the industrial sector and transportation sector in such emissions.

Beyond regulated carbon emissions, the “green movement” is sweeping the building

industry. All major building product companies, building designers, and building operators need measurement methods, test methods, fundamental data, and life-cycle environmental and economic analysis tools to objectively promote their approaches and products to achieve sustainability.

BFRL will apply its expertise in refrigeration systems, thermal insulation, building integrated photovoltaic systems, indoor air quality, and life cycle economic and environmental analysis methods to promote healthy and sustainable residential and commercial buildings.

BFRL's research on Healthy and Sustainable Buildings will produce a wide range of data, measurement methods, test methods, simulation models, and analysis tools that will assist the U.S. in this "transition towards sustainability." These BFRL products include:

- Building for Environmental and Economic Sustainability (BEES) software program;
- performance data on refrigerant/lubricant heat transfer;
- artificial intelligence-aided design procedures for refrigeration heat exchangers;
- new apparatuses/test methods/standard materials for advanced thermal insulation/

low-temperature insulation/high-temperature insulation;

- validated design models for building integrated photovoltaic systems;
- a new seasonal performance testing and rating methodology for residential fuel cells;
- contaminant-based design procedures for predicting indoor air quality;
- methods to evaluate and predict the performance of residential ventilation and indoor air quality control approaches, including the use of different types of air cleaning devices; and
- new/revised test methods and rating procedures for evaluating the energy performance of residential and commercial appliances and products.

ACTIVITIES AND ACCOMPLISHMENTS

**BEES Life-Cycle Performance Measurement**

**B**EES (Building for Environmental and Economic Sustainability), a software package for measuring the life-cycle environmental and economic performance of building products, has had a major impact in the increasingly popular field of healthy and sustainable buildings. The tool implements a systematic methodology for synthesizing science-based environmental and

economic performance data into a single score that can be understood and applied by the building community. Nearly 18,000 copies of BEES 3.0 have been requested by users in more than 80 countries.

BEES is becoming the universally accepted metric for product performance measurement and is already having an impact on innovation and commerce. While BEES initially focused on green purchasing for the construction sector, its success has spawned multiple enhancements and applications. Most significant is the U.S. Department of Agriculture (USDA)-sponsored expansion of BEES to enable evaluation of environmental and economic performance for biobased products used in any industry sector. The 2002 Farm Bill (P.L. 107-171) tasked NIST with providing technical support for a preferred purchasing program for biobased products created by the law and managed by USDA. The Final Rule implementing the program, *Guidelines for Designating Biobased Products for Federal Procurement* (7 CFR Part 2902), in which USDA establishes the guidelines for designating product categories made from biobased products that would be afforded Federal procurement preference, mandates that

before a product category can be designated for preferred purchasing, a representative sample of products must undergo BEES evaluation and BEES results must be made available to the Federal procurement community. [www.bfrl.nist.gov/oea/bees.html](http://www.bfrl.nist.gov/oea/bees.html)

**CONTACT:**  
 BARBARA LIPPIATT  
 OFFICE OF APPLIED ECONOMICS  
 (301) 975-6133  
[blippiatt@nist.gov](mailto:blippiatt@nist.gov)

## Residential and Commercial Photovoltaic Research

Residential buildings use approximately 37 percent of the electricity consumed within the United States. Placement of photovoltaic modules on the roofs of new and existing structures offer an aesthetically pleasing means of reducing the ever increasing electrical demand on central power plants, eliminating transmission and distribution electrical line losses, and reducing environmental emissions.

A three-year program that focused on the use of photovoltaic panels to replace building materials normally used in commercial building vertical facades has been completed. It accomplished the construction and operation of the only building integrated photovoltaic (BIPV) test facility within the U.S.; improvements in photovoltaic performance prediction models that are now capable of predicting annual energy production to within 5 percent; and the delivery of validation data to system modelers.

A recently-completed study in conjunction with Sandia National Laboratories demonstrated that photovoltaic measurements taken under outdoor conditions can be replicated and provided data required for the next phase of NIST's photovoltaic program – improving the photovoltaic industry's ability to accurately measure the power output of photovoltaic modules at standard rating conditions.

A residential photovoltaic test facility has now been constructed that will result in improved models to predict the electrical energy production and demand load reduction potential of photovoltaic roofing products. The facility will also be used to provide

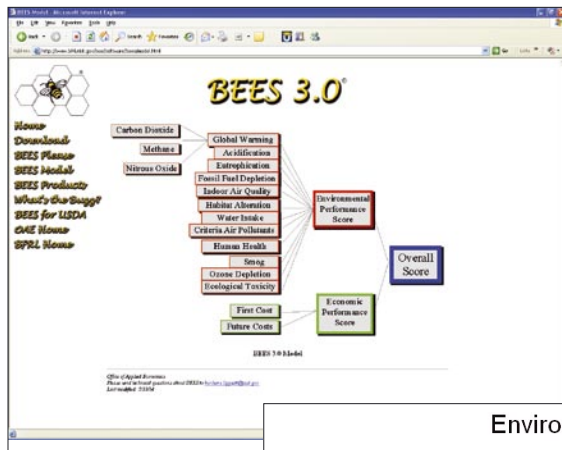

BEES 3.0 Software.

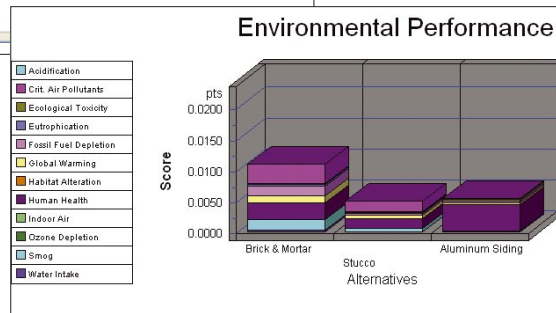





**Residential Building Photovoltaic Panel.**

a side-by-side comparison of various mounting techniques as well as provide data on the performance of various photovoltaic cell technologies.

**CONTACT:**  
 HUNTER FANNEY  
 BUILDING ENVIRONMENT DIVISION  
 301-975-5864  
[hunter.fanney@nist.gov](mailto:hunter.fanney@nist.gov)

## Guarded Hot Plate Facility

A new 500 mm guarded-hot-plate facility has been constructed for determination of the steady-state heat transmission properties of industrial insulation materials. Recent laboratory comparisons of high-temperature guarded-hot-plate apparatus have revealed a high level of scatter, on the order of  $\pm 20$  percent, in the test data for different insulation materials. One

of the primary goals of the new test facility is to provide high-temperature thermal insulation standards for the insulation user community.

The new apparatus builds on the concept of using line-heat-sources in circular metal plates, a concept pioneered by NIST researchers in 1964 and later implemented in several room-temperature guarded-hot-plate apparatus constructed at NIST. The new apparatus will handle specimens 500 mm in diameter and thicknesses from 10 mm to 100 mm. The apparatus has been designed to test insulation specimens over an extensive range of conditions – from 90 K to 900 K and under vacuum conditions, if desired.

**CONTACT:**  
 ROBERT R. ZARR  
 BUILDING ENVIRONMENT DIVISION  
 301-975-6436  
[robert.zarr@nist.gov](mailto:robert.zarr@nist.gov)

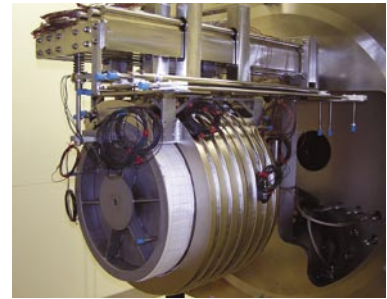

**Front view of the Guarded Hot Plate (top), Installation of edge-guard assemblies, cold-plate assemblies, and hot plate (bottom).**

### ACSIM Simulation Model

ACSIM is a software package for simulating vapor-compression air-to-air refrigeration and air-conditioning equipment operating with single-component refrigerants and refrigerant mixtures. The package combines simulation modules for a compressor, finned-tube heat exchangers, and connecting tubing. The goal of this software package is to facilitate the development of optimized systems.

The evaporator and condenser simulation models used by ACSIM are those developed for BFR's EVAP-COND simulation package. These models use a "tube-by-tube" modeling scheme, which allows for specification of complex refrigerant circuits, modeling refrigerant distribution between these circuits, and accounting for non-uniform air distribution. A graphical user interface facilitates input of complex system and heat exchanger design data and provides a convenient platform for reviewing detail simulation results.

For the evaporator and condenser, the simulation output include local parameters for each tube such as inlet and outlet quality, temperature, enthalpy, entropy, pressure drop, mass flow rate for the refrigerant, and inlet and outlet temperature for the air. The output for a complete system includes global performance parameters and detailed thermodynamic parameters at the key ten locations of the system.

Although ACSIM can be used for simulating various types of air-to-air systems, its basic features make it most suitable for simulating residential air conditioners. The package includes the option for automated simulations of a so called mixed system, where one condensing unit and several indoor sections are specified. With this option, ACSIM will perform simulations for all combinations of the condensing unit and indoor sections at a user-specified set of operating conditions.

Currently, ACSIM is undergoing beta testing. After completion of testing, it will be placed on the BFR's Web site for free download. The demand for ACSIM is expected to match that of EVAP-COND which has been download by over 1000 organizations from over 40 countries.

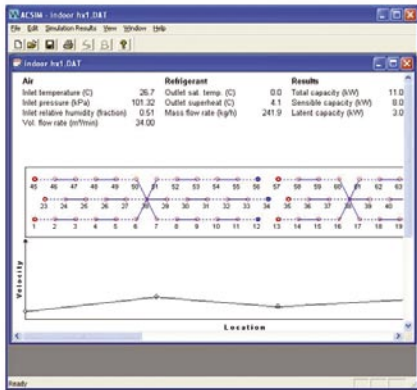

Screen shots from the ACSIM Simulation Model.

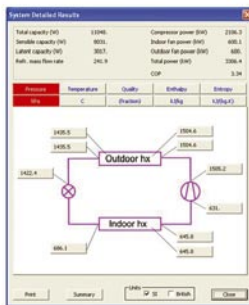

Operating Conditions Data

Test Bar:  Test Bar  Test condition

Units:  SI Units  British Units

Parameter	Value	Unit
Indoor Air Dry-bulb temperature	26.7	C
Indoor Air Wet-bulb temperature	19.4	C
Indoor Air Dew-point temperature	15.7	C
Indoor Air Relative humidity	0.511	fraction
Indoor Air Inlet pressure	101.318	kPa
Outdoor Air Dry-bulb temperature	27.8	C
Outdoor Air Wet-bulb temperature	21.9	C
Outdoor Air Dew-point temperature	19.3	C
Outdoor Air Relative humidity	0.600	fraction
Outdoor Air Inlet pressure	101.318	kPa

**CONTACT:**  
 PIOTR DOMANSKI  
 BUILDING ENVIRONMENT DIVISION  
 301-975-5877  
[piotr.domanski@nist.gov](mailto:piotr.domanski@nist.gov)



Indoor Air Quality Test Chamber.

## Indoor Air Quality Chamber

A stainless-steel test chamber has been designed and installed in NIST's Building 226 for use in a wide range of indoor air quality (IAQ) research projects. This 32 m<sup>3</sup> chamber is instrumented for the measurement of contaminant concentrations, environmental parameters and ventilation rates, and has a custom air conditioning system to supply clean air to the space with precisely controlled temperature and humidity levels. This system employs both high efficiency particle filtration and gaseous air cleaning to ensure high-quality supply air to the space.

This unique facility will be used to characterize contaminant emissions from building materials and

furnishings as well as to test air cleaning and other IAQ technologies under well-controlled test conditions. Current research plans for the chamber include the development of full test methods for portable air cleaners, studies of emission characteristics of building materials and furnishings, and development of new tracer gas measurement methods for characterizing building ventilation. Other research possibilities include evaluation of gas and particle sensors, research into aerosol transport mechanisms, and indoor air chemistry.

**CONTACT:**  
 ANDREW PERSILY  
 BUILDING ENVIRONMENT DIVISION  
 301-975-6418  
[andrew.persily@nist.gov](mailto:andrew.persily@nist.gov)

## Cybernetic Building Systems

### Intended Outcome and Background

The intended outcome of the Cybernetic Buildings Systems Program is to make available tested and demonstrated open Cybernetic Building Systems for improved productivity, life-cycle cost savings, energy conservation, improved occupant satisfaction and market leadership. This work will be carried out in close cooperation with the U.S. building industry, industrial partners, building owners/operators and newly developing service companies.

During the next ten years, the building controls industry in the United States will be undergoing a radical change from one with a vertical structure to one with a horizontal structure. Building control companies, equipment and system manufacturers, energy providers, utilities, and design engineers will be under increasing pressure to improve performance and reduce costs. Cost reduction can be achieved by developing Cybernetic Building Systems that integrate more and more building services, including energy management, fire and security, transportation, fault detection and diagnostics, optimal control, the real-time purchase of electricity and the aggregation of building stock. The BFRL program, which will include a full-scale demonstration of one or more Cybernetic Building Systems, will involve the following tasks:

- develop standard communication protocols;
- develop enabling technologies, such as fault detection and diagnostic (FDD) methods;
- develop performance evaluation tools;
- develop a standard-based information infrastructure supporting the design, commissioning, operation and maintenance of heating, ventilation, air-conditioning and refrigeration systems;
- construct a Virtual Cybernetic Building System in the laboratory to facilitate the development and evaluation of new products and systems by manufacturers;
- conduct basic research on the dynamic interactions of a fire, HVAC/distribution and the zones of a commercial building through utilization of existing and new simulation models, and validate this new simulation program through both laboratory and field studies;
- develop a consortium of manufacturers and service providers interested in producing, testing, demonstrating and selling Cybernetic Building Systems;
- test and evaluate different security concepts and supervisory security systems for the critical infrastructure protection of integrated building systems; and
- conduct a full-scale demonstration of a Cybernetic Building System in a government owned office building complex.

#### ACTIVITIES AND ACCOMPLISHMENTS

### Developing, Managing and Disseminating Building Information During Emergencies

There are multiple projects dealing with building information during emergencies. Their objectives are: (1) to develop standard building information services that enable ready access to building systems data by first responders; (2) to develop standard methods for managing heterogeneous wireless sensor networks in buildings, facilitating access by first responders and other emergency personnel; and (3) to develop methods for ensuring the secure dissemination of building information to emergency responders.

An emerging technology known as Web services is making it possible to provide Internet access to information sources and services that previously were locked in proprietary systems. At the same time, numerous researchers are developing sensor network technologies that make it possible for first responders to place sensors inside and outside a building and make them Internet-accessible

via Web services or similar technology. While these developments hold great promise, several problems arise for first responders. For example, how can they find out what building systems information is available in a specific situation and then find the information they want? Second, how can they fuse the information from their temporary and possibly mobile sensors with systems information available from the building?

To address the first problem, a top-down framework for describing building systems and sensors will be developed from the previous bottom-up Industry Foundation Classes (IFC)-based building information modeling work. This project previously explored the use of Web services and building information models generated for planning and design purposes in creating simulation models for threat analysis and mitigation. The framework will be implemented in a Web service that can answer the first-responders' question: what can I know about the systems in this building or facility and how do I find it? This work will involve implementing the American Society for Heating, Refrigerating and Air-Conditioning Engineers (ASHRAE) BACnet Web Services specification by placing BACnet-specific services (e.g., read a

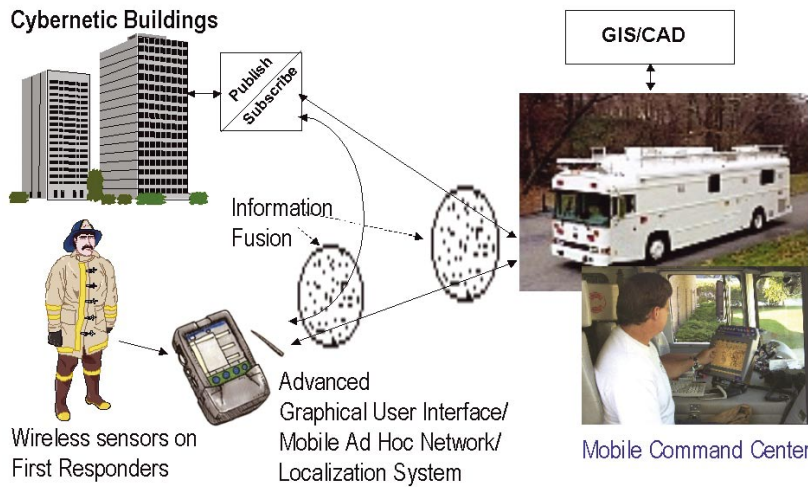

**Secure Dissemination of Building Information to Emergency Responders.**

sensor) in the context of the building and its systems (e.g., what sensor should be read). This work will also establish the framework for two-way access to detailed systems information. To address the sensor-fusion problem, an auxiliary Web service will be developed that can translate among the various kinds of location data likely to be present in an emergency event. For example, this Web service will translate a geospatial location (e.g., a GPS datum from a mobile sensor) to a building-specific location such as a room on a floor, and vice versa. Following this, Web services will be developed to fuse data from sensors that are related by their proximity.

This project will also include an examination of issues surrounding the implementation of wireless sensor networks, using a manufactured house at NIST as a testbed. Experiments will be conducted with these networks to gather experience with competing wireless sensor networking technologies. Specific tasks to be carried out include the following: (i) selection of sensor networks, (ii) deployment of sensor networks, and (iii) exploration of Web services for data conglomeration.

Controlling access to this information, and limiting its availability to legitimate users without hampering the accessibility of the information to authorized users, is another critical aspect of any system for providing emergency responders with building

information. This process is complicated by the fact that emergency responders can come from a wide range of departments, including fire, police, EMS, HAZMAT and public safety and health. Among these agencies are large numbers of individuals, as well as departments from various jurisdictions, including local, state and federal agencies. The proposed project will address authentication and authorization issues related to the secure dissemination of building information to emergency responders. Authentication refers to the verification of the identity of information requestors, including using biometric traits, passwords, smart cards or other methods. Authorization refers to the rights and privileges that an individual has at any point in time before or during an incident. The project will also include the development of standards and protocols for the representation and transfer of building information. One additional element will be the development of methodologies to allow the control of building systems by emergency responders, for example for smoke control, elevator operation or other emergency procedures.

**CONTACT:**  
 DAVID HOLMBERG  
 BUILDING ENVIRONMENT DIVISION  
 301-975-6450  
[david.holmberg@nist.gov](mailto:david.holmberg@nist.gov)

## HVAC Fault Detection and Diagnostics

Building heating, ventilation, and air conditioning (HVAC) equipment routinely fails to satisfy performance expectations envisioned at design. Equipment and control failures often go unnoticed for extended periods of time. Additionally, higher expectations are being placed on a combination of different and often conflicting performance measures, such as energy efficiency, indoor air quality, comfort, reliability, limiting peak demand on utilities, etc. To meet these expectations, the processes, systems, and equipment used in both commercial and residential buildings are becoming increasingly sophisticated. These conditions necessitate the use of automated fault detection and diagnostics (FDD) to ensure fault-free operation.

BFRL has developed two fault detection and diagnostic (FDD) tools to assist operators in monitoring the performance HVAC systems: AHU Performance Assessment Rules (APAR) and VAV box Performance Assessment Control Charts (VPACC). AHU Performance Assessment Rules (APAR) uses a set

**Air Handling Unit Temperature Control Schematic.**

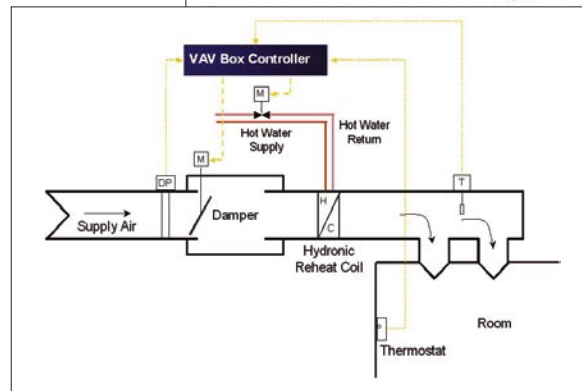
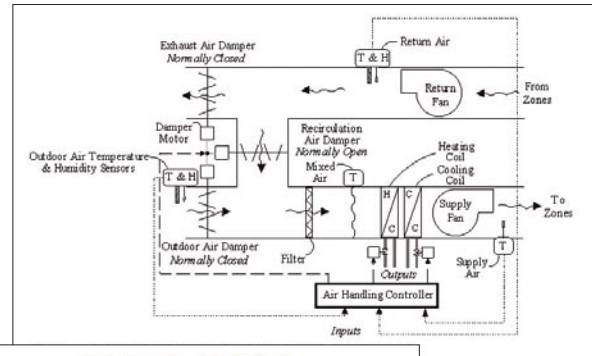

**VAV Box Schematic.**

of expert rules derived from mass and energy balances to detect common mechanical faults or control problems in air-handling units. Control signals are used to determine the mode of operation for the AHU. A subset of the expert rules corresponding to that mode of operation is then evaluated to determine if there is a fault or control problem. VAV Box Performance Assessment Control Charts (VPACC) implements an algorithm known as a CUSUM chart. The basic concept behind CUSUM charts is to accumulate the error between a process output and the expected value of the output. Large values of the accumulated error indicate an out of control process.

A series of research projects were conducted in which batch implementations of APAR and VPACC were developed and refined using data collected from simulation, emulation, laboratory testing, and real buildings. The tools were found to be successful at finding a wide variety of faults including stuck or leaking dampers and control valves, sensor drift, and improper control sequencing. APAR and VPACC were then embedded in the control programming of commercial AHU and VAV box controllers. The advantage of embedding FDD in the local controller for each piece of equipment is that the algorithm then

has local access to sensor data and control signals, eliminating the need to communicate this information over the building control network. This approach is highly scalable, and therefore suitable to larger HVAC systems. Any faults that are detected can be reported to the building operator using the control system's alarm/event handling capability. Several control system manufacturers are currently considering the commercialization of these FDD tools.

In addition to APAR and VPACC, a rule-based, system-level FDD method for HVAC systems was developed. It functions as an interface between multiple, equipment-specific FDD tools and a human operator. The method resolves and prioritizes conflicting fault reports from equipment-specific FDD tools, performs FDD at the system level, and presents an integrated view of an HVAC system's fault status to an operator. A simulation study to test and evaluate the method was recently conducted.

**CONTACT:**  
JEFFREY SCHEIN  
BUILDING ENVIRONMENT DIVISION  
301-975-5874  
[jeffrey.schein@nist.gov](mailto:jeffrey.schein@nist.gov)

## Virtual Cybernetic Building Testbed Includes Access Control Enhancements

The BFRL Virtual Cybernetic Building Testbed (VCBT) is a real-time emulator of a sophisticated building automation system, consisting of real controllers and a simulated building environment. The VCBT includes several building HVAC controllers, a fire alarm system, and a lighting controller, all on a local area network (LAN), along with a computer system with the capability of simulating the operation of an actual building. Thus, from the controllers' point of view, all sensors and actuators are installed in a real building. The "virtual building" environment is provided by computer models of building operation, including HVAC systems, thermal interactions with the environment, and special scenarios, such as fires or other emergencies. Communication among the controllers is accomplished using the BACnet protocol.

Enhancements have been made to the VCBT in order to develop and demonstrate methods for obtaining interoperability among the various controllers as part of an integrated building automation system. Following this approach, information

on sensor readings, building occupancy, and control can be shared by the different sub-systems to improve overall system performance, capability and building security.

A building physical access control system, including biometric identity verification, was one of the enhancements added to the VCBT. The access control capability was incorporated in the form of an access controller application running on a server connected to the LAN. The access control system includes three virtual access zones, each associated with a virtual access point, at which identity is checked using an actual biometric device. A smart card reader was also incorporated at one access point. The smart card reader, the fingerprint reader and the iris scanner all connected directly to a computer workstation, while the hand shape reader is connected directly to the LAN. Users were enrolled individually on each biometric device, using a BioAPI application.

**CONTACT:**  
STEPHEN TREADO  
BUILDING ENVIRONMENT DIVISION  
301-975-6444  
[stephen.treado@nist.gov](mailto:stephen.treado@nist.gov)

TO ENABLE ENGINEERED  
FIRE SAFETY FOR  
PEOPLE, PRODUCTS,  
AND FACILITIES;  
AND ENHANCE  
FIRE FIGHTER  
EFFECTIVENESS.

GOAL 2

## FIRE LOSS REDUCTION

U.S. annual losses attributable to fire — 3600 lives, 22 000 serious injuries, \$10 billion in direct property loss, and \$128 billion total cost.

Core research to significantly reduce fire loss is organized around three technical programs:

- *Advanced Fire Service Technologies Program* — Enabling a shift to an information rich environment for safer and more effective fire service operations through new technology, measurement standards, and training tools.
- *Reduced Risk of Fire Spread Program* — Reducing residential fire deaths and property loss by adapting measurement and predictive methods to better understand conditions leading to flashover and to external fire spread from vegetation and adjacent buildings; enabling early and certain fire and environment sensing; advancing cost-effective fire suppression technologies; and enabling new/improved materials whose fire resistance does not negatively impact performance, cost, or the environment.
- *Advanced Measurement and Prediction Methods Program* — Leading the world in fire measurement and prediction methods, and accelerating their transfer to practice, to enable engineered fire safety for people, products, facilities, and first responders.

- *Fire Standards, Codes, and Testing Program* — Providing the infrastructure necessary to facilitate the transfer of BFRL-developed technology into practice through participation with codes and standards organizations, maintenance of the premier international research bibliography and electronic data for the fire community, and the development of laboratory facilities with a premium on accurate, innovative and safe large-scale fire experiments.

### Fundamental Fire Science

#### Intended Outcome and Background

Engineering correlations to predict ignition, flame spread, fire growth and suppression developed through fire testing over the past 25 years have improved fire codes and technologies in the United States and produced a slow decline in the number of deaths and injuries due to unwanted fires (excluding the singular event of the WTC collapse); however, the total economic burden of fire in the U.S. continues to rise. To counteract these losses economically and to pre-empt the anticipated increase in fire-related deaths and injuries associated with a larger and more aged population, new fire safety technologies and performance-based codes are needed; these can be achieved with a higher level of understanding of the dynamics of fire and with more certain measurement methods.

During the next ten years, the building industry in the United States and the rest of the world



will be undergoing a radical change as prescriptive fire codes for built facilities are replaced by performance-based codes. Designers of fire protection systems for new buildings and retrofit situations will be under increasing pressure to improve performance and reduce costs by implementing new and clever passive and active fire protection, based on their *expected* performance rather than their adherence to a prescribed building code. Of course, a key assumption in this approach is that it is possible to predict accurately the effect of design changes on the actual fire performance. NIST will take a leadership role in this coming “revolution” and assure that the basic tools used to predict fire behavior are accurate and appropriate. To enable this work to succeed, BFRL must create the scientific and engineering knowledge base that will allow the development of the predictive tools that are the foundation of performance-based design for fire protection systems.

The framework for organizing the wide range of BFRL’s knowledge of fundamental fire physics is the NIST Fire Dynamics Simulator, FDS. This open-source, NIST-developed and supported computational fluid dynamics code is used world-wide by combustion researchers, fire protection engineers, and fire researchers to predict flame spread and fire and smoke progression through a burning building. Much of the work in the Fundamental Fire Science Program is aimed at improving the underlying knowledge base used to develop the algorithms used in FDS. Advancements

come both from accurate laboratory measurements at all scales and improved mathematical descriptions in the code. Many of the improved laboratory methods are aimed at increasing the accuracy of full-scale measurements made in the BFRL Large Fire Facility, while other small and intermediate scale tests are necessary for first understanding the underlying fire physics.

The overall goal of reducing fire losses guides the research conducted in this program, and a conscious effort is made to impact other national and international fire laboratories, industrial partners, and standards-making bodies consistent with our vision in methods of measurement and prediction of the behavior of fire and its effects. During the next decade, BFRL will continue to work with industry, fire testing laboratories, national and international organizations that determine fire standards and codes, university researchers, other government agencies, and international fire researchers to reduce fire losses. This program will underpin that work, providing the knowledge and tools to reduce fire loss and become the recognized source of accurate measurement and the predictive methods used.

ACTIVITIES AND ACCOMPLISHMENTS

### Fire Dynamics Simulator and Smokeview

The Fire Dynamics Simulator (FDS) is a computational fluid dynamics model of fire driven flows. It is used widely in the fire protection engineering community for a variety of applications including design, forensic reconstruction, and teaching. In the past three years, FDS and Smokeview played a significant role in both the World Trade Center and The Station nightclub investigations. In the WTC investigation, the model was used to predict the fire temperature and movement on the impact floors of both towers, and these temperature predictions were then used by structural engineers to assess the weakening of the steel and the eventual collapse of the buildings. In the nightclub fire investigation, FDS/Smokeview was used to model the ignition and spread of a devastating fire in a small nightclub in Rhode Island. A pyrotechnic display for a rock band ignited a fire that killed 100 people.

In both investigations, the model was consistent with the observations of eye

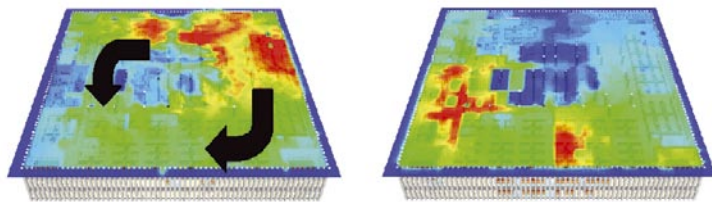

FDS/Smokeview prediction of fire movement on the 94<sup>th</sup> floor of WTC 1 (North Tower).

witnesses and the photographic evidence. This type of forensic reconstruction has been carried out by BFRL staff and outside fire protection engineers for numerous fire events where the model aids in tying together the physical and visual evidence.

**CONTACT:**  
KEVIN MCGRATTAN  
FIRE RESEARCH DIVISION  
301-975-2712  
[kevin.mcgrattan@nist.gov](mailto:kevin.mcgrattan@nist.gov)

## Consolidated Model of Fire and Smoke Transport

The Consolidated Model of Fire and Smoke Transport, CFAST, is a computer program that fire investigators, safety officials, engineers, architects and builders can use to simulate the impact of past or potential fires and smoke in a specific building environment. CFAST is a two-zone fire model developed by BFRL that is used to calculate the evolving distribution of smoke, fire gases and temperature throughout compartments of a building during a fire. These can range from very small containment vessels, approximately 1 m<sup>3</sup> to large spaces on the order of 1000 m<sup>3</sup>.

The latest version of the software, until now a DOS program, has been rewritten to work with Windows and has been tested with Windows 2000 and XP. The CFAST package

includes NIST's Smokeview program, which visualizes with colored, three-dimensional animations the results of the CFAST simulation of a specific fire's temperatures, various gas concentrations and growth and movement of smoke layers across multi-room structures.

Available reports on the model include a Technical Reference Guide (NIST Special Publication 1026), a User's Guide (NIST Special Publication 1041), and a number of journal articles on the evaluation of the model's capabilities. The new software and documentation is available at <http://cfast.nist.gov>.

**CONTACT:**  
RICHARD PEACOCK  
FIRE RESEARCH DIVISION  
301-975-6664  
[richard.peacock@nist.gov](mailto:richard.peacock@nist.gov)

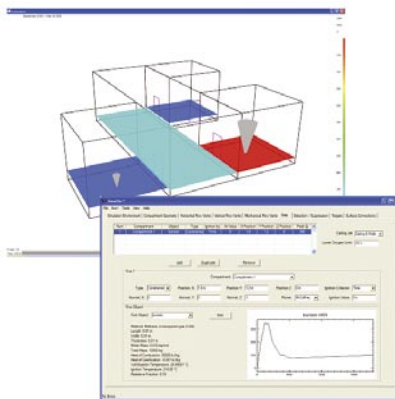

Images from the Consolidated Model of Fire and Smoke Transport.

## Fire Structure Interface and Thermal Response of the World Trade Center Towers

Fire-driven movement of hot gases and smoke is becoming a well developed area of fire science. Nonetheless, with the recent total collapse of World Trade Center (WTC) buildings 1 and 2 due to the aircraft impact and ensuing fires, it is clear that there is an additional need to understand the interaction of the fire with the building mechanical structure. Following the collapse of the WTC towers, there was an active debate in the engineering community regarding the maximum temperature reached in the steel structure due to the fires and the role of thermal weakening of the steel in the building collapse. While photographic evidence could document the fire growth and movement through the building, no methods existed for coupling the thermal response of the structural elements to the observed fire behavior. The Fire-Structure Interface (FSI) was developed during NIST's investigation of the WTC disaster to address this specific need.

The FSI couples the NIST Fire Dynamics Simulator (FDS) with an ANSYS-based finite element structural analysis package. FSI employs a technique borrowed from other compartment fire models, dividing the compartment into a hot, soot laden upper

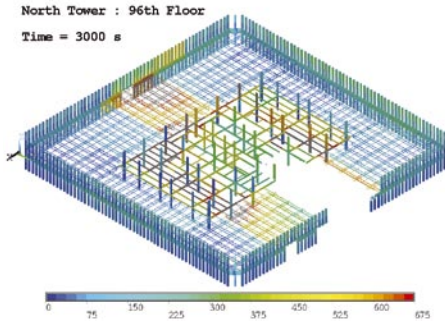

Figure shows the steel temperatures (in °C) of floor 96, WTC 1, at one instant in time.

layer and a cool relatively clear lower layer. The properties of the two layers are extracted from temporal averages of the results of an FDS simulation, and the resulting heat flux to the structural elements is calculated based on the heat conduction and thermal radiation from each layer.

The methodology was used extensively in NIST’s WTC Investigation to predict the thermally-induced structural response to the fires which were growing in space and time. Structural and fireproofing damage due to aircraft impact was incorporated into the models. Four global simulations, two each for WTC 1 and WTC 2, were performed. Based on the results of the global simulations, fireproofing thickness and fireproofing damage due to aircraft impact were identified as the most important parameters having the largest effect on steel temperature and on the thermally-induced structural response.

**CONTACT:**  
 KULDEEP PRASAD  
 FIRE RESEARCH DIVISION  
 301-975-3968  
 kuldeep.prasad@nist.gov

### Reduced-Scale Tests of the Fire Growth and Spread Prediction Capabilities of FDS

The prediction capabilities of the NIST Fire Dynamics Simulator (FDS) software are being extended to include fire growth and spread. Predicting these phenomena is challenging, and experimental data are required to validate the code’s accuracy. Clearly, intermediate and large-scale tests are required; however, they are expensive and time consuming. It is also necessary to validate the sub-grid scale models with small-scale tests. The ultimate goal of the present work is to improve the treatment of flame spread on the solid phase in FDS. As a first step, experiments were conducted in which small-scale polymer samples were subjected to increasing radiant flux, and the burning rate and its surface variation were measured. FDS was used to predict the average burning rate as well as its variation over the sample surface.

This provides a measure of the model’s capacity for predicting fire growth, since an ability to predict the burning of such a simple configuration is a clear prerequisite for modeling large fires which will also involve burning on the scale of cone samples. The figure below shows some images of the burning polymer samples in the cone calorimeter at increasing imposed radiant flux. The right-most image shows a color contour of the heat release rate (red  $\approx 2.5 \times 10^4$  kW/m<sup>3</sup>, blue  $\approx 0$ ) predicted by FDS for a PMMA sample at 60 kW/m<sup>2</sup> incident flux (since the calculation is axisymmetric, only a half-image is presented; the left side is the axis of symmetry). Following that are images of the remaining sample (from burning at an imposed flux of 0 kW/m<sup>2</sup>), and its measured and predicted topography. This project has delineated the relative importance of various numerical, physical, and experimental parameters on the model-predicted burning of the sample. The value of

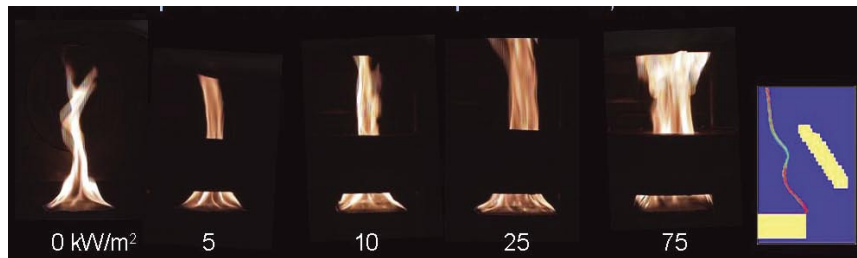

Flame image from burning PMMA polymer subjected to heat fluxes of (0, 5, 10, 25, and 75) kW/m<sup>2</sup> in the cone calorimeter, along with a color contour (right-most image) of the FDS-predicted heat release rate per unit volume in the flame. (The simulation shows the radial and axial profile from the axisymmetric calculation; the yellow horizontal rectangle is the right half of the PMMA sample, and the thick yellow line at 45° is the right-side of the cone heater.)

this research will be an understanding of the performance of FDS for such applications, allowing further improvements and accurate application of the code for predicting fire growth and spread in a building fire.

**CONTACT:**  
 GREG LINTERIS  
 FIRE RESEARCH DIVISION  
 301-975-2283  
 linteris@nist.gov

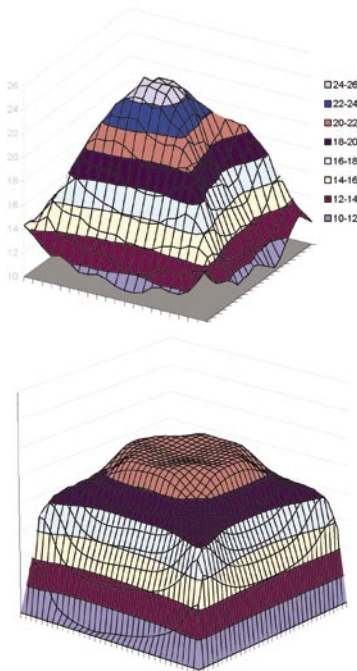
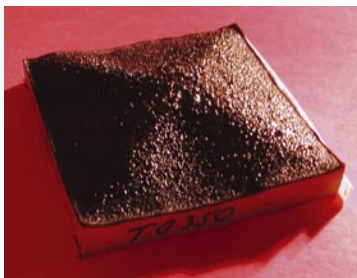

Actual sample and the measured and predicted sample mass topography for a PMMA sample at 0 kW/m<sup>2</sup> incident flux.

## Advanced Measurements of Fire-Induced Flows

The behavior of an enclosed fire is controlled by doorway and window ventilation. Inflowing air provides the necessary oxygen to sustain the fire (but can also moderate hot temperatures), while out-flowing hot gases transport heat and toxic fumes to new locations, spreading the fire and the hazard. Hence, quantifying doorway flows is essential for understanding enclosure fire behavior.

The primary method of measuring gas velocity in fire-induced flows has been with bi-directional probes, which measure the gas pressure and temperature at a few points to allow estimation of the local mass flow rate of the gases. While these devices can withstand the harsh fire environment, they are limited in their coverage and are somewhat inaccurate.

This project is improving fluid flow measurements in full-scale fires through state-of-the-art laser measurement techniques. Using Particle Image Velocimetry (PIV), the flow is seeded with particles, and carefully timed laser pulses and cameras track the location of the particles in two dimensions. From the particle location and time data, velocity vector fields are computed. Unlike the bi-directional probe, PIV is a non-intrusive technique that is capable of probing thousands of points simultaneously, therefore producing a

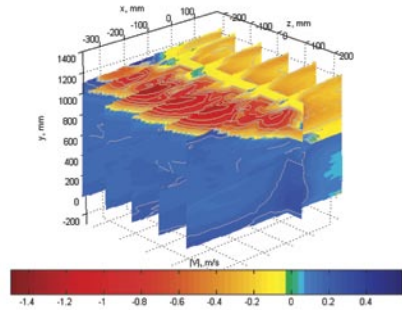

Volumetric mapping of SPIV measurements in the reduced-scale fluid flow analog experiment (inflow in blue, outflow in red).

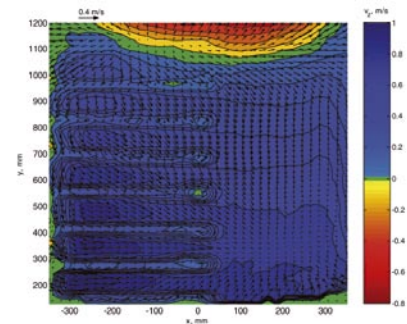

Sectional view of the SPIV-measured flow velocity field in the doorway of an ISO 9705 test room (inflow indicated by blue, outflow by red).

planar interrogation of a region in a single measurement. Stereo PIV (SPIV) is an extended technique in which the full velocity vector, and therefore, three-dimensional flows, can be measured.

Prior to full-scale tests, the SPIV technique was applied to a reduced-scale flow analog. These tests revealed technical challenges, including the seeding of large quiescent flows and limitations to the scattered light as the scale increases. A methodology for conducting SPIV measurements in full-scale fire

test was developed, and applied using a standard ISO 9705 test room and a steady natural gas fire. The measurements demonstrate the first ever PIV measurements in the doorway of an enclosure containing a fire, yielding three dimensional gas velocities at high accuracy. Such detailed measurements are essential to support the validation of high fidelity computer models such as the Fire Dynamics Simulator (FDS), as well as to improve the use of existing standard measurement techniques such as the bi-directional probes.

**CONTACT:**  
 RODNEY BRYANT  
 FIRE RESEARCH DIVISION  
 301-975-6487  
[rodney.bryant@nist.gov](mailto:rodney.bryant@nist.gov)

## Visibility in Smoky Environments

In a building fire, visibility through smoke hampers both egress and rescue efforts. In a smoke-filled room, visibility is affected by the luminous intensity of objects (light emitting and reflecting), contrast, colors, external lighting, and the characteristics of the smoke, including its concentration, distribution, and physical properties. Experiments conducted by others in the past have examined human perception in smoke filled spaces, including psychological reaction to smoke and visibility limits of specific objects, in particular, exit signs. The present project

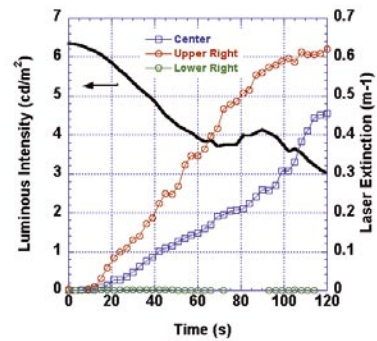
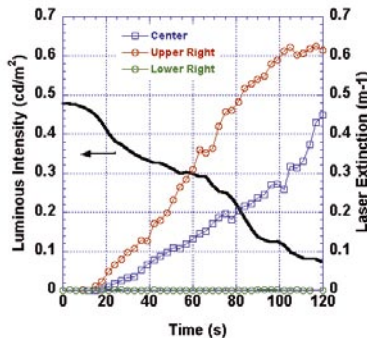

Video images of an exit door in a corridor being filled by smoke from a propene-air flame at 0, 60 s, and 120 s (left, right: corridor lights off, on).

goes beyond previous work by collecting *quantitative* data on the visibility of such objects through smoke with simultaneous characterization of the smoke properties. Capabilities have recently been developed at NIST to predict the

visibility through smoky environments. The Smokeview program, however, needs quantitative data to test and improve the computational algorithms. In this project, a series of experiments have been conducted to gather video

images of and other data for well-characterized smoke-filled scenes to assess exit sign visibility performance, and to allow verification of the visibility degradation predicted by Smokeview for the experimental configuration.

Tests were conducted in a 16m long corridor with a burn room attached. Measurements were made of exit sign luminous intensities, ambient light intensities, laser light extinction, spot luminance, and gas temperatures before and during smoke-filling of the corridor. Obscuring aerosols examined included black soot from propene combustion, pyrotechnic (white-colored) smoke bombs, and ISO test dust. Exit signs studied included: reflective signs, internally illuminated signs, photoluminescent signs, an electroluminescent sign, and a self-luminous tritium sign. Companion tests were performed on individual signs using the NIST Fire Emulator/Detector Evaluator.

The data are being used to assess exit sign performance in smoky conditions, and are available for comparing with simulated scenes. A quantitative understanding of and a predictive capability for visibility through smoke will be useful in fire fighter training, fire reconstruction studies, and fire safety system design.

**CONTACT:**  
THOMAS CLEARY  
FIRE SCIENCE DIVISION  
301-975-6858  
[thomas.cleary@nist.gov](mailto:thomas.cleary@nist.gov)

## Advanced Fire Service Technologies

### Intended Outcome and Background

The Advanced Fire Service Technologies Program assists the fire service to take advantage of existing technologies such as thermal imaging and positive pressure ventilation techniques, and is anticipating the integration of new innovative technologies, such as tactical decision aids, training simulators, and improved protective clothing. The full capabilities and limitations of equipment and systems being introduced into the fire service need to be understood with respect to the needs of fire fighters.

For existing technologies, it is critical that performance can be measured and evaluated in a scientifically sound method and that the technology can be successfully transferred to the fire service through training programs and fire fighting simulators. There is also a simultaneous need to look ahead to developing innovative technologies and understand how better protective equipment, tactical decision aids and training can allow the fire service to reduce fire fighter fatalities and injuries as well reduce property losses.

BFRL has made many contributions to understanding the performance of fire fighter protective clothing. The measurement and modeling experience will now be

used to examine the performance of new nano-carbon tube composite materials and passive protection systems for protective clothing. In 2006, BFRL research will help industry to move forward in delivering practical materials that can be used in advanced protective clothing. BFRL has also been successful in furnishing decision tools for law enforcement for the selection of equipment based on attributes weighted by the user and information from testing available to the public.

Virtual training, long the norm in aviation, military combat, and law enforcement training, is being used by the fire service as part of education for incident commands and drivers. As BFRL research in fire modeling, understanding of the dynamics of fire fighting, and measurement of equipment performance come together, the opportunity to move forward with effective fire fighter simulations emerges. BFRL has generated effective visualizations of fire conditions as part of the work involved in fire and accident investigations.

BFRL, in cooperation with the U.S. Fire Administration, produces a Web-based newsletter, *FIRE.GOV*, directed at providing information to fire service readers on current research and activities that can impact their work, published in an easily accessible electronic form. Also included in the newsletter are contact information and links to researchers and organizations involved in on-going research, serving to keep the research and fire service communities connected.

BFRL is taking a leadership role that is recognized nationally for technology and standards that will enable the transfer of science, metrics, and technology, into the hands of fire fighters, incident commanders, and other first responders.

ACTIVITIES AND ACCOMPLISHMENTS

**Performance Metrics for Infrared Cameras (Thermal Imagers)**

The potential benefits of thermal imaging to fire fighters became evident in the early to mid 1990s. Since then IR technology for first responder applications has matured to the point that most emergency response organizations either have purchased or are considering the purchase of thermal imaging cameras (TICs.) Thermal imagers are a significant tool for the fire service, enabling fire fighters to find their way out of burning structures, locate fires and victims, provide guidance to fire attack teams, and perform overhaul operations and fire investigations more effectively.

Currently no performance metrics or testing protocols are available to

evaluate current technologies. Imager performance (noise, spatial and temperature resolution, time response, and display saturation) is being considered in terms of measurements made under conditions simulating realistic fire environments.

NIST is investigating the effectiveness of various optical performance metrics applicable to TICs used in first responder applications. BFRL researchers have been conducting performance evaluations at NIST for the past two years, in which images from TICs having different detector types are compared in a variety of conditions. Preliminary results from these tests show that the image quality varies between detector types and between TICs for different conditions. An example of the differences found in image quality is shown, right, in which three TICs are viewing an identical scene. While each TIC provides valuable information on the location of hot gases and fire, the amount of information available to an observer differs considerably between the three TICs.

The results of this research are being used to provide the strategies, technologies, procedures, best practices, research and development that can significantly improve thermal imaging technology for the first responder community.

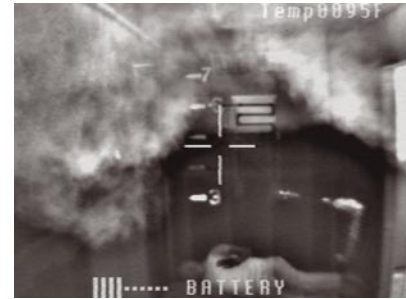

**View of a corridor with a heated mannequin on the floor, and a temperature target and reflective strips on the back wall. Hot, smoke-laden gases are entering the corridor from an adjacent room on the right. The three TICs are viewing an identical scene at the same moment.**

## Computer Modeling of Respiratory Protection for First Responders

Respirators protect the lungs of first responders in a wide range of hazardous environments. However, the level of protection from inhalation of toxic materials under normal and high stress situations is not well understood. Respirators are used over a short time period during fire fighting and are recommended for continuous use during cleanup of debris and hazardous materials. Hazardous environments may include fine particulates and chemical and biological toxins. First responder exposure to these hazards is affected by leaks, poor fit, heavy breathing and coughing, and temporary removal of respirators to clean them or to communicate with coworkers.

Current performance and fit testing protocols for face pieces for self-contained, positive pressure, powered air

purifying, and half-mask respirators relies on data collected by the U.S. Air Force over 40 years ago. The National Institute for Occupational Safety and Health (NIOSH) has demonstrated that this database does not adequately represent the facial characteristics of the fire and law enforcement communities. In the post 9/11 environment, a need has emerged to understand how and where face pieces may leak and compromise the protection afforded a first responder. BFRL's unique experience in computational fluid dynamics modeling and aerosol measurement has developed computer simulation of the mask/face scenario in combination with aerosol metrology inside the respirator face piece. BFRL researchers have generated a computer simulation that can input facial geometries directly from laser based head/face scanners. NIOSH is currently developing a more representative face geometry database using paid human subjects and a head/face scanner. Utilizing BFRL aerosol measurement expertise, a prototype in-mask aerosol monitor has also been developed.

**CONTACT:**  
KATHY BUTLER  
FIRE RESEARCH DIVISION  
301-975-6673  
[kathryn.butler@nist.gov](mailto:kathryn.butler@nist.gov)

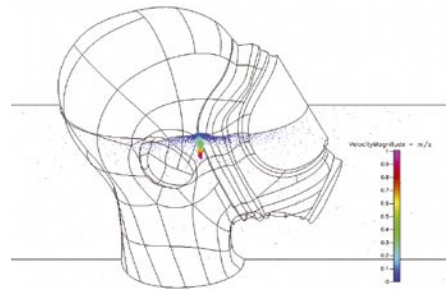

Computer model image of leak from inside mask to outside environment.

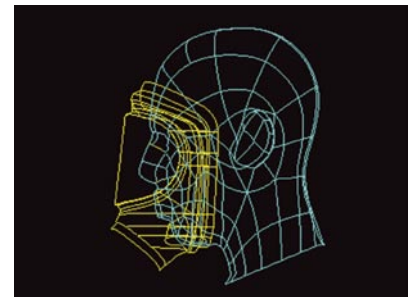

Respirator face piece and head form are combined into single geometry for computer modeling of leaks.



## Carbon Nanotube Fabric for Fire Fighter Protective Clothing

The incidence of burn injuries may be significantly reduced if protective clothing could be made from fabrics with unidirectional heat conduction properties. It is now known that the thermal conductivity of carbon nanotubes (CNT's) is at least three orders of magnitude greater along the tube axis than other materials used to make protective fabrics. If this enhancement in thermal properties could be realized in materials suitable for making protective clothing and combined with a passive chemical-based system to absorb the energy, it would lead to a dramatic improvement in protection for fire fighters. Furthermore, it has recently been demonstrated that CNT materials are highly reflective so that they will absorb only a small fraction of

the radiation from a fire. This congruence of favorable thermal properties was previously thought to occur only in metals, which are clearly not suitable for clothing.

The purpose of this research is to realize the potential for making woven or non-woven fabrics that exhibit these metal-like properties from CNT fibers. In this pursuit, a wide range of solvents, compatibilizers, and functionalized CNT's have been examined in the effort to prepare flexible fibers. Once we have perfected the technique for making macroscopic fibers from CNT's, we will test them using a fire fighter mannequin in experiments that will provide information about the temperatures that these materials reach in actual fires.

**CONTACT:**  
 MARC NYDEN  
 FIRE RESEARCH DIVISION  
 301-975-6692  
[marc.nyden@nist.gov](mailto:marc.nyden@nist.gov)

## Virtual Fire Fighter Trainer

The experience of fighting fires in a burning building has no equal, but is it the only way to train? Is it the only way to demonstrate how different tactics will affect a fire? BFRL is creating a virtual reality training simulation of various fire situations to demonstrate how life-threatening conditions can develop in structures. Using this technology, fire fighter training instructors can provide realistic visualization of fire growth and suppression and test fire fighting tactics using computers rather than in an actual emergency situation.

Two methods are being used to create a fire fighting training tool. The first and simpler method is to use the Fire Dynamic Simulator (FDS), and the fire visualization program, Smokeview to create animations illustrating various fire behaviors. These animations will be viewable in a standard DVD player. The DVD menus will be used to walk a fire fighter through a series of decisions. The second method will be more interactive. Using Smokeview, the trainee will "walk" through an FDS generated fire scene observing and making decisions.

For use in these training tools, FDS and Smokeview have been re-worked by adding enhanced fire-related simulation

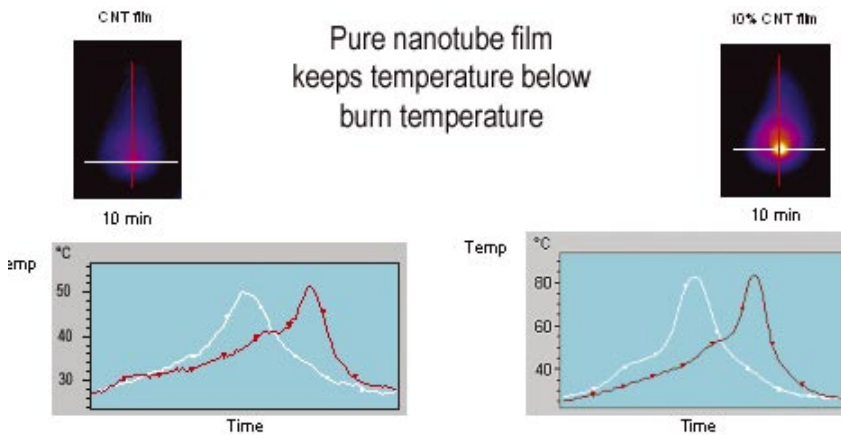

Carbon nanotube (CNT) film dissipates heat better than 10 percent CNT film. Peak temperatures are significantly lower for CNT film as compared to peak temperatures for 10 percent CNT film.

technologies such as “real” visibility through smoke. Other features have been added to make the visualizations look 3D and to make it easier for the trainee to “move about” in the simulation scenario. Continued refinements of FDS will increase the system’s

ability for simulation smoke and gas flow caused by fire, wind, ventilation and structural conditions.

**CONTACT:**  
 GLENN FORNEY  
 FIRE RESEARCH DIVISION  
 301-975-2313  
[glenn.forney@nist.gov](mailto:glenn.forney@nist.gov)

## What is the True Cost of Fire Fighter Injuries

What is the cost of a fire fighter injury on the fire ground? What is the probability of a fire engine accident when responding to an emergency call? The BFRL wanted an estimate of the economic consequences of injuries to fire fighters for the purpose of evaluating what new research would both positively impact costs and reduce injuries. A new report prepared by TriData Corporation, *The Economic Consequences of Fire Fighter Injuries and Their Prevention, NIST-GCR-05-874*, addresses the cost of these injuries not only to the fire fighters themselves, but also to their departments, the insurance industry, and society.

A TriData research team conducted the cost-of-injury research by reviewing the existing literature and looking at various models that could be used to calculate financial losses from injuries. The estimated cost of addressing fire fighting injuries and of efforts to prevent them is \$2.8 to \$7.8 billion per year. The cost elements that comprised the studies were based on workers compensation payments and other insured medical expenses, including long-term care, lost productivity, administrative costs of insurance, etc. The TriData team applied a new approach to the

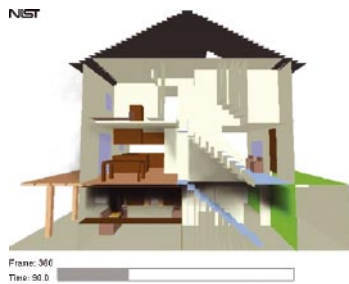

**Townhouse at three different time steps during a simulated fire.**

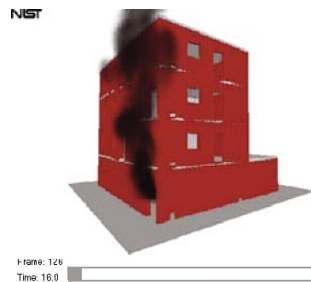

**Different scenarios allow fire fighters to train via different “virtual” structures including ranch-house, colonial-house, and training tower.**

analysis and looked at costs that typically have not been factored into fire fighter injuries. These include the labor costs for investigating injuries, plus the time required for data collection, report writing, and filing, insurance coverage, and the cost for safety training, physical fitness programs, and protective gear and equipment.

By suggesting ways to assess what injuries cost, the study provides local governments with ideas they can use to pursue their own injury impact and prevention analysis. At the state and federal level, larger-scale research and analyses can be pursued to identify what actions would be most likely to reduce the incidence and severity of fire fighter injuries.

**CONTACT:**  
 NELSON BRYNER  
 FIRE RESEARCH DIVISION  
 301-975-6868  
[nelson.bryner@nist.gov](mailto:nelson.bryner@nist.gov)



Report is available on CD and on the Web site: <http://fire.nist.gov>.

## Reconstruction of the Cook County Administration Building Fire

B F R L is often asked to assist in reconstructing specific fires that may involve multiple fire fighter or civilian fatalities, extensive property damage, or exhibit some unusual fire phenomena. Reconstructions may include simulating the incident using computer-based fire models, lab-scale tests of ignition, fire spread, and heat release rate, and full-scale experiments to document fire growth and spread.

The Governor of Illinois asked NIST to provide technical assistance to the Governor's Review Team who were investigating the tragic office fire in the Cook County Administration Building on October 17, 2003, that resulted in six fatalities and numerous injuries. The NIST team visited the fire scene to collect data for use in simulating the fire, including building dimensions, floor plans, door and window locations, materials of construction and furnishings, and fuels. The NIST team also documented the fire damage in order to compare fire model predictions with the observed physical damage. Interior finish materials and furnishings from the fire floor that were undamaged from flames were obtained for use in laboratory-scale heat release rate experiments. The heat release data was necessary for the fire model input and allowed better evaluation with the results from the fire model.

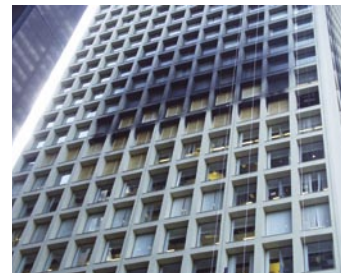

View of east side of the Cook County Administration building, Chicago, Illinois.



Computer animation showing flame iso-surface in office suite at 7 min 30 s after flaming ignition.

The Fire Dynamics Simulator (FDS) provided insight into the fire development in Suite 1240. The simulations examined the impact of the spread of smoke into the southeast stairway with and without a functioning smoke exhaust shaft. Another simulation examined the impact of automatic fire suppression sprinklers. The simulation suggested that had automatic sprinklers been present in the storage room where the fire is believed to have originated, they would have controlled the fire and limited the fire spread to the room of fire origin. The results of this reconstruction are available in NIST Special Publication SP-1021, *Cook County Administration Fire, 69 West Washington, Chicago, Illinois, October 17, 2003: Heat Release Rate Experiments and FDS Simulations*.

**CONTACT:**  
 DAN MADRZYKOWSKI  
 FIRE RESEARCH DIVISION  
 301-975-6677  
[daniel.madrzykowski@nist.gov](mailto:daniel.madrzykowski@nist.gov)

## Rhode Island Nightclub Investigation

On February 20, 2003, at The Station nightclub in West Warwick, Rhode Island, stage pyrotechnics were used to initiate the performance of a band. Unfortunately, the pyrotechnics ignited the polyurethane foam insulation lining portions of the walls and ceiling of the platform and the fire raced along the ceiling and wall areas over the dance floor. In less than two minutes, the smoke appeared to fill the volume over the platform and dance floor, vented from exit doorways, and dropped to within two feet of the floor. Flames were observed breaking through the roof in less than five minutes. Egress from the non-sprinklered building was slowed down by crowding at the main entrance. There were 100 fatalities.

NIST investigated this deadly fire. The nightclub platform area was reconstructed in NIST's large fire laboratory to examine, in a controlled environment, how the fire may have spread in a full-scale reconstruction of the nightclub, and to measure the temperature, heat flux, and gaseous products. A non-fire retarded foam sample purchased by NIST ignited within 15 seconds when exposed to a pyrotechnic device in an

experimental configuration similar to the setup on the nightclub's platform. It took less than 90 seconds after ignition of the foam in the drummer's alcove for conditions in the middle of the room to be lethal at head height. In addition to full-scale and small-scale fire tests, computer simulations were made and reviews conducted of the history of the building and the model codes and standards that could have applied to a building of this type. The results of this investigation are available in NIST NCSTAR2, *Report of the Technical Investigation of the Station Nightclub Fire, Vol. 1 & 2*.

**CONTACT:**  
NELSON BRYNER  
FIRE RESEARCH DIVISION  
301-975-6868  
[nelson.bryner@nist.gov](mailto:nelson.bryner@nist.gov)



Experimental recreation of The Station nightclub fire (top) compared to FDS prediction (bottom).

## Fire Standards, Codes and Testing

### Intended Outcome and Background

New technologies and the knowledge generated by research can lead to substantial reductions in fire losses if they make their way into practice. However, the effective transfer of the results from theoretical studies, numerical simulations, and bench-scale experiments that are being conducted to reduce fire losses and improve security cannot be accomplished in the absence of the following elements: (i) well-instrumented laboratory facilities to demonstrate that the research results are meaningful under realistic full-scale conditions; (ii) a comprehensive network of international fire research information, and repository for BFRL data, to inform researchers, practicing engineers, the fire service, and code-making and regulatory bodies; and (iii) intimate relationships with building and fire codes and standards organizations established through committee work and leadership assignments. As the only federal laboratory responsible for building fire safety, BFRL has the mandate and capability to maintain this critical infrastructure.

The fire standards, codes and testing program provides the infrastructure

necessary to facilitate the transfer of BFRL-developed technology into practice in support of the BFRL Goals of Fire Loss Reduction and Homeland Security (including the implementation of recommendations from the NCST investigations of The Station nightclub fire and the World Trade Center disaster) through participation with codes and standards organizations, maintenance of the premier international research bibliography and electronic data for the fire community, and the development of laboratory facilities with a premium on accurate, innovative, and safe large-scale fire experiments.

This program is organized to produce the following outcomes:

- the rapid adoption of the NIST recommendations from the WTC Investigation;
- a Large Fire Laboratory (LFL) with advanced measurement capabilities that promote the understanding of full and reduced-scale fire phenomena;
- reference data against which predictions can be compared and validated, as well as made available electronically to the fire community;
- tools and knowledge that enable the implementation of performance-based fire codes, allow assessment of key test methods, and address international barriers to standards and the role of uncertainty in regulations;

- transfer of BFRL research results to industry as well as to organizations that create fire standards and codes;
- guidance to North American fire testing laboratories to identify and address research needs; and
- a fire research information system (FRIS) that is *the* source of easily-accessible fire and building-related information for BFRL and our external customers.

Activities in domestic and international standards with respect to trade are increasing, and BFRL is often requested to provide input or participate. The infrastructure established in this program supports standardization activities related to homeland security and fire investigations. NIST needs to actively support the adoption of the recommendations of any investigation. This program also provides support for the newly formed North American Fire Testing Laboratory (NAFTL) organization, the U.S./Japan Natural Resources Development Program (UJNR) Panel on Fire Research and Safety, the Inter-jurisdictional Regulatory Collaboration Committee (IRCC), International Council for Research and Innovation in Building and Construction (CIB), and the International Forum of Fire Research Directors (FORUM).

ACTIVITIES AND ACCOMPLISHMENTS

## Codes and Standards Support

NIST staff are valued members of U.S. and international codes and standards development committees where they make significant technical contributions and provide leadership in ensuring a technical foundation for regulations. The opinions of NIST staff are widely recognized as objective and without commercial interest. Positions on key technical documents are identified and memberships sought through normal channels. In recent years, there has been an additional effort to hold positions at a policy level, particularly in the international arena which has an increasing influence on trade. A primary focus of activities in the United States and global codes and standards arena will be to facilitate the rapid adoption of the NIST recommendations from the WTC Investigation. This will require the development of strategic alliances, speaking in support during deliberations and at code hearings, and mounting an effective defense of criticisms.

Key standards identified in the WTC Investigation report as targets of specific recommendations have representation by NIST staff who will be tasked to provide the support needed through the process of consideration and adoption.

These include: ASTM International, National Fire Protection Association (NFPA), Society of Fire Protection Engineers (SFPE), American Society of Civil Engineers (ASCE), American Society of Mechanical Engineers (ASME), International Code Council (ICC), International Organization for Standardization (ISO), International Council for Research and Innovation in Building and Construction

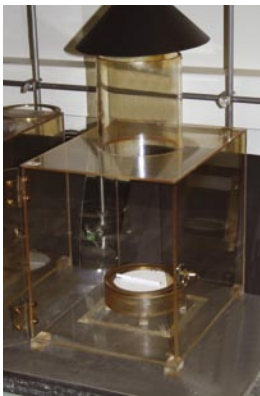

**Reduced-ignition propensity test method (ASTM E2187) developed by a team led by Richard Gann of the Fire Research Division, and adopted by the States of New York, Vermont and California and the Dominion of Canada to reduce cigarettes as an ignition source for fires.**

(CIB), International Forum of Fire Research Directors (FORUM), Inter-Jurisdictional Regulatory Collaboration Committee (IRCC), and Council on Tall buildings and Urban Habitat (CTBUH.)

Recent accomplishments include the following:

- Provided leadership in many U.S. and international fire code and standards organizations (NFPA Standards Council, ISO TAG8, CIB W14, ICC Performance Code Committee, IRCC, CIB TG50, ISO TC92, NFPA Residential Sprinkler and Fire Test Committee, Fire Fighter Protective Clothing Committees, and ASTM E5 Fire Standards, ASTM E515 Contents and Furnishings, ASTM F23 on Protective Clothing.

- Worked with the U.S. Fire Alarm Industry Consortium to develop a standardized information display system and to incorporate BACnet as an underlying communication protocol into the National Fire Alarm Code (NFPA72) and into a National Electrical Manufacturer Association (NEMA) standard.

- Provided leadership to get ISO documents 19706 (guidance) and 16312-1 (criteria for toxicity test methods) approved as Technical Specifications.
- Developed a technical plan to support Federal Trade Commission and New York State regarding legislation on less fire-prone cigarettes.

Domestic and international regulations and reference standards have a growing role in assuring free access to global markets for U.S. companies and in reducing non-tariff barriers to such trade. Not only are these activities important to addressing NIST's role in trade but also to ensuring the rapid introduction of the benefits of NIST research into practice.

**CONTACT:**  
 RICHARD W. BUKOWSKI  
 FIRE RESEARCH DIVISION  
 301-975-6853  
[richard.bukowski@nist.gov](mailto:richard.bukowski@nist.gov)



**NIST's new SRM 1082 consists of 10 packs of cigarettes that have been specially made to be less likely to ignite household furnishings.**

## BFRL Research Information Service (BFRLRIS) and the BFRL Digital Library (FireDoc)

As of June 2005, BFRL's Digital Library, *FireDoc*, has over 71,000 citations and has been growing at a rate of roughly 2,400 a year. The number of publications available online in PDF format has increased, not just by adding new publications, but also by adding older publications as interest indicates. BFRL Publications Online currently has 3,500 abstract pages available to the public.

To continue to meet the growing information needs of the building and fire research communities, BFRLRIS is expanding the availability of electronic building and fire research test data and the key international bibliographic database for fire research, *FireDoc*. *FireDoc* is a major resource to the fire community worldwide because of its unique service as a searchable database for more than 60 journals, numerous conferences as well as other resources. BFRL also continues to support development of Experimental Database for Fire Sciences (EDaFS) to make data and videos from fire experiments available online in an interactive environment.

BFRLRIS is working with other organizations through a digital library effort, *Fire and Building Educational*

*Resource Collection (FABREC)*, in an effort to combine BFRL databases and outside resources within a searchable Web portal. Worcester Polytechnic Institute (WPI), the National Science Foundation (NSF), and BFRL have formed a partnership to create this digital library, which consists of an online collection of resources that are pertinent to the fire science community and related building fields, and are accessible through a central Web site. Because so much information is being published in nontraditional means through the Internet, BFRL will continue to develop FABREC so that the fire and building communities have a single starting point to discover needed information.

The information that BFRL generates is becoming more visible to the world because of the speed and ease of use of BFRLRIS, with BFRL publications becoming available on the Web within a week of notification of publication. BFRLRIS is making information from around the world easily available to the building and fire research communities, and will continue to expand and evolve to meet the changing needs of researchers.

<http://bfrlris.nist.gov>

**CONTACT:**  
PAUL RENEKE  
FIRE RESEARCH DIVISION  
301-975-6696  
[bfrlris@nist.gov](mailto:bfrlris@nist.gov)

## Large Fire Laboratory Operations

The Large Fire Laboratory (LFL) is a key part of the BFRL infrastructure necessary to facilitate the transfer of BFRL-developed technology into practice. The LFL has a 9 by 37 meter test area where three hoods, instrumented for oxygen calorimetry, are used to exhaust combustion products. The smallest calorimeter is 3 by 3 meters with a range of 10 kW to 750 kW. The intermediate calorimeter is 6 by 6 meters and is designed to operate from 100 kW to 3 MW, while the 9 by 12 meter calorimeter has a lower operating range of 200 kW and can accommodate peak heat release rates up to 15 MW. The Large Fire Laboratory is equipped with a 600 channel data acquisition system and a 3,300 standard cubic meters/min emissions control system.

The LFL is used to facilitate technology transfer in the area of heat release rate (HRR) measurements, a key parameter used to characterize fires. Energy release, in the form of HRR, is essential to fire research and is explicitly required in many standard fire tests used for product listing.

BFRL is continuously developing and improving its HRR measurement capabilities. The publication of NIST IR 7052 *The NIST 3 Megawatt Quantitative Heat Release Rate Facility* in 2004 was a significant step towards establishing the LFL as a world class



2.0 MW heptane fire from liquid spray burner.

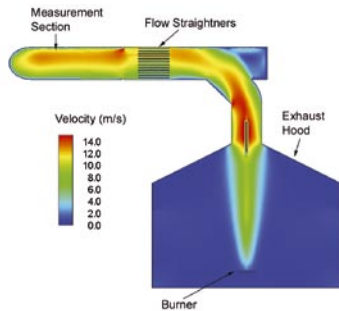

CFD model results of 3 MW fire plume velocity field interaction with 9 m x 12 m exhaust hood and 2 m duct.

facility for large fire measurements. This document provides a detailed description and uncertainty analysis for the 6 meter square hood calorimeter.

With the recent addition of the 3 meter square hood, the LFL facility can now measure HRR from small appliances and furniture (tens of kW) to fully developed room fires (10 MW in the 9 x 12 meter hood). The 3 meter hood exhaust duct contains instrumentation for measuring smoke and convective enthalpy.

The addition of an instrument for measuring natural gas composition allows for precise determination of the



Large Fire Laboratory (left) and Flue Gas Cleaning System (right).

energy value used with a standard reference burner. A liquid fuel spray burner was developed in order to obtain a well controlled reference fire using fuels that produce soot and other products of incomplete combustion.

Current activities include the development of a tracer gas dilution technique and CFD modeling to validate and improve the exhaust duct flow measurements. The results of the CFD modeling will be used to optimize the location of transducers in the duct and modify flow conditioning hardware. New instrumentation is being installed to directly account for the effects of water and  $\text{NO}_x$  on HRR.

The WTC investigation and subsequent interactions with the fire and structures communities have highlighted the need for a national Structural Fire Endurance Laboratory to investigate the effects of severe thermal loading on structural members. A preliminary design study for the proposed Structural Fire Endurance Laboratory is underway.

**CONTACT:**  
 ALEXANDER MARANGHIDES  
 FIRE RESEARCH DIVISION  
 301-975-4886  
[alexander.maranghides@nist.gov](mailto:alexander.maranghides@nist.gov)

## Reduced Risk of Fire Spread

### Intended Outcome and Background

Annual fire losses in the United States remain higher than in most industrialized countries, despite significant reductions during the past two decades. Statistics for 2004 indicate that there were 3,900 fire deaths, 17,785 fire injuries, and nearly \$10 billion in direct fire losses in the U.S. The actual financial cost of fire to the U.S. economy is many times higher than the direct losses due to such associated costs as fire insurance and fire departments. Of these totals, fires in residences were responsible for 3,190 of the fire deaths, over 14,000 of the injuries, and \$6 billion of the total \$8.3 billion in structural fire losses.

Analysis of fire statistics suggests that roughly 80 percent of the fire deaths and property losses in structures are associated with the occurrence of flashover. Flashover is the dramatic and sudden transition from a relatively small, slowly developing fire spreading systematically across adjacent fuel surfaces within a room to a much larger and dangerous fire in which all flammable surfaces within the enclosure are involved. Flashover is generally accompanied by a significant increase in the heat release rate, extension of flames out of open doors and windows (with a corresponding increase in the likelihood of fire spread to adjacent rooms), and



a dramatic increase in the production of toxic fire products. Clearly, reducing the risk of flashover in residential fires provides an opportunity to significantly reduce the high human and property costs of fire to the nation. This is one of the two major areas of focus for the Reduced Risk of Fire Spread (RRF) Program.

Total property losses due to fire in 2004 were reduced by 20 percent from those of 2003. Fire property losses in 2003 were unusually high due to a series of wild-fires in October of that year in Southern California that caused an estimated \$2.04 billion in property damage and destroyed over 3,000 structures, mostly residences. The high losses were due to fires burning in wildlands that spread into areas at the edges of urban areas, igniting the structures. Such fires are referred to as wildland/urban interface (WUI) fires. While still infrequent, highly damaging WUI fires are occurring with increasing frequency due to increased construction in wildland areas around cities, a widespread build up of wildland fuel due to the effective suppression of small wildland fires that would otherwise limit the accumulation of such fuels, and a persistent drought in parts of the United States that increases the likelihood and severity of wildland fires. When these conditions are combined with high winds, the conditions are present for difficult-to-contain, catastrophic wild

fires capable of causing immense damage. Despite the demonstrated potential for heavy property loss, there is a poor understanding of WUI fire behavior that hinders the development of countermeasures designed to protect structures from ignition by such fires. The second area of focus for the RRF Program is providing this understanding and aiding the development of effective countermeasures for protecting structures.

The intended outcome of the flashover component is to reduce the risk of flashover cost-effectively by enabling new/improved materials whose fire resistance does not negatively impact performance, cost, or the environment; and early and certain fire and environment sensing and automatic fire suppression technologies compatible with occupants and the environment.

Reducing the risk of flashover can be equated with reducing fire spread, fire growth, and the maximum value of the heat release rate. There are two general approaches for accomplishing these goals. The first is to limit the availability of fuel (e.g., through the use of fire-retarded fuels) and air (e.g., by controlling ventilation) such that a fire cannot become sufficiently intense to induce flashover. The second is to provide physical intervention (e.g., through automatic sprinklers, or by a fire company following early detection) to reduce the fire size before it can grow to a dangerous level. Both approaches are important and are included in this program.

BFRL is working to develop cost-effective approaches that reduce the flammability of polymers while maintaining or even improving their physical characteristics. Success in this approach will provide a strong incentive for polymer producers and product manufacturers to utilize safer materials in commodity applications.

Active measures to limit fire growth require reliable early fire detection and effective suppression approaches. Directed research designed to enhance fire detector response while reducing the number of false alarms and to improve fire suppression effectiveness is being conducted.

As noted above, the understanding of WUI fire behavior and ignition processes for structures exposed to such fires is poor. Part of the reason for this lack of understanding is that the subject falls between traditional studies of building fires and forest fires, which are usually the responsibility of different branches of the Federal Government. BFRL researchers, working with the U.S. Forest Service, have recently initiated studies designed to fill this gap. Initial efforts are aimed at characterizing the conditions generated by WUI fires, developing improved models for predicting their spread, and identifying mechanisms for structure ignition by burning vegetation.

## ACTIVITIES AND ACCOMPLISHMENTS

## BFRL Initiates Studies of Wildland/Urban Interface (WUI) Fires

Fires occurring in the wildland-urban interface, where houses and vegetation are both present, can result in significant damage to communities. In the 2003 fires near San Diego,

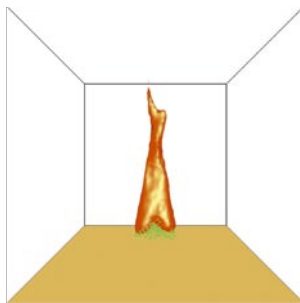

**Top:** A burning 3 m tall Douglas fir tree 20 s after ignition near the bottom of the tree. Information from these experiments, conducted in BFRL's Large Fire Laboratory, is being used to develop and evaluate a computer model of burning trees. An example from the model is shown below.

over 3,000 homes were lost. Most houses, once ignited, were completely destroyed. Wildland-urban interface fires start as uncontrolled wildfires spreading through vegetative fuels to communities. Seasonal drought, increasing population in wildland-urban interface areas, and a historically high fuel load in today's forests all contribute to the ongoing threat of wildland-urban interface fires throughout the United States.

Vegetative fuels in the wildland-urban interface include surface fuels (such as grass), isolated trees and shrubs as well as groups of trees or shrubs. Through both experiments and computer modeling, BFRL is investigating how fires spread through these vegetative fuels and ignite structures, which then themselves become a part of the overall fire spread process. For example, very limited data exists on the heat release rate and firebrand production generated by a single burning tree. Both of the properties have significant impacts on the fire spread process.

Trees of different heights and moisture contents are being burned in BFRL's Large Fire Laboratory to measure their heat release rate, firebrand production, the influence of moisture, and provide data for model evaluation and development.

**CONTACT:**  
 WILLIAM E. MELL  
 FIRE RESEARCH DIVISION  
 301-975-4797  
[william.mell@nist.gov](mailto:william.mell@nist.gov)

## BFRL Facility Ready to Aid Development of Fault-Free Fire Detection

BFRL has worked for several years developing the Fire Emulator/Detector Evaluator (FE/DE), a unique facility designed to reproduce conditions representative of those that develop during typical residential fire scenarios, as well as those arising from common nuisance sources found in homes. The FE/DE provides a foundation for test procedures designed to simulate a range of both early fire and nuisance scenarios. It provides the capability to discriminate between the effectiveness of existing fire alarm technologies while encouraging the development of new technologies designed to provide improved fault-free detection of fires.

The FE/DE is a single-pass wind tunnel designed to reproduce the local environment fire alarms may experience in use. The FE/DE controls airflow, temperature, and humidity, along with fire or nuisance aerosols and combustion gases. It was used extensively during a Home Smoke Alarm Project to calibrate smoke alarms and carbon monoxide detectors (NIST Technical Note 1455, Performance of Home Smoke Alarms). It has been used to study the response of current fire

detection hardware, along with novel particulate and gas-sensing technologies. The FE/DE has been used for research studies ranging from fire detection to visibility through smoke to ignition of substrates from flaming or glowing wood embers. A Chinese version of the FE/DE has been developed at the University of Science and Technology of China in Hefei, China and is being used for fire detection research. Given the mature state of development of the FE/DE, efforts are now under way to promote the adoption of detection standards based on its advanced testing capabilities.

**CONTACT:**  
 THOMAS CLEARY  
 FIRE RESEARCH DIVISION  
 (301) 975-6858  
[thomas.cleary@nist.gov](mailto:thomas.cleary@nist.gov)



The Fire Emulator/Detector Evaluator.

## BFRL Research Underpins Standards for the Fire Safety of Mattresses

Each year, bed fires in homes cost the nation nearly 500 lives, over 2000 serious injuries, and \$250 million in property loss. For the past five years, NIST has worked closely with the mattress industry to understand how bed fires proceed from the ignition of bedclothes to the full involvement of the bed (as in the accompanying pictures of an unimproved bed, taken about 5 min apart).

The U.S. mattress industry requested that BFRL work with them to develop the technical underpinnings for a mattress/foundation standard that would serve as the basis for limiting the consequences of residential bed fires. In addition to developing the testing methodology, BFRL performed the hazard analysis necessary to determine the relationship between the size of the fire and the threat to life safety. The research led to an understanding of the relationship between reduction in the size of the bed fire and improvement in life safety. BFRL and the industry decided that the proper approach for improved fire safety was to limit the possible size of a bed fire. This size is characterized by the rate of heat release of the burning bed.



Example of fire growth on a bed incorporating an unimproved mattress.

Recently, a mattress flammability regulation was adopted by the State of California that incorporates the standard test method developed by BFRL. When adopted nationwide, it is estimated that losses from bed fires would be cut in half. In the past, California flammability standards have rapidly become *de facto* national standards; the U.S. Consumer Product Safety Commission has announced their intention to adopt the standard nationally in 2006. Adoption of the national standard will allow the mattress industry to deliver the same improved products throughout the country.

**CONTACT:**  
 THOMAS OHLEMILLER  
 FIRE RESEARCH DIVISION  
 (301) 975-6481  
[tohemiller@nist.gov](mailto:tohemiller@nist.gov)

## Flammability Measures for Electronic Equipment

Although fires originating from consumer electronics are rare, the hazard presented when exposed to a small external ignition source (such as a candle) is not well known. Even when the equipment is not the first item involved in a fire, its contribution to the total fire load and impact on flashover of a room can be significant.

BFRL recently completed a three-year experimental study examining the bench-scale and full-scale fire performance of commercial polymeric



Photograph shows the burning of a monitor made from high impact polystyrene (no flame retardant).

materials used in electronic equipment. The ignition resistance, self-extinguishing behavior, heat release rate (HRR), and combustion product yields of 18 different materials at two thicknesses were characterized using three standard bench-scale fire tests. Five of these materials were made into 19" computer monitor enclosures for full-scale fire testing (using real and simulated internal components). The results of this study were used to assess the predictive value of the bench-scale tests in determining full-scale fire performance and to describe the fire hazard of the full-scale specimens when exposed to different ignition scenarios.

The results showed that materials which passed the UL94 vertical burn test provided adequate resistance to fire spread from a localized ignition source

(small flame) in the full-scale tests. However, when the ignition source was more severe (such as a nearby burning keyboard) the UL94 test was less likely to predict the materials fire performance. In this case, the HRR from the cone calorimeter test was shown to correlate well with the full-scale fire behavior.

There is a current international effort (IEC TC108) to develop a hazard based safety standard for electronic equipment. The findings of this study have been used to help develop a draft standard for external ignition of electronic equipment.

**CONTACT:**  
 MATTHEW BUNDY  
 FIRE RESEARCH DIVISION  
 301-975-6880  
[matthew.bundy@nist.gov](mailto:matthew.bundy@nist.gov)

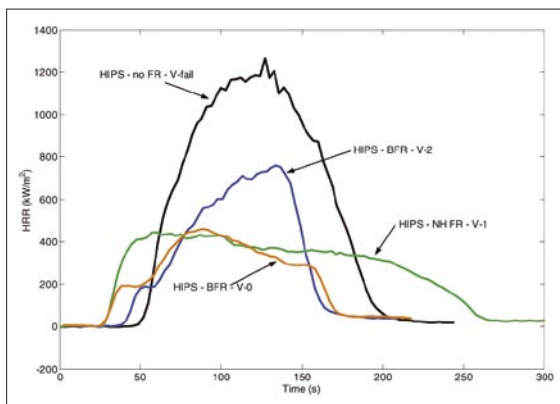

Heat release rate curves of high-impact polystyrene with different levels of flame retardant.

## Single Sprinkler Design Tests for Residential Use

Currently, residential sprinklers are an effective, yet underutilized means of reducing the loss of life, injuries, and property damage caused by uncontrolled fires in homes. It is estimated that less than 3 percent of single family homes have a fire sprinkler system. Economics play a major role in this regard, based in part on how much water a residential sprinkler system will require. In 2002, minimum sprinkler spray density design criteria of 0.05 gpm/ft<sup>2</sup> were specified in National Fire Protection Association (NFPA) 13D, *Standard for the Installation of Sprinkler Systems in One- and Two-Family Dwellings and Manufactured Homes*. This, coupled with the trend of smaller water meters in new homes, raised concerns about the expense of providing the water supply for the new two-sprinkler design required by NFPA13D.

Anecdotal information indicated that in the majority of sprinklered residential fire incidents, only a single residential sprinkler was activated and mitigated the fire hazard. However this information is not well documented and may not reflect current sprinkler designs.

Under the sponsorship of the U.S. Fire Administration (USFA), NIST is

investigating the feasibility of a single sprinkler design option for NFPA 13D residential sprinkler systems. Working with Underwriters' Laboratories (UL), a series of experiments were conducted to examine the capabilities of a single sprinkler design. The objective was to have a design that required 20 gpm or less.

Fifteen fire experiments were conducted with the "standard" corner fuel package used by UL to perform listing tests on residential sprinklers. The single sprinkler controlled the fire in each of these experiments. Seven experiments were conducted with the fuel located between two sprinklers. This was done to force the activation of two sprinklers. With two sprinklers operating, the water flow was limited to 70 percent of the current listed requirements. With the fuel located between two sprinklers, the fire was only controlled in two out of the seven experiments. The results of this limited set of experiments indicate that some loss of reliability will result if the single sprinkler design is implemented. This information has been provided to the NFPA Technical Committee on Residential Sprinkler Systems to assist them in their decision making with regard to this design strategy.

**CONTACT:**  
 DAN MADRZYKOWSKI  
 FIRE RESEARCH DIVISION  
 301-975-6677  
[daniel.madrzykowski@nist.gov](mailto:daniel.madrzykowski@nist.gov)



Two examples of results for fire test using sprinkler systems are shown. The top photograph demonstrates high wall wetting by the sprinkler, leading to rapid fire control with a single sprinkler in a corner test. The image below shows that flame extension occurred on the wall and ceiling for a wall test with two sprinklers in which the water flow was reduced below current design levels.

## BFRL's Two-Year Study Revisits Smoke Alarm Response

In the mid-1970s, a series of tests performed with funding from the National Bureau of Standards provided the understanding of smoke detector response and demonstrated the effectiveness of smoke detectors for sensing growing fires with sufficient sensitivity to allow people to escape fires in residences. This study played an important role in the subsequent development of code requirements and the wide-spread installation of detectors in residences.

In the following three decades, smoke detectors have played a dominant role in reducing per capita fire deaths in the United States. During these years there have been significant changes in building contents and smoke detector technology. As a result, it was deemed appropriate to update the earlier study. The findings of a two-year investigation on the *Performance of Home Smoke Alarms* are described in a series of reports that appeared in late 2003 and early 2004.

The findings indicate that the typical time available for individuals to escape a growing fire following detection had decreased from 17 minutes to 3 minutes. Despite this significant drop in available escape time, the findings showed that the two primary types of smoke detectors, ionization and photoelectric, used widely in residences provided sufficient time for escape as long as evacuation was initiated quickly following alarm.

The findings also showed that variables such as open or closed doors, placement of smoke alarms and interconnectability of the devices (so that all sound an alarm when one detects fire) all affected an individual's chances of survival during a fire. The response times of smoke detectors and sprinkler systems were also compared, confirming earlier findings that smoke detectors were more sensitive and responded faster than sprinkler systems.

The response of smoke detectors to nuisance sources (non fire signatures such as cooking or shower aerosols) remains a major problem. Nuisance alarms vastly outnumber alarms due to actual fires. Alarms due to nuisance sources can cause individuals to ignore legitimate alarms or to even disable the detector. During this study, various

types of nuisance sources were characterized along with the response of smoke detectors to the sources. This information will prove useful in the development of more reliable smoke detectors.

**CONTACT:**  
RICHARD W. BUKOWSKI  
FIRE RESEARCH DIVISION  
301-975-6853  
[richard.bukowski@nist.gov](mailto:richard.bukowski@nist.gov)



This photograph shows the wide range of instrumentation used to characterize the environment around smoke detectors during the recent investigation on home smoke alarms.

## High Throughput Nanocomposite Flame Retardant Program Produces Layered Double Hydroxide Nano-Flame Retardant

B F R L researchers have demonstrated for the first time that a new class of nano-based additives for polymers acts as an effective fire retardant at levels which do not adversely affect the polymer properties to the same degree as additives currently in widespread use. The new type of nano-flame retardant, layered double hydroxide, LDH, (see figure) gives intumescent, self-extinguishing properties when combined with conventional flame retardants. The LDH was produced using high throughput synthesis equipment (colloid mill) and is capable of increasing the volume of intumescent char formed when nano-dispersed with ammonium polyphosphate in epoxy coatings. This

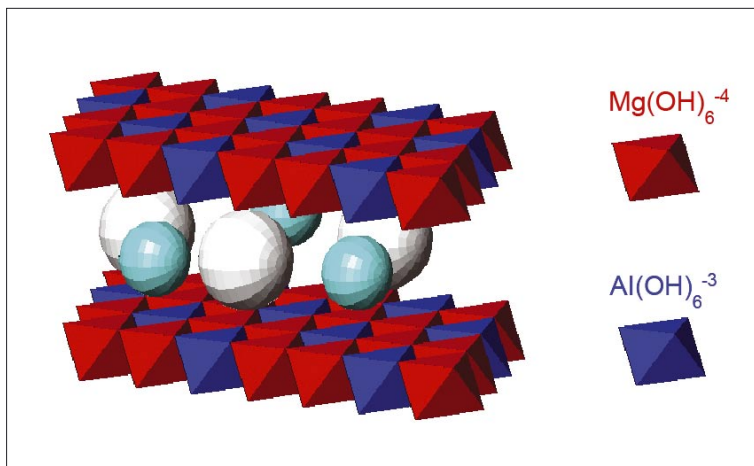

Drawing shows the layer structure of the LDH formed by the combination of the two metal hydroxides along with the "gallery" anions (carbonate,  $\text{CO}_3^{2-}$ ) and water located between the layers.

new nano-flame retardant is also useful in fire-resistant coatings on steel and in flame-retarding thermoplastics. Future work will focus on use of LDH in these applications, in polyurethane flexible foams, and in polyurea blast coatings.

Due to environmental concerns related to the halogenated flame retardants widely used today, new flame retardant nano-additives such as these are of great interest to industry since they are inherently non-halogenated and because they

impart improvements in the modulus of the polymers with which they are combined, in contrast to most non-halogenated flame retardants that usually reduce the modulus and flexibility of the polymer.

**CONTACT:**  
JEFFREY GILMAN  
FIRE RESEARCH DIVISION  
301-975-6573  
[jeffrey.gilman@nist.gov](mailto:jeffrey.gilman@nist.gov)

# HIGH PERFORMANCE CONSTRUCTION MATERIALS AND SYSTEMS

TO ENABLE  
SCIENTIFIC AND  
TECHNOLOGY-BASED  
INNOVATION TO  
MODERNIZE AND  
ENHANCE THE  
PERFORMANCE OF  
CONSTRUCTION  
MATERIALS AND  
SYSTEMS.

GOAL 3

The strategy to meet this goal includes the development of world-class science based tools – measurements, data, models, protocols, and reference standards – to

- fully integrate and automate the construction process to achieve significant cycle-time reductions;
- predict and optimize the performance and minimize the environmental impact of concrete in the built environment;
- predict the service life of high-performance polymeric infrastructure materials; and
- enhance the safety and performance of structures under extreme loads.

The desired outcomes are to enhance global competitiveness of U.S. industry and the safety and sustainability of the nation's buildings and physical infrastructure.

## Service Life Prediction (SLP) of Polymeric Materials

### Intended Outcome and Background

The lack of a methodology for generating accurate, precise, and timely service life estimates for polymeric materials, components, or systems exposed in their intended service environments has greatly hindered product innovation as well as the acceptance of polymeric materials into new applications. Product innovation is hindered

by the long times-to-market. These long times-to-market arise due to the lengthy field exposures that companies require before a product can be introduced into the market. Field exposure results are viewed as the only true exposures. It takes a long time to generate a field exposure history of sufficient length and depth to convince a decision maker that the risk of introducing a new product into the marketplace is low. Long exposure times, and, correspondingly, long times-to-market, can be reduced if a link can be established between field and laboratory results. Laboratory exposures often can be designed to greatly accelerate degradation. Establishing such a link, however, has remained elusive.

The goal of the SLP program is to address these needs through the implementation and validation of a reliability-based methodology and associated metrologies and life testing protocols. Specifically, the objectives of the program are: (1) to establish an experimental and mathematical link between field and laboratory exposure results, (2) to predict the service life of polymeric materials exposed in their intended operating environment, (3) to gain a fundamental understanding of the failure mechanisms causing a polymer to degrade, and (4) to determine the contribution made by individual components and constituents of a polymeric material to the service life of the product. This research is being conducted under the auspices of a number of NIST/industry consortia and through collaborative efforts with researchers in other NIST laboratories, Federal agencies, universities, and foreign research institutes.

Linking field and laboratory exposure results and, thus, predicting the service life of weathered polymeric materials exposed in their intended



service environments has been a task that has defied all attempts at a coherent, scientific solution over the last century. About a decade ago, the Polymeric Materials Group of BFRL implemented, and is currently validating, a reliability-based methodology for predicting the weathering service life of polymeric materials. This methodology has been adapted from those used in “high-tech” industries like the electronics, aerospace, nuclear, and pharmaceutical fields. In these realms, predicting the service life of products manufactured in these industries has proven to be very successful.

Unlike the conventional methodology that was designed to make comparisons among competing products (e.g., product A is expected to perform better than product C, which is expected to perform better than product B), the reliability-based methodology is a predictive one that is capable of generating service life estimates of known precision and accuracy. The underlying premises of the reliability-based methodology, however, are radically different from those of a conventional methodology. Probably one of the most important differences is the tenet that field exposure results can be used as the standard of performance against which laboratory exposure results must match. Field exposure results are neither repeatable nor reproducible, whereas well-designed laboratory experiments, the standard of performance in a reliability-based methodology, can be designed to

be both repeatable and reproducible. Field exposure experiments are viewed as just another laboratory experiment, albeit one in which the exposure variables cannot be controlled, but they can be characterized in the same manner as these variables are characterized in the laboratory.

Research continues also in developing advanced metrologies to elucidate the fundamental failure mechanisms that cause a polymeric material to degrade. These advanced metrologies include nanomechanics, nanochemistry, particulate dispersion, photoreactivity of pigmentary and nanoparticles, and macro- and nanoscale photochemical and photophysical measurements for filled-polymers. Much of this research is pioneering and is aimed at satisfying metrological needs that have become apparent during our service life prediction research.

Finally, several research tools are being developed to automate the data collection process and to improve productivity in processing the collected data. These tools include the development of a high-throughput measurements laboratory and the creation of an informatics system. The high-throughput measurements laboratory, which is being designed to speed up the analytical measurement process by a factor of ten or more, is under construction. An informatics system also has been created that is designed to collect, integrate, and process the massive amount of experimental data at near real-time speeds.

#### ACTIVITIES AND ACCOMPLISHMENTS

### Coatings Service Life Prediction

The introduction of new coatings, as well as the improvement of the service life of existing ones, has been hindered by the lack of a methodology for generating accurate, precise, and timely estimates of the service life of these materials in their intended operating and service conditions. The objective of this project is to validate a reliability-based methodology to link laboratory and field exposure results and to quantitatively predict the expected weathering service life of an organic coating when exposed in its targeted operating and service environment.

In 2005, we established an experimental link between field and laboratory exposure results for a model epoxy coating, and are presently in the process of validating a cumulative damage model for mathematically linking the results from these two sources. Our ability to establish these links depended upon a number of incremental advances that have been made over the last decade. These advances include: (1) the construction of the NIST Simulated Photodegradation by High Energy Radiant Exposure (SPHERE) that essentially eliminates or, at least, greatly mitigates all known sources of experimental error from laboratory

exposure studies, (2) the derivation and validation of a number of models for characterizing field exposure environmental variables in the same manner that these variables are characterized in the laboratory, (3) the observation that appearance-related degradation is almost always heterogeneous and occurs initially at nanoscale dimensions, (4) the use of the total effective dosage model for characterizing the severity of an exposure environment, and (5) the establishment of mathematical links among the different physical and chemical measurements and the total effective dosage. In addition, we have made significant advances in validating some links between field and laboratory experiments. Specifically, we have verified that both the reciprocity and additivity laws are obeyed for the study polymer over wide temperature and relative humidity conditions.

Starting in 2006, we will begin to assess the contribution that individual constituents make to the service life of a polymeric product. The model constituent that has been selected will be pigments. Pigments make up between 30 percent and 90 percent of the total cost of a polymeric material and, therefore, any improvements realized in this area could have great economic benefits. This research sets the foundation for engineering polymeric materials

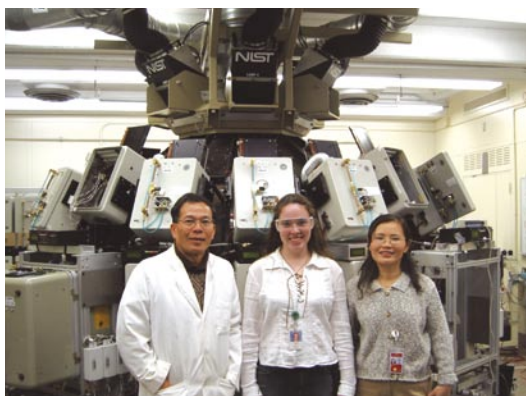

**BFRL researchers with the NIST Simulated Photodegradation by High Energy Radiant Exposure (SPHERE).**



**BFRL researchers using atomic force microscopy to characterize the nanoscale morphological properties of pigmented polymeric coating films.**

with respect to their service life. This new phase will also introduce several metrologies that we have been developing and perfecting over the last five years. These include measuring particular dispersion in a polymeric matrix, quasi-static and dynamic bulk and nanomechanical measurements of polymers, assessing the photoreactivity of pigment filled polymeric systems, and chemical characterization of unaged

and degraded filled systems. In addition, we expect to introduce working prototypes of both our high-throughput measurement and informatics capabilities.

**CONTACT:**  
 JONATHAN W. MARTIN  
 MATERIALS AND CONSTRUCTION  
 RESEARCH DIVISION  
 301-975-6707  
[jonathan.martin@nist.gov](mailto:jonathan.martin@nist.gov)

## Sealants Service Life Prediction Exposure Consortium

Modern building design increasingly relies on elastomeric building materials to provide waterproofing, blast protection, and energy conservation. The most easily recognized elastomeric building materials are window seals and sealants. Although these materials represent a small percentage of the initial construction cost of a structure, their failure represents a very large fraction of the energy loss, maintenance, and repair costs of constructed facilities. Furthermore, the failure of aged

building joint sealants is often detected only after substantial water damage to and thermal loss from a structure has already occurred, making repair costs much higher than they need to be. Water intrusion is the most commonly cited complaint made by homeowners.

Despite the importance of joint sealants in the building envelope, their longevity has always been questioned. Moreover, conventional methods for assessing durability are capable only of generating a subjective assessment of longevity. In the absence of quantitative predictions of known precision and accuracy, building joint sealant selections must be based on first-cost.

To address these issues, BFRL researchers have participated since October of 2001 in a NIST-led

industrial consortium including ten major sealant companies plus three federal agencies. In 2005, significant progress was made in establishing the importance of mechanical strain in concert with the established factors (temperature, humidity, UV radiation) that affect the in-service performance of organic building materials, including sealants. Additionally, new outdoor and laboratory exposure devices are being used to challenge long-held beliefs about material weathering, and are critical in developing a firm scientific basis for a greater understanding of these processes.

Taking the first steps in developing new methods to predict the in-service performance of elastomeric building materials requires knowledge of the relative importance of each of the primary weathering factors on the durability of the sealant. In conjunction with two monitored outdoor exposure sites, this data will form the foundation of new methods to assess the service life of elastomeric building materials.

**CONTACT:**  
CHRISTOPHER WHITE  
MATERIALS AND CONSTRUCTION  
RESEARCH DIVISION  
301-975-6707  
[christopher.white@nist.gov](mailto:christopher.white@nist.gov)



State-of-the-art field exposure apparatuses for naturally stressing sealant samples are positioned on BFRL's roof. Numerous physical and environmental variables continuously are being monitored, including stress and strain within the sealant while environmental variables, as well as sealant temperature and moisture content, are varied.

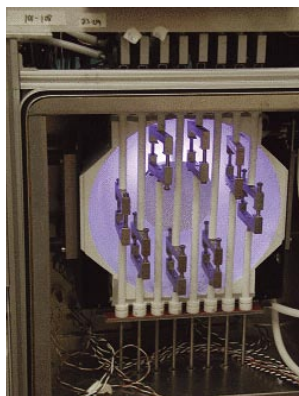

Custom designed, state-of-the-art, laboratory, sealant testing chambers attached to the NIST SPHERE. Temperature, humidity, ultra-violet, and mechanical load can be independently controlled for eight ASTM C719 sealant specimens.

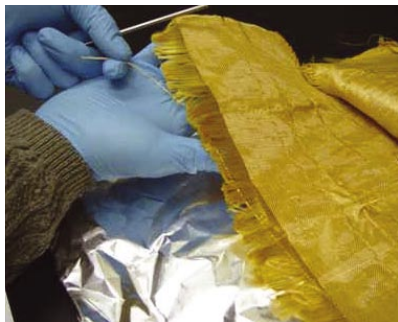

Extraction of yarns from body armor panel for chemical and mechanical analysis.



A useful technique for obtaining information on the molecular structure of polymeric materials is attenuated total reflectance (ATR) infrared spectroscopy, shown here in the process of analyzing a ballistic fiber bundle.

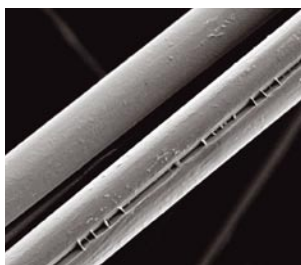

Scanning electron micrograph of ballistic fibers, revealing fiber surface morphology on a micron scale.

## Life Testing Protocols for Soft Body Armor Yarns

In 2003, a police officer was shot and seriously wounded in the line of duty when a bullet penetrated his body armor. This incident alarmed the law enforcement community, not only because it was the first reported case in which a National Institute of Justice (NIJ)-certified body armor vest was penetrated by a bullet that it was rated to protect against, but also because the body armor in question was just six months old. This premature field failure of a widely used model of body armor focused attention on the need for a fundamental understanding of ballistic fiber degradation as well as scientifically based accelerated aging protocols to aid in service life prediction of body armor.

To meet this research need, BFRL researchers have been performing research to: (1) identify the environmental and operational variables, acting individually or in combination, that physically and chemically degrade vest fibers, (2) identify and understand the underlying chemical and physical degradation mechanisms, and (3) initiate the development of standardized test protocols for accelerating, predicting, and monitoring the service lives of ballistic fibers and body armor.

Recent research has focused on the identification of chemical indicators of PBO fiber tensile strength loss. In particular, Fourier transform infrared (FTIR) spectroscopy has proven extremely useful in elucidating chemical changes that occurred in the fibers. Other measurement techniques utilized in this program include dynamic mechanical thermal analysis, quasi-static tensile testing, microscopy, and moisture sorption analysis.

Preliminary investigations also have been initiated to determine the effect of fiber bending and fatigue on yarn and fabric mechanical properties in conjunction with environmental factors. As experimental data becomes available, scientific models will be derived and refined to explain the degradation mechanisms observed in ballistic fibers as a function of the environmental factors, individually and combined.

### CONTACT:

JOANNIE W. CHIN  
MATERIALS AND CONSTRUCTION  
RESEARCH DIVISION  
301-975-6815  
[joannie.chin@nist.gov](mailto:joannie.chin@nist.gov)

## Photoreactivity of Semiconductor Nanoparticles

Commercial polymers are comprised of a large number of chemical constituents. Each constituent contributes to the performance, in particular the service life performance, of a polymer. Identifying methodologies and metrologies for ascertaining the contribution that individual constituents make to the service life performance of a polymer could lead to the formulation of dramatically improved polymeric performance.

One of the most expensive constituents in a polymer is the pigment. 30 percent to 90 percent of the total cost of a polymer is often attributed to the cost of the pigment. All pigments are photoreactive and, depending on its degree of photoreactivity, a pigment can affect the service life of a polymer. Industry currently uses semi-quantitative titration-style methods to assess the photoreactivity of pigments. A need exists for a fast, quantitative, reliable, and scientifically based metrology for in-line measurement of the photoreactivity of pigments.

Research efforts have focused on developing methodologies and metrologies for understanding the fundamental mechanisms that govern the photoreactivity of  $\text{TiO}_2$  pigments by themselves and when they are imbedded in a polymer matrix. In most commercial applications, a low photoreactivity is desirable; while in homeland security and healthcare applications, a high photoreactivity is preferred. BFRL has developed several metrologies for assessing photoreactivity, including electron paramagnetic resonance (EPR) spectroscopy, chemical assay methods, and photoconductivity measurements. Much of this research is done collaboratively with researchers in other NIST laboratories. Ongoing measurements include the chemical nature, number density, and mobility of the activated species produced in a photoreactive process. Models will be derived that relate these parameters to material physico-chemical properties, thereby improving our understanding of the semiconductor photoreactivity.

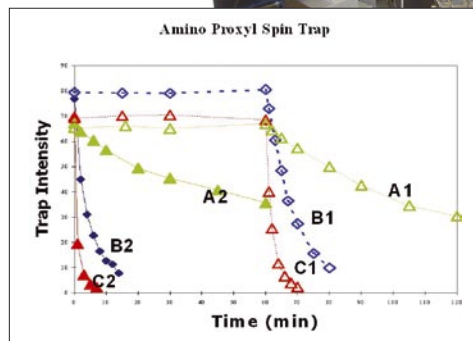
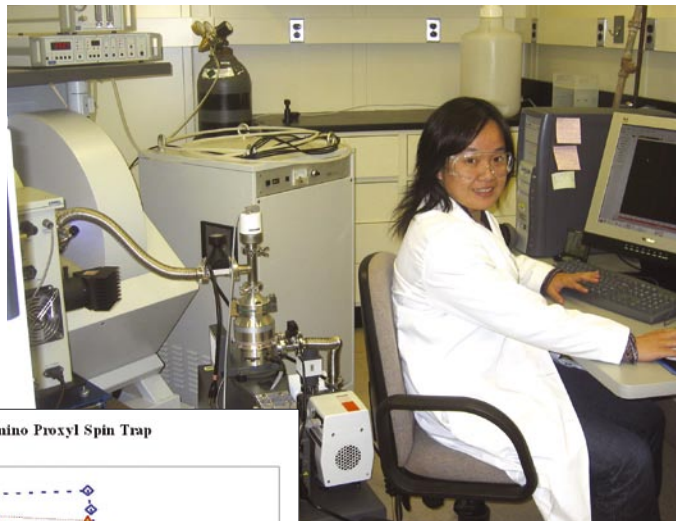

A BFRL researcher uses the electron paramagnetic resonance (EPR) spectrometer to determine the generation of free radicals in titanium dioxide ( $\text{TiO}_2$ ) suspensions; inset shows EPR data, concentration changes of the nitroxide free radical traps, 3-amino proxyl (AP) as a function of UV irradiation time for a series of  $\text{TiO}_2$  materials.

**CONTACT:**  
 STEPHANIE S. WATSON  
 MATERIALS AND CONSTRUCTION  
 RESEARCH DIVISION  
 301-975-6448  
[stephanie.watson@nist.gov](mailto:stephanie.watson@nist.gov)

## Structure and Dispersion Measurements of Particulates in a Polymeric Matrix

Poor dispersion of the pigment in commercial polymeric products can be expensive as well as detrimental to a product's appearance and service life performance. The objective of this research is to develop a non-destructive, quantitative, efficient, and effective method for characterizing pigment dispersion and coating structure via light scattering. Particulates of interest include nanoparticles and pigmentary particles. Dispersion in both the cured and uncured state is of interest to the polymeric research community.

In 2004, BFRL completed the construction of its state-of-the-art light scattering laboratory for characterizing materials. The equipment in this laboratory is capable of characterizing the morphology (nano-domain due to dispersion in mixing or phase separation) and dispersion of particulates in a cured and uncured resin under various processing conditions. Current research efforts focus on metal oxide nanoparticles because of their cost and their contributions to a product's appearance and service life performance. The metrologies being developed, however, are generic to all structure-property relationships for nanoparticles and nanoparticle-polymer systems. We have shown that light scattering

(dynamic and static) methods can be used in characterizing nanoparticles dispersed in a polymer network over a wide temperature range in liquid to gel (quasi-solid) state matrixes, and we can determine the mobility and size of the nanoparticle clusters in these states. Additionally, by studying optical scattering profiles reflected from unexposed and weathered coatings, we can measure the optical property and surface morphology changes in nanoscale and microscale, and relate these changes to mechanical and chemical changes resulting from photodegradation.

**CONTACT:**  
 LI-PIIN SUNG  
 MATERIALS AND CONSTRUCTION  
 RESEARCH DIVISION  
 301-975-6737  
[li-piin.sung@nist.gov](mailto:li-piin.sung@nist.gov)

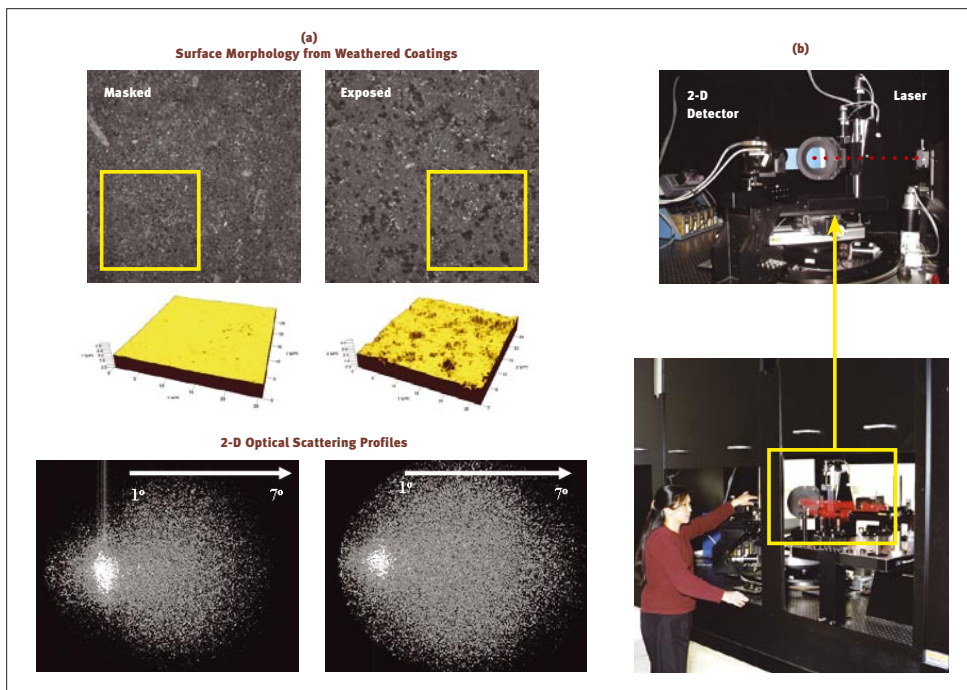

(a) Surface morphology and optical scattering profiles from a weathered PVDF coating (masked vs. exposed areas). (b) BFRL researcher measures the optical scattering from a coating surface using a five-axis goniometric optical instrument equipped with a two-dimensional (2-D) detector.

## Physical and Optical Characterizations of Polymer Surfaces

Scratch, mar and abrasion resistance greatly affect a coating's appearance. These variables have become among the most important performance factors in determining the service life of interior architectural and automotive coatings.

The propensity of a polymeric coating to scratch and mar depends on many physical, chemical, environmental, and geometrical factors including its hardness, the morphology of the scratch or mar, viewing angle, and scratch conditions. Although many metrologies have been developed, none are capable of generating repeatable and reproducible results. NIST's mission is to develop a standard protocol, with a strong engineering and scientific basis, which is capable of generating repeatable and reproducible results. This research is being conducted in cooperation with industry via the NIST/Industry Polymers Interphase Consortium.

The protocol development has three steps. First, instrumented indentation has been used to quantify coating properties such as elastic modulus, hardness, and yield stress over length scales that are relevant to the scratch resistance and material heterogeneity. Second, a scratch test followed by a well-defined test protocol using the same-instrumented indenter is used to induce

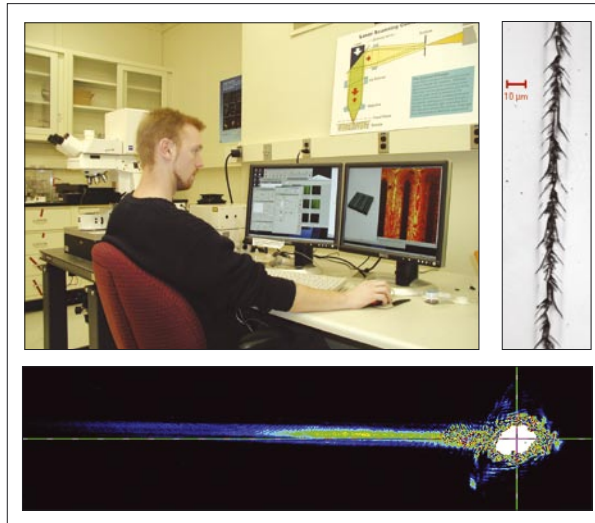

BFRL researcher characterizes the damages on the coating surface morphology (an illustration of damage is shown in the right) due to a scratch test, using a laser scanning confocal microscope. A corresponding optical scattering profile due to the scratch also is shown in the lower graph.

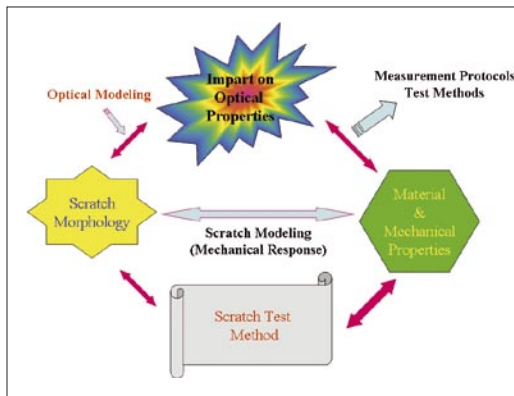

Schematic of the iterative methodology used in the appearance base scratch resistance metrology under development through the NIST/Industry Polymer Interphase Consortium.

surface damage. Scratch characterization includes the measurement of morphology, residual depth, and frictional coefficients. Finally, optical scattering measurements are conducted to identify the onset of plastic deformation by analyzing specular and off-specular intensities. The ratio of these two scattering (specular and off-specular) signals provides information on surface roughness, substrate color, incident wavelength, and angle, and is used to evaluate the visibility of the scratch. The combination of absolute physical and optical

measurements permits the quantitative evaluation of scratch resistance for each material. Therefore, performance (e.g., durability, appearance) may be objectively related to material/mechanical properties. Future research will expand to include polymeric materials and their appearance-based scratch resistance as a function of environmental aging.

**CONTACT:**  
 LI-PIIN SUNG  
 MATERIALS AND CONSTRUCTION  
 RESEARCH DIVISION  
 301-975-6737  
[li-piin.sung@nist.gov](mailto:li-piin.sung@nist.gov)

## Nanochemical Characterization of Filled and Unfilled Polymer Systems

Initial indications of the weathering of a polymeric product are often observed as nanoscale defects dispersed heterogeneously over the surface of a weathered film. Over time, these nanoscale defects tend to grow in size, aggregate, and coalesce. At some point during the aggregation and coalescence processes, the defects become humanly perceptible. Thus, both nanoscale and macroscale measurements provide important information regarding weathering. Nanoscale measurements help elucidate the fundamental failure mechanisms causing a polymeric product to degrade, whereas macroscale measurements provide critical customer perceived failure information. This project addresses nanoscale chemical measurements for both filled and unfilled polymers.

Techniques to achieve nanoscale chemical measurements are still in early stages of evolution, with vanguard efforts in only a few laboratories worldwide. NIST has developed an AFM-based technique that can map chemically heterogeneous surfaces at a nanoscale spatial resolution (5 nm – 10 nm). This novel technique requires a combination of three components: (1) phase imaging in tapping mode AFM, which is

sensitive to material properties at the nanoscale, (2) NIST-patented environmental chamber to provide the required amount of moisture at the tip-sample environment (Fig. 1), and (3) hydrophilic AFM tips. By controlling the appropriate RH of the tip/sample environment, we have successfully

applied this technique to image nanoscale chemical properties of a variety of model samples, including patterned self-assembled monolayer that contains hydrophilic and hydrophobic nanodomains (Figures 2 and 3) and hydrophobic/hydrophilic polymers using unmodified and functionalized

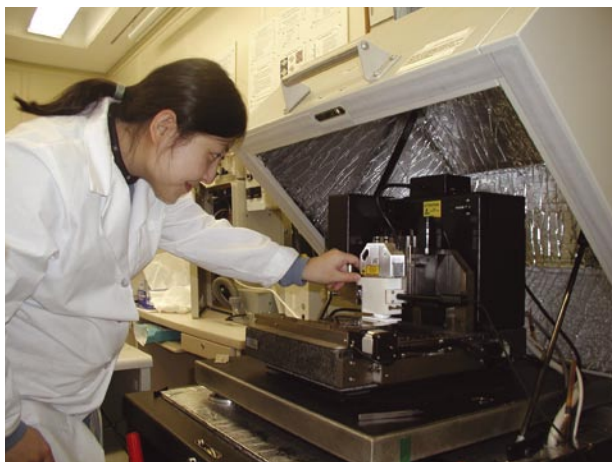

**Figure 1:** AFM measurement using NIST-patented relative humidity-controlled chamber.

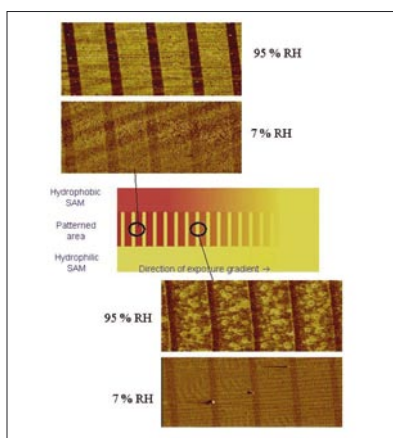

**Figure 2:** Effect of RH on AFM phase image contrast for a hydrophilic/hydrophobic gradient sample; (unmodified Si tip; stripe: hydrophilic; matrix: hydrophobic).

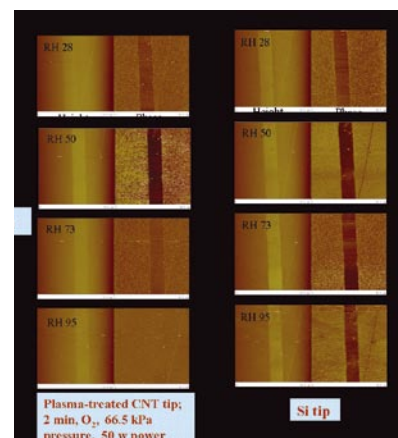

**Figure 3:** Effect of RH on AFM phase image contrast for a hydrophilic/hydrophobic patterned sample using plasma-treated CNT tip (a) and Si tip (b); stripe: hydrophilic; matrix: hydrophobic.



conventional AFM and carbon nanotube (CNT) tips. For all samples, we found that, in the low relative humidity (RH) range (<25 percent), the image contrast between a hydrophilic region and a hydrophobic region is poor even for cases where the surface free energy difference between the hydrophilic and hydrophobic regions is large ( $\Delta\gamma \approx 35 \text{ mJ/m}^2$ ). However, in the RH range between 25 and 80 percent, the image contrast is greatly enhanced even between regions that have relatively small difference in surface free energy ( $\Delta\gamma \approx 5 \text{ mJ/m}^2$ ).

This NIST-developed chemical force microscopy is a useful technique to provide chemical information at the nanoscale spatial resolution. The potential application of this nanochemical technique in materials and biomaterials is very high. Another use of this technique is to identify and characterize the chemical nature of the nanodomains where degradation initiates. GM Corporation has expressed a strong interest in using this technique to map the hydrophilic domains in fuel cell membranes, which affect membrane performance.

**CONTACT:**  
TINH NGUYEN  
MATERIALS AND CONSTRUCTION  
RESEARCH DIVISION  
301-975-6707  
[tinh.nguyen@nist.gov](mailto:tinh.nguyen@nist.gov)

## Mechanical Property Characterization of Polymer Film Surfaces and Interfaces

Over the last two decades, instrumented indentation (IIT) has proven to be an invaluable tool for characterizing the mechanical properties of metal and ceramic thin films. Recently, IIT research has focused on the characterization of mechanical properties of polymeric films.

IIT has the potential to provide the mechanical property information required to predict structural changes in coatings exposed to weathering, and facilitate a more comprehensive prediction of coating service life. The service life of these coatings highly depends on changes in the polymer matrix, filler particle size, shape, and distribution,



BFRL researcher uses the MTS Nano Indenter XP to characterize the surface mechanical properties of a polymeric film subjected to an accelerated weathering environment.

processing variables, and weathering conditions. Current work involves the measurement of static and dynamic surface nano-mechanical properties as a function of surface loading rate, indentation strain, and indentation geometry. Specific materials of interest include industrially relevant filled and unfilled thermoplastic and thermoset polymeric films subjected to a controlled accelerated aging atmosphere. Mechanical property measurements are correlated to chemical and thermal characterization to provide a complete picture of material property changes as a function of the aging environment and time.

**CONTACT:**  
AARON M. FORSTER  
MATERIALS AND CONSTRUCTION  
RESEARCH DIVISION  
301-975-8701  
[aaron.forster@nist.gov](mailto:aaron.forster@nist.gov)

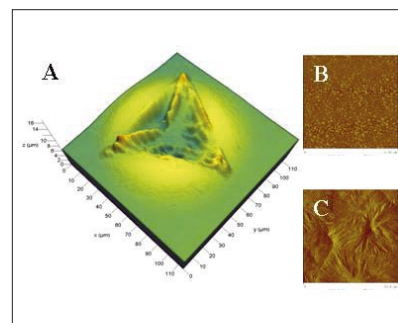

(A) Confocal microscopy image of an indent into a thermoplastic film using a Berkovich indenter. The measured mechanical properties can be influenced by the local crystallinity surrounding the indentation. AFM phase images of (B) a thermoplastic film quench cooled that exhibits small crystallites. (C) Slow cooling the film increases the size of the crystallites.

## HYPERCON: Prediction and Optimization of Concrete Performance

### Intended Outcome and Background

The objective of the HYPERCON program is to develop and implement materials science-based tools for concrete that will enable the prediction and optimization of the initial cost and service life performance of concrete for public and private uses. As of 2005, the concrete industry is in a period of rapid change – rapid positive change that needs these kinds of performance prediction tools in order to reach a successful outcome. Two examples illustrate the current industrial climate, which in turn demonstrate the need for HYPERCON research on more accurate and reliable ways to predict concrete properties.

The National Ready-Mixed Concrete Association (NRMCA), which represents most of the ready-mixed concrete producers in the U.S., is progressing in its sweeping P2P initiative. P2P stands for “Prescription to Performance” and indicates the desire of the NRMCA to change all concrete specifications from a prescriptive form, which does not allow innovation

and proprietary formulation, to a performance form, which will drive innovation and research for proprietary advantage in the marketplace. This initiative will make an enormous change in the industry. The Strategic Development Council (SDC) of the American Concrete Institute (ACI), an organization of top executives from all parts of the \$110 billion/year concrete industry, has published *Roadmap 2030*, a 30-year research roadmap that is designed to achieve momentous goals and drastically change the cement and concrete industry. One of these goals is: *The concrete industry will reduce the time required for the acceptance of new technology from fifteen to two years.* The SDC Accelerated Technology Acceptance program has begun to make progress toward this goal.

HYPERCON research is designed, working closely with industry, to help the cement and concrete industry transform itself into a performance-based entity using the tools of computational and experimental materials science. This task requires not only cutting edge research but also high quality knowledge transfer, so that research becomes embedded in practice at an accelerated rate. BFRL researchers carry out this dual task by working directly with industry in joint projects like the Virtual Cement and Concrete Testing

Laboratory (VCCTL) consortium, and by taking leadership roles in various standards committees of importance to the cement and concrete industry. These leadership roles include chair of the ASTM Co1.123 Cement Characterization sub-committee, membership on the Advisory Board for the Co1 Executive committee, and chair of the ACI 226 Materials Science of Concrete committee.

Performing world-leading concrete materials science in collaboration with industry, and transferring that research into practice, is how HYPERCON is delivering value to the cement and concrete industry. Computational tools like finite element techniques revolutionized structural design, so that today no one would consider designing a major building without the use of these programs. The intended outcome of the HYPERCON program is that industry adoption of HYPERCON research will be such that nobody will design concrete mixtures for major construction projects without using HYPERCON materials science-based tools.

## ACTIVITIES AND ACCOMPLISHMENTS

## The Virtual Cement and Concrete Testing Laboratory (VCCTL)

The Virtual Cement and Concrete Testing Laboratory (VCCTL) is a computational materials science software package designed to reduce the reliance of the concrete industry on empirical tests, replacing them with well-validated, scientifically based models that operate on extensive scientific databases. This software package, developed in close collaboration with an industrial consortium, mimics a complete physical testing laboratory, with databases of cement and aggregates

instead of bins and hoppers, material combination and concrete curing models instead of mixers and molds, a software interface instead of a cart to take materials and samples around the laboratory, and accurate models for performance prediction instead of instrumented testing machines. Industrial consortium members, who have contributed both financial and research resources to the joint project through 2005, include: W.R. Grace, Holcim, Cemex, SIKA, Degussa, Portland Cement Association, International Center for Aggregate Research, VDZ, and ATILH. Thus the VCCTL consortium includes cement, aggregates, chemical admixtures, and concrete producers, uniting all the major

materials aspects of the concrete industry in a joint project that will be of major benefit for the entire industry. The consortium started in January 2001 with VCCTL 1.0, and is currently in Phase II as of December 2005, with VCCTL 6.0 scheduled to be released in spring, 2006. VCCTL 5.0 is already being used by some of the industrial members to help them in their research and development and quality control work.

Many accomplishments have been made as of 2005. Two of special note include the current development of HydratiCA, a new, third generation cement hydration model that will have detailed dependence on known chemical and physical equations governing hydration and the processes it involves, and which will have realistic kinetics, something that has not been possible with previous hydration models. The second is the total rewriting of the software interface that controls the VCCTL software (the “lab cart” that ties together materials and measurements) from HTML to Java. This allows vastly improved ease-of-use, and the potential for much greater functionality.

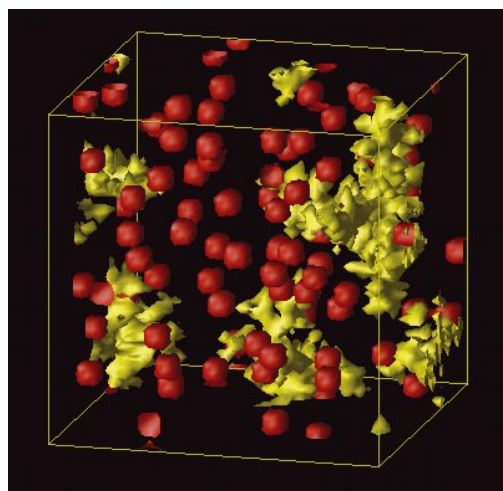

Sample of a cementitious mineral microstructure that has undergone dissolution, diffusion, and precipitation according to exact chemical and physical equations with real kinetics.

**CONTACT:**

EDWARD J. GARBOCZI  
MATERIALS AND CONSTRUCTION  
RESEARCH DIVISION  
301-975-6708  
[edward.garbocki@nist.gov](mailto:edward.garbocki@nist.gov)

## Concrete Rheology

Measuring and controlling the rheology of the concrete is crucial for correct placement to occur. In HYPERCON, rheology/processing of concrete is studied experimentally, using quantitative multi-scale rheometry, and computationally, using dissipative particle dynamics (DPD) methods on parallel computers. There is tight

synergy between the two parts, using experimental measurements of cement paste and mortar rheology as the input to DPD computer programs that compute the rheology of concrete by adding virtual aggregate particles to a cement paste matrix or cement particles to a water matrix. By using a multi-scale approach, HYPERCON researchers are rapidly becoming able to predict the rheology and hence the flowability of a concrete from its constituent ingredients.

Recent accomplishments include pushing the experiments to the field concrete level, completing the multi-scale measurement range, and adapting the DPD code to be able to predict the rheology of dense aggregate packings like those found in real concrete.

**CONTACT:**  
 NICOS MARTYS  
 MATERIALS AND CONSTRUCTION  
 RESEARCH DIVISION  
 301-975-5915  
[nicos.martys@nist.gov](mailto:nicos.martys@nist.gov)

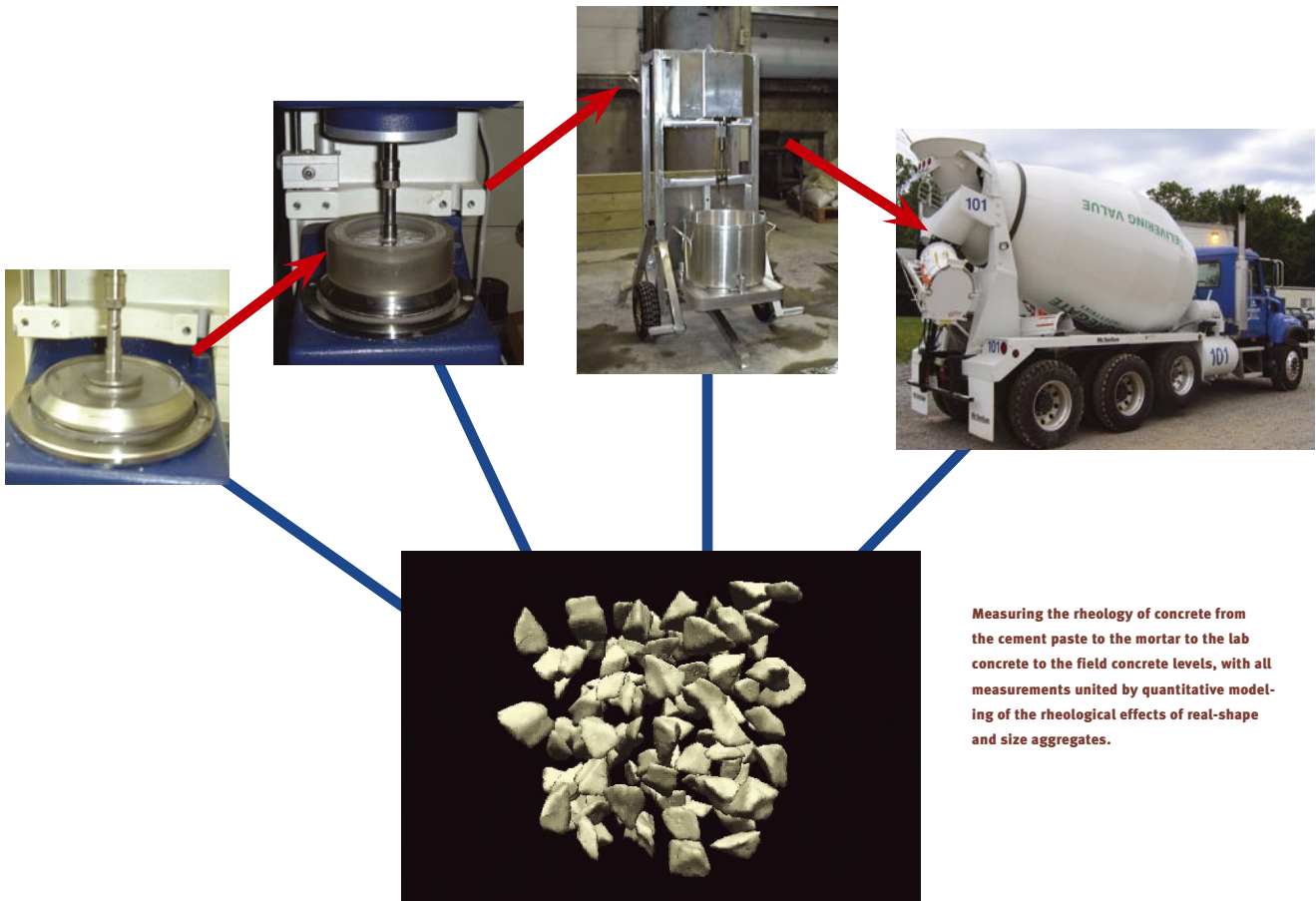

Measuring the rheology of concrete from the cement paste to the mortar to the lab concrete to the field concrete levels, with all measurements united by quantitative modeling of the rheological effects of real-shape and size aggregates.

## Material Characterization

The ASTM standard C-150, “Standard Specifications for Portland Cement,” specifies composition limits for Portland cement that are based upon a bulk chemical analysis and theoretical calculation of potential phase composition; calculations developed by R.H. Bogue at NIST more than 75 years ago. X-ray powder diffraction (XRD) measurements have been demonstrated to provide a more complete direct mineralogical analysis with greater accuracy than that provided by the Bogue calculations. XRD capabilities extend to the more complex hydraulic cements of today, which incorporate other materials like limestone, fly ash, and blast furnace slag. BFRL has been leading an effort within the ASTM C-1 committee to develop the new standard ASTM C-1365, which uses XRD measurements and Rietveld analysis to directly measure the phase abundance of clinker and cements. Using the new standard ASTM C1365 will open the door for innovation in the American cement manufacturing industry.

Direct imaging of cement microstructure promises new insights into material property – performance relationships. The scanning electron microscope,

along with advanced image processing and analysis methods, provides another means for direct analysis of cement microstructure: mineralogy, distribution, and surface area.

**CONTACT:**  
 PAUL STUTZMAN  
 MATERIALS AND CONSTRUCTION  
 RESEARCH DIVISION  
 301-975-6715  
[paul.stutzman@nist.gov](mailto:paul.stutzman@nist.gov)

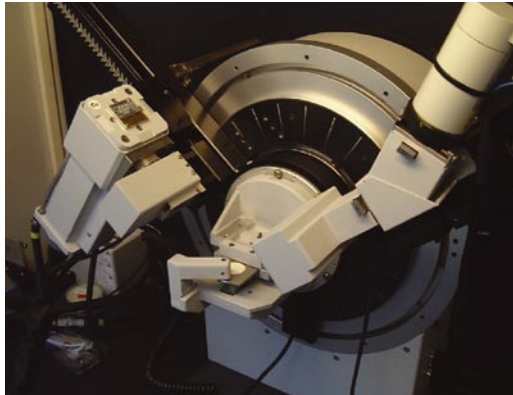

A close-up shot of the X-ray diffraction unit the results of which are utilized in the Rietveld analysis.

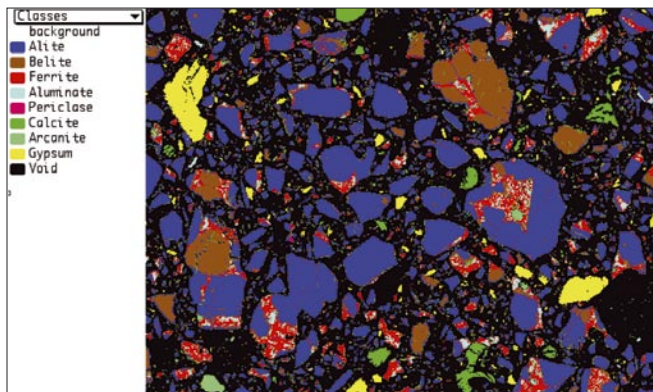

This image is a color-coded composite image of a cement (250 micrometer field width) made from a series of SEM backscattered electron and X-ray images. The color-coding facilitates phase identification with individual minerals having a distinct color.

## Aggregate Shape

The three-dimensional shape of aggregates and cement particles controls many concrete properties like rheology and early-age strength and hydration kinetics. “Aggregate” means anything from the microfine (less than 75 micrometers) size all the way up to rocks that are tens of millimeters in diameter. Models in the past could only represent aggregates as spheres. Now X-ray microtomography, tomography, and laser range-finding have been used to characterize aggregate and cement particle surfaces, with mathematical techniques like spherical harmonics used to produce a nearly exact analytical mathematical model of the particles.

The figure below shows Virtual Reality Modeling Language (VRML) pictures of cement particles, microfine aggregates, sand, and gravel particles. These real shapes, because they are now mathematically modeled, can go into VCCTL aggregate and cement particle databases, which serve as computational bins and hoppers to supply the computations in the VCCTL software package. These improved aggregate models allow VCCTL to more realistically simulate concrete behavior.

**CONTACT:**  
EDWARD J. GARBOCZI  
MATERIALS AND CONSTRUCTION  
RESEARCH DIVISION  
301-975-6708  
[edward.garbocki@nist.gov](mailto:edward.garbocki@nist.gov)

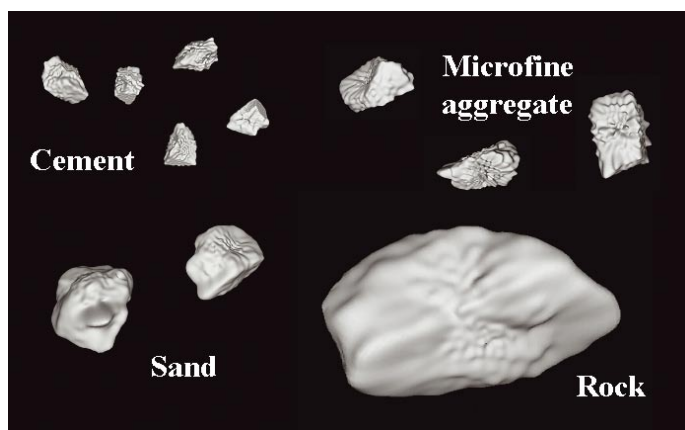

Virtual Reality Modeling Language (VRML) pictures of cement particles, microfine aggregates, sand, and gravel particles.

## Internal Curing with Lightweight Aggregates

Internal curing refers to the process by which the hydration of cement occurs because of the availability of additional *internal* water that is not part of the mixing water. For many years, concrete has been cured from the outside in. Internal curing is for curing from the inside out. Internal water is generally supplied via internal reservoirs, which in this project are saturated lightweight fine aggregates. Internal curing distributes the extra curing water throughout the 3-D concrete microstructure so that it is more readily available to maintain saturation of the cement paste during hydration, avoiding self-desiccation (in the paste) and reducing autogenous shrinkage.

Recently, NIST has used X-ray microtomography at the Pennsylvania State University (with Dr. Philip Halleck) to study water movement at the fine aggregate scale during hydration. Since X-rays are sensitive to density, an empty pore shows contrast with a pore that is full of water, so that emptying pores can be imaged during hydration. Of the following two images, the first image shows the 3-D blue (empty pore) regions that have emptied during hydration as water is pulled out of the lightweight aggregates to supply the water demand of the hydrating cement paste. The second image shows a 2-D

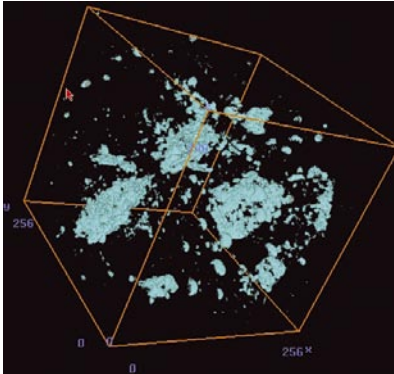

**Three-dimensional subtracted image of 1 d hydration – initial microstructure showing water-filled pores that have emptied during internal curing (4.6 mm on a side).**

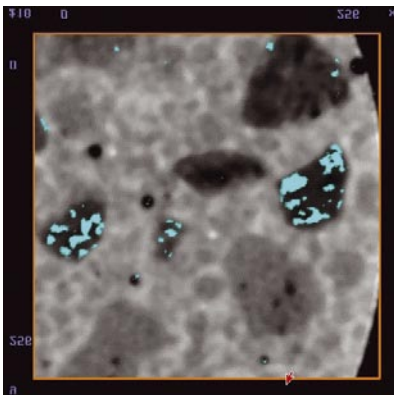

**2-D image with water evacuated regions (pores) overlaid on original microstructure (4.6 mm by 4.6 mm).**

slice where the blue empty pore regions have been overlaid on the mortar microstructure, showing clearly that the extra water came from the (formerly) saturated lightweight aggregates. Better control of the curing process will lead to improved concrete performance.

**CONTACT:**  
DALE BENTZ  
MATERIALS AND CONSTRUCTION  
RESEARCH DIVISION  
301-975-5865  
[dale.bentz@nist.gov](mailto:dale.bentz@nist.gov)

## Construction Integration and Automation Technology (CONSIAT)

### Intended Outcome and Background

The focus of CONSIAT research at NIST is to continuously reduce cycle time and life-cycle costs in the delivery of construction projects by providing the critical science-based performance measurement tools that will enable early industry integration and automation of the construction process.

The Construction Industry Institute (CII) – an organization with about 100 members representing the Nation’s leading owners, contractors, and suppliers of constructed facilities – has made the development of Fully Integrated and Automated Project Processes (FIAPP) a top priority. However, the construction industry faces special challenges including low R&D investment, the fragmentation of the industry, and the strong project-oriented nature of its processes.

The CONSIAT program is providing the critical science-based performance measurement tools to enable: integration of construction site metrology data and other field information into project information management systems; delivery of just-in-time information to guide field operations; and automation of the construction process – including development of necessary measurement and calibration procedures.

CII, with the support of NIST, created FIATECH, a collaborative, not-for-profit

consortium that will conduct leveraged research and development in partnership with suppliers, with firms in the software/information technology industries, and with the public sector. NIST is working in close partnership with the FIATECH Consortium to maximize the relevancy of the projects and the leveraging of resources on both sides, and to minimize the time to implementation of the program results. NIST is also participating in the FIATECH-led Capital Projects Technology Roadmapping effort. The resulting industry roadmap is being used to help align CONSIAT research areas with appropriate industry needs.

### ACTIVITIES AND ACCOMPLISHMENTS

## 3-D Imaging Systems for Construction Applications

NIST researchers have been working to facilitate the use of LADARs (laser detection and ranging) on a construction site for rapid capture of 3-D information and to aid in automating some construction processes. Efforts have been focused on 1) developing test protocols and prototype test artifacts; 2) establishing a LADAR performance evaluation facility; and 3) performing construction object recognition.

There are currently no standard test methods for evaluating the performance of 3-D imaging systems nor their

end-products derived from the data. This lack of standard test methods is inhibiting wider market acceptance of these systems, not only in the construction sector, but also in the manufacturing and transportation sectors. Standard test methods for the performance evaluation and use of 3-D imaging systems will provide a basis for fair comparisons of such systems, reduce the confusion with regard to terminology, and increase user confidence in these systems.

Since 2003, three workshops have been held at NIST on the Performance Evaluation of 3-D Imaging Systems. Participants of these workshops included most of the instrument vendors, users, and researchers. Results of the workshops indicated there was a strong need to develop standard test protocols for the performance evaluation of ground-based 3-D imaging systems such as laser scanners, 3-D range cameras, and flash LADARs and methods for assessing the accuracy of the derived

output such as 3-D models, volumes, or geometric dimensions. Immediate efforts should focus on developing a protocol for determining range uncertainty of an instrument.

One application for 3-D imaging systems is the identification and location of construction objects of interest. BFRL is currently experimenting with large-scale pick-and-place of structural steel, where the data from the laser scans are used to identify the general pose (position and orientation) of a target object for initial positioning of a robotic crane. Previous efforts have focused on segmenting an object from a high resolution point cloud obtained from a 3-D imaging system and identifying the object and its pose.

**CONTACTS:**  
GERALDINE CHEOK  
MATERIALS AND CONSTRUCTION  
RESEARCH DIVISION  
(301) 975-6074  
[cheok@nist.gov](mailto:cheok@nist.gov)

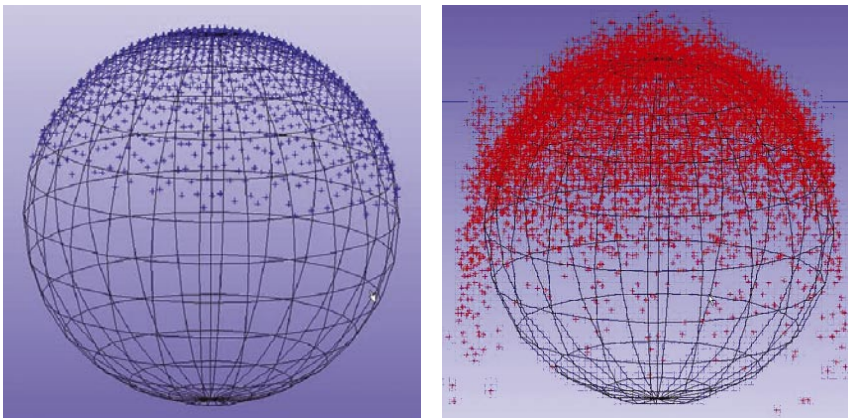
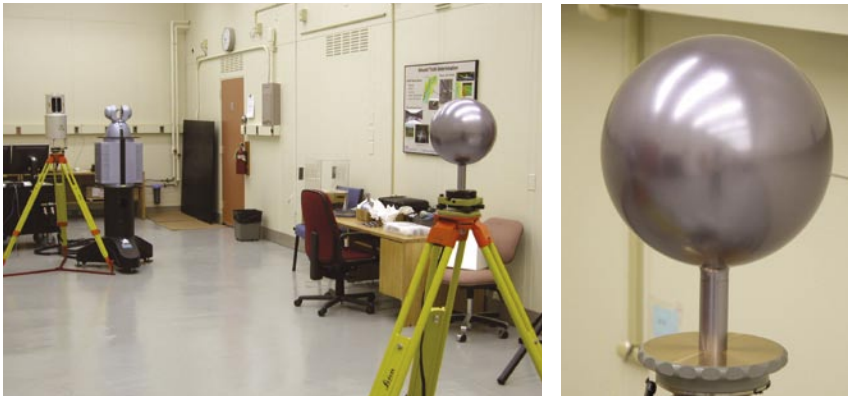

Test facility and the scans of a sphere using two different instruments.

## Innovative Technologies for Automated Construction

The Construction Metrology and Automation Group (CMAG) has been conducting research in automating the structural steel erection process for the past four years. This effort focuses on developing methodologies and performance metrics for advanced concepts in construction automation, laser-based site metrology, laser radar (LADAR)



imaging, construction component tracking, sensor-based data exchange, and construction process visualization. The American Institute of Steel Construction (AISC) has supported CMAG's efforts and continues to be an active participant in this research.

CMAG researchers have successfully equipped a unique cable-suspended six degree of freedom robotic crane – the NIST RoboCrane™ – with real-time laser tracking and demonstrated an autonomous steel assembly process using a simple two-column frame and ATLSS connectors. The build sequence was driven by a script generated from a commercial 4-D CAD package which was parsed for the robot controller, and used to create a sequence of goals or tasks for the robotic crane. The beams were gripped using a CMAG-designed automated gripping mechanism.

CMAG researchers are focused on improving the robotic crane's performance and functionality, and on experimenting with several technologies that will be integrated into the robot's systems over the next two years. The improvements include increasing the laser tracking system's data update rate to 20 Hz, thus allowing real-time laser-based pose tracking of the robot; designing and implementing a rudimentary load sensing system to prevent the robot from releasing a beam if the load is not supported; conducting experiments to evaluate the

robot's performance; developing new data exchange software to allow the laser tracking data to be shared with multiple clients over the network; and upgrading the CMAG-developed robot controller to include automated homing, ground liftoff and landing, and motion characterization functions. A preliminary version of an Intelligent Job Site visualization tool – *JobSight* – was also developed which can display the robotic crane (and other robots), some construction components, and LADAR data within a graphical environment, and which can be used to display the proposed planned path of the robotic crane.

In addition to the above improvements in the robot's performance and functionality, CMAG researchers have also conducted experiments with a radio frequency identification (RFID) system and a high frame rate LADAR unit, both of which will be used in future efforts for construction component identification and locating and collision detection and avoidance, respectively. Finally, in a related effort, steel beam pose determination in a non-cluttered scene using LADAR data was demonstrated (though not integrated in the automated assembly process). This capability will be used in future efforts to provide pose information of various construction components to the robot's task planner.

Future efforts will focus on integrating the high frame rate LADAR system

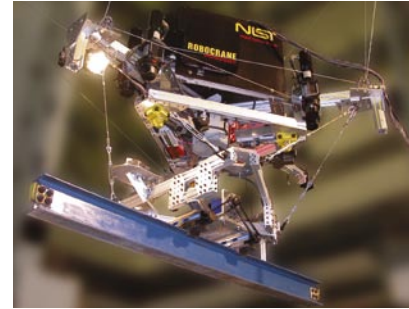

**The NIST RoboCrane™ outfitted with a specially-designed steel-beam gripping mechanism.**

for obstacle detection, and combining the RFID system with high resolution LADAR scanning for construction object recognition and tracking. In addition, CMAG will continue efforts toward expanding the functionality of *JobSight* to include the ability to display a model of the construction site and to display the objects within its database in real-time (whenever that information is available). Finally, a new controller for the robotic crane, based on the NIST Real-Time Control System (RCS) architecture, will be developed and will integrate the various systems already developed as part of these efforts into a cohesive and modular framework.

**CONTACT:**  
ALAN LYTLE  
MATERIALS AND CONSTRUCTION  
RESEARCH DIVISION  
(301) 975-6048  
[alan.lytle@nist.gov](mailto:alan.lytle@nist.gov)

## Harmonization of Structural Steel Product Data Models

**B**FRL researchers have been working to support the harmonization of the CIMsteel Integration Standards (CIS/2) product data model with the representation of structural steel in the Industry Foundation Classes (IFC). CIS/2 is the product data model that has been endorsed by the American Institute of Steel Construction (AISC) for their Electronic Data Interchange Initiative. The purpose of the initiative is to create a means for collaboration and data sharing among the various parties involved in steel construction. The IFC are the product data model developed by the International Alliance for Interoperability (IAI) to facilitate interoperability in the building industry. Harmonization of CIS/2 and IFC is important so that structural steel product information can be coordinated with other parts of the building such as windows, walls, doors, floors, HVAC, MEP, and cladding that have been modeled in other CAD software. The harmonization work has identified areas in the IFC product model that need to be modified to accommodate structural steel information.

In the past year the world's first CIS/2 to IFC translator was released by NIST. The IFC capabilities were added to NIST's existing CIS/2 to VRML (Virtual Reality Modeling Language) Translator. The translator generates an IFC file from a CIS/2 file that has been

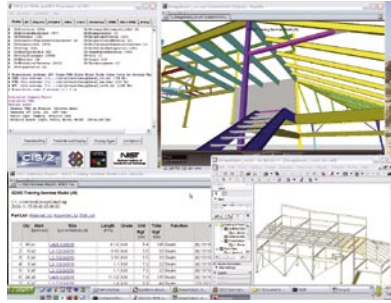

The CIS/2 to VRML and IFC Translator translates a CIS/2 file of a steel structure into a 3-D interactive model in the form of a VRML file and an IFC model.

exported by a steel analysis, design, or detailing software package. Options in the translator allow for generating IFC files with different shape representations, element representations, and versions of the IFC schema including IFC2x2 and the recently released IFC2x3. These options are important because the multiple methods for representing the same object in IFC are not all supported by applications that import IFC files. The resulting IFC files have been used by software vendors to test their IFC import capabilities and in a separate research effort to develop a mapping between IFC and CIS/2. Users are also using the IFC files for coordinating the structural steel with the rest of the building. The translator has been downloaded by over 800 users worldwide.

NIST researchers are members of the CIS/2 International Technical Committee. Current work by the committee is focused on what modifications are needed for CIS/2 to better harmonize with IFC.

**CONTACT:**  
 ROBERT LIPMAN  
 BUILDING ENVIRONMENT DIVISION  
 (301) 975-3829  
[robert.lipman@nist.gov](mailto:robert.lipman@nist.gov)

## Interoperability Standards for Capital Facilities – Improving Equipment Design, Specification, Purchase, Fabrication, and Installation

**T**he Construction Industry Institute (CII) Project Team 180, eCommerce for Construction, reported at the August 2002 CII Annual Conference that leading adopters of eCommerce for capital facilities projects have not succeeded in exploiting this technology for the design and delivery of equipment. The lack of interoperability standards is a primary barrier.

To address this need, BFRL established and is leading the Automating Equipment Information Exchange (AEX) Project in collaboration with the FIATECH Consortium, and with participation from owners, engineering and construction companies, equipment suppliers and software suppliers. The AEX Project is documenting industry information requirements and transaction priorities for the design, procurement and delivery of a variety of equipment types. In addition, the AEX Project established collaboration agreements with relevant industry organizations, e.g., American Petroleum Institute, Process Industry Practices, American Society for Heating, Refrigerating, and Air-Conditioning Engineers (ASHRAE) and the Hydraulic Institute on the delivery of XML schemas for information on

engineered equipment. In July 2004, the AEX Project published the AEX XML Schemas, Version 1.0.

During 2005, the AEX Project developed software implementations of the AEX schemas and conducted the AEX pump interoperability demonstration across all stakeholders in the pump supply chain from initial design requirements to completing mechanical design, procurement, request for quote, quote, quote assessment and supplier selection. Eight organizations participated with nine applications demonstrating implementations of the AEX schemas. Building on the success of the AEX interoperability demonstrations, DuPont started a pilot project in November 2005 to begin use of the AEX XML specifications for automating information exchanges with key suppliers.

**CONTACT:**  
 MARK PALMER  
 BUILDING ENVIRONMENT DIVISION  
 (301) 975-5858  
[mark.palmer@nist.gov](mailto:mark.palmer@nist.gov)

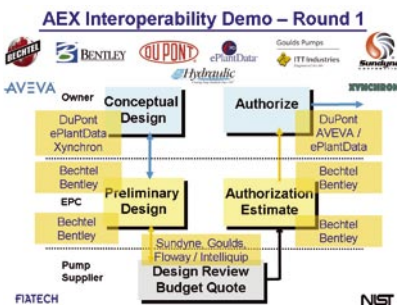

AEX Interoperability Demo— Round 1.

## Costs of Inadequate Interoperability in Construction – NIST Report Released

Inadequate interoperability (the ability to exchange and use information) increases the cost burden of construction industry stakeholders and results in missed opportunities for creating significant benefits for the construction industry and the public at large. The lack of quantitative measures of the annual cost burden imposed by inadequate interoperability, however, has hampered efforts to promote the use of integration and automation technologies in the construction industry.

To address this need, BFRL and NIST’s Advanced Technology Program commissioned a study to identify and estimate the efficiency losses in the U.S. capital facilities industry resulting from inadequate interoperability among computer-aided design, engineering, and software systems. Although the focus of the study is on capital facilities—commercial/institutional buildings and industrial facilities—it benefits key stakeholders throughout the construction industry.

*Cost Analysis of Inadequate Interoperability in the U.S. Capital Facilities Industry* (NIST GCR 04-867), prepared for NIST by RTI International and the Logistic Management Institute, estimates the cost of inadequate interoperability in

the U.S. capital facilities industry to be \$15.8 billion per year. These cost impacts are of interest to owners and operators of capital facilities; design, construction, operation and maintenance, and other providers of professional services in the capital facilities industry; and public- and private-sector research organizations engaged in developing interoperability solutions.

The material contained in the report will promote an increased awareness of interoperability-related issues—both challenges and opportunities—in the capital facilities industry. The report addresses the cost burden issue by presenting both quantitative and qualitative findings and identifying significant opportunities for improvement. The report also analyzes the barriers to improved interoperability in the capital facilities industry and recommends actions for NIST and others to address these barriers.

Since August 2004, 120 thousand requests have been made for the pdf file of the report on the BFRL Web site. Electronic copies of NIST GCR 04-867 are available at <http://www.bfrl.nist.gov/oac>.

**CONTACT:**  
 ROBERT E. CHAPMAN  
 OFFICE OF APPLIED ECONOMICS  
 (301) 975-2723  
[robert.chapman@nist.gov](mailto:robert.chapman@nist.gov)

TO DEVELOP AND IMPLEMENT THE STANDARDS, TECHNOLOGY, AND PRACTICES NEEDED FOR COST-EFFECTIVE IMPROVEMENTS TO THE SAFETY AND SECURITY OF BUILDINGS AND BUILDING OCCUPANTS, INCLUDING EVACUATION, EMERGENCY RESPONSE PROCEDURES, AND THREAT MITIGATION.

# GOAL 4

## HOMELAND SECURITY

The strategy to meet this goal is a three-part NIST-led public-private response program that includes:

- a federal building and fire safety investigation to study the most probable factors that contributed to post-aircraft impact collapse of the World Trade Center (WTC) Towers and the 47-story WTC 7, and the associated evacuation and emergency response experience;
- a research and development (R&D) program to (a) facilitate the implementation of recommendations resulting from the WTC Investigation, and (b) provide the technical basis for cost-effective improvements to national building and fire codes, standards and practices that enhance the safety of buildings, their occupants, and emergency responders; and
- a dissemination and technical assistance program (DTAP) to (a) engage leaders of the construction and building community in ensuring timely adoption and widespread use of proposed changes to practices, standards, and codes resulting from the WTC Investigation and the R&D program, and (b) provide practical guidance and tools to better prepare facility owners, contractors, architects, engineers, emergency responders, and regulatory authorities to respond to future disasters.

The desired outcomes are to make buildings, occupants, and first responders safer in future disaster events.

### Investigation of the World Trade Center Disaster

On August 21, 2002, the National Institute of Standards and Technology (NIST) announced its building and fire safety investigation of the World Trade Center (WTC) disaster. This WTC Investigation was then conducted under the authority of the National Construction Safety Team (NCST) Act, which was signed into law on October 1, 2002.

The specific objectives were:

1. Determine why and how WTC 1 and WTC 2 collapsed following the initial impacts of the aircraft and why and how WTC 7 collapsed;
2. Determine why the injuries and fatalities were so high or low depending on location, including all technical aspects of fire protection, occupant behavior, evacuation, and emergency response;
3. Determine what procedures and practices were used in the design, construction, operation, and maintenance of WTC 1, 2, and 7; and
4. Identify, as specifically as possible, areas in current building and fire codes, standards, and practices that warrant revision.

To meet these objectives, NIST complemented its in-house expertise with an array of specialists in key technical areas. In all, over 200 staff contributed to the Investigation. NIST and its contractors compiled and reviewed tens of thousand of pages of documents; conducted interviews with over a thousand people who had been on the scene or who had been involved with the design,

construction, and maintenance of the WTC; analyzed 236 pieces of steel that were obtained from the wreckage; performed laboratory tests, measured material properties, and performed computer simulations of the sequence of events that happened from the instant of aircraft impact to the initiation of collapse for each tower.

The scarcity of physical evidence that is typically available in place for reconstruction of a disaster led to the following approach:

- Accumulation of copious photographic and video material. With the assistance of the media, public agencies and individual photographers, NIST acquired and organized nearly 7,000 segments of video footage, totaling in excess of 150 hours and nearly 7,000 photographs representing at least 185 photographers. This guided the Investigation Team's efforts to determine the condition of the buildings following the aircraft impact, the evolution of the fires, and the subsequent deterioration of the structure.
- Establishment of the baseline performance of the WTC towers, i.e., estimating the expected performance of the towers under normal design loads and conditions. The baseline performance analysis also helped to estimate the ability of the towers to withstand the unexpected events of September 11, 2001. Establishing the baseline performance of the towers began with the compilation and analysis of the procedures and

practices used in the design, construction, operation, and maintenance of the structural, fire protection, and egress systems of the WTC towers. The additional components of the performance analysis were the standard fire resistance of the WTC truss-framed floor system, the quality and properties of the structural steels used in the towers, and the response of the WTC towers to the design gravity and wind loads.

- Simulations of the behavior of each tower on September 11, 2001, were conducted in four steps:
  1. The aircraft impact into the tower, the resulting distribution of aviation fuel, and the damage to the structure, partitions, thermal insulation materials, and building contents.
  2. The evolution of multi-floor fires.
  3. The heating and consequent weakening of the structural elements by the fires.
  4. The response of the damaged and heated building structure, and the progression of structural component failures leading to the initiation of the collapse of the towers.

For such complex structures and complex thermal and structural processes, each of these steps stretched the state of the technology and tested the limits of software tools and computer hardware. For example, the investigators advanced the state-of-the-art in the measurement of construction material



The published results of the NIST World Trade Center Disaster Investigation.

properties and in structural finite element modeling. New modeling capability was developed for the mapping of fire-generated environmental temperatures onto the building structural components.

The output of the four-step simulations was subject to uncertainties in the as-built condition of the towers, the interior layout and furnishings, the aircraft impact, the internal damage to the towers (especially the thermal insulation for fire protection of the structural steel, which is colloquially referred to as

*fireproofing*), the redistribution of the combustibles, and the response of the building structural components to the heat from the fires. To increase confidence in the simulation results, NIST used the visual evidence, eyewitness accounts from inside and outside the buildings, laboratory tests involving large fires and the heating of structural components, and formal statistical methods to identify influential parameters and quantify the variability in analysis results.

- Combination of the knowledge gained into probable collapse sequences for each tower, the identification of factors that contributed to the collapse, and a list of factors that could have improved building performance or otherwise mitigated the loss of life.
- Compilation of a list of findings that respond to the first three objectives and a list of recommendations that responds to the fourth objective.

The results of this extensive research led to the conclusion that the tragic consequences of the September 11, 2001, attacks were directly attributable to the fact that terrorists flew large jet-fuel laden commercial airliners into the WTC towers. Buildings for use by the general population are not designed to withstand attacks of such severity; building regulations do not require building designs to consider aircraft impact. In our cities, there has been

no experience with a disaster of such magnitude, nor has there been any in which the total collapse of a high-rise building occurred so rapidly and with little warning.

While there were unique aspects to the design of the WTC towers and the terrorist attacks of September 11, 2001, NIST has compiled a list of recommendations to improve the safety of tall buildings, occupants, and emergency responders based on its investigation of the procedures and practices that were used for the WTC towers. The recommendations call for action by specific entities regarding standards, codes and regulations, their adoption and enforcement, professional practices, education, and training; and research and development.

The extensive details of the investigation, results and recommendations can be found in the report *Federal Building and Fire Safety Investigation of the World Trade Center Disaster: Final Report of the National Construction Safety Team on the Collapse of the World Trade Center Towers* (NCSTAR 1) and the 42 companion reports. These reports are available on the Web site: [http://wtc.nist.gov/reports\\_october05.htm](http://wtc.nist.gov/reports_october05.htm).

**CONTACT:**  
SHYAM SUNDER  
DEPUTY DIRECTOR, BFRL  
(301) 975-6850  
[sunder@nist.gov](mailto:sunder@nist.gov)

## Research and Development for the Safety of Threatened Buildings

### Intended Outcome and Background

Building and fire codes in the United States exist, among other reasons, to ensure the safety of occupants in the event of anticipated excessive loads due to wind, earthquake, and snow, and the likelihood of a probable worst case fire. The tragic collapse of the World Trade Center in 2001 (along with the terrorist attacks on the Pentagon, Hart Senate Office Building, and the Murrah Federal Building) has focused the general public, governments at all levels, and the construction and building products industries on the need to understand the possible impacts of terrorist acts on building operations, structural integrity, and emergency response procedures, and on the need to develop economically justifiable strategies to mitigate the potential loss of life from future extreme threats. The standard test methods and building practices upon which current building and fire codes are based rank the performance of one material, component or system against alternative designs, with the expectation that some minimum rating translates into a sufficient level of safety of the material, component or system when installed in the actual building. Safety factors are used to account for our ignorance about the magnitude of actual loads, and of the

uncertainty in response of the complex building frame to these loads. The prediction of failure modes in a closely-coupled building system is beyond our current capability, and standard test methods tell nothing of the expected performance of the building should the mechanical or thermal load exceed a prescribed value. In addition, building designers, operators, occupants and first responders are now faced with chemical and biological threats that were unforeseen as little as four years ago. How should HVAC systems be designed and operated to contain a poisonous aerosol or gas? How have people changed their behavior in response to an emergency since 9/11? Should the same emergency egress and fire service access techniques and strategies be used in the case of a biological threat as for a fire? Can new technologies be developed or design practices be adapted to increase the safety of the building occupants without undue economic burden on the owners/operators? Additional research and development is being conducted in this program to answer questions like these, to provide guidance and tools to assess and reduce future vulnerabilities, and to better prepare facility owners, contractors, designers, and emergency personnel to respond to future disasters, natural or intentionally initiated.

The Safety of Threatened Buildings Program is part of the response of NIST to the events of 9/11, and has been developed through extensive discussions and partnerships with industry, academia, professional societies, codes and standards

organizations, emergency services, and other government agencies. The Program is responsive to recommendations from the 2002 *FEMA Building Performance Study* and the 2005 *NIST Federal Building and Fire Safety Investigation of the World Trade Center Disaster: Final Report*. The program is also responsive to the specific hazards posed by the introduction of a noxious aerosol into the environment such as occurred in the Hart Senate Office Building, and a blast such as occurred in the Murrah Federal Building. However, the fruits of the research are not limited to these specific structures, and will be applicable to the built environment in general. The overarching goal of all of this work is to provide a technical foundation that supports improvements to building and fire codes, standards, and practices that reduce the impact of extreme threats to the safety of buildings, their occupants and emergency responders, and to restore public confidence in the safety of tall buildings nationwide.

Four general outcomes are anticipated that support near- and long-term improvements reducing the vulnerability of the structure, building occupants and first responders to extreme threats:

increased structural integrity,  
enhanced fire resistance,  
improved emergency egress and access, and  
building emergency equipment standards and guidelines.

#### **Increasing Structural Integrity–**

Structural integrity is being increased through the development and implementation of performance criteria for codes and standards, tools and practical guidance for prevention of progressive structural collapse. System design concepts, retarded collapse mechanisms, built in redundancy, and hardening structures though retrofit are being considered. Performance criteria for fire safety design and retrofit of structures are being developed through examination of five key factors: the suitability of standard fire resistance test methods; the role of structural connections, diaphragms, and redundancy in enabling load transfer and maintaining overall structural integrity; the effectiveness of alternative retrofit, design and fire protection strategies to enhance structural fire endurance; the fire behavior of structures built with innovative materials; and models to predict the fire hazard to structures from internal and external fires. Guidance on methods to enhance fire resistance of steel and concrete structures based upon our current state of knowledge are being developed as well.

**Enhancing Fire Resistance –** Fire resistant steels exist and are in use elsewhere in the world. More efficient and accurate tests for performance of steels under building fire conditions are needed and are being developed to help industry incorporate fire resistant steels into U.S. construction practice. Fundamental mechanical and thermal properties of fire protective materials are being measured. This requires the

development of new test methods and instrumentation, and a data base that spans the full range of expected temperatures and mechanical loads. These data will supplement, or may even replace the need for, the ASTM E119 test in certain situations, and in any case are key to the implementation of meaningful performance codes and design criteria.

Facilities do not yet exist that are suitable for demonstrating in a quantitative manner the improved performance of new materials, systems and processes in their end-use within a building under actual fire conditions. Hence, simulations are required to bridge the fundamental data and the results of bench- and pilot-scale tests to the environment in which they would be exposed during extreme fire conditions. The severity of a fire is dependent upon many parameters that are beyond the control of the building designer, especially when one considers the range of terrorism threats that are possible. The performance in a fire of non-structural elements such as walls and ceilings is directly linked to the structural integrity of the building because a collapsed wall, ceiling or floor exposes more areas of the building to the fire while providing additional fuel and air upon which the fire can feed. The technical basis for accurate measurement methodology and simulation tools for the inclusion of fire-resistant properties of walls and ceilings in performance-based fire safety design is being developed under this program.

#### **Improving Emergency Egress and**

**Access** – By working with the primary stakeholders (elevator and construction industries, fire services, professional societies and code making bodies), the role of elevators in providing access by the fire service to a fire in a high-rise building is being greatly enhanced over current practice. The development of hardened fire service elevators and new emergency operation procedures/controls will lead to improved egress capabilities from tall buildings, especially for mobility-impaired or injured occupants. However, the behavior of people in an emergency situation has been altered in unpredictable ways by the events of 9/11. Current egress models are inappropriate and/or insufficient for the design and placement of doors and stairways and the control of elevator movement to handle the total emergency evacuation of a tall building. Behavioral and engineering studies are being conducted, drawing on experts in academia and elsewhere, to enable the development of simulation tools that better capture the movement of people within a building under fire and other emergency situations.

#### **Developing Building Emergency Equipment Standards and Guidelines –**

Partnering with ASHRAE and other federal agencies, NIST-developed indoor air quality (IAQ) simulation tools are being extended to analyze and guide the assessment and subsequent reductions in the vulnerability of buildings to

chemical/biological/radiological attacks. Standard building information models that facilitate the simulation of building system behavior during adverse events are being developed to allow communication among IAQ controls and other building controls associated with, for example, security, transportation, energy and fire alarm systems. A user-friendly tool is being developed for building owners and managers to aid in the selection of cost-effective strategies for the management of terrorist and environmental risks.

#### ACTIVITIES AND ACCOMPLISHMENTS

### **Prevention of Progressive Structural Collapse**

**P**rogressive collapse refers to the spread of a structural failure, by a chain reaction, that is disproportionate to a localized triggering failure. Progressive collapse can result not only in disproportionate structural failure, but also disproportionate loss of life and injuries. The triggering event can result from abnormal loads such as blasts, accidental fires, and deliberate terrorist acts. There is no accepted, science-based design practice to provide overall structural integrity that considers both traditional design loads and abnormal loads. The building industry needs criteria and guidelines to address explicitly progressive collapse resistance



design. In addition, methodologies are needed to retrofit existing buildings to enhance progressive collapse resistance.

The project considers four distinct but interrelated strategies to mitigate progressive collapse:

- system design concept,
- retard collapse after triggering event,
- built-in redundancy for alternate load paths, and
- retrofit and design to “harden” structure.

The project is guided by the recommendations from two national industry workshops. Advanced modeling and simulation tools are being developed to evaluate the vulnerability of complex structural systems, including the evaluation of new system design concepts, as well as predicting the progressive collapse potential of buildings. The project will exploit knowledge gained from controlled demolition technology. The project will also be developing performance criteria and methods to mitigate progressive structural collapse for the development of pre-standards for both new and existing structures.

**CONTACT:**  
 FAHIM SADEK  
 MATERIALS AND CONSTRUCTION  
 RESEARCH DIVISION  
 301-975- 4420  
[fahim.sadek@nist.gov](mailto:fahim.sadek@nist.gov)

## Fire Safety Design and Retrofit of Structures

Current building design practice does not consider fire as a design condition to predict and evaluate structural performance in the presence of an uncontrolled fire. Instead, fire endurance ratings of building members, derived from a standard fire endurance test (e.g. ASTM E-119), are specified in building codes. There is an urgent and critical need to develop and implement verified and improved standards, technology, and practices that explicitly consider structural fire loads in the design of new structures and the retrofit of existing structures.

The technical approach calls for the development of a unified performance-based methodology to evaluate the fire behavior of concrete and steel structures by incorporating current knowledge concerning fire load, material response, and overall structural response into the methodology. The methodology will include key factors not considered in the current practices such as actual structural performance of structural components – including connections and diaphragms – in a real fire environment; state-of-the-art knowledge in properties of innovative materials at high temperature; the need to couple thermal and structural analysis in a practical, verified model; and the need for a reliability-based approach for

specifying the magnitude, location, and spatial distribution of fire hazards on structures.

This project will partner with U.S. industry to develop a consensus national R&D roadmap for fire safety design and retrofit of structures to focus industry and NIST resources into developing and implementing improved fire safety design provisions and methodologies. In the longer term, the project will develop measurement-based simulation models and tools to predict structural fire performance, combining expertise in fire dynamics and thermal-structural modeling. This project will also develop risk and reliability-based models to predict and specify the fire hazard and structural fire loads and the loss in structural resistance. Such a comprehensive model-based approach to structural fire safety will enable sensitivity studies to establish the most important factors affecting the fire performance of the complete structure and to evaluate the effectiveness of alternative retrofit, design and fire protection strategies.

**CONTACT:**  
 JOHN GROSS  
 MATERIALS AND CONSTRUCTION  
 RESEARCH DIVISION  
 301-975-6068  
[john.gross@nist.gov](mailto:john.gross@nist.gov)

## Fire Resistive Materials for Structural Steel

The WTC investigation and numerous contacts with fire-resistive material (FRM) manufacturers have indicated that both adhesion and the thermal properties of the FRMs are critical as primary influences on their successful performance during actual fires. The project addresses both issues. Underlying both, however, is the FRMs' microstructure. Quantitative

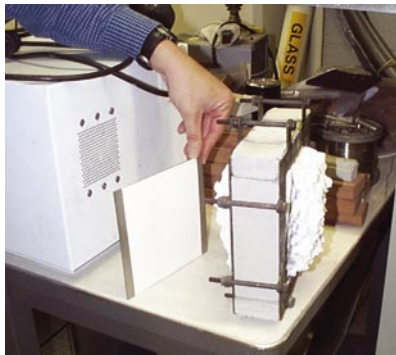
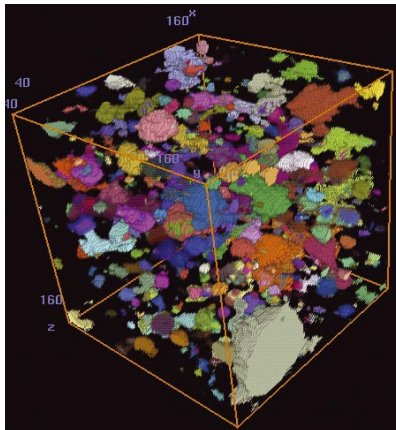

Model and test of sprayed fire resistive material exposed to heat.

3-D characterization of microstructure has received a significant emphasis during the initiation of this project. In these areas, existing techniques have been successfully applied to a new class of materials, new experimental techniques have been developed, and computer models have been used to demonstrate the fundamental linkages between microstructure and performance properties. Recognizing that the durability of these materials must be addressed as part of any comprehensive program, the staff members of this project are actively participating in the activities of UL STP 263 Committee on Fire Tests of Building Construction and Materials, where a first-of-its-kind durability standard for FRMs is currently being drafted.

By establishing strong collaboration with the FRM manufacturing industry, the foundation has been laid for what will hopefully lead to the formation of a NIST/industry consortium on Performance Assessment and Optimization of Fire Resistive Materials. The goals of the consortium will be to continue to develop a new metrological infrastructure to support the industry and to facilitate the all important technology transfer from BFRL's research labs to the industry.

**CONTACT:**  
 DALE BENTZ  
 MATERIALS AND CONSTRUCTION  
 RESEARCH DIVISION  
 301-975-5865  
[dale.bentz@nist.gov](mailto:dale.bentz@nist.gov)

## Standard Test Method for Evaluating the Fire Resistance of Structural Steel

Current standard tests for fire resistance (ASTM E 119, ISO 834) are expensive, difficult to interpret, and use heating curves that represent a limited subset of real fires. More importantly, these tests are known to provide little useful data for ranking different steel grades or for predicting actual fire performance. In addition, most modern types of structural steels have not been characterized for performance under building fire conditions, and new fire-resistive (FR) structural steels have recently been developed. Manufacturers claim that these new steels possess superior elevated-temperature strength compared to ordinary structural steels. Such FR steels, with or without protection, may significantly improve building performance in fires. As a result, a more meaningful, cost- and time-efficient test method to evaluate the actual fire resistance of steels, rather than assemblies, is needed.

Research is assessing the performance of the temperature ramp test and several other possible standard tests. If warranted, we will develop a new ASTM standard test method. In a parallel thrust, we are characterizing the isothermal, high-temperature deformation of ordinary and fire-resistive (FR) steels, and are using these data and

material models to validate results of the temperature ramp test. We anticipate that researchers will find the material models useful to simulate the deformations of structures involved in fires. In addition to characterizing their high-temperature deformation resistance, we are using them to evaluate the proposed test methods.

**CONTACT:**  
 WILLIAM LUECKE  
 METALLURGY DIVISION  
 301-975- 5744  
[william.luecke@nist.gov](mailto:william.luecke@nist.gov)

## Methodology for Fire Resistance Determination

Compartmentation has been the cornerstone of limiting compartment-to-compartment and building-to-building fire spread. At present, standard fire resistance testing of wall/floor/ceiling assemblies provides a relative indicator of resistance on a scale that is arbitrary but has proven valuable over time. However, these procedures have significant limitations that restrict their value for performance-based design and especially for high-risk occupancies. The initial focus is on the most common partitions, which are based on gypsum panels attached by screws to a steel lattice frame. The thrust of the project is to provide a means for assessing the performance of building partitions in actual fires, and possible effects

on the fire from the changing geometry of the building.

Concepts that could satisfy the proposed objective are:

- Additional instrumentation of the current large-scale furnaces, combined with computer simulation of the arbitrary fire, that could provide for a more absolute (i.e., non-relative) estimation of time to failure.
- Reduced-scale testing that could provide information on residual strength and thermal transport, providing the sample surface area were large enough to include proper spacing of fasteners, backing, etc.
- Estimation of the time to failure of the partition from knowledge of the rigidity of the framing/fastening of the partition assembly or some measure of embrittlement upon heating. (This would not necessarily indicate whether the damage to the partition resulted in a large opening or just cracks.)

There are nine components being pursued:

- Work in close collaboration with fire safety engineers and other fire performance modeling efforts to define the types of data and the spatial resolution appropriate to characterize the fire performance of partition assemblies.
- Review the various domestic and international standard apparatus and procedures to establish a candidate set of apparatus modifications and revised operating protocols.

- Conduct real-scale compartment fire tests for a range of fire types, characterizing the thermal and mechanical performance of gypsum/steel partition assemblies.
- Develop software tools to predict fire resistance performance of gypsum panel fasteners.
- Calculate the thermal effects from a given fire using finite element techniques augmented to include the constitutive equations for gypsum wallboard. The model will be formulated to accommodate other materials.
- Couple the thermal response of gypsum wallboard assemblies with FDS simulations for real fires.
- Examine crack initiation and propagation, the integrity after the initial failure, and the criteria at which fasteners separate.
- Adapt or develop bench-scale methodology for determining the thermo-physical, mechanical properties and residual strength of the panels and the adherence of fasteners.
- Validate the partition integrity model through comparison with literature data (e.g., ASTM E119) and/or parallel experiments.

We are working with manufacturers, engineering firms, and standards bodies to integrate the results of this project into practice. ISO TC92 Committee on Fire Safety (SC2 – Fire Containment),

which maintains ISO 834, is currently examining the extent to which ISO standards for fire resistance can be adapted to provide information for fire safety engineering. ASTM E5 Committee on Fire Standards, which maintains ASTM E119, is undertaking a similar effort for its standards. Once a technically sound methodology has been established for gypsum and glass based wall partitions, this project will develop the framework for walls of arbitrary construction and extend this methodology to ceilings and floors.

**CONTACT:**  
SAMUEL MANZELLO  
FIRE RESEARCH DIVISION  
301-975-6891  
[samuel.manzello@nist.gov](mailto:samuel.manzello@nist.gov)



Response of glass-based partition to a real-scale fire.

## Emergency Use of Elevators and Fire Fighter Lifts

The use of elevators during fires has been prohibited in the United States and permitted in some countries for fire service use but not for occupant egress. In tall buildings, egress and access times utilizing only stairs are too long, and stair capacity is insufficient for simultaneous evacuation of buildings in excess of about 40 stories. Use of protected elevators is the only practical means of egress for people with limited mobility, who may make up more than 6% of the population of tall buildings.

ASME A17.1 Emergency Operations Committee has established task groups to develop the needed system design and operational requirements for the Elevator Code. Both model building code organizations are participating in this activity and are holding building code language for proposals at an appropriate time to coordinate with A17.1. Protected elevators are planned by the developers and designers of Freedom Tower following the emerging guidance in A17.1. Protected elevators are also being included in several buildings in London by Arup Fire at the request of clients, and facilitated directly by NIST activities.

NIST has established a coalition of the elevator and fire alarm industries, relevant codes and standards developers, fire service, disability advocates, and interested parties to develop the needed design, installation, and operational protocols to permit the use of protected elevators. These activities are moving forward in a coordinated manner such that the regulatory community will permit these systems in the United States and in a number of other countries.

The relevant codes and standards in the United States and Canada may be changed to permit these systems by 2009. Other countries could recognize these systems within their disability regulations on a similar time frame. The adoption of nearly identical requirements across numerous countries will open global markets for the U.S. elevator and fire alarm industries.

**CONTACT:**  
RICHARD W. BUKOWSKI  
FIRE RESEARCH DIVISION  
301-975-6853  
[richard.bukowski@nist.gov](mailto:richard.bukowski@nist.gov)

## Occupant Behavior and Egress

The objective of this project is to provide the technical foundation that supports improvements in best practices for design and performance prediction of egress in large buildings, including the interaction of building occupants and first responders. Current prescriptive code requirements base egress capacity on single-floor loads, independent of the number of stories, which can lead to multi-hour evacuation times for tall buildings. Egress design based on system performance rather than prescriptive requirements would allow innovative and economical building design by architects and engineers. Unfortunately, the safety of economical and innovative design alternatives cannot be assessed due to limitations of current egress models. While there are dozens of models to simulate the evacuation of occupants from a given building geometry, there is limited contemporary data to support the model inputs or assumptions and even less information available to validate the models for actual emergencies. Collection and analysis of such data would provide a basis for performance-based building code requirements, the practice of egress system design, and ensure robustness for analysis of emerging issues.

NIST held a workshop on building occupant movement during fire emergencies. Participants at the workshop representing varied disciplines – psychology, human factors, sociology, engineering, computer science, government agencies, and toxicology – discussed common efforts towards more accurate prediction methods and information on human behavior in fires and other emergencies. Research needs expressed during the workshop included the need for real-time data of occupant evacuation, design, and code requirements that reflect the risk inherent in specific building designs, a central repository for this type of data in one place available to the public and accurate guidance on development of emergency plans for different types of emergencies.

We will be archiving existing evacuation data, as well as any new data developed in efforts related to this project. The foundation of a long-term, systematic collection of evacuation data is being established. This project collaborates with the General Services Administration to collect baseline data from selected federal buildings to obtain first order statistics. These include occupant flow speeds, pre-evacuation activities, exit discharge rates, occupant densities, along with appropriate details of building geometry. In addition to collection of data during fire drills, the project will work with GSA to monitor existing buildings and collect data in the event of an

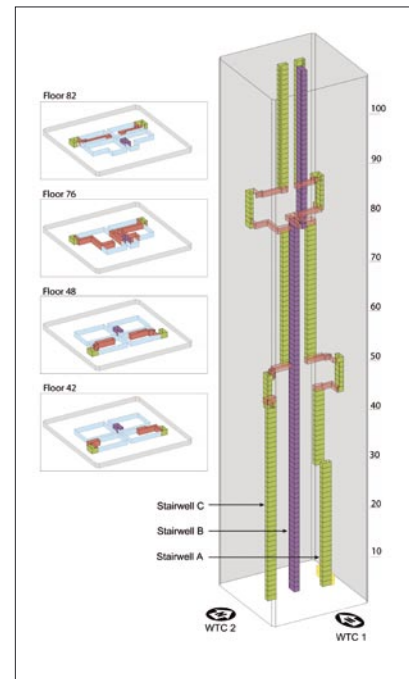

**People movement data through stairwells in WTC 1 and 2 provides researchers with unique data on occupant behavior during an extreme fire emergency.**

actual emergency. As appropriate, these data will be made available through the BFRL Research Information Service.

Evaluation of the validity and sensitivity of models applied to building egress is at least as complex as the evaluation of fire growth models. A current grant to Ove Arup is providing selected data sets to evaluate the uncertainty in two egress models. Through the analysis of two available egress models, the grant developed a guide for the evaluation of egress models to be submitted as an ASTM guide. The work spotlights the need to understand the uncertainty and variability associated with the model, and model application for a specific

scenario, in addition to the data issues already discussed above.

The application of a range of well-characterized egress models to design alternatives for building egress would assist in identifying important design alternatives and quantifying their impact on building egress. Analysis with current and future models should easily be able to account for the effects of stairway width or doorway restrictions at building exits, but may be less able to account for potentially important effects such as stairway counterflow, elevator-assisted egress, or the impact of fire conditions on egress. Such analyses would provide the basis for improved codes and standards for building egress, and in particular, provide the basis for the evolution of a new generation of fire safety evaluation systems that include trade-offs based on important egress design parameters.

BFRL reviewed nearly 30 available egress models published as NIST Technical Note 1471. This review provides information on newly developed models, a detailed explanation of model features and theoretical basis, and each model's validation methods and limitations. It is intended to provide model users with a resource to narrow choices on the appropriate model or models to use for specific projects.

**CONTACT:**  
 JASON AVERILL  
 FIRE RESEARCH DIVISION  
 301-975-2585  
[jason.averill@nist.gov](mailto:jason.averill@nist.gov)

## Cost-Effectiveness Tool for Managing Terrorists Risks in Constructed Facilities

The owners and managers of constructed facilities are now faced with the task of responding to the potential for future terrorist attacks in a financially responsible manner. Economic tools are needed to direct limited resources to investments in mitigation strategies that will provide the most cost-effective reduction in personal injuries, financial losses, and damages to buildings, industrial facilities, and infrastructure. Economic tools include evaluation methods, standards that support and guide the use of those methods, and software for implementing the evaluation methods.

The economic tools under development in this project focus on a decision methodology, embedded in user-friendly, decision-support software, that helps building/facility owners and managers choose the most cost-effective mix of mitigation strategies. Three mitigation strategies are considered: (1) engineering alternatives; (2) management practices; and (3) financial mechanisms. The cost-effectiveness software tool will provide decision makers with the basis for generating a risk mitigation plan that responds to the potential for future terrorist attacks, as well as natural and other man-made hazards, in a financially responsible manner.

Significant OAE products to date include the public release of version

1.0 of the cost-effectiveness software tool (CET), a report documenting the decision methodology, and a series of ASTM standards.

CET Version 1.0 includes a comprehensive case illustration, extensive on-line help features, and links between terms used in the software and technical resource documents. All analyses employed in the software are consistent with ASTM standard practices.

*Cost-Effective Responses to Terrorist Risks in Constructed Facilities* (NISTIR 7073) has been in strong demand since its release in 2004. It presents a three-step protocol for developing a risk mitigation plan for optimizing protection of constructed facilities. This protocol helps decision makers assess the risk of their facility to damages from low-probability, high-consequence events, both natural and man-made hazards; identify engineering, management, and financial strategies for abating the risk of damages; and use standardized economic evaluation methods to select the most cost-effective combination of risk mitigation strategies to protect their facility. By using these economic evaluation methods, the owners and managers of constructed facilities can reduce the life-cycle costs associated with low-probability, high-consequence events.

We have launched collaborative efforts with the Wharton Risk Management and Decision Processes Center, the Construction Industry Institute, ASTM International, the EPA Safe Buildings Program, and the DHS

Measure of Economic Performance	Cost Type	Cost
Cost Type by Budget Category	Capital Investment	\$1,708,438
Cost Type by Component	Building Envelope Elements	\$1,838,152
Cost Type by Mitigation Strategy	Engineering/Architecture	\$3,028,737

Summary of life-cycle costs for two risk mitigation strategies (CET Version 1.0).

Science and Technology Directorate to produce a suite of standards to promote more cost-effective responses to natural and man-made hazards. We are working through the Building Economics Subcommittee (E06.81) of ASTM to produce the suite of standards. Thus far, two key standards have been significantly revised, balloted, approved, and reissued by ASTM. Three additional standards have been significantly revised and are currently being re-balloted. These standards cover all of the evaluation methods employed in the cost-effectiveness software tool and a format for reporting the results of an economic evaluation. A sixth standard, which covers the decision methodology, has been drafted and is about to enter the ASTM balloting process. In addition to the standards, OAE is preparing a training course on how to apply the standards to aid the owners and managers of constructed facilities in the selection of cost-effective strategies for the management of risks associated with natural and man-made hazards.

**CONTACT:**  
 ROBERT E. CHAPMAN  
 OFFICE OF APPLIED ECONOMICS  
 301-975-2723  
[robert.chapman@nist.gov](mailto:robert.chapman@nist.gov)

## Technologies and Advanced Building Airflow Models for CBR Protection

Assessing and then reducing building vulnerability to airborne chemical, biological and radiological (CBR) releases is complicated by variations in buildings, ventilation systems, and agent characteristics. The expertise within BFRL in the areas of building infiltration and ventilation, airflow measurement and modeling, and contaminant transport prediction is providing technical support to the efforts of other federal agencies and the private sector in the area of CBR vulnerability. Already, the CONTAM model for predicting airflow and contaminant transport in multizone building systems has been widely used in analyzing CBR data, including the DARPA-sponsored Immune Building Toolkit and in the development of a high-fidelity model of the Pentagon as part of DARPA's Pentagon Protection Program.

BFRL will continue to work with other federal agencies and private sector partners to develop guidance to reduce building vulnerability to CBR incidents. For example, NIST continues to work with EPA's Homeland Security Research Center on three major efforts under their Safe Buildings Program. In addition, BFRL will continue its development of analysis approaches to understand the impacts of enhanced filtration on building safety within the

context of building envelope air-tightness improvements and pressurization strategies. In order to address the need for improved modeling capabilities, BFRL will enhance the capability of building airflow models in several critical areas that have been identified through the application of CONTAM to building protection. These areas include short time step simulations to better represent sensor performance and the use of sensor outputs to impact HVAC operation. Additional work will be pursued to integrate calculation methods for zones with non-uniform contaminant concentrations into general multizone analysis.

**CONTACT:**  
 ANDREW PERSILY  
 BUILDING ENVIRONMENT DIVISION  
 301-975-6418  
[andrew.persily@nist.gov](mailto:andrew.persily@nist.gov)



Airflow Models for CBR protection.

## AASHTO

AMERICAN ASSOCIATION OF STATE  
HIGHWAY AND TRANSPORTATION OFFICIALS

### AASHTO Materials Reference Laboratory (AMRL)

Established at NIST (then NBS) in 1965, the AASHTO Materials Reference Laboratory (AMRL) is a research association with a staff of 48 that provides a highly valued quality assurance mechanism for laboratories that use AASHTO standards for highway materials; it also provides technical assistance to the AASHTO Accreditation Program (AAP) that currently accredits about 1100 laboratories. With Mr. Peter Spellerberg as Manager and Mr. Robert Lutz as Assistant Manager, the AMRL provides, upon request, as reimbursable services, laboratory inspection and proficiency sample programs. In 2005, over 1600 laboratories participated in AMRL programs. For those laboratories that wish to participate in the AAP, results of the relevant laboratory inspections carried out by the AMRL and the ASTM-sponsored Cement and Concrete Reference Laboratory (CCRL) are the basis for accreditation. AMRL's quality assurance services are complemented by standards-related research carried out in collaboration with BFRL researchers.

## ACI

AMERICAN CONCRETE INSTITUTE

Dr. Geoffrey Frohnsdorff, guest worker in the Materials and Construction Research Division, is a member of ACI's Board of Direction.

### ACI Committee 216, Fire Resistance and Fire Protection of Structures

Dr. Long Phan, Materials and Construction Research Division, chairs the joint ACI/TMS (The Masonry Society) Committee 216 on Fire Resistance and Fire Protection of Structures. He led the effort to revise the committee guide for *Determining the Fire Endurance of Concrete Elements*.

### ACI Committee 236, Materials Science of Concrete

Dr. Chiara Ferraris, Materials and Construction Research Division, chairs ACI Committee 236 on Materials Science of Concrete and Subcommittee ACI 236A on Workability of Fresh Concrete. As the chair of ACI 236A, she led efforts to coordinate an international study to compare and correlate concrete rheometers. As chair of ACI 236 she is fostering a better understanding on how prediction of concrete properties could be improved by better knowledge of material science.

### ACI Committee 318, Structural Concrete Building Code

Dr. H.S. Lew, Materials and Construction Research Division, serves on ACI Committee 318, which is responsible for developing ACI Standard 318—*Building Code Requirements for Structural Concrete*. Dr. Lew introduced new provisions for adoption by ACI 318. Dr. Lew serves on Subcommittee C on safety, serviceability and analysis and the subcommittee for new materials, products and ideas.

Dr. Nicholas J. Carino, Materials and Construction Research Division, served

on ACI 318 Subcommittee A, which is responsible for the portions of ACI Standard 318 dealing with construction through 2004. Dr. Carino has led efforts to update the code as a result of changes to applicable ASTM standards. He was also appointed as chair of the Editorial and Notation Task Group, which is responsible for general editorial issues in ACI 318.

### ACI Committee 440 Fiber Reinforced Polymers

Dr. Dat Duthinh, Materials and Construction Research Division, is an Associate Member of the Committee, whose mission is to develop and report information on fiber reinforced polymers for internal and external reinforcement of concrete. The Committee is currently working on a "Guide for the Design and Construction of Externally Bonded FRP Systems for Strengthening of Unreinforced Masonry" and updates of other documents.

### TAC Specifications Committee

Dr. Nicholas J. Carino, Materials and Construction Research Division, served as chair of the TAC Specifications Committee, which is responsible for coordinating the standard specifications issued by ACI and maintaining the Specification Manual covering the standard format of ACI specifications.



### ACI Concrete Research and Education Foundation (ConREF)

Dr. H.S. Lew, Materials and Construction Research Division, serves as vice-chair of the ACI/Concrete Research and Education Foundation's Board of Trustees, which is responsible for establishing overall strategic goals for development of concrete technology and administering funds for education, research, and scientific purposes in order to increase the knowledge and understanding of concrete materials and improve concrete design and construction.

### AHAM HRF-1

#### Household Refrigerators/ Household Freezers

Dr. David Yashar, Building Environment Division, served on the committee responsible for revising *AHAM HRF-1 Household Refrigerators/Household Freezers*. This standard governs the evaluation of volume measurement, performance measurement and energy consumption of household refrigerators and household freezers. The efforts of the committee have led to the publication of the first revision of the standard in 14 years to be approved by the American National Standards Institute (ANSI), ANSI AHAM HRF-1-2002. In 2002-2003, the task force continued to review and revise the text and diagrams to publish an edition which superseded the 2002 edition. This version of the standard contains information specifically relating to compact refrigerators that is based on BFRL research. Dr. Yashar also served as a member of the ANSI canvass board for this standard.

### AISC

#### AMERICAN INSTITUTE OF STEEL CONSTRUCTION

Mr. Robert Lipman and Dr. Kent Reed, Building Environment Division, participate in the AISC Electronic Data Interchange Initiative. The purpose of the initiative is to create a means for collaboration and data sharing among the various parties involved in steel construction. In addition to serving on the International Technical Committee which continues to develop the CIS/2 (CIMSteel Integration Standards) specification, they are participating in an international collaboration to harmonize CIS/2 with the Industry Foundation Classes of the International Alliance for Interoperability. This work will enable the seamless interchange of building information between the architectural and structural engineering communities.

#### AISC Committee on Specifications

Dr. John L. Gross, Materials and Construction Research Division, serves on the American Institute of Steel Construction Committee on Specifications. The Committee is responsible for developing requirements for the design, fabrication and erection of steel buildings and publishes the *Specification for Structural Steel Buildings*. Dr. Gross serves on Technical Subcommittee 3 (TC3) – Loads, Analysis and Systems, and TC 8 – Temperature Effects.

### ASCE

#### AMERICAN SOCIETY OF CIVIL ENGINEERS

#### SEI/ASCE Executive Committee on Codes and Standards

Dr. H.S. Lew, Materials and Construction Research Division, serves on the SEI/ASCE Executive Committee on Codes and Standards. He works closely with committees that develop standards for seismic evaluation and rehabilitation of buildings, for the testing and evaluation of seismic isolation systems and components, and for the blast load resistance of buildings.

#### ASCE Committee ASCE-7

Dr. Emil Simiu, Materials and Construction Research Division, is a member of the ASCE Committee on Minimum Design Loads for Buildings and Other Structures (ASCE-7).

#### ASCE Committee on Structural Condition Assessment of Existing Buildings

Mr. James Pielert, AASHTO Materials Reference Laboratory, is on the control group of the ASCE Standards Committee on Condition Assessment of Existing Buildings.

#### ASCE Council on Natural Disaster Reduction Technical Committee on Risk and Vulnerability and Technical Committee on Mitigation

Dr. Dat Duthinh, Materials and Construction Research Division, is a Member of the Committee, whose mission is to develop goals and guide action for ASCE's role in hazard mitigation and disaster reduction.

### **ASCE Committee 29-99 Standard Calculation Methods for Structural Fire Protection**

Dr. Long Phan, Materials and Construction Research Division, is a member of the ASCE Standards Committee on Standard Calculation Methods for Structural Fire Protection.

### **ASHRAE**

**AMERICAN SOCIETY OF HEATING, REFRIGERATING  
AND AIR CONDITIONING ENGINEERS, INC.**

### **ASHRAE Standards Committee**

Mr. Brian Dougherty, Building Environment Division, served on the ASHRAE Standards Committee from July 2001 to June 2005. The committee is responsible for overseeing the development and maintenance of all ASHRAE standards, guidelines, and code language documents. Mr. Dougherty was a member of the Technical Committee Liaison Subcommittee and, for two years, chaired the Inter-Society Liaison Subcommittee.

Mr. Steven Bushby, Building Environment Division, began serving on the ASHRAE Standards Committee in July 2005. Mr. Bushby is a member of the Standards Projects Liaison Subcommittee and the Standards Reaffirmation Subcommittee. Mr. Bushby has responsibility for overseeing twelve standard and guideline project committees.

### **ASHRAE 16 Method of Test for Rating Room Air Conditioners and Packaged Terminal Air Conditioners**

Dr. W. Vance Payne, Building Environment Division, is the Vice Chairman of the Standard Project Committee formed to update this standard. The standard prescribes a method of testing for obtaining cooling capacity and airflow quantity for rating room air conditioners and packaged terminal air conditioners. The committee is currently recruiting members from the manufacturing community and other interested parties. The last update of this standard was in 1983.

### **ASHRAE 37R-2005 Methods of Test for Rating Electrically Driven Unitary Air Conditioning and Heat Pump Equipment**

Mr. Brian Dougherty of the Building Environment Division acted as the lead editor on this recently published revision of the standard, which was last updated in 1988. The revised standard reflects current laboratory practices and instrumentation and better addresses newer equipment features. The laboratory test methods described in the standard are used to obtain the performance data that is ultimately used in calculating federally mandated seasonal rating descriptors.

### **ASHRAE Standard 62.2 Ventilation and Acceptable Indoor Air Quality in Low-Rise Residential Buildings**

Steven Emmerich, Building Environment Division, serves as vice-chair of ASHRAE SSPC 62.2. This committee is responsible

for maintaining Standard 62.2 Ventilation and Acceptable Indoor Air Quality in Low-Rise Residential Buildings. This standard was first published in 2003. Mr. Emmerich is also chair of the subcommittee that is developing a companion guideline and overseeing development of a users' manual.

### **ASHRAE Standard 116 Methods of Testing for Rating Seasonal Efficiency of Unitary Air Conditioners and Heat Pumps**

Mr. Brian Dougherty, Building Environment Division, is a voting member on the Standards Project Committee working to update this companion standard to ASHRAE Standard 37. Each project committee member has been assigned a particular section of the 1995 standard to review and propose revisions. The project committee should have a revised standard ready for public review in 2007.

### **ASHRAE Standard 118.2 Method of Testing and Rating Residential Water Heaters**

Dr. William Healy, Building Environment Division, is a voting member of ASHRAE SPC 118.2 Method of Testing and Rating Residential Water Heaters. This standard governs the evaluation of the energy factor which rates the thermal efficiency of residential water heaters and the first-hour rating which provides a metric for the amount of hot water provided by a tank. The committee is currently considering

changes in this test procedure to correct errors in calculations and to make the procedure more consistent. Work has been undertaken to determine the differences between the ASHRAE procedure and the Department of Energy's procedure in an effort to align the two methods of test.

#### **ASHRAE Standard SPC 41.4 Standard Method for Measurement of Proportion of Lubricant in Liquid Refrigerant**

Dr. Mark Kedzierski, Building Environment Division, serves on the committee responsible for revising the measurement standard for determining the mass concentration of miscible lubricant-and-liquid-refrigerant mixtures and, in limited cases, immiscible mixtures. The goal of this revision is to assure that the standard is applicable to new refrigerants and lubricants.

#### **ASHRAE Standing Standards Project Committee 135**

Mr. Steven T. Bushby, Building Environment Division, served in various positions on ASHRAE Standing Standards Project Committee 135 (SSPC 135) and its predecessor committee from 1987 – June 2004, including a term as chair. In July of 2004 Dr. David Holmberg became a member of the committee and he currently leads the Utility Integration Working Group. SSPC 135 is responsible for maintaining the BACnet communication protocol standard (ANSI/ASHRAE Standard 135) and a companion standard

ANSI/ASHRAE 135.1 Method of Test for Conformance to BACnet. These standards have been adopted by CEN, ISO and over thirty countries around the world. The BACnet standard provides a way to integrate building automation and control products made by different manufacturers for applications such as heating, ventilating, and air-conditioning control, lighting control, access control, and fire alarm systems.

#### **ASHRAE 135.1P Method of Test for Conformance to BACnet**

Mr. Steven T. Bushby, Building Environment Division, was the principal author of a draft standard, *ASHRAE 135.1P, Method of Test for Conformance to BACnet*. This proposed standard defines detailed testing procedures for verifying that control products correctly implement the BACnet communication protocol. Although still in the public review process, 135.1P has already been adopted by the newly-created BACnet Manufacturers Association and the BACnet Interest Group – Europe (BIGEU), as the basis for testing and listing programs in the United States and Europe. Mr. Bushby served as Chairman of ASHRAE Standing Standard Project Committee 135 (SSPC 135) that maintains the BACnet communication protocol standard for building automation and control systems. In 2001 a revised version of the standard was published that included all addenda approved since 1995. Two new addenda have since been prepared and published for public

review and comment. Addendum *a* to 135-2001 adds a number of new features including more advanced scheduling capabilities, more detailed error reporting, and the ability to dynamically discover the presence of MS/TP slaves. Addendum *b* to 135-2001 modifies trending features to fix some problems that have been encountered in deployed BACnet systems. BACnet has been translated into Chinese, Japanese, and Korean. It has been adopted as a Korean national standard, a European Community pre-standard, and has recently been adopted as an ISO standard.

#### **ASME**

**AMERICAN SOCIETY OF MECHANICAL ENGINEERS**

#### **ASME Solar Energy Division**

Dr. A. Hunter Fanney, Building Environment Division, is an active member of ASME. He is an ASME Fellow, and past Chairman of the Solar Energy Division. This Division is responsible for coordinating all solar energy activities within ASME including the *Journal of Solar Energy Engineering*, annual conferences, student activities, and awards. He has served as an Associate Editor of ASME's Journal of Solar Energy Engineering and is currently serving as Senior Advisor to the Division as well as Chairman of the Frank Kreith Energy Award. Over the past seven years, Dr. Fanney and his colleagues have received four ASME best paper awards in the topical area of photovoltaics.

### ASTM International

---

#### ASTM Committee C01 Cement

Mr. Jan Prowell, Research Associate with CCRL, chairs ASTM Subcommittee C01.97, Manual of Cement Testing.

#### ASTM C01.23 Subcommittee on Computational Analysis

Mr. Paul Stutzman, Materials and Construction Research Division, is the official voting member for NIST on Committee 01, Cement, chairs the ASTM C 01.23 Compositional Analysis Subcommittee as well as the task groups on X-Ray Diffraction Analysis and Microscopy, and also is a member of the Executive, Administrative Coordination, Coordination of Standards, and Sulfate Content Subcommittees. Under his leadership, standards for improved characterization of Portland cements in terms of the phases present using these two techniques have been established.

#### ASTM C01.25.01 Subcommittee on Particle Size Analysis

Dr. Chiara Ferraris, Materials and Construction Research Division, is an active participant in this subcommittee. Recently, the Standard Reference Material (SRM) 114p certificate was amended to include the particle size distribution (PSD) measured by laser diffraction. A draft method for measuring PSD of cement by laser diffraction is under ballot to the ASTM subcommittee. SRM114q was developed and will include the PSD by laser defraction.

#### ASTM Committee C09 Concrete and Concrete Aggregates

Dr. Nicholas Carino, Materials and Construction Research Division, served as chair of ASTM Committee C09. In addition, he served on numerous subcommittees.

Mr. Paul Stutzman of the Materials and Construction Research Division serves on this committee and on the Petrography, Resistance to the Environment, and Concrete's Resistance to Fluid Penetration Subcommittees.

Mr. Peter Spellerberg, AASHTO Materials Reference Laboratory, is secretary of ASTM Subcommittees C09.61 on Testing for Strength, C09.96 on CCRL.

Mr. Raymond Kolos, Research Associate with CCRL, chairs ASTM Subcommittee C09.97, Manual of Testing for Concrete and Concrete Aggregates.

Dr. Chiara Ferraris, Materials and Construction Research Division, is a member of the Subcommittee C09.66 on Resistance to Fluid Penetration and lead the effort to develop "Test Method for Measurement of Rate of Absorption of Water by Hydraulic-Cement Concretes." The document was approved as ASTM C1585-04.

#### ASTM C16 Committee on Thermal Insulation

Mr. Robert R. Zarr, Building Environment Division, chairs the ASTM C16 task group on computerized database formats for thermal transmission data obtained by ASTM C16 Standard Test Methods. Mr. Zarr also chairs the committee's task groups on the design and operation of line-heat-source guarded-hot-plate apparatus.

#### ASTM Committee C24 on Building Seals and Sealants

Dr. Chris White, Materials and Construction Research Division, is an active member of ASTM C24 and is also a member of the RILEM Committee on Sealant Durability.

#### ASTM Committee D04 Road and Paving Materials

Mr. Peter Spellerberg, Research Associate with AMRL, is the Secretary of ASTM Committee D04 on Road and Paving Materials.

#### ASTM Committee D18 Soil and Rock

Mr. Ronald Holsinger, Research Associate with AMRL, is on the Executive Committee of ASTM Committee D18 on Soil and Rock; is the secretary of D18.05; and chairs D18.03.

#### ASTM Subcommittee D20.96 Biodegradable Plastics Subcommittee

Ms. Barbara Lippiatt, Office of Applied Economics, has published a standard, "Standard Practice for Evaluating and Reporting Environmental Performance of Biobased Products" as ASTM D7075-04.

#### ASTM Subcommittee D22.05 Indoor Air Quality

Dr. Andrew Persily, Building Environment Division, is vice-chair of ASTM Subcommittee D22.05. This subcommittee has approved and is currently developing a suite of standards related to indoor contaminant measurement, analysis and interpretation. Several of these standards are based directly on research and methods developed by BFRL.

### **ASTM E5 Committee on Fire Standards**

Mr. James Lawson, Fire Research Division, is currently the chairman of ASTM Subcommittee E5.15 on Fire Standards for Furnishings and Contents. This committee develops fire standards for building construction, transportation, and furnishings. These fire standards are used by the building codes and other regulating authorities throughout North America. In addition, Mr. Lawson is a voting member of the ASTM F23 Committee on Protective Clothing. This technical committee develops standards for protective clothing and equipment used by the fire service in North America.

### **ASTM Subcommittee E06.23 Lead Hazards Associated with Buildings**

Dr. Walter Rossiter and Dr. Mary McKnight, Materials and Construction Research Division, served as members of many ASTM E06.23 task groups. Both have played key roles in the development and revision of standards.

### **ASTM Subcommittee E06.41 Infiltration and Ventilation Performance**

Dr. Andrew Persily, Building Environment Division, chairs ASTM Subcommittee E06.41. Under his leadership, more than 15 standards for evaluating building airtightness, ventilation performance and other aspects of air leakage and airflow in buildings are approved or under development.

### **ASTM Subcommittee E06.66 Performance Standards for Dwellings**

Dr. Robert Chapman, Office of Applied Economics, completed and obtained approval of the economics attribute standard that ties together the E06.66 family of standards that define total building performance. The standard guide was published by ASTM with the designation E 2156. In addition to describing how to measure economic performance, the guide includes a detailed example of how to apply the methodology to a durability-related investment decision that builds on the companion durability attribute (ASTM Standard Guide E 2136.)

Dr. Andrew Persily, Building Environment Division, has recently initiated development of the health and hygiene attribute standard in collaboration with HUD.

### **ASTM Subcommittee E06.81 Building Economics**

Dr. Harold E. Marshall, Office of Applied Economics, has been the chairman of ASTM's Building Economics Subcommittee, E06.81, since its inception in 1979. He has played major authorship, educational, and leadership roles in writing and shepherding successfully over 20 standards and two software products through the ASTM standardization process. One standard that merits particular attention is an elemental building classification called UNIFORMAT II.

This standard is helping owners, project managers, designers, builders, and facility managers construct and manage their buildings more cost effectively.

Dr. Robert E. Chapman, Office of Applied Economics, is the secretary and Techniques Task Group chairperson of ASTM's Building Economics Subcommittee. In addition to his strong leadership role in the subcommittee, he has provided over the last two years the technical content and write-ups for revising two standard economic methods to provide case illustrations of economic decision making in support of improved, cost-effective protection against natural and man-made hazards affecting the nation's infrastructure. Dr. Chapman has also drafted a new standard guide for developing a cost-effective risk mitigation plan for protecting infrastructure that has been submitted to the ASTM balloting process.

### **ASTM Committee E11 on Quality and Statistics**

Mr. Ronald Holsinger, Research Associate with AMRL, is on the Executive Committee of ASTM Committee E11 on Quality and Statistics.

### ASTM E44.09

Dr. Hunter Fanny of the Building Environment Division is a member of subcommittee E44.09 that deals with numerous issues concerning the testing and evaluation of photovoltaics. Current areas of interest include developing rating methodologies for photovoltaics that use short-term data to predict long-term performance, and improved indoor and outdoor test procedures.

### ASTM Standing Committee on Publications

Dr. Mary McKnight, guest worker in the Materials and Construction Research Division, serves on the ASTM Standing Committee on Publications. The Committee advises the Society's Board of Directors on the formulation of publications policy and administers the Society's publications program, except for the *Annual Book of ASTM Standards*.

### CCRL

#### CEMENT AND CONCRETE REFERENCE LABORATORY

Established at NIST (then NBS) in 1929 as the Cement Reference Laboratory in response to a request from Congress, the ASTM-sponsored Cement and Concrete Reference Laboratory (CCRL) is a research associateship that provides a highly valued quality assurance mechanism for laboratories that use ASTM cement and concrete standards. With Mr. Peter Spellerberg of AASHTO as General Manager and Mr. Raymond Kolos of ASTM as Director, and a staff of

25 ASTM research associates, the CCRL provides, upon request, as reimbursable services, laboratory inspection and proficiency sample programs. In 2005, over 1000 laboratories participated in the CCRL programs. For cement and concrete laboratories that wish to participate in the AASHTO Accreditation Program (AAP), results of laboratory inspections carried out by the CCRL are the basis for accreditation. CCRL's quality assurance services are complemented by standards-related research carried out in collaboration with BFRL researchers.

### CIB

#### INTERNATIONAL COUNCIL FOR RESEARCH AND INNOVATION IN BUILDING AND CONSTRUCTION

### CIB W14 Fire

Mr. Richard Bukowski, Fire Research Division, is chair of CIB Working Commission 14 on Fire. The oldest working commission in existence, W14 has a long history of making major contributions to the fire science and engineering fields.

### CIB TG37

#### Performance-Based Buildings

Mr. Richard Bukowski, Fire Research Division, participates in CIB TG37, a task group that is developing infrastructure and policy in support of performance regulatory systems, internationally. TG37 is closely linked to the Inter-jurisdictional Regulatory Collaboration Committee (IRCC) that is made up of the chief building code official for each member country and who share common experiences and problems in the operation of performance regulatory systems.

### FIATECH AEX Project

Although most architecture and engineering organizations have adopted aspects of 3-D modeling, project Web sites, and information integration technologies in the design and initial documentation phases of capital facilities projects, the capabilities and benefits of these technologies are not being exploited in the supplier integration, procurement, fabrication, inspection, materials management and construction phases. Additionally, the use of engineering and construction information for facility commissioning, maintenance, repair and operations is restricted by the lack of effective information sharing and re-use capabilities.

In collaboration with the FIATECH consortium, Mr. Mark Palmer, Building Environment Division, leads the Automating Equipment Information Exchanges (AEX) Project to develop interoperability standards for automating the design, purchase, fabrication, installation and operation of equipment for capital facilities. The AEX project developed and tested XML schemas to support a first set of priority types of equipment, as selected by industry participants. These included centrifugal pumps, centrifugal fans, electric motors and shell and tube heat exchangers. During 2005, the AEX project developed software implementations of the AEX schemas and conducted the AEX Pump Interoperability Demonstration across all stakeholders in the pump supply chain from initial design

requirements to completing mechanical design, procurement, request for quote, quote, quote assessment and supplier selection. Eight organizations participated with nine applications demonstrating implementations of the AEX schemas. These interoperability demonstrations were presented at numerous industry conferences and proved to industry that the use of the AEX XML schemas can automate the information exchanges among all participants in the equipment supply chain, with significant savings in cost and time and improved quality.

## IAAI

INTERNATIONAL ASSOCIATION  
OF ARSON INVESTIGATORS

### IAAI Engineering Committee

Mr. Daniel Madrzykowski, Fire Research Division, was reappointed as the Chair of the IAAI Engineering Committee. Under Mr. Madrzykowski's leadership, the committee has been developing and reviewing articles for the *IAAI Fire and Arson Investigator*, assisting with the development of standards and a review process for IAAI technical training programs, and collaborating with IAAI chapters in mutually beneficial large scale fire experiments to address USFA and DoJ funded research programs at NIST.

### Learning at a Distance Steering Committee

Mr. Daniel Madrzykowski, Fire Research Division, has been instrumental in the development of two programs for the IAAI CFITrainer.net Web site; Introduction to Fire Dynamics and Fire Modeling and An Analysis of the Station Nightclub Fire. CFITrainer.net ([www.cfitrainer.net](http://www.cfitrainer.net)) is an online training resource for fire investigators around the world. After viewing a program and completing the assigned reading, a student can take an on-line skills assessment in order to receive credit. The education and training modules also will help fire investigators to meet requirements in NFPA 1033 Standard for Professional Qualifications for Fire Investigators. The site is sponsored by the U.S. Department of Homeland Security, the Bureau of Alcohol Tobacco and Firearms, and the Insurance Committee for Arson Control. The site has been featured as a DHS Fire Prevention and Safety Grant success story, [http://www.firegrantsupport.com/stories/fps\\_stories.aspx](http://www.firegrantsupport.com/stories/fps_stories.aspx).

## IAI

INTERNATIONAL ALLIANCE FOR INTEROPERABILITY

NIST is a government member of the International Alliance for Interoperability/ North America. Dr. Kent Reed, Building Environment Division, represents NIST in the IAI/NA, is a member of the IAI technical Advisory Group that functions at the international level, and participates

in the Model Support Group that develops the Industry Foundation Classes (IFC) Specification. The IAI is a global standards-setting organization dedicated to promoting effective means of exchanging information among all software platforms and applications serving the Architecture, Engineering, Construction, and Facility Management (AEC+FM) community.

## ICC

INTERNATIONAL CODE COUNCIL

### ICC Performance Committee

Mr. Richard Bukowski of the Fire Research Division completed a three-year assignment to the ICC Performance Building Code and ICC Performance Fire Code drafting committees. These two committees eventually merged and produced the ICC Performance Code for Buildings and Facilities, the first combined U.S. building and fire code and the first U.S. performance based code. This document has entered into the ICC code development process where it is open to code change proposals prior to formal adoption. Mr. Bukowski has been named to the ICC Performance Code development committee, which is responsible for accepting or rejecting these proposed changes.

### IEC

#### INTERNATIONAL ENGINEERING CONSORTIUM

#### IEC/TC 59 A Electric Dishwashers

Ms. Natascha Castro, Building Environment Division, is a member of the U.S. Technical Advisory Group to IEC/TC 59A. This committee determines the U.S. position on issues related to IEC standards related to the performance and energy consumption of dishwashers.

### IFSTA

#### INTERNATIONAL FIRE SERVICE TRAINING ASSOCIATION

Mr. Daniel Madrzykowski, of the Fire Research Division, was appointed to the “Essentials of Fire Fighting” Validation Committee. *The Essentials of Fire Fighting Handbook* is the principle document used to train fire fighters in the United States. Mr. Madrzykowski’s committee position provides an opportunity to integrate NIST research results into this document and the instructors’ multi-media packages as a means to improve fire fighters’ understanding of fire behavior and the impact of fire fighting tactics on fire behavior.

### ISO

#### INTERNATIONAL ORGANIZATION FOR STANDARDIZATION

#### ISO TAG8

Mr. Richard Bukowski, Fire Research Division, is the U.S. representative to ISO TAG8. TAG8 is a technical advisory group to the Technical Management Board (TMB) of the International

Organization for Standardization (ISO) which develops ISO standards. A current activity is the development of an ISO policy on performance standards.

#### ISO TC 86 Refrigeration and Air-Conditioning

ISO’s Technical Committee 86 Refrigeration and Air-Conditioning is composed of eight subcommittees that address topics such as terms and definitions, safety, and testing and rating methods for refrigeration and space-conditioning equipment. Mr. Brian Dougherty, Building Environment Division, participates as a member of the U.S. Technical Advisory Group (TAG) for ISO TC 86. The TAG monitors and formulates the U.S. position on all TC 86-sponsored standards activities. Mr. Dougherty serves as a member of Panel 6 that makes recommendations to the full TAG on ISO standards activities dealing with factory made air-conditioning and heat pump units. Brian Dougherty is also a member of the U.S. delegation on ISO Working Group 1 within Subcommittee 6. WG1 is revising two testing and rating standards that apply to unitary air-conditioners and heat pumps while developing a third testing and rating standard for multi-split air-conditioners and heat pumps.

Dr. David Yashar, Building Environment Division, served on Panel 5 of the U.S. Technical Advisory Group to ISO/TC 86 for Household Refrigerators. This committee was formed to review and comment on the latest version of the ISO test procedure, ISO 15502 Household Refrigerating Appliances – Characteristics

and Test Methods, which encompasses test procedures for different types of refrigerating appliances. This standard was ratified in October 2005, under the condition that a revision of ISO 15502 be initiated. Dr. Yashar is currently serving as a member of the working group for this revision, ISO TC 86/SC 5/WG 1, alongside delegates from standards bodies representing the Americas, Asia, and the South Pacific in addition to those representing the European Union. The ultimate goal of this WG is to work towards a globally acceptable test procedure. This effort is estimated to continue through the end of 2008.

#### ISO TC92 Fire Safety

Dr. Richard G. Gann of the Fire Research Division chairs SC3, Fire Threat to People and the Environment, and participates in the Technical Program Management Group. He has formulated an agenda for standardization documents for the use of toxic potency information in fire risk and hazard assessment. The Subcommittee has now issued its first eight documents in a decade and has seven more documents in various stages of development. Dr. Gann also chaired the subcommittee’s first Workshop on Fire Threat to the Environment, beginning the development of an agenda in that area. Dr. Gann led the adoption of ASTM E2187-02b, “Standard Test Method for Measuring the Ignition Strength of Cigarettes,” and its revision E2187-04 with consensus from regulators, public safety advocates, and the cigarette industry. This method has attracted attention both domestically and



internationally. It is cited in regulations in the States of New York, California, Vermont, New Hampshire, and Illinois and in Canada. The method is under consideration in legislation in the United Kingdom and Australia. A coalition of organizations has been formed by the National Fire Protection Association to promote the use of the method in regulations in the remaining 45 States.

The International Standards Organization Technical Committee on Fire Safety (TC92) is divided into 4 subcommittees (SC1-SC4). Dr. Walter Jones, of the Fire Research Division, is the U.S. expert for SC4, Fire Safety Engineering. He is the principal author of the guide on model validation and verification that is now being balloted as an international standard (ISO 16730, *Fire Safety Engineering: Assessment, Verification and Validation of Calculation Methods*), and will continue this work by developing a guide to implementing this standard using examples.

ASTM International (formerly American Society for Testing and Materials) has a similar organization for fire safety engineering, Committee E5. Dr. Walter Jones leads two technical groups of this committee on “Uses and Limitations of Models” which sponsors E1895 (*Determining Uses and Limitations of Deterministic Fire Models*), and “Model Assessment,” which has developed E1355 (*Evaluating the Predictive Capability of Deterministic Fire Models*).

Dr. John Gross of the Materials and Construction Research Division participates in SC4 WG12, Structures in Fire,

and in WG8, Fire Terms and Definitions.

Dr. William Grosshandler, of the Fire Research Division, is a member of SC1, the subcommittee on Fire Initiation and Growth, and a member of SC2, Fire Containment.

### **ISO TC 205 WG 3 Building Control System Design**

Mr. Steven Bushby, Building Environment Division, is convener of ISO/TC 205 WG 3 Building Control System Design. The working group is developing a multi-part international standard that addresses several issues related to building control systems including control system functionality, communication protocols, system specifications, and project management. ANSI/ASHRAE standards 135 and 135.1 (BACnet and its companion testing standard) have been adopted as ISO standards through this committee.

### **ISO TC 205 Maintenance Agency for EN ISO 16484-5 and EN ISO 16484-6**

Mr. Steven Bushby chairs a maintenance agency created by ISO TC 205 Building Environment Design for the purpose of streamlining the process for updating and maintaining EN ISO 16484-5 and EN ISO 16484-6. These standards are the international versions of the ASHRAE BACnet standard and are its companion testing standard. The purpose of this activity is to keep these European and ISO standards synchronized with the underlying ASHRAE standards upon which they are based.

## **NFPA**

**NATIONAL FIRE PROTECTION ASSOCIATION**

### **NFPA Standards Council**

Mr. Richard Bukowski, of the Fire Research Division, is a member of the NFPA Standards Council. The Standards Council is the body that administers the NFPA Codes and Standards system including making all committee appointments, initiating and terminating standards projects and issuing all documents. This is an especially important time for the Standards Council in administering the development of the NFPA Building Code and related codes through strategic partnerships. Appointments to the thirteen-member Council run for two, three-year terms.

### **NFPA Alternative Approaches to Life Safety Committee**

Mr. David Stroup, Fire Research Division, chairs NFPA 101A Committee on Alternative Approaches to Life Safety. The Alternative Approaches to Life Safety standard provides methodologies for measuring equivalency to the prescriptive requirements of *NFPA 101, Life Safety Code*. The document includes several Fire Safety Evaluation Systems (FSES) developed at NIST for various building occupancy types. As chair of the committee responsible for this fire safety standard, Mr. Stroup presents the committee’s report for adoption at the NFPA fall meeting.

### **NFPA Toxicity Advisory Committee**

Dr. Richard G. Gann, Fire Research Division, chairs the NFPA Toxicity Advisory Committee. This committee brings special expertise on combustion toxicity to advise any other NFPA technical committee on toxicity issues that might be part of any proposal under consideration.

### **NFPA Automatic Sprinkler Committees**

Mr. Daniel Madrzykowski, Fire Research Division, is chair of the Technical Committee on Residential Sprinkler Systems. This committee is responsible for developing the standard on the design and installation of sprinklers in one-and two-family dwellings, and in residential occupancies up to 4 stories in height. In addition, Mr. Madrzykowski serves on the Technical Correlating Committee on Automatic Sprinklers and is the NIST alternate on the NFPA Technical Committee on Sprinkler System Discharge. Mr. Madrzykowski revised the residential sprinkler section in the *NFPA Automatic Sprinkler Systems Handbook, 9th ed.*, and was principal author on the Residential Sprinkler Chapter in the *NFPA Fire Protection Handbook*.

### **NFPA 921 Guide for Fire and Explosion Investigations**

Mr. W. D. Walton, Fire Research Division, is a member of the NFPA 921 Committee, Guide for Fire and Explosion Investigations. This committee provides guidance to investigation professionals based on scientifically defensible materials and referenced technical data. NIST utilizes its research expertise to provide the latest technical and scientific research information to the committee. At the current time, NIST is studying the formation of fire burn patterns, which is one of the tools used by investigators to determine the origins and causes of fires and explosions. The burn pattern research is supported by the National Institute of Justice via the NIST Office of Law Enforcement Standards and the United States Fire Administration. Mr. Daniel Madrzykowski, Fire Research Division serves on this committee as alternate.

### **NFPA Technical Committee on Gaseous Fire Extinguishing Systems**

Dr. Jiann Yang, Fire Research Division, is a member of the NFPA Technical Committee on Gaseous Fire Extinguishing Systems developing standards for replacements for halon extinguishing agents. This activity is coordinated with the BFRL research on halon replacements.

### **NFPA National Fire Alarm Code Technical Correlating Committee**

Mr. Richard Bukowski, Fire Research Division, serves on the TCC for the National Fire Alarm Code. Like other TCC's this committee addresses technical consistency and correlation among the technical committees responsible for specific parts of the Code.

### **NFPA and ASTM Rail Transportation Committees**

Mr. Richard Peacock, Fire Research Division, represents NIST on the NFPA 130 committee and the ASTM E5.17 committee developing standards for fire safety in passenger rail vehicles.

### **NFPA Safety to Life Correlating Committee**

Mr. Richard Bukowski, Fire Research Division, is a member of the Technical Correlating Committee (TCC) for the Safety to Life Project. The TCC provides oversight to the technical committees developing requirements for individual topics and assures that the requirements are consistent and correlated throughout the document.

### **NFPA Urban/Wildland Interface Committee**

Mr. Daniel Madrzykowski, of the Fire Research Division, served as member of the NFPA Technical Committees on Forest and Rural Fire Protection through 2004 and has contributed to the standards and guides on Application of Class A Foam in Structural Fire Fighting and Fire-Fighting Chemicals for Class A Fuels. (Dr. William Mell, also of the Fire Research Division, replaced Madrzykowski in 2005.) Mr. Madrzykowski also serves as NIST's principal member on the Water Mist Fire Protection Systems Technical Committee.

**NFPA Committee for the Standard on Protective Ensemble for Structural Fire Fighting**

Mr. James Lawson of the Fire Research Division serves on this committee, while Mr. Robert Vettori serves as alternate. This standard specifies the minimum design, performance, and certification requirements, and test methods for structural protective ensembles that include protective coats, protective trousers, protective coveralls, helmets, gloves, footwear, and interface components.

**NFPA Fire Test Technical Committee**

Mr. James Lawson is a voting member of this committee. This committee has responsibility for documents on fire testing procedures, for reviewing existing fire test standards and recommending appropriate action to NFPA, for recommending the application of and advising on the interpretation of acceptable test standards, and for acting in a liaison capacity between NFPA and the committees of other organizations writing fire test standards.

**NFPA Research Section**

Mr. Dan Madrzykowski, Fire Research Division, was elected as the Chair in 2004. The Research Section's principle activity is the facilitation of communication between researchers and research end users. One means the Research Section uses to provide a forum for technology transfer is the development of technical programs for the Annual NFPA World Safety Conference.

**OASIS**

**ORGANIZATION FOR THE ADVANCEMENT OF STRUCTURED INFORMATION STANDARDS**

In technical work funded by the NIST Systems Integration for Manufacturing Applications program, Mr. Edwin Begley of the Building Environment Division completed the specification of the Materials Markup Language (MatML) during 2002 and delivered it to the industry-based MatML Steering Committee. The MatML Schema, currently available at <http://www.matml.org>, contains the formal specification for the materials markup language and represents the efforts to date of a cross section of the international materials community with contributions from private industry, government laboratories, universities, standards organizations, and professional societies. The specification has been submitted as the base technical document to the newly formed OASIS Materials Markup Technical Committee.

**RILEM**

**INTERNATIONAL UNION OF RESEARCH AND TESTING LABORATORIES FOR MATERIALS AND STRUCTURES**

**RILEM Technical Committee HTC Mechanical Concrete Properties at High Temperatures: Modeling and Applications**

Dr. Long Phan, Materials and Construction Research Division, is a Senior Member of RILEM Technical Committee HTC, Mechanical Concrete Properties at High Temperatures: Modeling and Applications. The committee is working to develop recommendations to standard methods for determining properties of concrete at high temperatures.

**SFPE**

**SOCIETY OF FIRE PROTECTION ENGINEERING**

**SFPE Board of Directors**

Mr. Daniel Madrzykowski of the Fire Research Division serves on the SFPE Board of Directors. The purpose of the Society is to advance the science and practice of fire protection engineering and its allied fields, to maintain a high ethical standard among its members and to foster fire protection engineering education.

**UN/CEFACT**

**UNITED NATIONS CENTRE FOR TRADE FACILITATION AND ELECTRONIC BUSINESS**

As part of the NIST work for the GSA Office of Governmentwide Policy to develop the technical foundation and strategy for the U.S. participation in UN/CEFACT (United Nations Centre for Trade Facilitation and Electronic Business), Mr. Mark Palmer, of the Building Environment Division, chairs the U.S. Technical Advisory Group for UN/CEFACT and is a vice chair for UN/CEFACT. As vice chair of UN/CEFACT, Mr. Palmer defined and instituted needed improvements in the UN/CEFACT organization, management, procedures and work program. Additionally, he led the development of the UN/CEFACT eBusiness standards strategy and the UN/CEFACT strategy for cooperation with other eBusiness standards development organizations.

# STAFF HIGHLIGHTS AND AWARDS



## GOLD MEDAL 2005

*The Gold Medal Award is the highest honor awarded conferred upon an employee by the Department of Commerce. It is bestowed for "distinguished performance characterized by extraordinary, notable, or prestigious contributions that impact the mission of the Department of Commerce and/or one operating unit and which reflect favorably on the Department."*

**Shyam Sunder**, Deputy Director of BFRL, was honored for outstanding leadership as the lead investigator of the three-year, \$16 million investigation of the World Trade Center disaster, recognized to be the most complex and sophisticated building failure investigation in U.S. history.



**Shyam Sunder**  
Deputy Director, BFRL

Also recognized for scientific and engineering achievement and administrative and technical support in conducting the investigation of the World Trade Center disaster are:

**Richard Gann, William Pitts, Kevin McGrattan, Anthony Hamins, Kuldeep Prasad, Thomas Ohlemiller, Kathy Butler, Howard Baum, Jiann Yang, Jason Averill, James Lawson, Robert Vettori, Richard Bukowski, Richard Peacock, Erica Kuligowski, and William Grosshandler** of the Fire Research Division; **Fahim Sadek, John Gross, Therese McAllister, Frank Davis, Emil Simiu, H.S. Lew, and Stephen Cauffman** of the Materials and Construction Research Division; and **Stuart Dols**, of the Building Environment Division.

## SILVER MEDAL 2005

*The Silver Medal is the second highest honor awarded by the Department for "exceptional performance characterized by noteworthy or superlative contributions that have a direct and lasting impact".*

**Piotr Domanski**, of the Building Environment Division, was honored for the development of simulation models that design and evaluate the performance of vapor-compression refrigeration and air-conditioning systems. These models provide equipment manufacturers in a \$30 billion per year industry with the most technically-sophisticated and user-friendly tools for optimizing air-conditioning systems working with a variety of



2005 Gold Medal Award winners.



Piotr Domanski

deadly nightclub fire in West Warwick, Rhode Island, on February 20, 2003. This was the worst fire disaster in almost three decades in the United States, killing 100 individuals. They reconstructed the event through test of mock-up sections of the nightclub in the NIST Large Fire Laboratory and subsequent simulation of the entire event using the NIST Fire Dynamics Simulator (FDS). The comprehensive set of recommendations included requiring sprinkler systems in all nightclubs, forbidding the use of certain finishing materials known to easily ignite, and changing the way safety is analyzed in the design of egress from such nightclubs.

were recognized for their outstanding technical support to the capital facilities industries in developing XML schemas, software tools, and test case data sets for the electronic data exchange of facilities equipment information. This work has demonstrated phenomenal reduction in the time required to execute the typical bid-specification-quote cycle involving owners, engineering companies, and equipment suppliers.

The short-term impact of this work is the accelerated adoption of the AEX project results among the FIATECH membership. The long-term impacts of this accomplishment will be the diffusion of improved eBusiness capability throughout the building and construction industries and the extension of the NIST AEX Testbed concepts to support other industry sectors.

**Alexander Maranghides** and **Laurean Delauter** of the Fire Research Division are recognized for conducting full-scale fire tests that were critical to the success

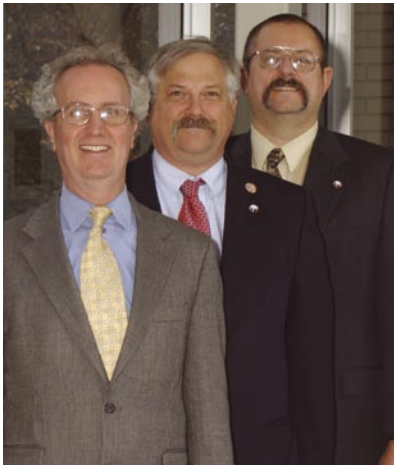

William Grosshandler, Nelson Bryner and Daniel Madrzykowski.

### BRONZE MEDAL 2005

*The Bronze Medal Award is the highest honorary recognition available for Institute presentation. The award, approved by the Director, recognizes work that has resulted in more effective and efficient management systems as well as the demonstration of unusual initiative or creative ability in the development and improvement of methods and procedures. It also is given for significant contributions affecting major programs, scientific accomplishment within the Institute, and superior performance of assigned tasks for at least five consecutive years.*

ozone-friendly refrigerants and refrigerant mixtures. Their use is enabling the manufacturers to successfully combat international competition and to meet increasing environmental demands from customers.

**William Grosshandler, Nelson Bryner,** and **Daniel Madrzykowski** of the Fire Research Division were awarded a Silver Medal for completing a comprehensive and sound technical investigation of a

**James Barnett** and **Mark Palmer**, of the Building Environment Division, along with representatives from the Manufacturing Engineering Laboratory,



Alex Maranghides and Laurean DeLauter.

## STAFF HIGHLIGHTS AND AWARDS

of the World Trade Center investigation. The experiments provided information on the burning behavior of combustibles and the effects of jet fuel to office workstations, the examination of fire growth to multiple workstations over the recreated large section of a floor and the heating of insulation and uninsulated structural steel by large fires. These tests required the construction and instrumentation of the largest test facility ever used in NIST fire tests. The experimentation test fixtures performed flawlessly under the extreme thermal conditions characteristic of total fire involvement and temperatures in excess of 200 degrees F.

**Stephen Kerber, Kevin McGrattan, William Walton, and Erica Kuligowski** of the Fire Research Division received Bronze Medals for their support to the National Construction Safety Team (NCST) investigation of The Station nightclub fire in West Warwick, Rhode Island on February 20, 2003. Each member applied unique expertise that was necessary to ensure accuracy and quality of the analysis, simulations, and preparation of the final report and recommendations. The simulation results closely matched the results of the mock-up experiments and video of the actual fire. This enabled NIST to extend the analysis beyond observation of the fire and experiments and state with confidence what would have happened in the nightclub with the use of alternate technologies such as an engineered sprinkler system.

### BRONZE MEDAL 2004

**Richard Bukowski, Richard Peacock, Jason Averill, Thomas Cleary, Nelson Bryner, and Doug Walton** of the Fire Research Division were recognized for their research into characterization of the performance of home smoke alarms. This two-year project, conducted in collaboration with the U.S. Fire Administration, the Centers for Disease Control and Prevention, the Consumer Product Safety Commission, and the residential fire protection equipment industries, studied the response of smoke alarms in full-scale laboratory experiments and live-fire field tests in order to determine if current detection technology provides sufficient warning for occupants to escape residential fires. The study concludes that interconnected smoke alarms are required to provide sufficient warning for occupants to escape based on the observed reduction in escape time from the previous comprehensive study done in 1977. The observed reduction in the escape time is the result of new materials being used in home products, and this result should stimulate the research into and development of fire-safe materials. It also supports the concept

that smoke detectors as well as sprinklers are required to protect the occupants. The database for this comprehensive project has been made available on line and is likely to be the primary source for fire detection performance assessment over the next decade in supporting legislation and product development that will lead to safer homes.

**George Mulholland** of the Fire Research Division was honored for exceptional scientific achievements in nano-particle metrology. His research has provided the semiconductor industry with a calibration method that significantly



George Mulholland



2004 Bronze Medal Award winners for the home smoke alarms project.

increases the acceptance rate of silicon wafers. His work is cited by industry sources as being essential to alleviating a major roadblock to the continued reduction of semiconductor features. This work has saved the industry significant amounts of money by improving consistency of particle measurement and reduction in the number of wafers being rejected by customers.

**Alan Lytle** and **Geraldine Cheok** of the Materials and Construction Research Division were honored as part of a team that was recognized for exceptional accomplishment in developing, implementing, and administering the first comprehensive Technology Readiness Level (TRL) assessment of unmanned ground vehicles. Alan Lytle provided key support for the experimental design, planning, execution, and analysis. Gerry Cheok provided critical technical expertise in 3-D laser imaging which enabled high-resolution modeling of the terrain ground-truth used in the robot performance assessment. The TRL assessment conducted by this team has been noted and referenced by key people throughout the Department of Defense, including the Office of the Secretary of Defense Joint Robotics Program. The work is related to both the development of performance measures for autonomous systems for construction and standards for capturing existing conditions of construction projects using 3-D laser imaging.

### 2005 WILLIAM P. SLICHTER AWARD

**Mark Palmer** of the Materials and Construction Research Division is the 2005 recipient of the NIST Slichter Award which is granted for outstanding achievements by NIST staff in building or strengthening ties between NIST and industry. Mr. Palmer was recognized for his work to enable electronic business in the U.S. building and construction industries, notably through his interactions with the FIATECH Consortium and the Construction Industry Institute and through his interactions with all U.S. industry with respect to UN/CEFACT. His past work with the U.S. shipbuilding and process plant industries to deliver technical solutions to information interchange problems was also noted.



2005 William P. Slichter Award Winner, Mark Palmer.



Jonathan Martin

### 2004 WILLIAM P. SLICHTER AWARD

**Jonathan Martin**, of the Materials and Construction Research Division, is recognized for his continued efforts in establishing numerous industry consortia aimed at addressing critical research needs of the coatings and sealants industry. Over a 10-year period, industry consortia members (20 different companies) have provided \$1.5 million in support of the consortia research. He created the Coatings Service Life Prediction (SLP) consortium in 1994, Sealants in 2001 and Polymer Interphase in 2001. Technical and scientific advances that are made in these consortia are then transferred to industry through quarterly oversight board meetings and through international symposia co-organized between NIST and industry.

## STAFF HIGHLIGHTS AND AWARDS

### 2004 BFRL COMMUNICATION AWARD

**Mark Kedzierski** of the Building Environment Division received the 2004 BFRL Communication Award for the best communication published in the calendar year. The award was established to recognize and stimulate excellence in bringing the Laboratory's results to the attention of potential users. Kedzierski was cited for the paper entitled "A Semi-Theoretical Model for Predicting R123/Lubricant Mixture Pool Boiling Heat Transfer", which was published in the *International Journal of Refrigeration*, Vol. 27, No. 3. The paper presents Kedzierski's fundamental research on pool boiling heat transfer of refrigerant/lubricant mixtures and includes a model that allows predicting the influence of lubricant on the heat transfer coefficient based on lubricant properties.

### 2004 BFRL COMMUNICATOR AWARD

**Glenn Forney** of the Fire Research Division was awarded the BFRL Communicator Award for the development of elegant scientific visualization software, enabling comprehensive technical communication by engineers and scientists to a lay audience, and revolutionizing the nature of information exchange used in fire safety practice, fire investigation, personnel training, planning of costly large-scale fire experiments, and performance-based design of fire protection systems.

### 2003 BFRL COMMUNICATION AWARD

**Laura Schultz, Hayden Brown, and Stephen Weber** of the Office of Applied Economics were awarded the 2003 BFRL Communication Award for the NEST Toolbox software. It is a Web-based program that allows homeowners to perform customized economic analysis of their homes. NEST helps users identify and evaluate durable materials to enable homeowners to select the building options with the lowest life-cycle cost while meeting their performance requirements. Within a year of its release, NEST had 8,600 users and was featured in a cover story in the *Washington Post's* Real Estate section.

### 2003 BFRL COMMUNICATOR AWARD

**Robert Chapman** of the Office of Applied Economics is the recipient of the 2003 BFRL Communicator Award. He produced studies, published reports, made presentations, drafted ASTM standards, designed software, and collaborated with public- and private-sector organizations to select cost-effective strategies to protect constructed facilities from man-made and natural hazards. His products reached a broad cross-section of government and industry managers tasked with making capital investment and facilities management decisions. His most widely distributed publication describing this work was *Applications of Life-Cycle Costs to Homeland Security Issues in Constructed Facilities: A Case Study*, October 2003. It provided metrics to help building owners and managers choose cost-effective ways to protect buildings and their occupants.

### 2005 BFRL SAFETY AWARD

**Michelle Donnelly** of the Fire Research Division was honored for her meticulous implementation of the NIST safety policies within the Fire Research Division. She arranged with the NIST Fire Department to conduct CPR/Defibrillator training for the division, with the result that a clear majority of the staff is now certified at some level. Michelle worked tirelessly to ensure that all the laboratories in the division met the deadline to comply with the new NIST-wide compressed gas-cylinder restraining systems. In addition, she inspected the laboratories in the division regularly to enforce NIST laboratory safety policies.

### 2005 BFRL STAFF SUPPORT AWARD

**Michael Selepak** of the Fire Research Division was awarded for his work with the Fire Equipment Evaluator (FEE). Mike assisted in the design and procurement of the equipment used to build the FEE and then did a superb job in assembling the pieces and making the final adjustments that were required to provide an acceptable air flow in the test chamber. He then assisted in conducting the tests and reducing the data required to define the operating characteristics of the FEE.



## 2004 ASHRAE DISTINGUISHED SERVICE AWARD

**Steve Bushby**, of the Building Environment Division received the ASHRAE Distinguished Service Award in 2004. Bushby, previous chair of SSPC 135, BACnet – *A Data Communication Protocol for Building Automation and Control Networks*, and SSPC 135.1, *Method of Test for Conformance to BACnet*, a convener for the International Organization for Standardization (ISO) TC 205, *Building Environment Design*, and a panel leader for the U.S. technical advisory committee to ISO TC 205, created and managed the BACnet Interoperability Testing Consortium, a cooperative research and development agreement between NIST and 22 private sector partners. This work led to establishment of an industry-run testing and listing program for BACnet products in the United States and Europe.

## 2004 ALICE HAMILTON AWARD

**Andrew Persily** of the Building Environment Division was co-recipient of the 2004 Alice Hamilton Award in the educational materials category from the National Institute for Occupational Safety and Health (NIOSH). Along with several other individuals, Persily received this award for leadership through science based on the publication of the document *Guidance for Filtration and Air-Cleaning Systems to Protect Building Environments from Airborne Chemical, Biological, or Radiological Attacks*. This publication,

developed by an interagency workgroup under the Office of Homeland Security, provides guidance to building designers, owners, and operators on options for using particulate filtration and gaseous air cleaning to increase building protection against intentional releases of harmful agents. The Alice Hamilton Award is issued by NIOSH annually in the field of occupational safety and health in recognition of significant contributions to the field.

## ASHRAE FELLOW

**George Walton** of the Building Environment Division was elevated to the grade of Fellow by the American Society of Heating, Refrigerating and Air-Conditioning Engineers. This award was based on his contributions to the arts and sciences of HVAC engineering in the areas of building simulation, energy calculations and multizone airflow modeling.

## ASHRAE STANDARDS ACHIEVEMENT AWARD

**Andrew Persily** of the Building Environment Division received the 2004 ASHRAE Standards Achievement Award for his service in the area of standards leadership during his tenure as chair of the committee responsible for ASHRAE Standard 62.1, *Ventilation for Acceptable Indoor Air Quality*.

## EPA AWARD

**Cynthia Howard Reed** of the Building Environment Division received the U.S. EPA 2004 Scientific and Technological Achievement Award for her role in a research effort on continuous monitoring of ultrafine, fine and coarse particles in a residence. This work was recognized for its contributions to the development of particle measurement methods and the production of a high quality database of indoor and outdoor particle levels.

## ASME BEST PAPER AWARD

**Hunter Fannee, Mark Davis, and Brian Dougherty** of the Building Environment Division were awarded an ASME Best Paper Award for the paper, “Comparison of Photovoltaic Module Performance Measurements,” at the 2005 International Solar Energy Conference. This paper was written jointly with Sandia National Laboratories’ researchers David King, William Boyson, and Jay Kratochvil. All authors received a certificate and were honored during the conference. The conference was sponsored by the International Solar Energy Society, the American Solar Energy Society, the American Society of Mechanical Engineers (ASME), the American Institute of Architects, the Wind Energy Association, and the American Society of Heating, Refrigerating, and Air-Conditioning Engineers.

## STAFF HIGHLIGHTS AND AWARDS

### GUEST WORKER ELECTED INTERNATIONAL THERMAL CONDUCTIVITY FELLOW

**Daniel Flynn**, guest worker in the Building Environment Division, was elected a fellow of the International Thermal Conductivity Conferences in 2005. The fellow citation reads: “Recognition is hereby given for outstanding contributions to the field of thermal conductivity. This certificate is presented as a token of the high esteem in which this person is held by professional colleagues.” Flynn, who retired from NIST at the end of 1990, was employed by NIST for 31 years and has more than 70 publications in heat transfer and thermal conductivity measurements. Flynn was a founder of the International Thermal Conductivity Conferences in 1961 and, in 1967, he was co-chairman of the Seventh International Thermal Conductivity Conference held at NIST with the largest attendance to date. Flynn has designed and operated techniques for measuring thermal conductivity from room temperature to over 2,000 degrees Celsius on a variety of metals, alloys, ceramics, and soils. Most recently, he has designed a new guarded hot-plate apparatus for development of high-temperature reference materials needed by the thermal insulation testing community.

### IAFSS PHILLIP THOMAS MEDAL OF EXCELLENCE

**Darryl W. Weinert**, guest scientist from Victoria University, Melbourne, Australia, **Thomas Cleary**, **George Mulholland**, Fire

Research Division, and **Paula Beever**, New Zealand Fire Service, were presented with the IAFSS Phillip Thomas Medal of Excellence at the International Association for Fire Safety Science (IAFSS) September 2005 meeting in Beijing, China for their paper entitled “Light Scattering Characteristics and Size Distribution of Smoke and Nuisance Aerosols.”

### BEST SAE TECHNICAL PAPER

**David Urban**, **DeVon Griffin**, **Gary Ruff**, NASA Glenn Research Center; **Thomas Cleary**, **Jiann Yang**, **George Mulholland**, Fire Research Division; and **Zeng-guang Yuan**, National Center for Microgravity Research were awarded an SAE (Society for Automotive Engineers) Best Paper Award for their paper entitled “Detection of Smoke from Microgravity Fires,” at the 35th International Conference on Environmental Systems and 8th European Symposium on Space Environmental Control Systems held in July 2005 in Rome, Italy.

### HOWARD W. EMMONS LECTURESHIP AWARD

**Howard Baum** of the Fire Research Division was awarded the Emmons Lectureship Award and was invited to deliver the Emmons Plenary Lecture at the 8th International Association for Fire Safety Science Symposium, which is the premiere international fire research conference. Dr. Baum presented a lecture entitled, “Simulating Fire Effects on Complex Building Structures.” The

lecture assessed the current state of our ability to simulate the consequences of a fire in a large building, and suggested some areas in which improvement is needed.

### 1ST PLACE ROON FOUNDATION AWARD AND JOHN GORDON AWARD

At the 2004 International Coatings Exposition held in Chicago, IL, with approximately 6000 participants in attendance. **Joannie Chin**, **Jonathan W. Martin**, **Tinh Nguyen**, and **Eric Byrd** of the Materials and Construction Research Division received the 1st Place Roon Foundation Award in recognition of their paper entitled “Validation of the Reciprocity Law for Coatings Photodegradation”; while **LiPiin Sung** and **Jonathan W. Martin** received the John Gordon Award for their paper entitled “Relating Gloss Loss to Topographical Features of a PVDF Coating.” Both papers are related to the research activities of the Coatings Service Life Prediction Consortium. This consortium has been on-going at NIST since 1994.

### SEI/ASCE’S WALTER P. MOORE, JR. AWARD

**H.S. Lew** of the Materials and Construction Research Division received the 2005 Walter P. Moore, Jr. Award at the Structural Engineering Institute Award Luncheon, April 22, 2005, at the Structures Congress in New York City. The award recognizes Lew’s technical

excellence in investigation of the causes of building failures due to natural and man-made disasters, which have led to significant improvements in structural standards and professional practice. The Walter P. Moore, Jr. Award is presented annually by the Structural Engineering Institute of the American Society of Civil Engineers to a structural engineer who has demonstrated technical expertise in and dedication to the development of structural codes and standards

**SFPE’S HAROLD E. NELSON SERVICE AWARD**

**David D. Evans** of the Fire Research Division received the Harold E. Nelson Service Award from the Society of Fire Protection Engineers (SFPE). The purpose of the Harold E. Nelson Award is to recognize the dedicated and inspired service to the ideals and goals of the Society. Throughout his distinguished research career at NIST’s Building and Fire Research Laboratory, Evans’ focus has been on applying fire science to solve practical fire protection problems. He developed the first detector actuation model, DETACT, and has made critical advances in the understanding and modeling of fire sprinkler performance. He has served SFPE for over twenty years in various capacities ranging from membership in the editorial board of the *Journal of Fire Protection Engineering* as well as other scientific Journals, on the SFPE Education Committee, to long service on the SFPE Board of Directors culminating in his Presidency of the Society in

1999. In 1998, Evans led the Society in the development of a strategic plan which fundamentally changed its direction toward meeting the needs of the practicing fire protection engineer.

**AMERICAN CONCRETE INSTITUTE’S WASON MEDAL FOR MATERIALS RESEARCH**

**Long T. Phan** and **Nicholas J. Carino**, of the Materials and Construction Research Division received the American Concrete Institute’s (ACI) Wason Medal for their co-authored paper entitled “Effects of Test Conditions and Mixture Proportions on Behavior of High-Strength Concrete Exposed to High Temperatures.” The award was presented at the Opening Session and Awards Program during ACI’s convention in Washington, DC, March 14, 2004. The Wason Medal for Materials Research was established by ACI in 1917 for “original research work on concrete materials and their use, or a discovery that advances the state of knowledge of materials used in the construction industry.”

**AMERICAN CONCRETE INSTITUTE’S CONCRETE RESEARCH COUNCIL ROBERT E. PHILLEO AWARD**

**Nicholas J. Carino**, of the Materials and Construction Research Division received the American Concrete Institute’s (ACI) Concrete Research Council Robert E. Philleo Award at the Opening Session and Awards Program during ACI’s convention in Washington, DC, March 14, 2004. This award is given “in recognition

of a person, persons, or an organization for outstanding research in the concrete materials field, or for outstanding contributions to the advancement of concrete technology through application of the results of concrete materials research.” It is given in memory of an Institute past president and Honorary Member who was also chairman of the Concrete Materials Research Council, now the Concrete Research Council.

**STANDARDS ENGINEERING SOCIETY ROBERT J. PAINTER AWARD**

**Nicholas Carino**, of the Materials and Construction Research Division, was awarded the 2004 Robert J. Painter Memorial Award by the Standards Engineering Society. The award recognized Dr. Carino for special service in the field of standardization. Specifically, the award acknowledged his many technical and leadership contributions to ASTM Committee C09 on Concrete and Concrete Aggregates.



**Nicholas Carino**

**BFRL RESOURCES 2001-2005**  
(\$ MILLIONS)

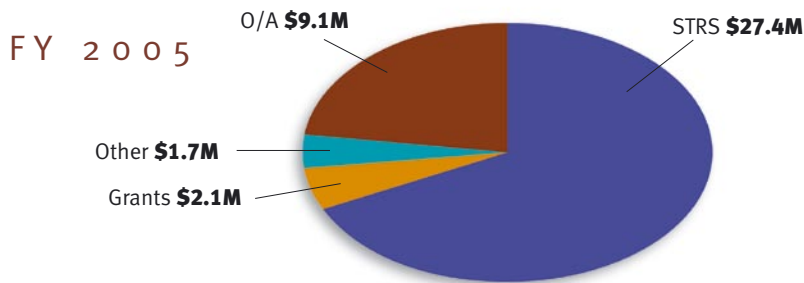
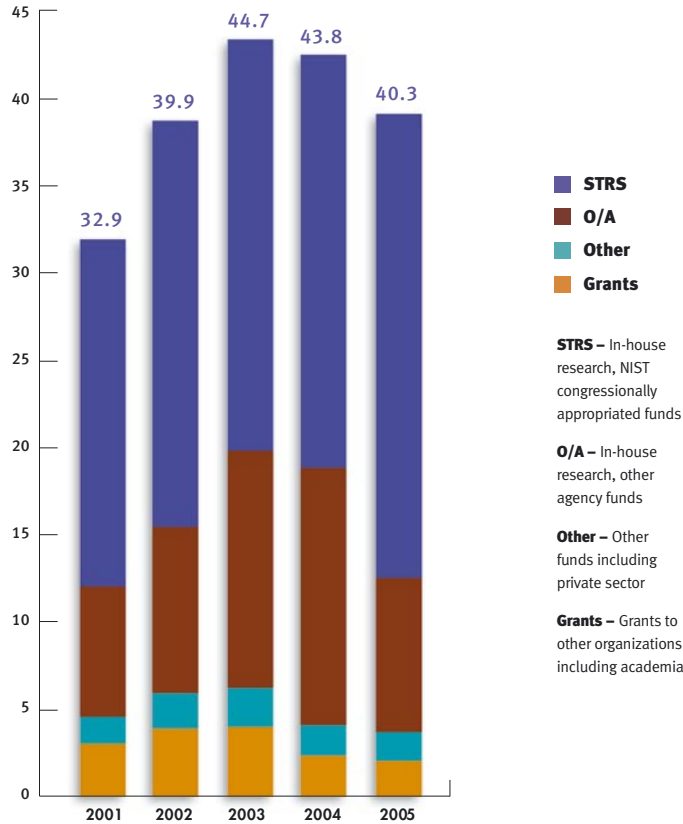

**Organizations Funding BFRL's Research**

Federal agencies and industry groups, which currently support about one-third of BFRL's overall research, are recognized below:

**FEDERAL AGENCIES**

- Consumer Product Safety Commission
- Department of Agriculture
- Department of Defense Agencies
- Department of Energy
- Department of Health and Human Services
- Department of Homeland Security
- Department of Housing and Urban Development
- Department of Interior
- Department of Justice
- Department of Labor
- Department of State
- Department of Transportation
- Department of Treasury
- Environmental Protection Agency
- Federal Emergency Management Agency
- General Services Administration
- National Aeronautics and Space Administration
- National Institutes of Health
- National Science Foundation
- Nuclear Regulatory Commission
- Smithsonian Institution

**PRIVATE SECTOR AND NON-FEDERAL GOVERNMENT**

- Advanced Fire Alarm System Consortium
- Air and Refrigerating Technology Institute
- Air Products
- Albemarle
- American Association of State Highway & Transportation Officials
- American Fire Sprinkler Association
- Association Technique l'Industrie des Liant Hydrauliques (ATILH)
- ASTM International
- Atlas Material Testing Technology, LLC
- Atofina Chemicals
- Barrier Dynamics
- Building Joint Sealants Consortium
- California Energy Commission (CEC)
- Cemex
- DAP
- DeGussa
- Dow Chemical Company
- Dow Corning Corporation
- Dupont Company
- Dyckerhoff
- FM Global
- Holcim
- International Center for Aggregate Research (ICAR)
- Interphase/Interface Consortium
- Kaneka
- Master Builders Technology
- MTS
- National Association of Fire Testing Laboratories
- National Electrical Manufacturers Association
- National Fire Sprinkler Association, Inc.
- National Ready-Mixed Concrete Association
- New York State
- Northwestern University
- NYACOL Nano Technologies
- Poly One
- Portland Cement Association
- PPG
- Sasol
- Samsung Cheil
- Sherwin Williams
- Sika Technology AG
- Sleep Products Safety Council
- Solvay
- Tremco
- Underwriters Laboratories
- Verein Deutscher Zementwerke (VDZ)
- Virtual Cement and Concrete Testing Laboratory Consortium
- Visteon
- Wacker
- W.R. Grace

## BFRL ORGANIZATION

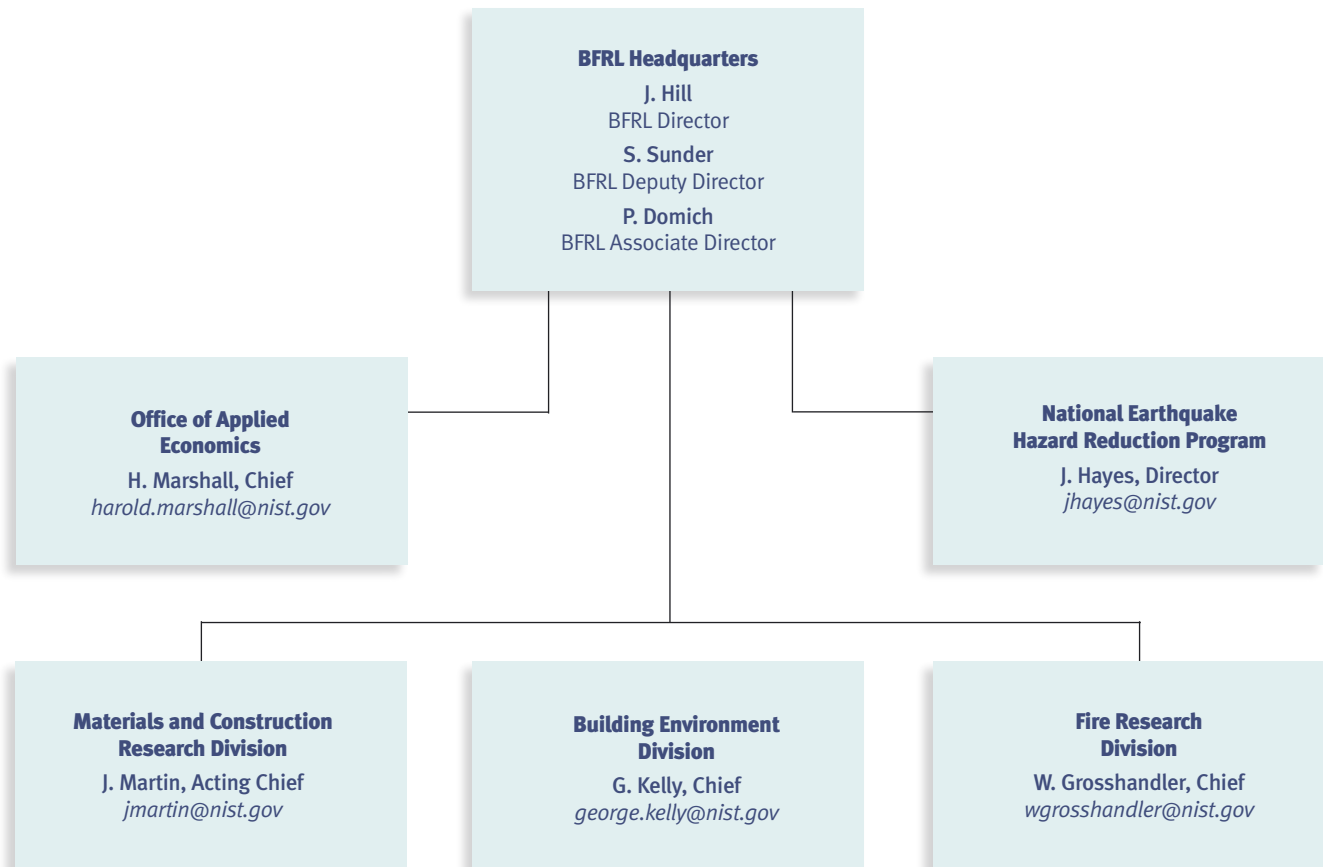

- Structures
- Construction Metrology and Automation
- Polymeric Materials
- Inorganic Materials

- HVAC&R Equipment Performance
- Mechanical Systems & Controls
- Heat Transfer & Alternative Energy Systems
- Computer-Integrated Building Processes
- Indoor Air Quality & Ventilation

- Fire Fighting Technology
- Fire Metrology
- Analysis & Prediction
- Integrated Performance Assessment
- Materials & Products

### Publications and On-line Information

Access to BFRL's published research results, which now come in many forms including printed publications, Web sites, CD ROMs and more, can be found online at *BFRL Research Information Services* (<http://www.bfrlris.gov>). This includes access to *BFRL Publications Online* where many full texts of publications from 1994 to the present are available. To request copies of these free publications or to discuss BFRL's research reports, contact *BFRL Research Information Services*, 301-975-6696, [bfrlris@nist.gov](mailto:bfrlris@nist.gov).

### BFRL Inquiries

If you have general questions about BFRL programs or are interested in working with BFRL, contact us at [bfrl@nist.gov](mailto:bfrl@nist.gov) or call 301-975-5900. Questions about specific programs should be directed to the contacts listed under each Division in the Chapter, *BFRL Finances & Organization*.

The mailing address for all BFRL personnel is:

**Building and Fire Research Laboratory**  
100 Bureau Drive  
National Institute of Standards  
and Technology  
Gaithersburg, MD 20899-8600

### Visit the Laboratory

Potential collaborators are encouraged to visit BFRL when in the Washington area. To schedule a visit, contact us at [bfrl@nist.gov](mailto:bfrl@nist.gov) or call 301-975-5900.

### The National Institute of Standards and Technology

The National Institute of Standards and Technology (formerly the National Bureau of Standards) was established by Congress in 1901 "to assist industry in the development of technology... needed to improve product quality, to modernize manufacturing processes, to ensure product reliability...and to facilitate rapid commercialization... of products based on new scientific discoveries." An agency of the U.S. Department of Commerce's Technology Administration, NIST's primary mission is to promote U.S. innovation and industrial competitiveness by advancing measurement science, standards, and technology in ways that enhance economic security and improve our quality of life. It carries out this mission through a portfolio of four major programs:

### Measurement and Standards

**Laboratories** that provide technical leadership for vital components of the nation's technology infrastructure needed by U.S. industry to continually improve its products and services; an **Advanced Technology Program** providing cost-shared awards to industry for development of high-risk, enabling technologies with broad economic potential; a grassroots **Manufacturing Extension Partnership** with a network of local centers offering technical and business assistance to smaller manufacturers; and a highly visible quality outreach program that confers the **Malcolm Baldrige National Quality Award** in recognition of business performance excellence and quality achievement by U.S. manufacturers, service companies, educational organizations, and health care providers.



Editors:

**Kellie A. Beall**

Information Specialist  
Building and Fire Research Laboratory  
National Institute of Standards  
and Technology

**James E. Hill**

Director  
Building and Fire Research Laboratory  
National Institute of Standards  
and Technology

**U.S. Department of Commerce**

Carlos M. Gutierrez, Secretary

**Technology Administration**

Robert Cresanti,  
Under Secretary for Technology

**National Institute of  
Standards and Technology**

William A. Jeffrey, Director

**NIST SP 838-19**

March 2006

Disclaimer: any mention of commercial products is for information only; it does not imply NIST recommendation or endorsement, nor does it imply that the products mentioned are necessarily the best available for the purpose.

