



**Coral Reef Monitoring Manual
for the Caribbean and Western Atlantic**

**National Park Service
Virgin Islands National Park
June 1994**

Coral Reef Monitoring Manual for the Caribbean and Western Atlantic

Prepared by:

Caroline S. Rogers, Ph.D
Ginger Garrison
Rikki Grober
Zandy-Marie Hillis
Mary Ann Franke

With support from:

Southeast Regional Office, National Park Service
Office of International Affairs, National Park Service
The Nature Conservancy
World Wildlife Fund

Developed at:

Virgin Islands National Park
P.O. Box 710
St. John, USVI 00830
(809) 693-8950

June 1994

PDF Creation

January 2001
Dr. Donald G. Catanzaro
National Park Service

CONTENTS

FOREWORD

- Purpose
- Acknowledgements
- Photo and Illustration Credits

I. INTRODUCTION

Getting Started	1
Monitoring Objectives	3
Designing a Monitoring Program	4
Basic Monitoring Principles.....	5
Data Collection and Analysis	6
General Surveys and Maps.....	7
Site Selection	15

II. PHYSICAL AND CHEMICAL MONITORING

Overview	1
Temperature	2
Dissolved Oxygen	3
Salinity	3
Measurement of pH	4
Water Transparency and Light	4
Sediment Deposition	7
Chlorophyll	9
Bacterial Concentrations	10
Nutrients	11
Currents	13

III. BIOLOGICAL MONITORING

Overview	1
Monitoring Individual Stony Coral Colonies.....	3
Comparison of Monitoring Methods	12
Quadrats.....	13
Chain Transects	16
Line and Point Intercept Transects.....	21
Octocorals and Sponges.....	21
Algae	24
Recruitment of Benthic Organisms.....	27
Underwater Photography	29
Census of Reef Fishes.....	36

IV. STRESSES TO CORAL REEFS

Overview.....	1
SCUBA Diving and Snorkeling.....	2
Boat Groundings and Anchors.....	3

V. GLOSSARY

VI. INFORMATION SOURCES

Other Coral Reef Monitoring Manuals.....	1
References	2
People to Contact for Assistance	7

Appendix A: Underwater Photography

Appendix B: Statistical Analysis

Appendix C: Materials and Suppliers

Appendix D: List of Reviewers

FOREWORD

PURPOSE

We have developed this manual as a practical guide for scientists, students, and park managers who need to describe coral reefs or document changes in them over time. Although no book can substitute for a hands-on training program or on-site assistance from someone experienced in the technique you want to learn, the need for coral reef monitoring is urgent and the number of "experts" is still small. Many of those who need to begin a coral reef monitoring program have little choice but to get started on their own.

Like many ecological processes, changes in a coral reef may be slow and almost imperceptible over the short term, or highly variable from one year to the next. Consequently, looking at the long-term trends in the condition of coral reefs is vitally important. While this manual emphasizes monitoring the overall ecological and structural components of a reef, a more comprehensive program will also focus on the effects of human activities such as snorkeling, boating, diving, fishing, and shoreline development.

This manual cannot include all the monitoring techniques currently in use, or prescribe the single "best" technique to use in a particular situation. It does aim to explain some of the methods that have proved useful in coral reef monitoring programs. Some of these steps can be taken even if you have little or no background in ecological monitoring; for the more complicated procedures, you may find it necessary to refer to more detailed texts or to contact someone with more experience for guidance. Other manuals that provide guidance on coral reef monitoring procedures are listed in [Part VI, "Information Sources."](#)

As new or improved methods evolve, they should replace or supplement those described in these pages; you may develop some useful modifications of your own. Although it's not realistic to expect all coral reef monitoring programs to use exactly the same techniques, this manual is intended to encourage the increasing standardization of methods which can assist with discussion and comparison of data throughout the region.

ACKNOWLEDGEMENTS

National Biological Survey biologists, Caroline Rogers, Ginger Garrison, and Rikki Grober worked with National Park Service scientist Zandy-Marie Hillis to compile this manual. We are extremely grateful to Mary Ann Franke, a technical writer and communications expert, who volunteered to serve as editor and became one of the authors, contributing over six months of her time to this project. Her contributions have been invaluable and are reflected in the overall organization and layout of the text as well as its readability and clarity.

Draft versions of this manual were sent to over 40 scientists, park managers and other potential users in the U.S., Caribbean, and Australia for review ([see list in Appendix D](#)). The responses we received greatly enhanced the quality of this document and made it more comprehensive.

Special thanks to Jim Petterson (National Park Service) for assistance with the section on statistics, and to Manny Hernandez (University of Puerto Rico) and Richard Laydoo (Institute of Marine Affairs, Trinidad) for information on measuring currents. Betty Buckley (University of Rhode Island) helped us greatly with the section on nutrients and chlorophyll. Jim Beets, Alan Friedlander, and Joe Kimmel pleased all of us by revising the section on monitoring of fish assemblages after compelling themselves to come to a reasonable consensus. Jane Israel donated several hours of her time, coming to the rescue at the bitter end.

We wish to specifically thank Dominic Dottavio, formerly the Regional Chief Scientist with the NPS Southeast Regional Office, who recognized the value of long-term monitoring of coral reefs and provided funds for this manual and for our research over the last several years. Rob Milne, Director of the NPS Office of International Affairs, promised financial support for the production of this manual right from the start and has expressed his interest in preparing a Spanish translation.

We also wish to thank The Nature Conservancy and the World Wildlife Fund for assistance with publication and other costs. The Nature Conservancy has worked with us on several training sessions for marine park management. As part of a training program in the Dominican Republic, the World Wildlife Fund has prepared a reef monitoring manual in Spanish for non-scientists.

PHOTO AND ILLUSTRATION CREDITS

Cover photo taken near Little St. James Island, USVI, by Dick and Tina Burks. Other color photos by L. McLain (III-3, III-7), L. Lewand (III-6 top), P. Edmunds (III-6 bottom, A-1, A-2), C. Rogers (III-9), V. Zullo (III-14), W. Gladfelter (III-23), M. Taylor (III-34), and J. Porter (A-6). All black and white photos by H. Tonnemacher except for page III-11 by R. Halley. Figure on page I-8 courtesy of D. Hubbard. Original artwork by L. Smith-Palmer, Z. Hillis, K. Norfleet, and C. Rogers. Technical drawings by Katydid, St. John, USVI.

I. INTRODUCTION

Long-term monitoring is the repeated surveying of organisms or environmental parameters over time to help us understand a variety of natural processes. A monitoring program can provide information on the abundance of the biota, the diversity of the site, the condition of particular habitats, and changes in the environment. It may also enable us to predict the effects of human activities on ecological processes. Without long-term data, we cannot make appropriate decisions on whether and how a natural environment needs to be managed.

The terms "long-term research" and "long-term monitoring" are often used interchangeably. However, for many people, "research" implies manipulative, experimental activities, while "monitoring" refers to more routine data collection. This manual uses the term "long-term monitoring" with the recognition that biological and environmental monitoring are valid research activities. If you have questions about other terms used in this manual, you may find help in the [Glossary, Part V](#).

GETTING STARTED

People interested in setting up monitoring programs often hesitate because they don't know exactly how to go about it, or they lack sufficient money or staff. It's important to realize that monitoring does not have to be complicated or expensive to be effective. To assist you in deciding which methods are within your budget, Appendix C provides approximate prices for equipment described in this manual.

In most areas, SCUBA is needed for effective access to the reef, but if your study site is shallow, snorkeling can provide much information. Most techniques used to sample hard-bottom communities involve using quadrats, transects, photography, videotaping, or a combination of these methods. Valuable data can be obtained through simple procedures. It's better to jump in and start a limited but well thought-out monitoring program to gather baseline data than to wait until funding and personnel are available for a more comprehensive approach. The reef site you're concerned about now may be quite different in another year.

If underwater photographs had been taken at established locations on Caribbean reefs over the last twenty years, we would have a good visual record of changes in the reef structure over time, including shifts in the relative abundance of plants and animals, and the percent of the bottom covered by living organisms -- information that would make it easier now to document the need for management action, or to distinguish the consequences of human activities from the changes due to natural processes.

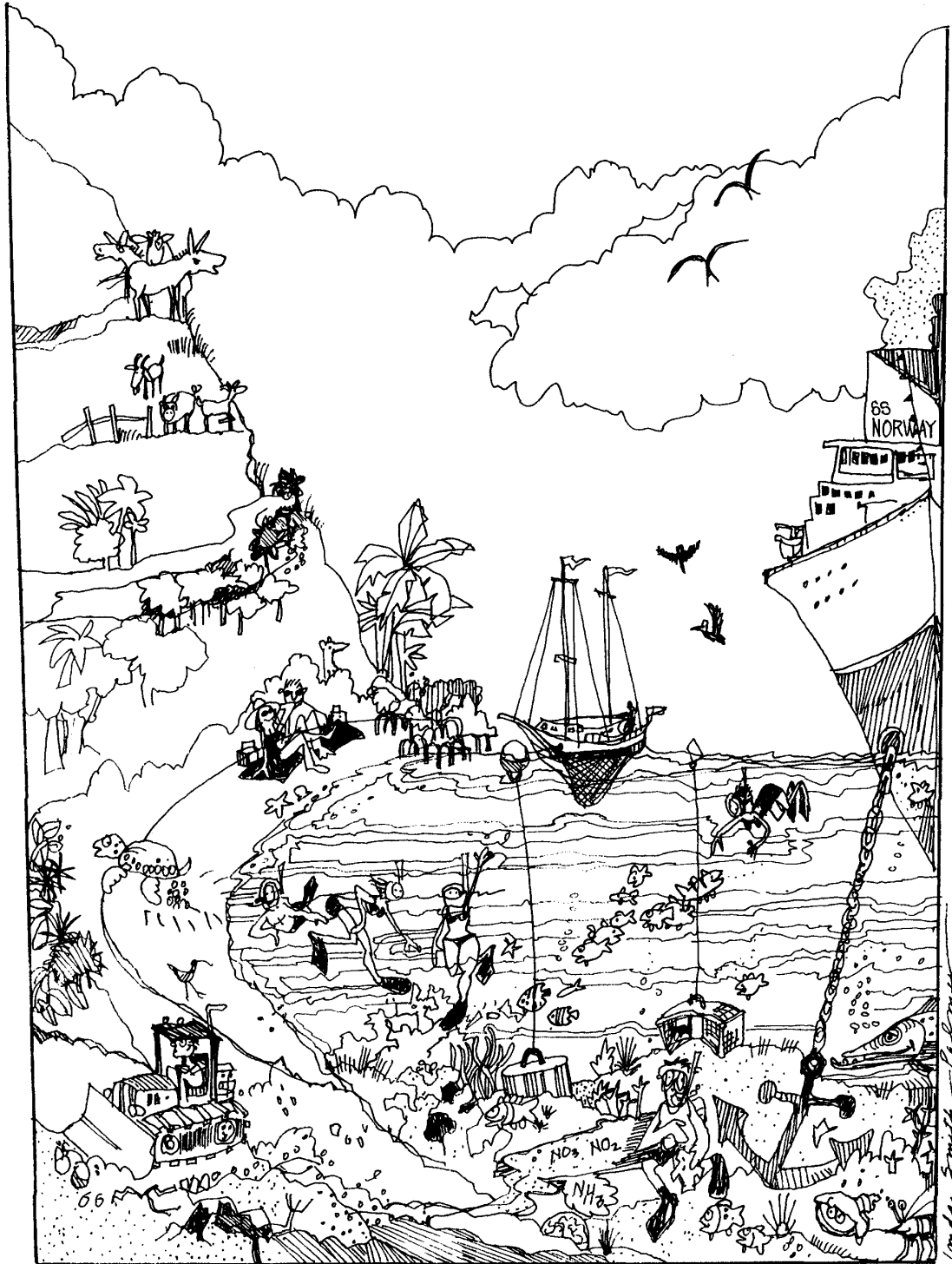

Data on undisturbed or pristine reefs are especially valuable for comparison purposes, since concern about reef deterioration is often what prompts a monitoring program. Baseline data should be collected as soon as possible to characterize the site as it currently exists. You need to have some idea of the level of "normal" short-term variations that occur on the reef to distinguish them from significant long-term changes.

MONITORING OBJECTIVES

To set up an effective coral reef monitoring program, you'll need to start by asking: "What do we want to know?" Your objective may be quite general, such as "to determine the present status of the reef and natural rates of change," or it may be more specific, such as,

- to detect changes in abundances of a particular group of organisms;
- to discover possible cause-and-effect relationships;
- to determine if a specific management action is working (e.g., prohibition of spearfishing); and/or
- to measure the effect of both natural and human-induced stresses.

Some stresses or disturbances, like hurricanes or dredging, are of such magnitude as to cause immediately visible effects, while others, like over-fishing or pollution, may slowly undermine the health of the coral reef system and not be readily apparent through casual observation. An established monitoring program can help provide the necessary information to examine the effects of different stresses.

Some Stresses Affecting Coral Reefs

- Sediments from dredging or land clearing
- Nutrient influx from sewage
- Agricultural runoff (pesticides, nutrients)
- Boat groundings and anchors
- Physical damage from SCUBA, snorkeling, and swimming
- Shoreline development
- Industrial pollution
- Over-fishing
- Collecting for aquariums
- Oil spills
- Storms
- Disease
- Thermal stress
- Urban runoff

DESIGNING A MONITORING PROGRAM

Regardless of whether your objectives are specific or general, they are the starting point in the design of your monitoring program and will help determine how you approach a question, the level of detail of your study or what questions you should try to answer. For example, a scientist may want to compare the condition of an undisturbed reef to that of a reef under stress from human activities. A developer may be asked to monitor reef conditions to determine if sedimentation rates are increasing as a result of dredging or upland development. Coastal zone managers may issue permits that require monitoring the effects of sewage effluent from a large hotel on a nearby reef. Dive tour operators may want to know if certain reefs are deteriorating from overuse. A fisheries officer may want to find out whether a ban on spearfishing is resulting in an increase in certain fish species.

In addition to having a clear understanding of your objectives, you'll need to answer the following questions to determine which monitoring methods will be most appropriate.

Designing a Monitoring Program

- What are our objectives?
- Where are we going to monitor?
- How often should we collect data?
- For how long should we continue collecting data?
- What methods will give us the best data?
- Who will conduct the monitoring?
- What methods are realistic for us, given the available time, money, equipment, people, and skills?
- How will we assure the data are of the highest quality?
- How will we analyze the data we collect?
- How will we store and retrieve the data?

Despite the many references in this manual to quantitative data, it's important to keep in mind that qualitative data can also be useful. While quantitative analysis is preferred in academic circles and courts of law, you may find that qualitative information (e.g., photographs or videotapes of anchor damage) are sufficient to document the need for management action. Since no specific criteria have been established as to what constitutes optimum reef conditions, the best approach is to look for relative changes in a particular reef over time. To use your resources and time wisely, you'll need to devote considerable time designing your monitoring program.

BASIC MONITORING PRINCIPLES

Coral reefs are the most complex marine ecosystems on earth, and it is not practical to monitor all of the reef's animals and plants and their many interactions. However, here are some basic principles to keep in mind regardless of your specific monitoring objectives.

- To have historical data for assessing the extent and cause of changes, obtain information on:
 - basic environmental parameters such as temperature, salinity, and turbidity
 - the abundance of stony corals, octocorals, algae, sponges, and reef fish
- To have both qualitative and quantitative records at well-documented site locations, use a combination of photographic and transect or quadrat methods.
- Sample often enough to obtain documentation of changes in reef organisms of interest, but not so frequently that your sampling is destructive or inefficient.
- Establish procedures for long-term monitoring that are as free as possible from observer bias, and easily repeated by people who may be assigned the task in the future, and make sure the procedures are well-documented.
- Make sure your monitoring site is clearly defined and easy to locate, not only by you but by others who have never visited the site.

Using the monitoring techniques described in this manual can help you determine what changes are taking place on a coral reef; they may also provide evidence that more detailed study or management action is needed. But no monitoring program can provide a complete picture of a reef's condition, and the resulting data can only be as precise as the work done to obtain them.

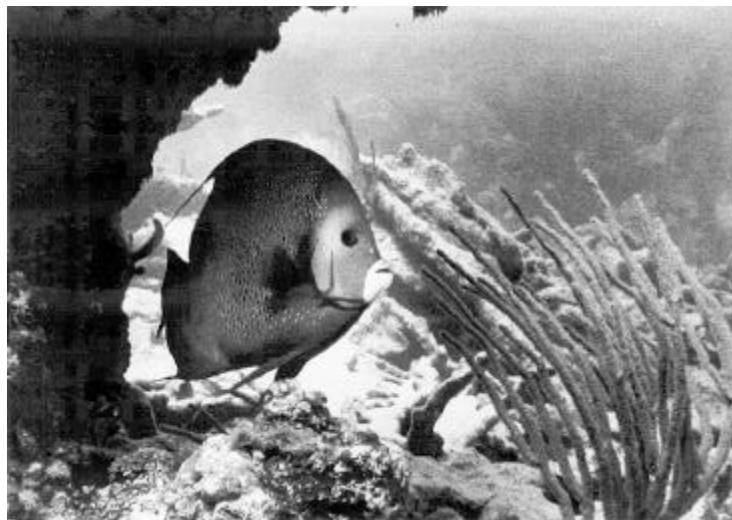

DATA COLLECTION AND ANALYSIS

Data collection in the field can be fraught with difficulties, including logistical problems, equipment failures, and bad weather. Errors can result from not sampling in exactly the same place each time, from not clearly communicating instructions to new data collectors, or from mistakes in recording or transcribing the data. Here are some suggestions for increasing your chances of success.

- Preliminary testing and sound design should be included in any monitoring program. Before actual data collection begins, the methodology and equipment should be field tested under the conditions that will be found at the study site to make sure they can provide reliable and repeatable information.
- Long-term monitoring methods intended for use at permanent sites should be repeated within a short time interval, preferably by different observers, to assess the variation inherent in the method. Only when monitored values change by more than the "method variance" has a real change been detected. The variability between data collectors should be checked by having them record data for the same sample and comparing the results.
- A pilot study can also help determine the most effective sample size for obtaining the required information. For example, the optimal sample size can be calculated by plotting sample effort versus the number of species seen during your pilot study.
- Very basic data (date, time, location, depth, weather conditions, personnel, study site, species, method) may become critical at a later date so be sure to record it each time you do field work.
- All field notes should be reviewed as soon as possible after collection to make sure they are clear and complete, then photocopied for the file, transcribed into a permanent data book, and entered into a computerized data base, with a copy of the file kept in a second location.
- Be careful that the demands of data collection don't use up your resources to the detriment of data management and analysis. In planning your monitoring program, be sure to allow for the time and expense needed to interpret and understand the data you collect. The use of computerized data bases can greatly enhance and simplify data organization and statistical manipulation.

Underwater data collection: If you use a mylar sheet or a white slate, you can reuse it after transcribing the data and scouring it with cleanser. Some people prefer to use an opaque waterproof paper made by Nalgene as a permanent record, eliminating the need for transcription. You can secure the data sheets to the clipboard with rubber bands or elastics, and tie on your pencil. If you want a pencil that won't float away when it becomes untied, you can use Faber-Castell solid graphite pencils.

GENERAL SURVEYS AND MAPS

Most of the biological monitoring methods in this manual focus on censusing small sections of a coral reef (several square meters) and detecting changes over time. However, you may need to quickly survey a large area in certain situations. For example, a general survey of most or all of a reef will be essential if you want to assess storm damage or determine the appropriate boundaries for a new marine park. A preliminary survey can also be helpful in selecting a study area for a long-term monitoring program. The use of aerial photographs and a manta tow survey are two techniques used in making this kind of general assessment.

Aerial Photography

Aerial photographs provide a good starting point for a general survey of a coral reef. At a scale of 1:5000, many reef features are visible, and if the photos are taken during calm and clear conditions, water clarity may allow resolution of major features to a depth of 60 feet or more. Aerial photographs can be used to:

- Assist in selecting appropriate study sites.
- Document the distribution and extent of major marine ecosystems and the patterns of land and marine use which might affect these systems (e.g., construction of tourism facilities, clearing of hillsides, the increase in boats using an area).
- Provide a record of large-scale changes in shallow reefs and seagrass beds resulting from natural events such as storms or from human activities such as construction of marinas or other coastal development.

Groundtruthing: Aerial photos with high resolution can sometimes be used to identify major zones and habitats, although changes in the condition or abundance of reef organisms do not generally show up. You may need to SCUBA dive or snorkel to determine exactly what certain areas represent; the photograph may indicate only the location of drop-offs and the transition between zones. This field effort to verify the zonation patterns or habitat types in the photographs is referred to as "groundtruthing". (See "Manta Tow Survey," I-12.)

Mapping: You can create "base maps" of marine communities from enlarged aerial photographs (usually at least 10" x 10"). It is best to use professionally produced aerial photographs with a known scale. Photographs taken from a plane with a 35-mm camera are fine for general views; however, because they are usually not taken perpendicular to the surface, measurements of features are inaccurate. This is an important consideration if you are trying to produce a precise resource map.

To create a "base map", trace all distinguishing coastal and marine features onto drafting acetate from the aerial photograph. Using scale markers, such as a boat positioned a known distance from a landmark, will enhance the accuracy of the drawing. These base maps can be used to make rough estimates of the size of major habitats and zones. (See "Digitizing," III-34.)

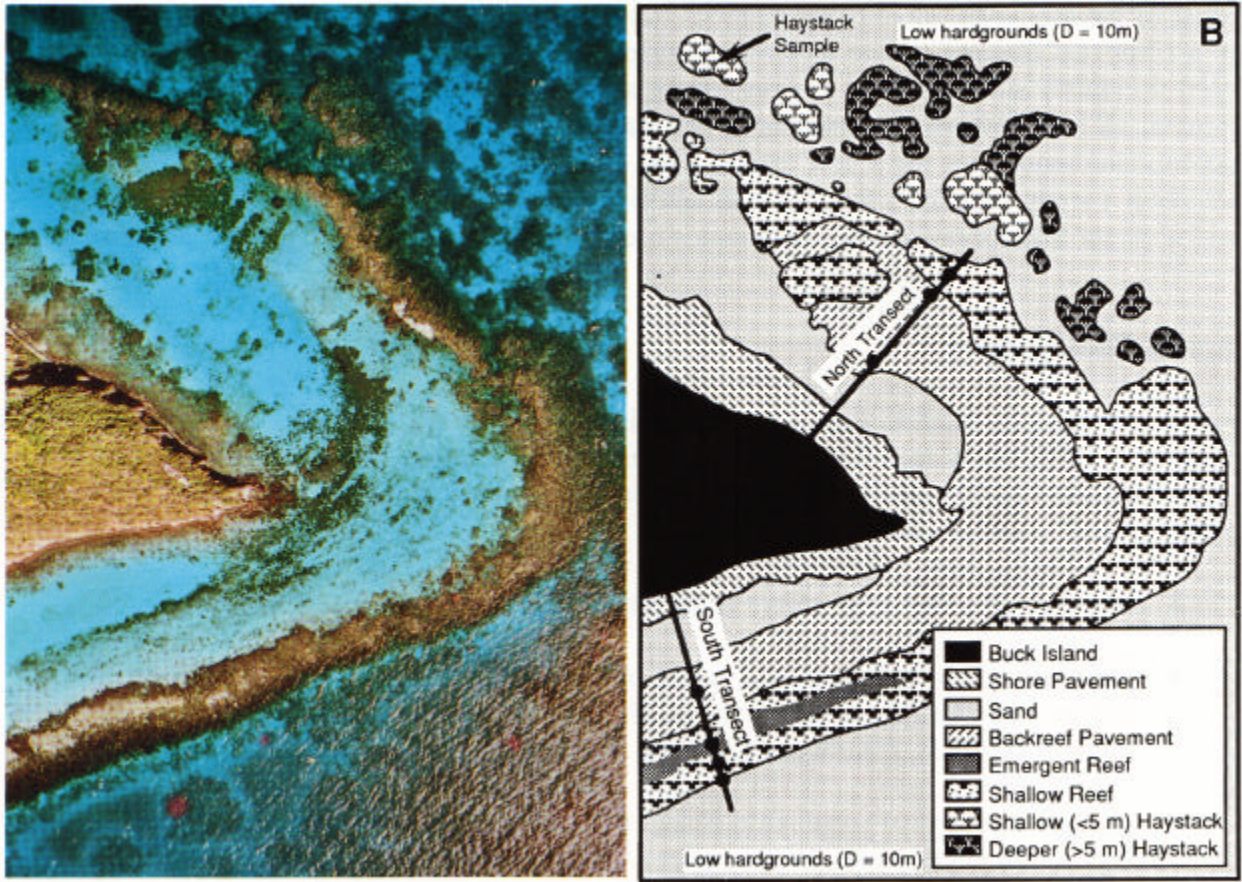

Aerial View

Base Map

(Photo by NOAA, with map showing major features and study transects. Haystacks are patch reefs of broken and cemented elkhorn coral.)

GIS: Maps developed from aerial photographs can be used with a geographic information system (GIS), which enables you to use a computer to analyze large amounts of spatially located data, identify locations within a specified environment that meet certain criteria, and display the environment graphically or numerically. A GIS could be helpful in documenting changes in land use patterns (e.g., road building or land clearing), and large scale changes in the areal extent of marine ecosystems, especially seagrass beds. A GIS is a powerful way to integrate and display large amounts of geographic data. However, geographic information systems are only as good as the data they are based on, and some of the data must be collected through labor-intensive field techniques.

To find out what maps or aerial photographs may be available for the area you are interested in, contact the U.S. Geological Survey, the U.S. Coast Guard, the National Oceanographic and Atmospheric Agency (NOAA), the U.S. Navy, the National Park Service Geographic Information System in Denver, or the agency responsible for mapping and charting in your country or island, (e.g., Lands and Surveys, or Hydrographic Office).

Major Habitats and Reef Zones

It's often helpful to know how the reef you are interested in compares in its overall structure to other reefs in the region or to reefs referred to in scientific reports. Marine zones and habitats can be differentiated on the basis of their community structure and composition with consideration of relief, depth, location and size using the following definitions.

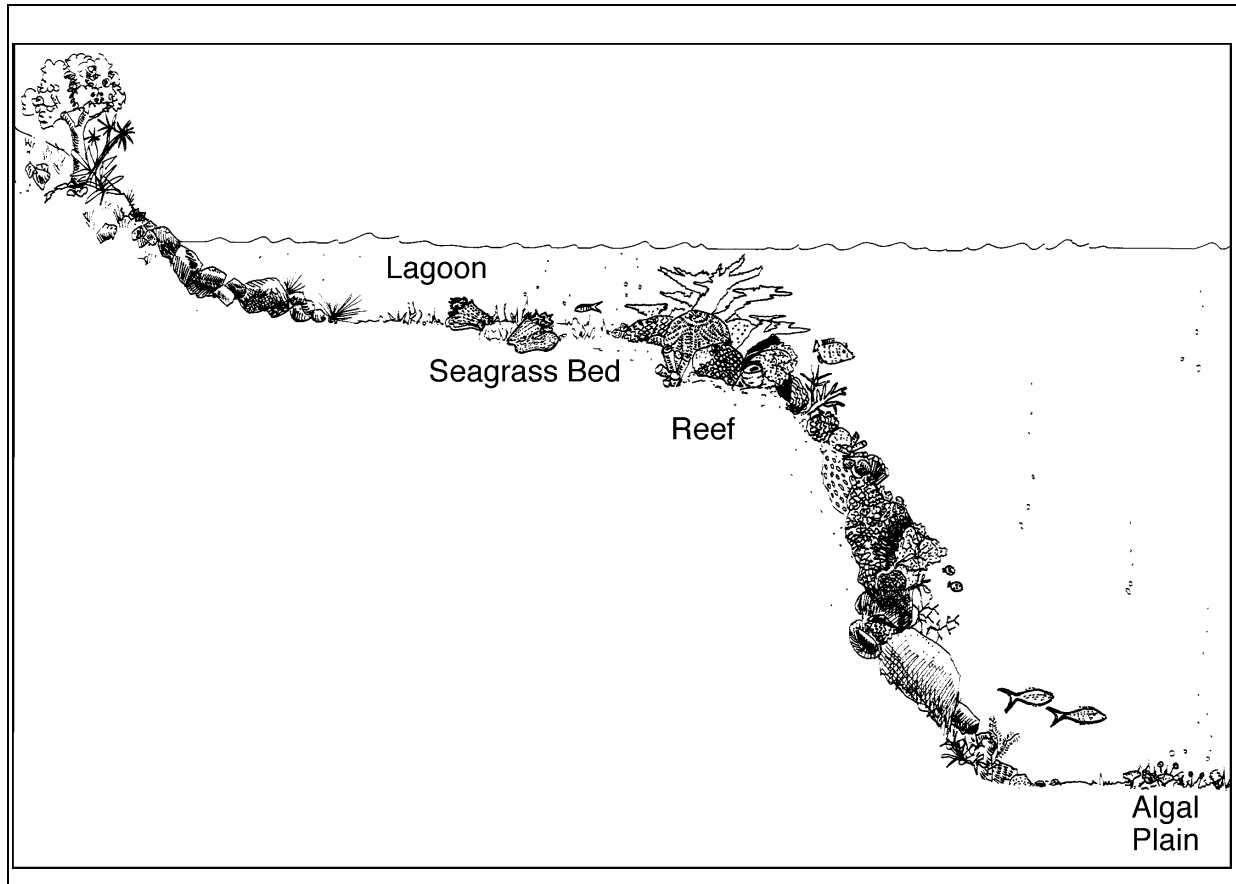

Marine Habitats

- 1) **Shore or intertidal zone:** The region between the highest water line and the mean low tide level.
- 2) **Sub-tidal bedrock:** An extension of bedrock from the land or submerged boulder and rock deposits from shore.
- 3) **Lagoon:** A relatively calm area of water adjacent to the shore and landward of a barrier reef, or encircled by an atoll.
- 4) **Seagrass bed:** Areas with soft substrate dominated by one or more species of seagrasses, such as turtle grass (*Thalassia testudinum*), manatee grass (*Syringodium filiforme*), and shoal grass (*Halodule wrightii*).

- 5) **Reef:** A major geomorphic feature generated from live coral and coralline algal growth that is an actively growing wave-resistant structure.
- 6) **Algal plain:** A deep water area (usually over 12 meters) dominated by algae, often including *Penicillus* spp., *Halimeda* spp., and *Avrainvillea* spp.

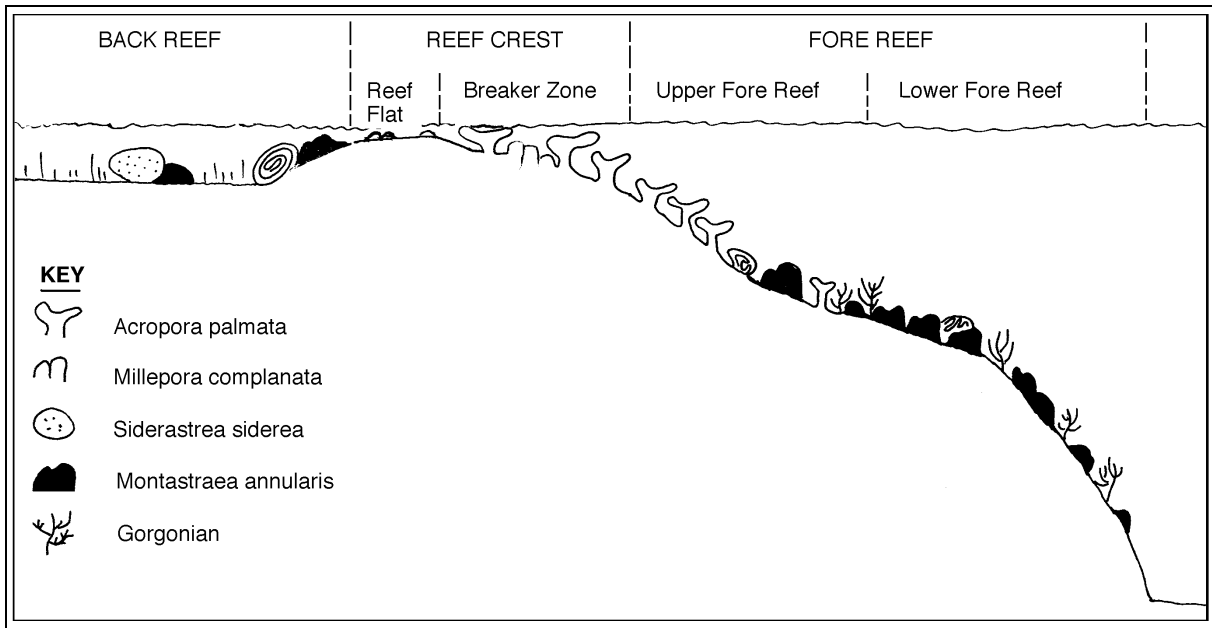

Example of Reef Zones

Reef zones

A reef may include the following zones (not all zones are found on all reefs):

- 1) **Back reef:** the portion landward of the reef crest.
- 2) **Reef crest:** the shallow portion that separates the fore and back reef areas.
- 3) **Reef flat:** a platform of coral fragments and sand that may be exposed at low tide.
- 4) **Breaker zone:** the area most exposed to breaking waves, often dominated by elkhorn coral and fire coral.
- 5) **Fore reef:** area seaward of the reef crest, may include a buttress region dominated by boulder coral (coral "spurs" alternating with sand channels, or "grooves").
- 6) **Upper fore reef:** a shallow fore reef typically dominated by branching coral (*Acropora palmata*) with high structural complexity.

- 7) **Lower fore reef:** a deeper fore reef, may be dominated by massive head corals with low structural complexity, or by gorgonians.
- 8) **Gorgonian-dominated pavement:** hardground dominated by gorgonians; occurs at a wide range of depths.
- 9) **Algal ridge:** a usually emergent barrier formed when crustose coralline algae deposit several layers of calcium carbonate on reef crests (found only in a few places in the Caribbean).

Types of Reefs

A reef may be classified as one of these types:

- **Patch reef:** An isolated complex of corals providing a major change in topography.
- **Bank reef:** A large linear complex of corals located offshore that does not form a shallow water barrier.
- **Barrier reef:** A reef separated from the shoreline by a deep lagoon or channel.
- **Fringing reef:** A reef bordering a shoreline.
- **Shelf edge reef:** A reef located at the edge of the continental shelf.
- **Atoll reef:** A reef in the open sea that forms a complete or partial ring around a lagoon with a fore reef that drops off into deep water.

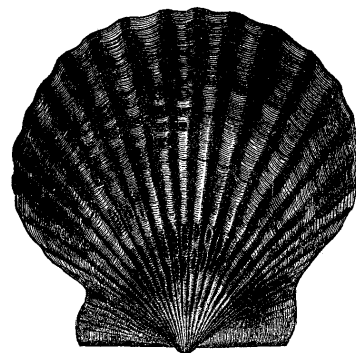
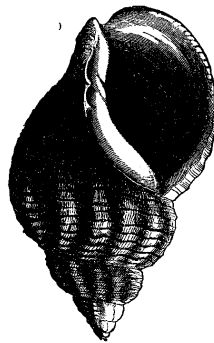
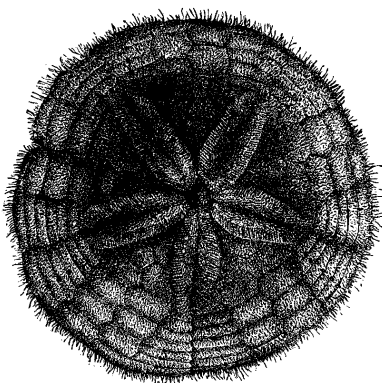

Manta Tow Survey

Although a standard methodology for doing a manta tow survey does not yet exist, a snorkeler is typically towed over the reef by a small outboard motor boat, stopping periodically to record data.

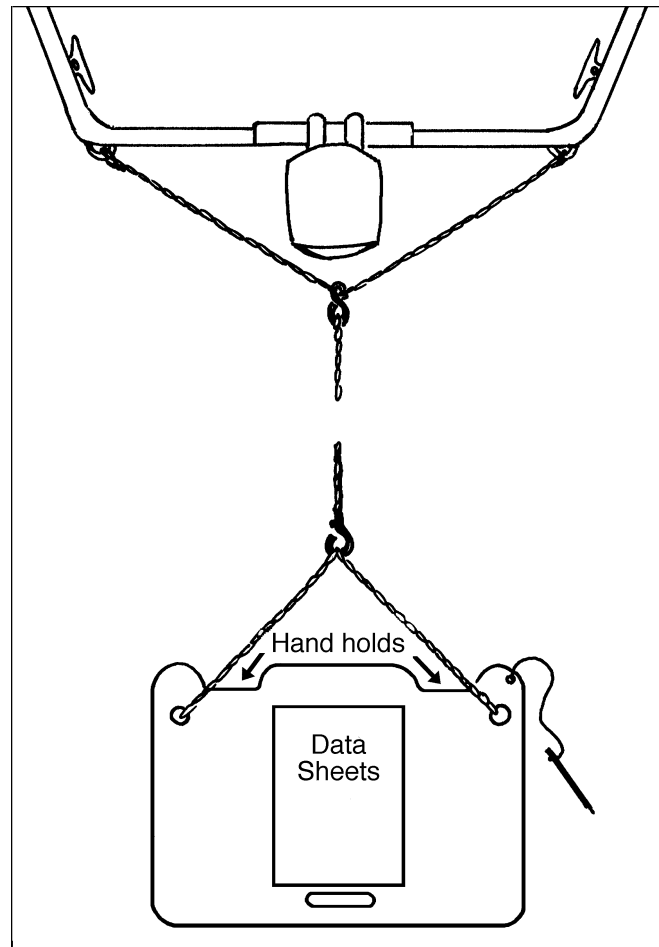

Manta Board

- 1) The observer holds onto a diving plane made from marine plywood about 2-cm thick, with two indented handle grips near each corner at the top and a single handhold at the bottom. Attached to the board is a data sheet and a pencil.
- 2) The boat driver, equipped with an aerial photo or map of the reef, tows the observer across the reef (3-5 km per hour during calm weather), making certain that all ecological zones of the reef are surveyed. It may be helpful to start at one edge of the reef and drive in a zigzag pattern across to the other edge; however, factors such as wind, currents and angle of the sun may determine the direction of the tow.
- 3) Using a waterproof watch to time the intervals, the driver stops the boat every 2 minutes so that the observer can record whatever data are needed for the survey. The driver records the location of each 2-minute tow, and begins the next when the observer signals readiness.

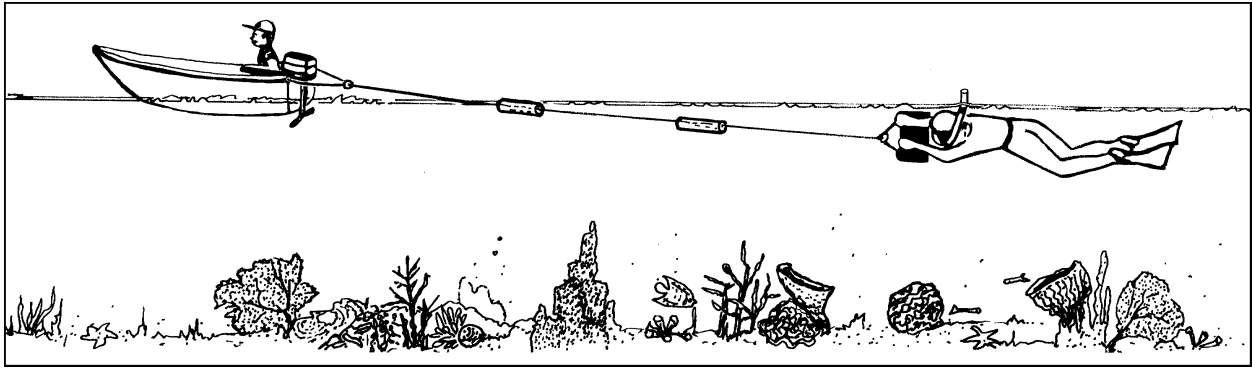

Manta Tow Technique

Sample Manta Tow Survey Data Sheet

Location: _____ Date: _____

Observer: _____ Time: _____

Tow	Percent Live Cover			Other Features
	Stony Corals	Octo-corals	Algae	
1				
2				
3				
4				
5				
6				
7				
8				
9				
10				
11				
12				
13				
14				
15				

The sample data sheet on the preceding page shows one way to organize information gathered during a manta tow survey. Your own sheet should reflect the particular purpose of your survey, e.g., looking for evidence of storm damage or coral bleaching. Estimating live percent cover (the percent of the bottom covered by living organisms) can be difficult, especially for a beginner, and in areas where organisms are unevenly distributed. You may also wish to note other features or specific organisms such as conchs or urchins. However, the number of different variables on which data can be collected will be limited by the observer's skill and experience.

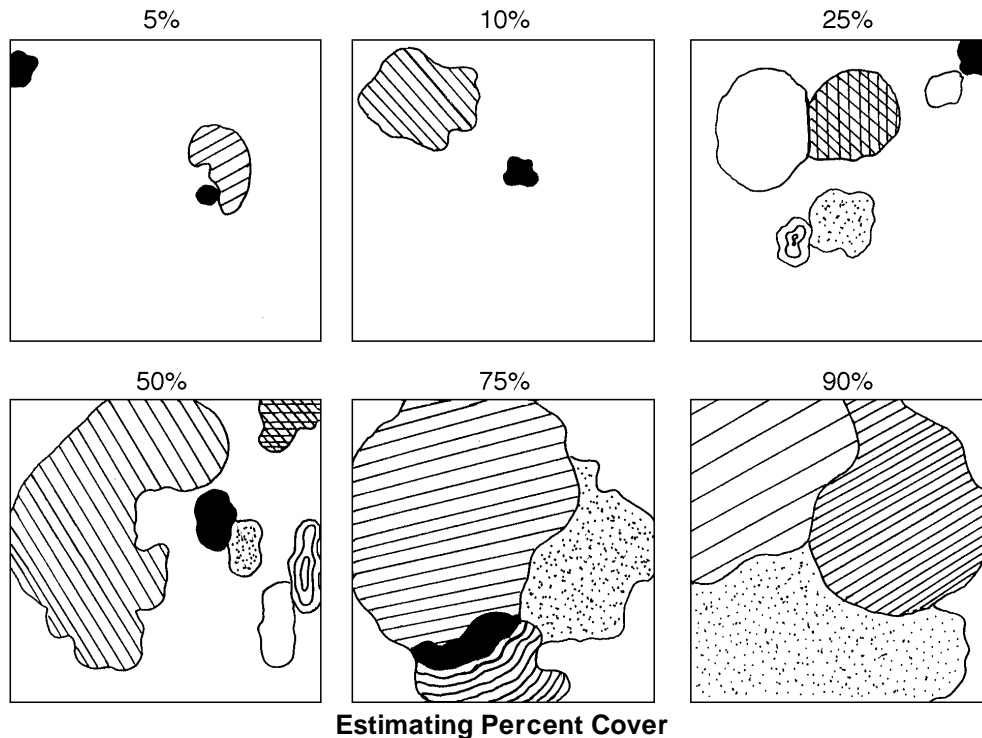

The precision of the manta tow survey is limited by the difficulty of visually assessing the dominant reef organisms while being towed behind a boat. Another drawback is that inappropriate areas may be surveyed (e.g., large areas of sand or deep water) because the tow path is controlled by the boat driver. However, the advantage of this technique is that it enables you to see the "representativeness" of separate study sites in the context of the wider variability of the reef environment.

If necessary because of depth, a manta tow survey can be done by a SCUBA diver using an aquaplane that can be tilted to control depth. For more information about this method, see the reference below.

Reference

Miller, J.W. (1991) "Scientific Diving Procedures," *NOAA Diving Manual*, National Oceanic and Atmospheric Administration, Manned Undersea Science and Technology Office, U.S. Department of Commerce, Washington, D.C., pages 8-28 to 8-30.

SITE SELECTION

The type and location of sites you select for your monitoring program will depend on your objectives and the monitoring methods available to you. You'll probably have to make some trade-offs because no site is likely to meet all your criteria. Here are some considerations:

Control sites: To assess changes resulting from human-caused stresses, try to include both "control" sites (undisturbed) and degraded sites. For example, if your objective is to determine whether pollution is damaging a coral reef, the study sites must be located near the source of the pollution with suitable control sites elsewhere. Locating a good control site can be difficult, because even reefs which are similar in species diversity and depth profile may differ in other significant ways. The most valuable data are obtained from repeated sampling at permanent sites over an extended period of time.

Representative sites: If you are going to be sampling at selected sites to answer questions about a larger study area, some groundtruthing will be necessary to make sure your sites are representative in terms of depth, topography, and species diversity. The site with the best-developed reef structure is not necessarily the best study site. If coral cover is 80-90%, local abundances are more likely to decrease than increase over time even in the absence of major disturbances.

Reef complexity and "patchiness" complicate site selection for long-term monitoring. The term "patchiness" refers to the uneven, variable distribution of coral reef organisms in space, i.e., one portion of a reef may differ greatly from another portion in the amount of cover by reef organisms. ("Cover" refers to the amount of substrate occupied by an organism, often expressed as a percent.) In some cases, the zone with the largest percent cover by stony corals will not be the zone with the greatest number of species. In general, the larger the area over which the sites are distributed, the more representative the sampling.

Stratified sampling: If you are studying an area that contains a variety of depths, marine habitats, or other identifiable zones, it may be appropriate to stratify your study area into relatively homogeneous zones and choose a proportional number of sampling sites within each zone.

Random sampling: Your sampling within a selected study area or stratified zone must be random or most statistical tests will be invalid. Deciding on a means of site selection before visiting the reef can help eliminate the temptation to avoid an area that would be difficult to sample, or to use a "healthy-looking" site. You can assure random selection of quadrats (square or rectangular sampling areas), transects (linear sampling areas), or individual colonies by using:

- a random numbers table from a basic statistics book;
- random numbers in a phone book, with the last two or three digits used to select distances along a transect line or compass bearings from a given point; or

- a calculator with a random number generator that can provide pairs of numbers to indicate "x" and "y" coordinates for quadrats along a transect line. For example, the numbers 15 and 6 could designate placement of a quadrat 15 meters along a transect line and 6 meters to the south of it.

Once you have randomly selected a quadrat or transect, if you need to further subdivide it for sampling purposes, you can select sampling locations within the quadrat or along the transect on either a random basis (as described above) or a "systematic" basis, e.g., at the intersection points of a grid laid over the quadrat, or at 5-meter intervals along the transect.

Repeat Sampling: Either temporary or permanent sites can be used to assess change over time in marine communities, but the results have different statistical implications. Sites that are randomly selected each time are considered inherently less biased because the "representativeness" of a permanent site can always be questioned. However, sampling done at different sites each time may not be sensitive enough to measure change because of patchiness in the reef. In addition, the use of temporary sites requires more samples to give the same level of statistical confidence as provided by repeat sampling at permanent sites. Permanent sites are generally recommended for the long-term monitoring described in this manual because they offer the greatest amount of information, consistency, repeatability, and reliability.

Marking the Site

Once you've selected a permanent site, you need to carefully mark and document its location so that you can easily find it again.

Reference markers: Reference markers should be clearly visible from a distance. Re-bar, brass, or survey stakes may last for several years, but should be checked regularly, as even durable materials will deteriorate eventually. A survey stake is a copper-covered steel marker with a bronze head. They come in several lengths, with 24", 30", and 36" the most useful. Reference stakes can also be made from square stainless steel tubing; tubing 1-2 inches in diameter with 1/8 inch wall thickness usually holds up well. Stainless steel eye pins can also be used. (See ["Materials and Suppliers"](#), Appendix C.)

Installing markers: Driving nails, spikes, rods, or pipes into the substrate with a sledge hammer or pile driver may work in some locations, but is impractical or futile in others. You can install markers in hard substrate using a pneumatic drill with a carbide masonry bit powered by air from a SCUBA cylinder or a surface-deployed compressor. A few pointers: pneumatic tools are noisy and require downward force, so the diver will need to be heavily weighted and wear ear protection and a thick wetsuit. A pneumatic drill needs careful maintenance to ensure safe and effective operation.

Drilling with compressed air becomes less efficient with increasing depth. Hydraulic systems provide a more powerful, less noisy, but more expensive alternative. Once the holes have been drilled, the stakes can be cemented into place using hydraulic cement mixed on the surface and brought down in ziplock bags or sealed tupperware containers.

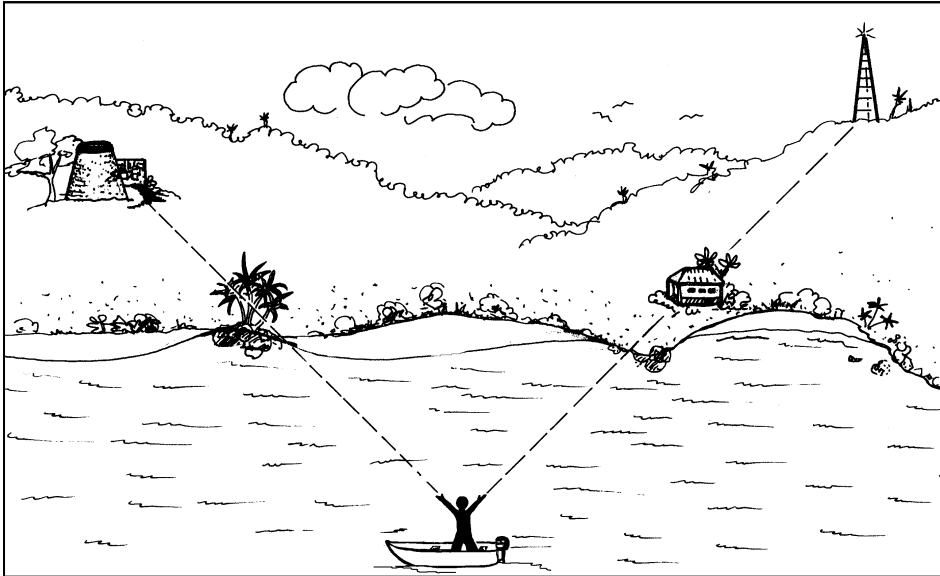

Recording the Location

Record the location: To find the site easily again in the future, you need to record its location as precisely as possible. Here are some suggestions:

- The generally preferred way is to photograph at least two pairs of conspicuous and permanent landmarks that are in the same sight line from the boat and at least 90° apart. For example, you might see a red house behind the highest point of a rocky outcropping on the shore in one direction, and a water tower behind a conspicuous tree in another direction. To return to the site, you find the place where these features are lined up.
- If you cannot find pairs of lined-up landmarks, you can photograph at least three single landmarks and record the compass bearings to them from a boat at the site. Again, the wider the angle between landmarks, the better your documentation.
- If you select landmarks that are found on a map, you can use your compass bearings or pairs of lined-up features to record your site on the map.
- Recording the depth at the site can help confirm correct relocation, especially if used in combination with compass bearings or pairs of land features.
- You can record or photograph any conspicuous coral colonies or other features to help you navigate underwater.
- You can attach a submerged buoy to a piece of dead coral with flagging tape. (If you attach it to a stake, its movement in the water may loosen the stake.)
- If you have a handheld GPS (Global Positioning System), you can determine the coordinates of the site's latitude and longitude. However, the accuracy of a GPS varies from ± 3 to ± 50 meters, depending on the specific instrument and whether there is a base station nearby.

II. PHYSICAL AND CHEMICAL MONITORING

OVERVIEW

The physical and chemical properties of the water at the study site should be measured regularly for possible correlation with any changes observed on the reef. Most coral species can survive only within narrow salinity and temperature ranges, and any marked changes in parameters such as light transmission, sedimentation, and dissolved oxygen may affect the growth or survival of reef organisms.

Parameter	Why/Where It May Be of Special Importance
Temperature	Recent concern over widespread "bleaching" and its possible association with high water temperatures, along with more general concern over global warming have increased the interest in water temperature data from coral reef environments.
Dissolved oxygen	Necessary for survival of marine animals; low levels may indicate high bacterial concentrations.
Salinity	Of interest near reefs which may be subjected to fresh water influx (e.g., those near rivers), or high salinity and warm water from water-making facilities.
pH	Unlikely to vary much over time, but changes may indicate that the reef is being affected by a new source of pollution, or by additional pollution from an existing source.
Light transmission	The amount of light available for photosynthesis of free-living and symbiotic algae affects the growth of corals and other organisms.
Sedimentation	Sediments may reduce light available for photosynthesis, deplete dissolved oxygen, and cause smothering of organisms.
Nutrients	Increases can lead to changes in the relative abundance of organisms such as macroalgae or bacteria.
Current speed and direction	Currents transport nutrients, sediments and other pollutants, food, fish and coral larvae to the coral reef ecosystem.

Water temperature, salinity, turbidity, and dissolved oxygen should be measured as part of a minimal monitoring program. In the open ocean, these may fluctuate very little over time, but in shallow, nearshore areas, wider variations can occur. For example, heavy rainfall may cause salinity and temperature to decrease. All of these parameters can be conveniently measured in the field.

For example, an instrument such as the Hydrolab Datasonde will measure temperature, salinity, dissolved oxygen, pH, and conductivity while remaining at the site for continuous monitoring. What you choose to measure and how you measure it will depend on your monitoring objectives and budget.

TEMPERATURE

Water temperature can be measured by holding a simple thermometer 0.5 m below the surface and/or at the depth of the study site. Read the water temperature while the thermometer bulb is still in the water. A maximum/minimum thermometer left at the site will record the warmest and coldest that the water has been since the thermometer was last set. Monthly monitoring is generally adequate unless temperature is a special concern because of coral bleaching or effluent from a nearby thermal power plant.

A thermistor is a temperature sensor. A thermistor coupled with a microprocessor and placed inside a waterproof housing can automatically take the water temperature at periodic intervals.

Using a Thermistor/Microprocessor

- You should calibrate a new thermistor using a National Bureau of Standards thermometer, and recalibrate it each time it's deployed. The instrument should generally be returned to the manufacturer for recalibration every 1½ years.
- Attach the instrument to a survey or reference stake on the reef with several plastic cable ties or similar material.
- The instrument may function for 1 to 2 years with the same batteries, but to guard against loss or distortion of data, it's best to retrieve the unit every six months, download the data, and replace the batteries. If you have a second instrument, you can replace the unit immediately so there are no gaps in the data.

Both the Ryan and the Hugrun Seamon instruments can be read to within 0.1°C precision, and can be set to record the temperature at designated intervals up to every two hours. The Ryan unit will drift up to 0.3°C over a period of months if not recalibrated. You can retrieve the data and create a thermograph showing the date and time by using two computer programs: Microsoft's "Windows" and Ryan's "Windows" software.

The Hugrun Seamon instrument comes with a software program that will create tables and graphics showing the date, time, and temperature. Data may be imported into Lotus or QuattroPro software for more complex graphics and analysis.

DISSOLVED OXYGEN

Dissolved oxygen is the amount of oxygen available for respiration by aquatic organisms and is expressed as mgO₂ per liter of water (or parts per million, ppm). Dissolved oxygen can be easily measured in the field using an oxygen meter or inexpensive test kit based on titration.

SALINITY

Salinity is an estimate of the concentration of dissolved salts in seawater, expressed as ‰ or ppt (parts per thousand). It can be used to detect an influx of fresh water from either natural or anthropogenic sources. Salinity is typically 34 to 37 ppt in reef waters. At sites where underground fresh water sources exist, it's best to measure both bottom and surface salinity. Here are three instruments that can be used to measure salinity.

- **Hydrometer:** A hydrometer is a glass tube that measures salinity by comparing the weight of a seawater sample to that of fresh water. The seawater should be collected in a clean bottle at least 0.5 m below the surface. The hydrometer is put in a jar filled with the seawater until the hydrometer floats.

Using the number on the hydrometer scale at the water surface and the temperature of the water, you can determine the salinity from tables provided with the hydrometer. Although a hydrometer can be used in the field, it is fragile and easily broken, so the test is best done in the lab.

- **Refractometer:** This instrument is more expensive than a hydrometer, but it's less fragile, easy to use in the field, and provides sufficiently precise data for most purposes. The refractometer, which resembles a small telescope, measures the bending of light as it passes through sea water as a result of the dissolved salts. You place a few drops of the water sample under the transparent cover and look through the eyepiece to see the reading on a calibrated scale. The refractometer must be frequently recalibrated using distilled water. This instrument may be unreliable in waters that have a high suspended sediment load.
- **Salinity Meter:** A salinity meter often combines temperature and conductivity sensors in a single unit. The salinity meter is comprised of a probe connected by an electric cable to a deck readout. The probe is lowered to the desired depth and salinity read from the meter dial, or the data can be transmitted directly to a computer.

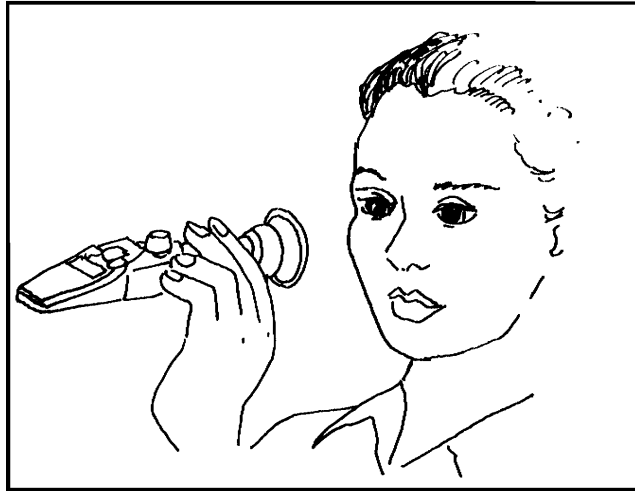
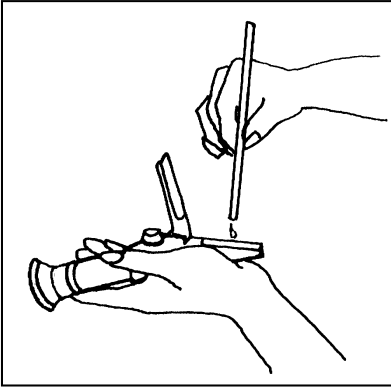

Refrac

tometer

MEASUREMENT OF pH

The pH of a water sample, which is a measurement of the hydrogen ion concentration, ranges from 1 to 14, with "1" being the most acidic and "14" the most alkaline; a pH of "7" is considered "neutral". The pH of reef waters (ranging from 7.5 to 8.4) does not vary much over time, but may be valuable to record for long-term monitoring as changes in pH may indicate that the reef is being affected by pollution. You can use a simple pH meter, or a more elaborate meter that will also measure temperature, salinity, dissolved oxygen and conductivity.

WATER TRANSPARENCY AND LIGHT

Light is essential for zooxanthellae, the single-celled plants which are found in most stony corals, octocorals and zoanthids, and some anemones and jellyfish. Suspended particles in the water absorb and scatter light, reducing light penetration. You can measure light transmission directly with a transmissometer, or indirectly, by measuring visibility in water with a Secchi disc, or by measuring the amount of scattered light with a turbidimeter. The measurements taken in these different ways do not have any simple mathematical correlations, e.g., the Secchi disc depth cannot be used to predict the turbidimeter reading, and suspended matter concentrations are not directly correlated with the percent of light transmission.

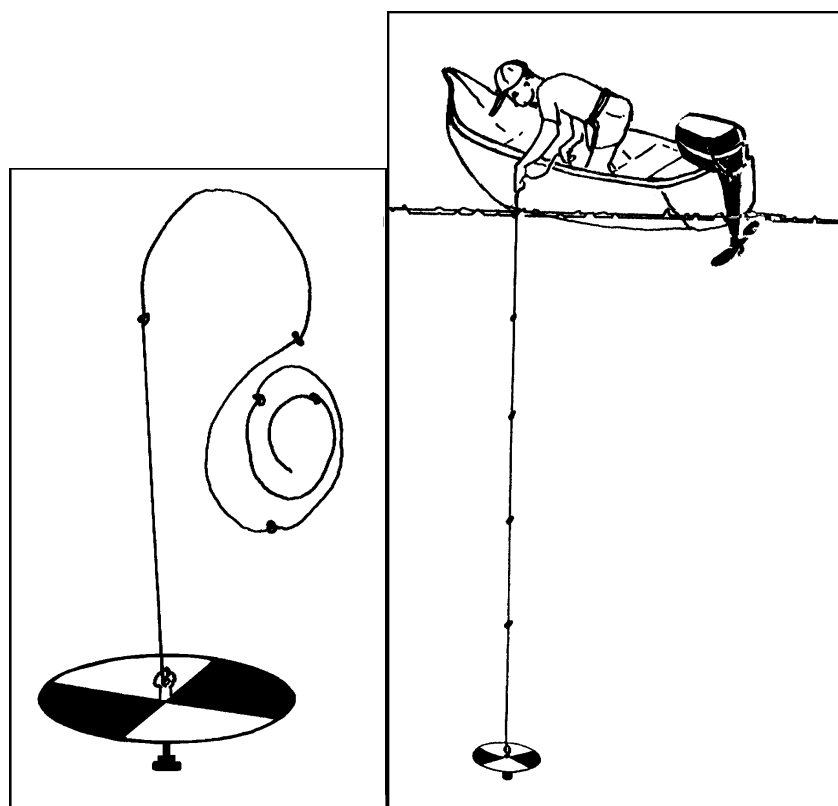

Using a Secchi Disc

Secchi Disc

Vertical transparency: To measure the water's vertical transparency, mark off meters on a line or rope and attach it to a weighted disc, 20 to 30 cm in diameter. The disc can be white or divided into four equal sections in an alternating black and white pattern. The rope needs to be made of a material that does not stretch, e.g., polypropylene or double-braided nylon. Lower the disc into the water until you can no longer see it. Slowly pull up the disc until it just reappears and record the depth at that point. If the bottom is visible, record "B" for bottom. For good comparative data, it is best to take the readings at about the same time of day at different locations, or at the same location over time.

Horizontal transparency: The Secchi disc can also be used to measure horizontal visibility in the water. One person holds the disc perpendicular to and 0.5 m below the water surface with the end of a tape measure; a second person swims away from the disc, drawing out the tape measure until the disk disappears from view, then slowly returns until the disc reappears, and records the distance.

Turbidimeter

A turbidimeter or nephelometer determines water clarity in the laboratory by passing a beam of light through a water sample and measuring the amount of light scattered by the particulates at a 90° angle to the light beam. The amount of scattered light is directly proportional to the turbidity. Use water samples of about 100 ml in volume collected from your study site. The turbidimeter reads in Nephelometer Turbidity Units (NTU's).

You must be careful in interpreting turbidimeter readings, because they can fluctuate widely due to the small volume of each sample, the drift in the instrument and other factors not directly pertaining to water clarity. Three samples should be analyzed and the average of the three used as the data value. Look for consistent trends in the data, or substantial increases or decreases over time. For example, if after several months of values of less than 1.0 NTU at a particular site you get a series of values over 2.0 NTU, you can generally conclude that turbidity has increased significantly. Smaller changes are harder to interpret.

Measuring Light Penetration

Light transmission: A Martek transmissometer is used to measure the amount of light that is not scattered or absorbed by particulates or soluble molecules in a one-meter path of water. This instrument is expensive, heavy and awkward to carry, but it can provide a field test that is not affected by the angle of the sun or time of day.

Photosynthetically active radiation: PAR is the amount of sunlight available to plants for photosynthesis (wavelengths of 380 to 710 nm). The amount of PAR can vary with cloud cover, phytoplankton in the water column, or turbidity. A Li-Cor quantum meter with an underwater sensor and a cable for lowering the sensor over the side of a boat at the study site can be used to record PAR at selected depths and calculate light attenuation.

Ultraviolet radiation: The decrease in ozone in the upper atmosphere and concurrent increase in UV radiation reaching the earth's surface has made data on the amount of UV radiation reaching the reef of special interest. There is some evidence that bleaching may be caused by a synergism between higher water temperatures and higher UV intensities. UV radiation (shorter wavelengths than PAR) can be monitored continuously with a spectroradiometer by installing a sensor permanently on the reef.

Suspended Matter

The amount and type of matter suspended in the water column affect light transmission and can be measured to monitor changes in water quality. Measuring the concentration of suspended matter in reef waters requires collection of samples in the field and filtration in the lab. In many locations, the concentrations are so low that it may take several liters of water to get a detectable amount of particulate matter on the filter. However, baseline data on suspended matter concentrations are valuable for comparison purposes.

Measuring Suspended Matter

- 1) Weigh a 0.45 micron Millepore filter that has been rinsed with distilled water and dried.
- 2) With a Van Dorn or similar water sampler, collect at least three samples of seawater (1 liter each) at just below the surface and at approximately 1 meter from the bottom. Transfer each sample to a clear polyethylene bottle.
- 3) In the lab, shake the sample and then filter a measured volume of sample water through the Millepore filter using a vacuum pump. Let it dry (at 60°C if possible) until the weight is constant.
- 4) To determine the mg/l suspended matter, divide the difference between the final filter weight and the initial weight after filtration by the number of liters in the sample (in this example, 1). Calculate the average value for your samples.

Install Equation Editor and double-click here to view equation.

In determining the possible causes of an increase in suspended matter, you need to consider the duration as well as the rate of change. Increases may occur after storms which stir up marine sediments or cause runoff from the land, during plankton blooms, and during dredging operations.

Reference

Parsons, T.R., Maita, Y., Lalli, C.M. (1984) *A Manual of Chemical and Biological Methods for Seawater Analysis*, Pergamon Press, New York, NY.

SEDIMENT DEPOSITION

Data on sedimentation rates are especially important for reefs vulnerable to sedimentation from dredging operations and erosion. By collecting samples both at and above the substrate, you can estimate the sediment being stirred up from and transported along the bottom (the "bedload" component) as well as the sediment that is settling out of the water column.

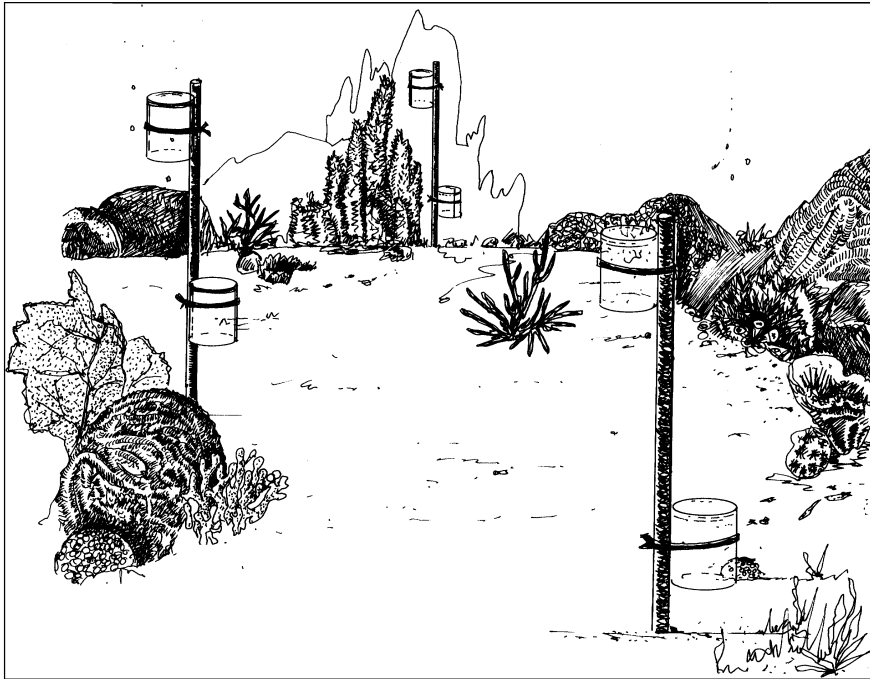

Sediment Traps

Measuring Sediment Deposition

- 1) Using straight-sided plastic jars (about 10-cm high and 8-cm diameter) with tight-fitting lids, secure the open jars to reference stakes at 50 cm and 10 cm above the substrate. Take at least three samples at each height at each location.
- 2) After a selected number of days (generally no more than 14), cap the jars underwater and bring them to the laboratory. Remove any small organisms in the jar with tweezers.
- 3) Weigh #2 Whatman filters and filter the samples by pouring the jar contents through the filter, using a Buchner funnel.
- 4) Rinse each filter several times by running distilled water gently through the filter in the funnel to remove salts from the sediment.
- 5) Dry the sediment filters in a drying oven at 70°C until a constant weight is attained.
- 6) Calculate the sedimentation rate as mg of sediment per cm² per day. The sediment weight is the total weight minus the filter weight, and the area of the jar opening is δr^2 (r = radius in cm).

$$\text{Sedimentation Rate} = \frac{\text{Sediment Weight}}{\text{No. of days at site} \times \pi r^2}$$

CHLOROPHYLL

Phytoplankton, the microscopic plants that drift in the water column, contain chlorophyll, which captures energy from sunlight for photosynthesis. By measuring the amount of chlorophyll *a*, *b*, and *c* in a water sample, you can estimate the concentrations of phytoplankton. Because a nutrient influx may cause a phytoplankton bloom, an increase in chlorophyll may also indicate an increase in nutrients.

Measuring Chlorophyll

- 1) Filter a 2-liter water sample (which was kept in the dark and on ice) through a 47-mm glass fiber filter with 0.2 atm vacuum while adding 3-5 drops of MgCO₃. (The volume of water needed will depend on the amount required to produce a visible color on the filter.) Dry the filter under vacuum.
- 2) Place the filter in a 15-ml centrifuge tube, add 10 ml of 90% acetone, and shake thoroughly.
- 3) Cover the tube with aluminum foil and put in refrigerator to extract for 18-24 hours, then mix and centrifuge the contents for 10 minutes at 4,000 rpm.
- 4) Carefully pour off the liquid portion into a 10-cm path length spectrophotometer cuvette.
- 5) While the sample is at room temperature, use a spectrophotometer to quickly measure the extinction at 750, 664, 647, and 630 nm. Correct the measured extinction by subtracting the 750-nm reading from the 664, 647, and 630-nm readings. (At 750 nm, no pigment absorbance shows.)
- 6) Calculate the amount of chlorophyll in the sample using these formulas:

$$\text{Chlorophyll } a = 11.85 E_{664} - 1.54 E_{647} - 0.08 E_{630}$$

$$\text{Chlorophyll } b = 21.03 E_{647} - 5.43 E_{664} - 2.66 E_{630}$$

$$\text{Chlorophyll } c = 24.52 E_{630} - 1.67 E_{664} - 7.60 E_{647}$$

E = Absorbance at noted wavelengths (corrected by 750-nm reading)

$$\text{mg/l} = \frac{\text{Chlorophyll } a, b, c \times \text{ml acetone}}{\text{No. of liters filtered seawater} \times \text{cm path length}}$$

Reference

Parsons, T.R., Maita, Y., Lalli, C.M. (1984) "Determination of chlorophylls and total carotenoids: spectrophotometric method," *A Manual of Chemical and Biological Methods for Seawater Analysis*, Pergamon Press, New York, NY, pp. 101-104.

Although it is expensive, a fluorometer also provides a sensitive measurement of chlorophyll *a* from a smaller sample of filtered water than does the spectrophotometer. You can place a test tube of the water sample in the fluorometer, or use a pump and tubing to do continuous flow measurements at the site. To determine the concentration of chlorophyll *a* in the sample, use the following formula:

$$\text{Chlorophyll } a, \text{ mg/l} = F_s (r/r-1) (R_b - R_a)$$

where F_s = response factor for the sensitivity setting used; R_b = fluorescence of sample extract before acidification; R_a = fluorescence of sample extract after acidification; and r = the before-to-after acidification ratio of a pure chlorophyll *a* solution.

Reference

U.S. Environmental Protection Agency (1992) Method 445.0: In vitro determination of chlorophyll *a* and pheophytin *a* in marine and freshwater phytoplankton by fluorescence, *Methods for the Determination of Chemical Substances in Marine and Estuarine Environmental Samples*, Environmental Monitoring Systems Laboratory, Cincinnati, Ohio.

BACTERIAL CONCENTRATIONS

Checking for bacteriological pollutants is important if you suspect contamination from boat effluent, sewage pipes, old septic tanks, overloaded leach fields, or runoff from agriculture. Marine waters are usually examined for coliform bacteria by counting bacteria cultured on petri dishes. To prepare a bacterial culture requires an autoclave, incubator H₂O bath, refrigerator, pH meter, and depth sampler. If you have an incubator, you can obtain a kit from the Hach Company that contains materials for culturing 80 to 100 samples. If you do not have the expertise to analyze the samples yourself, you can send them out to a laboratory. Breweries and sugar processing plants usually have bacterial labs.

Reference

Parsons, T.R., Maita, Y., Lalli, C.M. (1984) *A Manual of Chemical and Biological Methods for Seawater Analysis*, Pergamon Press, New York, NY.

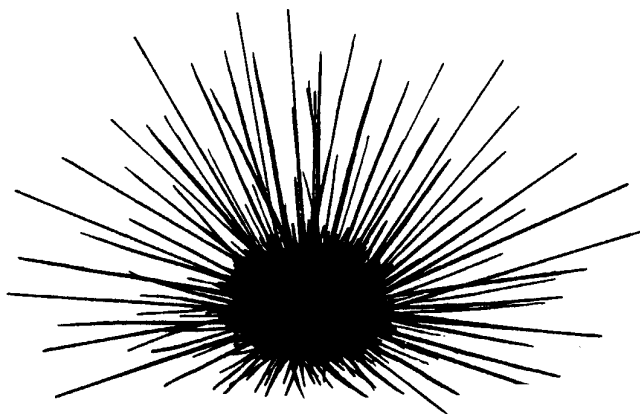

NUTRIENTS

Nutrients are naturally found in coastal waters and required by organisms on the reef. Coral reefs typically occur in warm waters with very low nutrient concentrations. High concentrations of nutrients can cause phytoplankton or algal blooms. As these algae decompose, dissolved oxygen concentrations may be greatly reduced, especially in shallow, near shore waters, posing a potentially lethal threat to the other reef organisms. High nutrient concentrations may also indicate contamination from bacteria species such as *E. coli*, that can be dangerous to human health. The presence of these blooms or bacteria may indicate pollution from sewage, industrial runoff and agriculture.

Nutrient Sampling

Ideally, both the water column and bottom sediments are sampled at least four times a year to monitor the nutrients in a reef system. This requires collection of:

- water samples for analysis of dissolved inorganic and organic nutrients (nitrates, nitrites, ammonia, phosphates, and silicates); and
- sediment core samples for total carbon, nitrogen, phosphorus (C, N, P).

Sediments store nutrients and may provide an integrated record of nutrient conditions. The history of nutrient loading from upwelling (the process by which deeper water is brought to the surface by currents and winds) can be determined by trace metal (Cd, Mn, Ba) analyses in coral cores. Humic and fulvic acids correlate with nutrients carried from land in fresh water runoff. (See "Core samples," III-11.)

Nutrient Analysis

While basic data on nutrient composition are useful, nutrient analysis is not simple and good data are difficult to obtain. Most researchers lack the laboratory facilities needed for nutrient analyses, but you can arrange to ship samples to a laboratory for analysis. These samples may require special treatment such as instant cooling or the addition of fixatives before shipping in order to halt any biological activity that may alter nutrient concentrations. Ask for specific shipping instructions and guidance from the testing laboratory.

Because phytoplankton rapidly remove nutrients from the water, nutrient analysis may not show a nutrient influx where a phytoplankton bloom is present. Where there is concern about the possible presence of nutrients, it may be appropriate to supplement nutrient analysis with chlorophyll measurement and bacterial sampling, discussed earlier.

In the fall after the rainy season, the nutrient-rich waters of the Orinoco, the second largest river in South America, are discharged into the Gulf of Paria, which separates Trinidad from Venezuela, creating a plume of fresh water that is swept northwest into the Caribbean by ocean currents. Analysis of water samples can indicate the extent of the plume.

The Orinoco Plume

The fresh water of the Orinoco plume nourishes marine algae, causing a phytoplankton bloom that can be detected by Landsat satellites. The geographical extent of the plume and the relative mixing of fresh water with seawater can be determined by using images from Coastal Zone Color Scanners mounted on satellites to estimate the average pigment concentration from phytoplankton near the surface -- the ratio of the blue (443 nm) or blue-green (520 nm) wavelengths to the green (550 nm).

By the time the Orinoco plume is southwest of Puerto Rico, the fresh water has mixed with sea water, the nutrients have been taken up by the phytoplankton and recycled many times, and the silicates have usually been tightly recycled by the diatoms, so that the water is only slightly different chemically from "normal" Caribbean sea water. However, the salinity may still be slightly lower than average, the concentration of silicates slightly higher, and the water may look reddish-brown and turbid. Chlorophyll breakdown products from the algal bloom can be detected using a spectrophotometer.

When the plume reaches the Mona Passage, west of Puerto Rico, it is usually imperceptible. However, sometimes a prolonged south wind (over several days) will push the plume north instead of northwest, causing the seawater to turn brownish overnight with a dramatic decrease in water clarity from Antigua to St. Martin, and up as far as the Virgin Islands. The presence of the plume can be detected by checking for decreased salinity and an increased concentration of silicates (3 to 5 μM).

Reference

Müller-Karger, F.E., McClain, C.R., Fisher, T.R., Esaias, W.E., Varela, R. (1989) "Pigment distribution in the Caribbean Sea: Observations from space," *Progress in Oceanography*, 23:23-64

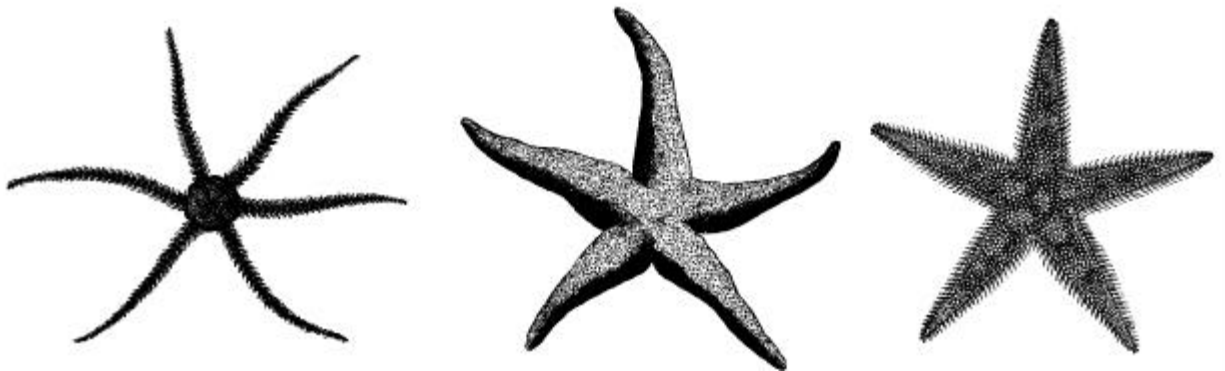

CURRENTS

It's important to know the direction and velocity of the prevailing currents in the area of your study site because they transport larval reef organisms as well as harmful sediments and pollutants such as oil.

Current meters that can be left *in situ* at a study site are very expensive. To get an approximate idea of current direction and velocity, you can release Rhodamine B or a fluorescein dye and time their passage through the water, or release drift devices ("drogues") and take sightings on their successive positions. Drogues are probably the best indicators of currents in small, semi-contained water masses with sluggish or slow currents.

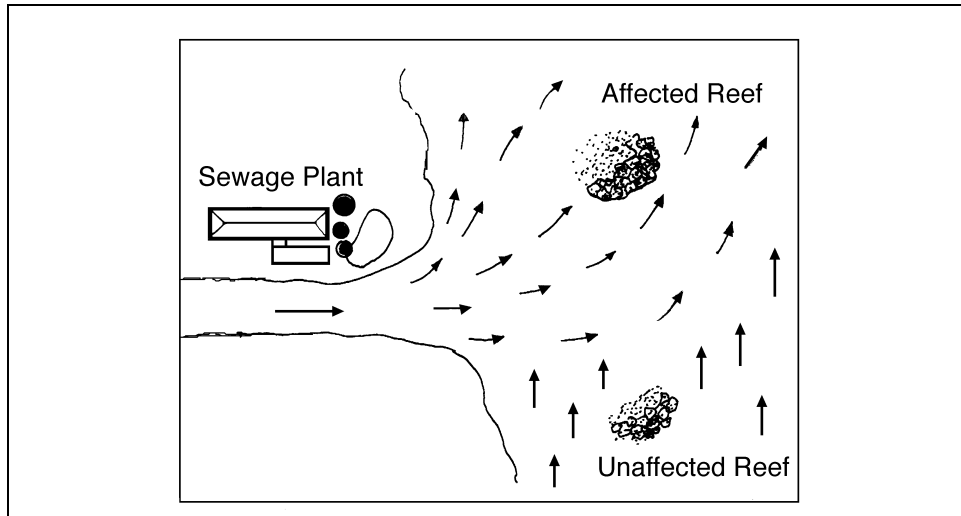

Example of Currents

A variety of types of drogues can be purchased or constructed. The drogue apparatus should include a buoy that is large enough to support a flagpole, radar reflector mast or radio antenna, and to prevent the weight of the drogue from pulling it underwater. To ensure that the drogue is influenced by water currents rather than wind, the surface area of the parts in the water must be greater than the surface area of parts exposed to the air. The larger the drogue, the more precise the measurements can be, so use as large a drogue as practical.

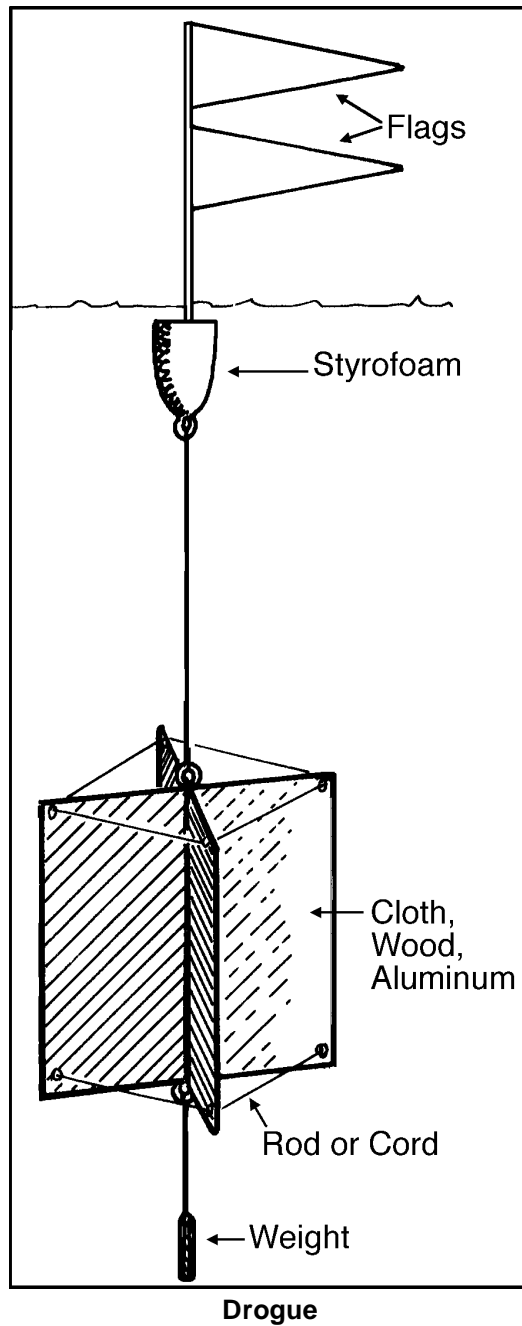

III. BIOLOGICAL MONITORING

OVERVIEW

In designing a coral reef monitoring program, you'll need to make some compromises between the accuracy and completeness of your data, and the time, difficulty and/or expense of getting it. You may also need to consider whether the risk of damaging the reef by using certain monitoring methods is warranted.

Your monitoring program will need to reflect the diversity of your study area through the study sites selected (composition) and respond to any changes that occur over time. For example, changes in coral cover can be adequately measured with much less sampling effort when cover is uniformly high than when it is low and patchy. No single set of measurements will be ideal or even workable for all locations or at all times, and your methodology must be flexible in order to avoid over or under-sampling.

Since using only one data-gathering technique is unlikely to provide all the information that will be useful to you, it's best to use a combination of methods, if possible. This manual emphasizes documenting changes in percent cover and the spatial arrangement of stony corals (including the fire coral *Millepora*) because they create the structure of the reef. Some procedures for monitoring octocorals, sponges, algae and fish are also included.

Certain marine organisms, often referred to as "keystone species", have functional roles that are more important than their abundance or biomass suggests. Changes in the population size and distribution of these species can be reliable indicators of broader changes in the local marine community. Examples of keystone species are: starfish (*Acanthaster*) in Pacific coral reefs, and sea urchins (*Diadema antillarum*) in the Caribbean.

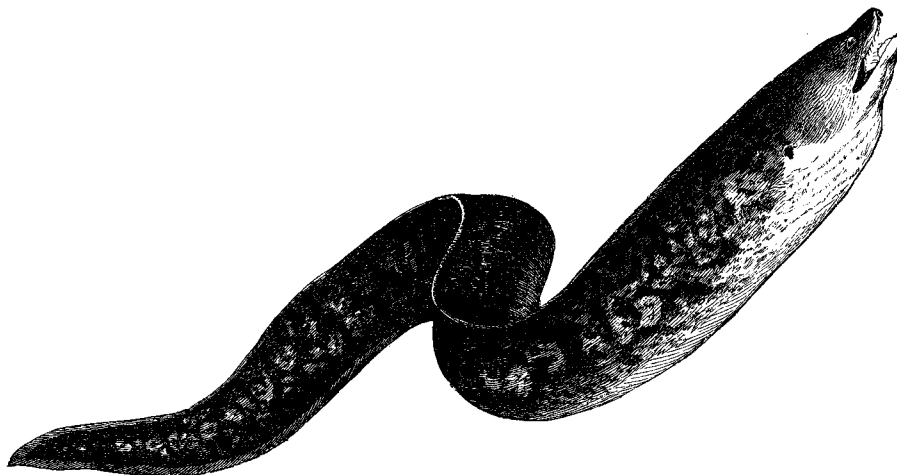

Sampling Units

This manual includes three approaches to monitoring corals and other reef components: through the use of individual colonies, quadrats, and linear transects. These approaches may be used separately or combined with each other, and underwater photography is an important complement to any of them. The following chart summarizes the kinds of monitoring each sampling unit is best suited for. For a more detailed comparison of quadrats, photo-quadrats, and chain transects, [see page III-12](#).

Sampling Unit	Monitoring Uses
Coral colony	Monitor general condition of specific stony corals, including growth, bleaching, diseases, algal overgrowth.
Quadrat	Measure percent cover, species diversity, relative abundance, density and size; and monitor corals, octocorals, sponges, seagrasses, and algae.
Linear transect	Measure percent cover, species diversity and relative abundance in zones dominated by head corals; estimate spatial index; unsuited to elkhorn zones, octocoral-dominated pavement areas, or areas where colonies are small and scattered.

Monitoring Frequency

Monthly observations are generally best for monitoring individual coral colonies. Quadrat and transect surveys done every six months provide sufficient data for assessing changes in percent cover and species diversity, and reduce the risk of damaging reef organisms during the survey process. Of course, in the event of a storm, oil spill or other disturbance, it's important to assess the effects as soon as possible, survey permanent quadrats or transects for which data were obtained before the disturbance, and continue to monitor the aftermath and recovery.

Data Analysis

It's easy to collect more data than you have the time, resources, or budget to analyze immediately, but don't allow raw data to accumulate to the point where analysis becomes overwhelming or occurs too late to be useful. Short-term data can be helpful in getting financial support for long-term monitoring goals. In planning your monitoring program, be sure to carefully gauge the effort and expense that may be involved in analysis.

Reference

Hughes, T.P. (1992) "Monitoring of coral reefs: a bandwagon?" *Reef Encounter* 11:9-12.

MONITORING INDIVIDUAL STONY CORAL COLONIES

General Condition

Observing individual stony (hard) coral colonies over time can be a simple way to monitor bleaching, algal overgrowth, predation, disease, sediment smothering, and damage from SCUBA divers or snorkelers. Here are the basic steps for gathering baseline data.

- 1) **Mark the colony.** The colony can be marked for future monitoring by using a plastic cable tie with number-coded "cattle tag" attached to a 3-inch hardened masonry nail that has been driven into the substrate near the colony. Any encrusting organisms that grow on the tags can be scraped off to reveal the number.

As each colony is marked, record the compass bearing and distance from the previous colony, and which side of the colony the tag is on (N,S,E,W). It's also a good idea to place a few survey stakes or other reference markers nearby and record the distance and compass bearings to each colony or group of colonies. If the coral colonies are dislodged by a storm, the reference markers are more likely to survive and enable you to locate the remaining marked colonies.



Marked Colony

- 2) **Identify the species.** Over 40 species of stony corals appear in the Caribbean and western Atlantic. Learning to identify them takes practice and a good reference book. (See "Information Sources," VI-5, for suggestions.) The taxonomy of corals, like that of many animals, is subject to change. For example, it's been suggested that *Montastraea annularis*, long considered the most abundant and wide-ranging coral in the region, is actually three "sibling" species, two of which have significantly different growth rates, and one of which has unusual coloration that may be confused with bleaching.

Reference

Knowlton, N., Weil, E., Weigt, L., Guzman, H. (1992) "Sibling species in *Montastraea annularis*, coral bleaching, and the coral climate record," *Science* 255:300-333.

3) **Record the condition.** The suggested abbreviations shown below may be helpful in describing the colony.

Abbrev.	Condition	Abbrev.	Condition
blea	bleached coral; white, with tissue remaining	fr	freshly grazed coral tissue
dcw	dead coral; white, cleaned coral skeleton without tissue	gr	older grazed area, overgrown with algae
dcs\turf	cleaned coral skeleton without tissue but with algal turf grown over the skeleton	rg	older grazed area that has been grown-over by tissue
dca	dead coral with algal turf; skeleton not visible or conspicuous, older	bbd	black band disease
light	light-colored; bleached but not completely white	wbd	white band disease
lr	light ridges (noted on <i>D. strigosa</i>)	mucus	mucus coat, noted on <i>P. astreoides</i> ; often with adhering sediment or algal growth; <i>S. siderea</i> has tufts or globs of adhering mucus; often seen in summer in Florida
discol	discolored tissue: unusual color not due to bleaching -- purple, pink, bluish, etc. (<i>S. siderea</i> has a violet color which appears luminescent during bleaching events)	mustard	mustard-colored tissue on <i>P. astreoides</i>
		ss	sediment spot; small sediment-filled spot or hole

4) **Photograph the colony.** Each colony should be photographed or videotaped when its condition is first recorded. Include a slate in the photo with an identification number, date and scale (a color chart in the photo may help document subtle changes over time). Take the photo from the angle which best represents the entire colony.

You can have a photograph laminated and bring it with you in the next survey to assess changes. These photographs are intended for qualitative rather than quantitative analysis because it's impossible to replicate the camera angle and distance exactly unless a rigid framer is used. For more information about underwater photography, see III-29.

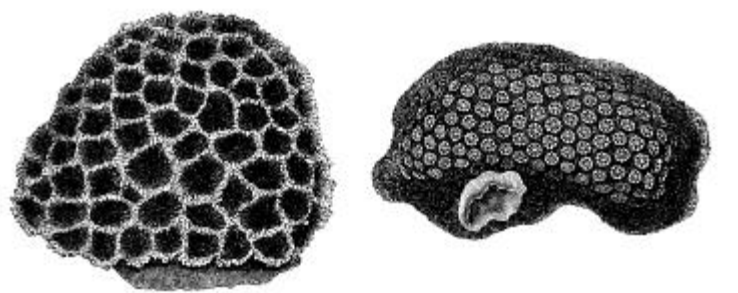

Mapping the colonies: If you are tagging colonies that are abundant within a limited area (up to 100m²), you may find it useful to create a map. Draw the coral colonies to scale on a grid

while underwater. To position the colonies on the grid (each square equals 1m²), lay two weighted lines (marked in meters with flagging tape) parallel to each other, one meter apart. Leap-frog one line over the other until you have mapped the entire area. Maintain a compass bearing along both weighted lines to keep them parallel. Although this technique provides a good way to relocate colonies for repeat sampling and document their condition over time, it is labor intensive: a 100m² area at 3-4 m depth can take 6 hours to map.

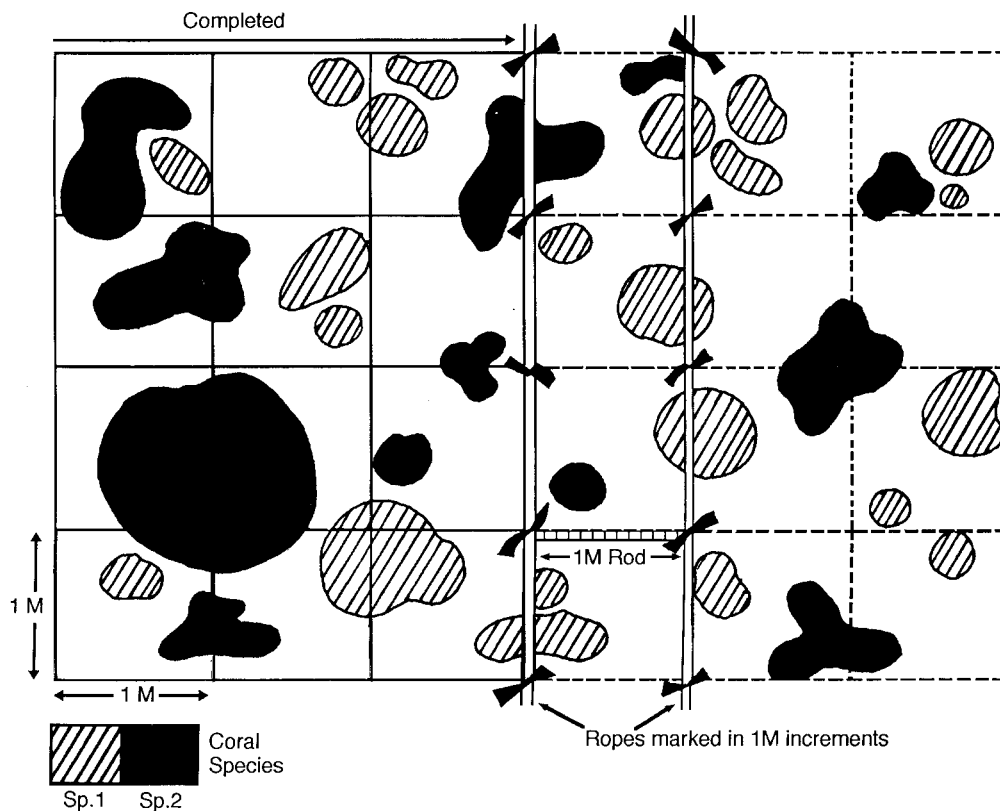

Map of Coral Colonies

Monitoring frequency: Monthly observations are generally the most effective for assessing the cause and effect of changes in individual stony coral colonies. If observations are done less often, damage that has occurred since the last survey may be difficult to see. Algae may grow rapidly over freshly broken areas, sometimes within a week.

References

French, K., Lewis, S., Hillis, Z. (1990) Coral monitoring conditions guide at the Buck Island Reef National Monument, report prepared for the U.S. Department of the Interior, National Park Service.

Bythell, J.C. Gladfelter, E.H. and M. Bythell (1993) "Chronic and catastrophic natural mortality of three common Caribbean reef corals," *Coral Reefs* 12(3/4): 143-152.

Coral Diseases

Diseases of stony corals have been observed throughout the Caribbean and western Atlantic, even on reefs far removed from human activities. Monitoring coral colonies will provide information on the distribution of diseases throughout the region. We need to learn more about the extent and severity of these diseases and their causes. To assess the effects of coral diseases, it is best to monitor individual colonies.

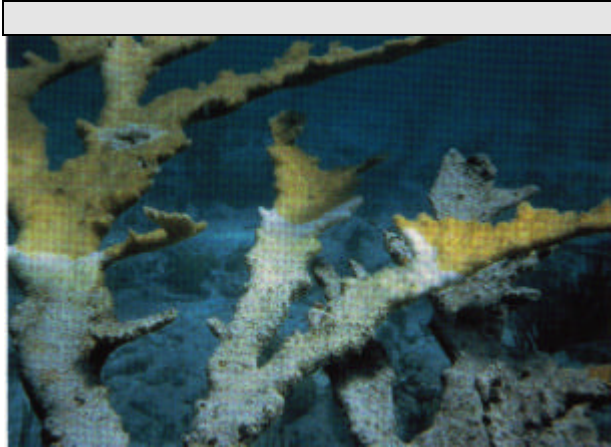

Elkhorn with White Band Disease

White Band: Of unknown etiology; primarily affects species of *Acropora*. It appears as a white band that begins around the base of a colony or branch and progresses distally. The "white band" is bare skeleton devoid of zooxanthellae-bearing coral tissue. White band disease usually progresses rapidly, killing the entire colony.

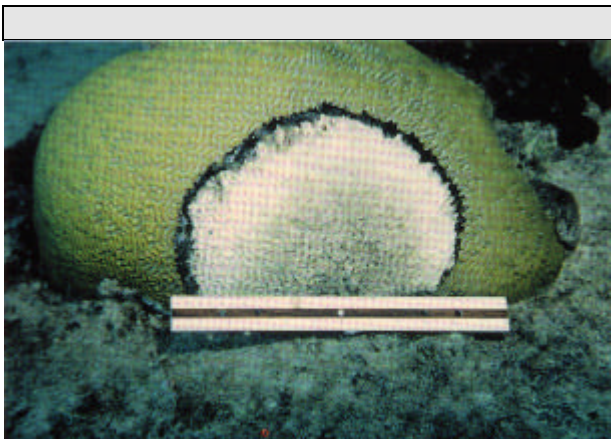

Head Coral with Black Band Disease

Black Band: Caused by the cyanobacterium ("blue-green alga") *Phormidium coral-lyticum*, most commonly infecting *Montastraea annularis*, *Diploria* spp., *Colpophyllia natans*, and *Siderastrea siderea*. It shows up as a dark pencil-thick band that forms a halo on the coral head. The area on one side of the band appears normal, while the other side exhibits a gradual shift from stark-white to algal-covered skeleton. The coral may die from the disease or it may eventually grow back over the dead area.

References

Gladfelter, W.B. (1982) "White-band disease in *Acropora palmata*: implications for the structure and growth of shallow reefs," *Bulletin of Marine Science* 32(2):639-643.

Rutzler, K., Santavy, D. (1983) "The black band disease of Atlantic reef corals; I. Description of the cyanophyte pathogen," *PSZNI Marine Ecology* 4(4):301-319.

Coral Bleaching

The tissues of stony corals and other symbiont-bearing Cnidarians appear bleached when they lose their endosymbiotic algae (zooxanthellae), or when the zooxanthellae lose their pigmentation. Bleaching must be distinguished from "photo-acclimation", in which the concentration of pigments changes simply in response to changes in light. There is some evidence that bleaching may be a response to higher water temperatures and/or ultraviolet radiation. Significant bleaching events occurred in the Caribbean in 1987 and 1990. To monitor bleaching activities, it is best to collect data on individual colonies.

In Florida, the zooanthid known as the golden sea mat (*Palythoa*), which has been observed as the first organism to exhibit bleaching from increased water temperature, may be used as an indicator species for bleaching. It usually precedes bleaching of *Montastraea* by a week. Mortality of part or all of a bleached coral can occur and algae may grow over the stark white skeleton. Some species of Octocorallia (e.g., *Briareum asbestinum*, *Plexaura homomalla*), and sponges may also appear bleached due to loss of their symbiotic algae.

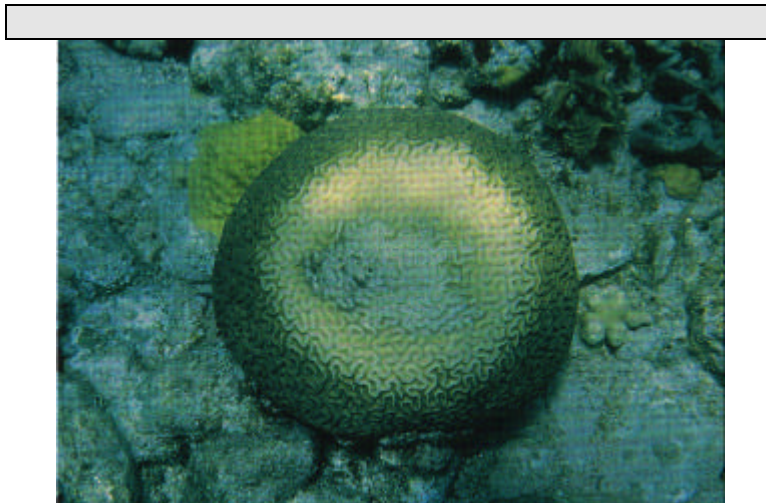

Bleached Coral

When bleaching or white band disease is suspected, it's important to consider other possible causes for changes in appearance, such as:

- predation by the "fireworm" *Hermodice sp.* or the mollusk *Coralliophila sp.*, both of which can leave large areas of stark white skeleton.
- a nearby sea fan (octocoral) or clump of macroalgae (such as *Dictyota*) that shades or abrades the coral.
- the use of coral heads as handholds in SCUBA-diving areas causing death and eventual coverage by algae.
- color differences in coral species between areas and individuals; e.g., the purple *Porites sp.* of St. John, USVI has never been seen at Buck Island, St. Croix, USVI, which is only 35 miles away.

How to Monitor Bleached Corals

- 1) Record the following information:
 - when and where the bleaching was first noticed
 - which species are affected
 - the size range of the colonies
 - which parts are bleached or pale (e.g., ridges, branch tips, grooves)
 - the depth at which affected colonies are growing
 - the density of bleached colonies, i.e., the number within a known area (e.g., 12 colonies in a 10m² area)
 - any unusual environmental conditions (storms, oil spills)
- 2) Tag both bleached and unbleached colonies with numbered tags, following the procedures outlined above under "General Condition."
- 3) Photograph the colonies and, if possible, videotape them. Photography dependent on natural light will be affected by depth, light quality in the water column, time of day and season. If you are evaluating color quantitatively, use a strobe, the same type of film, and the same F stop for all photographs. Including a color chart in the photo which has gradations of the color characteristic of the species can help document subtle changes.
- 4) To assess recovery and/or condition over time, observe and photograph each study coral every one to two months and record changes. Are polyps extended? Is mucus being released?
- 5) Select a subset of colonies for growth measurements using one of the methods described in the next section, "Coral Growth".
- 6) Record data on temperature, turbidity, salinity, and light if possible.

If adequate laboratory facilities are available, you can sample tissue from affected colonies and centrifuge it to determine both the density of the zooxanthellae and the concentration of pigment.

References

D'Elia, C.F., Buddemeier, R.W., Smith, S.V. (1991) "Workshop on Coral Bleaching, Coral Reef Ecosystems and Global Change," Report of Proceedings, Maryland Sea Grant College Publication, College Park, Maryland.

Jaap, W.C. (1985) "An epidemic zooxanthellae expulsion during 1983 in the lower Florida Keys coral reefs: hyperthermic etiology," Proceedings of the 5th International Coral Reef Symposium, 6:143-148.

Coral Growth

The growth rate of a coral colony is highly variable. It depends on the species and may fluctuate significantly within an individual colony and from month to month. While *M. annularis* may grow less than 1 cm a year, branching corals such as *A. palmata* may grow as much as 10 centimeters a year. Four ways to monitor coral growth are described below, from the simplest to the most complicated. The method you choose may depend on what kind of coral you are monitoring.

Branching corals: To provide a baseline for measuring growth in branching corals, you can wrap a plastic cable tie around a branch with a tag to identify the sample. Using a flexible plastic ruler, periodically measure the distance from the baseline to the end of the branch to determine the net linear extension. Growth may be evident in measurements taken as often as once a month. Note that over time the cable tie may become embedded in the skeleton.



Branching Coral with Cable Tie

Head coral: A simple way to monitor growth in head corals is to drive a nail into the substrate next to the head, or into a dead portion of the coral. Tag the nail and use it as a reference point from which to make measurements.

Photographs: With relatively flat head and plate corals, you can estimate growth by digitizing the photographic image to calculate the area of living coral and comparing data from successive photographs. Growth may be evident in measurements taken every six months. However, make sure to take the photos from the exact same angle and distance each time, and to place a scale (such as a ruler) along the edge of the photo-quadrat for referencing size. For more guidance, see "[Underwater Photography](#)", III-29.

Alizarin Red S Bone Stain: If done correctly, this method can provide a more precise measurement of coral growth than photographs, and it can be used with either branching or head corals. However, it requires removing live coral and does not provide measurement of the same coral's growth at subsequent intervals.

Measuring Coral Growth with Alizarin Red S Bone Stain

- 1) Place a clear plastic 1-liter bag containing about 20 mg of the stain over the end of a coral branch or over an entire colony and tie it off in one corner securely with cotton string. The final concentration of stain in the bag will be about 10-15 mg/l seawater. If the stain is too diluted, it will be difficult to measure the growth.
- 2) Remove the bags after 24 hours except in the case of *A. palmata*. Four hours is sufficient for staining faster-growing corals like *A. palmata* but not for slower growing head corals. Also, in high-energy zones where *A. palmata* often grows, wave and surge action can move the plastic bags back and forth, damaging the coral colony.
- 3) Label each treated coral with a numbered plastic tag.
- 4) Collect the corals after 2 to 4 months, remove the live coral tissue with a water jet, and measure the growth since staining.

➤ For *Acropora* and other branching species:

To determine the linear extension of new skeleton, take the mean of 10 equally spaced measurements along the zone of the new growth.

To determine the calcification rate per branch perimeter, remove the new (unstained) growth with a saw and divide its weight by the perimeter of the branch at the base of the new growth and the number of days since staining. This value (g/cm/time) relates calcification to the original amount of calcifying tissue present.

➤ For head corals:

To determine the growth of roughly hemispherical corals, section them vertically through the center with a rock saw. Measure the distance between the upper limit of the stain line and the periphery of the colony using a dissecting microscope and ocular micrometer. The average of 10 such measurements spaced evenly across the colony can be used as a mean extension value for that colony.

Reference

Gladfelter, E.H., Monahan, R.K., Gladfelter, W.B. (1978) "Growth rates of five reef-building corals in the northeastern Caribbean," *Bulletin of Marine Science* 28:728-734.

Core samples: A historical record of coral growth can be obtained from cores of head corals that have skeletons with annual density bands, similar to tree rings. These species include *Montastraea annularis*, *M. cavernosa*, *Diploria strigosa*, *Siderastrea siderea*, and *Solenastrea bournoni*.

The core sample is cross-sectioned parallel to the growth axis with a rock saw to produce slabs about 4 mm thick. X-radiographs of the slabs will reveal density bands and allow estimates of annual growth. The slabs can also be analyzed for a variety of chemical constituents that may provide information about the history of contaminants and other sea water characteristics. For example, freshwater may contain fluorescent soil acids that are transported to coastal reef areas during periods of high runoff and incorporated into the growing skeleton. These fluorescent bands will show up when the slab is illuminated with UV light.

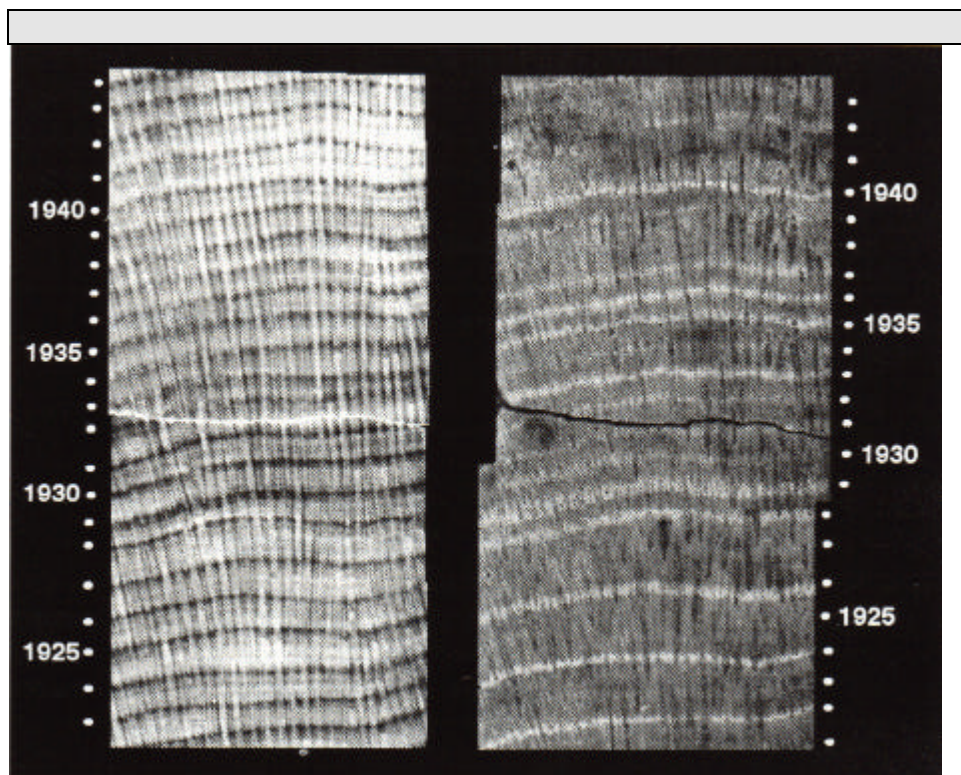

Annual growth bands in *Montastraea annularis*

Coring requires use of an underwater hydraulic drill, pumps and coring equipment and is therefore a costly monitoring method. You may be able to get a hospital laboratory to produce the X-ray. Holes left by coring should be filled with Portland cement.

Reference

Halley, R.B., Curry, R. (1993) "Coastal Geology and National Parks: An example from Biscayne National Park," *Park Science* 13(1):4-5.

COMPARISON OF MONITORING METHODS

Quadrats, photo-quadrats and chain transects provide alternative ways to obtain and document the information needed to measure percent cover, species diversity, and relative abundance. As summarized below, each method has its advantages and limitations. Ideally, a coral reef monitoring program will include more than one method where appropriate. For more about using photo-quadrats, see "[Underwater Photography](#)," III-29. Chain transects are described in more detail in the next section.

	Quadrats	Photo-Quadrats	Chain Transects
Equipment	Relatively inexpensive	May be very expensive, depending on equipment used	Relatively inexpensive
Difficulty	Relatively simple, but at least for initial survey must be done by someone who can identify species in the field	May be difficult to set up depending on equipment used, but simplest methods can be done by non-specialists	Tedious and exacting; must be done by specially trained divers
Damage to reef	Slight risk in areas of high relief, especially if grid is used	Depending on equipment used, may be risky in topographically complex areas	Even well-trained divers find it difficult to avoid causing some damage, especially in areas with branching corals
Data obtained	If grid is used, can provide reasonably accurate measures of percent cover, species diversity, relative abundance, density and size	Can be used to estimate percent cover, species diversity, relative abundance, density and size	Measures all surface areas below line to determine percent cover, species diversity and relative abundance; estimates spatial index
Limitations	Cannot be used to measure spatial relief; provides data only on projected surface area; difficult in elkhorn or staghorn-dominated areas	Cannot be used to measure spatial relief; provides data only on projected surface area; unsuited to areas with large or abundant octocorals that conceal other species	Cannot be used to directly measure species density or colony size; not suited to areas where stony corals are widely-spaced and small; impossible in elkhorn or staghorn-dominated areas
Use of data	Data are ready to use when diver leaves the water	Measurements cannot be determined until after photographs have been digitized	Data are ready to use when diver leaves the water
Replication of survey	Relatively easy, if done by the same person each time or by people who have been trained together	In permanent photo-quadrats, precision depends on apparatus used and ability to take photo from exactly same spot	Even with well-marked transect, impossible to position the chain exactly the same each time
Calculating percent cover	Can be easily calculated, manually if necessary	Digitizing is time-consuming to do manually and difficult without access to computer and software; use of random dots also time-consuming	Can be easily calculated, manually if necessary

Reference

Ohlhorst, S.L., Liddell, W.D., Taylor, R.J., Taylor, J.M. (1988) "Evaluation of reef census techniques," *Proceedings of the 6th International Coral Reef Symposium* 2:319-324.

QUADRATS

The term "quadrat" generally refers to a square or rectangular sampling unit within which organisms are counted or measured, or to the frame which marks this area. Quadrats can be used to estimate percent cover of each species or other reef components and obtain information about density, abundance, diversity, and colony size.

Limitations: Quadrats are generally preferable to linear transects in monitoring Octocorallia and smaller stony corals. However, because a quadrat provides data only on the horizontal plane of the reef surface and not on spatial relief, its use is inherently problematic on an irregular and highly three-dimensional reef surface. Taxa with plate-shaped morphologies tend to be over-represented relative to columnar species such as "pillar coral" (*Dendrogyra cylindrus*) in census data, while cryptic taxa tend to be omitted completely. In these situations, linear transects may be more appropriate.

Installation

Size: Although one-meter square quadrats are frequently used, the size of the quadrat may depend on the size of the organisms you are monitoring. While phycologists often use $\frac{1}{4}\text{m}^2$ frames, coral biologists often use $\frac{1}{4}\text{m}^2$, 1m^2 , or larger.

Location: The quadrats should be far enough apart so that their boundaries do not overlap. The problem of parallax, in which the size and location of an object is affected by the angle from which it is viewed, may be exacerbated if a series of quadrats abut each other. Quadrats can be permanently or randomly placed to obtain general data on reef conditions. Quadrats can be sampled along transects by placing the frame on alternate sides of a line or centering it along the line.

To mark a permanent quadrat, you can use concrete nails or re-bar stakes at two corners on the diagonal or at all four corners of the quadrat. If you are using a quadrat frame or grid, the pins should rest on the inside of the corners. For more information about marking the site, [see "Site Selection", I-15](#).

Construction: Small quadrat frames can be made from iron re-bar or stainless steel. For larger quadrats, in which weight becomes more of an issue, aluminum or PVC pipes are easy to handle underwater and less likely to damage the substrate. To decrease buoyancy and reduce resistance in carrying the frame through the water, you can drill small holes in it. The frame is usually removed from the site between monitoring visits.

Quadrat grids: To simplify measurements on relatively flat substrate, you can create a grid on the quadrat with string. For example, a 1-m quadrat can be strung with 10 vertical and horizontal lines to create a grid of 100 squares, with each 10-cm square representing 1% of the quadrat. By counting the number of squares (or fractions of squares) occupied by each species, you can estimate abundance and percent cover within the quadrat. In areas where the topographical complexity makes using a quadrat grid difficult, you can create a reference scale by drilling a hole or marking off every 10 cm on each side of the frame with paint.

Data Collection and Analysis

Percent cover: For quadrats with relatively few species and little live coral and plant cover, you can estimate cover for each species while in the field by counting the number of squares (or partial squares) covered by each species and recording these numbers as shown on the sample data sheet below.

Sample Data Sheet	
Quadrat #5	# of Squares
A. agaricites	1.0
P. astreoides	0.7
S. siderea	4.0
M. annularis	2.0
P. astreoides	6.5
A. agaricites	5.0
D. strigosa	10.0
S. siderea	8.8
macroalgae	20.0
sand	42.0

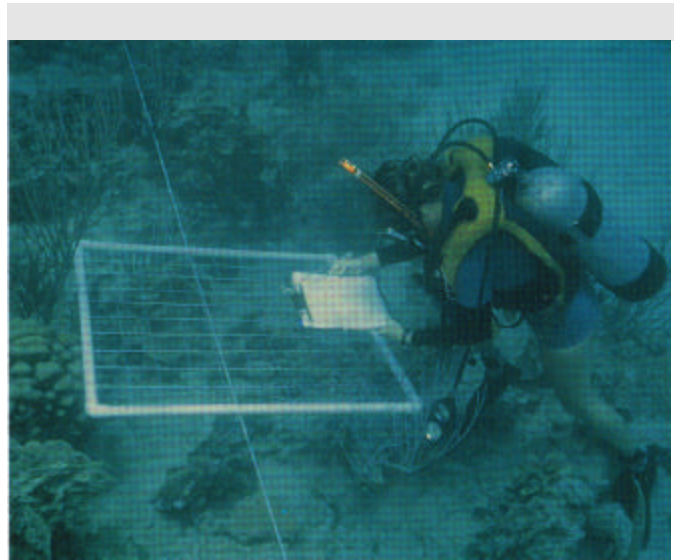

Using a Quadrat Grid

If the quadrats contain several species and more live cover, to reduce the likelihood of error, you can record the data square by square on a grid written on your underwater slate, and tally the squares after the dive.

From the data in the above example, you can calculate the number of coral species (5), and the total live coral cover (38%) by adding up the number of squares occupied by each coral species ($1 + 0.7 + 4.0 + 2.0 + 6.5 + 5.0 + 10 + 8.8 = 38$; space occupied by algae and sand are not calculated for live coral cover). However, more typically you would use data from several quadrats and derive average percent cover, etc. (Before doing parametric statistical analysis (which assumes a bell-shaped distribution), percentage data from quadrats and transects must be arcsin transformed. For more information about statistical analysis, [see Appendix B.](#))

Frequency and density: You can calculate the "frequency" of a species by counting the number of quadrats in which the species is observed and dividing by the total number of quadrats. The "density" is the number of different species or colonies found within a given area, usually per square meter. It is important to remember that the number of coral colonies can be independent of species diversity and coral cover. For example, a hurricane that causes significant mortality (loss of cover) may bring about an increase in the number of coral colonies because of fragmentation, but the colonies would be of a smaller size. Or, two reefs may have the same number of colonies, but entirely different percent cover.

Species diversity: Increasing concern about the loss of species and degradation of ecosystems has led to an interest in measuring genetic, species, and ecosystem diversity, known collectively as "biodiversity". In coral reef monitoring, most of the data collected pertains to the number of species, sometimes called "species richness", and their relative abundances. The Shannon-Weaver index (H'), which combines both number of species and relative abundance, is calculated using this formula:

$$H' = -\sum p_i \ln p_i$$

where $p_i = n_i/N$, in which N = the total number of colonies of all coral species in the quadrat (or total number of centimeters of live coral under the line, for a chain transect), and n_i = the number of colonies of each coral species in the quadrat (or the number of centimeters for each species).

Reference

Shannon, C.E., Weaver, W. (1949) *The Mathematical Theory of Communication*, University of Illinois Press, Urbana.

Quadrat grids vs. photo-quadrats: You can get the same information about projected area from a quadrat on which a grid has been strung as from the two-dimensional view provided by a photograph (see "[Underwater Photography](#)," III-29). However, certain calculations may take longer if done underwater rather than from a photograph, and use of a quadrat grid requires expertise in species identification for each sampling. With photographs, species identification may only need to be done on-site for the initial survey, so subsequent photos can be taken by any competent diver. Photography can also be combined with the use of a grid quadrat.

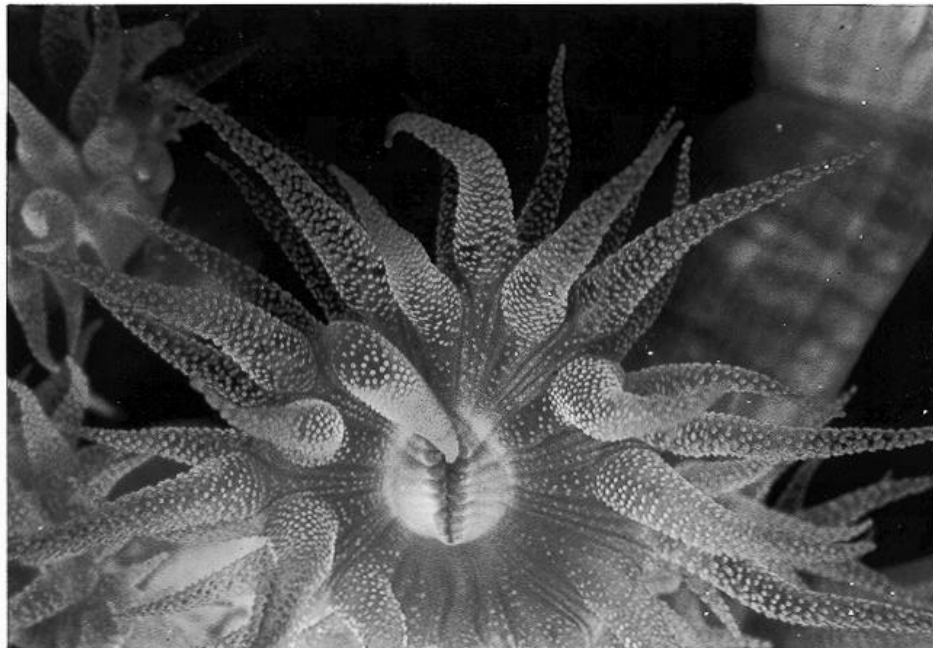

CHAIN TRANSECTS

A linear transect is a line of a specified length laid out within a study site. Transects are generally positioned parallel to the shore, along depth contours (e.g., at 5, 10, and 15 meters).

A transect laid perpendicular to shore may be appropriate if you want to include different reef zones (or depths) in the same transect. Preliminary transects can be used to delineate the different zones within your study area, or to determine the necessary length of permanent transects for long-term monitoring. Measurements can be taken along the entire surface beneath the line, using a chain as described below, or at specified intervals, as explained under "[Line and Point Intercept Transects](#)," III-21.

A chain transect is a relatively inexpensive and accurate way to gather information on species diversity, the relative abundance of different species, and the amount of hard substrate or sand. It is most effective for documenting changes in abundant larger coral species, and best suited to areas dominated by head (rather than branching) corals. Information on the percent cover by all major reef components can be calculated easily on a computer, or by hand if necessary.

By following the surface contour of the reef, chain transects provide data that you can use to estimate the "spatial index" of the reef: the ratio of reef surface contour distance to linear distance. As part of a long-term monitoring program, the spatial index provides a way to quantify changes in the topographical complexity of the reef.

Limitations

Although chain transects provide certain information not available from quadrats, they do have certain disadvantages.

- Chain transects are inappropriate in *Acropora palmata* (elkhorn) zones, octocoral-dominated pavement areas, or in areas where stony coral colonies are widely-spaced and small. However, if the sampling chain crosses over an octocoral holdfast, it should be included in the data. The amount of living coral in dense *A. palmata* zones is probably best estimated with photographs.
- The chain transect method, also known as the "ball and chain method", is tedious and time-consuming. It's not unusual to spend over an hour on 10 m of transect.
- The reef may be damaged if the chain becomes entangled in branching coral.
- It's impossible to position the chain in exactly the same location each time. Changes noted during repeat sampling may reflect shifting in the chain's position rather than actual changes in cover on the reef; however, these shifts are unlikely to cause significant changes in results for the most abundant organisms.

Data Collection

- 1) **Mark the transect.** For a preliminary transect, tie each end of a line marked off in meters or a waterproof fiberglass tape measure (20 to 30 m is usually sufficient) to a piece of dead coral along the depth contour at a randomly selected site. Keep the line as taut as possible and at the height of the tallest feature along the transect (usually a coral colony), and try to keep to the selected depth as much as possible (within a few feet). If the line is too high above the substrate, parallax will make your work more difficult and your data less accurate.

Note: Three-strand nylon lines stretch when wet, so check the measurement after the line has been soaked. To avoid stretching, use a polypropylene or double-braid nylon line, or fiberglass tape measure.

Permanent transects should be marked with metal stakes to indicate the exact beginning, middle and end of each transect. Attaching bright-colored flagging tape to the stakes will make them easier to find for repeat sampling. To help position the line in the same place each time, it's also a good idea to mark off every five meters with a nail, or other small reference marker. (See "Marking the Site," I-16.)

- 2) **Position the chain.** Drape a light-weight chain (such as a dog chain) over, around, and under all natural fixed surfaces directly below the line. A 5-foot length of chain with 1.3-cm links (77 per meter) works best in many situations. Smaller links take longer to count, and larger links may miss certain features. Be sure to use chains with the same size link each time you sample. Sampling progresses in 1-m increments, recording at which meter the data are collected. Periodically check your position by holding the chain against the tape and then letting it drop to the substrate.

Suggestion: You can prevent errors in counting links by marking off every 10 links with small pieces of brightly colored flagging or surveying tape.

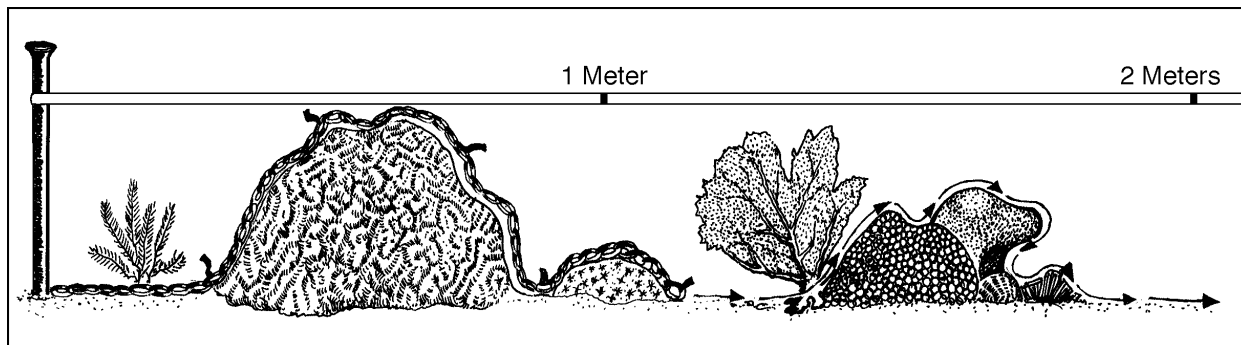

Positioning the Chain

Positioning the Chain

- 3) **Measure the surfaces.** Count the number of links it takes to outline the surface of each species or reef component that is of concern to you. If your objective is to determine the appropriate length for permanent transects and you are primarily interested in stony corals, you need to record only cover by live coral (by species); all other surfaces, living and dead, can be put into the category of "other" or "non-coral". Include the fire coral *Millepora* (also to species).

For permanent transects, you may want to include reef components such as sponges, bleached coral, dead coral with algae, rubble (pieces of branching corals or plates, rather than intact dead coral heads), macroscopic algae, octocorals (holdfasts only), sand, and pavement (hard carbonate substrate of low relief, sometimes dominated by octocorals).

The chain must touch a solid structure at all times, even if it must be held up against the underside of a coral branch or ledge. Do not attempt to measure mobile organisms with links! But you may want to make note of important herbivores such as the spiny sea urchin *Diadema antillarum* when they are under or near the line. The substrate below the urchin is what should be counted in the transect data.

The objective: to measure as carefully as possible the surfaces under the line, even when there are several layers. For example, if an *Agaricia* is positioned over a *Montastraea* colony and directly under the line, you measure the live upper surface of the *Agaricia* plate, the dead undersurface, and the top of the *Montastraea* colony.

- 4) **Record the data.** Using mylar sheets or waterproof paper on a clipboard or an underwater slate, record the number of links for each category in each meter of line (not each meter of chain). For each meter of line, check to make sure that you've recorded at least the number of links equivalent to 1 meter.

Sample Field Notes			
Date:			
Location:		Depth:	
Divers:			
Surfaces -- # Links			
Meter 1:		Meter 2:	
Ma	-- 5	Aa	-- 5
sand	-- 25	Ds	-- 7
Aa	-- 8	maca	-- 4
dca	-- 24		
rubble	-- 35		

- Record each colony or other surface as you come to it along the transect; don't combine separate colonies of a species and record a total for the species within each meter. Abbreviate species names, being careful not to use confusing abbreviations, e.g., *M.a.* could be *Montastraea annularis* or *Millepora alcicornis*.
- If hard substrate or dead coral is covered with sediment less than 1 cm thick, refer to this portion of the transect as "pavement" or "dead coral with algae".
- If sediment on pavement or dead coral is at least 1 cm thick, record it as "sand".
- "Macroscopic algae" (abbreviated "maca") refers to conspicuous algal plants such as the brown alga *Dictyota* and red alga *Martensia*, whose fronds project more than 1 cm above the substrate. If possible, identify the alga to genus or species.
- Dead corals with turf algae (abbreviated "dca") often make up a larger portion of the transect than live corals.

If time and energy permit, you can check the variability among different observers or the same observer's results when repeating a transect by doing each transect two or three times. It is usually adequate to survey the transects every six months.

This process requires a major investment of time, but gives you a lot of information in return.

Chain transects are much more difficult in some areas than others. Don't give up! If you encounter small caves or big holes, try to position the chain so that you can estimate the amount of dead coral or sponges, etc., in these places. If you come upon a deep sand channel more than two meters across, make note of it and start recording where the reef itself begins again.

Data Analysis

Preliminary transects: To determine the appropriate length for a permanent transect, plot the cumulative number of coral species (or other species of interest) against the number of meters along the preliminary transect line. After a certain number of meters, depending on the site, there will typically be a leveling off as the number of additional species decreases. At sites around St. John, 20-m transects have been appropriate, while scientists in Florida have found that 25-m transects were preferable.

After analyzing the results from the preliminary transects, you can establish permanent transects placed randomly along each of the selected depth contours within selected study areas or zones.

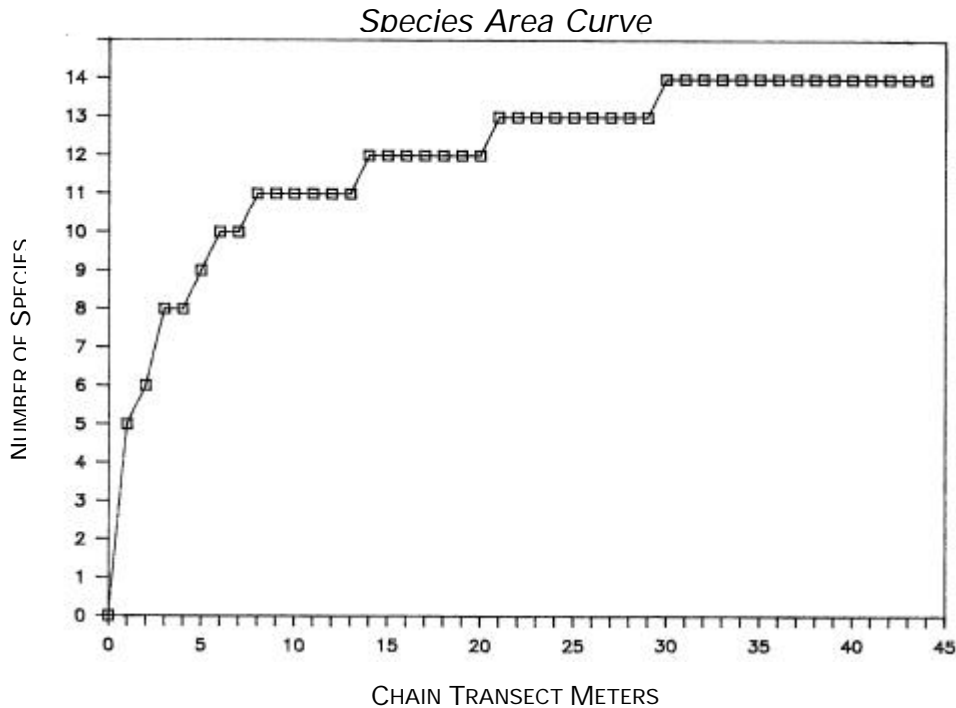

Percent cover and structural complexity:

- To determine the percent of live coral cover or other component, divide the number of links for that component by the total number of links in the transect.

$$\text{Percent live coral cover} = \frac{\text{No. of links live coral}}{\text{Total no. of links along transect}} \times 100$$

- To determine an index of topographical complexity calculate the ratio of the length of the chain (in centimeters) to the length of the line.

$$\text{Structural complexity} = \frac{\text{No. of transect links} \times \text{cm per link}}{\text{Total transect length (cm)}}$$

The preceding calculations can be done with a calculator, but they are easier if you have a software package such as Lotus or Microsoft Excel. Biologists in Virgin Islands National Park have developed a simple Lotus-based program to analyze chain transect data and will provide a copy on request. A more sophisticated software program that can also calculate the species diversity index H' is available from Dr. James Porter, University of Georgia. For information about statistical analysis, [see Appendix B](#).

Reference

Rogers, C.S., Gilnack, M., Fitz, H.C. (1983) "Monitoring of coral reefs with linear transects: a study of storm damage," *Journal of Experimental Marine Biology and Ecology* 66:285-300.

LINE AND POINT INTERCEPT TRANSECTS

Line intercept and point intercept transects are other ways to gather data that can be used to estimate percent cover, relative abundance, and diversity. The intercept method is simpler and quicker than using a quadrat or a chain transect, so you can survey a larger area in the same period of time. However, like the quadrat, intercept transects cannot be used to calculate a spatial index, and like the chain transect they may not provide accurate sampling in areas where coral colonies are small and widely scattered.

To do a line intercept transect, secure a fiberglass tape measure to both ends of the transect with the tape draped over the reef in between, and record each species or substrate component and its length under the tape. In a point intercept, you record only what is located at each specified point along the line, e.g., every 20 cm. Depending on your objectives and available resources, you may want to survey several lines at each site, use a longer line, or longer intervals. To test the adequacy of your sample size, check the cumulative species recorded against the number of transects surveyed. The number of points scored by a given species divided by the total number of points yields the percentage cover.

Reference

Ohlhorst, S.L., Liddell, W.D., Taylor, R.J., Taylor, J.M. (1988) "Evaluation of reef census techniques," Proceedings of the 6th International Coral Reef Symposium 2:319-324.

OCTOCORALS AND SPONGES

Octocorals (soft corals) and sponges are important components of the reef. Octocorals, a group of Cnidarians (Coelenterata) that includes "gorgonians", occur in most reef habitats, and dominate some reef zones. Their abundance often varies inversely to stony coral cover. Species identification can be tedious and difficult, but it's worth making the effort to learn to identify them in the field so you can avoid destructive sampling. Valuable information can be obtained from surveying octocorals at the level of families or genera rather than species.

Quadrats: To survey octocorals, quadrats of one square meter are standard, but 0.25-m² quadrats are also used. Still photography can be used to identify specimens, growth of new recruits, and progression of disease. Photo-quadrats and grid quadrats are inappropriate for most habitats because octocorals occur in widely ranging sizes and tend to overlap, preventing proper placement of a grid. In addition, large octocorals may conceal other benthic organisms in a photograph.

Belt Transects: For a quick assessment of octocoral abundance and distribution, you can look at the species within a belt transect of specified width across the study area, e.g., 1 meter wide and 20 to 25 meters long. Along depth contours, use fiberglass tapes with the ends secured. Count and identify (to lowest possible taxa) all octocorals within each linear meter of transect. Twenty transects are generally sufficient for adequate sampling in the Caribbean.

Data to Record: Species identifications, number of colonies, height measurements, and number of newly settled recruits (≥ 5 cm tall).

References

Kinzie, R.A. (1973) "The zonation of West Indian gorgonians," *Bulletin of Marine Science* 23(1):93-155.

Goldberg, W.M. (1973) "The ecology of the coral-octocoral communities off the southeast Florida coast; geomorphology, species composition, and zonation," *Bulletin of Marine Science* 23(3):465-488.



Sponges: While there are about 40 species of corals in West Indian reefs, there are about 300 common species of sponges. They are critical constituents of the reef. For example, they help construct the reef framework (sclerosponges); they contribute significantly in creating reef sediments through bioerosion and spicule formation; and their varied forms of growth and abundance increase topographic complexity, which enhances local diversity. In addition to being a net primary producer of oxygen, a single species such as the chicken liver sponge may contribute 50-120% of the nitrogen required to sustain reef productivity. This species is frequently eaten by certain reef fish (mostly angel fish), and it is the most important food item for the endangered hawksbill turtle.

Sponges can generally be sampled along with other attached benthos in quadrats or chain transects (see previous sections). Although some species are identifiable in the field, many can only be identified in the lab.



Reference

Vicente, V.P. (1982) Common sponges. In: Kaplan, E.H. *A Field Guide to Coral Reefs (Caribbean and Florida)*, The Peterson Field Guide Series, Houghton Mifflin Company, Boston, pp. 127-133.

ALGAE

Many reefs in the Caribbean and western Atlantic have relatively low amounts of live coral cover (often less than 40%) and high amounts of cover by algal turf and macroscopic algae. But the biomass of macroscopic algae can vary widely across a reef and over time, often seasonally. Macroalgae populations may fluctuate depending upon local nutrient fluxes (sometimes associated with heavy rains or upwelling) and temperature changes. However, dramatic increases in algal cover and biomass may indicate an increase in nutrients from sewage or agricultural fertilizers, or a decrease in grazing by herbivorous fish or sea urchins.

Algae can be loosely grouped into the four categories shown below. The "1 cm" distinction between macroscopic and turf algae is somewhat arbitrary.

Macroscopic algae (macroalgae)	"Fleshy" algae which are not hard to the touch and project more than 1 cm above the substrate.
Calcareous algae	A wide range of red and green algal species that are hard to the touch; <i>Halimeda</i> is often the most common genus.
Crustose coralline algae	Appear as hard smooth pavement covering small or large area; color varies from dark pink to purple, or may show a grayish hue; do not confuse with hard bare substrate that tends to be yellowish or whitish in appearance.
Turf algae (algal turf)	May look fleshy and/or filamentous but do not rise more than 1 cm above the substrate; <i>Gelidium pusillum</i> and <i>Coelothrix irregularis</i> are common species.

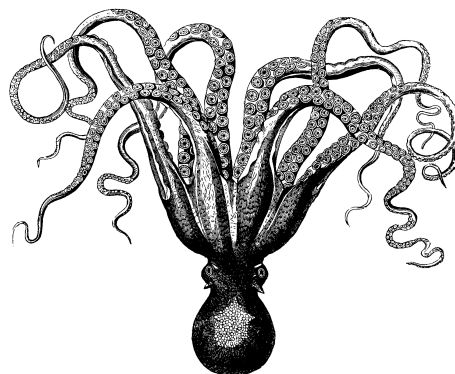

Algal Biomass

You can make a rough estimate of algal biomass (wet) expressed as g/m^2 by removing all of the algae within a 0.25-m^2 quadrat. To obtain an adequate random sample, you'll need to collect and weigh the algae from at least 15 quadrats.

To estimate algal biomass (dry) of endolithic forms (algae growing in the substrate itself), you can use settling plates made of natural substrate (e.g., cross-sections of elkhorn coral), or a variety of other substances such as ceramic tiles.

Estimating Algal Biomass

- 1) Secure at least three settling plates to dead coral, or attach them to a survey stake, re-bar or other apparatus and leave them at the site. Algae will usually begin to grow on the plates within a week. (See method for monitoring recruitment of benthic organisms in the next section.)
- 2) Use a grid and three pairs of random numbers to select three 1-cm^2 subsamples on each plate. Scrape the subsamples to a depth of 1 mm and preserve them in a 1% formalin solution, combining all subsamples from the same plate. Decalcify the sample using a dilute acid (5% HCl or HNO_3).
- 3) Filter the sample onto pre-weighed filters, rinse it with deionized water, and dry it to a constant mass at 60°C .
- 4) To determine the g/cm^2 of biomass, divide the difference between the final filter weight and the initial filter weight before filtration by the number of 1-cm^2 subsamples that were filtered (in this example, 3).

$$\text{g/cm}^2 \text{ biomass} = \frac{\text{Final weight} - \text{initial weight}}{\text{No. of cm}^2 \text{ of subsamples}}$$

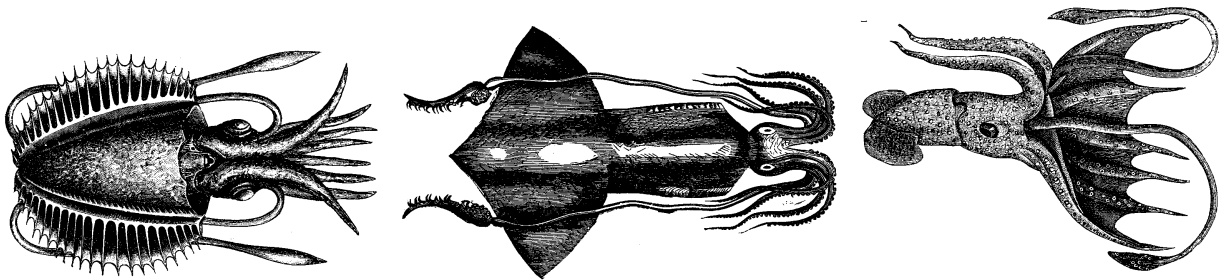

Algal Species Composition

In determining algal species composition, you want to be sure to get an adequate sampling of macroscopic and algal turf communities. Here are some sampling methods.

Estimating Turf Algae Species Composition

- 1) As described for estimating biomass, scrape four 1-cm² subsamples from each plate, preserve the sample in 1% formalin solution, and decalcify it.
- 2) Mount all subsamples from the same plate on the same slide, and note the algal species present while scanning the slide at 100x magnification.
- 3) To estimate relative abundance, put a 10x10 ocular grid over the slide and count the intersections on each species in at least 50 viewing fields.
- 4) To calculate the percent relative abundance for a species, divide the total intersections for that species in all viewing fields by the total intersections for all species in all viewing fields and multiply by 100.

$$\% \text{ relative abundance} = \frac{\text{No. of intersections for a species}}{\text{Total intersections for all species}} \times 100$$

Macroalgae: To estimate the macroalgal species composition on a setting plate, count the intersections of an 8cm x 8cm grid (64 total points) located on top of each macroalgal species.

Photo-quadrats: You can estimate algal abundances using a Nikonos camera with a 28-mm lens and close-up frame. Project the resulting 35-mm color slides onto an 8½x11 sheet of paper with randomly located dots. (See "Dot Grid," III-34.) The number of dots falling on each algal component — algal turf, crustose algae (primarily corallines), calcareous algae and macroalgae — can be summed and expressed as a percent of the total algal cover.

References

Bohnsack, J.A. (1979) "Photographic quantitative sampling of hard-bottom benthic communities," *Bulletin of Marine Science*, 29(2): 242-252.

Carpenter, R.C. (1990) "Mass mortality of *Diadema antillarum*; I. Long-term effects on sea urchin population dynamics and coral reef algal communities," *Marine Biology*, 104:67-77.

RECRUITMENT OF BENTHIC ORGANISMS

Recruitment is the influx of new members into a population by reproduction or immigration. The establishment of new coral recruits generally indicates good conditions for reef development and growth. For overall reef assessment, photographs taken every three months are usually adequate to document recruits more than 5 mm across. You can also examine recruitment on settling plates that are secured to the substrate or tied to a sampling apparatus in a "tree" with four horizontal branches. The following instructions explain how to construct the kind of permanent recruitment sampling apparatus shown below.

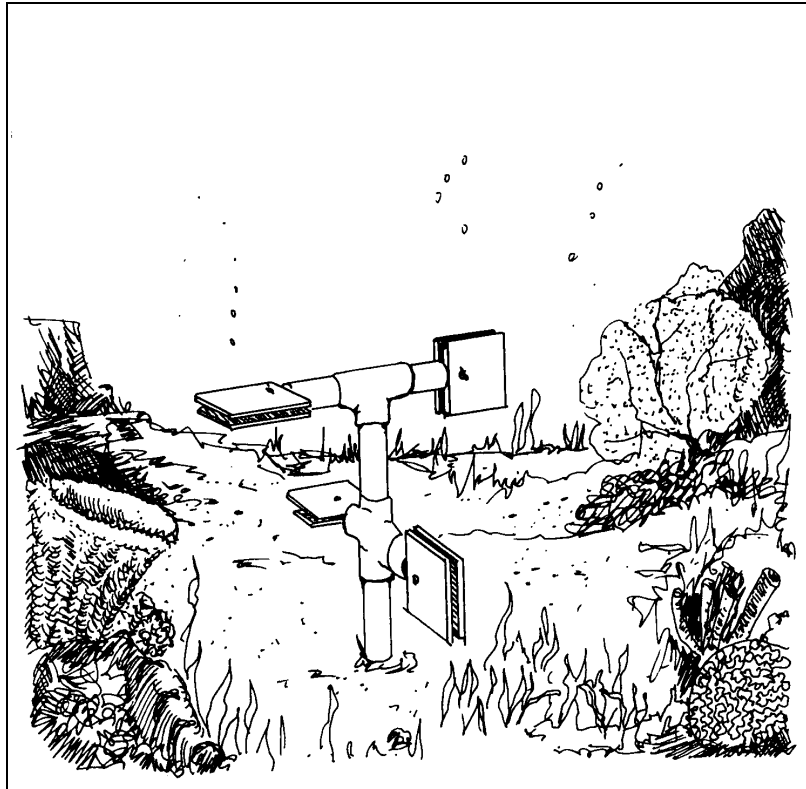

Recruitment Sampling Apparatus

Constructing a Recruitment Sampling Apparatus

- 1) Using PVC cement and pipe arrays (Schedule 40, 1¼-inch diameter) designed to fit over stainless steel reference stakes, glue two 17.8-cm (7-inch) pieces of pipe into opposite ends of a cross fitting. Insert a T fitting into the top pieces.
- 2) Glue a 9.9 cm (3.5 inch) piece of pipe with a 10.8 x 3.8 x 0.64 cm (4¼ x 1½ x ¼-inch) length of PVC flat stock into the open ends of the T and cross fittings.
- 3) For each recruitment array, bolt four pairs of 10.8 cm square ceramic tiles (4¼ inch) to the flat stock piece with ¼-inch stainless steel hardware so the unglazed surfaces are exposed.
- 4) Arrange two pairs horizontally and vertically on an array to help determine whether organisms prefer particular orientations for settlement.
- 5) Secure the array to the stainless steel stake using two ¼-inch set screws.
- 6) Every 6 or 12 months (depending on your study objectives) remove a pair of tiles for examination and replace them with clean tiles.

After collecting the settling plates, examine them using a dissecting scope. Stony corals and other organisms on the plates should be identified to the lowest possible taxon and enumerated to determine abundances and densities, e.g., the number of recruits of each species per settling plate, or per square meter.

References

- Rogers, C.S., Fitz, H.C., Gilnack, M., Beets, J. Hardin, J. (1984) "Scleractinian coral recruitment patterns at Salt River Submarine Canyon" (St. Croix, U.S. Virgin Islands), *Coral Reefs* 3:69-76.
- Jaap, W.C., Wheaton, J.L., Donnelly, K.B., Kojis, B.L., McKenna, Jr., J.E. (1992) "A three-year evaluation of community dynamics of coral reefs at Fort Jefferson National Monument, Dry Tortugas, Florida, USA," Proceedings of the 7th International Coral Reef Symposium.

UNDERWATER PHOTOGRAPHY

Uses

Photography is useful in documenting general reef conditions, changes in reef structure, and the effects of natural and human-caused damage. The variety of sampling techniques available makes it possible to use photography for either a quick qualitative assessment of reef changes or a detailed quantitative analysis. Videotapes are especially useful for showing park managers and non-divers the marine environment.

Photographs and videotapes provide a record of community composition and spatial arrangement of reef organisms that is not available from other forms of data, and that may become of great importance later. For example, although no one anticipated the 1983 die-off of the black sea urchin *Diadema antillarum*, photographs indicate its previous density. In many cases, a photograph will speak more loudly and clearly than a statistical report on changes in percent cover over time. A picture can be worth a thousand numbers.

As a monitoring technique, photography also has the advantage of being relatively easy for volunteers or others who are not trained reef biologists. For example, dive tour operators visit the same dive spots frequently and can provide useful observations on reef conditions and photograph specific sites every few months to document change.

Limitations

Although photography can provide much valuable information, it has limitations that need to be considered when you design a monitoring program and choose your sampling sites.

- Organisms under coral plates or rock ledges will not be visible in a photo, and even those organisms which are visible cannot always be readily identified in a photograph. On-site observation is needed to distinguish between certain species.
- Obtaining quantitative information from photographs of areas with large or abundant octocorals is difficult because they overshadow other organisms.
- Because photographs provide only a two-dimensional view of the reef, they cannot be used to estimate spatial relief. However, stereophotography will provide three-dimensional photographs that can yield information on relief. It is technically more complex and requires sophisticated analytical systems.
- To accurately detect small changes within a small area, you must photograph the area from exactly the same spot each time. Shifts in coral heads or rubble due to storms or bioerosion can make this almost impossible. (This problem can be minimized if a monopod is used, as explained later.)
- Corals may be damaged if you place a quadropod over or near them, especially in topographically complex areas.

- Analysis of photographs to assess changes in percent cover by different species can be done through digitizing of the photographs ("image processing"). Manual digitizing is very time consuming, and many people do not have immediate access to the hardware and software necessary for computer digitizing. However, you can store the photographs (preferably in a cool dry place to avoid fungus damage) until you have the capability to analyze them yourself or send them to a colleague for analysis. (Although less accurate, you can also use a grid of random dots to estimate cover.)
- Photo coverage of large areas is problematic. If a photo is taken from a long distance away, the resolution and water clarity may not be sufficient to identify organisms. An alternative is to take a series of overlapping photos and create a photo-mosaic. Under optimal conditions, it is possible to make a repeatable and accurate mosaic.
- Any movement of the camera, frame, and other apparatus components will reduce the quality of the photograph. Photos taken on rugged topography are very difficult to match and align. An alternative to photomosaics is a series of independent photographs taken from fixed references.

Appropriate Sites

There are some special considerations in site selection if you plan to use underwater photographs or videotapes, especially if they are your only or primary means of data collection.

- The substrate in the site must be able to accommodate whatever permanent stakes will be needed to anchor a camera mounting apparatus.
- If the surrounding area has extreme topography, the depth of field established by the mounting apparatus will place limits on the photographic coverage.
- Photography can be used in high relief areas if qualitative analysis is sufficient for your purposes.
- Dense gorgonian areas should be avoided. A large sea fan can obstruct an entire photograph.

For more guidance on choosing study sites, see "[Site Selection](#)," I-15.

Replication

Long-term monitoring requires a process of data acquisition that is repeatable. If your objective is to precisely measure change at specific locations over time, you must make sure that your photographic coverage is the same each time. For example, you can:

- Use a mounting apparatus so that the camera is always positioned at the same angle and distance from the substrate (or subject), and mark the exact sites for placement of the apparatus.
- Attach the apparatus to a reference marker, or move it between two reference markers, so the photographic coverage is always the same.
- Include a ruler or other scale, compass, identifying number, and the sampling date in the photo or video image.

To see whether you can repeat the photograph exactly, repeat a series of photos at the same location when you do the first sampling and check them for consistency.

Parallax: When you view the same object from different angles or distances, its position and size may appear to change, a phenomenon known as "parallax". In photography, if your camera is not properly aligned for a series of photos, parallax may also result in an overlap of frames. The longer the distance between the camera and the surface you are photographing, the greater the likelihood of parallax.

Color variations: Factors affecting color, such as daily and seasonal changes in available light and variability in strobe output, must also be taken into consideration when photographs are compared. To help document subtle changes over time, you can include a color chart that has gradations of the color characteristic of the species in the photo. Use consistent manual exposures instead of automatic settings for more consistent colors.

Equipment

If you don't have the time, money, or expertise for sophisticated underwater techniques, it's still important to use whatever underwater camera equipment is available to photograph your study site at the outset and periodically thereafter, so you have a visual record that can be used to document major changes in the reef.

Nikonos cameras: Most of the methods referred to in this manual specify use of a Nikonos camera, a compact, rugged, and generally dependable waterproof unit that comes with an automatic light metering system and flash exposure. However, unlike a single-lens reflex (SLR) camera, the Nikonos models III-V require you to compose the shot through a viewfinder, not directly through the lens, and you must focus by measuring or estimating the distance. This is not a problem if you use a close-up framer. The newest Nikonos is an SLR camera (see next page).

Nikonos close-up kit: The Nikonos close-up kit, which comes with several "mini-framer" camera attachments and a threaded tripod mount, provides a simple way to document coral recruitment and monitor other changes in small areas with low relief. Either a 28-mm or a 35-mm lens can provide resolution of about 3-5 mm with Kodachrome 64 film. Permanent photoquadrats located on hard substrate can be marked for resampling by pounding masonry nails into three corners of the photoframe, leaving at least 2 cm of nail above the substrate. Keep in mind that masonry nails will not last for more than two or three years underwater.

SLR camera: If you want a photograph of exactly what you see through the viewfinder, you may prefer to use an SLR camera in a waterproof housing with a dome port, so you can focus precisely. Although the resulting photographs can be excellent, this equipment is generally bulkier and more fragile than Nikonos cameras, and more difficult to attach to a mounting frame. Some SLR cameras also have auto-focus and auto-bracketing, and can imprint the date and time on the negative or slide. The Nikonos SLR camera does not require a waterproof housing, and a variety of lenses (including zoom) are available.

Lenses and strobes: Special lenses and strobe lights can help improve the quality of your underwater photos. Sea water acts as a filter and reduces contrast, especially diminishing colors with longer wavelengths; the farther the light travels through it, the more pronounced the effect becomes. Only blue and some green wavelengths extend below 250 meters. Underwater photography is therefore often done with a wide angle lens (15 to 28-mm) to get the camera as close to the subject as possible.

In clear shallow water, photographs can be taken using natural light, but as depth increases, an electronic flash unit (strobe) or other artificial light is necessary to provide sufficient light, accurate color and contrast. However, using a strobe to illuminate the subject will also illuminate suspended particulates, which may create white specks on the photograph. To minimize this effect, it's generally best to position the strobe so it concentrates light on the subject rather than illuminating the water between the lens and the subject. Use rechargeable nicad batteries to reduce costs. After 36 photos, the batteries should be fully discharged and then recharged.

Maintenance: Underwater camera equipment requires meticulous care before and after dives to prevent corrosion. Use isopropyl alcohol to clean the lens, and rinse the camera (final wash) with distilled or deionized water to avoid salt deposits. Internal O-rings in the Nikonos camera and underwater housings should be replaced by the manufacturer or Nikonos repair facilities every 6-12 months.

Film: Your choice of film may depend largely on personal preference as well as on water visibility and the darkness of substrate. While more expensive, color film makes it easier to distinguish among components such as crustose coralline algae, encrusting foraminiferans, and bare rock, which may not be possible from black and white photographs. Higher-speed films (ASA/ISO of more than 100) are appropriate for natural-light photography that requires quick exposures (e.g., if there is unavoidable motion underwater), but they lack the fine grain of slower films. Having an artificial light source permits use of faster exposure speeds and slower film, which can result in sharper photos.

Mounting apparatus: To photograph larger areas for repeated sampling, you need an apparatus that will position the camera at a constant angle and distance, and a way to anchor the apparatus to the reef at each permanent site while you are taking the photos. Two of the most common methods use an aluminum or PVC monopod (anchored to one survey stake) or quadrapod (anchored either at opposite corners or at all four corners).



Monopod

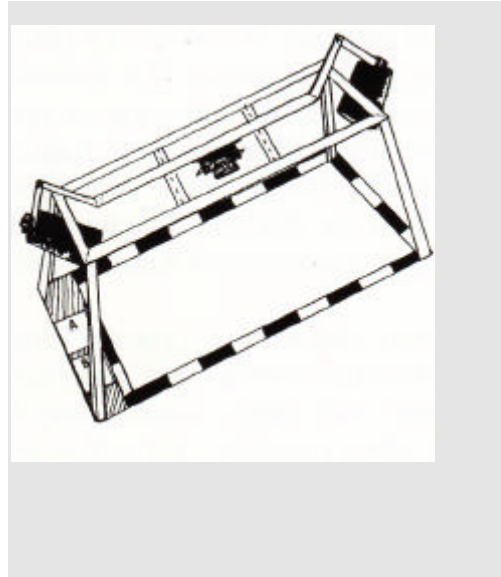

Quadrapod

Advantages: Less risky to reef, especially in areas where corals are large or abundant; easier to construct and faster to use.

Limitations: Since replication may be less precise, it is better for providing qualitative than quantitative data.

More stable; can provide better replication by minimizing the effect of surge or unsteady hands.

Finding an appropriate site with substrate that can be marked (and drilled) at up to four corners may be difficult in some locations.

Although the dimensions of the apparatus should reflect the size of the colonies you are monitoring, your ability to maneuver a large apparatus underwater without injuring the reef is limited. Neither the quadrapod nor the monopod is well-suited to areas with very high relief. [For suggestions on some specific mounting devices, see Appendix A.](#)

Analysis of Photographs

After the photos have been taken, various methods of differing sophistication are available to analyze them.

Dot Grid: If you place a grid of random dots over a slide image of a photo-quadrat on a backlit projector, you can assume that the proportion of dots that lie on a substrate is equal to the proportional area of the substrate. Random dots are preferable because they do not require that each image be scaled. Each configuration of dots should be used only four times, but you can rotate the sheet to get four different configurations.

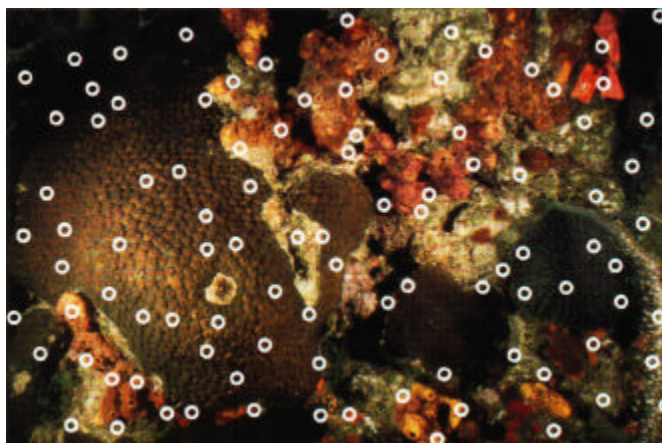

Dot Grid on Photograph

You can determine the optimal number of dots by conducting a preliminary statistical analysis. A grid of 100 dots is usually adequate for large organisms, but 200 is better statistically, and more dots will decrease the variance for some species. If a projector is not available, you can obtain similar results using a binocular microscope with a grid of random points photographed onto 35-mm film and placed beneath the slide.

Digitizing: A more accurate but time-consuming method of determining percent cover is to outline each coral colony or other organism in the photograph with a digital planimeter, or to use an electronic planimeter connected to a computer or image analyzer. Because a coral reef is three-dimensional, the outlined area is *projected*, not *actual* surface area. Changes in these areas over time indicate changes in total live coral cover and relative abundances of different species. The underside of colonies in view are not surveyed, nor are vertical surfaces.

Several software programs are available which can assist analysis by digitizing selected areas (such as coral colonies) within photographs. The program developed by Dr. James Porter and Ms. Linda Chiang of the University of Georgia uses Microsoft Quick Basic and a Jandel digitizer to analyze areas within photostations (see Appendix A, page 6). After tracing the outline of each coral colony onto mylar sheets from photographs, you digitize them to get estimates of projected surface areas. To obtain a copy of the manual containing a diskette with the software program, see "[People to Contact](#)," VI-7, for address and phone number.

Jandel's Sigma Scan is a popular software package that includes management of digitized data. Contact Jandel Scientific, 65 Koch Road, Corte Madera, CA 94925 for details.

Scanning: Another way to quantify photographic data is to scan the image into a computer data base. Scanning is less time consuming than digitizing; however, the hardware and software are relatively costly. Both slides and prints can be scanned but the images may have fuzzy boundaries, which can confound data processing.

Reference

Porter, J.P. (1990) Methods for the Analysis of Coral Reef Community Structure;
I. Photostation, A. Field methods and data acquisition, Report to National Park Service.

Videotaping

Videotaping has certain advantages over still photography for ecological monitoring. Although videotape is ideal if you want to photograph a large area quickly, it has limitations in comparative and quantitative analysis. Theoretically, two videos taken of the same area at different times can be run side by side, making a single video to observe gross changes. However, reproducing the exact path, speed, and distance from the substrate for repeated sampling of a video transect remains difficult. A "cable car" mechanism has been used to slide the camera over the substrate at a fixed distance to create a visual belt transect ([see Appendix A, p. 7](#)). Once the cable carriage apparatus is set up, it is relatively easy to use, but experience is required to get reliable results.

You should not underestimate the value of simply swimming around the reef with the video camera and recording. This method will provide qualitative information about the condition of the reef. Video images can be imported into graphic analytical programs with a frame-grabbing package that evaluates the various colored polygons. These tools, both the underwater video camera and computer analysis of video information, are expensive but can speed up data collection.

Limitations: Videotaping can generally provide only qualitative data. Because the distance between the camera lens and the reef surface is not constant, it's difficult to determine the relative scale of the components. To partially alleviate this problem, you can bolt a rod with a measurement scale to the bottom of the camera housing so that the image has a scale in it.

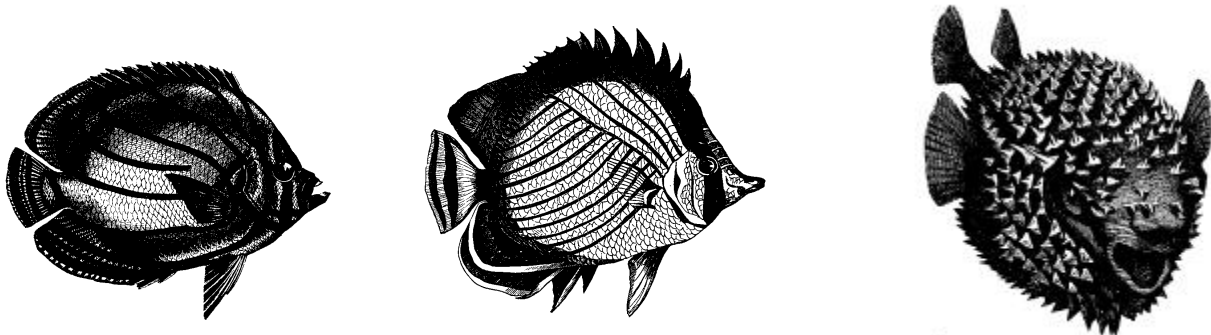

CENSUS OF REEF FISHES

Reef fishes depend on reefs for food and shelter. In turn, reefs are affected by fish species that feed on macroalgae and algal turf (herbivores), and those that feed on coral polyps (coral-livores). Through their waste, fish also provide an important source of nutrients, a very limited resource on coral reefs.

The main objectives for reef fish censuses are to compare fish populations among reefs and other habitats, and to quantitatively monitor species composition and relative abundance over time. For example, a reduction in the top predators (piscivores), declines in species abundance, and shifts to smaller average sizes may indicate fishing pressure. Fish censusing is difficult in coral reef environments because of the structural complexity of the habitat and the diversity, mobility, and abundance of reef fishes. Fish censusing also requires extensive training, as it may be necessary to recognize over 300 different species.

Assessing Fish Populations

Different fish species that appear together are referred to as a "fish assemblage." Three aspects of reef fish assemblages that can be monitored are:

- Diversity: the number of different species;
- Structure: species composition and relative abundance; and
- Population density: the number of fish of a given species per unit area.

Although attempts have been made to develop a single censusing method that will accurately measure all three characteristics, fish biologists generally agree that no such single method exists. You will need to decide what information is most important for your management needs and then select one or more appropriate methods.

Census Methods

The most common methods for visual fish censuses are: stationary counts, belt transects, and random swim techniques. In choosing a method, be sure to consider the behavior of the relevant fish species (e.g., cryptic, schooling, attracted or repelled by divers).

- The **stationary census** (Bohnsack and Bannerot, 1986) focuses on the relative abundance and frequency of occurrence of all species observed at the site.
- The **belt transect** (Brock, 1954) method yields better density estimates and covers a larger area per census.
- The **random swim technique** (Jones and Thompson, 1978) provides more complete information on total species richness.

Limitations: All visual census methods have the following limitations:

- Observers generally underestimate the abundance of most species.
- Only the "observable" portion of the fauna is counted, so cryptic, nocturnal and pelagic species are most likely to be underestimated.
- Observers must be able to identify fauna quickly and correctly; expertise and consistency among observers is difficult to obtain.
- The presence of a diver will affect the behavior of fish.

Frequency and Number of Censuses: How many censuses, how many sites, and how often you should sample will depend on your monitoring objectives. Initially, you may want to census fish over several consecutive days to determine if there is any short-term variability. To detect seasonal changes in abundance and species richness, fish should be censused monthly until a baseline is established. To detect long-term changes sampling should be conducted at least once a year, at approximately the same time of day. It is preferable to census during the same month or at least in the same season each year, with at least 10 censuses conducted each time at each site. Statistical analysis may indicate more samples are necessary to optimize sampling. Methods for optimizing sample number appear in Green (1979) and Bros and Cowell (1987).

References

Bros, W.E., Cowell, B.C. (1987) "A technique for optimizing sample size," *Journal of Experimental Marine Biology and Ecology*, 114:63-71.

Green, R.H. (1979) *Sampling Design and Statistical Methods for Environmental Biologists*, John Wiley & Sons, New York, 257 pages.

Stationary Fish Census

The Bohnsack and Bannerot (1986) method has been very widely used throughout the Caribbean. The basic technique is presented here, although you may find a variation of this method better for your particular area. Appropriate modifications (e.g., changing the size of area sampled, the amount of time spent per census, how the time is allocated while underwater) will depend on local conditions (e.g., visibility, depth) and management needs.

- 1) **Establish a sampling radius.** At each randomly selected site, record the depth, maximum relief of the site, and percent cover by various bottom type classifications (e.g., sand, corals, algae, rubble, etc.). Stretch a tape measure out 15 meters along the reef to mark the sampling diameter; take up a position at the 7.5-m mark.

- 2) **Make a species list.** While rotating at the 7.5-m mark, scan the field of view within an imaginary cylinder extending from the bottom up to the water surface and having a radius of 7.5 m. Record all species observed during the first 5 minutes. To simplify data collection, abbreviate each species name by using the first two letters of the genus and species names (e.g., the Nassau grouper, *Epinephelus striatus*, would be EPST), or the first three letters, if necessary to distinguish between similar names.

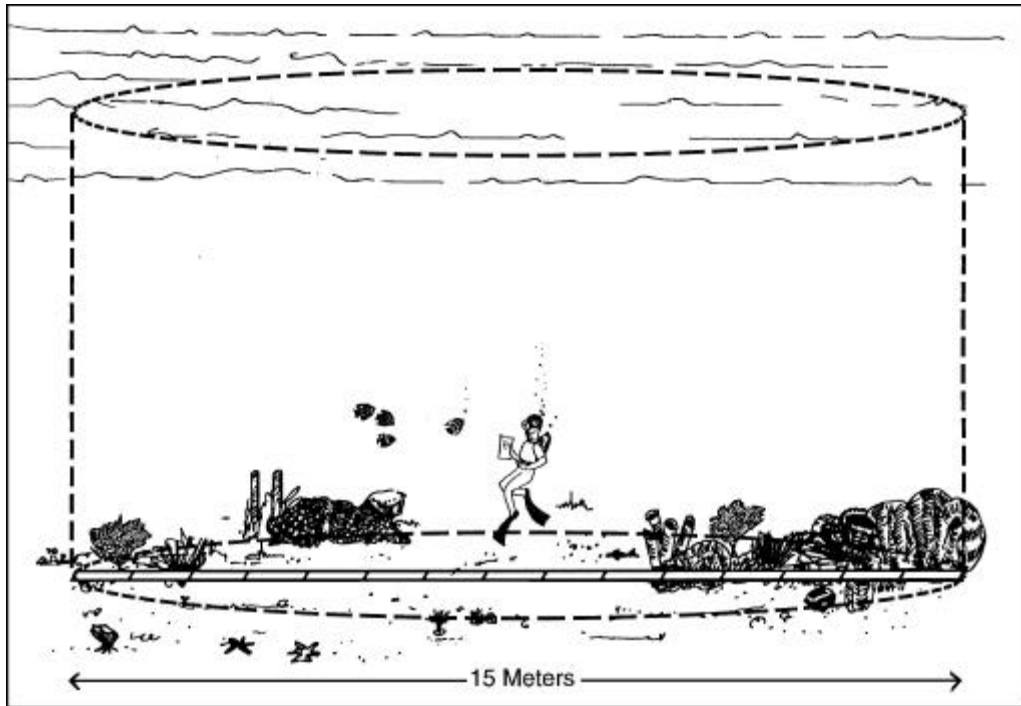

Stationary Fish Census

During this initial 5-minute period, list only the different species you observe within the cylinder. Do not record data on fish size or numbers of individuals -- except for species that are moving through the cylinder and unlikely to remain there, e.g., sharks, rays, mackerels, jacks.

- 3) **Record number and size of each species on the list.** When the initial 5-minute period is over, begin recording data on the size and abundance of the species you have listed.
- Working up from the bottom of your species list, count and measure the number of fish of each species, one species at a time, rotating at the 7.5-m mark until the entire area is scanned.
 - When large schools are present, the number of fish may be estimated by counting by 10's, 20's, 50's, or even 100's.
 - To estimate fish fork length (from the tip of the upper jaw to the end of the middle caudal rays), compare it to a ruler. Divide each species into size classes based on the minimum and maximum fork length to the nearest cm. The number of classes may depend on the number of fish and the extent of their variation in size, but generally each class should include a size range of no more than 5cm.

- If a species listed during the initial 5-minute sampling period is no longer present, record data from memory.
- Any additional fish species observed in the sampling cylinder after the initial 5-minute listing period are ignored unless you want to include them on a site species list.

Each census should take no longer than 15 minutes, including the time needed to record depth, relief of the site, and percent coral cover, sand, and algae. Your underwater data record may look something like the sample shown below, listing the species and the number of individuals of that species counted in each size category. In this example, the observer saw one *Epinephelis striatus* 15 cm long and two 5-7 cm long.

Sample Fish Census Data Sheet			
Species	No. and length of fish by size category		
CHCY	3 (1-2)	56 (3-4)	101 (5-7)
HAAU	2 (10-12)	16 (16-19)	
EPST	2 (5-7)	1 (15)	
GYCI	1 (300)		
CARO	3 (3-4)		

When you enter the data into a computer spreadsheet, record the number of each species and the minimum, maximum and average size of fish in each size class.

Modifications: Some investigators have found a smaller radius is preferable in locations where visibility is low. However, the same radius should be used in all surveys to allow for comparability of data over time and among locations; using a modification at your site will make it difficult to compare data with other areas using the standard method.

One modification reduces the cylinder radius to 5 meters and includes any species observed during the entire 15-minute period (Kimmel, 1993). Because many fish adapt to the presence of a diver during the 15-minute period, this modification results in inclusion of more small, cryptic, and sedentary fish (e.g., gobies, blennies, morays). This modified method may also yield better density estimates for small, abundant territorial species.

References

Bohnsack, J.A., Bannerot, S.P. (1986) "A stationary visual census technique for quantitatively assessing community structure of coral reef fishes," NOAA Technical Report NMFS 41: 1-15.

Kimmel, J.J. (1993) "Suggested modifications to diver-oriented point counts for fishes," Proceedings of the 73rd Annual Meeting, American Society of Ichthyologists and Herpetologists, Austin, Texas.

Belt Transect Census

Belt transects (Brock, 1954) cover a larger area per census than stationary counts and are considered most useful for counting patchily distributed species. They can be conducted along permanent transects marked with survey stakes or other markers, or along reef transects that are randomly selected each time.

The length and width of a belt transect may vary according to the species targeted for a census, but you must use the same dimensions for all transects sampled. A narrow transect (2 m wide) may be good for small, cryptic species, while a wider transect (4 to 5 m) can be useful for groupers, snappers, and parrotfish. Here's the basic technique:

- 1) Swim at a constant speed along the selected area while stretching a fiberglass measuring tape 50 or 100 meters along the bottom.
- 2) As you swim along the transect and unreel the tape, record the fish species, the number of individuals, and the minimum and maximum lengths of species within a prescribed distance (1 to 5 meters) on either side and above the line, including species that are underneath you or cross in front of you. Do not record fish entering the transect area behind you.

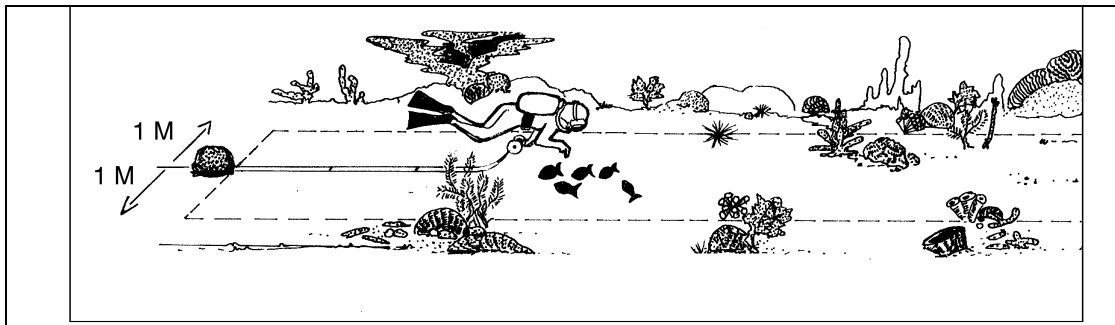

Belt Transect Census

Swimming speed must be standardized for repeated censuses; highly mobile species may be over-estimated at slow speeds, while cryptic species may be overlooked at faster speeds.

Reference

Brock, V.E. (1954) "A preliminary report on a method of estimating reef fish populations," *Journal of Wildlife Management* 18:297-308.

Random Swim Technique

The random swim technique provides good information on relative abundance and species richness, but not on population density. The entire census period is spent searching for unrecorded fish species rather than recording other data about the fish. To obtain reliable data, replicate sample censuses must be conducted.

Variations of this technique appear in Jones and Thompson (1978), and in Kimmel (1985). The basic technique for a 50-minute census is presented below.

- 1) Begin the census at a random location in the selected reef area.
- 2) The census period is divided into five 10-minute intervals. Record the name of each species in the interval in which it is first seen.
- 3) To estimate its abundance, each species is given a score based on the interval within which it is first observed. (More abundant species are likely be recorded in the earlier intervals, and the more cryptic or rare species later on.) Species observed in the first interval receive a score of 5, in the second 4, and so on.

Your data sheet may looking something like this:

Sample Random Swim Data Sheet				
2/5/94: Upper platform, Coral cover: 21%, Depth: 52'				
0-10 min	11-20 min	21-30 min	31-40 min	41-50 min
GOEV STPL STDO SCVI SPRU OCCH HYPU CARU CARO	HARA HAMA HABI CHCY ABSA CHMU STPA	POPA HOTR CHCA ANVI CAPU	CHAN SAVE OPMA SCCO	EPCR LAGO SETO
Score: 5	Score: 4	Score: 3	Score: 2	Score: 1

References

Jones, R.S., Thompson, M.J. (1978) "Comparison of Florida reef fish assemblages using a rapid visual technique," *Bulletin of Marine Science* 28:159-172.

Kimmel, J.J. (1985) "A new species-time method for visual assessment of fishes and its comparison with established methods," *Environmental Biology of Fishes* 12:23-32.

Comparison of Fish Census Methods		
	Advantages	Disadvantages
Stationary Census	Good for relative abundance; allows for large sample sizes in distinct habitats.	Takes longer to train people; less likely to provide a complete site-species list (unless modified).
Belt Transect	Large area can be sampled per census; can target more mobile species; may provide more accurate density estimates for species such as snappers and groupers.	Fewer samples per unit of time than stationary methods; may not provide data on small habitats.
Random Swim	Mostly likely to provide a complete species list; describes a larger portion of species per sample.	Fewer samples per unit of time; provides less quantitative data and no density estimates.

Data Analysis

You need to consider how you'll analyze the data when you design your fish censusing method. It's usually important to analyze data on frequency of occurrence, abundance, richness, evenness and diversity of species at individual sites and among sites. Data on changes in relative abundance and frequency of occurrence can provide information on population changes for individual species. Changes in average size and structure of size classes of important species can also be evaluated.

Data may be summarized using a data management program such as dBase 4 or Paradox, and then analyzed with a statistical package such as SAS or Minitab. Several statistical techniques are available to analyze the data when you have multiple variables (cluster analysis or detrended correspondence analysis) and test for differences among sites (parametric/ non-parametric techniques) or over time (time-series analysis). The references listed below provide explanations of these and other statistical methods.

References

- Johnson, R.A., Wichern, D.W. (1992) *Applied Multivariate Statistical Analysis*, Prentice-Hall, Englewood Cliffs, New Jersey, 642 pages.
- Ludwig, J.A., Reynolds, J.F. (1988) *Statistical Ecology: A Primer on Methods and Computing*, John Wiley and Sons, New York, 337 pages.
- Green, R.H. (1979) *Sampling Design and Statistical Methods for Environmental Biologists*, John Wiley & Sons, New York, 257 pages.

IV. STRESSES TO CORAL REEFS

OVERVIEW

The charts below summarize the suggested components of a basic monitoring program that will address a variety of situations. In all cases, it is a good idea to use photography to document your study sites.

For this situation:	For a basic monitoring program, you should:
Coral bleaching	Monitor individual coral colonies; measure water temperature, PAR, and UV.
Damage by boats, snorkelers, divers	Measure physically damaged area; record number of broken coral branches.
Over-fishing	Census reef fishes.
Sediments from dredging or runoff	Measure sedimentation rates and bacterial concentrations.
Orinoco plume	Measure water temperature, water transparency, salinity, and chlorophyll concentration.

In these situations, you should be monitoring at established quadrats or transects in the affected areas and at control sites.

Baseline monitoring	Monitor individual coral colonies and live coral cover; measure water temperature, algal biomass, water transparency, and salinity; census reef fishes.
Sewage or other nutrient influx	Monitor individual coral colonies; measure nutrients, water temperature, algal biomass, live coral cover, salinity, dissolved oxygen and bacterial concentrations.
Desalination plant effluent	Measure water temperature and salinity.
Storm damage	Monitor individual coral colonies; measure algal biomass; census reef fishes.
Oil spill	Monitor individual coral colonies.

A detailed, comprehensive discussion of the effects of all these stresses on reefs is outside the scope of this manual. Some of the human activities that cause physical damage to the reef structure are described below with suggestions for monitoring.

SCUBA DIVING AND SNORKELING

The growing number of snorkelers and divers is resulting in increasing damage to coral reefs. The harm caused by SCUBA diving depends on the skill and training of the divers and dive operators. Especially at heavily used sites, divers may stir up sediments and break corals. However, unless you actually see the damage taking place, it's difficult to know for certain its cause.

In very shallow areas where fragile branching corals are abundant, damage from snorkelers can present a management problem. For example, a park manager may need information to determine whether an underwater trail should be closed and snorkelers moved to another location to allow the initial site to recover. Ideally, underwater trails should be placed in areas deep enough to reduce damage from fins, but the best protection comes from educating snorkelers and divers.

To quantify damage to elkhorn coral (*Acropora palmata*), you need to consider both the number and size of the breaks. Here's an easy way to do this:

Estimating Damage to Elkhorn Coral

- 1) While swimming parallel transects across the reef area, count the number of freshly broken branches of elkhorn coral.
- 2) Measure the "length" and "width" of each fracture area or stump with a small plastic ruler marked in millimeters. Because most fracture areas in elkhorn corals are elliptical, the length and width measurements can be used to calculate areas using the formula for an ellipse.

$$\text{Fracture Area} = \text{Length} \times \text{Width} \times 0.8$$

- 3) Although you don't have to swim exactly the same transects each time, it's helpful to know the total area being surveyed so that you can estimate the density of coral breaks, i.e., the number of breaks per square meter.

Monthly observations of snorkel sites are most effective. If surveys are made more often, distinguishing new breaks from old ones is often difficult, so the same break may be counted more than once. If surveys are made less often, breaks occurring since the last survey will be difficult to see, as algae grow rapidly over freshly broken areas (sometimes within a week).

Reference

Rogers, C.S. McLain, L., Zullo, E. (1988) "Damage to coral reefs in Virgin Islands National Park and Biosphere Reserve from recreational activities," Proceedings of the 6th International Reef Symposium 2:405-410.

BOAT GROUNDINGS AND ANCHORS

Dramatic increases in boating in Florida and the Caribbean have led to an increase in boat groundings and anchor damage. This section contains some suggestions on how to conduct a general survey of damage from small boats and large cruise ships, and how to assess the damage resulting from a particular anchoring or grounding incident. Aerial photographs of popular bays and anchorages can be used to estimate the increase in number of boats using an area over time.

Depending on the depth, you'll need to use snorkeling or SCUBA to record the necessary data.

It is important that only experienced divers investigate near anchors and anchor chains, especially those of large ships. If the anchor is being raised, you should not be anywhere near the ship! If the damage occurred in a protected area and legal action may be taken, do not attempt any rehabilitation until you've consulted with the appropriate legal authorities.

General Survey of Anchor Damage

If you are concerned about the effects of anchoring in a particular bay or at a dive site, you can dive on the anchors from several boats and:

- 1) Record the time of survey, boat length, type of boat, type of anchor, length of anchor chain resting on bottom, depth, and bottom type (coral, seagrass, sand, rubble, pavement, and mud).
- 2) Rate the observed damage on a scale of 1 to 5, from negligible to severe.
- 3) Analyze your data to describe the magnitude of the damage from anchoring, and restrict anchoring if appropriate.

Specific Incidents

When you wish to assess the damage caused by a specific boat grounding or anchoring incident, your approach will depend partly on the size of the affected area. But in all cases it is essential to record the site location by marking it on a map or listing the compass bearings to fixed locations; determine the GPS or LORAN coordinates. Landmarks, compass bearings, and buoys are often needed to help find the site again. For more suggestions, see "[Marking the Site](#)," I-16.

For a small grounding site or anchor scar: If feasible, mark the perimeter of the damage and/or the location of the grounded boat by installing re-bar stakes or other permanent markers which will facilitate future monitoring. Then record distances and compass bearings from stake to stake, and estimate the size of the damaged area by measuring it, or plotting stake locations and digitizing the resulting map. Because underwater compasses do not give accurate compass readings, it is important to use surface buoys attached to the bottom and a "boxed" (calibrated) compass on the boat to determine the exact location of the scar.

For a larger grounding site or longer anchor scar: Extend a tape measure across the approximate center axis of the scar, which may have several turns.

- 1) Secure the tape to stakes or coral rubble at both ends and at intermediate points as needed so this base line will remain in place during measurements.
- 2) Record the compass bearings of the scar. If the scar is not straight, record the bearing of each segment. These data will be important for locating the site again and for constructing computerized maps of the scar.
- 3) To measure the overall size of the scar, measure the perpendicular distance from the base line to the edge of the scar at 2-3 m intervals. The edge of the scar will usually be quite conspicuous because of the presence of injured corals and/or loose debris.

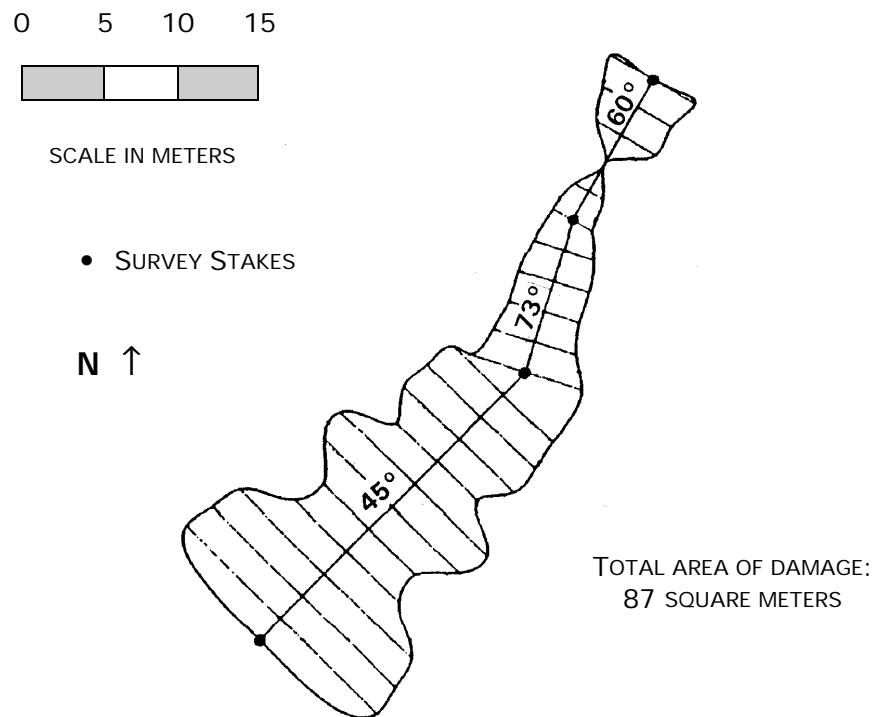

Map of Anchor Scar with Compass Bearings

For very large areas: An alternate method, especially appropriate for very large areas, is to construct a grid of 10-m squares (or other appropriate size) over the scar. Estimate the percent of damage within each square, as described in the next section. While it is important to be as quantitative as possible, constraints on divers' bottom time may require compromises on accuracy and detail if the area is in deep water or is very large.

Aerial photography: If the damage is several hectares in size, it may be best to use aerial photogrammetry. To provide a reference scale in the image, you can use blue plastic tarpaulins, 12 ft by 12 ft on the sea floor adjacent to the damage.

Estimating Coral Damage

To estimate the percent of live corals and other organisms as well as the amount of damage, use 1 m² quadrats made of PVC pipe and divided into 100 squares with nylon line. Each square therefore represents 1% of the quadrat.

- 1) Place the quadrats randomly along the measuring tape or transect lines, and randomly on nearby undamaged reef so that you can estimate what the coral community in the affected area was like before the damage occurred.
- 2) Record not only the amount of damage, but the type (e.g., abrasion, scour, pulverization, fragmentation). If a 10-m grid is used, two observers should estimate the amount of remaining live cover and average their two values.
- 3) If possible, count the number of overturned or fragmented coral heads and pieces of substrate in the entire area. Otherwise, count the numbers in a known area (e.g., 20 m²) and extrapolate to the entire affected area. Depending on the size of the area and your available resources, you may need to set an arbitrary size limit on the coral heads and rubble that you include in your count.

You can also estimate the percent live cover in the damaged and nearby undamaged areas on the reef by using a linear chain transect or line intercept transect method. Depending on your objective, you may decide to measure only live coral colonies or all reef components.

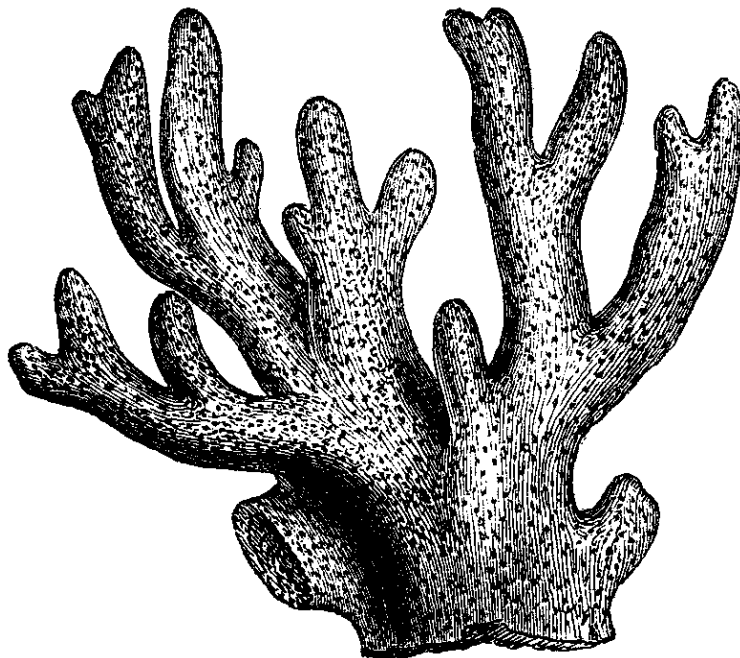

SUMMARY

The monitoring techniques described in this manual are presented as a guide to some of the methods that have proved useful in coral reef monitoring programs in the Caribbean and western Atlantic region. This manual does not include all monitoring techniques currently in use, but it provides details on numerous methods used to examine and document information on the physical, chemical and biological parameters of the coral reef ecosystem. Other manuals on coral reef monitoring that you may find helpful are listed under "Information Sources," VI-1.

These tools will enable you to collect the baseline data necessary to document changes in the ecological and structural components of the reef. You can then use that information to evaluate and assess impacts, both natural and human, to the coral reef ecosystem. Baseline information is a prerequisite to understanding the natural system, and a better understanding of the current status of the reefs is essential before management decisions can be made.

A comprehensive monitoring program should encompass physical, chemical and biological components. Information collected about the physical condition of the reef will help to explain biological characteristics noted at the study site. Most of us are operating under many constraints with limited personnel, equipment and funding, but it is crucial that we begin collecting baseline information. No matter how small your budget, there are monitoring techniques outlined in this manual that can provide valuable information. Do not underestimate the usefulness of collecting even the most basic data; qualitative documentation is better than nothing. Although you will need to tailor a program which is suited to your specific objectives, budget and time frame, use of standardized methods outlined in this manual will facilitate discussion and comparison of data throughout the region.

Good luck!

V. GLOSSARY

- algae** -- one celled or many-celled plants that have no root, stem, or leaf systems.
- algal turf** -- densely packed algae that project less than one centimeter above the substrate they are growing on; usually filamentous.
- belt transect** -- a narrow band of predetermined width set across a study area, and within which the occurrence or distribution of plants or animals is recorded.
- benthic** -- bottom-dwelling; living on or under sediment, pilings, etc.
- bioerosion** -- the breakdown of skeletal material when organisms bore into it.
- biomass** -- the total weight of organic material of a particular species or in a particular habitat per unit of area or volume.
- biota** -- the total plant and animal life of a given area.
- bleaching** -- loss of color from reduction in the number of zooxanthellae and/or the amount of photosynthetic pigments.
- bloom** -- a sudden increase in the density of phytoplankton or benthic algae in an area.
- chain transect** -- a linear transect under which a chain is draped to gather data on all the surfaces beneath the chain.
- chlorophyll** -- a group of pigments present in plant cells which are essential in the use of light energy for photosynthesis.
- cnidarian** -- a member of the Phylum Cnidaria (also known as Coelenterata), which includes corals, octocorals, hydroids, jellyfish, and anemones.
- digitize** -- to determine the area of an item in a photograph or on a map by outlining it manually with a planimeter or electronically with a computer.
- dinoflagellates** -- unicellular algae in the Division Pyrrophyta.
- endolithic** -- growing within a rock or other hard inorganic substratum.
- endosymbiotic** -- living within another organism.
- fire coral** -- a member of the Class Hydrozoa which forms a calcium carbonate skeleton; the fire corals *Millepora* spp. are very conspicuous on Caribbean and western Atlantic reefs.

foraminiferans -- an order of planktonic and benthic protozoans that possess protective coverings usually composed of calcium carbonate.

gorgonian -- a soft coral of the Order Gorgonacea; most octocorals, including sea fans, whips, and branching soft corals.

hardground -- cemented hard rock surface that has become lithified.

holdfast -- an organ of attachment or anchoring structure, as that of octocorals.

in situ -- Latin term meaning "in the normal or natural position".

lagoon -- a body of water separated from the sea by a bank or coral reef; the region between a shore and a barrier reef or inside a ring of islands composing an atoll.

linear transect -- a line of a specified length across a study site beneath which data are gathered to provide a random sampling of organisms within that zone.

macroalgae -- algae that project more than one centimeter above the substrate, such as *Dictyota* and *Halimeda*.

octocoral -- a member of the Subclass Octocorallia, which includes gorgonians, sea fans, and other organisms; the polyps bear eight tentacles which usually have small projections.

parallax -- a distortion that occurs when viewing the same object from different angles or distances so the object's position and size may appear to change.

patchiness -- uneven or variable distribution.

pavement -- hard carbonate substrate of low relief, sometimes dominated by octocorals.

pelagic -- free-swimming or floating organisms that live exclusively in the water column, not on the bottom.

photic zone -- the region of sea water penetrated by at least 1% of subsurface radiation.

photo-quadrat -- a quadrat that is photographed for purposes of species monitoring or measuring.

plankton -- drifting or slowly swimming organisms that are subject to currents; mostly microscopic algae, protozoans, and larval forms of higher animals.

piscivorous -- feeding on fish.

polyp -- the basic structural unit of a cnidarian, consisting of a tubular or cylindrical body having an oral end which bears the mouth and tentacles.

protozoa -- a phylum of one-celled animal with nuclear material contained within a nuclear sheath.

quadrat -- a two-dimensional square or rectangular sampling unit within which organisms are counted or measured, or the frame that marks this area.

scleractinian -- member of the Order Scleractinia, the stony corals of the reef that produce calcium carbonate cups called corallites.

sessile -- attached to the bottom or to rocks, pilings, etc. and unable to move.

spatial index -- the ratio of reef surface contour distance to linear distance; used as a measure of the reef's topographical complexity or three-dimensional relief.

symbiont -- a symbiotic organism; either of the two organisms participating in symbiosis, which is an interactive relationship between two species.

thermal stress -- energy burden placed on an organism by temperatures either higher or lower than the organism can tolerate.

transect -- a line or narrow belt used to survey the distributions of organisms or substrate across a given area.

zoanthid -- small anemone-like Cnidarians (solitary or colonial).

zooxanthellae -- photosynthetic, dinoflagellate algae that live symbiotically in the tissues of certain marine invertebrates, including reef-building corals.

VI. INFORMATION SOURCES

Other Coral Reef Monitoring Manuals

CARICOMP (Caribbean Coastal Marine Productivity, 1991) *Manual of Methods for Mapping and Monitoring of Physical and Biological Parameters in the Coastal Zone of the Caribbean*, Florida Institute of Oceanography, 35 pages.

Cintrón, G., Lysenko, N., Sang, L., and J.R. García (1993) *Manual de Metodos para la Caracterizacion y Monitoreo de Ecosistemas de Arrecife de Coral*, MacArthur Foundation and World Wildlife Fund, 25 pages.

Coyer, J. and J. Witman (1990) *The Underwater Catalog: A Guide to Methods in Underwater Research*, Shoals Marine Laboratory, Ithaca, New York, 72 pages.

Dahl, A.L. (1981) *Coral Reef Monitoring Handbook*, South Pacific Commission Publications Bureau, Noumea, New Caledonia, 21 pages.

Dartnall, A.J. and M. Jones (1986) *A Manual of Survey Methods for Living Resources in Coastal Areas*, Australian Institute of Marine Science.

IUCN Publications (1993) *Monitoring Coral Reefs for Global Change*, a review of inter-agency efforts compiled by John C. Pernetta, IUCN Publications Services Unit, Cambridge England, 102 pages.

Kenchington, R.A. and B. Hudson, eds. (1984) *Coral Reef Management Handbook*, UNESCO Regional Office for Science and Technology for Southeast Asia, 281 pages.

UNEP/AIMS (1993) *Monitoring Coral Reefs for Global Change*, Reference Methods for Marine Pollution Studies No. 61 (United National Environment Programme), 72 pages.

UNESCO (1984) *Comparing Coral Reef Survey Methods*; Report of a regional UNESCO/UNEP Workshop, Phuket Marine Biological Centre, Thailand, UNESCO Report in Marine Science No. 21, 170 pages.

Reference Books and Articles

Dubinsky, Z., Ed. (1990) *Ecosystems of the World*, Volume 25: Coral Reefs, Elsevier Science Publishing Company, Inc., New York, 550 pages.

Kaplan, E.H. (1982) *A Field Guide to Coral Reefs* (Caribbean and Florida), The Peterson Field Guide Series, Houghton Mifflin Company, Boston, 289 pages.

Likens, G.E., ed. (1988) *Long-Term Studies in Ecology: Approaches and Alternatives*, Springer Verlag, New York.

Magnuson, J.J. (1990) "Long-term ecological research and the invisible present," *Bioscience* 40(7):495-501.

Sale, P.F., ed. (1992) *The Ecology of Fishes on Coral Reefs*, Academic Press.

Strandberg, C.H. (1967) *Aerial Discovery Manual*. John Wiley and Sons, Inc. New York.

Methods for Coral Reef Research

Jaap, W.C., Wheaton, J.L., and K. Boomer Donnelly (1990) "Materials and methods to establish multipurpose, sustained, ecological research stations on coral reefs at Dry Tortugas," Proceedings of the American Academy of Underwater Sciences, 10th Annual Scientific Diving Symposium, pp. 193-211.

Littler, M.M., and D.S. Littler (1985) "Nondestructive sampling," in *Phycological Methods*, Littler, M.M. and D.S. Littler, ed., Cambridge University Press, pp. 161-175.

Ohlhorst, S.L., Liddell, W.D., Taylor, R.J., and J.M. Taylor (1988) "Evaluation of reef census techniques," Proceedings of the 6th International Coral Reef Symposium 2:319-324.

Stoddart, D.R. and R.E. Johannes, eds. (1978) *Coral Reefs: Research Methods*, UNESCO Monographs on Oceanographic Methodology 5.

Weinberg, S. (1981) "A comparison of coral reef survey methods," *Bijdragen tot de Dierkunde*, 51(2):199-218.

Physical and Chemical Monitoring

Parsons, T.R., Maita, Y., and C.M. Lalli (1984) *A Manual of Chemical and Biological Methods for Seawater Analysis*, Pergamon Press, New York, NY, 173 pages.

Strickland, J.D.H. and T.R. Parsons (1972) *A Practical Handbook of Seawater Analysis*, Fisheries Research Board of Canada, Ontario, Canada.

Underwater Photography and Other Techniques

Coyer, J. and J.D. Witman (1990) *Underwater Catalog: A Guide to Methods in Underwater Research*, Shoals Marine Laboratory, Cornell University, Ithaca, New York, 72 pages.

DeCouet, H.G. and A. Green (1989) *The Manual of Underwater Photography*, Verlag Christa Hemmen, Weisbaden, German, 394 pages.

Maney, E.J., Jr., Ayers, J., Sebens, K.P., and J.D. Witman (1990) "Quantitative techniques for underwater video photography," Proceedings of the 10th Diving for Science Symposium, pp. 255-265.

Reef Damage Assessment and Rehabilitation

Birkeland, C., Randall, R.H., and G. Grimm (1979) "Three methods of coral transplantation for re-establishing a coral community in the thermal effluent area of the Tanguisson Power Plant," University of Guam Marine Laboratory Technical Report 60, 24 pages.

Bouchon, C., Jaubert, J., and Y. Bouchon-Navaro (1981) "Evolution of a semi-artificial reef built by transplanting coral heads," *Tethys* 10(2):173-176.

Desvousges, W.H., Dunford, R.W., and J.L. Domanico (1989) "Measuring natural resource damages: an economic appraisal," Report of the Research Triangle Institute.

Gittings, S.R., Bright, T.J., Choi, A., and R.R. Barnett (1988) "The recovery process in a mechanically damaged coral reef community: recruitment and growth," Proceedings of the 6th International Coral Reef Symposium 2:225-230.

Guzman, H.M. (1991) "Restoration of coral reefs in Pacific Costa Rica," *Conservation Biology* 5(2):189-195.

Harriot, V.J. and D.A. Fisk (1988) "Coral transplantation as a reef management option," Proceedings of the 6th International Coral Reef Symposium 2:375-379.

Harriot, V.J. and P.L. Harrison (1984) "Methods to accelerate the recolonization of corals in damaged reef systems," Report to Great Barrier Reef Marine Park Authority, 58 pages.

Maragos, J.E. (1974) "Coral transplantation: a method to create, preserve, and manage coral reefs," UNIHI-Seagrant-Ar-74-03, 29 pages.

Fish Census Techniques

Bell, J.D., Craik, G.J.S. Pollard, D.A. and B. C. Russell (1985) "Estimating length frequency distributions of large reef fish underwater," *Coral Reefs* 4:41-44.

Bortone, S.A., Hastings, R.W. and J.L. Ogleby (1986) "Quantification of reef fish assemblages: A comparison of several in situ methods," *Northeast Gulf Science* 8(1):1-22.

Brock, R.E. (1982) "A critique of a visual census method for assessing coral reef fish populations," *Bulletin of Marine Science* 32: 269-276.

Harmelin-Vivien, M. L., J. G. Harmelin, C. Chauvet, C. Duval, R. Glazin, P. Lejeune, G. Barnabe, F. Blanc, R. Chevalier, J. Duclerc and G. Lasserre (1985) "Evaluation visuelle des peuplements et populations de poissons: methodes et problemes," *Rev. Ecol. (Terre Vie)* 40: 467-539.

Kaufman, L.S. and J.P. Ebersole (1984) "Microtopography and the organization of two assemblages of coral reef fishes in the West Indies," *Journal of Experimental Marine Biology* 78:253-278.

Kimmel, J.J. (1985) "A new species-time method for visual assessment of fishes and its comparison with established methods," *Environmental Biology of Fishes* 12:23-32.

St. John, J., Russ, G.R., and W. Gladstone (1990) "Accuracy and bias of visual estimates of numbers, size structure and biomass of a coral reef fish," *Marine Ecology Progress Series* 64:253-262.

Thresher, R.E. and J.S. Gunn (1986) "Comparative analysis of visual census techniques for highly mobile, reef associated piscivores (Carangidae)," *Env. Biol. Fish.* 17:93-116.

Fish Identification

Bohlke, J.E., and C.C.G. Chaplin (1993) *Fishes of the Bahamas and Adjacent Tropical Waters (Second Ed.)*, Univ. of Texas Press, Austin, Texas.

Chaplin, C.C.G. (1972) *Fishwatchers' Guide to West Atlantic Coral Reefs*, Horrowood Books.

Hoese, H.D. and R.H. Moore (1985) *Fishes of the Gulf of Mexico, Texas, Louisiana and Adjacent Waters*, Texas A&M Press.

Humann, P. (1989) *Reef Fish Identification; Florida, Caribbean, Bahamas*, New World Publications, Inc. Jacksonville, Florida.

Randall, J.E. (1983) *Caribbean Reef Fishes*, T.F.H. Publications, Inc., Neptune City, New Jersey, 350 pages.

Robins, R.C., Ray, G.C., Douglass, J. and E. Freund (1986) *A Field Guide to Atlantic Coast Fishes of North America*, Peterson Field Guide Series, Houghton Mifflin Company, Boston, Massachusetts.

Stokes, F. (1984) *Divers' and Snorkelers' Guide to the Fishes and Sea Life of the Caribbean, Florida, Bahamas, and Bermuda*, The Academy of Natural Sciences, Philadelphia.

Identification of Corals, Octocorals and Other Invertebrates

Bayer, F.B. (1961) *The Shallow-Water Octocorallia of the West Indian Region*, Martinus Nijhoff, The Hague, Netherlands, 373 pages.

Colin, P.L. (1978) *Caribbean Reef Invertebrates and Plants*, T.F.H. Publications, Inc., Neptune City, New Jersey, 512 pages.

Gladfelter, W.B. (1988) *Tropical Marine Organisms and Communities (St. Croix)*, ARGUS.

Goldberg, W.M. (1973) "The ecology of the coral-octocoral communities off the southeast Florida coast," *Bulletin of Marine Science* 23(3):465-488.

Humann, P. (1993) *Reef Coral Identification; Florida, Caribbean, Bahamas*, New World Publications, Inc., Jacksonville, Florida, 338 pages.

Humann, P. (1992) *Reef Creature Identification; Florida, Caribbean, Bahamas*, New World Publications, Inc. Jacksonville, Florida, 320 pages.

Kinzie, R.A. (1973) "The zonation of West Indian gorgonians," *Bulletin of Marine Science* 23(1):93-155.

Soest, R.W.M. van (1981) "A checklist of the Curacao sponges (Porifera Demospongiae)," Zoology Museum, University of Amsterdam, 39 pages.

Weidenmayer, F. (1977) "Shallow water sponges of the Western Bahamas," *Experientia Supplement* 28, Birkhauser Verlag, Basel, Switzerland.

Wells, J.W. (1973) "New and old scleractinian corals from Jamaica," *Bulletin of Marine Science* 23(1):16-58.

Marine Plants

Littler, D.S., Littler, M.M., Bucher, K.E., and Norris, J.N. (1989) *Marine Plants of the Caribbean*, Smithsonian Institution Press, Washington, D.C., 263 pages.

Taylor, W.R. (1972) *Marine Algae of the Eastern Tropical and Subtropical Coasts of the Americas*, University of Michigan Press, Ann Arbor, Michigan, 870 pages.

Coral Diseases

Edmunds, P.J. (1991) "Extent and effect of black band disease on a Caribbean reef," *Coral Reefs* 10(3): 161-165.

Gladfelter, W.B. (1982) "White-band disease in *Acropora palmata*: implications for the structure and growth of shallow reefs," *Bulletin of Marine Science* 32(2): 639-643.

Peters, E.C. (1993) "Diseases of other invertebrate phyla: Porifera, Cnidaria, Ctenophora, Annelida, Echinodermata," *Pathology of Marine and Estuarine Organisms*, John A. Couch and John W. Fournie, eds., CRC Press, Boca Raton, Florida.

Peters, E.C. Oprandy, J.J., and P.P. Yevich (1983) "Possible causal agent of white band disease in Caribbean acroporid corals," *Journal of Invertebrate Pathology* 41:394-396.

Peters, E.C. (1984) "A survey of cellular reactions to environmental stress and disease in Caribbean scleractinian corals," *Helgolander Meeresunters* 37: 113-137.

Rutzler, K., Santavy, D. (1983) "The black band disease of Atlantic reef corals," I. Description of the cyanophyte pathogen, *PSZNI Marine Ecology* 4(4): 301-319.

Coral Bleaching

D'Elia, C.F., Buddemeier, R.W., and S.V. Smith (1991) "Workshop on Coral Bleaching, Coral Reef Ecosystems and Global Change," Report of Proceedings, Maryland Sea Grant College Publication, College Park, Maryland.

Jaap, W.C. (1985) "An epidemic zooxanthellae expulsion in the lower Florida Keys coral reefs: hypothermic etiology," Proceedings of the 5th International Coral Reef Symposium, 6:143-148.

Williams, E. H., Jr. and L. Bunkley-Williams (1990) "The world-wide coral reef bleaching cycle and related sources of coral reef mortality," *Atoll Research Bulletin* (Smithsonian) 335:1-71.

Williams, E. H., Jr., C. Goenaga and V. Vicente (1987) "Mass bleachings on Atlantic coral reefs," *Science*, 238:877-878.

PEOPLE TO CONTACT FOR ASSISTANCE

If you have a question about monitoring procedures, or you would like help in locating information on a specific topic, these individuals may be able to assist you or to put you in touch with someone else who can.

Dr. Jim Beets
University of Richmond
Department of Biology
Richmond, VA 23173
(804) 272-3798

Mr. Walter Jaap
Ms. Jennifer Wheaton
Florida Marine Research Institute
100 8th Avenue, S.E.
St. Petersburg, FL 33701
(813) 896-8626

Dr. Jim Bohnsack
National Marine Fisheries
75 Virginia Beach Drive
Miami, Florida 33149
(305) 361-4252

Dr. Joe Kimmel
National Marine Fisheries Service
Southeast Regional Office
St. Petersburg, FL 33702
(817) 893-3721

Dr. Pete Edmunds
Department of Biology
California State University
Northridge, CA 91330
(818) 885-2502

Dr. Jim Porter
University of Georgia
Department of Zoology
Athens, GA 30602
(706) 542-3410

Dr. Betsy Gladfelter
Gallows Bay Station
P.O. Box 26472
St. Croix, USVI 00824
(809) 773-1383

Dr. Caroline Rogers
National Biological Survey
Virgin Islands National Park
P.O. Box 710
St. John, USVI 00830
(809) 693-8950

Ms. Zandy-Marie Hillis
Buck Island Reef National Monument
P.O. Box 160
Christiansted, USVI 00820-0160
(809) 773-1460

Appendix A: UNDERWATER PHOTOGRAPHY

Of the many methods available for photographic sampling, six devices are described in this section in approximate order of increasing complexity. Although these devices vary in sophistication and cost, the goal is always to make sure that each photograph is taken of the exact same area, at the exact same distance and angle. These methods will continue to evolve as experience and new technology lead to better techniques. For more general information and suggestions about underwater photography, [see III-29](#).

Method A: Quadrapod for Large Photo-quadrats

In quadrapod methods, an underwater camera is mounted in the center of an aluminum or PVC frame with the lens facing the substrate. Four legs made from 1-inch PVC pipe that connect this frame to the corners of a larger rectangle (the photo-quadrat), so that the apparatus looks like a 3-dimensional trapezoid. To secure a Nikonos to a 7/8-inch thick PVC mounting plate, use a 1/4-inch bolt that threads into the tripod mount of the camera. Using Ikelite "quick handles" and 18-inch supports, you can also attach two strobes to the back of the mounting plate, or a single SB103 strobe to the top of the frame.



Quadrapod for Large Photo-quadrats

The exact dimensions of the quadrapod will depend on the size of the area you wish to photograph and your lens size, but you can use this method to photograph large areas without expensive equipment. This approach can also be used to take photographs along a transect line stretched between two permanent reference markers.

For example, to cover an area of approximately 55 x 80 cm with moderate or no relief, you could use a 28-mm Nikonos lens with a quadrapod that holds the camera 95-cm above the reef surface. Or, if the focal plane of the film is located 1.63 m above the quadrapod base, your photograph will cover a 1 x 0.75-m area.

Although automatic "through-the-lens" exposure will work, using the camera on a manual setting will give you a more consistent color balance between frames, e.g., f/8 or f/11 at 1/60th of a second exposure with ISO 64 or 110 slide or print film.

At study sites 10 to 30 feet deep in the U.S. Virgin Islands, good results have been obtained with Kodachrome 64 film, a shutter speed of M90, aperture 5.6, focus 1.2 m, and manual settings. The minimum reliable resolution is for organisms with about 4 to 5 cm diameter, but the large scale of the photographs results in underestimating the corals growing in hollows and cracks not visible in the slides.

(Pete Edmunds, California State University, provided most of the information on this method.)

Method B: Quadrapod for Small Photo-quadrats in Low Relief Areas

This method is appropriate for reef surfaces with low relief, such as encrusting communities. It allows the largest possible area to be photographed with the camera close to the subject, increasing the clarity and compactness of design.

Mark two diagonal corners of each permanent quadrat (0.25 m²) by cementing two stainless steel rods into holes drilled in the substrate. The rods can serve as alignment points for the corners of a quadrapod that will support two strobes and a Nikonos camera with 15-mm lens.



Quadrapod for Small Photo-quadrats

Reference

Coyer, J. and J. Witman (1990) *The Underwater Catalog: A Guide to Methods in Underwater Research*, Shoals Marine Laboratory and New York Sea Grant Program, Cornell University, Ithaca, New York.

Method C: Monopod

In this method, the only structure that touches the reef substrate is the survey stake holding the photostand, or "monopod". Especially in areas where corals are large or abundant, these methods are less likely to cause damage than those which require supporting a camera on a bulky frame or quadrat. However, like quadrapods, monopods are better suited to areas without high relief.

The camera is attached to the monopod, an L-shaped apparatus that is fitted over a permanently installed survey stake. Although you can vary the dimensions of the photostand according to the size of your chosen photo-quadrat and the relief of the substrate you are photographing, the long side of the monopod is generally about 4 feet, and the short side about 2 feet. The higher the photostand, the greater the potential for parallax.

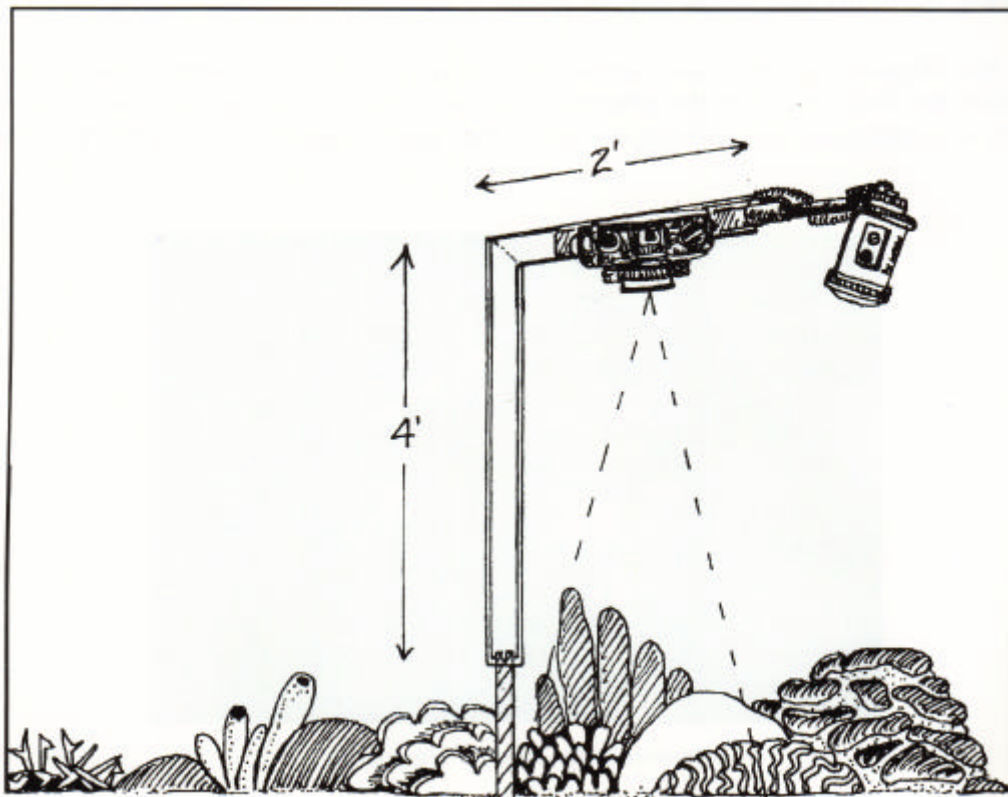

Monopod

Constructing a Monopod Photostand

- 1) Using square aluminum tubing with an inside diameter of 1 inch, weld a 2' piece to a 4' piece at a 90 degree angle.
- 2) Weld a mounting plate to the 2' piece.
- 3) Screw the camera onto the plate so that the lens faces the substrate.
- 4) Using a pneumatic drill and ½-inch bit, drill a hole in the pavement or dead coral to a depth of about 1 foot.
- 5) With a sledgehammer, pound a piece of 1 inch square stainless tubing approximately 1' long (the reference "stake") into the hole.
- 6) To increase the stake's stability, use Pettit 2-part underwater patching compound to epoxy it into place.

Taking the photographs: Mount a Nikonos V underwater camera with a 28-mm lens and a single SB103 Nikonos strobe with diffuser on the photostand. Slip the photostand over the stake and rotate it to take photographs at each of the four possible locations. With a preset focal length of 1.3 m, the total coverage area of each photograph will be 0.7 m² (2.8 m² per stake).

(This photographic method was developed by Craig Tobias, Virginia Institute of Marine Sciences, and Walter Jaap, Florida Marine Research Institute.)

A monopod apparatus has been developed which uses a stereophotographic system to do three-dimensional analysis, but analyzing the data from such techniques and replicating exact camera position over time are difficult.

Reference

Done, T.J. (1981) "Photogrammetry in coral reef ecology: a technique for the study of change in coral communities," Proceedings of the 4th International Coral Reef Symposium, Manila, Philippines 2:315-320.

Method D: Camera Mounting Frame

This apparatus for mounting a camera fits has two points of support on the substrate, so that you can move the camera along a horizontal bar and take a series of photos at designated positions which can be replicated in subsequent surveys.

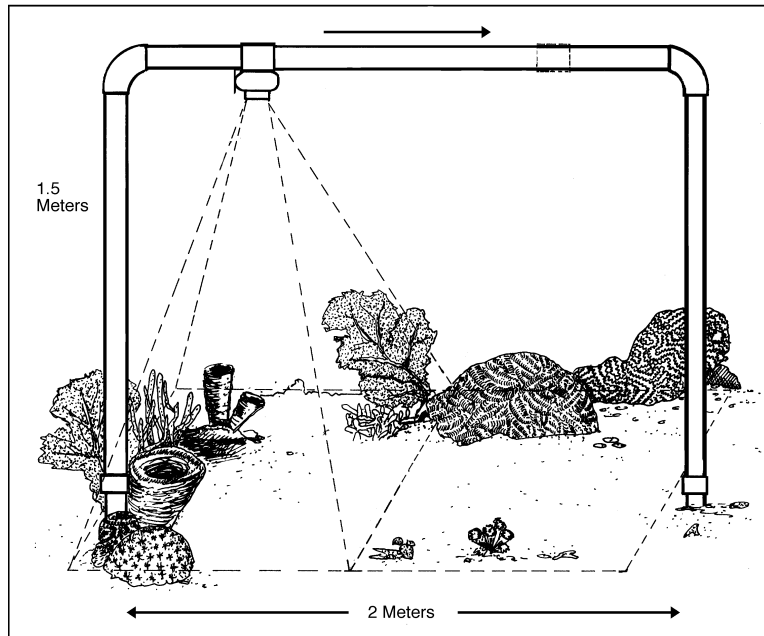

Camera Mounting Frame

Constructing a Camera Mounting Frame

- 1) For a camera mounting frame to photograph two adjacent 1m^2 quadrats, cement two $1\frac{1}{2}$ " PVC fittings 2 meters apart on the reef using a mixture of Portland cement and plaster of Paris.
- 2) Insert two PVC uprights supporting a 2-m horizontal bar with elbows into the PVC fittings. The length of the uprights is determined by the focal length of your camera lens: a 15-mm lens supported 1.5 m above the substrate will cover slightly more than 1m^2 ; a 28-mm lens will need to be slightly higher to get the entire quadrat in the photo.
- 3) Using screws or etched lines, mark the horizontal bar at 0.5 and 1.5 m along its length to indicate where the camera is to be positioned for the two photos.
- 4) To permit easy positioning of a mylar tracing grid over the photographs, attach a taut line between the uprights just above the substrate with a bead at 0.5 and 1.5 m to indicate the center of each quadrat.

(This method was developed by Allan Smith, Caribbean Natural Resources Institute.)

Method E: Photostation

This "photostation" is marked by 8 stainless steel stakes which frame a three-part quadrat as shown below. The stakes are inserted into holes drilled in the reef and cemented in place. One-inch PVC pipe is used to construct a grid measuring 2.25 m x 2 m with 12 rectangles, each measuring 0.75 m x 0.5 m.

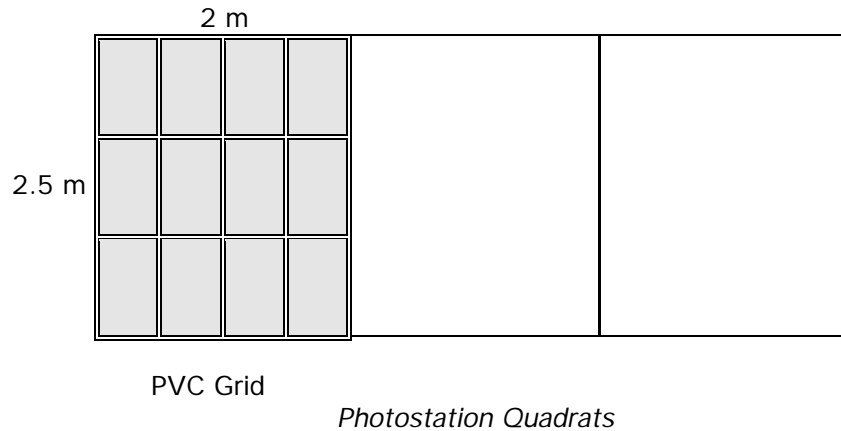

The PVC grid is used as a guide for a camera attached to a quadrapod photoframer with a base of 0.75 m x 0.50 m. Place a Nikonos fitted with a 28-mm underwater lens 1 m above the grid to include the framed area in the photo. To cover the area marked off by the eight stakes (13.5 m^2), move the grid three times and take 36 photographs. Each photo should include a velcro-backed frame number and a small placard with date and place information.

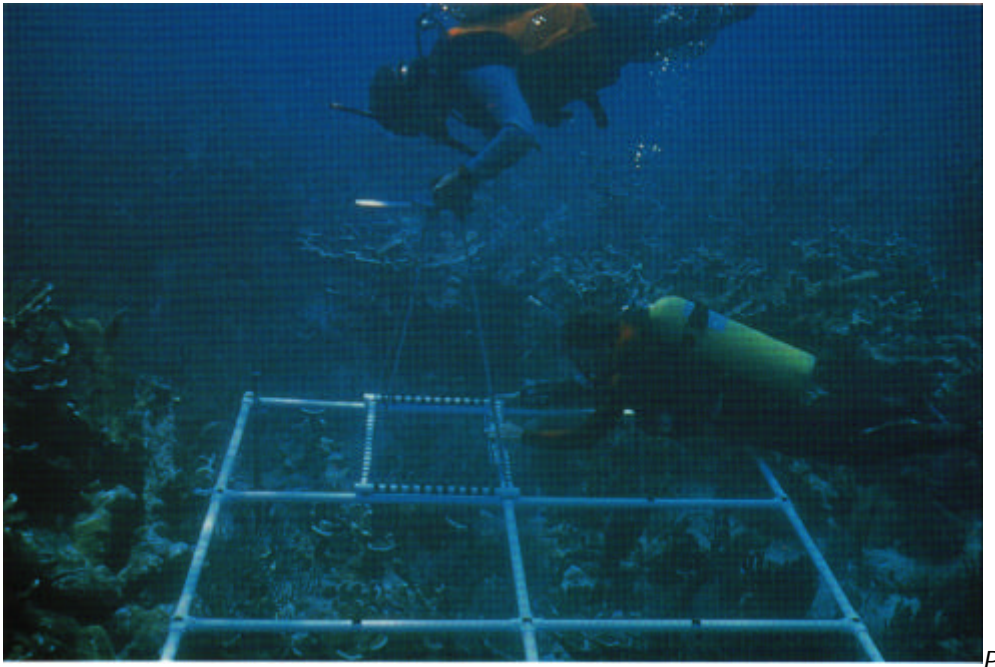

Photostation Apparatus

Considerations: This method has limited application. Because of the large size of the

apparatus, it can only be used in certain locations, and because of the time required, it is difficult to get sufficient replicates. The PVC frame is not rigid, so the photoframer may move. Assembling a series of photographs to create a mosaic is problematic; the magnification changes from photograph to photograph because of parallax and the irregular surface.

Reference

- Porter, J.P. (1990) Methods for the analysis of coral reef community structure.
I. Photostation, A. Field methods and data acquisition. Report to National Park Service.

Videotaping

This apparatus can be used to videotape a reef using a Sony TR81 hi-band 8 camera in an Amphibico housing.

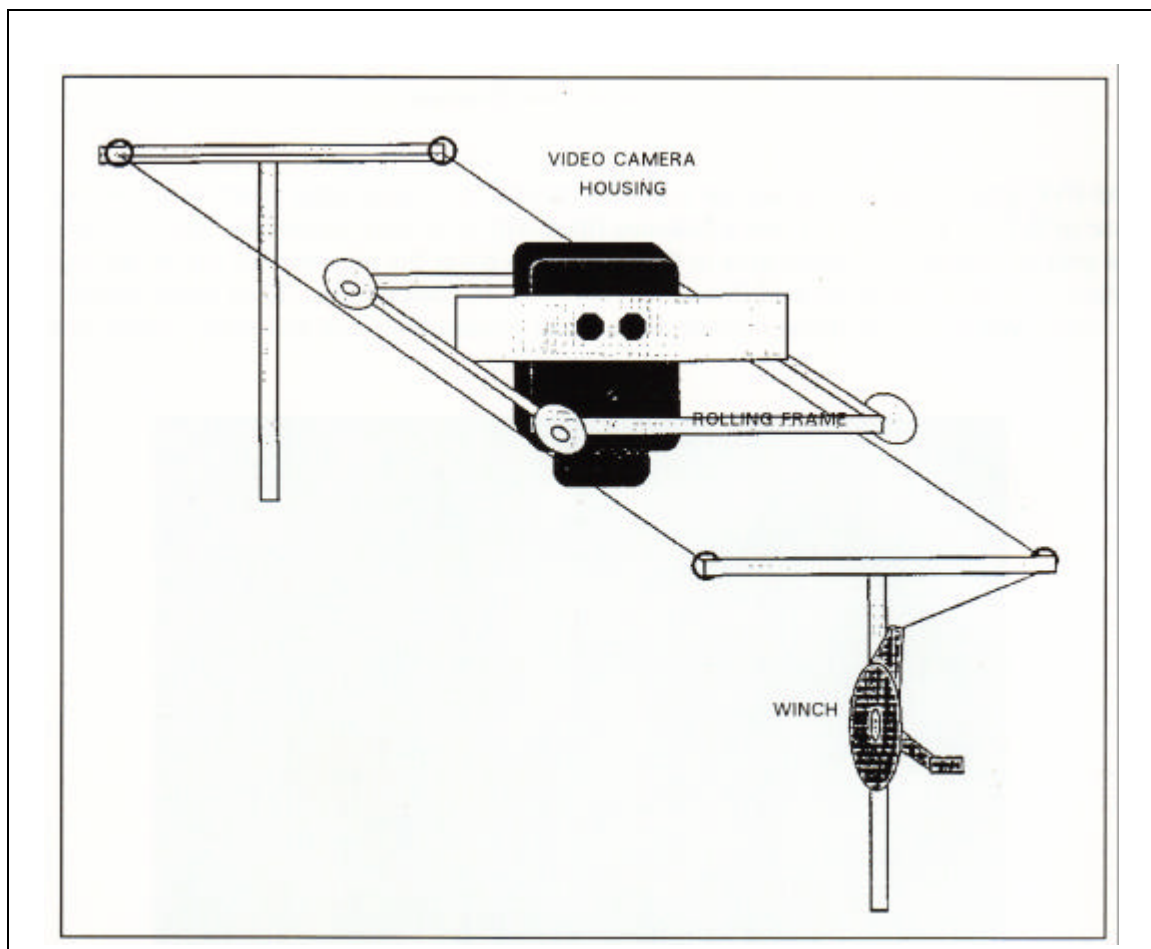

Videotaping Apparatus

- The housing is mounted on an aluminum "carriage" with four grooved, nylon wheels that roll on two cables deployed between two T-shaped aluminum poles that are slipped over square reference stakes. A stainless steel cable is deployed from a "down-rigger" fishing winch mounted vertically on one pole.
- After the clutch on the winch is released, a diver swims with the cable to the other pole, slips the cable through two eyebolts on the top of the T, returns the cable to the first pole, and snaps the stainless steel clip on the cable end to another eyebolt. Tension is taken up with the winch until the cable is taut, and the clutch is re-engaged.
- With the camera aimed vertically, the video carriage is suspended on the cables as the diver pushes it very slowly to the opposite pole and back, providing a video record of the reef area between the stakes. A tape measure in the video field provides a size reference.

Because there is some bowing in the middle of the cable and the sea floor is irregular, the camera cannot be maintained at a fixed distance from the bottom. Once on site, the time required to deploy and recover the equipment is about 10 minutes.

Reference

Jaap, W.C., Wheaton, J.L., Donnelly, K.B. (1990) "Materials and methods to establish multipurpose, sustained, ecological research stations on coral reefs at Dry Tortugas," Proceedings of the American Academy of Underwater Sciences, 10th Annual Scientific Diving Symposium, pp. 193-211.

Appendix B: STATISTICAL ANALYSIS

While a detailed explanation of statistics is beyond the scope of this manual, some generalizations can be made about statistical analysis as it pertains to coral reef monitoring. The guidelines in this appendix, which assume a basic knowledge of statistics, are based largely on Zar (1984) and Green (1979). References are listed at the end of this section. If possible, consult a statistician or field biologist/ecologist with familiarity with experimental design before you begin your monitoring program.

Your Hypothesis

As you formulate your hypothesis, you need to keep in mind the objectives of your monitoring program and the questions you are trying to answer. As Green (1979) points out, "In an environmental study there should be a logical flow: purpose > question > hypotheses > sampling design > statistical analysis > tests of hypotheses > interpretation and presentation of results."

There are a variety of statistical tests you can do with the data you have collected to determine whether you should accept or reject your particular hypothesis, referred to as the null hypothesis (H_0). Your null hypothesis might be that an oil spill caused no decrease in the percent of live coral on a reef flat. The alternative hypothesis (H_a) would be that the oil spill did result in such a decrease.

If you reject the null hypothesis when in reality it is true, you commit a Type I error. Usually a significance level of 5% ($\alpha = 0.05$) is used to estimate the probability of Type I error. Type II error is the risk of concluding that H_0 is true when it is false.

Sampling

How many samples do you need to meet your monitoring objective? For example, how many quadrats should be measured to determine whether sewage flowing over the reef has significantly increased the biomass of macroalgae? If you take too few samples, you won't be able to answer the questions you've raised. However, if you take more samples than you need, you'll be wasting time and money. Also, some sampling techniques can damage reef organisms and should not be done more often than necessary.

The number of samples you'll need depends on three factors:

- the level of precision you want (e.g., the precision of the sample mean is the closeness with which it estimates the true mean of the entire population);

- the degree of confidence ($1 - \alpha$) you want (e.g., 0.95 would give you a 1-in-20 chance of concluding incorrectly that you have estimated the mean within the specified level of precision); and
- the variability in the population (s^2), estimated from a preliminary sample.

There are many formulas you can use to determine the number of samples required and the resulting confidence interval, but certain general principles apply in most situations. For example, the higher the degree of confidence and the more variable the population, the more samples you'll need to take. Similarly, precision increases as sample size increases. For many purposes, a precision of $< 10\%$ of the mean is required. At the desired Type I error level ($\alpha = 0.05$), the estimated sample mean would then have a 95% chance of being within 10% of the true mean.

The confidence interval indicates the range within which the true population mean (or other parameter) will fall, given the specified degree of confidence. For example, with a confidence level of 0.95, a confidence interval of $\{17.5 \leq x \leq 20.5\}$ would indicate that the true population mean lies somewhere between 17.5 and 20.5, 95% of the time. The more variable the population, the wider the confidence interval.

It's also possible to calculate the number of samples required to determine a significant difference in the means of two independent samples (two-sample test). You'll need to know the expected variability of your data, the significance level, and the power of the test ($1 - \beta$).

A software program run within a Lotus 1-2-3 worksheet is available to calculate the minimum number of samples you should take, and to graph high, mean, and low standard error versus number of samples. See Bros and Cowell, 1987.

Analysis of Variance

Many statistical tests involve analysis of variance (ANOVA). In general, ANOVA provides a way of determining if means from three or more samples differ significantly from each other. "Repeated measures ANOVA" is appropriate if you are interested in determining if there is a significant difference among mean values for three or more samples obtained from permanent quadrats or transects on several different occasions.

If ANOVA indicates a significant difference in means among groups, multiple comparison tests are performed to identify which means differ significantly from each other. Note that the changes you detect are representative only of your fixed study sites and may or may not reflect general changes for the entire reef.

If you wish to compare two sets of samples where there is a relationship between one data point in the first sample and a corresponding one in the second sample, use a paired t-test. For example, you could use a paired t-test to look at differences in percent cover of the dominant species in permanent transects before and after a hurricane or other stress.

Parametric vs. Non-Parametric Tests

ANOVA and paired t-tests are examples of parametric tests. Non-parametric tests are used when your hypothesis does not involve a population parameter (e.g., the mean or variance) and when the assumptions required for use of parametric procedures are not met. For example, ANOVA assumes that samples have been drawn from populations that have normal distributions and equal variances. Many types of ecological data do not conform to these assumptions. An inherent assumption of non-parametric statistics is that different groups have similar distribution. Visual census data on reef fishes collected with the Bohnsack method can be analyzed using non-parametric tests such as the Mann-Whitney U test.

K-Dominance Curves

Univariate measures (e.g., percent cover, Shannon diversity H') have been shown to be less sensitive than multi-dimensional scaling and certain graphical descriptors (k-dominance curves) in detecting changes in coral community structure over time. K-dominance curves, which may be used to show differences in species diversity of two or more samples, are independent of any bias towards species richness or evenness, a problem which affects combined indices such as H' .

Example of K-Dominance Curve

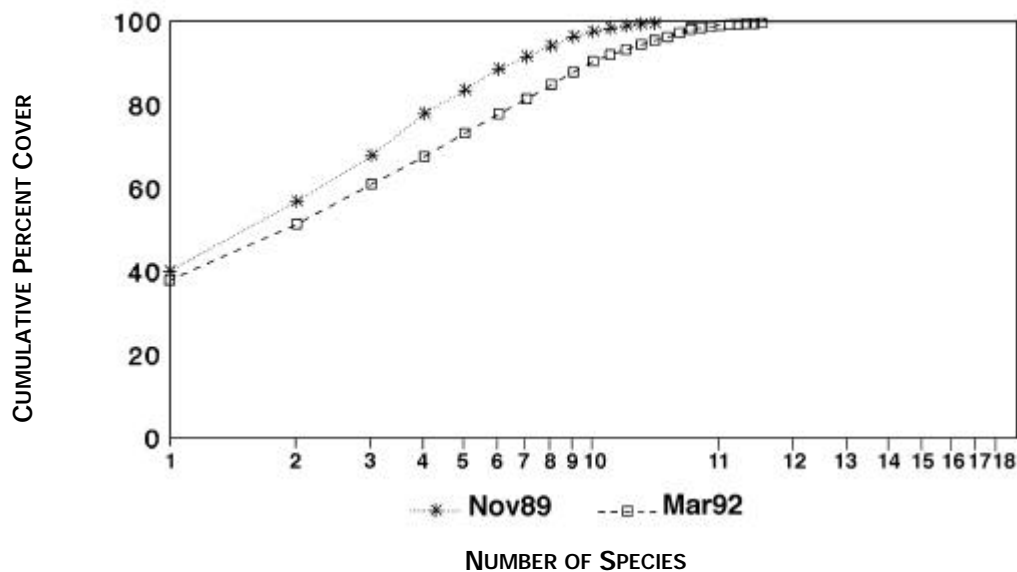

To create a K-dominance curve, you calculate the percentile abundance or cover by rank in descending order, with the most abundant species first. Comparing the curves over time or among samples taken at different sites may indicate changes in ranking or the status of species richness. Graphs in which the curve is lower than the baseline imply increased diversity; if the curve is higher than the baseline, the diversity in the sample has decreased. Non-intersecting k-dominance curves indicate a difference in species diversity of two samples, with the upper curve representing a less diverse sample. (See Lamshead et al. 1983, Warwick et al. 1990, Warwick and Clarke, 1991).

Multivariate Analyses

Multivariate analyses are another way to evaluate time series of data sets. Examples of multivariate techniques include classification analysis, multi-dimensional scaling, principal component analysis, and ordination. In the classification technique, data from all samples are compared; a matrix is generated of similarity or dissimilarity among the data sets. Another procedure in classification produces a dendrogram which geographically classifies the stations in a descending hierarchical order. These techniques are useful in detecting patterns of change or stability. Many of the rigid assumptions of parametric statistics are difficult to achieve in fixed station monitoring programs, thus the non-parametric and multivariate analyses are strong tools to tease apart the dynamics in the systems.

The Community Analysis System is a PC-based software program that can create simple hierarchical species abundance tables, species area curves, K-dominance curves, or sophisticated dendrogram graphics. It is available from: Ecological Data Consultants, Inc. P.O. Box 760, Archer, Florida 32618.

References

- Bros, W.E., Cowell, B.C. (1987) "A technique for optimizing sample size," *Journal of Experimental Marine Biology and Ecology*, 114:63-71.
- Daniel, W.W. (1978) *Applied Nonparametric Statistics*, Houghton Mifflin Company, Boston, 510 pages.
- Green, R.H. (1979) *Sampling Design and Statistical Methods for Environmental Biologists*, John Wiley & Sons, New York, 257 pages.
- Lambhead, P.J.D., Platt H.M., Shaw, K.M. (1983) "The detection of differences among assemblages of marine benthic species based on an assessment of dominance and diversity," *Journal of Natural History* 17:859-874.
- Ludwig, J.A., Reynolds, J.F. (1988) *Statistical Ecology: A Primer on Methods and Computing*, John Wiley & Sons, New York, 337 pages.
- Peterman, R.M. (1990) "Statistical power analysis can improve fisheries research and management," *Canadian Journal of Fish and Aquatic Science* 47:2-15.
- Sokal, R.R., Rohlf, F.J. [1981]) *Biometry*, 2nd edition, W. H. Freeman & Co., San Francisco, 859 pages.
- Warwick, R.M., Clarke, K.R., and Suharsono (1990) "A statistical analysis of coral community responses to the 1982-1983 El Niño in the Thousand Islands, Indonesia," *Coral Reefs* 8(4):171-179.
- Warwick, R.M., Clarke, K.R. (1991) "A comparison of some methods for analyzing changes in benthic community structure," *Journal of the Biological Association*, United Kingdom 71:225-244.
- Zar, J.H. (1984) *Biostatistical Analysis*, 2nd edition, Prentice Hall, New Jersey, 718 pages.

Appendix C: MATERIALS AND SUPPLIERS

Suppliers and Catalog Companies

Supplies

Forestry Suppliers, Inc.
205 West Rankin Street
P.O. Box 8397
Jackson, MS 39284-8397
Phone: 1-800-647-5368 (U.S.)
(601) 354-3565

Steel survey stakes, fiberglass tape measures, vinyl flagging, clipboards, compasses, Secchi disks, labware, sample bags

Hamm's Spectrum Art Supply
1756 Central Avenue
St. Petersburg, FL 33712

Faber-Castell graphite pure 2900 HB pencils

Ryan Recorder
8801 148th Avenue NE
P.O. Box 599
Redmond, WA 98073-0599
Phone: 1-800-999-7926
Fax: 206-883-3726

Hugron
Skiopholti 50c
Rezkjavik
Iceland
Fax: 354-1-689061

Thermistors

Martek Instruments, Inc.
P.O. Box 97067
3216-0 Wellington Court
Raleigh, NC 27624-7067
Phone: (919) 790-2371
Fax: (919) 790-2375

Transmissometers, multi-parameter water quality meters

Hydrolab Corporation
P.O. Box 50116
Austin, TX 78763
(512) 255-8841
1-800-949-3766

Multi-parameter water quality meters

Ben Meadows Company
3589 Broad Street
P.O. Box 80549
Atlanta, GA 30366
1-800-241-6401

Nalgene waterproof paper, vinyl flagging, fiberglass tape measures, sledge hammers, field books

47th Street Photo
455 Smith Street
Brooklyn, NY 11231
1-800-221-7774

Film in bulk quantities, cameras, electronics, computers

Suppliers and Catalog Companies**Supplies**

Fisher Scientific
711 Forbes Avenue
Pittsburgh, PA 15219
(412) 562-8300

Labware, balances, microscopes,
centrifuges, conductance/salinity
meters, Whatman filters

Hach Chemical Company
P.O. Box 389
Loveland, CO 80539
1-800-227-4224

Hach kits for bacterial cultures

Turner Designs
845 W. Maude Avenue
Sunnyvale, CA 94086
Phone: (408) 749-0994
Fax: (408) 749-0998

Nephelometers, fluorometers

Global Computer Supplies
1050 Northbrook Parkway,
Dept. 44
Suwanee, GA 30174

Computer supplies

Goldberg's Marine
201 Meadow Road
Edison, NJ 08818
1-800-BOATING

West Marine
P.O. Box 50050
Watsonville, CA 95077

1-800-538-0775

Boating and marine supplies

Millepore Corporation
80 Ashby Road
Bedford, MA 01730
1-800-221-1975

Filters, filtering equipment

Thomas Scientific
P.O. Box 99
Swedesboro, NJ 08085-0099
(609) 467-2000

Lab instruments and supplies,
microscopes, vacuum pumps,
thermometers, glassware,
balances, refractometers,
fluorometers, oxygen meters

McMaster-Carr Supply Company
P.O. Box 4355
Chicago, IL 60680-4355

Nylon tags to mark coral colonies

For other suppliers of items for underwater use, see: *The Underwater Catalog: A Guide to Methods in Underwater Research* (1990), by J. Coyer and J. Witman, Shoals Marine Laboratory and New York Sea Grant Program, Cornell University, Ithaca, New York.

APPROXIMATE EQUIPMENT COSTS (1994)

Installing Markers

Hydraulic systems for drilling	\$5,000
Stainless steel tubing	\$5 a foot
Survey stakes (30" long)	\$124 for 10 stakes

Physical and Chemical Monitoring

Instruments to measure temperature, salinity, dissolved oxygen, pH and conductivity	\$1,600 - \$7,200
Hugrun Seamon thermistor	\$1,300
Ryan Thermistor and underwater case	\$752
Ryan "Windows"	\$200
Microsoft "Windows" software	\$86
Pneumatic tools	\$100
GPS (Global Positioning System)	\$1,000 and up
Turbidimeter/Nephelometer	\$600
Light Transmissometer	\$8,000
Li-Cor quantum meter	\$1,400 - \$2,000
Spectroradiometer	\$16,000
Dissolved oxygen meter	\$500 and up
Refractometer	\$400
pH meter	\$60 - \$1,600
Centrifuge	\$400 and up
Fluorometer	\$3,500 and up

Hach kit	\$30 and up
Secchi disc	\$115
Spectrophotometer	\$4,400 and up

Biological Monitoring

Clipboard	\$2
All-weather field book	\$13
Underwater slate	\$10
Graphite pencil	\$2
Mylar sheets	\$0.50
Fiberglass tape measure (50 m)	\$45
" " " (100 m)	\$100
Number coded nylon tags	\$1 each
Vinyl flagging (150' roll)	\$1.35
Sledgehammer (2-lb.)	\$14
" (4-lb.)	\$20
Nikonos V camera with strobe and 28-mm lens	\$1,500
15-mm lens for Nikonos camera	\$1,000
Nikonos SLR with strobe and zoom lens	\$7,000
Construction of basic monopod or quadropod	< \$100
Sony Handicam Super High 8mm video camera	\$1,300

Appendix D: LIST OF REVIEWERS

Bill Alevizon
Caribbean Conservation Corporation

Donald K. Atwood
Ocean Chemistry Division
Atlantic Oceanographic and
Meteorological Laboratory, NOAA

Paul Bartels
Department of Biology
Warren Wilson College, North Carolina

Jim Beets
Department of Biology
University of Richmond, Virginia

Gigi Beretta
Australian Institute of Marine Science

Jim Bohnsack
National Marine Fisheries Service
Miami, Florida

David Booth
Australian Institute Marine Science

John Bythell
University of Newcastle-upon-Tyne
Center for Tropical Coastal
Management Studies

Kalli De Mayer
Bonaire Marine Park

Mary Falconer
The Nature Conservancy

Alan Friedlander
Department of Zoology
University of Hawaii, Honolulu

Ellen Gorman
National Biological Survey
Virgin Islands National Park

Robert B. Halley
U.S. Geological Survey
St. Petersburg, Florida

Doug Harper
National Marine Fisheries Service
Miami, Florida

Julie Hawkins
Eastern Caribbean Center
University of the Virgin Islands

Walter C. Jaap
Florida Marine Research Institute
St. Petersburg, Florida

Joe Kimmel
National Marine Fisheries Service
St. Petersburg, Florida

Richard Laydoo
Environmental Research Programme
Institute of Marine Affairs, Trinidad

Malden Miller
Montego Bay Marine Park, Jamaica

John Ogden
Florida Institute of Oceanography
St. Petersburg, Florida

Julie Overing
Conservation and Fisheries Department
Ministry of Natural Resources and Labour
Tortola, British Virgin Islands

Jim Petterson
National Park Service
Virgin Islands National Park

Callum Roberts
Eastern Caribbean Center
University of Virgin Islands

Allan "Kaf" Smith
Caribbean Natural Resources Institute

Kathleen Sullivan
The Nature Conservancy
Miami, Florida

Craig Tobias
Virginia Institute of Marine Sciences

Ed Towle
Island Resources Foundation
St. Thomas, USVI

Tom Van't Hof
Saba, Netherlands Antilles

Vance P. Vicente
National Marine Fisheries Service
Hato Rey, Puerto Rico

Bert Williams
Department of Marine Science
University of Puerto Rico-Mayaguez

Nicholas Wolff
University of Rhode Island

