

## **A Crush Zone Design for An Existing Passenger Rail Cab Car**

Eloy Martinez and David Tyrell  
Volpe National Transportation Systems Center

Robert Rancatore and Richard Stringfellow  
TIAX LLC

Gabriel Amar  
Taylor, Raynauld, Amar and Associates

### **ABSTRACT**

A Crash Energy Management (CEM) cab car crush zone design has been developed for retrofit onto an existing Budd M1 cab car. This design is to be used in the upcoming full-scale train-to-train test of a CEM consist impacting a standing freight consist of comparable weight. The cab car crush zone design is based upon the coach car crush zone design that has been previously developed and tested.

The integrated system was developed after existing national and international CEM systems were reviewed. A detailed set of design requirements was then drafted, and preliminary designs of sub-assemblies were developed. The preliminary designs were analyzed using detailed large deformation finite element software. Performance of the cab car crush zone under ideal and non-ideal loading conditions was analyzed prior to development of the final design.

The key components of the design include: a long stroke push-back coupler capable of accommodating the colliding locomotive coupler, a deformable anti-climber to manage the colliding interface interaction, an integrated end frame on which the deformable anti-climber is attached, a set of primary energy absorbers designed to crush in a controlled manner while absorbing the majority of the collision energy, and a survivable space for the operator which pushes back into an electrical closet.

The cab car crush zone is designed to control both lateral and vertical vehicle motions that can promote lateral buckling of the train and override of the impacting equipment. The design is capable of managing the colliding interface interaction with a freight locomotive and passing crush back to successive crush zones. Detailed fabrication drawings have been developed and submitted to a fabrication shop. In addition, existing Budd M1 cars are being prepared to receive the retrofit components.

### **INTRODUCTION**

In the event of a head-on collision between a passenger train and another train a considerable amount of energy must be dissipated prior to the equipment coming to rest. This energy is consumed in various mechanisms. Key concerns in terms of

structural crashworthiness are the plastic deformations of individual cars and the gross motions of the colliding equipment as well as the full consist. Possible catastrophic deformation modes include override occurring at the colliding interface and large scale lateral buckling, which may expose the consist to side impacts.

The Crash Energy Management (CEM) design approach has been applied towards the development of an enhanced consist design, which incorporates cab car and coach car crush zone designs. The crush zones help manage the longitudinal crush through designed progressive collapse in unoccupied end areas of vehicles along the full length of the consist, as well as minimize the lateral and vertical motions at all interfaces. This designed progressive crush in unoccupied areas of vehicles allows for the complete preservation of occupied volume for the passengers and crew members at predicted closing speeds twice that of conventional consists: 25 to 30 mph versus 13 mph [40.2 to 48.3 km/hr versus 20.9 km/hr] as determined from the train-to-train testing of conventional equipment [1].

Full-scale impact tests have been conducted to measure the crashworthiness performance of conventional passenger rail equipment and equipment with CEM features. In the train-to-train test of conventional equipment, the colliding cab car traveled at 30 mph [48.3 km/hr], crushed by approximately 22 feet, and overrode the locomotive [2]. The space for the operator's seat and for approximately ten rows of passenger seats was lost. Computer simulations of the train-to-train test of equipment with CEM indicate that structural crush will be pushed back to all of the coach car crush zones, and all of the crew and passenger space will be preserved. The train-to-train test of equipment with crush zones planned for February 2006 is expected to confirm these predictions.

Single-car and two-car impact tests have been conducted for conventional equipment and equipment with crush zones [3, 4, 5, 6]. For the conventional equipment, some of the occupant volume was crushed, the crush focused on the impact car, and the cars buckled out laterally and derailed. For the equipment with crush zones, all of the occupant volume was preserved; the crush was distributed; and the cars remained in-line and on the

track. After each test, analyses techniques have been further refined; the pre-test analysis predictions have closely overlaid the test measurements for the last several tests.

Using the coach car crush zone designed for the full-scale tests as a starting point [7,8], a cab car crush zone design has been developed. The added complication for the cab car is the need to control the interaction at the colliding interface of the collision and maintain a survivable space for the operator. To do this, it is necessary to accommodate the impacting coupler on the opposing freight or passenger train and distribute the loads into the superstructure through a deformable anti-climbing system.

The organization of this paper mimics the approach applied in developing such a design. First, this paper discusses a survey of current domestic and international CEM systems as well as current CEM specifications. Next, the paper presents a detailed set of design requirements followed by the cab car crush zone functions and features. The design concept that was generated is described and analyses are presented for several load cases. A preliminary integration sequence is discussed. The summary presents the approach and applicability of the design for retrofit onto existing equipment.

## **SURVEY OF EQUIPMENT**

The use of crush zones for the mitigation of collision energy has been established for some time in the automotive industry and recently applied in the rail industry. Domestically at least three examples of such systems in current use exist. The first is the Acela intercity train. The Acela provides Tier II service, with peak traveling speeds between 125 mph [201.2 km/hr] and 150 mph [241.4 km/hr]. The Acela must have CEM under 49 CFR Part 238 Subpart E – Specific Requirements for Tier II Passenger Equipment [9]. The Acela power car makes use of a combination of push-back couplers with some energy absorption, a ribbed plate anti-climbing mechanism mounted on the end underframe within a composite shroud, and prismatic stainless steel tubes as the primary energy absorbers. The energy absorption capacity at the lead cab end is  $3.7 \times 10^6$  ft-lbf [5 MJ] in a total crush length of 40 inches [1 m]. Additionally, the trailing end of the power car and the lead end of the first trailing coach car have requirements similar to the lead end of the power car. The other connections between the rest of the coach cars have a minimum energy absorption capability of  $0.75 \times 10^6$  ft-lbf [1 MJ] by using external crush elements and push-back couplers. The H-type couplers provide the required anti-climbing resistance.

The New York City Transit Authority uses a car design referred to as the R142. The specification for this car design requires some degree of energy absorption with a push-back mechanism and an anti-climbing capability. Two manufacturers provided qualified designs, Bombardier and Kawasaki. The Bombardier design makes use of a shear pin mechanism with no energy absorption behind the coupler, ribbed plates for the anti-climbing mechanism with no energy absorption, and high strength low alloy (HSLA) crush elements capable of absorbing  $0.75 \times 10^6$  ft-lbf [1 MJ] in an unspecified stroke length. The Kawasaki design uses similar push-back and anti-climbing mechanisms. However, instead of HSLA tubes,

the design has cut-outs in the underframe with an allowable crush stroke of 20 inches [0.5 m]. Using this approach, the Kawasaki design absorbs the same amount of energy.

Kinki-Sharyo supplied a light rail vehicle to New Jersey Transit with CEM features. This equipment is operated on the Hudson-Bergen line. The coupler is capable of absorbing  $0.06 \times 10^6$  ft-lbf [0.08 MJ] of energy using a hydraulic/gas spring mechanism with a 13-inch [0.33 m] stroke length. After a prescribed trigger load is reached, the coupler shears back, and the ribbed plate anti-climbing mechanism engages. The primary energy absorbers are constructed from extruded aluminum prismatic members capable of absorbing  $0.26 \times 10^6$  ft-lbf [0.35 MJ] of energy in a 20-inch [0.5 m] stroke length.

Internationally, several CEM cab and coach car designs exist. Examples include: the TGV, TGV Duplex, the XTER, the modified Mark I, the Talgo XXI, the AGC, the Itino, the TRAXX locomotive, the Pendolino, and the TER2N. These designs share three common features. The first is the use of a push-back coupling mechanism that allows the ends of vehicles to come together and transmit load over a larger area. The second is an anti-climbing mechanism that restricts vertical motions between colliding vehicles – whether at the colliding interface or between coupled interfaces. The third common feature is some means of absorbing large amounts of energy at each crush zone interface. The energy absorption is usually specified at varying levels for each component in the complete system along with a prescribed maximum allowable crush stroke. For cab cars or locomotives many of the designs incorporate a survivable volume for the cab operator. In general, these designs were developed to perform at a prescribed energy absorption level for a given collision scenario.

## **CURRENT CEM SPECIFICATIONS**

Before addressing the design requirements for the cab car, it is worthwhile to review three sets of current specifications for CEM equipment, namely, those specified in: 49 CFR Part 238 Subpart E [9], the American Public Transportation Association (APTA) SS-C&S-034-99 [10], and European Union Technical Specification for Interoperability, TSI, for high speed equipment [11]. All three include strength-based requirements for specific structural elements of the car design in addition to the CEM requirements. After discussing these three sets of specifications, key aspects of the previously developed coach car design requirements are reviewed.

49 CFR Part 238 Subpart E – Specific Requirements for Tier II Passenger Equipment requires that the crush zones be situated on either end of the occupied volume, hence at the ends of the vehicles. The total energy absorption required for each end of the consist is  $9.6 \times 10^6$  ft-lbf [13 MJ] with a minimum absorption in front of the operating cab of  $3.7 \times 10^6$  ft-lbf [5 MJ]. Additionally, another  $2.2 \times 10^6$  ft-lbf [3 MJ] of energy must be absorbed between the operator's cab and the first trailer car. The leading end of the first trailer car behind the operating cab must absorb  $3.7 \times 10^6$  ft-lbf [5 MJ] of energy. No restriction on the lengths of the crush zones exists. However, a restriction on the power car does exist in that no passengers are allowed in the leading unit. In addition to the energy absorption

requirements, a collision scenario is defined. The scenario is a 30 mph collision between a Tier II train and an identical standing train on tangent track. The constraints on performance for this collision condition are the secondary impact velocity for a 50<sup>th</sup> percentile male must not exceed 25 mph [40.2 km/hr] in any trailing coach cars, and the deceleration in any trailing coach car must not exceed 8 g. There is no restriction on the deceleration levels in the power car.

The North American industry standard APTA SS-C&S-034-99 prescribes several strength-based load cases to be fulfilled for key structural elements. These requirements will not be discussed further in this paper, with the exception of the buff strength requirement. Four buff strength requirements are specified for CEM equipment:

- 1) If a shear-back coupler or drawbar is used, the required strength on the line of draft may be reduced to not less than 125 percent of the maximum load developed by the coupler or drawbar during push back, including the operation of energy absorbing features if present in the coupler or drawbar.
- 2) The car body structure shall be designed to resist a minimum end-compression load of 800,000 lbf (3560 kN) for vehicles equipped with shear-back couplers or drawbars with or without energy absorbing features. The buff load is applied over an area not exceeding 6 inches (152 mm) high and a width not exceeding the distance between outboard webs of the collision posts, centered vertically and horizontally on the underframe end sill or buffer beam construction. No permanent deformation in the car body structure under this load shall occur.
- 3) The buff strength of unoccupied zones of the car body must be compatible with the CEM design, but in no case less than 50% of the value required for occupied zones.
- 4) The occupied volume of the cars must be able to resist the applied buff loads during operation of the CEM crush zone without experiencing permanent deformations.

In addition to these buff requirements, the APTA standard also requires the clear evaluation of a collision scenario that the design must survive. The car manufacturer and the operating authority must describe the collision scenario and the method of determining compliance of the design in a CEM and Collision Survivability Plan. The minimum required information for such a plan includes the prescription of the closing speed at impact, the arrangement and orientation of the colliding equipment at impact, the state of braking of the consist(s) involved, and the state of the equipment during the impact event, i.e., if the equipment remains upright and in-line.

Alternative collision conditions are suggested. The first is an impact between two identical consists on a tangent track in all possible orientations – cab car-to-cab car, cab car-to-locomotive, and locomotive-to-locomotive. The second alternative collision scenario is between the CEM consist and a freight train. The last suggested scenario is a grade crossing collision. For this scenario, the CEM consist is assumed to be in the most unfavorable arrangement and orientation upon

impact with a highway vehicle. The collision should represent the most severe risk for the intended operation.

The acceptance criteria should include at a minimum: a limit on the deceleration of trailing equipment for the entire time frame of the collision event; a limit on the velocity at contact with the seat back of the seat ahead of a 95th-percentile male in row seating anywhere in the consist subjected to the validated acceleration history; and a restriction on the extent of crush to areas considered to be unoccupied or of low occupant density. The APTA Standard suggests that the design of the CEM system should be based upon specific zones listed in order of highest to lowest survivability: Zone A - High-density passenger and crew space, such as cabs and passenger seating space; Zone B - Low-density passenger and crew space, such as entryways and toilets; and Zone C - Unoccupied space.

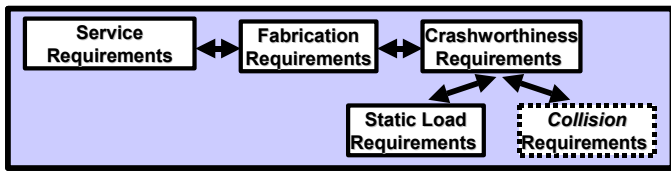
The TSI for high-speed equipment discussion focuses only on crashworthiness performance requirements. The CEM consist must be designed to survive the following three collision conditions: the collision between two identical high speed consists at a closing speed of 22.5 mph [36 km/hr]; the collision between a high-speed consist and a railway vehicle equipped with side buffers at a speed of 22.5 mph [36 km/hr] (The railway vehicle must be a four-axle freight car UIC 571-2 with an 179,000 lbm [80 tonne] mass; and the collision with a 33,100 lbm [15 tonne] truck represented by a rigid mass presenting a vertical surface for impact at a speed of 62.5 mph [110 km/hr] at a level crossing. The key acceptance criteria for the three collision conditions include the following:

- For the first collision scenario, plastic deformations in the operator or passenger compartments must not adversely affect their safety.
- For the second and third collision scenarios, the operator compartment may plastically deform but no permanent deformations are allowed in the passenger compartments. In addition, the rear of the operator's compartment must have a rigid survivable volume with a minimum length of 2.5 feet [0.75m].
- The CEM consist must be capable of absorbing a minimum of  $4.4 \times 10^6$  ft-lbf [6 MJ] of energy with  $3.3 \times 10^6$  ft-lbf [4.5 MJ] absorbed in the first vehicle of the train.
- The operator and passenger compartments in the lead vehicle must be able to resist a 340,000 lbf [1,500 kN] buff load in excess of the mean crush force of the lead vehicle for these collision conditions.
- The mean deceleration of the operator and passenger compartments in the lead vehicle must not exceed 5 g.
- Anti-climbing mechanisms must exist between all vehicles in the CEM consist.

### **CAB CAR CRUSH ZONE DESIGN REQUIREMENTS**

In addition to the crashworthiness requirements, the cab car crush zone design must also comply with service and fabrication requirements. A flow diagram of the interrelationship of the three categories of requirements is shown in Figure 1. Most of these requirements are the same for

CEM cab cars as for conventional equipment. The distinction from current practice is in the collision requirements.



**Figure 1. Flow Chart of Structural Design Requirements**

The service requirements for the CEM cab cars are essentially the same as for conventional equipment: the ability to couple/uncouple with conventional equipment while maintaining comparable in-train buff and draft responses as well as braking performance; the design must be capable of withstanding the normal in-train buff and draft forces without pre-maturely triggering or failing due to fatigue of the new components; and the design must be able to negotiate the tightest curves that comparable conventional equipment can without interference. The necessary space for all equipment that is required for regular operation must be preserved for the modified equipment.

Fabrication requirements in the modified equipment arise principally from desires to retrofit existing equipment and to use materials and techniques common to the rail equipment manufacturing industry. The design developed is to be retrofitted onto the end of a Budd M1 passenger rail car. The envisioned test consist includes a CEM retrofitted Budd M1 cab car, trailed by a CEM retrofitted Budd M1 coach car, two CEM retrofitted Budd Pioneer coach cars, and another retrofitted Budd M1 cab car followed by an F40 passenger locomotive.

The crashworthiness requirements are sub-divided into static/quasi-static load requirements and CEM requirements. The static/quasi-static load requirements used are the North American industry standards in APTA SS-C&S-034-99 and in the 49 CFR Part 238 Subpart C- Specific Requirements for Tier I Passenger Equipment.

The cab car crush zone is designed as part of an overall CEM consist design, which includes the coupled interactions between the cab car and CEM retrofitted coach cars. The key CEM requirement for both the cab car crush zone is the need to absorb  $2.5 \times 10^6$  ft-lbf [3.4 MJ] of energy in a total crush stroke of 3 feet [0.9 m].

The scenario for the planned full-scale train-to-train test include a CEM-retrofitted cab and coach car consist and a standing freight consist of equal mass on tangent track at a closing speed of 30 mph [48.3 km/hr]. This is a worst-case scenario in terms of managing the interactions at the colliding interface of the collision. It is expected that the design will also perform well for collisions between two like consists at the same closing speed on tangent track. This expectation is based upon the fact that the colliding interface interactions will tend not to be as complicated.

For the test conditions defined, the cab car crush zone must prevent climbing between the colliding cab car and the standing locomotive. Override is a catastrophic deformation mode

where it is possible to lose significant operator and passenger survivable space resulting in fatalities due to bulk crushing. This deformation mode was observed in the train-to-train test of conventional single level equipment. In that test, the lead cab car overrode the standing locomotive and the cab car's underframe crushed about 22 feet [6.7 m] resulting in the loss of approximately ten rows of passenger seats [2].

In addition to preventing override, the cab car crush zone must have an increasing force crush characteristic that is effective in passing crush back to trailing coach cars retrofitted with crush zones. The inter-car vertical and lateral motions must be minimized thereby reducing the likelihood of saw-tooth or large scale lateral buckling. Large scale lateral buckling is highly undesirable because it subjects the consist to possible interactions with wayside objects or oncoming trains on adjacent tracks.

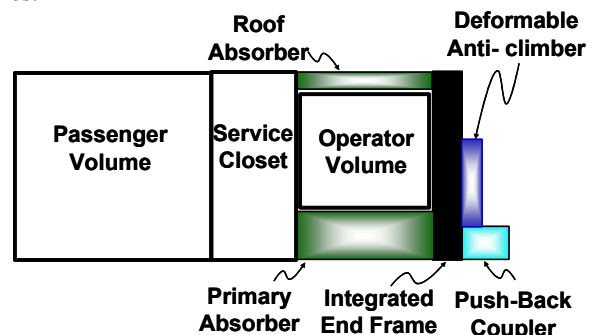
The cab car crush zone design must also perform for a set of deviations from the ideal cab car led consist collision with a standing freight consist. All the deviations occur at 30 mph [48.3 km/hr] on a tangent track between the CEM consist and the standing freight consist. The first deviation is where a majority of the load is carried through the coupler. The second is where the entire load is carried through the superstructure (i.e., the end frame through a deformable anti-climber). In addition, there are several offset loading conditions. The offset loading conditions include vertical misalignments between the colliding equipment of +/- 6-inches [152.4 mm], lateral misalignments between the colliding equipment of +/- 6-inches [152.4 mm], and a combined vertical and lateral offset of the same magnitude.

**CAB CAR CRUSH ZONE FUNCTIONS AND FEATURES**

The cab car crush zone concept includes the following four key elements:

1. A deformable anti-climber arrangement
2. A push-back coupler mechanism
3. An integrated end frame, which incorporates an operator volume
4. Roof and primary energy absorbing elements

Figure 2 is a schematic of the cab car crush zone design features.



**Figure 2. Schematic of Cab Car Crush Zone Conceptual Design (Side View)**

The two features that help manage the colliding interface interaction are the pushback coupler and the anti-climbers. The first component to experience collision forces is the coupler on the cab car. The coupler pushes back within a prescribed load

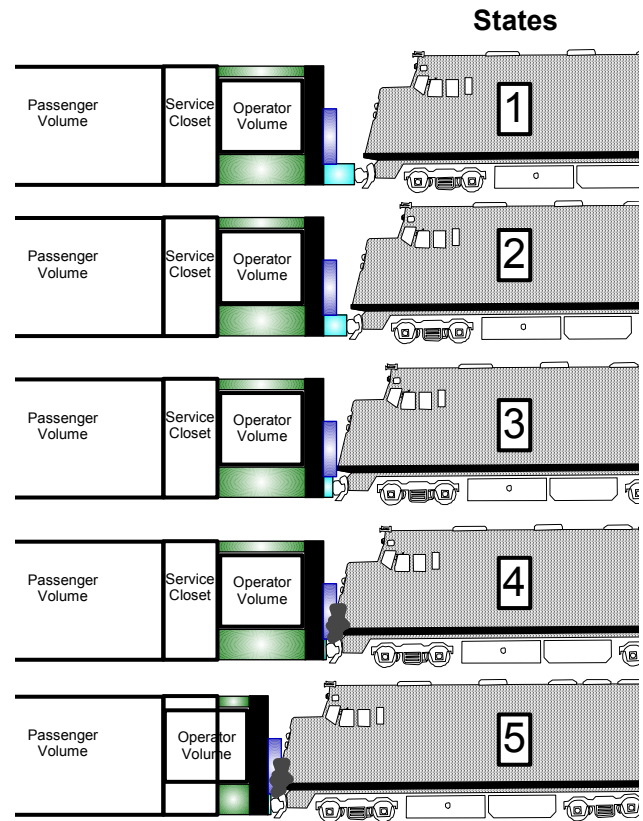
range and absorbs some of the collision energy. As the coupler pushes back, it eventually allows the load to transfer directly to the car's underframe and end frame components. The second key feature is a coach car compatible anti-climber to allow vertical interlock after the push-back couplers have activated for the case where like cab cars, or a cab car and a coach car are coupled. To assist in the management of the colliding interface between it and a locomotive, the cab car is equipped with a deformable anti-climber mounted to an integrated end frame structure. The deformable anti-climber extends laterally between the collision and corner posts and vertically between the bottom of the window shelf member and the top of the buffer beam. The purpose of this integrated structure is to distribute the collision forces into the end frame and then back into the roof and underframe.

To support the load transferred by the deformable anti-climber, it is necessary that the end frame be well integrated. The collision and corner posts are connected into the buffer beam and the anti-telescoping plate, and they are tied together on each respective half by the shelf and deformable anti-climber support structures. The design of these components can be accomplished using the strength and deformation requirements stipulated in the APTA standard. Another feature of this design is a rigid compartment to enable the operator to safely ride out the collision. This space must include the operator's seat, the control stand, and other equipment typically found in a cab car.

The integrated end frame is securely attached to a sliding sill that is connected to a fixed sill through a set of shear bolts. The purpose of the fixed sill/sliding sill assembly is to allow guided longitudinal pushback of the integrated end frame. This pushback motion enables the energy absorbers to be compressed between the relatively rigid sliding components and the fixed components in the occupied area of the car.

The energy absorbing elements include a secondary energy absorber placed behind the push-back coupler, a set of primary energy absorbers located at the level of the underframe, and a set of roof absorbers connected between the anti-telescoping plate and the fixed part of the roof structure within the confines of the occupied area of the car.

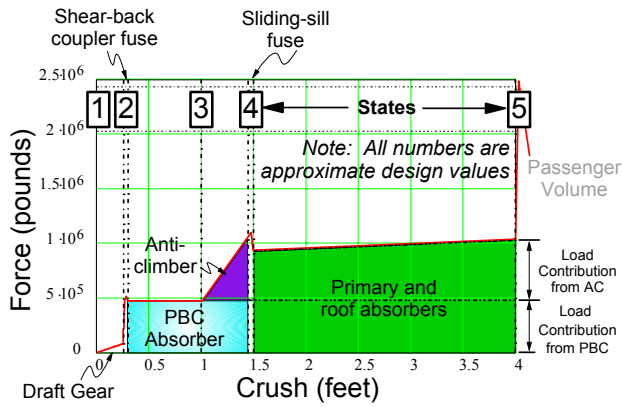
Figure 3 is a schematic illustrating the idealized kinematics of the cab car crush zone design. The couplers of the colliding equipment contact one another, as shown in state 1. After the stroke of both sets of draft gears are exhausted, the load increases on the structural fuse and activates when a prescribed load range is met, as shown in state 2. After some crush occurs in the pushback coupler energy absorber, the deformable anti-climber is also engaged, as shown in state 3. During this state, the load is shared between the anti-climber and the coupler. Next, when the combined load on the coupler and the deformable anti-climber reaches the prescribed trigger load range, the energy absorber structural fuse releases in state 4. The primary and roof absorbers crush and reach state 5 when their stroke is exhausted.



**Figure 3. Schematic of Idealized Kinematic Cab Car Response**

Figure 4 shows the idealized force-crush characteristic for the cab car crush zone conceptual design. This force-crush characteristic is similar to the idealized coach car crush zone design characteristic. However some differences related to the additional requirements for this crush zone design exist. For example, in order to accommodate impacts with conventional equipment, the stroke of the pushback coupler (PBC) absorber is longer. In addition, a deformable anti-climber (AC) is included to help accommodate a range of potential impacting equipment, including locomotives as well as alternative cab car designs. The primary and roof energy absorbers are essentially the same as previously developed for the coach car crush zone.

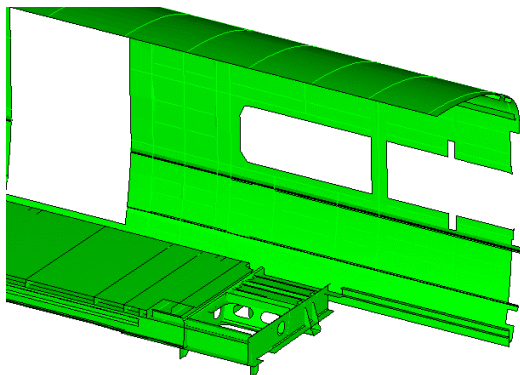
Features of the cab car crush zone force-crush characteristic that are similar to those of the coach car crush zone include the tiered force plateaus with elevated trigger loads. It is important to maintain a sufficient difference in magnitude between the two force plateau regions to assure that crush passes back from one activated interface to the next. This is the critical characteristic that allows the management of energy through the full length of the consist for collisions with a sufficient amount of energy. It also makes it possible for the CEM equipped consist to manage lower energy events by restricting crush to replaceable components.



**Figure 4. Idealized Cab Car Force-Crush Characteristics**

**CAB CAR CRUSH ZONE DESIGN**

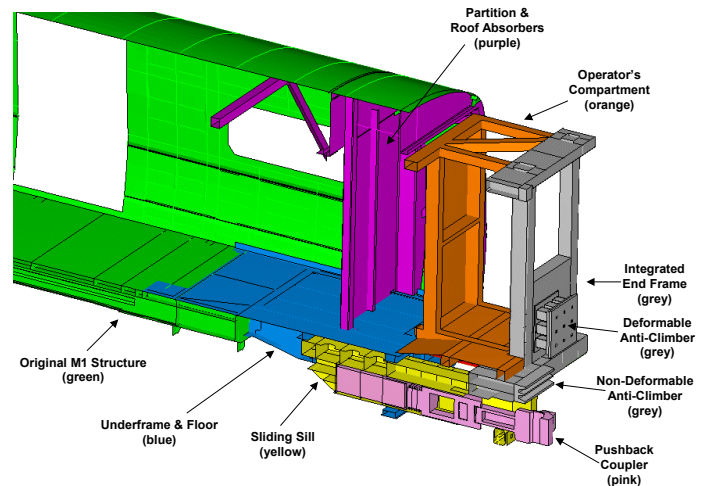
As a first step in the analysis and design process, a finite element model was developed of the existing Budd M1 car structure between the body bolsters. The cab car crush zone design is developed for integration onto this existing car platform while maintaining the original design volume envelope. Figure 5 shows a portion of a quarter model of the Budd M1 original car body structure. One of the key differences between the Budd M1 car and the retrofitted Budd Pioneer car is the location of the doorways on the vehicle; the Budd M1 car has doorways aft of the body bolster at quarter points. The interior cross-section of the Budd M1 car is wider and taller, giving the impression of added interior space. The shape of the body bolster is also very different compared to the Pioneer car bolster. These design differences between the two cars resulted in changes as to how the developed crush zone design would be integrated onto the existing structure.



**Figure 5. Finite Element Model of Original M1 Budd Car Body Structure**

Figure 6 shows the final cab car crush zone design that was developed. The key elements of the design include features to control the colliding interface interaction, a fixed/sliding sill interface that allows push back of the entire front end structure of the cab car into the service closet space, and a set of primary and roof energy absorbers. As stated earlier, the key elements that help manage the colliding interface interaction are the

push-back coupler and the deformable anti-climber. The push-back coupler was designed with a pushback stroke of 21.25 inches [540 mm]. The size of the bellmouth was increased to allow the introduction of conventional couplers. A non-deformable anti-climber compatible with the coach car anti-climbers is included, as well as a deformable anti-climber, which consists of a number of stainless steel tubes filled with an energy absorbing material and tied together through a stiffened plate. The plate was designed with a waffle pattern of stiffeners to help distribute load into all the individual square crush elements. The deformable anti-climber was designed so as not to experience any material failure during crush. Figure 6 shows the pushback coupler and both the regular and deformable anti-climber.



**Figure 6. Cab Car Crush Zone Design – Quarter Model**

A fixed/sliding sill arrangement was again chosen, based upon the success demonstrated from the coach car design. It is similar to designs incorporated in many North American freight cars as a means of carrying vertical, lateral, and offset longitudinal loads and bending moments during pushback. This choice eliminates the need to do additional design work to assure that otherwise plastically deforming elements are still capable of resisting such loads and moments. An additional advantage is that the energy absorbing elements are passive - they do not have to carry any service loads. This feature reduces the risk associated with failure of such elements due to fatigue prior to use in the event of a collision. Figure 6 shows the sliding and fixed sills. The operator's compartment is also shown in the figure.

Care was taken during the development of the design to assure that the pushback coupler trigger load was smaller than the sum of the primary energy absorbers (PEA) and roof absorbers trigger loads. This margin is needed to guarantee that the pushback coupler always activates before the sliding sill. In addition to the separation of trigger loads, it was also necessary to ensure that the tiered force plateaus for the coupler energy absorber, and the combined primary energy and roof absorbers were sufficiently separated. This helps to assure that during push back of the coupler, the primary energy absorbers are not prematurely activated. The pushback coupler energy absorber, the primary energy absorbers situated underneath the

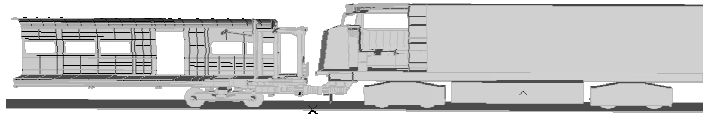
operator's compartment, and the roof absorbers are also shown in Figure 6.

The next section of the paper presents a subset of the analyses conducted to demonstrate the compliance of the developed design with the requirements discussed earlier.

**ANALYSES OF CAB CAR BEHAVIOR – IDEAL, NON-IDEAL, AND OFFSET LOAD CASES**

This section only presents a subset of the analyses conducted. To start, the ideal load case will be discussed, followed by a description of the results from the two non-ideal load cases. Only the worst case scenario for an offset load case will be discussed.

The ideal load case is for the impact of a cab car with a freight locomotive on tangent track with the couplers of the two vehicles aligned both vertically and laterally. The non-linear large deformation finite element model developed and shown in Figure 7 was used to analyze this load case. Symmetry boundary conditions were imposed about a vertical-longitudinal plane on both the locomotive and the cab car. The cab car was fully fixed at one-half the car's length. An F40 locomotive was used as the striking locomotive. The entire cab structure and draft gear pocket, including the underframe, were modeled as deformable while the rest of the locomotive was rigid. The impact speed was set at 30 mph [48.3 km/hr]. The model is constructed from approximately 270,000 elements.



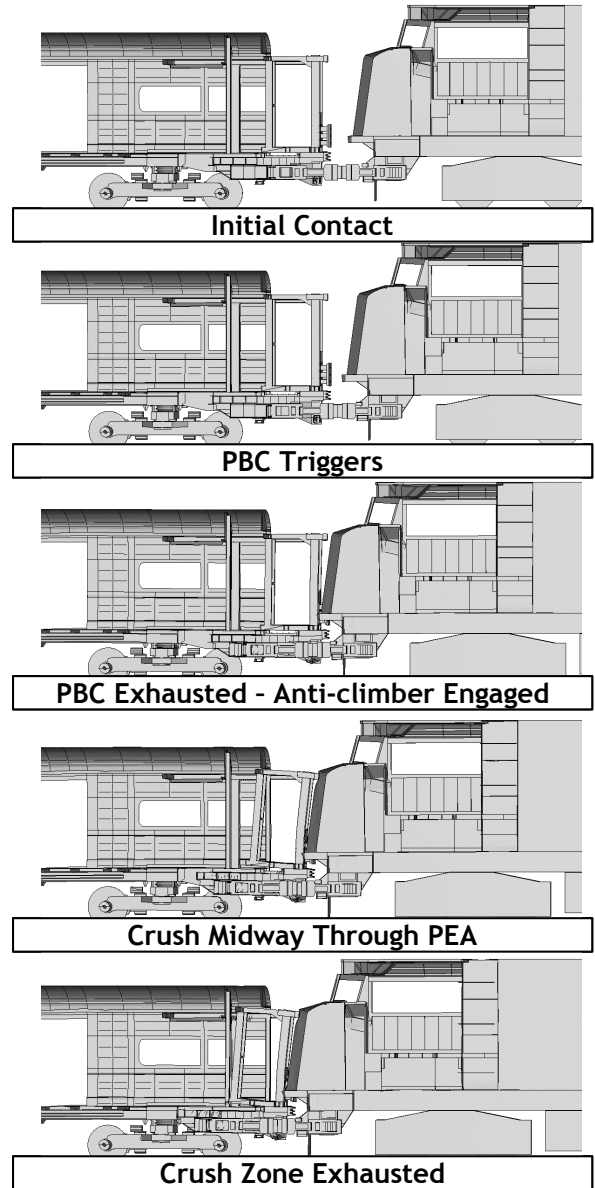
**Figure 7. Non-Linear Large Deformation Finite Element Model - Ideal Load Case Model**

Results from this analysis are shown in Figure 8. The deformation sequence starts at initial contact between the two couplers. The subsequent state shows when the pushback coupler shear bolts have triggered. Very little rotation of the operator's compartment occurs. The third state shows the deformation when the pushback coupler has bottomed out and when the deformable anti-climber is just starting to engage. As the deformable anti-climber crushes, the load builds up to a sufficient level that the shear bolts in the sliding sill/ fixed sill interface activate and allow push-back of the operator's compartment. The fourth state shows the deformation when the primary and roof absorbers are about halfway crushed. Again, the operator's compartment is pushing straight back into the area reserved for a service closet. The final deformation state shows the sliding sill just bottoming out on the fixed sill. At this state, the primary and roof absorbers are completely exhausted, and load is being transferred into the occupied volume aft of the body bolster. For sufficiently high collision energies, the occupant volume starts to load up and undesirable deformations occur aft of the body bolster.

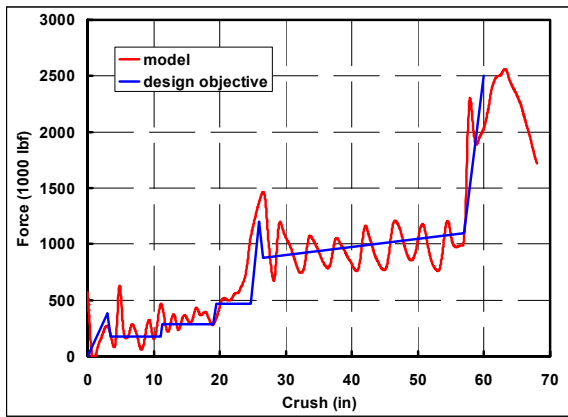
Figure 9 is a plot of the predicted force-crush response for the ideal loading condition compared against the idealized force crush characteristic. The two curves show excellent agreement.

The predicted trigger load peaks are slightly higher than the prescribed trigger loads, but the system is robust and functions well despite this fact. The required energy absorption,  $2.5 \times 10^6$  ft-lbf [3.4 MJ], is easily achieved. The total crush stroke for the cab car crush zone is 57 inches [1.5 m], which is longer than the coach car crush zone allowable length of 36 inches [0.9 m].

Figure 10 shows a comparison of the final deformation state of the two non-ideal load cases analyzed. In one case, most of the load goes through the coupler; in the other the entire load goes through the deformable anti-climber. For both cases presented, the operator's compartment is preserved and the crush zone performs well.

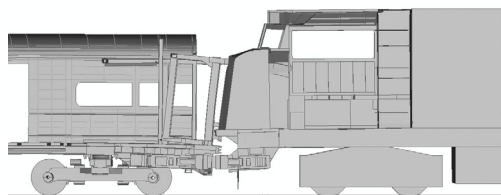


**Figure 8. Predicted Ideal Load Case Deformation Sequence**

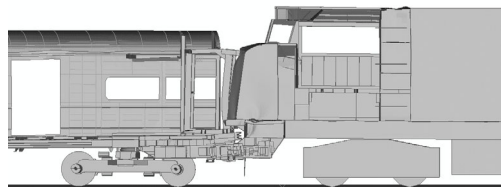


**Figure 9. Comparison of Predicted and Desired Ideal Load Case Scenario Force-Crush Characteristics**

Several analyses were conducted for the non-ideal load scenario where the load goes mainly through the coupler. The design of the pushback coupler is very robust, and the likelihood of jamming of the coupler with very little crush is very small. Even if the coupler is allowed to experience only the draft gear compression prior to “locking,” the force-crush characteristic maintains a set of tiered force plateaus that allows crush to occur in the subsequent crush zones. The operator’s compartment is protected despite there being large rotations of this space. The results for the coupler loading scenario presented are for the most likely case where some crush is allowed during push back but the coupler eventually “locks”. For the non-ideal loading scenario through the deformable anti-climber, there is much less rotation of the operator’s compartment during pushback into the service closet.



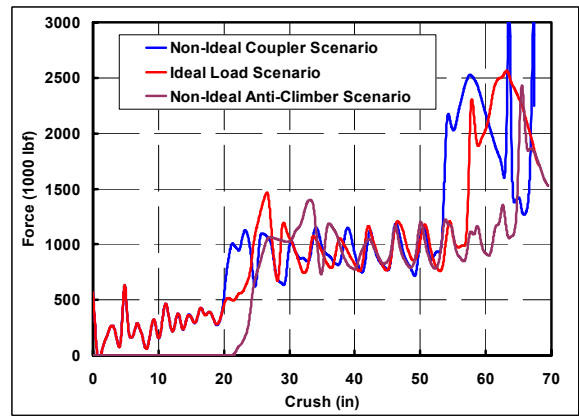
**Non-Ideal Coupler Scenario - System Exhausted**



**Non-Ideal Anti-Climber Scenario - System Exhausted**

**Figure 10. Comparison of Final Deformation State For Non-Ideal Loading Scenarios**

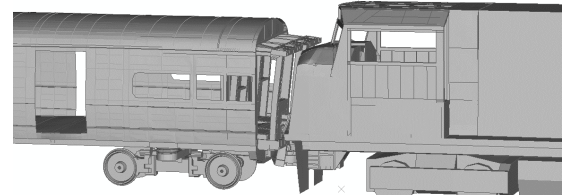
Figure 11 is a comparison of the predicted force-crush characteristics for the non-ideal loading scenarios and the ideal loading scenario. Even for these worst-case scenario conditions, the shape of the force-crush curve is very similar to that of the ideal condition. The tiered force plateaus with elevated trigger loads allow for efficient distribution of crush down the length of the CEM consist.



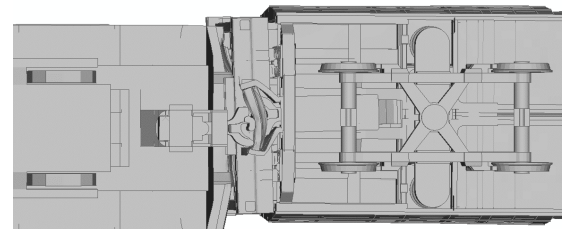
**Figure 11. Comparison of Predicted Non-Ideal and Ideal Load Case Scenario Force-Crush Characteristics**

For the coupler loading scenario, the trigger load for the fixed/sliding sill is reached sooner than for the ideal load case. The loading scenario through the deformable anti-climber is not offset, the locomotive hits at a later displacement due to the differences in initial positioning. For both these non-ideal loading scenarios the crush zone still absorbs the minimum required amount of energy,  $2.5 \times 10^6$  ft-lbf [3.4 MJ].

The last loading scenario presented is the worst of the offset loading conditions that the crush zone design is required to satisfy. For this load case, the cad car and the locomotive are misaligned by 6 inches vertically (the locomotive is lower) and laterally. Figure 12 shows bottom and isometric views of the last deformation state. This model required a half car model because of the laterally asymmetric loading condition. The half car model is constructed from approximately 500,000 elements. The cab car is fully fixed at the half-length. The locomotive is assigned an initial velocity of 30 mph.



**Isometric View - System Exhausted**



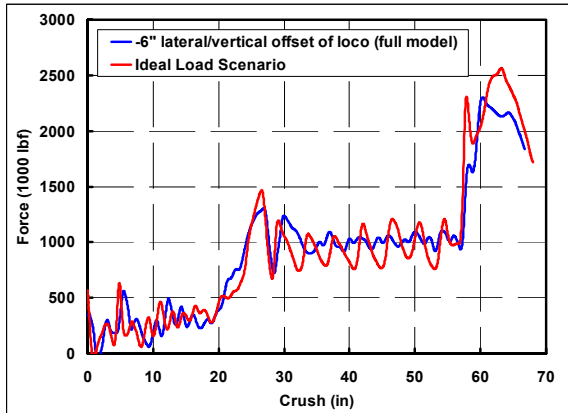
**Bottom View - System Exhausted**

**Figure 12. Isometric and Bottom Views of Offset Loading Scenario—6 in. Vertical/-6 in. Lateral – System Fully Exhausted**

The force-crush characteristics for this loading condition are compared with the ideal loading condition in Figure 13. The two curves lay almost one atop the other, and the desired



characteristics of tiered force plateaus and distinct trigger loads are present. Again, the design easily satisfies the minimum energy absorption requirement,  $2.5 \times 10^6$  ft-lbf [3.4 MJ]. The crush stroke before exhausting the system for both cases is 57 inches [1.5 m].

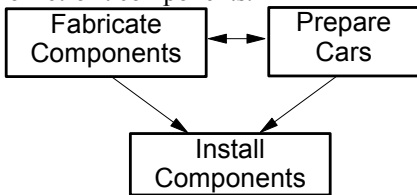


**Figure 13. Comparison of Predicted Worst Case Offset and Ideal Load Case Scenario Force-Crush Characteristics**

The cab car crush zone design developed has satisfied requirements for all the ideal, non-ideal, and offset loading scenarios defined. The minimum energy absorption requirement is satisfied, and all the force-crush characteristics have the important features required to ensure that crush is transferred from one interface to another. The next section of the paper presents a simplified integration sequence for the design.

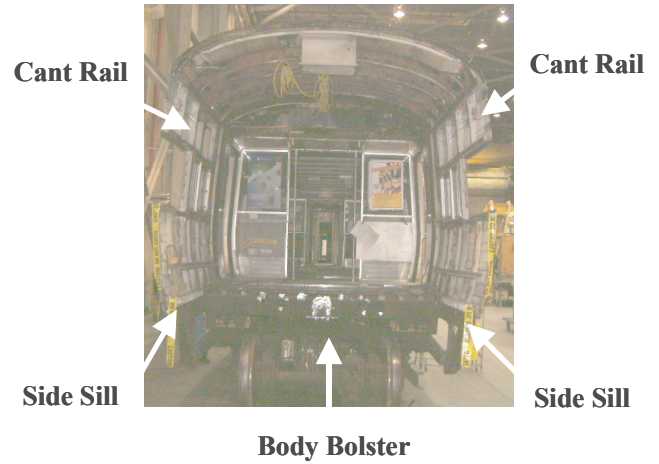
**INTEGRATION SEQUENCE FOR CAB CAR CRUSH ZONE**

The cab car crush zone design was developed for retrofit onto an existing Budd M1 passenger car. Figure 14 is a schematic of the process followed during the integration phase of the newly developed crush zone design. The crush zones will be fabricated at a separate rail shop and shipped to the Transportation Technology Center in Pueblo, CO. The Budd M1 cars are being prepared for installation, while the crush zones are being fabricated. A cut-out sequence was developed for use by the assembly team. The ends of the cars have been removed, and the edges on the cut-out planes ground smooth in preparation for retrofit components.



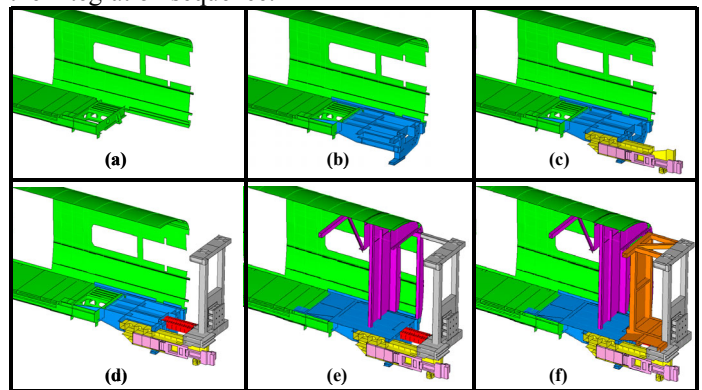
**Figure 14. Flow Chart, Retrofit of Crush Zones onto Existing Conventional Cars**

Figure 15 is a pre-integration photograph of one of the prepared Budd M1 cars. A limited number of attachment points are available on the existing vehicle where load is passed back into the main carbody structure.



**Figure 15. Pre-Integration Photograph of Budd M1 Car**

The strategy followed in developing the integration sequence is very similar to that used for the coach car designs. Once the existing car structure has been prepared, a set of components is used to build up the existing body bolster, side sills, and floor structure to serve as the fixed components into which the sliding components will push back. Next, the sliding sill assembly, including some pushback coupler components, will be attached to the fixed components. The integrated end frame is then welded to the sliding sill, followed by placement of the primary and roof energy absorbers. Then the operator’s partition wall is built up along with floor structure in the operator’s compartment. Finally, the operator’s compartment is completed by building up the sides and back wall, and the coupler is installed. Figure 16 shows a few of the key steps of the integration sequence.



**Figure 16. Simplified Integration Sequence for Cab car Crush Zone Design**

**SUMMARY**

The CEM design approach has been applied towards the development of an enhanced consist design, which incorporates cab car and coach car crush zone designs. The crush zones help manage the longitudinal crush through designed progressive collapse in unoccupied areas of vehicles along the full length of the consist, as well as minimize both the lateral and vertical motions at all interfaces.

Using the coach car crush zone design as a starting point, a cab car crush zone design has been developed. The added

complication for the cab car is the need to control the interaction at the colliding interface of the collision while maintaining a survivable space for the operator. To do this, it is necessary to accommodate the impacting coupler on the opposing freight or passenger consist and distribute the loads into the superstructure through a deformable anti-climbing system.

The cab car crush zone has been designed for a range of impact conditions including both ideal and offset conditions. In addition, the cab car crush zone has been designed for conditions in which the entire impact load is transmitted through the coupler and the entire impact load is transmitted through the deformable anti-climber. Detailed simulations have been conducted to evaluate the effectiveness of the final design.

An ongoing series of in-line full-scale impact tests of conventional and CEM passenger equipment is nearing completion. In the sixth and final in-line test, currently scheduled for early 2006, a cab car led passenger consist will impact a standing locomotive led consist. The CEM coach car end structure that was tested in one-car and two-car full-scale impact tests will be installed on the ends of each passenger car, and a cab car crush zone will be installed on the impacting end of the cab car. In the train-to-train test of conventional equipment, the space for approximately 46 passengers and the operator was destroyed. Under the same impact conditions, the CEM equipment is expected to preserve the space for all of the occupants.

## ACKNOWLEDGEMENTS

The cab and coach car crush zone designs developed and described in this paper were conducted under the Equipment Safety Research Program sponsored by the Office of Research and Development of the Federal Railroad Administration. The authors would like to thank Dr. Tom Tsai, Program Manager, and Claire Orth, Division Chief, Equipment and Operating Practices Research Division, Office of Research and Development, Federal Railroad Administration, for their support.

Patricia Llana, Staff Engineer, TIAX LLC, constructed the finite element models.

## REFERENCES

- [1] Tyrell, D.C., Perlman, A.B., "Evaluation of Rail Passenger Equipment Crashworthiness Strategies," Transportation Research Record No. 1825, pp. 8-14, National Academy Press, 2003.
- [2] Tyrell, D., "Passenger Rail Train-to-Train Impact Test Volume I: Overview and Selected Results," US Department of Transportation, DOT/FRA/ORD-03/17.I, July 2003.
- [3] Jacobsen, K., Tyrell, D., Perlman, A.B., "Impact Tests of Crash Energy Management Passenger Rail Cars: Analysis and Structural Measurements," American Society of Mechanical Engineers, Paper No. IMECE2004-61252, November 2004.
- [4] Jacobsen, K., Tyrell, D., Perlman, A.B. , "Impact Test of a Crash-Energy Management Passenger Rail Car," American

Society of Mechanical Engineers, Paper No. RTD2004-66045, April 2004.

[5] Tyrell, D., Severson, K., Zolock, J., Perlman, A.B., "Passenger Rail Two-Car Impact Test Volume I: Overview and Selected Results," US Department of Transportation, DOT/FRA/ORD-01/22.I, January 2002.

[6] Tyrell, D., Severson, K., Perlman, A.B., "Single Passenger Rail Car Impact Test Volume I: Overview and Selected Results," US Department of Transportation, DOT/FRA/ORD-00/02.1, March 2000.

[7] Mayville, R., Johnson, K., Tyrell, D., "Development of a Rail Passenger Coach Car Crush-Zone," Proceedings of the 3rd International Symposium on the Passive Safety of Rail Vehicles, Berlin, March 21-22, 2002.

[8] Martinez, E., Tyrell, D., Perlman, A.B. , "Development of Crash Energy Management Designs for Existing Passenger Rail Vehicles," American Society of Mechanical Engineers, Paper No. IMECE2004-61601, November 2004.

[9] U.S. Department of Transportation, Federal Railroad Administration, "49 CFR Part 216 et al., Passenger Equipment Safety Standards; Final Rule," Federal Register, May 12, 1999.

[10] American Public Transportation Association, Member Services Department, APTA SS-C&S-034-99 Standard for the Design and Construction of Passenger Railroad Rolling Stock, Authorized January 11, 2000.

[11] European Union Technical Specification for Interoperability, TSI, for High Speed Equipment, Official Journal of the European Communities, EN L 245/446, Annex A Passive Safety – Crashworthiness, December 9, 2002.