



U. S. Department of  
Transportation  
Federal Railroad  
Administration

# Passenger Rail Two-Car Impact Test Volume II: Summary of Occupant Protection Program

Office of Research  
and Development  
Washington, D.C. 20590

## Rail Passenger Equipment Collision Tests



**NOTICE**

**This Document is disseminated under the sponsorship of the Department of Transportation in the interest of information exchange. The United States Government assumes no liability for its contents or use thereof.**

**NOTICE**

**The United States Government does not endorse products or manufacturers. Trade or manufacturers' names appear herein solely because they are considered essential to the objective of this report.**

**REPORT DOCUMENTATION PAGE***Form Approved  
OMB No. 0704-0188*

Public reporting burden for this collection of information is estimated to average 1 hour per response, including the time for reviewing instructions, searching existing data sources, gathering and maintaining the data needed, and completing and reviewing the collection of information. Send comments regarding this burden estimate or any other aspect of this collection of information, including suggestions for reducing this burden, to Washington Headquarters Services, Directorate for Information Operations and Reports, 1215 Jefferson Davis Highway, Suite 1204, Arlington, VA 22202-4302, and to the Office of Management and Budget, Paperwork Reduction Project (0704-0188), Washington, DC 20503.

|   |  |   |   |   |  |
|---|--|---|---|---|--|
| 1. AGENCY USE ONLY (Leave blank)  |  | 2. REPORT DATE<br>January 2002                              |   | 3. REPORT TYPE AND DATES COVERED<br>Final Report<br>March 2000-June 2000      |  |
| 4. TITLE AND SUBTITLE<br>Passenger Rail Two-Car Impact Test – Volume II: Summary of Occupant Protection Program   |  |   |   | 5. FUNDING NUMBERS<br><br>R1021/RR228   |  |
| 6. AUTHOR(S)<br>Caroline VanIngen-Dunn*   |  |   |   |   |  |
| 7. PERFORMING ORGANIZATION NAME(S) AND ADDRESS(ES)<br>U.S. Department of Transportation<br>Research and Special Programs Administration<br>Volpe National Transportation Systems Center<br>Cambridge, MA 02142-1093   |  |   |   | 8. PERFORMING ORGANIZATION<br>REPORT NUMBER<br><br>DOT-VNTSC-FRA-01-08.II     |  |
| 9. SPONSORING/MONITORING AGENCY NAME(S) AND ADDRESS(ES)<br>U.S. Department of Transportation<br>Federal Railroad Administration<br>Office of Research and Development<br>1120 Vermont Avenue, NW: Mail Stop 20<br>Washington, DC 20590  |  |   |   | 10. SPONSORING/MONITORING<br>AGENCY REPORT NUMBER<br><br>DOT/FRA/ORD-01/22.II |  |
| 11. SUPPLEMENTARY NOTES<br>*Simula Technologies, Inc.<br>10016 S. 51 <sup>st</sup> Street<br>Phoenix, AZ 85044  |  |   |   |   |  |
| 12a. DISTRIBUTION/AVAILABILITY STATEMENT<br>This document is available to the public through the National Technical Information Service,<br>Springfield, Virginia 22161.<br>This document is also available on the FRA web site at <a href="http://www.fra.dot.gov">www.fra.dot.gov</a> .   |  |   |   | 12b. DISTRIBUTION CODE  |  |
| 13. ABSTRACT (Maximum 200 words)<br>Two full-scale impact tests of rail cars fitted with seat/occupant experiments were conducted at the Federal Railroad Administration's Transportation Technology Center located in Pueblo, Colorado. The first test was conducted on November 16, 1999, with a single rail car that was impacted against a rigid barrier at 35.1 mph (56.5 km/h). The second test, conducted on April 4, 2000, involved two rail cars coupled together impacting a rigid barrier at 26 mph (41.8 km/h). The objective of the interior tests was to determine the corresponding level of occupant safety for the impact scenarios. The cars were equipped with anthropomorphic test devices (ATDs). The following three experiments were in the lead car: (1) forward-facing unrestrained occupants seated in rows, compartmentalized by the forward seat in order to limit the motions of the occupants; (2) forward-facing restrained occupants with lap and shoulder belts; and (3) rear-facing unrestrained occupants. The trailing car had one experiment similar to the first one in the lead car: forward-facing unrestrained occupants seated in rows, compartmentalized by the forward seat in order to limit the motions of the occupants. All the seats remained attached during the test, and all the unrestrained test dummies were compartmentalized. The connection between the seat back and seat pan for the seat with seatbelts was strengthened over the seat tested in the single car test, which helped compartmentalize the unrestrained dummies initially seated behind the seat with seatbelts.<br><br>The principal goal of the Occupant Protection Tests for Full-Scale Passenger Rail Impacts program was to obtain scientific evidence and data that defines a realistic rail car crash pulse, the rail car's structural response, and a corresponding level of occupant safety. |  |   |   |   |  |
| 14. SUBJECT TERMS<br>Transportation, safety, crashworthiness, occupant protection, passenger rail vehicles, passenger seats, seat belts   |  |   |   | 15. NUMBER OF PAGES<br><br>40   |  |
|   |  |   |   | 16. PRICE CODE  |  |
| 17. SECURITY CLASSIFICATION OF REPORT<br><br>Unclassified   | 18. SECURITY CLASSIFICATION OF THIS PAGE<br><br>Unclassified | 19. SECURITY CLASSIFICATION OF ABSTRACT<br><br>Unclassified | 20. LIMITATION OF ABSTRACT<br><br>Unlimited |   |  |

## PREFACE

This test summary report for the two-rail-car impact test is provided by Simula Technologies, Inc. under a contract for the Occupant Protection Tests for Full-Scale Passenger Rail Impacts, Contract No. DAAD01-99-C-0012. Two full-scale impact tests of rail cars fitted with seat/occupant experiments were planned and conducted. The first test was conducted on November 16, 1999, involving a single rail car that was impacted against a rigid barrier at 35.1 mph (56.5 km/h). The second test, conducted on April 4, 2000, involved two rail cars coupled together impacting a rigid barrier at 26 mph (41.8 km/h). Simula Technologies worked closely with the personnel at the Volpe National Transportation Systems Center (Volpe Center) to support the Federal Railroad Administration (FRA) in the conduct of these full-scale passenger rail equipment tests performed on-site at the FRA's Transportation Technology Center (TTC) in Pueblo, Colorado.

The work described in this report was performed as part of the Equipment Safety Research Program at the Volpe Center sponsored by the FRA. Tom Tsai, Program Manager, and Claire Orth, Division Chief, Equipment and Operating Practices Research Division, Office of Research and Development, FRA, direct this program. David Tyrell, Senior Engineer, Volpe Center, developed the test requirements and initiated and monitored this work.

Gunars Spons, FRA Resident Engineering Manager at the TTC, directed and coordinated the activities of all the parties involved in the test. Barrie Brickle, Senior Engineer, TTC, implemented the equipment-related portions of the test.



# TABLE OF CONTENTS

| <u>Section</u>  | <u>Page</u> |
|---|-------------|
| 1. INTRODUCTION .....   | 1           |
| 2. TWO-CAR SEAT/OCCUPANT EXPERIMENTS.....   | 3           |
| 2.1 Experiment No. 1-1, Forward-Facing Row-to-Row Commuter Seats, Lead Car.....                     | 3           |
| 2.2 Experiment No. 2-1, Forward-Facing Row-to-Row Commuter Seats, Trailing Car.....                 | 3           |
| 2.3 Experiment No. 1-2, Row-to-Row Amtrak Seats with Restraints, Lead Car .....                     | 5           |
| 2.4 Experiment No. 1-3, Rear-Facing Commuter Seat, Lead Car .....                                   | 5           |
| 3. TWO-CAR IMPACT TEST SEAT/OCCUPANT EXPERIMENT RESULTS.....  | 7           |
| 3.1 Experiment No. 1-1, Forward-Facing Row-to-Row Commuter Seats, Lead Car.....                     | 7           |
| 3.1.1 Experiment No. 1-1, Seat Outcome .....  | 7           |
| 3.1.2 Experiment No. 1-1, ATD Outcome.....  | 9           |
| 3.2 Experiment No. 2-1, Forward-Facing Row-to-Row Commuter Seats, Trailing Car.....                 | 10          |
| 3.2.1 Experiment No. 2-1, Seat Outcome .....  | 11          |
| 3.2.2 Experiment No. 2-1, ATD Outcome.....  | 12          |
| 3.3 Experiment No. 1-2, Forward-Facing Row-to-Row Intercity Seats with Restraints,<br>Lead Car..... | 12          |
| 3.3.1 Experiment No. 1-2, Seat Outcome .....  | 12          |
| 3.3.2 Experiment No. 1-2, ATD Outcome.....  | 14          |
| 3.4 Experiment No. 1-3, Rear-Facing Commuter Seat, Lead Car .....                                   | 14          |
| 3.4.1 Experiment No. 1-3, Seat Outcome .....  | 14          |
| 3.4.2 Experiment No. 1-3, ATD Outcome.....  | 15          |
| 4. CONCLUSIONS.....   | 19          |
| REFERENCES .....  | 21          |
| APPENDIX A SEAT ATTACHMENT LOADS.....   | 23          |
| APPENDIX B INJURY DATA COMPARISON BETWEEN SINGLE-CAR TEST<br>AND TWO-CAR TEST.....                  | 27          |

## LIST OF FIGURES

| <b><u>Figure</u></b>  | <b><u>Page</u></b> |
|---|--------------------|
| 1. Seat Experiment Layout in the Leading Car.....   | 4                  |
| 2. Seat Experiment Layout in the Trailing Car.....  | 4                  |
| 3. Experiment No. 1-1 – Post-Test Seat Photograph of Pedestal and Side Arm Shroud<br>Deformation.....   | 8                  |
| 4. Experiment No. 1-1 – Post-Test Photograph where Occupants Remain<br>Compartmentalized.....   | 8                  |
| 5. Experiment No. 1-1 – Post-Test Photograph of Side Arm Frame and Shroud<br>Deformation.....   | 9                  |
| 6. Experiment No. 2-1 – Post-Test Photograph where Seat Occupants Remain<br>Compartmentalized.....  | 10                 |
| 7. Experiment No. 2-1 – Post-Test Photograph of Side Wall Frame and Shroud<br>Deformation.....  | 11                 |
| 8. Experiment No. 1-2 – Post-Test Photograph of View of Intercity Seats.....  | 13                 |
| 9. Experiment No. 1-2 – Post-Test Photograph of Seat Back Deformation Due to Knees<br>Impacting from Behind.....                                  | 13                 |
| 10. Experiment No. 1-3 – Post-Test Photograph of Seat Frame Deformation.....  | 16                 |
| 11. Experiment No. 1-3 – Post-Test Photograph of Seat Back Deformation.....   | 16                 |
| 12. Experiment No. 1-3 – Post-Test Photograph of ATDs on the Floor Following<br>Rebound.....  | 17                 |
| A-1. Experiment No. 1-1 – Forward-Facing Row-to-Row Commuter Seats, Lead Car<br>Front Row Seat Attachment Loads (Maximums).....                   | 25                 |
| A-2. Experiment No. 2-1 – Forward-Facing Row-to-Row Commuter Seats, Trailing<br>Car Front Row Seat Attachment Loads (Maximums).....               | 25                 |
| A-3. Experiment No. 1-2 – Forward-Facing Row-to-Row Intercity Seats with Restraints,<br>Lead Car. Front Row Seat Attachment Loads (Maximums)..... | 26                 |
| A-4. Experiment No. 1-3 – Rear-Facing Commuter Seat, Lead Car. Seat Attachment<br>Loads (Maximums).....   | 26                 |

## LIST OF TABLES

| <b><u>Table</u></b>  | <b><u>Page</u></b> |
|--|--------------------|
| 1. Experiment No. 1-1 - Row-to-Row Commuter Seats; Occupant Injury Loads.....                                | 10                 |
| 2. Experiment No. 2-1 - Row-to-Row Commuter Seats – Trailing Car; Occupant<br>Injury Loads.....              | 12                 |
| 3. Experiment No. 1-2 – Row-to-Row Intercity Seats with Restraints – Lead Car;<br>Occupant Injury Loads..... | 15                 |
| 4. Experiment No. 1-3 – Rear-Facing Commuter Seats – Lead Car; Occupant<br>Injury Loads.....                 | 17                 |
| B-1. Row-to-Row Commuter Seats – Maximum Injury Loads.....   | 29                 |
| B-2. Row-to-Row Intercity Seats with Restraints – Maximum Injury Loads.....                                  | 29                 |
| B-3. Rear-Facing Commuter Seat – Maximum Injury Loads.....   | 30                 |





## EXECUTIVE SUMMARY

The principal goals of the occupant protection experiments, which are being carried out as part of the full-scale passenger rail equipment impact tests, are to make occupant injury measurements with anthropomorphic test devices (ATDs), to observe the motions of the test dummies, and to measure the loads imparted to the seats.

Two full-scale crash tests of rail cars fitted with seat/occupant experiments were planned and conducted. The first test was conducted on November 16, 1999 (see References 1 and 2), and the second was performed on April 4, 2000. The first test involved a single rail car that was impacted against a rigid barrier at 35.1 mph (56.5 km/h). The second impact test conducted on April 4, 2000, involved two rail cars coupled together impacting a rigid barrier at 26 mph (41.8 km/h).

The seat/occupant experiments that were incorporated into the second full-scale two-rail-car impact test were similar to those performed in the first single-car test and were intended to represent typical commuter and intercity seat configurations with typical-sized occupants.

Under initial observation, the injuries to the occupants in the two-car dynamic impact test appeared to produce lower injury measures than that of the original single-car test. Post-test inspection showed that all seats experienced minimal deformation and remained attached to the floor and/or wall, thereby successfully retaining the test dummies within their respective compartments.



# 1. INTRODUCTION

Two full-scale crash tests of rail cars fitted with seat/occupant experiments have been conducted. The first was conducted on November 16, 1999, and the second was performed on April 4, 2000. The first test involved a single rail car that was impacted against a rigid barrier at 35.1 mph. The second test, involved two rail cars coupled together impacting a rigid barrier at 26 mph. One part of each test was to evaluate occupant protection.

The principal goals of the occupant protection experiments, which are being carried out as part of the full-scale passenger rail equipment impact tests, are to make occupant injury measurements with test dummies, to observe the motions of the test dummies, and to measure the loads imparted to the seats. Interior seating test configurations with data acquisition technology and quantified occupant injury parameters and seat strength characteristics were incorporated in each test. Implementation of the occupant protection experiments included reviewing, setting up, and preparing the car interiors and their seat/occupant configurations, instrumenting and filming the configurations during impact, and reporting the data measured by the anthropomorphic test devices (ATDs) and seat attachment load cells during vehicle impact.

The two-car dynamic impact test was conducted on April 4, 2000. An overview of the measured results of the experiments are presented in Reference 5, and a complete set of test data, including the interior seat/occupant data is available in Reference 6. Details in this report are the measured results of the four seat/occupant experiments from the two-car test. The following three experiments were in the lead car:

1. Forward-facing unrestrained occupants seated in one row, compartmentalized by the forward seat in order to limit the motions of the occupants.
2. Forward-facing restrained occupants with lap and shoulder belts (incorporating a minor modification to the seat from Test No. 1) seated in one row and unrestrained occupants seated in the row behind them.
3. Rear-facing unrestrained occupants (the seat was modified from Test No. 1) seated in one row.

The trailing car had one experiment similar to the first one in the lead car:

Forward-facing unrestrained occupants seated in one row, compartmentalized by the forward seat in order to limit the motions of the occupants (the seat was modified from Test No. 1).

The measured results of the four seat/occupant experiments from the two-car test (Test No. 2) are provided in Section 3 of this report.



## **2. TWO-CAR SEAT/OCCUPANT EXPERIMENTS**

Seat/occupant experiments were incorporated into a full-scale two-rail-car impact test. The seat/occupant experiments were intended to represent typical commuter and intercity seat configurations with typically sized occupants. Note that none of the currently produced rail seats are designed to meet the recently published FRA safety standards (see Reference 7). The intercity seat/occupant experiment was designed to provide information about restraint systems in rail seats. This experiment involved an intercity seat modified with restraints (there is no seat like this in service today), and used 95th-percentile ATDs and one 5th-percentile ATD. The commuter rail seats used on this test were M-Style seats manufactured by Coach and Car Equipment Corporation (CCEC), which is located in Elk Grove Village, Illinois. The intercity seats tested were provided as used equipment from Amtrak.

### **2.1 EXPERIMENT NO. 1-1, FORWARD-FACING ROW-TO-ROW COMMUTER SEATS, LEAD CAR**

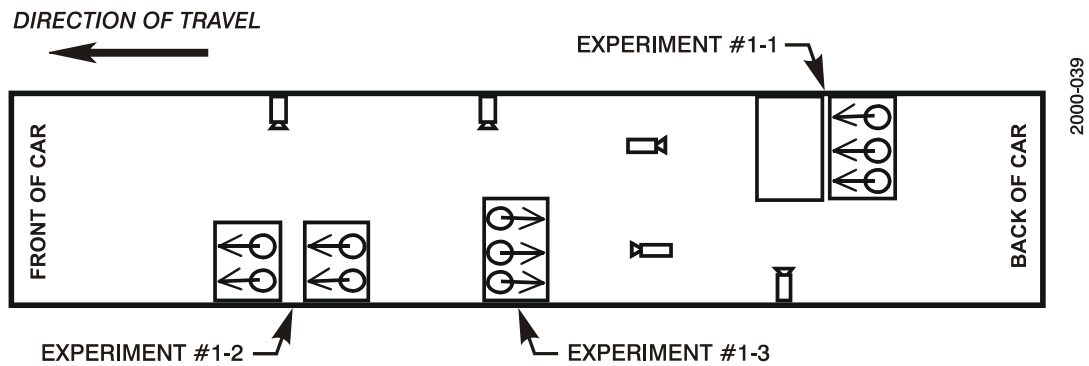
The focus of this experiment was on the rear seat occupants impacting the front row seat and observing the reaction of the front row seat (floor and wall attachment loads and seat structural response). Experiment No. 1-1 consisted of two row-to-row three-place passenger commuter seats; specifically the M-Style seat of transit authorities such as Metro North Railroad, the Long Island Rail Road (LIRR), the Southeast Pennsylvania Transit Authority (SEPTA), Northern Indiana Commuter Transportation District (NICTD) service, New Jersey Transit, and Maryland Area Rail Commuter (MARC) service. The seat pitch between the seats was 32 inches (81.2 cm), and the rear seat was occupied by three 50th-percentile ATDs. This experiment was installed aft in the rail car, in front of the rear-body bolster, on the right side (all orientations are made with respect to an occupant facing the front, impacting end of the rail car, see Figure 1).

The seats were bolted onto retrofitted steel bars (2.0 in. x 0.75 in. [5 cm – 1.9 cm]) that replaced the original wooden floor of the rail car. These steel bars represented the retrofit floor design in SEPTA's Silverliner 3 rail car. Two floor load cells served as an interface between the seat pedestal and the steel floor bar. At the wall mounting points, two load cells served as an interface between the seat attachment points and the heater guard. (The heater guard is a lip that extends horizontally from the wall of the car.) The rear row seat was similarly installed, but instead of load cells, spacer blocks of equivalent height were used.

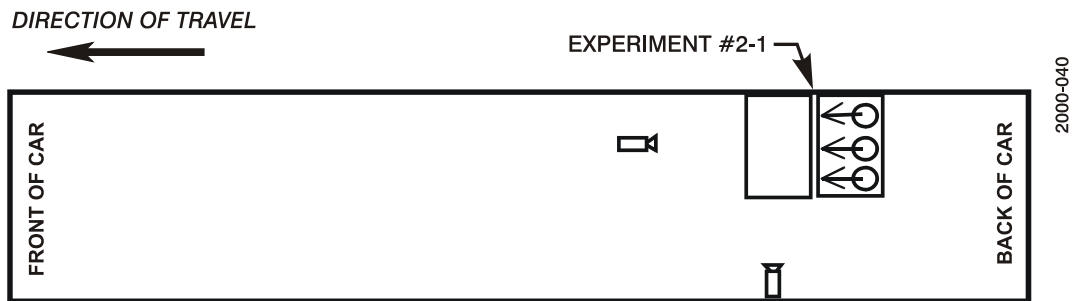
### **2.2 EXPERIMENT NO. 2-1, FORWARD-FACING ROW-TO-ROW COMMUTER SEATS, TRAILING CAR**

The focus of this experiment was on the rear-seat occupants impacting the front-row seat and observing the reaction of the front-row (floor and wall attachment loads and seat structural response). Experiment No. 2-1 consisted of two row-to-row three-place passenger commuter seats; specifically, the M-Style seat of transit authorities. The seat pitch between seats was 32 inches (81.2 cm), and the rear seat was occupied by three unrestrained 50<sup>th</sup>-percentile ATDs. This experiment was installed aft in the rail car, in front of the rear-body bolster, on the right side (all orientations are made with respect to an occupant facing the front, coupler end to the impacting rail car; see Figure 2).

The seat in Experiment No. 2-1, was similar to Experiment No. 1-1, with the exception of some seat design modifications that were incorporated into the seat based on the outcome of the same experiment already conducted in the single-car impact test. The front row seat modifications include a stiffener at the seat/pan hinge point in the frame, as well as flanges to strengthen the side wall attachment weldments. The seat was also designed with a stronger pedestal mount. These seat modifications were made because, during the single-car impact test with the same seat/occupant configuration, the seats collapsed under the impact loads of the test at the seat pedestals, side wall attachment to the frame, and at the elbow junction at the seat back/pan hinge point on the frame. As a result, it was recommended to modify a similar commuter seat for this two-car impact test with a stronger pedestal and weld seams on the seat frame to compare results to the single-car impact test.



**Figure 1. Seat Experiment Layout in the Leading Car**



**Figure 2. Seat Experiment Layout in the Trailing Car**

### **2.3 EXPERIMENT NO. 1-2, ROW-TO-ROW AMTRAK SEATS WITH RESTRAINTS, LEAD CAR**

The focus of this experiment was on the rear seat occupants impacting the front row seat occupied with restrained ATDs, and observing the reaction of the front row seat, the restrained occupants in this seat, and the unrestrained ATDs impacting the seat from behind.

Experiment No. 1-2 consisted of two row-to-row two-place passenger intercity seats that were provided by Amtrak from their used-seat inventory. These intercity seats were manufactured by AMI of Colorado Springs, Colorado. The front row intercity Amtrak seat was modified by adding lap and shoulder belts to it. The seat back panel and hinge point between the seat pan and the seat back were both strengthened to bear the load of the lap and shoulder belts, as well as the load of the unrestrained occupants impacting the seat from behind. Energy-absorbing (EA) devices were also incorporated into the modified seat to bear some of the impact load. These EAs were installed 2 inches (5 cm) below the previous installation mounting point from the first test with the intent of reducing the angle to which the seat back rotated. The two original Amtrak seat pedestals were replaced with higher strength pedestals that were re-used from the first test. The rear seat was occupied by two unrestrained 95th-percentile ATDs, and the front seat was occupied by two restrained ATDs (a 5th-percentile in the aisle seat and a 95th-percentile in the window seat).

The Amtrak seats were floor-mounted and bolted onto steel bars (2.00 in. x 0.75 in. [5 cm – 1.9 cm]) that replaced the original wooden floor. Two floor load cells served as an interface between each seat pedestal and the steel bars to which they were attached. The rear row seat was similarly installed, but instead of load cells, spacer blocks of equivalent height were used.

### **2.4 EXPERIMENT NO. 1-3, REAR-FACING COMMUTER SEAT, LEAD CAR**

Experiment No. 1-3 consisted of a single, rear-facing commuter seat that was modified from the first test. The seat modifications performed were similar to those made on the seat in Experiment 2-1, and included improved side wall attachments on the frame, and a higher strength pedestal. This rear-facing seat was occupied by three unrestrained 50th-percentile ATDs.

This seat was installed like the other commuter seats, where two floor load cells served as an interface between the seat pedestal and the steel floor beam, and, at the wall mount, two load cells served as an interface between the seat attachment and the heater guard.

This experiment was installed in the leading car more toward the center of the rail car, unlike the first test where it was installed in the aft section of the car (see Figure 1).





### **3. TWO-CAR IMPACT TEST SEAT/OCCUPANT EXPERIMENT RESULTS**

The outcome of the seat/occupant experiments in the two-car impact test appeared to be far less severe and, under initial observation, less injurious to the occupants than the outcome of the single-car test. Post-test inspection showed that all seats experienced minimal deformation and remained attached to the floor and/or wall, thereby successfully retaining the ATDs within their respective compartments. However, data analysis shows that all the unrestrained, instrumented ATDs in the forward-facing seats (Experiments 1-1, 1-2, and 2-1) measured injury loads that exceeded at least one injury criterion. The aft-facing ATD in Experiment 1-3 and the restrained 5th-percentile ATD in Experiment 1-2 did not experience loads that exceeded the injury criteria. This outcome for the 5th-percentile ATD was an improvement over the outcome of the single-car test, and was most likely due to the effective compartmentalization of the unrestrained ATD in the seat row behind it. In the single-car test, the unrestrained ATD projected over the seat in front of it and impacted the 5th-percentile ATD, causing a high neck compression load. Additional details are discussed below.

A comparison of the injury data recorded by the ATDs in the first (single-car) test and the injury data recorded by the ATDs in the second (two-car) test is provided in Tables B-1 through B-3 of Appendix B.

Note on Injury Criteria: The instrumentation of the test dummy measures head accelerations, select head/neck interface forces and moments, chest accelerations, and femure axial force. The National Highway Transportation Safety Administration (NHTSA) defines the injury criteria, along with maximum values for the criteria, for use in setting regulatory standards for highway vehicles. The head injury, chest, and femur criteria and values used in this paper are from the NHTSA interim final rule modifying the Federal Motor Vehicle Safety Standard (FMVSS) No. 208 (Occupant Crash Protection – see Reference 3). The neck injury values are from Reference 4.

#### **3.1 EXPERIMENT NO. 1-1, FORWARD-FACING ROW-TO-ROW COMMUTER SEATS, LEAD CAR**

The ATDs in this experiment were effectively compartmentalized; however, the load of the instrumented ATD exceeded the neck flexion injury criterion. There was minimal deformation of the pedestal and minor deformation of the side arm shroud, helping to limit the forward rotation of the seat back and keeping the unbelted rear seat occupants compartmentalized (Figures 3 and 4).

##### **3.1.1 Experiment No. 1-1, Seat Outcome**

There was no observable deformation in the aft row seat; however, all the aft-row cushions detached from the frame.

The pedestal in the front row seat deformed minimally under impact loads. The side arm frame and its shroud both deformed slightly on the aisle side of the seat (Figure 5), while the side wall attachments rotated forward under the impact load from the occupants in the row behind it.



**Figure 3. Experiment No. 1-1 – Post-Test Seat Photograph of Pedestal and Side Arm Shroud Deformation**



**Figure 4. Experiment No. 1-1 – Post-Test Photograph where Occupants Remain Compartmentalized**



**Figure 5. Experiment No. 1-1 – Post-Test Photograph of Side Arm Frame and Shroud Deformation**

The seat back rotated forward, but not enough to cause the ATDs to travel over the seat back. The seat and the floor attachments of the seat to the pedestal remained intact. The load cell attachment of the seat to the side wall remained intact. All the front row seat cushions detached.

The measured peak seat attachment loads are provided in Appendix A (See Figure A-1).

### **3.1.2 Experiment No. 1-1, ATD Outcome**

All injury measurements were made from instrumentation installed on the Hybrid III 50<sup>th</sup> percentile ATD seated in the aft row, aisle side. Instrumentation measured head acceleration in three principal directions ( $A_x$ ,  $A_y$ ,  $A_z$ ) to determine head injury (HIC); upper neck tension/compression force ( $F_z$ ), upper neck shear force ( $F_x$ ), and upper neck flexion/extension moment ( $M_y$ ) to determine neck injury; chest principal direction accelerations to determine chest injury; and right and left femur axial force for leg injury. From high-speed video, kinematics of the ATD during the collision can be incorporated with time histories of the injury criteria to describe occupant response as follows. The ATD's knees impacted the seat back ahead of it, peaking at approximately 70 msec and then again at approximately 120 msec and 200 msec. After the knees impacted the seat back, the instrumented ATD began to stand and travel forward, catching its chin on the upper portion of the front seat back, causing the neck to measure a neck flexion moment ( $+M_y$ ) that exceeded the injury criteria (see Table 1). The side arm of the seat deformed primarily as a result of the ATD's upper body impacting the seat rather than the knees' initial impact, which appeared to have little effect on the initial seat deformation.

| <b>Table 1.</b>  |  |                            |
|--|--|----------------------------|
| <b>Experiment No. 1-1 - Row-to-Row Commuter Seats; Occupant Injury Loads</b> |  |                            |
|  | <b>Hybrid III 50th-Percentile, Aisle Seat Occupant</b> |                            |
|  | <b>Criteria</b>  | <b>Recorded Peak Loads</b> |
| HIC  | 1,000  | 69                         |
| Neck Fx (lb)   | +697/-697  | +437/-27                   |
| Neck Fz (lb)   | +742/-900  | +164/-258                  |
| Upper Neck My (ft-lb)  | +140/-42   | +148/-8                    |
| Chest (G)  | 60   | 15                         |
| Left Femur (lb)  | -2,250   | -556                       |
| Right Femur (lb)   | -2,250   | -555                       |

### **3.2 EXPERIMENT NO. 2-1, FORWARD-FACING ROW-TO-ROW COMMUTER SEATS, TRAILING CAR**

The seat tested in the trailing car was modified with a stiffener at the seat/pan hinge point in the frame, as well as with flanges to strengthen the side wall attachment weldments. The seat also had a stronger pedestal mount. The results of this experiment showed minimal deformation of the seat frame, some deformation of the upper headrest, and no deformation to the modified pedestal. The stiffness exhibited by the seat resulted in the unbelted rear seat occupants remaining compartmentalized (see Figure 6). The Hybrid III 50th-percentile ATD in the rear aisle seat was instrumented, and recorded an extension moment in the neck load cell that exceeded the injury criterion at approximately 600 msec from initial impact.



**Figure 6. Experiment No. 2-1 – Post-Test Photograph where Seat Occupants Remain Compartmentalized**

### 3.2.1 Experiment No. 2-1, Seat Outcome

There was no observable deformation in the aft-row seat, nor did the aft-row cushions detach from the frame.

The modified pedestal in the front row seat did not deform. The side wall frame and its shroud both deformed slightly on the window side of the seat (see Figure 7). The side arm on the aisle side did not deform. The upper part of the seat back absorbed much of the energy from the impacting ATDs, due in part to the increased stiffness from the lower part of the seat back and pedestal. The seat and the floor attachments of the seat to the pedestal remained intact. The load cell attachment of the seat to the side wall remained intact. All the front row seat cushions detached.

The measured peak seat attachment loads are provided in Appendix A (See Figure A-2).



**Figure 7. Experiment No. 2-1 – Post-Test Photograph of Side Wall Frame and Shroud Deformation**

### 3.2.2 Experiment No. 2-1, ATD Outcome

All injury measurements were made from instrumentation installed on the Hybrid III 50<sup>th</sup> percentile ATD seated in the aft row, aisle side. Instrumentation measured head acceleration in three principal directions (Ax, Ay, Az) to determine head injury (HIC); upper neck tension/compression force (Fz), upper neck shear forces (Fx and Fy), and upper neck flexion/extension moment (My) to determine neck injury; chest principal direction accelerations to determine chest injury; and right and left femur axial force for leg injury. From high-speed video, kinematics of the ATD during the collision can be incorporated with time histories of the injury criteria to describe occupant response as follows. The ATD's knees impacted the seat back ahead of it, followed by a head impact with the upper portion of the forward seat back which results in dome deformation of the upper portion of the seat. In this particular experiment, the ATD's face impacted the upper seat back, followed by the head going over the top of the seat. Upon returning to its seated position, the chin caught on the top of the seat back causing a high extension moment (-My) measured on the upper neck. The seat deformed minimally and may have contributed to the excessive ATD neck moment (see Table 2).

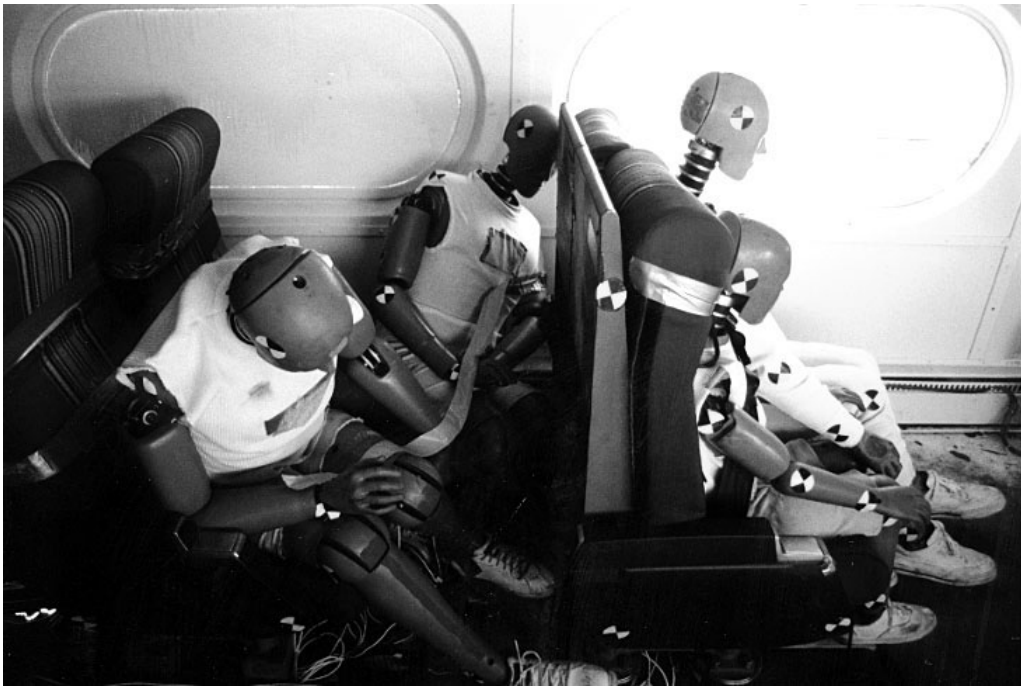
| <b>Table 2.</b>   |  |                            |
|---|--|----------------------------|
| <b>Experiment No. 2-1 - Row-to-Row Commuter Seats - Trailing Car;</b> |  |                            |
| <b>Occupant Injury Loads</b>  |  |                            |
|   | <b>Hybrid III 50th-Percentile, Aisle Seat Occupant</b> |                            |
|   | <b>Criteria</b>  | <b>Recorded Peak Loads</b> |
| HIC   | 1,000  | 118                        |
| Neck Fx (lb)  | +697/-697  | +350/-4                    |
| Neck Fy (lb)  | +697/-697  | +26/-9                     |
| Neck Fz (lb)  | +742/-900  | +323/-261                  |
| Upper Neck My (ft-lb)   | +140/-42   | +91/-42                    |
| Chest (G)   | 60   | 15                         |
| Left Femur (lb)   | -2,250   | -646                       |
| Right Femur (lb)  | -2,250   | -532                       |

### 3.3 EXPERIMENT NO. 1-2, FORWARD-FACING ROW-TO-ROW INTERCITY SEATS WITH RESTRAINTS, LEAD CAR

The intercity seats used in this two-car test were the same seats used in the single-car test. Minimal changes were made to the front row seat from the first test. These modifications included lowering the position of the energy absorbers to increase the effective moment arm between the point of knee impact and the horizontal actuation of the energy absorbers. The objective to reduce the forward motion of the seat back and effectively contain the unrestrained occupants from behind was met (Figure 8); however, the neck injury loads in these ATDs were exceeded.

#### 3.3.1 Experiment No. 1-2, Seat Outcome

The forward motion of the front seat's back panel (due to loading from the belted occupants) was greatly reduced from the first test. There was very little seat back panel deformation. What little seat back panel deformation did occur was due to the unrestrained ATD's knees impacting the seat from behind (Figure 9). While the seat stiffness helped compartmentalize the unrestrained



**Figure 8. Experiment No. 1-2 – Post-Test Photograph of View of Intercity Seats**



**Figure 9. Experiment No. 1-2 – Post-Test Photograph of Seat Back Deformation Due to Knees Impacting from Behind**



ATDs in the rear seat, it may have contributed to the excessive loads measured in the unrestrained (and instrumented) ATD's neck and knees. There was no notable deformation in the pedestals or in the longitudinal metal floor beams to which the seat was attached. The aft row seat cushions detached.

The measured peak seat attachment loads are provided in Appendix A (See Figure A-3).

### **3.3.2 Experiment No. 1-2, ATD Outcome**

For this experiment, a 95th-percentile ATD is situated in the rear aisle seat and was instrumented to measure head acceleration in three principal directions ( $A_x$ ,  $A_y$ ,  $A_z$ ) to determine head injury (HIC); upper neck tension/compression force ( $F_z$ ), upper neck shear forces ( $F_x$  and  $F_y$ ), and upper neck flexion/extension moment ( $M_y$ ) to predict neck injury; chest principal direction accelerations to determine chest injury; and right and left femur axial force for leg injury. A 5th-percentile ATD is situated in the front aisle seat and was instrumented to measure upper neck forces ( $F_x$ ,  $F_y$ , and  $F_z$ ), and upper neck flexion/extension moment ( $M_y$ ) to predict neck injury; and the shoulder belt was instrumented for tension load. From high-speed video, kinematics of the ATDs during the collision can be incorporated with time histories of the injury criteria to describe occupant response as follows.

The head, chest, and femurs of the rear seat occupants impacted the front row seat backs, causing some deformation in the seat back. The 95th-percentile ATD in the rear seat recorded neck flexion ( $-M_y$ ) and shear ( $+F_x$ ) loads, as well as right femur load in excess of the injury criteria. The high neck flexion moment occurred as a result of the ATD's chin impacting the seat back in front, and then "sticking" to the seat back while the ATD's shoulders and upper body continued to travel forward. While the head continued forward, the chin remained stuck in position, leaving the neck to go into severe flexion. Both the maximum neck shear and the maximum neck moment occurred at the same time. The peak knee load occurred when the right knee impacted the side frame of the seat in front. Similar excessive loads occurred to the instrumented ATD in the same experiment during the single-car test.

The restrained occupants in the front row remained seated, and the instrumented 5th-percentile ATD recorded loads that were all well below the respective injury criteria (See Table 3).

## **3.4 EXPERIMENT NO. 1-3, REAR-FACING COMMUTER SEAT, LEAD CAR**

The seat used in this test was modified from the first full-scale impact test with improved side wall attachments on the frame, and a higher strength pedestal. Minimal to no deformation occurred to the pedestal, and some deformation of the seat back occurred. The instrumented 50th-percentile ATD in the aisle seat measured neck loads that were all below the injury criteria.

### **3.4.1 Experiment No. 1-3, Seat Outcome**

The seat resisted the inertial loads of the seated ATDs. Due to the strengthened pedestal and seat frame, minimal deformation of the seat occurred. Deformation occurred in the seat pan frame primarily on the aisle side. It appears that the stiffened pedestal acted as a pivot point about which the aisle side of the seat frame deformed (Figure 10). The aft-facing seat pan rotated toward the front of the car under the inertial loads of the ATDs. Some deformation of the seat back also occurred as it rotated toward the front of the car (Figure 11).

| <b>Table 3.</b>  |  |                                |  |                                |
|--|--|--------------------------------|--|--------------------------------|
| <b>Experiment No. 1-2 – Row-to-Row Intercity Seats with Restraints - Lead Car;<br/>Occupant Injury Loads</b> |  |                                |  |                                |
|  | <b>Hybrid III 5th-Percentile, Aisle<br/>Seat, Front Row Occupant</b> |                                | <b>Hybrid III 95th-Percentile, Aisle<br/>Seat, Back Row Occupant</b> |                                |
|  | <b>Criteria</b>  | <b>Recorded Peak<br/>Loads</b> | <b>Criteria</b>  | <b>Recorded Peak<br/>Loads</b> |
| HIC  | 1,000  | (not measured)                 | 1,000  | 593                            |
| Neck Fx (lb)   | +438/-438  | +20/-70                        | +856/-856  | +897/-60                       |
| Neck Fy (lb)   | +438/-438  | +21/-25                        | +856/-856  | +25/-62                        |
| Neck Fz (lb)   | +468 / -567  | +168/-68                       | +910/-1,104  | No data                        |
| Neck Mx (ft-lb)  |  | (not measured)                 |  |                                |
| Neck My (ft-lb)  | +70 / -21  | +22/-14                        | +190/-58   | +209/-12.56                    |
| Chest (G)  | 60   | (not measured)                 | 60   | 28                             |
| Left Femur (lb)  | -1,530   | (not measured)                 | -2,594   | -815                           |
| Right Femur (lb)   | -1,530   | (not measured)                 | -2,594   | -2,765                         |
| Aisle Seat<br>Shoulder Belt (lb)   | N/A  | 445                            | N/A  | (Unrestrained)                 |
| Window Seat<br>Shoulder Belt (lb)  | N/A  | 782                            | N/A  | (Unrestrained)                 |

The peak measured seat attachment loads are provided in Appendix A (See Figure A-4).

### 3.4.2 Experiment No. 1-3, ATD Outcome

All three 50th-percentile ATDs were found lying on the floor in front of the seat after the test was over. It is likely that these ATDs may have been found in their seats post-test if there had been a seat installed in front of them. Without the additional row of seats, the ATDs were able to fall to the floor after rebounding in their seat. Most of the ATD's rebound was likely due to the seat releasing the energy it absorbed during the impact (Figure 12).

All injury measurements were made from instrumentation installed on the Hybrid III 50<sup>th</sup> percentile ATD seated in the aft row, aisle side. Instrumentation measured upper neck tension/compression force (Fz), upper neck shear force (Fx), and upper neck flexion/extension moment (My) to determine neck injury. From high-speed video, kinematics of the ATD during the collision can be incorporated with time histories of the injury criteria to describe occupant response as follow. The 50th-percentile ATD in the aisle seat recorded loads and moments that were below the respective injury criteria (see Table 4). Some neck hyperextension was observed in the ATDs upon initial impact.



**Figure 10. Experiment No. 1-3 – Post-Test Photograph of Seat Frame Deformation**



**Figure 11. Experiment No. 1-3 – Post-Test Photograph of Seat Back Deformation**



**Figure 12. Experiment No. 1-3 – Post-Test Photograph of ATDs on the Floor Following Rebound**

| <b>Table 4. Experiment No. 1-3 – Rear-Facing Commuter Seats – Lead Car;<br/>Occupant Injury Loads</b> |                 |                            |
|---|-----------------|----------------------------|
| <b>Hybrid III 50th-Percentile, Aisle Seat Occupant</b>  |                 |                            |
|   | <b>Criteria</b> | <b>Recorded Peak Loads</b> |
| Neck Fx (lb)  | +697/-697       | +278 /-46                  |
| Neck Fz (lb)  | +742/-900       | +87/-33                    |
| Neck My (ft-lb)   | +140/-42        | +10/-16                    |



## 4. CONCLUSIONS

The following conclusions can be drawn from the occupant protection portion of the two-car test.

- All the seats remained attached and provided occupant compartmentalization as a positive means of occupant protection.
- All the instrumented ATDs in the commuter seat/occupant experiments measured neck flexion and/or extension moments that exceeded the injury criteria.
- The difference in performance between the unmodified commuter seat in the leading car and the modified commuter seat in the trailing car was minimal. They both provided occupant compartmentalization, but, in both cases, the load of the instrumented ATDs exceeded neck injury criteria.
- Modifying the intercity seat to reduce the seat back rotation angle during impact improved occupant protection by providing compartmentalization and avoiding severe neck loads in the restrained 5th-percentile ATD in the front row. However, the unrestrained (and compartmentalized) 95th-percentile ATD measured injury loads that exceeded the same injury criteria that had been exceeded in the single-car test: knee, neck flexion, and neck shear.
- The aft-facing seat was modified and did effectively retain the occupants in their seats. If a seat row had been installed in front of the test seat, it may have prevented the ATDs from falling to the floor during the rebound phase of the deceleration.



## REFERENCES

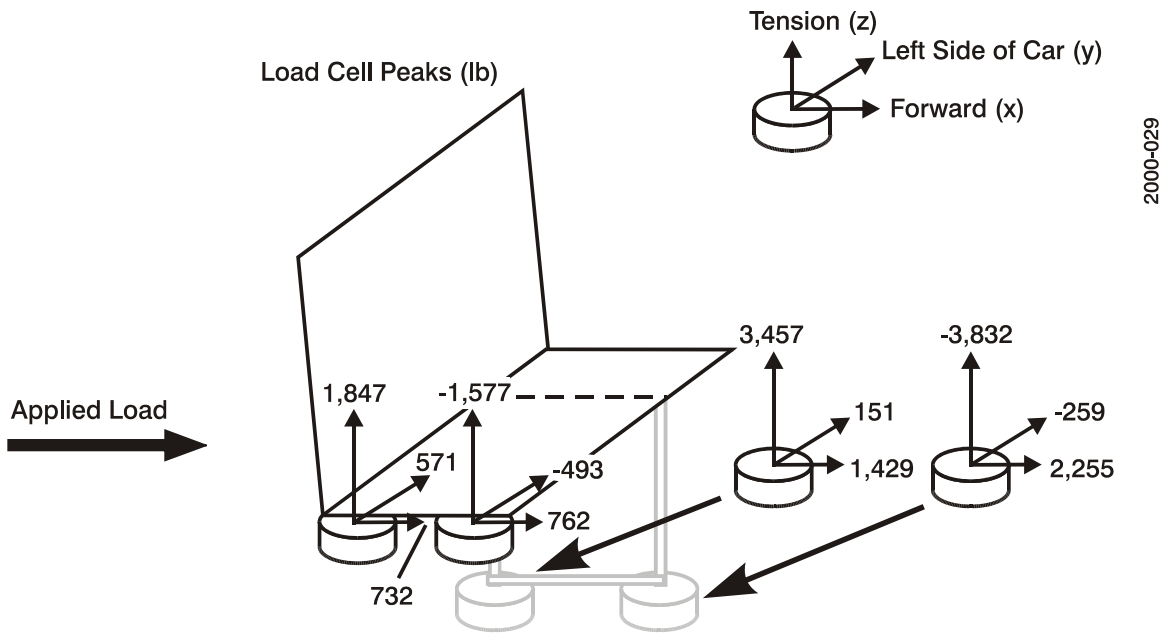
1. Tyrell, D., K. Severson, and A.B. Perlman. "Single Passenger Rail Car Impact Test – Volume I: Overview and Selected Results," U.S. Department of Transportation, DOT/FRA/ORD-00/02.1, March 2000.
2. VanIngen-Dunn, C. "Single Passenger Rail Car Impact Test – Volume II: Summary of Occupant Protection Program," U.S. Department of Transportation, DOT/FRA/ORD-00/2.2, March 2000.
3. Eppinger, R., E. Sun, F. Bandak, M. Haffner, N. Khaewpong, M. Maltese, S. Kuppa, T. Nguyen, E. Takhounts, R. Tannous, A. Zhang, and R. Saul, "Development of Improved Injury Criteria for the Assessment of Advanced Automotive Restraint Systems – II," Supplement to NHTSA Docket No. 1998-4405-9, 1999.
4. Melvin, J.W. and A.M. Nahum, Eds. "Accidental Injury: Biomechanics and Prevention," Springer-Verlag, 1993.
5. Tyrell, D., K. Severson, and B. Perlman, "Passenger Rail Two-Car Impact Test Volume I: Overview and Selected Results," U.S. Department of Transportation/Federal Railroad Administration, DOT/FRA/ORD-00/22.1, January 2002.
6. Brickle, B., "Passenger Rail Two-Car Impact Test Volume III: Test Procedures, Instrumentation, and Data," U.S. Department of Transportation/Federal Railroad Administration, DOT/FRA/ORD-01/22.3, January 2002.
7. U.S. Department of Transportation, Federal Railroad Administration, "49 CFR Part 216 et al., Passenger Equipment Safety Standards; Final Rule," Federal Register, May 12, 1999.



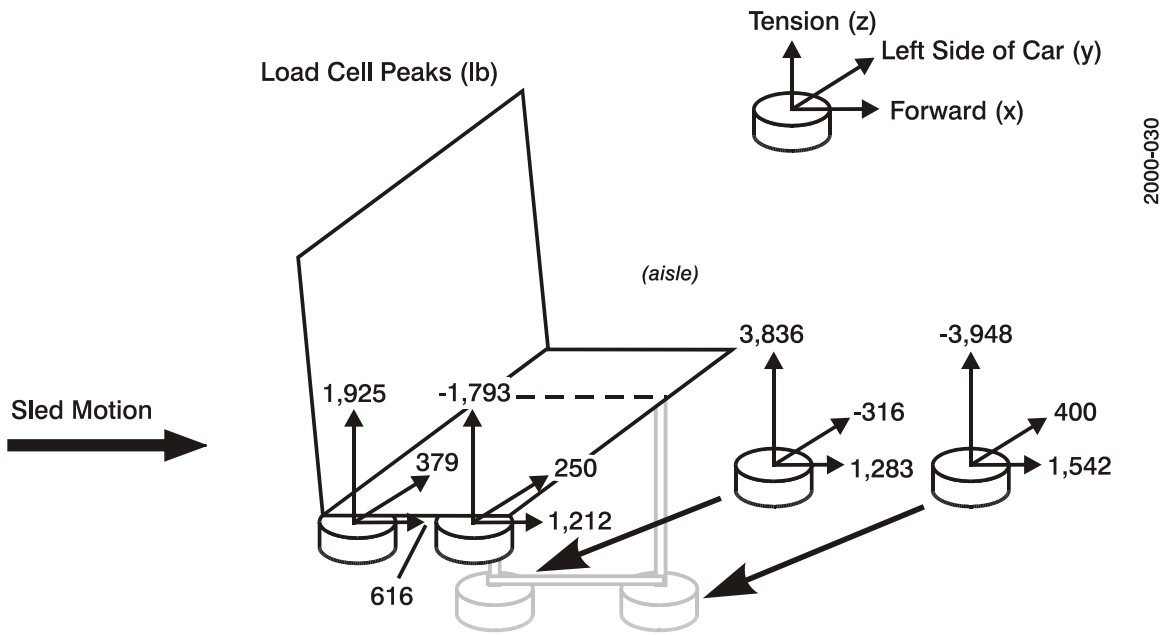


**APPENDIX A**  
**SEAT ATTACHMENT LOADS**

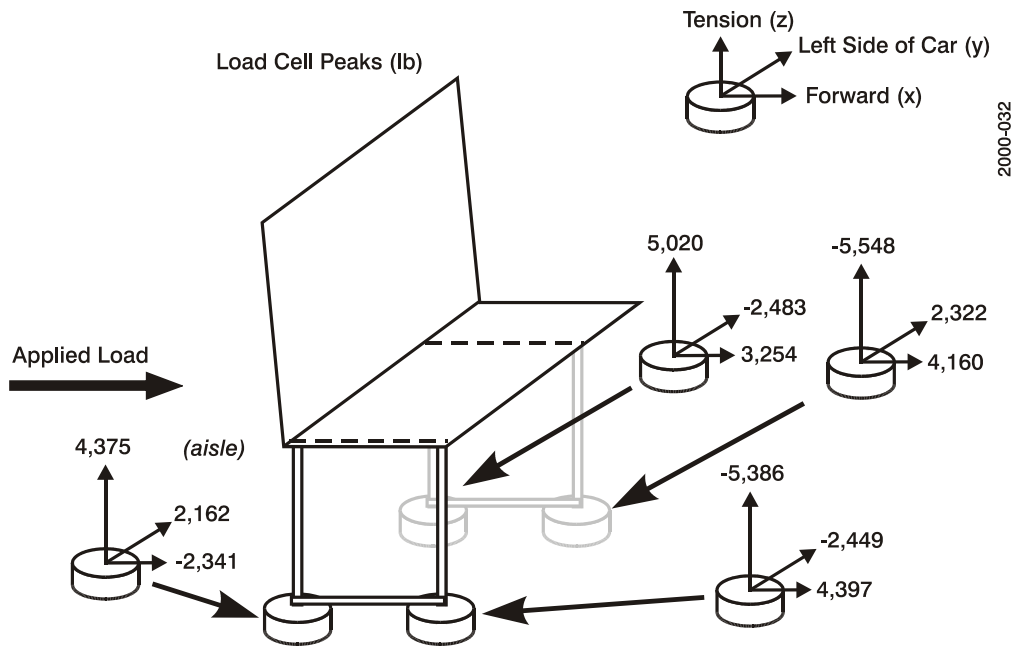




**Figure A-1. Experiment No. 1-1 – Forward-Facing Row-to-Row Commuter Seats, Lead Car Front Row Seat Attachment Loads (Maximums)**

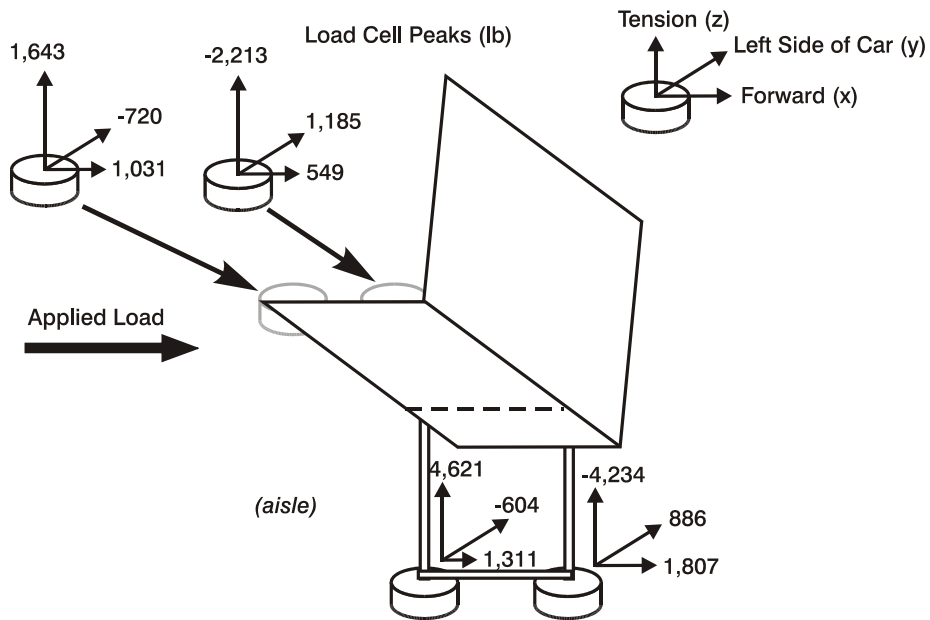


**Figure A-2. Experiment No. 2-1 - Forward-Facing Row-to-Row Commuter Seats, Trailing Car Front Row Seat Attachment Loads (Maximums).**



2000-032

**Figure A-3. Experiment No. 1-2 - Forward-Facing Row-to-Row Intercity Seats with Restraints, Lead Car. Front Row Seat Attachment Loads (Maximums).**



2000-031

**Figure A-4. Experiment No. 1-3 - Rear-Facing Commuter Seat, Lead Car. Seat Attachment Loads (Maximums)**

## **APPENDIX B**

### **INJURY DATA COMPARISON BETWEEN SINGLE-CAR TEST AND TWO-CAR TEST**



| <b>Table B-1.</b>                                       |   |                               |                           |                     |
|---|---|-------------------------------|---------------------------|---------------------|
| <b>Row-to-Row Commuter Seats – Maximum Injury Loads</b> |   |                               |                           |                     |
|   | <b>Hybrid III 50th-Percentile Back Row Occupant</b> |                               |                           |                     |
|   | <b>50th-Percentile Criteria</b>                     | <b>Single-Car Window Seat</b> | <b>Two-Car Aisle Seat</b> |                     |
|   |   |                               | <b>Leading Car</b>        | <b>Trailing Car</b> |
| HIC   | 1,000   | 202                           | 69                        | 118                 |
| Neck Fx (lb)  | +697/-697   | +242/-45                      | +437/-27                  | +350/-4             |
| Neck Fy (lb)  | +697/-697   | +93/-20                       | +37/-17                   | +26/-9              |
| Neck Fz (lb)  | +742/-900   | 327/-45                       | +164/-258                 | +323/-261           |
| Upper Neck My (ft-lb)                                   | +140/-42  | 37/-17                        | +148/-8                   | +91/-42             |
| Lower Neck My (ft-lb)                                   | +140/-42  | 33/-94                        | (Not measured)            | (Not measured)      |
| Chest (G)   | 60  | 14                            | 15                        | 15                  |
| Left Femur (lb)   | -2,250  | -671                          | -556                      | -646                |
| Right Femur (lb)  | -2,250  | -806                          | -555)                     | -532                |

| <b>Table B-2.</b>  |   |                               |                           |   |                               |                           |
|--|---|-------------------------------|---------------------------|---|-------------------------------|---------------------------|
| <b>Row-to-Row Intercity Seats with Restraints – Maximum Injury Loads</b> |   |                               |                           |   |                               |                           |
|  | <b>Hybrid III 5th-Percentile, Restrained Front Row Occupant</b> |                               |                           | <b>Hybrid III 95th-Percentile, Unrestrained Back Row Occupant</b> |                               |                           |
|  | <b>5th-Percentile Criteria</b>                                  | <b>Single-Car Window Seat</b> | <b>Two-Car Aisle Seat</b> | <b>95th-Percentile Criteria</b>                                   | <b>Single-Car Window Seat</b> | <b>Two-Car Aisle Seat</b> |
| HIC  | 1,000   | (Not measured)                | (Not measured)            | 1,000   | 854                           | 593                       |
| Neck Fx (lb)   | +438/-438   | +15/-126                      | +20/-70                   | +/-856  | +1,510/-99                    | +897/-60                  |
| Neck Fy (lb)   | +438/-438   | +17/-13                       | +21/-25                   | -856  | 30/-461                       | +25/-62                   |
| Neck Fz (lb)   | +468/-567   | +251/-299 <sup>(1)</sup>      | +168/-68                  | +910/-1,104   | +539/-710                     | No data                   |
| Neck My (ft-lb)  | +70/-21   | +22/-23                       | +22/-14                   | +190/-58  | +305/-44                      | +209/-13                  |
| Chest (G)  | 60  | (Not measured)                | (Not measured)            | 60  | 27                            | 28                        |
| Left Femur (lb)  | -1,530  | (Not measured)                | (Not measured)            | -2,594  | -1,959                        | -815                      |
| Right Femur (lb)   | -1,530  | (Not measured)                | (Not measured)            | -2,594  | -3,116                        | -2,765                    |
| Aisle-Seat Shoulder Belt (lb)  | N/A   | 1,603                         | 445                       | N/A   | (Unrestrained)                | (Unrestrained)            |
| Window Seat Shoulder Belt (lb)   | N/A   | 449                           | 782                       | N/A   | (Unrestrained)                | (Unrestrained)            |

<sup>(1)</sup>Time-dependent threshold exceeds injury criteria.



| <b>Table B-3.</b>                                       |                                     |                                       |                                     |                                    |
|---|-------------------------------------|---------------------------------------|-------------------------------------|------------------------------------|
| <b>Rear Facing Commuter Seat – Maximum Injury Loads</b> |                                     |                                       |                                     |                                    |
| <b>Hybrid III 50th Percentile, Aisle Seat Occupant</b>  |                                     |                                       |                                     |                                    |
|   | <b>95th-Percentile<br/>Criteria</b> | <b>Single-Car<br/>95th-Percentile</b> | <b>50th-Percentile<br/>Criteria</b> | <b>Two-Car<br/>50th-Percentile</b> |
| Neck Fx (lb)  | +856/-856                           | (Unreliable data)                     | +697/-697                           | +278/-46                           |
| Neck Fz (lb)  | +910/-1,104                         | +226/-62                              | +742/-900                           | +87/-33                            |
| Neck My (ft-lb)   | +190/-58                            | +29/-47                               | +140/-42                            | +10/-16                            |